

LTP
72
LEM

TRANSISTOR RADIO

servicing course

BY WAYNE LEMONS



6.95
-11 E

Transistor Radio Servicing Course

by
Wayne Lemons

BIBLIOTHEK
7307547
T.H. EINDHOVEN



HOWARD W. SAMS & CO., INC.
THE BOBBS-MERRILL CO., INC.
INDIANAPOLIS • KANSAS CITY • NEW YORK

FIRST EDITION
FIRST PRINTING—1972

Copyright © 1972 by Howard W. Sams & Co., Inc., Indianapolis, Indiana 46268.
Printed in the United States of America.

All rights reserved. Reproduction or use, without express permission, of editorial or pictorial content, in any manner, is prohibited. No patent liability is assumed with respect to the use of the information contained herein.

International Standard Book Number: 0-672-20914-4
Library of Congress Catalog Card Number: 72-76105

Preface

The idea and reason for this book goes back a year or so ago when a good friend of mine, Mr. Jerry Parks, a time-study engineer, got interested in transistor radios. He wanted a book that would start him at the bottom and take him all the way through the service techniques practiced by professionals, and he could not find any book that covered the subject in an up-to-date manner. So with that criterion in mind I wrote this book for Jerry. It includes revisions suggested by Jerry and my son Kirk, who read the manuscript and answered the questions at the end of the sections. It was through their suggestions that the answers to the questions are not just A, B, C, and D answers but include the reason for the answer as well. In many cases it is explained why some other answer is *not* correct.

I suggest that you try your best to answer all the questions at the end of the chapter before referring to the answers, then check yourself and see whether or not you understand what is being said at that particular point in the course. And don't be afraid to disagree with the answers given, because that is one way we all learn. However, to our knowledge, every answer is the correct one and each has been double or triple checked for accuracy. If you do disagree, though, do not hesitate to write me in care of the publishers, and you can be sure that I will do my best to get a letter back to you within a short time.

Radio service starts out being mechanical, as many things do. However, it can and does develop into an art, but NOT before you start DOING it. You no doubt have an old transistor radio or two around the house someplace—dig them out and start putting into practice what you are learning. Identify the various parts. Obtain a good volt-ohmmeter, if possible, and make measurements on the actual chassis. Things that sound simple on paper sometimes are the most difficult; conversely, sometimes the simplest things to do are the hardest to get down on paper clearly.

A good radio service technician can find almost any trouble with a small voltmeter and ohmmeter but it is axiomatic that the good technician also is the one who is continually adding to his equipment to help him make a quicker and more accurate diagnosis. Equipment will not make a good technician any more than a good camera will make a good photographer, but good equipment and tools make a good technician better and probably make a poor technician little if any worse.

WAYNE LEMONS

Contents

CHAPTER 1

PRINCIPLES OF RADIO	9
Properties of Vacuum Tubes — Radio Wave Propagation — How a Radio Works — What Is an Alternating Signal? — Audio or Audible Frequencies — Radio Frequencies — The Block Diagram of a Radio — The Radio Transmitter — Modulation — Detection — Back to the Block Diagram — About Voltage, Current, and Resistance — Test Questions	

CHAPTER 2

CAPACITORS AND RESISTORS	25
Capacitors — Variable Capacitors — Symbols for Capacitors — Tips About Capacitors in Radio and Electronic Equipment — Connecting Capacitors in Series — Capacitors in Parallel — Resistors — Resistors in Series — Resistors in Parallel — More Than Two Resistors in Parallel — Variable Resistors — Test Questions	

CHAPTER 3

INDUCTORS AND TRANSFORMERS	39
Inductors — Transformers Cannot Operate on DC—or Can They? — Impedance Match- ing — Transformer Construction — Autotransformers — Service — RF Transformers — Test Questions	

CHAPTER 4

THE MIXER-OSCILLATOR STAGE	47
Tuning — Resonance — Experimenting With Tuning a Crystal Radio — The Oscillator — Test Questions	

CHAPTER 5

THE INTERMEDIATE-FREQUENCY AMPLIFIER	53
I-F Transformers — Tuning the I-F Transformer — Oscillator and Tracking Adjust- ments — The Actual Circuit — Summary — Test Questions	

CHAPTER 6

THE DETECTOR 59
 Why Detection Is Necessary – Typical Detector Circuit – The Volume Control –
 Detector – Circuit Variations – Polarity of Diode Connection – Test Questions

CHAPTER 7

AUDIO AMPLIFIERS 63
 Speakers – Class-B Output Stages – Troubleshooting Methods – OTL Circuits –
 Another Type of OTL Circuit – The Higher-Voltage Single-Ended Output Stage
 – Direct-Coupled Audio Circuits – Checking the Audio in an Auto Radio – Test
 Questions

CHAPTER 8

TRANSISTOR AMPLIFYING AND SIMPLE AF AMPLIFIERS 69
 Switching – Single-Battery Biasing – The Need for Bias – Voltages Shown on
 Schematics – A Practical Transistor Amplifier – PNP Circuits – Adding a Transistor
 Amplifier to a Crystal Radio – A Shunt-Feed Circuit – Test Questions

CHAPTER 9

TEST EQUIPMENT 77
 Features of the VOM – Measuring Resistance – The Vacuum-Tube Voltmeter or
 Transistorized Voltmeter – Using a Voltmeter – Using the Ohmmeter – Testing
 Diodes With an Ohmmeter – Testing Transistors With an Ohmmeter – Signal Gen-
 erator – Signal Tracers – The Oscilloscope – DC Power Supplies – Test Questions

CHAPTER 10

A-M RADIO: CONVERTER SECTION 89
 Following the Signal – Trimmers – Variations in the Converter Circuit – Test
 Questions

CHAPTER 11

A-M RADIO: THE I-F AMPLIFIER 95
 I-F Amplifier Operation – Automatic Gain Control (AGC) – Testing the I-F Am-
 plifiers – Tuning or Alignment – Variations in I-F Circuits – Test Questions

CHAPTER 12

A-M RADIO: AUDIO AMPLIFIERS 105
 Amplifier Circuit Description – Other Audio Circuits – Direct-Coupled Circuits –
 Other Output Circuits – Testing the OTL Circuit – The “TL” Amplifier – Single-
 Ended Audio – Hints on Audio Circuit Repairing – Test Questions

CHAPTER 13

THE AM/FM RADIO	121
Frequency Modulation – The Antenna and RF Circuit – How to Find Troubles in the RF Amplifier – Voltage-Checking the RF Amplifier – The FM Converter (Mixer-Oscillator) – How to Check Oscillators – The FM I-F Amplifiers – Testing the I-F Amplifier – The FM Demodulator – AGC Circuits – Combination AM/FM I-F Amplifiers – Testing the Combination Circuit – Test Questions	

CHAPTER 14

TROUBLESHOOTING RADIO CIRCUITS	135
“Hot” and “Cold” Sides of Circuits – Checking Transistor Stages With a Resistor – Signal Tracing – Transistor Testing by Substitution – Transistor Basing – Disconnecting Printed-Circuit Components – Troubleshooting with an Ohmmeter – Voltage Tests – Visual Troubleshooting – Radio-Frequency Circuits – Parallel-Resonant Circuits – Coupling Methods – Test Questions	

CHAPTER 15

TESTING AND REPLACING COMPONENT PARTS	149
Testing Components With an Ohmmeter – Testing Capacitors – Testing Resistors – Testing Components With a Voltmeter – Double Checking – Voltage Interpretation – Replacing Transistors – General Hints on Replacing and Removing Parts – Test Questions	

CHAPTER 16

FET AMPLIFIERS AND IC CIRCUITS	159
FET Construction and Operation – The JFET in Circuit – The IGFET – Testing an IGFET or a MOSFET With an Ohmmeter – ICs – Test Questions	
ANSWERS TO TEST QUESTIONS	167
INDEX	187

CHAPTER 1

Principles of Radio

Radio was predicted as a possibility by a mathematician, James Clerk Maxwell, about 100 years ago. Heinrich Hertz, a German physicist, proved the Maxwell theories were correct. In 1895 an Italian, Guglielmo Marconi, began developing a practical radio and transmitter. By 1901 he was able to send a radio signal across the Atlantic. Radio seemed like magic then and it still seems so today. In 1906, an American, Dr. Lee De Forest, added a grid to the vacuum-tube diode, or "valve" as the developer, J. A. Fleming, called it. The grid made the diode tube an amplifier, and for the first time, it became possible to transmit and receive voice and music by radio. Before this, spark-gap transmitters were used and information could only be sent by code—that is, by turning the spark on and off in a dot and dash code sequence.

The vacuum-tube amplifier, which De Forest called an "audion," was able to respond to the many variations in the spoken word or music and amplify these variations with good fidelity. These variations were used to "modulate" or produce a change in the high-frequency signal generated by another audion tube. This signal, called a "carrier," was radiated through the air, carrying with it the voice or music modulation.

The audion could amplify the weak signal arriving at a distant receiving location. De Forest developed a regenerative receiver circuit permitting tremendous amplification in the radio receiver and using only one tube. This circuit, which was also patented by Edwin H. Armstrong, the inventor of the superheterodyne receiver so common today, was essential to early radio because the first audions were expensive as well as delicate.

Essentially, the regenerative circuit uses feedback, in controlled amounts, from the output of the amplifier back to the input, which easily builds up the received signal to headphone level, even from distant stations. In addition, the regenerative circuit uses few other parts, is highly selective, and requires little power. Its big disadvantages are that it is difficult to tune and tends to radiate a signal of its own like a small transmitter, especially when only one tube is used. Because of its excellent performance and sim-

plicity, the circuit is still a favorite with experimenters, even in this day of inexpensive transistors.

PROPERTIES OF VACUUM TUBES

The vacuum tube is a "space" amplifier; that is, the current travels through open space inside an evacuated glass or metal envelope. Until 1948, all serious amplification of radio and audio signals was by vacuum tube. In 1948, John Bardeen and Walter Brattain of Bell Telephone Laboratories announced the development of the transistor. At the time it was hardly more than a novelty—extremely delicate, noisy, and not suitable for amplification of higher frequencies. But "solid state" was on its way. "Solid state" means that the conduction and change in conduction takes place within a "solid" piece of material, such as germanium or silicon, and there are no longer any discrete spaces over which the electrical current flows.

Vacuum tubes require much higher voltages to attract the current across the space, and it is not at all unusual for tube-type radio receivers to have dc voltages in excess of 100 volts and often as much as 300 volts or more. Today most solid-state devices use no more than 25 or 30 volts, and nearly all portable battery-operated radios use no more than 9 volts.

A vacuum tube requires a heater or filament to "agitate" the electrons away from the cathode so they will be attracted to the plate of the tube. A transistor requires only a voltage difference between its elements to start current flow. The heater or filament in a vacuum tube consumes about 90% of the power needed to supply an amplifier, so the transistor, with its low current requirements, was especially attractive to the designer of the portable radio receiver, and it was here that the first real commercial use of the transistor began. Early transistor radios were not the sophisticated performers that we know today. They had less sensitivity, were more noisy, had poorer tone quality, and were more temperamental than their tube counterparts. With time, manufacturers learned how to produce transistors with more gain, more stability, wider frequency response and the circuits to match.

For the first time, the transistor became a serious rival for the vacuum tube, and today has all but replaced it in many circuits where it once reigned supreme.

RADIO WAVE PROPAGATION

Radio waves travel through the air at the speed of light (186,000 miles per second) and, depending on several factors—power, frequency, terrain, time of day, and time of year—may travel miles, hundreds of miles, thousands of miles, or even millions of miles through space.

The propagation of radio waves has been compared to the results of dropping a pebble in a pool of water. The pebble disturbs the water, sending out ripples in ever-widening circles. This is probably as good an analogy as any, except that it is not known that radio requires a medium through which to travel. Long before we landed on the moon, this was demonstrated by bouncing signals off the moon and picking up the faint return or echo signals.

Bouncing signals off the moon was a landmark, but much earlier than this, during World War II, radio waves were being bounced off earthbound objects, such as enemy ships, tanks, and airplanes, and their distance and direction were being accurately calculated. Fig. 1-1 shows how a radio signal can be beamed out over

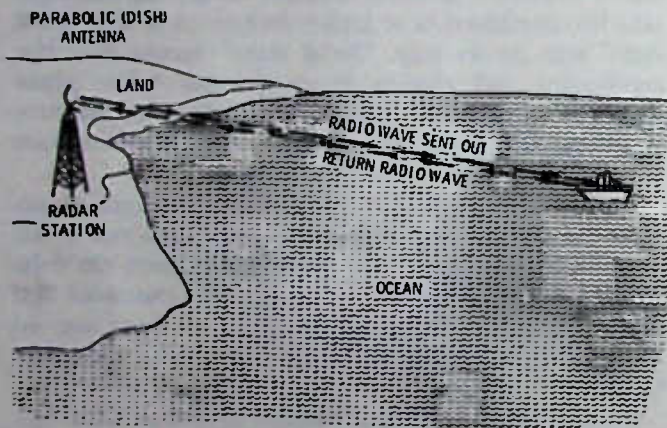

Fig. 1-1. Radar finds a ship and determines how far away it is.

the ocean and the reflected signal from ships or planes detected by the sender. This system is called radar (radio detection and ranging). It is still in use today with highly sophisticated methods which will show not just one ship or plane, but all ships and planes in a circle around the radar station, and will calculate their speed, altitude, and distance.

The police radar in use today is a refinement of one of the earliest types of radar called the Doppler system. The returning radio signal is reflected back to the receiver as a car approaches the radar transmitter. Special detector circuits compute the speed in miles per hour and apply that information either to a meter or a digital readout. For example, in Fig. 1-2, the radar

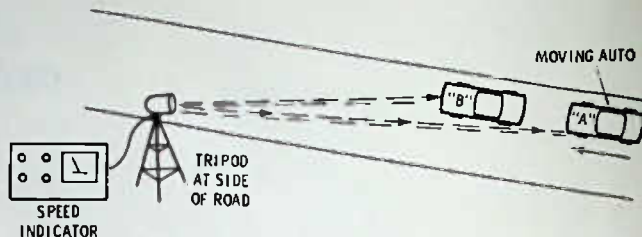

Fig. 1-2. Radar used to check speed of traffic.

unit first receives a reflection when the car is at point "A" then an instant later receives the reflected signal from the car at point "B," etc.

It is not within the scope of this book to discuss radar in detail, but radar is an intriguing part of the radio story and it has proved beyond question that the calculations of the speed of radio waves were extremely accurate. For example, in Fig. 1-1, the distance to the ship is determined by measuring very accurately the time interval between when the signal leaves the radar antenna and when it is received back. Knowing that radio waves travel at a speed of 186,000 miles per second there and back, the distance can be accurately indicated. Obviously the trip out and back for the radio wave, even if the ship is 50 miles away, is in microseconds (millionths of a second), but electronics is also used for measuring time and a microsecond is a "long" time for electronic circuit actions.

HOW A RADIO WORKS

The first radio receivers had no amplification. Later in this chapter there is a wiring diagram of a crystal set that will pick up nearby a-m broadcast stations, if you use a good antenna and ground system and listen with a pair of headphones. The crystal set has no amplification.

De Forest's audion tube made all the difference, because now a tiny signal coming in to the antenna could be made larger and larger, while still retaining its original character. This building up of the signal is called amplification. Today transistors are used in most broadcast receivers because they are smaller, use less power, have almost no heat problems, start operating as soon as power is applied, and cost less; however, it was the vacuum tube that started it all.

The idea behind any amplifier is that a tiny alternating voltage such as a radio signal can be used to control a higher current from a battery or other power supply, and control this higher current in exact step with itself. For example, assume you want to receive a broadcast signal at 600,000 cycles per second (600 kilohertz—hertz is the official name now for what several years ago was called cycles-per-second. Kilo is a prefix meaning 1000. Thus 600,000 cycles per second is 600 kilohertz) which we want to amplify (see Fig. 1-3). You feed this signal into the input of the amplifier and

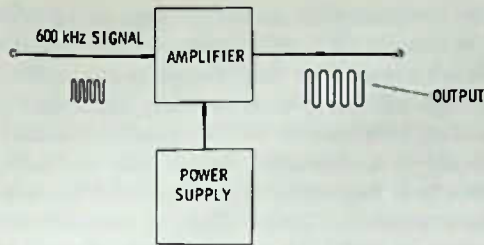

Fig. 1-3. "Black box" description of an amplifier.

at the output get an exact replica, only with greater amplitude. This occurs because the amplifier is able to use the small signal going into it to control a much larger current from its power supply.

Amplification might be compared to an automobile, where a pound or so of pressure on the accelerator can easily control 100 horsepower. Moving the accelerator up and down causes the car to respond accordingly. In an electronic amplifier, moving the voltage fed to a transistor up and down moves the current up and down at the same rate, but in greatly increased amounts from the power supply.

WHAT IS AN ALTERNATING SIGNAL

You probably understand that a direct current (dc), such as that supplied by a battery, is the kind of current that is steady and unchanging. You may even think that the electricity that lights the lights, toasts your bread, heats your coffee pot, and does many other things in your home is a steady current also. Not so. Nearly every power company supplies alternating current. In the United States that current is 60 Hz. (You will still see many things labeled "60 cycles" or "60 cps"—cycles-per-second—especially items not manufactured in the past decade.) This means that the voltage coming into your home is changing direction at a rate of 60 times per second. This is fast enough so that even though the table lamp you use is going on and off 120 times per second (there are 60 positive half cycles and 60 negative half cycles each second) you are not able to see it happen. Even if the lamp could dim out and brighten up that fast, your eyes retain or "hold" what they see for a fraction of a second, so that you are unable to recognize changes of much more than 15 cycles per second.

Alternating current is depicted as in Fig. 1-4. This is called a "sine wave." The sine wave is a graph show-

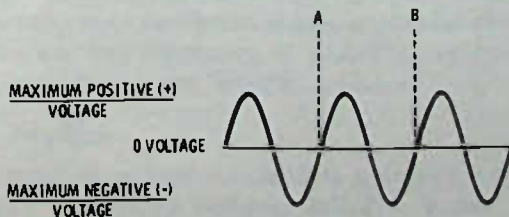

Fig. 1-4. Sine-wave symbol for alternating current. Time lapse between A and B for 60-Hz current is 1/60 second.

ing the voltage (or current) as it recurs in time. The number of times the sine wave repeats itself each second is called "frequency," and so for the power line the frequency is 60 Hz.

AUDIO OR AUDIBLE FREQUENCIES

Although, so far as the eye is concerned, 60 Hz is fast; to the ear this is a low frequency. If you listen closely to a radio operating on the power line you will no doubt hear a slight hum. This hum is at either 60 Hz or 120 Hz, depending on the type of power-supply circuit used.

The audio-frequency band is considered more or less arbitrarily to be 20 Hz to 20,000 Hz (20 kHz). Few people hear well much above 16 kHz and, if you are over 25 years of age, you probably do not hear well above 12 to 14 kHz. Women usually are slightly better than men in hearing high frequencies.

Fortunately most of the sounds you use are concentrated in the band between about 100 Hz and 8000 Hz, and telephone conversations are restricted to a much narrower band than this—from about 400 Hz to around 2500 Hz. This gives the telephone its characteristic "crisp, tinny" sound but the actual intelligibility or "readability" of the sound is improved.

A-m radio stations try to reproduce sound with good fidelity over the range of about 100 Hz to 10,000 Hz. Fm stations may extend this range a bit more from about 50 Hz to 15,000 Hz. High-fidelity amplifiers usually reproduce all frequencies equally well between about 20 Hz to 20,000 Hz, but almost no present-day speaker system, even the most expensive ones, can reproduce this range as faithfully as the amplifier can amplify it. Often the tone controls of hi-fi amplifiers are set by the user to reduce the higher frequencies (treble), because most of the hiss and noise heard on records or in radio transmissions is at frequencies above 8000 Hz.

RADIO FREQUENCIES

Audio frequencies (abbreviated af) are all low frequencies compared to radio frequencies; for example, the lowest frequency for a standard broadcast station is 540,000 Hz (540 kHz). Although all frequencies above 20,000 Hz are considered to be radio frequencies (abbreviated rf), most use is made of those frequencies above 150 kHz. However, some special long-distance radios, especially in government service such as communication with submarines, operate even to frequencies below 20 kHz.

The low end of the broadcast band (540 kHz) is still a low frequency compared to the fm broadcast band, which is from 88 to 108 megahertz (mega is the prefix for million). Even fm is a low frequency compared to the radar and microwave frequencies, which are measured in gigahertz (giga is a billion).

THE BLOCK DIAGRAM OF A RADIO

A favorite recourse of engineers when drawing out a system is to use "black boxes"—simply a rectangle, triangle, or square to indicate a portion of the circuit which may have a number of individual parts to do one specific job. For instance, in Fig. 1-5 a "black box"



Fig. 1-5. "Black box" diagram of pa amplifier.

is used to symbolize a public-address amplifier rather than to show all the various transistors (or tubes), resistors, capacitors, transformers, etc., that are actually the component parts of the amplifier. Fig. 1-6 shows how the one big block can be broken down to smaller blocks for a more complete representation of the amplifier design. Either Fig. 1-5 or Fig. 1-6 is a useful representation of the same system. While Fig. 1-6 could be more useful in understanding the pa amplifier itself, Fig. 1-5 is less confusing in explaining the overall system, especially if there are many auxiliary systems connected with the main system.

The circuit used almost universally in radio receivers, whether they are tube or transistor types, is called the superheterodyne or "superhet" for short. The superhet differs from earlier radios in that it changes

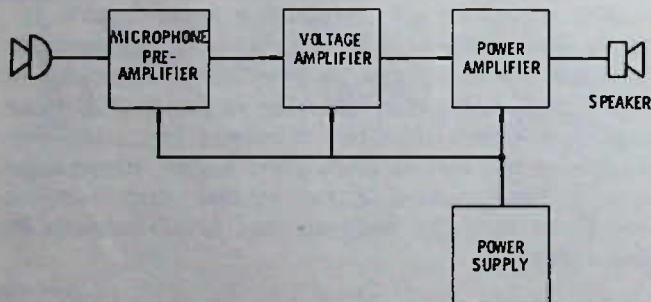

Fig. 1-6. A more detailed "black box" diagram is called a block diagram.

whatever frequency it receives into some other frequency before much amplification of the signal occurs. The idea is to provide a fixed-frequency amplifier, built to have high efficiency and stability, and then change all incoming frequencies to this fixed frequency.

Obviously it is necessary to be able to "select" stations since it is impossible to effectively listen to more than one station at a time. Thus, if we want to listen to a station on 600 kHz we obviously do not want to listen also to a station at 1200 kHz or some other frequency. This ability to select one station and reject others is referred to as the "selectivity" of the receiver.

How is the station selected and how is its frequency changed to a new frequency for amplification? Let us look at the block diagram of a standard broadcast radio shown in Fig. 1-7. Suppose that the radio is tuned to a station on 1000 kHz. The 1000 kHz signal is fed from the antenna into a mixer stage. The block just below the mixer is an oscillator stage. An oscillator is an electronic device that generates a signal at a particular frequency. Now, just as hitting two notes on a piano produces a third sound, beating together (called heterodyning) two rf signals produces other frequencies. The two most prominent resultant frequencies are the difference and the sum frequencies. Usually, in radio, the difference frequency is the one used. In Fig. 1-7 the difference between 1000 kHz and 1455 kHz is 455 kHz, and this is the frequency to which the i-f (intermediate frequency) amplifier is tuned. (Methods of tuning or selection of a particular frequency will be covered later in this book). Since the i-f amplifier is tuned to 455 kHz, it essentially rejects any other frequency created by the mixing, such as, for example, the 2455-kHz "sum" frequency.

Next, suppose that the station to be tuned in is at 1200 kHz. How can it be selected while rejecting the 1000 kHz? Although there is some tuning done in the mixer stage that enhances the 1200 kHz signal and diminishes the 1000 kHz, the main selective action occurs because the oscillator frequency is changed by tuning (turning the radio dial moves the necessary electrical parts that do the tuning) to 1655 kHz. The

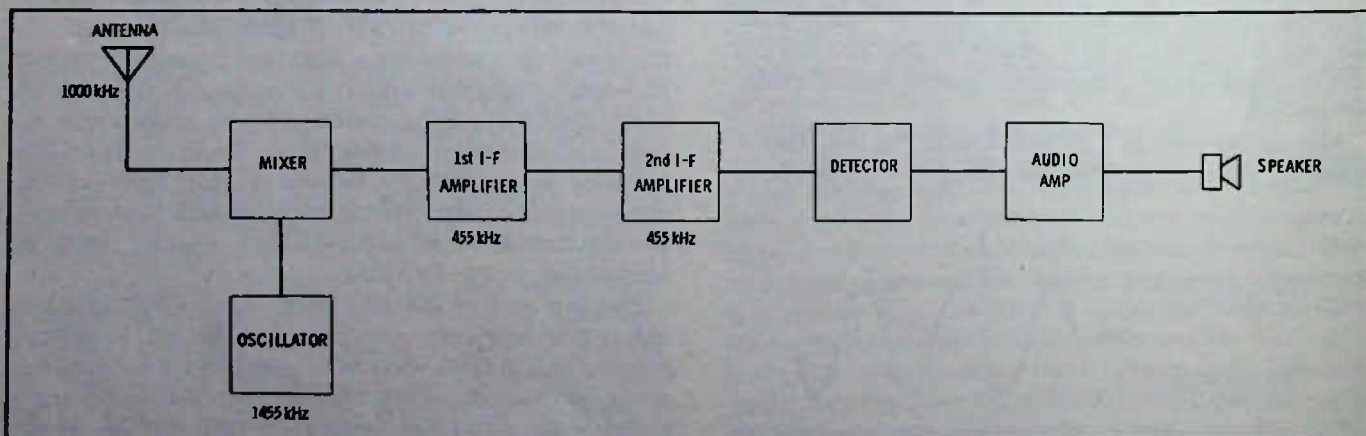

Fig. 1-7. Block diagram of superhet standard broadcast radio.

1200 kHz signal beats against the 1655 kHz of the oscillator and the result is 455 kHz. This signal is amplified by the i-f amplifier, which is sharply fixed-tuned to accept only 455 kHz, plus or minus no more than about 20 kHz. The previous 1000-kHz signal, even though it might still be strong in the mixer, beating against the 1655-kHz signal produces a difference frequency of 655 kHz, and so it is completely rejected by the 455-kHz i-f amplifier.

By this method of changing the oscillator frequency and having a sharply tuned i-f amplifier, all the broadcast frequencies can be selected, changed in frequency, and amplified efficiently. Thus we have a rather simple, selective, and sensitive radio.

THE RADIO TRANSMITTER

Once the signal has been changed to the i-f it may be amplified by one or more transistor amplifiers before it reaches the "detector." Essentially, the purpose of the detector is to separate the audio (that part of the signal that can be heard) from the rf or radio frequency. The fact that there are both radio and audio frequencies that need to be separated traveling together makes it necessary for us to look again at the transmitter and at how the audio is mixed with the radio frequencies in the first place; again let us look at a block diagram.

Radio Frequency Oscillator

In Fig. 1-8 are the basic parts of a simple radio transmitter. There is a radio-frequency oscillator, which is usually controlled to a specific frequency by a "crystal."

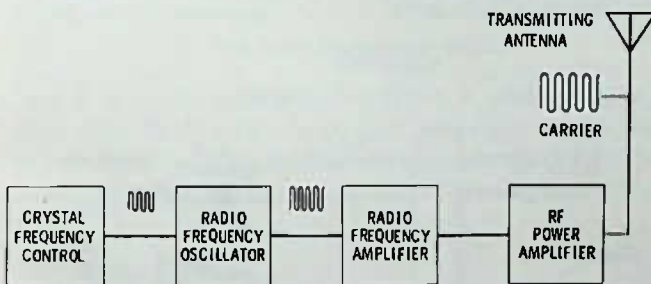

Fig. 1-8. Block diagram of a radio transmitter.

tal." The crystal is a specially ground quartz chip that has the property of vibrating at a single frequency and creating a tiny alternating voltage for each vibration. A radio-frequency oscillator using a crystal for holding it stable on one frequency is called a crystal-controlled oscillator or just "crystal oscillator."

Buffer Amplifier

Following the crystal oscillator is generally a radio-frequency amplifier, sometimes called a "buffer" amplifier, which increases the output of the oscillator enough that a larger power amplifier can be driven.

The buffer amplifier in many cases may be a "multiplier"—usually a "doubler or a tripler," meaning that the input frequency is changed to either double or triple the oscillator frequency. For example, a standard broadcast station operating on 540 kHz could use a crystal oscillator on 270 kHz, which could then become 540 kHz after being doubled in the buffer amplifier, or the crystal oscillator could operate at 180 kHz and be tripled to 540 kHz. Multiplying must be in a whole-number mathematical relationship with the original signal. In radio this is called harmonic relationship. In other words, it is a multiplication by 2, 3, 4, etc. For instance, the 2nd harmonic of 100 kHz is 200 kHz; the 3rd harmonic is 300 kHz, etc.

Power Amplifier

The power amplifier in a transmitter is called the "final amplifier" or just "final" for short. It builds up the power of the radio signal before the signal is applied to the antenna. Both transmitter and receivers have some sort of antenna system. The transmitting antenna is normally a tower or a transmitting element mounted on a tower. (The receiving antenna in most modern-day broadcast radios is "built in," that is, inside the radio cabinet.) Although this transmitter will send out a radio-frequency signal from the antenna which, depending on the power and other factors such as the frequency used, may radiate for a hundred miles or even hundreds of miles, it still is not of much use to us in this form. Although the radio signals may reach us, there is no information that we can easily use, because our ears cannot hear radio frequencies. Now it is necessary that we use a radio frequency since only a radio frequency can travel these great distances through space, but we need to have this radio frequency "carry" audio frequencies, voice, music, etc., so that we can get information or entertainment from radio. It is because the radio frequency is used to "carry" other frequencies that the radio frequency power output of a transmitter is called a "carrier."

MODULATION

The process of inserting audio frequencies or other information into the carrier is called "modulation." There are several different methods of modulation possible, but the two most common are "amplitude modulation" (a-m) and "frequency modulation" (fm). Fm will be discussed later in this book. Amplitude modulation is used on the standard broadcast band (535 kHz to 1605 kHz) and on most shortwave bands (bands of frequencies above about 2000 kHz are often called "shortwave" frequencies, although frequencies higher than about 50 MHz are usually referred to by other names, such as vhf [very high frequency], etc.). A-m also is used, for example, in Citizens Band (CB) transmitters.

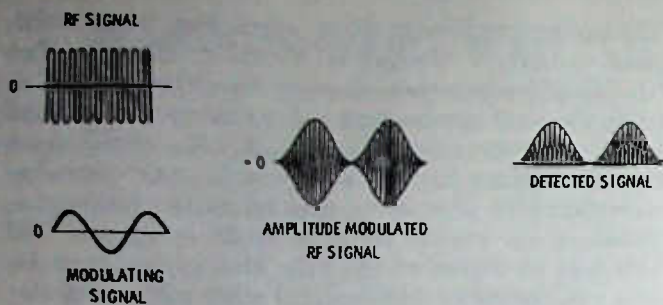

Fig. 1-9. Amplitude modulation is the changing of the rf power output in step with a modulating signal.

Amplitude modulation is modulation that is placed on the carrier by changing the power (or amplitude) of the carrier in accordance with an audio or other signal. In Fig. 1-9, for example, an audio frequency is shown being mixed with a radio frequency to produce an rf signal whose power output varies in accordance with the af signal. Fig. 1-10 is a block diagram of a radio transmitter for voice modulation.

A characteristic of amplitude modulation is that the modulation is symmetrical, that is, the power output goes up in a positive direction and at the same time goes down the same amount in a negative direction. This means that if this raw signal is applied to the vibrating diaphragm of a headphone, or to a speaker, there is no output since the positive excursion tries to move the diaphragm in one direction and the negative excursion tries to move it exactly the same amount in the opposite direction. The two audio signals cancel themselves out and the diaphragm in the headphone does not move. So if a modulated rf signal is applied to a headphone you hear nothing. And this gets us back to "detection" in the radio receiver, why it is necessary, and how it works.

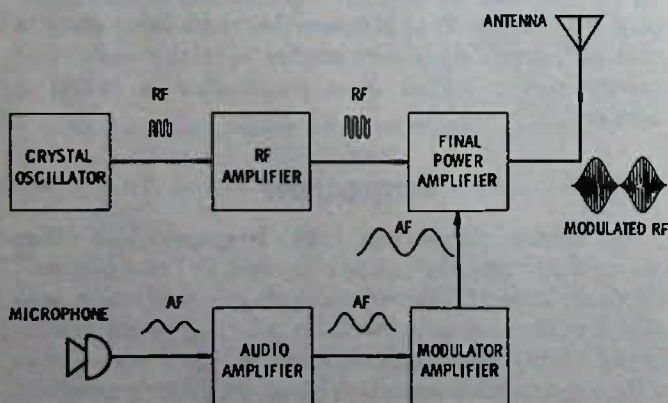

Fig. 1-10. Block diagram of radio transmitter with facilities for voice modulation.

DETECTION

If you look again at Fig. 1-9 you can see that one side of the modulated signal is a mirror image of the other. Since the mirror image is what causes the signal

to cancel the audio modulation, why not cut the signal in half along the zero line and eliminate one half or the other?

The part of the signal going upward is considered to be the positive-going half and the part going downward is the negative-going half. If either the positive or negative half is applied to a headphone diaphragm, it will vibrate in step with the change in rf power, because the audio-cancelling effect has been removed.

How can the signal be cut in half? The answer—by passing the signal through some sort of device that allows electric current to flow in only one direction. This type of action is pictured in Fig. 1-11.

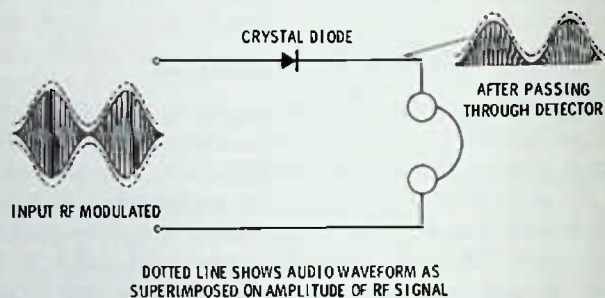

Fig. 1-11. A crystal diode allows current to pass in one direction only.

One of the oldest forms of detection is by means of a "crystal." (Do not confuse this with the quartz crystal used to hold a radio transmitter on frequency.) Early crystals were made of lead sulfide, called "galena." A tiny pointed wire called a "cat whisker" was used to find a sensitive spot, Fig. 1-12. Present-day crystals are fixed-junction type crystals, often no larger than a pencil lead and less than a half inch long, as shown in Fig. 1-13.

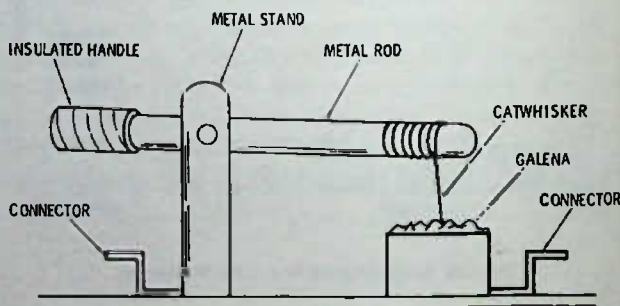

Fig. 1-12. Crystal and catwhisker detector unit used in early days of radio and still available for the experimenter.

Fig. 1-14 shows crystal-detector circuits using a fixed diode detector. The rf coil in the circuit of Fig. 1-14A allows the negative half of the signal to have a return path to ground while the positive half cycles are flowing easily through the detector diode to the headphones. The circuit in Fig. 1-14B does not use a coil. The negative half of the signal flows directly to ground while the positive half is blocked and must travel through the earphones instead.

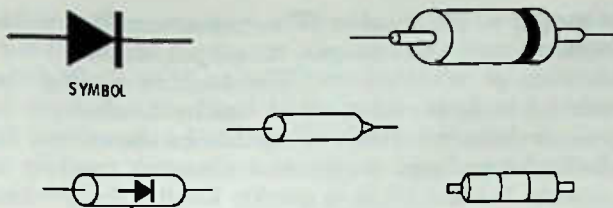
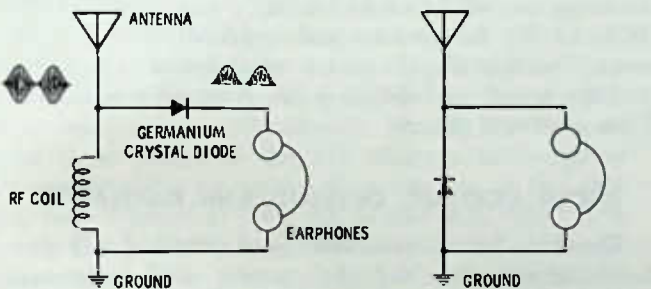

Fig. 1-13. Representative diodes drawn to approximate scale. White line or color bands around diode normally indicate cathode end.

Both of these circuits have the disadvantage of no selectivity; that is, there is no tuning and so all signals on the antenna will be detected. If you live close to a single a-m station, it will be the only one you can hear anyhow, and being able to select stations is unimportant. Later you will be told how to add tuning and selectivity to a crystal radio.

The antenna wire should be from 25 to 100 feet long, and a ground wire should be connected to a cold-water pipe or to a stake driven in moist ground.

The circuit of Fig. 1-14B, though simpler, may not work as well in some cases as the circuit in Fig. 1-14A,



(A) Diode in series, passing positive excursions of signal. (B) Diode in parallel; positive excursions operate headphones.

Fig. 1-14. Two crystal detector circuits.

but it is easily constructed and for a nearby station may work fairly well. If you plan to build a crystal set, we recommend that you follow the instructions in the next few paragraphs.

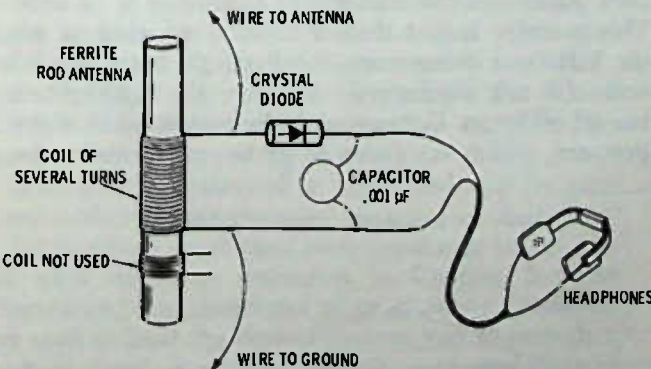

• DOTS ARE TWISTED OR SOLDERED CONNECTIONS

(A) Pictorial diagram.

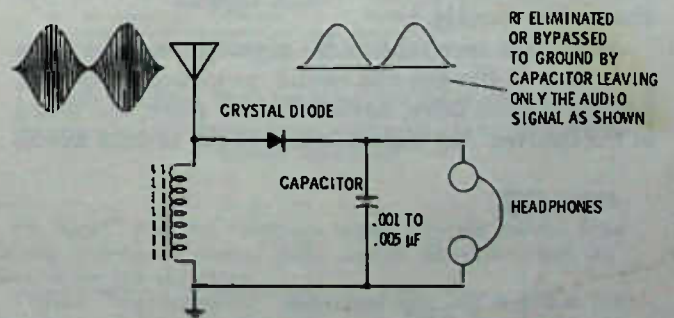

(B) Schematic.

Fig. 1-15. Crystal radio for receiving local a-m broadcast station.

For a practical radio to receive a single station close by you might want to use the following procedure. Find a discarded radio that has a ferrite-rod antenna coil. You will recognize the coil easily—it is a black, round or rectangular rod about 3 to 8 inches long, mounted externally to the radio chassis inside the radio cabinet. This coil will usually have two sets of windings on it—one with several turns of wire and one with only a few turns. Use the coil with several turns of wire. Buy a germanium diode from a dealer—just ask him for an inexpensive diode detector (type 1N34 is a popular detector diode). Obtain a set of headphones with an impedance of 2000 ohms or more. Also ask the dealer for a .002-μF capacitor, or you may be able to salvage one out of the old radio (any size from about .001 μF to .005 μF will be satisfactory—the voltage rating is not important).

Fig. 1-15 shows both a pictorial diagram and a regular "schematic" diagram for the crystal radio receiver to listen in on a local a-m broadcast station. If you have more than one local station close by you will need to build a "tunable" receiver, which will be described later, otherwise you will hear a jumble of stations.

The new component added in this circuit is the capacitor, which has not previously been discussed. A capacitor is an electrical device that has the property of passing alternating current through it while blocking or stopping any flow of direct current (dc). The capacitor has still another property that can be used to advantage. It allows alternating current of high frequencies to pass through more easily than lower frequencies.

Using a capacitor across the headphones in this last manner essentially bypasses all the rf around the headphones, leaving a "smoothed out" audio signal. Add-

*In reality the audio signal is simply a series of radio-frequency pulses whose heights correspond to the audio modulation. A capacitor of the correct size will not have time to discharge between the rf pulses but provides a "bridge" between the pulses that "cleans up" the audio signal.

ing a capacitor not only improves the sensitivity of the circuit in many cases, but it can also be selected to give the most desirable audio tone quality. The size of the capacitor is not too critical, but too large a capacitor will reduce the apparent audio volume and also make the audio more "bassy" since more of the treble or high frequency tones will be bypassed by the capacitor around the headphones. See Fig. 1-16.

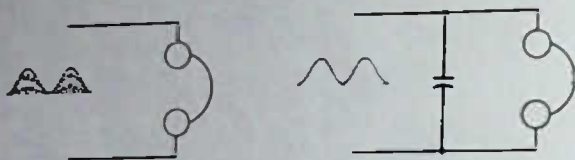

Fig. 1-16. Capacitor across headphones to bypass rf.

BACK TO THE BLOCK DIAGRAM

The block diagram of Fig. 1-17 is a slightly modified version of the previous one in this chapter. The mixer and oscillator circuit have been included in one block since, as a practical matter, one transistor is frequently both mixer and oscillator. A volume-control block has been added to show its location in the signal path. The detector is a crystal detector, and it detects the i-f signal, which, although changed in frequency from the original incoming frequency, still retains the audio modulation.

After the signal is detected and the rf signal has been bypassed, the audio signal is passed on to the volume control. The volume control taps off the amount of audio signal desired by the radio user. This signal is applied to a set of audio amplifiers—sometimes only one transistor, sometimes two or more—before being fed to the power amplifiers. These power amplifiers provide an increased audio current flow for operating the speaker or speakers. In transistor radios using batteries, there are usually two transistors working together in the power amplifier. The advantage of this system is that the power required depends directly on the audio volume setting so that batteries last longer when volume is kept low. Or if the radio is accidentally left on at low volume, the batteries are not discharged as quickly.

As can be seen, the radio signal in a receiver is picked up in the antenna circuit, processed, amplified, processed some more, amplified some more, and heard at the speaker. Any defect in any of the circuits affects

the output at the speaker. The common radio trouble symptoms are: weak output, no output, distorted output, hum or whistles, etc. The trick in finding the trouble is in determining which link in the chain, so to speak, is defective. Each of the blocks shown can be called a "stage," and when you are hunting troubles in a receiver the first job is to quickly localize the trouble, if possible, to a particular stage or stages. Once the trouble is localized, you can concentrate on finding the actual faulty part or parts in that stage.

So far this chapter has been devoted primarily to an overlook at radio transmission and reception, using the block-diagram approach, with little emphasis on the actual electronics circuits used other than the simple crystal receiver. Since the superheterodyne is almost universally "the" receiver circuit, we will concentrate on it in the further chapters of this book. Superhets are used in a-m, fm, tv, and in all other kinds of receivers. The basic difference between various superhet receivers is in the intermediate-frequency amplifiers. Broadcast and many other radios, including a great many CB receivers, use 455 kHz for the i-f, many automobile radios use 262 kHz as the i-f, while fm receivers use an i-f of 10.7 MHz^o, and tv uses a 40-MHz i-f for the picture and a 4.5-MHz i-f for the sound. Incidentally, the picture modulation in tv is a-m and the sound modulation is fm. Next we will discuss basic electrical theory.

ABOUT VOLTAGE, CURRENT, AND RESISTANCE

The three basic measurements of electrical and electronic circuits are voltage, current, and resistance. These three have a definite mathematical relationship in every circuit. This relationship is known as *Ohm's law*. But before taking up the relationship we must first define the terms.

Voltage

Voltage is the term used for electrical pressure. A flashlight battery, for example, has 1.5 volts of pressure. An automobile battery has a pressure of 12 volts. This pressure is just that—it is there whether or not the battery is doing work—the flashlight battery is 1.5 volts (if not discharged) whether the flashlight is turned off or on. Voltage might be compared to water pressure, which continues to press against the water

^oMHz stands for megahertz—mega = 1,000,000

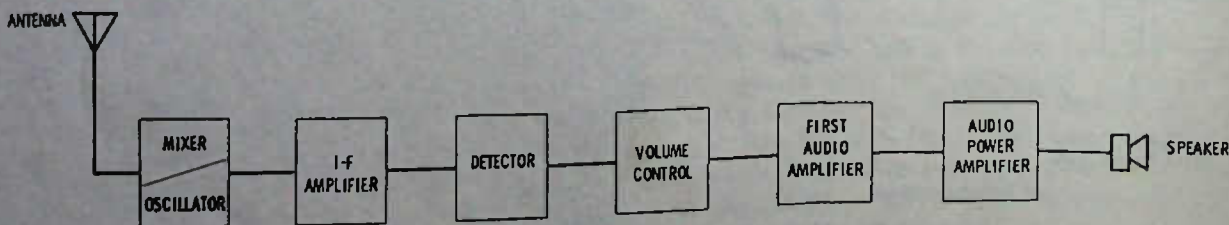

Fig. 1-17. Block diagram of superheterodyne radio.

whether the faucet is turned off or on. Without pressure no water flows if the faucet is turned on, but the pressure itself is *not* the water—it is simply the “push” behind the water. Voltage is the same—it provides the push for the electric current but is not the current itself. Voltage, logically enough, is measured with a voltmeter.

Current

Current is the working part of electricity, in a sense. It is the part that moves through a circuit and can be compared to water moving through pipes.* The amount of current in a particular circuit depends directly upon the amount of voltage. In other words, twice as much current flows in a given circuit if the voltage is doubled, or half as much current flows if the voltage to the circuit is cut in half.

Current is measured in *amperes*, often abbreviated A or amp(s). In electronic circuits it is not often that as much as one ampere flows, so electronic circuits usually show the current in *milliamperes* (abbreviated mA and usually called “milly-amps”). A milliampere is $\frac{1}{1000}$ of an ampere or, said another way, it takes 1000 milliamperes to make one ampere. Thus, a current of 15 mA is 0.015 ampere or a current of 260 mA is 0.26 ampere. Moving the decimal point three places to the right will change amperes or a fractional part of an ampere into milliamperes. Moving the decimal point three places to the left changes milliamperes into amperes (or a fraction of an ampere, as the case may be). Examples: 0.48 mA is 480 mA; 0.002 A is 2 mA; 12A is 12,000 mA; 0.064 A is 64 mA (decimal point moved three places right); 26 mA is 0.026 A; 1.6 mA is 0.0016 A; 350 mA is 0.356 A; 3200 mA is 3.2 A (decimal point moved three places left).

Current is measured in a circuit with an ammeter (not amp meter) or a milliammeter, as the condition requires.

Resistance

The third basic ingredient of a circuit is *resistance*. Resistance is just what it sounds like, something to “hold back” or resist the flow of current. The more resistance a circuit has, the less current flows. In a given circuit, if the resistance is doubled, the current is cut in half. If the resistance is cut to one third, the current increases three times.

Resistance is measured in ohms and can be measured with an *ohmmeter*.

Every circuit must have some resistance to get useful work done—see discussion in Chapter 2 under “Resistance.” In electronics a great many “resistors” are used to limit the flow of current and to provide a “voltage drop” essential to normal circuit operation.

*Experiments have shown that electricity tends to flow at the outer edges of conductors much more readily than at the center.

Fig. 1-18 is a simple circuit using a battery, a resistor, and a small pilot lamp. With the resistor in the circuit, the lamp is dim (brightness depends upon the actual value of the resistor in ohms), and with the resistor shorted out^o, the lamp is brighter. The lamp itself is a resistance, otherwise the battery would be shorted out and would run down very quickly.

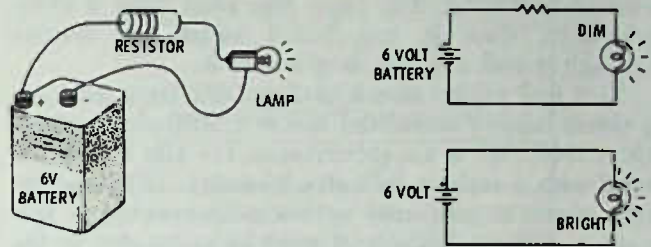
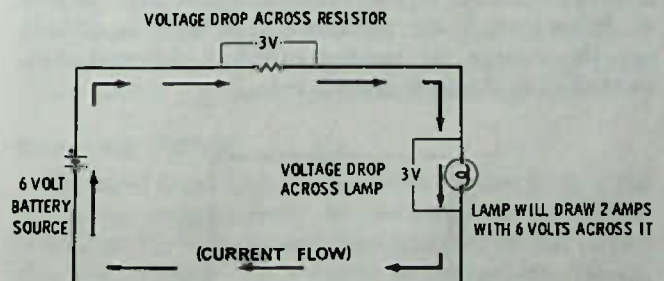

Fig. 1-18. Resistance in a circuit reduces current.

Earlier, you learned that if the voltage is doubled the current in the circuit will also be doubled, and if the resistance is doubled the current will be cut in half, etc. Let us apply this information to the circuit in Fig. 1-19 and determine what size resistor would be needed to drop the voltage across the lamp to 3 volts.

Since we are starting with 6 volts from the battery, and since we want to use only 3 volts across the lamp, it means that we must have a 3-volt drop across the resistor ($3 + 3 = 6$). The note near the lamp says that it draws 2 amperes with 6 volts across it. If we have only 3 volts across it then it should draw just half as much, or 1 ampere.** Now if you look at the circuit you will see that for the current to flow from one side of the battery to the other *all* the current must travel through both the resistor and the lamp. Since we have decided on 1 ampere of current for the lamp, it fol-



NOTE: VOLTAGE DROPS ACROSS CIRCUIT COMPONENTS MUST EQUAL VOLTAGE SOURCE.

Fig. 1-19. Using Ohm's law to calculate size of resistor.

(Note: arrows indicate conventional direction of current rather than electron movement.)

^oA “short” is a low resistance which prevents current from flowing through its normal path, instead taking a “short cut” through the low resistance.

**Some “knowledgeable” individual may tell you that this does not work with lamps because a lamp has more resistance when it is hotter than when it is cooler, which is true, but for the purpose of calculation we can disregard this factor, since in both cases the lamp is lit and therefore the resistance will not vary too much from the Ohm's law expectation.

lows that there is 1 ampere of current through the resistor also.

What size is the resistor? Ohm's law tells us that we can divide the amount of current into the voltage drop and find the resistance. Dividing 1 ampere into 3 volts gives us 3 ohms. The resistor needs to be 3 ohms in this case to provide a 3-volt drop because 1 ampere of current is flowing. The lamp also must have 3 ohms resistance, since it, too, has 1 ampere of current through it and a 3-volt drop across it.

Next look at the circuit of Fig. 1-20. Here we have a 6-volt battery connected across a 2000-ohm resistor ($K = 1000$. "K" is an abbreviation for kilo and when used with a resistor indicates kilohms). (The current in a circuit is measured with a milliammeter, in this case, and the milliammeter must be connected so the current flows through it to reach the resistor; therefore, a good milliammeter should not retard the current flow significantly, and in this case we will assume that it does not retard it at all, but simply measures the amount.)

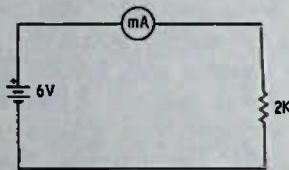

Fig. 1-20. How much current will the milliammeter indicate?

To find the current in a circuit, divide the resistance in ohms into the voltage in volts. In this case, that would be 2000 into 6, which comes out 0.003 ampere. If amperes are changed to milliamperes by moving the decimal point three places to the right we have an answer of 3 mA. The above calculation may suggest an easier way. If the resistance in K ohms is divided into the voltage, the current in mA is obtained automatically, so 2 into 6 gives 3 mA.

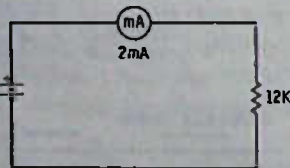

Fig. 1-21. What is the battery voltage?

Let's take still another example of calculating with Ohm's law. Fig. 1-21 shows a circuit with a 12K resistance and 2 mA of current flow. How much is the voltage? To get the voltage of a circuit when the resistance and the current are known, multiply the current times the resistance. Since again we are using both K ohms and milliamperes we can multiply directly, 12×2 , and get the answer of 24 volts.

But suppose the resistance were 450 ohms? We have two choices in the calculations: we can change the mA

to amperes or the resistance to K ohms. For example, changing the current of 2 mA we get 0.002 ampere and multiplying 450×0.002 gives us 0.9 volt. Or we could have changed 450 ohms to 0.45K ohms and multiplied 0.45 times 2, giving us the same answer of 0.9 volt.

Ohm's Law

But all the foregoing is meaningless unless you can remember what is to be divided and what is to be multiplied, etc. To get the formula for Ohm's law on a more scientific basis we have to recognize the symbols that are used in Ohm's law calculations for voltage, current, and resistance. The symbols are E, I, and R. E stands for voltage (electromotive force), I stands for current (intensity of flow), and R stands for resistance. Ohm's law states:

$$E = I \times R$$

$$I = \frac{E}{R}$$

$$R = \frac{E}{I}$$

where,

- E is the voltage in volts,
- I is the current in amperes,
- R is the resistance in ohms.

Even this is a bit difficult to remember until you have had considerable experience, so a "crutch" is used by nearly everyone to mark Ohm's law in the memory. One crutch is a sort of dunce cap with letters as shown in Fig. 1-22A.



(A) Standard units (volts, ohms, and amperes).



(B) Optional units (volts, kilohms, and milliamperes).

Fig. 1-22. Memory aid for Ohm's law.

To use the "dunce cap" all you need to do is to cover the factor you want and the formula for it is given. If you cover the E you have IR , or $I \times R$. If you cover the I you have E/R , or E divided by R, and if you cover the R you have E/I .

For electronics, since so often the resistances will be in the K-ohm region and current will nearly always be in the milliampere region, the dunce cap can be modified as in Fig. 1-22B. Just remember, though, when you use this short cut the current must be in mA and the resistance in K ohms or, if they are not, they must be changed to these units before the calculations are made. The Greek symbol omega (Ω) is used to indicate ohms in many instances. Of course there is a good mathematical reason why the mA-K formula works. Milli equals $\frac{1}{1000}$ and K equals 1000,

so their effects cancel in the calculation, or, said another way: milli is 10^{-3} power and kilo is 10^3 power so the -3 and the $+3$ powers cancel.

Wattage

There is another measurement included in Ohm's law that is necessary in many calculations. This is *wattage*. Wattage is the amount of heat dissipated in an electric circuit. If you touch a high-wattage incandescent lamp you can get burned, because any time electric current flows, the movement creates some heat. In transistor radios there is very little heat, except in one or two circuits. Heat in an electric circuit is the result of the current and the resistance of the circuit. If the current in a circuit is doubled (the resistance remaining the same), the heat will increase FOUR times. If the current is tripled, the heat increases NINE times. So the formula for wattage in a circuit is I^2R , or the current in amperes multiplied by itself times the resistance in ohms. The symbol P (for Power) indicates circuit wattage.

Even though current and resistance are considered the source of all circuit heat, it is obvious that voltage also must be considered, since increasing the voltage increases the current. So the formulas for power in watts can be stated like this:

$$P = I^2R$$

$$P = EI$$

$$P = \frac{E^2}{R}$$

where,

- P is power in watts,
- E is voltage in volts,
- I is current in amperes,
- R is resistance in ohms.

For example, a circuit with a current of 2 amperes and a resistance of 3 ohms will dissipate 12 watts of power ($2 \times 2 \times 3$). A circuit with 120 volts and 2 amperes will dissipate 240 watts (120×2), and a circuit with 9 volts and 300 ohms of resistance will dissipate 0.27 watt (9×9 divided by 300).

But what about using milliamperes and kilohms together in a calculation? Fine. The answer will be in milliwatts, though. Here are the formulas:

$$P \text{ in mW} = (\text{mA})^2 \times K \text{ ohms,}$$

$$P \text{ in mW} = \text{volts} \times \text{mA,}$$

$$P \text{ in mW} = \text{volts squared} \div K \text{ ohms.}$$

If any two parts of a circuit are known, the other factors of the circuit can be calculated. This is shown by Table 1-1, which can be used to make any Ohm's-law calculation in direct-current circuits. For example, suppose you know the wattage dissipated in a circuit and the voltage, and you wish to find the resistance, R. Look in the table at R and see that the formula for

Table 1-1. Convenient Forms of Ohm's Law

UNKNOWN	FORMULA FOR UNKNOWN		
	E	IR	$\frac{P}{I}$
I	$\frac{E}{R}$	$\sqrt{\frac{P}{R}}$	$\frac{P}{E}$
R	$\frac{E}{I}$	$\frac{P}{I^2}$	$\frac{E^2}{P}$
P	I^2R	EI	$\frac{E^2}{R}$
IF YOU USE THE UNITS BELOW THE ANSWER WILL BE IN THE UNITS ON THE SAME LINE			
E	I	R	P
VOLTS	AMPERES	OHMS	WATTS
VOLTS	MILLIAMPERES	K OHMS	MILLIWATTS
VOLTS	MICROAMPERES	MEGOHMS	MICROWATTS

obtaining R when voltage and wattage are known is E^2/P . At the bottom of the table are the units of measurement that can be used together for quicker calculations. For example, if the circuit has 50 microamperes—a microampere is a millionth of an ampere, abbreviated μA —and the resistance is 10 megohms—megohm is one million ohms—you can find the voltage of the circuit by simply multiplying 50×10 , giving 500 volts, or you can find the power in the circuit as 25,000 microwatts ($50 \times 50 \times 10$), which is 25 milliwatts.

It may seem that you have spent longer than necessary on this section. However, be assured that the Ohm's law calculations are by far the most important of all in understanding the operation of electronic circuits. There are more-sophisticated formulas that may be used for specific circuits, but if you understand Ohm's law as given here, you can by deduction break down almost any circuit into its basic operation.

Measuring Voltage

The most important test in electronic servicing is the dc voltage measurement. As you have just learned, if you know the voltage and the resistance of the circuit you can calculate the current in the circuit. Hence, the voltmeter can be used to read not only voltage but current as well, and the circuit will not have to be opened somewhere to insert the meter, as it would have to be if a milliammeter were used. Fig. 1-23 is an example. In this transistor circuit there is a 5K (5000 ohm) emitter resistor, and all the current in the circuit must travel through this resistor in getting from one side of the battery to the other. The voltmeter placed across the resistor reads 6 volts. How much current is flowing? Using Ohm's law, $I = E/R$, we take 5 into 6, giving us 1.2. Since we are dealing with K ohms the answer is in mA, or 1.2 mA of current in the circuit.

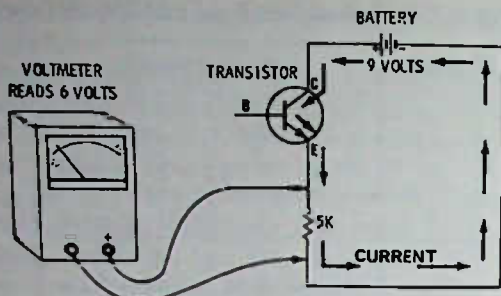

Fig. 1-23. How much current is flowing in this circuit?

We could have broken the circuit at any place and inserted a milliammeter and gotten the 1.2 mA reading, but breaking a circuit means cutting a printed circuit or a wire to insert the meter. This is not only time consuming, but the break must be repaired after the test is made. Fig. 1-24 is another example of meter reading in a transistor circuit. By taking just one voltmeter reading, we can determine three or four things about the circuit. The meter is reading 3 volts, and the voltage drop is being read across a 1.5K resistor. What is the current? The answer—2 mA ($3 \div 1.5$). How much will the voltmeter read if placed across the 500-ohm resistor? Do you need to place the voltmeter across it to find out? No. The current must be the same in both the 1.5K resistor and the 500-ohm (0.5K) resistor since they are in the same path between the + and - of the battery power supply. Knowing that 2 mA is flowing through the 0.5K resistor, Ohm's law tells us that the voltage drop across it is 1 volt (2×0.5). Or, in this instance, it could be calculated another way rather easily. A 500-ohm resistor is just $\frac{1}{3}$ as large as a 1500-ohm resistor, so the voltage drop across it when the same amount of current is flowing in the two will be $\frac{1}{3}$ as large.

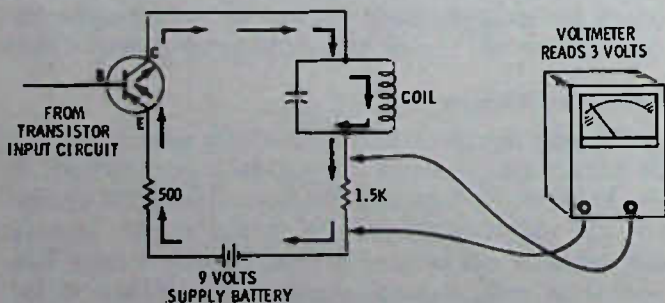

Fig. 1-24. Testing for current by measuring voltage.

The next question might be, how much voltage drop is there across the transistor? In other words, what would the voltmeter read if it were placed from C to E of the transistor? The answer is 5 volts. Why? The battery voltage is 9 volts; there is a 3-volt drop across one resistor and a 1-volt drop across another, leaving 5 volts across the transistor. (The coil is a very low resistance having virtually no more voltage drop than a few inches of wire, which is negligible.)

Another question that can be answered is: What is the resistance of the transistor? We have found now that there is 5 volts across it and we know there is 2 mA flowing through it—again we can resort to Ohm's law, $R = E/I$. So $R = 5/2$, or 2.5, and since we are dealing with current in mA, the resistance answer will be in K ohms, or 2.5K ohms (2500), so the transistor under these conditions is equivalent to a 2.5K resistor.

Incidentally, a transistor behaves like a resistor that is variable. The amount of its resistance is controlled by the amount of voltage and current applied between its base terminal and the emitter terminal (B and E). If more or less voltage is applied at the base, the resistance between C and E changes, allowing more or less current to flow in the circuit from the supply battery. Because it takes less current to change the resistance than the amount of change in current from the supply battery, the transistor can "amplify" a small current into a much larger current. More about that in Chapter 8.

Fig. 1-25 is the pictorial circuit of Fig. 1-24. You can set up this circuit and get the actual values shown, take readings, etc. You can use a 470-ohm, $\frac{1}{2}$ -watt resistor instead of the 500-ohm, if a 500-ohm resistor is not available. The transistor can be almost any sort of pnp transistor, either germanium or silicon type. The battery is the type used in many portable transistor radios. The variable resistor can be an old volume control out of a tube-type radio, and the 10K resistor is simply for protection of the transistor in case the variable resistor (potentiometer) is turned to minimum resistance. You can see the action of the transistor by watching the voltmeter while changing the resistance of the pot. (The pot supplies more or less current to the base of the transistor, which changes the transistor resistance between C and E, depending on the change in current to the base.)

In the preceding "paper" calculation, we deduced the voltage drop across the 500-ohm resistor. In actual servicing, you might read the voltage drop across both resistors to make sure that the voltage drop was correct. Suppose that for some reason the 500-ohm resistor had changed in value to, say, 2000 ohms. The voltage drop across it would now be 5 volts, leaving only a 1-volt drop across the transistor. This incorrect reading would immediately spot the source of trouble in this case. In this case, the voltage across the transistor was calculated, but it is always faster to use the voltmeter and make the check than to make calculations, and when circuitry is complex, calculations become even more difficult to make quickly.

Most wiring diagrams, called schematics, have the voltage readings listed at the transistor terminals. These are voltages to ground. The "ground" is the common connection made from one side of the battery or other power supply. All of these points could be connected together with a line (some schematics are even drawn that way) but it is a simpler representa-

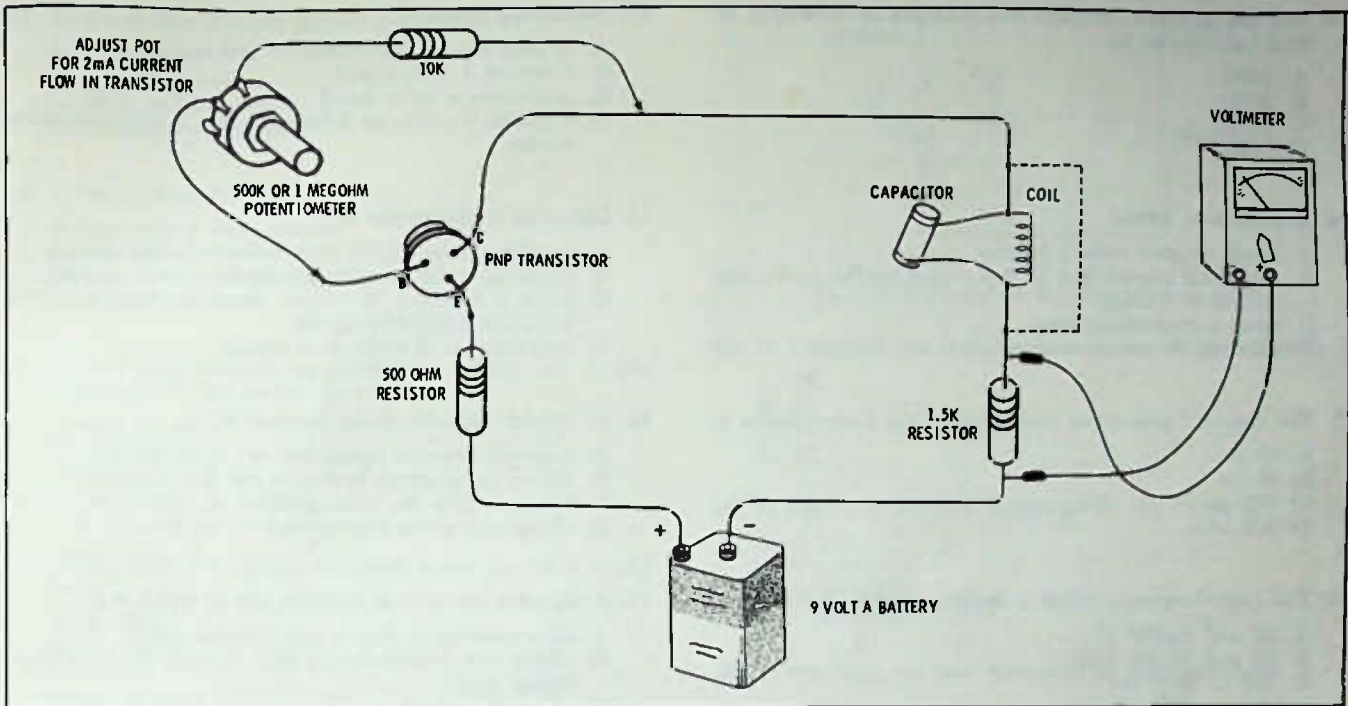

Fig. 1-25. Pictorial diagram of schematic in Fig. 1-24. For testing use, coil and capacitor may be omitted and a wire used instead.

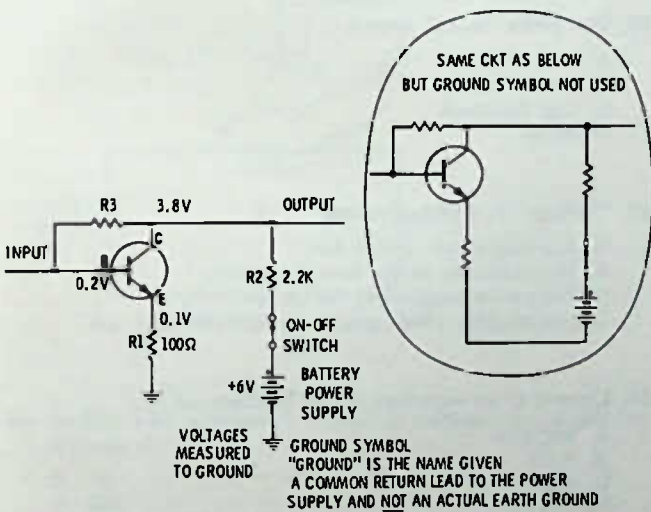

Fig. 1-26. Transistor circuit with voltages to ground indicated.

tion to use a ground symbol for all wires or components returning to a common point. Metal shields such as the shield cans around transformers are connected to the ground and can be used as a connection for one of the meter probes when measuring voltages to ground.

Fig. 1-26 is part of an actual transistor amplifier used in a transistor radio. With the voltages-to-ground given, what is the voltage drop, or what would a voltmeter read if you placed it across R2? The answer is 2.2 volts. Why? There is 3.8 volts on one side of the resistor and 6 volts (to ground in both cases) on the other side. 3.8 from 6 leaves 2.2 volts across the resistor. How much current is flowing in the resistor? The answer is 1 mA. Why? $I = E/R$. $I = 2.2/2.2$ or 1 mA. How much voltage from C (collector) to E (emitter)? 3.7 volts. ($3.8 - 0.1$). Does the voltage reading from emitter to ground appear to be correct? Yes, because we know there is 1 mA flowing in the circuit and we know that 100 ohms is 0.1K, so 0.1 times $1 = 0.1$ V ($E = IR$).

TEST QUESTIONS

1. The prefix "kilo" means

- A. 1000.
- B. 1/1000.
- C. 1,000,000.
- D. hertz.

2. "Hertz" is a modern-day term that used to be called

- A. frequency.
- B. kilo.
- C. cycles per second.
- D. amplitude.

3. The first practical transistor was invented or developed at Bell Laboratories in
 - A. 1903.
 - B. 1921.
 - C. 1939.
 - D. 1948.

4. Amplification means
 - A. using a higher voltage battery.
 - B. increasing current flow in step with a smaller controlling current or voltage.
 - C. using a magnifying glass.
 - D. allowing electric current to flow in one direction.

5. The standard power-line frequency in the United States is
 - A. 50 Hz.
 - B. 60 Hz.
 - C. 120 Hz.
 - D. 600 kHz.

6. The audio-frequency range is considered to be between
 - A. 20 and 20,000 Hz.
 - B. 20 and 20,000 kHz.
 - C. 100 to 8000 Hz.
 - D. 400 to 2500 Hz.

7. The term "rf" stands for
 - A. real frequency.
 - B. reorganized field.
 - C. radio frequency.
 - D. raised frequencies.

8. The term "selectivity" means
 - A. the choosing of a particular radio circuit.
 - B. how loud a radio will play.
 - C. the beating of two signals together to produce a third.
 - D. the ability of a radio to choose between stations that are broadcasting.

9. The radio circuit that is most common and works by changing the incoming radio frequency into another frequency is called a
 - A. trf or tuned-radio-frequency receiver.
 - B. superheterodyne.
 - C. regenerative or superregenerative.
 - D. local oscillator or intermediate-frequency receiver.

10. In a superhet receiver that has an intermediate frequency of 455 kHz and is tuned to receive a station at 1340 kHz, the local-oscillator frequency will normally be at
 - A. 1795 kHz.
 - B. 455 kHz.
 - C. 1340 kHz.
 - D. 2250 kHz.

11. The 3rd harmonic of 330 kHz is
 - A. 990 kHz.
 - B. 333 kHz.
 - C. 430 kHz.
 - D. 630 kHz.

12. Modulation means
 - A. to turn a radio transmitter off and on.
 - B. detecting a radio signal.
 - C. generating a radio signal.
 - D. a system for placing information on a radio-frequency carrier.

13. Detection is the process of
 - A. inserting audio signals on a radio-frequency carrier.
 - B. removing audio or other signals from an rf carrier.
 - C. using a capacitor to remove the radio frequency and leave the audio frequencies.
 - D. amplification of audio or rf signals.

14. A "crystal" detector works because it
 - A. responds to audio signals but not to rf signals.
 - B. allows the rf signals to flow in one direction only.
 - C. has essentially the same qualities as a capacitor.
 - D. allows only alternating current to pass through it.

15. A capacitor has several qualities, one of which is it
 - A. allows current to flow in one direction only.
 - B. allows low frequencies to pass through it easier than higher ones.
 - C. allows higher frequencies to pass through it easier than lower ones.
 - D. can replace headphones to reproduce audio signals so they can be heard.

16. The prefix "mega" means
 - A. one million.
 - B. one-millionth.
 - C. one thousand.
 - D. many.

17. "Voltage" in a circuit means
 - A. the amount of current flow.
 - B. the resistance to the flow of current.
 - C. the power supplied to the circuit.
 - D. the pressure which pushes the current.

18. Current in an electrical circuit is measured in
 - A. amperes.
 - B. volts.
 - C. ohms.
 - D. watts.

19. The device that measures the resistance of a circuit is a (an)
 - A. voltmeter.
 - B. ammeter.
 - C. ohmmeter.
 - D. resistometer.

20. Current of 600 milliamperes is the same as
 - A. 6 amperes.
 - B. 600,000 amperes.
 - C. 60 amperes.
 - D. 0.6 ampere.

21. A current flow of 0.004 ampere is the same as
 A. 4 amperes.
 B. 4 milliamperes.
 C. 4000 milliamperes.
 D. 0.000,004 milliampere.
22. A "short circuit" is one that
 A. goes only a short distance.
 B. uses short pieces of wire.
 C. has a low resistance path for current to flow.
 D. is a light dinner.
23. If, in a given circuit, you double the voltage and double the resistance, the current flow will
 A. stay the same.
 B. double.
 C. halve.
 D. quadruple.
24. In Fig. 1-27, the voltage measured across the lamp would be
 A. 5 volts.
 B. 6 volts.
 C. 3 volts.
 D. 4 volts.

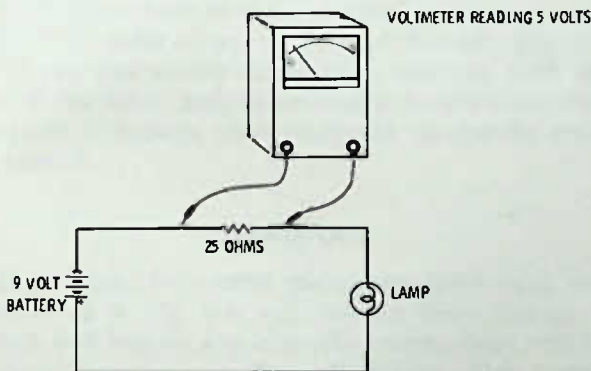

Fig. 1-27. Test circuit for Questions 24, 25, and 26.

25. In Fig. 1-27, how much current in milliamperes is flowing through the lamp?
 A. 15.
 B. 400.
 C. 200.
 D. 25.
26. In Fig. 1-27, the resistance of the lamp is
 A. 20 ohms.
 B. 25 ohms.
 C. 200 ohms.
 D. 400 ohms.

27. In Fig. 1-28, the current flowing through the transistor is
 A. 4 milliamperes.
 B. 4 amperes.
 C. 2 amperes.
 D. 2 milliamperes.

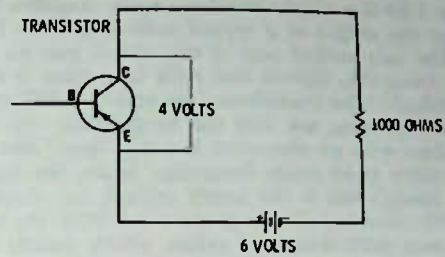
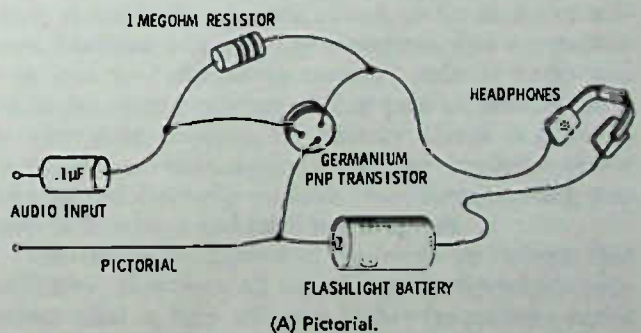
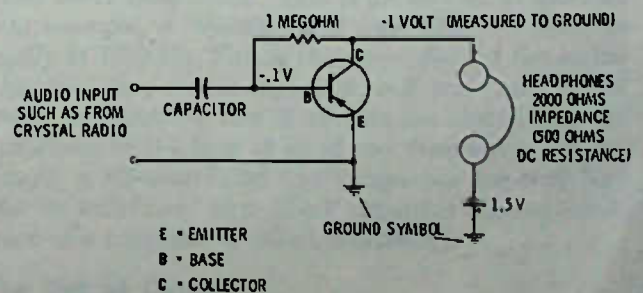

Fig. 1-28. Test circuit for Questions 27 through 30.

28. In Fig. 1-28, the equivalent resistance of the transistor is
 A. 1K.
 B. 2K.
 C. 3K.
 D. 4K.
29. In Fig. 1-28, the heat dissipated by the 1K resistor is
 A. 1 watt.
 B. 2 watts.
 C. 1 milliwatt.
 D. 4 milliwatts.
30. In Fig. 1-28, the heat dissipated by the transistor is
 A. 4 watts.
 B. 8 watts.
 C. 8 milliwatts.
 D. 4 milliwatts.
31. The term "ground" as used concerning an electronic circuit means in most cases
 A. a direct connection to the earth through a water pipe or stake.
 B. a "common" connection for all the circuits.
 C. a short circuit.
 D. a coil of wire.



(A) Pictorial.



(B) Schematic.

Fig. 1-29. Audio amplifier circuit for Questions 32 and 33.

32. In Fig. 1-29 is a simple transistor audio amplifier that can increase the output of a crystal radio fifty- or a hundred-fold. The only critical part of this circuit may be the size of the 1-megohm resistor and even here there is considerable latitude. The headphones are rated at 2000-ohms impedance, meaning not that the headphones will measure 2000 ohms with an ohmmeter but will "look" like a 2000-ohm resistor at an audio frequency. Again, the impedance of the headphones is not overly critical, but should be at least 600 ohms impedance or more and NOT the type normally used with transistor radios, which usually are not more than 8 ohms. In this circuit, assuming the dc resistance of the headphones is 500 ohms, the amount of current flowing through the phones is

- A. 1 mA.
- B. the same as that flowing through the transistor.
- C. the same as that flowing out of the battery.
- D. all the above are true.

33. In Fig 1-29, how much voltage drop is there across the 1-megohm resistor?

- A. 0.9 volt.
- B. 1 volt.
- C. 1.5 volts.
- D. Impossible to tell.

CHAPTER 2

Capacitors and Resistors

In this chapter and the next, you will find considerable detail on the components, or at least the basic components, used in radio. You may be tempted to skip these chapters for now and come back to them after you have studied more about the "whole" radio. This you can do, of course, but we suggest that you read through these chapters before continuing. You will not grasp all of what is meant perhaps, but you can relate the ideas of the component parts to the whole radio a bit better, in our opinion, if you read straight through these chapters now. After you have finished the book, you can come back to these chapters as your comprehension of radio advances. So read through, grasping what you can readily understand, continue with the rest of the book, and, as necessary, review these two chapters to enlarge your viewpoint on specific areas of interest.

CAPACITORS

If you take two metal plates, insulated from one another as in Fig. 2-1, and connect them through a switch to a battery and close the switch, there will be a short instantaneous flow of current. This occurs even though there is no physical connection between the plates. In simple terms, what happens is that as soon as the switch is closed, electrons* in the upper metal plate are attracted to the positive side of the battery and the same number are pushed into the lower metal plate by the negative side of the battery. The capacitor is now said to be "charged." In other words, if we now open the switch, or remove the battery, the capacitor plates will still have an electric charge across

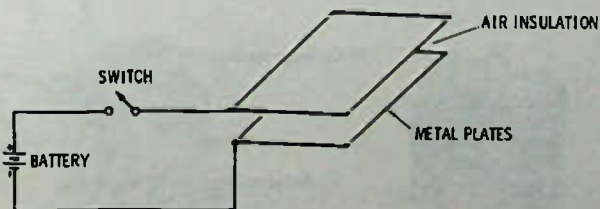

Fig. 2-1. A simple capacitor.

*Electrons is the name given to electrical charges.

them equal to the battery voltage. A capacitor, therefore, can store electricity. The amount of electricity that the capacitor will store depends on the size of the metal plates and how close together the plates are, without touching. The larger the plates or the closer together, the more electric charge that will be stored. Two metal plates as shown will store very little charge, but many plates held close together can store considerable charge.

After the capacitor is charged, if a wire is connected between the two plates, they will be instantly discharged through the wire. If we measure the energy during discharge we find it to be equal to the "charging" energy, but flowing in the opposite direction. The capacitor now has no voltage across it—no charge—and so is said to be "discharged."

Current flows in a capacitor circuit only during charge and discharge. If the switch in Fig. 2-1 is left turned on (closed), there will be no current flow except the initial charging current. A capacitor, therefore, is essentially an open circuit, so far as direct current (as from a battery) is concerned. But a capacitor can pass ac (alternating current) such as audio and radio frequency currents. It can pass ac because ac is continuously changing in polarity (from positive to negative and back again); thus, the capacitor plates charge and discharge on each alternation, causing current to flow back and forth in the circuit.

The larger the capacitor, the more ac current that will flow. However, all capacitors are frequency conscious—that is, they will pass higher frequencies easier than lower frequencies. This is an inverse proportion. For example, a capacitor will pass 2000 Hz twice as easily as 1000 Hz. This is true regardless of the actual electrical size of the capacitor, but any capacitor of twice the electrical size of another has exactly half the resistance to the flow of ac of any frequency. For example, a .02-microfarad (μF) capacitor has only half the "ac resistance" of a .01- μF capacitor (the ac resistance of a capacitor is called *reactance*).

The Unit of Capacity

The unit of capacity is the "farad," but a farad is such a large unit that it is not a practical measurement

for the small capacitors used in radio. Capacitors in radios are rated in either microfarads, which means a millionth of a farad, or in picofarads, which is a millionth of a microfarad. For example, in the crystal receiver in Chapter 1, a .001-microfarad capacitor was suggested. That means that the capacitor was one-thousandth of a microfarad, or 1000 picofarads. Abbreviations for microfarads differ but we will use μF in this book. The abbreviation for picofarads is pF. (A number of years ago picofarads were designated "micromicrofarads" and the abbreviation was mmf or mmfd.) Although it is not popular with American manufacturers, many foreign manufacturers have adopted the term "nanofarads" abbreviated either N or nF. A nanofarad is halfway between the microfarad and the picofarad. For example, the .001- μF capacitor would be a 1-nanofarad capacitor, or a .01- μF capacitor would be a 10-nanofarad capacitor. A capacitor labeled 20N, for example, and of foreign make, is probably a .02 μF .

Dielectric

The "dielectric" of a capacitor is the insulation between the plates. The standard dielectric is air and it is said to have a "dielectric constant" of 1 (see Table 2-1). It has already been indicated that the capacity of a capacitor depends upon the size or area of the metal plates and also on the spacing between the plates. In addition, the capacity (or capacitance) of a capacitor is directly related to the kind or type of dielectric. For example, in Table 2-1, note that Plexiglas has a dielectric constant of 2.8, which means that if a piece of Plexiglas were placed between the plates of the simple capacitor in Fig. 2-1, the capacitance of the capacitor would increase by 2.8. In other words, 2.8 times as much energy would flow during charge and discharge as would flow if only air were used as the insulator. The reason for this is difficult to explain. The electric charges place "stress" on the dielectric, which can be compared to squeezing a spring. A stronger spring requires more energy to "charge" but will release more power on "discharge" than a weaker spring, consequently the stronger spring could be said to have more capacity.

Table 2-1. Dielectric Constants of Common Materials

Material	Dielectric Constant
Air	1
Bakelite	4.5 to 5.5 approx
Ceramics	5 to 1000 or more
Fiber	5 to 7.5 approx
Glass	7 to 8 approx
Mica	5 to 6 approx
Paper	3 approx (varies with type)
Plexiglas	2.8
Polystyrene	2.6
Porcelain	5 to 6 approx

Capacitors used in radio today are mainly of three types: ceramic, paper, and electrolytic. Once mica dielectric capacitors were used considerably, but the excellent properties of the ceramics and their economy have just about eliminated the mica types, except in special high-quality circuits where the capacity value must remain extremely stable.

Ceramic capacitors are usually of the "disc" type and range in value from about 1 pF to about .01 μF , although both larger and smaller sizes are sometimes used. The ceramic capacitor works well at all frequencies, and high grade types have excellent stability and may be manufactured in tubular form (see Fig. 2-2). Less expensive types are not quite so stable but have ample stability for use in all but the most critical bypass circuits, since in bypass circuits the actual capacitance, within a reasonable tolerance, is not too critical. For example, a circuit calling for a .005- μF bypass will probably work just as well with a .004- μF bypass, or, in the oversize direction, with a .01 μF or even greater.

Ceramics have high dielectric constants—the ones with lower constants are usually somewhat more stable; that is, they change less in capacity with change in environment—and so come in fairly large capacitances, compared to physical size.

Paper capacitors, once used almost exclusively in a-m broadcast radio, are now used only for sizes above about .05 μF , if at all. The paper capacitor has large



(A) Electrolytic types.

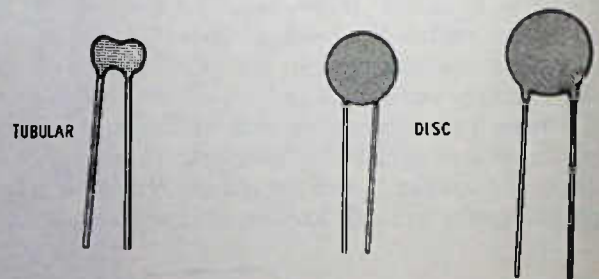

(B) Ceramic types.



(C) Encapsulated mylar capacitor.

Fig. 2-2. Capacitors.

physical size compared to capacity and also stops acting as an efficient capacitor as the frequency exceeds several megahertz. This prevents their use in most fm and tv circuits, except for the low-frequency portions of the circuits, such as in audio stages.

Electrolytic capacitors are generally not made in smaller than 1- μ F sizes and popular sizes now can be purchased up to at least 2000 μ F, especially in low-voltage types for transistor circuits. Electrolytic capacitors use an electrolyte (similar to what might be used in a battery) as the dielectric, and for this reason electrolytics are polarized, that is, they must be connected into the circuit so that the positive (+) side connects to a higher positive voltage than the negative (-) side. Neither ceramic nor paper capacitors have polarity requirements, so they may be connected in either direction in a circuit.

Capacitor Voltage Ratings

Most capacitors have clearly marked voltage ratings; this is the maximum working voltage for the capacitor and has nothing to do with the capacitance operation in a circuit. In other words, a .05- μ F capacitor rated at 200 volts can be replaced, if physically possible from the standpoint of size, with a 400-volt or 600-volt rated capacitor; however, the 200-volt capacitor should not be replaced with a capacitor rated at less than 200 volts, such as only 100 volts or 50 volts. In transistor circuits where the dc voltage applied is not more than 9 or 12 volts, a capacitor rated at 25

volts is more than safe to use. For electrolytics in a 9-volt circuit using batteries, the voltage rating may be only 10 volts, although a 12- or 15-volt rating may be used. In other words, never use a capacitor that has a lower voltage rating than the voltage that will be across it, but it is all right to use the same capacitance-rated capacitor with a higher voltage rating than the circuit requires.

VARIABLE CAPACITORS

As you will see later when tuned circuits are discussed, a variable capacitor—one whose capacitance can be changed, usually by rotating a shaft—is often used as the “tuning” element in a radio receiver. There are many kinds of variable capacitors (see Fig. 2-3). They may be single-unit capacitors, called “single gang,” but usually there will be 2 or more capacitors operated by a single shaft. Most receivers of the lower-cost home-entertainment type use a 2-gang capacitor, meaning that there are two separate variable capacitors in one unit, rotated by a single control. For example, in a superhet-type receiver discussed in Chapter 1, one section of the variable capacitor unit “tunes” the incoming signal for best circuit response while the other section of the same variable capacitor tunes the oscillator to the correct frequency so that the incoming station will have its frequency changed to the intermediate frequency.

Commercial receivers and those used by shortwave listeners, amateur radio licensees, etc. often have a variable capacitor with 3 gangs, or even more on occasion—the reason for these will become apparent later in this book.

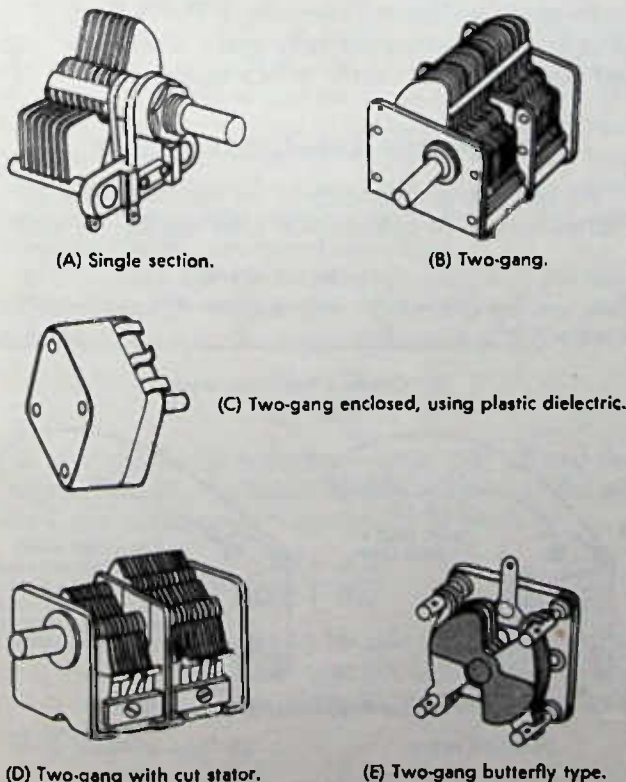

Fig. 2-3. Variable capacitors.

SYMBOLS FOR CAPACITORS

In electronics, symbols are used extensively when laying out circuits on paper. When circuits are laid out on paper they are called schematic diagrams. Capacitor symbols are shown in Fig. 2-4. The symbols vary somewhat in actual practice but not enough to cause much confusion. For example, a curved line is used on some capacitors to indicate the side that goes

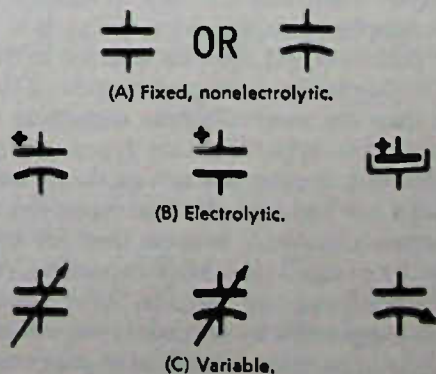

Fig. 2-4. Capacitor symbols.

toward "ground," or the common connection for components in a circuit. "Ground" is seldom taken to mean an actual earth ground; instead, it is the common circuit. For example, in an automobile, only one wire is used to carry current to a light and the car body is then used as the return wire to the other side of the battery. All the electrical equipment has one side returned through the metal parts of the car rather than through a separate wire. In the case of the automobile, we would call the car body or chassis a "ground" because it is common to all circuits. Fig. 2-5 is a simplified diagram of such a system. The four lights in the diagram have a common return to the car battery through the car body or chassis. The lights are also connected in parallel through the light switch to the battery.

Electrolytic capacitors are polarized (see discussion on electrolytics in this chapter) and the + side is always marked. Sometimes both the + and - side will be marked on the schematic.

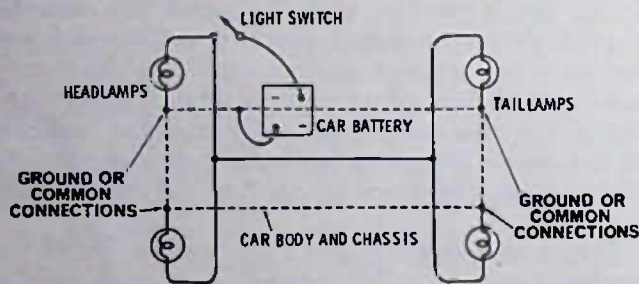

Fig. 2-5. Simplified diagram of an automobile lighting system.

TIPS ABOUT CAPACITORS IN RADIOS AND ELECTRONIC EQUIPMENT

You will find some sort of capacitors in just about all circuits. They are used to block dc, while allowing ac to pass, and they are used to remove ac from dc lines so that circuits will not interact even though supplied by the same source of dc voltage. They are used to change the "tone" of a radio, making it sound more bassy or more treble. Variable capacitors are used in tuning circuits.

Electrolytic capacitors are used to filter out hum in dc power supplies powered from the ac line. Electrolytics are polarized and must be inserted in the circuit with the + side to the most positive side of the circuit in which they are used. Ceramic capacitors are both tubular and disc type. Tubular types are generally more stable but usually are not made in sizes much larger than a few hundred pF. Disc capacitors make excellent bypass capacitors because they are capable of high capacity in small size. Mica capacitors, once used for all higher-frequency circuits, have been almost completely supplanted by ceramic types, either tubular or disc. Mylar capacitors are similar to paper capacitors, but use Mylar instead of paper, because of the higher

dielectric constant. These capacitors are normally encapsulated in epoxy to eliminate moisture, which always causes deterioration of any capacitor. Paper capacitors use either a wax or plastic encapsulation to keep out moisture.

A good capacitor of either the ceramic, mica, Mylar, or paper type must have no leakage; that is, no passage of direct current between the two terminals. If leakage exists, the capacitor must be considered to be defective. In many circuits, even slight leakage will upset the circuit performance.

Electrolytic capacitors by their nature do have leakage and may have extremely high leakage (high direct-current flow through them) if connected into the circuit incorrectly (wrong polarity). The leakage of electrolytics must be taken into consideration in circuit design so that it is not a problem.

The working voltage of a capacitor means the maximum voltage that should be across the capacitor.

Electrolytic capacitor values are not usually critical, especially if they are larger in value than the original. It is not unusual for an electrolytic to vary from 50% to 100% in actual value from the value rated as nominal on the case by the manufacturer.

A capacitor suspected of being open can be checked easily by simply connecting another capacitor temporarily across the suspected capacitor. For example, whistles in a transistor radio, or a weak radio, are often caused by an open electrolytic capacitor. Almost any electrolytic of suitable voltage rating can be temporarily placed across the suspect to see whether the radio starts performing normally. If the radio does appear to start working normally again, replace the original capacitor permanently with a similar unit.

CONNECTING CAPACITORS IN SERIES

To connect components in an electrical circuit in "series" means to connect one after another in such a

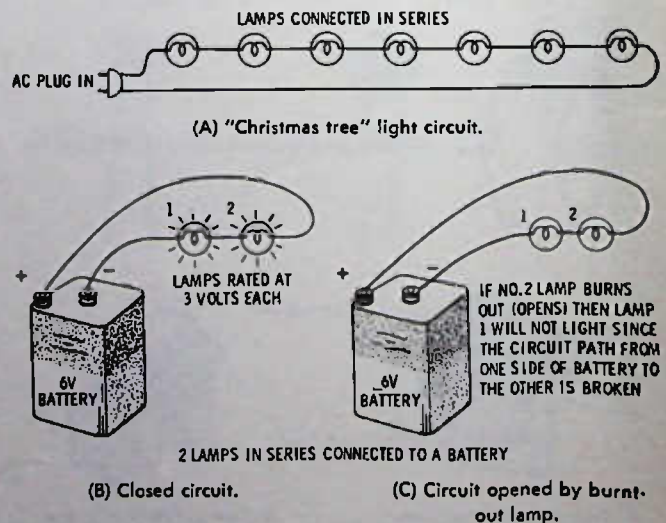

Fig. 2-6. Series connections.

way that all the current in the circuit must pass through all the parts in the circuit. Two examples are shown in Fig. 2-6. One is the familiar "Christmas Tree" light circuit, where each of the lamps is in series with the other lamps. Obviously, in this circuit, if one of the lamps burns out, the path for the electrical current between one ac plug prong and the other one is broken, so none of the lamps receive any electricity. In the lower part of Fig. 2-6 a battery is shown connected to two lamps in series, and, again, if either lamp should burn out, the other lamp will not light, since the circuit path is broken. (Every circuit must have a complete electrical path from one side of the power supply to the other side.)

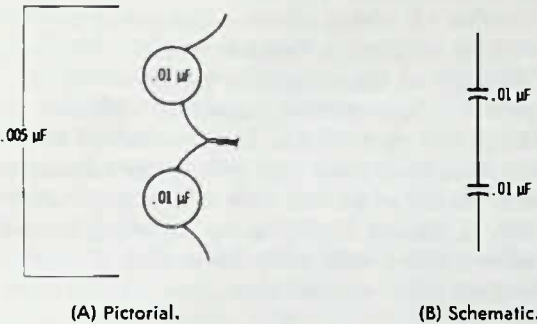

Fig. 2-7. Equal-sized capacitors in series.

If capacitors are connected in series, the effective capacity is reduced. For example, if two .01-μF capacitors are connected in series as in Fig. 2-7, the effective capacity is reduced to one half or .005 μF. If the capacitors each had 100-volt ratings, then the new voltage rating would be 200 volts. In other words, if two capacitors of identical size are connected in series, the resultant capacity is equal to the capacity size divided by 2; if three are connected in series, then the total capacity is equal to the size of one capacitor divided by 3; etc. The voltage rating is multiplied by 2, 3, etc., depending on the number of capacitors.

If capacitors are not the same capacity and are connected in series, then a new formula must be used. For two capacitors the simplest formula is

$$\frac{C1 \times C2}{C1 + C2}$$

For example, if one capacitor were a .006 μF and the other a .003 μF, the total capacity would be .002 μF when the capacitors are connected in series.

$$\frac{.006 \times .003}{.006 + .003}$$

Since the capacitors are to be calculated in the same units (μF) then for quick calculation drop the decimal points and then return them to the answer, making the problem:

$$\frac{6 \times 3}{6 + 3} \text{ or } \frac{18}{9} = 2$$

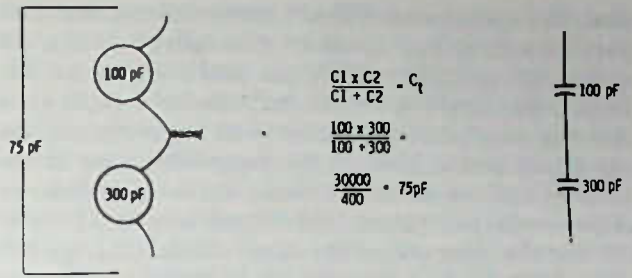

Fig. 2-8. Capacitors of different values in series.

Returning the correct decimal designation dropped in the previous step for easier calculation, the answer is:

$$.002 \mu F$$

Fig. 2-8 shows another problem worked out, using capacitors of unequal ratings.

CAPACITORS IN PARALLEL

Parallel circuits are those where each of the parts in the circuit is connected directly across the power supply. For example, the lights in your home or shop are connected in this manner almost invariably. Fig. 2-9 shows examples of parallel hookups. Note that the current from the power supply has more than one path to travel, so that if one lamp burns out or is turned off it does not affect the other lamps in the circuit. For instance, lamps B and C could both be burned out or turned off but still there would be a path between the + and - of the battery through lamp A, so it would continue to light; or lamp A could be out and either or both B and C be lit.

When capacitors are connected in parallel, the calculation of total capacitance is easy: simply add the capacitances. For example, if two .02-μF caps are connected in parallel, the resultant capacity is .04 μF. It makes no difference if the capacitors are of different

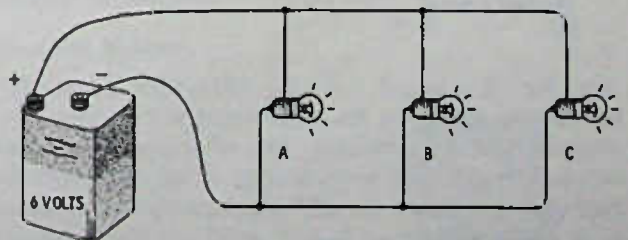

(A) Pictorial.

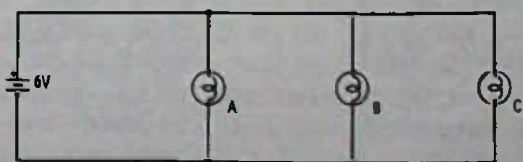

(B) Schematic.

Fig. 2-9. Lamps connected in parallel across a battery.

size. For instance, a 220-pF capacitor connected in parallel with 470 pF gives a total capacity in the circuit of 690 pF (220 + 470), etc. And it makes no difference how many are connected; the total capacity is still the sum of all the individual capacitances. Be careful, of course, that all the capacitances are in the same unit measurement when the summing is done. In other words, you cannot add 680 pF to .001 μ F without first changing one or the other. (Either change .001 μ F to 1000 pF or change 680 pF to .00068 μ F, moving the decimal point 6 places to make the transition.)

Other variable capacitors are used that are seldom changed, once the initial circuit value is correctly adjusted (Fig. 2-10). These are generally single-unit capacitors with some sort of screwdriver adjustment

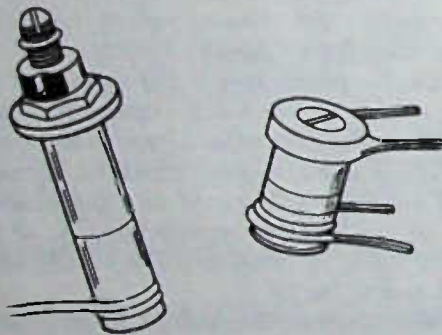

(A) Ceramic.

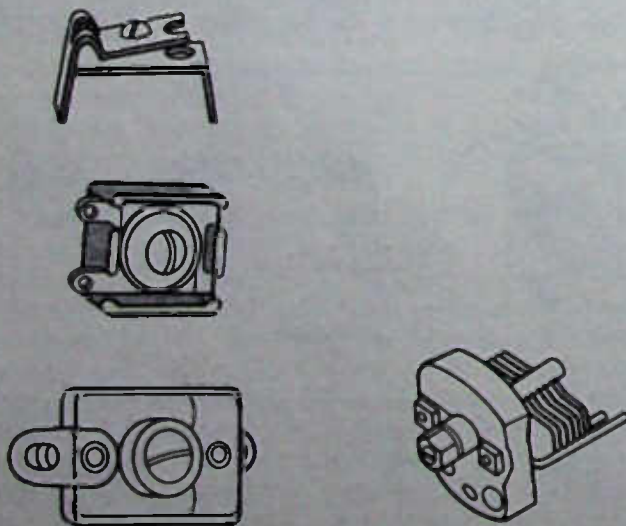

(B) Mica.

(C) Air dielectric.

Fig. 2-10. Trimmers are used to adjust the initial capacitance of a circuit, or to "tune" it.

and are frequently called "trimmers" and sometimes "padders." A trimmer is a small capacitance of usually no more than about 30 pF which may be adjusted from about 5 pF or less up to as much as 30 pF. Some trimmers in higher frequency circuits may adjust from less than 1 pF to no more than 2 or 3 pF. On the other hand, a "padder" is an adjustable capacitor that may have a maximum capacity of 500 pF or more and may be able to vary the capacity of the circuit by as much as 100 pF or more.

The dielectric in trimmer capacitors may be ceramic, mica, or air. Sometimes in expensive equipment, small air trimmers are used. Padders and trimmers usually are similar in appearance, except that the padder may be larger or have more "plates."

The number of plates affects capacitance in direct relation to the number; a variable capacitor with four "plates" facing four other plates of the same size should have twice the capacity of a capacitor with only two plates facing two other plates. In capacitors, a favorite method of increasing plate area to increase capacitance is to use a "stack" of plates, with alternate plates tied in parallel, as shown in Fig. 2-11. "Stacking" is used mainly in capacitors with air or mica dielectric, either of fixed or variable construction.

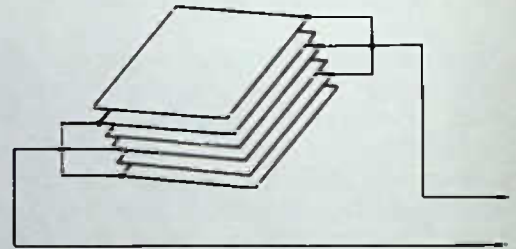

Fig. 2-11. "Stacking" the plates of a capacitor increases the capacity.

RESISTORS

A resistor, as the name suggests, resists the flow of electric current. Resistance is necessary for any circuit to do useful work; in fact, without resistance every circuit would be a short circuit. Resistance allows electric current to flow in useful amounts to do a specific amount of work. Resistance in a circuit might be compared to a dam across a waterway. The dam provides extremely high resistance to water flow and might be compared to an open electrical circuit where no current is flowing. If we reduce the resistance of the dam by allowing water to flow through a tube, we can put the water pressure to work turning a turbine generator. The tube will not let all the water run out of the reservoir at once, so the tube provides a resistance channel.

But let us suppose the dam should break down (offer virtually no resistance to the water). All the water would rush out, doing no useful work, but creating destruction instead. This could be compared to an

electrical short circuit. For example, a wire across a car battery will get hot and burn in two, whereas, a large wire might be able to withstand the tremendous current of the short-circuited battery, but the battery would be run down very quickly, and what useful work has been done? The values of resistors are measured in ohms, as far as resistance is concerned. For example, a 100-ohm resistor has twice the resistance to the flow of current as a 50-ohm resistor. Since resistance for electronic circuits is often in the thousands or millions of ohms, the letter "K" is used to indicate "1000" and "meg" for "1,000,000." For example, a 22K resistor is a 22,000-ohm resistor. A 2.7 meg resistor is a 2.7 megohm resistor or 2,700,000 ohms.

Wattage

Standard resistors may be connected in the circuit in either direction, since they do not have "polarity."

Something else about resistors that is important is their "wattage" rating. The wattage rating refers to how much current can flow through the resistor without overheating it so that it is damaged. A 1/2-watt resistor, for example, can dissipate 1/2 watt of heat without damage while a 1-watt resistor can get rid of twice as much heat. Heat, as indicated, is a function of the current in the resistor. If the current in a given resistor is doubled, the heat is increased by FOUR times. If a circuit uses a 1/2-watt resistor, you can use a 1-watt resistor of the same ohms value if there is enough room to mount the larger resistor.

Value Tolerance

Another rating of resistors is "tolerance." This means the possible variation from the nominal or marked value of the resistor. For example, the resistor may have 20% tolerance, which in turn means that a 1000-ohm resistor could be anywhere between 800 and 1200 ohms (± 200 ohms). A 10% tolerance would mean the resistor would be between 900 and 1100 ohms.

Color Code

Although today the nominal values of many replacement resistors are marked in English, the common practice is to color code the resistors for quick and permanent identification. Fig. 2-12 is a color-code chart. Note that the first color band is the one nearest the end of the resistor. Suppose that a resistor has brown,

BLACK - 0	GREEN - 5
BROWN - 1	BLUE - 6
RED - 2	VIOLET - 7
ORANGE - 3	GRAY - 8
YELLOW - 4	WHITE - 9
GOLD BAND - 5% TOLERANCE	
SILVER BAND - 10% TOLERANCE	
NO COLOR BAND - 20% TOLERANCE	

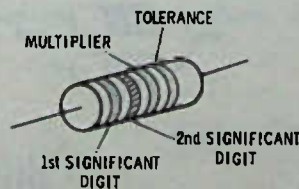

Fig. 2-12. Color code for resistors.

red, orange, and silver bands—what value resistor is it? Looking at the color code, we see that brown = 1, red = 2, and orange = 3, and silver equals 10% tolerance. Does this mean that the resistor is 123 ohms with a 10% tolerance? NO. Note that the first two color bands are significant digits so the first two bands are 1 and 2, but the 3rd band is a multiplier that literally means "how many zeros?" Since orange stands for 3, this band stands for three zeros. The real value of the resistor, then, is NOT 123 ohms but 12,000 ohms, with a 10% tolerance.

Another problem: what color bands would be on a 100-ohm resistor? The answer: brown (1), black (0), and brown (1 zero). What about a 10-ohm resistor? The answer: brown (1), black (0), and black (NO zeros).

What about a resistor of less than 10 ohms—say, a 4.7-ohm resistor—how would it be marked? The answer: yellow (4), violet (7), and the third band, gold, which indicates the moving of the decimal point one place to the left. A 0.39-ohm resistor would have color bands: orange-white-silver. In other words, if the third color band is silver, the decimal point is to be moved two places to the left or in front of the two significant digits. See Fig. 2-13.

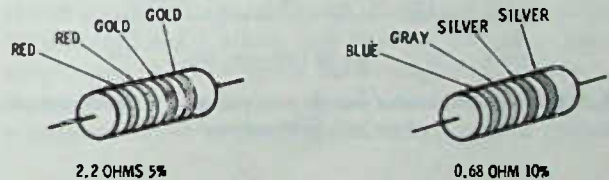

Fig. 2-13. Color code for resistors of less than 10 ohms.

The Greek letter Ω (omega) is usually used to indicate ohms, especially on schematic diagrams. For example, a 220 Ω resistor is a 220-ohm resistor. A 330K resistor may be marked just that way, or it may be marked 330K Ω , etc.

Standard Values

Resistors, especially 1/4-, 1/2-, 1-, and 2-watt size, carbon-composition resistors, are provided in nominal sizes that have few "round" numbers. The actual nominal sizes have been agreed upon by domestic manufacturers for convenience. The sizes are chosen so that a resistor will not be a "loner" or discard. That is, it will always be within tolerance, if not for one specific size, then for the next lower or higher value within 10%. For example, the standard sizes are 10, 12, 15, 18, 22, 27, 33, 39, 47, 56, 68, 82, 91, 100, 120, 150, 180, 220, 330, 390, 470, etc. right up through 2.2 megohm, 2.7 megohm, 3.3 megohm, and so forth.

Manufacturing of carbon resistors is an art, but not an exact one. That is it is difficult to control the mix so that every resistor comes out of the machines with exactly, or even nearly exactly, the same resistance.

Suppose that the manufacturer makes a batch that is on the borderline between 56 and 68 ohms. Plus or minus 10% of 68 means that the resistor could be as low as $68 - 6.8$, or 61.2, but suppose when it is measured it is found to be 60 ohms. It is out of tolerance as a 68-ohm resistor, but it can now be called a nominal 56 ohms since +10% of 56 would be 5.6 ohms and when added to 56 would mean that the resistor would still be in tolerance at 61.6 ohms. The idea then should be clear: there are no "orphan" resistors. No matter what the actual value, they will fall within 10% tolerance of one of the standard values set up by the industry.

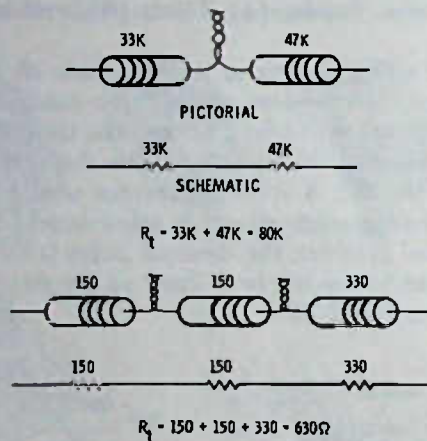

Fig. 2-14. Resistors in series provide total resistance R_t equal to the sum of the individual resistances.

RESISTORS IN SERIES

To obtain additional resistance if a resistor of the correct size is not available, resistors can be connected in series. The total resistance will then be the sum of each of the series resistors. For example, as in Fig. 2-14, a 33K resistor and a 47K resistor in series makes 80K total resistance. A 330-ohm resistor in series with two 150-ohm resistors makes a total resistance of 630 ohms.

Another advantage obtained by using series resistors, other than obtaining the necessary resistance, is in wattage rating. Suppose that a circuit should call for a 6800-ohm, 2-watt resistor. If this resistor were not available, you could use two 3300-ohm, 1-watt resistors as a replacement. The two 3300-ohm (3.3K) resistors add up to only 6600 ohms, but this is still well within a 10% (actually within 5%) tolerance, and since each resistor can dissipate 1 watt, it will be a satisfactory replacement for the 2-watt unit. Notice, though, that for the wattage rating to be additive in exact proportion, the two resistors must be of equal value. If one of the resistors, for example, were 5600 ohms and the other 1200 ohms, then the 1-watt, 5600-ohm resistor would overheat in the circuit. Since it is more than four times the 1200-ohm resistor, it will have more than four

times the heat build up. In this particular case, for safety's sake, the 5600-ohm resistor should be a 2-watt unit, while the 1200-ohm resistor could be a 1/2-watt unit.

RESISTORS IN PARALLEL

You can also duplicate an unavailable resistor for repair purposes by connecting resistors of suitable value in parallel. Resistors connected in parallel have less resistance to current than either of the parallel resistors would have by itself, since there are now two paths for current. For example, in Fig. 2-15, the two 1000-ohm (1K) resistors in parallel provide a total resistance of 1000 divided by 2, or 500 ohms. Resistors in parallel might be compared to dual-lane traffic on a highway as compared to single-lane traffic. If the lanes are identical, twice as many cars could drive the dual lane as the single lane, so the "resistance" to the flow of traffic would be cut in half.

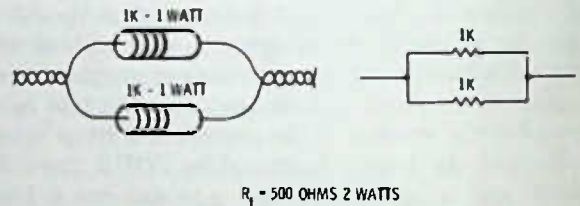

Fig. 2-15. Equal-value resistors connected in parallel.

So far the calculations have been easy, but what if the two resistors in parallel are of different size? Now we must use the formula learned earlier in this chapter for capacitors in series. The formula for resistors of unequal value when only two resistors are to be considered is:

$$\frac{R_1 \times R_2}{R_1 + R_2}$$

Fig. 2-16 shows a problem worked out for a 2.2K and 3.3K resistor in parallel. Note that in any case where parallel resistors of unequal size are used, the total resistance will always be smaller than the LEAST resistor in the circuit. This is true because no matter what the size of the parallel resistors around any resistor, more paths are provided for current, so the total resistance to current is reduced.

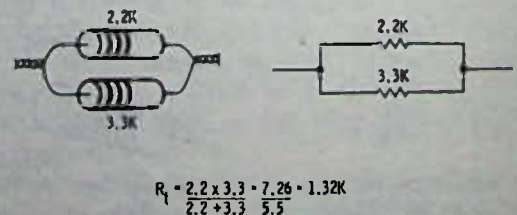

Fig. 2-16. Calculation of total resistance of two unequal-value resistors in parallel.

MORE THAN TWO RESISTORS IN PARALLEL

There are two ways to calculate more than two resistors of unequal value placed in parallel. One way is to use the formula in Fig. 2-17:

$$\frac{1}{R_t} = \frac{1}{R_1} + \frac{1}{R_2} + \frac{1}{R_3}$$

There is a considerable disadvantage to this method, especially with resistor sizes as they are, because finding the common denominator is difficult. A faster way,

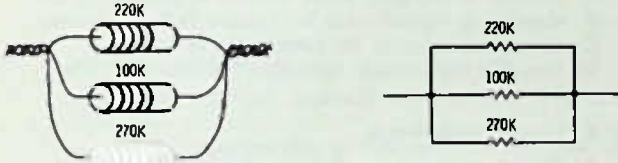

$$\frac{1}{R_t} = \frac{1}{R_1} + \frac{1}{R_2} + \frac{1}{R_3} = \frac{1}{220} + \frac{1}{100} + \frac{1}{270} = \frac{135}{29700} + \frac{297}{29700} + \frac{110}{29700} = \frac{542}{29700}$$

TO REMOVE $\frac{1}{R_t}$ INVERT $\frac{29700}{542} = 54.8 \text{ K}$

Fig. 2-17. Calculating value of more than two unequal resistors in parallel.

in most cases, is to use the formula for two resistors on any two of the resistors in parallel, then use the resulting answer and the two-resistor formula with the remaining resistor as in Fig. 2-18. Because resistors in most circuits have 10% tolerance, when calculating resistors it is perfectly permissible to round off the figures in order to make the calculations easier. In the

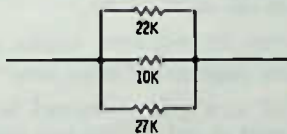

$$R_t = \frac{22K \times 10K}{22K + 10K} = \frac{220}{32} = \text{APPROX } 7K$$

$$\text{THEN } \frac{7K \times 27K}{7K + 27K} = \frac{189}{34} = 5.5K \text{ APPROX}$$

Fig. 2-18. Three resistors in parallel calculated by 2-resistor formula.

case of Fig. 2-18 there is no standard resistor of 5.5K, and if a single resistor were to be used the nearest thing available would be a 5.6K. So you can see that accurate calculations to several decimal places are completely uncalled for.

VARIABLE RESISTORS

In order to have control over volume in a radio it is necessary to have a variable resistance. Variable resistors may also be used for tone controls, and some times a screwdriver-adjusted variable resistor may be used to set transistor bias for most efficient operation or for best tone quality.

Because variable resistors "control" some function or another the variable resistors themselves are often called controls. For example, the variable resistor that controls the volume is called a volume control; a variable resistor controlling the tone is called a tone control; etc.

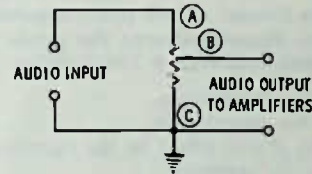

Fig. 2-19. Volume-control circuit.

Most variable resistors used in radios are potentiometers, that is, they pick off a voltage between 0 and the full available voltage. Fig. 2-19, for example, shows a volume-control circuit. Note that the resistance between (A) and (C) does not change. Movable arm (B) simply moves up or down between (A) and (C) selecting the amount of voltage (signal) desired between the maximum signal at point (A) and zero signal at point (C).

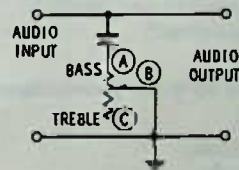

Fig. 2-20. Simple tone-control circuit using a variable resistor and a capacitor.

Some tone-control circuits, such as the one shown in Fig. 2-20, may use only two terminals on the potentiometer. The resistor here allows the capacitor to bypass more or less of the high frequencies in an audio circuit. With the arm (B) at the (A) side, the capacitor is a direct bypass to ground and the audio will sound "bassy." With the arm at the (C) end, the resistance in series with the capacitor allows it to pass LESS of the higher frequencies and so there is more treble in the sound.

TEST QUESTIONS

1. The insulation between capacitor plates may be air or some other insulating material. The insulation in a capacitor is called
 - A. insulation.
 - B. plate area.
 - C. dielectric.
 - D. electrons.
2. A capacitor that is connected across a battery or has been connected across a battery is
 - A. charged.
 - B. discharged.
 - C. a short circuit.
 - D. defective.
3. If a capacitor formed of two plates separated by air has a piece of glass slipped between the plates without moving the plates apart, this will
 - A. increase the capacitance.
 - B. decrease the capacitance.
 - C. have little, if any, effect on the capacitance.
 - D. discharge the capacitor.
4. A small capacitor is connected across a battery for several seconds. If a meter is now inserted to measure the current flow of the battery into the capacitor, it should read
 - A. high current.
 - B. low current.
 - C. zero current.
 - D. alternating current.
5. A microfarad is a millionth of a farad. It is also
 - A. one-thousandth of a picofarad.
 - B. one-millionth of a picofarad.
 - C. the same as a micromicrofarad.
 - D. one million picofarads.
6. A nanofarad used by some manufacturers is the same as
 - A. a microfarad.
 - B. 1000 microfarads.
 - C. 1000 picofarads.
 - D. one-thousandth of a farad.
7. At the present time the capacitor made in small sizes which can be made physically the smallest for its capacitance has a dielectric of
 - A. mica.
 - B. ceramic.
 - C. Mylar.
 - D. Plexiglas.
8. The type capacitor that works best at high frequencies is
 - A. paper.
 - B. ceramic.
 - C. Mylar.
 - D. Plexiglas.
9. One difference in electrolytic capacitors from other types is
 - A. they are generally made in smaller values of capacitance.
 - B. they have less leakage current.
 - C. they are polarized and should be connected in the circuit with the + to the most positive side of the circuit.
 - D. they are smaller physically.
10. Concerning the voltage rating of capacitors:
 - A. A replacement with a higher voltage rating than the original is permissible.
 - B. A replacement with the same voltage rating as the original is essential.
 - C. In transistor radio service the voltage rating of a capacitor should not normally be less than 100 volts.
 - D. The voltage rating indicates the maximum capacity value.
11. A variable capacitor is one that
 - A. changes in capacity when voltage is applied.
 - B. changes in capacity due to changes in temperature.
 - C. changes in capacity by mechanical means.
 - D. normally has ceramic insulation between the plates.
12. A "2-gang" capacitor is
 - A. the type normally used in small portable a-m radios.
 - B. the type normally used in expensive commercial receivers.
 - C. a fixed capacitor with two sections.
 - D. a fixed capacitor and a variable capacitor made in one unit.
13. The common name given to a wiring layout drawn on paper for an electronic circuit is a
 - A. schematic.
 - B. wiring diagram.
 - C. electronic diagram.
 - D. ground circuit.
14. A ground circuit is
 - A. an electronic wiring diagram.
 - B. a circuit that goes to a rod driven in the ground (earth).
 - C. the name given to the circuit common to all parts of the circuit.
 - D. the antenna circuit of a radio.
15. Electrical parts connected in series have
 - A. one end of each part connected to ground or to a common point.
 - B. the same amount of current flowing through each part.
 - C. the ability to keep working, even though one part is removed from the circuit.
 - D. less resistance to current flow than any one part by itself.
16. For an electrical circuit to be complete it must have
 - A. a current path from one side of the power supply to the other.
 - B. an "open" in the circuit.
 - C. a current path from the negative side of one power supply to the positive side of another power supply.
 - D. an alternating current supply.
17. Two capacitors rated at .01 μF , if connected in series have a circuit capacitance of
 - A. .02 μF .
 - B. .005 μF .
 - C. .01 μF .
 - D. .001 μF .

18. Two capacitors, one rated at $.03 \mu\text{F}$ and one rated at $.05 \mu\text{F}$ connected in series have a circuit capacitance of approximately

- A. $.02 \mu\text{F}$.
- B. $.08 \mu\text{F}$.
- C. $.04 \mu\text{F}$.
- D. $.026 \mu\text{F}$.

19. Two capacitors, a $.05$ and a $0.1 \mu\text{F}$, connected in parallel have a circuit capacitance of

- A. about $.033 \mu\text{F}$.
- B. $.075 \mu\text{F}$.
- C. $.08 \mu\text{F}$.
- D. $0.15 \mu\text{F}$.

20. A "trimmer" capacitor is

- A. a variable capacitor generally used to tune a radio to different stations.
- B. a variable capacitor that is only adjusted to "tune up" a radio for best sensitivity.
- C. a variable capacitor using air only as a dielectric.
- D. a variable capacitor designed to change the capacity of a circuit by several hundred picofarads.

21. The three things that affect the capacity of a capacitor are

- A. the voltage applied, the area of the plates, and the dielectric.
- B. the dielectric used, the distance between the plates, and the applied voltage.
- C. the distance between the plates, the area of the plates facing one another, and the dielectric type.
- D. the type of metal used in plates, the area of plates, and the distance between plates.

22. One of the following is *not* true about capacitors. Which one?

- A. Steady direct current will not flow through them.
- B. Current flows when a capacitor is first connected across a battery.
- C. Alternating current flows through capacitors.
- D. Slight moisture improves the efficiency of capacitors.

23. A transistor radio that has whistles or squeals in the speaker when turned on might have a defective

- A. antenna.
- B. speaker.
- C. tuning mechanism.
- D. electrolytic capacitor.

24. A parallel circuit is one that

- A. has the same current flowing through each part of the circuit.
- B. has the working parts each connected across the power supply so that removing one part does not stop the other from working.
- C. has all parts placed side by side.

25. In Fig. 2-21, which circuit is most truly a parallel circuit?

- A. A.
- B. B.
- C. C.
- D. D.

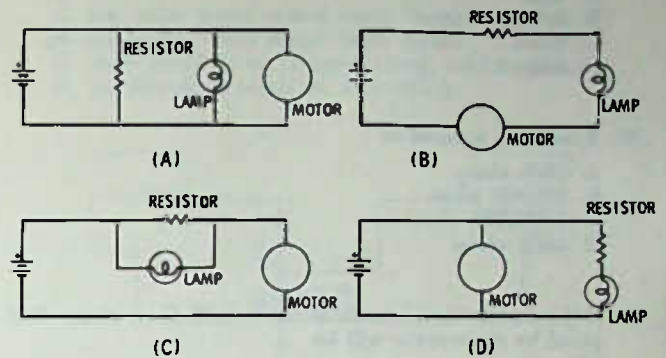

Fig. 2-21. Circuits for Questions 25, 26, and 27.

26. In Fig. 2-21, which circuit is most truly a series circuit?

- A. A.
- B. B.
- C. C.
- D. D.

27. In the circuit of 2-21C,

- A. the light will not light if the motor is disconnected.
- B. the motor will have no current flow through it if the lamp burns out.
- C. the motor will have no current flow through it if the resistor alone burns out.
- D. we have a series circuit.

28. In Fig. 2-22, which capacitor symbol would you take to indicate an electrolytic type?

- A. 1.
- B. 2.
- C. 3.
- D. 4.

29. A resistance is

- A. an electromotive force.
- B. a small capacitor.
- C. a limitation on the flow of electrical current.
- D. a battery.

30. A wire connected directly across a battery would be

- A. a high resistance.
- B. a short circuit.
- C. a medium resistance.
- D. a normal load.

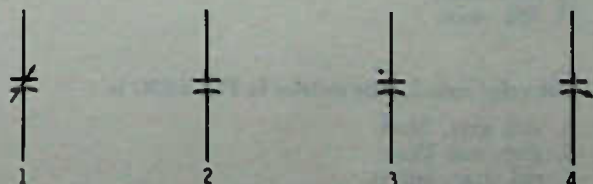

Fig. 2-22. Symbols for Question 28.

31. The unit of resistance measurement is
 A. ohm.
 B. henry.
 C. farad.
 D. ampere.
32. A megohm is equal to
 A. 1000 ohms.
 B. 100,000 ohms.
 C. 1,000,000 ohms.
 D. 100K ohms.
33. If the current in a resistor is cut in half, the wattage dissipated by the resistor will be
 A. cut in half.
 B. doubled.
 C. quadrupled.
 D. cut to one-fourth.
34. A 2.2K resistor with a 20% tolerance rating means
 A. it could be anywhere between 1760 and 2640 ohms.
 B. it could be any resistance value 10% either side of its rated value.
 C. it will withstand 20% more current than rated.
 D. it will withstand 20% more wattage than rated.

35. A resistor with the color bands as shown in Fig. 2-23A is
 A. 27 ohms.
 B. 271 ohms.
 C. 2700 ohms.
 D. 270 ohms.

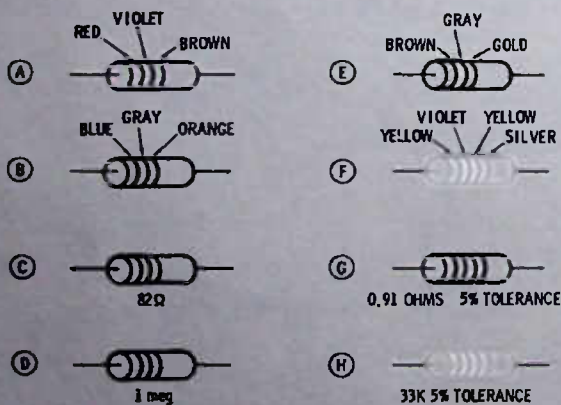

Fig. 2-23. Resistor coding for Questions 35 through 42.

36. A resistor with the color bands as shown in Fig. 2-23B is
 A. 6.8 ohms.
 B. 680 ohms.
 C. 68K ohms.
 D. 683 ohms.

37. The color code for the resistor in Fig. 2-23C is
 A. red, gray, black.
 B. gray, red, black.
 C. red, gray, brown.
 D. gray, red, brown.

38. The color code for the resistor in Fig. 2-23D is
 A. brown, black, green.
 B. brown, black, blue.
 C. brown, brown, blue.
 D. black, brown, blue.

39. The resistor size in Fig. 2-23E is
 A. 185 ohms.
 B. 1.8 ohms.
 C. 0.18 ohms.
 D. 18 ohms 5% tolerance.

40. The resistor value in Fig. 2-23F is
 A. 270,000 ohms plus or minus 27K ohms.
 B. 274 ohms plus or minus 5%.
 C. 274 ohms plus or minus 10%.
 D. 470K plus or minus 47,000 ohms.

41. The color code for the resistor in Fig. 2-23G is
 A. white, brown, silver, gold.
 B. white, black, brown, gold.
 C. white, black, black, silver.
 D. white, brown, silver, silver.

42. The color code for the resistor in Fig. 2-23H is
 A. red, red, red, gold.
 B. orange, orange, orange, gold.
 C. orange, orange, yellow, gold.
 D. red, red, orange, gold.

43. You might commonly expect to find these values in American made, carbon-composition resistors:
 A. 33K, 39K, 47K, 56K, 68K.
 B. 30K, 40K, 50K, 60K, 70K.
 C. 25K, 35K, 45K, 55K, 60K.
 D. 32K, 38K, 45K, 58K, 69K.

44. In Fig. 2-24, the resistors are connected in
 A. parallel.
 B. series.
 C. tandem.
 D. unison.

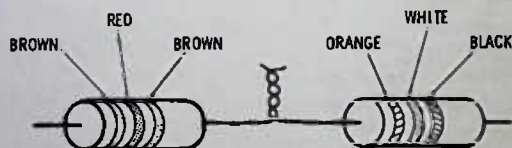

Fig. 2-24. Drawing for Questions 44 and 45.

45. The total resistance of the two resistors connected as in Fig. 2-24 is
 A. 120 ohms.
 B. 159 ohms.
 C. about 29 ohms.
 D. 39 ohms.

46. You have to replace a resistor in a radio. The value of the original resistor was 1500 ohms. You do not have a 1500-ohm resistor but do have several 1000-ohm resistors. To form a 1500-ohm resistor you would connect

- A. three in series.
- B. three in parallel.
- C. two in series.
- D. two in parallel and one in series.

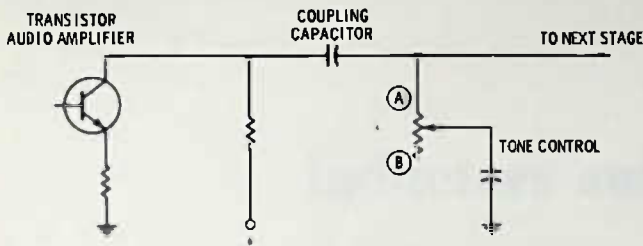

Fig. 2-25. Schematic for Question 49.

47. If you connected two 330-ohm resistors in parallel with a 220-ohm resistor, the three in parallel would equal approximately
- A. 150 ohms.
 - B. 133 ohms.
 - C. 94 ohms.
 - D. 880 ohms.
48. A volume control in a radio may be called a
- A. variable resistor.
 - B. a control.
 - C. a potentiometer or pot.
 - D. all of the above.

49. In Fig. 2-25, if the tone control arm were moved to the **A** position,
- A. the audio would sound more "bassy."
 - B. the audio would sound more treble.
 - C. there would be no change in tone, only in volume.
 - D. the dc voltage would be shorted out.

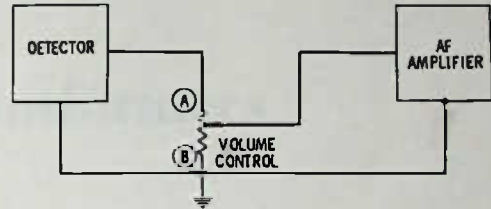

Fig. 2-26. Schematic for Question 50.

50. In Fig. 2-26, if the volume control arm is at point **B**
- A. volume will be minimum.
 - B. volume will be maximum.
 - C. volume will be about midway.
 - D. the resistance from the detector output to ground will be zero.

The first part of the report deals with the general principles of the method of moments. It is shown that the method of moments is a special case of the method of maximum likelihood estimation.



The second part of the report deals with the application of the method of moments to the estimation of the parameters of a normal distribution.

The third part of the report deals with the application of the method of moments to the estimation of the parameters of a binomial distribution.

The fourth part of the report deals with the application of the method of moments to the estimation of the parameters of a Poisson distribution.

The fifth part of the report deals with the application of the method of moments to the estimation of the parameters of a gamma distribution.

The sixth part of the report deals with the application of the method of moments to the estimation of the parameters of a beta distribution.

The seventh part of the report deals with the application of the method of moments to the estimation of the parameters of a chi-square distribution.

The eighth part of the report deals with the application of the method of moments to the estimation of the parameters of a t-distribution.

The ninth part of the report deals with the application of the method of moments to the estimation of the parameters of an F-distribution.

The tenth part of the report deals with the application of the method of moments to the estimation of the parameters of a hypergeometric distribution.

The eleventh part of the report deals with the application of the method of moments to the estimation of the parameters of a negative binomial distribution.

The twelfth part of the report deals with the application of the method of moments to the estimation of the parameters of a multinomial distribution.

The method of moments is a simple and powerful method for estimating the parameters of a distribution. It is based on the idea of equating the sample moments to the theoretical moments of the distribution.



The method of moments is a special case of the method of maximum likelihood estimation. It is based on the idea of equating the sample moments to the theoretical moments of the distribution.

The method of moments is a simple and powerful method for estimating the parameters of a distribution. It is based on the idea of equating the sample moments to the theoretical moments of the distribution.

The method of moments is a simple and powerful method for estimating the parameters of a distribution. It is based on the idea of equating the sample moments to the theoretical moments of the distribution.

The method of moments is a simple and powerful method for estimating the parameters of a distribution. It is based on the idea of equating the sample moments to the theoretical moments of the distribution.

The method of moments is a simple and powerful method for estimating the parameters of a distribution. It is based on the idea of equating the sample moments to the theoretical moments of the distribution.

The method of moments is a simple and powerful method for estimating the parameters of a distribution. It is based on the idea of equating the sample moments to the theoretical moments of the distribution.

The method of moments is a simple and powerful method for estimating the parameters of a distribution. It is based on the idea of equating the sample moments to the theoretical moments of the distribution.

The method of moments is a simple and powerful method for estimating the parameters of a distribution. It is based on the idea of equating the sample moments to the theoretical moments of the distribution.

The method of moments is a simple and powerful method for estimating the parameters of a distribution. It is based on the idea of equating the sample moments to the theoretical moments of the distribution.

The method of moments is a simple and powerful method for estimating the parameters of a distribution. It is based on the idea of equating the sample moments to the theoretical moments of the distribution.

The method of moments is a simple and powerful method for estimating the parameters of a distribution. It is based on the idea of equating the sample moments to the theoretical moments of the distribution.

Inductors and Transformers

Another basic component in radio circuits is the inductor. This is a fancy name for a coil of wire wound on a form of some sort. The wire may be wound around a cardboard form only, in which case we say the coil^o is an air-core conductor; that is, the core or inside of the coil has nothing but air to affect its inductance.

If we were to wind the coils of wire around a cardboard form which had a piece of iron inside, this would be called an iron-core inductor. Putting iron inside an inductor has the effect of increasing the inductance, the same as if many more turns of wire were used. For example, a 300-turn coil of wire wound over a nail might have the same effect in a circuit as a 1000-turn, air-core coil.

But there is a disadvantage to using iron in a coil, especially a solid piece of iron. A solid piece of iron tends to absorb a lot of the energy in the coil, and this is undesirable. To minimize this effect, the iron used in an inductor is laminated—that is it is made up of flat thin pieces of iron insulated from one another, as in Fig. 3-1.

The iron core works more efficiently in low frequency circuits if it is a closed core—that is, if the core not only goes through the center of the coil but also surrounds it on two sides as in Fig. 3-2. Most of the low frequency inductors (or their close relatives, the transformers) that you will see in radio use the closed-core construction. Actually, low-frequency inductors per se are rarely used in transistor radios, except as in the example of transformers, which are covered in the next section of this chapter.

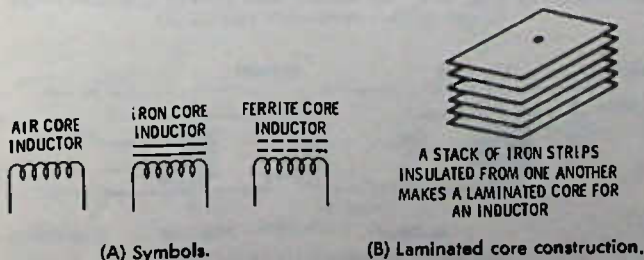

Fig. 3-1. Inductor symbols and construction.

RF Inductors

The losses of even laminated iron are prohibitive when dealing with higher frequencies. However, this can be overcome and still the Q (quality) of the coil will be improved. (The quality of any inductor rests almost entirely on its inductance as compared to the number of turns used, so that a higher quality coil is always possible if you can reduce the number of turns

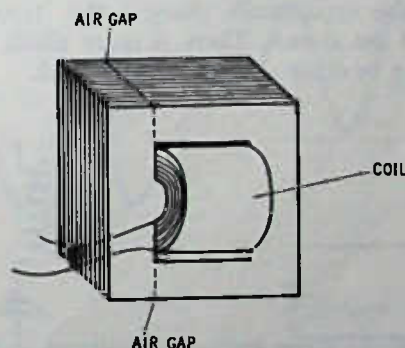

Fig. 3-2. Iron-core inductor with a "closed" core. Air gap prevents core saturation.

and still maintain the inductance value. This is what iron or ferrite cores do.) Iron cores can be used at radio frequencies if the iron is ground into a powder and then the particles are suspended in an insulating binder so that each fine particle is insulated from all other particles. The binder hardens, creating a solid material usually referred to as ferrite. The use of ferrites makes it possible for tuned circuits to tune more sharply—that is, be more selective—and the additional selectivity also increases the sensitivity.

The built-in antennas used in transistor radios in the a-m broadcast section have ferrite cores. These are fixed cores—that is, they are not adjustable.

Since ferrites can be formed into any practical shape, it has become popular practice to make ferrite cores adjustable. Because the core can be moved in and out of the inductor, the amount of inductance can be quickly and easily changed. This is important, since it

^oAn inductor may also be called either a coil or a choke.

makes a convenient means of tuning various radio circuits. See the chapters on i-f amplifiers.

An inductor is in some ways the exact opposite of a capacitor. A capacitor offers less and less resistance to alternating current as the frequency goes higher. For example, a specific capacitor will have twice the reactance at 1000 kHz as at 2000 kHz. (The "resistance" or opposition of a capacitor or inductor to alternating current is called "reactance." To designate, if necessary, between the two, they are called "capacitive reactance" and "inductive reactance.") However, an inductor, other things being equal, will have twice the reactance at 2000 kHz as at 1000 kHz. A capacitor blocks the flow of direct current while an inductor passes direct current easily.

Because of the opposite reactance of inductors and capacitors you might expect that they could be used together for some purpose, and they are. Any inductor and capacitor when connected in parallel or in series, as in Fig. 3-3, become sensitive to one frequency only. This of course makes possible the selection of stations in radio. The parallel-resonant circuit is used almost exclusively in radio except for a few rather special auxiliary circuits sometimes used. Changing either the inductance (by moving a ferrite core in and out of the coil) or the capacitance changes the "resonant" frequency of the circuit. There is more about resonance and tuning in other chapters of this book.

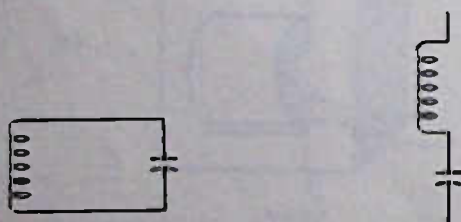

(A) Parallel-resonant circuit.

(B) Series-resonant circuit.

Fig. 3-3. Resonant or tuned circuits used in radio.

Inductance is measured in henrys, and where small inductances are involved this may be broken down into millihenrys or microhenrys.

When inductances are placed in series and there is no mutual inductance between them, the inductances add. For example, a 5-millihenry coil in series with a 3-millihenry coil would be 8 millihenrys. If there is mutual inductance between the two coils then the total inductance will be even greater. For example, an inductor with 20 turns might have an inductance of 5 microhenrys, but close-winding another 20 turns on the same core could mean a total inductance of perhaps 15 microhenrys, whereas two separate 20-turn inductances would be only 10 microhenrys when they are connected in series but are separated from one another.

The foregoing assumes, when the windings are all on one core, that all windings are wound in the same direction. If part of the windings are wound in the op-

posite direction, and if the windings so wound are close together, the reverse-wound windings can reduce the amount of total inductance below what would be obtained if the two coils were connected some distance apart.

Inductances connected in parallel reduce the inductance in the same manner as resistors in parallel. For example, a 4-millihenry coil connected in parallel (again no mutual inductance) with a 6-millihenry coil results in total circuit inductance of 2.4 millihenrys:

$$\frac{4 \times 6}{4 + 6} = \frac{24}{10} = 2.4$$

Transformers for Audio Frequencies

If a coil is wound on an iron core and still another coil is wound over it, but having no actual connection to the first one, there will still be a transfer of energy from one coil to the other if energy is applied to one. The transfer of energy is by what is called "mutual inductance." A transformer is so called because it has the property of changing one ac voltage into another voltage through the mutual inductance. For example, if one coil on a transformer has 1000 turns and another coil wound under or over the first coil has 500 turns, and if a 100-volt ac voltage is applied to the 1000-turn coil, the voltage developed across the 500-turn coil will be half as much, or 50 volts. On the other hand, if 100 volts is applied to the 500-turn coil, the voltage developed across the 1000-turn coil will be twice the applied voltage, or 200 volts.

In other words, a transformer has the ability to step down or step up an ac voltage. The step down or step up is in direct relation to the number of turns on the respective coils. If the turns ratio is 10 to 1, the voltage ratio, either step down or step up, will be 10 to 1 also.

The winding on a transformer that acts as the source is called the *primary* winding, and the winding where the voltage is taken off is called the *secondary* winding. A transformer may have one primary and several secondaries, and each of the secondaries may have a different voltage output.

The schematic representation of the audio or power transformer (a power transformer is designed especially for stepping up or down the power-line voltage) is shown in Fig. 3-4. All audio and power transformers

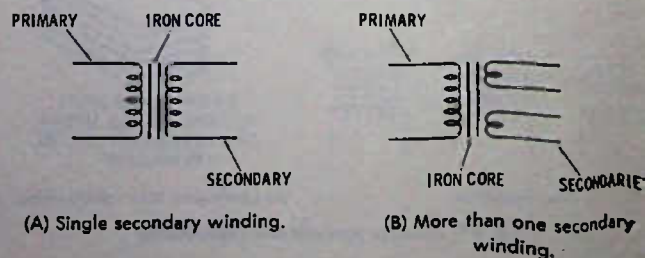

(A) Single secondary winding.

(B) More than one secondary winding.

Fig. 3-4. Schematic symbols of audio or power transformer.

use a closed core construction as explained in this chapter concerning inductors.

As with inductors, iron-core transformers are practical only at power and audio frequencies, even with laminated iron cores. Above the audio frequencies, the losses in the core cause the efficiency of the transformer to drop out of sight.

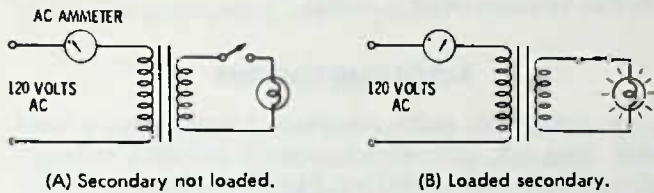

Fig. 3-5. Effect of load on power transformer.

A well-designed transformer has practically no losses (efficiencies of up to 98% are not uncommon), and if the primary is connected to a source, but there is no load on the secondary, there will be virtually no current flow in the primary. This is demonstrated in Fig. 3-5.

If the Voltage Is Stepped Down, What About Current?

In the circuit of Fig. 3-5 suppose that the voltage step down for the lamp is 10 to 1. This would mean that the voltage on the secondary lighting the lamp would be 12 volts. Next suppose that the lamp draws 10 amperes of current at 12 volts. How much current will the ammeter in the primary circuit read? The answer is 1 ampere (assuming there are no transformer losses, which generally are negligible). In other words, if the voltage is stepped down by a given amount, the current available is stepped up by the same ratio. On the other hand, if the voltage is stepped up, the current available is reduced in like ratio. Fig. 3-6 shows

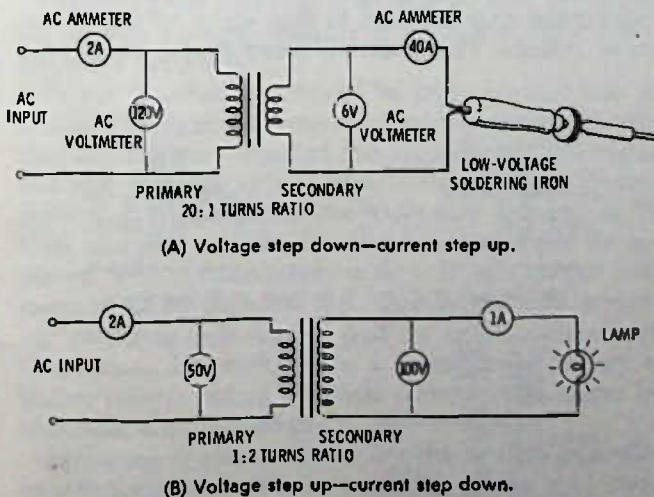

Fig. 3-6. Voltage transformation is accompanied by inverse current transformation.

some examples of step-up and step-down action, checked by the use of ammeters and voltmeters in the primary and secondary circuits of transformers.

TRANSFORMERS CANNOT OPERATE ON DC—OR CAN THEY?

A transformer cannot operate on a steady dc voltage such as from a battery. A transformer works because of a rise and fall in voltage applied to it. Ac rises and falls—that is, it goes first positive and then negative—or, said another way, the current travels back and forth in an ac circuit rather than in one direction only as with dc.

But a transformer will operate if the dc voltage changes. The examples that concern us in radio are those transformers used as audio coupling or output transformers in audio amplifiers. All these transformers work on a changing dc voltage called pulsating dc. So far as a transformer is concerned, it cannot tell the difference between ac and pulsating dc, since both are changing voltages and in fact have, or can have, identical waveforms except for the zero reference line. Here is what we mean: Fig. 3-7 shows an ac waveform and

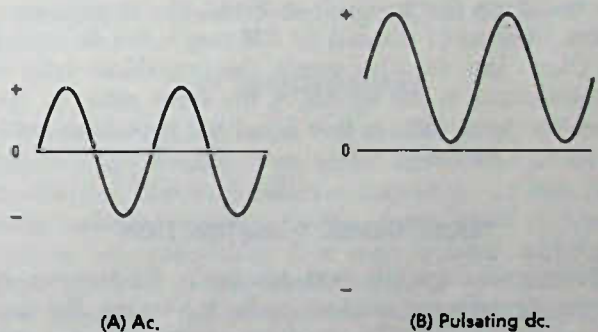

Fig. 3-7. Ac and pulsating dc can both operate a transformer.

a pulsating dc waveform, and, as can be seen, both are identical in shape. The only real difference is that one moves above and below the zero voltage line and the other is always above (or it could be always below*) the zero voltage line. For instance, the ac voltage might be going from -5 volts through zero to +5 volts, which is a total change of 10 volts. The pulsating voltage might start at +4 volts and go to +14 volts. Still, the change is 10 volts, and it is this change that causes the transformer to work.

As a practical example, transistors operate from dc voltage, but as the ac signal is fed into the transistor, the dc voltage is changed up and down, so a transistor amplifier can be connected to the primary of a transformer and produce an ac voltage output at the secondary.

*"Below" does not mean "less than nothing" but means a negative voltage.

IMPEDANCE MATCHING

As discussed in more detail later, one of the uses for a transformer in radio is in "matching impedances." What this really means is that some circuit may work at high voltage and low current, but this circuit needs to be coupled to another circuit which requires a higher current and lower voltage. (A higher-voltage circuit is called a high-impedance circuit, while a low-voltage, higher-current circuit is referred to as a low-impedance circuit.) A good way to get a good transfer of signal from one type of circuit to the other is to use a transformer as an impedance-matching device, since that is what a transformer does best—steps up or steps down voltage while stepping down or stepping up current.

Because both current and voltage are being considered, it is called impedance matching rather than, say, current matching or voltage matching. Impedance is measured in ohms, and ohms is a unit of resistance to current flow. But voltage and current always have a direct relation to the resistance of the circuit, so both can be considered in an impedance measurement. For instance, a circuit that has 6 volts across it and 6 mA of current, has an impedance of 1K (1000 ohms). If we transform that to 1 volt at 36 mA, the impedance is about 28 ohms (1 divided by .036 amp). See discussion on Ohm's law. In other words, the impedance ratio of a transformer is the square of the turns ratio. In this case, the turns ratio is 6 to 1 but the impedance ratio is 36 to 1 (6×6).

TRANSFORMER CONSTRUCTION

Most radio transformers for audio frequencies or power transformation are made similar to the one shown in Fig. 3-8. The windings are wound on a special form called a "bobbin" and then slipped over the center of the "E" laminations. The "I" laminations are then placed across the end of the "E" and the entire core is clamped inside a metal case to hold the laminations together and to provide mounting tabs to hold the transformer to the chassis of the radio.

Because the "E" and "I" laminations have some tendency to buzz when used on power transformers, especially on those supplying considerable power, power transformers often use only "E" laminations with

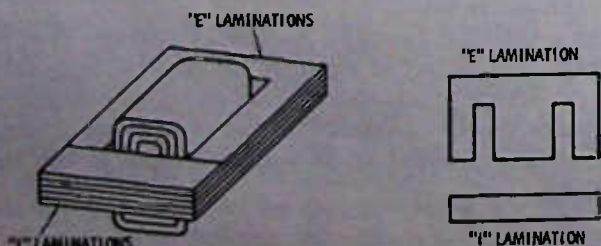

Fig. 3-8. Construction of audio transformer.

alternate laminations facing one another so that they are interleaved into the windings. On larger transformers, bolts with an insulating sleeving over them are used to clamp the laminations together to prevent transformer buzz.

The laminations are usually made of silicon steel, called "transformer iron." The laminations are insulated from each other, usually with a thin coating of shellac or some other material.

AUTOTRANSFORMERS

Sometimes in radio circuits a transformer is used that does not have direct current isolation between the primary and secondary. Fig. 3-9A shows an audio

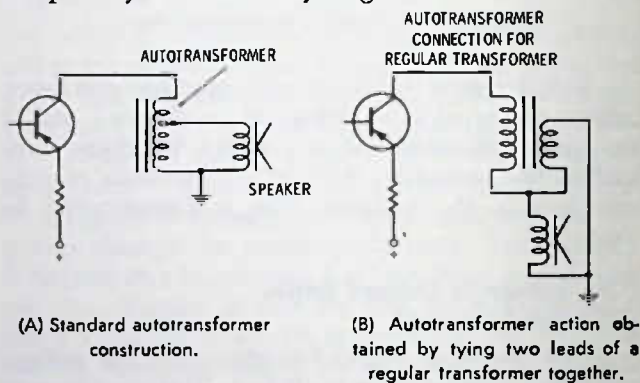

Fig. 3-9. Circuits using autotransformers.

output stage in an automobile radio that uses a transformer of this sort. There is really no difference between this transformer and a regular transformer except that the windings have a connection between primary and secondary. Any transformer, though, can use an autotransformer (sometimes called autoformer) connection, as shown by the alternate drawing in Fig. 3-9B. The step-up or step-down ratio, as with other transformers, depends on the turns ratio between the primary and secondary. Fig. 3-10 shows how an autotransformer may be used to step up or to step down an ac voltage. The autotransformer is also used quite

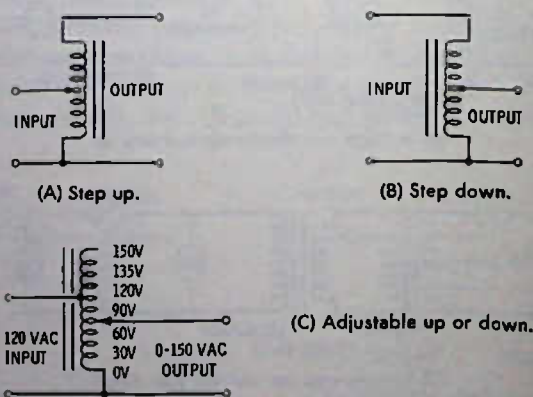

Fig. 3-10. Autotransformer connections.

often for an adjustable transformer to both step down or step up the input voltage. This is made possible by exposing the turns of wire and removing the enamel insulation along one side of the turns in a narrow slot so that a wiper arm can connect to individual turns as a knob is rotated. Because the voltage can be changed in one-volt steps or less, the adjustable autotransformer is often used for a light dimmer or for adjusting power to a radio transmitter, etc.

SERVICE

As a rule, transformers are rugged and seldom give trouble. A power transformer may be damaged if a circuit to which it is connected develops a short that draws excessive current. In larger equipment, a fuse in the primary circuit protects the transformer from damage in case of overload, but fuses are seldom used in radio circuits. Power transformers that have been damaged by overload have a characteristic smell from the charred varnish and enamel. A technician will recognize this smell, once he has experienced it.

Audio transformers usually do not burn up because not enough current flows in them. The most common fault for small audio transformers is an open circuit, which may be caused by a broken lead. Repair of an open transformer winding is seldom practical, since the break is generally under the insulation of the winding and not in external leads.

Another fault of transformers is shorted turns; that is, a short occurs between one winding and another winding wound over it. This is the same thing as adding a shorted secondary winding to the transformer. A power transformer may burn out if shorted turns develop, but in an audio transformer the symptom is usually to make the signal weak, and perhaps it sounds "tinny" because of the severe mismatch that develops. Substitution of a suspected transformer is about the only sure method of the diagnosis, although, as the technician gains experience, he may be able to discern by the sound output whether or not a particular transformer is defective.

Power transformers should be replaced with one of similar electrical characteristics, which means not only that the voltage output at the secondary is the same, but also that the secondary can supply the required current. For example, if the secondary is rated at 12 volts and 200 mA, the transformer should not be replaced with a transformer with a 12-volt output and rated at LESS than 200 mA. Usually, though, mounting problems will dictate that an exact replacement transformer be used, since a transformer having a higher current rating is almost certain to be larger in size.

Mounting is also generally a consideration in audio transformers, especially in transistor radios, and electrically the transformer should be identical (within 25% at least) with the original.

Audio output transformers are generally rated in terms of "ohms impedance" and "wattage." For example, a typical output transformer may have 500-ohms primary impedance and a 1-watt rating. The secondary impedance is generally considered to be 3 to 8 ohms to match a speaker, unless otherwise noted. If the primary is center-tapped—that is, if it has three leads—it is for a *push-pull* output circuit using two output transistors. The wattage rating indicates the maximum amount of output audio that the transformer will handle without serious distortion. Obviously a 10-watt transformer, although otherwise the same electrically, is wound on a larger iron core and uses larger wire on the windings; hence, it is physically larger than a 5-watt transformer, for example.

Exact replacement driver transformers for audio are recommended, since any marked change in impedance will cause serious distortion in the sound. However, so long as the electrical characteristics are similar and mounting is not a problem, a different replacement transformer than the original can be made to perform well. Unfortunately, many manufacturers of radios do not provide the exact electrical data for their transformers, so unless you are "circuit wise" you may have a few headaches trying to use something besides a replacement furnished by the original manufacturer.

RF TRANSFORMERS

Transformers for radio frequencies have a much different appearance from audio transformers. An rf transformer, like an rf inductor, uses either no core (air core) material or uses ferrite cores. Most rf transformers are adjustable, if a core is used, although there are fixed rf transformers that have a core; the best example is the antenna coil (note that sometimes the term "coil" is used even though the item may actually be a transformer).

An rf transformer is simply an rf inductor that has more than one winding on it. If only a few turns are used on the secondary as compared to the primary, then, as with other transformers, there is a step down in voltage but a step up in available current. All transistors except field-effect transistors (FETs) have a low-impedance input, meaning they require low voltage but higher current for operation. The crystal radio discussed earlier (and also later) in this book uses an antenna coil, about which it was said to not use the winding with few turns, but only the larger winding. However, in order to use this same coil in a transistor radio, it is necessary to step down the impedance of the tuned circuit so that the signal can be matched to the low impedance input of a transistor. Fig. 3-11 is an actual schematic circuit of the front end of an a-m transistor radio showing how the secondary coil feeds the input (base) of the transistor.

Nearly all rf transformers have one or both of the windings tuned. That is, in conjunction with a capaci-

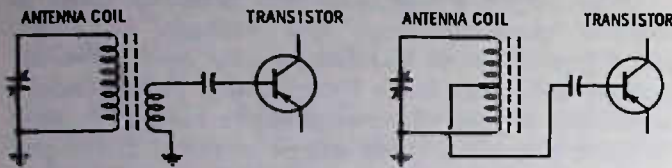

(A) Separate primary and secondary.

(B) Autotransformer connection.

Fig. 3-11. Antenna coil (transformer) circuit in a typical transistor radio.

tor, they form a resonant circuit that works best at one certain frequency.

There is more discussion about tuned circuits and how they work in other chapters of this book, such as the chapter on i-f amplifiers.

Transformers for rf may use windings to feed signals "in" as well as "out." For example, a long wire antenna can be connected or coupled into the antenna-coil circuit by wrapping several turns of wire around the ferrite core (it does not have to be directly over the other windings but should be over the ferrite core at

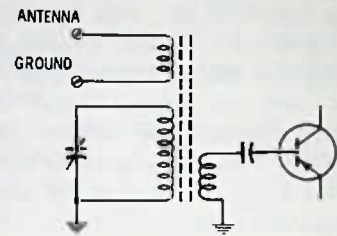

Fig. 3-12. An outside antenna "primary" added to a built-in ferrite antenna.

some point) and a long wire antenna connected to one end and a ground to the other end to increase the sensitivity of the radio without producing the "tuning" effect. If a long wire antenna were connected directly to the coil, however, it would cause such serious detuning that the radio likely would work better without an antenna than with one. Fig. 3-12 shows the schematic representation of a built-in antenna-coil circuit that has had an outside antenna and ground connection added.

TEST QUESTIONS

1. An inductor may also be called
 - A. a coil.
 - B. a choke.
 - C. a resistor.
 - D. either A or B.
2. Putting a suitable core inside an inductor
 - A. increases the inductance.
 - B. decreases the inductance.
3. A solid piece of iron
 - A. makes an excellent core material for low frequencies.
 - B. is less desirable than a laminated core.
 - C. decreases the losses in an inductor.
 - D. is the only useful core for radio frequencies.
4. An "air gap" in an iron core inductor prevents
 - A. saturation of the core when high current flows.
 - B. a "swinging" effect to lower the inductance at high currents.
 - C. transformer action.
 - D. both effects given in A and B.
5. Iron core material used at high frequencies
 - A. is impossible or impractical.
 - B. reduces inductance but also reduces losses.
 - C. is called ferrite.
 - D. is laminated.
6. A capacitor allows higher frequencies to pass more readily than lower frequencies. This is not true of
 - A. an inductor.
 - B. a resistor.
 - C. a straight wire.
 - D. any of the above.
7. The resistance of an inductor to the flow of ac is called
 - A. henrys.
 - B. reactance.
 - C. reluctance.
 - D. restriction.
8. A capacitor and a coil connected together are at some frequency
 - A. resonant.
 - B. unstable.
 - C. a tuned circuit.
 - D. both A and C.
9. The unit of inductance is
 - A. ohm.
 - B. inductive reactance.
 - C. inducti.
 - D. henry.
10. Two chokes are connected as shown in Fig. 3-13. The two have identical characteristics. Because of the closed core around them, there is little or no mutual inductance (coupling) between the two. The total inductance of the two is
 - A. half the inductance of either one.
 - B. the same as the inductance of one.
 - C. double the inductance of either one.
 - D. zero inductance if they are wound in opposite directions.
11. The transfer of energy from one transformer winding to another is by
 - A. a metallic connection.
 - B. mutual inductance.
 - C. compatibility.
 - D. reluctance.

$$\frac{100}{8} = 12.5$$

$$\frac{I_1}{I_2} = \frac{R_2}{R_1}$$

$$\left(\frac{R_1^2}{R_2^2} = \frac{n_1^2}{n_2^2} \frac{I_2^2}{I_1^2} \right) \times \left(\frac{I_1^2}{I_2^2} = \frac{R_2}{R_1} \right) \Rightarrow \left(\frac{R_1}{R_2} = \frac{n_1^2}{n_2^2} \right)$$

INDUCTORS AND TRANSFORMERS

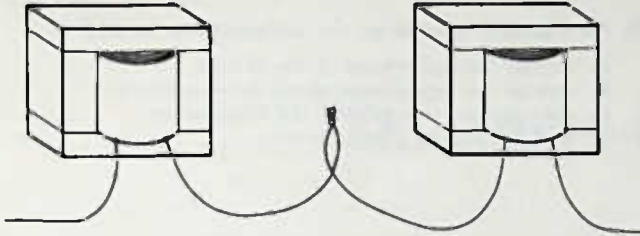

Fig. 3-13. Drawing for Question 10.

12. In Fig. 3-14, if the output voltage is 30 volts, assuming no losses in the transformer, what is the input voltage?

- A. 30 volts.
- B. 120 volts.
- C. 20 volts.
- D. 40 volts.

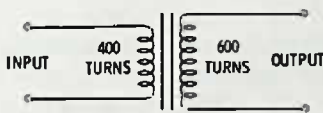

Fig. 3-14. Circuit for Questions 12 and 13.

13. In Fig. 3-14, if 50 volts steady direct current is applied to the primary winding, the steady output voltage will be

- A. zero.
- B. 75 volts.
- C. 37.5 volts.
- D. 100 volts approx.

$$\frac{U_2}{U_1} = \frac{I_1 R_1}{I_2 R_2} = \frac{I_1 R_1}{I_2 R_2}$$

14. Audio and power transformers use

- A. a solid iron core.
- B. a ferrite core in most cases.
- C. an open core.
- D. a laminated iron core.

$$\frac{R_2}{R_1} = \frac{n_2 I_1}{n_1 I_2}$$

15. The output winding of any transformer is called

- A. the primary.
- B. the secondary.
- C. closed core.
- D. laminated winding.

16. In an efficient transformer the energy transferred from input to output

- A. depends on the turns ratio.
- B. is 100%.
- C. is above 90%.
- D. is direct current.

17. Assuming no losses in the transformer, a 120-volt transformer drawing 2 amperes from the power source steps the voltage down to 6 volts. This is the only output winding on the transformer. If an ammeter were placed in the circuit to see how much current was being taken from the 6-volt winding, it would read

- A. 2 amperes.
- B. 6 amperes.
- C. 40 amperes.
- D. not enough information to tell is given in the question.

18. A transformer can operate

- A. only on direct current.
- B. only on alternating current.
- C. only on changing direct current.
- D. none of the above are correct.

19. In Fig. 3-15, if either voltage 1, 2, or 3 were fed into the input of the transformer, the output voltage would be

- A. the same as that fed into it.
- B. the same as that shown in (1).
- C. zero voltage, if either 2 or 3 fed into it.
- D. either the same as 2 or 3, depending upon the direction of the windings on the output side.

$$\Psi_1 R_1 = \Psi_2 R_2$$

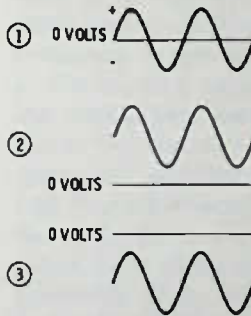

$$\frac{R_1}{R_2} = \frac{n_1 I_1}{n_2 I_2}$$

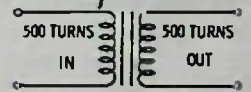

Fig. 3-15. Drawing for Question 19.

20. One use made for a transformer is

- A. to change ac to dc.
- B. to step up or step down steady dc voltage.
- C. to eliminate a metallic connection between the power line and the electronic device.
- D. change steady dc to pulsating dc.

21. Transformers are used in impedance matching, as in matching the output of one transistor to the input of another one, or a transistor to a loudspeaker. Suppose you need to match an 8-ohm speaker to a transistor requiring an 800-ohm load. The turns ratio for the transformer should be

- A. 10 to 1.
- B. 49 to 1.
- C. 100 to 1.
- D. 28.3 to 1.

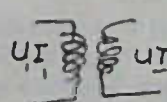

$$\frac{U_1^2}{R_1} = \frac{U_2^2}{R_2}$$

$$U_2 = n U_1 = I_1 R_1$$

22. In Fig. 3-16, which transformer(s) is/are connected as an autotransformer(s)?

- A. 1, 2, and 3.
- B. 1 and 2.
- C. 1 only.
- D. 2 only.

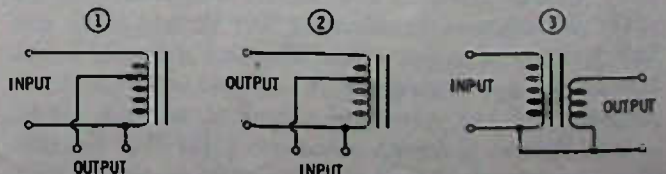

Fig. 3-16. Circuits for Question 22.

23. In radio service, the transformer which you might expect to burn and give off an odor because of the overheating is
- A. an audio output transformer in a portable radio.
 - B. an interstage transformer used to couple audio from one stage to the next.
 - * C. a transformer used to supply power to a radio from the ac power line.
 - D. an antenna transformer.
24. If you had to make do with a replacement transformer that is rated to supply 10 volts at 1 ampere from the power line, you might use a transformer with a secondary rated at
- A. 10 volts, 400 milliamperes.
 - B. 10 volts, 20 amperes.
 - C. 9.5 volts, 1 ampere.
 - D. 15 volts, 750 milliamperes.
25. An adjustable core in an rf transformer can be used to
- A. change the inductance of the rf coils.
 - B. change the capacitance across the transformer.
 - C. change the turns ratio of the transformer.
 - D. make it into an af transformer.

The Mixer-Oscillator Stage

In Chapter 1 you familiarized yourself with the block diagram. This sort of block diagram has been used for years in getting across the basic functions of a radio circuit. This is fine so far as it goes, but once you have passed this stage, the great temptation for authors and teachers is to jump directly to the schematic diagram, which is a giant step indeed. In this book we do something not often done, and that is to continue with the block diagram or "black box" approach, adding one or two circuits at a time, along with pictures and diagrams, to minimize the confusion of "explaining everything at once."

TUNING

Without tuning, radio as we know it would be impossible. Tuning is the process of selecting one station and excluding the others. You learned in Chapter 1 that in the superhet the oscillator (called local oscillator) in the receiver was tuned to a specific frequency, which in turn beat against the station frequency to produce a difference frequency called the intermediate frequency (i-f).

Tuning in the antenna or station frequency input stage is also desirable, especially to prevent "images." Basically, images occur in superhet radios if two stations can be heard that are separated by *twice* the intermediate frequency. For example, suppose you are listening to a radio tuned to 560 kHz. With a 455-kHz i-f, the local oscillator is operating at 1015 kHz. Now, let's suppose that within the hearing range of the receiver there is a station on 1470 kHz. If a 1470-kHz signal beats against the 1015-kHz local-oscillator signal, again there is 455-kHz output for the i-f coming out of the mixer. This means that the 560-kHz station and the one on 1470 kHz could be heard at the same time if there were no tuning in the antenna circuit.

So all radios use at least a 2-gang variable capacitor for tuning. One of the capacitors is for tuning the antenna input circuit and the other is used to tune the oscillator. In the example just mentioned, with the station tuned to 560 kHz, the antenna circuit is also tuned to this frequency and this will greatly reduce any 1470-kHz signal that might reach the antenna circuit.

RESONANCE

If any coil of wire is placed across any capacitor, such as in Fig. 4-1, the circuit will be "resonant" at some frequency; that is, it will react critically to this frequency much as a tuning fork will vibrate at a particular tone when struck. What happens is that at the critical frequency, an oscillatory current is set up inside the circuit which charges the capacitor; then when the capacitor is charged, it discharges into the coil, the coil returns the energy into the capacitor, and the cycle starts over. The only thing preventing this action from going on forever is the presence of small resistance losses. It's a bit like swinging a child in a swing: give him a shove and he will continue to swing back and forth at the same speed for quite some time, though each oscillation (back-and-forth cycle) will be slightly less vigorous than the preceding one. Once the child starts swinging, though, it takes only a light tap at the proper instant to keep the swing going continuously. The tap makes up for the losses in the swing "circuit" caused by air friction, etc.

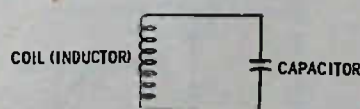

Fig. 4-1. Parallel-resonant circuit.

In a tuned radio circuit, or resonant circuit, the same as with the child's swing, it takes only a light tap at the right time to keep the circuit oscillating, or, as it is often called, "ringing." But as with the child's swing, if you should "tap" the circuit at, say, the bottom of the swing, you would stop or greatly retard the action of the swing rather than keep it going smoothly. In radio, then, if the incoming station signal is at the same frequency as the resonant frequency of the tuned circuit, the tuned circuit will respond strongly, but any other signals will be reduced considerably. One tuned circuit is not sufficient to separate stations that are fairly close together in frequency, but for stations as far apart as the image frequency (as, for example, 560 and 1470 kHz) one tuned circuit is enough to prevent serious problems, even though both stations might

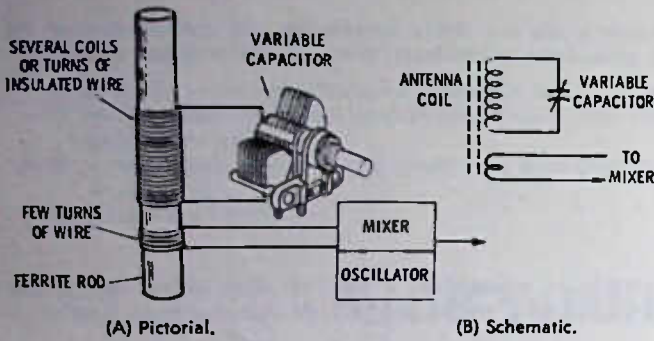

Fig. 4-2. Common method of tuning an antenna coil.

be received with approximately the same amount of signal.

The tuned circuit in Fig. 4-1 has a serious disadvantage for radio tuning—it is fixed at one frequency with no way of changing from one frequency to another. To tune a circuit, either the capacitor or the coil must be electrically changed, by some mechanical (or maybe even electrical) means. The most common way of changing the circuit, especially in a home radio, is to use a variable capacitor and a fixed coil, as in Fig. 4-2. The coil is wound on a ferrite rod, which has the effect of making the coil appear to have more turns. Thus, fewer turns are needed on the coil and the resistance of the circuit is reduced. This means that less input signal is required to “tap” the circuit and keep it “ringing” at a particular frequency.

When the correct incoming frequency is striking the antenna circuit, it causes an increase in voltage across the tuned circuit. By transformer action this voltage is induced into the smaller coil, which effectively reduces the voltage but “steps up” the current that is used to drive the transistor mixer ampli-

fier. (In tube or field-effect transistor circuits, the transformer action is not necessary, and the signal is tapped off at the top of the tuning capacitor, but for bipolar transistors, which are the most common ones in use at the present time, the step-up in current is necessary.)

EXPERIMENTING WITH TUNING
A CRYSTAL RADIO

Fig. 4-3 shows how to add a variable capacitor across the antenna coil of the crystal radio first diagrammed in Chapter 1. Adding the variable capacitor not only makes the radio selective but also improves its ability to pick up stations with more volume (improved sensitivity). The antenna on this circuit should be only a short piece of wire, perhaps six or eight feet long, otherwise the tuning of the circuit will be broad and the selectivity poor. Be sure to connect the circuit to a good earth ground. An ideal ground is a cold water pipe. Use a clamp around the pipe to make a firm connection and run the ground wire as far as necessary. The length of the ground wire is not too critical, although usually a short one is slightly better. You can vary the length of the antenna wire to find the most suitable length between good sensitivity and good selectivity. If you want to use a long wire antenna to increase sensitivity, you can keep the selectivity up by simply wrapping a few turns of the antenna wire over the coil, making no metallic connection at all. The radio signals will feed through the capacity between the coil and the wire and couple in enough signal without “loading” the circuit and affecting the tuning.

For radio signals that are near the low end of the broadcast band, you will find that you can use a longer

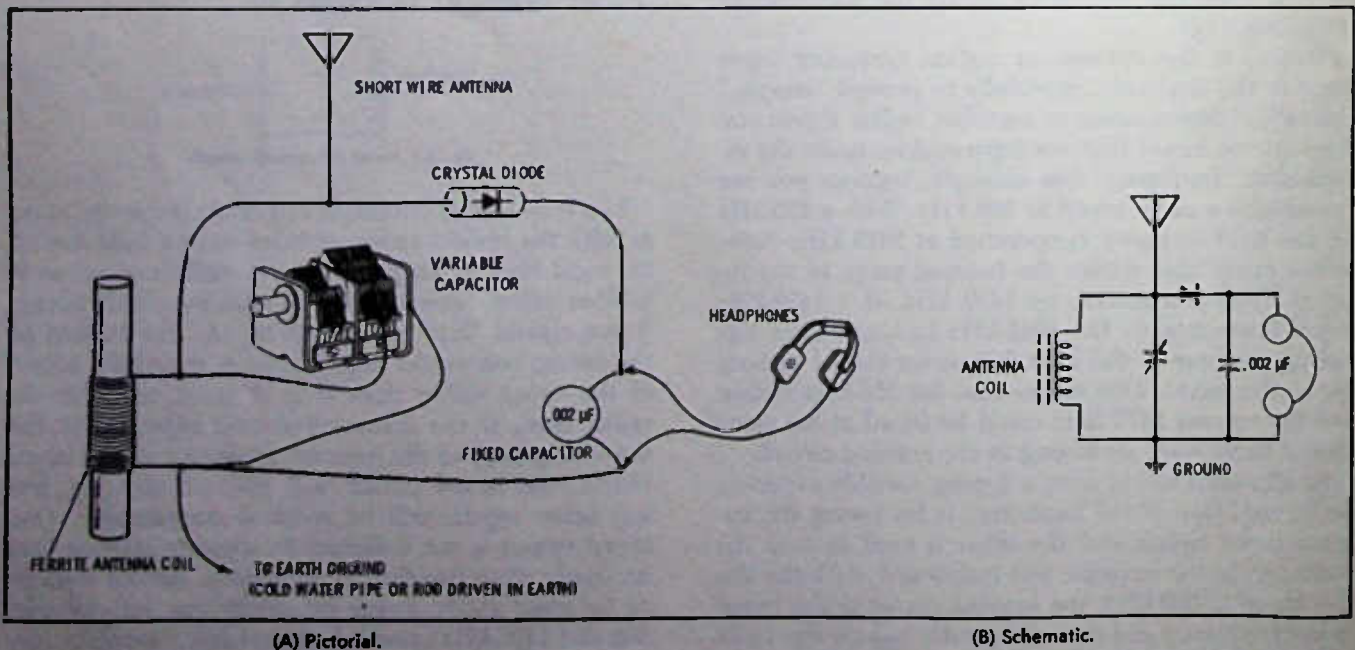

Fig. 4-3. A tunable crystal radio.

antenna wire connected directly to the circuit as shown in the schematic, but you will also find that the variable capacitor will have to be rotated to less capacity to tune in the stations for maximum. This is because adding length to the antenna is the same as adding capacity across the coil. Early crystal sets made use of this phenomenon to eliminate the variable capacitor from the circuit by bringing out various taps on the coil where the antenna wire could be connected. Fig. 4-4 shows one circuit of this type.

On the modern a-m superhet, no antenna wire is used at all. The pickup directly from the coil is sufficient to operate the radio at full volume for all but extremely distant stations. However, since crystal radios have no amplification, you will generally need an antenna unless you live close to a fairly powerful station. No earth ground is used on the modern superhet either. The ground is simply the metallic parts of the radio which are connected together as a common terminal.

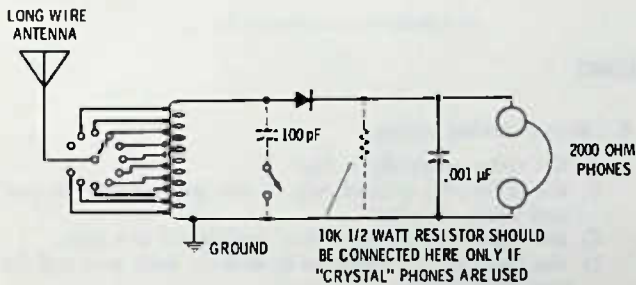

Fig. 4-4. Tapped-coil method of tuning a crystal set. Dotted-in capacitor can be used if desired.

If you build the crystal radio, you will get considerable insight into how tuned circuits operate. With a good antenna and ground you may be able to get a number of distant stations, especially at night when a-m broadcast signals "skip" due to sky reflections. If you are going to buy headphones, be sure to buy the best high-impedance phones^o (2000 ohms or more) that you feel you can afford. Later on, this book will show you how to make a simple transistor amplifier for the crystal radio that will increase the volume considerably and will operate for several months from a single flashlight battery.

What happens in this circuit is that a signal is picked up on the antenna coil, which will be tuned close to the incoming frequency; let's say a station on 1230 kHz. This signal is fed by transformer action to the input of the transistor. The transistor amplifies the signal in the collector circuit and sends it along toward the i-f amplifier. Another tuned circuit is used in the oscillator.

^oCrystal headphones have the highest impedance and high sensitivity, but if you use them you will need to place about a 10K, 1/2-watt resistor across them in the circuits shown in this book.

Note the dotted line between the two variable capacitors. This means they are ganged together—that is, both rotated by the same knob. The oscillator tuned circuit is at 1685 kHz (1230 + 455) and a portion of the oscillator voltage is fed back through a .05-μF capacitor to the base to sustain the oscillation in the circuit at the 1685-kHz frequency. The two signals mix in the collector circuit of the transistor, and the i-f amplifier, which we will study in more detail next, will "see" the difference frequency of 455 kHz and this is what it will amplify.

The 100K and 10K resistors in the base circuit of the transistor are called "bias" resistors and they are for supplying "turn on" current for the transistor from the power supply. The 1.5K resistor and the .02-μF capacitor in the emitter circuit of the transistor help to maintain an automatic level inside the transistor for best mix between the input signal and the oscillator.

The oscillator coil is "tapped down" on the tuned circuit side, for two reasons. First, only a small amount of signal is needed to be fed back for sustaining oscillation, and second, it prevents loading of the tuned circuit, which would make it tune broadly rather than sharp.

THE OSCILLATOR

An oscillator, as was pointed out earlier, is an electronic device that actually generates a signal at a specific frequency. It is an amplifier that uses a tuned circuit, usually in the input, and part of the output of the amplifier is "fed back" to keep the tuned circuit working vigorously (Fig. 4-5). This is the same idea

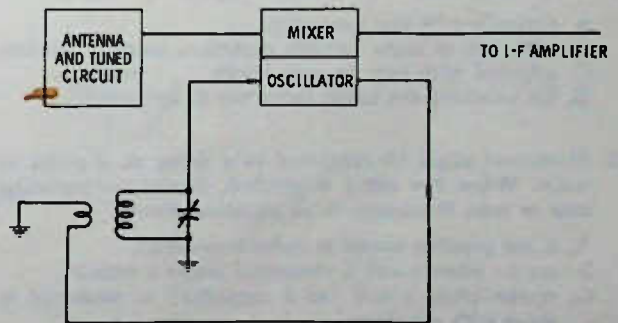

Fig. 4-5. Oscillator is amplifier that "feeds back."

as discussed earlier in this chapter concerning the "tapping" or "pulsing" of the tuned circuit by the signal input. The oscillator uses its own increased (amplified) output to make up for circuit losses and provide a steady output signal.

In most less expensive a-m broadcast radios, including most portables and many table radios, the same transistor is used for the local oscillator and the mixer amplifier as well. (Local oscillator is the term used to indicate an oscillator used in receivers. Transmitters also use oscillators often controlled by quartz crystals.)

The mixing of the signal and the oscillator occurs within the transistor.

Although we are not yet ready to learn all about how a transistor mixer-oscillator circuit works and how to check it for trouble, still it should be helpful for you to look at a representative circuit now (Fig. 4-6). If you have a schematic of a small transistor radio available, you will see a similar circuit almost surely. Several complete circuits are also included in this book.

A transistor amplifies in somewhat the same manner as described for a tube in Chapter 1, except that the transistor does not require any heating as a tube filament does. The transistor is a close relative of the crystal detector, both of which are "solid" pieces of germanium or silicon, and this is why transistors are called "solid-state" devices. What happens in a transistor is that a small current between the base and emitter causes considerably more current between the collector and emitter, and this produces amplification

when the collector-emitter current flows through next tuned or untuned circuit.

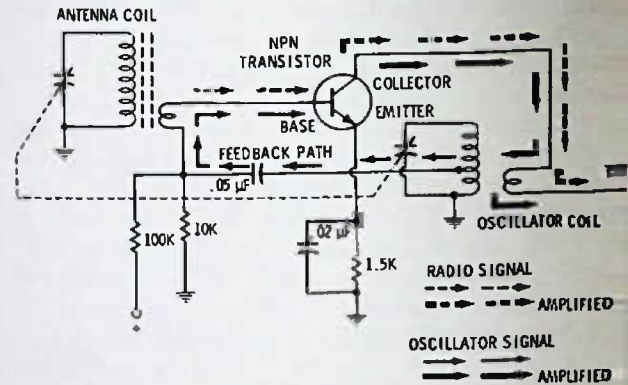

Fig. 4-6. Circuit of transistor mixer oscillator. Note different manner drawing antenna coil, which allows for cleaner schematic layout.

TEST QUESTIONS

1. An "image" in a superhet radio (with an i-f of 455 kHz) tuned to a frequency of 600 kHz would occur (assuming the local oscillator to be tuned above the incoming frequency) at
 - A. 1055 kHz.
 - B. 1510 kHz.
 - C. 145 kHz.
 - D. 910 kHz.
- 1055
 455
 1510
2. A superhet radio uses a variable capacitor
 - A. normally with one gang only.
 - B. with two or more variable capacitors ganged together.
 - C. adjusted with two separate knobs.
 - D. for receiving the image frequency or frequencies.
 3. Resonance might be compared to a string on a guitar or violin. When the string is plucked, it emits a particular note or tone. Resonance in an electrical circuit
 - A. is not possible except at radio frequencies.
 - B. occurs when a coil is connected across a resistor.
 - C. occurs when a coil (or a capacitor) is connected in series with a resistor.
 - D. occurs when a coil and capacitor are connected either in series or in parallel.
 4. A tuned circuit responds
 - A. only at one particular frequency and at no other.
 - B. best at one particular frequency.
 - C. at one frequency plus the image of that frequency.
 - D. to all frequencies in the broadcast band equally well.
 5. The "tuning" of a circuit can be done
 - A. only with a variable capacitor.
 - B. with either a variable capacitor or a variable inductor.
 - C. with only a variable inductor.
 - D. only with a variable resistor.

6. "Broad" tuning means
 - A. the radio selectivity is high.
 - B. the radio will respond only to one particular frequency and reject all others.
 - C. the radio may get more than one station at a time.
 - D. the radio can be expected to pick up both a-m and broadcast bands.
7. "Loading" a circuit means to require the circuit to supply power to some other circuit or to be affected adversely some sort of coupling to the circuit. One method of minimizing the loading on a tuned circuit in a transistor amplifier is
 - A. to couple to the next circuit by a step-down transformer winding.
 - B. to couple to the next circuit by a step-up transformer winding.
 - C. to connect a bipolar transistor directly across the tuned circuit.
 - D. to use a large capacitor across the tuned circuit.

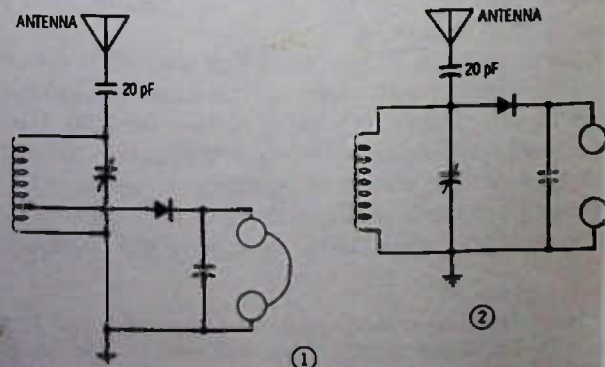

Fig. 4-7. Schematic for Question 8.

8. In Fig. 4-7, which of the two crystal-set circuits would you expect to tune sharper (be more selective)?

- A. 1.
- B. 2.

9. An oscillator might be described as

- A. an electronic device for generating radio signals.
- B. an amplifier to increase the signal strength coming in on the antenna.
- C. a fixed-frequency amplifier in a superheterodyne radio.
- D. a replacement for a long wire antenna.

10. In a superhet radio tuned to receive a 960-kHz signal, the oscillator frequency is at 1415 kHz. What is the intermediate frequency?

- A. 10.7 MHz.
- B. 2370 kHz.
- C. 1415 kHz.
- D. 455 kHz.

1415

$\frac{1415}{960} = 455$

11. In the "black box" of Fig. 4-8, what would you expect the circuit to be?

- A. An audio amplifier.
- B. An oscillator. *radio amplifier*
- C. An i-f amplifier.
- D. A coil and capacitor.

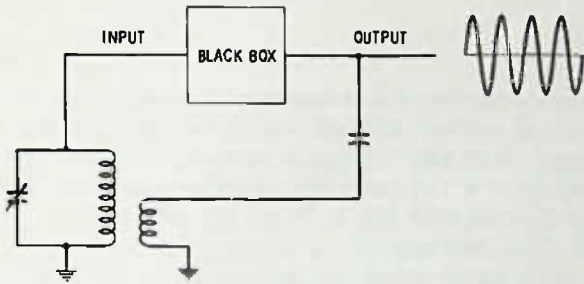
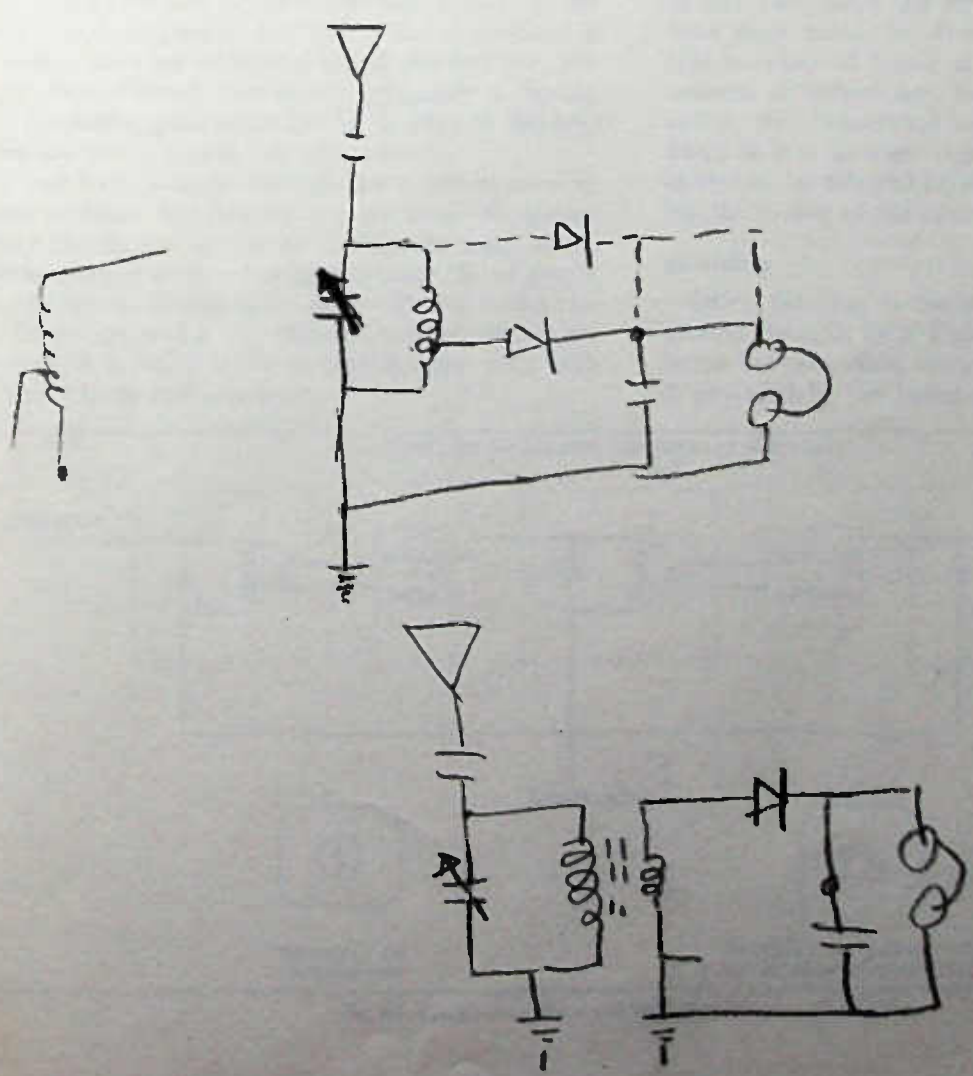

Fig. 4-8. Schematic for Question 11.

12. In a transistor we can get increased current between emitter and collector by

- A. supplying a small current between base and emitter.
- B. supplying a small current between collector and emitter.
- C. tying a tuned circuit across the collector and emitter.
- D. placing a short across the base and emitter.



The Intermediate-Frequency Amplifier

The next step in a transistor a-m broadcast radio, or most other superhet radios, for that matter, is the i-f (intermediate frequency) amplifier. The most popular i-f for broadcast radio is 455 kHz, but a number of automobile radios use an i-f of 262 kHz instead. Circuits for both frequencies are almost identical. The 262-kHz circuit, because of the lower frequencies involved, will tune a bit sharper and will have a bit more sensitivity, both of which are important factors in car radios where maximum performance is essential. The disadvantage of the lower-frequency circuit is the closer image frequency, but this is not a problem in car radios since an additional tuned antenna (rf) circuit is used. (Recall that image frequency is the desired frequency plus twice the i-f, so that in 262-kHz radios the image is only 524 kHz away.)

As you have already learned, the superhet receiver selects stations by beating an oscillator frequency against the desired frequency so that the result is the same frequency as the i-f amplifier. Since the i-f amplifier is fixed-tuned—that is, it can be adjusted to the correct frequency and is not changed as the stations are changed—it is much easier to manufacture with both good selectivity and sensitivity.

I-F TRANSFORMERS

Most present-day a-m radios use a two-transistor amplifier, with three i-f transformers, as shown in Fig. 5-1. A “slug” inside the can screws up and down inside the coils for initial adjustment of the i-f transformer to 455 kHz. The slug is made of material similar to that used in the core of the antenna coil—ferrite. Ferrite is essentially powdered iron that is suspended in a glue that has hardened. Placing a core of this sort inside the coil makes the coil appear to have more turns. In other words, a coil with a specific number of turns of wire will have a specific amount of inductance, but if a suitable core is inserted, the inductance increases. The core may be fixed, as it is in some coils, such as the antenna coil, or it may be adjustable, as it is in i-f coils for adjusting the tuning of the circuit.

Shielding

Often the slug is made so that it is also a shield around the coil, as in Fig. 5-2. This improves the isolation between coils, even though additional shielding is provided by the metal cans. Shielding is necessary

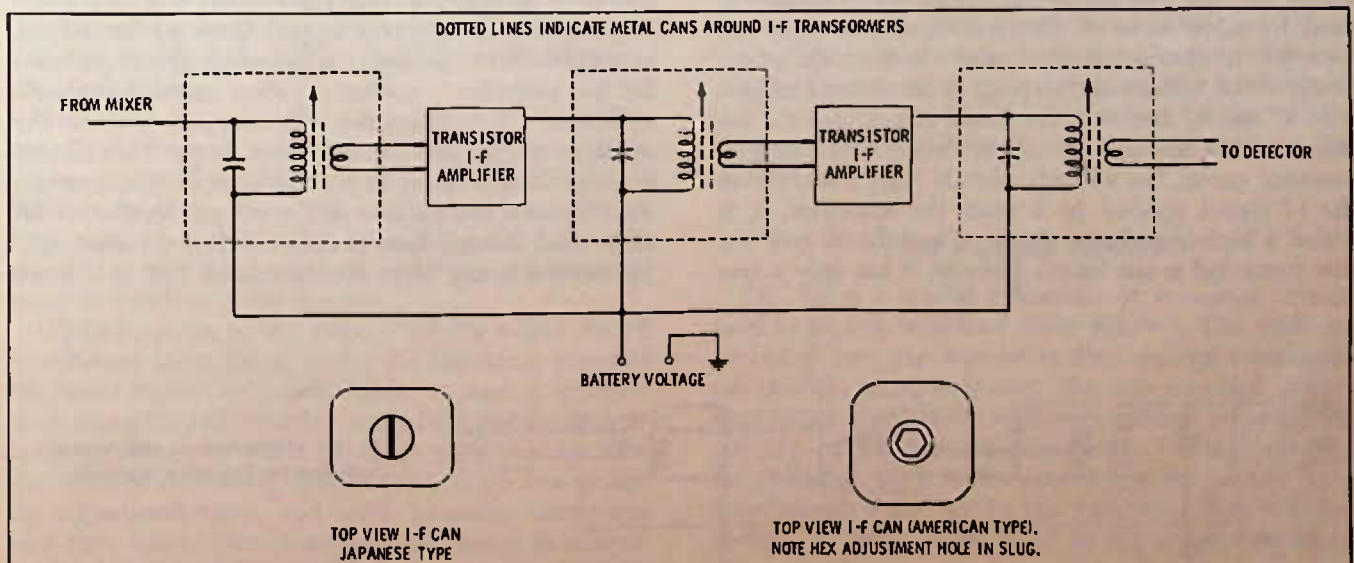

Fig. 5-1. Combination circuit and block diagram of an i-f amplifier.

in circuits tuned to the same frequency, such as i-f amplifiers, since some of the energy from the output of an amplifier might get into the input of the same or other amplifiers and cause oscillation. Obviously, the amplifier must process only the signal coming into it and not "take off" on its own. Oscillating i-f stages at best will cause whistles in the output and at worst will prevent any signals at all from getting through.

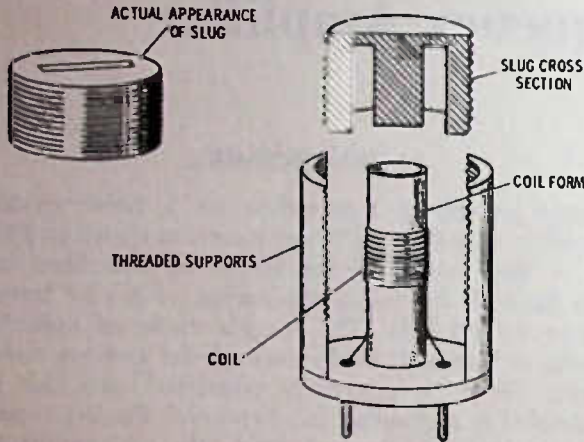

Fig. 5-2. Construction of an adjustable coil in which the tuning slug also serves as a coil shield.

Oscillation in an i-f amplifier of a transistor radio (causing whistles or "motorboating" and the like) is usually caused by an open electrolytic capacitor. To check, use a known good capacitor and temporarily connect it across any suspected capacitor, making sure to observe correct polarity (+ to + and - to -).

Referring to the block diagram of Fig. 5-1, note that there is only one tuned circuit in each of the i-f transformers. The resonant, or tuned, circuit is made up of a coil and capacitor, with the tuning done by a slug inside the coil. The signal transfer to the next stage is done by a few turns of wire wound on the same coil form as the tuned circuit. Again, we have this step-down of the voltage and step-up of the current to provide a "match" between the tuned circuit and the input circuit of the next transistor. Because the parallel-resonant circuit has a comparatively high reactance to the i-f signal applied to it from the transistor, it is called a high-impedance circuit. The take-off coil is a few turns and is not tuned. Because it has only a few

turns, the voltage induced in it is low, but the current is increased in the process. This is called a low-impedance circuit.

Impedance Matching

"Matching" is a term used in electronics to indicate that the output of one circuit couples efficiently to the input of the next one. If an attempt is made to couple a high-impedance circuit into a low-impedance circuit, or vice versa, without some sort of matching circuit, the coupling between the two circuits may cause more loss of signal than the next amplifier can make up for.

Not all amplifiers require low-impedance inputs such as those required for most bipolar transistor circuits. The vacuum tube and the field-effect transistor (FET) can both use high-impedance inputs. An example of an i-f amplifier with high-impedance input is shown in Fig. 5-3. Note that there is one other thing this amplifier has that the amplifier in Fig. 5-1 does not have: an additional tuned circuit inside the i-f can. Since a step-down is needed, the pickoff coil is also tuned and this improves the selectivity of the i-f somewhat.

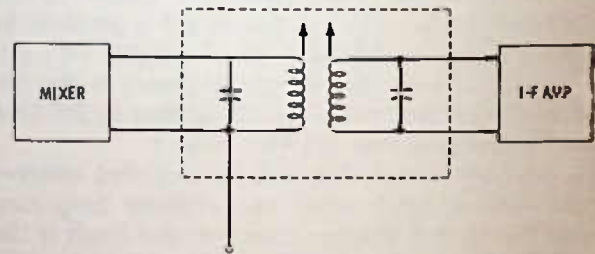

Fig. 5-3. I-f amplifier circuit for amplifiers using high-impedance inputs.

To overcome this loss of selectivity in the i-f circuit some manufacturers use i-f transformers made like the one at A in Fig. 5-4. This transformer has two tuned circuits, but the output is tapped down on the secondary or pickoff, coil to provide the necessary low impedance for the transistor amplifier. Another method is shown at B, in Fig. 5-4, where the coil is tapped down on the amplifier output side. Any tapping down of a coil that is resonant will result in a more sharply tuned circuit since there is less loading on the circuit. So, the circuit at B, even though there is only one tuned circuit, will be more selective than the circuit of Fig. 5-1. Since

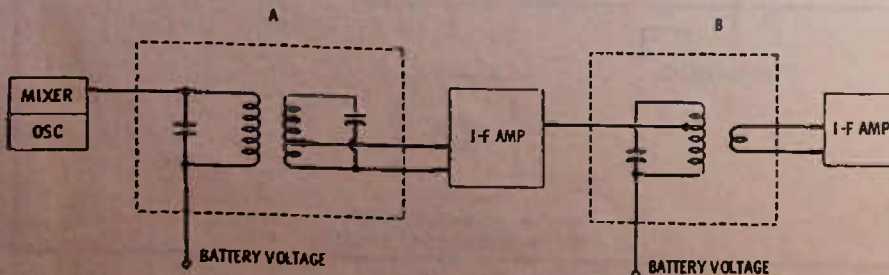

Fig. 5-4. I-f transformers with tapped windings for improving selectivity.

the amount of signal the pickup coil receives is directly dependent upon the amount of tuned current in the resonant coil, the gain is not affected. In fact, the gain of the stage may be improved because of the sharper tuning.

TUNING THE I-F TRANSFORMER

Normally, the i-f amplifiers will not need to be retuned often, if at all, unless someone moves the tuning slugs. However, for a radio that has poor sensitivity (weak) it is a good idea to check the tuning, if no other common troubles for weakness have shown up in diagnosis.

Tuning an i-f scientifically is done with a signal generator (an electronic device that can be quickly adjusted to supply a definite strength of output signal at a desired frequency) and with some sort of output meter. The complete tuning of a receiver, using the signal generator and meter, will be covered in more detail later, but a creditable job of tuning can be done "by ear" if you are careful and if you understand what you are doing. This is a touchup adjustment for a radio that is already working—make sure that you do not attempt to tune a radio if it is dead—the chances of the tuning being so far off as to completely kill all sounds from the radio are small.

Tune in a station, if possible, and check the dial reading. If the reading on the radio dial is close to where the station should be heard, the local oscillator of the radio is close to being correctly tuned. Incidentally, in many transistor radios, the oscillator coil and the i-f coils are identical in appearance. If you are not sure which is the oscillator coil, tune in a station and then just barely adjust each of the coils. The one that causes the station to change position on the dial is the oscillator coil; the i-f coils will simply reduce (or sometimes increase) the volume.

If the stations at the low end of the dial (between 540 kHz and about 750 kHz) are close to the correct point on the dial, do NOT adjust the oscillator coil—not now, at least.

Next, tune the radio dial away from a station. Now you should hear only noise or grinding in the speaker (volume control should be turned full up). If there is little or no noise, move the radio near a fluorescent lamp until you hear noise. Hold the radio only near enough to the lamp to barely pick up a noticeable noise or grinding in the speaker.

While listening to the noise, carefully adjust the i-f transformer slugs one at a time for maximum noise. If the noise comes up considerably, so that it is fairly loud, move the radio further away from the fluorescent lamp. Continue to adjust the slugs until you are sure the noise is maximum. Keeping the noise low makes the adjustment easier and more accurate, since your ears have much more sensitivity to *change* in volume level when the volume level is low.

OSCILLATOR AND TRACKING ADJUSTMENTS

Now you are ready to adjust the oscillator slug, but first turn the radio dial to a vacant spot on the dial near 600 kHz and again, while listening carefully, adjust the oscillator coil for maximum noise. This last adjustment is called "tracking." What it does is to make sure that when the oscillator is tuned correctly to pick up a certain station, the antenna circuit will be tuned to the frequency of that station. When this happens, the radio is said to be "tracked" and the sensitivity of the radio will be maximum.

The other tracking adjustments for the radio are the trimmers on the tuning capacitor. These are screw-driver adjustments and are adjusted at the high end of the dial (from around 1350 kHz or higher). There is usually one trimmer for the oscillator and one for the antenna circuit. If a station comes in at the right spot (or close to it) at the high end of the dial, then the oscillator trimmer does not need adjustment. Instead, tune the radio to another vacant spot (a place where no station is received), but this time at the high end (above 1300 kHz), and adjust the antenna-circuit trimmer on the tuning capacitor for maximum noise. (Again, you can tell which trimmer is which by a very tiny adjustment. The oscillator trimmer will change the spot on the dial where you get a station, while the antenna trimmer will simply make the station weaker or louder.) Caution: Be careful not to adjust trimmers on the tuning capacitor on an am-fm radio until you are sure which trimmers are which. This is also true of slugs in i-f transformers since separate transformers are used for a-m and fm. If you try to "adjust" an fm transformer while listening to the a-m band, you can throw off the circuit and not be aware of it at the time. No slug should ever be tuned, nor any other adjustment, unless you are listening to the radio, and you should note the approximate position of the adjustment so that if you turn it and nothing happens you can return it to the same spot. When "trying" an adjustment, never turn it more than an eighth of a turn as a check. An eighth of a turn should make at least a noticeable difference in the radio's output—either a change in volume or a shift in frequency.

THE ACTUAL CIRCUIT

Fig. 5-5 is a partial schematic of an actual circuit used in an a-m broadcast radio receiver. This particular circuit uses pnp transistors. Pnp and npn transistors are similar in performance, the one essential difference being the polarity of battery voltage required. In the pnp circuit, the negative battery voltage goes to the collector, while in the npn circuit the positive battery voltage must go to the collector. This will be covered in much more detail in the chapter on transistor amplifiers.

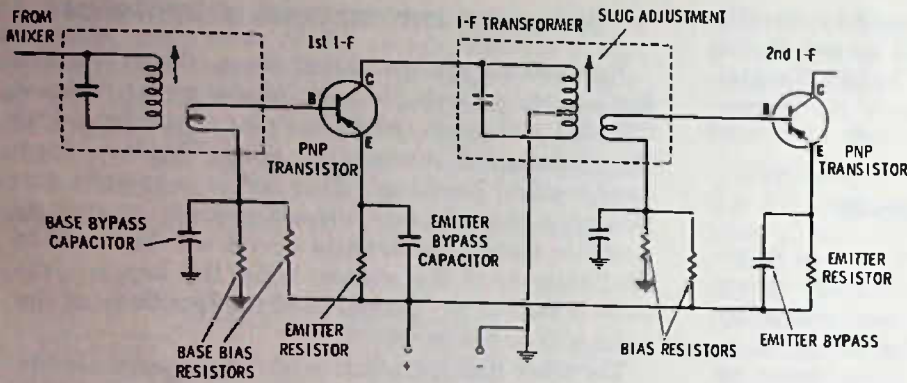

Fig. 5-5. Partial i-f amplifier circuit in an — broadcast radio.

This particular circuit uses only a single tuned circuit inside each i-f can. To increase the selectivity, the battery circuit is "tapped up" on the coil rather than the collector being "tapped down." Either system has the effect of preventing the battery and collector circuit from being wholly across the tuned circuit with possible loading effects. Loading of a tuned circuit reduces how sharply it tunes—that is, how selective it is to a particular frequency or narrow band of frequencies. If a resistor is placed across a tuned circuit, the tuned circuit will tune more broadly; it will accept a wider band of frequencies and at the same time the gain of the circuit is lowered (Fig. 5-6). Sometimes resistors are deliberately placed across a tuned circuit to broaden the response, but usually this is not desirable in a-m radio. If the collector and battery circuit are connected directly across a tuned circuit, the effect is the same as putting a resistor across the circuit. Tapping down (or up) effectively reduces loading and produces a sharper circuit response.

SUMMARY

The intermediate-frequency amplifier is a fixed-tuned amplifier. The selectivity and sensitivity of the i-f amplifier largely determine the sensitivity and selectivity of the entire radio. The i-f amplifier tuning can be checked by making tiny adjustments while listening for increase in background noise in the radio. Do not attempt to adjust an i-f amplifier if the radio is dead

(no sound output), because the trouble is almost surely elsewhere. If the i-f amplifier is detuned very much, it may be impossible to get it back accurately without elaborate equipment—that is, unless you have had considerable experience in adjusting the amplifiers. Squeals, whistles, or motorboating sounds in a radio may be caused by oscillation in the i-f. This is usually caused by a defective bypass capacitor, most often an electrolytic bypass that has opened up. Temporarily connect another capacitor across the old one observing correct polarity, to see if the trouble clears away. Tuning may seem to eliminate the oscillation but this is seldom the reason for the squealing. Even if detuning eliminates the whistles or squealing, the sensitivity of the radio will be lowered excessively, in all probability. In a well-designed radio, no amount of detuning, or of peak tuning, should cause the radio to "take off" into whistles or squeals. This means, in other words, that mistuning is normally neither the cause nor the cure for i-f amplifier oscillations.

One thing in portable radios that may be overlooked when the problem is squealing or whistles is a defective battery. Always replace the battery as a check before going further.

Most transistor radios that are used here in the United States are built in Japan, so most of these will have i-f adjustments that can be made with an ordinary screwdriver. Be careful, though, not to put excessive pressure on the slug as it is adjusted, and be

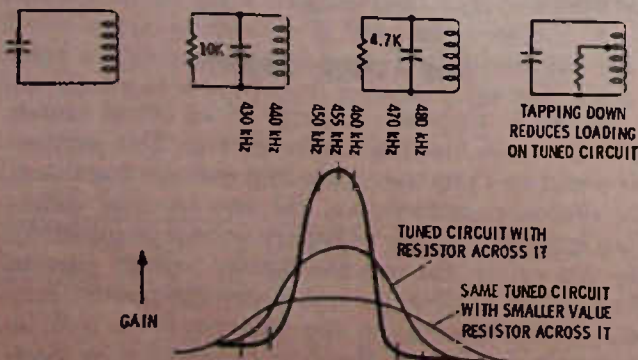

Fig. 5-6. Effect of loading on tuned circuit.

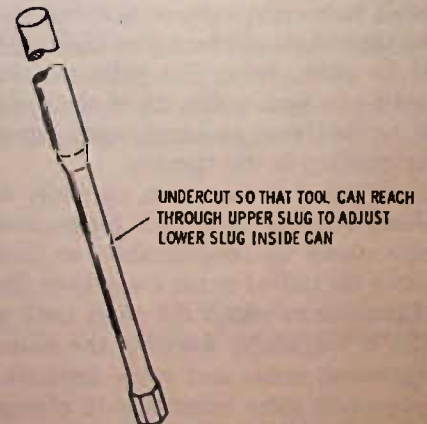

Fig. 5-7. Hex adjustment tool for "American" type i-f transformers.

oscillators.
~~tuned transformer~~ i.f transformers, i.f Amplifier.
 Intermediate Frequency Amplifier.

THE INTERMEDIATE-FREQUENCY AMPLIFIER

sure not to use a screwdriver either too large or too small for the slot. The "Japanese" i-f can has only one adjustment slug.

In radios using American-type i-f transformers, the adjustment is normally made with a hex tool (Fig. 5-7). This is a plastic tool that fits a hexagon-shaped hole in

the adjustment slug. Often, in the American-type coil, there will be two slugs in the coil (i-f coils or transformers) to adjust, one at the top and the other at the bottom. You can normally adjust both slugs from the top by simply passing the tool down through the top slug and into the hex hole in the bottom slug.

TEST QUESTIONS

1. The intermediate frequency used most often in small and large broadcast radios on a-m is
 - A. 262 kHz.
 - B. 455 kHz.
 - C. 10.7 MHz.
 - D. 465 kHz.
2. The intermediate-frequency amplifier
 - A. is tuned to various station frequencies by the radio dial.
 - B. is always tuned above the station's incoming frequency.
 - C. increases the power of the local-oscillator signal.
 - D. is fixed-tuned to one particular frequency.
3. The tuning of the i-f transformers in transistor radios is nearly always done with
 - A. variable capacitors.
 - B. moving the transformer core in and out of the transformer winding.
 - C. changing bias on the transistors.
 - D. variable resistors or pots.
4. The "slugs" in an i-f transformer are made of
 - A. ferrite.
 - B. laminated iron.
 - C. Plexiglas.
 - D. carbon.
5. The most common trouble causing "oscillation" in i-f amplifiers is
 - A. defective transistors.
 - B. open i-f transformers.
 - C. transformers not in tune.
 - D. electrolytic capacitor open.
6. "Matching" in an electronic circuit means
 - A. a high impedance connected directly to a low impedance.
 - B. a method of transferring the maximum amount of signal between different kinds of circuits.
 - C. selecting of component parts so that they are compatible.
 - D. transformer coupled stages.
7. A field-effect transistor has an advantage over the bipolar type because it has
 - A. high input impedance.
 - B. low input impedance.
 - C. low output impedance.
 - D. smaller size.
8. The instrument used to provide a signal for tuning an i-f amplifier is commonly called a
 - A. signal sweeper.
 - B. signal oscillator.
 - C. signal generator.
 - D. output meter.
9. If you move a slug in a transformer and the station you are listening to changes to another place on the dial, you can be sure you have adjusted
 - A. an i-f transformer.
 - B. an oscillator coil.
10. The best way to peak up the i-f transformers in a radio by ear is
 - A. tune radio off station and tune i-f's for maximum noise.
 - B. tune to a strong local station and tune i-f's for maximum output.
 - C. use any station and adjust radio for maximum volume, using the volume control before tuning the i-f's.
 - D. by using an output meter.
11. "Tracking" a radio means
 - A. adjusting the i-f's for maximum output.
 - B. adjusting the oscillator circuit so radio dial reads correctly.
 - C. adjusting volume control for medium volume.
 - D. adjusting oscillator and antenna circuits so that there is maximum output from the radio over the entire range of the dial.
12. The "trimmer" on the oscillator section of the tuning capacitor should be adjusted so that
 - A. the dial reads correctly at the low end of the dial.
 - B. the radio dial reads correctly at the high end of the dial.
13. You should be careful about adjusting i-f transformers without test equipment by
 - A. not turning any adjustment unless you are listening carefully for results.
 - B. using only the correct alignment tool.
 - C. not turning any adjustment more than a slight amount if it makes no difference in the output.
 - D. all the above are correct.
14. An npn transistor uses
 - A. a negative voltage on the collector with respect to emitter.
 - B. a positive voltage on the collector with respect to emitter.
15. Transistor radios made in Japan generally
 - A. use a single-tuned i-f transformer with a slug turned by a hex tool.
 - B. use a single-tuned i-f transformer with a slug tuned by a regular screwdriver.
 - C. use dual-tuned i-f transformers tuned with a hex tool.
 - D. use dual-tuned i-f transformers tuned by variable capacitors.

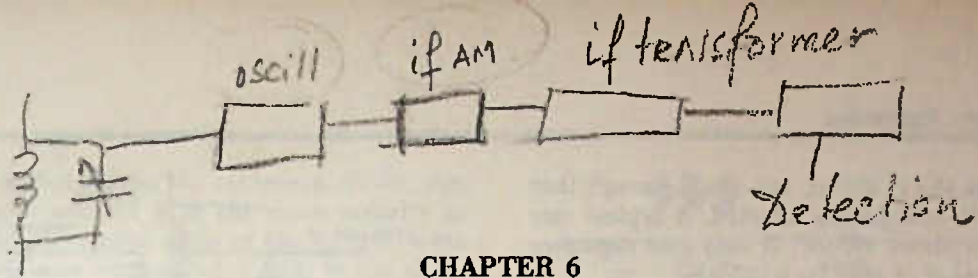

CHAPTER 6

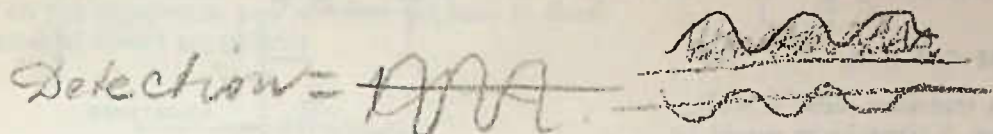

The Detector

Once the signal has been selected, processed, and amplified by the mixer-oscillator and i-f stages, the next step is detection. As explained in Chapter 1, detection is the process of removing the audio and radio frequency signals, keeping the audio for further amplification and discarding the no longer needed rf signal.

WHY DETECTION IS NECESSARY

To detect an a-m signal, it is only necessary to put the signal through a device that will essentially "cut the signal in half." This "halving" of the signal is required since the total signal has an algebraic sum of zero, so far as audio is concerned, so that even if it were possible to use some sort of frequency-discriminative filter to separate the rf and af, still the af signal would not cause a speaker cone to vibrate. Fig. 6-1 shows a representation of an amplitude-modulated signal and why detection by rectification is necessary. ("Rectification" is a term used in electronics to describe the action of a diode on an alternating-current voltage. Diodes used in this manner are called "rectifiers.") In Fig. 6-1, the rf signal is represented by the straight vertical lines, and the audio signal is represented by the wavy-line border of the waveform. Note that the audio is self-cancelling—the negative amplitude at each point equals the positive amplitude at the same instant and therefore cancels it out. Rectification allows only one-half of the signal to pass, so that the audio signal is no longer self-cancelling. Since each half of the waveform is a mirror image of the other, either half will give a usable audio signal. For reasons to be discussed in detail later, the polarity of the detector diode (that is, which way it is connected into the circuit) is important. Replacement of a detector diode should always be in the same polarity as the original, otherwise the radio may not work or at best will work erratically.)



Fig. 6-1. Amplitude-modulated rf signal.

TYPICAL DETECTOR CIRCUIT

Fig. 6-2 is a typical a-m detector circuit. The i-f signal in the last i-f transformer is picked off through another low-impedance winding, and fed to the crystal diode detector. Sometimes the last i-f transformer will have a slightly higher impedance than those used for the transistors in earlier stages, meaning that the pickoff winding may have a few more turns of wire.

Current in any circuit must have a complete path from one end of the source to the other. The source, in the case of this detector, is the pickoff winding of the i-f transformer. The current travels through the diode, but in order to return back to the grounded side of the pickoff coil, it must also travel through resistors R1 and R2. Because there is current through these resistors dependent upon the incoming signal, a pulsating, positive-going audio signal appears at (B). There would still be an rf signal at point (B) except that the rf bypass capacitor "short circuits" the rf signal, or at least the greater portion of it, around the resistors and directly back to the ground side of the pickoff coil. What rf may be left is bypassed around the volume control by C2. Many circuits do not even use the filter resistor and C2 but connect the volume control directly to point B in the circuit. C1 and C2 are large

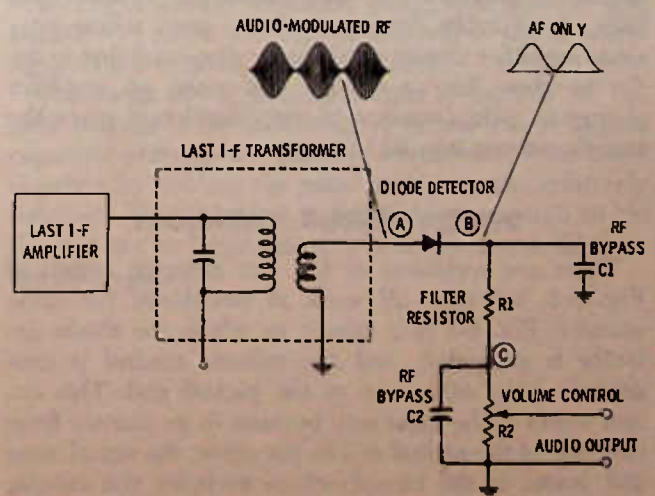

Fig. 6-2. A-m detector circuit.

enough to bypass the rf signal, but small enough that the audio signal is not greatly affected. A typical size for C1 and C2 is about .01 μ F. If only one capacitor is used in the circuit, it may be a .02 μ F.

THE VOLUME CONTROL

The volume control in a transistor radio is seldom larger than about 10K ohms. A typical size would be 5K ohms. In tube circuits, the volume control is usually 500K or more. The reason again is the difference in input impedance between a tube, which has high impedance, and a bipolar (npn or pnp) transistor, which has relatively low impedance.

The arrow on the volume control indicates that the resistance is variable; therefore, a variable audio voltage can be picked off along the volume control resistance. If the arrow (which will be the center connection of the volume control) is at the ground side, there can be no audio voltage at the output terminals, since the voltage is taken off between the center terminal and ground. As the control is rotated, the center arm moves toward point C in the diagram, thus picking off more and more audio voltage for feeding to the audio amplifiers, and so the volume becomes greater and greater until maximum volume occurs. Notice that this method of controlling volume does not change the resistance of the circuit between C and ground for the detector circuit. It changes only the pickoff point along the resistance. This is important, as you will see later on, since the voltage at C can be filtered and used to automatically control the previous circuits to prevent fading and blasting as the signal input to the antenna changes. This is called an automatic gain control (agc), or sometimes an automatic volume control (avc) circuit. This circuit is an important factor in the superior performance of present-day radios under many different signal conditions and is one of the chief reasons that small built-in antennas are practical. This circuit also keeps car radios from fading or blasting as you go away or toward the station, up and down hills, etc. Further discussion of avc must follow later since amplifier theory needs to be discussed first in order to show how a voltage can make an amplifier change in gain (amount of amplification it gives the signals coming into it).

DETECTOR-CIRCUIT VARIATIONS

There are variations to the a-m detector circuit of Fig. 6-2, but they all work in essentially the same manner. Fig. 6-3 is a circuit in which the diode detector is grounded, and the volume control is connected to the other end of the pickoff coil. This circuit works in the same way because in its journey from one side of the pickoff coil to the other, the signal must still travel in the circuit which includes the volume control.

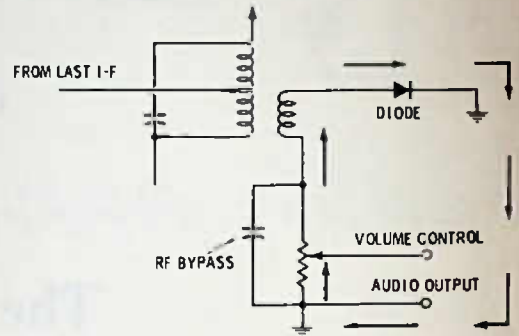

Fig. 6-3. Variation of detector circuit.

Another variation, which really is not a variation but simply a different sort of diode, is to use a transistor as a diode. A transistor is, so far as external measurement is concerned, two diodes facing one another, shown in the inset of Fig. 6-4. Sometimes a manufacturer may find he can buy a transistor as cheaply as a diode, or he may be overstocked on transistors, so he uses the transistor as a diode, usually between the base and collector. However, it is also possible to use the emitter-base junction. The third element is usually left unconnected, or possibly tied to the emitter.

There have been a few transistor detector circuits developed where the transistor not only detects but also acts as an amplifier of the audio signals as well. However, because these circuits are generally hard to handle without creating too much distortion*, they are seldom seen in a-m broadcast radio.

Diode detectors do not often give trouble in broadcast radio. It is rather a rare thing to find a defective detector, but it can happen. They can be checked with fairly good accuracy using an ohmmeter (an instrument discussed under test equipment). Probably, more frequent trouble in detectors is a broken printed circuit or wire leading to the transformer or to the diode itself, although this kind of trouble is also rather

*"Distortion" is a term for any change of a signal as compared to the original signal, that is, in the output sound compared to how the original sounded. There is no amplifier radio that does not distort the signal slightly, but normally when we say the audio is distorted, we mean that the distortion is high enough to make the sound muddy or garbled, hard to understand, etc.

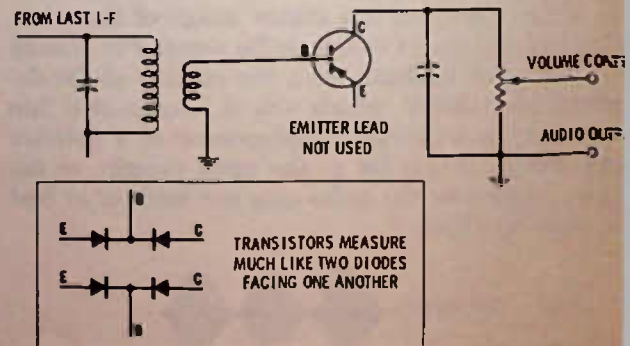

Fig. 6-4. Transistor used as diode detector.

rare. Remember that if you do replace a diode, you should be sure to connect it in the same polarity as the original. Fig. 6-5 shows some of the various ways that a new diode may be marked. Later, in the chapter on test equipment, you will find out how to check unmarked diodes for polarity.

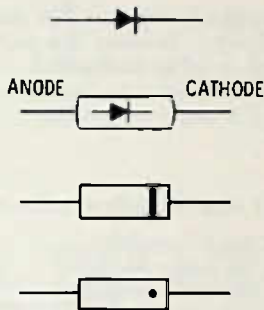

Fig. 6-5. Diodes are marked in various ways to indicate polarity. Usually they are marked at the cathode end.

Another precaution to observe in the replacement of detector diodes is the kind of diode used. Presently, there are two popular types of diodes—the germanium type and the silicon type. The germanium type is nearly always used in a-m detector circuits, since it will start conducting on a much weaker signal. Silicon diodes are more often used in rectifier or biasing circuits.

POLARITY OF DIODE CONNECTION

Although the detection process is not in itself affected by the polarity in which a detector diode is installed in the circuit, the voltage taken off at the detector diode—that is, the dc voltage due to the rectification process—is often used for automatic control of previous circuits, since the dc voltage developed at the detector is directly proportional to the signal strength. For this last reason, diodes should always be installed properly, not because of the detection process itself.

Fig. 6-6 shows two identical detector circuits, except the diode is reversed in the second one. With the cathode of the diode toward the output circuit (the volume control) there is a positive output. The audio is positive going, and the rf develops a positive dc voltage that can be read with a voltmeter across the volume control. The capacitor not only removes the rf signal but acts as a filter to hold the dc voltage steady, since the capacitor does not have time to discharge between each of the rf positive half cycles.

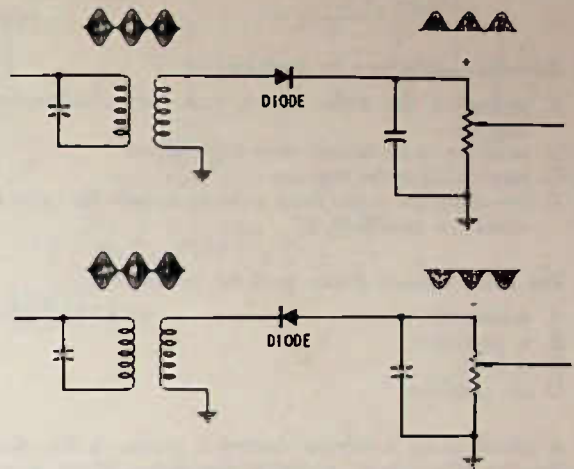

Fig. 6-6. Reversing a diode reverses polarity of output voltage.

In the lower picture, the diode is reversed and a negative output voltage is developed.

At the risk of confusing the issue, it should be pointed out that the diode detector is not actually rectifying the audio but, rather, the rf signal. The composite audio is both positive and negative and so, just

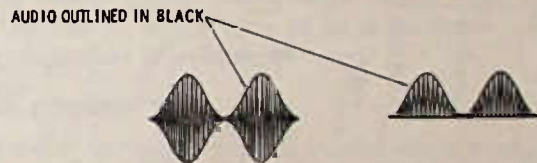

Fig. 6-7. Diode rectification has the effect of cutting the modulated signal in half.

as it has a cancelling effect on the diaphragm of headphones, it would have the same cancelling effect on the diode detector if, indeed, it was audio that was being "split in half."

Fig. 6-7 should make this clear. Modulation makes individual cycles of the rf larger and smaller, and as these cycles are so close together and so much faster than the audio, the audio modulation appears on the rf as a symmetrical waveform going both positive and negative. A diode will clip off one-half of the rf waveform which removes this "symmetry."

The audio signal, then, is simply a "sample" of the peak outputs of the individual rf cycles. The rf bypass capacitor prevents any possible interference from these rf pulses by holding the pulse voltage peaks relatively constant. The rf bypass must be large enough to do this but not so large that it will do the same thing to the audio pulses.

TEST QUESTIONS

1. Detection might best be described as
 - A. separating the audio signals from the radio-frequency signals.
 - B. inserting audio signals onto an rf carrier.
 - C. amplifying audio signals.
 - D. removing the audio from a signal so only the radio frequency is amplified.
2. The most common device used for detection is
 - A. a transistor.
 - B. a capacitor.
 - C. a diode.
 - D. an amplifier.
3. A circuit using a volume control is shown in Fig. 6-8. A drawing of a volume control is also shown. If you were to connect the volume control in the circuit so that volume would increase with clockwise rotation of the control shaft, you would
 - A. connect A to 1, B to 2, C to 3.
 - B. connect A to 3, B to 2, C to 1.
 - C. connect A to 2, C to 3, B to 1.
 - D. connect A to 2, B to 3, C to 1.

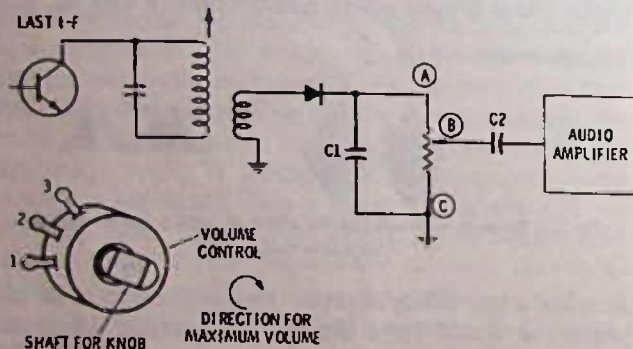
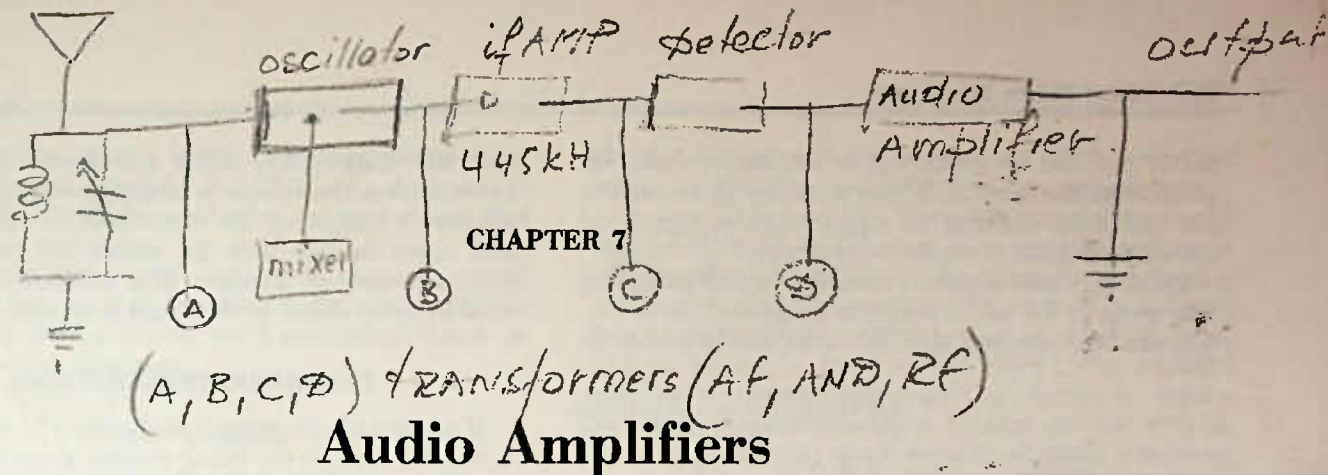

Fig. 6-8. Schematic and drawing for Questions 3, 4, and 10.

4. In Fig. 6-8, the purpose of C1 is
 - A. detection.
 - B. audio bypass.
 - C. coupling.
 - D. radio-frequency bypass.
5. If a diode is used as a detector it is most likely to be
 - A. a germanium type.
 - B. a silicon type.
6. Distortion
 - A. can be completely eliminated in electronic circuits.
 - B. is the difference between the reproduced sound and the original sound as transmitted.
 - C. is the amount of amplification during detection.
 - D. both A and B above are correct.
7. Detection in a superheterodyne radio occurs
 - A. preceding the i-f amplifier.
 - B. preceding the audio amplifiers.
 - C. following the audio amplifiers.
 - D. in the antenna circuit.
8. A substitute for the diode when used in detection is
 - A. a capacitor.
 - B. a transistor.
 - C. a coil.
 - D. a volume control.
9. Rectification is a term used to indicate that an alternating voltage passes through some device that allows only one half of the alternating cycle to flow. "Rectification" may be used to indicate what happens in detection but is not often used
 - A. about i-f amplifier circuits.
 - B. about antenna input circuits.
 - C. about power-supply circuits.
 - D. about audio circuits.
10. In Fig. 6-8, the dc output of the detector (voltage across volume control) will be
 - A. positive at point A with respect to C.
 - B. negative at point A with respect to C.



There are more variations in audio amplifiers in transistor radios than in almost any other circuit; however, there are similarities, too, since most portable transistor radios use what is called a class-B audio output circuit. The reason will become apparent presently. First, look at block diagram A in Fig. 7-1. The audio level picked off at the volume control is fed to a transistor audio amplifier. This transistor builds up the amplitude of the audio signal enough to "drive" the output stage or stages. The output stages then provide enough power gain to drive the speaker to produce ample audio volume without exceeding practical limits of distortion.

SPEAKERS

The speaker, by its nature, is a low-impedance device—that is, it requires considerable current at low voltage for operation. In most vacuum-tube circuits, an audio output transformer is used to match the high output impedance of the tube to the low impedance of the speaker. In transistor circuits this is not always so, since the transistor itself can be made to match a fairly low impedance. However, many transistor circuits do use an output transformer for matching, as well as interstage audio transformers for matching, thus providing the right kind of signals for a class-B audio output.

CLASS-B OUTPUT STAGES

In Fig. 7-1B is a block diagram of a class-B audio output stage using both an interstage (between stages) audio transformer and an output transformer. The idea of a class-B stage is that one of the audio output transistor amplifiers takes one-half of the signal, and the other output transistor operates on the other half of the signal. This might be compared to a two-cylinder engine, in which one cylinder delivers the power to the crankshaft while the other is idling, waiting for its turn as the crankshaft makes a half turn.

The advantage of class-B stages in portable radios is that during the time when there is no signal input to

the output transistors they draw very little current; the amount of current drawn by a class-B output depends directly on the strength of the input signal. If you play the radio at low volume, it draws very little current as compared to that drawn at high volume. Since the output stage of any radio is the stage that draws the major portion of the battery current, controlling the output stage current by the volume level saves considerable battery power. For a single-ended stage (class A), the current would have to be at maximum all the time, regardless of volume.

Phase Inversion

In order to make a class-B output stage work, it is necessary to provide out-of-phase signals. That is, the signal going into one transistor must be positive-going while at the same instant the signal going to the other output transistor is negative. This makes a sort of switching arrangement so that the audio signal coming into the output transistors is switched from one transistor to the other on alternate audio cycles.

One excellent method of providing out-of-phase signals is with a transformer. By its very nature, the sig-

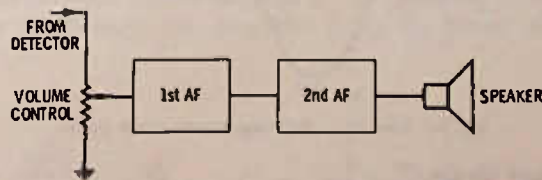

(A) Single-ended output.

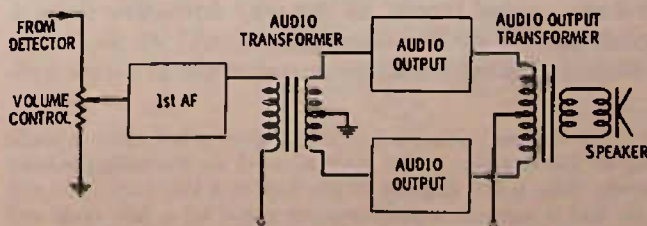

(B) Class-B output.

Fig. 7-1. Block diagrams of audio amplifiers.

nal at one end of a winding is 180 degrees* out-of-phase with the other end—that is, at any given instant, one end of the winding has a positive-going signal and the other end has a negative-going signal.

By using a center-tapped transformer and grounding that point so far as the signal is concerned, as in Fig. 7-2, one transistor and then the other can be turned on

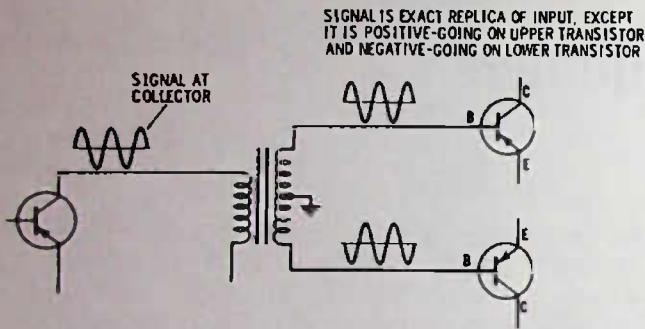

Fig. 7-2. Audio transformer with center-tapped secondary provides out-of-phase signals for class-B output stages.

for each half of the audio signal alternations. By using a center-tapped output transformer, each of the transistors can work as an independent of sorts and yet aid the other in driving the speaker back and forth on alternate half cycles. If there is no signal coming in (no volume) then neither of the transistors will be "turned on" and so will draw no current from the battery. (Actually both transistors must draw a small amount of current, called idling current, continuously, or distortion will occur at low-volume signals.)

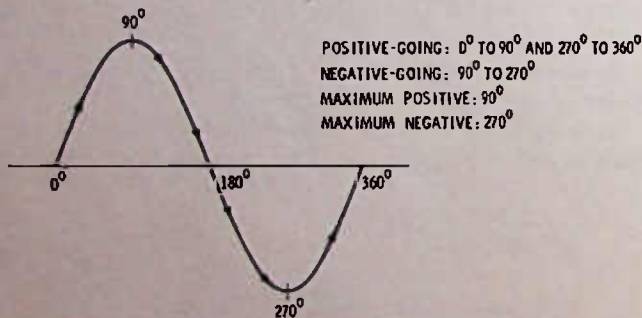

Fig. 7-3. Sine wave showing degree check points.

Current Drain

Typically, a small portable radio using class-B audio output stages will draw about 5 milliamperes with the volume control turned all the way down and draw a peak current of 50 milliamperes (mA) or so at full volume. If a milliammeter is connected in series with

"180 degrees" means a half cycle, since a full cycle is made up of 360 degrees. A full alternation of an alternating-current cycle, then, is 360 degrees. If you look at a sine wave, you will see that it contains a positive-going signal for a half cycle and a negative-going signal for the other half cycle. Thus, two signals 180 degrees out-of-phase with each other are exactly opposite in polarity. See Fig. 7-3.

the radio battery, the meter will show a steady, low current when the volume is turned down, but when the volume is turned up the meter needle will "kick" up and down in step with the words and music heard from the speaker. The use of a milliammeter is covered in more detail in the chapter on test equipment.

TROUBLESHOOTING METHODS

If a radio sounds "tinny" or distorted at low volume it may be because the idling current is insufficient, more likely it is a defective speaker, or perhaps more than a weak battery. Radios that sound all right but are not as loud as they should be can have trouble almost anywhere in the radio. However, if the trouble is in the audio stages, it is likely that it is caused by an open electrolytic capacitor. Try connecting an electrolytic of almost any size (10 μF at 10 volts is usually adequate for portable radios; use a higher voltage rating for larger power-line-operated transistor radios) across each of the electrolytics in the audio amplifier and see whether the volume level returns to normal. If it does, replace the defective capacitor.

If the radio is dead, you can usually tell whether the audio stages are working (at least working to some degree) by holding the speaker next to your ear (or your ear next to the speaker) while turning the volume control. If you hear a staticlike rushing noise as you change the volume, then probably the audio amplifier is working well enough to produce some output and you can conclude that the cause for the dead radio is somewhere other than in the audio stages.

If you do not hear noise in the speaker as the volume control is rotated, then the trouble very likely is in the audio stages. If the radio has an earphone jack, use an earphone to see if the radio plays through it—does, then the trouble is likely in the speaker, or it may be that the earphone jack is defective (the earphone jack disconnects the speaker when the phone is plugged in—it may not be remaking the circuit when the earphone is removed.)

Since in most circuits the earphone jack connects directly across the terminals to the speaker, many technicians have a test-speaker handy. An earphone and cord is connected to the test speaker. This permits a quick check of the radio speaker and earphone by substitution with a known good speaker.

Sometimes squeals in a transistor radio are caused in the audio amplifier. A good indication of this, though not an absolute one, is that if the howl or squeal changes in pitch as the volume control is turned, or if there is no change in the volume of the howl, the most likely location of the fault is in the audio amplifier. The cause may be an open electrolytic, or it may be a broken printed circuit. In some cases, it could be that a replacement part is of the correct type or has been installed incorrectly, perhaps with the leads to the wrong terminals.

Twisting the printed board or putting gentle pressure on it may cause the howls to stop, and in this case the trouble likely is a broken printed circuit or a broken wire connection.

Remember that a weak battery can cause abnormal squeals or howls, so, if in doubt at all, always replace the battery with a known good one before going on to more serious diagnosis.

OTL CIRCUITS

More and more, both portable and more expensive transistor radios, stereos, and the like have gone to the output-transformerless (OTL) circuit. This means that the transistors drive the speaker directly, and there is no output transformer between the transistor output stages and the speaker. The circuits may or may not have an interstage audio transformer. If they do have a transformer, it is of a special type that has two separate secondary windings, instead of the usual center-tapped secondary. This arrangement is essential because of the method of biasing the transistors (biasing methods and the reason for biasing are included in the chapter on transistor amplifiers and amplifying). Fig. 7-4 shows a block diagram of an OTL circuit using an interstage amplifier.

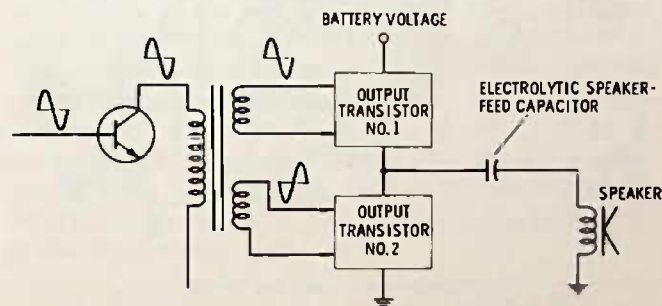

Fig. 7-4. An OTL circuit.

This is still a class-B stage, so it draws little current at low volume and more current from the battery at high volume. In this circuit, the transistors are turned on, first one and then the other, on alternate half cycles of the audio input signal. When transistor No. 1 turns on, a connection is made to the battery voltage through the speaker and the feed capacitor. On the next half cycle, when transistor No. 2 turns on, the feed capacitor discharges to ground through the speaker and the transistor, so the speaker cone moves in the opposite direction. The amount the feed capacitor charges and discharges and the speed with which it does are determined by the incoming audio signal. The louder the input signals, the more the transistors turn on, the more the feed capacitor charges, and the more the speaker cone moves. The frequency of the audio determines how quickly the speaker cone moves in and out. For example, a 1000-Hz tone would make

the speaker cone move in and out 1000 times per second; a 2000-Hz tone, 2000 times per second; etc.

In circuits such as this, the speaker impedance used may be higher than that used in an output-transformer circuit, although not always. For example, the speaker may have an impedance (usually referred to in catalogs as voice-coil impedance) of up to about 40 ohms, but sometimes as high as 100 ohms. The standard speaker impedance for transistor radios is usually around 8 ohms. Replacing a 40-ohm speaker with an 8-ohm speaker may work surprisingly well. However, you may find that the radio battery will run down sooner, and if the radio is habitually played at high volume, it could happen that the output transistors might overheat. So, if possible, always replace a speaker with one of similar impedance to the original, with no more than a 25% difference for best overall results. Even if the problem of battery rundown or of overheating transistors does not exist, a lower-impedance speaker will often have poorer tonal response, especially for bass notes.

ANOTHER TYPE OF OTL CIRCUIT

Another kind of OTL circuit does not require either an output transformer or an interstage transformer for changing the phase of the signal input. In this circuit, two different types of output transistors are used. We have mentioned before that npn and pnp transistors can have similar characteristics, except that the collector voltage should be positive for one and negative for the other for proper operation. The two transistors also require a different polarity of "turn on" voltage—that is, the npn turns on with a small positive voltage on the base while the pnp turns on with a small negative voltage. Fig. 7-5 is a complete schematic of the output stage of this sort of OTL circuit.

In this circuit, when the audio signal is positive-going, the upper npn transistor turns on, and the speaker cone moves because of the charging of capacitor C1 through the transistor from the 9-volt battery.

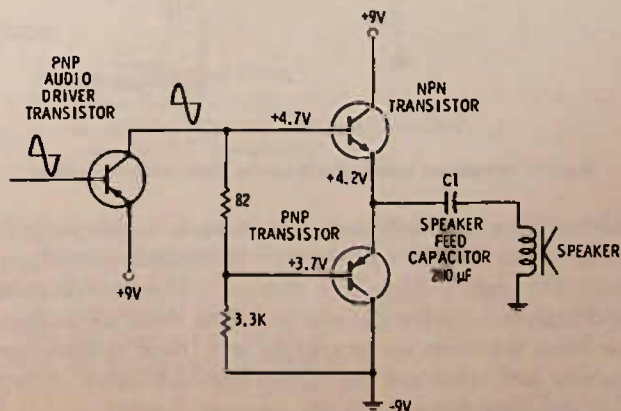

Fig. 7-5. OTL circuit using npn and pnp transistors eliminates need for driver transformer.

On the next half cycle, the audio signal is negative and this negative-going voltage will turn on the lower pnp transistor. Capacitor C1 now discharges to ground through the transistor and the speaker, and the speaker cone moves in the opposite direction. Note the similarity of speaker operation in this circuit and the circuit of Fig. 7-4. The same rules apply here as to speaker impedance.

When a circuit of this type is used in a stereo receiver or radio operated from the power line, or in a high fidelity amplifier, the speaker impedance required is usually between 4 and 16 ohms, and, under normal conditions, the circuit will operate any speaker satisfactorily that is within this impedance range.

THE HIGHER-VOLTAGE SINGLE-ENDED OUTPUT STAGE

When a circuit has only one output transistor, it is called "single ended," and, because there is only one transistor, the circuit must operate in class A. Class A means that ideally the current flow in the output stage is always the same regardless of volume. Although the class-A stage draws more current than the class-B stage, this is no problem on line-operated radios or in auto radios. A class-A stage requires fewer parts, one less transistor, and has good fidelity (low distortion). It generally maintains better fidelity without critical adjustment, especially when listening at low volume levels.

Home Radios

Fig. 7-6 is a class-A output stage used in a home radio. The collector voltage on this transistor is above 80 volts. Since this transistor uses higher voltage and

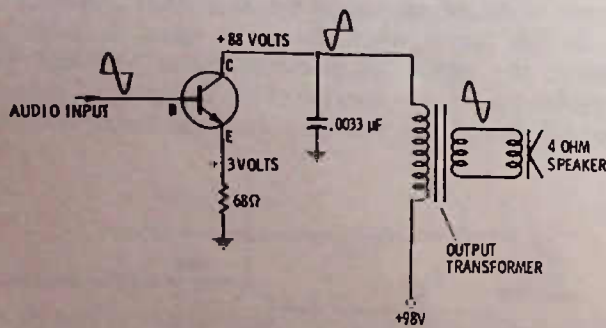

Fig. 7-6. Line-power operated radio using high-voltage transistor.

lower current, it will naturally have a higher impedance, so an output transformer is necessary to transform the high voltage/low current into lower voltage and high current for the speaker. The .0033 μ F capacitor from the collector to ground is a "tone control" capacitor and takes out the higher-pitched "hissy" noises that are objectionable to the average listener.

If this transistor must be replaced, it has to be with one of the same general type, one designed to use

higher collector voltages. If a lower-voltage transistor is installed in the circuit, it will almost invariably short out quickly, causing the 68-ohm resistor in the emitter to burn open. If you find the 68-ohm resistor open in this circuit, it likely indicates a shorted transistor, either the output transistor or one directly coupled to it. This is the case in some circuits. To check for shorts in a transistor, measure between the collector and emitter terminal with an ohmmeter as described in the chapter on test equipment.

Automobile Radios

Another place where class-A output stages are used is in automobile radios. Older radios use an output stage similar to that in Fig. 7-7 with a transformer input and output. Sometimes the output transformer is not used, with the speaker driven directly as in Fig. 7-7B or with an audio-frequency choke connected across the speaker as in Fig. 7-7C. An automobile class-A stage may draw up to about 1 to 2 amperes current (compared with about 44 mA for the circuit in Fig. 7-6). The high current is necessary to provide high-level output, needed in auto radios, with

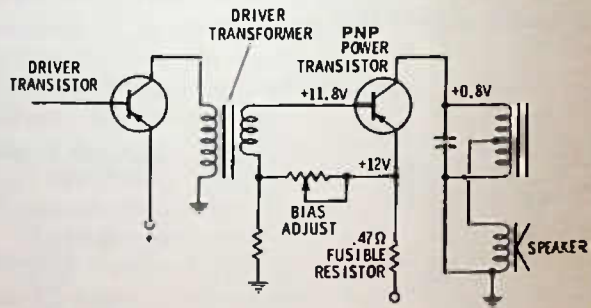

(A) Transformer input and output.

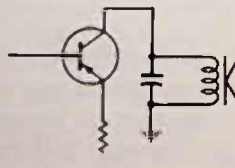

(B) OTL circuit.

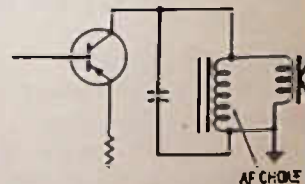

(C) Af choke across speaker.

Fig. 7-7. Some class-A audio output stages used in auto radios.

about 12 to 14 volts between collector and emitter. Note, that even though the collector has only 0.8 v shown, this is a measurement to ground: between the collector and emitter the voltage would be 11.2 volts which is the same as saying that the collector is 11 volts negative in respect to the emitter.

The most common trouble in these circuits is a shorted output transistor. Because of the high currents these transistors normally run at much higher heat levels than the small transistors in portable radios.

They are larger and are often mounted on heat sinks, which are finned pieces of metal designed to carry the heat away from the transistor. If the transistor shorts, it nearly always shorts between the collector and emitter. In so doing it causes the fusible resistor in the emitter circuit to open and prevents damage to other parts of the set and prevents a possible fire if the fuse in the battery power supply fails to blow. If you find the fusible resistor open, you will probably have to replace the output transistor, even though it may temporarily check all right. It is possible, of course, as sometimes happens, that the fusible resistor will simply go out because of "fatigue," not because the output transistor is defective; however, this occurrence is fairly rare.

One thing which happens that can blow out the fusible resistor and still leave the transistor undamaged is the installation of the storage battery in the car so that the battery cables are accidentally reversed. Since this reverses the polarity to the radio, the radio cannot work, yet the output transistor will draw enough current to blow the fusible resistor. The other operations of the car may not be noticeably affected by this battery reversal. To check the battery polarity, use a voltmeter with the + lead on the "hot" lead to the radio and the - lead (the + lead is normally the red lead and the - lead is normally the black one) to the metal frame of the car. Set the meter to a dc voltage range of more than 12 but less than about 60 volts. The meter should read up scale. If the meter pointer moves off scale to the left, the battery is in backward. Incidentally, the larger post on a storage battery is the positive (+) terminal. It has been standard practice now for several years for the manufacturers of American cars to ground the negative battery terminal to the metal frame of the car.

DIRECT-COUPLED AUDIO CIRCUITS

Direct coupling in an amplifier circuit means that there are no transformers and no capacitors between one transistor and the next. The direct-coupled circuit

is extremely popular, especially since silicon transistors came into good supply for new designs several years ago. Diagnosing the troubles in direct-coupled stages can be much more difficult because any defect in one transistor has an effect on the entire operation of the one it is direct coupled to. Sometimes as many as four or five transistors may be directly coupled with additional direct coupling from some transistors *back* to other transistors to provide for automatic bias balancing. In this chapter we will not discuss these circuits further, since first you should understand about transistor circuits, how they are biased, what biasing really is, etc. Direct-coupled circuits are discussed in some detail in the chapter on transistor amplifiers and amplifying, after discussing considerably less complex methods of coupling and biasing.

CHECKING THE AUDIO IN AN AUTO RADIO

As in other transistor radios, if the audio stages are working you can generally hear a noise as you turn the volume control back and forth. Also, if the radio uses a class-A output stage—as many of them, probably 80%, do—you should hear a definite "thump" in the speaker when you turn the set off and on. If you do not hear this thump, then it is likely that the trouble is in the speaker or in the output stage, or it could be that the power is just not getting to the radio because of a blown fuse or a defective on-off switch.

The bias control on the output stage was once used for nearly all auto radios; however, some sort of automatic bias control is now more commonly used. For those radios with a bias control, you can usually do a passable job of setting the control by ear, if you have some method of measuring the amount of current the radio is pulling. Using an ammeter, you should set the bias control for the minimum amount of current. This will, no doubt, produce distortion in the speaker when tuned to a local station. Next, slowly turn the bias control for best tone quality possible with the least amount of current drawn, at both low *and* high volume.

TEST QUESTIONS

- Most portable transistor radios have
 - a class-A audio output circuit.
 - a class-B audio output circuit.
 - a class-C audio output circuit.
 - only one transistor in the audio output circuit.
- A radio speaker is
 - a low-impedance device.
 - a high-impedance device.
 - a medium-impedance device.
 - connected across the volume control.
- The output circuit in a radio which draws the least amount of battery power as compared to output (in other words has the highest efficiency) is
 - a class-A output stage.
 - a class-B output stage.
 - an output stage with only one transistor.
 - both B and C are correct.
- If we have two identical signals, one going positive and the other going negative, we would say they are
 - "in phase."
 - 180 degrees out of phase.
 - 360 degrees out of phase.
 - 90 degrees out of phase.
- In a class-B audio output, if you connect a meter to read the battery current flow to it, the meter will

TRANSISTOR RADIO SERVICING

- A. read zero current when volume is low.
B. read lowest current when volume level is high.
C. read more current flow when volume is low.
D. read maximum peak current when volume is maximum.
6. If a direct current milliammeter reads 40 milliamperes, this is the same as
A. 40 amperes.
B. 0.4 amperes.
C. 0.04 amperes.
D. 40,000 amperes.
7. Something that should NOT cause a radio to sound "tinny" is
A. full battery voltage.
B. a defective speaker.
C. insufficient idling current in a class-B output stage.
D. a weak battery.
8. If you hear a noise in the radio speaker when you move the volume control it is a good indication that
A. the speaker is defective.
B. the volume control is not working.
C. the battery is dead or very, very weak.
D. the audio stages are not "dead."
9. A "dead" radio or a "dead" stage means a radio or a stage which does not perform at all. A possible cause of a completely dead radio might be
A. a bad speaker.
B. a defective earphone jack.
C. a dead battery.
D. all of the above.
E. only A and C above.
10. If you hear squeals in the speaker of a defective radio that drop to zero when the volume is turned down, the trouble is most likely to be in
A. the audio stages.
B. the speaker.
C. the i-f amplifiers or converter stages.
D. the volume control.
11. The two things most likely to cause squeals in a transistor portable radio are
A. speaker and earphone jack.
B. battery and electrolytic capacitors.
C. defective transistor and volume control.
D. i-f transformer or audio transformer.
12. An OTL circuit is one that has
A. no output transformer.
B. no interstage transformer.
C. no capacitors.
D. no resistors.
13. The voice-coil impedance of a speaker used in transistor radios will normally be
A. between 4 and 100 ohms.
B. between 100 and 500 ohms.
C. above 1000 ohms.
D. almost any impedance from 1 ohm to 100,000 ohms.
14. Class-A stages used in radios to be operated from the power line usually have transistors in the output using
A. low collector voltage.
B. high collector current.
C. higher collector voltage.
D. no output transformer.
15. When a capacitor is used between the collector and ground or collector and emitter circuits in audio amplifiers it is to
A. bypass all the audio.
B. bypass only the radio frequencies.
C. reduce the high frequency audio in the output.
D. increase the "treble" response of the amplifier.
16. Auto (car) radios which use class-A output stages
A. may use output transistors with collector current of 1 amp or more.
B. do so to reduce the amount of current drawn by the radio so the radio can be played for long periods without running down the car battery.
C. generally use two output transistors.
D. have very low levels of audio output at the speaker.
17. The most common short in a transistor occurs between
A. the collector and base.
B. the emitter and base.
C. the collector and the case of the transistor.
D. the collector and emitter.
18. Most cars, and especially American-made cars, use
A. a positive ground on the battery, that is, the positive side of the battery is connected to the frame of the car.
B. same as above, except the negative side is grounded.
C. battery connections in which neither side is connected to the car frame.
D. a 6-volt storage battery.
19. A direct-coupled circuit is one
A. coupled through capacitors rather than transformers.
B. that is more easily serviced, since troubles in it are easier to find.
C. that uses neither transformers nor capacitors for coupling.
D. that operates on either ac or dc supply voltage.
20. If you turn on a car radio and hear a "thump" in the speaker you can be sure that
A. the fuse to the radio is open.
B. the radio uses a class-B output circuit.
C. the speaker is not open and the output stage is likely all right.
D. the fusible resistor has burnt open.

Transistor Amplifying and Simple AF Amplifiers

Broadcast radio uses transistors extensively today. The transistor has almost replaced the vacuum tube as a means of amplifying signals because it operates several times more efficiently, operates on low voltages, and does not have to "warm up," so it can provide instantaneous operation when supplied with power. Besides all this, it takes up much less room, costs less to manufacture, and has a much longer expected life, with practically no change in the amount of amplification it produces throughout its useful life.

How does a transistor amplify? It is not within the scope of this book to cover all the physical properties of the transistor nor just why the crystal structures of which they are made react as they do. More to the point for the radio technician is how they react when installed in circuits, what circuit elements are required, how to test for defective transistors, etc. Amplification, as discussed in Chapter 1, is a process of controlling electric current in step with smaller amounts of current, reproducing in the output an exact but larger replica of the input (see Fig. 8-1).

To "make" this larger signal at the output possible, it is necessary to have some sort of direct-current voltage source. In transistor portable radios this source is a battery; in auto radios it is the car battery. In line-operated transistor radios the ac power-line voltage is rectified and filtered before being applied to an amplifier.

SWITCHING

One of the best ways to understand an amplifier is to start with a "switching" concept. Take for example, the switch that turns on a 100-watt lamp in your home. The tiny pressure you put on the switch controls 100 watts of power. Turning off the switch stops the current flow.

Now suppose you have a "dimmer" on the lamp instead of a switch. If you rotate the dimmer control, the lamp will get brighter or dimmer; thus you are

reproducing with the lamp, in a sense, the rotation of the control. In an electronic amplifier, the input signal itself provides this "dimmer" action. As the signal goes up, the transistor draws more current, and as the signal goes down, the transistor draws less current. If the current drawn by the transistor control circuit (input) changes 0.1 mA and the controlled current (output) changes 1 mA, the gain of the circuit is 10. If the change is linear, that is, a change of 0.1 mA changes the output current 1 mA, or an input change of 0.2 mA changes the output current 2 mA, or an input change of .05 mA changes the output current by 0.5 mA, etc., we have a class-A amplifier. No amplifier can be designed to be linear over a large range of inputs, but any amplifier can be functionally linear within a specific range of inputs. This is one reason that more than one amplifier is needed in a radio, so that successive amplifiers can be adjusted for linear operation, depending upon their expected input voltage or current.

Fig. 8-2 is a simple npn transistor amplifier circuit using a silicon transistor. We can tell the transistor is an npn because the arrow on the emitter points outward (Not Pointing IN). We know it is a silicon transistor, because the voltage between the base and the emitter is more than 0.4 volt (germanium transistors, the other general type, use a maximum bias of 0.2 volt). But before we consider the entire amplifier, we should first consider the properties of the transistor.

In Fig. 8-3 we have a small pilot lamp connected in a circuit that includes a battery and the collector-

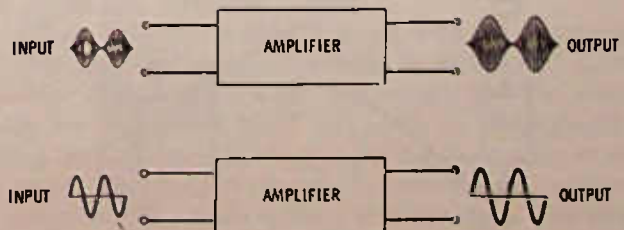
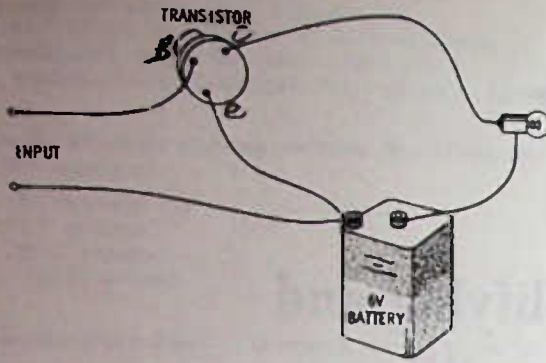
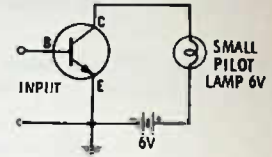

Fig. 8-1. Simple amplifiers, showing relation of output to input.



(A) Pictorial.



(B) Schematic.

Fig. 8-3. Pilot lamp does not light in this circuit because transistor is "turned off."

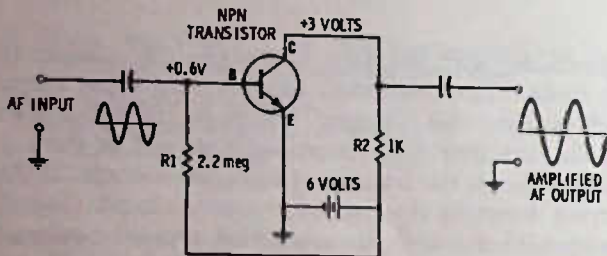

Fig. 8-2. Audio amplifier circuit.

SINGLE-BATTERY BIASING

It is not necessary to have a separate battery for turning on the lamp. By selecting a suitably sized resistor *R*, we can connect this resistor to the + side of the 6-volt battery and to the base as in Fig. 8-5, and again the necessary 0.6 volt will appear at the base, switching on the lamp.

Basically, then, a transistor is a switch that can be controlled by a voltage between the base and the emitter. Since less current is required between the base and emitter than will flow between the collector and emitter, the transistor can amplify current flow.

In Fig. 8-5, if the resistor value is changed so that more or less current can flow in the base-emitter circuit, more or less current will flow in the collector-emitter circuit, making the lamp get brighter or dimmer.

It is just because a transistor can act as a "dimmer" rather than just a straight on-off switch that we can apply a varying current (ac or pulsating dc) to the base-emitter circuit and get out an amplified current changing at the same *rate* as the input. How?

Let us suppose, as in Fig. 8-6, that an alternating current signal is added to the base-emitter circuit. It is fed through a capacitor that blocks the dc on the base and prevents the dc from possibly being shorted out

emitter circuit of the transistor. With this circuit, almost no current can flow in the C-E circuit of the transistor, so the lamp cannot light. If a wire were connected across C and E the lamp would light. On the other hand, if we could by some method cause the circuit inside the transistor between C and E to conduct current, the lamp would light. Fig. 8-4B shows how a transistor can be "turned on." Connecting a small voltage between the base and collector "closes" the C-E "switch," and in this way a 1.5-volt battery closes the circuit on a 6-volt battery. In a sense we can say that the 1.5 volts has been "amplified" enough to light a 6-volt lamp. (In reality only about 0.6 volt is needed to turn on this transistor. Resistor *R* drops the voltage down to this level from the 1.5-volt battery.)

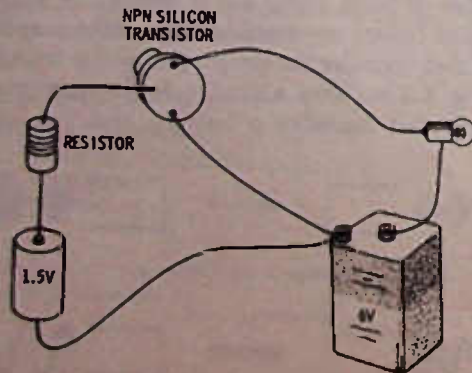

(A) Pictorial.

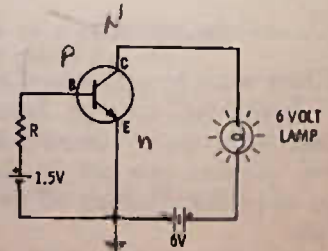

(B) Schematic.

Fig. 8-4. Bias battery "turns on" the transistor, causing lamp to light.

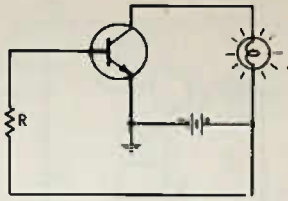

Fig. 8-5. Single battery provides transistor bias and current for lamp.

by the ac source. Suppose that resistor R has been selected so that the lamp is half bright. And suppose that the frequency of the input signal is 2 Hz. The ac signal as shown is varying between +0.1 volt and -0.1 volt. For ease in explanation, let us say that the dc bias voltage (the voltage between the base and emitter) is 0.5 volt. What will happen to the glow of the lamp when the ac is applied? It will get brighter and dimmer at the rate of 2 times per second. Why? Because the ac voltage is added on the positive half cycle, making the total voltage between base and emitter go up to 0.6 volt, which will cause the lamp to glow brighter. On the negative half cycle, 0.1 volt is subtracted from the 0.5-volt bias so that now there is only 0.4 volt between the base and emitter, and the lamp glows dimly. So, without the ac input voltage, the lamp glows at half brightness, but with the ac input, the lamp responds to the change in input voltage and gets brighter and dimmer at the same rate as the ac input voltage.

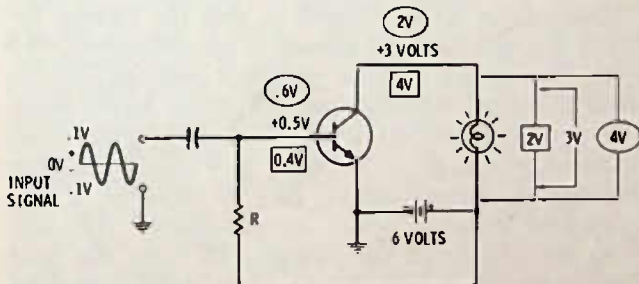

Fig. 8-6. Adding ac signal voltage to the circuit of Fig. 8-5.

Let us look at the other voltages around the circuit of Fig. 8-6. With no input signal and only the bias voltage, we indicated that there was 0.5 volt between the base and emitter (bias voltage). The lamp is also indicated as half bright. Since it is a 6-volt lamp, let us assume that it is half bright with 3 volts across it (this might not be the case, but it works well for the purpose of this explanation). Since the supply is a 6-volt battery, and since there is 3 volts across the lamp, then there must also be 3 volts between the collector and emitter of the transistor. When the signal voltage goes positive, the transistor draws more current and the lamp gets brighter. This means that there is more voltage across the lamp—let's say it goes to 4 volts across the lamp. The collector voltage (the voltage across the transistor) must now drop to 2 volts because there is only 6 volts available from the battery. This makes

sense, of course, because the transistor is acting like a smaller resistance (has more current through it) when the bias voltage increases. On the negative half cycle of the signal, the transistor current is decreased, and the lamp gets dimmer. Now, assume that there is only 2 volts across the lamp. How much will the collector voltage be? Four volts. If the above figures are used, then we have a transistor on which a change of 0.1 volt on the base causes a 1-volt change in the collector circuit. We can say that this circuit has a voltage gain of 10.

THE NEED FOR BIAS

If we are to reproduce faithfully both the negative and the positive half of the input signal, there must be enough dc bias on the transistor to hold the lamp at half-brightness. Suppose we removed R from the circuit of Fig. 8-6. Nothing would happen in the output circuit since without resistor R, the lamp would not glow. The 0.1 volt positive of the ac signal could not turn on the transistor, since at least 0.4 volt is required for that. If we increased the ac voltage so that it went positive by 0.4 volt, the lamp would glow dimly only at the peak of the ac signal and be out for the remainder of the input cycle. Bias voltage is necessary to turn on the transistor, but it should not turn it fully on. The signal, then, can increase or decrease the transistor current so that the output current becomes an amplified replica of the input signal.

We should point out that not all amplifiers work in class A, which is the type of amplifier discussed here, and, in fact, it is sometimes desirable that only the peaks of the input signal "trigger" an output signal, but in radio and audio amplification in receivers, the class-A circuit is used more than any other. Many audio output stages use class B, as has already been discussed, and mixer-oscillator stages commonly operate class B, or even class C.

VOLTAGES SHOWN ON SCHEMATICS

Voltages given at various points on schematics are generally read between those points and ground unless otherwise indicated. In the amplifier of Fig. 8-7 the emitter is grounded, so the voltages are being read between base and emitter (this is called the "bias" voltage) and between the collector and emitter (this is called the "collector" voltage).

Often, a resistor is used in series with the emitter as in Fig. 8-8. This resistor is usually bypassed with a capacitor, though not always. The resistor provides what may be called "self bias" and helps to automatically keep the transistor drawing about the same amount of current, regardless of changes in environment, or even changes of the supply voltage, within reason. The bias voltage is still 0.6 volt—the difference between 1.1 and 0.5 on the base and emitter. The collector voltage to

ground (common) is 5 volts, but the voltage between the collector and emitter is 4.5 volts. The emitter resistor tends to stabilize the bias, since, if the transistor starts to draw more current, there will be additional current through R3, which will make the emitter voltage more positive. A higher emitter voltage (more positive) subtracts from the positive voltage on the base, in effect reducing the bias (base to emitter) voltage, and tends to reduce the transistor current, thus cancelling the effect (or a great deal but not all) of the original increase in current.

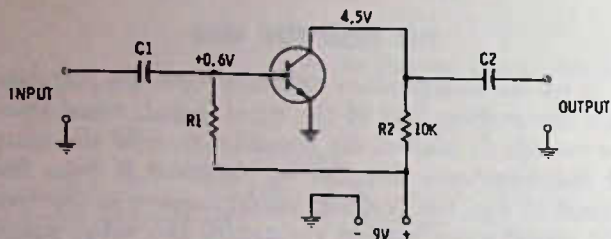

Fig. 8-7. Transistor audio amplifier.

The bypass capacitor effectively short circuits the emitter resistor for signal voltage input so that the resistor does not tend to reduce the bias when the bias is increased because of signal voltage. If this bypass capacitor should open, the gain (amplification) of the stage will be reduced considerably. Some circuit designs use an unbypassed emitter resistor, or sometimes there will be two resistors in the emitter, only one of which will be bypassed. Although the gain of a stage is reduced by leaving the emitter resistance or a portion of it unbypassed, still, this may be desirable since the circuit will tend to automatically compensate for varying gain at different frequencies. For example, a particular amplifier might amplify 100 Hz by 10 times, a 5000-Hz signal by only 8 times, and a 10,000-Hz signal by only 6 times. Since the audio spectrum covers all these frequencies, and more, it would mean that the amplifier was not faithfully reproducing input signals at the same output level. An unbypassed emitter resistor will often help to correct for this fault, making the amplifier stage more "flat."*

A PRACTICAL TRANSISTOR AMPLIFIER

The circuit of Fig. 8-7 is a practical circuit. Refinements could be and often are added to produce an am-

*A "flat" amplifier is one that amplifies all frequencies within its specified frequency range the same amount whether they are 20 Hz, let's say, or 20,000 Hz. No amplifier is perfect, but some approach it closely. An amplifier that is flat within plus or minus 2 dB is a good enough amplifier that only a "golden ear" could fault it; however, some higher priced amplifiers may be flat within 0.1 dB—a good spec, indeed! Most small portable radios and even home radios of the small type may do well to be flat within 3 dB. Flatness must be stipulated for corrected interpretation. For example, flat from 300 to 3000 Hz is not too good for an audio amplifier.

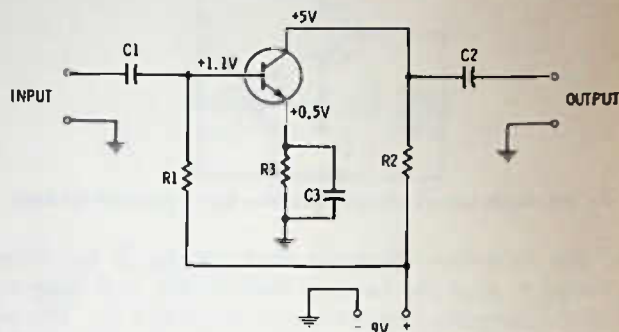

Fig. 8-8. Transistor amplifier stabilized by emitter resistor.

plifier with better linearity over a wider range of inputs and also to provide stabilization by automatically changing the bias to a lower value if the transistor starts to draw more than normal current for any reason, such as an outside temperature increase. (Transistor current always tends to increase if the transistor case warms up, but it is a greater problem with germanium than with silicon transistors.) However, this circuit will work. Note that it is the same circuit as we have been discussing except that the small pilot lamp is now replaced with a 10K resistor. This is called the "collector-load" resistor, and it is the change in current through this resistor that produces the voltage change that is picked off by C2 going to the output terminals.

Bias resistor R1 is selected so that the voltage between the collector and ground is approximately +4.5 volts. This means that the transistor and the load resistor have approximately equal voltages across them. This permits the collector voltage to go "two ways," up or down. It can go up as much as 9 volts (transistor drawing no current—turned off) or down to 0 volts (transistor drawing heavy current—turned full on). With the voltage at the collector 4.5 volts, the transistor is turned on half. If an ac input signal is applied, the voltage on the collector will rise and fall in step with the input voltage. Depending on the input voltage amplitude, the voltage on the collector could change as much as 9 volts, but in the interest of linearity a change of no more than 1 or 2 volts might be the maximum permissible.

The stabilizing effect of an emitter resistor has already been mentioned. Another way of helping to automatically bias a transistor, especially in audio amplifiers, requires no more parts than the circuit of Fig. 8-7.

Fig. 8-9 shows how this is done. The base-bias resistor, R1, instead of being connected directly to the + side of the power supply, is tied to the collector. Now suppose that the transistor starts to draw more current. More current flows through R2, which means there is more voltage drop across R2 and less voltage available at the collector. Since the bias resistor is tied to the collector, this means a lower voltage source for

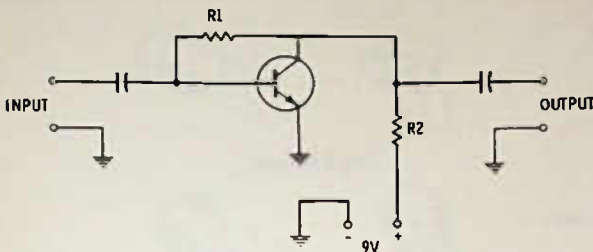

Fig. 8-9. Resistor from collector to base stabilizes operation, but reduces gain.

the base-bias resistor, reduced base bias, and a reduction in transistor current. So again, there is the self-correcting tendency when the transistor current tends to change for any reason. As with the unbypassed emitter resistor, this circuit also tends to feed back the signal. That is, as the signal tends to increase the transistor current, the bias voltage is reduced, par-

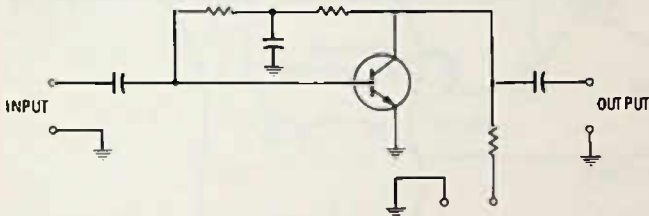

Fig. 8-10. Alternate version of Fig. 8-9 gives slightly greater signal gain.

tially counteracting the original change and so reducing the amount of change, which is the same as saying the amplification is reduced. Again, though, there are some good effects and some "flattening" of the amplifier frequency response with this sort of bias.

You can obtain the advantage of the collector stabilization circuit without loss of gain in the stage, using the circuit of Fig. 8-10. Here the bias resistance is made up of two resistors with a capacitor connected from their junction to ground. Any audio change coming back through the resistors from the collector circuit is bypassed to ground so that only the dc bias voltage stabilization remains. This circuit will have more gain than the circuit of Fig. 8-9, but the frequency response will not be as good.

PNP CIRCUITS

So far we have talked only of npn transistors, but the circuits for pnp transistors are identical except for one thing—the battery or supply voltage is reversed. All the circuits shown so far in this chapter will apply equally well to pnp transistors if the battery supply voltage is inverted. Fig. 8-11 shows an audio amplifier using a pnp; note its similarity to the amplifier in Fig. 8-9.

The difference in the symbol for the pnp is in the arrow on the emitter, which points inward (Pointing in Proper) instead of outward as in the npn.

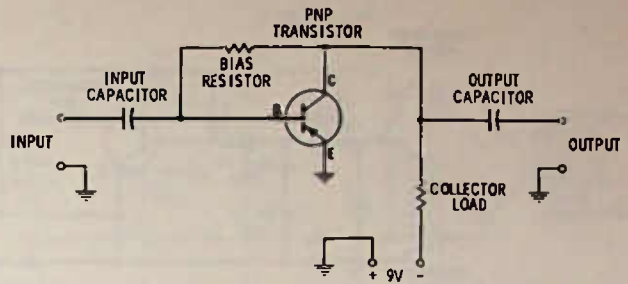

Fig. 8-11. Pnp amplifier circuit is similar to npn circuits, but supply polarity is reversed.

ADDING A TRANSISTOR AMPLIFIER TO A CRYSTAL RADIO

A description of how to build an inexpensive untuned crystal radio appeared earlier in the book and a little later a tuned one was described. At best, a crystal radio is not noted for high volume, especially if the station to be received is more than a few miles away. If a transistor amplifier is added, it is possible to receive stations at a greater distance and to get more headphone volume on the locals.

Fig. 8-12 is an addition to the crystal radio which uses an inexpensive pnp germanium transistor powered by a single small flashlight battery. The one-megohm bias resistor is a nominal value and may not even be necessary in some cases, since germanium transistors often have enough internal leakage to provide sufficient bias for this low-level circuit. No switch for turning off the battery is shown in this circuit. It is mounted on the headphone jack, and the act of unplugging the phones disconnects the battery from the transistor. Even if the circuit is left connected, it is possible that the battery may last for several weeks, especially if the headphones are high impedance, the only type that should be used with this circuit for best results. A tiny earphone such as the low-impedance ones that come with a transistor radio will not work well here since the gain will be so low.

Other types of transistors can be used in this circuit, including silicon types, but germanium is probably best unless a higher battery voltage is used.

Low-impedance headphones or an earphone of low impedance such as the one supplied with most portable radios can be operated from the crystal set, using two silicon transistors in a circuit similar to Fig. 8-13. This circuit will accept either low- or high-impedance phones. This is known as a Darlington circuit, with the first transistor driving the second one in a direct-coupled circuit. A .001- μ F capacitor is placed across the bias resistor. This has about the same effect as would a .02- μ F capacitor placed across the phones.

The 25- μ F electrolytic capacitor that bypasses the 100-ohm emitter resistor in the second stage can be omitted, but the headphone volume will not be as great.

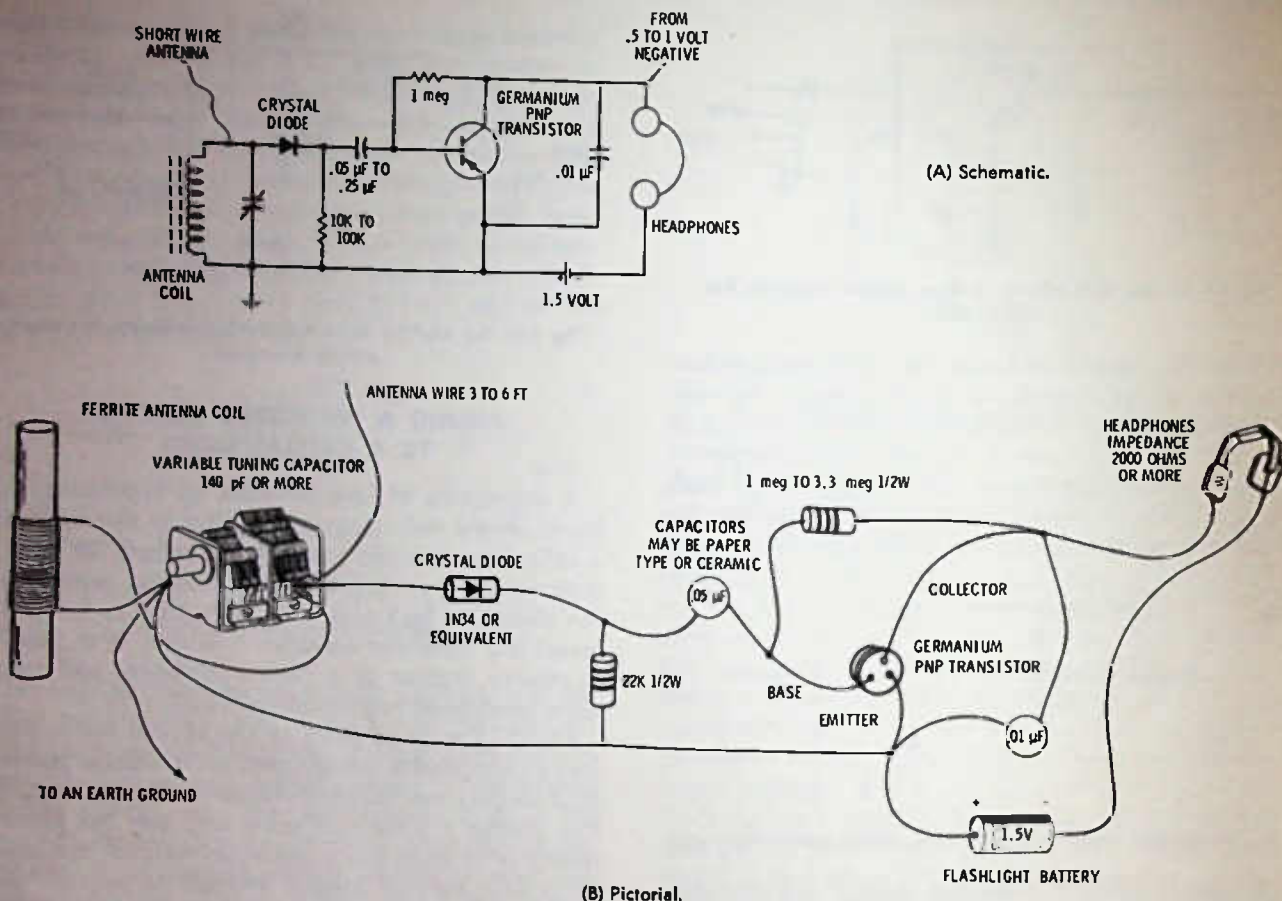

Fig. 8-12. Crystal radio with a one-transistor audio amplifier.

Silicon transistors are available in either metal or epoxy plastic cases. The lead arrangement is not necessarily the same on transistors that appear somewhat alike, but the most common arrangement is shown in Fig. 8-14. Note that the triangular lead arrangement corresponds to the schematic lead arrangement. With the leads pointed toward you, the center lead to the left is the base, the emitter is at the bottom, and the collector is at the top. But on the straight-line lead arrangement used in many epoxy transistors, the collector lead is in the center, with the emitter to the left and the base to the right when the flat side of the transistor is up.

Almost all silicon transistors will work in this audio amplifier circuit, even though they are recommended for rf circuits, but you will find the better grade of rf transistors to be generally more expensive than those recommended for general-purpose audio applications.

A SHUNT-FEED CIRCUIT

The circuits of Figs. 8-12 and 8-13 are called "series feed" circuits, which basically means that the direct current from the battery, as well as the ac signal voltage, passes through the headphones. To use this circuit, the headphones must have a direct-current path

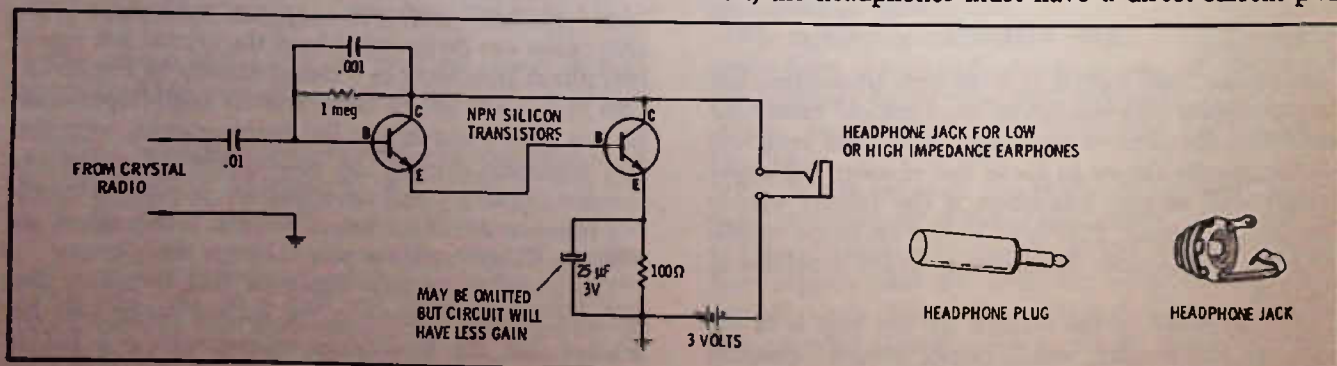

Fig. 8-13. A two-transistor audio amplifier.

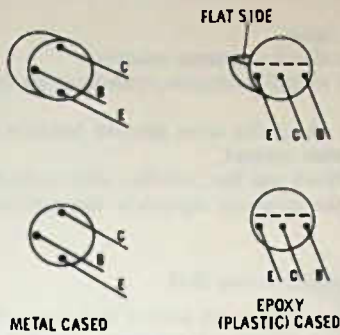

Fig. 8-14. Common basing diagrams for silicon transistors (lead view).

through them (which most headphones do have). An exception is crystal phones, which have high sensitivity but will not pass direct current. In order to use this type of phones, it is necessary to feed the collector voltage from the battery through a resistor and the headphones are fed through a capacitor. Fig. 8-15

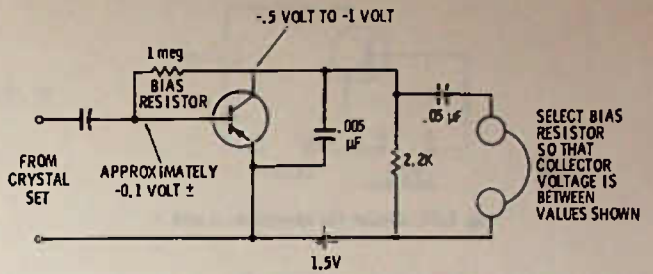

Fig. 8-15. Shunt-feed circuit for crystal headphones (may be used with other phones, too).

shows a shunt-feed circuit suitable for use with crystal headphones but which will also work as well with other kinds of headphones, if desired. Again, in this circuit the 1-megohm bias resistor may have to be selected for best results, and for some cheaper transistors, it may not even be necessary, because of internal leakage in the transistor itself.

TEST QUESTIONS

- All amplifiers have this in common:
 - they must have a source of direct current.
 - they are direct coupled.
 - they all amplify voltage rather than current.
 - they must use transistors.
- A transistor amplifier is built which when tested shows that a 0.2-volt alternating current on the base produces a 4-volt alternating current on the collector. The gain of this amplifier stage is
 - 0.8.
 - 10.
 - 2.
 - 20.
- A single-transistor amplifier which produces a high-fidelity replica of its input signal at the output is
 - a voltage amplifier only.
 - a class-A amplifier.
 - a class-B amplifier.
 - a current amplifier only.
- In Fig. 8-16, using Ohm's law and deduction, which answer is correct?
 - The transistor is germanium, npn, with collector current of 0.5 mA.
 - The transistor is silicon, npn, with collector current of 2 mA.
 - The transistor is silicon, npn, with collector current of 0.5 mA.
 - The transistor is silicon, pnp, with collector current of 0.5 mA. (Hint: For all practical purposes, the same current flows through the emitter resistor as through the collector resistor.)
- In Fig. 8-16, the emitter voltage in respect to ground is
 - 0.5 volt.
 - 1 volt.
 - 2 volts.
 - 6 volts.
- In Fig. 8-17, the polarity of battery voltage for normal operation of this circuit should be
 - positive from A to B and also from C to D.
 - negative from A to B and also from C to D.
 - positive from A to B and negative from C to D.
 - negative from A to B and positive from C to D.
- The transistor in Fig. 8-17 is
 - a pnp silicon.
 - an npn silicon.
 - a pnp, but could be either germanium or silicon.
 - an npn, but could be either germanium or silicon.

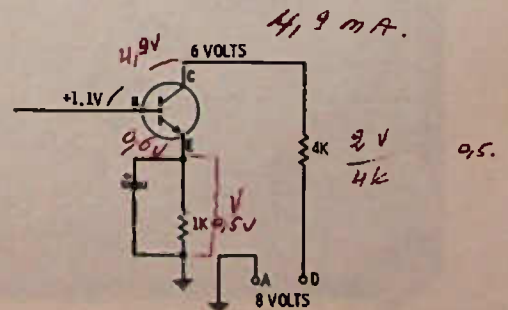

Fig. 8-16. Circuit for Questions 4 and 5.

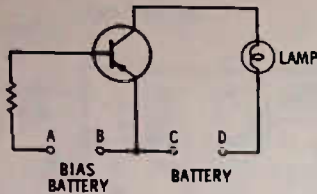

Fig. 8-17. Circuit for Questions 6 and 7.

8. A good definition of "bias" might be
- the voltage applied to the collector of a transistor.
 - the voltage (dc) read between collector and base.
 - a dc voltage between base and emitter to cut off the collector current.
 - a dc voltage between base and emitter which holds the collector current turned on but not turned on maximum.

9. In Fig. 8-18, the bias voltage on this transistor amplifier is
- +0.2 volt.
 - +4.9 volts.
 - 0.2 volt.
 - +3.8 volts.

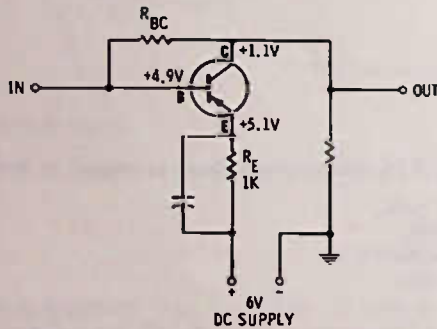

Fig. 8-18. Circuit for Questions 9, 10, and 11.

10. In Fig. 8-18, without the bypass capacitor around the emitter resistor, this circuit would
- have more gain (amplification).
 - have less direct current flow.
 - have no amplification at all.
 - have reduced gain.
11. In Fig. 8-18, if resistor R_{BC} were made smaller (less resistance) so that the base voltage decreased to +4.8 volts, you would expect the emitter voltage to

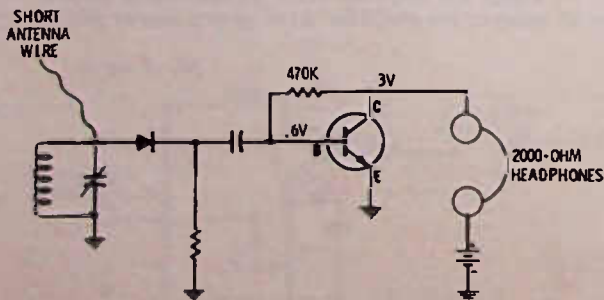

Fig. 8-19. Circuit for Questions 15 and 16.

- stay the same.
 - decrease about the same amount.
 - decrease slightly because transistor current would decrease.
 - decrease about the same amount because of an increase in transistor current.
- (Hint: Work out the problem with voltage drops across the resistors, especially the emitter resistor.)

12. A "flat" amplifier is one that
- has no "sparkle" in its output and seems sluggish.
 - has a poor frequency response, causing musical notes to be off pitch.
 - is mounted horizontally.
 - responds equally well over a wide band of frequencies.
13. In a typical class-A transistor audio amplifier, the collector voltage may
- change from zero to maximum battery voltage as the signal input voltage swings positive and negative.
 - be at zero until a signal arrives at the base or input circuit.
 - swing no more than a volt or a fraction of a volt with a positive and negative voltage change caused by signal on the input.
 - be maximum until a signal voltage is applied to the input. (It should be pointed out that a meter on the collector of a class-A amplifier should show NO change in voltage, with signal or without, because the meter cannot register quickly enough to indicate the actual collector voltage changes caused by the changing signals. In fact, if the meter does show a change in collector voltage with signal, either there is too much signal input or else the circuit is incorrectly biased.)

14. A certain transistor can be used in a circuit if it is
- a pnp and has negative collector voltage and negative bias voltage with respect to the emitter.
 - an npn and has negative collector voltage and negative bias voltage with respect to the emitter.
 - a pnp and has negative collector voltage and positive bias voltage with respect to the emitter.
 - an npn and has positive collector voltage and negative bias voltage with respect to the emitter.
15. Fig. 8-19 is a crystal radio with a transistor amplifier. Which of the following statements is the only one totally correct?
- The transistor is an npn, silicon type, and the battery voltage is above 3 volts.
 - The transistor is a germanium npn, and the battery voltage is no more than 3 volts.
 - The transistor is a pnp silicon type, and the battery voltage probably is 3 volts.
 - The transistor is an npn silicon type, and the battery voltage is no more than 3 volts.

16. In Fig. 8-19, the headphones are
- shunt fed.
 - series fed.

Test Equipment

Without question, the single most important and useful piece of test equipment for the radio technician is the volt-ohm-milliammeter (vom). The vom is a self-contained unit that can be used for measuring voltage, resistance, or current by simply selecting the correct function with a switch or sometimes by switching the test leads to different plugs.

FEATURES OF THE VOM

A good vom will measure both dc and ac voltage, with full-scale readings switchable from about 3 volts or less to 1000 volts or more. Resistance can be read with good accuracy from zero to at least 10 megohms or more. Direct current can be read from about 50 or 60 microamperes to 1 ampere or more. There are many vom's manufactured, and each one will have slightly different voltage and current ranges, but all work on virtually the same principle. Each will have several different sets of figures called "scales" on the meter face (see Fig. 9-1). The scales on a meter are "unit" scales that require that you mentally add or subtract zeros, depending on the range selected. For example, the same set of scale numbers may be used for 3-volt, 30-volt, and 300-volt ranges, as shown by Fig. 9-2. The scale shown can be used for any meter range that is a multiple or submultiple of 10. For example, in the position shown, the meter pointer could be indicating 75 volts, 7.5 volts, or 0.75 volt, depending on the position of the range switch. The range switch position indicates the maximum scale reading obtained when the pointer is at the right-hand limit of the scale.

Depending on the meter manufacturer and other factors, the same scales may be used for both ac and dc voltage readings, as well as current readings. On the other hand, the manufacturer may find it desirable to have separate ac and dc scale numbers, and often the ac scales may be printed in red.

The units of measure for each scale will be listed at the left edge of the scale, e.g., DC, AC, OHMS, or Ω , etc.

When reading an unknown voltage or current, you should always first switch the meter function or range switch (some meters use a single switch, others use two) to a high range, place the test leads on the

points where the test is to be made, and then reduce the meter range until the meter pointer reads up scale enough to make an easy readout possible. Obviously, some judgment must be made as to the range. For example, if you are testing a radio that uses a 9-volt battery, the maximum voltage possible in the radio is 9 volts, so setting the meter on a 300-volt range as a trial would be foolish. On the other hand, if the radio operates from the power line, it is possible to have as much as 130 volts or so at some point in the radio, especially if no stepdown power transformer is used in the radio.

MEASURING RESISTANCE

Resistance is measured with the ohmmeter section of the vom. In every case resistance must be measured

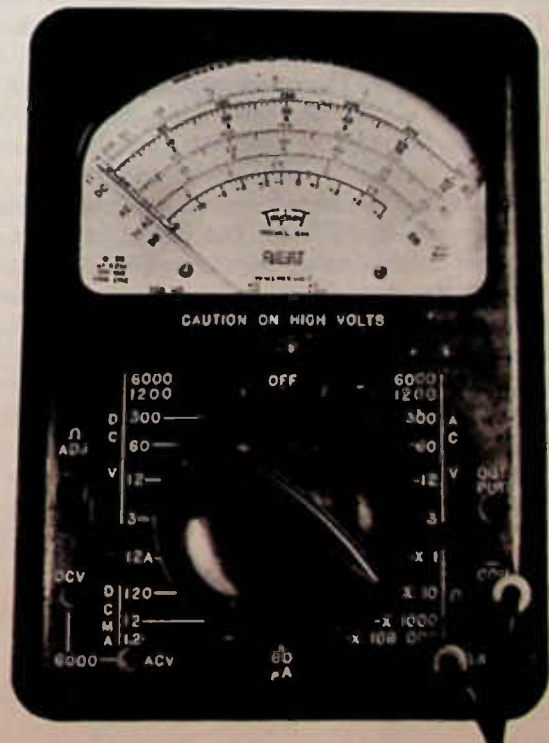

Fig. 9-1. Typical vom.

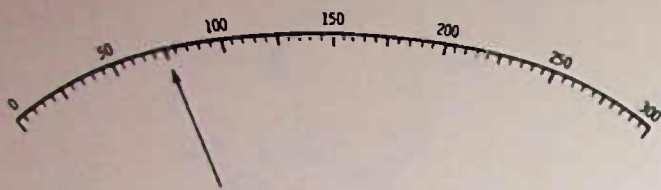

Fig. 9-2. Detail of scale easily used for several ranges by using range multipliers.

with no power applied to the circuit, not only so the reading will not be erroneous, but to prevent very possible damage to the meter or the meter circuits or both.

An ohmmeter is self-powered by means of internal batteries in the meter case. Basically, an ohmmeter is simply a voltmeter connected so that the resistor you are measuring becomes a part of the meter circuit, making the meter read a value corresponding to the value of the resistor. The ohmmeter scale is calibrated in ohms, of course, rather than volts. Fig. 9-3 is a basic ohmmeter circuit. The upper circuit shows how a lamp could be used to check continuity (whether a wire is broken, etc.) because if the wire is connected between lead 1 and 2, the circuit is complete and the lamp lights unless the wire is broken. The lamp and battery are fine for checking wires, but it takes considerable current to light the lamp. If you attempted to measure a resistor of more than 100 ohms or so, this lamp would not light; or, if you tried to measure a transistor, for example, you might burn out the transistor by passing too much current through it.

The meter is used because it requires very little current to deflect it from zero to full scale. For example, the 20,000 ohms-per-volt meter will deflect to full scale with a current of only 50-millionths of an amp (50 microamperes). This small amount of current can be passed by almost any electronic device without damage; and, in addition, resistances can be measured up to several megohms with low-voltage batteries.

The resistor in the ohmmeter circuit limits the current; so the meter will read just full scale when test leads 1 and 2 are shorted together. This resistor and the internal battery are why an ohmmeter is essentially a voltmeter—with the leads shorted together, the meter is reading the battery voltage. Since this is a 50-microampere meter, the resistor value to read full scale on 3 volts, is 60,000 ohms (Ohm's law, $R = E/I$). (Note that for each volt on the meter, it requires a series resistance of 20,000 ohms. This is why a 50-microampere meter is called a 20,000 ohms-per-volt

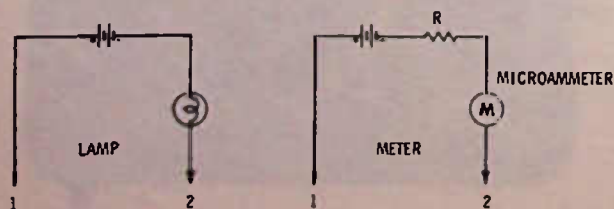

Fig. 9-3. Basic ohmmeter circuit.

meter when used in a voltmeter circuit.) It follows that if we added another 60,000-ohm resistor in series with the meter (between test leads 1 and 2) the meter pointer would indicate half scale so that point on the ohmmeter can be marked 60K. Other resistors can be connected in series with the leads and the correct calibration marks made. All this is done by the ohmmeter manufacturer, but we have included this information to aid in understanding how the ohmmeter works and why there should be no power in the circuit when you are testing resistance.

A "meter zero" control is found on all ohmmeters to compensate for slight differences in battery voltage. The meter should be zeroed by holding the test leads together and adjusting the meter zero control until the meter pointer reads exactly 0 at the proper end of the meter scale.

Only one ohmmeter scale is used, but several ranges are included on the meter in multiples of 10. These maybe be marked "R x 1," "R x 10," "R x 100," etc., which simply means that you multiply the meter reading by the multiplier indicated on the range switch. For instance, in Fig. 9-4 the meter pointer is indicating 4. This means 4 ohms if the ohmmeter range scale is on R x 1 (some meters have R1 or X1 or some other easily understood abbreviation) but if the ohmmeter range is on R x 1000, then the meter is reading 4000 (4 x 1000). Notice that the distance between scale marks is not linear, but becomes more crowded at the left end of the scale. The ohms range should be set so that a reading is obtained in the right half of the meter scale, if possible.

THE VACUUM-TUBE VOLTMETER OR TRANSISTORIZED VOLTMETER

A useful tool for the radio technician is an amplified voltmeter. Older types use vacuum tubes and are known as vtvm's (vacuum-tube voltmeters) while newer amplified voltmeters use solid-state circuits and are called "transistorized vom's," "solid-state vom's" or "FET (for field-effect transistor) vom's."

The real advantage of these voltmeters is that they do not significantly "load" the circuit while making measurements. This means that a measurement can be taken without changing circuit action in most cases. With even a 20,000 ohms-per-volt vom, on lower voltage scales the resistance of the meter circuit can upset the circuit so that the meter readings are incorrect. The circuit in Fig. 9-5 shows how the voltage can

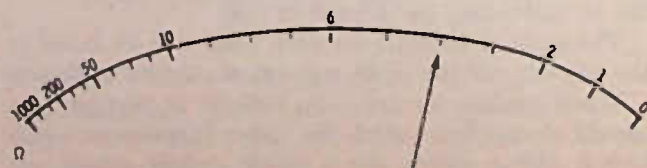

Fig. 9-4. Typical ohmmeter scale with right-hand zero.

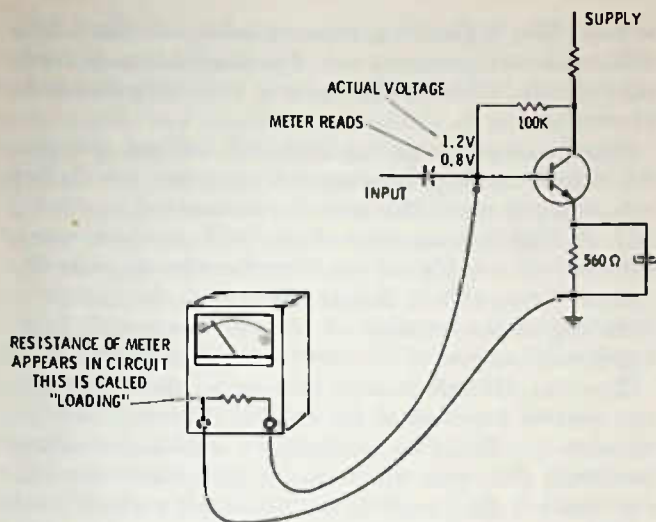

Fig. 9-5. Effect of meter resistance on a voltage measurement. Current through a 100K resistor reduces actual voltage of 1.2V to 0.8V on the 20,000 ohms-per-volt meter.

change when a vom is connected in the circuit. This is because the meter resistance pulls more current through the 100K bias resistor; so the voltage is lowered at the base.

This loading occurs only in circuits where the resistance of the meter is a significant part of the circuit. In Fig. 9-5, we might assume that the vom is 20,000 ohms (1-volt scale), which is quite a load on a base fed with a 100K resistor, but if the voltage is read across the 560-ohm emitter resistor, the 20,000 ohms of the meter would be such an insignificant amount as to make no noticeable variation on either the voltage reading or the circuit performance.

Vacuum-tube voltmeters and solid-state vom's normally have a circuit loading of no less than 10 megohms, and some may have a circuit loading as high as 22 megohms. Input impedances at 10 or 11 megohms are the most popular, and this much impedance is sufficient for all radio circuits.

The disadvantage of the vtm is that it must be plugged into the power line for power and takes a minute or so to warm up. The solid-state vom uses an internal battery for power, but has a slight disadvantage in that the battery can be run down rather easily if you forget to turn it off after use, especially if it is left on an ohmmeter scale.*

The ohmmeter on most vtm's and many solid-state vom's is a "powered" type. That is, the meter reads all the way to the right when the test leads are *apart* and all the way to the left when the leads are shorted together—just opposite to the vom. Thus, the ohmmeter

*Not all solid-state ohmmeters use the transistors in the ohmmeter circuit. Instead they use the same circuit as a vom; so leaving the circuit on OHMS will not run down the transistor battery, though it may run down the ohmmeter batteries if the test leads are accidentally touching together.

reads "up scale," with the higher resistance readings to the right instead of to the left.

USING A VOLTMETER

The voltmeter, if used wisely, is able to find more than 80% of the circuit troubles in a transistor radio, or at least localize them to a narrow area. Most radio schematics include typical voltage readings on the terminals of the transistors. Unless otherwise stated, these voltages will be from the terminal to ground, or common. This is why a clip terminal on your voltmeter lead is a convenience—you can clip this to a common connection and leave it there to make all preliminary voltage readings. Unfortunately, unlike tube-type radios which always used a negative common or ground, transistor radios may use either one. This means that you may need a clip on either the positive or negative lead of the voltmeter unless your meter has a polarity-reversing switch. The polarity-reversing switch actually just reverses the leads so that you can always have the meter reading up scale regardless of the actual circuit polarity.

Even though voltage readings are given to ground, you may want to read the voltage drop across a resistor to get a more significant reading. For example, examine the circuit of Fig. 9-6. If you read the emitter voltage to ground and then the base voltage to ground, it is difficult to determine if the bias is correct and in the right polarity, because the meter pointer has dropped back to zero after each reading. However, measuring between base and emitter, you can read out the $-.1$ volt on a low voltage range without too much trouble.

Although loading has been mentioned as a problem, with a little "voltmeter sense" the radio technician learns to compensate for the slight difference that occurs because of loading; so after a bit of practice, the 20,000 ohms-per-volt vom creates little if any problem to a practical man. However, for the purist who likes to know the correct reading as precisely as possible, the vacuum-tube or solid-state voltmeter is the best tool to use. Still another choice is available: the 100,000 ohms-per-volt meter. If this last meter is used on a 3-volt scale or higher, it will offer little if any serious loading on any radio circuit. Nearly all serious technicians have both the vom and the ampli-

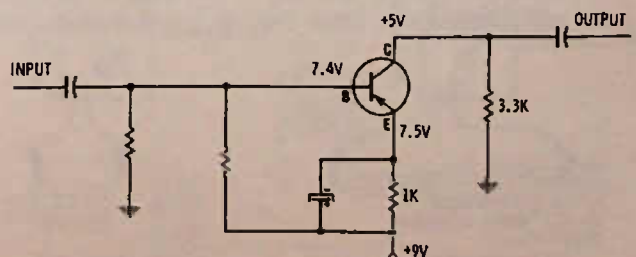

Fig. 9-6. Transistor audio circuit, showing voltage readings to ground.

fied voltmeter in their test equipment inventory, if for nothing more than to check out one against the other.

USING THE OHMMETER

The ohmmeter is used for measuring continuity of circuits as well as resistance. Continuity measurements are those that are zero or near zero ohms (no conductors have completely zero ohms, but they are so close that they indicate zero on the meter) such as wires, printed-circuit conductors, etc. (Fig. 9-7). Broken wires often cannot be found by visual inspection since the insulation may not be broken, just the wires inside. Often wires break near where they make a connection to a plug, such as at the snap-on battery connections and the like. You can check power-line cords by connecting the ohmmeter leads across the cord and turning on the switch—of course the line cord must NOT be plugged into electricity, otherwise good-by ohmmeter!

Besides continuity, you can check resistances to see whether or not they are the correct value, remembering that usually a resistor can be from 10 to 20% away from its coded value and still work all right in the circuits. Checking resistors in a transistor circuit is a bit tricky. The reason is that transistors themselves are resistances and are low resistances if the proper polarity voltage is applied—see the section on testing transistors with an ohmmeter a little later in the chapter. So, to check a resistor in-circuit, take two readings across it with the ohmmeter, one with the leads across it in one direction and the other with leads re-

versed. The highest resistance reading—if there is a difference—is the correct one. The low resistance reading indicates that the ohmmeter is causing a transistor to conduct.

Sometimes reversing the leads still will not give you the correct reading, because one transistor (or diode) may conduct when the leads are connected one way, and another transistor or diode will conduct when the ohmmeter leads are connected in the opposite direction. Being able to decide either from the circuit or from experience whether or not the “in-circuit” reading is valid, is part of the “art” of radio servicing.

You can, though, always be sure of the reading if you remove one lead of the resistor from the circuit—so when you make an inconclusive resistance reading in-circuit, then you will want to disconnect one end and make a final reading before being sure of your diagnosis. (Obviously checking each resistor in a radio is not an efficient method of troubleshooting, not only because it is time consuming, but also because resistors are probably one of the least possible causes of trouble unless they show obvious faults such as being burnt (even a burned resistor means some other part is defective, causing it to burn) or broken in two. The secret of radio service, or any other kind of repair service, for that matter, is to be able to localize the trouble first (that is, find the defective stage) and then make individual checks of the parts as necessary.

TESTING DIODES WITH AN OHMMETER

A diode, as you have already learned, is a device that allows electric current to flow through it in one direction but not in the other. Fig. 9-8 shows how a vom will test a diode. Do not be confused because the + lead is connected to the cathode of the diode for conduction. Actually, the + from the vom is for voltmeter readings, but on OHMS the + lead actually has the more negative voltage on it. Incidentally, this is not true of ALL vom's, but it is of most. Also, vtvm's, and some solid-state vom's, have a plus voltage on the

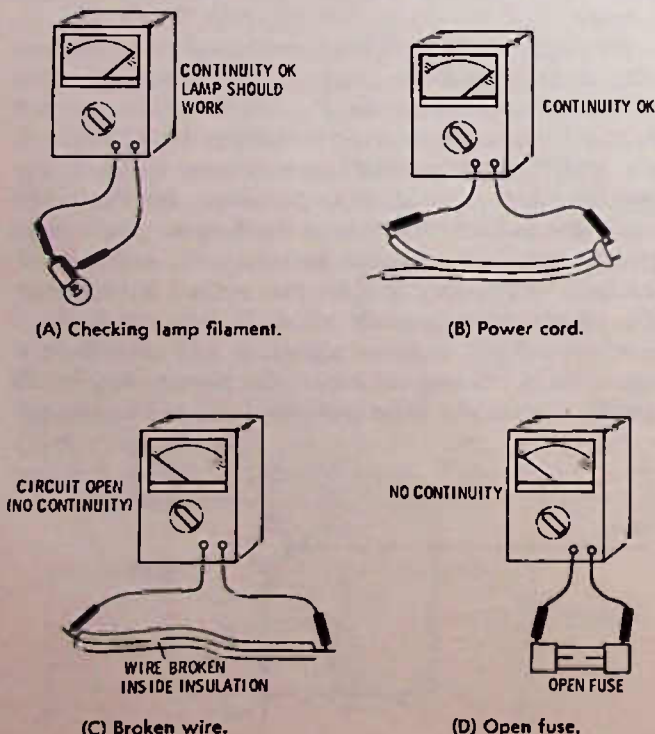

Fig. 9-7. Some examples of continuity measurement with an ohmmeter.

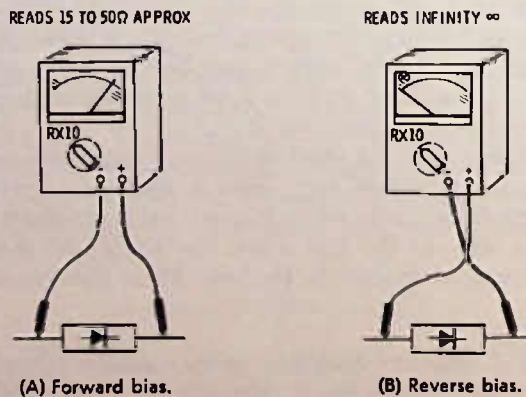

Fig. 9-8. Checking diodes with a vom. Polarity marks are for voltage measurement. Polarity of ohmmeter leads is normally the reverse of this (see text).

+ lead when in the ohmmeter position. It really does not make any difference so far as testing is concerned, but it is important if you are trying to find out which is the anode and which is the cathode of an unmarked or faintly marked diode. You should check a known good diode that has obvious markings to see which lead of your ohmmeter has a positive voltage on it. Again, most vom's will be like the one in Fig. 9-7.

You can check most radio diodes without disconnecting them from the circuit by first taking a reading in one direction and then in the other. In the "reverse" direction you will get a reading of whatever resistance is in the circuit, and in the forward direction, you will get from about 20 to 100 ohms on the $R \times 10$ scale of the ohmmeter from most diodes (Fig. 9-9). It is usually best, unless you are sure of the circuit, to measure directly across the diode. However, in Fig. 9-9, which is a typical radio circuit, you could get the same effect, if it is easier to get at, by measuring across the volume control—trace it out and see, if you doubt it.

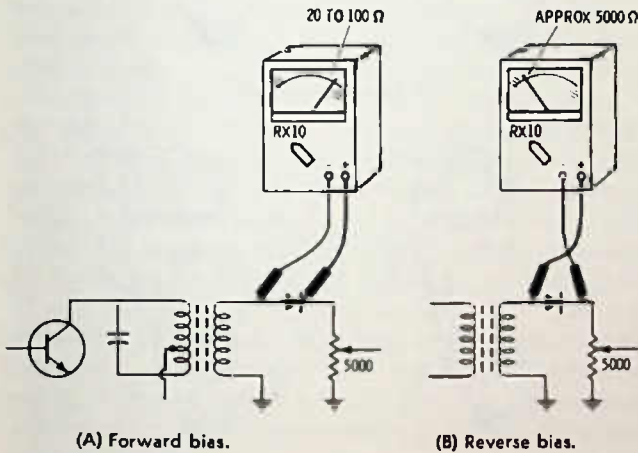
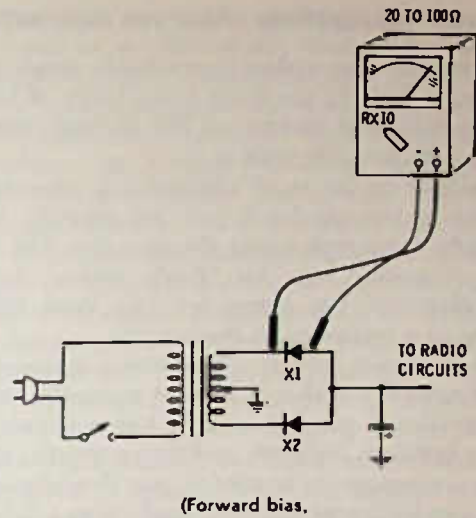

Fig. 9-9. Measuring diodes in-circuit.

Rectifier diodes can often be tested in-circuit, but there is always a possibility of getting a false indication. If you get a difference in the forward and reverse readings, this would seem to be a good indication of diode action, but not always. The dc supply circuit is tied to all transistors in the radio, and you may get a false indication through one of these transistors. Another problem: suppose X1 is open and X2 is all right. In reality, because of the low resistance of the power transformer winding, you are reading across diode X2 when checking across X1. The converse is also true; looking across X2 is also looking across X1. See Fig. 9-10.

Another problem sometimes occurs with rectifier diodes: they may check all right with an ohmmeter, yet break down when in the circuit and quit working or cause burning. This is not too true when the diodes are used in circuits of 20 volts or less, but for circuits with higher voltage it is a good idea to check diodes



(Forward bias.

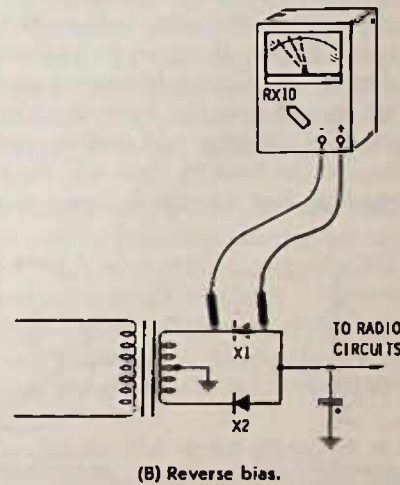

(B) Reverse bias.

Fig. 9-10. Measurement of rectifier diode may give an inconclusive result (see text).

by substitution or use the circuit of Fig. 9-11 for testing. When the diode is good, the lamp should light at about half brightness (since it is allowing only one-half of each ac cycle to pass). If the lamp lights at full brightness, the diode is shorted. If the lamp does not light, the diode is open. This circuit can be used to test diodes in a radio by disconnecting one end of the diode from the radio and then running test leads to the tester. The power transformer can be any 12-volt transformer capable of 100 mA or more of output. Do not use this circuit to test small detector diodes.

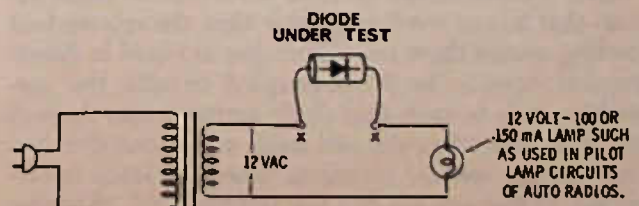

Fig. 9-11. Rectifier diode tester. (Not for use with detector diodes.)

TESTING TRANSISTORS WITH AN OHMMETER

An ohmmeter also makes a reasonably good transistor tester; in fact, its accuracy rivals many of the less expensive transistor testers on the market. In-circuit testing is also possible with it.

A transistor, so far as an ohmmeter is concerned, is equivalent to two diodes facing one another, with a third diode connected across the two (see Fig. 9-12). Since a transistor has this "diode action" between various elements, the ohmmeter can "read out" the condition of a transistor in many cases.

Fig. 9-13 shows how an ohmmeter (you need only one, but several are shown here to make the explanation more clear) can be used to test a transistor by checking between elements and then reversing the test leads. In a germanium transistor, you should get diode action (one high and one low reading—use $R \times 10$ or $R \times 100$ scale) between base and emitter, base and collector, and between collector and emitter in most cases. This is not always the case in a silicon transistor. The reading from collector to emitter occurs when the voltage of correct polarity from the ohmmeter is placed between the collector and emitter, and there is enough leakage to the base to "turn on" the transistor. If the transistor has low internal leakage, you will not

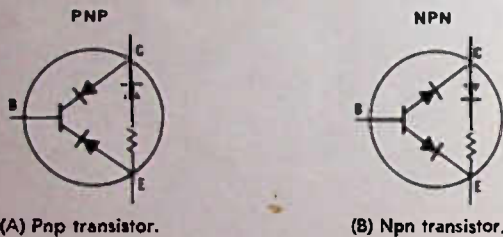
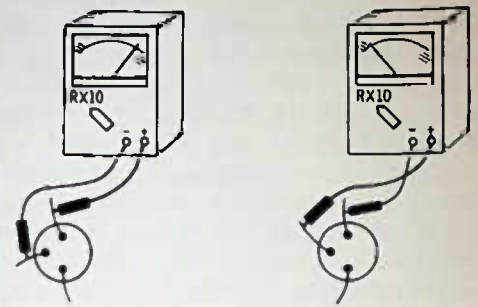

Fig. 9-12. Diode representation of transistors, based on ohmmeter tests.

get this reading unless you connect a resistor between the collector and base. You can use about a 47K resistor if you wish, but most of the time just touching your fingers from the collector to base will cause enough current to flow to bias the base circuit on, so the ohmmeter reads, showing that current will flow through collector and emitter.

The foregoing applies to transistors out of the circuit. When the transistor is in the circuit, the bias circuit will normally turn on the transistor when you make the measurement from collector to emitter so that you get the diode action.

Most transistors can be read in-circuit for diode action—that is, one reading greater than the reverse-lead reading, except those transistors that are used in direct-coupled circuits. In direct-coupled circuits, the connections may be such that diode action occurs through one transistor when the test leads are in one direction and through another transistor when the leads are reversed, so that you get two low readings and, of course, an inconclusive result. For an accurate check, in this



(A) Base-to-collector test.

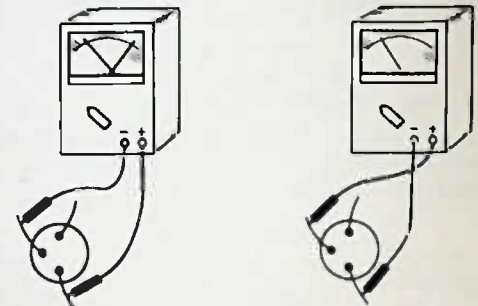

(B) Base-to-emitter test.

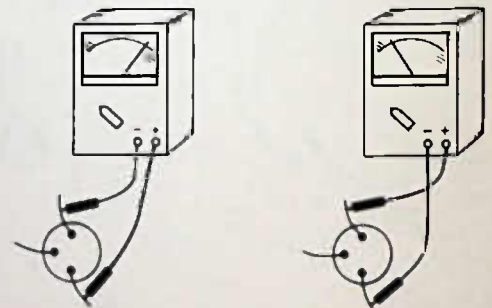

(C) Emitter-to-collector test (see text).

Fig. 9-13. Ohmmeter tests of an npn transistor by reversing test leads.

case, you will need to remove at least the one connection that goes directly to another transistor; then take the measurements again.

If you check from base to emitter of any transistor in any circuit and find that you have a high resistance in both directions (using a standard ohmmeter), then you can be sure that that transistor is open. This is also true if you read between base and collector. A high resistance in both directions between collector and emitter may mean that the transistor is not receiving proper bias from the circuit, or it could mean an open transistor, but you should remove the transistor for a final check. If you get a low resistance between collector and emitter, it likely means a shorted transistor, but because a few circuits can deceive you in this regard, remove the transistor and make a final check before replacing with a new one. You can leave one lead of the transistor connected in the circuit and

make a valid test with either the ohmmeter or any good transistor checker.

SIGNAL GENERATOR

The signal generator is a useful and necessary tool for the professional radio technician. The signal generator is a tunable oscillator and output circuits with audio modulation. The generator is used to provide a test signal, either for checking amplifiers or for alignment. Usually you can turn off the modulation to make it simpler to check for unwanted noise in the radio.

Fig. 9-14 shows how a signal generator can be used to localize a defective stage. Suppose you cannot hear any stations on the radio, or they are very weak. Tune the signal generator to 455 kHz (or whatever other frequency the i-f might be) and inject a signal into point A, which can be the base of the converter transistor. Be sure the generator is set for internal modulation. Do you hear the tone in the output? If you do, is it loud and clear? You will have to learn how to set the attenuators on your signal generator for the correct amount of signal. A signal generator can have such a strong output that it can push a signal through an otherwise dead radio simply by "brute force." If the signal comes through all right and the radio won't pick up stations, then the trouble obviously is in the converter stage. If you get no signal at the converter stage, move up to point B, the base of the 1st i-f transistor. Do you hear the signal? If so, then the circuit from the 1st i-f through the output stages is working. If not, then move to point C and try again. You will, of course, have to turn up a little more signal from the generator since you now have less amplification—this again, is why you must find out by checking on a good radio just where the attenuators should be set for each input test point.

Most signal generators also have an audio tone output alone, either switchable to the output cable or in

some cases taken out with another cable. You can feed this signal in at the volume control and check the audio stages, again moving forward in the stages if there is no output across the volume control.

Many technicians prefer to trace from the speaker back when using a signal generator. Starting with the speaker, you can usually hear a weak tone with the audio tone turned up full, then move back to the collector of the driver transistor, and the volume should increase considerably since now you have the amplification of the output stages. Reduce the audio output from the generator so that you do not overload the circuits. Next move back to the base of the driver; and again, you should hear an increase in output volume, indicating that the driver stage is amplifying. This continues back through any other audio stages, always turning down the generator for low output before moving back to check the next stage. When you have tested back to the detector, the generator is changed to rf output at the intermediate frequency. Go to the base circuit of the last i-f and turn up the generator so you can hear the output in the speaker weakly. Next, move back to the next i-f amplifier base and you should hear a considerable increase, indicating that the amplifier is working.

With a little practice you can use your signal generator not only to find dead stages but weak stages as well. The **ONLY** way to become proficient at this technique, though, is by **DOING** it!

You can also check alignment of the amplifier stages as you move through, by tuning each transformer for maximum in the circuits **FOLLOWING** the generator connection.

You can also use the signal generator to tune up the antenna and oscillator circuits, but the "noise" method described in Chapter 5 is a much more effective way and apt to give better radio sensitivity unless you have had considerable practice using the generator learning to "rock" the circuits into tune.

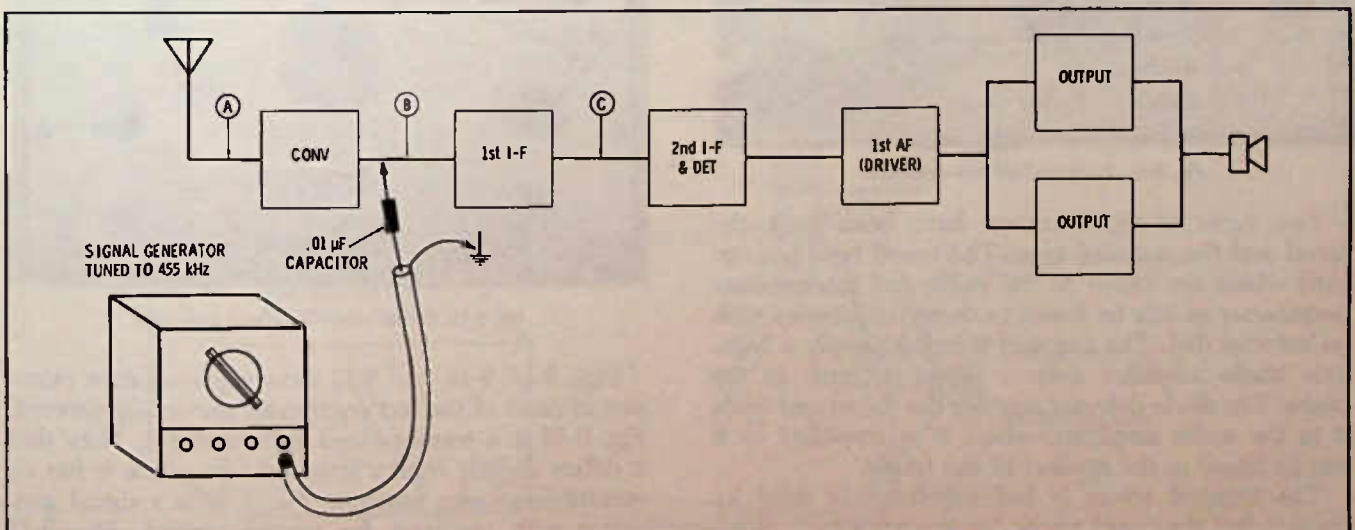

Fig. 9-14. Using a signal generator to locate a defective stage in a radio.

SIGNAL TRACERS

Back in the heyday of radio when there were probably more "professional" radio technicians than today, the signal tracer was a standby in almost every shop. The signal tracer is basically an amplifier that can "pick off" the signal as it moves through a set so that the technician can listen. Starting at the antenna circuit, the signal tracer (if there is a strong local signal or if the tracer has tuned circuits) can pick up a signal, then move to the output of the converter to see if the signal has reached that point, move on through the i-f's, and finally out through the audio. The technician, with a signal tracer, is able to find where the signal stops on its way through a defective radio and so localize the defect to a particular stage.

speak, so that just getting close to a transistor amplifier is all that is needed to pick up even fairly weak signals. With the untuned tracer you generally need to actually touch the circuit test point in order to get enough signal to drive the speaker, especially in the early stages of the radio.

Signal tracers, like any other piece of test equipment, are a valuable tool if you learn to use the particular tracer you own according to the recommendations of the manufacturer. No set of instructions, though, can take the place of actual day-to-day experience with the unit. You will soon learn what to expect from most any radio at any given test point, and with this information you are a long way toward becoming a good radio technician. Even the expert radio technician is greatly hampered if he has to use equipment with which he is not familiar or if he has not had time to find out what to expect from it in the way of indications on defective radios.

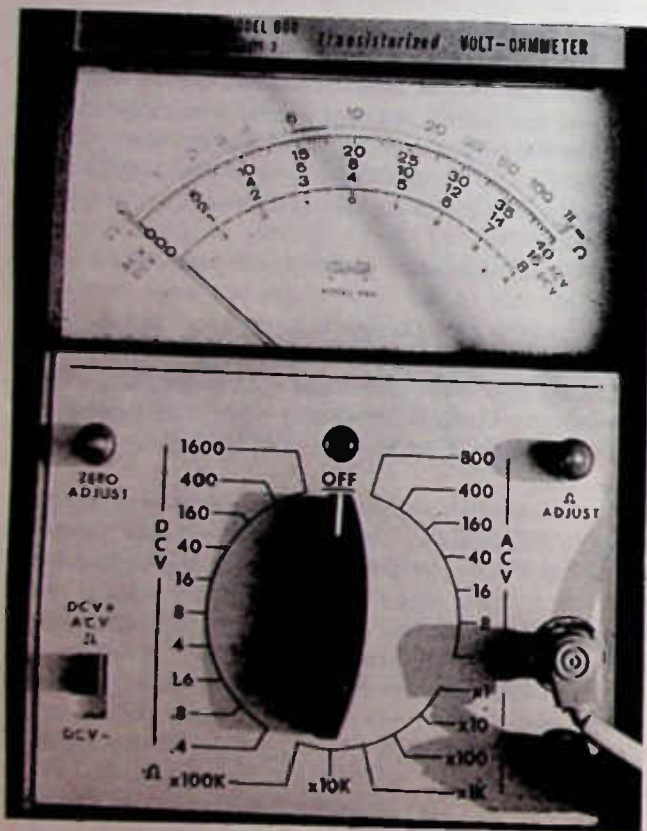

Fig. 9-15. Transistorized volt-ohmmeter.

Two types of signal tracers have been built—the tuned and the untuned type. The tuned type has circuits which are tuned to the radio and intermediate frequencies or can be tuned to these frequencies with an external dial. The untuned tracer is simply a high-gain audio amplifier with a diode detector in the probe. The diode detector rectifies the signal and feeds it to the audio amplifier, where it is amplified so it can be heard in the speaker of the tracer.

The untuned tracer is less expensive in most instances, but the tuned tracer has the advantage of being able to pick up signals "out of the air," so to

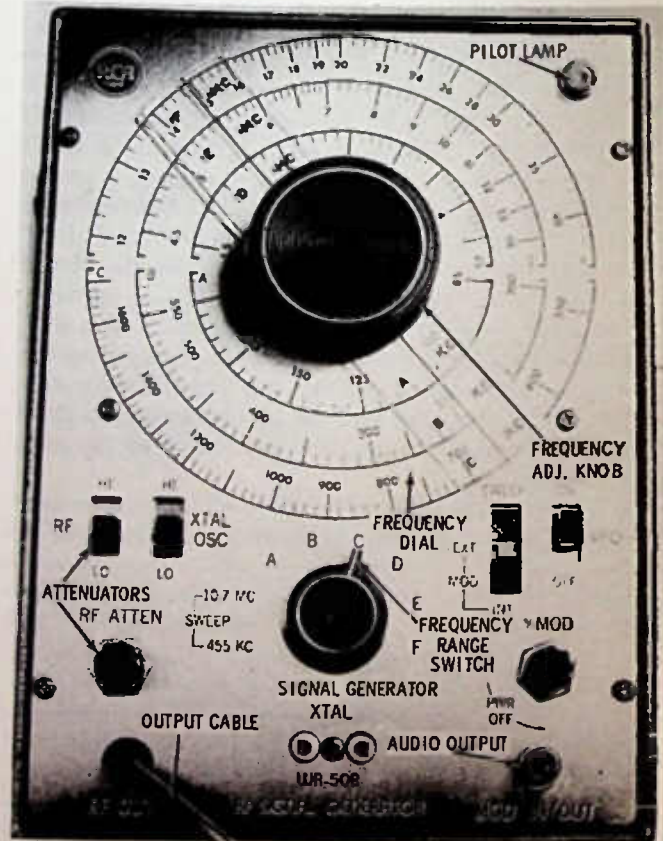
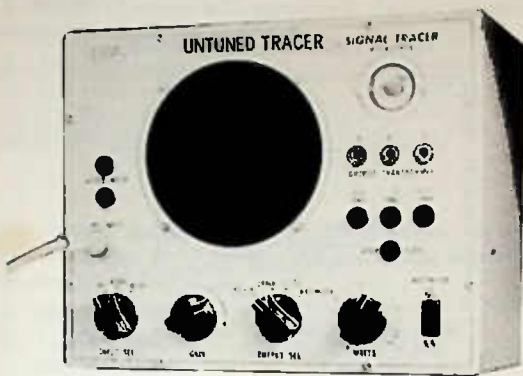
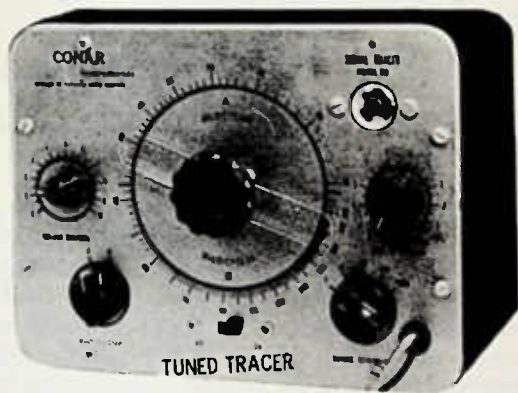

Fig. 9-16. Crystal-controlled signal generator.

Figs. 9-15, 9-16, and 9-17 show representative examples of some of the test equipment previously covered. Fig. 9-15 is a transistorized volt-ohmmeter. Note that it differs slightly from a standard vom, since it has no current-measuring function. Fig. 9-16 is a signal generator with provision for crystal control. Fig. 9-17 shows two examples of signal tracers.



(A) Untuned tracer.



(B) Tuned tracer.

Fig. 9-17. Representative signal tracers.

THE OSCILLOSCOPE

The oscilloscope is an electronic unit using a cathode-ray tube (which works a bit like tv) that draws an electronic graph on the screen corresponding to the signal voltage at a particular test point. Modern

oscilloscopes can easily amplify frequencies through the broadcast band and much higher. Obviously, then, the oscilloscope can be used to follow a signal through a radio from the antenna to the output. As with the signal tracer, you have to learn by first working with a radio that has NO faults, in order to get a standard of comparison. If you have a strong local station, you may want to use this as the signal source; in fact, an actual signal is generally best for any sort of signal tracing if that signal is steady and if it is strong enough to produce usable output on the tracer or scope in the early stages. An oscilloscope has about the sensitivity of the untuned signal tracer.

However, some technicians prefer to use a signal generator input, often radiated "through the air." Fig. 9-18 shows how a signal generator may be connected to radiate a steady, strong test signal within several feet. A "through-the-air" pickup is best since it eliminates any possible detuning in the radio due to connecting the signal generator into the circuit.

This also provides a good "check point" for the dial or for setting the oscillator trimmers at the high end of the band. Just tune the signal generator and "phantom" antenna to 1300 kHz or higher, to a "dead" spot on the dial where no radio stations are picked up in your area.

DC POWER SUPPLIES

Power supplies made for powering radios during testing are available from several manufacturers. You can build one if you wish. The circuit in Fig. 9-19 is a simple power supply that is adjustable between zero and about 15 volts. The circuit shows components that will produce an output of up to 1000 milliamperes (1 ampere). For small portable radios only, you need no more than about 100 mA, but by making the

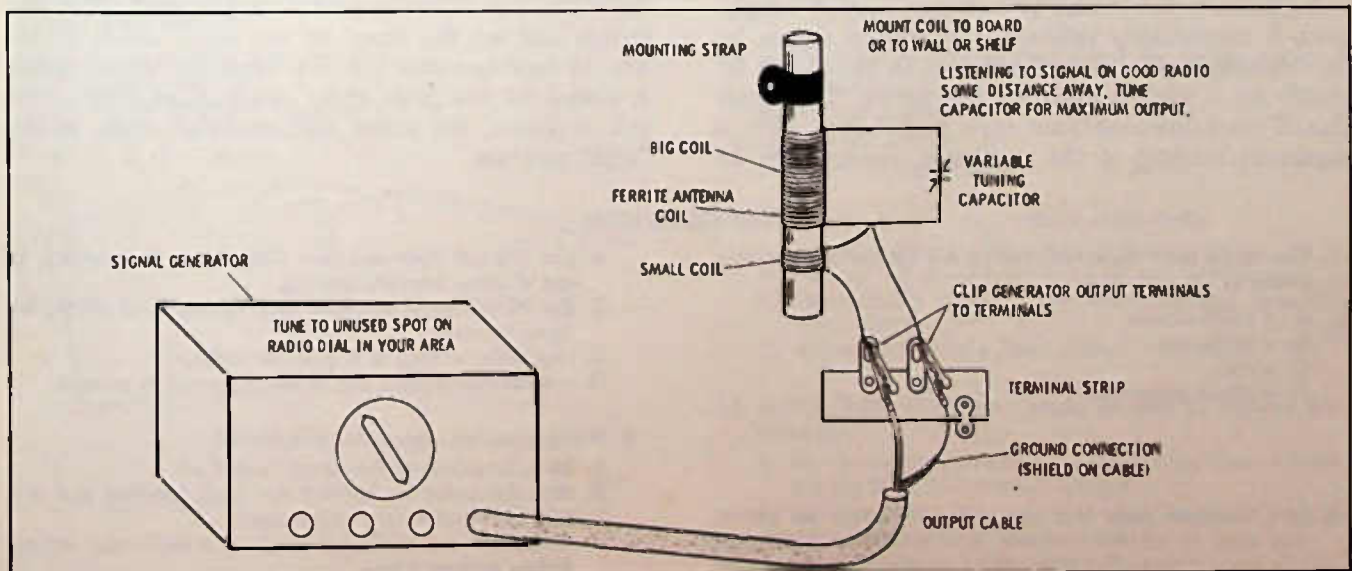

Fig. 9-18. "Phantom" antenna used to radiate generator signal in shop area for signal tracing.

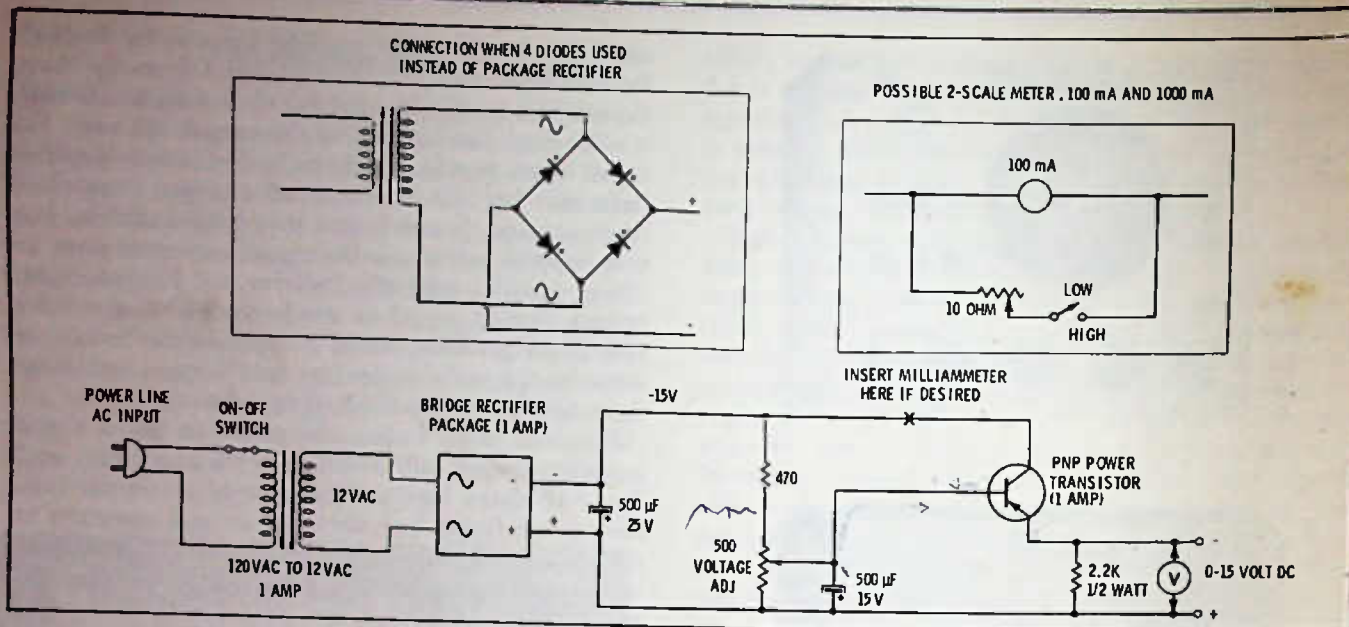

Fig. 9-19. Power supply with electronic filtering, used to power portable radios.

unit able to pass 1 ampere you get considerable safeguard in case of overload due to defective parts in the radio.

This circuit has "electronic" filtering in that the base circuit is held at low ripple by the capacitor in the base circuit (low ripple at the base is assured because the base current is very low; and, hence, does not discharge the capacitor between "charges"), thus any ripple appearing in the output (will be negative going) reduces the transistor bias and so increases the resistance to the source during the ripple. This method of filtering makes the effective output filtering equal to the base capacitor ($500 \mu\text{F}$) times the gain of the transistor, which is around 30. In other words, the effective output filtering is about the same as that given by a $15,000\text{-}\mu\text{F}$ capacitor.

A milliammeter is nice to have in a power supply, since it immediately indicates the current drawn by the transistor radio. Any shorts will be shown up instantly by a high reading on the meter. The meter should be a low-resistance type and should have a maximum reading of the maximum expected to be

taken from the power supply under normal use. For example, if only portable-type radios are to be tested with this supply, then a 100-mA full-scale-reading meter would be suitable. A 1-ampere meter could be used, but for small radios the reading would make such small movement of the meter needle that it would be difficult to make an accurate readout.

If the power supply is to be used on radios drawing up to one amp, as well as on portable radios, then a circuit such as that in the inset of Fig. 9-19 might be used. A 100-mA meter is used, with a shunt circuit that can be switched in to make the meter read 1000 mA. The adjustable shunt resistor is set so that the 100-mA meter reads 1000 mA when the meter switch is closed and 1 amp of current is being drawn from the power supply. Another way to set the shunt is to draw 100 mA from the power supply, then close the switch and set the shunt so the meter reads at 10. The 10 now becomes 100 mA when the shunt switch is closed for the high meter reading; so when 1000 mA is drawn, the meter will read full scale in the "high" position.

TEST QUESTIONS

1. The single most important instrument for testing transistor radios is
 - A. a milliammeter.
 - B. a wattmeter.
 - C. a vom.
 - D. a signal generator.
2. In a transistor radio that uses a 6-volt battery for power, you want to measure voltage at a particular point, and you are not sure what the voltage may be. You should set the voltmeter range switch to
 - A. the 150-volt scale and then drop down, if necessary, to get a more accurate reading.
 - B. the 10-volt scale and then drop down, if necessary, for more accuracy.
 - C. any scale, so long as it is for dc voltage.
 - D. a milliamper scale first to see if current is present.
3. When using an ohmmeter, you should
 - A. have the power to the circuit turned off.
 - B. zero the meter by holding the leads together and setting the "meter zero" adjustment.
 - C. always set the ohmmeter range to a high-value setting before making a test.
 - D. A and B above are correct.

4. A 20,000 ohms-per-volt meter will deflect full scale with current through the meter of
- 50 microamperes.
 - 100 microamperes.
 - 20,000 volts.
 - 20,000 ohms.

5. Fig. 9-20 is the circuit of a 20,000 ohms-per-volt voltmeter. For the meter to be reading full scale what should the size of resistor R be?
- 20,000 ohms.
 - 60,000 ohms.
 - 120,000 ohms.
 - 240,000 ohms.

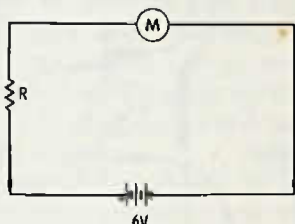

Fig. 9-20. Circuit for Questions 5 and 6.

6. In Fig. 9-20, suppose the meter were reading only half scale. What size would resistor R be?
(Choose answer from those given in question No. 5.)

7. In Fig. 9-21, the ohmmeter is reading

- about 400 ohms.
- about 4000 ohms.
- nearly 5 ohms.
- a little over 500 ohms.

8. A voltmeter that does not load the circuit which it tests, to any great extent is

- a vacuum-tube voltmeter (vtvm).
- a solid-state vom.
- a 1000 ohms-per-volt meter.
- either A or B above.
- A, B, or C above.

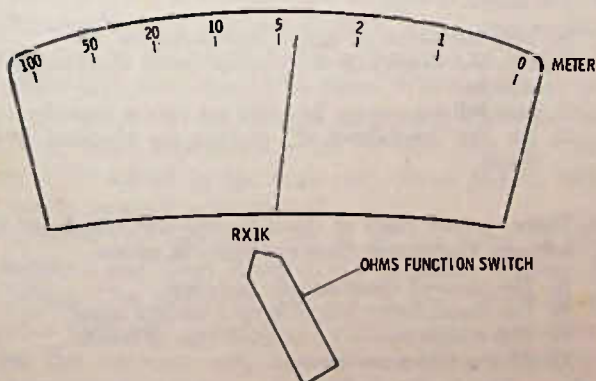

Fig. 9-21. Drawing for Question 7.

9. In Fig. 9-22, looking at the voltage readings, what would you suspect was wrong in the circuit?

- Transistor bias too high.
- Transistor bias too low.
- Transistor shorted collector-to-emitter.
- 6.8K resistor open.

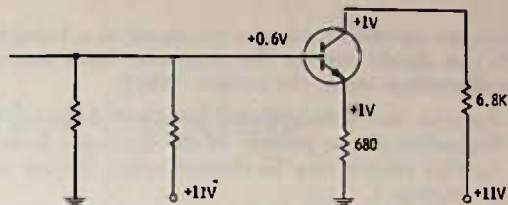

Fig. 9-22. Circuit for Question 9.

10. In Fig. 9-23, the emitter current is

- about 1 mA.
- about 4 mA.
- about 0.5 mA.
- showing a significant difference as compared to the collector current.

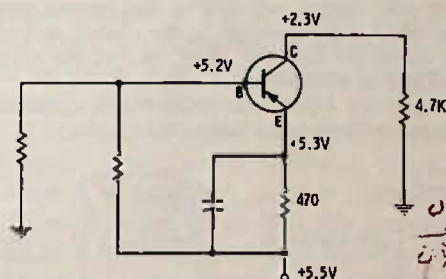

Fig. 9-23. Circuit for Questions 10, 11, 12, and 14.

11. In Fig. 9-23, the amount of bias indicates that

- the transistor is reverse biased.
- the transistor is a germanium type.
- the transistor is a silicon type.
- the transistor should be drawing excessive current.

12. In Fig. 9-23, the voltage drop across the emitter resistor is

- 2 volts approx.
- 0.2 volt approx.
- 5.3 volts approx.
- about 0.2 milliamperes.

13. A "polarity switch" on a vom or other meter

- internally reverses the meter lead connections.
- changes the meter from ac to dc and back again.
- automatically changes the meter ranges, depending upon voltage.
- makes meter into a "zero center" type meter.

14. In Fig. 9-23, which way would be best to measure transistor bias?

- By measuring all voltages to ground and then subtracting the base and emitter voltages.
- By measuring the emitter and collector voltages to ground and then subtracting the two.
- By measuring between base and emitter.
- By measuring between C and B.

15. "Continuity," as measured with an ohmmeter, means the circuit or part has
- high or infinite resistance.
 - a complete path through which current should flow in the desired amount.
 - one ohm resistance or less.
 - no internal shorts.
16. If you are measuring across a resistance in a transistor circuit, you should reverse the ohmmeter leads and take a second reading across the resistor. Why?
- Resistors are polarized and measure different values, depending on the polarity of the ohmmeter leads.
 - Another resistor may be shunted across the one you are measuring.
 - A diode or transistor in the circuit with the resistor may cause the ohmmeter reading to be incorrect.
 - An ohmmeter measures a resistor correctly only when the leads from the ohmmeter are in a certain polarity.

17. If you get an inconclusive reading when measuring a resistor in the circuit, and you have strong suspicions that the resistor is defective, you should
- and must remove the resistor completely from the circuit and check with the ohmmeter.
 - and may remove one end of the resistor only, leaving the other end connected in the circuit, and check with an ohmmeter from the "free" end of the resistor to the end still in the circuit.
 - immediately replace the resistor with a new one.
 - place a milliammeter across the resistor.

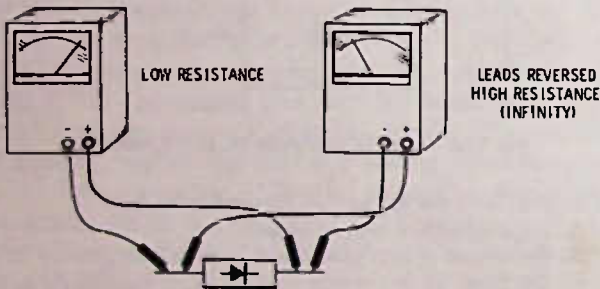

Fig. 9-24. Diagram for Question 19.

18. The + lead on the vom, it can be safe to assume,
- is the positive lead, so far as the ohmmeter circuit is concerned.
 - is the negative lead, so far as the ohmmeter circuit is concerned.
 - might be either the positive or negative lead, depending upon the manufacturer of the meter.
 - is not used at all for the ohmmeter circuit.
19. In Fig. 9-24, the vom is reading the resistance of a normal semiconductor diode. The readings show that
- the vom has the positive side of the ohmmeter circuit going to the + lead of the meter.
 - the vom has the positive side of the ohmmeter going to the negative (-) lead of the meter.
 - there is not enough information to tell about ohmmeter polarity.
 - the diode is defective.

20. In Fig. 9-25, the transistor

- appears to be all right, so far as an ohmmeter test goes.
- appears to be a pnp, rather than an npn as shown schematically.
- has a collector-emitter short.
- cannot have a collector-emitter short, since the base is between the collector and emitter, and there is no short shown between either the collector and base or the emitter and base.

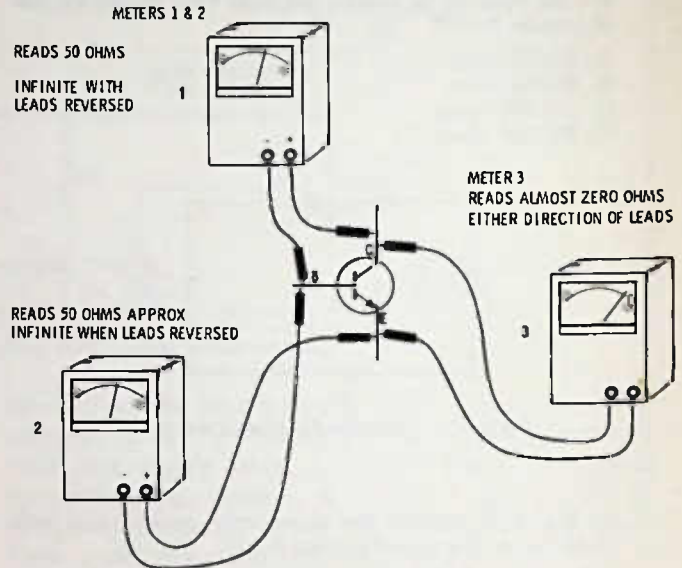

Fig. 9-25. Diagram for Question 20.

21. For final checking of any transistor that appears suspect after an in-circuit ohmmeter test, you may make a completely valid test by
- disconnecting two leads from the circuit.
 - disconnecting one lead from the circuit.
 - disconnecting all three leads from the circuit.
22. A normal service-type signal generator.
- has both rf and af output signals available.
 - has audio only.
 - has radio frequency only.
 - is not tunable.
23. If you inject a signal from a signal generator into a radio, you should
- keep the output no higher than necessary.
 - turn the output up full, except when checking audio circuits.
 - turn full attenuation by using the output controls.
 - use the "modulated rf" position for checking audio stages.
24. There are two types of signal tracers—the tuned and the untuned. Concerning these two types of tracers:
- The untuned tracer usually costs less.
 - The tuned tracer will pick up a weaker signal.
 - The oscilloscope is an untuned type of tracer.
 - All the above are correct.

A-M Radio: Converter Section

In this chapter we want to take a complete typical a-m broadcast radio and, following the schematic, discuss how it works, what can go wrong, and ways to diagnose the troubles that may occur. We will start with the "front end" of the radio and move toward the speaker with the signal.

The entire schematic is shown in Fig. 10-1. Note that the sizes of each capacitor and resistor, as well as a designation number, are on the schematic. For example, the coupling capacitor from the antenna coil to the first transistor is an $.01\text{-}\mu\text{F}$ capacitor labeled C10. This labeling will be used throughout this chapter so that there will be no mistaking which part is being discussed.

FOLLOWING THE SIGNAL

The signal is first picked up by the antenna coil (see Fig. 10-2), which is resonant or "tuned" to the incoming signal frequency. For the sake of explanation, let us say this signal is at 820 kHz. The antenna coil is L1. The pickoff coil, a few turns of wire wound near the larger antenna coil, inductively couples the signal through C10 to the base of mixer-oscillator transistor Q1 (also called a converter). The other side of the small coil goes to ground, or common, as indicated by the ground symbol. As with audio transistors, the converter transistor must be biased. This is done by connecting a 40K resistor, R6, from the -8.8V source to the base and a 7K resistor, R5, to ground. These two resistors make up a "voltage divider" which applies the correct bias to the transistor. The purpose of coupling capacitor C10 now should be clear. Without it, the dc bias voltage would be shorted to ground through the coil, but, since capacitors block dc and pass ac, C10 couples the signal to the base and allows the dc bias voltage to remain undisturbed.

We leave the incoming signal at this point in the explanation and drop down to the oscillator section of this stage. The oscillator coil, L2, is also tuned by a variable capacitor ganged with the variable capacitor across the antenna coil, but the oscillator capacitor has less capacity (fewer or smaller plates) and so the oscillator coil which it tunes is resonated at a higher

frequency. If the radio is properly aligned, the oscillator frequency should always be 455 kHz above the incoming signal. In this case, we have arbitrarily chosen 820 kHz as the incoming signal frequency (it could be any frequency in the broadcast band from 540 to 1600 kHz) so this means the oscillator frequency should be 820 kHz plus 455 kHz, or 1275 kHz.

The oscillator signal is fed to the emitter through C11, a $.01\text{-}\mu\text{F}$ capacitor. The feedback circuit for the oscillator is from the collector-circuit coil, which is a part of the oscillator coil. This feedback keeps the circuit oscillating (generating a signal) by feeding back a portion of the output signal in proper phase to reinforce the input signal of the oscillator tuned circuit. The 2K resistor, R7, in the emitter circuit tends to limit the transistor current so that the transistor does not amplify in a linear manner and therefore becomes a better mixer. (If the circuit were perfectly linear, there would be no mixing and therefore no 455-kHz output signal. Linear circuits are used in audio stages, since, obviously, if we have a 1000-Hz signal and a 4000-Hz signal being amplified at the same time, we do not want a 3000-Hz and a 5000-Hz beat signal also.)

Mixing of the signal frequency coming in on the base and the oscillator frequency fed into the emitter occurs in the collector circuit, since both signals are affecting the transistor signal bias voltages. How can you troubleshoot this stage? You can read the voltages. The voltages listed on schematics are usually measured to ground (common). Common is the + side of the battery in this circuit. The most significant voltages in this particular circuit are the emitter and base voltages. Note that the schematic calls for -1 volt from emitter to ground. Suppose you have zero voltage? Zero voltage would mean there is no transistor current. This could mean that the transistor is bad, or it could mean that the transistor has no dc bias. Measure the base voltage. If it is also zero, then it is likely that the trouble is in the bias-resistor circuit. Probably, R6 is open or the printed circuit to R6 is broken. Make sure, of course, that the set is turned on and the battery is all right. Another possible trouble is that C10 is shorted, which would leak all the dc bias

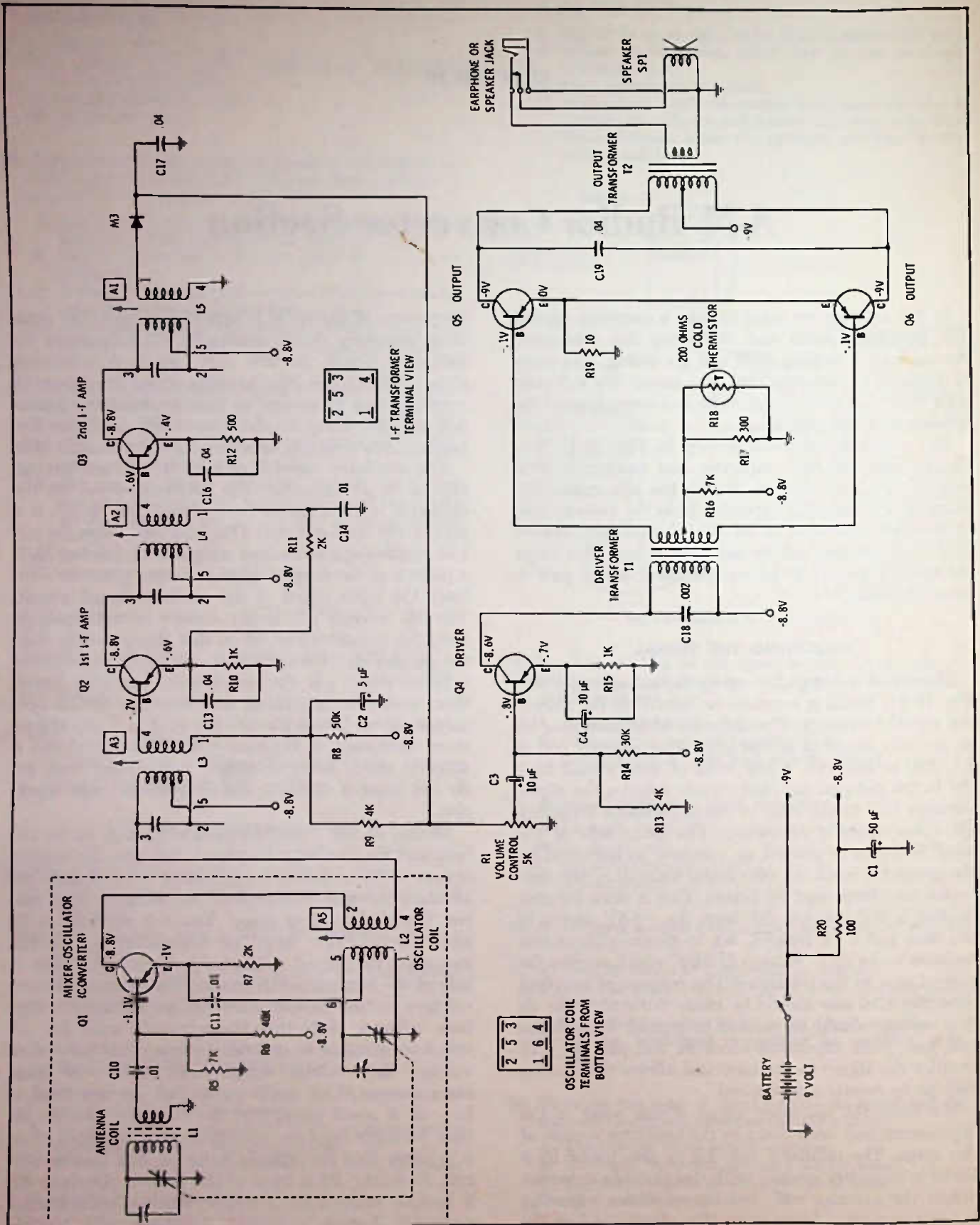

Fig. 10-1. Complete schematic of a typical broadcast radio.

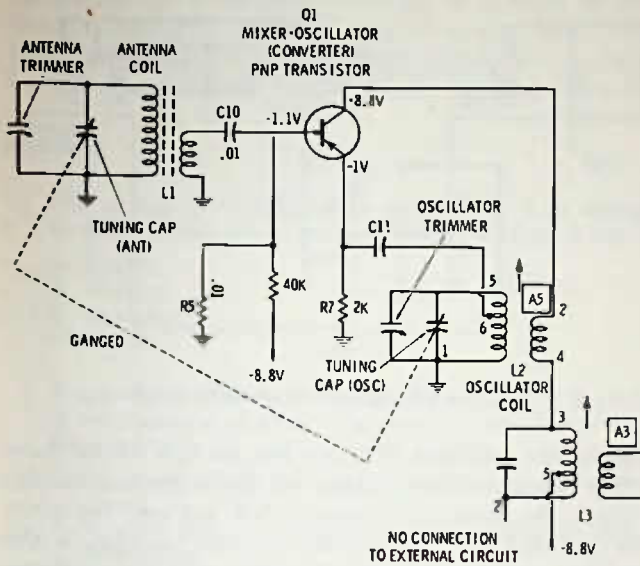

Fig. 10-2. Mixer-oscillator (converter) circuit of a-m broadcast radio.

voltage to ground through the antenna coil. However, a shorted capacitor is a fairly infrequent trouble; so you normally look for the other faults first. If the bias voltage is normal, or appears to be, you should measure the collector voltage to ground. In this case, it should be about -8.8 volts. If the voltage is near zero, then check for an open oscillator coil by checking at terminal 4 of the oscillator coil. If there is -8.8 volts at terminal 4 and not at terminal 2, the oscillator coil is open. If there is not -8.8 volts at terminal 4, move to terminal 5 on the 1st i-f transformer (Fig. 10-1) and see if there is -8.8 volts there. If not, perhaps the battery is bad or the switch not turned on, or there is a printed circuit broken that carries the voltage source to the i-f transformer. Check on other terminals that should have -8.8 volts. Keep following the circuit back toward the battery, or from the battery toward the i-f transformer circuits, until you find where the voltage is lost. A possibility is an open 100-ohm resistor R20 in the -8.8 -volt circuit. If this resistor is burned, you can expect there has been or still is a short on the -8.8 -volt side. This could be the $50\text{-}\mu\text{F}$ capacitor, C1.

But suppose the voltages are apparently about correct (voltages may sometimes vary 20 to 25% without being abnormal; so it is difficult to say exactly what is the "correct" voltage for any particular circuit) yet all you hear in the radio is a hissing or static noise but no station? You can strongly suspect that the oscillator circuit is not working. How can you tell? An easy way is to measure the bias voltage on the transistor, between the base and emitter. Or you can simply measure the base voltage to ground, or the emitter voltage to ground. Then, while turning the tuning capacitor from one end of the dial to the other, you should get a slow variation in reading because the strength of oscillation varies with frequency, and this

shows up in the dc bias voltage readings. Another method is to measure the voltage on the base or emitter and, while taking the measurement, touch a finger to the terminals of the oscillator coil. This will load the coil and cause the bias readings to change. Still another way to see whether the oscillator is working is with another a-m radio that is known to be working normally. Use the normal receiver to check the defective one in the following manner.

1. Tune in a station on the working radio, preferably near the high end of the a-m dial.
2. Holding the defective radio close to the working radio, turn it on and then slowly tune the dial of the defective radio from one end to the other.
3. If you hear a whistle in the working radio at some point on the dial, this indicates that the oscillator in the defective set is working.

The whistle is caused by the beating of the oscillator signal from the set being tested with signals in the working radio. When the two signal frequencies are close together, the beat between them will be an audible whistle that changes to a lower and lower pitch, finally comes to "zero beat," and then starts rising in pitch again. If the oscillator in the defective set is inoperative, obviously there will be no beats and no audible signal. If you have two working radios, try this out to see how well it works.

TRIMMERS

There are two variable capacitors shown in parallel with the main tuning capacitors in this schematic. These are trimmers, which allow for small corrections to "tune" or "align" the radio so that it tracks. Tracking means that when the antenna coil is tuned to 1300 kHz, the oscillator frequency should be at 1755 kHz so that we get 455-kHz output and maximum volume. But suppose the oscillator is at 1755 kHz and the antenna circuit is tuned to 1500 kHz. We still get the 1300-kHz station since the i-f will only accept the 455-kHz difference, but since the antenna circuit is not tuned to 1300 kHz but is peaked at 1500 kHz instead, the signal will be weakened considerably.

The trimmers allow us to make small changes in the capacity of the circuit to correct for minor errors in tracking. To set the trimmers without using a signal generator, you can simply set the dial of the radio to a known station at the high end of the dial. Let us say that you know of a station at 1400 kHz. Set the dial to 1400 kHz. If the station comes in, then the oscillator trimmer is all right. If the station does not come in, leave the dial at 1400 and adjust the oscillator trimmer (which is an integral part of the tuning capacitor mechanism) whichever way is necessary to get the station to come in at the 1400 spot on the dial.

Next, adjust the antenna trimmer until the station is loudest. Now check at the low end of the dial by tuning to a quiet spot (no station) and adjust A5, the slug in the oscillator coil, for maximum noise in the speaker. You may have to hold the radio near a fluorescent light to increase the noise, but the lower the noise is and still provides a good indication, the more accurate the adjustment will be.

Next, tune in a known station at the low end of the dial and see if the dial calibration is close. It should be.* If you turned the oscillator slug very much, you should return to the high end of the dial and again adjust the trimmers as already discussed. Go back and forth between the adjustments at the low and high ends until no other improvement in the sensitivity of the radio is possible.

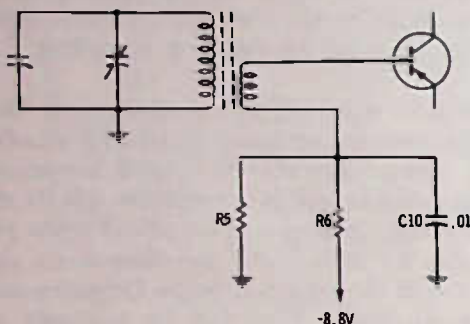

Fig. 10-3. Variation of circuit for coupling station signal into first transistor.

VARIATIONS IN THE CONVERTER CIRCUIT

Depending on the designer and the physical layout he may want, there are variations in circuits that do not affect the performance in any way, but may or may not make the method of testing a circuit change slightly. Fig. 10-3 shows a variation in coupling the signal from the antenna coil circuit. The secondary coil is connected directly to the base on one side instead of through a capacitor. Instead of the other side being directly grounded, it is grounded so far as the ac signal is concerned by capacitor C10, but the dc bias voltage is applied at the bottom of the coil, feeding through the coil to the transistor. Again, the capacitor provides a low-loss signal path but blocks or prevents the dc bias from being shorted out as well.

Fig. 10-4 has several variations in it. Instead of a pnp germanium transistor which uses negative volt-

*The mass-produced dials on radios should not be expected to give an exact readout of the station frequency, especially in less expensive radios; so some compromise is necessary on occasion to obtain the best sensitivity. If it is impossible to get the circuit to track near the right spot at both the high and low ends of the band, then probably someone has been "diddling" with the i-f tuning, and the i-f is tuned to an incorrect point. This takes a signal generator to correct, and the method of doing this is covered in the next chapter.

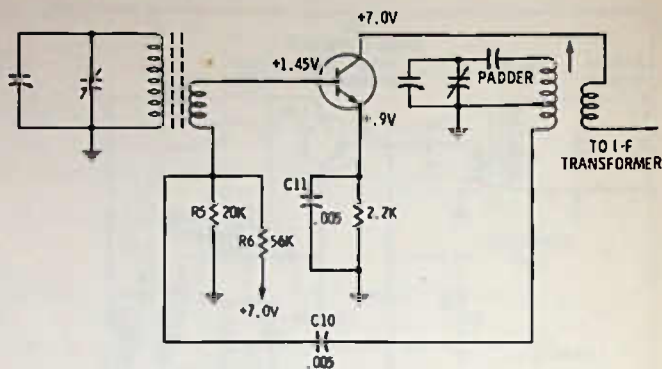

Fig. 10-4. Variation of mixer-oscillator circuit.

age on the collector, this one has an npn silicon transistor using positive voltage on the collector. In this circuit, the oscillator voltage is fed, not into the emitter, but into the base circuit. Another variation is the padder capacitor, which is in series with the oscillator variable tuning capacitor. The padder makes it possible for both the antenna and oscillator variables to be of identical physical size and capacity. The padder, in series with the coil and the capacitor, causes the oscillator frequency to be 455 kHz higher than the signal frequency.

Regardless of variations, the testing procedures for the circuits remain essentially identical. Note that the silicon transistor has more dc bias (about .55 volt, in this case), where germanium transistors use a bias of only about 0.1 volt. In converter circuits, though, do not depend on the exact bias reading too much, since it will vary with tuning, as has already been indicated—in fact, if the bias does not vary with tuning, the oscillator circuit is not working!

There is another variation which, in reality, is not a variation, except in which circuit is made positive or negative. Fig. 10-5 shows exactly the same circuit as Fig. 10-1 and 10-2, except that the emitter circuit is "hot" and the collector circuit is grounded (connected to the common, which in this case is the negative side of the battery). Look at the voltages indicated at the transistor terminals: zero voltage read to

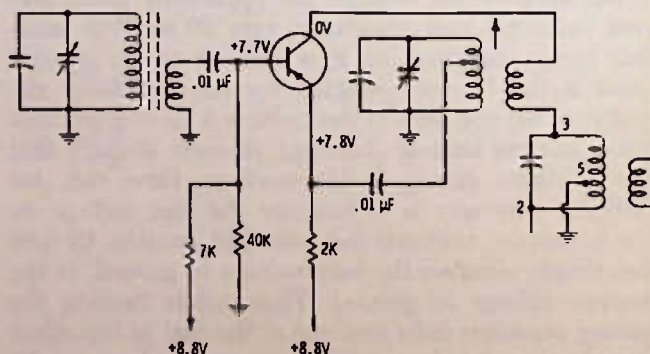

Fig. 10-5. Same as Fig. 10-2, but with reversed battery polarity.

ground at the collector, +7.8 volts to ground at the emitter, and +7.7 volts to ground at the base. But note that if you read the voltages across the transistor in either circuit they are identical. Reading between

collector and emitter in either circuit, there is a negative 7.8 volts. Reading between the base and emitter (bias voltage) there is still a negative 0.1 volt (+7.7 volts is 0.1 volt more negative than +7.8 volts).

TEST QUESTIONS

1. The process of "turning on" a transistor by a dc voltage so that the transistor is ready to amplify a signal is called
 - A. biasing.
 - B. labeling.
 - C. connecting.
 - D. tuning.
2. A capacitor is often used to couple the rf signal to the base of the transistor amplifier. The reason a capacitor is used for coupling is
 - A. so dc voltage can be applied through it along with the signal.
 - B. to allow radio frequency to pass but restrict the audio frequencies.
 - C. to raise the impedance of the incoming signal.
 - D. to couple the rf signal without shorting out the transistor bias.
3. In a superhet radio, if the incoming signal to be received is at 1400 kHz and the i-f is 455 kHz, the frequency of the local oscillator must be
 - A. 1400 kHz.
 - B. 1855 kHz.
 - C. 455 kHz.
 - D. 2310 kHz.
4. A circuit that uses some of the output signal to feed back into the input, creating what might be called a "vicious cycle," is
 - A. an amplifier.
 - B. a power supply.
 - C. an oscillator.
 - D. a linear circuit.
5. One name for a circuit where the incoming received frequency and the local-oscillator signal are beat together is a "mixer." Another name for this circuit, especially if only one transistor is used for both a local oscillator and the rf amplifier, is a (an)
 - A. i-f amplifier.
 - B. audio amplifier.
 - C. converter.
 - D. bias amplifier.
6. In a transistor circuit, if the oscillator is working and you tune the radio while measuring the bias on the converter transistor,
 - A. the bias changes as you tune the radio across the dial.
 - B. the bias should stay almost perfectly the same as you tune.
 - C. the bias should rise sharply whenever you touch the tuning knob.
 - D. the bias should drop to zero at the high end of the dial.
7. Normally, the oscillator and antenna trimmers are a part of the variable capacitor unit and are adjustable with a screwdriver. When aligning a radio, the trimmers should be

- A. adjusted for best results at the low-frequency end of the dial.
 - B. adjusted for best results at the high-frequency end of the dial.
 - C. adjusted for best results near the center of the dial.
 - D. screwed down snug, but not overtightened.
8. To adjust for best tracking at the low-frequency end of the dial,
 - A. set the dial to a quiet spot near the low end of the dial, but not on a station; tune the oscillator coil slug for maximum noise.
 - B. set the dial to a quiet spot near the low-frequency end of the dial, and adjust the antenna trimmer for maximum noise.
 - C. set the dial at the low-frequency end on a moderately strong station; adjust the oscillator-coil slug for maximum output of the station.
 - D. make sure that tracking is all right at the high-frequency end of the dial.
9. In Fig. 10-6, the trimmer capacitors are
 - A. C3 and C5.
 - B. C1 and C2.
 - C. C4 and C6.
 - D. C6 and C7.
10. In Fig. 10-6, the main purpose of C1 is to
 - A. block dc voltage.
 - B. couple signal to base of transistor.
 - C. supply dc bias to base.
 - D. "track" the radio dial.
11. In Fig. 10-6, the transistor shown here is
 - A. a pnp.
 - B. npn.

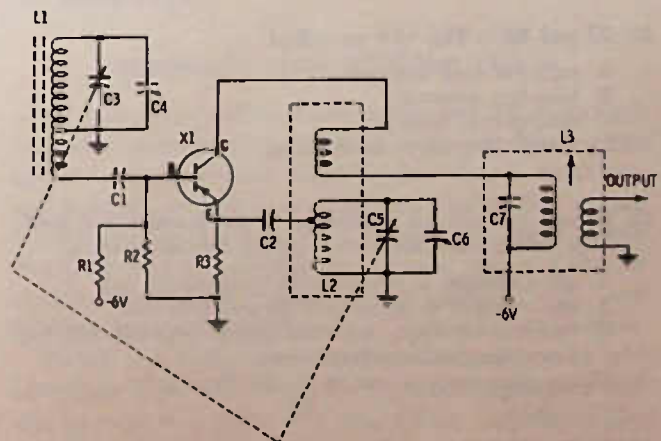

Fig. 10-6. Circuit for Questions 9 through 16.

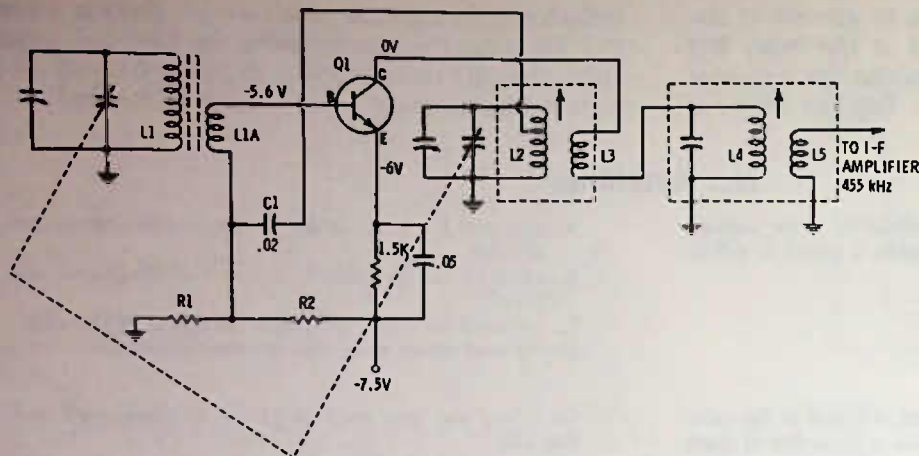

Fig. 10-7. Circuit for Questions 18 through 24.

12. In Fig. 10-6, the output of L3 goes directly to
- the detector.
 - the audio amplifier.
 - the i-f amplifier.
 - the mixer or converter.
13. In the circuit of Fig. 10-6, the oscillator feedback signal
- goes to the base circuit of the transistor.
 - goes to the antenna circuit of the transistor amplifier.
 - goes to the emitter circuit of the transistor.
 - is fed to the i-f through C7.
14. In Fig. 10-6, which is a partial circuit of a broadcast a-m radio, the tuned circuit that will be tuned highest in frequency is
- L1-C3,C4.
 - L2-C5,C6.
 - L3-C7.
 - R1-R2.
15. Looking at the circuit in Fig. 10-6, about how much voltage should be on the collector of the transistor?
- 5 volts.
 - Zero volts.
 - 6 volts. *-6 volts*
 - Difficult to tell.
16. R1 and R2 in Fig. 10-6 are called
- collector load resistors.
 - base-bias resistors.
 - emitter-bias resistors.
 - a high-frequency tuned circuit.
17. If both the variable capacitors in the antenna and oscillator circuits have identical capacity, it is necessary to
- use a trimmer in parallel with the oscillator coil.
 - use a padder in series with the oscillator coil.
 - turn the oscillator coil slug farther into the coil (to lower the oscillator frequency).
 - use more turns of wire on the oscillator coil.
18. In Fig. 10-7, if the collector voltage reads about -7 volts to ground you would suspect that
- either L4 or L3 is open circuited (wire broken).
 - transistor Q1 is shorted.
 - R1 is open, so transistor has no bias, or C1 could be shorted.
 - the transistor itself is open between collector and base or collector and emitter.
19. In Fig. 10-7, judging from what you know about transistors, the one used is
- a pnp silicon.
 - an npn silicon.
 - a pnp germanium.
 - an npn germanium.
20. In Fig. 10-7, the bias voltage on Q1 is
- 5.6 volts.
 - 6 volts.
 - zero volts.
 - +0.4 volt.
21. In Fig. 10-7, assuming the voltages shown are correct, the collector current of Q1 is approximately
- zero.
 - 1 mA.
 - 2 mA.
 - 1.5 mA.
22. In Fig. 10-7, the tuning capacitor across L1 normally
- will have more maximum capacity than the tuning capacitor across L2.
 - will have less maximum capacity than the tuning capacitor across L2.
 - should have the same maximum capacity as the tuning capacitor across L2.
 - is used to make that circuit resonant to 455 kHz.
23. In Fig. 10-7, the oscillator feedback is fed from the collector circuit to
- ground.
 - the emitter circuit of Q1.
 - the base circuit of Q1.
 - 7.5 volts.
24. In Fig 10-7, if L3 should open so that no current could flow in the collector circuit, the voltage from the emitter of Q1 to ground should be about
- zero.
 - 5.6 volts.
 - 6 volts.
 - 7.5 volts.

A-M Radio: The I-F Amplifier

The intermediate-frequency amplifier is "where it's at" in the superheterodyne type radio. The i-f amplifier selects the signal, allowing only a narrow band of frequencies to pass, and amplifies these signals so they can be fed to the detector. It is in the i-f amplifier where most, if not all, of the automatic gain control (agc) occurs. The agc circuits tend to increase the level of weaker signals while decreasing the level of stronger signals and in this manner maintain nearly the same volume level, even if the signals fade in and out, etc. This will be discussed again later in this chapter.

I-F AMPLIFIER OPERATION

The i-f amplifier shown in Fig. 11-1 uses a frequency of 455 kHz. The transistors used are germanium pnp types. Pnp transistors require that the collector voltage be negative with respect to the emitter and also require that the base bias be slightly negative with respect to the emitter. The base bias will range from about 0.1 to 0.2 volt, depending on the circuit and the particular transistor. All except sealed i-f amplifiers have tuning adjustments for originally setting up the circuit. Normally these adjustments will not change drastically without the help of someone with a screwdriver. In other words, once an i-f amplifier is tuned, it does not normally get out of tune by more than a very slight amount, unless the screws are turned. There are exceptions to this, of course, but not many.

This particular amplifier, as with other Japanese types, has only one tuned circuit for each i-f transformer. The adjustment is made with a screwdriver, and, because of the "shielded" design of the slug, a metal screwdriver may be used, but be sure that it fits the slot, or you may "chew" out the slot so it cannot be used. Plastic alignment tools are available and should be used when possible. But before we talk further about tuning, let us take an overall look at the i-f amplifier circuit.

Coming from the convertor (mixer-oscillator), the signal is fed through the 1st i-f transformer to the base of the 1st i-f amplifier. Again, as has already been explained, a step-down action is used, which lowers

the signal voltage but increases the current. The 1st i-f transistor is biased by a negative voltage taken through a 50K resistor, R8. The other part of the bias voltage divider is a 4K resistor, R9. R9 does not go back to ground but goes to the audio and agc source voltage line. The reason for using this connection is covered in this section when agc is discussed in detail.

An emitter resistor in this circuit (R10) provides protective bias for the transistor, since, as explained earlier, an emitter resistor tends to reduce the base bias if the total transistor current tends to increase. R10 is bypassed by a .04- μ F capacitor, C13, to prevent the increase and decrease in signal voltage from affecting the dc bias of the transistor.

The output of the 1st i-f amplifier is fed through the 2nd i-f transformer to the 2nd i-f amplifier. The base bias for this transistor is obtained through 2K resistor R11 connected to the emitter of the 1st i-f transistor. The reason for this will become clear a little later, when the agc circuit is discussed.

The output of the 2nd i-f amplifier is fed through i-f transformer L5 to the diode detector, X3.

The diode rectifies the signal, allowing, in this case, only the positive portions of the signal to pass. This signal is fed from the cathode of the diode detector to the volume control. The .04- μ F capacitor, C14, removes the rf (i-f) while having very little effect on the audio signal.

AUTOMATIC GAIN CONTROL (AGC)

All high-gain radios need some sort of automatic control to prevent strong signals from overloading the circuit and yet permit higher gain when a weak signal is being received. In transistor radios this circuit is called automatic gain control (agc) by most circuit designers and manufacturers. In tube radios a similar circuit is called automatic volume control (avc), and in some instances that term is used in transistor radios.

To get automatic control action, we need some sort of voltage that varies with the signal strength and that can be used to regulate the gain of the amplifiers. The output of the diode detector produces such a voltage. If you take a dc voltmeter and measure at the detector

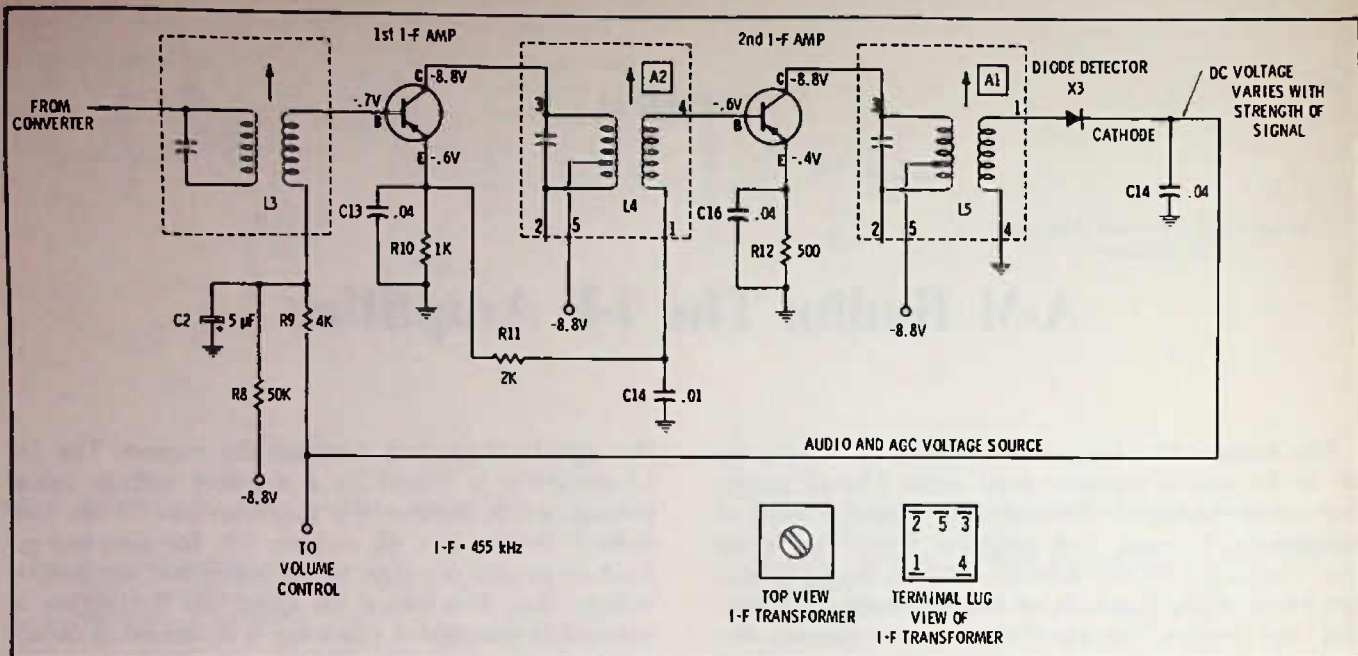

Fig. 11-1. Schematic of i-f amplifier for broadcast radio.

output, you will find that that voltage will change to a higher value when a station is tuned in and to a lower value when no station or a weak station is tuned in.

When the cathode of a diode is toward the output line, the dc voltage will be positive. Fig. 11-2 shows how reversing the diode in the circuit reverses the dc polarity in the output circuit.

You might think that since there is audio on this line the meter needle would move up and down with changes in audio. This does happen to a small extent if the meter responds quickly enough, and it is because of this audio that additional processing must be done before using the agc voltage. Obviously, we do not want the gain of the i-f amplifiers to vary in step with the audio, since everytime a louder note oc-

curred it would be "compressed" by having the gain of the amplifier reduced.

This is why the agc voltage is fed through another resistor and why, following that resistor, a rather large bypass (C2 in Fig. 11-1) is used. C2 is called the agc bypass capacitor, and, along with R9, it forms what is called an "RC filter," which takes out all the audio signals and leaves only the dc voltage.

Now, suppose that we tune in a strong station, what happens? The positive voltage output of the detector diode increases. This applies more positive voltage through the 4K resistor to the base of the 1st i-f amplifier. These are pnp transistors, which require a negative bias on the base, and a more negative bias makes the transistor draw more current; a less negative bias makes the transistor draw less current. A positive voltage is a "less negative" voltage; so if the positive voltage is applied to the base of the 1st i-f amp, the transistor current is reduced, and thereby the gain is lowered.

Next, suppose that we tune in a weaker station. Now the detector-diode output voltage is lower (less positive) and there is less positive (more negative) voltage applied to the 1st i-f. What happens? The transistor current goes up and the i-f amplifier gain increases.

Another interesting thing happens in this circuit. The bias for the 2nd i-f amplifier is supplied by the emitter voltage of the 1st i-f. When the agc voltage causes more current flow in the 1st i-f transistor, what happens to its emitter voltage? It goes up (more negative). This increased negative voltage is fed to the 2nd i-f amplifier and, since it, too, is a pnp transistor, a more negative voltage on its base increases its current also. If the current through the 1st i-f drops, then

YOU CAN REMEMBER THAT THE POSITIVE OUTPUT IS ON THE "LINE" SIDE OF THE DIODE BY REMEMBERING THAT A SINGLE LINE DRAWN AS SHOWN WILL MAKE A+ SYMBOL.

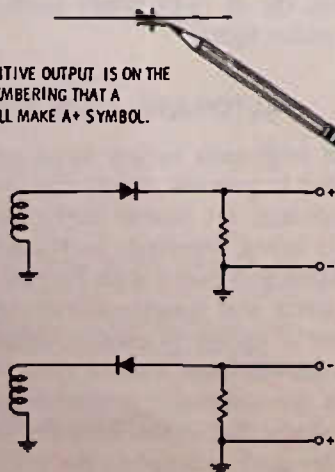

Fig. 11-2. Reversing a diode in the circuit reverses the polarity of the dc output voltage.

the current through the 2nd i-f drops also. This is the method used here, and in a number of circuits by different manufacturers, to provide age action to two transistors by applying the actual age voltage only to the 1st amplifier.

To make sure there is no interaction between the two amplifiers through the bias circuit, which might cause instability, an additional smoothing filter (usually called a decoupling circuit) is added between the emitter and the next base (R11-C14).

TESTING THE I-F AMPLIFIERS

If trouble is suspected in the i-f amplifiers, a good first check is the emitter voltage. This voltage indicates the amount of current flow in the transistor. The 1st i-f has -0.6 volt at the emitter, and the emitter resistor is $1K$; so the current (calculated by Ohm's law) is 0.6 mA. (Note that whatever the voltage is across a $1K$ resistor it will be the same as the number of milliamperes flowing through the resistor.) Suppose this voltage is zero or very close to it. What then? This means the transistor is not drawing current. It could be that the transistor is open, but it could also be that there is no bias voltage to the base to "turn on" the transistor. Check the base voltage. If it is zero or very near it, then likely the $50K$ resistor, R8, is open, or the $5\text{-}\mu F$ age bypass capacitor, C2 might be shorted. CAUTION: Always make sure that you have supply voltage before making checks of bias and current flow. If the battery is dead, the switch not turned on, or, for some other reason, there is no collector voltage available at the collector, then you will have no current flow.

But what if the emitter voltage is high, say, 1.5 volts. What might be the trouble? Probably, too much negative bias. This could be caused by the $4K$ resistor, R9, being open, or it could mean that the transistor has excessive leakage between the collector and base.

What is the emitter voltage reads very high—say, above 5 volts? The problem is almost sure to be just one thing: the transistor is shorted or very leaky from collector to emitter.

The 2nd i-f bias is controlled by the emitter voltage on the 1st i-f stage in this circuit; so any fault in the 1st i-f will cause an apparent fault in the 2nd i-f. If the 1st i-f checks out all right, measure the emitter voltage of the 2nd i-f transistor. The voltage indicated on the schematic is 0.4 volt. The emitter resistor is 500 ohms ($\frac{1}{2}K$); so the current through this transistor is 0.8 mA. If the transistor current is considerably different from this, you should check the bias, etc., as for the first stage. Remember that in both the 1st and 2nd stage if you get a change in transistor current when you tune across the radio dial, chances are that the i-f amplifiers are working, since if they were not amplifying there could be very little, or no voltage

change at the detector, and with no change in voltage at the detector diode, there should be no change in the transistor current as you tune across the dial. The possible exception to this would be that if you were near enough to a local station the signal would be strong enough to overload the transistors. (May we point out here that it is the exceptions that make electronics servicing not only intriguing at times, but also mad-deningly frustrating at other times.)

The problem of measuring the emitter voltage of transistors is not always quite so easy as just measuring the emitter voltage to ground. Take, for example, the circuit in Fig. 11-3. This circuit is identical to the previous ones except that the designer has elected to make the negative side of the battery supply at ground or common. Since the pnp transistor requires a negative voltage on the collector (with respect to the emitter) it means that the collector circuit is grounded and the emitter circuits are tied to the +, which in this case is the "hot" side. If you measure the emitter voltage to ground, you no longer are measuring the emitter current through a $1K$ resistor. Instead, you are measuring the emitter voltage *subtracted* from the + supply voltage.

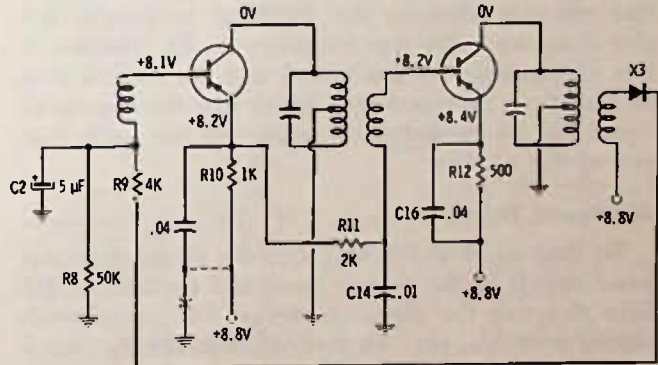

Fig. 11-3. Same circuit as Fig. 11-1, but with reversed supply polarity.

The emitter voltage is $+8.2$ and the voltage on the other side of the emitter resistor is $+8.8$ volts; so the voltage drop across the $1K$ emitter resistor is 0.6 volt, just as it was in the other circuit. You can best measure the emitter current by measuring across the emitter resistor, or you can find the $+8.8$ -volt line and connect the + lead of your meter to this point. Now measure the emitter voltage and base bias voltage just as you did in the other circuit where the + lead of the meter was connected to ground or common. Note that the $+8.8$ -volt line is also a "common," but to differentiate between the two, we call the line opposite the ground or common line the "bus." So, for the circuit of Fig. 11-3, measure the emitter and bias voltages from the $+8.8$ -volt bus rather than from ground. It is easier to make a correct interpretation and it saves calculations by subtractions.

TUNING OR ALIGNMENT

In a previous chapter on i-f amplifiers, we explained how you can set up the i-f amplifier transformer adjustments "by ear." The "ear" method is fine for a touch up, that is, to "tweak" the last little bit of sensitivity out of an i-f circuit for maximum volume, especially on weaker stations. But, if the i-f transformer adjustments have been turned a round or so, it is difficult to get them back to their correct frequency without using a signal generator. True, if the oscillator trimmer or the coil in the oscillator slug has not been tampered with, you can simply tune the i-f transformers for maximum noise (from a nearby fluorescent light) and probably have a passable if not excellent alignment. Unfortunately, when someone "diddles" the i-f transformer adjustments, he usually is not content with those alone but tries all the others as well.

The Signal Generator

A signal generator is simply an oscillator much like the local oscillator used in a receiver, except that it is so designed that the output level can be adjusted, and it also provides enough signal so that it can be fed by way of a coaxial cable to a set. It has a dial that not only changes the oscillator frequency, but also indicates what the frequency is. In addition to this, the oscillator is modulated with an audible tone so that it can be heard and also so that the amount of signal can be measured by measuring the audio output of the receiver.

Alignment Procedure

To align an i-f at 455 kHz, turn the signal-generator band switch to the proper band and the dial to 455 kHz. Because the signal generator has considerable output available, you can generally connect the signal-generator leads right across the antenna coil or between a "hot" connection to the tuning capacitor and ground. Turn up the signal generator output until you hear a tone in the speaker. Even with the i-f amplifiers considerably out of tune, you can usually hear a tiny bit of signal. Even if you do not hear a signal, you should be able to hear one by adjusting just one transformer. When that i-f transformer is tuned to 455 kHz, enough signal should get through the other i-f transformers, even though they may be a long way out of tune, so that the signal may be heard. If not, then check the connections to the signal-generator output cable, make sure it is connected to a "hot" terminal on the tuning capacitor, etc.

Once you hear the signal, adjust each of the transformer slugs for maximum signal, but be sure you keep turning down the attenuators on the signal generator to keep the signal weak; otherwise, the agc will take over and try to prevent a change. Thus, you will not get a good, sharp tuning indication. If you are using your ears to judge the signal strength (not the

best method by any means) keep the signal so low that you have to hold your ear close to the speaker, even with the receiver volume control up full. The reason for this is that the ear is much more sensitive to change in volume level at low volume levels.

Using Output Meters

There are meter methods of output indication that are more accurate than the "ear" method, and these should be used whenever possible, but, still, the signal should be kept low so that the agc action will be minimum during the alignment.

One of the simplest methods to connect a meter is on the end of an earphone jack, with about 2 or 3 feet of connecting cord between the jack and the meter. Fig. 11-4 shows representative circuits. In Fig. 11-4A an output transformer is used in reverse, so to speak, to provide a step-up in impedance to match the meter, which in this case has a maximum reading of 1 milli-ampere and an impedance of about 1000 ohms.

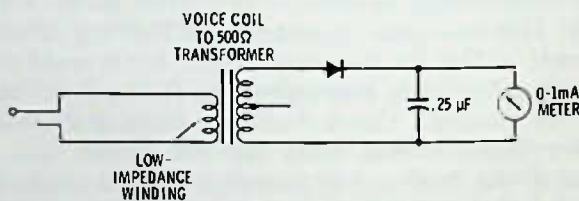

(A) Step-up transformer with low-sensitivity meter.

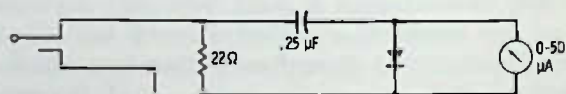

(B) High-sensitivity meter.



(C) Voltage-doubler output.

Fig. 11-4. Examples of output-meter circuits.

Almost any output transformer used in portable transistor radios is suitable for this circuit. The diode can be almost any small detector diode. The capacitor across the meter is not always needed, and its size is not critical.

The circuit at Fig. 11-4B does not use a transformer, but does use a more sensitive meter. This meter reads full scale with only 50 microamperes (a microampere is a millionth of an ampere). A 22-ohm resistor takes the place of the speaker load, and a capacitor isolates the radio circuit from the meter, because in some radio circuits there is a dc current through the speaker circuit. This could damage the meter, or at least make it read off-scale so that an output reading would be impossible.

The circuit of Fig. 11-4C is virtually the same as at Fig. 11-4B, except that a less sensitive meter is used. The two diodes make it a "voltage doubler" circuit. The actual values in these circuits are not terribly critical; for example, the 22-ohm resistor can be anywhere from 10 to 33 ohms in most cases. The 0.1- μ F capacitors can be 0.25, or even 10 μ F, etc.

To use the output meter for alignment, first turn the volume control on the radio all the way down, then plug in the meter into the earphone or external speaker jack. Next, turn the volume control on the radio up to full volume. The meter should not indicate unless you are receiving a station or have the signal generator turned on, or unless there is considerable noise being picked up by the radio.

Turn on the signal generator after first turning the attenuators all the way down. Turn up the attenuators until the meter starts to indicate about $\frac{1}{8}$ of full scale on the dial. (Pull out the meter and listen to the speaker to make sure you are reading the correct signal, then plug the meter back in.) Start adjusting the i-f transformers so that the meter reads maximum. If the meter goes off-scale, reduce the output from the signal generator by turning down its attenuators (NOT by turning down the volume control of the radio.) Keep adjusting after this manner until you have coaxed the last bit of output from the circuit.

Remove the output meter, and check out the antenna and oscillator circuit tuning as previously described, by using noise signals and a known station at the high end of the dial.

Phantom Connection of Signal Generator

If the i-f circuit is not terribly out of tune, and you want to perform a touchup using the signal generator, you can often couple enough signal into the set for alignment, without even making a direct connection between the signal generator and the radio.

Simply clip the two output leads from the signal generator together, and hang them around or near the antenna-coil core. If you can hear the signal, you are in business, and if you can hear the signal your output meter should also be able to detect it.

Alternate Output Meter

Most transistor radios, especially portables, have class-B audio-output stages. These stages draw maximum current with maximum audio input signal. If, for your radio testing, you use a power supply that has a milliammeter in the output to read current flow, you can use this milliammeter as an output meter, since, as the signal increases during alignment, the milliammeter will show an increase in current drawn by the radio because of the class-B audio stages.

Another Alternate Output Meter

You can use a vtvm or a vom or transistor-operated meter directly across the volume control in many ra-

dio circuits and read the change in detector output voltage as the alignment proceeds. However, you cannot always depend on this method, since some radios have a separate agc diode or a detector load resistor that is not also the volume control. Be sure to check the schematic.

VARIATIONS IN I-F CIRCUITS

It would be practically impossible, in all probability, to illustrate each of the small variations in i-f circuits that have occurred over the years with various manufacturers, but some of the major differences should be pointed out and discussed.

Not all radios use the emitter 1st to base 2nd for applying agc to both i-f stages. In fact, a good many radios use agc only on the 1st i-f stage and use fixed bias on the 2nd stage in much the same manner as the converter stage is biased (see Fig. 11-5A). Another manufacturer saved a couple of resistors and a capacitor by using the emitter bias of the 1st audio amplifier to fix-bias the 2nd i-f amplifier transistor (Fig. 11-5B). Sometimes you will find diodes in the signal path with-

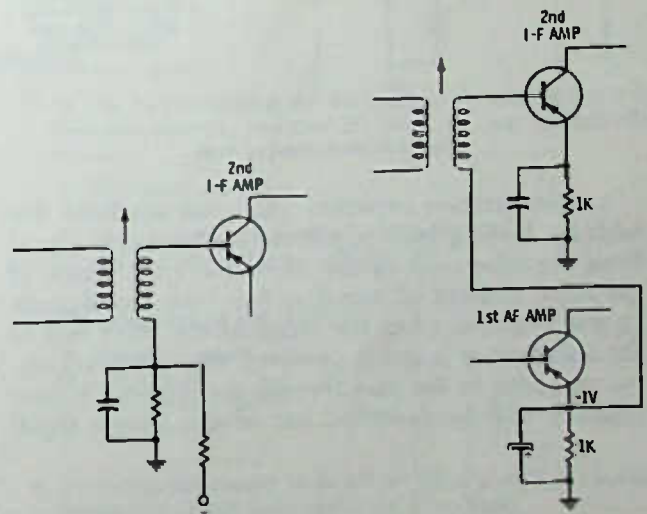

(A) Fixed bias. (B) Bias from emitter of 1st i-f.
Fig. 11-5. Biasing arrangements for 2nd i-f amplifier.

out immediately seeing their reason for being. These are usually connected in such a way that if an extremely strong signal is received (one so strong that the normal agc circuit cannot turn the gain down enough) these diodes will conduct and short out part of the signal or drastically detune a circuit so that the gain of the stage is reduced sharply. A shorted diode could cause a problem such as weak output. To check, tune in a station (one not too strong) and temporarily disconnect the diode. If the volume increases a great deal and the radio starts getting many more stations, either the diode is defective (check with an ohmmeter) or its biasing circuit has been fouled up. If the

radio is not to be used near a strong local station, you can leave the diode out.

Neutralization

One variation that is used quite extensively, especially in older transistor radios, is neutralization. It is still used in fm radios quite frequently, but that is discussed under FM I-F Amplifiers in another chapter. Fig. 11-6 is a neutralized a-m i-f amplifier stage. In the inset of Fig. 11-6, note that the output signal (at the collector) could get back to the input (at the base) through the inherent capacity between the collector and base connections inside the transistor. This feedback, if strong enough, could even cause the 455-kHz stage to oscillate and put out a signal of its own, something that will cause whistles or, at best, hiss and noise that are objectionable.

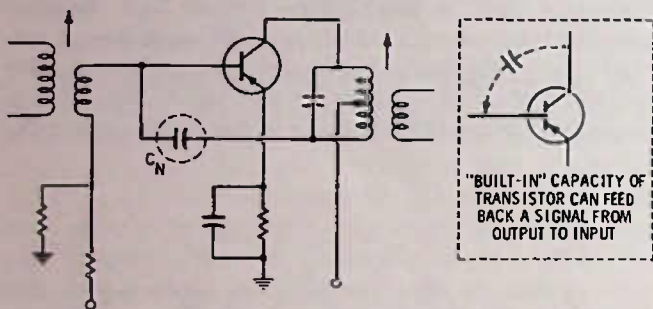

Fig. 11-6. Neutralized i-f stage.

A neutralization capacitor (C_n) can eliminate this fault by feeding back a portion of the output signal from the other end of the i-f output transformer. If the same amount of signal is fed back out-of-phase (going negative when the signal at the other end of the transformer is going positive) then whatever signal gets back to the base through the collector-to-base capacity will be cancelled out of the inverse signal

supplied by the neutralizing capacitor. If an i-f stage will not tune to a peak without starting to produce a whistle in the audio circuit, then it could be that the neutralization capacitor is defective or missing. With newer transistors, a-m i-f amplifiers seldom, if ever, need neutralization, since the collector-to-base capacity is so very small as to be negligible.

Dual-Tuned I-F Transformers

Fig. 11-7 is an i-f circuit that uses dual-tuned i-f transformers. This means there are two tuning slugs in each transformer, which improve the selectivity of the circuit and the sensitivity as well, if the transformer is carefully designed. Npn transistors are used, which means that a positive voltage is required on the collector (with respect to the emitter) and a positive base bias is required. In the case of silicon transistors such as these are, the bias voltage will be around 0.6 volt.

Other Features

Another major difference in the circuit of Fig. 11-7 is the agc circuit. Instead of using the detector diode as the source of agc voltage, some of the i-f signal is picked off through the 10-pF capacitor and fed to two diodes. Diode X1 is returned to the +11.5-volt source, and, since the two diodes are connected to pass a positive voltage, the +11.5 volts biases the 1st i-f amplifier through resistor R1. But added to this bias will be the rectified i-f signal provided by the voltage-doubler diodes (X1 and X2) so that the positive voltage increases with an increase in signal. This is exactly backward to most agc radio circuits, which reduce the bias on the i-f amplifier when the signal increases. But the gain of a transistor amplifier can be decreased by increasing the bias above the normal amount. When the bias is high enough, any increase in signal cannot cause any increase in collector current; so there is no increase in signal level. In addition, the 1K resistor,

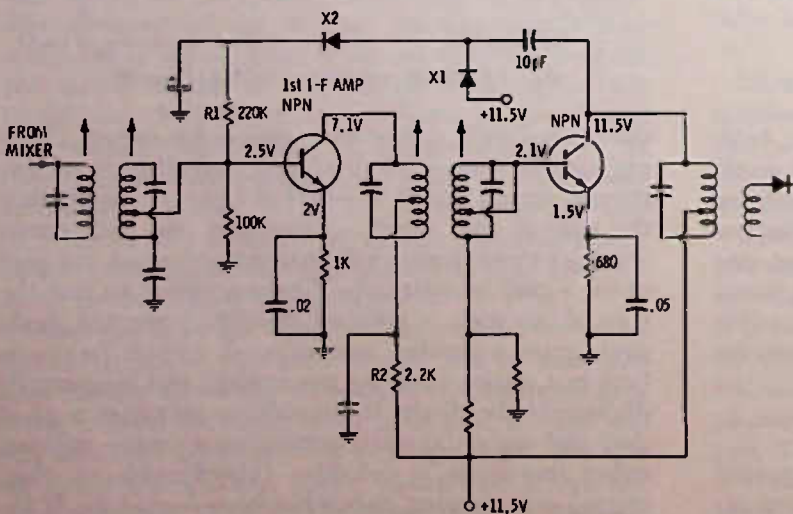

Fig. 11-7. I-f amplifier using forward agc.

R2, in the collector circuit will have more current through it and, therefore, more voltage drop across it. As a result, there will be less voltage on the collector circuit, which in turn reduces the "saturation" point for the bias. Hence, there is a "quicker" reduction in gain. This type of agc, which causes an increase in transistor current in order to reduce the gain, is called "forward" agc. Not too many radios use this type of

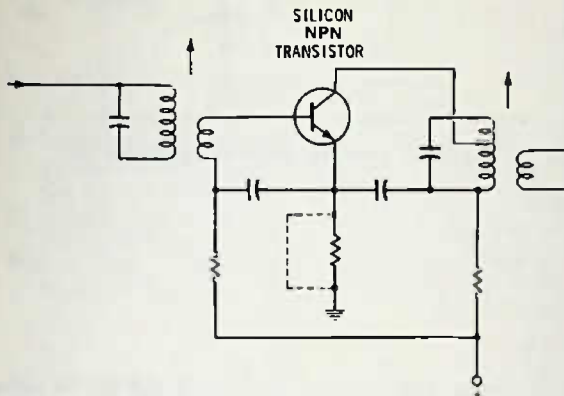

Fig. 11-8. Silicon transistor circuit showing some variations that may not be possible with germanium transistors.

agc, although it is quite common to find it in agc circuits used in transistor tv.

Some other innovations are shown in Fig. 11-8. Note that the bypass capacitors in the input and output circuits return to the emitter, and, since this return is direct, there is no need for an emitter bypass capacitor. Because a silicon transistor is used, which is much less sensitive to leakage, there is not so much need for a voltage-divider circuit in the base circuit. In fact, it is often not used when silicon transistors are used. Just one resistor is used from the B+ line, and it is selected to provide the right amount of bias. Because the silicon does not have this tendency toward "thermal runaway,"* the emitter resistor may be omitted altogether in some circuits.

*Thermal runaway is the condition of a transistor starting to draw more current as it warms up, which in turn heats the transistor more, making the transistor draw more current, and so on and on until the transistor actually burns itself up. The emitter resistor prevents this by providing an increase in reverse bias with an increase in current. Silicon transistors, though, are relatively insensitive to change in current with heat and because of low forward resistance create much less internal heat with current flow.

TEST QUESTIONS

- The letters "i-f" stand for
 - inferior frequency.
 - intentional frequency.
 - instant frequency.
 - intermediate frequency.
- The letters "agc" stand for
 - automatic gate compensation.
 - automatic gain control.
 - average gain compensation.
 - average gate control.
- If the i-f transformer adjustments are sealed and do not appear to have been tampered with, your best bet is to
 - leave them alone.
 - dig out the seal and adjust each time the radio is serviced.
 - not remove the seal since this is sure to detune the radio.
 - forget about trying to service the i-f amplifier.
- The "untuned" winding of a single-tuned i-f amplifier is
 - a step-up winding to provide additional current to the base of the i-f amplifier transistor.
 - a step-down winding to step up the current to the base of the i-f amplifier transistor.
 - used only for applying bias to the i-f amplifier transistor.
 - a high-impedance winding.
- In a transistor circuit where the input is to the base and the output is from the collector (common-emitter circuit), you expect
 - the base to have a higher impedance than the collector.
 - the reverse of A is true.
- In Fig. 11-9, assuming the transistor is drawing 1.5 mA of collector current, resistors R3 and R4 are respectively about
 - 330 ohms and 1K.
 - 1K and 330 ohms.
 - 330 ohms and impossible to calculate R4.
 - 1K and impossible to calculate R4.
- The transistor in Fig. 11-9 is
 - pnp germanium.
 - pnp silicon.
 - nnp germanium.
 - nnp silicon.
- To reduce the current in transistor Q1, the voltage applied by the agc circuit must make the base more
 - positive.
 - negative.
 - more positive.
 - more negative.

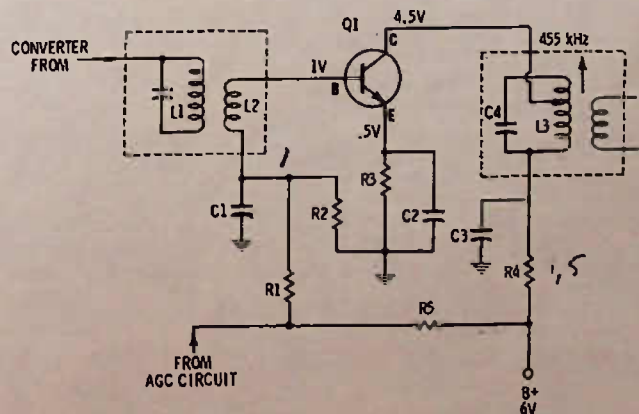

Fig. 11-9. I-f amplifier circuit for Questions 6 through 10.

- A. positive.
B. negative.
9. If C4 opens, in Fig. 11-9, the symptom would be
A. high output from the radio.
B. little difference in the performance of the radio.
C. very low output from the radio, even on a strong station.
D. loss of dc voltage on the collector of Q1.
10. If R1 opens, in Fig. 11-9, the voltage on the emitter of Q1
A. would drop to zero.
B. would rise to 4.5 volts.
C. would rise to 6 volts.
D. would rise to about 1 volt.
(all voltages with respect to ground or common)
11. In Fig. 11-10, if the signal strength to the i-f amplifier increases, the agc voltage will increase in a
A. positive polarity direction.
B. negative polarity direction.

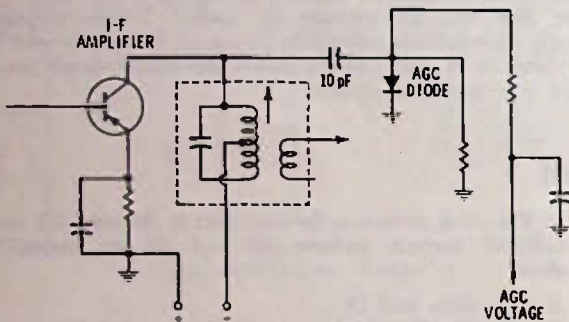

Fig. 11-10. Circuit for Question 11.

12. When you have troubles in an i-f amplifier, one of the best first checks you can make is to see if the transistor is drawing current. This can be done easiest by
A. disconnecting the wire or printed circuit going to either the emitter or collector and connecting a milliammeter across the broken connection.
B. checking the bias voltage from base to ground.
C. checking the voltage drop across the emitter resistor.
D. feeling the transistor to see if it is warm.
13. In Fig. 11-11, the easiest way to check if the transistor is drawing current would be by
A. measuring the emitter voltage.
B. measuring the base voltage.
C. comparing the collector voltage to the B+ voltage.
D. disconnecting the emitter and placing a milliammeter between the emitter and ground.
14. In Fig. 11-11, when the signal strength increases, the voltage across the volume control, and, consequently, the agc voltage will go more
A. positive.
B. negative.
15. In Fig. 11-11, the current through the collector circuit of the transistor is about

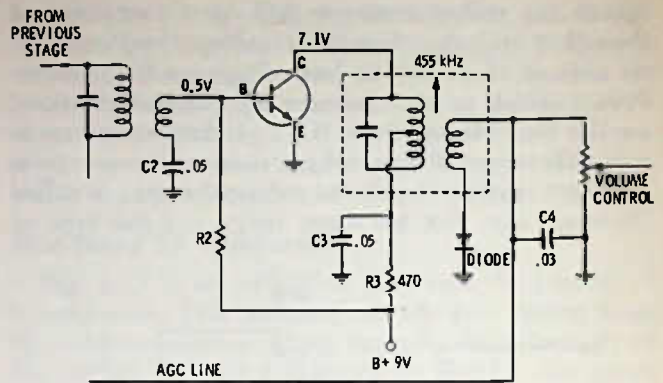

Fig. 11-11. Circuit for Questions 13 through 16.

- A. 4 mA.
B. 1 mA.
C. 2 mA.
D. 14.3 mA.
16. The circuit shown in Fig. 11-11 could logically be called
A. an agc-controlled i-f amplifier.
B. first i-f amplifier stage.
C. last i-f and detector stages.
D. detector and 1st audio amplifier.
17. If the emitter circuit is "hot" so far as the dc voltage is concerned, it is usually best to measure bias for a transistor
A. from base to ground.
B. from emitter to ground.
C. from base to emitter.
D. from collector to base.
18. When aligning (tuning) an i-f amplifier, the signal input should be
A. as weak as possible, so that you can better discern a change during adjustment of transformers.
B. strong, so that the agc will be working during alignment.
C. at the frequency indicated by the radio dial.
D. increased as the radio gets nearer in tune or alignment.
19. A good place to connect an output meter when aligning a radio is
A. across the antenna coil.
B. to the earphone jack.
C. from emitter to ground of last i-f amplifier.
D. across the power-supply voltage.
20. An output meter is in reality a dc milliammeter that uses diode rectifiers to change the audio signal to dc current, proportional to the audio signal strength. If a 50-micro-ampere meter is used, how much direct current is required to make the meter read half scale?
A. 50 millionths of an ampere.
B. One milliampere.
C. 25 milliamperes.
D. .000025 ampere.

21. If a transistor radio uses a class-B audio output stage (as most portable sets and many other types do) you can judge maximum audio output during alignment by
- A. reading the battery-supply voltage.
 - B. reading the current supplied by the power supply to the radio.
 - C. ear much better than by meter.
 - D. checking the heat of the output transistors.
22. Neutralization is a circuit refinement that
- A. is used extensively on newer transistor a-m radios.
 - B. feeds back a cancellation signal to eliminate the effects of signal feed-through from base to collector, caused by the capacitance between the base and collector.
 - C. reduces the amplifier output when signal strength is strong and prevents the amplifier from overloading.
 - D. is a type of detection used quite frequently in older type a-m transistor radios and on many fm radios.
23. "Thermal runaway" occurs
- A. most often in silicon transistors.
 - B. where an increase in current increases the heat of the transistor, which in turn increases the current even more, finally causing possible damage to the transistor.
 - C. when the bias on a transistor falls below its normal value.
 - D. when the bias is reversed on a transistor, that is, a negative bias on an npn transistor or a positive bias on a pnp.
24. "Forward" agc is a type of agc that
- A. increases the transistor bias so that the transistor current increases as the signal strength increases.
 - B. is applied only to the front end of a radio or only to one transistor, which in turn supplies bias to one or more succeeding transistors.
 - C. relies on the signal itself to bias the base circuit of the i-f transistors.
 - D. increases the output of the radio when the signal strength increases.

[The page contains extremely faint, illegible text, likely bleed-through from the reverse side of the document. The text is arranged in several columns and paragraphs, but no specific words or phrases can be discerned.]

A-M Radio: Audio Amplifiers

The circuit of Fig. 12-1 is what might be called the "classic" audio amplifier circuit used in portable radios. It is gradually giving way to a number of other different circuits, some using only one transformer, some using no transformers at all, but there are still new radios being built that use essentially this same circuit. The circuit is also popular in portable tape recorders and players.

AMPLIFIER CIRCUIT DESCRIPTION

The audio signal taken off the detector is fed to the volume control, where the signal is then picked off at the desired level through electrolytic capacitor C3 to the base of the driver transistor. The capacitor is necessary to prevent the volume control from shorting the driver transistor bias voltage. It is large so that it can pass all the audio, including the bass notes, with almost no loss. The bias for the driver transistor is a voltage-divider circuit like those used in converter and i-f circuits. Because this is a germanium transistor circuit, the voltage-divider circuit is needed since it provides a low resistance to ground from the base circuit, which effectively prevents leakage between collector and base of the transistor from being a big problem.

The emitter resistor, R15, supplies protective bias to prevent thermal runaway* and it is bypassed by C4 so that the audio signal will not be affected by the resistor. If this emitter bypass capacitor opens, the gain of this driver stage will drop drastically, and the audio output from the speaker will be weak. If the capacitor is suspected of being open, try temporarily connecting another capacitor across it and see if the volume level returns to normal. If it does, replace C4.

The collector connects to the primary of an audio transformer. The capacitor C13 across the primary is NOT for the purpose of "tuning," as it might appear. It is for bypassing the higher audio frequencies and eliminating objectionable hiss and noise. It does have to be selected so that there is no resonance problem within the audio range, however. The amplified audio

in the primary is coupled through the transformer to a 3-lead secondary—in other words, the secondary is really two windings, with the two windings tied together at the center and a lead brought out. The purpose of this tapped secondary is to provide an alternate + and - signal to the bases of the output transistors with respect to emitters. (The emitters are essentially at ground potential, as is the center tap of the audio transformer.) The center tap of the transformer also provides an excellent place to insert bias voltage to both transistors. As has already been discussed in the chapter on audio amplifiers, the output stages of a transistor radio where two transistors are used are nearly always in class B. That is, the transistors are mostly biased by the signal, itself, with only enough dc bias to prevent distortion at low volume levels.

Thermistors and Thermal Runaway

If you look at the values of resistors R16 and R17 and compare them to the driver stage, for example, you see that there is a considerable difference in the ratio of the resistors. The driver stage is $7\frac{1}{2}$ to 1 whereas the ratio of R16 and R17 is about 43 to 1. But that's not all; there is another resistor in parallel with R17 to make the ratio about 58 to 1, and this is only when the radio is first turned on and everything is cool. The circled resistor is called a "thermistor," and it has the property that it decreases in resistance as it heats up. The thermistor prevents thermal runaway in the output stages, which are much more susceptible than other stages, since they draw more current and thus get hotter. Unlike transistors in other stages, they cannot use a large emitter resistor because it would use some of the power needed to drive the speaker. As the output transistors start to heat up, the thermistor also heats up, decreasing its resistance and reducing the amount of bias on the output transistors.

Class-B Output

The class-B output stage works with low bias because each of the output transistors functions only during half of the audio cycle. When the signal is negative on the upper transistor, it conducts, and cur-

*See discussion of thermal runaway earlier in the book.

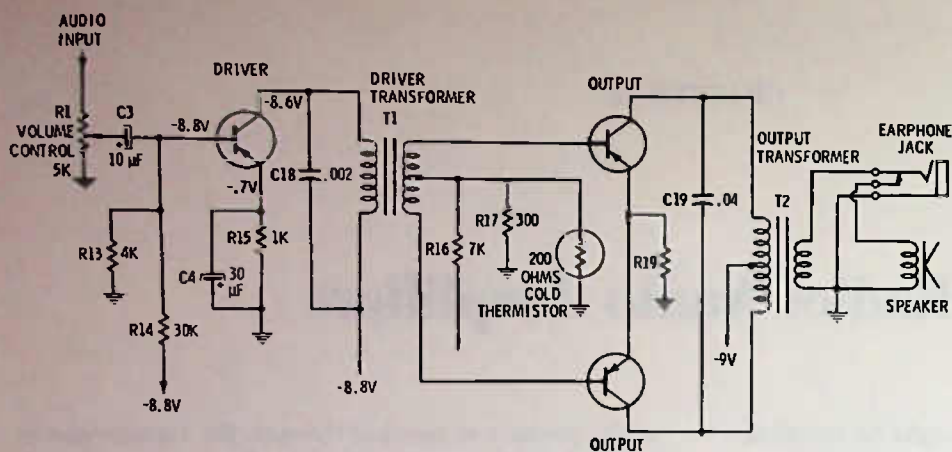

Fig. 12-1. Driver and output stages of an audio amplifier.

rent flows through the upper half of the output transformer primary. This induces current in the secondary of the output transformer, and the speaker is moved in one direction. On the next half cycle of audio, the bottom transistor has a negative voltage on the base, so it conducts, and current flows through the lower half of the output transformer. This induces current in the secondary and moves the speaker in the opposite direction.

In other words, when one transistor is working, the other is idle, except that a slight amount of bias must be provided to prevent crossover distortion at low volume levels, where the audio signal is not strong enough to "turn on" the transistors far enough to produce a linear output.

Uses of Earphone Jacks

The circuit of Fig. 12-1 shows an earphone jack in its normal location, in the speaker circuit. When an earphone is plugged in, a switch in the jack opens the speaker circuit so the speaker is inoperative. An external speaker, instead of an earphone, can also be plugged into this jack, if desired. A large speaker will improve the tone quality of just about any transistor portable radio. The technician should also have a test speaker with a plug on it that fits this earphone jack so he can make a quick diagnosis as to whether there is speaker trouble.

Speakers and Distortion

Common speaker troubles are: a dead radio—no sound output, a weak and distorted radio sound especially at low volume, a "rattley" or "paper" sound from the speaker.

Other things that can cause distorted sound at low volume might be a complete lack of base bias on the output transistors, such as would occur if R16 opened or the printed circuit to it breaks. A weak, "tinny" sound may also be caused by C18 or C19 being partially shorted. Distorted or unclear sound may be caused by improper bias or no bias on the driver transistor. Check the emitter voltage and make sure that

there is the right amount of bias between base and emitter on the driver transistor. Sometimes C3 will develop leakage, which will make the radio sound distorted at certain volume levels and perhaps not at others. If you get a drastic change in base bias on the driver transistor as you rotate the volume up and down, capacitor C3 may be leaky. If a new one is installed, make sure that its polarity is correct, otherwise you will have the same problem, since an electrolytic may be very leaky when connected in the reverse direction from that required.

Transformers

Transformers T1 and T2 do not often give trouble except, on occasion, one winding will open up, which may cause loss of the audio or may just cause a high level of distortion. If the primary of T1 opens, there will be no audio. If one side of the secondary opens and not the other, there will be considerable distortion, since only one of the output transistors can work, and so only half of the audio signal will be processed. This same kind of distortion can happen if one side of the primary of output transformer T2 opens.

On fairly rare occasions, a transformer will develop "shorted turns" and cause either weak or distorted audio, usually both. There are not too many ways of making a valid check for this sort of trouble, except, if it is suspected, to temporarily tack in a new transformer after disconnecting the original one from the circuit.

An audio signal tracer (see chapter on test equipment) should let you determine whether the distortion is occurring in the stages of T1 or T2. In other words, if the signal appears not to have distortion at the base terminals of the output transistors, then the trouble is not likely to be in T1.

OTHER AUDIO CIRCUITS

There are more variations of audio circuits in transistor radios than in any other circuit. Although the designer's purpose is simple—to start with a small

amount of audio at the detector and arrive at the speaker with enough audio for at least "room" volume—the ways of achieving this end are numerous and sometimes complex.

One rather common variation is to add one or two stages of RC-coupled audio amplification preceding the driver and output stages. RC means "resistance-capacity" and means that a resistor instead of a transformer is used in the collector load circuit and a capacitor is used for blocking the dc between the collector of one stage and the base circuit of the next, while allowing the audio signal to pass through without attenuation. A typical RC-coupled stage is shown in Fig. 12-2, using a pnp germanium transistor. Note that in this case the battery supply has the negative terminal common; so the collector-circuit load resistor returns to ground. Base biasing is obtained in the same manner as for transformer-coupled stages.

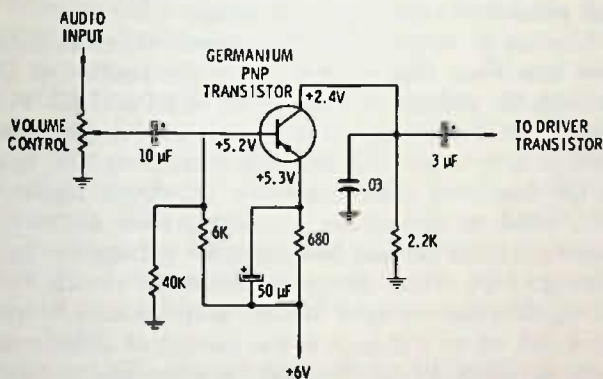

Fig. 12-2. RC-coupled audio stage for additional audio gain.

The approximate normal current for a stage of this sort is about 1 mA, though it can vary considerably. This stage has a current of just over 1 mA, as can be determined by the collector voltage. The collector is +2.4 volts, meaning that the drop across the 2.2K collector load resistor is 2.4 volts. A current of 1 mA through a 2.2K resistor would give a voltage drop of 2.2 volts. Another place where the transistor current can be calculated is across the emitter resistor. Here there is +6 volts on one side and +5.3 volts on the emitter side, meaning that across the resistor there is a voltage drop of 0.7 volt. A current of 1 mA through a 680-ohm resistor would give calculated voltage drop of 0.68 volt.

NOTE: It is a good idea to remember that the voltages on schematics may vary slightly from the voltage calculated with Ohm's law. This is to be expected for various reasons:

1. The voltage readings are usually shown to only one decimal place.
2. Reading a meter with extreme accuracy is diffi-

cult, especially on low voltages and fractional voltages.

3. The conditions under which the measurements are made may not be exactly the same as those in the field.
4. Resistors may vary in tolerance up to 10 and 20%, which will affect the voltage drop across them by like amounts, assuming that current remains constant.

In other words, voltage readings are for reference to give the technician an indication of what the actual voltage should be, but there are too many variables to expect that the voltages given on schematics and those you will take will be exactly the same—the very fact that different meters are being used in the measurement means, in all probability, a different set of readings. At least, you can expect as much as a 5% error on this account in many cases. The whole idea should be to recognize significant changes in voltage readings. If you are supposed to have -2.8 volts, for example, and you find -2.6 volts, you can safely assume that the voltage is within normal limits, and you should look elsewhere for the circuit problem. More important in the small voltage readings encountered in parts of transistor circuits is the polarity of the voltage. For example, the bias voltage on the pnp transistor in Fig. 12-2, if measured between the base and emitter, should be negative (on the base) about 0.1 volt; since, according to the schematic, there is +5.3 volts on the emitter and +5.2 on the base—the base is more negative than the emitter by 0.1 volt. So long as that base is negative and so long as the voltage reads between about .08 and 0.12 volt, you can be pretty sure it is all right, but an even better test is the collector voltage—if it is near the right amount, then it is obvious that the transistor must be drawing the right amount of current, and it is the bias that provides this transistor current flow.

One way to make sure that the transistor is reacting in the circuit is by measuring the collector voltage or the emitter voltage of a transistor—whichever circuit has a resistance in it, if not both—and then temporarily shorting across between the base and emitter. Shorting from base to emitter with a jumper wire drops the bias to zero, and the current in the transistor should drop to zero. This should produce a significant change in either the collector or emitter currents, or, if both have resistances in the circuit, in both the collector and emitter voltages.

Fig. 12-3 is a simpler preamp circuit, in that no emitter resistor and bypass are used. Again, the current flow is a bit over 1 mA (judging by the collector voltage). The biasing is done with a single 100K resistor from the collector. This serves two purposes. It provides protective bias as well as regular bias, since, if the transistor starts to draw more current, there will be more voltage drop across the 4.7K collector

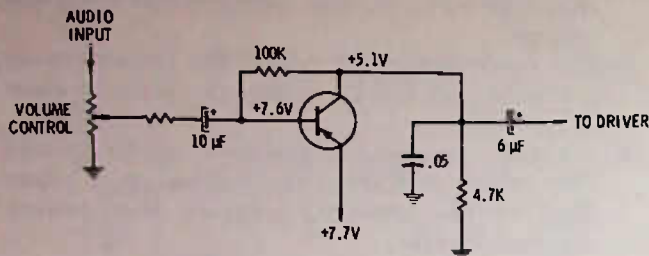

Fig. 12-3. Simple preamplifier circuit.

resistor. This in turn causes the collector to go more positive (less negative), resulting in less negative voltage applied to the base, tending to reduce the transistor current flow. In addition, the resistor also feeds back some of the output signal through the 100K resistor which, though reducing the gain of the stage to some extent, can provide a stage with a flatter frequency response over the audio range.

Something that should be noticed about this stage is that the transistor is operating with only about 2.6 volts across it (between collector and emitter). This is ample voltage, however, for a preamplifier circuit. Note also that this is a pnp transistor, which requires a negative voltage on collector and base, but remember that these voltages are in respect to the emitter. When you place a meter across from collector to emitter, you find that the collector voltage is -2.6 with respect to the emitter, and the base voltage is -0.1 volt with respect to the emitter. The point is, do not let the voltages shown on the schematic (all referenced to ground) deceive you as to the polarities on the transistor.

Silicon transistor preamplifier circuits are very similar to germanium transistor circuits. The essential difference in the circuits is in the amount of bias used. So far as troubleshooting is concerned, the same general techniques are used. Measure the voltages, then determine if they are of the correct polarity and if they are near the right amplitude. Silicon transistors are often designed to operate with a bit more current than germanium types, though not always. A silicon transistor which is less subject to heat can operate at higher currents without creating problems due to heat, and often has somewhat simpler bias circuits.

DIRECT-COUPLED CIRCUITS

Two or more transistors are said to be direct coupled when they are interconnected so that the output of one transistor is tied directly to the input of the next transistor, with no dc blocking capacitors. This means that the circuit must be so arranged that the dc voltage on the output of the 1st transistor is the same amount required on the input element of the next transistor. The circuit of Fig. 12-4 is a good example. For the moment, disregard the first transistor, Q1, and look at Q2. We have a transistor circuit with a 3.3K

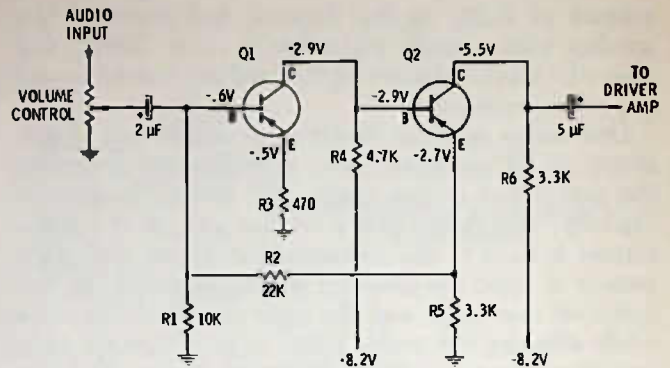

Fig. 12-4. Direct-coupled 2-stage audio preamplifier circuit.

collector load resistor and a 3.3K emitter resistor. The base bias is supplied by the 4.7K resistor from the -8.2 -volt source. Q2 draws current but without Q1 connected, the base bias will be high, so that we might expect a collector voltage of perhaps -4.4 volts and an emitter voltage of -3.8 volts.

Now let us attach Q1 in the circuit. Q1 receives its base bias from that -3.8 volts on the emitter of Q2 through the voltage divider circuit of R1 and R2. This causes Q1 to draw collector current and increases the voltage drop across R4 and the voltage on the base of Q2 decreases (less negative). Q2 draws less current, which in turn means less voltage drop across the emitter resistor R5 and less negative voltage for base biasing of Q1. What happens is that the circuit finds an equilibrium (a spot where both transistors can work and where a change in the current of either transistor is reflected back through the other one to counteract the change because of the bias connection to the emitter of Q2).

As an instance, suppose that Q1 tries to draw more current. This means less bias and less emitter voltage for Q2. The reduced Q2 emitter voltage reduces the bias on the base of Q1, so the current in Q1 tries to reduce and the circuit is stabilized. The reverse is also true. If Q1 should lower in current, it receives more bias from the emitter voltage of Q2; this tends to increase current in Q1.

Since there are no bypasses for the signal in this circuit, it follows that the signal voltage is also fed back in such a way as to tend to reduce the amplifier gain. This is what happens, and the gain of these two stages may not be as much as that of one single stage. At this point, the designer is not interested in gain so much as in linearity. He wants the signal to be amplified over the entire audio range with as little variation as possible in the amount of amplification for any individual frequency. This can be obtained, using this circuit, over much wider volume input levels than if only a single stage is used. In other words, this circuit will tend to maintain good fidelity for the high-volume addict as well as for the person who likes his music softly in the background. Even if the circuit has no gain, but processes the signal in a good, "clean"

fashion, it may be all the designer cares about since he still has ample gain in the driver and output stages.

The servicing of a defective direct-coupled stage is a bit involved, since a defect in either Q1 or Q2 or their circuits is going to affect the other transistor voltages. Suppose, for example, that transistor Q2 opens. Let us see if we can determine what the Q1 voltages would do.

With Q1 open, its collector voltage would rise to -8.2 volts, since with no current flow there would be no voltage drop across R6, but the collector voltage on Q2 would not affect Q2 voltages. But what about the emitter voltage of Q2? With no current flow through Q2, we could expect the emitter voltage to drop to zero. With zero voltage on the Q2 emitter, there would be zero bias voltage for Q1. With no bias on Q1 there would be no current flow. Thus, Q1's collector voltage would rise to -8.2 volts,* and its emitter voltage would drop to zero.

What would happen to the voltages around the circuit if Q1 should open? With Q1 open, it would be the same as previously discussed in explaining the circuit: Q2 would draw higher current, its emitter voltage would increase, and its collector voltage would drop. It is possible that Q2 would "saturate"—that is, develop almost zero resistance across it from collector to emitter. This would mean that there would be -4.1 volts on the collector and -4.1 volts on the emitter. (The voltage divides exactly in this case because the collector load and emitter resistors are the same size— $3.3K$.)

Suppose Q1 shorts, what then? With Q1 shorted (transistors nearly always short between the collector and emitter) the voltage on the collector would drop to about -0.75 volt, and, since the collector is shorted to the emitter, there would be -0.75 volt there also. This would lower the bias considerably on Q2, and its current would decrease significantly. These are just some of the different ways that a direct-coupled circuit can be defective, and how the voltage drops around the circuit change. For practice, see if you can determine what would happen in the circuit if Q2 developed a collector to emitter short.

OTHER OUTPUT CIRCUITS

One of the first variations on the classic two-transformer audio driver and output circuit was the so-called OTL (output transformerless) circuit. This is a class-B circuit that uses a driver transformer with the two secondaries brought out to four leads, instead of three, and the speaker driven directly by the current

*Remember that Q2 is open and we are assuming the open is between base and emitter, where most opens in transistors occur. Therefore, the base circuit of Q2 cannot draw any current, so, with Q1 drawing no current, there is no voltage drop across R4, and the collector voltage on Q1 (as well as the base voltage on Q2) rises to -8.2 volts.

through the output transistors, rather than by first being impedance matched through an output transformer.

Fig. 12-5 shows the first type of design. The speaker was connected to the emitters of the two transistors and to the center tap of the battery power supply. The transistors are in a "stacked" position, that is, one is in series with the other, with the emitter of Q1 tied to the collector of Q2. The driver transformer must have split secondary connections so that each one of the transistors can be biased separately—Q1 has a -4.7 -volt bias to ground and Q2 has -0.2 -volt bias to ground though each has its correct -0.2 volt between base and emitter.

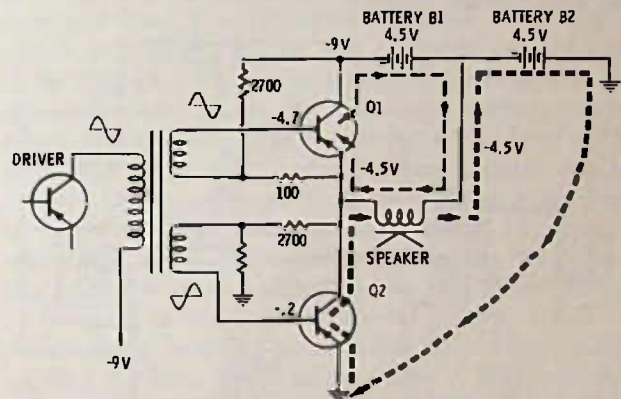

Fig. 12-5. OTL circuit using a center-tapped battery supply.

Let us see what happens when an audio signal is fed to the output transistor base circuits. These are npn transistors; so a negative voltage is required for "turn on." When a negative half cycle of audio reaches the base of Q1, the current increases through it. At the same instant, the audio voltage is positive on Q2 so it is "turned off." If we follow the current through the transistor Q1, we find that it travels out of the battery, through the speaker, through Q1, and back to the battery. And let us suppose that current traveling in this direction through the speaker causes the speaker cone to pull inward. On the next half cycle, Q2 has the negative signal; so its current increases and Q1 is turned off. This time, the current travels out of battery B2, through the ground connections, to the emitter of Q2, to the collector circuit, and through the speaker back to the battery. But this time the current is traveling through the speaker in the opposite direction; so the speaker cone moves outward.

The tapped battery supply was a disadvantage, especially to those small sets that use a single 9-volt battery. For that reason, the circuit of Fig. 9-20 and others similar to it were developed. This particular circuit shows npn transistors being used—it makes no difference whether they are npn or pnp so long as both are the same type and the battery polarity is correct. Either germanium or silicon types may be used in the circuit. The bias resistors are selected so that the

idling current of the transistors is sufficient to prevent crossover distortion at low volume.

In Fig. 12-6, the speaker is fed with a capacitor. The side of the capacitor is normally from about 100 to 300 μ F. This circuit works almost the same as the one with the tapped battery supply, except that here when Q1 is conducting, the capacitor C1 charges up through the speaker, causing the speaker cone to move in one direction. On the next half cycle when Q2 conducts, the capacitor discharges through Q2 and the speaker cone moves in the opposite direction. It might be said that the capacitor is the "other" battery in this circuit, being charged up on each half cycle by the supply battery and then being discharged on the next half cycle of the audio.

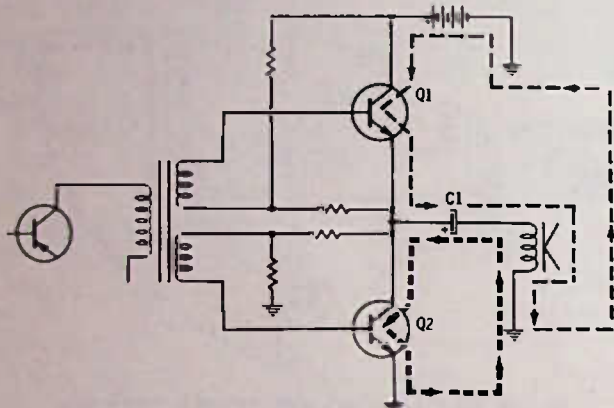

Fig. 12-6. OTL circuit uses capacitor to feed audio to speaker.

TESTING THE OTL CIRCUIT

If trouble occurs in the OTL circuit, the simplest and perhaps the best and fastest method to find the trouble is with the trusty vom. Make sure voltage is reaching the collector of Q1. Next, check the voltage on the collector of Q2. The collector on Q2 should have about half as much voltage as the collector of Q1. If the collector voltage of Q2 is high or low, suspect a defective output transistor—it could be either one or both (in the OTL circuit when one output transistor becomes defective the other may be damaged also) at any rate, it is not a bad idea to replace both with a matched pair, even if only one tests bad. Check the transistors for a short by measuring between the collector and emitter of the suspected transistor, using an ohmmeter (radio must be turned off). If the reading is only a few ohms or less, reverse the ohmmeter leads and check again. If the reading is the same, there is almost no doubt that the transistor is shorted—remove it from the circuit and make a final ohmmeter test across it to make sure.

Low or high voltage on the collector of Q2 could also be caused by a defect in the bias resistor circuits (true only of the circuit in Fig. 12-6). To check bias, check between the base of the transistor and its emitter. The bias will be around 0.2 volt for germanium

transistors and around 0.7 volt for silicons. For npn transistors the bias will be positive on the base with respect to the emitter, and for pnp the bias will be negative.

THE "TL" AMPLIFIER

The "transformerless" amplifier has gained some popularity and will probably be used more and more as the circuit state of the art progresses. It is extremely popular as an integrated-circuit packaged audio amplifier since it uses mostly resistors, transistors, and diodes, all of which are easily produced in IC packages.

The simplified circuit of Fig. 12-7 should explain how this circuit operates, so far as the speaker is concerned. Two different type transistors are used—one

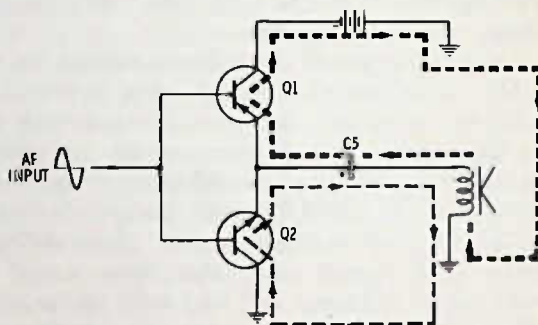

Fig. 12-7. Simplified "TL" amplifier.

is an npn and the other a pnp. In some circuits, one of the transistors is a silicon and the other a germanium type, while others use both germanium or both silicon. Using a pnp and an npn transistor makes phase inversion at the bases unnecessary, in fact, considering the signal, both bases are essentially tied together. What happens when a signal comes in? The negative half cycle of the audio increases the current of Q1, the pnp, and turns off Q2, the npn. Capacitor C5 charges from the battery through the speaker and capacitor C5. On the positive half cycle of the incoming audio, transistor Q1 is turned off, but transistor Q2 is turned on, discharging capacitor C5 through the speaker and moving the speaker cone in the opposite direction. NOTE: In this book we are using conventional current direction, rather than "electron" current direction. This is easier to follow since we assume the current to be flowing in the same direction as the arrows on the transistors are pointing.

Fig. 12-8 is a complete "TL" circuit as used in an a-m-fm radio. The transistors are fed from driver transistor Q3 which gets its dc collector voltage through R6, R4, R5, and X1. The diode is forward-biased (is conducting) so it is essentially a short circuit* for the

*Typical forward bias resistance for a diode is less than 50 ohms.

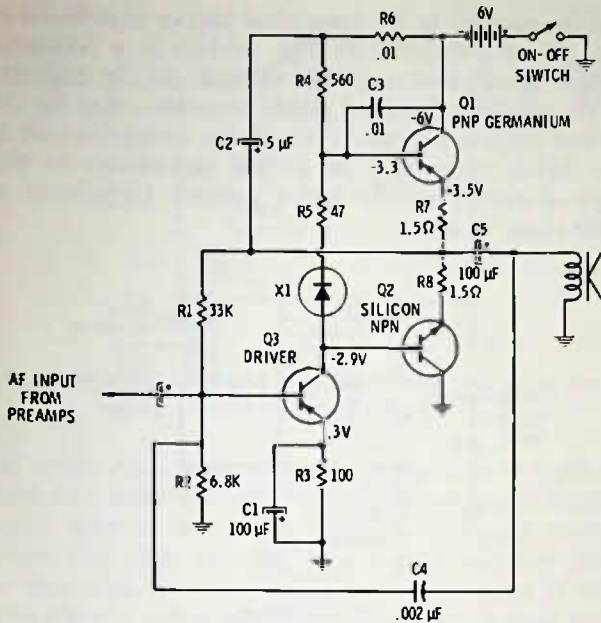

Fig. 12-8. "TL" audio amplifier. Note that one npn and one pnp are used as output transistors.

audio signal but it, along with R5, provides a dc voltage drop so that the dc bias for the transistors is correct. The diode also acts as a bias regulator of sorts, since, if the circuit heats up, the diode will conduct more (look like a smaller resistance) and so there will be less voltage drop across it. The 1.5-ohm resistors in the emitter circuits of the output transistors are for protection only. In the event that either of the transistors should short, the 1.5-ohm resistor burns open and "turns off" the circuit, preventing damage to other parts of the circuit and the battery.

The bias for the driver is taken from the speaker takeoff point and so receives not only the required dc voltage, but an audio voltage as well. This is an "inverse" feedback circuit such as was discussed under direct-coupled circuits, and it tends to balance out current changes in the circuit, as well as provide improved circuit linearity so far as the audio is concerned. There is still another feedback circuit—C4, which feeds back a signal from the speaker direct to the base of the driver. Since a capacitor feeds back high frequencies better than low frequencies, the high frequencies, as compared to the bass frequencies, are reduced by this connection. The bass frequencies receive more amplification and the bass is boosted.

The principal disadvantages with the TL circuit are the difficulty in providing good linearity and the fact that biasing is somewhat critical. With careful design, though, it can do a good job of reproducing audio, especially for radios. To test, check the dc voltages. Check the bias of the transistors by measuring between base and emitter. Recognize that the bias on the output stages is determined by the current through the driver stage. If the driver-stage bias is upset, there

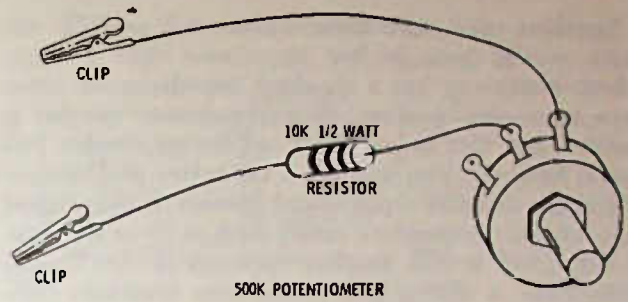

Fig. 12-9. Test circuit for adjusting bias on transistor circuit.

will be considerable distortion in the output. Check the emitter voltage of the driver to determine if the driver current is approximately correct. If a different transistor from the original is replaced in the driver circuit, it is likely that the bias to the driver will have to be juggled a bit. If the emitter voltage is low, decrease the size of R1 by shunting another resistor across it. Try various sizes starting with about 220K, then 100K, then 47K, and see if the current can be brought to its proper point. If the current is too high in the driver stage, shunt a resistor across R2, starting with about a 15K, then a 10K, etc. Getting the correct bias on this stage can sometimes be best accomplished by listening to the radio at normal volume (music is preferred for listening tests, rather than voice) while juggling the bias on the driver stage. A 500K variable resistor with a 10K limiting resistor in series with it can be used to "adjust" the bias to the correct point, then measure the variable resistance to see what size resistor should be used in shunting either R1 or R2 permanently as needed. See Fig. 12-9.

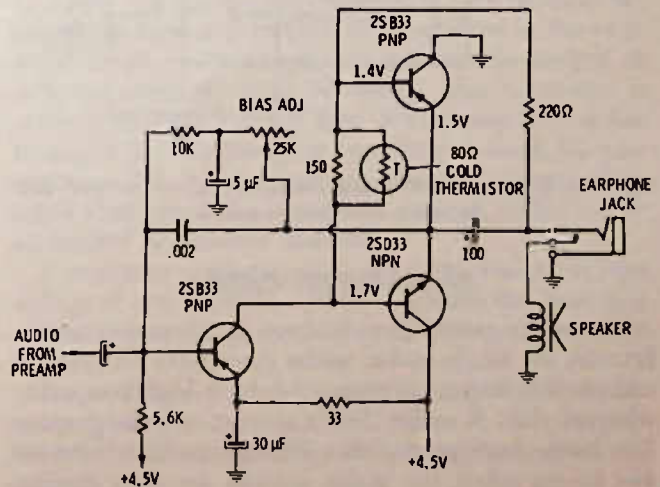

Fig. 12-10. "TL" circuit with thermistor as bias stabilizer and a "bias adjust" control for initial setup of the circuit when changing transistors.

Fig. 12-10 is a TL circuit that has a bias-adjust control built into the circuit. A thermistor is used instead of a diode as the automatic bias voltage stabilizer. Thermistors, much like diodes, have lower resistance as they warm up.

Speakers used with these TL as well as OTL circuits usually have higher impedance than 8 ohms, which is more or less a standard impedance for cone-type voice-coil speakers. If a replacement speaker is needed and can be mounted, an 8-ohm speaker will work; however, you will get a bit better performance if you use an exact replacement speaker, if the original had a higher impedance rating such as 20 or 40 ohms.

Fig. 12-11 is still another variation of the TL circuit. Here, a silicon and germanium transistor combination is used for the outputs; a silicon transistor with the emitter not connected serves as a diode for establishing the necessary dc bias differential between the two transistors and also acts as a bias regulator, since its collector-base forward resistance is reduced as the heat increases. A silicon transistor is used for the driver and only one bias resistor and no emitter resistor, attesting to the stability of the silicon transistor amplifier under varying conditions. Besides the input and output electrolytics, only two capacitors are used in this circuit, both for bypassing the higher frequencies to eliminate "hissy" noise in the output when a station is tuned in.

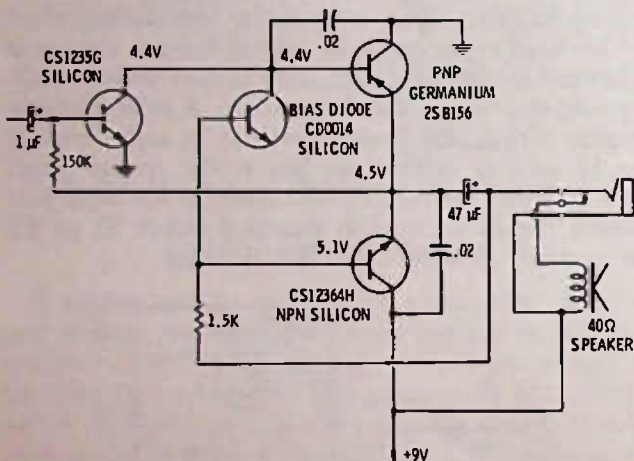

Fig. 12-11. A Motorola "TL" circuit that returns speaker to "hot" side of battery rather than to ground.

SINGLE-ENDED AUDIO

Almost no portable radios use single-ended audio because the single-ended audio stage must be class A, and class-A stages continuously draw higher current, whereas class-B audio draws current only in proportion to the amount of audio. This means that batteries last longer when the audio circuits are class B. For table radios operated from the power line, however, the single-ended class-A output is feasible, since the additional current used is of virtually no concern.

Two single-ended circuits are shown in Fig. 12-12. At Fig. 12-12A is a low-voltage single-ended audio stage, using a germanium power transistor driven by a small silicon transistor in a direct-coupled circuit. The output transformer is an autoformer type match-

ing the speaker to the somewhat higher impedance of the power transistor. At Fig. 12-12B is a transistor output circuit that uses over 90 volts on the collector of the specially designed power transistor. Bias for the output stage is supplied through the emitter circuit of the driver transistor. The output transformer in this type of circuit usually has a primary impedance of 1000 ohms or more.

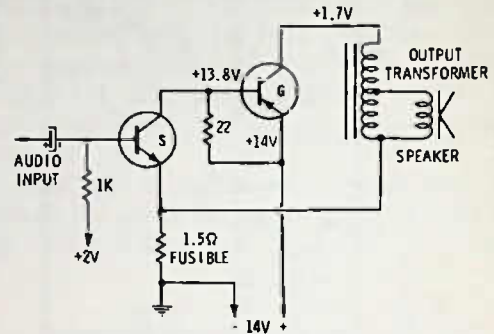

(A) Low voltage.

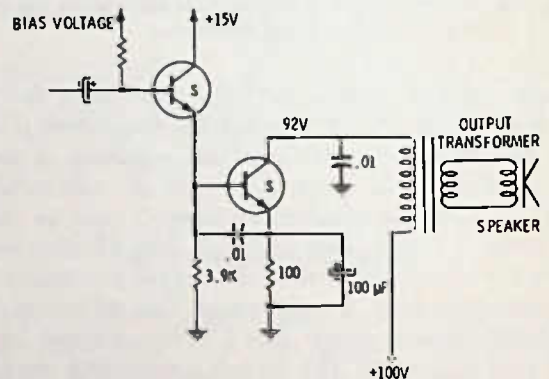

(B) Fairly high voltage.

Fig. 12-12. Single-ended output stages.

Trouble in either of these circuits can usually be spotted quickly by voltage measurement. As in any circuit, if the output is weak, one of the first things to check for is an open electrolytic, either one of the bypasses or those coupling the signal from previous stages.

A low-power single-ended stage (about 300 milliwatts) of the type shown in Fig. 12-13 is often used in small clock radios and similar radios. It will give ample room volume and has a "clean" undistorted output if the volume level is not turned too high.

In this circuit, if the trouble is insufficient volume, check the 200-µF emitter bypass and also the 3-µF input coupling capacitor. For distortion, check for an open 10K resistor in the bias circuit. If the transistor overheats, check bias voltage; if high, it may be caused by a defective transistor or by a change in value of the 2.7K resistor. This symptom can also be caused by a leaky 3-µF capacitor, allowing dc voltage from the previous stage to affect base bias on the output stage.

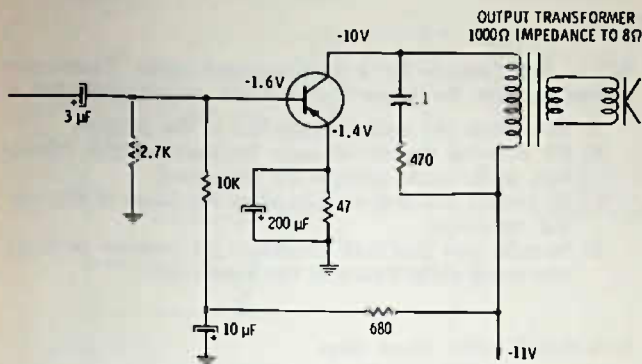

Fig. 12-13. Low-power class-A audio output stage. Total current for circuit is about 30 mA.

If a transistor must be replaced, be sure to replace metal heat sinks if used. These are sometimes circular, finned devices and other times are simply metal sleeves that slide over the transistor. Make sure that the heat sink does not touch any metal parts of the radio circuit, unless originally attached.° A heat sink carries away heat from the transistor itself, so that it does not draw excessive current.

HINTS ON AUDIO CIRCUIT REPAIRING

Transistors that mount with bolts often use an insulator between the transistor and the chassis. This insulator must be reinstalled, since the collector connection on these power transistors is made directly to the metal case of the transistor.

Squeals in audio amplifiers are usually traced to an open electrolytic somewhere in the circuit. Try bypassing each one as a test. On rare occasions a transistor will cause squeals and have to be replaced. A wire from the output transformer passing too close to the volume control circuit may cause squeals or whistles.

A speaker with an earphone plug is an extremely useful device for checking out a transistor radio, especially for checking the speaker, earphone jack, etc. A test speaker is also a good place to install an output meter for use when checking alignment—be sure to use an on-off switch on the meter so that it will not work except when you have the output level set correctly, otherwise you could damage the meter—or, if you like to have the meter working all the time, install a sensitivity control as shown in Fig. 12-14. The sensitivity control will turn the meter off or on, or anywhere in between. For protection, keep the meter at a low sensitivity except when actually doing alignment; then it should be turned to maximum.

°This is because the metal case of some transistors is connected internally to the collector terminal.

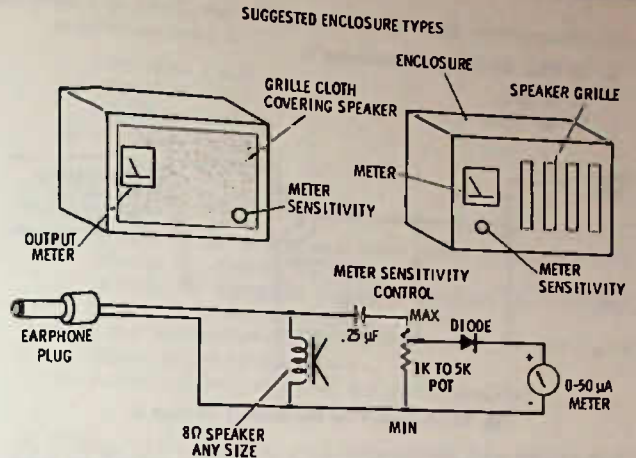

Fig. 12-14. Combination test speaker and output meter with sensitivity control.

For distortion at low volume, check the speaker first, and, if this is not the trouble, check for incorrect base bias on one of the audio transistors.

For direct-coupled circuits try to determine from the schematic how the circuit will react to trouble, since the voltages on the entire direct-coupled circuit will be affected by trouble in any part in the circuit.

When the symptom is a weak radio, the most common trouble is an open electrolytic capacitor. It is often easier to temporarily shunt a good electrolytic across each of the electrolytics of the set, one at a time, to see if there is a significant improvement, rather than to attempt any other sort of diagnosis.

You can check to see if any transistor will respond to a bias change by using a jumper wire to short between the base and emitter—if the current in the transistor drops, as measured across either an emitter or collector resistor, then, obviously, the transistor is working at some level of bias. If you suspect that the transistor has no bias, you can always check by connecting a 10K resistor from the collector to base while again checking for a change in voltage across either an emitter or collector resistance.

It is always easier to get an accurate reading of bias voltage if you measure directly between the base and emitter, rather than reading each voltage separately to ground.

For transistor circuits, use at least a 20,000 ohms-per-volt vom, a vtvm or a FET/vom so that the meter itself will not upset the circuit by its internal resistance.

You can nearly always tell if a signal is getting through the audio circuits of an audio amplifier by turning the volume control and listening for a scratchy sound or some other disturbance in the speaker that changes as the volume control is turned.

TEST QUESTIONS

1. In Fig. 12-15, the transistor is
 A. a pnp.
 B. an npn.

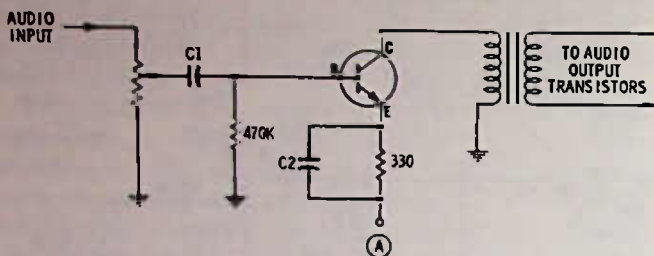

Fig. 12-15. Circuit for Questions 1 through 6.

2. In Fig. 12-15, the polarity of the supply voltage at point (A) should be
 A. positive.
 B. negative.
3. In Fig. 12-15, C1 and C2 are electrolytics. They should be connected in the circuit
 A. with the + sides connected to the base and emitter.
 B. with the + side of C1 connected to base and the + side of C2 connected to point (A).
 C. with the + side of C1 connected to the volume control and the + side of C2 connected to the emitter.
 D. with the negative (-) sides of both capacitors connected toward the transistor.
4. In Fig. 12-15, suppose that C2 opened because of an internal defect in it. The amplifier stage would
 A. have increased volume but poorer frequency response.
 B. have decreased volume with, perhaps, better frequency response.
 C. probably cause whistles or squeals in the output stages.
 D. develop nearly zero emitter voltage (measured to ground).
5. In Fig. 12-15, if C1 opened, the result would be
 A. low audio output with perhaps a tinny sound.
 B. zero bias on the transistor.
 C. significant increase in collector voltage.
 D. significant decrease in dc voltage across emitter resistor.
6. In Fig. 12-15, if C1 shorted or became very leaky, the result would be
 A. a decrease in audio available at the base of the transistor.
 B. the emitter dc voltage changing with a change in the setting of the volume control and probable distortion of audio.
 C. a significant increase in audio output.
 D. that the volume control would have no effect on audio output.
7. One of the best ways to check for an open electrolytic in a circuit is to
 A. remove the capacitor and insert a new one in its place.
 B. use an electrolytic capacitor checker.
 C. measure the dc voltage drop across it.
 D. temporarily connect a known good capacitor across the one suspected of being defective.

8. The main reason for a center-tapped audio transformer feeding from the driver to the audio output transistors is
 A. to increase the audio voltage fed to the outputs.
 B. for isolating the driver stage from the output transistors, so far as dc voltages are concerned.
 C. to provide out-of-phase signals to the bases of the output transistors.
 D. to make sure that both transistors get positive- or negative-going audio signals at the same time.
9. A class-B audio output stage
 A. uses only one transistor, to save battery power.
 B. operates with very low dc bias voltages.
 C. has less current flow from the battery at high volume than when low-level signals are being fed to it.
 D. is not normally used in portable radios.
10. A thermistor is a device that
 A. is much like a transistor, but has decreased amplification when it gets hotter.
 B. increases in resistance as it gets hotter.
 C. decreases in resistance as it gets hotter.
 D. is used to increase transistor bias as the transistors tend to draw more current due to heat.
11. In a class-B output stage
 A. only one transistor is working at a time, for all practical purposes.
 B. only one transistor is used.
 C. both transistors work together and supply power to the output transformer or speaker on each half cycle of audio.
 D. battery current remains constant, regardless of the audio-signal input.
12. "Distortion" is a term used in radio servicing that means
 A. the radio case is warped so that controls will not work, or the "works" of the radio are difficult to remove from it.
 B. the gain of a stage is low.
 C. the radio does not have a clear, understandable output.
 D. the normal phase inversion of an audio amplifier with a negative-going input signal results in a positive-going output signal.
13. In Fig. 12-16, the purpose of diode X1 is to
 A. rectify the audio and provide bias for the output stages.
 B. prevent positive audio pulses from occurring at the center-tap of the transformer.
 C. act in the manner of a thermistor to control the bias, depending on the surrounding temperature of the circuit.
 D. make sure that only negative pulses are applied to the output transistors.
14. In Fig. 12-16, the purpose of R3 is to
 A. improve the frequency response of the output stages.
 B. protect the circuits if an output transistor should short.
 C. provide the necessary bias for the output transistors.
 D. increase the audio-output signal.

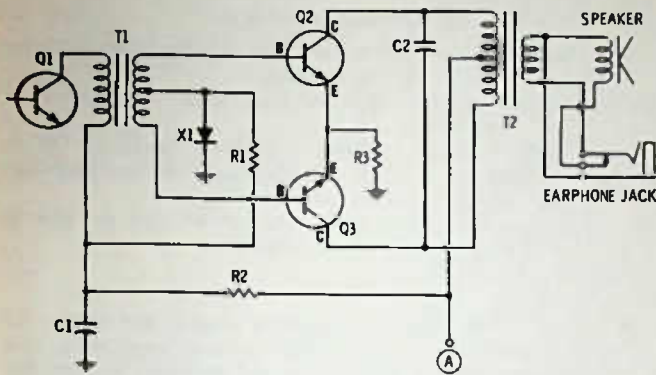

Fig. 12-16. Circuit for Questions 13 through 17.

15. In Fig. 12-16, the dc bias on Q2 as compared to Q3 is
 - A. higher.
 - B. lower.
 - C. the same.
 - D. negative.
16. In Fig. 12-16, the polarity of the voltage with respect to ground at point **(A)** should be
 - A. positive.
 - B. negative.
17. In Fig. 12-16, the purpose of C2 is
 - A. to bypass higher audio frequencies.
 - B. to bypass lower audio frequencies.
 - C. to tune T2 to resonance.
 - D. to keep the dc voltage on Q2 and Q3 at the same value.
18. In a transistor audio amplifier, an RC circuit is
 - A. a tuned circuit.
 - B. a circuit that uses a resistor to supply dc voltage to the collector and a capacitor to couple the audio signal to the next stage.
 - C. a circuit that uses a transformer with a capacitor across it to control the tone of the amplifier.
 - D. a circuit that is resistance-controlled—that is, the gain or bias is controlled by changing one or more variable resistors.
19. In Fig. 12-17, how much bias does the transistor have?
 - A. -8.5 volts.
 - B. -0.5 volt.
 - C. +0.5 volt.
 - D. Not enough information to tell.

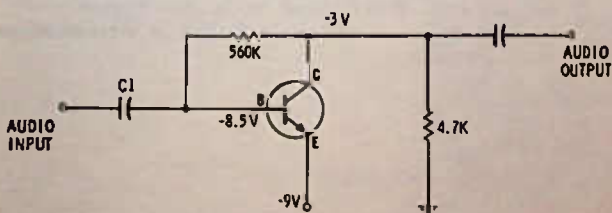

Fig. 12-17. Circuit for Questions 19, 20, 21, 22, 24, and 25.

20. In Fig. 12-17, the collector current (and consequently the emitter current) is
 - A. more than 1 mA.
 - B. more than 2 mA.
 - C. less than 1 mA.
 - D. less than 0.5 mA.
21. In Fig. 12-17, the 560K resistor
 - A. provides both dc bias and some audio feedback which reduces the gain of the stage.
 - B. provides dc bias only, but it is regulated or stabilized because it is connected to the collector.
 - C. is for degenerative audio feedback only, so as to give better frequency response.
 - D. provides neutralization of the audio amplifier.
22. In Fig. 12-17, if you shorted between the base and emitter with a jumper wire, and the transistor were good, you would expect
 - A. the collector voltage to rise to near 9 volts to ground.
 - B. the collector voltage to drop to near zero volts to ground.
 - C. the transistor to be damaged or overheated because of heavy current flow.
 - D. no change in dc voltages, but a loss of the audio signal.
23. If you were to measure the bias voltage on a transistor between base and emitter and find that the voltage were 2.5 volts, you would expect that
 - A. the transistor is a silicon type.
 - B. the transistor is a germanium type.
 - C. the transistor is defective or connected in the circuit wrong.
 - D. the base bias resistor has changed to a low value, or, if a bleeder circuit is used, one of the resistors is open.
24. In Fig. 12-17, how much is the collector voltage with respect to emitter, and what polarity?
 - A. Positive 6 volts.
 - B. Negative 3 volts.
 - C. Positive 3 volts.
 - D. Negative 6 volts.
25. In Fig. 12-17, if you measured the collector voltage to ground and found it was almost 9 volts, the likely trouble might be
 - A. an open 4.7K resistor.
 - B. a shorted transistor.
 - C. too much transistor bias, which might be caused by a leaky capacitor C1.
 - D. any of the above.
 - E. none of the above.

26. The transistor type that is least likely to be affected by the temperature around it and that generates less internal heat in the same type circuit is

- A. the thermistor.
 - B. the npn.
 - C. the pnp.
 - D. the silicon.
27. A class-B output circuit in a radio may draw no more than 4 to 8 mA, with no signal input, but perhaps as much as

50 or 100 mA on peaks, when the signal input is high. What about the current drawn by the driver stage?

- A. Current will normally run at least 10 mA, or more.
- B. Current increases with the signal input, as it does for the output stages.
- C. Current is normally less than 10 mA and does not change with change in the amount of signal input.
- D. Current is extremely small, since the driver stage has no dc bias.

28. Fig. 12-18, is a direct-coupled circuit of a type used in some car radios. Note that Q1 is an npn and Q2 a pnp. If the current increases through Q1 for any reason,

- A. the current through Q2 should also increase.
- B. the current through Q2 should decrease.
- C. the bias voltage fed back through R4 and R5 should go more positive at the base of Q1.
- D. the voltage drop across R4 should decrease.

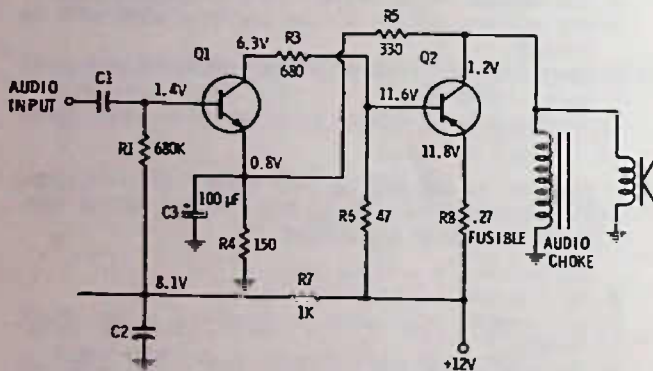

Fig. 12-18. Circuit for Questions 28 through 34.

29. In Fig. 12-18, if Q1 should short (collector to emitter) the current

- A. through R6 will increase considerably.
- B. through R6 will decrease considerably.
- C. through R4 will decrease.
- D. through the speaker and audio choke will decrease.

30. In Fig. 12-18, R7 and C5 isolate the bias resistor, R1, from the +12-volt line. This kind of circuit is normally called

- A. a decoupling circuit.
- B. an unlatching circuit.
- C. an isolation circuit.
- D. a bias-smoothing circuit.

31. Looking at the circuit in Fig. 12-18, why do you suppose that R3 is needed?

- A. To reduce the collector voltage on Q1.
- B. To limit the amount of current flow, should Q1 short out.
- C. To reduce the volume or signal level going to Q2.
- D. To act as a collector load resistor for Q1.

(Hint: The above question is not answered directly in the text, but you should be able to decide why it is needed.)

32. In Fig. 12-18, the purpose of C3 is to

- A. prevent the signal coming into Q1 from being transferred directly to the speaker.
- B. reduce the dc voltage fed back from the collector of Q2 to the base of Q1.
- C. eliminate audio feedback from the collector of Q2 to the base of Q1 while still allowing a dc bias stabilization voltage to be fed back.
- D. bypass the higher audio frequencies and so give a more "bassy" tone to the amplifier.

33. In Fig. 12-18, a fusible resistor is used in the emitter of the output transistor (Q2). This resistor, when used, will burn open (like a fuse) if the Q2 transistor current becomes excessive or if Q2 should short. If you were to find this resistor open and you wished to check Q2 to see if it were shorted, you would measure with an ohmmeter between

- A. the collector and emitter of Q1.
- B. the collector and base of Q2.
- C. the collector and emitter of Q2.
- D. the emitter and base of Q2.

34. In Fig. 12-18, the transistors are:

- A. Q1 is a silicon npn and Q2 is a germanium pnp.
- B. Q1 is a germanium npn and Q2 is a germanium pnp.
- C. Q1 is a silicon pnp and Q2 is a silicon npn.
- D. Q1 is a silicon pnp and Q2 is a germanium npn.

35. In a direct-coupled circuit, an increase in current in one transistor

- A. should always cause an increase in current in the other transistors in the same circuit.
- B. should always cause a decrease in current in the other transistors of the same circuit.
- C. may cause either an increase or a decrease in the currents of other transistors in the circuit.
- D. may occur if the set is operated in low temperatures.

36. In direct-coupled circuits, a replacement transistor may be

- A. almost any that is of the same general type.
- B. more critical to replace and should be an exact replacement whenever possible.
- C. less critical than in RC-coupled circuits.
- D. either a silicon or germanium, regardless of the original type.

37. In direct-coupled circuits, often,

- A. frequency response is sacrificed in favor of gain.
- B. gain is sacrificed in favor of economy.
- C. gain is sacrificed in favor of frequency response.
- D. there are fewer transistors used than in a transformer-coupled circuit.

38. Fig. 12-19 is

- A. a direct-coupled circuit.
- B. an OTL circuit.
- C. a class-B circuit.
- D. both B and C above.

39. The notes by the thermistors in Fig. 12-19 indicate that they measure 110 ohms cold. If they are heated, their resistance would
- increase.
 - decrease.
 - remain unchanged.
 - go to zero immediately.

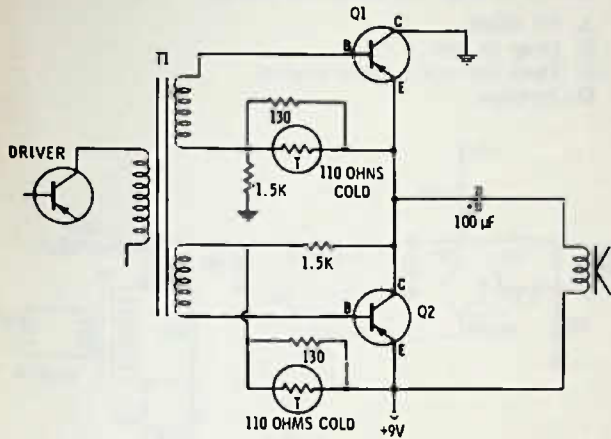

Fig. 12-19. Circuit for Questions 38 through 43.

40. In Fig. 12-19, when the signal voltage is positive-going on the base of Q1,
- it will also be positive-going on the base of Q2.
 - it will be negative-going on the base of Q2.
 - it might be either positive or negative-going on the base of Q2.
 - the dc bias must be positive on Q1.
41. In Fig. 12-19, so far as the speaker is concerned,
- there should be no direct current through it.
 - the cone should move back and forth as Q1 and Q2 conduct.
 - it should make a loud "pop" when the set is first turned on.
 - all the above are correct.
 - only A and B above are correct.

42. In Fig. 12-19, if the output signal is distorted—that is, difficult to understand—you might expect that one of the transistors was not working. If Q1 were shorted (collector to emitter),
- this would not cause distortion, since one transistor can drive the speaker. The second one simply adds more power so you can have more volume.
 - the collector voltage (dc) on Q2 would be near zero.
 - the emitter voltage on Q1 would be near 9 volts.
 - the +9 volts would be shorted direct to ground (voltages measured to ground).

43. In Fig. 12-19, suppose Q2 should open or should lose its bias
- Q1 would continue to work normally, since its bias and voltages would not be affected to any great extent.
 - audio output would drop to nothing or be heavily distorted, if the volume control were turned full up on a strong station.
 - Q1 would overheat; and, therefore, its current would increase, eventually cutting it off and causing severe distortion.
 - you would be able to tell it, because Q2 would overheat from excessive collector current.

44. In an OTL or a TL circuit you can best check the bias on individual transistors by
- measuring from the base to emitter of each transistor.
 - measuring from the base to ground and the emitter to ground of each transistor and then subtracting one from the other.
 - by feeling them to see whether or not they are warm.
 - by reading the bias at the center tap of the driver transformer.

45. Fig. 12-20 is a TL circuit that uses the same type of transistor for both the outputs (just as in the OTL circuit), but instead of a transformer, a transistor is used as a phase inverter to "turn the signal over" on Q5 as compared to Q4. This occurs because in any transistor with the input going into its base and the output taken from the collector, the signal is reversed 180 degrees—that is, if the

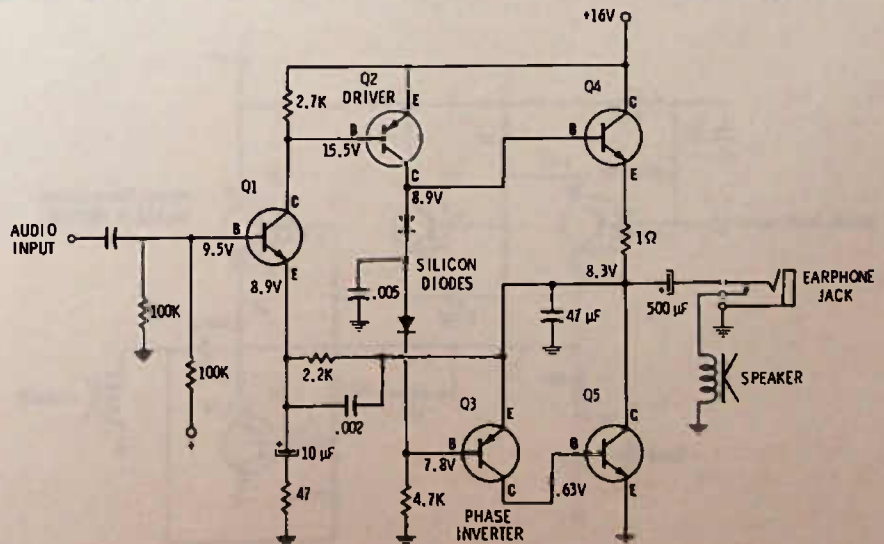

Fig. 12-20. Circuit for Questions 45, 46, and 47.

signal is positive-going at any instant at the base, it will be negative-going at the collector. The silicon diodes are used in this circuit to feed the signal from the collector of Q2 to the base of Q3. Diodes are often used like this since a forward-biased diode has a resistance of less than 100 ohms, which will, as in the case of a thermistor, have even less resistance as the temperature of the circuit rises. The audio travels through these transistors without rectification, since they are already forward biased, but the bias differential between Q4 and Q3 is maintained stable regardless of reasonable temperature changes. Knowing that the signal does reverse as it goes through each transistor, supposing a negative-going voltage is applied at Q1, what direction will the amplified voltage be going at the base of Q4?

- A. positive.
- B. negative.

46. In Fig. 12-20, if the signal input at the base of Q1 is negative-going at some instant, at that same instant the voltage at the base of Q5 will be

- A. positive-going.
- B. negative-going.

47. Judging from the bias on the various transistors in Fig. 12-20, the indication is that

- A. they are all germanium types.
- B. they are all silicon types.
- C. Q1, Q2, Q3 are silicon, Q4 and Q5 are germanium.
- D. Q1, Q3, Q4, Q5 are silicon, Q2 is a germanium.

48. In Fig. 12-21 is a TL circuit that uses an npn and a pnp output transistor so that out-of-phase signals do not have to be developed prior to driving the output stages. The transistors, judging from bias voltages are

- A. all silicon.
- B. all germanium.
- C. Q1 and Q2 are silicon and Q3 and Q4 are germanium.
- D. Q1 and Q2 are germanium and Q3 and Q4 are silicon.

49. In Fig. 12-21, if you shorted between the base and emitter of Q1, current through the emitter resistor of Q4 should

- A. increase.
- B. decrease.
- C. stay the same.

(Hint: Because the transistors are in series, if either is turned off the other cannot draw current, except for as long as it takes the 500- μ F capacitor to discharge.)

50. In Fig. 12-22, suppose that output transformer T1 should open (the primary winding) what would happen to the current through the driver transistor?

- A. No effect.
- B. Drop to zero.
- C. Drop but only a slight amount.
- D. Increase.

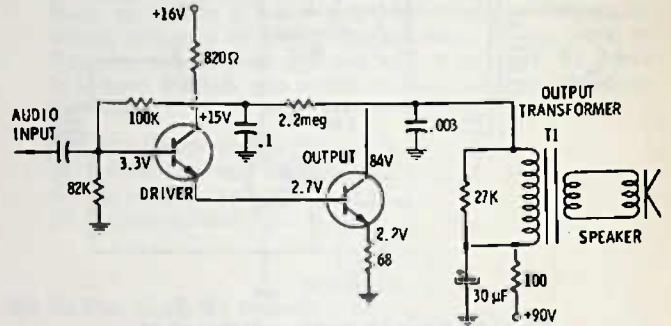

Fig. 12-22. Circuit for Questions 50 through 53.

51. Judging by the emitter-resistor voltage drop (and disregarding the slight amount of base current which is less than 2 mA) how much current is flowing in the collector circuit of the output transistor in Fig. 12-22?

- A. Less than 5 mA.
- B. More than 5 but less than 10 mA.
- C. Between 30 and 35 mA.
- D. About 330 mA.

52. The output stage in Fig. 12-22 is

- A. a pnp class-A stage.
- B. a pnp class-B stage.
- C. an npn class-A stage.
- D. an npn class-B stage.

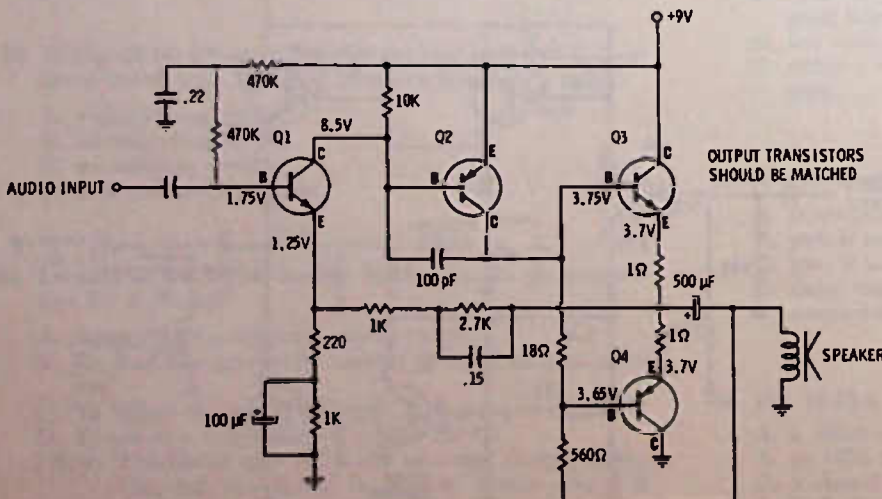

Fig. 12-21. Circuit for Questions 48 and 49.

53. If you were to increase the amount of dc bias on the driver transistor in Fig. 12-22, what would be the effect on the collector voltage of the output transistor?
- A. No effect.
 - B. Increase.
 - C. Decrease.
 - D. Rise above 90 volts.
54. Open electrolytics in an audio circuit can cause
- A. a weak radio or one that howls or whistles.
 - B. a weak radio only.
 - C. a radio that howls or whistles only.
 - D. excessive dc bias voltages on transistor(s).

First column of handwritten text, containing several lines of notes or a list.

Second column of handwritten text, continuing the notes or list.

Third column of handwritten text, continuing the notes or list.

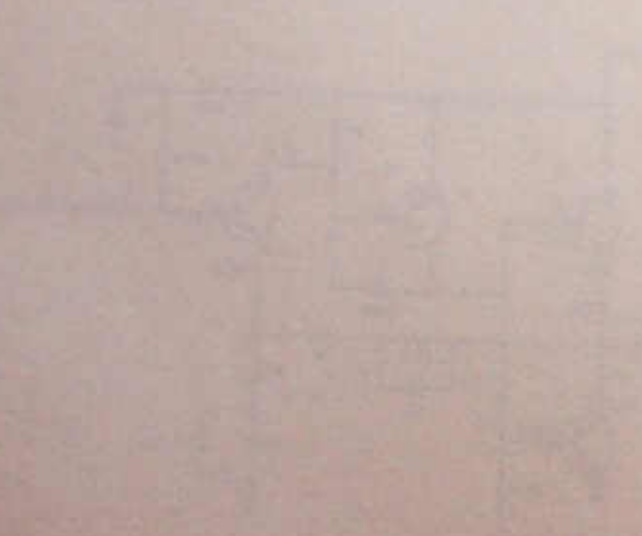

Second column of handwritten text at the top right, possibly a title or introductory text.

Third column of handwritten text in the upper right section.

Fourth column of handwritten text in the middle right section.

Fifth column of handwritten text in the lower right section.

Sixth column of handwritten text at the bottom right of the page.

The AM / FM Radio

More and more, the "a-m only" radio is disappearing from the scene, as the public begins to realize that fm is radio also and that things happen on fm that do not happen on a-m. Fm (frequency modulation) operates on higher radio frequencies than a-m. The fm broadcast band is from 88 to 108 MHz (megahertz, which is a million cycles per second) as compared to 535 to 1605 kHz for the standard broadcast a-m band.

FREQUENCY MODULATION

Frequency modulation puts the voice and music on the rf carrier, not by changing the power output in accordance with the voice or music, but by changing the frequency of the output in accordance with the desired modulation. The power output of an fm station does not change at all when in use, but the frequency of the output signal can vary as much as 75 kHz on each side of the center frequency. For example, a station with an assigned frequency of 90.3 MHz, when modulated at maximum (called 100% modulation), would be swinging back and forth in frequency from 90.225 to 90.375 MHz.

The amount of frequency swing indicates the "loudness" of the signal, while the rapidity with which it swings indicates the frequency of the audio tones. For example, a 1000-Hz tone sent by fm would cause the frequency to swing back and forth 1000 times per second. If the tone were sent out at a low level, the frequency might change only 5 kHz on each side of 90.3 MHz, but if sent out at full volume, the swing would be as defined for 100% modulation, 75 kHz on each side of the center frequency.

Freedom From Static

One of the big advantages of fm is the fact that it is "static free." This occurs for two reasons: One, there is less static on these higher frequency bands even with a-m, and two, static causes a change in the "power" of the signal reaching the antenna. More accurately, static is an overpowering amplitude-modulated signal, created by lightning and atmospheric disturbances, and this amplitude-modulated signal will

be "detected" by an a-m detector and passed on to the speaker. With fm, these noise pulses can be "clipped" off and eliminated, since the fm detector needs to respond only to frequency change and not to amplitude changes. Fig. 13-1 gives some idea of how an rf signal is frequency modulated and how the fm signal can be limited in the receiver to eliminate noise, or any other amplitude modulation.

Intermediate Frequency

Since an fm broadcast radio operates at a higher frequency and also has a wider bandpass* it must of necessity have a higher intermediate frequency. The i-f standardized for fm is 10.7 MHz.

10.7 MHz was chosen because it is relatively free of short-wave broadcast signals, it can easily accommodate a bandpass of 200 kHz or more, and it is high enough that no image frequency falls in the fm band. (Recall that image frequency always occurs at twice the i-f, so, since the fm band is only 20 MHz broad—88 to 108—no image within the band is possible.°)

Fig. 13-2 is a block diagram of an fm-only radio, minus the audio stages. There is a similarity between this and the a-m superhet circuit. One difference is the rf stage, which is nearly always used in an fm radio and not too often used in the a-m version. Too, there are three i-f stages on fm, and sometimes four, while on a-m there are generally only two and some-

*Bandpass is the term used to indicate how wide a frequency range that an amplifier will pass. For example, an a-m radio with 455-kHz i-f's might have a 20-kHz bandpass—that is, it might pass from 445 kHz to 465 kHz, though for a-m a 10-kHz bandpass is adequate. For fm the bandpass must be at least 150 kHz, because the frequency swings back and forth that far. For ease of tuning and best fidelity, an fm radio is usually designed with a bandpass of at least 200 kHz.

°This does not mean that images do not occur outside the band. For example, an fm radio tuned to 98.6 MHz has an oscillator frequency of 109.3 MHz, and 10.7 MHz above that is the image frequency (120 MHz), which is right in the middle of the aircraft radio bands. This accounts for the fact that sometimes you may hear a strong aircraft broadcast on an fm radio and shows why the airlines will not allow you to use an fm radio on board, since if you are tuned to 107.5 MHz, for example, the fm oscillator is at 118.2 MHz, and this could block out reception on an aircraft radio.

times only one. Another difference is, the fm detector is often called a demodulator. The demodulator must derive audio signals from the frequency changes it sees, rather than from amplitude changes. A fourth difference is the afc (automatic frequency control) line that nearly all fm radios have. The afc uses a corrective signal from the demodulator that counteracts any tendency for the oscillator frequency to change.

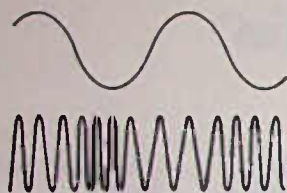

FM SIGNAL CHANGES IN FREQUENCY
(A) How carrier is modulated.



FM SIGNALS CAN BE CLIPPED (CALLED LIMITING) TO REMOVE NOISE BUT SIGNAL STILL RETAINS ITS FREQUENCY CHANGE AND THIS CAN BE DETECTED BY THE FM DEMODULATOR

(B) Noise reduction by clipping.

Fig. 13-1. Fm signal.

Without afc^o, an fm radio has a real tendency to drift off the station so that the dial has to be changed, especially during warmup, for the first 30 minutes or so. The afc circuit automatically corrects for this drift, making the radio user unaware of drift. The radio is generally tuned in with the afc switch "off" so that the afc circuit will not try to "pull in" the station when the dial gets close to the right place. Then the afc switch is turned on to hold the station correctly tuned.

*Some high-priced fm radios have been built with such good heat stability that afc was not considered necessary, but a radio this well designed costs several hundred dollars.

The reason drift is a problem on fm is because the frequencies are much higher than for a-m, and this means the electrical components that make up the tuned circuits are much smaller. For example, an antenna coil on fm may be only a couple of turns of wire and the capacitor no more than a single plate facing another one. Thus, even a slight mechanical or electrical change can become a major factor in the circuit. In fm, even the length of the leads that go to capacitors, transistors, etc. becomes a significant portion of the whole tuned circuit. This is why in replacement of parts in an fm tuner circuit, not only should the parts be the same type, but they should also have the leads cut to the same short length as the original. Failure to do so almost surely means detuning and lowered sensitivity of the tuner, as well as additional noise, etc.

THE ANTENNA AND RF CIRCUIT

The antenna on portable fm sets is usually a "whip" or "rabbit ears" (two whips). On home radios, the antenna may be built into the power cord, or it may be a coupling to the power line itself by a small capacitor. Sometimes it will be a short piece of wire. On fm stereo console home radios and the like, it may be two wires and sometimes a "folded twin-lead" antenna.

The antenna circuit is called a "low impedance" circuit because it uses transformer coupling or some other impedance-changing device between the antenna and the first tuned circuit.

Fig. 13-3 shows only a few of the several dozen antenna-circuit variations that are used, but all fall in these general categories. Fig. 13-3A is a broadband input circuit—in other words, the input is not sharply tuned, but is broadly resonant over the entire 88 to 108 MHz band. The coupling capacitors (7 pF and 20 pF) not only provide isolation between the antenna and the coil and the coil and the transistor bias circuit, but also are selected to provide the broad resonance required when an antenna rod or wire is connected.

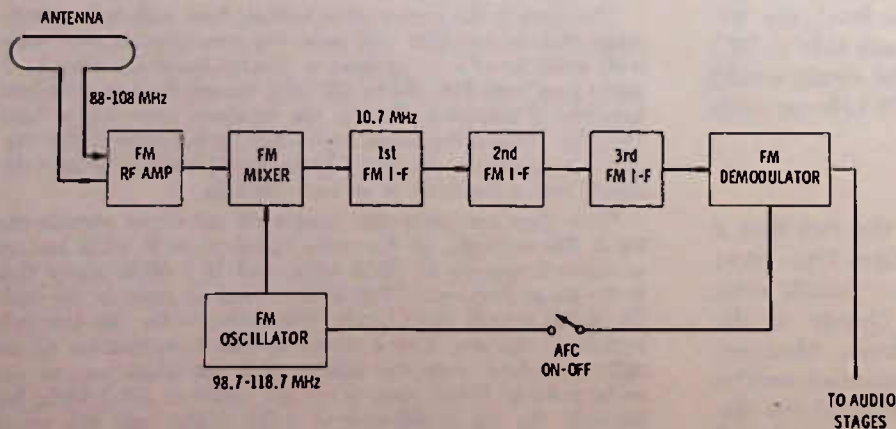

Fig. 13-2. Block diagram of fm radio.

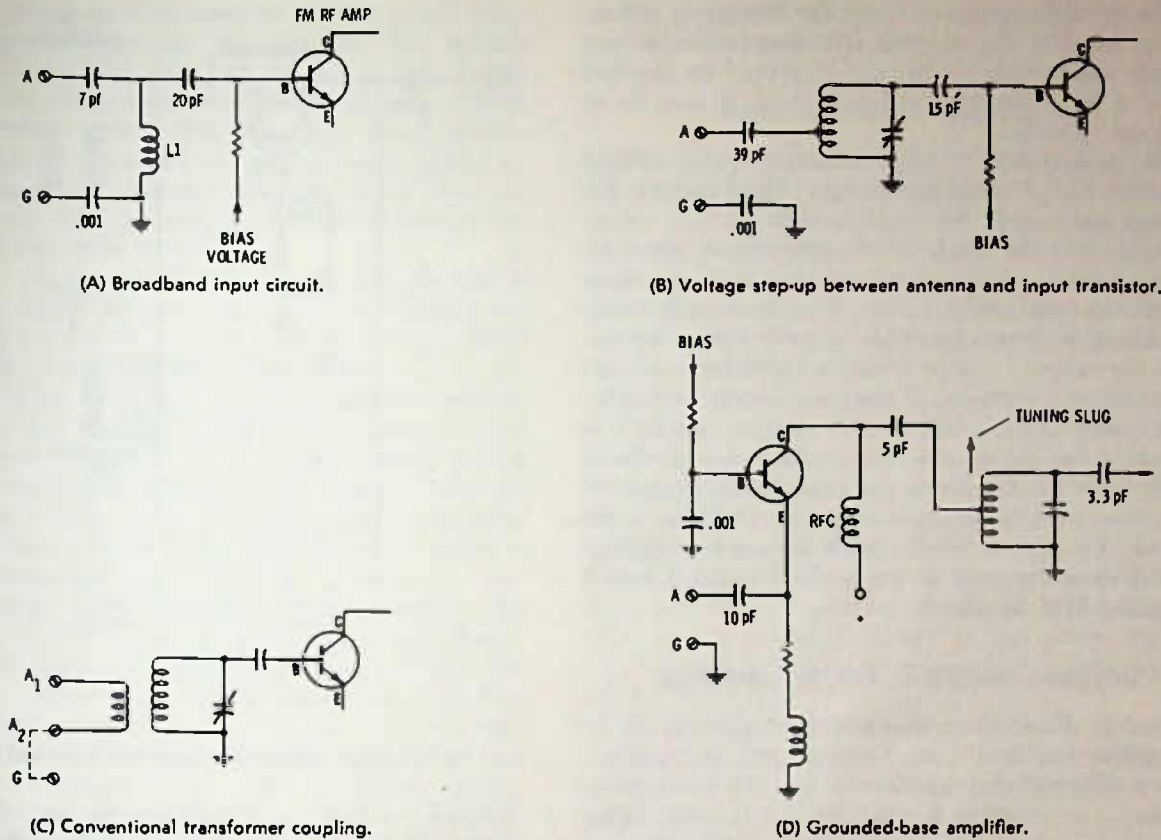

Fig. 13-3. Some fm antenna circuit variations.

In Fig. 13-3B, the tuned input circuit is tapped down to provide a step-up voltage between the antenna and the total resonant circuit. The 39-pF capacitor is for isolation and to prevent an incorrect antenna, which might be attached, from so detuning the circuit that reception would be weak and "hissy." Again, the 15-pF capacitor couples the signal to the transistor but blocks the dc bias from being shorted out through the coil.

Fig. 13-3C shows a conventional transformer coupling. The antenna coupling coil may be only one or two turns of wire wrapped around a 4- or 5-turn, tuned circuit. A metal strap is connected as shown by the dotted lines, when a rod-type antenna is used, but if a roof-type antenna is used with a twin-lead (like tv antenna lead), the leads are connected across the A₁-A₂ terminals and the strap to ground may be disconnected.

In Fig. 13-3D is what is called a grounded-base amplifier. Here, the signal is inserted on the emitter terminal, and the base is grounded by a .001-μF capacitor, so far as the signal is concerned, while still allowing dc bias to the base to remain. The advantage of this circuit is, the base effectively shields the input signal from the output signal so that there is practically no possibility of feedback from output to input, which can cause "birdies" (whistles) and the like. Since fm is at higher frequencies than a-m, a much

smaller capacity will pass them, and output-input feedback is a much greater problem. The grounded-base circuit is quite popular as an rf amplifier, and it is also sometimes used as an i-f amplifier. It is less susceptible to feedback because the input is low impedance, and low impedance circuits do not "pick up" signals so easily through small capacities.

Note that the tuning in Fig. 13-3D is by a slug which moves in and out of the coil. The capacitor across the coil is for trimming and is screwdriver-adjusted during initial alignment of the radio-frequency stages.

The rfc (radio frequency choke) provides a method of supplying dc voltage to the collector while forcing the rf signal to "stay on top" and be transferred to the tuned circuit through the 5-pF capacitor.

HOW TO FIND TROUBLES IN THE RF AMPLIFIER

An rf amplifier simply takes the input signal, at whatever frequency, and amplifies it at that frequency before sending it on to the mixer, where it is changed to the intermediate frequency. This means that if the rf amplifier becomes defective, stations may still be received if they are strong local ones, but distant stations may not be heard at all, and even local ones may have excessive background hiss.

If the trouble seems to be of the foregoing nature, it could be that the antenna circuit is broken or not properly connected; so this circuit should be checked also. If a local-distance switch is used, it may be in the "local" position.

Many technicians use the following quick method of testing the rf amplifier circuit. They remove the antenna and touch the input circuit with a screwdriver, making the blade of the screwdriver act as an antenna, and try to tune in a station with the radio dial. If a station cannot be tuned in, or is really weak, the technician then moves his screwdriver to the collector (or output) circuit of the rf amplifier and again tries to tune in stations. If the radio works noticeably better when the collector (or output circuit) is touched, then the trouble is almost surely in the rf circuit, with the transistor the most likely trouble. Rf transistors seem to be extremely susceptible to faults because of surge voltages (such as nearby lightning flashes) or when used in car radios operated near a strong local fm signal, etc.

VOLTAGE-CHECKING THE RF AMPLIFIER

There is almost always an emitter resistor in the fm rf amplifier transistor circuit and a quick dc measurement should tell you whether or not the transistor is drawing current. If it is not drawing current, either the transistor or the bias circuit is defective. Typical current in an rf transistor is from about 1 to 3 mA. Use Ohm's law to determine about how much voltage should be at the collector. For example, if the emitter resistor is 330 ohms (about $\frac{1}{3}K$), then about 0.3 to 1 volt might logically be expected across the resistor. If the voltage is excessive across the resistor, then the problem likely is a shorted transistor.

Other problems which could occur in the rf amplifier might be a serious detuning caused either by someone "diddling" with the trimmers on the fm tuning capacitor or across the fm slug-tuned coils. The small bypass capacitors and tuning capacitors are not often the cause of fm circuit troubles and sometimes, if they are, it may not be profitable to try to replace the offending part, unless you have had considerable experience with a particular-type tuner or with working on high-frequency circuits. Both parts placement and length of leads of replacement parts can be critical factors in whether an fm tuner works efficiently, or even works at all.

THE FM CONVERTER (MIXER-OSCILLATOR)

The fm mixer and oscillator may use two transistors, one for each function, but many circuits use one transistor for both jobs. Fig. 13-4 is such a circuit. This is a "grounded-base" oscillator and mixer circuit. The signal from the rf stage is fed to the emitter through a 3.3-pF capacitor. The oscillator signal feedback is

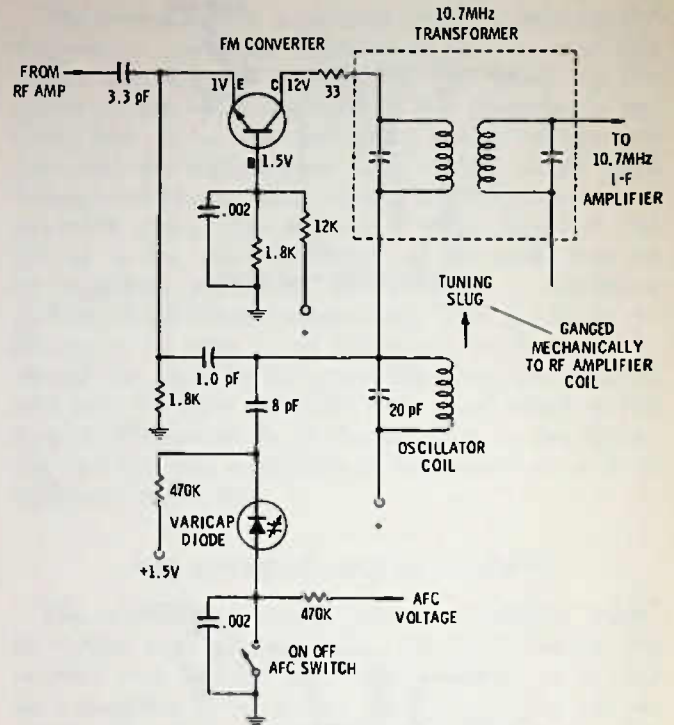

Fig. 13-4. Single transistor serving as both mixer and oscillator.

through a 1.0-pF capacitor from the top of the oscillator coil, which is directly tied to the collector (output) circuit through the primary of the i-f transformer.

The oscillator coil in this circuit has slug tuning. The slug moves in and out of the coil as the dial is turned. The coil has a 20-pF capacitor across it. Across the coil, besides the 20-pF capacitor, is a "varicap" diode in series with an 8-pF capacitor. The opposite end of the diode is effectively at rf ground because of the .002- μ F capacitor. A varicap is a diode that changes capacity in a linear fashion as the reverse voltage across it is changed. This means that by applying a dc voltage to the diode the fm oscillator circuit can be tuned. An afc (automatic frequency control) voltage is taken from the fm demodulator circuit through a 470K resistor and fed to the diode on the lower side. On the other side, +1.5 volts is applied through another 470K resistor to the diode. The fm demodulator, when tuned in to the center of a station, has zero dc voltage output on the afc line. If the station is off-tune in one direction, the dc voltage goes positive, and if the station is off-tune in the other direction, the dc output voltage goes negative. With the station tuned in properly, there is +1.5 volts on the cathode of the diode, which represents some specific capacity. Now, if the oscillator starts to drift off frequency, the demodulator circuit will go either positive or negative, which either increases or decreases the capacity of the varicap and puts the station back in tune. (Actually, the varicap cannot pull the oscil-

lator completely in tune since to do this would drop the demodulator voltage to zero; so the varicap would have its original effect on the circuit. Fortunately, an fm demodulator can operate slightly off tune and still sound good, and, since the actual off-frequency pull is slight, an afc circuit works perfectly. In fact, the afc circuit can hold the circuit closer to being in tune than it is possible for the average person to tune an fm radio by ear.)

To turn off the afc in this circuit, the afc line is grounded, which assures that there is zero voltage on the anode side of the diode. The set is then tuned in (which should provide zero voltage on the afc line) and when the afc switch is opened, the oscillator tuning will not change. Turning off the afc provides more accurate tuning because it allows the afc circuit the maximum pull-in range. If you tune with the afc on, the afc circuit will continually try to compensate for an off-tune condition of the dial which makes it next to impossible for the radio user to get "centered" tuning. Some radios, notably automobile fm radios, do not have afc switches; this gives broader tuning and makes it easier for the user to get the radio on a station while driving down the road. The disadvantage of this method is that when the auto moves out into the fringe area of the signal, the user may have to retune because the afc circuit can no longer capture and hold the signal.

Afc circuits also can cause another trouble in car radios or in home fm radios that are tuned to weak stations. If, because of location (in the auto radio) or because of atmospheric conditions, another station—even on an adjacent channel—gets strong enough, it can "capture" the afc circuit and cause the radio to change to the new channel.

Fig. 13-5 is a separate oscillator transistor. This is essentially the same oscillator circuit as in Fig. 13-4, with collector-to-emitter feedback. The base is grounded for signal by the .01- μ F capacitor. A "bias balancing" circuit (R3 and R5) helps to keep the transistor drawing appreciably the same amount of current. If the collector circuit starts to draw more current, less negative voltage (more positive) appears at point A, which in turn reduces the bias of the transistor, tending to reduce the collector current.

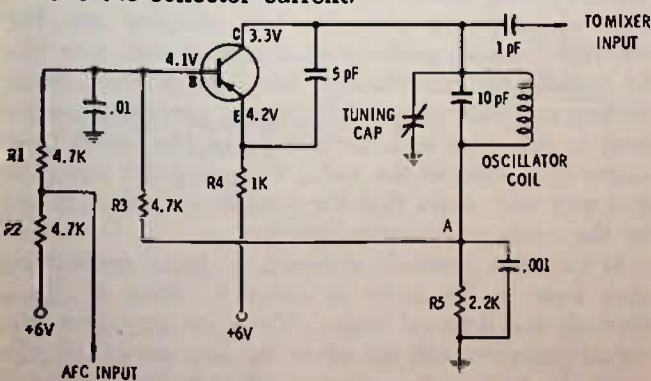

Fig. 13-5. Separate fm oscillator with afc.

The afc circuit operates by changing the bias of the oscillator transistor.

HOW TO CHECK OSCILLATORS

Checking an fm oscillator is a bit more difficult than checking an a-m oscillator, for at least two reasons: One, because of the high frequency, the leads of your test equipment will cause serious detuning if you connect to a signal circuit, and, two, because leads must of necessity be short in fm tuner sections, the circuit is often so crammed together that it is difficult to find a suitable test point.

A little ingenuity is needed. The circuit of Fig. 13-4, for example, can be checked for base bias because the base is at ground so far as rf is concerned. If the base bias is about normal, then check the emitter voltage—the emitter circuit is "hot" so far as signal is concerned, but even if the oscillator is detuned, the transistor should still be drawing current because of the base bias. Also, if you use a vtm or solid-state vom that uses an isolation resistor at the probe tip, then you can measure this voltage without serious detuning of the oscillator.

While monitoring this voltage with the isolated test probe, touch some point on the oscillator coil circuit and see if the emitter voltage changes—the voltage should go up if the oscillator is working.

In Fig. 13-5, an ideal place to check transistor current without upsetting the signal circuit is at point (A). A test probe with an isolation resistor can measure the voltage at the emitter without appreciable effect on the circuit. But even with considerable effect, the transistor must draw current and should indicate approximately the right voltage, perhaps a bit high, at any of the transistor elements.

Test Tip: If you are using a vom with open test leads, you can provide signal isolation that will not seriously upset the high frequency circuit, by temporarily soldering or wrapping a 22K, 1/2-watt resistor to the test probe tip and using the opposite end of the test resistor to touch the various transistor elements, Fig. 13-6. The resistor will cause the vom to read approximately 1 volt low. In other words, if you get a reading of 2.3 volts you know that the actual reading is about 3.3 volts, or if you get a reading of 0.5 volt, the actual reading is about 1.5 volts, etc. This method is also useful for checking voltage in the rf stages and in the i-f amplifiers, when upsetting the signal voltage might cause significant changes in the operation of an amplifier and thus cause erroneous voltage readings.

THE FM I-F AMPLIFIERS

It would be nice if the fm i-f amplifiers were always separated from the a-m i-fs, so far as parts and transistors are concerned. Some radios do have completely

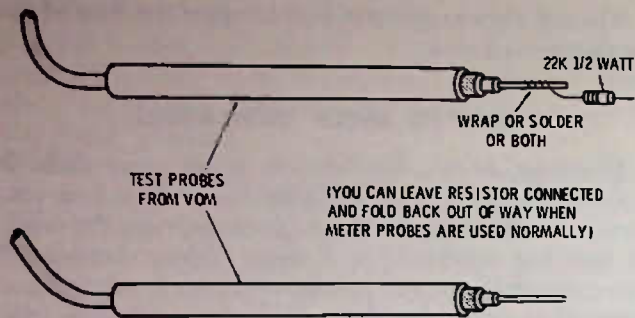
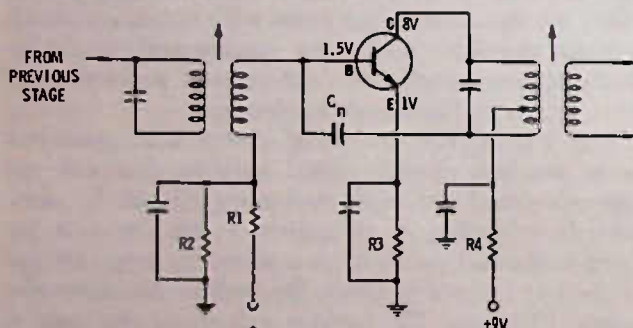

Fig. 13-6. Isolation probes used with vom.

separate i-f strips, but many use a "combo" strip that utilizes at least part of the a-m transistors in the fm i-f circuit.

But, first, let us consider the separate strip. From earlier discussion in this chapter, you noted that the fm strip usually has one or several i-f stages more than the a-m. This is necessary for at least two reasons: One, the broader bandwidth and higher frequency require more amplification in order to obtain the same voltage output as a lower frequency narrow band amplifier. Two, there must be enough amplification to provide "limiting." That is, the signal must be amplified enough so that clipping off the top and bottom will not seriously affect the output. To get more gain and to provide limiting action, the fm amplifier uses at least 3 stages and, except in a few instances, no agc is applied. When agc is applied to the i-f, it is normally only to the first stage.



(A) Negative battery ground.

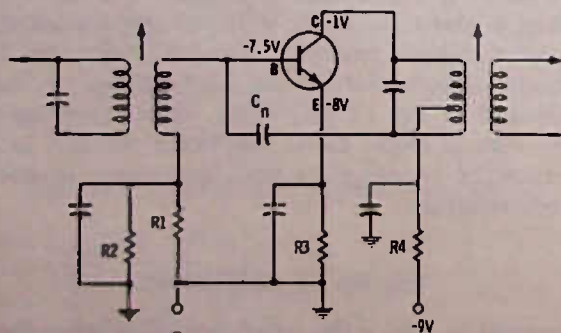

(B) Positive battery ground.

Fig. 13-7. Two fm i-f circuits identical except for ground polarity.

Fig. 13-7 shows two typical fm i-f amplifiers. Both of these amplifiers are identical, both use npn silicon transistors, etc. The only difference is that one circuit is wired to have the battery with a negative ground and the other to have the battery with a positive ground. The voltages across the transistors are identical, as to both amount and polarity, but when read to ground there is considerable difference. These drawings show how possible confusion can occur concerning the transistor voltages. If you read the voltages of Fig. 13-7B, using the negative side of the battery as common for the meter you would read exactly the same voltages as are shown for Fig. 13-7A.

As can be seen from Fig. 13-7, the fm i-f amplifier stage and an a-m i-f stage have much in common. The big difference is not in the dc circuits, but in the i-f transformers, which, in the case of fm, are tuned to 10.7 MHz.

In a-m i-f's you will not see too many neutralized circuits, especially in later model radios, but in fm i-f's there is still quite a lot of it done in the design. In Fig. 13-7, C_n is the neutralizing capacitor and may range in size from about 1 pF to 10 pF. In addition, a "losser" resistor is also used in many circuits between the collector and the primary of the i-f transformer. This resistor helps isolate the collector tuned circuit from the input tuned circuit and so aids in preventing possible self oscillation of the i-f amplifier.

TESTING THE I-F AMPLIFIER

As in other circuits, the dc voltage readings on a particular stage will often show up the particular fault, since the most faults occurring in the dc circuits, or even in the signal circuits or the transistor, will show up as erroneous voltage readings.

You can usually tell if an i-f amplifier is working by simply using a screwdriver and touching the base connection of the 1st i-f transistor—in most cases you should hear an increase in noise (hiss) in the speaker, if the i-f is working normally.

The signal generator is, of course, an ideal test method, since by injecting a 10.7-MHz signal into the i-f you should be able to measure the output by checking the voltage across the a-m rejection capacitor. The signal generator is generally best coupled into the circuit by simply pushing an insulated wire into the i-f transformer can through the hole in the top or bottom and then clipping the signal generator output lead to this wire and the ground of the signal generator to ground of the radio. Coupling the signal in this way will assure that the circuits are not detuned by the signal generator connections.

If the i-f is seriously detuned, a direct connection may have to be made in order to drive a signal through the detuned stages. To make sure that the signal generator will not affect the bias circuits of the radio, be sure to connect a small capacitor in series

with the hot lead of the signal generator. This can be any size from about 100 pF to 1000 pF, with the smaller size preferable. See Fig. 13-8.

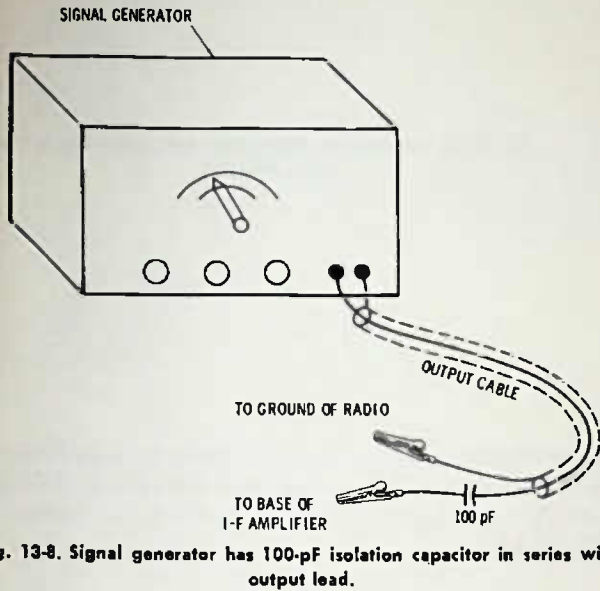

Fig. 13-8. Signal generator has 100-pF isolation capacitor in series with output lead.

THE FM DEMODULATOR

The most common of all fm demodulators is the ratio detector, a circuit of which is shown in Fig. 13-9. With some variations, this circuit is probably used in 90% of all modern fm radios, especially transistor radios. It can be recognized by the fact that the diodes face in opposite directions, coming off the demodulator transformer. The ratio detector also has an "a-m rejection" capacitor, usually about 1 to 10 μ F.

The ratio detector can reject a-m because one of the detector diodes is going positive and the other is going negative; so at the center tap of the transformer, where the audio is taken off, the amplitude voltages cancel.

The fm ratio detector, as well as the discriminator, Fig. 13-10, works basically on the principle shown in the basic detector circuit of Fig. 13-11. In this circuit, L1 is tuned higher than the i-f, while L2 is tuned lower than the i-f. When only the i-f is coming in (no audio modulation), both L1 and L2, being tuned the same distance above and below the i-f, will receive identical signals, and the same amount of voltage is developed at points A and B, so that these two voltages cancel and you hear nothing in the output. As the audio swings the frequency up and down, first L1 receives the stronger signal, increasing the voltage at A, and then on the next half cycle the voltage at B increases, so that we have an audio voltage output across R1 and R2.

In the refined circuitry of today, in both ratio detector and discriminator, the high-low frequency-selection circuit still exists. Because of "double-humping" of the response through the coupling circuits, it is possible to tune the circuit with only one slug. This provides much quicker and easier balance of the circuit, with better linearity.

The discriminator circuit responds to a-m signals as well as fm signals, and when a discriminator circuit is used, a "limiter" stage must precede the circuit to clip off all amplitude modulation and noise. The ratio detector, because of the reverse-connected diodes, tends to cancel a-m and noise automatically. Most designers, though, still provide for some clipping or limiting in the amplifiers to make sure that the signal is as noise-free as possible.

The output on the audio line of most ratio detectors and some discriminators is a zero dc voltage when the circuit is perfectly in tune. If the signal shifts away from the center frequency, then one of the diodes draws more current, and there is either a positive or negative dc voltage output, depending upon whether the frequency goes high or low. It is this voltage that is used for the automatic frequency control (see Fig.

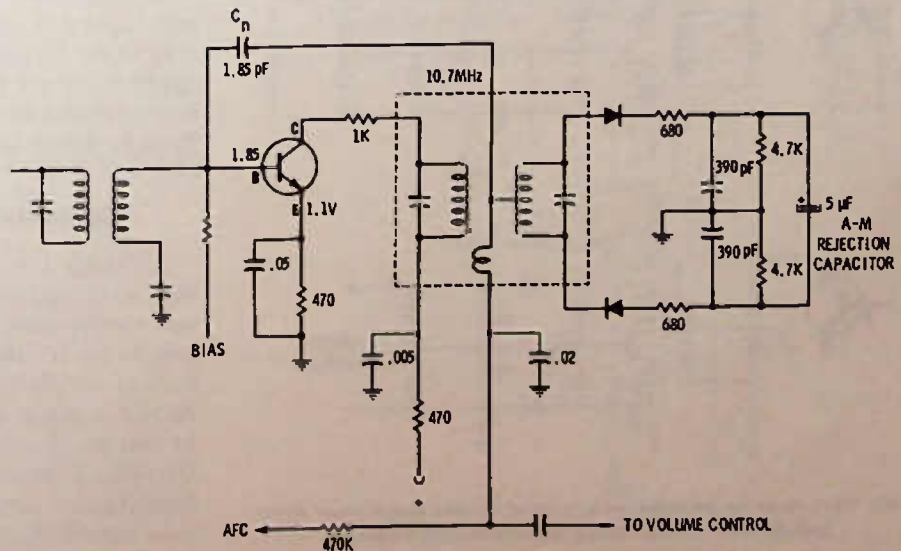

Fig. 13-9. Fm demodulator. This is a ratio detector.

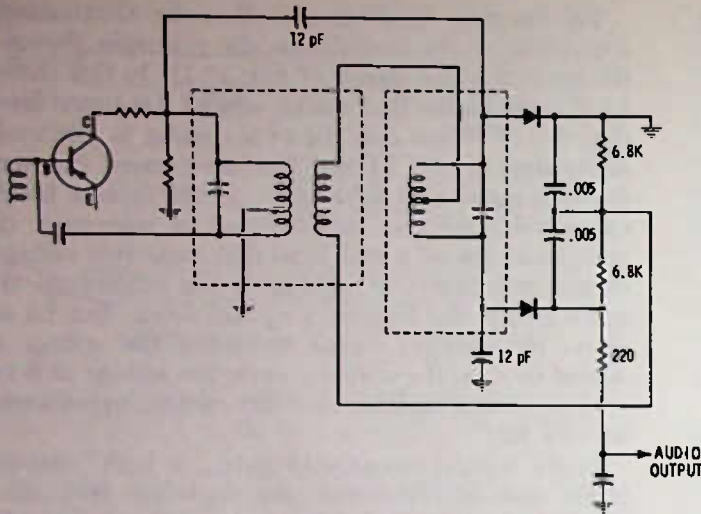

Fig. 13-10. Discriminator circuit. Note that diodes face in the same direction.

13-9). It is also this voltage that is used to properly tune the i-f amplifiers in the following manner. Feed in a 10.7-MHz signal and first detune the secondary of the ratio detector, then, while reading the voltage across the a-m rejection capacitor, set all the i-f transformers for maximum output. Keep the signal generator output low (no more than 1 volt, preferably less, across the a-m rejection capacitor) and tune each coil for maximum. Now move the meter to the afc (audio output) line. The meter should be an amplified type, if possible, that has a zero-center position (short the meters test leads together to set up the meter for zero center). Adjust the secondary of the demodulator transformer until the meter reads exactly zero voltage. Fig. 13-12 shows the alignment setup. Not all ratio detector circuits have the A4 and A5 adjustment in the same can. Many radios, especially Japanese makes, will have separate cans usually mounted next

to one another. Many American-made i-f transformers have a dual core, one at the top and one at the bottom. A hex alignment tool is needed, as shown in Fig. 13-13.

AGC CIRCUITS

It is possible to take off an agc voltage from the ratio detector from one side of the a-m rejection capacitor to ground. However, there are some disadvantages in doing this, because of circuit tuning that changes the point of maximum agc with signal strength changes. A great many designers use another diode for agc, as in Fig. 13-14. If this is taken off the last i-f, it provides more agc voltage output, but also tends to not peak with maximum signal because of the detector tuning—the same fault as with taking off the agc direct from the ratio detector, though perhaps not quite so noticeable. For this reason, several designs take off the agc signal voltage from the i-f stage ahead of the final one.

As indicated before, many fm i-f strips do not have agc applied at all, while others may have agc applied only to the first stage. Those using an agc circuit often apply the control voltage to the rf stage only, and the main purpose here is to prevent overloading on an extremely strong local signal.

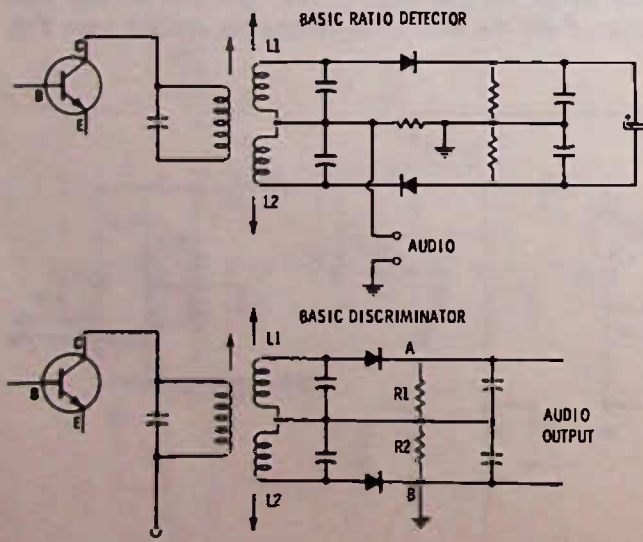

Fig. 13-11. Basic fm detectors are two tuned circuits. One is tuned above and the other is tuned below the intermediate frequency.

COMBINATION AM/FM I-F AMPLIFIERS

Although few radios use combination front ends, that is, rf and converter for both a-m and fm, many use combination i-f amplifiers. The switching from a-m to fm is often just a matter of switching on the battery supply to those sections of the amplifier that do not function on both bands. For example, the last i-f and the demodulator circuit are switched off when the radio is on a-m and the audio is switched from the demodulator output to the detector output. On occasion, there will be switching between the 455-kHz and

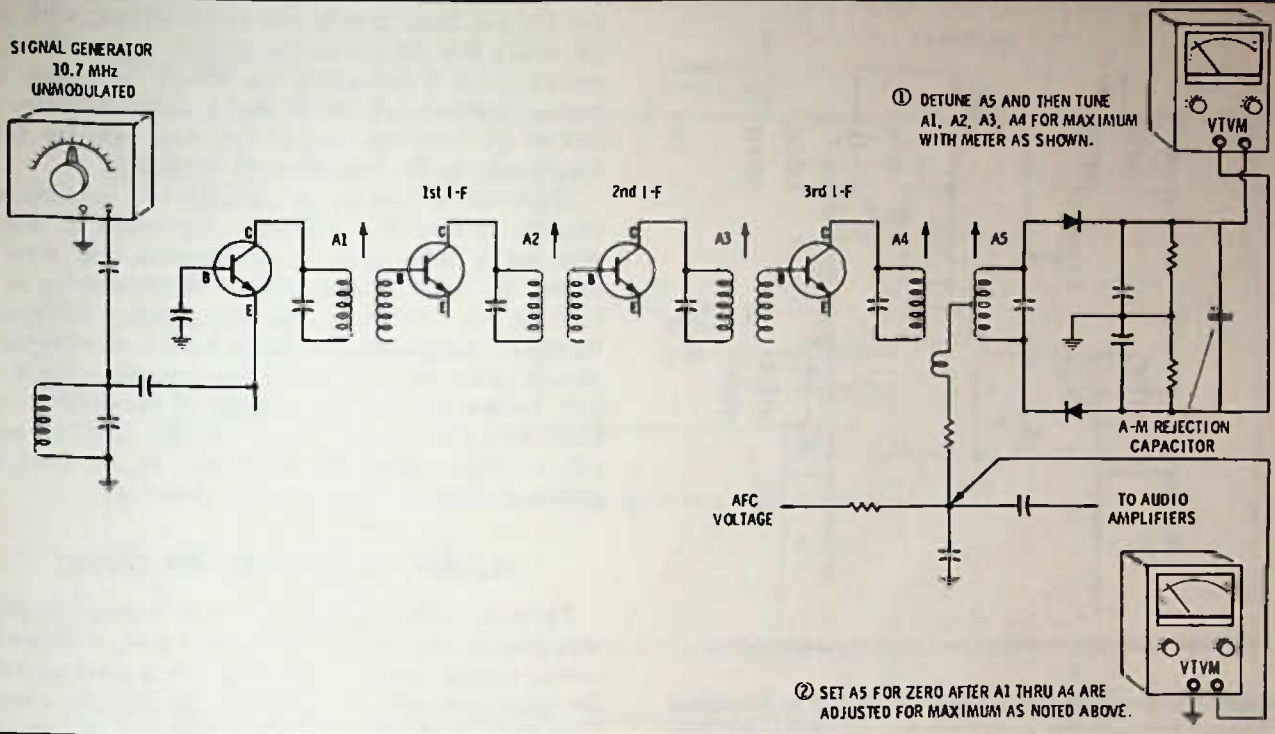

Fig. 13-12. Setting up (alignment) of fm radio that uses ratio detector. Keep signal generator output low.

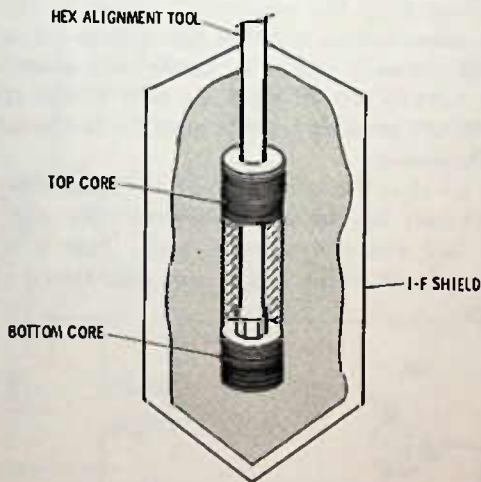

Fig. 13-13. Hex alignment tool reaches bottom core by first passing through top core.

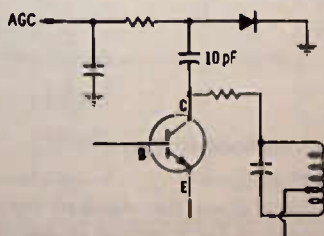

Fig. 13-14. Separate diode used for agc voltage.

the 10.7-MHz i-f transformers, but generally not. Instead, the transformers are connected in series (or sometimes in parallel) with the 10.7-MHz transformers connected closest to the transistor, as in Fig. 13-15. The circuit works because so far as the 455-kHz transformer is concerned, the few turns of wire on the 10.7-MHz transformer appear to be no more than a

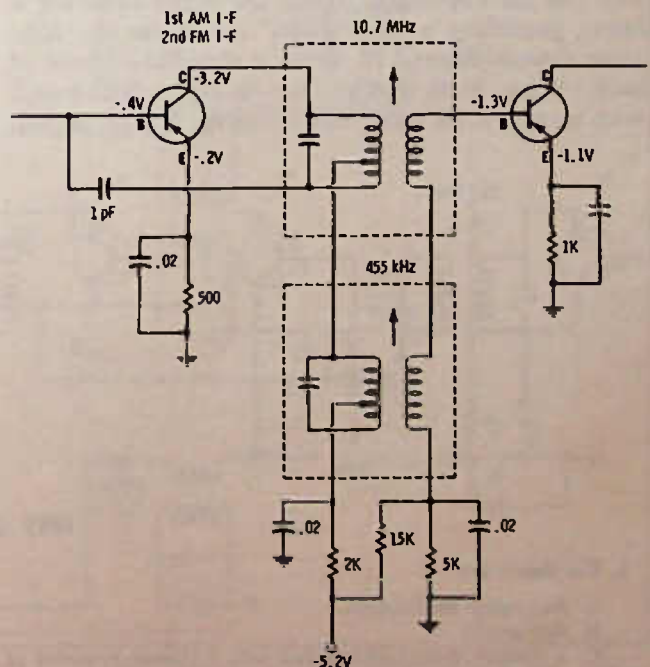

Fig. 13-15. Combination am/fm i-f amplifier.

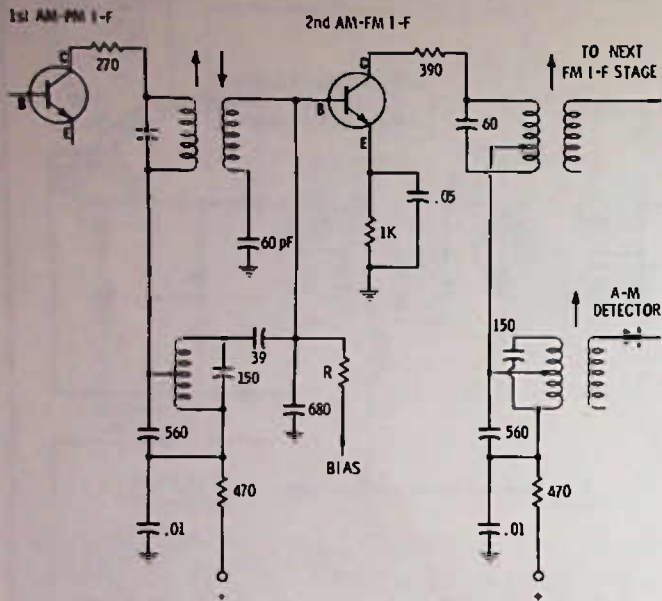

Fig. 13-16. Combination am/fm circuit using capacity matching.

straight wire, while the 10.7-MHz signal is bypassed to ground through the capacitor circuit of the 455-kHz transformer.

Another combination circuit is shown in Fig. 13-16. In this circuit, a type of circuit matching is done that has not before been included in the discussion. This is the capacity coupling or matching technique. Instead of using a step-down transformer to lower the impedance to the base of the transistor, two capacitors of unequal size are used across the resonant circuit. The capacitors themselves become a part of the circuit, but the impedance across the larger capacitor is lower, providing a "step down" match for the transistor circuit. Fig. 13-17 shows a simplified layout of each circuit. Note that the fm circuit is dual tuned, with transistor Q2 being fed across the 680-pF capaci-

tor. On a-m there is only one tuned circuit, with a 39 pF and a 680 pF across the circuit. Again, the base circuit of Q2 is fed across the 680-pF capacitor. The two capacitors block the dc that is in the collector circuit of Q1 from the base of Q2. Base bias for Q2 is fed directly to the base through resistor R.

There are a number of variations in combination circuits, so that it is virtually impossible to discuss each minor refinement or modification, but they all follow the basic idea of getting one transistor to do a single job. With transistor cost coming down continuously, the trend seems to be back toward separate circuits again, since, in most cases, a combo circuit will only reduce by two the number of transistors used. Considering the much "cleaner" design that two separate amplifiers have, the temptation to use dual amplifiers is doubly inviting to the designer.

TESTING THE COMBINATION CIRCUIT

There is one slight advantage in testing combination circuits and that is, for the most part, if either the a-m or the fm portion is working, it is a good sign that the other portion is all right, too. An exception would be a case in which one or the other section were detuned, or cases in which some damage to one transformer might prevent it from working at its normal frequency, but would not stop it from passing the signal voltage from the unaffected section of the amplifier. In other words, if either the a-m or fm section is working normally, there is hardly any question that the dc circuits are all right, as well as the transistor itself; so any possible trouble must be in the tuned circuits themselves.

Fig. 13-18 is the schematic of a combination amplifier, not only for the am/fm circuits, but also for the fm i-f and a-m converter as well. This is a circuit used in a home radio, and it uses dual-tuned i-f transformers.

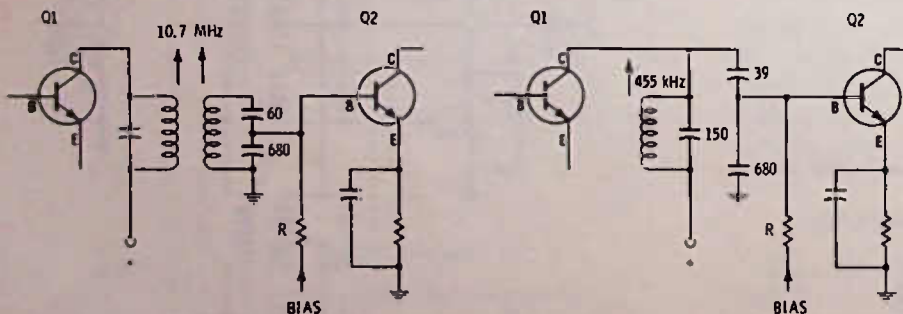

Fig. 13-17. Equivalent circuit of Fig. 13-16, showing the combination circuit separated.

TEST QUESTIONS

1. Fm stands for
 - A. frequency modulation.
 - B. fine music.
 - C. a system of modulation that uses a change in power of the rf carrier corresponding to the audio signal.
 - D. frequency modification.
2. The fm broadcast band is from
 - A. 535 to 1605 kHz.
 - B. all frequencies above the standard broadcast band up to the low end of the television broadcast band.
 - C. 88 to 108 kHz.
 - D. 88,000,000 to 108,000,000 hertz.

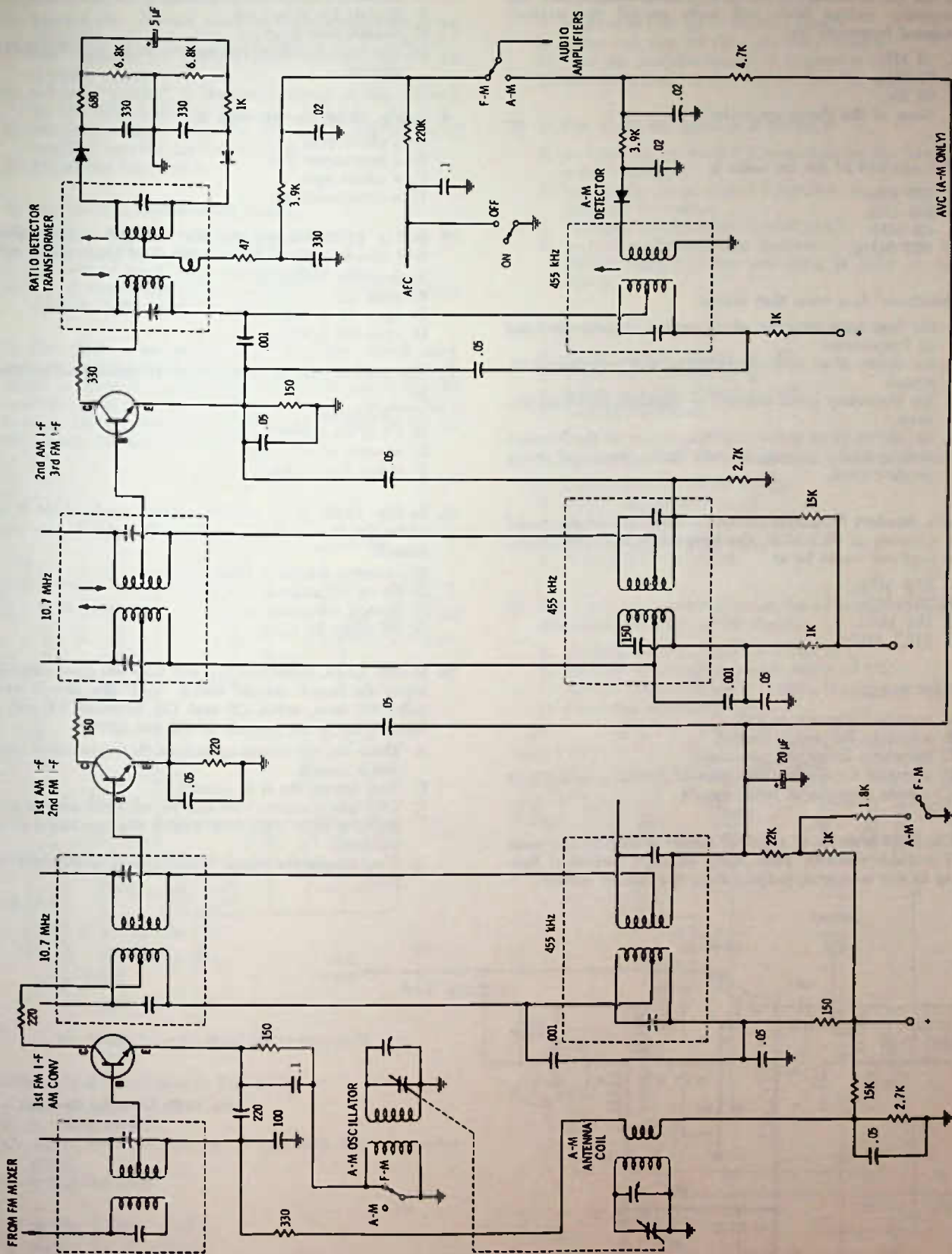

Fig. 13-16. Combination am/fm i-f circuit with 1st fm i-f also serving as a-m converter. The am/fm changeover switch shorts out the a-m oscillator coil when on fm.

3. In the fm broadcast band, 100% modulation means the frequency swings back and forth around the station's assigned frequency by

- A. 75 MHz.
- B. 75 kHz.
- C. 75 Hz.
- D. None of the above are correct.

4. The standard i-f for fm radio is

- A. 455 kHz.
- B. 262 kHz.
- C. 4.5 MHz.
- D. 10.7 MHz.

5. "Bandpass" is a term that means

- A. the frequency response of a circuit to a particular band of frequencies.
- B. the ability of an audio amplifier to pass radio frequency signals.
- C. the frequency band assigned to standard broadcast stations.
- D. the ability of an audio amplifier to pass all the frequencies normally associated with those produced by a musical band.

6. In a standard broadcast receiver for fm which was tuned to a station at 90.3 MHz, the image frequency that might be received would be at

- A. 68.9 MHz.
- B. 79.6 MHz.
- C. 101 MHz.
- D. 111.7 MHz.

7. "Afc" means

- A. average frequency control.
- B. automatic frequency control.
- C. automatic frequency conversion.
- D. a system for holding the gain of a radio constant over a wide variation of input signals.

8. Fig. 13-19 is an fm rf amplifier circuit as used in one make of portable receiver. How much collector current is flowing in this transistor, judging from the emitter voltage?

- A. Between 1 and 2 mA.
- B. Slightly less than 1 mA.
- C. Slightly over 2 mA.

D. The emitter voltage has nothing to do with the collector current.

9. In Fig. 13-19, the transistor is

- A. a silicon pnp.
- B. a germanium pnp.
- C. a silicon npn.
- D. a germanium npn.

10. In Fig. 13-19, suppose that the base and emitter voltages read zero to ground. The trouble most likely would be

- A. defective transistor.
- B. open R3.
- C. open R1 or R4.
- D. open C4 or C6.

11. The same trouble as in Question 10 could also be caused by

- A. C5 shorted.
- B. C4 or C6 shorted.
- C. absence of +5 volts.
- D. either B or C above.

12. In Fig. 13-19, if the emitter voltage reads about 5 volts while the base voltage reads nearly normal, you should suspect

- A. excessive transistor bias.
- B. C4 or C6 shorted.
- C. shorted transistor.
- D. R4 might be open.

13. In Fig. 13-19, capacitors C1 and C10 are fixed capacitors across the tuned circuits which "pad" the circuit so the coils will tune, using C3 and C8, between 88 and 108 MHz. What is the purpose of C2 and C9?

- A. These are the tuning capacitors that vary when the fm dial is turned.
- B. They bypass the rf to ground.
- C. They are trimmers that can be adjusted with a screwdriver or other alignment tool so the two tuned circuits will track.
- D. They couple the signal from the coil to the next transistor.

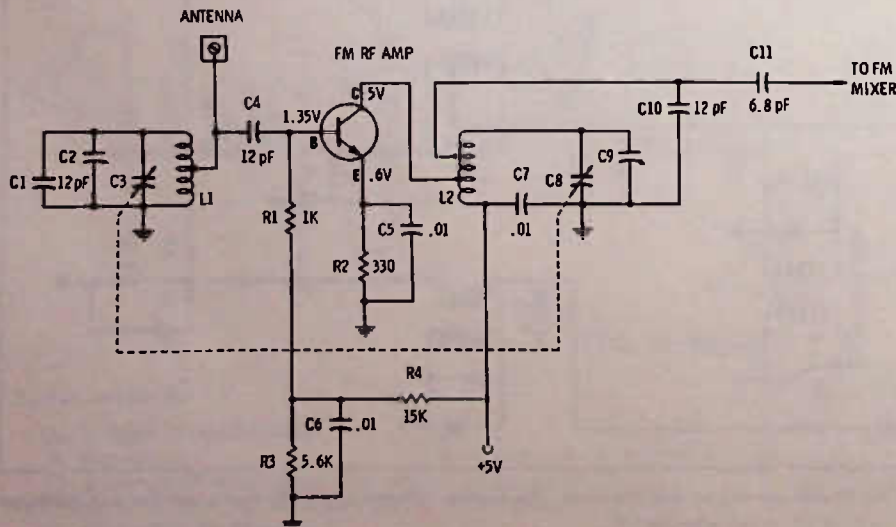

Fig. 13-19. Circuit for Questions 8 through 15.

14. In Fig. 13-19, C7 is needed to
- prevent the +5 volts going to the collector from being shorted to ground, while still making an rf "short circuit" between L2 and the other capacitors in the L2 resonant circuit.
 - act as a "padder" in the tuned circuit so that L2 will be 10.7 MHz higher in frequency than L1.
 - couple the signal from the collector circuit of the rf amplifier into the L2 tuned circuit.
 - bypass the bias circuit.

15. In Fig. 13-19, if capacitor C5 opened,
- the bias would be zero on the transistor.
 - the gain of the rf stage would be reduced.
 - the gain of the rf stage would drop to zero.
 - the rf stage would likely oscillate on its own, causing whistles in the output of the radio.

16. In Fig. 13-20 is an fm mixer and oscillator circuit using separate transistors for the two functions. The oscillator signal is coupled into the mixer stage through C11. The oscillator itself is a "grounded base" circuit with feedback through C5 between the collector and emitter of Q2. In this circuit the oscillator coil is
- L1.
 - L2.
 - T1.

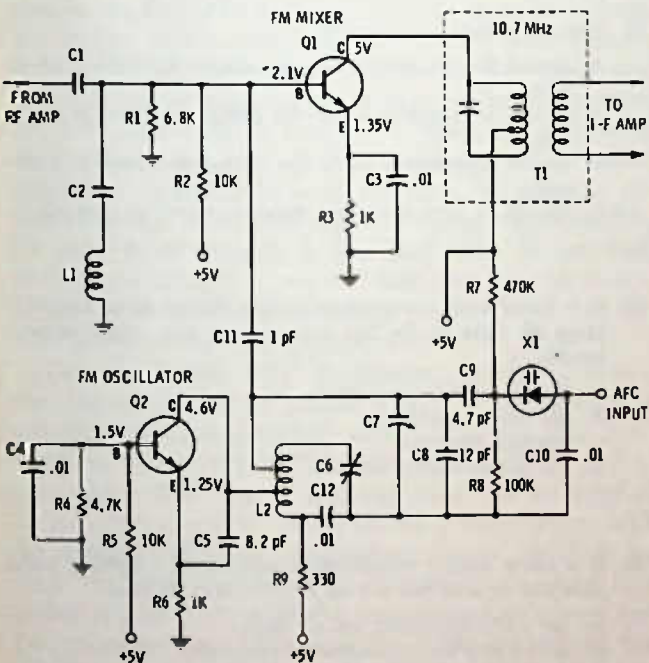

Fig. 13-20. Circuit for Questions 16 through 22.

17. The oscillator transistor in Fig. 13-20
- is a germanium npn.
 - is a silicon npn.
 - cannot be determined as to type with the information given.
 - is also the mixer.
18. X1 in Fig. 13-20 is used to
- rectify the afc voltage.
 - change capacity, depending on the afc voltage.
 - provide a negative output voltage to the afc line.
 - provide positive bias to the npn oscillator transistor.

19. The purpose of R7 and R8 in Fig. 13-20 is to
- make sure that X1 is forward biased.
 - make sure that X1 does not draw current.
 - tune the oscillator circuit to frequency.
 - provide a load on the +5-volt line for stabilization.
20. In Fig. 13-20, the purpose of C2-L1 is
- to tune the fm band for maximum on the base of the mixer transistor.
 - to trap out an unwanted frequency, to prevent it from reaching the mixer.
 - to bypass the base-bias circuit of Q1.
 - to tune to the oscillator frequency, to prevent it from feeding back into the preceding rf stage or antenna circuit.
21. If C4 shorted in Fig. 13-20, it would result in
- higher emitter voltage on Q2.
 - higher base voltage on Q2.
 - higher collector voltage on Q2.
 - none of the above.

22. In Fig. 13-20, if R1 were to open, it would result in
- higher emitter voltage on Q1.
 - higher base voltage on Q1.
 - higher collector voltage on Q1.
 - A and B are both true.
 - A, B, and C are all true.
23. Fig. 13-21 is a combination am/fm i-f amplifier section. In this circuit the a-m and fm signals
- are both fed into the base circuit of Q1.
 - are both fed into the emitter circuit of Q1.
 - are fed into the base and emitter circuits respectively.
 - are mixed together in Q1.

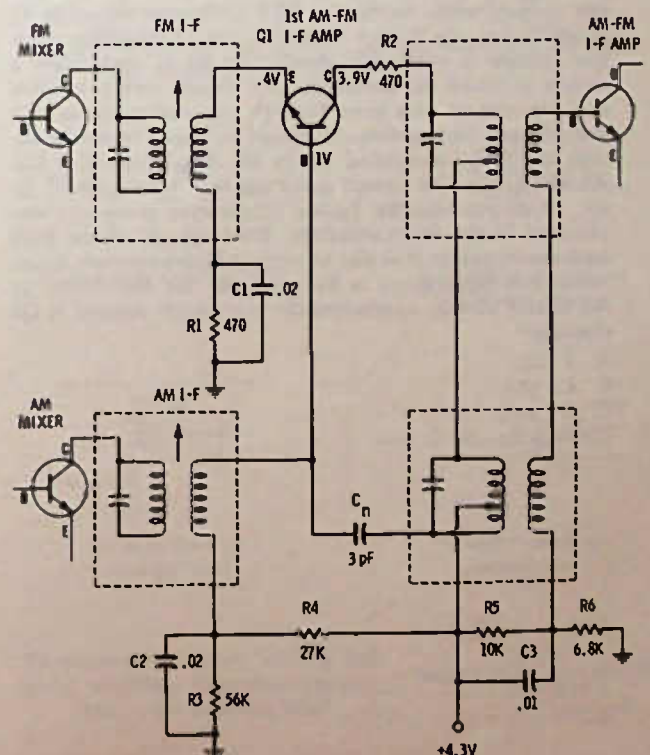

Fig. 13-21. Circuit for Questions 23, 24, and 25.

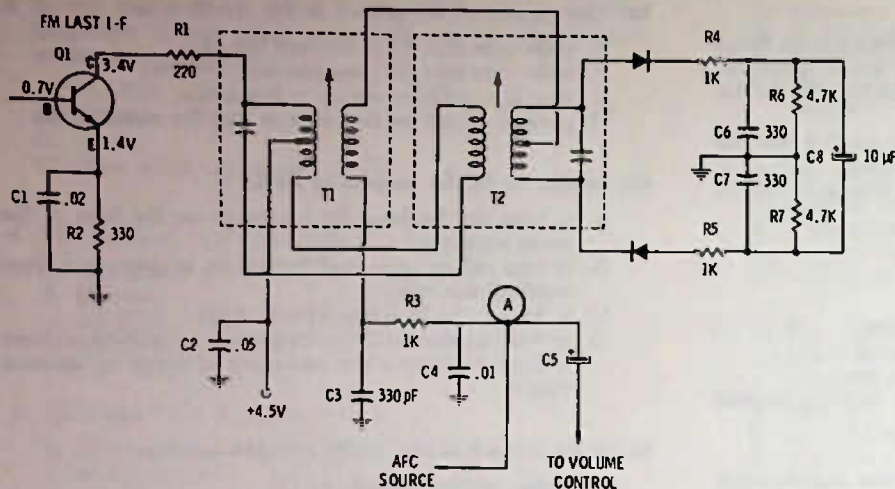

Fig. 13-22. Circuit for Questions 26, 27, and 28.

24. If the collector of Q1 in Fig. 13-21 reads 4.3 volts, it might indicate
- an open transistor.
 - an open resistor R1.
 - open resistor R4.
 - all the above.
25. In Fig. 13-21, capacitor C₁
- couples the a-m signal around Q1 directly into the collector circuit.
 - neutralizes the circuit on a-m and fm.
 - neutralizes the circuit on a-m only.
 - neutralizes the circuit on fm only.
26. Fig. 13-22 is an fm demodulator circuit. In setting up (aligning) an fm amplifier, a meter is connected between point (A) and ground, and T2 is adjusted for zero voltage output, while feeding a 10.7 MHz (or whatever i-f is used) into the earlier stages of the i-f amplifier strip. The voltage at point (A) should also be at zero, when a station is tuned in correctly, and should swing positive and negative as you tune through the station signal. T1 and previous i-f transformers should be tuned to maximum, with the meter connected across the 10- μ F capacitor C8. R3 and C4 in this circuit make up the "de-emphasis" filter, which removes the higher frequencies previously emphasized in the fm transmitter. Pre-emphasis of the high frequencies makes it easier to remove high-frequency noise, while still maintaining a flat response for the audio. In the circuit shown, approximately how much current is Q1 drawing?
- 4 mA.
 - 1.2 mA.
 - 1.4 mA.
 - Slightly over 2 mA.
27. The circuit in Fig. 13-22 is a
- discriminator.
 - ratio detector.
 - quadrature detector.
 - a-m detector.
28. The afc voltage at point (A)
- should be maximum when the station is tuned in properly.
 - should be negative when the station is tuned in properly.
 - should be positive when the station is tuned in properly.
 - should be zero when the station is tuned in properly.
29. If a radio with a combination a-m/fm i-f strip amplifier plays all right on fm but not on a-m, you might suspect trouble in
- the i-f amplifier transistors.
 - the audio amplifiers.
 - the a-m converter.
 - the power supply circuits.
30. If a radio with a combination a-m/fm i-f amplifier plays normally on a-m but not on fm, you can be sure
- the audio amplifiers are all right.
 - the i-f amplifier transistors are all right.
 - the fm rf amplifier is defective.
 - both A and B above are correct.

Troubleshooting Radio Circuits

"HOT" AND "COLD" SIDES OF CIRCUITS

Every electronic circuit must have a "hot" and a "cold" side, so far as circuit analysis is concerned, with the exception of what is called a "balanced" circuit, which has two "hot" terminals.

Technically and actually, the "hot" side of the circuit is no more "hot" than the "cold" side. For example, in Fig. 14-1A, if you try to measure voltage across the battery you must touch both connections—neither is hot, except in relation to the other, and either is hot in relation to the other. The designation of "hot" and "cold" is simply an explanatory gimmick to designate one side of the circuit against the other side. The circuit that is at common, or ground, potential is the "cold" side and the circuit opposite this, or away from ground, is the "hot" side. If you look at Figs. 14-1B and C you will find that it is not necessarily the + side of the battery that is "hot," but the side that is away from the common.

This "hot" and "cold" designation carries over into the signal circuits of radio. And it is essential, if a circuit is to work correctly, that it have one side "hot" and the other side "cold." Figs. 14-1D, E, F, and G show how this idea of hot and cold can be applied to transformers. Fig. 14-1D shows a transformer with no ground reference established; hence, there is no "hot" or "cold." In Figs. 14-1E and F, we show that either top or bottom of the transformer windings can be grounded. In either case the opposite ends of the windings become the hot ends. Fig. 14-1G could represent either a power supply transformer or the input transformer to a balanced class-B output stage. The "hot" ends of the windings are opposite the grounded ends, as shown.

Fig. 14-2 is a transistor i-f amplifier. An "H" indicates a hot circuit and a "C" indicates a cold circuit. Let us suppose that C4 opens—what happens? There is no longer a "cold" end to the primary of transformer T2 and resistor R5 now becomes part of the collector load circuit, because now the "cold" end of the signal circuit is on the "hot" dc line. (Note here that a "hot" dc line is not the same as a "hot" signal circuit. Capacitor

C5 on the dc line bypasses the signals to ground, and so far as signal is concerned the + dc line is cold, but so far as the dc power supply voltage is concerned the + dc line is hot.) With C4 open, the circuit gain will decrease, because now the resistor becomes a considerable part of the total collector-load circuit and any signal voltage drop across the resistor obviously cannot be transferred by transformer action to the next stage.

What if C5 opens? Now we have a problem that is a bit different. With C5 open, the dc supply line is no longer "cold," so any signal that might get back to the

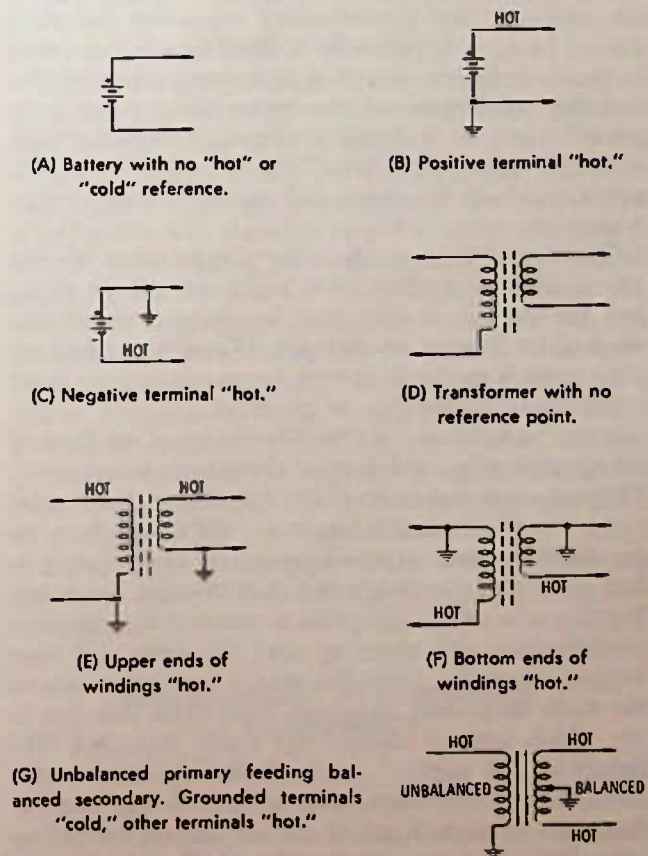

Fig. 14-1. "Hot" and "cold" circuits.

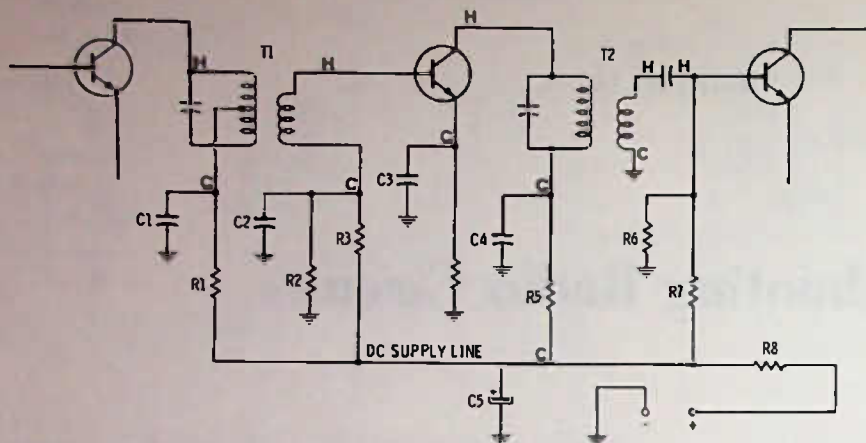

Fig. 14-2. "Hot" and "cold" signal circuits in a transistor amplifier.

dc line is not bypassed to ground and could feed back along the dc line to another stage. Besides this, R8 now becomes a "load" for both transistors and any voltage change, at the signal rate, that appears across this resistor is common to the collector circuits of both stages. This can mean that as one transistor tries to draw more current it causes the other transistor to draw less current; this change is reflected through the signal circuits to make the first transistor draw even more current. The final result is a cutting off of each transistor at an audible rate, which can be heard in the speaker as motorboating or squeal. Since many of the squealing and motorboating symptoms are often caused by open bypasses on a major supply line (such as the dc or the avc lines), it is recommended that the first step in diagnosis is to bypass these points temporarily, just by bridging a suspected capacitor with a known good capacitor. This is especially recommended in case the suspected capacitor is an electrolytic.

The size of the test capacitor is not critical. Generally a 25- μ F capacitor with sufficient voltage rating can be used as a substitute bypass for almost any electrolytic from 1 to 100 μ F. When the actual replacement is made, it is best to use as near an exact replacement as possible or practical.

Some technicians use the "brute force" method of substitution when a defective electrolytic is suspected. They clip one end of an electrolytic through a flexible jumper to the common bus in the radio and then begin touching each exposed point, not really caring to find out if that circuit is a hot or cold point, but knowing that when the right point is touched the squeal or motorboating will clear up and the radio will start working normally. Once the spot is found that returns the radio to normal, they can trace from this spot to see which original electrolytic needs replacing. The beauty of this method, crude though it might at first seem, is that the trouble can often be found long before the various test points can be located, unless you have had previous experience with the same model radio.

CHECKING TRANSISTOR STAGES WITH A RESISTOR

Fig. 14-3 suggests a method of checking the transistor and its circuits. Obviously, this method checks only the ability of the transistor and circuits to respond to a change in dc bias, but it is rare indeed that a transistor that responds to dc bias will fail to respond to a signal.

The method is to use a 1K resistor across various points while monitoring for any voltage change. First, place the resistor between collector and base while measuring the emitter voltage. The 1K resistor should increase the bias, causing a good transistor to draw more current. If there is no change in voltage reading (it could have been zero to start with if the transistor were defective or if the bias feed resistor were open), then either the transistor is defective or the base circuit has a dead short.

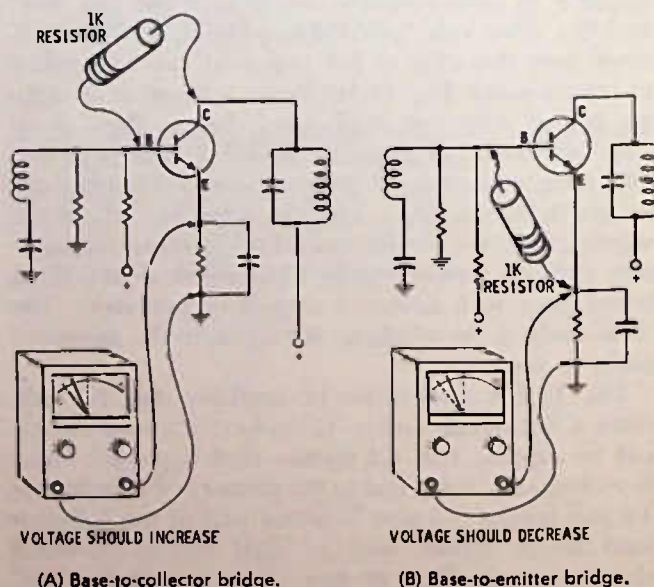

Fig. 14-3. Using a 1K resistor to check dc circuits of a transistor stage.

The 1K resistor can also be used between the base and emitter to lower the transistor current, and, consequently, the emitter voltage, as read by the vom. (The base can be shorted to emitter with a straight piece of wire to completely cut off the transistor current, but the 1K resistor is safer, since, if an accidental short is placed between the collector and emitter, the transistor could be ruined.)

SIGNAL TRACING

When using a signal tracer or an oscilloscope in a transistor radio circuit, you will find that after the signal passes through an i-f transformer, for example, there is a considerable loss between the collector of one stage and the base circuit of the next. The reason is the change in impedance, which drastically reduces the voltage to the base circuit, but increases the current required for proper operation of the transistor. A signal tracer or oscilloscope is looking "across" the circuit and so sees voltage changes only. Therefore, it sees an apparent low signal at the base, as compared to the previous collector.

There is an exception to this: If the transistor is defective; or if, for some reason, there were zero bias on the transistor, or reverse bias—then the transistor is not drawing current from the secondary of the transformer; so the voltage at the base terminal may appear to be quite high when checked with either scope or tracer.

Do not forget also, when signal tracing, that the probe of the test instrument can create a considerable load on a tuned circuit, causing quite serious detuning, especially on the fm band. In this case, it may be that you should use only the base circuit as a signal test point, then move on to the base circuit of the next stage. Even though the signal level may be small, at the base circuit, the loading of a test instrument probe is not a serious factor and will not greatly disturb the circuit operation in most cases.

TRANSISTOR TESTING BY SUBSTITUTION

You can temporarily connect a new transistor on the print side of a printed board much easier than you can insert it in the holes from the component side of the board. The old transistor must be removed before a replacement can be soldered in as a test. Or, there is another thing you can do when the transistor is difficult to remove because of circuit crowding: it may be easier to use a knife or single-edge razor blade to cut the printed conductor going to two of the transistor terminals, Fig. 14-4, and solder in the new transistor on the circuit side of these cuts. If a new transistor does not correct the trouble, the cuts made by the knife can be simply repaired by flowing solder across the cut or by connecting a small piece of wire across the break.

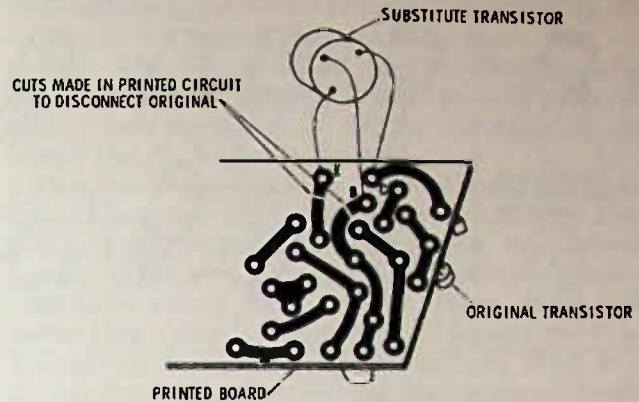

Fig. 14-4. Temporary substitution of transistor on circuit board.

Although it might not be considered good engineering practice, it is sometimes prudent to shorten the leads of the new transistor and solder it in permanently on the print side of the board, rather than risk the damage to other components that removal and reinstallation of a defective transistor might possibly cause—this will not happen often but, when necessary, the new transistor will work just as well installed on the print side as on the component side. Make sure, of course, that it will not obstruct or hinder the replacement of the radio in the cabinet or cause some other mechanical discrepancy.

TRANSISTOR BASING

Fig. 14-5 shows various basing diagrams for transistors in use today. Transistors that have different lead arrangements can be used in a circuit if the electrical characteristics of the new transistor are close enough to permit the change. It can happen that a technician will install a new transistor, thinking it has the same basing connections, and find out after much frustration that the leads have a different arrangement than the original. One tip-off is when you measure the bias voltage—it is impossible to have more than about 0.7 volt from base to emitter of a silicon transistor or more than about 0.2 volt on a germanium transistor, unless the transistor is defective. If the base to emitter voltage reads significantly above these amounts, then you either have an open transistor or it is connected in the circuit incorrectly.

You can use your ohmmeter to find out which is the base, emitter, and collector—see chapter on test equipment.

DISCONNECTING PRINTED-CIRCUIT COMPONENTS

The technique of slitting across the printed circuit is useful when there is a need to "divide" the circuit to find where the trouble is; however, a considerable amount of deduction is possible so that cutting the printed conductor may not be necessary. Taking the

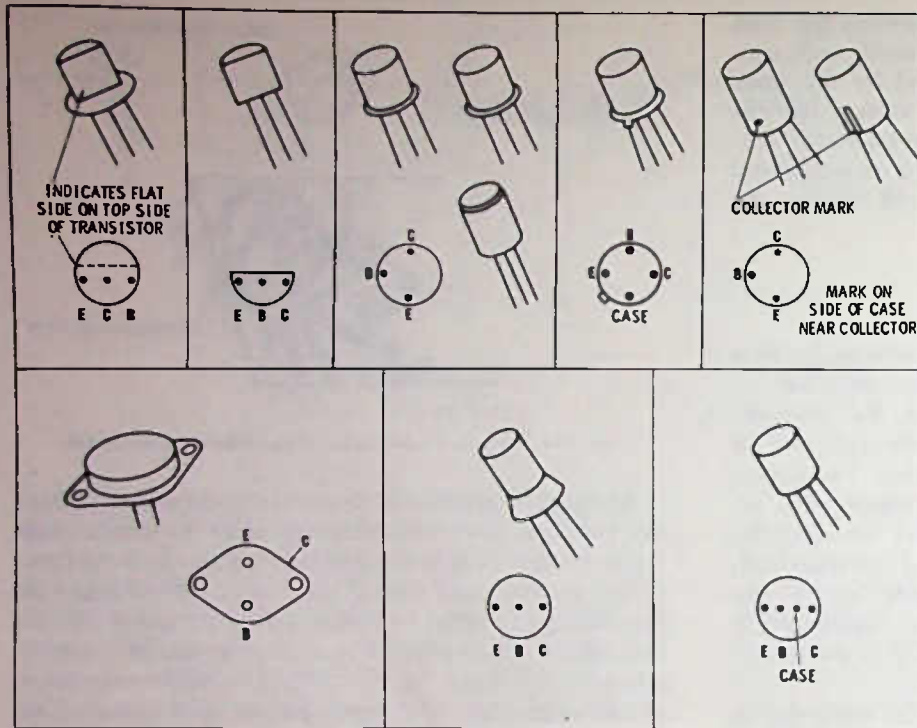

Fig. 14-5. Basing diagrams for a number of popular transistors found in transistor radios.

example shown in Fig. 14-6, suppose that meter M2 reads about 110 ohms, then when the meter is moved to the M1 position it reads about 10 ohms. (In each case, the ohmmeter leads should be reversed and another reading taken to make sure that some transistor or diode is not causing the low reading.) The two readings indicate that the trouble is on line B and not on line D (in this case the trouble is a virtually shorted dc supply line which should read at least 1000 ohms or more to ground when the on-off switch of the radio is turned off). At this point, though, it is diffi-

cult to go further in the diagnosis. The trouble could be found in one of at least three different capacitors, either C2, C3, or C6. It cannot be C1 or C4, since, if they were shorted, the resistance reading on line B would be at least 1000 ohms to ground. To find which of these three capacitors may be faulty, it will be necessary to disconnect them, one at a time, hoping to be able to guess correctly so that not all have to be disconnected. Disconnecting capacitors from a printed circuit is often not an easy job, and the slitting of the printed circuit may be more practical for

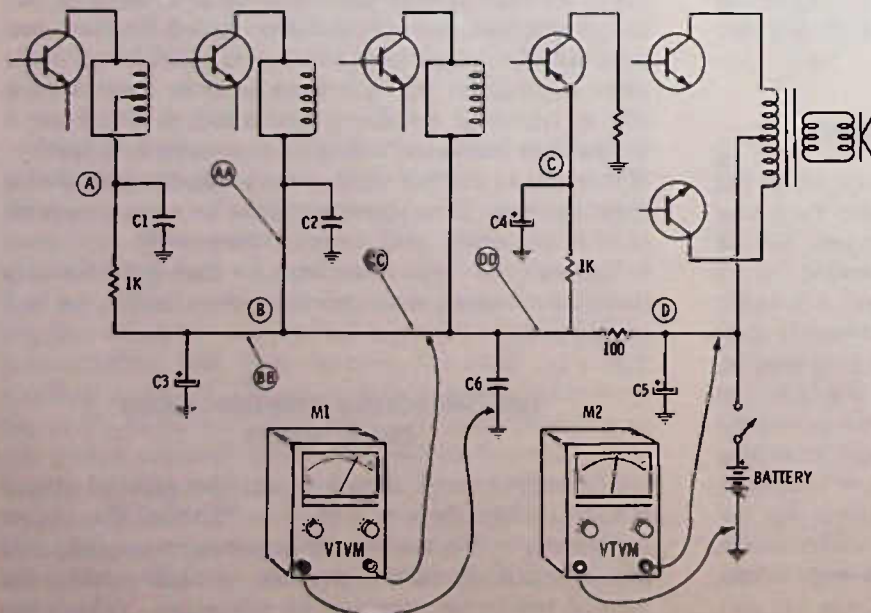

Fig. 14-6. Troubleshooting in dc supply circuit.

testing. Where should the printed circuit be cut in Fig. 14-6? It depends to some extent on experience as to which of these capacitors is the most likely one to short and it also depends on the layout of the printed circuit—but in Fig. 14-6 you can make a choice between AA, BB, or CC. There is no use in cutting at point DD, since all the capacitors are still in the circuit on line B. If experience indicates on a particular model that C2 is the most likely problem, then cutting the circuit at AA would be the logical first place. But, in most cases it will be the electrolytic capacitor which will be defective; and so, if you have no experience with a particular model, a cut at BB would be the logical first choice. If you do cut the printed circuit at BB and the ohmmeter on line B shows that the resistance has gone up significantly, then you can be sure that C2 and C6 are NOT at fault. Cutting the line at B does NOT absolutely prove that C3 is at fault, but it does prove that either C3 is at fault, or, if something else is at fault it is on the same part of the line as C3.

TROUBLESHOOTING WITH AN OHMMETER

Generally, faults on a supply line that show a low resistance reading will not be the result of a shorted rf or i-f transistor, since, in most every case, there is at least a few hundred ohms resistance between the supply line and the transistor or between the transistor and ground, so that even with the transistor shorted it will not reflect a complete short across the supply line. Shorted audio output transistors may show up as a direct short across the battery or dc line. To check a transistor for shorts, measure directly between the collector and emitter.

In Fig. 14-6, suppose that meter M1 reads around 100 ohms, and meter M2 reads near zero ohms—could the fault be (so far as the low-resistance reading is concerned) on line B? The answer is no. The meter on line B is reading a low resistance through the 100-ohm resistor in the supply line, indicating a near short on line D.

It is obviously impossible to set up here even a minimum number of situations that can occur in diagnosing a radio with an ohmmeter, but the technician can, by study of the circuit, decide what he can learn from such a diagnosis, and, just as important, what he can NOT learn.

The ohmmeter is a useful test instrument, but remember that there must be no power in the circuit if it is to make an accurate test. Also remember that power can STAY in a circuit even after the switch is turned off. Each of the capacitors, and especially the electrolytic capacitors, may hold an electrical charge for at least a short while after a radio is turned off. And, as has been pointed out several times before, the ohmmeter measurements can easily be misleading because of the diode action of the transistors, which makes them read a low resistance when the ohmmeter

leads are connected in one direction, compared to the reading in the reverse connection. In some cases, especially with direct-coupled circuits, the ohmmeter may read the low resistance of one transistor with the leads in one direction and the low resistance of another when the leads are reversed.

There are ohmmeters on the market today that have reduced terminal voltage at the test leads, so that they will not "trigger" the transistor on. If you have a meter of this sort, it should give accurate resistance readings in almost any solid-state circuit. Most such meters have a switch so that they can be used either as "normal" or as low-lead voltage meters. This is a good feature, since, for checking transistors in-circuit, you need to be able to read the "diode action" of the transistor, but not when you are checking resistance.

If you are using a "regular" ohmmeter only, again reverse the leads and make a second measurement in the circuit. The higher of the two readings is the one that is more nearly correct.

VOLTAGE TESTS

The voltmeter is probably the best method of checking for troubles, or at least for localizing troubles to a narrow area. The radio is turned on, and voltages are read at test points. These may be test points such as the transistor terminals, or they may be on the supply line. In Fig. 14-7 is the skeleton layout of the i-f and af stages in a radio. Suppose we had the same trouble as discussed earlier, with a short on the B line. Reading the voltage at D would likely give us full battery voltage if new batteries were in use. However, with partially run down batteries, the internal resistance of the batteries would cause a significant voltage drop because of high current through the 100-ohm resistor and the B-line short. (If the batteries are fairly well run down, even the normal current pulled by the radio will cause the battery voltage to drop; and, in fact, this is a good way to check for weak batteries. If the voltage drop is about 10% or more, you should replace the batteries.)

Next, if you measure the voltage on the B line you may find that it is zero or practically so, indicating that the line is "shorted" and that all the voltage drop is across R10. If there is no voltage on the B line, then the trouble obviously cannot be at any point isolated by any resistor such as at point A, C, E, F, etc.

Again, you have gone as far as you can go without "dividing" the circuit. Which would be the logical place to slit the circuit—at AA or BB? The answer is AA, since all that you would learn by slitting the circuit at BB you already know—that the short is on the B-line side of R10. Slitting the circuit at AA and measuring the voltage will give you additional information. If the voltage on the right side of the cut at AA now increases to near the voltage read at D, you know that capacitor C6 is NOT defective and that the trou-

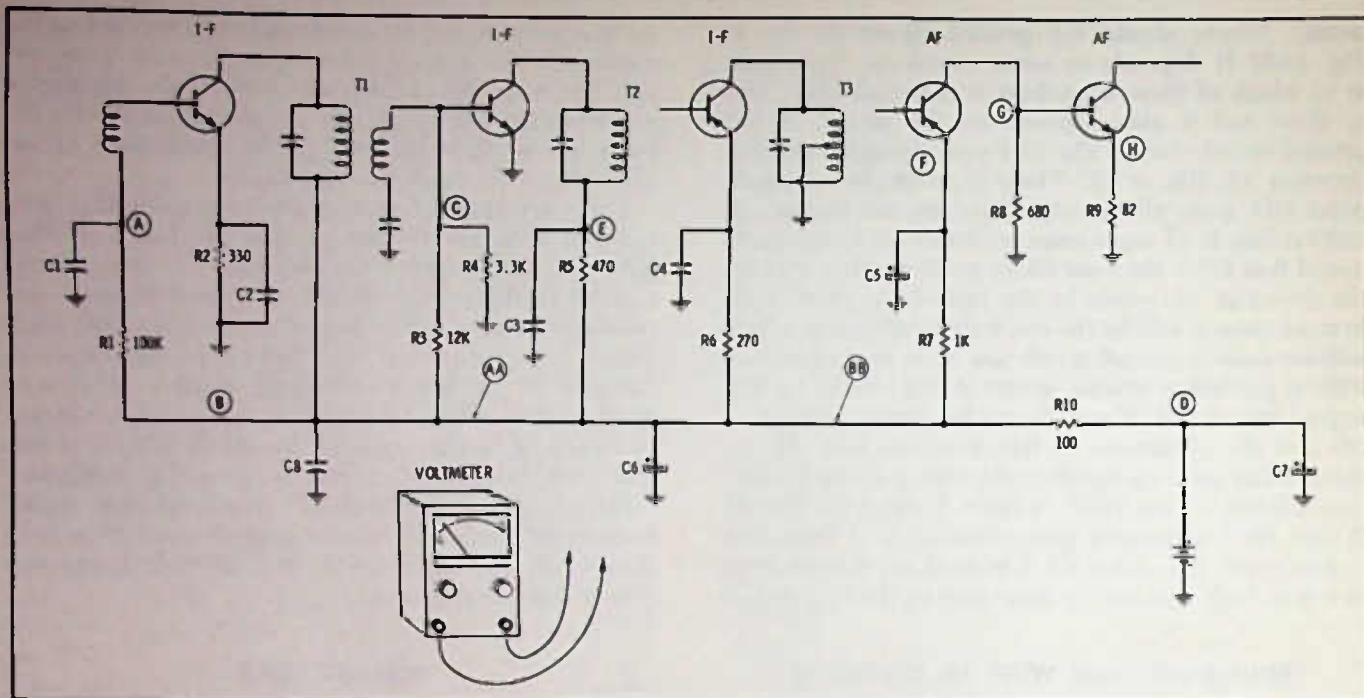

Fig. 14-7. Troubleshooting with a voltmeter.

ble is to the left of the (AA) cut. On the other hand, if the voltage does not rise, the problem is either C6 or something in the circuit to which it is tied. If the voltage does go up on the C6 side of the line, you may want to divide the circuit again for further isolation. However, be sure to repair the cut at (AA), or else use your ohmmeter for the remainder of the tests. Let me point out that there is no "best" method for every situation—this is for the technician to decide, based on all the circumstances and upon the method he feels most at home with.

CAUTION: The printed circuit layout will not be (almost surely not) the same as the schematic layout. For example, C6 may not be located along the (B) line following the junction to the 3rd i-f transistor but may be all the way back at the junction of R10 and R7, or it could be at the lower end of R1, etc. You will have to follow the physical layout, using the schematic only as an electrical "connection" guide and not for the actual physical point of connection. Often, though, the printed circuit, physical layout, and location of parts are included as part of the service information, along with the schematic.

You can even isolate a circuit by voltage readings or by ohmmeter readings that might seem almost impossible, but if there is the least resistance involved and considerable current is flowing through it, there will be a voltage drop across it. For example, in Fig. 14-7, suppose the voltage on the (B) line is normal or nearly so, but the voltage at point (E) is only a fraction of a volt. Is C3 the trouble, or could it be that the transistor is shorted or may be drawing too much current because of excessive bias? The transformer wind-

ing may have 2 ohms or so of resistance; not much, but enough to produce a slight voltage drop if the transistor is the cause of the low voltage. This drop might not be more than .0012 volt, but with a low range voltmeter you might be able to tell the difference in voltage at point (E) as compared to the collector of the transistor. If you cannot see any significant change in the voltmeter reading, you may easily be able to see the change in ohmmeter reading. For example, with the transistor shorted, the reading at point (E) might be, say 5 ohms, while the reading at the collector might be 3 ohms, showing that the short (heavy leakage) was on the transistor side.

If the bias circuit of the transistor is causing the trouble, then the ohmmeter is of no help, but if the bias circuit is at fault, simply shorting the base to emitter on the transistor will cause the collector voltage to go up to the (B) line voltage, since this will cut off the flow of current in 470-ohm resistor R5 and through transformer T2 (shorting the base to emitter stops collector current flow in a transistor).

VISUAL TROUBLESHOOTING

Do not dive into any radio with sophisticated test equipment and techniques without first giving the radio a rather thorough "sight" test. Are there any wires loose? They may have been test points used by the manufacturer, if they are short, but a long loose wire is a sure sign of trouble. Can the batteries be installed incorrectly? If so, check to make sure it has not been done. Can you see any crack in the printed board? If so, the conductors on the opposite side are also likely

to be cracked, causing either a complete fault or an intermittent one.

Turn the radio on and the volume full up, and touch each part with the eraser side of a pencil, moving the part gently about—is there any noise? Does the radio start playing again? Maybe the part is not soldered in properly, or maybe you are putting pressure on the printed board in such a way as to cause some other open circuit to show up.

Check all switches on the radio. Sometimes there is a switch, such as a Phono or Headphone switch that makes the radio appear to be dead. Local-Distance switches may be in the LOCAL position, making the radio fail to pick up stations as it should.

Look at the transformer adjustment screws. If they show signs of being "roughed up," then you may have more than one trouble. It often happens that when a radio goes bad a user may take off the back, see the screws, and decide to become a "screwdriver technician." In many radios, wax or paint has been placed around the tuning slugs in the top of transformers to prevent the slug from shifting from its final alignment position. If the wax has been dug out—look out! You are almost sure to have an alignment job AFTER, or sometimes before, you find the real trouble. (Regular canning paraffin like you can buy in the grocery store makes a good resealer for transformer adjustments. *Caution:* Do not use any sort of wax sealer in any transformer which uses a hex tool since the wax can run into the threads and make it next to impossible to adjust the slugs. The fact that a hex tool is required is all that is normally necessary to assure that there will be no "unauthorized" alignment attempted.)

RADIO-FREQUENCY CIRCUITS

In talking about capacitors and inductors, we have said that the capacitor and the inductor are in many ways exact opposites. The capacitor passes high frequencies better than it does lower ones, but the inductor passes lower frequencies better than it does higher ones; the capacitor blocks the passage of di-

rect current, but the inductor passes direct current with ease. Another characteristic of capacitors is their type of reactance. The reactance of a capacitor is such that when a voltage is placed across it, the current rises before the voltage does. In other words, if we connect a voltage across a capacitor there is high current for an instant, then the current diminishes to zero—because of the high current, at first the voltage is near zero across the capacitor, but rises as the current diminishes. Fig. 14-8 shows a demonstration set-up for this effect. The resistor is used in the circuit to slow down the action so that the meters have time to register. When the switch is closed, immediately the ammeter (or milliammeter) will show high current, which then starts to drop off. On the other hand, when the switch is first closed, the voltmeter will indicate zero, then slowly rise as the current in the circuit diminishes. (Incidentally, for this test, the current can be monitored with a voltmeter across the resistor, as indicated by dotted lines, instead of with the ammeter.) If you would like to set up this demonstration, a good choice might be a 10- μ F capacitor, a 100K resistor, and a battery voltage of 9 volts. Use a vom on a voltage range of 15 volts or more, or use a vacuum-tube voltmeter or solid-state vom.

An inductor has just the opposite effect in the same set up. If you connect a circuit as in Fig. 14-9 you find that when the switch is first closed, the voltage across the inductor is high, then tapers off almost to zero. The ammeter shows low current at first, rising as the voltage across the inductor drops. (An inductor is often called a choke.)

Because of these opposite reactions you might wonder what happens if you connect a capacitor and an inductor in series. What happens is entirely dependent upon the frequency of alternating current placed across the circuit. If the frequency is high, the coil will have almost total effect on the circuit, but if the frequency is low, almost the total reactance of the circuit will be capacitive. But there is a critical frequency for any capacitor-inductor combination. This is where the reactance of the two are exactly the same,

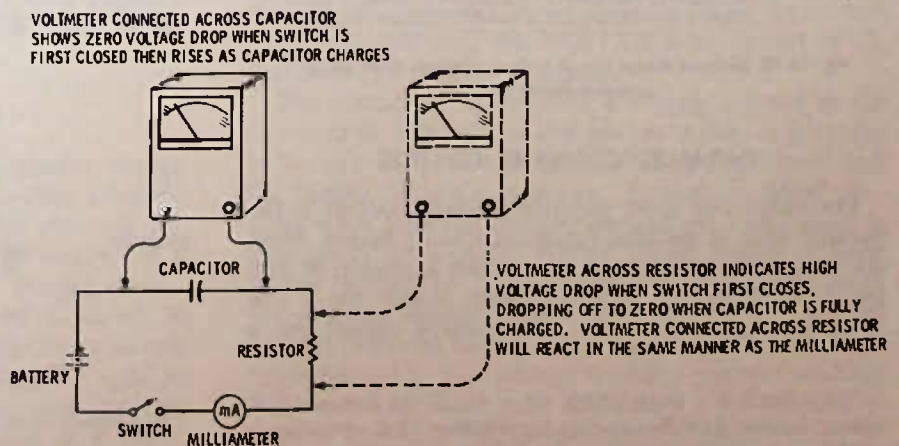

Fig. 14-8. Demonstration circuit to show dc charging action of a capacitor.

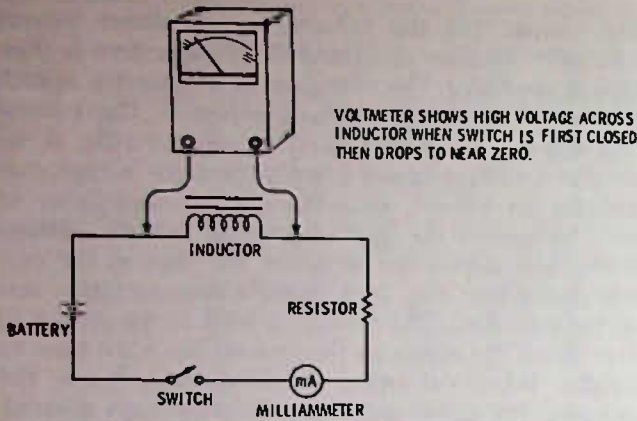

Fig. 14-9. Demonstration circuit to show voltage across inductor as dc voltage is first applied.

but since the reactances are exact opposites, there is a complete cancellation of their effects, and the circuit looks essentially like a straight piece of wire—in other words, it has a very low resistance to the flow of current at this particular frequency. When this happens we say that the circuit is *resonant*. Fig. 14-10 is this type of circuit and is called a *series-resonant circuit*. The series-resonant circuit is most often used as a “trap” to prevent an interfering signal from reaching the input circuit of a radio. For example, tv receivers often have traps in the antenna circuit to eliminate images that can occur from fm broadcast stations.

When used as a trap, either the coil or the capacitor is normally made adjustable for critical adjustment in trapping the unwanted signal.

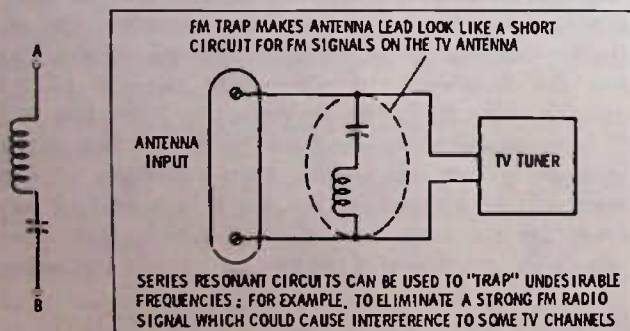

Fig. 14-10. Series-resonant circuit and an example of its use as a resonant-circuit trap.

PARALLEL-RESONANT CIRCUITS

For radio, the most popular resonant circuit is the parallel one. A parallel-resonant circuit occurs when the capacitor and coil are connected as shown in Fig. 14-11. Whereas the series-resonant circuit has a low impedance* at resonance, the parallel circuit has a

*Impedance is a term which takes in all the factors which restrict current flow for ac circuits, whether that restriction is resistance, capacitive reactance, or inductive reactance.

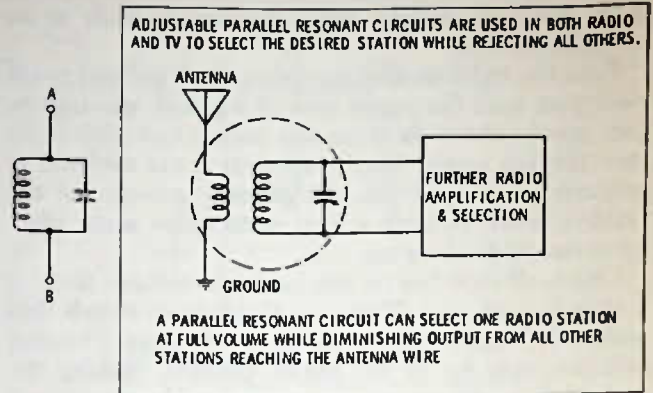
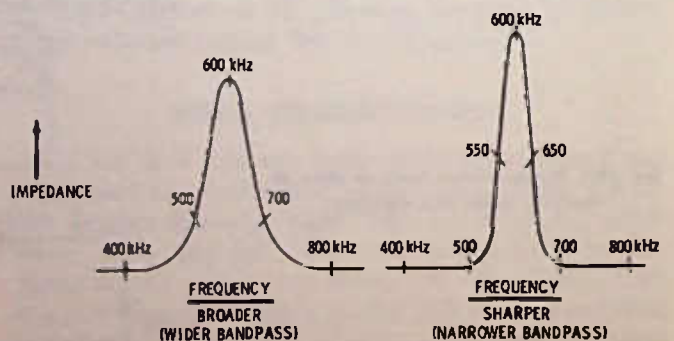

Fig. 14-11. Parallel-resonant circuit and its use to select the signal of a radio station.

high impedance between points A and B. For example, if the circuit in Fig. 14-11 is resonant at 600 kHz, at a frequency of 400 kHz and 800 kHz it will look like a low impedance, but for the frequency of 600 kHz it becomes a high impedance. This effect is shown graphically in Fig. 14-12. Two curves are shown. The one on the right is “sharper,” meaning that the response is high at the resonant frequency and lower at the frequencies on either side of resonance. The sharpness of a resonant circuit response depends on its Q, or quality. The Q of a resonant circuit improves as its resistance is reduced. For example, you can increase the Q of a coil by winding it with larger wire or by winding it with stranded wires insulated from one another except at the ends. (This happens because rf currents tend to travel on the outside of the wire. If several strands of small wire are connected in parallel, more “outside” surfaces are available on which the rf currents can travel at lower resistance.) A third way of increasing “Q” is to use a suitable core material. By putting a suitable core inside a coil, the same inductance is possible using fewer turns of wire, which means less resistance.

It is common practice, when it is desirable to have a broader resonant circuit (wider bandpass), to place a resistor across the parallel-resonant circuit, as shown in Fig. 14-13. Either parallel or series resistance broad-



(A) Relatively wide bandpass. (B) Relatively narrow bandpass.

Fig. 14-12. Resonance curves.

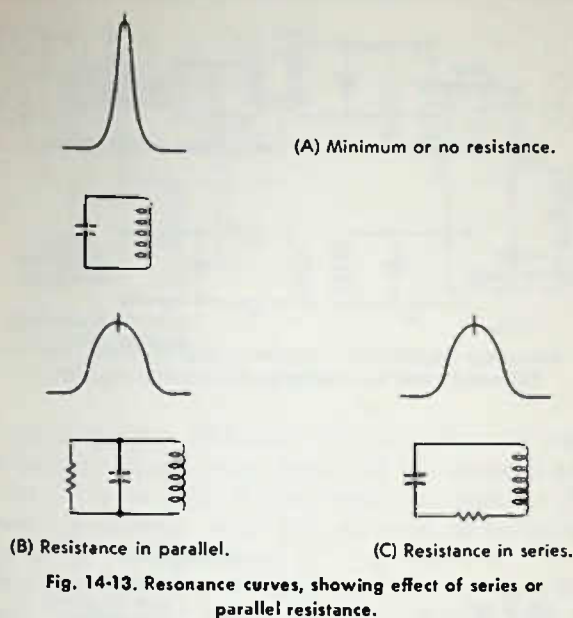

ens the resonance curve and lowers the impedance and, consequently, the gain of an amplifier circuit in which the resonant circuit is used. The "resistance" of the amplifier itself always appears as a resistance in the resonant circuit, therefore the Q of the circuit is reduced, according to the reflected "resistance." Wider bandpass is not so often needed in radio, although sometimes it may be desirable for one or more circuits. Normally, the resistance "load" of the transistor provides more than the designer would like, plus the fact that any method of coupling to the next stage in an amplifier also "loads" the resonant circuit, broadening it out. It is difficult to develop an extremely narrow bandpass circuit and impossible with only one tuned circuit. It is even undesirable, in most cases, since there must be some bandpass in order to permit the modulation on the rf signal to pass. For example, if you modulate a 600-kHz signal with a 5-kHz tone, the radio must be able to pass a band at least from 595 to 605 kHz. This is true because the 5-kHz tone beats with the 600-kHz signal to produce what are called "sidebands," and these sidebands (at least one of them) must pass before we can detect any demodulation.

COUPLING METHODS

There are many ways to couple (transfer energy from) one resonant circuit to either another resonant circuit or an untuned circuit. Fig. 14-14 shows 9 different methods of coupling a signal into and out of a resonant circuit, and there are others besides. Transformer coupling into a resonant circuit is shown in Fig. 14-14A. The number of turns on the untuned coil will depend upon the input impedance. This type of circuit might be used to couple a long wire antenna into the antenna input circuit of a radio, or it might

be used in an rf amplifier stage to couple from the output to the tuned input of the next stage.

In Fig. 14-14B, a common circuit is used to couple energy from a resonant circuit into a low impedance. This is typically used in bipolar transistor amplifiers to couple between the collector circuit of the previous amplifier and the low-impedance base circuit of the next amplifier. Fig. 14-14C is a dual-tuned resonant circuit that may be used to couple in i-f amplifiers of tube-type radios or in amplifiers using field-effect transistors (FETs), where the input impedance of the amplifier is high.

Fig. 14-14D is a high-impedance circuit that is coupled with what at first appears to be a series-resonant circuit. However, it is really a parallel-resonant output circuit using the capacity of the output circuit to complete the circuit. Since the circuit capacity is usually fixed, the variable capacitor tunes the circuit for resonance and maximum output.

The circuit of Fig. 14-14E provides a high-impedance resonant circuit to be coupled by low impedance to another resonant circuit which supplies a high-impedance circuit. Capacitor C is normally quite a bit larger than either of the other two capacitors. Capacitor C thereby provides a low impedance tap in the circuit, since it is in series with both coils. There is no mutual coupling between the coils, either because of the distance between them or shields between them. This circuit is a favorite in auto radios where additional selectivity is needed in the antenna or rf stages.

Fig. 14-14F is a circuit found most often in transistor radio i-f amplifier stages. The input is tapped down on the resonant circuit, which provides less loading on the coil and higher selectivity—in other words, the transistor is "matched" to the tuned circuit for optimum transfer of energy and circuit "sharpness." The output is also tapped down to feed a low-impedance source, such as the base of a transistor, without seriously loading the tuned circuit.

At Fig. 14-14G is a "tap down" on the resonant circuit, but, instead of tapping the coil, the connection is made between two capacitors in series across the coil. The relative size of the capacitors determines the "tap" point, and, the larger C2 is in respect to C1, the lower the output impedance.

The circuit at Fig. 14-14H is closely related to the circuit at G, although at first glance it does not appear to be. The input usually is of medium impedance and the output of low impedance, making an ideal coupling stage between bipolar transistors. This circuit is popular in auto radios where "slug" tuning is used almost exclusively. The resonant circuit is made up of the coil and the two capacitors. The input is tapped into the resonant circuit across C1, and the output is taken across C2. This circuit is such a popular one that it has a special name . . . it is called a "pi" circuit because it looks like the Greek letter pi (π).

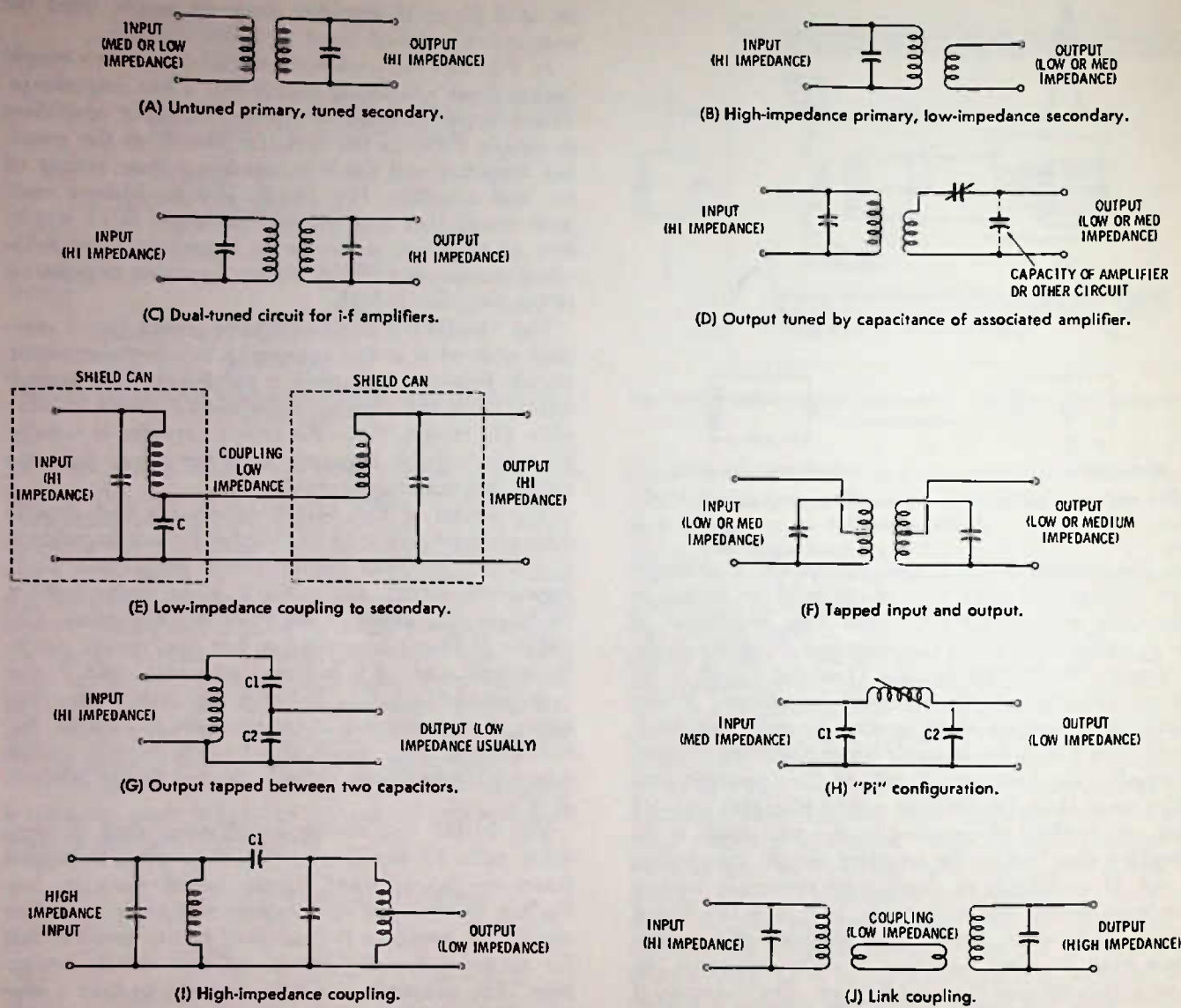

Fig. 14-14. Some ways in which circuits can be coupled.

Fig. 14-14I is a high-impedance coupling between two tuned circuits. In this case, C1 must be small to prevent the loading of one circuit from seriously affecting the other, especially during "tune up."

A link-coupled circuit is shown in Fig. 14-14J. Link coupling is most often used to transfer a signal from one place to another over a short or longer distance, for example, from the tuner section of a radio to the i-f section. Using a low-impedance link, the signal can be transferred with minor effect on the tuning of either of the resonant circuits and, to a great extent, without regard to the length of the line, over reasonable distances.

If the signal is transferred at high impedance, the line capacity itself has a great effect on the tuned circuits, especially at higher frequencies, so that any transfer over distances of more than an inch or so becomes impractical.

If you look at the schematics of broadcast radios, you will see all of these coupling types, no doubt along with variations and intermixes of these. One thing that can deceive you in your study of the circuit is the fact that the capacity in the resonant matching circuit may appear to be for some other use, or even of no use at all. In Fig. 14-15A, the fact that the right hand section of the transformer is tuned is a giveaway that the circuit is resonant, but how? The two main elements of the resonant-circuit capacity are C1 and C2, but to get them "across" the coil you must also go through the bypass C3. C3 is so much larger than the other two (10 times as large as C2, for example) that it can essentially be considered as a "straight wire" as to its effect on the resonant-circuit tuning. C1 and C2, though, provide an impedance step down of 10 to 1, providing a suitable match to the base of the transistor and still not loading the tuned circuit so much that it

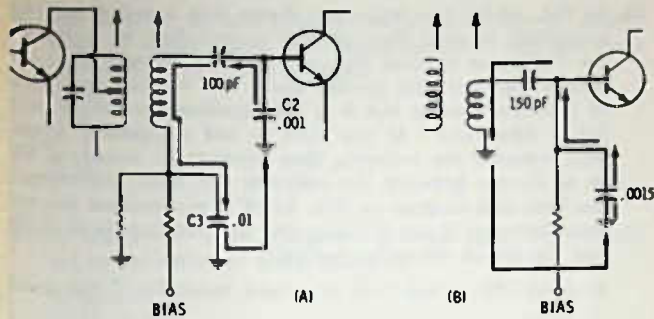

Fig. 14-15. Resonant circuits not having conventional appearance on schematic.

has no selectivity. Obviously, if C3 opens, the resonant circuit will no longer tune, but the essential reason for C3 is to apply a low impedance path for the resonant frequency, while still allowing dc to be applied to the base for bias.

The circuit in Fig. 14-15B is essentially the same circuit, except that the capacitor tied from base to

ground is the matching capacitor but may appear to be simply a bias bypass.

The various reasons that set designers use all the different types of coupling is not the main purpose of discussion here, but our intent is to inform you of the various types of coupling so that you will better understand how to service them. Basically, if you find a circuit that will not "peak" or "tune up," then you know that that circuit has a fault. It may be in the coil or the capacitor, or it may be some possible fault external to the tuned circuit but directly coupled to it.

Most faults in tuned circuits occur because of open coils, and these can be found with an ohmmeter, but other troubles may occur, such as open capacitors, or, rarely, a shorted or very leaky* capacitor, or sometimes shorted turns between the coil windings.

*"Leaky" means it allows dc current to "leak" through, in other words, it has dc resistance. A good capacitor should test "open" on an ohmmeter—that is, it should give no reading on the meter.

TEST QUESTIONS

Refer to Fig. 14-16 for Questions 1 through 7.

1. The transistor bias voltage from B to E is
 - A. -11.1V.
 - B. +0.1V.
 - C. -0.1V.
2. The collector voltage from C to E is
 - A. -2.2V.
 - B. -5.5V.
 - C. -3.3V.
 - D. +3.3V.
3. The voltage drop across the 2.2K resistor from D to A is
 - A. 2.2K.
 - B. +3.3V.
 - C. 2.2V.
 - D. .022V.
4. Using Ohm's law, the current in the collector circuit is
 - A. 0.001A.
 - B. 10 mA.
 - C. 0.1 mA.
5. The type of transistor is
 - A. npn.
 - B. pnp.
6. The transistor material is
 - A. silicon.
 - B. germanium.
7. Operation of the transistor is
 - A. saturated.
 - B. normal.
 - C. almost cut off.

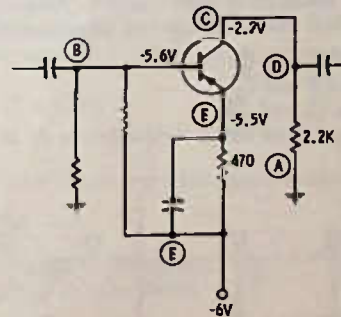

Fig. 14-16. Circuit for Questions 1 through 7.

8. Fig. 14-17 shows an i-f amplifier circuit. All the points that are "hot," so far as signal voltage is concerned, are
 - A. B, C, E, F, G.
 - B. G, E, D, A.
 - C. B, C, F.
 - D. B, C.

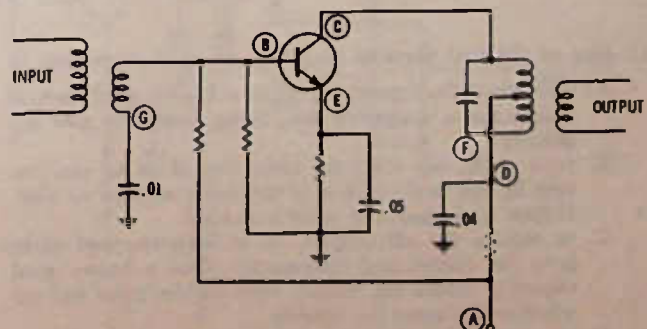

Fig. 14-17. Circuit for Questions 8 and 9.

9. In Fig. 14-17, the points that are "hot," so far as dc voltages are concerned, are

- A. A, B, C, D, E, F, G.
- B. A only.
- C. A, C, D, F.
- D. B, C, E.

10. Fig. 14-18 is a two-stage audio amplifier showing why this circuit may oscillate on its own, if the supply line does not have sufficient filtering in it to remove all the signal. Note that by normal signal inversion in a common-emitter amplifier, a negative-going voltage to the base of Q1 becomes a larger positive-going voltage on the collector of Q1. This voltage is fed to the base of Q2 and at the collector of Q2 (inverted again) it is a large negative-going pulse. Without good filtering on the + supply line, some of this large negative-going voltage might be fed back on this line. It does nothing to the circuit except provide a bit of degenerative feedback for the first transistor, since the feedback from collector of Q2 is opposite in phase to the signal at the collector of Q1. But if it is fed back to the base of Q1, it is in-phase, reinforcing the signal already there, and the circuit may start to oscillate. The rate of oscillation may be slow or rapid, depending upon many factors in the circuit, such as how poor the supply-line filtering is, etc. One electrolytic on the supply line may be all that is necessary to eliminate this trouble; but, to be sure, the designer may put in a resistor in series with the supply line and then add a filter capacitor to ground. This is called a decoupling filter circuit. Where in Fig. 14-18 would you feel that a decoupling filter should be installed?

- A. Between (A) and (B)
- B. Between (B) and (C)
- C. Between (C) and (D)
- D. Between any of those mentioned in A, B, or C above.

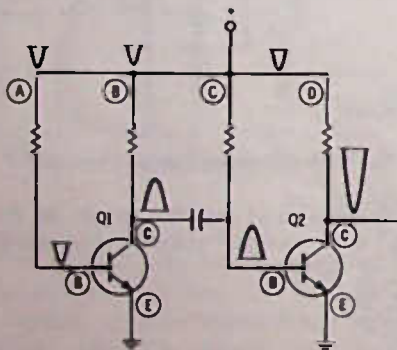

Fig. 14-18. Circuit for Question 10.

11. One of the best ways to check for an open electrolytic is

- A. with the radio turned off, place a known good electrolytic across a suspected one, being careful to note the polarity.
- B. same as A, but with the radio turned on so you can note by the performance of the radio whether an electrolytic replacement is what is needed.
- C. to remove the electrolytic, or at least one end of it, from the circuit and temporarily place a known good capacitor across the circuit; turn on the radio and see whether this cures the trouble.
- D. to remove the electrolytic and check with an electrolytic-capacitor tester.

12. In Fig. 14-19, two ways are shown that a meter may be connected to read the collector current flow in a transistor (collector current flow and emitter current flow are almost identical; the emitter has a tiny amount more due to the base current but it is not significant so far as testing is concerned). If you wish to test a transistor stage, first, measure the voltages, then temporarily jumper a 1K or so resistor between the collector and base, or between the base and emitter. In Fig. 14-19 if you connect the resistor between B and C (assuming the transistor is all right and the circuit otherwise normal),

- A. meter No. 1 will read more and meter No. 2 will read less.
- B. meter No. 1 will read less and meter No. 2 will read more.
- C. both meters will read more voltage.
- D. both meters will read less voltage.

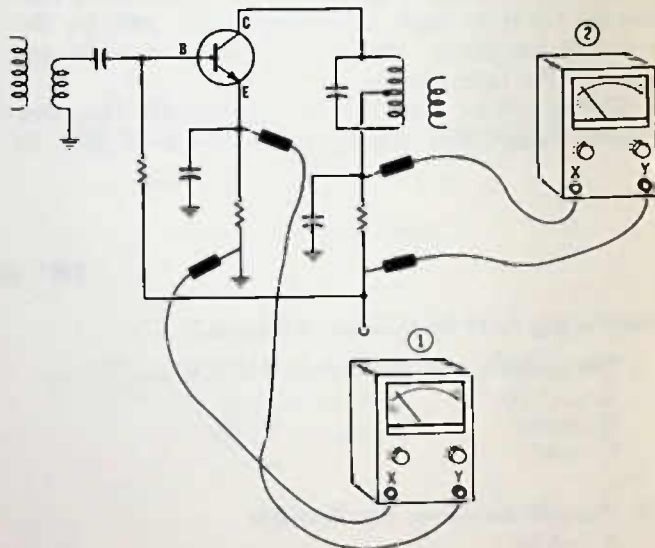

Fig. 14-19. Circuit for Questions 12, 13, and 14.

13. Concerning the lead polarities of the meters,

- A. the X leads of the meters are the + (positive) ones and the Y leads are negative.
- B. the opposite of "A" above is true.

14. In a transistor circuit such as Fig. 14-19, if you connect a resistor between B and E, the voltage drop across either a collector-circuit or an emitter-circuit resistor should, assuming the transistor and circuit are working normally,

- A. increase.
- B. decrease.
- C. remain the same.
- D. Resistor voltage depends on whether the transistor is an npn or a pnp.

15. When checking transistors in-circuit, using a resistor or jumper wire, be careful that you do not short between

- A. the emitter and collector, since you might damage the transistor.
- B. the base and emitter, for the same reason as above.
- C. the collector and base, for the same reason.
- D. the + and - side of the supply line, for the same reason.

6. Fig. 14-20 is an a-m radio i-f amplifier. Using an oscilloscope or signal tracer, you would expect to find the maximum amount of signal at point
- A.
 - B.
 - C.
 - D.
17. In Fig. 14-20, using a signal tracer or scope, you should get an indication of more signal at
- A. C than H.
 - B. H than J.
 - C. C than J.
 - D. C than B.
18. Assume that a radio using the circuit of Fig. 14-20 has weak output and you are using a signal tracer or scope to find the trouble. You check at C and H and you get a strong indication of signal; at J, you get signal, but it is considerably less than at either C or H; at I, you get about the same signal as at J. The trouble could be
- A. T2 defective, because you are getting less signal out of it than going into it from Q1.
 - B. the supply voltage is zero or very low.
 - C. transistor Q1 shorted.
 - D. transistor Q2 defective.
19. In Fig. 14-20, you should get an indication of rf (i-f) with audio modulation at all the test points indicated except
- A. D, E, G, K, L, N
 - B. H
 - C. A, F, H, N
 - D. I and G
20. In a capacitive circuit,
- A. the current lags behind the voltage.
 - B. the voltage lags behind the current.
 - C. the current leads the voltage.
 - D. both B and C are correct.
21. If an inductor is placed in series with an alternating frequency, it will
- A. pass a lower frequency better than a higher frequency.
 - B. pass a higher frequency easier than a lower frequency.
 - C. pass all frequencies essentially the same.
 - D. block the dc voltage that is in the circuit.
22. A series-resonant circuit is one that, at resonance, allows
- A. all frequencies to pass equally well.
 - B. all low frequencies to pass through it equally well, but not high frequencies.
 - C. all frequencies to pass through it about equally well, except the frequency to which it is resonant.
 - D. only a narrow band of frequencies to pass through it and rejects other frequencies.
23. The Q of a resonant circuit is higher if
- A. a resistor is placed across it.
 - B. it has lower resistance in the windings.
 - C. the capacitor in the circuit is slightly leaky.
 - D. a resistor is placed in series with the winding.
24. Other things being equal, the Q of a resonant circuit is improved by
- A. winding the coil with larger wire.
 - B. using a suitable core material in the coil.
 - C. using several strands of insulated wire twisted together instead of one solid wire of equivalent size.
 - D. all of the above.
25. "Impedance" is a term which means
- A. the same as resistance.
 - B. the sum total of restrictions in a circuit to a particular alternating current voltage.
 - C. the reactance of a circuit either at or away from resonance.
 - D. the Q of a circuit.
26. If a circuit is to have more bandpass, it should have a
- A. higher Q.
 - B. lower Q.
 - C. less resistance in the circuit.
 - D. less loading on the circuit.
27. In Fig. 14-21, the coupling circuit is known as
- A. a transformer.
 - B. a link.
 - C. an impedance.
 - D. a mutual cable.

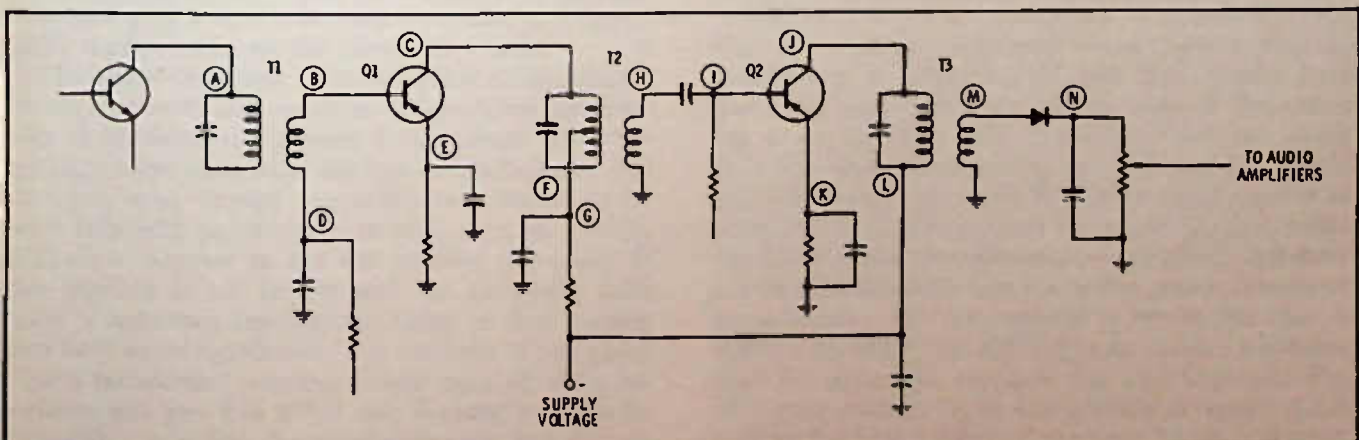

Fig. 14-20. Circuit for Questions 16 through 19.

28. In Fig. 14-21, the low impedance circuits are between

- A. A and B, E and F
- B. C and ground, D and ground, C and F
- C. C and F only.
- D. C and ground, D and ground, only.

29. The circuit in Fig. 14-21 is more likely to be used when the signal

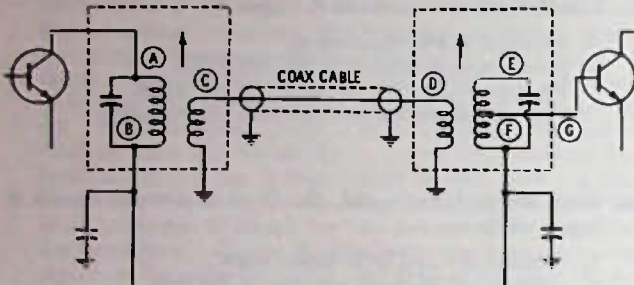

Fig. 14-21. Circuit for Questions 27, 28, and 29.

- A. is to travel several inches from one circuit to another.
- B. is to travel no more than two inches at the most.
- C. is strong so that losses will not be a problem.
- D. is to be changed in the coupling from one frequency to another.

30. A good way to find out whether a transformer or coil winding is broken inside the shield can is to

- A. remove the can and make a visual inspection of the windings.
- B. try to tune the circuit and see if the adjustment has any effect.
- C. check to see that it has the same voltage on each side of it.
- D. C. above is usually a good check, or you can check the winding with an ohmmeter.

31. One of the first things to do if you are trying to fix a "dead" radio is

- A. check to see if it is aligned properly.
- B. check the resistors to make sure they are within 20% tolerance.
- C. measure all the voltages on the transistors.
- D. check for "cockpit" trouble.

Testing and Replacing Component Parts

TESTING COMPONENTS WITH AN OHMMETER

Considerable information as to whether a part is probably good or bad can be obtained by using an ohmmeter. The ohmmeter can check the amount of dc that may be expected to pass through a part, or, more specifically, how much resistance a part offers to dc current. Some parts should show low resistance, others should show higher resistance, and some (capacitors, for example) should show no meter reading (infinite resistance). As with almost any other test instrument, the ohmmeter test of a component is almost never 100% valid, but it can often prove a part either good or bad, or at least good or bad so far as the information needed for further testing is concerned. For example, if you check the primary winding of an i-f transformer for continuity and there is continuity, this pretty well eliminates the transformer as a reason for the transistor not receiving collector voltage, since the continuity check shows that current can easily pass through the transformer. It does not tell, though, whether the transformer primary has a few shorted turns, in which case it will not tune to its specified frequency, even though the primary will still pass dc.

If you keep in mind that the ohmmeter is a direct-current testing device and that as such it can find most troubles in the direct-current circuits, but that it cannot give a sure indication about the ac (signal) path, then you can use the ohmmeter wisely.

The ohmmeter, using a direct-current circuit, checks for dc continuity and resistance. It can often find troubles in ac-circuit components if the person doing the testing understands what the test results indicate. For example, even though a transformer is meant to be used only with pulsating dc or with ac, a dc reading will show whether or not the winding is broken. If the winding is not broken and the ohmmeter indicates a resistance reading, the value of that reading can have some significance. For example, if you know that a transformer winding should have 11 ohms resistance and you find it has only 3 ohms, you can be reasonably sure that the winding is defective. But do not be too sure—if there is some other part of the cir-

cuit across this winding, you can get an erroneous reading. Reverse the ohmmeter leads and read again; or, better yet, if an in-circuit reading is inconclusive, remove one lead of the winding and check between the disconnected winding and the one still in the circuit. You know then that there is no other part affecting the ohmmeter reading except the one you are testing.

You can also use comparison testing in-circuit, at times, to come up with a valid conclusion. In Fig. 15-1, suppose you test with an ohmmeter between A and C and read 60 ohms; you may suspect that this is not the right value, but how can you be reasonably sure, since there is nothing on the schematic to indicate what the A-to-C resistance should be? The next step is to measure from B to C. If you also get 60 ohms reading here, you can be reasonably sure that 60 ohms is the right resistance for A to C. Why? Because it is very rare that both sides of a center-tapped transformer winding will go bad, and if they did, it is even more rare for the defect to be exactly the same on both sides. If, for example, the reading on one side is 60 ohms, but on the other side it is 10 ohms, you have reason to suspect very strongly that the transformer is defective, and if you pull the leads free from the circuit (you can leave one of the three in circuit and still make a valid test) and the unbalance still exists, you **KNOW** the transformer winding is defective.

Obviously, there are exceptions to almost any rule. For the circuit just mentioned we can be sure that the transformer is center-tapped and thus should have about the same resistance on one side of the center tap as on the other side. Normally, there can easily be a few ohms discrepancy, since the outside-wound coil will require more wire to get the same number of turns (the coil is wound over the top of the first, hence the diameter and circumference are greater). But there are transformers with taps not in the center, though on the schematic they may appear to be. In this case, it will be normal for one winding to have more resistance than the other. For example, the transformer in Fig. 15-2 is not center-tapped, but actually is tapped about 25% up from the lower end, as shown by the resistance readings of the winding.

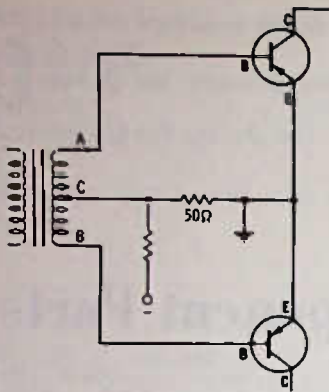

Fig. 15-1. Circuit suitable for testing with ohmmeter.

Something about transformers you can NOT determine with an ohmmeter is their turns ratio. In Fig. 15-3, for example, the two secondaries have step-down turns ratios, yet neither of the secondaries would appear to have their particular turns ratio, if dc resistance were used as an indication. The actual turns ratio for secondary winding A is 4 to 1, with only $\frac{1}{4}$ as many turns on it as for the primary, yet it has $1\frac{1}{2}$ times more resistance. On the other hand, the B winding has a step-down ratio of 10 to 1 but a resistance step down of 24 to 1. Why is this? The an-

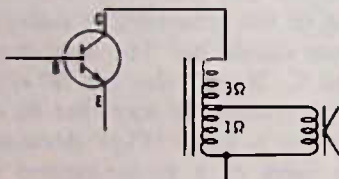

Fig. 15-2. Resistances indicate that transformer is not center-tapped.

swer is that the windings are each wound with a different size wire. Winding A is wound with much smaller wire than the primary, so that even though it has only $\frac{1}{4}$ as many turns, yet its dc resistance is higher because of the smaller wire. The B winding is wound with larger wire than the primary, and so has a greater resistance ratio than turns ratio. The reason these windings are wound with this wire size is that the 30-volt winding is meant to supply only a small amount of current; so it can be wound with much smaller wire, which takes up less space and the transformer can be smaller physically. The 12-volt winding supplies considerable current, so it requires a larger wire in the winding to prevent excessive heat loss and voltage drop in the winding itself.

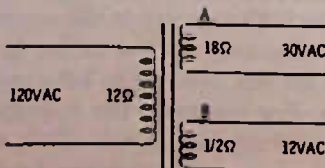

Fig. 15-3. Turns ratio is not necessarily indicated by dc resistances.

The ohmmeter still is a valid test for the transformer, because the most likely trouble is an open winding. This the ohmmeter can tell for sure—obviously you should have no power applied to the transformer when making an ohmmeter test.

TESTING CAPACITORS

An ohmmeter across a capacitor, *other* than an electrolytic type, should not read on the ohmmeter scale at all, since a good capacitor should have no leakage, no passage of direct current. All capacitors will charge when the leads of the ohmmeter are first connected, but because the charging time is short in capacitors below about $.25 \mu\text{F}$, this will not register on the ohmmeter because it does not overcome the inertia of the meter movement.

To check capacitors for leakage, you must have at least one end disconnected from the circuit. And when you connect the ohmmeter leads across the capacitor, make sure that your hands are not touching the metal parts of the probes, since if they are, the ohmmeter will read the resistance of your body instead of checking for resistance across the capacitor.

Unfortunately, an ohmmeter will not always catch a leakage across a capacitor, since the capacitor may not "break down" under the low voltage applied by the ohmmeter. However, in transistor radios small leakages in capacitors do not often occur, or at least do not affect the circuit too much if they do occur. The most common trouble is a shorted or very leaky capacitor, or an open one.

Electrolytic capacitors by their nature have some leakage, and since they are polarized, this leakage is greater in one direction than in the other. An electrolytic is nearly always $1 \mu\text{F}$ or larger; so you should be able to see the charging current on the meter. When you first connect the ohmmeter leads across the capacitor (place on $R \times 100$ or $R \times 1000$ scale), you should see the meter deflect upward and then drop back nearly to zero. Reversing the leads across the capacitor, you will see the meter again deflect upward and fall back. If you do not see this deflection, the capacitor is open. If the deflection is not nearly so great as a new one of the same rated capacity, you can suspect that the capacitor is partially open (has lost capacity). If the ohmmeter reads the same low resistance in both directions, the capacitor is leaky and must be replaced (this is on the initial connection to the capacitor; many will read the same high resistance after the initial charge or discharge).

TESTING RESISTORS

The most obvious use of the ohmmeter is for checking continuity and resistance. Continuity means checking to make sure that wires are not broken, a fuse is all right, a switch will turn off and on, the pilot-lamp

filament is good, line-cord connections are all right, coils or transformer windings are not open, there are no shorts across capacitors, etc.

Resistors can be checked against their rated color-code values. Remember that most resistors will have no better than 10% accuracy, and some will be no better than 20%. In all but the most critical circuits, the size of the resistance is somewhat arbitrary in value, with a considerable change in resistance often making no significant change in performance of the radio. Obviously, this does not mean that a 1000-ohm resistor should or even could be replaced with a 4.7K resistor, but it can likely be replaced, without any noticeable difference in circuit performance, with a 1.2K or 820-ohm resistor.

Essentially, the point is that if you find a 20% discrepancy in a resistor, do not expect this to be the reason the radio is not working—it won't be. A change in resistor value might cause the radio to be weak or to have distorted tone, if the change is 25% or so, but even here the likelihood is not too great.

Most resistors that cause trouble either change to a high resistance—for example, a 22K resistor might read 200K—or they change to a low resistance—for example, a 100-ohm resistor might change approximately to 10 ohms or so.

The resistor that changes to a lower value than its rated value will nearly always be a resistor of 1000 ohms or less, and in addition it will show signs of discoloration due to overheating.

Reading resistors in-circuit is an art at best. Even if you reverse the ohmmeter leads to prevent the transistors from "diodeing," still a lot of resistors that are more than 10K ohms will have some other resistance circuit in the radio shunting them and causing them to read less than normal. Technicians have to develop a built-in "probability" factor to tell them whether or not an off-resistance value really indicates a possible trouble or is just a normal result of other circuit components. The only final safe way to be sure is to disconnect one end of the resistor and take a measurement across that resistor alone.

A study of the schematic will indicate whether or not other leakage can be expected. Start at one side of the resistor and see if you can go through any other dc path to the other side of the resistor. If the other path has 10 times more resistance than the resistor you are checking, you will have less than 10% error reading the resistor in-circuit. Do not forget that there is a path from plus to minus of the power-supply line through electrolytics and through bias bleeder resistors. Also, in electric power supplies, the rectifier diodes can provide a path between plus and minus when the ohmmeter leads are connected in one of the two possible directions, so, even if there is no transistor to produce diode action, you should reverse the ohmmeter leads and take a second reading whenever doing in-circuit measurements.

TESTING COMPONENTS WITH A VOLTMETER

Whereas the ohmmeter makes checks when there is no power applied to the circuit, the voltmeter is the basic tester for circuits that have power applied. Unfortunately, in transistor radios, a voltage reading can be misleading if always referenced to ground. For example, in Fig. 15-4A, a zero voltage at the collector indicates an open circuit between the +9-volt line and the collector. If there is +9 volts at the top of the 470-

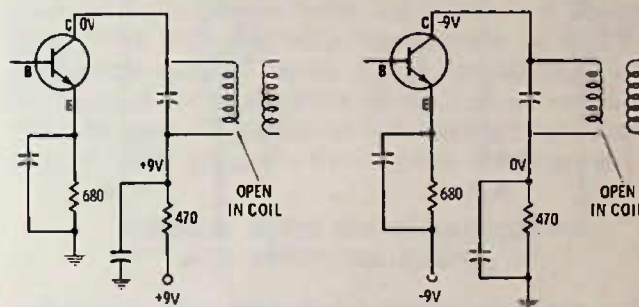

(A) Positive battery supply.

(B) Negative battery supply.

Fig. 15-4. Checking for an open coil, using voltage measurements.

ohm resistor, then the obvious trouble is an open in the coil. But, in Fig. 15-4B, which is the same circuit, except that the + side of the power supply is at ground, an open in the transformer results not in zero voltage, but in -9 volts on the collector. This is because the voltmeter reads the -9 volts through the emitter-collector resistance of the transistor. For this reason, in order to avoid confusion, you may want to read all transistor voltages to the emitter or to the side of the battery to which the emitter goes. For example, you would get zero voltage at the collector (if the coil is open) if you measured the collector voltage from the negative side of the battery.

Voltage readings, if properly interpreted, can pinpoint a majority of radio troubles. The secret, of course, is in the proper interpretation, and to do this requires a thorough knowledge of not only how circuits react when working normally, but how they react when NOT working, or when working erratically. For instance, what is the probable trouble in the circuit of Fig. 15-5? The layouts of the circuits at A and at B are essentially alike, except for which side of the dc supply goes to ground, but different troubles are indicated in the two circuits by the voltages as shown (which are read to ground). In Fig. 15-5A, either R2 could be open or C2 could be shorted, causing zero voltage at their junction. But in Fig. 15-5B it could be that the performance of the radio would still be normal, or at least not changed enough to be noticed. The reason is, that we see a 1-volt drop across R1, which seems to show conclusively that the transistor is drawing about 2 mA. This means that the collector circuit is not open. But we see there is no voltage drop

across 1K resistor R2. This means that either no current is flowing through R2 (which seems impossible since the transistor is drawing normal current) or that R2 is shorted (seldom if ever does a resistor short, although it may change to a low value of resistance if, overheated, but in this case it will almost surely be discolored) or C2 is shorted (which is the most probable trouble—capacitors quite often short or develop high leakage).

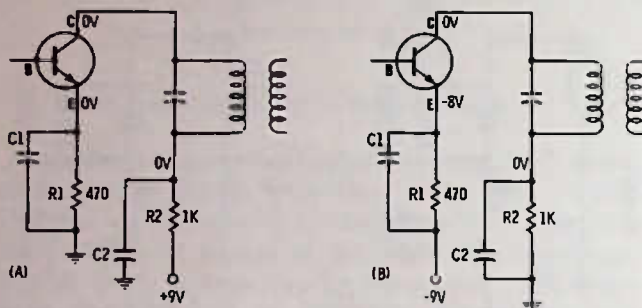

Fig. 15-5. What is the trouble? Is the trouble the same in both circuits? See text.

Note: We have indicated "zero" voltage in the above diagnosis. It is possible in actual practice that there might be a very slight voltage reading at the "zero" points.

DOUBLE CHECKING

In any sort of troubleshooting, just as in being a detective, the clues to the trouble may point to an innocent component, and so every component should be put on trial to make sure that the one suspected is really the offender. Double checking in electronic troubleshooting usually takes the form of checking the part with the same or another test instrument after it has been removed, or at least all its leads but one removed from the circuit. However, for the final double check we may use more deduction which has little chance of error.

For instance, in Fig. 15-5A, we cannot know, using only the voltmeter in-circuit, whether or not R2 is open or C2 is shorted. Let us see how many ways we could double check:

1. Disconnect one lead of C1 and see if the voltage now rises to near normal. If it does, we know that C1 was shorted.
2. Disconnecting C1 might be a bit of a problem, so first why not check R2 by simply placing another similar resistor across R2 temporarily. Now, if the voltage rises, R2 was open.
3. Another double check on the resistor could be made by turning off the radio and checking across it with an ohmmeter.
4. Another check on the capacitor could be made

with the ohmmeter by disconnecting one lead from the circuit and checking across it for any leakage (see previous discussion on checking capacitors with an ohmmeter).

VOLTAGE INTERPRETATION

To keep from getting confused, an understanding of voltage readings is most important in service. A misinterpretation can send you on a wild goose chase and get you no closer to finding the trouble than you were before you started. Remember that voltages occur only in respect to some other point in the circuit, and the polarity of that voltage is also in respect to some other point. There is no such thing as a positive voltage, except in respect to some other point that is negative to it. As has been pointed out before, the voltages on a schematic are, almost without exception, voltages in respect to ground. That is, one voltmeter probe is touched to the point where the voltage is shown, and the other voltmeter probe is touched to chassis ground.*

REPLACING TRANSISTORS

Most transistor manufacturers make available a replacement line of transistors where a few numbers can be used as a replacement for almost any radio transistor. The manufacturer generally supplies a cross-reference chart, and cross-references are also available from Howard W. Sams & Co., Inc.

Generally speaking, transistors are interchangeable so long as pnp is used to replace pnp, germanium replaces germanium, etc., and if they are employed in a similar application (rf, i-f, audio, etc.). This means that an i-f amplifier transistor designed or used by one particular manufacturer will probably work in any other manufacturer's i-f circuit, so long as the frequency is the same. For example, a pnp germanium transistor recommended for 455-kHz i-f service by RCA would probably work in a Motorola radio, and the converse is true.

Generally speaking also, a transistor that is designed to work at higher frequencies can be used for a replacement in a lower-frequency circuit. For example, an i-f amplifier or rf amplifier transistor will work as an audio driver, but here the converse is not apt to be true, especially if the transistor is a germanium type. A transistor designed as an rf amplifier for an fm receiver will also work as a 10.7-MHz amplifier.

*Chassis ground is a term often used to indicate the common circuit tied to the metal parts of the radio components. Before printed circuits, nearly all radios were built inside a metal chassis pan, and all ground connections were made to this chassis. With printed circuits, often no metal chassis is used as such, yet the common circuit will normally be connected to any metal parts, such as transformer shield cans, dial mechanisms, and the like.

Any transistor used as a replacement should have a voltage rating that is at least as high as the original. For example, if you are going to replace a transistor in an automobile radio it should have a rating of at least 14 or 15 volts—that's V_{CEO} (voltage between collector and emitter with the base open). For battery-operated portables, the voltage rating needs to be no greater than the battery voltage used, but it can be. The point is, do not use a transistor with a V_{CEO} rating of 9 volts in an automobile radio. Automobiles use a 12-volt battery, and when the motor is running, the alternator will be putting around 14 volts on the battery line.

Any replacement transistor installed in an rf or i-f circuit will almost surely change the tuning of the circuit slightly, so it is a good idea to peak up the circuit after installation. If an attempt to peak up the circuit causes the radio to start squealing or whistling, especially as you tune from station to station, try a different replacement transistor.

A replacement transistor that you are not sure about should be tacked-in on the print side of the board after the original transistor has been removed. This makes it much easier to try two or three different replacements without damage to the board, which can occur if you try to mount each new trial transistor in the original holes through the board. The selected transistor can then be mounted in place on the top of the board.

For best results, you should match replacement audio-output transistors whenever possible, but especially if there is any noticeable distortion, particularly at low volume levels. If an audio-output transistor goes bad, many technicians replace both transistors with a new matched pair rather than change only one and risk a mismatch problem.

Replacing transistors in a direct-coupled circuit, especially if there are three or four transistors involved, can be a tricky business (sometimes it is even tricky when you use exact replacement types) but for the most part you can assume that a replacement is satisfactory if (1) the amplifier seems to work normally and with good tone quality and (2) if no parts in the circuit overheat. (It is normal for some circuits to have transistors that run warm but these should only be output transistors. It is also normal for one or two resistors to warm up a bit in some circuits. As a good rule of thumb, if you can bear to hold the part with your fingers it probably is *not* overheating. Small transistors used as rf, oscillator, mixer, i-f, and early audio stages should NOT be hot to the touch.)

Transistors that originally had four leads generally have one of these leads tied to an internal shield or to the metal case of the transistor. In many circuits you can replace a 4-lead transistor with a 3-lead one, if the 3-lead transistor is designed for use in the same kind of circuit and if the 3-lead transistor meets the other qualifications as to material and polarity. The

fourth lead is nearly always tied to ground, and when a 3-lead transistor is used, the ground connection is just ignored.

Transistors replaced in high-frequency circuits should always have their leads cut rather short. Use the original transistor as a guide. In lower-frequency circuits, the lead length is unimportant, except that they should not be left so long that they might become shorted should the transistor be moved around inadvertently.

When the transistor leads are to be inserted through the holes in the printed board and there is not enough room down between other components to tilt the transistor so one lead can be started through at a time, use a pair of diagonal cutters to clip a bit off one lead and a bit more off another so that the leads are "stair-stepped." This will make the insertion much easier.

GENERAL HINTS ON REPLACING AND REMOVING PARTS

It is best, when replacing transistors or other parts in a printed circuit, to use a small soldering iron, especially one with a small tip, so that you are not so apt to run solder between the terminal you are soldering and some other separate terminal.

When removing parts from the circuit, a soldering iron with a "suction" tube to draw off the melted solder is a great asset and makes a much neater job possible with ease. Otherwise, you must heat all the leads of a component at the same time or else twist and distort the part out of shape in getting one or two of the terminals loose at a time. If you are sure a component is defective, you can sometimes use cutters to break the original component apart, separating the various terminals so they can be removed from the circuit individually.

In some cases, you may not want to remove the old leads from the printed board, especially if you want to replace something from the top without removing the chassis. In this case, you may be able to use cutters to remove the old part, leaving the original leads sticking up out of the board a fraction of an inch. The new part should have eyelets formed in its leads, Fig. 15-6, not only to make a good mechanical connection

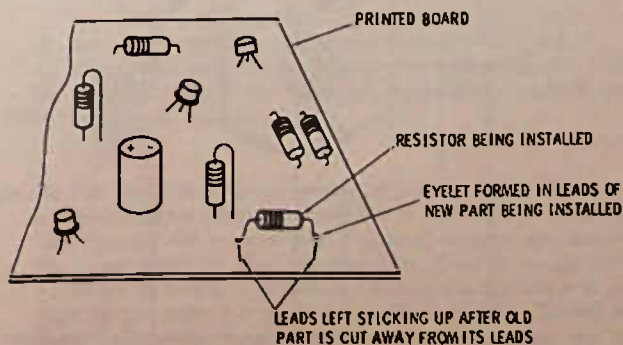

Fig. 15-6. Installing a new resistor from top of printed-circuit board.

to the original leads but also this larger bulk of metal will help prevent the heat made in soldering the new connections from melting the solder away from the printed conductor on the bottom side of the board. In any event, the new soldered connection should be made as quickly as possible, for this reason.

Often original parts such as capacitors or resistors may have both leads at one end, rather than one at each end. Fig. 15-7 shows how to install a part with a lead on each end as a replacement for one with leads on just one end. If the exposed lead might touch some other metal part and be shorted out, wrap a single layer of tape around the part and the exposed lead before installing it.

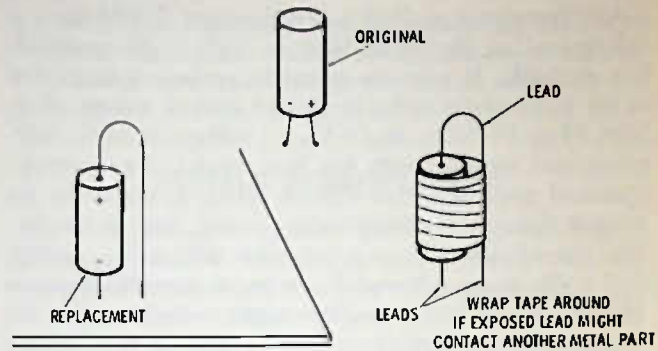

Fig. 15-7. A part with a lead at each end replacing a part with both leads at one end.

TEST QUESTIONS

1. If you wished to temporarily connect in a replacement transistor for one in the set suspected of being defective, you can do so by
 - A. soldering the known good transistor directly across the old transistor.
 - B. soldering in the replacement on the printed side of the board, if you disconnect at least one lead of the original transistor.
 - C. soldering in a replacement to the same points in the circuit as the original transistor, if you remove at least two of the leads of a three-lead transistor originally in the circuit.
 - D. holding the transistor leads in place on the printed side of the board across the one suspected of being defective.

2. If the transistor in Fig. 15-8 were measured out-of-circuit, you might find that both ohmmeter readings would indicate fairly high resistance between collector and emitter. In-circuit, one reading may be low and the other high. Can you explain why?

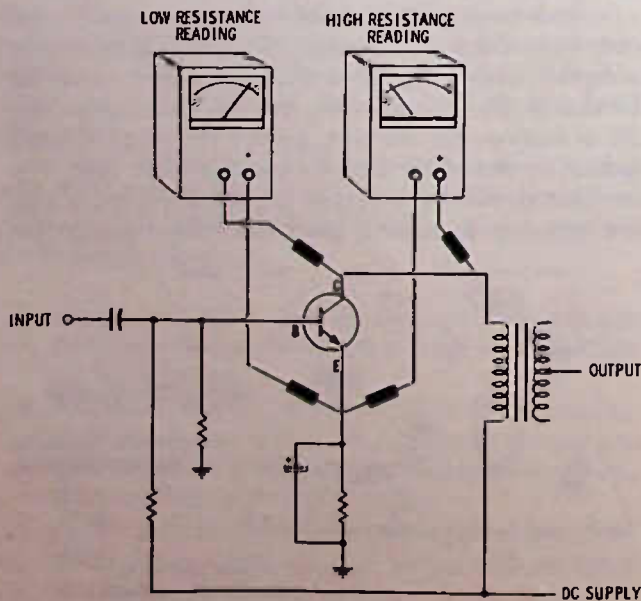

Fig. 15-8. Circuit for Question 2.

- A. In-circuit, the transistor has resistance between the collector and emitter.
 - B. In-circuit, the meter itself, when connected as shown, can bias the transistor "on," causing the collector-emitter resistance to be considerably reduced.
 - C. The resistor between the base and emitter automatically biases the transistor on, so that when the voltage from the meter is the correct polarity, the transistor resistance is reduced.
 - D. As indicated by the symbol, the transistor is a pnp instead of an npn, so that when a negative voltage from the meter is connected to the collector, it conducts and becomes a low resistance as shown.
-
3. In Fig. 15-9, with the radio turned on, you find that you have no voltage at point C. Without further checking, you could be sure that
 - A. the dc supply voltage is good.
 - B. the radio is not turned on, or the switch is defective.
 - C. the trouble is not C1.
 - D. the trouble is C3.

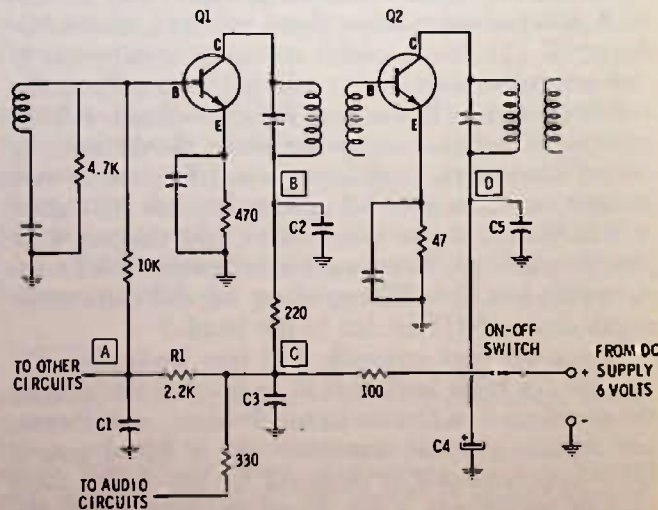

Fig. 15-9. Circuit for Questions 3 through 10.

4. In Fig. 15-9, with the radio turned off, you measure with an ohmmeter and find that at point B there is about 250 ohms resistance to ground. Reversing the ohmmeter leads and taking another reading shows still approximately 250 ohms resistance. The next step you should take in checking for this too-low resistance on the supply line is to

- A. disconnect the collector lead of the transistor or the lead to the i-f transformer to make sure that the transistor is not shorted or does not have a low resistance.
- B. move to point C and take another measurement.
- C. move to point D, because the resistance readings indicate the trouble is most likely here; either C4 or C5.
- D. check across C1; it is probably shorted.

5. In Fig. 15-9, with the switch turned off, you measure about 60 ohms from point D to ground. The trouble could be

- A. either C4 or C5 is leaky, perhaps both.
- B. Q2 is shorted.
- C. either A or B above.
- D. either A or B above, or possibly C3 is shorted.

6. In the preceding question, a good way to determine whether the trouble is C4 or C5, without removing the capacitors, would be

- A. check directly across each capacitor to see which one shows the short or heavy leakage.
- B. use an in-circuit capacity tester.
- C. slit across the printed circuit so you can isolate between the two.
- D. none of the above are practical.

7. If you read the resistance of a dc supply line, with the set turned off, and making sure you reverse the ohmmeter leads and take two readings, or else use a low-voltage ohmmeter that will not turn on the transistors, you should have a resistance reading to ground from the supply line

- A. of at least 1000 ohms in nearly every case.
- B. of at least 100,000 ohms in most cases.
- C. of less than 220 ohms in most cases.
- D. of almost zero ohms.

8. In Fig. 15-9, with the switch on and reading the voltages with a meter, you find 6 volts at the collector of Q2, 5.7 volts at point C, and zero volts at point A. The voltage reading you should get at the collector of Q1 is

- A. dependent on how much current Q1 draws but should be less than 5.7 volts.
- B. 5.7 volts.
- C. dependent on how much current is being drawn from point C by the audio amplifiers.
- D. zero.

9. The cause of the trouble in the preceding question could be

- A. a short in the audio circuits taken off at point C.
- B. a base-to-emitter short in Q1.
- C. C2 shorted.
- D. R1 open, or C1 shorted.

10. In Fig. 15-9, if you measured from the collector of Q1 to ground and read 560 ohms, and from point B to ground and read 566 ohms, you should look for the trouble, if, indeed, there is trouble,

- A. on the supply line either at point C or D.
- B. at C2 which may have a leakage of approximately 560 ohms.
- C. in transistor Q1.
- D. in the audio circuits.

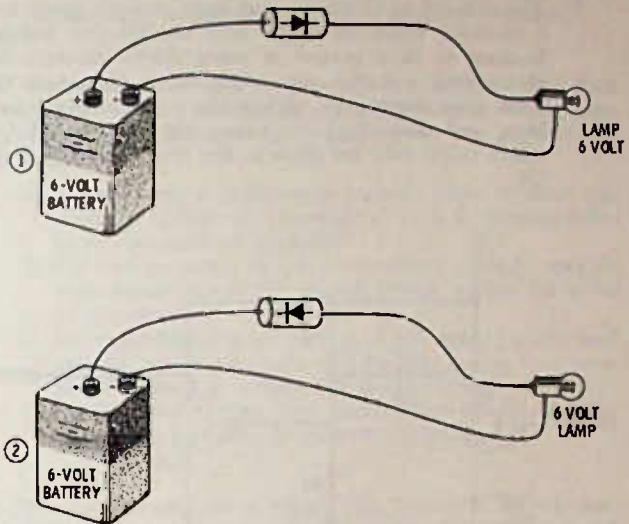

Fig. 15-10. Diagram for Questions 11, 12, and 13.

11. A diode has the ability to pass current easily in one direction but not in the other. This ability can be noted by measuring a diode with an ohmmeter and then reversing the leads—one reading will be a high resistance and the other a low resistance if the diode is good. In Fig. 15-10,

- A. the lamp in circuit No. 1 will be lit and in circuit No. 2 will not be.
- B. the opposite of A. above.
- C. both lamps will be lit.
- D. neither lamp will be lit.

12. If the same diode is used in both circuits of Fig. 15-10, first in circuit No. 1 and then in circuit No. 2, and the lamp lights in both cases,

- A. this is normal.
- B. the diode is shorted.
- C. the diode is open.
- D. could be either B or C above.

13. Assuming the diode you were using in Fig. 15-10 was made to pass no more than 25 milliamperes of current and the lamp draws 300 mA at 6 volts,

- A. the diode would be damaged in circuit No. 1 only.
- B. the diode would be damaged in circuit No. 2 only.
- C. the diode would not be damaged in either circuit.
- D. the diode would be damaged, regardless of which circuit it was connected into.

14. In Fig. 15-11 is a circuit where either transistor Q2 has a collector-emitter short or the bias is excessive. We know this because the emitter and collector voltage are almost the same, meaning that the transistor itself is nearly zero resistance between C and E. Assuming the transistor is all right in this case, we suspect that C1 might be shorted or leaky because the base bias is too high. How can we be sure?

- A. Measure across it in-circuit with an ohmmeter.
- B. Measure the voltage drop across it in-circuit.
- C. Disconnect the end of the capacitor from the base circuit and measure the voltage from this disconnected end to ground. If there is approximately 4.5 volts, the capacitor is leaky.
- D. The method in C above is all right in most cases, but a sensitive voltmeter might read considerable leakage because so little current is being drawn through the electrolytic. A better way might be to disconnect the 100K bias resistor by slitting the printed circuit perhaps, and then check for voltage on the base of Q2, which could only get there in this case through a leaky C1.

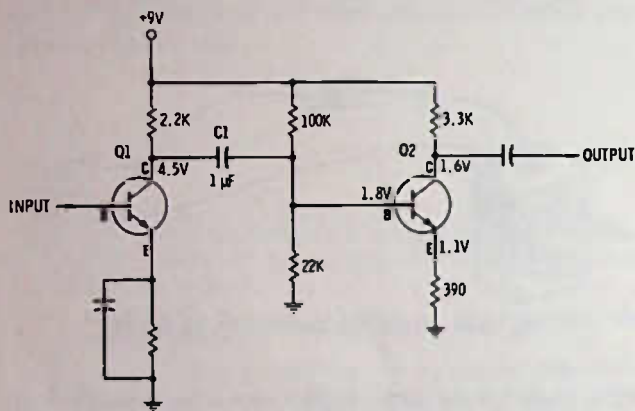

Fig. 15-11. Circuit for Question 14.

- 15. If you measure a .05- μ F ceramic capacitor with an ohmmeter,
 - A. when you first connect the capacitor to the ohmmeter leads, you should see a large reading, which should then fall off to zero.
 - B. you should get a steady dc reading of around 100,000 ohms, or perhaps as high as 1 or 2 megohms if the capacitor is a high-quality one.
 - C. you should get a zero resistance reading, if the capacitor is all right.
 - D. you should get an infinite resistance reading and probably no deflection of the meter when you first connect the test leads to the capacitor.

- 16. "Continuity" is a term that means
 - A. the voltage in the circuit is normal.
 - B. the power supply is turned on, feeding the radio.
 - C. the circuit will pass direct current.
 - D. the signal path is normal as measured with an ohmmeter.

- 17. A 1.5K resistor has a resistance of
 - A. 15 ohms.
 - B. 150 ohms.
 - C. 1500 ohms.
 - D. none of these.

- 18. In most circuits used in radio, if a resistor is within 20% of its rated value, it will
 - A. likely work in the circuit as well as one of the rated value.
 - B. likely cause the radio to be weak.
 - C. probably cause the radio to be dead.
 - D. almost surely cause other parts to overheat.

- 19. In Fig. 15-12, the voltmeter readings of this inoperative circuit are shown. What part or parts are probably the cause of the voltages shown? (Voltages measured to ground.)

- A. Transistor Q2 shorted, collector-to-base.
- B. R4 open, not allowing voltage to reach collector.
- C. C2 or R3 are shorted or have very low dc resistance.
- D. C1 shorted.
- E. T1 is open between R2 and the base of Q2.
- F. Either D or E above are likely troubles.

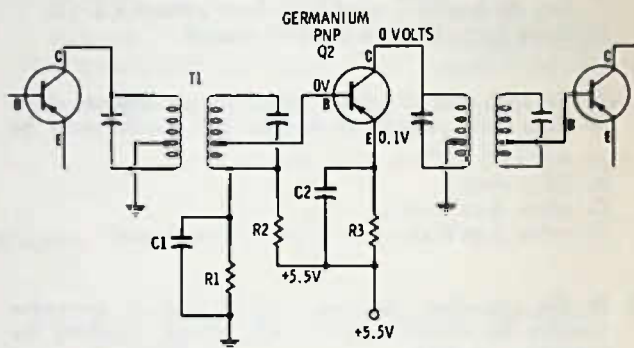

Fig. 15-12. Circuit for Question 19.

- 20. Fig. 15-13 is an audio amplifier circuit. The problem is distortion, which has been localized to this stage by a signal tracer—that is, the signal sounds all right at the volume control but is distorted at the collector of Q1. You measure the voltages on the transistor and find that the collector is about 5.5 volts negative. The base voltage to ground measures about 0.15 volt and the emitter voltage about 0.2 volt. What part would you suspect first?

- A. The transistor.
- B. C2 shorted or very leaky, lowering the emitter voltage.
- C. R1 open or a high resistance.
- D. R2 high resistance.

- 21. In a radio with a circuit similar to Fig. 15-13, the audio output is weak but the radio still seems to receive a number of stations. The signal tracer is used and there seems to be plenty of audio at the base of Q1. There is also about the same amount of audio at the emitter, but the audio output at the collector does not seem to be too much greater than at the base of the transistor. The trouble is almost sure to be

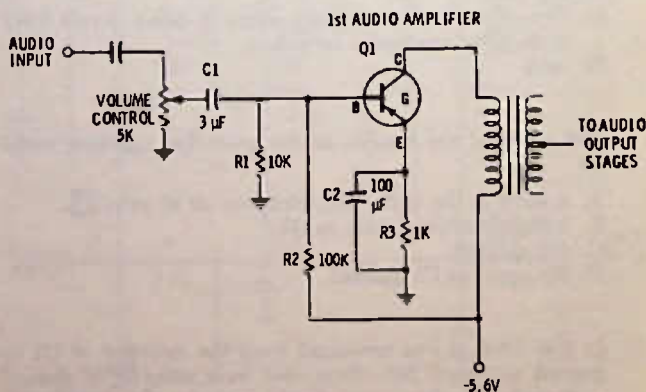

Fig. 15-13. Circuit for Questions 20 through 23.

- A. the transistor.
 B. the transformer primary open.
 C. capacitor C1 open, or partially open.
 D. capacitor C2 open.
22. In Fig. 15-13, the emitter voltage that would normally be shown on the schematic is 1.5 volts, but the radio is distorted and you find the voltage on the emitter is about 3.5 volts. A trouble you might suspect would be
- A. R1 open.
 B. R2 open.
 C. R3 open.
 D. C2 open.
23. In Fig. 15-13, if you were installing new electrolytics for C1 and C2, you would connect them in the circuit with
- A. the positive toward the base on C1 and positive toward the emitter for C2.
 B. the positive toward the volume control on C1 and the positive toward ground on C2.
 C. the positive lead of both capacitors toward the transistor.
 D. the positive lead of both capacitors away from the transistor.
24. In Fig. 15-14, which way should capacitors C1 and C2 be connected? Use answers given in Question 23.

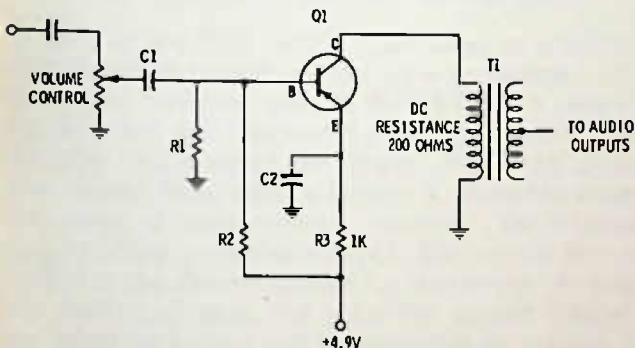

Fig. 15-14. Circuit for Questions 24, 25, and 26.

25. In Fig. 15-14, if you have no audio and you check the collector voltage of Q1 and find it to be nearly 5 volts, you would suspect
- A. a shorted transistor Q1.
 B. excessive bias on transistor.
 C. open primary of T1.
 D. open R3.
26. In Fig. 15-14, suppose the transistor is a germanium type, and it draws about 1 mA of current. If you measured the base voltage to ground, you would expect to read about
- A. 4.8 volts.
 B. 3.8 volts.
 C. 0.1 volt.
 D. 0.5 volt.
27. A resistor that has burned enough, in the circuit, to cause it to be discolored will likely, if not cracked apart, be
- A. lower than its rated resistance.
 B. higher than its rated resistance.
 C. about the same as its rated resistance, within about 20%.
 D. acting much like a diode.
28. In a transistor radio the metal parts of the radio such as transformer shield cans, metal braces, and the like will be connected to the
- A. ground or common terminals of the circuit.
 B. the hot portion of the circuit.
 C. the base of one of the transistors.
 D. the negative side of the battery in every instance.
29. If you find a defective transistor in the i-f circuit of a portable radio and you want to replace it with a similar transistor, but of different type number, you can probably do so if
- A. the replacement is the same polarity (npn or pnp) and material (silicon or germanium) and is recommended as an a-m radio i-f amplifier.
 B. the voltage rating of the replacement is high enough, even though not of the same material but for use in fm i-f circuits.
 C. the replacement is one that is of the same polarity and material and is recommended for use in the fm rf amplifier stage of an automobile radio.
 D. the transistor is the same general type in all respects, but is recommended as an audio amplifier.
30. You need to replace a silicon npn transistor in the converter stage of a portable a-m radio. The replacement could probably be one of the same type but recommended for use in
- A. an audio amplifier.
 B. an audio output stage.
 C. a 455-kHz i-f amplifier.
 D. a 10.7-MHz i-f amplifier.
31. If a transistor is replaced in an i-f amplifier, you should
- A. leave the i-f tuning the same as it was with the original transistor.
 B. use a newer-type silicon transistor, if the original was a germanium type.
 C. repeak the i-f transformers for maximum sensitivity after installing the new transistor.
 D. repeak the i-f transformers, and if you hear whistles or squeals as the radio is tuned from station to station, you should back off the tuning adjustments until there are no longer any oscillations (whistles, squeals, and the like).
32. To make sure the replacement transistor will work normally, you should
- A. always install the transistor permanently in the circuit in the same position as the original.
 B. tack-solder the transistor on the printed side of the board after removing the original transistor from the circuit.
 C. always use the same type number as the original.
 D. use a transistor checker to test the replacement transistor before you put it in the circuit.
33. If a transistor is hot to the touch and is used as an rf amplifier or converter, this is
- A. an indication that the transistor is drawing too much current.
 B. normal in most of these type circuits.
 C. an indication that a silicon transistor is being used.
 D. an indication that the transistor bias voltage is too low.

34. When replacing a 4-lead transistor, you should
- A. always use a 4-lead replacement.
 - B. if a 3-lead replacement is used, tie the emitter to ground.
 - C. if a 3-lead replacement is used, solder a wire from the transistor case to ground.
 - D. try a 3-lead replacement transistor of the same general type, if a 4-lead replacement is not available.
35. To make it easier to insert a new transistor in the holes made for it in the printed board when the board is crowded with other parts, you should
- A. ream out the holes so they are larger.
 - B. see that the holes are free of solder, and stagger-cut the leads of the replacement transistor.
 - C. solder longer wires on the transistor so they can be threaded through the holes in the printed board.
 - D. solder it in from the printed side rather than from the component side.

FET Amplifiers and IC Circuits

The FET (field-effect transistor) is now being used more and more in transistor radios, especially in the tuners, but also in other sections. The FET, unlike the bipolar transistors (npn's and pnp's), can be controlled with voltage alone. Since no current flow is needed in the input circuit, the FET has, or can have, a high-impedance input, even higher than a vacuum tube.

FET CONSTRUCTION AND OPERATION

Basically, an FET can be considered as a resistor through which current will flow if a dc voltage is applied. The "resistive" part of the FET has a connection at either end. One end is called the "source," and the other end is called the "drain." Fig. 16-1A shows how current flows when a battery is connected across this piece of semiconductor material (the material may be either p type or n type). The current here is limited to the desired amount by the resistor. By adding another element, the gate, the current between the source and drain can be controlled by voltage. If enough voltage is applied to the gate, as in Fig. 16-1B, the current is cut off (called "pinch off" in the FET) between the source and drain as indicated by the milliammeter.

Bias Requirements

In a simple field-effect transistor, the gate is a diode-type junction, the same as in bipolar transistors, but instead of being forward biased as with the bipolars, it is reverse biased when used as a gate. A reverse-biased diode has little if any current; hence, it is a high impedance.

The JFET

A field-effect transistor with the diode junction is called a JFET (for junction field-effect transistor). The JFET requires some sort of bias to keep its gate reverse biased to prevent gate-current flow, which would upset the circuit that is designed for high impedance.

A JFET can be checked with an ohmmeter as shown in Fig. 16-2. You can also find out which lead is the

gate in this manner, since it will be the one that has diode action with either of the other two leads. An ohmmeter reading between the drain and source will be the same, regardless of the polarity of the ohmmeter leads. The reason for needing to find the gate lead is indicated by the FET basing diagrams in Fig. 16-3, and this is only for some of the most popular types.

The schematic symbol for a JFET is shown in Fig. 16-4. The JFET may have either an n channel or a p channel (the channel is the piece of semiconductor material of which one end is the source and the other end the drain). They are identical in operation, except that the polarities are reversed. The n-channel type uses a negative bias on the gate with respect to the

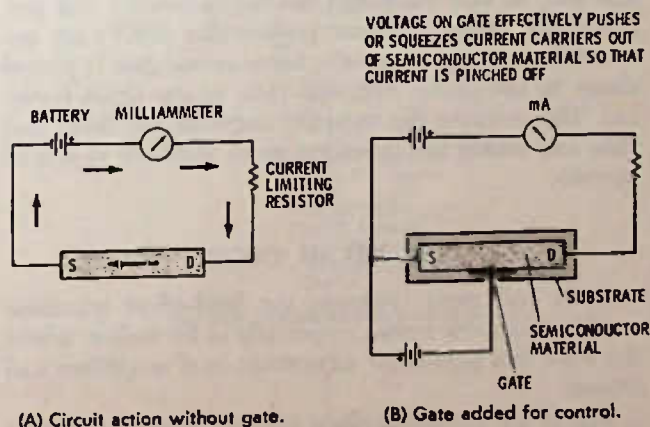

Fig. 16-1. Simple field-effect transistor.

source (which means that the source can be, or is in fact, positive in respect to the gate) and a positive voltage between the drain and source. The p-channel type requires a positive bias for pinch off with respect to the source, and the drain-source voltage is negative. The most popular JFET is the n-channel type. This may be, in part, due to the methods of manufacture, but because the n-channel type uses the same polarity voltages as a vacuum tube and because the FET is more nearly like a vacuum tube as to how it reacts in the circuit, this may also account for why the n channel type is more popular.

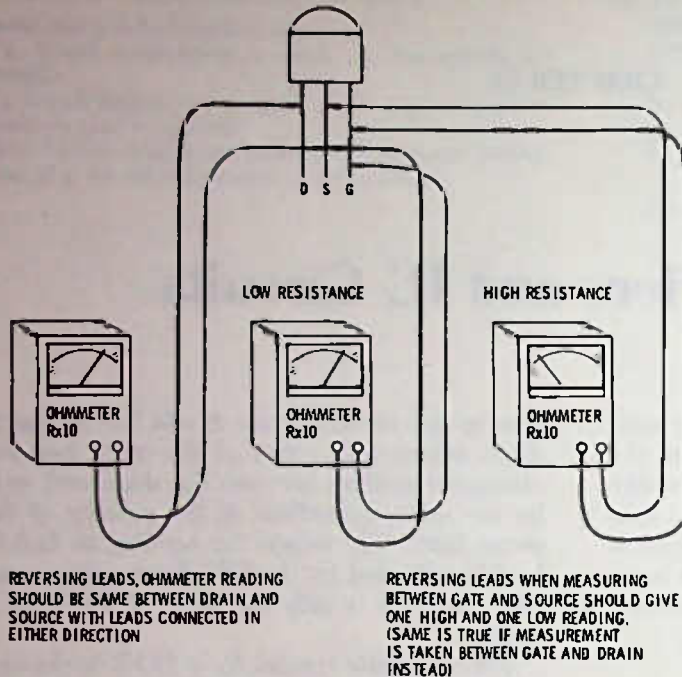

Fig. 16-2. Checking JFET with ohmmeter.

In the simple JFET types, it makes no difference which of the terminals you call drain or source. You can reverse the designations and not affect the operation of the transistor, since current will flow between drain and source, regardless of which battery polarity you use, as was indicated by the ohmmeter test just described. However, most present-day JFETs are not reversible with good results, because the gate is placed closer to the source terminal than to the drain terminal. This reduces the capacity between the drain and gate and makes the transistor more stable in rf and i-f circuits.

THE JFET IN CIRCUIT

More and more, you see the field-effect transistor used in transistor radios, especially in fm radios, where the FET has particular advantage in rf amplifiers and mixers.

The JFET is used in these circuits, although another kind of FET, to be discussed following this section, is also popular. The FET has the advantage of less tendency toward cross modulation in the rf and mixer stages. Cross modulation is the effect caused by two

strong incoming signals beating against one another, providing spurious responses on the dial. For example, a strong local station may be heard at one or more other places on the dial besides the spot assigned to it, or a police radio signal may inject itself into the circuit by sheer strength. This effect is generally the result of overloading in the front end (rf amplifier stage), causing it to act as a mixer of incoming signals with one another and producing beats that, in turn, beat with the local oscillator and one another to produce all sorts of unwanted response. The FET, because it can be controlled over a wider range of bias and still remain a linear amplifier, helps to eliminate these problems (mixing does not occur in a linear amplifier—one that has an output that is a replica of the input, except in amplitude).

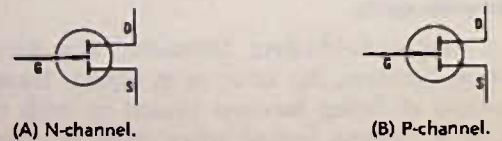

Fig. 16-4. Symbols for junction field-effect transistors.

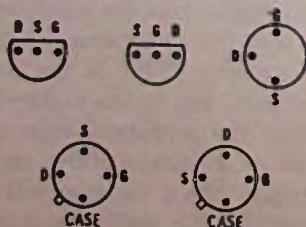

Fig. 16-3. Some basing diagrams for field-effect transistors.

Fig. 16-5 is a "grounded-gate" FET amplifier, using an n-channel FET. A negative agc voltage provides bias that varies with the strength of the incoming signal. The grounded-gate circuit uses the source terminal as the input and the drain terminal as the output. Fig. 16-6 is a JFET mixer circuit. There are a number of variations to this circuit that can be used. Checking this stage is best done, at least in preliminary testing, by measuring terminal voltages. Touching the oscillator coil or tuning the radio across the dial should

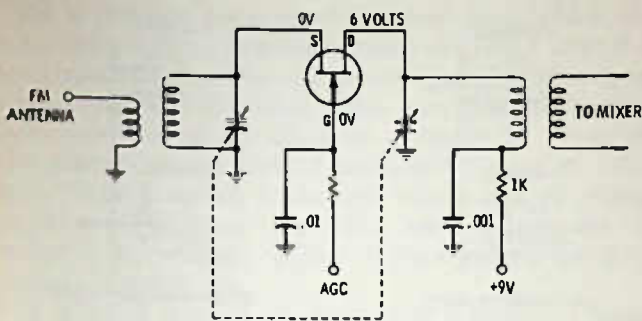

Fig. 16-5. Grounded-gate FET rf amplifier in an fm broadcast radio.

result in a change in source voltage. If the source voltage is nearly normal, but does not change as the radio is tuned, the likely trouble is in the oscillator portion of the circuit, rather than in the mixer.

Fig. 16-7 is a simple JFET audio-voltage amplifier. Generally the FET-type transistor is not used for developing or amplifying power, since controlling of heavy current by a voltage field is difficult at the present state of the art. There seems to be little doubt that the power FET will come in time, however.

Fig. 16-8 is a JFET used to match a low-level audio circuit to a bipolar transistor. This overall circuit has excellent voltage gain because the JFET does not require any current (only voltage) from the audio

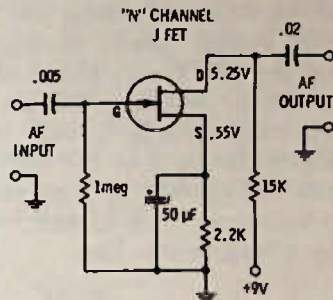

Fig. 16-7. Audio amplifier using JFET.

Fig. 16-9 is a special circuit not used much in radio, but it can be used on public address amplifiers for controlling volume levels at a distance. This is a p-channel JFET, meaning that its current is pinched off with an increase in positive voltage. Changing the current flow is the same as saying that the resistance is

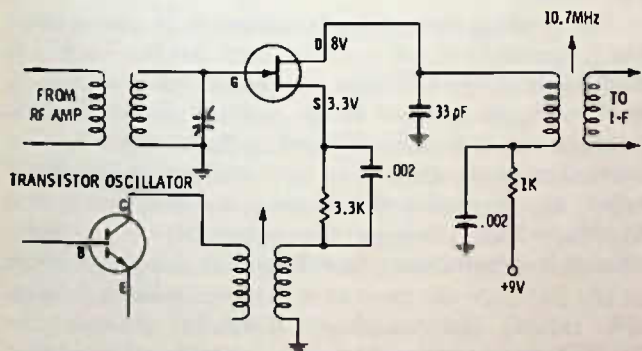

Fig. 16-6. JFET used as a mixer in an fm radio.

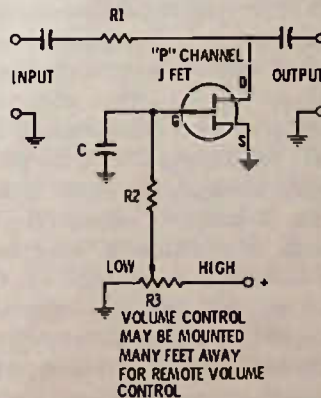
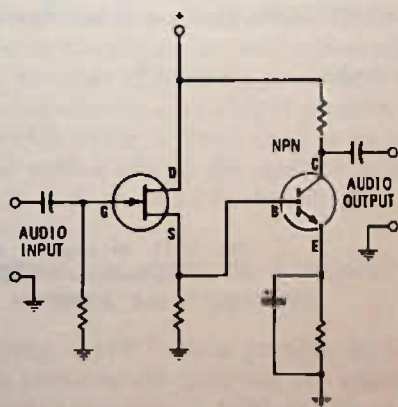
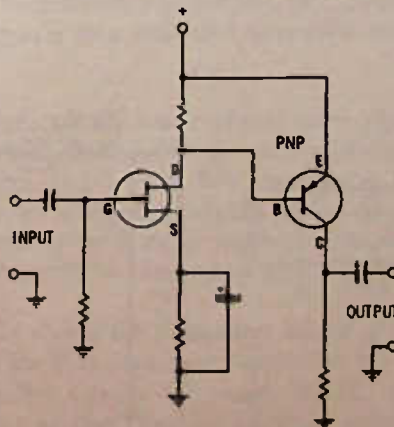

Fig. 16-9. Remote volume control circuit.



(A) Circuit for npn transistor.



(B) Circuit for pnp transistor.

Fig. 16-8. JFET used to match high-impedance audio to low impedance of bipolar transistor.

changing. With maximum positive voltage, the JFET has no current flow and therefore appears to be a very high resistance, resulting in none of the audio being bypassed to ground (maximum volume). With the dc voltage from the remote volume control at zero (ground end), the JFET conducts rather vigorously and so represents a rather low resistance, bypassing most of the audio to ground and resulting in low volume. This circuit cannot completely cut off the audio, since the JFET still has some resistance with zero bias, but, by selecting the size of R1, the minimum volume can be made virtually zero without noticeably affecting the level of the amplifier at full volume. The gate is bypassed by capacitor C to prevent any audio variations, such as hum, which might be picked up by a long remote line.

THE IGFET

The insulated-gate field-effect transistor has several advantages over the JFET, although at the present time it is slightly less rugged. The insulated gate is just what the name implies: instead of the gate being "junctioned" in as a diode, it is completely separated from the drain-source channel by an extremely thin film of insulation. Included in this family of transistors is the MOSFET (metal oxide semiconductor field-effect transistor).

The "beauty" of these transistors is that the polarity of the bias voltage can be either positive or negative without causing problems. The current flow in an n-channel IGFET, for example, can be reduced by applying a negative voltage, the same as for the JFET, but by applying a positive voltage the current flow can be increased. In addition to being both n-channel and p-channel IGFETS, or MOSFETS, there are "depletion," "enhancement," and "depletion-enhancement" types. Like the JFET, the depletion type has current flow at zero bias but has reduced current flow as bias is applied. The enhancement type has no significant current flow with zero bias, but requires bias before current will flow. The depletion-enhancement type has some current with zero bias, less with a negative bias,

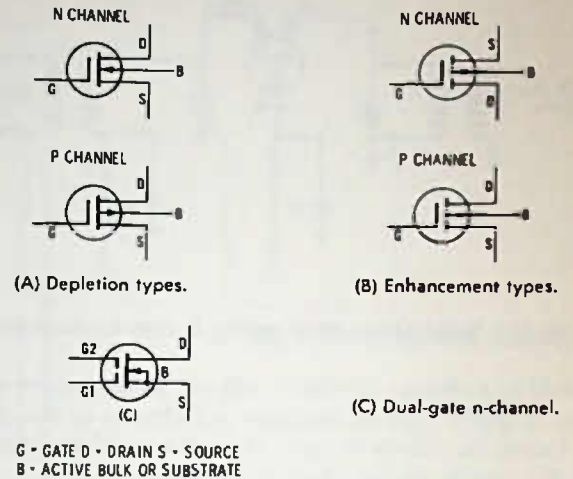

Fig. 16-10. Schematic symbols for IGFET and MOSFET transistors.

and more with a positive bias. All types have extremely high input impedance. In fact, it is possible to have input impedances exceeding 1000 megohms.

The symbols for the IGFETs and MOSFETs are shown in Fig. 16-10. Also shown is the symbol for a dual-gate MOSFET. The dual-gate transistor is popular in rf amplifiers, with one gate used as the signal input terminal and the other gate used essentially for age control.

The symbols show 4 leads, although in many cases the B terminal (which is not for base but for "bulk") is tied internally to the source terminal, as is shown in the dual-gate symbol. If an external B terminal is brought out, it is normally tied to the source.

Insulated-gate transistors, especially the MOSFET types, are shipped with the leads twisted or shorted together. This prevents the possibility of a static charge buildup during branding and shipping, which might puncture the insulation between gate and channel, ruining the transistor. Basically, though, the MOSFET transistor is rugged in circuit and can withstand 50 volts or so between gate and channel.

Fig. 16-11 is an fm rf amplifier circuit, using a dual-gate MOSFET. Note that no neutralization is used.

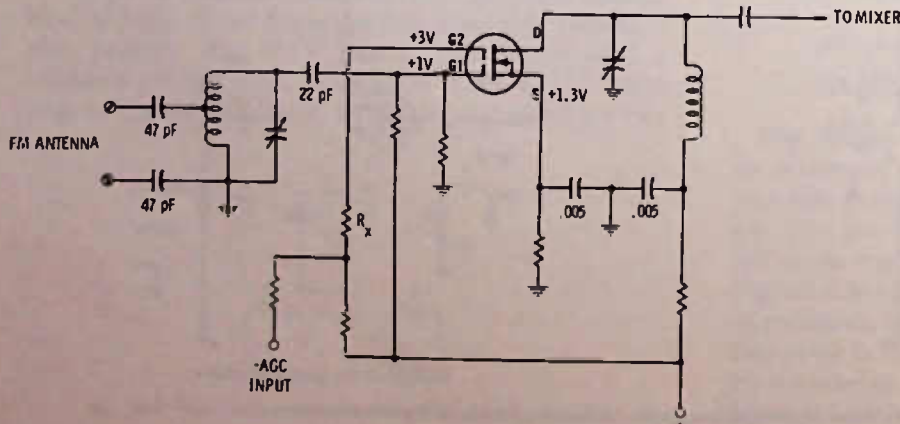

Fig. 16-11. RF amplifier in fm receiver, using dual-gate MOSFET n-channel transistor.

This is possible because of the dual gate, which allows the placing (in manufacture) of Gate 1 near the source terminal so that the capacity between the input and output is minimized. Note, also, that both gates have positive voltage on them, although by virtue of the source voltage Gate 1 has negative bias of -0.3 volt. Gate 2, which is the agc input, may go either positive or negative, depending upon the amount of negative agc voltage applied to buck out the positive voltage through R_x .

Fig. 16-12 is an i-f amplifier using a MOSFET transistor. Because the gate circuit draws no current, it does not load the tuned circuit, and there is no need to tap down on the transformer winding. Dual-tuned transformers are used.

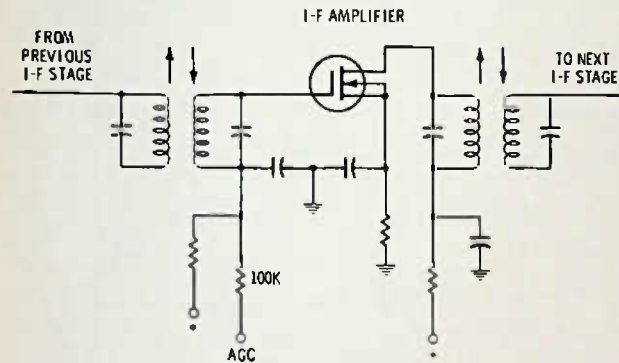

Fig. 16-12. I-f amplifier using MOSFET transistor.

The checking of all sorts of FET amplifiers revolves around voltage testing, signal tracing, etc. As with a bipolar transistor, the unipolar (FET) transistor must draw current in order to operate, and when current is drawn through resistors in the supply circuits to the transistor, a voltage drop occurs, and the current drain can be calculated with Ohm's law after a voltmeter reading is taken.

By nature, the FET is a low-voltage device, with perhaps no more than about 30 volts, and often much less, applied between the drain and the source. The current flow may be from below 1 mA to 10 mA or so. Dual-gate transistors generally have more current flow than single-gate transistors but not necessarily so.

The FET, because of inherent noise, does not work well in low-impedance audio-input circuits, and the bipolar transistor so far is found used as an audio amplifier almost exclusively in the audio stages of portable radios as well as in table models.

TESTING AN IGFET OR A MOSFET WITH AN OHMMETER

When testing a JFET, it is possible to check the diode action between the gate and the channel when the meter leads are reversed. With the insulated gate, there should be NO reading on the ohmmeter when checking between gate and channel (either source of

drain). If there is an ohmic reading, then the gate insulator is punctured and the transistor is defective.

As with the JFET types, reading between the source and drain should give you the same reading, regardless of the polarity of the meter leads.

To check the gate circuit, you must put some sort of voltage on the gate to see if the drain-source resistance changes. You could use a separate 1.5-volt battery between source and gate, if you wish, but you can use a 10K resistor, as shown in Fig. 16-13, to place a + bias on the base (remember the negative lead on most vom's is the positive lead so far as the ohmmeter circuit is concerned). The check in Fig. 16-13 is for n-channel FETs; the ohmmeter leads would be reversed for p-channel FETs.

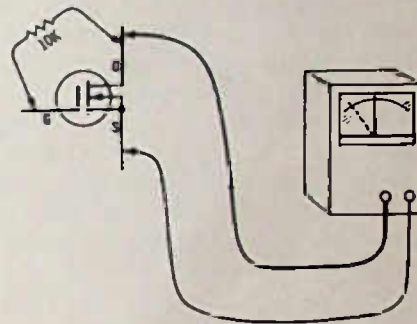

Fig. 16-13. Testing insulated-gate type FET with an ohmmeter. Change in dc resistance indicates gate circuit is controlling.

NOTE: Nothing in this book should be taken as indicating that transistor test instruments are not useful, or even not necessary in making various kinds of tests on transistors. Some of these testers are designed to check transistors in-circuit as well as out of circuit. The emphasis, though, in this book is to point out methods of testing, using common pieces of test equipment that are basic to any kind of shop or home service. If you know how to make an ohmmeter or voltmeter test you are often able to find a fault faster than you can find the test leads for a sophisticated tester.

ICs

Integrated circuits are nothing more than a packaged amplifier containing several transistors, diodes, resistors, etc., but seldom any capacitors. This means that inside an integrated circuit direct-coupling is almost exclusively used, or, if capacitor coupling is used, the capacitor will be connected externally to the pack or module.

Fig. 16-14 shows the triangular shape of the symbol often used for ICs, especially when the IC is a single-stage amplifier circuit. Checking an IC is generally just a matter of checking the external voltages, and if they are incorrect it is likely caused by the IC itself, assuming that the voltages being fed to it by the

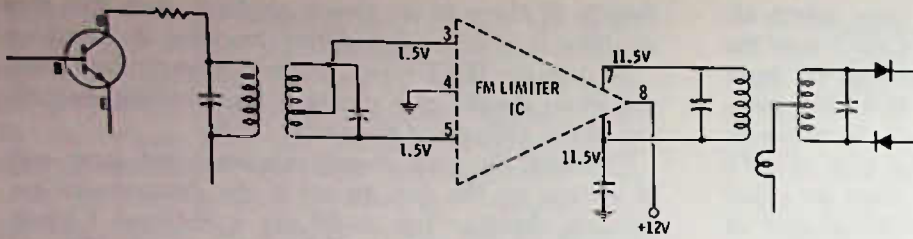

Fig. 16-14. Schematic of an integrated-circuit amplifier used in an fm radio.

power supply are normal and that external resistors or capacitors used with the IC are all right. Always use a solid-state vom or vtvm whenever possible in checking ICs, because a meter with considerable internal resistance can change the bias enough when some measurements are made, that damage to the IC could result.

True ICs cannot be repaired, but many manufacturers use a "module" form of construction in which some parts of the module are replaceable. Or, if you wish, and expense is not a problem, you can replace the entire module as a unit. In a few cases, these modules plug in, and can be unplugged and a new one quickly installed for a test, but in radio, especially portable radio, this is seldom the case—each connection has to be unsoldered and the new one soldered back in place.

ICs such as the one used in Fig. 16-14 are often mounted in a case not much larger than a transistor.

The IC audio-output amplifier as shown in Fig. 16-15 is about as big around as a ball-point pen and about 1 inch long. Fig. 16-16 shows the equivalent circuit inside the IC. Note that there are 6 npn transistors and 1 pnp transistor, plus 3 resistors and 3 diodes. The transistors are all direct-coupled.

The reason that manufacturers use ICs is that an equivalent circuit using discrete components is considerably more expensive; so it can be expected that more ICs will be used as the state of the art progresses. It is entirely possible that mechanical tuning is on its way out. Advances in the use of varactors (di-

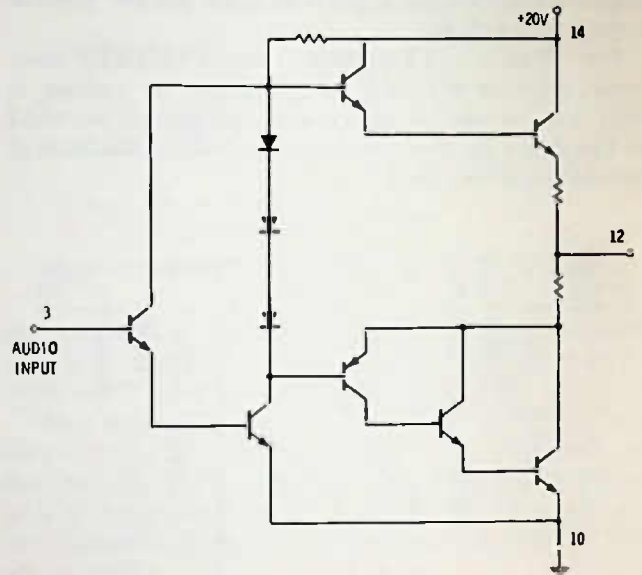

Fig. 16-16. Equivalent circuit of audio amplifier IC shown in Fig. 16-15.

odes that change in capacity as the bias across them is changed) will become the exclusive tuning element. At this writing, an fm tuner is easy to make, using only 2 or 3 varactors, and an a-m tuner is possible, though as yet not as practical as the fm tuner. Tuning is accomplished by a change in dc voltage. The same voltage line is fed to all varactors; and because the voltage is dc, it can be fed over long distances, if desired, for remote tuning.

Because the varactor is no larger than any other small diode, a complete fm tuner can be made in an

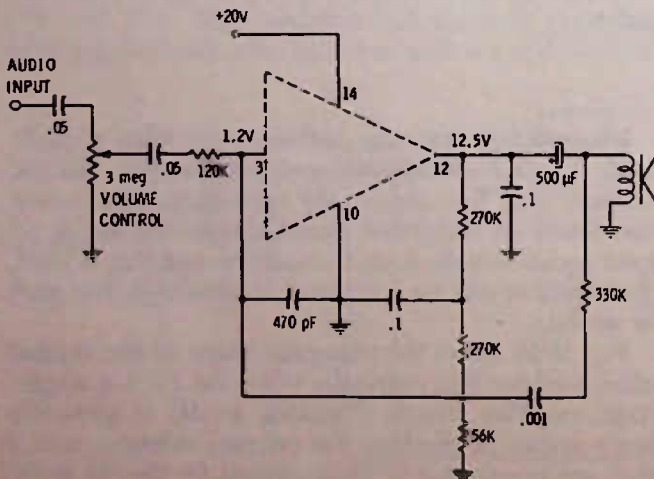

Fig. 16-15. An IC audio amplifier package with external circuitry.

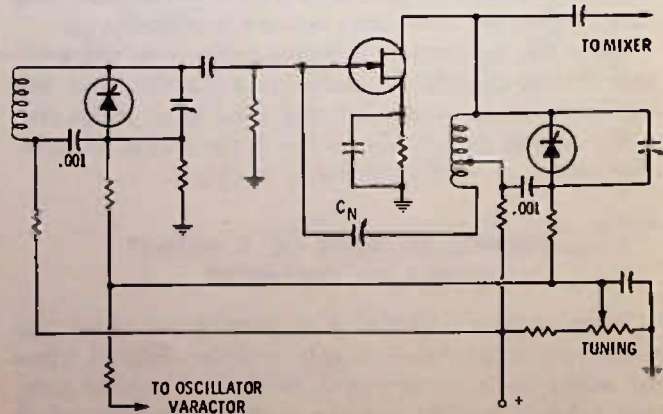

Fig. 16-17. An fm rf stage tuned by varactors.

extremely small space. Fig. 16-17 shows a typical circuit for an fm rf amplifier using a JFET and varactors. Note that the varactors are reverse biased. The amount

of reverse bias changes the capacity of the diode with a change in 10 volts or less making possible a complete sweep of the fm band from 88 to 108 megahertz.

TEST QUESTIONS

1. A field-effect transistor uses
 - A. voltage only to control its resistance.
 - B. current only to control its resistance.
 - C. a piece of n-type and a piece of p-type material in parallel connected from source to drain.
 - D. zero voltage between source and drain.
2. The control element of the FET is called the
 - A. source.
 - B. drain.
 - C. substrate.
 - D. gate.
3. A JFET has
 - A. a diode junction between the gate and the source-drain material.
 - B. a thin insulation between the gate and source-drain material.
 - C. a diode junction between the source and drain.
 - D. no gate.
4. If you measure between source and drain of an FET you will find that with an ohmmeter the reading will be
 - A. high when ohmmeter leads are in one direction and low when the leads are in the other direction across the source and drain.
 - B. the same, regardless of which way the ohmmeter leads are connected.
 - C. an extremely high resistance if the transistor is a depletion type.
 - D. nearly zero resistance.
5. Fig. 16-18 is a JFET rf amplifier for an fm stereo radio. Judging by the voltages given on the circuit, the transistor has a drain-source current of around
 - A. 1 mA.
 - B. 1.5 mA.
 - C. 2.5 mA.
 - D. 25 mA.

6. If a radio using this type of circuit received only strong local stations, indicating that the rf amplifier was not working; and you measured the source voltage and found it to be zero, you should first
 - A. replace the transistor.
 - B. check to see if the transistor has bias voltage on the gate.
 - C. check to see if the source bypass capacitor is shorted.
 - D. check to see if there is voltage on the drain terminal.
7. C_n is the neutralizing capacitor for this circuit, which cancels out feedback between the drain and the gate, preventing the circuit from possibly oscillating. Normally neutralizing capacitors should NOT be adjusted, since they are set at the factory. However, if you suspect that it has been readjusted and you wished to check it out, you could
 - A. tune to an fm station and set C_n for the loudest output from the speaker.
 - B. tune off station and adjust C_n for maximum noise as heard from the speaker.
 - C. adjust C_n until you hear whistles in the output, and then back it off until the whistles stop.
 - D. tune in a station, then disconnect the dc voltage going to the drain and adjust C_n for minimum output of the station as heard in the speaker.
8. Fig. 16-19 shows an audio amplifier circuit using a JFET. If you measured between the source and drain with a voltmeter it would read
 - A. 10 volts.
 - B. 1 mA.
 - C. 7.8 volts.
 - D. 6.4 volts.
9. The JFET in Fig. 16-19, judging by the polarity of the voltages, is
 - A. a p-channel type.
 - B. an n-channel type.
10. An IGFET or MOSFET is characterized by
 - A. having the gate insulated from the drain-source material.
 - B. having extremely high input impedance, regardless of the bias voltage polarity.
 - C. both A and B above.
 - D. both A and B above, plus having the ability to amplify to considerable power such as that needed for driving a loudspeaker.

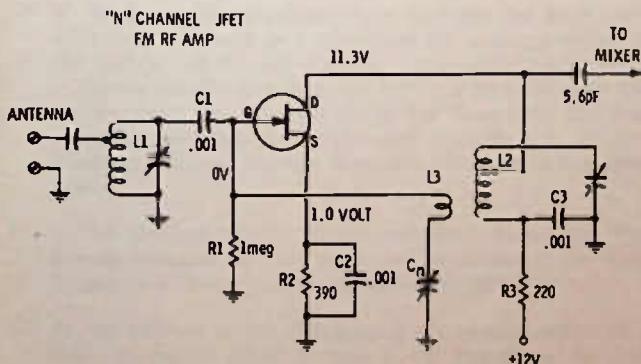

Fig. 16-18. Circuit for Questions 5, 6, and 7.

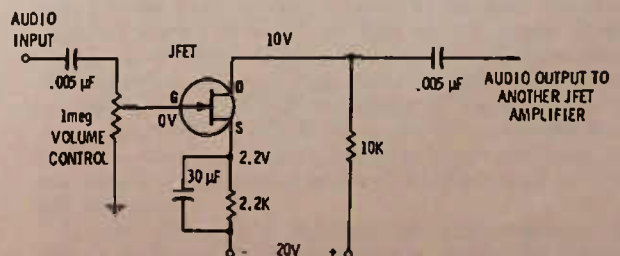

Fig. 16-19. Circuit for Questions 8 and 9.

11. An enhancement-type field-effect transistor has
- considerable source-drain current without bias on the gate.
 - maximum source-drain current with zero bias voltage on the gate.
 - zero current with zero bias on the gate.
 - reduced current as bias is increased on the gate.

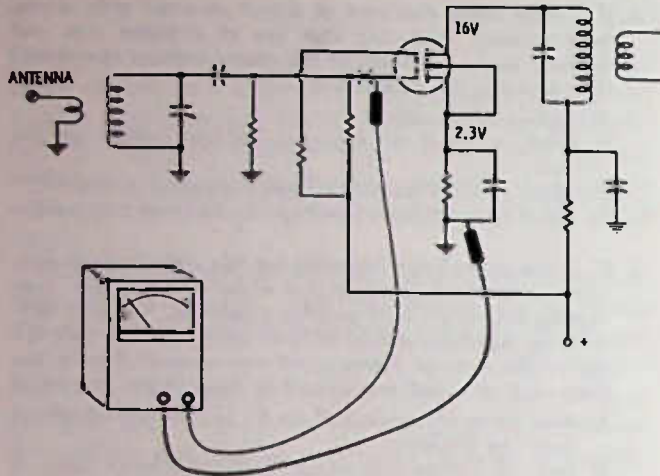

Fig. 16-20. Circuit for Question 12.

12. In Fig. 16-20, after disconnecting one gate from its circuit of this dual-gate MOSFET amplifier, it was found that the "floating" gate had a voltage on it of over 0.5 volt. This would indicate
- a normal condition.
 - a breakdown of the gate insulation.
 - excessive agc voltage.
 - that the transistor is forward biased.
13. Integrated circuits (ICs) should be checked by
- reading the external dc voltages with a high-impedance voltmeter.
 - individually testing the internal transistors in the unit.
 - jumpering between various terminals to see whether they start working again.
 - heating the ICs with a soldering iron to see whether they start working again.
14. A varactor or varicap is
- an inductor that changes reactance when biased with a dc voltage.
 - a capacitor that can be mechanically adjusted for tuning a circuit.
 - a diode that changes in capacity when the reverse dc voltage bias is changed across it.
 - a variable resistor that will change the tuning of a circuit when placed across an inductor.

Answers to Test Questions

CHAPTER 1

1. A. "Kilo" is an international term meaning 1000. For example, a kilohertz is 1000 hertz (formerly kilocycles was used instead of kilohertz), kilowatt is 1000 watts, a kilowatt-hour is 1000 watt-hours, a kilovolt is 1000 volts, etc.
2. C. Hertz replaced the term "cycles-per-second" some years ago. The term is in honor of a German scientist, Heinrich Hertz, whose discoveries were of great importance in the development of radio.
3. D. 1948.
4. B. Amplification is a method of controlling a larger flow of current with a smaller flow of current or with voltage change.
5. B. 60 Hertz, also called 60 cycles, 60 cps (for cycles per second), but as indicated above, hertz is now the international "proper" term.
6. A. Although not many people can hear this extended range, it is possible and so the arbitrarily (to some extent) designated band of audio. Most amplifiers use this rating because, if good performance is present throughout the 20- to 20,000-Hz range, it is certain that there is ample leeway to satisfy even a "golden" ear.
7. C.
8. D.
9. B. The term "heterodyne" means signals beating together. Heterodynes in older radios produced undesirable whistles and squeals. Superheterodyne was a coined term that indicated the use of heterodyne signals for useful work.
10. A. In almost all superheterodyne receivers the local oscillator frequency will be higher than the incoming signal by the amount of the intermediate frequency. It is possible to design a radio in which the oscillator runs lower in frequency than the incoming signal but since coils and tuning capacitors must be larger and since there is no particular advantage, the low frequency oscillator is not often used.
11. A. All generated radio frequencies have harmonics. The second harmonic is two times the fundamental, the third harmonic is three times the fundamental, etc.
12. D. Modulation is the changing of the characteristics of a radio frequency signal in such a way that it can be used to send information. The modulation may be voice, music, tone, etc.
13. B.
14. B. A crystal diode is simply a rectifier—a one-way street for radio frequency or other alternating current signals. Rectification removes the "mirror image" effect of a-m radio signals.
15. C. Capacitors pass higher frequencies easier than lower ones. The reactance (alternating current resistance) of a capacitor, for example, might be 1500 ohms at 500 kHz but that same capacitor would have only 750 ohms at 1000 kHz and only 75 ohms at 10,000 kHz.
16. A. "Mega" means 1,000,000. The "a" in mega is dropped when used as a prefix with ohm, thus a million ohms is one megohm.
17. D. Voltage is pressure. Voltage may also be called "electromotive force" or "potential." The letter "E" is used to indicate voltage as well as the letter "V," for example, E_x means the voltage across a resistor, while V_{CE0} means the voltage allowable across a transistor from collector to emitter with the base terminal open, etc.
18. A. Amperes, often abbreviated amps. In electronic circuits the milliampere is most often used. A milliampere is $\frac{1}{1000}$ ampere.
19. C. Ohmmeter. Do not use an ohmmeter in a circuit that has power applied to it from any other source.
20. D. 600 milliamperes is $\frac{600}{1000}$ of an ampere, or 0.6 amp.
21. B. $\frac{4}{1000}$ of an ampere is 4 milliamperes since the prefix "milli" is equal to $\frac{1}{1000}$.
22. C. A short circuit is in most cases an undesirable condition. It is a low resistance path for current which allows the circuit to bypass the normal load. Fig. A-1 indicates two different kinds of short circuits. In the first, if a short occurred across the lamp, the fuse in the power supply circuit would blow, because the wire would have small resistance and extremely high current would flow. In the second circuit, if we had two lamps of the same size in series, the voltage would divide across the lamps and both would be dim, but by placing a short across one lamp we can cause it to be extinguished and the other lamp to have full brightness.
Current always takes the path of least resistance, so when a really low resistance path is available, the current flows through this path and not through the normal circuit load.

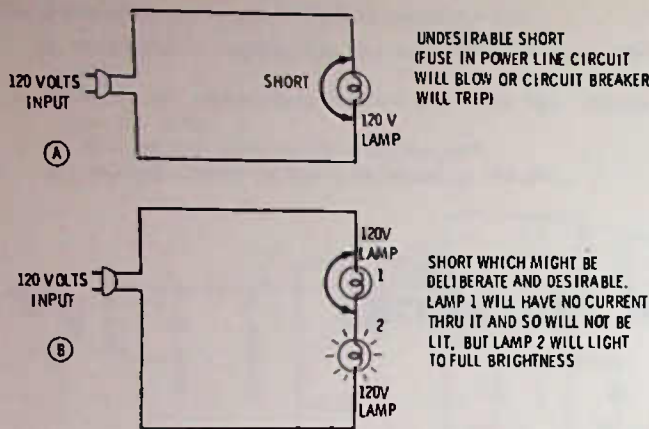

Fig. A-1.

23. A. Doubling the voltage will double the current if all other things remain equal; however, doubling the resistance in this case cuts the current in half, so the net result is no change.
24. D. It stands to reason that if there is a 5-volt drop across the resistor and a 9-volt battery source, there must be 4 volts across the lamp.
25. C. 200 milliamperes, or 0.2 ampere. We have no way of knowing what the resistance of the lamp is without further calculation, but we do know that the current through the lamp has to be the same amount as that through the resistor. By Ohm's law we can find the current through the resistor.

$$\frac{5 \text{ volts}}{25 \text{ ohms}} = 0.2 \text{ ampere, or 200 milliamperes.}$$

26. A. From Question 25 we know that the current through the lamp is 200 milliamperes, or 0.2 ampere. From Question 24 we know that the voltage drop across the lamp is 4 volts. Using Ohm's law

$$\frac{4 \text{ volts}}{0.2 \text{ amp}} = 20 \text{ ohms.}$$

Another method of determining this would be to note that across the resistor there is a 1-volt drop for every 5 ohms resistance (5 volts for 25 ohms), so since this same must hold true in a series circuit for all, the lamp with 4 volts across it must have 20 ohms resistance (4 volts times 5 ohms).

27. D. If there is a 4-volt drop across the transistor then there must be a 2-volt drop across the 1000-ohm resistor. Using Ohm's law for milliamperes and K ohms, we divide 2 volts by 1K and find the current is 2 mA.
28. B. Using Ohm's law (we know that 2 mA of current is flowing through the transistor) and dividing the voltage by the current:

$$\frac{4 \text{ volts}}{2 \text{ mA}} = 2K \text{ or } 2000 \text{ ohms.}$$

In another method that could be used here, we had already determined there was a 2-volt drop across 1K, then for a 4-volt drop with the same current the resistance must also be twice as large, or 2K.

29. D. Since we have now determined all the parameters concerning the 1K resistor (how much voltage across it, how

much current through it) we can use any one of three formulas.

$$P = EI$$

$$P = I^2R$$

$$P = \frac{E^2}{R}$$

Just for practice we will work the problem with each formula.

$$P = E \times I \text{ is } P = 2 \times 2\text{mA} = 4 \text{ milliwatts.}$$

$$P = I^2R \text{ is } P = 2\text{mA} \times 2\text{mA} \times 1K = 4 \text{ milliwatts.}$$

$$P = \frac{E^2}{R} \text{ is } \frac{2 \times 2}{1} = 4 \text{ milliwatts.}$$

30. C. Using $P = EI$ we have $P = 4 \times 2\text{mA}$, or 8 milliwatts.
31. B. A "ground" normally means a common return connection for all circuits. For example, the negative side of an automobile battery in most cars is connected directly to the frame or motor. All the connections from the headlights, taillights, stoplights, radio, etc., which go to the negative side of the battery are instead simply tied to the metal frame of the car. In other words, all the metal parts of the car become the common or ground conductor.
32. D. With 500 ohms dc resistance in the headphones and with a 0.5-volt drop across them, by Ohm's law we know that the current is 1 mA. We also know that the only current flowing out of the battery is that flowing through the headphones and transistor. In other words, if 1 mA is flowing through the headphones then there must also be 1 mA flowing through the transistor and 1 mA flowing out of the battery, because this is a series circuit.
33. A. There is a -1 volt on one side of the resistor and a -0.1 volt on the other. The difference is the voltage drop, or 0.9 volt. The voltages shown are measured to ground as most voltages shown on schematics will be.

CHAPTER 2

- C. Dielectric.
- A. Charged. A capacitor will stay charged after being removed from the battery. It will eventually discharge even if no connection is made from one side to the other, but a good capacitor may stay charged several days; a capacitor with exceptionally low leakage can stay charged for months.
- A. Increase the capacitance, since glass has a higher dielectric constant than air.
- C. Zero current. Current flows into a capacitor only when it is initially connected to the battery. If there is no resistance in series with the battery, the capacitor will charge to the battery voltage almost instantaneously.
- D. One million picofarads, since a picofarad is one-millionth of a microfarad and one millionth-millionth of a farad. The picofarad was once called a micromicrofarad.
- C. A nanofarad is 10^{-9} farad. A microfarad is 10^{-6} and a picofarad is 10^{-12} . Consequently a nanofarad is halfway between a picofarad and a microfarad. The correct answer to this question is 1000 picofarads.
- B. Ceramic. Ceramic may have dielectric constants of 1000 or more.

8. B. Ceramic. Ceramic is not only a fine dielectric but works well at higher frequencies. To a great extent this is because the capacitor plates can be made physically much smaller and thus have less inductance in themselves as compared to, for instance, a paper capacitor.
9. C. Electrolytics by their nature are polarized and must be connected in the circuit correctly.
10. A. A higher voltage rating, in just about every case, would even be an asset when replacing a capacitor, since a capacitor with a higher voltage rating is not so apt to break down under stress. Unfortunately, for the same type capacitor, a higher voltage rating means a larger physical size, and mounting in a small radio could be a problem and could easily make the repair look "jury rigged."
11. C. Although there are varactors or varicaps that change capacity when voltage is applied they are not referred to as variable capacitors. A variable capacitor is considered to be one that can be mechanically adjusted for different capacities. Variable capacitors of larger than 500 pF are seldom used. Variable capacitors used in radios have a maximum capacity generally of no more than 365 pF, and many radios have capacitors with a maximum capacity of less than 200 pF. Variable capacitors used for the fm band on radios may have no more than 10 pF maximum capacity. The minimum capacity may go as low as 3 pF, although the minimum capacity is often determined by the various wiring capacities in the circuit. Any wire running near another wire forms a small—very small—capacitor so that it is never possible to reduce capacity to zero in any circuit.
12. A. Most small portable radios use only a 2-gang capacitor.
13. A. Schematic.
14. C. The term "ground" as used in radio is also sometimes called "common." It is the part of the circuit that is common to parts of all the other circuits in the receiver. It may be either the + or - side of the power supply, depending on the method used in designing the set. You could use a wire and connect all the "ground" terminals together if you wished, but the ground symbol, a convenience in drawing schematics, shows that a particular point is tied to many other points.
15. B. A series circuit is one in which all the current of the circuit flows through all the parts of the circuit. Because of this, the same amount of current necessarily must flow through each part.
16. A. An electrical circuit is a path for electrical current to flow. Current cannot flow unless there is a voltage source to push it through the resistance of the circuit. The voltage difference must be across a particular voltage source. In other words, you can connect from the positive terminal of one battery to the negative terminal of another battery not connected to the first, and there will be no current flow. An "open" circuit is one that is incomplete, has some part not connected, or has a switch that is turned off. A "closed" circuit is a complete circuit—one in which current can flow.
17. B. .005 μ F. Connecting capacitors of equal size in series reduces the circuit capacity to one-half that of either capacitor.
18. A. Approximately .02. Actually .0186 μ F. When two capacitors are connected in series, the total capacity is always less than the smaller capacitor. Unequal capacitors in series can be found by the formula
- $$\frac{C_1 \times C_2}{C_1 + C_2}$$
19. D. 0.15 μ F. Capacitors in parallel add capacity to the circuit in direct proportion to their size.
20. B. A trimmer capacitor is a smaller variable capacitor that is connected in parallel with the variable tuning capacitor. The trimmer can be adjusted to set a specified value of minimum capacity for the circuit to compensate for the capacity of the wiring, etc. It is adjusted only when aligning or "tuning up" a radio. The adjustment can usually be made with a small screwdriver. Usually the trimmer is an integral part of the main tuning capacitor.
21. C. The voltage applied to a capacitor has nothing to do with its capacity, neither does the type of metal used in the capacitor plates.
22. D. Moisture is bad for any capacitor. Moisture can conduct electricity, and there should be no direct connection for current between the plates of a capacitor.
23. D. The most common cause of whistles and squeals is an open electrolytic capacitor. Do not forget that in a battery portable radio, squeals or whistles may occur when the battery is weak.
24. B. A parallel circuit is like those normally found in the home or shop. Turning off one lamp or appliance does not cause any other lamp or appliance to turn off. Each part is across the circuit.
25. A. B is a series circuit; C is a series-parallel circuit; and D is also a series-parallel circuit.
26. B.
27. A. The motor, if taken out, would open the circuit so that no current could flow. However, if either the lamp or the resistor opened, there would still be a current path through the other to the motor. Not as much current would flow through the motor if either the resistor or the lamp burned open, but both would have to burn open before the circuit to the motor would be completely broken.
28. C. Number 3 we know is an electrolytic since it has the + symbol indicating how it is to be connected in the circuit.
29. C. Resistance is a limitation of current; any electrical component has some resistance and the more resistance it has, the less the current through it, for a given voltage.
30. B. A short circuit is any circuit where more than the normal current flows or where the resistance is unintentionally low.
31. A. Ohm.
32. C. One million ohms. "Mega" is a prefix meaning one million. When used with ohms the "a" in mega is omitted.
33. D. Wattage varies with the square of the current (I^2R). Thus, in a circuit with 10 ohms resistance and 4 amperes of current, the wattage is $4 \times 4 \times 10$, or 160 watts. Reducing the current to one half, or 2 amperes, we calculate the wattage— $2 \times 2 \times 10$ equals 40 watts—so, reducing the current one-half cuts the wattage to one-fourth the original.

34. A. Tolerance rating is the percentage above or below the labeled value the resistor can be and still be "in tolerance."
35. D. Red equals 2, violet equals 7, and brown equals one zero—270 ohms.
36. C. 68,000 ohms. Blue is 6, gray is 8, the multiplier is orange, which stands for three zeros.
37. B. Gray, red, black. Gray for 8, red for 2, and black for no zeroes.
38. A.
39. B. The gold band for the 3rd ring indicates moving the decimal point one place to the left.
40. D.
41. A. The 3rd band being silver indicates that the decimal point should be moved 2 places to the left. The 5% tolerance band is gold but must be the 4th band. The answer, therefore, is white for 9, brown for 1, silver to move the decimal point 2 places left, and gold for 5% tolerance.
42. B. Orange 3, orange 3, orange 3 zeros, gold 5% tolerance.
43. A.
44. B. Series.
45. B. The color code indicates a 120-ohm and a 39-ohm resistor.
46. D. Connecting two 1000-ohm resistors in parallel makes 500 ohms, then connecting 1000 ohms in series with this parallel combination makes 1500 ohms. See Fig. A-2.

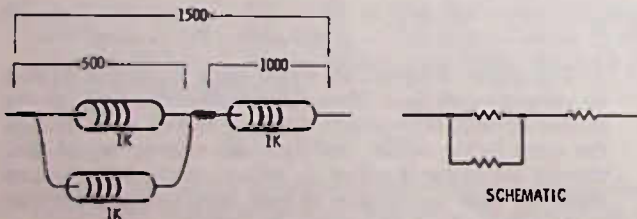

Fig. A-2.

47. C. The easiest way to arrive at the answer is to take the two 330-ohm resistors by themselves, which would give you a total of 165 ohms in parallel. Then use the formula

$$\frac{R_1 \times R_2}{R_1 + R_2}$$

to get the answer.

$$\frac{165 \times 220}{165 + 220} = \frac{36300}{385}$$

or about 97 ohms.

48. C. A potentiometer or POT for short. A potentiometer taps off voltage rather than changes current as a variable resistor might do. A pot has three terminals connected in the circuit, while a variable resistor or "rheostat" has only two. A pot is sometimes used as a rheostat by using only two of its terminals or by tying two of the terminals together to form one connection.
49. A. The tone control capacitor would now be connected directly to ground across the audio going to the next stage

from the coupling capacitor. Higher frequencies would be bypassed much more readily than the lower frequencies, so the lower frequencies would continue on to the next stage while the higher frequencies would be reduced, so the tone would have a more bassy sound.

50. A. There is maximum volume present at point (A) in the schematic, so with the volume control arm at (B) it is at ground or the lowest point of volume in the circuit.

CHAPTER 3

1. D. An inductor may be called either a coil or a choke. It is common practice in the electronics field to refer to an inductor as one or the other, for example; "antenna coil," "rf (radio frequency) choke," "filter choke," etc.
2. A. The key word here is "suitable." Putting the incorrect core into a coil may not increase the inductance at all but may simply increase the losses in the coil. For example, a solid iron core in an rf coil will increase the losses so much that the coil can no longer function.
3. B. A solid piece of iron is never recognized as a good core material because of losses in the form of eddy currents. Essentially, a solid piece of iron would look like a great number of shorted turns and this produces a severe loss. See Fig. A-3. Laminating the core (breaking it up into thin strips insulated from one another) greatly minimizes this shorted-turn effect and greatly increases the efficiency of the inductor.
This same process is carried further in the "ferrite" coils used at rf frequencies. Here the iron is powdered and placed in a suitable insulating binder that keeps each little speck of iron dust separated from the others. With such small specks of iron there are almost no eddy currents created.
4. D. The air gap in the core prevents core saturation, which is the point where the inductance of the coil decreases because of heavy passage of current. This effect is utilized, or at least used to be to quite an extent, in power supplies as a form of regulation. The choke without an air gap is called a "swinging choke." In most cases, though, we do not want the inductance to change because of core saturation; hence, the air gap.
5. C. Ferrite means "of iron." The older name used for this material was "powdered iron."
6. D. An inductor is just the opposite of a capacitor in allowing low frequencies to pass through more easily than high

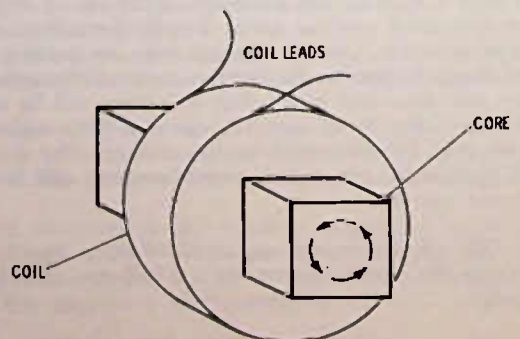

Fig. A-3.

- frequencies. Pure resistance or a straight wire is not frequency selective, at least in the ordinary sense—it can be noted that a straight piece of wire “looks like” an inductor at higher frequencies such as in the fm band, so here the wire leads must be kept as short as possible to prevent these inductive losses.
7. B. Reactance; more specifically, inductive reactance as opposed to capacitive reactance.
 8. D. A coil and capacitor combination is a tuned circuit or a resonant circuit at some frequency, unless inherent losses of the circuit prevent a readable resonance or the ratio of the size of one to the size of the other is not a practical combination; for example, a .25- μ F paper like capacitor across a one-turn inductor will not likely be resonant, or at least will not have the attributes of a resonant circuit, because it would be difficult to store enough energy in a one-turn coil to overcome the losses in the .25- μ F capacitor and the “ringing” action would probably not take place.
 9. D. The henry. (The plural of henry is henrys.)
 10. C. Inductors in series add inductance. Since there is no mutual coupling between the two, it makes no difference which way the coils are wound.
 11. B. Mutual inductance, which is the interlinking of the magnetic field around the primary with the turns of wire on the secondary.
 12. C. 20 volts. The step-up ratio is 1 to 1.5, meaning that for every volt of input in the primary there is 1.5 volts of output in the secondary.
 13. A. Zero. The reason a transformer can work is because of a changing magnetic field, one that is continuously expanding and subsiding so that the field “cuts across” the secondary windings. A steady dc voltage will expand the field outward but then there is no change in the field and so no coupling between the primary and secondary. Therefore, there is zero output voltage.
 14. D. Laminated iron cores are used for frequencies up to the upper limit of the audio range, which is 20,000 Hz., and sometimes a bit higher than this, although not often.
 15. B. The output winding is the secondary. If you turn the transformer around, using the secondary as a primary and the primary for the secondary, the rule still applies—the winding to which ac is fed is called the primary and the winding that is used as the “take off” winding is called the secondary.
 16. C. An efficiency of 100% is obviously impossible, but 98% is feasible. Obviously no more energy can be transferred to the secondary than is available in the primary, but in a good transformer there is only a slight loss in energy (power) transfer.
 17. C. 40 amperes. The voltage is stepped down by 20 to 1 which means that the current in the secondary will be 20 times that in the primary, assuming no losses in the transformer. If we changed the input to power it may be more clear. In the primary there is 240 watts (120×2) and in the secondary there is 240 watts ($6 \text{ volts} \times 40 \text{ amperes}$).
 18. D. A transformer can work on either changing direct current or on alternating current. The answer says “only on” which makes both B and C incorrect, although both would be correct if the “only” had been omitted.

19. B. Regardless of whether ac, or pulsating dc, is fed into a transformer, the output will be alternating current. The dc component can be restored, if desired, by impressing a dc voltage onto the secondary output.
20. C. It is important in electronic devices that there be no direct connection back to the power line. This is true because one side of the power line is grounded and the other is “hot.” If an electrical device should be plugged into the power line so that its metal parts were “hot” and you touched the metal parts while standing on a ground or while touching some grounded object (maybe another appliance) you could easily get a lethal shock. A transformer prevents this from happening by eliminating any direct metallic connection between the power-line ground (which is actually an earth ground) and the radio. Some radios do not use a transformer and they have to use great care that no metallic parts, connected to the common side of the circuit, can be touched by the radio user. For example, metal mounting screws often screw into an insulating plastic block. Control shafts, such as those on tuning or volume controls, either are made of plastic—the entire control insulated from the metal parts of the chassis—or in some cases the plastic knobs that slip over the shafts are “captive.” That is, they cannot be removed far enough for the metal shaft to be exposed. Interlock cords are used extensively. This is a power cord that automatically unplugs from the radio circuit when the back of the radio is removed for service. A “cheater” cord is needed by the radio technician to remake the connection from the radio to the power line (Fig. A-4).

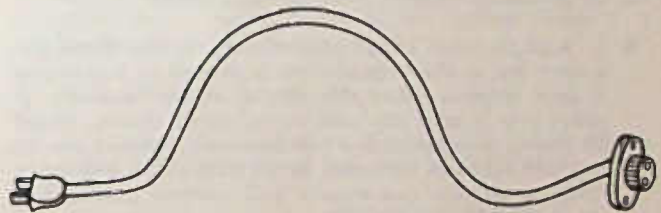

Fig. A-4.

21. A. The impedance ratio is the square of the turns ratio. In this problem, the impedance ratio needed is 800 to 8 or 100 to 1. The square root of 100 is 10, so the turns ratio needed is 10 to 1. Conversely, the impedance ratio is the square of the turns ratio. For example, a transformer with a 6-to-1 turns ratio would have a 36-to-1 impedance ratio.
22. A. All three are. The autotransformer has no direct current isolation between the primary and secondary—its only use is to step up or step down voltage. Any transformer becomes an autotransformer if you make a direct connection from one side of the primary to one side of the secondary.
23. C. Only in power transformers is there enough energy normally to cause burning and odor when an internal short occurs in the transformer or too high a load is placed on the secondary. The latter may occur, for example, if a rectifier diode or an electrolytic capacitor should short. Although in a high power audio amplifier the output transformer might burn if a defect in the circuit occurred, an output transformer in a portable radio probably would not burn if the battery voltage were shorted directly across it.
24. C. Although you could use B, it would no doubt be impractical from the standpoint of physical size and mounting. The transformer with a 9.5-volt output is only 5%

- away from the original and certainly not far enough away from the correct size to cause any significant change in the radio output. As a matter of fact, an 8-volt transformer probably would work pretty well. It is best, however, not to increase the voltage output, since this increases the current drawn by the radio and causes extra heat, etc. Still a 10.5-volt transformer would not be likely to cause a problem in this case.
25. A. The adjustable core varies the inductance of a coil and so can change the resonant frequency as effectively as a variable capacitor across the circuit. Most modern radios use adjustable cores (slugs) for tuning wherever possible, since it is mechanically less complex to make the cores adjustable than to build a small adjustable capacitor.

CHAPTER 4

1. B. The image frequency is always twice the intermediate frequency from the desired input signal. In this example the oscillator would be at 1055 kHz, meaning that a signal at 1510 kHz is also 455 kHz away from the oscillator frequency.
2. B. There must be at least two gangs, one for the antenna input tuning, and one for the oscillator tuning. If there is an extra rf amplifier stage in the radio, an extra gang is required for tuning this, making a 3-gang capacitor necessary.
3. D. Resonance requires a coil and a capacitor.
4. B. A single tuned circuit responds best to one single frequency but it also responds nearly as well to frequencies a short distance either side of that single frequency. A radio, even a good one with several tuned circuits, would be unable to separate two equal-powered stations, one at, say, 550 kHz and the other at 560 kHz but is able quite easily to separate two equally well received stations that are at 550 kHz and 580 kHz.
- An oscillator circuit generates a single frequency because the most feedback for the oscillator occurs at the resonant frequency of the tuned circuit of the oscillator.
5. B. Changing either the capacitance or the inductance of a circuit changes the resonant frequency of the circuit. Both methods of tuning can be and are employed in modern radio. Most portable radios use variable-capacitor tuning, while most or all auto radios use variable-inductance tuning. Variable inductance tuning generally takes the form of mechanically moving ferrite slugs simultaneously in and out of the various coils in the circuit.
6. C. Broad tuning is the receiving of a wider band of frequencies while sharp tuning means receiving a narrower band of frequencies. We might say an a-m radio is "broad" if it would not separate stations 20 kHz apart, while it would be "sharp" if it would reject a station just 5 kHz away from the desired station. (All a-m broadcast stations must be at least 10 kHz apart but this is not true of shortwave stations.)
7. A.
8. A. This is because the circuit is "tapped down" and therefore the load on the circuit is reduced. The output is also reduced in this case, so that often a compromise must be made between good selectivity and good sensitivity.
9. A.

10. D.
11. B. An oscillator. An oscillator is an amplifier with a tuned circuit which uses a feedback from the output into the input to keep the oscillator working.
12. A. All bipolar (npn or pnp) transistors require a small "turn on" current or bias. If there is no bias from base to emitter, the emitter-to-collector current will be zero in a good transistor.
- Placing a short between base and emitter is one way that technicians can check to see whether a transistor is working. If shorting B to E on a transistor drops the transistor current to zero, it shows that the transistor will respond to a change in bias.

CHAPTER 5

1. B. 455 kHz is the standard intermediate frequency for a-m home radios. 262 kHz is used quite extensively in automobile radios.
2. D.
3. B. This is often called "slug tuning" because the ferrite core by its appearance comes quite naturally by the name "slug."
4. A.
5. D. Electrolytic capacitors are used in radios to isolate the power supply and control circuits that go to all amplifiers so that they do not carry interacting signals. If, for example, the output of one amplifier gets back into the input of another amplifier we have an oscillator, something we don't want in an i-f circuit.
- Bad transistors have been known to cause squeals but it is rather rare.
6. B.
7. A. A field-effect transistor (FET) requires only a voltage (no current) as a control, so it does not load the circuit. There is a complete chapter in this book on field-effect transistors and circuits.
8. C.
9. B. Moving the slug in an i-f transformer will affect only the loudness of the signal, but the changing of the oscillator tuning slug changes the frequency of the oscillator and in turn changes the station selected.
10. A. This is the best answer to this question. Assuming that the antenna and oscillator circuits are not out of tune, tuning for maximum noise through the i-f amplifier is a good way to peak it up.
- Another good way, and one that may be more satisfactory to some technicians is to tune in a weak station and then tune the i-f transformers for maximum output from the station.
- Neither of the above methods is completely "professional" but with a little practice you can align, or at least peak up, any radio satisfactorily in this way.
11. D. Tracking simply means that you want the antenna circuit to be tuned exactly 455 kHz (or whatever the i-f is) away from the oscillator circuit, whether the dial is set at the low, medium, or high points of the dial. Perfect tracking is impossible, but it can be sufficiently close that there

is no noticeable change in selectivity over the span of the dial.

12. B. Ordinarily, trimmers are set at the high end of the dial and the slug in the oscillator coil at the low end of the dial.
13. D. A, B, and C are all good precautions to take.
14. B. You can remember this by noting the *middle* letter of the transistor type. nPn takes positive voltage on the collector (to emitter) and a positive bias on the base (again in respect to the emitter). A pNp transistor takes a negative collector voltage and negative bias.
15. B. American radios tend to use the dual-tuned, hex-tool type, however.

CHAPTER 6

1. A.
2. C.
3. A. This answer may be a bit difficult to understand unless you can look at a volume control or have looked at one. The center terminal of the volume control is connected to the rotating arm, which is turned by the control shaft, and which moves between terminals 1 and 3. Turning the shaft clockwise on the control shown in Fig. 6-8 moves the arm toward terminal 1, which is the same as saying that arm (B) (in the schematic) is moving toward terminal (A) and maximum volume. Minimum volume is when the arm is moved to the ground terminal (C).
4. D. The radio frequency (now the intermediate frequency) is no longer needed since the detection has taken place so it is removed (or more correctly perhaps, smoothed out).
5. A. Germanium diodes will conduct with lower applied voltage than silicon diodes, which means that they are likely to have less distortion on extremely weak signals.
6. B. It is impossible to completely eliminate distortion, though it can be removed to an insignificant degree. Any difference between the transmitted signal and the received signal can technically be called distortion. Distortion as used by radio technicians means *noticeable* loss of tone quality or ability to understand what comes from the speaker—clearly.
7. B. Detection immediately follows the i-f amplifiers and obviously precedes the audio amplifiers. (It used to be

common practice to call the converter or mixer stage the *first* detector and the detector we are talking about in this chapter, the *second* detector. The mixer is called a detector in this case because of its job of “changing” from one frequency to another.)

8. B. A transistor can be used as a detector by using it as a diode. Fig. A-5 shows how a transistor may be used as a detector, and there are other variations possible as well.
9. C. Rectification as a term is normally used only in connection with power-supply circuits, though technically it can be used in almost any diode circuit where ac is changed to pulsating dc.
10. A. The arrow in a diode used as a detector (rectifier) points toward the positive output terminal. A positive dc voltage can be read with a meter across the volume control (A to C) whose strength or amplitude depends upon the amount of signal detected by the diode.

CHAPTER 7

1. B. The class-B audio output uses two transistors, but is much more efficient. In other words, it uses less battery power for the amount of audio output.
2. A. By the nature of manufacture, a speaker uses a voice coil that has only a few turns of wire, relatively speaking. This means that in order to get power to operate the cone back and forth there must be a high current/low voltage audio source. Any high current/low voltage device is a low-impedance device.
3. B. See answer to Question 1.
4. B. 180 degrees out of phase. To be in phase both signals would have to be going the same direction at the same time.
5. D. The meter should read maximum when volume is maximum. It cannot read zero at low volume because there must always be some current flow in a radio, but it will read the lowest amount of current when the volume is turned all the way down.
6. C. 40 milliamperes is 40 thousandths of an ampere, or 4 hundredths of an ampere.
7. A. All the other answers to this question are things that *can* cause a “tinny” sound in the radio.
8. D. The tiny disturbance created as the volume control is turned, if amplified enough so that you can hear it in the speaker, is a good indication that the audio amplifier is at least amplifying—it could of course be causing distortion but in a dead radio this not YET the problem you are looking for.
9. D. All of the troubles listed in A, B, and C can cause a dead radio. A defective earphone jack may cause the trouble since the jack has a switch which turns the speaker off when an earphone is plugged in. If this switch fails to close when the earphone is removed, there will be no sound from the speaker. If you can hear the radio all right with an earphone, but the speaker is silent when you remove the earphone, then either the earphone jack or the speaker is defective, or a wire is broken which connects the two.

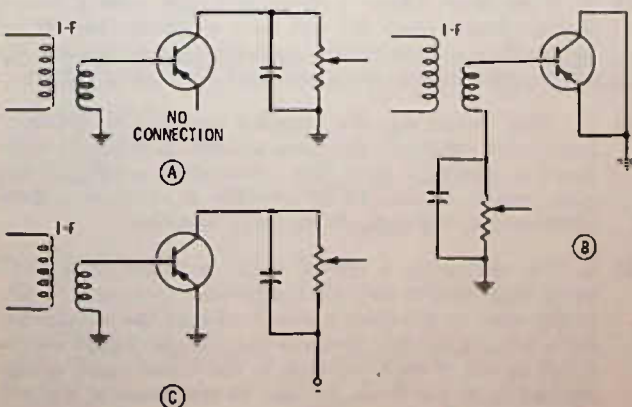

Fig. A-5.

10. C. Note that the question says “most likely.” Turning the

volume control down eliminates all signals from the detector on, so removing the squeals by turning down the volume would seem to indicate trouble prior to the volume control. However, it is possible for the trouble to be a feedback from the output of the audio amplifier into the top side of the volume control such as might be caused by a wire from the output stage running too close to the "hot" lead from the volume control. Usually, though, if this is the trouble, you will hear a marked change in the pitch of the squeal or whistle as you turn the volume control.

CHAPTER 8

12. A. OTL stands for "output-transformerless."
13. A.
14. C. These radios use a simple power supply that rectifies the 120-volt power-line voltage for a direct-current output in the 100-volt range. By using a high-voltage transistor it is possible to get ample power output from a transistor circuit, while keeping the power-supply current relatively small.
15. C. A capacitor reduces the higher audio frequencies and thus eliminates a lot of "hash" in the output. Part of this hash can be radio frequencies that have slipped through into the audio amplifier and are being amplified but the purpose of the capacitor is not JUST for bypassing radio frequencies.
16. A. It is not unusual at all for an automobile radio to have a class-A output transistor that draws 1 ampere or more. Current drain is not a big problem with car radios, but ample power output is essential. As for current drain, consider that the modern auto radio draws no more than about 1.5 amps of current or less, while a comparable tube automobile radio never drew less than 4 to 5 amperes. A fully charged automobile battery can easily run a transistor auto radio for a whole day without the motor running and the battery still start the car with no trouble.
17. D. Although a transistor is a "sandwich" with the base element located between the collector and emitter, when a transistor shorts, it blasts right through the base material and the short occurs between collector and emitter. The "blasted through" base is not connected to the short, because all the base material is burned away, so if you measure from collector to base or from emitter to base you still get diode action in just about every case.
Do not overlook the fact that shorts could occur between the collector and base or emitter and base but it is rare for it to happen.
18. B. About the time of the advent of the transistor radio in the 1950s all American cars started using the negative ground as standard. A few new cars manufactured outside and imported into the USA do use a positive battery ground, but most use a negative ground the same as American cars.
19. C. Direct coupling has both the direct current supply voltages, bias voltages, etc. coupled by the same components as the signal . . . in other words there are no coupling devices such as a capacitor or transformer which blocks the dc voltage from one stage to another.
20. C. If the fuse were open, you would not hear a thump. Likewise, if the fusible resistor in the output circuit were open. If a class-B output stage is used, there are equal and opposite currents through the speaker when the radio is turned on, so you likely will hear little, if any, thump.

1. A.
2. D. If a 0.2-volt change causes a 4-volt change in an amplifier stage, the stage gain is 20 ($0.2 \times 20 = 4$ volts).
3. B.
4. C. The voltages indicate a supply of 8 volts, and there is 6 volts on the collector. This indicates a 2-volt drop across the 4K resistor. Using Ohm's law, 4K divided into 2 volts equals 0.5 mA. Now we know that the collector current is 0.5 mA and this means that there is 0.5 mA through the 1K emitter resistor and consequently there will be a 0.5-volt drop across this resistor, or, said another way, 0.5 volt, emitter to ground. The schematic shows 1.1 volts base voltage and with a 0.5-volt emitter voltage the bias is 0.6 volt, which is the clue that the transistor is a silicon type. The collector and base voltage are positive with respect to the emitter, indicating that the transistor is an npn, as does the direction of the arrow on the transistor symbol.
5. A. See answer in Question 4.
6. D. This is a pnp transistor, meaning it needs a negative bias voltage and a negative voltage from collector to emitter. Or, said another way (if you want), it needs a positive voltage from emitter to collector (C to D).
7. C. The arrow on the emitter (pointing in proper) indicates a pnp transistor. The symbols for both germanium and silicon transistors are identical and since we have no indication of the amount of bias voltage we have, there is no way of ascertaining which type the transistor is. (Some manufacturers put a small S or G inside the transistor symbol to indicate whether the transistor is silicon or germanium.)
8. D. The whole idea of bias on a transistor is to get the transistor "in the middle of the road" so it can go either way when a signal is applied to it. Without bias it has no current flow, with too much bias it would "saturate" or have maximum current flow.
9. C. Although both the base and emitter voltages are positive with respect to ground, the voltage on the base is 0.2-volt LESS positive, which is the same as saying MORE negative by 0.2 volt. In other words a meter connected from base to emitter would read -0.2 volt.
10. D. Removing the bypass capacitor, or, if it should open up in service, reduces the amplifier gain considerably.
11. B. If the base voltage is dropped to 4.8 volts it means that the base is made 0.1 volt more negative, and this increases the transistor current, increasing the drop across R_E and lowering (makes more negative) the emitter voltage.
12. D. "Flat" means that the amplifier amplifies all pertinent frequencies essentially the same amount. It might be compared to mowing a lawn "flat"; everything growing is the same height. Flatness in an amplifier is normally a good characteristic, especially in an audio amplifier.
13. C. The voltage on a typical audio amplifier must NOT swing from zero to maximum, otherwise there will be distortion since no transistor is able to change the voltage that far in a linear fashion. Normally the voltage change will be a volt or less in each direction as the signal input voltage changes back and forth. Be sure to read note at the end of Question 13.

14. A.
15. A. The symbol and the battery polarities indicate that the transistor is an npn. The bias indicates it must be a silicon type. The fact that there is 3 volts on the collector indicates that there must be MORE than 3 volts battery supply, because, with any current flow at all, there will be some voltage drop across the headphones.
16. B. Since the battery current flows through the headphones going to the collector, the circuit is said to be series fed, in other words, the same current flows through the headphones as through the transistor collector circuit. Fig. A-6 shows the circuit with the earphones shunt or parallel fed.

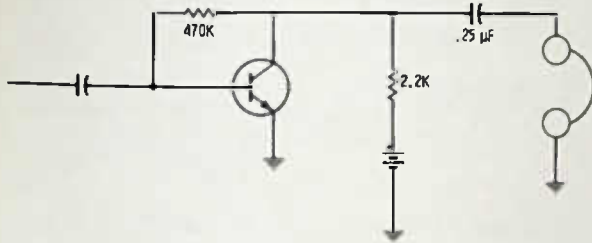

Fig. A-6.

CHAPTER 9

1. C. A vom is a volt-ohm-milliammeter and, if properly used in radio diagnosis, can do more jobs than any other single instrument. An expert technician can find just about any trouble using only a vom, but in most cases the expert will have many other sophisticated instruments; so he can do a better job on certain less-common troubles.
2. B. If the radio uses a 6-volt battery, then that is the highest voltage that will be found in it. Starting with a 10-volt scale (or even a 6-volt scale if available) will insure that the meter pointer will not be driven off-scale. If you find the voltage is too small to read accurately on the larger scale, then turn to a lower voltage scale, once you have found what to expect.
3. D. It makes no difference which ohmmeter range you use except, of course, you must turn it to a range that gives you the best usable reading.
4. A. A 50-microampere meter will deflect full scale if a 20K resistor is connected in series with it and 1 volt placed across the combination, Fig. A-7. By Ohm's law:

$$\frac{1 \text{ volt}}{.000005 \text{ ampere}} = 20,000 \text{ ohms}$$

5. C. In a 20,000 ohms-per-volt meter, for a 6-volt full scale reading, the resistance in the circuit must be $6 \times 20,000$, or 120,000.

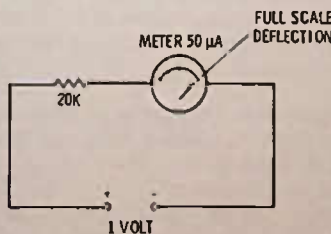

Fig. A-7.

6. D. If the meter were reading half scale on 6 volts, then the full-scale reading must be 12 volts. For a 12-volt full-scale reading, the resistance must be $12 \times 20,000$ ohms, or 240,000 ohms.
7. B. The needle is between 2 and 5 on the scale, but near enough to 5 to indicate it is reading close to "4." Since the function switch is set at $R \times 1K$, the resistance is the pointer reading times 1K, or, in this case, around 4K.
8. D. Neither the vtvm nor the solid-state vom load the circuit to any great extent. A typical input impedance (loading) for a meter of this type is around 11 megohms, regardless of which voltage scale is used. However, a 1000 ohms-per-volt meter on the 10-volt scale, for example, has a loading on the circuit of 10,000 ohms—much too much for testing in most transistor circuits, especially bias circuits.
9. C. Only a short of the transistor could cause the trouble. Actually the bias is reversed, which means that a normal transistor would be cut off, and in this type of circuit it is impossible to have emitter voltage with reverse bias; consequently, the only explanation of the voltages indicated is that the transistor is shorted.

10. C. Ohm's law calculations:

$$\frac{0.2\text{-volt drop across emitter resistor}}{470\text{-ohm emitter resistor}}$$

equals .0005 amperes (+) or 0.5 mA.

11. B. The transistor is a pnp with a bias of -0.1 volt.
12. B.
13. A.
14. C. This is always the best way to read the transistor bias whenever possible or convenient.
15. B. Continuity is sometimes considered to be a low resistance, such as 1 ohm or less. However, we may measure the continuity of a transformer winding, for example, and that resistance may be normally several ohms, sometimes more than a 1000 ohms.
16. C.
17. B.
18. C. Most of the time in present-day meter circuits the lead is actually connected to the negative side of the ohmmeter circuit. Fig. A-8 shows why this occurs. In order for the meter to read up-scale on ohms, the + side of the battery in the ohmmeter circuit must connect to the + side of the meter—this leaves the + test lead connected to the

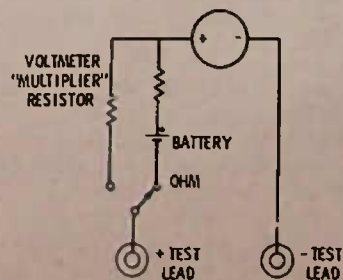

Fig. A-8.

negative terminal of the battery. But there are some meters which provide a reversing circuit when switching to ohms, in order to maintain the correct polarity.

19. B. A+ voltage on the anode of a diode should make it conduct. Since here the "negative" lead of the meter is connected to the anode, when the diode shows conduction, it indicates a reversal of polarity when the ohmmeter is switched into the circuit.
20. C. The fact that the collector to emitter reads a low resistance, regardless of the direction of the ohmmeter, is evidence enough of a transistor short.
21. A. Taking two of the three leads out of the circuit is all that is needed to make a valid "out of circuit" check.
22. A. Most service signal generators have both audio and radio frequency outputs available. Usually the audio is at one frequency only—often around 400 hertz.
23. A. Anytime a signal is injected into a radio, it should be at no greater level than is required to give a usable output indication. This ensures that circuits will not be overloaded and be caused to act erratically.
24. D.

CHAPTER 10

1. A.
2. D. Capacitors do not pass dc current but do pass alternating current.
3. B. The local oscillator normally runs higher than the incoming frequency. It must be the intermediate frequency away from the incoming frequency, for example, if the incoming signal desired is 1250 kHz and the radio i-f is 455 kHz, then the local oscillator must be at $1250 + 455$, or 1705 kHz.
4. C. An oscillator is simply an amplifier which has a portion of its output signal fed back into the input in such a way as to sustain an oscillation at some frequency. The frequency is dependent upon the circuit values.
5. C.
6. A. It is normal for any oscillator circuit to produce a slight change in output with a change in frequency, and this shows up as a change in the dc bias on the transistor, because the transistor itself rectifies the oscillator signal and creates a measure of self-bias.
7. B. It is possible that they may need adjusting at some other point on the dial for some compromise effect, but not often.
8. A. Tuning with noise is the simplest method of low-end tracking. The old method of rocking the tuning capacitor as you adjusted the low-end trimmer for the maximum output of a low-end station is difficult and neither as easy nor as effective as the noise method.
9. C. Trimmers are drawn in different manners by different electronic draftsmen but in Fig. 10-6 the fact that C3 and C5 are shown ganged together (by the dotted line) indicates that these make up the main tuning capacitor.

10. A. If dc were not needed on the base of the transistor, the signal could be coupled to it by a straight wire, so the primary purpose of C1 is for dc blocking.
11. B.
12. C. This is a converter stage and it processes both the incoming signal and the local-oscillator signal, providing an i-f output.
13. C. The feedback signal is taken from a tap on the oscillator coil, through C2, to the emitter, but a signal is also fed from the collector circuit "tickler" coil which is a part of the oscillator coil. In other words, the output from the collector is fed to the emitter to sustain the oscillation.
14. B. This is the oscillator tuned circuit.
15. C. The collector voltage should be very near to 6 volts, since the coil L3 and the tickler coil on the oscillator will have only a few ohms resistance.
16. B.
17. B. A capacitor in series with the coil effectively reduces the capacity of the tuned circuit, raising the frequency. Turning the slug further into the coil or adding turns to the oscillator coil would decrease the resonant frequency, as would a trimmer across the coil.
18. A. The only way to get that much voltage between collector and ground is for either L3 or L4 to open; otherwise the collector will be held at ground potential by the low resistance of these windings.

19. B.
20. D. The base is -5.6 volts and the emitter is -6 volts, so the base is 0.4 volt more positive than the emitter.
21. B. There is a 1.5-volt drop across the 1.5K emitter resistor, indicating 1 mA of current flow.
22. A. The antenna circuit must tune to a lower frequency, so it needs a tuning capacitor of greater maximum capacity.
23. C. The feedback is through L3 into 4 and then through C1 and L1A to the base of the transistor.
24. D. Since this would eliminate emitter current it would also eliminate the voltage drop across the 1.5K emitter resistor, so, from emitter to ground the voltage should be -7.5 volts.

CHAPTER 11

1. D.
2. B. "Gain" is a term which means amplification. If a stage has gain, it will have increased signal output as compared to its input. Automatic gain control varies the amplification of one or more stages to hold the output at the speaker fairly constant, regardless of the strength of the incoming radio signal.
3. A. Leave them alone, especially if there is every indication that the radio is working normally after it has been repaired. A detuned i-f will show up as a radio with a weak output, but there are many other things that can cause this; so do not be too quick to suspect tuning problems, especially if the tuning does not appear to have been bothered.

- 4. B.
- 5. B.
- 6. A. The emitter resistor would be about 330 ohms, according to Ohm's law. $330 \times .0015 = 0.5$ volt approx. $1K \times 1.5 \text{ mA} =$ the 1.5-volt drop across R4. Find the answers by dividing the current (1.5 mA) into the voltage drop across the resistor.
- 7. D.
- 8. B.
- 9. C. An open C4 would mean that the i-f transformer would not be tuned to its normal resonant frequency; so there would be little output from the radio except on very strong stations. You can spot this trouble easiest by trying to tune the transformer. If turning the slug of the transformer does not have an effect on the output, this is a good indication of transformer trouble. Capacitor C4 is generally a part of the transformer assembly. **DO NOT ATTEMPT A "TUNING" DIAGNOSIS UNLESS YOU CAN HEAR AN OUTPUT OF SOME SORT FROM THE RADIO.**
- 10. A. An open R1 would remove bias from Q1, reducing the emitter current to zero. With no voltage drop across R3, there could be no voltage on the emitter.
- 11. B. When the voltage of a diode is taken from the anode side, it will be negative; from the cathode side it will be positive.
- 12. C. A radio i-f transistor, normally, should not feel warm to the touch. Measuring the emitter voltage drop is one of the quickest ways to calculate the transistor current flow using Ohm's law ($E/R = I$).
- 13. C. Since there is no emitter resistor in this circuit, the easiest way to detect current flow is by measuring the voltage drop in the collector circuit. This is dropped almost entirely across R3, since the i-f transformer primary has low dc resistance.
- 14. B. Again, the voltage is being taken off the anode side of the diode.
- 15. A. There is approximately a 2-volt drop across the 470-ohm resistor, R3, and this requires a bit over 4 mA, as ascertained by Ohm's law.

$$\frac{2 \text{ volts}}{470 \text{ ohms}} = 4.2 \text{ mA, approx.}$$

- 16. C. No agc is applied to this stage, the bias is fixed. There is an agc voltage output taken from the detector circuit, but it returns to another circuit.
- 17. C.
- 18. A.
- 19. B. This is a convenient place, especially if you have an adapter cord for your input meter that will plug into the earphone jack.
- 20. D. 25 microamperes, or .000025 ampere.
- 21. B. Since the current of a class-B stage increases as the volume increases, a check of the current supplied to the

radio will indicate an increase or decrease in volume level. Remember that volume level cannot be as correctly judged by your ear as with a meter.

- 22. B. Neutralization was once used much more than it is now in radios because older-type transistors generally had more base-collector capacity. Neutralization, when needed, contributes to a low noise, stable, "clean" amplifier.
- 23. B. Thermal runaway is not possible unless the transistor can draw excessive current because of circuit values. For example, a resistor in the emitter or collector circuit can prevent thermal runaway by limiting the total current possible. An emitter resistor not only limits the amount of current available to flow through the transistor, but also reduces the transistor bias as the transistor current increases. Fig. A-9 shows a transistor circuit that will prevent thermal runaway, even though the transistor bias is not affected, so long as the transistor will not be damaged by the passage of 9 mA of current. The 1K resistor would limit the circuit current to 9 mA, even if the transistor were a short circuit.

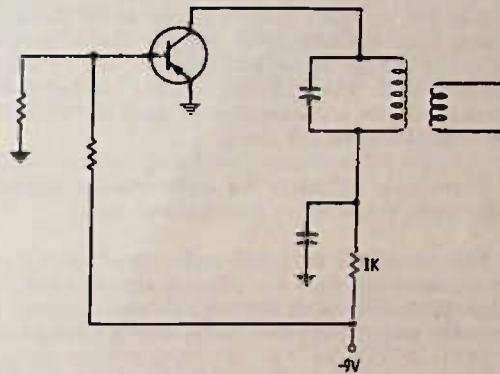

Fig. A-9.

- 24. A. Forward agc biases the transistor so that more current flows. Resistors in the collector circuit prevent the transistor, along with emitter resistors, from being damaged by excessive bias. When a transistor is biased so that a further increase of bias does not increase the amount of collector current, the transistor is said to be "saturated," and the transistor gain is dropped to zero. A transistor not quite fully saturated has lowered gain; therefore, various degrees of near saturation can provide a gain control of the signal, the same as cutting down the flow of transistor current.

CHAPTER 12

- 1. B. The arrow is pointing out on the symbol. Since the arrow always points toward 'n' material, the base must be 'p' material, and, since the base is in the middle, the 'p' must also be in the middle, thus npn.
- 2. B. The collector circuit for an npn transistor must be positive, and in this circuit the collector is grounded. The emitter must then be tied to a negative source of voltage.
- 3. C. Since point (A) is the most negative point (to ground), then any part away from point (A) is more positive. C2, then, is more positive on the emitter side, and C1 is more positive on the volume control side, since this point is closer to ground potential than the base of the transistor.

4. B. If C2 opens, there will be degeneration in the circuit since the voltage on the emitter will try to follow the voltage change on the base. This lowers the gain of the amplifier, but degeneration is often useful and often designed in (when gain is otherwise ample) to provide a better frequency response. The circuit would not whistle or squeal, because it takes more gain rather than less gain for oscillation to start. (An exception might be if C2 was part of a dual capacitor mounted in one package, and a leakage developed between the two after C2 opened, but this would be a very rare occurrence.)
5. A. Since the capacitor should not pass direct current, it should have no effect on the dc voltages of the transistor, unless it is leaky or shorted. Its sole purpose is to couple the audio and block the dc in the process. If it should open, the audio output would drop drastically. Due to inherent capacities of the leads and other wires in the circuit, a bit of audio may leak through, but it will sound "tinny" since no low frequencies will pass.
6. B. With C1 passing dc, the bias on the transistor would change with the setting of the volume control, upsetting the bias and probably causing rather severe distortion, depending upon the amount of leakage. The dc emitter voltage would change as the bias changed due to moving the volume control, with maximum emitter voltage (across the 330-ohm resistor but minimum to ground) when the volume control was turned down.
7. D. There is no substitute for substitution in this situation. It is simple, trustworthy, dynamic and quick.
8. C. This provides a push-pull audio signal driving one output transistor and then the other on alternate half cycles at audio. In reality, with this class-B arrangement, each of the audio output transistors works only about half the time.
9. B. Since the signal itself can be used to provide the major portion of bias, the dc bias is relatively low.
10. C.
11. A.
12. C. There is always some distortion in any amplifier, but it is normally so small as to be completely unobjectionable. The term "distortion," when used in radio servicing, is normally taken to indicate distortion severe enough to be objectionable to the user of the radio.
13. C. A diode, when heated, has increased current which means it effectively has less resistance; therefore, diodes, or even a diode junction of a transistor, are often used as temperature-compensating devices rather than using a thermistor.
14. B. This is a small protective resistor only. Normally, there would be no difference in the performance of the circuit if the resistor were shorted out. It will, though, burn open in case of a shorted output transistor and thus protect more expensive parts.
15. C. Both use the same bias, which is fed in at the center tap of the audio input transformer.
16. A. The transistors are npn, so they require a positive voltage between collector and emitter.
17. A. This might be called a tone-control capacitor. It provides a fixed bypass that reduces or eliminates the "hissy" parts of the audio signal.

18. B. "RC" means resistance coupled, or resistance-capacitance coupled.
19. C. The base is -8.5 volts, and the emitter is 9.0 volts. Thus, the base is +0.5 volt more positive than the emitter.
20. C. The voltages indicate a 3-volt drop across the 4.7K collector resistor. By Ohm's law,

$$\frac{3}{4700} = 0.64 \text{ mA.}$$

21. A. The resistor provides stabilized bias because of its collector connection, but also provides some audio feedback, since the output is connected to the input through the resistor. Fig. A-10 shows how the circuit could be modified if the audio feedback were not desirable.

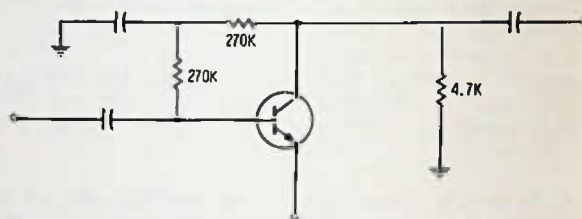

Fig. A-10.

22. B. The current of the transistor should drop to zero when the base and emitter are shorted, since this reduces the transistor bias to zero. With no transistor current, there will be no current through the 4.7K collector resistor, and so no voltage drop across the resistor.
23. C. It is impossible to have 2.5 volts of bias on a transistor under normal circuit conditions, since the transistor will conduct vigorously, reducing the resistance across the base-emitter junction and maintaining a voltage drop of less than 1 volt in all cases.
24. A. The collector voltage is -3 volts and the emitter is -9 volts; therefore, the collector is 6 volts more positive than the emitter.
25. D. If the 4.7K resistor opens, it would have a high voltage drop across it, and a measurement from collector to ground would likely be 9 volts, or nearly so. If the transistor should short it, it would look like a very low resistance; so again all the voltage drop would be across the 4.7K resistor. The same is true if the bias on the transistor were excessive.
26. D.
27. C. The driver stage usually draws only a small amount of current, perhaps one to four milliamps. Since it is a single-ended stage (in nearly every case) it, of necessity, must be class A and, as such, cannot have or should not have any change in dc current with a change of signal input, unless overloaded.
28. A. This is the most nearly correct answer. An increase in current through Q1 will increase the current through Q2, but because of this, there will be more positive voltage fed through R5 back to the Q1 emitter, which will in turn reduce the bias and tend to prevent any increase in current in Q1 from affecting the current in Q2.

29. A. A shorted Q1 would mean there was less resistance in the R6, R3, R4 path from + to - of the power supply; so the current through R6 must increase. Because of the increased current through R6, there will be more negative bias on the pnp output transistor and more current through the audio choke and speaker.
30. A.
31. B. R3 limits the amount of current, should Q1 short, and helps to protect the output stage. It also provides a better match between the Q1 output circuit and the Q2 input circuit.
32. C.
33. C. Shorts in transistors most often occur between collector and emitter. In fact, they do not often occur between any other two elements.
34. A. The amount of bias indicates Q1 is a silicon type and Q2 is a germanium. The direction of the arrows on the symbol and the voltage polarities indicate that Q1 is an npn and Q2 a pnp.
35. C. Direct-coupled circuits can be connected so that an increase in one transistor produces either a decrease or an increase in current in another transistor. This depends on whether the transistors are pnp or npn and whether the coupling is from the collector or from the emitter. Every direct-coupled circuit must be studied individually to determine what effect a fault in one section will have on another section.
36. B. Direct-coupled circuits depend for bias and collector voltages on the current of all the transistors so coupled. This makes substitution a bit more tricky, especially if you are not prepared to change the biasing circuit slightly.
37. C. This is the best answer here; though, no doubt, there are exceptions. Transistors are inexpensive, so more transistors may be used in a circuit than would be dictated if gain alone was the only consideration. Better frequency response is always a worthy design cause, simply because it makes the radio sound better.
38. D. "OTL" means "output transformerless." A class-B circuit is one that uses two transistors in the output with low dc bias so as to provide excellent efficiency (high power output as compared to battery power consumed). Another advantage of class B is that the transistors can be smaller for a given power output because not nearly so much average heat is generated.
39. B. This lowers the bias to the transistors; so they also draw less current; or, put in a better way, they are kept at about the same current flow, since they will draw more current when hot.
40. B.
41. E. When the set is first turned on, both transistors will have essentially the same bias and the same current; so one will be trying to pull the speaker cone in while the other is trying to put it out, resulting in no movement at all. The 100- μ F capacitor prevents any direct current through the speaker in this circuit. As one transistor draws more or less current because of the audio signal fed to the base, the capacitor (100 μ F) will charge and discharge through the speaker, and sound output results.
42. B. With Q1 shorted, the collector and emitter of Q1 would both be at ground potential. Since the emitter of Q1 and the collector of Q2 are tied together, the voltage on the collector of Q2 would be near zero when measured to ground.
43. B. With Q2 open, or not conducting, there would be no, or practically no, dc voltage source to Q1. A heavy signal drive on the base could produce a weak, distorted output, either because of direct base-to-emitter drive or because of a dc leakage to the Q1 emitter through the Q2 bias circuit.
44. A. This is a good idea in any circuit since you can be sure that you are reading the bias and not just some bias "source."
45. B. If a negative-going voltage is at the base of Q1, it should be positive-going at the collector, as well as at the base of Q2. At the collector of Q2, it will be negative-going again, as it will at the base of Q4, which is tied directly to the collector of Q2.
46. A. Transistor Q3 turns over the signal from the collector circuit of Q2 so that Q5 has a positive-going signal on its base. This is the situation we need in this circuit—when the base of Q4 is negative-going, the base of Q5 should be positive-going.
47. B. All the transistors have more than 0.4-volt bias; so they are all silicon transistors.
48. C.
49. B. This is a bit difficult to diagnose, but suppose that Q1 has no bias and it normally has positive bias—the bias then is made more negative by placing a short between the base and emitter. This, in turn, produces a more positive voltage on the collector, and a more positive voltage on the collector provides a more positive voltage for the base of Q2. Even though Q2 is a pnp, it must still reverse this change, so that the collector of Q2 now goes negative. This negative voltage applied to Q3 cuts it off, so that even though Q4 has more base voltage, it has virtually no emitter voltage; and it, too, is cut off.
50. B. An open T1 would remove the bias voltage from the driver transistor through the 2.2-megohm and 100K resistors.
51. C. Ohm's law again. A drop of 2.2 volts across 68 ohms requires a current of slightly over 32 mA.
52. C. Any radio output stage using a single transistor must be operated in class A. This means that the average direct current through the transistor does not change with a change in signal input. The arrow on the transistor symbol and the collector voltage polarity indicate that the transistor is an npn.
53. C. Increasing the bias on the driver would increase the emitter voltage of the driver and so increase the current through the output transistor. This would increase the voltage drop across the 100-ohm resistor and the output transformer in the output transistor circuit and reduce the collector voltage on the transistor.
54. A. An open electrolytic can cause any of these symptoms, depending upon how the electrolytic is used in the circuit.

CHAPTER 13

1. A. Information is placed on an rf carrier by varying the frequency by a small percentage on each side of an assigned center frequency. The more the frequency swing, the louder the received signal. The maximum frequency swing allowed by the FCC is 75 kHz either side of the center frequency for broadcast radio. Two-way fm radio has a maximum allowable frequency deviation of only 5 kHz either side of the center frequency. Television uses fm sound modulation with a maximum allowable deviation of 25 kHz either side of the center frequency. Ideally, there is no change in power output of an fm transmitter with modulation—only a frequency change.
2. D. 88 to 108 megahertz or 88,000,000 to 108,000,000 hertz.
3. B. See comment to Question 1.
4. D. 10.7 MHz is standard, but many other intermediate frequencies have been used in the past. The frequency chosen must be high enough that an image does not occur within the fm band and also high enough that the normal bandpass will easily pass the entire 150 kHz swing of the 100% modulated broadcast signal.
5. A. If an amplifier will pass signals from 10.6 MHz to 10.8 MHz with nearly the same amplitude, we could say that it has a bandpass of 200 kHz. (10,600 kHz and 10,800 kHz are 200 kHz apart).
6. D. The image frequency is always two times the intermediate frequency away from the desired signal. Since the local oscillator in nearly all receivers runs above the incoming signal frequency, the image is also above the incoming frequency.

$$90.3 \text{ MHz} + 2 \times 10.7 \text{ MHz} = 111.7 \text{ MHz}.$$
7. B. Automatic frequency control prevents the effect of oscillator drift in an fm receiver which would make retuning of the radio dial necessary. A radio with an afc switch should be switched to "afc off" when a station is being tuned in and then to "afc on" after the station is tuned in.
8. A. There is 0.6 volt across the emitter resistor which is 330 ohms. By Ohm's law

$$\frac{0.6}{330} = 1.8 \text{ mA}.$$
9. C. The 0.75-volt bias indicates a silicon transistor and the polarity of the collector to emitter voltage as well as the transistor symbol indicates an npn type.
10. C. The fact that there is no voltage on the base indicates a defective bias circuit, which in turn would mean no emitter current flow and no emitter voltage. Either R1 or R4 open could cause this trouble, as well as a shorted C4 or C8. A defective transistor would not likely cause this trouble. Even a base-to-emitter short (highly unlikely) would not cause completely zero voltage, though the voltage would be very small on base and emitter.
11. B. See comment on Question 10. If either of these two capacitors were shorted, the bias voltage would be dropped to zero.
12. C. The trouble here must be a shorted transistor collector-to-emitter (where a transistor usually shorts). It cannot be caused by excessive bias since if the voltage on the emitter is +5 and the base +1.35, then the base is 3.65 volts *negative*, and the npn transistor requires a positive bias for turn on.
13. C. These are trimmers, and generally they are mechanically a part of the main tuning capacitor.
14. A. This capacitor is used for dc blocking only. Its large size indicates almost no reactance at fm frequencies and so almost no effect on the tuning of the circuit.
15. B. The stage gain would be reduced, but it would not drop to zero. (Even if there is no change in amplitude of a signal between the input and output, this is NOT zero gain but a gain of ONE.
16. B.
17. B. Although there is only 0.25 volt bias on the transistor, this is more than a germanium type would have. The fact that the transistor is oscillating causes the dc bias to be reduced somewhat. This occurs because of the self rectification of the oscillator signal by the base-to-emitter "diode" of the transistor.
18. B. This is a reverse-biased "varactor" which changes in capacity as the reverse bias is increased or decreased. The change in capacity "tunes" the oscillator coil circuit through C9 and C10. R7 and R8 provide a fixed bias voltage for the varactor diode so that it will always remain reverse biased, regardless of the change in afc voltage fed to the varactor anode.
19. B. See comment in Question 18.
20. B. This is a series resonant trap and it is usually tuned to 10.7 MHz, which prevents any "leakage" from the rf circuit through the mixer to the i-f circuit. This leakage might be from a strong short-wave signal at or near 10.7 MHz.
21. C. With C4 shorted there would be no bias on Q2. With no bias on Q2 there would be no collector current and so no voltage drop across R9; so the collector voltage would rise to 5 volts.
22. D. Both the base bias and the emitter voltage would increase. The collector voltage would normally decrease if there were any resistance in the +5-volt line prior to its connection to the collector circuit of Q1.
23. C. The signals are NOT mixed together since we cannot listen to both a-m and fm at the same time; so one or the other is turned off by the a-m/fm function switch.
24. D. Anything that stops the transistor current flow will cause the collector voltage to rise because there will be no voltage drop across R2, and so the full 4.3 volts will appear at the collector.
25. C. Essentially, this is an a-m neutralizing capacitor, since the takeoff is from the a-m i-f section and also because the fm signal fed into the emitter as it is would not normally require neutralization.
26. A. Using Ohm's law:

$$\frac{1.4\text{V}}{330 \text{ ohms}} = 4+ \text{ mA}.$$

27. B. The tip-off is the direction of the diodes. If connected in opposition, the circuit is a ratio detector.
28. D. The zero voltage indicates that the two diodes are receiving identical amounts of voltage, which means that they will have zero voltage output at the center tap of the transformer winding. However, as the frequency swings back and forth, the voltage at point A will go positive and negative (audio output) but the average dc voltage is still zero, since the audio goes as far positive as it does negative, and vice versa.
29. C. Since the transistors work for both fm and a-m, it would be highly unlikely for a transistor to be defective. The audio amplifier and the power supply are common to both circuits; so the most logical choice for trouble would be in the a-m converter, which is not used during fm reception.
30. A. You can be sure of the audio amplifiers, but not of the i-f transistors, since the fm circuit, even in a combination strip, has more transistors than the a-m circuit. This means that an i-f transistor in the fm-only portion of the amplifier could be defective. You cannot be sure that the fm rf amplifier is defective, since obviously there are other trouble spots possible, such as the fm mixer, oscillator, etc., as well as trouble in the fm-only part of the i-f circuit.

CHAPTER 14

1. C. -0.1 volt. -5.6 is 0.1 volt more negative than -5.5 volt.
2. D. $+3.3$ volts.
3. C. 2.2 volts. Negative.
4. A. 0.001 A. $I = E/R$.
5. B. Pnp. It uses a negative collector voltage and negative bias with respect to the emitter.
6. B. Germanium. It is working with only 0.1 -volt bias. Silicon transistors require at least 0.4 -volt bias.
7. B. Normal. One milliampere of current is a normal value for a germanium small-signal transistor such as this audio circuit uses.
8. C. The signal is "hot" on the base and on the collector but also at point F because this is in the tuned circuit and is not bypassed to ground. This takeoff point is sometimes used to feed a neutralization voltage through a small capacitor back to the base of the transistor.
9. A. All points not grounded in this circuit have a dc voltage on them and are, in that sense, "hot."
10. D. It could be at any of those places, since anything that will eliminate the output pulse from the supply line will stop the oscillation. If the supply line is to feed still another audio amplifier preceding these two, with the supply voltage taken from point A to feed this amplifier, the logical place for the decoupling filter is between A and B. In reality, this is a design problem and not truly a service-type problem, but it does help in service if you understand why the designer is required to do certain things.
11. B. If the trouble is an open electrolytic, there is no need to remove it from the circuit before you try a new capacitor since it has already removed itself electrically from the circuit by opening. You could remove the electrolytic and test it, but what if it is good? Then you have done a lot of work for nothing, and, besides, an electrolytic is not the easiest thing to test, except with sophisticated capacitor checkers.
12. C. A resistor between collector and base will increase the transistor bias, which should increase the transistor current. The voltage drop across both the collector and emitter resistors should increase.
13. B. This is an npn transistor; so the supply voltage to the collector should be $+$ with respect to ground. The collector side of the collector resistor, then, must be less positive (more negative) than the supply. The emitter is more positive than the ground (which is the negative side of the supply); so the "Y" leads are the positive leads, otherwise the meter pointer would try to go past zero on the left-hand side of the scale.
14. B. A resistor between base and emitter should lower the transistor bias; so the current will decrease, as will the voltage drop across the resistors.
15. C. A short between the collector and emitter might damage something else in the circuit, but not the transistor. A short between collector and base, though, may damage the transistor because of the excessive bias. Fortunately, even a mistake of this nature will not damage the transistor, because resistors in the circuit prevent excess current—this can be either an emitter or collector resistor.
16. C. This might not seem correct, since you might expect more signal at M but remember that T3 steps down the voltage a bit to match the detector circuit and prevent undue loading on the tuned circuit.
17. A. There will always be a higher indication of signal voltage at a collector than at the following base. The capacitor between H and I should not attenuate the signal noticeably. There should be no signal voltage at K unless the bypass capacitor across the emitter resistor of Q2 is open. Point L is the supply-voltage line, and there should never be a significant signal voltage here unless a supply line bypass capacitor is open.
18. D. As indicated in the preceding answer, it is normal to get less voltage on the base side of a transformer coupling. If the supply voltage were low or zero, you would not have a signal at C or E or I. If transistor Q1 were shorted, the same reasoning applies, but you could have about the same signal at J as at I if the transistor were defective, simply because of the capacity feedthrough from the base to the collector.
19. A. You should have no rf indication where the circuit has been made "cold" by a bypass capacitor.
20. D. It is commonly said that in a capacitive circuit the current leads the voltage. This is the same thing as saying the voltage lags behind the current.
21. A.
22. D. A series-resonant circuit is sometimes called an "acceptor" circuit, meaning that it will accept or pass the resonant frequencies and reject all others, except those close to the resonant frequency. These it will allow to pass in varying amounts, depending on their distance away from resonance and on the "Q" of the circuit.

23. B. Any load on a resonant circuit, whether in series or in parallel, lowers the Q of the circuit.
24. D. Winding a coil with larger wire lowers the resistance of the winding, as does using several strands of wire in parallel. The wires in parallel have lower "rf resistance" than a solid wire of the same physical size, because of the phenomenon known as skin effect, as explained in the text. A suitable core material increases the Q because it requires fewer turns of wire to make the coil have the same inductance; so again the resistance of the circuit is lowered.
25. B. Impedance takes in all the restrictions to the flow of alternating current. Impedance and resistance are seldom the same. For example, a pair of headphones may have 2000 ohms impedance at 1000 Hz, but if you measure the resistance with an ohmmeter, it might be only 300 ohms. The additional alternating current impedance occurs because inductors are used inside the earphones.
26. B. Any lowering of the Q of a circuit will make it tune more broadly, or, in other words, have a wider bandpass.
27. B.
28. B. A link couple is always at low impedance. A low-impedance circuit is not greatly affected by the residual capacity of the circuit, which could easily bypass higher frequencies to ground in a high-impedance circuit. The base of any bipolar transistor should be fed at low impedance, and that is what the "tap down" on the tuned circuit (between G and F) does.
29. A. Link coupling is a favorite design device for transferring a high frequency signal over some distance.
30. D. You can check the windings to see if the voltage is the same on both sides, or you can check the windings with an ohmmeter. The radio must be on in the first case and off for the ohmmeter check.
31. D. Check to make sure all the switches are on, the batteries are correctly in place, etc. Alignment is almost never the cause of a dead radio unless the tampering with the tuning has been extreme. Resistors can normally be 20% off their rated value and still the radio will work normally. Measuring voltages on all transistors is poor technique—you should first try to isolate the trouble to a particular stage or stages before resorting to "blind" voltage readings.
- on the transistor and the meter will read a lower collector-to-emitter resistance.
3. C. The only thing that you can be almost positively sure is not the trouble is C1; since, if it were shorted, it could not drop the voltage at C to zero because C1 is separated from point C by a 2.2K resistor. If you have no voltage at point C it could easily mean that there is no supply voltage, or that the radio is not turned on, or even that C3 is shorted; but you can't be sure without further checking.
4. B. A 250-ohm resistance indicates that the short could be on the "C" side of the 220-ohm resistor; so this should be the next check. For example, a 30-ohm short to ground at point C would read as a 250-ohm short at point B. It is not likely to be at point D because a short here would need at least as much as 320 ohms (220 ohms plus 100 ohms) at point B. Obviously it cannot be C1, since, even if C1 were shorted, the resistance reading from point B of that short would be at least 2420 ohms.
5. D. This is tricky, admittedly. It could possibly be C3 shorted, since a short here could cause the 100-ohm resistor to burn and change to a lower value—say, around 60 ohms. It could be either C4 or C5, or both, though it is highly unlikely that two capacitors will short at the same time, and it could be Q2 shorted. Since the emitter resistor is only 47 ohms, a reading of 60 ohms could be possible from point D. Note also that when we say "shorted capacitor" it means one with a low resistance across it. Often this resistance may be near zero ohms, with the battery voltage across it, but with the low voltage of the ohmmeter only across it, it is not unusual for a defective capacitor to have several ohms resistance (sometimes several hundred ohms resistance) as read with an ohmmeter.
6. C. Only this method is practical or remove one lead from one of the capacitors from the circuit. Checking directly across either capacitor of course will do no good since so far as the ohmmeter and reality is concerned you are measuring across both capacitors because they are connected together.
7. A. There are so many variations that a hard and fast rule is impossible, but if you read less than 1000 ohms, you can be sure you should check to find out why.
8. B. Tricky again, but note that Q1 is biased by voltage from point A, so, with zero voltage at A, Q1 should be drawing no current. Therefore, the 5.7 volts at C should also be at the collector. The current the audio circuits draw is of no consequence, since the voltage at C is already given. Therefore, we can be sure that any trouble, if there is some, in the audio circuits is not adversely affecting the voltage at C.

CHAPTER 15

1. C. On a three-lead transistor you must take at least two leads out of the circuit before soldering in a new transistor, for a valid test. Even if you have removed two leads and proceed to solder in the test transistor, trying to hold the leads in place is a tricky business, at best, and gives you no chance to check the radio over the dial, nor does it allow you to "touch up" the tuning of the i-f to see if a new transistor is the answer to all the problems and will work equally as well as the original transistor did.
2. B. This is a bit difficult, perhaps, to see; but remember that the meter is a voltage source. When the meter is connected across the transistor so that there is positive voltage on the collector of this npn transistor, a positive voltage is also supplied through the bias resistors to the base of the transistor, which can, if the bias is sufficient, turn
9. D. A base-to-emitter short in the transistor would have little effect on the voltage at A, since there is a 10K resistor plus the 470-ohm emitter resistor in the circuit between A and ground. If R1 is open, though, no voltage can get to point A and if C1 were shorted, any voltage trying to reach point A through R1 would be shunted to ground.
10. C. Note that point B has a resistance *higher* than the resistance at the collector. This means that the problem must be on the collector side. The 6-ohm difference represents the resistance of the transformer winding. Q1 is probably shorted, or nearly so, and the ohmmeter is reading the short to ground through the 470-ohm emitter resistor.

11. A. When a positive voltage is applied to the *anode* of a diode, the diode will conduct. The anode is the "arrow" side and the bar side is called the *cathode*. The diode when connected as in circuit No. 1 allows current to pass from the anode to the cathode, and current flows through the lamp.
12. B. If reversing the diode still permits the lamp to light, then the diode must be shorted.
13. A. This is the circuit within which enough current could flow in order to damage the diode. No current flows in circuit No. 2; so the diode could not be damaged.
14. D. This is the best answer. An electrolytic capacitor may show some leakage voltage if open-circuited; however, with the 22K circuit resistor drawing current, the leakage will have to be pretty severe to make a change in the bias voltage on Q2. Of course, another good check is to remove one lead of the capacitor and see if the voltage on the base drops down to its normal value. If it does, obviously the capacitor is causing the trouble.
15. D. Do not be confused by the term "zero resistance." This is *not* the same as no ohmmeter reading. No ohmmeter reading is infinite resistance. Zero resistance is a short circuit and the ohmmeter will read full scale, or 0 ohms. A capacitor as small as a .05 μF is not likely to show any charge current since the charge occurs so quickly that the meter needle does not have time to react. Any good capacitor that is not an electrolytic should have no direct current flow through it, otherwise it should be discarded. For example, a 1-megohm resistance reading indicates a leaky capacitor, and it should be replaced. Even though the capacitor is not yet causing any serious symptoms in the circuit, it will grow progressively worse, probably rather quickly.
16. C. Continuity simply means that you get a definite reading when measuring the circuit with an ohmmeter. You should get continuity, and in this case nearly zero resistance when you measure across a fuse, a switch, a length of wire, a coil, etc.
17. C. $K = 1000$.
18. A. 20% tolerance is permissible in almost any radio circuit.
19. D. With C1 shorted there would be zero voltage at the base of Q2. But what about the transformer open? Would that mean zero voltage on the base? Or suppose R2 were open. Not in this circuit. With C1 shorted, the base is tied directly to the negative side of the battery, and this means the transistor has excessive bias. Except for the emitter resistor to protect it, the transistor would no doubt have burned out.
20. D. The emitter voltage indicates the transistor is drawing only about 0.2 mA of current, and generally a transistor in this kind of circuit should draw at least 1 mA or more. The base voltage reads only .05 volt more negative than the emitter, indicating low bias. R2 may be open; but, if so, why is there any base voltage? This could occur because of normal leakage usually found in a germanium transistor, but, because there is a 10K resistor (R1) from base to ground, the leakage in the transistor would have to be quite severe to produce even 0.15 volt. Chances are, R1 has increased to a higher than normal value.
21. D. Capacitor C2, if open, would not bypass the audio voltage changes around the 1K emitter resistor. So, for example, when the audio signal is going positive, the current through the transistor decreases; and the voltage on the emitter would go more positive (less negative). This tends to cancel out the transistor signal bias and greatly reduces the gain of the stage, especially when such a large emitter resistor is used. If the emitter resistor were only 100 ohms, for example, it could be left unbypassed and there still would be considerable gain in the stage, though not as much as with the emitter resistor bypassed with a suitably large capacitor.
22. A. If R1 opens, the base will receive a much higher negative voltage, increasing the bias and the current through the transistor, which is indicated by the increase in emitter voltage.
23. B. This is a pnp transistor with negative voltages developed on collector, emitter, and base. Since both C1 and C2 have one end tied to ground or near to ground (C1 is at ground when the volume control is turned down, but since any dc voltage is isolated from the volume control, it can have no voltage except to ground), then the negative side of the electrolytic should go toward the transistor and the positive side toward ground or away from the transistor in this case.
24. A. This circuit has the "hot" side of the supply voltage applied to the emitter, which makes both the emitter and base positive TO GROUND, and, since the capacitors are tied as they are with C2 returned to ground, then the + side of C2 must go to the emitter. (This method of bypassing is permissible because the + and - side of the supply has a filter capacitor across, making the bypassing to either the + or the - of the supply all right.) C2 could be connected directly across R3; and its voltage rating would have to be no larger than the voltage drop across R3, whereas as connected in Fig. 15-15, the voltage rating must be considerably higher.
25. C. If the primary winding opens, the collector will be "floating," and a voltmeter connected to it will read the voltage on the emitter since the transistor is still biased and will conduct through the meter.
If the transistor were shorted, the voltage on the collector would be about 0.9 volt. This would occur because the 1K emitter resistor would have a voltage drop across it of about 4 volts. Fig. A-11 shows how this would happen.
26. B. A germanium transistor normally has about 0.1-volt bias between base and emitter. With 1 mA of current flowing, the drop across R3 would be 1 volt, meaning there should be 3.9 volts on the emitter. The base would be 0.1 volt more negative, or +3.8 volts.

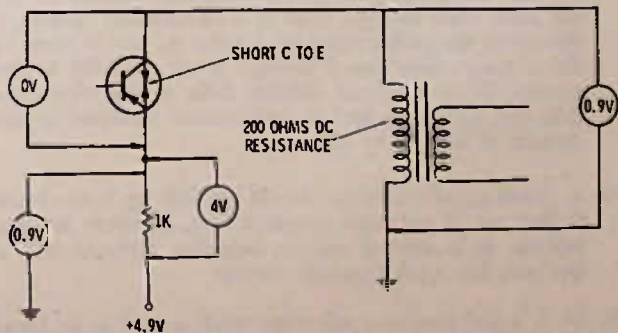

Fig. A-11.

27. A. A burned resistor, unless it has burned enough to crack and open up, will normally have less resistance than its rated value. Incidentally, if a resistor is burned in a transistor radio that uses no more than a 9-volt supply, its value will almost surely be less than 330 ohms and probably less than 100 ohms. This information may be useful if no schematic is available for a particular radio. Another thing, burned resistors are always CAUSED by something else—either a shorted capacitor, transistor, wiring short, etc.
28. A. They will be connected to common or ground in almost every example, although there are exceptions. The ground circuit may be either negative or positive, depending on the design of the circuit.
29. C. A transistor suitable for replacement in the rf circuit of an fm car radio would have more than ample frequency capability, and the voltage rating should be more than enough for any battery-operated portable radio.
30. D. It is almost certain that the 10.7-MHz transistor will work perfectly well. The transistor for 455 kHz probably would also, since silicon types are not so frequency sensitive as germanium types, but a converter transistor must oscillate to above 2000 kHz in an a-m radio; so the selection of a transistor recommended for 455 kHz service would not be a good choice on the face of it, even though in actual practice it could possibly work out all right. Transistors recommended for audio frequencies just might work also, since the silicon type seldom has an upper frequency limit of less than a few megacycles, which is not true of germanium audio at all; but again, the best selection, if a choice is possible, is the 10.7-MHz amplifier transistor.
31. C. If repeaking causes oscillations in the amplifier, replace with a different replacement transistor and tune the amplifier again. It is NOT good practice just to detune the amplifier until the oscillations cease, though in some instances it might be permissible or even preferred to more testing and selection. This is especially true if the radio is to be used for casual listening only and an inexpensive repair is the most important consideration.
32. B. Unless an exact replacement is being used, a quick "tack in" check is good insurance against a lot of extra work and possible damage to the printed board.
A transistor checker is NOT a good indication at all as to whether a transistor will work correctly in a particular circuit. A transistor that checks good on a checker is merely exhibiting the ability, in most cases, to control dc current; or, at best, its ability to amplify some low-frequency alternating current. The only true test is performance in the circuit for which it is intended. Of course, even here, you need some method of judging transistor performance, especially if the radio is to be used in receiving weak stations. Often, radio technicians keep a record of the agc voltage output of each radio they service, or they use some other method, such as a signal-tracer reading, to determine the performance of a radio on one or more radio stations whose signal strength is not expected to vary greatly. When they get another radio of the same type, they can quickly judge its performance measured professionally as well as by ear.
33. A. Small-signal transistors should not heat up to the touch. If they do, it indicates excessive bias, excessive collector voltage, or a shorted emitter capacitor perhaps; but, at any rate, too much transistor current.
34. D. A 3-lead transistor will often work as well as its 4-lead counterpart, but sometimes not. Never solder any lead to

the case of a transistor; the heat generated by the soldering iron may ruin the transistor inside. Besides, many silicon transistors are now often housed in an epoxy (plastic) case because they generate much less internal heat than germaniums.

35. B. Clean out the holes and stagger-cut the leads of the replacement transistor. Do not ream out the holes (make them bigger), since you are likely to ruin the print connection on the conductor side of the board. If installing a transistor on the print side of the board, solder the leads to the print someplace other than in the holes. Remember that the holes will be reversed compared to the lead layout when the transistor is connected on the bottom or conductor side of the printed board.

CHAPTER 16

1. A. This is the big advantage of the field-effect transistor. It can be controlled with no power used at all, just voltage. This means that no step-down transformers are needed to match impedance between the output of one stage and the input of the next. In this respect the FET is similar to the vacuum tube, but it has many of the advantages of the bipolar transistor, such as small size, high efficiency, and the like.
2. D. A "gate" is a good name for a control element, since it can let through more or less current, depending on "how far the gate is opened."
3. A. The JFET (for junction field-effect transistor) is a sort of diode in cross section. In fact, there is diode action when you take an ohmmeter reading between the gate and either the source or drain. A JFET could be compared to a diode with a lead connected to either side of its n-type material and the p-type material connected as a gate (see Fig. A-12). A diode is two pieces of semiconductor material, one of which has been doped so as to have an oversupply of negative charges (electrons) called the "n" material and the other doped so as to have an excess of positive charges (holes) and called "p" material). This arrangement when the two are "junctioned" together allows current to flow in only one direction. In an FET, a negative voltage on the gate forces the negative charges out of the channel between the source and drain, reducing the number of current carriers and increasing the resistance from source to drain.

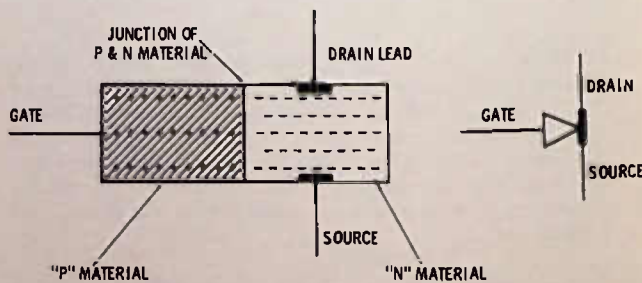

Fig. A-12.

4. B. The source and drain are just different ends of a piece of n- or p-type semiconductor; so either way the ohmmeter leads are connected between source and drain the reading is the same.
5. C. The voltage drop across the 390-ohm source resistor is 1 volt. 390 into 1 (Ohm's law again) is approximately .0025, or 2.5 mA.

6. D. If there is no source voltage, the logical next step is to see if there is any voltage at all being supplied to the circuit. The drain is a good place to check. If the drain voltage is zero, then the trouble is in the power-supply circuit. Perhaps R3 is open, C2 is shorted, L2 open; or perhaps the trouble is further back in the power supply—perhaps the switch is not working or the batteries are run down.
7. D. A neutralizing capacitor is used to cancel the signal that can travel between the gate and drain, or, conversely, the drain and gate because of the inherent capacity of the transistor. If the drain voltage is removed, the only signal that can reach the mixer is through the capacity of the transistor. Adjusting the neutralizing capacity until we have minimum signal indicates that C_n has cancelled the effect of the FET's internal capacity.
8. C. 7.8 volts. The drain is +10 volts and the source is +2.2 volts. The difference between these two voltages is 7.8 volts, for the same reason that 10 above zero is 8 degrees warmer than 2 above zero.
9. B. An n-channel type. In any transistor, a good way to remember which is the "N" material is to remember that the arrow of the symbol always points to "n" material. The "n" channel FET uses positive voltage between drain and source, and a negative voltage on the gate reduces the current (increases the resistance) through the source and drain.
10. C. Both answers A and B are correct. D is not correct, since, so far, field-effect transistors lack the current needed to develop much power at the voltages used.
11. C. Enhancement means that the transistor must be "enhanced" by bias before current will flow. In this respect it is like a bipolar transistor having zero current with zero bias.
12. B. The only possible source of voltage when the gate is disconnected from the external circuit would be through a breakdown in the insulation between the gate and the source-drain material. Any voltage reading of more than 0.1 volt, if this test is made, indicates a transistor needing replacement.
13. A. Normally, this is the only test that can be made on integrated circuits. A high-impedance voltmeter such as a vtvm or a FET vom should be used so that the meter resistance itself will not upset the bias voltages going to the IC. Jumpering between terminals can destroy the IC, as can any other external tampering such as heating. ICs cannot be repaired, and when one is suspected of being defective, replacement is the only sure test.
14. C. A varactor is a reverse-biased diode especially made to change capacity in a fairly linear rate as the reverse bias is increased or decreased. The more reverse voltage used, the smaller the capacity of the varactor becomes.

Index

A

Actual circuit, 55-56
Adding transistor amplifier to crystal radio, 73-74
Adjustments, oscillator and tracking, 55
Agc circuits, 128
Alignment procedure, 98
Alternate output meter, 99
Alternating signal, 11
Am/fm radio, 121-134
Ammeter, 17
Amperes, 17
Amplifier
 buffer, 13
 circuit description, 105-106
 final, 13
 fm i-f, 125-126
 grounded-base, 123
 power, 13
 TL, 110-112
Amplitude modulation, 13-14
Answers to test questions, 167-185
Antenna and rf circuit, 122-123
Antenna, transmitting, 13
Armstrong, Edwin H., 9
Audio
 amplifiers, 63-68, 105-119
 circuit repairing, hints on, 113
 circuits, direct-coupled, 67
 -frequency band, 11
 -frequency transformers, 40-41
 or audible frequencies, 11
 single-ended, 112-113
Audion, 9
Autoformer, 42
Automatic
 gain control, 50, 95-97
 volume control, 60
Automobile radios, 63-64
Autotransformers, 42-43

B

Band, audio-frequency, 11
Bardeen, John, 9
Basing, transistor, 137
Bias
 need for, 71
 requirements of FET, 159
 voltage, 71
Biasing, single-battery, 70-71
Black box, 12
Block diagram of a radio, 12-13
Bobbin, 42
Brattain, Walter, 9
Buffer amplifier, 13

C

Calculating current, 18
Capacitive reactance, 40
Capacitor(s), 25-27
 and resistors, 25-37
 ceramic, 26, 28
 disc, 28
 electrolytic, 27
 formulas, 29
 in parallel, 29-30
 in series, 28-29
 mica, 28
 mylar, 28
 padder, 30
 symbols, 27-28
 testing, 150
 trimmer, 30
 variable, 27
 voltage ratings, 27
 working voltage, 28
Carrier, 13
Cat whisker, 14
Ceramic capacitors, 26, 28

Charged, 25
 Checking the audio, 67
 Checking transistor stages with a resistor, 136-137
 Circuit(s)
 actual, 55-56
 agc, 128
 crystal detector, 15
 direct-coupled, 108-109
 low-impedance, 54
 OTL, 65
 parallel-resonant, 142-143
 pnp, 73
 radio-frequency, 141-142
 shunt feed, 74-75
 Class-B output stage, 63-64, 105-106
 Collector-load resistor, 72
 Collector voltage, 71
 Color code, resistor, 31
 Combination am/fm i-f amplifiers, 128-130
 Combination circuit, testing, 130
 Constant, dielectric, 26
 Construction, transformer, 42
 Control
 automatic gain, 60, 95-97
 automatic volume, 60
 tone, 33
 volume, 33, 60
 Converter section, 89-94
 Coupling methods, 143-145
 Crystal, 13, 14
 detector circuits, 15
 oscillator, 13
 radio, 15
 tuning, 48-49
 Current, 17
 calculating, 18
 drain, 64

D

Dc power supplies, 85-86
 De Forest, Dr. Lee, 9
 Demodulator, fm, 127-128
 Detection, 14-16
 Detector, 13, 59-62
 circuit, typical, 59-60
 circuit variations, 60-61
 Diagram, schematic, 27
 Dielectric, 26
 constant, 26
 Difference frequency, 12
 Diode connection polarity, 61
 Diode, varicap, 124
 Direct-coupled audio circuits, 67, 108-109
 Disc capacitors, 28
 Discharged, 25
 Disconnecting printed-circuit components, 137-139
 Discriminator, 127

Distortion, 60
 Doppler system, 10
 Double checking, 152
 Doubler or tripler, 13
 Drain, current, 64
 Dual-tuned i-f transformers, 100

E

Earphone jacks, uses of, 106
 E laminations, 42
 Electrolytic capacitors, 27
 Electronic filtering, 86

F

Farad, 25-26
 Features of the vom, 77
 Ferrite, 39
 FET
 amplifiers and IC circuits, 159-166
 bias requirements, 159
 construction and operation, 159
 Final amplifier, 13
 Fleming, J. A., 9
 Fm
 converter, 124-125
 demodulator, 127-128
 i-f amplifiers, 125-126
 signal, 122
 Folded twin-lead, 122
 Following the signal, 89-91
 Formulas
 capacitor, 29
 resistor, 32-33
 wattage, 19
 Freedom from static, 121
 Frequency, 11
 difference, 12
 image, 47
 intermediate, 12, 121-122
 modulation, 13, 121
 sum, 12
 Frequencies
 audio or audible, 11
 radio, 11
 shortwave, 13

G

Galena, 14
 Generator, signal, 83, 98
 Giga, 11
 Ground, 20, 28
 Grounded-base
 amplifier, 123
 oscillator, 124

H

Harmonic relationship, 13
 Heat sink, 67
 Henrys, 40
 Hertz, 10
 Hertz, Heinrich, 9
 Heterodyning, 12
 Hex tool, 57, 128
 Hints on audio circuit repairing, 113
 High-impedance phones, 49
 Home radios, 63
 Hot and cold sides of circuits, 135-136
 How a radio works, 10-11
 How to check oscillators, 125

I

IC, 163-165
 I-f amplifier
 operation, 95
 combination am/fm, 128-130
 fm, 125-126
 testing, 97, 126-127
 I-f circuits, variations in, 99-101
 I-f transformers, 53-55
 dual-tuned, 100
 tuning, 55
 IGFET, 162-163
 I laminations, 42
 Image
 frequency, 47
 mirror, 14
 Impedance matching, 42, 54-55
 Inductance, mutual, 40
 Inductive reactance, 40
 Inductors
 and transformers, 39-46
 iron core, 39
 RF, 39-40
 Intermediate frequency, 12, 121-122
 amplifier, 53-57
 Inversion, phase, 63
 Iron-core inductor, 39

J

JFET, 159
 in circuit, 160-162

K

Kilo, 10

L

Law, Ohm's, 18-19
 Light, speed of, 10

Limiter, 127
 Low-impedance circuit, 54

M

Marconi, Guglielmo, 9
 Matching, impedance, 42, 54-55
 Maxwell, James Clerk, 9
 Measuring
 resistance, 77-78
 voltage, 19-21
 Mega, 11
 Methods of coupling, 143-145
 Mica capacitors, 28
 Microfarads, 26
 Microhenrys, 40
 Milliammeter, 17
 Milliamperes, 17
 Millihenrys, 40
 Mirror image, 14
 Mixer-oscillator stage, 47-51
 Modulation, 13-14
 amplitude, 13-14
 frequency, 13, 121
 Module, 164
 MOSFET, 162
 Motorboating, 54
 Mutual inductance, 40
 Mylar capacitors, 28

N

Nanofarad, 26
 Need for bias, 71
 Neutralization, 100

O

Ohmmeter, 17
 testing diodes with, 80-81
 testing transistors with, 82-83
 troubleshooting with, 139
 using, 80
 Ohms, 17
 Ohms impedance, 43
 Ohm's law, 16, 18-19
 Omega, 18
 Operation, i-f amplifier, 95
 Oscillator, 49-50
 and tracking adjustments, 55
 crystal, 13
 grounded base, 124
 radio frequency, 13
 Oscillators, how to check, 125
 Oscilloscope, 85
 Other audio circuits, 106-108
 Other output circuits, 109-110
 OTL circuit, 65
 testing, 110

- Output
 - class-B, 105-106
 - meter, alternate, 99
 - push-pull, 43
 - stage
 - class-B, 63-64
 - single-ended, 66-67

P

- Padder capacitor, 30
- Parallel
 - capacitors, 29-30
 - resistors, 32
 - resonant circuits, 142-143
- Phantom connection of signal generator, 99
- Phase inversion, 63
- Phones, high-impedance, 49
- Picofarad, 26
- Plexiglas, 26
- Pnp circuits, 73
- Polarity of diode connection, 61
- Potentiometer, 33
- Power
 - amplifier, 13
 - supplies, dc, 85-86
- Practical transistor amplifier, 72-73
- Primary winding, 40
- Principles of radio, 9-24
- Printed-circuit components, disconnecting, 137-139
- Procedure, alignment, 98
- Propagation, radio wave, 10
- Properties of vacuum tubes, 9-10
- Push-pull output, 43

R

- Rabbit ears, 122
- Radar, 10
- Radio(s)
 - am/fm, 121-134
 - automobile, 63-64
 - block diagram of, 12-13
 - crystal, 15
 - frequencies, 11
 - frequency oscillator, 13
 - home, 63
 - principle of, 9-24
 - transmitter, 13
 - wave propagation, 10
- Reactance, 25
 - capacitive, 40
 - inductive, 40
- Rectification, 59
- Rectifiers, 59
- Relationship, harmonic, 13
- Replacing transistors, 152-153

- Resistance, 17
 - measuring, 77-78
- Resistor(s), 17, 30-32
 - collector-load, 72
 - color code, 31
 - formulas, 32-33
 - in parallel, 32
 - in series, 32
 - testing, 150-151
 - tolerance, 31
 - values, standard, 31-32
 - variables, 33
 - wattage, 31
- Resonance, 47-48
- Rf
 - amplifier
 - voltage-checking, 123
 - troubles, 123-124
 - inductors, 39-40
 - transformers, 43-44
- Ringling, 47

S

- Scales, 77
- Schematic
 - of typical broadcast radio, 90
 - voltages, 71-72
- Secondary winding, 40
- Selectivity, 12
- Self bias, 71
- Series
 - capacitors, 28-29
 - resistors, 32
- Service, transformer, 43
- Shielding, 53-54
- Shortwave frequencies, 13
- Shunt-feed circuit, 74-75
- Simple af amplifiers, 69-76
- Signal
 - alternating, 11
 - generator, 55, 83, 98
 - phantom connection, 99
 - tracers, 84
 - tracing, 137
- Sine wave, 11
- Single
 - battery biasing, 70-71
 - ended audio, 112-113
 - ended output stage, 66-67
- Sink, heat, 67
- Skip, 49
- Solid state, 9
- Speakers, 63
 - and distortion, 106
- Speed of light, 10
- Stacking, 30
- Stage, 16
- Standard values of resistors, 31-32

Static, freedom from, 121
 Stress, 26
 Sum frequency, 12
 Summary, 55-56
 Superheterodyne, 12
 Switching, 69-70
 Symbols for capacitors, 27-28
 Symmetry, 61

T

Test equipment, 77-88
 Test questions, 21-24, 34-37, 44-46, 50-51, 57, 62, 67-68, 75-76, 86-88, 93-95, 101-103, 114-119, 130-134, 145-148, 154-158, 165-166
 Tests, voltage, 139-140
 Testing
 capacitors, 150
 components with an ohmmeter, 149-158
 components with a voltmeter, 151-152
 diodes with an ohmmeter, 80-81
 IGFET or MOSFET with an ohmmeter, 163
 resistors, 150-151
 the combination circuit, 130
 the i-f amplifiers, 97, 126-127
 the OTL circuit, 110
 transistors with an ohmmeter, 82-83
 The i-f amplifier, 95-103
 Thermal runaway, 105
 Thermistors, 105
 TL amplifier, 110-112
 Tolerance, resistor, 31
 Tool, hex, 57
 Tone control, 33
 Tracers, signal, 84
 Tracking, 55
 Transformer
 construction, 42
 service, 43
 Transformers, 106
 for audio frequencies, 40-41
 i-f, 53-55
 rf, 43-44
 Transistor
 amplifier, practical, 72-73
 basing, 137
 replacing, 152-153
 testing by substitution, 137
 Transistorized voltmeter, 78-79
 Transmitter, radio, 13
 Transmitting antenna, 13
 Trimmer capacitor, 30, 91-92
 Troubles, rf amplifier, 123-124
 Troubleshooting
 methods, 64-65
 radio circuits, 135-148
 visual, 140-141
 with an ohmmeter, 139

Tuning, 47
 a crystal radio, 48-49
 or alignment, 98-99
 the i-f transformer, 55
 Typical detector circuit, 59-60

U

Unit of capacity, 25-26
 Uses of earphone jacks, 106
 Using
 a voltmeter, 79-80
 output meters, 95-96
 the ohmmeter, 80

V

Vacuum-tube voltmeter, 78-79
 Vacuum tubes, properties of, 9-10
 Valve, 9
 Varactor, 164
 Variable
 capacitors, 27
 resistors, 33
 Varicap diode, 124
 Variations
 detector circuit, 60-61
 in converter circuit, 92-93
 in i-f circuits, 99-101
 Visual troubleshooting, 140-141
 Voltage, 16-17
 bias, 71
 -checking the rf amplifier, 123
 collector, 71
 interpretation, 152
 measuring, 19-21
 ratings, capacitor, 27
 tests, 139-140
 Voltages shown on schematics, 71-72
 Voltmeter
 test of components, 151-152
 transistorized, 78-79
 using, 79-80
 vacuum-tube, 78-79
 Volume control, 33, 60
 Vom, features of, 77

W

Wattage, 19
 formulas, 19
 resistor, 31
 Whip, 122
 Why detection is necessary, 59
 Winding
 primary, 40
 secondary, 40
 Working voltage of capacitor, 28



TRANSISTOR RADIO

servicing course

BY WAYNE LEMONS

The author has directed special attention to presenting material that is useful both to beginner and professional service technician—in fact, the aim is to bring the beginner to professional level. This book is a complete course in transistor radio servicing, suitable for self instruction or supervised study. All aspects of the transistor radio are discussed, section by section, for both a-m and fm receivers.

Starting with basic principles of radio, the text proceeds with a discussion of components—resistors, capacitors, inductors, and transformers—then takes up the radio receiver by stages—the mixer-oscillator stage, the intermediate-frequency amplifier, the detector, and the audio amplifier and output stages. Later chapters tell how to use test equipment, how to troubleshoot, and how to remove and replace circuit components.

A feature that makes the book especially effective as instructional material is the liberal use of questions and answers. The questions are multiple choice and the answers are not mere A, B, C, D, or yes-no answers, but often explain why that particular answer is best and contain much material of a supplementary nature to the text.

ABOUT THE AUTHOR



Wayne Lemons is a dyed-in-the-wool technician, and then some. Like most technicians, he dreaded the thought of repairing transistor radios, but couldn't very well say no to his regular customers. Not one to do things halfway, he decided to make the work profitable by developing the necessary service techniques. It took him six months to do it, but now he can afford to fix transistor radios for other dealers, at wholesale prices! Wayne is a very busy man, dividing his time between servicing, teaching electronics, and writing articles for the benefit of other servicemen. he finds time to conduct service seminars in and around his home state of Missouri. Other Sams books by Mr. Lemons include *TV Servicing Made Easy*, *Auto Radio Servicing Made Easy*, *Transistor Radio Servicing Made Easy*, and (with Carl Babcoke) two volumes of *Color TV Servicing Made Easy*.



HOWARD W. SAMS & CO., INC.
THE BOBBS-MERRILL CO., INC.
INDIANAPOLIS • KANSAS CITY • NEW YORK