

**ELECTRONIC TECHNOLOGY SERIES**

# **LIMITERS and CLIPPERS**

**a** **RIDER** **publication**

**\$1.25**

# **LIMITERS and CLIPPERS**

Edited by

**Alexander Schure, Ph. D., Ed.D.**



**JOHN F. RIDER PUBLISHER, INC.**

116 West 14th Street • New York 11, N. Y.

*Copyright 1955 by*

**JOHN F. RIDER PUBLISHER, INC.**

All rights reserved. This book or parts thereof may not be reproduced in any form or in any language without permission of the publisher.

**FIRST EDITION**

*Library of Congress Catalog Card No. 55-12538*

**Printed in the United States of America**

## PREFACE

The practitioner in electronics is often confronted with the need to limit the maximum instantaneous voltage of a signal and/or modify the waveshape of a signal. The terms "limiter" and "clipper" have assumed almost synonymous and interchangeable meanings in text and technical usage referring to circuits designed to solve the problems, although in actuality precise definitions do apply to each of the terms. These definitions, distinctions, and applications are presented in this booklet for the more important variations of limiter and clipper circuits.

The topics are arranged in logical sequence from the simpler types of circuits to the more complex evolutions required for specialized application in speech clipping or in communications, television, radar, and amateur broadcast receivers and transmitters. Thus discussion and analyses of series and parallel diode limiters of both the negative and positive types, limiting to specified magnitudes, limiting above and below ground potential, peak passing diodes, multi-grid limiters, and saturation and cutoff limiters precede the chapter devoted solely to limiter and clipper circuit applications.

The waveshaping applications have been limited to clipper circuitry, since other types of waveshapers (such as those involved in the multivibrator pulse and inductive and capacitive integrating and differentiating types of circuits) are presented in other review book in this series.

Grateful acknowledgement is made to the staff of the New York Technical Institute for its preparation of the manuscript for this booklet.

*New York, N. Y.*  
*December, 1955*

A. S.

## CONTENTS

<i>Chapter</i>		<i>Page</i>
1	Series Diode Limiters .....	1
2	Parallel Diode Limiting .....	10
3	Limiting to Specified Magnitudes .....	17
4	Triode Limiters .....	26
5	Saturation and Cutoff Limiters .....	37
6	Other Limiter Applications .....	48

## Chapter 1

### SERIES DIODE LIMITERS

#### 1. What are Limiters and Clippers?

Limiters and clippers have wide application in modern electronic circuits. Some of their better known uses are:

- a. Noise-rejection in communications and broadcast receivers
- b. Waveshaping and noise-filtering in tv receivers
- c. Waveshaping and signal-voltage regulating in radar systems
- d. Speech clipping in a-f amplifiers and modulators
- e. Waveshaping in square-wave generators

The terms "limiter" and "clipper" are almost always used interchangeably. That is why we consider them together in this book. However, from the point of view of application, one or the other may be preferred in a given case. The evolution of the terms and their general meanings allow certain distinctions to be made, as follows.

A *limiter* controls maximum instantaneous voltage or current, never allowing it to exceed a certain value. Wide ranges of input voltage or current to this device produce output voltage or current varying over only a specified range.

A *clipper* "chops" or "cuts" off the waveform of a signal at a certain amplitude level, thus the term "clipper." Since the amplitude of the waveform is "cut down," clipping is inevitably accompanied by limiting.

A device referred to as a limiter ordinarily has amplitude limitation as its objective; one referred to as a clipper ordinarily has waveshaping as its objective. The same circuits may be used for either or both.

Although the clipper is used as a waveshaper, it is not the only type of waveshaping device. The term “waveshaper” describes a general group of devices, of which the clipper is one example. Inductive and capacitive integrating and differentiating circuits are other examples, but are outside the scope of this book.

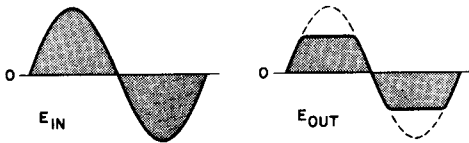

Fig. 1. Square wave produced by clipping.

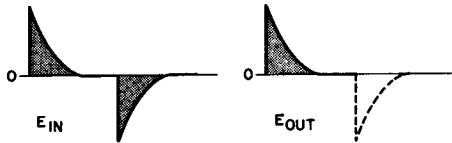

Fig. 2. Effects of clipping on a peaked wave.

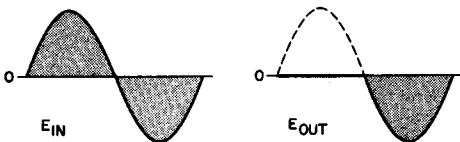

Fig. 3. Clipping positive portion of a sine wave

To summarize, limiters and clippers do either or both of the following two things: (a) limit the maximum instantaneous voltage of a signal, and (b) modify the waveshape of a signal. All of the uses of limiters or clippers fall into these classes. As the discussion in this book develops, a number of examples of these uses will be shown.

One type of limiter or clipper removes all or part of either the negative or positive portion of the input wave. As an example, a sine wave may be changed to a square wave by means of a clipper of the type shown in Fig. 1. Peaked waves, in which both positive and negative peaks are present, may be developed from square waves, and are often used to trigger—to start the operation of circuits. Usually, only the positive peaks or only the negative peaks are used. Figure 2 shows the effect of clipping or limiting on a



peaked wave. Another use of a clipper is as a protective device to keep the input voltage of a circuit from going too far positive or negative. Figure 3 shows a wave shape that is prevented from going too far positive. There are many other uses of diode limiters in electronic circuits.

**2. Series Diode Limiting**

The characteristics of a diode are such that the tube conducts only when the plate is at a positive potential with respect to the cathode. If the cathode is held at ground potential, the plate need be positive only with respect to ground to establish an electron flow through the tube. A positive potential with respect to ground may be placed on the cathode, in which case the tube does not conduct until the positive voltage with respect to ground on the plate rises to a value in excess of the cathode potential. Likewise, the cathode may be held at a negative potential with respect to ground, in which case the tube will conduct while the plate is positive with respect to ground, and continue to conduct while the plate is negative as long as the plate is less negative than the cathode.

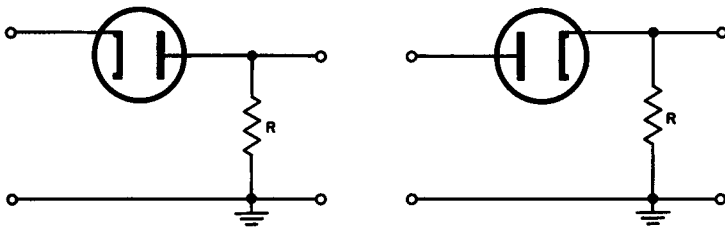

Fig. 4. Series diode limiters.

As the plate becomes more positive with respect to the cathode, the current through the tube increases and the plate-to-cathode resistance decreases rapidly from an open circuit to an average value on the order of 500 ohms. One of the ways of classifying diode clippers is according to whether the diode is in series or in parallel with the output. If the diode is in series with the output, the circuit is called a series diode limiter. Two different ways of connecting limiters of this type are shown in Fig. 4. Note that in each part of the figure the output is taken across resistor  $R$  and the diode is in

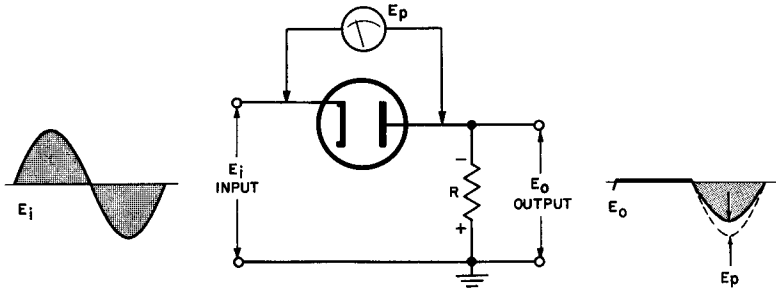

Fig. 5. Series diode limiter arranged to clip positive peaks

series with this output. However, the two circuits are not alike; the diodes are connected in opposite directions with respect to the input and the output. Hence, series diode limiters are classified according to whether they are positive diode limiters or negative diode limiters. Naturally, a negative limiter clips the negative portion and a positive limiter the positive portion of the sine wave.

### 3. Series Diode as a Positive Limiter

A positive limiter, together with its input and output waves, is shown in Fig. 5.  $E_o$ , the output wave, is shown by a solid line. The "clipped" portion of the output wave is shown by a broken line. When the positive portion of  $E_i$  is applied to the circuit, there is no electron flow through the tube, current does not flow through  $R$  and the voltage across  $R$  ( $E_o$ ) is zero. When the negative half of  $E_{in}$  is applied to the circuit, the tube does conduct and current flows through resistance  $R$ , developing the voltage in the output ( $E_o$ ).

Thus, only the negative half of the input wave appears at the output. Because of the voltage drop across the tube, the amplitude of the negative half-cycle of the output is slightly less than that of the negative half-cycle of the input. This voltage drop across the tube ( $E_p$ ) is ordinarily negligible, because the resistance of the tube during conduction is negligible in comparison with the resistance of the load.

An alternate viewpoint is that, since the rectifying characteristics of the tubes are utilized, it may be considered as a switch. This is justified if the value of  $R$  is very large as compared to the resistance value of the diode while the diode is conducting. Thus, in Fig. 5, the output voltage remains at zero throughout the positive

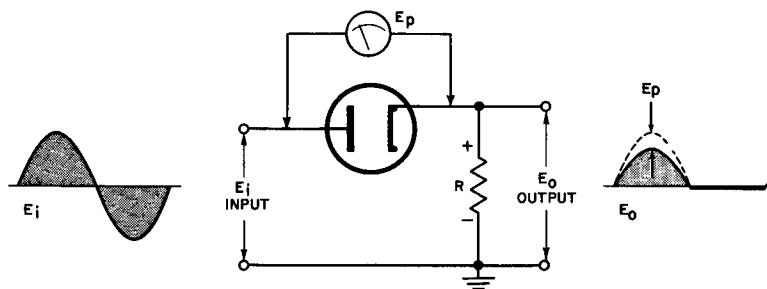

Fig. 6. Series diode limiter arranged to clip negative peaks.

half-cycle of the input signal because the diode switch is open and no current flows through  $R$ . During the negative half-cycle, on the other hand, the cathode is negative with respect to the plate, and the tube conducts. The switch is closed, and the output developed across  $R$  follows the applied voltage and, neglecting the very small drop across the tube ( $E_p$ ), is essentially equal to the applied voltage.

In view of the above explanation, we may summarize the operation of a series positive diode limiter as follows:

- a. On the positive half-cycle of the input, the tube does not conduct, the entire input voltage is dropped across the tube, and there is no output.
- b. On the negative half-cycle of the input voltage the tube conducts, there is very little voltage drop across the tube, and substantially the entire voltage drop is across the load resistor.

#### 4. Series Diode as a Negative Limiter

A series diode limiter connected for negative clipping removes the negative portion of the sine wave. Such a clipper, together with its input and output waves is shown in Fig. 6.

When the positive half-cycle of the input wave ( $E_i$ ) is applied to the circuit, the tube conducts, current flows through resistance  $R$ , and  $E_o$  is developed as the output voltage. The magnitude of  $E_o$  is lessened by the voltage drop across the plate resistance of the tube. When the negative half-cycle of the input voltage is applied to the circuit, the tube does not conduct, current does not flow through resistance  $R$ , and the voltage across  $R$  ( $E_o$ ) is zero.

Thus, we may summarize the operation of series diode negative limiters as follows:

a. On the positive half-cycle, the tube conducts, there is a very small voltage drop across the tube, and almost the entire voltage drop appears across the load resistor.

b. On the negative half-cycle, the tube does not conduct, the entire voltage is dropped across the tube, and no output voltage appears across the load resistor.

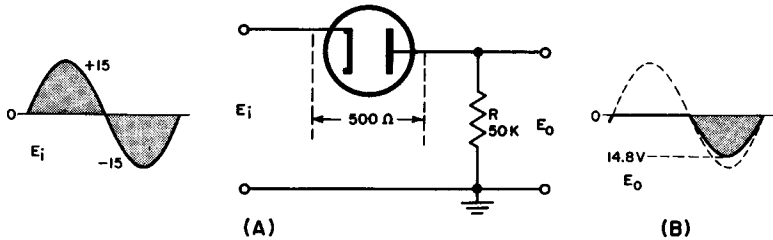

Fig. 7. Positive limiter.

At this point, it is well to consider the method of determining the amplitude of the output voltage of a series limiter circuit. For the purposes of the problem, we will use the positive limiter shown in Fig. 7. The following procedure applies equally to negative limiters, except that the output curve is drawn on the positive side of the base line.

In Fig. 7, when  $E_i$  is positive, the tube does not conduct and  $E_o$  is zero during the entire positive alternation of  $E_i$ . When  $E_i$  is negative, the tube does conduct. The maximum negative value of  $E_o$  during this negative alternation of  $E_i$  is then equal to:

$$E_o = \left( \frac{R}{R + R_p} \right) E_i$$

where  $E_i$  is the maximum negative value of  $E_i$  during the negative alternation. Substituting from the figure, we find that:

$$\begin{aligned} E_o &= \frac{50,000}{50,000 + 500} \times 15 \\ &= (0.99) (15) \\ &= (14.8 \text{ volts}) \end{aligned}$$

The ratio  $\frac{R}{R + R_p}$  remains the same for all input voltages, so the instantaneous output voltage during the negative alternation is always 0.99 times the input voltage at the same time (except for a slight modification due to the change of plate resistance of the

diode as its current changes). This is sufficient information to draw  $E_o$  as shown in (B) of Fig. 7.

In communications, reception can be marred by strong noise pulses in the received r-f signal. These unwanted pulses are generated by such sources as the ignition systems of gasoline engines. The interference thus created is often referred to as "impulse noise." Its sharp pulses shock-excite the receiver's audio system into producing loud popping noises. Audio transients thus generated last much longer than the thin r-f pulses that cause them. For this reason they override, or *mask* most of the desired signal.

Clipper-limiter circuits are used to suppress this interference. They clip the noise pulses down to normal audio peak level in the detector, before they can get into the a-f amplifier. The effect is to "kill" receiver output either partly or completely during each short r-f noise pulse. The noise pulses are so short, compared to the time between successive pulses, that elimination of receiver output for their duration does not seriously interfere with reception. The relatively long-lasting audio transients, which result from high voltage-peak pulses in the a-f section, are thus eliminated by limiting at the detector.

An example of a useful and successful series limiter as applied to communications receivers is shown in Fig. 8. This limiter circuit is known as a series noise-peak limiter. The limiter has been used successfully for frequencies ranging from 15 kc to well over 400 mc. It satisfies the requirements for voice-modulated signals because it does not introduce a sufficient degree of distortion in the signal to cause serious impairment of the quality of words or music. This circuit is especially common in communications receivers that have been designed for shipboard and amateur use.

As you can see from the figure, this circuit is economical to construct, since it requires only one fixed capacitor, two fixed resistors, and a diode tube. This circuit will operate from the output of the second detector circuit. The only control required for the limiter circuit is an "ON-OFF" switch.

Referring to the circuit of Fig. 8, assume that a d-c voltage of  $-10$  volts is applied across resistors  $R1$  and  $R2$  by a constant carrier. The cathode of the diode limiter tube is initially at a value of about  $-10$  volts with respect to ground. This is easily understood when we realize that the limiter tube cathode is connected to point  $a$  in the circuit. This connection is made through resistances

$R3$  and  $R4$ . The plate of the diode limiter tube is at about  $-5$  volts with respect to ground, being at center tap across the 10-volt source.

The plate is thus momentarily at a value of  $+5$  volts with respect to the cathode, and the diode tube becomes conductive, because its plate-to-cathode resistance is negligible in comparison to the other resistances in the circuit.

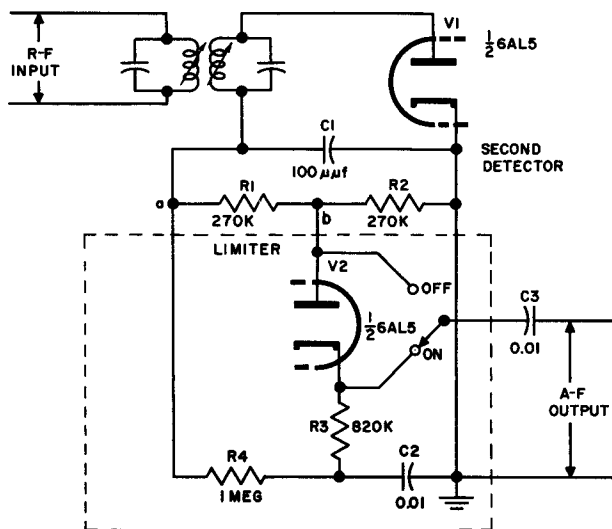

Fig. 8. Series Noise-peak limiter.

Assume the switch is in the "ON" position. Output capacitor  $C3$  is effectively connected to point  $b$  through the diode limiter tube whenever this tube is conductive because of the net d-c voltage between plate and cathode. As long as the diode remains conductive, it passes the a-f signal. The a-f signal appears at  $C3$ . This output is about 45 percent of what it would be without the limiter circuit due to the position of tap  $b$  at half load resistance and the series diode impedance. This reduction is generally of little significance, since it affects only reserve gain of the receiver and not the sensitivity.

Under the above conditions, capacitor  $C2$  is charged through resistor  $R4$  to a value of about  $-7$  volts. Any appreciable cathode

voltage change would require about 0.01 seconds (10,000  $\mu\text{sec}$ ) due to the time constant of resistor  $R_4$  and capacitor  $C_2$ .<sup>1</sup> The time constant of resistors  $R_1$  plus  $R_2$  and capacitor  $C_1$  is 50 microseconds. Thus the potential of the diode limiter plate may change in 1/200th of the time required for the cathode to arrive at the new potential. Now assume that a noise pulse of 100 volts peak is placed across resistances  $R_1$  and  $R_2$ . The plate voltage of the diode limiter tube becomes about  $-50$  volts with respect to ground. In other words, the plate of the tube is momentarily about 43 volts more negative than the cathode. This causes the diode to cease conduction.

In effect, the action outlined above disconnects output capacitor  $C_3$  from point  $b$ , and the audio amplifier has no appreciable input for the duration of the noise pulse. By the time the cathode has assumed a more negative potential, the noise pulse has decayed and the diode tube is conductive again. This restores the audio frequency input to the audio frequency amplifier.

## 5. Review Questions

- (1) What is another name for a limiter?
- (2) Sketch from memory the circuit of a positive series diode limiter.
- (3) Explain the operation of the circuit you have just drawn.
- (4) Series diode limiters may be classified as either positive or negative.

Upon what does this classification depend?

- (5) During which portion of the input wave does a series positive limiter conduct?
- (6) What part of the input wave does a series positive limiter remove?
- (7) What determines the difference in value between the input and output voltages of a series diode limiter?

<sup>1</sup> As a basis of comparison here, a time of  $RC$  seconds is assumed, and is the time for a change to reach about  $2/3$  its full value.

## Chapter 2

### PARALLEL DIODE LIMITING

#### 6. Parallel Diode Limiting

Diode limiters also may be connected in parallel with the output. In this case the circuit is known as a parallel, or shunt, limiter circuit. Two different methods of connecting diode limiters in parallel are illustrated in Figs. 9 and 10.

You will note that the two circuits are not alike in that the diodes are connected in opposite directions with respect to the polarity of the output. As in the case of series diode limiters, this characteristic distinguishes one circuit as a positive diode limiter (Fig. 9), and the other as a negative diode limiter (Fig. 10).

#### 7. Parallel Diode As a Positive Limiter

A positive parallel diode limiter clips the positive portion of the input wave. A limiter of this type, together with its input and output waves, is shown in Fig. 11.

In analyzing the circuit, let us consider the positive and negative halves of  $E_i$  separately. When the positive half of the input wave is applied the diode conducts, and current flows through both the tube and  $R$ . This produces a negligible voltage drop ( $E_p$ ) across the tube and a voltage drop  $E_r$  across  $R$ . Since  $E_p$  is the output voltage ( $E_o$ ), the magnitude of the output voltage is very small.



When the negative half of the input wave is applied to the circuit, the diode does not conduct, current does not flow through the tube and  $R$ , and virtually the entire voltage is developed across the tube. Hence the output is the same as the input, minus a voltage drop (usually small) in  $R$  due to any current drawn by the load.

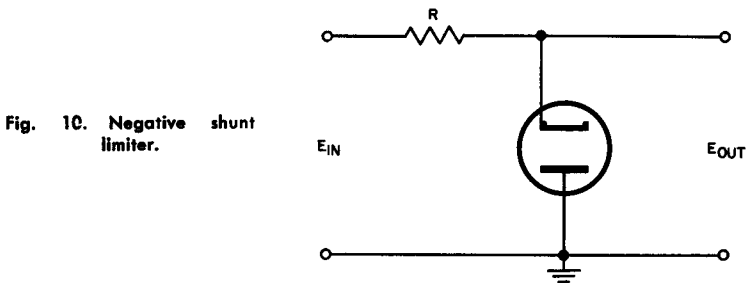
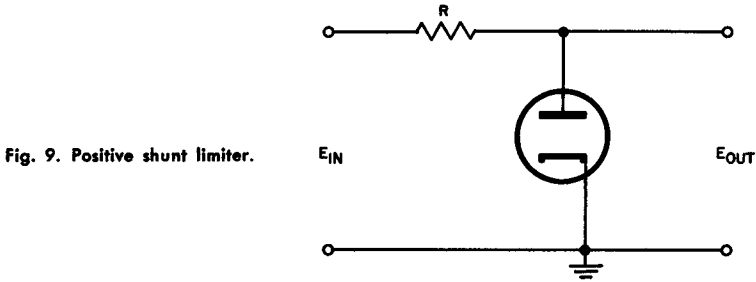

To summarize the operation of the positive parallel diode limiter:

a. On the positive half-cycle of the input wave the tube conducts, almost the entire voltage is developed across series resistor  $R$ , and very little voltage is developed across the tube. This causes the amplitude of the output to be very small.

b. On the negative half-cycle, the tube does not conduct, no voltage is developed across series resistor  $R$ , and almost the entire input voltage is developed across the tube. This causes the amplitude of the output to be substantially equal to the amplitude of the input.

We will now consider the procedure for developing the output wave of a positive parallel diode limiter. The circuit of Fig. 12 is that of a positive shunt limiter with an input sine wave as shown. To draw the output wave, showing the voltages between which the output varies, proceed as follows:

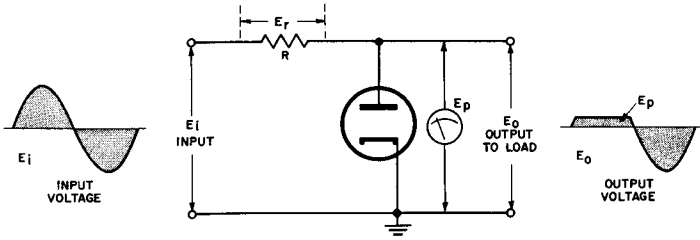

Fig. 11. Positive shunt limiter operation.

When the input wave is positive, the tube conducts. The maximum positive value of the output wave during the positive alternation of the input wave is then equal to

$$E_o = E_p \left( \frac{R_p}{R_p + R} \right) E_i$$

where the input wave is at the maximum positive value of the input wave during the positive alternation. Substituting the values in Fig. 12, we have

$$\begin{aligned} E_{out} &= \frac{500}{500 + 50,000} \times 15 \\ &= (0.01) (15) \\ E_{out} &= 0.15 \text{ volts} \end{aligned}$$

When the input wave is negative, the tube does not conduct and the output wave is equal to the input wave during the entire negative alternation of the input wave. This is enough information to draw the output curve as shown in (B) of Fig. 12.

### 8. Parallel Diode As a Negative Limiter

The negative shunt limiter is so connected that the circuit clips most of the negative portion of the input wave. A limiter of

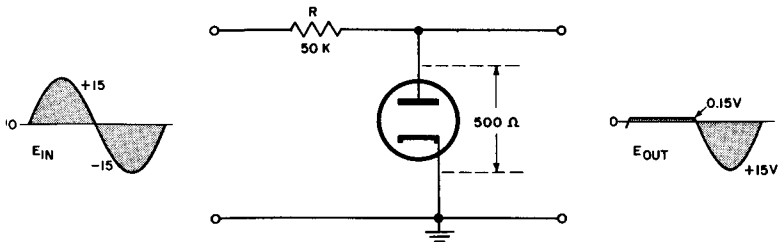

Fig. 12. Positive shunt limiter operation with typical values

this type, along with its input and output waves, is shown in Fig. 13. Again, in analyzing the circuit, let us consider the positive and negative halves of the input wave separately. When the positive alternation of the input wave is applied to the negative shunt limiter circuit, the diode does not conduct, current does not flow through the tube and resistor, and the entire voltage is dropped across the tube. Hence the amplitude of the output wave is equal to that of the input wave, except for a drop in  $R$  due to load current (normally small).

When the negative alternation of the input wave is applied to the negative shunt limiter circuit, the tube conducts, and current flows through both the tube and the resistor. The voltage drop ( $E_p$ ) across the tube is small, thus causing the output to be equally small.

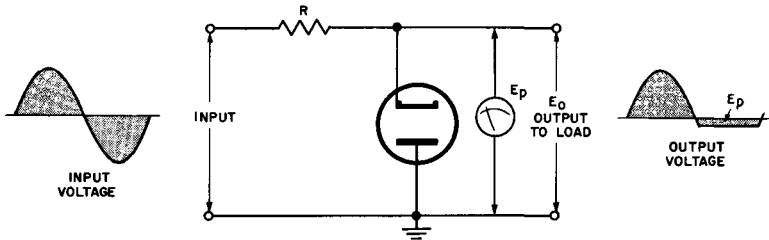

Fig. 13. Negative shunt limiter operation.

The output curve for the negative parallel diode limiter is ascertained in the same manner as for the positive parallel diode limiter, except that the output curve is drawn on the positive side of the base line.

Consider now the circuit of Fig. 14. This is a diode shunt limiter circuit used to remove extraneous noise from the a-f signal before the signal is applied to the audio frequency amplifier.

Resistances  $R1$  and  $R2$ , bypassed by capacitor  $C1$ , provide a detector diode load with a time constant of 10 microseconds. The cathode of the diode limiter tube is connected to a variable tap on  $R1$ , as shown. The time constant of the diode tube plate circuit is one second, so that the diode tube conducts and shunts part of the detector diode plate load on noise pulses and modulated peaks in the signal.

During the signal peaks, the audio frequency output of the detector is reduced by an amount that depends on the value of resistor  $R3$  plus the portion of resistance  $R1$  between point  $a$  and the cathode of the diode limiter tube, and the noise peak voltage. The depth of modulation above which distortion begins is determined by the relative values of  $R1$  and  $R2$ , and by the setting of the variable contact of  $R1$ .

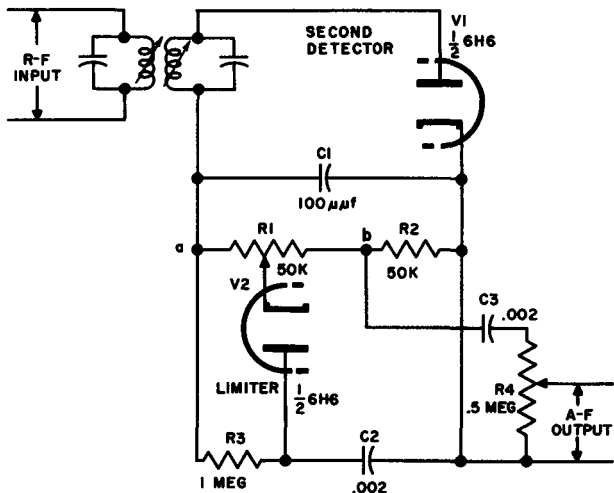

Fig. 14. Diode shunt limiter circuit.

The performance of this circuit is not very satisfactory, some improvement being noticeable on signals having pulse-type interference above 10 mc. The shunting effect of the diode limiter tube is appreciable only when the variable contact on  $R1$  approaches point (B).

In many cases it may be desirable to utilize crystal diodes in the limiting circuits instead of vacuum tube diodes. The use of crystal diodes may result in space and weight savings and reduce the cooling problem. However, silicon and similar types of crystal are unacceptable for limiter circuits because of their inadequate voltage and current handling capabilities. The more expensive germanium

crystal diodes will serve satisfactorily for some limiter circuit applications.

When selecting a crystal diode for limiter use, remember that the crystal must be capable of handling high impressed voltages and fairly large instantaneous current values. Remember too, that the crystal diodes have relatively low back resistance compared to thermionic diodes, and that the inverse current characteristics may have slope peculiarities that render them unfit for use in some limiter applications. Finally, if a cooling problem already exists, the temperature sensitivity of the crystal diode and its tendency to "drift" when operated at a high temperature should be considered.

One of the interesting forms of applications of the series diode limiter principle is the *threshold limiter*. It is probably most commonly used in *squelch* (also known as "quiet automatic volume control" [qavc]) systems. These systems are employed in communications receivers; their purpose is to cut off all output from the receiver when a signal of sufficient strength is not being received. This eliminates the annoying noise level usually present between transmissions of the received station.

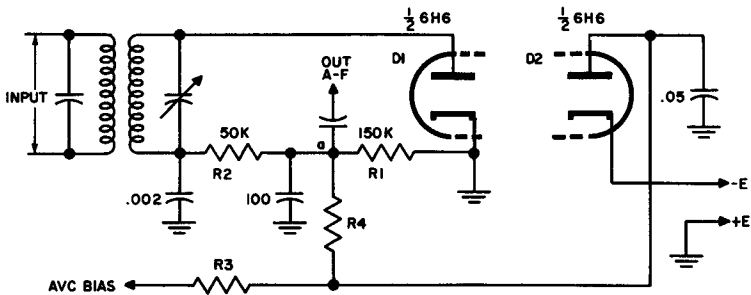

Fig. 15. Threshold limiter.

A typical squelch circuit is shown in Fig. 15. Diode  $D1$  is the second detector of the superheterodyne receiver,  $R1$  is the detector load resistor,  $R2$  the i-f filter resistor, and  $R3$  the avc filter resistor. Diode  $D2$  is added to provide squelch. A fixed bias voltage ( $-E$ ) is fed through  $D2$  and  $R4$  to point  $a$ , and thus through  $R2$  and the transformer secondary to the plate of  $D1$ . The  $D1$  plate being negative with respect to the  $D1$  cathode,  $D1$  is non-conducting in the

absence of a signal. It remains similarly non-conducting for any i-f signals not strong enough to cause the voltage drop across  $R1$  (at point  $a$  with respect to ground) to equal or exceed  $E$ . Since these signals arrive at a "cut-off" diode  $D1$ , no detection takes place, and there is no a-f signal.

Now consider stronger signals, sufficient to make the point  $a$  d-c potential greater than  $E$  with respect to ground. The voltage drop across  $R1$  due to rectification of the i-f signal by  $D1$  then exceeds voltage  $-E$  applied to the cathode of  $D2$ . This means the plate of  $D2$  becomes more negative than the cathode of  $D2$ , so  $D2$  becomes non-conducting. Being thus cut off,  $D2$  no longer transmits bias  $-E$  to  $D1$ . Accordingly,  $D1$  becomes fully conducting and demodulates the signal in the normal way.

To summarize results: the a-f output signal is zero for all signals below the level necessary to develop  $E$  volts across  $R1$  (known as the *threshold* level). The a-f output is normal for all signals above this level. The threshold level can be adjusted by adjustment of the value of  $E$ .

Note that the avc lead is connected to the plate of  $D2$ . This means that the avc voltage remains fixed at  $-E$  volts until a signal of over threshold strength is received. Then the avc voltage becomes the drop across  $R1$  due to received signal.

## 9. Review Questions

- (1) What is another name for a negative shunt limiter?
- (2) Parallel diode limiters are classified either positive or negative. What determines this classification?
- (3) In a negative shunt limiting circuit, during which portion of the input wave does the tube conduct?
- (4) Why does a negative shunt limiter not clip the complete negative alternation of the input wave?
- (5) Sketch from memory the circuit of a negative shunt limiter.
- (6) Explain the operation of the circuit you have just sketched.
- (7) Determine the output curve of the negative shunt limiter you have sketched.
- (8) Why do silicon-type crystal diodes make poor limiters?
- (9) List three considerations in the use of crystal diodes in place of thermionic diodes.

## Chapter 3

### LIMITING TO SPECIFIED MAGNITUDES

#### 10. Limiting Above Ground Potential

In the limiting circuits treated thus far, we have seen that in each case the input waveform was clipped at, or nearly at, a value of zero. In other words, the clipped portion of the input wave was, in each instance, very near ground potential. It is not necessary to restrict clipping to these values. Actually, the clipped portion of the input wave may be predetermined and regulated by the addition of a battery to either of the circuits shown in Figs. 11 and 13. The resulting circuits would appear as shown in Fig. 16. In each of the circuits in this figure, the output is taken across both the tube and the battery.

The circuit of Fig. 16 (A) is a positive limiter that limits the positive alternation of the input wave to a magnitude equal to the voltage across the battery ( $E$ ). The circuit of Fig. 16 (B) likewise limits the negative alternation of the input wave to a magnitude equal to the voltage across the battery.

Since the circuit of Fig. 16 (A) depicts a positive limiter, it is similar to the circuit of Fig. 10, except for the addition of the battery in the cathode circuit. It then follows that the output waveform for the circuit in Fig. 16 (A) will be similar to the output waveform for Fig. 12, except that the circuit of Fig. 16 (A) passes more of the positive alternation of the input wave.

Note that the output is taken across both the tube and the battery; therefore, this is the circuit of a parallel diode limiter. The diode and the battery are in series with the resistor ( $R$ ). Therefore,

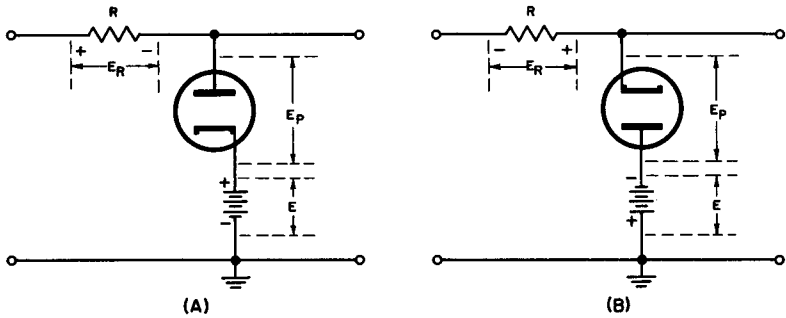

Fig. 16. Clipping above or below ground potential.

any input current that flows through the tube also flows through  $R$ , developing an  $IR$  drop, which reduces the magnitude of the output voltage.

Let us now consider each alternation of the input wave and determine how the output wave is produced. When the positive alternation of the input wave is applied to the circuit, the voltage between the plate of the tube and ground is equal to the input voltage until the tube conducts. Conduction begins when the value of the input voltage exceeds the value of the voltage across the battery. At that instant, a voltage,  $E_r$ , is developed across the resistor, and a voltage,  $E_p$ , is developed across the tube. Since the resistor's value is so much greater than the plate-to-cathode resistance of the tube (in comparison with the voltage across the resistor) is so small that it may be neglected.

During the time the tube conducts, the output voltage is equal to battery voltage  $E$  plus voltage drop  $E_p$  across the tube.  $E_p$  however, as has been Established, is negligible; hence, during the conduction of the tube, the output voltage is considered to be equal to the battery voltage.

As the input voltage decreases and becomes just less than the battery voltage, the tube ceases to conduct, the resistor voltage becomes equal to zero, and the output voltage again becomes equal to the input voltage.

When the negative alternation of the input wave is applied to the circuit, the tube does not conduct at any time, current does not flow through the resistor and the tube, and the output voltage is equal to the input voltage at all times during the alternation.



To summarize, in a positive shunt clipper in which a battery voltage is connected in series with the tube, the following events take place:

- a. When the tube conducts, the output voltage is equal to the battery voltage.
- b. When the tube does not conduct, the output voltage follows the input voltage.

The problem of drawing the output wave of a positive shunt limiter and determining the voltages between which the output wave varies is quite simple. In Fig. 17, observe that during the positive alternation the output wave is like the input wave, except when the tube conducts. When the tube conducts, the output wave is equal to the battery voltage, in this case 12 volts. This establishes the top of the positive alternation of the output wave. During the negative alternation of the input wave, the tube does not conduct and the output voltage is equal to the input voltage at all times during the alternation of the input wave. This gives us sufficient information to draw the output curve as shown in (B) of Fig. 17.

### 11. Limiting Below Ground Potential

Circuit (B) of Fig. 16 shows a parallel diode that clips the input wave at some value below (more negative than) ground potential. The circuit is similar to the limiter shown in (A) of Fig. 16, except that the connections to the tube and the polarity of the battery have been reversed. The output waveform has its negative portion clipped at a value greater than zero. In this circuit, as in circuit (A), the output is taken across both the tube and

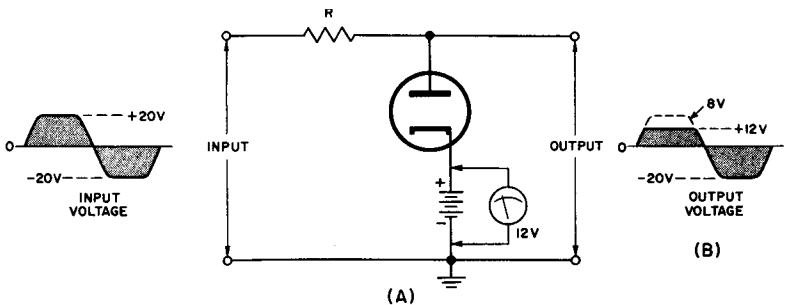

Fig. 17. Positive shunt limiter clipping above ground potential.

the battery. The resistance,  $R$ , the tube, and the battery are in series with the input voltage. For this reason, any input current flowing through the tube flows also through the resistor. This develops an  $IR$  drop, which lessens the magnitude of the voltage output.

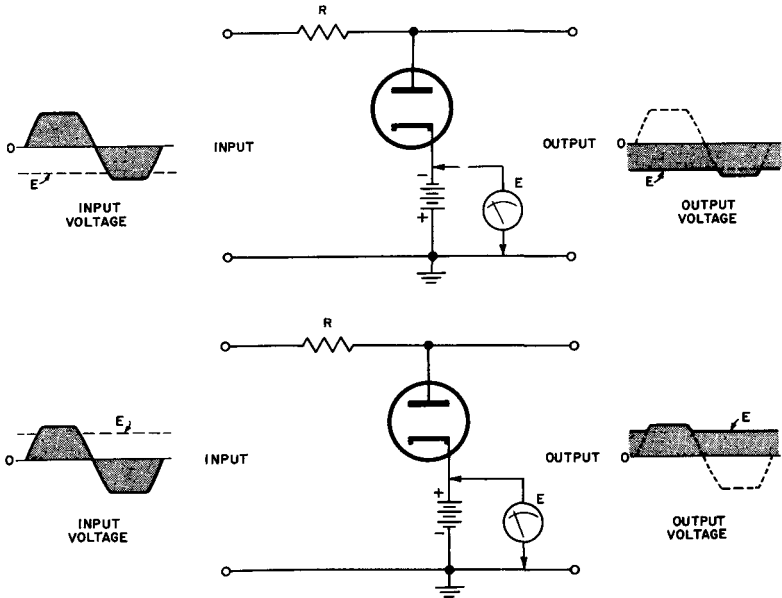

Fig. 18. Parallel diode limiters which pass peaks only.

During the positive alternations of the input voltage, the tube does not conduct. Thus input current does not flow through the resistor and tube, and the voltage drop across the resistor is equal to zero. Hence the output voltage is equal to the input voltage at all times during the positive alternation of the input wave.

During the negative alternation of the input voltage, the voltage between the cathode of the tube and ground is equal to the input voltage until the tube conducts. Conduction occurs when the input voltage becomes more negative than the battery voltage. When current begins to flow, a voltage ( $E_r$ ) develops across the resistor and another voltage ( $E_p$ ) develops across the tube. In this case, as in (A), the value of resistance  $R$  is so much greater than the value of the plate-to-cathode resistance that the voltage

drop in the tube is negligible in comparison with the voltage drop across the resistor. Therefore, while the tube is conducting, the output voltage is equal to the battery voltage.

As the input voltage again becomes less negative than the battery voltage, the tube ceases to conduct, the voltage drop across the resistor becomes equal to zero, and the output voltage follows the input voltage.

We find from the above that, in a negative shunt clipper with a battery voltage in series with the tube, (a) when the tube conducts, the output voltage is equal to the battery voltage, and (b) when the tube does not conduct, the output voltage follows the input voltage.

The output waveform for limiters that clip on the negative half-cycle is developed in the same manner as for limiters that clip on the positive alternation, except that the clipped portion of the waveform is drawn on the opposite side of the base line.

## 12. Parallel Diodes That Pass Peaks Only

Often in utilizing limiter circuits, it is desirable to pass only the positive or negative peaks of the input waveform to the circuits that follow. When the batteries in the circuits of Fig. 16 are reversed, the circuits of Fig. 18 result. The circuit of Fig. 18 (A) passes only the negative peaks of the input voltage, and the circuit of Fig. 14 (B) passes only the positive peaks of the input voltage. We will discuss each of these circuits separately.

The diode tube in Fig. 18 (A) conducts at all times, except when the input voltage has a negative value in excess of the value of the battery voltage. During the conduction time, the output voltage is equal to the battery voltage; during the time the diode tube is not conducting, the output voltage is equal to the input voltage. As you have observed, the output curve of Fig. 18 (A) shows that only the negative peaks of the input signal have been passed.

The diode tube in Fig. 18 (B) also conducts continuously, except when the input voltage has a positive value equal to, or greater than, the value of the battery voltage. During the time the tube is conducting, the output voltage is equal to the battery voltage; during the time the tube is not conducting, the output voltage is equal to the input voltage. The output curve for the circuit of

Fig. 18(B) indicates that only the positive peaks are being passed by this limiter circuit.

Fig. 19 shows the circuit of a parallel diode limiter arranged to pass negative peaks only. From this circuit, we will determine the shape of the output wave and the voltages between which the output varies.

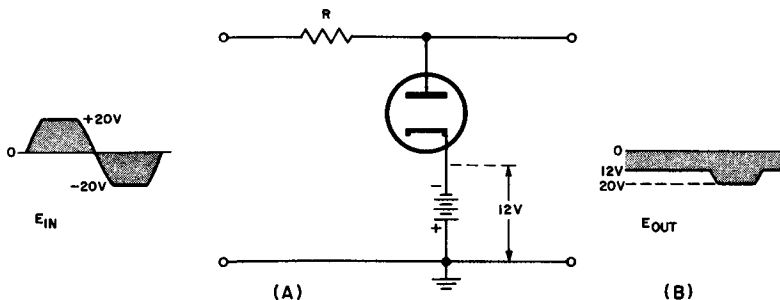

Fig. 19. Parallel diode limiter arranged to pass only negative peaks.

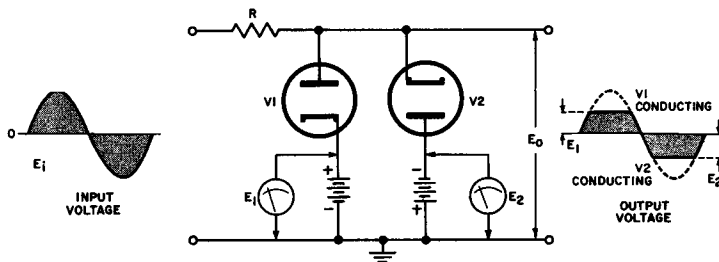

Fig. 20. Double diode limiter circuit.

The diode tube conducts at all times, except when the input voltage has a negative value greater than the magnitude of the battery voltage, which is  $-12$  volts. Since only the portions of the negative input wave in excess of  $-12$  volts are passed we may establish a base line at 12 volts as shown in Fig. 19(B). Since we know that the input wave varies from  $-20$  to  $+20$  volts, we may now establish the most negative limit of the output curve at  $-20$  volts. The output curve may now be drawn from this information as shown in Fig. 19(B).

### 13. Double Diode Limiting

It is quite often necessary to clip both the positive and the negative alternations of the input waveform at preselected levels. To accomplish this, two diode tubes may be connected in parallel as shown in Fig. 20. Note that the circuit of Fig. 20 resembles the two circuits of Fig. 16, which we have already analyzed, and the same principles of operation apply.

While the positive alternation of the input wave is being applied to the circuit,  $V2$  does not conduct at any time.  $V1$ , however, conducts only while the positive input voltage is greater than the battery voltage applied to  $V1$ . While  $V1$  is conducting, an  $IR$  drop is developed across resistor  $R$ , decreasing the voltage between the plate of  $V1$  and ground. This maximum voltage between the plate of  $V1$  and ground is limited to the magnitude of the battery voltage  $E_1$  applied to  $V1$ .

In other words, during the positive alternations of the input wave,  $V1$  and its battery, together with the resistor, function as a positive shunt limiter that limits the input wave to a magnitude equal to the value of the battery voltage above ground potential.

During the negative alternation of the input voltage,  $V1$  does not conduct at any time.  $V2$  conducts only while the input voltage is more negative than the battery voltage applied to  $V2$ . While tube  $V2$  is conducting, there is an  $IR$  drop across resistor  $R$ , which decreases the voltage between the cathode of  $V2$  and ground. This maximum voltage between the cathode of  $V2$  and ground is limited to the magnitude of the battery voltage applied to  $V2$ .

To summarize, during the negative alternation of the input voltage,  $V2$  and its battery, together with the resistor, function as a shunt limiter that limits the value of the input waveform to a maximum magnitude equal to the battery voltage below ground potential.

We will now consider the problem of drawing the output curve for a double-diode limiter circuit. In Fig. 21  $V1$  conducts while the input voltage is greater than 9 volts. During this time, the output voltage is equal to the battery voltage; therefore, we may draw a line 9 volts up on the positive side of the base line. This establishes the positive limit of the output voltage. Since the output voltage follows the input voltage when the input voltage is

## LIMITERS AND CLIPPERS

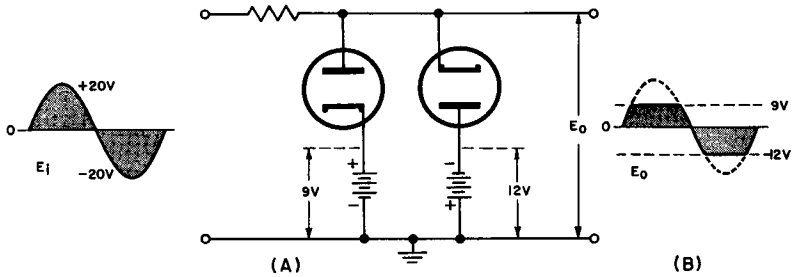

Fig. 21. Double diode shunt limiter.

less than 9 volts, we may draw the rest of the positive alternation of the output wave as shown in Fig. 21 (B).

During the negative alternation of the input waveform,  $V_2$  conducts while the input voltage is more negative than  $-12$  volts. Since the output voltage is equal to the battery voltage at these times, we may draw a line 12 volts down on the negative side of the base line to establish the most negative point in the output wave. Since the output voltage follows the input voltage when the input voltage is less than 12 volts, we now have enough information to complete the output curve as shown in Fig. 21 (B).

Parallel diodes may be used as video limiter circuits when connected as shown in Fig. 22. The circuit is explained as follows: each tube is non-conductive as long as the instantaneous value of the input voltage is less than the battery voltages applied to the diode tubes. For larger input voltages, one diode or the other shunts the voltage, depending on whether the positive or negative portion of the input wave is being applied. In order to establish effective limiting with this circuit, both the source and the load

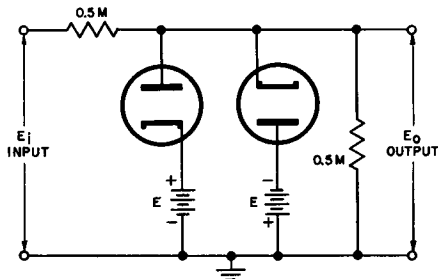

Fig. 22. Typical video clipper circuit.

must have a much larger resistance than the diodes. A small adjustable biasing voltage applied to the diodes in this circuit helps to establish symmetrical clipping.

#### 14. Review Questions

- (1) Draw from memory the circuit of a limiter arranged to clip on the positive input alternation.
- (2) Explain the operation of the circuit you have just drawn.
- (3) Why is it sometimes necessary to clip on the positive input half-cycle?
- (4) Draw from memory the circuit of a parallel diode limiter arranged to pass peaks only.
- (5) Explain the operation of the parallel diode limiter drawn above.
- (6) Explain how the output curve for a parallel diode limiter may be determined.
- (7) Draw from memory the circuit of a double-diode limiter.
- (8) Explain the operation of the double-diode limiter circuit just drawn.
- (9) Explain how the output curve for a double-diode limiter circuit is determined.

## Chapter 4

### TRIODE LIMITERS

#### 15. Triode Limiting

Instead of diodes triodes, tetrodes, or pentodes may be used for clipping and limiting. The principles governing triode clippers also apply to tetrodes and pentodes, hence the following discussion covers only triode circuits.

When triodes are used as clippers or limiters, they produce waveforms that closely resemble the output waveforms of diode clippers. Triode circuits, however, do more than limit the input signal—they amplify the input signal after it has been limited.

Under normal conditions, the grid-to-cathode voltage of an operating tube is negative. However, when the grid is positive with respect to the cathode, it attracts electrons just like another plate. Of course, this current flow is very small in comparison with the current flow between cathode and plate.

Every circuit has resistance, and the space between the cathode and grid of a triode tube is no exception to this rule. This resistance is comparable to the resistance that exists between the plate and cathode. Just as the resistance between the plate and cathode is called plate resistance ( $R_p$ ), the resistance between grid and the cathode is called grid-to-cathode resistance ( $R_{gk}$ ). The magnitude of the grid-to-cathode resistance depends upon the grid-to-cathode voltage and the space charge. In normal circuits the magnitude of this resistance varies from a near infinite value to a value of the



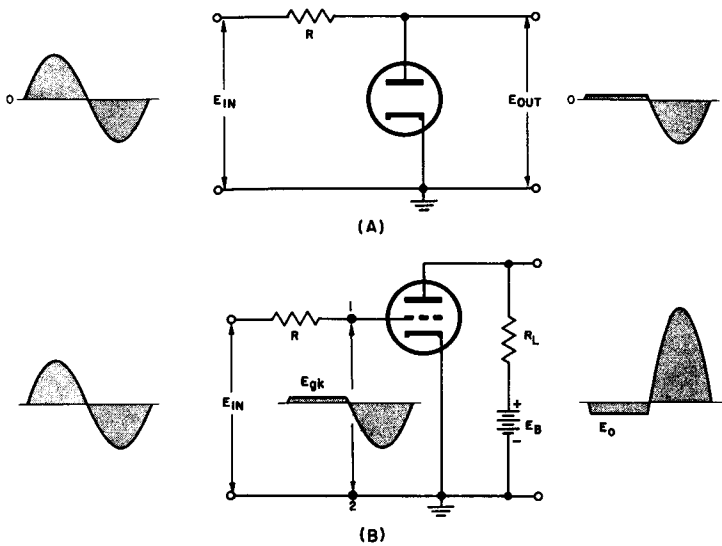

Fig. 23. Limiting in the grid circuit.

order of 1000 ohms when the grid is positive with respect to the cathode.

The values for  $R_{gk}$  are similar to the values of  $R_p$  in the diode, as explained in the sections on diode limiting. Thus the grid circuit of the triode in the circuit of Fig. 23 (B) may be considered similar to the diode circuit of Fig. 23 (A). Since the circuit of Fig. 23 (A) (with  $R$  a resistance of very large value) is a positive diode limiter that yields the output wave shown when a sine wave is applied to the circuit, it is evident that the voltage between points 1 and 2 of Fig. 23 (B) is the same as the voltage of the output. The voltage appearing across the load resistor ( $R_L$ ) is the same as the voltage on the grid, except that it is amplified and *inverted*. *Positive*-going grid voltage increases plate current and voltage drop in  $R_L$ , producing a *negative*-going plate output voltage. Thus, input positive alternations become plate output negative alternations, and vice versa.

### 16. Unbiased Grid Limiting

One of the simplest types of triode limiters is shown in Fig 24. In this circuit, a triode is in series with a load resistor,  $R_L$ , and the

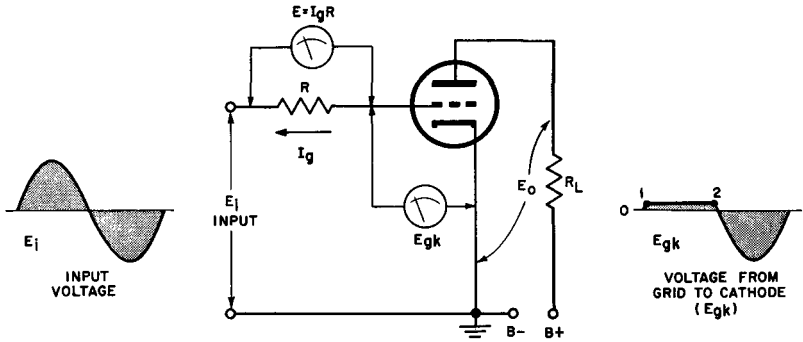

Fig. 24. Unbiased grid limiter.

$B+$  voltage is placed across the combination. In the grid circuit, there is a resistor,  $R$ , which is selected so that it is very large in comparison with the magnitude of the grid-to-cathode resistance of the triode tube, during the time the grid-to-cathode voltage is positive. When no signal is applied to the grid of the tube, the tube is at zero bias.

When an input signal is applied to the grid of the tube, we have essentially the same set of conditions that prevails in the grid circuit of Fig. 23 (B). During the positive alternation of the input wave, current flows from the cathode to the grid inside the triode, and through resistor  $R$ . Since the current flows through a resistance composed of the grid-to-cathode resistance of the tube and resistor  $R$  in series, the following equation is used to determine the grid current of the tube:

$$I_g = \frac{E_{in}}{R + R_{gk}}$$

In flowing through resistor  $R$ , this current develops a voltage drop of opposite polarity to that of the input voltage. Hence, the voltage on the grid of the triode tube ( $E_{gk}$ ) is equal to the input voltage minus the voltage drop ( $I_g R$ ) across the resistor. The mathematical equation for this is:

$$E_{gk} = E_{in} - I_g R$$

Because resistance  $R$  and grid-to-cathode resistance  $R_{gk}$  act as a voltage divider, the grid voltage is:

$$E_{gk} = E_{in} \left( \frac{R_{gk}}{R + R_{gk}} \right)$$

The larger resistance  $R$  is in comparison to the grid-to-cathode resistance of the triode tube, the smaller the grid voltage becomes. The result is the limiting of the positive alternation of the input wave that appears on the grid of the tube. Note how this limiting action is illustrated in the wave between points (1) and (2) of Fig. 24.

During the negative alternation of the input wave, no current flows from the cathode to the grid of the triode tube, hence no voltage drop is developed across resistance  $R$ , and the grid voltage remains equal to the input voltage.

Figure 25 illustrates development of the grid voltage waveform in this circuit. When the input voltage is positive, the tube conducts, a voltage drop is placed across resistor  $R$ , and the grid voltage remains less than the input voltage throughout this alternation of the input wave. If it is assumed that the grid-to-cathode resistance is on the order of 1000 ohms during the positive alternation, the grid voltage may be found according to the following equation:

$$E_{gk} = E_{in} \left( \frac{R_{gk}}{R + R_{gk}} \right)$$

Substituting from the figure, we have

$$E_{in} \frac{(1000)}{100,000 + 1000} = \frac{E_{in}}{101}$$

$$E_{gk} = 0.0099 E_{in}$$

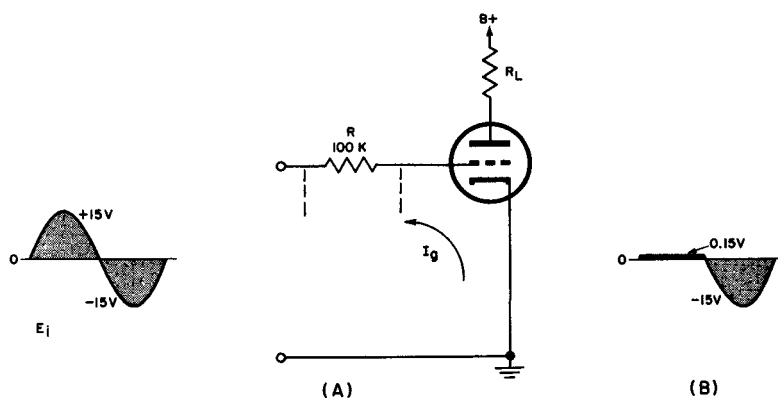

Fig. 25. Grid limiting circuit.

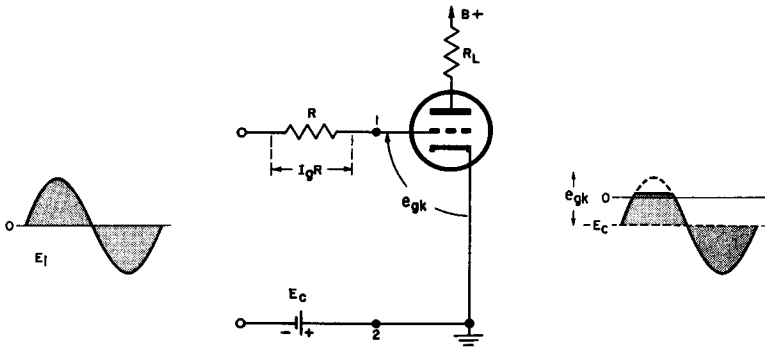

Fig. 26. Biased grid limiter.

When the input voltage ( $E_{in}$ ) is at its most positive value of 15 volts,

$$E_{gk} = (0.0099) (15)$$

$$E_{gk} = 0.15 \text{ volt}$$

We now know the positive limit of the output wave, and may draw a line 0.15 volt on the positive side of the reference line. Note from the equation above that the grid voltage during positive input half-cycles is nearly zero in circuits in which resistance  $R$  is kept to a large value.

Since, on the negative alternation of the input wave, the tube does not conduct, the grid voltage waveform follows the input waveform. This gives us the information necessary to draw the grid voltage curve as shown in (B) of Fig. 25.

### 17. Biased Grid Limiting

If a battery voltage is applied to the control grid of the triode tube in the circuit of Fig. 24, the circuit of Fig. 26 results. This is a typical biased grid limiter circuit.

When no signal is applied, the voltage on the grid of the triode tube is equal to the voltage of the biasing battery ( $E_c$ ) and no grid current flows (even though current is flowing in the plate circuit).

During the positive alternations of the input wave, the grid draws current only when the value of the input voltage exceeds

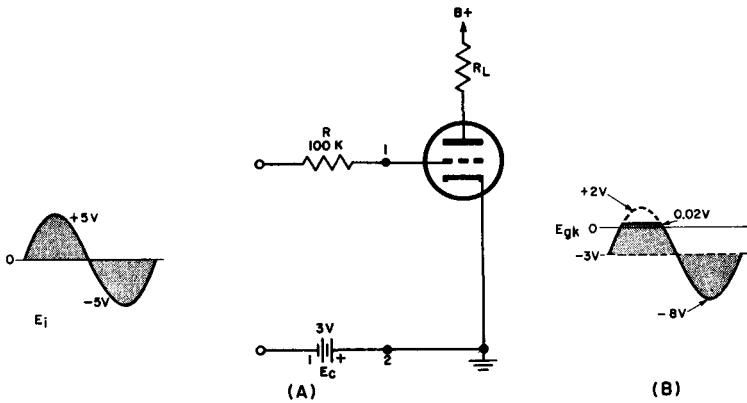

Fig. 27. Biased grid limiting circuit.

the value of biasing voltage  $E_c$ . Positive limiting takes place at this time, and the signal on the grid becomes slightly greater than zero. When the input voltage is less than the biasing voltage, the signal on the grid follows the input signal and is equal to the input voltage minus the biasing voltage.

During the negative alternation of the input voltage, no grid current flows, and the signal on the grid follows the input signal and is equal to the input voltage plus the biasing voltage. The wave shape between points (1) and (2) (grid-to-cathode or  $E_{gk}$ ) is as shown in Fig. 26.

We may draw the waveform of the grid voltage of a biased grid limiting circuit in the following manner:

The circuit of Fig. 27 is a biased grid-limiting circuit having a sine-wave input as shown ( $E_{in}$ ). Assume that the grid-to-cathode resistance is about 1000 ohms when the grid draws current. We must now draw the waveform of the voltage that appears on the grid, and indicate the voltages between which the output wave varies.

When the input alternation is positive, the grid voltage follows it and increases by the same amount until the input voltage is equal to the biasing voltage; the value of the grid voltage during this time is given by the equation:

$$E_{gk} = E_{in} - E_c$$

At the time the input voltage and the biasing voltage are equal, the grid voltage is, of course, zero. When the input voltage be-

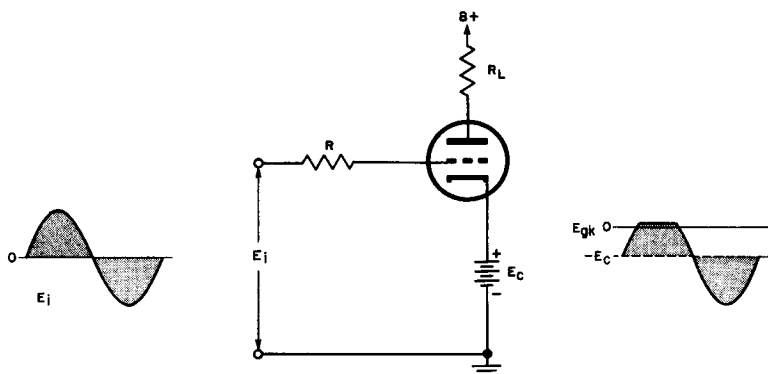

Fig. 28. Biased grid limiter with battery in cathode circuit.

comes greater than the biasing voltage, the value of the grid voltage is:

$$E_{gk} = (E_i - E_c) \frac{R_{gk}}{R + R_{gk}}$$

At the maximum positive value of the input wave, then, the value of the grid voltage is:

$$\begin{aligned} E_{gk} &= \frac{(5 - 3) 1000}{100,000 + 1000} \\ &= \frac{2000}{101,000} \\ E_{gk} &= 0.02 \text{ volt} \end{aligned}$$

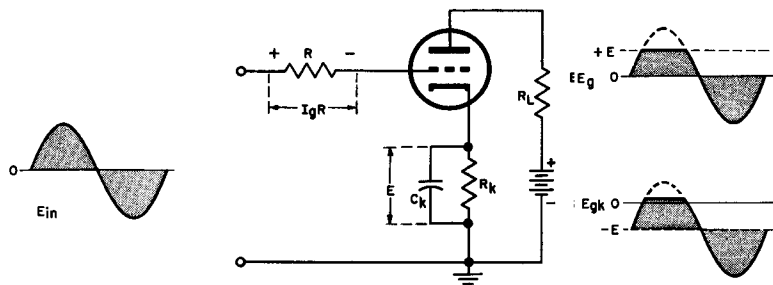

Fig. 29. Grid limiter with cathode bias.

We know now the most positive limit of the output wave and may draw a line 0.02 volt on the positive side of the reference line.

As the input voltage again becomes less than the 3-volt biasing voltage, no grid current flows and the grid voltage follows the input voltage. The value of the grid voltage is now:

$$E_{gk} = E_{in} - E_c$$

When the input voltage is negative, the tube does not conduct, no voltage is developed across the grid resistor, and the grid voltage is numerically equal to the input voltage plus the biasing voltage, or  $-8$  volts. Eight volts is therefore the most negative point in the output wave. The output wave may now be drawn as shown in Fig. 27 (B).

Grid limiting by biased triodes is not restricted to circuits of the type shown in Fig. 26, where the battery or biasing voltage is applied to the grid current. The grid limiting function may also be accomplished by placing the battery in the cathode circuit as indicated in Fig. 28. This circuit is similar in its operation to the biased grid circuit, and, with identical input waves, has an identical grid-to-cathode wave. The only difference in the two circuits is in the manner of applying the biasing voltage.

A still more common method of obtaining the bias for a biased grid limiter is shown in Fig. 29. This circuit is especially desirable because it does not use a battery to bias the grid of the triode tube. Bias is developed by keeping the grid at zero potential when no input signal is applied and keeping the cathode at a positive potential by the flow of the tube's plate current through the cathode resistor ( $R_k$ ). This circuit again is similar to the grid limiting circuit in Fig. 26, except for the manner of biasing the tube. When this circuit has an identical input wave, it is similar in operation and has the same grid-to-cathode wave as the circuit in Fig. 26.<sup>1</sup>

<sup>1</sup> It should be noted that this statement assumes that cathode bypass capacitor  $C_k$  is large enough to have a low reactance compared with resistance  $R_k$ . If this condition is not met, plate current signal fluctuations produce a signal voltage (drop) across  $R_k$ . This voltage is applied between cathode and grid so as to oppose the input voltage, in what is known as *degenerative feedback*. If  $C_k$  is too small, low-frequency components of the input wave are discriminated against and the amplification is reduced.

### 18. Triode Limiting Amplification

Since the main advantage of the triode tube limiting circuit over the diode tube limiting circuit is the amplification factor, let us analyze the output of a cathode-biased grid limiter circuit to see how the limiting and amplification are accomplished. For this purpose, let us examine the circuit of Fig. 30.

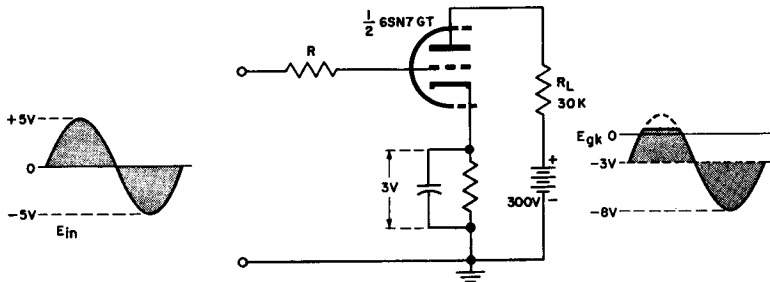

Fig. 30. Cathode-biased grid limiter with values assigned.

The tube used in this circuit is part of a 6SN7-GT, a twin triode-type. Since we use only half the tube, or one triode, we refer to it in the schematic as  $\frac{1}{2}$  6SN7-GT.

On the  $I_p$ - $E_p$  curves of a 6SN7-GT, let us draw a load line for the circuit of Fig. 30. This load line is drawn by joining 300 volts to 10 ma and is shown in Fig. 31. The 300 volts is the applied B+ voltage. The 10 ma is obtained by dividing 300 volts by the plate load of 30,000 ohms. Curve *a* in the figure is the grid-to-cathode wave shape for the circuit and is the same as the wave obtained in Fig. 27 (B).

We will now observe what happens to the plate current and voltages as this grid-to-cathode wave is applied to the circuit.

a. When the grid voltage is at zero potential, the value of the plate current ( $I_p$ ) is about 7.5 milliamperes, and the value of the plate voltage ( $E_p$ ) is about 70 volts.

b. When the grid voltage is -8 volts, the plate current is about 3.3 milliamperes, and the value of the plate voltage is about 200 volts.



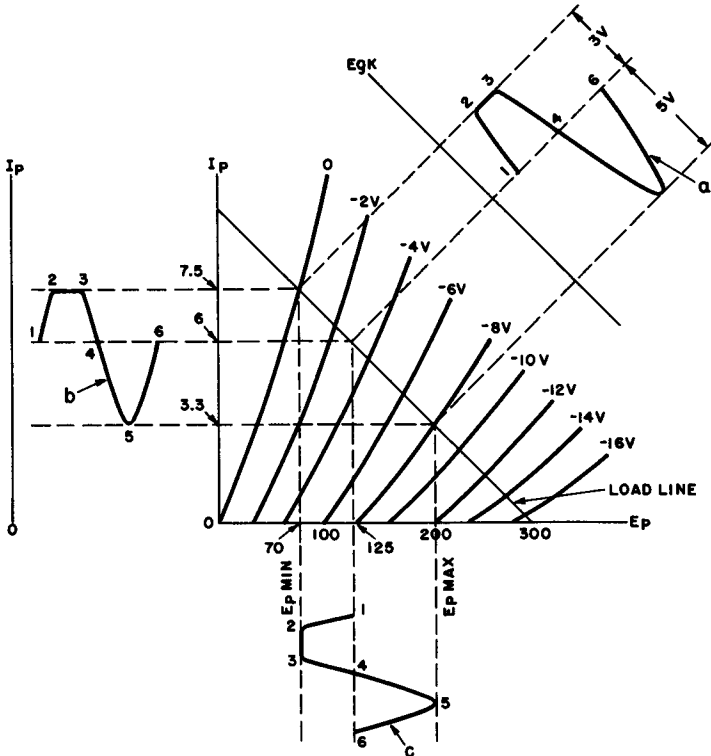

Fig. 31.  $I_p$ - $E_p$  characteristics for the circuit of Fig. 30.

c. When the grid voltage is  $-3$  volts, the plate current is about 6 milliamperes, and the plate voltage is about 125 volts.

Let us now see how curves *b* and *c* are determined: At point (1) the grid voltage is  $-3$  volts, the plate current is 6 ma, and the plate voltage is 125 volts. At point (2) the grid voltage is at zero, the plate current is 7.5 ma, and the plate voltage is 70 volts. Between point (2) and point (3), these conditions remain much the same. From point (3) to point (4), the grid voltage goes in a negative direction.

At point (4), the grid voltage is again  $-3$  volts, the plate current is 6 milliamperes, and the plate voltage is 125 volts. At point (5), the grid voltage reaches its maximum negative value of  $-8$  volts, and the plate current is 3.3 milliamperes, while the plate voltage is equal to about 200 volts. At point (6), the grid voltage has returned to  $-6$  volts, with the plate current at 6 milliamperes, and the plate voltage at 125 volts.

You will observe that curve  $b$  follows curve  $a$ , but curve  $c$  is 180 degrees out of phase with curve  $a$ , and is the resulting amplified output curve for the 1/2-6SN7-GT limiting circuit.

### 19. Review Questions

- (1) What is the important operating difference between a triode tube limiter circuit and a diode tube limiter circuit?
- (2) Upon what does the magnitude of the grid-to-cathode resistance of a triode tube depend?
- (3) Sketch from memory the circuit of an unbiased grid limiter.
- (4) Explain the operation of the unbiased grid limiter circuit you have just drawn.
- (5) During which portion of the input wave does current flow in the grid circuit of an unbiased grid limiter?
- (6) Draw from memory the circuit of a cathode-biased grid limiter.
- (7) Explain the operation of the cathode-biased grid limiter circuit you have drawn above.
- (8) Name three methods of obtaining the biasing voltage for a grid limiter.
- (9) During which portion of the input wave does current flow in the grid circuit of the biased grid limiter?
- (10) Explain the use of  $E_p-I_p$  curves in analyzing the output of a biased grid limiter circuit.

## Chapter 5

### SATURATION AND CUTOFF LIMITERS

#### 20. Saturation Limiting

When grid-limiting resistor  $R$  of the circuit in Fig. 19 is removed, the resulting circuit, together with its input and output waves, is as shown in Fig. 32. With any a-c voltage applied to the circuit, the grid is driven positive. Because there is no resistance in series with the grid and input, grid current flows. If the internal resistance of the input signal source is low, there is no clipping action. A high source resistance would take the place of  $R$  in the grid limiter.

Even neglecting source impedance, however, limiting does occur in the plate circuit. This is shown in the output curve of Fig. 32. As the grid becomes more and more positive, plate current increases until saturation occurs. Any further positive increase in grid voltage after saturation occurs results in no appreciable increase in plate current.

Since the plate voltage also remains relatively constant, *saturation limiting* results. Note that the plate current at saturation is determined by the B+ plate supply voltage and the load resistor ( $R_L$ ). No matter how small the magnitude of the plate resistance becomes, the plate current can never be as great as the B+ supply divided by the load resistor, or:

$$I_p = \frac{B+}{R_L}$$

In order to show the saturation limiting effects graphically, we must use the load line for the circuit of Fig. 32 on the  $I_p$ - $E_p$

curve for a 6SN7-GT tube as shown in Fig. 33. This figure also contains the waveforms of the plate current, plate voltage, and grid voltage.

Let us assume that saturation is reached when the grid is 2 volts positive with respect to the cathode and develops the wave shapes for  $I_p$  and  $E_p$  as the grid voltage ( $E_{gk}$ ) varies. Remember that the grid voltage follows the input voltage. (We will assume the signal source has perfect regulation.)

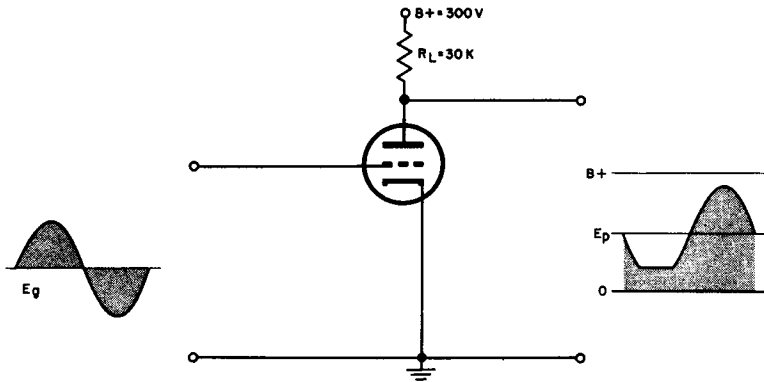

Fig. 32. Circuit for saturation limiting.

At point (1) the grid voltage is zero, the plate current is 7.5 milliamperes, and the plate voltage is 75 volts. At point (2) the grid voltage is +2 volts, the plate current is at the saturation point with a current of about 8.7 milliamperes, and the plate voltage is 35 volts.

From point (2) to point (3) the grid voltage rises to its peak (about 6 volts) and then falls back to 2 volts. During this time there is no increase in plate current or decrease in plate voltage, because the plate is at saturation.

From point (3) to point (4) the grid voltage returns from +2 volts to zero potential, causing the plate current to return to 7.5 milliamperes, and the plate voltage to increase to 75 volts. At point (5) the grid voltage becomes -6 volts, plate current drops to 4.8 milliamperes, and plate voltage increases to 160 volts. From point (5) to point (6) the grid voltage returns to zero potential, causing the plate current and the plate voltage to return to their original values.

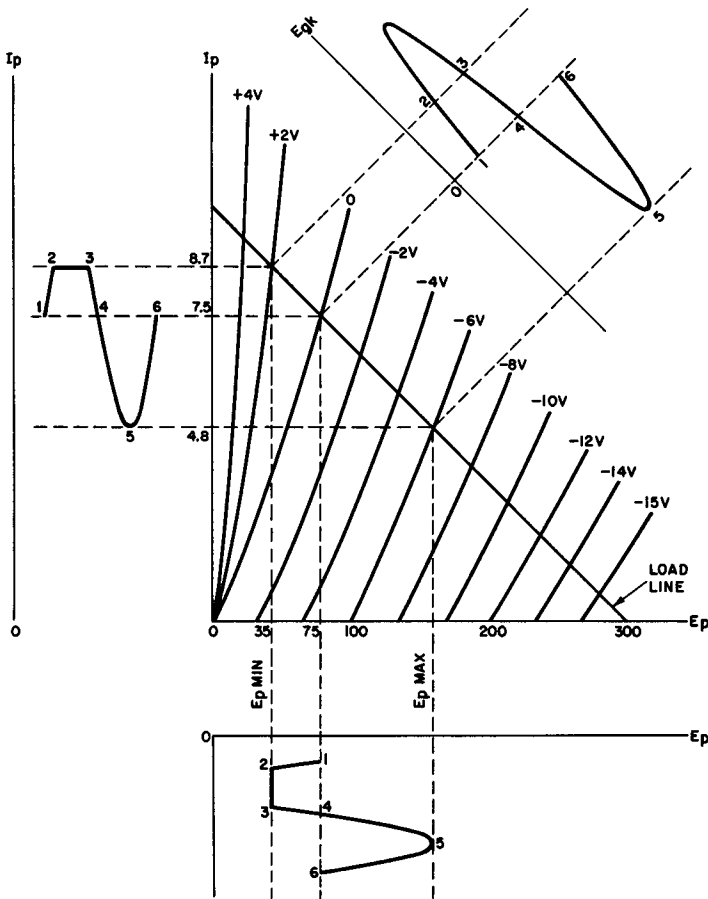

Fig. 33.  $I_p$ - $E_p$  curves for the circuit of Fig. 32.

In summary, when a sinusoidal grid wave of sufficient amplitude to drive the triode tube to saturation is applied to the circuit, a flat-topped plate current wave and a flat-bottomed plate voltage wave result. This action is referred to as saturation limiting.

When we compare saturation limiters with grid limiters, we find that they are similar in that the negative going portion of the plate voltage wave is limited in each case. With identical input voltages, saturation limiters produce a wave shape of greater negative going magnitude on the plate of the tube than do the grid limiters. This is because more of the positive alternation of the

grid signal is utilized. The saturation limiter has the disadvantage, however, that it requires considerably more power to drive the grid than does the grid limiter.

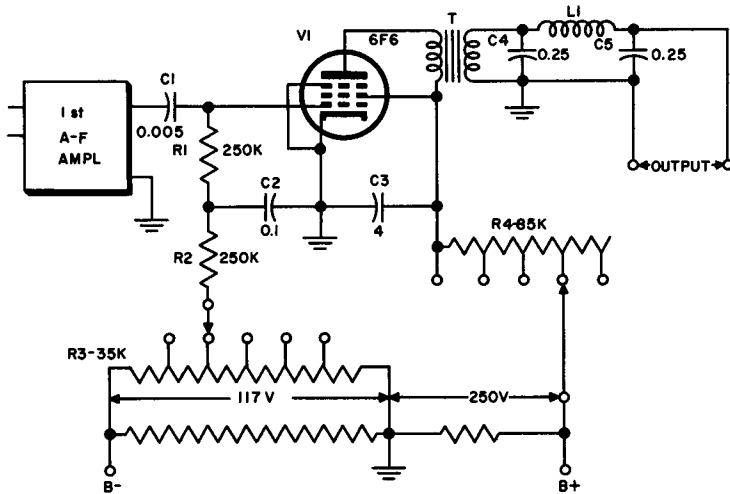

Fig. 34. Typical saturation-type a-f output limiter.

Let us now consider the application of saturation limiting to a communications problem. Fig. 34 shows the circuit of a typical saturation-type audio frequency output limiter. Control of the various screen, plate, and control grid voltages of the pentode in the circuit will provide audio frequency output limiting. To further clarify, referring to the circuit in the figure, we observe that a low pass filter composed of  $L_1$ ,  $C_4$ , and  $C_5$  filters out any distortion produced by the output stage of the limiter. Its cutoff frequency is 1200 cps, hence for signal on the order of 1000 cps, the harmonics are filtered out to a considerable degree.

The control grid, screen, and plate voltages of the pentode tube may be varied by the double-pole switch that contacts taps on resistors  $R_3$  and  $R_4$ . These voltages keep the gain below saturation fairly constant for all switch settings, but still permit control of the limiting level.

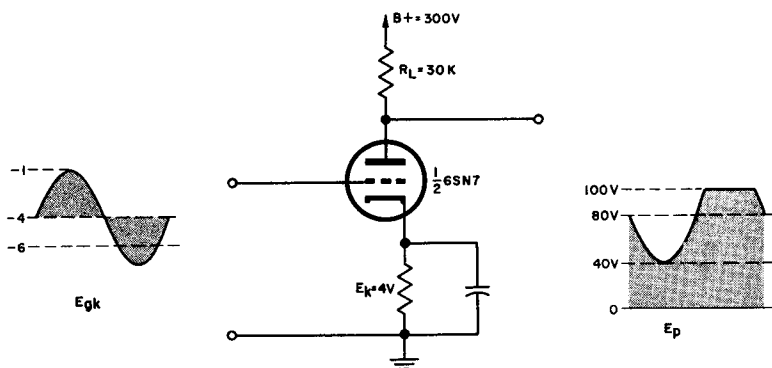

Fig. 35. Circuit for cutoff limiting.

This circuit will operate satisfactorily only for cw (continuous wave) signals, or similar applications in which one or more tones of limited maximum output and low frequency are desired.

## 21. Cutoff Limiting

When a grid signal of sufficient amplitude to drive the grid voltage to plate-current cutoff is applied to the circuit of Fig. 35, the plate current is decreased to zero. Referring to the circuit, it is obvious that if no plate current is developed, no voltage is developed across the load resistor ( $R_L$ ). The plate, then, is at  $B+$  voltage, and clipping takes place on the positive peak plate voltage wave. The plate remains at  $B+$  during the entire time the triode is held below cutoff.

The effect of cutoff limiting on the input waveform is shown in Fig. 35. Because of the cathode bias, we may assume that the tube has a voltage of 4 volts on the cathode. From the  $I_p - E_p$  curve, cutoff point and time may be determined. Since the grid of the tube is at ground potential with no input signal applied, the grid voltage with respect to cathode at this time is equal to  $-4$  volts.

When a sine wave of 3 volts is applied to the grid circuit, the grid-to-cathode voltage varies between  $-7$  volts and  $-1$  volt. Assume the cutoff bias here is  $-6$  volts. Then the tube goes below cutoff for part of the negative portion of the input wave. During this time, the voltage on the plate is equal to the  $B+$  voltage.

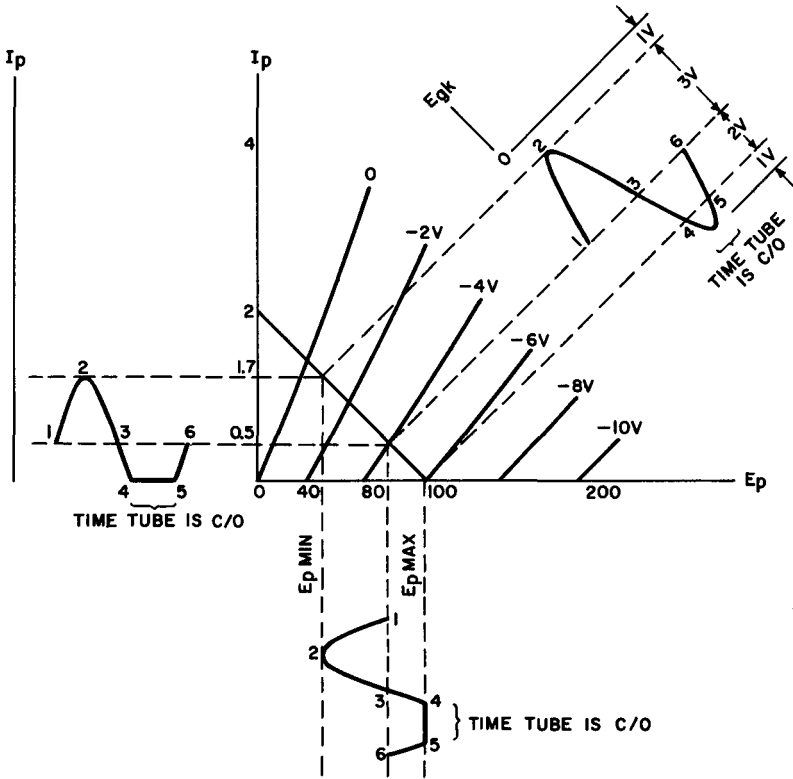

Fig. 36.  $I_p$ - $E_p$  characteristics for the circuit of Fig. 35.

Let us analyze the output of the circuit in Fig. 35. Referring to the output curves shown in Fig. 36, we find that at point (1), before a signal is applied, the grid voltage is equal to  $-4$  volts. The plate current is about  $0.5$  milliamperes, and the plate voltage is at  $80$  volts. From point (1) to point (2) the grid voltage changes from  $-4$  volts to  $-1$  volt. Concurrently, the plate current increases from  $0.5$  to  $1.7$  milliamperes, and the plate voltage drops from  $80$  to  $40$  volts.

From point (2) to point (3) the grid voltage swings from  $-1$  volt to  $-4$  volts. The plate current and plate voltage swing back to  $0.5$  milliamperes and  $80$  volts respectively.

From point (3) to point (4) the grid voltage decreases from  $-4$  volts to  $-6$  volts. The plate current, as a result, swings to zero,



and the plate voltage becomes  $B+$  (100 volts). From point (4) to point (5) the grid voltage remains below cutoff and no change takes place at the plate of the tube.

From point (5) to point (6) the grid voltage goes above cutoff to  $-4$  volts, the plate current returns to 0.5 milliamperes, and the plate voltage is restored to 80 volts.

In summarizing, we may say that cutoff limiting is achieved by means of an input voltage of such a magnitude as to drive the grid below the cutoff point for a portion of the input cycle. For a sine-wave input, we may further say that cutoff limiting may be identified by the flat-topped plate voltage during the time the plate voltage is at  $B+$ .

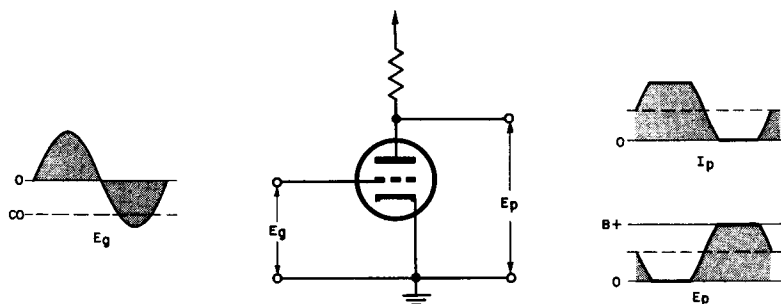

Fig. 37. Typical overdriven amplifier circuit.

## 22. Overdriven Amplifier

We will now consider the application of saturation limiting combined with cutoff limiting in order to produce a square wave from a sine wave. This type of circuit is shown in Fig. 37 and is known as an overdriven amplifier, or limiting amplifier. It is called overdriven because the input signal is so large that it drives the tube to saturation in one direction and below cutoff in the other direction.

Referring to Figs. 37 and 38, it will be observed that the circuit is operated at zero bias, and since there is no grid resistance, the input voltage is equal to the grid voltage.

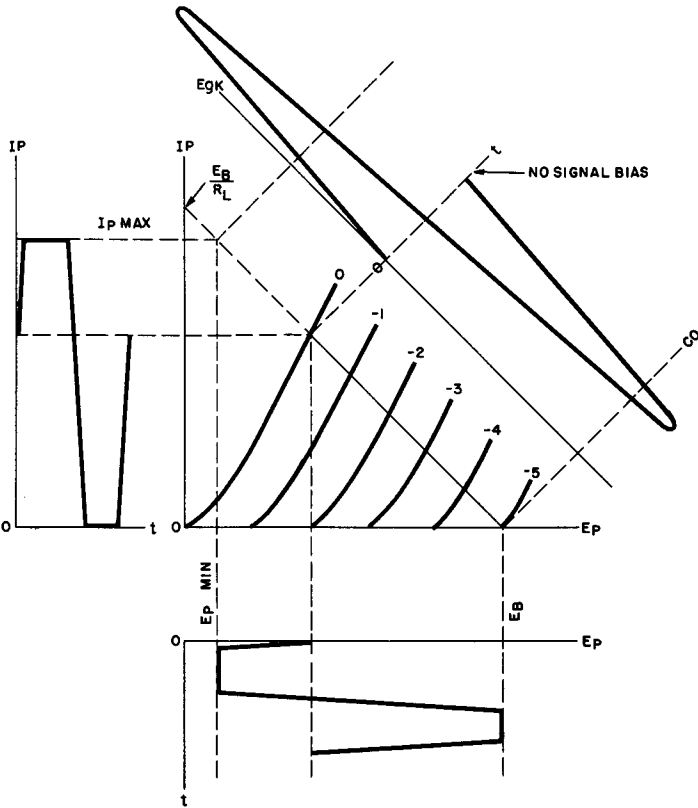

Fig. 38.  $I_p$ - $E_p$  characteristics for typical overdriven amplifier.

When the positive alternation of the input signal occurs, the tube is driven to saturation during part of the alternation. During this saturation time, the top of the plate current wave and the bottom of the plate voltage wave are flat.

When the negative alternation occurs, the grid is driven beyond cutoff in the negative direction. This causes the plate current to become zero and the plate voltage to rise to the B+ value. As a result, the bottom of the plate current curve and the top of the plate voltage curve are flat.

The plate voltage waveform amplitude of the overdriven amplifier is thus limited on both the positive and negative portions of the cycle and becomes a good approximation of a square wave.

Greater symmetry of the plate voltage may be obtained if the bias (and thus the operating point) of the tube is adjusted.

The driving circuit of an overdriven amplifier should have a relatively low impedance and be capable of delivering ample power, because considerable current is drawn during the positive swing of the grid voltage. The value of the load resistor ( $R_L$ ) should also be made as large as practicable for the plate voltage supply available.

Let us now consider the application of saturation and cutoff limiting to communications circuits. Figure 39 shows a circuit that uses saturation and cutoff limiting to clip a radio-frequency wave. It is the circuit of a tuned-radio-frequency receiver for receiving modulated continuous wave (mcw) or limited-bandwidth voice signals. Limiting is used to control volume and "clip" noise. Radio frequency limiting, in combination with noise limiting, is achieved in this circuit by plate saturation combined with grid cutoff limiting. A high input impedance must be maintained in the control grid circuits of the saturated tubes.

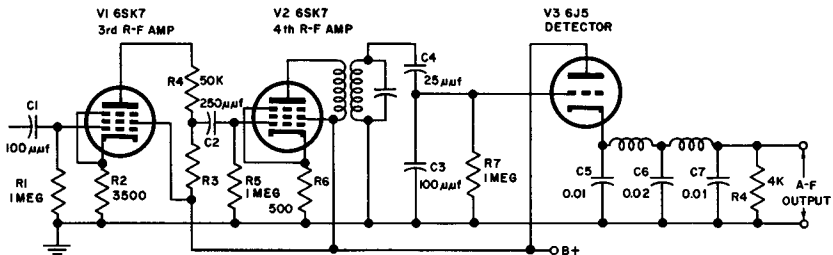

Fig. 39. Typical r-f limiter circuit.

The third and fourth radio frequency amplifier stages are used as saturation limiters by operating the tubes with 45 volts applied to both the screen and the plate circuits. The two stages combined provide a gain equivalent to that of one radio frequency amplifier stage at a much lower limiting level than is feasible with one stage alone. This is a result of voltage dividing action of  $R_3$  and  $R_4$ , and  $C_3$  and  $C_4$ . The single tuned circuit following the four amplifier stages filters out any radio frequency distortion in the signal that has been caused by the preceding limiters, and also

provides further selectivity. The low pass filter, following the detector stage, further purifies the audio frequency output and improves the signal-to-noise ratio.

The initial a-c input resistance of the third radio frequency amplifier stage is about 1 megohm, until the signal input voltage is larger than the negative bias supplied by the voltage drop across the cathode resistor to the control grid. The a-c input resistance then drops to about .5 megohm because the grid becomes, in effect, a diode rectifier conductive for that portion of the positive alternation of the input signal that exceeds the value of the grid bias voltage.

The negative bias thus developed across grid leak resistance  $RI$  by grid rectification is applied to capacitor  $CI$  to limit the increase in space current. During a noise peak, the effective positive instantaneous voltage on the grid of the tube is the difference between the rectified voltage across resistance  $RI$  (maintained by charging capacitor  $CI$ ) and the positive half-cycle voltage of the noise peak. The limiting function occurs in the plate circuit as a result of plate saturation.

On the negative alternation of the radio frequency input signal, the grid cutoff action limits the change in the plate current. The phase shift from grid to plate causes the positive noise peaks applied to the grid of the third radio frequency amplifier to appear as modified negative peaks at the grid of the fourth radio frequency amplifier where the peaks are further limited by grid cutoff action. The positive peaks at this point are also being limited in the fourth radio frequency amplifier circuit by plate circuit saturation effects. The combined effect of the two limiter tubes is thus to limit both peaks of the radio frequency input signal, whether the peaks are caused by noise or by the signal itself.

An infinite impedance detector is used because it has a low output impedance and does not provide any limiting effect. This circuit is used chiefly for cw (continuous wave) reception at very low carrier frequencies. This circuit can also be used for mcw (modulated continuous wave) reception if the saturation limiting is within suitable limits and an exceptionally good avc (automatic volume control) circuit is used to control the preceding gain to a level just below the limiting level on the desired signals. Under this arrangement, distortion on mcw can be kept low over a considerable range of carrier input values.

**23. Review Questions**

- (1) Sketch from memory the circuit of a saturation limiter.
- (2) Describe the operation of the saturation limiter circuit you have just drawn.
- (3) What is the resulting output wave when a limiter is driven to saturation?
- (4) How do saturation limiters compare with grid limiters?
- (5) Sketch from memory, the circuit of a cutoff limiter.
- (6) Describe the operation of the cutoff limiter circuit you have just drawn.
- (7) How may cutoff limiting be identified, assuming a sine-wave input to the circuit?
- (8) Why is the term "overdriven" applied to overdriven amplifiers?
- (9) In an overdriven amplifier, during which portion of the input cycle is the tube driven to saturation?
- (10) What characteristics must the driving circuit for an overdriven amplifier possess? Why?

## Chapter 6

### OTHER LIMITER APPLICATIONS

#### 24. Noise Clippers

In addition to tube and circuit noise, much of the noise interference experienced in the reception of high-frequency signals is caused by domestic or industrial electrical equipment, or by vehicle ignition systems. The interference falls into two types, the "hiss" type, consisting of overlapping pulses similar in effect to receiver random noise, and "shot" or "machine gun" type interference consisting of separated pulses of high amplitude, called *impulse noise*.

Impulse noise, because of the short duration of the noise pulse compared to the time between pulses, must have a high amplitude. Hence, a noise high enough to cause interference has a noise level much higher than that of the signal being received. Naturally, the idea of the limiter in this case is to allow the message to pass through while the noise is eliminated. From this we can see that the greater the noise, the higher the level of noise elimination.

Another method of eliminating the noise interference is to render the receiver inoperative during the reception of the noise pulse. We are not here concerned with such devices; however, should they be encountered, they are known as "silencers" rather than limiters.

A typical noise clipper circuit is shown in Fig. 40 (A). This circuit acts to clip the noise peaks at the second detector of a super-heterodyne receiver by means of a biased diode. This biased diode

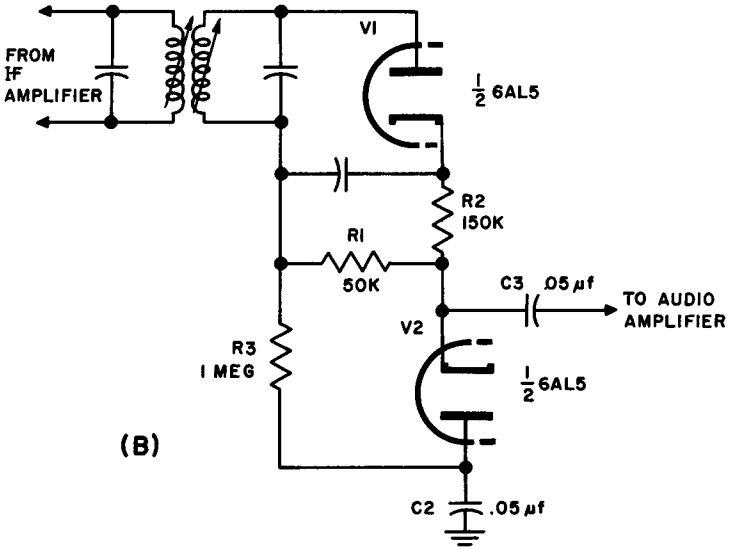
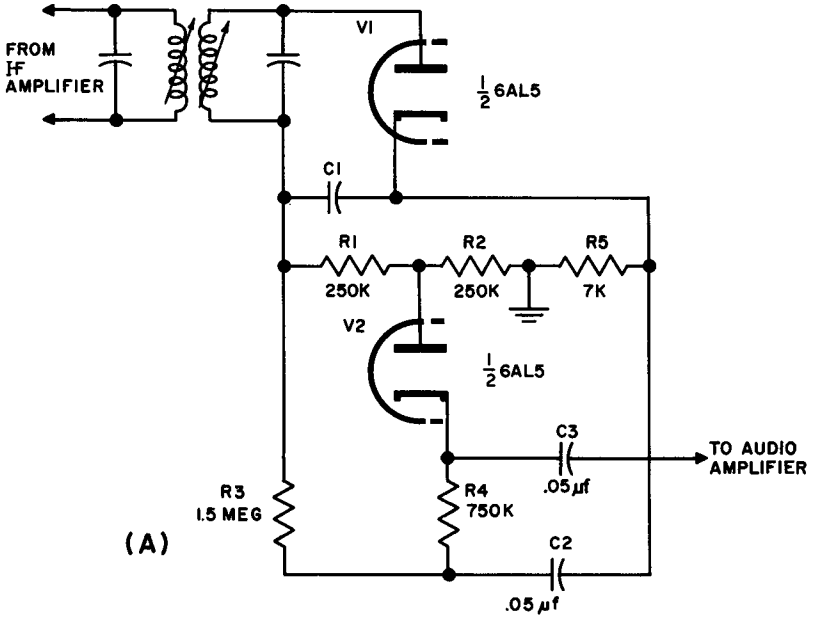

Fig. 40. Noise clipper circuit.

becomes nonconducting above a predetermined signal level. In this case, the clipper tube receives its threshold bias from the rectified carrier developed across the second detector diode load resistors. The audio output of the detector must pass through the clipper diode to the audio amplifier tube. The circuit actually operates as a series clipper.

The circuit shown in part (B) of Fig. 40 is also an example of a typical noise clipper connected to a second detector in a superheterodyne receiver. In this case note that the clipper diode is reversed and that shunt operation takes place. Also note that in both cases, the output to the audio amplifier is obtained through an audio coupling capacitor from the cathodes of the clipper diodes.

Details on the operation of these circuits have already been discussed in Chapters 1 and 2 of this book.

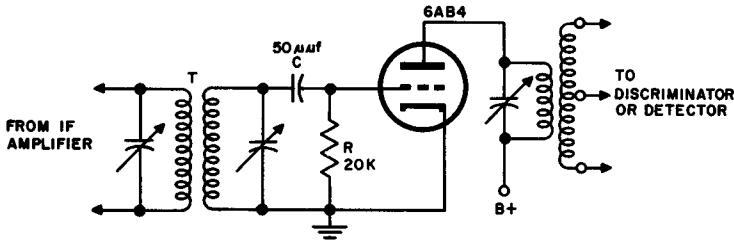

Fig. 41. Typical f-m limiter circuit.

## 25. F-M Limiters

The limiter is used in f-m receivers to remove a.m. and to pass on to the discriminator an f-m signal of constant amplitude. The simplified circuit of a typical f-m limiter is shown in Fig. 41.

As the f-m signal travels from the transmitter to the receiver, it is combined with natural and man-made noises, or static disturbances, which cause variations in the amplitude of the modulated signal.

In addition, there are signal variations caused by fading, such as might be encountered in moving vehicles. All these undesirable



variations in the amplitude of the f-m signal are amplified as the signal passes from stage to stage of the receiver up to the input of the limiter circuit ( $T$ ). The action of the circuit on a received signal is shown in Fig. 42 (A).

This condition of the signal, in which both frequency modulation (desired) and amplitude modulation (undesired) are present at the same time, is shown in (B) of Fig. 42. It is the purpose of the f-m limiter to eliminate these variations in amplitude due to noise impulses before the f-m signal is applied to the discriminator circuit. The character of the signal after leaving the limiter circuit should be as shown in (C) of Fig. 42.

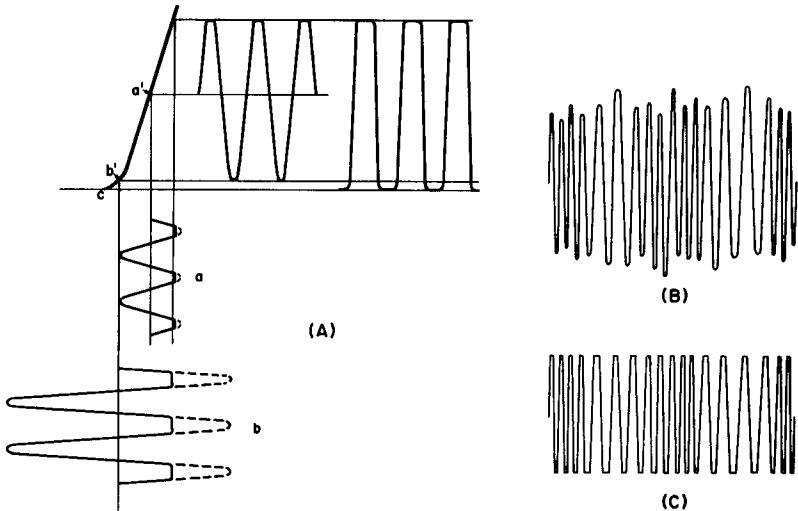

Fig. 42. Limiter action in f-m receiver.

Note that the grid of the tube in the circuit of Fig. 41 is resistor-biased. The tube is of the sharp cutoff type and is operated with a very low plate voltage and with grid-leak bias, so that it overloads easily.

Let us analyze the circuit. Note that no initial bias exists in the circuit. As the first alternation of the input is applied to the grid circuit, it begins to drive the grid positive, thus causing a flow of grid current. This flow of current during the positive peaks of the input signal loads tuned circuit  $T$ . Because of this loading,

there is a drop, or clipping, of the voltage across the tuned circuit during the positive peaks. The positive peaks therefore are removed by the grid-limiting function of the circuit.

As is the case in all grid-resistor-biased circuits, the current flowing in the grid circuit, with the aid of capacitor  $C$ , develops a voltage drop across grid resistor  $R$ . The value of this voltage drop depends on the amount of grid current, which in turn depends on the strength of the input signal.

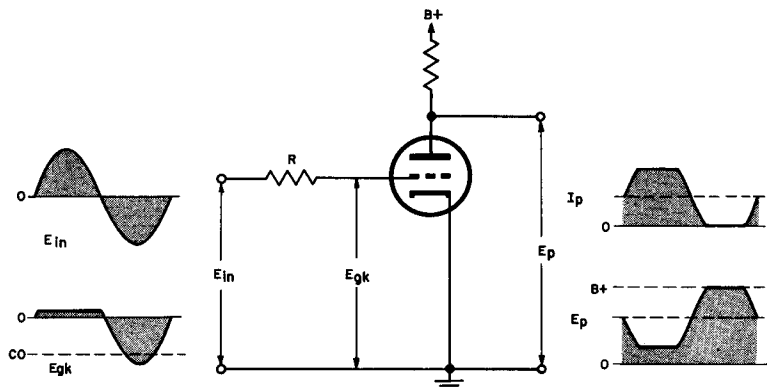

Fig. 43. Grid and cutoff limiter.

Let us assume a weak signal,  $a$ , is applied to the limiter circuit. This input signal is shown in part one of Fig. 42. The positive peaks of the signal will be clipped in the grid circuit because of grid-current flow. This current will produce a grid bias, which will change the operating point of the tube from zero bias to some point such as  $a'$ . The negative peak in this case will not go beyond cutoff and there will be no clipping of the negative peak. You will notice that there has been some amplification without further clipping.

If the amplitude of the input signal is increased as shown at  $b$ , an increased grid current flows. This produces a larger voltage drop across the grid resistor, placing a greater bias on the tube as indicated at  $b'$ . Since the negative peaks of the input now swing beyond cutoff (point  $c$ ), there is no flow of plate current during the most negative period. Consequently, the negative peaks are being clipped in the plate current through the cutoff limiting function of the tube.

Because of the limiter action described above, an f-m signal of constant amplitude is developed in the output stage. This signal

may now be applied to either the detector circuit or the discriminator circuit.

## 26. Wave-Shaping Circuits

A combination of grid limiting and cutoff limiting may be employed to produce a square wave output from a sine-wave input. Figure 43 illustrates such a circuit along with its grid voltage, plate current, and plate voltage waveforms. Note that resistor  $R$  of this circuit must be of a value on the order of 1 megohm in order to limit the grid voltage essentially to zero during the positive swing of the input cycle.

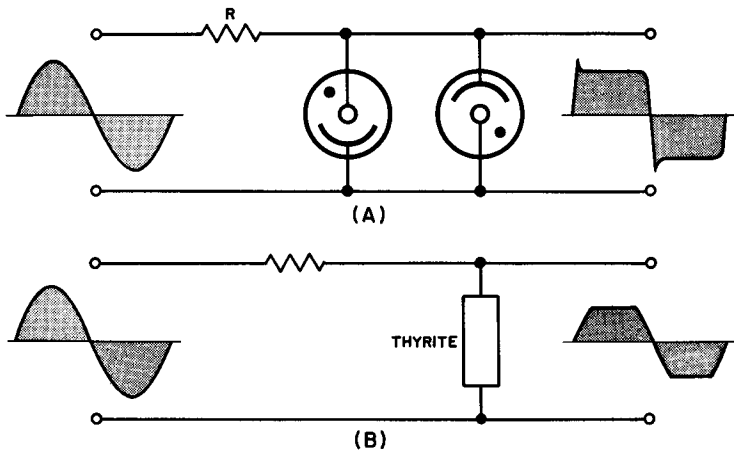

Fig. 44. Voltage regulator and thyrite limiter circuits.

A combination of saturation limiting and cutoff limiting may also be utilized to provide a square wave output from a sine-wave input. Figure 37 shows a typical circuit of this type.

In passing, we might also consider a pair of very simple wave shaping circuits as shown in (A) and (B) of Fig. 44. The first of these circuits employs voltage regulator tubes in parallel with the output; the second is a thyrite circuit. In either case, the resistance in the circuit must be of a value that keeps the current conduction in the elements within the rating of the elements. Note that the

output curve of the voltage regulator circuit has spikes on the leading edges of the waveform. This is because the initial voltage required to start a voltage regulator is considerably higher than the voltage required to operate the tube after its initial period.

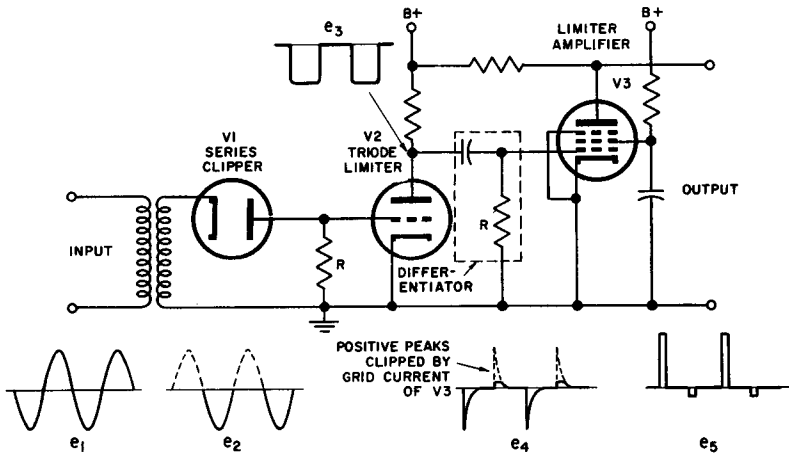

Fig. 45. Waveshaping circuits.

We would like to close with a few cautions. It should be remembered that no limiter is a cure-all. When noise peaks do not substantially exceed the desired signal peak values, and occur so frequently that they fill in the modulation, only some very elaborate limiter arrangements will afford any appreciable degree of relief. Within their inherent limitations, however, the limiter circuits recommended can be useful additions to the communications receiver, and also to the broadcast receiver that must operate under conditions of high ambient static or similar disturbance.

## 27. Squarers and Peakers

A circuit that may be used to change sine waves into square waves, which in turn are turned into peaked waves and then limited and amplified, is normally called a squarer and peaker. A typical squaring and peaking circuit is shown in Fig. 45.

Referring to the circuit, we find that sine-wave input  $e$  is applied to the cathode of the series diode limiter. Since the diode cannot conduct except when the voltage applied to the cathode becomes negative with respect to the plate (that is, negative with respect to ground), the output waveform appears as  $e_2$ .

Voltage  $e_2$  is then applied to the grid of the triode limiter tube. Through cutoff limiting, the waveform shown as  $e_3$  results. This waveform, upon being passed through the differentiator circuit, assumes the shape shown for voltage  $e_4$ . Note that there are two parts to this wave shape. The first illustrates the waveform developed by the differentiator when the grid of  $V3$  is not drawing current. The second shows the waveform resulting when  $V3$  is drawing grid current. Observe that the larger part of the positive peak is clipped off in the latter instance. In the last stage of the squarer and peaker, the tube is normally conducting saturation current. Since this is so, positive pulses on the grid of the limiter-amplifier cannot greatly affect the plate current. Negative pulses on the grid tend to reduce the flow of plate current. The voltage on the plate then rises to the supply voltage during the pulse. This causes the output of this particular circuit to be a series of positive pulses as shown in ( $e_5$ ).

## 28. Review Questions

- (1) Name two types of noise interference.
- (2) Name two methods of eliminating noise.
- (3) Draw from memory a typical noise clipper circuit.
- (4) Explain the operation of the noise limiter circuit you have just drawn.
- (5) What is the purpose of the limiter circuit in f-m receivers.
- (6) Sketch from memory a typical f-m limiter circuit.
- (7) Explain the operation of the f-m limiter circuit just drawn.
- (8) Give three common uses of limiter circuits.
- (9) Describe the function of a squarer and peaker circuit.
- (10) Draw the wave shapes in sequence, as formed in the various stages of a typical squarer and peaker. Describe the circuit operation, using these wave shapes.

## INDEX

- Adjustable biasing voltage, 25
- Audio transients, 7
  
- Biased diode, 48, 49, 50
- Biased grid limiter circuit, 33
- Biased grid limiting, 30, 31
- Biased grid limiting, computations for, 30, 31, 32
  
- Cathode biased grid limiter circuit, 34, 35, 36
- Clippers, definition and use of, 1
- Clipping, function of, 2, 3
- Communications receiver limiter applications, 8, 9, 54, 55
- Crystal diode, 15
- Cutoff limiting, 41, 42, 43, 53
- Cutoff limiting, applications of, 45
  
- Diode clippers, 3
- Double diode limiter circuit, 23, 24
- Double diode limiting, 23
  
- F-m discriminator, 52, 53
- F-m limiter, 51, 52
  
- Grid limiters, 39, 40
- Grid limiting, 33
- Grid rectification, 46
  
- Impulse noise, 48
- Infinite impedance detector, 50, 51
- Instantaneous output voltage, 6
- Interference, 7
- Interference suppression, 7
  
- Limited bandwidth, 45
- Limiter applications, 48, 50, 51, 52, 53
- Limiters, defects of, 54
- Limiters, definition and use of, 1
- Limiters, formula applicable to, 6, 12, 28, 29, 31, 32, 33, 37
- Limiters, function of, 2
- Limiting above ground potential, 17
- Limiting below ground potential, 19
- Load line computation, 34
  
- Mcw circuit, 46
- Modulated continuous wave (mcw), 45
  
- Negative diode limiters, 4
- Negative shunt clipper, 21
- Negative shunt limiter, 12
- Noise clippers, 48
  
- Overdriven amplifier, 43, 44, 45, 46
  
- Parallel diode clipper, 19, 20, 21
- Parallel diode limiter, 17
- Parallel diode limiter, analysis of, 17, 18
- Parallel diode limiting, 10
- Parallel diode positive limiting, analysis of, 10, 11, 12
- Parallel diodes, 24
- Parallel negative diode limiting, analysis of, 11, 12, 13, 14
- Parallel positive diode limiting, 10
- Peak-passing parallel diodes, 21, 22
- Plate circuit limiting, 37
- Plate saturation, 46
- Positive diode limiters, 4
- Positive limiter, 17
- Positive shunt clipper, 19
  
- Q<sub>avc</sub>, 15, 16
- Quiet automatic volume control, 15, 16
  
- Rectifying characteristics, 4
  
- Saturation limiters, 39, 40
- Saturation limiting, 36, 37, 43, 53
- Saturation limiting, applications of, 45, 46
- Saturation limiting effects, 37, 38, 39
- Saturaton limiting, problem in, 40
- Series diode limiters, 4
- Series diode limiting, 3
- Series diode negative limiter, 5, 6
- Series positive diode limiter, 5
- Silencers, 48
- Squarers and peakers, 54, 55
- Squelch circuits, 15, 16
- Square wave output, 53
- Squaring and peaking circuit, 54, 55
  
- Threshold level, 16
- Threshold limiter, 15
- Triode limiters, 26, 27, 28, 29, 30, 55
- Triode limiting amplification, 34
  
- Unbiased grid limiting, 27, 28
  
- Video limiter circuit, 24, 25
  
- Waveshaper, 2
- Wave-shaping circuits, 53, 54
- Wave-shaping device, 2