

**ELECTRONIC TECHNOLOGY SERIES**

# **MULTIVIBRATORS**

**a** **RIDER** **publication**

**\$.90**

# **MULTIVIBRATORS**

Edited by

**Alexander Schure, Ph. D., Ed.D.**



**JOHN F. RIDER PUBLISHER, INC.**  
480 Canal Street • New York 13, N.Y.

*Copyright 1956 by*

**JOHN F. RIDER PUBLISHER, INC.**

All rights reserved. This book or parts thereof may  
not be reproduced in any form or in any language  
without permission of the publisher.

FIRST EDITION

*Library of Congress Catalog Card No. 56-8364*

**Printed in the United States of America**

## PREFACE

Originally "multivibrator" meant only a free-running, square-wave oscillator normally utilized to produce either harmonics or subharmonics for test purposes. Current applications of multivibrator circuits are so extensive that a listing of just a few of the specialized devices utilizing this type of oscillator indicates the importance of the subject. Cathode ray oscilloscopes, television receivers, tv cameras, tv transmitters, computers, radar, electronic switches, multiplex telegraph transmitters—these are but a few of the specialized devices that require these particular types of relaxation oscillators.

The necessity of a careful study of this topic cannot be stressed too highly. The book has been organized to help the student crystallize the important ideas pertaining to multivibrators and their circuit applications. Although the treatment is nonmathematical, the analyses are sufficiently extensive to permit the technician, practicing engineer, or advanced student to develop these fundamental concepts and basic applications to best advantage. No attempt is made to treat or list all possible applications since this is an obvious impossibility in a work of this size. The illustrative circuits chosen, however, are sufficiently representative of major design considerations.

Particular attention is given to the basic principles of the multivibrator and the major types, namely: the bi-stable multivibrator, mono-stable multivibrator, and a-stable multivibrator. Less definitive terms (sometimes more popular in terminology) are explained to help the reader recognize them. A sample design problem is also presented in sufficient detail to permit an understanding of the procedures followed in a design analysis.

Grateful acknowledgement is made to the staff of the New York Technical Institute for its assistance in the preparation of the manuscript for this booklet.

*New York, N. Y.*  
February 1956

A. S.

## CONTENTS

<i>Chapter</i>		<i>Page</i>
1	Basic Principles .....	1
2	The Bi-Stable Multivibrator .....	6
3	Mono-Stable Multivibrator .....	24
4	A-Stable Multivibrator .....	36

## Chapter 1

### BASIC PRINCIPLES

#### 1. What a Multivibrator is

There was a time when the word “multivibrator” referred only to a free-running, square-wave oscillator used to produce harmonics and subharmonics for test purposes. Today the term carries a much deeper and broader significance. Multivibrators are found in television, radar, computers, long distance communications systems, diversity receiving equipment, electronic switches, radio-control, stroboscopes, cathode-ray oscilloscopes, and an incredibly large number of other specialized devices.

A multivibrator is a type of relaxation oscillator<sup>1</sup> employing a two-stage amplifier, with the output of the second stage regeneratively coupled to the input of the first stage. However, within these limits there are different types. These types differ somewhat in circuitry and considerably in function. Various terms have been used in the past to distinguish them. Some of these terms are inconsistent, some ambiguous or indefinite. In this book, each important type is discussed in a separate chapter. The latest accepted terms are used in referring to these types, and each chapter heading

<sup>1</sup> A *relaxation oscillator* may be defined as an oscillator in which one or more voltages or currents change abruptly and periodically to produce, as a rule, a non-sinusoidal waveform. Relaxation oscillations are generally obtained by utilizing the time delay of capacitive charge or discharge through a resistor.

is the proper term for the type discussed in that chapter. These heading are:

Bi-stable Multivibrator (Chap. 2)

Mono-stable Multivibrator (Chap. 3)

A-stable Multivibrator (Chap. 4)

Other popular terms, less authoritative or definitive, will also be explained later, to help the reader recognize them.

## 2. Definitions

Before beginning the discussion and analysis of multivibrator circuits, it is necessary to define some of the terms that will be used in subsequent chapters.

*Multivibrator.* A type of relaxation oscillator consisting basically of a two-stage resistance-coupled amplifier whose output is coupled regeneratively to its input. Types differ mainly in methods of coupling. The type of coupling used influences mode of operation. The outstanding feature of multivibrator operation is that electrical operation can be rapidly changed from one to the other of two *states*. These two states are: (a) conduction in tube 1 and cutoff in tube 2, and (b) conduction in tube 2 and cutoff in tube 1.

*Stable state.* Electrical state in which a multivibrator remains indefinitely, unless the circuit is acted upon from an external source (for example, by a trigger voltage).

*A-stable Multivibrator.* A multivibrator in which neither of the two tubes reaches a stable state during operation, hence a circuit capable of free-running oscillation caused by self-excitation. The circuit continually alternates between one state and the other at a definite rate, determined by circuit constants. In the past, this circuit has been referred to merely as a "multivibrator."

*Bi-stable Multivibrator.* A multivibrator in which either tube becomes stable in either one of its states. The circuit locks in either condition and remains that way until reversed by the application of a suitable external excitation pulse.

*Mono-stable Multivibrator.* A multivibrator in which only one of the two states can become stable. The circuit returns itself to its normal stable state after it has been temporarily shifted to the other state by application of an external excitation pulse.

Some other names, not as specific or authoritative, but sometimes applied to the different multivibrator circuits are as follows:

*A-Stable Multivibrator.* Free-running multivibrator.

*Bi-Stable Multivibrator.* Binary, binary counter, locking circuit, frequency divider, repeater, regenerator, flopover circuit, Eccles-Jordan trigger circuit.

*Mono-Stable Multivibrator.* One-shot multivibrator, flip-flop.

### 3. Pulse Formation

If the reader clearly understands how pulses are formed in vacuum tube circuits, a study of multivibrators is easier. The following points constitute a brief review of some of the primary actions in simple pulse circuits.

a. A *positive-going* pulse is one that "rises" toward its maximum (most positive) value in a positive direction, regardless of the polarity of the absolute value of the voltage during the pulse. For example, pulses at both (A) and (B) of Fig. 1 are positive-going, even though the absolute value of the voltage at (B) never becomes positive.

b. A *negative-going* pulse is one that "rises" to its maximum (most negative) value in a negative direction, regardless of the polarity of the absolute value of the voltage during the pulse. For example, pulses at (A) and (B) of Fig. 2 are both negative-going, even though at (A) the absolute value of the voltage never becomes negative.

c. A sudden rise in plate current in a vacuum tube yields a negative-going voltage pulse at the plate (between plate and cathode). Similarly, a sudden drop in plate current results in a positive-going plate voltage pulse.<sup>2</sup>

d. A negative-going voltage pulse applied to the grid of a tube yields a positive-going voltage pulse at the plate; a positive-going grid voltage pulse produces a negative-going plate voltage pulse.

e. Coupling capacitors do not change the direction of rise of the coupled pulse; the same applies to coupling resistors.

f. A negative-going voltage pulse applied to the cathode of a tube causes a negative-going voltage pulse to appear at the plate; a positive-going pulse on the cathode yields a positive-going plate pulse.

<sup>2</sup> The plate voltage is equal to the value of the B-supply minus the drop in the plate resistor. As plate current increases, the voltage drop in the plate resistor increases, and thus plate voltage decreases.



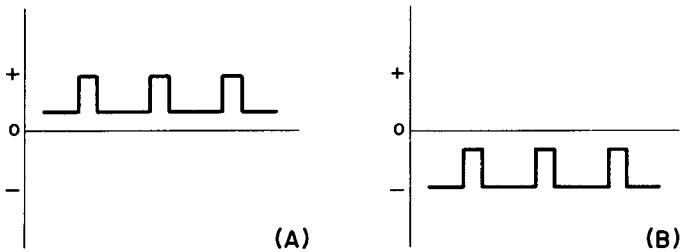

Fig. 1. Examples of "positive-going" pulses.

Multivibrator circuits have two important properties that lead to many valuable applications. The first is the abrupt waveform generated; i.e., somewhere in the circuit there is a very rapid change of voltage with time, say of the order of 100 volts per microsecond. This allows the circuits to be used where high resolutions in time are to be effected, as in accurate time measurements, in time modulation circuits, in pulse counting apparatus, and in frequency division. The second property of the multivibrator is its ability to generate square waves. Not only is the rise and flyback time very short, but the circuit remains in one state for a relatively long time so that the output is substantially constant over the interval between transitions. This output can be used to turn another circuit on or off, a process called "gating." There are many applications of "gates" of this nature. Such a gate can be used to turn on or off a tube for a definite time sequence relative to the rest of the circuit. For example, a sweep can be started, a pulse appearing in a certain time interval can be counted or rejected, a cathode ray tube can be blanked, or a receiver can be made inoperative. The time over which this constancy of output appears may be measured in seconds, milliseconds, or microseconds, so flexible is the circuit. In some multivibrators, the width (length of flat top of square wave) is governed by the voltage at some point in the circuit or by the value of some circuit parameter. This suggests a host of applications, such as time modulation, coding, and others involving definite time sequence.

#### 4. Multivibrator Action

The voltage on a capacitor cannot change instantaneously. If there is to be an abrupt change in voltage between any two points

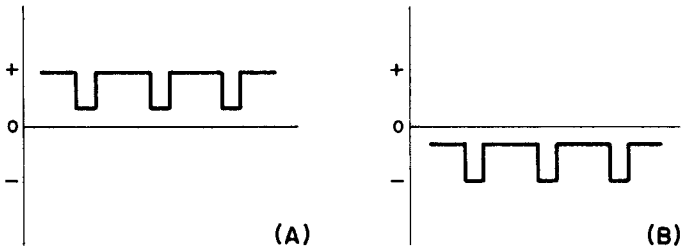

Fig. 2. Examples of "negative-going" pulses.

in a circuit, the capacitive loading between these points must be as low as possible. For a given capacitance, the change in voltage in a given time is proportional to the charge delivered in this time and hence to the current. Thus large charging and discharging currents are prime requisites of abrupt waveforms. These sudden changes are initiated by turning a tube off or on. Doing this calls for tubes that have a very steep transfer characteristic; that is, the change in plate current for a given change in grid voltage is large (a high value of transconductance).

Throughout many of the discussions to follow, the terms "on" and "off" will be used to describe the state of a tube. Caution must be exercised at this time to be consistent about the meanings of these words as used in the text. When a tube is described as "on" or "full-on," this means that the tube is conducting with its cathode-grid voltage essentially at zero or at such a value that the plate circuit is fully conductive. When a tube is described as "off," it is to be taken as being at the cutoff point with no plate current flowing at all.

## 5. Review Questions

- (1) Give six electronic applications of multivibrator circuits.
- (2) Define: multivibrator, a-stable multivibrator, bi-stable multivibrator, and mono-stable multivibrator.
- (3) What is meant by a "stable state" in a multivibrator?
- (4) List four salient points in pulse formations.
- (5) What is meant by a "negative-going pulse"?
- (6) What is gating?
- (7) Why is a high-transconductance tube desirable for steep waveform?
- (8) What is meant by the terms "on" or "off" with respect to a tube operating as a multivibrator?

## Chapter 2

### THE BI-STABLE MULTIVIBRATOR

#### 6. Fundamental Circuit

The basic bi-stable multivibrator circuit is illustrated in Fig. 3. As is evident from an inspection of the circuit diagram, each tube is an amplifier, the plate of which is directly coupled through a resistor to the grid of the other. The load resistances ( $RL$ ) are much smaller in value than the coupling resistances ( $R1$  and  $R2$ ). Typical values are 15k ohms for the load resistors and 1 megohm apiece for the coupling resistors.

From the symmetry of the circuit one might suspect that the quiescent current in each tube would be the same. This is not the case, however, as will be shown in the following text; in addition, the starting state is an unstable condition, which almost immediately causes one tube to go off and the other to go on. Suppose there is a momentary increase of current  $I_{p1}$  in tube 1. This causes a negative voltage pulse to appear at the plate of  $V1$ . This negative pulse is immediately transferred to the grid of  $V2$  through  $R1$ . (See Par. 3.) As this grid goes more negative than previously as a result of this pulse, plate current  $I_{p2}$  of  $V2$  decreases, causing a positive voltage pulse to appear at its plate. Since this plate couples to the grid of  $V1$  through  $R2$ , a similar positive pulse instantaneously appears at this grid, further increasing plate current  $I_{p1}$ . Since it was just this effect that started the action, and since the

effect is being intensified by repeated pulse transfer from tube to tube, it constitutes a *runaway* situation, which continues until either one of two things happens:

a.  $V2$  may reach cutoff. In this case  $E_{p2}$  becomes equal to the supply  $B+$  voltage. (The voltage drop that occurs either in  $RL$ , as a result of the current flow from  $B-$  to  $B+$  through  $RL, R2, R3$ , or through  $RL, R1, R4$  is neglected in this discussion).

b.  $V1$  may go full-on. Depending upon the supply voltages and the circuit parameters, one of these conditions will be attained before the other; this will be the stable state, in which the circuit will remain. For example, if  $V2$  is cut off, any momentary increase in  $I_{p1}$  will only drive the grid of  $V2$  further negative, causing no change in  $I_{p2}$  or  $E_{p2}$ . Similarly, if  $I_{p1}$  should decrease slightly, its

Fig. 3. Basic bi-stable multi-vibrator circuit.

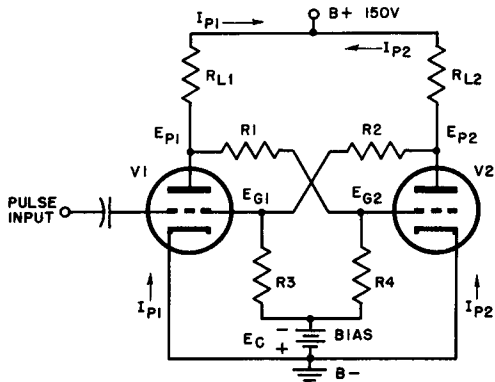

effect would be to make  $E_{p2}$  somewhat less negative, but if the tube is sufficiently beyond cutoff, this will have no effect. An analogous argument may be used to show that, if one tube is full on, the circuit is also stable.

## 7. Function of Bias Voltage

The statement in Par. 5 that a stable state cannot exist with both tubes carrying the same quiescent current must be qualified somewhat in this way: there are ranges of bias voltages for which both tubes may be full on or both tubes may be cut off. Except for these extreme conditions, however, the original statement still holds.

Taking specific component values for, say, a 6SN7 twin-triode:  $RL$  is 20k ohms,  $R1$  and  $R2$  are 1 megohm,  $R3$  and  $R4$  are 1 megohm, and a supply voltage of 250 volts, it may be shown by analysis of tube behavior, as bias voltage is changed from zero to 280 volts or more, that there are actually five stable states (as tabulated in Table 1).

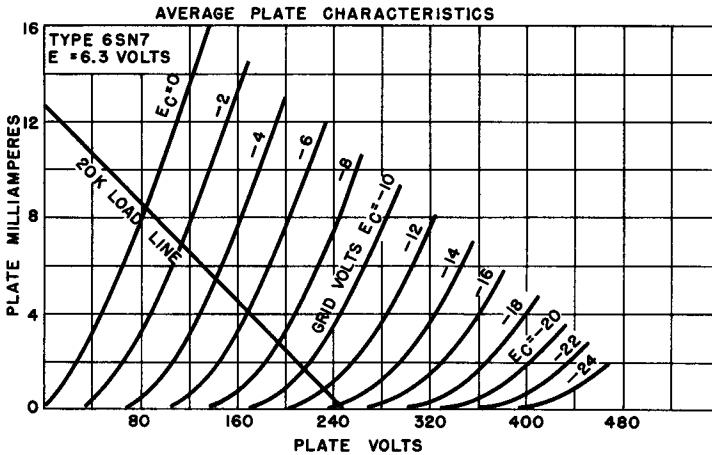

Fig. 4. Plate characteristics for the 6SN7GT, showing the load line for the conditions in the circuit of Fig. 3.

How the five different stable states can exist may be better understood by remembering the following basic facts:

- “Full-on” (as previously defined) is the state in which the net voltage on the grid is zero.
- Net voltage on a grid is equal to the algebraic sum of the voltage coupled from the other tube plate and the bias voltage.
- A tube remains “part-on” if its net grid voltage is more positive than the cutoff value, but more negative than zero.
- A tube is “cut off” if it has enough negative grid voltage (net) to reduce the plate current to zero.

For illustration of how the values and conditions of Table 1 are obtained, consider the  $E_p - I_p$  curves for the 6SN7 in Fig. 4. The plate load for each tube is 20k ohms, so a load line is drawn representing this value. It is drawn between the 250-volt plate voltage on the horizontal axis and 12.5 ma on the vertical axis. The current value is that resulting from application of the 250-volt plate

voltage across the 20k ohm plate load. All possible conditions for each tube in this circuit fall along the load line thus drawn. Cutoff grid voltage is about  $-30$  volts (cutoff is gradual). The following discussion of the five possible states can be checked against the graph of Fig. 4. Let us examine the conditions of Table 1.

a. Bias is between zero and 42 volts. Both tubes have a minimum plate voltage of about 84 volts, due to the drop across plate resistance of each during greatest conduction. This value is derived by locating the point along the load line (Fig. 4) for zero grid volts ( $E_c = \text{zero}$ ). Even when the coupled voltage from the other tube tends to be positive, the grid voltage stays close to zero, due to the flow of grid current through  $R_3$  and  $R_4$ . Thus, until considerable bias is applied, neither tube can affect the other; they are both so far in conduction that even moderate changes of voltages cannot change this stable state.

b. When the grid is no longer positive (and thus does not shunt the grid resistor to low impedance) the voltage at a grid is about one-half the voltage of the plate to which it is coupled. This is because of the voltage-dividing action of coupling and grid resistors  $R_2, R_3$  and  $R_1, R_4$ . When the external bias  $E_c$  is raised to about 42 volts (half the plate voltage of 84 volts) one of the tubes, being slightly different from the other, starts to have its current limited appreciably before the other tube. Let us say  $V_2$  plate current starts to become less.  $V_2$  plate voltage (and thus  $V_1$  grid voltage) becomes more positive.  $V_1$ , still in the "full-on" condition, is not affected appreciably, maintaining about the same coupled voltage on the grid of  $V_2$ . Thus no "runaway" condition occurs,  $V_1$  already being saturated. As bias is increased, current gradually decreases in  $V_2$ , and  $V_1$  is full on while  $V_2$  is part on.

c. When bias  $E_c$  has been raised to 52 volts, it exceeds the positive voltage fed from  $V_1$  plate to  $V_2$  grid by enough to cut  $V_2$  off. Further increases (up to 125 volts) keep  $V_2$  cut off and  $V_1$  full-on.

d. When the bias reaches 125 volts, it equals the portion of  $B+$  voltage fed to  $V_1$  grid from  $V_2$  plate during cutoff of  $V_2$ . Then the net  $V_1$  grid voltage starts to become negative and the plate current of  $V_1$  is reduced. With such a high bias,  $V_2$  cannot be pulled out of cutoff and further increase of bias simply reduces  $V_1$  plate current through the part-on condition.

e. When the bias reaches 140 volts, it exceeds the full  $B+$  voltage coupled from  $V_1$  to  $V_2$  (125 volts) by enough to cut off  $V_1$ . Thus in this range (over 140 volts) both tubes remain cut off.

TABLE 1

Bias	V1	V2
zero to 42 volts	full-on	full-on
42 to 52 volts	full-on	part-on
52 to 125 volts	full-on	cut off
125 to 140 volts	part-on	cut off
more than 140 volts	cut off	cut off

Of course, since the circuit is symmetrical, the two right-hand columns may be interchanged to apply to either of the two tubes. It is further evident from the table that careful consideration must be given to the choice of the bias voltage on the basis of tube type and circuit values if the circuit is to be truly bi-stable; i.e., one tube full-on and the other cut off.

### 8. Trigger Action of the Bi-Stable Multivibrator

In considering the stability of the circuit in Par. 6, it was pointed out that small spurious changes in current were ignored by the multivibrator. However, if a *large* positive pulse is intentionally injected into the grid of the cutoff tube, instantaneous plate current flows in this tube and a new runaway process begins, in which the conditions of the two tubes interchange. This is known as a *transition* and is explained in exactly the same way as was used to show why a "part-on, part-on" condition is not possible. Referring again to Fig. 3, assume that V1 is cut off and V2 is full-on. A positive pulse is now applied to the grid of V1, driving it into conduction. As its plate current rises, a negative pulse is transferred from its plate to the grid of V2, causing the plate current of V2 to drop; again, as a result of this decrease of  $I_{p2}$ , a positive pulse is transferred from the plate of V2 to the grid of V1, causing it to rise further above cutoff. As in the previous case, the process is cumulative and results in a transition.

The action just described accounts for the name "trigger circuit." In most applications it is desirable to have a large change in voltage at the plate of one tube upon the injection of a pulse. Hence the circuit is usually designed so that, in the quiescent state, one tube is full-on and the other is cut off, as explained previously.

The term bi-stable refers to this state and to its companion with the conditions of the tubes interchanged.

### 9. Self-Biased Bi-Stable Multivibrator

The bias supply of Fig. 3 may be eliminated by using self-bias (Fig. 5). The cathodes are tied together and returned to ground through a common resistor,  $R_k$ . If the two halves of the circuit were absolutely identical, the voltage drop across  $R_k$  would remain constant and there would be no need for a bypass capacitor. Assume, however, that the *on* current of  $V1$  is greater than the *on* current of  $V2$  because of different tube characteristics or differences in the resistors. Then, as the transition occurs, the rise of current in one tube is greater or smaller in rate than that of the other, causing degenerative action, which tends to slow down the transition. It is advisable

Fig. 5. Bi-stable multivibrator, circuit in which the external bias supply is eliminated by use of cathode bias resistor  $R_k$ .

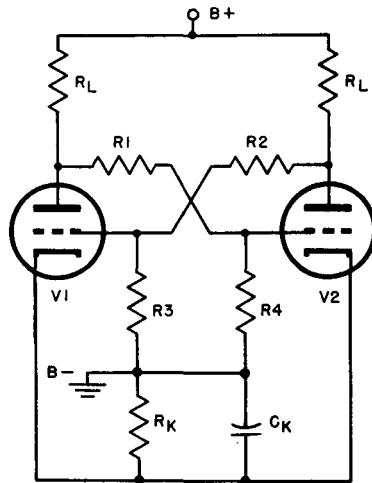

to bypass  $R_k$  with a capacitor that will give a time constant considerably higher than the transition time. Experience indicates that if the product of  $R_k C_k$  equals 100 microseconds, it is ample; thus, if  $R_k$  is 10k ohms (a normal value),  $C_k$  may be 0.01  $\mu$ f.

The operation of the self-biased circuit is identical to that of the separately (fixed bias) biased arrangement of Fig. 3. The self-biased circuit does have two distinct advantages, however: (a) no separate bias battery or supply is required, and (b) the quiescent



conditions are less dependent upon individual tube characteristics, due to the "automatic" biasing action of  $R_k$ .

A design procedure for a self-biased, bi-stable multivibrator will be given later in this chapter.

### 10. Simultaneous Application of Pulses to Both Grids

In many applications, a succession of triggers is applied simultaneously to both grids. This is done by connecting the grids together by means of small capacitors (25 to 100  $\mu\mu\text{f}$ ) and applying the trigger pulses to the junction point of the capacitors (Fig. 6). A positive trigger has no effect upon the *on* tube but will start the *off* tube drawing current to begin the runaway action and resultant transition. Assuming that there is an incoming train of positive pulses, the next one trips the new *off* tube to restore the original conditions. Thus two pulses are required to complete one multivibrator cycle, each of the pulses having been "stretched" into a constant voltage extending to the next pulse. A circuit of this kind is well suited for use as an electronic switch, for example, to display two waveforms simultaneously on an oscilloscope. The multivibrator output can be made an excellent square wave having a relationship to the pulses, as shown in Fig. 7 and discussed in Par. 12.

### 11. Input and Output Considerations

*Square-wave Output.* The waveform at the plate of the multivibrator is normally a good square wave, but it must be coupled to its load through an  $RC$  network. Other types of coupling systems (transformer or impedance coupling) are not practicable because of their poor high frequency response and their tendency to load the output circuit.  $RC$  coupling is thoroughly feasible, provided the time constant of the coupling network is chosen to be sufficiently high. If the time constant is too low, the coupling system tends to differentiate the square wave. Normally, a time constant of ten times the width of the square wave is considered long enough to produce an output waveform essentially the same as that which exists on the multivibrator plate. This is the type of waveform that is ideal for electronic switching.

*Pulse Output.* In binary counting or two-to-one scaling systems (Par. 12 and Fig. 7), it is desired that two input pulses produce one output pulse of essentially the same waveform as the input; each of

these output pulses may then be used as the input to a succeeding scaler, which again reduces the counting rate by a factor of two. Such a cascaded "binary counter" is very useful in counting neural impulses of high repetition rate, cosmic rays, radioactive particles, etc. when the impulses arrive too fast to be counted on a slow mechanical register. The production of such output pulses is quite easy. The normal square wave on the multivibrator plate is differentiated by an  $RC$  network having a time constant that is small

Fig. 6. How trigger pulses may be applied to both tubes at the same time, through capacitors  $C1$  and  $C2$ .

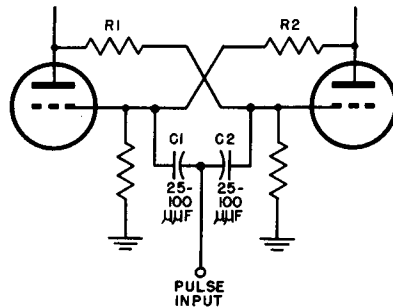

compared to the time between pulses. "Peaking" takes place, and a series of positive and negative pulses result, as shown in Fig. 7. This means that for every two positive input triggers there is one positive output pulse. If  $n$  scale-of-two circuits are used in cascade, a frequency division of  $2^n$  is obtained. For example, six such units provide a scale of 64, one output pulse being obtained for every 64 input pulses.

*Plus and Minus Triggers.* Negative triggers function as satisfactorily as positive ones. In the case of a negative trigger, the *on* tube current is decreased, and this initiates the action. As a matter of fact, positive and negative triggers may be present in any mixture—regular or random—and each pulse will trip the circuit regardless of polarity. Nor do the pulses have to be of the same amplitude, as long as the smallest of them have sufficient intensity to initiate the transition. When positive pulses are used, excessive amplitude must be avoided because a pulse that is too large has a tendency to charge the input capacitors, and (once the pulse has passed) there may be

an effective negative pulse as the capacitor discharges. If the input pulse width is narrow, the positive and negative triggers follow each other so rapidly that they tend to cancel without activating the multivibrator at all; if the pulse width is great, both the true and the spurious trigger will start transitions, giving an incorrect count.

*Shunt Capacitance.* Emphasis has been placed on the abrupt voltage changes that take place in a multivibrator; this is what makes high speed counting possible, since the resultant waveforms are steep sided and lend themselves to high repetition rates. A ca-

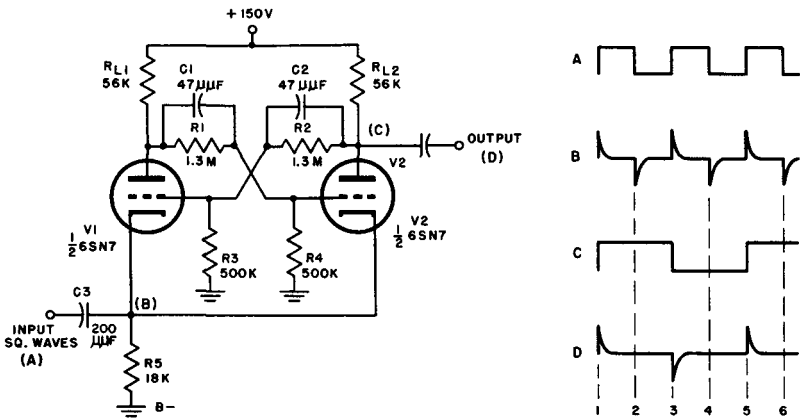

Fig. 7. Binary counter type of multivibrator, with trigger pulses applied at the cathode.

pacitor shunting such a voltage tends to prevent the abrupt change and, therefore, slows down the circuit reaction. The obvious conclusion is, therefore, that such capacitances must be held down to the lowest possible values. The input capacitors (Fig. 6) must be made very small so that the input time constant may be of the order of 15 microseconds. This in turn demands that the trigger pulse width be even smaller than this; otherwise, input differentiation may occur and cause erratic action as explained previously. Improved performance is obtained if the input trigger is not square but has an exponentially sloping lagging edge; such a waveform reduces the tendency toward differentiated overshoot and stabilizes the tripping action. Since this is just the waveform obtained from a multivibrator through a short time-constant  $RC$  coupling network, these circuits may then be used in cascade for scaling applications with no intervening pulse shaping networks.

For the same reason that it is desirable to have a gradually sloping lagging edge, it is necessary for the trigger pulse to have a very rapid rise time at its leading edge. If the rise time were long, the short time-constant input circuit would attenuate the pulse to the point where it could not trip the circuit at all. Experience indicates that reliable triggering may be obtained by using an input pulse having these characteristics (Fig. 8):

Rise time: 0.1 microseconds

Decay time: 1.0 microseconds, exponential

Shape: peaked

Amplitude: 20 to 50 volts

*Commutating Capacitors.* For fast, reliable operation, the circuit of Fig. 5 and Fig. 6 requires one minor modification: the addi-

Fig. 8. Characteristics of pulse suitable for reliable triggering of multivibrator.

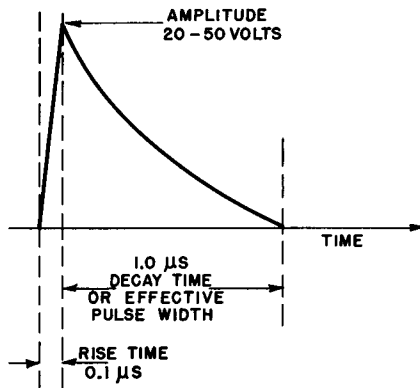

tion of capacitors across the coupling resistors,  $R1$  and  $R2$ . Without these, a very fast input trigger of the order of 1 or 2 microseconds can come and go without activating the circuit. The reason for this is as follows: suppose that an ideal negative pulse shuts off  $V2$  in zero time. The voltage at the plate of  $V2$  rises to  $B+$  value instantaneously, unless there is heavy capacitive loading; it may be safely assumed that the loading is light enough to allow this instantaneous action to occur. The voltage at the grid of  $V1$ , however, cannot follow this sudden change because of the fact that the input capacitance of the tube as an amplifier may be as high as  $50 \mu\mu f$  and because the input trigger capacitor,  $C1$  (Fig. 6), is also essentially in shunt with the grid circuit of  $V1$ . A total capacitance of ap-

proximately 100  $\mu\mu\text{f}$  combined with about 1 megohm of resistance ( $R2$ ) yields a time constant of 100 microseconds, certainly too long to respond to a 1-microsecond trigger. This difficulty is overcome by shunting  $R1$  and  $R2$  by so called commutating capacitors of about 50  $\mu\mu\text{f}$  apiece, as illustrated in Fig. 7. This balances out the effect of the shunt grid capacitances and permits the grid voltage to follow the plate voltage changes instantaneously.

## 12. Practical Binary Scale-of-two Counter

The circuit shown in Fig. 7 and variations of it are utilized in such equipment as time-division multiplex communications devices, locking tone keyers, and frequency shift keying units, in addition to being found in computers, radiation counters, and frequency measuring apparatus. It differs from the circuit just discussed in that the input triggers are introduced at the cathode rather than at a grid or plate, and is included here to show how this variant method of excitation operates.

Assume that  $V1$  is full-on and  $V2$  is cut off. A square wave (A) is now applied to the input terminal and is differentiated by  $C3R5$  to form pulses (B). First consider the case of a positive pulse. The voltage drop already existing across  $R5$  due to the cathode current of tube  $V1$  is momentarily increased, the cathodes of both tubes being driven more positive. Tube  $V2$ , already cutoff (cathode positive and grid relatively negative) is not affected by this increase in the positive potential of its cathode. Tube  $V1$ , however, had its grid at a slightly higher positive potential than its cathode. (The amount is limited by the grid current flowing through  $R3$ .) The positive pulse excitation applied across  $R5$ , effectively inserted into the grid circuit to make the grid relatively negative, is amplified in the conducting tube,  $V1$ . This reduces the plate current and produces a positive pulse at the plate of  $V1$  that is then transferred through  $C1$  and  $R1$  to the grid of  $V2$ . If it is of sufficient magnitude, it starts the runaway action, with  $V2$  becoming conductive and  $V1$  reaching cutoff. The status is thus reversed.

Upon the arrival of the next negative pulse in the pulse train, both cathodes are driven more negative, tending to increase both plate currents.  $V2$ , already full-on, is affected very little, developing a very slight increase in its plate current, which results in a negative pulse at its plate; small as this may be, it is transferred to

the grid of the cutoff tube,  $V1$ , and helps to hold  $V1$  cut off. Thus the negative pulse (if not too large) does not trigger a transition, and  $V2$  remains conductive until the next positive pulse arrives. See Fig. 7 (C), points 1 through 3.

Since the circuit is symmetrical and the input excitation is applied to both cathodes, the foregoing discussion holds true for any initial tube condition (either  $V1$  or  $V2$  conductive). As the waveforms in Fig. 7 show, two input square wave cycles are required to produce one output cycle; similarly, if the output is differentiated by an  $RC$  network connected to the plate of  $V2$ , one output pulse is obtained for every two input pulses (D).

If it is preferred, excitation may be applied to the grids through capacitors as in Fig. 6. In this event, transitions are brought about by negative rather than positive pulses, but the same scale-of-two action is obtained.

### 13. The Bi-stable Multivibrator as a Regenerator

In reading the preceding paragraph, particularly that portion dealing with the ineffectiveness of negative pulses as triggers, it may have occurred to the reader that the cutoff tube, even though "held" at cutoff by the small pulse fed back from the conducting tube, tends to go into conduction when the cathode is driven negative. Whether it does or does not depends largely on the amplitude of the pulse. If it is assumed that the conducting tube circuit is such that the tube is really full-on (i.e., drawing near-maximum plate current), a negative pulse applied to its cathode would produce an almost negligible holding pulse to the cutoff tube, since its plate current cannot rise significantly, even with excitation of the right sign.

On the other hand, if the amplitude of the pulse is two or three times greater than that required for reliable scale-of-two triggering, there will come a point at which a negative pulse applied to the cathodes will also cause a transition to take place by driving the cutoff tube into conduction to start the runaway process once again. Thus, the system acts not as a frequency divider but as a repeater or regenerator, putting out square-wave voltage or pulses at the same frequency as that of the input excitation. The comparative waveforms for this result are given in Fig. 9.

#### 14. The Bi-stable Multivibrator as a Locking Circuit

In this application, the multivibrator functions in exactly the same manner as the regenerator, except that the pulses are delivered at a slower rate, so that the circuit may stay locked-in in either of its two stable states until the arrival of the next pulse. The arrangement provides the electronic equivalent of a pulse-energized electromagnetic relay locking in whichever position it is "kicked to."

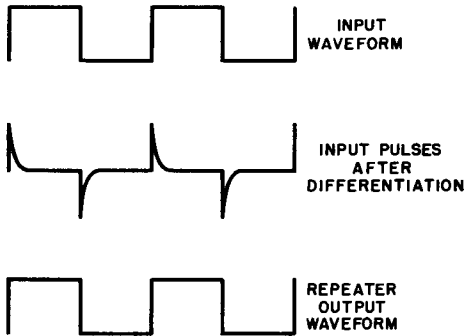

Fig. 9. Waveforms for regenerator, or repeater, type of multivibrator.

As a rule alternate positive and negative pulses of voltage are applied to one grid instead of to the two cathodes in parallel, as in the case just discussed. The cathode is generally connected directly to ground instead of through a resistor, bias being obtained from a battery or other similar source.

#### 15. Diode Trigger Feed

The basic methods of triggering a bi-stable multivibrator have been described in the preceding paragraphs. Mention also has been made of the fact that the multivibrator tube should not draw grid current while being tripped, and that the input circuit should not load down the grids. Flow of grid current may always be avoided, regardless of input pulse amplitude, by using negative triggers exclusively.

The grid loading problem and much of the trigger waveshape difficulty may be overcome by feeding the pulse to the multivibrator through diodes, as illustrated in Fig. 10. The diodes may be dual tubes, such as the 6H6, 6AL5, or germanium (or silicon) crystal rectifiers.

In the arrangement of Fig. 10, the input pulse must be negative, but positive pulses may also be used if the diodes are reversed. The diodes function as follows: assume that  $V1$  is full-on and  $V2$  is cut off. Under these conditions, the plate of diode  $V3$  is negative with respect to its cathode, since the voltage on this tube is that which appears across  $R_{L1}$ . Hence  $V3$  is not conducting. Diode  $V4$  is in the non-conducting state too, because its plate voltage comes from the drop across  $R_{L2}$ , and (since  $V2$  is cut off) there is zero voltage across this resistor; with no difference of potential between cathode and plate,  $V4$  must also be quiescent. These conditions represent a stable condition until the arrival of a negative trigger pulse.

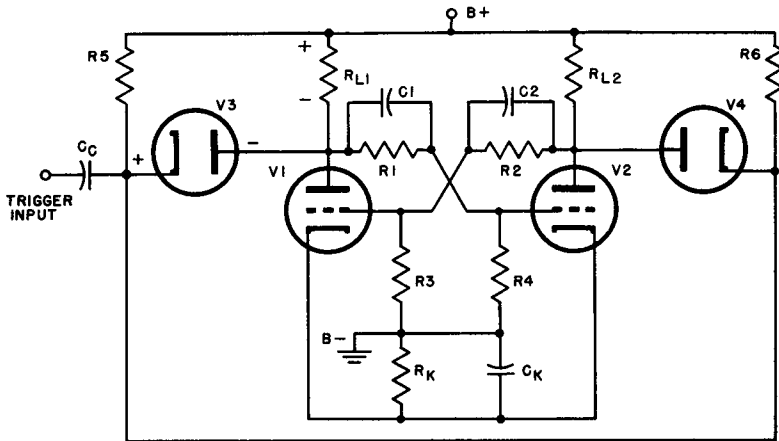

Fig. 10. Circuit employing diodes to minimize trigger-source loading.

With neither diode conducting, the multivibrator is essentially disconnected from the trigger source and is thus loaded down only by the diode interelectrode capacitances, which are very small and may be ignored. A negative trigger pulse is now fed through the coupling capacitor,  $C_C$ . Unless it is very great in amplitude, it has no effect upon  $V3$ , because this tube's plate is so negative with respect to its cathode that only an unusually large input pulse could reverse these conditions. The instantaneous negative voltage on  $V4$ , however, causes this tube to conduct (the path is through  $R_{L2}$  and  $R6$ ) so that a relatively large negative trigger appears at the



MULTIVIBRATORS

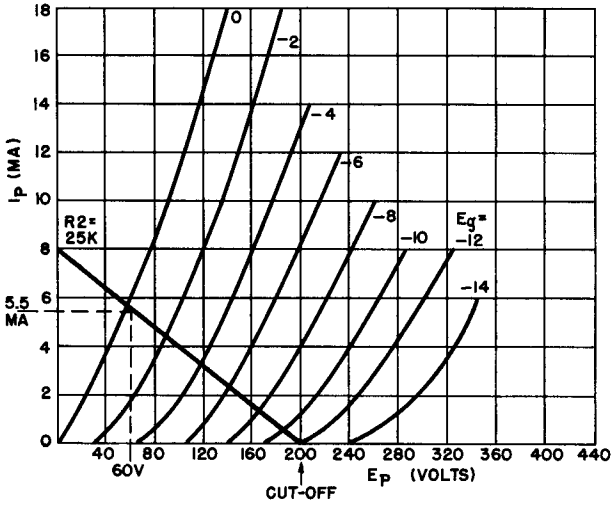
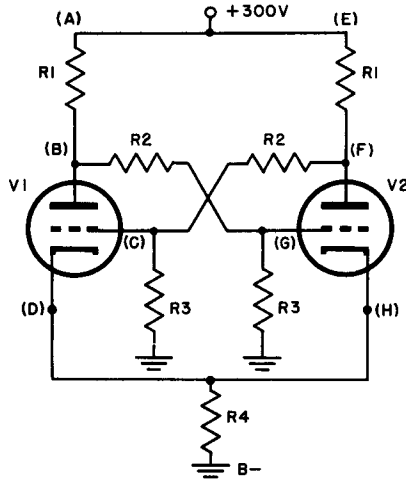

Fig. 11. Bi-stable multivibrator circuit and 6SN7 characteristic curves used in simplified design procedure in text.

plate of *V2*. This is coupled to the grid of *V1* through *R2C2*, starting the runaway cycle and resulting in a reversal of status, with *V1* cut off and *V2* conducting.

Much less attention need be paid to the trigger shape when diode coupling is used than in the simpler circuits. Although the input pulse must still have a very short rise time, the shape of the

pulse and the characteristics of its trailing edge are comparatively unimportant. Even if the pulse has a positive overshoot, it cannot get through the diodes and cannot cause spurious triggering. The time constant of  $R5C_c$  and  $R6C_c$  is not critical, although it should be short compared to the interval between pulses. At the instant of diode conduction, the time constant changes from  $R6C_c$  (assuming  $V_4$  is already cut off) to the product of  $C_c$  and the joint resistance represented by  $R6$  in parallel with the series combination of  $R_{Lz}$  and the internal diode resistance. If this is small compared with the pulse interval, there will be differentiation of the trigger, but this can do no harm since the diodes are impervious to positive overshoots. Capacitor  $C_c$  will charge, however, and must discharge before the next pulse arrives; otherwise, the pulse will not reach the diodes. This accounts for the need for making  $R6C_c$  (and  $R5C_c$ , of course) smaller than the pulse interval.

## 16. Simplified Design Procedure for Bi-Stable Multivibrator

A rigorous procedure for determining the circuit parameters of a specific bi-stable multivibrator is rather tedious and time consuming. For the average worker in electronics, the simplified sequence given below more than suffices, even though certain fundamental assumptions and compromises with rigidity must be made.

*Given:* A 6SN7 is to be set up as a bi-stable multivibrator and is to be used with a power supply that provides 300 volts (Fig. 11).

*Assumptions:*

a. With a power supply voltage of 300 volts available, we shall want the cathodes quite positive with respect to ground, so that we shall have plenty of "play" between these points to establish operating bias. *Assume the cathode-to-ground voltage desired to be about 100 volts.*

b. Assume a reasonable value of load resistor  $R1$ . The triode sections of a 6SN7 have the same characteristics as the 6J5. *A suitable load resistor might be about 25,000 ohms.* This will later be tested and, should it prove too high or too low, the process may be repeated with a different assumed value.

c. During the quiescent condition, one triode will be cut off and the other will be full-on. To insure complete cutoff, *the required bias voltage may be assumed to be about twice the actual cutoff bias value.* For the full-on condition, *the control grid will have to be zero or slightly positive for this triode section.*

d. The individual values of  $R_2$  and  $R_3$  are considerably higher (10 to 20 times) than that of resistor  $R_1$ , so that *the voltage drop across  $R_1$  due only to voltage divider current is negligible.*

*Procedure:*

a. The load resistor,  $R_1$ , is chosen as 25,000 ohms (assumption b). A load line for this resistance is to be drawn in the 6SN7 plate characteristic curves. Since the cathodes are to be at 100 volts positive (assumption a), the load line is to be constructed for a plate-cathode potential of 200 volts. This load line is shown in Fig. 11.

b. The conducting tube has a control grid voltage that is close to zero (assumption c). Find the plate current that flows in the conducting tube at this bias voltage from the intersection of the load line in the  $E_g = \text{zero}$  curve. This current is 5.5 ma. The figure also shows that at this plate current *the voltage across the tube is 60 volts and the drop across  $R_1$  is 140 volts.*

c. 5.5 ma must also flow through the cathode resistor, because only one tube is to conduct at a time when quiescent. To obtain a cathode potential of 100 volts, then, the cathode resistor must be:

$$R_4 = \frac{100}{5.5 \times 10^{-3}} = 18,000 \text{ ohms}$$

d. According to the average plate characteristics (Fig. 11), the tube, with 200 volts plate-to-cathode potential, cuts off at  $-12$  volts of bias. To insure against spurious triggering, assume the grid voltage needed is  $-25$  volts (assumption c).

e. Assume  $V_1$  to be non-conducting at the moment. Its cathode potential is 100 volts positive and its grid potential is  $-25$  volts with respect to cathode. Therefore, the voltage coupled from  $V_2$  (point F) is  $+75$  volts, and the voltage drop across  $R_3$  must be 75 volts. But the potential at point F is 160 volts with respect to ground (140-volt drop across  $R_1$  subtracted from supply voltage of 300 volts  $= 160$  volts at point F). Thus there must be an  $IR$  drop of 85 volts from F to C and a 75-volt drop from C to ground. This determines the ratio of  $R_2$  to  $R_3$  as 85/75.

f. These resistors are to be high in value (assumption d). If  $R_2$  is arbitrarily selected as 500k ohms,  $R_3$  must be 440k ohms to agree with the ratio derived in (e).

g. These resistors, chosen to place the grid of the non-conducting tube (point C) 75 volts above ground must now be tested to determine whether or not they conform with the second part of assumption c; i.e., that point G is at zero potential or

slightly positive. With  $V1$  non-conducting, and its grid at  $-25$  volts with respect to cathode, its plate voltage with respect to ground (point B) will be very nearly 300 volts (assumption d). Using resistors of 500k ohms and 440k ohms, point G would, if isolated, have a potential of  $+135$  volts with respect to ground, or 35 volts more positive than the cathode. When point G is connected to the grid of  $V2$ , grid current flows and prevents the grid from becoming more than a fraction of a volt more positive than the cathode. Thus the initial assumption is justified, and the resistor choices, including the selection of  $R1$ , are practicable.

### 17. Review Questions

(1) Draw the circuit of the bi-stable multivibrator, utilizing a bias supply. Assign typical values to the components and explain the circuit operation.

(2) What role does the bias voltage play in a bi-stable multivibrator?

(3) What is a "trigger circuit"? Explain "trigger action" in a bi-stable multivibrator.

(4) Define transition; refer to Fig. 3 and explain why this effect prevents a "part-on, part-on" condition.

(5) How may the circuit of question 1 be adapted for self-biased operation? Draw and explain the resultant changes in circuit operation.

(6) Describe the modifications necessary when a succession of triggers are applied simultaneously to both grids in the modified circuit of question 5.

(7) What type of coupling is normally utilized for square wave output? Why are other types of coupling normally not applied?

(8) Explain the operation of plus and minus triggers in binary counters or two-to-one scaling systems. Draw the circuit of a practical binary scale-of-two counter.

(9) Explain the function of shunt capacitance and commutating capacitors in multivibrator operation.

(10) Draw comparative waveforms illustrating the action of the bi-stable multivibrator as a regenerator.

## Chapter 3

### MONO-STABLE MULTIVIBRATOR

#### 18. Conversion of Bi-Stable to Mono-Stable Multivibrator

Many multiplex telegraph transmitters and radar systems utilize the mono-stable form of multivibrator for timing and "delay" purposes. The mono-stable type (Par. 2) is distinguished from the bi-stable variety by its self-restoring action. In the bi-stable multivibrator, a correct trigger produces a stable transition from one tube to the other; the mono-stable multivibrator may go through the same transition, but returns to its original condition spontaneously. This action is often called "flip-flop" in contrast with the bi-stable behavior which is referred to as a "flopover."

If the resistive coupling from one of the plates to the opposite grid in the bi-stable multivibrator is changed to capacitive coupling, a mono-stable system results. In the basic circuit, the corresponding grid resistor is returned to a positive potential, rather than to ground or to a bias source (Fig. 12, point A).

#### 19. Circuit Operation

In the quiescent condition,  $V_2$  is full-on. Its control grid voltage is zero or very slightly positive with respect to the cathode, the

circuit values being so chosen as to establish  $V1$  below cutoff. The circuit will trigger if a positive pulse is applied to the grid of  $V1$  (or the plate of  $V2$ ), or if a negative pulse is applied to the grid of  $V2$  (or the plate of  $V1$ ). In this circuit, the trigger pulse is applied to only one tube at a time, not to both tubes simultaneously as in the bi-stable type.

Suppose that an isolated negative pulse is injected into the grid of  $V2$ . The plate current of  $V2$  decreases and a positive pulse appears at the plate of  $V2$ , and is transferred through  $C1$  to the grid of  $V1$ , causing the plate current of  $V1$  to rise. The negative pulse at the plate of  $V1$ , which results from this rise of plate current, is immediately passed on to the grid of  $V2$  through coupling capacitor  $C2$ , reinforcing the original trigger. This starts the famil-

Fig. 12. Basic monostable multivibrator circuit.

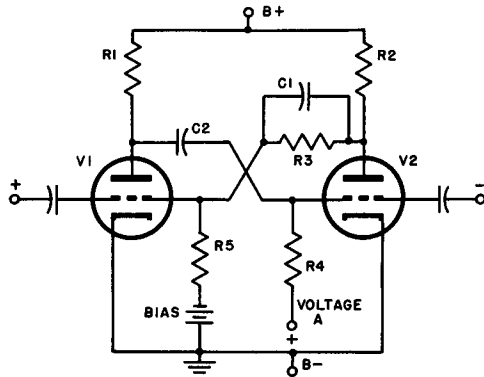

iar runaway action, with the grid voltage of  $V2$  rapidly forced negative to a point beyond cutoff. At the same instant,  $V1$  reaches the full-on condition, since the transfer of voltages just described brings the grid of  $V1$  into the zero or slightly positive region. However, this is only a quasi-stable state. After a fixed time interval has elapsed, the circuit, without the need for an additional trigger, reverts to the original condition, in which  $V2$  is full-on and  $V1$  is cut off.

## 20. Explanation of Reversion Action

A thorough understanding of the reasons for the waveforms obtained from a mono-stable multivibrator requires a careful analysis of the voltage changes that occur in the circuit with the superimposition of the trigger pulse. (Refer to Fig. 13.)

Let  $t = 0$  represent the instant when the trigger pulse is injected,  $t = 0-$  an instant before pulse injection, and  $t = 0+$  the time when the "flip" is completed; i.e., when  $V1$  has gone from cutoff to full-on. At  $t = 0-$ , the grid potential of  $V2$  is zero or

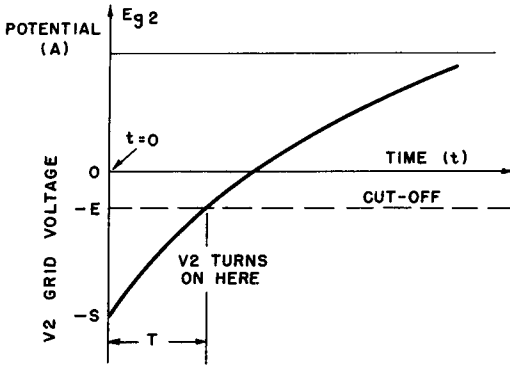

Fig. 13. Waveforms of grid voltage of  $V2$ , showing related circuit actions.

very close to it as a result of the grid current flow through  $R4$  (Fig. 12). At  $t = 0+$ , the voltage on the grid of  $V2$  falls to the point labeled  $-S$  on the axis of Fig. 13. This point is the negative swing of the plate potential of  $V1$  as this tube goes from cutoff to full-on (as its plate voltage drops from a value virtually equal to  $B+$  to its lowermost limit at the full-on condition). As a result of this swing after the trigger has acted, capacitor  $C2$  becomes charged, but once the quasi-stable state is attained, it begins to discharge through  $R4$ ; since  $R4$  is much larger than  $R1$ , the discharge time constant is approximately equal to  $R4C2$  with  $R1$  being ignored. The equation of the discharge curve is:

$$E_{g2} = A - (A + S) \Sigma^{-t/R4C2}$$

This equation is obtained from the consideration that at the beginning of the discharge process  $E_{g2} = -S$  and at  $t = \text{infinity}$ ,  $E_{g2} = A$ .

If the magnitude of the grid cutoff voltage of  $V2$  is assumed to be  $-E$  as shown on the curve, this tube will start to draw current when  $E_{g2} = -E$ . At the same instant, the plate voltage of  $V2$  begins to drop, providing the pulse that pulls the grid voltage of  $V1$  along with it. This is the beginning of the restoring action that returns the system to its initial stable state.

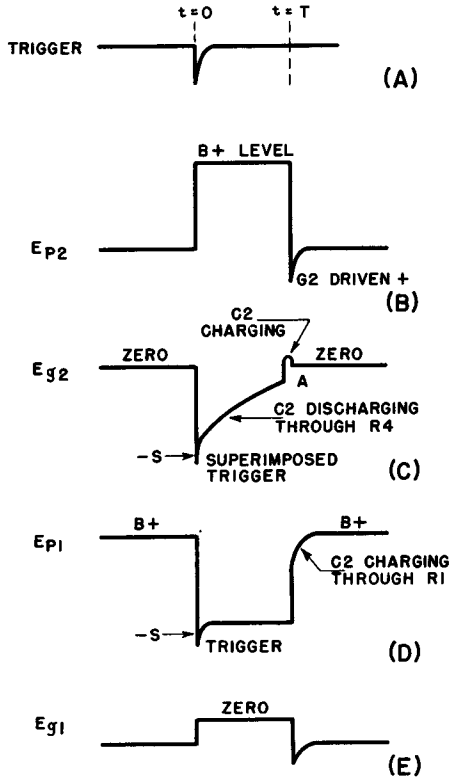

Fig. 14. Waveforms in monostable multivibrator.

The foregoing analysis assists in explaining the waveforms shown in Fig. 14. Consider first the region near  $t = 0$ .  $E_{p2}$  rises very rapidly toward B+ (diagram B) with a time constant equal to the product of  $R2$  and the capacitance at the plate of  $V2$ , which is always quite small. This results in a steeply rising leading edge to the B+ level.  $E_{g2}$  starts at  $-S$  and increases toward voltage  $A$



with a time constant of  $RC_2$ , as already explained; the trigger is, however, superimposed at the start of the change (diagram C).  $E_{p1}$  (diagram D) starts at  $B+$  and drops almost instantaneously to the lower limit of its swing  $-S$ , but again the trigger is superimposed on the waveform, having been transmitted through  $C_2$  from the grid of  $V_2$  to the plate of  $V_1$ .  $E_{g1}$  rises quickly from cutoff to zero, or it may overshoot slightly into the positive region (diagram E).

Now consider the conditions that obtain at the end of time  $T$ , the end of the quasi-stable state. As  $E_{p1}$  rises toward  $B+$  (diagram D), this change of voltage appears at the grid of  $V_2$ , driving it positive, and the resulting grid current charges  $C_2$  until  $E_{g2}$  returns to zero as shown in diagram (C). This overshoot in  $E_{g2}$  causes a very large negative overshoot in  $E_{p2}$  (diagrams C and B), which drops very quickly as a consequence of the heavy current drawn by  $V_2$ .  $E_{p1}$ , however, rises comparatively slowly (diagram D), because the current that charges  $C_2$  must pass through  $R_1$ . In addition, the overshoot in  $E_{p2}$  reflects itself in a similar overshoot in  $E_{g1}$  (diagram E).

Since the mono-stable multivibrator generates a rectangle for a peaked trigger, it can be used to *gate* other circuits; furthermore, since the output can be differentiated to give an output pulse that is *delayed* a predetermined time  $T$  after the incidence of the trigger pulse, it may be utilized for accurately controlled delay purposes.

## 21. Self-biased Mono-Stable Multivibrator

The circuit of Fig. 12 has the disadvantage that a source of negative voltage is required. A mono-stable multivibrator in which self-biasing is accomplished is illustrated in Fig. 15. In addition to this change, it should be observed that coupling resistor  $R_3$  and its shunt capacitor (Fig. 12) are both missing; feedback takes place through common cathode resistor  $R_5$ , making other feedback components unnecessary. Another advantage of this arrangement is that the plate of  $V_2$  is not connected to anything except  $R_2$ , i.e., to no significant capacitance except that of the output capacitor (and the tube's plate-to-ground capacitance), which may be very small. Thus a very fast waveform is obtainable at this point.

Its operation may be described as follows: in the quiescent state,  $V_1$  is cut off, due to the high bias applied to its cathode.

This bias is the drop across  $R_5$ , and results from the high plate current flowing through  $V_2$ , this tube being in the conducting state, since its grid is effectively at cathode potential through  $R_4$ . Now a positive trigger of sufficient amplitude is applied to the grid of  $V_1$  through coupling capacitor  $C_c$ , causing  $V_1$  to rise out of cutoff and begin to conduct. The flow of the plate current produces a negative pulse at the plate of  $V_1$ . This pulse is transferred to the grid of  $V_2$  through capacitor  $C$ . The plate current of  $V_2$  then decreases, the voltage drop across  $R_5$  drops, permitting  $V_1$  to draw still more plate current, increasing the negative pulse at its

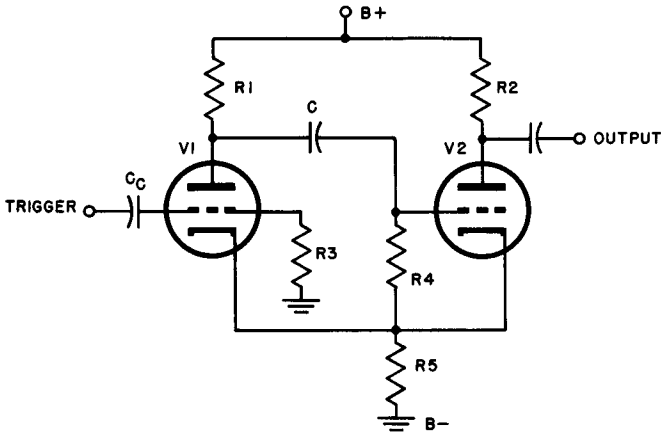

Fig. 15. Self-biased monostable multivibrator.

plate, etc. The transition to the state in which  $V_1$  is full-on and  $V_2$  is cut off proceeds as before and the circuit remains in the quasi-stable condition until  $C$  discharges sufficiently to allow the grid of  $V_2$  to rise from the voltage beyond cutoff to the point where conduction may once more begin. As  $V_2$  begins to pass plate current, the voltage drop across  $R_5$  again starts to increase, reducing the plate current of  $V_1$ , which in turn transmits a positive pulse to the grid of  $V_2$  to bring the circuit back to its original stable state.

In analyzing the circuit operation of this arrangement, the question of the relative conductivities of the tubes when either is full-on often arises. With no trigger applied, the grid of  $V_2$  is at cathode potential so that its bias is zero; when  $V_1$  is full-on, however, its grid is always negative with respect to its cathode, since

the former is returned to ground; hence there is always some negative bias. Thus in the stable state the current through  $R5$  is considerably higher than in the quasi-stable condition, and it is this variation of cathode current that accounts for the feedback.

## 22. Self-biased Mono-stable Multivibrator with Positive Grid Return

For very precise timing applications, the circuit shown in Fig. 16 is preferred over that of Fig. 15. The significant difference between the two arrangements is that  $R4$  in the latter case is returned to  $B+$  rather than to the cathode; also, the grid of  $V1$  is at a fixed voltage,  $E$ , controllable by the setting of  $R3$ .

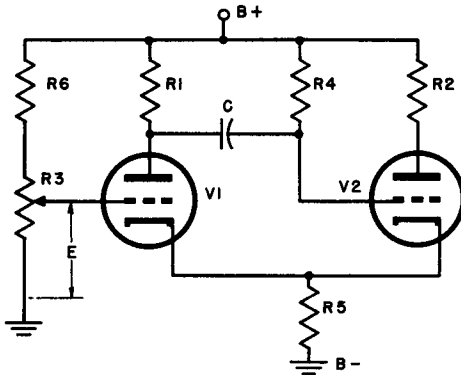

Fig. 16. Modification of self-biased monostable multivibrator, for accurate timing.

Let us examine the sequence of operational events first, then determine the advantage that the positive grid return has over the ground grid return. In the quiescent state,  $V2$  is full-on with its grid-cathode voltage at zero potential or slightly positive. Voltage  $E$  is made less positive than the cathode potential of  $V1$  by an amount equal to at least the cutoff voltage of the tube, thus  $V1$  is non-conductive. A negative trigger injected into the grid of  $V2$  causes the plate current of the tube to decrease, with a consequent reduction of the drop across  $R5$ . If the change is sufficient,  $V1$  will begin to conduct and start the runaway action. At the end of the transition period, which is virtually instantaneous, the grid of  $V2$  has been driven far below its cathode, but its potential immediately begins to rise exponentially toward  $B+$  with a time constant equal to  $R4C$ . ( $R1$  is neglected since, as usual, its resistance is very much

lower than  $R4$ .) As soon as the potential on the grid of  $V2$  rises above cutoff, the circuit flips back to the stable state.

The more accurate timing action of this circuit as compared to the one using cathode return is explained as follows: referring to the instant when the circuit has reached the quasi-stable state with  $V2$  cut off and  $V1$  full-on, capacitor  $C$  in both cases begins to discharge toward the point where  $V2$  will come out of cutoff and start to conduct. To cut  $V2$  off, in the multivibrator of Fig. 16,  $C$  must charge to a relatively high voltage, because the grid of the tube is connected to the high positive voltage of the supply; thus, to allow conduction to occur once again in  $V2$ , only a comparatively small discharge need occur, taking place along the very linear portion of the curve (Fig. 17A). Angle A indicates that the approach to the cutoff voltage is very rapid, so that slight changes in circuit conditions and voltages have negligible effect upon the time required for  $C$  to discharge to the conduction point. Contrast this with the behavior of  $C$  in the circuit of Fig. 15, illustrated at (B)

Fig. 17. Comparison between timing action in circuit of Fig. 16(A) and in circuit of Fig. 15(B).

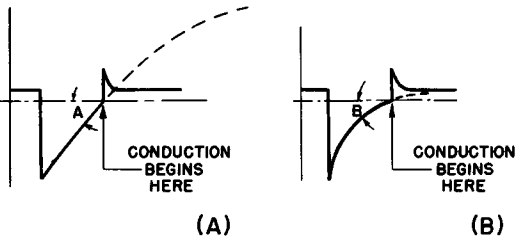

of Fig. 17. Here  $C$  takes on a much smaller total charge at the end of the transition period, and hence must discharge almost completely before the restoring action commences. Hence its discharge occurs over a much greater length of the curve, approaching the cutoff point at a relatively small angle (angle B indicating slow approach). In this situation, the same small variations in tube or circuit conditions are apt to produce a serious change in the timing.

In addition to its timing accuracy, the circuit of Fig. 16 has another marked advantage over other types. The time required for the completion of one cycle is a linear function of voltage  $E$ , hence this arrangement makes an excellent delay gate, whose width is easily and linearly controlled by the setting of  $R3$ .

### 23. Frequency Division or "Counting Down"

The mono-stable multivibrator is well-suited to frequency division applications, particularly when odd divisions, difficult to obtain with the bi-stable type, are required. Consider a regular train of pulses spaced a time,  $T$ , apart as in Fig. 18; assume that the output pulse width of the mono-stable multivibrator has been adjusted to occupy a time somewhere between  $2T$  and  $3T$ . Referring to the positive grid return setup of Fig. 16, the first negative pulse in the train, applied to the grid of  $V_2$ , almost instantaneously triggers the transition, so that a positive voltage appears at the plate of  $V_2$  (point A, Fig. 18).  $V_2$  remains cut off through the

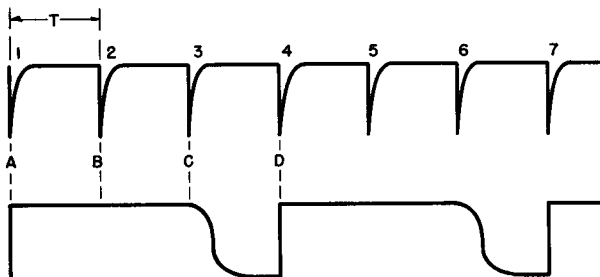

Fig. 18. Waveforms illustrating frequency division (counting down) in a mono-stable multivibrator.

interval while pulses 2 and 3 appear and, since these are negative pulses like the first, they cannot affect the circuit, because  $V_2$  is already cut off. After pulse 3 has passed, the charge on  $C$  decays sufficiently to permit the circuit to return to the true stable state quickly (between c and d) so that it is in readiness for the arrival of pulse 4, which causes the process to repeat.

When the time constant,  $R_4C$ , and the magnitude of  $E$  are properly selected to yield this effect, the multivibrator will produce output pulses, after differentiation, which correspond to input pulses 1, 4, 7, 10, 13, etc. This, then, is a 3:1 frequency division, as used in DuMont Image Orthicon Camera Chain TA-124-E, described in the next paragraph. The stability of this type of frequency divider depends upon the constancy of the multivibrator period and, if it is desired to count down, say, 100:1 the width would have to lie between  $99T$  and  $100T$ . If, for any reason, the

width should wander outside these limits, there would be a false count, perhaps 99:1 or 101:1 stable divisions as high as 25:1 can be obtained under laboratory conditions; in commercial equipment the division is usually limited to 7:1 or less for dependability.

#### 24. A Commercial Three-to-one Mono-stable Multivibrator

The 3:1 count multivibrator to be described is used in an Image Orthicon Camera Chain (DuMont TA-124-E) for counting down trigger pulses which originate in a 31.5-kc controlled blocking oscillator. This frequency is successively divided by a cascaded

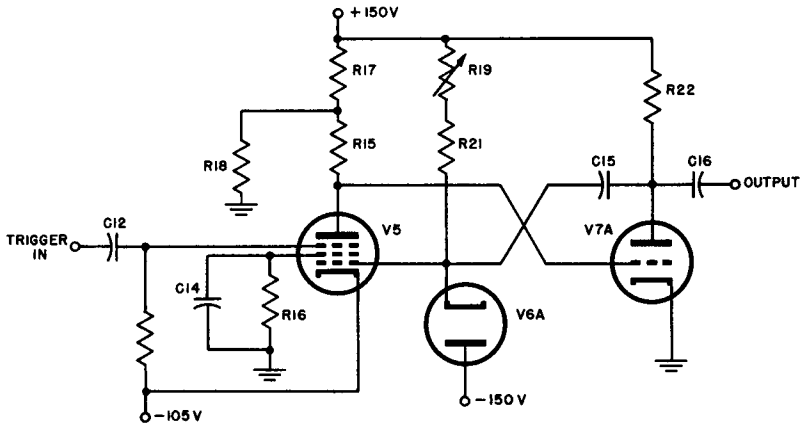

Fig. 19. Circuit of 3:1 count-down multivibrator. (After DuMont)

group of four mono-stable multivibrators by counts of 3, 5, 7, and 5, the output frequency of the group being 60 cycles, the television field-rate:

$$31.5/3 = 10.5 \text{ kc}$$

$$10.5/5 = 2.1 \text{ kc}$$

$$2.1/7 = .3 \text{ kc} = 300 \text{ cps}$$

$$300/5 = 60 \text{ cps}$$

The circuit of the 3:1 count multivibrator is given in Fig. 19. V5 is conducting because a positive potential of nearly 150 volts is applied to its control grid through R19 and R21, while its cathode is at a potential of -105 volts. The grid current flowing through

$R21$  and  $R19$  makes this grid, therefore, zero or fractionally positive. Assuming little voltage drop in the tube, this heavy conduction forces the plate of  $V5$  (hence the grid of  $V7A$ ) to assume a voltage close to that of the cathode of  $V5$ . For this reason,  $V7A$  must be at cutoff or beyond, its control grid close to  $-105$  volts, with cathode at ground potential. This is the stable state of the system.

The application of a negative pulse to the suppressor of  $V5$  produces a sharp drop in plate current, a positive pulse at its plate and therefore at the grid of  $V7A$ , and a rise of  $V7A$  into conduction. Thus a negative pulse appears at the plate of this tube and is transferred to the control grid of  $V5$  through  $C15$ , dropping the plate current of  $V5$  still further. The action ceases temporarily when  $V5$  is at cutoff and  $V7A$  is full-on, with capacitor  $C15$  charged to the new voltage conditions. As the charge leaks off, a point is reached at which  $V5$  can again begin to conduct; this, of course starts the process in which the system returns to its stable state. The output square wave is differentiated through  $C16$  and the grid circuit of the next stage, providing a strong negative trigger pulse of the desired waveform for activating the succeeding counters.

Note the connection of diode  $V6A$ . In the quiescent state, the cathode of this tube is virtually at zero potential and its plate sees  $-150$  volts of applied potential from the power supply; thus  $150$  volts of inverse potential appears between its electrodes. The reader may recognize this as a simple diode clamping system whose function is to limit the pulse voltage applied to the control grid of  $V5$  regardless of variations that may appear at the plate of  $V7A$ . Should the fed-back pulse amplitude become too great,  $V6A$  conducts and instantaneously reduces its size to its former "clamped" value.

The time constant of the system is chosen by the proper adjustment of  $R19$ ; since this resistor governs the time required for discharge of  $C15$ , this is the interval in which the circuit remains in the quasi-stable state; it controls the frequency division ratio, in this case 3:1.

## 25. Review Questions

- (1) How is a bi-stable multivibrator changed to a mono-stable multivibrator?
- (2) Draw the circuit of a mono-stable multivibrator.
- (3) Detail and explain the circuit operation of a mono-stable multivibrator.

- (4) Explain "reversion action" in a mono-stable multivibrator.
- (5) Diagram the waveforms obtainable from a mono-stable multivibrator.
- (6) How may a mono-stable multivibrator be used to gate other circuits?

For accurately controlled delay purposes?

- (7) How does the circuit of Fig. 15 act as a multivibrator?
- (8) Redraw Fig. 15 so as to convert it to a self-biased mono-stable multivibrator with positive grid return.
- (9) Show the application of a mono-stable multivibrator to frequency division or counting down.
- (10) Explain the operation, advantages, and applications of the circuit drawn in answer to question 8.



## Chapter 4

### A-STABLE MULTIVIBRATOR

#### 26. Action of the Fundamental Circuit

The a-stable multivibrator differs from the bi-stable type in that the plate of each tube is capacitively coupled to the grid of the other rather than being coupled through resistors. Compare Fig. 20 with Fig. 5. This difference converts the bi-stable multivibrator to a form in which the transition from one stable state to the other occurs automatically and periodically, with the result that free-running square-wave oscillations are obtained.

The circuit may be set up symmetrically with  $R_{L1} = R_{L2}$ ,  $C1 = C2$ ,  $R_{g1} = R_{g2}$ , and the two tubes having identical parameters. One might suppose that such symmetry would lead to a stable condition in which both tubes are full-on or part-on, depending upon the sizes of the grid resistors and the amount of contact-potential bias developed. This supposition is indeed a possibility until one considers that even if the arrangement is *absolutely symmetrical*, instantaneous conduction in both triodes cannot be identical at successive intervals due to inherent tube "noise," unequally distributed emission along the length of the cathode, and other random effects that must inevitably contribute to an instantaneous difference between the two plate currents. As soon as this difference exists, circuit action commences. In actuality, oscillations start as soon as the tubes are heated and the plate potential is applied.

Let us start by assuming both plate currents to be equal and assuming also that a burst of electrons from the cathode of  $V1$  increases the plate current of this tube slightly; instantly, the plate potential drops and a negative pulse appears at the grid of  $V2$ . The resulting positive pulse at the plate of  $V2$  is then fed back to the grid of  $V1$  through  $C1$ , further increasing its plate current, thus starting the transition, which terminates when  $V1$  is full-on and  $V2$  is cut off. As in the other multivibrators discussed in previous chapters, the transition occurs almost instantaneously.

An analysis of the grid and plate waveforms is best started from this point and, for clarity, certain reasonable figures may be assumed for the circuit voltages and component values. These are shown in Fig. 20.

Fig. 20. Basic a-stable multivibrator circuit.

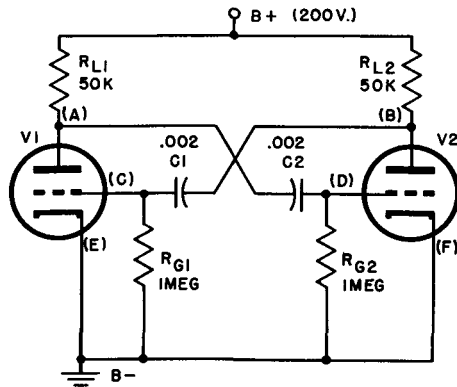

With  $V2$  non-conducting, the potential at point B must be equal to the supply voltage, since there is no drop in  $R_{L2}$ , (i.e.,  $E_{p2} =$  approximately 200 volts). At the same time, a full-on condition in tube  $V1$  means that its grid is at or near zero potential with respect to ground, so that  $C1$  must be charged to about 200 volts negative on the  $V1$  grid side. When the grid of  $V1$  is near zero, however, the potential at point A is about 40 volts. This figure is obtained by drawing the 50k ohm load line into the plate characteristics of 1/2 6SN7 or a 6J5, typical multivibrator tubes. Consideration must also be given to the voltage at the grid of  $V2$  at this instant: at cutoff, a very high negative potential must appear on the grid; as we have done before, we might assume a voltage of at

least twice cutoff, but, as we shall see, it is actually much greater than this. As a matter of fact, it is approximately equal to the swing of the  $V_2$  plate voltage during transition. ( $200 - 40 = 160$  volts.)

$$E_{p2} = 200 \text{ volts}$$

$$E_{g2} = -160 \text{ volts}$$

$$E_{p1} = 40 \text{ volts}$$

$$E_{g1} = \text{zero volts}$$

Therefore:

$$\text{Charge on } C1 = 200 \text{ volts}$$

$$\text{Charge on } C2 = 65 \text{ volts}$$

Consider now what must be happening in the grid circuit of  $V_2$  if there is a  $-160$ -volt difference between the grid and cathode: a current must be flowing through grid resistor  $R_{g2}$  under the pressure of this difference of potential. Obviously, this current must be flowing out of  $C2$ , because grid current cannot flow when the grid is so negative with respect to cathode; thus the voltage across  $C2$  must be changing. This capacitor must be "moving" up along an exponential discharge curve, which would terminate when  $R_{g2}$  stops taking current or, in other words, when point  $D$  reaches ground potential (if other events did not prevent it). Something does happen, however, that changes the smooth discharge of  $C2$ : at the same time point  $D$  arrives at the  $-12$ -volt level,  $V_2$  begins to conduct, sending a negative pulse to point  $C$ , producing a positive pulse at  $A$  and, therefore, a positive pulse at  $D$ . Thus the potential at  $D$  is suddenly lifted above the zero axis (Fig. 21), but drops quickly to approximately zero as the  $V_2$  grid draws current and brings the potential at  $D$  to ground level.

All that remains now is to show that, at the instant when  $V_2$  begins to conduct,  $E_{p1}$  (point  $A$ , Fig. 20), jumps from its conducting plate voltage of 40 volts to its cutoff plate voltage of 200 volts, completing the second transition. As  $V_2$  starts to conduct, point  $B$  begins to become less positive, carrying  $C$  with it. The time required for  $V_2$  to go from the condition where conduction just starts to the tip of the overshoot (Fig. 21) is virtually zero, hence  $C$  goes to the  $-160$  volt point just as quickly, with  $V_1$  cutting off almost instantaneously. The process now repeats, this time with  $C1$  discharging along an exponential curve until conduction in  $V_1$  again commences. The grid voltage waveforms for  $V_1$  are, therefore, exact reproductions of those for  $V_2$ , but are displaced by  $1/2$  cycle along the time axis.

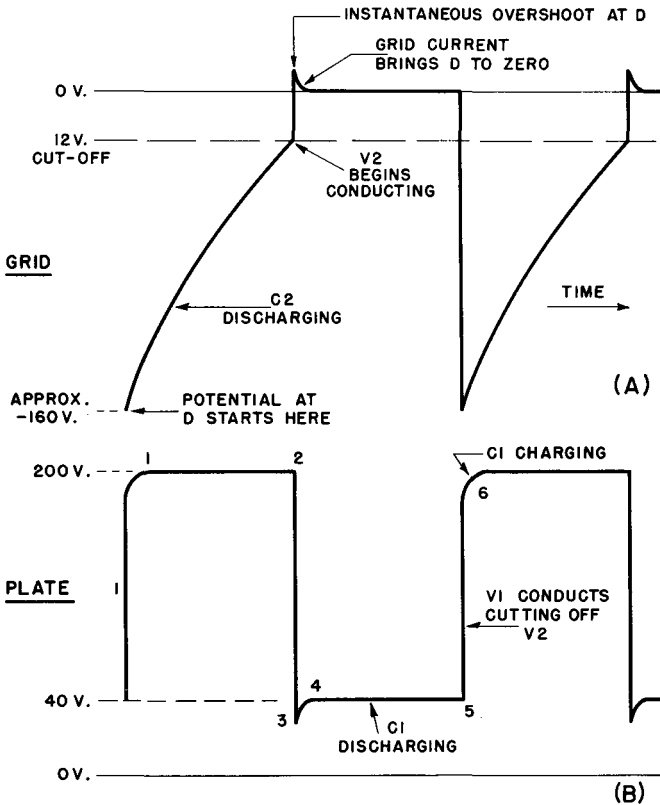

Fig. 21.  $V_2$  waveforms in a-stable multivibrator.

The output waveforms at the plate of  $V_2$  are shown in Fig. 21 (B). They begin at the point where the grid of  $V_2$  is well below cutoff ( $-160$  volts), no current is flowing in the plate-cathode circuit, and the plate potential is equal to that of the supply (200 volts). The voltage at  $B$  remains at this level until the instant when  $V_2$  begins to conduct; now the almost instantaneous change takes place in which the grid of  $V_2$  soars above the zero line (instantaneous overshoot), taking the plate voltage down into an overshoot below the 40-volt line, as shown from 2 to 3 in Fig. 21 (B). The plate potential of  $V_2$  is quickly established at 40 volts as grid current brings the  $V_2$  grid to zero (3 to 4), remains at 40 volts as  $C_1$  discharges (4 to 5), and then returns to the 200-volt level when  $V_1$  begins to conduct and cuts off  $V_2$  (5 to 6).

The rounded corners at 1 and 6 are due to the charge time of  $CI$ . Since this period is extremely short, such defects in the square waveform are not noticeable in practice. Of course, the output waveform at the plate of  $V1$  is the same as that for  $V2$ , again being displaced along the time axis by  $1/2$  cycle.

## 27. The Frequency of the Multivibrator

Formulas for computing the frequency of an a-stable multivibrator are available, but these are complex, difficult to apply, and outside the scope of this book. A surprisingly accurate measure of the frequency of a multivibrator may be obtained, however, by applying the foregoing analysis.

Three factors are of importance in frequency determinations:

- a. The  $RC$  time constant of each capacitor-resistor combination in the grid circuits of the tubes. Assume these to be symmetrical.
- b. The actual cutoff voltage of the tubes.
- c. The plate voltage swing between the conducting and the non-conducting state.

Again, a numerical example helps to explain the procedure. We shall use the circuit and values of Fig. 20. When a tube goes from a non-conducting to a conducting state, its plate voltage drops from 200 volts to 40 volts. This forces the grid of the other tube to jump from about zero volts to a level of  $-160$  volts. This tube remains non-conductive until the capacitor discharges from  $-160$  volts to the cutoff level,  $-12$  volts in our example. While the total possible discharge range is from  $-160$  volts to zero volts, i.e., 160 volts of change, the actual range is only 148 volts ( $-160$  to  $-12$ ).

The real change is then:

$$\frac{148}{160} = .925 = 92.5 \text{ percent of the possible change}$$

The time required for a capacitor to discharge 92.5 percent of its voltage may be found in the universal time constant charts and is virtually equal to 2.6 time constants. The time constant of either  $RC$  combination in the example of Fig. 20 is ( $R = 1$  megohm  $C = .002 \mu\text{f}$ ):

$$TC = 1 \times .002 \text{ seconds}$$

$$2.6 \text{ TC periods} = .002 \times 2.6 = .0052 \text{ seconds}$$

The time of .0052 seconds, then, specifies the interval during which either tube is cut off while the other is conducting, so that the time required to complete a full cycle is  $2 \times .0052 = .0104$  seconds. The frequency (reciprocal of period) is, therefore,  $1/.0104 = 96.1$  cycles per second.

## 28. Synchronization of the A-Stable Multivibrator

The dependence of the a-stable multivibrator period on a number of circuit and voltage conditions acting together leads to poor frequency stability, a condition which is advantageous when it is desired to *synchronize* the oscillator with some external signal source. A crystal oscillator, in contrast, is so stable that it is difficult if not impossible to make it synchronize with any frequency removed from its natural one. Thus the instability of the multivibrator, a characteristic having an unpleasant implication, is the very thing that makes it so useful in most of its applications.

In modern practice, multivibrators are commonly synchronized by peaked waveforms, although other shapes, such as square or sinusoidal waves, may be employed if the conditions warrant. In any case, either a negative or positive pulse of sufficiently great amplitude may be used if correctly injected. Figure 22 illustrates the importance of pulse amplitude (positive pulse) in triggering a multivibrator before the end of its natural period so that it will synchronize at a frequency somewhat higher than its free-running repetition rate. In (A), the pulse, at the time it appears, is too small to pull the tube out of cutoff, so that it comes and goes without affecting the multivibrator frequency in any way. The natural half-period, as determined by the factors discussed in Par. 27, is shown here as  $t$ . When the pulse amplitude is greater (Fig. 22 B), even though it appears at the same time as before with relation to the multivibrator cycle, switching does take place at point 1 rather than at point 2 when there are no sync pulses. Note that the half-period is now substantially shorter ( $tI$ ), which means that the multivibrator frequency is higher. The action is repetitive, of course, and synchronization holds cycle after cycle; under these conditions, the multivibrator is said to be "locked in."

A positive trigger injected into a conducting tube cannot alter the frequency of the multivibrator, because the tube is already con-

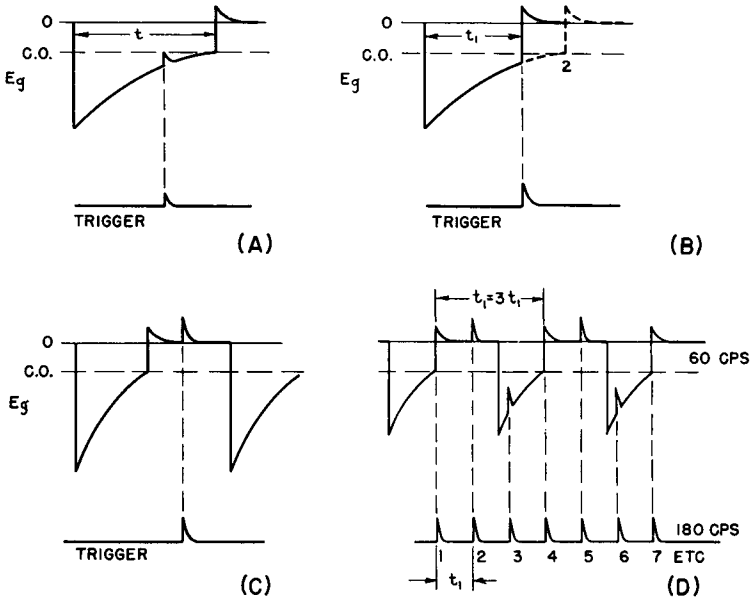

Fig. 22. Grid waveforms in a-stable multivibrator, showing trigger pulses. (A) trigger too weak, (B) trigger controlling properly, (C) late trigger due to natural multivibrator frequency higher than trigger frequency, (D) sync at submultiple of trigger frequency.

ducting. The pulse rides the top of the waveform (Fig. 22C), without influencing the multivibrator one way or the other. Negative synchronizing pulses are often present in timing equipment, and may be utilized to lock-in a multivibrator by injecting them into the grid circuit of the conducting tube. The action is an indirect one in this situation; the negative pulse does not cause the conducting tube to revert suddenly to the cutoff state; rather it is amplified and inverted in phase by the conducting tube and is then applied as a positive pulse to the grid of the tube in the cutoff state. Hence the action is similar to that depicted in Fig. 22 at the instant of switching.

In general, the natural period of the multivibrator must be greater than the interval between synchronizing pulses (Fig. 22B) if locking-in is to be realized; otherwise, the pulses arrive at the grid of the tube after it has gone into conduction, and cannot affect the frequency. Thus the sync pulse repetition rate must be of higher frequency than that of the multivibrator for successful synchronization. In some applications, the aim is to synchronize

the multivibrator at some sub-multiple of the sync frequency; for example, the synchronization of a 60-cps multivibrator by pulses having a repetition rate of 180 cps. This is illustrated in Fig. 22 (D). The multivibrator is tripped on pulses 1, 4, 7, 10, 13, etc., the relationship between periods being 3:1 as shown in the diagram.

Synchronizing pulses are commonly injected into the multivibrator system by means of coupling capacitors to the grid of one of the tubes or through a transformer having a low impedance secondary as shown in Fig. 23.

### 29. Cathode-Coupled A-stable Multivibrator

The circuit of Fig. 24 should be compared with that of Fig. 15, the self-biased mono-stable multivibrator. It will be noted immediately that the only difference between these two arrangements is that in the mono-stable circuit  $R4$  is returned to cathode, while in the a-stable circuit this resistor is returned to ground. In the

Fig. 23. Transformer coupling of trigger to a-stable multivibrator.

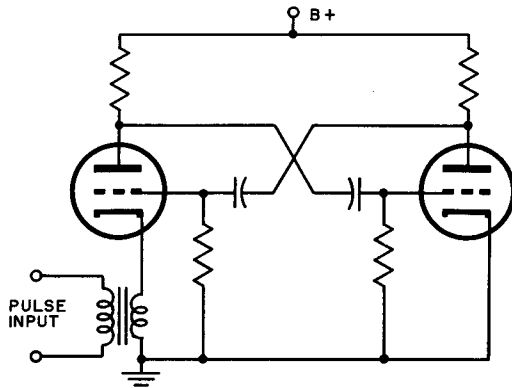

last few sentences in Par. 21, it was pointed out that the cathode return of  $R4$  to  $V2$  is capable of placing this tube in the stable state, because the grid bias is zero under these conditions, resulting in a heavy current through  $R5$ , the common cathode resistor. The large voltage drop across  $R5$  provides a sufficiently high bias for  $V1$  to keep it cut off; hence the circuit is stable. In the case of the ground-return grid resistor ( $R3$  of  $V1$  in Fig. 15), the current through  $R5$  is not nearly as great, and the voltage drop across it



is too small to keep  $V2$  cut off after (C) discharges; therefore, this results in the quasi-stable state.

It should be evident from this that should *both* grid resistors be returned to ground as in Fig. 24 the circuit would have no stable state at all. In short, with either tube conducting the quasi-stable condition would obtain and, of course, must result in free-running oscillations.

The sequence of voltage transfers that result in one cycle of free-running oscillation is outlined below:

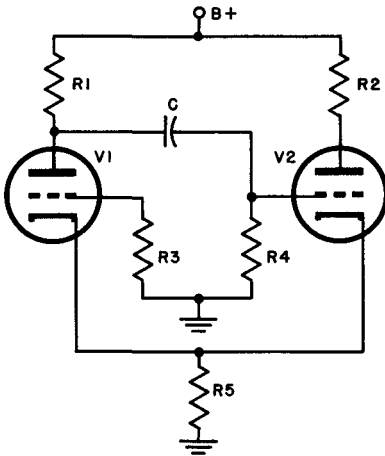

Fig. 24. Circuit of a-stable cathode-coupled multivibrator.

a. With the application of power, plate current starts to flow in both tubes. Its size is limited by the bias applied as a voltage drop across  $R5$ .

b. Assume that the plate current of  $V1$  is slightly greater than that of  $V2$ . This produces a negative pulse at its plate that is transferred instantaneously through (C) to the grid of  $V2$ , starting the transition which terminates with  $V1$  full-on and  $V2$  cut off.

c. When C discharges sufficiently,  $V2$  rises out of cutoff, draws plate current, and increases the drop across  $R5$ , thus raising the bias on  $V1$ .

d. The plate current of  $V1$  drops slightly, generating a positive pulse at its plate, which is instantaneously coupled to the grid of  $V2$ , increasing its plate current still further. Thus the transition

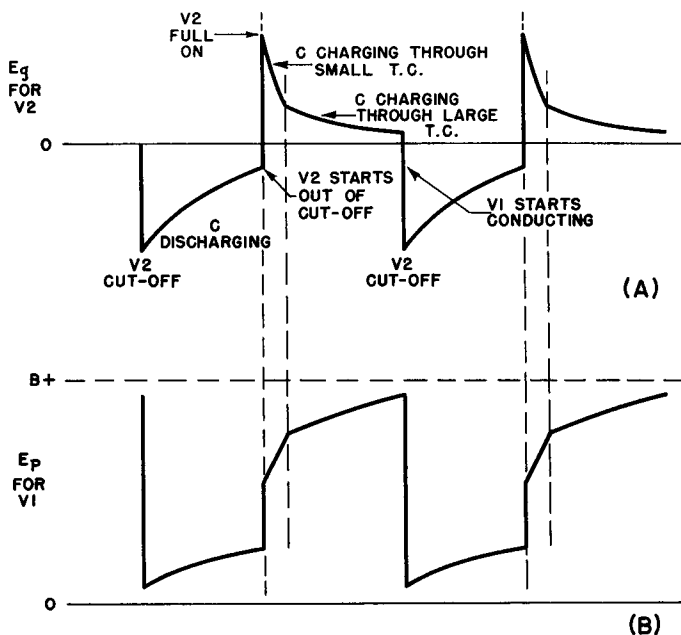

Fig. 25. Waveforms in cathode-coupled a-stable multivibrator.

to the state in which  $V_2$  is full-on and  $V_1$  is cut off takes place.  $V_1$  is held non-conducting by the large voltage drop across  $R_5$ .

e. At the instant when the grid of  $V_2$  is driven positive by the pulse from the plate of  $V_1$ , grid current begins to flow in  $V_2$ , and  $C$  begins to charge through two separate paths:

1.  $R_5$ , cathode-to-grid resistance of  $V_2$ , and  $R_1$
2.  $R_4$  and  $R_1$

The short time constant of these parallel paths permits  $C$  to charge quickly until the grid reaches cathode potential. Now grid current ceases, but the capacitor continues to charge through path (b) at a slower rate than before, because the time constant of this path alone is higher. When the voltage across  $R_5$  drops to the cutoff voltage of  $V_1$ , this tube instantly starts to conduct, renders  $V_2$  non-conducting by passing a negative pulse from its plates through  $C$  to the grid of  $V_2$ , and the cycle is complete, with  $V_1$  full-on and  $V_2$  cut off.

Figure 25 (A) illustrates the voltage variations at the grid of  $V_2$  and shows the change in waveform that occurs when  $C$  transfers

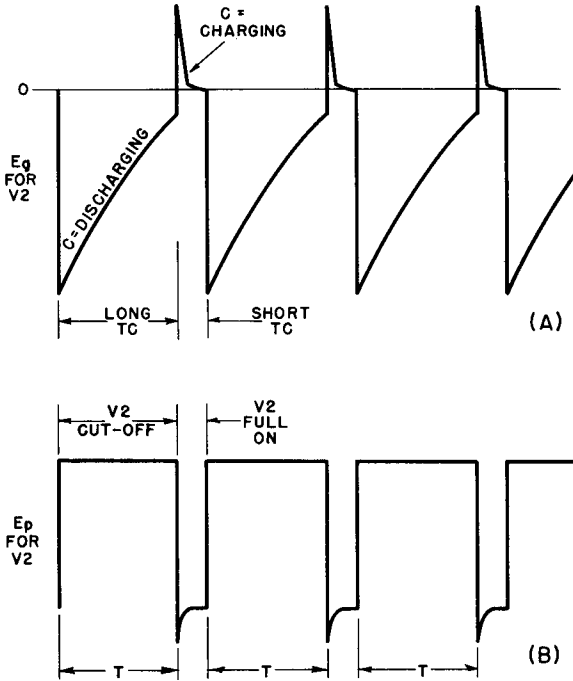

Fig. 26. Asymmetrical waveforms in cathode-coupled a-stable multivibrator in which V2 grid draws current over most of cycle.

from the low to the high TC charge path. The effect this has upon the voltage at the plate of V1 is pictured in Fig. 25(B). Since the output square-wave from a cathode-coupled multivibrator is almost always taken from the plate circuit of V2 (in which square waves like those in Fig. 21(B) are produced) the distorted voltages at the V1 plate are of no significance.

The cutoff interval for V2 is proportional to the time constant on discharge for capacitor C, while V1 remains cut off for a period that is a function of the charge time constant of the same capacitor. The latter, as the foregoing discussion points out, may be subdivided into two distinct TC periods depending upon the presence or absence of grid current in V2. It is, therefore, quite easy to make the charge time constant much shorter than that of discharge by proportioning the circuit constants in such a way as to have V2 draw grid current for most of the half-cycle. When this is done, the output of the multivibrator becomes asymmetrical, as dia-

grammed in Fig. 26. The property of asymmetry is often useful in specialized radar and television applications.

### 30. Review Questions

- (1) Differentiate between the a-stable multivibrator and the bi-stable type.
- (2) Draw a circuit representing an a-stable multivibrator.
- (3) Explain in detail the circuit operation of the a-stable multivibrator.
- (4) Enumerate three factors of importance in the frequency determination of the a-stable multivibrator.
- (5) Explain how an a-stable multivibrator may be synchronized with external signal sources.
- (6) What is meant by "locked in" when the term is applied to a multivibrator?
- (7) What changes are necessary in Fig. 15 to convert the circuit to a cathode-coupled a-stable multivibrator?
- (8) Explain the operation of the cathode coupled a-stable multivibrator.
- (9) What type of waveform is most commonly employed to synchronize the a-stable multivibrator?
- (10) Recapitulate briefly the differences between the fundamental classes of multivibrators reviewed to this point.

## INDEX

- A-stable multivibrator, 2, 3, 36
- A-stable multivibrator, action of, 36, 37, 38, 39
- A-stable multivibrator, frequency of, 40, 41
- A-stable multivibrator, synchronization of, 41, 42, 43
- Asymmetrical waveforms, 46
  
- Bias voltage, function of, 7
- Binary, 3
- Binary counter, 3
- Binary scale-of-two counter, 16
- Binary scale-of-two counter, analysis of, 16, 17
- Bi-stable multivibrator, 2, 3
- Bi-stable multivibrator, analysis of, 8, 9, 10
- Bi-stable multivibrator as a regenerator, 17
- Bi-stable multivibrator, circuit diagram of, 7
- Bi-stable multivibrator, circuit of, 6
- Bi-stable multivibrator, design procedure, 21, 22, 23
- Bi-stable multivibrator, locking circuit, 18
- Bi-stable multivibrator, trigger action of, 10
- Bi-stable to mono-stable conversion, 24
  
- Cascaded binary counter, 13
- Cathode-coupled a-stable multivibrator, 43
- Cathode-coupled a-stable multivibrator, circuit of, 44
- Cathode-coupled a-stable multivibrator, waveforms in, 45, 46
- Commutating capacitor, 15
- Count-down multivibrator, 33, 34
- Counting down, 32, 33
- Cut off, 8
  
- Decay time, 15
- Design procedure, bi-stable multivibrator, 21, 22, 23
- Diode trigger feed, 18, 19
  
- Eccles-Jordan trigger circuit, 3
  
- Flip-flop, 3
- Flopover circuit, 3
- Frequency divider, 3
- Frequency division, 32
- Full-on, 5, 8
  
- Gating, 4, 28
  
- Grid waveforms in a-stable multivibrator, 42
  
- Locking circuit, 3, 18
  
- Mono-stable multivibrator, 2, 3, 24
- Mono-stable multivibrator, circuit operation, 24, 25
- Multivibrator action, 4
- Multivibrator, definition of, 1, 2
- Multivibrator, properties of, 4
  
- Negative going pulse, 3
- Negative triggers, 13
- Net voltage, 8
  
- "Off," 5
- "On," 5
- One-shot multivibrator, 3
  
- Part-on, 8
- Peaked trigger, 28
- Plus and minus triggers, 13
- Positive going pulse, 3
- Positive trigger, 12
- Pulse output, 12
- Pulse width, 14
  
- Regenerator, 3, 18
- Relaxation oscillator, 1
- Repeater, 3
- Reversion action, 26
- Rise time, 15
  
- Self-biased bi-stable multivibrator, 11
- Self-biased bi-stable multivibrator, circuit of, 11
- Self-biased mono-stable multivibrator, 28, 29, 30
- Self-biased mono-stable multivibrator positive grid return, 30, 31
- Shunt capacitance, 14
- Square-wave output, 12
- Stable state, 2
- Synchronization of a-stable multivibrator 41, 42, 43
  
- Three-to-one mono-stable multivibrator, 33, 34
- Trigger circuit, 10
- Trigger pulses, simultaneous applications of, 13
  
- Waveforms, mono-stable multivibrator, 27