

Lawson W. Dams

DIAL CORD *Stringing* GUIDE

DC-6

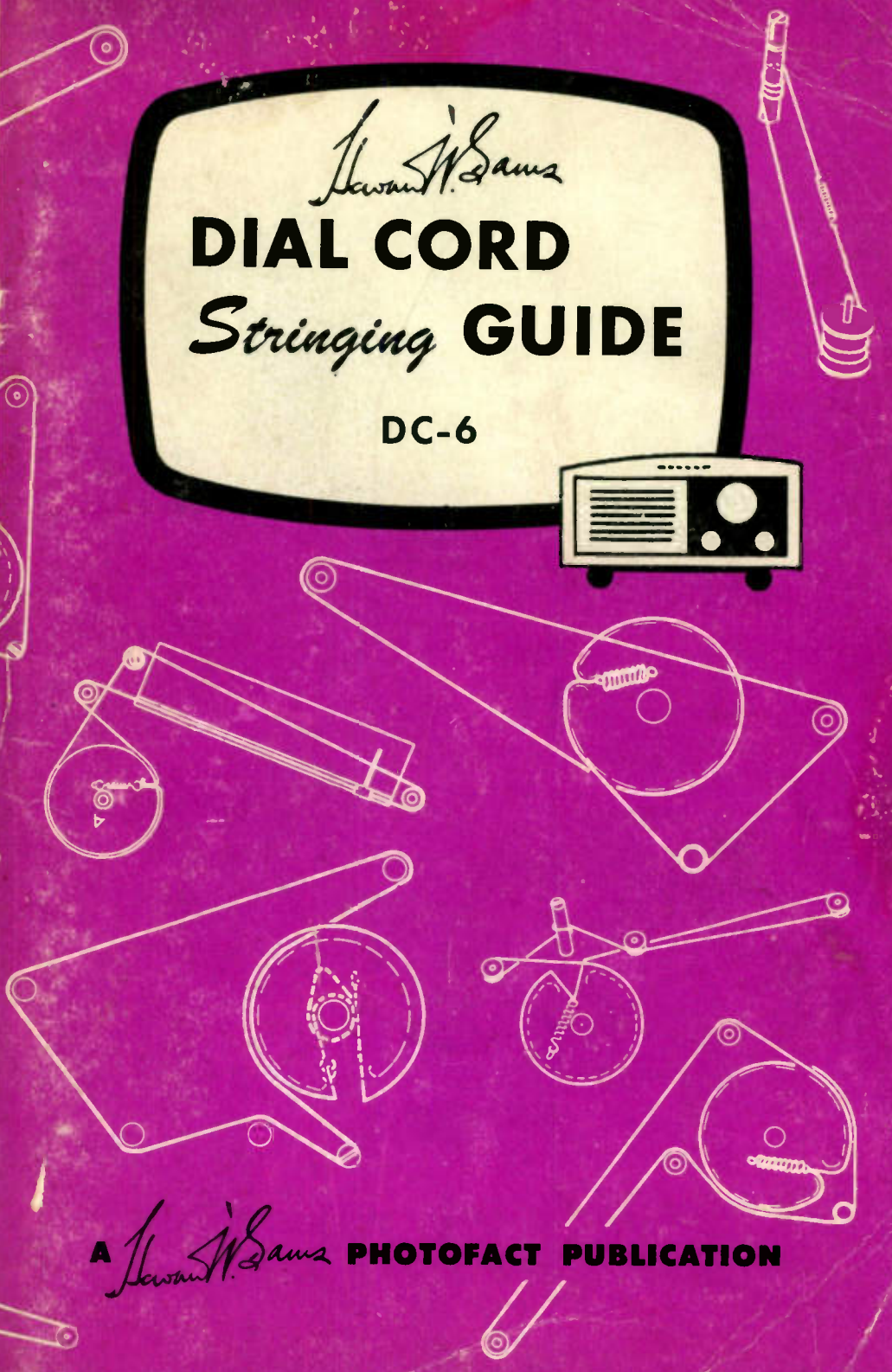

A *Lawson W. Dams* **PHOTOFACT PUBLICATION**

\$1.00

Howard W. Sams
DIAL CORD
Stringing **GUIDE**

DC-6

FIRST EDITION • FIRST PRINTING • MAY 1958

Reproduction or use, of editorial or pictorial content, in any manner, without express permission, is prohibited. No responsibility is assumed with respect to application or patent liability of the included material.

© Howard W. Sams & Co., Inc., 1958
Indianapolis 5, Indiana

Printed in the United States of America

Compiled and Published by
HOWARD W. SAMS & CO., INC.
Indianapolis, Indiana

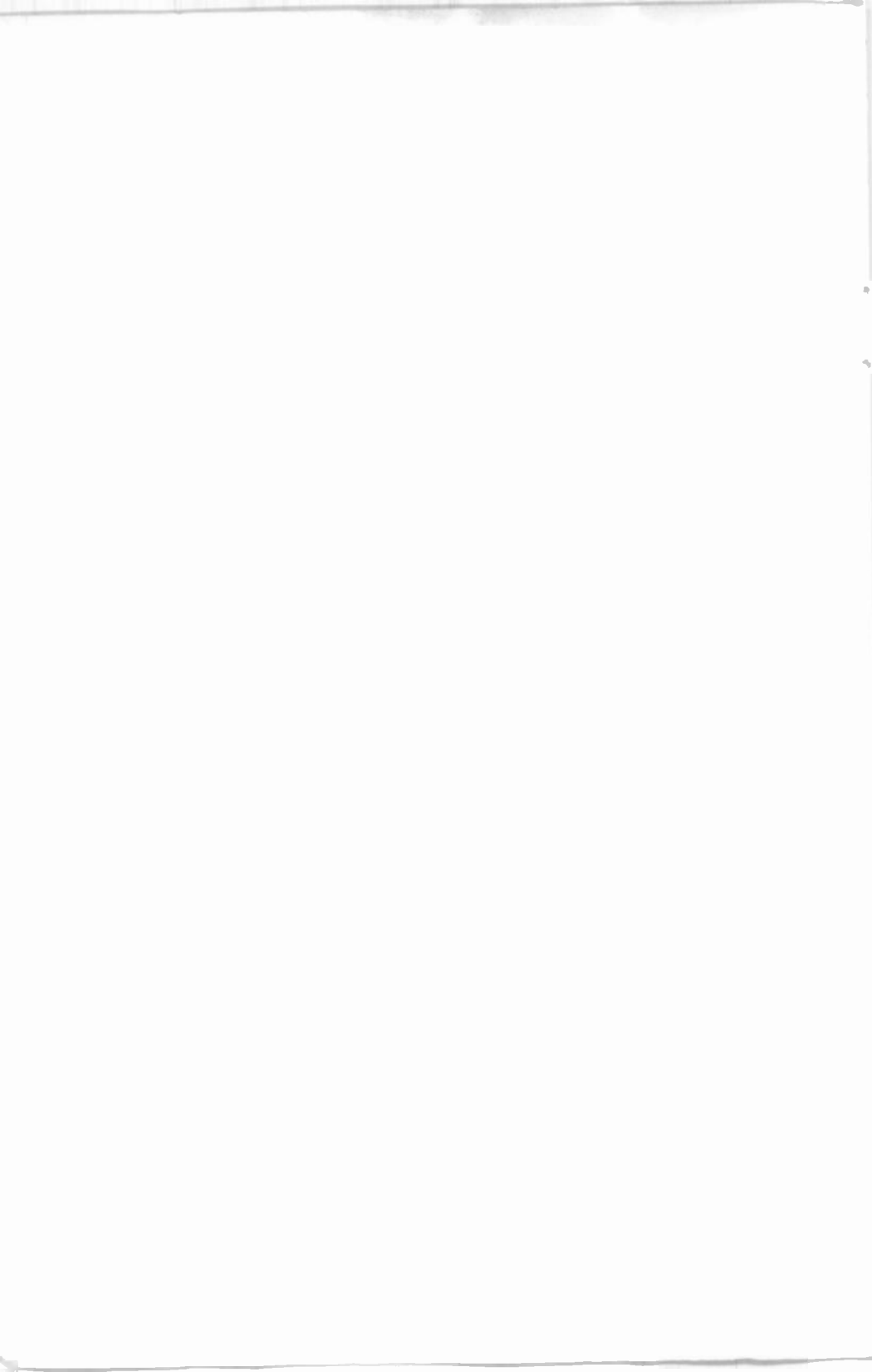

INDEX

Name & Model or Chassis No.	Vol. No.	Diag. No.	Name & Model or Chassis No.	Vol. No.	Diag. No.	Name & Model or Chassis No.	Vol. No.	Diag. No.
ADMIRAL			ADMIRAL (cont'd)			ADMIRAL (cont'd)		
Chassis			KU2216, KU2217	5	1813	7C61, 7C62, A,		
UL5K1	2	553	L23B6, L23B7	6	2253*	7C82UL	1	7
UL7C1	1	9	L23B2Z, L2327Z	5	1815	7C83, A, 7C63UL	1	9
3C1	3	1064	LC8322C36, LC8322C37	6	2391*	7C65B, M,W	2	558
4A1	1	4	LC8322C39	6	2391*	7C63	2	559
4B1	1	10	LS23B6, N	6	2334*	7G11, 7G12, 7G14,		
4H1, 4J1, 4K1	3	1065	TA18A11, TA18A12,			7G15, 7G16	2	560
4L1	3	1066	TA18A13	6	2400*	7P32, 7P33, 7P34,		
4R1	3	1067	TS101, TS102,			7P35	1	8
481	3	1068	TS103, TS104	6	2309*	7RT41, 7RT42,		
4T1	4	1459	TS105AL, TS106AL,			7RT43	2	561
4W1	4	1460	TS107AL	6	2309*	7T01, 7T01M-UL	2	564
4Z1	5	1808	TS140, TS141,			7T04, -UL	2	564
5A3	4	1461	TS142, TS143	6	2309*	7T06	1	10
5B1, 5B1A	1	5	TS144AL, TS145AL	6	2309*	7T10	2	553
5B2	3	1068	TS171, TS172AL,			7T12	1	10
5C3	4	1462	TS172ALN, TS173AL	6	2351*	7T14, 7T15	2	553
5D2	3	1068	TS1010	6	2309*	9B14, 9B15, 9B16	2	562
5D3	5	1809	TS1011AL, TS1012AL,			24X15, 8, 24X16, 8,		
5E2	4	1463	TS1013AL	6	2309*	24X17, 8	3	1066
5E3	5	1810	4H15, A, B, C, C.N, S, SN	3	1065	30F15, A, 30F16, A,		
5G2	4	1464	4H16, A, B, C, C.N, S, SN	3	1065	30F17, A	3	1065
5H1	1	8	4H17, A, B, C, C.N, S, SN	3	1065	32X15, 32X16,		
5J2	4	1465	4H18, C, C.N, S, SN	3	1065	32X26, 32X27,		
5K1	2	553	4H19, C, C.N, S, SN	3	1065	32X35, 32X36	3	1066
5L2	4	1466	4H115, 4H116,			34R15, A, 34R16, A	3	1064
5M2	4	1467	4H117 (8 or SN)	3	1065	34R37, 34R45, 34R46	3	1068
5N1	2	554	4H126A, B, C, C.N, S, SN	3	1065	36X35, A, 36X36, A,		
5R1	2	555	4H137A, B, C, C.N, S, SN	3	1065	36X37, A	3	1066
5S2	4	1468	4H145A, B, C, C.N, S, SN	3	1065	37F15, A, B,		
5W1	3	1069	4H146A, B, C, C.N, S, SN	3	1065	37F16A, B	3	1068
5X1	3	1070	4H147A, B, C, C.N, S, SN	3	1065	37F27, A, B,		
5X2	4	1469	4H155A, B, C, C.N, S, SN	3	1065	37F28, A, B	3	1068
5Y3	4	1460	4H156A, B, C, C.N, S, SN	3	1065	37F35, A, B	3	1068
6A1	1	2	4H157A, B, C, C.N, S, SN	3	1065	37F55, 37F56,		
6A2	3	1071	4H166A, B, C, C.N, S, SN	3	1065	37F57	3	1068
6C3, A	5	1811	4H167A, B, C, C.N, S, SN	3	1065	37K15, A, B,		
6E1, 6E1N	1	6	4R11, 4R12	3	1067	37K16, A, B	3	1064
6J2	4	1471	4T11	4	1459	37K27, A, B	3	1064
6L1	2	561	4W18, 4W19	4	1460	37K35, A, B,		
6M1	1	7	4Z11, 4Z12, 4Z14,			37K36, A, B	3	1064
6M2	4	1471	4Z18, 4Z19	5	1808	37K55, 37K56, 37K57	3	1064
6Q1	2	1072	5A32/12, 5A32/15,			37M15, 37M16	3	1064
6R1	2	556	5A32/16, 5A33/12,			39X16, A, B		
681	3	1073	5A33/15, 5A33/16,	4	1461	39X17, A, B	3	1066
6W1	3	1074	5D31, 5D32, 5D33	5	1809	39X35, 39X36, 39X37	3	1064
7B1	1	2	5E21, 5E22, 5E23	4	1463	47M15, 47M16, 47M17	4	1473, 1474
7C1	1	9	5E31, 5E32, 5E33	5	1810	121M10, 121M11A,		
7E1	2	558	5E36, 5E39	5	1810	121M12A	4	1473, 1474
7G1	2	560	5G21, 5G21/15,			221K45A, 221K46A,		
9A1	2	559	5G22, 5G22/15,			221K47A	4	1473, 1474
9B1	2	562	5G23, 5G23/15	4	1464	222DX168, 222DX16,		
10A1	1	3	5J21, 5J22, 5J23	4	1465	222DX17, 222DX26,		
14UY3B, C	6	2309*	5K11, 5K12, 5K13,			222DX27, 222DX48,		
14UY3D	6	2361*	5K14	2	553	222DX49	4	1475
15HF1	5	1812	5L21, 5L22, 5L23	4	1466	321DX15, A, 321DX16, A,		
17A F1	6	2400*	5M21, 5M22	4	1467	321DX17, A	4	1472
19D2, A	5	1813	5R10, 5R11, 5R12,			321DX15L, 321DX16L,		
19E2, A, 19G1, A	5	1813	5R13, 5R14	2	555	321DX17L	4	1472
19N1 (Radio Ch.)	4	1472	5S21AN, 5S22AN,			321DX35B, 321DX36, B,		
19P1	5	1813	5S23AN	4	1462	321DX27B	4	1472
20D2	5	1814	5W11, 5W12	3	1069	321F15, 321F16,		
20Y4H, HF (Radio Ch.)	6	2353*	5X11, 5X12, 5X13,			321F18	3	1068
21C3Z	5	1815	5X14	3	1070	321F27, 321F35,		
21W1 (TV Ch.)	4	1473	5X21, 5X22, 5X23	4	1469	321F36, 321F46,		
21W1 (Radio Ch.)	4	1474	5Y22	4	1470	321F47, 321F49	3	1068
22A2, 22A2A (TV Ch.)	4	1473	6A21, 6A22, 6A23	3	1070	321F65, 321F66,		
22A2, 22A2A (Radio Ch.)	4	1474	6C22, A, 6C23, A	5	1811	321F67	4	1473, 1474
23C3, 23E2	4	1475	6C71	1	3	321K15, 321K16,		
22M1 (TV Ch.)	4	1473	6J21, 6J22	4	1471	321K35, 321K36,		
22M1 (Radio Ch.)	4	1474	6N25, 6N26, 6N27	4	1469	321K46, 321K47,		
22P2	5	1816	6P32	1	6	321K49, 321K65,		
22Y1 (TV Ch.)	4	1473	6Q11, 6Q12, 6Q13,			321K66, 321K67	3	1064
22Y1 (Radio Ch.)	4	1474	6Q14	3	1072	321M25A, 321M26A,		
28A21	6	2391*	6R11	2	556	321M27A	4	1473, 1474
29S21	6	2391*	6RT41, A, 6RT42, A,			322DX16	4	1475
			6RT43, A	1	5	322DX16A	5	1816
			6RT44	1	2	421M15A, 421M16A,		
			6811, 6812	3	1073	421M35, 421M36,		
			6T01	1	1	421M37	4	1473, 1474
			6T02, 6T03	1	5			
			6T05	1	1			
			6T06, 6T07	1	4			
			6T11	1	5			
			6T12	1	4			
			6T44A	1	2			
			6W11, 6W12	3	1074			

* Signifies Coverage in this Volume

Name & Model or Chassis No.	Vol. No.	Diag. No.
ADMIRAL (cont'd)		
520M11, 520M12,		
520M15, 520M16,		
520M17	4	1473, 1474
521M15A, 521M16A,		
521M17A	4	1473, 1474
AEROMOTIVE		
181-AD	1	11
AIRADO		
SU-41D, SU-52, B, C	1	12
3100	2	563
AIRCASLE		
C-300	3	1075
G-516, G-518	2	564
G-521	2	565
G-724	2	566
G-725	2	567
REV-248	3	1076
PX	1	13
WEU-262	3	1077
9	2	568
102B	3	1078
106B	1	11
171, 172	3	1080
198	3	1061
201	3	1082
350	3	1063
472.354	4	1476
568	1	14
572	2	569
602-182144	3	1084
602-PR-8.1	3	1085
606-400WB	3	1086
607-314, -315	3	1067
810.C351	4	1477
610.CLI52B, M	4	1478
610.F100	4	1479
610.F151	4	1480
610.H400	4	1481
810.P-651.1	4	1481
610.8500	4	1480
610.W-100	5	1817
651	1	15
652.575E, V	5	1818
652.5X5	5	1819
652.6T1E, V	4	1482
652.8TF1	5	1820
788.5400, UL	5	1821
782.FM-99-AC	5	1822
5000, 5001	1	11
5002	1	16
5003, 5004,		
5005, 5006	1	17
5008, 5009	2	570
5010, 5011, 5012	1	18
5015.1	3	1068
5020	1	16
5022	3	1089
5024	2	571
5025	2	572
5027	2	574
5028, 5029	2	574
5036	3	1090
5044	3	1091
6050	3	1092
6053	3	1093
6514, 6541, 6544	1	15
6547	1	15
6611, 6612, 6613,		
6630, 6631, 6632,		
6634, 6635	1	19
7553	2	575
90061	3	1094
10002	2	576
10003-1	2	560
108014, 108504	2	577
121104	3	1095
127084	2	578
131504	2	579
138104	2	578

Name & Model or Chassis No.	Vol. No.	Diag. No.
AIRCASLE (cont'd)		
139144	2	580
149554	3	1096
150084	3	1097
AIR CHIEF (See Firestone)		
AIR KING		
A-501, A-502	2	581
A-510	2	574
A-511, A-512	2	582
A-600	2	583
A-804	3	1098
A-825	2	583
A-850	2	584
17K1C	4	1483
4601	1	30
4603	1	31
4604, D	1	34
4607, 4608	1	32
4609, 4610	1	30
4700	2	585
4704	1	37
4705, 4706	1	35
4708	1	37
AIR KNIGHT		
CA500	1	6
N5-RD291	1	6
AIRLINE		
GSE-1606A,		
GSE-1607A	5	1823
GSE-1625A,		
GSE-1626A	6	2335*
GSL-1079A	6	2139*
GSL-1581A,		
GSL-1582A	5	1824
GTM-1853A,		
GTM-1854A	6	2376*
WG-1572C	5	1825
WG-1635A,		
WG-1638A	6	2174*
WG-1637A	6	2339*
WG-2602A, B,		
WG-2603A, B	6	2176*
WG-2618A, B,		
WG-2819A, B	6	2176*
WG-2638A,		
WG-2639A	6	2178*
04BR511A, 04BR512A	1	40
04BR615A, B	1	43
04WC468	1	38
04WGS68, 04WGS69, B	1	39
04WG619, 04WG621,		
04WG621NI	1	41
04WG672	1	42
04WG673, 04WG674	1	44
04WG695	1	45
04WG727, 04WG728,		
04WG732	1	45
04WG803	1	44
04WG804	1	45
04WG1108A	1	46
05GSE-3030A, B, C	3	1099
05GSE-3037A, -3042A	3	1099
05WG-1813A	3	1100
05WG-2748 F,		
05WG-2749D	3	1101
05WG-2752	3	1102
05WG-3038A, -3045A	3	1103
14BR474	1	48
14BR521A, 14BR522A	1	40
14BR523A	1	48
14BR613A	1	48
14BR624A	1	48
14BR1474	1	48
14WC469	1	47
14WGS18, 14WGS19	1	6
14WG10B,		
14WGS11B	1	49
14WGS34A, 14WGS25A,		
14WGS28A	1	11
14WGS80	1	42
14WGS83A	1	51

Name & Model or Chassis No.	Vol. No.	Diag. No.
AIRLINE (cont'd)		
14WG690	1	50
14WG737	1	52
14WG739	1	47
14WG740, 14WG741	1	52
14WG756, 14WG757	1	56
14WG808M, MA,		
14WG808W, WA	1	56
14WG1202B,		
14WG1203B, M, W	1	54
15BR-1536B,		
15BR-1537B	4	1485
15BR-1543A, B,		
15BR-1544A, B	4	1486
15BR-1547A	4	1487
15BR-1548A,		
15BR-1549A	4	1488
15BR-2756B,		
15BR-2757A	4	1489
15BR-3035A	4	1490
15GSE-2764A	4	1491
15WG-1545A, B,		
15WG-1546A, B	4	1492
15WG-2745C	3	1104
15WG-2749E, F,		
15WG-2752D, E	4	1493
15WG-2758A	4	1494
15WG-3050A, B	4	1495
25BR-1542A	4	1496
25BR-3058A, B,		
25BR-3061A,		
25BR-3067A,		
25BR-3068A,		
25BR-3069A	4	1497
25GHM-1073A	5	1826
25GSE-1555A, B,		
25GSE-1556B,		
25GSE-1557B	4	1498
25GSE-3065A	4	1499
25GSL-1814A	4	1500
25WG-1570A, B, C,		
25WG-1571A, B,		
25WG-1872A, B	4	1501
25WG-1573A	4	1502
25WG-2758B	4	1494
25WG-2758C, D	4	1503
25WG-2765D, E	4	1494
25WG-2766A, B	4	1503
25WG-3060A	4	1504
25WG-3070A	4	1504
35BR-1557A,		
35BR-1558A,		
35BR-1559A	5	1827
35BR-3156A,		
35BR-3167A,		
35BR-3168A,		
35BR-3169A	5	1828, 1829
35BR-6796A	5	1830
35GHM-1073B, C	5	1826
35GHM-1074A	5	1831
35GSE-1555C,		
35GSE-1556C	4	1498
35GSL-2770A	5	1832
35WG-1573B	5	1833
35WG-2767A	5	2105
35WG-3171A, B	5	1834
35WG-3173A, B	5	1834
35WG-3175A	5	1834
35WG-3177A	5	1834
35WG-3179A	5	1834
45BR-3188A	5	2031
54BR1501A,		
54BR1502A	1	40
54BR1503A, B, C	1	58
54BR1504A, B, C	1	58
54BR1505A, B	1	55
54BR1506A, B	1	55
54KPI209A, B	1	53
54WG1801A, B	1	6
54WG3007A, B	1	6
54WG3500A,		
54WG2700A	1	57
61-6787	5	1835
61-6792	5	1836
61-6793	5	1919
61-6794	5	1856
61-6795	5	1857

* Signifies Coverage in this Volume

Name & Model or Chassis No.	Vol. No.	Diag. No.	Name & Model or Chassis No.	Vol. No.	Diag. No.	Name & Model or Chassis No.	Vol. No.	Diag. No.
AIRLINE (cont'd)			AIRLINE (cont'd)			ANDREA (cont'd)		
61-12601	5	1858	84WG2506	2	801	CO-U15	2	602
62-123	1	11	64WG2506B	3	599	CO-VK15, CO-VK16	3	1120
62-131, -133	1	11	84WG2712A, B	2	600	CO-VK125	3	1119
62-142	1	11	64WG2714A, F, G, H, J	2	601	CO-VL19	4	1506
62-144	1	11	84WG2716A, B	2	600	CO-VP21	6	2241*
62-152	1	11	84WG2720A	2	600	CRP-24W	6	2352*
62-158	1	11	64WG2721A, B	2	601	C-VK126	3	1119
62-237	1	11	84WG2724A	2	600	T-16	2	603
62-239	1	11	84WG2728A	2	600	T-U15	2	602
62-270	1	59	84WG2732A, B	2	600	T-U16	2	603
62-292	1	11	84WG2734A	2	600	T-VK12	3	1119
62-294	1	11	93WG510	1	72	T-VN21	5	1842
62-303	1	59	93WG754, 93WG755	1	74	T-VK127B, M	3	1119
62-309	1	59	93WG800	1	74	W89P	6	2361*
62-321	1	59	93WG1102	1	80	2C-VN21	5	1842
62-347	1	59	93WG1103, 93WG1104	1	46	101X	6	2352*
62-373, -374	1	11	93WG1110	1	60			
62-417	1	59	94BR-1538A	3	1107	ANSLEY		
62-443	1	59	94BR-2740A, -2741A, B	3	1108	53	2	604
62-447	1	59	94GAA3654A	3	1109	APEX		
62-449	1	59	94GSE-2735A, -2736A	3	1110	4B5	2	574
62-451	1	59	94WG-1509A	3	1111	APPROVED ELECTRONIC INSTRUMENT CORP.		
62-471, -472	1	61	94WG-1804D	3	1112	FM Tuner	2	605
62-704, -705, -706, -707, -708, -709, -710, -711, -712	1	60	94WG-1804A, C, D	3	1114	A-710	4	1507
62-752, -753	1	64	94WG-2745A	3	1115	ARCADIA		
62-901	1	64	94WG-2746A, B, -2747A	3	1114	37D14-600	1	78
62-910	1	60	94WG-2748A, C,			ARIA		
64BR1051A, B	1	62	94WG-2749A	3	1116	554-1-61A	1	79
64BR1205A,			94WG-3008A	3	1117	ARTHUR ANSLEY		
64BR1206A	1	65	94WG-3016A, B, C	3	1117	R-1	4	1508
64BR1208A	1	63	94WG-3028A	3	1117	ARTONE		
64BR1503, B	1	58	ALGENE			524	3	1121
64BR1504, B	1	58	ARSU	2	555	ARVIN		
64BR1513A, B	2	586	AR6U	2	565	15-550KB-UHF	5	1842
64BR1514A, B	2	586	ALLIED RADIO (See Knight)			21-550KBU, KMU	5	1844
64BR1808A	1	66	ALLSTATE			21-551TBU, TMU	5	1844
64BR2200A	1	63	6240	5	1837	21-552KBU, KMU	5	1844
64BR2701A	1	66	6264, 6266	5	1836	21-553TBU, TMU	5	1844
64WG1052A	1	67	6264	5	1639	140P	2	606
64WG1207B	1	69	6286-4, 6287-4	5	1840	150TC, 151TC	2	607
64WG1511A, B	1	68	6330	5	1841	152T, 153T	2	608
64WG1512A, B	1	68	Chassis			180T, 161T	2	609
64WG1801C	1	6	528.6264, 528.6266	5	1838	182TFM	2	610
64WG1804A, B, C	1	71	528.6284	5	1839	240P, 241P, 244P	2	611
64WG1807A, B	1	71	528.6286-4	5	1840	250P	2	612
64WG1809A, B	1	68	528.6287-4	5	1840	280TFM, 281TFM	2	614
64WG2007A, B	1	6	528.6300	5	1841	350-PB, -PL,		
64WG2009A, B	1	68	ALTEC LANSING			351-PB, -PL,		
64WG2010B	1	68	ALC-101	3	1118	352-PL, 353-PL	3	1122
64WG2500A	1	57	303A	4	1505	353T, 356T, 357T	3	1123
64WG2700A, B	1	57	304A	6	2216*	358T	2	608
74BR1513B	2	586	AMC			450T, 451T	3	1124
74BR1514B	2	586	20C2B, 20C2B,			460T, 461T	3	1125
74BR2001A, B	2	587	20T2B, 21CD2A,			482-CB, 472-CM	3	1126
74BR2701A	2	588	21C2A	5	2007	480TFM, 481TFM	3	1127
74KR1210A	2	589	125P	1	82	482CFB, 482CFM	3	1128
74KR2706B	2	590	126	1	76	547, A	2	614
74KR2713A	2	591	AMERICAN COMMUNICATIONS			551T	4	1590
74WG1052B	1	67	(See Liberty)			552A, N	1	77
74WG1056A	2	593	AMERICAN MOTORS			553	4	1510
74WG1207B	1	69	8990377 (6MR)	6	2240*	554CCB, 554CCM	4	1809
74WG1509A,			8990455 (7MR)	6	2240*	555, A	1	77
74WG1510A	2	594	A. M. I. (Automatic Musical Instruments)			558	1	81
74WG1511B,			PBA (Mark I)	6	2334*	580TFM	4	1511
74WG1512B	1	68	ANDREA			581TFM	5	1845
74WG1802A,			BT-VK12	3	1119	582CFB, 582CFM	4	1812
74WG1803A	2	595	C-VN21	5	1842	650-P	4	1513
74WG1804C	1	71	Signifies Coverage in this Volume			651T	5	1846
74WG1807A, B	1	71				652-P, 654-P	4	1513
74WG2002A	2	594				655SWT	4	1511
74WG2004A	2	595						
74WG2007B, C	1	6						
74WG2009B,								
74WG2010B	1	68						
74WG2500A	1	57						
74WG2504A, B, C	2	596						
74WG2505A	1	70						
74WG2700A, B	1	57						
74WG2704A, B, C	2	596						
74WG2709A	2	597						
84GAA3967A	3	1105						
84HA1529A,								
84HA1530A	3	1106						
84KR1520A	2	592						
84WG2015A	2	598						

Name & Model or Chassis No.	Vol. No.	Diag. No.
ARVIN (cont'd)		
857-T	4	1514
864, A	1	6
865	1	83
753T	5	1847
758T	5	1848
760T	5	1849
760TFM	5	1845
857T	5	1850
858T, 859T	5	1851
955T, 956T	6	2163*
956T1	6	2405*
957T	6	2221*
958T	6	2177*
2120CM, 2121TM	3	1129
2123TM, 2124CCM,		
2126CM	3	1129
2160, 2161,		
2162, 2164	3	1130
2410P	2	611
2583, 2584	6	2314*
3561	6	2325*
4080T, 4081T	3	1131
5561	6	2310*
5578	6	2409*
6173TM-UHF	4	1515
6213TB-UHF,		
6213TM-UHF	4	1516
6215CB-UHF,		
6215CM-UHF	4	1515
6640	1	6
7210CB-UHF,		
7210CM-UHF	4	1515
7212CF-UHF,		
7212MEA-UHF	4	1515
7214CM-UHF,		
7216CB-UHF	4	1515
7218CB-UHF,		
7218CM-UHF	4	1515
7219CM-UHF	4	1515
7276CB-UHF,		
7279CM-UHF	5	1852
9210CB-UHF,		
9210CM-UHF	5	1852
9211TB-UHF	5	1853
9212CF-UHF,		
9212MEA-UHF	5	1852
9213TM-UHF,		
9215CM-UHF	5	1853
9216CB-UHF	5	1852
9218CB-UHF,		
9218CM-UHF	5	1852
9219CM-UHF	5	1852
9240CB-UHF,		
9240CM-UHF	5	1852
9245CM-UHF	5	1853
9577	6	2377*
Chassis		
RE-202	1	77
RE-204	1	81
RE-206, -1, -2	1	6
RE-209	2	606
RE-213	3	1123
RE-228, -1	2	607
RE-229	1	83
RE-231	1	77
RE-232	2	609
RE-233	2	608
RE-237	2	610
RE-242	2	614
RE-243, RE-244	2	611
RE-248	2	612
RE-253	2	613
RE-254, -255, -256,		
-259	2	611
RE-267-1, -2	3	1122
RE-273	3	1123
RE-277, RE-277-1	3	1127
RE-277-2	3	1122
RE-281	3	1124
RE-284	3	1125
RE-287-1	3	1126
RE-288-1	3	1128
RE-292	4	1513
RE-297	4	1509
RE-306	4	1509
RE-307	4	1514

Name & Model or Chassis No.	Vol. No.	Diag. No.
ARVIN (cont'd)		
RE-308	4	1510
RE-310	4	1512
RE-313	4	1511
RE-323	5	1846
RE-327	4	1511
RE-333	5	1845
RE-342	5	1849
RE-348	5	1847
RE-350	5	1848
RE-374	5	1851
RE-378	5	1850
RE-392	6	2163*
RE-393	6	2221*
RE-397	6	2177*
TE-282	3	1131
TE-289-2, -3	3	1129
TE-290	3	1130
TE-330, TE-332	4	1515
TE-340, -1, -2	5	1852
TE-341, -2	4	1515
TE-395, -1	5	1852
TE-362	5	1853
TE-363, -1, -2, -3	5	1852
TE-373	5	1853
TE-379	5	1844
1.40300	6	2314*
1.40400	6	2314*
1.40600	6	2325*
1.40800	6	2310*
1.41700	6	2377*
1.42400	6	2405*
1.43500	6	2409*

ASTATIC

CB-1	5	1854
UHF	5	1855

ATLAS

AB-45	1	73
-------	---	----

AUDAR

AV-7T	4	1518
PR-6	1	84
PR-6A	1	85

AUTOMATIC

Tom Boy	2	555
Tom Thumb Buddy	2	615
Tom Thumb		
Camera-Radio	2	616
Tom Thumb Jr	2	555
B-44	2	616
C51	4	1517
C54	4	1518
C-60	1	86
C-80X	2	555
C-300	3	1075
C-351	4	1519
CL-152B,M	4	1520
CM-333	5	1919
D-200	3	1132
D-251	4	1521
DM-132	5	1836
F-100	3	1133
F-151	4	1522
F-152	6	2233*
F-241	6	2245*
M-86	2	618
P-651	4	1523
PM-236	5	1856
MM-430	5	1857
S-551	4	1522
TR-12	5	1858
TV-P490	3	1134
TV-1649, TV-1650,		
TV-1651	4	1524
601, 602 (Series A)	1	73
601, 602 (Series B)	2	555
612X, 613X	1	73
614X, 616X	1	86
620	1	87
640 (Series B)	1	73
660, 662, 666	2	619

Name & Model or Chassis No.	Vol. No.	Diag. No.
AUTOMATIC (cont'd)		
720	2	620
AVIOLA		
509	1	88
601	1	89
608	1	91
612	1	89
618	1	91
BELL SOUND		
PA-3715-B,		
PA-3725-B,		
PA-3750-B	5	1859
2210	5	1860
2255	5	1861
3715	2	621
3715-B	5	1859
3725	2	621
3725-B	5	1859
3728	2	621
3750	2	621
3750-B	5	1859
BELLTONE		
500	1	90
BELMONT		
A6D110	1	94
4B17	1	93
4B112, 4B113	1	65
4BA1, 4BA2	1	48
5D16	1	48
5D110	2	622
5D128	1	96
5DA1	1	48
5P19	1	95
6D111 (Series A & B)	1	92
6D120	2	623
8A59	1	66
533 (Series B & C)	1	43
718	1	48
BENDIX		
FB21CU	4	1525
FM21C, FM21CU	4	1525
FM27C	4	1525
HB21C, HB21CU	4	1525
HB27C	4	1525
HM21C, HM21CU	4	1525
KM21CU	4	1525
PAR-80	2	624
TB21CU, TB24DS	4	1525
TM17C, TM21CU,		
TM24DS, DU	4	1525
0526, 0526A, B, C, D, E, F	1	97
0626A	1	97
55L2, 55L3	2	625
55P2, 55P3	2	625
55X4	2	626
65P4	2	627
75B5, 75M5, 75M8,		
75P6	2	629
75W5	2	628
95B3, 95M3, 95M9	2	628
110, 110W, 111,		
111W, 112	2	625
114, 115	2	625
300, 300W, 301, 302	2	627
416A	2	630
526MA, MB, MC	2	631
613	2	632
626A	1	97
636A, B, C	1	98
646A	1	99
656A	1	100
676B, C, D	1	101
697A	2	633
736B	1	100
753F, M, W	4	1526
847B, S	2	634
951, 951W	3	1135
1217, B	2	635

* Signifies Coverage in this Volume

Name & Model or Chassis No.	Vol. No.	Diag. No.
BENDIX (cont'd)		
1217D	2	636
1518, 1519	2	637
1521	2	637
1524, 1525	2	637
1531	2	638
1533	2	638
6100	3	1136

Chassis		
C-19	4	1526
T14-3, T14-10, -11	4	1525

BLONDER TONGUE

BTU-2	5	1862
-------	---	------

BRAUM

HM2, HM3	6	2375*
MM3	6	2375*
MS3	6	2375*
Super 99	6	2375*
TS2	6	2375*

BREWSTER

9-1084, 9-1085, 9-1086	1	103
------------------------	---	-----

BROOKS LABORATORIES, INC.

ST10	4	1527
ST-10A	5	1863
ST-14A	4	1827
ST-15A	5	1864

BROWNING

L-300	6	2178*
L-500	6	2188*
PF-12	2	639
RJ-12	2	640
RJ-12A	2	640
RJ-12B	4	1528
RJ-14A	2	640
RJ-20A	3	1137
RJ-42	5	1865
RJ-43	5	1866
RJ-48	5	1867
RJ-49 (AM)	5	1867
RJ-49 (FM)	5	1868
RV-10	2	641
RV-10A	3	1138
RV-11	2	641
RV-31	4	1539
RV-32	5	1869

BRUNSWICK

A1020	1	102
A2020	1	102
A2800	1	107
A2700	1	102
A3720	1	102
D1683	2	642
C-3300	2	642
D-1000, D-1100	2	643
D-6876	2	644
T-4000, T-4000 1/2	2	644
T-8000, S.88, SX, T-8000 1/2	2	644
T-9000	2	643
512, 513, 812, 816	4	1530
1680	1	107
1700	1	102
2600	1	107
2689	1	107
5000	2	645
5125, 6165, 8125, 8165	4	1530

BUICK

980690, 980733	1	104
980744, 980745	1	104

BULOVA

100, 110	6	2362*
----------	---	-------

BULOVA (cont'd)

300 Series	6	2357*
------------	---	-------

BUTLER BROS.

(See Air Knight or Sky Rover)

CAPEHART

C-14	5	1870
P-213	5	1871
RP-152	4	1531
RP-153	5	1872
RP-154B,M	5	1873
RP-254	5	1872
T-54	5	1874
T-522	4	1532
1T174B-1, BS-1, M-1, MS-1, S-1	5	1875
1T174-1	5	1875
2T214B-1, BS-1, D-1, MD-1, MS-1, M-1, S-1	5	1875
2T214-1	5	1875
4C174M-1, MS-1	5	1875
5C214B-1, D-1, MD-1, M-1	5	1875
5C214-1	5	1875
7H214B-1, D-1, M-1	5	1875
7H214-1	5	1875
9F214BD-1, MD-1	5	1875
9F214-1	5	1875
11F244B-1, M-1	5	1875
11F244-1	5	1875
11RP-125F	5	1873
12F274M-1	5	1875
14W214-1	5	1875
15W214BD-1, MD-1	5	1875
15W214-1	5	1875
16T244BS-1, ES-1, M-1, MS-1, S-1	5	1875
16T244-1	5	1875
17RPQ155F	6	2140*
18W214FD-1	5	1875
19C214M-1, MD-1	5	1875
19K75	6	2229*
21T214ES-1	5	1875
22K75	6	2229*
23C214B-1, M-1	5	1875
35P7	3	1139
88P66BNL	6	2257*
325F, M, 326M, 332B, M, 334M	3	1140
1005B, M, W	3	1141
1006B, M, W	3	1141
1007AM	4	1533
3011B, M, 3012B, M	3	1140

Chassis

C-318	4	1533
CR-85	5	1871
CR-129	5	1873
CR-147	5	1872
CR-200	6	2140*
CR-204	6	2329*
CT-27, CT-38, CT-45	4	1534
CT-108, CT-110	5	1875
CT-112, CT-116	5	1875
CT-123, CT-124	5	1875
CT-127, CT-129	5	1875
CT-131, CT-134	5	1875
CT-144, CT-146	5	1875
CX-37-1 Series	5	1875

CAVALIER

6A2	5	1876
-----	---	------

CBS COLUMBIA

C220	6	2271*
C230, C231, C232	6	2271*
C240	6	2271*
U3C627, U3C628	6	2263*
U3C631, U3C632, U3C633	6	2263*
U3C634, U3C635, U3C636	6	2263*
U3T802	6	2263*
U3T815, U3T816	6	2263*

CBS COLUMBIA (cont'd)

U3T821, U3T822, U3T823, U3T824	6	2263*
U22C05	6	2164*
U22C07, B	6	2164*
U22T09, B, EB	6	2164*
U22T19, B	6	2164*
U22TK301	6	2187*
U22TK321	6	2187*
U23C49, U23C59	6	2164*
U23C8013, U23C8014	6	2187*
U23T15, U23T19 (Ch. 922-7)	6	2164*
U23TK001, U23TK002, U23TK003, U23TK004	6	2187*
U23TS005, U23TS006, U23TS007, U23TS008	6	2187*
6K321U, 6K322U	6	2363*
6K327U, 6K328U	6	2263
6T301U	6	2263*
6T303U, 6T304U	6	2263*
7K325U, 7K326U	6	2278*
7K329U, 7K330U	6	2278*
7K332U, 7K333U, 7K334U	6	2278*
7T307U	6	2278*
7T309U, 7T310U	6	2278*
22CK009, 22CK010	6	2187*
22CX1, 22CX2, 22CX3, 22CX4	6	2187*
22K38	5	1872
22TK301	6	2187*
22TK321	6	2187*
22TX1, 22TX2	6	2142*
23CK011, 23CK012	6	2187*
23C8013, 23C8014	6	2187*
23TK001, 23TK002, 23TK003, 23TK004	6	2187*
23TS005, 23TS006, 23TS007, 23TS008	6	2187*
2001 (UHF Conv.)	4	1535

Chassis

616	6	2271*
636	6	2271*
656	6	2271*
921-11, -13, -21	6	2164*
922-7	6	2164*
1601, 1602	6	2142*
1603, 1604, 1605	6	2187*
1606, 1607, 1608	6	2187*
2002	6	2263*
3002	6	2278*
3012	6	2278*

CENTURY (20th)

100X, 101, 104	1	73
----------------	---	----

CHANCELLOR

35P	2	574
-----	---	-----

CHEVROLET

985538	1	105
985696	1	108
985697	1	106
985792	1	109
985793	1	110
985794	1	106
986146	2	646
986516	4	1536
986869	5	1878
986771	5	1879
987088	5	1880
987573	6	2345*

CHRYSLER (See Mopar)

CISCO

1A5	2	574
9A5	1	73

CLARION

C100, C101	1	11
------------	---	----

* Signifies Coverage in this Volume

Name & Model or Chassis No.	Vol. No.	Diag. No.	Name & Model or Chassis No.	Vol. No.	Diag. No.	Name & Model or Chassis No.	Vol. No.	Diag. No.
CLARION (con't'd)			CORONADO (con't'd)			CRAFTSMEN (Also See Radio Craftsmen)		
C102	1	113	RA33-9858D	5	1881	C900	5	1887
C103, C104, C105	1	116	RA44-8340A	6	2175*	C1000	5	1888
C105A	1	90	RA44-8341A	6	2175*	CP-14, CP-18, CP-19	6	2354*
C108	1	13	RA48-8342A	6	2318*	CT-2	6	2292*
11011	1	115	RA48-8352A	6	2320*	CT-3	6	2295*
11305	1	90	05RA1-43-7755A	3	1144	CT-4	6	2354*
11801, 11802V-M	2	647	05RA1-43-7755B	3	1144	CTA-5	6	2354*
12110M	2	848	05RA1-43-9901A	3	1145			
12310W	2	649	05RA2-43-8230A	4	1538	CROMWELL		
12708	2	619	05RA2-43-8515A	3	1146	1020	3	1156
13101	2	579	05RA4-43-9876A	3	1147			
14601	2	574	05RA37-43-8360A	3	1148	CROSLEY		
			15RA1-43-7654A	4	1539	BC-13B, M, BC-15M	6	2323*
CLEARSONIC			15RA1-43-7902A	3	1149	BT-15M	8	2323*
5C86	1	11	15RA33-43-8365	4	1540	D-35BE, CE, GN, MN,		
			15RA37-43-9230A	4	1540	TN, WE	4	1545
COLLINS AUDIO PRODUCTS			15TV1-43-8958A, B	4	1541	DC-11B, M, DC-13M	6	2347*
FMA-6	3	1142	15TV1-43-9021A, B	4	1541	DC-15M, DC-17B	6	2347*
45-D	3	1143	15TV2-43-9101A,			DC-19N	6	2347*
			15TV2-43-9102A,	4	1542	DT-13B, M	6	2347*
			(Radio Ch.)			DU-17CDB, CDM,		
COLLINS RADIO			15TV4-43-8948A,	4	1543	CHB, CHM, CHN,	4	1546
75A-1	2	650	15TV4-43-8949A	4	1543	(Ch. 356-1, -2)		
75A-2	4	1537	35RA2-43-5101A	4	1544	DU-17CDB, CDM	4	1546
			35RA4-43-9856A	5	1883	(Ch. 356-3, -4)	4	1546
COLONIAL			35RA37-43-8355	5	1884	DU-17CHN1	4	1546
629	1	112	35TV2-43-9023A	5	1885	DU-17COB, COM	4	1546
671, A	1	112	35TV2-43-9050A	5	1835	(Ch. 356-1, -2)	4	1546
			35TV2-43-9061A	5	1835	DU-17COL, COM,	4	1546
COLUMBIA RECORDS			43-5005	2	658	(Ch. 356-3, -4)	4	1546
340	6	2145*	43-631	1	13	DU-17PDB, PDM,		
530	6	2326*	43-6451	1	124	PHB, PHM, PHN,		
			43-6485	2	657	PHN1	4	1547
			43-7601, 43-7601B	1	38	DU-17TOB, TOL, TOL1,		
			43-7602	1	38	TOM	4	1546
			43-7651, 43-7652	1	86	DU-20CDM, CHB,		
			43-7851	2	599	COB, COM	4	1546
			43-8160	1	121	DU-21CDM1, CDN,		
			43-8180	1	11	CHM, COB, COL,	4	1546
			43-8213	1	124	COLB, COM	4	1546
			43-8240, 43-8241	1	127	E10BE, CT, RD, WE	4	1548
			43-8305	1	71	E15BE, CE, SL, TN, WE	4	1549
			43-8312A	1	68	E30BE, GN, MN, TN	4	1550
			43-8330	1	123	EU-17COLBU, COLU	5	1889
			43-8351, 43-8352	1	126	EU-17COM	4	1546
			43-8353, 43-8354	2	658	EU-17TOB	4	1546
			43-8420	2	659	EU-17TOLBU, TOLU	5	1889
			43-8470	1	71	EU-17TOB	4	1546
			43-8471	1	68	EU-17TOB	4	1546
			43-8576	1	71	EU-21CDB	4	1546
			43-8685	1	125	EU-21CDLBU, CDLU	5	1889
			43-9196	1	128	EU-21CDM, CDN	4	1546
			43-9201	2	622	EU-21COBa	4	1546
			45RA1-43-7666A	5	1885	EU-21COLBU, COLU	5	1889
			45TV2-43-9023B	5	1834	EU-21COMA	4	1546
			45TV2-43-9061B	5	1834	EU-21CO8BU, CO8U	5	1889
			45TV2-43-9064A	5	1834	EU-21TOLBU, TOLU	5	1889
			45TV13-43-9038A	5	1886	F-17TOLBU, -1, TOLU,		
			45TV13-43-9081A	5	1886	-1, TOSBU, TOSU	5	1889
			94RA1-43-7656A	3	1150	F-21CDLBU, -1, CDLU,		
			94RA1-43-7657A	3	1150	-1, COLBU, -1, COLU	5	1889
			94RA1-43-7751A	3	1151	F-21TOLBU, -1, TOLU,		
			94RA1-43-8510A	3	1152	-1	5	1889
			94RA1-43-8511A	3	1152	F-21 TOSBU, TOSU	5	1889
			94RA1-43-8510B	3	1153	F-24CDBU, CDMU	5	1889
			94RA1-43-8511B	3	1153	F-24COLU	5	1889
			94RA31-43-9841A	3	1154	F-24PDBU, PDMU		
			94RA33-43-8130C,			(TV Ch.)	5	1889
			94RA33-43-8131C	3	1155	F-27COBU, COMU	5	1889
			7656A, 7657A	3	1180	G-17TOBU, TOMU,		
			7751	3	1151	TOWU	5	1890
			7755A, B	3	1144	G-21 TOBU TOMU	5	1890
			7901A	3	1145	GF-21CDLU, CDMU,		
			7902A	3	1149	COBU	5	1889
			8130C, 8131C	3	1155	H-17TOBU, TGMU,		
			8360A	3	1148	TOWU	5	2269
			8510A, 8511A	3	1152	H-21COBU, COMU,		
			8510B, 8511B	3	1153	CO8BU, COWU	5	1890
			8515	3	1146	H-21HCBU, HCWU	5	1890
			9841A	3	1154	H-21TCBU, TOMU,		
			9876A	3	1147	TOMUF, TOWU,		
						TOWUF	5	1890
						J-21CABU, J-21CAMU	6	2269*
						J-21CKBF	6	2210*
						J-21CKBU	6	2211*
						J-21CKGF	6	2210*
CORONADO			CORONET					
RA1-9243A, B,			C-2	1	130			
RA1-9244A, B,								
RA1-9245A, B,								
RA1-9246A, B	6	2176*						

* Signifies Coverage in this Volume

Name & Model or Chassis No.	Vol. No.	Diag. No.	Name & Model or Chassis No.	Vol. No.	Diag. No.	Name & Model or Chassis No.	Vol. No.	Diag. No.
CROSLLEY (cont'd)			CROSLLEY (cont'd)			DETROLA (cont'd)		
J-21CKGU	6	2211*	285	3	1157	558,558-1-49A	1	145
J-21CKHF	6	2210*	301	3	1159	568,568-13-221D	1	14
J-21CKHU	6	2211*	302	4	1549	571,571A,571AL,		
J-21CKMF	6	2210*	311	4	1545	571AX,571B,571BL,		
J-21CKMU	6	2211*	312	3	1180	571BX,571L,571X	1	117
J-21CKSMF	6	2210*	356-1,-2,-3,-4	4	1546	572	1	144
J-21CTKMF	6	2210*	357,-1	4	1546	572-220-326A	1	114
J-21CTKMU	6	2211*	359,360,361	4	1546	576,576-1-6A	1	144
J-21LKBF	6	2210*	380,381,383,384	4	1546	579	1	120
J-21LKBV	6	2211*	393,394,396	5	1689	583	1	14
J-21LPKBF	6	2210*	402-1,403-1,404-1	5	1689	610A,611A	2	678
J-21LPKBU	6	2211*	411-1,412-1	5	1689	7156	2	679
J-21LPKMF	6	2210*	416-1	5	1689	7270	1	146
J-21LPKMU	6	2211*	426	5	1690			
J-21RABU, RAMU	6	2269*	431,-2	5	1690			
J-21TABU, TAMU,			432	6	2269*			
TAWU	6	2269*	472	6	2210*	DEWALD		
J-21TJBU, TJMU	5	1890	473	6	2211*	A500, A500I, A500W	1	148
J-21TKBF	6	2210*	476	6	2210*	A501, A502, A503	1	148
J-21TKBU	6	2211*	477	6	2210*	A504, A505	1	149
J-21TKDBF	6	2210*	484	6	2269*	A507	2	680
J-21TKDBU	6	2211*	490	6	2323*	A509	2	681
J-21TKDMF	6	2210*	494	6	2347*	A514	2	682
J-21TKDMU	6	2211*				A602, A605, A608	1	150
J-21TKLBF	6	2210*				B-400	2	682
J-21TKLBU	6	2211*	DALBAR			B-402	2	683
J-21TKLMF	6	2210*	100	1	134	B-403	2	627
J-21TKLMU	6	2211*	400	1	11	B-504	2	684
J-21TKMF	6	2210*	1000	1	134	B-506	2	685
J-21TKMU	6	2211*	Barcombo Jr.	1	134	B-510, B-512	2	686
J-21TOWU	5	1890	Barcombo Sr.	1	134	B-612	2	687
JC-8BK, BN, TN, WE	6	2284*				B-614	2	688
9-101, 9-102	2	660	DAVID BOGEN			D-E517A	4	1554
9-103, 9-104W	2	661	AM901	4	1553	D-508	3	1161
9-113, 9-114W	2	661	FM50	6	2272*	D-517	3	1162
9-117	2	595	FM400A	5	1691	D-518	3	1163
9-118W	2	660	FM801	6	2272*	D-519	2	685
9-119, 9-120W	2	560	R300	4	1553	D-616	3	1164
9-121, 9-122W	2	662	R501	5	1692	DT-120, DT-122	3	1165
9-201, 9-202M, 9-203B	2	663	R604	2	667	DT-161	3	1165
9-207M	2	664	R630	4	1553	DT-162R, DT-163A	3	1166
9-209	2	665	R660	6	2284*	DT-190D	3	1166
9-212M, 9-213B	2	665	R701	5	1693	DT-1020, DT-1020A	3	1165
9-202	2	666	R710	6	2270*	DT-1030, DT-1030A	3	1165
10-135, 10-136E,			R755	5	1694	DT-X-160	3	1165
10-137, 10-138,			R765	6	2270*	E-530	3	1167
10-139, 10-140	3	1157	R775	5	1694	E-522	4	1555
10-307M, 10-308,			RR29, W	6	2284*	E-170	3	1166
10-309	3	1158	RR501	6	2284*	ET-140R, ET-141R	3	1166
11-100L, 11-101U,			RR501	5	1692	ET-171, ET-172	3	1166
11-102U, 11-103U,			RR550	6	2270*	ET-190D	3	1166
11-104U, 11-105U	3	1159	UCT	5	1695	F-405	4	1556
11-106U, 11-107U,			UCT-1	5	1695	F-523	4	1555
11-108U, 11-109U	4	1549				H-300	5	1897
11-126U, 11-127U,						511	3	1168
11-128U, 11-129U	3	1160	DEARBORN					
11-907MU, 11-308BU	4	1551	100	2	614	DUMONT		
11-550MU, 11-560BU	4	1549				RA-103D, RA-104A	3	1169
46FA, 46FB	1	6				RA-109-A3	3	1170
56FA, 56FB, 56FC	2	595	DELCO			RA-109-A7	3	1170
56PA, 56PB	1	11	R1175	1	135	RA-110A	3	1169
56TA, 56TA-L,			R1176, R1177	1	136	RA-112-A1, -A2,		
56TC, 56TC-L	1	73	R1178, R1179	1	139	-A3, -A4, -A5, -A6		
56TD	1	67	R1181	1	136	(Below Serial No.		
56TG	1	131	R1206, R1207, R1208,			126393)	4	1567
56TJ	1	129	R1209	1	138	RA-112-A1, -A2, -A3,		
56TL-L, 56TN,			R1212	1	137	-A4, -A5, -A6 (Above		
56TN-L, 56TP	1	73	R1214	1	140	Serial No. 126293)	4	1558
56TU	2	668	R1216, R1217	1	141	RA-113-B1, -B2, -B3,		
56TV, 56TS	1	133	R1220	1	142	-B4, -B5, -B6, -B7,		
56TU	1	131	R1227, R1228, R1229	1	143	-B8 (Below Serial		
67TW	1	73	R1230A, R1231A,			No. 135323)	4	1557
68CP, 68CR	2	670	R1232A	1	73	RA-113-B1, -B2, -B3,		
68TA, 68TW	2	660	R1233	2	674	-B4, -B5, -B6, -B7,		
68CR, 68CS	1	132	R1234, R1235	1	143	-B8 (Above Serial		
87CQ	2	671	R1236, R1237	2	674	No. 135323)	4	1558
88CR	2	671	R1238	2	574	RA-119A	4	1559
88TA, 88TC	2	672	R1242	2	669	RA-166, RA-167,		
106CS	1	66	R1243	2	675	RA-168, RA-169,		
146CS, 146CP,			R1244, R1245, R1246	2	676	RA-170, RA-171	4	1560
148CQ	2	673	R1251, R1252, R1253,			RA-302	5	1898
154927 (UHF Conv.)	4	1552	R1254, R1255	2	677	RA-307	5	1899
			R1408	1	73	RA-322	5	1900
Chassis						RA-378, RA-379	6	2368*
R-104	6	2284*	DETROLA					
10E, 10E-1	4	1548	554	1	79	DYNAVOX		
15-20E	4	1549				3-P-801	2	689
30E, 30E-1	4	1550						

Name & Model or Chassis No.	Vol. No.	Diag. No.	Name & Model or Chassis No.	Vol. No.	Diag. No.	Name & Model or Chassis No.	Vol. No.	Diag. No.
ECA			EMERSON (cont'd)			EMERSON (cont'd)		
101,102	1	19	528	2	694	809A	5	1907
104	1	18	530	2	695	810B	5	1908
105	1	151	531,532,533	1	162	844	6	2315*
106	1	18	534	2	693	847	6	2316*
108	1	154	535	1	159	851B,852B,853B	6	2366*
131	1	19	536,536A	2	696	1001G,1002,1003	1	169
132	2	690	537	2	694	1003G	5	1903
201	1	152	539	1	159	1013C	5	1904
204	2	574	540A	1	165	1041F,1045F,1047F	6	2166*
ECHOPHONE			541	1	73	1051D,1055F	6	2166*
EC112	1	153	543,544	1	159	1075F	6	2165*
EC113	1	153	546	2	695	1075H	6	2166*
EC308	1	157	547A	2	697	1085F	6	2165*
EC403,EC404	2	677	550 (Ch. 120056)	2	693	1144D,1145D	5	1907
EC600	1	147	551A	2	696	1213	6	2393*
EX306	1	157	552	1	159	1220	6	2393*
EDWARDS			553A	2	696	1239	6	2393*
Fidelotuner	2	691	557B	2	698	1245,1247	6	2393*
ELCAR			558	2	699	1273,1275	6	2393*
602	1	155	559A,560	2	697	1281	6	2393*
ELECTRO			563	3	1171	2057,2059	6	2393*
B30	1	163	567 (Ch. 120042)	1	165	2061,2063	6	2393*
ELECTROMATIC			568A	2	700	Chassis		
606A,607A	1	156	570	3	1172	120000	1	11
ELECTRONIC LABS.			573B	2	701	120002	1	158
76E,76K	1	167	574	3	1172	120003	1	180
76RU	1	161	575	3	1173	120006	1	182
76W	1	167	576A	2	702	120007	2	693
710B,710M	1	167	577B	2	702	120012-B	2	701
710PB,710PC	2	692	578	2	697	120016	2	697
710T,710W	1	167	583	2	701	120025-B	3	1174
7701	1	167	584	2	699	120029	1	11
ELCTRO-TONE			585,586	3	1174	120030	2	555
585	1	16	587	3	1175	120036	2	696
706	1	18	588	2	697	120038	2	694
712	1	18	597	3	1176	120039-B	2	701
ELECTRO-VOICE			602	2	703	120041	1	158
3303,3304	6	2385*	604A	2	702	120042	1	165
EMERSON			613A	3	1177	120043	2	694
D8365,D8372	1	164	621 (Ch. 120098-B)	3	1178	120046	1	159
EQ368,EQ410	1	166	622 (Ch. 120098-P)	3	1178	120048-B	2	698
ER369,ER370	1	166	628	3	1178	120049	2	695
EV384	1	166	630	3	1178	120050	2	697
FH413	1	162	634B	3	1179	120056	2	693
FH440	1	162	635	3	1180	120058	2	699
FJ412	1	160	636A	3	1175	120059	2	697
FW423	1	160	640	3	1181	120069-A	2	702
GB439,GB441	1	162	641B	3	1182	120072-A	2	703
GH437,GH447, GH2-447	1	160	642 (Ch. 120117-A)	3	1183	120082-A	2	703
501,502,503,504	1	11	643A	3	1184	120088-B	3	1174
905 (Ch. 120002 & 120041)	1	158	645	3	1185	120090-B,-D	3	1174
906	1	160	646A,646B	3	1186	120098-B	3	1178
907,909,910,910A,911	1	158	652 (Ch. 120032-B)	3	1187	120098-P	3	1178
911 (Ch. 120010)	1	73	653 (Ch. 120080-B)	3	1168	120099-B	3	1178
912(Ch. 120006)	1	162	653B	4	1561	120130-B	4	1563
912 (Ch. 120056)	2	693	656,657B	3	1189	120132-B	3	1187
914	2	693	661B	4	1562	120134B,-G,-H	4	1562
915 (Ch. 120056)	2	693	665B (Radio Ch.)	4	1563	120136-B	4	1561
915	1	162	666B (Ch. 120132-B)	3	1190	120150-B	4	1566
916 (Ch. 120056)	2	693	667B,668B	4	1562	120151-B	4	1567
916	1	162	671B	3	1191	120174-B	5	1903
918	1	158	672B	3	1191	120175-B	5	1901
919	2	555	674B	4	1562	120176-B	5	1902
980	1	11	677B,678B	4	1562	120177-B	5	1902
922,923	1	158	679B	4	1563	120180-D	5	1904
924	1	170	684B,685B	4	1561	120189-B	5	1906
925	1	159	691B	4	1561	120193-B,-F	5	1903
			695B	4	1564	120195-D	5	1904
			703B (Ch. 120097-B)	4	1565	120197-B,-D	5	1903
			718B	4	1566	120198-D	5	1904
			724B	4	1567	120199-B	5	1905
			744B	5	1901	120209-D,-F	5	1903
			745B,746B	5	1902	120211-D,-F	5	1904
			752A,B	5	1903	120221-A	5	1907
			755A,B	5	1903	120222-B	5	1908
			759C,761C	5	1904	120238-F	6	2166*
			768A,C	5	1903	120238-H	6	2165*
			770C,772A	5	1903	120249-D	6	2166*
			774A	5	1903	120279-B	5	1907
			776A (TV Ch.)	5	1903	120309	6	2315*
			778B	5	1905	120327-B	6	2366*
			784A	5	1903	120328	6	2316*
			784E,G,K	5	1903	120334-B	6	2366*
			785C,E,K	5	1904	120335-B	6	2366*
			793E,794A	5	1903	120344-G	6	2393*
			799E	5	1903	120352-G	6	2393*
			808B	5	1906			

* Signifies Coverage in this Volume

Name & Model or Chassis No.	Vol. No.	Diag. No.
EMERSON (cont'd)		
120354-G	6	2393*
120361-G	6	2393*
EMPRESS		
55, 56	1	174
ESPEY		
RR13, RR13L	1	168
7B	2	567
7C	4	1568
18B	3	1193
31	3	1194
100, 101	5	1909
201	5	1910
300, 301	5	1911
400	5	1957
401	6	2143*
500	5	1957
511C, 512B	4	1568
524	3	1193
581	1	73
651, 652, 653	1	15
700	5	1909
710	5	1911
751	3	1193
6511, -2, -B, 6514, 6516, 6517, 6520, -2, 6521, 6533	1	15
6540, 6541, 6542, 6545, 6546, 6547, 6590	1	15
6611, 6612, 6613, 6614, 6615	1	172
6630, 6631, 6632, 6634, 6635	1	172
7541	1	15
FADA		
H-274T, H-276T	5	1912
H-442C, H-542C	5	1912
P100	2	704
P130	3	1195
S4C20, S4C40, 84T15, 84T30	4	1569
86C55, 86C70, 86T65	3	1196
S7C20, S7C30, S7C70, S7T65	3	1196
S9C10	3	1196
S20T20	3	1196
S1060, S1065	3	1196
UDL2100T	5	1913
UH17KD	6	2161*
UH17LO	6	2161*
UH17L1, UH17L2, EB	6	2161*
UH21KA	6	2161*
UH21K1, UH21K1LO	6	2161*
UH21L1, UH21L2, EB, LO	6	2161*
UH21T	5	1913
U1700CD, U1770CD	5	1914
U2100C, T, U2150C	5	1913
602	1	178
605, 606	1	185
809, 810	1	73
637	1	175
652	1	171
700	2	705
711	2	574
740	2	574
795	2	706
830	3	1197
845	3	1198
855	3	1199
1000 Series	1	173
1001	1	175

FARNSWORTH

BC66	1	176
CB103, BC105	1	177
BC601, BC601X	1	186
BK106, BK107, BK108	1	177
BK110, BK111, BK112	1	186
BK602	1	186
BK6025, BK6025X	1	186

FARNSWORTH (cont'd)

BT20	1	73
BT22	1	176
BT52, BT53, BT54	1	73
BT55, BT56, BT61, BT63	1	176
BT600, BT600X	1	186
CC70	1	187
CK58, CK66	1	179
CK73, CK74, CK75	1	187
CK111	1	177
CT50, CT51, CT52, CT53, CT54	1	179
CT61, CT62, CT63, CT64	1	179
DK73, DK75	1	187
EC280	1	28
EK-061, EK-062, EK-063	2	707
EK-262, EK-263, BL, WL	1	28
EK-264, BL, WL, EK-265	1	28
EK-661	2	707
ET-060, ET-061, ET-062, ET-063, ET-064, ET-065, ET-066	1	180
GK-100, GK-102, GK-103, GK-104	2	707
GK-111, GK-112, GK-114, GK-115	2	707
GK-140, GK-141, GK-142, GK-143, GK-144	2	708
GT-060, GT-061, GT-064, GT-065	2	709

Chassis

150	1	180
152, 153	1	28
156, 157	2	707
158, 159	1	180
162	1	28
170	2	707
193, 194	2	707
201	2	707
216	2	707

FEDERAL

1030T	1	138
1040T, 1040TB	2	710
1540T	1	138

FERRAR

CB1-B	1	184
T61-B	2	711

FIRESTONE

4-A-2	1	21
4-A-3	2	560
4-A-10	2	712
4-A-11	2	713
4-A-12	2	714
4-A-15	2	715
4-A-17	2	716
4-A-20	1	20
4-A-21	1	22
4-A-21X	1	24
4-A-22	1	22
4-A-22X	1	24
4-A-23	1	25
4-A-24	1	23
4-A-25	1	26
4-A-26	2	717
4-A-27	2	718
4-A-31	1	26
4-A-37	1	27
4-A-41	2	719
4-A-42	2	644
4-A-60	2	720
4-A-61	2	721
4-A-66	3	1200
4-A-71	2	722
4-A-78, 4-A-79	3	1201

FIRESTONE (cont'd)

4-A-85	3	1202
4-A-86	3	1203
4-A-86 (Late)	4	1570
4-A-87	3	1204
4-A-108	4	1571
4-A-110	4	1580
4-A-113, 4-A-114	5	1915
4-A-115	5	1916
4-A-127, 4-A-128	5	1917
4-A-133	5	1918
4-A-143	6	2163*
4-A-147, 4-A-148	6	2208*
4-A-153	6	2325*
4-A-154	6	2302*
4-A-159	6	2314*
4-A-162	6	2177*
4-B-1, 4-B-2	1	29
4-B-56	3	1133
4-B-57	3	1075
4-B-58	3	1132
4-B-60	4	1523
4-B-61	4	1519
4-B-62, 4-B-67	4	1523
4-B-69	5	1858
4-B-71	5	1856
4-B-72	5	1919
4-B-74	5	1920
4-B-77	6	2153*
4-B-78	6	2179*
4-C-3, 4-C-6	1	36
4-C-16, 4-C-17	3	1205
4-C-18	3	1206
4-C-21	4	1517
4-C-24	5	1921
4-C-30	6	2296*
4-C-34	6	2321*
13-G-3	3	1207
13-G-4	3	1208
13-G-33	3	1209
13-G-48	4	1572
13-G-57	4	1573
13-G-128, 13-G-129, 13-G-130, 13-G-132	5	1834
13-G-145, 13-G-146	5	1834
S7400-4, -5, -7	1	33

FISHER

FM-40	6	2393*
FM-80	5	1922
50R, 50RT	5	1923
70RT	5	1924

FLUSH WALL

5P (Early)	2	614
5P (Late)	5	1925

FORD

7070 (51A-18805-E2)	2	723
5BF (FDH-18805-B1)	5	1926
5MF (FDH-18805-E2)	5	1927
5MFB (FDH-18805-A2)	5	1926
6MFD80	1	181

FREED EISEMANN

46	1	193
717, 750	5	1928

GAMBLE SKOGMO (Also See Coronado)

C4B15, C4B16	1	48
C5D14	1	40
C5D16	1	48
15C6A	1	191
15C6B	1	190
864	1	80
3128 (Late)	1	182
4132	1	182
4164	1	183
4956	1	45

GAROD

5A-1	2	724
------	---	-----

* Signifies Coverage in this Volume

Name & Model or Chassis No.	Vol. No.	Diag. No.
GARRD (cont'd)		
5A-2	1	192
5A-3	2	725
5A-4	2	726
5AP1-Y	1	189
5D,5D-2	1	194
5D-3,5D-3A	2	727
5D-4,5D-5	2	728
5RC-1	2	726
6A-2	2	724
6AU-1	1	82
6BU-1A	1	195
6DPS,6DPS-A	1	196
10TZ,10TZ1,10TZ2, 10TZ3,10TZ4,10TZ5	2	729
11FMP	2	730
12TZ,12TZ1,12TZ2, 12TZ3,12TZ4,12TZ5, 12TZ6A,12TZ7A	2	729
15TZ,15TZ6,15TZ7	2	729
62B	2	661
306	2	731
900TV,910TV, 1000TV,1001TV	2	732
1100TVP,1110TVP, 1200TVP,1210TVP	2	732
GENERAL ELECTRIC		
G61	1	197
G64,G65	1	200
G66,G68,G69	1	197
G75	1	200
G78	1	197
G85	1	198
G86	1	197
G95	1	202
G99	1	198
GDE-73	1	204
GE-52	1	206
GE-73,GE-78	1	204
GE-93,GE-96	1	205
H73,H77,H78, H79,H87	1	203
H116,H118	1	203
H800,H800U,H801	1	207
H810,H810U,H811	1	207
H820,H820U,H821,H822, H823,H825	1	208
H830,H830U,H831, H832,H832U,H833	1	208
H834	1	203
H838,H840	1	203
H708	1	209
H736	1	209
HE74,HE74L	1	204
HE100,HE100H, HE100L,HE100LH	1	199
HE105,HE105L	1	199
HE740,HE740L	1	204
H7119	1	203
H7737	1	209
H7905,H8908,H7908B	1	203
H71005	1	203
H71205	1	203
J62,J63	1	210
J64	1	211
J71	1	211
J105	1	211
J902,J903	1	212
J614	1	212
J620	1	210
J664	1	212
J709	1	209
J718,J738	1	211
J805,J806,J809, J818,J828	1	211
J1106,J1108	1	211
JE81	1	213
JE101,JE107	1	215
JE810	1	213
L800,L801,L810,L811	1	212
L831,L842,L843	1	212
L850,L851,L852	1	214
L853	1	212
L880	1	214
L863,L873,L874	1	212

Name & Model or Chassis No.	Vol. No.	Diag. No.
GENERAL ELECTRIC (cont'd)		
LF115,LF116	1	216
LFC1118,LFC1128, LFC1228	1	216
UHF-17C127	6	2250*
UHF-17T15	6	2250*
UHF-17T17	6	2250*
UHF-21C114, UHF-21C115, UHF-21C116, UHF-21C117	6	2250*
UHF-21C119, UHF-21C120, UHF-21C121	6	2250*
UHF-21C225, UHF-21C226, UHF-21C227, UHF-21C228, UHF-21C229, UHF-21C230, UHF-21C231, UHF-21C232, UHF-21C233	6	2250*
UHF-21T10, UHF-21T11, UHF-21T12	6	2250*
UHF-21T15, UHF-21T19, UHF-21T20	6	2250*
UHF-21T21	6	2250*
X115,X125,X145	1	220
X225A,X225V	1	212
10C101,10C102,10T1, 10T4,10T5,10T6	3	1210
12C101,12C102,12C105	3	1210
12C107,12C107B, 12C108,12C108B, 12C109,12C109B	3	1211
12T1	3	1210
12T3,12T3B,12T4, 12T4B	3	1211
14C102,14C103	3	1211
14P1210-UHF, 14P1211-UHF, 14P1212-UHF	6	2195*
14T2,14T3	3	1211
14T007-UHF, 14T008-UHF, 14T009-UHF, 14T010-UHF, 14T011-UHF, 14T012-UHF, 14T014-UHF	6	2195*
16C103	3	1211
16C110,16C111	3	1211
16C113	3	1211
16C115,16C116,16C117	3	1211
16T1,16T2,16T3, 16T4,16T5	3	1211
17C101,17C102	3	1211
17C103,17C104, 17C105,17C107, 17C108,17C109, 17C112,17C114	4	1574
17P1328-UHF, 17P1329-UHF, 17P1330-UHF, 17P1331-UHF	6	2195*
17T1,17T2,17T3,17T4, 17T5,17T6,17T7	4	1574
17T14-UHF	6	2137*
17T16-UHF	6	2137*
17T20-UHF	5	1928, 1930
17T21,17T22	6	2147*
17T21-UHF, 17T22-UHF	6	2147*, 2274*
17T025-UHF, 17T026-UHF, 17T027-UHF	6	2289*
20	1	210
21C40-UHF	5	1931
21C102-UHF	6	2137*
21C103-UHF, 21C104-UHF	5	1928, 1930

Name & Model or Chassis No.	Vol. No.	Diag. No.
GENERAL ELECTRIC (cont'd)		
21C106,21C107, 21C108,21C109	6	2147
21C106-UHF,21C107- UHF,21C108-UHF, 21C109-UHF	6	2147, 2274
21C110,21C111,21C112, 21C113	6	2147*
21C123,21C124	8	2147*
21C123-UHF,21C124- UHF	6	2147*, 2274*
21C125,21C126,21C127	6	2147*
21C125-UHF, 21C126-UHF, 21C127-UHF	6	2147*, 2274*
21C130-UHF, 21C131-UHF	5	1931
21C133-UHF, 21C134-UHF	6	2273*
21C135-UHF, 21C136-UHF	6	2273*
21C137-UHF, 21C138-UHF	6	2297*
21C141-UHF, 21C142-UHF	6	2274*
21C143-UHF, 21C144-UHF	6	2297*
21C151-UHF, 21C152-UHF	5	1931
21C156-UHF, 21C157-UHF	6	2297*
21C158-UHF, 21C159-UHF	6	2297*
21C160-UHF, 21C161-UHF	6	2297*
21C162-UHF	6	2297*
21C172-UHF	6	2297*
21C238-UHF	6	2137*
21C240-UHF, 21C241-UHF (Early)	5	1928, 1930
21C240-UHF, 21C241-UHF (Late)	5	1928, 1932
21C347-UHF, 21C348-UHF	5	1930
21C349-UHF	5	1930
21C350-UHF, 21C351-UHF	5	1930
21C1449-UHF, 21C1450-UHF	6	2195*
21C1545-UHF	6	2274*
21C1547-UHF, 21C1548-UHF	6	2274*
21C1549-UHF	6	2274*
21C1550-UHF, 21C1551-UHF	6	2274*
21C1552-UHF, 21C1553-UHF	6	2274*
21C1554-UHF, 21C1555-UHF	6	2274*
21C1556-UHF, 21C1560-UHF	6	2274*
21C1562-UHF	6	2274*
21C1564-UHF	6	2274*
21T17-UHF,21T18-UHF	6	2137*
21T22-UHF,21T23-UHF	5	1928, 1930
21T24-UHF,21T25-UHF	5	1928, 1930
21T26-UHF, 21T27-UHF (Early)	5	1928, 1930
21T26-UHF, 21T27-UHF (Late)	5	1928, 1932
21T28-UHF	6	2137*
21T30-UHF,21T31-UHF	5	1930
21T32,21T33	6	2147*
21T32-UHF,21T33-UHF	6	2147*, 2274*
21T35,21T36,21T37	6	2147*

* Signifies Coverage in this Volume

Name & Model or Chassis No.	Vol. No.	Diag. No.
GENERAL ELECTRIC (cont'd)		
21T35-UHF,		
21T36-UHF,		
21T37-UHF	6	2147*
		2274*
21T038,21T039	6	2147*
21T041,21T042,21T043	6	2147*
21T045-UHF,		
21T048-UHF	6	2274*
21T050-UHF	6	2297*
21T054-UHF,		
21T055-UHF	6	2297*
21T056-UHF,		
21T057-UHF	6	2297*
21T060-UHF,		
21T061-UHF	6	2297*
21T1439-UHF	6	2195*
21T1539-UHF,		
21T1540-UHF	6	2274*
21T1541-UHF,		
21T1542-UHF	6	2274*
21T1543-UHF,		
21T1544-UHF	6	2274*
24C180,24C181	6	2147*
24C182-UHF,		
24C183-UHF	6	2297*
24C1690-UHF,		
24C1661-UHF	6	2274*
24C1670-UHF,		
24C1671-UHF	6	2274*
24T070,24T071	6	2147*
35	1	215
40	1	216
41,42,43,44,45	2	733
50	1	218
100,101	1	217
102,102W	2	734
103,105	1	217
106	1	221
107,107W	2	734
114,114W,115,115W	2	734
118	2	735
119M,119W	2	735
123,124	3	1212
131	2	735
135,136	3	1213
143	3	1214
145	2	736
150	2	737
160	2	738
165	3	1215
180	1	219
200,201,203,205,		
205M	1	222
210,211,212	2	739
218,218 "H"	3	1216
219,220,221	1	227
226	3	1217
250	1	225
254	2	740
260	1	225
280	2	676
303	1	223
304	2	741
321	1	224
326,327	1	226
354,355	2	742
356,357,358	2	743
376,377,378	2	744
400,401	3	1218
404,405	3	1219
408	3	1220
409	4	1575
410	3	1219
411	3	1218
412	4	1576
412F	4	1577
414	4	1576
414F	4	1577
415	4	1576
415F	4	1577
416	4	1576
416F	4	1577
417	1	230
422,423	4	1578
427,428,429	5	1933
430	4	1576
431,432	5	1934

Name & Model or Chassis No.	Vol. No.	Diag. No.
GENERAL ELECTRIC (cont'd)		
440	5	1935
442,443,444	5	1933
446,447,448	5	1936
465,466,467	6	2225*
475,476,477	6	2188*
480	6	2156*
502	2	733
535	4	1579
546,547,548,549	4	1580
551,552	4	1581
564,565,566	5	1937
572,573,574,575	5	1938
577,578	5	1939
580,581,582	5	1940
590	5	1941
600	3	1221
601,603,604	3	1222
605,606,607,608	4	1582
610,611	4	1583
612,613	5	1942
614	4	1584
630,631,632	5	1943
650	3	1223
741	4	1585
752,753	3	1224
754	4	1586
755	3	1225
757	3	1225
800A,B,C,D	3	1226
805,806,807,809	3	1226
810	4	1587
811	3	1227
		A&B
814 (Fine Tuning)	3	1227A
814 (Focus Control)	3	1226
617	3	1226
821	3	1226
830,835,840	3	1229
660,661,662	6	2369*
911,H,912,913	6	2201*
911D,912D,913D	6	2379*
914D	6	2379*
920,921	6	2205*
GENERAL IMPLEMENT		
9A5	2	574
GENERAL TELEVISION		
1A5,2A5,3A5,5A5	1	73
9A5	2	574
14A4F	1	6
15A5,17A5,19A5,		
21A4,22A5C,23A6	1	73
4B5	2	574
5B5G,5B5Y	2	745
9B5P	2	574
24B6,25B5	2	574
GILFILLAN		
56A,56B,56BC-1,		
56BCR,56C,56D,56E	1	73
58M,58W	2	555
66A,66AM	1	229
66B	1	73
66D,66DM,	1	229
66P,66PM	1	231
68BD	2	746
68F	2	747
96C,96P,96U	2	748
106-48	2	749
GLOBE		
5BP1	1	233
6AP1	1	228
6D1	1	232
6P1	1	228
6U1	1	232
7CP1	2	614
6AC	1	237
456	2	750
457	2	560
500	2	751
517	2	752

Name & Model or Chassis No.	Vol. No.	Diag. No.
GLOBE (cont'd)		
551	1	11
552	2	753
553	2	614
GON-SET		
10-11(Meter Converter)	2	669
GOODRICH (Also See Mantrol)		
92-523,92-524,		
92-525,92-526,		
92-527,92-528	4	1588
GRANCO		
LCU	5	1944
MTU	5	1945
T160	6	2195*
T170	6	2306*
620	5	1946
620V	6	2275*
720	6	2146*
730P,740P	6	2279*
750	6	2281*
760,770,780	6	2306*
GRANTLINE		
500,501	1	234
501-7	2	784
508-7	2	755
510-A	2	756
605,606(Series A)	1	92
651	1	15
5610	2	757
6547	1	15
GROMMES		
GRT-1	6	2196*
GUILD		
484	6	2199*
556	6	2205*
665	6	2205*
HALLICRAFTERS		
CA-2,CA-2A,CA-4	2	758
S-38	1	235
S-38B	3	1230
S-38C(Run 2)	4	1589
S-40	1	236
S-40A	2	759
S-40B	3	1231
S-41B,S-41G,S-41W	1	242
S-47	2	677
S-51	2	585
S-52	2	759
S-53	2	760
S-53A,AU	4	1590
S-55,S-56	2	761
S-58,S-59	2	762
S-72	3	1232
S-72L	4	1591
S-76,S-76U	4	1592
S-77	4	1593
S-78	3	1233
S-78A	4	1594
S-80	4	1595
S-61,S-82	4	1596
S-94	6	2197*
S-95(Run 1)	6	2197*
ST-74	3	1234
ST-83	5	1947
SX-42	2	763
SX-43	2	764
SX-71	3	1235
SX-99,SX-99U(Mark I)	6	2190*
TW-500,TW-600	5	1948
TW-1000	5	1949
TW-2000	5	1950
5R10	3	1236
5R10A	4	1597

* Signifies Coverage in this Volume

Name & Model or Chassis No.	Vol. No.	Diag. No.	Name & Model or Chassis No.	Vol. No.	Diag. No.	Name & Model or Chassis No.	Vol. No.	Diag. No.
HALLICRAFTERS (cont'd)			HARVEY-WELLS			HOFFMAN (cont'd)		
5R30, A, 5R31A, 5R32, A, 5R33, A, 5R34, A	4	1598	ATR-3-6	2	765	W1201U	6	2378*
5R40, 5R41, 5R42	6	2169*	ATR-3-12	2	765	W1251U	6	2376*
5R50, 5R51, 5R52	4	1598	HOFFMAN			W3201U	6	2359*
5R60, 5R61	5	1951	A-200	1	239	W3214U	6	2359*
8R40, 8R40C	4	1599	A-202	1	240	W3251U	6	2376*
17K111B, M	6	2170*	A-300	1	82	W3311U, W3321U	6	2378*
17T101B, M	6	2170*	A-309	1	240	21B907, 21M906, 21P908	5	1954
17T171B, M	6	2170*	A-401	1	82	Chassis		
21K141B, M	6	2170*	A-501	1	241	102	1	62
21K151M	6	2170*	A-700	1	236	103	1	239
21K200B	6	2157*	B-400	1	244	1088T	1	241
21K201B	6	2158*	B-1000	1	18	1108	1	238
21K210M	6	2157*	B1161U	6	2359*	114	1	16
21K211M	6	2157*	B1191U	6	2378*	119	1	240
21K220B	6	2157*	B1201U, B1211U	6	2378*	123	2	767
21K221B	6	2157*	B1231U, B1241U	6	2378*	323U, 324U	6	2359*
21K230M	6	2157*	B1251U	6	2376*	326U	6	2369*
21K231M	6	2157*	B2021U	6	2359*	329U	6	2378*
21T121B, M	6	2170*	B3151U	6	2359*	331U, 332U	6	2376*
21T161B, M	6	2170*	B3191U	6	2359*	420U	6	2359*
24K240B, M	6	2157*	B3201U	6	2359*	421U	6	2378*
24K241B, M	6	2156*	B3234U	6	2378*	706U	6	2359*
24K250B, M	6	2157*	B3241U, B3251U	6	2378*	HOTPOINT		
27K251B, M	6	2157*	B3261U, B3271U	6	2378*	14S201-UHF, 14S202-UHF,		
		2158*	B3291U	6	2378*	14S203-UHF,		
			B3304U	6	2376*	14S204-UHF	6	2274*
400, 406, 409, 410, 411, 412	2	677	B3311U, B3321U	6	2378*	14S206-UHF,		
611, 612	5	1952	B3364U	6	2378*	14S207-UHF	6	2195*
621, 622	5	1952	B4041U, B4061U	6	2359*	17S301-UHF,		
680, 681	3	1237	BG1151U	6	2359*	17S302-UHF	6	2289*
690	3	1237	BT1144U	6	2363*	17S305-UHF,		
715, A, 716	3	1237	BW1144U	6	2363*	17S306-UHF	6	2195*
730, 731	3	1237	C-501	2	766	218400-UHF	6	2195*
740, 741	3	1237	C-502	2	767	218401-UHF, 218402-UHF,		
810A, 811, 815, 818, 820, 822	3	1236	C-803	2	766	218403-UHF	6	2297*
860, 861	3	1238	C-504	2	767	218405-UHF	6	2195*
670, 671	3	1236	C-506, C-507	2	768	218408-UHF	6	2274*
880	3	1238	C-511	2	766	218451-UHF,		
1005, 1006, 1015, 1016, 1017, 1018, 1019	4	1600	C-512	2	767	218452-UHF	6	2297*
1025	4	1601	C-513	2	766	218455-UHF,		
1621, 1622	5	1953	C-514	2	767	218456-UHF	6	2274*
17611-H, 17616, 17617, 17626-A, 17606, 17690, 17631, 17632, 17633, 17634	4	1602	C1008, C1007	2	767	218501-UHF,		
20823C	4	1602	GT1144U	6	2363*	218502-UHF	6	2297*
20990, 20990B, 20994	4	1601	K1151U	6	2359*	218506-UHF,		
21925, 21928, 21940, 21980	4	1602	K1191U	6	2378*	218507-UHF,		
Chassis			K1211U	6	2378*	218508-UHF	6	2274*
A1100D	4	1600	K1231U, K1241U	6	2378*	218557-UHF,		
A1400D	6	2157*	M1161U	6	2359*	218508-UHF	6	2274*
		2158*	M1191U	6	2378*	218558-UHF	6	2297*
B1300D	6	2170*	M1201U, M1211U	6	2378*	218559-UHF,		
B1400D	6	2157*	M1231U, M1241U	6	2378*	218564-UHF	6	2274*
CI400D	6	2157*	M1251U	6	2378*	218565-UHF,		
		2158*	M2021U	6	2359*	218566-UHF	6	2274*
DI300D	6	2170*	M3151U	6	2359*	218605-UHF,		
D1400D	6	2157*	M3181U	6	2359*	218606-UHF	6	2274*
F1300D	6	2170*	M3201U	6	2359*	24S801-UHF,		
H1300D	6	2170*	M3214U	6	2359*	24S802-UHF	6	2297*
Z1000D	4	1600	M3234U	6	2359*	HOWARD		
HARMON KARDON			M3241U, M3251U	6	2378*	4BT	1	171
A-200	6	2251*	M3261U, M3271U	6	2376*	220, 221	1	171
A-310	6	2260*	M3304U	6	2378*	270, 271	1	171
A-400	6	2276*	M3311U, M3321U	6	2378*	300 Series	1	243
D-200	6	2276*	M3364U	6	2378*	307-4, 207TP-2	1	243
D-1100	6	2256*	M4041U, M4061U	6	2359*	430 (Series 2)	1	246
FM-100	6	2317*	MG1151U	6	2359*	438	1	248
T-100	6	2342*	P1151U	6	2359*	460	1	250
T-120	6	2317*	P1201U, P1211U	6	2378*	472AC, 472AF, 472C	2	769
T-1040	6	2401*	P1231U, P1251U	6	2378*	472F	2	770
TA-10	6	2342*	P3214U	6	2359*	474	2	555
TA-120	6	2346*	P3234U	6	2378*	482, 482A	2	761
TA-1040	6	2386*	P3241U, P3251U	6	2378*	500 Series	1	245
			P3261U, P3271U	6	2378*	716 FM	1	249
			P3281U	6	2378*	765, 768, 780	1	248
			P3304U	6	2378*	806, 806	1	247
			P3311U, P3321U	6	2378*	808 (Series X)	1	259
			P3364U	6	2378*	810	1	247
			PT1144U	6	2363*	865, 868	1	255
			SG1144U	6	2363*	901A-E, -H, -I, -M, -P, -W	1	73
			SP1161U	6	2359*	906, 906C	1	253
			SP2021U	6	2359*	909M	2	771
			SP3151U, SP3161U	6	2359*			
			SP3181U	6	2359*			
			SP3201U	6	2359*			
			SP4041U, SP4061U	6	2359*			
			W1161U	6	2359*			

* Signifies Coverage in this Volume

Name & Model or Chassis No.	Vol. No.	Diag. No.	Name & Model or Chassis No.	Vol. No.	Diag. No.	Name & Model or Chassis No.	Vol. No.	Diag. No.
HOWARD (cont'd)			KNIGHT (cont'd)			MAGNAVOX (cont'd)		
920	1	73	948X703	6	2290*	CR-189A, CR-189B	1	267
HUDSON			948X711	6	2313*	CR-190	1	271
DB39	1	256	948X728	5	1980	CR-190A, CR-190B	2	780
DB40	1	252	948X730	6	2311*	CR-192A, CR-192B	1	267
8A39	1	256	97-870	3	1248	CR-193	1	263
8A40	1	252	200	5	1957	CR-197C	2	781
JACKSON			449	3	1249	CR-198A, CR-198B,		
150,153	3	1239	511B	3	1250	CR-198C	1	263
254	4	1603	723	5	1909	CR-200A, B, C, D, E, F	2	782
255	4	1604	LA FAYETTE			CR-207A, B, C, D	2	781
256	3	1240	B33	1	6	CR-208A, B	2	783
JEFFERSON TRAVIS			B112	1	41	CR-330AA-1	5	1962
MR-2B, MR-3	1	251	B195	1	183	CR-700	5	1963
JEWEL			BB9 (A)	1	191	CR-702A, B	5	1964
500A, B, C, 501A, B, C,			BB9 (B)	1	190	CR-703, A, B, BB	6	2191*
502A, B, C, 503A, B, C,	1	18	FA15W, FA15Y	1	257	CR-712AA	8	2207*
504A, B, C, 505A, B, C	1	18	J62, J62C	1	237	CR-714AA	6	2200*
950, 960U, 961	3	1241	MC10B, MC10Y	1	11	CR-715AA, AB, BB	6	2207*
950B, 950U	3	1242	MC11, MC12	2	77	CR-718AA	8	2191*
9507U	3	1243	MC13	1	111	CR-717	8	2267*
KAPPLER			LEARADIO			CR-718, CR-721	6	2298*
102T	2	772	R971	2	778	CR-722	6	2297*
KARADIO			RM402C	2	779	CR-723	6	2277*
M80B	5	1955	561, 563, 563	1	260	CR-724	6	2207*
1276	3	1244	565, 565BL, 566, 567, 568	1	260	CR-726	8	2277*
KNIGHT			661	1	270	CR-730	6	2277*
D-182	1	249	1281PC	2	761	CR-741	6	2207*
D-197	1	249	6610PC, 6611PC,			MAGUIRE		
8X9L727	5	1909	661PC	1	270	500BI, 500BW, 500DI,		
8X11L719	5	1911	6614, 6615, 6616,			500DW	1	269
8X14L721	5	1966	6617PC, 6619	1	260	561BI, 561BW, 561DI,		
8X19L720	5	1967	LEWYT			561DW	1	269
4D-450	2	633	615A	1	265	571	2	784
4G-420	3	1245	711	2	850	661, 661A	1	269
5A-150, 5A-153,			LEXINGTON			700A, 700E	1	268
5A-154	1	15	6545	1	15	MAJESTIC		
5A-190	1	11	LIBERTY			4P1	5	1968
5B-160	1	18	A6K, A6P	1	264	5A410, 5A430	1	272
5B-175, 5B-176	1	16	6K	1	264	5A445, 5A445R	2	614
5B-185	2	773	507A	1	264	5AK711, 5AK731,		
5C-290	2	573	LINCOLN			5AK780	2	785
5D-250, 5D-251	2	570	813L-N	1	185	5C-2, 5C-3	4	1609
5D-455	2	574	LINCOLN (Allied Radio Corp.)			5LA5, 5LA6	3	1251
5F-565	2	572	5A-110	1	26	5LA7, 5LA8	3	1252
5J705	4	1605	LYRIC			6FM714	2	786
5K715	4	1606	546T, 546TY, 546TW	1	73	6FM773	2	787
6A-122	1	264	MADISON-FIELDING			7C432, 7C447	1	274
6A-127	1	261	FM-15	6	2410*	7FM877, 7FM888	2	787
6A-195	1	16	MAGIC TONE			7JK777R	2	788
6B-122	1	254	500, 501	1	19	7JL868	2	788
6B-127	1	261	MAGNAVOX			7P420	2	789
6C-225	2	578	Chassis			78433, 78450, 78470	2	790
6D-225, 6D-226	2	578	CMUA-422AA	5	1961	7YR752	2	791
6D-235	2	745	CMUA-435AA,			7YR753, 7YR772	2	789
6D-360	2	649	CMUA-436AA	5	1961	8FM744, 8FM775,		
6G-400	3	1249	CMUA-440AA,			8FM776, 8FM889	2	792
6H-580	3	1246	CMUA-441AA,			8JL885	2	793
6K718	5	1968	CMUA-442AA	6	2167*	86452, 86473	1	273
7B-220	2	754	CMUA-455AA,			12FM475, 12FM776,		
7D-405	2	774	CMUA-456AA	5	1961	12FM779, 12FM895	2	794
8B-210	1	258	CMUD-477AA	6	2230*	20FP68, 20PP69,		
8D-340	2	645	CR-101, CR-101M	1	262	(Radio Ch.)	4	1610
9G-200, 9G-201	3	1247	CR-108M	1	266	21P62, 21P63,		
10B-249	2	775	CR-122	1	266	(Series 110, 111)	5	1966
11C-300	2	645	CR-187, CR-188	1	263	80FMP2	4	1610
11D-302	2	567	MAGNAVOX			Chassis		
12R810	4	1607	CMUA-422AA	5	1961	5B01A, 5B05A	2	785
19F-492, 19F-497,			CMUA-435AA,			6B02D	2	786
19F-498	2	776	CMUA-436AA	5	1961	6B11D	2	787
20R811	4	1607	CMUA-440AA,			7B04A	2	791
93-326	4	1608	CMUA-441AA,			7B09A, 7B09A1	2	789
948445	5	1559	CMUA-442AA	6	2167*	7C11D	2	787
948X702	6	2313*	CMUA-455AA,			7C25A	2	788
			CMUA-456AA	5	1961	8B08D, 8B07D, 8B08D,		
			CMUD-477AA	6	2230*	8C07D	2	792
			CR-101, CR-101M	1	262	12B36E, 13C22E	1	794
			CR-108M	1	266	4501, 4504	1	272
			CR-122	1	266	4506	2	614
			CR-187, CR-188	1	263	4702, 4703	2	790
						4705	2	789
						4706, 4707	1	274
						4708R	2	788

* Signifies Coverage in this Volume

Name & Model or Chassis No.	Vol. No.	Diag. No.
-----------------------------	----------	-----------

MAJESTIC (cont'd)

4810	1	273
4810B	2	793
41201	2	794

MALLORY

TV-101	4	1535
--------	---	------

MANTOLA

R459	1	118
R643	1	4
R652,R652N	1	6
R654-PM, -PV	1	276
R655W	1	275
R662,R662N	1	6
R664PM, PV, W	2	795
R7543	1	73
R75143	2	574
R75152	2	796
R75343	2	574
R76143	2	574
R76162	2	796
R76262	2	797
R78162	2	798
24B6	2	574
92-529	4	1611

MASCO

AFR	6	2328*
AMF,AMP	6	2331*
RK-58LR	4	1612

MASON

45-1A,45-1B,45-1P	1	73
45-3,45-4,45-5	1	73

MATTISON

630DKM,630MDXL	5	1967
----------------	---	------

MAYFAIR

510,510W	2	799
520,520W	2	799
530,530W	2	799
550,550W	2	799

MECK

CD-500,CE-500	2	800
CR-800	2	801
EF-730,EG-731	3	1253
MM510T,MM512T, MM516C,MM516T	3	1254
PM-5C5-DW10, PM-5C5-PW10	1	6
RC-5C5-P	1	6
RC-6A7-P6	2	802
XOB,XQA,XQR,XRA, XRPT,XSA,XSPT,XTA, XTR,XX90T	3	1254
4C7	2	803
6A6-W4	1	187
9030	5	1968

MEDCO (See Teleonic)
MEISSNER

4E	4	1613
8BT	4	1614
8C	2	804
9AJ	3	1255
9-1065	1	6
9-1091A,9-1091B	2	805
9-1091C	3	1256
9-1093	2	806
16A	3	1257
2961 Series	2	807

MERCURY (Pacific Mercury)

2001,2181 (Radio Ch.)	4	1615
2217,2218,8,2224, 2284	4	1616

MERCURY (cont'd)

2701	5	1993
Chassis		
155	4	1615
200-11	4	1616

MIDLAND

M6B	1	278
-----	---	-----

MIDWEST

KD-16	5	1969
P6,PS6	1	276
R12,RG12,RT12	2	808
R16,RG16	2	808
RN-16	5	1969
RT-16	2	808
S8,ST8	1	282
S12,SG12,ST12	2	809
S16,SG16,ST16	2	809
TM8	1	282

MINERVA

L-702	1	171
L-728	1	19
W-117	1	6
W-117-3	1	11
W-702-B	1	171
W710,W710A	1	281
W-728	1	19
410,411	2	810
702H,702H-1	2	810
729	2	704

MITCHELL

1254	4	1617
1278	5	1970
1287	5	1971

MONITOR

M510	2	811
M3070	2	812
RA50	2	813
TA85M,TW50M	1	129

MONITORADIO

AR-1,AR-3	4	1618
AR-4	6	2182*
DR-200	5	1972
M-51A	4	1619
M-101	4	1618
MR-10	6	2348*
MR-32	5	1973
MR-33	6	2348*

MONTGOMERY WARD (See Airline)
MOPAR

600,601,602	1	112
620,621	6	2307*
802	1	111
802 Revised	1	111
805	3	1258
806,809	3	1259
812	4	1620
814	4	1621
819	4	1620
829	5	1974
830	5	1975

MOTOROLA

BK2M	4	1622
BK-6	1	279
CR-6	1	280
CR-76	2	815
CTM3	5	1976
CT1M	4	1623
CT2M	4	1622
CT-6	1	279
CT52M6	5	1977

MOTOROLA (cont'd)

CTM4,A	6	2171*
CTM6	6	2285*
FD-6,FD-7	1	279
GMT2M,HJ2M,HN2M	4	1624
HN4M6	5	1977
HN53M6	5	1977
KR2M	4	1624
NH6	1	279
OE2M	4	1624
OE6	1	279
PC2M	4	1624
PC6	1	279
PD2M	4	1624
SROB	3	1260
SR1B	3	1282
SR2M (Early)	4	1625
SR2M (Late)	4	1624
SR52M6	5	1977
VF102,VF102A, VF102C	2	814
VF103,VF103M	3	1261
VK101,VK101M	2	814
VT101	2	814
Y14P3-1,-2,Y14P4-1	6	2349*
Y14P5-1,-2,-3,Y14P6-1	6	2349*
Y14P7-1,-2,Y14P8-1,-2	6	2349*
Y14P10-1,-1A,-2,-2A, Y14P11-1,-1A,-2,-2A	6	2345*
Y17P1-1A,-2A	6	2388*
Y17P2-1A	6	2388*
Y17T27CH,Y17T28-1, -2,-3	6	2355*
Y17T30CHA, Y17T31GPA	6	2388*
Y21CTBG,MG	6	2324*
Y21CTTB,M	6	2355*
Y21F5,B (Radio Ch.)	5	1937
Y21F8B,BA,W,WA	6	2388*
Y21K45B,BA,M,MA	6	2324*
Y21K53B,BA,M,MA	6	2324*
Y21K54B,M	6	2324*
Y21K56B,M	6	2324*
Y21K57B,M,MCH	6	2324*
Y21K58B,M	6	2324*
Y21K59M,MCH	6	2324*
Y21K67B,M	6	2324*
Y21K70B,M	6	2388*
Y21K73B,BA,M,MA	6	2388*
Y21K75B,BA,CW,CWA, M,MA	6	2388*
Y21K76B,BA,CW,CWA, M,MA	6	2388*
Y21K77B,M	6	2388*
Y21K80CW,CWA, M	6	2388*
Y21K81B,M	6	2388*
Y21T33B,BA,CH,CHA, MGA	6	2324*
Y21T33B,BG,CH,MG	6	2324*
Y21T34B,BA,M,MA	6	2324*
Y21T35B,M	6	2324*
Y21T36B,M	6	2324*
Y21T37B,M	6	2387*
Y21T40BG,BGA, MG,MGA	6	2388*
Y21T42B,BA,M,MA	6	2388*
Y21V1W,WA	6	2388*
Y24K13B,M	6	2324*
Y24K14B,M	6	2324*
Y24T5BG,MG	6	2324*
Y24T6B,M	6	2324*
YA21C5B,MC	6	2324*
YA21F6W,Y	6	2324*
YA21K54B,M	6	2324*
YA21K56B,M	6	2324*
YA21K57B,M,MCH	6	2324*
YA21K58B,M	6	2324*
YA21K59M,MCH	6	2324*
YA21K60B,M	6	2324*
YA21K61MCH,W	6	2324*
YA21K62M,CW	6	2324*
YA21K63CW	6	2324*
YA21K67B,M,Y	6	2324*
YA21T33BG,CH,MG	6	2324*
YA21T35B,M	6	2324*
YA21T36B,M	6	2324*
YA24K14B,M	6	2324*
YA24K15M,MCH	6	2324*

* Signifies Coverage in this Volume

Name & Model or Chassis No.	Vol. No.	Diag. No.
MOTOROLA (cont'd)		
YA24T6B,M	6	2324*
5C1,5C2,5C3,5C4, 5C5,5C6	3	1262
5H1U,5H12U,5H13U	3	1263
5M,5M-12	6	2144*
5X1U,5X12U,5X13U	3	1264
5X2U,5X22U,5X23U	3	1265
6F11,6F11B	3	1268
6L1,6L2	3	1267
6TAS8	6	2144*
6X11U,6X12U	3	1268
7F11,B	3	1269
7MX	6	2353*
8FM21,8FM21B	3	1270
9FM21,9FM21B	3	1271
9-24,9-24A	1	285
9-44	1	288
16-C	1	284
16F1,BH,H	3	1280
17-D	1	287
17F1,A,B,BA, 17F2W,WA	3	1281
17F3B,BA,17F4,A, 17F5,A,B,BA	3	1281
17F11(Radio Ch.)	4	1626
17F12,A,B,BA	4	1626
17F13,B,17F13BC, 17F13C	4	1626
18-O,19-B	1	289
21F1,B	4	1627
21F5,B(Radio Ch.)	5	1978
25-F	1	290
26-C,26-C7	1	291
27-D,27-D6	1	293
28-O,29-B,29-B6	1	291
30-P	1	291
35-F	1	294
35-N	1	292
36-C1,36-C2	1	295
37-D1,37-D2	1	296
38-O	1	291
39-B1,39-B2	1	291
40-P	1	286
43-H	1	297
44-K	1	298
45-B12	1	158
45-N	1	299
47B11	2	816
51-A,51-C	1	73
51F11	1	300
51F12	1	301
51R11	1	300
52-C	1	73
52C1,52C1A,52C6	4	1628
52H11U,52H12U, 52H13U,52H14U	4	1629
53-A,C	1	73
53H1,53H2,53H3,53H4	5	1978
53LC1,53LC2,53LC3	5	1980
53X1,53X2,53X3,53X4	5	1981
54-A,C	1	73
55F11	1	303
55X11	1	302
55X11A	1	304
55X12	1	302
55X12A	1	304
55X13	1	302
55X13A	1	304
56W1,B	6	2206*
56X1,56X2,56X3	6	2214*
56X11	2	669
57W1,B,MC	6	2206*
57X1,57X2	6	2206*
57K11,57K12	2	817
58A11,58A12	2	669
58X11,58X12	2	818
59H11U,59H12U	3	1272
59X11,59X121	3	1273
59X21U,59X221U	3	1274
60-KW	1	305
61-A,61-B	1	305
61-C,61-D	1	306
61-E	1	305
61-F	1	307
61T21	1	308
61T23	1	314
61X11,61X12,61X13	1	301
62-A,62-B	1	305

Name & Model or Chassis No.	Vol. No.	Diag. No.
MOTOROLA (cont'd)		
82C1,82C1A,82C2,82C2A, 82C3,82C3A	4	1630
82CW1	4	1631
82-E	1	305
82-F1	1	312
82L1U,82L2U,82L3U	4	1632
82X11U,82X12U, 82X13U	4	1633
82X21	5	1982
83-A,83-E	1	305
83LS8	5	1983
83L1,83L2,83L3	5	1984
83X1,A,83X2,83X3	5	1985
83X21	5	1986
84X1,84X2	5	1987
85F11,85F12	1	303
85F21	1	309
85L1,85L2	6	2172*
85T21,85T21B	1	310
85X11,85X11A,85X12, 85X12A,85X13, 85X13A,85X14, 85X14A,85X14B	1	19
86C1,86C2	6	2236*
86X1,86X2	6	2214*
87C1,87C2	6	2236*
87F11,87F12,87F12B	2	819
87F14	2	820
87F16BN	2	821
87L11	2	822
87X1,87X2	6	2206*
87X11,87X12,87X13	2	820
87X2M21	2	823
88F11,88F12,88F14, 88F14B,88F14M	2	819
88T11,88X11,88X11A, 88X12,88X12A	2	825
89L11	3	1275
89X11,89X121	3	1276
71-A	1	313
72-C	1	311
72X2M21,72X2M22	4	1634
75F21	1	315
75F31,75F31A, 75F31B	2	826
76F31	2	826
77FM21,77FM22, 77FM22M,77FM22WM, 77FM23	2	823
77X2M21,77X2M22, 77X2M22B	2	823
78F11,78F11M,78FM12M, 78FM21,78FM21M, 78FM22M	2	827
79X2M21,79X2M22	3	1277
81-C	1	306
81F21,81F22	1	308
81K31	1	316
82-A	1	317
83F1	1	312
83K1	1	321
85F21,85K21	1	309
88FM21	2	827
93F1	1	312
95F31,95F31B,95F33	1	320
99FM21R	3	1278
101F21,101R21	1	319
103CK2	1	318
103F,103F2	1	312
103K1	1	322
107F31,107F31B	2	828
250,251	1	325
395,395-12	5	1988
396,396-12	6	2264*
401A,412	4	1635
506,506-12	6	2286*
Chassis		
AS-22	1	279
HS-2	1	19
HS-8	1	158
HS-22,HS-26	1	309
HS-30,HS-31	1	303
HS-32	1	310
HS-36,HS-36A	2	826
HS-38,HS-39	1	320
HS-50	1	304
HS-52	1	309

Name & Model or Chassis No.	Vol. No.	Diag. No.
MOTOROLA (cont'd)		
HS-58	2	820
HS-59	2	822
HS-60	2	817
HS-63	2	819
HS-64	2	823
HS-69	2	821
HS-72	2	816
HS-87	2	828
HS-89	2	823
HS-91	1	315
HS-94	2	669
HS-97	2	823
HS-98	2	826
HS-102	2	823
HS-108	2	814
HS-119	2	824
HS-122	2	820
HS-124	2	818
HS-125	2	819
HS-127,HS-127A	2	825
HS-128,HS-132,HS-133	2	827
HS-137	2	814
HS-144	2	825
HS-150,HS-155	2	827
HS-158	2	669
HS-168	3	1277
HS-170	3	1278
HS-175	3	1275
HS-180	3	1273
HS-181	3	1276
HS-192	3	1274
HS-210	3	1272
HS-226	3	1262
HS-228	3	1262
HS-230	3	1269
HS-243	3	1264
HS-244	3	1263
HS-245	3	1268
HS-246	3	1271
HS-247	3	1270
HS-253	3	1281
HS-258	3	1262
HS-259	3	1265
HS-261	3	1281
HS-262	3	1262
HS-264	3	1266
HS-265	3	1269
HS-270,HS-271,HS-272	3	1262
HS-299	4	1630
HS-302	4	1626
HS-303	4	1634
HS-308	4	1632
HS-309,HS-310	4	1628
HS-313	4	1629
HS-314	4	1633
HS-316	4	1627
HS-319	4	1628
HS-324	4	1631
HS-326	5	1982
HS-328	5	1985
HS-336	5	1981
HS-337	5	1979
HS-347	5	1980
HS-361	5	1984
HS-385	5	1986
HS-415	5	1983
HS-440	5	1987
HS-455	6	2172*
HS-456	6	2206*
HS-458	6	2236*
HS-477	6	2214*
HS-478	6	2214*
HS-525,HS-526	6	2206*
HS-529	6	2236*
OB	3	1260
QTS-502,Y	5	1978
R16M8	5	1977
TS-3,TS-5,TS-7	2	814
TS-8	3	1261
TS-422Y	6	2355*
TS-423Y	6	2349*
TS-425Y	6	2358*
TS-426Y	6	2388*
TS-428Y	6	2388*
TS-537Y,TS-538Y	6	2324*
TS-539Y	6	2324*
TS-542Y	6	2388*

* Signifies Coverage in this Volume

Name & Model or Chassis No.	Vol. No.	Diag. No.
MOTOROLA (cont'd)		
TS-544Y	6	2388*
TS-905Y	6	2355*
TTS-423Y	6	2349*
TTS-537Y, TTS-539Y, TS-539Y	6	2324*
VTS-538Y, VTS-539Y	6	2324*
WTS-423Y, WTS-425Y	6	2349*
WTS-537Y, WTS-538Y	6	2324*
WTS-539Y	6	2324*
WTS-544Y	6	2388*
1B	3	1282

MURPHY		
113,122	1	258

NATIONAL		
Criterion	5	1989
HRO-50	3	1283
HRO-50R1	4	1636
HRO-60	4	1637
NC-33	2	829
NC-46	1	328
NC-57	2	830
NC-98	5	1990
NC-108R, NC-108T	2	831
NC-125	4	1638
NC-2-40DR, NC-2-40DT	2	832
SW-54	4	1639

NATIONAL UNION		
571,571A,571B	1	117
G-613	1	324
G-619	1	189

NEWCOMB		
CO-100	6	2261*
CO-200	6	2261*
CO-712	6	2340*

NORDIC		
501F55	6	2149*

OLDSMOBILE		
982160	1	323
982282	1	323
982375	1	323
982543, 982579	4	1640

OLYMPIC		
"Cremona" 5804T/W	6	2402*
"Cremona" 5805T/W	6	2402*
"Kolbold" 5720W	6	2404*
"Magnet" 5735W	6	2402*
"Meteor" 5781W	6	2407*
"Moderns" 5783W	6	2407*
C21BG15, C21BG16	6	2246*
C24BH22, C24BH24	6	2246*
HF500	5	1991
K21BG12, K21BG13, K21BG14	6	2241*
K24BH31, K24BH32, K24BH33	6	2246*
T21BG10	6	2246*
6-501, 6-501VU, 6-501WU	1	328
6-502, 6-502P, 6-502U	1	328
6-503	1	328
6-504, 6-504L	1	6
6-601V, 6-601W, 6-602	1	329
6-604 Series	2	833
6-606, 6-606A, 6-606U	1	272
6-617, 6-617U	1	329
7-421V, 7-421W, 7-421X	2	834
7-435V, 7-435W	2	834
7-526	2	704
7-532V, 7-532W	2	833
7-537	2	835
7-622, 7-638	2	774
7-724, 7-728	2	836
7-925, 7-934, 7-936	2	837

OLYMPIC (cont'd)		
8-451	2	838
8-533V, 8-533W	2	839
8-618	2	840
8-925, 8-934, 8-936	2	841
9-435V, W	4	1641
17K41, 17K42, 17K50(Radio Ch.)	4	1642
20K43, 20K51, 21K61, 21K62, 21K63B	4	1642
21K223, 21K225	6	2150*
21K239	6	2150*
51-421W	4	1643
110	6	2246*
469	4	1644
505, B	5	1992
572B, M	5	1992
574	6	2150*
575	6	2212*
576, 577	6	2150*

PACKARD-BELL		
5DA	1	73
5D8	2	574
5FP	1	73
5RC1	6	2367*
5RC3, 5RC4	6	2367*
10RP1, 10RP2	6	2247*
11RP2	6	2247*
100	2	574
551, 551-D	1	333
556	1	333
561, 563	1	330
566	1	333
568	1	73
571, 572	2	842
651	1	333
661	1	331
662	1	332
673A, 673B	2	843
682	2	844
771	2	845
861	1	332
872	2	846
880, 880A	2	843
881A, 881B	2	847
884, 892	3	1284
1052	1	334
1054B	1	337
1063	1	272
1181, 1181A	3	1285
1273	2	848
1472	2	849
2301-TV(Radio Ch.)	3	1286
2303(Radio Ch.)	3	1286
2311, 2811A(Radio Ch.)	4	1645
2801-TV, 2801A-TV(Radio Ch.)	3	1286
2803TV	3	1287

PEDERSON		
AFM-2A	6	2246*

PENTRON		
AFM	5	1994

PHILCO		
A-T2294	4	1646
A-UT2272	5	1995
B570, B574	5	1996
B652	5	1997
B714, X	5	1996
B956	5	1996
B1349, B1352	5	1999
B1752, B1753	5	1999
B1756	5	2000
C-666 (Codes 121 & 125)	6	2141*
C667	5	2001
C1348	5	1999
C-4608	1	111
C-4608 Revised	1	111
CR-2	2	850
CR-4, CR-6	2	851

PHILCO (cont'd)		
CR-8	2	852
CR-9	2	853
CR-12	2	852
CR-501, CR-503, CR-505	3	1288
E-748	6	2392*
E-818	6	2392*
E-976	6	2360*
E42088	6	2370*
E4605, C, T	6	2370*
E4607, L, T	6	2370*
E6606	6	2370*
E6608TN	6	2370*
E6610L, M	6	2370*
RT-14	5	2002
UE4202, UE4203	6	2336*
UE4204, L, UE4205L, M	6	2336*
UE4206S, SD, SL, STM	6	2336*
UE4207SC	6	2336*
UE42088	6	2370*
UE4600, UE4601SL, SM	6	2336*
UE4602, L, TL, TM	6	2336*
UE4603L, M, UE4604, HM	6	2336*
UE4605, C, T	6	2370*
UE4606L, M, T, TL	6	2336*
UE4607, L, T	6	2370*
UE4608	6	2336*
UE4610N	6	2336*
UE4612G	6	2336*
UE4614S, SL	6	2336*
UE4700N	6	2336*
UE4800, UE4802M, L	6	2336*
UE4804L	6	2336*
UE6200	6	2336*
UE6404M, L	6	2336*
UE6602L, M, T, TL	6	2336*
UE6604L, M, T	6	2336*
UE6606	6	2370*
UE6608TN	6	2370*
UE6610L, M	6	2370*
UN6-100	1	336
UN6-450, UN6-500	1	335
UT-21A	5	2003
UT-21B	5	2004
18BU3000, 18BU3001	5	1995
18BU3002	5	2005
18BU3100, L, HM	5	1995
18BU3102, L	5	2005
18BU3104	5	1995
18D3020UC, UG, UM	6	2192*
18D3122U	6	2192*
22BU4000	5	1995
22BU4002, 22BU4004	5	2005
22BU4008, 22BU4009	5	1995
22BU4100, L, 22BU4101	5	1995
22BU4102, L, 22BU4106	5	2005
22BU4108	5	1995
22BU4109HM	5	2005
22BU4110, L	5	1995
22BU4302	5	2005
22BU4303	5	1995
22BU4304, 22BU4306, 22BU4307HM	5	2005
22BU4308	5	1995
22C4016, 22C4020	5	2006
22C4119, 22C4120, L	5	2006
22C4123, 22C4124, L	5	2006
22C4126, L, 22C4128M, 22C4129	5	2006
22C4132L	5	2006
22C4310, L, 22C4312, L	5	2006
22D4029G, L, 22D4030E, L, UE, UL	6	2192*
22D4039G, L	6	2192*
22D4034, L	6	2215*
22D4041, L	6	2215*
22D4131, L	6	2192*
22D4134, L	6	2215*

* Signifies Coverage in this Volume

Name & Model or Chassis No.	Vol. No.	Diag. No.
PHILCO (cont'd)		
22D4135	6	2192*
22D4138, L, U, UL, XL, XW	6	2192*
22D4137, L, 22D4138, L, U, UL	6	2192*
22D4139, L, UX, UXL	6	2192*
22D4140, L	6	2215*
22D4144, L	6	2215*
22D4150, L, U, UL	6	2192*
22D4151, L, 22D4152, HM, M	6	2215*
22D4153, L, X, XL, 22D4154, U	6	2192*
22D4155, L	6	2192*
22D4156, L, 22D4157	6	2215*
22D4158, U	6	2192*
22D4159, 22D4160, L, X, XL	6	2215*
22D4161, L, 22D4165	6	2215*
22D4170, L, 22D4171, L, 22D4172, L	6	2192*
22D4320L, M, T, W	6	2192*
22D4321L, M, T, W	6	2192*
22D4324HM, M	6	2215*
22D4326	6	2215*
22D4420, L, 22D4422	6	2215*
22D5100, 22D5102, L, M	6	2203*
24BU5106, L	5	2005
24B6300	5	2005
24C8005	6	2192*
24C8010, 24C8012	6	2154*
24C8105M, 24C8108	6	2192*
24C8109, L, 24C8110, L	6	2154*
24C8112	6	2154*
24C8310	6	2154*
24D6016	6	2215*
24D6120L, M, 24D6122L, M	6	2215*
39-40, 39-45	1	339
39-55	1	342
39-116	1	342
39-770	1	338
40-110	1	341
40-130, 40-135, 40-140, 40-145	1	340
40-150, 40-155	1	344
40-158	1	348
40-160, 40-165	1	345
40-170CS	1	340
40-180, 40-185, 40-190	1	344
40-195, 40-200, 40-201	1	338
40-205, 40-215, 40-216, 40-217	1	342
40-503, 40-506, 40-507	1	340
40-516	1	342
40-525, 40-526, 40-527	1	340
40-710, 40-715	1	351
40-725, 40-748, 40-755, 40-758, 40-760	1	349
40-2710	1	351
40-2725, 40-2780	1	349
41-230, 41-235	1	350
41-250, 41-255	1	353
41-260, 41-265	1	352
41-280, 41-285, 41-287, 41-290	1	353
41-295	1	338
41-296	1	353
41-300, 41-315X	1	338
41-316	1	342
41-608, 41-609	1	355
41-610, 41-611	1	353
41-616	1	342
41-629	1	353
41-712, 41-713	1	354
41-714	1	346
41-722, 41-745, 41-758, 41-759	1	347
41-788	1	356
42PT-2, 42PT-4, 42PT-7	1	343
42-121	1	363
42-122	1	358
42-123	1	361
42-124, 42-125, 42-126	1	364
42-35	1	357
42-380	1	363
42-395	1	363

Name & Model or Chassis No.	Vol. No.	Diag. No.
PHILCO (cont'd)		
42-400	1	338
42-706	1	343
42-724	1	360
42-730	1	366
42-760, 42-761, 42-762	1	359
42-788	1	356
42-1002	1	362
42-1003, 42-1005	1	367
42-1008, 42-1009M, 42-1009W	1	365
42-1012, 42-1013M, 42-1013W	1	368
42-1015, 42-1016	1	338
46-131	1	370
46-131 Revised	2	854
46-132	1	371
46-142	2	854
46-200, 46-200-1, 46-201, 46-202, 46-203	1	173
46-250, 46-250-1, 46-251	1	372
46-350	1	373
46-420, 46-420-1	1	377
46-421, 46-421-1	1	374
46-427	1	375
46-480	1	376
46-1201	1	379
46-1203	1	378
46-1209	1	380
46-1213	1	382
46-1226	1	380
47-204, 47-205	2	745
47-1227	2	855
47-1230	2	856
48-141, 48-145	2	857
48-150	2	858
48-200, 48-200-1, 48-206, 48-214, 46-225, 48-230	2	560
48-250, 48-250-1	2	859
48-300, 48-360	2	860
48-460, 48-460-1	2	861
48-461	2	859
48-464	2	862
48-472-1	2	863
48-472 Revised	2	864
48-475	2	865
48-482	2	866
48-485	2	867
48-1201	2	868
48-1253	2	869
48-1256	2	870
48-1260	2	868
48-1262	2	868
48-1263	2	871
48-1264	2	872
48-1266	2	856
48-1270	2	873
48-1274, 48-1276	2	874
48-1282	2	867
48-1284	2	875
48-1286	2	867
48-1290	2	873
48-2500, 48-2500-5	3	1289
49-101	3	1290
49-500, 49-500-1	2	745
49-503	2	560
49-504, 49-504-1	2	859
49-505	2	876
49-506	2	745
49-601, 49-602	2	877
49-605, 49-607	2	878
49-900E, 49-900-1	2	879
49-902	2	745
49-904	2	880
49-905	2	881
49-906	2	882
49-909	2	884
49-1076, 49-1077 (Radio Ch.)	3	1291
49-1100	2	867
49-1101	2	883
49-1175 (Code 122 & Code 124), 49-1278 (Code 123), 49-1279, 49-1280	3	1291
49-1401	2	884

Name & Model or Chassis No.	Vol. No.	Diag. No.
PHILCO (cont'd)		
49-1405	2	885
49-1475, 49-1480 (Codes 121A or B, 123A or B, 123TA or B)	3	1292
49-1600, 49-1601, 49-1602, 49-1603, 49-1604, 49-1605	2	886
49-1606, 49-1607	2	883
49-1613	3	1293
50-T701, 50-T702	4	1647
50-T1104, 50-T1105, 50-T1106	3	1294
50-T1400, 50-T1401, 50-T1402	3	1294
50-T1403, 50-T1404, 50-T1406 (Codes 123, 124, 125)	3	1294
50-T1408 (Codes 121 & 122)	3	1294
50-T1430	3	1294
50-T1432 (Code 122)	3	1294
50-T1432 (Code 124)	3	1294
50-T1476, 50-T1477, 50-T1478, 50-T1482	3	1295
50-T1481, 50-T1482, 50-T1484	3	1295
50-520, 50-520-1	3	1296
50-522, 50-522-1, 50-524	3	1297
50-526	3	1298
50-620	3	1299
50-621	3	1300
50-920, 50-921, 50-922	3	1301
50-925, 50-926	3	1302
50-1420, 50-1421, 50-1422, 50-1423	3	1303
50-1720	3	1304
50-1721, 50-1723, 50-1724	3	1305
50-1727	3	1306
51-T1443PL, PM, PW (Radio Ch.)	3	1307
51-T1872, 51-T1874, L, 51-T1875, 51-T1876	3	1308
51-T2175, 51-T2176	3	1309
51-530	3	1310
51-629	3	1311
51-631	3	1312
51-632	3	1311
51-930, -931, -932	4	931
51-934	3	1313
51-1330	4	1649
51-1730, (L)	4	1650
51-1731, 51-1732 51-1733, (L)	3	1314
51-1734	4	1651
52-540, -152, 541, -1, 52-542-1	4	1652
52-640, -641	4	1653
52-643	4	1654
52-940, -941, -942	4	1655
52-944	4	1656
52-1340	4	1649
53-T2295, T2286, T2287	4	1646
53-561, -562	4	1657
53-563	4	1658
53-566	4	1659
53-651	4	1653
53-652	5	1997
53-656, -658	4	1660
53-702, -706, -707	4	1657
53-800, -804	4	1661
53-950, -952, -954	4	1682
53-956	5	1998
53-958	4	1683
53-960	4	1664
53-1350, -1750	4	1665
53-1754	4	1666
Chassis		
R-181U, D-181	5	1995
R-191U, D-191	5	2005
R-201, D-201	5	1995
R-207, D-208	5	2005*
TV-1230U	6	2303*
TV-300U, TV301U	5	2006

* Signifies Coverage in this Volume

Name & Model or Chassis No.	Vol. No.	Diag. No.	Name & Model or Chassis No.	Vol. No.	Diag. No.	Name & Model or Chassis No.	Vol. No.	Diag. No.
PHILCO (cont'd)			PURITAN			RCA VICTOR (cont'd)		
TV-304U	6	2192*	501	1	385	U-217E	1	443
TV-330U, TV-332U	6	2192*	501X	1	124	U-128, U-129	1	414
TV-350U	5	2008	502	1	385	U-130	1	390
TV-354U	6	2154*	502X	1	124	U-132, U-134	1	401
TV-390U, TV-392U	6	2215*	503, 803W	1	388	V-101	1	440
TV-394U, TV-396U	6	2215*	504, 504W	1	387	V-102	1	413
TV-400U	5	2008	506, 506X, 507, 507W	1	30	V-140	1	446
7L40AU, U, 7L41AU, U	6	2336*	508	1	25	V-170, V-175	1	413
7L45AU, U	6	2336*	509	2	893	V-200	1	447
7L70	6	2370*	515	2	894	V-201	1	139
7L70U	6	2370*, 2371*				V-205	1	447
7L71	8	2370*	RCA VICTOR			V-209, V-210	1	142
7L71U	6	2370*, 2371*	A55	3	1317	V-215, V-219,	1	142
7P50AU, U, 7P51AU, U	6	2336*	A-82	4	1669	V-221, V-225	1	142
PHILHARMONIC			A-108	3	1318	V-300, V-301, V-302	1	447
100C	2	887	A-108	4	1670	V-405	1	447
100T	2	888	BK-42, BT-42	1	427	VHR-202, VHR-307	1	447
149C, 249C	2	889	BX6	3	1319	VHR-212	1	142
349C	2	890	BX55, BX57	3	1320	VHR-307, VHR-407	1	447
920, 924	5	2007	B-58	1	419	X-55, X-60	1	107
5000, 5300, 5201, 5250	4	1530	E-80	1	43	X711	3	1322
5400, 5401, 5450	4	1530	HF-2, HF-4	1	390	1R81	4	1673
5600, 5601, 5650	4	1530	HF-6, HF-8	1	401	1X591, 1X592	4	1671
5700, 5700RT, 5701, 5750, 5750RT	4	1530	K-50	1	107	2BX63	4	1674
5800	4	1530	K-80	1	434	2C521, 2C522,	4	1675
6810	1	196	K-81	1	107	2C527	5	2014
8701, 8702, 8703	1	196	K-82, K-81, K-82	1	434	267	5	2014
8710, 8711, 8712	1	196	K-105	1	434	2810	4	1676
9120, 9121, 9820, 9821	5	2007	M-50, M-60	1	409	2U87	4	1677
PHILIPS PETROLEUM CO. (See Woolarc)			M-70	1	489	2X61, 2X62, 2X621	4	1678
PILOT			MI-12107	5	2012	2XFP91, 2XFP91,	4	1678
AF-905	4	1667	PKX00	4	1671	2XFP92, 2XFP93,	4	1679
AF-723, U	5	2008	Q-11, Q-12	1	397	2XFP94	4	1679
AF-724	6	2228*	Q-14, Q-14E	1	412	3XK671	6	2262*
AF-821A, U	4	1668	Q-15, Q-15E	1	412	3RFP91	5	2016
AF-824	5	2009	Q-16, Q-16E, Q-17	1	416	4C671, 4C672	5	2017
AF-825	6	2146*	Q-18	1	398	4T141	3	1383
AF-850	6	2146*	Q-22, Q-22A	1	391	4X641	5	2018
AF-860	5	2010	Q-23	1	416	4X661	5	2019
FM-607	5	2011	Q-24	1	391	4X511	5	2020
HF-56	6	2146*	Q-25	1	420	5BX41	5	2021
T-411-U	1	381	Q-26	1	396	5C581	5	2022
T-500	1	73	Q-27	1	420	5C591, 5C592	5	2022
T-510, T-511	1	381	Q-30, Q-31	1	423	5Q5, 5Q6, 5Q6	1	398
T-521	1	383	Q-33	1	429	5Q12, 5Q12A	1	400
T-530	1	393	Q-44	1	426	5Q65, 5Q66, 5Q68	1	398
T-601	2	614	Q-41, QB-2	1	391	5X560, 5X562, 5X563	5	2023
T-741	2	891	QB-3	1	399	6BY4A, B	6	2222*
POLICALARM			QB-5	1	397	6HF1, 6HF2	6	2265*
PR-8	3	1315	QB-6, QB-9	1	391	6HF3	6	2232*
PR-9	6	2329*	QH-51C	1	428	6QU	1	400
PR-31	3	1316	QK-23	1	392	6Q1, 6Q4, 6Q4X	1	402
PONTIAC			QU-2C, QU-2M	1	392	6Q7, 6Q8, 6QK8	1	400
983667	1	384	QU-3C, QU-3M	1	396	6T84	3	1383
983679	1	386	QU-5	1	392	6XD5	6	2193*
983680	1	394	QU-7, QU-8	1	407	7BT10K	6	2254*
983775	1	386	QU-51M	1	428	7BX8J, 7BX8L	6	2305*
983910	1	108	QU-52C, QU-52M	1	392	7BX9H	6	2305*
983911	1	386	QU-55	1	430	7HF1-1	6	2344*
984170	1	108	QU-56C, QU-56M	1	432	7QB, 7QBK	1	403
984171	1	386	ST-1	5	2012	7Q4, 7Q4X, 7QK4	1	405
PORTO BARDIO			T-55, T-56, T-60,	5	2013	7T143 (Radio Ch.)	3	1327
PA510, PB520	2	892	T-62, T-63	1	107	8BT10K	6	2254*
PREMIER			T-64, T-65, T-80	1	433	8BX6, 8BX65	2	895
15LW	1	127	TA-128, TA-129,	3	1321	8CTEE, FE, LE	6	2330*
PURE OIL (See Paritan)			TA-169	1	395	8C8DE, JJ, ME	6	2330*
			TRK-5	1	395	8QB, 8QBK	1	403
			TRK-9, TRK-12	1	410	8Q1	1	406
			TRK-90, TRK-120	1	410	8Q2	1	404
			TT-5	1	395	8Q4	1	406
			U-10, U-12, U-20	1	107	8QU5C, 8QU5M	1	404
			U-25, U-26	1	395	8R71, 8R72, 8R74,	2	896
			U-30	1	414	8R75, 8R76	2	896
			U-40, U-42, U-43	1	107	8RF13	6	2344*
			U-44, U-45	1	425	8TE39 (Radio Ch.)	3	1324
			U-50	1	400	8TK30	3	1324
			U-70	4	1672	8TR29	3	1324
			U-115	1	443	8TV321, B, 8TV323, B	3	1325
			U-119	1	395	8V90, 8V91	2	897
			U-121	1	443	8V111, 8V112	2	897
			U-122E	1	395	8X8D, J, L, N	6	2331*
			U-123 (1 band)	1	443	8X53	2	898
			U-123 (2 band)	1	441	9BX56	3	1326
			U-124, U-125	1	395	9M1, 9M2	1	409
			U-126	1	414	9QK, 9Q1	1	408
						9Q4	1	405
						9T89	3	1327

* Signifies Coverage in this Volume

Name & Model or Chassis No.	Vol. No.	Diag. No.
RCA VICTOR (cont'd)		
9T147	3	1327
9TW333	3	1325
9W101,9W102, 9W103,9W105	3	1328
9X561,9X562	3	1329
9X571,9X572	3	1329
9X641,9X642	3	1330
9X651,9X652	3	1331
9Y7	4	1680
9Y51	3	1332
9Y510,9Y511	3	1332
10Q1	1	406
10X	1	411
11QK,11QU,11Q4	1	414
11K1	1	411
12AX,12AX2	1	411
12QK,12QU,12Q4	1	414
12X,12X2	1	411
14AX,14AX2,14X,14X2	1	411
15X	1	397
16K,16T2,16T3,16T4	1	413
16X4	1	415
16X11,16X13,16X14	1	397
17K	1	139
178349U,178350U, 178351U	5	2024
178360U	5	2024
1787090U,1787092U, 1787093U	6	2374*
1787099U	6	2374*
17T352U,17T361U	5	2024
18T	1	139
19K	1	417
21CD7895U, 21CD7897U	6	2301*
21CD7915U, 21CD7916U, 21CD7917U	6	2301*
21CD7935U, 21CD7936U, 21CD7935U, 21CD7936U	6	2327*
21CD7956U, 21CD7958U, 21CD7975U, 21CD7995U	6	2327*
21CD7999U, 21CD7999U	6	2327*
21C87815U, 21C87817U	6	2301*
21CT860U,21CT861U, 21CT862U	5	2026
21CT863U,21CT864U	5	2026
21CT7835U, 21CT7837U	6	2301*
21CT7855U, 21CT7857U	6	2301*
21CT7865U, 21CT7866U, 21CT7867U	6	2301*
21D346U	5	2025
21D527U	5	2026
21D641U,21D645U, 21D647U,21D648U	6	2202*
21D652U	6	2202*
21D667U	6	2202*
21D670U	6	2202*
21D7174U,21D7175U, 21D7176U,21D7177U, 21D7215U,21D7216U, 21D7217U	6	2301*
21D7235U,21D7237U	6	2301*
21D7425U	6	2301*
21D7445U,21D7446U, 21D7447U	6	2301*
21D7479U	6	2301*
21D7485U,21D7487U, 21D7488U	6	2301*
21D7505U,21D7506U, 21D7507U	6	2301*
21PD8115U	6	2397*
21S348KU	5	2027
21S355KU,21S357KU	5	2027
21S362KU,21S367KU, 21S369KU	5	2027
21S501U,21S502U	5	2026
21S503NU,U, 21S504NU,U	5	2026
21S505U, 21S506NU,U, 21S507NU	5	2026

Name & Model or Chassis No.	Vol. No.	Diag. No.
RCA VICTOR (cont'd)		
21S510NU,21S511NU	5	2026
21S516NU,21S517U, 21S518U,21S519NU,U	5	2026
21S521NU,U, 21S522NU,U, 21S523NU,U	5	2026
21S525U,21S526NU,U	5	2026
21S537NU,U	5	2026
21S548,NU,U, (Radio Ch.)	5	2028
21S548NU,U, (TV Ch.)	5	2026
21S5022U,21S5251U, 21S5252U	5	2024
21T197DE,21T242	4	1676
21T244	4	1681
21T385U,21T386U, 21T387U,21T388U	6	2301*
21T395U	6	2302*
21T6082U,21T6083U, 21T6087U	6	2183*
21T6114U,21T6115U, 21T6117U	6	2183*
21T6125U,21T6127U, 21T6225U,21T6227U	6	2202*
21T6255U,21T6256U, 21T6257U	6	2183*
21T7112U,21T7113U, 21T7117U	6	2301*
21T7152U,21T7153U, 21T7157U	6	2301*
21T7352U,21T7355U, 21T7357U	6	2301*
21T7375G,G,U,U, 21T7377,G,G,U,U	6	2301*
21T7385U,21T7386U, 21T7387U,21T7388U	6	2301*
21T7415U,21T7416U, 21T7417U	6	2301*
21T7427U	6	2301*
21T8221U,21T8222U, 21T8225U,21T8226U, 21T8227U	6	2397*
21T8245U,21T8246U, 21T8247U	6	2397*
21T8475U,21T8477U, 21T8478U	6	2397*
24D542U,24D543U, 24D544U	5	2026
24D655U,24D658U, 24D673U,24D676U	6	2202*
24D679U	6	2202*
24D7295U,24D7296U, 24D7297U	6	2301*
24D7315U,24D7317U, 24D7345U,24D7547U	6	2301*
24D7566U,24D7568U	6	2301*
24D7587U	6	2301*
24D7705U,24D7706U, 24D7708U	6	2301*
24S512U,24S513U, 24S514U	5	2026
24S529U,24S531U, 24S532U	5	2026
24T6142U	6	2202*
24T6285U,24T6287U, 24T7272U,24T7275U, 24T7277U	6	2301*
25BK	1	418
25BT2	1	419
25BT3	1	418
26BP	1	421
26X1,26X3,26X4	1	397
27K	1	422
28T	1	139
28X,28X5	1	140
29K,29K2	1	141
34X,35X	1	411
36X	1	397
45-W-10	4	1682
45X18	1	424
55AU	1	429
55F,55FA	1	419
55U	1	429
56X,56X2,56X3	1	431
56X5,56X10,56X11	1	397
58AV,58V,59AV,59V1	1	142
64F1,64F2,64F3	1	138

Name & Model or Chassis No.	Vol. No.	Diag. No.
RCA VICTOR (cont'd)		
65AU	1	429
65BR9	2	899
65U	1	429
65X1,65X2	1	138
66BX	1	435
66X1,66X2,66X3,66X4, 66X14,66X15	1	436
66X11,66X12,66X13, 66X14,66X15	2	900
67AV1,67V1	1	437
68R1,68R2,68R3,68R4	2	901
75X11,75X12	2	902
77U	2	903
77V1	2	904
77V2	2	905
94BK2,94BT2	1	442
95T5,95T5LW	1	443
96BK6,96BT6	1	442
96E	1	443
96E2	1	395
96K,96K2,96K3,96K6	1	395
96T,96T1	1	443
96T2,96T3	1	395
96T4,96T5,96T6	1	441
96T7	1	395
96X1,96X2,96X3,96X4	1	444
96X11,96X12, 96X13,96X14	1	444
97E,97K,97K6,97K2	1	395
97T,97T2	1	395
97X	1	443
97Y	1	398
98EY	1	395
98K	1	414
98K2,98T,98T2	1	395
98X,98YG	1	395
99K,99T	1	414
110K,110K2,111K	1	445
21K	1	141
515	1	397
516,517,522,526,527	1	411
610V1,610V2	2	906
612V1,612V2,612V3	1	448
648PTK,648PV (Radio Ch.)	3	1333
710V2	2	906
711V1,711V2,711V3	2	907
730TV1,730TV2 (Radio Ch.)	2	906
910KG,911K	1	414
Chassis		
CTCS,A	6	2301*
CTCSAA,AB	6	2327*
CTCSB,C,D,E,N,P,R,T	6	2301*
CTCSU,W	6	2327*
KCS70	4	1673
KCS78H,J	5	2024
KCS84H,K	5	2026
KCS88F,H	5	2027
KCS88J,JX,K,KX,L,LX, M,MX,VA,VAX	5	2026
KCS89A	5	2026
KCS90A	5	2026
KCS92D,DX,E,EX,F,FX, H,HX,M,MX,NU	5	2026
KCS96A,C	6	2183*
KCS97A,AA,AB,AC, AD,D,E,F,H,J,K,N,P, T,U,W	6	2202*
KCS98A,C,E,F	6	2301*
KCS103A,B,C,D,N,P, R,T	6	2301*
KCS104A,AA,AB,AC,AD, AE,AF,B,E,F,H, J,K,L	6	2301*
KCS107A,B,C,D	6	2397*
RC-604,RC-605	1	142
RC-606	1	437
RC-606C	2	905
RC-608	2	901
RC-610,RC-610A, RC-610B	2	906
RC-613A	2	906
RC-615	2	904
RC-616,RC-616A	2	897
RC-616B,C	3	1325

* Signifies Coverage in this Volume

Name & Model or Chassis No.	Vol. No.	Diag. No.
RCA VICTOR (cont'd)		
RC-616H	2	897
RC-616J,K	3	1325
RC-616N	3	1325
RC-616,RC-616A (Model 8V90)	2	897
RC-618,RC-618B, RC-616C (Model 9W101)	3	1328
RC-622	3	1318
RC-1004E	1	419
RC-1011	1	431
RC-1017,RC-1017A	1	429
RC-1023B	1	397
RC-1034	1	138
RC-1037,RC-1037A	1	138
RC-1038,RC-1038A	1	436
RC-1040,RC-1040A	1	435
RC-1040C	2	895
RC-1045	2	899
RC-1046	2	900
RC-1050,RC-1050B	2	900
RC-1057A	2	903
RC-1057B	4	1660
RC-1060,RC-1060A	2	896
RC-1064(Model 18X53)	3	898
RC-1064(Model 185X1)	1	136
RC-1068	3	1326
RC-1070A	3	1322
RC-1077,A,B	3	1332
RC-1079,A,B,C	3	1329
RC-1079K,L	4	1671
RC-1082	3	1319
RC-1085,A	3	1331
RC-1085B	4	1678
RC-1087	3	1317
RC-1088,A	3	1320
RC-1090	3	1323
RC-1092	3	1327
RC-1094	4	1669
RC-1096	4	1670
RC-1096A	4	1682
RC-1103	4	1673
RC-1110	4	1671
RC-1111,A	4	1676
RC-1115	4	1674
RC-1117A	4	1677
RC-1117B	4	1676
RC-1117C	4	1677
RC-1117D	5	2014
RC-1120,A	4	1675
RC-1121,A	4	1679
RC-1125	6	2262*
RC-1129	5	2016
RC-1134	5	2020
RC-1140	5	2018
RC-1141	5	2017
RC-1142	5	2017
RC-1146A	6	2193*
RC-1148A	5	2022
RC-1150	5	2023
RC-1153,A	6	2222*
RC-1154,A	6	2265*
RC-1155	6	2232*
RC-1156,A	6	2254*
RC-1162,RC-1163	6	2305*
RC-1166	6	2330*
RC-1167,A	6	2331*
RC-1168,A	6	2344*
RK-121	1	448
RK-121A	3	1233
RK-135,RK-135A, RK-135A-1	3	1324
RK-135D	3	1321
RK-191	5	2028
RS-1147	5	2021
5378	6	2374*

RADIOLA

61-1,61-2,61-3,61-5	1	397
61-8,61-9	2	898
61-10	1	397
752U	2	908
762X11,762X12	2	909

RADIO CRAFTSMEN

(Also See Craftsmen)

RC-1 (Tuner)	2	910
--------------	---	-----

Name & Model or Chassis No.	Vol. No.	Diag. No.
RADIO CRAFTSMEN (cont'd)		
RC-10	3	1334
10	4	1663
800	4	1684
RADIONIC		
6W	1	167
Y82N,Y786	2	911
RADIO RECEPTOR		
C-1709-P	5	2029
HF155	6	2184*
HF255	6	2237*
HF355	6	2259*
RAY ENERGY		
AD	1	449
AD4	1	453
SRB-1X	1	450
RAYTHEON		
C-1735A,C-1736A	4	1685
C-2108A,C-2110A, C-2111A	4	1688
C-2112A,C-2113A, C-2114A,C-2115A, C-2116A,C-2118A	4	1667
C-2137A,C-2138A	5	2030, 2031
C-2401A,C-2402A	5	2031
CR-41,A,CR-42,A, CR-43,A	4	1688
FR81A,FR82A	5	2032
M-2131A	5	2030, 2031
PR-51,A	5	2033
RC-1618A,B, RC-1619A,B	3	1336
RC-1718A,B, RC-1719A,B	3	1336
RC-1720A	4	1689
UC-2139A,UC-2141A, UC-2142A	5	2030
UC-2144A,UC-2145A	5	2030
UC-2167,UC-2168	6	2151*
UC-2403A,UC-2404A, UC-2405A,UC-2406A	5	2030
UHF-100	4	1690
UM-2133A,UM-2134A, UM-2135A,UM-2136A	5	2030
UM-2182C,G,UM-2183A, C, G, K	6	2151*
5R-10B,5R-11W, 5R-12R	6	2162*
10AXF43	3	1335
Chassis		
4P12,A	5	2033
5D166	6	2162*
9AF25A	6	2032*
21T8	6	2030*
21T11	6	2030*, 2031*
21T26AGH	6	2151*
21T193AGH	6	2151*
21T274AGH	6	2151*
24T2	5	2030
24T3	5	2031
RECORDIO		
6B10,6B20,6B30,6B32	1	451
7D42,7D44	2	912
7E40,7E44	2	913
9G10	3	1337
9G40M,9G42	3	1338
9H40B	3	1339
Chassis		
7D1	2	912
REGAL		
BP48	2	914
C-527	4	1691

Name & Model or Chassis No.	Vol. No.	Diag. No.
REGAL (cont'd)		
CR-761	2	915
CR-762	4	1692
L76	1	171
P-175	4	1693
W700,W800,W801	1	171
W900,W901	1	454
17HD36,19C36,19D36, 20C36,20D36,20HD36 (Radio Ch.)	4	1694
205	2	916
271	4	1693
575	4	1695
747	2	917
777	2	918
1049	1	452
1107	2	919
1500	2	920
1749	2	921
1877	4	1696
7251	2	922
REGENCY		
RC-600	4	1697
REMLER		
MP-5-B-3	1	173
5300B,5300B1,53001	2	923
5310	2	924
5400,5410	2	925
5500,5505,5510,5515, 5520,5530	2	926
6000	3	1340
ROLAND		
5P4	5	2034
5T2M	4	1698
5T5	5	2035
5T6	6	2227*
5T7,5T9	6	2213*
5X1,5X2,5X3,5X4	5	2036
5X8U	6	2228*
6P2	5	2034
6T1M	4	1699
6T6	6	2242*
8FT1M	4	1700
8XF6M	4	1701
8XF3-M,8XF4-M	5	2037
10TF1	5	2038
10XF1	5	2039
10XF2	6	2208*
ROYAL		
AN150	4	1702
SCOTT (E. H.)		
16A	2	927
310	4	1703
510	3	1341
515	4	1704
800-B	1	456
1000	4	1705
1510	4	1706
2000	5	2040
2510	5	2041
9052	5	2042
SCOTT (H. H.)		
310-A	6	2180*
SENTINEL		
L-2841,L-284NA, L-284NI,L-284NR, L-284W	2	928
1U-284GA	2	928
1U-2841,1U-284NA, 1U284NI,1U-284W	1	26
1U-285,1U-285P	1	261
1U-293I	1	459
1U-293CT	2	929
1U-293T,1U-293W	1	459

* Signifies Coverage in this Volume

Name & Model or Chassis No.	Vol. No.	Diag. No.
SENTINEL (cont'd)		
1U-2941,1U-294N, 1U-294T,1U-294W	1	459
1U-312PG,1U-312PW	3	1342
1U-3131,1U-313W	2	935
1U-314E,1U-314I, 1U-314W	2	928
1U-318PM,1U-318PT	2	937
1U-335PG,PI,PM,PW	3	1343
1U-338-I,1U-338-R, 1U-338-W	3	1345
1U-339-K	3	1345
1U-340-C	3	1345
1U-343	4	1707
1U-344	4	1708
1U-345P	4	1709
1U-416	3	1346
1U-419,1U-420	3	1346
1U-420B	3	1347
1U-423,1U-423B, 1U-423-17	3	1347
1U-424,1U-424-17	3	1347
1U-425	3	1347
1U-428,1U-429,1U-430, 1U-431,1U-432, 1U-435	3	1347
1U-438,1U-439,1U-440, 1U-441,1U-443, 1U-444,1U-448, 1U-447-A,1U-448, -A,1U-449,-A,1U-450, -A,1U-451,-A	4	1710
1U-520,1U-521, 1U-522,1U-523, 1U-525	5	2043
1U-542	5	2043
1U-562,1U-564	5	2043
1U-581,1U-582, 1U-584,1U-585	5	2044
1U-921,1U-924, 1U-991	5	2045
1U-1202C,1U-1205C, 1U-1208C	8	2243*
1U-1212,1U-1215, 1U-1218	6	2243*
263,264,273	1	459
284GA	2	928
284I,284NA, 284NI,284W	1	26
285P	1	261
289T	1	23
292K	1	454
293 Series	1	459
293CT	1	459
293I	2	929
293T,293W	1	459
294I,294N,294T	1	459
295T	2	930
296B,296M	2	775
302-I,302-T,302-W	2	932
305-I,305-I-3,305-W, 305-W3	2	933
309-I,309-N, 309-R,309-W	2	934
313-I,313-W	2	935
314-E,314-I,314-W	2	928
315-I,315-W	2	929
316PM,318PT	2	937
332	2	935
333	2	929
335PG,PI,PM,PW	3	1343
338-I,338-R,338-W	3	1344
339-K	3	1345
340-C	3	1345
343	4	1707
344	4	1708
345P	4	1709
416,419,420	3	1346
420B	3	1347
423,423B,423-17	3	1347
424,424-17	3	1347
425,428,429,430,431, 432,435	3	1347
438,439,440,441,443, 444,446,452,453	4	1710
Chassis		
CR-739	8	2207*

Name & Model or Chassis No.	Vol. No.	Diag. No.
SETCHELL CARLSON		
416	1	192
427	2	938
437	2	939
447	2	940
458-RD	3	1348
469	3	1349
570	3	1350
SIGNAL		
AF252	2	942
241	2	941
341-A,341-T	2	943
SILVERLINE		
63A,84	5	2046
SILVERTONE		
R-381	1	460
R-1181	1	458
5,8	4	1711
10,11	4	1712
15,16,18	4	1713
25,27	4	1714
41,41A	3	1351
51,53	3	1352
54,58	3	1352
64,85,87	3	1353
69	4	1715
102A	4	1716
106,107(Ch. 132.889-2)	4	1717
112	3	1354
120	3	1354
125	3	1355
141(Ch. 132.889-2)	4	1717
143,143A	3	1356
144(Radio Ch.)	4	1718
150-14,163-16	4	1719
179-16,180-16,194-16, 195-16	3	1357
220,222,223,224	3	1358
225	3	1359
771	1	458
1017,1018	4	1720
1040,A,1045,A	4	1721
1052,A,1053,A,1054,A, 1055,A	4	1722
1058,1059, 1062,1063	4	1723
1771	1	458
1781,1781A	1	462
2003,2004,2005,2006	4	1724
2009,2010,2011,2012, 2013	4	1725
2011	1	73
2014,2015,2016, (Ch. 132.011)	4	1722
2014,2015,2016 (Ch. 132.40500)	6	2244*
2022	4	1722
2023,2024,2025, 2026,2027	4	1712
2028	4	1726
2051	1	73
2056,2060,2061	4	1727
2063,2064	4	1723
2200,2202,2203	4	1728
2225	4	1729
2276,2277	5	2047
2411	1	73
2461	1	458
2511	1	73
2761	1	458
3004	5	2048
3025,2026,3027	5	2049
3040	4	1730
3040A	5	2050
3045,3046	4	1730
3052,3053,3054,3055	5	2051
3058,3059,3063, 3064,3067	5	2052
3068	5	2053
3108	4	1515
3109,3110B,3112B	5	2054
3136	5	2077

Name & Model or Chassis No.	Vol. No.	Diag. No.
SILVERTONE (cont'd)		
3150L,3151B,C	5	2054
3170D	5	2054
3175	4	1515
3181,3185	5	2077
3200,3202,3203	5	2055
3276,3277	5	2047
3376,3377	5	2056
4016,4017	5	2057
4025,4026	5	2058
4041,B	5	2059
4045A,B,C		
4046A,B,C	5	2060
4056,4057	5	2061
4068A	5	2062
4111	5	2054
4112B	5	1844
4113,4114,4115,4116, 4117,4118,4119	5	2054
4126,4127	5	2054
4127A	5	2063
4128,4129	5	2054
4131,4139	5	2054
4140D,4143D, 4145D,4149	5	2054
4150D,4153D,4155D	5	2054
4200	5	2064
4204,4206	5	2065
4225	5	2066
4808,4809	1	461
4628,4629	1	461
4638,4639	1	461
4648,4649	1	461
4666	1	465
4667	1	463
4686	1	465
4728,4748	1	461
4766	1	465
4767,4777	1	463
4791,4792	1	465
4798	1	463
5018,5017	6	2173*
5045,5046	5	2067
5101,A	5	2068
5106,5107,A,5112A,C	5	2068
5113B	5	1844
5115,A,B,C,D		
5117,A,C,D	5	2068
5125,5127,A,B,C, 5129,A,B,C,D		
5131,A,B,C,D	5	2068
5227	5	2069
5502	1	466
5511,5511-A	1	460
5571,5571-A	1	460
5581	1	458
5601-A	1	460
5621	1	458
6008,6009	1	464
6011,6012	1	467
6014,6015	6	2244*
6016	1	464
6016(Ch. 132.820)	2	944
6016(Ch. 132.40500)	8	2244*
6017,6018,6019	1	464
6020,6021	6	2198*
6022	1	464
6025,6026	6	2252*
6036,6038	1	470
6045	6	2249*
6046	1	464
6046(Ch. 528.34900)	6	2249*
6047,6048,6049	1	464
6050	1	6
6051,6052	1	466
6062,6063,6064	6	2381*
6066A	6	2398
6067	8	2381*
6068	1	464
6068(Ch. 528.39800)	6	2398*
6068A	6	2398*
6069	1	464
6069(Ch. 528.39800)	6	2398*
6069A	6	2398*
6071	1	6
6072	1	469
6074,6079	1	470
6092,6093	1	466

* Signifies Coverage in this Volume

Name & Model or Chassis No.	Vol. No.	Diag. No.	Name & Model or Chassis No.	Vol. No.	Diag. No.	Name & Model or Chassis No.	Vol. No.	Diag. No.
SILVERTONE (cont'd)			SILVERTONE (cont'd)			SILVERTONE (cont'd)		
6100	1	73	7112	1	491	101.810	1	488
6104,6105	1	466	7115,7118,7117	1	490	101.811	1	485
6106A,6111A	2	945	7187,7168	1	466	101.813	2	956
6111	1	466	7200,7202	6	2300*	101.814,101.814-1A	2	946
6122,6132	1	464	7210	2	951	101.817	1	483
6136,6138	1	470	7220	1	475	101.819A	2	952
6146,6148	1	464	7222	8	2308*	101.820	2	951
6157	1	473	7224	8	2389*	101.821	2	959
6168	1	464	7226(Ch.101.819A)	2	952	101.822,101.822A	2	962
6190	1	474	7226(Ch.528.45800)	8	2396*	101.825,101.825-1A,		
6200-A	1	475	7228	1	410	101.825-1B	1	490
6220,6220-A	1	475	7228(Ch.528.48700)	6	2399*	101.829	2	947
6230,6230-A	1	477	7230	1	395	101.829-1	3	1362
6285-A	1	478	7245	1	492	101.831,101.831A,		
6286,6287	4	1731	7905	1	396	101.831-1	2	961
6293	3	1360	7915	1	406	101.833	2	947
6301	1	474	8005	2	953	101.835	2	952
6303	1	476	8009	6	2406*	101.839	2	957
6320	1	480	8010(Ch.132.940)	2	954	101.846	3	1362
6321,6322,6323,6324	1	471	8010(Ch.528.50144)	6	2406*	101.852	2	958
6325,6325,6336,6337	1	472	8011,8012	8	2406*	101.859	3	1368
6346,6346A	1	472	8020	2	955	101.859-1,101.859-2	3	1353
6359,6360,6361,6362,			8021,8022,8023	6	2408*	101.860	4	1723
6363,6364	1	472	8024	3	1361	101.860-3	5	2052
6368,6379,6380,			8025(Ch.478.206-1)	3	1361	101.861,-1	4	1727
6381,6382	1	472	8025,8026,8027	8	2403*	101.864,101.866	3	1362
6407,6408,6409	1	472	(Ch.528.53090)			110.451,110.452	1	468
6421,6424	1	471	8050	2	956	110.454	1	469
6425,6435,6436,6437,			8051	2	957	110.466,110.466-1	2	949
6438,6438-A,6438-B,			8065,8066	8	2337*	110.473	2	960
6439,6439-A,6440,			8080	2	958	132.011,-1,		
6441	1	471	8083,8083-A,			132.012-1,132.021	4	1722
6446	1	472	8084,8084-A	2	947	132.022	4	1725
6447	1	471	8090	2	959	132.024,-1,-2	4	1724
6449	1	460	8100,8101,8101-A,			132.026-3	4	1727
6490,6490-A	1	472	8101-B,8101-C	2	947	132.026-6	5	2061
6495,6497	1	472	8103	2	960	132.027	4	1722
6551,6561	1	482	8105,8105A	2	947	132.045,-1,	4	1515
6621,6661	1	482	8124,8125,8126,			132.053,132.056	5	2051
6721,6751,6751-A	1	482	8127,A,B,C			132.066	5	2049
6761,6761-A	1	482	8128,A,B,C	2	961	132.067	5	2065
6921	1	482	8132,8133	3	1362	132.807-2	2	946
6960	5	2070	8200,8201	1	475	132.816,132.816A	1	467
7008,7007	6	2299*	8210	3	1363	132.820	1	464
7010(Ch.132.40000)	6	2314*	8220,8221,8222	1	475	132.825-4	1	6
7011,7012	6	2314*	8224	6	2389*	132.826-1	1	6
7020	6	2335*	8226	6	2396*	132.839	2	953
7021	1	481	8230,8231	2	952	132.840	2	954
7021,7022			9005,9006	3	1364	132.841	2	955
(Ch. 528.46600)	6	2335*	9022	3	1365	132.858	3	1364
7025 (Ch.132.807-2)	2	946	9101,9102	2	947	132.871	3	1365
7025,7026,7027,			9105	3	1366	132.875	3	1366
(Ch. 528.46700)	6	2319*	9115,9116	3	1367	132.877	4	1713
7034	1	479	9122	3	1362	132.881	4	1711
7035	6	2350*	9133,9134	3	1368	132.884,-1,-2	4	1713
7037	1	483	9270	3	1379	132.887	3	1352
7038	1	484	9280	3	1370	132.888	3	1352
7045,7046	6	2312*	41122,41292,41312,A	5	2068	132.889,-2	4	1717
7048	1	483				132.890	3	1357
7049	1	466				132.896,-1	4	1712
7053,A,AB,B	6	2372*	Chassis			132.08500	5	1844
7054(Ch.101.808)	1	489	100.111	3	1356	132.09000,132.09001	6	2198*
7064,A,AB,B			100.174	5	2053	132.39900	6	2299*
(Ch. 528.47300)	6	2372*	100.201	4	1715	132.40000	6	2314*
7057,7058	8	2356*	100.425-2,-4,-6	5	2077	132.40200	6	2300*
7061,A,7062,A,7063	6	2350*	101.660-1A	1	73	132.40500	6	2244*
7065	1	73	101.662-2B,			132.42800	6	2406*
7065(Ch.528.47800)	6	2337*	101.662-2D,			135.243	3	1351
7066	1	73	101.662-3C	1	466	434.140	2	960
7066(Ch.528.47800)	6	2337*	101.662-4E			456.150-14,-18,-61	5	2047
7067	1	468	101.662-5F	2	945	456.200-111,-112,-113,		
7067(Ch.528.46220)	6	2350*	101.666-1B	1	478	-114,-115,-121,-122,		
7068	1	466	101.672-1A,			-123,-124,-125	5	2056
7068(Ch.528.46220)	6	2350*	101.672-1B	1	466	478.206-1	3	1361
7069,7070	1	483	101.773	2	961	478.222,478.224	3	1367
7071	1	487	101.800-1,			478.240	4	1718
7080(Ch.101.809)	1	486	101.800-1A	1	475	478.257	3	1355
7080(Ch.101.809-2)	2	947	101.800-3	1	475	478.289	3	1354
7080-A	2	947	101.801-1A	1	477	478.311	3	1354
7085	2	948	101.802,101.802-1	1	477	478.319,478.338	4	1719
7086	2	949	101.807,101.807A	1	461	528.168	3	1370
7090	1	488	101.808	1	469	528.171-1	3	1359
7100	1	485	101.809	1	466	528.173	3	1358
7102	2	948	101.809-1A,			528.194	4	1721
7103	2	949	101.809-1B	2	947	528.210,-1	4	1720
7104,7106	1	491	101.809-2,			528.229	4	1728
7111	2	950	101.809-3C	2	947	528.230	4	1726

* Signifies Coverage in this Volume

Name & Model or Chassis No.	Vol. No.	Diag. No.	Name & Model or Chassis No.	Vol. No.	Diag. No.	Name & Model or Chassis No.	Vol. No.	Diag. No.
SILVERTONE (cont'd)			SONORA (cont'd)			SPARTON (cont'd)		
528.233	4	1729	306	3	1372	8W10	3	1374
528.253, 528.254	4	1730	314, 315, 379	5	2071	8-46	1	499
528.259	5	2055	389, 390	5	2072	8-57	2	979
528.261, 528.263, -1, -2, 528.264, -1, -2,			401	2	969	9L8A	3	1376
528.266, -1	5	2064	441, 442	5	2071	10-77PA	1	504
528.268	5	2063	456, 459	5	2073	12L7	2	978
528.270, 528.286	5	2064	477, 478	5	2071	29U213	5	2074
528.304, -1	5	2059	502	6	2296*	29U273	5	2075
528.306	5	2058	568	6	2332*	417, 417A	2	974
528.307	5	2066	585	6	2332*	666A	2	976
528.311	5	2050	604	6	2396*			
528.312, -1	5	2060	606	6	2323*			
528.6286, -1, -3, 528.6287, -1, -3	4	1731	615	6	2323*			
528.6293-2	3	1360				STARRETT		
528.31500, 528.31600, 528.31700	5	2068	SOUND, INC.			Gotham	3	1377
528.33200	5	2069	5R2	2	973	John Hancock	3	1378
528.33800, 528.33900	5	2068				STEELMAN		
528.34200	5	2068	SPARTAN			AF1100	4	1733
528.34600, 528.34601, 528.34602, 528.34603	5	2068	Chassis			3A16U	6	2228*
528.34900	5	2067	CR-712	6	2307*	3AR3	5	2076
528.34900	6	2349*	CR-741AA	6	2207*	3AR6-1, 3AR6U-1	6	2228*
528.39800	6	2398*				3AR6UA-8	6	2228*
528.39900	6	2381*	SPARTAN			6000	4	1734
528.40400	6	2352*	4AW17, 4AW17A	2	974			
528.40700	6	2398*	5AM26PB	1	500	STEWART WARNER		
528.45800	6	2396*	5A118	2	974	A51T1, A51T2, A51T3, A51T4	1	515
528.46000, 528.46001	6	2358*	5AW06	1	503	A61CR3, A61CR2, A61CR3, A61CR4	2	985
528.46200, 528.46230	6	2350*	5AW16	2	975	A61P1, A61P2, A61P3	2	986
528.46400	6	2389*	6AW26PA	1	502	A72T1, A72T2	2	987
528.46600	6	2335*	6-66A	2	976	A72T3, A72T4	2	986
528.46700, 528.46701	6	2319*	7AM46, 8AM46	1	499	A92CR3, A92CR3B, A92CR6, A92CR6B	2	720
528.47200	6	2312*	10A776-PA, 10A776-PA, 10B5M76-PA, 10B5M76-PA	1	504	B51T1, B51T2, B51T3	2	968
528.47300	6	2372*	100, 101	2	974	B61T1, B61T2	2	717
528.47800	6	2337*	121	2	977	B72CR1	2	990
528.48000	6	2308*	141	2	977	C51T1, C51T2	2	969
528.48700, 528.48701	6	2399*	141A	3	1373	R3581, R3589	1	513
528.52040	6	2406*	141X	3	1374	R3861, R3869	1	513
528.53090	6	2303*	150, 151, 152, 155	3	1375	01-5H	1	509
549.245	3	1369	100, 1001, 1009	2	978	01-8A, 01-8B, 01-8C	1	509
549.100-3	4	1716	1006, 1006, 1007, 1008	2	979	01-8D, 01-8DX	1	507
725.101-1	5	2070	1010	2	980	01-8F, 01-8F9	1	509
757.110	4	1724	1015	1	504	01-8G, 01-8GZ	1	507
757.130	5	2048	1020, 1021, 1023	2	978	01-8CT, 01-8CT-Z, 01-8A, 01-8A-Z	1	508
757.140	5	2064	1030, 1030A, 1031, 1031A	2	981	010-6AX, 010-6BX, 010-6CX	1	509
757.150	5	2057	1051, 1052	2	982	11-6U, 11-8U-Z	1	505
757.15001	6	2173	1058, 1059, 1080, 1061, 1064, 1072	2	977	11-7A1, 11-7A9	1	506
			1080	3	1376	11-8D, 11-8F, 11-8R	1	510
SIMPLON			1080A	3	1373	11-8R8, 11-8R9	1	508
CA-5	2	963	1081	3	1376	11-9B, 11-9B-Z	1	506
WV2	1	494	1081A	3	1373	11-10A	1	510
			1210, 1211	3	1374	21C-9325F, G	5	2077
SKY KNIGHT			4900TV (Radio Ch.)	3	1376	21C-9340E, K, KB, L, LB, M, MB, P	5	2077
CB-500-P	1	6	4916, 4917, 4918 (Radio Ch.)	4	1732	5 T	5	2077
			5082, 5083 (Radio Ch.)	3	1374	51746, 51756	2	983
SKY ROVER			5088, 5089, 5090 (Radio Ch.)	3	1374	51736, 51736, 517146, 517176	1	20
NS-RD-250, NS-RD-251	1	20	5182, 5183, 5188, 5189 (Radio Ch.)	3	1374	61T16, 61T36	1	20
			22312, 22313, 23322, 23323	5	2074	61TR36, 61TR46	1	511
SONORA			24542, 25544	5	2075	62T16	1	512
RB-207, RBU-176	1	451	Chassis			62T36	1	20
RCU-208	1	495	PC-5-6-26	1	502	62TC36, 62TC36, 62TC36	1	512
RDU-209	1	189	4E10	3	1375	72CR36, 72CR26	1	510
RET-210	2	964	5A7	2	974	2050A, 2050Z	1	513
RGMF-212, RGMF-230, RKRU-215	2	965	5-06	1	503	9000-B, 9001-C, 9001-D, 9001-E, 9001-F, 9002	1	20
RMR-219, RMR-220	1	496	5-16	2	974	9002A, 9002B, 9002P, 9002R	2	984
RMR-245	1	496	5-26PB	1	500	9003	1	514
RQU-223	1	501	6B9	2	982	9004	1	510
RK-223	1	497	6L8	2	981	9005-A, 9005-B	1	14
WBRU-239	2	966	6S10	4	1732	9007-A, 9007-F, 9007-G	1	516
WDU-233, WDU-249	2	967	7L7	2	980	9014-E	1	20
WEU-262	2	968	7L6	1	499	9017	1	20
WKRU-254A	2	969	7-46	1	499	9104-A, -B, -C	3	1379
WLRU-219A, WLRU-220A	2	970	8L9	2	977	9108A, B, 9113A	3	1380
WLRU-254A	2	970	8L10	3	1373			
100	2	971						
101, 102	2	972						
171, 172	3	1371						

* Signifies Coverage in this Volume

Name & Model or Chassis No.	Vol. No.	Diag. No.
9121-A, -B, 9122-A	4	1735
9150-B, -D, -DZ	4	1736
9151-A	3	1361
9152-A, -B, -C	3	1362
9154-C, -CZ	4	1737
9161-A, -B, -C	4	1738
9162A, B, 9164-A, -B	4	1739
9165-A, -B	4	1740
9162-C, -H, -J	5	2078
9203-A (Radio Ch.)	4	1735

STRATOVOX

579-1-58A	1	120
-----------	---	-----

STROMBERG-CARLSON

AWP-6	6	2181*
HFRP	6	2217*
K-22CB, CM, HB, HCB, HCM, HCW, HM, HW, TB, TM, TQ	6	2185*
KH-22CB, CM, HB, HCB, HCM, HCW, HM, HW, TB, TM, TQ	6	2185*
SR-401	4	1741
SR-405 (Series 103)	5	2079
SR-406	6	2343*
SR-407	6	2338*
TC-10	3	1383
TC-19	3	1384
TS-15, TS-16, TS-125	3	1385
16CM, 16TM	3	1386
16RP (TV Ch.)	3	1386
16RP (Radio Ch.)	2	997
17CM, 17TM	3	1386
17RP (TV Ch.)	3	1386
17RP (Radio Ch.)	2	997
21TM, TQ, 22TM, TQ	5	2080
24 Series	4	1742
116CM, 116TM	3	1386
116RP (TV Ch.)	3	1386
116RP (Radio Ch.)	2	997
117 Series	3	1387A
119CDM, CM, 119M5A, D, G, I, M, R, 119RPM2 (TV Chassis)	3	1387A
119M5A, D, G, I, M, R, 119RPM2 (Radio Ch.)	3	1387B
621A Series, 622 Series	5	2081
624 Series	5	2080
625 Series (TV Ch.)	5	2080
625 Series (Radio Ch.)	5	2082
1100-H, 1100-HI	1	517
1101-HB, 1101-HI, 1101-HM	1	454
1101-HPW	2	685
1101-HW, 1101-HY	1	454
1105 (Series 10-11)	1	519
1110PTW (Series 10)	1	519
1121 (Series 10-11-12)	1	520
1121-HW, 1121-LW, 1121MI-0, 1121-M2-W, 1121-M2-Y	1	520
1121-PPM, 1121-PFW, 1121-PGM, 1121-PGW, 1121-PLM, 1121-PLW, 1121-PSM	1	520
1135-PPM, 1135-PLM, 1135-PLW	2	992
1200	2	991
1202	2	993
1204	2	994
1210M2-M, 1210M2-W, 1210M2-Y	2	995
1210-PGM, 1210-PLM, 1210-PGW	2	995
1220 Series	2	996
1235 Series	2	992
1400	2	991
1407-PPM, 1407-PLM	2	997
1500	3	1388
1507	3	1389
1608	4	1743

STUDEBAKER

AC-2113	4	1744
AC-2301	4	1745
SUPREME 750	2	998
SUTCO 21-A (UHF Conv.)	4	1746

SWANK

DU101	1	521
-------	---	-----

SYLVANIA

C32M Series	4	1535
1-075	3	1390
1-076	3	1391
A&B 1-090	3	1391A
1-113, 1-114	3	1390
1-124, 1-125	3	1390
1-125-1	3	1392
1-128	3	1391
A&B 1-177	3	1390
1-197	3	1390
1-197-1	3	1392
1-210	3	1390
1-245, 1-246	3	1390
1-245-1, 1-246-1	3	1392
1-247	3	1391A
17P101, J Series	6	2282*
17P102 Series	6	2282*
17P103 Series	6	2282*
21C401 Series	6	2287*
21C402 Series	6	2159*
21C404 Series, 21C405 Series	6	2287*
21C407 Series, 21C408 Series	6	2287*
21C409 Series	6	2282*
21C501 Series, 21C502 Series (Ch. 1-533-2)	6	2218*
21C501 Series, 21C502 Series (Ch. 1-533-4)	6	2287*
21C508 Series, 21C509 Series, 21C510 Series	6	2287*
21C512 Series, 21C513 Series	6	2282*
21C601 Series	6	2216*
21C605 Series, 21C607 Series	6	2287*
21D802 Series	6	2382*
21P101 Series	6	2382*
21T101 Series, 21T102 Series	6	2287*
21T103 Series	6	2159*
21T104 Series, 21T105 Series, 21T106 Series	6	2287*
21T107 Series, 21T108 Series	6	2267*
21T110 Series	6	2287*
21T113 Series, 21T114 Series, 21T115 Series	6	2382*
21T201 Series (Ch. 1-533-2)	6	2216*
21T201 Series (Ch. 1-533-4)	6	2287*
21T206 Series	6	2267*
21T207 Series, 21T208 Series	6	2287*
21T211 Series	6	2287*
21T213 Series	6	2382*
21T301 Series	6	2287*
21T303 Series	6	2287*
24C402 Series	6	2287*
24C601 Series	6	2216*
24C603 Series	6	2287*

SYLVANIA (cont'd)

24T101 Series	6	2287*
24T201 Series	6	2287*
24T301 Series (Ch. 1-533-2)	6	2218*
24T301 Series (Ch. 1-533-6)	6	2287*
105BU, 105MU	4	1747
105-14 "U" Series	5	2083
120BU, 120MU	4	1747
120-14 "U" Series	5	2083
128BU, 128LU, 128MU	4	1747
172KU, 172MU, 175BU, 175LU, 175MU	4	1747
175-18 "U" Series	5	2083
178BU, 178MU, 177BU, 177MU	4	1747
176B, 178BU, 178M, 176MU	4	1747, 1746
300 "U" Series, 301 "U" Series	5	2083
306 "U" Series	5	2083
325 "U" Series, 326 "U" Series	5	2083
331 "U" Series, 336 "U" Series	5	2084
372 "U" Series, 373 "U" Series	5	2083
375 "U" Series, 376 "U" Series, 377 "U" Series	5	2083
386BU, MU	5	2084
410 "U" Series	5	2083
511 "U" Series	5	2085
514 "U" Series	5	2085
518 "U" Series	5	2086
529 "U" Series	5	2083
540B, BA, 540H, HA, 540M, MA	2	1393
541B, H, M, 542BR, CH, GR, RE, YE	4	1749
543	5	2087
546	5	2086
593	5	2087
596BU, 596MU	5	2088
598	5	2086
612 "U" Series	6	2159*
614 "U" Series	6	2159*
622 "U" Series	6	2159*
1110X	3	1394
1202DG, PL, TU	6	2264*
1210X	3	1394
2301DG, H	6	2365*
2303DG, H, PI	6	2333*
5130B, M, W, 5140B, M	3	1395
5150M	3	1396
5848	5	2086
7110XFA, 7120MFA, 7130MFA	3	1396
7140MA, 7140WA	3	1396
7150M	3	1396
7160B	3	1396
Chassis 1-108	3	1391
A&B 1-139	3	1390
1-168	3	1391A
1-186	3	1392
1-274	3	1396
1-290	3	1395
1-357	3	1396
1-361	3	1394
1-437	3	1396
1-442	3	1396
1-504-1, -2, -4	4	1747
1-508-1, -2, -3	4	1747
1-510-1, -2, -4	4	1747
1-512-2, 1-513-2, -4	5	2084
1-514-4, -6, 1-516-2, -6	5	2083
1-522-2	5	2088
1-526-2, -4, -6	6	2159*
1-527-2	5	2085
1-530-2, -4, -6	5	2083
1-532-4, -6	6	2287*
1-533-2	6	2218*

* Signifies Coverage in this Volume

Name & Model or Chassis No.	Vol. No.	Diag. No.
1-533-4	6	2287*
1-537-4	8	2382*
1-539-2	6	2382*
1-540-2,-4	8	2382*
1-601-1	4	1749
1-602,-2,-3	5	2087
1-602-4,-5,-6,-7	5	2086
1-602-9	6	2333*
1-603-1	4	1748
1-615-1	6	2364*
1-615-2	6	2365*

TELEFUNKEN

"Elite"	8	2294*
"Jubilee"	8	2282*
"Operetta"	6	2291*
"Opus No. 8" (Ch. A,B)	6	2288*
"Opus No. 7"	6	2288*

TELESONIC

1635	1	9
1636	2	88
1842	1	187
1843	2	1000

TELEPHONE

TV-208	3	1397
TV-208TR	3	1398
TV-220T	3	1398
TV-250	3	1399
TV-254,TV-255,TV-256	3	1399
TV-282	3	1400
TV-283	3	1399
TV-284	3	1398
TV-285	3	1399
TV-300,TV-301(Ch.TW)	3	1401
TV-304,TV-305(Ch. TX)	3	1401
TV-306,TV-307,TV-308	3	1398
TV-314	3	1402
TV-416	3	1403
TV-318,TV-322,TV-323	3	1404
TV-324,TV-325,TV-326	3	1405
TV-328,TV-329	3	1405
TV-330,TV-331,TV-332,TV-333	3	1398
TV-335,TV-336	3	1405
TV-340,TV-345,TV-348,TV-349,TV-352	3	1405
TV-358,TV-359	3	1405
100,100A,101	2	1001
109	1	258
111,113	2	1001
117-A	1	268
122,123,125,127,130,131	2	1001
133,134	1	258
135	1	260
138	2	1002
142,143,144,145	2	1003
148	2	1004
150	2	1005
156	2	1006
157	2	1005
158	2	1008
159	2	1007
160	2	1009
161,162	2	1005
166,167,188	2	1005
171	2	1005
172	2	1006
174	2	1005
176	2	1006
185	2	1010
198	2	1008
206	3	1408
228	4	1750
235	4	1751

Chassis

Series A	2	1001
----------	---	------

TELEPHONE (cont'd)

Series AA	2	1007
Series AE	2	1005
Series AH	2	1010
Series AT	2	1008
Series BL	4	1750
Series BQ	4	1751
Series C,C,A,D	1	258
Series H	1	260
Series J	1	258
Series N	2	1002
Series R	2	1003
Series S	2	1004
Series T	2	1005
TAC	3	1398
TAH	3	1403
TAJ	3	1402
TAM	3	1404
TAO	3	1398
TAP,TAP-1,TAP-2	3	1405
TS	3	1399
TW,TX	3	1401
TY,TZ	3	1398
Series U	2	1006
Series Y	2	1009

TELEVOX

RP	2	1011
----	---	------

TEMPLE

E510	1	189
E511	1	11
E519	1	189
F811	1	324
F818	1	523
F817	1	524
G410	2	893
G513	2	1012
G515,G516	1	189
G518	2	564
G521	2	565
G522	2	564
G619	2	1013
G622	2	1014
G721,G722,G723	2	1015
G724	2	568
G725	2	567
G1430	2	1016
H622	2	1014

TEMPOTONE

500E Series	1	269
-------------	---	-----

TRAV-LER

12L50,12L50A	3	1407
14R50,A,14C50,A	3	1407
16G50A,16R50A,16T50A	3	1407
20A50	4	1752
55-37,55-38	5	2089
62R50,63R50	4	1752
64R50,-1,-2,65G50,-1,-2,75A50,-1,-2	4	1752
219-8A,-8B	4	1753
521-R90,521-R91	8	2180*
621-R40	6	2180*
5000,5000-1	1	11
5002	1	73
5007,5008,5009,5010,5011,5012	1	18
5015,5019	2	572
5020	1	73
5021	2	936
5022	3	1408
5027	2	571
5028,5029	2	574
5030,5031	2	572
5036	2	1017
5051	2	936
5060,5061	3	1409
5066	2	1005
5091	5	2091
5170	4	1754
5301	8	2092*

* Signifies Coverage in this Volume

TRAV-LER (cont'd)

5310	8	2093*
5372	8	2094*
5510	6	2180*
8040	2	1018
8050	2	1019

Chassis

11A2	4	1753
32A1	4	1752
104,105	1	18
109	1	73
800	2	936

TRUETONE

D705	1	80
D934	1	468
D1015,D1018	1	40
D1034A,B,C	3	1410
D1042	1	45
D1046A,B,C,D	3	1410
D1070	1	43
D1117	1	525
D1118	1	182
D1124	1	48
D1145	1	41
D1172,D1178	1	41
D1202	1	182
D1215	1	40
D1224	1	48
D1234A,B,D1240A	4	1755
D1435A,D1436A	5	2095
D1812	2	591
D1844	1	189
D1845	1	38
D1747,D1748	2	588
D1752	2	798
D1835	2	1020
D1836,A	2	599
D1840	2	810
D1845	2	596
D1846A,B,C	2	599
D1949,D1950	2	1021
D1992(Radio Ch.)	3	1411
D1994(Radio Ch.)	3	1412
D2017,D2018	3	1413
D2020	3	1414
D2025A	3	1413
D2027A	3	1415
D2102A,B,D2103A,B	4	1756
D2127	1	182
D2133	1	526
D2145	4	1757
D2149	1	41
D2210,D2211	1	40
D2214A	4	1758
D2224	1	182
D2226	4	1759
D2237A	4	1760
D2261	1	48
D2263	4	1761
D2325-A	4	1762
D2383	4	1763
D2385	5	2096
D2410A,D2411A,D2412A,D2413A	5	2097
D2410B,D2411B,D2412B,D2413B	5	2098
D2418A,D2419A,D2420A	5	2099
D2483	5	2100
D2553A	5	2101
D2560A	5	2102
D2610,D2611	1	527
D2612,D2613	1	20
D2615	1	529
D2616	1	528
D2616B	2	1022
D2619	2	1023
D2620	1	531
D2621	1	530
D2622	1	275
D2623	1	18
D2624	1	78
D2626	2	1024
D2630	1	78
D2634	1	125
D2640	2	1025

Name & Model or Chassis No.	Vol. No.	Diag. No.	Name & Model or Chassis No.	Vol. No.	Diag. No.	Name & Model or Chassis No.	Vol. No.	Diag. No.
TRUETONE (cont'd)			VOGUE			WESTINGHOUSE (cont'd)		
D2642	1.	275	553R,554R	1.	11	H-186M,H-187	2.	1049
D2644	1.	13				H-188	2.	1037
D2645	1.	68	WALGREEN			H-190,H-191,A	2.	1050
D2661	1.	527				H-195	2.	1048
D2663	1.	4	568	1.	14	H-198	3.	1419
D2665	2.	1026	571	1.	117	H-202	2.	1061
D2692	2.	1027				H-203	3.	1418
D2710	2.	1028	WATTERSON			H-204	2.	1061
D2718	2.	1029				H-207AM	3.	1418
D2745	1.	36	4581,RC4581	1.	73	H-207A(DX),H-207B(DX)		
D2748	2.	1030	4582	1.	11	(Radio Ch.)	3.	1419
D2801A,D2802,A	6.	2395*	4583	1.	73	H-212	3.	1418
D2810	2.	1031	ARC-4591A	1.	73	H-214,A	3.	1420
D2815	2.	1022	4782	1.	556	H-217,A,B(Radio Ch.)	3.	1419
D2819	2.	1032	4790	1.	132	H-220	2.	1050
D2919	2.	1033	4900	2.	1039	H-251	3.	1432
D2963	3.	1416				H-300T5,H-301T5	3.	1421
D5120A	4.	1764	WECOR			H-302P5	3.	1423
D5130A,B	4.	1765	1691	6.	2255*	H-303P4,H-304P4	3.	1423
D5210A	4.	1766				H-307T7,H308T7	3.	1419
D5265A	4.	1767	WELLS-GARDNER			H-309P5,H-309P5U	3.	1424
D3819	1.	95				H-310T5,H-310T5U		
D3830,N	1.	73	A10 Series	1.	61	H-311T5,H-311T5U	3.	1425
D3720	2.	1034	A20 Series	1.	64	H-312P4,H-312P4U		
D3721	2.	1035	A22 Series,			H-313P4,H-313P4U		
D3722	2.	811	A25 Series,			H-314P4,H-314P4U		
D3789A	6.	2390*	A24 Series	1.	60	H-315P4,H-315P4U	3.	1426
D3809,D3810	2.	633	S2	1.	64	H-316CT,H-316CT	3.	1427
D3840	2.	1036	T3 Series	1.	64	H-318T5,H-318T5U		
D4320,B,D4321,A	5.	1881	WG-30A8-A-496	5.	2105	H-321T5,U,H-322T5,U		
D4425B,D4426A	5.	1881	1A17	1.	46	H-323T5,U	3.	1428
D4620	2.	656	1A29	1.	45	H-324T7,H-325T7,U		
D4623A,D4624A,	6.	2304*	1A62 Series,1A62-4	1.	183	H-326CT	3.	1427
D4625A,D4626A	6.	2304*	1A63 Series,1A63-3,			H-327T9U	3.	1429
D4818	2.	580	1A63-4	1.	183	H-328CT,U	4.	1771
D6608A,D6609A	6.	2268*	5A256	1.	72	H-331P4,U,H-332P4	4.	1772
ZD1093A	3.	1417	6A43,6A44	1.	41	H-334T7U,UR		
ZD1094A	3.	1410	6A65 Series	1.	47	H-335T7U	4.	1771
ZD1104A(Radio Ch.)	4.	1768	6B10,6B16,6B18	1.	532	H-338T5U,H-337T5U	3.	1428
ZD1315A	4.	1769	7A40,7A41	1.	45	H-338T5U,H-341T5U	4.	1773
ZD1316A	5.	1829	7A66	1.	526	H-342P9U	4.	1774
ZD1325A	4.	1769	7D11 Series	1.	182	H-345T5,H-346T5	4.	1773
ZD1326A	5.	1829	8A30,8A31	1.	45	H-348P5,H-349P5	4.	1774
ZD1331A,B,ZD1336A	5.	1834	8A51 Series	1.	41	H-350T7,H-351T7	4.	1775
ZD1344A,B	4.	1770	37A10-551-S	6.	2176*	H-354CT	4.	1776
ZD1353A	5.	2104	37A10-562	6.	2176*	H-357C10	4.	1777
ZD1359A	5.	2077	237A10-553-S	6.	2176*	H-359T5,H-360T5	4.	1778
ZD1415A,ZD1416A,	5.	1829	237A10-564	6.	2176*	H-361T6	4.	1779
ZD1426A	5.	1829	321MS39-322,-372-3,	5.	1834	H-368P5,H-369P5	4.	1774
ZD2312A	4.	1769	-376-2			H-370T7,H-371T7	4.	1780
ZD2313A	5.	1829	2321MS39-324,-370,-396-1	5.	1834	H-382T5,H-383T5	4.	1781
ZD2313C	5.	1829				H-385T5,H-386T5		
ZD2314A	4.	1769	WESTINGHOUSE			H-387T5,H-388T5	4.	1782
ZD2315A	5.	1829	H-17TUI5A,B,C,E,			H-391T5,H-392T5	5.	2106
ZD2321A	4.	1769	H-17TUI76,A,B,C,E,			H-393T6	4.	1783
ZD2334A	5.	1834	H-17TUI77,A,B,C,E	6.	2322*	H-397T6,H-398T5	5.	2107
ZD2414A,ZD2415A,	5.	1829	H-17TU237A,H-17TU238,			H-400P4,H-401P4,		
ZD2422A,B	5.	1829	H-17TU239A	6.	2322*	H-402P4,H-403P4	4.	1784
ZD6000	5.	1829	H-104,A,H-105,A,			H-405P5,H-406P5	5.	2108
			H-107,A,H-108,A,			H-420T5,H-421T5	5.	2106
			H-110,H-111	1.	533	H-422P4,H-423P4,		
			H-113,H-114,H-116,			H-424P4,H-425P4	5.	2109
			H-117,H-119	1.	535	H-434T5,H-435T5,		
			H-122	1.	534	H-436T5,H-437T5,		
			H-125,H-126	1.	536	H-438T5	5.	2110
			H-130	1.	534	H-443T5,H-444T5,A		
			H-133	1.	539	H-445T5,A		
			H-137,H-138	1.	533	H-448T5,A	5.	2111
			H-147	2.	936	H-457T6,H-458T6,		
			H-148,A	1.	538	H-459T6,H-460T6	5.	2112
			H-153,A	1.	534	H-466R5,H-467R6,		
			H-154	1.	633	H-468R6	5.	2112
			H-155,H-156	1.	534	H-469R12,H-470R12	5.	2113
			H-187	2.	1040	H-475T5,H-476T5,		
			H-161	2.	1041	H-477T5,H-478T5	5.	2114
			H-164	2.	1042	H-480C12	5.	2113
			H-165	2.	1043	H-482PR5	5.	2115
			H-166,H-167	2.	1042	H-486T5,H-487T5,		
			H-168,A,B	2.	1041	H-488T5,H-489T5	5.	2116
			H-169	2.	1044	H-536T6	6.	2168*
			H-171,A,C	1.	534	H-547T5,H-548T5,		
			H-176	2.	1045	H-549T5,H-550T5	6.	2238*
			H-182	2.	1046	H-600T16,H-601K12,		
			H-183,A	2.	1047	H-602K12	3.	1430
			H-185	2.	1048	H-603C12	3.	1431
						H-604T10,A	3.	1432
						H-608C12	3.	1431

* Signifies Coverage in this Volume

Name & Model or Chassis No.	Vol. No.	Diag. No.
WESTINGHOUSE (cont'd)		
H-609T10	3	1432
H-611C12, H-615C12	3	1433
H-633C17, H-634C17	3	1434
H-680C17, H-661C17 (Radio Ch.)	4	1777
H-567T17, H-668T17, (Ch. V-2217-2)	4	1785
H-673K21, H-676T21, (Ch. V-2217-2)	4	1785
H-678K17, H-679K17, (Ch. V-2217-2)	4	1785
H-681T17, (Ch. V-2217-2)	4	1785
H-688K24, H-689T16, H-690K21, (Ch. V-2217-2)	4	1785
H-692T17, H-695K21, H-699K17, (Ch. V-2217-2)	4	1785
H-700T17, H-701T17, H-701K21	4	1785
H-702K17, H-703K17, H-704T17, H-705K17	4	1785
H-710T21, H-711T21, (Ch. V-2217-2)	4	1785
H-713K21, H-714K21, (Ch. V-2217-2)	4	1785
H-715K21 (Ch. V-2217-2)	4	1785
H-720K21, H-721K21, (Ch. V-2217-2)	4	1785
H-723K21 (Ch. V-2217-2)	4	1785
H-730C21, H-732C21, H-733C21	4	1786
H-1251	1	536
WR-12X7	1	537
WR-12X8	1	511
WR-12X9, WR-12X12	1	597
WR-12X14	1	415
WR-12X15	1	137
WR-12X16	1	140
WR-15X8	1	411
WR-42X3	1	413
WR-42X4, 42X5	1	437
WR-42X7	1	413
WR-42X14, 42X15	1	437
WR-42X42	1	446
WR-156	1	458
WR-166A, A	1	540
WR-170, 172, 175, 176	1	107
WR-186	1	537
WR-256	1	443
WR-260	1	541
WR-264	1	395
WR-270, WR-272	1	107
WR-274	1	102
WR-290	1	417
WR-366, 368, 370	1	420
WR-372, 373	1	107
WR-374	1	102
WR-388	1	417
WR-473, 474	1	107
WR-476	1	102
WR-480, 482, 484	1	537
Chassis		
V-2102, -1	1	533
V-2103	1	534
V-2103-3	3	1420
V-2107	1	539
V-2118	2	1041
V-2119-1	2	1042
V-2120	2	1043
V-2122	2	1040
V-2123	2	1045
V-2124-1	2	1044
V-2127	2	1047
V-2128, -1	2	1046
V-2128-2	2	1051
V-2130-21DX, 22DX	3	1419
V-2131, -1	2	1048
V-2132	2	1049
V-2133	2	1037
V-2134	2	1050
V-2136	3	1419
V-2136-1, -2	3	1427
V-2136-4, -5R	4	1771

Name & Model or Chassis No.	Vol. No.	Diag. No.
WESTINGHOUSE (cont'd)		
V2137	3	1418
V-2137-2	3	1419
V-2137-5U	4	1771
V-2148	3	1421
V-2150-41	3	1430
V-2150-61, A, B	3	1430
V-2150-81, -82, -84	3	1432
V-2150-91A, -94, -94C	3	1432
V-2151-1	3	1422
V-2152-01	3	1431
V-2152-16	3	1433
V-2153	3	1423
V-2153-1	3	1426
V-2156	3	1424
V-2156-1U	4	1774
V-2156-2	5	2108
V-2157, U, -1, -1U	3	1428
V-2157-2, -2U	3	1428
V-2157-3U	3	1429
V-2157-4U	4	1773
V-2157-6	4	1778
V-2157-10	4	1781
V-2157-11, -12	4	1782
V-2157-13, -14	5	2106
V-2161, U	3	1425
V-2164-2	4	1784
V-2173	3	1434
V-2180-1	4	1775
V-2180-2	4	1776
V-2180-3, -5	4	1777
V-2180-6	4	1780
V-2180-9, -10	4	1786
V-2180-13	5	2113
V-2181-1	4	1779
V-2182-2	4	1783
V-2184-2	5	2107
V-2188-1	5	2109
V-2189-2	5	2110
V-2189-4	5	2111
V-2189-7	6	2168*
V-2214-1, V-2215-1	4	1785
V-2216-1, -2, -3, -4, -5	4	1785
V-2217-1, -2, -3, -4, -5	4	1785
V-2218-1, -2, -11	4	1786
V-2219-1	4	1785
V-2229-1, -2, -3	5	2112
V-2229-5	5	2115
V-2236-1	5	2114
V-2236-2	5	2116
V-2261-1	6	2258*
V-2360-201	6	2322*
WOOLAROC		
3-1A, 3-2A	1	20
3-3A	1	25
3-4A	1	516
3-5A	2	574
3-6A/5	2	1052
3-9A, 3-10A	1	385
3-11A	1	387
3-12A/3	2	1053
3-17A, 3-18A	2	1054
3-20A	1	584
3-29A	1	398
3-70A	2	1055
3-71A	2	761
3-81A	2	1016
ZENITH		
A600, L	6	2387*
G500	3	1435
G503	3	1436
G510, G510Y	3	1437
G511, G511W, G511Y	3	1438
G516	3	1439
G615, G615W, G615Y	3	1440
G660, G663, G665	3	1441
G723, G724	3	1442
G725	3	1443
G881, G882, G883, G884, G885	3	1444
G2322, G2340, R, G2346R, G2353E (Fine Tuning)	3	1445
G2323, G2340, R, G2346R, G2353E (Vol. Cont)	4	1807
G2420E, -E, OX, -R, -ROX	3	1445

Name & Model or Chassis No.	Vol. No.	Diag. No.
ZENITH (cont'd)		
G2441, R, G2442E, R, G2448R (Fine Tuning)	3	1445
G2441, R, G2442E, R, G2448R (Vol. Cont)	4	1807
G2454R, -ROX	3	1445
G2951, R, OX, ROX, G2952, R, OX, ROX	3	1446
G2957, R, G2958R (Fine Tuning)	3	1445
G2957, R, G2958R, (Vol. Cont)	4	1807
G2957, R, G2958R (Radio Ch.)	3	1451
G3059, R, G3062 (Fine Tuning)	3	1445
G3059, R, G3062 (Vol. Cont)	4	1807
G3059R, G3062 (Radio Ch.)	3	1451
H-401, G	4	1787
H-500	4	1766
H-503, Y	4	1787
H511, H511W, H511Y	3	1442
H-615	4	1789
H-615Z1	4	1790
H661E, H661R, H665, R, R, Z, Z	3	1447
H-664	4	1791
H723	3	1448
H723Z	3	1449
H-723Z2	4	1792
H724	3	1448
H-724Z, H-724Z1	4	1792
H725	3	1443
H860, H860R	3	1450
H860RZ	3	1451
H2029R, H2030E, H2030R, H2041R, H2052R, H2053E	4	1793
H2226E, R, H2227E, R	3	1452
H2250R, H2255E	3	1452
H2326E, E, Z, R, R, Z, H2329R, R, Z, H2330E, R	3	1453
H2341R	3	1453
H2352R, R, Z, H2353E, E, Z	3	1453
H2437E, R	3	1454
H2438R, H2439R	3	1454
H2443E, H2445R, H2447R, H2449E (TV Ch.)	3	1454
H3074	4	1794
H3267, R (TV Ch.)	3	1454
H3267R (Radio Ch.)	3	1451
H3273E, H3274R, H3284R	4	1794
H3467R (TV Ch.)	3	1454
H3467R (Radio Ch.)	3	1455
H3469E (TV Ch.)	3	1454
H3469E (Radio Ch.)	3	1455
H3475R (TV Ch.)	3	1454
H3475R (Radio Ch.)	3	1455
H3477R (TV Ch.)	3	1454
H3477R (Radio Ch.)	3	1455
H3478E (TV Ch.)	3	1454
H3478E (Radio Ch.)	3	1455
H3490EQ	4	1794
HF772E, H, R	6	2383*
HF1180R	6	2360*
HF1182E	6	2360*
HF1284, E, G, L, Y	6	2360*
HFM1184E	5	2117
HFM1190R	5	2117
HFR845R	6	2152*
HFR1283E, HFR1286R	5	2118
HFR1290R	5	2118
HFX1283E	6	2219*
HFX1284E	6	2266*
HFX1286R	6	2219*
HFX1290R	6	2266*
J402	4	1795
J420T	4	1798
J514	4	1797
J615, F, G, W, Y	4	1798
J616	4	1797
J644, J645E, R	4	1799
J733, G, R, Y	4	1800
J860, J860R	4	1801

Name & Model or Chassis No.	Vol. No.	Diag. No.	Name & Model or Chassis No.	Vol. No.	Diag. No.	Name & Model or Chassis No.	Vol. No.	Diag. No.
ZENITH (cont'd)			ZENITH (cont'd)			ZENITH (cont'd)		
6C21	1	549	7H04	3	1448	12X20	6	2219*
6C22	1	542	7H04Z	3	1449	12Z20	6	2350*
6C40	1	544	7H04Z2	4	1792	13D22	2	1063
6C41	1	543	7J03	4	1800	17Z31,U,17Z32,Q,U,U	6	2373*
6C50	2	555	7K01	4	1803	17Z34Q,QU	6	2373*
6E02,6E05	2	1058	7K20	4	1805	19K20,19K22,-3,		
6E40	2	1059	7L05	5	2128	19K23,19K24-3	4	1806
6G01	3	1441	7T02,7T04	6	2194*	19L25,19L26,		
6G06	3	1440	7X02	6	2204*	19L27,19L28	5	2119
6G05Z1	4	1790	7Y02	6	2280*	19M20,U,Z,19M21,U,		
6G20	3	1451	7Y03	6	2283*	UZ,Z	5	2133
6H01	3	1447	7Y04	6	2280*	19R20,U,19R21,U,		
6H02	4	1791	7Z20	6	2283*	19R22,U	5	1934
6J02	4	1799	8C01	1	551	20H20,20J21,20J22	4	1793
6J03	4	1797	8C20	1	552	20M20,U,Z,20M21,U,		
6J05	4	1798	8C21	1	542	UZ,Z	5	2119
6K02	4	1804	8C40	1	542	21J20,21J21	4	1793
6K03	4	1797	8E40T(Z1),(Z2)	2	1057	21K20	4	1806
6L03	5	2123	8E20	2	1062	21K20-3	5	2119
6L20	5	2127	8G30	3	1444	21L21	5	2119
6L40	5	2126	8H20	3	1451	22H20	3	1452
6R03	5	2131	8H20 Revised	3	1450	22L20	5	2119
6Z06	6	2341*	8H20Z	4	1801	23G22,23G23		
7E01	2	1060	8L20	5	2130	(Fine Tuning)	3	1445
7E02,Z	2	555	8L21	5	2129	23G22,23G23(Vol. Cont.)	4	1807
7E22	2	1061	8T01	5	2135	23H22,Z	3	1453
7F01	3	1443	8Y02	6	2239*	24G20,-OX	3	1445
7F02	3	1442	9E21	2	1062	24G21,-OX	3	1445
7F03	3	1457	9E21Z	3	1458	24G22,24G23,24G24,		
7F04	3	1442	10H20Z	4	1794	24G25(Fine Tuning)	3	1445
7G01,Z	3	1443	10L20	5	2130	24G22,24G23,24G24,		
7G02	3	1442	11C21	1	35	24G25(Vol. Cont.)	4	1807
7G04	3	1442	11M20	5	2117	24H20	3	1454
7H02	3	1448	11Z20	6	2350*	28K20	4	1806
7H02Z,7H02Z1	4	1792	12R20,12R21	5	2118	29G20	3	1446

* Signifies Coverage in this Volume

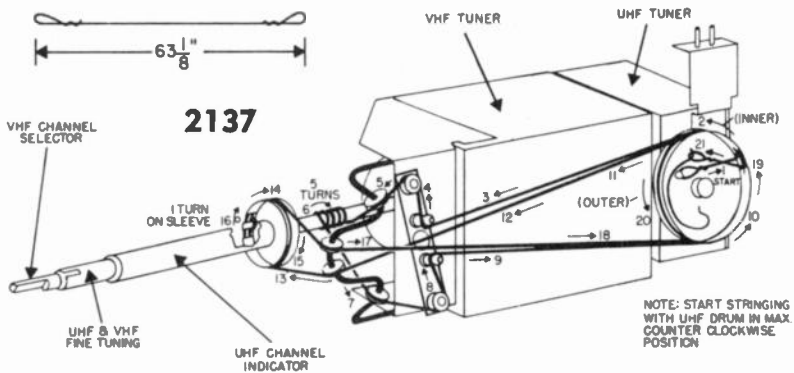
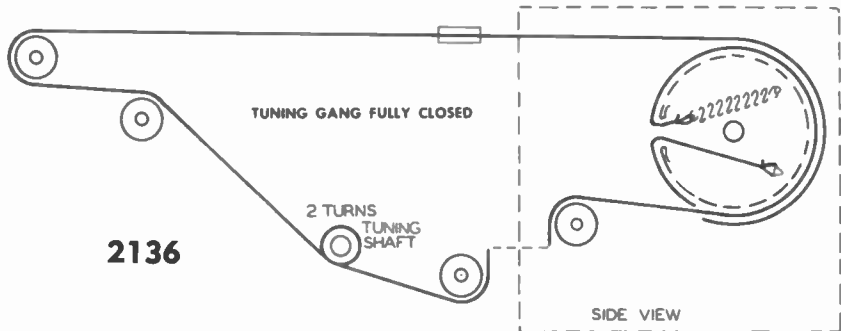

TUNING GANG FULLY CLOSED

2138

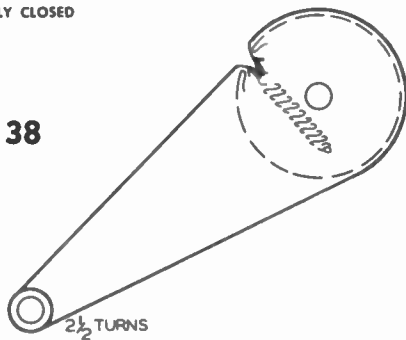

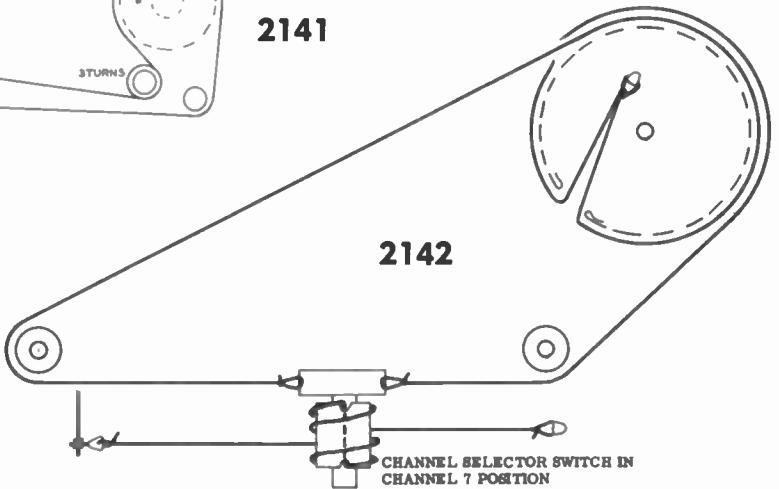
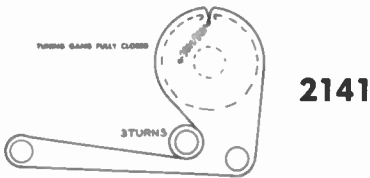
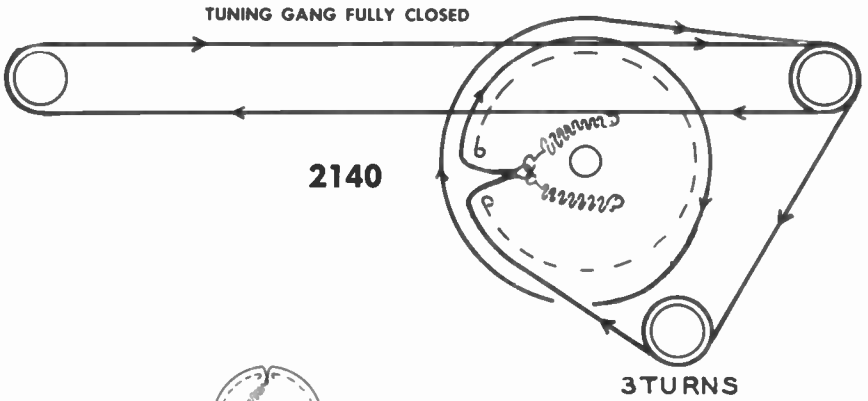
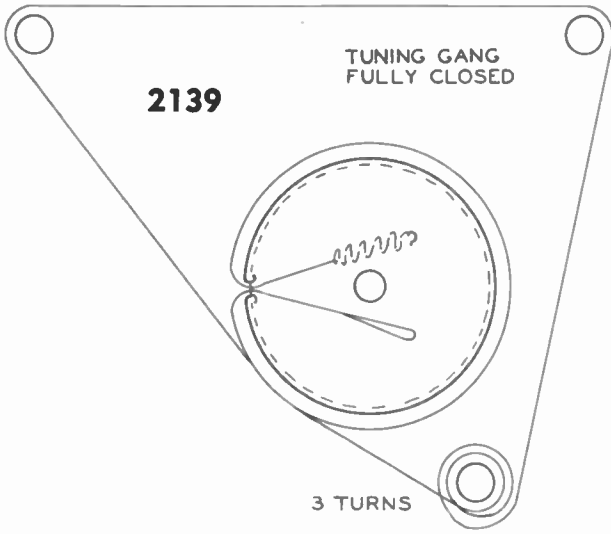

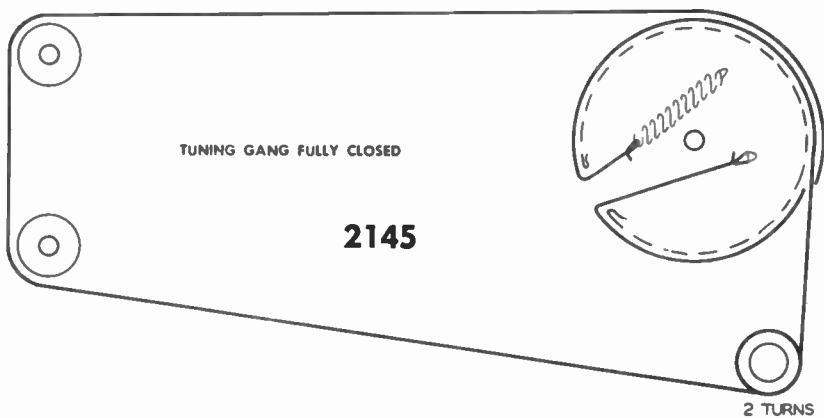
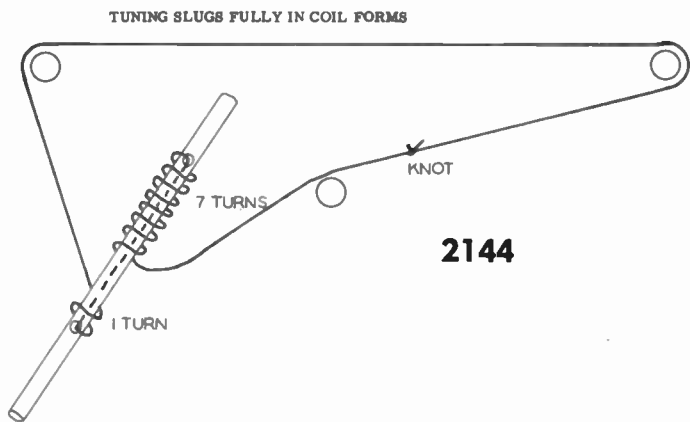
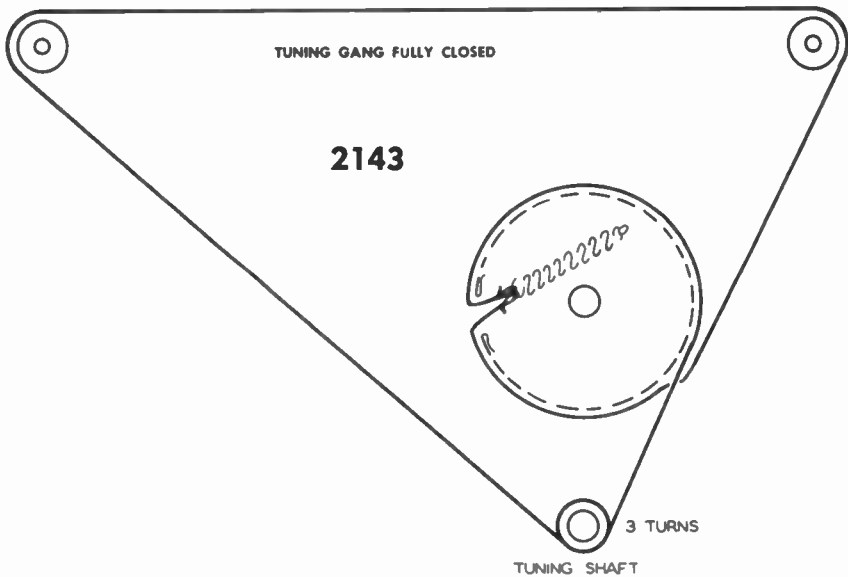

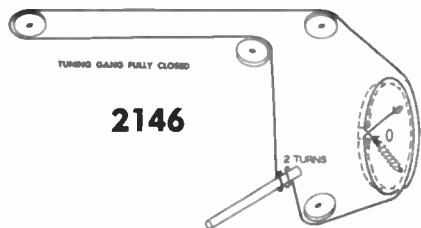

CONTRAST CONTROL DRIVE STRINGING
 CONTRAST CONTROL FULLY COUNTER CLOCKWISE POSITION

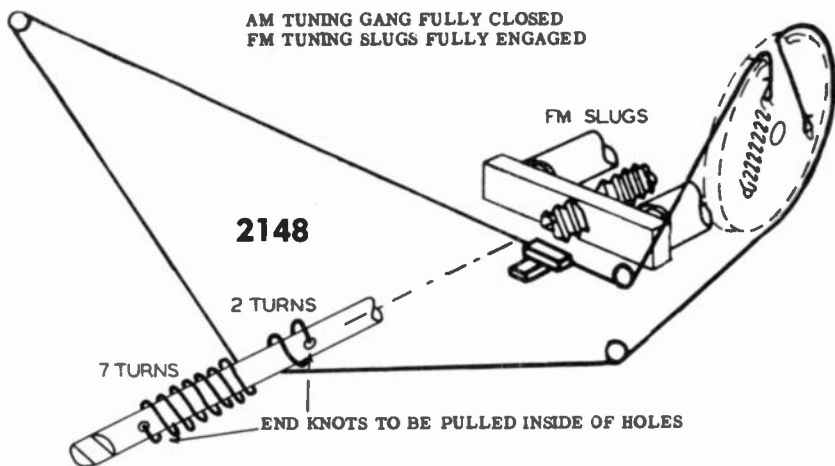

TUNING SLUGS FULLY ENGAGED

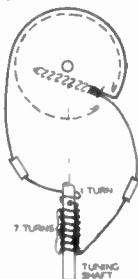

2150

TUNING GANG FULLY CLOSED

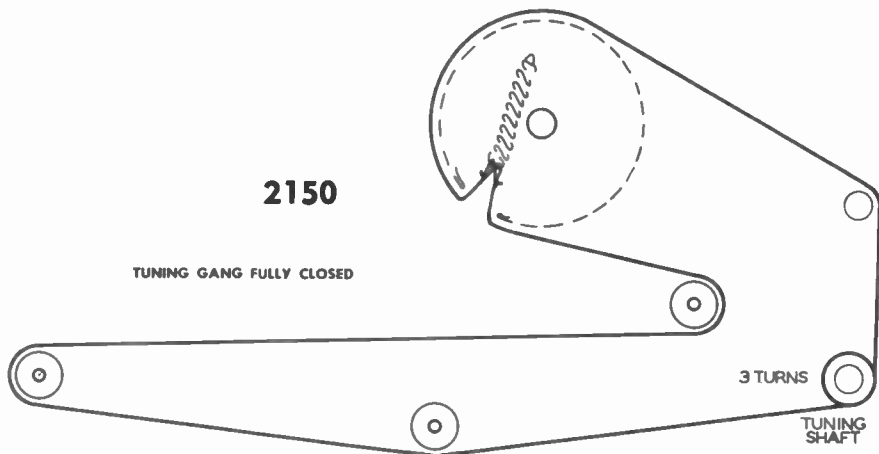

3 TURNS UHF TUNING SHAFT

2151

UHF TUNING PULLEY MAX. COUNTER CLOCKWISE

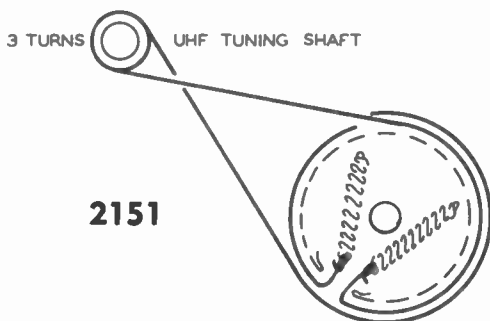

2152

TUNING GANG FULLY CLOSED

2 1/2 TURNS

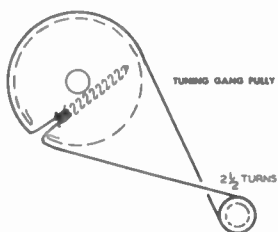

TUNING SLUGS FULLY ENGAGED

7 TURNS

GUIDE POST

TUNING SHAFT

2153

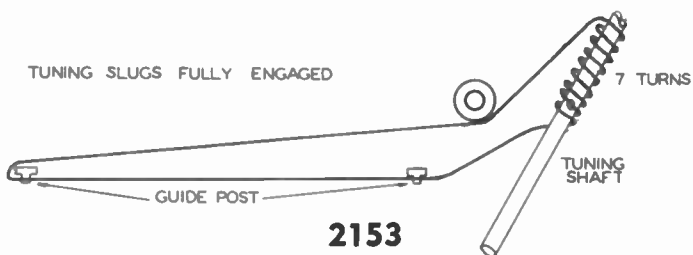

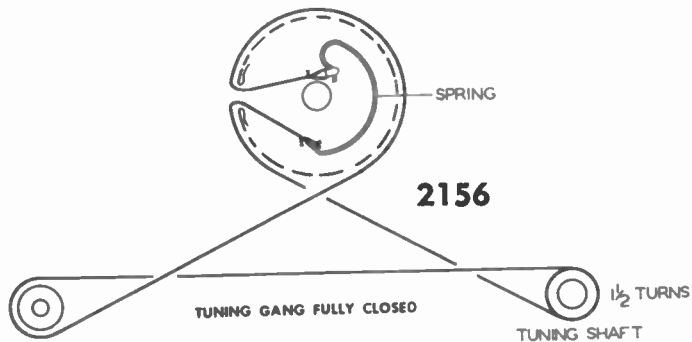
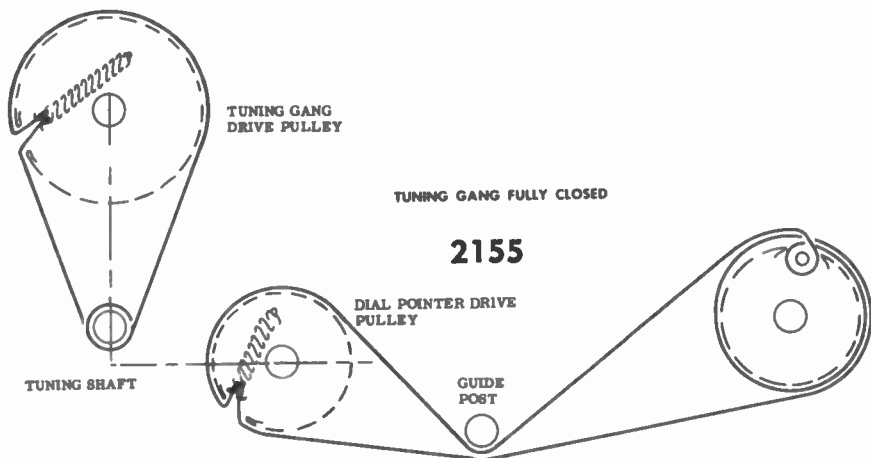
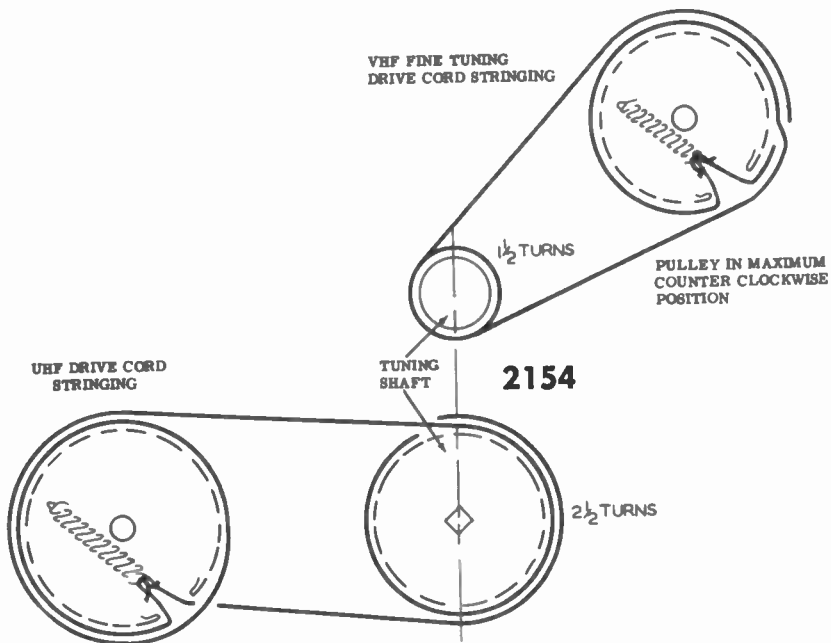

VHF DRIVE CORD STRINGING

1. Cut a 52" length of dial cord and tie one end to the dial spring.
2. Turn the VHF tuner channel selector switch to channel 2 position.
3. Place the free end of the dial cord spring over the hook in the pulley on the front of the VHF tuner.
4. Stretch the spring and take one full turn around the pulley before following the sequence as shown.
5. From point "H" return the end of the dial cord over the top of the pulley to point "A" and tie the cord to the spring. Be sure that the string is sufficiently tight to stretch the spring and thereby maintain proper string tension.
6. Cut off any surplus string and place a drop of quick drying cement on the knots to prevent them from working loose.
7. Position the pointer over channel 2 on the dial and clip the pointer to the dial string. A drop of cement may be used to insure that the pointer will not slip.
8. Check the action of the system to be sure that it operates freely and the pointer indicates the proper VHF channel.

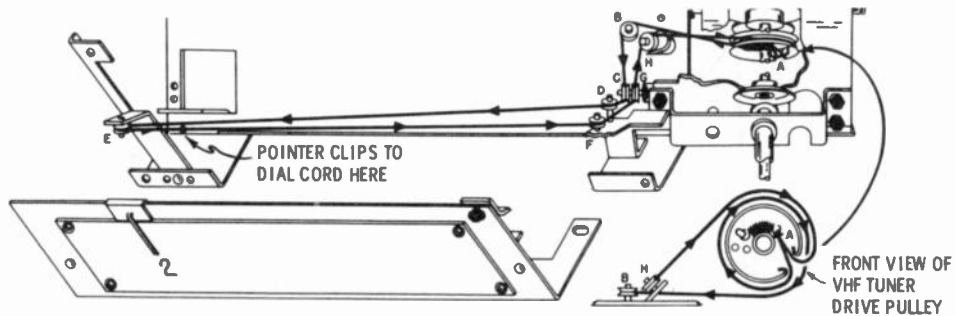

UHF DRIVE CORD STRINGING

1. Cut an 80" length of dial cord and tie one end to the dial spring.
2. Turn the UHF tuner drive pulley to the full counter clockwise position (Channel 14).
3. Place the free end of the dial cord spring over the hook in the back side of the pulley.
4. Stretch the spring and pass the string out the notch in the edge of the pulley and up over the top of the pulley to position 2 and the on to 3. From position 3 take four full turns counter clockwise around the large pulley on the fine tuning shaft before continuing on to points 4, 5, 6 and 7. From point 7 take approximately a 3/4 turn around the UHF drive pulley and pass the dial cord through the notch in the pulley rim.
5. Tie the dial cord to the dial spring at 1 and cut off any surplus string. Place a drop of quick drying cement on the knots to prevent them from working loose.
6. Position the UHF pointer over the index mark on the left end of the UHF dial scale and clip the pointer to the dial string. A drop of cement may be used to insure that the pointer will not slip on the string.
7. Check the action of the system to be sure that it operates freely and the pointer indicates the proper UHF channel.

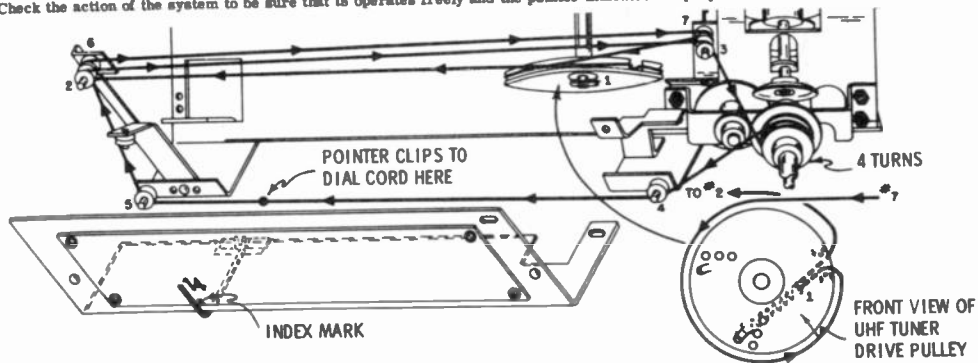

UHF TUNING PULLEY IN MAX. COUNTER CLOCKWISE POSITION.

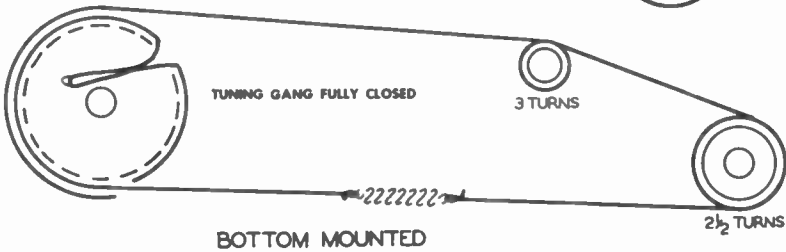
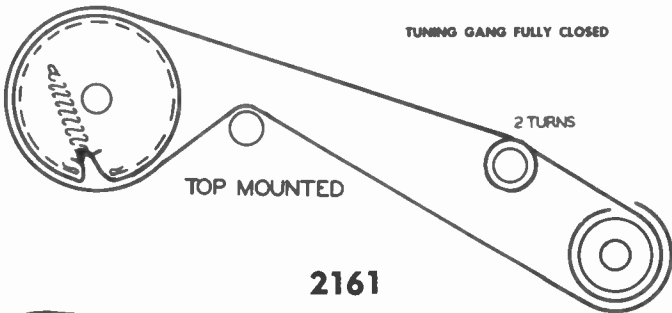
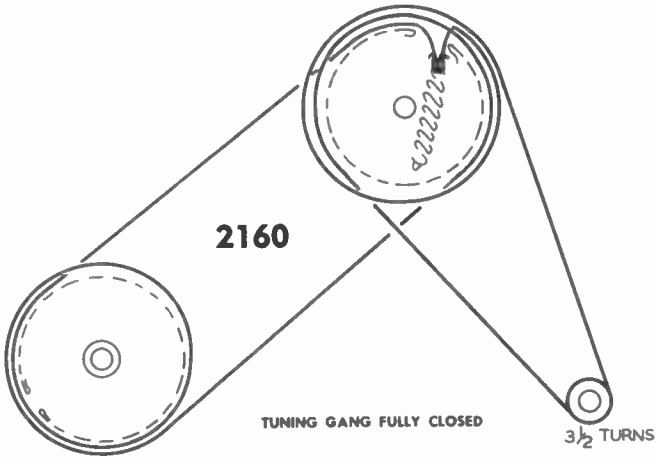
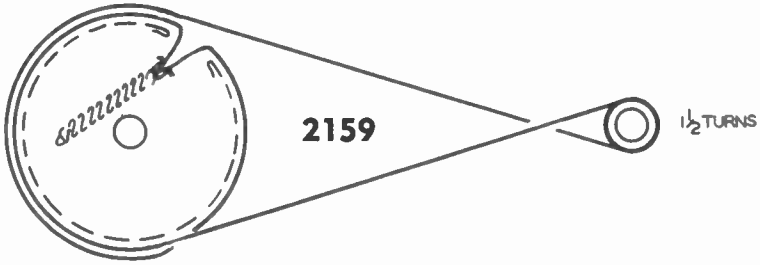

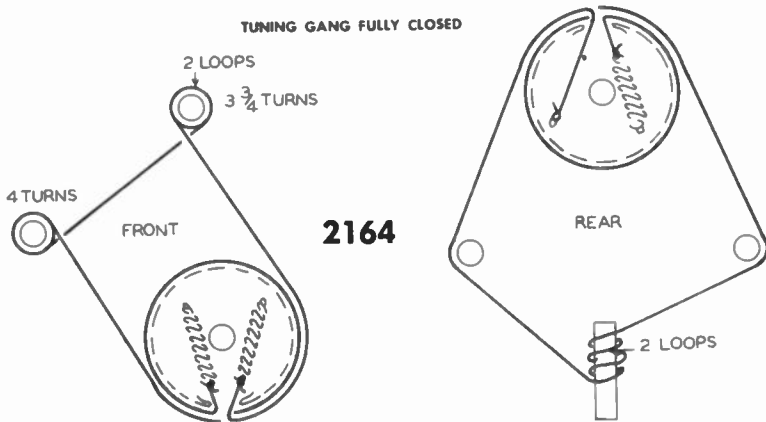
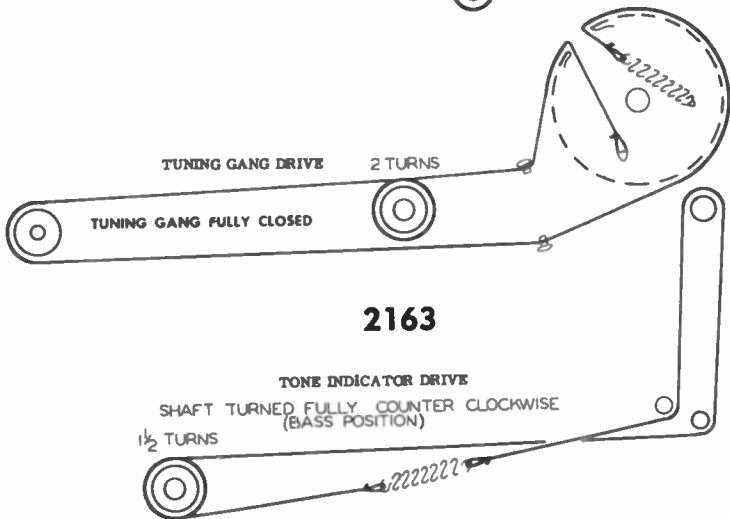
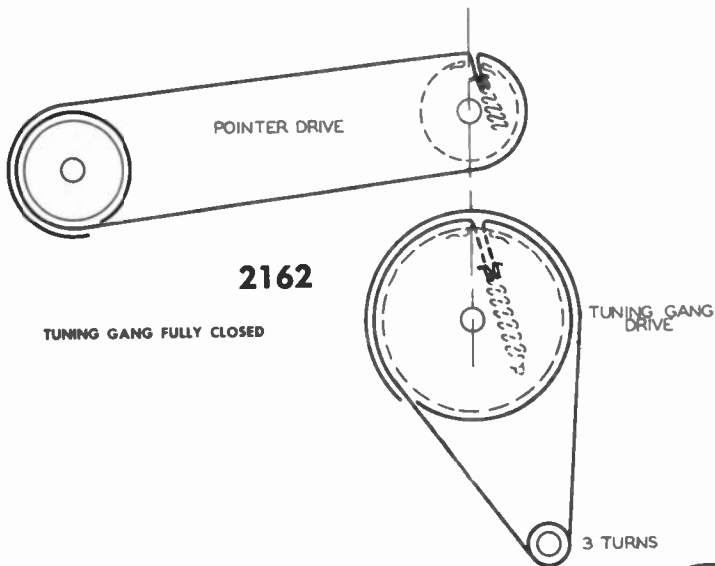

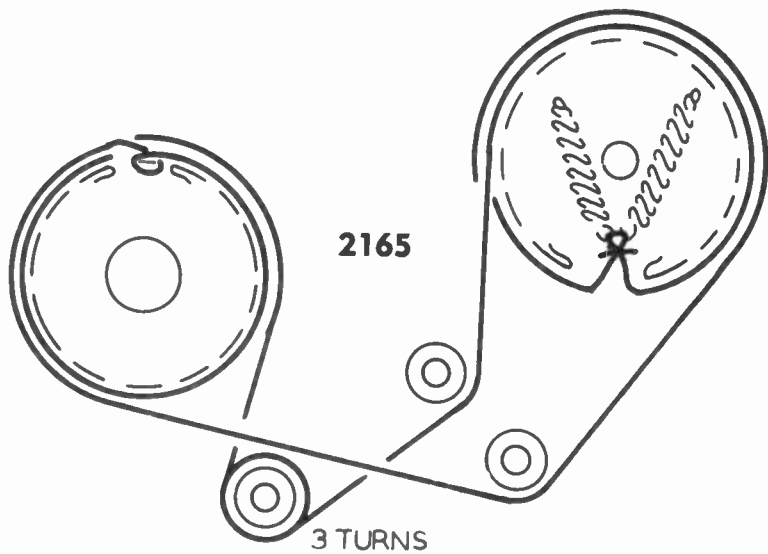

TUNING GANG FULLY COUNTER CLOCKWISE

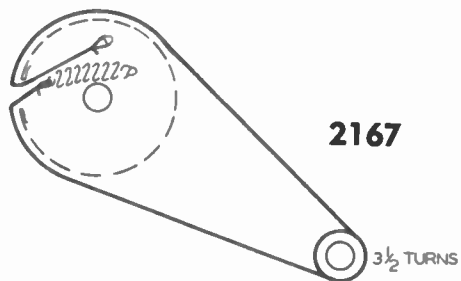
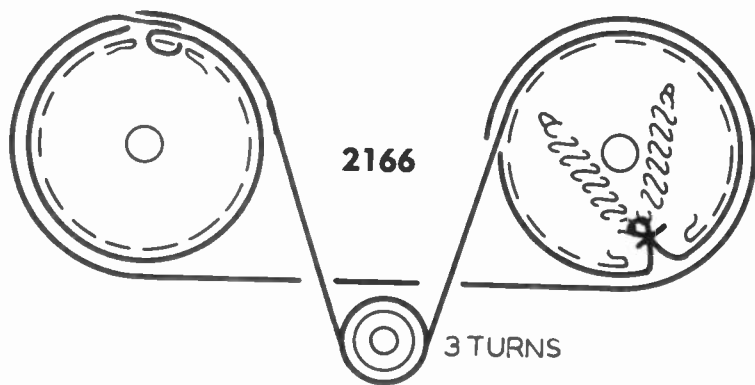

TUNING PULLEY MAX. COUNTER CLOCKWISE POSITION

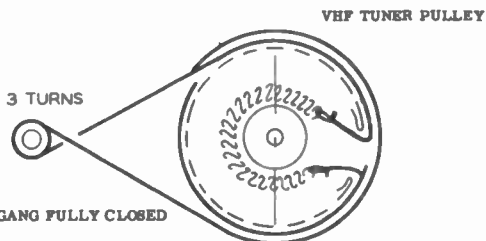
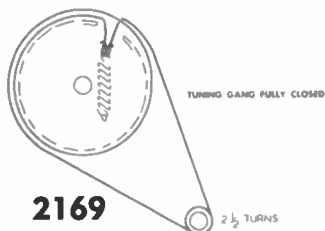
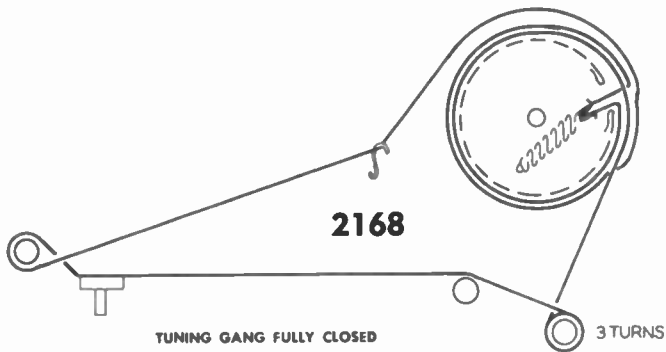

UHF TUNER PULLEY

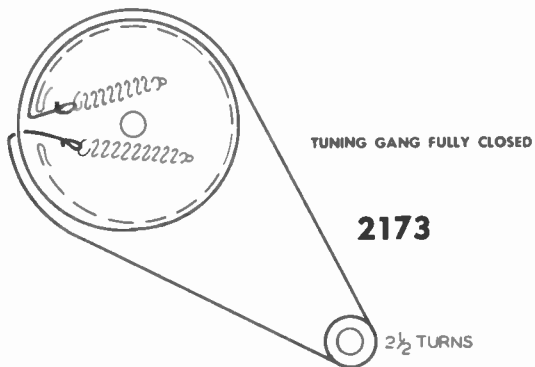
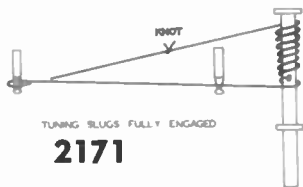
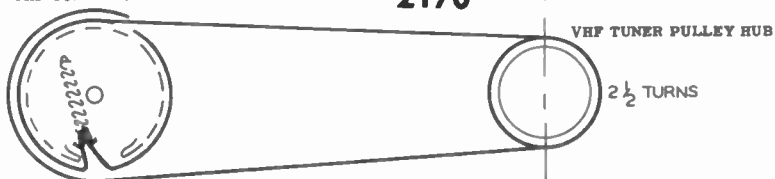

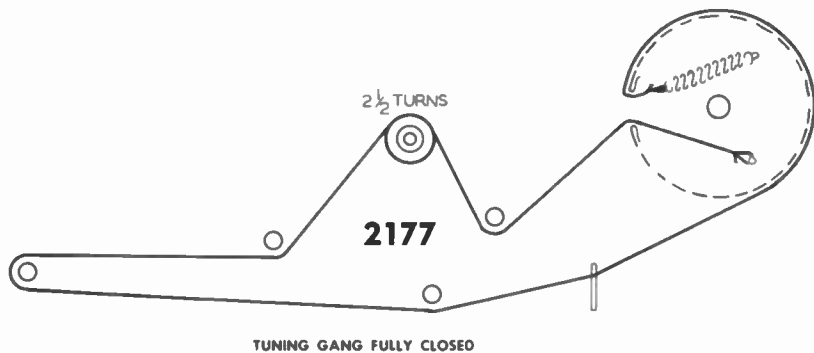
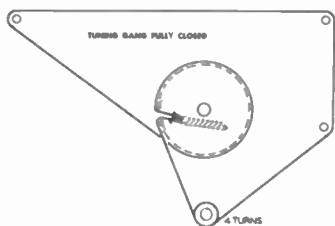
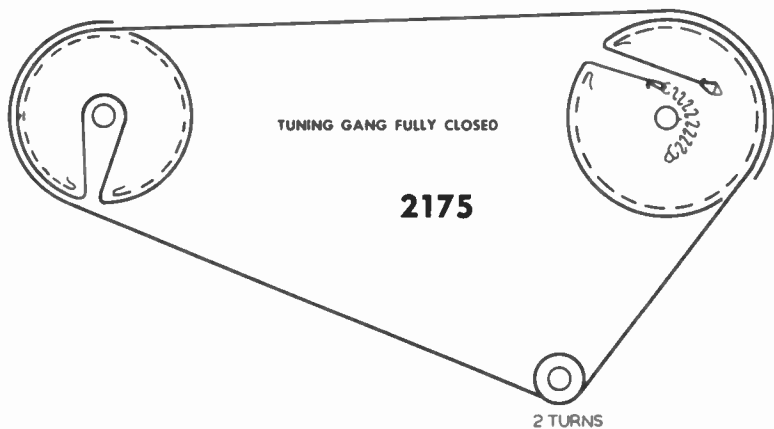
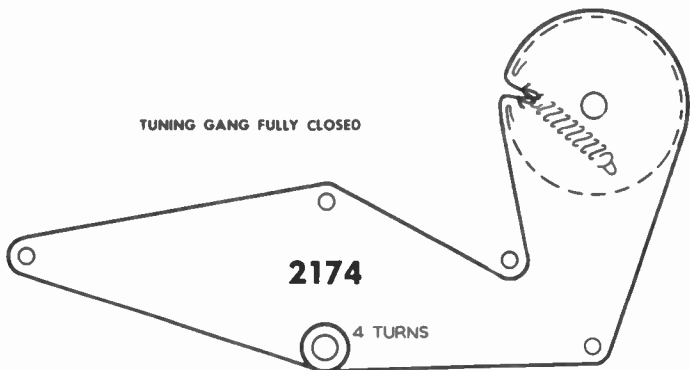

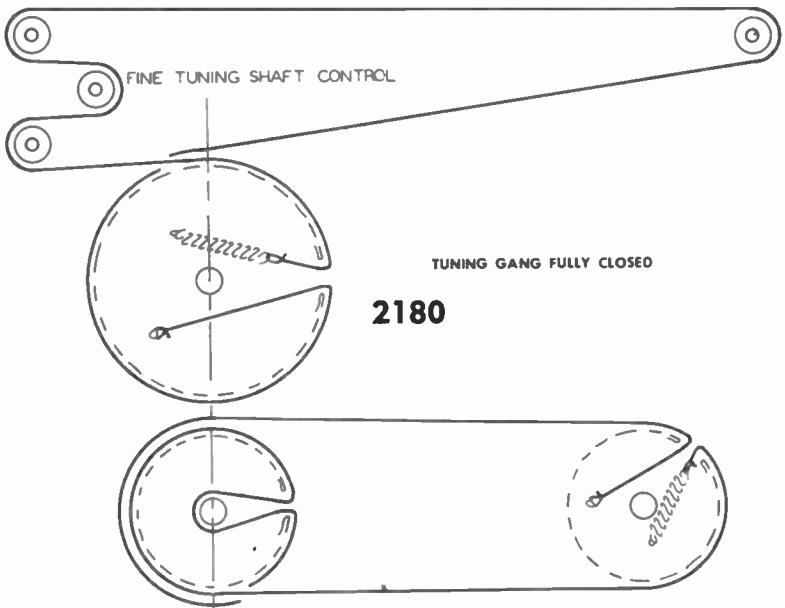
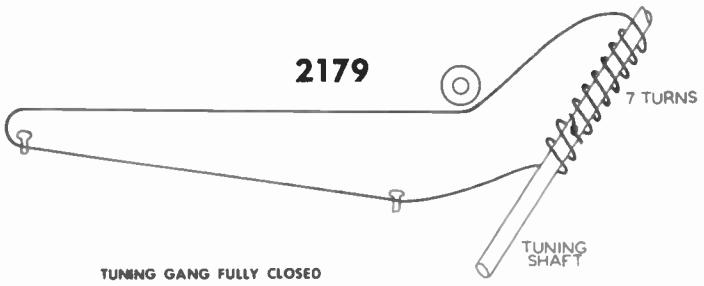
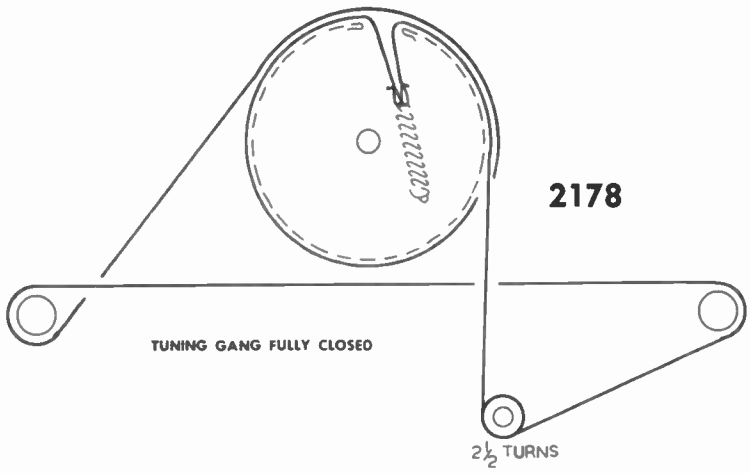

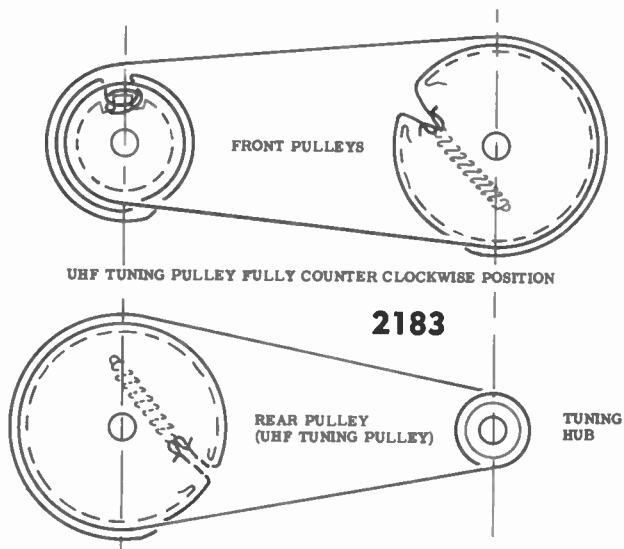
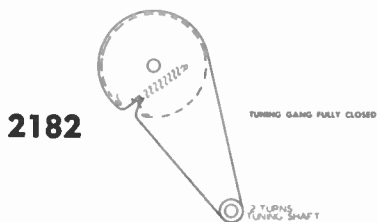
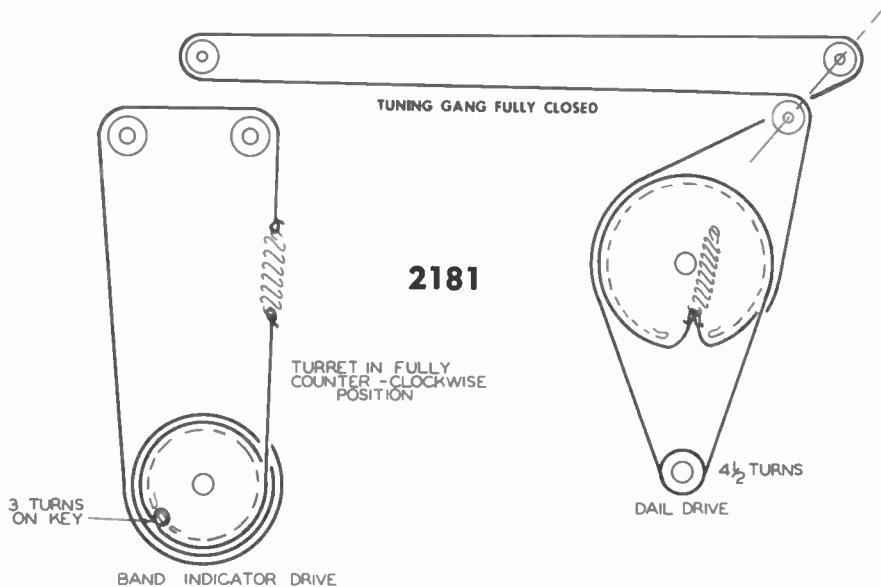

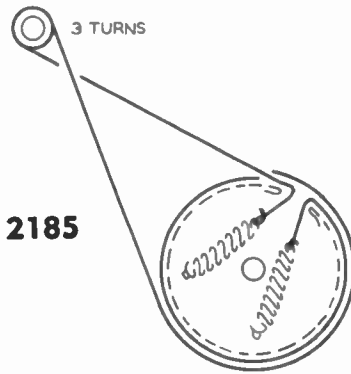
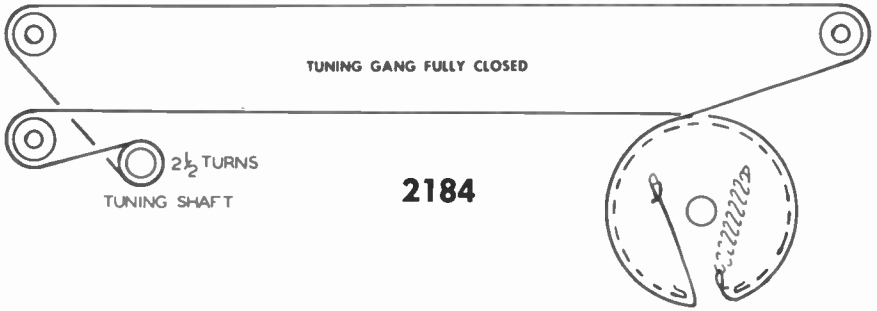

TUNING PULLEY IN MAX COUNTER CLOCKWISE POSITION

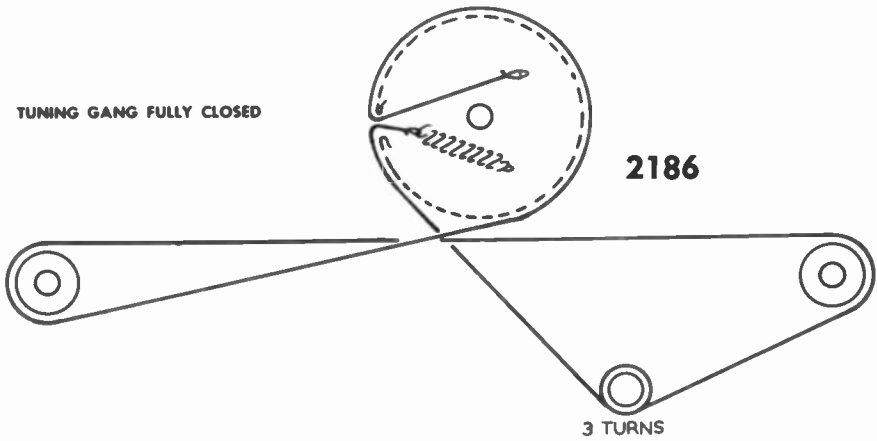

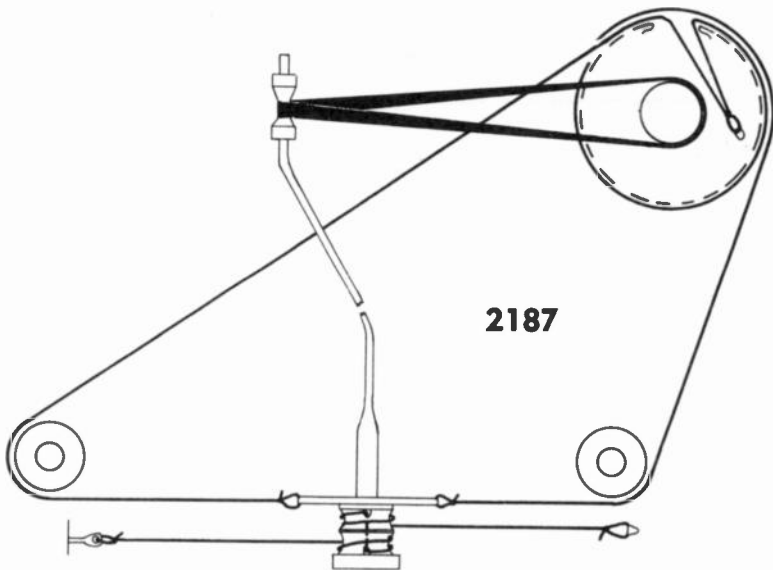

SHOWN IN CHANNEL 7 POSITION

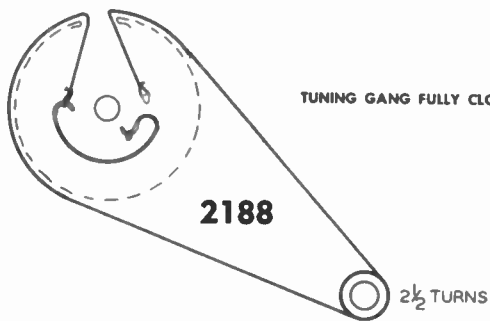

TUNING GANG FULLY CLOSED

TUNING SLUGS FULLY ENGAGED

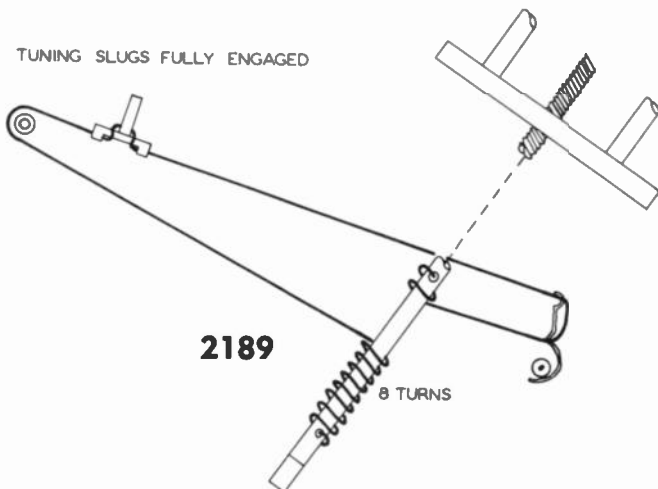

8 TURNS

BANDSPREAD DRIVE

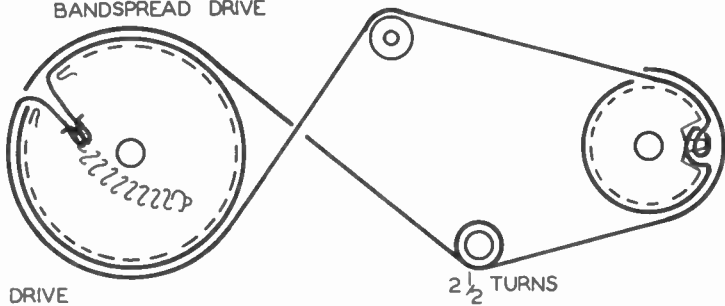

TUNING GANG DRIVE

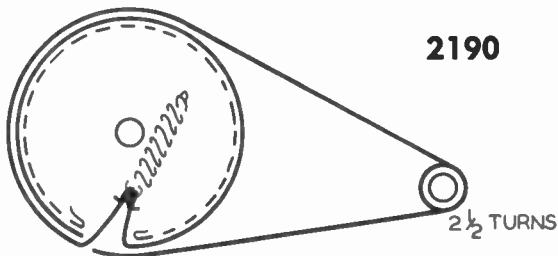

2190

TUNING GANG & BANDSPREAD GANG FULLY CLOSED

2191

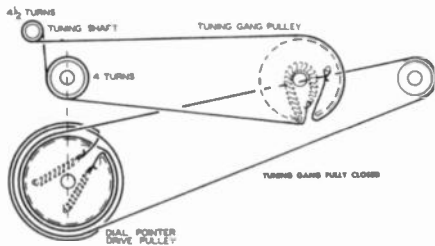

VHF FINE TUNING

2192

UHF TUNING PULLEY

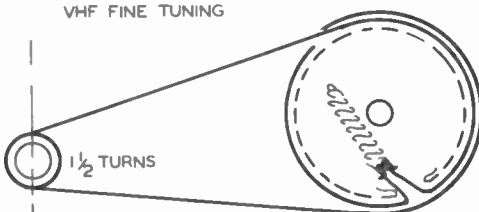
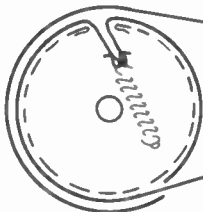

VHF FINE TUNING PULLEY
MAX. COUNTER CLOCKWISE POSITION

4 1/2 TURNS

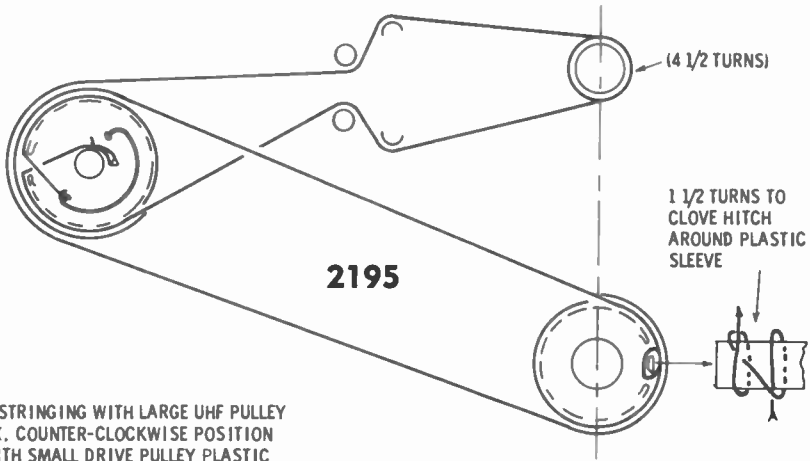
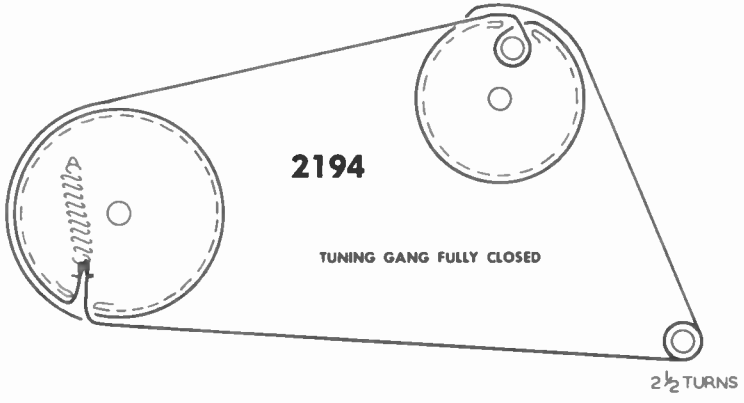
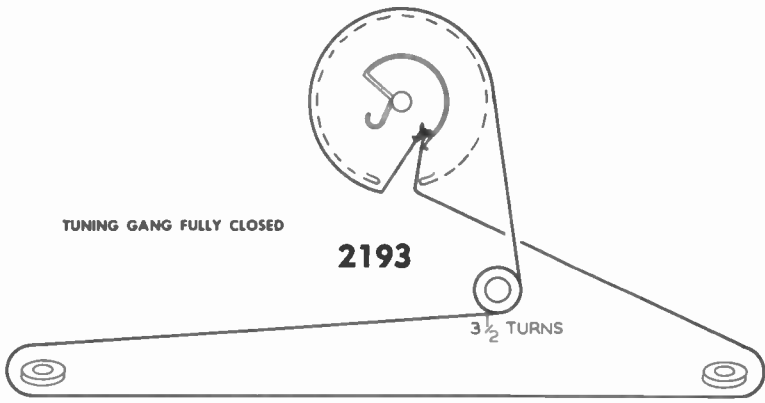

START STRINGING WITH LARGE UHF PULLEY AT MAX. COUNTER-CLOCKWISE POSITION AND WITH SMALL DRIVE PULLEY PLASTIC SLEEVE TAB AT 5 O'CLOCK (VIEWED FROM FRONT OF TUNER)

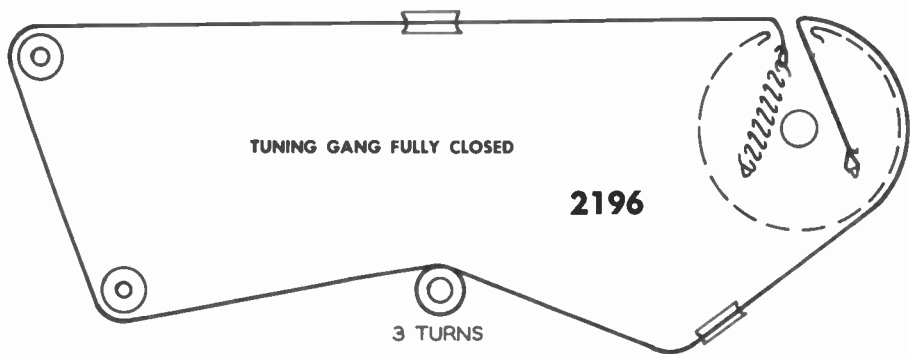

TUNING GANG FULLY CLOSED

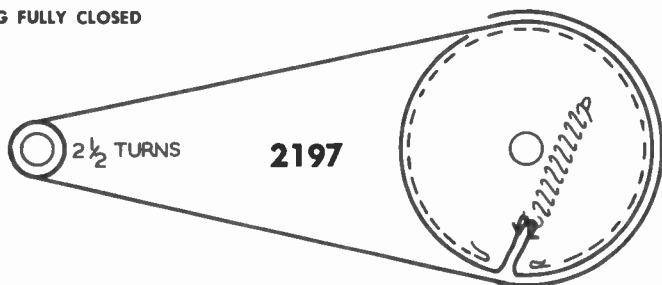

TUNING GANG FULLY CLOSED

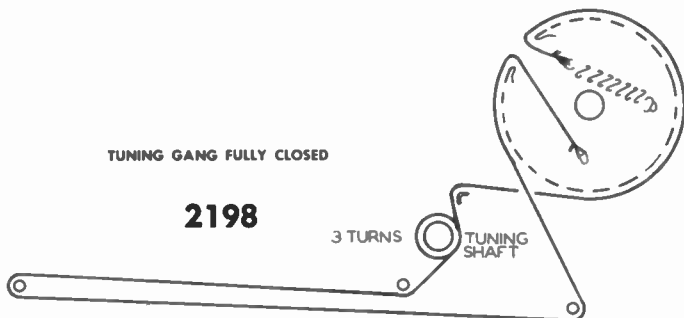

TUNING GANG FULLY CLOSED

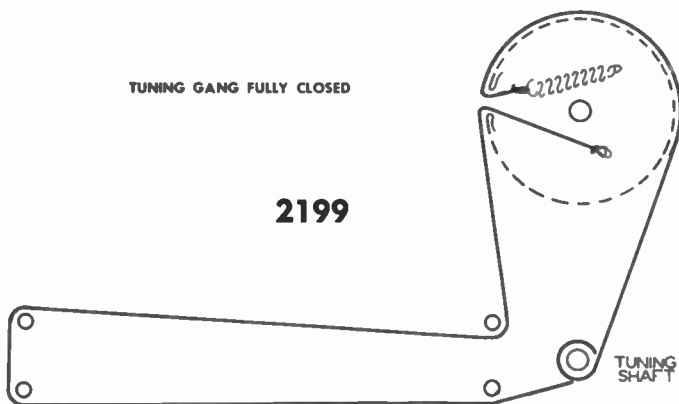

TUNING GANG FULLY OPEN

$3\frac{3}{4}$ TURNS

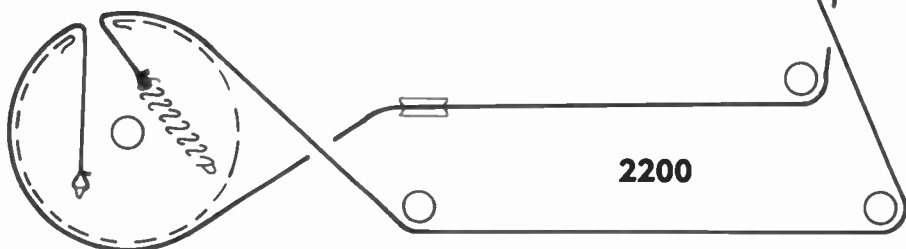

TUNING GANG FULLY CLOSED

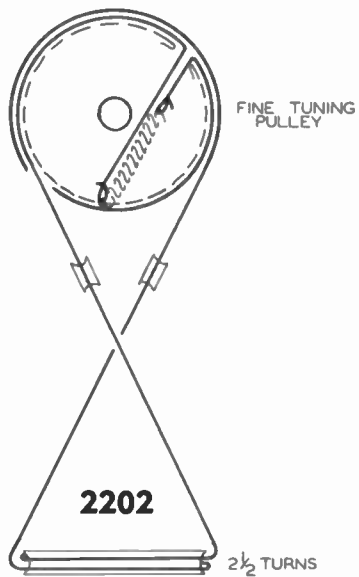
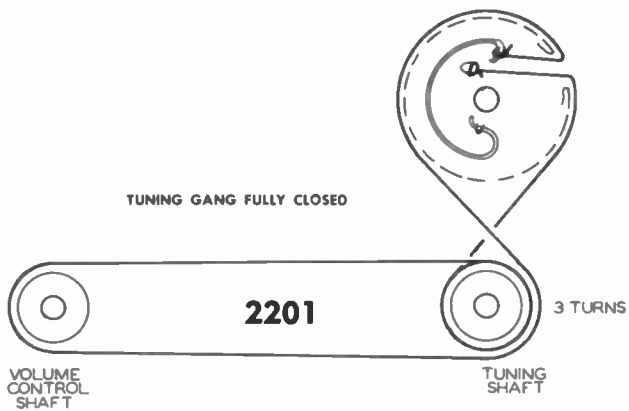

FINE TUNING PULLEY IN MAX. COUNTER CLOCKWISE POSITION

TUNING GANG FULLY CLOSED

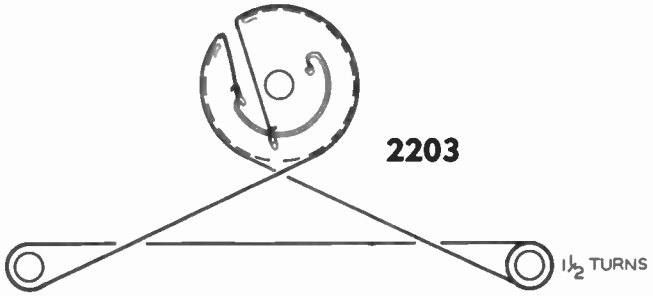

DIAL POINTER DRIVE

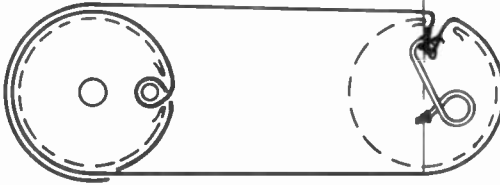

2204

TUNING GANG FULLY CLOSED

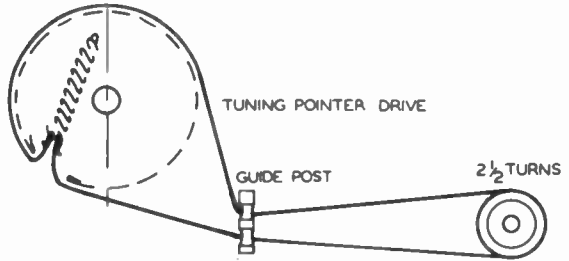

TUNING GANG FULLY CLOSED

TUNING GANG FULLY CLOSED

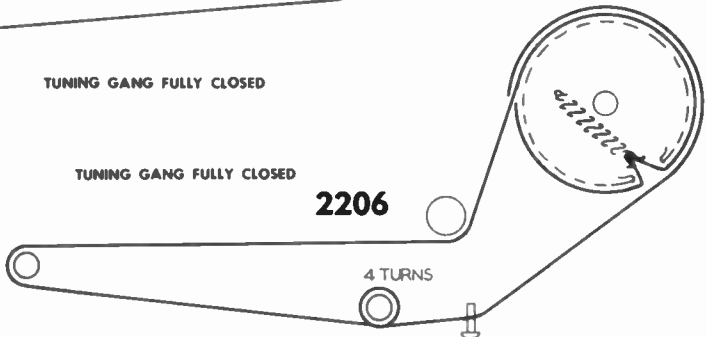

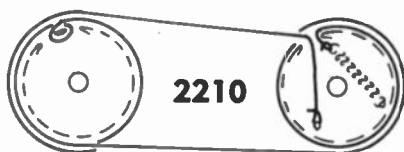
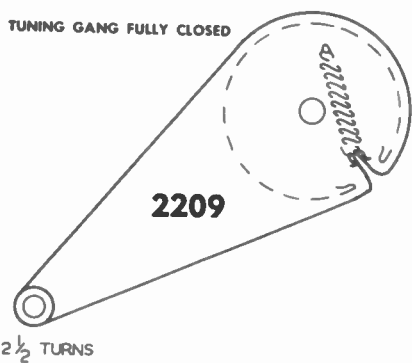
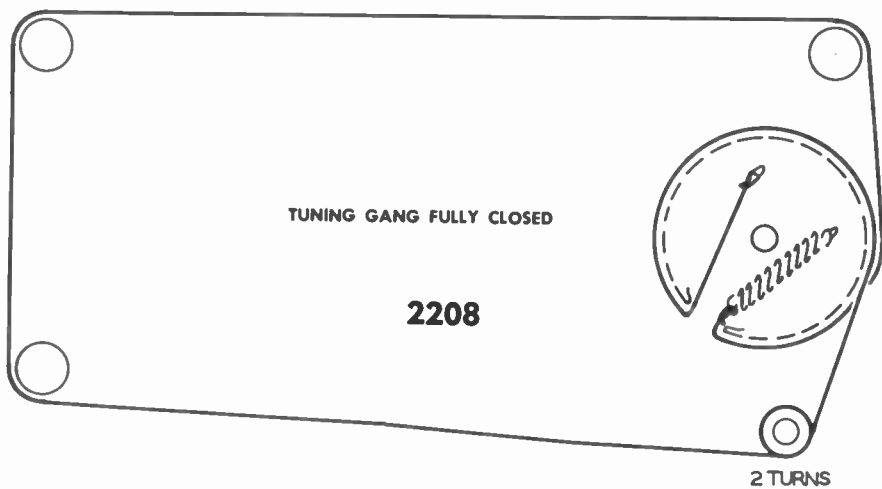
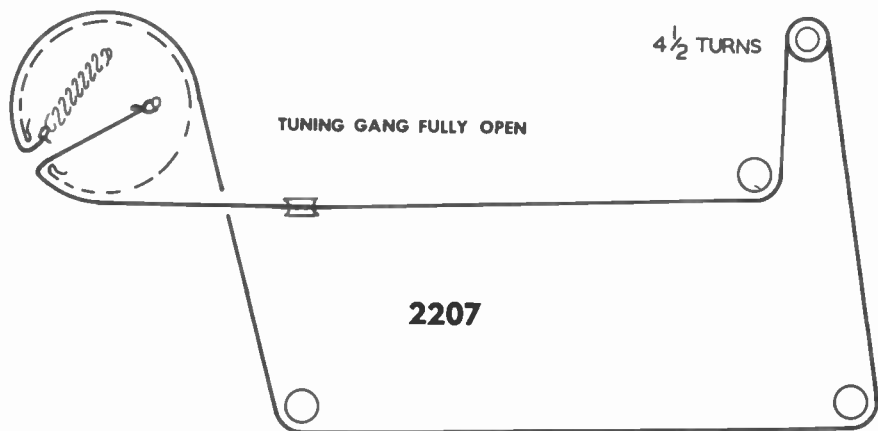

PULLEYS IN COMPLETE
COUNTER-CLOCKWISE
POSITION AGAINST
STOP.

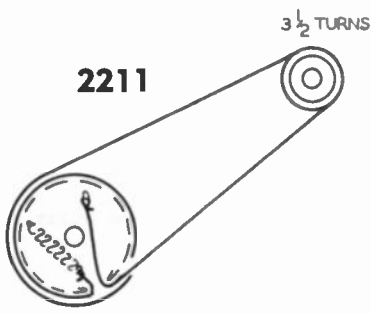

2211

3 1/2 TURNS

PULLEYS IN COMPLETE
COUNTER-CLOCKWISE
POSITION AGAINST
STOP.

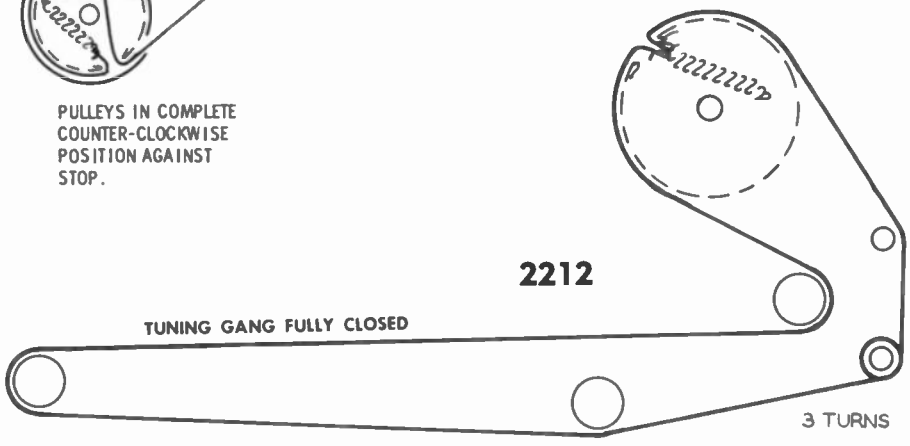

2212

TUNING GANG FULLY CLOSED

3 TURNS

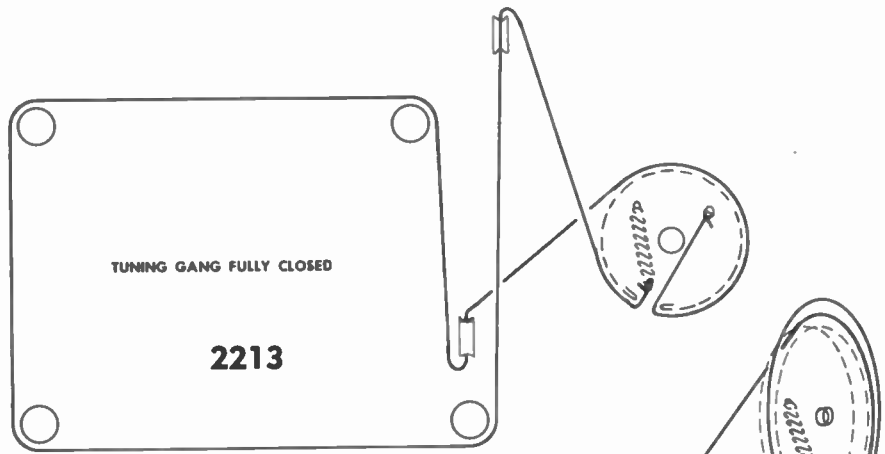

TUNING GANG FULLY CLOSED

2213

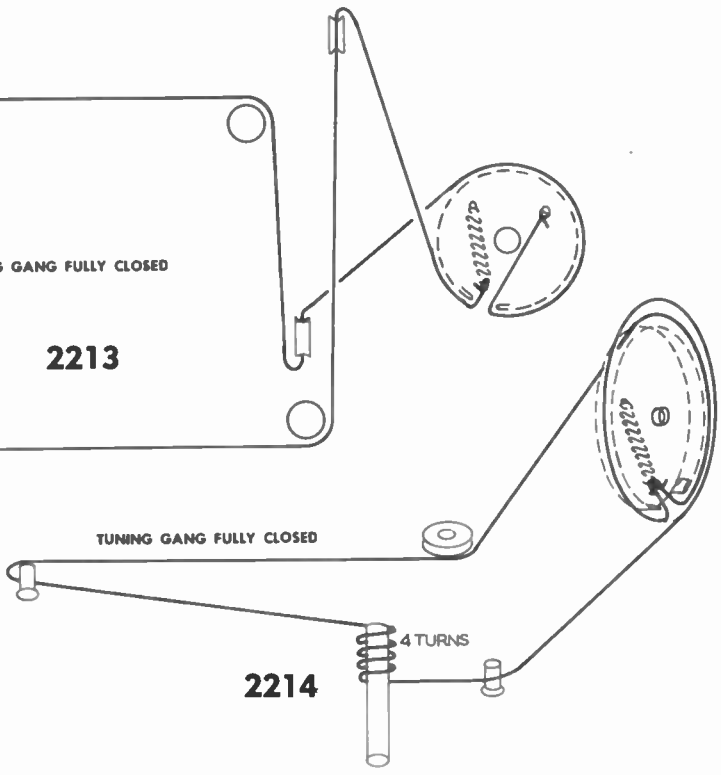

2214

4 TURNS

TUNING GANG FULLY CLOSED

VHF FINE TUNING PULLEY IN MAX. CLOCKWISE POSITION

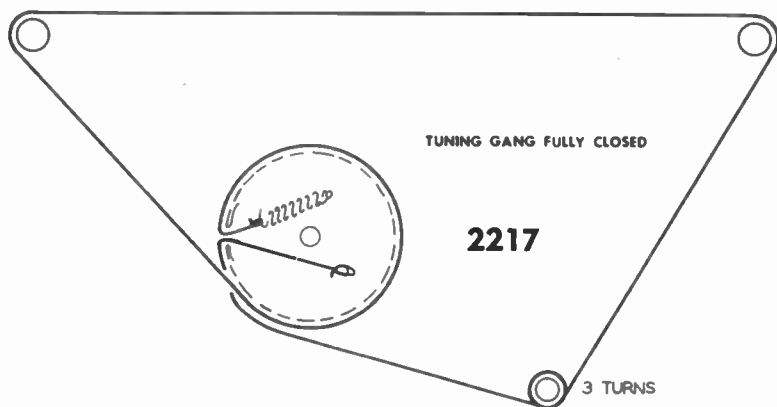
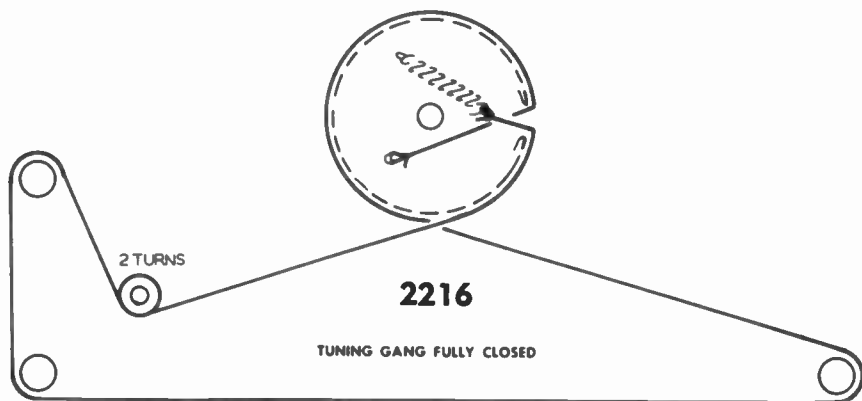
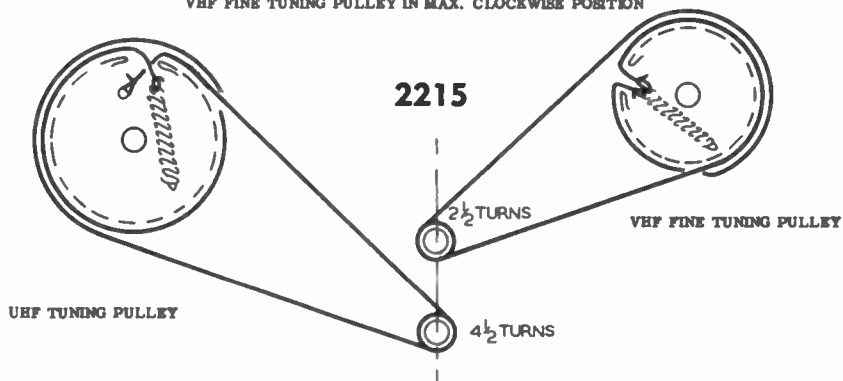

UHF PULLEY IN MAX.
COUNTER CLOCKWISE POSITION

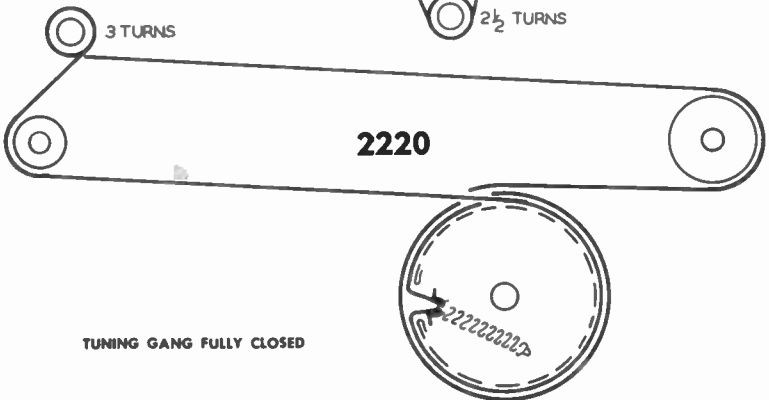
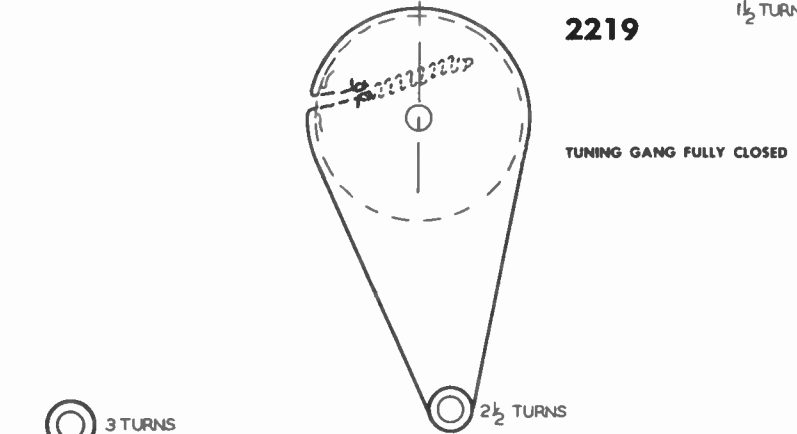
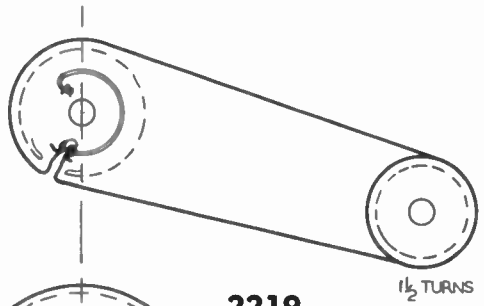
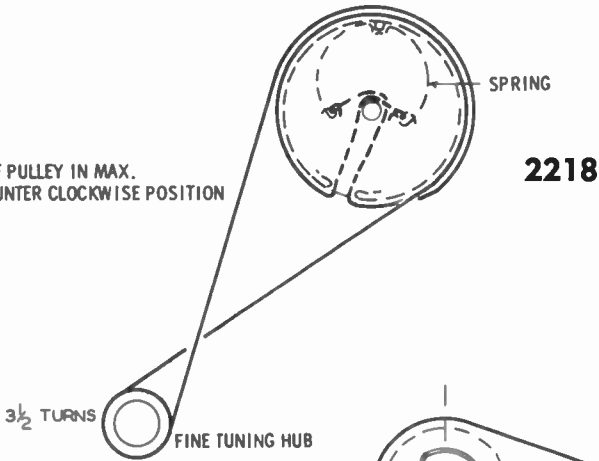

TUNING GANG FULLY CLOSED

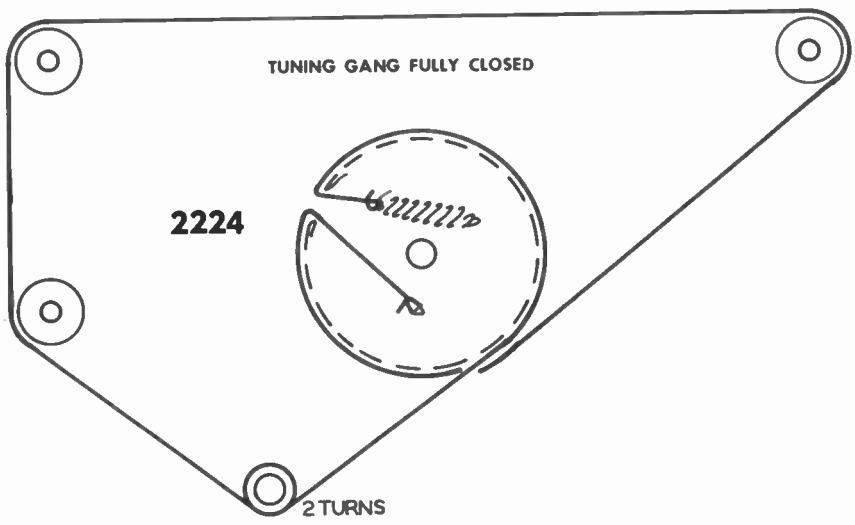
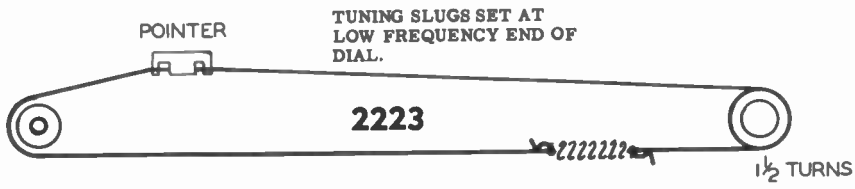
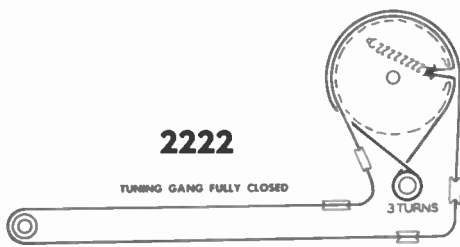
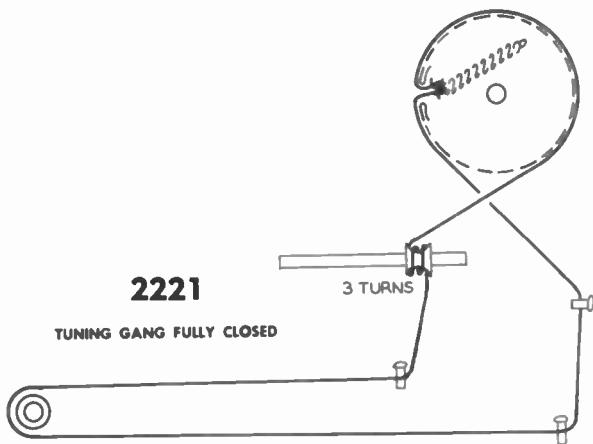

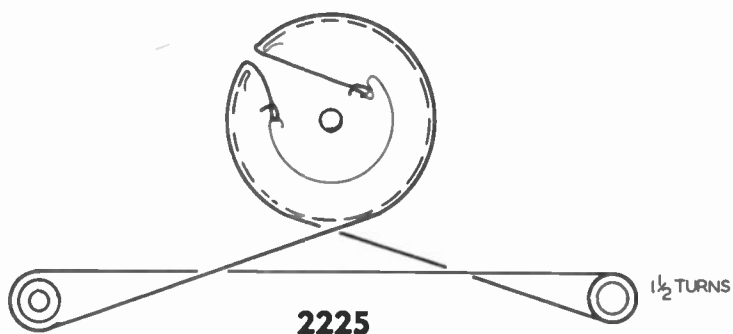

2225

TUNING GANG FULLY CLOSED

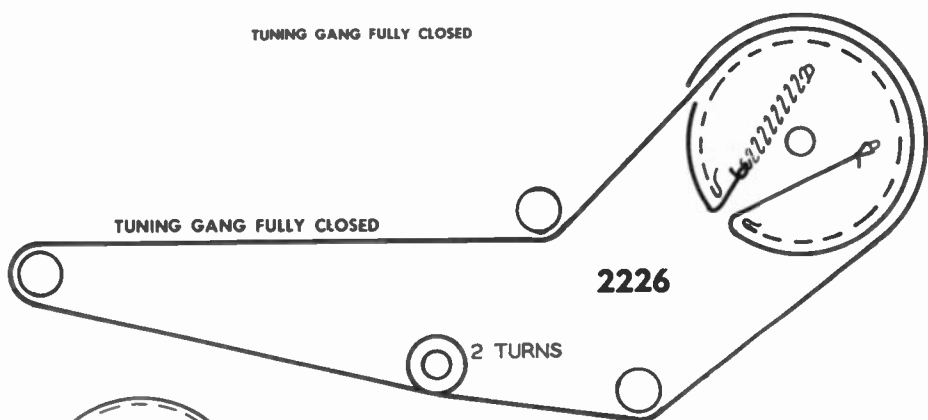

2226

TUNING GANG FULLY CLOSED

TUNING GANG FULLY CLOSED

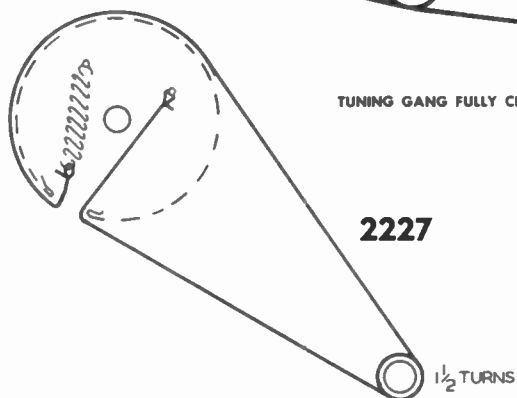

2227

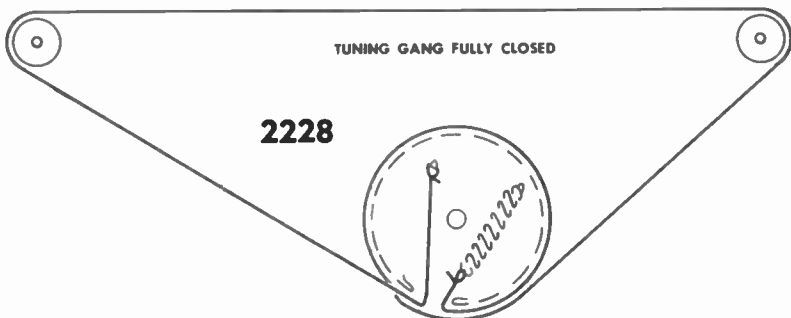

2228

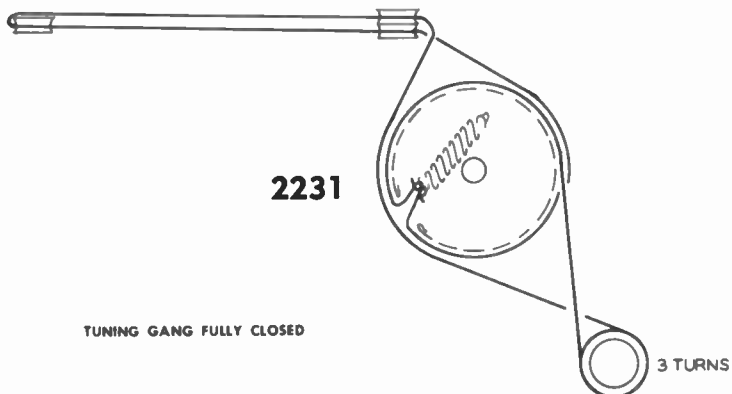
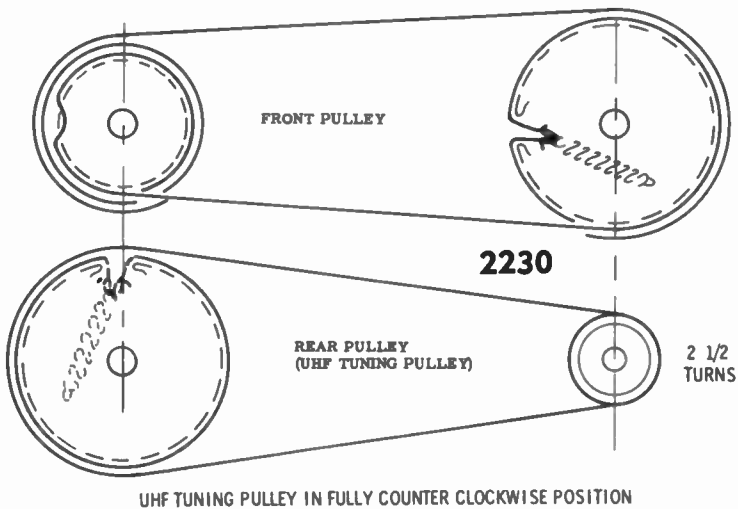
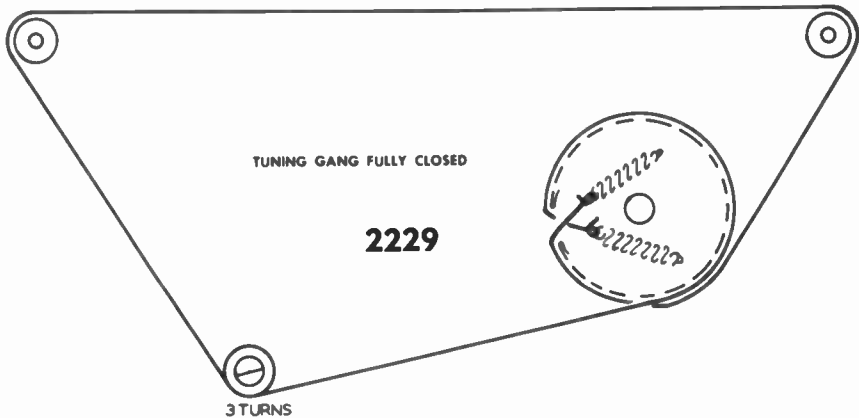

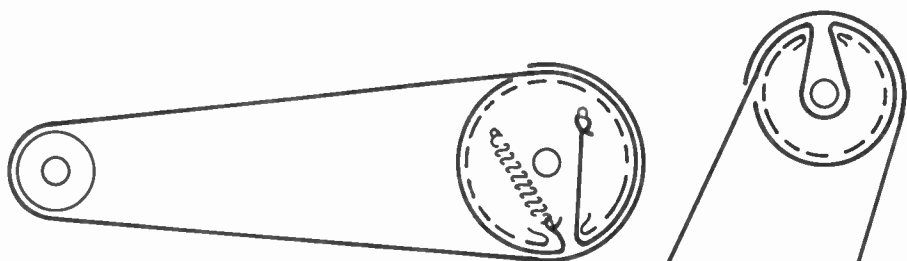

TUNING GANG FULLY CLOSED

2232

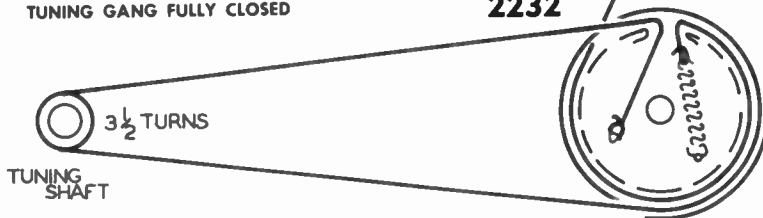

TUNING
SHAFT

2233

TUNING GANG FULLY CLOSED

GUIDE POST

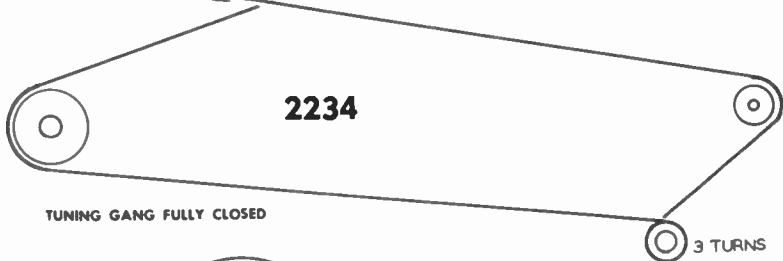
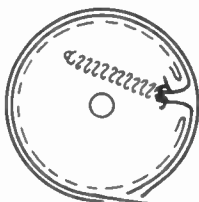
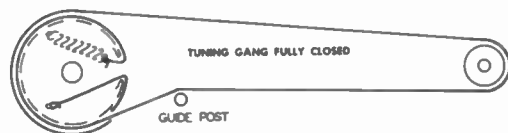

2234

TUNING GANG FULLY CLOSED

3 TURNS

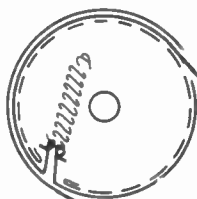

TUNING GANG FULLY CLOSED

2235

3 1/2 TURNS

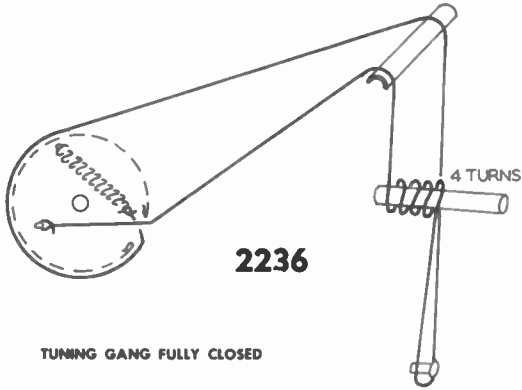

TUNING GANG FULLY CLOSED

2237

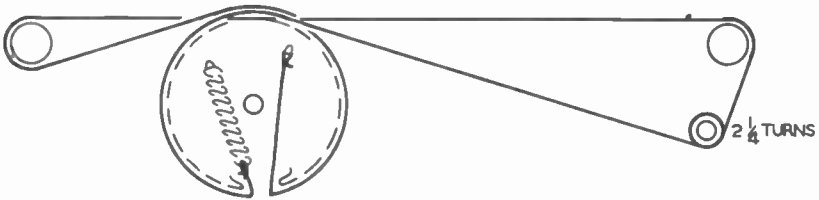

TUNING GANG FULLY CLOSED

2238

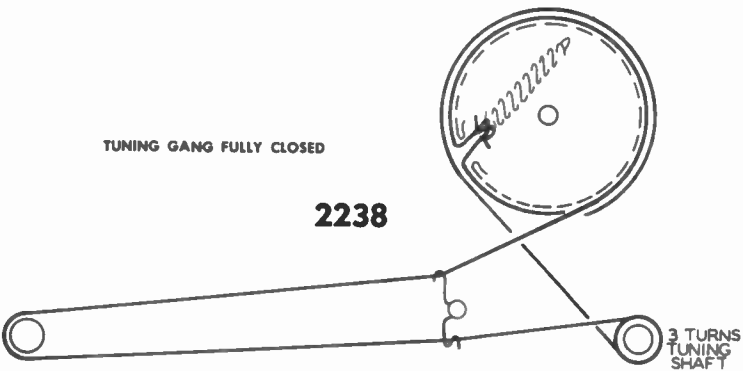

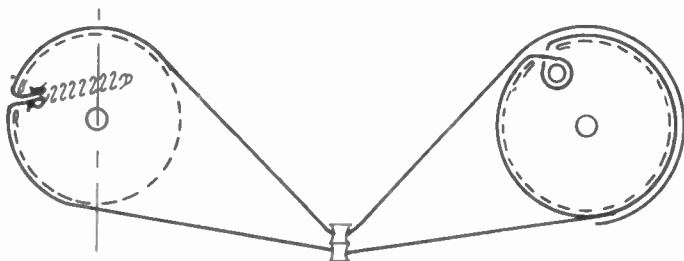

2239

TUNING GANG FULLY CLOSED

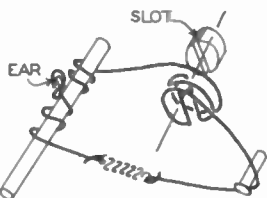
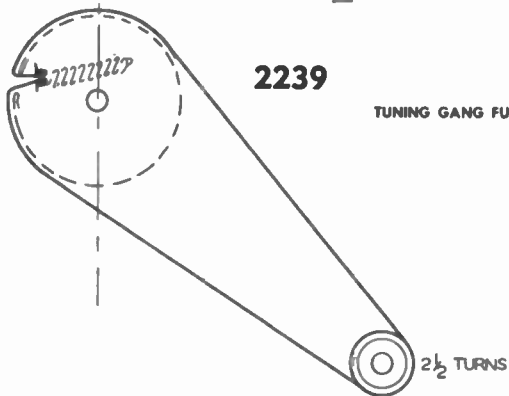

2240

When restringing ear should be at 90° to slot in pulley as shown

TUNING GANG FULLY CLOSED

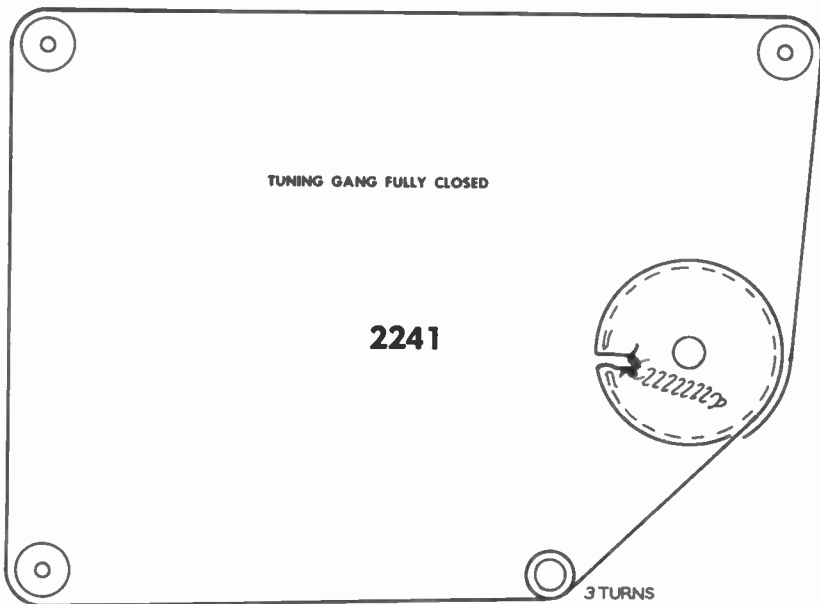

TUNING GANG FULLY CLOSED

2241

3 TURNS

TUNING GANG FULLY CLOSED

2242

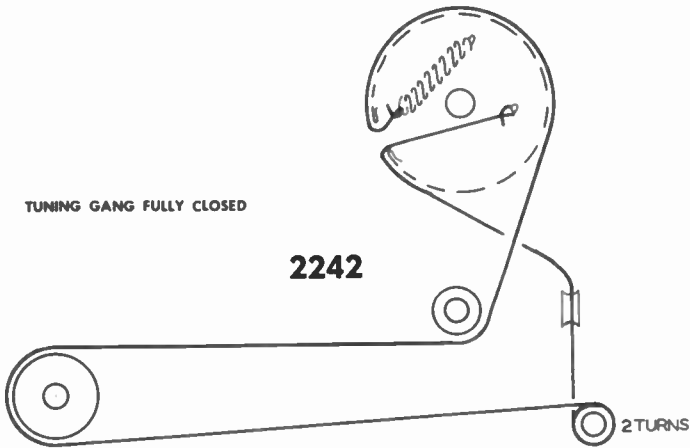

DRIVE PULLEY

CONTRAST CONTROL PULLEY



CONTRAST CONTROL PULLEY IN MAX. COUNTER CLOCKWISE POSITION.

TUNING GANG FULLY CLOSED

2244

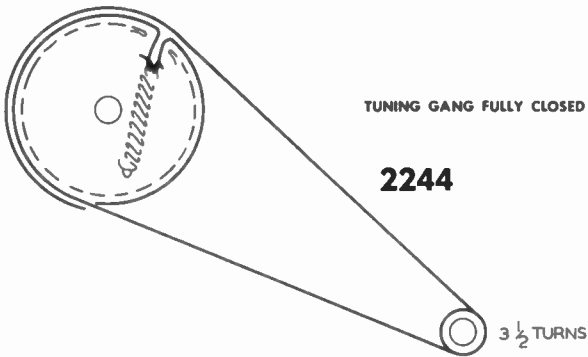

2245

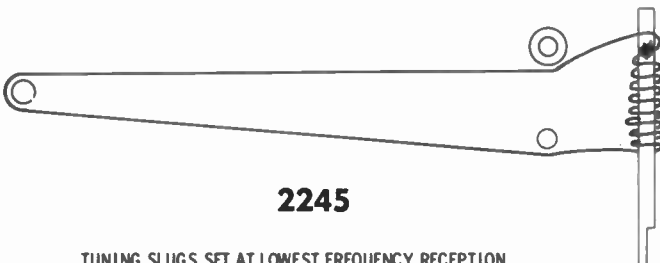

TUNING SLUGS SET AT LOWEST FREQUENCY RECEPTION.

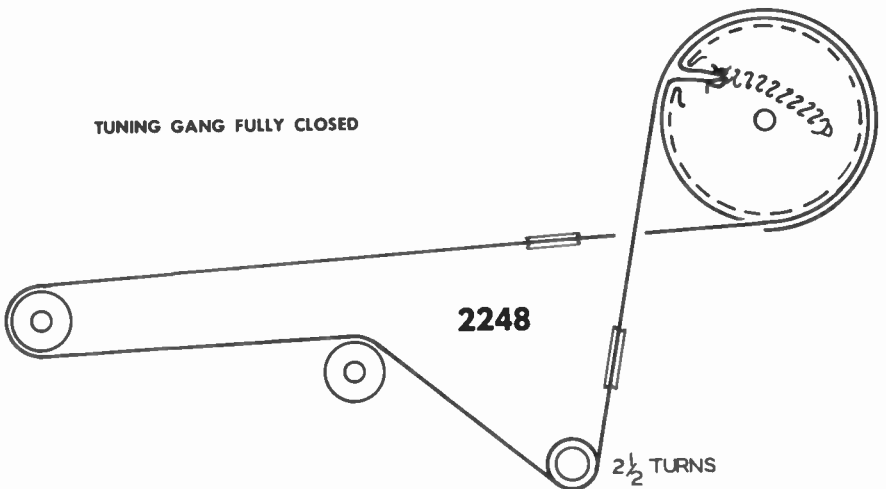
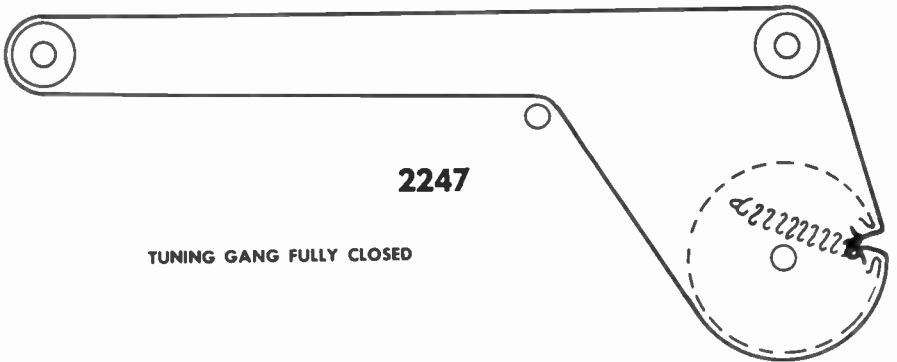
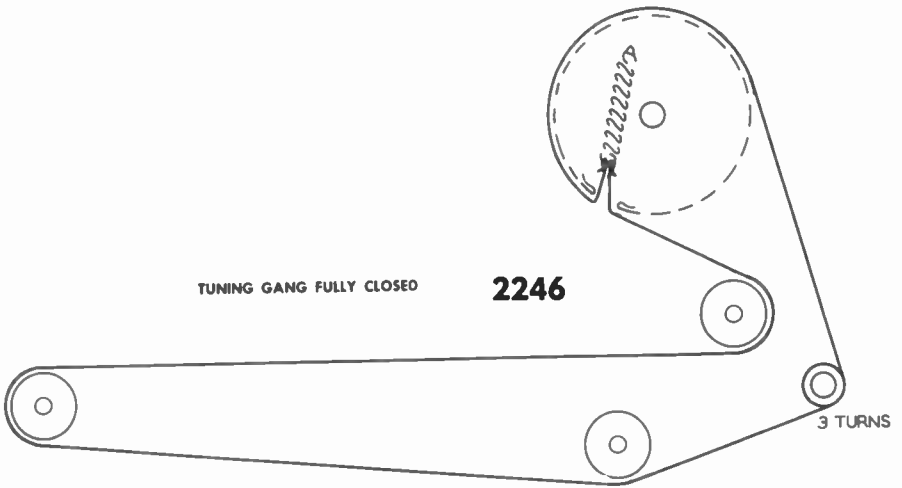

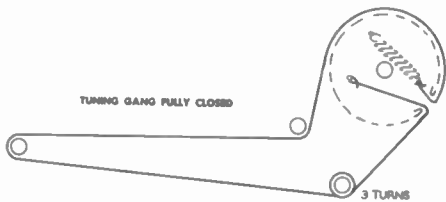

2249

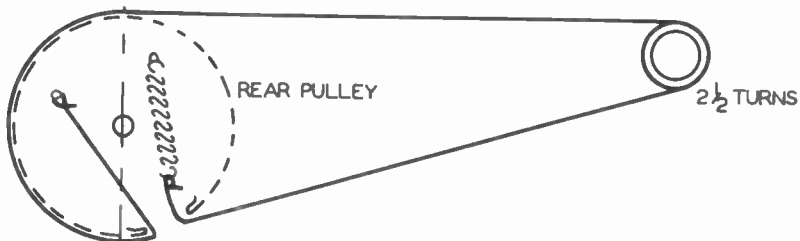

2250

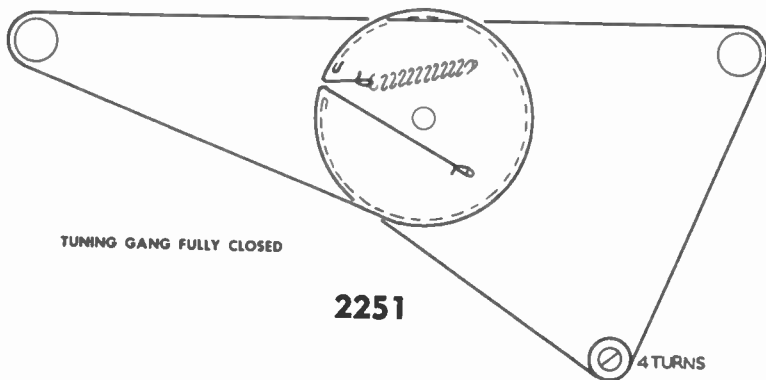
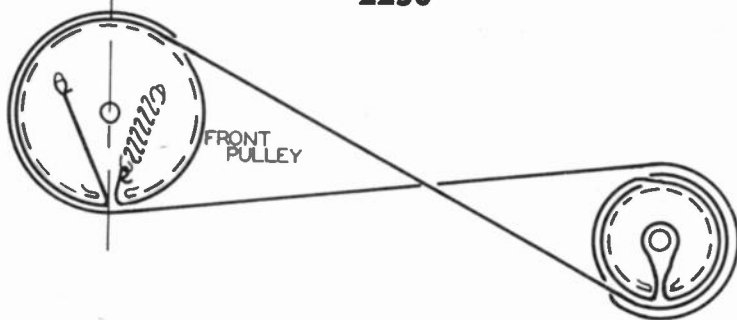

2251

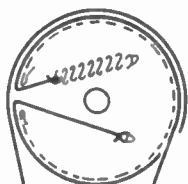

TUNING GANG FULLY CLOSED

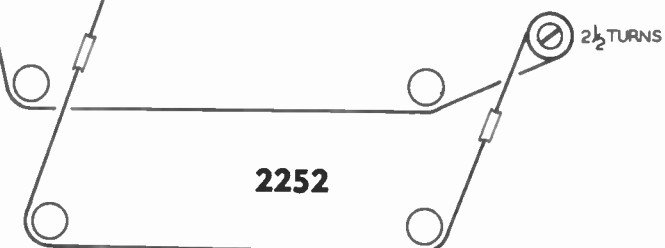

2252

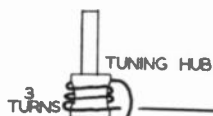

TUNING HUB

3 TURNS

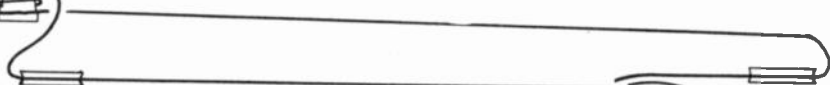

TUNING GANG FULLY CLOSED

2253

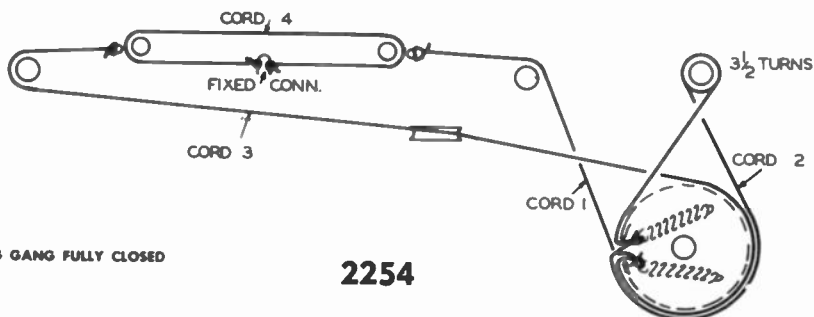
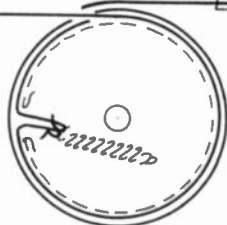

TUNING GANG FULLY CLOSED

2254

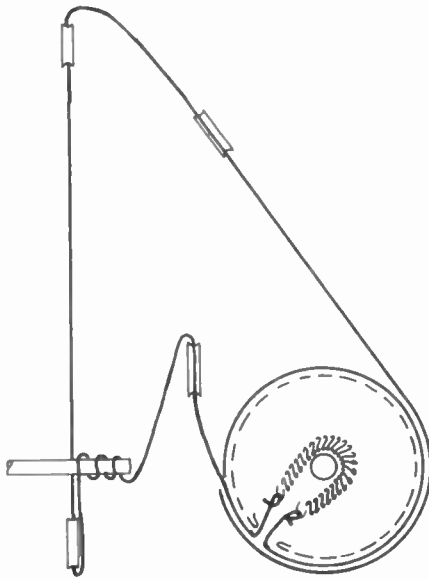

2255

TUNING GANG FULLY CLOSED

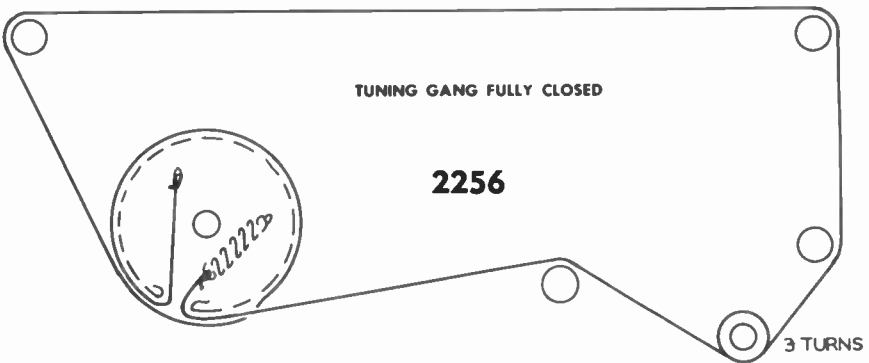

TUNING GANG FULLY CLOSED

2256

3 TURNS

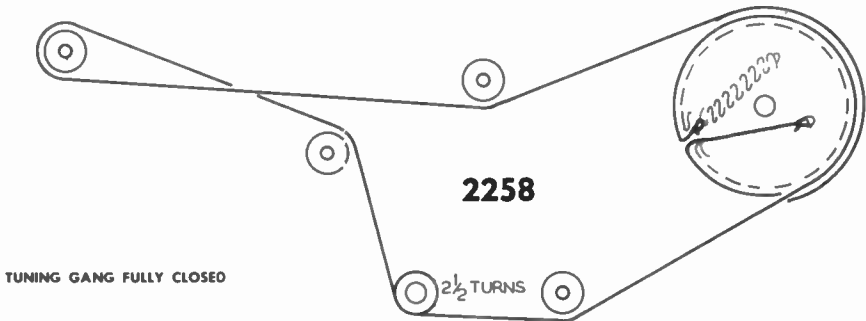
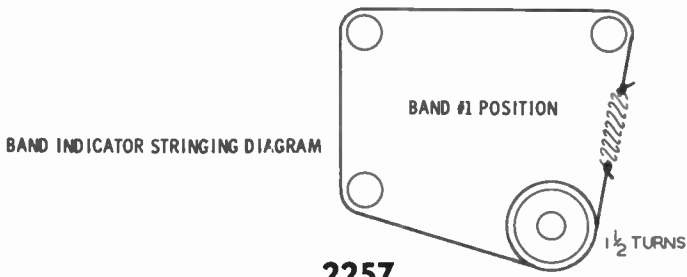
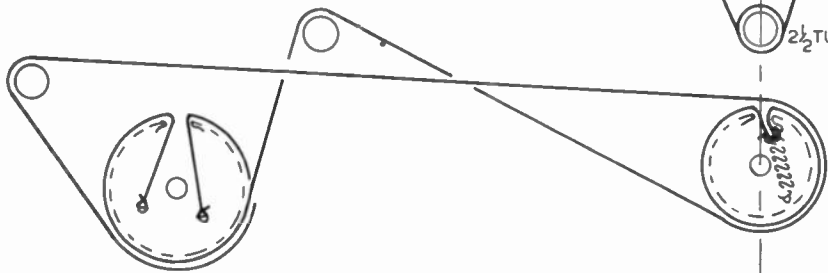
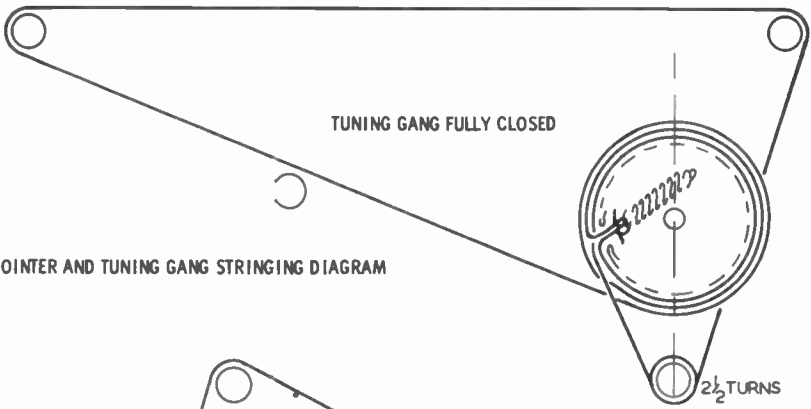

TUNING GANG FULLY CLOSED

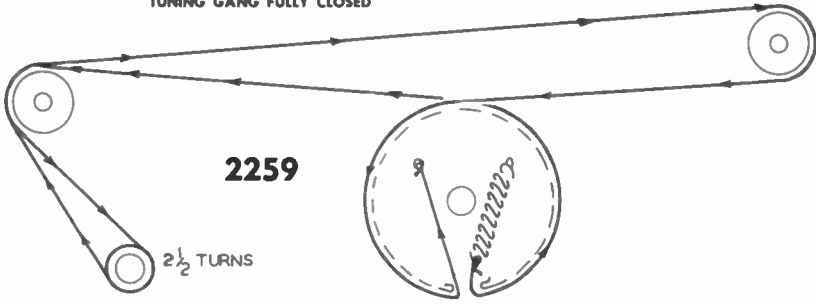

TUNING GANG FULLY CLOSED

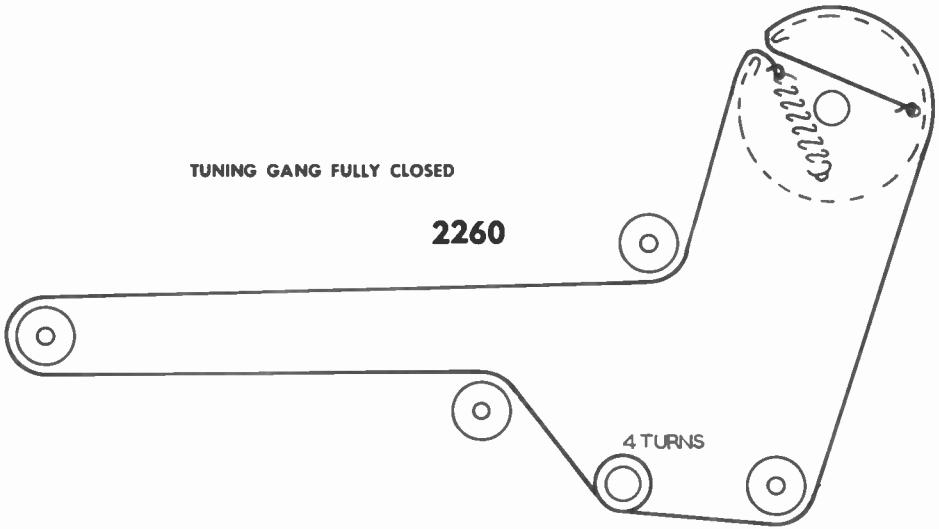

TUNING GANG FULLY CLOSED

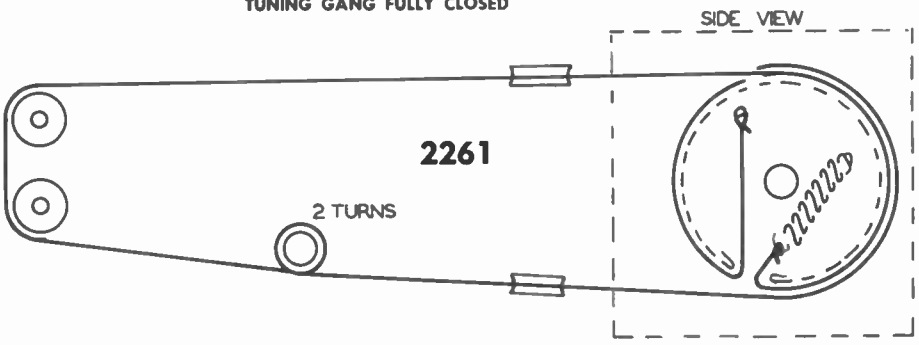

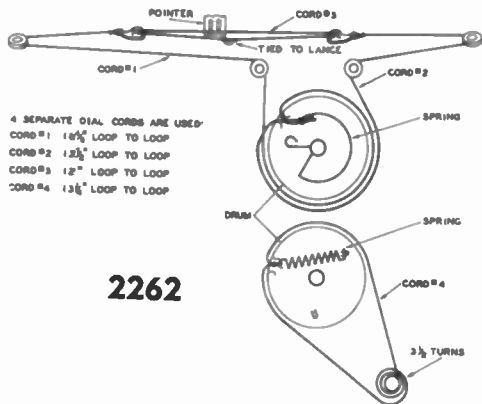

4 SEPARATE GIAL CORDS ARE USED:
 CORD #1: 18 1/2" LOOP TO LOOP
 CORD #2: 12 1/2" LOOP TO LOOP
 CORD #3: 12" LOOP TO LOOP
 CORD #4: 13 1/2" LOOP TO LOOP

2262

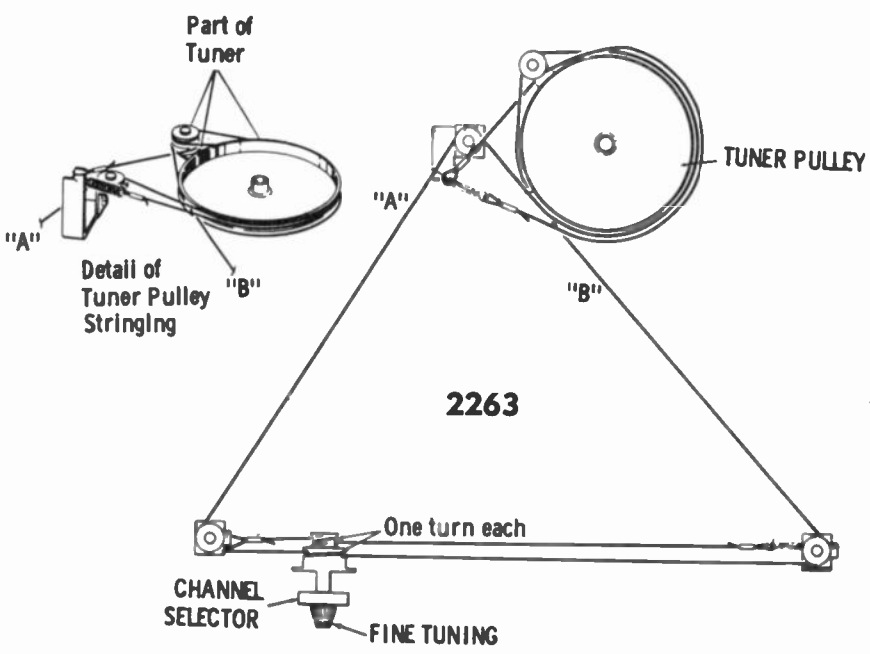

2263

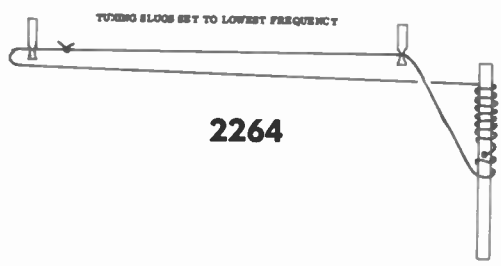

2264

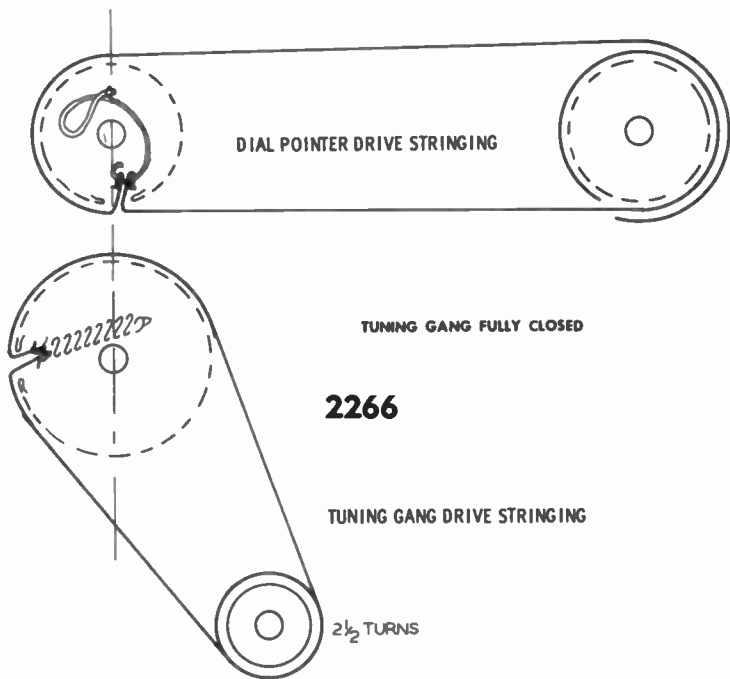
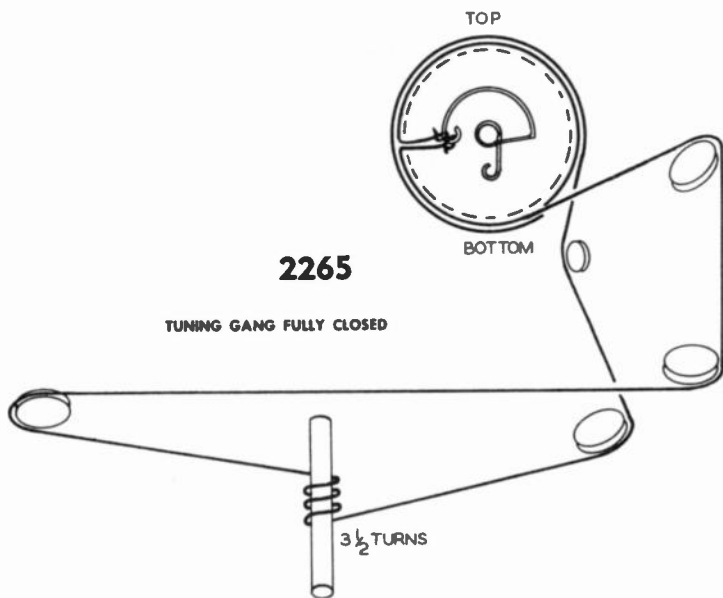

SIDE VIEW

TUNING GANG FULLY CLOSED

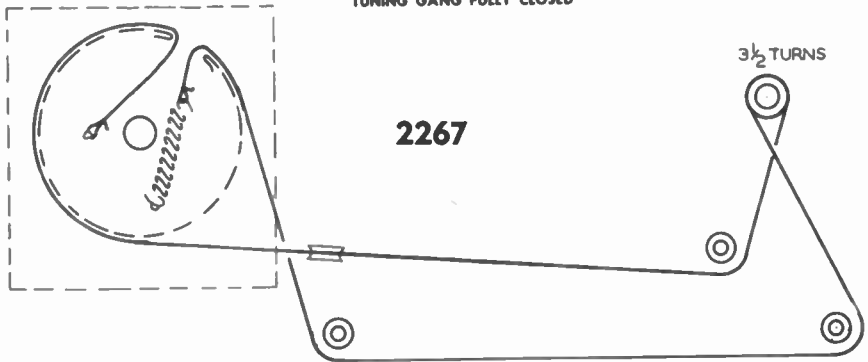

TUNING GANG FULLY CLOSED

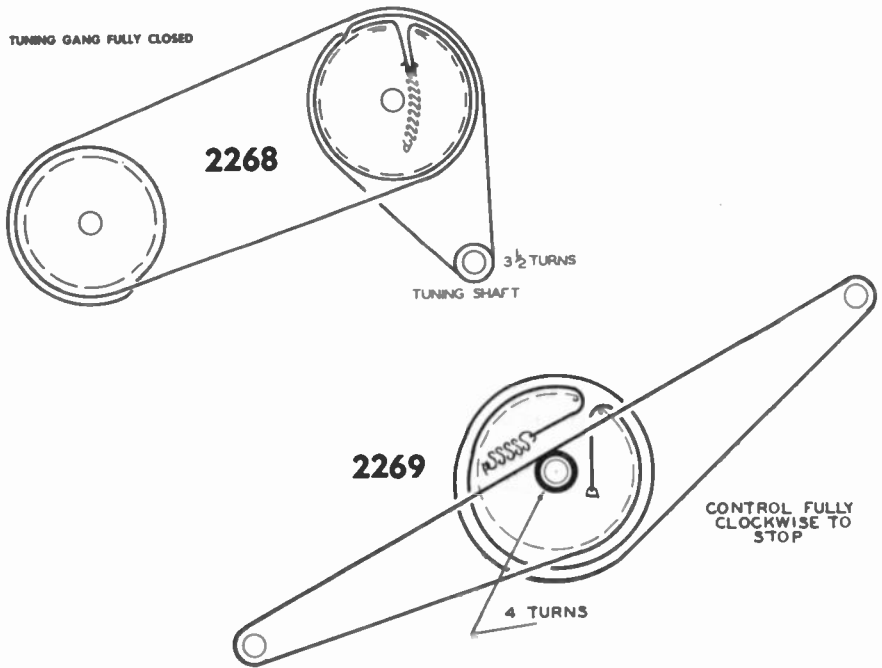

2269

CONTROL FULLY
CLOCKWISE TO
STOP

4 TURNS

TUNING GANG FULLY CLOSED

SIDE VIEW

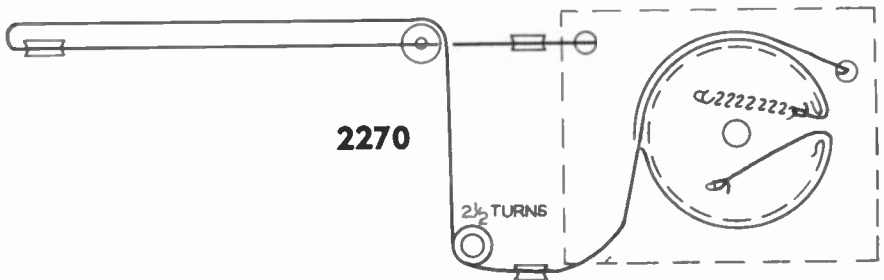

TUNING GANG FULLY CLOSED

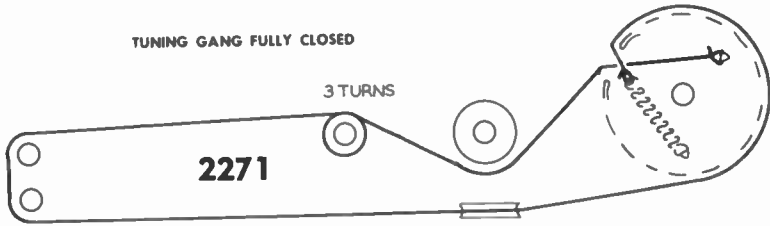

TUNING GANG FULLY CLOSED

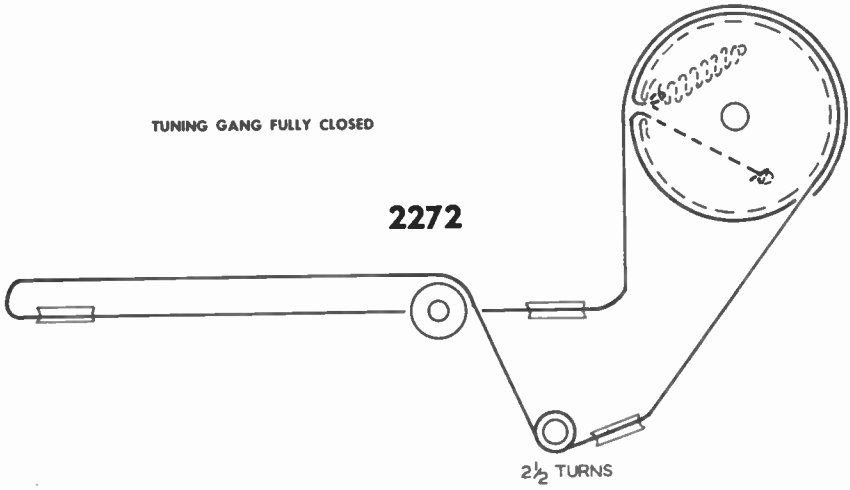

UHF PULLEY MAX. CLOCKWISE

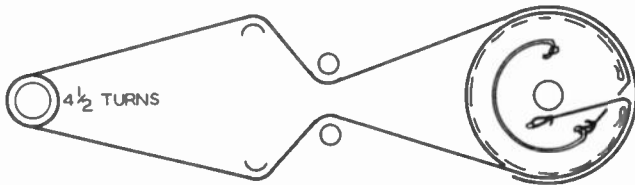

"REAR" UHF DIAL STRINGING (USED WITH VHF TUNER RJX-083)

UHF PULLEY FULLY COUNTER CLOCKWISE POSITION
WITH SMALL PULLEY TAB LOCATED AT 8 O'CLOCK.

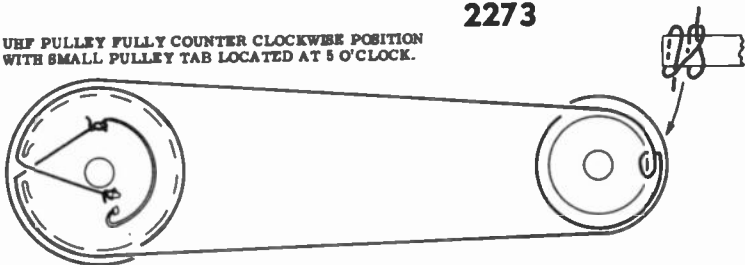

"FRONT" UHF DIAL STRINGING (USED WITH VHF TUNER RJX-083)

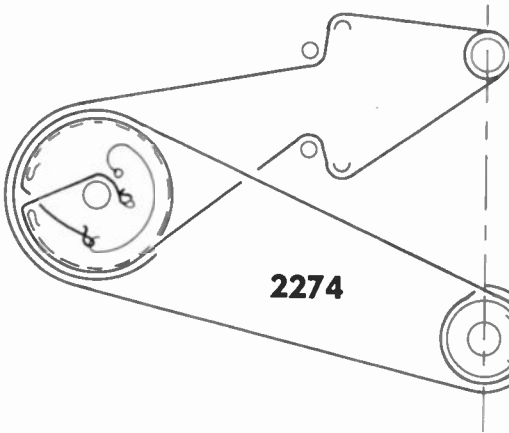

UHF PULLEY AT MAX. COUNTERCLOCKWISE POSITION AND WITH SMALL DRIVE PULLEY PLASTIC SLEEVE TAB AT 3 O'CLOCK

2274

CLOVE HITCH AROUND PLASTIC SLEEVE "DETAIL"

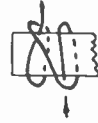

TUNING SLUGS SET TO LOWEST FREQUENCY.



TUNING SLUG CORE GUIDE BAR

2275

VOLUME CONTROL SHAFT

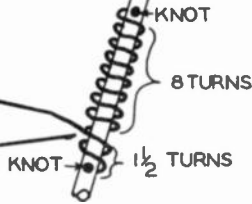

TUNING GANG FULLY CLOSED

2276

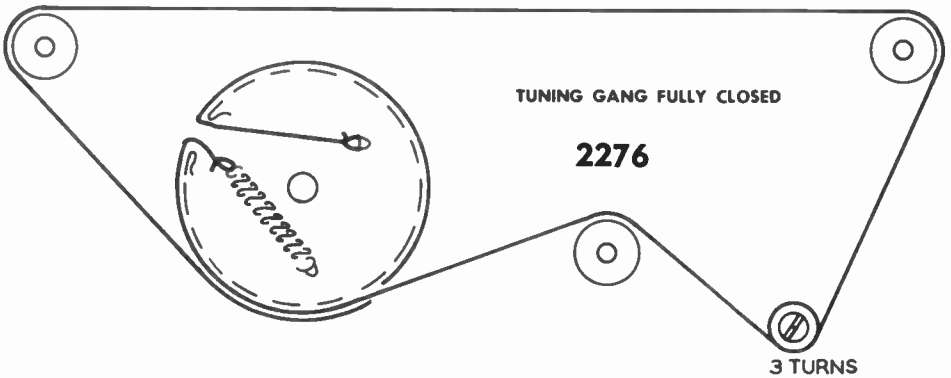

3 TURNS



TUNING GANG FULLY CLOSED



2277

TUNER PULLEY (A) IN EXTREME COUNTER-CLOCKWISE POSITION, AND PULLEY (B) POSITIONED WITH OPENING 45-DEGREES FROM VERTICAL AXIS.

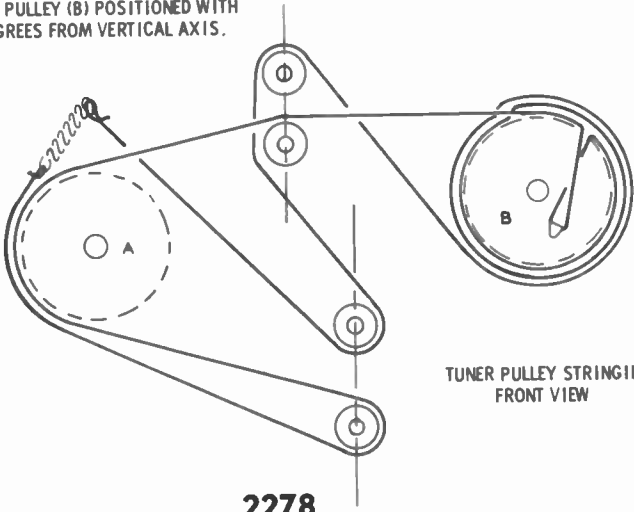

TUNER PULLEY STRINGING - FRONT VIEW

2278

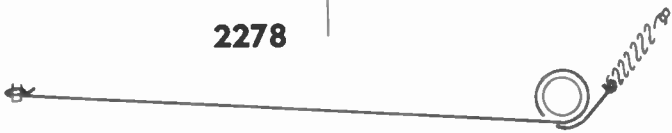

FINE TUNING PULLEY STRINGING - REAR VIEW

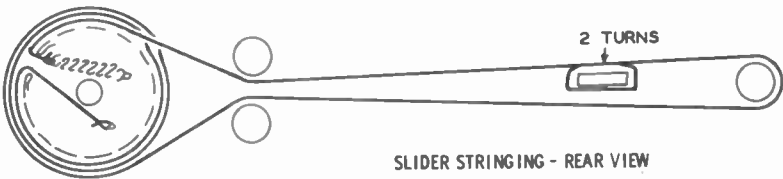

SLIDER STRINGING - REAR VIEW

AM TUNING GANG FULLY CLOSED & FM TUNING SLUGS SET TO LOWEST FREQUENCY.
KNOT TIED ON EACH END OF DIAL CORD PULLED INSIDE OF HOLES.

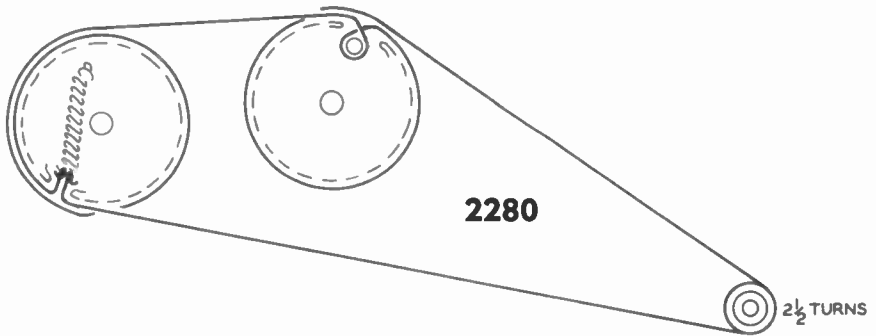
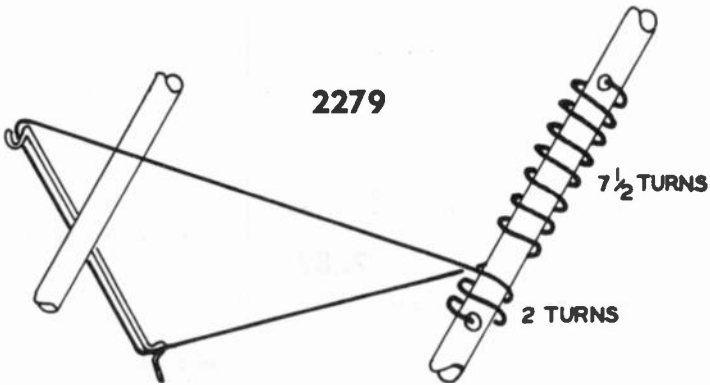

TUNING GANG FULLY CLOSED

AM TUNING GANG FULLY CLOSED AND FM TUNING SLUGS
SET TO LOWEST FREQUENCY.

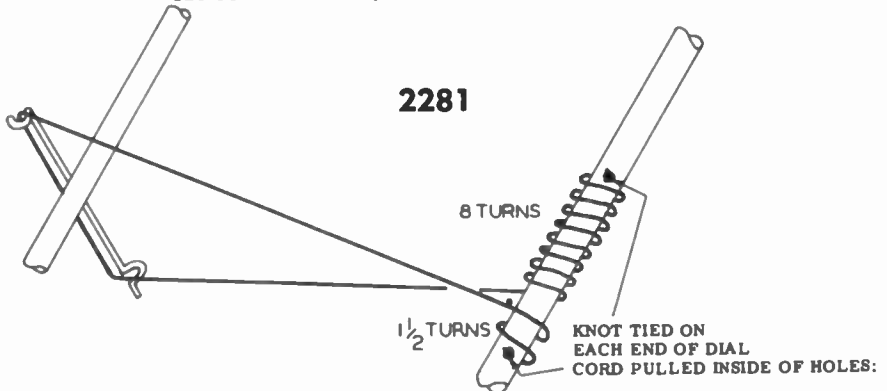

LENGTH OF CORD MEASURED FROM CORE TO CORE
OVER PULLEY : $3 \frac{2}{8}$ "

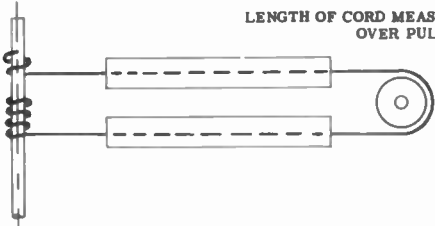

TUNING CORES SET TO
HIGHEST FREQ. SETTING

TUNING GANG FULLY CLOSED

2282

POINTER SET @ HIGH END OF DIAL SCALE

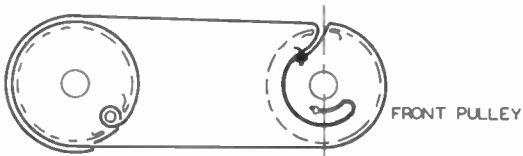
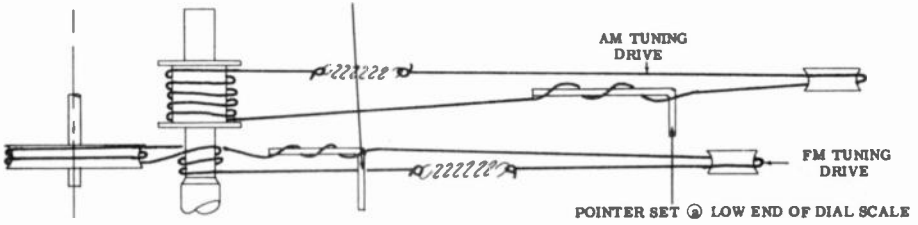

2283

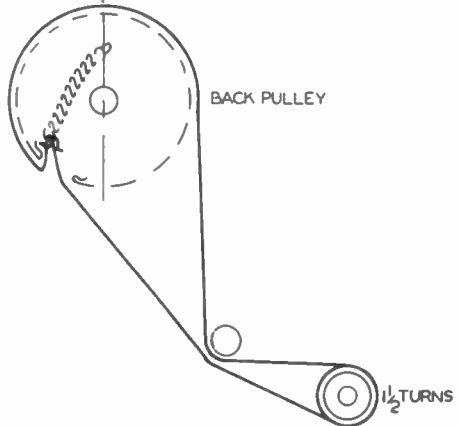

TUNING GANG FULLY CLOSED

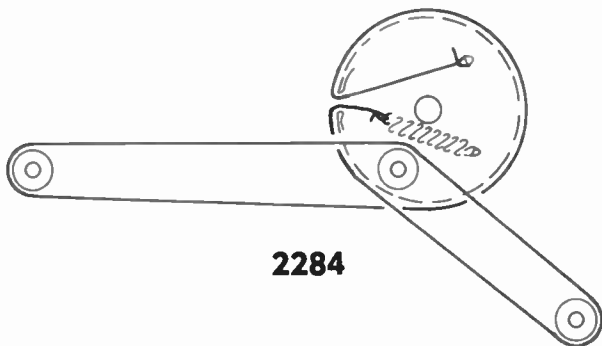

2284

TUNING GANG FULLY CLOSED

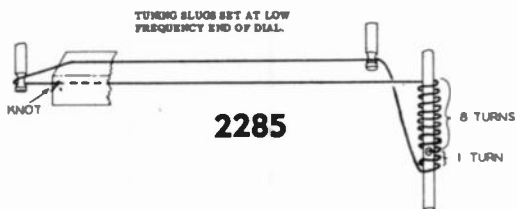

2285

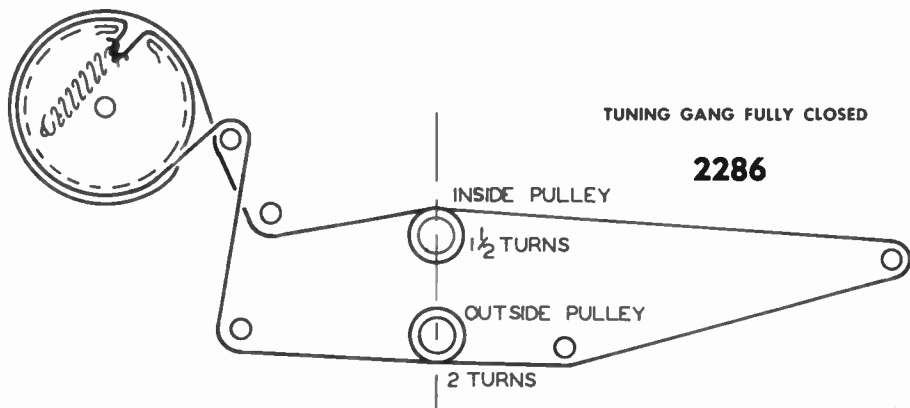

TUNING GANG FULLY CLOSED

2286

POSITION UHF DIAL WITH CHANNEL 45 MARKING CENTERED IN DIAL WINDOW BEFORE PLACING STRING AROUND UHF DIAL.

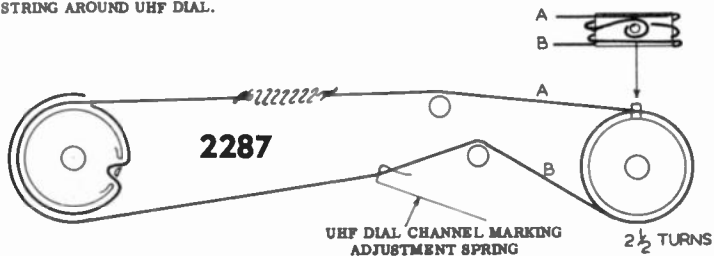

2287

UHF DIAL CHANNEL MARKING ADJUSTMENT SPRING

2 1/2 TURNS

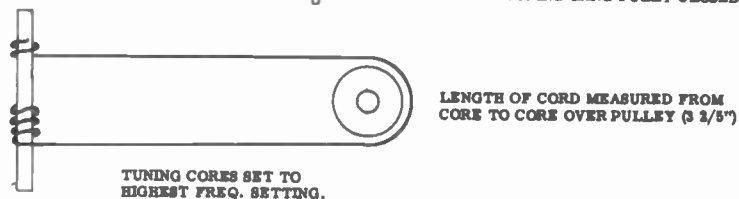
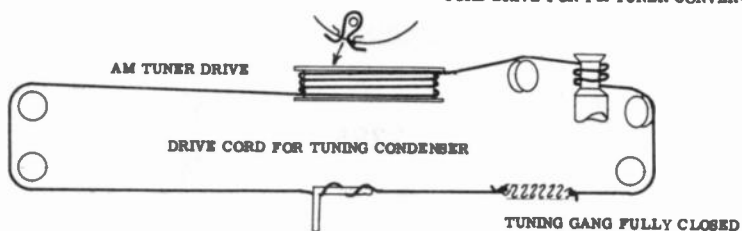
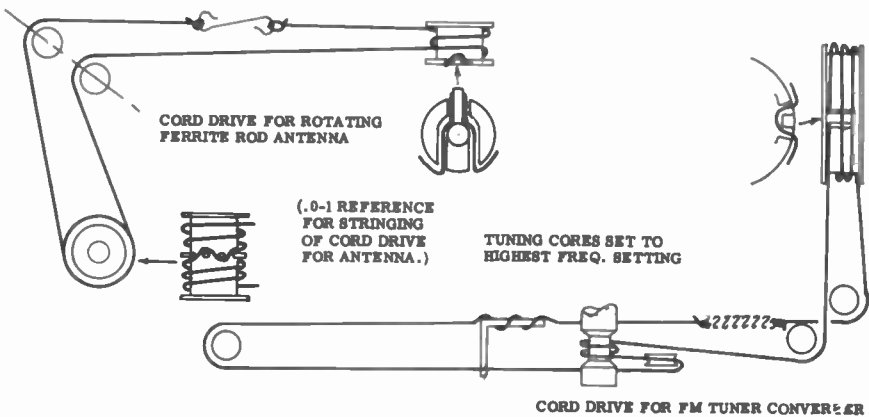

2288

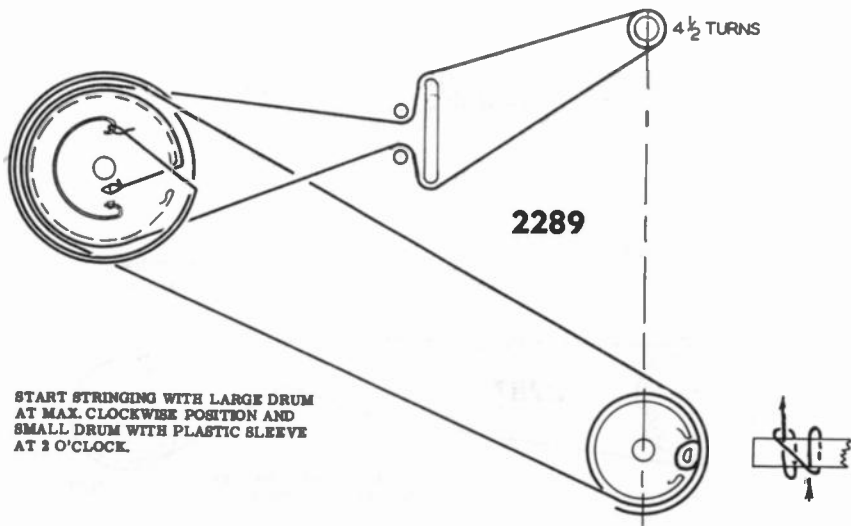

TUNING GANG FULLY CLOSED

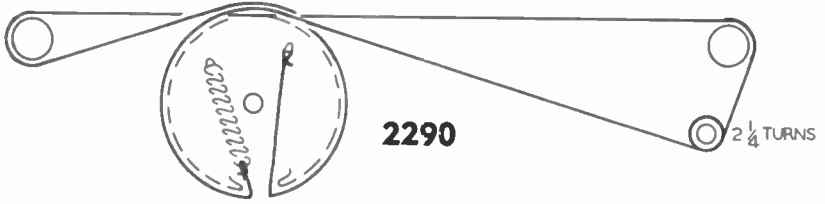

LENGTH OF CORD MEASURED FROM CORE TO CORE
OVER PULLEY: - 3 2/5"

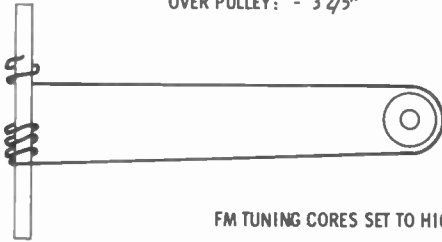

DRIVE-CORD WITH CORE IN THE F.M. - R.F. AND MIXER-STAGE

2291

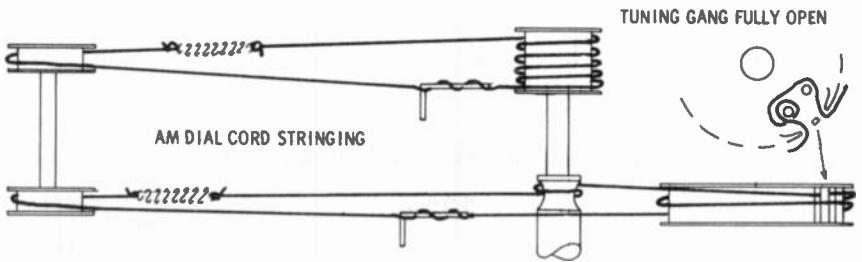

FM TUNING CORES SET TO HIGHEST FREQ. SETTING

TUNING GANG FULLY CLOSED

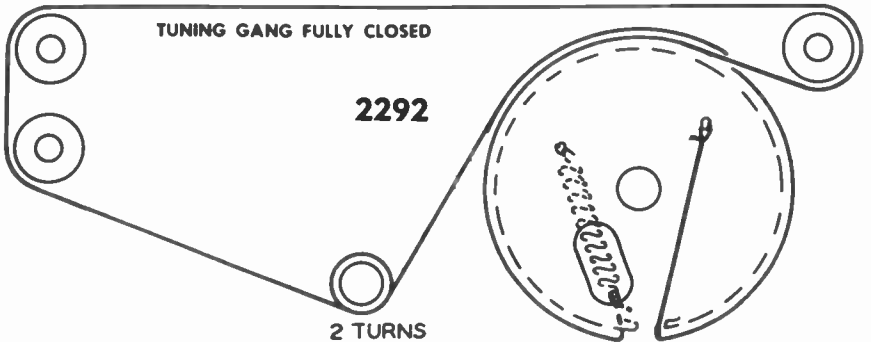

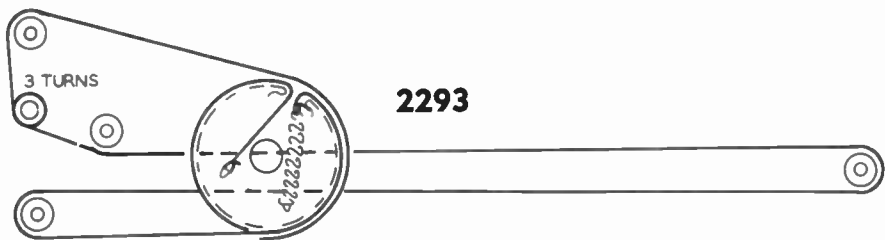

2293

TUNING GANG FULLY CLOSED

TUNING CORES SET TO LOWEST FREQUENCY SETTING.

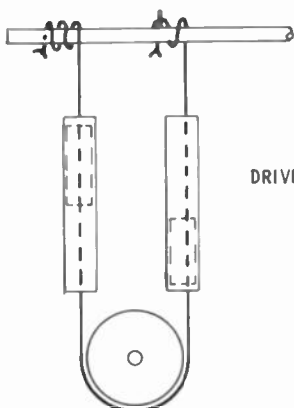

DRIVE CORD FOR FM TUNING CORES

LENGTH OF CORD MEASURED FROM CORE TO CORE OVER PULLEY - 3 2/5"

2294

TUNING GANG FULLY CLOSED

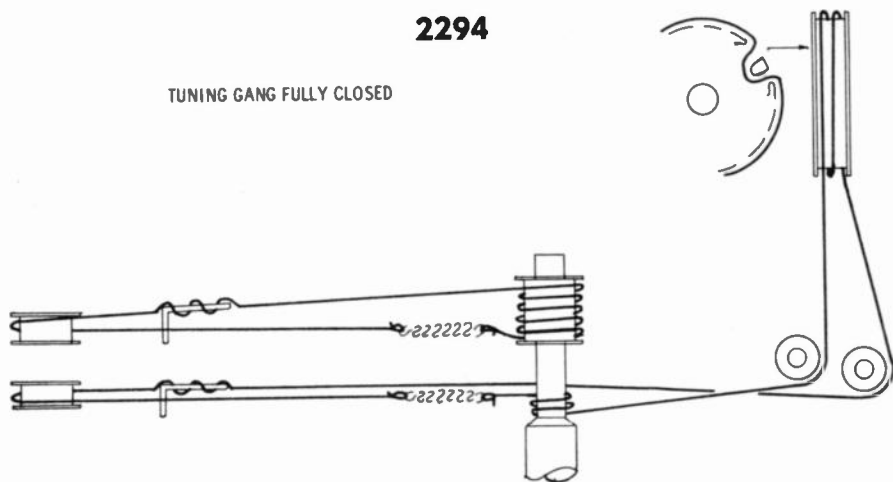

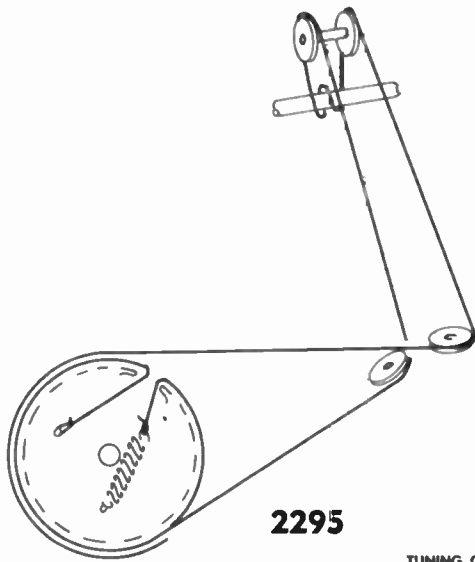

2295

TUNING GANG FULLY CLOSED

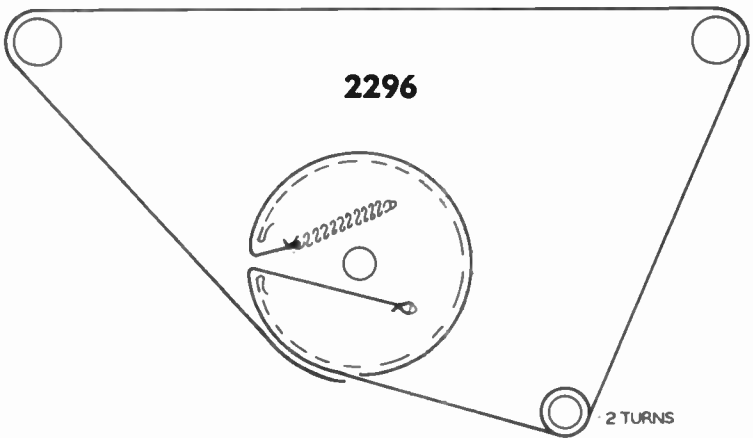

2296

2 TURNS

TUNING GANG FULLY CLOSED

TUNING GANG FULLY CLOSED

2297

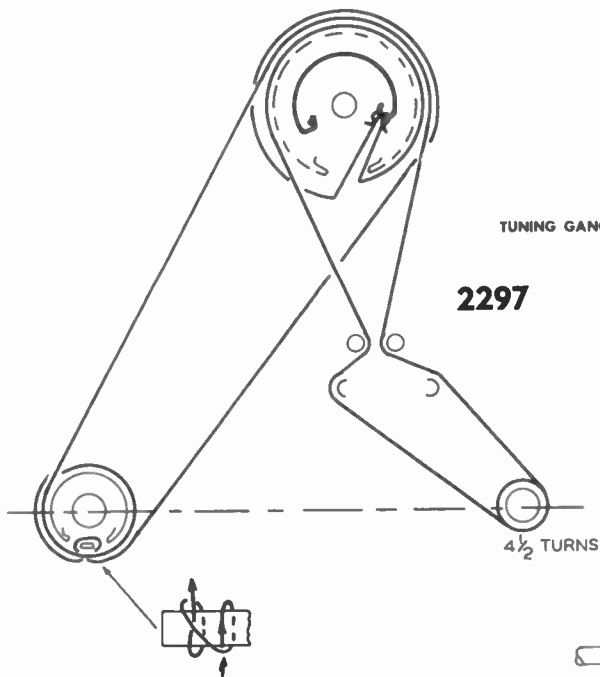

TUNING GANG FULLY CLOSED

2298

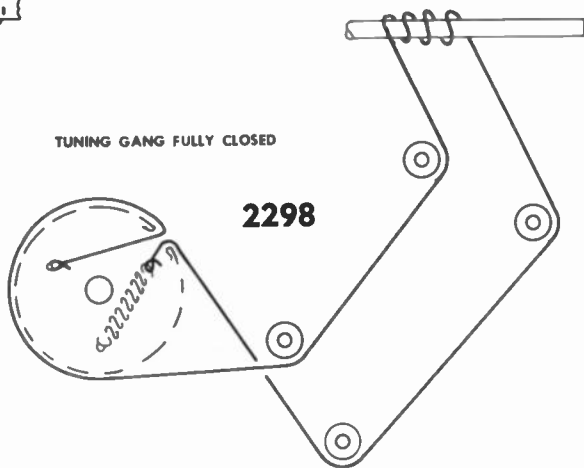

2299

2 TURNS

TUNING GANG FULLY CLOSED

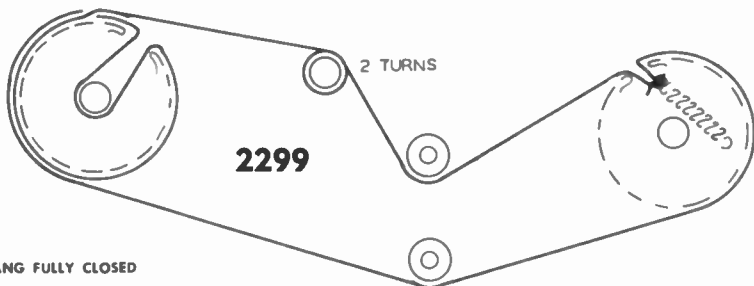

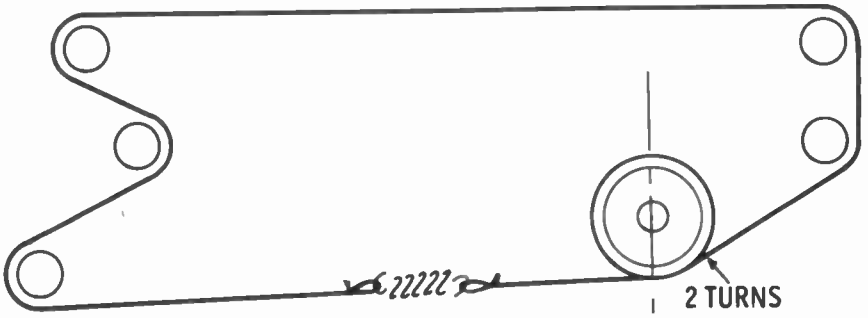

2300

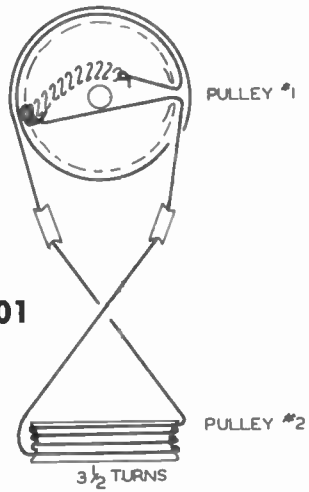
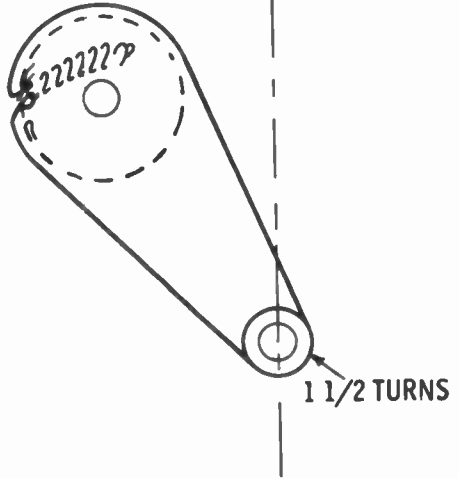

2301

FINE TUNING SHAFT & PULLEY #1 IN MAX. CLOCKWISE POSITION.

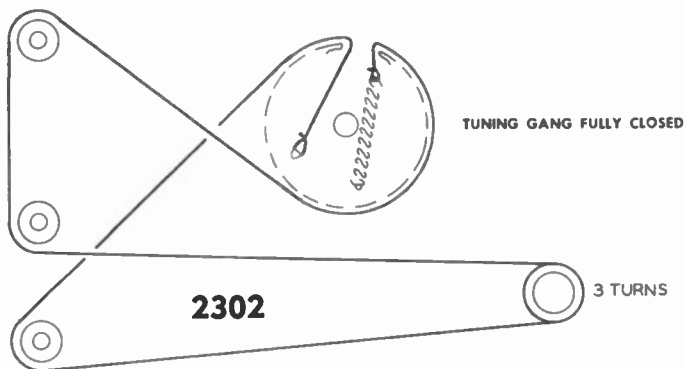

UHF TUNING PULLEYS

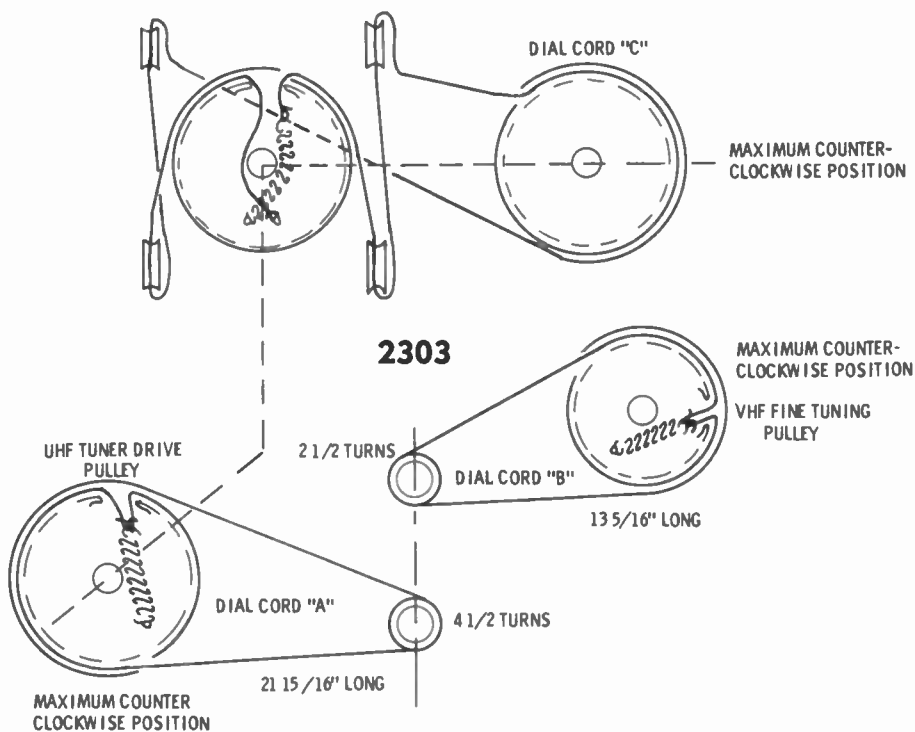

TUNING SLUGS SET AT LOWEST FREQUENCY.

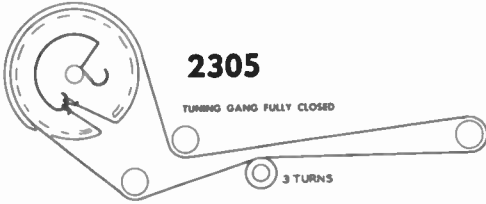
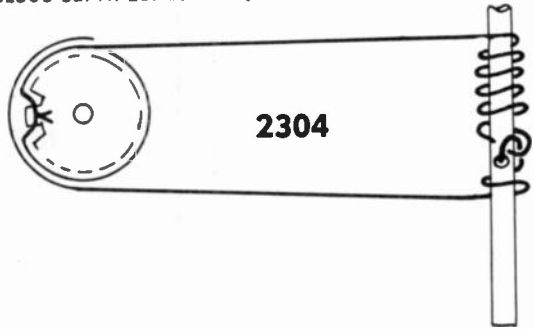

SLUGS TO BE FULLY DISENGAGED
AM TUNING GANG FULLY OPEN

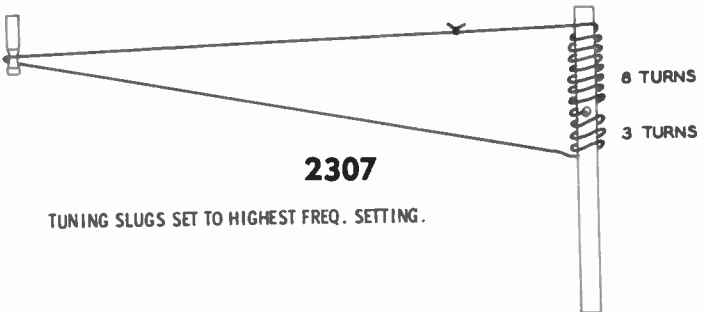
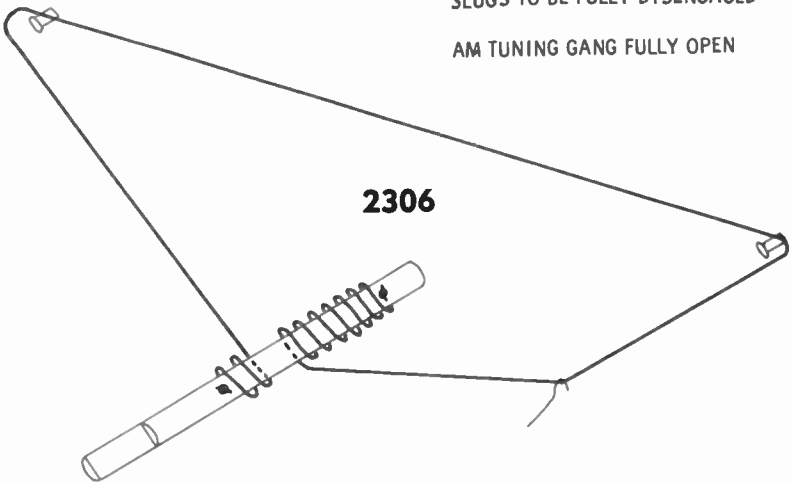

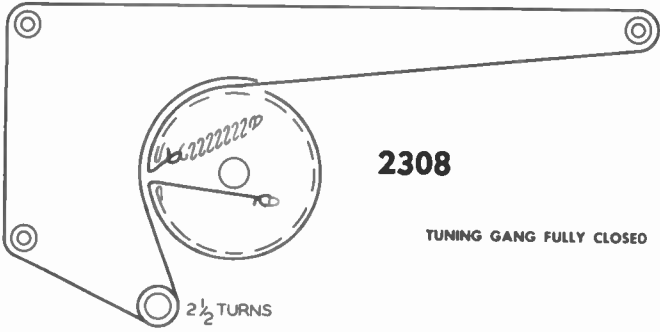

2308

TUNING GANG FULLY CLOSED

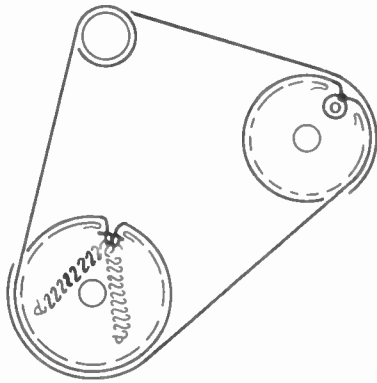

2309

EARLY PRODUCTION VERSIONS

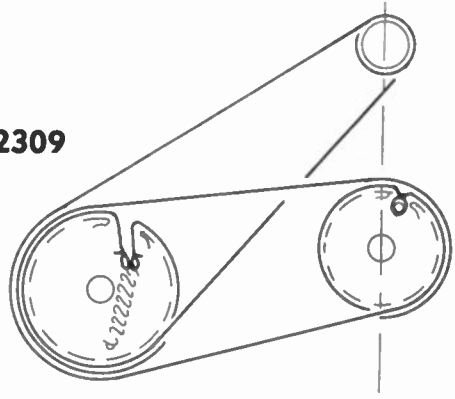

LATER PRODUCTION VERSIONS

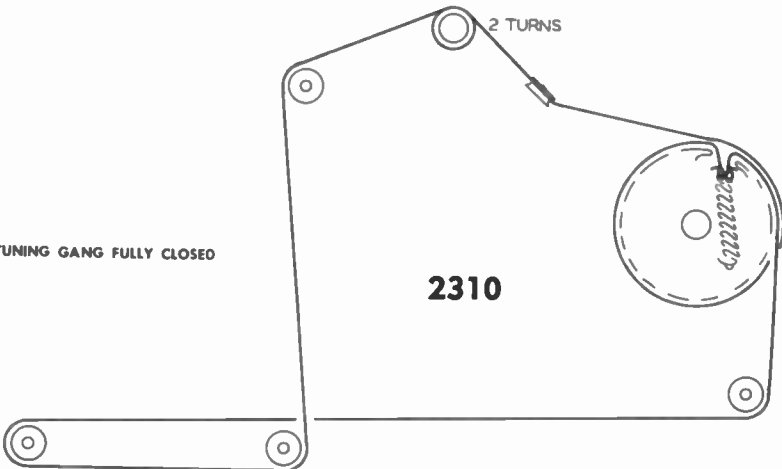

TUNING GANG FULLY CLOSED

2310

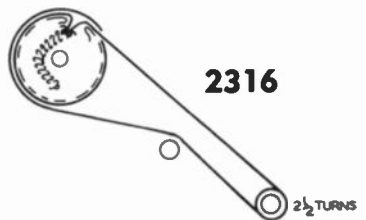
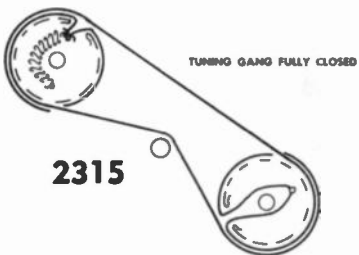
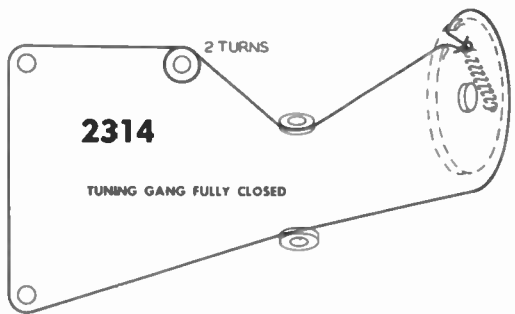
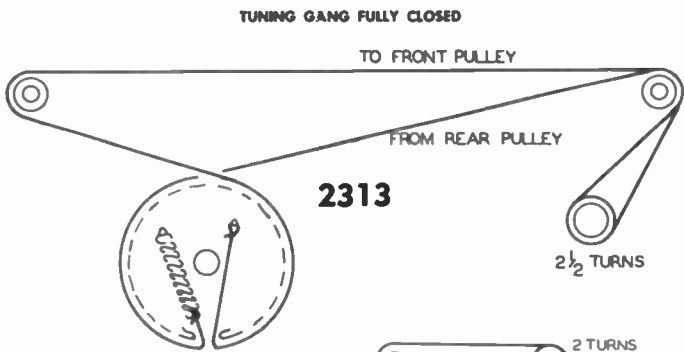
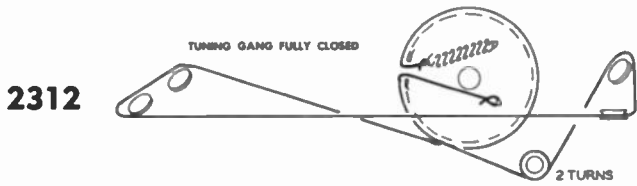
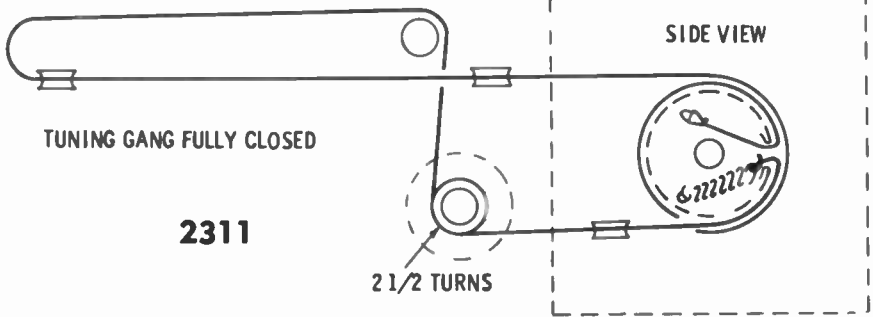

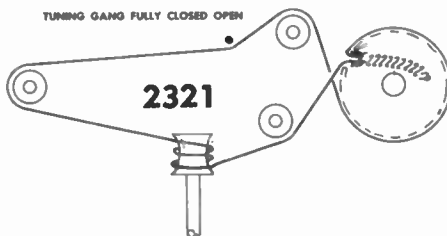
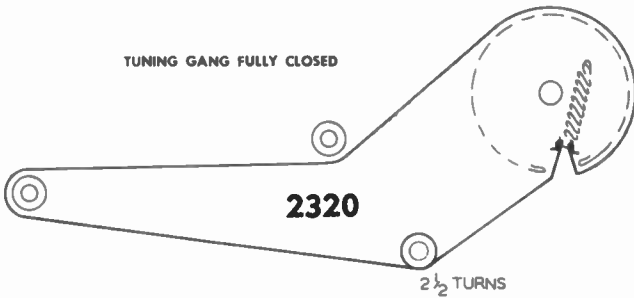
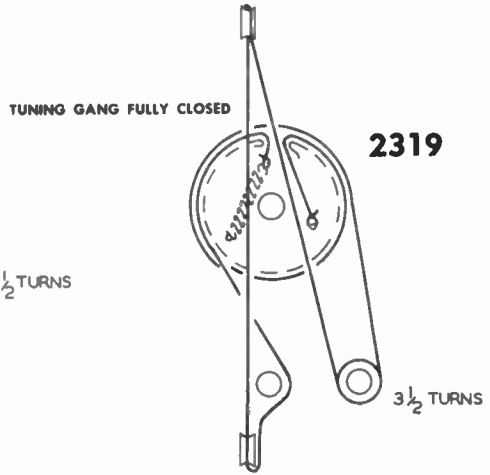
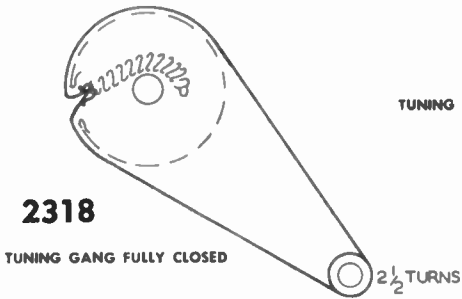
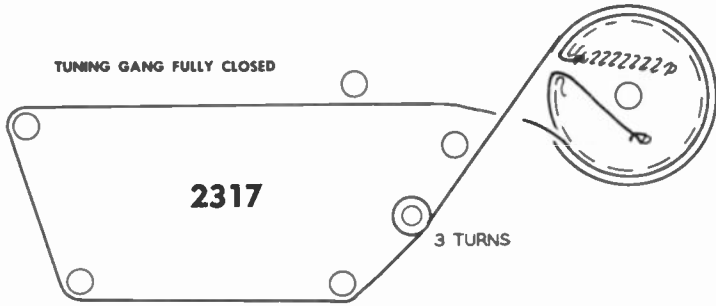

DIAL CORD PULLEY

FINE TUNING SHAFT

2322



FINE TUNING ROTOR SET MIDWAY

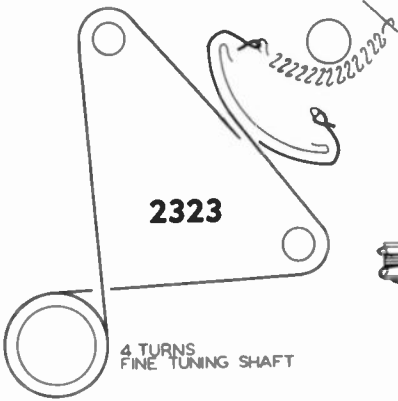

2324

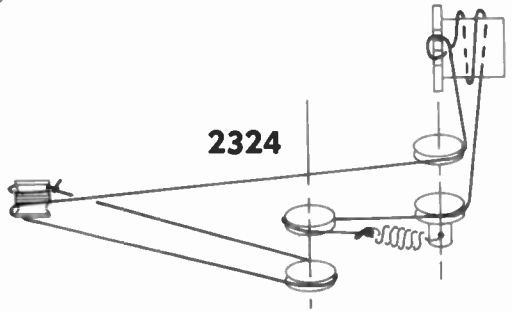

1 1/2 TURNS

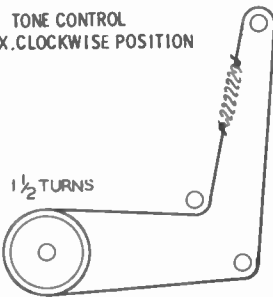

2325

TUNING GANG FULLY CLOSED

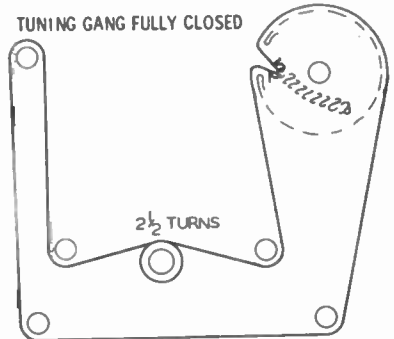

TONE DIAL CORD

TUNING DIAL CORD

TUNING GANG FULLY CLOSED

2326

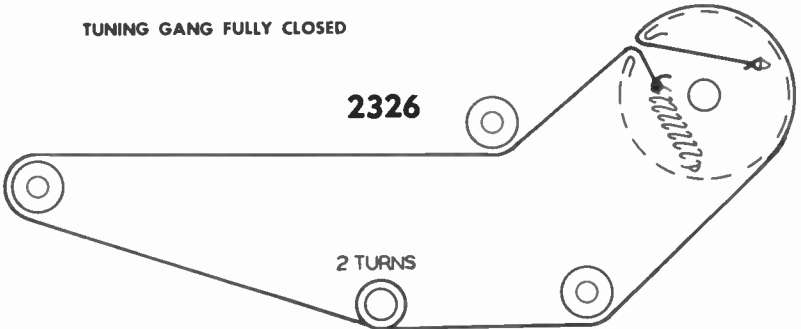

TURN FINE TUNING SHAFT WITH
PULLEY P1 FULLY CLOCKWISE

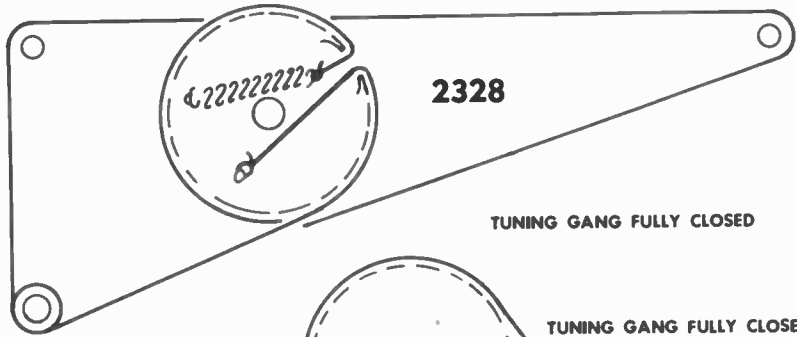
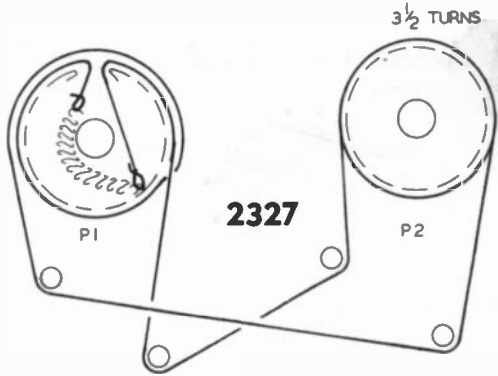

TUNING GANG FULLY CLOSED

3 1/2 TURNS

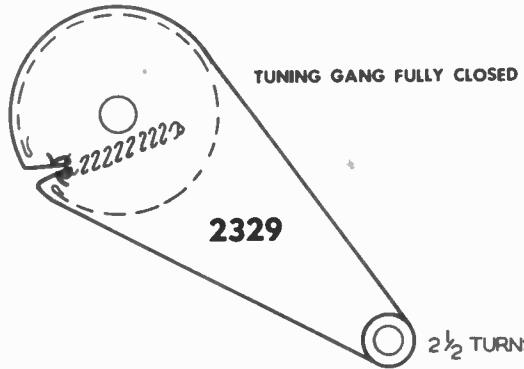

TUNING GANG FULLY CLOSED

2 1/2 TURNS

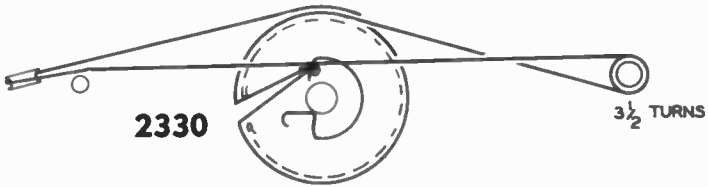

3 1/2 TURNS

TUNING GANG FULLY CLOSED

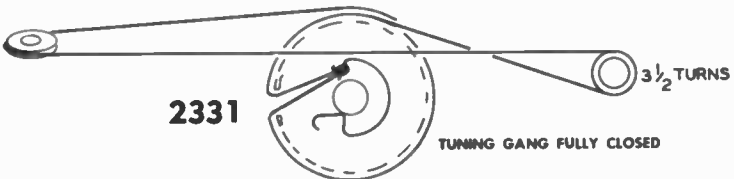

3 1/2 TURNS

TUNING GANG FULLY CLOSED

TUNING GANG FULLY CLOSED

2332

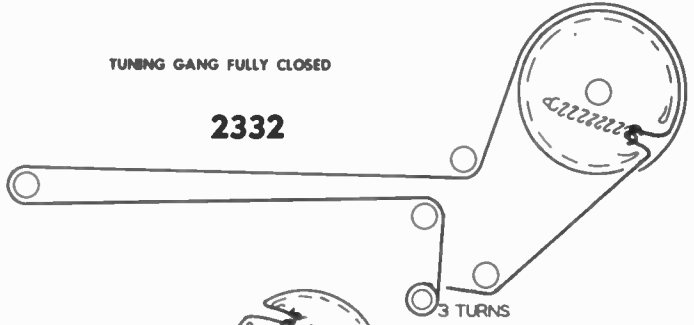

TUNING GANG FULLY CLOSED

2333

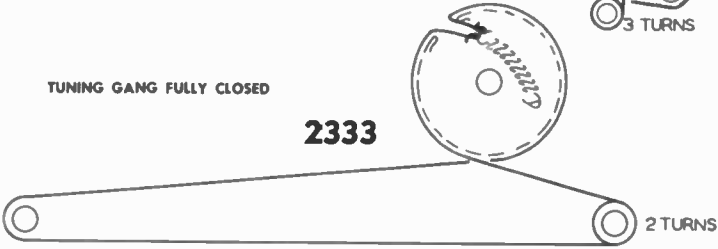

TUNING GANG FULLY CLOSED

2334

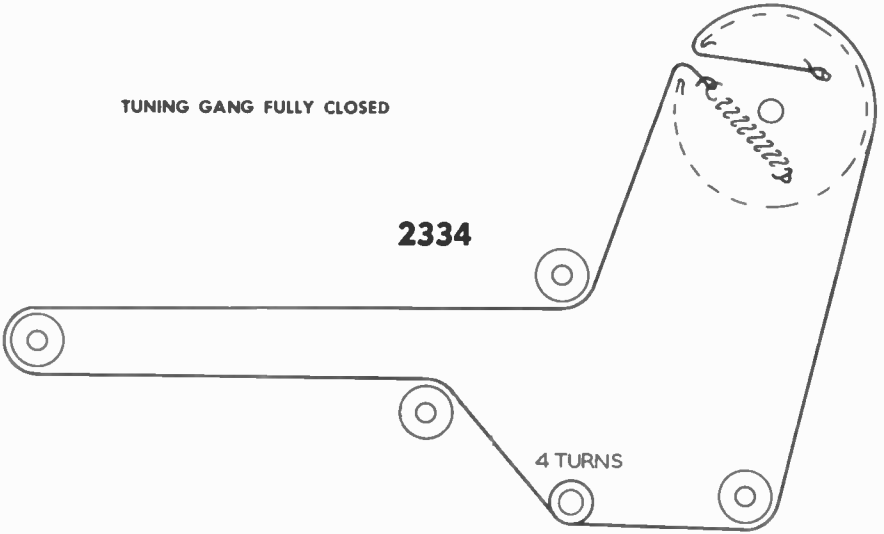

TUNING GANG FULLY CLOSED

2335



2336

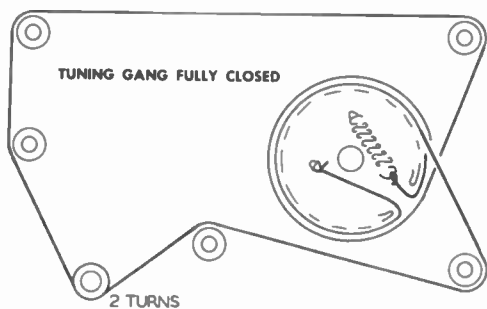
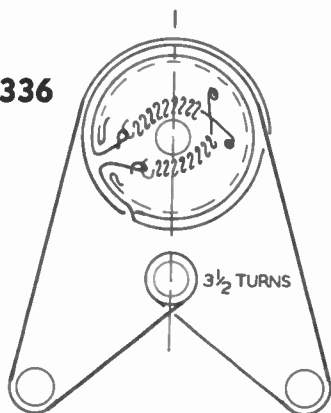

FIG. 1 STRINGING OF TUNING CONTROL

2337

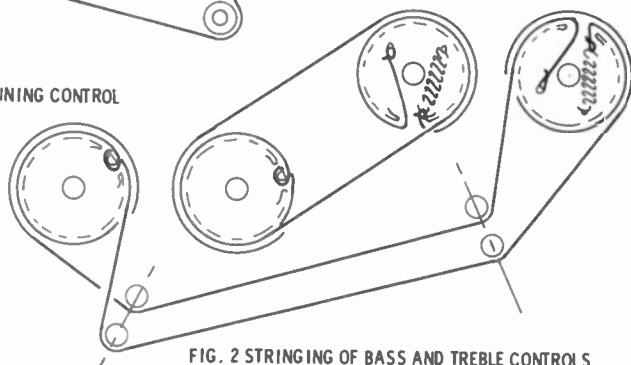

FIG. 2 STRINGING OF BASS AND TREBLE CONTROLS

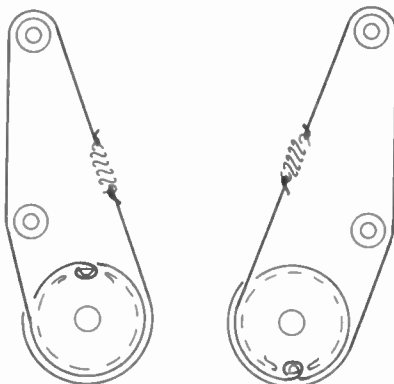
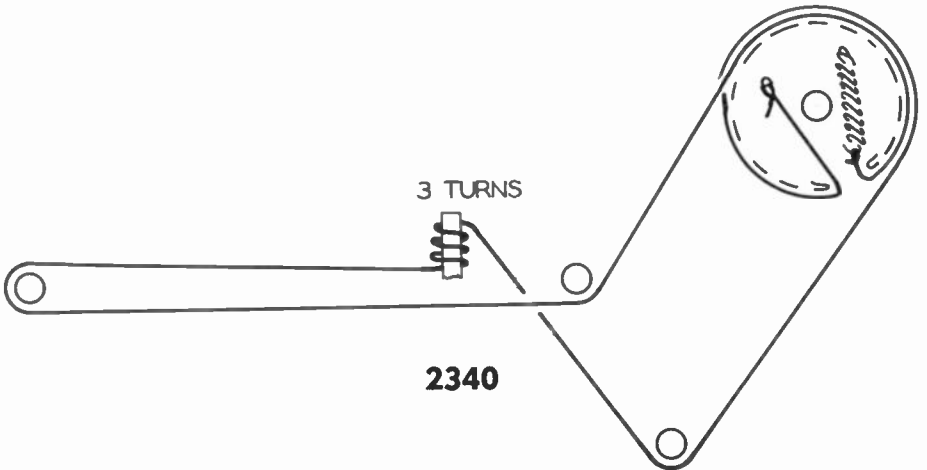
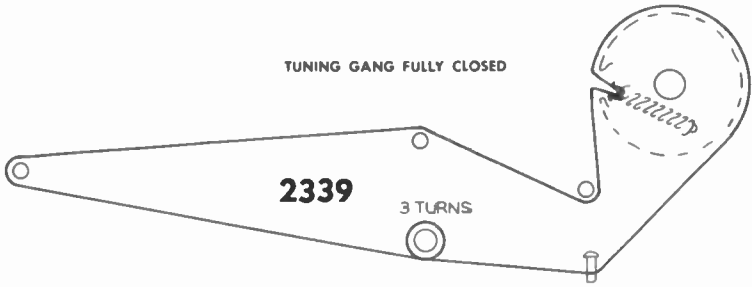
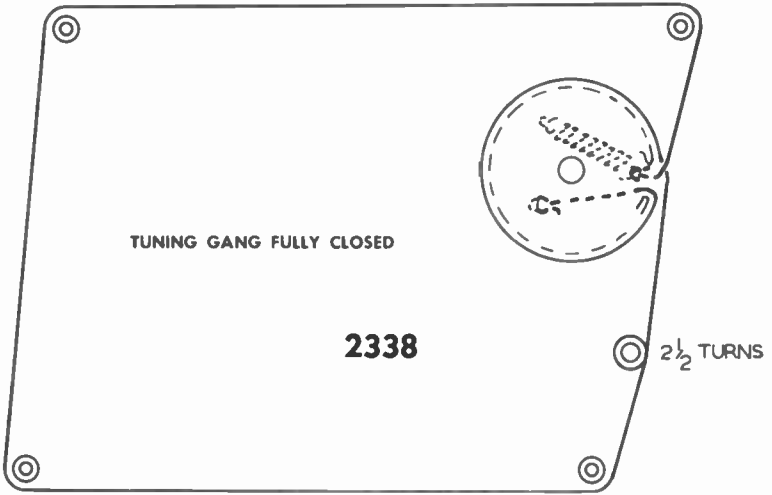
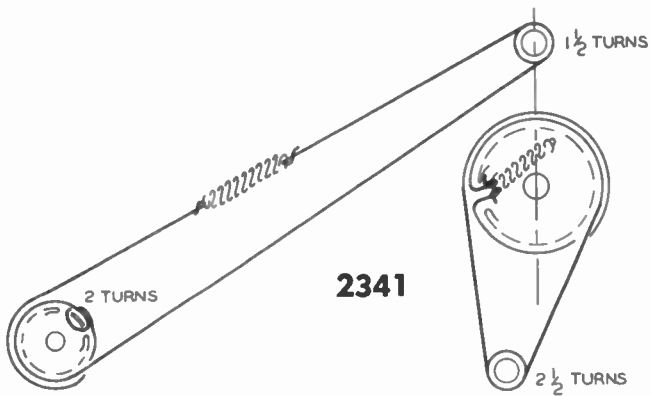
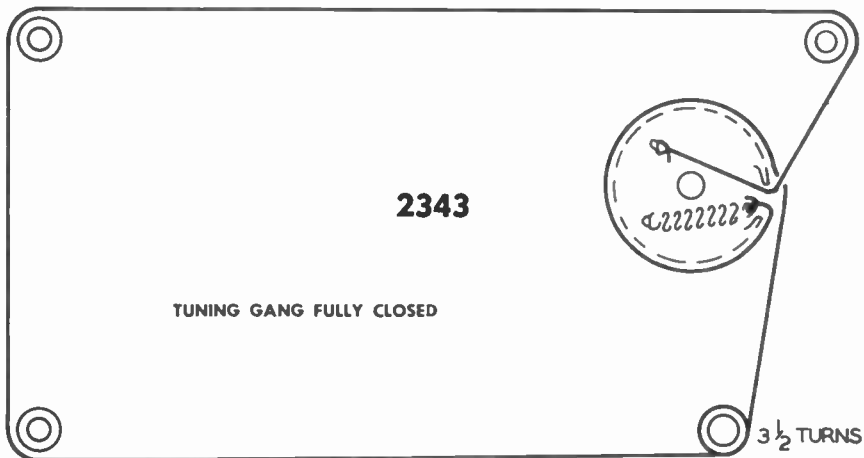
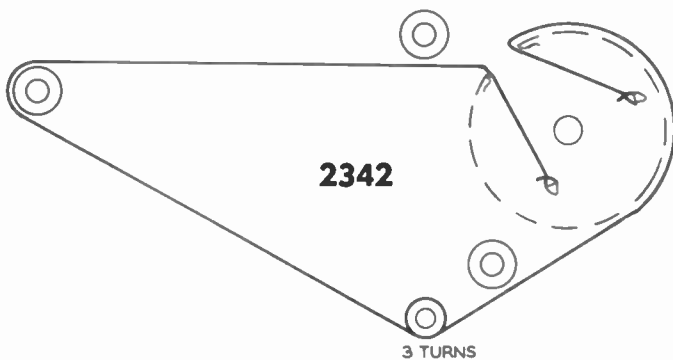

FIG. 3 STRINGING OF BASS & TREBLE POINTERS





TUNING GANG FULLY CLOSED



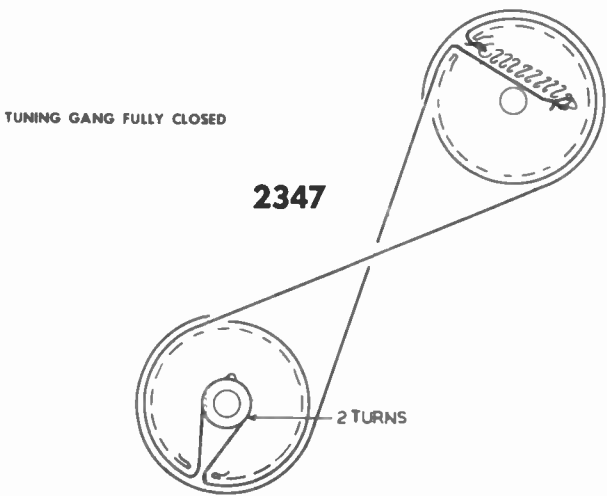
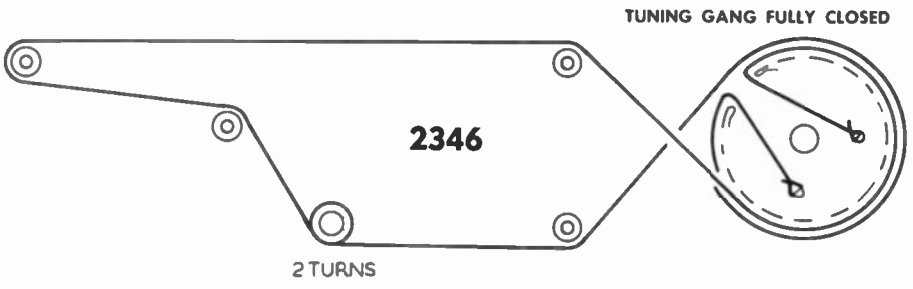
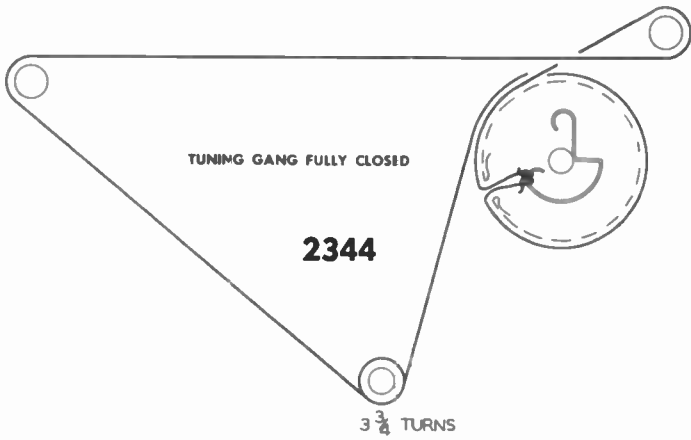

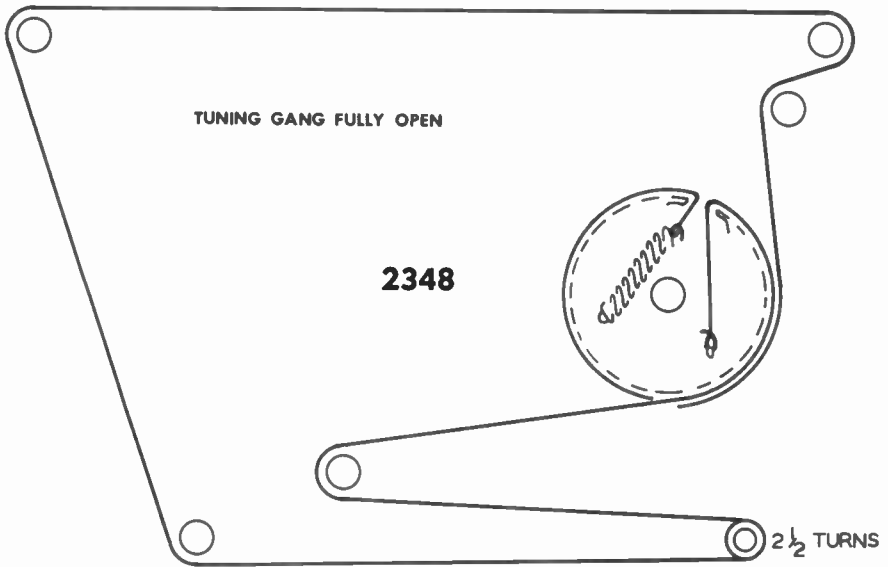

START RE-STRINGING WITH LARGE UHF PULLEY IN MAX. COUNTER-CLOCKWISE POSITION (AS VIEWED FROM FRONT OF TUNER.)

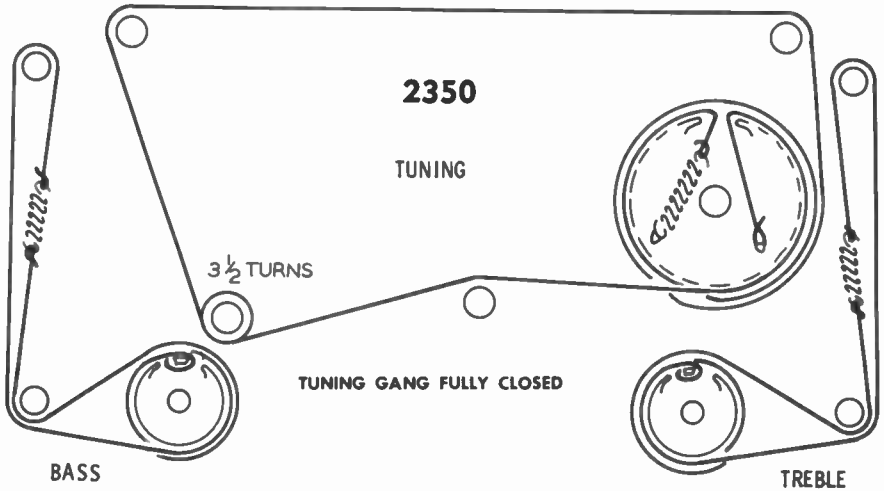
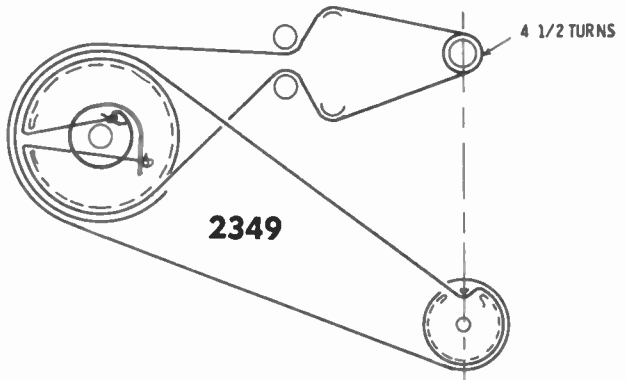

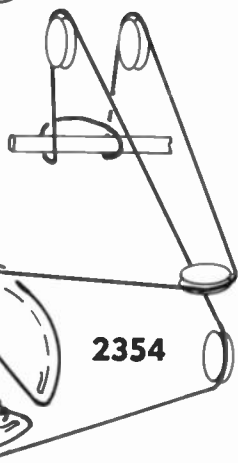
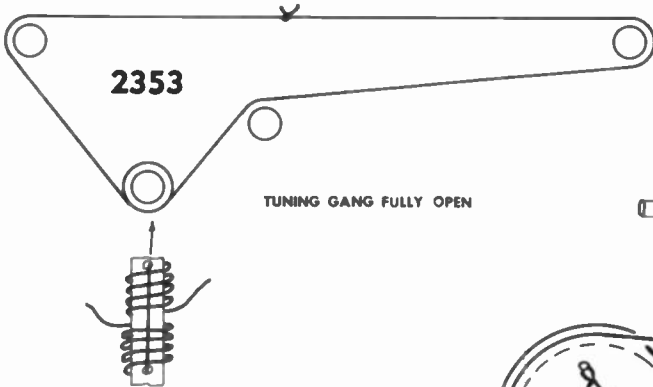
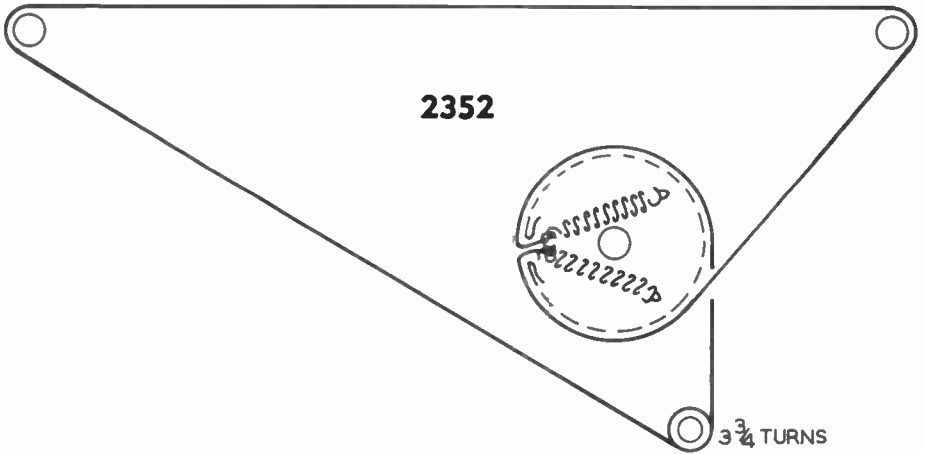
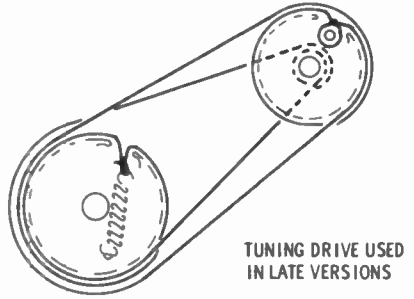
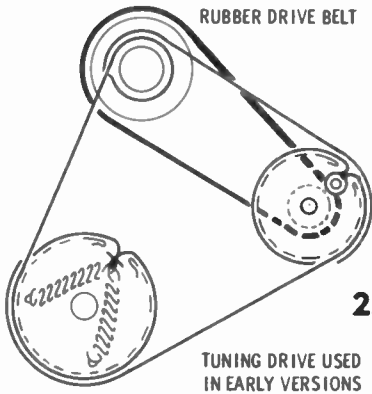

SLUG MOUNTING MUST BE ALL THE WAY OUT
EXTREME LOW FREQUENCY POSITION

2355

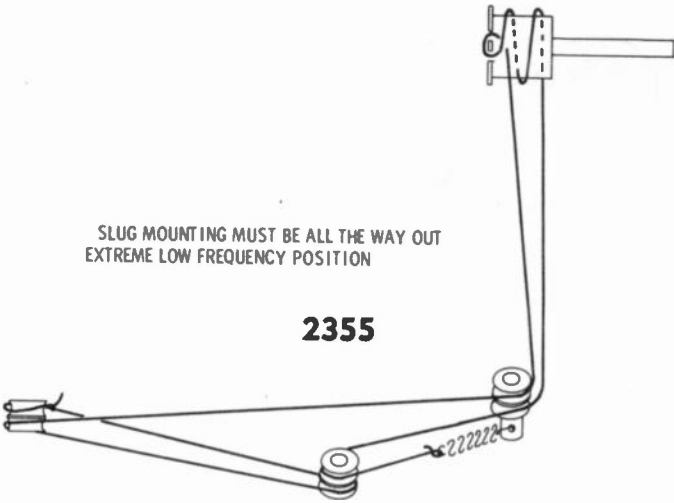

2356

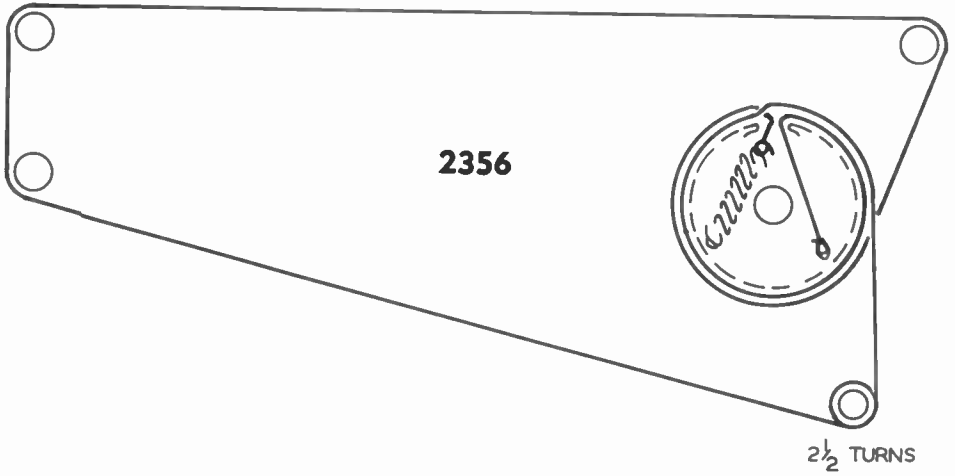

2357

TUNING GANG FULLY CLOSED

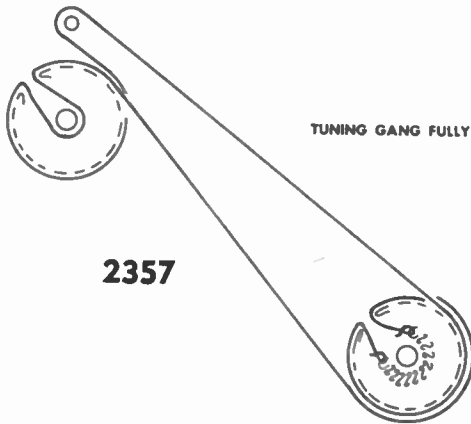

START RE-STRINGING WITH LARGE UHF PULLEY IN MAX COUNTER-CLOCKWISE POSITION (AS VIEWED FROM FRONT OF TUNER).

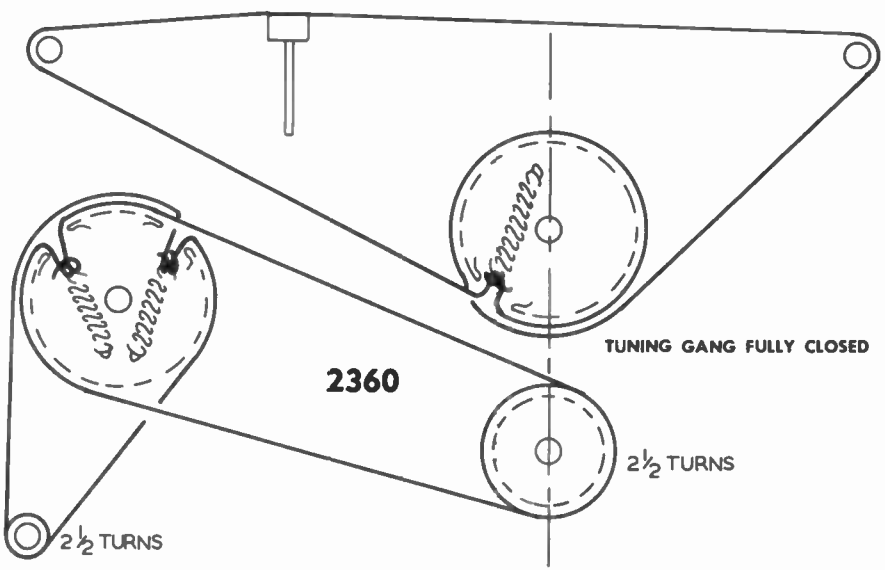
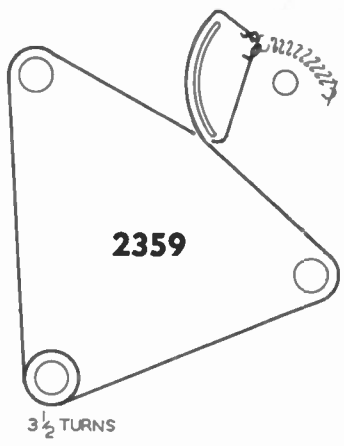
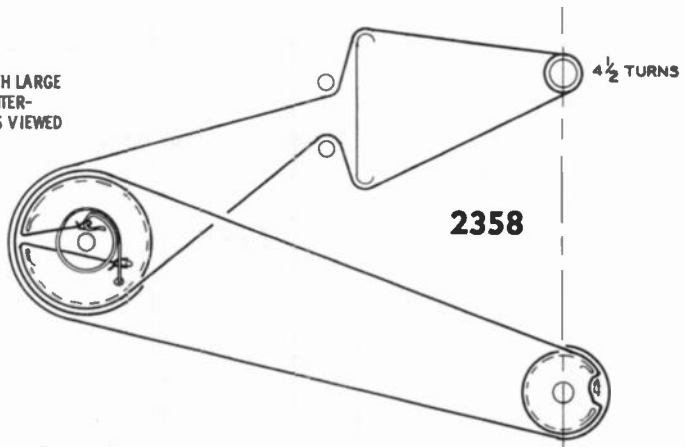

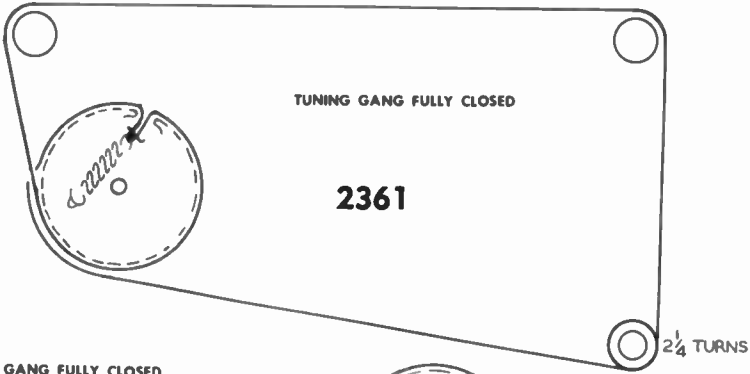

TUNING GANG FULLY CLOSED

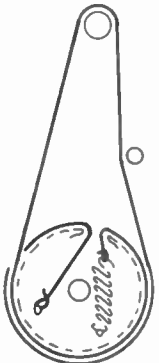
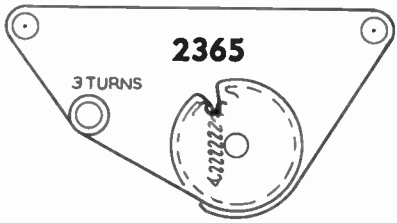
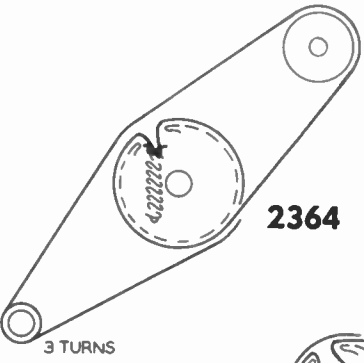
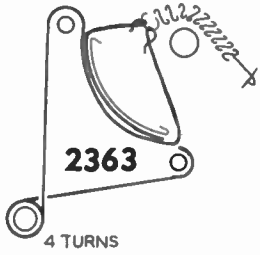
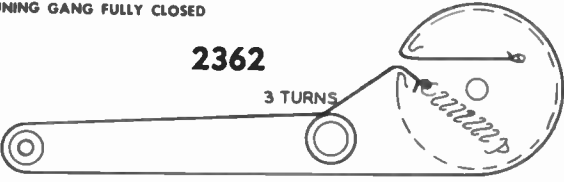

TUNING GANG FULLY CLOSED

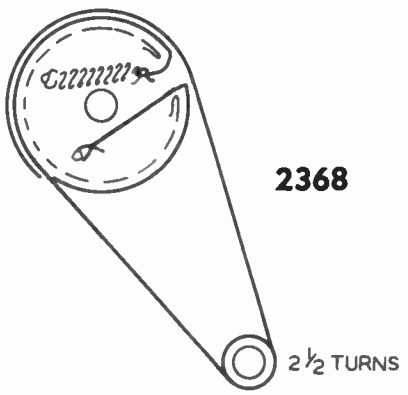



TUNING GANG FULLY CLOSED

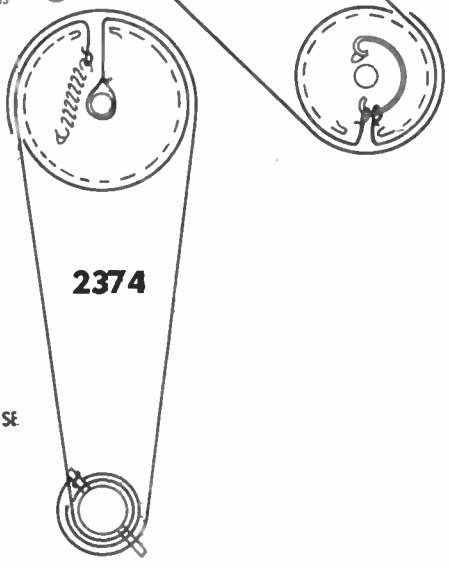
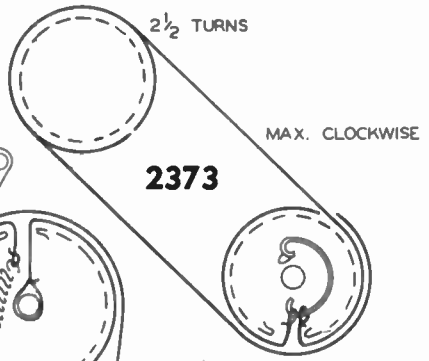
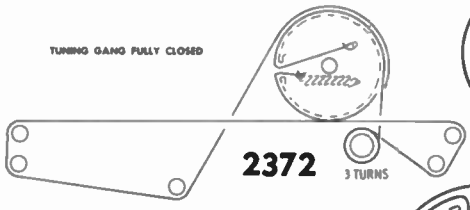
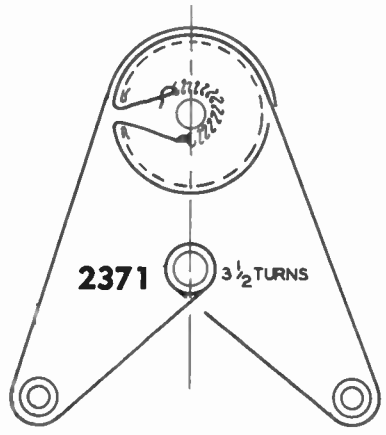
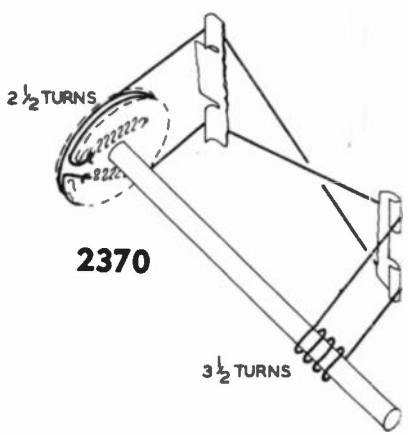

TURN BOTH FINE TUNING CAM
AND UHF PULLEY FULLY COUNTER-CLOCKWISE

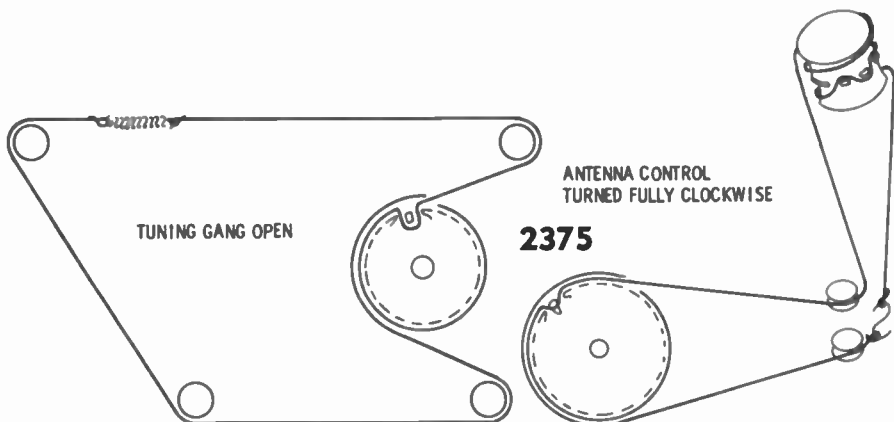

TUNING GANG OPEN

ANTENNA CONTROL
TURNED FULLY CLOCKWISE

2375

AM DIAL CORD

FM DIAL CORD

ANTENNA DIAL CORD

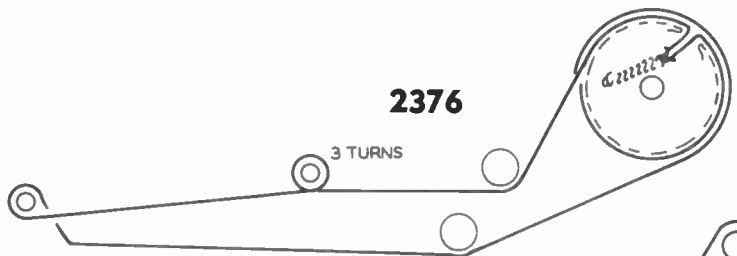

2376

3 TURNS

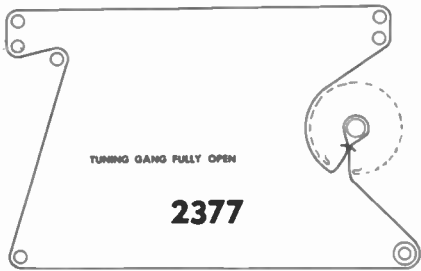

TUNING GANG FULLY OPEN

2377

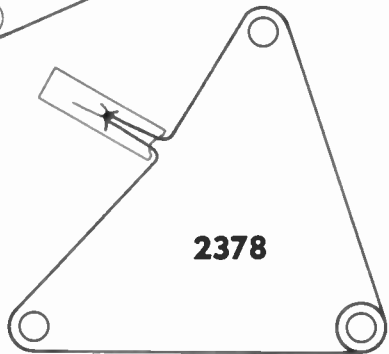

2378

2½ TURNS

TUNING GANG APPROX. 1/3 OPEN

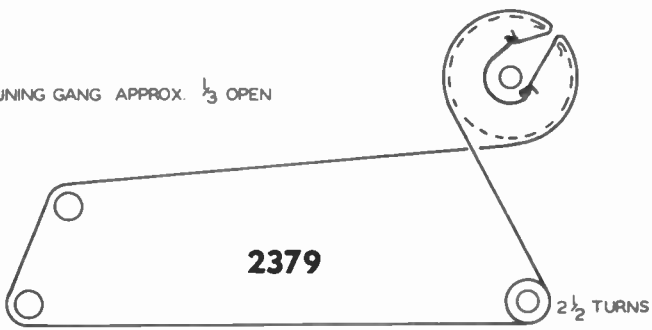

2379

2½ TURNS

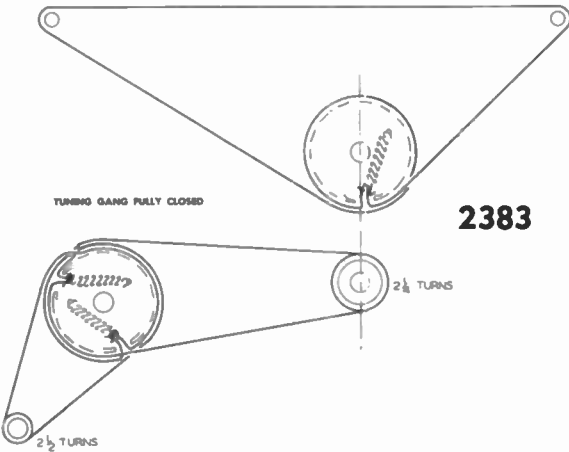
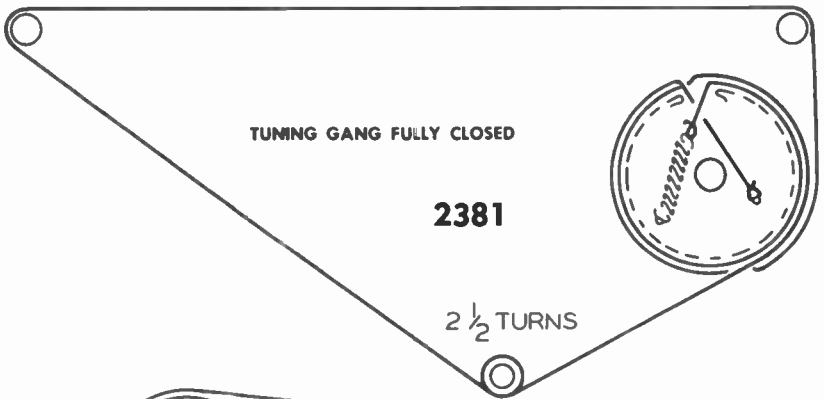
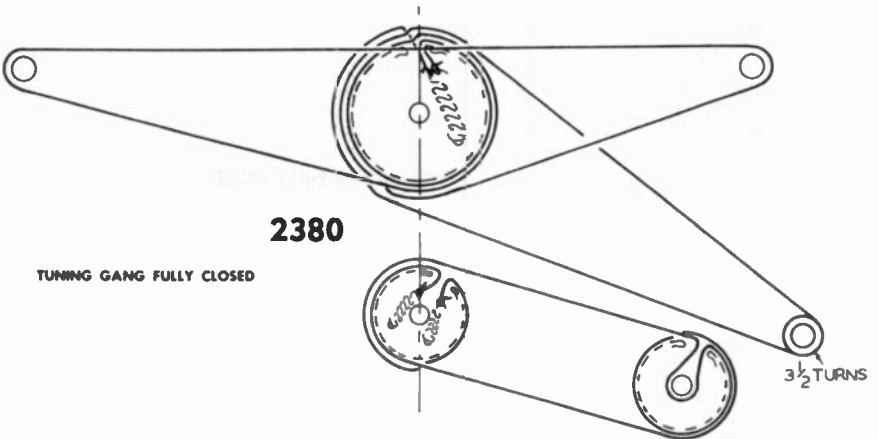

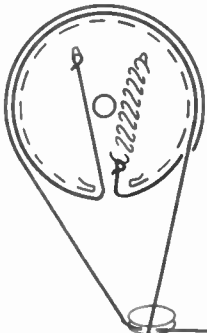

TUNING GANG FULLY CLOSED

2384

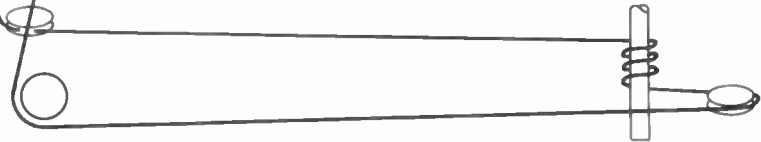

FM

AM

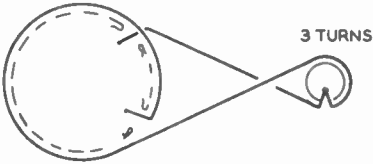

3 TURNS

2385

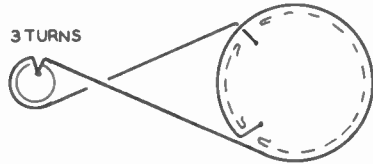

3 TURNS

TUNING GANG FULLY CLOSED

TUNING GANG FULLY CLOSED

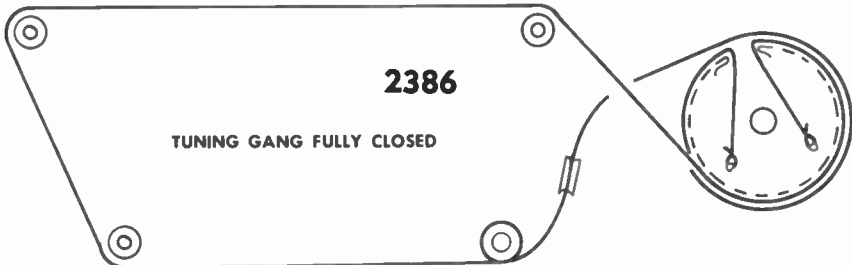

2386

TUNING GANG FULLY CLOSED

2 1/2 TURNS

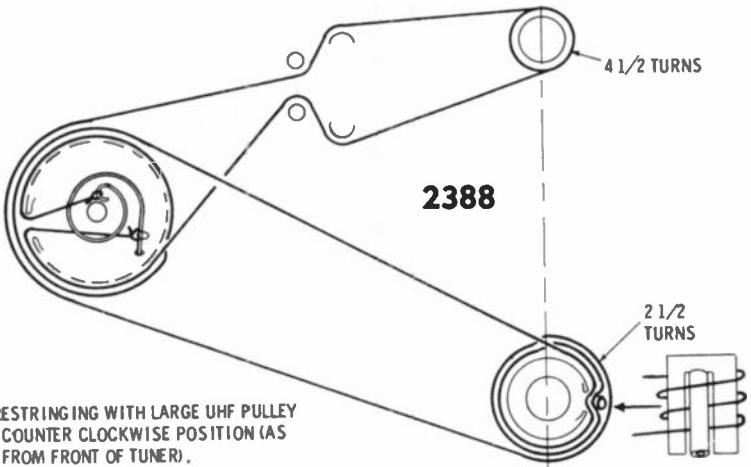
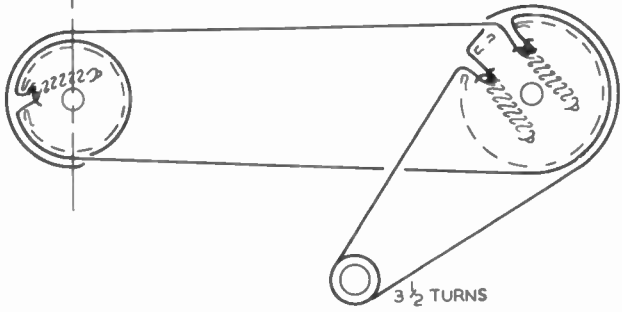
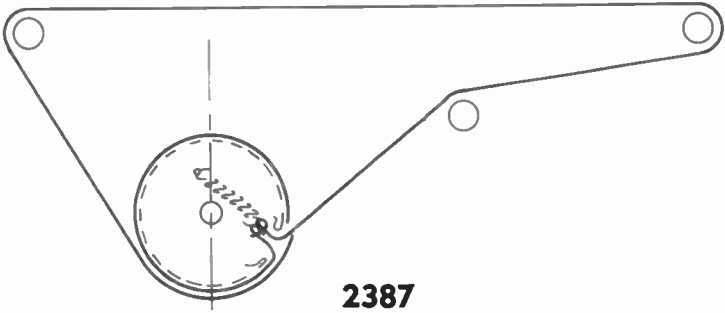

START RESTRINGING WITH LARGE UHF PULLEY
IN MAX COUNTER CLOCKWISE POSITION (AS
VIEWED FROM FRONT OF TUNER).

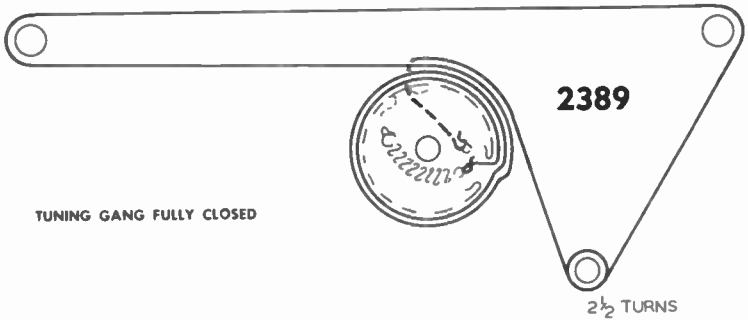

TUNING GANG FULLY CLOSED



2390

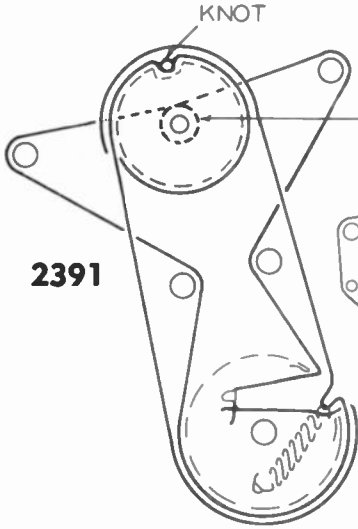

2391

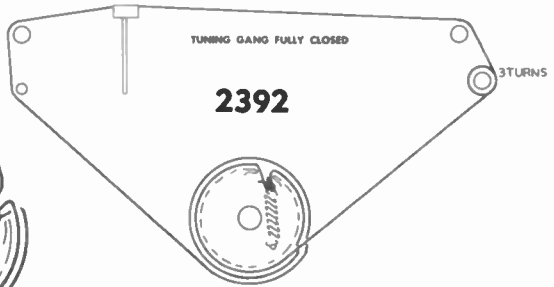

2392

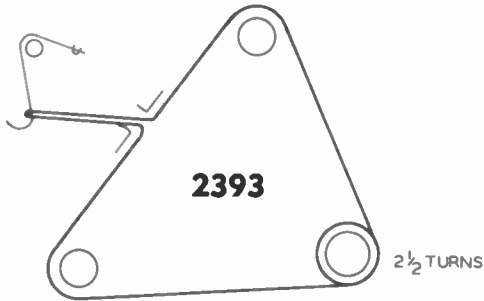

2393

2 1/2 TURNS

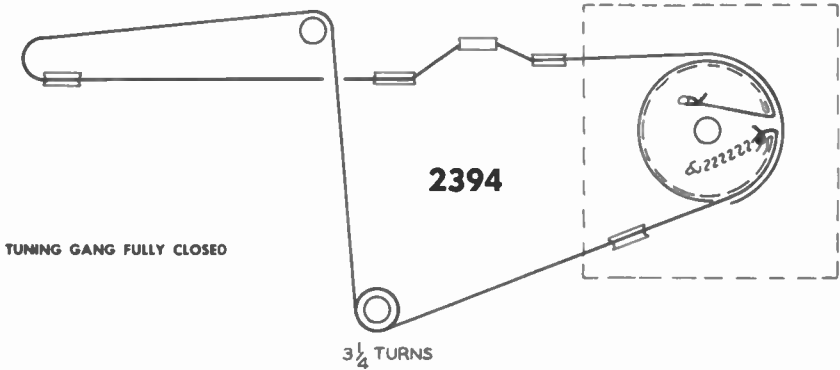

2394

TUNING GANG FULLY CLOSED

3 1/4 TURNS

TUNING GANG FULLY CLOSED

2395

3 TURNS

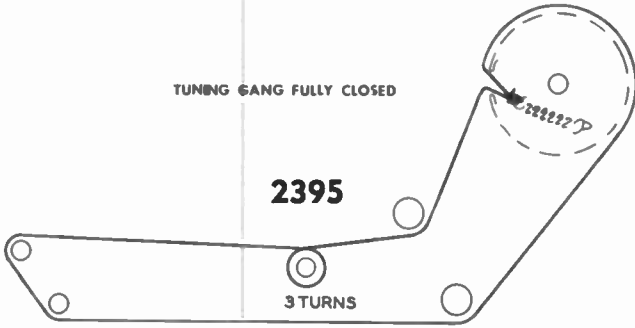

TUNING GANG FULLY CLOSED

2396

2 1/2 TURNS

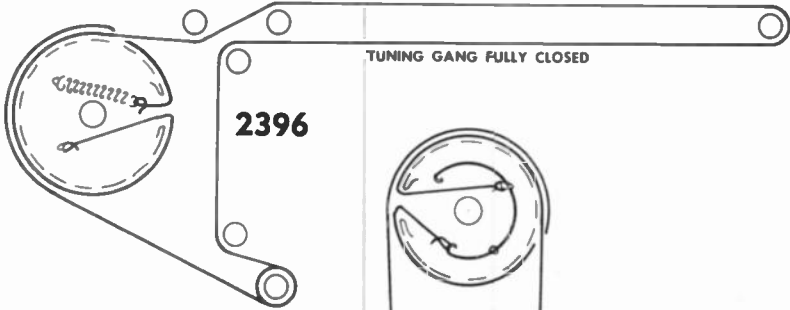

2397

3 1/2 TURNS

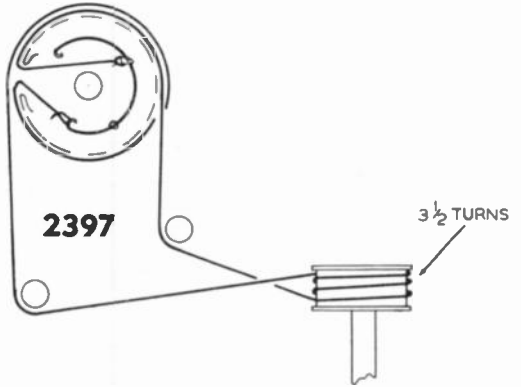

2398

2 1/2 TURNS

TUNING GANG FULLY CLOSED

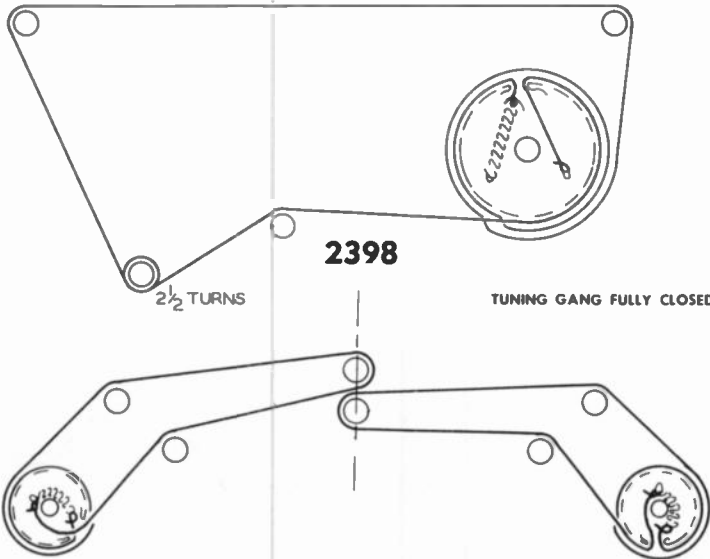

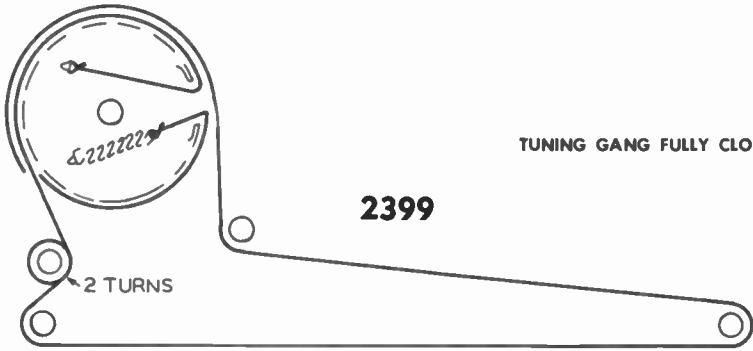

TUNING GANG FULLY CLOSED

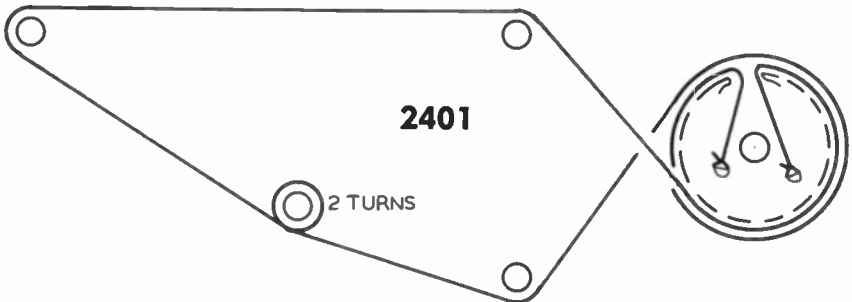
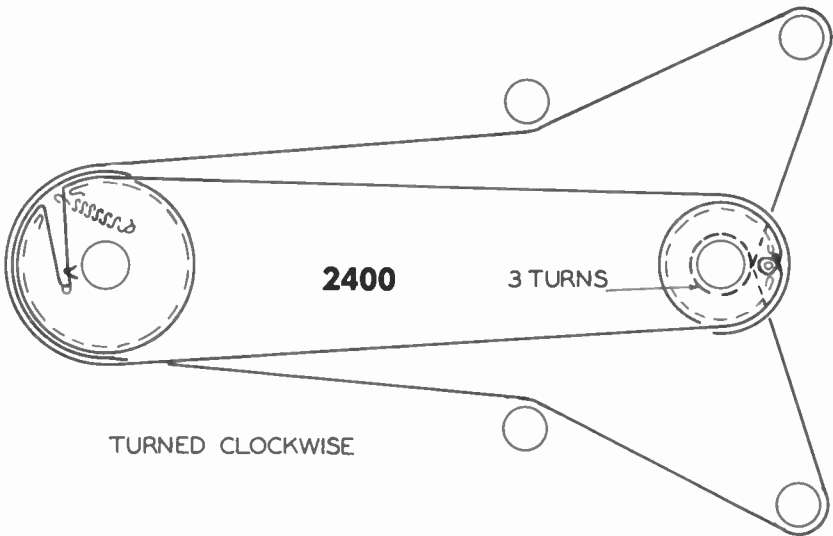

TUNING GANG FULLY CLOSED



BASS CONTROL CLOCKWISE

2402

TUNING GANG FULLY CLOSED

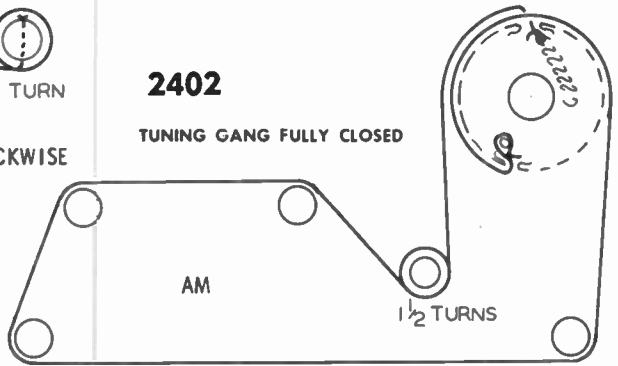

AM

1 1/2 TURNS

TUNING GANG FULLY CLOSED

FM

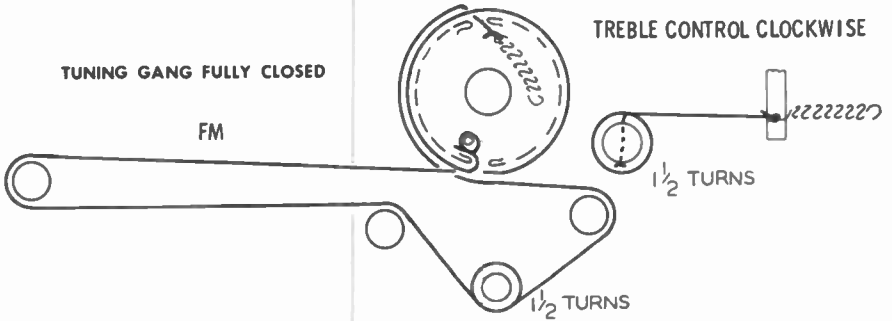

TREBLE CONTROL CLOCKWISE

1 1/2 TURNS

TUNING GANG FULLY CLOSED

2403

3 TURNS

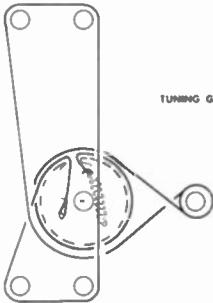

TUNING GANG FULLY CLOSED

2404

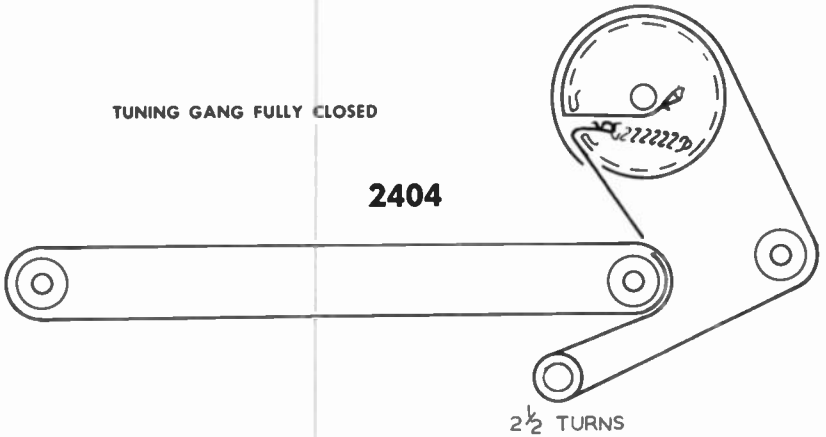

2 1/2 TURNS

TUNING GANG FULLY CLOSED

2405

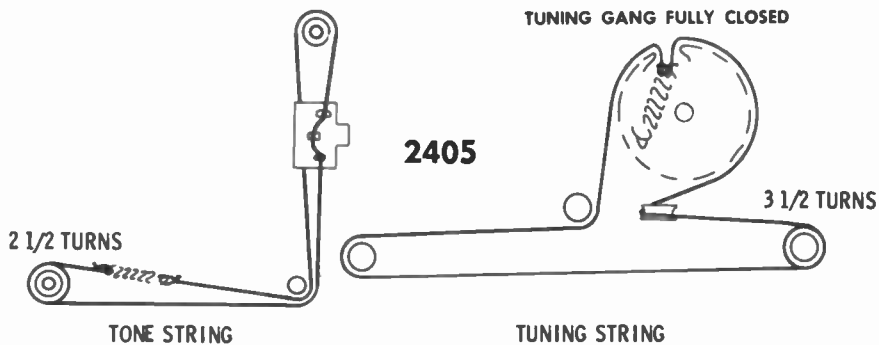

TUNING GANG FULLY CLOSED

2406

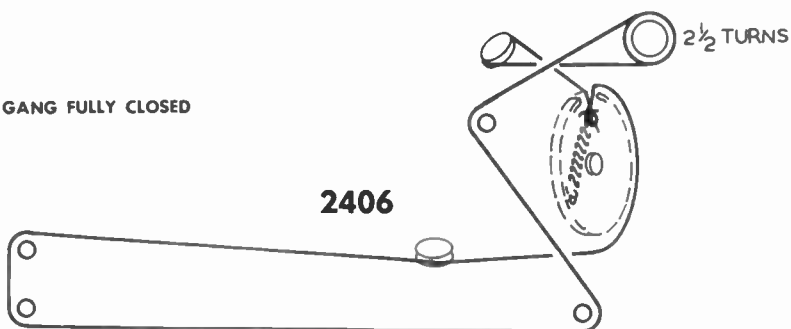

1 1/2 TURNS

ANTENNA CORD

CONTROL FULLY
CLCCKWISE

2 1/2 TURNS

2407

AM FM DIAL CORD

TUNING GANG FULLY CLOSED.

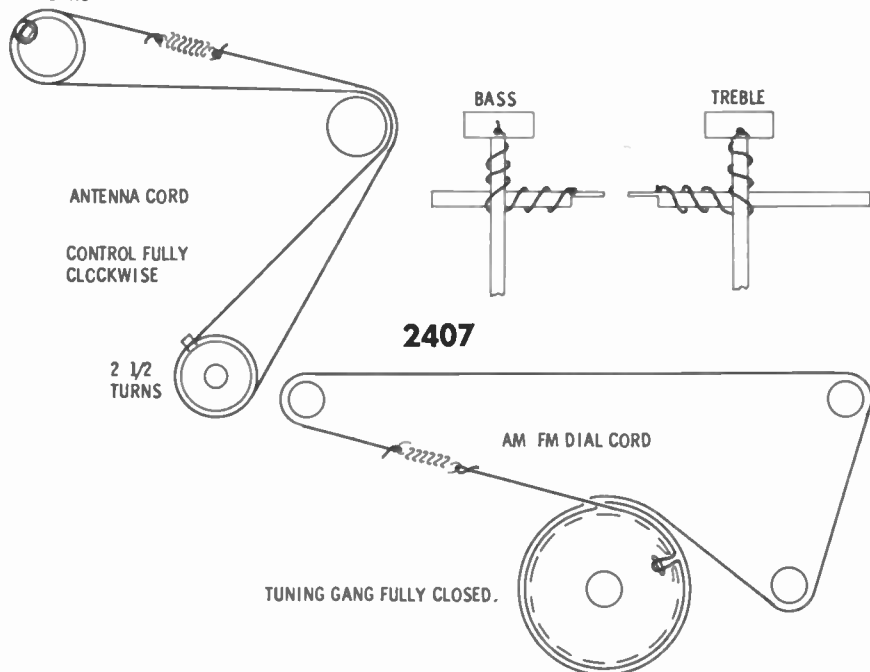

TUNING GANG FULLY CLOSED

