



A *Howard W. Sams* PHOTOFAC T PUBLICATION • KOG-1

know your SIGNAL GENERATORS

by ROBERT G. MIDDLETON

A practical text on
signal generators...
theory, operation,
and applications.



Know Your Signal Generators

by

ROBERT G. MIDDLETON



HOWARD W. SAMS & CO., INC.

THE BOBBS-MERRILL COMPANY, INC.

Indianapolis • New York

FIRST EDITION
FIRST PRINTING—JUNE, 1965

KNOW YOUR SIGNAL GENERATORS

Copyright © 1965 by Howard W. Sams & Co., Inc., Indianapolis, Indiana. Printed in the United States of America.

Reproduction or use, without express permission, of editorial or pictorial

No patent liability is assumed with respect to the use of the information contained herein.

Library of Congress Catalog Card Number: 65-24553

Preface

Signal generators are some of the most frequently used test equipment in modern electronics work: A-m generators are used for alignment and signal-injection tests of broadcast radio receivers. Standard signal generators are used in maintenance and troubleshooting of two-way radio units and other communications equipment. Marker generators with crystal calibrating facilities are often combined with f-m generators for alignment of f-m radio and TV receivers, and uhf signal generators are finding increased application. F-m stereo multiplex generators are required for adjusting and troubleshooting stereo-broadcast receivers and adapters. Specialized types of signal generators, such as dip meters, long favored by radio amateurs, are also widely used in radio and TV service shops. Another specialized signal generator, called an analyzer, has recently found wide acceptance.

Because of the extensive applications of generators, a thorough understanding of the operating principles, capabilities, and maintenance of the various types of signal generators is essential. Since electronics technology is expanding rapidly, newcomers are entering the field at an unprecedented rate. Hence, this book is written for the beginner as well as the old-timer who wants to know what makes the newer types of generators "tick." In this book you will find explanations of generator circuits, some of the more basic applications, how to calibrate the various bands, analysis of common troubles, and practical tips on how to keep a generator in top operating condition.

Most signal generators employ vacuum tubes; however, there is a definite trend toward the use of transistorized circuitry, particularly in f-m stereo multiplex generators. Accordingly, this topic is given appropriate coverage. Semiconductor-diode modulators are also detailed, inasmuch as they are now used extensively in service shops and laboratories. There is also a definite trend toward the use of all-electronic

f-m generator circuitry, and consideration is given to permeability-tuned oscillators, as well as junction-diode frequency modulators.

Topical treatment is practical throughout, with a minimum of mathematics. It is assumed that the reader has a basic knowledge of Ohm's law for d-c and a-c circuits. Theory is presented only when it is necessary to clarify practical considerations. Professional technicians, apprentices, students in technical schools, hams, and hobbyists will find that this book "speaks their language."

ROBERT G. MIDDLETON

Contents

CHAPTER 1

BASIC PRINCIPLES	7
Signal-Generator Features — Mode Modulation — General Shielding Considerations — Uhf Signal Generators—Transistorized Signal Generators—Signal Genera- tor and Signal Tracer	

CHAPTER 2

GENERATOR ACCURACY AND CALIBRATION	34
Frequency Calibration and Accuracy Ratings ibration Interharmonic Beats—Equalization of Harmonic Amplitudes— Measurement of Generator Output Voltage — Measurement of Harmonic Amplitudes—Counter Calibration	

CHAPTER 3

MODULATION OF GENERATOR SIGNAL	57
Sine-Wave Amplitude Modulation—Maximum R-f Output—Vari- able Modul Wave Modulation of Signal Generator—Frequency Modulation of Signal Generators — Video Sweep Modulation — Specialized Types of Pulse Modulation	

CHAPTER 4

UHF SIGNAL GENERATORS	80
Oscillator Tuning—Feedback Considerations—Plate-Tuning Con- siderations—Effect on Frequency—Load Inductance—Transit	

Time—Uhf Tubes—Limitations in External
Oscillator—Electrical Tuning—Attenuators—Uhf Signal Gen-
erator Modulation

CHAPTER 5

F-M STEREO MULTIPLEX SIGNAL GENERATORS	99
Fundamentals of Stereo Mu	
Signals—F-m Stereo Multiplex Signal Generator—Stereo-Signal Generation	

CHAPTER 6

SPECIALIZED TYPES OF SIGNAL GENERATORS	115
Accuracy	
Meter—Operation as a Wavemeter—Operation as an Auxiliary Signal Generator—Modulation of a Grid-Dip Meter—Harmonic Response of Stubs—Analyzer Type of Generator—Transistor Radio Analyzer—Radio Test Sets	

CHAPTER 7

SUPERSONIC GENERATORS	133
Basic Circuitry—Wien-Bridge Oscillator—Beat-Frequency Gen- erators	
INDEX	143

Chapter 1

Basic Principles

There are many types of signal generators in common use. The most familiar instrument is the amplitude-modulated (a-m) generator which has a multitude of applications, such as alignment of radio receivers, stage-gain measurements, resonant-frequency determination, calibration of auxiliary equipment, signal-substitution tests in troubleshooting procedures, and measuring the Q of tuned circuits. Marker generators are a somewhat more elaborate type of signal generator, and almost everyone has at least a basic understanding of their operation. The chief distinction between a marker generator and an ordinary a-m generator is that a marker generator has an output of up to 250 mc, plus *calibrating* facilities. Quartz-crystal oscillators are commonly built into marker generators; this feature permits frequencies to be set to considerably higher accuracy than is possible with an ordinary a-m generator.

The a-m and marker generators are comparatively simple instruments which provide known frequencies within rated accuracy limits; however, they do not supply a known output voltage. The output voltage is adjustable over the necessary range, but no indication is provided concerning the number of microvolts or millivolts that are applied to the receiver or circuit under test. Hence, you cannot use an a-m generator or a marker generator to measure the sensitivity of a receiver. Sensitivity is defined as the number of microvolts that must be applied to a radio or TV receiver to obtain a standard output (usually 1 volt dc from the second detector). Similarly, you cannot use an a-m generator or a marker generator to calibrate a field-strength meter. The purpose of a field-strength meter is to indicate the number of microvolts that are applied to its input terminals.

Oldsters will recall that almost any device that generated an r-f signal was called a signal generator in the early days of

generators. Even today, instruments such as grid-dip oscillators are sometimes considered as signal generators. But as the state of the art developed, the standards for test-signal sources became higher. Many of us will recall that during World War II technicians at military bases gained valuable experience with precise signal sources. Military technicians were required to align receivers so that the tuning dials accurately indicated the incoming frequency. The receivers had to be carefully serviced to provide rated sensitivity. Moreover, it was the responsibility of the technician to check out selectivity, AVC characteristics, and image rejection.

Mobile radio technicians have much the same responsibility. Mobile receivers are not fully useful unless they have a sensitivity of 1 microvolt or better. Selectivity must be optimized to pass an f-m signal without objectionable distortion, and also to reject adjacent signals. Four known accurate frequencies are necessary to align a triple-conversion superheterodyne. Only a high-quality signal generator suffices for front-end alignment. Evidently a suitable generator must provide both f-m and a-m carrier modulation. Hence, a generator that is quite satisfactory for application in one service area may be utterly useless in another application area.

Technicians employed in radar activity require signal generators which supply unusually high frequencies and also provide pulse modulation of the carrier. Receiver noise measurements are vital, and hence the inherent noise level of the generator must be minimized. By way of comparison, the inherent noise level of a TV marker generator might be quite high, but this would be of no concern—the signal levels utilized in the alignment of TV receivers are higher than those signals employed in alignment of radar receivers or communications equipment.

Communications equipment is multiplexed in some cases. Signal generators used in maintenance and troubleshooting of multiplex receivers must provide comparatively elaborate carrier modulation. Various forms of pulse-amplitude modulation are most common, although specialized types of frequency modulation are also encountered. Single-sideband output may be required from a signal generator in testing other types of receiving systems. In any case, your selection of a signal generator must be made on the basis of its intended application.

Technically, a basic signal generator is a source of sine-wave voltage of known frequency and amplitude. The frequency might be chosen between 10 kc and 10,000 mc. The amplitude is usually measured in microvolts, although some

signal generators supply an output of several volts. On the other hand, a test oscillator is commonly defined as a source of sine-wave voltage that has a known accurate frequency, but an amplitude which is not known. However, test oscillators are often loosely termed signal generators. In an attempt to avoid confusion between the two basic types of instruments, complete and highly accurate generators have become known as *standard-signal generators*. Test oscillators should therefore never be referred to as standard-signal generators.

SIGNAL-GENERATOR FEATURES

The plan of a typical signal generator is depicted in Fig. 1-1. It comprises a sine-wave oscillator, a calibrated tuning capacitor, an output meter calibrated in microvolts, a precision attenuator, and a shielding system to prevent objectionable

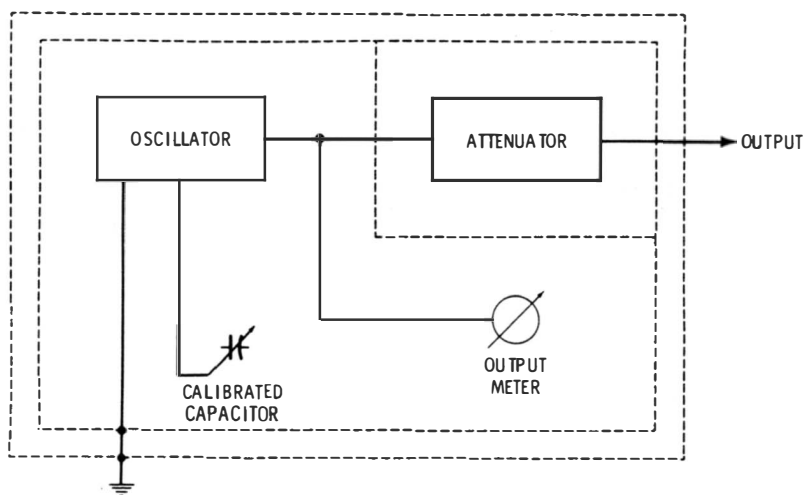

Fig. 1-1. Plan of a typical signal generator.

leakage of high-frequency energy into surrounding space. True signal generators provide a good sine-wave output and they also minimize harmonics to the lowest percentage possible. On the other hand, test oscillators often have a highly distorted sine-wave output. The distortion components consist of even and odd harmonics. Higher frequency bands of a test oscillator often use the same output as on lower frequency bands—the high-frequency bands are merely calibrated in terms of harmonic frequencies.

Oscillators used in conventional generators are tunable over various bands of frequencies. It is not practical to design LC oscillators that provide a band-tuning range greater than about 3 to 1. Hence, band switching is required to select different coils for each band (Fig. 1-13). Oscillator circuits are designed to generate as pure a sine wave as possible. The output amplitude on each band is also maintained as uniform as possible to minimize resetting of the level control for the output meter. Some generators employ a form of AGC control to achieve maximum uniformity of output.

Oscillators with output frequencies up to 250 mc generally utilize a carefully designed version of the Hartley or Colpitts circuits (Fig. 1-2). Frequency stability is an important con-

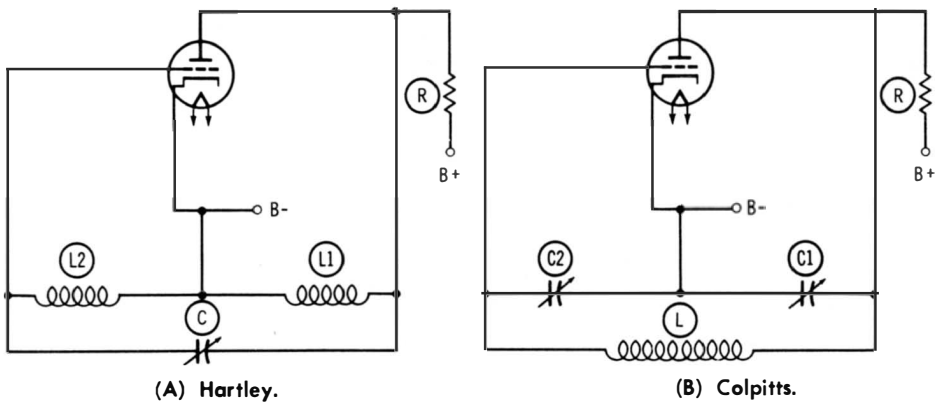

Fig. 1-2. Basic oscillator circuits.

sideration, inasmuch as it determines the accuracy rating of the generator, with respect to frequency. Stability is dependent on the effect of temperature, with respect to the resonant frequency. Warmup drift is unavoidable, but a well-designed generator quickly achieves its equilibrium condition and remains reasonably free from frequency drift with changes in ambient temperature. Temperature-compensating capacitors are often used in the oscillator circuitry for this reason.

Since the interelectrode capacitances of vacuum tubes differ, circuit configurations are used that make the oscillating frequency primarily dependent on the value of tuning capacitance only. This feature is also desirable because the interelectrode capacitances of a tube tend to change somewhat with age. A good sine-wave output requires that the resonant circuit have a high Q, and that the oscillator be lightly loaded. Since the frequency of an oscillator tends to change when the B+ varies, they usually have regulated power supplies.

Two general methods are used to make the oscillating frequency comparatively independent of tube interelectrode capacitances. The simplest method is to make the inductance fairly small and to use a large tuning capacitor. It follows

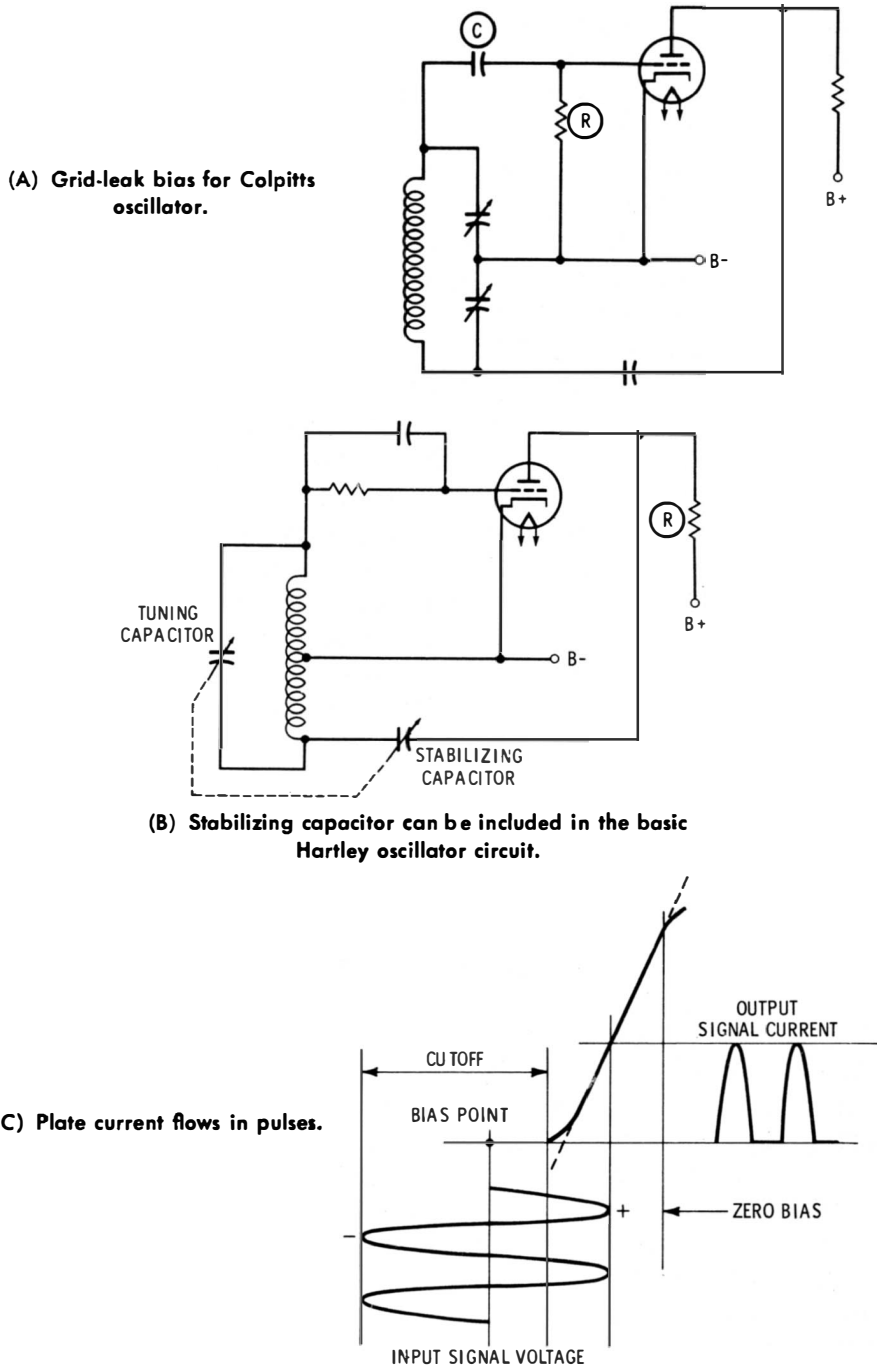

Fig. 1-3. Grid-leak bias arrangements.

from the basic circuitry shown in Fig. 1-2 that interelectrode capacitance then becomes a small *percentage* of the total tuning capacitance. In turn, the effect of tube aging or tube replacement on frequency stability is minimized. The other method is to tap down the tube connections to the coil so that the interelectrode capacitances are shunted across only a part of the inductance.

Frequency stability is also found to be dependent on the biasing arrangement used. No bias source is indicated in Fig. 1-2. An oscillator can be operated with cathode bias, fixed bias, or signal-developed bias. As previously noted, AGC bias may be employed. Signal-developed (grid-leak resistance) bias contributes basically to frequency stability. The grid-leak resistance is made as large as possible, while still permitting steady oscillation. Fig. 1-3A illustrates a typical configuration. Signal-developed bias also assists in maintaining a reasonably uniform output amplitude over the tuning range. If the amplitude starts to rise, more bias is developed, which in turn, reduces the amplitude of oscillation to some extent.

Frequency stability can be improved in the Hartley configuration by including a stabilizing capacitor, as depicted in Fig. 1-3B. This arrangement is called an impedance-stabilized oscillator. When the stabilizing capacitor has a certain critical value, the oscillating frequency remains practically unchanged over a wide range of plate-voltage variation. As the tank circuit is tuned to different frequencies, the stabilizing capacitance must also be varied; hence, it is necessary to gang the two capacitors. This complication has caused the impedance-stabilized oscillator to find limited application, except in special-purpose generators for spot-frequency operation.

MODE OF OPERATION

Few oscillators in signal generators are operated in class A. One arrangement to be described later uses class-A operation. The cathode resistor biases the tube to its linear operating region. However, arrangements such as depicted in Fig. 1-3 employ grid-leak resistance bias which permits the tube to conduct only at the peak of oscillation. The plate current flows in pulses; hence the oscillator operates in class C. It might seem that lack of sine-wave plate-current flow would be conducive to harmonic generation. However, the oscillatory waveform has a practically pure sinusoidal tank circuit has a high Q.

The efficiency of a class-C stage may be as high as 85%, compared with an efficiency of 25% for a class-A stage. Fig. 1-3C shows how grid-leak resistance bias places the operating point beyond cutoff. In turn, the plate current flows in pulses which are clipped tops of sine waves. However, if the Q of the tank is high, it produces a practically pure sine wave. The reason for this circuit action is the flywheel effect of the high- Q tuned circuit. The tuned circuit is shock-excited once every cycle by the plate-current pulses. As depicted in Fig. 1-4, the rate of decay of a shock-excited sine wave depends on the Q of the circuit. Evidently, if the tuned circuit has a high Q , the

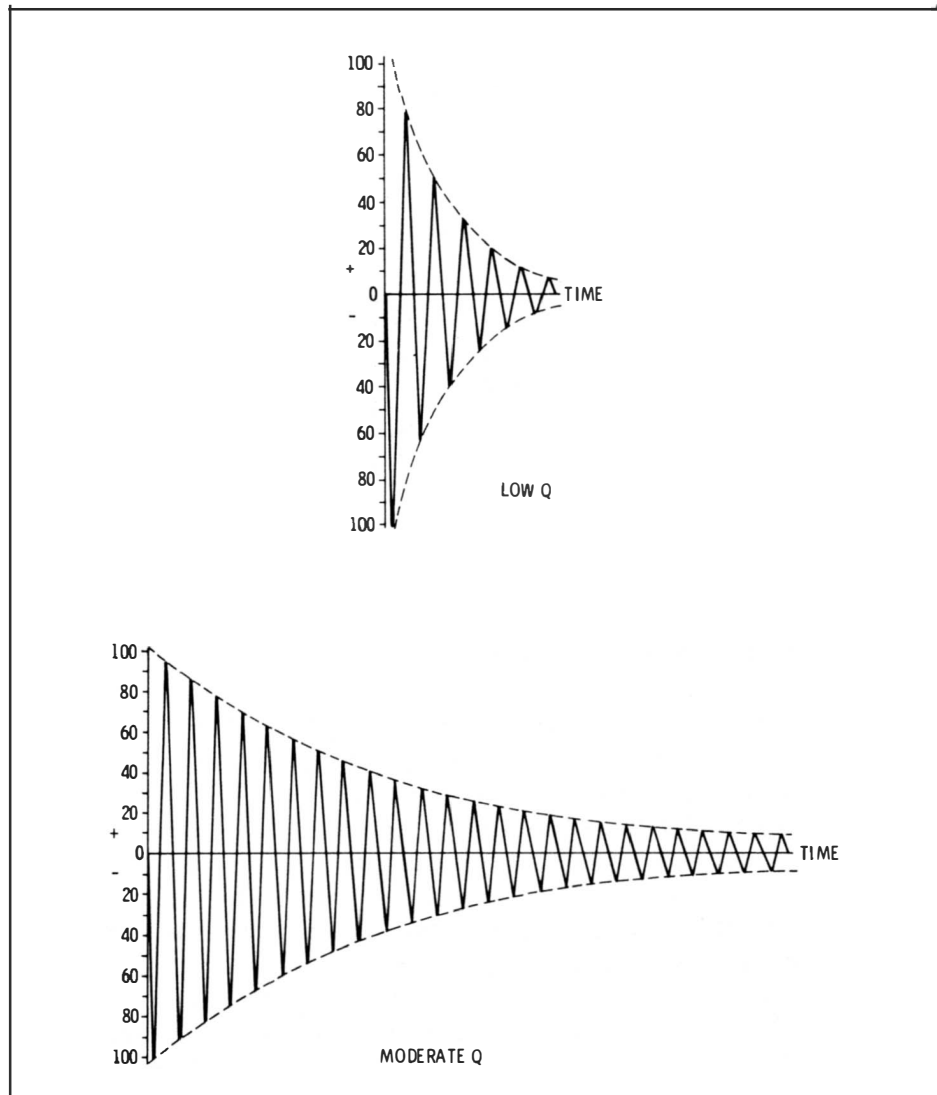

Fig. 1-4. The Q of the tank circuit determines the rate of decay of the sine wave.

sine-wave output decays very little from one cycle to the next.

We find that the Q of the tank circuit depends not only on the Q of the coil itself, but also on the amount of power which is drawn from the oscillator. If more power is drawn, the generated sine wave decays more from one cycle to the next (Fig. 1-4). Hence, the oscillator generates a purer sine wave, if it is lightly loaded. Frequency stability is also improved under light loading, because the tuned circuit is better isolated from conditions in the generator output system. Of course, some means of coupling must be provided between the oscillator and the output system.

There are two principal coupling systems used to minimize loading of the oscillator. Fig. 1-5 depicts the use of a buffer stage. A power tube is generally preferred as a buffer, because it provides a comparatively large power output with very

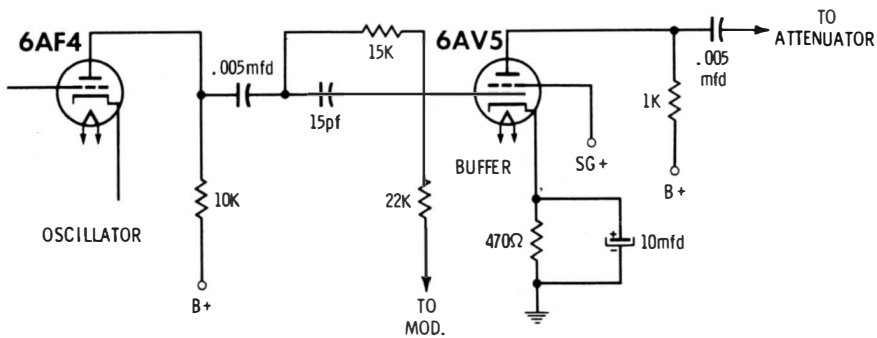

Fig. 1-5. A buffer stage minimizes the loading of the oscillator.

little grid-driving power. The buffer stage necessarily operates in class A because the sine-wave output from the oscillator must not be distorted. Hence, the 6AV5 in Fig. 1-5 is cathode-biased to its linear operating region. The efficiency of the buffer stage is low, but this is the price that is paid for good isolation of the oscillator section. A 6AV5 has a transconductance of 5900 micromhos; hence, it is inherently capable of considerable power amplification.

On the other hand, full advantage cannot be taken of the buffer's amplification potential, because the signal generator operates over a wide frequency range. In the arrangement of Fig. 1-5, the buffer must operate at frequencies up to approximately 10 mc. Since reasonably uniform frequency response is desirable, a rather low value of plate resistance must be used. Note that the plate load is a 1K resistor. Furthermore, the output from the buffer is fed to the attenuator, which has

a considerably lower resistance. In turn, the effective plate-load resistance of the buffer is approximately 150 ohms.

The voltage gain is basically equal in the plate-load resistance multiplied by the transconductance of the 6AV5, or less than unity—about 0.9. However, the power gain is quite large. In other words, the signal-output voltage is a bit less than the input grid-signal voltage, but the plate current is heavy while the grid current is nearly zero. The grid draws almost no power from the oscillator, but the plate supplies a much greater signal power. For example, suppose that the oscillator drives the buffer grid with 1 volt and an 0.3 milliamperere. This is driving power of 300 microwatts. On the other hand, the plate supplies (say) 0.9 volt across 150 ohms. This is a power of 5400 microwatts. Or stating it another way, the buffer stage has a power gain of 18.

Why does the grid draw any current at all in Fig. 1-5? It is because the grid has an input capacitance, plus the stray capacitance of its socket terminals. If the total input capacitance to the 6AV5 is 5 pf, the capacitive reactance of the grid-input circuit is about 3000 ohms at 10 mc. Hence, the grid-driving current is not zero, as might be supposed from simplified theory. Evidently, the buffer stage also has output capacitance, which must reduce the effective plate-load impedance at high frequencies. However, the plate-load resistance is quite low—approximately 150 ohms. Hence, the reduction in plate-load impedance is comparatively small. The output capacitance would have to be 100 pf before the capacitive reactance would be 150 ohms at 10 mc.

Since the buffer tube is a beam-power tube, its control grid is electrostatically shielded from the plate. This simply means that changes in output capacitance are isolated from the control grid, and in turn, isolated from the oscillator. Accordingly, when the attenuator is switched, the associated changes in

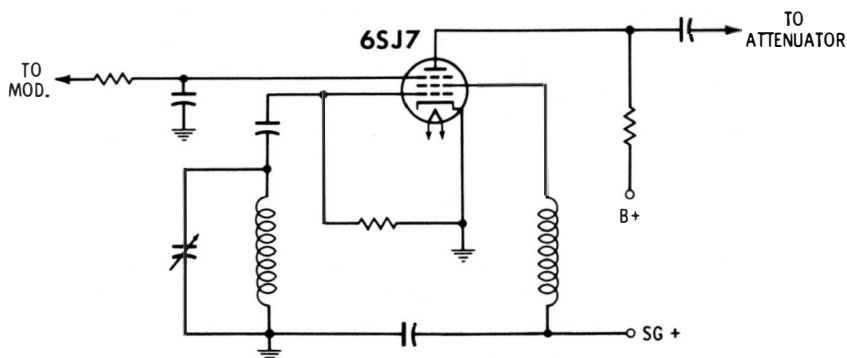

Fig. 1-6. Electron-coupled oscillator circuit.

output capacitance do not affect the resonant frequency of the oscillator circuit. Of course, the shielding action of a screen grid is never 100% perfect. In turn, there is a very slight effect on oscillator frequency when the output capacitance is changed. In most cases, this residual lack of 100% isolation can be disregarded. On the other hand, if you are servicing mobile equipment, for example, you may require a generator which has more extensive buffering than depicted in Fig. 1-5.

The second type of coupling system commonly used in test oscillators and simple signal generators consists of an electron-coupled oscillator configuration, as depicted in Fig. 1-6. Note that the screen grid, control grid, and cathode electrodes operate as a triode in the oscillator section. The electron stream rises and falls in amplitude at the oscillating frequency. A considerable portion of the electron stream passes through the screen grid and terminates at the plate. In turn, the output signal is taken from the plate.

Why does an electron-coupled configuration minimize loading on the oscillator? We know that the plate current of a pentode changes very slightly when the plate voltage changes. Note in Fig. 1-7 that if you select a certain value of control-grid voltage, the plate current changes little when you vary the plate voltage over a wide range. Furthermore, the screen grid in Fig. 1-6 operates as the anode (plate) in the oscillator sec-

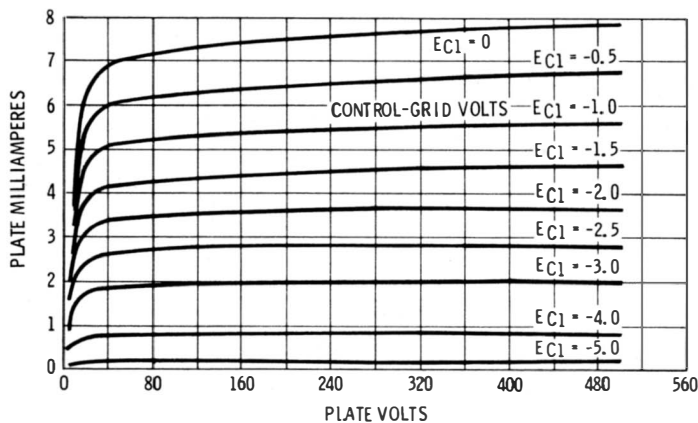

Fig. 1-7. Characteristics of a typical pentode.

tion. The screen grid is shielded from the plate by the suppressor grid. In turn, capacitance variations in the plate-output circuit are effectively decoupled from the screen grid. Hence, changing conditions in the plate-output circuit have little effect on the oscillating frequency.

The uniformity of output on each band can be improved by use of automatic control bias. A basic configuration is seen in Fig. 1-8. Diode M is back-biased from the cathode resistor. However, when the amplitude of the sine-wave signal exceeds the back-bias value, diode M starts to conduct. The diode cur-

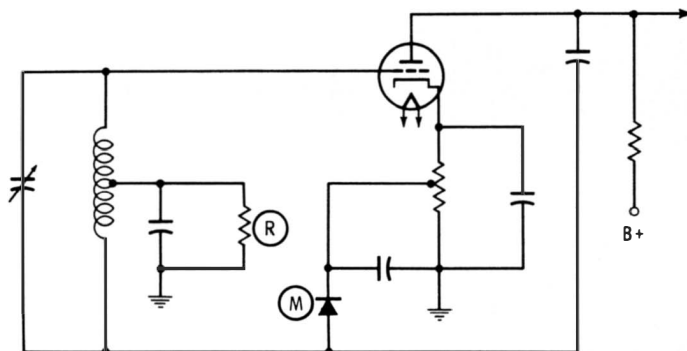

Fig. 1-8. Diode M develops a control bias which improves the uniformity of the output amplitude.

rent flows to ground through R, and an increased negative bias is applied to the grid of the tube. In turn, the amplitude of oscillation is reduced. Amplified AGC is sometimes used in signal generators, just as in receivers. Amplified AGC provides better control action.

AMPLITUDE MODULATION

Nearly all signal generators provide an amplitude-modulated output. Waveforms of unmodulated and modulated signals from an a-m generator are depicted in Fig. 1-9. Most generators have a modulating frequency of 400 cycles; some have a modulating frequency of 1000 cycles. A few provide a variable modulating frequency. Older generators often had a fixed percentage of modulation, such as 30%. However, the present trend is to provide a variable percentage of modulation. Many generators have a range from zero to 50% modulation; others provide up to 80% modulation. A few generators can supply a 100%-modulated output.

Sine-wave modulation is depicted in Fig. 1-9. This is the basic and usual modulation waveform. However, a few signal generators provide pulse modulation. For example, generators used to align radar receivers supply both sine-wave and pulse modulation. (See Fig. 1-10 for a representation of pulse modulation.) Older generators utilized internal modulation exclusively. Internal modulation means that the signal is modulated before it is applied to the attenuator. On the other hand, there

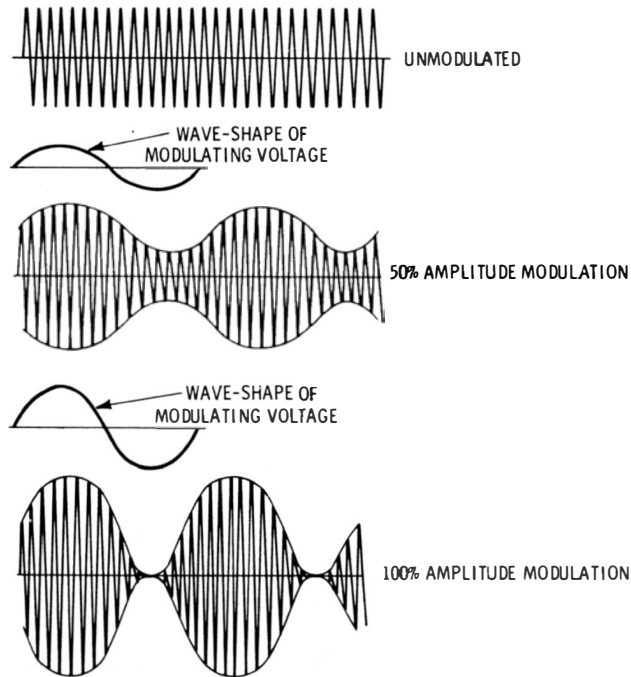

Fig. 1-9. Waveforms of unmodulated and modulated signals of an a-m generator.

is a strong trend to the use of external modulators. In this system, the modulator is not built into the generator, but it is a separate external unit. The output from the generator is modulated after it has passed through the attenuator.



Fig. 1-10. Pulse-modulated waveform of an a-m generator.

In the simplest signal generators the oscillator is modulated directly, as depicted in Fig. 1-11. For example, the plate voltage of the oscillator tube may be varied in accordance with the modulating signal shown in Fig. 1-9. Although this method is simple, it has some disadvantages. The chief disadvantage is *incidental frequency modulation*. We find that when the plate voltage on the oscillator is varied, the oscillating frequency, as well as the output amplitude, tends to change. This does really come as a surprise, because we know that regulated power supplies must be used to maintain oscillator frequency stability. What happens when the plate of the oscillator tube is

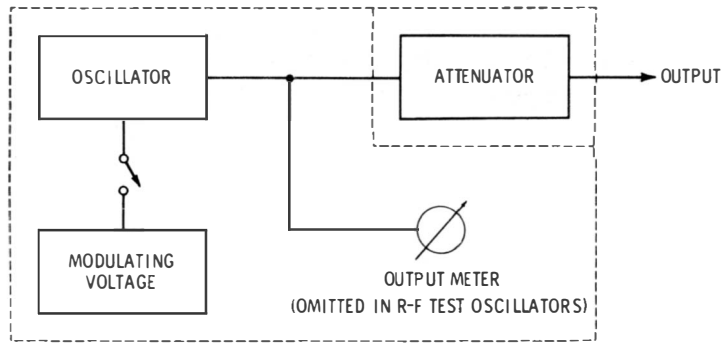

Fig. 1-11. In most signal generators the oscillator is directly modulated.

modulated is this: the *effective* interelectrode capacitances of the tube are varied somewhat along with the variation in plate resistance. In turn, the oscillating frequency swings up and down slightly.

This incidental frequency modulation is not excessive, provided that rather small modulating percentages are used. On the other hand, high percentages of modulation cause a large amount of incidental frequency modulation. Various means are used to avoid this difficulty. For example, in the electron-coupled arrangement of Fig. 1-9, the modulating voltage is applied to the suppressor grid. Again, in the buffer-stage arrangement of Fig. 1-5, the modulating voltage is applied to the control grid of the buffer tube. Note that the modulating voltage can be applied in series with diode M in Fig. 1-8 to minimize incidental frequency modulation.

The basic principle of an external modulator is shown in Fig. 1-12. Diode M is biased to a suitable point on its forward

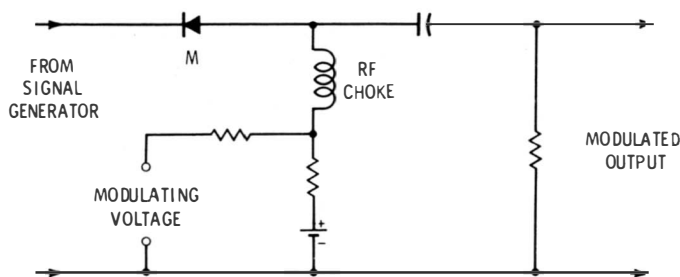

Fig. 1-12. Basic principle of an external modulator.

characteristic. Since its characteristic is nonlinear, a change in bias is accompanied by more or less r-f current flow. The modulating voltage causes a change in bias voltage, and the output signal is modulated accordingly. Incidental frequency

modulation is avoided, because the complete generator-output system is between the oscillator and modulator. When a pulse-modulating voltage is applied, 100% modulation can be obtained. On the other hand, sine-wave modulation is limited to 50% modulation or less, unless distortion of the modulation envelope can be tolerated.

ATTENUATORS

All generators are provided with some type of attenuator. Simple test oscillators often use a conventional potentiometer. To reduce feedthrough voltage at the minimum setting, two potentiometers may be utilized, as shown in Fig. 1-13. On the other hand, an attenuator for a standard signal generator (Fig. 1-1) is designed to provide accurately-known output voltages over a typical range from 1 microvolt to 50,000 microvolts, or perhaps higher. The output meter is calibrated

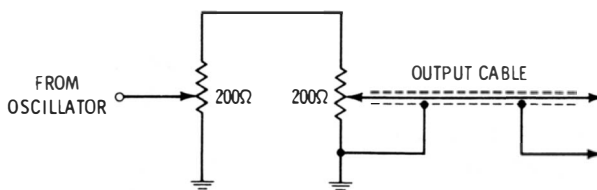

Fig. 1-13. Two potentiometers used as an attenuator.

with a "set carrier" mark; when the carrier-level control is adjusted to bring the pointer to this reference level, the number of microvolts output is indicated by the attenuator setting.

Attenuators have a low impedance, such as 15 or 50 ohms. There are two basic reasons for using low-impedance attenuator systems. First, stray capacitances have less serious effects in low-impedance circuits. A good attenuator system has an accuracy of $\pm 1\%$. This accuracy can be achieved only by minimizing the bypassing action of stray capacitances. For example, at 100 mc, 5 pf has a reactance of about 300 ohms. Unless the attenuator resistance is in the order of 50 ohms or less, it is obviously impossible to achieve high accuracy. The second reason for employing a low-impedance attenuator is to minimize loading errors. For example, if the circuit under test has an input resistance of 500 ohms, the attenuator must evidently have a much lower output impedance, such as 50 ohms or less, to maintain reasonable accuracy of attenuator calibration.

The step attenuator is a ladder configuration, comprising 62-ohm and 56-ohm shunt resistors with 510-ohm series re-

sistors. (Refer to Fig. 1-14.) When the fine attenuator is adjusted for full-scale indication on the meter, each step on the calibrated attenuator provides a known number of microvolts output. The output voltage is fed to a coaxial cable. It is impractical to use ordinary test leads, because the leads would radiate high-frequency energy. Moreover, standing waves cannot be controlled on open test leads. The attenuator calibration would be meaningless unless a coaxial output cable were used. It is also essential to terminate the output cable with a resistor which has a value equal to characteristic impedance of the coax cable. The terminating resistor eliminates standing waves and makes the input impedance of the cable purely resistive (Fig. 1-15).

Attenuators must be well shielded. A simple arrangement is depicted in Fig. 1-16. An important consideration in any shield design is make all high-frequency grounds at the same point in the shield structure. A single grounding point minimizes circulating r-f currents in the shield metal. Obviously, circulating ground currents cause radiation (leakage from the generator), and can cause feedthrough of high-frequency energy from input to output of the attenuator system. Feedthrough not only impairs attenuator calibration, but it also increases the minimum attainable signal level. Alignment of sensitive receivers may require that the attenuator reduce the available output to 1 microvolt.

Fig. 1-17 depicts the same basic ladder configuration as in Fig. 1-14, but with additional sections for greater attenuation and more elaborate shielding than shown in Fig. 1-16. Attenuator shielding is provided in addition to oscillator shielding as depicted in Fig. 1-14. In turn, both of these shield systems are supplemented by the generator case. The shielding provided in a standard signal generator is one of the basic features which distinguishes this type of instrument from a test oscillator. Without effective shielding, it is impossible to achieve accurate calibration of a step attenuator.

GENERAL SHIELDING CONSIDERATIONS

Since the high-frequency sections of a signal generator must be both electrostatically and electromagnetically shielded, it might be supposed that ferrous shield material might be required. However, nonmagnetic metals such as copper serve as efficient electromagnetic shields at high frequencies. The reason for this is that the skin effect restricts the flow of high-frequency currents to the surface of the shield. High-frequency energy cannot penetrate into the body of the copper.

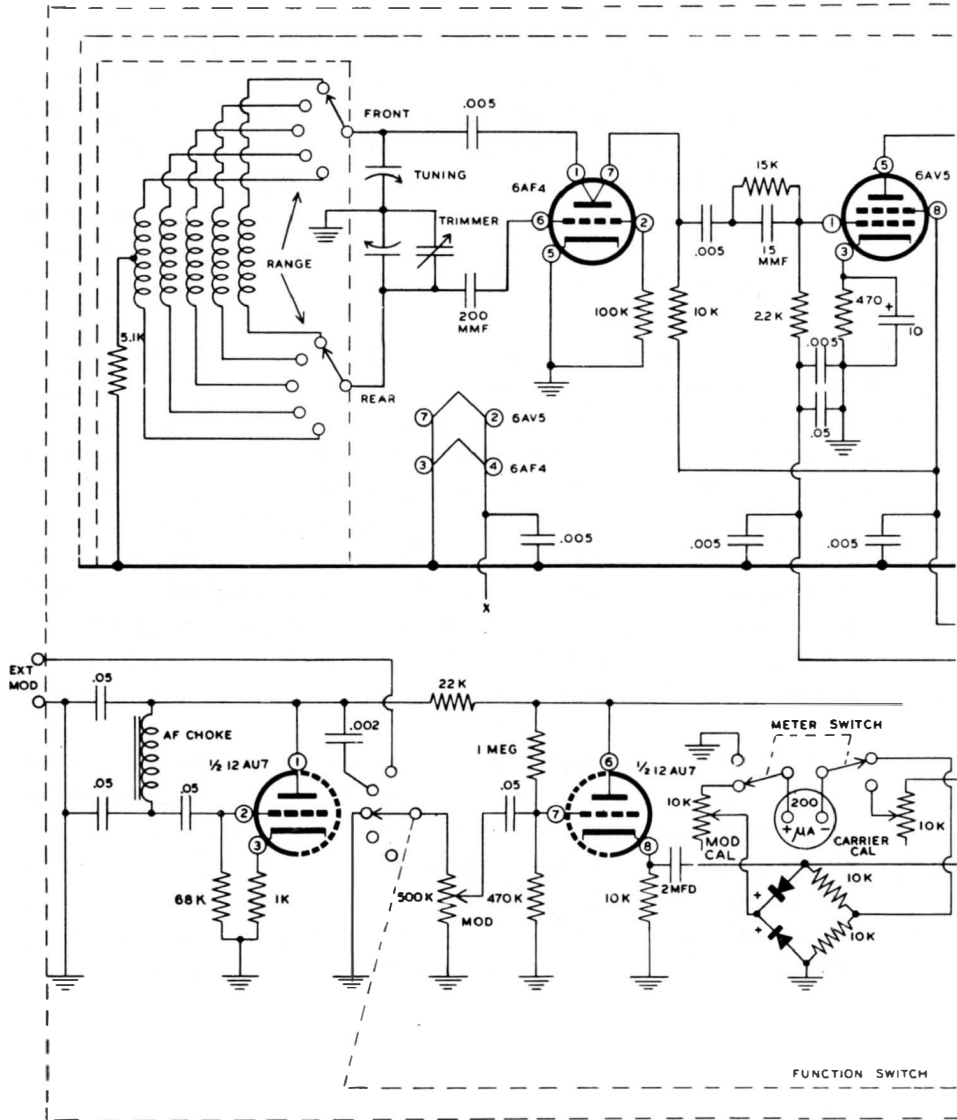

BAND A: 100 TO 290KC
 BAND B: 280 TO 1000KC
 BAND C: 0.95 TO 3.1MC
 BAND D: 2.9 TO 9.5MC

Fig. 1-14. Example of a step

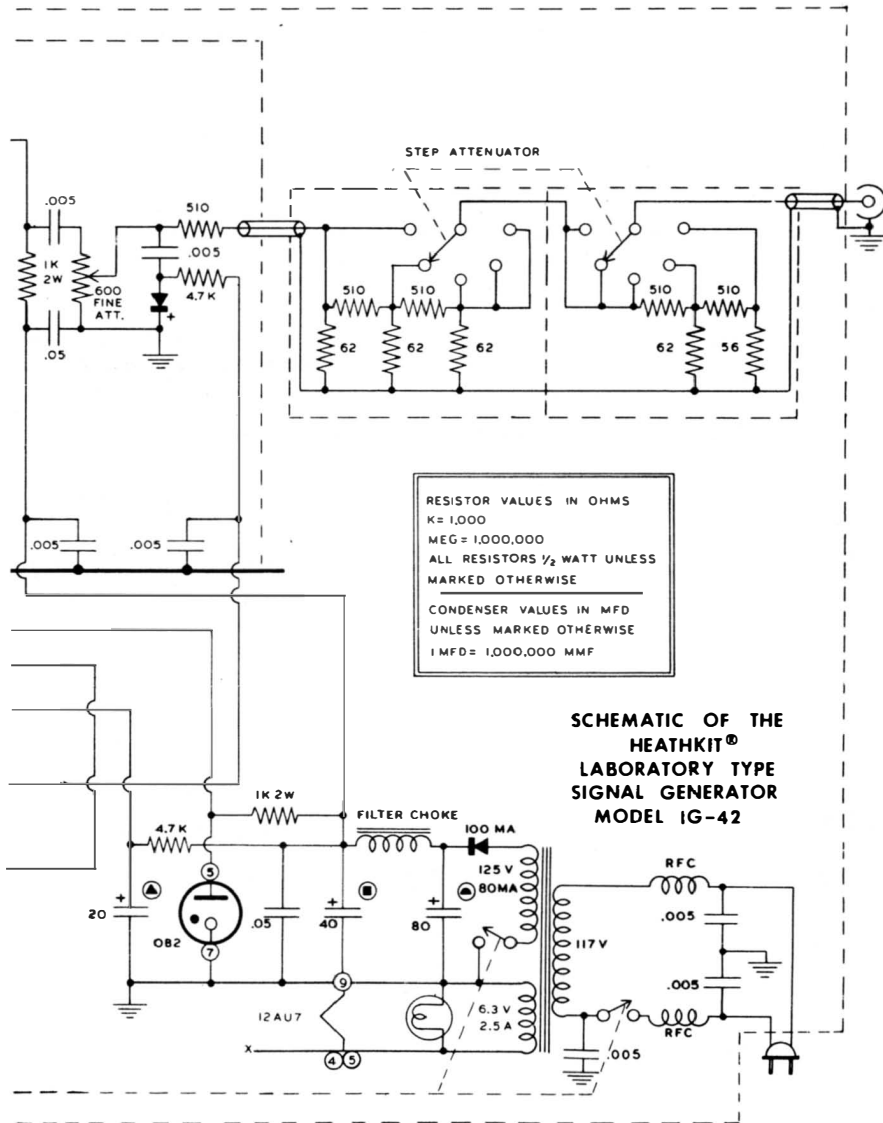

**SCHEMATIC OF THE
HEATHKIT®
LABORATORY TYPE
SIGNAL GENERATOR
MODEL IG-42**

attenuator used in a signal generator.

Courtesy Heath Co.

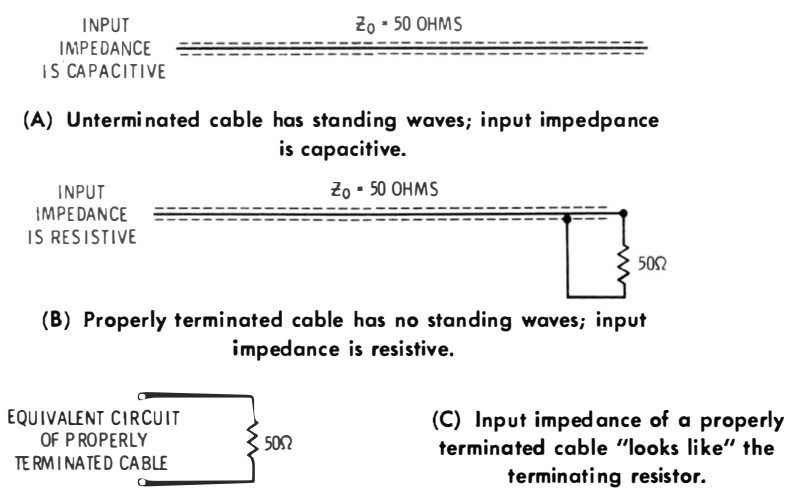
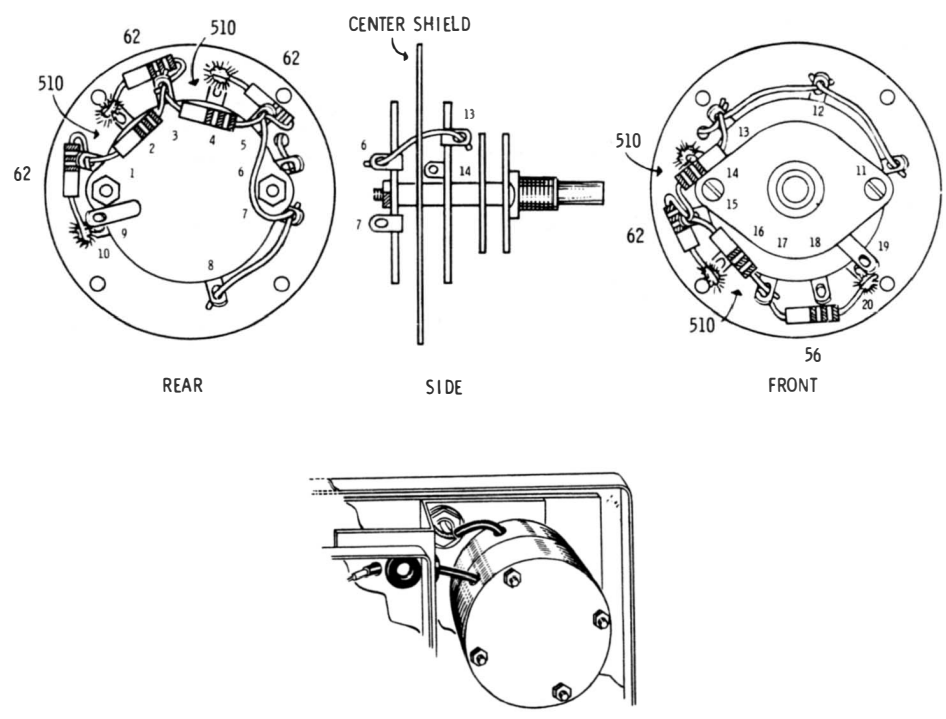

Fig. 1-15. Terminating resistor eliminates standing waves.

Hence, a copper shield blocks the passage of high-frequency electromagnetic fields.

The shielding problem would be considerably simpler if each compartment could be made water-tight. Unfortunately,



Courtesy Heath Co.

Fig. 1-16. Construction of a simple step attenuator.

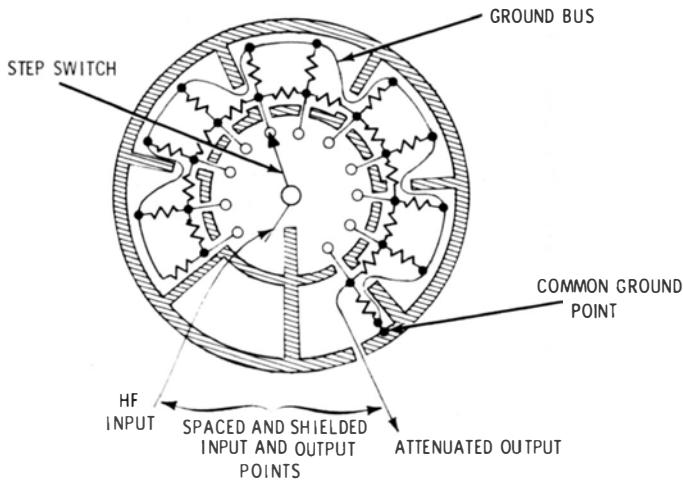

Fig. 1-17. A more elaborately shielded attenuator.

this is not possible in practice. Observe in Fig. 1-14 that input and output leads, as well as power-supply leads, must pass through the shield plates. The tuning-capacitor shaft as well as the switch shaft must be externally accessible. Moreover, tubes must eventually be replaced, and hence lids must be provided on associated shield compartments. In spite of these requirements, shield construction must be such that appreciable high-frequency leakage cannot occur.

High-frequency input and output leads consist of coaxial cable sections when the circuit impedance is comparatively low. Leads in high-impedance circuits must be exposed wires; however, double shielding may be utilized to minimize high-frequency leakage. Thus, the oscillator coils are often enclosed in a separate coil-shield compartment. Power-supply leads are bypassed or decoupled before they emerge from the shield box. Note the 0.005-mfd bypass capacitors in Fig. 1-14. When a wide attenuation range is necessary, such capacitors are of the feedthrough types. Better shielding action is obtained if all of the bypassed leads are brought out near the same place on the shield box—this grouping minimizes circulating ground currents.

In some cases, the bypassing action of a feedthrough capacitor alone is insufficient. Accordingly, the feedthrough capacitor is supplemented by an RC or LC low-pass filter, as depicted in Fig. 1-18. An RC filter is suitable for use with B+ supply leads. However, when heater leads must be filtered, an LC configuration is used. This is basically the same as the heater chokes and bypass capacitors used in i-f and r-f amplifiers of TV receivers. Access lids to compartments that con-

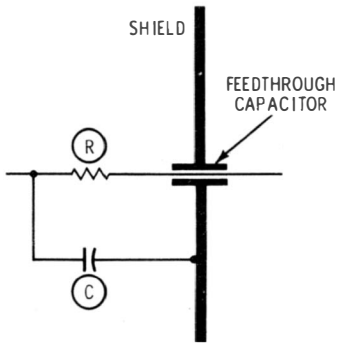

Fig. 1-18. RC low-pass filter supplements the feedthrough capacitor.

tain tubes must make good contact all around to the shield box. Hence, various bolts or specially designed spring clips are commonly provided to insure good contact.

When double-shielding is utilized, such as for oscillator coils, the inner shield box is connected to the outer shield box at only one point. This single high-frequency ground point minimizes the flow of circulating ground currents. If a power-supply lead must be brought through the shields, it should enter near the common grounding point; leakage is minimized by filtering the lead at the walls of *both* compartments. The extent to which such measures are employed depends primarily on the minimum signal-output level which the generator must provide.

Control shafts for tuning capacitors, switches, or potentiometers present another problem. Test oscillators may provide only a sliding spring contact against the shaft for high-frequency grounding. On the other hand, the residual leakage from this simple arrangement cannot be tolerated in calibrated signal generators. Two general methods are utilized to minimize leakage. In some cases, a metal control shaft is used. A specially designed collar is used where the shaft passes through the shield wall. The collar provides a very tight metal seal, while permitting shaft rotation. However, it is not always desirable to use a metal control shaft. If double-shielding is employed, it may not be practical to bring the shaft out near the common-grounding point. In such case, the shaft is very likely to set up circulating high-frequency ground currents.

This problem is overcome by using control shafts that are made of insulating material. Of course, a hole is present in the shield wall where the shaft passes through. To minimize high-frequency leakage via the entry, small metal tubes are provided, as depicted in Fig. 1-19. These tubes act as high-frequency chokes, and they greatly attenuate high-frequency energy which attempts to flow through them. It is necessary that the choke tubes have a diameter which is considerably

Fig. 1-19. Metallic tubes minimize high-frequency leakage.

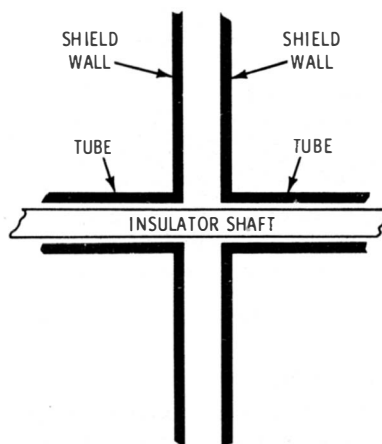

less than a half wavelength at the highest operating frequency of the generator. The length of the choke tubes is several times as great as their diameter.

UHF SIGNAL GENERATORS

The foregoing discussions and analyses concern basic features of generators that operate at frequencies below 250 mc. At higher frequencies, oscillators cannot employ conventional coils and capacitors, attenuators cannot utilize resistive ladder networks. Radiation and high-frequency leakage must be controlled by additional means. As explained subsequently, lumped-circuit analysis must be supplanted by transmission-line and waveguide analysis. Special tubes are used that have comparatively small interelectrode capacitances, low electrode inductance, and short transit time. At frequencies above 3000 mc, conventional tube construction is unsuitable, and other types of tubes such as Klystrons are required.

TRANSISTORIZED SIGNAL GENERATORS

There is a trend today toward transistorized signal-generator circuitry. It can be anticipated that this will be a growing trend. Since a transistor is an amplifier, it can be made to supply its own input and operate as an oscillator. As seen in Fig. 1-20, a transistor can be compared with a vacuum tube—the base is analogous to a control grid, the emitter to a cathode, and the collector to a plate. However, a transistor has low internal impedances (resistances) as compared with a tube. Hence, the base, or “grid,” draws appreciable current. For this reason, it is often said that a transistor is a current-operated device.

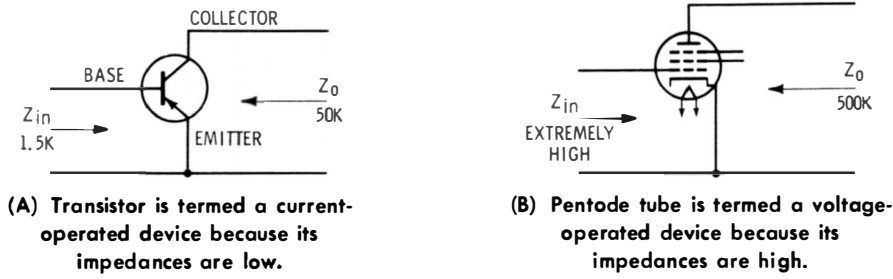

Fig. 1-20. Comparison of transistor and vacuum tube.

With the analogy to a vacuum tube in mind, it is easy to see how the sine-wave oscillator depicted in Fig. 1-21 works. The output from the collector is fed back, via the tuned tank circuit, to the base. A sine wave necessarily appears across the high-Q tank circuit. When the coupling between primary and secondary is sufficiently tight, the amplified output from the collector more than makes up for the circuit losses. In turn, sustained sine-wave oscillation occurs. The purity of the waveform depends solely on the Q of the tank circuit. This Q value is determined by the r-f resistance of the tank coil, and also by the amount of r-f current that is taken from the output.

As in a vacuum-tube type of signal generator, tuning capacitor C in Fig. 1-21 can provide a maximum frequency range of roughly 3-to-1. Hence, band switching must be employed to obtain a wide range of output frequencies. The configuration

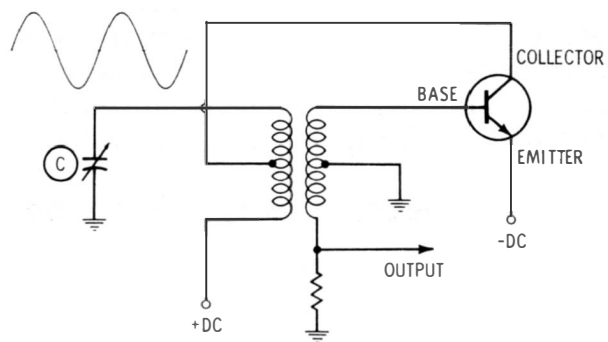
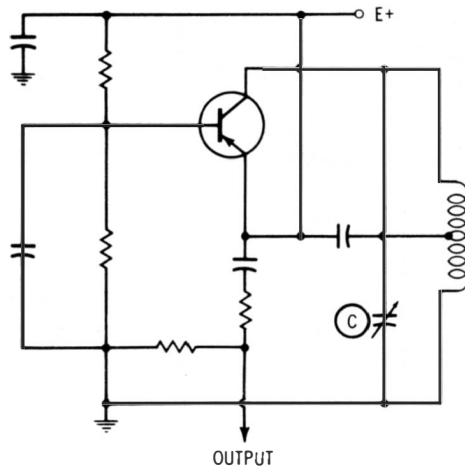

Fig. 1-21. A basic transistorized sine-wave oscillator.

depicted in Fig. 1-21 is a "tickler" type of oscillator. Since it requires two coils, generator designers often prefer to use a single tapped coil in a Hartley circuit, as shown in Fig. 1-22. This simplifies band-switching requirements, and reduces cost of manufacture. The tap point on a Hartley tank corresponds to the degree of coupling used in a tickler configuration.

The similarity of the circuit in Fig. 1-22 to the circuit in Fig. 1-21 is evident. In both arrangements the d-c supply voltage is applied to the emitter. This corresponds to the B+ voltage applied to the plate of a vacuum tube. It makes no difference whether the supply voltage is applied to the plate

Fig. 1-22. Basic transistorized Hartley oscillator for a signal generator.



or to the cathode of a vacuum tube, as long as the correct d-c distribution is realized. Similarly, the supply voltage can be applied to the emitter of a transistor, as long as the correct d-c distribution is maintained. The point of application is simply a matter of design convenience.

The r-f output is taken from the emitter circuit in both Fig. 1-21 and Fig. 1-22. Since the emitter has the lowest impedance (compared with the base and collector), load variations have least effect on the oscillating frequency. Just as in vacuum-tube types of signal generators, it is very desirable to maintain the oscillating frequency constant in spite of output load variations. In some applications the output cable may be connected to a high-resistance load, but in other applications the output cable may be connected to a low-resistance load. If the generator is well designed, the oscillating frequency will remain practically unchanged.

Next, let us see how the transistorized Hartley oscillator is elaborated in a typical signal generator. Fig. 1-23 shows the circuitry that is used. Two bands are detailed in Fig. 1-23, although the generator employs a total of seven bands. The seventh band is harmonically calibrated. Fundamental output is from 150 kc to 166 mc. A transistorized 400-cycle audio oscillator is provided for amplitude modulation of the r-f signal. A 400-ohm potentiometer serves as the r-f attenuator. Maxi-

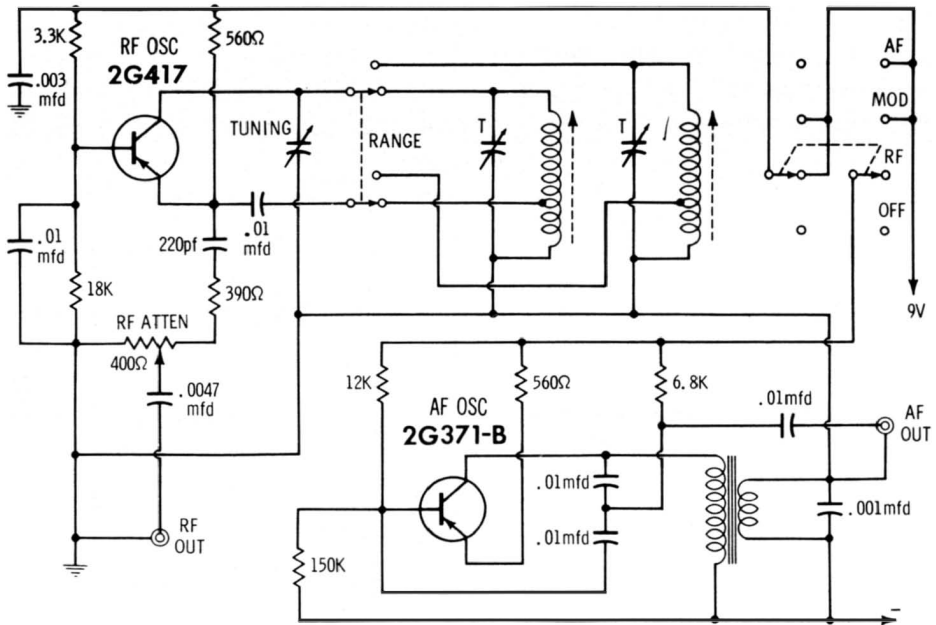

Fig. 1-23. Configuration of a transistorized signal generator.

imum r-f output is 50 millivolts rms. The percentage of modulation is fixed at approximately 30%.

Note that the tank coils are provided with both trimmer capacitors and tuning slugs. This feature permits optimum tracking of the tuning dial. In other words, a given frequency of oscillation can be obtained by increasing the trimmer capacitance and turning the slug farther out of the tank coil. Or, the trimmer capacitance can be reduced, and the slug turned farther into the coil. With the slug turned into the coil, the inductance is increased—the LC ratio is changed accordingly. This changes the frequency indication on the tuning dial. Hence, tracking can be optimized at the high and low ends of the tuning range.

The audio-oscillator circuit in Fig. 1-23 is somewhat novel in that it combines the features of both tickler-feedback (Fig. 1-21) and the Colpitts operation. In this case, the Colpitts arrangement generates a good sine wave, and tickler feedback provides a larger feedback voltage to obtain substantial output. Observe how the r-f oscillator is modulated: The audio-frequency output drops across the tickler coil, which is in series with the d-c supply voltage to the r-f oscillator. When the audio oscillator is operating, its sine-wave output is superimposed on the d-c voltage to the r-f oscillator. In turn, the r-f output is amplitude-modulated.

Note in passing that an r-f oscillator should not be amplitude-modulated when a signal generator is calibrated against a standard signal source. The reason for this is seen in Fig. 1-24. Amplitude modulation generates a pair of sideband frequencies. Suppose the r-f oscillator is operating at 1

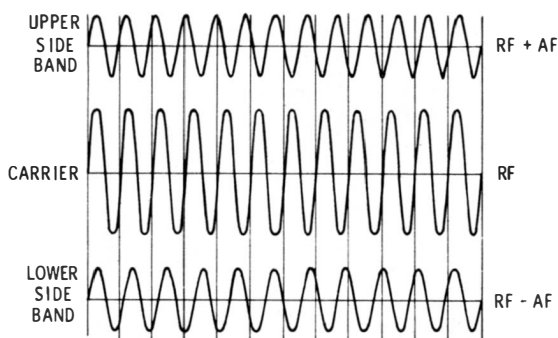

Fig. 1-24. Amplitude modulation generates a pair of sideband frequencies.

mc. If it is amplitude-modulated at 400 cycles, the generator then has three output frequencies. These frequencies comprise 1 mc plus 400 cycles, 1 mc, and 1 mc minus 400 cycles. In turn, it is difficult to determine true zero beat when the r-f carrier is amplitude-modulated.

SIGNAL GENERATOR AND SIGNAL TRACER

You will find that signal generators are sometimes combined with other instruments. For example, Fig. 1-25 illustrates a signal generator that is combined with a signal tracer for troubleshooting transistorized radio receivers. A simple transistor-testing circuit is also provided. The signal generator and signal tracer have independent functions, and they can be used separately if desired. Since this type of instrument has specialized application, the frequency range of the signal generator is comparatively restricted. Frequency coverage is from 200 kc to 1600 kc. The r-f output can be amplitude-modulated at 400 cycles.

As is the case with conventional signal generators, the 400-cycle audio signal is externally available for testing audio amplifiers. In addition, the audio-amplifier section of the signal tracer is externally available. It can be used to substitute for a defective audio amplifier in a radio receiver during preliminary troubleshooting procedures. Effectively, this type of instrument is a combination signal-injection and signal-tracing

device. The a-m generator section can be used for receiver alignment just as an ordinary signal generator.



Courtesy Hickok Electrical Instrument Co.

Fig. 1-25. Combination signal generator and signal tracer.

FREQUENCY-SYNTHESIZER GENERATORS

There is a growing trend to design lab-type signal generators as frequency synthesizers. These are generators of incremental frequency steps, and they are push-button operated. They are used in radio sounding, radar testing, doppler systems, spectrum analysis, and various other applications. A frequency-synthesizer generator does not use tuned LC circuits. Instead, quartz crystals are employed to generate basic frequencies of extremely high accuracy. Harmonics from these crystal oscillators provide higher frequencies. Mixers, frequency dividers, and amplifiers are used to combine the various fixed frequencies to synthesize a desired frequency output from the generator.

Obviously, only discrete frequencies can be obtained from a frequency-synthesizer generator. On the other hand, an extremely large number of frequencies are available. Each available frequency has unusually high accuracy. The percentage accuracy is the same as the percentage accuracy of the quartz-crystal oscillators. The smallest frequency step corresponds to the *resolution* of the frequency-synthesizer generator. A typical instrument has a resolution of 0.01 cps. Thus, when

the appropriate buttons are pressed, you can obtain an output frequency of 30,000,000.00 cycles, or 30,000,000.01 cycles.

A little arithmetic will show that a generator with a range from 0.01 cps to 50 mc will provide a total of 5 billion discrete frequencies. A typical frequency-synthesizer has a maximum drift rate per day of 3 parts in 10^9 . Thus, this type of generator has an accuracy which is about the same as that of a high-quality secondary frequency standard. The circuitry of a frequency-synthesizer generator is necessarily complex, and hence is not covered in this book. Interested readers may refer to engineering instrumentation texts for detailed information.

Chapter 2

Generator Accuracy and Calibration

We have seen that the accuracy rating of a signal generator may refer to frequency calibration, or to microvolt output calibration. Again, an accuracy rating may be placed either on the modulating frequency or on the percentage of modulation. An accuracy rating may state the carrier distortion (total harmonic distortion in the output signal). When the output signal is modulated, an accuracy rating may be placed on envelope distortion (harmonic distortion of the amplitude-modulated envelope). In the great majority of signal-generator applications, we are chiefly concerned with accuracy of frequency calibration. Hence, this chapter explains the most common methods and procedures used in frequency calibration.

A comparatively simple signal generator is illustrated in Fig. 2-1. A rating on the accuracy of frequency calibration specifies the *maximum* error which may occur in tuning-dial

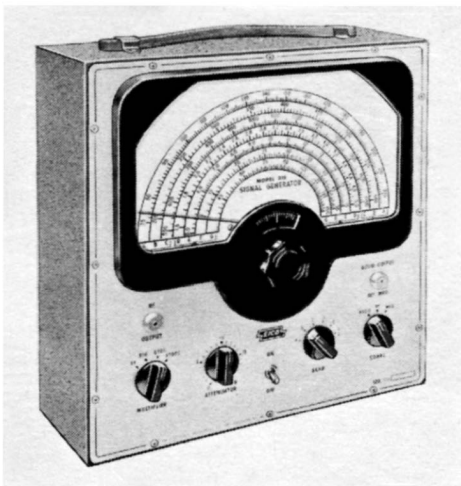

Fig. 2-1. A comparatively simple signal generator.

Courtesy Electronic Instrument Co.

indication. This does not mean that an error is always present. For example, if a tuning dial reads slightly high at one point and slightly low at another point, there is at least one intermediate point at which the dial reading is exactly correct. Since we have no prior knowledge of error distribution, unless we use some method of frequency calibration we are unable to work with more exact dial settings than rated.

FREQUENCY CALIBRATION AND ACCURACY RATINGS

The accuracy rating on frequency is commonly specified in terms of the dial reading. For example, if the rated accuracy is $\pm 1\%$ and the tuning dial is set to 40 mc, the generated frequency is between 39.6 and 40.4 mc. It is often desired to calibrate a generator to a much higher accuracy than its rating. There are two principal methods in common use for highly accurate calibration. One method, which incidentally provides maximum accuracy, is to beat the generator output against the standard frequencies transmitted by the National Bureau of Standards. Station WWV transmits on 2.5, 5, 10, 15, 20, and 25 mc 24 hours a day. These standard-frequency transmissions can be heard on any good short-wave radio receiver.

First, tune in the WWV transmission. If the signal happens to be modulated at 440 cycles or 600 cycles or the station announcement is being made, wait until the continuous-wave (CW) transmission interval starts. Then, place the signal-generator output cable near the input terminals of the radio receiver. Adjust the tuning dial of the generator for zero beat. When a zero beat is obtained the generator is operating at the WWV frequency. Of course, this is a spot-frequency check, which provides calibration only at 2.5, 5, 10, 15, 20, or 25 mc. However, you can take advantage of the fact that most signal generators have at least a small percentage of harmonic output.

For example, even a standard signal generator may be rated for 7% carrier distortion. This rating refers to total harmonic distortion. If you tune the generator to 1.25 mc and advance the output level, you will hear a beat between the second harmonic of the generator frequency and the 2.5-mc WWV signal. Hence, you can easily calibrate the generator to extremely high accuracy at 1.25 mc. Again, suppose you wish to calibrate the generator at 3 mc. Tune in the 15-mc WWV signal on the receiver and set the generator dial to 3 mc. In many cases, the fifth harmonic of the generator will produce an audible beat. It is sometimes necessary to couple the gener-

ator output to the antenna-input terminal of the receiver through a small capacitor.

Harmonic calibration increases the available number of spot-frequency checks. Nevertheless, many practical situations arise which require calibration at arbitrary frequencies that are not harmonically related to WWV signals. Hence, quartz-crystal oscillators are commonly used as *secondary frequency standards*. Note that WWV signals are *primary* frequency standards. In other words, WWV signals have the highest attainable accuracy, and therefore they are the standard of comparison. The National Bureau of Standards states that their atomic standards are accurate to two parts in 100 billion. Any oscillator or generator which is zero-beat against a WWV signal is called a secondary frequency standard, which implies that there is a probable experimental error. Nevertheless, the secondary standard can be adjusted to very high accuracy. A suitable secondary standard will provide spot-check frequencies at 100-kc intervals, for example.

Hence, quartz-crystal oscillators are the second principal method used for highly accurate calibration of signal generators. Marker generators often have built-in crystal oscillators. Some signal generators have crystal oscillators. In any case, it is easy to construct a quartz-crystal oscillator (Fig. 2-2). Since quartz crystals are cut to operate in various circuit configurations, it is advisable to query the crystal manufacturer for his recommendation. The crystal should be tunable through the desired frequency, such as 100 kc. It is much easier to use a calibrator which has a fundamental frequency, for example, of 100 kc, instead of 99 kc or 101 kc. If a 100-kc crystal is used, its harmonics will provide spot checks at successive 100-kc intervals.

At comparatively low frequencies, such as 100 kc, lead lengths and parts layout are not critical in an oscillator circuit.

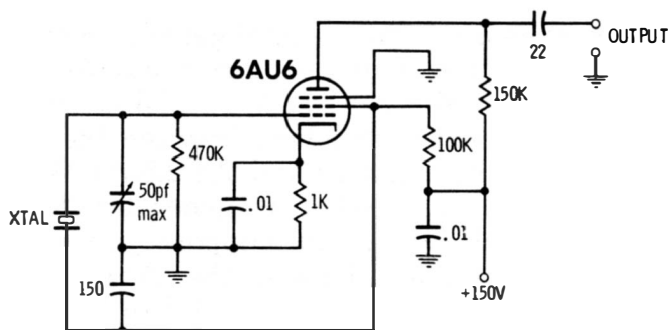

Fig. 2-2. Schematic of a shop-constructed calibrator.

Note the 50-pf trimmer capacitor connected between grid and cathode in Fig. 2-2. This is a maintenance control that is adjusted to calibrate the oscillator. Since a quartz crystal can be tuned only over a small range, it is necessary that the crystal be ground to oscillate at a frequency very slightly *higher* than 100 kc. Then, the trimmer capacitor is adjusted, as required, to bring the oscillating frequency to 100 kc with reference to WWV. It is not practical to calibrate the crystal oscillator directly, because it is difficult to identify the higher harmonics. Hence, it is advisable to use a signal generator to count harmonics at the outset.

Fig. 2-3 shows how 100-kc beat points are distributed on the various bands of a typical signal generator. The first band has a range from 50 to 150 kc—hence, only one beat occurs on the first band. Fig. 2-4 depicts a very simple method for

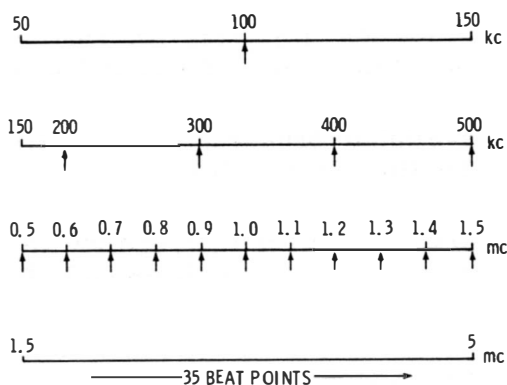

Fig. 2-3. Calibration points become more numerous on the higher bands.

beating a crystal oscillator against a signal generator. Few shops have radio receivers with a response below 550 kc. Hence, the arrangement in Fig. 2-4 is very useful for checking beats in the low-frequency range. A very strong beat is normally audible near the 100-kc point of the signal-generator dial. Its presence indicates that the crystal oscillator is operating as intended. If this fundamental beat is absent, check the oscillator circuit for a wiring error, or a defective quartz crystal.

After the fundamental beat has been verified, set the signal generator to the second band, depicted in Fig. 2-3 (150 to 500 kc in this example). You will expect to hear progressively weaker beats in the vicinity of the 200, 300, 400, and 500 kc dial points. Since there are only four beat points on this band, the first four harmonics (2nd, 3rd, 4th, and 5th harmonics)

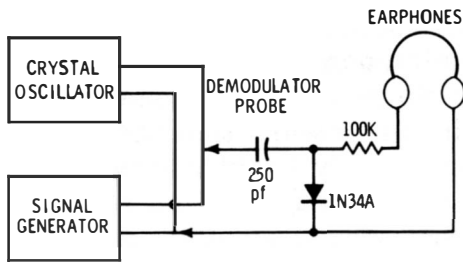

Fig. 2-4. A demodulator probe and earphones can be used to count harmonics.

are easily accounted for. It is not likely that the generator dial will indicate the exact harmonic frequencies. However, at this time we are concerned only with counting off the lower harmonics and verifying their presence.

Next, rough calibration of both of the signal generator and crystal oscillator can be made. Note that the third band in Fig. 2-3 (0.5 to 1.5 mc) includes the a-m broadcast band. Hence, the output from this generator band can be fed into an ordinary radio receiver for zero-beating against various broadcast stations. Since these frequencies are specified to fairly high accuracy, the third generator band can be calibrated against available broadcast-station frequencies. This preliminary calibration is helpful, because there are more harmonic check points on the third band (11 in this example). It is only necessary to note the discrepancy in generator calibration at the low end, middle, and high end of the third band.

Observe whether the successive harmonic beats on the third band agree with the generator calibration as determined from beats against a-m broadcast stations. It is not likely that agreement will be exact. Hence, touch up the trimmer adjustment in the crystal oscillator as required. This rough calibration of the oscillator is very helpful in identification of harmonics on the following generator band. You are then prepared to make the final calibration of the crystal oscillator. Note that the fourth generator band (Fig. 2-3) contains 35 beat points. Let us assume that you have calibrated the fourth band at 2.5 mc against WWV. This one setting is accordingly known to be very accurate.

In turn, final calibration of the crystal oscillator is made as follows: With the signal generator zero-beat at 2.5 mc against WWV, disconnect the antenna from the radio receiver, and apply the output from the crystal oscillator. It is not necessary to count harmonics on the fourth band, because the oscillator is already in rough calibration. Now, adjust the trimmer in the crystal oscillator for zero beat against the signal generator. The crystal oscillator is then calibrated to very high accuracy.

LOW-BAND CALIBRATION

The crystal oscillator can be used to accurately calibrate the low bands of the signal generator. The test setup shown in Fig. 2-4 is most convenient. In most cases, a check point occurs at 50 kc (Fig. 2-3), in addition to 100 kc. Even standard signal generators have a slight harmonic output—hence, the second harmonic of the generator produces an audible beat when the dial is set to 50 kc. In case you are calibrating a test oscillator, an audible beat can be expected when the dial is set to 150 kc—in this case, the second harmonic of the generator is beating with the third harmonic of the crystal (at 300 kc). Such *interharmonic beats* are comparatively weak, and they may pass unnoticed, unless you substitute an oscilloscope for the earphones depicted in Fig. 2-4.

There are two ways of calibrating the generator ranges. First, the errors in dial indications can be recorded at avail-

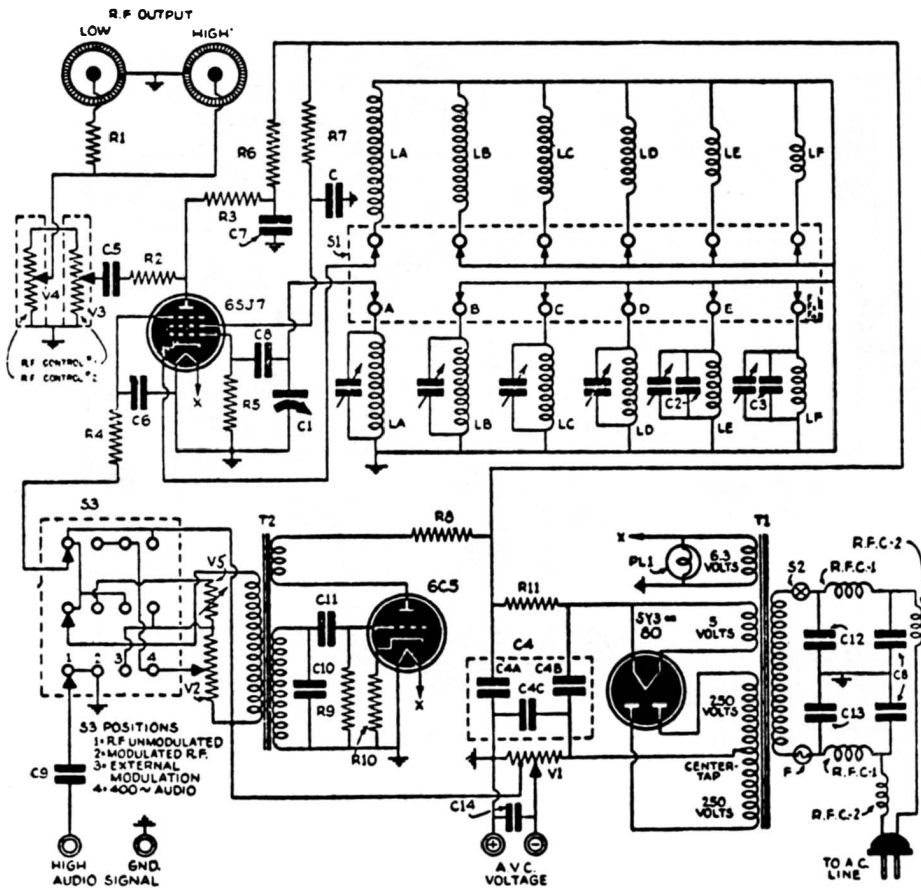

Courtesy Precision Apparatus Co.

Fig. 2-5. Trimmer capacitors in the signal generator can be adjusted.

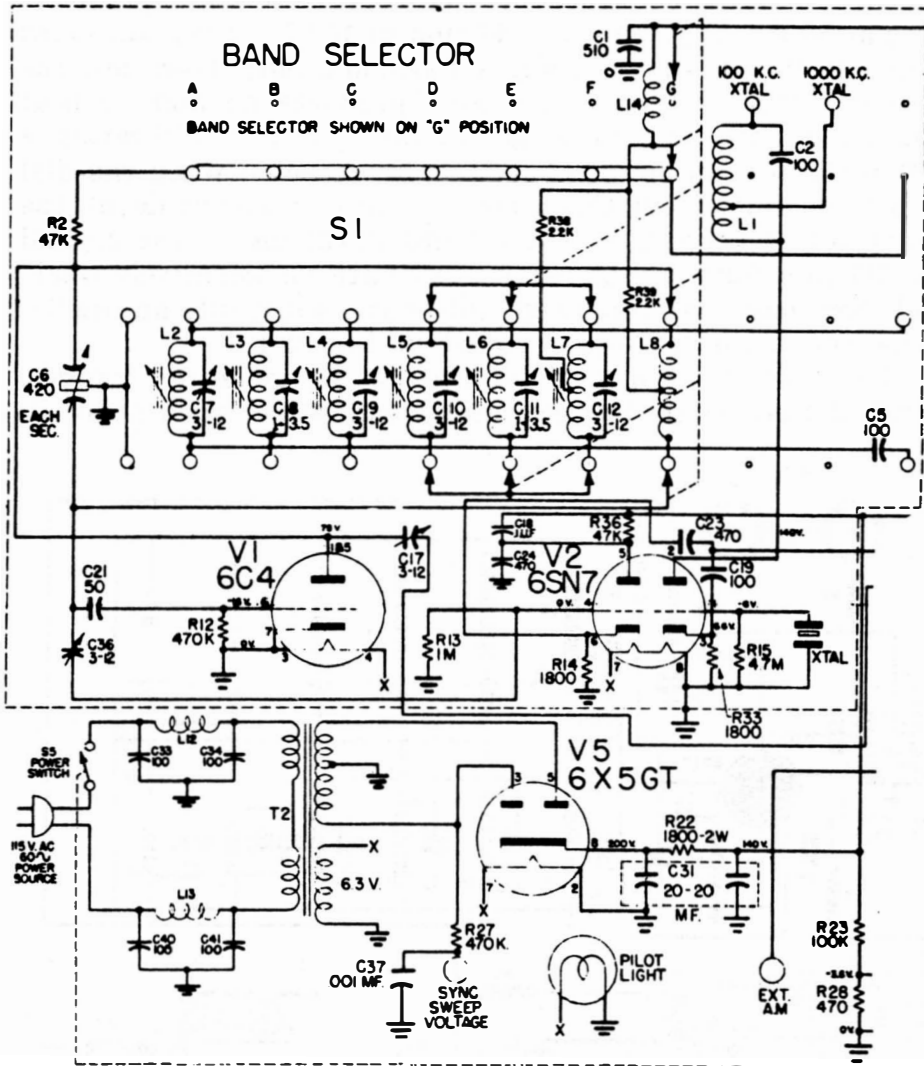

ALL VALUES FOR CAPACITORS ARE IN MMF UNLESS OTHERWISE INDICATED.
 ALL RESISTORS 1/2 WATT UNLESS OTHERWISE INDICATED.

* VALUE SHOWN FOR R-29 & R32 ARE APPROXIMATE, EXACT VALUE DETERMINED IN PRODUCTION.

+ = CONNECTION
 - = NO CONNECTION

Fig. 2-6. Slug tuning is sometimes

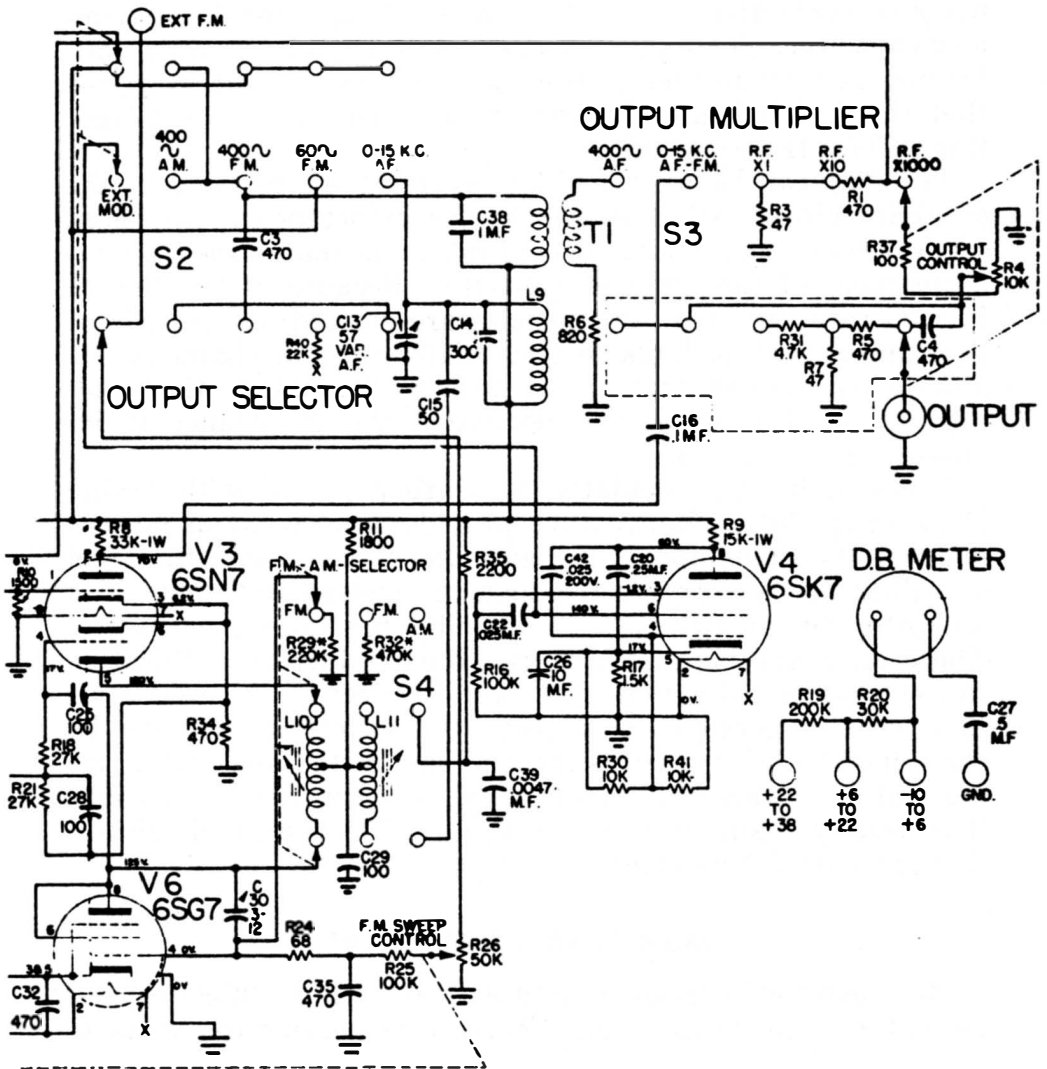

Courtesy Hickok Electrical Instrument Co.

provided for tracking adjustments.

able beat points. This may take the form of a chart or a graph. Second, when the dial error is consistently high or consistently low, it is advisable to touch up the trimmer adjustments in the generator. Fig. 2-5 shows a simple trimming configuration in which each coil is shunted by a trimmer capacitor. The trimmers are chiefly useful for exact calibration at midband on each range. In turn, it often happens that the dial indicates incorrectly at each end of its range; this called a tracking error.

Tracking can be controlled by varying the L/C ratio of the oscillator circuit. In other words, the inductance is increased or decreased, and midband calibration is maintained by re-adjustment of the trimmer capacitor. Because of the change in L/C ratio, resonant frequencies are shifted at the ends of the tuning ranges. Coils in test oscillators and signal generators often have several spaced turns at the ends of the windings. When the spacing is decreased the inductance is increased, and vice versa.

Occasionally, the oscillator coils are provided with tuning slugs (Fig. 2-6). This feature provides a convenient adjustment of the inductance. Slug adjustment has the same effect on calibration as varying the spacing between coil turns. You will often find that the tuning capacitor has slotted end plates. These slots are bent as required during factory calibration to compromise indication error on all ranges of the generator. It is seldom possible to improve the *overall* calibration by changing the factory adjustment of the slotted sections. After the dial indication has been tracked as accurately as possible, it is usually desirable to plot a graph of the residual calibration error for future reference.

HIGH-BAND CALIBRATION

High-band calibration is impractical with a 100-kc crystal oscillator, because the higher harmonics become too weak to be useful. Spot checks can be made at 5-mc intervals up to 25 mc against WWV transmissions. Calibration at frequencies from 25 mc to 250 mc must be made with suitable crystal oscillators. Some marker generators accordingly have built-in crystal oscillators which have a fundamental frequency of 5 mc. An oscilloscope is commonly used as the beat indicator. Maximum gain must be utilized when calibrating in the 200-mc range, because the higher harmonics are quite weak.

A 5-mc crystal oscillator can be calibrated directly against WWV transmissions. For example, tune in the 5-mc WWV signal on a short-wave radio receiver. Then, place the gener-

ator output cable near the receiver and turn the crystal oscillator on. Adjust the trimmer capacitor in the crystal circuit for zero beat. If it is more convenient to tune in a 10-mc or 15-mc WWV signal, the procedure is the same. In such case, the second or third harmonic of the quartz crystal is zero beat against the received signal.

Calibration of a marker generator with a 5-mc crystal oscillator is straightforward, provided that the generator has negligible harmonic output. A zero beat will be observed at each multiple of 5 mc on the tuning dial. The more elaborate marker generators have a practically pure sine wave (negligible harmonic output). On the other hand, many marker generators have a strong harmonic output, and the tuning dial is harmonically calibrated on one or more bands. If your marker generator has strong harmonics, you will find numerous interharmonic beats present when checking calibration with a 5-mc crystal oscillator.

Let us take a practical example. Consider a marker generator with coverage on fundamentals from 3.3 to 7.72 mc, from 15 to 37.5 mc, and from 70 to 125 mc. The tuning dial is calibrated both in terms of fundamentals and second harmonics (Fig. 2-7). Thus, the marker ranges are:

- Band A: 3.3 to 7.72 mc on fundamentals
6.6 to 15.6 mc on second harmonics
- Band B: 15 to 37.5 mc on fundamentals
30 to 75 mc on second harmonics
- Band C: 75 to 125 mc on fundamentals
150 to 250 mc on second harmonics

Of course, when the 5-mc crystal is turned on to check dial indication, many interharmonic beats are observed between 5-mc steps. An oscilloscope is used as the zero-beat indicator. When maximum vertical sensitivity is utilized, visible beats are displayed at the frequencies tabulated in Table 2-1. A brief analysis of the tabulation shows that interharmonic beats provide a great many check points in addition to the 5-mc steps. For example, only one check point at 5 mc would be present on Band A, if it were not for the harmonic output from the marker generator. However, generator harmonics up to the 13th contribute to interharmonic beats. Similarly, crystal harmonics up to the 13th produce visible interharmonic beats. Hence, there are 30 check points available on Band A.

Higher harmonics produce weaker interharmonic beats. Accordingly, the 5-mc beat point is strongest on Band A. If the scope sensitivity is turned down sufficiently, only the 5-mc

TABLE 2-1. INTERHARMONIC

Band A				Band	
Fundamental Megacycles	2nd Harmonic Megacycles	Var. Osc. Harm.	Xtl. Osc. Harm.	Fundamental Megacycles	2nd Harmonic Megacycles
*3.33	*6.67	3	2	*15.00	*30.00
3.46	6.92	13	9	15.83	31.66
3.50	7.00	10	7	16.00	32.00
3.57	7.14	7	5	16.25	32.50
3.64	7.28	11	8	*16.67	*33.34
*3.75	*7.50	4	3	17.00	34.00
3.89	7.78	9	7	*17.50	*35.00
*4.00	*8.00	5	4	18.00	36.00
4.09	8.18	11	9	\$18.33	*36.66
*4.17	*8.34	6	5	18.75	37.50
4.29	8.58	7	6	19.00	38.00
4.38	8.76	8	7	*20.00	*40.00
*4.44	*8.88	9	8	21.00	42.00
4.50	9.00	10	9	21.25	42.50
4.55	9.10	11	10	*21.67	*43.34
4.58	9.17	12	11	22.00	44.00
*5.00	*10.00	1	1	*22.50	*45.00
5.63	11.26	8	9	23.00	46.00
*5.71	*11.42	7	8	*23.33	*46.66
5.83	11.66	6	7	23.75	47.50
6.00	12.00	5	6	24.00	48.00
*6.25	*12.50	4	5	*25.00	*50.00
6.43	12.86	7	9	26.25	52.50
*6.67	*13.34	3	4	26.67	53.34
6.87	13.74	8	11	*27.50	*55.00
*7.00	*14.00	5	7	28.33	56.66
7.14	14.28	7	10	28.75	57.50
7.22	14.44	9	13	*30.00	*60.00
*7.50	*15.00	2	3	31.67	63.34
7.72	15.44	11	17	*32.50	*65.00
				33.33	66.66
				*35.00	*70.00
				36.67	73.34
				*37.50	*75.00

ASTERISK (*) INDICATES THE

BEAT FREQUENCIES.

B		Band C			
Var. Osc. Harm.	Xtl. Osc. Harm.	Fundamental Megacycles	2nd Harmonic Megacycles	Var. Osc. Harm.	Xtl. Osc. Harm.
1	3	*70.0	*140	1	14
6	19	72.5	145	2	29
5	16	*75.0	*150	1	15
4	13	77.5	155	2	31
3	10	*80.0	*160	1	16
5	17	82.5	165	2	33
2	7	*85.0	*170	1	17
		87.5	*175	2	35
		*90.0	*180	1	18
4	15	92.5	185	2	37
5	19	*95.0	*190	1	19
1	4	97.5	195	2	39
5	21	*100.0	*200	1	20
4	17	102.5	205	2	41
3	13	*105.0	*210	1	21
5	22	107.5	215	2	43
2	9	*110.0	*220	1	22
5	23	112.5	225	2	45
3	14	*115.0	*230	1	23
4	19	117.5	235	2	47
5	24	*120.0	*240	1	24
1	5	122.5	245	2	49
4	21	*125.0	*250	1	25
3	16				
2	11				
3	17				
4	23				
1	6				
3	19				
2	13				
3	20				
1	7				
3	22				
2	15				

STRONGER CALIBRATION POINTS

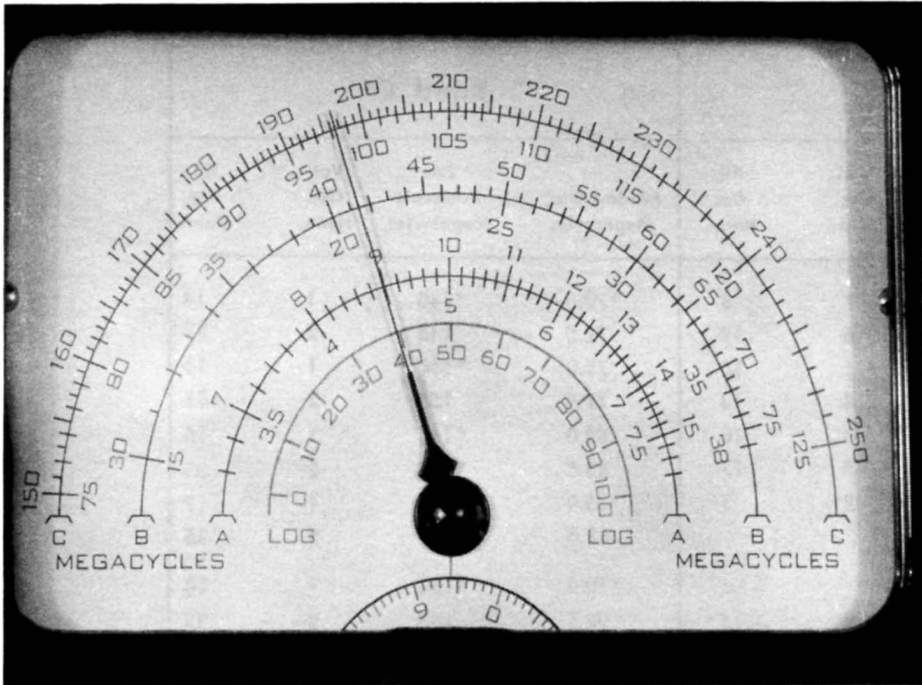

Fig. 2-7. Each band is calibrated in terms of fundamentals and second harmonics.

beat is visible. Then, if you increase the sensitivity somewhat, you will also see beat patterns at frequencies marked by asterisks in Table 2-1. These are comparatively strong interharmonic beats between the lower harmonics. Finally, if you advance the scope gain to maximum, you will also see beat patterns at the remaining frequencies noted in Table 2-1. These are comparatively weak interharmonic beats between the higher harmonics.

At first glance, the interharmonic beat frequencies seem to have no relation to the 5-mc crystal frequency. However, each interharmonic beat frequency is related to 5 mc by multiples. For example, an interharmonic beat is visible at 3.5 mc on Band A. In this case, the tenth harmonic of the marker generator is zero-beating with the seventh harmonic of the crystal oscillator. To put it another way, $10 \times 3.5 = 7 \times 5$. The interharmonic beat frequency is 35 mc, which is a multiple of 5 mc.

The accuracy of calibration at any point depends solely on the accuracy of the crystal-oscillator frequency. If you verify the crystal frequency first with respect to a WWV transmission, subsequent calibration of the marker generator will be highly accurate. Suppose that the quartz crystal is operating within $\pm 0.01\%$ of 5 mc, which is easily possible to realize. In such case, its actual frequency will be somewhere between

5,000,500 cycles and 4,999,500 cycles. Next, if you carefully calibrate the marker generator at 200 mc, its actual frequency will be somewhere between 200,020,000 cycles and 199,980,000 cycles. The possible error is ± 20 KC.

Since conventional marker generators tend to drift noticeably on high-frequency bands, good practice dictates that calibration be checked often. On the other hand, a crystal oscillator drifts very little. Hence, the crystal oscillator need be checked against WWV only at infrequent intervals. If a tube is replaced in the crystal-oscillator circuit, a calibration check should be made after a suitable run-in period. If the crystal oscillator is run-in overnight, the tube will have stabilized, and a meaningful calibration check can be made. After careful calibration against a WWV transmission, the crystal oscillator in a marker generator is typically rated at an accuracy of $\pm 0.01\%$ for a long period thereafter.

DUAL-CRYSTAL CALIBRATORS

Dual-crystal calibrators are utilized to obtain a systematic sequence of calibration points at closely spaced intervals. Fig. 2-8 depicts a typical arrangement in which either a 10-mc oscillator or a 1-mc oscillator can be switched into operation.

Fig. 2-8. Dual-crystal oscillator provides calibration checks at 10-mc or 1-mc intervals.

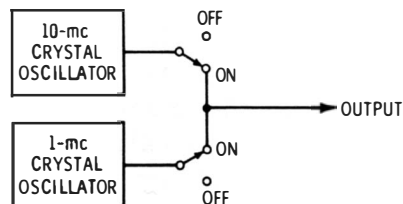

At first glance, it might seem that the 10-mc oscillator is not required, since it has no harmonics that are not provided by the 1-mc oscillator. Why should harmonics from the 1-mc oscillator be duplicated? There is a very practical reason:

1. If only a 10-mc oscillator is provided, the calibration check points are too widely separated along the tuning range.
2. If only a 1-mc oscillator is provided, confusion may arise concerning harmonic identification—particularly on the high bands of the generator.

Let us take practical examples of these facts. Suppose we need to set a marker generator to 45.75 mc, and can check

calibration only at 40 mc and 50 mc. This situation occurs when only a 10-mc oscillator is used. The generator's tuning dial is not likely to indicate exactly at either 40 mc or 50 mc. Hence, it becomes difficult to estimate the 45.75-mc setting with good accuracy. Evidently, we need to have more closely spaced calibration intervals, such as 45 mc and 46 mc. This requirement is easily met by using a 1-mc oscillator.

However, suppose that we have only a 1-mc oscillator available. In such case, appreciable generator drift can cause confusion. For example, suppose that the tuning dial does not indicate exactly at 45 mc and at 46 mc. Instead, the dial might indicate zero beats at 45.5 mc and at 46.5 mc. How can we tell which of these zero-beats indicates a 46-mc frequency? This is not possible unless we utilize a lower-frequency oscillator to show whether the dial indication is high or low. Therefore, we switch the 10-mc oscillator into operation first. The zero-beat at 40 mc is clearly defined without any doubt. In other words, the marker generator will never drift as much as 5 mc. Accordingly, it is obvious whether the 0.5-mc discrepancy previously noted is a "high" or "low" indication on the tuning dial. Furthermore, we can count off 1-mc intervals as follows:

1. First, switch on the 10-mc oscillator. Zero-beat the generator at 40 mc.
2. Second, switch on the 1-mc oscillator (Fig. 2-8). Then, advance the tuning dial and count off 41, 42, 43, 44, 45, and 46-mc zero-beat points. No question remains concerning the location of 45 and 46 mc.
3. Finally, set the tuning dial $\frac{3}{4}$ of the interval between the 45-mc and 46-mc zero-beat points. The output frequency is then set to 45.75 mc with quite high accuracy.

To facilitate dial settings at fractional intervals (such as $\frac{3}{4}$ of the distance between 45 mc and 46 mc), some marker generators have an adjustable pointer. The pointer can be turned slightly up or down on the tuning shaft by a pointer-control knob. Therefore, when you zero-beat the generator at 45 mc, the pointer control is turned to make the dial read exactly 45 mc. This is very helpful, because the subdivisions then read correctly, and no calculation is required to find the $\frac{3}{4}$ point between 45 mc and 46 mc.

With reference to Fig. 2-8, it is obvious that any slight drift in frequency of either the 10-mc oscillator or the 1-mc oscillator will produce a beat note. Therefore, a practical dual-oscillator system must either:

1. Provide a front-panel maintenance control for tuning one of the crystal oscillators over a range of several cycles. This permits the two crystal oscillators to be maintained at exact zero beat at all times.
2. Use a 10-mc crystal oscillator and a 1-mc LC oscillator which is locked in (synchronized with) the 10-mc oscillator.

We find both of these methods used in various marker generators. The first method employs a very small trimmer capacitor connected across one of the quartz crystals, with a shaft which is adjustable from the front panel. This control is typically called a "Crystal Adjust" control. In practice, we merely turn the crystal-adjust control until the slow beat between the two crystals is eliminated. Or, the two crystal oscillators are zero-beat.

The second method is illustrated in Fig. 2-9. When the slug in L10 is adjusted for an oscillating frequency slightly lower

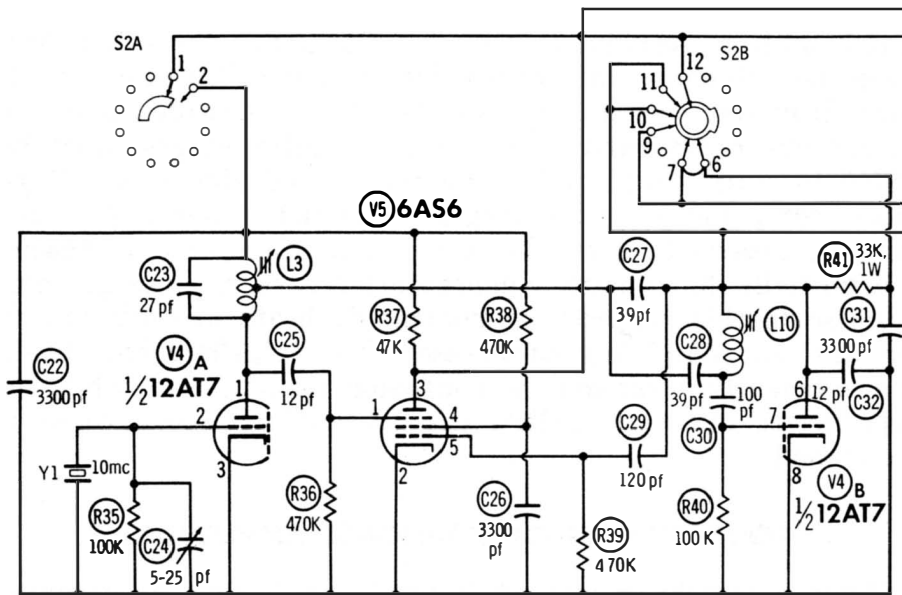

Fig. 2-9. The 1-mc oscillator (L10) is synchronized by the 10-mc crystal (Y1).

than 1 mc, the 10-mc output from Y1 then triggers the 1-mc oscillator. We say that the 1-mc oscillator locks in with the 10-mc oscillator. An LC oscillator will lock in over an appreciable range, just as a multivibrator will lock in with trigger pulses over an appreciable range. Capacitor C24 in Fig. 2-9 is a calibrating adjustment. It is used to zero-beat Y1 against a WWV signal. When Y1 is accurately calibrated, it follows

that the 1-mc oscillator is automatically calibrated to an equally high accuracy.

INTERHARMONIC BEATS

Marker generators that have dual calibrating oscillators may or may not produce interharmonic beats. This depends entirely on the generator oscillator circuit used. If the generator oscillator has negligible harmonic output, no interharmonic beats occur. To continue the previous example, when the 10-mc crystal oscillator is operating, we will find beat points only at 10-mc intervals along the tuning dial. Again, we will find beat points only at 1-mc intervals along the tuning dial when the 1-mc calibrating oscillator is operating. On the other hand, suppose the marker generator has appreciable harmonic output. Then, we will find additional beats (the weaker interharmonic beats) between the 10-mc intervals on the dial, when the 10-mc crystal oscillator is operating. And, we will find interharmonic beats when the 1-mc calibrating oscillator is operating.

It is more convenient to use a marker generator which produces no interharmonic beats during the calibration procedure. However, generators designed for negligible harmonic output are comparatively expensive. Buffer stages must be added to maintain light loading for a good sine wave. More tubes, components, and a larger regulated power supply become necessary. In turn, the cost of manufacture is increased substantially. Most marker generators represent a design compromise in this regard; interharmonic beats are minimized, but are not completely suppressed. The interharmonic beats are sufficiently weak that no confusion results, even when inexperienced operators follow the calibration procedure as it is outlined.

EQUALIZATION OF HARMONIC AMPLITUDES

When a simple crystal oscillator is used, such as depicted in Fig. 2-2, we find that the successive harmonics become progressively weaker. As a rough rule of thumb, technicians often consider that the strength of a harmonic is proportional to its order. For example, the tenth harmonic is roughly $1/5$ as strong as the second harmonic. A crystal calibrator is easier to use if the higher harmonics are about the same strength as the lower harmonics. Hence, a harmonic amplifier is sometimes used after the crystal oscillator. The simplest arrangement is depicted in Fig. 2-10.

The plate load is an impedance which has a rising response at high frequencies. Coil L is tuned to resonate at the highest harmonic frequency to be used in calibration. Hence, the stage has maximum gain at this resonant frequency. At lower harmonic frequencies, the stage gain falls off. The Q of the load impedance is comparatively low so that the gain does not fall off too rapidly at lower frequencies. Some calibrators make use of several plate-load impedances. When the generator is switched to a higher band, the calibrator load impedance is also switched to a higher peak frequency.

Note in Fig. 2-10 the small coupling capacitor (10 pf) used to feed the output of the booster amplifier to the mixer and

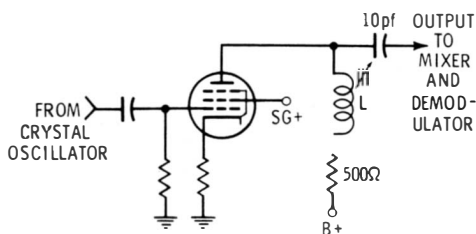

Fig. 2-10. A simple harmonic-booster amplifier.

demodulator section. The small capacitor has increasing reactance at lower frequencies. In turn, this reactance variation assists the plate-load impedance in equalizing the harmonic amplitudes. Elaborate TV calibrators are designed to provide practically as strong a beat output at 200 mc as at 20 mc. Since more tubes and components are necessary, generators that have extensive equalization of harmonic amplitudes are comparatively costly.

MEASUREMENT OF GENERATOR OUTPUT VOLTAGE

There are several ways to measure the output voltage of a signal generator. One of the simplest methods is shown in Fig. 2-11. A field-strength meter calibrated in microvolts is used to measure the signal voltage directly. Note that the output impedance of the generator should match the input impedance of the field-strength meter. For example, if the generator has a 75-ohm output impedance, the field-strength meter should also have a 75-ohm input impedance. This input impedance takes the place of a 75-ohm resistor used to terminate the output cable of the signal generator.

However, there are certain limitations to the method depicted in Fig. 2-11. First, a field-strength meter has a limited frequency range. For example, a vhf field-strength meter cov-

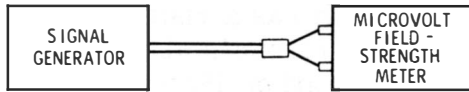

Fig. 2-11. A calibrated field-strength meter can be used to measure the signal-generator output.

ers frequencies from 54 mc to 216 mc. A uhf field-strength meter covers the frequency range from 470 mc to 890 mc. Hence, the generator output voltage can be checked only on those bands which fall within the frequency range of the field-strength meter. Another limitation concerns the accuracy of the field-strength meter. Instruments with high accuracy ratings are comparatively expensive.

Another way to measure the output voltage of a signal generator is to make a comparison test, as shown in Fig. 2-12.

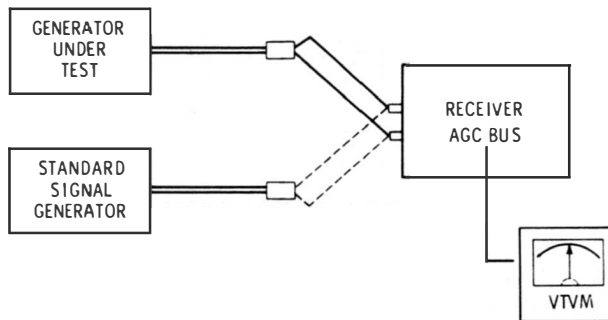

Fig. 2-12. Comparison test requires the availability of a standard signal generator.

This requires the availability of a standard signal generator. Outputs from the generators are compared by connecting one generator to a receiver, and then substituting the other generator. Attenuators are set to produce the same reading on a vtvm connected to the AGC line in the receiver. If the generator under test is accurate, its attenuator setting will be the same as for the standard signal generator. Errors in microvolt indication for the generator under test can be tabulated on a calibration chart, or they can be plotted as a curve on graph paper.

Recall that test oscillators do not have calibrated attenuators. A hand-drawn scale can be added to a test oscillator, and calibrated on the basis of readings obtained in the arrangement of Fig. 2-12. Sometimes it is desired to add a microvolt attenuator to a test oscillator. Several manufacturers of lab-type equipment and at least one service-equipment manufacturer offer microvolt attenuators. When the attenuator is added to a test oscillator, it is also necessary to include an r-f voltmeter with a carrier-level potentiometer. The necessity for

setting the carrier level to a reference value was noted in in Chapter 1.

MEASUREMENT OF HARMONIC AMPLITUDES

High-quality signal generators have very little harmonic output. For example, a marker generator might be rated for less than 2% total harmonic distortion. A wide-range signal generator might be rated for less than 7% total harmonic distortion. On the other hand, an oversimplified generator might have 50% total harmonic distortion. The amplitude of a certain harmonic (second harmonic, third harmonic, etc.) can be measured with either of the test setups shown in Figs. 2-11 and 2-12. First, note the level of the signal when the generator is tuned to its fundamental frequency. Then, tune the generator to twice this frequency. In turn, the level of the second harmonic can be compared with the level of the fundamental.

Let us take a specific example. Suppose we wish to measure the amplitude of the second harmonic from a signal generator that has a fundamental frequency of 1 mc. With reference to Fig. 2-12, tune the generator under test to 1 mc and set its attenuator to a chosen level, such as 1,000 microvolts. This setting is determined by comparison with the standard signal generator. Next, with the generator under test still tuned to 1 mc, tune the receiver to 2 mc. The vtvm reading will be much lower. Finally, substitute the standard signal generator and tune it to 2 mc. Reduce the setting of its microvolt attenuator to obtain the same reading on the vtvm as before. This might be a setting, for example, of 200 microvolts. Your conclusion is that the generator under test has a second-harmonic amplitude of 20%.

The same procedure can be used to measure the amplitudes of the third harmonic, fourth harmonic, etc. The higher harmonics are weaker, and they will become unmeasurable at some point. What is the total harmonic distortion? This is defined as the square root of the sum of the squares of the individual harmonic amplitudes. For example, let us say that the second harmonic has an amplitude of 20%, the third harmonic has an amplitude of 10%, and the fourth harmonic has an amplitude of 1%, all with reference to the fundamental amplitude. Then, the total harmonic distortion is equal to approximately 22.4%.

This is the *definition* of total harmonic distortion. A rating on total harmonic distortion obviously does not tell the relative amplitudes of individual harmonics. Hence, we are often

interested in breaking down a total-harmonic distortion figure into its individual harmonic amplitudes. In theory, a signal generator has an infinite number of harmonics in its output. However, in practice, we find that nearly all the distortion is contributed by the second and third harmonics.

COUNTER CALIBRATION

There is a growing trend to the use of precision electronic counters for calibration of signal generators. Basically, a counter is an electronic switch that operates on each cycle of the sine-wave input. The number of times that the electronic switch opens and closes is indicated by an illuminated scale. A counter also contains a precision time base. This time base permits the electronic switch to operate for a desired period, such as 0.001 second. Then, the electronic switch is turned off. Suppose that the counter measures a 1-mc frequency from a signal generator. If the time base is set for 0.001 second, the counter will read 1000. On the other hand, if the input frequency is more or less than 1 mc, the counter will read more or less than 1000.

Why are counters used as secondary frequency standards? It is because they are very easy to operate, can be designed for high accuracy, and save time when frequencies must be checked often. Let us see how a counter works. Its basic unit is a flip-flop circuit, such as shown in Fig. 2-13. Transistors X1 and X2 conduct and cut off alternately. Thus, there is one output pulse for two input pulses. The output pulse is fed to

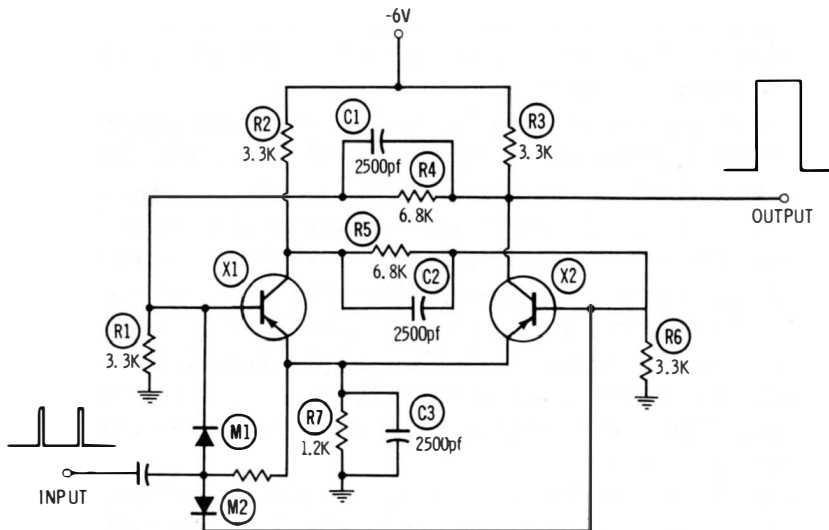

Fig. 2-13. Flip-flop circuit.

another flip-flop. In turn, four input pulses produce one output pulse. Diodes M1 and M2 are called steering diodes. They are alternately biased beyond cutoff by X1 and X2. In turn, the incoming pulse is “steered” to the diode which is to be “flipped.”

How are the input trigger pulses formed? This is shown in Fig. 2-14. The sine-wave output from the signal generator is clipped and limited to form a semi-square wave (Fig. 2-14B). Differentiation in an RC peaker produces pulses (Fig. 2-14C).

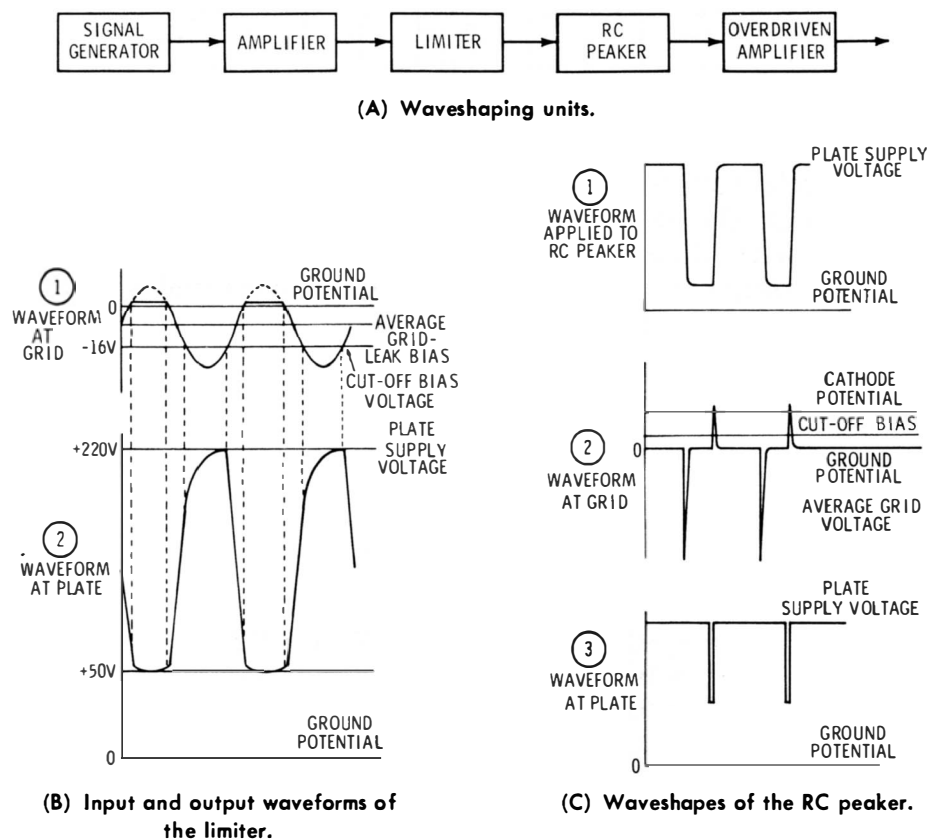

Fig. 2-14. Forming input trigger pulses.

Pulses of one polarity are clipped off, and then squared by passing through an overdriven amplifier. Thus, one output pulse is obtained for each sine-wave cycle from the signal generator. These output pulses are used to trigger the first flip-flop (Fig. 2-13) in a counter chain.

Operation of a simple frequency-counter chain is depicted in Fig. 2-15. Neon bulbs are commonly used as indicators to light transparencies with printed numerals. Each signal-gen-

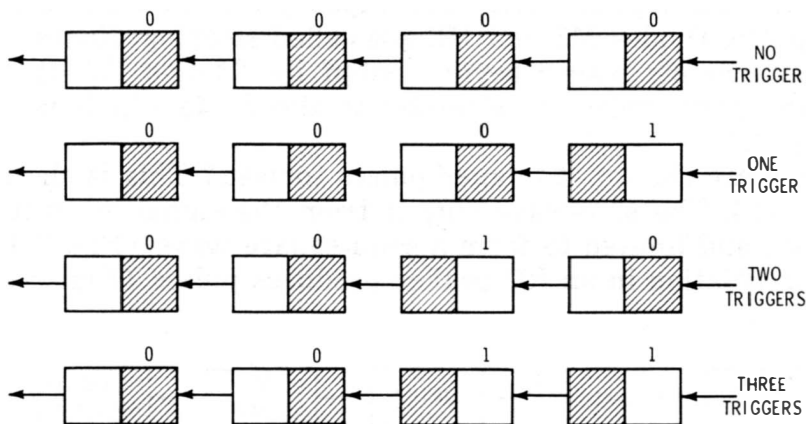

Fig. 2-15. Operation of a frequency-counter chain.

erator cycle (pulse) causes the input flip-flop to switch. Two cycles cause the second flip-flop to switch. Readers who are familiar with digital computers will immediately recognize that the simple counter chain in Fig. 2-15 provides binary readout. In other words,

$$\begin{aligned}
 0 &= 0000 \\
 1 &= 1 \\
 2 &= 10 \\
 3 &= 11
 \end{aligned}$$

or,

$$\begin{aligned}
 0 &= 0X2^3 + 0X2^2 + 0X2^1 + 0X2^0 \\
 1 &= 0X2^3 + 0X2^2 + 0X2^1 + 1X2^0 \\
 2 &= 0X2^3 + 0X2^2 + 1X2^1 + 0X2^0 \\
 3 &= 0X2^3 + 0X2^2 + 1X2^1 + 1X2^0
 \end{aligned}$$

However, counters used as secondary frequency standards to calibrate signal generators are elaborated to provide decimal readout. In the decimal arrangement, additional electronic switches are used so that the binary indication is changed into decimal indication. Thus, these switches operate neon bulbs behind transparencies printed with numerals 1, 2, 3, 4, 5, etc., instead of a binary series of zeros and units. Thus, if a decimal counter reads 1,000 we know that 1,000 cycles have passed through. A decimal counter reads in terms of conventional numbers.

Chapter 3

Modulation of Generator Signals

The most common types of generator signal modulation are sine-wave amplitude modulation and sine-wave frequency modulation. Pulse modulation is utilized in most color signal generators. An example of sine-wave amplitude modulation is depicted in Fig. 3-1A. The most common modulating fre-

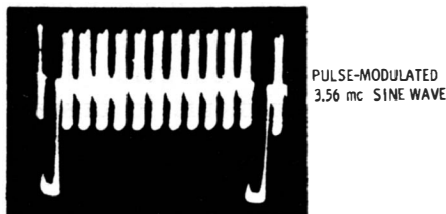
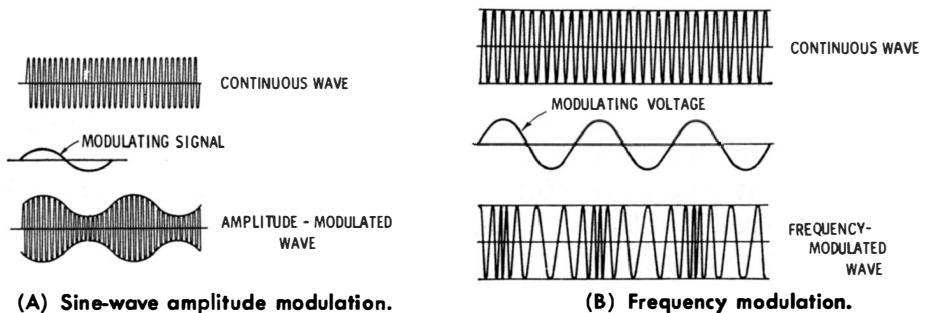

Fig. 3-1. Basic examples of generator signal modulation.

quency is 400 cycles; however, some generators utilize a 1-kc modulating frequency. An example of frequency modulation is seen in Fig. 3-1B. Most generators employ a 60-cycle sine-wave modulating signal for frequency modulation. Occasionally, a sawtooth waveform is used instead of a sine wave for frequency modulation. It has been noted that a few generators provide a choice of frequency modulation or amplitude modulation. An example of pulse modulation is shown in Fig. 3-1C. A color signal generator may have a single out-

put waveform. On the other hand, it may provide a choice of several pulse-modulated outputs, plus a 3.58-mc c-w output.

SINE-WAVE AMPLITUDE MODULATION

You will recall that the percentage of modulation is fixed in some generators but is adjustable in others. When the modulation percentage is adjustable, a front-panel control is provided, as seen in Fig. 3-2. Nearly all a-m generators have the

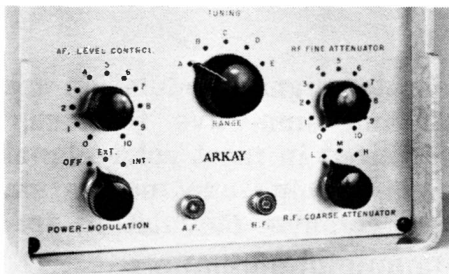

Fig. 3-2. The modulating signal is usually externally available.

Courtesy Arkay International

modulating signal accessible externally for use in audio-frequency tests. Note the AF connector in Fig. 3-2. The signal amplitude at this connector is adjustable by means of the AF Level Control. In other words, the level control is used to vary both the percentage of modulation, and the amplitude of the audio-frequency output signal.

The modulating signal is obtained from an audio oscillator. A basic requirement is the generation of a good sine wave. In the past, tickler-feedback audio oscillators were used extensively. The oscillator transformer carried grid, plate, and output windings. It is comparatively difficult to design this type of oscillator for a good sine-wave output. Hence, the present-day trend is to other oscillator configurations, such as the Colpitts circuit. A typical arrangement is shown in Fig. 3-3. The oscillating frequency is determined by the inductance of L1 and the capacitance values of C6 and C7. These values are chosen for a nominal resonant frequency of 400 cycles.

The percentage of modulation or the amplitude of audio-output voltage is varied by R10. The output from the oscillator is coupled to the r-f oscillator (or to the audio-output connector) by C4. If the oscillator is lightly loaded, adjustment of R10 does not change the oscillator frequency appreciably. Even under heavy-load applications, a small change in oscillator frequency can usually be disregarded. Note that iron-core inductors operate as nonlinear components unless the

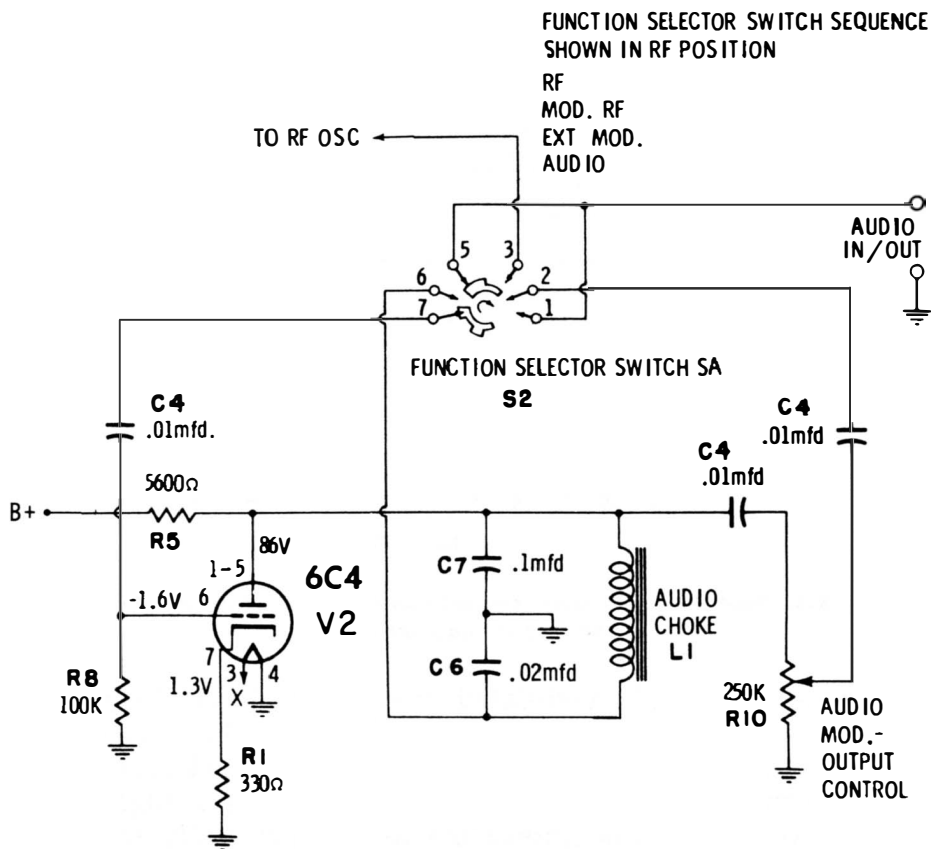

Courtesy Pacotronics

Fig. 3-3. Colpitts audio-oscillator circuit.

magnetic flux variation is kept well below the saturation region (Fig. 3-4). The Colpitts circuit is advantageous in this regard, because the d-c plate current does not flow through the coil. Furthermore, by operating the oscillator at a comparatively low power level, the a-c current flow through the coil is kept well below the core-saturation region. In turn, a good sine wave is generated.

The amount of feedback voltage (and hence the oscillator power level) is determined by the capacitance ratio of C6 and C7. In other words, the two capacitors form an a-c voltage divider. Thus, the a-c voltage drop across C6 is applied to the grid of V2. Since L1 is not a pure inductance but also has resistance, the ratio of C6 to C7 also affects the phase of the a-c voltage fed to the grid. Oscillation cannot occur unless there is sufficient in-phase voltage fed back to cancel out the losses in the circuit. Hence, the oscillation level depends on both the amplitude of the feed-back voltage and also on its phase.

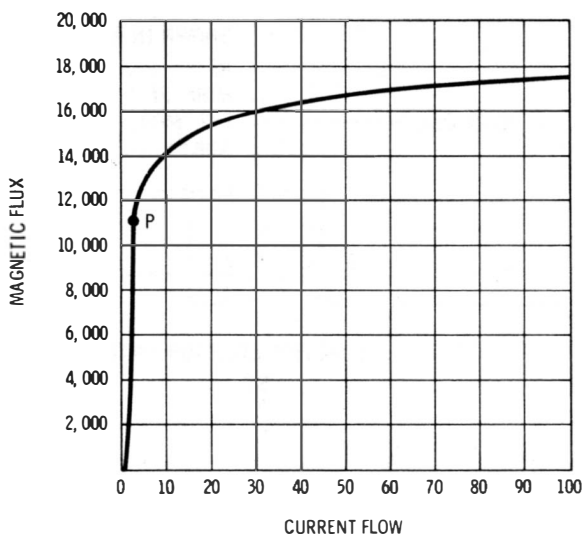
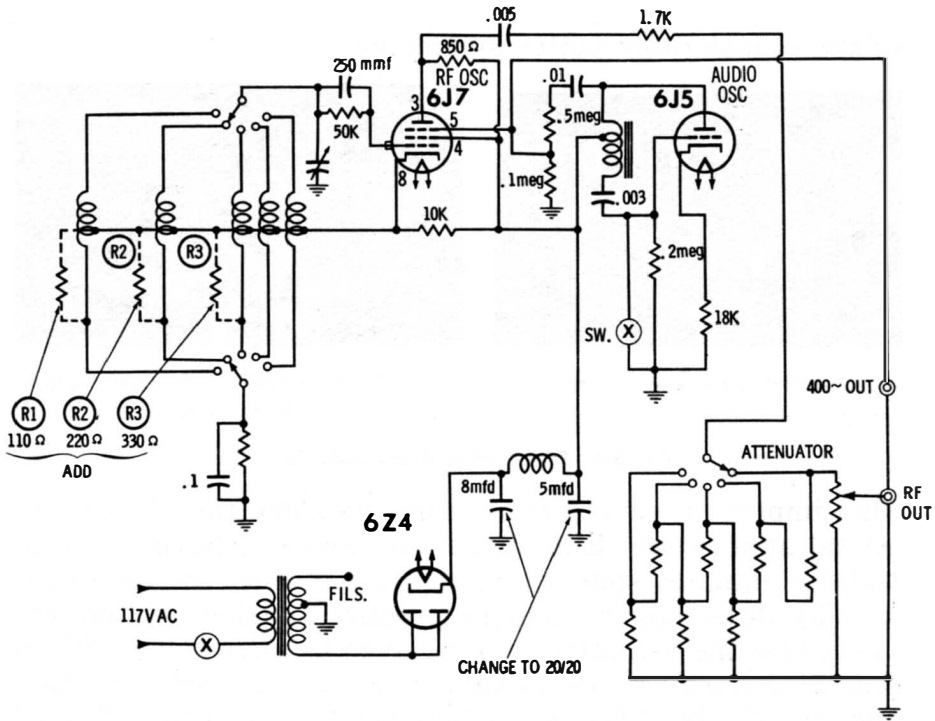

Fig. 3-4. Good sine-wave output requires that the operating range not extend past P on the iron-core curve.

A good amplitude-modulated waveform (Fig. 3-1A) requires not only that the audio oscillator produce good sine waves, but also that the r-f oscillator produce good sine waves. In other words, if the r-f oscillator generates a highly distorted waveform, it is impossible to symmetrically modulate the distorted waveform with a sine-wave signal. This principle is often confusing to the beginner—he finds it difficult to understand why the modulated r-f output might have a poor waveform although the modulating voltage has a good sine wave. It is easy to check both the r-f waveform and the a-f waveform with a wide-band scope. However, it is not always easy to pinpoint the circuit defect which is causing distortion.

For example, consider the circuit shown in Fig. 3-5. This is an older type of signal generator, which utilizes basic Hartley oscillator circuits. In this case, the audio oscillator produced an acceptable sine-wave output. On the other hand, the r-f waveform was highly distorted on the lower frequency bands—from 100 kc to 3 mc. Instead of displaying a sinusoidal r-f waveform, the r-f oscillator produced a clipped positive half-cycle and a highly peaked negative half-cycle. The electron-coupled output circuit responds to the plate-current flow in the oscillator tube, not to the voltage waveform across the tank circuit. Excessive feedback causes the tube to cut off over part of the cycle, thus clipping the output waveform.

There are two methods of reducing feedback and avoiding



(A) Circuit diagram.

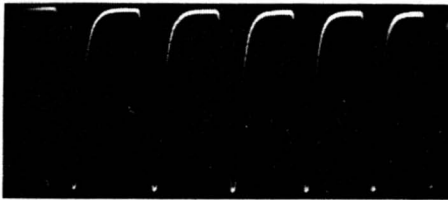

(B) R-f waveform.

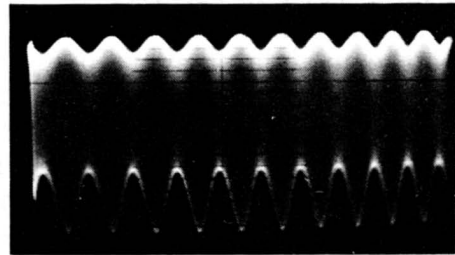

(C) Modulated r-f waveform.

Fig. 3-5. Signal generator using basic Hartley oscillator circuits.

grid overdrive. First, the tap point on the tank coil can be placed nearer ground. If a progressive-wound coil is present, a change in the tap point can impose a mechanical problem. Hence, the second method of feedback reduction may be more practical. If a resistor is shunted across the feedback coil (R1, R2, R3 in Fig. 3-5A), a portion of the feedback energy is dissipated as I^2R loss in the resistance. In turn, the grid drive is reduced, the plate current is no longer cut off, and an

acceptable sine wave results, as seen in Fig. 3-6A. When modulation is applied (Fig. 3-6B), the modulated r-f waveform displays considerably better symmetry.

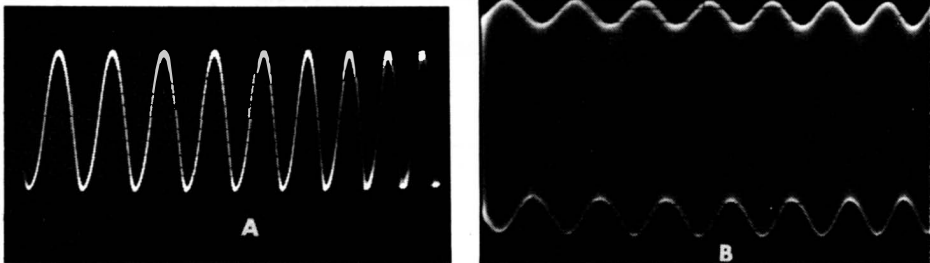

(A) An acceptable sine-wave output results.

(B) Modulated r-f waveform displays better symmetry.

Fig. 3-6. Effects of feedback reduction.

This improved waveform is more desirable for almost any practical application. Elimination of excessive harmonic output also eliminates spurious responses from a receiver under test. Why do strong harmonics produce spurious responses? It is because the oscillator in a receiver has harmonics. When a generator harmonic beats against a receiver-oscillator harmonic, and the beat frequency happens to fall in the i-f band of the receiver, it appears as a spurious response, or "birdie." It may also be asked why symmetrical modulation is desirable. If the modulation envelope is highly unsymmetrical, as in Fig. 3-5C, one receiver can *seem* to be much more sensitive than another. If the receiver happens to detect along the top of the modulated waveform in Fig. 3-5C, the output will be comparatively weak. On the other hand, if a receiver happens to detect along the bottom of the modulated waveform, the output will be comparatively strong.

Although the modulation envelope in Fig. 3-6B has an acceptable shape, the percentage modulation is less than standard. Specifications for receiver testing usually call for 30% modulation. However, the waveform illustrated in Fig. 3-6B has approximately 20% modulation. It is necessary to apply increased modulating voltage to the r-f oscillator to increase the percentage of modulation. In this case, an easy method consisted of taking the modulating voltage from the cathode of the audio oscillator instead of the plate. The circuit modification is shown in Fig. 3-7. This change resulted in 40% modulation, using a 0.01-mfd and 0.002-mfd capacitor in a voltage-divider arrangement.

In some cases the modulation envelope may be distorted by hum voltage. Assuming that the tubes do not have heater-

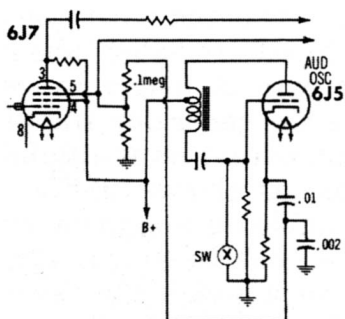

(A) Modulating voltage taken from the cathode.

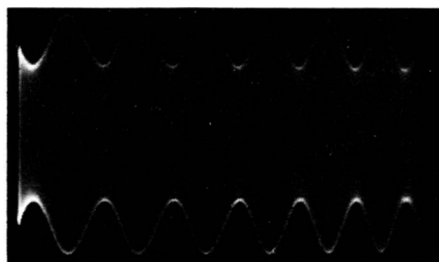

(B) Modulation percentage increased to 40%.

Fig. 3-7. Increasing the percentage of modulation.

cathode leakage, this symptom points to excessive B+ ripple voltage. In this generator, the ripple was reduced to a negligible value by increasing the filter capacitance, as indicated in Fig. 3-5. Thus, if you know your signal generator, it is possible to analyze a distorted output and pinpoint the circuit defects.

MAXIMUM R-F OUTPUT

Technicians sometimes ask how the maximum output from a signal generator can be increased. One method is to increase the plate and screen voltages at the r-f oscillator. For example, a typical generator utilizes a 6AU6 tube with 100 volts at the plate and 105 volts at the screen. The half-wave power supply in the generator provides 110 volts. If an additional rectifier and filter capacitor are used to form a voltage-doubler power supply, the output voltage is approximately doubled. Moreover, if a filter choke is used instead of a resistor, the output voltage is more than doubled. Since a 6AU6 is rated for operation up to 330 volts at plate and screen, the tube is still well within its maximum power dissipation. The maximum r-f output, in turn, is approximately doubled.

As would be anticipated, the audio-modulating voltage must also be increased to maintain the original percentage of modulation. This is no problem if the percentage modulation is adjustable, as in Fig. 3-3; the control is merely advanced as required. On the other hand, if the generator has a fixed percentage of modulation, as in Fig. 3-5, the coupling circuit between the audio oscillator and r-f oscillator must be changed to apply more signal voltage to the suppressor grid. For example, the 0.002-mfd capacitor can be reduced in value, or the 0.1-megohm resistor can be reduced in value.

There are two “side effects” to be considered when the signal output level is increased. First, the r-f oscillator tube runs hotter, and frequency drift may increase. A longer warm-up period is likely to be required before the generator stabilizes. There is also the problem of *minimum* output level attainable. Simple generator arrangements, such as shown in Fig. 3-5, have appreciable r-f leakage. If you double the maximum available output voltage, the minimum output level will also be approximately doubled. Hence, you must weigh the “side effects” against the desirability of increased output.

VARIABLE MODULATING FREQUENCY

Technicians who work with hi-fi systems need to check frequency response over the entire audio-frequency range. Hence, an audio oscillator is used for external modulation of the signal generator, as shown in Fig. 3-8. When external modulation is used, the signal generator is switched to “Ext. Mod.” (see Fig. 3-3). In turn, fixed-frequency oscillator V2 is disabled; the audio-oscillator signal is fed to the r-f oscillator for modulation of the carrier. You must adjust the output level of the audio oscillator to provide 30% modulation, in accordance with receiver test standards. This is done by connecting a wide-band scope at the output of the r-f signal generator depicted in Fig. 3-8. The pattern on the scope screen

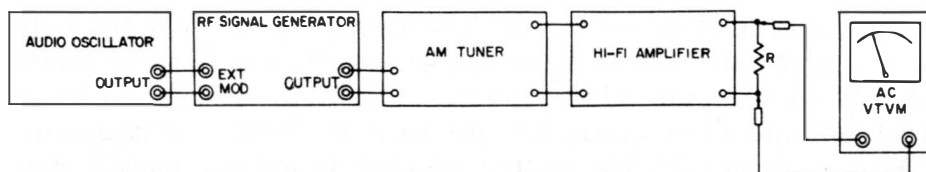

(A) External modulation of signal generator.

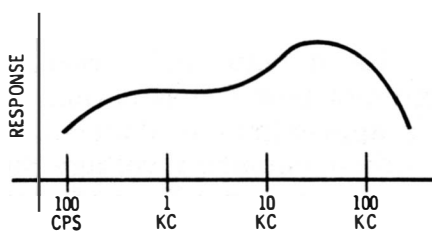

(B) Scope pattern indicated subnormal low-frequency and abnormal high-frequency response.

Fig. 3-8. Audio oscillator used for external modulation.

appears as seen in Fig. 3-9, and the percentage of modulation is calculated as noted in the diagram.

The frequency response of the system (Fig. 3-8) is then plotted over the entire audio-frequency range. If the frequency response is not flat, as exemplified in Fig. 3-8B, the trouble

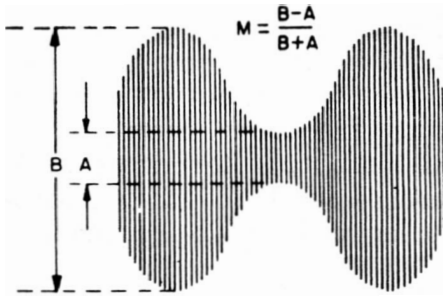

Fig. 3-9. Percent of modulation.

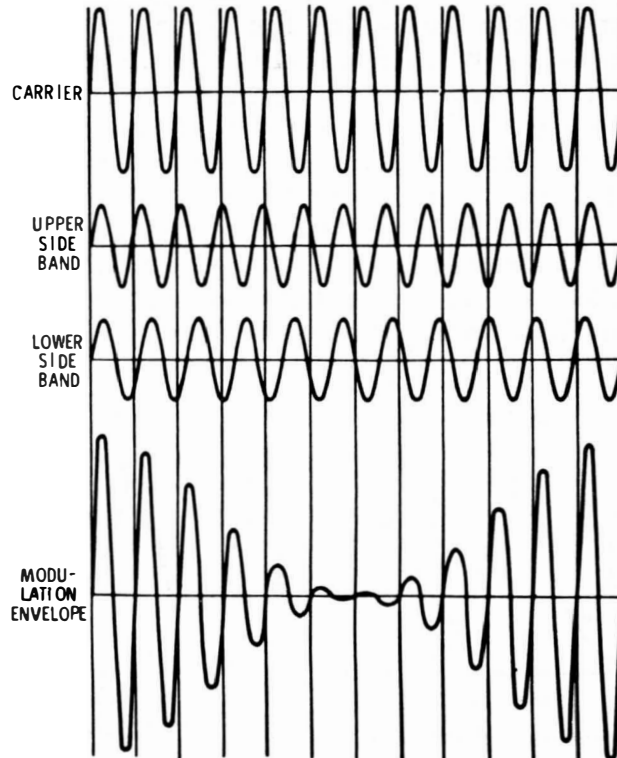

Fig. 3-10. Modulation of signal-generator carrier produces sidebands.

may be localized to the a-m tuner, to the hi-fi amplifier, or possibly to both. Note load resistor R in Fig. 3-8A; unless the hi-fi amplifier is normally loaded, its frequency response will be impaired. Remember that the frequency response might be different at 550 kc, 1 mc, and 1.5 mc on the a-m tuner dial. Hence, check the response at these three carrier frequencies. If hi-fi (flat) response is not obtained at all three carrier frequencies, the alignment of the a-m tuner must be investigated.

External modulation, as depicted in Fig. 3-8, requires uniform (flat) output from the audio oscillator over the entire

audio-frequency range. Only high-quality audio oscillators provide a satisfactorily flat output. However, you can use an ordinary audio oscillator if you monitor the output and adjust the level control when you change frequency. Simply connect a scope across the audio-oscillator output terminals in Fig. 3-8. Choose a convenient reference level and then maintain this value of vertical deflection at each audio-frequency setting in the test procedure.

Why does the alignment of the a-m tuner in Fig. 3-8 affect the audio-frequency response of the system? It is because modulation of the carrier in the signal generator produces sidebands, as shown in Fig. 3-10. The upper sideband has a higher frequency than the carrier, and the lower sideband has a lower frequency than the carrier. If the a-m tuner is misaligned, the sideband signals are distorted with respect to the carrier. In turn, the test waveform at the second detector in the a-m tuner is also distorted. Subnormal sideband response causes poor high-frequency response. On the other hand, abnormal sideband response (excessive double-humped curve) causes poor low-frequency response. These relations are shown in Fig. 3-11.

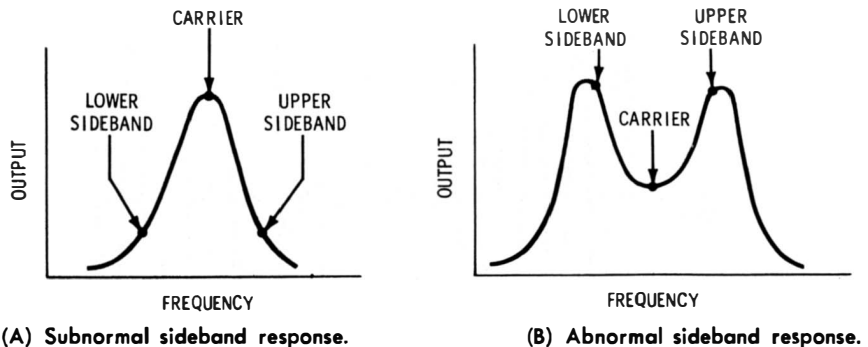

Fig. 3-11. Effects of sideband response on a response curve.

HARMONIC DISTORTION

Technicians who work with hi-fi systems are also concerned with harmonic distortion. A basic test setup is shown in Fig. 3-12. The total percentage of harmonic distortion is read on the harmonic-distortion meter. This test requires that the

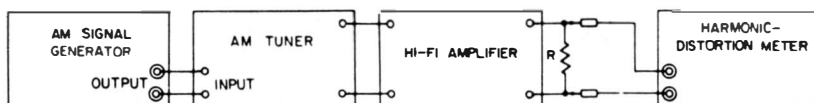

Fig. 3-12. Signal generator provides a check of harmonic distortion.

signal generator provide a good modulated waveshape. Otherwise, a deficiency in the signal generator would be falsely charged to the a-m tuner or to the hi-fi amplifier. A rough test of the generator waveform can be made by applying the 400-cycle output from the signal generator directly to the harmonic-distortion meter. If a low reading is obtained, you know that the modulating waveform of the signal generator is satisfactory. A wide-band scope can be used next to check the modulated r-f waveform (Fig. 3-7B). If visible distortion does not appear in the scope pattern, the signal generator can be used with reasonable confidence in harmonic-distortion tests.

Since most signal generators provide only a 400-cycle modulating frequency, external modulation must often be utilized to check harmonic distortion over the entire audio-frequency range. The test setup is shown in Fig. 3-13. A meaningful test

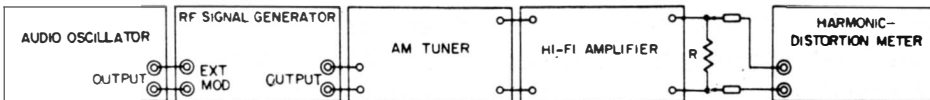

Fig. 3-13. Signal generator externally modulated by an audio oscillator.

requires that the audio oscillator have a good sine-wave output, and that the signal generator is modulated without substantial distortion. You can check the audio oscillator by applying its output directly to the harmonic-distortion meter. If the meter reading is low, the audio oscillator will be satisfactory. Next, connect the audio oscillator to the external-modulation terminals of the signal generator. Check the modulated r-f output from the signal generator with a wide-band scope. As before, if visible distortion does not appear in the scope pattern, the signal generator can be used with reasonable confidence.

SQUARE-WAVE MODULATION OF SIGNAL GENERATOR

Square-wave tests of hi-fi systems have become increasingly popular. A square-wave test will disclose transient distortion, which is missed in sine-wave tests. A suitable test setup is de-

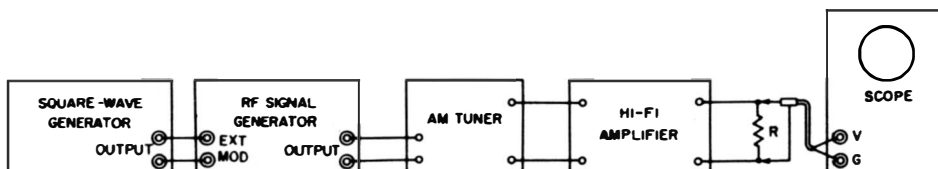
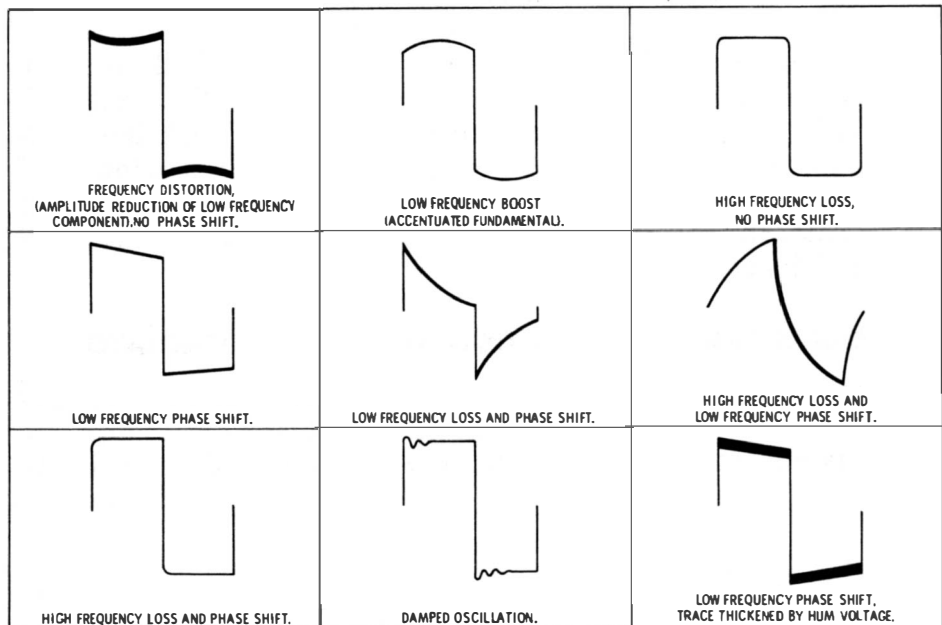

Fig. 3-14. Square-wave modulation of the signal generator.

picted in Fig. 3-14. Note that square-wave modulation of a signal generator is comparatively free from difficulties. The reason for this is that the modulation is simply an off-on sequence. However, there are certain practical points to consider :

1. The square-wave generator must have good waveform, and a sufficiently fast rise time.
2. The oscilloscope used as an indicator must have good square-wave response.
3. Neither the a-m tuner nor the hi-fi amplifier should be overloaded.

You can connect the output from the square-wave generator directly to the scope to determine whether the generator and the scope have satisfactory characteristics. Next, connect the output from the square-wave generator to the external-modulation terminals of the signal generator, and check the modulated r-f waveform with the scope. Advance the level of the square-wave signal for 100% modulation of the carrier. You are now prepared to make a test of transient response with the signal generator, as shown in Fig. 3-14. Typical square-wave distortions are illustrated in Fig. 3-15. Some photos of serious system distortion are seen in Fig. 3-16.



Courtesy Precision Apparatus Co.

Fig. 3-15. Typical square-wave distortions.

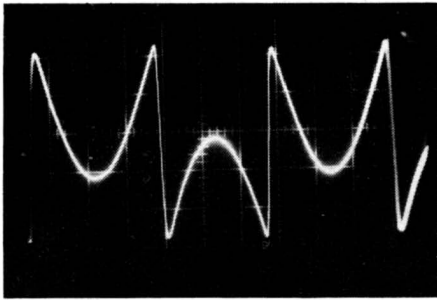

(A) Attenuation of square-wave fundamental.

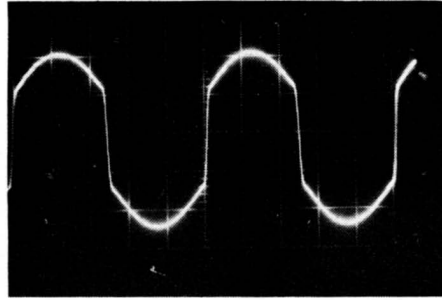

(B) Boost of square-wave fundamental.

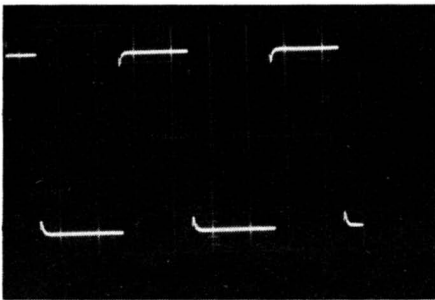

(C) Diagonal corner distortion.

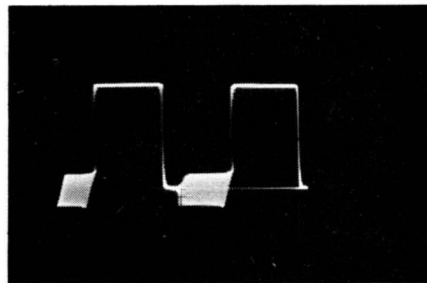

(D) Parasitic oscillation.

Fig. 3-16. Examples of serious system distortion.

Evidently, square-wave modulation is a special case of pulse modulation in which the “off” time is equal to the “on” time. If you use a pulse generator for external modulation of the signal generator, essentially the same test information is obtained. The only difference is that a pulse has stronger harmonics than a square wave. In turn, a pulse test at a low repetition rate is equivalent to a square-wave test at a low repetition rate plus another square-wave test at a high repetition rate.

Color signal generators have built-in pulse-modulation facilities and supply an output waveform such as illustrated in Fig. 3-1C. Since this type of signal is used only to check the performance of color-TV receivers, a detailed explanation of color signal generators is not included in this book. Interested readers may refer to texts such as *Know Your Color-TV Test Equipment*, published by Howard W. Sams & Co., Inc.

FREQUENCY MODULATION OF SIGNAL GENERATORS

Frequency-modulated generators (commonly called sweep generators) are in wide use. Many f-m generators are com-

bined with a-m generators, as illustrated in Fig. 3-17. A crystal oscillator is usually provided for calibration of the



Courtesy Simpson Electric Co.

Fig. 3-17. Typical fm/am generator.

a-m generator. When designed for TV application, such combination generators provide frequency coverage only from 4 mc to 250 mc in most cases. Hence, you cannot use the a-m generator to test a-m broadcast receivers. However, many of these combination generators can be used to test f-m broadcast receivers.

The chief requirement for an f-m generator is that it provide a uniform output over the swept band. You can easily check this characteristic by feeding the output from the f-m generator to a scope via an ordinary demodulator probe. If the generator has a flat output, the waveform shown in Fig. 3-18 will be displayed on the scope screen. Why is a flat output important? If the generator has “hills” and “valleys” in

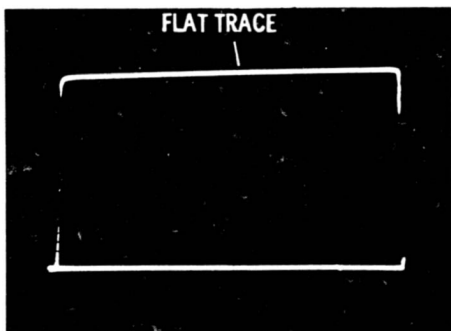

Fig. 3-18. A good output waveform from an f-m generator.

its frequency output, generator deficiencies will be falsely charged to the receiver under test. The most common causes of nonuniform output are defective tubes or faulty capacitors in the generator. Filter capacitors are prime suspects, because power-supply ripple can modulate the f-m oscillator.

Fig. 3-19 shows the circuit configuration for a typical f-m generator. The tank circuit of the f-m oscillator contains coils with ferrous cores. (Refer to Fig. 3-4.) The curve for the core characteristic shows that the magnetic flux is nonlinear with respect to substantial current flow. This is just another way of saying that the inductance of the coil becomes less when current flow is heavy. Or, the resonant frequency of the f-m oscillator in Fig. 3-19 can be varied by changing the total current flow. This change occurs at a 60-cycle rate, and the amount of frequency swing (deviation) is determined by the setting of R3, which is called the sweepwidth control.

Note that the swept trace appears above a baseline in Fig. 3-18. The base line represents zero signal output from the f-m generator. In other words, the f-m oscillator is "on" for 1/120 second, and is "off" during the next 1/120 second. This keying of the oscillator is accomplished by means of a 60-cycle square wave. A clipper tube (V3) is used to change the 60-cycle supply voltage into a 60-cycle square wave. This square-wave voltage is applied as grid bias to the f-m oscillator tube (V1). In turn, the tube is keyed off and on at 1/120-cycle intervals.

As in an a-m generator, several oscillator coils are used in an f-m generator to cover the total frequency range (3.6 to 220 mc) in several bands. Thus, the permeability-swept unit, M7 in Fig. 3-19, comprises three oscillator coils. On the other hand, marker generator V2 has only one oscillator coil. Tuning capacitor M3 provides a fundamental marker range from 19 to 60 mc. Second and third harmonics are used to mark frequencies from 60 to 180 mc. The 4.5-mc crystal oscillator

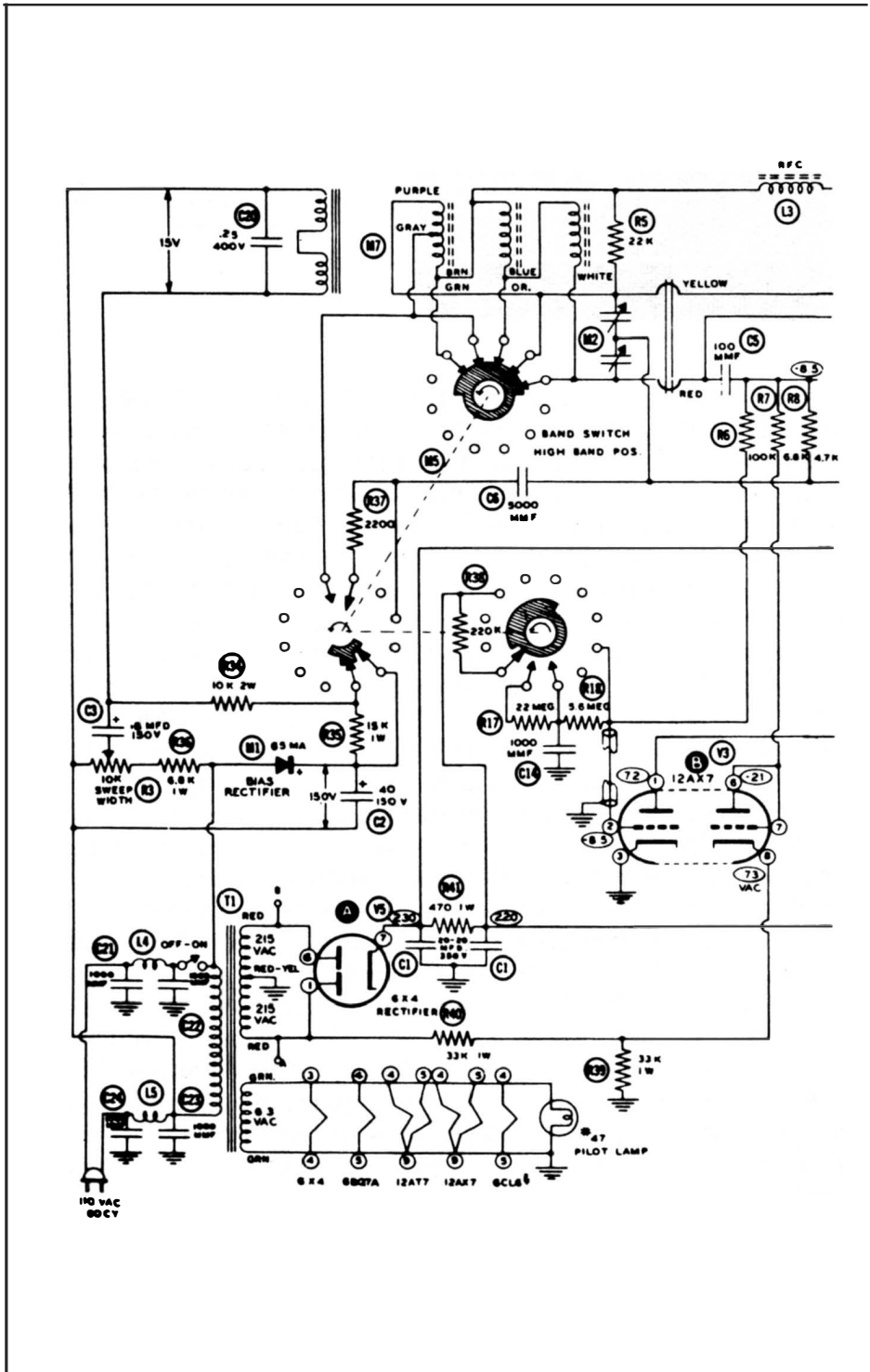
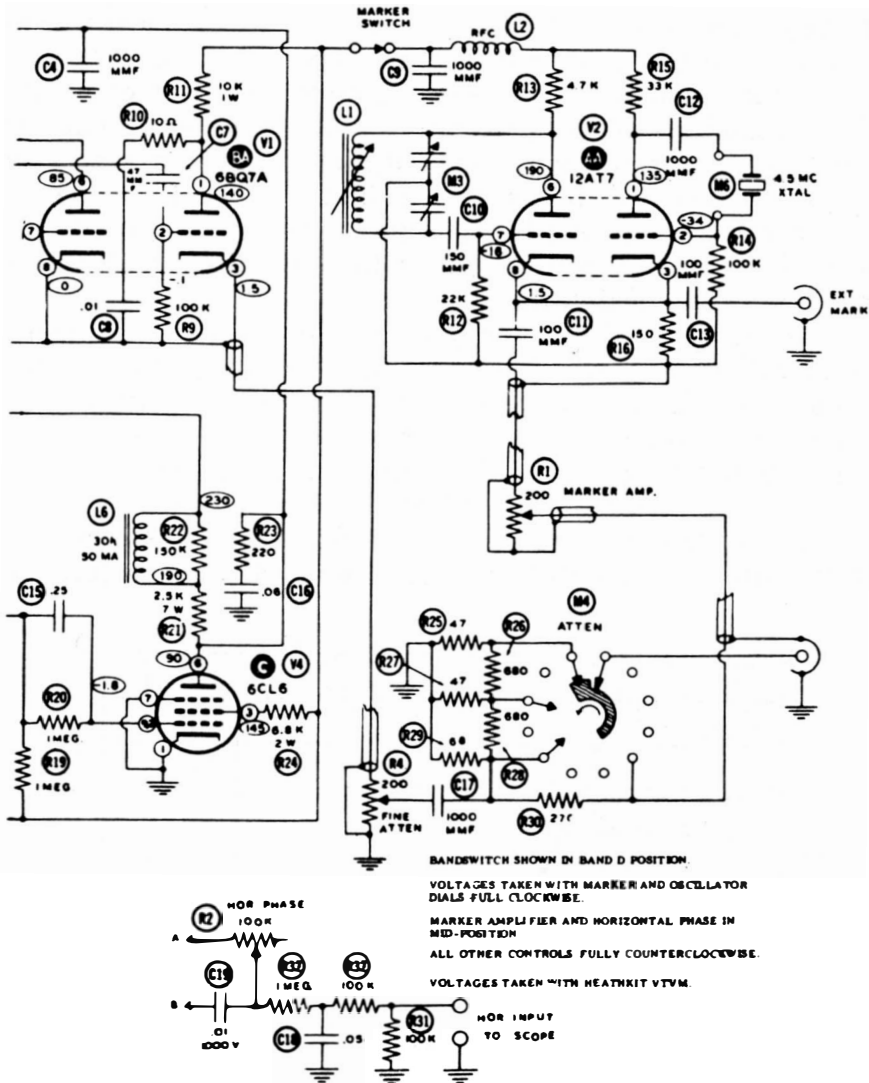

Fig. 3-19. Typical f-m generator with built-in



marker generator and crystal oscillator.

Courtesy Heath Co.

serves to calibrate the marker generator; its output can also be used to mark intercarrier sound curves.

There are other methods in addition to permeability tuning in common use to frequency-modulate the output from a generator. For example, the oscillator coil may be shunted by a vibrating capacitor. One plate of the capacitor moves back and forth at a 60-cycle rate. In turn, the oscillator output is frequency-modulated in the same manner as previously described. Standard signal generators that provide a choice of a-m output or narrow-band f-m output often use a reactance tube to frequency-modulate the oscillator tube. Like permeability-sweep arrangements, reactance-tube sweep circuits are preferred to vibrating-capacitor systems because of their immunity to mechanical failure.

The newest type of frequency modulator consists of a semiconductor diode unit which operates as an electronic capacitor. When a junction diode is reverse-biased, it has a terminal capacitance that varies in value with the applied voltage. Fig. 3-20 shows the capacitance characteristic for a typical diode. Its capacitance changes from .15 pf to 3.5 pf when the reverse bias varies over a range of 13 volts. Hence, the diode may be used to tune an oscillator coil. If a 60-cycle bias voltage is

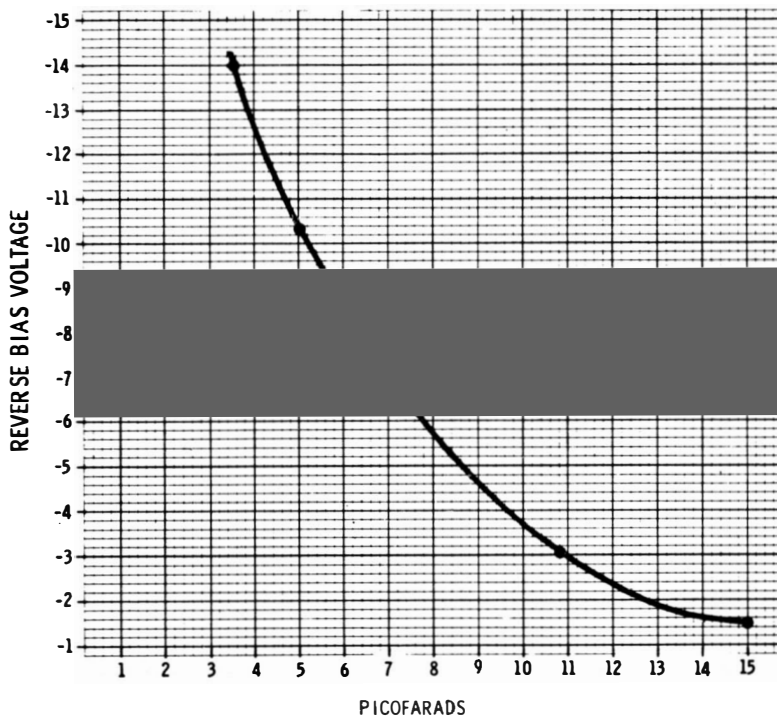

Fig. 3-20. Junction capacitance of a semiconductor diode versus bias voltage.

applied to the diode, the oscillator becomes frequency-modulated. Thus, a semiconductor diode is the solid-state equivalent of a reactance tube.

VIDEO SWEEP MODULATION

Video sweep modulation refers to the modulation of a video-frequency sweep signal on an r-f carrier. In other words, an f-m signal is amplitude-modulated on an r-f carrier. A semiconductor-diode modulator is used, with a test setup such as depicted in Fig. 3-21. This type of signal is used chiefly to check the overall frequency response of color-TV receivers, although it can also be used to check the overall response of black and white receivers. Note that the r-f output signal (VSM output) in Fig. 3-21 includes the picture carrier and

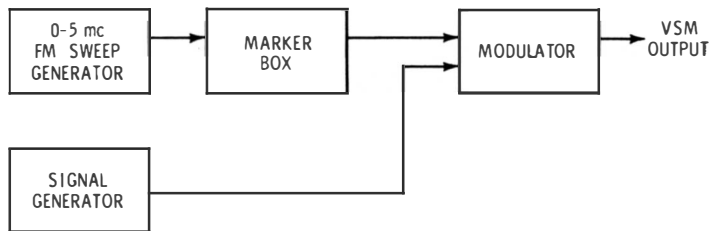

Fig. 3-21. Generation of a VSM signal.

two sidebands. The sideband frequencies vary in accordance with the sweep signal from the f-m generator. This VSM output signal is fed to the antenna terminals of the TV receiver under test. In the case of a color receiver, the frequency response of the r-f tuner, i-f amplifier, video amplifier, chroma bandpass amplifier, and chroma demodulators may be checked on a scope screen.

The VSM method of checking alignment is necessary to accurately determine the overall frequency response from the receiver's antenna terminals to the picture tube. In step-by-step alignment procedure, this cannot be done with any degree of accuracy because estimation is involved. Thus, in ordinary procedure, an r-f sweep generator is used to check the frequency response of r-f and i-f amplifiers, and a video-frequency sweep generator is used to check the response of the video amplifier and the chroma bandpass amplifier. Thus, in conventional alignment procedure the operator can only estimate the overall response. Furthermore, the effect of the picture-detector circuit, which changes the overall response more

or less, *cannot* be observed on either the i-f or video-amplifier response curves.

On the other hand, when a VSM signal is applied to the receiver, a scope connected at the picture tube displays the actual and complete overall frequency-response curve *including* the effect of the picture detector. This method is particularly important in the alignment of color-TV receivers in which the i-f and video-frequency sections individually do not have a flat response over their passband. In other words, in many modern color receivers, the response of the i-f and video-frequency sections are complementary. Thus, the first video-amplifier stage might have a *rising* frequency response which compensates for the *falling* frequency response of the i-f amplifier. In these receivers, the color subcarrier is normally placed at the 50% response point on the i-f curve. However, a correctly adjusted video amplifier or bandpass amplifier complements this i-f response and gives a flat overall i-f video curve.

Note in Fig. 3-21 that the output from the marker box is applied to the modulator. These are absorption markers. Hence, the output from the modulator consists of both the f-m signal and "dip" markers modulated on the r-f carrier. In turn, the if-video curve displayed on a scope screen has absorption markers, as illustrated in Fig. 3-22A. How are absorption markers generated? This is accomplished by shunting series traps across the circuit, as seen in Fig. 3-22B. The number of traps utilized depends on how many marker frequencies are to be displayed. The value of the series capacitor (1.5 to 15 pf) not only tunes the trap coil to the desired marker frequency, but it also determines the depth of the "dip."

Hence, we set the capacitor to obtain the desired depth of the absorption marker, and then tune the trap to the correct frequency by means of the slug adjustment. An individual absorption marker is identified in the scope pattern by touching one of the test terminals, such as T1, T2, or T3. Hand capacitance makes the absorption marker shift on the pattern, and also reduces its depth. Therefore, it is easy to identify a chosen absorption-marker frequency in the pattern.

Fig. 3-23 is a photo of a bandpass-amplifier response curve with absorption markers. Each "dip" represents a certain reference frequency. The operator touches one of the test terminals on the marker box. In turn, the corresponding "dip" shifts on the curve. However, the other "dips" remain fixed in position. Accordingly, the reference frequency is identified.

Absorption markers are most useful on the top of a curve. It is difficult to see an absorption marker near the base line. An absorption marker disappears completely in a trap.

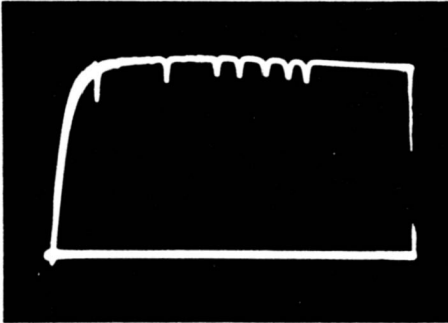

(A) Resulting pattern as seen on a scope.

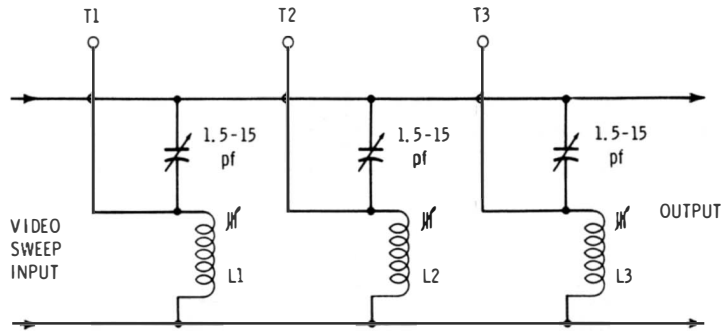

(B) Series traps generate the absorption markers.

Fig. 3-22. Output of marker box is applied to the modulator.

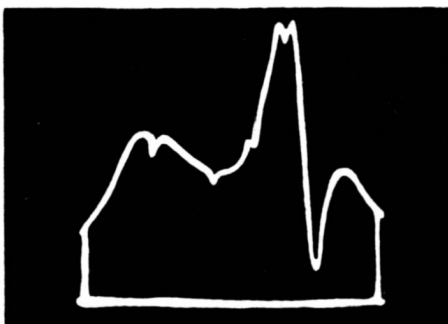

Fig. 3-23. Bandpass-amplifier response curve with absorption markers.

SPECIALIZED TYPES OF PULSE MODULATION

Signal generators designed for testing telemetry receivers employ specialized types of pulse modulation, as noted previously. Some of the basic modulation waveforms are depicted in Fig. 3-24. In pulse-amplitude modulation (PAM) the

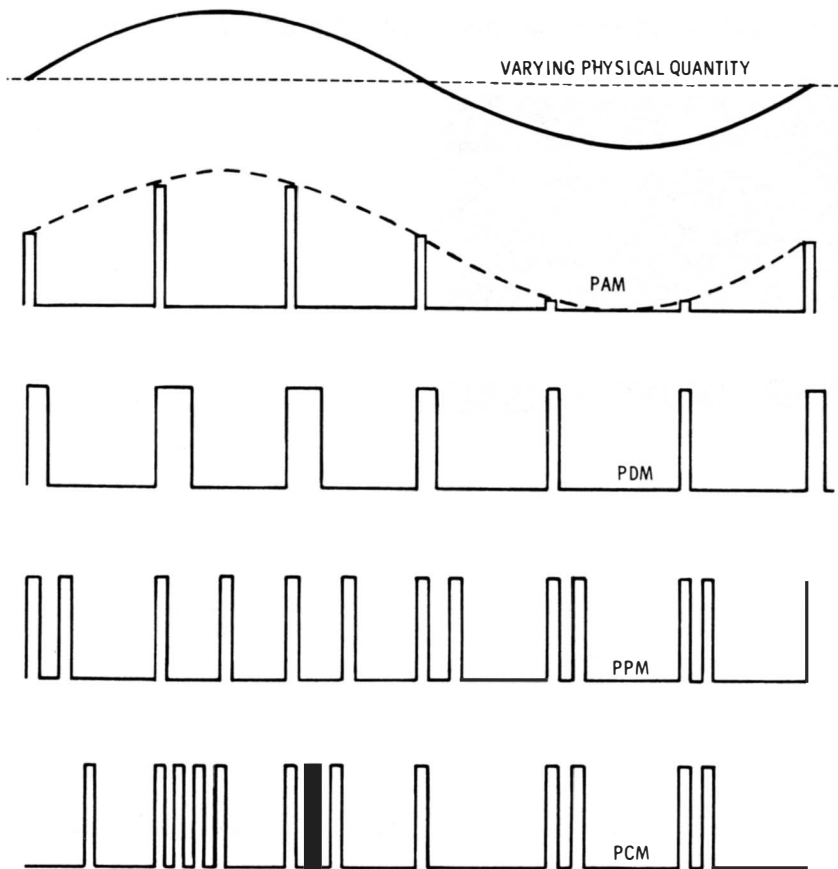

Fig. 3-24. Specialized types of pulse modulation.

height of the modulating pulses is varied. Again, in pulse-duration modulation (PDM), the height of the modulating pulses is constant, but the pulse width varies. Another type of pulse modulation is called pulse-position modulation (PPM), in which the pulses occur at varying times. Still another type of pulse modulation, called pulse-code modulation (PCM), is based on a code for each element of information, comprising pulses and spaces.

When pulse amplitude-modulated r-f signals are fed into an integrating circuit, the output reproduces the original waveform—this is a sine wave in Fig. 3-24. To decode PDM, PPM, or PCM generator signals, comparatively complex circuitry is required. Examples of receiver circuitry are explained in specialized tests, such as *Pulse Circuit Technology*, published by Howard W. Sams & Co., Inc. Why are these special types of modulation used in telemetry systems? It is

because more efficient use can be made of the communications channel. Moreover, a pulse-code modulated signal can be fed directly into an electronic computer for automatic processing.

Chapter 4

UHF Signal Generators

We know that ordinary coils and capacitors are not well suited to use in circuits that operate at frequencies above 250 mc. Hence, oscillators in uhf signal generators have constructions as shown in Fig. 4-1. This arrangement can be designed to generate frequencies from 250 mc to 2500 mc. The

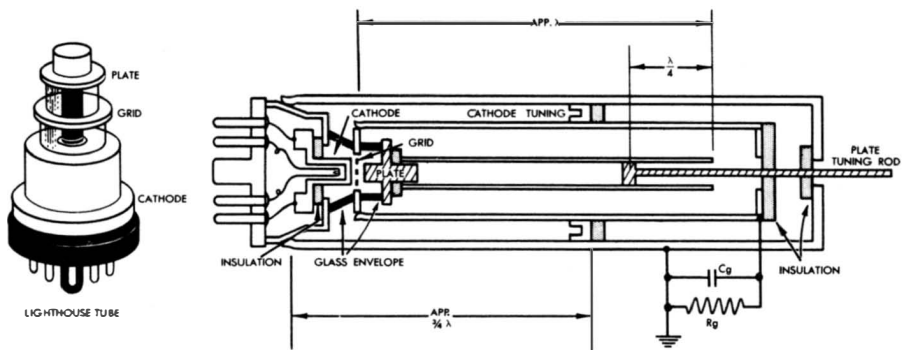

Fig. 4-1. Typical uhf-oscillator arrangement.

tuned circuits consist of three coaxial cylindrical conductors. The inner cylinder is connected to the plate of the oscillator tube. It is analogous to the plate coil in a conventional oscillator circuit. The next cylinder is connected to the grid of the tube; it is analogous to the grid coil in lumped-circuit oscillators. The outer cylinder is connected to the metal shell of the tube and is the ground-reference point. Note that the cathode is capacitively coupled via the insulation ring to the grounded cylinder; hence, the cathode is at r-f ground potential.

OSCILLATOR TUNING

The space between the cathode and grid cylinders forms a coaxial cathode line which is shorted at the far end by the

cathode tuning plunger. Note that the plunger does not actually contact the grid cylinder; this would produce a d-c connection from grid to cathode and short-circuit the grid bias. However, the capacitance between the plunger and the grid cylinder is large enough to be an effective r-f short circuit. Signal-developed bias is used in the oscillator circuit, and is produced by current flow through the grid-leak resistance R_g .

Next, consider the plate circuit. This consists of a coaxial line comprising the grid and plate cylinders. The line is an open circuit at the far end. D-c plate voltage is applied via the plate-tuning rod at the point where the plunger contacts the plate cylinder. With respect to the oscillating frequency, this contact point is $\frac{1}{4}$ -wavelength from the *far end* of the plate cylinder, as indicated in Fig. 4-1. This quarter-wave section, which is shorted at the point where B+ voltage is applied, presents a high impedance to r-f from the open-ended plate line. Thus, it operates as an r-f choke and prevents r-f energy from flowing into the power supply.

We find that the tuning of the plate line determines the resonant frequency and is the chief control of oscillator frequency. It has a secondary effect on feedback. The cathode line is the primary feedback adjustment, and it is usually adjusted for maximum output. However, there is some interaction between the plate line and the cathode line. Hence, to adjust the oscillator for maximum output at a given frequency, the plate and cathode plungers must be adjusted back and forth to find the optimum operating condition.

EQUIVALENT CIRCUITS

To clearly understand the oscillator action in Fig. 4-1, note the equivalent circuits depicted in Fig. 4-2. In Fig. 4-2A, coils L_k and L_p represent the inductances of the shorted cathode line and the open-circuited plate line, respectively. This is a true representation of the actual circuit, provided that the cathode line is less than $\frac{3}{4}$ wavelength long, and provided that the plate line is less than a full wavelength long. The arrangement in Fig. 4-1 is based upon $\frac{3}{4}$ wavelength and full wavelength, although operation is possible using $\frac{1}{4}$ and $\frac{1}{2}$ wavelengths. The reason for this choice is that at high uhf frequencies, $\frac{1}{4}$ and $\frac{1}{2}$ become inconveniently short from a mechanical standpoint.

However, keep in mind that if the cathode line is slightly less than $\frac{1}{4}$ wavelength, it acts like an inductance, and if the plate line is slightly less than $\frac{1}{2}$ wavelength, it will act as an

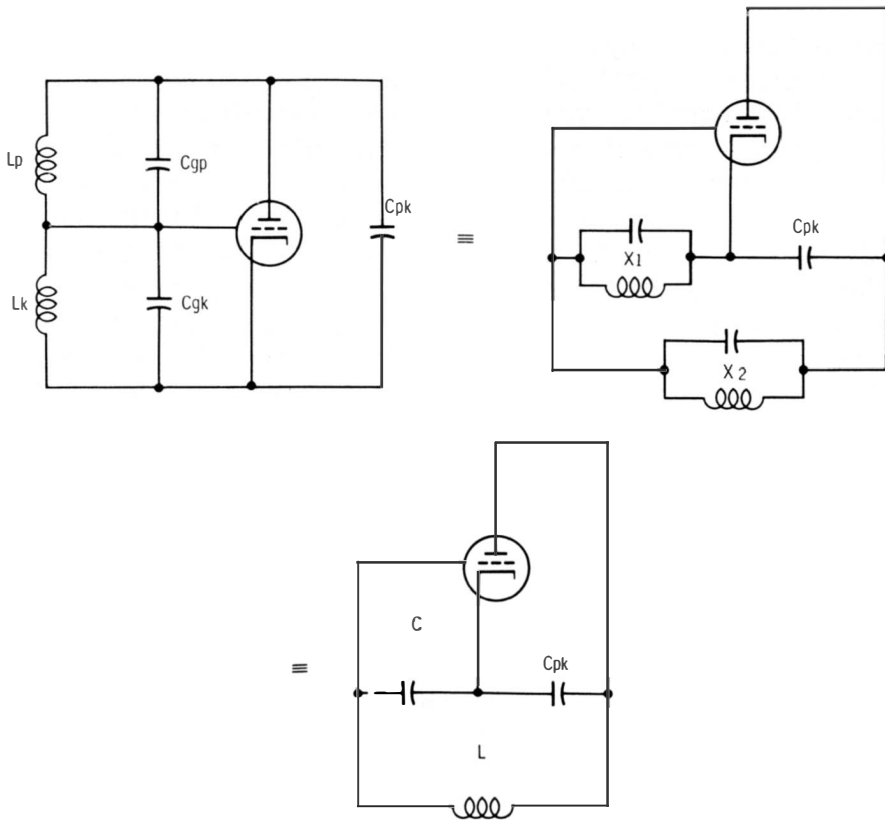

Fig. 4-2. Equivalent circuits for Fig. 4-1.

inductance. Note that no lead inductance is indicated in Fig. 4-2A because the coaxial lines connect directly to the tube electrodes. The interelectrode capacitances of the tube complete the equivalent circuit.

Next, consider the equivalent circuit in Fig. 4-2B. The parallel combination of L_p and C_{gp} is represented by X_2 . Similarly, the parallel combination of L_k and C_{gk} is represented by X_1 . Evidently, the reactances X_2 and X_1 along with C_{pk} , will form a resonant circuit. The reactance X_1 acts as a voltage-divider circuit with respect to C_{gk} . Since the voltage across X_1 is the voltage fed back to the grid, it must be 180° out of phase with the plate voltage to produce oscillation. This 180° phase difference can exist only if X_1 is a capacitive reactance. This consideration leads to the equivalent circuit in Fig. 4-2C, in which the reactance X_1 is now represented by a capacitor.

Any oscillatory circuit requires at least one inductance. Therefore, X_2 must be an inductive reactance. Accordingly, in Fig. 4-2C, reactance X_2 is represented as an inductance L . We can understand that Fig. 4-2C represents the arrange-

ment of Fig. 4-1 only at its resonant frequency. The circuit of Fig. 4-2C is recognized as a Colpitts oscillator. Now, if X_1 is capacitive, C_{gk} must conduct more heavily than L_k . In other words, this is simply the circuit action which defines X_1 as a capacitive reactance. Therefore, the oscillator frequency must be higher than the resonant frequency of L_k and C_{gk} . Again, for X_2 to be inductive, the oscillating frequency must be lower than the resonant frequency of L_p and C_{gp} . To put it another way, the feedback condition for oscillation requires that the oscillating frequency occur *between* the resonant frequencies of the plate circuit and the cathode circuit.

FEEDBACK CONSIDERATIONS

In the arrangement of Fig. 4-2C, the amount of feedback depends on the ratio of C to C_{gk} . This, in turn, depends on the tuning of the cathode line in Fig. 4-1. This is the reason that feedback is controlled principally by the cathode tuning plunger. If too little feedback is used, the output from the signal generator will be weak, or may stop completely. On the other hand, if too much feedback is used, the grid circuit consumes excessive power and "robs" the available output. Since C and C_{pk} are in series (Fig. 4-2C), and because C is usually much larger than C_{pk} , it is necessary to change C quite a bit to greatly affect the oscillating frequency. Hence, the position of the cathode tuning plunger in Fig. 4-1 has only a secondary effect on the frequency of oscillation.

PLATE-TUNING CONSIDERATIONS

Since the position of the plate tuning plunger in Fig. 4-1 determines the resonant frequency of the plate circuit, which in turn establishes the amount of inductance present in the plate circuit at the oscillating frequency (Fig. 4-2C), it follows that the plate tuning is the chief control of frequency. Note that if an ordinary triode were used, the oscillator would be inoperative. Tube-construction features that limit high-frequency oscillation are interelectrode capacitances, lead inductances, and transit time (Fig. 4-3). At low frequencies, such as 1 mc, the interelectrode capacitances in an ordinary tube have reactances which are high enough to avoid difficulties in circuit action. However, when an oscillator is operated at a sufficiently high frequency, the reactance of an interelectrode capacitance becomes of concern.

For example, a 1-pf capacitor has a reactance of 1590 ohms at 100 mc. If this capacitor is the interelectrode capacitance

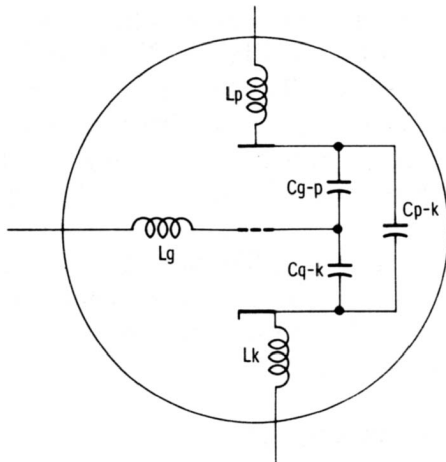

Fig. 4-3. Lead inductance and inter-electrode capacitance in a triode tube.

between the grid and plate of a tube and the r-f voltage between grid and plate is 250 volts, there will be an interelectrode capacitance current flow of 0.157 ampere in accordance with Ohm's law. This heavy r-f current flow will seriously disturb circuit action. On the other hand, at 1 mc the reactance of this capacitance becomes approximately 159,000 ohms, and the r-f current flow is only 0.00157 ampere. This small current flow does not seriously disturb circuit action.

A good point to remember is that the higher the frequency, or the greater the interelectrode capacitance, the greater is the current flow through this capacitance. In most uhf oscillators, interelectrode-capacitance currents are much greater than the output supplied by the oscillator.

EFFECT ON FREQUENCY

The tuned-plate tuned-grid oscillator configuration in Fig. 4-4 can be regarded as the equivalent circuit for the resonant-line arrangement used in some uhf signal generators. Since the interelectrode capacitances are effectively in parallel with the tuned coils, they must affect the resonant frequencies. Note that the plate-to-cathode capacitance is in parallel with the series combination of plate-to-grid capacitance and grid-to-cathode capacitance. All of these capacitances together form a part of the total capacitance of the tuned circuit. Evidently, the interelectrode capacitances establish the minimum capacitance attainable across the inductances. With a given minimum inductance, a high-frequency limit is imposed.

In addition, interelectrode capacitances have another undesirable aspect. The value of interelectrode capacitance is not fixed; it varies with the applied voltages and with the loading of the oscillator. This results in oscillator-frequency instability.

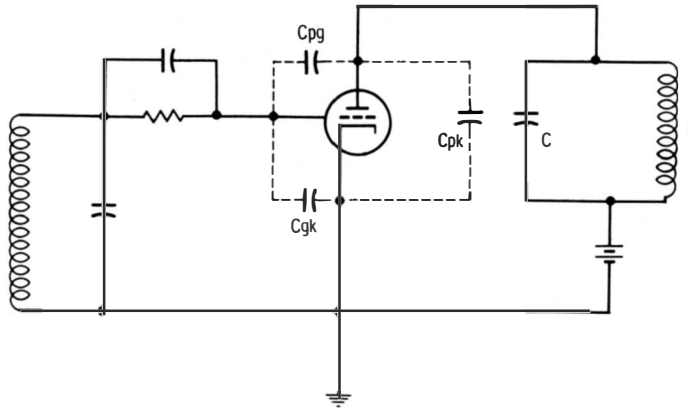

Fig. 4-4. Interelectrode capacitance affects frequency of oscillation.

Although the power supply may be regulated, slight changes in supply voltages will still be present. The oscillator is loaded by the attenuator in the signal generator, and some applications will draw more current than others from the attenuator. In turn, the loading on the oscillator changes, and the frequency shifts. Therefore it is desirable to make the interelectrode capacitances only a small part of the total tuning capacitance. For this reason, uhf-oscillator tubes are designed to have the minimum interelectrode capacitance possible.

LEAD INDUCTANCE

Another frequency-limiting factor in a tube is the inductance of the leads to the tube elements (Fig. 4-3). Although these inductances do not necessarily reduce the efficiency of the oscillator, they may nevertheless represent a major portion of the inductance in the tuned circuit. In turn, a high-frequency limit is imposed because the total inductance cannot be made small enough. Furthermore, since the cathode lead is common to both plate and grid circuits, lead inductance causes negative feedback, with a loss in oscillator efficiency.

TRANSIT TIME

A third limitation imposed by ordinary tube construction is transit time. This is the time required for electrons to travel from cathode to plate. At 1 mc, for example, transit time can be disregarded, since it occupies a very small portion of one cycle. On the other hand, at a sufficiently high frequency, transit time occupies an appreciable portion of one cycle and

impairs oscillator operation. The effect of transit time is of particular concern with regard to input impedance of the tube. Part of the current which flows in the grid circuit is the current which charges C_{gp} in Fig. 4-4. The voltage which produces this current is the vector sum of the input voltage (grid to cathode) and the output voltage across the plate load.

At lower frequencies, with a resistive load these two voltages are 180° out of phase and they add algebraically to determine the charging current. Since the input reactance is capacitive, this current is 90° out of phase with the input voltage. However, at higher frequencies where transit time is an important consideration, the plate current begins to lag the input voltage. This causes the plate voltage to be less than 180° out of phase with the grid-input voltage, and the voltage across the input capacitance lags the input voltage. Accordingly, the charging current is no longer 90° out of phase; it is partly in phase with the input voltage. This simply means that power is consumed in the grid circuit. It is equivalent to shunting a resistor between grid and cathode. At a certain limiting frequency, this resistance approaches a dead short circuit. Hence, tubes used as oscillators in uhf signal generators must have sufficiently fast transit time to permit reasonably efficient operation.

UHF TUBES

Several methods are used to reduce the undesirable effects of interelectrode capacitance in uhf tubes. The lighthouse tube, depicted in Fig. 4-5, is typical of uhf tubes used in signal generators. No known method of coping with interelectrode capacitance is completely satisfactory. Capacitance can be reduced by spacing the electrodes farther apart. However, wide

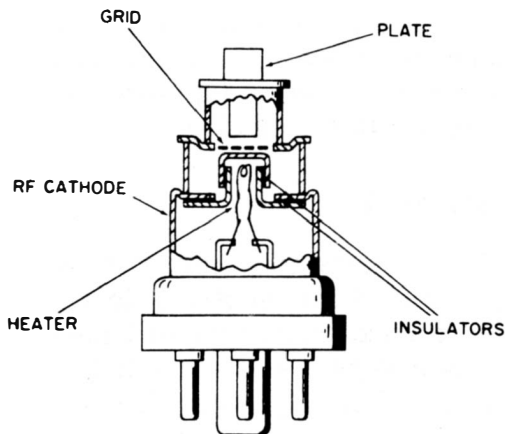

Fig. 4-5. Interior construction of a lighthouse tube.

spacing introduces difficulty due to increased transit time. Another approach is to reduce the size of the tube and the electrodes. This is a satisfactory method, provided that the tube is not required to supply substantial output. Uhf-signal generators typically provide a maximum output power of 1 milliwatt.

Another way of reducing the total interelectrode capacitance is to reduce the lead capacitance by separating the leads widely, and bringing them through the tube envelope from their connection point directly to each electrode. Recall that it is also helpful to reduce the inductance of the leads. Short leads have minimum inductance. Two short leads connected in parallel have still less inductance. In the lighthouse tube construction (Fig. 4-1), the leads are metal rings or disks that have unusually low inductance.

To reduce transit time, electrodes are spaced close together; however, this increases the interelectrode capacitance. Another approach is to use a higher plate voltage to attract the electrons more rapidly from cathode to plate. There are practical limits to the plate voltage that may be applied. Hence, uhf tubes such as the lighthouse house type are necessarily a design compromise. Expert compromise has made it possible to use comparatively inexpensive tubes in the uhf range—a feat which was once considered impossible.

LIMITATIONS IN EXTERNAL CIRCUITS

As in any signal generator, the output from uhf oscillators must be passed through an attenuator and made available for external application. In the flow and control of uhf energy, we are basically concerned with power losses due to skin effect and radiation. Skin effect causes a considerable increase in the uhf resistance of a conductor. This results in high I^2R losses. To minimize skin-effect losses, the conductors in the generator are made large in size and tubular in shape. Since uhf current flows only on the surface of the conductor, its area is maximized. In addition, the conducting surfaces are plated with silver, since silver has a higher conductivity than copper. The next problem is controlling uhf radiation in the signal generator.

Why do ordinary circuit configurations radiate? It is because of incomplete cancellation of electromagnetic fields in the region surrounding the circuit. When the frequency is low enough that the spacing between two parallel conductors equals only a very small fraction of a half wavelength, there

is almost complete cancellation of fields in all directions. At higher frequencies, however, the same spacing represents a larger fraction of a half wavelength. In turn, there is less cancellation of electromagnetic fields. In extreme cases, as when the spacing is a half wavelength, the fields will add in the direction of the plane of the two conductors. This causes the tuned circuits to radiate energy like an antenna.

Therefore, as the frequency is increased, it is necessary to reduce the spacing between the parallel conductors. However, there is a limit to how far you can go in reduction of spacing. Too close spacing would provide uncertain insulation for the operating voltages. Hence, at uhf, radiation is minimized by use of concentric lines instead of ordinary conducting leads. The outer cylinder of the line acts like a shield which prevents escape of uhf energy from its path of flow.

KLYSTRON OSCILLATOR

Signal generators which operate in the range from 2500 to 7500 mc commonly use Klystron oscillators. Fig. 4-6 shows the construction of a typical Klystron type of uhf tube. Operating voltages are noted in the circuit diagram of Fig. 4-7. The output from the oscillator is coupled into a hairpin loop and conducted to the attenuator via a coaxial cable. The cathode emits electrons which are attracted by the positive cavity grids. This positive voltage is equal to E_a , which may be about 500 volts. Observe that the control grid is placed between the cathode and the cavity grids; the grid is *positively* biased to 200 or 300 volts, and it controls electron flow.

Electrons emitted from the cathode travel toward the cavity grids at a velocity determined chiefly by E_a . Most of the electrons pass through the control grid, through the cavity grids, and continue toward the repeller plate. After passing the cavity grid, the electrons arrive at a region where the electric field opposes their motion, because the repeller plate is negative with respect to the cathode by voltage E_r . This voltage is approximately -100 volts. In turn, the net voltage between repeller and cavity grids is in the order of 400 volts. The electrons slow down, come to a stop, and then reverse their travel to pass again through the cavity grids. Finally, the electrons are collected either by the control grid, the shell, or the cathode of the Klystron.

An important consideration here is the cause of oscillation in the resonant cavity between the cavity grids. In most oscillators, oscillations start from some irregularity in current

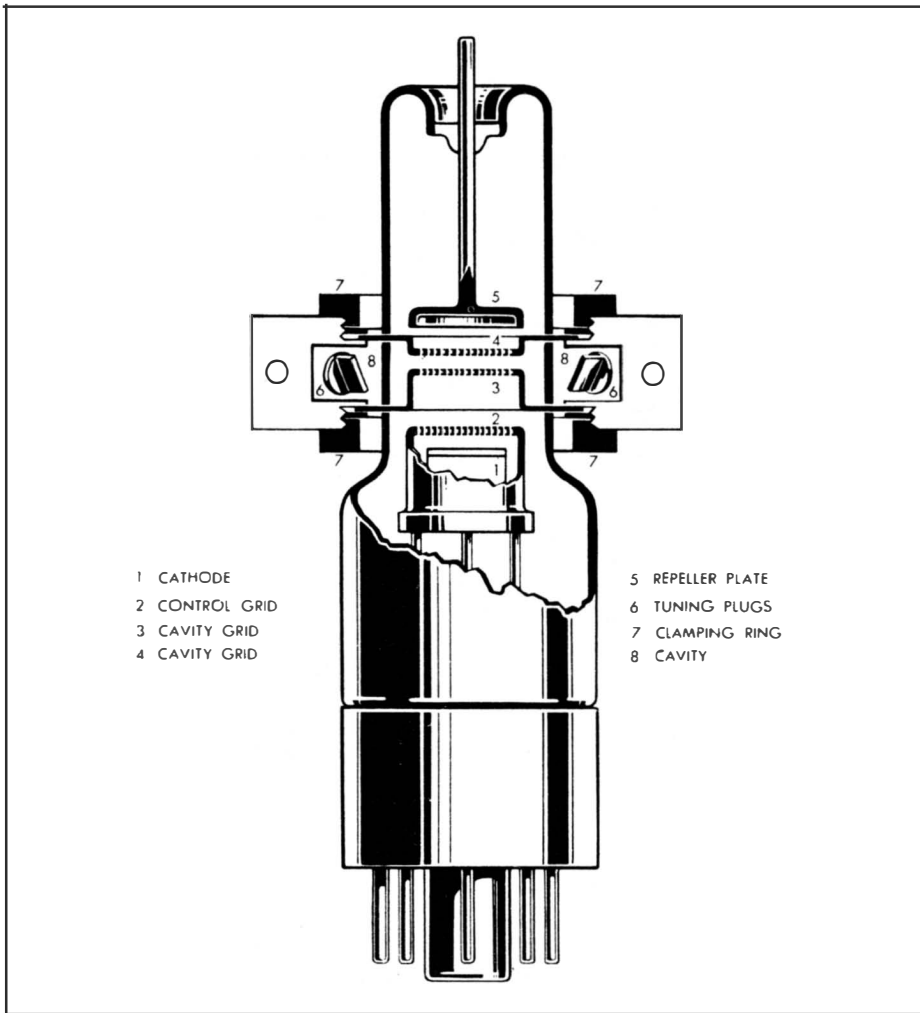

Fig. 4-6. Klystron type of uhf-oscillator tube.

flow, such as a transient which results from voltage being suddenly applied to the tube, or the starting transient may be due to shot effect. With this fact in mind, assume that oscillation of the electromagnetic field in the cavity is already taking place. From this assumption, let us examine the source of energy needed to sustain this electromagnetic field oscillation.

With the tank circuit (cavity) oscillating, a high-frequency voltage (denoted as e in Fig. 4-7) appears between the two cavity grids. This makes the electric field between the two grids reverse twice during each complete cycle of oscillation. As the electrons approach these grids, the electron stream is uniform. The time that is required for the electrons to pass through the small distance between the grids is short com-

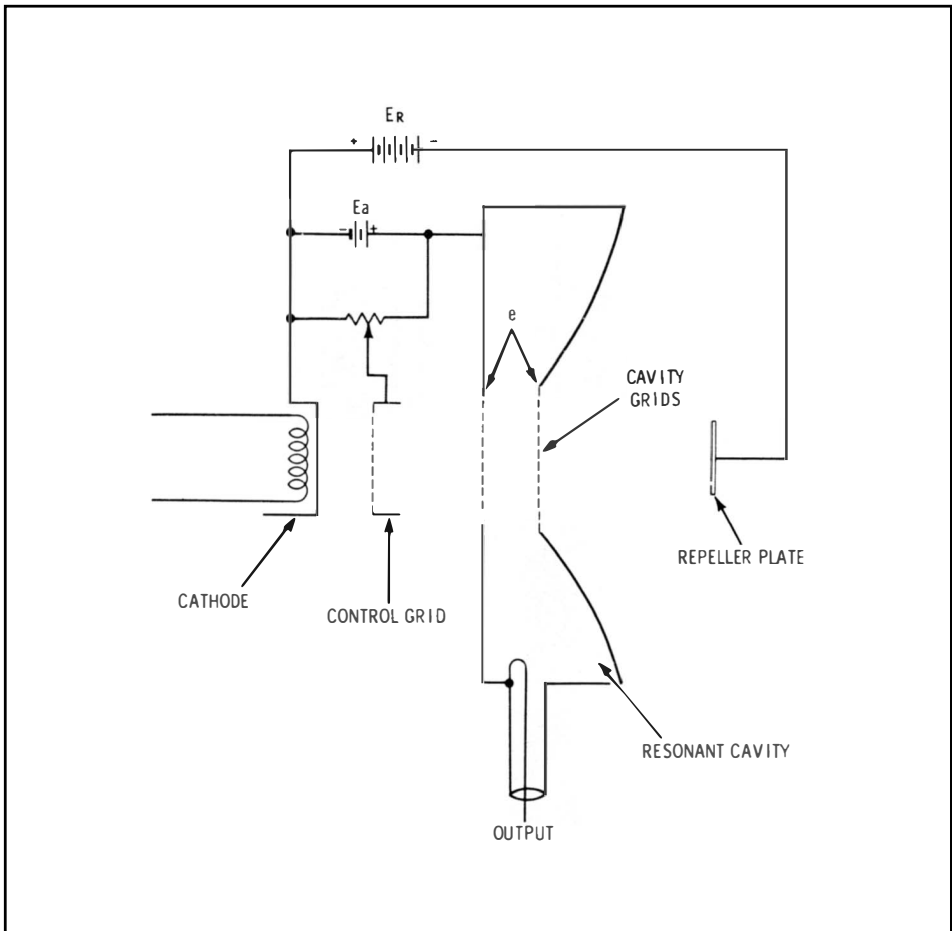

Fig. 4-7. Klystron oscillator circuit.

pared to the period of oscillation. Electrons that enter the space between the grids when e is zero will encounter no electric field and will pass on through with the same velocity. On the other hand, electrons that enter the space when e makes the left grid negative with respect to the right grid “see” a force field which tends to accelerate the electrons. The amount by which they are speeded up depends on the value of e .

Again, electrons that enter the space when e is reversed in polarity are slowed down. These accelerations and decelerations are small in comparison with the original speed of the electrons. Those electrons which are speeded up most will travel farther toward the repeller plate before being turned back. Conversely, electrons which are slowed down most will be turned back before traveling as far. We see that the electron stream is no longer uniform. With the proper values of

e , E_a , and E_r in Fig. 4-7, electrons returning to the cavity grids will arrive in "bunches."

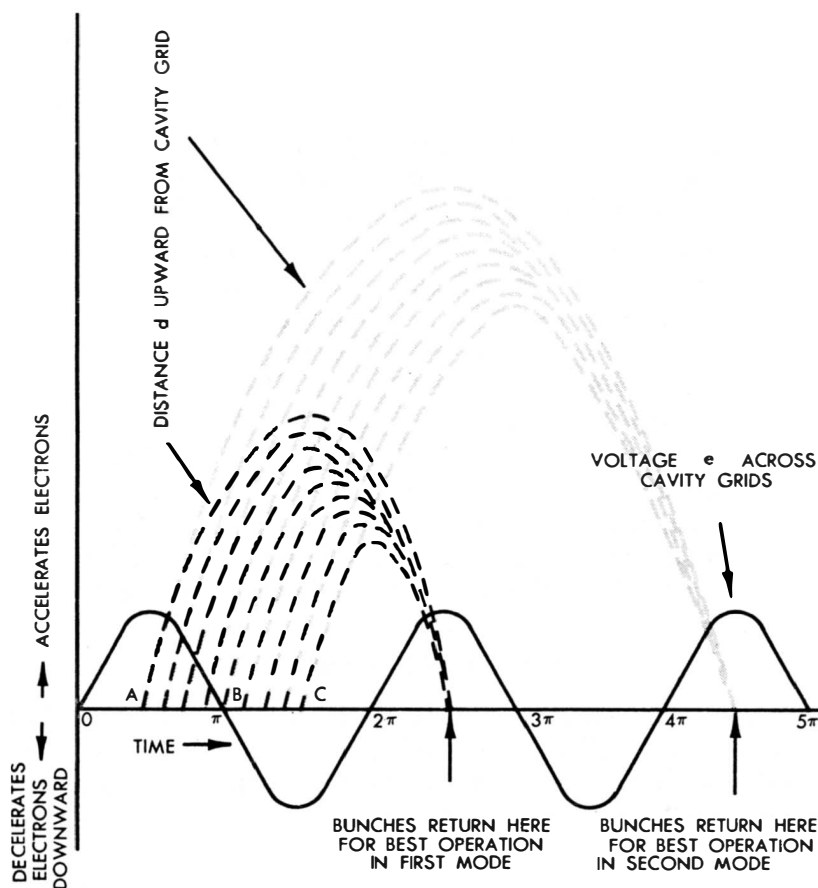

Fig. 4-8. Electrode bunching in a Klystron tube.

The diagram in Fig. 4-8 shows the position of electrons in the Klystron at various times during their transit. The zero distance position is midway between the cavity grids. Electron A, which arrives when e is positive, is accelerated and travels farther before being turned back. Electron B is unaffected. Electron C is decelerated and turns back after a shorter excursion. Hence, in the diagram these electrons and those passing through at intermediate times are shown arriving back at the grids at the same instant. This is the ideal situation, but it is not difficult to see that electrons will return to these grids in a stream which varies in intensity at the frequency of oscillation.

On the return trip, the electric fields set up by voltage e again act on the electrons. Since they are now traveling in the opposite direction, they will be decelerated if they return

when e is positive, and they will be accelerated when e is negative. If an electron is accelerated, we know that its kinetic energy is increased. This energy increase is taken from the electric field. On the other hand, an electron which is decelerated gives up energy to the electric field. Clearly, if the bunches of electrons can be made to arrive back at the grid when e is positive, they will give up energy to the alternating field. For maximum transfer of energy, the bunches must arrive when e is at its positive maximum.

The question arises as to where this energy originated. You have seen that if the electron stream from the cathode is uniform, some electrons are accelerated and some are decelerated on the outbound path. On the average, there are as many electrons absorbing energy from the field as there are those that give up energy to it. Hence, very little net energy is taken from the oscillating circuit during the bunching process. The average kinetic energy of the electron is that which is given to it by d-c voltage E_a in Fig. 4-7. Thus we see that energy is taken from the d-c electric field and given up to the a-c field to sustain uhf oscillation in the Klystron.

ELECTRICAL TUNING

Cavity size determines the basic frequency of oscillation in a Klystron tube. Thus, the oscillator can be tuned by a mechanical means that varies the cavity volume. In addition, a Klystron can be tuned electrically. We perceive that it is not necessary for the bunches of electrons to return to the grids on the first positive swing of e after the first passage. Fig. 4-8 depicts bunches of electrons which also arrive on the second positive swing. However, the net result is the same. We see that the time in transit for the average electron B is $\frac{3}{4}$ cycle, $1\frac{3}{4}$ cycle, $2\frac{3}{4}$ cycle, etc., and in actual practice there are three or four "modes" in which it is possible for the Klystron tube to oscillate.

The dark lines in Fig. 4-8 indicate paths of electrons operating in the first mode, while the light lines indicate paths of electrons operating in the second mode. A third mode is possible when the average transit time is $2\frac{3}{4}$ cycles, etc. Let us see how the transit time is controlled to produce oscillation in the different modes. Since the original velocity of an electron depends on the d-c voltage E_a in Fig. 4-7, and since the distance that the electron travels before turning back (and the speed with which it returns) depend upon the difference between E_a and E_r , we find it possible to adjust the two voltages E_a and E_r for any desired mode. The voltage E_a is usually

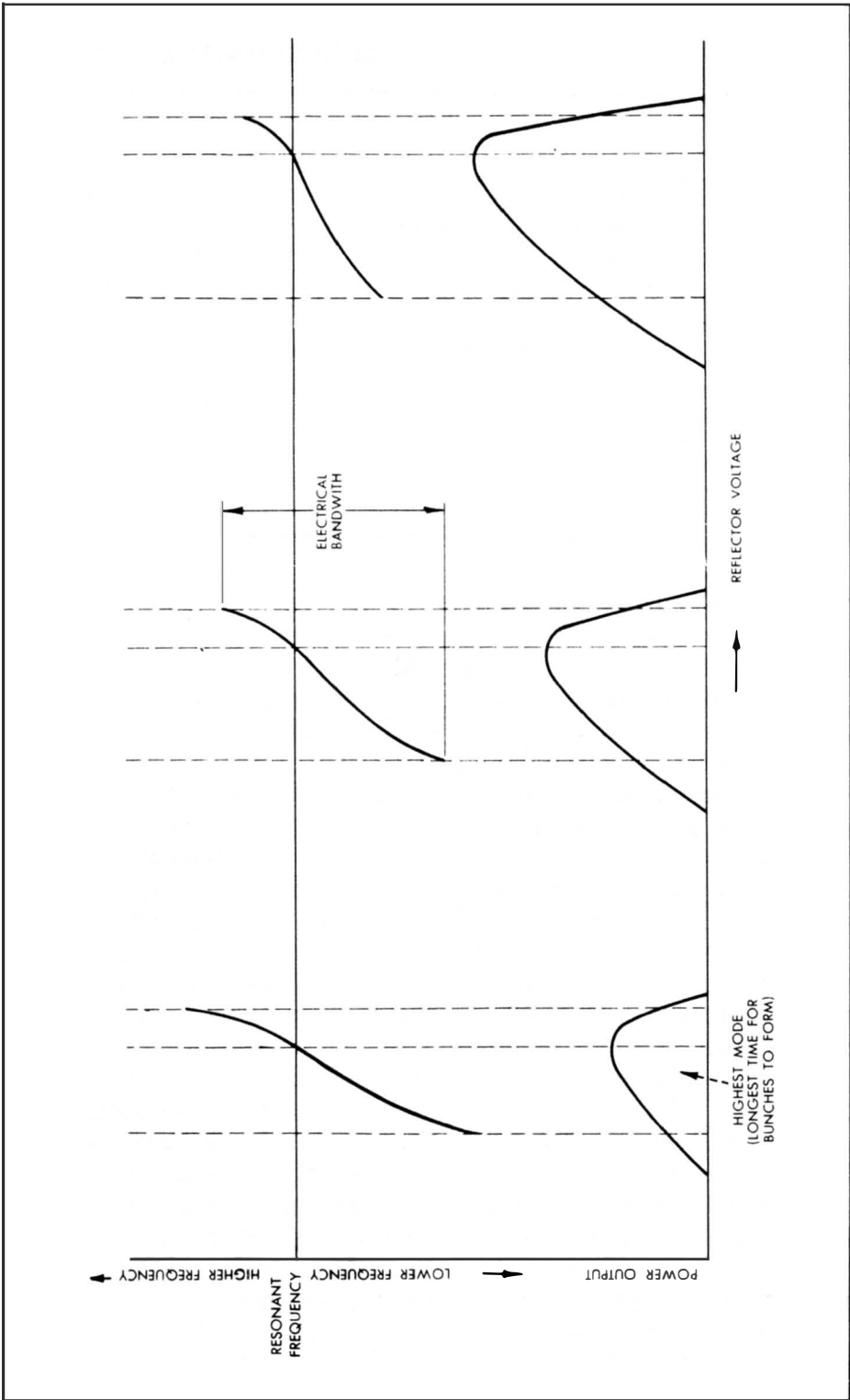

Fig. 4-9. Frequency and power-output variation vs repeller voltage, for three modes.

**TABLE
CHARACTERISTICS OF FOUR**

No.	Name	Mfr.	Freq. (Mcps)	Acc. Voltage
K417	Klystron	Sperry	3000	300-600
707A	McNally	W. E. and Raytheon	3000	250-325
726A	Shepherd- Pierce	W. E.	3000	300
723A	Shepherd- Pierce	W. E.	9400	300

fixed, since varying it produces greater initial velocity, which in turn causes a farther excursion and a greater return velocity. Hence, E_r is made variable.

For operation in the first mode, the round trip must be completed in the shortest possible time. This occurs when the repeller plate is made highly negative. Next, if the repeller is made less negative, the transit time will be increased. Fig. 4-9 shows power output and frequency of oscillation plotted against repeller voltage for three modes of operation. Note that the frequency at the point of maximum output is the same for all three modes, and is the resonant frequency of the cavity in accordance with its mechanical dimensions. Note also that the power output for the different modes at the resonant frequency is least in the highest mode, and greatest in the lowest mode.

We find that power and amplitude limitations are due to overbunching as well as to the usual losses in the oscillatory circuit. Overbunching occurs as follows: As oscillations build up and e becomes greater, the amount of acceleration and deceleration increases. This causes bunching to occur in a shorter period of time. Or, the bunching occurs before the electrons reach the grids on the return trip. This tends to reduce the magnitude of oscillation. In the higher modes of operation where the bunches are formed more slowly, the electrons are more susceptible to overbunching. The magnitude of e which results in overbunching, is lower, and oscillations are limited to a lower amplitude than in the lower modes of operation.

4-1.

KLYSTRON TYPE TUBES

Beam Cur. (Ma)	Repeller Voltage	Control Grid Voltage	Power Output (mw)	Elec. Tuning (Mcps)
5-30	+ 50 to - 500	+ 5 to + 50	150	5
25-35	0 to - 250	same as acc.	75	30
22	- 20 to - 300	same as acc.	100	20
18-25	- 20 to - 300	same as acc. (internal connection)	20	45

Thus, as shown in Fig. 4-9, the oscillating frequency in a Klystron is variable to a limited degree in any mode by varying the repeller voltage. When the repeller voltage is changed, it causes a bunch to return a little sooner or a little later than otherwise. Off resonance (mechanical resonance), the amplitude of oscillation decreases by an amount that depends on the Q of the cavity. In the tube under discussion, the electrical tuning range is comparatively small and has its maximum range in the highest mode. Table 4-1 gives a comparison of four different types of Klystron tubes. The maximum electrical tuning range is provided by the 723A, which has an electrical bandwidth of 45 mc.

ATTENUATORS

Output from a uhf oscillator in a signal generator is taken via a coaxial line, as depicted in Fig. 4-7. Recall that open leads cannot be used because of excessive radiation and leakage. Hence, conventional attenuators cannot be used. Instead, uhf attenuators are built into coaxial lines. Fixed sections such as shown in Fig. 4-10 may be manually inserted or switched in series with the output coaxial line. This is a resistive pi section built into the coaxial line. Its advantage is that it maintains a fairly good characteristic impedance, which minimizes standing waves in the output system.

To form a variable attenuator, a metal tube that can be partially slid over the resistance rod is provided. This tube

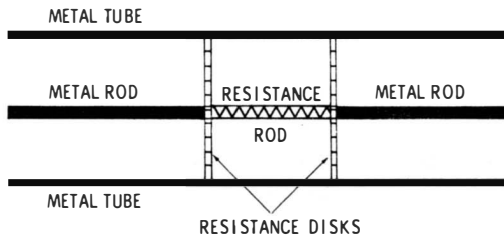

Fig. 4-10. Fixed attenuator section for a uhf generator.

changes the value of the series resistance and in turn varies the I^2R loss in the rod. When a sliding metal tube is used, the resistance disks shown in Fig. 4-10 are usually omitted. If several fixed attenuator sections are supplemented by a variable attenuator, the output from the uhf signal generator can be continuously controlled over as wide a range as desired.

Other forms of uhf attenuators that are based on principles of waveguides can be used. A waveguide is similar to a coaxial line that has no central conductor. In turn, the waveguide must have a certain diameter to conduct the uhf electromagnetic fields without attenuation. If the waveguide diameter is less than a critical value, it is said to be operating beyond cutoff. Attenuation of uhf energy is rapid when a waveguide is operated beyond cutoff. Thus, if a waveguide of ample dimensions is connected to a section which has a diameter less than the critical value, the narrow section operates as an attenuator. However, it is more difficult to maintain a good standing-wave ratio with a waveguide attenuator than with a resistive coaxial attenuator, such as depicted in Fig. 4-10.

UHF SIGNAL GENERATOR MODULATION

Uhf oscillators can be modulated directly; however, more difficulties are encountered than in the case of low-frequency oscillators. Hence, most uhf signal generators are externally modulated after the attenuator, and one or more semiconductor diodes are employed. Recall that a basic crystal-diode modulator is typically arranged as shown in Fig. 4-11. It is biased in the forward direction to a suitable operating point. Modulation occurs because the diode is a nonlinear resistance, and the modulating signal shifts the operating point up and down on the diode characteristic.

In uhf application, the diode modulator must have coaxial construction. Moreover, the characteristic impedance of the modulator must be maintained as uniform as possible. This

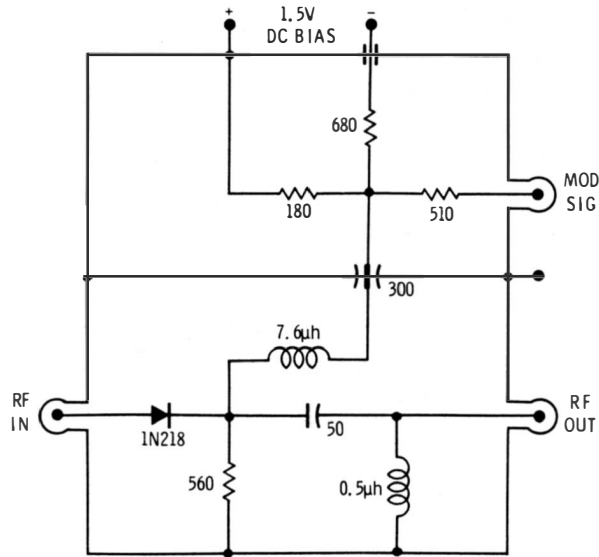

Fig. 4-11. Basic crystal-diode modulator.

is done by utilizing a number of diodes, as seen in Fig. 4-12. All the components in Fig. 4-12 are built into a coaxial line—the ground is the outer conductor of the coaxial section. Uhf chokes are placed at each end of the modulator; they act as a high-pass filter in combination with the small series capaci-

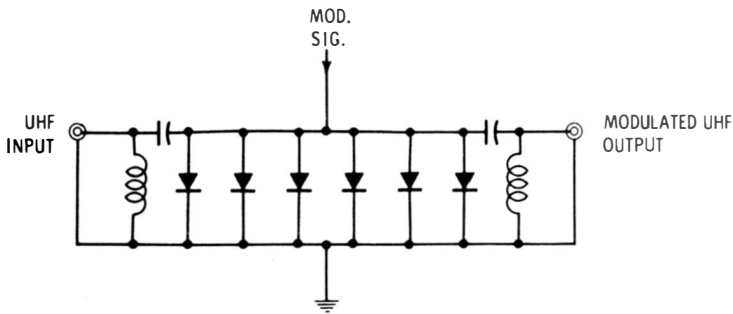

Fig. 4-12. Typical multiple-diode modulator.

tors. The filters prevent the modulating signal from flowing back into the generator, and they also prevent the modulating signal from flowing into the output cable from the modulator.

Why are several diodes used? It is because each diode places a shunt loss across the line. This loss imposes reflections of uhf energy. However, if each diode places only a small shunt loss across the line, the standing-wave ratio is reduced. Consider a reflection from a diode at the center of the modulator—the reflected energy travels in both directions, but this energy is gradually absorbed by the other diodes. Hence, a

minimum amount of reflected energy appears at the input and output ends of the modulator.

Furthermore, the diodes are selected to impose a graduated loss. In other words, the two diodes at the ends of the modulator are types which shunt comparatively little current across the line, while the two diodes at the center of the modulator are types which conduct much more current. Accordingly, most of the reflection occurs at the center of the modulator. The reflected energy from the center of the modulator is reduced to a satisfactorily low level by absorption in the other diodes. This type of modulator is used for either sine-wave or pulse modulation.

Chapter 5

FM Stereo Multiplex Signal Generators

Basically, an f-m stereo multiplex signal consists of two audio signals that occupy the same f-m channel; these audio signals provide stereophonic sound reproduction. The audio signals are identified as “Left” (L), and “Right” (R). These terms refer to the outputs from a pair of microphones at a sound studio, as seen in Fig. 5-1. The audio signal from the L

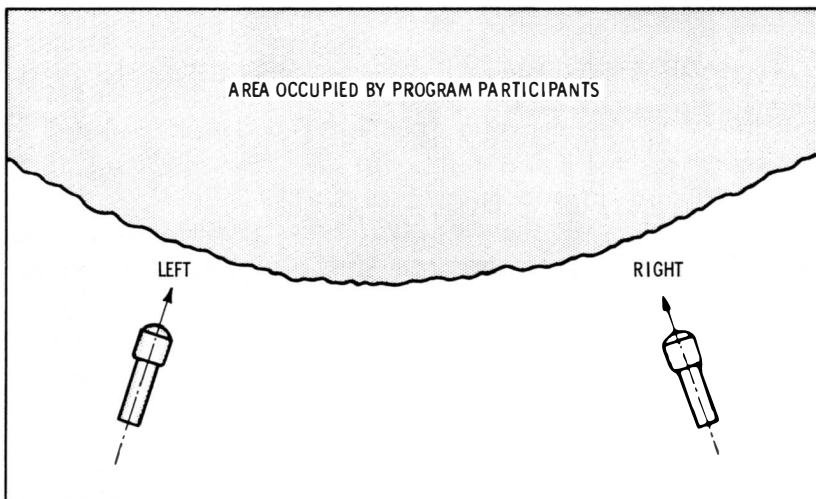

Fig. 5-1. Placement of stereo microphones.

microphone is slightly different from that of the R microphone. Again, the L and R signals may be the two outputs from a stereo record player. Sometimes the L and R channels carry unrelated audio signals, as exemplified by special sound effects. From the standpoint of signal generation, the basic fact is that a stereo signal consists of two audio waveforms which may vary independently in frequency and amplitude.

At the receiver, the L and R signals are fed to separate speakers. The speakers are placed an appreciable distance apart, in correspondence to the distance between transmitting microphones, as shown in Fig. 5-2.

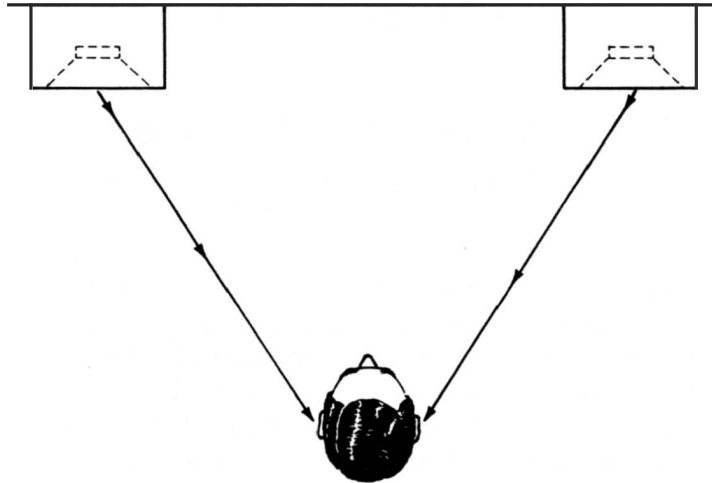

Fig. 5-2. Placement of stereo speakers.

FUNDAMENTALS OF STEREO MULTIPLEXING

Beginners might suppose that an f-m radio channel could be divided into two equal parts for the transmission of the L and R signals on individual carrier waves. However, this oversimplification is not feasible for two fundamental reasons. First, consider the fact that *one* audio signal requires all the available bandwidth in an f-m channel. Fig. 5-3 shows the bandwidth relations; each channel is flanked by a guard band. Although the center frequency of one channel is spaced 200 kc from the next, the guard bands reduce the available band-

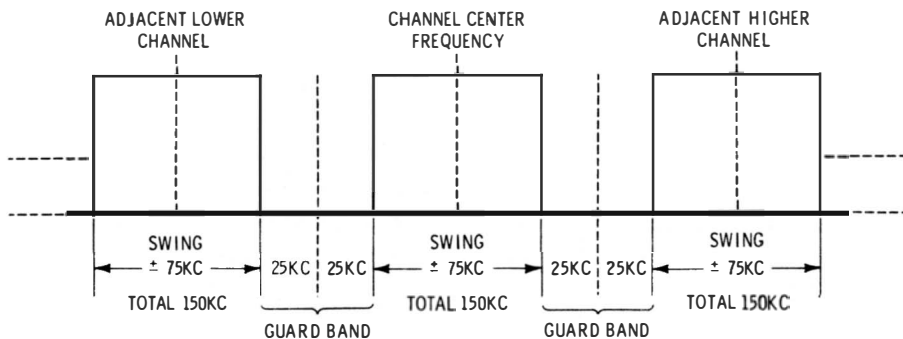

Fig. 5-3. Maximum frequency deviation in an f-m signal is $\pm 75\text{kc}$.

width of each channel to 150 kc. Or, the maximum available frequency swing in each f-m channel is ± 75 kc.

This frequency swing of ± 75 kc is required for high-fidelity transmission of one audio signal. Why is this frequency swing required? It is because hi-fi reproduction comprises audio frequencies up to 15 kc. In an a-m signal this corresponds to a frequency spread of ± 15 kc, or a bandwidth of 30 kc. However, an f-m signal is different; its sidebands have a greater spread. Since all the available bandwidth of an f-m channel is required to transmit a single audio signal, it is not feasible to cut this bandwidth in half in order to transmit a second audio signal in the same channel.

Therefore, we must consider how two signals can be multiplexed so that *each* signal occupies all of the available bandwidth in the channel. The basic concept of multiplexing is that each signal shall be transmitted without distortion and without interference to the other signal. Furthermore, each signal must have an electrical characteristic which permits "clean" separation from the combined signal at the receiver.

Furthermore, there is a *compatibility* requirement. In other words, the L and R signals in Fig. 5-1 must be able to be reproduced as a single normal audio signal by a conventional f-m receiver. Or, the multiplex transmission must "look like" an ordinary f-m signal to a conventional receiver, but it must "look like" separable L and R signals to a stereo-multiplex receiver. These technical requirements might appear to be insurmountable; however, the approved FCC method is comparatively simple. Let us analyze the system step by step.

It starts with the familiar monophonic (monaural) audio signal, which is picked up by a single microphone. What is the relation between this mono signal and a pair of L and R stereo signals? *The mono signal is the arithmetic sum of the L and R signals.* Hence, the first step is to employ two microphones as if they were one. If we mix the L and R signals as shown in Fig. 5-4, we obtain a mono signal. Then, if this L + R signal

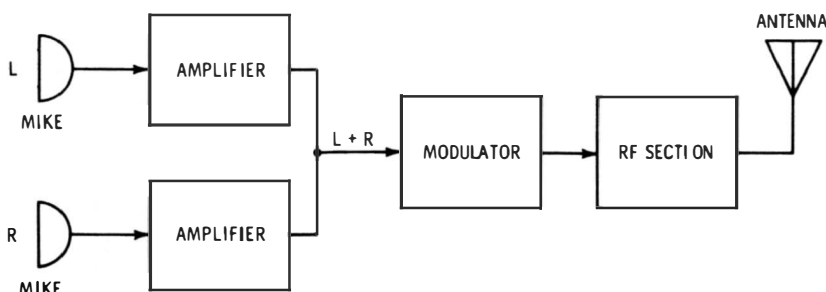

Fig. 5-4. Transmission of the audio signal for reception on an ordinary f-m receiver.

is modulated on the f-m carrier, the result is the same as if only one microphone were used.

Insofar as ordinary f-m receivers are concerned, only this monophonic audio signal is being transmitted. Actually, we shall see that additional information, to which an ordinary f-m receiver is unresponsive, is also being transmitted. The additional information is called a multiplexed signal. We sometimes say that the multiplexed signal is "encoded." This merely means that the encoded information is ignored by a receiver unless special circuits are used to pick out and demodulate the encoded signal. Let us see what a multiplexed signal consists of.

Suppose we add a 38-kc carrier to an audio program and modulate both signals on the r-f carrier, as depicted in Fig.

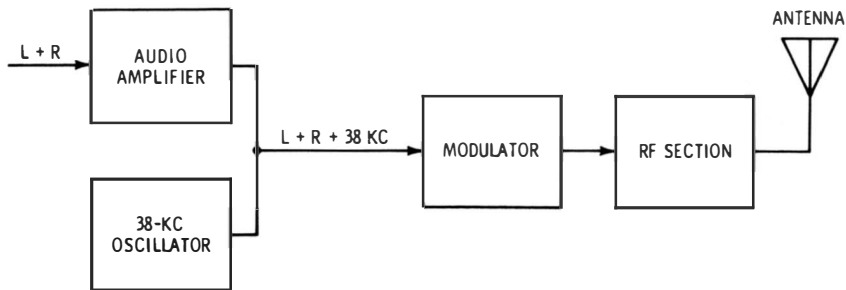

Fig. 5-5. The 38-kc signal is inaudible.

5-5. Evidently, only the audio signal can be reproduced at the receiver. The 38-kc carrier is far out of the range of audibility. Next, if we modulate the 38-kc carrier, this modulation will also be out of the range of audibility. If proof is needed, consider the following example. Even if we modulate the 38-kc carrier with a 15-kc audio signal, the lower sideband has a frequency of 23 kc, and the upper sideband has a frequency of 53 kc. Nobody can hear a 23-kc tone. Of course, this is a simplified example, because f-m sidebands occupy somewhat more channel space than a-m sidebands. Nevertheless, it illustrates the basic consideration.

For example, Fig. 5-6 depicts the output from an ordinary f-m receiver. The L+R signal has frequencies from zero to 15 kc. This signal is the same as if a single microphone had been used at the studio. When modulation is applied to the 38-kc oscillator in Fig. 5-5, sidebands are produced, such as shown in Fig. 5-6. Thus, frequencies from 23 to 53 kc are also fed from the output of the f-m receiver to the speaker. Since the speaker cannot reproduce such high frequencies, and the

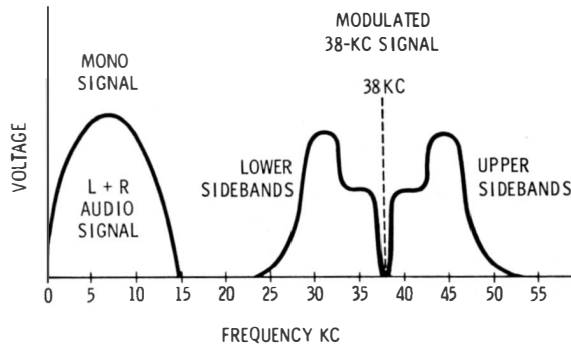

Fig. 5-6. Typical modulating signal that is applied to the r-f section.

ear could not respond to them in any case, it is just as if the 38-kc frequency and its sidebands were absent.

Next, let us see how the upper and lower sidebands in Fig. 5-6 can be recovered and fed to another speaker. Fig. 5-7 shows the basic arrangement. The sidebands are picked out by the 23 to 53 kc bandpass circuit. In turn, this signal is fed to a second discriminator and is demodulated. Accordingly,

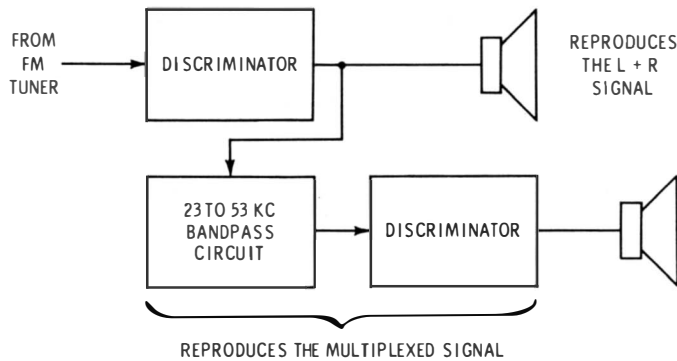

Fig. 5-7. A second discriminator makes the multiplexed signal audible.

the audio signal which modulated the 38-kc carrier is developed and is fed to the second speaker. The encoded signal, which was rejected by the first speaker, has been made audible from the second speaker. This is the fundamental principle of multiplex operation from transmitter to receiver.

FORMATION OF L AND R SIGNALS

Although the simple arrangement shown in Fig. 5-7 reproduces the two independent signals depicted in Fig. 5-6, it must be elaborated slightly to obtain an R signal from one speaker and an L signal from the other speaker and thereby

meet the requirements for stereo reproduction. Let us see what is necessary. First, the upper speaker in Fig. 5-7 is reproducing an $L+R$ signal. We need some easy way to cancel out the R signal, then the upper speaker will reproduce the L signal only. The way this is done is as follows. An $L-R$ signal is modulated on the 38-kc carrier in Fig. 5-6. Hence, the $L-R$ signal becomes available at the output of the second discriminator in Fig. 5-7.

This gives us both $L+R$ and $L-R$ signals to work with. If we add $L+R$ to $L-R$, we get $2L$. On the other hand, if we subtract $L-R$ from $L+R$, we get $2R$. Then, we can feed $2L$ to one speaker and $2R$ to the other speaker. This gives us stereo reproduction. You are probably saying, "This is all well and good, but how do we form the $L-R$ signal in the first place?" This is done with a phase inverter, as seen in Fig. 5-8. If we invert the polarity of the R signal and add it to the L signal, we obtain an $L-R$ signal.

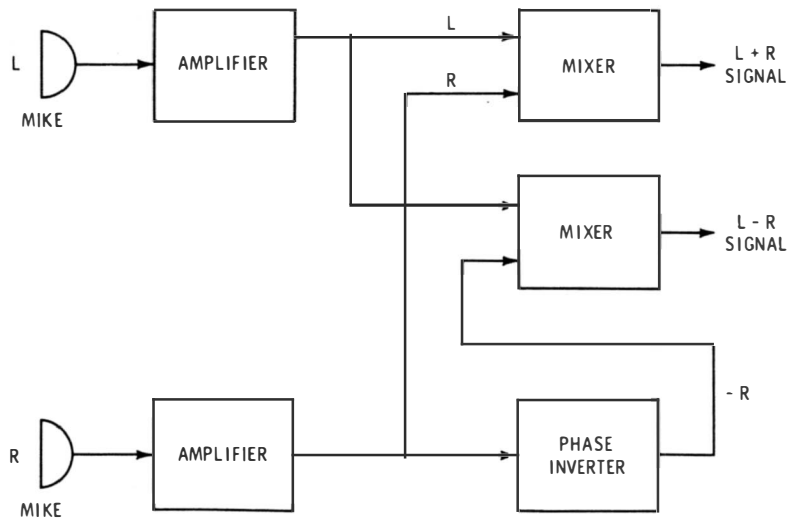

Fig. 5-8. Formation of $L+R$ and $L-R$ signals.

Now that we have the necessary $L+R$ and $L-R$ signals, it follows that the multiplex transmission is made as shown in Fig. 5-9. In turn, the upper and lower sidebands in Fig. 5-6 consist of the $L-R$ signal. To obtain stereo reproduction at the receiver, we add and subtract the $L+R$ and $L-R$ signals in mixers, as seen in Fig. 5-10. Accordingly, one speaker reproduces the R signal, while the other speaker reproduces the L signal. Stereo reproduction thus results from multiplexing the $L+R$ and the $L-R$ signals when suitable receiving equipment is used.

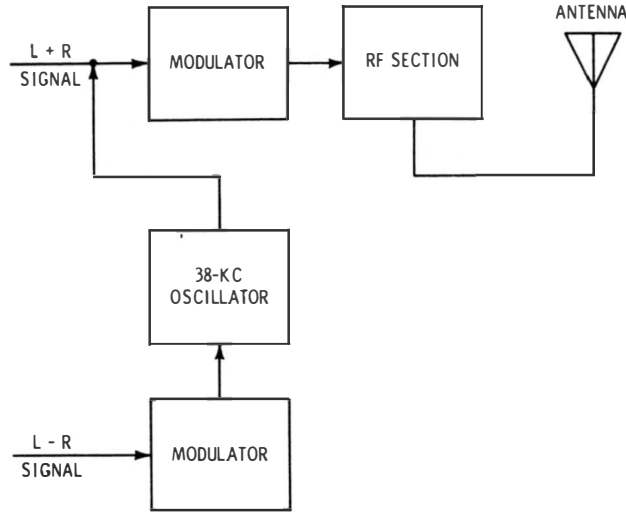

Fig. 5-9. How the $L-R$ signal is multiplexed with the $L+R$ signal.

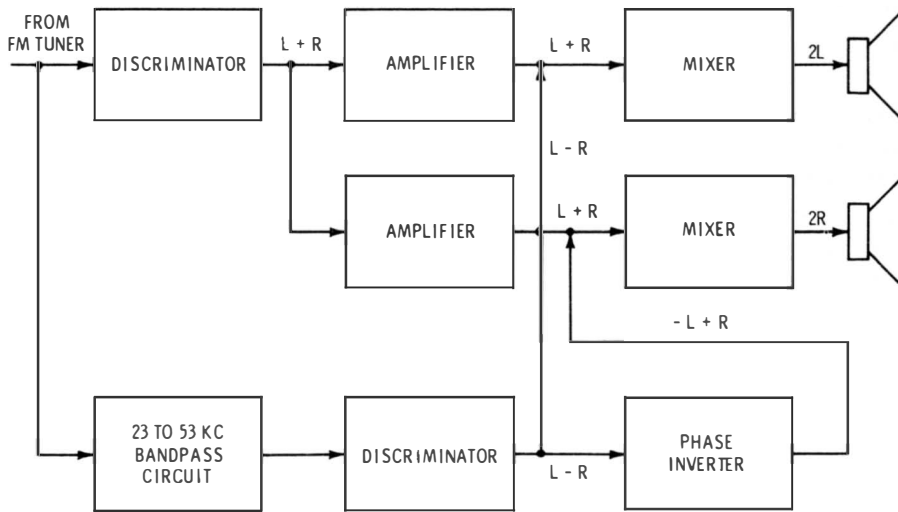

Fig. 5-10. Processing of the $L+R$ and $L-R$ signals to form L and R signals.

F-M STEREO MULTIPLEX SIGNAL GENERATOR

It follows that an f-m stereo multiplex signal generator must be a miniature transmitter, as previously described. The generator supplies a choice of $L+R$ or $L-R$ signals. It also provides a combined $L+R$ and $L-R$ output. The generator usually provides additional test signals, which will be explained. (Refer back to Fig. 5-6). We find that the 38-kc signal (technically termed the subcarrier) *could* be transmitted but that it is actually suppressed in practice. The 38-

kc subcarrier is suppressed to permit the upper and lower sidebands to be transmitted at a higher level than is otherwise possible. This improves the signal-to-noise ratio.

However, it is mandatory that the subcarrier frequency be reinserted with the sidebands at the receiver. If this were not done, the $L-R$ signal would be highly distorted. Furthermore, the reinserted subcarrier must have correct frequency and phase. How can this be accomplished? The practical answer is to transmit a *pilot* subcarrier. This pilot subcarrier must be "in the clear" so that it is not interfered with. Hence, the pilot carrier is set at 19 kc. It is seen in Fig. 5-6 that 19 kc falls in an empty space between the $L+R$ signal and the lower sidebands of the $L-R$ signal. This insures clean reception of the pilot subcarrier without any interference.

At the transmitter, the 19-kc pilot oscillator is locked to the 38-kc subcarrier, which has been suppressed. Therefore, the *second harmonic* of the 19-kc pilot frequency is produced at the receiver, and it is used for reinsertion of the 38-kc subcarrier with the upper and lower sidebands of the $L-R$ signal. This reinserted subcarrier is extremely accurate in both frequency and phase. Now, it is obvious that a stereo multiplex signal generator must supply a 19-kc pilot frequency, just as the transmitter does. This generator output is also useful for signal-tracing and signal-substitution tests, in addition to being required for normal receiver operation.

An f-m stereo multiplex generator also provides a 38-kc subcarrier signal. Although it is not used in tests of normal receiver operation, the 38-kc signal finds application in signal-injection tests during alignment procedures. Of course, the generator must supply a modulated r-f signal. Hence, it also contains a modulated oscillator. The r-f oscillator operates at a typical frequency of 100 mc. The $L+R$ and $L-R$ signals have a typical frequency of 1 kc. Since the generator provides a choice of individual basic signals that are steady and accurate, it permits the technician to pinpoint receiver troubles, and to adjust the receiver maintenance controls for optimum operation.

The available test signals are as follows :

1. Left monophonic output.
2. Right monophonic output.
3. Sidebands of L without 19-kc pilot.
4. Sidebands of $-R$ without 19-kc pilot.
5. Sidebands of L with 19-kc pilot.
6. Sidebands of $-R$ with 19-kc pilot.

7. L-channel composite signal without 19-kc pilot.
8. R-channel composite signal without 19-kc pilot.
9. L-channel complete composite signal.
10. R-channel complete composite signal.
11. 19-kc sine wave.
12. 38-kc sine wave.

In other words, every signal component present in the receiver circuits can be obtained by switching the generator to build up a complete signal step by step. One of the more critical receiver adjustments concerns good separation of the L and R signals. With reference to Fig. 5-10, this means that minimum output should be obtained from the R speaker when an L signal is applied, and vice versa. These maintenance adjustments can be made only with the aid of a generator. It is quite helpful to use vtvm or scope indication of output

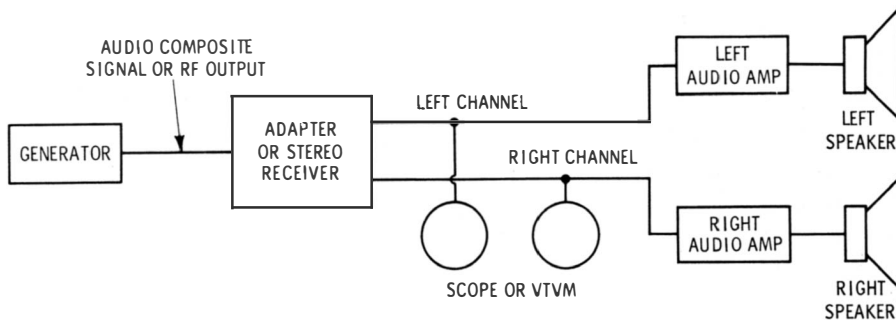

Fig. 5-11. A scope or vtvm accurately indicates the minimum output signal.

voltage, as depicted in Fig. 5-11. Instrument indication is also the best means of determining the optimum setting of the balance control for equal response from each speaker.

GENERATOR CIRCUITRY

A block diagram of a typical f-m stereo multiplex generator is shown in Fig. 5-12, which is helpful in following the circuit diagram in Fig. 5-13. There are 11 functional units, as follows:

1. 1-kc audio oscillator.
2. Phase inverter.
3. 19-kc oscillator.
4. 19kc-to-38kc doubler.
5. A-m modulator.
6. 38-kc carrier suppressor.

7. Audio composite adder.
8. Audio phase delay.
9. 67-kc oscillator.
10. Final amplifier and emitter follower.
11. R-f oscillator and f-m modulator.

Why is a 67-kc oscillator included? It is because the FCC provides a subsidiary communications authority which may be used for transmission of background music. This is called SCA transmission, and it employs a 67-kc subcarrier located beyond the upper sideband limit in Fig. 5-6. Since an incorrectly adjusted receiver may be plagued with "birdies" when SCA transmission is used a 67-kc check signal is desirable.

The internally generated 1-kc L and R signals are developed by a Colpitts-type oscillator which has a tuned 1-kc tank circuit (See Q1 in Fig. 5-13). The L and R output signals that are fed to the base-emitter junction of Q2 have the same frequency and amplitude. To produce the L-R and L+R signals, the output of the 1-kc oscillator (Q1) is applied to the base-emitter junction of Q2, the phase-inverter stage. The signal at the collector of Q2 is shifted 180° in phase with respect to the input signal. Both the emitter and collector signals are fed to the audio switch (S1). Note that the collector signal from the inverter stage is the -R signal; the emitter signal from the inverter stage is the +R signal.

Potentiometer R7 is called the L-R -R level adjustment. It is a screwdriver control which permits setting of the -R signal amplitude. The signal at the emitter of Q1 is controlled by R8, which is the L+R level adjustment, and by R9, which is the L-R L adjustment. These are also screwdriver controls. Note that the L+R level control (R8) determines the amplitude of the L+R signal, and the L-R L control (R9) determines the amplitude of the L-R signal. These are screwdriver controls.

A 19-kc quartz crystal (CR1) is used to generate the pilot frequency. This is a highly stable signal source which is rated to an accuracy of ± 2 cycles. The suppressed subcarrier, which has a frequency of 38 kc, is developed as the second harmonic of the pilot, and has a rated accuracy of ± 4 cycles. Switch S5 provides a choice of 5% or 10% pilot amplitude, with respect to the total composite output. Its voltage is approximately 0.5 volt peak-to-peak. The amplitude of the audio composite signal is variable from 0 to 4 volts peak-to-peak. This audio composite output consists of an L or R 1-kc sine wave with sidebands of L or -R, and the double-frequency 19-kc pilot. (See Fig. 5-14).

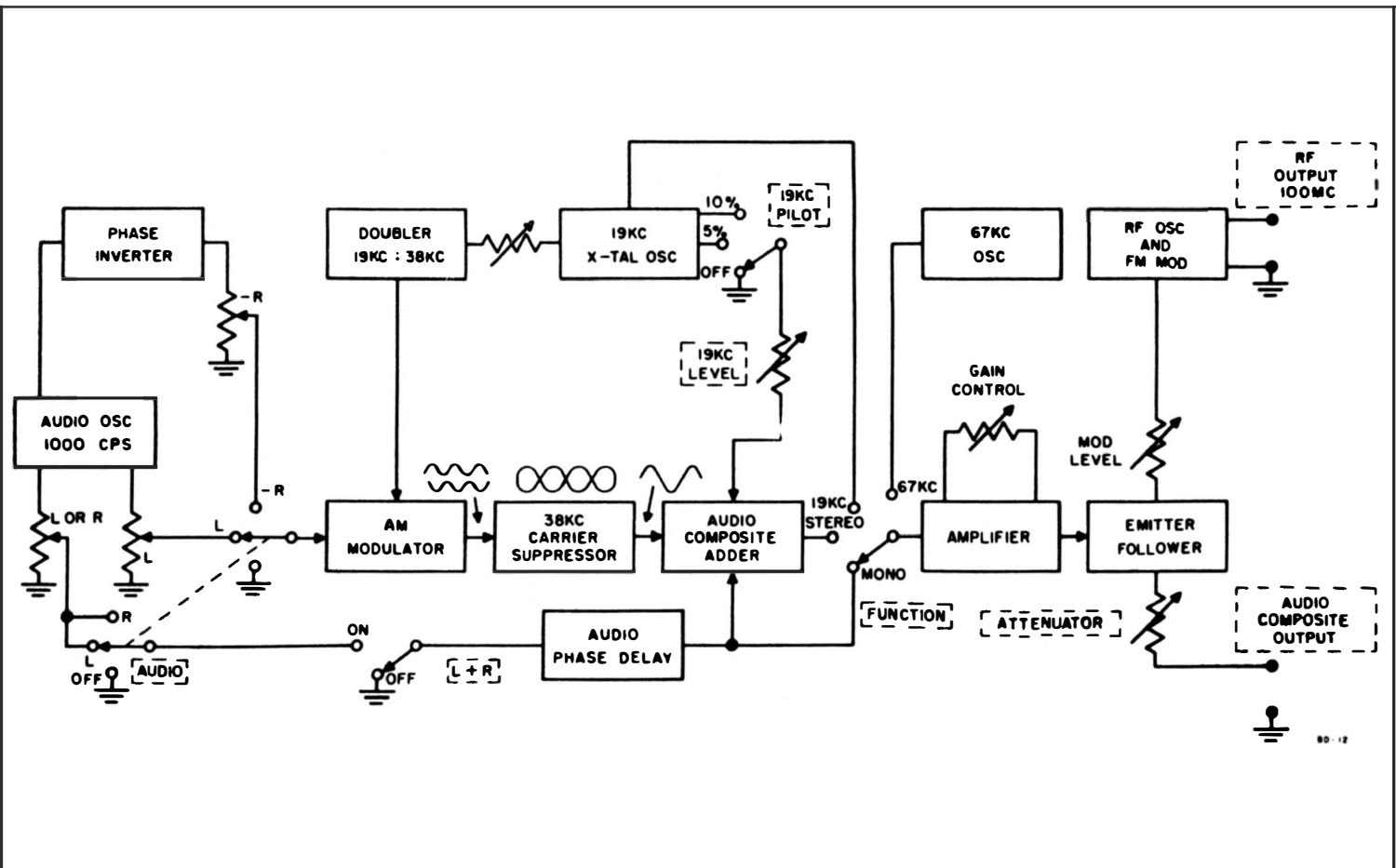

Fig. 5-12. Block diagram of an f-m stereo multiplex generator.

Courtesy Hickok Electrical Instruments Co.

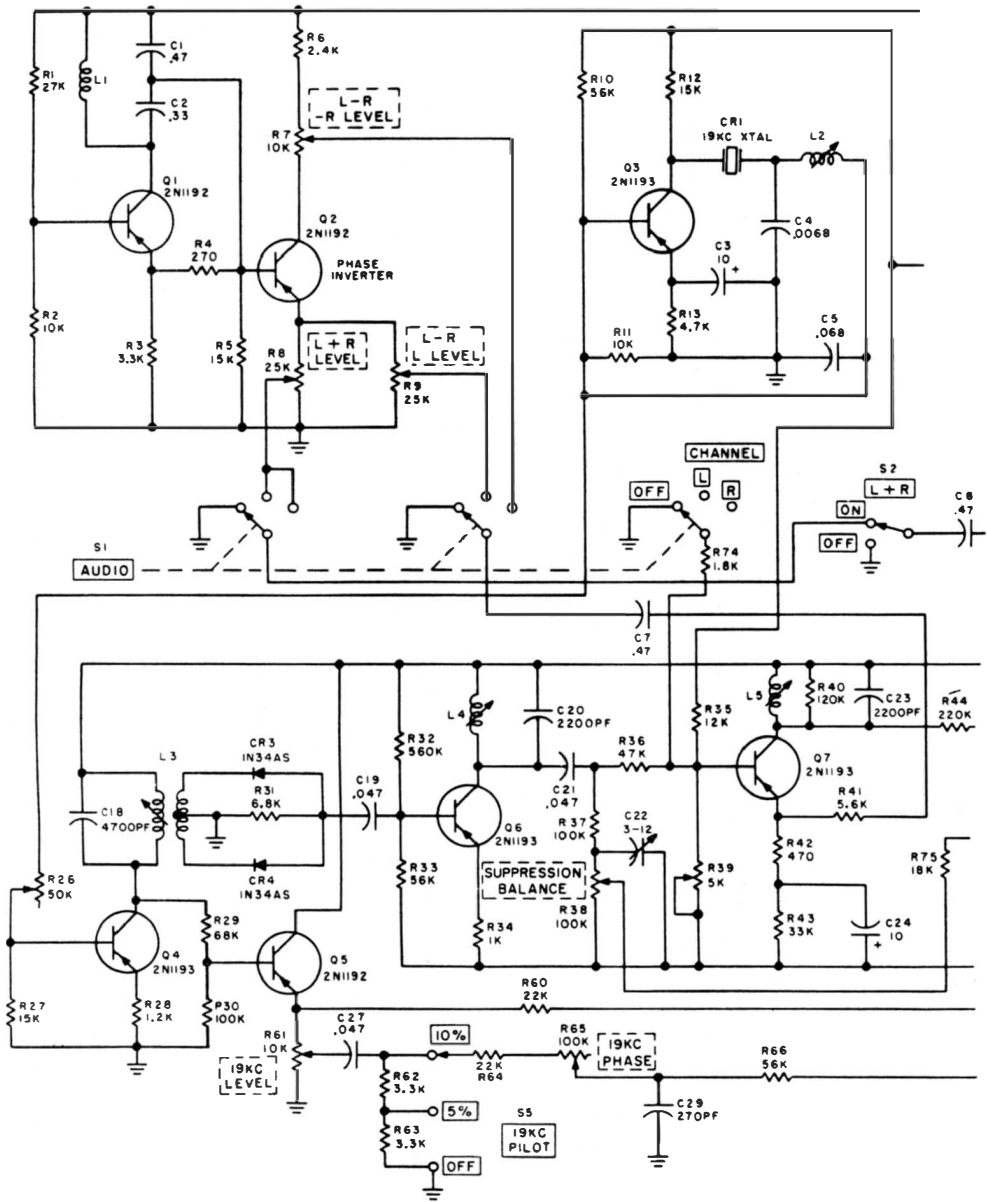
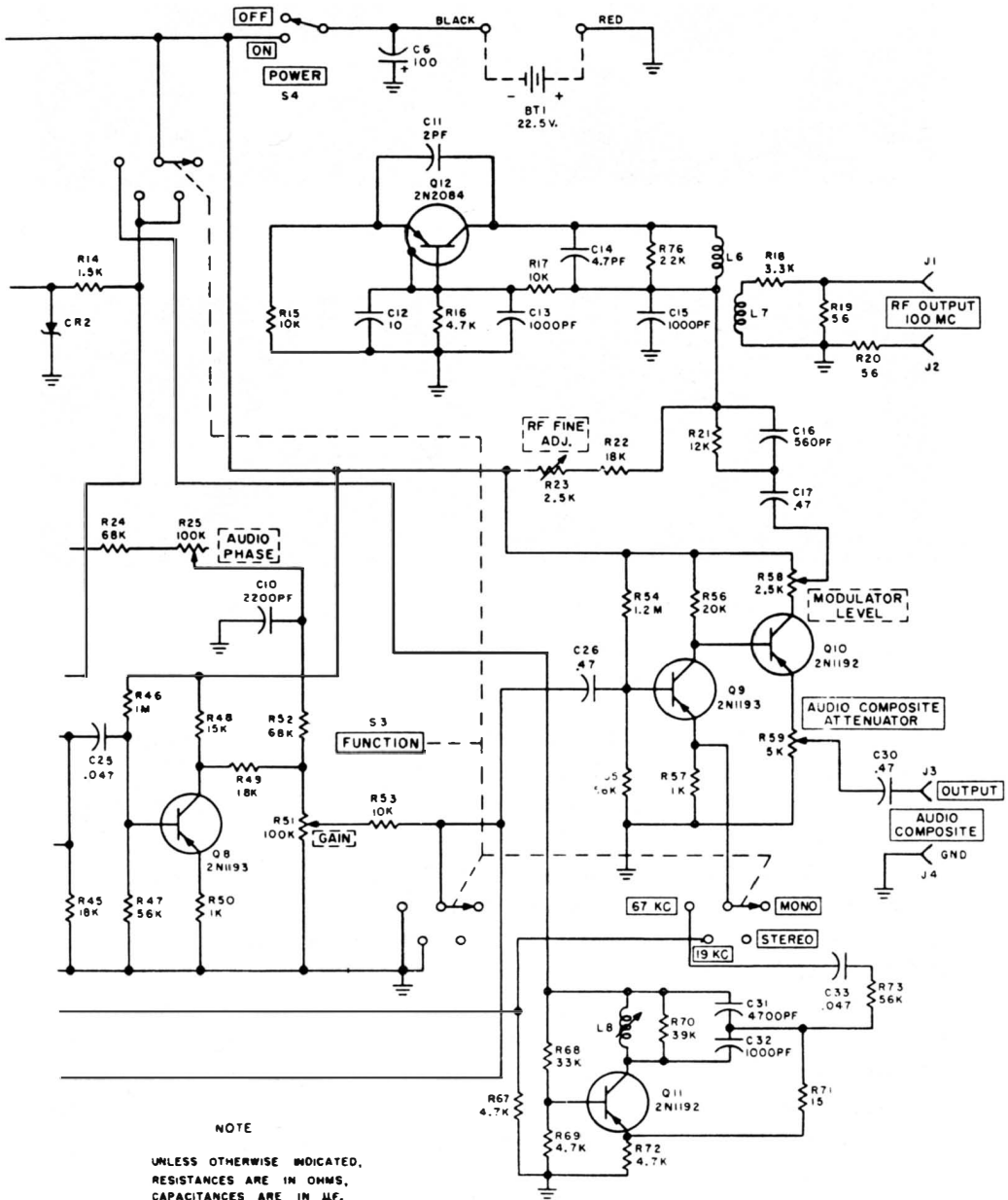

Fig. 5-13. Complete circuit diagram



© - HICKOK - 1963

Courtesy Hickok Electrical Instrument Co.

of an f-m stereo multiplex generator.

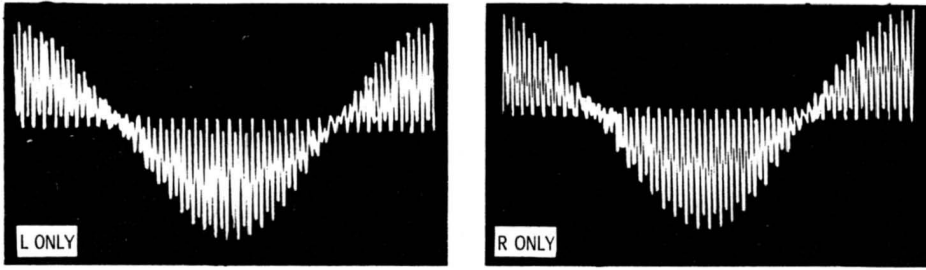

(A) Complete composite signals for L and R channels.

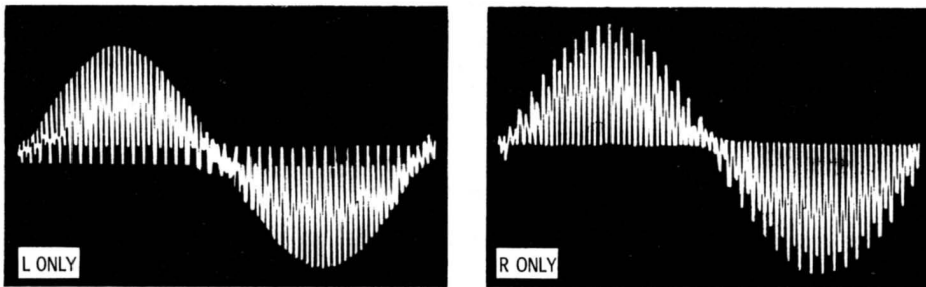

(B) Distortion caused by 90° phase error of reinserted 38-kc subcarrier.

Fig. 5-14. FCC-Zenith standard waveforms showing the necessity for reinsertion of the subcarrier in the correct phase.

The monaural (mono) output signal is a 1-kc sine wave which has an amplitude of 1.8 volts peak-to-peak. Note that the 38-kc output signal is also a sine wave; it has an amplitude of approximately 3 volts peak-to-peak. The 67-kc output is a sine wave that has an amplitude of at least 2 volts peak-to-peak. R-f output from J1 and J2 is approximately 500 microvolts. Channel separation provided by the generator is better than 35 db.

Maintenance of an f-m stereo multiplex generator that employs transistors consists chiefly of an occasional touch-up of the gain control (R51 in Fig. 5-13). Adjustment becomes necessary when the battery weakens. A scope is connected to the audio-composite output jacks J3 and J4. The scope must be calibrated for vertical sensitivity. If the peak-to-peak voltage of the signal is not within 5% of 3.6 volts, gain control R51 is adjusted as required.

STEREO SIGNAL GENERATION WITH BALANCED MODULATORS

Some stereo generators make use of balanced modulators. A typical arrangement is shown in Fig. 5-15. The output from this generator cannot be fed into the front end of a

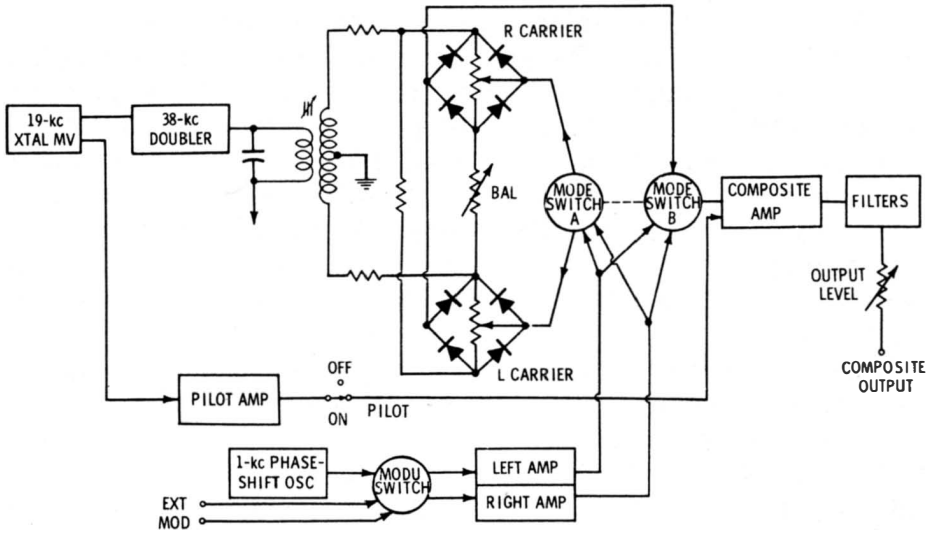

Fig. 5-15. Pair of bridge rectifier circuits form a balanced modulator.

stereo f-m receiver or tuner, but it can be applied directly to the input of a stereo adapter. In receivers that include stereo-multiplex circuits, the signal can be applied at the output of the second demodulator (usually a ratio detector). The key stage in Fig. 5-15 is the 19-kc oscillator, because all

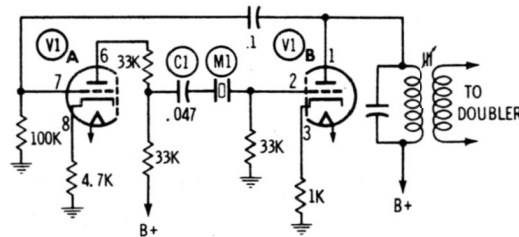

Fig. 5-16. Crystal-controlled 19-kc oscillator.

other circuit actions are controlled by the pilot signal generated in this stage.

The 19-kc oscillator is a crystal-controlled multivibrator, as detailed in Fig. 5-16. It is a simple cross-coupled multivibrator, with one important addition; the 19-kc crystal (M1) is part of the coupling capacitance, in combination with C1. Because of the resonant frequency of M1, only 19-kc signal voltage can be coupled from V1A to V1B. In turn, the multivibrator can operate only at 19 kc. This 19-kilocycle frequency is the precise frequency of the pilot carrier in the stereo f-m signal.

With reference to Fig. 5-15, one portion of the 19-kc signal is fed to the 38-kc doubler, and another portion is fed to the 19-kc pilot amplifier. The signal from the doubler is coupled via a tuned balanced-secondary transformer, to a pair of bridge-rectifier circuits that operate as balanced modulators. It is characteristic of balanced modulators that only sideband frequencies appear in the output. In other words, the carrier frequency is suppressed. Therefore, when audio or stereo signals, along with the 38-kc signal, are fed to the balanced-modulator bridges, only the sideband frequencies appear in the output.

Note the sources of audio signal. A single 1000-cps signal, developed internally via a phase-shift oscillator, can provide (by means of the modulation switch) an in-phase signal for both channels, or a signal for the right channel that is 180° out of phase with that in the left. The former combination is actually a monophonic signal, while the latter is a highly useful test signal for checking and comparing operation of the right and left channels in a receiver. As an alternative, a pair of inputs from an external source can be connected, via the modulation switch, as either a stereo or mono signal. Whatever the source or mode of audio signal, the output is fed to one corner of each balanced-modulator bridge.

The mode switch determines which audio-channel signal is received by either of the bridge circuits. With this arrangement, the mode switch can select a balanced-modulator output that contains sidebands of both L and R signals, sidebands of either L or R signals, or sidebands of a signal in which the right channel is 180° out of phase with the left. In all cases, the 38-kc subcarrier is suppressed. The mode switch has two sections; one section arranges the connections for the balanced modulator, and the other makes connections to the composite amplifier.

From the balanced modulators, the L – R sideband signals are fed to the composite amplifier where they are mixed with the direct L and R signals and with the pilot carrier. Additional filter networks help to remove any 38-kc subcarrier that might remain with the sideband signals. The composite stereo waveform is fed through a level control to the output terminal. Accuracy of phasing is easily checked with a scope, and any maintenance adjustments can be easily made on the basis of the composite stereo waveform.

Chapter 6

Specialized Types of Signal Generators

Various signal sources used in electronic test work are basically specialized types of signal generators. Such instruments lack the general utility of a conventional signal generator. On the other hand, they provide maximum convenience for particular classes of applications. For example, a grid-dip meter is basically a variable-frequency oscillator with an unshielded external tank. A d-c microammeter is provided in series with the grid-leak resistance of the oscillator to indicate grid-current flow (Fig. 6-1). When the tank coil is placed

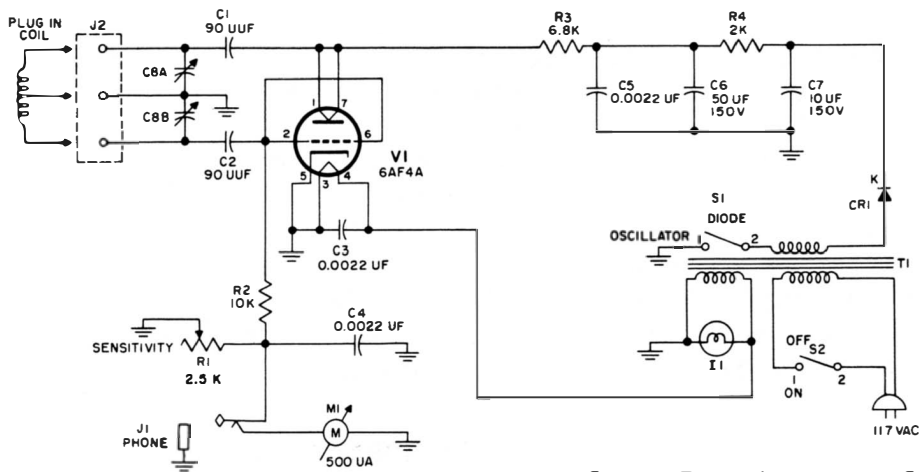

Courtesy Electronic Instrument Co.

Fig. 6-1. Schematic for a typical grid-dip meter.

in the vicinity of a tuned circuit, such as an i-f coil in a radio or television receiver, an impedance is coupled into the tank coil. This coupled impedance has a resistive component which reduces the amplitude of oscillation in the grid-dip oscillator. In turn, the grid-current flow becomes less, and the pointer drops back on the microammeter scale.

When the grid-dip meter is tuned to the resonant frequency of the tuned circuit under test, the coupled resistance reaches a maximum value, and the pointer dips to a minimum reading. It is this characteristic response of the grid-dip meter which gives the instrument its name. A GDM is provided with a tuning dial which is typically calibrated from 400 kc to 250 mc. Instead of using a range switch, the tank coils are designed as plug-in units. Eight coils may be used to cover the complete frequency range noted above. It is desirable that the GDM generates a good sine wave on all ranges.

Why is a pure sine wave needed? It is needed because harmonics can cause false dip indications. For example, suppose that the GDM has a substantial second-harmonic output. Then, if you set the tuning dial to 1 mc and couple the tank coil to a 2-mc circuit, a dip indication occurs. It could be falsely concluded that the 2-mc circuit has a resonant frequency of 1 mc. Hence, most grid-dip meters are designed to minimize harmonic output insofar as is practical. This requires that the oscillating circuit have as high a Q as possible. Because the meter loads the grid circuit, a conflicting situation is imposed. In practice, a microammeter is utilized instead of a milliammeter. Accordingly, grid-current demand is minimized, and the Q of the tank circuit is maximized.

Observe the typical GDM circuit shown in Fig. 6-1. This configuration is operated either as a Colpitts oscillator or as a shunt-fed Hartley oscillator. Tank coils for the first three ranges (up to 2.9 mc) are tapped, and the tap point is connected to ground. This is a Hartley arrangement. On the other hand, coils for the five higher ranges are not tapped. Hence, the GDM operates in a Colpitts configuration on these high-frequency ranges. Why is this circuit change made? It is because the amplitude of oscillation becomes weaker at lower frequencies in the Colpitts circuit. However, by going to a Hartley circuit at low frequencies, the amplitude of oscillation can be kept reasonably constant.

ACCURACY CONSIDERATIONS

Because the oscillator coil of a grid-dip meter is exposed, the basic accuracy of a GDM is less than that of an ordinary signal generator. If you move a GDM from a wooden bench to a metal bench, its oscillating frequency shifts 0.5% in a typical experiment. Next, when you place the tank coil near a tuned circuit, a frequency shift of 5% can occur. Minimum frequency shift takes place if the coupling is made as

loose as possible so that only a slight dip indication is obtained. Service-type grid-dip meters may have no accuracy rating. A lab-type GDM may have an accuracy rating of $\pm 2\%$. This compares with an accuracy rating of $\pm 1\%$ for a standard signal generator.

An accuracy rating of $\pm 2\%$ for a GDM is based on the frequency indication when the tank coil is distant from any metal object. The rating does not apply if there is a metal object, surface, or tuned circuit in the field of the tank. On the other hand, the accuracy rating of a signal generator is applicable under all circumstances. How can we easily check the accuracy of a grid-dip meter under various experimental conditions? Note the arrangement shown in Fig. 6-2. Some

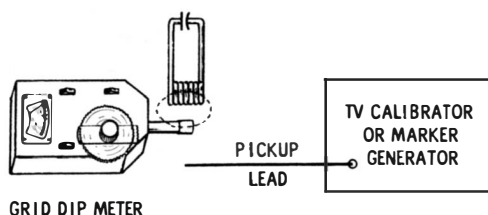

Fig. 6-2. The TV calibrator measures the frequency shift of the grid-dip meter.

marker generators operate as heterodyne frequency meters and can indicate frequencies to high accuracy. As we bring a coil under test in the vicinity of the oscillator tank (Fig. 6-2), the frequency shift that occurs is measured on the heterodyne frequency meter.

Frequency shift can occur in either direction when the coil is brought into the vicinity of the oscillator tank; the oscillating frequency may become higher, or it may become lower. This depends on which side of resonance the coil is tuned. A tuned circuit has inductive reactance at frequencies above resonance, but it has capacitive reactance at frequencies below resonance. Thus, the impedance coupled into the tank can be either capacitive or inductive. We recall that it is the resistive component of the coupled impedance that causes a dip indication. In other words, the coupled inductance or capacitance produces no dip; it only shifts the oscillator frequency.

OPERATION AS A HETERODYNE FREQUENCY METER

Within its accuracy limitations, a grip-dip meter also operates as a heterodyne frequency meter. A pair of headphones is plugged in in place of the indicating meter (Fig. 6-1). When

the GDM tank is coupled to a source of r-f energy, a beat note is heard as the oscillating frequency is tuned to the source frequency or to one of its harmonics. You should advance the sensitivity control of the GDM to maximum in this application. The r-f source must supply energy to energize the earphones after overcoming the losses in the grid circuit of the GDM. Since the grid circuit operates as a simple diode and provides no amplification, and because R1 and R2 (Fig. 6-1) form a 5-to-1 voltage divider, the GDM cannot approach the sensitivity of a conventional heterodyne frequency meter.

OPERATION AS A WAVEMETER

When S1 is set to its open position (Fig. 6-1), plate voltage is removed from V1; in turn, the triode operates as a diode. If the tank is coupled to a source of r-f energy, the GDM operates as a wavemeter. V1 rectifies the incoming r-f voltage and causes a deflection of M1 when the tank is tuned to the frequency of the r-f source. Inasmuch as the microammeter is less sensitive than a pair of earphones, more r-f energy than is needed for operation as a heterodyne frequency meter must be coupled into the tank. Note, however, that if the r-f source happens to be modulated at an audio frequency, earphones can be used for indication; in such case, the sensitivity of the wavemeter is considerably greater.

OPERATION AS AN AUXILIARY SIGNAL GENERATOR

A grid-dip meter can be used as an emergency substitute for a signal generator. To feed the r-f output from the GDM to a desired point of amplification, a coaxial cable can be coupled to the tank coil, as shown in Fig. 6-3. R-f energy

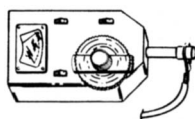

GRID DIP METER

Fig. 6-3. A loop couples r-f energy from the grid-dip meter to a coaxial cable.

is induced in the one-turn loop. The other end of the coax cable should be terminated with a resistor that has the same value as the characteristic impedance of the cable. This avoids large output variations due to standing waves. The far end of the cable may also be provided with alligator clips, in the same manner as a signal-generator output cable.

Since a grid-dip meter has c-w output only, it produces no audible output from a radio receiver. A d-c voltmeter connected at the output of the second detector is the most convenient signal-level indicator. Another method is to connect a vtvm to the AVC line. Alignment is customarily checked at near-maximum sensitivity of the receiver. Accordingly, the coupling loop in Fig. 6-3 is moved away from the tank coil to a distance at which the voltmeter reads a small value. Although this is an emergency-type attenuator arrangement and must be applied with care, it can be very useful when a conventional signal generator is not available.

Suppose you feed the output from the coaxial cable in Fig. 6-3 to an oscilloscope. The GDM waveform is then displayed on the scope screen (Fig. 6-4). A very good sine wave will probably be observed at the higher r-f frequencies, such as 5

(A) At lower frequencies, the output may not be a true sine wave.

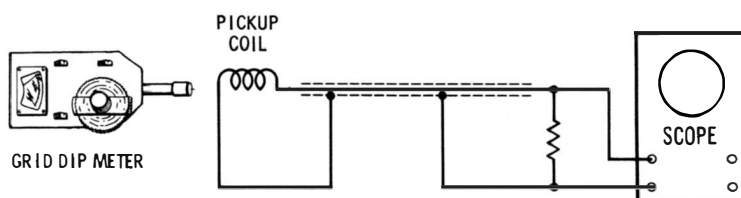
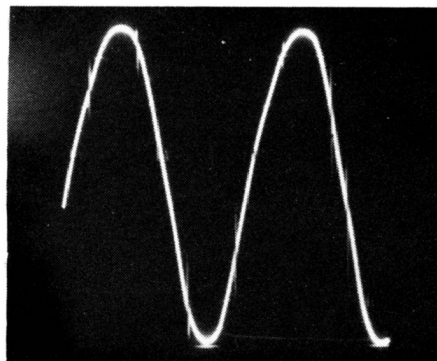

(B) Test setup.

Fig. 6-4. Output of a grid-dip meter displayed on a scope screen.

mc. On the other hand, at lower r-f frequencies, such as 465 kc, you will probably observe a noticeably distorted sine wave. This happens because a grid-dip meter is primarily designed for operation at fairly high r-f frequencies. It is comparatively costly to elaborate the circuitry to generate a pure sine wave at all frequencies. For the majority of applications, the additional cost is not justified.

MODULATION OF A GRID-DIP METER

It might be supposed that the r-f output from a grid-dip meter could be modulated by applying the output from an audio oscillator to the phone jack (Fig. 6-1). This would be expected to provide grid modulation, and it does. However, we find that the percentage of modulation that can be obtained is comparatively small. For example, if it is attempted to modulate the GDM at 30%, the modulation envelope suddenly jumps to 100% and becomes highly distorted. What happens is that the grid-dip oscillator stops operating on the downward excursion of the modulating voltage. Then, as the modulating voltage rises toward its upward excursion, the oscillator starts operating again.

Although the percentage modulation is limited to a rather low value when sine-wave modulation is used, you can obtain very good square-wave modulation. In other words, if you apply the output from a square-wave generator to the phone jack (Fig. 6-1), the grid-dip oscillator is switched on and off as the square wave rises and falls. The modulation percentage is 100%, and the modulation envelope has a very good square waveform.

HARMONIC RESPONSE OF STUBS

Although a grid-dip meter might have a very good sine-wave output at the higher r-f frequencies, beginners are often confused by its *apparent* harmonic output when checking the resonant frequency of a stub. For example, Fig. 6-5 shows a 300-ohm line stub, short-circuited at one end by a copper plate—this makes a very effective r-f short. The tank coil of the GDM is placed near the end of the stub. When the tuning dial is varied over a wide range of frequencies, it is found that numerous dips are obtained. These dip frequencies are harmonically related.

Note carefully that dip indications at harmonic frequencies are not caused by harmonic output from the grid-dip oscillator, but result from the multiple resonances of the stub itself. As seen from Fig. 6-5, the lowest resonant frequency occurs at $\frac{1}{4}$ wavelength. The r-f voltage is always zero at the shorted end of the stub, and the r-f current is greatest at the shorted end. Conversely, the r-f voltage is always greatest at the open end of the stub, and the r-f current is zero at the open end. At any *odd* multiple of the lowest resonant frequency, these conditions are again satisfied. Hence, the stub has multiple resonances.

(A) Test setup.

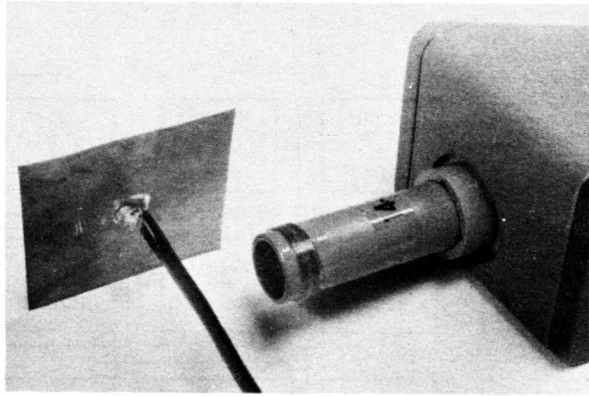

Shorted stub.

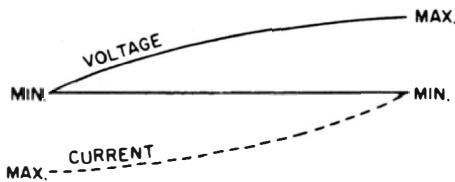

Lowest resonant frequency.

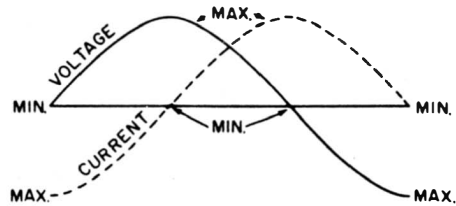

Third harmonic of lowest resonant frequency.

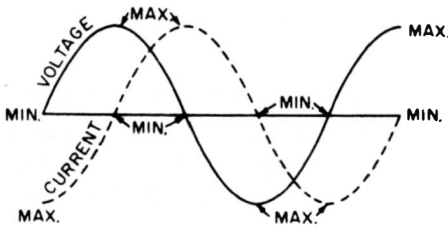

Fifth harmonic of lowest resonant frequency.

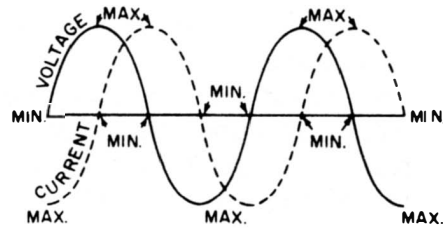

Seventh harmonic of lowest resonant frequency.

(B) Voltage and current distribution along a shorted stub.

Fig. 6-5. Checking the harmonic response of a stub.

ANALYZER TYPE OF GENERATOR

Another important specialized signal generator is called an analyzer. Fig. 6-6 shows a block diagram for a typical TV analyzer. Signal outputs are: modulated r-f output on the low vhf band, with harmonic outputs on channels 6, 7, 8, 12, and 13; modulated i-f output from 20 to 48 mc; video output over a 4-mc bandwidth; intercarrier-sound output at 4.5 mc, modulated with a 400-cycle sine wave at 25-kc deviation; 400-cycle audio output; pulse output at 60 cycles and at 15,750 cycles; composite vertical and horizontal sync pulses; 3.56-mc chroma signal output; yoke test signal; AGC keying pulse,

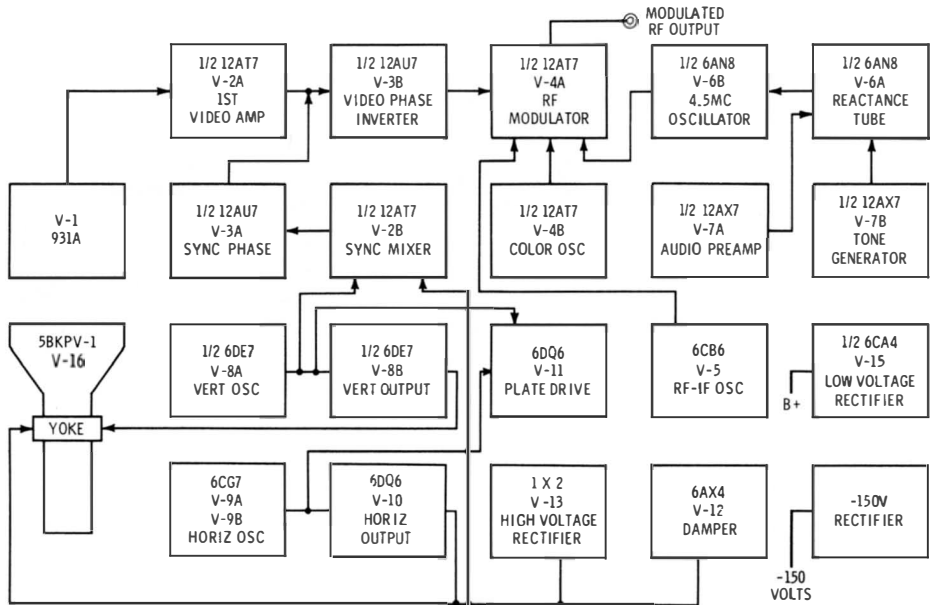

Courtesy B & K Mfg. Co.

Fig. 6-6. Block diagram of TV analyst.

and a wide variety of video signals generated by a flying-spot scanner.

The flying-spot scanner utilizes a small spot of light from a cathode-ray tube which sweeps across (scans) a slide transparency. As seen in Fig. 6-7, when the spot passes behind parts of the opaque "A" on the transparency, the light beam

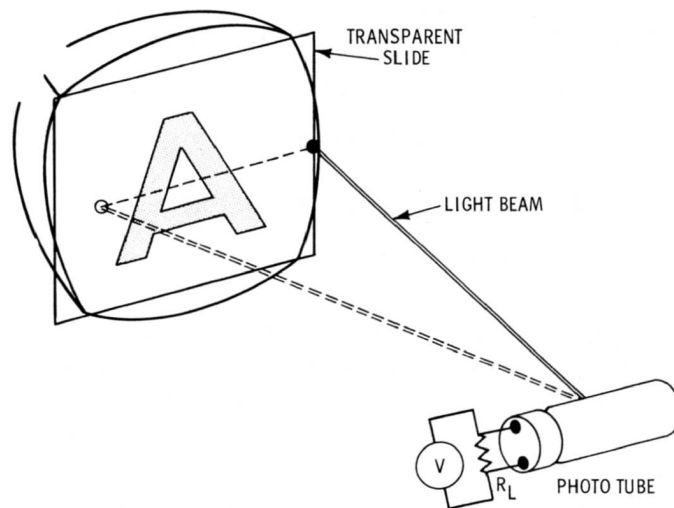

Courtesy B & K Mfg. Co.

Fig. 6-7. Changing video to an electrical signal.

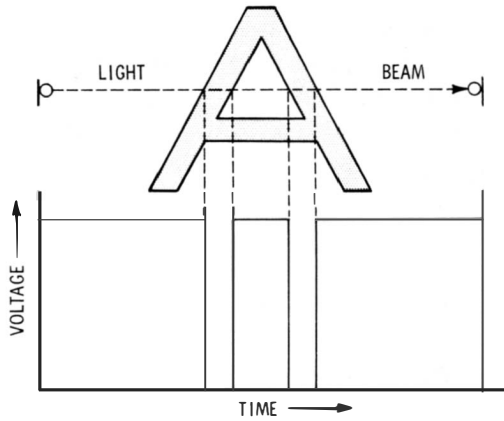

Courtesy B & K Mfg. Co.

Fig. 6-8. Light beam causes a voltage across the load resistor.

is blocked. Output from the phototube occurs only when the light beam is passed. In turn, a video-signal voltage appears across load resistance R_L . As shown in Fig. 6-8, the light beam scans from left to right; it also scans from top to bottom of the transparency, just as a TV picture-tube screen is scanned. Load resistor R_L in Fig. 6-7 corresponds to R102 in Fig. 6-9.

In turn, the video signal is coupled to the grid of V2A, the first video-amplifier tube. To maintain good high-frequency

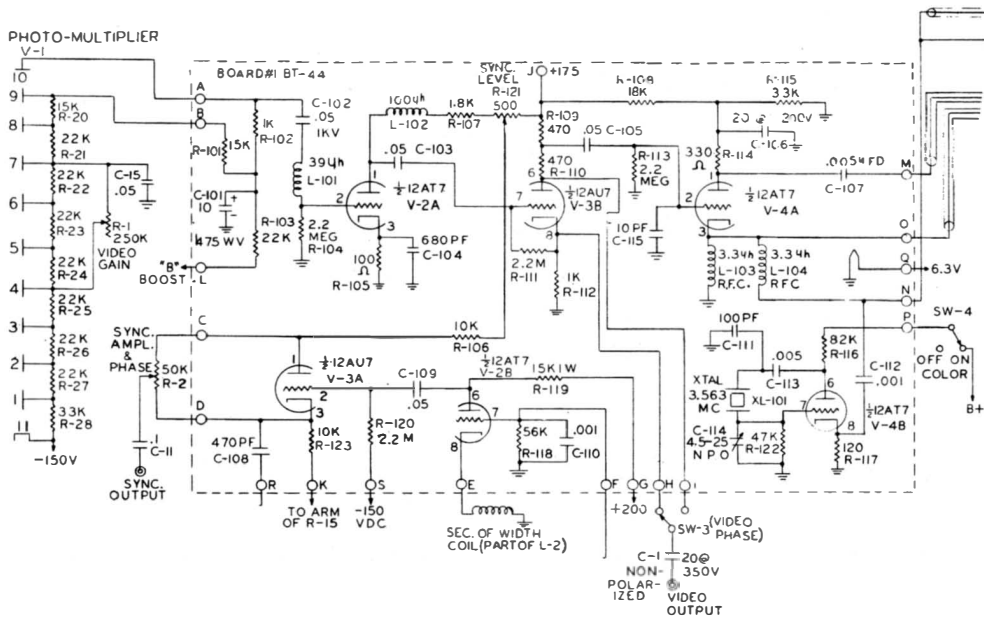

Courtesy B & K Mfg. Co.

Fig. 6-9. Schematic of the scanner section.

response, a peaking coil is used in the plate circuit, and cathode resistor R105 is partially bypassed. Note the 500-ohm potentiometer in the plate circuit of V2A; this pot is part of the plate-load resistance for V3A. It provides resistive coupling between these two stages which mix the sync signal with the video signal to form a composite signal. Thus, the composite video signal appears at the plate of V2A. In turn, the composite video is coupled to the grid of V3B.

Outputs are taken from both the plate and the cathode of V3B, and they are available at a front-panel terminal as either positive-going or negative-going composite video. The plate-load resistance for V3B comprises two 470-ohm resistors. The signal at the junction of these two resistances is coupled to V4A, the r-f modulator. Output from the r-f oscillator (not shown in Fig. 6-9) is fed to the cathode of V4A. The 4.5-mc sound signal, or the 3.56-mc chroma signal may also be switched into the cathode of V4A.

A quartz-crystal oscillator provides a highly stable 3.56-mc output from the V4B stage. This oscillator is switched on or off, as desired, by means of SW4. Output from V4B is fed to a front-panel terminal, and also to the cathode of V4A. Thus, the chroma signal is made available either at the video frequency or at the modulated r-f frequency. The r-f carrier is generated by V5 (Fig. 6-10). This is a Colpitts configuration

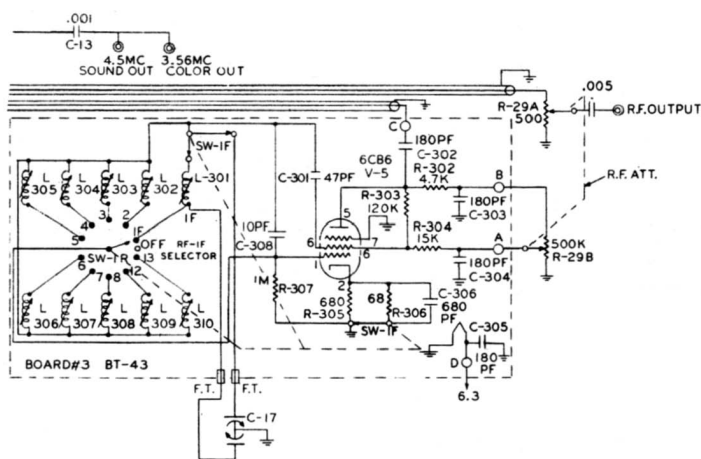

Courtesy B & K Mfg. Co.

Fig. 6-10. R-f and i-f oscillator section.

that can be operated at preset channel frequencies, or at a variable i-f frequency. The i-f range is tunable from 20 to 48 mc by means of C17. Attenuation is controlled by both R28A and R29B; thus, the attenuation provided by R29A is supplemented by varying the screen voltage of V5. Output from V5

is fed to the cathode of V4A (Fig. 6-9). R29A in Fig. 6-10 obtains a modulated r-f signal from the plate of V4A (Fig. 6-9).

Next, the sound system (Fig. 6-11) utilizes a 4.5-mc oscillator, which is one-half of a 6AN8; the 4.5-mc output is taken

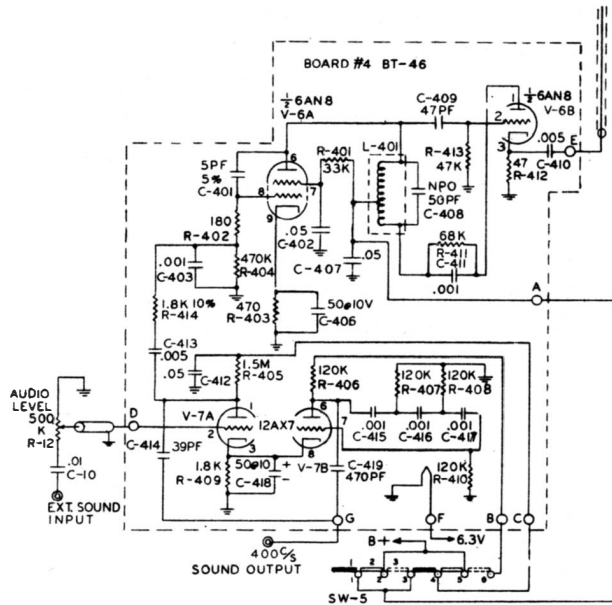

Courtesy B & K Mfg. Co.

Fig. 6-11. Schematic of the sound section.

from the cathode of V6B. Note that V6A is a reactance tube which provides frequency modulation of the 4.5-mc carrier generated by V6B. This reactance tube can be driven from two sources. One source is V7B, which is one-half of a 12AX7; it is a phase-shift oscillator that generates a 400-cycle tone signal. This 400-cycle source is also made externally available. The second section of the 12AX7 (V7A) is an audio amplifier which can be driven from an external signal source. Thus, V6B can be externally modulated for special test procedures.

The sync signal (Fig. 6-6) is obtained by mixing vertical pulses with horizontal pulses in V2B. Horizontal pulses are obtained from a width coil in the horizontal-output section; vertical pulses are generated by the vertical oscillator. These circuits are basically the same as those used in the scanning sections of a television receiver. Control R2 in Fig. 6-9 provides a choice of sync polarity. A few turns of wire, which form the secondary of width coil L2, provide the cathode return of V2B. The vertical pulse is fed to the grid of V2B.

Mixing is accomplished in the plate circuit; thus, at pin 6 of V2B we find both horizontal and vertical sync pulses.

This complete sync signal is coupled to the grid of V3A, which is a clipper-amplifier. Part of the load resistance for V3A is common to V2A, as previously noted. Thus, R121 operates as a sync-level control. We see that R2 is fed at each end with oppositely-polarized sync signals. It follows that when R2 is set to its center position, the two signals cancel out, and there is no output from the slider arm. But, as R2 is turned either clockwise or counterclockwise, we obtain either the plate or the cathode signal. In turn, either positive-going or negative-going sync is made available at the sync-output terminal.

Finally, let us consider the shorted-turns test configuration. The circuit arrangement is seen in Fig. 6-12. V14B is a simple pulse-oscillator tube. Its grid is coupled to a coax cable that is

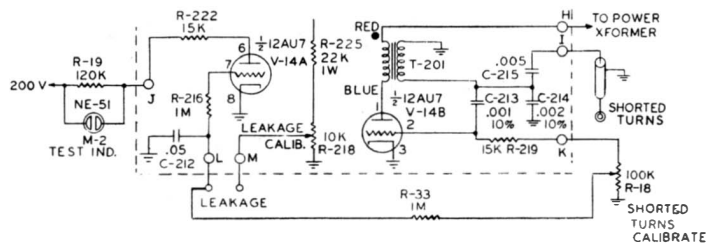

Courtesy B & K Mfg. Co.

Fig. 6-12. Shorted-turns oscillator and indicator circuit.

connected across a yoke or flyback transformer which is to be tested for shorted turns. T201 has a fairly high Q and is sensitive to the loading applied via the coax cable. Signal-developed bias at the grid of V14B is fed to V14A, which is a d-c amplifier tube. Evidently, the plate current drawn by V14A depends upon its grid bias. In turn, the voltage drop across R19 depends upon this grid bias. When V14A draws more than a certain current (the level of which is set by R18), the neon lamp M2 will glow.

Suppose that the coax cable is connected across a good yoke or flyback transformer. The Q of the winding under test will then be relatively high, and little power will be absorbed from T201. Hence, the grid bias developed by V14B is not changed appreciably, and the neon lamp does not glow. On the other hand, consider what happens when there is a shorted turn or two in the yoke or flyback winding under test. In such case, power is absorbed by the short circuit. T201 is loaded

appreciably, and the amplitude of oscillation is reduced. Consequently, the grid bias developed by V14B falls to a low value; V14A draws more plate current, and the neon bulb M2 glows. Different types of yokes and flyback transformers can be accommodated by setting R18 to a suitable calibration point.

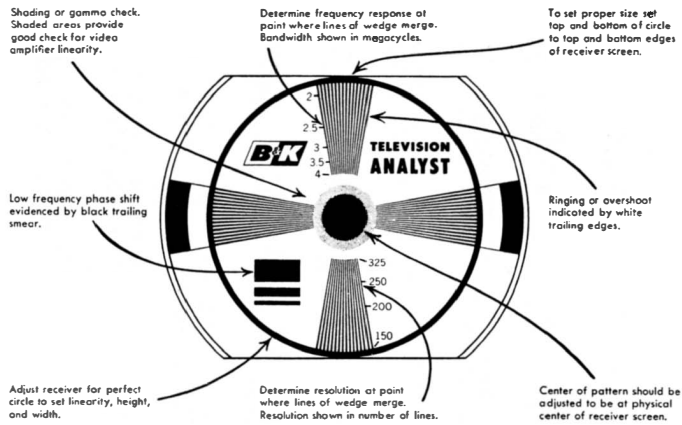

Courtesy B & K Mfg. Co.

Fig. 6-13. Test pattern.

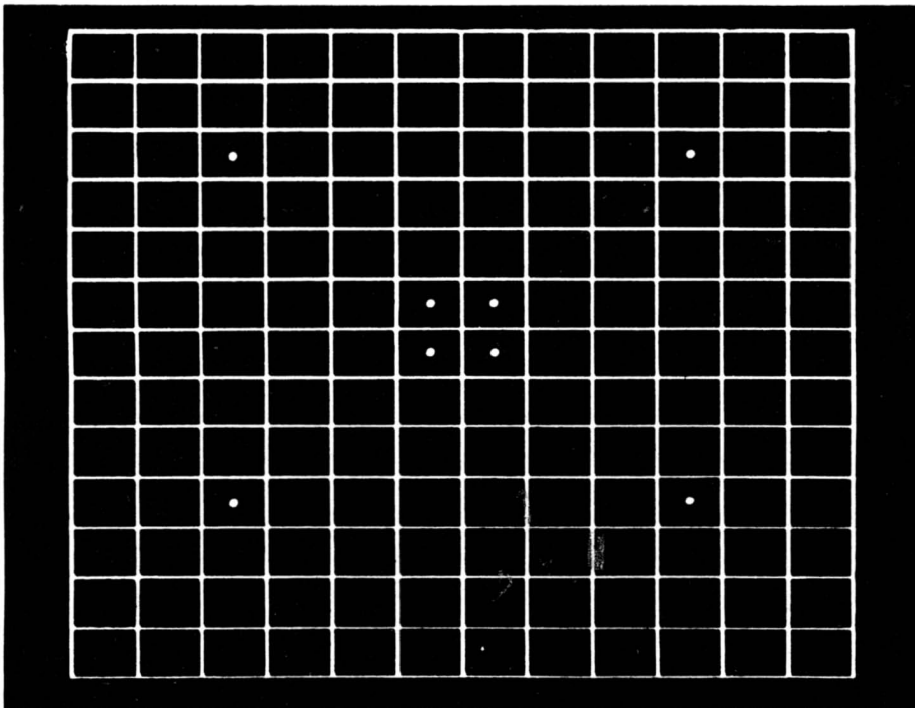

Fig. 6-14. Crosshatch pattern with dots, displayed by a flying-spot scanner.

Any desired type of pattern signal can be generated by a scanner. The most basic is a test pattern (Fig. 6-13). Beginners may be surprised at the large amount of information conveyed by a test-pattern signal. Another basic pattern is illustrated in Fig. 6-14. Crosshatch patterns are used both to

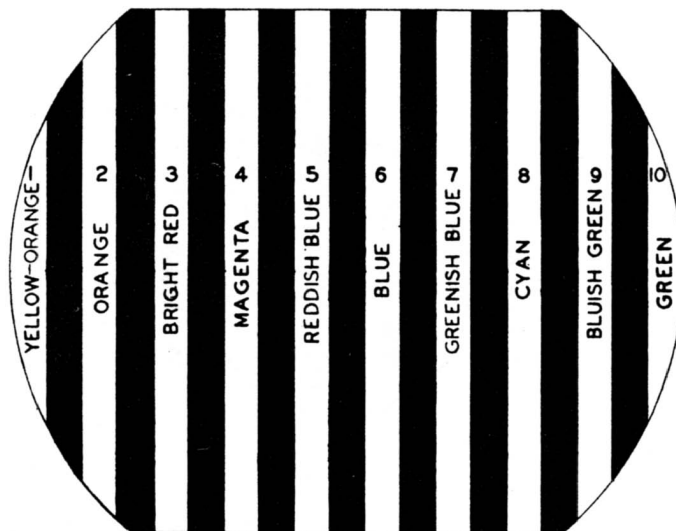

Fig. 6-15. Color bar pattern.

check linearity adjustments and convergence adjustments in color-TV receivers. Still another pattern is shown in Fig. 6-15. This color-bar pattern is obtained by inserting a white-and-black bar transparency in the scanner, with V4B (Fig. 6-9) operating. This combination provides a keyed-rainbow pattern.

TRANSISTOR RADIO ANALYZER

Another specialized type of signal generator is used for troubleshooting transistor radios. The circuit for a typical instrument is shown in Fig. 6-16. It comprises a self-modulated oscillator combined with a signal tracer. A transistor tester is also provided. Note that the signal source is a transistorized blocking oscillator which consists of transistor X3 and tank circuit L1 and C4. The oscillator has a fundamental frequency of 400 cps. Since the blocking action is abrupt, an extensive spectrum of harmonics is generated. Fig. 6-17 illustrates the output waveform. Maximum output is 10 volts peak-to-peak. Harmonics are useful up to 30 mc.

How does the blocking oscillator work? Transistor X3 in Fig. 6-16 operates in a Hartley configuration. Coil L1 is tapped at a point which provides a large amount of feedback. In turn,

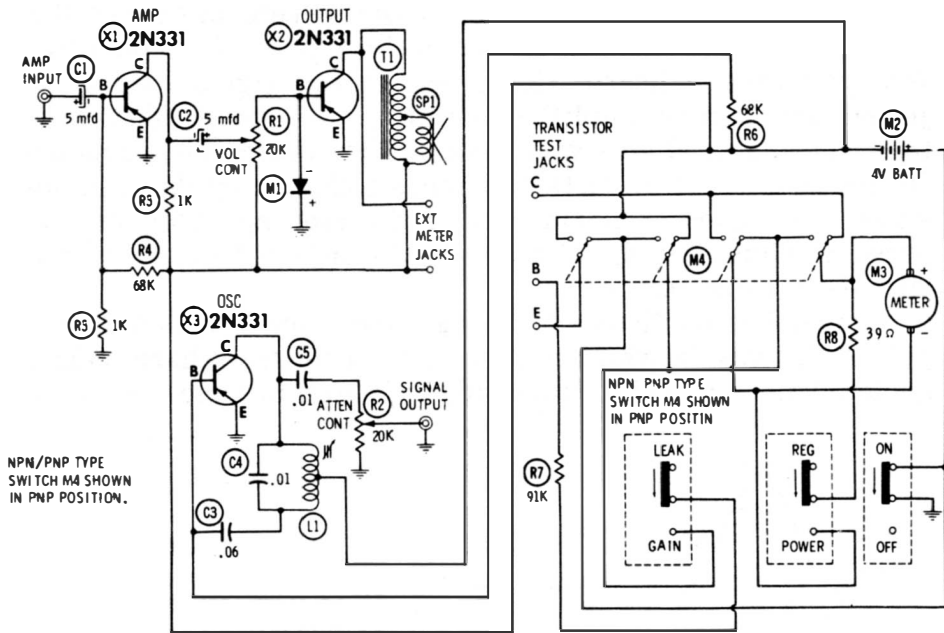

Courtesy Superior Instruments Co.

Fig. 6-16. Circuit of a harmonic generator.

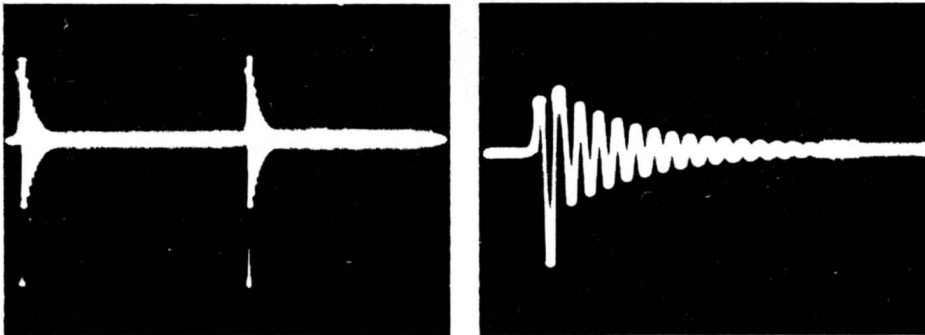

Fig. 6-17. Output waveform of the harmonic generator.

the base is strongly overdriven. The base draws considerable current on the peak of the drive, and this base current cannot flow to ground immediately. Instead, C3 charges to the peak voltage and then discharges at a comparatively slow rate through R6. After the peak of the drive signal passes, transistor X3 is biased beyond cutoff by the charge on C3. During this cutoff interval, the generator circuit rings at the resonant frequency of L1 and C6. This ringing waveform is seen in Fig. 6-17.

Thus, the r-f ringing frequency is a damped sine wave which recurs 400 times a second. Because the damped sine wave is unsymmetrical, this 400-cycle recurrence frequency is

directly audible. In other words, if the waveform of Fig. 6-17 is applied to an audio amplifier or to a pair of earphones, a 400-cycle tone is heard. Hence, the output signal may be injected into audio-amplifier circuits for signal-substitution tests. The damped sine wave has a fairly low radio frequency. However, since it consists of a pulse followed by damped sine waves, multiples or harmonics of the ringing frequency are present. Thus, the signal may also be injected into r-f or i-f circuits of radio receivers.

A pulse has particularly strong harmonics if it is a narrow pulse. The way in which a pulse is built up from harmonics is depicted in Fig. 6-18. Harmonic voltages become weaker at

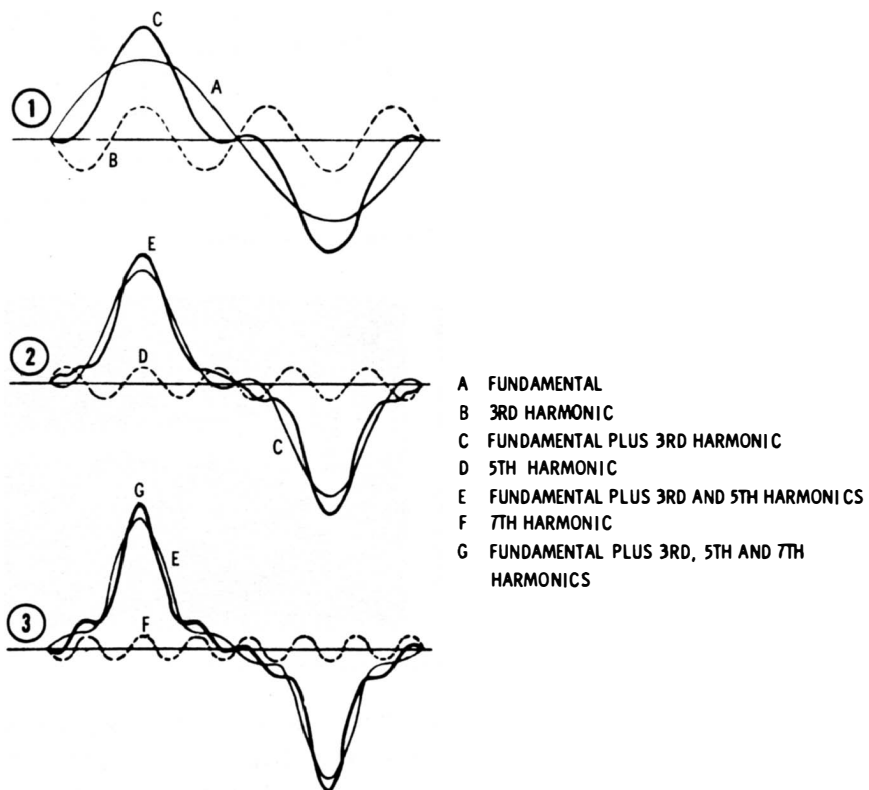
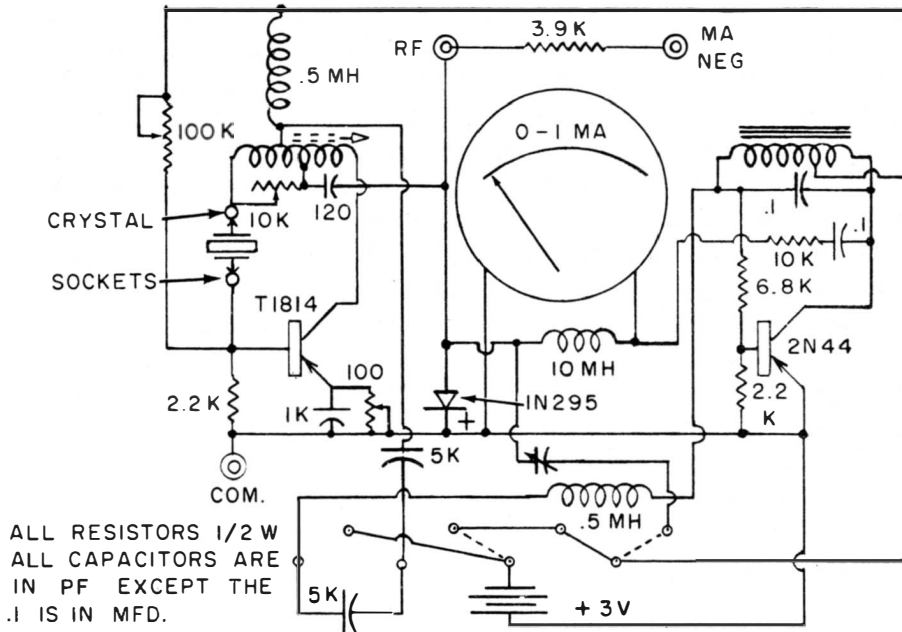

Fig. 6-18. Partial build-up of a pulse from sine-wave voltages.

higher frequencies. However, even the higher harmonics have appreciable voltage if the pulse is quite narrow. This is because the width of the pulse is inversely proportional to the strength of the higher harmonics. The buildup shown in Fig. 6-18 is for a comparatively wide pulse. If harmonics up to the 30th were added, the resultant waveform would be as narrow as the initial pulse seen in Fig. 6-17.

RADIO TEST SETS

Still another type of specialized signal generator is termed a two-way radio test set. The circuit for a typical instrument is shown in Fig. 6-19. It comprises two transistorized oscillator sections, and a germanium diode which operates as a mixer-modulator and an instrument rectifier. T1814 utilizes a



Courtesy Seco Electronics, Inc.

Fig. 6-19. A two-way radio test set is a specialized signal generator.

high-frequency type of transistor which operates in one of two modes, depending on the setting of the selector switch. The 2N44 transistor operates as an audio oscillator. Its output amplitude-modulates the r-f oscillator. The carrier frequency depends on the quartz crystal which is plugged into the crystal socket. This amplitude-modulated signal can be used for injection tests. When the modulating signal is switched off, the r-f signal can be used for calibration of signal generators.

A milliammeter is provided to test quartz crystals for activity. The high-frequency transistor operates as a third overtone (third harmonic) generator, in the same manner as tube oscillators used in most CB transmitter circuitry. Meter readings are proportional to the Q of the crystal which is plugged into the crystal socket. In other words, the higher the reading, the more active is the crystal. In this mode of operation, the tank circuit is broadly tuned for operation in the 26 to 28 mc range. When the circuit is switched to operate as an

untuned oscillator. operation is possible with crystals over a range of 1 to 20 mc. The output has a considerable harmonic spectrum, which is useful in calibration of signal generators, as explained previously.

It is interesting to note some basic facts concerning quartz crystals used in generators. The thickness of a crystal determines its oscillating frequency. One of the most popular crystals is the HC 6/U, in which the crystal plate is ground to a thickness of about 0.006 inch. Its fundamental frequency is 9 mc, which provides 27-mc third-overtone operation. However, the output also varies with the type of cut and the plate area. Larger crystals provide more output and can dissipate more power. The HC 6/U is either gold or silver plated. Plated surfaces serve as electrodes, to which leads are connected.

To insure maximum accuracy of the generated frequency, a fundamental type of crystal is customarily utilized. Harmonics can be used for checks at higher frequencies, and the percentage of accuracy of the harmonics will be the same as the percentage of accuracy of the fundamental. This accuracy is a function of the generator circuitry even when the crystal oscillates in its fundamental mode. Hence, when the highest possible accuracy is desired, a crystal that has been specially ground for operation in the generator circuit should be utilized.

Chapter 7

Supersonic Generators

Supersonic generators provide output frequencies above the range of audibility (above 15 kc). Thus, a supersonic generator might operate in the range from 15 kc to 1 mc. Familiar types of supersonic generators are commonly called audio oscillators, and they provide frequency coverage typically from 20 cps to 1 mc. This terminology is a holdover from earlier practice in which audio oscillators covered a frequency range from perhaps 20 cps to 20 kc. Regardless of terminology, a generator that operates in the range from 200 kc to 1 mc is actually a signal generator by conventional standards. It is also called a video-frequency generator.

BASIC CIRCUITRY

Many oscillators used in this type of signal generator have RC networks to provide feedback coupling between their output and input circuits and to determine the frequency of oscillation. Such generators are called RC oscillators. Examples of RC oscillators are the phase-shift configuration and the Wien-bridge arrangement. A phase-shift oscillator is depicted in Fig. 7-1. It consists of a single amplifier tube and a phase-shifting feedback circuit. We know that to sustain oscillation, feedback oscillator requires that the signal be fed back from the plate to the grid with a 180° phase shift. This function is performed by three RC sections.

Any one of these sections can be analyzed as shown in Fig. 7-2. When an a-c voltage is applied to this circuit, a current having an amplitude determined by the total impedance of the circuit flows in the circuit. Because of capacitor C, the impedance is capacitive, and the current leads the voltage by 60° , as shown at B and C of Fig. 7-2. The voltage drop E_R across resistor R is in phase with the current that flows through it. Therefore, output voltage E_R must also lead applied voltage E by 60° . When the output from this section is applied to a

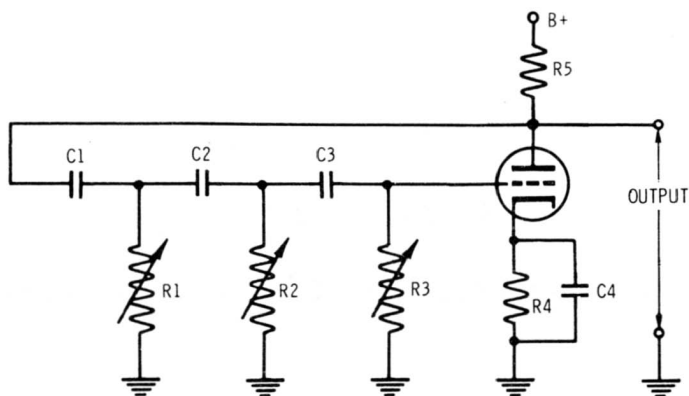

Fig. 7-1. Phase-shift oscillator.

second similar phase shifter, another shift of 60° occurs, and the output of the second phase shifter is 120° ahead of applied voltage E .

Similarly, the third phase shifter produces a total phase shift of 180° . When the resistance of R_1 , R_2 , and R_3 (Fig. 7-1) is varied, the phase angle of the current flowing in the circuit is also varied. If the resistance were reduced to zero, the current would theoretically lead the applied voltage by 90° . However, there are obvious reasons why a resistance value of zero is impractical. First, reducing R to zero would leave no impedance for developing a useful voltage. Second, with R equal to zero, the current would lead the voltage slightly less than 90° anyway, due to the inherent circuit resistance.

Therefore, in a generator circuit, resistor R is varied only down to the point where the current leads the voltage by about 60° . Of course, the value of R can be increased until there is very little phase shift. At a given setting, the amount of phase shift depends on the frequency. Thus, 180° phase shift (which provides oscillation) can occur at only one particular frequency. We see that the value of R corresponds to a certain frequency of oscillation. Of course, you can also vary the value of C to change the oscillating frequency.

In this type of generator, the oscillations are started by any slight circuit changes such as random noise voltages or small variations in plate-supply voltage. When such a disturbance occurs, the slight change is amplified, shifted 180° in phase, and applied to the grid of the tube for reamplification. This process continues until plate-current saturation is reached, after which the tube can provide no more output amplitude. Output is taken from the plate of the oscillator tube. It is then fed to a cathode follower, which provides isolation between the oscillator and generator output cable.

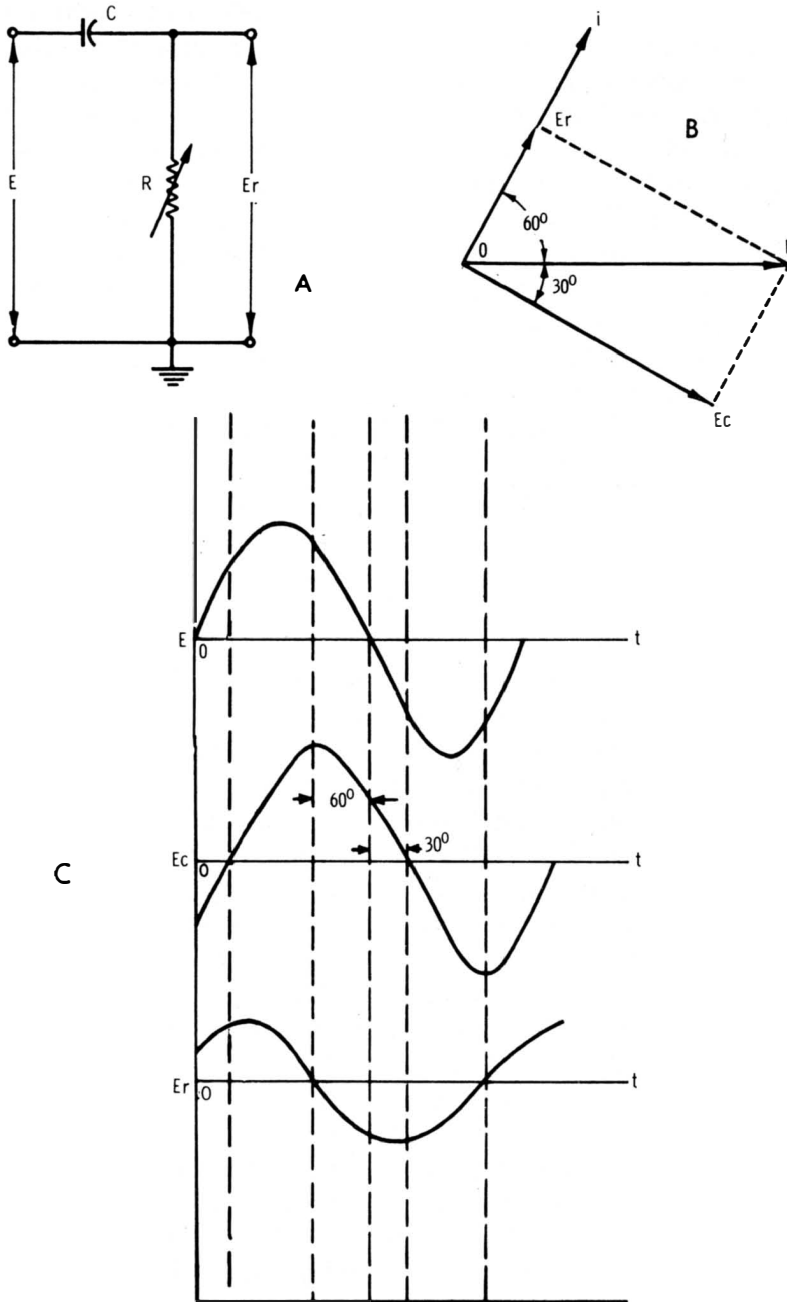

Fig. 7-2. Circuit action of an RC phase shifter.

WIEN-BRIDGE OSCILLATOR

Many generators utilize the Wien-bridge oscillator depicted in Fig. 7-3. It is a two-tube RC oscillator which is tuned by a resistance-capacitance bridge. V1 serves as an oscillator and amplifier; V2 is an inverter. The circuit would oscillate even

without the RC bridge, because of the 180° phase shift produced by V1 and V2. However, this arrangement would not generate a specific frequency, nor would it generate a sine wave. Therefore, the bridge circuit is utilized to insure the elimination of all feedback frequencies except one. This one frequency is determined by the values of R and C in the bridge.

The bridge oscillator in Fig. 7-3B facilitates circuit analysis. A degenerative feedback voltage is provided by R3 and lamp L_{p1} . The amplitude of this feedback voltage remains nearly constant for all frequencies, since the resistances are practically constant for all frequencies, and there is no phase shift across the voltage divider. Inverter tube V2 shifts the output of V1 by 180°. Thus, the voltage appearing across R2 in the bridge is in the correct phase to sustain oscillation. This action occurs when $R_1C_1 = R_2C_2$. The frequency at which the circuit oscillates is:

$$f = 1 \div (2\pi R_1 C_1)$$

Lamp L_{p1} is a nonlinear resistance. Fig. 7-4 shows how filament resistance increases when the applied voltage is increased. When more current flows, the filament becomes hotter, and this causes an increase in its resistance. It follows from Fig. 7-3 that the lamp compensates automatically for variation in circuit action, so that sufficient feedback voltage will always be applied to V2. When the current in the circuit increases, the lamp drops a greater voltage. This represents more degeneration, which reduces the gain of V1 and holds the output signal at a nearly constant amplitude.

Tuning the generator to different operating frequencies tends to change the circuit current. In typical generators, C1 and C2 in Fig. 7-3 consist of a ganged variable capacitor. When it is tuned, the capacitive reactances change, which tends to change the a-c signal levels. However, the lamp resistance largely compensates for this change, so that the output signal voltage remains about the same. Band-switching is accomplished in typical generators by use of different values of R1 and R2 in Fig. 7-3. This results in a different voltage-divider action, which tends to change the circuit current. Again, a compensating change in lamp resistance maintains the output signal voltage at about the same level.

Note the typical Wien-bridge generator configuration shown in Fig. 7-5. You will observe that this is the same basic configuration as in Fig. 7-3. Tuning is accomplished by variable capacitors C2 and C3, which are ganged. Trimmer capacitor

Fig. 7-3. Wien-bridge oscillator.

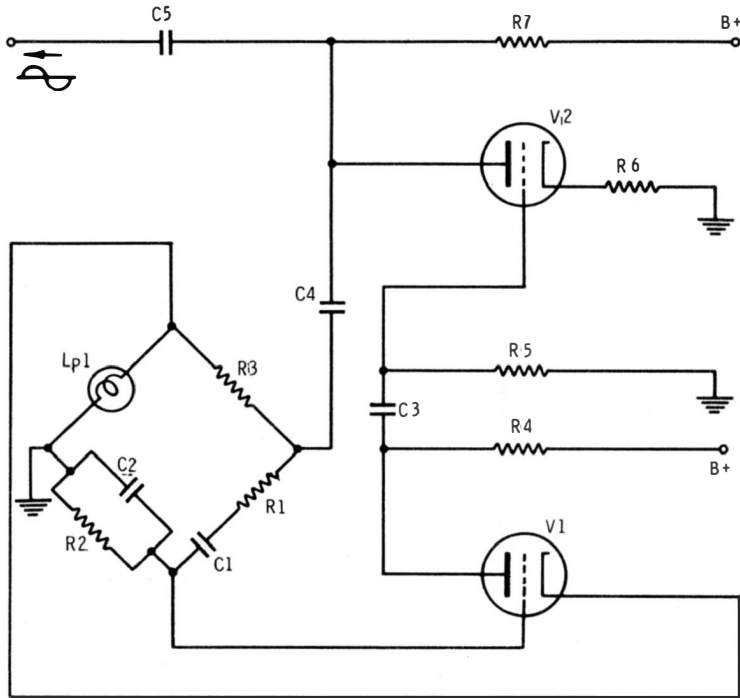

(A) Circuit diagram.

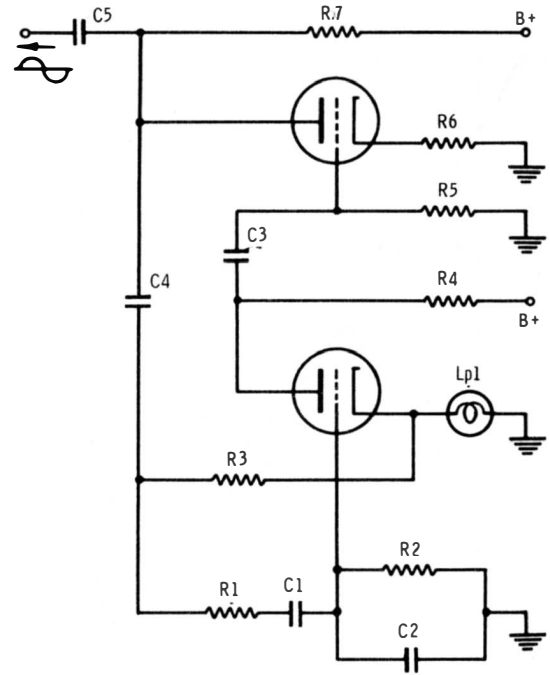

(B) Redrawn oscillator circuit.

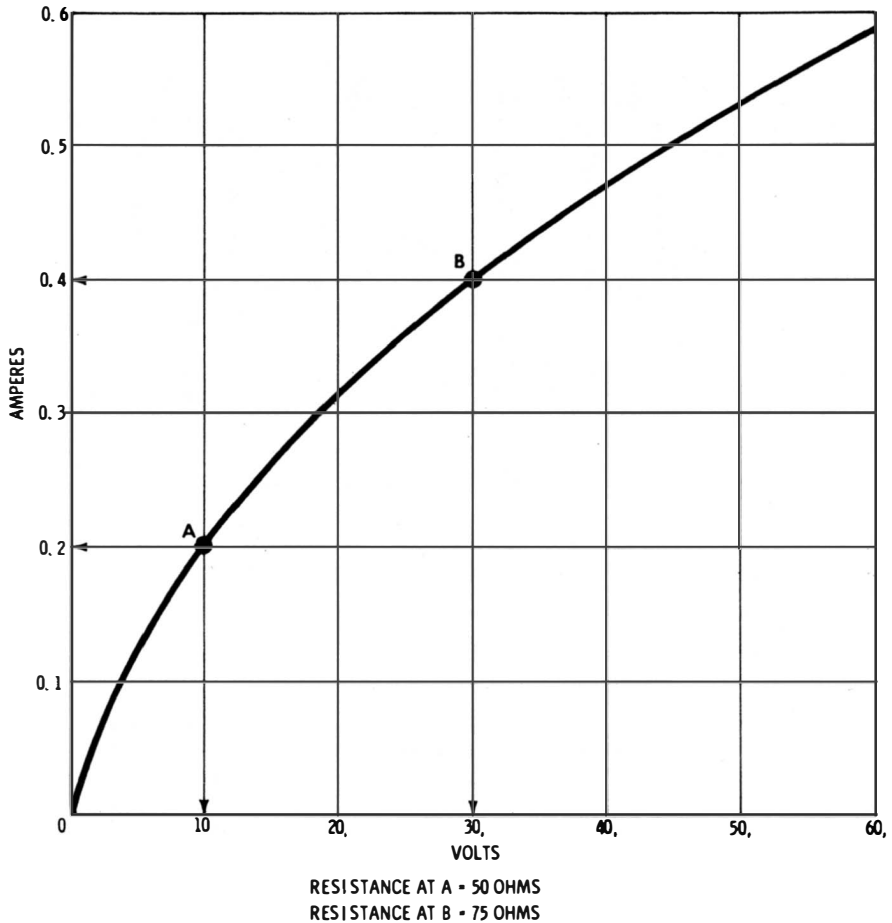

Fig. 7-4. Curve for positive temperature coefficient of resistance.

C1 is provided for dial calibration. Band switching is provided by S2, which switches different values of resistance into the bridge circuit. Good sine waves require that the feedback be limited to a value which does not drive V1 and V2 past their region of linear operation. Accordingly, R9 is provided as a maintenance adjustment to set the feedback level correctly for a good waveform output.

Output is taken from the plate of V2 fed to a cathode follower, shown in Fig. 7-6. A 50K potentiometer is used in the grid circuit as an attenuator. A maximum of 10 volts rms is available from the cathode. Rated distortion is less than 1%, and the output level does not vary more than ± 1.5 db from one band to the next. The hum level is less than 0.4% of the signal-output level. You will find that the hum level in simple Wien-bridge generators does not come from the power supply, as might be supposed. Instead, it is due to stray-field pickup by

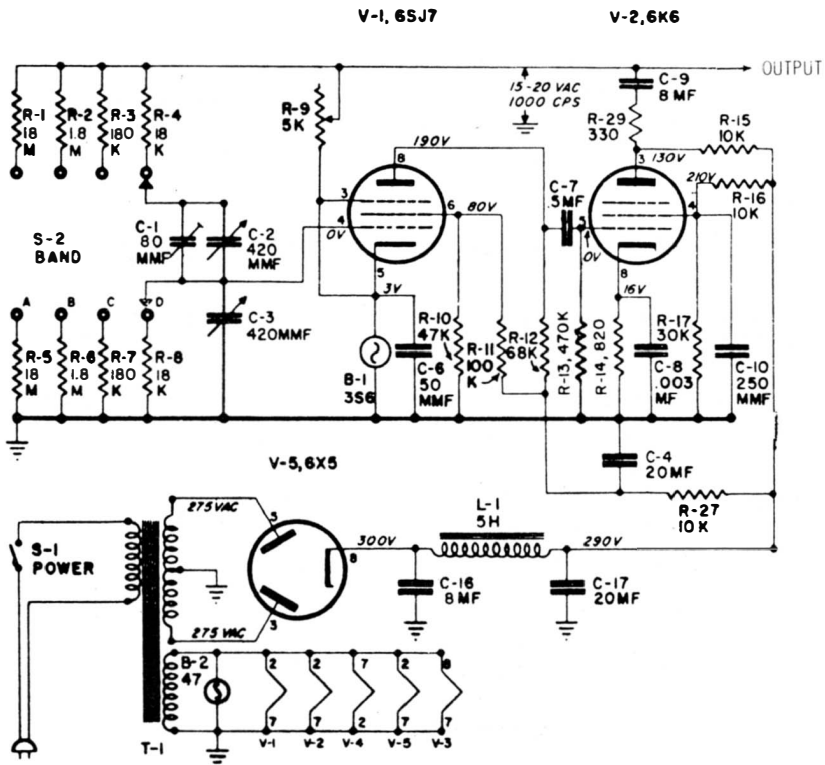

Fig. 7-5. Typical Wien-bridge generator.

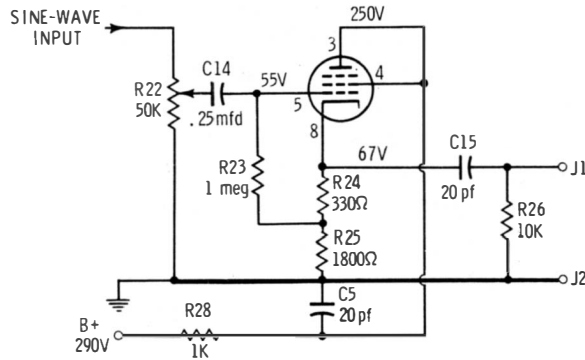

Fig. 7-6. Cathode-follower output.

the high-resistance bridge circuit (Fig. 7-5). Ample shielding is required to minimize the hum level.

BEAT-FREQUENCY GENERATORS

Although they are less popular than in the past, beat-frequency generators are still used rather widely. The basic arrangement is depicted in Fig. 7-7. Two r-f oscillators are employed, and their combined outputs are fed to a heterodyne

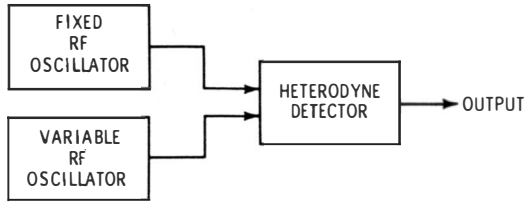

Fig. 7-7. Basic arrangement of a beat-frequency generator.

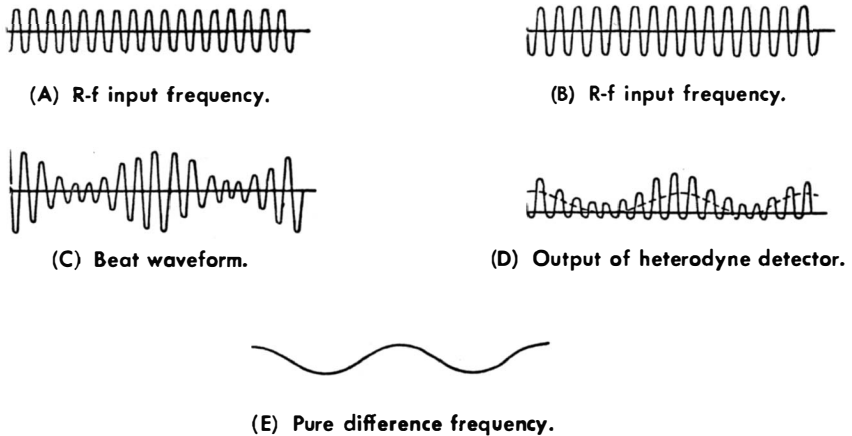

Fig. 7-8. Action of a heterodyne detector.

detector. Fig. 7-8 shows the action of a heterodyne detector. The r-f input frequencies are shown in Figs. A and B. These frequencies mix together to form a beat waveform (Fig. C), which is the same as a modulated r-f wave. Since the heterodyne detector is a rectifier, half of the signal excursion is rejected. In turn, the output waveform has an envelope which varies at the difference between the two r-f signals.

Output from the heterodyne detector is shown in Fig. 7-8D. This waveform contains not only the difference frequency, but also the sum frequency, and various harmonics of both the sum and difference frequencies. Hence, to obtain the pure difference frequency (Fig. 7-8E), a low-pass filter is employed, as shown in Fig. 7-9. The low-pass filter consists of series coils and shunt capacitors, terminated in the characteristic resistance of the filter. It has a cutoff frequency

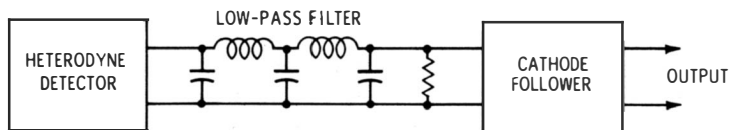

Fig. 7-9. Low-pass filter removes all but the difference frequency.

beyond which no frequencies can pass. However, it imposes practically no attenuation on frequencies below the cutoff frequency. Details of low-pass filters cannot be explained here, but interested readers may refer to books such as *101 Ways to Use Your Ham Test Equipment*, published by Howard W. Sams & Co., Inc.

Several requirements must be met in the design of a beat-frequency generator. The stability of the r-f oscillators must be maximized. For example, the fixed oscillator in Fig. 7-7 might operate at 100 mc. In turn, the variable oscillator might be tuned to operate at 100.05 mc. The difference-frequency output is then 50 kc. If either of the r-f oscillators drifts 10 kc, the output frequency will be in error by 20%. This is a drift of only 0.1% in the r-f oscillator frequency. Hence, there is a very demanding design problem.

Another requirement which must be met is ample decoupling of the two r-f oscillators. We know that when two oscillators are coupled and are tuned to the vicinity of the same frequency, the oscillators tend to synchronize at the same frequency. This is called pulling and locking. When oscillators pull, the output frequency changes. If they lock, output from the heterodyne detector falls to zero. Hence, buffers are used to isolate the r-f oscillators, as shown in Fig. 7-10. In this

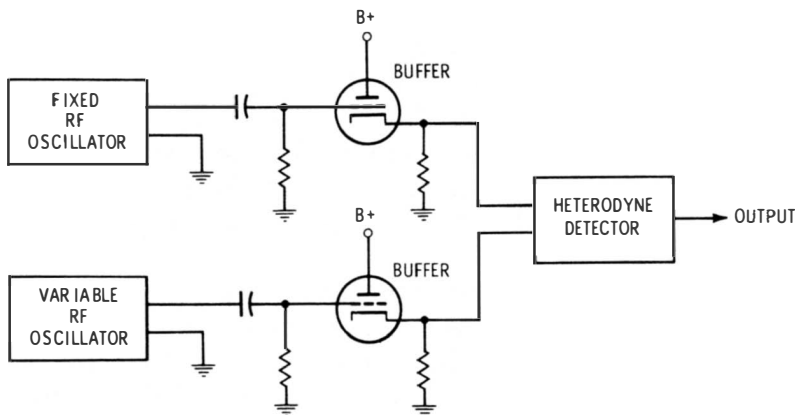

Fig. 7-10. Buffers isolate the r-f oscillators.

example, the buffers are cathode followers. However, RC amplifiers with very low values of plate-load resistances are also used in some generators. In such case, pentodes are preferred to triodes, in order to obtain better isolation.

Various types of heterodyne detectors are used. Some generators use a simple semiconductor diode in a low-resistance circuit, as shown in Fig. 7-11. Other generators use converter

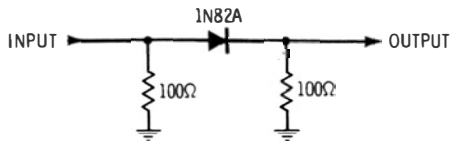

Fig. 7-11. Simple heterodyne detector.

tubes. The advantage of a tube is that it provides a gain instead of an insertion loss. To obtain a good sine-wave output, a heterodyne detector must not be overloaded. It is also helpful to make the r-f input voltage from the fixed oscillator considerably less than that from the variable oscillator. The r-f oscillators themselves must supply a good sine wave. When a semiconductor diode is used as a heterodyne detector, it is often helpful to supply a d-c bias. The necessary bias voltage depends on the characteristic of the diode.

The diode is operated on its forward interval. Best heterodyne-detector action occurs when the diode is forward-biased to the most rapidly curving point on its knee. Then, when the applied r-f voltages have suitable amplitudes, a good sine-wave difference frequency is produced. By the same token, converter tubes used for heterodyne detection must have optimum electrode voltages to obtain good output waveforms.

You will find that all beat-frequency generators have some cross-beats present in the output. Good design can hold these spurious outputs, or birdies, to a comparatively low level. Cross modulation occurs because the r-f signals are rectified. In turn, harmonics are generated. These harmonics can beat together at a frequency in the vicinity of the difference frequency. To minimize cross modulation, the operating point of the heterodyne detector must be carefully selected. Reduced drive to the detector also helps to minimize or eliminate cross modulation.

All video-frequency f-m generators operate on the beat-frequency principle. This is a necessary design because phase-shift or Wien-bridge oscillators cannot be deviated over a substantial range without band-switching. If the deviation is set to zero, the generator can be used as a beat-frequency c-w generator. Since its frequency stability is less than that of a Wien-bridge oscillator, however, most f-m generators are not recommended for c-w operation.

Index

- A**
Accuracy considerations, 116-117
Accuracy rating of a signal generator, 34-39
Accuracy ratings, 35-38
Amplitude modulation, 17-20
 sine wave, 58-63
Analyzer, transistor radio, 128-130
Analyzer type of generator, 121-128
Attenuator shielding, 21
Attenuators, 20-21, 95-96
 step, 20-21
Automatic control bias, 17
- B**
Beat frequencies, interharmonic, 44-45
Beat-frequency generators, 140-143
Beat points, 37
Beats, interharmonic, 39, 50
Bias, automatic control, 17
Buffer stage, 14-16
Bunching, 91
- C**
Calibration
 counter, 54-56
 harmonic, 36
 high-band, 42-47
 low-band, 39-42
Calibrators, dual crystal, 47-50
Choke tube, 26-27
Circuit, flip-flop, 54-55
Colpitts oscillator, 10
Compatibility, 101
Considerations
 feedback, 83
 plate-tuning, 83-84
Counter calibration, 54-56
- D**
Definition of total harmonic distortion, 53-54
Detector, heterodyne, 140
Distortion, harmonic, 66-67
Double-shielding, 26
Dual-crystal calibrators, 47-50
- E**
Effect on frequency, 84-85
Electrical tuning, 92-95
Electron-coupled oscillator, 16-17
Equalization of harmonic amplitudes, 50-51
Error
 maximum, 34-35
 tracking, 42
External modulator, 19
- F**
Features, signal generator, 9-12
Feedback considerations, 83
Field-strength meter, 51-52
Flip-flop circuit, 54-55
Flying-spot scanner, 122-123
F-m stereo multiplex signal generator, 105-112
 generator circuitry, 107-112
Formation of L and R signals, 103-105
Frequencies, interharmonic beat, 44-45
Frequency
 modulation, 69-75
 r-f ringing, 129
 stability, 12
 variable modulating, 64-66
Frequency standards
 primary, 36
 secondary, 36
Frequency-synthesizer generators, 32-33
Fundamentals of stereo multiplexing, 100-103
- G**
General shielding considerations, 21-27
Generator
 analyzer type, 121-128
 beat frequency, 140-143
 frequency-synthesizer, 32-33
Generator output voltage, measurement of, 51-53
Grid-dip meter, 115-120
 modulation of, 120
- H**
Harmonic
 amplitudes
 measurements of, 53-54
 equalization of, 50-51
 calibration, 36
 distortion, 66-67
 response of stubs, 120
Hartley oscillator, 10
 transistorized, 29-31
Heterodyne detector, 140
High-band calibration, 42-47
- I**
Impedance-stabilized oscillator, 12
Incidental frequency modulation, 18-20
Inductance, lead, 85
Interharmonic
 beat frequencies, 44-45
 beats, 39, 50
Internal modulation, 17
- K**
Klystron oscillator, 88-92
- L**
L and R signals, 101
 formation of, 103-105

Lead inductance, 85
Leakage, residual, 26
Lighthouse tube, 87
Low-band calibration, 39-42

M

Mark, set carrier, 20
Maximum error, 34-35
Maximum r-f output, 63-64
Measurement
 of generator output voltage, 51-53
 of harmonic amplitudes, 53-54
Meter
 field-strength, 51-52
 grid-dip, 115-120
Mode of operation, 12-17
Modulating frequency, variable, 64-66
Modulation
 amplitude, 17-20
 external, 19
 frequency, 69-75
 incidental frequency, 18-20
 internal, 17
 pulse-amplitude, 78
 pulse-code, 78
 pulse-duration, 78
 pulse-position, 78
 sine-wave, 17
 square-wave, 67-69
 uhf signal generator, 96-97
 video sweep, 75-79
Mono signal, 101

O

Oscillator
 Colpitts, 10
 electron-coupled, 15-16
 Hartley, 10
 impedance-stabilized, 12
 Klystron, 88-92
 tickler-type, 28
 transistorized Hartley, 29-31
 tuning, 80-81
 Wien-bridge, 135-139
Output, maximum r-f, 63-64

P

PAM, 78
PCM, 78
PDM, 78
Pilot subcarrier, 106
Plate-tuning considerations, 83-84
Points, beat, 37
PPM, 78
Primary frequency standards, 36
Pulse-amplitude modulation, 78
Pulse-code modulation, 78
Pulse-duration modulation, 78
Pulse modulation, specialized types of, 78-79
Pulse-position modulation, 78

R

Radio test sets, 131-132
Residual leakage, 26
Resolution, 32
R-f ringing frequency, 129

S

Secondary frequency standards, 36
Set carrier mark, 20
Shielding, attenuator, 21
Signal, mono, 101
Signal generator
 accuracy rating of, 34-39
 features, 9-12
 f-m stereo multiplex, 105-112
 generator circuitry, 107-112
 uhf, 27
Signal generator and signal tracer, 31-32
Signal generators, 27-31
Signals, L and R, 101
Sine-wave amplitude modulation, 58-63
Sine-wave modulation, 17
Skin effect, 21
Specialized types of pulse modulation, 78-79
Square-wave modulation, 67-69
Stability, frequency, 12
Step attenuator, 20-21
Stereo multiplexing, fundamentals of, 100-103
Stereo-signal generation with balanced modulators, 112-114
Stubs, harmonic response of, 120
Supersonic generators, 139-142
 basic circuitry, 133-134

T

Test sets, radio, 131-132
Tickler-type oscillator, 28
Total harmonic distortion, definition of, 53-54
Tracking error, 42
Transistorized Hartley oscillator, 29-31
Transistorized signal generators, 27-31
Transistor radio analyzer, 128-130
Transit time, 85
Transmission, WWV, 35
Tube, choke, 26-27
Tube, lighthouse, 87
Tubes, uhf, 86-87
Tuning, oscillator, 80-81

U

Uhf signal generator modulation, 96-97
Uhf signal generators, 27
Uhf tubes, 86-87

V

Variable modulating frequency, 64-66
Video sweep modulation, 75-78

W

Wien-bridge oscillator, 135-139
WWV transmission, 35

KNOW YOUR SIGNAL GENERATORS

by Robert G. Middleton

Since the early days of radio, signal generators have been one of the most versatile pieces of test equipment to be found on the test bench. This book is an authoritative text on the construction, operation, application, and maintenance of various types of signal generators.

From a coverage of the basic principles of generators, the text proceeds to explanations of generator accuracy, calibration, modulation of the generator signal, measurement of output voltages and harmonic amplitudes, and many more considerations.

The chapter on specialized types of signal generators should prove to be of special interest to the reader. Dip meters, analyzers, radio test sets, and uhf and super-sonic generators are adequately covered.

Another informative chapter is devoted to f-m stereo multiplex signal generators. Before discussing the generator itself, a very clear, concise discussion on the fundamentals of stereo multiplexing is presented. This is of great help for those who have not quite grasped the fundamentals of stereo-multiplex transmissions. The formation, transmission, and reception of the stereo signal is thoroughly explained and illustrated.

If you have a basic working knowledge of electronics, this book is a "must" for service technicians, apprentices, hams, and hobbyists.



ABOUT THE AUTHOR

Bob Middleton is one of the few full-time professional free-lance technical writers in the electronics field. His many books have proven invaluable to technicians and engineers, because they are based on his own practical experience. His home workshop is filled with a wide variety of test instruments, receivers, and other equipment which he uses in preparing the factual and practical content of his many books.

Other Sams books by Mr. Middleton include: nine volumes of his famous *101 Ways to Use Test Equipment* series, *TV Tube Symptoms and Troubles*, *Using the Oscilloscope in Industrial Electronics*, *Solving TV Tough-Dogs*, *Bench Servicing Made Easy*, *Troubleshooting With the Oscilloscope*, *Troubleshooting With the VOM & VTVM*, *Electronic Tests and Measurements*, *Test Equipment Circuit Manual*, *Practical TV Tuner Repairs*, *Elements of Transistor Technology*, *Scope Waveform Analysis*, *TV Servicing Methods Guidebook*, *Test Equipment Maintenance Handbook*, *Electronic Component Tests and Measurements*, *Pulse Circuit Technology*, and *Know Your Color-TV Test Equipment*.



HOWARD W. SAMS & CO., INC.

THE BOBBS-MERRILL COMPANY, INC.