

# Electronics & Technology Today

\$3.50  
MM70924  
MAY90

Canada's Magazine for High-Tech Discovery



**Engine Efficiency Meter  
Diode Data  
Noise Generator  
Digital Breadboard**



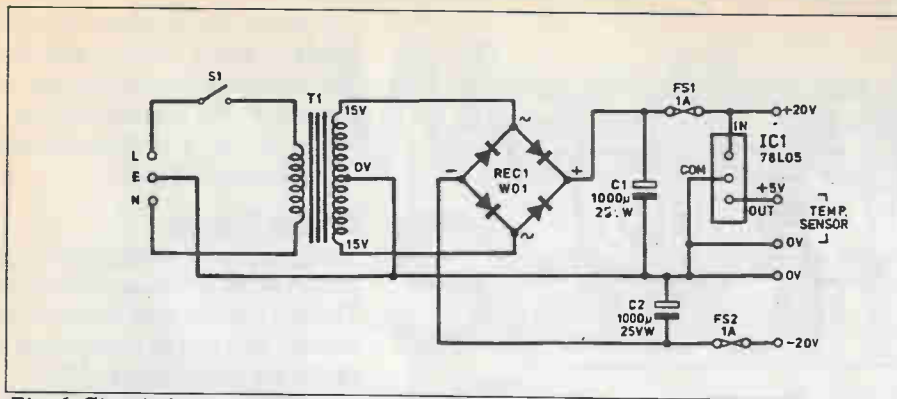

Fig. 6. Circuit diagram for the power supply.

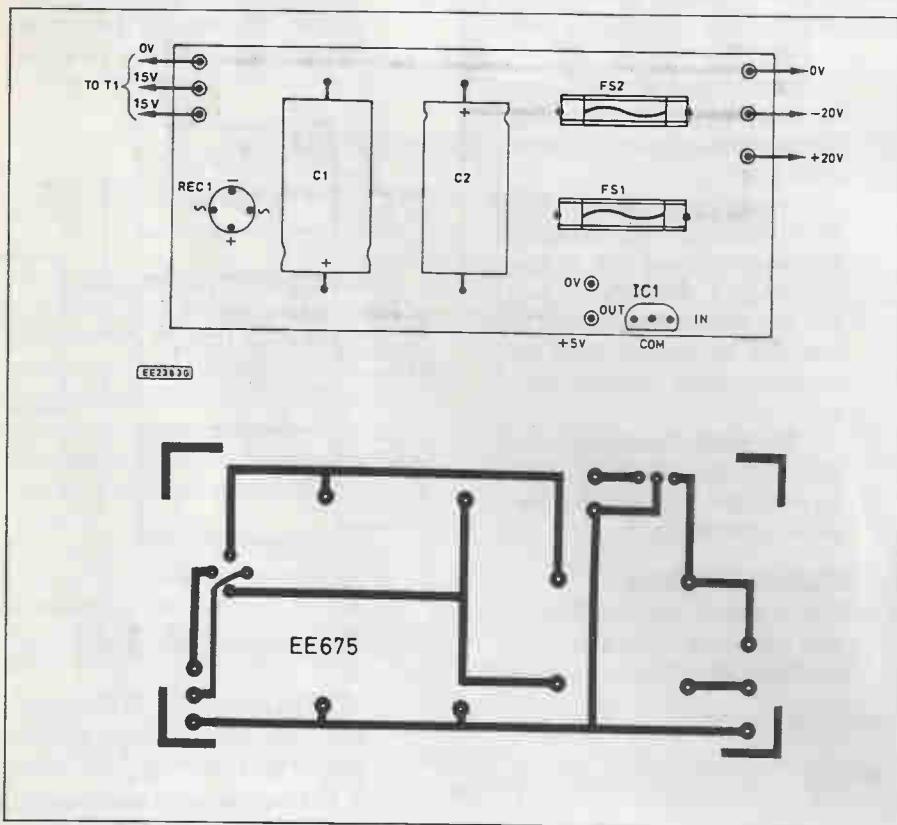

Fig. 7. Printed circuit board layout and pattern for the power supply.

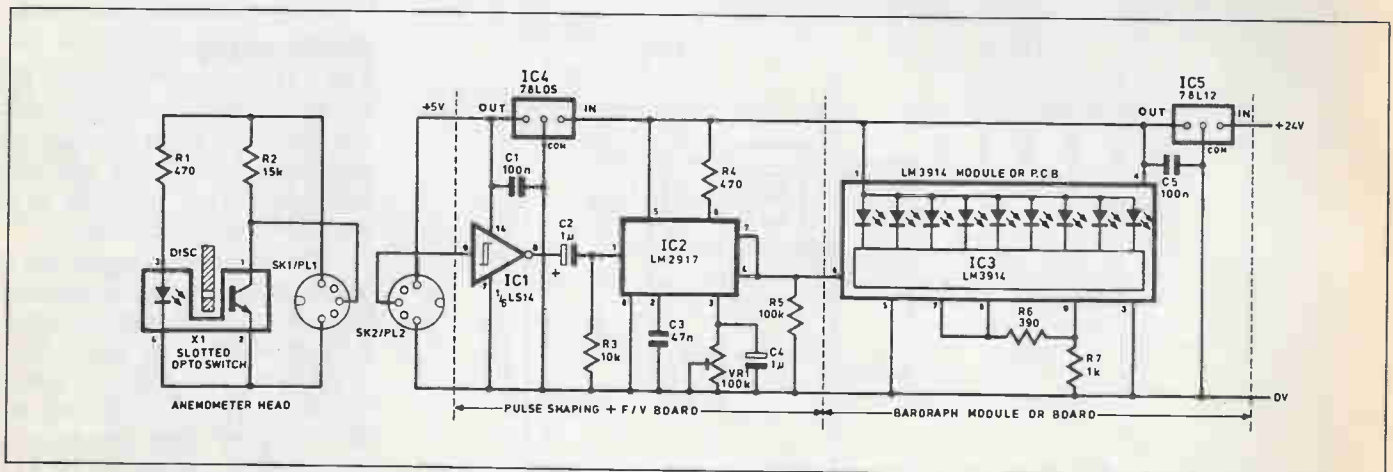

Fig. 8. Complete circuit diagram for the anemometer. Numbers around IC3 are for the single PCB module.

## Power Supply

### Capacitors

C1,2 ..... 1000µ25V

### Semiconductors

D1-D4 ..... 50V 1A bridge rec  
IC1 78L05 5V 100mA voltage regulator

### Miscellaneous

T1 ..... 20VA transformer, 30 VCT

Printed circuit board; FS1,2 1A fast blow fuse; PCB mounting fuse holders; connecting wire; solder, etc.

"clean" rectangular TTL level pulses at its output which is passed to the frequency to voltage converter IC2. A 78L05 voltage regulator IC4 provides the +5V supply to the slotted opto-switch and IC1.

The LM2917 frequency to voltage converter IC2 provides an output voltage which is proportional to the frequency of the input pulses and hence to the speed of the Anemometer head. The input to IC2 must swing above and below 0V in order that the converter can function correctly. This is achieved by the resistor capacitor network C2/R3 which produces an output consisting of positive and negative going spikes of a frequency equal to that of the input pulses.

The relationship between the input frequency and the size of the output voltage produced by IC2 depends upon capacitor C3 and preset VR1, the latter being made variable in order to provide a calibration facility. A 100k preset is used here in order to achieve an output voltage

# Anemometer (Wind Speed)

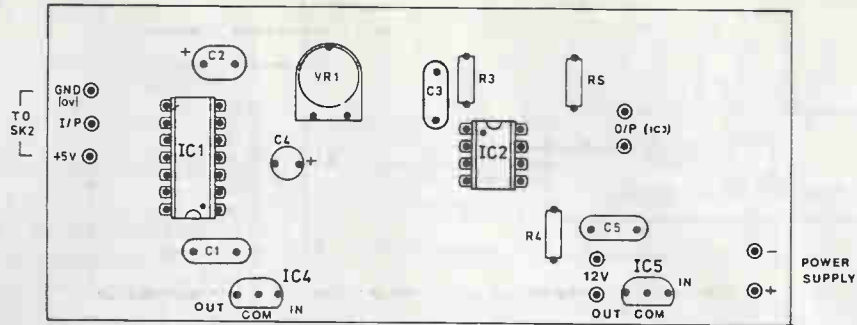

Fig. 9. PCB layout and pattern (below). Connections for the optoswitch X1 are shown below right.

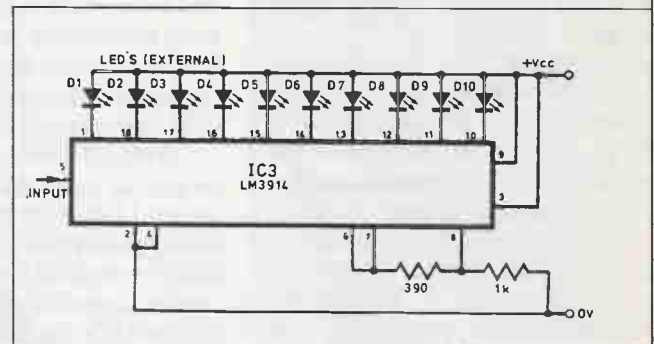
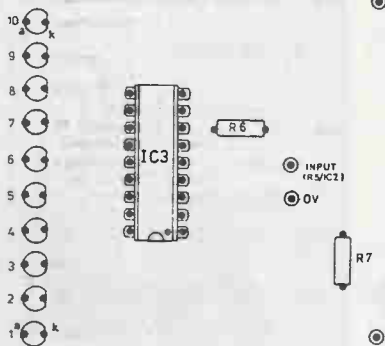
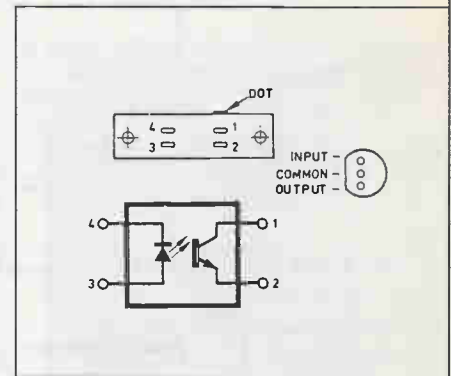
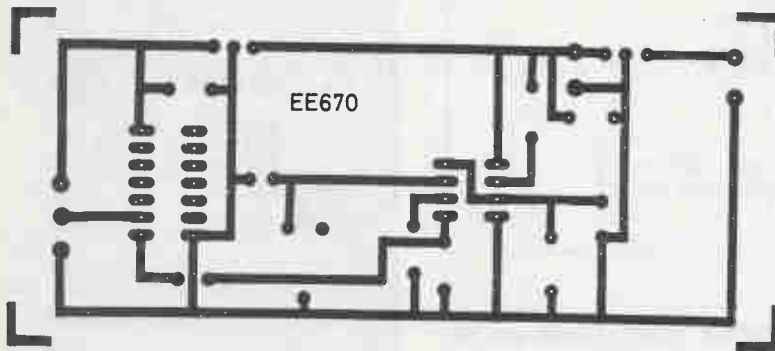

Fig. 10a. Anemometer circuit diagram using the LM3914 IC and individual LEDs.

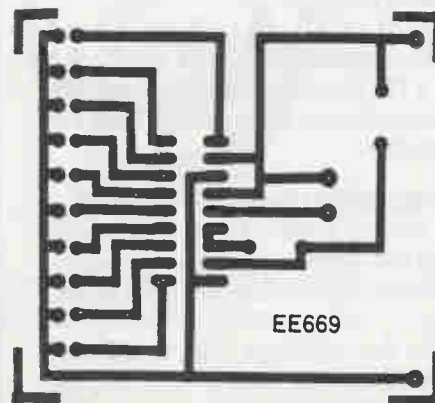

Fig. 10b. PCB component layout for bargraph display using the LM3914 IC and not the module.



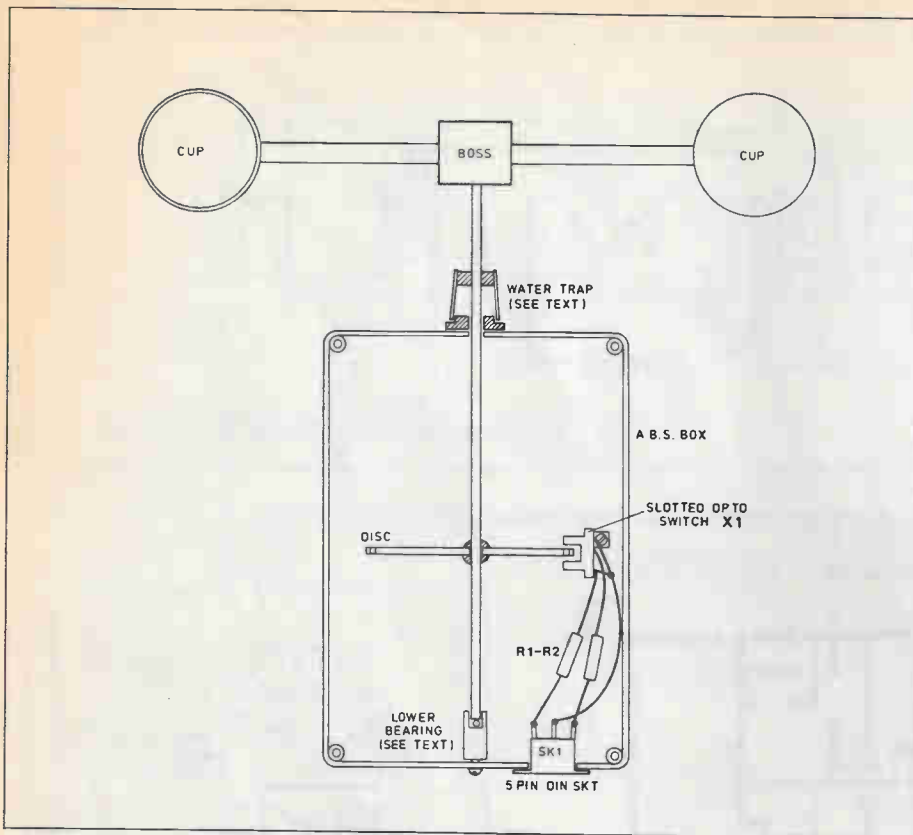

Fig. 11. Mechanical details for the Anemometer head.

range of 0V to 5V over the full range of the Anemometer "vanes" speed. Capacitor C4 provides a measure of smoothing of the output voltage by reducing any ripple present in it.

We now had a DC voltage, the magnitude of which is proportional to the speed of the anemometer head and all that remains is to measure this. A conventional DC voltmeter (0V-5V) could be used but in view of the fact that the wind speeds are normally determined only approximately, it was decided to employ an LM3914 ten-segment LED bar display for this quantity.

The LM3914 bargraph displays are available in two forms, either as an 18-pin DIP chip requiring separate LEDs or as a complete module including both the driver IC and the display LEDs. The prototype employs the latter (IC3), although there is no reason at all why the separate chip and LED alternative should not be used. A suitable printed circuit board design for this arrangement is given in Fig. 10.

The LM3914 IC and module contain a resistor divider network consisting of two precision resistors. A 1.25V reference voltage (developed internally) can be connected across the string and, in this case, each 125mV increase in the input voltage will switch on another of the LEDs.

The resistor string voltage can be changed in order to alter the range of the device and resistors R6, R7 achieve this. The values used result in the tenth LED being turned on by an input voltage of 5V. Resistor R6 also determines the display brightness and the selected value gives an LED current of approximately 20mA.

It should be noted that the display can be used in either dot or bar mode. With several LEDs switched on, the bar mode of operation draws a considerable current and it was decided to employ the dot mode in order to avoid this. Pin 10 of the module (pin 9 of IC) determines the mode selection and it should be left unconnected for a dot display; connecting it to +V will turn on the bar mode.

The LM2917 and LM3914, IC2 and IC3 are operated on a +12V supply and IC5, a 78L12 voltage regulator, provides this from the main unregulated 20V power supply line.

### Construction — Anemometer

The printed circuit board component layout and full size copper foil master pattern for the Anemometer section is shown in Fig. 9.

In the prototype, this board was mounted on the back of the display module, (IC3) using short spacers. The

## Anemometer Head

### Resistors

R1 470  
R2 15k  
All 0.25W 5% carbon film.

### Miscellaneous

X1 Slotted opto switch  
SK1/PL1 5-pin 180° DIN socket and plug  
Fibreglass "interrupt" disc see text; push-on control knob for water trap; case; materials for bearing, shaft, arms and wind cups — see text; 4mm ball bearing.

## Anemometer Display

### Resistors

R3 ..... 10k  
R4 ..... 470  
R5 ..... 100k  
R6 ..... 390  
R7 ..... 1k  
All 0.25W 5% carbon film.

### Capacitors

C1,5 ..... 100n  
C2,4 ..... 1u 16V  
C3 ..... 47n

### Potentiometer

VR1 ..... 100k trim

### Semiconductors

IC1 74LS14 HEX Schmitt trigger  
IC2 LM2917 frequency to voltage converter  
\*IC3 LM3914 IC or module (see text)  
IC4 78L05 5V 100mA voltage regulator  
IC5 78L12 12V 100mA regulator  
\*Ten 5mm LEDs required if IC used.

### Miscellaneous

SK2/PL2 5-pin 180° DIN socket and plug

Printed circuit board; 8-pin DIP socket; 14-pin DIP socket; 18-pin DIP socket; connecting wire; solder, etc.

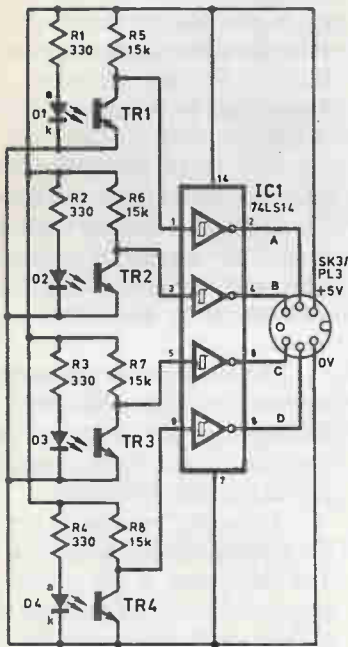

D1-4 OP160, TR1-4 OP500.

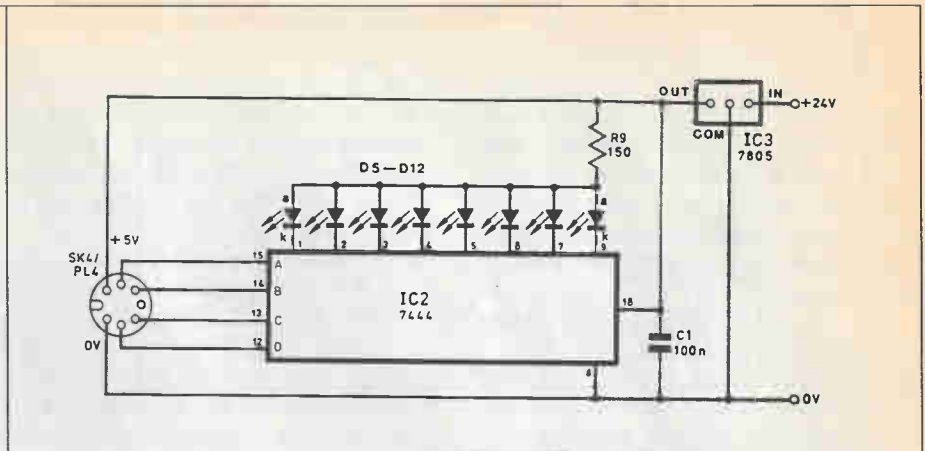
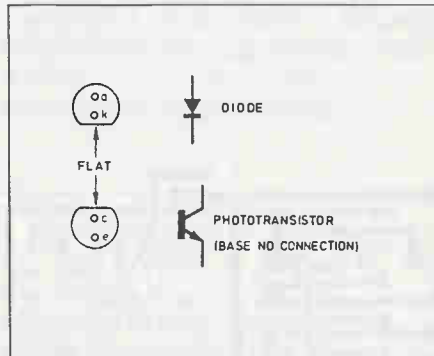

Fig. 12. Complete circuit diagram for the two sections of the Wind Direction Indicator. The connection details for the diodes and phototransistors are shown below.



### Wind Direction Vane Resistors

R1-4 ..... 330  
R5-8 ..... 15k  
All 0.25W 5% carbon film.

### Semiconductors

D1-D4 OP160 .... 3mm infrared LED  
TR1-4 ..... OP500 phototransistor  
IC1 ..... 74LS14 HEX Schmitt trigger

### Miscellaneous

SK3/PL3 7-pin 270° DIN socket and plug  
Printed circuit board; case for vane head; 14-pin DIP socket; strips 5mm Plexiglas (see text); coded disc (see text); mounting bracket for sensor strips.

### Wind Direction Display Resistors

R9 ..... 150  
0.25W 5% carbon film.

### Capacitors

C1 ..... 100n

### Semiconductors

IC2 7444 Excess 3-bit Gray decoder  
IC3 7805 5V 100mA voltage regulator  
D5-D12 5mm red LEDs

### Miscellaneous

SK4/PL4 7-pin 270° DIN socket and plug  
Printed circuit board; 16-pin DIP socket; LED clips.

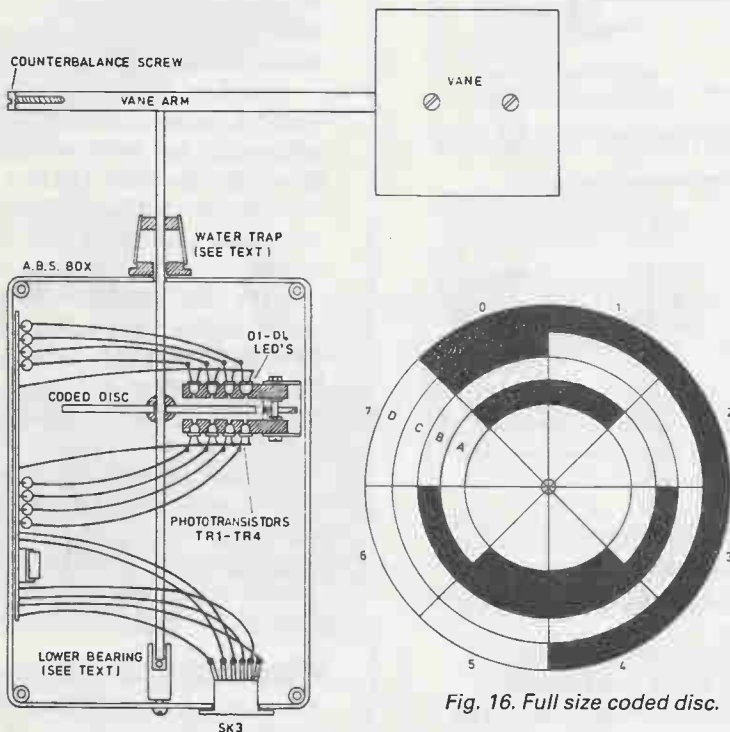

Fig. 16. Full size coded disc.

Fig. 15. Mechanical details for the Wind Direction Vane Head. The sensor bracket holding D1-4 and TR1-4 should be adjustable for aligning with the coded disc.

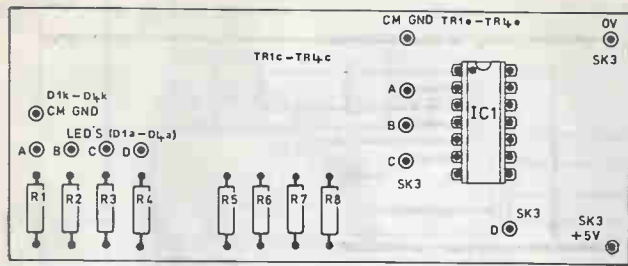

Fig. 13. PCB layout and pattern for the wind vane head.

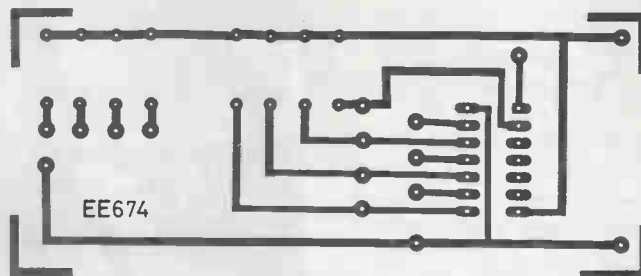
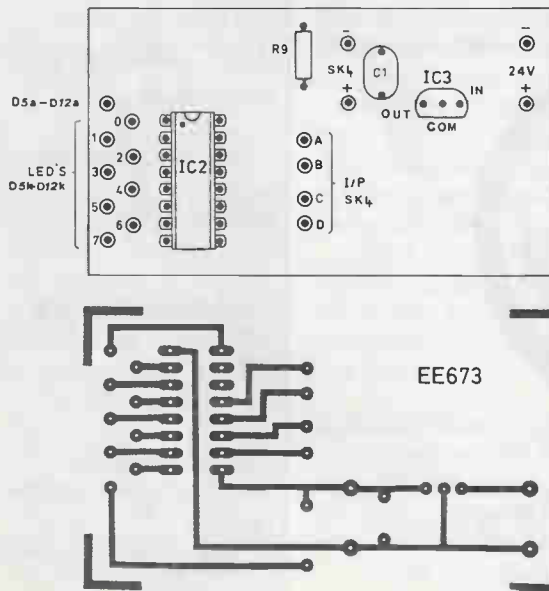

Fig. 14. Component layout and pattern for the wind direction display.



whole assembly was then mounted on the front panel of the Weather Station display with the row of LEDs positioned in a rectangular cutout; see Fig. 5.

Connections to the remote Anemometer head unit are made via a 5-pin DIN socket and plug on the rear panel of the unit. Only three wires are needed in fact (0V, +5V and the pulsed signal) and lightweight 3-core power cable can be used here.

The mechanical details of the Anemometer head are given in Fig. 11. The construction of the head should not present any significant problems, but as stated previously, it is important that the shaft/disc/arms assembly should rotate freely.

The lower end of the shaft rests on a 4mm ball bearing resting at the bottom of a drilling in a short length of nylon rod. Plexiglas or other plastics materials would provide suitable alternatives.

The upper "bearing" is merely a carefully drilled hole in the top of the ABS box. The shaft used in the prototype was a length of 4mm silver steel rod, but a piece of 3mm welding rod would do.

The water trap was fabricated from a cheap plastic push-on knob. The cap is drilled large enough to clear the shaft and then glued to the top of the box. While the body of the knob is also drilled through and fixed to the shaft with epoxy.

The boss supporting the arms was cut from 1in. wooden dowel and drilled to accommodate the arms themselves (3/8in dowel) and the shaft. The tops from used aerosols provided the wind cups and these were fixed to the arms with small wood screws.

The disc was cut from glass fibre printed circuit board and the positions of the 48 holes were marked using dividers. Next 2mm holes were then carefully drilled at these positions. The disc is fixed to the shaft using epoxy.

The gap of the slotted opto-switch X1 is quite narrow and some provision for adjusting its position relative to the disc should be made. A 5-pin DIN socket was used for connections to the Anemometer head unit.

### Wind Direction Indicator

As mentioned previously, the Wind Direction Indicator employs optical sensing of the wind vane position. The shaft of the vane carries a four band coded disc which rotates between four corresponding opto-sensors.

An excess 3-bit Gray code rather than



the natural binary code is used. In this, only one digit at a time changes as the disc rotates from one position to the next and such an arrangement is less likely to introduce errors than the binary code, in which two or more digits can change simultaneously. The system used provides an indication of wind direction to within a 45° arc.

The full circuit diagram for the Wind Direction Indicator section of the Weather Station is shown in Fig. 12. The circuit is split into two stages; wind vane head and direction "compass" or display.

Taking the Vane Head first, diodes D1 to D4 are the infra red LEDs, which are sited one side of the code disc, while TR1 to TR4 are the associated phototransistors sited the other side of the disc. The opto-switching outputs from the transistors are fed to four sections of IC1, a 74LS14 HEX

Schmitt inverter. The inverters are used to develop the required TTL level outputs for transferring to the display decoder IC2. The signals are transferred via 7-pin DIN sockets and plugs (SK3/PL3- PL4/SK4) and a six-core cable, which also carries the 5V DC supply, to the vane head.

In the display unit, IC2 is responsible for decoding the Gray code into one of the eight possible directions. The 7444 Gray to decimal decoder IC2 is used to turn on the appropriate "direction" LED (D5-D12) according to input code. A 7805 voltage regulator IC3 provides the +5V supply for both the display and head units.

### Construction — Wind Direction Indicator

The printed circuit board component layouts and full size copper foil master patterns for the Wind Direction Indicator section are shown in Fig. 13 and Fig. 14.

The mechanical arrangement of the disc and opto-sensors is shown in Fig. 15 while a full size diagram of the disc and its code is given in Fig. 16. Each sensor consists of an infra red LED and phototransistor combination mounted in 3mm holes drilled in small strips of 5mm Plexiglas. Care should be taken with the construction of this assembly in order to ensure correct alignment of each LED with code bands and associated phototransistor.

The disc itself is cut from 3mm clear Plexiglas and the sectors are then marked out using dividers. The appropriate sectors are then blacked out using good quality black paint.

The construction of the remainder of the wind vane head is similar to that of the Anemometer and Fig. 15 should be consulted. Once again, some provision should be made for adjusting the position of the sensor array relative to the disc.

### CompuScope 220



- \* 40 Megasamples per Second
- \* 20 Megasamples per Second
- \* 32K Or 256K Memory depth
- \* Optional GAGE Calc software includes: FFT, DIF, Integ.
- \* Save and Load Data, Configuration
- \* Post-mid-and-pre-trigger
- \* Simple menu-driven interface from \$1,425

### CompuGen 840 Arbitrary Waveform Generator



- \* 40 Million Conversions per second
- \* generate waveforms with mouse, algebraically, from disk
- \* Cut and Paste previously stored waveforms
- \* additional 8 bit TTL pattern generator
- \* integration with CompuScope 220 from: \$2,499

# TECHMA TRON

Your Source For PC based Instruments

## Nohau 8051 FAMILY and 68HC11 DEVELOPMENT SYSTEMS

- \* EMUL-PC into XT/AT/386
- \* optional TRACE board
- \* wide selection of pods
- \* User friendly software
- \* Source Level Debugging
- \* Real Time Trace
- \* Symbolic Trace
- \* Program Performance Analyzer
- \* Supports microcontrollers from Intel, OKI, Siemens, Phillips, Signetics, AMD MHS, Dallas, Motorola

## RACK-MOUNT COMPUTERS

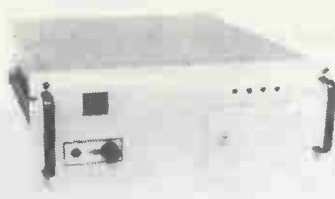

- \* Widerange of enclosures available
- \* Motherboard or Passive Backplane
- \* 286, 386SX, 386 CPUs
- \* Some units with sealed front panels
- \* optional power from 12 VDC
- \* Transportable and Wall-Mount units also

1415 Bonhill Road, Unit 17,  
Mississauga, Ont., L5T 1R2  
(416) 564-2588 FAX (416) 564-2589

130 Rue Principale,  
Laval, Que., H7W 3S6  
(514) 689-5889 FAX 689-0868

### The PC/La Personal Logic Analyzer

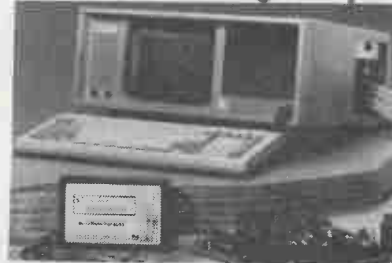

- \* 32 channels at 50 MHz
- \* optional 100 MHz pod
- \* 4K sample buffer per channel
- \* Hierarchical Triggering
- \* Save & Load Data, Configuration
- \* Disassembler available
- \* All functions software controlled
- \* Friendly menu-driven interface from: \$2,495

### ADC-30 ATP-M

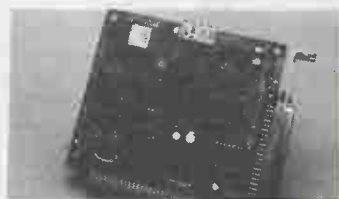

- \* 8 channels analog input, 12 bits
- \* conversion speeds up to 30 KHz
- \* 4 digital inputs, 4 digital outputs
- \* 3-16 bit counters
- \* BASIC software included
- \* optional thermocouple multiplexer, ATP-M, adds 16 inputs per ADC-
- \* 30 channel ADC-30 from: \$493; ATP-M from: \$522
- \* Prices exclude GST

Circle No. 96 on Reader Service Card

# Quick Capacitor Tester

A low-cost, handheld audio/visual unit that can identify short, open and working capacitors.

Mark Raven

On many occasions in the course of work at a small electronics shop, customers often ask if we could check a certain capacitor from their repair jobs to see if it is faulty or not.

If the capacitor is suspected short-circuit it can be easily checked using a multimeter on its Ohms range in the usual way, and although this gives an accurate indication of a short-circuit capacitor, it is a little slow, setting-up the range switch, adjusting the meter to read zero and holding the

probes onto the leads of the capacitor under test. (Often a hopelessly clumsy procedure, especially if the leads of the capacitor have been cut short).

The open-circuit types are considerably more difficult to identify, as values from a few picofarads (pF) to one or two microfarads (uF) read the same on the multimeter test whether open-circuit or OK.

The best tester for a capacitor is, of course, a wide range capacitance meter, but these are by no means cheap and are

not always available. What was needed was a cheap, handheld unit which could identify short, open and working capacitors quickly, and with a minimum of fuss. The following design not only does this, both audibly and visually, in a matter of seconds, but also gives some indication of leakage current, especially useful for electrolytic capacitors and also for diodes and transistor junctions.

## Principle of Operation

The tester described here works by making the test capacitor part of an audio oscillator circuit. A good capacitor will enable the circuit to oscillate, an open or short circuit capacitor will not. The frequency of oscillation gives an indication of the capacitor value.

A second part of the circuit checks the oscillator output and indicates, via the LED, if a short circuited capacitor

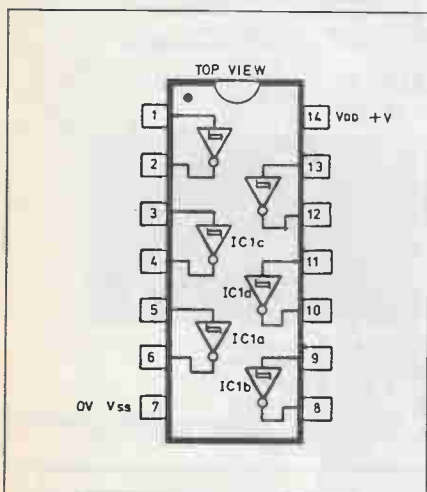

Fig. 1. The 4584 (40106) Hex Schmitt Trigger pinout details.

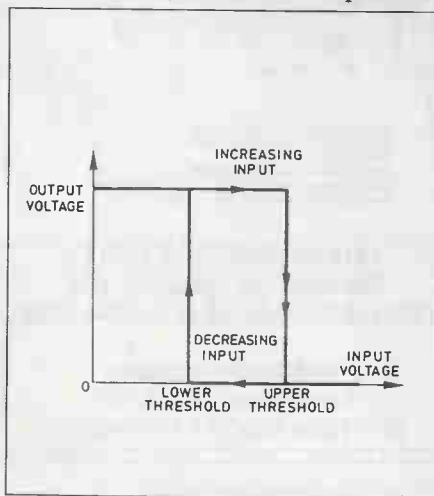

Fig. 2. Graph of the Schmitt trigger threshold levels.

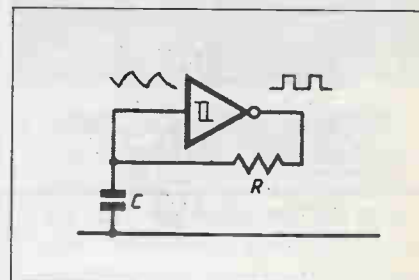

Fig. 3. Simplified Schmitt trigger inverter oscillator circuit.



# 5 sure steps to a fast start as a high-paid computer service technician

## 1. Choose training that's right for today's good jobs

Jobs for computer service technicians will almost double in the next 10 years, according to the latest Department of Labor projections. For you, that means unlimited opportunities for advancement, a new career, or even a computer service business of your own.



But to succeed in computer service today, you need training—complete, practical training that gives you the confidence to service any brand of computer. You need NRI training.

Only NRI—the leader in career-building, at-home electronics training for more than 75 years—gives you practical knowledge, hands-on skill, and real-world experience with a powerful AT-compatible computer you keep. Only NRI starts you with the basics, then builds your knowledge step by step until you have everything you need for a fast start as a high-paid computer service technician.



## 2. Go beyond "book learning" to get true hands-on experience

NRI knows you learn better by doing. So NRI training works overtime to give you that invaluable practical experience. You first read about the subject,

studying diagrams, schematics, and photos that make the subject even clearer. Then you do. You build, examine, remove, test, repair, replace. You discover for yourself the feel of the real thing, the confidence gained only with experience.

## 3. Get inside a powerful computer system

If you really want to get ahead in computer service, you have to get inside a state-of-the-art computer system. That's why NRI includes the powerful new West Coast 1010 ES computer as the centerpiece of your hands-on training.

As you build this fully IBM AT-compatible micro from the keyboard up, performing key tests and demonstrations at each stage of assembly, you actually see for yourself how every section of your computer works.

You assemble and test your computer's 101-key "intelligent" keyboard, install the power supply and 1.2 meg 5¼" floppy disk drive, then interface the high-resolution monitor. But that's not all.

You go on to install a powerful 20 megabyte hard disk drive—today's most-wanted computer peripheral—included in your training to dramatically increase the data storage capacity of your



computer while giving you lightning-quick data access.

By getting inside this powerful computer, you get the confidence-building, real-world experience you need to work with, troubleshoot, and service today's most widely used computer systems.

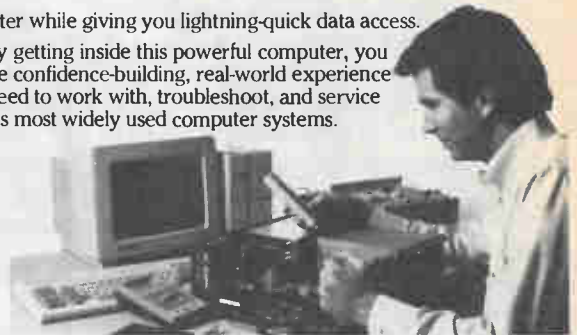

## 4. Make sure you've always got someone to turn to for help



Throughout your NRI training, you've got the full support of your personal NRI instructor and the entire NRI technical staff. Always ready to answer your questions and help you if you should hit a snag, your instructors will make you feel as if you're in a classroom of

one, giving you as much time and personal attention as you need.

## 5. Step into a bright new future in computer service—start by sending for your FREE catalog today!

Discover for yourself how easy NRI makes it to succeed in computer service. Send today for NRI's big, 100-page, full-color catalog describing every aspect of NRI's one-of-a-kind computer training, as well as training in robotics, TV/video/audio servicing, electronic music technology, security electronics, and other growing high-tech career fields.

If the coupon is missing, write to: NRI School of Electronics, McGraw-Hill Continuing Education Center, 330 Progress Avenue, Scarborough, ON M1P 2Z5. AT & IBM are registered trademarks of International Business Machines Corp.

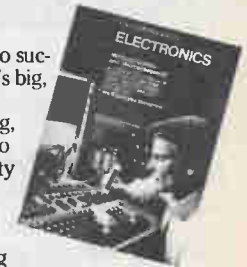

**NRI** School of Electronics



McGraw-Hill Continuing Education Center  
330 Progress Avenue, Scarborough, ON M1P 2Z5

- |  |  |
|--|--|
| <input type="checkbox"/> CHECK ONE CATALOG ONLY        | <input type="checkbox"/> Security Electronics          |
| <input type="checkbox"/> Computers and Microprocessors | <input type="checkbox"/> Electronic Music Technology   |
| <input type="checkbox"/> Robotics                      | <input type="checkbox"/> Digital Electronics Servicing |
| <input type="checkbox"/> TV/Video/Audio Servicing      | <input type="checkbox"/> Computer Programming          |
| <input type="checkbox"/> Telecommunications            | <input type="checkbox"/> Basic Electronics             |

Name \_\_\_\_\_

Street \_\_\_\_\_

City/Prov/Code \_\_\_\_\_

A member of Private Career Education Council

11-050

prevents oscillation. To enable leakage currents to be measured a separate circuit that acts as a simple continuity tester has been added. The oscillator is a Schmitt-trigger oscillator built around one of six inverters on the 458 CMOS hex Schmitt trigger (Fig. 1).

The difference between a standard inverter and a Schmitt trigger is important in this circuit, because it's the Schmitt trigger action which promotes the oscillation. A simple inverter gives an output which is the opposite logic level to that at its input. As the voltage on the input rises, the output will stay high until the input reaches the threshold level, at which point the output changes state and goes low. If the input voltage is now reduced the output will not

output of the Schmitt trigger is therefore high. Capacitor C then begins to charge via resistor, R at a rate defined by the value of resistor R. When the voltage at C, and therefore at the input of the Schmitt trigger, reaches its upper threshold, the output goes low. The capacitor then discharges through R, until the voltage at the input has dropped to the lower threshold level, causing the output to change back to its high state once again.

The process then repeats and continues indefinitely. The output is therefore, a squarewave, and its frequency is determined by the values of C and R.

### Circuit Description

The complete circuit diagram for the

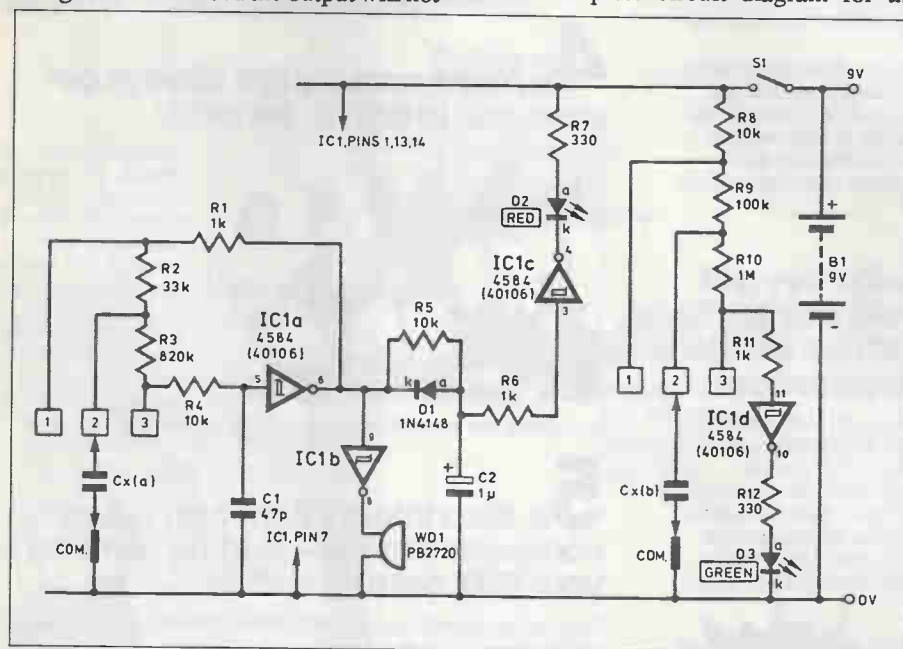

Fig. 4. Full circuit diagram for the tester.

go back to its high state until the input voltage has again reached the threshold level.

The important thing to remember is that a simple inverter has only one threshold level. The Schmitt trigger inverter however, is peculiar in that it has two threshold levels (see Fig. 2). When the output reaches the upper threshold the output goes low in the usual way, but if the input voltage is now reduced, the output will not change state until the input has dropped to the lower threshold level.

In the simplifier oscillator circuit (Fig. 3) we can see how the Schmitt trigger effect is utilized. As with all astable oscillator type circuits, we must first of all decide on the initial state of the circuits before we can describe its operation.

Let us assume to begin with that the capacitor, C, is discharged and that the

Quick Cap Tester is shown in Fig. 4. There are two quite separate circuits in this design, each built around different parts of the same IC, so for clarity each section will be described individually.

The capacitor under test, Cx(a), is placed across one of three test pads and the common pad on the printed circuit board (PCB). Assuming that the capacitor is OK it completes the Schmitt oscillator, giving a squarewave output at pin 6 IC1a. This is buffered by the IC1b to give a signal to drive the piezoelectric buzzer WD1.

The frequency varies according to which pad is chosen and the value of capacitor used. The series arrangement of resistors R1, R2 and R3 means that an audible note can be heard for a large range of different values of Cx(a). Resistor R4 protects the input by attempting to test a

## Parts List

### Resistors

R1,6,11	.....1k
R2	.....33k
R3	.....820k
R4,5,8	.....10k
R7,12	.....330
R9	.....100k
R10	.....1M
All .25W 5%	

### Capacitors

C1	.....47p
C2	.....1u50V

### Semiconductors

D1	.....1N4148, 1N914
D2	.....Red LED
D3	.....Green LED
IC1	.....4584 or 40106

### Miscellaneous

S1	.....SPST rocker switch
WD1	.....Piezo sounder
B1	.....9V battery

Plastic case, PCB, 14-pin DIP socket, 9V battery clip, nuts, washers, etc.

charged-up capacitor. Capacitor C1 reduces the maximum frequency of oscillation to about 100kHz. This is because the nature of CMOS devices is such that they draw more current the more often their outputs change state. Without C1 the circuit oscillates merrily at about 8MHz causing considerable current drain, and possible interference problems.

It is also worth noting that the audio frequencies produced when this unit is being used are considerably less than the 100kHz produced when it is in its standby mode. This makes for an interesting paradox, a unit that uses less current when it's being used than when it isn't. So if you want to extend the battery life of your tester, use it as often as possible.

Returning to the circuit, when pin 6 of IC1a is oscillating, capacitor C2 attempts to charge up via resistor R5, but as soon as pin 6 goes momentarily low diode D1 becomes forward biased and quickly discharge C2. Thus, during oscillation C2 never charges to a high enough potential to operate the inverter at IC1c and the LED. D2 remains off.



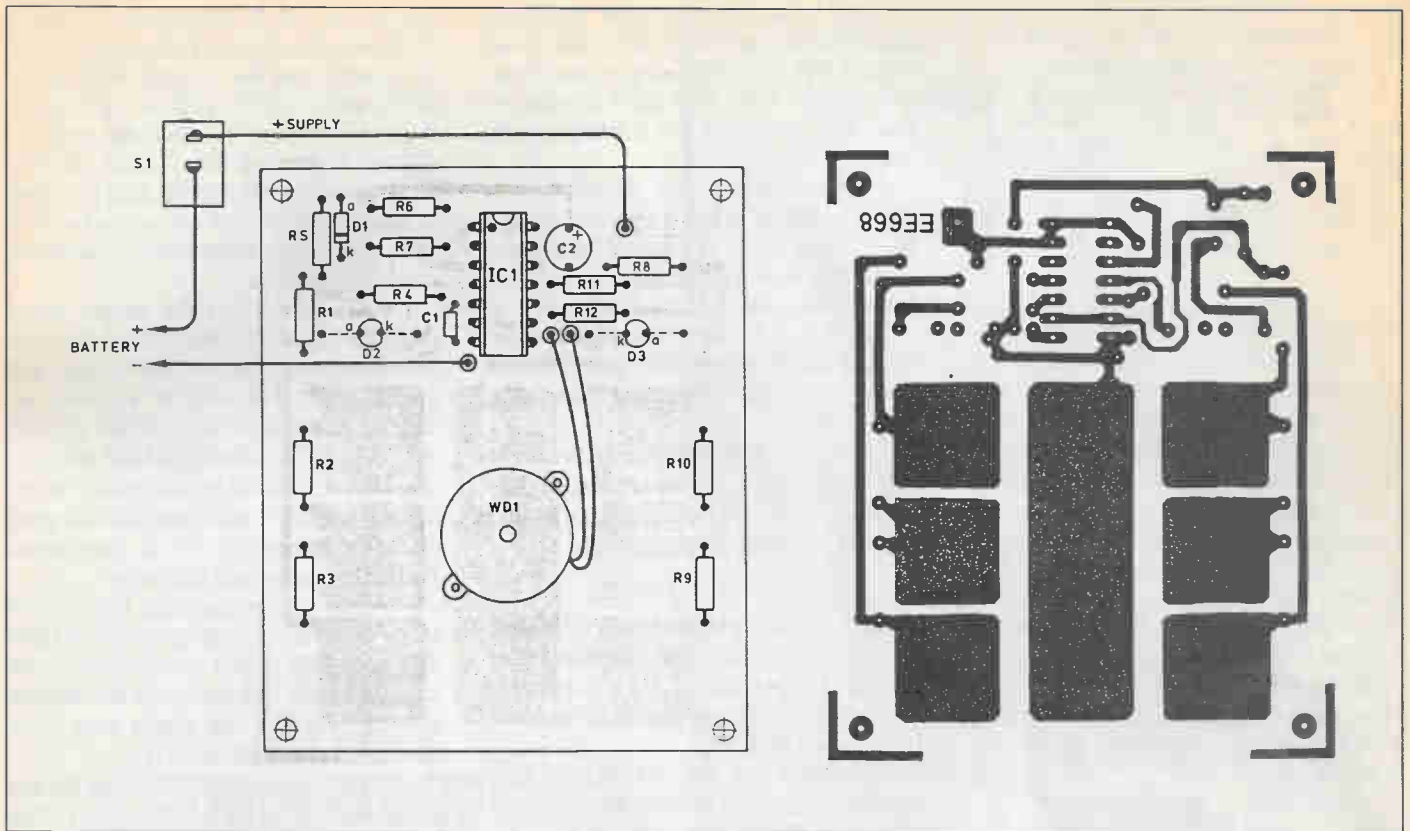

Fig. 5. PCB layout and foil side pattern. The diodes D2 and D3 are mounted on the track side.

If short-circuit is placed between any of the test-pads and the OV, pin 6 will go high for long enough to charge capacitor C2 to the upper threshold of IC1c and the short circuit indicator D2 will light. At very low frequencies, caused by large values of capacitors being tested, the LED may flicker or flash on and off as the capacitor charges and discharges. This is easily distinguishable from the result given by an actual short-circuit capacitor.

### Leakage

The second part of the circuit is the leakage current test. The capacitor under test is placed across another set of test-pads (1,2,3) in a similar way. Initially the input to IC1d is held high by resistors R8, R9 and R10, and therefore the LED D3 is off. If the capacitor (or diode or transistor junction) leaks more current down to ground (OV) than that initially flowing through the combinations of R8, R9 and R10, the input to IC1d will be pulled low, causing the LED D3 to light.

The series arrangement of resistors R8, R9 and R10, with the tap-offs to the three pads (1,2,3) means that different leakages can be measured (approx. 4uA, 40uA and 400uA with the resistor values given). Large value electrolytics, which look like a short-circuit when they are

charging up will cause the LED D3 to light for a couple of seconds or more depending on the value used. When charged however, the unit indicated just the remaining leakage current.

### Construction

The component layout and full size copper foil master pattern is shown in Fig. 5.

Assembly should be reasonably trouble-free as there are very few components and no wire links. Provided all of the visual precautions are taken, diode D1 and the LEDs are the correct way around, and the polarity of capacitor C2 is carefully observed the unit should work first time.

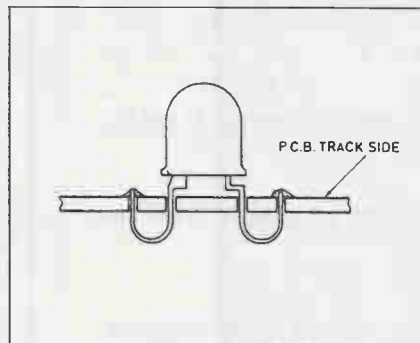

Fig. 6. The leads of diodes D2 and D3 are passed through one set of holes and soldered to adjacent pads.

The only difficulty some constructors may have is in the somewhat unconventional mounting of the LEDs D2 and D3, see Fig. 6. Because the large pads on the track side of the board are used as the test pads, the LEDs need to be mounted on the track side with the legs or leads going through the board and looped back on

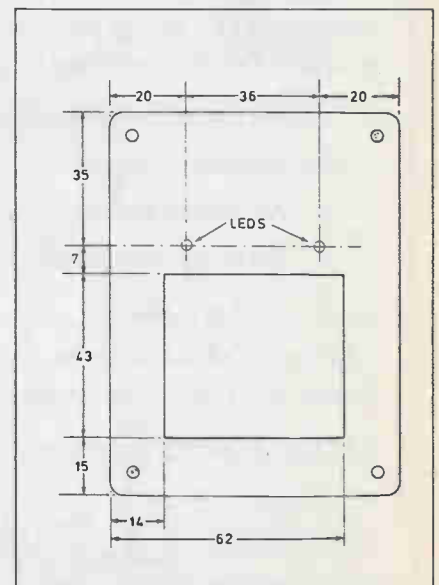

Fig. 7. Front panel drilling guide and details of the test pad circuit.



**DELIVERY FROM STOCK (OR CALL TODAY) (416) 252-8543 (OR TOLL-FREE) 1-800-668-6951**

# THE BEST

## DESIGNED AND MANUFACTURED AND INCLUDES EXCELTRONIX

### BEST COMPACT 386SX

"Featuring a small footprint, this powerful desktop computer has the capabilities of a 386 machine at an AT price. It is an excellent choice for small business or home office use. All essential peripherals are on the motherboard, leaving six I/O slots free for further expansion."

#### STANDARD CONFIGURATION:

- Intel 80386SX microprocessor running at 16MHz
- 1 meg memory optionally expandable to 4 meg on board
- Socketed for 80387SX math coprocessor
- LIM 4.0 support
- Page mode interleaved memory architecture
- Motherboard also includes:
  - two serial ports, one parallel port, real time clock/calendar, hard and floppy controller
- Phoenix BIOS
- 101 enhanced keyboard
- one 1.2 meg 5.25" or 1.44 meg 3.5" disk drive
- Our own Canadian designed and manufactured motherboard includes all above features and leaves you with six free expansion slots (five AT, one XT)
- CSA approved system

#### OPTIONS:

- Video display adapter (VGA, EGA or Mono)
- Video monitor (colour or mono)
- Hard disk (20 to 600Mb)
- Second floppy drive (any type)
- System board 16-bit RAM expansion to 4 Mb

#### 386SX AS DESCRIBED ABOVE WITH

- 1MB RAM & 40MB 3.5" 28ms hard drive \$1,895
- 2MB RAM & 100MB 3.5" 28ms hard drive \$2,495
- 2MB RAM & 200MB 3.5" 38ms hard drive \$2,995



### BEST COMPACT 386-20

"For business applications, such as accounting, financial 'what if' modelling, desktop publishing and database operations — the Compact 386 has the speed, power and reliability to satisfy all your needs."

- Intel 80386-20 microprocessor
- 20MHz processor clock speed
- 1 meg 32-bit memory expandable on board to 8MB of 32-bit memory and up to 16 meg with our 8 meg 32-bit plug-in memory board
- Socketed for 80387 math coprocessor
- Motherboard also includes:
  - two serial ports, one parallel port, real time clock/calendar, hard and floppy controller
- Phoenix BIOS
- 101 enhanced keyboard
- One 1.2 meg 5.25" or 1.44 meg 3.5" disk drive
- Our own Canadian designed and manufactured motherboard includes all above features and leaves you with six free expansion slots (five AT and one XT slot)

#### • CSA approved system

#### 386-20 AS DESCRIBED ABOVE WITH

- 1 MB of RAM and 40 meg 3.5" 25ms HD \$2,495
- 2MB RAM and 100MB 3.5" 28ms HD \$3,395
- 4MB RAM and 200MB 3.5" 28ms HD \$3,995



### BEST ELITE 386-33

"This 33 MHz zero wait state 386 tower with 32K cache memory provides superb, lightning-fast performance. Ideal for demanding power users, as a CAD/CAM workstation or flexible network server applications."

#### STANDARD CONFIGURATION:

- Intel 80386-33 microprocessor
- 33 MHz processor clock speed
- 32K cache memory, 0 wait state
- Socketed for the 80387 math coprocessor
- 1 meg 32-bit memory expandable on board to 16 MB of 32-bit memory
- Tower case
- 230 watt heavy duty power supply
- 1.2 meg 5.25" or 1.44 meg 3.5" floppy drive
- on board two serial ports, one parallel port and real time clock
- 8 expansion slots (six AT, two XT slots)
- Hard drive and floppy controller
- 101 enhanced keyboard
- CSA approved system
- Our Canadian designed and manufactured motherboard features the award winning LSI 386 chip set

#### OPTIONS:

- Video display adapter (VGA, EGA or Mono)
- Video monitor (colour or mono)
- Hard disk (20 to 600Mb)
- Second floppy drive (any type)
- System board 32-bit RAM expansion to 2, 4, 8 or 16Mb

#### SPECIAL: BASIC CONFIGURATION WITH:

- One meg RAM \$2,995
- Two meg RAM and 40 meg 28ms 3.5" HD \$3,795
- Two meg RAM and 100 meg 28ms 3.5" HD \$4,295
- Four meg RAM and 200 meg 28 ms 3.5" HD \$4,995

### BEST ELITE 486

- Intel 80486 microprocessor (approx. 50% faster 386)
- Microprocessor Includes built-in 8K of cache memory 0 wait state and a built-in math coprocessor
- 1 meg 32-bit memory expandable on board to 16MB of 32-bit memory
- Tower case
- 230 watt heavy duty power supply
- 1.2 meg 5.25" or 1.44 meg 3.5" floppy drive
- Motherboard also includes:
  - two serial ports, one parallel port, real time clock/calendar, hard and floppy controller
- Phoenix BIOS
- 101 enhanced keyboard
- One 1.2 meg 5.25" or 1.44 meg 3.5" disk drive
- Our own Canadian designed and manufactured motherboard includes all above features and leaves you with 7 free expansion slots (6 AT, 1 XT)

#### • CSA approved system

#### BASIC 486 SYSTEM PRICE WITH

- 1 meg ram \$3,995
- 2 meg RAM and 100 meg 28ms/3.5" HD \$5,295
- 4 meg RAM and 200 meg 28ms/3.5" HD \$5,995

NOTE: the above prices include the built-in 487 math co-processor

\* • BASIC BEST SYSTEM - 3 YEAR PARTS & LABOUR • BEST COMPUTER SYSTEM BOARDS - 5 YEARS PARTS & LABOUR • HAR

**Exceltronix**  
Computing Inc.

Circle No. 1 on Reader Service Card

**433 HORNER AVENUE, SUITE 1**  
**TORONTO (416) 252-8543**  
**OTTAWA (613) 235-2378**  
**EDMONTON (403) 483-4271**  
**WINNIPEG (204) 942-8993**

**Table 1: Capacitor Short/Open Test  
(Values that give audible output)**

Value	Test Pad
560p—1n	1
1n—4n7	1 or 2
4n7—220n	2
220n—33 $\mu$	3
Above 33 $\mu$ i.e.d. flashes on Pad 3	

themselves to be soldered to the board.

This can be achieved using a pair of long nosed pliers, but care must be taken not to bend the legs until the LED is seated firmly into position on the track side of the board, as they break very easily. Also, care must be taken not to let your soldering iron come too close to the body of the LED as the plastic used in their construction is particularly susceptible to high temperatures. In the prototype mode, the piezoelectric sounder WD1 was also placed on the component side of the board over a hole in the large common pad. This gave the best sound quality and convenience of positioning.

### Case

The whole board when completed should

be tested before final assembly. The board should be mounted in a plastic case about 102mm x 78mm x 40mm by means of four screws with extra nuts used as spacers. Four hole positions are marked on the board.

The lid of the case should have a cutout as shown in Fig. 7 to reveal the test pads. Using Fig. 7 as a guide, the corners of the cutout can be drilled and the four holes joined up to form the window.

Drill the LED holes 3mm in diameter for a close fit on the LED body. This is neater and more convenient than using LED clips.

Finally, a square hole must be cut in the side of the case for the miniature rocker on/off switch. These are cheaper and less obtrusive than the toggle types.

### Testing

Because of its simplicity, testing of the unit need be nothing more than just using it, as no setting up is required, but a few simple procedures will ensure that all of the functions are working OK.

First, try out the Short/Open test, which uses the three pads on the right hand side of the PCB as you look at it from the front. Use a piece of wire to short out each

pad in turn with the large central common (0V) pad. On all three pads, there should be a click from the sounder WD1 as the wire makes contact, and the LED above them should stay lit while the pads are shorted. If you hear the click but LED D2 does not light up, check that it's been soldered in the correct way around with its cathode (k - the short lead) towards the centre of the board.

Next, check out the ranges using capacitors that you know to be OK. A 10 nanofarad will bleep on the bottom and middle pads, but will be virtually inaudible on the top one. A 100nF (0.1 $\mu$ F) will buzz on the bottom pad and the LED may flicker, but will operate nicely on the top two ranges. A 1 $\mu$ F capacitor will work on the top ranges, but will click and cause the LED to flash on the bottom pad.

When you are satisfied that a good range of capacitors can be tested and that this part of the circuit is operational, you can go on to the leakage test on the left side of the board. For this you'll need three resistors, a 1k, a 100k and a 1M.

The 1m will light LED D3 on the top pad (4 $\mu$ A) but not on the others. The 100k will light it on the top and middle (400 $\mu$ A) ranges and the 1k will light it on all ranges, as will a short circuit. Again, if D3 fails to light, see that its cathode is toward the centre of the board.

In the event that you can get nothing at all from your unit, check for solder bridges, etc., and with a multimeter check the obvious points for power; for example pins 1, 13, and 14 of IC1 should be at 9V (supply voltage) and pin 7 should be at 0V, as should the common (ground) pad.

### In Use

After a little time using the tester, you quickly get to know how to interpret results. The current leakage detector side speaks for itself. The top pad detects leaks up to 4 $\mu$ A, the middle up to 40 $\mu$ A and the top to 400 $\mu$ A.

On the Short/Open test, Table 1 may help you to get used to the different ranges, though it does not take long to try your test capacitor on all ranges.

### Conclusion

The tester has been invaluable in the component shop, not only for testing capacitors, but also the leakage current in diodes and transistor junctions. On another note, the budding electronics experimenter may want to try to use the remaining two Schmitt trigger inverters on the 4584 IC for other tests or facilities. ■

## The DA/M<sup>TM</sup>

### The Lowest Cost Data Acquisition System

Our DA/M can solve more of your data acquisition problems at a lower price than any other product on the market. DA/M's are used for:

- Military meteorological stations.
- Building management.
- Automated hydroponic farming.
- Industrial process control.
- Your application

In fact, DA/M's can be used whenever you can't afford to use any one else's product.

Made in North America, DA/Ms are available NOW!



DATA ACQUISITION AND MANAGEMENT CORPORATION LTD.  
#140, 17303 - 102 Avenue  
Edmonton, Alberta, Canada T5S 1J8

Phone 1-403-486-3534

Fax 1-403-486-3535

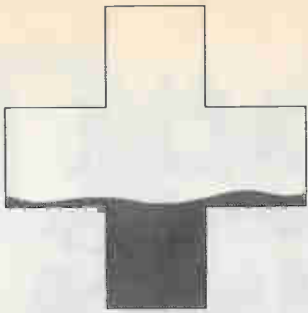

## IT TAKES MORE THAN BLOOD TO KEEP THE CROSS RED.

To The Red Cross, your money is also precious. We've served Canada for almost 100 years. And we can only continue with the financial support of people like you.

Your generosity is our life-blood. Please give what you can as soon as you can. Contact your local Red Cross.

We welcome VISA and MASTERCARD.

## HELP KEEP THE CROSS RED.



The Canadian  
Red Cross Society

# SUBSCRIBE TODAY!

## Be sure of your issue each month



### Moorshead Publications

1300 Don Mills Road, Toronto, Ontario M3B 3M8

SUBSCRIPTIONS:  NEW SUBSCRIPTION  RENEWAL

**Electronics & Technology Today**

One year (12 issues) \$22.95  Two years (24 issues) \$37.95

**Computing Now!**

One year (12 issues) \$22.95  Two years (24 issues) \$37.95

**Computers in Education**

One year (10 issues) \$25.00  Two years (20 issues) \$45.00

**Outside Canada (US Dollars)**

For U.S. please add \$3.00 per year  Other countries add \$5.00 per year

NAME \_\_\_\_\_

ADDRESS \_\_\_\_\_

TOWN/CITY \_\_\_\_\_ PROVINCE/STATE \_\_\_\_\_

CODE \_\_\_\_\_ DATE \_\_\_\_\_

POSTAL CODE \_\_\_\_\_

Cheque enclosed DO NOT send cash

MasterCard Account No. \_\_\_\_\_

Visa Account No. \_\_\_\_\_

American Express Account No. \_\_\_\_\_

Expiry Date \_\_\_\_\_

Signature \_\_\_\_\_



# ORDER FORM

## Software

_____	\$	_____
_____	\$	_____
_____	\$	_____
Sub Total	\$	_____
Tax (Ontario Residents) 8%	\$	_____
Postage	\$	_____
Total Enclosed	\$	_____

## Bookshelf

CODE (e.g. BP12)	TITLE (Short form acceptable)	PRICE
_____	_____	\$ _____
_____	_____	\$ _____
_____	_____	\$ _____
_____	_____	\$ _____

## Special Publications

ITEM	QUANTITY	AMOUNT
_____	_____	\$ _____
_____	_____	\$ _____

## Binders

ITEM	QUANTITY	AMOUNT
Moorshead Publications \$9.75 each (Ontario Residents add 8% P.S.T.)	_____	\$ _____

## Back Issues

\$4.00 each. Ontario residents add 8% P.S.T. Some issues may be out of stock. Please call the Reader Service Department at (416)445-5600 or enclose a self-addressed, stamped envelope for a complete list of available issues.

Orders from the Bookshelf are tax exempt.  
Please add \$1.00 for postage.  
Ontario residents add 8% P.S.T.  
for Specials and Software.

# Get the best of professional creative services

- Complete Desktop Publishing
- Expert Editorial Management
- Creative Marketing & Art Direction
  - Professional Photography
  - Extensive Direct Mail Services
- Moorshead Publications Reprints and much more...

Call  
**MP**  
COMMUNICATIONS  
Kenneth Marskell  
(416)445-5600

A New Division of Moorshead Publications  
1300 Don Mills Road, North York, Ontario M3B 3M8 FAX: 416-445-8149

# Designing With Logic, Part 4

This month we're going to have a look at a bit of actual circuitry. In designing with logic, sometimes you just have to put your pencil away and get down to hot lead

Steve Rimmer

**T**he simple sorts of logic arrays and single flip-flops that we've been looking at over the past few months rarely come up in real world logic design. Such things as binary adders, decade counters and so on are so commonly used that they're potted in single chips. Rather than having to wire together a binary adder, all you need do to have its functionality is to go spring about fifty cents for a single integrated circuit.

Logic design often assumes the aspect of assembling black boxes for this reason. After a while you'll stop being conscious of what the boxes are up to inside, only what their results are. In a sense, this is the proper mindset for designing with logic. The truth table of a logic array... whether it has been wired together with individual gates or potted in a chip... is the only thing that really matters. Transistors are for radio designers.

This month we're going to look at a very simple bit of logic design, but one that's both interesting and a spingboard to larger efforts. With two chips and an LED

display, you can make your soldering iron count to ten.

## Sixteen Fingers

The object of this exercise is to create a circuit which will count input pulses. The current count will be shown on a seven segment LED display. Because this is a simple counter, we'll only have one digit on hand. When the count exceeds nine it will wrap back to zero.

There are two basic problems to be overcome in this design. The first one is to find a way to count to ten. The second is to find a way to make the binary representation of numbers produced by a counter into something a seven segment LED display can make some sense of.

Counting with logic, as we saw last month, isn't particularly difficult.

A single flip flop is essentially a frequency divider or, if you like, a box that counts to two. The output of the flip flop will go high upon every second input pulse. An array of two flip flops with the input of the second connected to the output of the first will count to four. Three

will count to eight and four to sixteen. We only want to count to ten. Ten, regrettably, is not an even power of two.

In order to count to ten, as we discussed last month, one must watch the outputs of the four flip flops and reset the counter when the number ten appears. As such, the counter will be forced to wrap at ten rather than at sixteen.

The 7490 chip consists of four flip flops and all the logic necessary to make it reset at ten. This single package replaces four discrete chips. All you have to do is to send some pulses into its  $A_{IN}$  input and a four bit binary number ranging from zero through ten will appear at its output.

It's worth noting that the internal structure of the 7490 is a bit more complex than it may appear at first. It actually consists of a single flip flop for the first stage counter followed by three more flip flops and the gates to make them reset. As such, while we've made it behave like a decade counter by simply wiring the output of the first flip flop to the input of the remaining three, it can also be used in other ways.



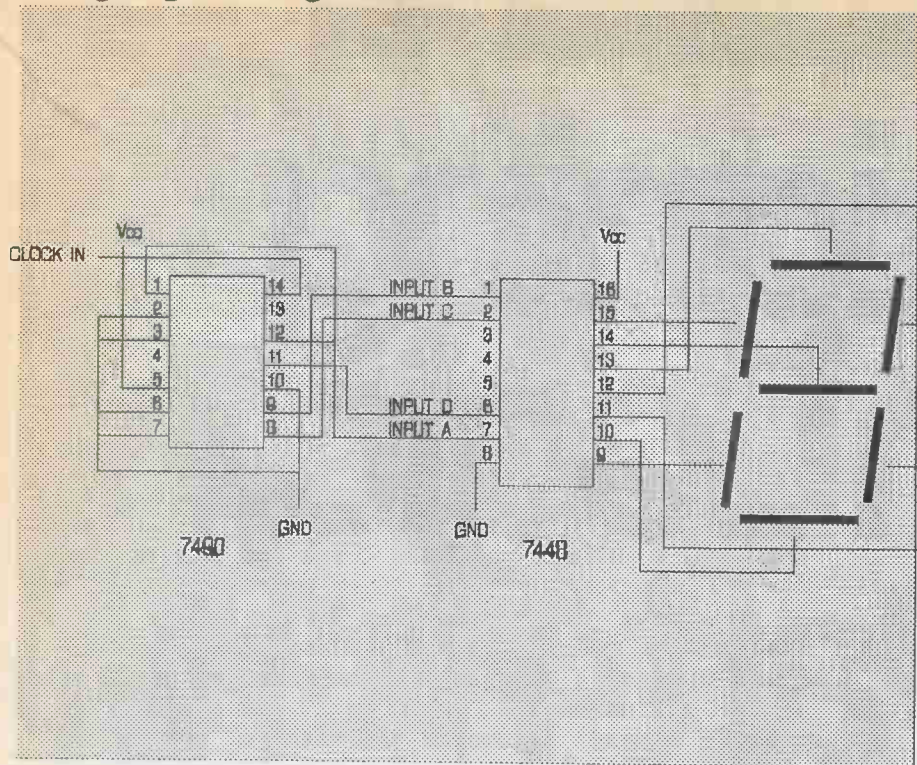

The first flip flop can be a divide by two counter and the other three a divide by five counter if you have need of these facilities.

The R<sub>01</sub>, R<sub>02</sub>, R<sub>91</sub> and R<sub>92</sub> inputs of the 7490 are grounded in this circuit. In some applications it's useful to be able to explicitly reset a counter, or bank of counters, to a known state before you start counting. This is handled by the R inputs. The 7490 allows for a variety of reset options. You can "jam" either a zero or a nine value into the counter prior to counting.

In this simple application it doesn't really matter where the counter starts, so we won't worry about the R inputs.

The second half of the circuit is the logic to turn the binary coded output of the counter into the on and off states to drive a seven segment LED display. Now, while the complexity of such a task might seem a bit daunting, its nature will be familiar to you. The black box in question has four inputs, corresponding to the four outputs of the counter, and seven outputs, one for each segment of the LED display. It's a finite state logic array, and can be repre-

sented by a truth table, if rather a large one.

If you wanted to, you could design a logic array to generate this truth table. In practice, it would be somewhat enormous.

The 7448 chip consists of all the logic to drive a seven segment display. It's dead easy to work with. In addition, it has a few other useful features, such as the ability to blank the display during periods when the data being sent to it might not be valid. This is useful, for example, in applications wherein the counter driving the display decoder might spend part of its time counting and, as such, in flux. Blanking the display for a fraction of a second while its counter is updating doesn't make it go dark, but just a little dimmer. Persistence of vision allows us to see it as continuously illuminated.

## Bigger Numbers

This little counter doesn't do very much, but you can make it into bigger things. For example, if you build a second one and gang them together, you can count from zero to ninety-nine. You can gang up as many decades of counters as you like.

In practice, wiring up eight lines... seven segments and ground... to every digit of a display is impractical. It's also unnecessary. Commercial devices which use seven segment readouts drive them through a technique called "multiplexing". In this case, there would be only one 7448, with its seven outputs connected to all the segments of the display. In practical terms, it would usually be necessary to use transistors to buffer the outputs of the 7448. Each of the common ground lines of the displays would be driven by a multiplex generator. This is simply a chip which accepts a binary input and turns on one of its output lines at a time.

In order to drive this display, then, a multiple decade counter would have to output two binary numbers... one to decide on which digit to display and one to select which of the LED displays it's to appear on. By scanning through all the LED displays quickly enough, someone looking at the readout would see all of them illuminated, even though only one is on at a time.

We'll look at counters and displays in greater detail next month, and we'll be back to details of handling a multiplexed display later in this series. ■

truth table

DECIMAL OR FUNCTION	INPUTS						BI/RBO†	OUTPUTS							NOTE
	LT	RBI	D	C	B	A		a	b	c	d	e	f	g	
0	H	H	L	L	L	L	H	H	H	H	H	H	H	L	1
1	H	X	L	L	L	H	H	L	H	H	L	L	L	L	1
2	H	X	L	L	H	L	H	H	H	L	H	H	L	H	
3	H	X	L	L	H	H	H	H	H	H	H	L	L	H	
4	H	X	L	H	L	L	H	L	H	H	L	L	H	H	
5	H	X	L	H	L	H	H	H	L	H	H	L	H	H	
6	H	X	L	H	H	L	H	H	L	L	L	H	H	L	
7	H	X	L	H	H	H	H	H	H	H	H	L	L	L	
8	H	X	H	L	L	L	H	H	H	H	H	H	H	H	
9	H	X	H	L	L	H	H	H	H	H	L	L	H	H	
10	H	X	H	L	H	L	H	L	L	L	L	H	H	L	
11	H	X	H	L	H	H	H	L	L	H	H	L	L	H	
12	H	X	H	H	L	L	H	L	H	L	L	L	H	H	
13	H	X	H	H	L	H	H	H	L	L	L	H	L	H	
14	H	X	H	H	H	L	H	L	L	L	H	H	H	H	
15	H	X	H	H	H	H	H	L	L	L	L	L	L	L	
BI	X	X	X	X	X	X	L	L	L	L	L	L	L	L	2
HBI	H	L	L	L	L	L	L	L	L	L	L	L	L	L	3
LT	L	X	X	X	X	X	H	H	H	H	H	H	H	H	4



# Digital Experimenter's Unit

A low-cost 5V supply and pulse generator with a wide range of output frequencies.

Robert Penfold

Testing even simple prototypes used to be a long and painstaking business. There was no alternative to actually building the unit using some form of soldered construction. What was probably worse than the initial time taken was the difficulty involved in making a few adjustments to circuit values. It required a lot of tedious desoldering and resoldering. Even modest changes could be very difficult to implement, necessitating a substantial amount of dismantling and rebuilding.

These days there are numerous solderless breadboards available that make building and testing prototypes much easier. Although you might think that these units are only suitable for building relatively small circuits, they can in fact be used for quite complex designs. Suitably large breadboards are available, or several smaller units can be clipped together. Components can be whisked out and new ones fitted with minimal effort. Quite large changes often taken no more than few minutes.

The main requirement for building most prototype digital circuits, apart from the breadboards, are a 5V power supply and a pulse generator to provide clock signals. Readymade units that combine these two functions with a solderless breadboard are available, but tend to be quite expensive. This unit provides a low cost alternative that's fairly basic, but offers a useful level of performance.

## Pulse Generator

Pulse generators range from something as simple as a fixed frequency squarewave

Fig. 1. Complete circuit diagram for the Pulse Generator section.

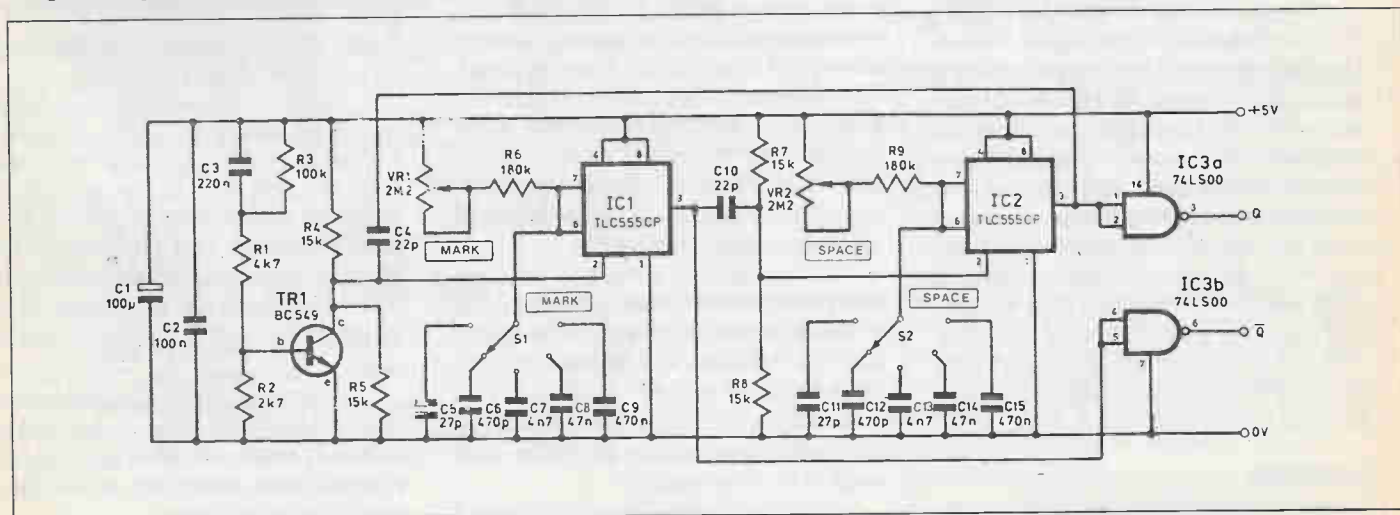

## Digital Experimenters Unit

generator to complex crystal-controlled circuits offering a wide range of output frequencies and mark-space ratios. Ideally a unit of this type should be able to operate at very low frequencies (about 1Hz) so that circuits can be run slowly enough for their operation to be accurately followed using a logic probe, or perhaps LEDs temporarily wired to strategic logic outputs. Operation at a higher frequency is also highly desirable so that circuits can be clocked at something approximating their normal rate.

Some circuits require short pulses for their clock signals, and the ability to vary the mark-space ratio to some degree significantly boosts the versatility of a pulse generator. Finally, a few circuits require two-phase clock signals. This simply means antiphase signals and it is a simple feature that should be available on any pulse generator.

This circuit achieves a wide range of output frequencies and mark-space ratios, but it's still quite simple and inexpensive. In fact it can provide any output frequency and mark-space ratio within reason. It lacks the high levels of precision associated with crystal-controlled pulse generator circuits, but for most purposes its accuracy is more than adequate.

Rather than setting an output frequency and mark-space ratio, the circuit is set for specific mark (high) and space (low) output durations. Both are continuously variable over five ranges:

1. 10 $\mu$ s-100 $\mu$ s
2. 100 $\mu$ s-1ms
3. 1ms-10ms
4. 10ms-100ms
5. 100ms-1s

The actual ranges covered are slightly wider than those shown above. This allows for component tolerances and avoids gaps in the coverage. This method of control avoids the erroneous results that can be obtained with simple circuits that have frequency and pulse length controls (that often permit the setting of impossibly long pulse durations for the selected frequency). When dealing with logic circuits it is often the pulse times rather than frequencies that are of interest anyway. However, if necessary it is not too difficult to work out the correct control settings for given frequencies and mark-space ratios.

### Example

As an example, assume that an output frequency of 10kHz and 1 to 4 mark-space

ratio are required. First work out the duration of one cycle by dividing the required output frequency into one ( $t = 1/f$ ). With the frequency in hertz, kilohertz, and megahertz, the answer is respectively in seconds, milliseconds and microseconds.

In this example, dividing 1 by 10kHz gives an answer of 0.1ms, or 100 $\mu$ s. With a 1 to 4 mark-space ratio the output is obviously in the high state for one-fifth of the time, and low for the other four-fifths. Multiplying 100ms by .2 and .8 gives answers of 20 $\mu$ s for the mark and 80 $\mu$ s for the space.

The circuit has Q and not-Q antiphase outputs. These are provided by standard LS TTL outputs, and the unit is therefore TTL compatible. It cannot, in theory, be guaranteed to drive CMOS circuits

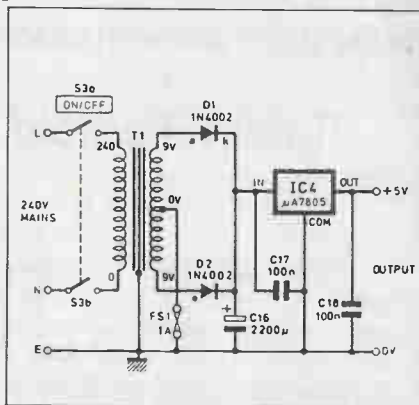

Fig. 2. Circuit diagram for the 5V 1A power supply.

properly. However, in practice the outputs switch between voltages that should enable any CMOS circuits to be driven properly.

### Pulse Generator

The full circuit diagram for the pulse generator appears in Fig. 1. This is based on two monostable multivibrators connected in a type of circuit called a *ring* oscillator. The monostables are connected such that as the pulse from one of them ceases, it triggers the other. Provided that a pulse is applied to one of the monostables at switch-on in order to initiate oscillation, the circuit will then oscillate indefinitely.

An oscillator of this type is unnecessarily complicated for some purposes, but it is well suited to an application of this type. One oscillator sets the mark duration while the other sets the space time. This makes it easy to obtain any pulse durations and separations within the pulse time range of the monostables.

Both monostables are of the standard 555 variety. They are actually based on a

low-power version of the 555, the TLC555CP. In this application it is the higher switching speed rather than the low power consumption that is of primary importance. It aids good accuracy at short mark-space ratios. Both monostables have a set of five switched capacitors to provide five ranges, plus a variable resistor to permit the pulse duration to be continuously varied over each range. Although C5 and C11 may look to be about 20p too low in value, the internal capacitance of the 555s makes up for the missing capacitance.

The monostables are of the negative edge-triggered type, and will therefore trigger in the required manner on the falling edge of the positive output pulses. However, the monostables are a form of the retriggerable type, and consequently require brief trigger pulses, or the output pulse durations will be stretched by the trigger pulses. A resistor and capacitor network at the input of the monostables provides suitable biasing and pulse shaping.

A common problem with ring oscillators is a reluctance to start. In order to provide reliable operation there must be a circuit to trigger one of the monostables at power-up. In this case a simple one-shot pulse generator based on TR1 is used to provide the triggering. At switch-on C3 charges up via the base circuit of TR1, momentarily switching on this device. When activated, TR1 pulls pin 2 of IC1 low and triggers it. TR1 then switches off and enables the circuit to operate normally.

### Outputs

The outputs of the two monostables provide complementary Q and not-Q outputs. These are buffered by two LS TTL NAND gates (IC3a and IC3b) that provide TTL-compatible output levels.

In practice, the outputs of IC1 and IC2 would probably be quite acceptable without this buffering, but having genuine TTL outputs avoids incompatibility problems. Also, overloads on the output of pulse generator can cause it to stall. Having buffered outputs should avoid this (but the oscillator can be restarted simply by switching it off and on again should it stall).

As current consumption of this circuit is only a few milliamps, it does not significantly reduce the power available for external units connected to the power supply section of the unit.

*continued on page 31*



# ALMOST FREE SOFTWARE

## VOLUME 58

ONE THIRD FEWER CALORIES

The highlight of this month's collection of Almost Free Software is unquestionably PC-Write Lite, the ultimate word processor, shareware or otherwise. If you've ever tried to come to terms with Word Perfect or Microsoft Word, you'll love the easy user interface, intuitive commands and well thought out mix of features of PC-Write Lite. It can be mastered by any Tory politician in less than an hour. Normal people can expect to do quite a bit better than this.

In addition to this little gem, we've collected a number of handy DOS utilities, a few digital gadgets and a really challenging graphic game that you won't be able to walk away from. There's also GUTS, which defies easy description but is well worth owning none the less.

Every program in this collection has been extensively checked to make sure that it functions as it should and that it contains no viruses or other nasties. Most sources of public domain software do not provide you with this assurance.

This collection carries the same promise that all our Almost Free Software does. If you don't feel that it's fair value once you've checked it out, we'll buy it back from you with no gripes or questions.

If you have problems with it, our help desk is as near as your phone... just call (416) 445-5600.

This is a two disk set which will unpack onto four floppies worth of software, about 1.4 megabytes in all.

**PC-WRITE LITE** might just be the perfect word processor. Far more powerful than many commercial packages, PC-Write Lite has a mix of features which makes it ideally suited for desktop publishing applications. It's painless to learn, aggressively supported and will run well on even the slowest PC. See the review in the February 1990 edition of Computing Now for a complete description of this exceptional package.

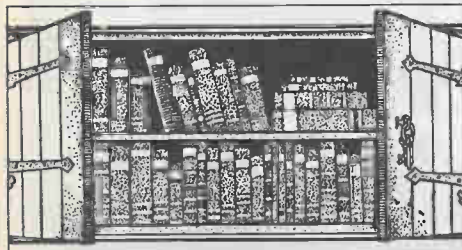

**RM\_TREE** is a disk pruning program which actually works. It allows you to wipe out subdirectories even if they aren't empty... all with one easy, wonderfully destructive command.

**DISKLITE** is fantastically clever, and a positive boon for anyone with a hard disk that lacks an activity light... hard cards are known for this. This tiny program flashes the caps lock light of your keyboard whenever a disk is accessed.

**DISKJUMP** will change the way you use Microsoft Windows. Makes popping from directory to directory painless, and allows you to have multiple copies of the Windows executive running in each directory you want to work in.

**RALPH** is an omnivorous file browser. It will accept straight ASCII, WordStar 5.0 and Word Perfect documents and let you cruise through them without having to boot up your word processor.

**JUNGLE JACK** is a VGA graphics game similar to Pipe Dream... without the copy protection. The object is to build a canal across the jungle before the river rises and washes away your plantation. Plan to waste a few evenings getting around this one. Requires a VGA card.

**CD LIBRARIAN** is a small, easy to understand database manager for compact disc collections. Keep track of your tunes even if your library grows to immense proportions.

**SNAPSHOT** is a versatile text screen grabber program. It conveniently turns any text screen into source code for your choice of programming language.

**FGRAB** is a quick way to grab lines from a text file. Given a word processing document or any other text file, it will allow you to browse through it and copy selected lines to a second file.

**EGADIGI** makes your screen font look... well, digital. Requires an EGA or VGA card.

**SND** will keep your hard drive clean and shiny, free of those nasty little unwanted files that gather in the corners. SND... search and destroy... will cruise through all your subdirectories and wipe out your choice of offending files.

**AUTOCON** is an amazing little time saver. If you frequently have to use different CONFIG.SYS files to run different sorts of applications, this thing will save you the frustration of boot floppies or manually changing your CONFIG.SYS file. It pops up a menu and lets you select the collection of drivers you want to use.



**KILLFILE** Isn't it nice to be able to unerase accidentally deleted files? Ever consider that someone else might be able to unerase your deliberately deleted files without your knowing it? This file killer kills 'em dead by overwriting every byte of your file with meaningless data before it bids it farewell.

**GUTS** is the one program no Windows user will want to be without. It draws all sorts of colourful abstract snakes, complete with user definable snake options, mouse control and so on. Not exactly a business solution, GUTS is hypnotic to watch none the less.

\$24.95 (TWO DISK SET)



# ALMOST FREE SOFTWARE

## VOLUME 59

### FOLDED SPACE AND FOLDED PAPER

How long has it been since you killed some aliens? Probably too long. This month, return with us to the stars from whence your ancestors came, to boldly go where no life form has gone before and slaughter whatever turns up when you get there.

If your soul is more zenlike than this, you might want to consider something a bit less genocidal. This month's disk also includes a program to introduce you to Origami, the Japanese art of paper folding. There's a complete integrated productivity package, featuring a word processor, spreadsheet and database manager. We've included a number of first class utilities, too.

Every program in this collection has been extensively checked to make sure that it functions as it should and that it contains no viruses or other nasties. Most sources of public domain software do not provide you with this assurance.

This collection carries the same promise that all our Almost Free Software does. If you don't feel that it's fair value once you've checked it out, we'll buy it back from you with no gripes or questions.

If you have problems with it, our help desk is as near as your phone... just call (416) 445-5600.

Please note that this is a two disk set which will unpack onto four floppies worth of software, about 1.4 megabytes in all.

**GALACTIC BATTLE** This is one of the most sophisticated alien killer games we've seen in many a mega-eon. It runs on any graphics card, will use a mouse or a joystick if you have one and your keyboard if you don't and is lightning fast. I love the smell of phasors in the morning...

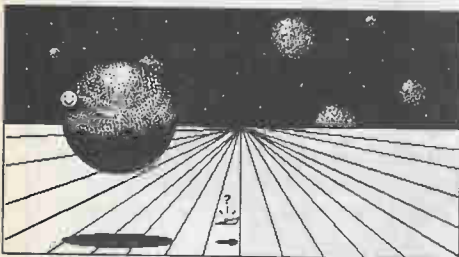

**LZEXE** is so unspeakably brilliant one wonders why it wasn't thought of before. It will reduce the size of most EXE files by up to seventy-five percent without impairing their functions. It does this by compressing them and putting some uncompression code before the program itself. Every time you run a compressed program, it automatically uncompresses itself and executes normally. This little jewel can free up megabytes on your hard drive with no real penalties.

**T-RULER** is a handy on screen pop up ruler for EGA and VGA cards. Unlike earlier EGA rulers, this one will flip either horizontally or vertically. Unspeakably useful, this.

**WORD PERFECT TEMPLATES** is a collection of pop up on screen keyboard templates for Word Perfect users. They're a lot easier to read than those fiddly paper templates and they don't get lost.

**TIMELOCK** is a security system for your PC which doesn't require that you remember to activate it. After a preset period of inactivity, it locks your keyboard until you type in a password. Just the thing for offices which have more fingers than hands to restrain them.

**EXPLOSIVE** is a screen blanker. However, whereas most screen blankers just blank your screen, this one pops into graphics mode and draws animated fireworks on it until you hit a key. Like Pyro on the Mac and FIREWORK for Windows, this little wonder saves your monitor from screen burn without making it appear that your system has been powered down.

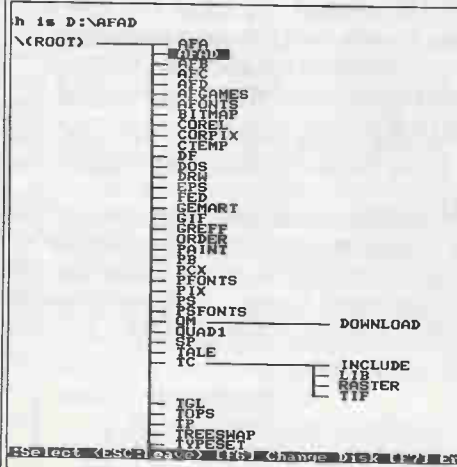

## ALMOST FREE GAMES

# VOLUME 5

This collection of games should ruin many an otherwise productive evening. Gathered over several months of extensive modem trolling, these are the best the public domain has to offer. While there isn't an alien to kill in the lot, you'll never notice the lack of green blood. If the monsters in the dungeons of Hack aren't dismembering you for a light snack, your anchovies will be kicked into the next universe by the Noid.

If you aren't into violence on quite this level, you might prefer to simply be splattered across the roads of France in Mille Borne or driven into desperate poverty in Monopoly.

Every program in this collection has been extensively checked to make sure that it functions as it should and that it contains no viruses or other nasties. Most sources of public domain software do not provide you with this assurance.

This collection carries the same promise that all our Almost Free Software does. If you don't feel that it's fair value once you've checked it out, we'll buy it back from you with no gripes or questions. If you have problems with it, our help desk is as near as your phone... just call (416) 445-5600.

Please note that this collection is supplied on a single quad disk and on multiple duals. If you can't read quads, please order the dual disk version.

**HACK** is not so much a game as a culture. Originally written for the Unix operating system, this legendary game has endured for years and been added to by countless... extremely warped... minds. Plunge headlong into an infinitely complex labyrinth of rooms, passages and monsters. Never forget the monsters. Playable on any monitor.

**KLONDIKE** is a gorgeous implementation of Klondike solitaire in EGA graphics. Requires an EGA or VGA card, and a mouse is an asset.

**NOID** was originally written as a sort of playable advertisement for the Dominoes Pizza restaurants in the States. It's a tight little game none the less as you try to figure out how to deliver your pizza without getting stomped by the Noid, a rather nasty little creature in a red rabbit costume. It's fast, peculiar and challenging. Requires a CGA, EGA or VGA card.

**MONOPOLY** is a glorious EGA implementation of the classic board game... with a few cosmetic changes to avoid the wrath of Parker Brothers. Buy and sell property, advance to go, collect two hundred dollars and fuel the fires of international monetary inflation. Requires an EGA or VGA card, and a mouse is an asset.

**MILLE BORNE** is a faithful graphics implementation of the classic French card game without the cards. Cruise around and avoid the road hazards. Requires an EGA or VGA card, and a mouse is an asset.

**MAHJONG** will take you back a few thousand years to those heady days when China was the centre of civilization and the ancestors of most of the rest of us were still in the trees. If they'd had computers back then, they'd have played the game using this software. Requires an EGA or VGA card, and a mouse is an asset.

**XTETRIS** No one with a television set can have missed the ads for Tetris... makes you think that Nintendo invented the beast. Here's an expanded version of the classic falling block game having different shapes and a whole new set of strategies. Requires a CGA, EGA or VGA card.

**SHOOTING** This is one of the few shooting gallery programs to crop up which is really fun to blast away at. It features a variety of targets, allowing you to frag everything from clay pigeons to defenseless skeet. Requires a VGA card and a mouse.

**CIPHER** is a word puzzle. Figure out what the scrambled phrases mean using only your native wit and, in times of extreme stress, a mallet upside your monitor. Requires an EGA or VGA card and a mouse.

The Monopoly, Klondike solitaire, Mah Jong and Mille Borne games are all the work of TEGE Systems Corporation of Vancouver. Programmers will be interested to note that both the source code for these programs and the sophisticated EGA user interface library upon which they're based is available from the author. Complete details are included with each game.

\$19.95 QUAD (\$31.95 DUAL)

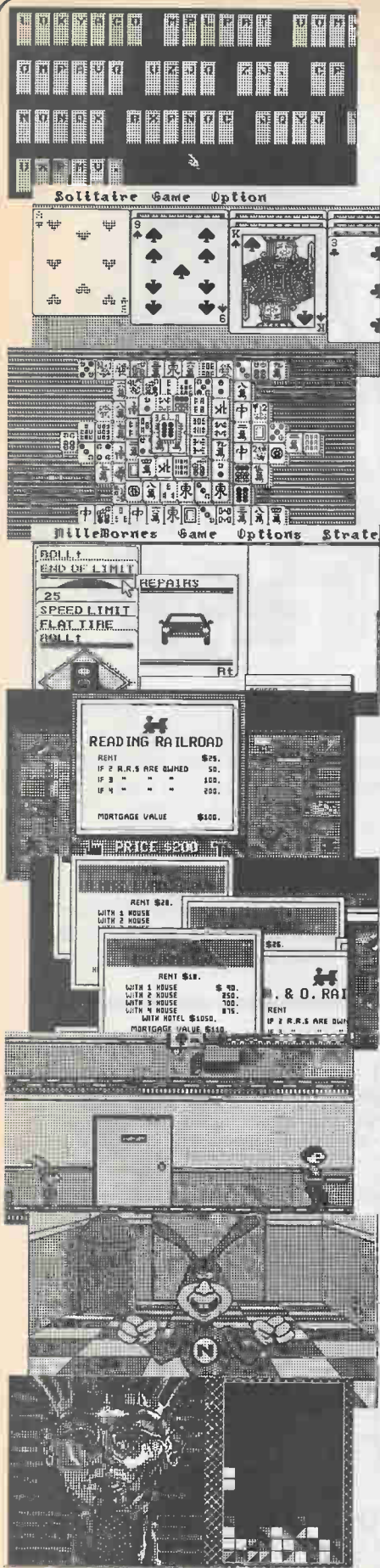



# RANGE

**MADE IN CANADA WITH PRIDE  
3 AND 5 YEAR WARRANTY\***

## BEST COMPACT 286

"The most widely supported 'workhorse' in terms of speed, power and reliability, this high-performance AT-class computer meets the requirements of business, engineering and academic users now and for years to come."

### STANDARD CONFIGURATION:

- 80286 microprocessor
- 12MHz and 16MHz versions available
- Math co-processor socket (80287)
- Motherboard also includes:  
2 serial ports, 1 parallel port, real time clock/calendar
- 8 expansion slots
- Floppy drive controller
- Hard drive controller
- Phoenix BIOS with setup program
- 1Mb 16-bit RAM
- 1 floppy disk drive
- Heavy duty power supply
- 101-key enhanced keyboard
- Keyboard lock and status display
- CSA approved

### OPTIONS:

- Video display adapter (VGA, EGA or Mono)
- Video monitor (colour or mono)
- Hard disk (20 to 320 Mb)
- Second floppy drive
- System board 16-bit RAM expansion to 4 Mb

**12MHZ VERSION WITH 1 meg. RAM with 40 meg. 28ms 3.5" hard drive \$1,395**

**16MHZ VERSION WITH 1 meg. RAM with 40 meg. 28ms 3.5 inch HD \$1,405**

## BEST PERFORMER 286

"A fast and powerful 'entry level' desktop computer, fully compatible with hundreds of MS-DOS software applications. It more than meets the needs of students and professionals as a powerful tool for word processing, graphics, programming and more."

### STANDARD CONFIGURATION:

- 80286 microprocessor
- 12MHz clock speed
- Math co-processor socket (80287)
- Motherboard also includes:  
2 serial ports, 1 parallel port, real time clock/calendar
- 10 year life for CMOS RAM battery
- Floppy drive controller
- Hard disk controller
- Phoenix BIOS with setup program
- 640Kb 16-bit system board RAM, expandable to 1MB
- 3 free expansion slots (2X16-bit, 1X8-bit)
- 1 floppy disk drive
- 101-key enhanced keyboard
- Case and keyboard lock
- Status display
- CSA approved system

### OPTIONS:

- Video display daughter card (EGA or TTL Mono)
- Video display adapter (VGA, EGA or Mono)
- Video monitor (colour or mono)
- Hard disk (20 to 200Mb)
- Second 3.5" floppy drive (720Kb or 1.44 Mb)
- Expandable to 2 or 4Mb on motherboard with daughter card

**PERFORMER 286 as described as above with:  
40MB 28ms 3.5" Hard Drive \$1,095  
1 meg RAM 100MB 28ms 3.5" Hard Drive \$1,795**

## BEST PERFORMER 88

"Primarily used as an intelligent terminal in local area networks or for access to mini and mainframe systems, this XT-class desktop computer is equally capable for stand-alone applications."

### STANDARD CONFIGURATION:

- 8088 microprocessor / 10MHz
- Math co-processor socket (8087)
- Motherboard includes:  
2 serial ports, 1 parallel port, real time clock/calendar
- Floppy drive controller
- Hard disk controller
- Phoenix BIOS
- 640 Kb system board RAM
- 3 free expansion slots
- 1 floppy disk drive (360 Kb or 720 Kb)
- Heavy duty power supply
- 101-key enhanced keyboard
- Case and keyboard lock
- Status display
- CSA approved system

### OPTIONS:

- Video display daughter card (EGA or TTL Mono)
- Video display adapter (VGA, EGA or Mono)
- Video monitor (colour or mono)
- Hard disk (20 to 200Mb)
- Second 3.5" floppy drive (720 Kb)

# THE BEST SPECIALS

## AVX 386-16 MHz\*\*

with 1 MEG RAM  
40 MEG Hard Drive  
1.2 MEG Floppy Drive

**\$1,495**



## COMPACT 286-10 MHz\*\*

with 640 K RAM  
40 MEG Hard Drive  
1.2 MEG Floppy Drive

**\$995**

\*\*THESE SYSTEMS COME WITH ONE YEAR WARRANTY LIMITED QUANTITY C.O.D. ONLY

# VIDEO DEALS

**BEST EGA Video w/ ROLAND DC355 Monitor**

**\$595**

**COME AND VISIT OUR NEW SHOWROOM AT 433 HORNER AVE. SUITE #12 ETOBICOKE, AND TEST FLY OUR NEW 386's AND 486's**

DRIVES & OTHER PERIPHERALS CARRY THE ORIGINAL MANUFACTURER'S WARRANTY

**2, ETOBICOKE M8W 4Y4**

**FAX (416) 252-5124  
MONTREAL (514) 849-5872  
HALIFAX (902) 454-0052**

**\*LEASING AVAILABLE**

**TOLL FREE ACROSS CANADA 1-800-668-6951**

427	401
QEW	GARDINER EXP
BROWNS LINE	HORNER AVE
	X 433

EASY ACCESS BY TRANSIT, ISLINGTON SUBWAY, TAKE THE 110A BUS TO BETA STREET STOP



## ALMOST FREE VENTURA SURVIVAL DISK

If you use the popular Ventura desktop publishing package, you'll probably be aware of a few of its... ahem... deficiencies. For example, you may have encountered the monumental difficulties involved in using it with additional soft fonts. Perhaps you've tried to pour image files into your documents and found them a bit awkward. What about the unspeakable boredom of having to use the same typefaces over and over again... it's driven lesser mortals back to their typewriters.

As long time Ventura users ourselves, we've developed and collected quite an assortment of Ventura support programs. These things perform all sorts of useful functions, mostly connected with making Ventura a better place to live. Much of the software in this collection is specifically intended to make Ventura co-exist peacefully with a LaserJet compatible printer. If you publish with Ventura, you can't afford to be without this collection of programs.

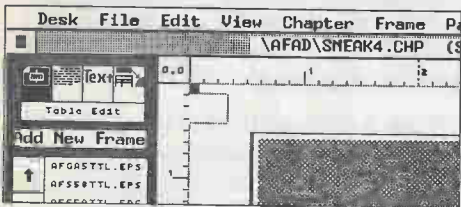

**FONTFLT** is a splendid program for making boring fonts into exciting ones. It inhales any standard LaserJet soft font and outputs a font with your choice of special effects added to it, including drop shadows, bounding boxes and even dripping blood.

**VFM** manages your Ventura soft fonts. It quickly makes width tables without any batch files to contend with, allowing you to add fonts to Ventura painlessly. This is a must for any Ventura user.

**GRAPHIC WORKSHOP** is the last word in graphics programs. It views, converts, dithers, halftones, reverses and prints all popular image files. It works with MacPaint, GEM/Ventura IMG, PC Paintbrush PCX, GIF, TIFF and EPS files and drives CGA, Hercules, EGA, VGA, ATI VGA Wonder, Headlead Video 7 and Paradise cards. It's an indispensable tool for graphics in desktop publishing.

**HP-SLASH** will reduce the often times voluminous sizes of soft font files by allowing you to selectively "prune" out unused characters and symbols. Saves on hard drive space and really speeds up font downloading.

**TCAP** is a memory resident program which captures text screens as GEM/IMG graphics suitable for pouring into Ventura documents as pictures. These screens preserve the original screen attributes and can be scaled to any size from within Ventura.

**GCAP** captures monochrome graphics screens into GEM/IMG files, suitable for pouring into Ventura chapters. A Windows compatible version is also included.

**FSEE** is a quick 'n nasty program to let you view the contents of a soft font file on your screen before you print it. It lets you see what the new fonts will look like without your having to download them and print them out.

**VPSCREEN** is a Ventura screen font editor. It allows you to change the way fonts look on your screen.

\$19.95

cat-a-log (kat/'lɒg/, -'lɒg/), n. 1. *Library Science*. a systematic list of the contents of a library. Cf. *union catalog*. 2. a list, usually in alphabetical order, with brief notes on the names, articles, etc., listed. 3. a book, leaflet, or file containing such a list or record. —v.t. 4. to enter in a catalog; make a catalog of. [late ME *cataloge* <LL. *catalogus* < Gk *katálogos* a register (akin to *katalégein* to count up) = *cata-* CATA- + *-logos* reckoning]

## ALMOST FREE SOFTWARE SPRING 1990

### INDEX

ALMOST FREE SOFTWARE	ONE
ALMOST FREE SOFTWARE	TWO
ALMOST FREE SOFTWARE	THREE
ALMOST FREE SOFTWARE	FOUR
ALMOST FREE SOFTWARE	FIVE
ALMOST FREE SOFTWARE	SIX
ALMOST FREE SOFTWARE	SEVEN
ALMOST FREE SOFTWARE	EIGHT
ALMOST FREE SOFTWARE	NINE
ALMOST FREE SOFTWARE	TEN

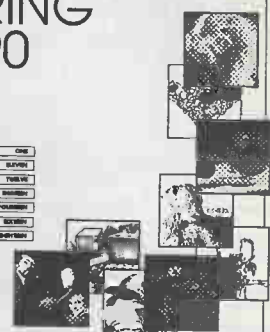

The new Almost Free Software catalog contains dozens of disks of public domain software, shareware, desktop publishing clipart and other tools to help make your computer the most powerful resource you have. It's brand new and it's free... just write, phone or FAX us for your copy.

**Moorshead Publications • 1300 Don Mills Road • Toronto • Ontario • M3B 3M8 • (416) 445-5600 • FAX: (416) 445-8149**

# ORDER FORM

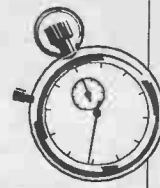

Please send me the following on:  
 5 1/4 inch disks  
 3 1/2 inch disks  
 Choose the format for the A: drive of your computer.

NAME \_\_\_\_\_

STREET ADDRESS \_\_\_\_\_

CITY/TOWN \_\_\_\_\_ PROV \_\_\_\_\_ POST CODE \_\_\_\_\_

PAYMENT:  VISA  MASTERCARD  AMERICAN EXPRESS  CHEQUE

CARD NUMBER \_\_\_\_\_ EXPIRY DATE \_\_\_\_ / \_\_\_\_

Please send me a copy of your Almost Free Software catalog

- AFSPC59 ..... \$24.95
- AFSPC58 ..... \$24.95
- GAMES #5 (QUAD) .... \$19.95
- GAMES #5 (DUAL) ..... \$31.95
- VENTURA SURVIVAL ... \$19.95

SUBTOTAL \_\_\_\_\_  
 8% P.S.T. \_\_\_\_\_  
 \$1.50 HANDLING \_\_\_\_\_  
 TOTAL \_\_\_\_\_

**MOORSHEAD PUBLICATIONS • 1300 DON MILLS ROAD • TORONTO • ONTARIO • M3B 3M8**  
 ORDER BY PHONE: (416) 445-5600 • PLEASE HAVE YOUR VISA, MASTERCARD OR AMERICAN EXPRESS CARD HANDY  
 ORDER BY FAX: (416) 445-8149 • PLEASE INCLUDE YOUR CREDIT CARD TYPE, NUMBER AND EXPIRY DATE WITH YOUR ORDER

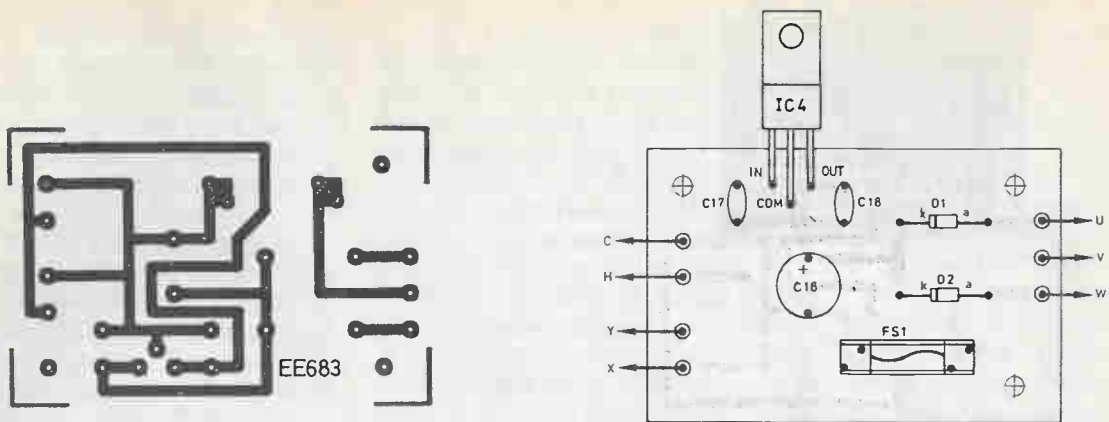

Fig. 3. Component layout and full-sized PCB foil pattern for the Power Supply.

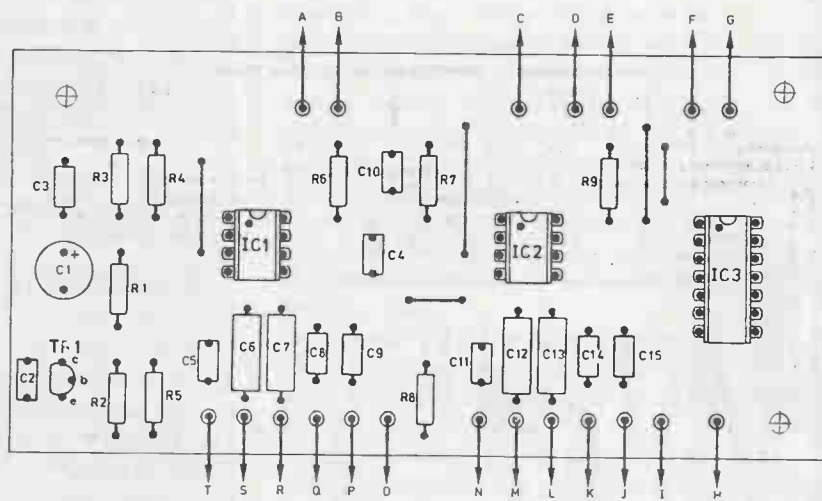
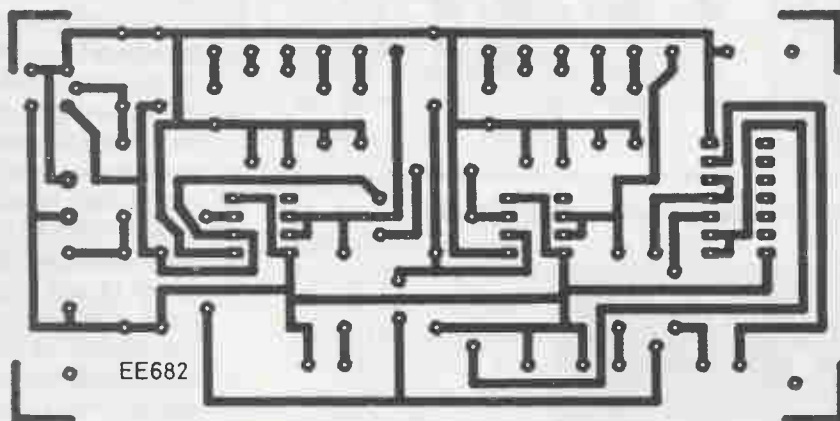

Fig. 4. Pulse Generator PCB component layout and copper foil master pattern.



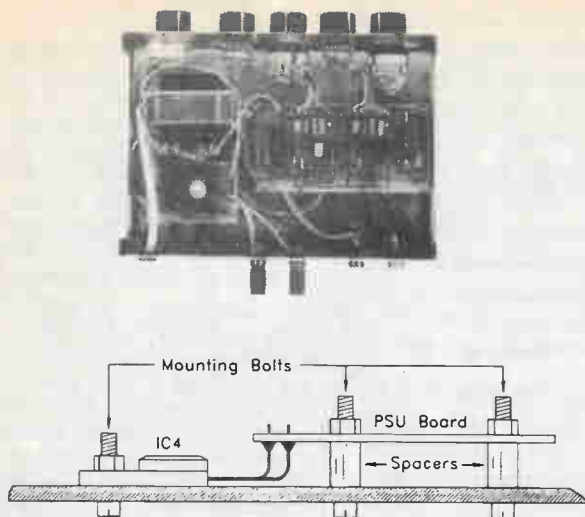

Fig. 5. A simple method of using the bottom of the aluminum case as a heatsink.

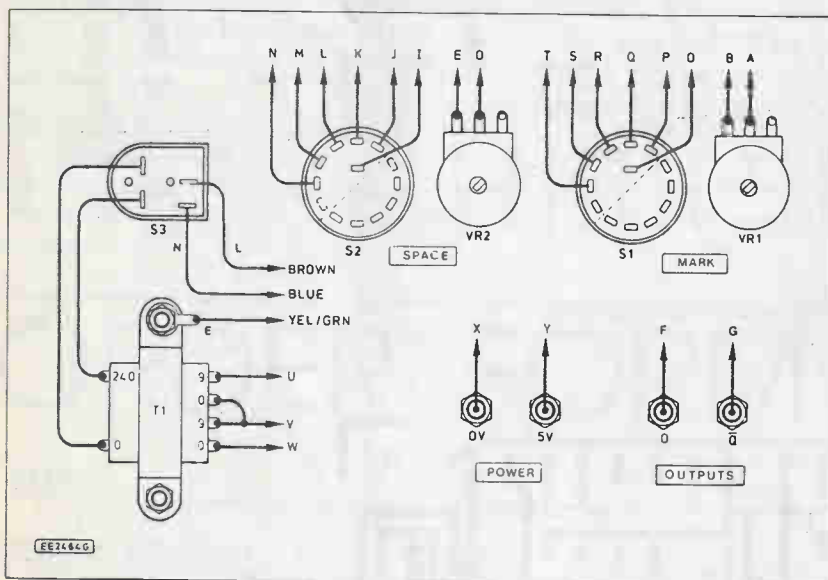
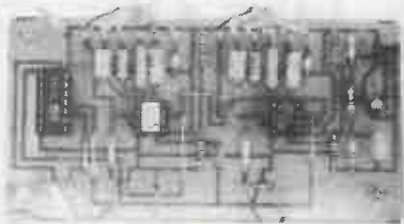

Fig. 6. Details of interwiring to the boards. Ribbon cable simplifies this.



### Power Supply

The power supply circuit (Fig. 2) is very simple and conventional. It has fullwave push-pull rectification followed by a 5V monolithic voltage regulator (IC4). The maximum output current is 1 amp. The maximum available output for external circuits is about 980mA or so.

Although at one time bench power supplies for logic circuits often had multiple output voltages and maximum output currents of several amps, this type of thing is not often needed these days. Most logic circuits will work quite happily from a single 5V supply rail, and modern logic ICs have relatively modest power supply requirements.

IC4 incorporates output current limiting which protects the unit against overloads and accidental short circuits on the output. Fuse FS1 provides further protection, but is mainly needed in case the circuit itself becomes faulty. It might be necessary to use a slow-blow fuse for FS1, as a fast-blow might be opened by the initial surge current as C16 charges up. However, a fast-blow gives slightly better protection and proved to be satisfactory on the prototype unit.

### Construction

Construction of a unit such as this can take one of several general forms. At the simplest level, the unit can be built as a normal project with separate breadboards. While this may not be the neatest approach, it does have the advantage of making it easy to use the unit with several breadboards. Often two or three circuits are under development at any one time, and with this discrete approach it is easy to have several breadboard circuits, and to connect up whatever one you want to work on.

Another approach is to have the breadboard or breadboards fitted on top of the unit. This is a simple but effective way of doing things in that it gives quite a compact finished unit which is easy to use, and construction is straightforward.

Modern breadboards often seem to lack any obvious means of screw fixing, but in some cases they can be fastened by means of self-tapping screws through holes in the case and into holes in the breadboards. In most instances the only options are to glue the breadboard in place, or to improvise some form of mounting bracket.

A third approach is to build the unit in the normal way, and then to fasten it and the breadboards on a fairly large



# Parts List

## Resistors

R1	.....4k7
R2	.....2k7
R3	.....100k
R4,5,7,8,	.....15k
R6,9	.....180k

## Potentiometers

VR1,2	.....2M2 linear
-------	-----------------

## Capacitors

C1	.....100u 10V
C2,17,18	.....100n
C3	.....220n
C4,10	.....22p
C5,11	.....27p
C6,12	.....470p
C7,13	.....4n7
C8,14	.....47n
C9,15	.....470n
C16	.....2200u

## Semiconductors

IC1,2	.....TLC555CP timer
IC3	.....74LS00 NAND gate
IC4	.....7805 5V regulator
D1,2	.....1N4002 1A 100V diode
TR1	.....2N3904

## Miscellaneous

T1	.....9-0-9 volt, 1A
S1,2	.....12-way 1-pole rotary
S3	.....power switch
FS1	.....1A fast-blow fuse

Metal instrument case, PCBs, red, black, green and blue terminals, 5 knobs, 28-pin DIP sockets, 14-pin DIP socket.

baseboard. The PSU/generator is fastened to the rear of the baseboard with the breadboards mounted toward the front. However, the breadboards and their components may tend to obstruct the operating controls of the generator. Either mount the unit well to the rear, or mount it on something that will hold it above and well clear of the breadboards.

## PSU/Generator

Whatever basic form the unit takes, the PSU/generator will presumably be constructed as a regular project first and then merged with the breadboards once it has been built and tested. Here we will only consider the construction of the unit itself

— constructors can please themselves as far as the overall form is concerned.

The PSU/generator circuits are built on separate PCBs (Fig. 3 and 4). This complicates construction slightly, but it does make things easier if you only want to build one or the other of these circuits. Construction of these boards is straightforward. None of the ICs are static sensitive, but we would still recommend the use of sockets for IC1 to IC3.

Five link wires are needed on the pulse generator board, and these can be made from hookup wire or resistor leads. The capacitors should be of the specified types or they may not fit into the board layouts easily. Fit pins to the points where connections to off-board components will be made.

## Heatsink

There is a slight complication with the power supply board in that IC4 will need to dissipate quite high power levels at high output currents and this necessitates the use of a substantial heatsink. The cheapest solution is to house the unit in a metal case which then acts as a heatsink as well. Some means of bolting IC4's heat-tab and the circuit board to the base panel is then required (the circuit board must be insulated from the case).

Probably the easiest way of achieving this is to use the method outlined in Fig. 5. Here IC4 is not mounted on the top side of the board in the usual manner, but has its leadout wires bent upward at right angles, and is fastened on the underside of the board.

## Case

A metal instrument case approximately 200 by 150 by 50mm will accommodate the parts. The PSU board and T1 are mounted toward the right, leaving room for the pulse generator on the right. For reasons of safety it is essential that the metal case be grounded to the power cord ground.

## Controls

The five controls are mounted on the front panel with S3 close to T1. Due to a lack of front panel space I mounted the output sockets on the rear panel, but if a larger case is used you can mount them on the front.

There is a fair amount of hard wiring to be done, as shown in Fig. 6, which should be used in conjunction with Fig. 3 and 4. Each connection point in one diagram connects to the point of the same letter in one of the other two diagrams

(point A in Fig. 4. to point A in Fig. 6). Ordinary hookup wire is suitable, but ribbon cable is probably easier to use and neater.

## Testing

Before connecting the output of the PSU to a circuit, use a multimeter to confirm that the correct voltage is present; it should be with five percent of five volts. If not, switch off and recheck all the wiring.

You really need a scope to thoroughly check the pulse generator. However, it can be checked by driving LEDs from the Q and not-Q outputs, with a 330 ohm resistor being used to limit the current. The cathode (k) terminals of the LEDs are the ones which connect to the 0 volt rail. With long mark and space durations you should be able to see the LEDs flash on and off as the outputs change state, with one LED switching on as the other switches off.

At short pulse durations the flashing of the LEDs will be too rapid for the eye to perceive it properly. However, varying the mark-space ratio of the output signal will alter the apparent brightness of the LEDs. The greater the proportion of the time the output is high, the brighter the LED driven from that output will be.

# AMAZING SCIENTIFIC & ELECTRONIC PRODUCTS

PLANS ARE IN STOCK	PARTS ARE AVAILABLE	PRICE
GRA1 — ANTI GRAVITY GENERATOR		\$10.00
LC7 — 40 WATT BURNING CUTTING LASER		\$20.00
RUB4 — HI POWER PULSED DRILLING LASER		\$20.00
BTC5 — 1 MILLION VOLT TESLA COIL		\$20.00
IN MCP1 — HI VELOCITY COIL GUN		\$15.00
LLS1 — LASER LIGHT SHOW 3 METHODS		\$20.00
EHI — ELECTRONIC HYPNOTISM TECHNIQUES		\$8.00
EM1 — LOWER POWERED COIL GUN LAUNCHER		\$8.00
JL3 — JACOBI LADDER 3 MODELS		\$10.00
S05 — SEE IN THE DARK		\$10.00
LEV1 — LEVITATION DEVICE		\$10.00
FMV1K — 3 MILE FM VOICE TRANSMITTER		\$34.50
PF81K — HAND CONTROLLED PLASMA FIRE SABER		\$49.50
NHG7K — HI FLUX NEGATIVE ION GENERATOR		\$34.50
PG6K — PLASMA LIGHTNING GLOBE		\$49.50
LHC2K — VISIBLE SIMULATED 3 COLOR LASER		\$44.50
HOD1K — HOWLING/TRACKING BEEPER TRANSMITTER		\$44.50
LGU4K — 2.5 MW HAND HELD VISIBLE LASER GUN		\$249.50
BTC3K — 250,000 VOLT TABLE TOP TESLA COIL		\$249.50
IGB2K — ION RAY GUN, project energy without wires		\$129.95
TRK1K — TELEKINETIC ENHANCER/ELECTRIC MAN		\$79.50
VWPM7K — 3 MILE AUTO TELEPHONE TRANSMITTER		\$49.50

ASSEMBLED	ASSEMBLED IN OUR LABS	PRICE
LI8T10 — INFINITY XMTR Listen in via phone lines		\$199.95
IPG710 — INVISIBLE PAIN FELD BLAST WAVE GENERATOR		\$74.50
ITM110 — 100,000 VOLT INTIMIDATOR UP TO 20"		\$99.50
TAT30 — AUTOMATIC TELEPHONE RECORDING DEVICE		\$24.50
PSF40 — PHASOR SONIC BLAST/WAVE PISTOL		\$89.50
DNE10 — ALL NEW 26" VIVID COLORED NEON STICK		\$74.50
LGU20 — 5 TO 1MW VISIBLE RED HeNe LASER GUN		\$199.50
BL510 — 100,000 WATT BLASTER DEFENSE WAND		\$89.50

EASY ORDERING PROCEDURE - TOLL FREE 1-800-221-1705 or 24 HRS ON 1-800-673-4730 or FAX IT TO 1-800-672-5406  
 VISA, MC, CHECK, MO IN US FUNDS, INCLUDE 10% SHIPPING. ORDERS \$100.00 & UP ONLY ADD \$10.00 CATALOG \$1.00 OR FREE WITH ORDER

**INFORMATION UNLIMITED**  
 P.O. BOX 716, DEPT. ETI AMHERST, NH 03031

Circle No. 97 on Reader Service Card

# Techies' Guide to C

## Part 17

This month we'll look at the potentially contentious... and confusing... issue of time as it appears in the C language.

Steve Rimmer

**H**uman beings have evolved a fairly simple system of dealing with the time. One can simply look at a watch or ask someone and move on to greater things. Computers have clocks, but no watches. As such, they have come to use a rather more complex system of timekeeping.

In asking for the correct time, we make all sorts of assumptions which a computer cannot. It's unspoken that one usually wants the correct time for the current time zone, and with whatever daylight savings time adjustments as are in use at the moment added to it. Likewise, the date is usually given in terms of the popular Gregorian calendar, as opposed to, say, the less frequently used Mayan one. These are all things that computers need to be told.

In addition to these purely human concerns, computers have a few of their own. For example, our system of dates refers to the number of years between the arbitrary year one and now. Considering that the middle ages saw a fairly sparse use of personal computers, most computer operating systems have seen fit to place the beginning of time at some rather more contemporary point. Computer time and dates are calculated as a number of seconds relative to an arbitrary start of the universe. Naturally, this start time varies between systems, as we'll see.

The format of the time and date values for computers vary a lot too. If you plan to work with files or other things having time and date stamps from varying systems, this will probably cause your brain to hurt after a while.

This month, let's see how the sands of time can be comprehended by your C programs without getting to your disk drives and voiding your system warranty. These examples pertain to Borland's Turbo C implementation, although they

should work with minor fiddling under most PC based C compilers.

### Double Time

On a PC under C, time is figured as being the number of seconds from January 1, 1970 GMT and the present. As this will be a fairly large number... there are about thirty-one million seconds in a year... time is stored in long integers.

Under C, the time and the date are derived from this single long integer. The easiest way to have this long integer passed to your program is like this.

```
long t;
time(&t);
```

There are a few things to note about this. First of all, you must include the *time.h* header in any program you want to work with time functions in. Secondly, note that for reasons which aren't terribly obvious, the *time* function does not usually return a long integer, but rather stores the time value in a long integer whose address is passed to it.

You can actually make it return a long value instead if you use it like this.

```
t=time(NULL);
```

This number, while containing the exact time, is not in a terribly useful form. There are numerous C functions to change this, although the one you use will no doubt require a bit of forethought. Several of them seem to have identical uses.

The easiest way to see what time it is involves the *ctime* function. This bit of code illustrates its use.

```
long t;
```

```
time(&t);
printf(ctime(&t));
```

The result of this call would be something like

```
Mon Apr 02 12:03:33 1991
```

Now, there are a number of important things to note about the string returned by *ctime*. The first is that you must have the *time.h* header in your program so that your compiler will know that *ctime* does, indeed, return a pointer to a string rather than an integer. Secondly, the string it returns is always exactly twenty-six characters long. The twenty-fifth of these will be a newline character, which is often inconvenient.

You might want to dispense with this.

```
long t;
char b[26];

time(&t);
strcpy(b,ctime(&t));
b[24]=0;
```

The *ctime* function will work with two global variables which are present whenever the *time.h* header is present in your program. You should set *timezone* to represent the number of seconds between GMT and your local time zone. Eastern standard time is five hours removed from GMT, so we would set *timezone* like this.

```
timezone=5*3600;
```

The value 3600 is sixty minutes multiplied by sixty seconds. Note that you don't have to declare *timezone* explicitly... it is provided for you by the compiler.

You can also adjust for daylight savings time if you like. Set *daylight* to a



non-zero value if you're presently using daylight savings time.

Now, bear in mind that the *time* function retrieves the time from your PC's clock. If you have set the clock in your computer to local time, you won't want to use the *timezone* and *daylight* values. They're only used if you keep the clock in your system set to GMT, in which case the displayed time can reflect the geographical location of the computer using your program.

If you write a program which requires that its time be adjusted by its users to reflect their displacement from GMT, you'll be interested in a function called *tzset*. When it's called, it searches the DOS environment for an environment variable called TZ and, if it discovers one, adjusts the *timezone* and *daylight* values accordingly.

To make this work, you must start at the DOS prompt and type in a SET command for the TZ variable. You can add this to your AUTOEXEC.BAT file if you want to make it permanent. Type the following:

```
SET TZ=EST5EDT
```

This is a fairly complex string. The first three characters represent the local time zone, in this case EST for Eastern Standard time. The number represents the number of hours between GMT and the local time zone. This would be 5 or +5 for Eastern Standard Time, 8 or +8 for Pacific time or -1 for the time in France, for example. Finally, the last three characters are optional, and represent the daylight savings time zone code... you'd only include EDT, in this case, if daylight savings time were in effect. This would cause the *daylight* variable to be set to a non-zero value.

By using an environment variable rather than hard coding these values into your program, you make it possible for your users to adjust the time zone values externally. All you have to do is to make sure your place the *tzset* function early in your program, before any time calculations occur.

Bear in mind that most people do not set their system clocks to GMT. This doesn't really matter, however. If you call *tzset* and it fails to find an environment string called TZ, it will do nothing. Thus, you can have your program work with the time zone values if your users want it this way... all they have to do is to install the TZ

environment variable... or with a system clock set to local time.

## Other Clocks

There are a number of other time related functions available under C. The *gmtime* will fetch the system time, but it stores it in a struct rather than in a long integer. This is the struct.

```
struct tm {
    int tm_sec;
    int tm_min;
    int tm_hour;
    int tm_mday;
    int tm_mon;
    int tm_year;
    int tm_wday;
    int tm_yday;
    int tm_isdst;
};
```

This allows you to work conveniently with the individual elements of the time and date without having to figure out how many seconds have elapsed since the dawn of computer time.

You can also get the time and date values separately in their own structs. The *time* struct looks like this.

```
struct time {
    unsigned char ti_min; /* Minutes */
    unsigned char ti_hour; /* Hours */
    unsigned char ti_hund; /* Hundredths of
seconds */
    unsigned char ti_sec; /* Seconds */
};
```

This is the date struct.

```
struct date {
    int da_year; /* Year - 1980 */
    char da_day; /* Day of the month */
    char da_mon; /* Month (1 = Jan) */
};
```

Note that as these structs pertain specifically to the DOS structure of time and date, they are defined in the *dos.h* header rather than in *time.h*

There are specific functions which use these structures. The *gettime* and *getdate* functions will load the appropriate structure with the system date. The *settime* and *setdate* functions will set the system time based on the contents of the structures passed to them.

As I mentioned at the beginning of this feature, there are numerous incompatible time and date formats about. We've had a look at time as seen by a PC, but if you encounter files from a Macintosh, for example, you'll find that they're

date stamped using a wholly different format. Time on the Mac starts in 1904.

In order to convert a Macintosh long integer time value into a PC long integer time value, you must subtract a constant from it. That constant is:

```
#define mac2pc_date 2082830400L
```

Assuming that *t* contained a Macintosh format date stamp, this would display the correct time of that date stamp on a PC.

```
t += mac2pc_date;
puts(ctime(&t));
```

Well, almost. There are a few catches here. If the date stamp from the Mac represents a date prior to January 1, 1970, the *ctime* function will return something meaningless. Granted, there were no Macintoshes before 1970, but this does not mean that Mac users might not have set their clocks incorrectly, or just changed the date stamps on their files. Secondly, a long integer on a Macintosh is stored differently than it is on a PC.

The Macintosh is based on a Motorola microprocessor, while a PC is based on an Intel chip. Motorola stores its multiple byte numbers with the bytes in the reverse order to that of Intel. Thus, if *t* is a raw Macintosh date stamp, you must send it through the following function before you can do anything with it.

```
long motr2intel(l)
long l;
{
    return(((1 & 0xff000000L) > 24) +
((1 & 0x00ff0000L) > 8) +
((1 & 0x0000ff00L) < 8) +
((1 & 0x000000ffL) < 24));
}
```

This works both ways, of course. It will also transform an Intel style long integer into a Motorola style long integer, the one being simply the compliment of the other.

The unfortunate thing about time and date values... on any computer... is that they've evolved gradually over time, and every new variation has been added to the previous accretion of formats to ensure backwards compatibility. As such, there are a lot of ways to tell the time on a PC.

If you're interested in properly understanding how the time functions work under C, you might want to warm up your compiler and try a few of the ones we've discussed herein. They do take a bit of getting used to. ■



# Engine Efficiency Meter

A unit that helps you to drive in the most fuel efficient way.

Steve Garrison

**W**e have our own domestic version of a black hole known as the family car fuel tank — whatever the noxious substance we attempt to run our car on, be it gasoline, diesel, cooking oil, etc., we are constantly astounded by the rate at which the needle plummets towards the red line. There have been a myriad of additives proposed to alleviate this depressing syndrome, some mechanical, some chemical, and of course a plethora of electronic circuits. If you're frightened of performing major surgery on your pride and joy, try this little circuit instead.

## Design Basis

The project is based on the simple fact that the engine is a device designed to convert energy stored in the chemical bonds of the chosen fuel into rotational kinetic energy — torque — at the wheels. The efficiency of this conversion is expressed by the torque curve of the engine — the curve for a typical car engine is shown in Fig. 1.

It shows that the engine produces more torque at some speeds than at others, the peak being somewhere near 3,500rpm in this case. This is different from the maximum power, which peaks much higher up the rev range and in a very inefficient operating range of the engine. Using this knowledge — that we get a higher efficiency of conversion at the top of the torque curve — the basis for this meter can now be understood.

The design intent is that the circuit should be able to pick out the peak of the torque curve, and be able to display its successful detection to the driver of the

vehicle. It uses an engine speed input taken from the ignition coil which is then processed by a digital band-pass filter to drive a tricolor LED as the indicator. The LED shows red outside the chosen band, and green when the area of peak torque (and thus efficiency) is reached.

The circuit is continuously variable when it comes to setting the speed band, allowing you to match it to any vehicle easily. It could, therefore, easily be used as a "red-line" warning for cars without rev-counters.

## Circuit Description

The input signal for the circuit (Fig.2) is taken from the ignition coil of the vehicle, where we can obtain a signal proportional in frequency to the speed of the engine. The connection is made to the low tension terminal of the ignition coil which is switched by the points (remember those?), or, more commonly these days, the ignition amplifier. This point is switched between car supply and ground at controlled times to generate the HT in the secondary of the coil, which is generally visible as sparks at the plugs.

The input circuit components (R1, D1, C1) clamp this signal to prevent any high voltage spikes or high frequency noise from entering the system, which could cause spurious triggering or fried chips. The components are mounted at the engine end of the cable to prevent the undesirable signals getting anywhere near our circuit board. This sanitized signal is then relayed via the protective shielded cable to the main body of the circuit,

where it is to be used as a clock signal, varying with the speed of the engine, and thus available for digital filtration

The speed signal is used to trigger two monostable blocks, contained in the 4538(IC1). The construction of these electronic blocks allows us to trigger their outputs into a transitory (or unstable) state for a period of time which we can set by external components i.e. pulses to order. These blocks are monostable since they

Fig. 1. The relationship of torque and power to engine speed.

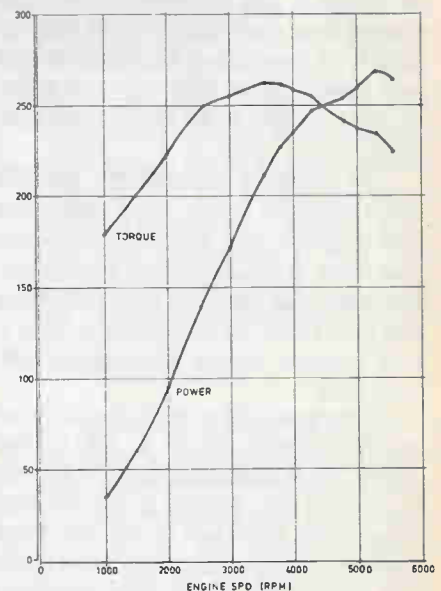



## Engine Efficiency Meter

ing, we can pinpoint a particular frequency of the trigger/clock pulses, and therefore, define the cut-off points for our filter. By setting the monostable pulse-widths to different values, we can define a window of frequencies that can correspond to the peak of the torque curve, and Fig. 4 shows the three states of the monostable outputs as the frequency increases.

In the figure, monostable A is set to a longer pulse width than monostable B, which means it will begin retriggering at a lower frequency than monostable B. Take a careful look at the output states — can you see how the exclusive OR gate is going to help us? If we sample the monostable outputs at the point marked X, just before we trigger them, we can use this gate to determine what frequency state we are in. At a frequency below that for retrigger of A the gate output is 0, and above this but less than the retrigger frequency of B we get an output of 1, and at a frequency when both monostables are retriggering the output returns to 0. A digital filter perhaps?

### Output

The remaining task, as I have suggested, is to sample the output of the EXOR gate to determine the frequency range we are in. And also latch it in some sort of memory to be able to display it to the driver. This function is achieved by a cousin of the monostable — the bistable. We use a specialized version in this circuit, known as the D-type, and in the configuration shown here (IC3), whenever it is triggered, the output assumes the same state that it finds on the D input at the instant of trigger. This condition is then held until the next trigger pulse — in effect the D-type has remembered the state of its input for us at a moment in time. Just what we need — the output of the EXOR gate can be memorized. But what do we trigger it with?

We use the same signal as we did for the monostables, which occurs just at the right moment for sampling. The secret is that we make use of what is known as the propagation delay of the monostables — the time it takes before the output of the device responds to a change at the input. Therefore, we can sample the state of the outputs just before they are affected — a matter of under a microsecond, but perfectly long enough in the digital world.

Finally, we need to display the condition that the D-type has found the EXOR gate in, in other words, the part of the torque curve that we are on. By using other circuitry in the D-type to good effect, we

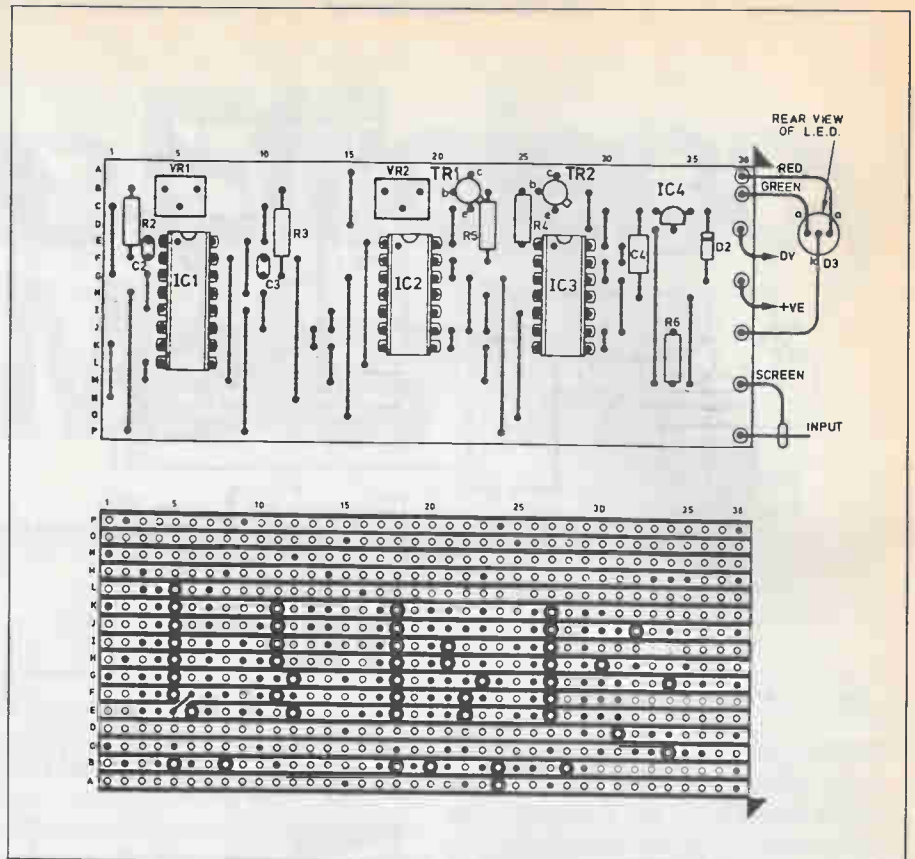

Fig. 5. Veroboard layout and wiring. Note the underside link on IC1.

can do this quite simply. The bistable has complementary outputs, which means that there is a "straight" output and an inverted output, known as Q and  $\bar{Q}$ . When the circuit detects a 1 at the output of the EXOR gate, Q is 1 and  $\bar{Q}$  is 0, and the reverse when it detects a 0.

It would seem to be a good idea to wire the LEDs directly from these outputs, but the current drive of CMOS chips is rather limited and to get the best out of our display we must resort to a little current amplification. Therefore, two PNP transistors are included to make sure our LED shines brightly.

To keep the pulse-widths of the monostables constant (and therefore accurate) over the car battery voltage range, we need to stabilize the voltage supply to the circuit. A 78L05 regulator comes to our rescue here, providing a stable 5V from the car supply, with a series diode protecting against reverse supply connections.

### Construction

The layout shown in Fig. 5 is based on a piece of 0.1 inch matrix board size 38 holes by 16 strips. This may, of course, be increased to suit a particular box, or if mount-

ing holes are to be included, but the size is felt to be the minimum to keep construction easy. Having cut the board, the track breaks should be made as indicated, either by using the appropriate spot face cutter, or a sharp drill bit. Before component assembly commences, the board mounting holes should be drilled — the location of these is shown on the layout diagram, with adjacent track breaks to prevent electrical shorts if metal mounting equipment is used.

And so to the component assembly stage, and it is recommended that this sequence is followed — IC sockets, links, capacitors, resistors, and terminal pins. Make sure that the copper tracks are bright and clean before beginning to solder — a rub with a piece of emery cloth or a PCB cleaning stick would do the job. Not forgetting also that a soldering iron tip in a similar condition helps enormously. The result of a little care and attention here will be quick soldering, tidier joints, not to mention a more reliable construction.

On the completion of the population of the board, a few careful minutes should be spent checking the board layout — the component positions, the links, all the track breaks, and most importantly, a



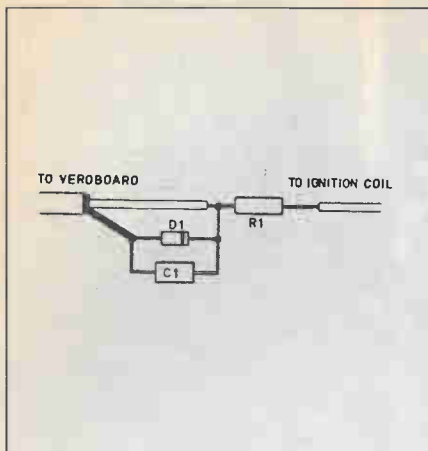

Fig. 6. Wiring of the protection components in the input lead.

close examination of the copper side for any dry joints, solder splashes, and bridges between tracks. Time spent here can save hours of trouble later on.

### Case

Once you have confidence in your efforts, the board can be temporarily fitted in the box using stand-off pillars as necessary. Flying connections to the circuit can now be added — these being to the tricolor LED (D3), signal input, and power.

If it has been decided to mount the LED on the box itself, a suitably sized and positioned hole should be drilled (taking care not to demolish the circuit board). A plastic bezel and collar may be used, or the LED simply pushed through and glued. Wiring should be undertaken with care as there are various approaches to tricolor LED leg identification by different manufacturers. Careful sleeving of the connections is recommended here to prevent shorts.

Alternatively, if it is decided to mount the LED on or in the car dashboard, remote from the box, a long flying lead can be fitted. Sleeving of the connections would be essential here to provide strain relief. Individual wires could be used or some low current 3-way power cable.

### Car Connections

Another hole in the box will be required for the signal pick-up cable, which is specified as single core, overall shielded. There are two connections to the board for this cable — one for the shield and one for the signal wire. Cut back about half an inch external insulation, and separate all shield wires from the central wire, twisting them into a bunch that can be soldered onto the shield terminal pin. Trim the insulation from the

signal wire carefully back a quarter of an inch, and, having twisted the exposed wires neatly, solder to the signal pin. Tinning the cable ends and the terminal pins beforehand makes life a little easier.

The other end of this cable is a little more complicated, for this is where the connection to the signal source will be made. First assess the distance between the box mounting position and the car ignition coil — not as the crow flies, but by the safest route avoiding fan blades, exhaust pipes, battery acid, etc. then cut the cable to length. Strip the outer insulation back about one and a half inches, and refer to Fig. 6 for how the components fit together.

Note that an extra piece of cable is added at the extreme end, and this should be of the type used for the power leads. To improve the long-term survival chances of the assembly in the engine compartment, it is recommended to lacquer/conformal coat the components than seal them in heat shrink or epoxy resin. The photo shows the final item with the connection wire protruding from the sensor. Finally, a hole needs to be provided for the power leads, which should be attached to the appropriate terminal pins, and cut to the desired length, having decided on the power supply point in the vehicle.

Before inserting the integrated circuits, a couple of final checks are advisable. Measure the resistance across the power leads to see if there are any shorts that haven't been spotted, then if all's well, remove the meter and apply 12V to the circuit. Use the meter to check that the ICs get a 5V supply to their power pins (see circuit diagram — wire extensions to the meter probes are useful to get into the IC sockets. Remove the supply ready for the grand finale — the insertion of the ICs, not forgetting to take care over identification, orientation, static, and pins bent underneath.

### Testing and Calibration

With the whole circuit assembled, it must now be calibrated to produce a meaningful display. The simplest way is to use a vehicle with a believable rev-counter and make the adjustments with the unit temporarily connected. Check the workshop or owners manual for the vehicle into which the unit is to be finally installed to find the engine speed at which the peak torque is developed, and that the engine on the calibration car has the same number and configuration of cylinders.

To define our window of peak torque, write down a figure for the upper limit 500 RPM above this speed, and the lower limit 500 RPM below, these figures being chosen so that the "green" window is not too difficult to maintain when driving. Hook up the unit of the vehicle to be used for calibration, taking care with the polarity of the supply connections. The fused radio supply may be a handy point to use for a supply source. Now attach the end of the sensor cable to the switched terminal of the ignition coil (normally marked -ve) ideally by using a Lucar connector on to the spare blade, or with a Scotchlock connector.

Having verified that the cable is away from moving parts and the LED is lit up, turn VR1 and VR2 clockwise to their positions of least resistance. Then start the engine and rev to the lower limit calculated above. While holding the speed at this value, turn VR1 slowly anti-clockwise until the LED just changes from red to green. This pot. is now adjusted. Now rev to the upper limit and adjust VR2 similarly until the LED just changes from green to red.

The unit is now calibrated and can be permanently installed on the chosen vehicle. If the adjustments don't appear to be having much affect on the LED, check all the connections, especially the one to the coil which should be switching between 0V and 12V either through the action of the points or the drive of the ignition amplifier.

### In Use

The Efficiency Meter seems to be of the most use when the vehicle is cruising, and thus under stable throttle conditions where the "green" can be maintained quite easily. You may be surprised to learn the difference between what feels like a "happy" cruising speed, in comparison with that indicated by the meter.

Since the settings for the thresholds are continuously variable, the circuit can be used for a variety of tasks on the car that are engine speed linked — such as a rev limit warning to prevent engine over-speed, or even, with a few imaginative modifications, a radio volume control which increases the sound level in "harmony" with engine noise.

In fact, the unit can be driven by any square wave applied at the input as long as the amplitude is 5V or greater. As a consequence, the circuit finds applications far beyond vehicle systems. ■

# What do Toshiba notebook computers have in common with their owners?



## They both excel at what they do.

More than a century ago, Toshiba established itself as a leader in technological innovation. Since then, the name has become synonymous with uncompromising quality and a high standard of excellence. So, it's not surprising that Canadians who demand a lot of themselves, choose Toshiba as their laptop/portable computer. They know they can depend on Toshiba's history of quality, outstanding price/performance and state-of-the-art technology.

For more information about Toshiba's notebook PC's and Canada's entire "first family" of laptop/portable computers, contact your nearest Canadian Authorized Toshiba Re-Seller, or call Toshiba direct at 1-800-387-5645.

**Canadians know the difference!**

### Introducing the 1000XE – the lightweight heavyweight with internal hard disk drive!

- Notebook 80C86 computer
- Outstanding backlit electroluminescent LCD display with 640 x 400 resolution
- MS-DOS and File Transfer software in ROM (Read Only Memory)
- Fast Internal 20 MB hard disk drive
- 1 MB standard RAM memory expandable to 3 MB
- Full function keyboard features dedicated cursor control keys and 12 function keys
- Weighs less than 6 lbs.
- Uses Toshiba's outstanding array of battery conservation techniques including – "AutoResume Mode"



### Introducing the 1200XE – an evolution in notebook computing!

- Notebook 80C286 computer
- Outstanding sidelit fluorescent LCD display with 640 x 400 resolution
- Internal 1.44 MB 3.5" Floppy disk drive and fast internal 20 MB Hard disk drive
- Full function keyboard features, dedicated cursor control keys and 12 function keys
- 1 MB of RAM memory standard, expandable to 5 MB
  - Weighs less than 8 lbs.
  - Uses Toshiba's outstanding array of battery conservation techniques including "AutoResume Mode"

# TOSHIBA

INFORMATION SYSTEMS DIVISION

Circle No. 2 on Reader Service Card

# HOW TO GET MORE INFO

For more information on any of the companies advertised in this issue, use the Electronics & Technology Today Reader Service Card.

## Here's how it works:

Each ad - and each product listed in the *For Your Information* and *New Products* sections - has a unique Reader Service Number.

Make a note of the number for each of the companies you are interested in...

You'll find the Reader Service Card bound into your copy of *Electronics & Technology Today*. Circle the appropriate numbers on the card, fill in the simple questionnaire (don't forget your own address!), and send it off.

A copy of your request is forwarded to each of the respective companies - who will be more than happy to respond to your interest by sending you a full information package.

Use our card to get the Whole Story

*Electronics & Technology Today*

### READER SERVICE CARD

May 1989

Card void 6 months after issue date

Circle the appropriate Reader Service number below for more information, the advertiser will send you further literature free of charge. PLEASE PRINT.

NAME: John Smith

TELEPHONE: (319) 591-7840

STREET: Mainstreet

CITY/TOWN: Cityville

PROVINCE: Alberta POSTAL CODE: M4L 5A4

COMPANY NAME: ABC Design

#### JOB FUNCTION (CHECK ONE)

- |  |                                     |
|--|-------------------------------------|
| <input checked="" type="checkbox"/> Corporate Management | <input type="checkbox"/> Education  |
| <input type="checkbox"/> Operational Management          | <input type="checkbox"/> Technology |
| <input type="checkbox"/> Computer Systems Management     | <input type="checkbox"/> Consultant |
| <input type="checkbox"/> Financial Management            | <input type="checkbox"/> Marketing  |

#### TYPE OF INDUSTRY (CHECK ONE)

- |  |  |
|--|--|
| <input type="checkbox"/> Government        | <input checked="" type="checkbox"/> Construction |
| <input type="checkbox"/> Education         | <input type="checkbox"/> Medical/Legal           |
| <input type="checkbox"/> Finance           | <input type="checkbox"/> Manufacturing           |
| <input type="checkbox"/> Computer Industry | <input type="checkbox"/> Other                   |

I have recently purchased the following products after reading about them in *Computing Now!*:

SYSTEM 2000 / 386 \$ 3,000

Where product purchased

Do you subscribe to *Computing Now!* Yes  No

Complete below if you wish to take out a subscription:

- |   |  |
|---|--|
| <input type="checkbox"/> One year \$22.95   | <input type="checkbox"/> Two years \$37.95 |
| <input type="checkbox"/> Bill me (subscription will start once payment is received)             |  |
| <input type="checkbox"/> I enclose my cheque (send with card in envelope)                       |  |
| <input type="checkbox"/> Visa <input type="checkbox"/> MasterCard <input type="checkbox"/> Amex |  |

Card No ..... Card Expiry Date .....

Circle the Reader Service Card Numbers for the items in which you are interested.

1 2 3 4 5 6 7 8 9 10 11 12 13 14 15 16 17 18 19 20  
 21 22 23 24 25 26 27 28 29 30 31 32 33 34 35 36 37 38 39 40  
 41 42 43 44 45 46 47 48 49 50 51 52 53 54 55 56 57 58 59 60  
 61 62 63 64 65 66 67 68 69 70 71 72 73 74 75 76 77 78 79 80  
 81 82 83 84 85 86 87 88 89 90 91 92 93 94 95 96 97 98 99 100



# PIN

# IT

# DOWN!

- INCREASE FUND-RAISING PROFITS!
- BUILD TEAM SPIRIT!
- RECOGNIZE VOLUNTEERS!
- REWARD YOUR EMPLOYEES!
- GET YOUR COMPANY NAME AROUND!

At The Pin Factory, we can help you pin down your business with our custom lapel pins, charms, key chains, souvenir spoons, belt buckles, money clips and other pressed metal products, manufactured with the newest production equipment available.

We can help you create your own special "one-of-a-kind" item. Special die cutting will give your item a custom shape, in virtually any colour of the rainbow. Choose from our wide range of production materials, including precious and semi-precious metals.

We give competitive pricing, quality products and efficient, courteous service on all your orders, large or small! So call us today and let us show you how we can help you pin it down!

## THE PIN FACTORY

9752 — 47 Avenue, Edmonton, Alberta T6E 5P3

Phone: (403) 435-5944 FAX: (403) 437-4105



# BABANI BOOKS

## NEW RELEASES

### BP 265: MORE ADVANCED USES OF THE MULTIMETER \$11.80

This book is primarily intended as a follow-up to BP239, and also should be of value to anyone who already understands the basics of voltage testing and simple component testing.

### BP 261: A CONCISE INTRODUCTION TO LOTUS 1-2-3 \$11.80

If you are a PC user and want to get to grips with Lotus 1-2-3, then this book will teach you how to do just that in the shortest and most effective way.

### BP 248: TEST EQUIPMENT CONSTRUCTION \$11.80

This book describes in detail how to construct some simple and inexpensive, but extremely useful, pieces of test equipment.

### BP 245: DIGITAL AUDIO PROJECTS \$11.80

This book takes a look at the basic principles involved in converting an audio signal into digital form and then converting it back to an analogue signal again. It also contains practical circuits for constructors to build and experiment with.

### BP 251: COMPUTER HOBBYISTS HANDBOOK \$23.80

This book provides a range of useful reference material in a single source so that it can be quickly and easily located. The subjects covered include microprocessors and their register sets; interfacing serial, parallel, monitor, games and MIDI ports; numbering systems; MIDI codes; operating systems and computer graphics.

### BP 247: MORE ADVANCED MIDI PROJECTS \$11.80

This book includes circuits for a MIDI indicator, THRU box, merge unit, code generator, pedal, programmer, channeliser and analyser.

### BP 260: A CONCISE INTRODUCTION TO OS/2 \$11.80

This book is for the multitasking PC user that wants to get the most out of their computer in efficiency and productivity.

### BP 264: A CONCISE ADVANCED USER'S GUIDE TO MS-DOS \$11.80

This book is for the PC user that is looking for ways to improve their system's efficiency and productivity, while learning something new.

### BP 256: AN INTRODUCTION TO LOUDSPEAKERS AND ENCLOSURE DESIGN \$11.80

This book explores many types of enclosures and drive units. Crossover units are also explained, the various types, how they work, the distortions they produce and how to avoid them.

### 246: MUSICAL APPLICATIONS OF THE ATARI STs \$15.00

A wide selection of topics is covered, including the internal sound chip, MIDI, applications programs such as sequencing and score writing, etc. Simple but useful add-on projects and MIDI programming.

### BP240: REMOTE CONTROL HANDBOOK \$12.00

Includes remote control systems, transmission links, digital electronics, methods of control, coders, decoders, etc.

### BP111: AUDIO \$14.00

Offers a wide range of material is covered from analysis of the sound wave, mechanism of hearing, acoustics, microphones and loudspeakers, amplifiers, and magnetic disc recording.

### BP239: GETTING THE MOST FROM YOUR MULTIMETER \$9.00

This book is aimed at beginners and those of limited experience of electronics. Using the simple component and circuit testing techniques in this book the reader should be able to confidently tackle servicing of most electronic projects.

### BP53: PRACTICAL ELECTRONIC CALCULATIONS AND FORMULAE \$11.75

A book that bridges the gap between complicated technical theory and the "cut and try" method. A good reference book.

### BP174: MORE ADVANCED ELECTRONIC MUSIC PROJECTS \$12.00

Complementing Book PB74, "Electronic Music Projects", BP174 provides projects, such as a flanger, a phaser, mini-chorus and ring modulators, percussion synths, etc. Each project has an Introduction circuit diagram and constructional notes.

### BP113: 30 SOLDERLESS BREADBOARD PROJECTS - BOOK 2 \$9.00

A companion to BP107. Describes a variety of projects that can be built on plug-in breadboards using CMOS logic IC's. Each project contains a schematic, parts list and operational notes.

### BP150: AN INTRO TO PROGRAMMING THE SINCLAIR QL \$7.80

Helps the reader make the best use of the Sinclair QL's almost unlimited range of features. Complements the manufacturer's handbook.

### BP192: MORE ADVANCED POWER SUPPLY PROJECTS \$8.00

A companion to BP176, this book covers switched mode supplies, precision regulators, tracking regulators, computer-controlled supplies, etc.

### BP222: SOLID STATE SHORT WAVE RECEIVER FOR BEGINNERS \$7.80

In this book, R.A. Penfold has designed and developed several modern solid state short wave receiver circuits that will give a fairly high level of performance, despite the fact that they use only relatively few and inexpensive components.

### BP197: INTRODUCTION TO THE AMSTRAD PCs \$20.00

The Amstrad PC is an MS-DOS computer for general and business use. This book explains all you need to know to start computing.

### BP48: ELECTRONIC PROJECTS FOR BEGINNERS \$7.80

F.G. Rayer, T. Eng. (CEJ), Assoc.IERE In this book, the newcomer to electronics will find a wide range of easily made projects. Also, there are a considerable number of actual components and wiring layouts, to aid the beginner.

### BP135: SECRETS OF THE COMMODORE 64 \$5.85

This book is intended as a beginner's guide to the Commodore 64.

### BP155: INTERNATIONAL RADIO STATIONS GUIDE \$9.00

An invaluable aid in helping all those who have a radio receiver to obtain the maximum entertainment value and enjoyment from their sets.

### BP130: MICRO INTERFACING CIRCUITS — BOOK 1 \$9.00

Aimed at those who have some previous knowledge of electronics, but not necessarily an extensive one, the basis of the book is to help the individual understand the principles of interfacing circuits to microprocessor equipment.

### BP131: MICRO INTERFACING CIRCUITS — BOOK 2 \$9.00

Intended to carry on from Book 1, this book deals with practical applications beyond the parallel and serial interface. "Real world" interfacing such as sound and speech generators, temperature, optical sensors, and motor controls are discussed using practical circuit descriptions.

### BP51: ELECTRONIC MUSIC AND CREATIVE TAPE RECORDING \$5.85

This book sets out to show how Electronic Music can be made at home with the simplest and most inexpensive equipment.

### BP74: ELECTRONIC MUSIC PROJECTS \$10.00

R.A. Penfold Although one of the more recent branches of amateur electronics, electronic music has now become extremely popular. The purpose of this book is to provide the constructor with a number of practical circuits for the less complex items of electronic music equipment, including such things as a Fuzz Box, Waa-Waa Pedal, Sustain Unit, Reverberation and Phaser Units, Tremelo Generator, etc.

### BP110: HOW TO GET YOUR ELECTRONIC PROJECTS WORKING \$7.80

R.A. Penfold We have all built circuits from magazines and books only to find that they did not work correctly, or at all, when first switched on. This book will help the reader overcome these problems by indicating how and where to start looking for many of the common faults that can occur when building up projects.

### BP86: AN INTRODUCTION TO BASIC PROGRAMMING TECHNIQUES \$5.85

This book is based on the author's own experience in learning BASIC and also in helping others, mostly beginners to programming, to understand the language.

### BP234: TRANSISTOR SELECTOR GUIDE \$15.00

Listings of British, European and eastern transistor characteristics make it easy to find replacements by part number or by specifications. Devices are also grouped by voltage, current, power, etc., includes surface-mount conversions.

### BP233: ELECTRONIC HOBBYIST HANDBOOK \$15.00

A single source of easily located information: colour codes, pinouts, basic circuits, symbols, etc.

### BP101: HOW TO IDENTIFY UNMARKED IC's \$1.95

An unusual and fascinating chart that is highly recommended to all those interested in electronics and which will hopefully pay for itself many times over, by enabling the reader to use IC's that might otherwise have been scrapped.

### BP121: HOW TO DESIGN AND MAKE YOUR OWN PCBs \$5.85

The purpose of this book is to familiarize the reader with both simple and more sophisticated methods of producing printed circuit boards. The book emphasizes the practical aspects of printed circuit board design and construction.

### BP125: 25 SIMPLE AMATEUR BAND AERIALS \$5.85

This book describes how to build 25 amateur band aerials. The designs start with the simple dipole and proceed to beam, triangle and even a mini-rhombic.

### BP180: ELECTRONIC CIRCUITS FOR THE COMPUTER CONTROL OF MODEL RAILWAYS \$9.00

Shows how home computers can easily be applied to the control of model railroads and other quite sophisticated control. A variety of projects are discussed as well as circuits for train position sensing, signal and electric points control, etc.

### BP100: AN INTRODUCTION TO VIDEO \$5.85

This book is for the person who has just, or is about to buy or rent video equipment but isn't sure what it's all about.



**BP78: PRACTICAL COMPUTER EXPERIMENTS** \$5.25

The aim of this book is to enable the reader to simply and inexpensively construct and examine the operation of a number of basic computer circuit elements and it is hoped gain a fuller understanding of how the mysterious computer "chip" works.

**BP185: ELECTRONIC SYNTHESIZER CONSTRUCTION** \$9.00

With this book a relative beginner should be able to build, with a minimum of difficulty and at a reasonably low cost, a worthwhile monophonic synthesizer and also learn a great deal about electronic music synthesis in the process.

**BP115: THE PRE-COMPUTER BOOK** \$5.85

Aimed at the absolute beginner with no knowledge of computing, this entirely non-technical discussion of computer bits and pieces and programming is written mainly for those who do not possess a microcomputer but either intend to one day own one or simply wish to know something about them.

**BP92: ELECTRONICS SIMPLIFIED - CRYSTAL SET CONSTRUCTION** \$5.25

This is a book written especially for those who wish to participate in the intricacies of electronics.

**BP72: A MICROPROCESSOR PRIMER** \$5.25

In an attempt to give painless approach to computing, this inexpensive book will start by designing a simple computer and then the short-comings of this simple machine will be discussed and the reader is shown how these can be overcome. Includes a glossary of microprocessor terms.

**BP42: 50 SIMPLE L.E.D. CIRCUITS** \$5.85

Contains 50 interesting and useful circuits and applications, covering many different branches of electronics, using one of the most inexpensive and freely available components.

**BP85: INTERNATIONAL TRANSISTOR EQUIVALENTS GUIDE** \$9.00

This book is designed to help the user find possible substitutes for a popular user-oriented selection of modern transistors and includes devices produced by over 100 manufacturers.

**BP140: DIGITAL IC EQUIVALENTS AND PIN CONNECTIONS** \$15.00

Shows equivalents and pin connections of a popular user-oriented selection of Digital Integrated Circuits. Includes European, American and Japanese devices.

**BP136: SIMPLE INDOOR AND WINDOW AERIALS** \$7.00

People living in apartments who would like to improve shortwave listening can benefit from these instructions on optimizing the indoor aerial.

**BP156: AN INTRODUCTION TO QL MACHINE CODE** \$10.00

The powerful Sinclair QL microcomputer has some outstanding capabilities in terms of its internal structure. With a 32-bit architecture, the QL has a large address range, advanced instructions which include multiplication and division. These features give the budding machine code programmer a good start at advanced programming methods. This book assumes no previous knowledge of either the 68008 or machine code programming.

**BP59: SECOND BOOK OF CMOS IC PROJECTS** \$7.80

This book carries on from its predecessor and provides a further selection of useful circuits, mainly of a simple nature. The book is well within the capabilities of the beginner and more advanced constructor.

**BP258 LEARNING TO PROGRAM IN C** \$19.00

This book is a guide to C programming. C statements are introduced and explained with the help of simple, but completely working programs.

**BP141: LINEAR IC EQUIVALENTS AND PIN CONNECTIONS** \$23.80

Adrian Michaels  
Find equivalents and cross-references for both popular and unusual integrated circuits. Shows details of functions, manufacturer, country of origin, pinouts, etc... includes National, Motorola, Fairchild, Harris, Intersil, Philips, ADC, AMD, SGS, Teledyne, and many others.

**BP7: RADIO AND ELECTRONICS COLOUR CODE AND DATA CHART** \$3.00

Opens out to Wall Chart approximately 584 X 457mm. Includes many Radio & Electronics Colour Codes in use in UK, USA, Europe and Japan. Covers Resistors, Capacitors, Transformers, Field Coils, Fuses, Battery Leads, etc.

**BP225: A PRACTICAL INTRODUCTION TO DIGITAL ICs** \$7.00

This book deals mainly with TTL type chips such as the 7400 series. Simple projects and a complete practical construction of a Logic Test Circuit Set are included as well as details for a more complicated Digital Counter Timer project.

**BP147: AN INTRODUCTION TO 6502 MACHINE CODE** \$10.00

The popular 6502 microprocessor is used in many home computers; this is a guide to beginning assembly language.

**BP88: HOW TO USE OP-AMPS** \$11.80

E.A. Parr  
A designer's guide covering several op-amps, serving as a source book of circuits and a reference book for design calculations. The approach has been made a non-mathematical as possible.

**ELEMENTS OF ELECTRONICS — AN ON-GOING SERIES** \$11.80 EACH OR ALL 5 BOOKS FOR \$44.00

F.A. Wilson, C.G.I.A., C.Eng.,  
Although written for readers with no more than ordinary arithmetical skills, the use of mathematics is not avoided, and all the math required is taught as the reader progresses. Each book is a complete treatise of a particular branch of the subject and therefore, can be used on its own with one proviso, that the later books do not duplicate material from their predecessors, thus a working knowledge of the subjects covered by the earlier books is assumed.

**BP62: BOOK 1.** This book contains all the fundamental theory necessary to lead to a full understanding of the simple electronic circuit and its main components.

**BP63: BOOK 2.** This book continues with alternating current theory without which there can be no comprehension of speech, music, radio, television or even the electricity utilities.

**BP64: BOOK 3.** Follows on semiconductor technology, leading up to transistors and integrated circuits.

**BP77: BOOK 4.** A complete description of the internal workings of microprocessor.

**BP89: BOOK 5.** A book covering the whole communication scene.

**BP194: MODERN OPTO DEVICE PROJECTS** \$9.00

This book provides a number of practical designs for beginners and experienced project builders. These projects utilize a range of modern opto-electric devices, including such things as fibre optics, ultra-bright LEDs and passive IR detectors.

**BP37: 50 PROJECTS USING RELAYS, SCR's & TRIACS** \$7.80

F.G. Rayer, T. Eng., (CE), Assoc.IERE.  
Relays, bi-directional triodes (TRIACs), and silicon controlled rectifiers (SCRs), have a wide range of applications in electronics today. This book gives practical working circuits which should present the minimum of difficulty for the enthusiast. In most of the circuits there is a wide latitude in component values and types, allowing easy modification and adaptation.

**BP84: DIGITAL IC PROJECTS** \$7.80

F.G. Rayer, T. Eng. (CE), Assoc.IERE.  
This book contains both simple and more advanced projects for the reader developing a knowledge of the workings of digital circuits. To help the newcomer to the hobby the author has included a number of board layouts and wiring diagrams.

**BP95: MODEL RAILWAY PROJECTS** \$7.80

Electronic projects for model railways are fairly recent and have made possible an amazing degree of realism. The projects covered included controllers, signals and sound effects: stripboard layouts are provided for each project.

**BP144: FURTHER PRACTICAL ELECTRONICS CALCULATIONS AND FORMULAE** \$15.00

This book covers many aspects of electronics where a knowledge and familiarity of the appropriate formulae is essential for a fuller understanding of the subject. An essential addition to the library of all those interested in electronics.

**BP44: IC 555 PROJECTS** \$10.00

E.A. Parr, B.Sc., C. Eng., M.I.EE.  
Every so often a device appears that is so useful that one wonders how life went on before it. The 555 timer is such a device included in this book are Basic and General Circuits, Motor Car and Model Railway Circuits, Alarms and Noise Makers as well as a section on the 556, 558 and 559 timers.

**BP94: ELECTRONIC PROJECTS FOR CARS AND BOATS** \$7.80

R.A. Penfold  
Projects, fifteen in all, which use a 12V supply are the basis of this book. Included are projects on Windscreen Wiper Control, Courtesy Light Delay, Battery Monitor, Cassette Power Supply, Lights Timer, Vehicle Immobiliser, Gas and Smoke Alarm, and more.

**BP49: POPULAR ELECTRONIC PROJECTS** by R. A. Penfold \$10.00

Includes a collection of the most popular types of circuits and projects which will provide a number of designs to interest most electronics constructors. The projects cover a wide range and are divided into four basic types. Radio Projects, Audio Projects, Household Projects and Test Equipment.

**BP99: MINI-MATRIX BOARD PROJECTS** by R. A. Penfold \$7.60

Twenty useful projects which can all be built on a 24 X 10 hole matrix board with copper strips. Includes Door-buzzer, Low-voltage Alarm, AM Radio, signal Generator, Projector Timer, Guitar Headphone Amp. and more.

**BP103: MULTI-CIRCUIT BOARD PROJECTS** by R.A. Penfold \$7.80

This book allows the reader to build 21 fairly simple electronic projects, all of which may be constructed on the same printed circuit board. Wherever possible, the same components have been used in each design so that with a relatively small number of components and hence low cost, it is possible to make any one of the projects or by re-using the components and P.C.B. all of the projects.

**BP98: POPULAR ELECTRONIC CIRCUITS, BOOK 2** \$9.00

R.A. Penfold  
70 plus circuits based on modern components aimed at those with some experience.

**BP127: HOW TO DESIGN ELECTRONIC PROJECTS** \$9.00

Although information on stand circuits blocks is available, there is less information on combining these circuit parts together. This title does just that. Practical examples are used and each is analysed to show what each does and how to apply this to other designs.

**BP195: AN INTRODUCTION TO SATELLITE TELEVISION** \$15.00

For the absolute beginner or anyone thinking about purchasing a satellite TV system, the story is told as simply as such a complex one can be.

**BP106: MODERN OP-AMP PROJECTS** by R. A. Penfold \$7.80

Features a wide range of constructional projects which make use of op-amps including low-noise, low distortion, ultra-high input impedance, high slew-rate and high output current types.

**BP107: 30 SOLDERLESS BREADBOARD PROJECTS - BOOK 1** \$9.00

R.A. Penfold  
A "Solderless Breadboard" is simply a special board on which electronic circuits can be built and tested. The components used are just plugged in and unplugged as desired. The 30 projects in this book have been designed to be built on a "Verobloc" breadboard. Wherever possible the components used are common to several projects, hence with only a modest number of components it is possible to build, in turn, every project shown.

**BP122: AUDIO AMPLIFIER CONSTRUCTION** \$6.75

A wide circuits is given, from low noise microphone and tape head preamps to a 100W MOSFET type. There is also the circuit for 12V bridge amp giving 18W. Circuit board or stripboard layout are included. Most of the circuits are well within the capabilities of even those with limited experience.

**BP179: ELECTRONIC CIRCUITS FOR THE COMPUTER CONTROL OF ROBOTS** \$12.00

The main stumbling block for most would-be robot builders is the electronics to interface the computer to the motors, and the sensors which provide feedback from the robot to the computer. The purpose of this book is to explain and provide some relatively simple electronic circuits which bridge the gap.

**BP108: INTERNATIONAL DIODE EQUIVALENTS GUIDE** \$7.00

Cross-references European, American and Japanese diode part numbers. Besides rectifier diodes, it includes Zeners, LEDs, Diacs, Triacs, SCRs, OCIs, photodiodes, and display diodes.

**BP118: PRACTICAL ELECTRONIC BUILDING BLOCKS — BOOK 2** \$7.60

R.A. Penfold  
This sequel to BP117 is written to help the reader create and experiment with his own circuits by combining standard type circuit building blocks. Circuits concerned with generating signals were covered in Book 1, this one deals with processing signals.

**BABANI BOOKS EXCLUSIVELY AVAILABLE IN CANADA FROM MOORSHEAD PUBLICATIONS. ORDER YOUR SELECTIONS BY TELEPHONE: (416) 445-5600 OR FAX: 416-445-8149 OR WRITE TO US AT 1300 DON MILLS ROAD, NORTH YORK, ONTARIO M3B 3M8**



# Diode Data

The characteristics, codes, data, encapsulations and various formulas relating to diodes, thyristors, triacs and LEDs.

Mike Tooley

**S**emiconductor diodes are generally a single p-n junction of either silicon (Si) or germanium (Ge) material. In order to obtain conduction, the p-type material (the p-type connection constitutes the anode while the n-type connection constitutes the cathode). The direction of current flow is from anode to cathode when the diode is conducting, as shown in Fig. 1. Very little current (negligible in the case of the most silicon devices) flows in the reverse direction (Fig. 2).

Diodes exhibit a low resistance to current flow in one direction and a high resistance to current flow in the other. The

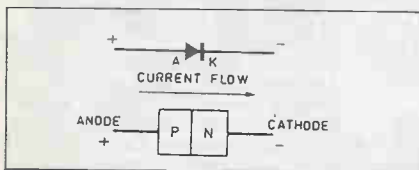

Fig. 1. Forward biased (conducting) diode.

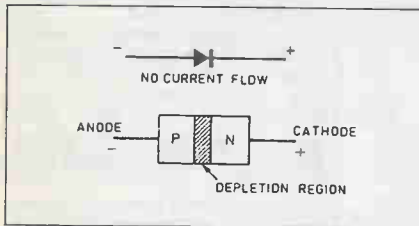

Fig. 2. Reverse biased (non-conducting) diode.

direction in which the current flows is referred to as the forward direction while that in which negligible current flows is known as the reverse direction. When a diode is conducting, a diode is said to be forward biased and a small voltage (ideal-

ly zero) is dropped across it. This voltage is known as the forward voltage drop. The maximum reverse voltage ( $V_{RM}$ ) or peak inverse voltage (PIV).

Typical values of forward current and forward voltage for commonly available silicon and germanium diodes are given below:

insert "forward current" table

Germanium diodes conduct at lower forward voltages than their silicon counterparts, but they tend to exhibit considerably more reverse leakage current. Furthermore, the forward resistance of a conducting silicon diode is much lower than that of a comparable germanium type. Hence germanium diodes are used primarily for signal detection purposes whereas silicon devices are used for rectification and for general purpose applications. Typical forward and reverse characteristics for comparable germanium and silicon diodes are shown in Fig. 3. Diodes are often divided into signal and rectifier types, according to their principal field of application. Signal diodes require consis-

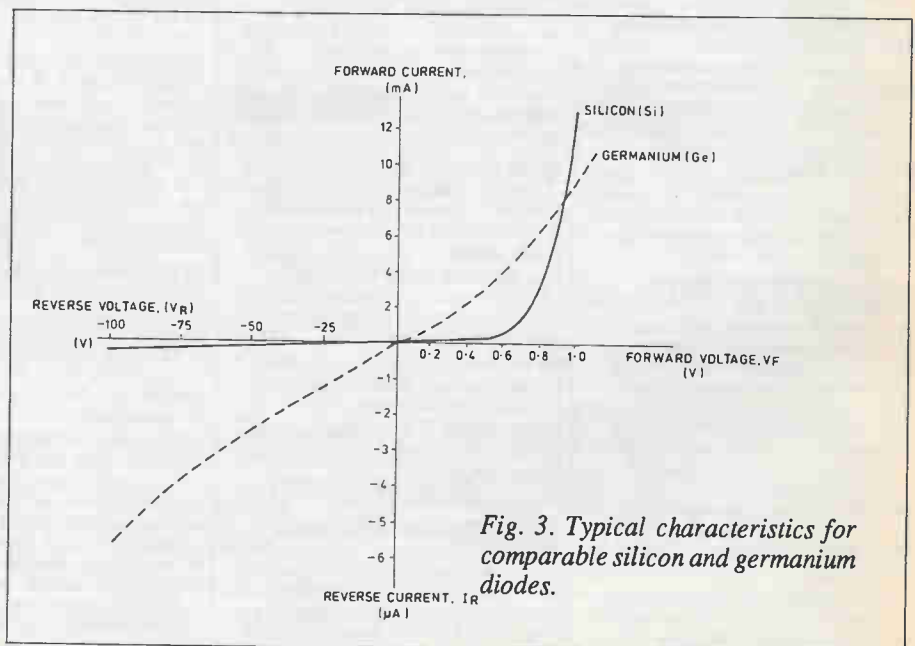

Fig. 3. Typical characteristics for comparable silicon and germanium diodes.

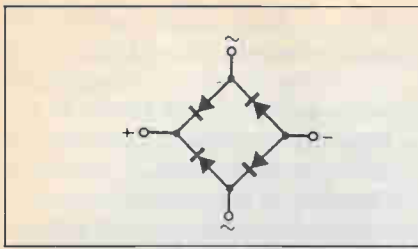

Fig. 4. Bridge rectifier arrangement.

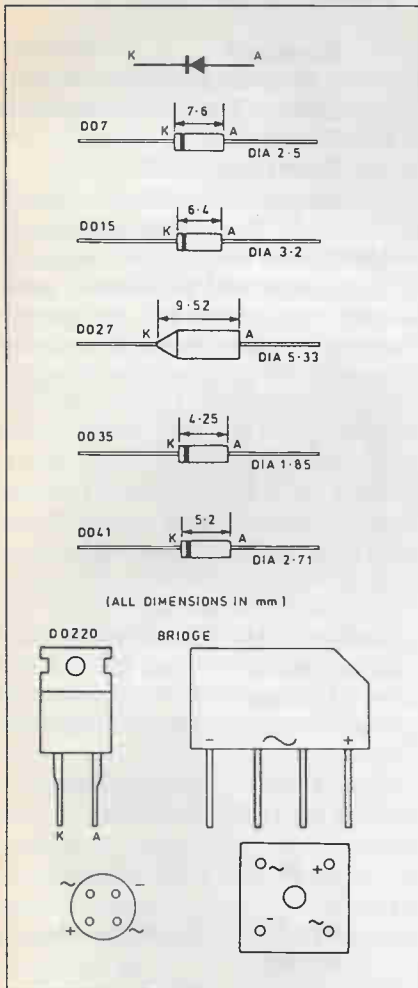

Fig. 5. Diode encapsulations.

tent forward characteristics with low forward voltage drop.

Rectifier diodes need to be able to cope with high values of reverse voltage and large values of forward current, consistency of characteristics is of secondary importance in such applications. Rectifier diodes are often available in the form of a bridge (see Fig. 4) which provides fullwave rectification. Various diode encapsulations are illustrated in Fig. 5.

### Diode Coding

The European system for classifying semiconductor diodes involves an al-

phanumeric code which employs either two letters and three figures (general purpose diodes) or three letters and two figures (special purpose diodes). The first two letters have the following significance:

**First letter - semiconductor material:**

- A germanium
- B silicon
- C gallium arsenide etc
- D photodiodes etc

**Second letter - application:**

- A general purpose
- B tuning (varicap) diode
- E tunnel diode
- P photovoltaic diode
- Q light emitting diode
- T controlled rectifier
- X varactor diode
- Y power rectifier
- Z zener diode

In the case of diodes for specialized applications, the third letter does not generally have any particular significance. Zener diodes have an additional letter (which appears after the numbers) which denotes the tolerance of the zener voltage. The following letters are used:

- A 1%
- B 2%
- C 5%
- D 10%

Zener diodes also have additional characters which indicate the zener voltage (e.g., 9V1 denotes 9.1V).

### Example 1

Identify each of the following diodes:

- (i) AA113
- (ii) BB105
- (iii) BZY88C4V7

Diode (i) is a general purpose germanium diode.

Diode (ii) is a silicon diode for tuning applications (sometimes referred to as varicap).

Diode (iii) is a silicon zener diode having 5% tolerance and 4.7V zener voltage.

### Diode data

The following tables summarize the characteristics of a variety of popular semiconductor diodes:

Note: Most of the bridge rectifiers listed are available in 200V, 400V and 600V versions. It is important to ensure

that manufacturers' voltage ratings are not exceeded.

### Hints and tips

\* When designing power supply cir-

#### Devices, applications, equivalents and case styles

Device	Material	Application	Near equiv.	Case style
1N4001	silicon	rectifier		DO41
1N4002	silicon	rectifier		DO41
1N4003	silicon	rectifier		DO41
1N4004	silicon	rectifier		DO41
1N4005	silicon	rectifier		DO41
1N4006	silicon	rectifier		DO41
1N4007	silicon	rectifier	BY127	DO41
1N4148	silicon	general purpose	1N914, 1N916	DO35
1N5400	silicon	rectifier		DO27
1N5401	silicon	rectifier		DO27
1N5402	silicon	rectifier		DO27
1N5404	silicon	rectifier		DO27
1N5406	silicon	rectifier		DO27
1N5407	silicon	rectifier		DO27
1N5408	silicon	rectifier		DO27
1N914	silicon	general purpose	1N916, 1N4148	DO35
1N916	silicon	general purpose	1N914, 1N4148	DO35
AA113	germanium	general purpose		DO7
AA119	germanium	RF detector		DO7
BAR28	Schottky	RF detector		DO35
BAX13	silicon	general purpose		DO35
BAX16	silicon	general purpose		DO35
BY126	silicon	rectifier	1N4005	DO15
BY127	silicon	rectifier	1N4007	DO15
H5CH1001	Schottky	RF detector		DO35
OA200	silicon	general purpose		DO7
OA202	silicon	general purpose		DO7
OA47	germanium	general purpose		DO7
OA90	germanium	RF detector		DO7
OA91	germanium	general purpose	OA95	DO7
OA95	germanium	general purpose	OA91	DO7

#### General purpose, signal and RF diodes

Device	Material	PIV	$I_f$	$I_{r, max}$
1N4148	silicon	100V	75mA	25nA
1N914	silicon	100V	75mA	25nA
1N916	silicon	100V	75mA	25nA
AA113	germanium	60V	10mA	200µA
AA119	germanium	45V	35mA	350µA
BAR28	Schottky	70V	75mA	200nA
BAX13	silicon	50V	75mA	200nA
BAX16	silicon	150V	200mA	100nA
H5CH1001	Schottky	60V	15mA	200nA
OA200	silicon	50V	80mA	100nA
OA202	silicon	150V	40mA	100nA
OA47	germanium	25V	110mA	100µA
OA90	germanium	30V	10mA	1.1mA
OA91	germanium	115V	50mA	275µA
OA95	germanium	115V	50mA	250µA

#### Silicon rectifier and power diodes

Device	PIV	$I_{fo}$	$V_f$	$I_{r, max}$
1N4001	50V	1A	1.1V	10µA
1N4002	100V	1A	1.1V	10µA
1N4003	200V	1A	1.1V	10µA
1N4004	400V	1A	1.1V	10µA
1N4005	600V	1A	1.1V	10µA
1N4006	800V	1A	1.1V	10µA
1N4007	1000V	1A	1.1V	10µA
1N5400	50V	3A	1.1V	10µA
1N5401	100V	3A	1.1V	10µA
1N5402	200V	3A	1.1V	10µA
1N5404	400V	3A	1.1V	10µA
1N5406	600V	3A	1.1V	10µA
1N5407	800V	3A	1.1V	10µA
1N5408	1000V	3A	1.1V	10µA
BY126	650V	1A	1.1V	10µA
BY127	1250V	1A	1.1V	10µA
BY397	200V	2A	1.1V	10µA
BY399	800V	2A	1.1V	10µA

#### Bridge rectifiers

Type/series	Encapsulation	Mounting surface	Max. forward current (A)
Vm	4-pin d.i.l.	PCB	0.9
DB	4-pin d.i.l.	PCB	1
WO	cylindrical	PCB	1
SK82	in-line	PCB	1.6
BR5	in-line	PCB	2
BR3	square	PCB	3
KBPC	square	PCB	2 to 6
BR6	square	PCB	6
BR15	epoxy-potted	heatsink	15
SK825	epoxy-potted	heatsink	6 to 35

uits (in which appreciable currents are present) it is important to allow for the forward voltage drop associated with each rectifier diode. In a bridge rectifier, for example, two diodes will be conducting any one time. The total forward voltage drop associated with these diodes can approach 2V and this should be allowed for when

## Diode Data

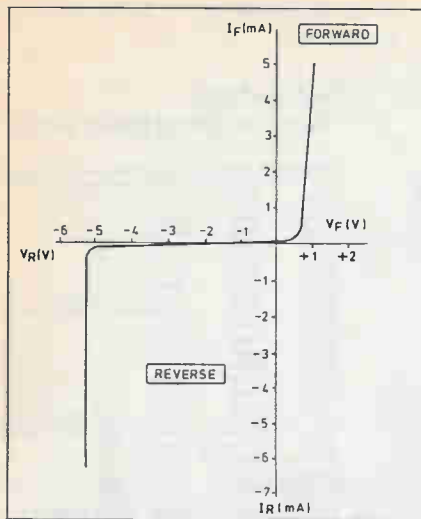

Fig. 6. Typical zener diode characteristics.

determining the AC input voltage to the rectifier.

\* The reverse leakage current of a diode increases markedly as the junction temperature increases. This results in a reduction in overall efficiency (ratio of forward current to reverse current) at high temperatures.

\* Operating a diode at, or beyond, the stated limits for  $V_{rrm}$  or PIV will result in a high risk of breakdown. Since rectifier failure can have disastrous consequences, it is always advisable to operate diodes well within the stated limits (to ensure safety, a 100% margin should be allowed).

\* Schottky diodes exhibit a forward voltage drop which is approximately half that of conventional silicon diodes

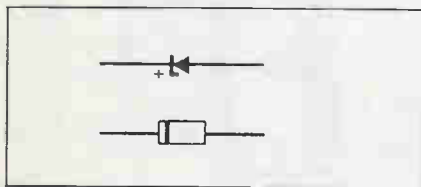

Fig. 7. Zener diode encapsulation.

coupled with very fast reverse recovery. Schottky diodes are thus preferred in switching applications (e.g., switched mode power supplies) where very low forward voltage drop and fast switching is a prime consideration.

### Zener diodes

Zener diodes are silicon diodes which are specially designed to exhibit consistent reverse breakdown characteristics. Zener diodes are available in various families (according to their general characteristics, encapsulation and power ratings) with reverse breakdown (zener)

voltages in the E12 and E24 series (ranging from 2.4V to 91V). A typical characteristic for a 5.1V zener diode is shown in Fig. 6.

The following series of zener diodes are commonly available:

#### BZX88 series:

Miniature glass encapsulated diodes rated at 500mW (at 25 deg.C). Zener voltages range from 2.7V to 15V (voltages are quoted for 5mA reverse current at 25 deg.C).

#### BZX55 series:

Low-power diodes rated at 500mW and offering zener voltages in the range 2.4V to 91V.

#### BZX61 series:

Encapsulated alloy junction rated at 1.3W (25 deg. Ambient).

Zener voltages range from 7.5V to 72V.

#### BZX85 series:

Medium-power glass-encapsulated diodes rated at 1.3W and offering zener voltages in the range 5.1V to 62V.

#### BZY93 series:

High power diodes in stud mounting encapsulation. Rated at 200W for ambient temperatures up to 75 deg.C. Zener voltages range from 9.1V to 75V.

#### BZY97 series:

Medium power wire-ended diodes rated at 1.5W and offering zener voltages in the range 9.1V to 37V.

#### IN5333 series:

Plastic encapsulated diodes rated at 5W. Zener voltages range from 3.3V to 24V.

Zener diodes are generally plastic or glass encapsulated in the same manner as conventional silicon diodes. As with conventional silicon diodes, the cathode connection is marked with a stripe (see Fig. 7).

The slope resistance of a zener diode is the rate of change of reverse voltage (zener voltage) with diode current. Slope resistance is measured in the breakdown region and expressed in ohms. An ideal zener diode would have zero slope resistance (i.e. the diode would conduct perfectly at its rated zener voltage). In practice, values of 200 or less can be achieved. The temperature coefficient of zener volt-

age is the change of zener voltage (from its rated value) which results from a temperature change of 1 deg.C. Temperature coefficient (which should ideally be zero) is expressed in mV/deg.C. In many voltage reference applications, it is essential for the reference diode to exhibit a zener voltage which does not vary with temperature. The following data (for the BZX55 series) is typical of most low-power zener diodes:

#### Example 2

A zener diode is to be used as a voltage reference. The diode has the following specifications:

Zener voltage (at 20°C): 9.1V

Temperature coefficient: +4mV/°C

If the equipment is designed to operate over the range -10 deg.C to +40 deg.C, determine the extreme values of reference voltage and the percentage change in the reference voltage over the

Zener voltage (V)	Slope resistance (Ω)	Temperature coefficient (mV/°C)
2.7	100	-3.5
3.3	95	-3.5
3.9	90	-3.5
4.7	80	-3.5
5.1	60	-2.7
5.6	40	-2.0
6.2	10	+0.4
6.8	12	+1.2
7.5	14	+2.5
8.2	16	+3.2
9.1	18	+3.8
10	20	+4.5

working range. The temperature coefficient is positive and thus the zener voltage will increase with temperature. At 40 deg.C the zener voltage will be given by:

$$V_z = 9.1V + ((40-20) \times 4mV) \\ = 9.1V + 80mV = 9.18V$$

At -10°C the zener voltage is:

$$V_z = 9.1V - ((20 - (-10)) \times 4mV) \\ = 8.98V$$

#### Hints and tips:

\* Zener diodes may be connected in series to obtain higher voltages. As an example, a 15.9V reference can be produced by connecting a 6.8V zener diode in series with a 9.1V zener diode.

\* Care must be taken to ensure that zener diodes operate within their rated power dissipation.

\* Zener diodes generally perform best when rated at voltages of between 5V and 6V. Hence, in order to obtain optimum performance (in terms of both slope resistance and temperature coefficient) reference voltage sources based upon zener diodes should utilise components which have zener voltages of between



5.1V and 6.2V where necessary, external circuitry can be used to provide voltage amplification.

\* Zener diodes can generate a significant amount of noise and, in applications which involve significant voltage gain (e.g. the stabilization of an amplifier bias supply) it is essential to provide adequate decoupling. A parallel connected capacitor of between 1uF and 100uF will provide effective in most applications.

## Thyristors

Thyristors (or silicon controlled rectifiers) are three-terminal devices which can be used for switching and AC power control. Thyristors can switch very rapidly from a nonconducting to a conducting state. In the off state, the thyristor exhibits negligible leakage current while, in the on state the device exhibits very low resistance. This results in very little power loss within the thyristor even when appreciable power levels are being controlled. Once switched into the conducting state, the thyristor will remain conducting (i.e., it is latched in the on state) until the forward current is removed from the device. In DC applications this necessitates the interruption (or disconnection) of the supply before the device can be reset into its nonconducting state. Where the device is used with an alternating supply, the device will automatically become reset whenever the main supply reverses. The device can then be triggered on the next half-cycle having correct polarity or permit conduction. Like their conventional silicon diode counterparts, thyristors have anode and cathode connections; control is applied by means of gate terminal (see Fig. 8). The device is triggered into the conducting (on state) by means of the application of a current pulse to this material.

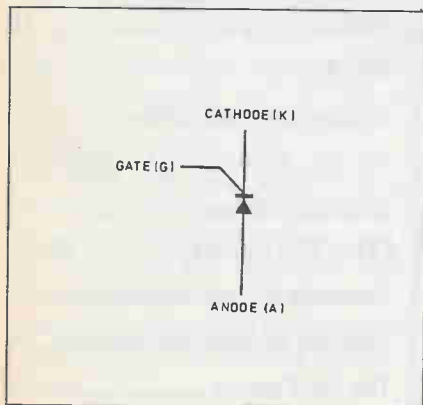

Fig. 8. Thyristor connections.

## Thyristor data

The table summarizes the characteristics of a variety of popular thyristors:

### Hints and tips:

\* Wherever possible, thyristor trigger pulses should have the fastest possible rise times. Signals with slow rise times or poorly defined edges are generally unsatisfactory for triggering purposes.

\* Sufficient gate current must be made available in order to ensure effective triggering.

\* Thyristors will turn on faster (and power dissipation within the device will be minimized) as gate current is increased. Care should, however, be taken to ensure that the peak value of gate does not exceed

Type	$I_{TAV}$	$V_{RRM}$	$V_{GT}$	$I_{GT}$	Case style
2N443	5.1A	400V	1.5V	30mA	TO220
2N444	5.1A	600V	1.5V	30mA	TO220
BT106	1A	700V	3.5V	50mA	Stud
BT152	13A	600V	1V	32mA	TO220
BTX18-400	1A	500V	2V	5mA	TO5
BTY79-400R	6.4A	400V	3V	30mA	Stud
BTY79-600R	6.4A	600V	3V	30mA	Stud
BTY79-800R	6.4A	800V	3V	30mA	Stud
TIC106A	3.2A	100V	1.2V	200µA	TO220
TIC106B	3.2A	200V	1.2V	200µA	TO220
TIC106C	3.2A	300V	1.2V	200µA	TO220
TIC106D	3.2A	400V	1.2V	200µA	TO220
TIC106E	3.2A	500V	1.2V	200µA	TO220
TIC106M	3.2A	600V	1.2V	200µA	TO220
TIC106S	3.2A	700V	1.2V	200µA	TO220
TIC106N	3.2A	800V	1.2V	200µA	TO220
TIC116A	5A	100V	2.5V	20mA	TO220
TIC116B	5A	200V	2.5V	20mA	TO220
TIC116C	5A	300V	2.5V	20mA	TO220
TIC116D	5A	400V	2.5V	20mA	TO220
TIC116E	5A	500V	2.5V	20mA	TO220
TIC116M	5A	600V	2.5V	20mA	TO220
TIC116S	5A	700V	2.5V	20mA	TO220
TIC116N	5A	800V	2.5V	20mA	TO220
TIC126A	7.5A	100V	2.5V	20mA	TO220
TIC126B	7.5A	200V	2.5V	20mA	TO220
TIC126C	7.5A	300V	2.5V	20mA	TO220
TIC126D	7.5A	400V	2.5V	20mA	TO220
TIC126E	7.5A	500V	2.5V	20mA	TO220
TIC126M	7.5A	600V	2.5V	20mA	TO220
TIC126S	7.5A	700V	2.5V	20mA	TO220
TIC126N	7.5A	800V	2.5V	20mA	TO220
TICP106D	2A	400V	1V	200µA	TO92
TICP106M	2A	600V	1V	200µA	TO92

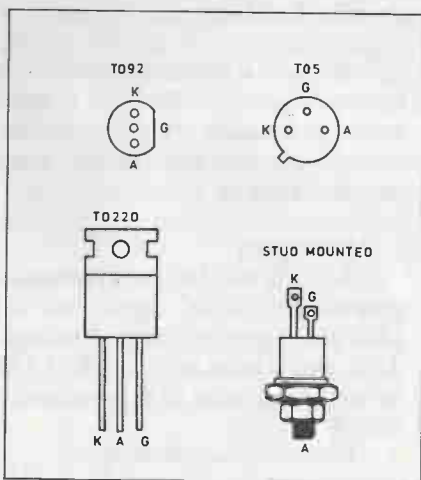

Fig. 9. Thyristor encapsulations and pin connections.

the rated value for the device.

\* The pulse width of the trigger pulse applied to the gate of a thyristor must be kept short in order to minimize gate power dissipation.

\* In order to obtain an adequate range of control in AC power control applications, the thyristor triggering circuit should be designed so that it will provide effective triggering over a sufficiently wide angle of the applied AC voltage. Failure to observe this rule will result in a limited range of control.

## Triacs

Triacs are a refinement of the thyristor which, when triggered, conduct on both positive and negative half-cycles of the applied voltage. Triacs have three terminals known as main terminal one (MT1), main terminal two (MT2) and gate (G), as shown in Fig. 10. Triacs can be triggered by both positive and negative voltages present at the gate. Triacs thus provide full-wave control and offer superior performance in AC power control applications when compared with thyristors which only provide half-wave control. In order to simplify the design of triggering circuits, triacs are often used in conjunction with diacs (equivalent to a bi-directional zener diode). A typical diac conducts heavily when the applied voltage exceeds approximately +/- 32V. Once in the conducting state, the resistance of the diac falls to a very low value and thus a large value of current will flow. The characteristic of a typical diac is shown in Fig. 11.

## Triac data

The following table summarizes the characteristics of a variety of popular triacs:

### Hints and tips

\* Thyristors and triacs switch on and off very rapidly. In AC power control applications, this rapid switching can result in transients which may be conveyed some distance via the AC mains wiring. To minimize such effects and prevent radiation of noise, an L-C filter should be fitted in close proximity to the power control device, as shown in Fig. 13.

## LEDs

Light emitting diodes (LEDs) can be used as general purpose indicators and, compared with conventional filament lamps, operate from significantly smaller vol-

Type	$I_{T(RMS)}$	$V_{RRM}$	$V_{GT}$	$I_{G(TYP)}$	Case style
BT139	15A	600V	1.5V	5mA	TO220
TIC206M	4A	600V	2V	5mA	TO220
TIC216M	6A	600V	3V	5mA	TO220
TIC225M	8A	600V	2V	20mA	TO220
TIC226M	8A	600V	2V	50mA	TO220
TIC236M	12A	600V	2V	50mA	TO220
TIC246M	16A	600V	2V	50mA	TO220
TICP206D	1.5A	400V	2.5V	2.5mA	TO92
TICP206M	1.5A	600V	2.5V	2.5mA	TO92

# Diode Data

Fig. 10. Triac connections.

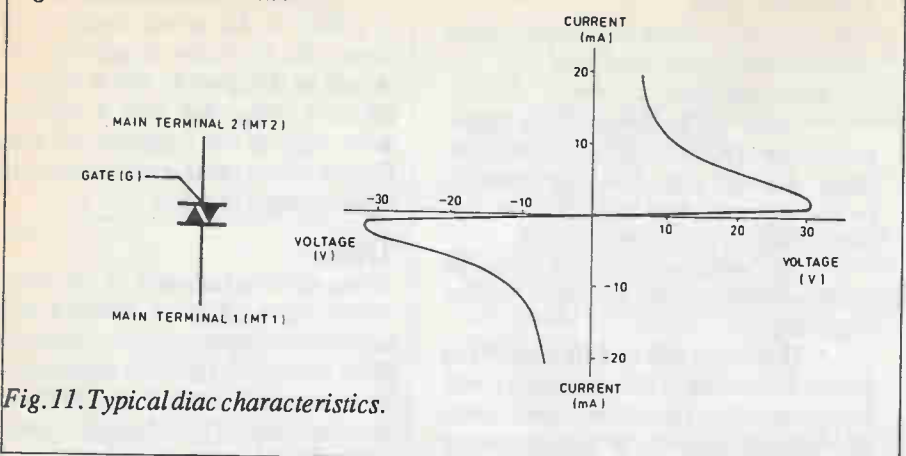

Fig. 11. Typical diac characteristics.

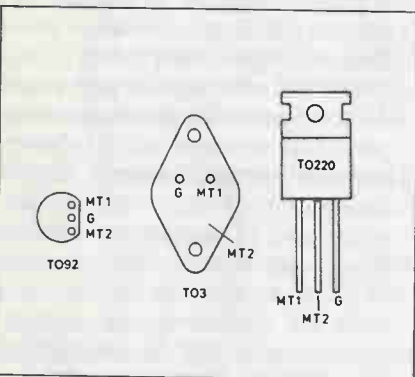

Fig. 12. Triac encapsulations.

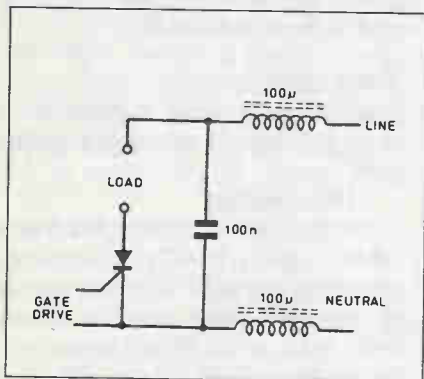

Fig. 13. Simple power line filter.

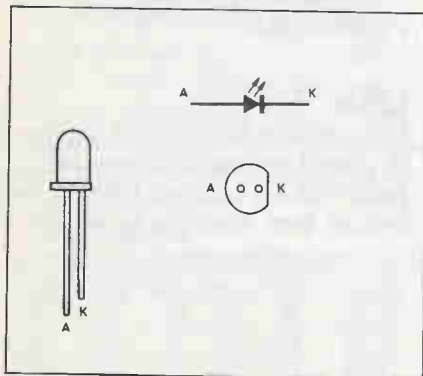

Fig. 14. Round LED encapsulation..

tages and currents. LEDs are also very much more reliable than filament lamps. Most LEDs will provide a reasonable level of light output when a forward current of between 5mA and 20mA is applied.

Light emitting diodes are variable in various formats with the round types being most popular. Round LEDs are commonly available in the 3mm and 5mm (0.2 inch) diameter plastic packages (see Fig.14) and also in 5mm x 2mm rectangular format. The viewing angle for round LEDs tends to be in the region of 20° to 40°, whereas for rectangular types this is increased to around 100°.

In order to limit the forward current to an appropriate value, it is usually necessary to include a fixed resistor in series with a LED indicator. The value of the resistor may be calculated from:

$$R = (V - V_f) / I$$

where  $V_f$  is the forward voltage drop produced by the LED and  $V$  is applied voltage. It is usually safe to assume that  $V_f$  will be 2V and choose the nearest preferred value for  $R$ .

### Example 3

An LED is to be used to indicate the presence of 21V DC supply rail. If the LED has a nominal forward voltage of 2.2V, and is rated at a current of 15mA determine the value of series resistor required.

Here we can use the formula:

$$R = (V - V_f) / I$$

$$= (21 - 2.2V) / .015 = 1.25k$$

The nearest standard value is 1k2. The power dissipated in the resistor will be .015 times 18.8V, or 280mW.

### Hints and tips:

\* Avoid inadvertent reverse LED connection. Reverse voltages in excess of about 5V will cause permanent damage.

\* For battery powered equipment (particularly where a number of LED indicators are used) minimal values of forward current should be employed in order to ensure long battery life. A forward current of 5mA (per LED) will be perfectly adequate in many applications.

\* Where several LEDs are to be used together, they should be connected in series (and not in parallel) in order to ensure equal levels of light output.

\* Yellow and green LED generally give less output (for a given forward current) than their standard red counterparts. To maintain an equal light output when several LEDs of different colours are used together, different values of series resistor may be employed. As a rule of thumb, series resistors for yellow and green LEDs should be chosen so that they are 10% to 15% lower in value than those used with red diodes (care should, however, be taken to ensure that operating currents are still within the manufacturer's specified upper limit).

\* In applications involving low AC voltages, a conventional low-current silicon diode (e.g. 1N4148) can be wired in parallel with a LED to provide a simple AC indicator.

## Advertisers' Index

March 1990

Cad/Cam & Robotics Exhibition	56
Data Acquisition Management Corp.....	19
Exceltronix .....	2, 3
Information Unlimited .....	33
McGraw - Hill.....	17
Orion Electronics.....	54, 55
Techmatron Instruments Inc ...	15
Toshiba Information Systems...	4
The Pin Factory .....	41

Fax: 416-445-8149

# Stereo Noise Generator

An experimenter's circuit that provides noise for many applications.

Andy Flind

**N**oise, electrically speaking, is strange stuff. From the amount of time and effort spent in trying to control it, especially in sensitive circuits such as preamplifiers, it might be thought that it's to be found everywhere in large quantities. When one wants some noise, it comes as some surprise to find that it is, in fact, quite difficult to generate.

## Why Noise?

Why should anyone actually want noise? Well, there are many possible uses for it. Amplified and fed into a loudspeaker, it produces a rushing sound, similar to a waterfall or high wind in trees. The obvious use is in sound effect generations, but the effect on its own is quite relaxing and thus of interest to people working with biofeedback and similar projects.

A soothing noise output is far better than a monotonous and irritating tone for a relaxation monitor; for example, pink noise, where higher frequency components are progressively reduced, has been used with some success to assist patients to relax in medical practice, particularly by dentists. A device is available for use in modern open-plan offices, where the sound produced reduces the chance of conversation being overheard without being too irritating for the occupants.

## Noise Sources

Various circuits using noise generators have appeared in the electronics press from time to time, usually in wind and rain effects projects. The noise sources vary, but common among them are Zener diodes and other reverse-biased junctions, such as ordinary silicon diodes and the base-emitter junctions of transistors. The problem with all these sources is that their output when used in this manner varies considerably between devices, and is almost always very small. This makes them unsatisfactory for circuits intended for publication, where the performance should be readily repeatable, and the high levels of gain needed to obtain usable output can cause problems of instability. So while they might be suitable for a one-off in the

designer's workshop, they do not lend themselves well to publication. Two rather more practical noise sources are the custom sound-effects chip, and noise diodes. The chips work, but most of them have rather high quiescent currents. A standing drain of 45mA is not much use where the power supply is a single 9V battery. Noise diodes were better.

## Pseudo-random

The solution eventually discovered was a pseudo-random generator, using a shift register with its output EXclusive-OR'd with the output taken from a tap partway along its length, and fed back to the input. Fig.1 shows the basic arrangement in block form. It will be seen that in this case a 33-stage register is used, with the tap at the 20th stage. The object is to obtain the longest possible apparently random output sequence before it repeats itself.

For any given number of steps in the register, there is a tapping that will give this longest sequence. The mathematics are tricky, so it's best to simply obtain the magic numbers from a reference book. The sequence repeat time obviously depends on the clock frequency, and without the arrangement shown, a 1MHz clock speed gives a repeat time of about a second, long enough to avoid any suggestion that it isn't actually random for most applications. Moving to Fig.2, the arrangement use is shown in more detail. To

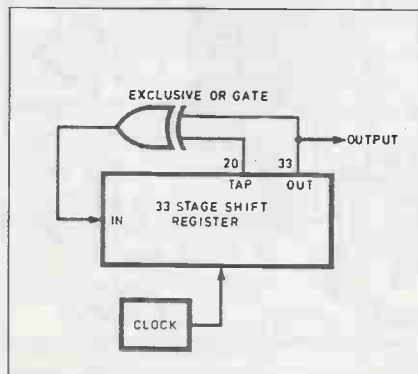

Fig. 1. Basic noise generator arrangement.



# **Electronics & Technology Today**

Canada's Magazine for High-Tech Discovery

Volume 14 , Number 5

May, 1990

## **FEATURES**

<b>Basic Electricity, Part 3</b> .....	20
Continuing our tutorial on basic circuits	
<b>Techie's Guide to C Programming, Part 17</b> .....	34
Steve Rimmer's popular guide to C.	
<b>Designing with Logic, Part 4</b> .....	23
Hardware and software approaches to logic circuits.	
<b>Diode Data</b> .....	44

## **PROJECTS**

<b>Personal Cassette Amplifier</b> .....	26
<b>Quick Capacitor Tester</b> .....	18
<b>Digital Experimenter's Unit</b> .....	25
<b>Engine Efficiency Meter</b> .....	36
<b>Stereo Noise Generator</b> .....	49
<b>Weather Station, Part 1</b> .....	8

## **INFORMATION**

<b>For Your Information</b> .....	6
<b>Advertisers Index</b> .....	48
<b>Subscriptions</b> .....	21
<b>Order Form</b> .....	22
<b>Software</b> .....	27
<b>Books</b> .....	42

Cover photo courtesy of Tektronix Canada.

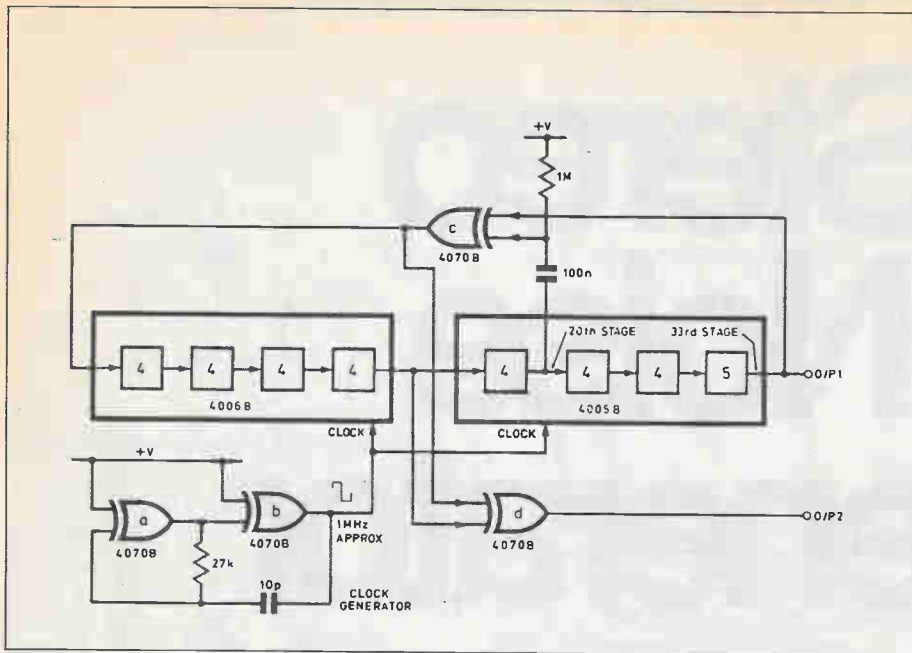

Fig. 2. Noise arrangement in more detail.

keep current consumption to a minimum the active devices are CMOS types, the most useful shift register for the purposes being the 4006B device. This is internally organized as four independent registers, two of which are four stages long and two either four or five, depending on connection. The first provides a total of sixteen stages and with the first four-stage of the second gives the twenty stages to the tap. The remaining stages, used as two fours and a five, take the total to thirty-three. A 4070B provides the EXclusive-OR function, and since it has three more gates

available, two of these has three more gates available, two of these serve as the clock generator.

It is possible for this circuit to enter a state where, if output and tap are both low, the output of the EX-OR gate will also be low so it will have nothing but low states circulating around it and the resulting output will appear to be a continuous low condition. To prevent this a simple self-starter has been added, using the 1M resistor and 100nF capacitor at one input to the gate. If the output from the tap is continuously low, the resistor will soon pull the gate

## Parts List

### Resistors

R1 .....	27k
R2 .....	1M
R3-6 .....	22k
R7-10 .....	10k
R11,12 .....	33k
R13-16 .....	47k
R17,18 .....	47k

All metal film types

### Capacitors

C1 .....	10p
C2,6 .....	100n
C3,4 .....	470p
C5 .....	100u25V

### Semiconductors

TR1,2 .....	2N3904, BC184
IC1 .....	4070B EX-OR gate
IC2,3 .....	4006B shift register
IC4,5 .....	CA3080 transconductance amp

### Miscellaneous

PCB, 3 14-pin DIP sockets, 28-pin DIP sockets

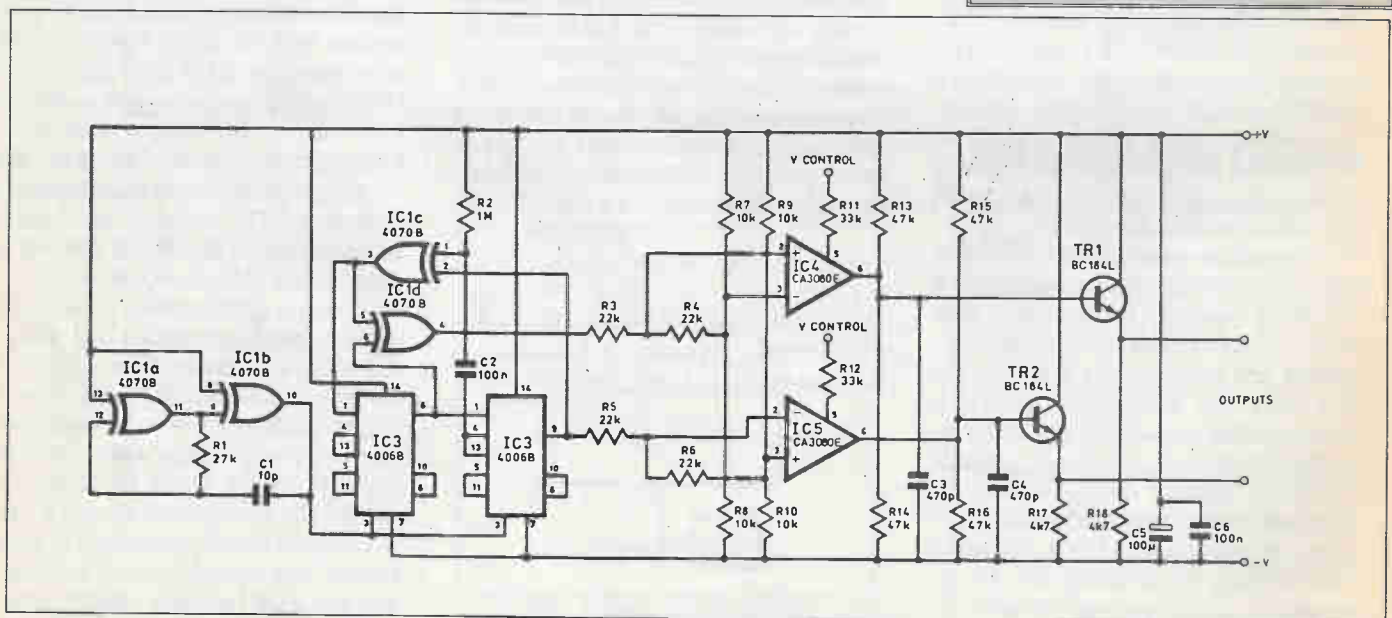

Fig. 3. Full circuit of the Stereo Noise Generator.

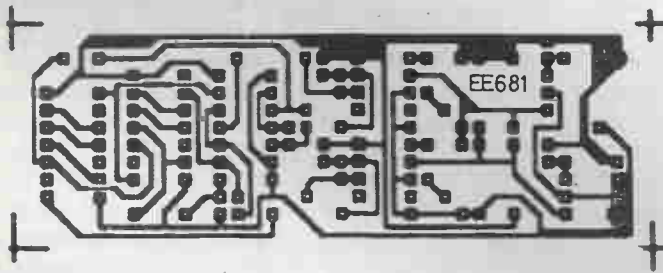
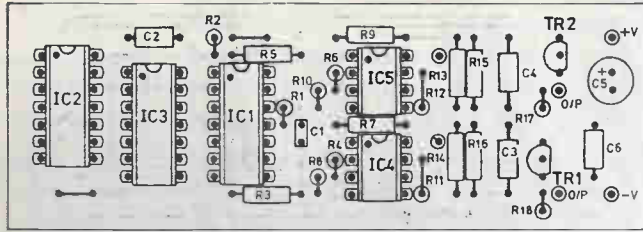

Fig. 4. PCB layout and wiring.

input high, setting the circuit into correct action.

### Stereo Noise

Mono noise, while more useful than simple tone for many applications, can still lack that certain something. Stereo, given by a separate noise source for each channel, gives an immediate impression of depth, like wind in tall trees or rushing water.

Simply picking off two or more tapping points from the circuit and combining them in the remaining gate of the EX-OR chip produces a second output. Obviously this is related to the first, but on the scope they look totally different and played through an amplifier they certainly sound right.

This is a project for experimenters, possibly for use in other designs, so to make it more useful and interesting an extra feature is included: independent voltage control of the output amplitude from each channel. This feature is optional, as are the output buffers; notes on this will be given later.

### Full Circuit

Turning to the full circuit of Fig. 3, the clock consists of IC1a and IC1b, connected as a simple astable running at approximately 1MHz. This drives the clock

inputs, pin 3 on IC2 and IC3. The output from the first four stages in IC2 is taken from pin 8 straight to the input of IC3, pin 1.

The output from IC3 is taken from pin 9 and EX-OR'd with the output from the 20th stage tap, from pins 4 and 13 by IC1c. The output from this gate is passed back to IC2's input, pin 1. It also goes to IC1d, where it is EX-OR'd with a tap from stage 16, pin 8 of IC1 to give the second output. Variable gain is provided by a pair of transconductance op amps, IC4 and IC5. The polarity of output of these depends on the input, but the output current depends on the bias current fed to pin 5, in this case, through R11 and R12.

The outputs are also pulled toward half the supply voltage by R13/14 and R15/16. Thus the amplitude of the output is symmetrical around the centre of the supply voltage, with amplitude governed by the voltage applied to R11 and R12. The output at this point still jumps between two levels, however. To shape it into something more like true analog noise, lowpass filtering is required.

The simplest filters possible are adequate, and are provided by C3/4, giving a corner frequency around 15kHz. This gives a noise bandwidth covering the full audio band. Finally, since the outputs have a fairly high impedance, they are buffered

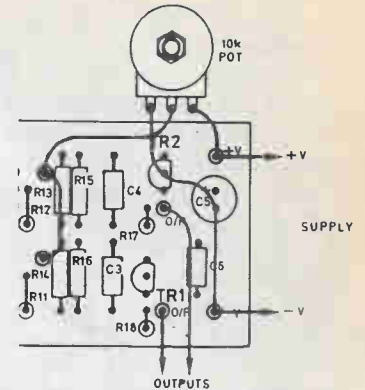

Fig. 5. Connections for testing the unit.

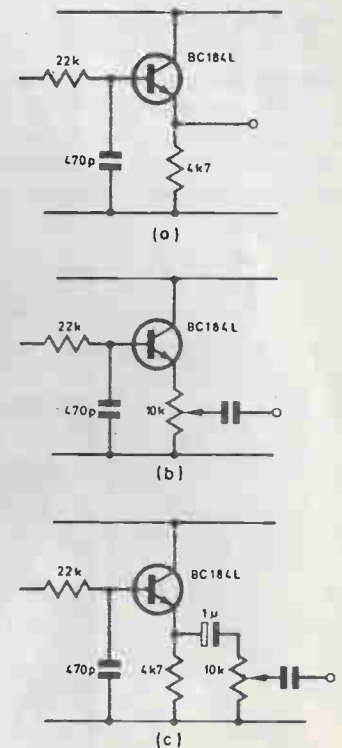

Fig. 6(a). Simple output circuit. (b) Output circuit with simple gain control. (c) Improved output with gain control.

by transistors TR1 and TR2, here used as emitter followers. C5/6 decouple the supply rails to the circuit.

### Construction

Construction is straightforward, though this project does have a fairly compact



## Stereo Noise Generator

layout; care and a fine-tipped soldering iron are required. The positions of all the components are shown in Fig. 4. Sockets are advised for the ICs.

Veropins or similar are useful for making external connections. Be sure that C5 is fitted the right way around. Did you know that electrolytics explode very satisfyingly when connected backwards to a hefty power supply? Listen: safety rules. Besides, the room fills up with shredded dielectric. If you get in trouble with your Mom, I'm going to deny everything. The board may be used with power supplies from 5V to 15V. Testing should start with the application of 10V, and checking of the voltage at the two outputs. Without IC4 and IC5 in place, the two output transistor bases will be at half the supply voltage, so the outputs should be 0.6V below this.

Next IC1, 2 and 3 should be plugged in and the power reapplied. A check on IC1 pin 10 should show roughly 5V, indicating that the clock is running. If a scope is available, the clock waveform can be observed — an approximate squarewave. Checks on IC1 pin 4 and IC3 pin 9 should similarly show about half the

Table 1. Performance details for Stereo Noise Generator.

Supply Voltage	Passive filter only		Transistor buffers		Buffers with IC4, IC5	
	Supply	Output	Supply	Output	Supply	Output
5	1.5mA	420mV	2.3mA	430mV	2.5mA	0-280mV
10	5.5mA	760mV	7.2mA	770mV	7.6mA	0-660mV

Table 1. Performance details for the noise generator.

supply voltage, indicating that they're switching their frigging little brains out.

IC4 and IC5 can be fitted, the two control inputs shorted together and fed from a 10k pot across the supply as shown in Fig. 5, and the outputs monitored with a scope. Noise signals should be present and should vary in amplitude with the pot setting.

### Options

Some options are possible if all the features aren't required. You can leave out the op amps, shorting pins 2-6 on each amp. This gives the simple output of Fig. 6a. A

level pot can be installed as in Fig. 6b. This is simple enough, but DC through a level pot may cause unwanted noise. Imagine that. A noise generator making unwanted noise. Kind of makes you think, doesn't it? No? Oh, well, get rid of the unwanted noise by using the circuit of Fig. 6c. You could also dispense with the output buffers entirely, and take the signals from the right-hand end of the 22k resistors. However, the circuit being driven should have an impedance of 100k or more.

Some typical performance figures for the circuit for different supply voltages and configurations are shown in Table 1.



10¢ ONCE BOUGHT A  
LOT OF CHOCOLATE BAR.  
\$1 ONCE BOUGHT A  
LOT OF HELP.

The giving begins with you.





Seminar Leader — Robert Cohen, BBA, MBA, president and CEO, The Cohen Group, Inc.

Author of more than 300 articles and of *The Ad Game... Recreating Creativity to Sell* (CCH, 1987) Robert has hosted three cable television series including "Anatomy of an Advertisement". During his seven years as a business professor, Robert taught at Trent University and York University's M.B.A. program.

- Topics include:
- Setting promotional objectives
  - Targeting audiences
  - Buyer behaviour
  - Budgets
  - Competitive analysis
  - Establishing a unique selling proposition (U.S.P.)
  - Media selection
  - Creativity, including layouts, type and colour selection, film work and printing
  - Co-op advertising programs
  - Publications

### Effective Marketing of Computer Products in the 1990s

# WINNING THE AD GAME

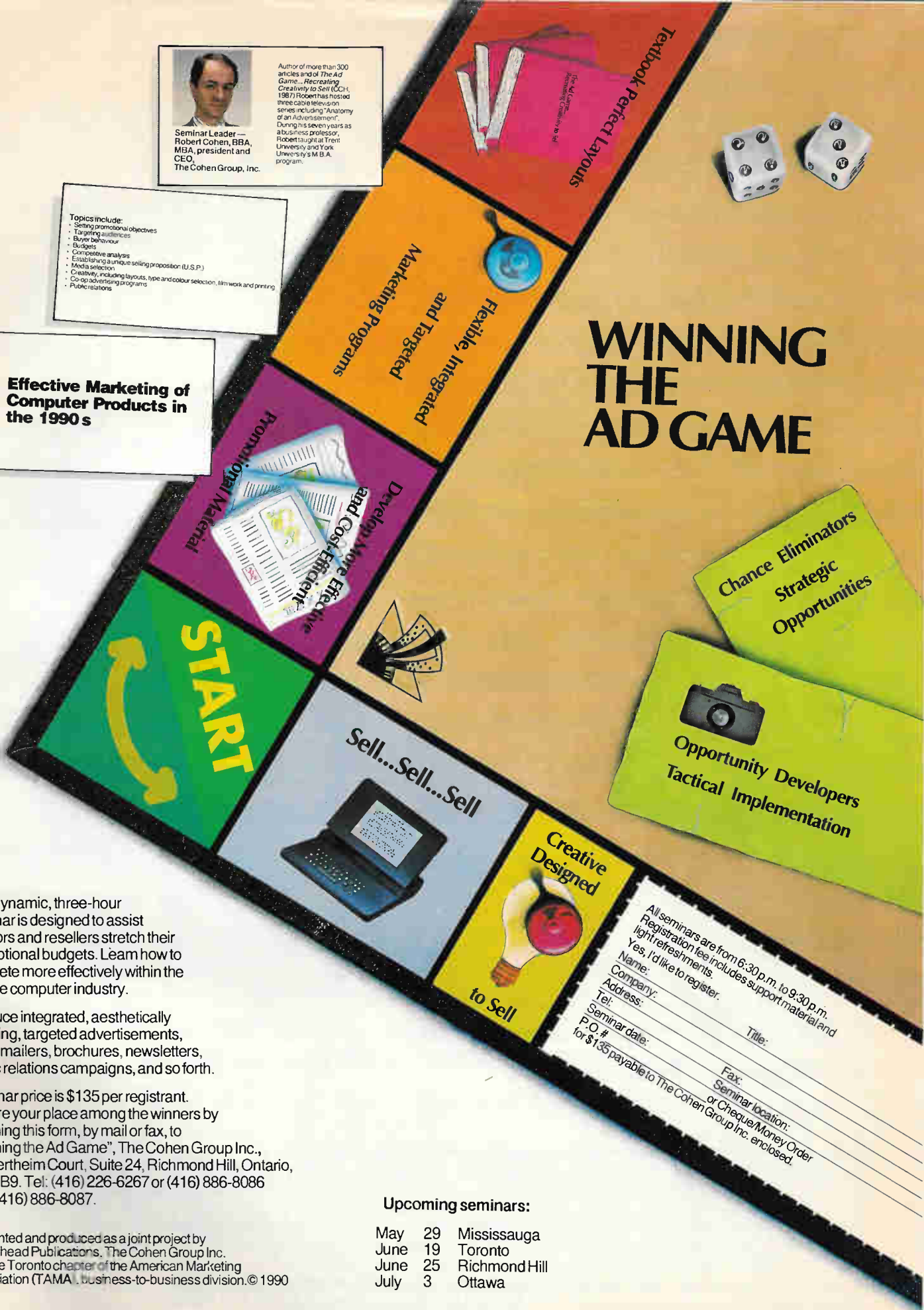

This dynamic, three-hour seminar is designed to assist vendors and resellers stretch their promotional budgets. Learn how to compete more effectively within the volatile computer industry.

Produce integrated, aesthetically pleasing, targeted advertisements, direct mailers, brochures, newsletters, public relations campaigns, and so forth.

Seminar price is \$135 per registrant. Secure your place among the winners by returning this form, by mail or fax, to "Winning the Ad Game", The Cohen Group Inc., 30 Wertheim Court, Suite 24, Richmond Hill, Ontario, L4B 1B9. Tel: (416) 226-6267 or (416) 886-8086 Fax: (416) 886-8087.

Presented and produced as a joint project by Moorshead Publications, The Cohen Group Inc. and the Toronto chapter of the American Marketing Association (TAMA), business-to-business division. © 1990

#### Upcoming seminars:

May	29	Mississauga
June	19	Toronto
June	25	Richmond Hill
July	3	Ottawa

All seminars are from 6:30 p.m. to 9:30 p.m.  
 Registration fee includes support material and light refreshments.  
 Yes, I'd like to register.

Name: \_\_\_\_\_ Title: \_\_\_\_\_  
 Company: \_\_\_\_\_  
 Address: \_\_\_\_\_  
 Tel: \_\_\_\_\_  
 Seminar date: \_\_\_\_\_  
 P.O.# \_\_\_\_\_  
 for \$135 payable to The Cohen Group Inc. enclosed.

Fax: \_\_\_\_\_  
 or Seminar location: \_\_\_\_\_  
 or Cheque/Money Order enclosed.



## A Sure Winner: Plays The Right Cards

Pick the Card That Gives You All The Advantages

**A THE BLAZING ORION 25MHZ CACHE 386 TAKES YOU TO THE LIMIT**

SAME SPEEDS AS SYSTEM 386 BUT WITH OUR 25MHZ CACHE 386 HAS 32 KB CACHE MEMORY 8 KB CACHE AUTO BOOTING ROM EPIC SOCKET FOR 80387-25 8 EXPANSION SLOTS 8/5 VER 4.0 DRIVER 1/0 CACHE UTILITY DIAGNOSTIC PROG FULLY COMP WITH MS DOS; OS/2; UNIX; CONCURRENT DOS 386; PC DOS/386; XENIX; ETC;

**\$2,495**

**K ORION 386**

TURBO 8/20 MHz INTEL 80386-20 CPU 1MB RAM EXP 4/8 MB 1.2 MB OR 1.4 MB DRIVE FLOPPY/HARD DISK CONT. SER/PAR/GAME/CLOCK AT 101 ENHANCED KEYBOARD COLOR OR MONO VIDEO CARD ASSEMBLED & FULLY TESTED IN CANADA 100% IBM COMPATIBILITY

**\$1,595**

386-25... \$1,795

**Q ORION 386 SX**

INTEL 80386 SX CPU TURBO 8/16 MHz 1MB RAM EXP TO 4/8 MB 1.2 MB OR 1.4 MB DRIVE FLOPPY/HARD DISK CONT. SER/PAR/GAME/CLOCK AT 101 ENHANCED KEYBOARD COLOR OR MONO VIDEO CARD ASSEMBLED & FULLY TESTED IN CANADA 100% IBM COMPATIBILITY

**\$1,195**

**J ORION 286**

TURBO 6/12 MHz 1MG RAM EXP TO 4/8 INTEL 80286 CPU 1.2 MB OR 1.4 MB DRIVE FLOPPY/HARD DISK CONT. SER/PAR/GAME/CLOCK AT 101 ENHANCED KEYBOARD COLOR OR MONO VIDEO CARD ASSEMBLED & FULLY TESTED IN CANADA 100% IBM COMPATIBILITY

**\$899**

286-16... \$999

**10 ORION 88**

8 EXPANSION SLOTS SWITCHABLE TURBO 360K OR 720K DRIVE SER/PAR/GAME/CLOCK AT STYLE CASE & KEYBOARD ASSEMBLED & FULLY TESTED IN CANADA 48 HOURS BURN IN 100% IBM COMPATIBILITY

**\$499**

XT 12MHz \$549 XT16 - \$599

You can't find a better deal than this: With ORION the odds are with you so there's no need to gamble ORION cards are marked!

Marked by superior design; quality manufacturing & loaded with features at prices that will make the competition fold!!! FOR A SURE BET GO WITH ORION



and compare our quality and prices! Before You Purchase ANY Computer!

## ORION DISKETTES

100% ERROR FREE & LIFETIME WARRANTY

### KAO DIDAK

KAO 5 1/2" DISKS	PER BOX	10 BOXES
MD2D 360K	\$ 8.49	\$ 7.95
MD2H 1.2M	\$11.45	\$10.95
FOR COLOR ADD	\$ 3.00	\$ 2.75
KAO 3 1/2" DISKS	PER BOX	10 BOXES
MF2DD	\$14.95	\$13.95
MF2HD	\$28.95	\$27.95
FOR COLOR ADD	\$ 4.00	\$ 3.75
DISCAROO COLOR	19.95	18.95
IN POUCH	\$22.95	\$19.95



ORION 5 1/2" DISKS	PER BOX	10 BOXES
OD2D 360K	\$ 6.99	\$ 6.49
OD2HD 1.2M	\$10.95	\$ 9.95
FOR COLOR ADD	\$ 3.00	\$ 2.50
ORION 3 1/2" DISKS	PER BOX	10 BOXES
OF2DD 1 MEG	\$12.95	\$11.95
OF2HD 2 MEG	\$24.95	\$22.50
FOR COLOR ADD	\$ 4.00	\$ 3.50

### NO NAME DISKETTES

NO NAME 5 1/2" DISKS	PER BOX	10 BOXES
NND2D 360K	\$ 4.99	\$ 4.49
NN2HD 1.2M	\$ 9.95	\$ 8.95
NO NAME 3 1/2" DISKS	PER BOX	10 BOXES
NNF2DD 1M	\$10.95	\$ 9.95
NNF2HD 2M	\$21.99	\$20.99

## SONY



5 1/2" DSDD 360K...	PER BOX	10 BOXES
W/PLASTIC CASE...	\$ 9.95	\$10.95
3 1/2" DSDD 1M.....	PER BOX	10 BOXES
3 1/2" HD 2M .....	\$18.95	\$17.95
3 1/2" HD 1.2M.....	\$34.95	\$32.95
5 1/2" HD 1.2M.....	\$18.95	\$17.95



### PORTABLE SYSTEMS

	88	286	386	386
	256K	512K	1 MEG	25MHz CACHE
9" AMBER DUAL CRT	1,195	1,695	2,495	3,695
9" EGA MONITOR	2,195	2,595	3,395	4,595
LCD 600X400 SCRIN	1,595	1,995	2,795	3,995
PLASMA 600X400 S	2,495	2,895	3,695	4,895

## Quality, Reliability and Service

**MOST ORDERS SHIPPED WITHIN 24 HOURS.**

**SERVING YOU FOR OVER 15 YEARS**

**If you find a better price call us before you buy.**

40 LANCASTER ST., W.  
KITCHENER, ONT. N2H 4S9

PH: (519) 576-9902  
FAX: (519) 576-9028



WHY WAIT? CALL ORION ELECTRONICS NOW!  
ORDER TOLL FREE

**1-800-265-2658**



Order desk & technical support open:  
9:00 a.m. to 6:00 p.m. Monday - Friday  
9:00 a.m. to 5:00 p.m. Saturday

For Service CALL  
1-519-576-9026





# ELECTRONICS SUPPLIES INC.

IMPORTERS & DISTRIBUTORS

INDUSTRIAL — COMMERCIAL — EDUCATIONAL

SALES & SERVICE

Your #1 Source For Quality Computer Components

Quality, Reliability and Service

## SEAGATE ST-225-20 MB HARD DISK SYSTEM

Includes hard disk controller, cables and instructions. All drives are pre-tested and come with a one year warranty. **\$349**

### Seagate Hard Drives

- ST225 KIT, 20MB, 65MS, (MFH).....\$349.95
- ST238R KIT, 30MB, 65MS, (RL).....\$389.95
- ST251-1, 40MB, 28MS, (MFH).....\$475.95
- ST 296 N 85MB 28MS (SCSI).....\$799.95
- ST4096, 80MB, 28MS, (MFH).....\$849.95
- SEAGATE 3 1/2" DISK DRIVES
- ST125, 20MB, 40MS, (MFH).....\$375.95
- ST138M, 32MB, 40MS, (MFH).....\$479.95
- ST138M, 32MB, 40MS, (SCSI).....\$529.95
- ST138R, 32MB, 40MS, (RL).....\$649.95
- ST157R, 50MB, 40MS, (RL).....\$479.95

### MiniScribe Hard Drives

- MINISCRIBE 1 YEAR WARRANTY
- 3053 - 5 1/4", 40MB, 25 MS.....\$575.95
- 3085 - 5 1/4", 70MB, 22 MS.....\$799.95
- 3650 - 5 1/4", 40MB, 61 MS.....\$399.95
- 8428 - 3 1/2", 20MB, 68 MS.....\$325.95
- 8438 - 3 1/2", 30MB, 68 MS.....\$349.95

### STAR HARD CARDS

- SC20A, 20MB, 65MS, MFH, XT, PS/2, 30 \$495.95
- SC20B, 20MB, 62MS, MFH, XT, PS/2, 30 \$475.95
- SC125, 20MB, 40MS, MFH, XT, PS/2, 30 \$495.95
- SC30A, 30MB, 65MS, RLL, XT, PS/2, 30 \$549.95
- SC30B, 30MB, 62MS, RLL, XT, PS/2, 30 \$549.95
- SC138M, 32MB, 40MS, MFH, XT, PS/2, 30 \$579.95
- SC138R, 30MB, 40MS, RLL, XT, PS/2, 30 \$549.95

### WESTERN DIGITAL Controller Boards

- WESTERN DIGITAL HARD DRIVE CONTROLLERS
- HARD DISK 20 MEG (MFH), XT.....\$ 79.95
- HARD DISK (MFH), XT.....\$ 84.95
- HARD DISK (RLL), XT.....\$ 84.95
- 6 - 12MHz, HD (MFH), AT, XT286 \$129.95
- 6 - 12MHz, HD/FD (MFH) AT, XT \$286 \$165.95
- 6 - 12MHz, HD (RLL), AT, XT \$286 \$189.95
- 6 - 12MHz, HD/FD (RLL) AT, XT \$286 \$189.95
- \* ALL OF THE ABOVE ARE 2:1 INTERLEAVE \*
- 16MHz, HARD DISK (MFH) AT, 386 \$169.95
- 16MHz, HD/FD (MFH) AT, 386.....\$189.95
- 16MHz, HARD DISK (RLL) AT, 386 \$189.95
- 16MHz, HD/FD (RLL) AT, 386.....\$199.95
- 16MHz, HD/FD ESDI INTERFACE AT, 386\$299.95
- \* ALL OF THE ABOVE ARE 1:1 INTERLEAVE \*

### Floppy Controller Boards

- AT XT FLOPPY DRIVE CONTROLLER
- XT FLOPPY CONTROLLER.....\$ 39.95
- AT/XT HI DENS 360/1.2/720/1.44 \$ 59.95

### WE CARRY A HUGE SELECTION OF HARD DRIVE CONTROLLERS. ASK FOR A COMPLETE LISTING.

- JOYSTICKS
- GRAVITS (CAN MADE 1 YR WAR).....\$49.95
- GRAVITS (SAME AS ABOVE BUT CLEAR).....\$54.95
- IBM COMPATIBLE JOYSTICK FROM.....\$19.95
- QUICK SHOT IBM/APPLE.....\$29.95
- TJ810 PERFECT MICRO IBM/APPLE \$34.95
- DELUXE JOYSTICK IBM/APPLE.....\$39.95
- WINNER 909 IBM/APPLE.....\$34.95
- COMPUTER JOYSTICK IBM.....\$29.95
- JOYSTICK 606 IBM.....\$32.95

### SCANNERS

- HANDYSCANNER 2.5".....\$ 299.95
- HANDYSCANNER 4, 1/8".....\$ 349.95
- LOGITECH SCANNER 6.1/8".....\$ 379.95
- CAT IMAGE SCANNER.....\$ 299.95
- CHIRON DESK SCANNER.....\$ 895.95
- SHAPE DESK SCANNER.....\$1,295.95

- EDIMAX LAN PROFESSIONAL
- AI-2350 STAR TOPOLOGY ARC LINK.....\$189.95
- AI-2351 BUS TOPOLOGY ARC LINK II \$239.95
- AH-2355 8 PORT ACTIVE HUB.....\$489.95
- AH-2356 4 PORT ARC LINK HUB.....\$479.95
- AH-2357 4 PORT PASSIVE HUB.....\$ 39.95
- EN-2360 ETHERNET NE-1000 COMP.....\$349.95
- TM-5000 50 OHM TERMINATOR.....\$ 8.95
- TM-930H 93 OHM TERMINATOR.....\$ 8.95

### SONY 3M Floppy Drives

- DATA CARTRIDGES
- DC1000.....\$34.95
- DC1000.....\$29.95
- DC600A.....\$42.95
- DC600H.....\$49.95
- DC600XTD.....\$49.95
- DC300KLP.....\$48.95
- QD000A.....\$39.95
- QD2000.....\$29.95
- QD300KLP.....\$37.95
- QD600XTD.....\$44.95

## TTX MONITORS

- 1201A - 12" COMP AMBER MONOCH.....\$129.95
- 1400F/A 14" TTL AMBER FLAT SCREEN \$169.95
- 1452F/W 14" VGA AM WMT FL SCREEN.....\$179.95
- 1452F ANALOG/VGA P52 COMPATIBLE.....\$199.95
- 1452 - 14" RGB 640 X 200.....\$299.95
- 2410 - 14" RGB 43mm POL.....\$389.95
- 2412AG - 39 EGA 640 X 350 AG.....\$479.95
- 2422 - 14" EGA 31mm A. GL.....\$499.95
- 5439AG - 39 VGA 640 X 480 AC.....\$479.95
- 5432AG - 29 VGA 720 X 480 AC.....\$499.95
- 5436AG - 28mm 1024 X 768 MULTISYNC \$699.95
- 6435S DOT PITCH .41mm EGA/CGA.....\$449.95
- 3435AG - 31mm 800 X 600 MULTISYNC.....\$649.95
- \* ALL TTX MONITORS WITH TILT/SWIVEL BASE \*

## DataTrain Monitor

- DC2005 - 14" .41mm DOT P. RGB T/S.....\$449.95
- DC2055 - 14" .52mm DOT P. RGB T/S.....\$349.95
- DC3535 - 14" .31mm EGA/CGA/T/S.....\$499.95
- DC355 DOT PITCH .41mm EGA/CGA.....\$449.95
- DC505 DOT PITCH .41mm EGA.....\$499.95
- DC600 M. RES VGA/DIG. D.P. .31mm.....\$599.95

### DATA TRAIN MONITORS: MONOCHROME

- V240A - 12" AMBER COMPOSITE.....\$139.95
- V242 - 12" TTL AMBER OR GREEN.....\$139.95
- V244 - 12" TTL, AMBER.....\$129.95
- V252 - 12" M. RES MONO AMB/GREEN.....\$149.95
- V262A - 12" 3:1AT SCREEN TTL AMBER \$159.95
- V272 - 14" DUAL FREQ AMBER/HT.....\$189.95
- V282A - 14" FLAT SCR, DUAL FREQ.....\$169.95
- V282W - 14" FLAT SCR, DUAL FREQ.....\$179.95
- V502 - 12" ANLG VGA/MCGA MONO WH.....\$139.95

### Modems FAX MACHINES

- 1200 INTERNAL.....\$ 74.95
- 1200 EXTERNAL.....\$ 89.95
- 2400 INTERNAL.....\$ 129.95
- 2400 EXTERNAL.....\$ 139.95
- 4800.....\$ 799.95
- 9600.....\$ 799.95
- ASHER FAX CARD 4800.....\$ 499.95
- ASHER FAX CARD 9600.....\$ 499.95
- PANAFAX UF150.....\$1,495.95
- PANAFAX UF250.....\$2,295.95
- PANAFAX UF140.....\$1,295.95
- PANAFAX UF260.....\$2,999.95
- RAVEN XF100.....\$1,399.95

### MICE

- LOGITECH HI RES SERIAL.....\$ 109.95
- LOGITECH HI RES BUS.....\$ 119.95
- DEKXA 2 BUTTON AT, XT.....\$ 59.95
- DEKXA DELUXE AT, XT.....\$ 69.95
- GENIUS GM-6 PLUS 200 X 800.....\$ 69.95
- GENIUS GM 6000 DELUXE PKGE.....\$ 89.95
- JVC OPTICAL 250-500 DPI.....\$ 99.95
- MOUSE PAD.....\$ 8.95
- MOUSE STAGE.....\$ 24.95

### SPECIALTY INDUSTRIAL BOARDS FOR IBM COMPUTERS

- SI-7210-C IEEE-488 CARD.....\$369.95
- SI-451P 4 SERIAL 1 PARALLEL.....\$189.95
- SI-851P 8 SERIAL 1 PARALLEL.....\$249.95
- SI-8520-X1 RS422 (PC/XT) 1 PORT \$119.95
- SI-8520-X2 RS422 (PC/XT) 2 PORT \$139.95
- SI-8520-A1 RS422 (PC/AT) 1 PORT \$139.95
- SI-8520-A2 RS422 (PC/AT) 2 PORT \$179.95
- SI-4232 CONVERTER (RS232-RS422).....\$139.95
- SI-7541 12 BIT AD/DA CARD.....\$195.95
- SI-8255 8255 I/O CARD.....\$139.95
- SI-2121 COPY BOARD.....\$139.95
- CLK 2900 2 SER/2 PAR FOR XT/AT.....\$ 69.95
- CLK 3200 8 SER PORT PC XT/AT.....\$379.95
- CLK 3300 MULTI USER CARD 4 PORT \$129.95
- CLK 3400 RS422 CARD XT/AT.....\$119.95
- CLK 3500 IEEE 488 CARD.....\$329.95
- CLK 3600 14 BIT A/D D/A CARD.....\$329.95
- CLK 3700 12 BIT A/D D/A CARD.....\$199.95
- CLK 3800 8255-8253 I/O CARD.....\$ 99.95

### GENDER CHANGERS

- 25/15/9 M/H OR M/F.....\$ 8.95
- 25-9 M/H OR F/F.....\$ 8.95
- JUMPERBOX DB25M/F F/F.....\$ 9.95
- NULL MODEM.....\$ 9.95
- RS232 MINI TESTER M/F.....\$13.95
- WRING BOX DB25M/F.....\$12.50
- RS232 REVERSER.....\$12.50
- SURF PROTECTOR DB25M/F.....\$14.95
- RS232 BREAKOUT BOX.....\$69.95
- MLP20 LOGIC MONITOR.....\$69.95

## Roland DG

- PR9101 9-PIN 192 CPS DESKTOP.....\$ 279.95
- PR9104 9-PIN 240 CPS DESKTOP.....\$ 349.95
- PR2417 24-PIN DESKTOP.....\$ 449.95
- ROLAND DG PRINTERS
- PR1215 216 CPS WIDE CARRIAGE.....\$ 579.95
- PR1550 288 CPS WIDE CARRIAGE.....\$ 749.95
- PR 2465 24 PIN WIDE.....\$ 699.95
- PR2017 17 CPA DAISY WHEEL.....\$ 449.95
- ROLAND LASER PRINTERS
- LP1100 11 PG/MIN SIZE.....\$2,295.95
- ROLAND FLATBED PLOTTERS
- DXV1100 A/B SIZE 8-PEN HP COMP.....\$1,299.95
- DXV1200 A/B SIZE ELECTROSTATIC.....\$1,795.95
- DXV1300 A/B SIZE 1 MB BUFF STD \$2,295.95
- DPX2200 C-SIZE PEN LOGIC.....\$5,985.95
- DPX3300 D-SIZE FLATBED PRO.....\$7,495.95
- ROLAND ROLLERBED PLOTTERS
- GRX300 D-SIZE ROLLERBED.....\$5,495.95
- GRX300M D-SIZE 1 MB RAM.....\$5,985.95
- GRX400 E-SIZE ROLLERBED.....\$6,495.95
- GRX400M E-SIZE 1 MB RAM.....\$7,495.95

## MANNESMANN TALLY

- MT81 9-PIN 130 CPS.....\$ 249.95
- MT222 24-PIN 220/75 CPS.....\$ 729.95
- MT230 24-WIDE 300/150/100/75.....\$1,795.95
- MT230-9 WIDE 300/150/100 9-PIN \$1,395.95
- MT905 LASER (HP SERIES II COMP) \$1,899.95
- 1 MEG EXPANSION.....\$ 499.95

## Panasonic PRINTERS

- EXP1180 11 192 CPS 9-PIN.....\$ 299.95
- EXP1191 11 240 CPS 9-PIN.....\$ 375.95
- EXP1124 11 192 CPS 24-PIN.....\$ 475.95
- EXP1524 16.5 240 CPS 24-PIN.....\$ 999.95
- EXP4450 11 PPM LASER PRINTER.....\$2,795.95

## EPSON A Printer For Any Application

- 24-PIN LETTER QUALITY DOT MATRIX PRINTERS
- LQ-1050 264/220/88/73 CPS.....\$1,095.95
- LQ-2500 270/90 CPS DRAPI/MLQ.....\$1,295.95
- LQ-500 180/60 CPS.....\$ 429.95
- LQ-510 180 CPS.....\$ 529.95
- LQ-850 264/220/88/73 CPS.....\$ 895.95
- LQ-950 24 PIN 2 X 12 DOT MATRIX \$ 999.95
- SQ-2500 540/180 INK JET 132 COL \$1,495.95

- LX-800 180/150 CPS.....\$ 249.95
- LX-810 180 CPS.....\$ 299.95
- EX-800 250/45 CPS.....\$ 699.95
- FX-1050 264/54 CPS.....\$ 799.95
- FX-850 265/54 CPS SMARTPARK.....\$ 599.95
- FX-86E 200/40 CPS 80 CLMN.....\$ 499.95
- DFX EPSON 533 CPS.....\$2,895.95
- JX-80 COLOR PRINTER.....\$ 499.95

## Sitara PRINTERS

- NX 1000 144/36 CPS.....\$ 269.95
- NX 1000C 144/36 CPS.....\$ 289.95
- NX 1000C 144/36 CPS (7 COLOR) \$ 375.95
- NX 1000 144/36 CPS.....\$ 375.95
- NX 15, 120/30 CPS MLQ.....\$ 549.95
- XR 1000 300/76 CPS MLQ.....\$ 595.95
- XR 1500 300/76 CPS MLQ.....\$ 799.95
- NX 2400 170/57 CPS LQ, 24 PIN \$ 499.95

### AEG OLYMPIA

- WPC 136-24 24 PIN 240 CPS COL \$ 749.95
- WP 136-24 24 PIN 240 CPS.....\$ 699.95

### Program Card for IBM-PC/XT/AT

- BW-601 BIPOLEAR PROM PROG.....\$399.95
- EW-701 EPROM WRITER 2716-1024.....\$299.95
- EW-704 EPROM WRITER 2716-1024.....\$349.95
- EW-901 EPROM WRITER XT/AT 2716-512 \$249.95
- EW-904 EPROM WRITER XT/AT 2716-512 \$325.95
- PAP-01 PAL PROGRAMMER.....\$399.95
- BPP-01 BPPROM PROGRAMMER.....\$399.95
- BU-201/T INTERFACE U. V. ERASER.....\$149.95

- INTERFACE CONVERTER
- SMITH CORONA SERIAL-PARALLEL.....\$ 49.95
- SP-100 SER-PAR, EXT POWERED.....\$ 89.95
- SP-100 PAR-SER, EXT POWERED.....\$ 89.95
- SP-200 SER-PAR, INTERFACE POW \$ 79.95
- SP-200 PAR-SER, INTERFACE POW \$ 79.95
- RR-100 RS232C/RS422A CONVERT.....\$ 69.95
- IC-11 RS232C/RS485 CONVERTER.....\$ 99.95
- IC-12 RS232C/CURRENT LOOP COM \$ 99.95

## MOTHER BOARDS

- XT 8MHz TURBO MB OK.....\$ 99.95
- XT 10MHz TURBO MB OK.....\$ 109.95
- XT 16 MB TURBO MB OK.....\$ 129.95
- AT 286 6/12 TURBO MB OK.....\$ 249.95
- AT BABY 286 8/16 OK.....\$ 289.95
- AT 16 MB MEG EMS OK.....\$ 299.95
- NEAT 286 16MHz OK.....\$ 599.95
- 386 16/20MHz OK.....\$ 999.95
- 386 16/25MHz OK.....\$1,095.95
- 386 25MHz W/32K CACHE OK.....\$1,995.45
- PS/2 COMP ALL IN ONE MB.....\$ 1695.95
- \*ALL 286/386 ARE BABY SIZE TURBO MB.\*

## Video boards

- MGA MONO GRAPHIC W/PR PORT.....\$ 49.95
- CGA COLOR GRAPHIC W/RGB COMP.....\$ 49.95
- MGA/CGA DUAL GRAPHIC CARD.....\$ 79.95
- GB MGA/CGA AUTO SWITCH.....\$ 89.95
- EGA CARD 640 X 350 256K.....\$ 149.95
- SUPER EGA 800/600/350 8 BIT.....\$ 169.95
- VGA CARD (8 BIT).....\$ 179.95
- VGA CARD (16 BIT).....\$ 199.95
- JUKO EGA 640 X 480.....\$ 139.95

## EGAWONDER

- MULTI GRAPHIC SOLUTION.....\$ 89.95
- MULTI GRAPH SOL GAME PORT \$ 99.95
- MULTI EGA SOLUTION.....\$ 249.95
- MULTI VGA SOLUTION.....\$ 299.95
- VGA SMALL WONDER.....\$ 225.95
- MAXI VGA SOL 256K/M.....\$ 379.95
- MAXI VGA SOL 512K/M.....\$ 449.95

## STB TTX GROUP

- STB AUTO EGA.....\$ 169.95
- STB AUTO VGA.....\$ 199.95
- STB VGA EXTRA/EM256KB.....\$ 259.95
- STB VGA EXTRA/EM512KB.....\$ 325.95
- STB VGA EM 16/256KB.....\$ 275.95
- STB VGA EM 16/512KB.....\$ 349.95

## Keyboards

- AT/XT 5060 STANDARD.....\$ 59.95
- AT/XT ENHANCED KEYBOARD.....\$ 69.95

## Add on boards

- XT PAR PRINTER PORT.....\$ 29.95
- XT RS232 SERIAL PORT.....\$ 34.95
- XT RS422 SERIAL PORT.....\$ 119.95
- XT I/O + 2 (S/P/C/G).....\$ 69.95
- XT MULTI I/O (S/P/C/G/DISK).....\$ 79.95
- XT GAME PORT (TWO PORT).....\$ 29.95
- XT THE CARD.....\$ 39.95
- AT I/O S/P NO GAME PORT.....\$ 49.95
- AT I/O S/P/G.....\$ 59.95
- AT I/O S/P/G.....\$ 79.95
- AT GAME PORT.....\$ 49.95

## Power supplies

- 150W CSA XT SIZE.....\$ 79.95
- 200W CSA XT SIZE.....\$ 89.95
- 200W CSA FULL SIZE.....\$ 99.95
- 200W CSA FOR TOWER CASE.....\$ 139.95
- PS/2 STYLE CASE.....\$ 99.95
- SMALL FOOT PRINT CASE.....\$ 99.95
- DESKTOP TOWER CASE.....\$ 139.95

## COMPUTER CASES

- AT STYLE CASE, XT, BABY, AT MB.....\$ 59.95
- AT FULL SIZE CASE.....\$ 89.95
- SMALL FOOT PRINT AT OR XT.....\$ 89.95
- PS/2 STYLE CASES.....\$ 89.95
- TOWER CASE AT, XT OR 386 FULL \$ 189.95
- TOWER MINI DESKTOP AT, XT, 386 \$ 189.95

## DISKETTE STORAGE BOXES

- DD-5 HOLDS 5 DISKS.....\$ 2.95
- DD-10 HOLDS 10 DISKS.....\$ 3.95
- DD-50 HOLDS 50 DISKS.....\$ 8.95
- DD-70 HOLDS 70 DISKS.....\$ 9.95
- DD-100L HOLDS 100 DISKS.....\$12.95
- DD-120L HOLDS 120 DISKS.....\$13.95
- DD-140L HOLDS 140 DISKS.....\$14.95
- DD-180L HOLDS 180 DISKS.....\$39.95
- CARDBOARD MAILER PKG/25.....\$26.95
- DISKETTE HOLDERS FOR 3 1/2" DISKS
- YD-5 HOLDS 5 DISKS.....\$ 2.95
- YD-10 HOLDS 10 DISKS.....\$ 3.95
- YD-20 HOLDS 20 DISKS.....\$ 7.95
- YD-40 HOLDS 40 DISKS.....\$10.95
- YD-80 HOLDS 80 DISKS.....\$12.95
- YD-150 HOLDS 150 DISKS.....\$39.95
- CARDBOARD MAILER PKG/25.....\$24.95

# PLEASE ASK FOR OUR FREE CATALOG

**TERMS** VISA/MC/COD/CHEQUE  
 ALL ITEMS SHIPPED BY CANPAR OR MAIL. ADD \$4.00 FOR ALL COD ORDERS. ALLOW 10 BUSINESS DAYS FOR SHIPPING WHEN PAYING BY PERSONAL CHEQUE.  
 ALL ITEMS SUBJECT TO PRICE SALE DELIVERY & HANDLING CHARGE 6%, MIN. \$5.00 ALL RETURNED MERCHANDISE MUST HAVE RMA NUMBER.  
 RESTOCKING CHARGE 20%. PRICE SUBJECT TO CHANGE WITHOUT ANY NOTICE.

WHY WAIT? CALL ORION ELECTRONICS NOW!  
 ORDER TOLL FREE  
**1-800-265-2658**

Order desk & technical support open:  
 9:00 a.m. to 6:00 p.m. Monday - Friday  
 9:00 a.m. to 5:00 p.m. Saturday  
**For Service CALL**  
**1-519-576-9026**

**40 LANCASTER ST., W. KITCHENER, ONT. N2H 4S9 PH: (519) 576-9902 FAX: (519) 576-9028**

DEALER INQUIRIES INVITED IMMEDIATE SHIPMENT ON PURCHASE ORDERS FROM QUALIFIED INSTITUTIONS (SCHOOLS, UNIVERSITIES AND GOVERNMENT INCLUDED) FOR IMMEDIATE ACTION USE OUR FAX

Circle No. 98 on Reader Service Card

# PLAN TO ATTEND

## CIM/D

### ENTER A NEW WORLD OF MANUFACTURING

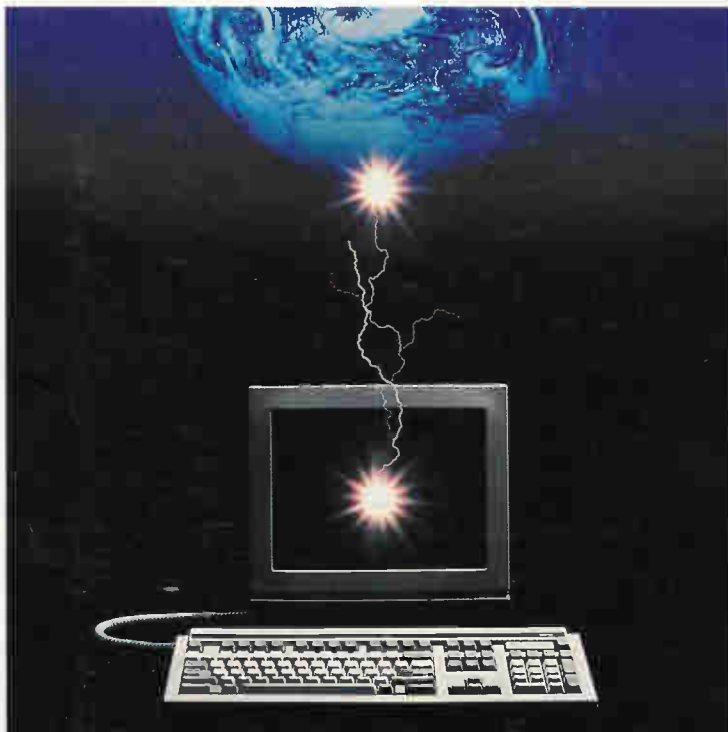

• FREE Cross-over registration to the First Canadian Architectural, Engineering and Construction (CAEC) Exposition.

• FREE parking for over 5000 cars.

• Pre-Register now and avoid line-ups.

• You can still register for the conference - phone for details.

### The 9th Canadian Integrated Manufacturing /Design Show

Incorporating the CAD/CAM & Robotics Exhibition and Conference

This is Canada's largest and most comprehensive exhibition of MANUFACTURING/DESIGN technology. CIM/D is your opportunity to join over 10,000 industry buyers to view, compare and purchase technology for automation and integration from over 200 leading companies.

CAD/CAM, CIM, CAE, CNC machine tools, factory automation, test and measurement, robotics, materials handling systems, inventory/

distribution solutions and more will be previewed at CIM/D.

CIM/D will put you at the pulse of today's manufacturing/design market.

**PLAN NOW TO ATTEND - CIM/D '90**

FOR MORE INFORMATION PLEASE CONTACT:



**REED-MACGREGOR EXHIBITIONS INC.**  
800 DENISON STREET, UNIT 7  
MARKHAM, ONT. L3R  
(416) 479-3939 FAX: (416) 479-5144.

JUNE 5-7, 1990 • INTERNATIONAL CENTRE • TORONTO



## Electronics & Technology Today

Electronics & Technology Today  
is published 12 times a year by:  
Moorshead Publications Ltd.

1300 Don Mills Road, North York, Ontario M3B  
3M8 (416) 445-5600 FAX: (416) 445-8149

Editorial Director: **Frank Lenk**  
Editor: **William Markwick**  
Publisher: **Kenneth Marskell**  
Director of Production: **Papu Leynes**  
Art Direction: **Kevan Buss**  
Circulation Manager: **Sharon Cernecca**  
Advertising Manager: **Paul Smith**  
Manager,  
Marketing and Sales Promotion: **Kim Rattray**  
Production: **Richard Rawlins**

President: **V.K. Marskell**  
Founder & Chairman: **Halvor Moorshead**  
Vice-President—Sales: **Allan Wheeler**  
Vice-President—Finance: **Bernie Shankman**

Office Manager: **Pirjo Dunphy**  
Reader Services: **Rick Cree**

Advertising Services: **Michelle Millett**  
**Carmela Parzanese**

Newsstand Distribution:  
Master Media, Oakville, Ontario

### Subscriptions:

\$22.95 (one year), \$37.95 (two years).  
Please specify if subscription is new or a renewal.  
Outside Canada (US Dollars). U.S.A. add \$3.00 per  
year. Other countries add \$5.00 per year.

Electronics & Technology Today  
is indexed in the Canadian Magazine Index  
by Micromedia Ltd.  
Back copies are available in microfilm form from  
Micromedia Ltd. 158 Pearl Street, Toronto, Ontario  
M5H 1L3 (416) 593-5211.

Printed by:  
Heritage Press Ltd., Mississauga, Ontario

ISSN 07038984

Moorshead Publications also publishes  
PETS Magazine, Computers in Education,  
Computing Now!, Business Computer News,  
Business Computer Reseller News,  
Government Purchasing Guide  
and VIDEO Trade.

Circulation independently audited by  
MURPHY & MURPHY Chartered Accountants.

Postal Information:  
Second Class Mail Registration No. 3955.  
Mailing address for subscription orders,  
undeliverable copies and change of address notice is:  
Electronics & Technology Today  
1300 Don Mills Road,  
North York, Ontario M3B 3M8.

# FOR YOUR INFORMATION

## COPYRIGHT

All material is subject to worldwide copyright.  
PCB designs are copyright and may not be sold  
without permission.

## LIABILITY

No responsibility whatever is accepted for  
failure of projects to perform for any reason, and  
no responsibility is accepted for any injury or  
damage caused by any fault in design.

## EDITORIAL QUERIES

We cannot answer telephone queries. Written  
queries must be accompanied by a stamped, self-  
addressed envelope, relate to recent articles and  
must not involve the staff in research.

## PCB SUPPLIERS

We do not supply printed circuits or kits, and we  
do not keep track of availability. However, PCBs  
for projects are available from the following mail  
order sources:

**B-C-D Electronics**, PO Box 6326, Stn. F.,  
Hamilton, Ontario L9C 6L9.

**K.S.K. Associates**, PO Box 266, Milton, On-  
tario L9T 4N9.

**Spectrum Electronics**, 14 Knightswood  
Crescent, Brantford, Ontario N3R 7E6.

**GeoDyssey Electronic Development  
Inc.**, 8744 Greenall Avenue, Burnaby, B.C.,  
Canada V5J 3M6.

## New RCC Location

RCC Electronics have announced that  
their Edmonton office has moved to a more  
central and larger location in Calgary. The  
new address is RCC Electronics, Calgary  
Advanced Technology Centre, Suite 107,  
6815-8th Street North East, Calgary, Al-  
berta T2E 7H7, (403) 274-8058, Fax 280-  
8639.

## Still Sound

Sony announces the Mavica MVC-A10  
still video camera with sound capabilities.  
The 2-inch floppy disk used as a storage  
medium can store 50 images, or 25 images  
with sound. Users can capture the existing  
sound when the picture is taken, or add nar-  
ration later. The maximum sound duration  
per frame is 9.6 seconds. At Sony A/V  
dealers, or contact Sony of Canada Ltd.,  
411 Gordon Baker Road, Willowdale, On-  
tario M2H 2S6, (416) 499-1414, Fax 497-  
1774.

Circle No. 21 on Reader Service Card

## Instrument Catalog

ITM Instruments Inc. announce their  
catalog of all types of scientific test equip-  
ment: anemometers, thermometers, pH  
meters, conductivity, DMMs, ammeters,  
scopes, tachs and lots more. You can con-  
tact them toll-free in Canada at 1-800-361-  
6042. The Toronto office is at 5715 Ken-  
nedy Road, Mississauga, Ontario L4Z  
2G4, (416) 283-3058, Fax 283-2335; they  
also have offices in Montreal and Ottawa.

Circle No. 22 on Reader Service Card

## Fastest Transistor

This month's fast transistor comes from  
IBM's Research Division in Yorktown  
Heights, NY. The silicon-based bipolar  
transistors operated at a speed of 75 billion  
cycles per second. They're known as  
Heterojunction Bipolar Transistors, or  
HBTs, and were first invented in the  
1950s. They have only recently been im-  
plemented in silicon, using a small amount  
of germanium as well.

The new transistors would obviously  
be ideal for extremely high speed com-  
puters, even if they're still only at the  
laboratory stage and will require substan-  
tial work before you can buy them at  
Radio Shack.



## Mini Memory Fax



**Product:** TF-251 Facsimile from Toshiba Facsimile Systems Division.

**Features:** Speed and accuracy are essential in today's business world. With the TF-251 you'll have both! Error Correction Mode automatically retransmits any block of data in which transmission errors occur and the ECM is part of the TF-251's built-in memory. This means that the TF-251 can store information in the memory for re-scanning and send after hours to one or more destinations saving long distance charges. That's where Relay Origination, Mailbox Origination and Multiaddressing come in handy. If the unit temporarily runs out of recording paper, approximately seven pages of incoming data can be stored in memory for later printout. The TF-251 is designed to fulfill the demands of a growing business or corporate department and, in the process, allow you more freedom to pursue new business.

Circle No. 24 on Reader Service Card

## Tough Terminals



**Product:** Copper Battery Terminals from Southern Fastener Company Inc.

**Purpose:** Terminals provide increased conductivity.

**Features:** Crimp-type connecting terminals constructed of copper with corrosion resistant plating reduce conductivity loss. Teflon-coated heat-shrink sleeve seals cables and connectors against battery gas, moisture, oil and other corrosive elements.

Circle No. 25 on Reader Service Card

## Detector Details



**Product:** Matheson-Kitagawa Toxic Gas Detector System Brochure from Matheson Gas Products.

**Purpose:** Pamphlet describes toxic gas and vapour reading unit.

**Features:** 4-page, 4-colour brochure lists features and benefits of detection system which consists of complete sampling and analysis kit. System includes over 230 detector tubes formulated with high-purity chemical reagents providing periodic checking, screening and quality control.

Circle No. 35 on Reader Service Card

## Industrial Booklet

### INDUSTRIAL & MAINTENANCE RELATED PRODUCTS



SAFETY SUPPLY CANADA  
"The Source"

**Product:** Industrial & Maintenance Related Products Catalogue from Safety Supply Canada.

**Purpose:** Pamphlet describes safety and health-related products.

**Features:** 24-page catalogue offers over 130 industry-proven products used to perform maintenance tasks safely. Items include non-sparking/explosive tools, emergency showers & eyewashes, clothing, flooring surfaces, plant safety and the SBS skin care program.

Circle No. 37 on Reader Service Card

## Raindrops and Actuators



**Product:** Airflow R3A Rainfall Accumulator/Actuator/Alarm from Airflow Developments Canada Ltd.

**Purpose:** Sampling system designed to test collected wastewater.

**Features:** Connected to raingauge tipping bucket, field adjustable pulse count and timer controls can be set for sampling criteria. LCD totalizing counter monitors total rainfall over duration of storm and if no set criteria is reached system resets for next rain event.

Circle No. 36 on Reader Service Card

## Stacks of Fax

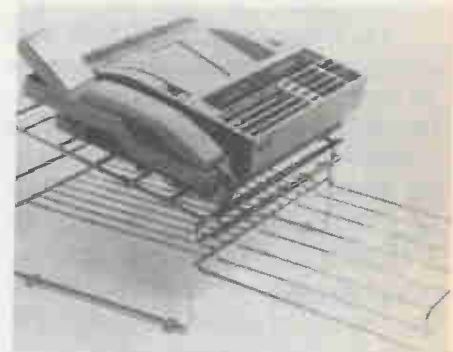

**Product:** Worcester Wire Fax Stand from Fellows Manufacturing of Canada Ltd.

**Purpose:** Stand keeps machine and paper in place.

**Features:** Two-tiered stand, consisting of chrome-plated wire, is designed to organize work while holding fax machine. Open wire construction keeps all fax supplies visible for easy access, cutting down on dust collection while detachable output tray catches outgoing and incoming transmissions.

Circle No. 79 on Reader Service Card

# Weather Station Part 1

Adding some high-tech to your weather forecasting.

Mike Feather

From the outset, it was decided that the following quantities should be measured: wind speed, direction, temperature, humidity, rainfall, and sunlight. An obvious omission from this list is atmospheric pressure. This can be measured relatively easily using one of the various forms of pressure transducer currently available.

The remaining quantities have been investigated and operational systems for the measurement of the first four are outlined below, with a full description of the construction of the weather station forming the remainder of this article. Systems for measuring the remaining quantities will be described in a future article.

## Wind Speed

The Wind Speed or Electronic Anemometer uses a conventional three cup rotating arm arrangement. Speed sensing of the rotating shaft can be achieved by a variety of techniques, but for economy and simplicity of construction, it was decided to employ a disc with peripheral holes rotating in the gap of a slotted opto switch. An outline block diagram for the Electronic Anemometer is shown in Fig. 1.

## Wind Direction

As with a conventional wind vane, this sensor uses a lightweight pointer that is free to rotate and line up with the wind direction. In this case, the electronic sensing has to detect not the speed, but the angular position of the shaft and vane.

Once again, opto electronic sensing is

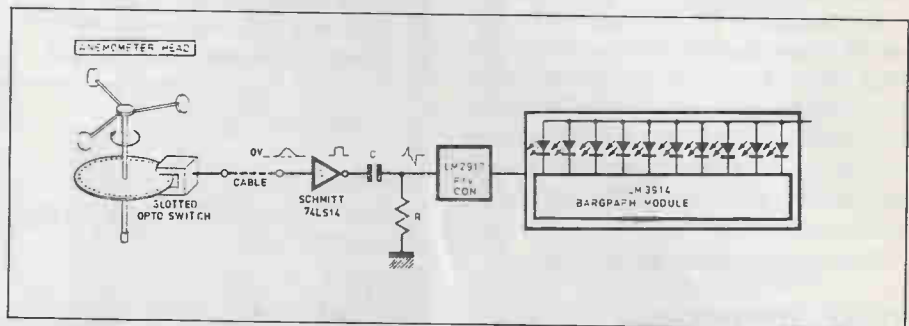

Fig. 1. Block diagram for the Electronic Anemometer (wind speed).

employed, but this time a coded disc is used which, together with four opto sensors, develops an excess 3-bit Gray code representing the vane position. An explanation of this code and the reason for its

use is given in the detailed description of the wind vane section of the weather station. An outline block diagram of the Wind Direction Indicator is shown in Fig. 2.

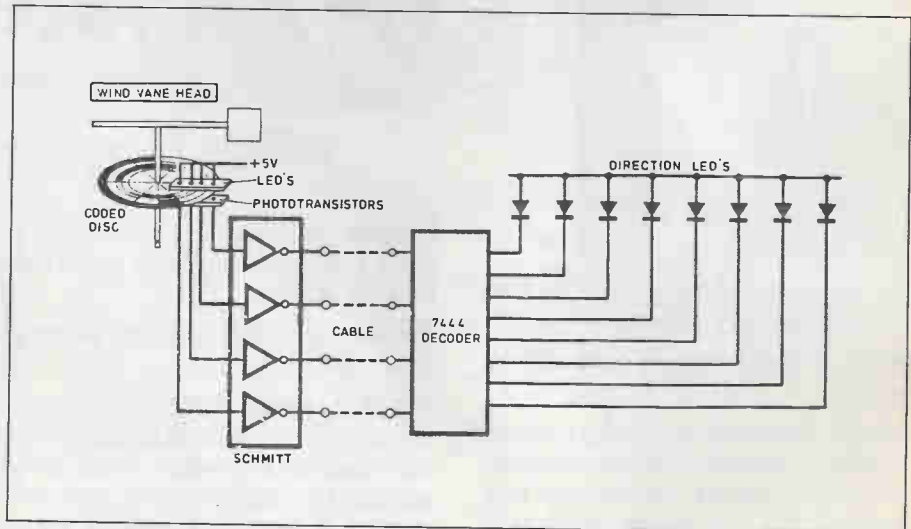

Fig. 2. Block diagram for the Wind Direction unit using a coded disc.

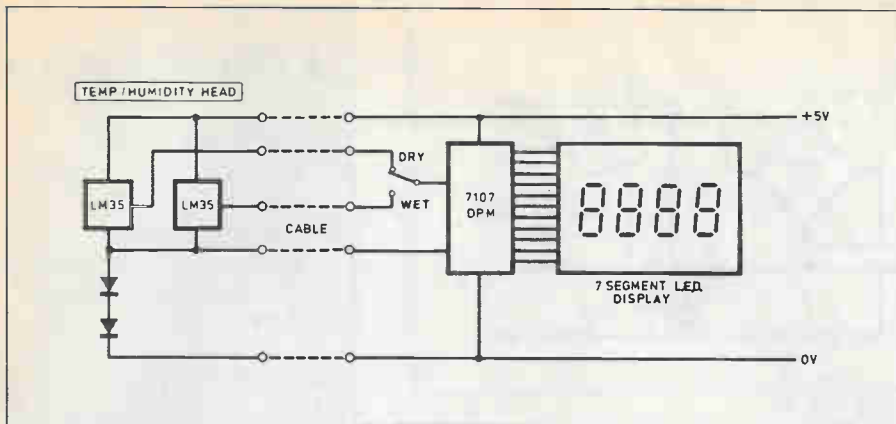

Fig. 3. Block diagram for the Temperature/Humidity unit.

In both the wind speed and direction sensors, the freedom of movement of the shaft is important and a simple low friction bearing system is described in the detailed construction notes.

### Temperature/Humidity

There are several different forms of temperature sensor available and the choice of which technique to employ depends upon cost, accuracy, resolution and ease of use.

The best compromise seemed to be to use the relatively new LM35 semiconductor temperature sensors manufactured by National Semiconductors. These devices, coupled with simple circuitry, can be made to develop 10mV/°C over a wide range of temperatures and an important advantage (compared with earlier semiconductor sensors) is the fact that at 0°C,

the sensor output is zero — thus obviating the need for providing a large voltage to offset the usual 273mV at 0°C.

A second temperature sensor is employed for humidity measurements and the system resembles a conventional wet and dry bulb hygrometer. The humidity is derived from the depression of the “wet bulb” sensor.

The general arrangement of the Temperature/Humidity sensing sections of the Weather Station is shown in Fig. 3.

### Station Displays

The Weather Station Display unit provides instantaneous readout of all the various

parameters just outlined and it includes displays, power supplies and any necessary signal conditioning circuitry. A block diagram of the internal circuitry used is shown in Fig. 4 while a possible panel layout is given in Fig. 5.

### Power Supply

The system power supply circuit diagram for the Weather Station is shown in Fig. 6. This is a conventional bridge rectifier circuit and provides an unregulated dual rail supply at approximately +/- 20V.

The +5V output is obtained from the voltage regulator IC1. Some smoothing of the two 20V supplies is accomplished by electrolytic capacitors C1 and C2.

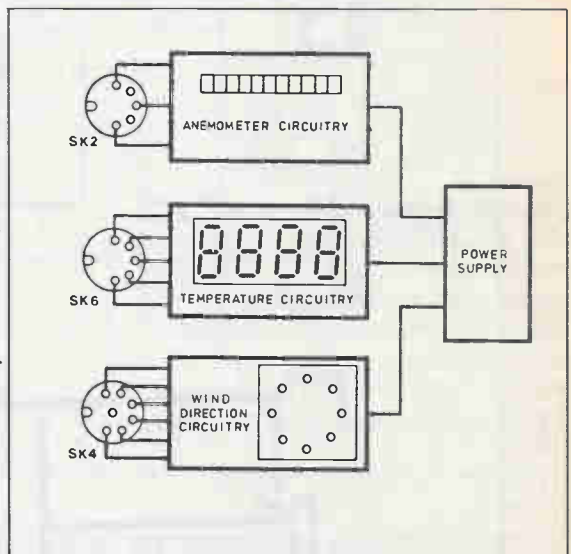
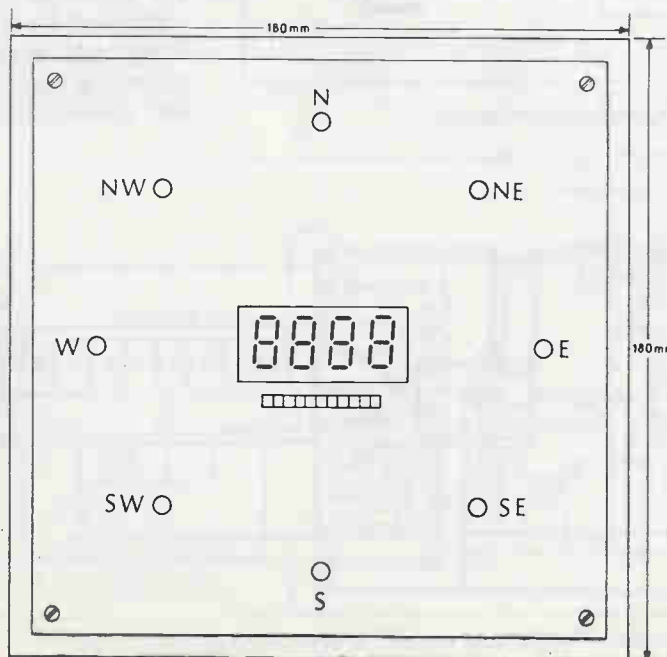

Fig. 4. Overall block diagram for the displays.

Fig. 5. Suggested weather station front panel display layout.



The printed circuit board component layout and full size copper foil master pattern for the Power Supply is shown in Fig. 7. The only points to watch out for are that the two capacitors and the voltage regulator IC1 are inserted on the board correctly.

### Anemometer

The full circuit diagram for the Anemometer section is shown in Fig. 8. The circuit is divided into three sections and consists of the remote head or sensor, pulse shaping and frequency to voltage converter, and bargraph display.

The phototransistor of the slotted opto-switch X1 develops crude pulses, the frequency of which is proportional to the shaft speed (see Fig. 1) and hence the “wind speed”. The pulses are transferred, via SK1/PL1/— PL2/SK2 and cable, to the display unit where they are applied to the input of one section of a 74LS14 HEX Schmitt inverter, IC1. This produces