

Electronics Today

\$3.25
MM70924

Camera
Contest!

November 1985

Canada's Magazine for Electronics & Computing Enthusiasts

Tools For Electronics

Making life easier on the testbench

Single Generator Project

A three-function oscillator

Direct Injection Box

Match those impedances

Semiconductor Numbering

A path through the jungle



BEST Computers

Made in Canada, IBM PC, XT & AT Compatible



Monitor not included. IBM registered trade mark of IBM Canada Ltd.

Features common to BEST MK II, MK III & MK IV

- Superb IBM PC & XT Compatibility
- Canadian Made
- 256K RAM Standard minimum (uses 41256K RAM chips)
- Expandable on board to 640K RAM
- Parallel Port (for printer)
- Serial Port (for communications)
- Real Time Clock/Calendar (with Battery Backup)
- Presocketed for optional co-processor — such as 8087 Math Processor
- IBM Compatible Keyboard
- Reset Switch
- Phoenix BIOS as used in many major brand IBM compatible systems.
- 150 Watt Power Supply which will handle a Hard Drive without upgrade.
- 7 Slots
- Flip top case
- 2 Slimline DS,DD 5 1/4", 360K Disk Drives
- Colour Video (RGB & Composite) Board or Hi-Res Monochrome Card (customer choice)
- Disk Controller Board

Warranty

We have such confidence in the time tested reliability of the BEST that we offer a 300-day warranty, way above the industry standard.

Please Note: Don't be put off by our spectacularly low price; this is due to the fact we do not deal with middlemen and our volume buying power of parts. All BESTs are manufactured in Canada to the highest quality standards using prime, guaranteed components by our sister company. All systems are pretested (burnt-in) for about 48 hours before shipping. Hundreds of happy customers report excellent reliability and compatibility.

BEST MK II. Regular \$1695. This Month:

Two 360K DS,DD disk drives, Serial and Parallel Ports, Real Time Clock, Phoenix BIOS, uses 8088 processor — full specifications given below.

\$1595⁰⁰

Other Configurations:

With 640K RAM \$1695
 With 10 Meg Hard Drive/1 Floppy/256K ... \$2495
 With 10 Meg Hard Drive/1 Floppy/640K ... \$2595
 With 20 Meg Hard Drive/1 Floppy/256K ... \$2795
 With 20 Meg Hard Drive/1 Floppy/640K ... \$2895



The FAST BEST MK III

As BEST MK II plus speed selectable: 4.77 and 8MHz (most software will run on the higher speed), uses 8088-2 processor.

\$1895⁰⁰

Other Configurations:

With 640K RAM \$1995
 With 10 Meg Hard Drive/1 Floppy/256K ... \$2795
 With 10 Meg Hard Drive/1 Floppy/640K ... \$2895
 With 20 Meg Hard Drive/1 Floppy/256K ... \$3095
 With 20 Meg Hard Drive/1 Floppy/640K ... \$3195



SUPER-FAST BEST MK IV

As BEST MK III plus TRUE 16-Bit machine, 8086-2 processor, IBM compatible 8-Bit I/O channel bus, even faster than MK III due to 16-Bit architecture. With 640K standard.

\$2500⁰⁰

Other Configurations:

With 10 Meg Hard Drive/1 Floppy/640K ... \$3395
 With 20 Meg Hard Drive/1 Floppy/640K ... \$3695



AVT-286

Superb IBM AT compatibility, 640K RAM, Two 5.25 in disk drives (one high density 1.2 Megabyte, one standard 360K), serial and parallel ports high quality keyboard, keyboard lock and status monitor.

\$3495⁰⁰

With 20 Megabyte fast stepping Hard Disk and Controller:

\$4950⁰⁰

40 Megabyte systems also available at reasonable prices.

Exceltronix

319 College Street, Toronto, Ont. M5T 1S2
 (416) 921-8941. Order line only 1-800-268-3798
 Ottawa, 217 Bank Street (613) 230-9000
 Visa, Mastercard and American Express accepted.

See our 1986 catalogue in the centre of this issue.

BEST AVT-286: the IBM AT Compatible

Designed and made in Canada with pride.

Proving once again that Multiflex is an industry leader, by producing more than just affordable alternatives in personal computer design, we are pleased to announce the **BEST AVT-286 Microcomputer, our new, fast IBM AT compatible.** The AVT-286 is based on the 80286 microprocessor. The AVT-286 is supported by the *Phoenix AT compatible Bios*, the same software house that supplies the Bios for all other BEST computers as well as many of the well known IBM compatibles currently manufactured.

Check the long list of standard features that are included on the new **BEST AVT-286:**

- The AVT-286 runs faster than the (12MHz) IBM AT but retains superb software compatibility.
- The main board features a standard 640K RAM using state-of-the-art memory chips for fast, reliable data processing.
- Seven expansion slots of which five support IBM AT signals. The two remaining slots are compatible with IBM PC or XT peripheral boards.
- Presocketed for the optional 80287 math co-processor
- Two floppy diskette drives, one formatted for a capacity of 1.2 Megabytes, the other for 360K to read and write normal diskettes.
- The BEST Colour Video board which offers the user four modes of operation, composite and RGB output.
- An AT compatible keyboard.
- On board Real Time Clock/Calendar with battery backup.
- Parallel Port (for printers etc.) and Serial Port (for communications).



Monitor not included. IBM PC, IBM XT and IBM AT are registered trade marks of IBM Canada Limited.

- Heavy duty Power Supply as standard allows for adding extra cards as well as a Hard Disk without requiring an upgrade.
- Attractive flip-top case.
- A keyboard lock with unique security key which prevents any unauthorised use of the system.
- A front control status panel provides information on the keyboard lock status, reset, power-on, disk activity and parity errors.
- A hardware reset button so the system can restart without having to power down.

The BEST AVT-286

Canadian designed and made, Super IBM AT compatibility, 640K RAM, Two 5.25in. Disk Drives (one high density 1.2Mb, one 360K), Serial and Parallel Ports, High quality keyboard, Keyboard lock and Status Panel. See detailed description above.

Simpler or more complex configurations available at most competitive prices.

\$3495⁰⁰

As standard configuration with a 20 Megabyte, fast stepping Hard Drive and Controller.

\$4950

Warranty

We have such confidence in the time tested reliability of the BEST that we offer a 300 day warranty which is way above the industry standard. On-site service plan available at extra cost.

BEST AT Compatible Enhancement Card

This card includes the following features: Two Serial Communications Ports, One Parallel Printer Port and Memory starting from 128K to 512K in selectable boundaries. This card will allow IBM AT users with 256K or 512K of on-board memory to expand their AT machine to full 640K capability as well as provide them with two serial ports and one parallel port.

\$299.00

1986 Exceltronix Catalogue

In the centre of this issue of Electronics Today, we are proud to present our 1986 catalogue; this catalogue also appears in the November issues of Computing Now! and Software Now! It will also appear in the December issue of Computers in Education.

Even though the prices of our products shown in the catalogue are as current as possible, we advise you to check our ads each month in Electronics Today and Computing Now!

We have done our best to include as much of our extensive product and parts range as possible but space limitations have prevented us from describing our entire store selection. If you want anything in the computer or electronics area, please check with us.

Note: We are very price competitive and will be happy to discuss discounts on large orders. Why not form a buying co-op? Get together with your friends to get our best price.

FREE Subscription Bonus

See the order form at the back of our catalogue to find out how to get a free subscription for one year to your choice of magazine. Select from Electronics Today, Computing Now!, Software Now! or Computers in Education.

Exceltronix If you want the Best, buy the BEST

Circle No. 2 on Reader Service Card

SURPLUSTRONICS

we will not be undersold



8088 Computer Systems

\$995

- Includes:
- 8088 motherboard
 - High quality legal Bios
 - One DS,DS 360K Drive
 - Power Supply with Fan
 - Keyboard
 - Flip-Top case
 - Disk Controller
 - With plenty of spare slots
- All you need for complete System is Video Board
- Colours: **\$159.00**
Mono **\$159.00**

\$339

8088 motherboard with 256K (expandable on board to 640K) Fully assembled and tested with legal Bios, Flow soldered provision for 8087.

256K Memory

41256 (150nS) **\$ 4.95**
Set of 9 **\$43.95**

64K Memory

4164 (150nS) **99¢!**

IBM Compatible Keyboards

(Keytronics Serial Output), no housing **\$39.95**

IBM Style Case

Flip-Top 8 slot **\$75.00**

IBM Compatible Switching Power Supply, 130W, with Fan **\$134.00**

Set of 8088, 8255A-5, 8237A-5, 8288, 8284, 8253A-5, 8259A **\$45.00**

IBM Peripheral Cards

Colour Video Board **\$159.00**

Floppy Controller **\$ 99.00**

Floppy Controller with RS232 **\$139.00**

Floppy Controller with clock/RS232 **\$149.00**

Parallel and Game Port Card **\$ 59.00**
Cable and connector extra.

Peripheral Interface Card **\$139.00**
Includes two serial ports, parallel port, game port and provision for (but not including) real time clock.

Clock/Calendar Option **\$ 29.00**
With battery backup.

256K & Multifunction Board.
Includes: Serial port, parallel port, game port, provision for optional real time clock/calendar and socketed for up to 256K RAM.
With 64K RAM **\$149.00**

512K Board. Socketed for 512K including: **\$119.00**

64K RAM **\$119.00**

IBM Compatible Disk Drives **\$159.95**
Brand New, fresh from factory. Shugart SA455 40 track, double sided, double density Slimline. We have ordered 10,000 from Shugart - that is why we can pass the savings on to you.

IBM Compatible Keyboards
Maxiswitch **\$135.00**
Cherry **\$ 99.00**

IBM Style Case

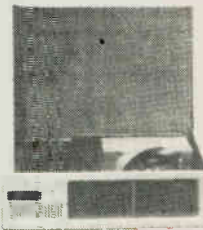

Flip-Top, 8 Slot **\$75.00**
With 150W Power Supply **\$219.00**

Disk Drives for IBM Computers

Shugart/Panasonic, 5 1/4" slimline, DD, DS 360K, 40 track **\$159.95**

Printers

Gemini 10X **\$299.00**
Gemini SG10 **\$379.00**
Gemini Daisy Wheel Powertype **\$599.00**
18 cps, Bi-Directional.

Monitors

Zenith ZVM123 Green and ZVM122 Amber ... **\$129.00**

Complete 6502 System

- Assembled and fully tested (flow soldered)
- 64K, 80 x 24 video with soft-switch, floppy controller.
- System comes with blank EPROM's on board, does come with any proprietary software or Basic **\$199.00**

Complete System

• 6502 board (as illustrated above) with case, keyboard and power supply **\$399.00**

Complete System

• Using 6502 board above in IBM style flip-top case, using powerful 75 watt power supply with fan, programmable serial keyboard adaptor, IBM style keyboard **\$459.00**

As above with one built in disk drive **\$599.00**

As above with two drives **\$749.00**

6502 Power Supply

For 6502 Case. CSA Approved 5V, 5A, + 12V 2.5A, -5V 0.5A, -12V 0.5A. **\$69.00**

Keppo Power Supply

5V 5A, +12V 2.8A, +12V 2A, -12V 0.5A, Open Frame

\$38.95



6502 Style Case



With Numeric Keyboard **\$129.00**

Panasonic Printers

Open Frame **\$29.95**

Ideal for experimenters

Mail Orders add \$5.00 minimum for shipping & handling. Ontario residents add 7% P.S.T. Visa, Mastercard and American Express cards accepted: send card number, expiry date, name of bank and signature. Send certified cheque or money order, do not send cash. All prices on this page are final sale. No warranty, No returns, No refunds but HUGE savings. Warranties available at extra cost.

IBM Style Power Supply

130W, +5V 13A, -5V 0.5V, +12V 4.5A, -12V 0.5A **\$145.00**

Power Bars with Surge Protectors

..... **\$49.95**

Plug In Surge

Suppressor **\$11.95**

Apple Cards

Assembled, flow-soldered/cleaned and 100% tested

16K RAM Card **\$ 39.00**
80 x 24 video card **\$ 39.95**
Z80A Card **\$ 39.00**
Parallel Printer Card (cables extra) **\$ 29.00**
128K RAM Card with 128K **\$ 85.00**
EPROM Programmer with Software **\$ 63.00**
(programs 2716, 2732, 2732A, 2764)
8" Floppy Controller. Final Sale
- As is **\$ 39.00**

Modem Bargain!

Apple Compatible plug-in Autoanswer, Autodial, Touch Tone or Pulse Dial. Excellent for use with most Bulletin Boards. 300 Baud. Final Sale as is ... **\$39.95**

Apple Compatible

Disk Drives 5-1/4" **\$175.00**

Apple Compatible Modem

EXCELLENT HAYES MICROMODEM COMPATIBILITY



Plugs into your Apple or compatible computer, Direct connect, 300 Baud, Autodial, Autoanswer, Touch Tone/Pulse Dial, complete with documentation.

\$139.95

Hayes is a registered trade name.

Surplustronics, 310 College Street, Toronto, Ontario, M5T 1S3

More lines to serve you better

(416) 960-1350



Our Cover

Illustrating our look at test bench tools, the background photograph of tools was provided courtesy of Len Finkler; the circuit holder was photographed by Ed Zapletal.



Audit Bureau of Circulations

Electronics Today is Published by:

Moorshead Publications Ltd. (12 times a year)
Suite 601, 25 Overlea Blvd.
Toronto, Ont. M4H 1B1
(416) 423-3262

Editor: William Markwick
Assistant Editor: Edward Zapletal
Director of Production: Erik Blomkwist
Production: Douglas Goddard
Naznin Sunderji
Sandra Hemburrow
Lisa Salvatori
Circulation Manager:
Advertising
Account Manager: Marlene Dempster

Publisher: H.W. Moorshead; Executive Vice-President: V.K. Marskell; Vice-President - Sales: A. Wheeler; General Manager: S. Harrison; Controller: B. Shankman; Accounts: P. Dunphy; Reader Services: M. Greenan, H. Brooks, R. Cree, L. Robson, N. Jones; Advertising Services: H. Brooks.

Newsstand Distribution:
Master Media, Oakville, Ontario

Subscriptions:

\$22.95 (one year), \$37.95 (two years). Please specify if subscription is new or a renewal.

Outside Canada (US Dollars) U.S. add \$3.00 per year. Other countries add \$5.00 per year.

Postal Information:

Second Class Mail Registration No. 3955. Mailing address for subscription orders, undeliverable copies and change of address notice is: Electronics Today, Suite 601, 25 Overlea Blvd., Toronto, Ontario, M4H 1B1

Printed by Heritage Press Ltd., Mississauga
ISSN 07038984.

Moorshead Publications also publishes Computing Now!, Computers in Education, and Software Now!

Advertisers' Index

Active Components Sales Corp.	27
Apron Design Ltd.	40
BCS Electronics Ltd.	64
Brunelle Instruments	27
Budgetron Inc.	8
Computer Parts Galore	28, 29
Dacor	31
Daetron	58
Duncan Instruments Ltd.	30
E. D. G. Electronics Distributors	59, 61, 63
Electronic Control Systems	27
Electronic Supplies Incorporated	36
Exceltronix	2, 3
I.B.M. Canada Ltd.	37
Information Unlimited	60
Kaientai Electronics Merchants Ltd.	26
K.B. Electronics	6
Len Finkler & Co.	33
Mark Gee Enterprises Ltd.	8
McGraw-Hill	25
Micromega Electronics Ltd.	8
Patron Components Inc.	35
Software Link Inc.	62
Soltech Industries Inc.	57
Sunix Inc.	40
Surplustronics	4
Varah Direct	7

(416) 423-3262

Electronics Today

November 1985

Vol. 9 No. 11

Canada's Magazine for Electronics & Computing Enthusiasts

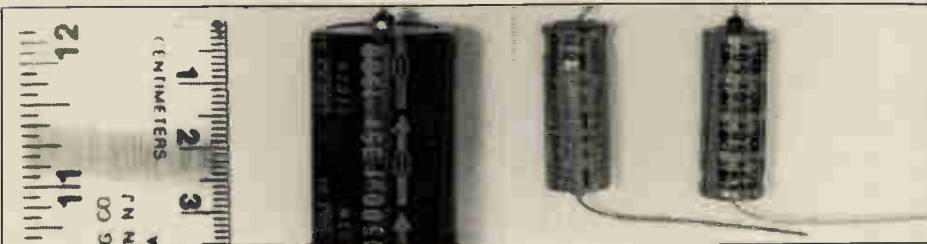

Features

Automatic Test Equipment	12
Radar Supremacy in WWII	20
Tools for Electronics	32
Camera Contest	11

Review

Zopan Function Generator	44
--------------------------	----

Projects

Battery Checker	9
Direct Injection Box	38
Audio Frequency Generator	55

Series

For Your Information	6
Designer's Notebook: Digital Sampling	22
Computing Today: Z80, Part 6	42
Electronics From The Start, Part 5	49

Columns and Information

Software	17	Subscriptions	52
Electronics Today Next Month	14	Product Mart	45
Computing Now! This Month	15	Books	46
Software Now! This Month	15	Binders	52
Order Form	51		

For Your Information

Spike Arrester



A six-outlet power bar which includes a spike arrester circuit is available from WT Devices. It's constructed from extruded aluminum and has a circuit breaker and an illuminated power switch. The protection circuit consists of a spike-clipping thyrector across the line and a triac in series

with the loads; the triac will switch off only at a zero-crossing of the AC input, preventing inductive surges. It's rated a 120VAC, 15A. Contact them at 5536 Montevideo Drive, Unit 18, Mississauga, Ontario L5N 2P4.

Circle No. 60 on Reader Service Card.

SmarTeam Modem



The SmarTeam 103/212A modem is a 300/1200 baud stand-alone unit with auto-answer, auto-dial, auto-speed, and full or half-duplex operation. It runs PC Talk, CrossTalk, Smartcom II and its own Teamtalk for the PC as

well as Macteam for the Macintosh. The suggested list price is \$495. The exclusive Canadian distributor is Budgetron Inc., 1320 Shawson Drive, Unit 1, Mississauga, Ontario L4W 1C3, (416) 673-7800.

Circle No. 59 on Reader Service Card.

Jerome and Francis Co. Ltd., representatives of oceanographic and electronic instrumentation, have enlarged their operations

and moved to 1869 Welch St., North Vancouver, BC V7P 1B7. The telephone number remains the same: (604) 986-1286.

Circle No. 58 on Reader Service Card.

We Import Direct and We Service What We Sell BEST QUALITY INSTRUMENTS AT LOWEST COST! Why Pay More? . . . Just a Few Examples:



DMM 601

3 1/2 dig. 0.25% acc.
0.1 mV - 1000 VDC
0.1 uA - 2 A AC/DC
0.1 mV - 750 VAC
0.1 ohm - 20 M ohms
Safety test leads incl.

\$63.90

Dmm 6010 (same as 601) except: max. 10 A AC/DC

\$69.50

Synthesized R.F. Generator SD 1003



8-512 (Model SD1004 MAX 1060 MHz) AM .O-90% FM In 10-30-100KHz steps. Output attenuation in 10dB steps with Vernier Fine Control. Price 30-40% below "Industry Standard" prices at \$3,600.00

OSCILLOSCOPE 33330



- 2 Chan.
20MHz bandwidth
Built-in components tester
5 mV vert. sensitivity
Special Price \$495.00
In areas not served by distributors.
Probes extra.

Precision Analog Multimeter Model 5050E

- Input resistance, 10M Ω /DC
- 43 measuring ranges
- AC/DC current max. 12A

Introductory Price \$67.50



Model 605 RF Generator

100KHz - 70 MHz
On fundamentals

Introductory price \$183.00

Authorized Distributor:

Waterloo Electronics Supply Co. In. 219 Hartwood Ave., Waterloo, Ont. 745-9421.

Mall Orders: Visa, Certified Cheque, Money Order or C.O.D.'s F.O.B. Oakville, Ontario residents add 7% P.S.T.

KB ELECTRONICS
355 Iroquois Shore Rd., Oakville, Ont. L6H 1M3
(416) 842-6888 Telex 06-982396 (KBEL OKVL)

Circle No. 4 on Reader Service Card

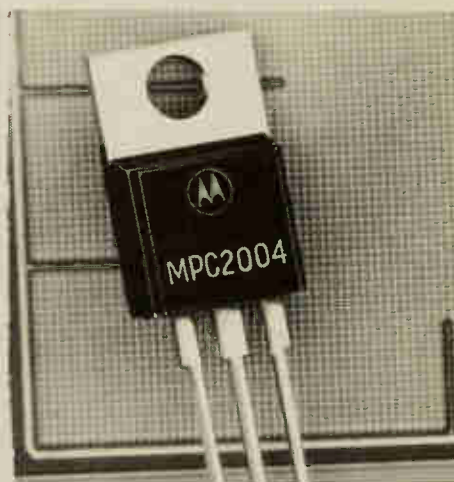

OV/OT Protection

Overvoltage and overtemperature protection of your power supply is easily added with the Motorola SMARTpower line of protector ICs. The IC, available as the MPC2000 series in current ratings from 7.5A to 35A for 5, 12 and 15V circuits, is simply placed across the supply output; a voltage comparator and/or thermal detector will trip an SCR which forces the main regulator into limiting or blows a fuse. A control pin is provided if you'd like to change the trip voltage or the time constant. From Motorola dealers, or contact Motorola Semiconductor Products, PO Box 20912, Phoenix, Arizona 85036, (601) 244-4911.

Circle No. 57 on Reader Service Card.

continued on page 24

Copyright

All material is subject to worldwide copyright protection. All PCB patterns are copyright and no company can sell boards to our design without our permission.

Liability

While every effort has been made to ensure that all construction projects referred to in this magazine will operate as indicated efficiently and properly and that all necessary components are available, no responsibility whatsoever is accepted in respect of the failure for any reason at all of the project to operate efficiently or at all whether due to any fault in the design or otherwise and no responsibility is accepted for the failure to obtain component parts in respect of any such project. Further no responsibility is accepted in respect of any injury or damage caused by any fault in design of any such project as aforesaid.

Editorial Queries

Written queries can only be answered when accompanied by a self-addressed, stamped envelope. These must relate to recent articles and not involve the staff in any research. Mark such letter Electronics Today Query. We cannot answer telephone queries.

Binders

Binders made especially for Electronics Today (ETI) are available for \$9.75 including postage and handling. Ontario residents please add provincial sales tax.

Back Issues and Photocopies

Previous issues of Electronics Today Canada are available direct from our office for \$4.00 each; please specify by month, not by feature you require. See order card for issue available.

We can supply photocopies of any article published in Electronics Today Canada; the charge is \$2.00 per article, regardless of length. Please specify both issue and article.

Component Notation and Units

We normally specify components using an international standard. Many readers will be unfamiliar with this but it's simple, less likely to lead to error and will be widely used everywhere sooner or later. Electronics Today has opted for sooner!

Firstly decimal points are dropped and substituted with the multiplier: thus 4.7uF is written 4u7. Capacitors also use the multiplier nano (one nanofarad is 1000pF). Thus 0.1 uF is 100nF, 5600pF is 5n6. Other examples are 5.6pF = 5p6 and 0.5pF = 0p5.

Resistors are treated similarly: 1.8Mohms is 1M8, 56kohms is the same, 4.7kohms is 4k7, 100ohms is 100R and 5.6ohms is 5R6.

PCB Suppliers

ETI magazine does NOT supply PCBs or kits but we do issue manufacturing permits for companies to manufacture boards and kits to our designs. Contact the following companies when ordering boards.

Please note we do not keep track of what is available from who so please don't contact us for information PCBs and kits. Similarly do not ask PCB suppliers for help with projects. K.S.K. Associates, P.O. Box 266, Milton, Ont. L9T 4N9.

B—C—D Electronics, P.O. Box 6326, Stn. F., Hamilton, Ont. L9C 6L9.

Wentworth Electronics, R.R. No. 1 Waterdown, Ont. L0R 2H0.

Danocinths Inc., P.O. Box 261, Westland MI 48185 USA.

Arkon Electronics Ltd., 409 Queen Street W., Toronto, Ont., M5V 2A5.

Spectrum Electronics, 14 Knightswood Crescent, Brantford, Ontario N3R 7E6.

HIVOD Photovoltaic Power Packs!

These lightweight, compact and very affordable power sources are new to the market. Combining ruggedness with maintenance-free operation, this unique product provides dependable DC outputs up to 12 volts from either direct sunlight or strong indoor lighting.

The HIVOD power pack is designed with electrically-matched silicon cells protected by glass and multiple layers of polymeric encapsulant in a tough ABS plastic casing. Each HIVOD is only 5" x 12" x 3/4" and weighs less than one pound for maximum portability. The weather-proofed casing allows safe and reliable indoor or outdoor operation at temperatures from -40°C to 60°C.

While the HIVOD can be used effectively as a direct power source in strong light, the usual application is to complement a rechargeable battery providing power to a host device. When the host device is turned off, the HIVOD recharges the battery. This unit is self-regulating and any back discharge is prevented by an integral blocking diode.

The range of applications includes power for portable radios, surveying equipment, remote sensing stations, electronic games, and many more. A must for experimenters. An ideal tool whenever and wherever conventional power sources just can't do the job efficiently!

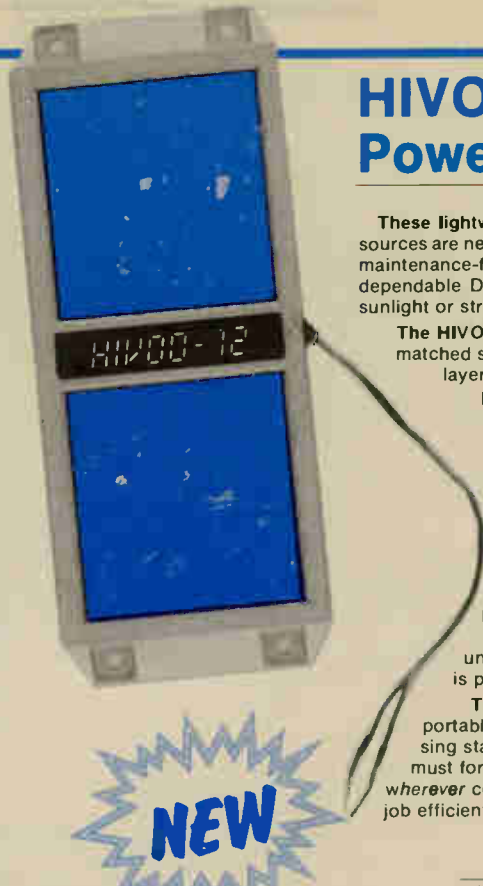

Available in 3, 6, 9 and 12 volt DC outputs, these HIVODs are fully warrantied for one year by the *Direct Guarantee*.

	Order Part #	Price
3V @ 220 ma	63903	\$54.45
6V @ 220 ma	63906	\$87.95
9V @ 170 ma	63909	\$97.95
12V @ 110 ma	63912	\$109.95

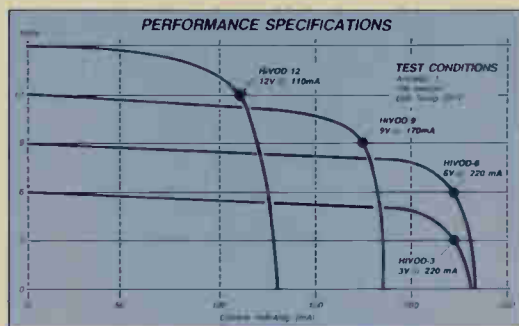
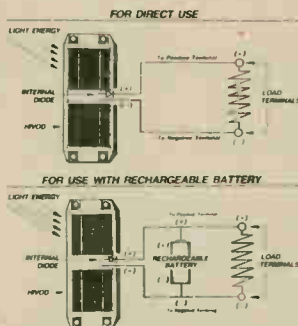

For more information on the HIVOD and our full range of electronic components, write, circle, or call today for your free copy of the:

1985/86 Varah's Direct Reference Guide & Electronic Mail Order Catalogue

Not just a price listing, this is a fully referenced book supplying pin-outs, electrical specs, and dimensions on over 2000 items from our multi-million dollar industrial inventory. Contact us today for your *free copy!*



Member, Canadian Direct Marketing Association

Locations:

Vancouver
Edmonton
Calgary
Winnipeg
Oakville
Nepean

Write:

Varah's Direct
504 Iroquois Shore Road
Oakville, Ontario
L6H 3K4
(please include your return postal code)

Circle:

The reader service number for this ad
Or Call:
(416) 842-8833
Monday to Friday
8:00 - 5:00, E.S.T.

EXCLUSIVE
CANADIAN DISTRIBUTOR

SmarTEAM™ 103/212A

1200 Baud Modem
Fully Hayes™ Compatible

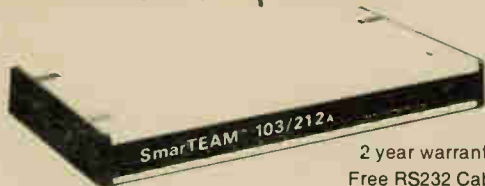

2 year warranty
Free RS232 Cable

SmarTEAM™ 1200B

Internal Modem Card 1200 Baud
For IBM™ PC XT, AT
and Compatibles

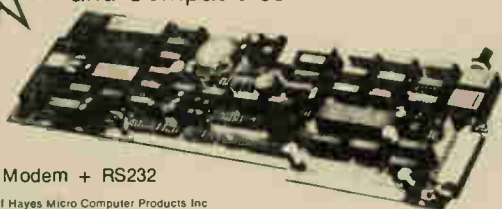

2 year warranty
1 Card Provides Modem + RS232

Hayes is registered Trademark of Hayes Micro Computer Products Inc
IBM is registered Trademark of IBM Canada Ltd

Exclusive Canadian Distributor:

We are signing up
Dealers Across Canada

Call Us Now!!!!

416-673-7800

BUDGETRON
INC.

Importer
Distributor

1320 Shawson Dr. Unit 1
Mississauga Ont. L4W 1C3
Tlx: 06-968080

Circle No. 6 on Reader Service Card

PC/XT Compatible ECS1-PC/XT

Special
\$1095.00

- 8088 processor
- optional Intel 8087
- numeric coprocessor
- 256K memory
- double sided double density disk drive
- detachable keyboard
- colour-graphic board
- 130 watt power supply
- support PC software
- 90 day warranty
- 8 slot Mother board



XT/PC MAIN PERIPHERAL

Mother Board 8 Slot\$249.00
Color Graphic Card\$149.00
Multifunction\$149.00
Monochrome Card\$139.00
Monochrome Graphic\$199.00
Game Port\$ 49.00
RS232 Card\$ 59.00
Parallel Interface\$ 59.00
Disc Controller Card\$ 89.00
Case\$ 69.00
Keyboard (Cherry)\$ 99.00
Power Supply 130 Watts\$139.00
Printer Cable\$ 25.00
RS232 Cable\$ 25.00
Disk Drive Cable\$ 15.00
Moving Message Board\$495.00
TTL and CMOF test Card\$ 99.00
150 Watt Power Supply\$159.00
Modem 1200 B\$395.00

AT Compatible **\$2995.00**

- 512K memory
- 1 1.2M drive
- Colour card
- Keyboard
- 200 watt power supply



ELECTRONIC CONTROL SYSTEMS

1590 Matheson Boulevard, Suite 1 & 2 Mississauga, Ontario L4W 1J1
(416) 625-8036 Hours — Mon. to Fri. 10-6. Sat. 10-2

Circle No. 11 on Reader Service Card



MICROHMEGA



MICROHMEGA ELECTRONICS LTD. 918 16 AVE. N.W. CALGARY, ALBERTA, CANADA T2M 0K3 (403) 289-6264

ADVANCED PROGRAMMABLE FUNCTIONS

SPEECH
MOTION
SOUND
SENSOR RESPONSE

OPTIONAL SOFTWARE:
"ERNIE'S MOTHER"
PROVIDES STRUCTURED
PROGRAMMING ENVIRONMENT
FOR WRITING ERNIE
CONTROL PROGRAMS
(APPLE 2 and C-64)



ERNIE ROBOT

SPECIFICATIONS

65C02 MICROPROCESSOR
4K ROM 2K RAM
SPO256AL2 SPEECH
SYNTHESIZER
40 KHZ ULTRASONIC
TRANSDUCERS
DUAL BUMPER SWITCHES
VMOS FET MOTOR CONTROL
LED POWER INDICATOR
OPTO ELECTRONIC WHEEL
POSITIONING SYSTEM
RECHARGEABLE BATTERY
POWER SYSTEM
(RECHARGER INCLUDED)

EVERYTHING YOU NEED IN ONE ECONOMICAL PACKAGE

EDUCATIONAL INQUIRIES: ELECTROLAB LTD., 25 DUNDAS ST. W. BELLEVILLE, ONTARIO K8N 5A5
(613) 962-9577

DEALER AND END USER: MICROHMEGA ELECTRONICS LTD. 918-16 AVE. N.W. T2M 0K3
(403) 289-6264

Household Battery Checker

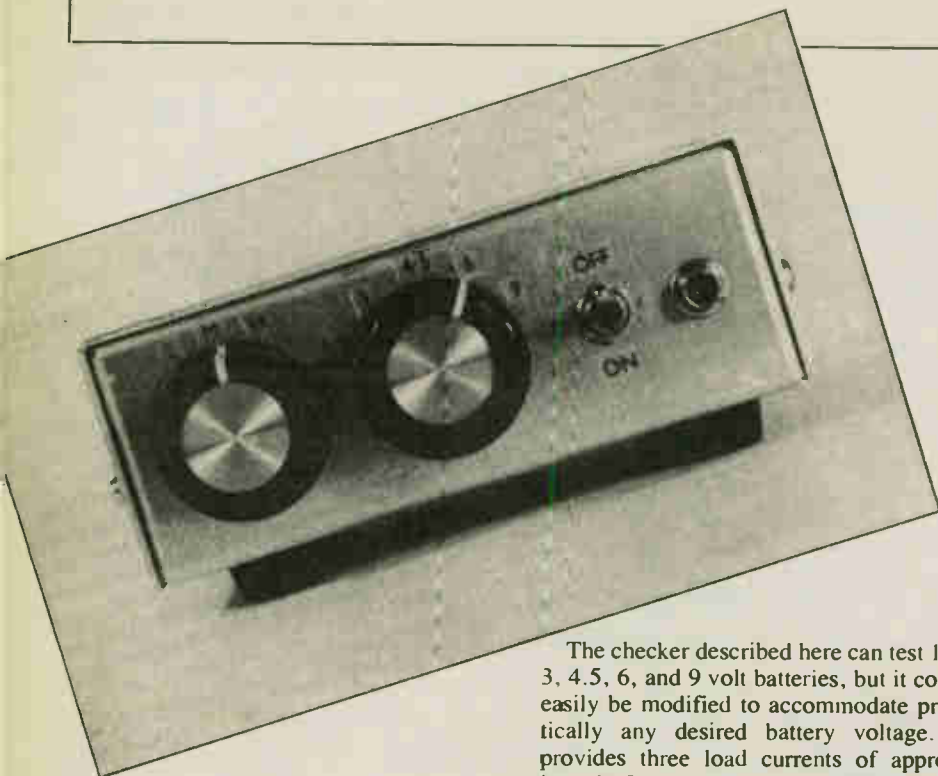

The checker described here can test 1.5, 3, 4.5, 6, and 9 volt batteries, but it could easily be modified to accommodate practically any desired battery voltage. It provides three load currents of approximately 8, 25, and 100 milliamps, which suits everything from a small radio battery to a large torch cell. The unit is very simple to operate, and a LED is used to indicate whether or not the battery under test is serviceable or exhausted.

Internal Resistance

The drop in voltage that occurs is something that can be rather puzzling to beginners in electronics, but it always occurs when power is drawn from any voltage source, including such things as the output of a hi-fi amplifier or the supply from an AC outlet. The cause of the voltage drop is internal resistance within the voltage source. Fig. 1 shows a voltage source loaded with a resistance R_b . R_a represents the internal resistance of the battery, and although in reality this is a resistance within the fabric of the battery, and dispersed throughout the battery, the effect is just the same as if it was a resistor connected in series with one of the output leads.

In this example the internal resistance is $10R$, and the load resistance is $90R$. By a straightforward potential divided action, one tenth of the battery voltage is dropped across the internal resistance, causing the output voltage to drop from 9 volts to 8.1 volts. Although these figures are only given as a simple mathematical example, a voltage drop of this order is quite typical for a 9 volt radio battery when nearing exhaustion the internal resistance can be as much as $50R$. For something like a freshly charged high capacity NiCad battery the internal resistance could be as low as a few milliohms. Internal resistance is an important factor since it limits the maximum voltage and current that a battery can provide, and it renders

BEING PRESENTED with batteries to be tested is somewhat of an occupational hazard for any electronics hobbyist. It would seem that this would be a deceptively easy task to perform; a simple voltage check with a multimeter is all that is required. A voltage test will confirm that a battery is exhausted if the measured voltage is well below the stated battery voltage, say about 75% or less. On the other hand, the battery might produce a potential which is quite close to its rated voltage, but could nevertheless be completely unusable in most pieces of equipment.

The cause of ambiguous results of this kind is the drop in battery voltage which occurs when high load currents are drawn. A battery might provide a perfectly respectable voltage when removed from the equipment in which it has been used, but could give as little as 50% of its rated voltage when replaced in the equipment and put to use.

One way around the problem is to always measure the voltage while the battery is in the equipment and the latter is operating, so that a loaded reading is obtained and any voltage drop the loading produces will be readily apparent. Although this might seem like the ideal solution it's not possible if you are only given the batteries and not the equipment from which they were taken, and in practice it can often be difficult to measure the battery voltage under operating conditions. This is just about impossible with flashlights for example. A more practical approach is to measure the voltage while using a resistor to load the battery with an appropriate current drain or, better still, to build a proper battery checker.

Testing ordinary dry cell batteries with a multimeter is deceptive, because the normal load current is not present.

This battery checker provides the right environment for checking them accurately.

By Robert Schmidt

certain types of battery unusable in some applications. A small radio battery could not provide the high currents needed to drive flashlight bulbs for instance.

Checker Operation

There are really two separate sections in the circuit; one to place a controlled load on the battery, and the other to check whether or not the battery voltage is higher than a certain threshold level. The load is provided by a constant current generator. This is more convenient than using a load resistor as it prevents any significant change in load current even with very large changes in the battery voltage. This avoids the need to have numerous switched load resistors with a separate resistor for each test voltage, and a separate set of resistors for each load current. As explained previously, three load currents are provided so that the current drain can be matched to suit the capacity of the test battery.

The voltage tester is built around a voltage comparator and a highly stable 1.15 volt reference source. The output of the precision voltage source is connected to the inverting input of the voltage comparator. The output of the comparator goes to virtually the negative supply potential if inverting (-) input is at a higher voltage than the non-inverting (+) input, or to virtually the full positive supply potential if the comparative input levels are reversed. An indicator LED is connected from the output of the voltage comparator to the positive supply rail. The LED therefore switches on if the non-inverting input is taken below 1.15 volts, or switches off if the non-invert-

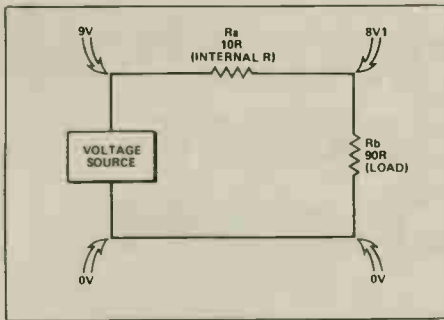

Fig. 1 A diagram representing the voltage drop when a voltage source is loaded.

ing input is taken to a higher potential than 1.15 volts.

The non-inverting input is fed with the output voltage of the battery, but via an attenuator which reduces the battery voltage to a suitable level. For instance, a 6 volt battery when under load and in usable condition would provide a potential of about 5 volts or more. The attenuator resistors would therefore have values calculated to give an output voltage of 1.15 volts with an input potential of 5 volts. If the battery voltage was above the 5 volt threshold level the voltage fed to the comparator would be more than 1.15 volts and the LED indicator would switch off to indicate that the battery was serviceable. If the battery potential was below the 5 volt threshold then the input voltage to the comparator would be less than 1.15 volts, and the LED would stay lit up to indicate that the battery was exhausted.

There is a very narrow range of battery voltages that gives an indeterminate output state from the comparator and something less than full brightness from the LED indicator. If the LED should only partially switch off it is best to take this as an indication that the battery is no longer reliable and to replace it, but in use an indeterminate LED stage may never be obtained as the range of voltages that give this effect is so restricted. It is more likely that the LED would switch off initially, and then turn on again as the battery voltage gradually falls below the threshold level under load. Again, it is probably best to take this as an indication that the battery is no longer usable and to renew it.

In practice there are five switched resistors in the upper arm of the attenuator, enabling the unit to check batteries of five different voltages. A current generator is included at the output of the comparator, but this merely sets the LED current at a suitable figure and does not play any active role in the operation of the unit.

Circuit Operation

A precision voltage detector integrated circuit (IC1) is at the heart of the unit, and it permits a very simple circuit to be used.

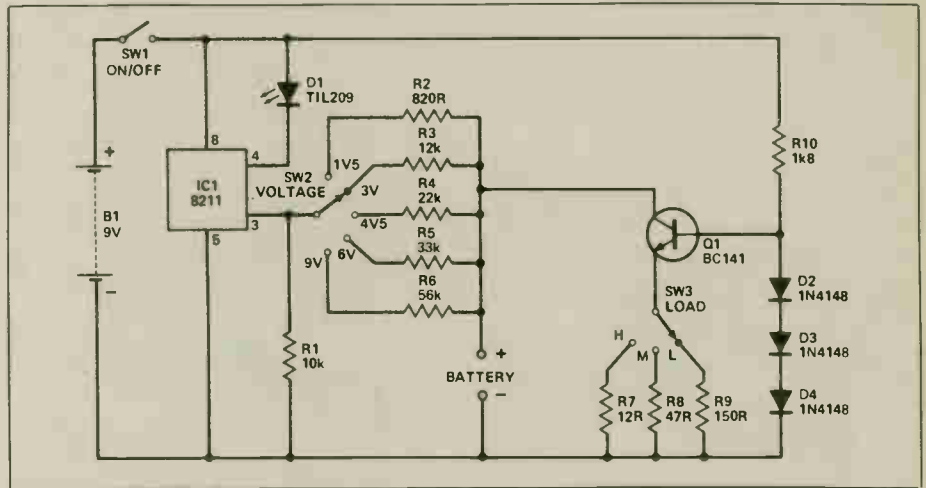

Fig. 2 The circuit is built around IC1, a precision voltage detector which gives a reliable reference voltage against which the battery voltage is checked.

The full circuit diagram of the checker appears in Figure 2.

IC1 contains the reference voltage generator, voltage comparator, and the constant current generator which sets the 'on' current of LED indicator D1 at a nominal figure of 7 milliamps. The attenuator is formed by R1 and whichever one of the five switched resistors (R2 to R6) is selected using SW2. For the record, the theoretical threshold voltages are 1.2443, 2.53, 3.68, 4.945 and 7.95 volts. R1 to R6 are all closer tolerance (1%) resistors, and coupled with the precision of the reference source of IC1 this gives good accuracy and reliable results without the need for any adjustment to the finished unit.

The circuit is not powered from the battery under test, but is powered from its own internal 9 volt battery. This gives better reliability and enables a wider battery voltage range to be accommodated. It is quite easy to calculate the series resistor value for voltages not included here if you wish to change the battery voltages covered by the unit. Simply multiply the required threshold voltage by 8.7 and then deduct 10. This gives the value of the series resistor in kilohms. It is unlikely that the required value will coincide precisely with a preferred value, and it is then a matter of either choosing the nearest preferred value or making up the required value from two or three resistors connected in series. Remember that the loaded output voltage of a battery which is in usable condition but nearing exhaustion is generally about 15% or so less than its stated output voltage.

The constant current generator which provides the load for the test battery uses Q1 in a conventional constant current generator circuit. R10 and the series of three diodes provide a potential of about 1.9 volts at the base of Q1, and taking into account the voltage drop across the base-emitter junction of Q1 this gives a potential of about 1.2 volts across the emitter resistor selected using SW3. The three switched

resistors (R7 to R9) give three different emitter currents. The battery under test feeds directly into the collector circuit of Q1, and as the collector current of a transistor is virtually identical to the emitter current, the current drain on the battery is mainly determined by the emitter resistance of Q1 and is largely independent of the test battery's voltage.

In Use

When the completed unit is switched on the LED indicator should light up. If it does not, switch off immediately and thoroughly recheck the wiring (including the polarity of D1 which can only light up if connected properly).

continued on page 60

PARTS LIST

Resistors

(All 0.4W 1% metal film)

R1	10k
R2	820R
R3	12k
R4	22k
R5	33k
R6	56k
R7	12R
R8	47R
R9	150R
R10	1k8

Semiconductors

IC1	8211
Q1	2N2297
D1	TL209 or similar panel LED
D2,3,4	1N4148

Miscellaneous

SW1	SPST
	sub-min toggle switch
SW2	6 way 2 pole rotary
	with end stop (set for 5 way)
SW3	3 way 4 pole rotary
B1	9 volt

Printed circuit board; case about 133 x 102 x 38mm, two control knob, battery connector, 8 pin DIL IC holder, 3.5mm jack socket and test leads, wire solder etc.

The Electronics Today Camera Contest

Win a Minolta Maxxum, the only 35mm camera with autofocus built-in. Micro-processor control of exposure for perfect point-and-shoot.

Our previous electronics trivia contest was so successful, we've adapted the idea for this one. This time we've put it in multiple-choice format. There are no trick questions.



Contest Rules

1. For each question, circle the answer that you think is correct.
2. Fill out the form below and mail it to us. If you don't want to cut the magazine, you can use a photocopy or send us the answers in a letter.
3. Only one entry, please. The last contest overloaded the post office so much, they had to borrow the editor's car.
4. Any persons associated with the contest, including employees (and their families) of Moorshead Publications are precluded from entering.
5. The prize will be awarded as described. No correspondence will be entered into regarding this contest.
6. The winner will be notified by mail or telephone within seven days of judging. The winner and correct answers will be published in the January, 1986 issue.
7. The winner will be selected by drawing an entry from the correct answers received.
8. The deadline for entries is December 15, 1985.

The Electronics Today Camera Contest

1. When the base of a transistor is the same voltage as the emitter, the transistor is:
 - a) saturated
 - b) operating normally
 - c) cut off
2. A circuit in which a single amplifier acts as both a sound IF amplifier and an audio amplifier is called:
 - a) an impossibility
 - b) a reflex-amplifier circuit
 - c) a reflectodyne circuit
 - d) an amplidyne
3. A ferrite bead behaves like:
 - a) an inductor
 - b) a temperature sensing resistor
 - c) a neutrode
4. Which amplifier configuration can be used to match a high impedance to a low impedance?
 - a) grounded base
 - b) grounded gate
 - c) emitter follower
5. Removing the capacitor across an emitter resistor in a transistor amplifier will:
 - a) increase the gain of the amplifier
 - b) increase the amplifier frequency response
 - c) lower the input impedance

Mail your entries to:

**Moorshead Publications
Electronics Today Camera Contest**

25 Overlea Blvd., Suite 601
Toronto, Ontario M4H 1B1

Name _____

Address _____

Town/City _____ Province _____ Postal Code _____

Telephone: Area Code _____ Number _____

Do you subscribe to Electronics Today? yes no

Automatic Test Equipment

A look at automatic test equipment and techniques used to implement it.

By W.P. Bond

AUTOMATIC test equipment has been around in one form or another for nearly three decades. In recent years, the introduction of LSI and VLSI circuits has totally changed the requirements for ATE, especially since the equipment and procedures must meet the needs of volume production. Cost is perhaps the most important consideration today, and this must be understood in relation to the two general types of test procedure: functional and in-circuit testing.

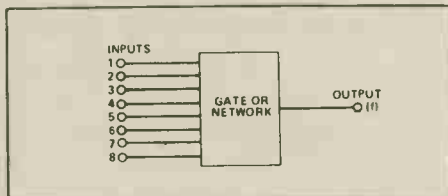

Fig. 1. 256 patterns would be needed to test every input combination.

Functional testing looks at all the functions of a circuit, taken in isolation from a whole system of which the circuit may be a part. The circuits involved, and of course the test procedures, can be digital or analog. Digital, or logic, circuits are simpler than analog circuits from the viewpoints of automatic testing. There are simple 'go/no-go' results obtainable from logic circuits, while analog devices need to be tested within a broad range of acceptable performances. It makes sense to begin an examination of ATE with logic circuits.

Some Logical Steps

There are four main categories of logic circuits:

- Combinational Logic: outputs are dependent solely on the present inputs.
- Sequential Logic: outputs are dependent on present inputs and on previous outputs, such as circuits with memory or feedback.
- Bus Structured Logic: combined circuitry of the above types on MPU-type boards with components connected by a bus-structure.
- Random Logic: combined circuitry without a bus-structure.

The testing procedure for any given circuit or circuit assembly will depend on the category it belongs to.

There are a number of other considerations that have to be kept in mind when devising test procedures, apart from the categorizing of the circuit concerned. Even in simple cases, functional testing may have to be uneconomically elaborate in order to detect all possible faults. The 8-input gate in Fig. 1 would require 256 test patterns if all input conditions were to be covered. Such exhaustive testing (ET) very quickly becomes unwieldy, even with straightforward combinational circuits.

Most circuits are not straightforward. One particular problem is caused by the presence of redundant logic, often built-in for reliability. The circuit in Fig. 2, for example, includes a redundant gate (G2) which can be shown by simplifying the output function $A.C + B.C + A.B$ using Boolean algebra or Karnaugh mapping. In this case, a fault in the redundant gate may mask faults in the non-redundant circuit

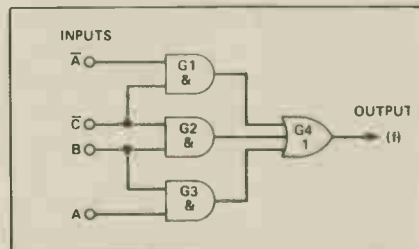

Fig. 2. Redundant gates can result in fault-masking.

elements. For example, in this case if the output from the redundant gate is permanently low (stuck at 0, or SA0), it will have no effect on the network output. But if it is permanently high, (stuck at 1, or SA1), then the network output will be permanently high regardless of what's happening on the other gates.

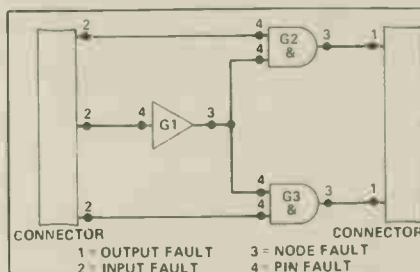

Fig. 3. Test points in a typical circuit section.



Fig. 4. Different fault, same truth table.

The typical test points are shown in Fig. 3 for a sample circuit. From Fig. 4, it should be clear that the same symptoms can follow from a variety of faults. An SA0 pin fault on the B input to the NAND gate in the figure will be indistinguishable at the output from an SA1 node fault; the same input test patterns will result in the same outputs. To locate faults successfully, it is important to test the circuit in question at more points than its inputs and outputs. Fig. 5 shows a small logic circuit with redundancy in which an SA1 pin fault would go undetected if the circuit were tested at inputs and outputs only. This sort of fault would be seen where an open circuit existed at the pin, since open inputs float high. Because of this, inputs tied to Vcc are sometimes classified as 'undetectable' for fault-finding purposes.

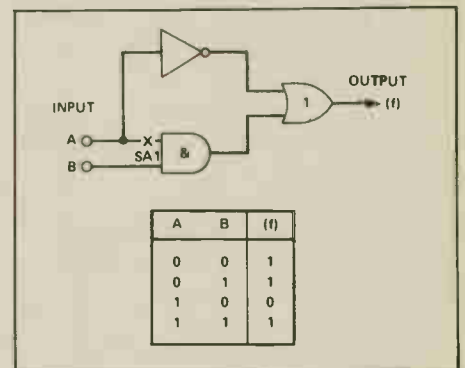

Fig. 5. The fault here is undetectable.

It's worth noting that there are two kinds of redundancy in circuits: fault-masking and self-checking. In the first, faults are masked by multiple circuits performing the same task. In the second, faulty circuits are switched out of the system and good circuits switched in to take their places.

Sequential logic presents the test procedure with yet more problems. Fig. 6 shows a circuit configuration in which

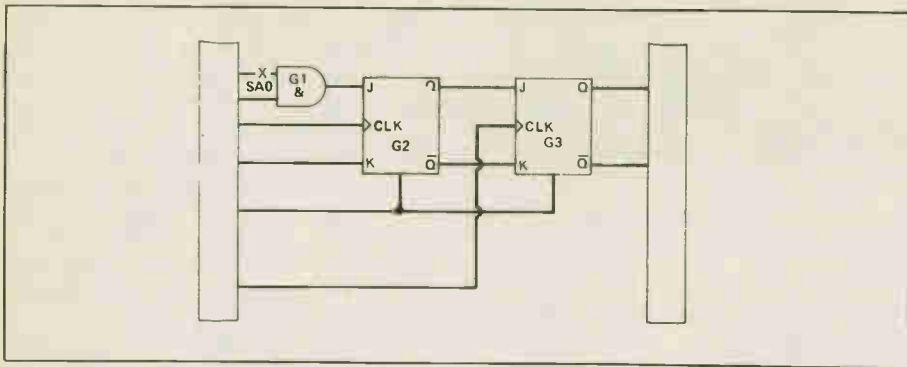

Fig. 6. A latent fault.

there is no direct path between the fault (SA0 at input 1) and any output. Here again, the importance of good 'test-pointing' becomes obvious. This requires a series of test patterns to 'walk' it to an output pin. The examples shown would require three consecutive test patterns to clock it through gates G2 and G3. With less than three test patterns, the fault would simply not appear at any output. The number of patterns required to propagate the fault to the output is called the degree of latency.

Changing inputs can give rise to their own problems. The commonest is called racing. Race hazards take the form of unwanted transients (signal spikes) caused at the output to a logic circuit when two or more inputs change at the same time. In Fig. 7, for example, inputs A and B are meant to change simultaneously from 1 and 0 respectively, to 0 and 1. If B reaches the 1 state slightly before A reaches the 0 state, then the output will display the negative-going spike as shown. Such glitches often occur in latching circuits with feedback: dividers, for example. Testing at the output can lead to spurious results in this situation. The simplest solution is to build in a time delay at the output test point greater than the propagation delay of the gate.

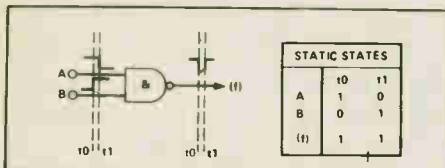

Fig. 7. Generating glitches.

Untestability

Testability must be designed into electronic modules if they are to be properly tested in the first place. Obvious though this sounds, it is all too often overlooked by circuit designers, perhaps because 'testability' itself is an awkward and ill-understood notion.

Testability implies not only the possibility of testing a module or circuit but also the existence of a set of guidelines aimed at maximizing test efficiency. Because of the specialized nature of individual complex analog designs, I will limit the

present discussion to functional testing of static digital circuits, although the principles do not lose in generality. It's worth noting that functional testing, although perhaps more easily understandable, is actually more rigorous than in-circuit testing and as much as ten times more costly.

Test procedures can be considered to have three main aspects: initializing, observing and controlling. For a circuit to be testable, each of these aspects must be catered for.

Initializing: this is the process by which all nodes of the device under test (DUT) are set to known states after power-up and before test patterns are applied.

Observing: in the context of ATE, this means minimizing the amount of human intervention needed to identify faulty components. Observing entails the correct monitoring of a circuit and involves the provision of suitable test points in the design. Observability is the key to maximizing the effectiveness of ATE.

Controlling: for proper functional testing, the ATE must be capable of controlling the DUT, usually by means of an edge connector. If all functions of the DUT cannot be exercised, then testing will be inadequate.

In the Beginning

LSI designs are most commonly sequential and the failure to initialize can mean testing circuits in forbidden or indefinite states. There are four main factors in designing-in the ability to initialize a circuit:

- there should be access to deep sequential circuits, which is a criterion of observability.
- there should be a means of isolating or breaking feedback loops.
- there should be access to reset and preset lines in memory elements.
- in certain cases (for example, VLSI devices where there is no access to reset or preset lines) it should be possible to use software initialization.

Fig. 8 shows a simple sequential circuit, a counter or shift register for example, with and without testability built in. If appropriate test points have not been provided on power-up, all the memory elements f(1) to f(n) will be in an unknown state (an x-state). The output will be also be in an x-state. Without access to reset or preset, a 'homing sequence' would have to be provided by the tester. Further, if a fault existed, the failure could be observed at the output, but without the use of a guided probe routine and suitable test points, fault isolation would be impossible. This is a failure of observability or diagnostic visibility.

In the lower diagram, test points and a reset line have been provided. Since the reset line, in particular, is no longer wired to Vcc, we need only apply a clear signal to initialize the circuit, rather than go through the elaborate sequence of a homing sequence.

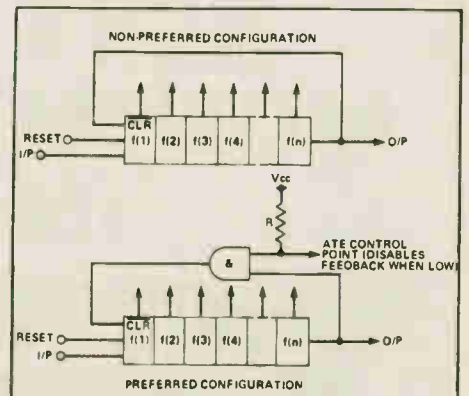

Fig. 8. Non-preferred and preferred sequential circuits.

In Fig. 9, a feedback loop has been introduced into the sequential circuit. Even if

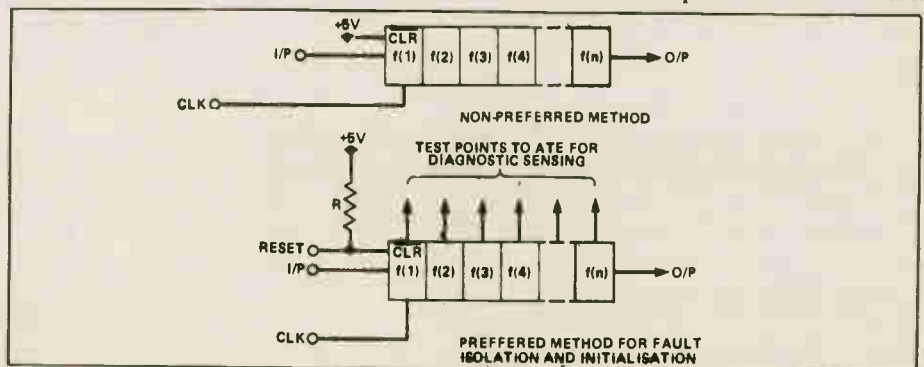

Fig. 9. Breaking a feedback loop.

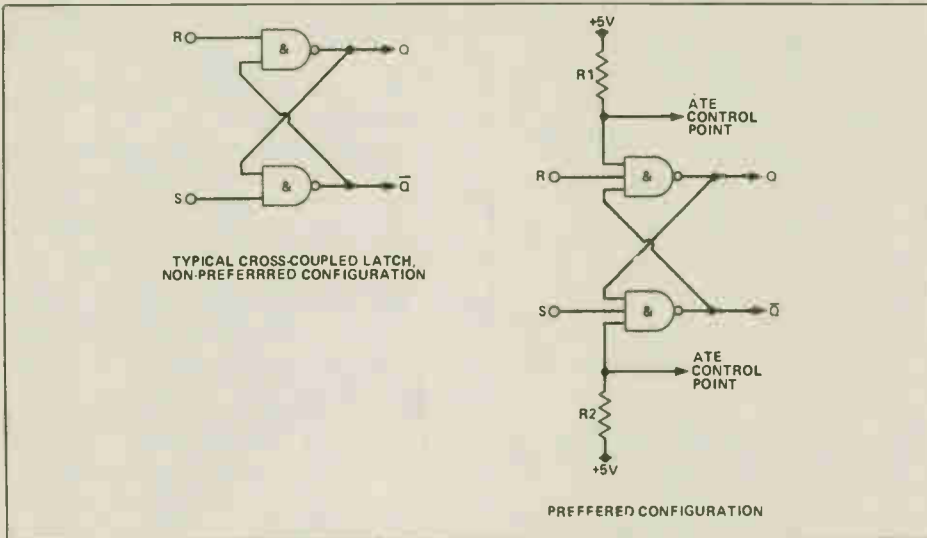

Fig. 10. Breaking the feedback loops in a latch.

test points and the reset line are accessible so that initialization does not require a homing sequence, the problem of fault diagnosis remains. Because of the feedback loop, a fault may be propagated to all points around the loop. To overcome this, the loop must be breakable. The lower diagram shows how this is done; when the control point goes low, the loop is broken.

In Fig. 10, a typical cross-coupled latch

is shown. By itself, this poses no initialization problem, even though the circuit will power-up into an x-state. However, if such latches are deeply embedded in a circuit and if component gates are from different chips, there may be a serious test problem. The preferred method of control is to use three-input gates as components so that access points exist to break the feedback loops.

In general, initializing combinational circuits presents no problems since outputs are purely dependent on inputs. The first test pattern to be applied will set all nodes to a predetermined state. Initializing sequential circuits is always more complicated since such circuits contain x-states after power-up. These must be flushed out of the system before testing can begin. Since ATE programs must themselves be tested by means of a computer simulation or model circuit, a further problem is encountered. The model circuit will almost certainly power-up into a different state from any other model or real circuit.

A set of test patterns needs to be devised which, when applied to the DUT, will set it to a known state regardless of its initial condition. This is known as a synchronizing sequence. In a simulation test, the model is then put into the same condition using the same synchronizing sequence before testing proceeds.

The synchronizing sequence can act as a homing sequence in the absence of a reset line. A simple example might involve a synchronous counter, for example a 74163, in which all the data inputs are set low, the parallel load is enabled and the clock pulsed. Obviously, access to the reset would achieve the same object at a lower overhead.

The difference between a synchronizing

NEXT MONTH IN Electronics Today

Electronics in Photography

Now they have cameras that do everything for you except press the shutter button, and they're working on that. We look at how it all operates.

The Electronics Today Photoflash

Build a softbox with 100 watt-seconds of power, or mount the tubes in reflectors, or just use the article as a design guide for flashtubes. Uses Radio Shack parts.

More On Transformers

We continue last month's look at transformers: autotransformers, audio matching, special purpose types. Our editor, an intrepid tinkerer, explains how to substitute for hard-to-find units.

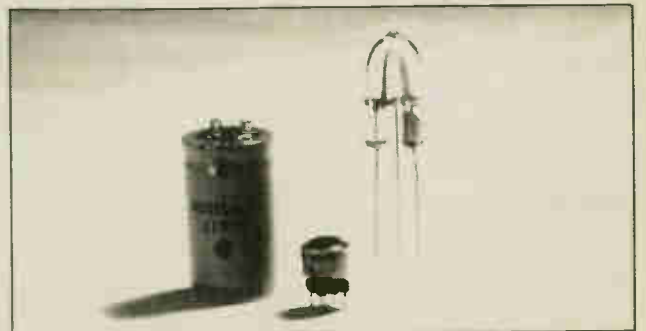

For Subscription or Advertising Information Call (416) 423-3262

sequence and a homing sequence, in general, is that the synchronizing sequence is always the same in each particular, while the homing sequence involves an algorithm to modify its stages in the light of the circuit behaviour. Homing sequences are, in effect, programs with loops and branches and are commonly known by the abbreviation AHS which stands for 'adaptive homing sequence'.

Figure 11 shows a standard divide-by-two circuit. While the right diagram illustrates a simpler arrangement from a test point of view in which initialization would require only a single-step synchronizing sequence (reset or preset directly), the left

diagram shows a simpler circuit which can be handled by use of an AHS.

The following algorithm would provide a suitable sequence:

1. Set CLK to 0.
2. Set CLK to 1.
3. If Q is 0, go to step 1.
4. Return to test (output Q, known to be 1).

Bad design is the bane of the tester's life. An examination of unhelpful design is shown in Fig. 12, a section of an actual circuit used in a ship's navigation system. Basic principles should immediately suggest that it was bad practice to tie J, K, and the preset inputs on IC1 (the 7476). Even though the reset lines are available to the

tester, close examination reveals another problem. Reset on the 7476 is asynchronous, that is, it works independently of the clock, while reset on the 74163 is synchronous; it needs a clock pulse to operate.

Since the clock pulse for the 74163 is derived from the 7476's Q output, the 163 will never receive a clock pulse when the 76's reset line is low. In other words, it's impossible to reset both ICs at the same time. To make matters worse, there were no direct outputs available for the 163, all of which makes it very difficult to initialize the circuit.

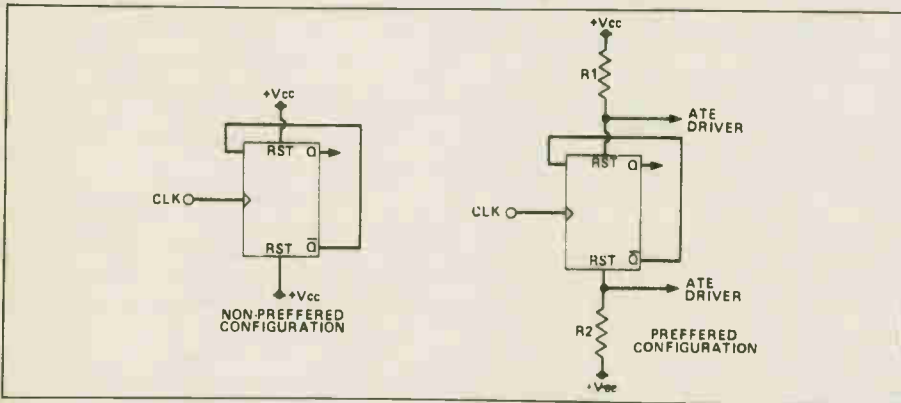

Fig. 11. Homing sequence versus synchronized sequence.

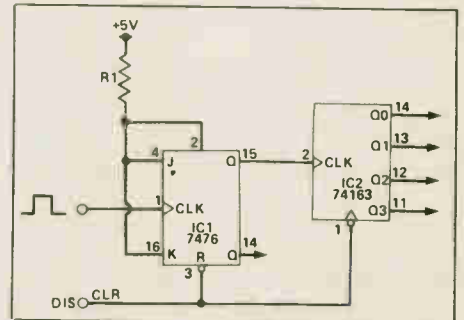

Fig. 12. An actual unhelpful design.

Now You See It

As has been suggested, the observability aspect of testing and the ability to initialize

This Month in

Computing! Now!

Software Now!

MacCharlie Review

Turn your Mac into a PC? Are you sure? We take a look at all the necessary voodoo needed to perform this magic.

Modems

We got lots of 'em. There are Modems for Business, High Speed Modems, and to top that off, there's even a Modem Survey.

Electronic Publishing

A look at what's happening in the world of high-tech publishing.

Telecommunications

Data communications and the arts: how Canadian artists are using micros to maintain unity and make their work more accessible to public.

TABBA

The Toronto Area Bulletin Board Association. Electronic bulletin board operators unite to control software piracy.

Software Piracy

A special report on software piracy and its implications for home and business users.

For Subscription or Advertising Information Call (416) 423-3262

circuits are not totally separable. Observability is really a way of talking about the effectiveness of ATE, which is clearly influenced by the position with respect to initialization. It's already been shown how feedback loops and the lack of circuit isolation can make it impossible to achieve the desired degree of diagnostic resolution, to use the jargon.

There are three ways in which the circuit designer can improve the observability:

- by partitioning circuitry (by function, for example).
- by providing ways to break feedback loops.
- by providing a means of isolating faults (test points, etc).

Functional testers are in practice 'edge connector oriented' and good controllability requires careful attention to the board design of any circuit. Effective ATE must be able to readily and properly exercise every component on the board. Good design, from the test point of view, will reduce the number of steps that need to be taken in order to cover all detectable faults.

The control functions that need to be available to the ATE can be grouped under five headings:

- Reset and preset inputs.
- Tri-state control lines, enable and disable signals.
- Feedback disable.
- Isolation and control inputs for free-running devices, in particular clocks.
- Synchronization signals, especially where microprocessor based modules are being tested, so that the DUT and ATE may be synchronized.

Reset and preset lines should never be tied together or hard-wired to Vcc or Gnd. They should be 'soft-wired' by use of pull-up or pull-down resistors to which test points are connected. CMOS inputs can be pulled high or low through an appropriate resistor because CMOS requires only very small bias currents to establish high or low states. TTL, however, can only be pulled high through a low-valued resistor because it requires quite a high current (about 2mA) to establish a low state. Active pulldowns should be used if overdriving is required. Passive resistors would have to be of too low a value for the ATE's drivers to source a high onto the input. For example, pulling four TTL inputs low would demand a resistor pulling 8mA across a maximum potential drop of 0.8V. It would have to be approximately 100 ohms.

Access to tri-state control lines is particularly important when testing memory boards or bit-slice processors in which circuit operation depends on ROM contents. Without access to the tri-state lines, it may be very difficult to control the circuit since the ROM contents may make it impossible to exercise all the circuit nodes. The ATE must be able to override such memory-based constraints.

Feedback loops have been dealt with above, and the preferred method, shown in Fig. 9, requires no operator intervention but can be handled entirely by the ATE software. Of course, switches or links could be used instead.

Control of the free-running devices and synchronization can be treated as two sides of the same problem, since one relates to situations in which the ATE must control the DUT - to single-step through a sequence of states, perhaps - and the other to situations in which the ATE must simply proceed in step with the DUT.

In the first case, serious synchronization problems occur where a clock-controlled circuit is operating at a greater rate than the fastest operation of the ATE. Synchronization is best achieved if the use of multiple clocks is avoided wherever possible. Multiple-phase clocks present no problem, but multiple clocks cannot be synchronized with. If a multiple clock system cannot be avoided, it should derive each clock signal from a master clock, divided down. This allows a common point for each ATE to latch onto.

On The Bus

When testing bus-structured circuits, synchronization alone is not enough. The ATE must be able to force the circuit's controlling microprocessor to relinquish control of its addresses and data buses.

If an MPU is used in conjunction with a Direct Memory Access (DMA) device, the DMA device must be capable of instructing the MPU to release its buses so that I/O or memory block transfers can take place without involving the MPU. Suitable control signals are available on many common MPUs which enable them to put their bus outputs in a high impedance state. Normally, a DMA controller would be used to handle the procedures involved.

The Z80, for example, features a bus request line, BUSRQ, and the 8085 features a similar HOLD line which are used to flag the MPU when the DMA device is about to make a data transfer. On the next cycle, the MPU will finish its present task and flag the DMA device that it has released its buses, using the BUSAK and HOLDKL lines. The DMA device then takes control of the buses. MPUs that do not contain built-in tri-state buffers on the bus lines (the 6502, for example) must be augmented by external tri-state devices if they are to be used with DMA devices, or indeed, with ATE.

In the case of MPU-controlled bus-structured circuits, effective testing can only be achieved if the ATE has direct memory access either through control lines on the MPU itself or through enable/disable lines on external tri-state buffers.

So Far . . .

The requirements for testability apply

equally to manual and automatic testing. While manual testing can proceed even with a badly thought-out circuit or module by the application of a little ingenuity, automatic testing is almost impossible with inadequate circuit design. In essence, the circuit designer's responsibility is to provide all the necessary test points and control lines to enable the ATE to track down all possible faults.

So far, we have dealt only with testing of digital boards. In a future article, we will turn our attention to in-circuit and analog testing. ■

ALMOST FREE SOFTWARE

OFFER

Moorshead Publications

Almost Free Software

Almost Free Software (CP/M) #1

Almost Free Software #1, #2 and #3 are for CP/M and are available in a variety of formats: Apple // + CP/M, 8 inch SSSD*, Access Matrix, Morrow Micro Decision, Superbrain, Xerox/Cromemco*, Epson QX-10VD, Sanyo MBC 1000, Nelma Persona, Kaypro II, Osborne and double densities, Teletideo, DEC VT-180, Casio FP-1000, Zorba.

Modem 7. Allows you to communicate with any CP/M based system and download files. Complete details were in Computing Now! November 1983.

PACMAN. You can actually play PACMAN without graphics, and it works pretty fast.

FORTH. A complete up-to-date version of FIG FORTH, complete with its own internal DOS.

DUU. The ultimate disk utility allowing you to recover accidentally erased disk files, fix garbled files, rebuild and modify your system. A real gem.

D. A sorted directory program that tells you how big your files are and how much space is left on the disk.

USQ/SQ. Lets you compress and uncompress files. You can pack about 40% more stuff on a disk with this system.

Finance. A fairly sophisticated financial package written in easily understandable, modifiable Microsoft BASIC.

BADLIM. Ever had to throw out a disk with a single bad sector? This isolates bad sectors into an invisible file, making the rest of the disk useable.

DISK. Allows you to move whole masses of files from disk to disk without having to do every one by hand, you can also view and erase files with little typing.

QUEST. A "Dungeons and Dragons" type game.

STOCKS. This is a complete stock management program in BASIC.

SEE. Also known as TYPE17, will TYPE any file, squeezed for not allowing you to keep documents in compressed form while still being able to read them.

**Order as AFS #1,
and specify system**

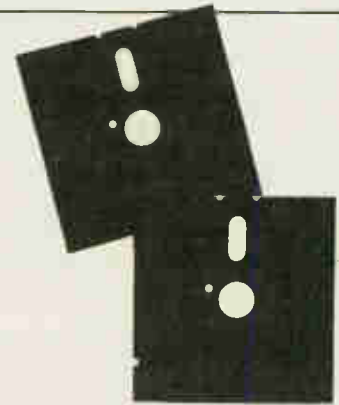

\$19.95 each

Except for 8" disks and those with two disks which are marked with an asterisk (*) above which are:

\$22.95

*single density formats require two disks. The package cost for these formats is \$22.95.

Almost Free Software (CP/M) #2

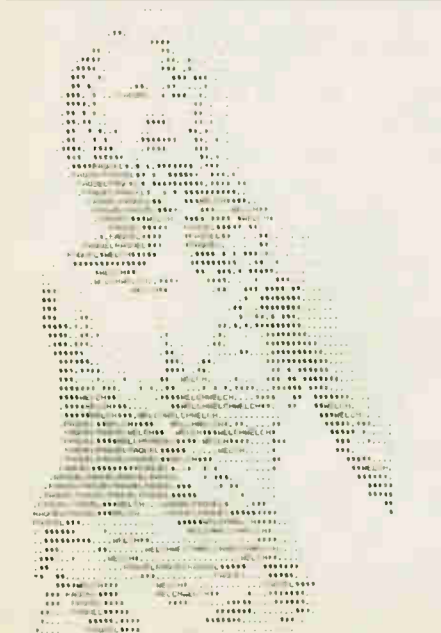

BISHOW The ultimate file typer, BISHOW version 3.1 will type squeezed or unsqueezed files and allow you to type files which are in libraries (see LU, below). However, it also pages in both directions, so if you miss something, you can back up and see it again.

LU Every CP/M file takes up unnecessary overhead. If you want to store lots of data in a small space, you'll want LU, the library utility. It permits any number of individual files to be stored in one big file and cracked apart again.

MORTGAGE This is a very fancy mortgage amortization program which will produce a variety of amortization tables.

NSBASIC Large disk BASIC packages, such as MBASIC, are great . . . and very expensive. This one, however, is free . . . and every bit as powerful as many commercial programs. It's compatible with North Star BASIC, so you'll have no problem finding a manual for it.

RACQUEL Everyone should have one printer picture in their disk collection.

Z80ASM This is a complete assembler package which uses true Zilog Z80 mnemonics. It has a rich vocabulary of pseudo-ops and will allow you to use the full power of your Z80 based machine . . . much of which can't be handled by ASM or MAC.

VFILE Easily the ultimate disk utility, VFILE shows you a full screen presentation of what's on your disk and allows you to mass move and delete files using a two dimensional cursor. It has heaps of features, a built-in help file and works extremely fast.

ROMAN This is a silly little program which figures out Roman numerals for you. However, silly programs are so much fun . . .

CATCHUM If you like the fast pace and incredible realism of Pacman, you'll go quietly insane over Catchum . . . which plays basically the same game using ASCII characters. Watch little "C"'s gobble periods while you try to avoid the delay "A's" . . . it's a scream.

**Order as AFS #2
and specify system**

\$19.95 each

Except for 8" disks and those with two disks which are marked with an asterisk (*) above which are:

\$22.95

*single density formats require two disks. The package cost for these formats is \$22.95.

Almost Free Software (CP/M)#3

OIL. This is an interesting simulation of the workings of the oil industry. It can be approached as either a game or a fairly sophisticated model.

CHESS. This program really does play a mean game of chess. It has an on-screen display of the board, a choice of colours and selectable levels of look ahead.

DEBUG. The DDT debugger is good but this offers heaps of facilities that DDT can't and does symbolic debugging... it's almost like being able to step, trace and disassemble through your source listing.

DU87. The older DUU program does have some limitations. The version overcomes them all and adds some valuable capacities. It will adapt itself to any system. You can search map and dump disk sectors or files. It's invaluable in recovering damaged files too.

ELIZA. This classic program is a micro computer head shrinker... it runs under MBASIC, and with very little imagination, you will be able to believe that you are conversing with a real psychiatrist.

LADDER. This is... this program is weird. It's Donkey Kong in ASCII. It's fast, bizarre and good for hours of eye strain.

QUIKKEY. Programmable function keys allow you to hit one key to issue a multicharacter command. This tiny utility allows you to define as many functions as you want using infrequently used control codes and to change them at any time... even from within another program.

RESOURCE. While a debugger will allow you to disassemble small bits of code easily enough, only a true text based disassembler can take a COM file and make source out of it again. This is one of the best ones available.

Order as AFS #3
and specify system

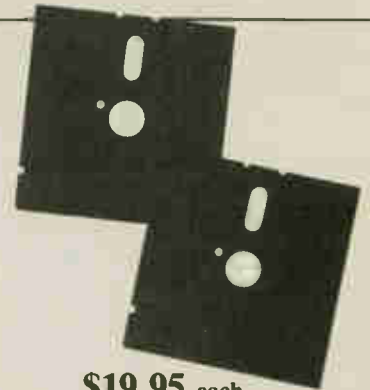

\$19.95 each

Except for 8" disks and those with two disks which are marked with an asterisk (*) above which are:

\$22.95

*single density formats require two disks. The package cost for these formats is \$22.95.

Almost Free Apple DOS Software

Almost Free Apple DOS Software#1

While CP/M is a wonderful thing in its own right, the Apple computer can also, and usually does, operate under DOS. For this reason, there's a multitude of programs available for it. Below, we offer a mini-multitude of our own.

The following programs will operate on any Apple //+, //e, //c, or true compatible operating under DOS 3.3. Apple users operating only under ProDOS may have to make alterations to some programs.

Picture Coder: All Apple HiRes pictures take up 36 sectors in their binary form. This program creates a textfile of a program in memory, squeezing out the zero bytes, that can later be EXECd into memory. The textfile often takes up less room on the disk.

DNA Tutorial: Operating under Integer BASIC, this program might appeal to 'clone' owners. In actuality, though, it's an interactive low-res graphics tutorial of DNA in its inherent forms. And you thought your Apple was only good for games...

Toad: Speaking of games, this program is an Applesoft BASIC implementation of 'Frogger' that can be controlled with either a joystick or the keyboard. The user's high scores are saved to disk.

Function Plotter: A fairly extensive Applesoft BASIC program that takes any inputted function and plots it on the HiRes Screen.

Data Disk Formatter: Apple DOS disks need not be bootable to be useful. This binary program formats a disk without setting DOS on the tracks, conserving useful disk space.

BASIC Trace: A program for the advanced Applesoft programmer, this file, when EXECd, displays the hexadecimal locations of each Applesoft line number of a program in memory.

Gemini Utility: A word processor pre-boot for Gemini printer users, this BASIC program initialises the printer's font or pitch before you boot your word processor.

Payments: This BASIC program allows you to keep track of payments and credits to and from up to 100 accounts on a single disk. A sample account is included.

Databox: A small but useful database program in Applesoft BASIC. Sample files are included to get you started.

Nullspace Invaders: A quick BASIC HiRes game testing coordination and judgement as you manipulate a monolith through mysterious gates.

Fine Print: The majority of this software has been obtained from on-line public access sources, and is therefore believed to be in the public domain. Any remaining programs were written in-house. The prices of the disks defer the cost of collecting the programs, debugging them, reproducing and mailing them, plus the cost of the media they're supplied on. The software itself is offered without charge.

Moorshead Publications warrants that the software is readable, and if there are any defects in the medium, we will replace it free of charge. While considerable efforts has been made to ensure that the programs have been thoroughly debugged, we are unable to assist you in adapting them for your own applications.

Order as AFAD #1
and specify system

Each disk is

\$19.95

or, as an introductory offer you
can order all three for

\$39.95

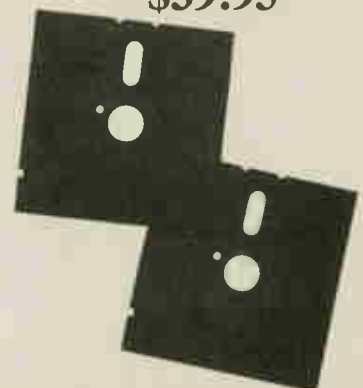

Software Services Moorshead Publications

25 Overlea Boulevard, Suite 601, Toronto, Ontario M4H 1B1

Moorshead Publications

Almost Free Apple DOS Software . . . #2

Amort: A monthly amortization program that calculates monthly payments to an inputted figure, calculates principle, interest on every balance, and prints out the resulting chart.

Voiceprint: An unusual program that uses the HiRes screen to sample sounds inputted through the cassette jacks at the back of your Apple. Sampling rate and other variables can be controlled, and two sounds may be compared side-by-side.

Calc NOW! Written in BASIC, this spreadsheet program is somewhat slower than VisiCalc, but still offers the power you expect from a spreadsheet. With sample files.

Cavern Crusader: A mix of BASIC and binary programming, winning this HiRes game is difficult, to say the least. For every wave of aliens shot in the cavern, there's always a meaner bunch in the wings.

Newcout: With source file. This binary program replaces the I/O hooks in the Apple with its own so you can operate your Apple through the HiRes screen. Comes with a character set.

Charset Editor: A utility to help you create your own character sets to use with Newcout.

Calendar: A BASIC utility useful for finding a particular day of any inputted month and year, or for printing out any given year.

LCLODR: With source. This binary utility BLOADs any given file into the 16K language card space at \$D000. The source is useful in showing how to use DOS commands through assembly language.

Cristo Rey: An animated HiRes BASIC program showing Cristo Rey by moonlight. For apartment-bound romantics.

ATOT: That's an acronym for 'Applesoft to Text'. EXEC this textfile to produce a textfile of your program.

Applesoft Deflator: This program takes a textfile made by ATOT and squeezes it, replacing PRINT statements with '?' and removing unnecessary spaces from the listing.

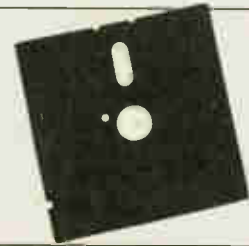

Order as AFAD #2
and specify system

Each disk is
\$19.95
or, as an introductory offer you
can order all three for
\$39.95

Almost Free PC Software

Almost Free PC Software #1

Our Almost Free Software disks, volumes one through three, for systems running CP/M have been so thunderingly popular that we have assembled a volume for IBM PC users. The considerably greater power of a sixteen bit system, coupled with its larger capacity disk drives, have enabled us to offer a collection of programs that will knock the socks off virtually any sentient life form booting the disk. Be warned... wear sandals when you unwrap this thing.

This software will run superbly on genuine IBM PC's and compatible systems.

PC-WRITE While not quite Wordstar for nothing, this package comes extremely close to equalling the power of commercial word processors costing five or six bills. It has full screen editing, cursor movement with the cursor mover keypad, help screens and all the features of the expensive trolls.

SOLFE This is a small BASIC program that plays baroque music. While it has little practical use, it's just a kick to toodle with. It's also a fabulous tutorial on how to use BASICA's sound statements.

PC-TALK Telecommunications packages for the IBM PC are typically intricate, powerful and huge. This one is no exception. It has menus for everything and allows full control of all its parameters, even the really silly ones. It does file transfers in both ASCII dump and MODEM7/XMODEM protocols and comes with... get this... 119424 bytes of documentation.

SD This sorted directory program produces displays which are a lot more readable than those spewed out by typing DIR. It's essential to the continued maintenance of civilization as we know it.

FORTH This is a small FORTH in Microsoft BASIC. It's good if you want to get used to the ideas and concepts of FORTH... you can build on the primitives integral with the language.

LIFE This is an implementation of the classic ecology game written in 8088 assembler. While you may grow tired of watching the cells chewing on each other, in time the source will provide you with a powerful example of how to write code.

MAGDALEN This is another BASIC music program. We couldn't decide which of the two we've included here was the best trip, so we wound up putting them both on the disk. Ah... the joys of double sided drives.

CASHACC This is a fairly sophisticated cash acquisition and limited accounting package written in BASIC. It isn't exactly BPI, but it's a lot less expensive and suitable for use in most small business applications.

DATAFILE This is a simple data base manager written in... yes, trusty Microsoft BASIC.

UNWS Wordstar has this unusual propensity for setting the high order bits on some of the characters in the files it creates. Looks pretty weird when you try to do something other than Wordstar the file, doesn't it... Here's a utility to strip the bits and "unWordstar" the text. The assembler source for this one is provided.

HOST2 This is a package including the BASIC source and a DOC file to allow users with SmartModems to access their PC's remotely. It's a hacker's delight.

The disk also includes various support and documentation files needed to run the software.

We can provide the Almost Free PC Software Disk volume one on either one standard double sided disk or on two single sided ones.

Order as AFPC #1
and specify system.

Only
\$19.95
or **\$22.95**
for two single sided disks.



Moorshead Publications warrants that the software will be readable. If defects in the medium prevent this, we will replace your disk at no cost. While we have made every effort to assure that these programs are completely debugged, we are unable to assist you in adapting them for your application.

THE PRESENT controversy over Star Wars reminds this writer of Canada's early efforts in RDF (range and direction finding) research. At that time, it was the other way around: Canada was in the forefront of developing workable radar detection of ships and planes by the outbreak of World War II, while the US was the neophyte. But perhaps it was better for the Allied cause that the early Canadian effort was overtaken by subsequent events which saw the ascendancy of a third party: Britain.

The prelude to WWII saw the first halting steps to develop what was then essentially an experimental radio device to locate enemy aircraft. The halcyon years of radar, following the war's onset in 1939, were best illustrated by the Tizard Mission to North America. It was headed by Sir Henry Tizard of the UK in 1940, and he initially appeared to find Canada more appropriate for RDF research than the US, even if both countries provided a haven free from the bombs and destruction that was England in 1940. As W.E. Knowles Middleton said in his book *Radar Developments in Canada, NRC 1939-1946*, "while the principles of radar appear to be simple, the actual realization of a workable system calls for technical ability of a high order. In the first place, the reflected energy received from a target such as an aircraft at a distance of some tens of kilometres may be only 10^{-18} of that radiated, so that the transmitter has to be very powerful and the receiver extremely sensitive. In the second place, the entire apparatus must be rugged enough to resist weather, transport and rough handling. The fact that very effective apparatus was produced so quickly under wartime conditions demonstrates a remarkable competence in electrical and mechanical engineering, and no less remarkable dedication to the common cause."

RDF

We called it RDF both in Canada and Britain, a secret set of letters under which we hammered out a workable machine. We stuck to the original letters for several years into the war, until events hatched a new name for what became a decisive weapon. Britain adopted the American acronym of Radar (radio detection and ranging) while going on to develop higher and higher frequencies. There was also a closer liaison between the UK and the US following the Tizard Mission in the Fall of 1940, while Canada chose to develop an already outmoded design operating on a much lower frequency.

The frequencies of RDF, like the early days of radio, were constantly in a state of flux until the best ones were found. The more conservative researchers, like Canada, stayed with whatever worked,



Radar Supremacy in WWII

Canada almost became a world leader in the development of radar, a look at some of the early experiences.

By James W. Essex

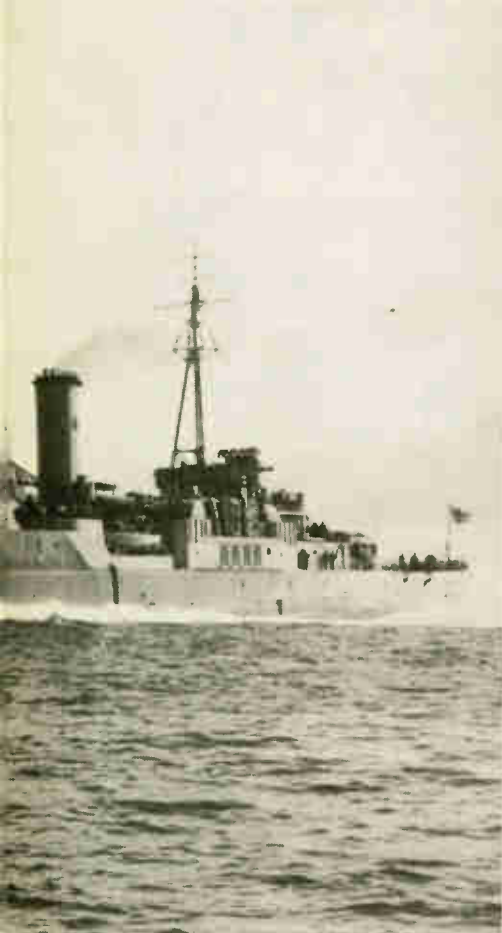

while overseas research pushed back the barriers. As WWII progressed, Britain went still higher with RDF frequencies, reaching 3000MHz, or 10cm. Microwave RDF came at an opportune time, helping not only to turn the tide in the Allies' favour, particularly in the Battle of the Atlantic in 1942-43, but assisting the growing US fleet in operations against the Japanese in the Pacific. Canada had only one representative there in the closing years of the war, a gift from the Royal Navy: the HMCS *Uganda*, Canada's first and only cruiser to see service in the Pacific (the author served as a Radar Mechanic on board from commissioning in October, 1944 to the war's end in the Pacific, serving in all major theatres of the Pacific campaign). Of course, being a former Royal Navy warship, it carried British-built RDF equipment.

Microwave RDF

When Britain and the US embraced the as yet untried S-band magnetron with fervour, it set the standard we'd all eventually follow. But our Canadian enterprise wouldn't go easily despite the UK's obvious lead, epitomized by Britain's Type 271 microwave RDF. Even before the US was into it in a big way, Canada was considered to have a substantial lead over the US; this lead resulted in a fair amount of

inertia at the top command levels, and Canada insisted on fitting corvettes with the Canadian-built RDF even though the microwave RDF was shown to be superior. Only when the tide of battle became desperate did authorities recant and accept the improved 271 from the British. To Canada's credit, we did eventually develop our own 3000MHz magnetron 10cm radar, but it wasn't completed until 1944 and was only operational by the war's end, too late to help.

It's interesting to note that when the Americans earlier saw our primitive research outside Ottawa, they wondered why we hadn't made a greater expenditure then. According to Middleton's book, "the American group said that if their organization had done as much and as satisfactory work as we had done in the last nine months, they would consider the construction of a million-dollar building on our farm justified". The two buildings Outside Ottawa early in the war cost \$50,000, including a number of shacks and tents.

At the time, the best the US could do was a paltry ten watts from an experimental magnetron demonstrated to the Tizard Mission in 1940. We were still experimenting with relatively standard transmitter tubes. The British, on the other hand, presented the Americans with a magnetron that could push 10kW. On the basis of this, the famous microwave lab at the Massachusetts Institute of Technology was begun at Boston. This was the forerunner of what the Americans came to call Radar. It eclipsed Canada's embryonic efforts before we got started; we stuck with a relatively primitive design using a frequency which today is approximately where Channel 11 is (this is dealt with in some length in my book, *Victory in the St. Lawrence, Canada's Unknown War*, describing the dismal performance of Canadian-built RDF in the Gulf of St. Lawrence in 1942).

The Navy

Canada's contribution began with our insistence on following our own independent course initiated by our Navy. This resulted in time spent on a costly, less efficient RDF than would have been the case had we followed Britain's lead. We might also have developed a better working relationship with Britain. Instead, closer liaison between the UK and the US followed, effectively bypassing Canada.

I recall when our first class of RDF recruits entered the University of Western Ontario in early 1941, where basic research was directed already in the 1.5 metre band, great store was placed in an improved RDF for our corvettes. The Yagi antenna (developed earlier by a Japanese physicist) was admirably suited for our use, both in dimensions and direc-

tivity. Weight was a consideration, as well as the ability to rotate independently of the ship, eliminating the need to maneuver, as was the case with fixed aerials. The relatively small dimensions of the yagi meant that mast-head mounting was possible, despite the myriad wires, cables and signal halyards.

Rotating the yagi was a problem; conduits had to make a 90 degree turn to enter the cabin, and the many cogwheels necessary to transmit the motion meant cramped quarters for the operator. It required a hefty steering wheel to turn; my first ship, the HMCS *Prince Robert* employed a used Chevrolet steering wheel, scrounged, I'm told, from a nearby auto wreckers in Victoria. *Prince Robert* was the first ship on the west coast to be outfitted with SW 1C RDF, just in time to escort the ill-fated Canadian garrison to Hong Kong later that year.

The *Robert's* 90-foot raked mast required climbing, even in inclement weather, to reach the petcock at the top of the yagi to 'blow out the line'. This was necessary whenever moisture penetrated, shorting the coaxial feed. In addition, the signals from the front and rear lobes of the yagi were almost equal in strength; only close comparisons of minute blip height would show if the target was ahead or astern.

It should be recalled that these limits had frightening consequences. The HMCS *Charlottetown* was torpedoed by the enemy right here in Canada, off Cap Chat on Gaspé's lower North Shore in 1942. Our RDF failed to detect the Nazi submarine's periscope; Canadian sailors paid the price and Canada lost a ship.

Following the evacuation of Dunkirk in May, 1940, it was decided to move much of the upcoming British research to North America. Tizard preferred "serving officers who had recently been in action and who had had some operational experience of radar or similar". Canada had a surfeit of officers who had already had war experience. With a little persuasion, we might have prevailed in radar research. But it was not to be: the cavity magnetron developed by the British was far superior to anything else, including the German Seetakt radar at 0.8 metres. However, it was fortunate for all of us that eventually the research won the day, even if Canada lost the chance for radar supremacy. ■

Designer's Notebook: Digital Sampling

THE WAVEFORM that is recovered from a digital sampling process is never quite the same as the waveform that went in. Analogue to digital and its opposite (D-to-A), break continuous waveforms into discontinuous elements. The trick is to get it as close as possible to the original. Without taking any special precautions, you'll certainly end up with a sound that's recognizable, but it'll be noisy and distorted. Why does it happen, and what can be done about it?

First of all, we have the problem that a fixed number of 'quantisation levels' are available according to the number of bits that will represent the sample digitally. We'd like each sample to equal the exact value of the analogue signal at the time. Instead, we must round it up or down to the nearest level for which a digital code is available. A 2V signal, for example, would be okay for an 8-bit sampler, but 2.005V would not.

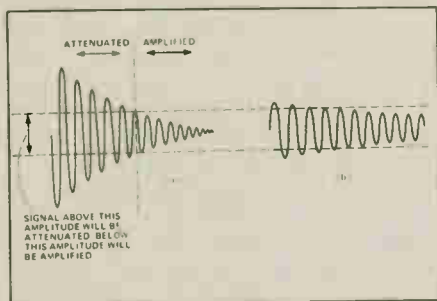

Fig. 1 (a) Input to compressor, and (b) the output from the compressor.

The result of the rounding process is known as quantisation noise and sounds very much like the kind of thermal noise hiss that any audio equipment will make to a greater or lesser extent. Intuitively, you can see why it sounds like noise by thinking of the difference between the true value of the audio signal and its quantised value as an extra and unwanted signal that is superimposed on the input.

For an arbitrary input, the value of this extra signal at each sampling will be random, in the sense that it will not be related in any obvious way to the harmonic structure of the input, will not repeat, and so on. There are certain inputs for which this will not be the case, but for general audio signals it's a reasonable way to look at the situation. The main difference between quantisation noise and thermal noise is that quantisation noise is only present when the sound is being reproduced, while thermal noise is there in the background all the time.

A look at the problems and solutions facing the designer of a digital sound sampler.

By Paul Chappel

For an 8-bit word length, the signal-to-noise ratio will be 48dB for a signal which is large enough to make use of all 256 available quantisation levels. This is certainly not hi-fi, but could be tolerated; a cheap domestic tape recorder will give similar results.

Unfortunately, the signal-to-noise ratio degrades very quickly as the amplitude of the input signal drops. For an input 20dB below the overload point (the point at which the A-D converter runs out of codes) the S/N ratio is a mere 28dB. Not too good. The reason for the degradation is fairly obvious; in the extreme case the input may be so small that it only alters the least significant bit in the binary code. The resulting variation between two possible output levels would not track all the nuances of the input with any degree of precision.

Companding

The simplest solution to this problem is to ask the user to adjust the input so that the ADC is operated as close as possible to its overload level without actually exceeding it. This is not as ridiculous as you might think. There are commercial samplers available that do this.

Assuming that the sound to be sampled can be repeated a few times to allow the input level to be adjusted, we are still left with the problem that as the sound decays the noise will increase. A piano note, for example, will begin with a high amplitude as the hammer strikes the string. The amplitude will then drop away quickly to a much lower sustain level. A sampler adjusted to accept the initial level would not give very good results during the sustain period.

Another possibility is to adjust the sound level electronically. Devices which do this are called companders (compressor/expanders) and are available ready made in the form of ICs. In essence, the compressor section will reduce the amplitude of signals that are above a certain pre-defined level and increase the amplitude of small signals,

so that the range of amplitudes is close to a constant level (Fig. 1). Therefore, the output will have a substantially reduced, or compressed, dynamic range and the signal can be kept close to the overload point of the sampler at all times. The expander section returns the dynamic range to normal after the signal has been translated back into the analogue form.

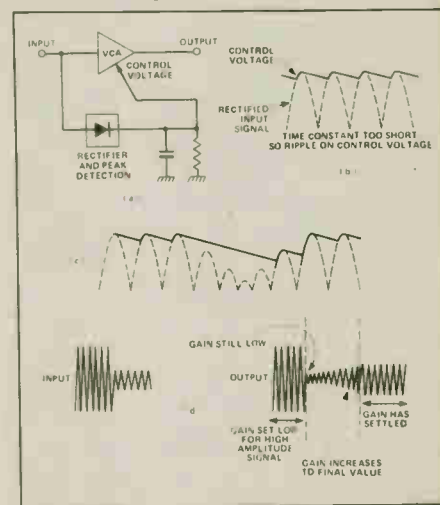

Fig. 2 There is a compromise between choosing too small a time constant, as in (b), and too long a time as in (c) and (d).

This is all very well in theory, but companders work by taking an average of the signal level and using this average to control a VCA which modifies the output level. The averaging process involves rectifying the input and integrating the result. A short time constant on the integrator will give an accurate average but will result in a good deal of ripple on the VCA control signal, while a long time constant gets rid of the ripple but will make the circuit slow to respond to amplitude changes (Fig. 2).

As rapid changes of gain in the VCA cause considerable distortion, compander circuits tend to err on the side of a slightly longer time constant. The resulting amplitude changes cause an effect often described as 'breathing'.

Instead of modifying the signal envelope, as is the case with companders, another possibility is to modify the waveform itself. Imagine we have a circuit with a kind of 's-law' characteristic as in Fig. 3. Any input to the circuit would be amplified much more around the zero-crossing part than it would be at its peaks. An input of varying amplitude would still be compressed, but this time the compression would be achieved by altering the shape of the wave rather than shrinking it as a

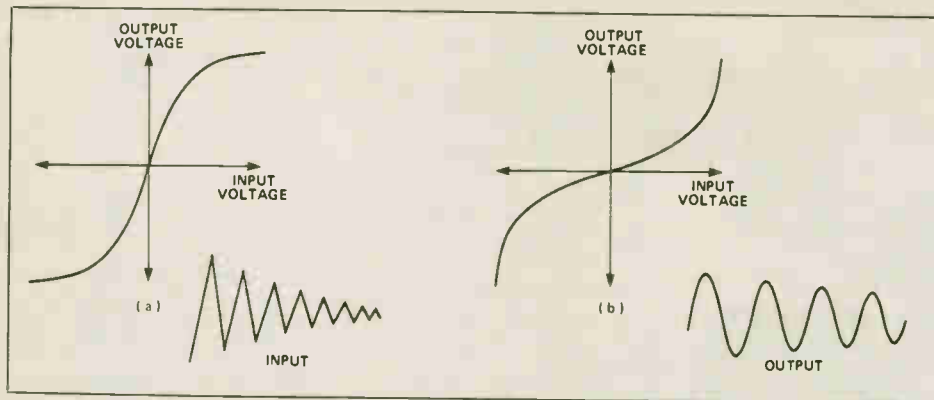

Fig. 3 (a) 'S'-law transfer characteristic. (b) The characteristic needed to restore the original signal. The waveforms show a triangular wave of diminishing amplitude before and after processing by (a). Note that the output changes far less in amplitude than the input.

whole. The waveform would end up very distorted, but could be restored to its original glory by a circuit with the inverse characteristic.

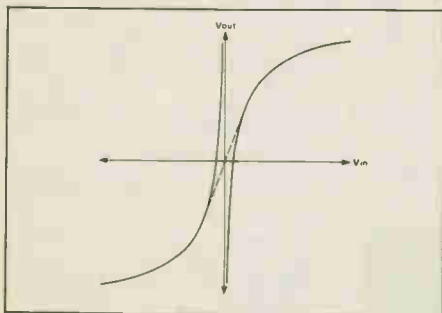

Fig. 4 Making an 'S'-law function from one curves. Note that if transistor junctions are used, the curves are offset along the V_{in} axis and will actually pass through the origin.

A circuit of this nature is not easy to construct as the inverse circuit must be a very precise match to the compressor. I have a feeling that something along these lines could be made by leaving out the integrating capacitors on a compander IC, but I haven't really looked into it.

Fig. 4 shows the curves simulated by a circuit using the base-emitter junctions of a pair of transistors with a bit of trickery to carry the function across the centre. The results were encouraging, but much more difficult to compensate for the temperature variations than I had anticipated. Log amplifiers exist in IC form (with temperature compensation) but they only work in two quadrants: you get the right hand side of Fig. 4 or the left, but not both.

However, all this is short-circuited by the fact that a similar kind of compression can be performed by the ADC. Just tuck the previous ideas away in the back of your mind for a moment because I'd like to approach the idea of 'digital companding' from a slightly different angle.

Resolution

The obvious way to increase the dynamic range of the sampling process is to use a

high resolution ADC. A 12-bit ADC will give 4096 quantisation levels and a S/N of 72dB at best; for a 16-bit ADC we have over 65,000 levels and a maximum S/N ratio of 96dB. If we're using 8-bit words to store the data we can't use a 12 or 16-bit ADC (assuming we could afford the 16-bit devices) and using two words for each sample would halve our sample time. Bearing in mind that we want to avoid the degraded S/N for low signal levels, suppose we do this instead:

Around the OV level, we pretend we've got a 12-bit ADC and space the quantisation levels accordingly so that they are 0.025% of full scale apart. After the first eight levels, 0.05% of full scale apart. The next eight levels will be 0.1% FS apart, the next eight 0.2% FS, and so on. The resolution around OV is now excellent. The penalty is that in the final section which takes care of the wave peaks the resolution is only equivalent to a 5-bit ADC. There are two very strong points in favour of this as opposed to linear conversion. First of all, audio signals generally have an amplitude spectrum concentrated in small signals rather than large ones and will often have crest factors (the ratio of peak to RMS amplitude) of five or more. Secondly, the human ear is much more sensitive to any inaccuracies of the wave around the zero-crossing point than it is to slight variations in the peaks. At the end of the day, the justification for this type of conversion is that it sounds so much better!

In IC form, there are two versions of the companding DAC. The first follows a law known as $\mu 255$, developed by Bell Laboratories. The idealised law is:

$$Y = 0.18 \ln(1 + uX)$$

where u has the value 255 for an 8-bit converter. This law is approximated by seven 'chords' which double in step size as described above. The rival system, the A-law, approximates the function:

$$Y + 0.18 (1 + \ln AX) \text{ for } 1/A \text{ (see ms pg 29)}$$

Where A has the value 87.6 for an 8-bit converter.

In both these cases, X is the analogue signal level as a fraction of full-scale. The formulae give the magnitude of the signal levels; a sign bit in the DAC is used to say whether they are above or below zero.

The main difference between the two laws is that the approximation of the A-law results in the first two 'chords' having the same step size, so the maximum resolution is only equivalent to an 11-bit linear DAC.

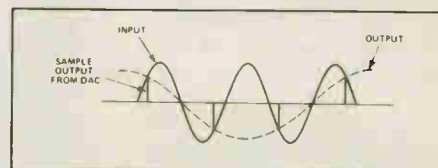

Fig 5 Alias distortion.

To tie in with the earlier idea of modifying the waveform with an 'S-law' analogue circuit, just imagine that the sample in memory from the variable-step ADC was fed out through an ordinary DAC. With allowances for the chord approximation, the waveform would look just as if it had been processed by the analogue 'S-law' circuit.

The advantage of companding during A-D and D-A conversion is that the technology required is just the same as that needed to produce a 12-bit DAC, which is not very difficult these days. To get the same degree of precision in a non-linear analogue circuit would be virtually impossible.

Sampling Rates

A well-known rule of thumb is the need to sample at more than twice the rate of the highest frequency component of any waveform that is to be reproduced; i.e., the famous Nyquist theorem. If you disobey the rule, you let yourself in for a dose of the dreaded alias distortion.

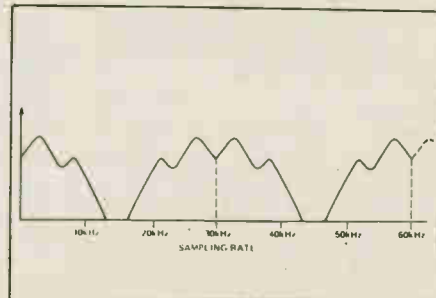
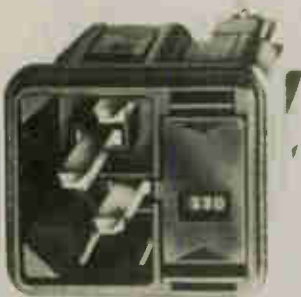

Fig. 6 The frequency spectrum of the input signal (a) and the output from the DAC, (b), showing the additional frequency components generated by sampling.

Longwaves

If, like most of us, you think that radio transmissions all work with very high frequencies, you'll be surprised to find out how much is happening below 500kHz, and even more surprised to find out that the spectrum extends all the way down to 9kHz. "The World Below 500 Kilohertz", a book by L. Peter Carron, Jr., details the commercial and non-commercial uses of low frequencies, as well as technical advice on how to listen to the low bands. There are navigation beacons, maritime voice bands, and military communications; you can also listen to natural generators such as earthquakes or solar flares. It's a fascinating book, a 64-page softcover available from the author for \$5.50 US. Contact: L.P. Carron Publishers, 205 Ridgewood Road, Easton, PA 18042. (215) 250-8898.

Power Entry Modules



Schurter Power Entry Modules provide a quick-disconnect feature for power cords. They're available with single or double fuses, a voltage selector switch and a lighted or unlighted power switch, depending on the model. All models are UL and CSA approved. Now you can add the power cord to the list of peripherals that you lose. From Lenbrook Electronics, Unit 1, 111 Esna Park Drive, Markham, Ontario L3R 1H2. (416) 477-7722.

Digital Electronics



Newport Electronics announces the Quanta Series 2000 digital panel meters for thermocouple types J, K, and T. Signal conditioning provides cold-junction compensation, linearization and sensor-break detection; there are options for analog outputs and control outputs such as isolated or parallel BCD. For more information, contact Metermaster division of R.H. Nichols Co. Ltd., 80 Vinyl Court, Woodbridge, Ontario L4L 4A3, (416) 851-8871.

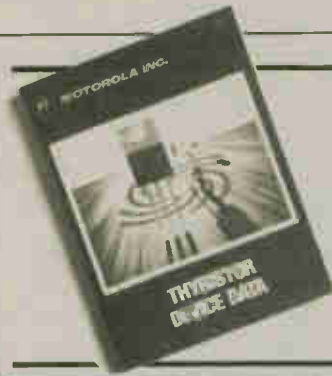

Thyristor Handbook

Motorola's new Thyristor Handbook, DL137, contains over 600 pages of information on triacs, SCRs, GTOs, triggers, etc. It includes theory and applications, cross references, selector guides, and a complete set of Motorola data sheets. There are sections on driver circuits, mounting, reliability and new technologies. Available from all Motorola sales offices and distributors.



Temperature Monitor

An intriguing way for manufacturers to monitor temperature during an industrial process: the Ball Corporation of Colorado sells a gadget called the Datatrace, consisting of a monitoring device about two inches long by one inch in diameter. The device is packaged along with the product (inside a can or bottle, say) and passed through the processing methods. Then the device is retrieved: is inserted into the playback console; a computer reads out up to 1000 time/temperature data points. The device can be reset and reused; battery life is about 1000 hours. So if you open a can of soup and find one of these, contact the Ball Corporation, 9300 West 108th Circle, Westminster, Colorado 80020. (303) 4460-5259.

Heath Laptop



Heath has announced a new laptop computer, the ZP-150, a diskless unit weighing 3.5kg and sporting a fold-down LCD display. The operating system is Microsoft WORKS, compatible with MS-DOS; the 224K of ROM contains a word processor, a

database, a spreadsheet, telcom software, etc. Serial and parallel outputs are provided. From Heath dealers, or contact the Heath company, 1020 Islington Ave., Toronto, Ontario M8Z 5Z3, (416) 232-2686.

A Toronto Loblaws supermarket is testing a prototype electronic shelf price display system. An LCD readout on the shelf displays the price and can be toggled by the customer to give a unit price, such as cents per litre; the product is identified by a card on the LCD. The displays are inter-

connected with the checkout counter, "ensuring 100% consistency between prices marked and prices read by checkout." The release doesn't mention that it will make it easier for supermarkets to raise prices. Hourly, if they want.

According to a press release, the 10th World Computer Congress and Business Equipment show will be held in Dublin in September, 1986. The release also says that the number of computer companies manufacturing in Ireland makes it 'the Silicon Valley of Europe'. Canada has Kanata, Ontario ('Silicon Valley North') and Scotland has 'Silicon Glen'.

According to another release, Fairchild Semiconductor is opening a \$100 million CMOS wafer-fabrication facility in Nagasaki, Japan; it will be constructed by 1986 and producing by 1987. The public relations writers must have been wrestling with themselves not to have called it 'Silicon Valley East' or similar.

CAD/CAM Graphics of Ottawa announce a new PCB artwork service called Artwork Express. It uses the Racal/Redac computerized PCB design system, said to be the most advanced system available, and is just part of their system which provides integrated and hybrid circuit board design, digitizing, plotting, N/C tapes, prototypes, drafting, documentation, etc. The Artwork Express service can also send the customer requirements from a Toronto office to the main equipment in Ottawa via modem, with a similar service for Montreal by the new year. For more information: CAD/CAM Graphics (1984) Ltd., 700 Industrial Ave., Ottawa, Ontario K1G 0Y9, (613) 526-0620.

Because gold doesn't corrode, it's the favourite coating for contacts in electronic equipment, but being a precious metal, it's subject to high prices and market fluctuations. There have been attempts at substituting for gold in the past, with varying levels of success. Now the Allied Corporation has produced a nickel-based alloy called Altraloy which it claims is the ideal replacement. It has excellent corrosion resistance, solderability, and can be plated on without an underplating. No mention was made about availability; if you'd like further information, you can contact their Corporate Technology Department at PO Box 2245R, Morristown, NJ 07960, (201) 455-5012.

Canada Remote Systems, the largest supplier of BBS public domain software, is now supporting the Apple Macintosh. Over 50 Mac disks will be on-line, giving a total of 20 megabytes of PD software. For more information, contact them at 4691 Dundas St. W., Islington, Ontario M9A 1A7, (416) 239-2835.

With NRI training at home, you can...

Move up to a high paying career servicing computers



And you can start by actually building NRI's 16-bit IBM-compatible computer.

You can create your own bright, high paying future as an NRI trained computer service technician. The biggest growth in jobs between now and 1995, according to Department of Labor predictions, will occur in computer service and repair, where demand for trained technicians will double. There is still plenty of room for you to get in on the action—if you get the proper training now.

Total computer systems training, only from NRI

To learn how to work on computers, you have to get inside one. And only NRI takes you inside a computer, with total systems training that gives you hands-on experience with computers, peripherals, and software. You'll build a Sanyo MBC-550 series computer, which experts have hailed as the "most intriguing" of all the new IBM-compatibles. The Sanyo even surpasses the IBM PC in computing speed and graphics quality.

Even if you've never had any previous training in electronics, you can succeed with NRI training. You'll start with the basics, rapidly building on the fundamentals of electronics until you master advanced concepts like digital logic, microprocessor design and computer memory. You'll probe into electronic circuits, using the exclusive

NRI Discovery Lab[®] and professional Digital Multimeter, that you keep.

You'll assemble Sanyo's intelligent keyboard, install the power supply and disk drive, and attach the high resolution monitor—all the while performing hands-on experiments and demonstrations that reinforce your skills.

Learn to service today's computers

As you complete your Sanyo, you grasp the "secrets" that qualify you for a new career. You'll learn to program in BASIC and machine language. You'll use utility programs to check out the operation of the Sanyo's 8088 microprocessor (the same chip used in the IBM PC). And you also get over \$1,000 worth of software, including WordStar and CalcStar.

Most importantly, you'll understand the principles common to all computers. Only a person who fully understands all the fundamentals can hope to be able to tackle all computers. NRI makes sure that you'll gain the knowledge and skills to maintain, troubleshoot and service computers.

Learn at home in spare time

With NRI training, you'll learn at home on your own time. That means your preparation for a new career or part-time job doesn't have to interfere

with your current job. You'll learn at your own pace, in the comfort and convenience of your own home. No classroom pressures, no rigid night school schedules. You're always backed up by the NRI staff and your instructor, who will answer questions, give you guidance and be available for special help if you need it.

Let others worry about computers taking their jobs. With NRI training, you'll soon have computers making good paying jobs for you.

Send for Free NRI Catalog

Send the post-paid reply card today for NRI's 100-page catalog, with all the facts about computer training plus career training in Robotics, Data Communications, TV/Video Servicing and many other fields. If some other ambitious person beat you to the card, write to NRI at the address below.

NRI SCHOOLS

McGraw-Hill Continuing Education Center
330 Progress Avenue
Scarborough, Ontario M1P 2Z5
or telephone 416-293-8787

We'll Give You Tomorrow.



IBM is a Registered Trademark of International Business Machines Corporation.

K.E.M.

HIGH SPEED EPROM PROGRAMMER \$175.00

FROM 2716 UP TO 27256. ALL ROUND TYPES. ONE TOUCH OPERATION INCLUDING 'A' AND 'CMOS' VERSIONS.

(EXAMPLE)

2764 — 30 SEC
27256 — 120 SEC

I/F CARD FOR **APPLE** OR **IBM**

UP TO 256!

IBM I/F CARD

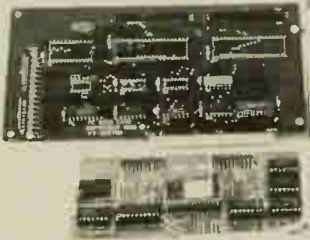

APPLE I/F CARD

UV LAMP WITH HOLDER \$26.98

FOR Photosensitive PCB Exposing or UV-EPROM Erasing. When you order, please let us know which type, exposing or erasing.

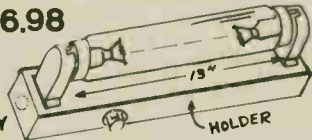

HIGH SPEED 10MIN ONLY ROBOTICS TRAINING I/O "ODEN" \$149.00

INCLUDES STEPPING MOTOR DRIVER, SPEAKER OUTPUT, 6 BIT LED DISPLAYS, PHOTO-, THERMAL-, SOUND-SENSORS, MANUAL DATA ENTRY SWITCHES, RELAYS.

& I/F CARD FOR **APPLE** OR **IBM**

DC MOTOR CONTROLLER & ULTRA SONIC RADAR UNIT(OPTION)

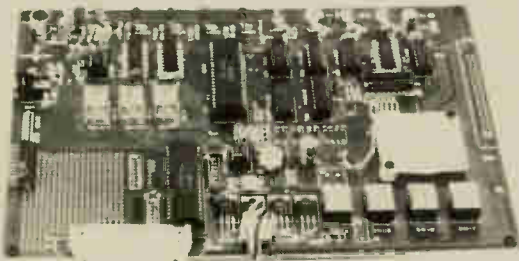

JUST CHANGE YOUR I/F CARD. YOU CAN SWITCH TO IBM OR APPLE.

EXTRA I/F CARD FOR 'PROGRAMMER' OR 'ODEN' \$69.00

STEPPING MOTORS & DRIVERS (ASK FOR DETAIL)

MOTORS (SEVERAL MODELS)	TORQUE RANGE	280g-cm --- 20Kg-cm
	PRICE RANGE	\$16.00 --- \$168.00
DRIVERS		\$68.00 --- \$169.00



PLUS \$5.00 FOR SHIPPING. PLUS PROV. TAX WHERE APPLICABLE. PLUS CANADA POST COD FEE IF REQUESTED. PRICES & SPECIFICATIONS ARE SUBJECT TO CHANGE WITHOUT NOTICE.

KEM (KAIENTAI) Electronics Ltd.

878 EAST HASTINGS STREET, VANCOUVER, B.C. V8K 4W4
PHONE (604) 281-1514

continued from page 24

For Your Information

Megabit ROM



A one-megabit ROM with an operating current of only 15mA and a standby current of 100uA from a single 5V source is available from Oki Semiconductor. It is organized into 131,072 eight-bit words and interfaces with most processors, including the

80C86/88. Access time is 250nS and the device is compatible with TTL. The 28-pin IC is available in 5000 lots at \$23 US each. Oki Semiconductor, 650 North Mary Avenue, Sunnyvale, California 94086, (408) 720-1900.

Circle No. 56 on Reader Service Card.
continued on page 37

If you'd like to learn how to design, apply and evaluate power supplies for state of the art electronic equipment, Lakeview Publications, publishers of Electronic Products and Technology, is presenting seminars on Linear and Switch-Mode Power Supplies in Ottawa, October 30 to Nov. 1, and

in Toronto November 5-7. The \$795 seminar fee includes sessions, course material, coffee and luncheons but not accommodation. Contact them at the Professional Education Division, Lakeview Publications Inc., Unit 28, 1200 Aerowood drive, Mississauga, Ontario L4W 2S7, (416) 624-8100.

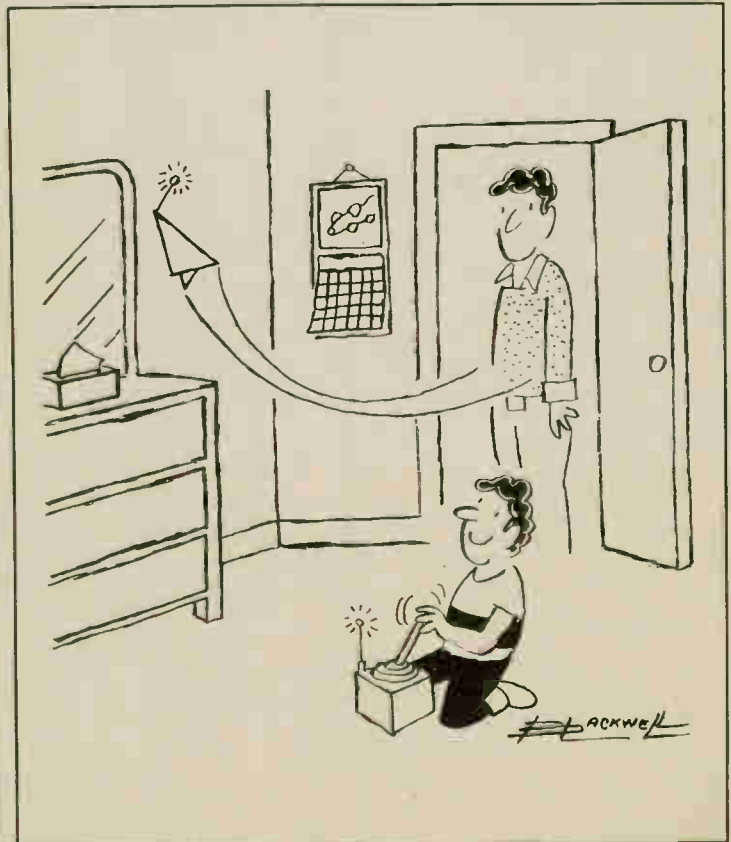

NEW 1986 CATALOG

CIRCLE READER SERVICE NO. FOR FREE COPY

THIS MONTH'S SPECIALS

DYNAMIC RAMS

4116	16K	1.39
4164	64K 150ns	2.19
4164	64K 200ns	1.89
41256	256K 150ns	8.69

EPROMS

2708	1K x 8	4K	9.39	ALL NEW CURRENT PRODUCTION PRODUCTS
2764	8K x 8 300ns	64K	5.99	
27128	16K x 8 300ns	128K	9.39	
27256	32K x 8 250ns	256K	18.69	TEXAS INSTRUMENTS
27512	64K x 8 250ns	512K	84.99	MOTOROLA

STATIC RAMS

6264	8K x 8 150ns	64K	14.19	Advanced Micro Devices
------	--------------	-----	-------	------------------------

FULL LINE OF MICROPROCESSORS AVAILABLE
WE ALSO STOCK...

- Books • Breadboard & Accessories
- Capacitors • Chemicals • Connectors
- Crystals • Plugs & Jacks • Fans
- Enclosures • Filters • Fuses • Heat Shrink Tubing • Heat Sinks • Kits
- Knobs • Peripherals • Probes • Opto
- PCB Products • Potentiometers ...

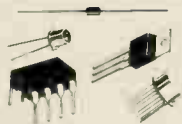

USA

P.O. BOX 9100
WESTBOROUGH, MASS
1-800-343-0874

Active

CANADA

5651 FERRIER ST.
MONTREAL, QUEBEC
1-800-361-5884

SELF SERVE STORES LOCATED NEAR YOU. JUST CALL...

WESTBOROUGH, MASS. 366-9684	OTTAWA, ONT. 728-7900	EDMONTON, ALTA. 438-5888
BELLEVUE, WASH. 881-8191	TORONTO, ONT. 977-7692	CALGARY, ALTA. 235-5300
MONTREAL, QUEBEC 731-7441/256-7538	DOWNSVIEW, ONT. 630-0400	VANCOUVER, B.C. 438-3321

Circle No. 10 on Reader Service Card

EMP MODEMS



\$469⁹⁵
Sugg. Retail

Auto 1200B/Auto 1200A-Special! \$299.95

- Bell 103/113/212A compatible • Interface: EIA RS232C • 0 to 300/1200 bps full automatic • Full duplex, auto dialer, auto answer, auto disconnect, redialer, Self-testing • Compatible with most personal computers and terminals • Compatible with all available communications software. DOC, FCC & CSA approved.

Modem MM101-\$79.95/MM101 Auto Answer-\$119.95

- 300 Baud - Full duplex • Bell 103 compatible • Direct connection between microcomputer and telephone. DOC, FCC & CSA approved.

Mail Orders: Send certified cheque or money order, plus \$5.00 for shipping and handling. Ontario residents add 7% P.S.T. to Circle No. 7 on Reader Service Card

For more information contact:

MARK GEE ENTERPRISES LTD.

2250 Midland Ave., Unit #26
Scarborough, Ontario M1P 4R9 (416) 298-9388
Telex 065-26270

Distributor and Dealer Inquiries Welcome

THE BRUNELLE Commander

SERIES

Dependability you can count on. Meets Toughest Demands.

MODEL 5050 Digital Multimeter

Model 5050 is a compact lightweight 3 1/2" digit multimeter suited for all types of lab or bench operation.



\$299.00

Featuring:

- 5 functions (AC/DC voltage, AC/DC current ranges up to 20 amps and resistance).
- 0.5" large 3 1/2" digit reg. LED display.
- High resolution 0.1mV, 0.1R, 0.1UA
- High accuracy 0.1%
- High current range 20A
- High voltage range 1,200V.
- Automatic Zero Circuitry.
- All range with protection circuit.
- 2 year warranty.

Model 4060 Digital

The Multimeter you've been waiting for ... at the price you've been hoping for.



\$99.95

Featuring:

- Handheld 7-function, 35 ranges with 200 uA, AC and DC. Hi-low ohms diode check.
- Built-in transistor test function.
- Overload protection. 2 amp fuse protects all meter ranges.
- Safety designed input jacks and test leads, tilt stand for bench use. Easy external battery access.
- Calibration certificate traceable to NRC supplied with meter.
- 1 year parts/labour guarantee.

Model 3030 Function Generator

Providing Sine, triangle, square, pulse and ramp out-puts over the 0.2Hz to 2MHz frequency ranges.



\$415.00

Featuring:

- Accuracy of $\pm 5\%$
- VCF input
- Variable DC offset
- TTL or CMOS pulse output
- Measurement range from 0.1Hz to 10MHz
- High input sensitivity of 20mv RMS
- 2 year warranty
- Digital display

Model 2200 Digital Capacitance Meter

The Digital Capacitance Meter you've been waiting for ... at the price you've been hoping for!



\$114.95

Featuring:

- Reading Rate: 0.5 seconds
- Overrange Indication: indication of "1"
- Test Voltage: 3.2 volts peak maximum
- "+" input terminal voltage is always higher than "-" input terminal
- Power Requirement: 9V battery
- Battery Life: Up to 200 hours typical with Alkaline. Up to 100 hours typical with Zinc-carbon.
- Accessories Supplied: Test Lead (1), spare fuse (1), instruction manual (1) 9V Battery (Zinc-carbon).



Brunelle Instruments Inc.
69th 6th Range South (Industrial Park)
Saint Elie D'orford, Quebec, J0B 2S0
Tel: 1-819-569-1408 Telex: 05-836266

Mail orders accepted. Send certified cheque or money order. Add 10% F.S.T. Add \$3.00 for shipping. Quebec residents add 9% P.S.T.

Available at leading component stores across Canada.

COMPUTER PARTS GALORE INC.

316 College St.
Toronto, Ontario M5T 1S3

Toll Free Orders Only
1-800-387-1385

Order Checking (416)925-8291
Technical Data (416)925-1105

MAIL ORDERS: We accept VISA, MC, AMEX, credit cards. Money orders, cheques (2 week wait) are also OK. Minimum packing and handling fee \$5.00 or 5%, whichever is larger. The only COD we use is via CANPAR (Add \$4.00 COD fee) or motor freight. We do not use postal COD at all. All Ont. res add 7%. All prices are subject to change without notice. Returns are subject to a 20% restocking charge.

IBM CASE

We have the nicest case of all the various competing cases, ask any friend who has bought someone else's case and then has seen ours. The lid is hinged with pushbutton access. The back is cut for 8 XT slots and it comes with all the case back inserts for cards, card guides, blind disc filler plates, standoffs, feet, screws, all for **\$79.95**.

Please specify back or side cutout for power supply.

We also have an IBM 8 Slot/6502 Board dual duty case for making IBM look-a-like 6502 systems **\$76.95**



MEGABOARD CASE, similar to the above. Fits the MEGABOARD exactly for back power supply **\$99.00**

NICADS 8.4V 7 "D" 4A.H CELLS



A great buy, a pack of 7 brand new GE NICADS giving 8.4v at 4 Amp hours. Each cell is 12v and separates easy. Used as 5V backup through a 7805. Gives 5v 1 Amp for 4 hours. **\$14.95**

WIRED CARDS FOR IBM

- (A) 384K RAM CARD. A 1/4 sized card that has 384K of 64K DRAM on board. With OK **\$ 89.95**
- (B) 512K RAM CARD. A full sized card with 512K of 64K DRAM on board. With 64K **\$119.00**
- (C) 576K RAM CARD. A very popular card with 576K of 64K and 256K DRAM on board. This is a 1/4 sized card for portable use. With OK **\$ 78.95**
- (D) KRAM RAM CARD. A clone of the JRAM with up to 2 MBYTE on board using 256K DRAM. 100% compatible, complete with software for using as RAMDISC and RAMSPOLL. With OK **\$139.00**
- (E) COLOR GRAPHICS. A clone of the popular PERSYST color card. Has three outputs and one input. A. RGB for IBM color monitor. B. Video 1v P to P composite color video. C. Video gray scale 1v P to P for seeing color on green or amber monitor **\$149.95**
- (F) MONOCHROME GRAPHICS/PRINTER. A workalike clone 100% IBM compatible for the HERCULES card. Has par printer port and hi-res text and graphics mono output **\$189.95**
- (G) 384K HEXPACK. A copy of the AST 6-PACK, 100% compatible with software. Has Clock/calendar/alarm and 384K DRAM and serial and parallel ports and game I/O. With OK **\$199.00**
- (H) 640K HEXPACK. Similar to above but with 640K on board using 256K and 64K DRAM. All other features the same. With OK **\$179.00**
- (I) DISC CONTROLLER. For 1-4 DS-DD drives. Full IBM standard with cable and instructions. **\$ 89.95**
- (J) DISK CONTROLLER + I/O CARD. A very good card that has a clock/calendar/alarm and game I/O and serial and parallel ports and a standard 1-4 drive controller card on a full sized card. Very efficient card **\$189.95**
- (K) I/O + 2. A clone of the very popular USA card of the same name. Has clock/calendar/alarm, with game I/O, serial and parallel ports **\$129.95**
- (L) PRINTER CARD. A standard centronics printer port for all parallel printers **\$ 59.95**
- (M) SERIAL CARD. A standard ASYNC serial card for modem use etc. **\$ 49.95**
- (N) MODEM CARD. A 300/1200 Baud modem using the 8910 WORLD chip. Compatible with many popular software packages. **\$189.00**
- (O) 8255 I/O CARD. Uses 2 8255's to give 16 lines of I/O for various uses. Fully locatable **\$129.95**
- (P) CLOCK CALENDAR CARD. A small card to add the clock/calendar/alarm battery to system **\$ 49.94**
- (Q) GAME PORT CARD. Adds two std game I/O ports to the system **\$ 39.95**

SYSTEMS

All MBE-XT systems share these attributes.

- High order compatibility due to the DTC bios which is recognized superior to others.
- 8 Slots for plug in cards, just like IBM
- Made right here in Canada
- Socketed for the 8087 Co-processor
- IBM compatible serial keyboard
- Disc controller using 9216 IC, the most advanced, for error free operation.
- Color graphics card with gray scale and video output for optimum useability.
- Properly made 135W power supply with accessory plugs.
- Strong steel case with push-button operable flip-top hinged at rear for easy access to insides.

SYSTEM 1. The basic MBE system. Has 256K on the main board, 135W power supply, 1 DSDD 1/2 height drive with controller, color graphics board and cherry switch keyboard **\$1149.00**

SYSTEM 2. The first upgrade level of the MBE system, has 640K RAM with 135 Watt power supply, 1 DSDD 1/2 height drive and controller, color graphics board, serial port, printer port, clock/calendar/alarm and game I/O with a cherry switch keyboard **\$1495.00**

For second drive add **\$ 150.00**

NEW SME-XT 640K TO 1M BYTE

**BARE PCB \$49.95
WIRED WITH 256K \$299.00**

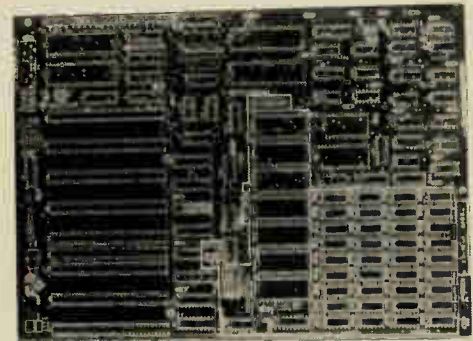

In response to popular demand we have developed an upgrade of the famous MBE-XT board. The new board is called the SME-XT and has space for up to 1 Mbyte on board. The most popular configuration is 640K which is the IBM max addressable memory. The extra RAM above 640K is normally used for system purposes such as video lookup, ROM sitting, and other uses. However, we can supply proms to allow full use of this overhead space on demand. The 256K RAMS are more highly evolved than 64K RAMS and board using them have far fewer problems with parity errors. We have decided to maintain the low-low price we pioneered with the MBE-XT and sell the new PCB at \$49.95 as well. All other attributes stay the same as the original IBM and the MBE-XT.

SME-XT **\$49.95**

HARD DRIVE BOX



This nicely made box is ideal for externally mounted hard or floppy drives. It has space for one full height or two half height drives and power supply space at rear. This is a well made and rugged units for only **\$59.95**

QUME

Yes we have the same QUME drives that IBM uses in their IBM-XT® system, 40 track, 1/2 height, double sided, double density. The exact ones you need to upgrade your old system or build your clone system up to the max. These are brand new drives that are from QUME's own inventory. They are absolutely perfect, at a perfect price of only **\$135.00**

MEMORY FLASH

- 64K-200Ns DRAM **\$1.25**
- 64K-150Ns DRAM **\$1.00**
- 256K-150Ns DRAM **\$4.75**
- Set of 941256 **\$39.95**

SWITCHING POWER SUPPLY

110V, 60Hz with Fan and two rear switched outlets

These power supplies fit our cases.

- 130 WATT + 5V - 14A; + 12V - 4.2A; ± 12V - 1/2A
- Back Switch **\$149.00**
- Side Switch **\$159.00**



KEYTRONICS 5150

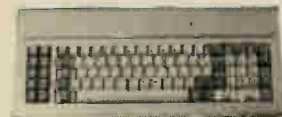

Yes the famous KEYTRONICS 5150 IBM® compatible keyboard. MADE IN USA. We bought a bunch and can sell them for only **\$119.00**

We also have some Taiwan copies that are quite good and all are checked for only **\$99.00**

And lastly we have some Taiwan copies of the famous KEYTRONICS 5151 keyboard with all the same enhanced features for only **\$139.00**

Toll Free Orders Only
1-800-387-1385
Order Checking (416) 925-8291
Technical Data (416) 925-1105

SOLDERLESS BREADBOARD

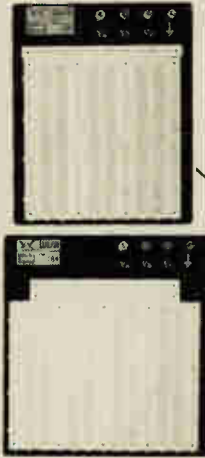

Solderless prototyping boards are the best way to quickly breadboard up a circuit. The holes are made especially for IC's, resistors, and other small parts with 22-28 gage wire leads, takes WW pins too.

- WB-106 \$42.95
- 3 IC strips, 5 power strips
- 4 Binding posts, Aluminum plate
- WB-104-3 \$29.95
- 2 IC strips, 1 power strip
- 2 Binding posts, aluminum plate
- WB-108 \$59.95
- 4 IC strips, 7 power strips
- 4 Binding posts, aluminum plate
- WB-104 \$33.95
- 2 IC strips, 4 power strips
- 2 Binding posts, aluminum plate.



This is a high quality Hall Effect keyboard made by Microswitch of Canada for AES data and now bought by us for 10% of the \$169.00 that AES paid for them in 10,000 lots. They are a very good word processing keyboard with both serial and parallel data outputs for use with APPLE and IBM type systems and come complete with a ribbon cable connector and complete pinout. \$24.95

8" DRIVE SWITCHING POWER SUPPLY

\$39⁹⁵

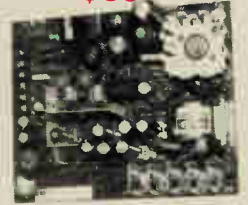

The greatest 8" Drive supply we have ever found Has 24V-2 2A 5V-3A and -12V-17A All you need for a dual 8" Drive system. A switching power supply by ASTEC

IBM POWER SUPPLY

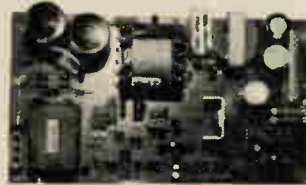

One of the nicest open frame IBM type switching power supplies we have ever seen. Came from the defunct NCR IBM compatible. runs the whole thing, has +5V-7A, +12V-3A, -5, -12-1/4A. A very good unit for starter system. Will not run hard disc system. A real Steal at \$49.95

PARTS, PARTS,

- 8088 CPU \$7.95
- 8087 Math Processor \$219.00
- 8237A-5 Prog. DMA Cntrl. \$8.95
- 8250 Serial Port \$9.95
- 8253A-5 Prog. Interval timer \$4.95
- 8255A-5 P.I.A. \$4.95
- 8259A Prog. Interrupt Cntrl. \$4.95
- 8284A ADC clock gen & driver \$5.95
- 8288 Bus Controller \$9.95
- 8272 Floppy Disk Controller \$9.95
- NEC 765 Floppy Disk Controller (equivalent to 8272) \$9.95
- Set of 8088, 8255A-5, 8237A-5, 8288, 8284, 8253A-5 and 8259A \$55.00
- 6502 CPU \$5.50
- 6845 CRT controller \$9.50
- 68A45 CRT controller \$9.95
- Z80A CPU (4 MHz) \$4.99
- MC3242 \$11.95
- 74LS367 \$.82
- 74LS259 \$ 1.39
- 74LS161 \$.99
- 74S74 \$.82
- 74S174 \$ 1.70
- 74LS323 \$ 4.55
- Card edge connector (50 pin) \$ 2.49
- RCA jack PC mount \$.69
- 6 pin power square connector \$.99
- Phono jack (small) \$.99
- MPSA 13 trans \$.55
- 2N3904 trans \$.19
- 2N3906 trans \$.27
- MPSU51 trans \$.79
- 2N4258 transistor or equiv \$.69
- 1K SIP 10 pin \$.69
- 1K SIP 8 pin \$.89
- 10K SIP 10 pin \$.75
- 4 pos dip sw \$.95
- 20 pin female header for disk drive \$ 1.79
- 20 pin male \$ 1.69
- 50 pf trim cap \$.89
- 220 ohm trimpot \$.69
- 20 conductor ribbon cable \$ 89.00

MOTHER BOARD

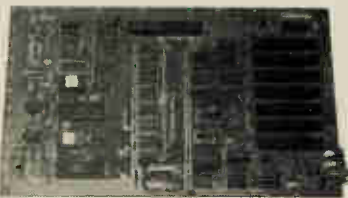

100% IIe® Compatible, for those of you who wish to build a clone of the very popular APPLE IIe®. This board is a reverse engineered copy of the IIe® and is 100% compatible. We have the motherboard and the custom ICs only. All other parts are widely sold. The custom ICs are workalike chips that do not infringe any copyrights. The software for operating the board must be obtained elsewhere as we do not have it for sale. When we say 100% we mean it.

- A very good buy at \$49.95
- Custom IC set(2) \$49.95
- Keyboard encoder (AY3-3600) \$14.95
- Character generator, U/LC \$14.95
- 48K 6502 Motherboard, same old 100% compatible 2+ clone \$29.95

IIe® ABS PLASTIC CASE \$59.95



This case is made to fit the Mother Board listed here for making IIe® clones and it makes a very nice looking copy. There is just enough difference to avoid design infringement. The case also has no brand names or other marks on it.
A good buy at \$59.95
ABS numeric case for 48K motherboard. Exact fit. \$49.95

PARTS, PARTS,

- 100ns delay line \$5.00
- 7ns delay line \$13.95
- 62 pin edge con (high quality) \$1.89
- 5 pin Din conn \$1.25
- Power conn \$1.25
- Dip switch 8 pos \$2.49
- 4.7k x 6 slip \$.69
- 4.7k x 8 pin slip \$.69
- 8.2k or 10k 16 pin Resistor or net \$.99
- 33ohm x 8 network \$1.10
- Small speaker \$1.99
- 1 of 50V high quality bypass capacitors \$ 1.10
- Trimcap \$.99
- 34 pin card edge con. \$5.95
- 2716 \$3.49
- 2732 \$3.95
- 2764 \$4.95

MBE-XT AN IBM® XT Compatible 8 Slot Motherboard

MBE-XT BARE PCB WITH MANUAL AND SCHEMATICS.

\$34.95

LAZY BOARD

What is your time worth?? We have had a bunch of MBE-XT boards stuffed and wave soldered so you can save all that time soldering them up. All you need are the IC's memory and BIOS and you are set to go 149.00

FULLY WIRED AND TESTED WITH 64K ON BOARD WITH MEGABIOS AND MANUAL

\$299⁰⁰

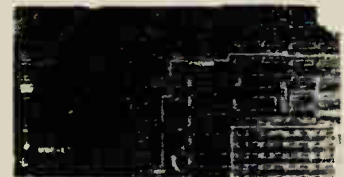

- 8088 16 Bit Microprocessor
- 8087 Math Processor. Optional
- Up to 256K Dram on Board
- Has Digital Delay Line for Error Free Memory Refresh
- 8 IBM Compatible Expansion Slots
- 4 DMA and Timer Channels
- 64K/128K Eproms Jumper Selectable
- Will run any Compatible BASIC
- IBM Power Plug Compatible
- Same PCB size as IBM XT
- Runs PC-DOS and CPM-86
- Compatible BIOS-in stock

MEGA BIOS

The amazing MEGABIOS® from DTC of Dallas. A fully rewritten BIOS that allows you to make a fully compatible legal system. Note they do not ask MEGABUCKS® for it, only \$39.95

TAIWAN BIOS, not as good or 100% compatible but it will get you running and save you bucks \$24.95

IBM BARE PCB

- (A) Color Graphics (Pcysyst) \$27.95
 - (B) Monochrome graphics \$24.95
 - (C) Disc controller \$17.95
 - (D) Disc controller + Printer \$24.95
 - (E) Disc controller + Game \$24.95
 - (F) IO + 2 IO clock etc. \$24.95
 - (G) Multifunction card 11 function \$34.95
 - (H) AST SIXPACK COPY \$17.95
 - (I) Parallel printer \$17.95
 - (J) RS-232 card \$17.95
 - (K) Simple modem card \$ 8.00
 - (L) Disc for above \$24.95
 - (M) 512K card \$24.95
 - (N) 256K short card \$19.95
 - (O) IBM 6" extender for service \$19.95
 - (P) Ww Proto, full sized with DB 9 & DB25 footprint \$24.95
 - (Q) WW Memory proto, full sized with 256K (1Meg) memory laid out on one end with DB 9, DB25 footprint \$29.95
 - (R) 512K Mapping PROM \$12.95
 - (S) Multifunction PROMS(2) \$24.95
 - (T) 2732 for color graphic \$10.00
- All cards come with a detailed parts list and placement drawing, we also have all parts needed for them

SWITCHING POWER SUPPLY



Another great bargain from PARTS GALORE, A small power supply switching style that give +5v-4A, ±12v 1A and -5v (adjustable) on a compact 4x8" open frame PCB. Cost Northern Telecom \$50.00 when they bought 5000 pieces. We got em when a subcontractor went belly up for 10% of that price and we are selling em for

\$16.95 NEW IN BOX TESTED

- AC power cable (3 Wire) for above \$2.50

Alias distortion is often presented as a kind of 'mistaken identity' of the sampled waveform (Fig. 5). This is OK for explaining how it might occur, but not much good for deciding what to do about it. A more enlightening view of the situation is to consider the frequency spectrum of the sampled wave, or the output from the DAC.

Two points before we start. First of all, the following discussion assumes that the output from the DAC represents the exact level of the input at the time of sampling. Any practical inaccuracies we have already put into the 'noise' pigeon-hole, and there they can stay for the time being. Secondly, it doesn't matter whether we use linear or log conversion. What we are getting out of the DAC is a stream of voltage levels representing the instantaneous value of the sampled wave, no matter what black magic was used to stuff it into the memory in between.

We'll start off with an analogue input which has a frequency spectrum as shown in Fig. 6a. After sampling at 30kHz, the output from the DAC will have a frequency spectrum as shown in Fig.6b. No doubt you've seen similar diagrams before. To get a feel for why it should be so, take a look at Fig. 7.

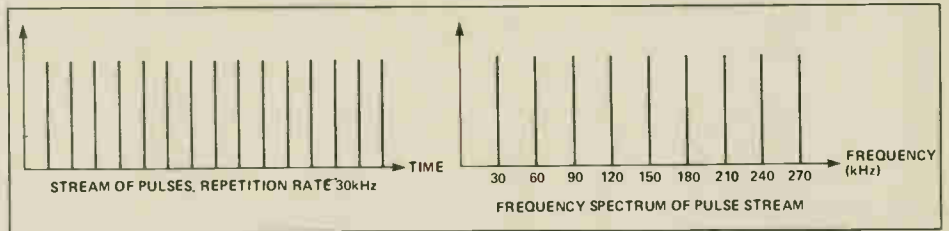

Fig. 7 A stream of sampling pulses and their frequency spectrum, which extends indefinitely.

First of all we have a series of sampling pulses of zero duration. Not very practical? OK, I admit it, it's a mathematical fudge. But bear with me for a moment. It so happens that a string of pulses like that has a frequency spectrum consisting of evenly-spaced sine waves all with the same amplitude. Now, if I took just one of these sine waves and amplitude modulated it, remembering your AM theory, you'd expect to see sidebands on either side, right? And varying the amplitude of the sample pulses in accordance with the amplitude of the input is pretty much like amplitude modulation. Fig. 6b shows all the 'sidebands'. The argument has many holes, but the conclusions are OK.

So what happens when the DAC output consists of real pulses that have a finite

width? Well, if I can lean on the previous rickety argument a little more, the unmodulated output spectrum from the DAC will now be a series of sine waves which diminish in amplitude as their frequency increases. So what we'd expect to see is the amplitude of the higher frequency 'sidebands' of the modulated spectrum decreasing in amplitude, too, as their frequency increases. This is exactly what happens.

The original spectrum of Fig. 6a is all we want to end up with, so it won't cause us any grief that the upper frequencies diminish in amplitude. We're going to filter them out anyway. What would cause us concern would be any alteration to the amplitude of the original spectrum, the part we want to keep.

At this point the intuitive argument col-



DUNCAN INSTRUMENTS LTD.
ELECTRONIC INSTRUMENT SPECIALISTS
121 MILVAN DRIVE, TORONTO, ONTARIO M9L 1Z8
(416) 742-4448 TELEX: 065-27271

All prices include Federal Sales Tax. In Ontario add 7% Provincial Sales Tax.
Call or write for additional information. Telephone and mail orders invited.

ORDER DESK 1-800-387-7418
BETTER PRODUCTS. BEST VALUE.
We provide the finest, state-of-the-art electronic instruments available. Backed by superior post sales service and a comprehensive 12 month warranty. Many of our products are unavailable anywhere else. Examine just a few of the many products we currently stock. Recognize value.

MODEL 6022 **\$595⁰⁰**
DUAL TRACE 20 MHz OSCILLOSCOPE

- 6" CRT with internal graticule
- 20 MHz bandwidth (-3 dB)
- Stabilized power supply
- Trace rotator
- Low power consumption
- X-Y mode; Add/Subtract; 5 trigger modes
- Built-in component tester
- Complete with two dual probes

SPECIAL UNTIL DEC. 31/85



MODEL 8055F **\$595⁰⁰**
DIGITAL FREQUENCY COUNTER

- Frequency range:
1 Hz - 550 MHz/3 ranges
- Sensitivity:
A: 1 Hz - 100 MHz ≤ 20 mV
B: 50 MHz - 550 MHz ≤ 150 mV
- 8 digit LED display

MODEL 8010F **\$395⁰⁰**
• 1 Hz - 120 MHz/2 ranges



MODEL 8016D **\$435⁰⁰**
DIGITAL DISPLAY
FUNCTION GENERATOR

- 0.2 Hz to 2 MHz frequency range
- Wave forms: Sine, triangle, square, pulse and ramp
- Output level: > 20V p-p open circuit
- V.C.F.: 0 to 10V (1000:1)
- Frequency counter: 6-digit display

MODEL 8015F **\$260⁰⁰**
Available without digital display



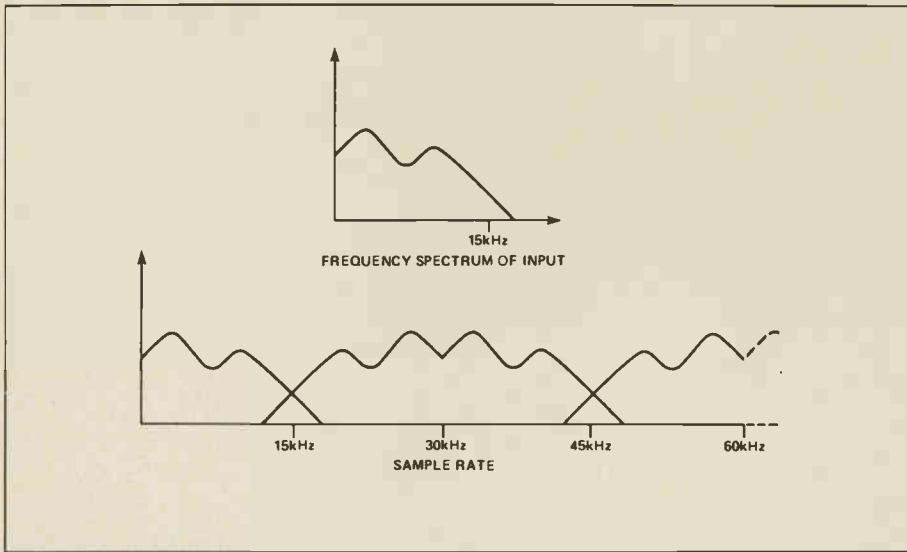

Fig. 8 The frequency spectrum of an input signal containing components above half the sampling frequency and the corresponding spectrum of the DAC output.

lapses under the strain and we must take account of the results of a full mathematical analysis. Yes, the amplitude of frequency components of the part of the spectrum we want to keep will diminish. The wider the output pulses from the DAC, the more significant this effect becomes. With a stair-step output from the DAC, which retains the previous output until another digital code comes along, the frequency response will gently roll off until, at half the sampling frequency, the output will be down by about 4dB. No need to panic, but it should be taken into account. Remember that this has got nothing to do with any filtering or whatever, we're just looking at the raw output from the DAC.

It seems sensible that if we're looking for perfection, the best thing to do would be to return the DAC output to zero in between sample outputs. Sad to say, this can cause more problems than it solves.

We've been looking at nice clean sterilized theory up to now. Unwanted odds and ends creep in, but they stay in their proper place and behave themselves and we know just what to do with them. When you actually come to build a circuit in real life, the results are much less predictable. For instance, DACs don't instantly jump to a new output level when a digital code is applied, they have a certain settling time and what happens at the output during that settling time is anybody's guess. Additional frequency components will be generated and they won't be in predictable places.

The answer is to make them small in comparison with the spectrum we want, which in essence means making the output hold time long in comparison with the settling time. In general, it is often better to put up with a predictable fall in performance that can be compensated for rather than to try correcting it at the expense of

introducing factors that can't be removed.

To return to Fig. 6, although there is no frequency component at the input which is above half the sampling frequency, there are already unwanted frequencies from the DAC which occur within the audio range. If we could block off all frequencies above 10kHz at the input, the unwanted frequency spectrum would at least be above 10kHz. This is not very sensible. The unwanted frequencies could burn out tweeters or beat with the bias oscillator of a tape recorder and produce audible products, for instance. There is the more obvious problem of losing bandwidth for no particular reason. Output filtering is the answer here.

Figure 8 shows the situation when frequencies above half the sampling frequency are present at the input. The overlap of wanted and unwanted frequencies is our alias distortion. The practical result is a kind of harshness or coarseness in the reproduced sound. These frequencies could also be eliminated by filtering at the output, at the expense of a good deal of usable bandwidth. Far better to have a filter at the input to prevent frequencies above half the sample rate entering the system in the first place.

The result of all this is that although we could, at a pinch, get away with filters just at the input or output, the maximum system bandwidth and best possible sound will be achieved by filtering both. Obvious, you think? Well, maybe, but I recently saw a design for a fairly expensive self-contained unit with no input filtering whatsoever and a pathetic and totally inadequate 2-pole filter on the output. The designer claims it can 'also be used as a treble control'. Surprisingly often, designers of commercial equipment, who really ought to know better, try to get away with inadequate filtering or even no filters at all. ■

write:

NATIONAL ELECTRONICS

Box 683

Stn. Q

TORONTO, CANADA, M4T 2N5

MONITOR

1498

8088

COMPUTER

FULLY COMPATIBLE
256K MEMORY
8 EXPANSION SLOTS
8 ROMS OK
8087 OK
MEGA-BIOS
TWO SLIM DRIVES 360K DS/DD
COLOUR VIDEO
DISK CONTROLLER
130 WATT SUPPLY
KEYBOARD
FLIP-TOP CASE

SPECIAL FREE TRIAL

* LIMITED TIME OFFER

Tools for Electronic

Treat yourself to some of the gadgets available from a huge variety of testbench tools.

By Bill Markwick



AFTER you get the testbench equipped with basics like the oscilloscope, generator and power supply, you might want to upgrade some the tools that you started out with. Lineman's pliers and Visegrips don't really make it when you're trying to pull 1/4 watt resistors out of a printed circuit. We didn't list retail sources for tools because there are so many, but if you have your heart set on something you can't find, there's a list at the end of distributors you can contact.

Pliers and Cutters

These are the tools you'll use the most, and the two main uses will be in stuffing a new PCB with parts and, if you're like me, pulling them back out again because you got the holes wrong.

Is there a difference between electronics pliers and the hardware store variety? You betcha. A pair of fine needle-nose pliers will let you insert or remove the tiniest part from the most awkward of locations in a way unmatched by even the best of the hardware-store types; a pair of miniature diagonal cutters will nip off the excess component leads effortlessly, and very close to the PCB. If you have 200 leads to cut, not an unreasonable amount, your wrist will thank you for getting sharp, accurate cutters; the leads are also cut squarely and neatly, not squeezed apart.

In addition, makers of professional tools can supply you with an amazing

variety of special-purpose pliers: one of my favorites, and a standard on any wiring line, is the model typified by the Xcelite 58-CGV. It's a pair of needle-nose pliers with a tiny cutting edge milled in just back of the jaw tip. It can bend leads, guide them, and cut them to length. For cutting the leads under the PCB, either before or after soldering, I prefer precision diags such as the Xcelite 74-CGV or

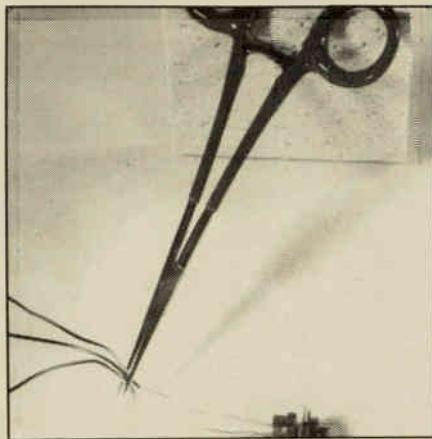

A hemostat with locking clamps near the handles; there's nothing like them for very small parts.

Crescent 941-4SC. The jaws will cut close to the PCB surface in a way unmatched by any low-cost model. There are also special miniature shears especially for PCB lead cutting, such as the Lenline LI011.

If I haven't convinced you of the im-

portance of good pliers and what a difference they make: borrow a pair and compare them to your \$5 hardware store types, and you'll see what a good investment they are. Ummm, that brings up another point... precision tools cost a fair amount. You'll find that the best pliers and cutters are in the \$15 to \$25 range. On the other hand, they'll last and last; you can hand them down to your grandchildren and tell them that you once made your very own musical doorbell.

Weird Tools

Well, they aren't really weird. They're just unusual and a bit hard to find, but they simplify those annoying little tasks that require three hands and more patience than you've got at the time.

Among these are forceps and hemostats. You can fantasize that you're saving the day by taking out somebody's appendix in a submarine. Both forceps and hemostats are like extra-thin, extra-long needle-nose pliers; the hemostats have a latch to hold them shut at various tensions. There's nothing like them for starting tiny nuts and bolts or grasping tiny leads for soldering or fishing for that microscopic washer you just dropped into the power supply. A typical example of forceps would be the Lenline CFM-5, an inexpensive curved model made of nylon (handy if you insist on tugging live wires); locking hemostats are typified by the Lenline 70-20C, a stainless steel curved type.

Electronics Today November 1985



Exceltronix *Computers and Components*

**1986
Catalogue**

\$1.00

Toronto Store and Mail Orders
319 College Street,
Toronto, Ontario M5T 1S2
(416) 921-8941

Ottawa Store
217 Bank Street, Ottawa
(613) 230-9000

**Warehouse
Pickup Counter**
335 Evans Ave.,
Toronto
(416) 252-5785
QEW and Kipling
- plenty of
parking but \$25
minimum

Long Distance Ordering
1-800-268-3798

*Operator to ask number correct locally. Shipping extra mail orders!

Local Orders (416) 921-8941

Order Form P. 23

The History and Development

of our successful and rapidly expanding All-Canadian company committed to high technology.



Our original store in Toronto is still at the same location (319 College Street — College and Spadina) but has greatly expanded to incorporate adjacent stores.

Now in its seventh year, Exceltronix and its associated companies, has grown from a single store, to three retail outlets, a large mail order division, and an ever expanding engineering and manufacturing facility with revenues for 1986 expected to exceed \$15 million.

Many of the products sold at our own retail outlets are manufactured by our associated company, **Multiflex Inventions and Technology** in Toronto. This direct link between manufacturing and retailing benefits our customers in several ways. Our competitive prices result from not having to deal with middlemen (with their markups) and enables us to respond rapidly to the changing needs of customers. We are proud of both the high quality of our products and their excellent reliability and consequently we are able to offer warranties far better than the industry standard. **Exceltronix** is probably most widely known for its highly successful line of IBM compatible **BEST** personal computers and peripherals, but when an off-the-shelf product will not satisfy your needs, the engineering division at **Multiflex** is able to analyze your problem and develop a cost effective solution. Proof of this is the Advanced Message Display System in the Toronto Subway System and the Vancouver LRT, manufactured by **Versa-Digital**, another associated company. These examples are just some of the many solutions that we have provided for Canadian industry and commerce and we will be happy to discuss your particular requirements.

Even though we have grown enormously, we have not lost the personal touch that contributed to that growth. Although we are now one of the largest manufacturers of computers in Canada, our dedicated and knowledgeable staff are happy to discuss your needs, be it for a computer to solve a problem or a single electronic component.

In the recent past, the microcomputer business has seen huge booms and some massive recessions. Despite this, **Exceltronix** and its associated companies have grown consistently and we continue to increase our market share. Being diversified, we have the resources to research and develop our products properly. Not being dependent on a single line, we have avoided the mistake of many computer companies of bringing out products before they are properly developed.

Our company is proud of the fast and excellent service in our stores and we now have available a team of specialists who can provide on-site analysis of your hardware, software and interfacing needs.

We have yet to see what tomorrow has to offer, but you can be assured that the **Exceltronix** group of companies will be accepting the challenge.

Associated Companies:

- Exceltronix Inc.**
- Multiflex Inventions and Technologies Inc.**
- BEST Computers Inc.**
- Toronto Computing Centre Inc.**
- Versa-Digital Technology Inc.**
- Digi-Media Inc.**
- XL Electronix Computer Music Centre Inc.**



Multiflex and **Versa-Digital** developed and manufactured the digital display signs used on the Toronto Subway System and the Vancouver LRT Transit System — and they are now controlled and updated using several **BEST** computers!



Our newly purchased 25,000 square foot facility, near Toronto airport, will allow us to expand research and development in the computer field. It will also take us into a new field of development: advanced underwater intelligent robotics.



In excess of \$1 million was devoted by **Multiflex** to development of new high tech products in 1985.

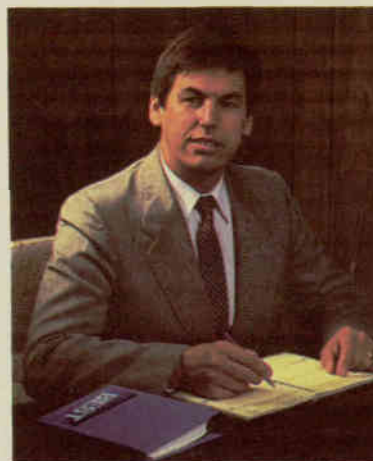

Eugen F. Hutka, the founder and President of **Exceltronix**, **Multiflex** and all the associated companies.

All prices and specifications in this catalogue are subject to change without notice.

Our Cover: We would like to thank **NASA** for the cover picture of the **Challenger**. We feel that this picture symbolizes our own success — it combines high tech, rapid growth and the fact that we are really taking off!



All our own products are manufactured in Canada to the highest quality, including being flow-soldered and ultrasonically cleaned.

We are proud to introduce the New **FAST** BEST Mark III

Made in Canada with pride.

To meet the demanding needs of industry for faster information processing, Exceltronix is pleased and proud to introduce the Mark III personal computer. Based on the success of the BEST Mark II, the Mark III goes a step beyond. The system is based on the 8088-2 microprocessor, which is capable of running almost twice as fast as any 8088 based system.

- Superb IBM PC/XT software and hardware compatibility has been retained.
- A hardware switch allows you to go from 4.77MHz to 8MHz operation. Any software that implements a lot of memory manipulation will run visibly faster. Compilers work much faster, spreadsheets will speed through calculations, and even video intensive games run quicker.
- All the same cost effective package that made the Mark II a success, has been continued in the Mark III. We consider features such as a Real Time Clock, Parallel Printer Port, Serial Communications Port and a minimum of 256K RAM memory, necessities in today's personal computer. These have been included in the base price along with a colour video board, so even if you don't need the options today, tomorrow you will not have to pay to have them installed.

**Superb
IBM PC/XT
Compatibility**



Monitor and printer not included. IBM is a registered trade mark of IBM Canada Limited.



The FAST BEST MK III

As BEST MK II plus speed selectable: 4.77 and 8MHz (most software will run on the higher speed), uses 8088-2 processor.

\$1895⁰⁰

Other Configurations:

With 640K RAM	\$1995
With 10 Meg Hard Drive/1 Floppy/256K	\$2795
With 10 Meg Hard Drive/1 Floppy/640K	\$2895
With 20 Meg Hard Drive/1 Floppy/256K	\$3095
With 20 Meg Hard Drive/1 Floppy/640K	\$3195

Standard Features common the BEST Mk II and MK III

- Superb IBM Compatibility.
- Phoenix BIOS, as used in many major brand IBM compatible systems.
- Minimum of 256K Memory using 41256K RAM chips, expandable to 640K or higher on the main board.
- Seven Expansion slots
- Real Time Clock/Calendar, with software with battery backup.
- Parallel Printer port
- Serial Communications Port with option for a second for only \$39 extra).
- Two double sided, double density 360K 5.25 inch floppy disk drives
- Colour graphics video board, with both RGB and composite video outputs.
- Pre-socketed for the optional Intel 8087 math co-processor
- A reset switch ● A 150 watt power supply, which will handle additional boards and a hard disk drive.
- IBM compatible, high quality keyboard.

Warranty

We have such confidence in the time tested reliability of the BEST that we offer a 300 day warranty which is way above the industry standard. On-site service plan available at extra cost.

Options:

Tape Drive-from	\$1295
Second Floppy on H.D. systems	\$180
Second Serial Port	\$39

The BEST Mark II

Made In Canada

Superb IBM PC/XT Compatibility

In the past two years, thousands of BEST personal computers have been working their way into the Canadian business, educational and home environment. Based on the 8088 microprocessor, the BEST Mark II is an inexpensive entry into the personal computer field.

As with all the BEST product range, it is made in Canada to the highest standard of quality.

It is the success of the original BEST and the Mk II that prompted us to develop the newer and faster Mk III and Mk IV.



Monitor not included. IBM is a registered trade mark of IBM Canada Limited.

BEST MARK II

Standard Mark II with 256K RAM and two 360K DD/DS diskette drives, Serial and Parallel Ports, Real Time Clock, Phoenix BIOS. Uses 8088 processor.

\$1695⁰⁰

Other Configurations:

With 640K RAM	\$1795
With 10 Meg Hard Drive/1 Floppy/256K	\$2595
With 10 Meg Hard Drive/1 Floppy/640K	\$2695
With 20 Meg Hard Drive/1 Floppy/256K	\$2895
With 20 Meg Hard Drive/1 Floppy/640K	\$2995

If you want the Best, buy the BEST

SUPER-FAST BEST Mark IV

Made in Canada with pride.

Superb IBM PC/XT Compatibility

In today's industry, more than ever, time is money. It is for that reason we developed the **Mark IV** personal computer.

Still retaining IBM PC and XT software and hardware compatibility, the **Mark IV** uses the true **16-bit 8086-2** microprocessor. Although the system runs at the same clock speed as the Mark III, the 8086-2 has a 16-bit external data bus compared to the 8088 and 8088-2's 8-bit data bus. This allows memory access to occur **much faster** than with most other IBM PC/XT and compatible computers.

The bus structure of the **Mk IV** remains compatible with the standard IBM 8-bit I/O channel but still has the benefits of the 16-bit architecture.

Couple the 8086-2 microprocessor with the 8087 math co-processor and you have **one of the fastest, most reliable business or engineering aids** available in this price range.

Since the **BEST Mark IV** is geared towards the serious microcomputer user, a **standard complement of 640K RAM** is installed on the main board, along with a long list of standard features.



Monitor and printer not included. IBM is a registered trade mark of IBM Canada Limited

Standard Features of the BEST Mk IV

- Superb IBM Compatibility.
- Canadian made
- Phoenix BIOS, as used in many major brand IBM compatible systems.
- 640K of RAM (Random Access Memory).
- Seven Expansion slots, so that you have lots of room to tailor the system to your needs, with the wide range of peripheral cards available.
- Real Time Clock/Calendar, with software and battery backup.
- Parallel Printer port, to interface dot matrix, letter quality printers and

digital plotters.

- Serial Communications Port that supports all RS232-C signals (a second serial port can be added for only \$39.00 extra).
- Two double sided, double density 360K 5.25 inch floppy disk drives, with the option of adding an additional two drives.
- Colour graphics video board, with both RGB and composite video outputs. Four modes of operation are available with this board.
- Pre-socketed for the optional Intel 8087 math co-processor.

- A reset switch, which can be a life saver, in the event of a program hanging your system.
- A 150 watt power supply, with more than enough power to supply expansion boards, disk drives, and hard disk drives.
- IBM compatible, high quality keyboard.

Warranty

We have such confidence in the time tested reliability of the BEST that we offer a 300 day warranty which is way above the industry standard. On-site service plan available at extra cost.

SUPER-FAST BEST MK IV

As BEST MK III plus TRUE 16-Bit machine, 8086-2 processor, IBM compatible 8-Bit I/O channel bus, even faster than MK III due to 16-Bit architecture. With 640K RAM.

\$2500⁰⁰

Other Configurations:

With 10 Meg Hard Drive/1 Floppy/640K	\$3395
With 20 Meg Hard Drive/1 Floppy/640K	\$3695
Options:	
Tape Drive-from	\$1295
Second Floppy on H.D. systems	\$180
300/1200 Baud Modem Board	\$379
BEST Monochrome Card	\$179

The History of the BEST line

As the personal computer industry expands at an unbelievable rate, it is comforting to know that a retail outlet has had many years experience of serving the computer buying public.

Equipped with the popular PHOENIX BIOS, the **BEST** satisfies the needs of students, educators, engineers and business people all across Canada. As more software and hardware appears on the market, peoples needs diversify and the **BEST** computer is keeping pace with these changes with astounding success.

Now we are pleased to offer you a complete line of personal computers to match all of data processing needs. All of the **BEST** personal computers are manufactured to the highest quality at our facility in Toronto.

You now have the option of four different models of the **BEST** series of personal computer ranging from the **Mark II** (an IBM PC/XT compatible) with a minimum of 256K of on-board memory through to the **AVT-286** (an IBM AT Compatible), a personal computer based on the Intel 80286 microprocessor.

All of the **BEST** personal computers come with standard features that other manufacturers consider expensive options. It is our belief that by including options such as printer ports, serial communications

ports, real time clock and video board, your use of a personal computer will be more profitable, and reliable. The excellent reliability enables us to offer warranties far, far better than the industry standard.

A complete description of the personal computers manufactured is included in this catalogue. Before you buy your system our computer fluent sales staff can provide you with advice on the hardware and software required to solve your problem. And remember that after you purchase the **BEST** computer that suits your needs, **Exceltronix** and its sister companies will be around long after some other retailers have come and gone, to offer you unparalleled service and selection, as we have been for the last six years.

Special Requirements?

We have the in-house experts in both hardware and software to interface a lot of complex equipment to IBM, **BEST** or compatible computers. We can recommend or customize existing software packages for your business or industrial needs. We have excellent in-store and on-the-road sales staff with computer expertise and a superb team of in-house hardware and software engineers.

We can probably help you with every aspect of your computer needs at reasonable, honest prices. Call us.

If you want the Best, buy the BEST

BEST AVT-286: the IBM AT Compatible Designed and made in Canada with pride.

Proving once again that Multiflex is an industry leader, by producing more than just affordable alternatives in personal computer design, we are pleased to announce the **BEST AVT-286 Microcomputer**, our new, fast IBM AT compatible. The **AVT-286** is based on the 80286 microprocessor. The **AVT-286** is supported by the *Phoenix AT compatible Bios*, the same software house that supplies the Bios for all other **BEST** computers as well as many of the well known IBM compatibles currently manufactured.

Check the long list of standard features that are included on the new **BEST AVT-286**:

- The **AVT-286** runs faster than the (12MHz) IBM AT but retains superb software compatibility.
- The main board features a standard **640K RAM** using state-of-the-art memory chips for fast, reliable data processing.
- **Seven expansion slots** of which five support IBM AT signals. The two remaining slots are compatible with IBM PC or XT peripheral boards.
- **Presocketed** for the optional 80287 math co-processor
- **Two floppy diskette drives**, one formatted for a capacity of **1.2 Megabytes**, the other for 360K to read and write normal diskettes.
- The **BEST Colour Video board** which offers the user four modes of operation, composite and RGB output.
- An **AT compatible keyboard**.
- On board **Real Time Clock/Calendar** with battery backup.
- **Parallel Port** (for printers etc.) and **Serial Port** (for communications).



Monitor not included. IBM PC, IBM XT and IBM AT are registered trade marks of IBM Canada Limited.

- **Heavy duty Power Supply** as standard allows for adding extra cards as well as a Hard Disk without requiring an upgrade.
- **Attractive flip-top case.**
- A **keyboard lock** with unique security key which prevents any unauthorised use of the system.
- A **front control status panel** provides information on the keyboard lock status, reset, power-on, disk activity and parity errors.
- A **hardware reset button** so the system can restart without having to power down.

The BEST AVT-286

Canadian designed and made, Super IBM AT compatibility, 640K RAM, Two 5.25in. Disk Drives (one high density 1.2Mb, one 360K), Serial and Parallel Ports, High quality keyboard, Keyboard lock and Status Panel. See detailed description above.

Simpler or more complex configurations available at most competitive prices.

\$3495⁰⁰

As standard configuration with a 20 Megabyte, fast stepping Hard Drive and Controller.

\$4950

Warranty

We have such confidence in the time tested reliability of the **BEST** that we offer a 300 day warranty which is way above the industry standard. On-site service plan available at extra cost.

Phoenix Pfaster286

Why throw away your PC or XT investment to achieve the performance of a 80286 based microcomputer? You can run software up to five times faster than an XT, and 60% faster than an AT. The Pfaster286 card is installed in your PC/XT motherboard, with no hardware changes and the software utilities included with the card allow you to boot your system in either the normal 8088 mode or go directly into the 286/coprocessor mode.



Pfaster286 features

- AT ROM compatibility
- 80286 CPU
- Optional 80287 floating point co-processor
- 8 MHz processing speeds, no wait states
- 1Mb RAM, expandable to 2Mb or-board

- Expandable to 4Mb RAM with the optional piggyback board
- 16Kb of EPROM, expandable to 256Kb
- Supports eight levels of priority interrupts, and four DMA channels
- Compatible with networking software
- Utilities to perform disk caching, print spooling and diagnostics.

The Pfaster286 can be used with any programs written for the 8088, but a few timing programs sensitive will only run on the 8088. Compilers, assemblers, development tools and most applications (such as 1-2-3 from Lotus) run on the Pfaster286 without modification at greatly increased speed.

Pfaster286 with 1M RAM Please Call
Each additional 512K RAM . . . Please Call
80287 option Please Call

The BEST IBM AT Compatible 4 Meg Memory Card

In order to take advantage of the memory addressing capabilities of the IBM AT or the BEST AVT-286

business computer, we developed a memory card to give the user up to 4 Megabytes of dynamic RAM. The memory card will run at speeds up to 16MHz, which is fast enough to meet the needs of any 80286 microprocessor on the market today. The design uses state-of-the-art (256K x 9) memory arrays, to allow for maximum memory in the smallest physical space. The ninth bit is used as a parity bit to insure the validity of the data. The card is available in memory sizes from 512K to 4 Megabytes in steps of 512K. Boundaries are switch selectable above 1 Meg in blocks of 512K.

Please call for most competitive prices.

BEST AT Compatible Enhancement Card

This card includes the following features: Two Serial Communications Ports, One Parallel Printer Port and Memory starting from 128K to 512K in selectable boundaries. This card will allow IBM AT users with 256K or 512K of on-board memory to expand their AT machine to full 640K capability as well as provide them with two serial ports and one parallel port.

\$299.00

If you want the Best, buy the BEST

Upgrade your IBM

BEST External Hard Disk Drive and Tape Back-up Unit

Easily Convert your IBM PC or Compatible Into a Hard Drive System with Tape Backup.

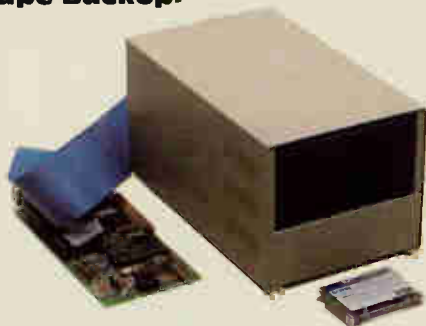

As more people become educated in the use of personal computers, the office computer becomes victim to late night hackers and curiosity seekers. The data upon which your business decisions are made every day is in danger of being wiped away by a wrong sequence of key presses or the data may be seen by those without proper authorization. Protect your data and yourself by removing the hard disk drive from the system.

Multiflex has designed a unit which allows you to physically remove the mass data storage device and lock it in another room without disassembling your entire system. The external hard disk drive and tape backup unit is self contained with its own power supply and connects to back of your system through a ribbon cable. Simply follow normal shut down procedures then unplug the unit and carry it to a safe location.

**With Seagate 20 Megabyte Hard drive and Scorpion Tape Backup unit
\$2795.00**

**With 10 Megabyte Hard Drive and Irwin Tape Backup unit
\$2395.00**

Convert your IBM PC or XT into a Hard Drive System within Minutes

Do it yourself with no mechanical alterations.



This unit rapidly converts your system into a Hard Drive unit, and it is compact enough to fit in a brief case. The unit contains its own power supply, fan, a reliable Seagate 20 Megabyte hard drive and a controller card which plugs into your existing system.

**With Seagate 20 Megabyte Hard Drive
\$1495.00**

**With 10 Megabyte Hard Drive
\$1295.00**

BEST EXPANSION System for your IBM PC

If you are one of the many who invested thousands of dollars in an IBM PC, you may be realizing the limitations of the hardware you own. The power supply may not be able to handle the addition of a hard disk drive or the five expansion slots may already be filled with necessities, leaving no room for the luxuries of more memory or communications hardware.

The BEST Expansion System was designed to function in a transparent fashion to the IBM operating system. The host system (IBM PC or XT) will look at a peripheral card in any of the eight slots of the expansion system as if it were installed in the slots on its own main board.



The Expansion System is packaged in an attractive flip-top case with its own power supply and ventilation fan. Two 3 foot long ribbon cables connect the host computer to the expansion system, which allows the expansion system to be placed on top, beside or underneath of your existing IBM PC or XT system.

The expansion chassis is powered by a 150 watt power supply with power connectors for two disk drives included as a standard feature. This power supply has enough power to run four diskette drives, expansion cards, or hard disk drives.

Although the system provides you with more slots and the capacity for a hard drive, your existing system will run with less load and therefore cooler.

Complete BEST Expansion System including the peripheral adapter to plug into your existing IBM PC or XT system, 8-slot expansion bus, with flip-top case and 150W power supply and cooling fan.

Price \$499.00

Add a Tape Drive to your Existing System

Those who have used computers for any length of time can explain the absolute necessity for an external backup of the data held in a Hard Disk. Our self-contained unit, including power supply, (which looks similar to the Hard Drive Unit illustrated left) has a cable and peripheral card which simply plugs into your IBM or compatible system.

Tapes for these systems are readily available.

**With Irwin Tape Drive and BEST Controller
\$1495.00**

**With Scorpion Tape Drive and Controller
\$1695.00**

Add Extra 360K Disk Drives to your System

If you need more than the two existing drives for your system, our self-contained external unit with two 5.25in. 360K disk drives with its own power supply, fan and controller will be of interest.

\$695.00

The BEST Colour Graphics Video Board



The BEST Colour Graphics Video Board was designed for those personal computer users who require an inexpensive, but versatile video display. The user has a choice of three types of monitors that can be connected to the card, a composite monochrome monitor, composite colour monitor or direct drive RGB colour monitor. Software utilizing a light pen can be run since the BEST Colour Video board supports the necessary hardware.

The video board is capable of operating in four modes, two text and two modes of graphics display

Text display

The BEST Video Card can display either 80 or 40 characters on one line. The character generator contains all the standard ASCII characters plus block graphic characters and a set of international characters such as the English pound and Japanese Yen. Depending on your choice of monitor, the application text can be displayed with a variety of foreground and background colours. In addition, black and white mode allows for the following attributes: reverse video, blinking and highlighting.

The operator can switch between 40 and 80 column display by using the DOS MODE command. The 80 column mode gives crisp characters on either colour or monochrome monitors. The 40 column text mode is suitable to use if you were to use a common television set in conjunction with a RF modulator that can be directly attached to the video board.

Graphics Display

The BEST video board is capable of displaying three styles of graphics.

Low resolution — Monochrome or Colour

In the low resolution mode either colour or monochrome graphics can be displayed. The screen is capable of displaying 200 rows of 320 pixels (a pixel is one dot on the screen). In the colour graphics mode each pixel can be one of four colours, and the background can be one of 16 colours. Many software packages are written with colour graphics capabilities. LOTUS 123, and Symphony for example become more powerful and easier to use with the addition of crisp and vivid colour graphics.

High resolution — monochrome

For applications such as computerized drafting or intricate business charts, colour may not be desired, but high resolution is required. The BEST card is able to double the resolution of the display to 200 rows of 640 pixels, by selecting the monochrome instead of colour graphics. In the high resolution mode an inexpensive composite monitor can still be used.

\$179.00 with warranty

The BEST Monochrome Card

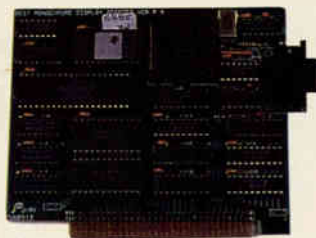

In the office environment where a great deal of word processing, or data entry takes place, eye fatigue may be a problem. A solution to this problem is an upgraded text display card for your BEST, IBM PC or compatible. The monochrome card displays a character that is made up of 7 x 9 matrix of dots in comparison to the 5 x 7 matrix used on the standard colour graphics video board. The finer dot pattern makes text appear much cleaner and easier to read. The monochrome card will display characters in four modes; normal, intensified, reverse video and blinking. The display is 80 x 25 characters.

Note: This is a half size board which will fit even those computers with restricted space.

\$179.00 with Warranty

Hercules

Colour Graphics Board **\$312.00**

4 colour graphics and printer board that fits into standard PCI/XT or compatible slot. Also included is a parallel interface.

Monochrome Board **\$600.00**

A high resolution monochrome display of graphics. Supports word processor, and business graphics software.

Phoenix Video Board

The choice of a video display card can be a difficult one. There are many different capabilities for each style of video card available. If your display needs are as diverse as the number of cards available, you may have to install two or three video cards in your system. Not only is this expensive, but it also steals precious expansion slots from your system. Phoenix Computer corp. has a designed an expansion card to satisfy all of your display needs. The Phoenix video card can emulate the following styles of display cards.

IBM colour graphics card — 40 or 80 column character display

320 x 200 colour graphics

640 x 200 monochrome graphics

IBM monochrome text display — 80 column high resolution text display

Techmar

Hercules high resolution monochrome graphics display 120 x132 column colour text display mode

Depending on which display mode you choose any monitor up to 25kHz colour monitors can be interfaced to the Phoenix video card. The setup software is menu driven, and allows the user to program its own character set, as well as selecting from a 64 colour pallet.

\$395.00 with Warranty

EPROM PROGRAMMER



External Card.

This card can program any one of the following EPROMs: 2716, 2732, 2732A, 2764 and 27128s. Two sockets are available on the adaptor board, one for the 28-pin EPROMs, the other for 24-pin types. These sockets are standard sockets, however as an option ZIF sockets can be used (we recommend ZIF sockets if large numbers of EPROMs will be programmed). Also as an option an extension board is available. This board attaches to the adaptor via a ribbon cable and extends out the back panel. This is to allow EPROMs to be programmed without removing the cabinet cover every time programming is to be performed. Also as a standard feature, the source software is supplied to allow users to modify the program to suit their needs.

As an option a serial port can be included on the card; this serial port has the same features as the port described with the floppy disk controller (see the floppy disk description for documentation of the serial port).

MAIN EPROM PROGRAMMER CARD (WITH SOFTWARE)

With 2 standard EPROM sockets **\$99.00**

EPROM PROGRAMMER WITH ZIF SOCKETS (WITH SOFTWARE)

With one 24-pin. ZIF socket and one 28-pin ZIF socket with provision for serial port **\$139.00**

EXTERNAL CARD

Ready to plug into the main EPROM Card (includes one 24-pin and 28-pin ZIF socket and cable). Saves you from opening the computer each time you want to program your EPROMs. **\$69.00**

SERIAL OPTION

For your main EPROM programmer. Provides you with a second RS232 serial port **\$49.00**

BEST MODEM

The BEST modem is a smart 1200/300 direct connect modem. It can either be a stand-alone unit in which case it requires a small wall adaptor, or it plugs in one of the IBM slots. When used as a stand-alone unit, the modem looks like a Hayes 1200 Smart Modem, that is, it emulates the same instruction set. When it is used in the IBM, it looks like an intelligent serial communications port which also supports a super-set of the Hayes instruction set.

The modem supports auto-dial, auto-answer, and auto-speed select directly from software control. The modem also has a speaker so that aural monitoring of the call is possible. There are also LED monitors so that the state of the modem can always be known. These LEDs are: Modem Ready, Auto-Answer enabled, Carrier Detected, Transmitting,

Receiving, Data Set ready.

Software packages such as Crosstalk, PC-talk, and Hayes' Smartcom II also will run with this modem.

A version with 300 Baud only is available.



300 Baud **\$179.00** 300/1200 Baud **\$379.00**

The BEST Quanta Board



Do you find that your PC is not able to communicate with the outside world and you are constantly having to tell it the correct time and date? A simple solution for a system's short coming would be the BEST Quanta Board. Another of the multi-function boards designed with the personal computer user in mind, its features include the following:

Serial Ports

- Two serial communication ports that are configured under PC or MS-DOS as COM1 or COM2. Both communications ports support RS232-C signals (TxD, RxD, DTR, DSR, RTS, CTS, CD, and RI) at communication rates of up to 9600 Baud. One or both the serial ports can be disabled, to alleviate contention between any other serial port your system may already contain. The serial ports can also be configured to support the IBM PC mA current loop. The current loop allows the system to communicate with some types of teletype printers.

Parallel Printer Port

- A parallel printer port which supports many of the popular dot matrix and letter quality printers, as well as digital plotters that are commercially available. The parallel port can be selected as the primary or secondary printer port (PL2 or PL3 using DIP switches).

Games Port

- A game port which allows up to four game paddles, or two joy sticks to be connected to the system. The port is not limited to entertainment software. The port actually gives a value proportional to the resistance on the input, which allows your system to control industrial applications and CAD (computer aided design) software.

Real Time Clock/Calendar

- A real time clock/calendar with software to interface the clock hardware with the TIME and DATE functions of MS-DOS and PC-DOS. The clock continues to keep the correct time when the system is powered down by utilizing a replaceable lithium battery. The clock is based on the MM58274 CMOS chip and it is accurate to within seconds every year.

\$159.00 Cables Extra.

BEST Multi-Function Disk Drive Controller



The BEST Multi-Function disk drive controller is much more than its name implies. This card makes the most use of an expansion slot in your system by including many needed options on one card. This board may be the last you will have to install in your IBM PC or compatible system because of the extra features we have included.

Floppy Controller

- Floppy disk drive controller, which can handle up to four double sided, double density 5.25in. 360K disk drives.

The controller circuitry will also control some Tape Back Up units such as those manufactured by Irwin Magnetics in place of one of the four disk drives.

Serial Ports

- Two serial communications ports that support RS232-C standard signals (TxD, RxD, CTS, RTS, DSR, DTR, and RI).

Parallel Printer Port

- Parallel Printer Port that can be configured as either your primary or secondary printer port.

Real Time Clock/Calendar

- Real Time Clock with software, to integrate the clock with your version of PC-DOS or MS-DOS. The clock is designed around an ICL clock chip and is accurate to within seconds a year. A battery back up continues to keep the time during power down.

This is the same floppy controller used in all versions of the BEST personal computer, with excellent reliability and compatibility. Using PC-DOS 2.0 or later, each diskette has a formatted capacity of 360 Kilobytes.

\$199.00

The BEST Economy Floppy Controller

If all you need is an IBM Floppy Controller for your IBM or compatible 360K DS/DD disk drives, we have an economy BEST Floppy Controller which does not have provision for the extra features described in the Multi-Function Disk Drive Controller.

\$99.00

The BEST 256K/512K PentaRAM Board

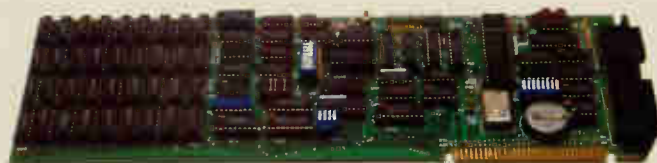

Almost every option your system is lacking can be supplied by the BEST PentaRAM board. This combination of options is one of the most economical ways (from the point of view of both your pocketbook and the expansion slots on your system) to expand your system. All communication ports follow the industry standards. The additional memory continues on from where your main board's memory stopped, in a completely transparent fashion. In detail the features of the BEST PentaRAM board are as follows:

Memory

- Up to 256K RAM using 4164's or 512K RAM using state-of-the-art 41256's can be added to your system. The starting memory boundary can be set to 256K, 384K, 512K, or 640K by configuring a bank of dip switches. The added memory is necessary for anyone wishing to operate a RAMdisk, and much of today's software requires a minimum of 384K RAM (Symphony, Framework, etc.) which many of the older PC's are not capable of holding on the main board. Each bank of memory contains an extra chip to support a parity bit for reliable data handling. (If the above boundaries do not match your system's configuration, they can be modified at the factory).

Serial Port

- A serial communication port that is configured under PC-DOS or MS-DOS as COM1 or COM2. The communications port supports RS232-C signals (TxD, RxD, DTR, DSR, RTS, CTS, CD, and RI) at communication rates of up to 9600 Baud. The serial port can be disabled, to alleviate contention between any other serial port your system may already contain. The serial port can also be configured to support the IBM PC mA current loop. The current loop allows the system to communicate with some types of teletype printers.

Parallel Printer Port

- A parallel printer port which supports many of the popular dot matrix and letter quality printers, as well as digital plotters that are commercially available. The parallel port can be selected as the primary or secondary printer port (PL2 or PL3 using DIP switches).

Games Port

- A game port which allows up to four game paddles, or two joy sticks to be connected to the system. The port is not limited to entertainment software. The port actually gives a value proportional to the resistance on the input, which allows your system to control industrial applications and CAD (computer aided design) software.

Real Time Clock/Calendar

- A real time clock/calendar with software to interface the clock hardware with the TIME and DATE functions of MS-DOS and PC-DOS. The clock continues to keep the correct time when the system is powered down by utilizing a replaceable lithium battery. The clock is based on the MM58274 CMOS chip and it is accurate to within seconds every year.

**PentaRAM Board with 256K and all options
\$299.00**

**PentaRAM Board with 512K and all options
\$379.00**

The BEST Parallel/ Game Card

\$69.00 (Cables Extra)



The BEST parallel/game card is an inexpensive addition to any BEST, IBM PC or compatible, which gives you the ability to connect almost any parallel printer or plotter to your system. The Parallel port is accessible through a DB25 connector located on the back of the card, which eliminates the need to disassemble the system case to connect the interface cable to the card. Printers such as the Epson family and Stai Micronics, Toshiba and others work with the BEST printer card with no special hardware except the connecting cable.

The game port is compatible w/ game paddles. Up to four game paddles or two joysticks can be connected via a 15-pin connector on the back of the card.

BEST 512K RAM Board

Switch selectable boundaries

**Complete with 512K-\$229.00
With 64K-\$149.00**

BEST PROTOTYPING BOARD \$28.95

Mail Orders: 319 College Street, Toronto, Ontario, M5T 1S2

Apple Compatible Products

MULTIFLEX 128K MEMORY CARD . . \$99.00 (with 128K of RAM on board)

128K Card can be used to function as RAM disk with your Apple.



128K RAM Card



Parallel Printer Card



Z80/64K Card



16K RAM Card



80 x 24 Card



Serial Card



EPROM Programmer



Z80 Card

MULTIFLEX SUPER SERIAL CARD . . . \$69.00

This card allows you to: • select desired baud rate • connect to a serial RS-232 modem, terminal, or a serial printer port • for example, connect two Apple computers (using this card) to communicate with each other, through the RS-232 link over hundreds of feet.

MULTIFLEX NEW SUPER 80 X 24 VIDEO CARD WITH SOFTSWITCH \$69.00

This new Multiflex card features: • superb 80 columns by 24 lines display, with upper and lower case, reverse video • includes built-in soft switch, allowing you to switch between the Apple's 40 column and the video cards 80 column from the keyboard. • superb compatibility.

WIZARD IPI INTERFACE \$69.00

MULTIFLEX PARALLEL PRINTER INTERFACE CARD WITH CABLE \$59.00

This card plugs into any of the Apple II+, IIe, or work-alike computers, and provides the user with a parallel interface capable of handling graphics and characters. Ideal for use with the Star Gemini and Epson Printers.

MULTIFLEX Z80-64K CARD

This spectacular card provides you with the functions of a Z80 card along with giving you extra 64K of self contained memory, on top of the existing memory in your Apple computer. (Software not included)

\$149.00

MULTIFLEX EPROM PROGRAMMER \$69.00

Features:

- Eprom programmer for Apple computers • Programs 2716, 2732, 2732A, 2764 • ZIF socket for the EPROM
- Complete with software • Comes with a built-in programming voltage supply.

Included with the card is a disk full of software, which using menus allows the user to program or verify EPROMS, check if they are blank, set pointers anywhere in memory, and save or load memory ranges to/from the disk drive, making this unit a very versatile piece of hardware for the hardware developer or hobbyist.

MULTIFLEX 16K RAM CARD \$43.00

Expand your 48K Apple II+ to 64K. The Multiflex 16K Ram Card allows other languages to be loaded into your Apple from disk or tape.

MULTIFLEX UPGRADED Z80 CARD \$45.00

This card allows the user to run Z80/8080 programs on his Apple II+ or IIe computer. Specifically, it allows him to run the CP/M operating system with all its attendant software such as word processors, accounting packages, etc. (CP/M software not included).

MULTIFLEX APPLE COMPATIBLE MODEM

EXCELLENT HAYES MICROMODEM COMPATIBILITY



Plugs into your Apple or compatible computer, Direct connect, 300 Baud, Autodial, Autoanswer, Touch Tone/Pulse Dial, complete with documentation.

Hayes is a registered trade name. **\$159.00**

Apple is a registered trade mark of Apple Canada Inc.

6502 Style Case

6502 Power Supply

CSA Approved,
5V 5A, 12V 2.5A,
-5V 0.5A -12V 0.5A
\$69.00



With Numeric Keypad

\$129.00

IBM Style Flip Top Case

APPLE COMPATIBLE DISK DRIVES

\$199.00

for Apple II+ and IIe

Now available for Apple IIc

\$229.00



Features:

- Apple compatible • Attractively packaged • Professionally built and tested
- Canadian Made • We believe that Multiflex put out more drives in the last year than all other Canadian manufacturers combined.

SLIMLINE DISK DRIVE \$179.00

Attractively packaged, Apple compatible, ultra reliable (90 day warranty).

IBM Compatible Software and Books



Accounting

IUS	
Accounts Payable	\$779.45
Accounts Receivable	\$779.45
Gen. Ledger-Fin. Reporter	\$779.45
Inventory Control	\$779.45
Order Entry	\$779.45
Payroll	\$975.95

Databases Integrated

Ashton Tate	
dBASE III	\$608.00
P.C. Tutorial	\$ 83.96
dBASE Upgrade	\$167.00

Micropro	
Infostar Plus	\$520.20

Stoneware	
Advanced DB Master	\$621.29

Databases - Non Integrated

Sorcim	
Easy Filler	\$417.76

Thorn EMI	
Perfect Library	\$516.99

Timework	
Data Manager 3	\$ 93.90

Filing

Software Publishing	
PFS File	\$146.21
PFS Report	\$130.55
PFS Solutions Mail List	\$ 20.63
PFS Proof	\$ 99.21

Spreadsheets

Lotus	
Lotus 1-2-3	\$ Call
Symphony	\$ Call
Symphony Upgrade	\$ Call

Word Processors

Broderbund	
Bank Street Writer	\$ 83.50

Hayden	
Writer	\$ 41.99

IUS	
Easy Writer II	\$396.00

Lifetree	
Volkswriter Delux	\$267.80
Volkswriter Scientific	\$646.63

Micropro	
Wordstar	\$307.97
Wordstar 2000	\$433.16
Wordstar 2000 Upgrade Kit	\$433.16

Multimate	
Multimate	\$304.89

Satellite	
Word Perfect	\$399.00
Word Perfect Sorter	\$ 62.75

Microsoft	
Microsoft WD/Mouse/Spell	\$563.72

Graphics Applications

Fox & Geller	
Dgraph III	\$258.42

Power Up	
Sign Designer	\$ 73.02

Software Publishing	
PFS Graph	\$146.25

Unison Advanced Products	
Print Master	\$ 62.61

Communication Terminal Pckg.

Microsoft	
Microsoft Access	\$262.00

Microstuff	
Crosstalk XVI	\$168.00

Software Publishing	
PFS Access	\$99.25

Thorn EMI	
Perfect Link	\$215.07

Programming Aids

Borland	
Turbo Pascal	\$ 75.00
Turbo Pascal MS DOS Generic	\$ 75.00
Turbo Pascal W/8087	\$114.77
Turbo Tutor	\$ 36.50

Digital Research	
C BASIC 86	\$208.88
CIS COBOL for CP/M 86	\$ 887.75
DR LOGO	\$156.60
Personal Basic	\$157.46
PL/I	\$783.31

Holt Rhinehart Winston	
Programming IBM PC BASIC	\$ 42.35

Programming Languages

Digital Research	
Concurrent PC DOS	\$308.10
CP/M 86	\$ 62.66

R Brandt/Prentice Hall	
Pascal programming	\$ 67.80

Utilities

Ashton Tate	
Framework	\$653.29

Borland	
Sidekick unprotected	\$ 88.72
Super Key	\$ 73.05
Turbo Graphics Toolbox	\$ 57.38
Turbo Toolbox	\$ 57.38

Digital Research	
Access Manager	\$417.77
Animator (3103-AA)	\$835.53
C BASIC Compiler C86	\$626.65
Display Manager 86	\$522.21
DR Graph (5017-AA)	\$203.66
Forms 2 (3104-AA)	\$208.88
Graph Draw	\$156.60

Microsoft	
Macro Assembler	\$156.66
Microsoft Mouse	\$231.80

Rosesoft	
Prokey 3.0	\$135.02

Software Research TECH	
Smart Key II Plus MS DOS	\$104.36

Entertainment

Infocom	
Zork 1	\$ 41.99
Zork 2	\$ 46.94
Zork 3	\$ 46.94

Simon & Schuster	
Frogger II	\$ 36.50
Super ZAXXON	\$ 36.50

Microsoft	
Flight Simulator	\$ 52.10

Muse	
Castle Wolfenstein	\$ 31.27

Blue Chips	
Tycoon	\$ 62.61
Millionaire	\$ 62.61

Datasoft

PAC Man	\$ 31.25
---------------	----------

Simon & Schuster	
The New York Times	\$ 20.83

Miscellaneous

MS DOS	\$129.00
PC DOS	\$129.00
GW BASIC	\$121.00

IBM Books

Handbook for the IBM PC	\$ 20.69
MS DOS Manual Reference	\$ 52.40
IBM Basic from Ground up	\$ 32.68
Book of IBM Software	\$ 26.13
IBM PC Encyclopedia	\$ 85.00
IBM PC User's Ref Manual	\$ 32.68
Lotus Guide to Learn Symphony	\$ 30.06
Through Micro Maze	\$ 13.03
Everyman's Dbase Primer	\$ 26.13
32 Visicalc Worksheets	\$ 26.13
Get Started w/MS Word	\$ 22.20
Manag. Bus. w/Multiplan	\$ 23.51
Basic Prog. W/Pro DOS	\$ 39.29
Inside Dbase III	\$ 52.00
Inside Frame Work	\$ 52.00
Inside Symphony	\$ 52.00
All About 1-2-3	\$ 13.03
1-2-3 Managerial Wrksh't	\$ 26.13

Misc. Titles

Programming In C	\$ 27.44
CP/M Bible Auth. Ref.	\$ 26.13
Microcook Book Vol. 1	\$ 20.89
Microcook Book Vol. 2	\$ 20.89
MPU Based Robot	\$ 22.20
Unix Primer Plus	\$26.13

Data Books

Motorola

DL128 Linear Data Book	\$14.95
DL129 High Speed CMOS	\$ 9.95
DL118 Opto Device Data	\$ 8.75
DL130 Cmos Integrated CCTS	\$ 9.95
DL110 RF Data Manual	\$14.95
DL111 Power Data Book	\$14.95
DL113 Memory Data Book	\$ 9.95
DL121 TTL Data Book	\$12.95
DL122 Mecl Data Book	\$ 9.95
DL126 Small Signal Trans.	\$15.00
DL105 Cmos Data	\$14.95
HB206 Voltage Regulator Handbook	\$ 9.95
SG73 Master Selection Guide	\$ 5.55
TB301 Basic Micro. & The 6800	\$35.00
TB303 The 6800 Family using Micropro & Microcom	\$34.00
MC68000um AD4 68000 Users Guide	\$12.50

Single Chip Microcomputer Data (includes 6800 Series and Support Chips)	\$19.95
---	---------

Other Data Books

Intel Micro System Components Handbook Vol. 1 and 2 (includes 8088 and support chips)	\$26.00
National Linear	\$19.95
National TTL	\$14.95
National CMOS	\$14.95

Keyboards



Keytronics 5151 (PC/XT compatible)	\$249.00
Keytronics 5150 (PC/XT compatible)	\$135.00
Keytronics 5151A (AT compatible)	\$279.00
Maxiswitch	\$135.00

Printer Ribbon's

Star Micronics		Epson	
SG10	\$ 4.50	FX80	\$10.95
SG15	\$ 4.50	FX100	\$15.95
SR10	\$ 4.50	LQ1500	\$24.00
SR15	\$4.50		
Power Type	CALL	Copal	
Radix 10	\$16.00	SC-1200	CALL
Radix 15	\$19.00	SC-550C1	CALL
Toshiba		Oki Data	
P-1351	\$15.50	ML80, 82A, 83, 92, 93	\$ 3.50
P-1340	\$15.50	ML182	CALL
P-351	\$15.50	ML183	CALL
		ML184	CALL

TOSHIBA High Quality Printers

P351

The Ultimate 3 in One Printer



Accepts font cartridges and downloadable font disks, Qume Sprint 11 emulation, IBM PC compatibility, and more.

- Letter quality at 100 cps
- High-speed drafts at 288 cps
- Superb graphics at 360 x 180 and 180 x 180 dots per inch.

\$1995⁰⁰

P1340



3 in One printing in the economy size. Superb graphics at 180 x 180 dots per inch. Letter quality and draft speeds. Qume Sprint 5 Emulation.

\$926⁵⁰

Specifications — P351

Print Method	Impact wire dot matrix
Print Head	24 pin; overlapping
Print Speed	Letter quality: 100 CPS Draft quality: 288 CPS (12 CPI) 240 CPS (10 CPI) Condensed print: 240 CPS (16.7 CPI)
Resolution	Graphic mode: 180 x 180 dots/inch 180 x 360 dot/inch
Line Lengths:	226 Characters per line (16.7 CPI) 163 Characters per line (12 CPI) 136 Characters per line (10 CPI)
Character Set	96 standard ASCII characters 31 graphics characters Special character sets for USA, UK, Sweden, France, Germany, Norway, Spain and IBM.
Character Fonts	Letter quality courier, prestige elite proportional spaced prestige elite are resident draft quality and condensed print are also resident. Downloadable fonts on disk and plug-in font cartridges are optional.
Horizontal Spacing	To 1/120" under software control 10 CPI, 12 CPI, 16.7 CPI, etc.
Vertical Spacing	To 1/48" under software control 10 CPI, 12 CPI, 16.7 CPI, etc.
Line Spacing Speed	6.25 IPS (continuous)
Paper/Copies	From 4" to 15" wide 4 parts carbonless paper including original.

Specifications — P1340

Printed Method	Impact wire dot matrix
Printed Head	24 pin; overlapping
Print Speed	Letter quality: 54 CPS Draft quality 144 CPS (12 CPI) 120 CPS (10 CPI) Condensed print: 78 CPS (16.7 CPI)
Line Lengths:	132 Character per line (16.7 CPI) 96 Characters per line (12 CPI) 80 Characters per line (10 CPI)
Character Set	96 standard ASCII characters
Character Fonts	Letter quality 24 x 36 dot matrix (proportional spacing). Draft quality 24 x 9 dot matrix, condensed draft quality 24 x 9 dot matrix.
Horizontal Spacing	10 CPI, 12 CPI, condensed 16.7 CPI, etc. Proportional spacing
Vertical Spacing	6LPI, 8LPI, etc.
Paper/Copies	From 4.5" to 10" wide, 4 parts carbonless paper including original. Single sheet or continuous form.

New from Star Micronics SG-10 Printer



Ideal for Text & Graphics

- Dual Mode - NLQ/draft standard (NLQ = near letter quality) • 120 CPS and 20% faster throughput • Bidirectional, logic/seeking • 2K buffer (expandable to 6K with optional buffer interface) • 100% IBM PC or Star standard control codes-switch selected • Friction and tractor standard • full 1 year warranty • 10" wide carriage • Standard parallel interface (serial optional) **\$379.00**

SG-10C for Commodore **\$399.00**
(No interface required)

SR-15

- 200 cps and 20% faster throughput • IBM PC or Star standard control codes switch selected • Dual Mode - NLQ/draft standard • Friction/tractor and automatic single sheet feed - standard • 15" carriage • 16K buffer • Bidirectional, logic seeking • Price/performance leader • Parallel port standard, serial optional • Full 1 year warranty. **\$995.00**

OKIMATE 20 (IBM) \$345.00 Colour



- Color Screen Print Software Package • 80 cps unidirectional printing • 40 cps correspondence quality • 24 element, long-life printhead with snap-in "no tool" replacement • IBM character sets 1 & 2 • High resolution 144 x 144 DPI graphics • Plain, thermal or acetate paper • Friction and pin feed paper handling (roll paper stand optional) • Variable width tractor feed.

Copial

SC5500I 180cps, 132 column
\$699.00

Star Micronics SG15

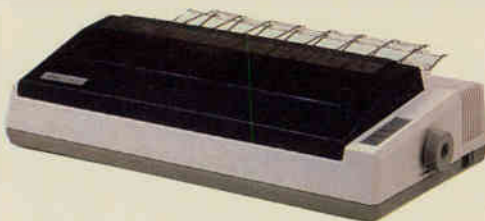

Same as SG10 except with 15" carriage and standard 16K buffer **\$599.00**

Radix

15" 200 cps, 100% duty cycle • 16k buffer • serial & parallel standard • proportional & downloadable characters • 240 x 144 Ultra High Res. • tractor & friction...

Radix 15 PC (for IBM PC) **\$995.00**

Star Printer Accessories

Printhead **\$80.00**
Printwheel **\$18.00**
Ribbons **\$4.50**
Paper (500 sheets) (8½x11) **\$9.95**
Paper (2,000 sheets) (8½x11) **\$32.00**
Dust covers **\$8.50**
Printer Stand (plastic) 10" **\$34.00**
Printer Stand (plastic) 15" **\$38.00**

ML182 \$390 IBM



- 120 cps bidirectional printing • Friction and adjustable pin feed paper handling • Parallel interface (serial optional) • All Points Addressable graphics • 5 foreign language sets • IBM Graphics compatible.

Star Micronics — Power Type daisywheel printer Letter Quality **\$535.00**



Print Speed: 18 c.p.s. bi-directional, logic seeking

Interface standard parallel (Centronics compatible) and serial RS232C-20mA current loop

Paper Slew Speed: 12 l.p.s. @ 1/6" spacing

Print Buffer: One line

Print Size: 10,12, 15 c.p.i and proportional spacing

Number of Columns: 110,132, 165

Character Sets: over 100 Type fonts available.

Special Features: proportional spacing; dual interface; standard printer mode and word processing mode; 32 easy access format switches

reverse paper feed; short form tear-off;

Line Spacing: 3,4,6,8 lines/inch; switch and software selectable

Paper Handling: single sheet: 5.5" to 8.5" wide; sprocket 4" to 13" wide; copies 3 carbonless sheets

Ribbon standard cassette

Okidata ML192 \$699.00

(Apple Imagewriter or compatible, Ile, Ilc, Mac)
• 120 cps • 2K Buffer, Serial int., upgradeable to 10K
• Tractor and friction • 10" • 19.2K Baud max. • Cable extra.

Okidata ML192 (IBM) \$679.00

• 160 cps • Parallel (optional Serial) • Correspondance quality • 10".

Okidata ML193 \$1089.00

(Apple imagewriter compatible Ile, Ilc, Mac)
• 120 cps • 2K Buffer, Serial int., upgradeable to 10K
• Tractor and friction • 15" • 19.2K Baud max. • Cable extra.

Okidata ML193 (IBM) \$1069.00

• 160 cps • Parallel (optional Serial) • Correspondance quality • 15".

Copial SC1500T \$499.00

180 cps, 80 column

Copial SC1200L \$329.00

120 cps, 80 column

Epson

CR220 **CALL**
Homewriters **CALL**
LX80 **CALL**
RX80 **CALL**
FX185 **CALL**
FX100 **CALL**
LQ1500 **CALL**
JX80 (Colour) **CALL**

**We also carry Toshiba Printers 1340 and 351
See page 11**

Prices subject to change without notice

Apple is a registered trademark of Apple Canada Inc.

Cable Assemblies



DB25 Male to DB25 Female **\$35.00**

RS232 Cable (6ft of round conductor) ... **\$39.00**

RS232 other lengths and connector configurations available on request.

Parallel cable 36 pin Centronics type connectors, male joined by 6ft of ribbon cable to female **\$35.00**

Parallel Cable for IBM interface DB25 through 6ft of ribbon to 36 pin centronics with appropriate connections **\$35.00**

Cable Assemblies for two 5-1/4in drives and controller (e.g. IBM) using three 34 pin connectors and appropriate length of 34 conductor cable **\$35.00**

20 pin Female header 24in. to 20 pin for Apple drives **\$6.95**

Serial A or B or C Switch Box .. \$59.00



Contains 3 RS232 connectors and a switch which switches all lines between A and output connector A and output connector C or connector B and output connector C. Example Applications. Switch between Serial printer and modem if you have only one serial port or switch on serial port or printer between two printers.

Monitors and Disk Drives

Zenith Data Systems



NEW

ZVM1220A

12in. diagonal screen • non-glare amber display
• composite input • 25 lines x 40/80 characters

\$135.00

NEW

ZVM1230A

12in. diagonal screen • non-glare green display
• composite input • 25 lines x 40/80 characters

\$135.00

CV-2560 • 25" diagonal screen • RGB/composite input • 25 lines x 80 characters • sound capability • green screen only switch • video "loop thru" feature

\$1049.00

ZVM 124 • 12" diagonal screen • non-glare amber display • PC monochrome input (TTL) • 25 lines x 80 characters • 720 x 350 pixels • IBM PC & compatibles

\$229.00

ZVM 131 • 13" diagonal screen • RGB/composite inputs • 25 lines x 40 characters • 320 x 240 pixels • sound capability • green screen only switch • video "loop thru" feature

\$479.00

ZVM 133 • 13" diagonal screen • RGB input • 25 lines x 80 characters • 640 x 240 pixels green screen only switch • 16 colours including PC brown

\$759.00



ZVM 135 • 13" diagonal screen • RGB/composite inputs • 25 lines x 80 characters • 640 x 240 pixels • sound capability • green screen only switch • video "loop thru" feature

\$787.00

ZVM 136 • 13" diagonal screen • RGB input • 25 lines x 80 characters • 640 x 480 pixels • long persistence phosphors for interlaced applications •

FOR BEST PRICE **\$1195.00**

Amdek

300A Amber **\$218.00**
310A Amber, 18MHz **\$229.00**
700 Ultra High Resolution **\$call**

NEC Monitors now available — Call for price

Irwin 10 Meg Tape Drive Backup



Hooks up to your existing floppy controller.
\$1199.00

5.25in. Disk Drives

SA455 **\$169.00**

• Shugart/Panasonic 5.25in. slimline, double sided, double density disk drive with 360K storage capacity. IDEAL FOR IBM COMPUTERS.

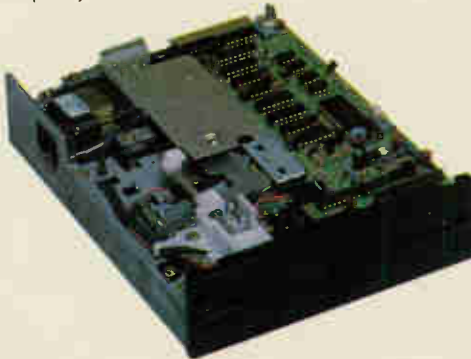

Toshiba Disk Drives

ND-04D 360K D5/DD
(black or grey) **\$169.00**

ND-08DE-G 1.2Mbyte AT Compatible, Grey **\$299.00**

For more details see page 14

Scorpion 20 Meg Tape Drive Backup and Controller. **\$1495.00**



Diskettes

Prices per box of 10

10% discount on 3 or more boxes.

Dysan DS/DD	\$35.95/10
Dysan SS/DD	\$27.50/10
Maxell DS/DD	\$35.95/10
Maxell SS/DD	\$28.95/10
Exeltronix DS/DD	\$24.95/10
BASF DS/DD	\$29.95/10
BASF SS/DD	\$22.95/10
Pinnacle DS/DD	\$21.95/10
Pinnacle SS/DD	\$16.50/10
Elephant DS/DD	\$24.95/10

Modems

Anchor Automation

Singleman 1200
300/1200 baud smart modem **\$469.00**
Volks Modem (300-1200) **\$399.00**

Hayes

1200B Modem (stand alone) **\$605.00**
1200 Modem **\$620.00**
300 Modem **\$365.00**
Smartcom II **\$188.00**

Joysticks & Input Pads

CH Products

Mach II **\$ 67.00**
Mach III **\$ 67.50**

Koala Technologies

Koala Pad W/PC Design **\$199.00**
The Speed Key System **\$259.95**

Kraft

Kraft Joysticks **\$ 65.00**

Mice

Microsoft
Microsoft Mouse **\$227.50**

Mouse Systems

PC Mouse **\$239.20**
PC Mouse/PC Paint **\$277.20**

Bill Boards

Compuerves Starter Kit **\$ 59.00**

Hard Disk Drives

10 MEG Seagate, slimline drive and hard disk controller. This controller can handle up to two-10 MEG hard drives.
\$995.00

Seagate 20 MEG. with controller **\$1195.00**

Cables (for 10 or 20 MEG) **\$38.00**

Quantity discounts available on two or more
See also Toshiba Hard Drives on p.14.

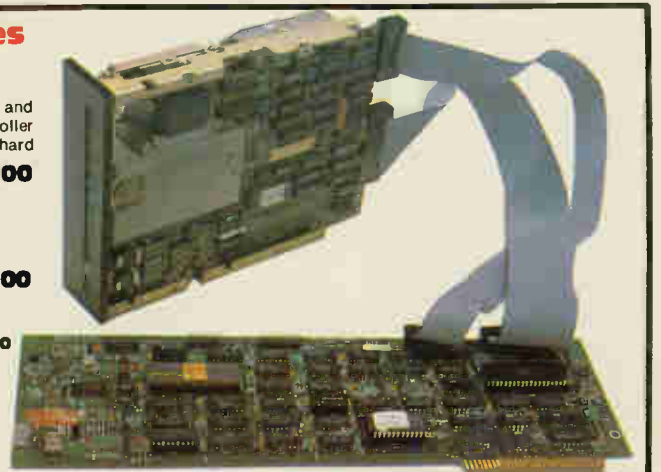

Wide selection of Floppy and Fixed Disk Drives

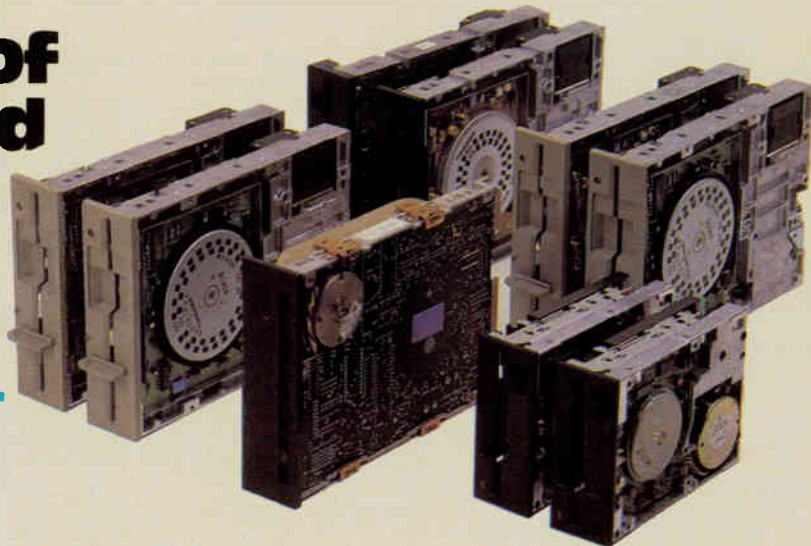

Upgrade your IBM PC/XT/AT or compatible with high quality Toshiba Drives.

ND-04D and ND-04DE-G 5 1/4" 360K DS/DD

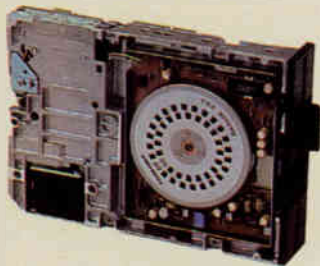

For your IBM PC/XT or compatible.
Grey or black available.
\$169.00

ND-353A and ND-354A 3 1/2" Drives



**500K and 1 Meg types
Call for best prices**

ND-08DE 5 1/4" 1.2 Meg/360K

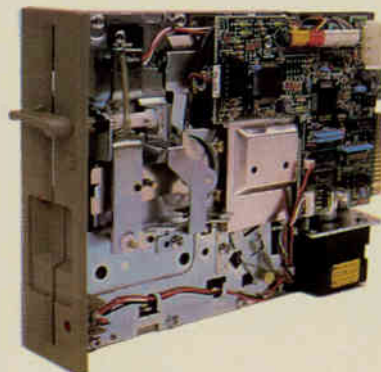

**For your IBM AT or compatible. Grey
\$299.00**

Wide Selection of Hard Disk Drives

10 Megabyte (MMI) .. **\$650.00**
MK 53FA, 43.5 Meg **\$2579**
MK 54FA, 60.5 Meg **\$2725**
MK 56FA, 86.5 Meg **\$2898**
Controllers available.

Prices and specifications subject to change without notice.

SPECIFICATIONS + CHARACTERISTICS

Unformatted Capacity:	MK-53FA	MK-54FA	MK-56FA
Mbytes per Drive (MFM)	43.2	60.5	86.5
Mbytes per Drive (RLL)	64.8	90.7	129.8
Bytes per Track (MFM)	10,416	10,416	10,416
Bytes per Track (RLL)	15,624	15,624	15,624
Heads per Surface	1	1	1
Data Surfaces	5	7	10
Cylinders per Drive	830	830	830

	All Drives
Data Transfer Rate (Mbits/sec) (MFM)	5.0
Data Transfer Rate (Mbits/sec) (RLL)	7.5
Access Time (ms) (includes settling):	
Track-to-Track	8.0
Random Average	30.0
Maximum	55.0

Quantity Discounts available.



Presents: NEW DIRECTIONS FOR THE CREATIVE ARTIST.

**THE YAMAHA CX5M MUSIC COMPUTER
ATTENTION YAMAHA DX-7 OWNERS:
CX YOUR DX!**

- Has the tedium of FM voice editing humbled you to factory presets?
 - With the CX5M's multi-menu graphic display, voice creation is a snap!
 - Why purchase \$150 RAM packs to save 32 voices when you could save hundreds on a CX5M cassette?
 - Plus you receive free: 200 voices for your DX-7!
- TAP YOUR DX-7'S POTENTIAL FOR ONLY \$675.00 (CX5M Computer, DX-7 Voicing Program, 200 Voices)**

**PERSONAL COMPOSER
THE ULTIMATE STUDIO SYSTEM ON AN IBM PC/XT**

- 32 trk sequencer (50,000 notes) w/full editing.
- Instant conversion of sequenced tracks to score including individual part extraction, multiple-format scoring and complete on-screen editing.
- Ultra high resolution graphics for copyright-quality printing.
- DX-7 graphic voicing program.

PROGRAM: \$595.00

Requires:

- IBM compatible 320K min. (Our Loaded BEST w/512K & 2 Drives is \$1795.00)
- Hercules compatible graphic card: \$380.00
- Roland MPU-401 processor and interface: \$399.00
- Monochrome monitor: \$229.00 (Zenith ZVM 122)
- Epson FX-80 printer: \$649.00

THE COMPLETE PERSONAL COMPOSER PACKAGE: \$4049.00

THE CX5M IS:

- A dynamic DX-9 sound module on-board (96 voices, graphically programmable)
- An efficient 8 part scoring system w/hardcopy printout.
- PLAYS 8 VOICE MULTI-TYMBRAL
- Send your music out over 8 independent MIDI channels.
- Produce audio-visual performances incorporating graphics and music.
- And the CX5M is a fully-fledged MSX computer for all your home and business needs.

THE COMPLETE CX5M PACKAGE IS ONLY \$825.00 (Computer, YK-01 Keyboard, FM Composing & Voicing Programs)

COMPUTER MUSIC CENTRE EXCLUSIVES:

- CMC 1 Voice Library (100 Voices: \$39.95)
- CMC 2 Song Library (15 Songs: \$39.95)
- CMC 3 DX-7 Voice Library (200 Voices: \$49.95)
- CMC 4 DX-7 Voice Library (500 Voices: \$99.95)

CX5M DISK DRIVES AND PRINTERS ARE HERE!

- Disk Drive \$395.00
- Printer \$365.00

Now Available: 4 track real-time sequencer
RX drum machine rhythm editor
Keyboard chord construction and progression tutorials

New! The MSX book - a must for CX5M owners. Complete documentation: \$32.95

HOT MIDI PRODUCTS FROM THE NAMM SHOW

TEXTURE FROM CHERRY LANE ON THE IBM PC/APPLE 11

The most complete 'workhorse' professional recording software on the market! Complete real-time, step-time, and MIDI data editing. Link up to 64 8 track sequences to create songs or sets of music.
PROGRAM PRICE: \$295.00

APPLE MACINTOSH MIDI HAS ARRIVED!

Southworth TOTAL MUSIC SYSTEM
99 tracks, 50,000 notes, automatic transcriptions, full editing of recording and scoring, even visual editing! Fully mouse driven.
SOFTWARE AND INTERFACE ONLY: \$649.00

IVL Technologies PITCHRIDER 7000:

The affordable MIDI Guitar interface is here!
Fully-polyphonic, velocity and pitch bend control.
OUR PRICE: \$849.00
PITCHRIDER 2000: MIDI interface for brass/woodwinds.
OUR PRICE: \$425.00

**MAJOR REDUCTIONS ON MIDI DEVICES
AND SIGNAL PROCESSORS**

ROLAND MIDI:

- SDE-2500 MIDI DIGITAL DELAY: \$765.00
- MPU-101 MIDI to CV interface: \$315.00
- MPU-103 MIDI Channel/Filter Converter: \$249.00
- MPU-104 MIDI Output Selector: \$109.95
- MPU-105 MIDI Input Selector: \$89.95
- MM-4 MIDI thru box: \$74.95

NEW BOSS MICRO RACK SERIES:

- RDD-10 Digital Delay: \$315.00
- RGE-10 Graphic Equalizer: \$219.00

SOME VERY SPECIAL PRICES

Roland Compu-Music: complete system \$295.00

Passport compatible MIDI Interface: \$165.00

Boss DE-200 Digital Delay: \$395.00

Alpha Syntauri 5 octave System: complete with Mountain Music cards and software \$995.00

Yamaha DX-9 FM Synthesizer: \$1195.00

E-MU Systems Drumulator: \$749.00

Roland System 100M Analog Module Rack: \$1395.00

Order By Phone/Mail/or Drop In
Phone Orders and Enquiries: (416) 921-8941
Canada-Wide Long Distance (Order Line Only) 1-800-268-3798



The 8088 Controller and Trainer System

Based on the success of our Multiflex starter systems, we are proud to announce the arrival of the 8088 Controller and educational Trainer System. With the option to upgrade to a full IBM PC compatible, the starter system is the perfect education tool to learn 8088 based hardware and assembler code. It is also ideal for use as a complex, high speed industrial controller at an affordable price. This 8088 System consists of two boards. The first board (as seen in the picture) is the motherboard which can be used as a general purpose controller and contains the following:

- Socketed for 64K static RAM
- Socketed for 64K of EPROM
- RS232-C serial communications port
- Controller Port
- 300 baud modem
- 3 IBM PC compatible expansion slots (when the multifunction board is used)
- Wire Wrap area

The motherboard is a very versatile controller for which it is very easy to write software on the IBM PC/XT.

The second component is a console which connects to the motherboard via a ribbon cable. The console contains a display, hex keypad and another keypad containing function keys to perform memory block moves, register examination, the examination of I/O ports and a myriad of other functions. This board also contains an EPROM programmer.

A further multi-function board which has been designed specifically for the system to make it IBM PC compatible is available. This multi-function card contains a floppy diskette controller, DMA controller and up to 512K dynamic RAM.



**Controller Board with 16K RAM
(optionally expandable to 64K)
\$250.00**

**Keyboard and Display Board with EPROM
programmer and monitor software
\$159.00**

**Multi-function Board with 64K RAM
(expandable to 512K)
\$250.00**

SPECTACULAR GANG EPROM PROGRAMMER AND EMULATOR

Totally self-contained (has its own display, entry keypad and power supply).

Based on the Z-8 microprocessor.

Can program up to 8 EPROMs simultaneously (anywhere from one to 8 EPROMs at the same time with the information in its own memory or master EPROM).

Each of the 8 EPROM programming sockets is individually buffered and isolated from one another providing protection in situations when there is a bad EPROM among the eight being programmed. Clearly indicates and singles out any defective or marginal EPROMs prior to or after programming.

After programming the unit does a full VERIFY routine of the EPROM (at a Max Vcc of 5.4V and at a Min Vcc of 4.5V) to ensure high reliability of your EPROMs. Very simple to use.

A standard unit contains 8x16K of on-board memory which is sufficient in most cases, but can easily optionally be upgraded to 8x64K of on-board memory.

The Gang Programmer can handle a wide selection of EPROMs: 2716, 2732, 2732A, P2732A, 2532, 2564, 2764, 27128, 27128A and optionally upgradeable to handle 27256, 27512, 2758 and 2724.

Gives you option of entering the data which you want to be programmed on the EPROM through a built-in keypad and display into the EPROM programmer's built-in RAM or by downloading the data to be programmed by

RS232 interface (110 to 9600 Baud). The RS232 is standard — not optional!

Data can be checked or modified, since you can examine any memory location of the programmers built-in RAM, this holds true even after you have down-loaded through the RS232 from your computer; you can check or modify the memory before finally programming it on your EPROMs.

Read Master EPROMs; you can plug in a programmed EPROM, dump it into the programmers RAM, check the contents on display by stepping through the memory and, if you wish, you can alter any location before copying to other EPROMs.

EPROM Programmer can also be (optionally) used as an EPROM emulator, saving hours of frustration, reprogramming and waiting.

Using the Emulator option, you can enter via the keyboard or down-load through the RS232 from your computer or development system, the information which you think is right for whatever project you are building. This is the same information which you would normally burn into an EPROM, plug into your new undebugged processor and moments later you realise that you forgot to enter a code or that you must add or delete some codes. This normally would mean waiting 20 minutes for erasing of the EPROM and reprogramming and wasting time.

Using the Emulator option, you simply plug in a 24 or 28 Pin buffered pod into the socket on your board where you would normally fit the



EPROM, the difference being now that you can have all the information in the programmers RAM, connected to the pod by a ribbon cable and you can start your testing. If you wish to change, add, delete any codes, you can modify the contents of the programmers RAM using the keypad and display and continue testing moments later. Keep in mind that the RAM is protected from being accidentally altered.

Complete package with EPROM Emulator, 8 ZIF sockets, Gang Programmer with 16Kx8 of RAM and RS232 **\$995.00**

Gang EPROM Programmer with 8 ZIF sockets, 16Kx8 RAM and RS232, without Emulator **\$695.00**

EPROM Programmer with only one ZIF socket, 16Kx8 RAM and RS232, without Emulator. Able to do all the functions describe but can handle only one EPROM at a time **\$499.00**

UV EPROM Erasers

Industrial quality EPROM erasers.
Erase time about 15-20 minutes
Starting at \$129.00

MICROPROCESSOR CHIPS

6500 Series	
6502	8-bit CPU (1 MHz) 4.95
6502A	8-bit CPU (2 MHz) 8.90
6522	VIA Versatile Interface Adaptor 6.95
6522A	VIA Versatile Interface Adaptor 8.95
6523	RIOT (128x8 RAM, I/O, Timer) 7.95
6545	CRT Controller 12.95
6551	ACIA Async. Comm. Interface Adaptor 8.75

6800 Series	
6800	8-bit CPU (1 MHz) 4.30
6802	On Chip 128 x 8 1MHz CPU 5.99
6800B	8-bit CPU (2 MHz) 7.99
6809	8/16-bit CPU (1 MHz) 9.95
68B09	8/16-bit CPU (2 MHz) 23.00
6810	128x8 static RAM 4.15
6821	PIA Peripheral Interface Adaptor 3.59
6840	Programmable Timer 8.10
6844	DMAC Controller 14.00
6845	CRT controller 8.95
6845S	CRT controller 9.95
6847	Video Display Generator 9.95
6850	ACIA 3.45
6852	Synchronous Serial Data Adaptor 5.80
6860	0-600 Baud Modem 11.95

68000 Series	
68000L8	16-bit CPU (8 MHz) 50.00
68000L10	16-bit CPU (10 MHz) 59.00
68008	16-bit CPU (8 bit data path) 52.00
68230	Parallel Interface Adapter 25.95
68400	6MHz 16-bit DMA Controller 110.00
68451	Memory Management Controller 189.00
68561	MPCC (68000 Compatible) 96.00
68681	Daunt 19.50

8080 Series	
8080	8-bit CPU 9.80
8085	8-bit CPU 9.45
8087	Math Processor (Intel) 179.00
8087-2	Math Processor Fast 8 MHz (Intel) 219.00
8088	16-bit CPU 8-bit Databus (AMD) 7.90
8088	16-bit CPU 8-bit Databus (Intel) 9.95
8088-2	16-bit CPU 8-bit Databus 8 MHz (Intel) 14.95
8212	3-bit I/O Port 3.35
8214	Priority Interrupt Controller 6.95
8216	4-bit Bidirectional Bus Driver 2.85
8224	Clock generator for 8080/8085 5.10
8226	Inverting Bus Driver 5.36
8228	System controller for 8080/8085 9.75
8230-5	High Speed DMA Controller (AMD) 8.30
8237A-5	High Speed DMA Controller (Intel) 10.95
8250	Serial Port 9.89
8251A	Programmable Communications Interface 8.32
8253A-5	Programmable Interval Timer (AMD) 5.95
8253A-5	Programmable Interval Timer (Intel) 8.95
8254A-5	Latest Programmable Interval Timer (Improved version of 8253A-5) 7.95
8255-5	Programmable Interface Adapter 4.89
8255A-5	Programmable Interface Adaptor 4.89
8257-5	Programmable DMA Controller 9.95
8259A	Programmable Interrupt Controller 4.95
8275	Programmable CRT Controller 24.00
8279-5PC	Programmable Keyboard Display Interface 7.50
8282PC	Octal latch, inverting 8.55
8283PC	Octal latch, inverting 12.00
8284A	Clock gen and driver 5.95
8286	8-Bit Bus trans. Non-inverting 8.50
8287PC	8-Bit Bus trans. Inverting 10.50
8288	Bus Controller 8.95
8289	Bus Arbiter 40.95
8272	Floppy Disk Controller (Equiv. to NEC 765) 8.95
8741ADC	Univ. Programmable Interface 34.95
8748DC	CPU, 4K EPROM, I/O 28.00
8749DC	CPU, EPROM, RAM, I/O 35.00
8755ADC	2048 x 8 EPROM, I/O 37.95

We now carry a wide selection of 80286 parts at most competitive prices.

Z80 Series	
Z80A	8-bit CPU (4 MHz) 4.50
Z80B	8-bit CPU (6 MHz) 10.00
Z80A-PIO	Parallel I/O 5.95
Z80A-CTC	Counter/Timer 7.79
Z80A-DART	Dual Asynchronous Receiver Transmitter 12.95
Z80A-DMA	Direct Memory Access 16.50
Z80A-SIO-D	Serial I/O ver. 0 18.95

Communications & Timers	
AY3-1015	UART (Single 5V Supply) 7.95
AY5-1013	UART 5.99
S1602	UART 18.95
TM59918	Bit Graphics Generator 18.95
TMS99532	FSK Modem 17.95
COM5016	Dual Baud Rate Generator 18.10
COM8116	Dual Baud Rate Generator (5V supply only) 16.75
AY53600	Keyboard Encoder 10.95
KR3300	Keyboard Encoder 8.95
MSM5832	Real-Time Clock 18.10
MSM58321	Real-Time Clock 18.10
SN5037	CRT Video Timer Controller 32.25

Floppy Controllers	
WD2143	4-phase Clock Generator for Floppy 14.50
FDC1771	Single Density Disk Controller 19.00
FDC1793	Double Density Disk Controller 47.00
FDC1795	Dual Density Sided Disk Controller 69.00
FDC2793	Dbl. Density Disk Controller c/w precomp. 45.00
FDC2795	DDDS Disk Controller c/w precomp. 59.95
FDC3216	Floppy Disk Data Separator 10.50
NEC785 (8272)	Floppy Disk cont. 8.95

74LS00 SERIES

74LS00	Quad 2 Input NAND gate 29
74LS01	Quad 2 Input NAND gate O/C 45
74LS02	Quad 2 Input NOR gate 29
74LS03	Quad 2 Input NOR gate O/C 45
74LS04	Hex Inverter 32
74LS05	Hex Inverter O/C 59
74LS08	Quad 2 Input AND gate 29
74LS09	Quad 2 Input AND gate O/C 45
74LS10	Triple 3 Input NAND gate 40
74LS11	Triple 3 Input AND gate O/C 45
74LS12	NAND gate inverter 50
74LS13	Dual Schmidt trigger 50
74LS14	Hex Schmidt trigger inverter 59
74LS15	Triple 3 Input AND gate 75
74LS20	Dual 4 Input NAND gate 45
74LS21	Dual 4 Input NAND gate 45
74LS22	Dual 4 Input NAND gate 45
74LS24	Quad 2 Input NAND Schmidt trigger 75
74LS26	Quad 2 Input positive NAND gate 45
74LS27	Triple 3 Input NOR gate 45
74LS28	Quad 2 Input NOR buffer 45
74LS30	8 Input NAND gate 45
74LS32	Quad 2 Input NOR gate 45
74LS33	Quad 2 Input NOR gate O/C 55
74LS37	Quad 2 Input NAND gate 45
74LS38	Quad 2 Input NAND gate O/C 50
74LS42	BCD to decimal decoder 60
74LS47	BCD to 7 segment decoder/driver 90
74LS48	BCD to 7 segment decoder/driver 99
74LS49	BCD to 7 segment decoder/driver 79
74LS51	And/or Invert gate 45
74LS54	4 wide and/or invert gate 45
74LS55	2 wide 4 input and/or invert gate 45
74LS53	Hex current sensing switch 1.70
74LS73	Dual JK flip flop w/hold clear 55
74LS74	Dual D flip flop 49
74LS75	4 bit bistable latch 60
74LS76	Dual JK master/slave flip flop 90
74LS77	4 bit bistable latch 1.00
74LS78	Dual JK flip flop preset, common clear 55
74LS83	4 bit binary full adder 94
74LS85	4 bit magnitude comparator 94
74LS90	Quad Input XOR gate 55
74LS91	Decade counter 65
74LS93	8 bit shift register 80
74LS92	Divide by 12 counter 96
74LS93	4 bit binary counter 96
74LS95	4 bit right/left shift register 80
74LS96	5 bit shift register async. preset 80
74LS107	Dual JK flip flop with clear 55
74LS109	Dual JK pos. edge triggered flip flop 60
74LS112	Dual JK edge triggered flip flop 60
74LS113	Dual JK edge triggered flip flop 55
74LS114	Dual JK edge triggered flip flop 55
74LS122	Reprogrammable monostable multivibrator 90
74LS123	Dual retriggerable monostable multivibrator 45
74LS125	Tri state quad bus buffer 60
74LS126	Quad 3 state buffer 60
74LS132	Quadruple 2 Input NAND Gate 89
74LS133	13 Input NAND gate 70
74LS136	Quad XOR gate 55
74LS137	3 of 8 decoder/demultiplexer 99
74LS138	3 to 8 decoder/multiplexer 68
74LS139	Dual 1 of 4 decoder/demultiplexer 68
74LS145	BCD to decimal decoder/driver 1.25
74LS147	10 to 4 priority encoder 2.00
74LS148	8 to 3 line priority encoder 2.15
74LS151	8 channel digital multiplexer 75
74LS153	Dual 4/1 multiplexer 75
74LS154	4 to 16 decoder multiplexer 1.05
74LS155	Decoder/demultiplexer 99
74LS156	Decoder/demultiplexer 85
74LS157	Quad selector/multiplexer 70
74LS158	Quad 2 input multiplexer (inverting) 75
74LS160	Decade counter with async. clear 99
74LS161	Sync. 4 bit counter 95
74LS162	Sync. 4 bit counter 95
74LS163	Sync. 4 bit counter 95
74LS164	8 bit serial shift register 89
74LS165	Parallel load 8 bit shift register 1.08
74LS166	8 bit PISO shift register 1.95
74LS168	Up/down decade counter 2.25
74LS169	4 bit binary counter 1.38
74LS170	4 x 4 register file 1.95
74LS173	4 bit 1 in state register 78
74LS174	Hex D flip flop with clear 80
74LS175	Quad D flip flop with clear 80
74LS181	4 bit ALU 2.75
74LS182	Look ahead carry 2.75
74LS190	Sync. up/down counter BCD 93
74LS191	Sync. up/down counter binary 93
74LS192	Binary up/down counter 93
74LS193	Binary up/down counter 93
74LS194	4 bit bi-directional shift register 93
74LS195	4 bit shift register 75
74LS196	Decade counter 1.50
74LS197	Presettable binary counter 1.05
74LS221	Dual monostable multivibrator 1.25
74LS240	Octal inverting bus driver 1.25
74LS241	Octal bus driver 1.25
74LS242	Quad inverting transceiver 1.20
74LS243	Quad transceiver 1.17
74LS244	Tri state octal driver 1.20
74LS245	Octal bus transceiver 1.39
74LS247	BCD to 7 segment decoder driver 1.05
74LS248	BCD to 7 segment decoder driver 1.35
74LS249	BCD to 7 segment decoder driver 1.35
74LS251	Tristate data selector multiplexer 78
74LS253	Dual 4 bit multiplexer 75
74LS257	Quad 2 input multiplexer 80
74LS258	Quad 2 input multiplexer 80
74LS259	8 bit addressable latch 1.30
74LS260	Dual 5 input NOR gate 79
74LS266	Quad 2 Input XNOR O/C 50
74LS273	Octal D flip flop 1.18
74LS275	7 bit slice Wallace tree 5.55
74LS279	Quad S-P latches 59
74LS280	9 bit odd/even parity checker/generator 3.25
74LS283	4 bit binary full adder 79
74LS289	64 bit RAM 6.25
74LS290	Decade counter 90
74LS293	4 bit binary counter 95
74LS295	4 bit shift register 1.50

74LS298	Quad 2 input multiplexer 1.12
74LS299	8 bit storage register 2.75
74LS320	Crystal oscillator 4.75
74LS321	Crystal oscillator 3.90
74LS322A	8 bit shift register 5.49
74LS323	8 bit bidirectional universal shift 3.49
74LS348	8 to 3 priority encoder 2.75
74LS352	Dual 4 bit multiplexer 1.05
74LS353	Dual 4 bit multiplexer 1.05
74LS354	Data selector multiplexer 4.75
74LS355	Data selector multiplexer 4.75
74LS356	Data selector multiplexer 4.75
74LS357	Data selector multiplexer 4.99
74LS365	Hex bus driver tri state (inverted output) 62
74LS366	Hex bus driver 62
74LS368	Hex bus driver (inverted output) 62
74LS373	Octal transparent latch 1.20
74LS374	Octal dual flip flop 1.20
74LS375	4 bit bistable latch 65
74LS377	Octal D register 1.23
74LS378	Hex D register 1.85
74LS379	4 bit register 1.85
74LS380	Multi function octal generator 9.00
74LS384	8 bit multiplier 7.95
74LS386	Quad 2 Input XOR gate 50
74LS390	Dual decade counter 1.28
74LS393	Dual 4 bit binary counter 1.12
74LS395	Tri state shift register 1.89
74LS396	Quad 2 input register 2.75
74LS398	Quad 2 Input multiplexer with storage 1.45
74LS399	Voltage controlled oscillator 3.30
74LS612	28.00
74LS640	Octal bus transceiver 2.20
74LS641	Octal bus transceivers 3.20
74LS646NT	Octal bus transceivers AND registers 10.95
74LS647NT	Octal bus transceivers AND registers 10.95
74LS652NT	Octal bus transceivers AND registers 10.95
74LS670	4 x 4 register file 3 state 1.85
74LS673	16 bit SISO shift reg 19.95
74LS682	8 bit magnitude comparator 3.99
74LS683	8 bit magnitude comparator-open collector 3.99
74LS684	8 bit magnitude comparator, 3-state 3.99
74LS688	8 bit magnitude comparator, 3-state 3.99
74LS689	8 bit magnitude comparator open collector 5.35
74LS795	Octal buffer (81LS95), 3-State 1.29
74LS796	Octal buffer (81LS96), 3-State 1.29
74LS797	Octal buffer (81LS97), 3-State 1.29
74LS798	Octal buffer (81LS98), 3-State 1.29

MEMORY

Check latest prices each month in Electronics Today and Computing Now!

Untouchable Prices!
Guaranteed Prime Stock
Call for large quantities prices.

Dynamic RAMs	
4116 1x16K (150ns)	\$ 0.75
4164 1x64K (150ns)	\$ 1.10
4164's (150ns), Set of 9	\$ 9.50
41256 1x256K (150ns)	\$ 4.99
41256 (150ns), Set of 9	\$ 44.75

Static RAM	
2114L 4x1k 200ns	\$ 2.25
6514 4x1k CMOS 450ns	\$ 1.20
6116 8x2k 150ns	\$ 4.95
2016 8x2k 150ns	\$ 3.99
62 64 8x8k 150ns	\$ 9.95
2716 450ns 8x2k	\$ 5.50
2716 300ns 8x2k	\$ 6.50
2732 450ns 8x4k	\$ 3.75
2732 250ns 8x4k	\$ 4.50
2764 300ns 8x8k	\$ 4.50
27128 350ns 8x16k	\$ 6.95

Commonly used parts for your IBM compatible (8088) systems and peripherals

Quantity Discounts Available	
8088 CPU	\$ 7.90
8087 Math Processor	\$ 179.00
8237A-5 Prog. DMA Cntrl.	\$ 8.90
8250 Serial Port	\$ 9.89
8253A-5 Prog. Interval timer	\$ 5.89
8255A-5 P.I.A.	\$ 4.89
8259A Prog. Interrupt Cntrl.	\$ 4.95
8284A ADC clock gen & driver	\$ 5.95
8288 Bus Controller	\$ 9.75
8272 Floppy Disk Controller	\$ 8.95
NEC 765 Floppy Disk Controller (equivalent to 8272)	\$ 8.95
8086 CPU	\$ 13.50
Set of 8088, 8255A-5, 8237A-5, 8288, 8264, 8253A-5 and 8259A	\$ 48.00

100ns delay line	\$ 4.95
7ns delay line	\$ 12.45
62 pin edge con (high quality)	\$ 1.79
5 pin Din conn	\$.99
Power conn	\$ 1.25
Dip switch 8 pos	\$ 1.75
4.7k x 5 slip	\$.39
4.7k x 8 pin sip	\$.44
8.2k or 10k 16 pin Resistor or network	\$.99
Small speaker	\$ 1.99
.1 uf 50V high quality bypass capacitors	\$.10
Trimcap	\$.99
34 pin card edge con. for your floppy controller	\$ 5.85

74LS322A	\$ 5.49
74LS629	\$ 3.30
74LS670	\$ 1.70
74S280	\$ 3.19
74LS125	\$.60
74S157	\$ 1.59
74LS244	\$ 1.20
74LS245	\$ 1.39

CMOS		348	Quad low-power 741	.88	74122	Retriggerable one shot multivibrator	.95	74ALS467	Octal buffer with 3 state output	2.45	
4000	Dual 3 input NOR gate	.33	350	3A 31-term positive adjust. regulator	7.25	74123	Dual retriggerable one shot	.67	74ALS468	Octal buffer with 3 state inverted output	2.45
4001	Dual 2 input NOR gate	.33	355	FET input op amp	.89	74125	Tri-state quad bus buffer	.95	74ALS518	8 bit magnitude comparator	3.75
4002	Dual 4 input NOR gate	.33	357	Monolithic J-FET input op amp	1.95	74128	Tri-state quad bus buffer	.95	74ALS519	8 bit magnitude comparator	3.75
4006	18 static shift register	.86		Monolithic J-FET input op amp (uncompensated)	1.95	74132	Quad 2 line driver	.95	74ALS522	8 bit magnitude comparator	3.75
4007	Dual complementary pairs/inverters	.35	358	Dual version of 324	.55	74136	Exclusive or NAND gate	.92	74ALS533	Octal D type transparent latches	2.45
4008	4 bit latches	.35	380	2W audio amp	1.10	74141	BCD to decimal decoder driver	1.79	74ALS534	Octal D type edge triggered FF	2.45
4009	Hex buffer/converter (inverting)	.89	393	Dual version of 339	.60	74142	Count enable decoder/driver	5.59	74ALS40	Octal buffer and line driver	2.19
4010	Hex buffer/converter	.89	393	Sample and hold amplifier	5.94	74143	Center decoder	.599			
4011	Quad 2 input NAND gate	.33	396	Timer	.45	74144	Center decoder	.599			
4012	Dual D edge triggered flip flop	.45	556	Dual timer	.82	74145	BCD to decimal decoder driver	1.29			
4014	8 bit static shift register	.89	558	Quad timer	1.90	74147	10 4 priority encoder	2.45			
4015	Dual 4 bit static shift register	.79	567	Tone decoder	.95	74148	Priority encoder	1.59			
4016	Quad bilateral switch	.46	709	Op amp	.78	74150	6 line to 1 line multiplexer	2.35	74S00	Quad 2 input NAND gate	.62
4017	Decade counter/divider	.75	710	Differential comparator	1.32	74151	8 channel digital multiplexer	.89	74S02	Quad 2 input NOR gate	.62
4018	Presetable divide by N counter	.82	711	Dual channel differential comparator	.39	74153	dual 4 line to -16 decoder	.89	74S03	Quad 2 input NOR gate QIC	.75
4019	Quad and/or select	.52	714	Precision op amp	4.45	74154	4 line to -16 decoder	1.99	74S04	Hex inverter	.62
4020	14 stage binary ripple counter	.85	715	High speed op amp	5.25	74155	Decoder/demultiplexer	.79	74S05	Hex inverter QIC	.75
4021	8 bit static shift register	.85	723	Voltage regulator	.59	74156	Decade multiplier/latch	.82	74S08	Quad 2 input AND gate	.62
4022	Divide by 8 counter/divider	.85	725	Instrumentation op amp	2.25	74157	Quad 2 input multiplexer	.89	74S09	Quad 2 input AND gate QIC	.79
4023	Triple 3 input NAND gate	.34	733	Differential video amp	1.15	74159	4-16 decoder	2.10	74S10	Triple 3 input NAND gate	.79
4024	7 stage binary counter	.55	739	Dual high performance op amp	2.05	74160	BCD decade counter, async. reset.	.89	74S11	Triple 3 input AND gate QIC	.79
4025	Triple 3 input NOR gate	.34	741	Operational amplifier	.59	74161	Synchronous 4 bit counter	1.09	74S15	Triple 3 input AND gate QIC	.79
4026	Decade counter/divider	1.30	747	Dual op amp	.75	74162	Syn. 4 bit counter	1.19	74S20	Dual 4 input NAND gate	1.99
4027	Dual JK flip flop	.50	748	Op amp	.60	74163	Syn. 4 bit counter	1.09	74S22	Dual 4 input NAND gate QIC	.79
4028	BCD to decimal decoder	.65	749	Dual audio preamplifier	2.89	74164	8 bit serial shift register	1.09	74S30	8 input NAND gate	.72
4029	Presetable up/down binary decade counter	.90	760	Power op amp	6.5	74165	Parallel load 8-bit shift register	1.25	74S32	Quad 2 input NOR buffer	.62
4030	Quad XOR gate	.42	776	High speed differential comparator	11.95	74166	8 bit shift register	1.79	74S37	Quad 2 input NAND buffer	2.48
4033	7 segment decoded counter	1.00	776	Multi-purpose programmable op amp	1.10	74167	Syn. rate multiplexer	4.65	74S38	Quad 2 input NAND buffer QIC	2.49
4034	8 stage universal bus register	1.95	1372	Modulator/demodulator	3.25	74170	4 by 4 register file	6.75	74S40	Dual 4 input NAND buffer	2.89
4035	4 stage PISO register	.92	1436	RF modulator	4.45	74172	16 bit register file	6.75	74S41	Dual D flip flop	1.99
4038	Triple serial register	2.00	1458	High voltage op amp	4.90	74173	4 bit in-state register	1.59	74S45	4 bit magnitude comparator	2.50
4040	12 stage binary ripple counter	.78	1488	Dual op amp	.54	74174	Hex D flip flop with clear	1.19	74S46	Quad 2 input XOR gate	1.00
4041	Quad true complement buffer	.79	1489	Quad line driver	.59	74175	Quad D flip flop with clear	.89	74S89	Dual JK positive edge triggered flip flop	2.50
4042	Quad clock D latch	.59	1496	Quad RS232 line receiver	.59	74176	Look ahead carry generator	1.45	74S112	Dual JK flip flop	1.69
4043	Quad tri-state NOR bus latch	.68	1496	Modulator/demodulator	1.35	74177	Presetable counter/latch decade	1.45	74S113	Dual JK negative edge triggered flip flop	1.25
4044	Quad tri-state NAND RA latch	.80	1558	Modulator/demodulator	1.35	74178	4 bit shift register	1.69	74S114	Dual JK negative edge triggered flip flop	1.45
4046	Micropower phase locked loop	.95	1595	Dual op amp	.79	74179	4 bit parallel access shift register	1.75	74S115	Dual JK negative edge triggered flip flop	1.45
4047	Low power monostable/bistable multivibrator	.75	1596	Four quad multiplier	1.98	74181	Arithmetic logic unit	3.55	74S124	Dual VCO	3.95
4049	Inverting hex buffer	.45	1800	Modulator/demodulator	6.25	74182	Look ahead carry generator	1.45	74S132	Quad 1 input Schmitt trigger NAND	2.20
4050	Hex buffer	.45	1889	Analog complex sound generator	5.00	74183	Binary to BCD converter	3.50	74S138	3-8 decoder/multiplexer	1.99
4051	Single 8 channel multiplexer/demultiplexer	.80	26LS29	Quad op amp	0.95	74190	Synchronous up/down decade counter	1.29	74S139	Dual 2-4 decoder/multiplexer	1.05
4052	Dual 4 channel multiplexer/demultiplexer	.80	26LS30	Quad RS423 line driver	3.95	74191	Up/down counter	1.29	74S140	Quad line driver	1.05
4053	Triple 2 channel multiplexer/demultiplexer	.80	26LS31	Quad differential line driver RS422	2.30	74192	Binary up/down counter	1.09	74S151	8 channel dual multiplexer	1.50
4054	4 segment display driver	.99	26LS32	Quad differential line driver RS422	2.45	74194	4 bit bi-directional shift register	1.25	74S153	Dual 4-1 multiplexer	1.50
4055	BCD to 7 segment recorder/LCD driver	1.75	3486	Floppy disk read amplifier	5.99	74195	4 bit parallel access shift register	1.09	74S157	Quad 2 input multiplexer	1.59
4056	BCD to 7 segment recorder/LCD driver	1.75	3487	Quad RS422/423 line receiver	2.25	74196	Presetable decade counter	1.45	74S158	Quad 2 input multiplexer	1.59
4060	14 stage binary counter/oscillator	.83	7647	Quad line driver RS 422	2.35	74197	Presetable binary counter	1.45	74S160	Decade counter with async. clear	4.95
4066	Quad bilateral switch	.52	76478	Quad line driver RS 422	2.35	74198	8 bit shift register	2.19	74S161	Syn. 4 bit counter	4.95
4068	8 input NAND gate	.34	76478	Analog complex sound generator	5.00	74199	8 bit shift register	2.19	74S162	Syn. 4 bit counter	3.69
4069	Hex Inverter	.34	76489	Analog complex sound generator	6.90	74201	Dual monostable multivibrator	1.29	74S163	Syn. 4 bit counter	2.75
4070	Quad 2 input XOR gate	.34	8726	Microprocessor cont. complex sound generator	8.30	74251	Tri-state 8 input multiplexer	3.15	74S168	4 bit up/down counter	1.75
4071	Quad 2 input OR gate	.36	8728	Quad in-state bus transceiver	1.75	74252	8 bit adder latch	3.15	74S169	4 bit up/down counter	1.75
4072	Dual 4 input OR gate	.34	TL070	Quad tri-state bus transceiver	1.50	74276	Octal D type flip flop	2.10	74S174	Hex D flip flop with clear	1.90
4073	Triple 3 input OR gate	.34	TL070	Low noise bifet op amp	.86	74279	Quad shift register/latches	2.10	74S175	Quad shift register with clear	1.80
4075	Triple 3 input OR gate	.34	TL071	Low noise bifet op amp	.78	74283	4 bit binary full adder	4.75	74S182	Look ahead carry generator	3.75
4076	4 bit D register	.90	TL072	Low noise bifet op amp	1.10	74285	Tri-state 4 bit multiplexer	1.65	74S189	16 x 4 RAM	4.50
4078	8 input NOR gate	.34	TL075	Low noise bifet op amp	1.95	74365	Hex bus driver 3 state output	.89	74S195	8 bit parallel access shift register	2.99
4081	Quad 2 input AND gate	.34	TL080	General purpose bifet op amp	.69	74367	Hex bus driver/inverted	.89	74S196	Presetable decade counter	4.95
4083	Dual AND gate	.34	TL081	General purpose bifet op amp	.75	74368	Hex bus drivers inverted data	.89	74S197	Presetable binary counter	4.95
4086	Expandable 4 by 2 AND/OR invert gate	.52	TL082	General purpose bifet op amp	.99	74390	Dual decade counter	2.19	74S201	256 bit RAM	8.95
4093	Quad 2 input NAND Schmitt trigger	.59	TL083	General purpose bifet op amp	2.50	74392	Dual 4 bit binary counter	2.19	74S241	Octal line driver	2.99
4094	8 stage shift register	.99	TL089	General purpose bifet op amp	2.50	74393	Dual 4 bit binary counter	2.19	74S244	Octal line driver	3.75
4097	Diff channel analog mux/demux	1.90	TL474	Switching voltage regulator	2.35	74398	Dual 4 bit binary counter	2.19	74S251	Tri-state data selector multiplexer	2.65
4099	8 bit addressable latch	1.50	ULN2002	7 segment transistor array	1.00	74490	Quad 2 input POS NAND gate	.57	74S260	Dual 5 input NOR gate	1.18
4099	Industrial control unit	2.98	ULN2003	7 segment transistor array	1.00	74500	Quad 2 input POS NAND gate	.57	74S280	8 bit universal shift storage register	6.50
4098	Strobex Hex inverter/buffer	1.25	ULN2003	7 segment transistor array	1.00	74501	Quad 2 input POS NAND gate QIC	.57	74S299	Octal D latch	2.90
4503	Hex tri-state buffer	1.49	XR2004	7 segment transistor array	1.00	74502	Quad 2 input POS NAND gate	.57	74S373	Octal D latch	3.50
4504	Hex level shifter	1.49	XR2005	Monolithic waveform generator	8.10	74503	Quad 2 input POS NAND gate	.57	74S374	Octal D latch	3.50
4506	Dual Expandable A/CI gate	2.50	XR210	FSK modulation/demodulator	4.99	74504	Hex inverter	.57			
4507	Dual 4 bit latch tri-state	1.75	XR215	Phase lock loop	4.99	74505	Hex inverter QIC	.57			
4510	BCD up/down counter	.95	XR215	FSK modulation/demodulator	4.99	74508	Quad 2 input POS AND gate	.57			
4511	BCD to 7 segment latch decoder/driver	.95	XR216	PCM repeater	11.95	74510	Quad 2 input POS AND gate QIC	.57			
4512	8 channel data separator	.89	XR219	Monolithic timing circuit	1.64	74512	Triple 3 input POS AND gate	.57			
4514	1 of 16 decoder/multiplexer	1.85	XR219	Stereo demodulator	1.25	74513	Triple 3 input POS AND gate	.57			
4515	1 of 16 decoder/multiplexer	1.85	XR220	Monolithic function generator	4.95	74514	Triple 3 input POS AND gate	.57			
4516	Binary up/down counter	.95	XR2207	Voltage controlled oscillator	2.79	74515	Triple 3 input POS AND gate QIC	.57			
4518	Dual BCD up counter	.89	XR2208	Operation multiplexer	2.99	74515	Triple 4 input POS AND gate QIC	.57			
4519	4 bit AND/OR select gate	.65	XR2209	Phase-locked loop	3.25	74516	Quad 4 input pos AND gate	.57			
4520	Dual binary up counter	.79	XR221	FSK demodulator/tone decoder	6.99	74516	Quad 4 input pos AND gate	.57			
4521	24 stage frequency divider	1.95	XR2212	Precision phase locked loop	8.99	74517	Dual 4 input POS NOR gate QIC	.57			
4522	BCD divide by N counter	1.25	XR2242	Long range timer	2.25	74518	Triple 3 input POS NOR gate	.57			
4526	4 bit binary divide by N counter	1.10	XR2567	Dual monolithic tone decoder	2.40	74518	Quad 2 input POS NOR gate	.57			
4527	BCD rate multiplier	1.10	XR4739	Dual low noise op amp	5.75	74518	Quad 2 input POS NOR gate	.57			
4528	Dual retriggerable/bistable monostable	1.10	XR14412	FSK modem system	8.75	74533	Quad 2 input POS NOR buffer	.65			
4529	Dual 4 channel mux	1.30				74535	Hex non inverter with QIC output	.58			
4530	Dual 5 input majority logic gate	1.05				74537	Quad 2 input NAND buffer	.67			

7400 Series TTL		7400 <th>Quad 2 input NAND gate</th> <th>.73</th> <th>74ALS00 <th>Quad 2 input POS NAND gate</th> <th>.57</th> <th>74ALS518 <th>8 bit magnitude comparator</th> <th>3.75</th> </th></th>	Quad 2 input NAND gate	.73	74ALS00 <th>Quad 2 input POS NAND gate</th> <th>.57</th> <th>74ALS518 <th>8 bit magnitude comparator</th> <th>3.75</th> </th>	Quad 2 input POS NAND gate	.57	74ALS518 <th>8 bit magnitude comparator</th> <th>3.75</th>	8 bit magnitude comparator	3.75	
7401	Hex inverter	.62 <td>7402</td> <td>Quad 2 input NOR gate</td> <td>.73 <td>74ALS01</td> <td>Quad 2 input POS NAND gate QIC</td> <td>.57 <td>74ALS519</td> <td>8 bit magnitude comparator</td> <td>3.75 </td></td></td>	7402	Quad 2 input NOR gate	.73 <td>74ALS01</td> <td>Quad 2 input POS NAND gate QIC</td> <td>.57 <td>74ALS519</td> <td>8 bit magnitude comparator</td> <td>3.75 </td></td>	74ALS01	Quad 2 input POS NAND gate QIC	.57 <td>74ALS519</td> <td>8 bit magnitude comparator</td> <td>3.75 </td>	74ALS519	8 bit magnitude comparator	3.75
7402	Quad 2 input NOR gate	.62 <td>7403</td> <td>Quad 2 input NAND gate QIC</td> <td>.79 <td>74ALS03</td> <td>Quad 2 input POS NAND gate QIC</td> <td>.57 <td>74ALS522</td> <td>8 bit magnitude comparator</td> <td>3.75 </td></td></td>	7403	Quad 2 input NAND gate QIC	.79 <td>74ALS03</td> <td>Quad 2 input POS NAND gate QIC</td> <td>.57 <td>74ALS522</td> <td>8 bit magnitude comparator</td> <td>3.75 </td></td>	74ALS03	Quad 2 input POS NAND gate QIC	.57 <td>74ALS522</td> <td>8 bit magnitude comparator</td> <td>3.75 </td>	74ALS522	8 bit magnitude comparator	3.75
7403	Quad 2 input NAND gate QIC	.79 <td>7404</td> <td>Hex inverter</td> <td>.62 <td>74ALS04</td> <td>Hex inverter</td> <td>.57 <td>74ALS533</td> <td>Octal D type transparent latches</td> <td>2.45 </td></td></td>	7404	Hex inverter	.62 <td>74ALS04</td> <td>Hex inverter</td> <td>.57 <td>74ALS533</td> <td>Octal D type transparent latches</td> <td>2.45 </td></td>	74ALS04	Hex inverter	.57 <td>74ALS533</td> <td>Octal D type transparent latches</td> <td>2.45 </td>	74ALS533	Octal D type transparent latches	2.45
7404	Hex inverter	.62 <td>7405</td> <td>Hex inverter gate QIC</td> <td>.75 <td>74ALS05</td> <td>Hex inverter QIC</td> <td>.57 <td>74ALS534</td> <td>Octal D type edge triggered FF</td> <td>2.45 </td></td></td>	7405	Hex inverter gate QIC	.75 <td>74ALS05</td> <td>Hex inverter QIC</td> <td>.57 <td>74ALS534</td> <td>Octal D type edge triggered FF</td> <td>2.45 </td></td>	74ALS05	Hex inverter QIC	.57 <td>74ALS534</td> <td>Octal D type edge triggered FF</td> <td>2.45 </td>	74ALS534	Octal D type edge triggered FF	2.45
7405	Hex inverter gate QIC	.75 <td>7406</td> <td>Hex inverter buffer/divider</td> <td>.65 <td>74ALS08</td> <td>Quad 2 input exclusive OR gate</td> <td>.77 <td>74ALS40</td> <td>Octal buffer and line driver</td> <td>2.19 </td></td></td>	7406	Hex inverter buffer/divider	.65 <td>74ALS08</td> <td>Quad 2 input exclusive OR gate</td> <td>.77 <td>74ALS40</td> <td>Octal buffer and line driver</td> <td>2.19 </td></td>	74ALS08	Quad 2 input exclusive OR gate	.77 <td>74ALS40</td> <td>Octal buffer and line driver</td> <td>2.19 </td>	74ALS40	Octal buffer and line driver	2.19
7406	Hex inverter buffer/divider	.65 <td>7407</td> <td>Hex inverter buffer/divider</td> <td>.65 <td>74ALS09</td> <td>Quad 2 input exclusive OR gate with FF</td> <td>.77 <td></td> <td></td> <td></td> </td></td>	7407	Hex inverter buffer/divider	.65 <td>74ALS09</td> <td>Quad 2 input exclusive OR gate with FF</td> <td>.77 <td></td> <td></td> <td></td> </td>	74ALS09	Quad 2 input exclusive OR gate with FF	.77 <td></td> <td></td> <td></td>			
7407	Hex inverter buffer/divider	.65 <td>7408</td> <td>Hex inverter buffer/divider</td> <td>.65 <td>74ALS109</td> <td>Dual JK positive edge triggered FF</td> <td>.77 <td></td> <td></td> <td></td> </td></td>	7408	Hex inverter buffer/divider	.65 <td>74ALS109</td> <td>Dual JK positive edge triggered FF</td> <td>.77 <td></td> <td></td> <td></td> </td>	74ALS109	Dual JK positive edge triggered FF	.77 <td></td> <td></td> <td></td>			
7408	Hex inverter buffer/divider	.65 <td>7409</td> <td>Hex inverter buffer/divider</td> <td>.65 <td>74ALS112</td> <td>Dual JK NEG edge triggered flip flop</td> <td>.77 <td></td> <td></td> <td></td> </td></td>	7409	Hex inverter buffer/divider	.65 <td>74ALS112</td> <td>Dual JK NEG edge triggered flip flop</td> <td>.77 <td></td> <td></td> <td></td> </td>	74ALS112	Dual JK NEG edge triggered flip flop	.77 <td></td> <td></td> <td></td>			
7409	Hex inverter buffer/divider	.65 <td>7410</td> <td>Quad 2 input AND gate</td> <td>.73 <td>74ALS113</td> <td>Dual JK NEG edge triggered flip flop with preset</td> <td>.77 <td></td> <td></td> <td></td> </td></td>	7410	Quad 2 input AND gate	.73 <td>74ALS113</td> <td>Dual JK NEG edge triggered flip flop with preset</td> <td>.77 <td></td> <td></td> <td></td> </td>	74ALS113	Dual JK NEG edge triggered flip flop with preset	.77 <td></td> <td></td> <td></td>			
7410											

Designers Dreambox



Features:

- Fully enclosed power supply
- On/off switch with indicator light
- Voltage plus 5V at 5A, plus 12V at 2A, minus 12V at 0.5A and 0 to 12V at 2A.
- With Prototyping Breadboard mounted right on the power supply box.

All this for only \$149.00

Other combination of set voltages and variable voltages available to order at slightly higher cost.

IBM Style Case



- Flip-Top, 8 Slot **\$ 75.00**
 With 150W Power Supply **\$219.00**

IBM Compatible Keyboards

- Maxiswitch **\$135.00**
 Keytronics 5150 **\$135.00**
 Keytronics 5151 (Enhanced) **\$249.00**

KEPCO POWER SUPPLIES

Rated 90W Max
 RFI filter and fuse on board
 115/230V

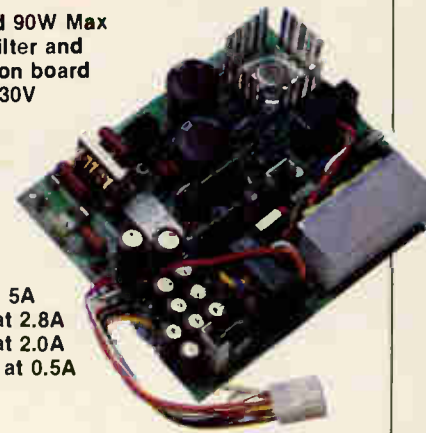

- 5V at 5A
 12V at 2.8A
 12V at 2.0A
 -12V at 0.5A

Open Frame \$ 49.00

MISCELLANEOUS PARTS

DB Connector Series

DB9P Solder Tail Male	\$1.75
DB9S Solder Tail Female	\$1.99
DP9P Right Angle PCB Mount Male	\$2.49
DP9S Right Angle PCB Mount Female	\$2.49
DB9P Flat Ribbon IDC Crimp Type Male	\$5.75
DB9S Flat Ribbon IDC Crimp Type Female	\$6.25
DB9 Shell (Economy Type)	\$0.75
DB9 Shell, High Quality	\$1.95
DB15 Solder Tail Male	\$1.95
DB15S Solder Tail Female	\$1.95
DP15P Right Angle PCB Mount Male	\$2.95
DP15S Right Angle PCB Mount Female	\$2.95
DB15P Flat Ribbon IDC Crimp Type Male	\$8.50
DB15S Flat Ribbon IDC Crimp Type Female	\$9.00
DB15 Shell (Economy Type)	\$1.99
DB15 Shell, High Quality	\$1.99
DB25 Solder Tail Male	\$1.95
DB25S Solder Tail Female	\$1.95
DP25P Right Angle PCB Mount Male	\$4.95
DP25S Right Angle PCB Mount Female	\$4.95

DB25P Flat Ribbon IDC Crimp Type Male	\$8.99
DB25S Flat Ribbon IDC Crimp Type Female	\$9.99
DB25 Flat Ribbon IDC Crimp, Economy M or F	\$5.95
DB25 Shell (Economy Type)	\$0.95
DB25 Shell, High Quality (Economy Type)	\$1.99
DB37 Solder Tail Male	\$4.25
DB37S Solder Tail Female	\$4.25
DP37P Right Angle PCB Mount Male	\$7.75
DP37S Right Angle PCB Mount Female	\$8.95
DB37P Flat Ribbon IDC Crimp Type Male	\$14.00
DB37S Flat Ribbon IDC Crimp Type Female	\$14.95
DB37 Shell, High Quality	\$2.95

Female Screen Lock Assemblies for DB Connectors \$2.49/Set

TRANSISTORS

DEVICE														
2N697	\$.50	2N391A	\$.45	2N3773	\$ 2.99	2N4339	\$.45	2N5771	\$.75	MPSA20	\$.30	TIP49	\$ 1.20	
2N2219A	\$.80	2N3394	\$.80	2N3819	\$.85	2N4400	\$.25	2N5772	\$.37	MPSA55	\$.48	TIP115	\$.99	
2N2221A	\$.40	2N3415	\$.28	2N3820	\$.85	2N4401	\$.25	2N6028	\$.45	MPSU51	\$.78	TIP122	\$ 1.60	
2N2222A	\$.50	2N3440	\$ 1.10	2N3904	\$.19	2N4402	\$.25	MJ802	\$ 4.50	MPSU56	\$.99	TIP125	\$ 1.00	
2N2270	\$.50	2N3442	\$ 2.25	2N3905	\$.25	2N4403	\$.25	MJ2955	\$ 1.83	PN2222A	\$.39	TIP142	\$ 2.95	
2N2369A	\$.50	2N3566	\$.78	2N3906	\$.28	2N4416	\$ 1.40	MJ4502	\$ 5.50	TIP29C	\$.70	TIP146	\$ 2.98	
2N2646	\$ 1.42	2N3568	\$.78	2N4052	\$.86	2N4453	\$ 4.22	MJE340	\$ 2.50	TIP30C	\$.70	TIP2955	\$ 1.85	
2N2906	\$.40	2N3638A	\$.78	2N4112	\$.28	2N4856	\$ 1.39	MJE802	\$ 4.95	TIP31C	\$.70	TIP3055	\$ 1.50	
2N2907A	\$.52	2N3642	\$.78	2N4123	\$.20	2N4891	\$.85	MPF102	\$.65	TIP32C	\$ 1.10			
2N3053	\$.70	2N3643	\$.78	2N4124	\$.50	2N5245	\$.75	MPS5515	\$.42	TIP33C	\$ 1.60			
2N3055	\$ 1.89	2N3645	\$.78	2N4208	\$.67	2N5400	\$.27	MPSA05	\$.35	TIP34C	\$ 1.85			
2N3117	\$ 1.50	2N3703	\$.28	2N4222	\$ 1.98	2N5457	\$.57	MPSA13	\$.35	TIP35C	\$ 3.10			
2N3227	\$ 4.18	2N3704	\$.31	2N4248	\$.85	2N5485	\$.57	MPSA14	\$.35	TIP41C	\$ 1.15			
2N3250	\$.70	2N3705	\$.29	2N4250	\$.78	2N5770	\$.49	MPSA18	\$.35	TIP42C	\$ 1.90			

Delta Ribbon Connectors

Quantity Discounts Available

36 Contacts Plug (IDC) Flat Ribbon Crimp Type Male	\$8.95
36 Contacts Socket (IDC) Flat Ribbon Crimp Type Female	\$9.95
36 Contacts Chassis Mount Female	\$6.95
36 Contacts Solder Cable Male	\$8.85
36 Metal Shell (for solder male)	\$2.95

Flat Cable Card Edge Connectors (Disk Drive Connectors)

50 Pin Edge Connector (8" Drive)	\$5.95
40 Pin Edge Connector	\$4.95
34 Pin Edge Connector (5 1/4")	\$5.85
20 Pin Edge Connector (Hard Drive)	\$4.79

Capacitors

.1uF 50V Bypass Monolithic 10¢
 100 of the above **\$8.95**

TANTALUM CAPACITORS

0.1uF 35V	\$.26	68uF 25V	\$.45
0.15uF 35V	\$.26	68uF 35V	\$.58
0.22uF 35V	\$.26	10uF 25V	\$.58
0.33uF 35V	\$.26	10uF 35V	\$.81
0.47uF 35V	\$.28	15uF 25V	\$.95
0.68uF 35V	\$.28	15uF 35V	\$ 1.79
1.0uF 35V	\$.27	22uF 25V	\$ 1.30
1.5uF 35V	\$.27	22uF 35V	\$ 2.25
2.2uF 25V	\$.25	33uF 25V	\$ 1.95
2.2uF 35V	\$.30	33uF 35V	\$ 2.49
3.3uF 25V	\$.35	47uF 10V	\$ 1.25
3.3uF 35V	\$.40	47uF 25V	\$ 2.70
4.7uF 25V	\$.40	47uF 35V	\$ 3.99
4.7uF 35V	\$.50	68uF 10V	\$ 1.90
6.8uF 16V	\$.40	68uF 25V	\$ 2.70

Other Values Available on Request.

Ceramic

Ceramic Disc. Large Selection of Values
All 10 Cents each.

Note, when ordering these, specify what voltage you require. Mosts are available in 50V and 100V.

Good In-Store Stock of Electrolytic Capacitors
Special Quantity Discounts Available.

Card Edge PC Mount Connectors

50 Pin Connector (used on Apple Comps)	\$2.45
62 Pin Connector (used on IBM Comps)	\$2.45
62 Pin High Quality Economy	\$1.85
S-100 Connector (S-100, Z-80 Systems)	\$4.95

DIP Switches

4-position	\$1.30
6-position	\$1.55
8-position	\$1.75
10-position	\$1.85

Two Row Right Angle Header Strips (Male)

40 Pin 20x2	\$3.45
34 Pin 17x2	\$2.80
26 Pin 13x2	\$2.45
20 Pin 10x2	\$1.95
16 Pin 8x2	\$1.40
10 Pin 5x2	\$0.95

Two Row Straight Header Strips (Male)

50 Pin 25x2	\$3.90
40 Pin 20 Pin 10x2	\$1.95
16 Pin 8x2	\$1.40
10 Pin 5x2	\$0.95

Female Header Strips (Flat Ribbon Crimp Type Socket Connector)

50 Pin Female Header 25x2	\$4.99
40 Pin Female Header 20x2	\$4.35
34 Pin Female Header 17x2	\$3.20
26 Pin Female Header 13x2	\$2.95
20 Pin Female Header 10x2	\$1.89
16 Pin Female Header 8x2	\$1.95

Two Position Female Jumpers (Shunts) 20 cents each

Heat Sinks

TO220	\$0.39
TO3	\$2.99

LEDs

Large LEDs	
T-1 3/4 (Normal Size)	\$ 0.25
Red (General purpose)	\$ 0.25
Green (General purpose)	\$ 0.39
Yellow (General Purpose)	\$ 0.39
Red (Extra Bright)	\$ 0.59
Green (Extra Bright)	\$ 0.85
Yellow (Extra Bright)	\$ 0.85

Small LEDs (T-3/4)

Red	\$ 0.30
Green	\$ 0.35
Yellow	\$ 0.35

Rectangular LEDs 75 cents each

Bar Graph Display

8-Segment (Red, Green or Yellow)	\$4.95
35 LED Matrix 2' or 3' (Great for Digital Signs)	\$9.95

Rectifier Diodes

1N4001 50V 1A	\$.07
1N4004 400V 1A	\$.09
1N4007 1000V 1A	\$.11
1N5403 300V 3A	\$.40
1N5404 400V 3A	\$.40
1N5406 600V 3A	\$.60

Switching and Signal Diodes

1N34A	\$.19
1N91A	\$.5
1N4448	\$.5

Zener Diodes

1 Watt. All Values 25 cents each.

Voltages Available
 3.9, 4.3, 4.7, 5.1, 5.6, 6.2, 7.5, 8.2, 9.1, 10, 12, 13, 15, 16, 18, 20, 22, 24, 27, 30, 33, 36

Switches

Momentary push-button switches	\$0.99
Momentary push-button switches SPDT	\$3.95
On-Off Switch, SPDT	\$3.95

Parts for your Modem

Small Speakers	\$1.84
600 ohm to 600 ohm (1.1) Isolation transformers	\$9.95
Relay for your modem (HE721A0500) 5V	\$4.99
DAA 1812 for Modem (Contains Built-in Transformer, relay and surge protector)	\$39.00

SCR'S

2N5064	\$.75	MCT2	\$1.25
2N6337	\$.55	MCT6	\$1.99
TIC106D	\$1.25	4N25	\$1.10
TIC116D	\$1.99	4N35	\$1.20
TIC126D	\$1.99	4N30	\$1.39
		4N33	\$.88
		MOC3011	\$1.75
		MOC3031	\$2.25
		MOC30C2	\$2.99
		FND500	\$2.99
		FND507	\$2.99
		TIL313	\$1.95
		TIL312	\$1.95
		RBG-1000	\$5.99

TRIACS

TIC206D	\$1.55
TIC216D	\$1.99
TIC226D	\$1.87
TIC263D	\$4.25

Voltage Regulators

7805 5V 1A	\$ 99	78LGASC Adjust 5A	\$14.7
78L06 6V 1A	\$ 75	78S40 Switching regulator	\$ 3.84
78H05 5V 5A	\$ 9.44		
78P05 5V 10A	\$ 14.97	NEGATIVE:	
7906 6V 1A	\$ 99	7906 5V 1A	\$ 99
78L06 6V 1A	\$ 75	79L055V 1A	\$ 75
7812 12V 1A	\$ 99	7906 6V 1A	\$ 85
78L12 12V 1A	\$ 75	7912 12V 1A	\$ 85
78H12 12V 5A	\$ 10.95	79L12 12V 1A	\$ 99
7815 15V 1A	\$ 99	7915 15V 1A	\$ 99
7824 24V 1A	\$ 99	79LUC Adjust 1A	\$ 1.65
78LUC Adjust 1A	\$ 1.80	79HGASC Adjust 5A	\$ 17.99

CRYSTALS

32.768KHZ	\$1.15	10.24MHZ	\$2.99
1.00MHZ	\$6.95	12.00MHZ	\$2.25
1.8432MHZ	\$3.99	14.00MHZ	\$2.99
2.00MHZ	\$2.50	14.318MHZ	\$2.19
2.457MHZ	\$3.75	16.00MHZ	\$1.99
3.57MHZ	\$1.55	16.00MHZ	\$2.29
4.00MHZ	\$1.99	18.432MHZ	\$1.99
5.00MHZ	\$1.95	20.00MHZ	\$2.15
5.017MHZ	\$3.50	17.43MHZ	\$2.99
5.068MHZ	\$1.95	22.118MHZ	\$2.99
8.00MHZ	\$1.95	48.00MHZ	\$3.99
10.00MHZ	\$1.95		

Wire Wrap Wire. All Colours (30 gauge)

25 ft.	\$2.80
50 ft.	\$5.00
100 ft.	\$8.95
Wire Wrap Run/Wrap Tool/Strip Tool	\$18.25
Wire Wrap Gun and Bit	\$83.00

IC Extractor	\$3.99
IC Insertion Tool	\$18.95
High Quality 24-40 Pin Extractor	\$23.50

5IP Resistor Networks

Part #	Pins	Common	Pln #	
6-1-XXX	6	1	0.39	
8-1-XXX	8	1	0.44	XXX = Value
10-1-XXX	10	1	0.59	

Trim Pots

P.C. MOUNT MULTITURN TRIMPOTS

RESISTANCE	10K	50K	100K	200K
10	\$.65	\$.75	\$.85	\$ 1.05
20	\$ 1.15	\$ 1.35	\$ 1.55	\$ 1.85
50	\$ 2.15	\$ 2.45	\$ 2.85	\$ 3.25
100	\$ 3.15	\$ 3.55	\$ 4.15	\$ 4.75
200	\$ 4.15	\$ 4.65	\$ 5.35	\$ 6.05

\$1.65 ea.

TRIMPOTS

RESISTANCE	10K	50K	100K	250K	500K	1M
100	\$.85	\$.95	\$ 1.15	\$ 1.35	\$ 1.65	\$ 1.95
250	\$ 1.35	\$ 1.55	\$ 1.85	\$ 2.15	\$ 2.55	\$ 2.95
500	\$ 2.35	\$ 2.65	\$ 3.15	\$ 3.65	\$ 4.15	\$ 4.75
1000	\$ 3.35	\$ 3.85	\$ 4.45	\$ 5.05	\$ 5.75	\$ 6.45

OPEN CASE 35¢ ENCLOSED CASE 85¢

Resistors

We carry a full range of 1/4 Watt, 5% resistors...5 cents each.

Multiflex Products

Multiflex Economy Video Display Terminal

Now available from MULTIFLEX is an economy video display terminal. Originally designed as a low cost access unit for our mail-ordering and bulletin board system, this terminal is a semi-intelligent system which is controlled by a Z80A microprocessor and a 6845 CRT controller chip. The keyboard is fully ASCII encoded and the character generator contains the full 128-character set as well as a 128-character alternate set both of which are in the 5x7 dot matrix format. The screen display is 80 characters by 24 lines if the unit is hooked to an external monitor. (Monitor not included). There are 3 software selectable attributes (dim, reverse video, and alternate character set) which can be chosen one at a time for the whole screen. The attribute can then be switched on and off for each individual character. A 2K buffer is provided for normal operation. However when the optional 6K memory upgrade is purchased, 4 screen pages can be loaded from the host machine, edited, locally, and then downloaded back to the host again saving on connect time and phone line bills. Also included are 2 RS232 ports: one for a modem and one so that a printer can be attached to the terminal. The baud rates on these ports are software programmable and can range from 110 to 9600 baud. With all these features, you would expect to pay a lot for this system, but all this is available to you, complete with an attractive case, for an extremely low price.

A&T board with keyboard (as picture top right) with one RS232 and 2K buffer \$169.00



Terminal Complete: Tested and 90 days warranty with 2 RS232 ports, 2K buffer case and power supply (Hydro approved)

\$299.00

Special Pricing is available when both items on this page are purchased together

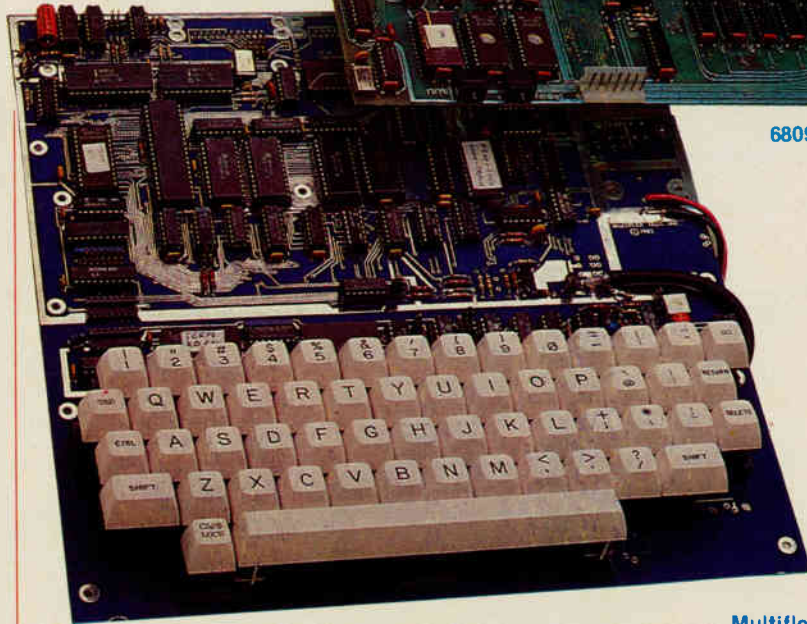

6809 Board

Multiflex Terminal

U of T 6809 Single Board Computer

The 6809 Single Board Computer, designed at the University of Toronto and distributed exclusively by EXCELTRONIX, is a compact hardware unit which was designed originally as a lab board for teaching students about microprocessor systems. Its many features, however, make it an ideal unit for stand-alone control applications or software development systems as well.

The system is designed around the Motorola MC6809 microprocessor. This is an 8-bit processor with full 16-bit internal architecture, 2 index registers, 2 stack pointers, 2 8-bit or 1 16-bit accumulators, a direct page register and a wide range of addressing modes, including a program-counter-relative mode. This mode allows the user to write completely position independent software, important in systems software development.

There is provision for up to 48K bytes of dynamic RAM on-board. The refreshing of this RAM is controlled by an 8202 Dynamic RAM Controller. This chip allows for completely transparent refreshing of the RAM (ie. no wait states to slow the system down). There is also provision for up to 12K of EPROM using 2532 chips.

There are 4 complete I/O circuits built onto the board. 2 of them are serial (RS232); one is used for a terminal (which is required for use of the board with the supplied monitor software), and the other one is user defineable, but it is set up to

communicate with either a modem or a printer. Also on-board are 2 6522 VIA chips. These provide 2 parallel ports per chip along with 2 16-bit timer/counters. One of the parallel ports and one of the timers are used by the monitor software to provide a cassette interface (which operates at 300 baud). The second parallel port on that chip is wired into a connector which is ideal for interfacing a parallel printer or keyboard. The 2nd VIA is not used at all and is completely free for the user. For further expansion of the system, a fully buffered version of the CPU signals (data, address, control lines and a signal indicating whether or not the current address is located on the board) is available at a cable connector.

The software provided with the system is in a 2532 EPROM and allows the user to: test the memory; dump blocks of memory; examine and modify single memory locations; read or write from the cassette port; set and examine breakpoints; single step and/or execute machine language programs and set and examine the processor registers. All this is accomplished through a 9600-baud terminal interface (one of the serial ports) Included is a full screen editor/assembler which allows the user to work in 6809 assembly language rather than machine language. All this makes this board an ideal trainer, control unit or software development unit for just about anyone.

Includes U of T course documentation

A&T with 48K \$299

Europe's best selling oscilloscopes, made in West Germany

HAMEG



OSCILLOSCOPE HM 203-5

20 MHz Standard Oscilloscope

Y: 2 channels, DC-20 MHz, max. sensitivity 2mV/cm;
X: 0.2s/cm-20ns/cm incl. x 10 magnification;
triggering up to 40 MHz; Component Tester

\$770.00

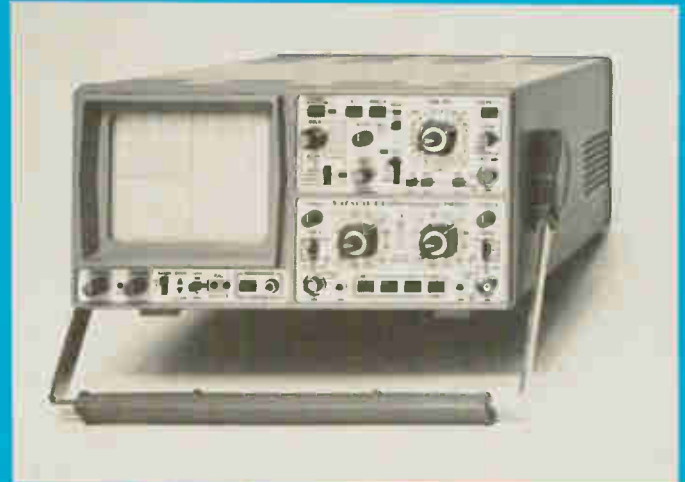

OSCILLOSCOPE HM 204-2

20 MHz Multifunction Oscilloscope

Y: 2 channels, DC-20 MHz, max. 1mV/cm, delay line;
X: 1.25s/cm-10 ns/cm incl. x 10 magnification, delayed sweep;
triggering up to 50 MHz; var. hold-off time; Component Tester.

\$1055.00



OSCILLOSCOPE HM208

20 MHz Digital Storage Oscilloscope

Y: 2 channels, DC-20 MHz, max. sensitivity 1mV/cm;
X: 0.25 s/cm-20ns/cm incl. x 10 magnification, trig. to 40 MHz.
Storage: max. clock rate 20 MHz; Single and X-Y operation.

\$3166.00

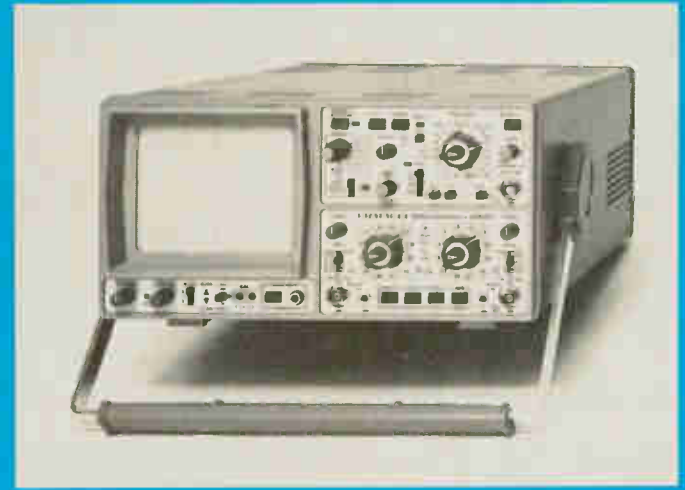

OSCILLOSCOPE HM 605

60 MHz Multifunction Oscilloscope

Y: 2 channels, DC-60 MHz, max. 1mV/cm, delay line;
X: 2.5s/cm-5ns/cm incl. x 10 magnification, delayed sweep;
triggering up to 80 MHz; var. hold-off time; Component Tester.

\$1405.00

HAMEG GmbH

West Germany is represented,
distributed and serviced in Canada by:



990 Alness St. Unit 7,
Downsview, Ontario,
M3J 2S2
(416) 861-5585
TELEX 065-28169

Now Available from Stock
for the complete line of HAMEG instruments write or phone

Exceltronix

319 College Street, Toronto, Ont. M5T 1S2
(416) 921-8941 1-800-268-3798

Multiflex Low-Cost Logic State Analyzer

Ideal for educational institutions and hobbyists.

You've just completed a microprocessor system, and it doesn't work. What next? You can use an oscilloscope to check for clock signals and the like, but if everything appears to be in order you can't go much further without sophisticated equipment. In these situations, professionals turn to their logic state analyzers, each of which cost thousands of dollars. MULTIFLEX has the answer for all those people who don't want to take a mortgage on their house just to get a computer working. The MULTIFLEX Logic State Analyzer has all the essential features of those more expensive units at a fraction of the cost. This is a high-quality piece of test equipment, suitable for industrial or scientific use, but its price is well within the price range of a hobbyist.

Easy to understand and operate, the Logic State Analyzer allows you to monitor 16 points in a digital system (i.e. data and/or address bus, or control lines) which carry continually changing signals. You can select a bit pattern you expect will appear at these points. Once the pattern appears the Analyzer will trigger and record ("freeze") the next 1023 bit patterns so that they can be examined step by step even though data is no longer available in the unit being examined. For software development the Analyzer is invaluable, especially in dedicated systems. If you design a microprocessor system for a specific function, and you have no monitor, assembler or other such software, the best and often only way to debug the system is to use a logic analyzer. It will let you look closely at the data flow as a program is executing, or monitor the address lines to make sure that the instructions are being executed in the proper sequence. The various control lines such as memory read and write, DMA, interrupts, or enable and disable signals can also be examined. You can, of course, monitor any combination of these signals, such as the data bus and half of the address bus, or half of each plus 4 control lines. The combinations are endless.

**Complete, assembled
and tested
\$369**

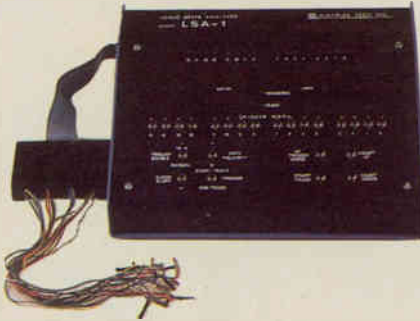

Note from Industry to Educational Institutions:

At Multiflex we interview many technicians each year, from a variety of Colleges. Only a few applicants know what a Logic State analyzer is and even fewer know how to use one.

Yet in our industry, it is almost as important to know how to operate logic analyzers as it is to use an oscilloscope since the technician will need to use a logic or timing analyzer to trouble-shoot complex equipment.

We have spoken to many other companies and found that they are experiencing the same problems with technicians coming fresh from College. So, we asked educational institutions why they don't teach this aspect of electronic engineering. The teachers are fully aware of the problem but explained that they cannot afford the high cost of logic analyzers; even those institutions which have them can afford only one or two which gives the students little chance to learn them.

Our LSA is a time-proven product which is considerably less expensive than the alternatives.

Here is your chance to prepare technicians for the real world!

EPROM Emulator

If you are a computer designer who values your time, you can't afford to be without this!

Did you ever write a piece of code, burn it into an EPROM, plugged it in and it didn't work?

Did you then go through the code (using an analyzer or your brain power) and then discover you left out some crucial Byte which caused the processor go the point of no return?

If the above holds true, how many EPROMs have you reprogrammed, erased and damaged? More important how many hours have you wasted?

Put an end to all the above problems and save time, money and frustration: Buy an EPROM Emulator.

It allows you to download over RS232 (at 300 to 9600 Baud) a program from your computer into the Emulator's memory (16Kx8) and then simply plug a 24 or 28 Pin header connected via ribbon cable to the Emulator in place of your EPROM and you have successfully emulated an EPROM.

If you need to change your code, simply change it on your computer, download to the Emulator's memory and you are back in business in seconds.

This stand-alone product emulates the following EPROMs: 2716, 2732, 2764 and 27128. Can be used with any computer with an RS232 interface.

This product is a must for any hardware development since it allows the user to test and modify EPROM data roughly 20 times faster than conventional methods.

The Emulator normally comes attractively packaged and contains its own power supply. However, to make it more affordable for beginners, we have separated the price into several categories:

1. Complete Emulator with 16Kx8 memory, attractively packaged with power supply. Fully assembled and tested with warranty. **\$189.00**
2. As above but with 8Kx8 of memory **\$159.00**
3. Emulator with 4K RAM, no housing or power supply (requires +5V at 1.5A Max, +/- 12V at 0.03A. Fully assembled and tested. **\$99.00**



S100 Starter System

Complete, Assembled and Tested

\$299

**Options:
64K Dynamic RAM and Multiplexers**

..... **\$19.95**

Big Piggyback Board with RS232 and Real Time Clock

\$179

RS232 Option for Motherboard

\$38.00

DC to DC Converter Option ..

\$29

Extra S100 Connectors ...

\$5.95

S100 Video Board

\$149

S100 Floppy Disk Controller **\$199**

S100 256K RAM Card (with 256K)

\$250

S100 CPU Board with 64K ..

\$149

MULTIFLEX's Z80 computer is a versatile and expandable stand-alone computer system designed and built right here in Canada. It uses the newest technology to provide the user with the most capabilities for the smallest price-tag. Its adaptability to any situation and extremely low cost allow it to be used in many applications ranging from a trainer to a complete CP/M-based computer comparable to the best on the market, at a fraction of the price.

The actual layout of the system is a two board design. One board (the "motherboard") contains a 24-line parallel I/O chip for interfacing to the external world, an RS232C serial port with baud rates selectable from 110 to 9600 baud, a hex address and data display, a

hex keypad, 14 monitor function keys, 2 user definable keys, a 40-chip wire wrap area with full access to all the bus signals, on-board provision for regulators so that the board can be supplied with standard S-100 voltages, an EPROM programmer which will handle 2708 (1Kx8), 2716 (2Kx8), 2732 (4Kx8) 2532 (4Kx8), 2764 (8Kx8) and the brand new 27128 (16Kx8) EPROMs, a DC-to-DC converter to supply the programming voltage to the EPROM programmer and four (4) slots for IEEE S-100 compatible boards for further expansion. This is an extremely useful and important feature as it allows expansion of the system with all boards using this industry-standard bus structure, which are available from MULTIFLEX, as well as from hundreds of manufacturers worldwide.

The other board is the CPU card. This card plugs into one of the S-100 slots on the motherboard and is IEEE 696/S-100 compatible with the full 24-bit address path to allow up to 16 megabytes of memory to be addressed. The processor used is the Z80 (running up to 6 MHz) and there is provision on-board for 64K of dynamic memory (using 4164 chips) which will operate without wait states. Provided for as well is a 2K to 32K (selectable in 2K blocks) common resident area in memory for use with multiple memory banks. There are also 4 sockets on board which will handle 2732 (4Kx8) or 2764 (8Kx8) EPROMs or the new 6116/2016 (2Kx8) static RAMs (all of which can be software deselected if desired) to allow the user complete versatility in setting up the board to meet his own specifications. Also on board is 1 parallel port with 24 lines of I/O and 3 16-bit counter/timers for applications which require the unit to keep track of real time. Another feature of the CPU board is that it was designed by our engineers to run the CP/M 2.2 disk operating system so that if a floppy disk controller board is added to the system a fully configured CP/M machine can be set up for a very low cost.

The monitor software that comes with the kit is a well-written extensive package which allows the user to have complete versatility in machine language programming and execution as well as control of all the features on the board. The monitor functions include: examine/modify memory locations, memory block moves, compare 2 blocks of memory, examine CPU register, ex-

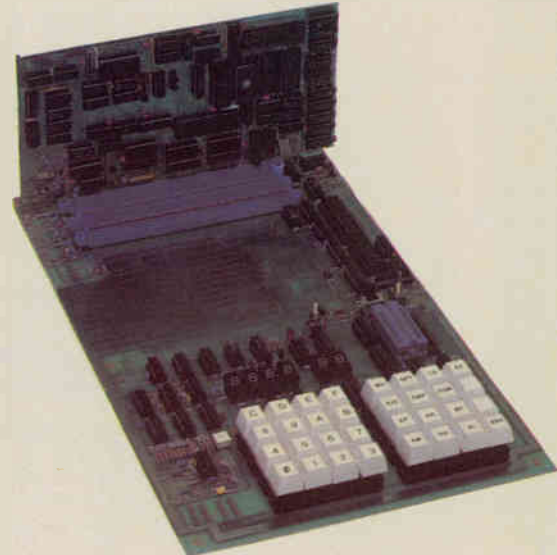

amine I/O ports, load and save from cassette calculate relative branch offsets, set breakpoints single step programs, execute programs, and program EPROMs. Each of these process is invoked by a single keypress. Also available to the use are 2 spare keys definable for special functions as required by specific applications and applicator programs.

The standard kit includes the CPU board with a Z80A (4HM2) processor, 2K of RAM (a 6116), and 4K of EMPROM (a 2732) as well as the motherboard with all the features mentioned above except the RS232C port and the DC-to-DC converter. Also supplied are sockets for all IC's and 1 S-100 connector.

Versadigital Signs

Every business needs attention. In today's competitive marketplace you need to get the customers' attention and you need to get your message across - as boldly and as dynamically as possible.

Two versions are available, single and double row. Each row holds up to 21 standard characters and can be expanded to up to 42 characters. The LED (Light Emitting Diode) display is available in red (standard or extra bright), green and yellow. Standard, wide (2", upper and lower case) and bold tall (4", upper case) come with the display. All can be displayed normally or in inverse (black characters on a lit background) image format. You can even program your own characters and graphic symbols. As well as the standard LED display, larger, brighter incandescent light bulb displays can be built to your specifications. All programming features are retained, and the standard LED display is included for ease of programming.

A wide variety of features allow you to catch the public's attention - choose from Wipe-On and Wipe-Off, Spell-On, Flash and Blink, Shift left and right, Scroll up and Down - in any order and at individually selectable speeds.

Up to six different events can be displayed simultaneously within dynamically selectable boundaries. Up to 128 labelled messages can be stored within the units memory for display at any preselected time and date and in any order. 12,288 character memory is standard on the Versadigital Display. This can be expanded to 36,864 with optional external read only memory modules.

Text can be entered through the Display's own keyboard, from an ordinary cassette recorder, from optional external memory modules, or optionally over telephone lines, radio or infra-red link or over AC wiring. A comprehensive set of commands allow complete control over the display's facilities. A powerful word processor type editor lets you easily write, edit, run, save (on cassette) and transmit messages.

The Sign That Can Sell Your Product

Research has shown that digital displays can increase sales by up to 30%. The Versadigital Display virtually assures that figure by increasing the readers' involvement. An optional inter-



Versadigital signs are in use throughout the Toronto subway system and Vancouver LRT. Send for reprint of article in Computing Now!, July 1984.

The sign that also talks

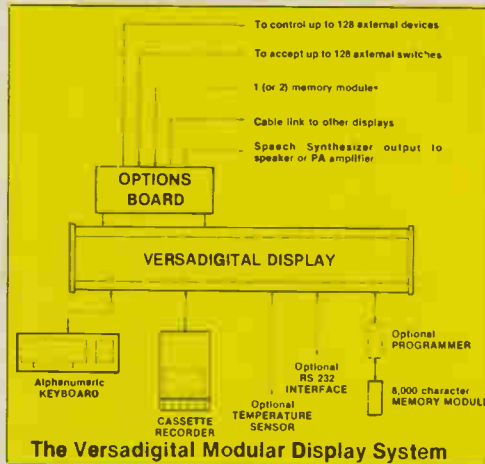

The Versadigital Modular Display System

face allows up to 128 switches to be connected to the Display, enabling customers to select specific messages without having to wait for the sign to cycle through its repertoire.

The optional External Accessory Interface allows you to write messages that actually point to the product being discussed. At selected points within your message you can program the Display to turn on an external light or a bell. Thus your message might be saying "You won't find these shoes anywhere else ..." and the Display will then activate a lamp highlighting the product. Up to 128 external devices can be controlled in this fashion. This feature alone makes the Versadigital Display the most effective sales tool you can have.

Versadigital Technology in conjunction with Multiflex Inc. also manufactures Time and Temperature displays and can build dynamic plaza maps to your specifications. Our extensive engineering experience enables us to design to a wide variety of situations. Whether it is modifying a current product, or designing new equipment, tell us what you need, we can deliver!

All prices in this catalogue are subject to change without notice.

Distributed by Exceltronix Inc.
319 College Street, Toronto, Ont., M5T 1S2
(416) 921-8941

Digital Modem



DO YOU HAVE A PROBLEM? Lack of wires for two-way communications? Do you have a single coax cable between four floors of a building?

If the above holds true for you, as it may well do, if you wish to put equipment in some older Government buildings which were wired years ago, using a single coax to communicate between main frames and which may now be obsolete, you need our solution. If you want to communicate using RS232 between your computers and all you have is a single coax between rooms or floors or buildings, now you can do it without rewiring using our economical solution.

About a year ago we were approached by a Government agency asking if we could solve the problem described above. Well, we solved their problem economically, in fact it worked so well that they bought hundreds of units from us.

The Digital Modem consists of two boxes (approx. 6" x 4") and two wall adaptors. Now you can simply have the RS232 of your computer terminal or other devices plugged directly into one of our Digital Modem boxes (which has a wall plug adaptor to get its power) and you can run up to 800 feet over a single wire to another of our Digital Modem boxes (which again has its own CSA approved power supply) and you again plug in the RS232 DB25 connector to your equipment. Now you can communicate at 9600 Baud or faster (or slower) simultaneously in both directions using your existing single coax cable wiring.

Digital Modem Pair \$350.00

(Two Boxes and two adaptors)
Quantity Discounts.
It works perfectly!

All prices and specifications in this catalogue are subject to change without notice. Please follow our ads monthly in Electronics Today and Computing Now!. Whatever market conditions exist, you will find our prices the most competitive in Canada.

If there was ever a fastener made to bedevil and frustrate the repairer, it's the snap ring or circlip. Those are those pesky little C-shaped rings with tiny holes in the ends, generally used to secure something by clamping into a groove in a shaft. You can dig and dig at them with needlenose pliers and what-have-you and they just spin and turn without coming off. It's worth the money to have the special pliers to remove them: the Hunter Model 444 has interchangeable tips that can take off any type of ring, internal or external, even at awkward angles. Also available: less expensive models for internal or external only.

Buy a burnisher! These are very thin strips of metal with fine diamond dust coated on them, and they'll clean corroded contacts of any kind without damaging the plating or the contact angle. Relays will last a lot longer if you use a burnisher instead of sandpaper, and they're better for cleaning sparkplugs than wadding up the abrasive strip off a matchbook. They're also hard to find: try asking an electronics retailer for the Lenline D-300 (medium) or D-400 (fine) or something similar.

Screwdrivers, etc.

There isn't much you can say about screwdrivers, except this: all types and models of screws should be instantly banned by government decree in favour of that wonderful Canadian invention, the Robertson square-headed screw. There's nothing like it.

You might want to invest in a low-cost set of jeweller's screwdrivers. They remove the tiniest of slot-head screws much better than your pocket knife. The cheaper ones won't take much torque without distorting, but you probably won't use them that much.

A set of Allen keys (also called hex head wrenches) is invaluable, not only for electronic assemblies, but for all sorts of machinery. You can get them as separate keys, as screwdrivers, and even as a single wrench with points that swing out like a sparkplug gap gauge. Definitely worth it, and if you encounter Allan screws much, you'll benefit from a set of screwdriver-types rather than the separate keys.

Nutdrivers (for ordinary nuts and bolts) are another worthwhile tool. Try tightening a transformer mounting bolt that's right next to the core, or try tightening a tiny 4-40 nut with a regular wrench. If you get three sizes to fit 4-40, 6-32 and 8-32 nuts, you're well covered for general uses.

Chemicals

Not exactly a tool, but indispensable for certain jobs. The most useful of the aerosols would be contact cleaner. It's marketed under names like Workman "Wishh", Tech Spray EZ Kleen, or

Chemtronics Contact Restorer. All good stuff, though all of them spell funny. Contact spray can restore dodgy switches, quiet noisy volume controls and get silicone heatsink gunk off your fingers.

Second most used would probably be freezing spray. For some unfathomable reason, complex digital ICs which have died or gone erratic can be made to work for a short time by cooling them down a whole lot. Perhaps it physically shrinks

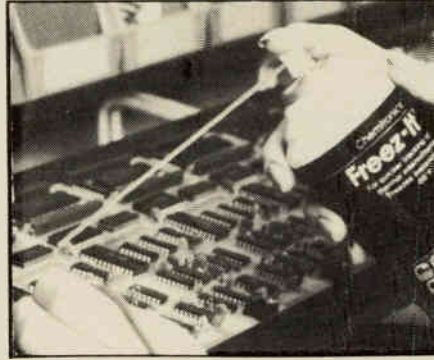

Freez-it from Chemtronics is typical of the many freezing sprays that will restart dead components for troubleshooting.

the substrate, healing tiny wounds. In any case, all the sprays work by squirting Freon onto the component; the rapid evaporation cools the part to about -50 degrees C. Another use is finding hairline cracks in PCB copper; the very cold copper will turn white from frost, outlining cracks. Defective passive components can also be identified by cooling. Look for names like Chemtronics Freez-it, Tech-Spray Minus 62, MG Super Cold Spray, Varah's Extra Cold, etc. I've never tried spraying a warm beer with it, but it might work.

If you've done repairs to a PCB, you should clean off the residue left from soldering, particularly in high impedance circuitry. There are various flux strippers available, such as Varah's Flux Remover, Tech Spray Light Duty Stripper, or one from Chemtronics with the notable name of Flux-Off.

Other good stuff would be a general purpose lubricant spray (my favourite is WD-40), a general purpose solvent (white mineral spirits), high voltage silicone grease such as the GC brand (great for electronic ignition wiring) and a solvent such as methyl hydrate or acetone (good for cleaning off adhesive spills and so forth).

Holders

I used to let PCBs skid around the bench while I tried attaching probes, and then I'd turn them over and chase them around while I tried to extract dead components and solder in new ones. One day I splurged for a PCB holder and it made me wonder how I could have done without it. It's like, *luxury*. One of the simplest and

LENLINE

High Performance Tool Kits for the Electronic Pro on the Go

PICK THE KIT THAT FITS YOUR NEEDS.

You can't beat LENLINE for top quality, durability and value in travelling tool kits. Choose from 8 standard kits (just 2 of them shown here)—or design your own with a customized tool assortment.

Quality tools for a wide range of on-site installation, repair and service tasks are thoughtfully organized in cases of legendary PLATT toughness and excellence. Send for complete full-colour catalogue today.



TC200/TC200M COMPACT SOFT-SIDE

55 basic tools needed for most on-site jobs housed in a handy, handsome, easy-to-tote zippered case of padded vinyl. 29 tool pockets, inc. one for your favourite tester. Metric version available.



TC400 DELUXE HARDSIDE SUPERKIT

Tough ABS thermoplastic case by PLATT, deep enough to hold an extra pallet for additional tools. Comes with a versatile assortment of tools to handle virtually every task you'll encounter in the field.

2 FREE CATALOGUES

GET THE WHOLE KIT & CABOODLE

YES: Send me your Full-colour LENLINE Electronic Tool Kit Catalogue **PLUS** complete catalogue of LENLINE tools, parts and accessories.

Name _____

Company _____

Address _____

City/Prov. _____

P/Code _____ Phone () _____



MAIL TODAY TO:
Len Finkler & Co.
80 Alexdon Rd.,
Downsview, Ont. M3J 2B4
OR PHONE CUSTOMER SERVICE
(416) 630-9103

LF-20

least expensive (under \$20) is the Double Hand Holder, Model 76030 from Active Components. It consists of a base holding a horizontal bar at the ends of which are two alligator clips.

Naturally, there's the problem of keeping components from falling out when you're stuffing a new board. You can always bend the leads, but this makes for difficult lead-snipping and a large solder blob. Lenline has a series of holders which can lower a sheet of foam onto the components, holding them in place while you turn the jig over and start soldering. They aren't inexpensive, with the 210 x 180 mm Model PCSS-1 running about \$50, but they sure make life easier if you build any number of boards. The Panavise unit on our cover is the Model 315 Circuit Board Holder; it's meant to fit into the Panavise 300 series bases. The whole assembled gadget gives you all sorts of angles for assembling or repairing boards.

If you work on repairing whole units rather than individual boards, there are stands which can hold and rotate a complete computer, typewriter, etc. These are in the area of \$350 from Panavise.



One of the many types of vises or clamps will ease building or repair.

A vise of some kind is indispensable, especially when you have to cut or drill something. That reminds me. They always ship volume controls with 2 or 3 inch shafts and you always have to saw them off. How many people mount controls 3 inches back from the front panel? Anyway, if you do only occasional hacking and hewing, I find the small imported hardware store vises are fine. On the other hand, if you're repairing or manufacturing as a business, there are more elegant solutions to gripping things, such as the Panavise series of vises that fit into various bases, such as vacuum bases, low-profile types, swivelling types, etc. Most of the fancy vises are in the \$35 region, and most of the bases are \$30-\$40.

Making Holes

It's a challenge when you don't have a machine shop and you have to make holes larger than the ones you can drill with the old Black and Decker. The majority of chassis openings for electronics projects will be large round or rectangular holes

for connectors or meters or similar gadgetry. The fastest way to drill round holes up to about 3/4 inch is the cone cutter, available from electronic suppliers or hardware chains such as Canadian Tire. It consists of a steel cone with a sharpened slot in it and a shank for mounting in power drills; they cut much faster than twist drills, particularly in aluminum. In fact, they cut a hole so fast you may need a depth stop on the drill.

The second way to make variously shaped holes is the Greenlee chassis punch. It's the most elegant way of making a precision hole, but also expensive (\$15-\$75, depending on size). The punches are available in round, square, keyed, D-shaped, and relay-socket shapes. First, you drill a pilot hole in the panel and thread on the punch and its backing die; then you tighten the bolt with a wrench and the punch is drawn into the die, easily cutting out the desired shape. It's slow, but the hole looks as if it had been punched out with a 50-ton press.

For larger holes, or even smaller ones if you don't care about rough edges, try one of the metal nibblers such as the GC 805, the Lenline Model 03, the Varah 66172, or the Adel Nibbling Tool. They're V-shaped with tiny jaws at the join, and take a small bite out of sheet metals up to about 1/16 thick. It takes a while to munch out a large opening, but it's sometimes the only way, especially if elbow room is limited.

If you're working with a new chassis and have lots of room, try a hacksaw-type blade in an electric jigsaw; it'll cut large holes very quickly, though you might want to wear earplugs.

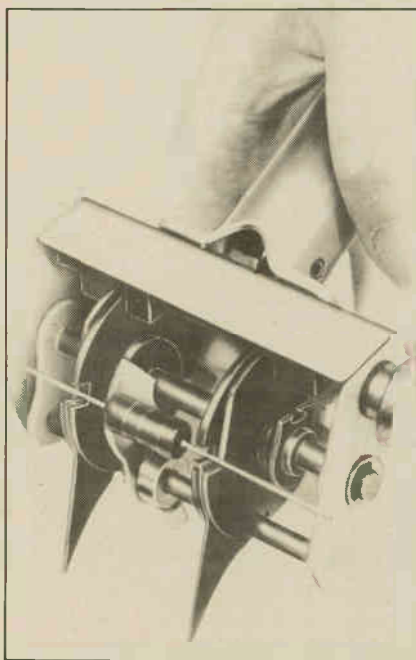

The Lenline PR2 adjustable lead bender makes for a faster, professional-looking PCB.

Wire Strippers

When you first begin the amazing, rewarding and fulfilling hobby of electronics, assuming you don't chuck it all out in the first few days, you probably started stripping insulation by carefully biting it away with sidecutters, or by using the famous Miller 100-series (the flat ones with the yellow handles; everybody has a pair). If you get into any kind of volume production at all, or even if you just want a bit of

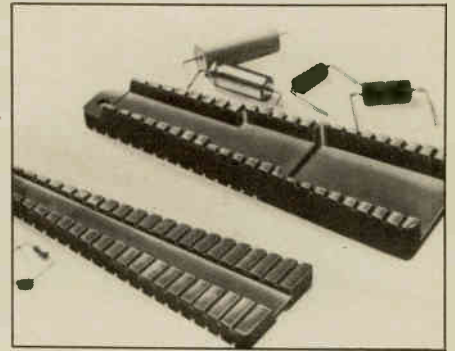

The fixed lead bender is available in various sizes for smaller jobs.

luxury, check out some of the fancier models. They look like a complex pair of pliers with hinged jaws; one set of jaws grips the wire and the other strips the ends. They're a bit more expensive than the manual types with prices in the \$15-\$75 range depending on quality, but it's the only way to face terminating a 100-pair cable. Look for models such as the GC Speedex or Speed-o-matic, or the Lenline 70-156A or STR23.

You can also get gadgets that will bend component leads before insertion into a PCB. If you only make the occasional board, these may be unnecessary, but if you're making any kind of quantity they not only speed things up, but make the finished work look a bit more elegant. The best deal for limited runs would be the simple jigs like the Lenline PD801. Then you can get fancier with the automatic models. They look a bit like the better wirestrippers, and have the advantage of being completely adjustable as to the spacing of the bends; one model is the Lenline PR-2.

Test Clips

You can always poke at test points with alligator clips or even paper clips, but you waste time and risk shorting things, particularly on DIP packages. There are lots of test probes and IC pullers available; so many, in fact, that I've run out of room to list them. There are probes that clip onto ICs for monitoring the pins, and clips with cables that let you run the IC away from the circuit for easy substituting. IC pullers are a necessity; you can't get an IC in and out of restricted quarters without bending the pins, and you'll find a large variety of pullers and inserters at any electronic tool dealers.

Solder, Desolder...

I accumulated so much material on this subject that it's going to have to wait for a future issue. In short, if you're still soldering with a pencil that looks like one of those woodburning-kit heaters, the delights of a real soldering station await you. You won't believe how much better the temperature-controlled types are.

As usual, I've run out of space. There are so many different kinds of tools for so many applications, it staggers the word processor. In future issues I'll be concentrating on specific areas of tool use; I'll start with a look at soldering/desoldering tools. ■

If you can't locate the tools mentioned, the distributor can give you a list of dealers:

Lenline: Len Finkler and Company, 80 Alexdon Road, Downsview, Ontario M3J 2B4, (416) 630-9103; also represent a wide range of tool companies: Edsyn, Lindstrom, American Beauty, Panavise, Miller, Platt, etc.

Varah's Direct, 504 Iroquois Rd., Oakville, Ontario L6H 3K4, (416) 842-8833; outlets in Edmonton, Calgary, Vancouver, Dartmouth, Nepean, and Winnipeg. Wide range of hand tools.

Electro-Sonic, 1100 Gordon Baker Road, Willowdale, Ontario M2H 3B3, (416) 494-1555; carry Lenline, Hunter, Miller, GC, OK, etc.

B.T.W. Electronics Parts, 1542 Warden Avenue, Scarborough, Ontario M1R 2S8, (416) 441-1733; carry Chemtronics, AP, GC, Lenline, OK, Vaco, etc.

Lenbrook Electronics, Unit 1, 111 Esna Park Drive, Markham, Ontario L3R 1H2, (416) 477-7722; wide range of test clips, IC handling tools, Johnson probes, etc.

Electronic Supplies Inc., 306 Rexdale Blvd., Rexdale, Ontario M9W 1R6, (416) 741-4000; outlets in Chatham, London, Sarnia, and Windsor. Represent Cooper Group (Xcelite, Weller, Crescent, etc), Lenline.

Chemtronics: Paco Electronics, 20 Steelcase Rd. W., Unit 10, Markham, Ontario L3R 1B2, (416) 475-0740.

Active Division of Future Electronics, 5651 Rue Ferrier, Montreal, Quebec H4P 1N1, (514) 731-7441; outlets in Toronto, Downsview, Ottawa, Calgary, and Vancouver. A wide range of hand tools from Ungar, Vaco, GC, Cooper, etc.

If you still need help finding a retail store, the main distributor for Crescent, Xcelite, Nicholson, Weller, Wiss, Turner, etc. is Cooper Tool Group Ltd., 164 Innisfil St., Barrie, Ontario L4N 3E7, (705) 728-5564.

Electronics Today November 1985

PATRON COMPONENTS INC.

Stock Distributor of Memories I.C. (U.S.A./Japan),
All New Parts. Min. 100 pieces

RAM/EPROM:

- 16K DRAM (4116) from \$0.50 EPROM (2716) \$2.45
- 64K DRAM (4164) from \$1.10 EPROM (2764) \$3.15
- 128K DRAM (4128) from \$8.05 EPROM (27128) \$3.95
- 256K DRAM (41256) from \$5.45 EPROM (27256) \$11.85
- 16K SRAM (6116,2016) from \$2.10
- 64K SRAM (6264,5565) from \$6.70

T.T.L.:

(74LS00 etc.) from \$0.17

4000 CMOS:

(CD4001 etc.) from \$0.17

LINEAR:

(LM324 etc.) from \$0.21

MICROPROCESSOR:

8088 Kit set (8088, 8253, 8237, 8284, 8288, 8259, 8255)
from \$33.10 per set

Please call for other 8000 series MPU/O.E.M. price and delivery.

XT COMPATIBLE ONLY \$999.

System includes:

- 256K XT (Japan) Board w. Japan DRAMs
- One DSDD Disk Drive
- Controller Card
- Colour Graphic or Monochrome Display Card
- Case, Keyboard & 130W Power Supply
- Option: two DSDD Drive system for \$1159.00

PERIPHERAL BOARDS

512K Ram Card (OK)	\$129.99
384K Multifunction Card (Loaded)	\$200.00
Monochrome Display Card	\$111.50
Monochrome Graphic/Printer Card	\$161.50
Colour Graphic Card	\$124.00
ATI KB-5000 Keyboard	\$ 99.00
Tatung RGB Colour Monitor (12")	\$499.00
Panasonic JA551-2/5 Disk Drive	\$149.00
Seagate (10MB) ST212 Hard Disk Drive	\$700.00
(20MB) ST225 Hard Disk Drive	\$940.00
Hard Disk Controller + Cable	\$250.00
Control Card + Cable	\$ 86.00
Mainboard (8 slot) 256K (Loaded)	\$299.00
Mainboard (OK)	\$259.00

Dealer inquiries invited — Prices lowest in town.

Mail order accepted. Min. \$5.00. Postage and Handling. Please add 7%
P.S.T. Visa, Certified Cheque accepted.

PATRON COMPONENTS INC.

4002 Sheppard Ave. E, Suite 506,
Agincourt, Ont. M1S 1S6
Tel: (416) 299-7731

Office Hours:
Mon-Fri. 9-6 p.m.
Saturday 10-5 p.m.

SHEPPARD AND KENNEDY

Circle No. 17 on Reader Service Card

**FAST
SERVICE**

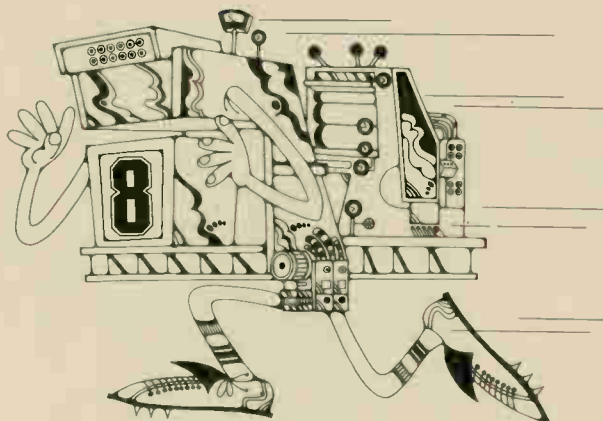

**BEST
PRICES**

5.99

TUBES

5.99

Over 10,000 Tubes in stock

1BC2A	\$ 7.85	6AL3	\$ 6.15	4RA5	4.85	6CM3	8.30	35LR6	12.70	38HE7	13.10	6XG6A/ ELS19	15.25	12BH7A	6.30
1G3GTA/ 1B3GT	6.85	6AQ5A/ 6HG5	6.40	4LJ8	9.20	6CW5	8.20	35W4	5.50			6KT8	8.20	123Y7A	7.20
2KY2	5.70	6AP8	7.50	5A05	6.55	6DK3	8.05	6GK6	7.70	6HL8	9.65	6L6GC	10.55	12BV7I	7.20
2GX5/ 2EQ5A	6.15	6AUGA	6.75	5AR4/ 5A05	8.85	6DH3	6.95	6HW8	15.90	6U10	8.75	6LB6	13.30	12DQ7	7.20
2HA5	6.50	6AUBA	3.30	5GH8A/ PQ3501	6.60	6DQ3	7.10	6HA5	6.30	6V6GTA	5.15	6LF6	12.70	12CL3	6.80
3A3C	7.10	6BA11	10.30	5GJ7	7.50	6DX8	7.95	6HE5	9.40	6X9	17.85	6LJ8	8.75	13nW4	6.80
3AT2B	9.90	6BK4C/ 6EL4A	12.80	5GS7	9.65	6EA8	6.55	6HQ5	6.15	8AC10	8.80	6LH8	6.55	12GH7A	8.60
3AW2A	7.20	6BL8	6.80	5U4GB	8.35	6EC4	8.60	6HS8	7.80	8CG7I	7.30	6LR6	12.70	12HG7	8.60
3BW2/ 3BS2B/ 3BT2A	7.30	6BQ5	7.20	5U4GB 5AS4A	8.35 8.35	6EH7	8.05	6HV5A	11.15	8EG7I	7.30	6LT8	8.75	12HL7	8.20
				6EJ7	9.10	6EM7	8.30	6H26	6.30	8GJ7	7.95	6LU8	10.75	12MD8	8.95
				6FM7	9.30	6G77	9.30	6J10/ 6Z10	12.20	8JV8	7.40	6LH6	30.70	13GF7	9.60
				6G77	9.30	6G77	9.30	6JA5	9.20	8LT8	8.45	6LX6	13.10	13Z10	12.60
3CB6	9.75	6BW11	10.85	6JC5/ 6J28	9.40	6G8A	3.95	6JAS	9.20	9GH8A	6.85	6LX8	6.65	13J10	12.60
3CH3B	8.15	6CA4	13.80	6JB5/ 6JB5	9.40	6GH8A	6.55	6J28	9.85	9JW8	6.85	LCF302	6.60	15HF8	11.65
3CU3A	7.70	6CA7	13.60	6J28	9.85	6H8A	6.55	6J28	9.85	9WL8	9.70	6MJ6	13.30	15A8	10.00
3DB3/ 3CX3	7.20	6CB6A/ 6CT6	1.50	6J28	9.85	6AG9	22.75	6J28	9.85	10GF7	9.55	6LQ6	13.30	PC182	10.00
3DC3	7.70	6CG3/ 6BW3	7.65	6J28	9.85	6AG9	22.75	6J28	9.85	10GK6	7.50	6JEC6	13.30	16LU8A	10.75
3DF3	7.20	6CE3/ 6CD3	7.10	6J28	9.85	6AG9	22.75	6J28	9.85	10JA5	9.30			17BF11A	12.20
3DJ3	7.10	6CG7/ 6PQ7	6.40	6J28	9.85	6AG9	22.75	6J28	9.85	10KR8	8.20	24JE6C	11.35	26HU5	14.35
3GK5	6.15	6CG7/ 6PQ7	6.40	6J28	9.85	6AG9	22.75	6J28	9.85	11AF9	22.10	24LQ6	11.35	26LX6	13.00
3HA5/ 3HM5	6.85	6CG7/ 6PQ7	6.40	6J28	9.85	6AG9	22.75	6J28	9.85	11Hn7	8.20	25CQ3	7.10	30KD6	13.00
				6J28	9.85	6AG9	22.75	6J28	9.85	12AT7	6.70	25AX5	14.25	31S6C	11.30
				6J28	9.85	6AG9	22.75	6J28	9.85	12AU7A	5.90	25JZ8	9.65	33GY7A	12.60
				6J28	9.85	6AG9	22.75	6J28	9.85						
4ER7	8.60	6CG8A	7.70	6J28	9.85	6AG9	22.75	6J28	9.85	12AX7A/ 7025A	6.15	38HK7	12.80		
4EJ7	8.40	6CJ3/ 6DW4B	7.10	6J28	9.85	6AG9	22.75	6J28	9.85	12BE6	7.40	40KG6A	16.70		
4GJ7	7.70			6J28	9.85	6AG9	22.75	6J28	9.85			42EC4	8.95		
				6J28	9.85	6AG9	22.75	6J28	9.85			50C5	7.20		

- TRY US FOR
- NEEDLES AND CARTRIDGES
- AUDIO AND VIDEO ACCESSORIES
- SEMICONDUCTORS
- WIRE AND CONVERTERS AND MUCH MORE

• We reserve the right to substitute. Prices to extent of Inventory.

• Mail Order:
Certified Cheque, Money Order, COD'S FOB Rexdale.
Ontario Residents add 7% P.S.T.

THE WHOLESALE SOURCE

YOU'VE BEEN SEARCHING FOR! . . .

ELECTRONIC SUPPLIES INCORPORATED



306 Rexdale Blvd.
REXDALE, Ontario M9W 1R6
(416) 741-4000
INDUSTRIAL ORDER DESK
(416) 741-6000

BRANCHES:

32 Wesley Lane at Beath, CHATHAM, ONT. N7M 5W6 (519) 322-4000
288 Colborne St., LONDON, Ont. N6A 2E7 (519) 433-0101

1173 Midway St., Unit 4, SARNIA, ONT. N7S 5S5 (519) 344-2448
800 Wyandotte St. E., WINDSOR, ONT. N9A 3Z2 (519) 258-2246

The Mitel Corporation of Kanata, Ontario, announced in September that the company's common shareholders voted in favour of the proposed British Telecom acquisition of 51 percent controlling interest. The cost to British Telecom at \$8 per share was \$320 million. Both companies confirmed that BT would exercise full management control as soon as the agreement becomes effective; the acquisition is conditional upon regulatory clearances in the UK and Canada.

The Philips and Siemens companies of Europe are cooperating on the BICMOS project; the goal is to produce an IC containing both CMOS and bipolar transistors. The CMOS transistor is ideal for digital switching because of its very low quiescent and input currents, and the bipolar is better suited for analog circuits requiring low noise, good matching, and high current density. The chips would be used in A-D converters, memories, digital processing, etc.

RMS Digital Meter



Newport Electronics announces their Model 204B-RMS, a true RMS digital panel meter capable of handling signals with crest factors up to 3:1. The bandwidth is DC to 100KHz, allowing measurement of signals with both DC and

AC components. A parallel BCD output is provided; peak and valley hold is available as an option. Contact Metermaster Division of R.H. Nichols Co. Ltd., 80 Vinyl Court, Woodbridge, Ontario L4L 4A3, (416) 851-8871.

Circle No. 55 on Reader Service Card.

GTO Capacitors



The new MKV B25855 capacitors from Siemens are for use with Gate-Turn-Off thyristors; their low inductance (30nH) and high peak currents (up to 2500A) make them ideal for damping capacitors. Contact Siemens Electric Ltd., 1180 Courtney Park Drive, Mississauga, Ontario L5T 1P2, (416) 673-1995.

Circle No. 54 on Reader Service Card.

Chip Clip



A low-profile chip clip for testing ICs in-circuit, the LPCC-16, is available from OK Industries. One end of a 24-inch cable is terminated with a 16-pin clip which clamps onto the IC under test; the other end has a 16-pin DIP plug used for connecting probes, etc. Contact Len Finkler and Co., 80 Alexdon Road, Downsview, Ontario M3J 2B4, (416) 630-9103.

Circle No. 53 on Reader Service Card.

Looking for a new computer to upgrade your Apple clone? Cray Canada has announced their new X-MP series, nine models of supercomputers suitable for large-scale processing of data from petroleum exploration, structural analysis, weather forecasting,

etc. The top-of-the-line 416 has four CPUs and 16 megabytes of RAM, has ten times the performance of the Cray-1, and costs \$16 million. It'll run Lotus and WordStar at the same time if you buy an extra RAM card.

continued on page 51

Microtrainer

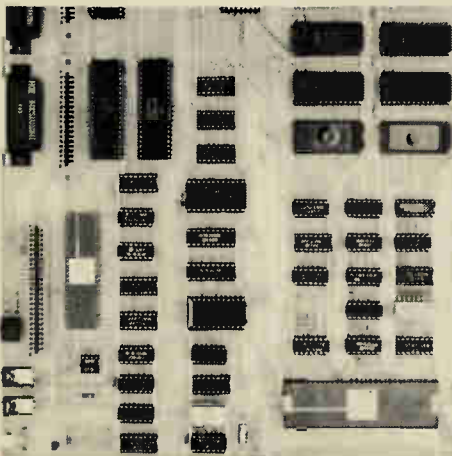

The Microtrainer 68K is a 68000-based Single Board Computer designed especially for learning about microprocessors and microelectronics. It's used with on-board video circuitry and parallel keyboard interface, or it can be connected to a dumb terminal. It has two connectors for easy interfacing to experimenter boards. Memory can be expanded to 80K on-board; a cross-assembler to run on the IBM PC and several plug-in experimenter boards are available in a complete line of teaching hardware. Contact Waterloo Distance Education, Inc., PO Box 62, Waterloo, Ontario N2J 3Z6, (519) 884-4340.

Circle No. 52 on Reader Service Card.

Discover a new line of IBM Personal Computer Software

From as low as \$24.99

Personally Developed IBM Software programs with value in mind

Choose from

- Business applications
- Entertainment
- Education
- Programming
- Productivity
- 58 programs in all

■ PLUS Special Value Packages to save you even more money!



Note: These IBM Personal Computer Software Products are not available in Quebec.

IBM is a registered trademark of International Business Machines Corporation. IBM Canada, a related company, is a registered user.

Call IBM Canada Ltd. today for your **FREE CATALOGUE** While quantities last.

1-800-387-6100

Direct Injection Box

Clean up your on-stage sound with this low-cost, high and low impedance splitter.

By Andrew Armstrong

EVEN WITH the large number of electric musical instruments in use today, sound is still frequently transferred from instrument to PA system by means of a microphone. Electric guitarists often regard their stage amplifier as part of the instrument and wish the sound to include the distortions, cabinet resonances and even the microphone in the case of tube amplifier. This demands a microphone placed directly in front of the musician's loudspeaker, with all the consequent problems of distortion and increased risk of feedback.

Microphones have to be used in any case for vocalists and acoustic instruments, which makes it all the more important to avoid using them on electric instruments wherever possible so as to keep the risk of feedback to a minimum. Electric keyboards can usually be fed directly into the PA system, but an on-stage amplifier may still be required so that the sound can be heard by the musician and acoustic instruments may also need local amplification in the noisy environment of an amplified band.

The solution to some of these problems is a direct injection box, a unit which takes the incoming signal from the instrument (or from the microphone in the case of an acoustic instrument) and splits it to produce two outputs, one of which is fed to the main PA while the other is taken to a nearby amplifier and speaker controlled by the musician. A DI box (as they are generally known) usually has a high impedance input, a low impedance output for the mixer which is sometimes balanced, and either a high or low impedance output for the stage amplifier.

Well Balanced Design

This design is based around a very low noise dual op-amp which allows it to be used at low signal levels without significant noise problems. The gain is normally set at unity but a voltage gain of 2:1 can be achieved by making a few component changes. The unit operates from a single 9V battery and powers up automatically

when a jack plug is inserted into the input socket. In addition, a low-voltage detector is included which lights an LED when the battery needs replacing.

The unbalanced output can be taken from the output of the first op-amp which gives a reasonably low impedance driver, or, if preferred, can be connected directly to the input. The advantage of this arrangement is that the unbalanced output will then continue to operate even if the unit develops a fault or the battery runs down. The input impedance of the DI box circuitry is quite high and will not excessively load a connection made in this way.

The mixer output is balanced and can either be used directly with high impedance balanced inputs or set at 600R by adding two 300R resistances. A circuit for a low impedance balanced input has also been included, as an add-on, to enable the unit to be used with equipment which does not already have a balanced input.

The normal type of balanced line to use for audio work is 600R. To be completely correct, the source resistance for each signal connection should be 300R and each one should be terminated with a 300R resistance to ground at the receiving end. In many cases, a high impedance is used at the receiving end and the sending end impedance is just 'low'.

As long as the signal level is suitable, this unit may be used as a proper 600R driver. The 5532 op-amp specified has very

low noise, typically $5 \text{ nV}/\sqrt{\text{Hz}}$, so very low level signals may be used without a severe signal-to-noise penalty. The voltage swing which the op-amp can drive into 600R is somewhat less than it could drive into 10k for example, so, taking account of the reduced efficiency when operating from a single 9V supply rather than a dual 15V supply, signals of over two volts peak to peak may clip. When the battery is exhausted, the 5532 may only manage two volts peak to peak into a high impedance. This should be adequate for most purposes, but if it is not, the project may easily be adapted to give more output.

If the box is operated with 300R output resistors into a terminated 600R line, the output signal will be potted down by 2:1. To compensate for this, voltage gain is provided by the addition of optional components R4 and C2. Equally, if the input signal is of a very low level, adding these components will boost it to a level considerably above the level of the interference picked up on the line. This is particularly useful to prevent buzz from phase controlled lights being audible on microphone circuits. For the purpose of driving a balanced line, a voltage gain of two times is required.

In order to gain the greatest benefit from the DI box, its output should be fed into a balanced (or differential) input. Unfortunately, the equipment you use it with may not have a differential input, but read on.

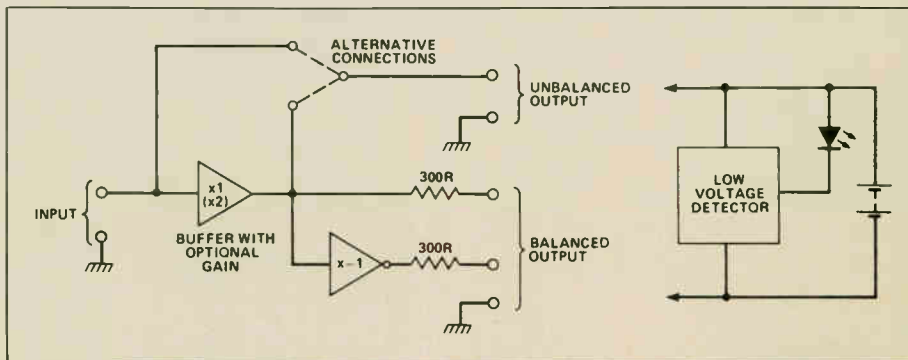

Fig. 1 The block diagram of the direct injection box.

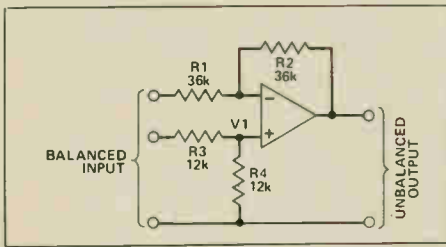

Fig. 2 A standard differential input arrangement.

The circuit in Fig.2 shows the conventional configuration of a differential receiver. Most text books show all four resistors in the circuit to be of equal value, but that is not always the best way to do things. At first glance, it would appear that the impedance on the non-inverting input is $R3 + R4$, while that on the inverting input is $R1$. This is not so. If the op-amp is working linearly (ie not clipping) then for all practical purposes, the voltage on the inverting input of the op-amp is the same as that on the non-inverting input.

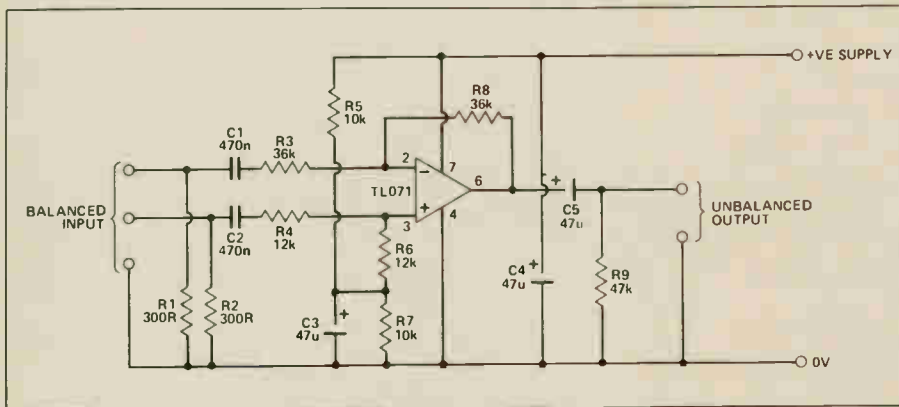

Fig. 3 A practical circuit for a differential input stage.

The non-inverting input has half the positive signal voltage, and since the inverting input has the same signal present, resistor $R1$ has a voltage across it equal to half the positive input signal plus the negative input signal. The signals are meant to be balanced, so the voltage across $R1$ is 1.5 times the negative input signal. The current flowing in this resistor is therefore 1.5 times as high as would be expected if $R1$ were feeding a virtual ground point, so the apparent impedance is $1/1.5$ times the value of $R1$. Therefore $R1$ should have a value of 1.5 times the desired input impedance. Another way to visualize this is to think of the virtual ground point as being one third of the way along the resistor from the inverting op-amp input to the input signal.

The component values shown in this circuit are for a 48k input impedance, 24k on each line. should a 600R input impedance be required, it is best to use 300R resistors to load the input, rather than using very low value resistors around the op-amp. There are two reasons for this.

First of all, the differential impedance of the circuit shown is correct, but the common mode impedance is not balanced. The addition of 300R load resistors will swamp any differences and the best performance will be obtained. The second reason is that the op-amp would be required to drive heavy currents into its feedback resistors if low value resistors were used around the op-amp, and this would restrict the output swing.

Power Consumption

The one drawback of the excellent NE5532 dual op-amp is that its current consumption is quoted as eight milliamps typical, sixteen maximum. If the DI box is to be used with reasonably large signals and not into a low impedance load, it may be preferable to use the LM358 op-amp in order to cut the power consumption. The gain bandwidth product of this device is only 1MHz, so there is not a lot of scope for providing voltage gain without the risk of slight degradation of sound quality.

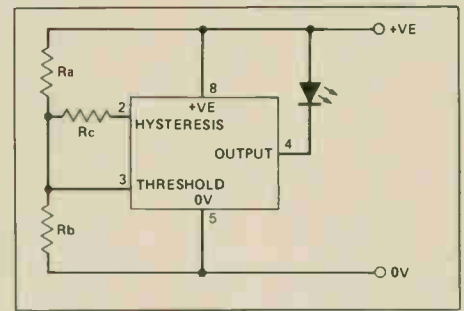

Fig. 4 The low voltage warning circuit using the 8211 micro power sensor.

Another alternative would be the TL072 which has a gain bandwidth product of 3MHz and a noise figure of $18\text{nv}/\sqrt{\text{Hz}}$, both of which are quite acceptable. This is a BiFET device, so it would be possible to use a very high input impedance if necessary, a megohm for example. The maximum current consumption of this is 5mA total, so the battery life should be reasonable.

If the application requires substantial voltage drive into a 600R load, the DI box may be constructed with 25V rated electrolytic capacitors and powered from two 9V batteries in series. There is not room in the case of the prototype unit for another battery, so a large sized case would have to be used. The low battery warning would have to be recalculated to work at a different voltage as well, of course, in order to give warning before the unit stopped working correctly, rather than afterwards.

Low Battery Alarm

This part of the circuit uses the 8211 micro-power sensor. This handy chip draws a quiescent current of about 25uA and provides a current limited LED drive which switches on when the voltage on its threshold input falls below 0.15 volts. Referring to Fig. 4, the threshold voltage for the LED to switch off is given by the formula:

$$V = 1.15 \times \frac{R_a + R_b}{R_b} \text{ volts}$$

Hysteresis is added by R_c ($R14$ in the final circuit), but if this is not required pin 2 should be left open circuit.

The addition of hysteresis does not affect the switch off voltage but the switch on voltage is lowered. This voltage is calculated from the formula:

$$V = \left(\frac{R_a \times R_c}{R_a + R_c} + R_b \right) \times \frac{1.15}{R_b}$$

The component values specified in the circuit diagram give nominal switching voltages of 6.55 (off) and 5.60 (on). If this end of life voltage is too low, it may be raised by reducing R_b in the sensing circuit.

How it Works

IC1A works as a buffer with selectable gain, $R4$ and $C2$ being added only if voltage gain is required. The offset voltage on the inputs is minimized by having a similar net DC resistance on each input. The output of this buffer drives the in-phase output and also a unity gain inverter, IC1B, which in turn drives the other output. Both outputs have their impedance set by series resistors and are DC blocked by electrolytic capacitors. The capacitors are polarised by load resistors $R11$ and $R12$.

The low battery detector is based on a purpose designed IC which contains a very low current band gap voltage reference, a comparator, and a current limited output drive circuit. For this reason, the LED needs no current limiting resistor.

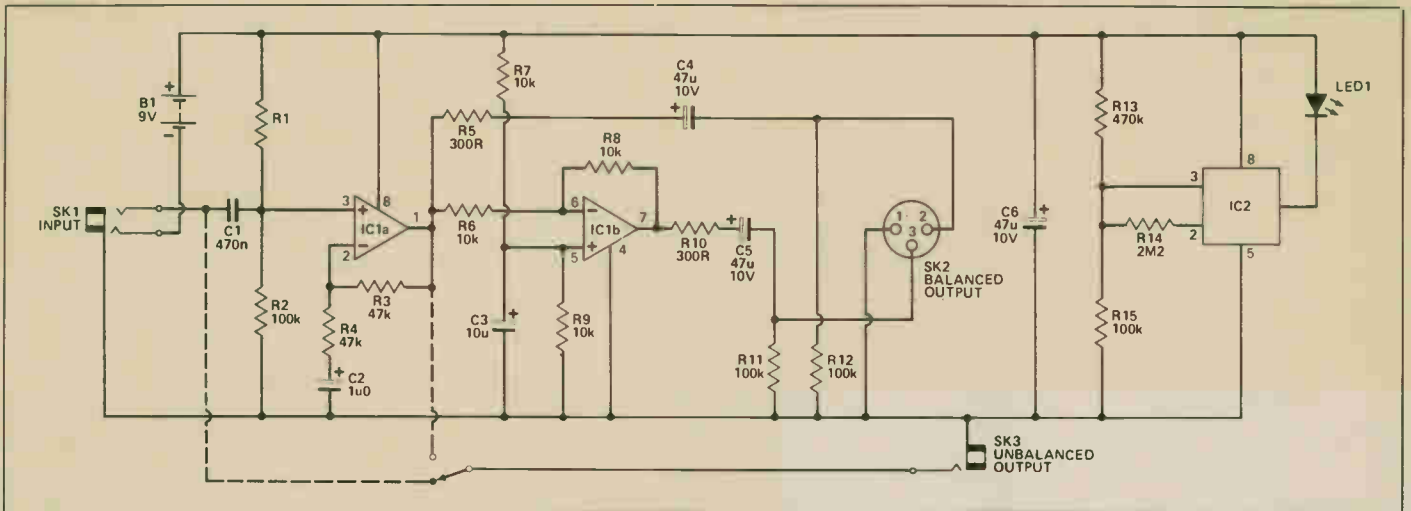

Fig. 5 Complete circuit diagram of the direct injection box.

Construction

Before starting to assemble the DI box, you must decide which of the various circuit options you wish to incorporate. Some of these will affect your choice of components while others, like the choice of unbalanced output take-off point, will only involve wiring changes. The components which may be affected are all marked in the parts list. SK1 is specified as a stereo jack socket

even though the signal is mono, the extra connection is used to connect the battery negative to the PCB when the input is plugged in. The rest of the assembly is straightforward; Fig. 7 shows the suggested layout within the case.

Testing

If a regulated power supply is available it should be used for initial testing. Set the

power supply to about 4V, if the LED does not light, then reverse its connections and try again. Once the LED works, increase the voltage until the LED goes off, then reduce it until the LED switches on again. Measure the voltage and check that it is about 5.6V. Individual units may vary due to component tolerance, but if the voltage is not acceptable the value of R13 or R15 should be changed.

BUGS EATING YOU ALIVE?

Single stepping through a program works but...
Break points help but...

how do you kill those really
frustrating software bugs quickly?

The BUGBUSTER is a powerful hardware assisted debug package which runs on all Apple II/III and compatibles. It will trap and store a REAL-TIME disassembled trace on ANY program condition you specify. The 512 cycle trace can be viewed on screen or stored on a printer or diskette. Optional hardware inputs can be used to debug Apple hardware.

ONE YEAR PARTS AND LABOUR WARRANTY
Dealer enquiries invited



APTRON DESIGN LTD.

P.O. Box 13193, Kanata, Ontario, Canada K2K 1X4 (613) 831-0163

Please send:

- more information
- demo disk & manual @ \$10
- BUGBUSTER AP512 board & software @ \$199
- optional hardware probes @ \$25 set
- Ontario residents add 7% PST
- Cheque Enclosed
- Money Order Enclosed
- Bill my VISA
- Bill my MasterCard

Card# _____ Expiry Date _____ / _____

Signature _____ (not valid without signature)

Name _____ Company _____

Address _____

City _____ Prov. _____ Postal Code _____

Mail to Apron Design Ltd., P.O. Box 13193, Kanata, Ont. K2K 1X4

NEW
LOW
PRICES

THE AFFORDABLE

XT COMPATIBLE

HIGHEST QUALITY, RELIABILITY AND COMPATIBILITY
(ALL MAJOR BOARDS MADE IN JAPAN)

STANDARD SYSTEM NOW ONLY **\$1,195**

- 256K XT System Board, w/o BIOS
- Controller Card
- Case, Keyboard, Heavy Duty Power Supply
- Two DSDD Disk Drives
- Colour Graphic Card
- Box of Nashua Diskettes FREE

90 DAY WARRANTY



PRO 25M HARD DRIVE
SYSTEM NOW ONLY

\$2,295

- 256K XT System Board, w/o BIOS
- One DSDD Disk Drive
- Controller Card
- Colour Graphic Card
- One Seagate 25MB Hard Disk Drive with Controller
- Case, Keyboard Heavy Duty Power Supply
- Box of Nashua Diskettes FREE

Options with purchase of above system only

	Special	Regular
A) 384K (Installed) Multifunction Card	\$239.00	\$275.00
B) Monochrome Graphic and Printer Card	195.00	229.00
C) NEC RGB Colour Monitor, 1216 DFA	450.00	495.00
D) Zenith Monochrome TTL Monitor, ZVM 124	169.00	195.00
E) Roland NLQ Printer, 1111A	409.00	429.00
F) 512K RAM Card	168.00	195.00

SPECIAL OF THE MONTH: SEAGATE HARD DISK DRIVES
COMPLETE WITH CONTROLLER AND CABLES
10MB, ST212... \$895.00 25MB, ST225... \$1195.00

Mail orders, cheque, money order, Visa, MasterCard accepted. \$5.00 for shipping and handling. Ontario residents add 7% P.S.T.

SUNIX INC. (Formerly Audiovision)
578 MARLEE AVE. (At Glencoln Subway)
Toronto, Ontario M6B 3J5
Tel: (416) 781-3263
In Dallas, USA: (214) 985-1842

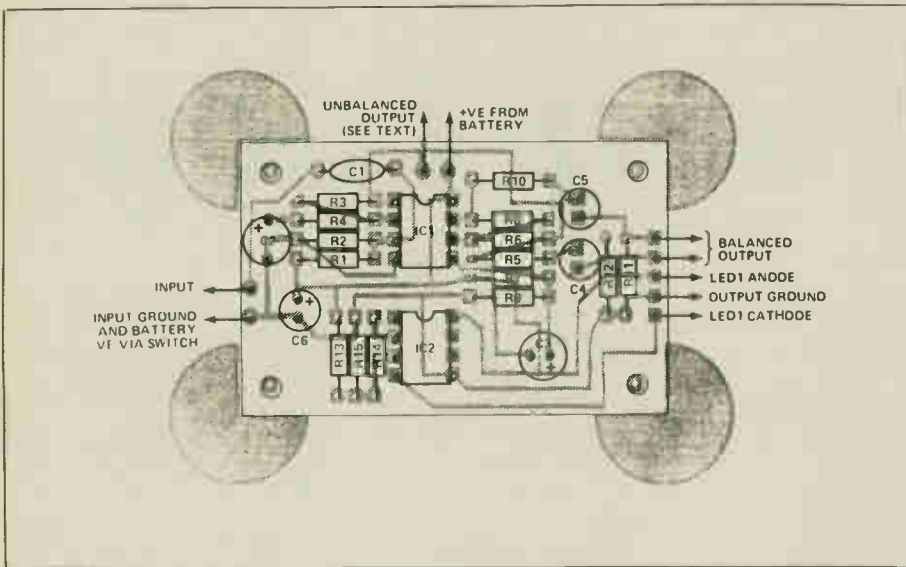
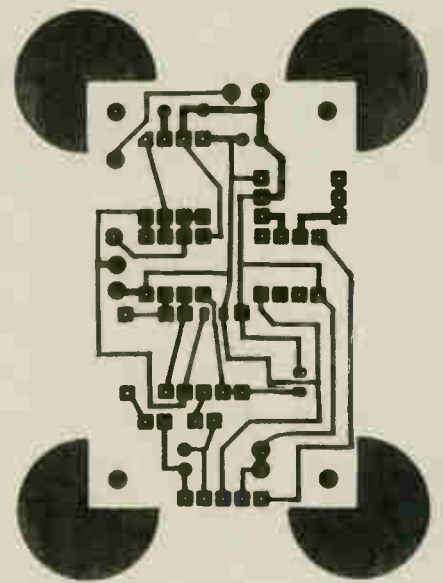

Fig. 6 The component overlay for DI box.



PCB for the DI box.

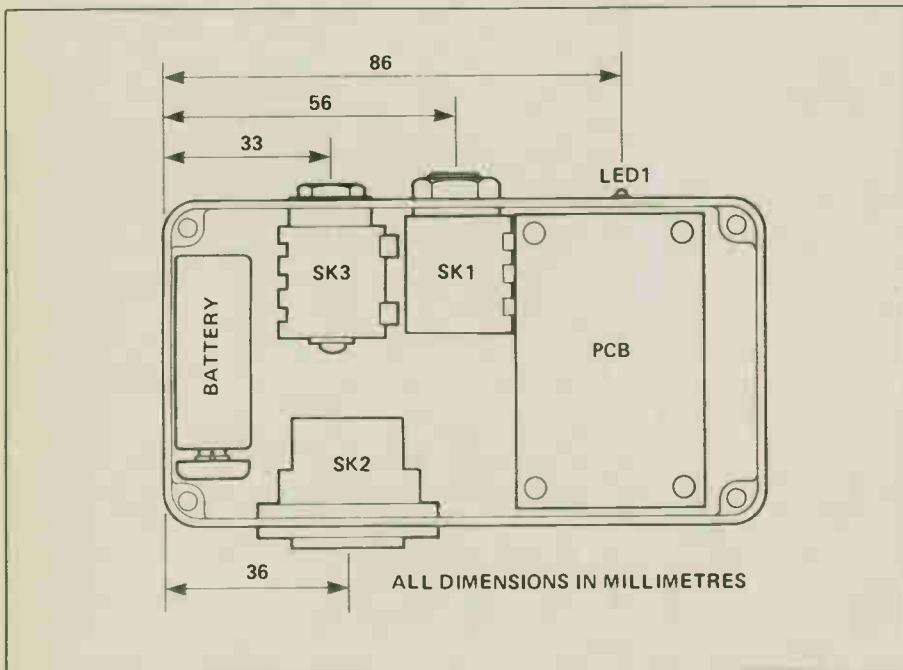

Fig. 7 Layout of the major components within the case.

Now apply 9V, either from a battery or from the power supply, and use a voltmeter to check that the op-amp output pins are at about 4.5V and that the outputs are at 0V. If they are not, the most likely fault is a reversed electrolytic capacitor. Finally, connect up a signal source and a suitable amplifier and check that everything works correctly and that the sound is what it should be.

A practical circuit for a differential input is shown in Fig. 3. The 300R input resistors

are optional but should be included if the input is connected to a 600R balanced output. The power may be drawn from any DC source with a voltage in the range 6-30V or a dual rail supply could be used and the biasing component omitted. If the arrangement is to be battery powered, it might be an idea to include a low voltage monitor of the type used in the main DI box.

Parts List

Resistors

(1/4 W 5% unless otherwise stated)

R1,2,11,12,15	100k
R3	47k
R4	47k (see text)
R5,10	300R 1%
R6,8	10k 1%
R7,9	10k
R13	470k
R14	2M2 (see text)

Capacitors

C1	470n polyester
C2	1u0 tantalum (see text)
C3	10u 10V radial electrolytic
C4,5,6	47u10V radial electrolytic

Semiconductors

IC1	NE5532 dual op-amp
IC2	ICL8211 micropower sensor

Miscellaneous

SK1	1/4" stereo jack socket
SK2	XLR 3-pole chassis plug (XLR-3-32 or equivalent)
SK3	1/4" mono jack socket
PCB	die cast box, approx 110 x 60 x 30mm; panel-mounting bush for LED1; battery connector; nuts and bolts to mount SK2 and the PCB.

Computing Today

Z80 Design Part 6

More interfacing with the Z80. Hooking up to relays, motors, lamps etc.

By Hagen Kornberger

RELAYS can be used to control a great number of devices such as lamps, motors, and other high current devices. Fig.10 shows the driver circuit needed for a typical relay. Five volt relays are available and some are even packaged with pin spacing the same as IC's so they can be placed in sockets; other relays require higher coil voltages so an extra power supply is necessary.

The maximum load that can be placed on the relay depends on the switch contact ratings. Fig. 11 shows how two relays are used turn a motor on and off and change the direction as well. However relays have some disadvantages. They have a slow response time, are mechanical and therefore suffer in reliability, and they tend to generate quite a bit of unacceptable radio frequency interference.

Solid state switches can replace relays and eliminate the disadvantages. Power transistors can be used to switch high current DC motors, lamps, etc, and SCR's

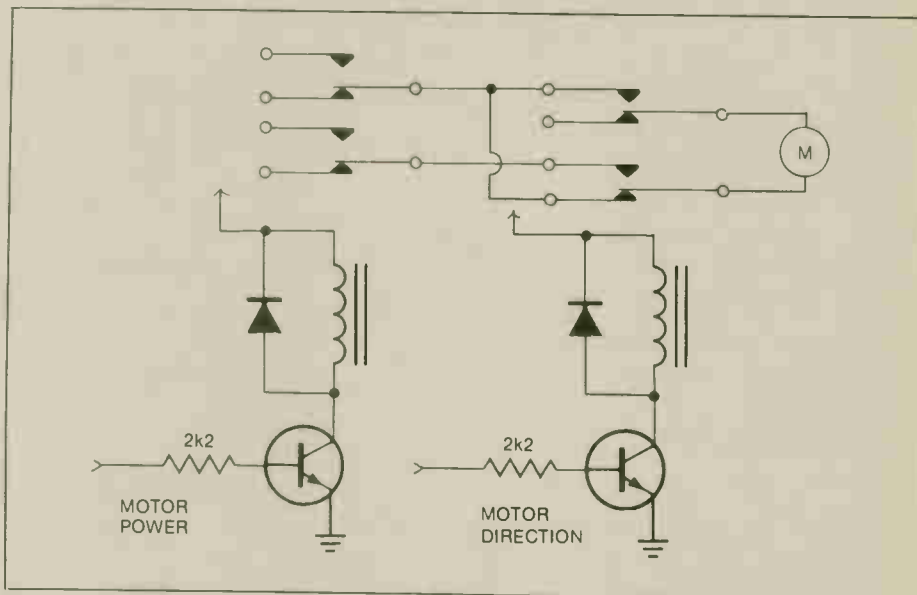

Fig. 11 Circuit details for the relay control of a motor.

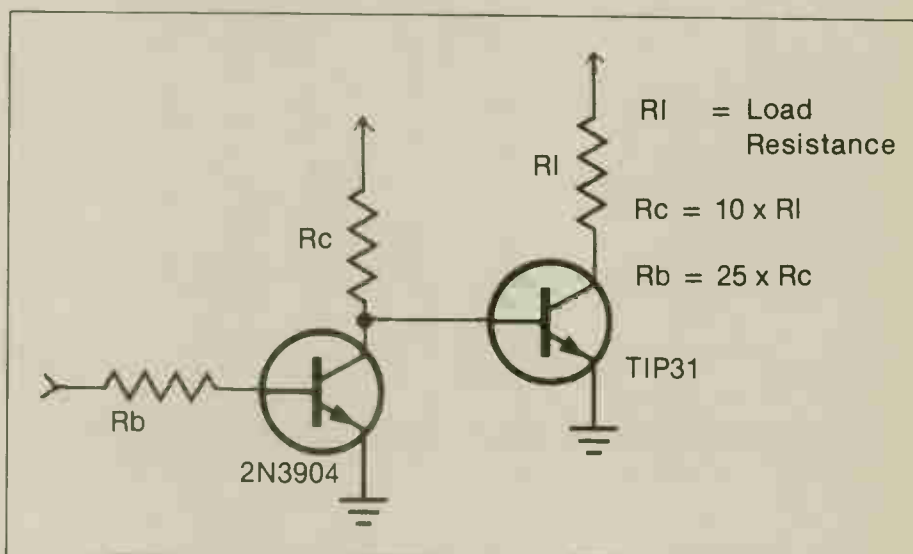

Fig. 12 Circuit diagram for a power transistor switch.

and TRIAC's can be used to control AC devices. In cases where the load voltage is to be isolated from the computer voltage, such as line operated loads, opto-isolators are available.

Turning on and off a DC load with a power transistor is quite the same as lighting an LED with a driver transistor. However, if the current is large an additional driver transistor will be required to

drive the power transistor. If the load current is 1 amp and the gain of the transistor is 10 (typical for power transistors), then a base current of 100ma is required to drive the transistor into saturation. Driving the transistor into saturation is important as this keeps the power dissipation of the transistor down. Fig. 12 shows a power transistor switch and the appropriate calculations for the resistors.

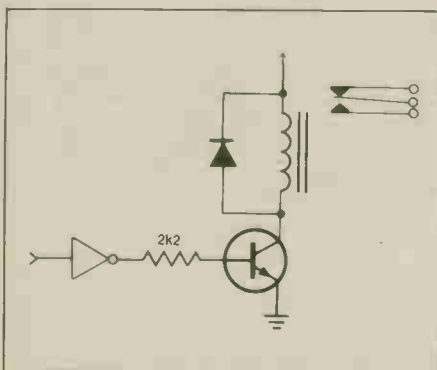

Fig. 10 Details of a relay driver circuit.

Varying the speed of DC motors is quite easily done. For full speed the motor is turned on and left on; for no speed, or stop, the motor is simply turned off. For speeds in between, the motor is shut on and off rapidly. The speed of the motor depends on the duty cycle or the ratio of the time when the motor is on to when the motor is off. A 50 percent duty cycle makes the motor go at medium speed.

Changing the direction of the motor is quite easily done. Fig. 13 shows the schematic of a four power transistor switch quite commonly referred to as a power-H driver. The advantage of this type of circuit over others is the need for only a single polarity power supply. Two output bits are needed to define the speed and direction of the motor.

For precision movement a stepper motor is required. Stepper motors are operated by pulsing them, meaning that each time a pulse is applied, the motor turns a certain number of degrees. Four windings inside the motor make the motor turn. The windings are pulsed in sequence and depending on the direction of the sequence, they make the motor turn forward or in reverse. IC's are available to drive the stepper motors but the Z80, with the appropriate software, is quite capable of handling this task. Fig. 14 shows the schematic of the driver circuit.

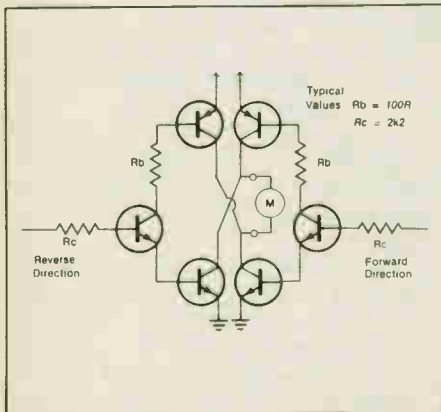

Fig. 13 The circuit of the Power-H driver.

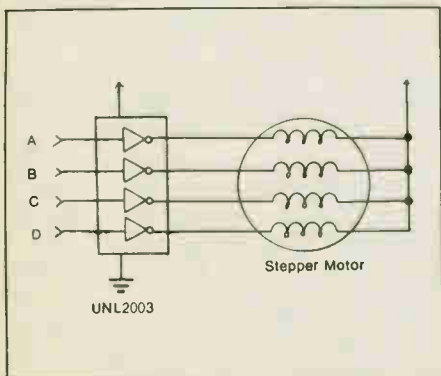

Fig. 14 The stepper motor driver.

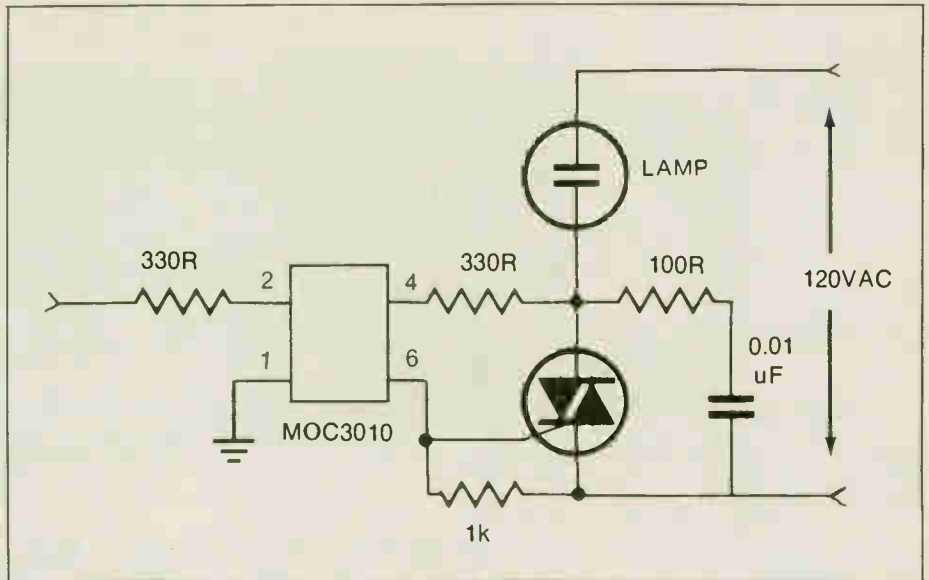

Fig. 15 Circuit diagram of a Triac switch.

To switch AC devices, triacs are commonly used. These offer the advantage of switching on for the full wave of an AC cycle as opposed to SCRs. Triacs are usually used in conjunction with triac output opto-isolators to isolate the CPU from the power line. Fig. 15 uses an MOC3010 opto-isolator IC readily available from Radio Shack (cat. no. 276-134).

Generating Sound

Producing an electronic *beep* with a fixed duration and frequency, and with minimum Z80 intervention, can be done with a single 556 timer as shown in Fig. 16. The first section of the timer is a one-shot multivibrator, and the second section is an astable multivibrator. By pulsing the trigger input of the one-shot multivibrator, a beep with a duration and frequency selected by the components will be heard on the speaker.

Generating a variety of frequencies can be done with software. In this case only an output amplifier is needed for the sound to be heard on the loudspeaker. Generating a specific frequency is a simple matter of using a timing loop in between the on-off transition period. Changing the characteristic of the sound can be done by altering the duty cycle of the waveform.

Output Ports

Although the PIO is quite convenient to use it is quite costly when multiple output ports are required. Fig. 17 shows an 8 bit output port wired up using the 74LS374 8 bit D-type flip-flop. The output port is addressed at 80 hex. Seven more output ports can be wired up without additional address decoding.

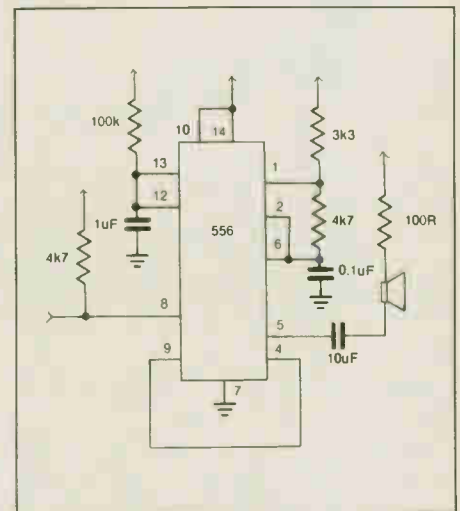

Fig. 16 Circuit to generate a 100ms beep.

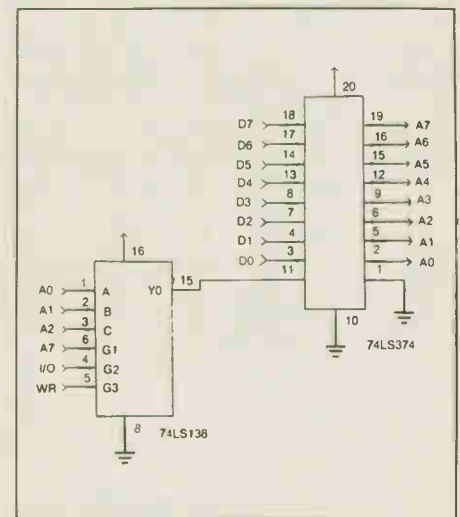

Fig. 17 Details of the alternate output port using the 74LS138 and 74LS374.



Zopan 1404A Function Generator

A low cost 3-waveform generator for most testbench needs arrives from Poland.

By Bill Markwick

FUNCTION Generators are handy things to have around; their advantages include several types of waveforms, wide frequency range and excellent amplitude stability. The Zopan 1404A is manufactured in Warsaw, Poland, and is being offered to the Canadian market by KB Electronics of Oakville. Its features include a very wide frequency range from .05Hz to 1MHz in seven overlapping decade ranges, push-button switching, and a single-square-triangle 600 ohm output via a BNC jack.

The function generator works by creating a ramp voltage, usually by charging a capacitor with a constant-current source. This ramp is turned into a triangle by having a voltage comparator discharge the capacitor via another CCS when the ramp voltage reaches a prescribed limit. The big advantage to this method is that you can easily change frequency by voltage-controlling the capacitor's charging rate. Square waves are easily obtained by triggering a gate on the triangle's zero crossing, and sine waves are produced (usually) by passing the triangle through a non-linear element such as a diode matrix or the base-emitter section of a differential amp; this produces a fair amount of distortion in the sine - the Zopan is listed at less than 3%, 10Hz to 50KHz, rising to less than 5% up to 1MHz. This is adequate for most testing other than distortion measurements.

This method of generation also lends itself to controlling the amplitude and frequency by external voltages, and the Zopan has BNC inputs for voltage con-

trol of both. It also has two waveform controls for symmetry (of the square wave) and DC offset (of all three). Symmetry is the ratio of a rectangular wave's positive side to its negative side, useful for checking the response of logic circuit inputs to waveforms with duty cycles other than the usual 50%. The offset control applies a DC voltage of up to plus and minus 5V to the signal for testing circuits that aren't at ground potential.

The output voltage is listed as a nominal 10V, but this requires some clarification. The sinewave showed a level of 11V peak-to-peak, or 3.9V RMS, with the output unloaded. The triangle was 12Vpp and the square was 14Vpp. These values fell to half when a 600 ohm resistor was connected across the output.

The frequency stability is rated at plus or minus .5% short-term, and plus or minus 1% over seven hours. The amplitude stability wasn't specified, but pushing the range buttons over the full frequency span caused an amplitude change of tiny fractions of a dB, and these may have been caused by the test equipment itself. Great for instant checking of audio amp response.

The voltage control of frequency, while not extremely widerange, will be useful in testing filters and other frequency-sensitive circuits. The application of a voltage from zero to -8V caused a frequency variation of 28:1 on each range. Similarly, the amplitude jack was suited to modulating the output waveform with

another signal, or DC, but had the odd effect of noticeably increasing the sinewave distortion, though it didn't bother the square or triangle; perhaps the distortion could be trimmed to a lower value with the internal adjustments.

There were no switches to defeat the symmetry or offset adjust, making it necessary to use a DC voltmeter to zero the output. But then, that's what keeps the cost down.

Looking inside the unit, which is easily done by removing four screws and sliding out the metal frame, reveals a neat, well-planned construction. Except for one IC, the unit uses discrete transistors throughout, which may confirm suspicions that eastern countries are behind the west in IC production. The other components seem to be Polish-made, though the calibration trimpots looked like Philips types.

In short, the Zopan 1404A fills the bill for a low-cost versatile signal source. It's presently retailing for \$289.95. Contact: ■

*KB Electronics,
355 Iroquois Shore Rd.,
Oakville, Ontario L6H 1M3,
(416) 842-6888.*

Product Mart *Where Buyers Find Sellers*

HOBBILT ÉLECTRONIQUE

**WE DON'T SELL COMPUTERS.
WE JUST SELL THE PARTS!**

Send your name and address along with \$1.00 to: 7454 Langelier, St. Leonard Montreal, Que. H1S 3A7.
Tel: (514) 259-5581.

"DIGITAL ORGAN AND DRUM KITS, Demo LP \$8.00 (Plus \$2.00 P/H), Professional Mixer and Speaker Kits, Eprom Programmer Kit, Free Information from **SELTRON INSTRUMENTS,** 39 Southbridge St., Leamington, Ontario N8H 4N4.

J&J ELECTRONICS LTD., Box 1437E, Winnipeg Manitoba R3C 2Z4. Surplus and Semiconductor Specialists. Do you get our bargain flyer? Send \$1.00 to receive the current literature and specials and to be placed on the mailing list for future publications.

25 TESTED low cost plans regulated power supplies, electronic locks, alarms, lie detectors, testers, electronic jewelry, etc., \$6.50. Kits & parts available also. **TRS-80 I/O** interface plans \$15.00. Send to **J E ELECTRONICS,** Box 122, Delson, P.Q. J0L 1G0.

ARKON ELECTRONICS LTD., 409 Queen St. W., Toronto, Ont. M5V 2A5. Mail Orders accepted on our large inventory of computer products: Software, Hardware, Parts and Accessories. Write us with your request.

TECHNICAL BOOKS. Metalworking, woodworking, electronics, plans, science. Large catalogue \$1.00. **ERIC KEATS & COMPANY,** P.O. Box 796, Station A, Scarborough, Ontario, M1K 5C8.

"POSITIVES on film of ET projects \$2. to \$5. Your own artwork 8 x 10's \$8./-ve, \$12./+ve. Please add \$1 postage. Write for other rates including discounts and drafting aids. **ADB GRAPHICS,** P.O. Box 203, Delta, B.C., V5K 3N6."

MPF III Apple IIe Compatible \$1395.00 64K Slim Drive, Z80 Printer Card, 80 Columns Amber or Green Monitor, Shipping \$10.00. Send SASS for catalog. **RAITRONIC'S,** 6650 Ross St., Vancouver, B.C. V5X 4B2.

**DO SMALL
ADVERTISEMENTS
ATTRACT ATTENTION?
WELL, THIS ONE DID!**

WHERE BUYERS FIND SELLERS

For more information Call:
(416) 423-3262

PRODUCT MART

HARDWARE/software product design and prototyping. Mainframe communication interfacing and protocol conversion. **THE LISMA COMPUTER CORPORATION,** 4865 Sheppard Ave., East, Scarborough, Ontario M1S 3V8 (416) 297-0297.

EXCITING scientific and electronic devices you can build. Many fascinating plans and kits available. Catalogue \$2.00. Mail order only. **DUKER ENTERPRISES** 8307-160 Street, Edmonton, Alberta T5R 2H2.

TS2068 or Spectrum compatible disk drive controller card. Uses Shugart SA455 or compatible drive. 160 KB per disk, 2K DOS on EPROM \$119.95 **LARKEN ELECTRONICS,** R.R. #2, Navan, Ontario K4B 1H9.

OSCILLOSCOPES- New 27 page booklet packed with easy to read diagrams covering modern oscilloscope function, operation, terms and selection. Send \$5.00 for "OSCILLOSCOPES A-Z" with special bonus offer. **HARRY BROWN AND ASSOCIATES INC.,** P.O. Box 11386, Stn. H, Ottawa, Ontario K2H 7V1.

SALE-TIMEX-SINCLAIR SOFTWARE

LARGEST selection in Canada. Many new. Send \$1.00 refundable, for free catalogue. Hardware, Software, Audio, Electronics, Robotics, Free DMM offer. More **GLADSTONE ELECTRONICS,** 1736 Avenue Rd., Toronto, Ontario M5M 3Y7.

PRINTED CIRCUIT BOARDS for ETI and Ham Radio Projects. Reasonable rates high quality G10 epoxy, fast delivery. Our full list is free. Try us we have boards since 1977 available. **B-C-D ELECTRONICS,** P.O. Box 6326, Station F, Hamilton, Ontario L9C 6L9.

ELECTRONIC SURPLUS INDUSTRIES LIMITED, we sell used industrial/military test instruments, including oscilloscopes by HP Tektronix, Philips; Signal generators, meters, components, tubes, etc. 1191 Lawrence Avenue West, Toronto, Ontario M6A 1E2 416-787-1837.

FOR \$10 per kit \$2 handling, receive free flyer and any of the following. #1: 1000 asst'd pcs choke — capacitor — resistor — transistor — hardware — etc. #2: 200 asst'd ceramic — #3: 100 asst'd silver mica — #4: 100 asst'd mylar — #5: 50 asst'd tantalum — #6: 50 asst'd electrolytic — #7: 50 asst'd feed-through — #8: 50 asst'd metallic silver mica (Elenco) #9: 25 asst'd variable — #10: 100 asst'd 5MM L.E.D. — #11: 100 asst'd i/c sockets — #12: 6 AA nicad batteries — #13: 15 PL-259 connectors — #14: 10 UG88 connectors — #15: 10 asst'd Lorlin switch. All new material. Unconditional guarantee. **SURPLUS ELECTRO QUEBEC,** 2264 Montee Gagnon, Blainville, Quebec J7E 4H5.

BABANI BOOKS

Imported from England and exclusively available in Canada from Moorshead Publications.

BP53: PRACTICAL ELECTRONICS CALCULATIONS AND FORMULAE \$11.75
A book that bridges the gap between complicated technical theory and the 'cut and try' method. A good reference book.

BP136: 25 SIMPLE INDOOR AND WINDOW AERIALS \$6.65
People living in apartments who would like to improve short wave listening can benefit from these instructions on optimising the indoor aerial.

BP147: AN INTRODUCTION TO 6502 MACHINE CODE \$7.75
The popular 6502 microprocessor is used in many home computers, this is a guide to beginning assembly language.

BP150: AN INTRO. TO PROGRAMMING THE SINCLAIR QL \$7.75
Helps the reader make the best use of the Sinclair QL's almost unlimited range of features. Complements the manufacturer's handbook.

BP225: A PRACTICAL INTRODUCTION TO DIGITAL ICs \$6.65
This book deals mainly with TTL type chips such as the 7400 series. Simple projects and a complete practical construction of a Logic Test Circuit Set are included as well as details for a more complicated Digital Counter Timer project.

BP130: MICRO INTERFACING CIRCUITS - BOOK 1 \$8.55
Aimed at those who have some previous knowledge of electronics, but not necessarily an extensive one: the basis of the book is to help the individual understand the principles of interfacing circuits to microprocessor equipment.

BP131: MICRO INTERFACING CIRCUITS - BOOK 2 \$8.55
Intended to carry on from Book 1, this book deals with practical applications beyond the parallel and serial interface. "Real world" interfacing such as sound and speech generators, temperature and optical sensors, and motor controls are discussed using practical circuit descriptions.

BP111: AUDIO \$13.25
This one is ideal for readers who want to really get into sound. A wide range of material is covered from analysis of the sound wave mechanisms of hearing, room acoustics, microphones and loudspeakers, amplifiers, and magnetic disc recording.

BP141: LINEAR IC EQUIVALENTS AND PIN CONNECTIONS ADRIAN MICHAELS \$21.95
Find equivalents and cross-references for both popular and unusual integrated circuits. Shows details of functions, manufacturer, country of origin, pinouts, etc., includes National, Motorola, Fairchild, Harris, Motorola, Intersil, Philips, ADC, AMD, SGS, Teledyne, and many other European, American, and Japanese brands.

BP156: AN INTRODUCTION TO QL MACHINE CODE \$7.75
The powerful Sinclair QL microcomputer has some outstanding capabilities in terms of its internal structure. With a 32-bit architecture, the QL has a large address range, advanced instructions which include multiplication and division. These features give the budding machine code programmer a good start at advanced programming methods. This book assumes no previous knowledge of either the 68008 or machine code programming.

BP47: MOBILE DISCOTHEQUE HANDBOOK \$5.25
Divided into six parts, this book covers such areas of mobile "disco" as Basic Electricity, Audio, Ancillary Equipment, Cables and Plugs, Loudspeakers, and Lighting. All the information has been considerably sub-divided for quick and easy reference.

BP59: SECOND BOOK OF CMOS IC PROJECTS \$7.75
This book carries on from its predecessor and provides a further selection of useful circuits, mainly of a simple nature: the book will be well within the capabilities of the beginner and more advanced constructor.

BP32: HOW TO BUILD YOUR OWN METAL & TREASURE LOCATORS \$7.75
Several fascinating applications with complete electronic and practical details on the simple, and inexpensive construction of Heterodyne Metal Locators.

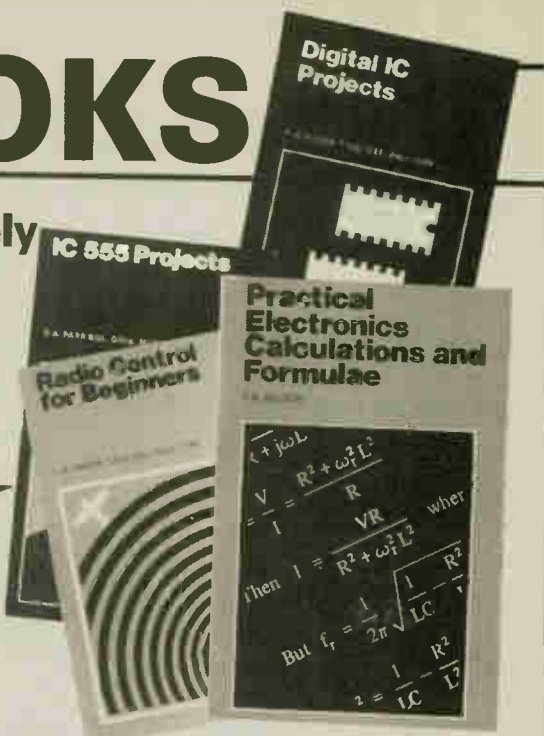

ELECTRONIC THEORY

ELEMENTS OF ELECTRONICS — AN ON-GOING SERIES

F.A. WILSON, C.G.I.A., C.Eng.

BP62: BOOK 1. The Simple Electronic Circuit and Components \$11.70

BP63: BOOK 2. Alternating Current Theory \$ 8.55

BP64: BOOK 3. Semiconductor Technology \$18.55

BP77: BOOK 4. Microprocessing Systems And Circuits \$11.70

BP89: BOOK 5. Communication \$11.70
The aim of this series of books can be stated quite simply: it is to provide an inexpensive introduction to modern electronics so that the reader will start on the right road by thoroughly understanding the fundamental principles involved.

Although written especially for readers with no more than ordinary arithmetical skills, the use of mathematics is not avoided, and all the mathematics required is taught as the reader progresses.

Each book is a complete treatise of a particular branch of the subject and therefore can be used on its own with one proviso: that the later books do not duplicate material from their predecessors, thus a working knowledge of the subjects covered by the earlier books is assumed.

BOOK 1. This book contains all the fundamental theory necessary to lead to a full understanding of the simple electronic circuit and its main components.

BOOK 2. This book continues with alternating current theory without which there can be no comprehension of speech music radio television or even the electricity utilities.

BOOK 3. Follows on semiconductor technology leading up to transistors and integrated circuits.

BOOK 4. A complete description of the internal workings of microprocessor.

BOOK 5. A book covering the whole communication scene.

PROJECTS

BP48: ELECTRONIC PROJECTS FOR BEGINNERS \$ 7.75
F.G. RAYER, T.Eng.(CEI), Assoc.IERE

Another book written by the very experienced author — Mr F.G. Rayer — and in it the newcomer to electronics will find a wide range of easily made projects. Also, there are a considerable number of actual component and wiring layouts to aid the beginner.

Furthermore a number of projects have been arranged so that they can be constructed without any need for soldering and thus avoid the need for a soldering iron.

Also, many of the later projects can be built along the lines as those in the 'No Soldering' section so this may considerably increase the scope of projects which the newcomer can build and use.

BP37: 50 PROJECTS USING RELAYS, SCR's & TRIACS \$ 7.75
F.G. RAYER, T.Eng.(CEI), Assoc.IERE

Relays, silicon controlled rectifiers (SCR) and bidirectional triodes (TRIACs) have a wide range of applications in electronics today. This book gives tried and practical working circuits which should prevent the minimum of difficulty for the enthusiast to construct. In most of the circuits there is a wide latitude in component values and types allowing easy modification of circuits or ready adaptation of them to individual needs.

BP221: 28 TESTED TRANSISTOR PROJECTS \$5.00
R. TORRENS

Mr Richard Torrens is a well experienced electronics development engineer and has designed, developed, built and tested the many useful and interesting circuits included in this book. The projects themselves can be split down into simpler building blocks which are shown separated by boxes in the circuits for ease of description, and also to enable any reader who wishes to combine boxes from different projects to realise ideas of his own.

BP71: ELECTRONIC HOUSEHOLD PROJECTS \$ 7.20
R. A. PENFOLD

Some of the most useful and popular electronic construction projects are those that can be used in or around the home. The circuits range from such things as 2 Tone Door Buzzer, Intercom through Smoke or Gas Detectors to Baby and Freezer Alarms.

BP73: REMOTE CONTROL PROJECTS \$8.10
OWEN BISHOP

This book is aimed primarily at the electronics enthusiast who wishes to experiment with remote control. Full explanations have been given so that the reader can fully understand how the circuits work and can more easily see how to modify them for other purposes depending on personal requirements. Not only are radio control systems considered but also infra red, visible light and ultrasonic systems as are the use of Logic ICs and Pulse position modulation etc.

BP90: AUDIO PROJECTS \$ 7.60
F.G. RAYER

Covers in detail the construction of a wide range of audio projects. The text has been divided into preamplifiers and mixers, power amplifiers, tone controls and matching and miscellaneous projects.

BP74: ELECTRONIC MUSIC PROJECTS \$ 7.20
R.A. PENFOLD

Although one of the more recent branches of amateur electronic electronic music has now become extremely popular and there are many projects which fall into this category. The purpose of this book is to provide the constructor with a number of practical circuits for the less complex items of electronic music equipment including such things as a Fuzz Box, Waa/Waa Pedal, Sustain Unit, Reverberation and Phaser Units, Tremolo Generator etc.

BP44: IC 555 PROJECTS \$ 7.75
E.A. PARR, B.Sc., C.Eng., M.I.E.E.

Every so often a device appears that is so useful that one wonders how life went on before without it. The 555 timer is such a device. Included in this book are Basic and General Circuits, Motor Car and Model Railway Circuits, Alarms and Noise Makers as well as a section on the 556, 558 and 559 timers.

BP82: ELECTRONIC PROJECTS USING SOLAR CELLS \$ 7.75

A collection of simple circuits which have applications in and around the home using the energy of the sun to power them. The book deals with practical solar power supplies including voltage doubler and tripler circuits, as well as a number of projects.

BABANI BOOKS

BP49: POPULAR ELECTRONIC PROJECTS \$7.75
R.A. PENFOLD
 Includes a collection of the most popular types of circuits and projects which, we feel sure, will provide a number of designs to interest most electronics constructors. The projects selected cover a very wide range and are divided into four basic types: Radio Projects, Audio Projects, Household Projects and Test Equipment.

BP94: ELECTRONIC PROJECTS FOR CARS AND BOATS \$7.60
R.A. PENFOLD
 Projects, fifteen in all, which use a 12V supply are the basis of this book. Included are projects on Windscreen Wiper Control, Courtesy Light Delay, Battery Monitor, Cassette Power Supply, Lights Timer, Vehicle Immobiliser, Gas and Smoke Alarm, Depth Warning and Shaver Inverter.

BP95: MODEL RAILWAY PROJECTS \$7.60
R.A. PENFOLD
 Electronic projects for model railways are fairly recent and have made possible an amazing degree of realism. The projects covered include controllers, signals and sound effects. Stridboard layouts are provided for each project.

BP93: ELECTRONIC TIMER PROJECTS \$7.60
F.G. RAYER
 Windscreen wiper delay, darkroom timer and metronome projects are included. Some of the more complex circuits are made up from simpler sub-circuits which are dealt with individually.

BP113: 30 Solderless Breadboard Projects-Book 2 \$8.85
R.A. Penfold
 A companion to BP107. Describes a variety of projects that can be built on plug-in breadboards using CMOS logic IC's. Each project contains a schematic, parts list and operational notes.

BP104: Electronic Science Projects \$8.85
Owen Bishop
 Contains 12 electronic projects with a strong scientific flavour. Includes Simple Colour Temperature Meter, Infra-Red Laser, Electronic clock regulated by a resonating spring, a Scope with a solid state display, pH meter and electrocardiograph.

BP110: HOW TO GET YOUR ELECTRONIC PROJECTS WORKING \$7.60
R.A. PENFOLD
 We have all built circuits from magazines and books only to find that they did not work correctly, or at all, when first switched on. The aim of this book is to help the reader overcome just these problems by indicating how and where to start looking for many of the common faults that can occur when building up projects.

BP84: DIGITAL IC PROJECTS \$7.60
F.G. RAYER, T.Eng.(CEI), Assoc. IERE
 This book contains both simple and more advanced projects and it is hoped that these will be found of help to the reader developing a knowledge of the workings of digital circuits. To help the newcomer to the hobby the author has included a number of board layouts and wiring diagrams. Also the more ambitious projects can be built and tested section by section and this should help avoid or correct faults that could otherwise be troublesome. An ideal book for both beginner and more advanced enthusiast alike.

BP67: COUNTER DRIVER AND NUMERAL DISPLAY PROJECTS \$7.05
F.G. RAYER, T.Eng.(CEI), Assoc. IERE
 Numeral indicating devices have come very much to the forefront in recent years and will, undoubtedly, find increasing applications in all sorts of equipment. With present day integrated circuits, it is easy to count, divide and display numerically the electrical pulses obtained from a great range of driver circuits.

In this book many applications and projects using various types of numeral displays, popular counter and driver IC's etc are considered.

BP99: MINI-MATRIX BOARD PROJECTS \$7.60
R.A. PENFOLD
 Twenty useful projects which can all be built on a 24 x 10 hole matrix board with copper strips. Includes Doorbuzzer, Low-voltage Alarm, AM Radio, Signal Generator, Projector Timer, Guitar Headphone Amp, Transistor Checker and more.

BP103: MULTI-CIRCUIT BOARD PROJECTS \$7.60
R.A. PENFOLD
 This book allows the reader to build 21 fairly simple electronic projects, all of which may be constructed on the same printed circuit board. Wherever possible, the same components have been used in each design so that with a relatively small number of components and hence low cost, it is possible to make any one of the projects or by re-using the components and PCB all of the projects.

BP107: 30 SOLDERLESS BREADBOARD PROJECTS - BOOK 1 \$8.85
R.A. PENFOLD
 A "Solderless Breadboard" is simply a special board on which electronic circuits can be built and tested. The components used are just plugged in and unplugged as desired. The 30 projects featured in this book have been specially designed to be built on a "Verobloc" breadboard. Wherever possible the components used are common to several projects, hence with only a modest number of reasonably inexpensive components it is possible to build, in turn, every project shown.

BP106: MODERN OP-AMP PROJECTS \$7.60
R.A. PENFOLD
 Features a wide range of constructional projects which make use of op-amps including low noise, low distortion, ultra-high input impedance, high slew rate and high output current types.

CIRCUITS

How to Design Electronic Projects
BP127 \$8.95
 Although information on standard circuit blocks is available, there is less information on combining these circuit parts together. This title does just that. Practical examples are used and each is analysed to show what each does and how to apply this to other designs.

Audio Amplifier Construction
BP122 \$8.95
 A wide circuits is given, from low noise microphone and tape head preamps to a 100W MOSFET type. There is also the circuit for 12V bridge amp giving 18W. Circuit board or strip-board layout are included. Most of the circuits are well within the capabilities for even those with limited experience.

BP80: POPULAR ELECTRONIC CIRCUITS - BOOK 1 \$7.75
R.A. PENFOLD
 Another book by the very popular author, Mr R.A. Penfold, who has designed and developed a large number of various circuits. These are grouped under the following general headings: Audio Circuits, Radio Circuits, Test Gear Circuits, Music Project Circuits, Household Project Circuits and Miscellaneous Circuits.

BP98: POPULAR ELECTRONIC CIRCUITS, BOOK 2 \$8.85
R.A. PENFOLD
 70 plus circuits based on modern components aimed at those with some experience.

BP39: 50 (FET) FIELD EFFECT TRANSISTOR PROJECTS \$6.75
F.G. RAYER, T.Eng.(CEI), Assoc. IERE
 Field effect transistors (FETs), find application in a wide variety of circuits. The projects described here include radio frequency amplifiers and converters, test equipment and receiver aids, tuners, receivers, mixers and tone controls, as well as various miscellaneous devices which are useful in the home.

This book contains something of particular interest for every class of enthusiast - short wave listener, radio amateur, experimenter or audio devotee.

BP87: SIMPLE I.E.D. CIRCUITS \$5.40
R.N. SOAR
 Since it first appeared in 1977, Mr R.N. Soar's book has proved very popular. The author has developed a further range of circuits and these are included in Book 2. Projects include a Transistor Tester, Various Voltage Regulators, Testers and so on.

BP24: 50 PROJECTS USING IC 741 \$6.75
 A unique book containing 50 projects that can be simply constructed. It is an op amp and a few components. Originally published in Germany, this book will be an invaluable asset to any hobbyist.

BP88: HOW TO USE OP AMPS \$8.85
E.A. PARR
 A designer's guide covering several op amps, serving as a source book of circuits and a reference book for design calculations. The approach has been made as non-mathematical as possible.

BP65: SINGLE IC PROJECTS \$6.05
R.A. PENFOLD
 There is now a vast range of ICs available to the amateur market, the majority of which are not necessarily designed for use in a single application and can offer unlimited possibilities. All the projects contained in this book are simple to construct and are based on a single IC. A few projects employ one or two transistors in addition to an IC but in most cases the IC is the only active device used.

223: 50 PROJECTS USING IC CA3130 \$5.00
R.A. PENFOLD
 In this book, the author has designed and developed a number of interesting and useful projects which are divided into five general categories: I - Audio Projects II - R.F. Projects III - Test Equipment IV - Household Projects V - Miscellaneous Projects.

BP117: PRACTICAL ELECTRONIC BUILDING BLOCKS BOOK 1 \$7.60
 Virtually any electronic circuit will be found to consist of a number of distinct stages when analysed. Some circuits inevitably have unusual stages using specialised circuitry, but in most cases circuits are built up from building blocks of standard types.

This book is designed to aid electronics enthusiasts who like to experiment with circuits and produce their own projects rather than simply follow published project designs.

The circuits for a number of useful building blocks are included in this book. Where relevant, details of how to change the parameters of each circuit are given so that they can easily be modified to suit individual requirements.

BP102: THE 6809 COMPANION \$7.60
 Written for machine language programmers who want to expand their knowledge of microprocessors. Outlines history, architecture, addressing modes, and the instruction set of the 6809 microprocessor. The book also covers such topics as converting programs from the 6800, program style, and specifics of 6809 hardware and software availability.

BP118: PRACTICAL ELECTRONIC BUILDING BLOCKS - Book 2 \$7.60
R.A. PENFOLD
 This sequel to BP117 is written to help the reader create and experiment with his own circuits by combining standard type circuit building blocks. Circuits concerned with generating signals were covered in Book 1, this one deals with processing signals. Amplifiers and filters account for most of the book but comparators, Schmitt triggers and other circuits are covered.

BP24: 50 PROJECTS USING IC741 RUDI & UWE REDMER \$6.75
 This book, originally published in Germany by TOPP, has achieved phenomenal sales on the Continent and Babani decided, in view of the fact that the integrated circuit used in this book is inexpensive to buy, to make this unique book available to the English speaking reader. Translated from the original German with copious notes, data and circuitry, a "must" for everyone whatever their interest in electronics.

BP83: VMOS PROJECTS \$7.70
R.A. PENFOLD
 Although modern bipolar power transistors give excellent results in a wide range of applications, they are not without their drawbacks or limitations. This book will primarily be concerned with VMOS power FETs although power MOSFETs will be dealt with in the chapter on audio circuits. A number of varied and interesting projects are covered under the main headings of: Audio Circuits, Sound Generator Circuits, DC Control Circuits and Signal Control Circuits.

RADIO AND COMMUNICATIONS

BP96: CB PROJECTS \$7.60
R.A. PENFOLD
 Projects include speech processor, aerial booster, cordless mike, aerial and harmonic filters, field strength meter, power supply, CB receiver and more.

BP222: SOLID STATE SHORT WAVE RECEIVER FOR BEGINNERS \$47.60
R.A. PENFOLD
 In this book, R.A. Penfold has designed and developed several modern solid state short wave receiver circuits that will give a fairly high level of performance, despite the fact that they use only relatively few and inexpensive components.

BP91: AN INTRODUCTION TO RADIO DXing \$7.60
 This book is divided into two main sections one to amateur band reception, the other to broadcast bands. Advice is given to suitable equipment and techniques. A number of related constructional projects are described.

BP105: AERIAL PROJECTS \$7.60
R.A. PENFOLD
 The subject of aerials is vast but in this book the author has considered practical designs including active, loop and ferrite aerials, which give good performances and are reasonably simple and inexpensive to build. The complex theory and math of aerial design are avoided.

OTHER PUBLISHERS

PH121: HARDWARE INTERFACING WITH THE TRS-80 J. UFFENBECK (1983) \$19.45
TRS 80 Model I and Model III owners now have a book to help them understand how to use their personal computers to monitor and control electronics interfaces between the computer and the home or industrial environment. Contains 14 hands-on experiments using BASIC.

SB22026 POLISHING YOUR APPLE® \$7.45
Clearly written, highly practical, concise assembly of all procedures needed for writing, disk-filing, and printing programs with an Apple II. Positively ends your searches through endless manuals to find the routine you need! Should be in the hands of every new Apple user, regardless of experience level. Ideal for Apple classrooms too!

A BEGINNER'S GUIDE TO COMPUTERS AND MICROPROCESSORS — WITH PROJECTS. TAB No. 1015: \$14.45

Here's plain English introduction to the world of microcomputers — its capabilities, parts and functions — and how you can use one. Numerous projects demonstrate operating principles and lead to the construction of an actual working computer capable of performing many useful functions.

TAB1370: A MASTER HANDBOOK OF IC CIRCUITS \$21.95
A circuit for every occasion. You'll find all the circuits you're looking for in this 532 page volume. The 932 circuits are broken down according to specific functions and in six categories. It's literally a cornucopia of ideas, projects, and designs that you can build now.

TAB1544: ELECTRONIC PROJECTS FOR PHOTOGRAPHERS \$21.95

This book gives you needed tips on the principles of electronics and building techniques, hints on how to set up a work area, and much more. Build all kinds of practical accessories for your camera, studio, or darkroom with this helpful guide.

SB22361: INTRODUCING THE APPLE MACINTOSH \$20.95

A wealth of information on hardware, software etc for the Mac. Included are such topics as making your desktop more efficient, improving your productivity with the Mac, getting the most from your mouse, how the 68000 microprocessor works and much, much more.

PH131: ZAP! POW! BOOM! ARCADE GAMES FOR THE VIC 20 T. HARTNELL & M. RAMSHAW (1983) \$17.45

Move through the maze eating dots with MAZEMAN. Sail through space zapping the ASTROIDS. Outshoot the fastest draw in town GUNFIGHT. Owners of the VIC 20 can now play these games — and more — simply by following the programs outlined in this handy guide.

THE BASIC COOKBOOK. TAB No. 1055: \$10.45

BASIC is a surprisingly powerful language... if you understand it completely. This book, picks up where most manufacturers' documentation gives up. With it, any computer owner can develop programs to make the most out of his or her machine.

HANDBOOK OF MICROPROCESSOR APPLICATIONS TAB No. 1203 \$16.45

Highly recommended reading for those who are interested in microprocessors as a means of accomplishing a specific task. The author discusses two individual microprocessors, the 1802 and the 6800, and how they can be put to use in real world applications.

MICROPROCESSOR INTERFACING HANDBOOK: A/D & D/A TAB No. 1271 \$16.45

A useful handbook for computerists interested in using their machine in linear applications. Topics discussed include voltage references, op-amps for data conversion, analogue switching and multiplexing and more.

HOW TO BUILD YOUR OWN WORKING MICROCOMPUTER TAB No. 1200 \$16.45

An excellent reference or how-to manual on building your own microcomputer. All aspects of hardware and software are developed as well as many practical circuits.

PH180: 1984 CANADIAN BUSINESS GUIDE TO MICRO-COMPUTERS K. DORRICOFF \$11.95

Written by the managing director of Deloitte, Haskins & Sells, a Canadian partnership of public accountants and other professional advisors to management, this book is one of the most complete comprehensive guides to microcomputers available. Starting with a general overview of microcomputers and their business applications, the author helps you assess your computer needs, compares and evaluates computer systems and application packages, and gives you tips on "doing it right." A must for anyone thinking of purchasing a microcomputer for business.

COMPUTER PROGRAMS IN BASIC AB01 \$15.45

A catalogue of over 1,600 fully indexed BASIC computer programs with applications in Business, Math, Games and more. This book lists available software, what it does, where to get it, and how to adapt it to your machine.

PH217: BASIC COMPUTER PROGRAMMING FOR KIDS P. CASSIDY & J. CLOSE \$16.45

Fully illustrated with photographs and drawings, this book teaches the reader the history of computers and computing and gently introduces binary mathematics and the basic theory of how computers work. Written in an easy, conversational tone.

PH51: PASCAL FOR THE APPLE IAIN MacCALLUM \$34.20

A step-by-step introduction to Pascal for Apple II and Apple II Plus users. The package of text and software diskette provides readers with worthwhile and interesting programs which can be run immediately and the results studied. Includes over 200 exercises with full solutions. Book/Disk Package.

PH52: APPLE GRAPHICS GAMES PAUL COLLETTA \$40.95

Contains 10 arcade-style games written especially for Apple II, including Spider, Piano, Pairs and Poker, as well as education, math, and designing games. Book/Disk Package.

PH57: START WITH BASIC FOR THE COMMODORE VIC 20 D. MONRO \$33.45

This book/cassette package shows the reader how easy it really is to create programs using the full capacity of the machine. Includes helpful exercises and step-by-step instructions to put the full power of the VIC 20 at the user's fingertips. Book/Cassette Package.

SB21822: ENHANCING YOUR APPLE® II — VOLUME 1 D. LANCASTER \$25.50

Who but Mother Nature or Don Lancaster could successfully enhance an Apple? YOU can, with help from Volume 1 in Don's newest series for Sams. Among other things, you'll learn (1) to mix text, LORES, and HIREX together anywhere on the screen in any combination (2) how to make a new-wire modification that will open up whole new worlds of 3-D graphics and other special effects plus (3) a fast and easy way to tear apart and understand somebody else's machine language program. Other goodies abound!

PH106: PROGRAMMING TIPS AND TECHNIQUES FOR THE APPLE II J. CAMPBELL (1983) \$23.45

An advanced exploration of the intricacies of structures programming. Further develops the skills necessary to solve programming problems. Special chapter on sound and graphics which discusses both high and low resolution graphics for the Apple II.

HB131: THE BEGINNER'S GUIDE TO BUYING A PERSONAL COMPUTER \$6.45

Written for the potentially interested computer buyer in non-technical language, this affordable book explains the terminology of personal computers, the problems and variables to be discussed and discovered while making that initial buying decision. The book does not make recommendations, but does present a great deal of information about the range of hardware available from the largest personal computing manufacturers. Readers discover the meaning and impact of screen displays, tape cassette storage and disk storage, graphics and resolution, and much more. Comparison charts clearly define standard and optional features of all the current mass market personal computers.

DESIGNING MICROCOMPUTER SYSTEMS HB18: \$18.95

POOCH AND CHATTERGY

This book provides both hobbyists and electronic engineers with the background information necessary to build microcomputer systems. It discusses the hardware aspects of microcomputer systems. Timing devices are provided to explain sequences of operations in detail. Then, the book goes on to describe three of the most popular microcomputer families, the Intel 8080 Zilog Z-80 and Motorola 6800. Also covered are designs of interfaces for peripheral devices, and information of building microcomputer systems from kits.

S100 BUS HANDBOOK HB19: \$26.00

BURSKY
Here is a comprehensive book that exclusively discusses S-100 bus computer systems and how they are organized. The book covers computer fundamentals, basic electronics, and the parts of the computer. Individual chapters discuss the CPU, memory, input/output, bulk-memory devices, and specialized peripheral controllers. It explains all the operating details of commonly available S-100 systems. Schematic drawings.

110 THYRISTOR PROJECTS USING SCRs AND TRIACS MARSTON HB22: \$13.45

A grab bag of challenging and useful semiconductor projects for the hobbyist, experimenter and student. The project range from simple burglar, fire, and water level alarms to sophisticated power control devices for electric tools and trains. Integrated circuits are incorporated wherever their use reduces project costs.

PH104: ACCOUNTANT'S BASIC PROGRAMMING FOR THE APPLE II A PARKER & J. STEWART (1983) \$20.45

Shows the reader how to program the Apple II to perform a variety of accounting functions such as payroll, accounts payable, accounts receivable, tax inventory, customer statements, and more.

HOW TO PROFIT FROM YOUR PERSONAL COMPUTER: PROFESSIONAL, BUSINESS, AND HOME APPLICATIONS LEWIS HB01 \$18.95

Describes the uses of personal computers in common business applications, such as accounting, managing, inventory, sorting mailing lists, and many others. The discussion includes terms, notations, and techniques commonly used by programmers. A full glossary of terms.

AN INTRODUCTION TO MICROPROCESSORS EXPERIMENTS IN DIGITAL TECHNOLOGY HB07 \$18.95

SMITH

A "learn by doing" guide to the use of integrated circuits provides a foundation for the underlying hardware actions of programming statements. Emphasis is placed on how digital circuitry compares with analog circuitry. Begins with the simplest gates and timers, then introduces the fundamental parts of ICs, detailing the benefits and pitfalls of major IC families, and continues with coverage of the ultimate in integrated complexity — the microprocessor.

MICROCOMPUTERS AND THE 3 R'S DOERR HB09 \$16.45

This book educates educators, on the various ways computers, especially microcomputers, can be used in the classroom. It describes microcomputers, how to organize a computer-based program, the five instructional application types (with examples from subjects such as the hard sciences, life sciences, English, history, and government), and resources listings of today's products. The book includes preprogrammed examples to start up a microcomputer program, while chapters on resources and products direct the reader to useful additional information. All programs are written in the BASIC language.

HB107: GRAPHICS COOKBOOK FOR THE APPLE WADSWORTH HB107 \$15.95

Learn how to use your Apple II to "paint" shapes, objects, and letters in low-resolution graphics. The author provides a library of microcomputer graphics including such multicoloured illustrations as robots and flying saucers, trees, sailboats, and colourful picture backgrounds. Contains complete annotated Applesoft BASIC programs to draw all the pictures described in the book as well as suggestions for improving programming techniques.

HB116: THE BASIC CONVERSIONS HANDBOOK FOR APPLE II, TRS-80™, AND PET™ USERS BRAIN BANK \$14.50

A complete guide to converting Apple II and PET programs to TRS-80, TRS-80 and PET programs to Apple II, and TRS-80 and Apple II programs to PET. Equivalent commands are listed for TRS-80 BASIC (Model I, Level II), Applesoft BASIC and PET BASIC, as well as variations for TRS-80 Model III and Apple Integer BASIC. Also describes variations in graphics capabilities.

SARGON: A COMPUTER CHESS PROGRAM SPRACKLEN HB12 \$27.50

"I must rate this chess program an excellent buy for anyone who loves the game." Kilobaud

Here is the computer chess program that won first place in the first chess tournament at the 1978 West Coast Computer Faire. It is written in Z-80 assembly language, using the TDI macro assembler. It comes complete with block diagram and sample printouts.

BASIC COMPUTER PROGRAMS FOR BUSINESS: STERNBERG (Vol. 1) HB13 \$21.50

A must for small businesses utilizing micros as well as for entrepreneurs, volume provides a wealth of practical business applications. Each program is documented with a description of its functions and operation, a listing in BASIC, a symbol table, sample data, and one or more samples.

AUDIO AND VIDEO INTERFERENCE CURES KAHANER HB21 \$8.95

A practical work about interference causes and cures that affect TV, radio, hi-fi, CB and other devices. Provides all the information needed to stop interference. Schematic wiring diagrams of filters for all types of receivers and transmitters are included. Also, it supplies simple filter diagrams to eliminate radio and TV interference caused by noisy home appliances, neon lights, motors, etc.

PH107: APPLE LOGO PRIMER G. BITTER & N. WATSON (1983) \$19.95

A pictorial starter book that will make LOGO easy for anyone. Includes easy to follow examples and reference tables. Also included is a workshop outline for teachers and leaders who want to train others.

SB22047: 26 BASIC PROGRAMS FOR YOUR MICRO \$17.45

Features 26 previously unpublished, simple-to-complex games you can run on almost any brand of microcomputer as long as you have enough RAM on board. Most take between 500 and 5000 bytes, with the highest taking 13K. Conversion charts that let you key them into your Radio Shack, TRS-80, Apple II, Timex/Sinclair 1000 (ZX81), Spectrum, Atari, or PET are included. Also features notes on program techniques and structures.

Electronics from the Start

Part 5

A continued look at capacitors, specifically electrolytic types. They pack high value of capacitance into a small space.

By Nick Bellenberg

Electrolytic capacitors enable us to use large values of capacitance and voltage, while keeping the physical volume of the components themselves relatively small. Ordinary foil type electrolytic capacitors have two sheets of aluminum foil wound in a spiral (similar to non-electrolytic types). The difference here is that the paper dielectric which separates the conductive plates is impregnated with an electrolyte (Fig. 1). Through the chemical process of electrolysis, like that which takes place in a battery or electroplating process, the electrolyte causes a thin film (approx. 10^{-4} mm in depth) of aluminum oxide to be deposited on one of the aluminum foils. This process is known as **forming** (Fig. 2), and the oxide layer acts as an electrically strong

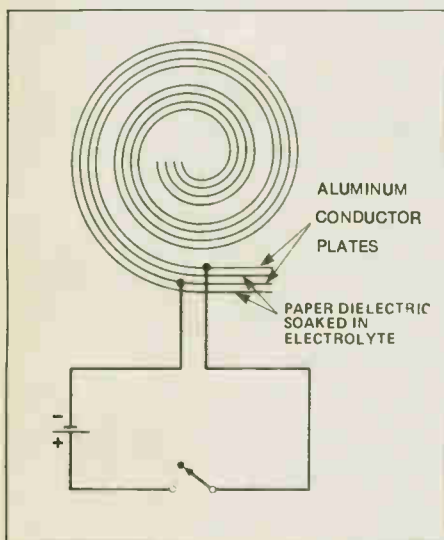

Fig. 1 Making an electrolytic capacitor: a layer of aluminum oxide is formed on the plates by electrolysis. This acts as a strong dielectric.

dielectric, meaning that it can resist very high voltages in relation to its thickness.

In Figs. 3 and 4 you can see that the capacitor's outer aluminum can has a crease or band around one end. This is to indicate the positive pole of the capacitor. This positive pole exists because during the forming process the oxide layer is only deposited on the anode (the plate connected to the positive side of the power source used). From this point on, the capacitor must be oriented correctly in circuit. The positive terminal (anode) to the positive side of the circuit, and the negative terminal (cathode) to the negative voltage.

If the capacitor is not oriented properly in the circuit, the dielectric film can break down and in some cases the whole device will explode. The explosion is caused by a gas being given off by the electrolyte, which causes pressure to build up eventually rupturing the component's casing or blowing the end off.

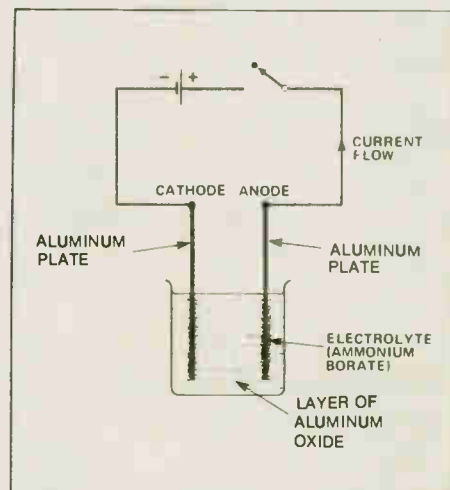

Fig. 2 The chemical process of electrolysis: putting a current through the electrolyte causes aluminum oxide to form on the anode plate.

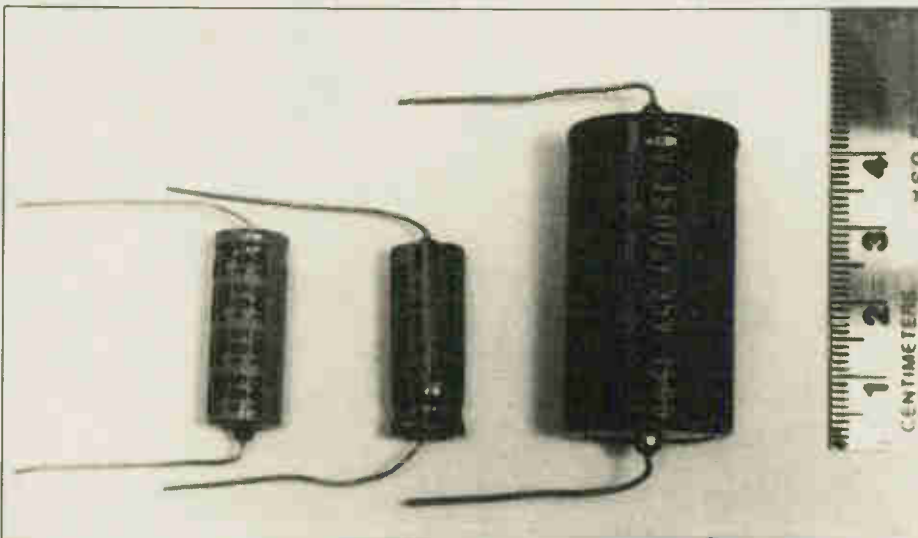

Fig. 3 Three axial electrolytics. From left to right, 100uF, 50V; 220uF, 40V; 1500uF.

Polarization

Electrolytic capacitors are therefore said to be **polarized**. Large alternating voltages (AC) must never be applied to these types of capacitor, although variable voltages are permissible as long as the positive lead of the component is not subjected to negative potentials.

As well as being able to withstand relatively high voltages, electrolytic capacitors

also have the advantage of being self-healing if the dielectric oxide layer is broken by a voltage surge or dielectric weakness. This is because after the voltage overload is removed, the action of electrolysis will occur again and reconstruct the oxide layer.

Figures 3 and 4 show a variety of capacitance, voltage rating, and size. Note the two different methods in which the connecting leads are attached to the capacitors.

The Christmas Gift that keeps on giving...

As a reader you know the value of the magazine you hold. Regular monthly features on computer and electronics, articles and news on the rapidly changing technology of computers, and more.

You are kept informed and even a step ahead to help your buying decisions and increase your general knowledge.

When considering a Christmas gift for a friend or associate this year perhaps the answer is in your hands. It is a gift that will keep on giving for twelve months and is a monthly reminder of you the giver. It is a special and thoughtful gift indeed.

PLEASE SEND THE FOLLOWING CHRISTMAS GIFTS. I HAVE INDICATED THE MAGAZINE OF MY CHOICE.

From:
Name _____

Address _____

City _____ Province _____

Postal Code _____

Publication _____

Christmas Gift Rates

Computing Now! 12 Issues \$22.95
 Electronics Today 12 Issues \$19.95
 Software Now! \$19.95
 Computers in Education \$25.00

- My cheque is enclosed.
 Charge my Visa Mastercard
 American Express account.

Account Number _____

Expiry Date _____



To:

Name _____

Address _____

City _____ Province _____

Postal Code _____

Publication _____

To:

Name _____

Address _____

City _____ Province _____

Postal Code _____

Publication _____

Send to:

Moorshead Publications
 25 Overlea Blvd., Suite 601, Toronto, Ontario
 M4H 1B1 (416)423-3262

Electronics from the Start

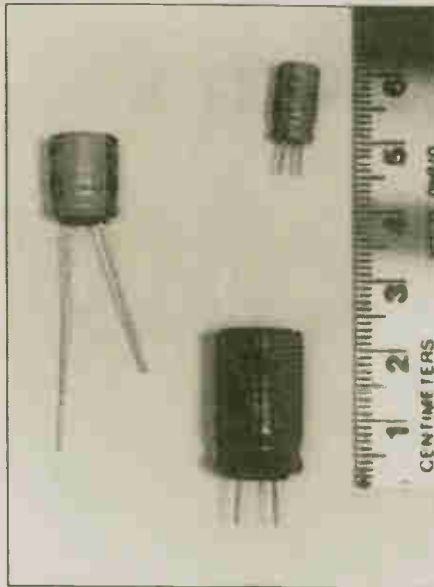

Fig. 4 Three radial devices.

The components with a connecting lead at each end are known as axial devices (Fig. 3), while those which have leads coming from the same end are known as radial devices (Fig. 4).

The capacitors shown are manufactured in such small sizes by an etching technique that is applied to the foil plates. Etching the plates roughens their surfaces, thereby increasing the overall surface area. This means that the overall dimensions of a given foil can be made smaller than they would be if it was perfectly smooth.

One disadvantage of electrolytic capacitors, though, is that they have a very wide tolerance: typically $\pm 20\%$ or $-10 + 50\%$. In other words, the actual capacitances of components can be quite a great deal different to the rated values. This also means that when an electrolytic capacitor is chosen for a circuit, those available from a typical supplier's catalogue should always be able to fit the bill. In this case the nearest



Fig. 5 Various tantalum bead capacitors. The long lead indicates the positive connection.

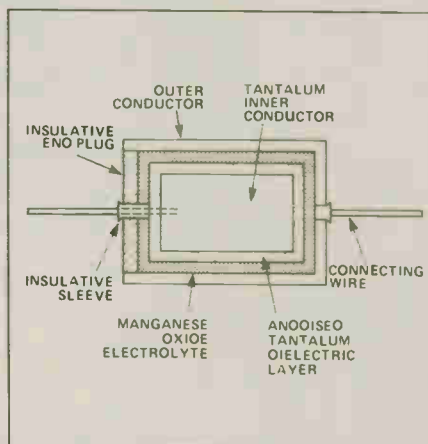

Fig. 6 A schematic of a tantalum bead capacitor: the electrolytic is manganese oxide.

capacitance to the one needed, and the equal or next largest voltage should be chosen. Suppose a circuit that you have designed calls for a 70uF capacitor rated at 10V. Looking at a supplier's list, the actual capacitor to choose would be the 60uF 16V one.

Other Types

Fig. 5 shows a variety, tiny, tantalum bead electrolytic capacitors. Tantalum is a metal of very high purity and its oxidation by electrolysis means that tantalum capacitors work in a similar manner to aluminum foil types. Fig. 6 shows a schematic diagram of tantalum capacitor with a manganese oxide electrolyte.

These components have the advantage of providing high capacitance in very small packages. However, working voltages are

Battery Holder

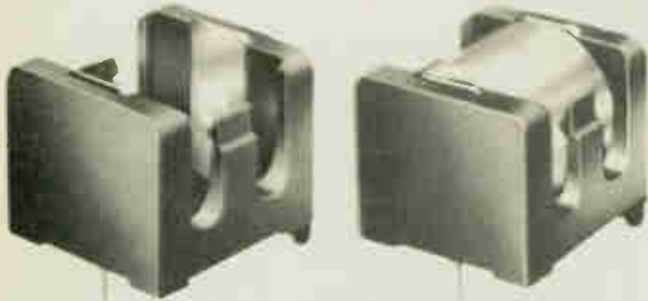

The new, under 1/2" high BH-1/3N single cell battery holder from Memory Protection Devices accepts all standard 1/3N 3V lithium cylinder cells. Its low profile permits PCB stacking and

eliminates the need for soldering in the battery. Contact Memory Protection Devices, 320 Broad Hollow Road, Farmingdale, NY 11735, (516) 454-0340.

Last month we looked at a software solution to error correcting in RAM; the program could compensate for bits which had changed state due to cosmic radiation or particle decay. Now the University of Southern California is experimenting with a hardware solution; Dr. John Choma of the School of Engineering de-

vised that since a CMOS memory cell is actually two transistors fused together, a barrier could be inserted between them. An oxide trench is fabricated between the transistors to prevent undesirable currents from flowing in the semiconductor bulk. Test devices show no latch-up.

A new low-cost audio mixer from Promark of England is available in Canada. It permits eight, four and two track track mixing. Insertion points allow a wide range of effects; LED meters are provided for monitoring of levels. Operational understanding is aided by clear signal paths leading to colour-cod-

ed connectors, and the comprehensive owner's manual covers everything from making your own leads to the finer points of eight-track mixdown. Contact Heint Electronics, 16 Mary Street, Aurora, Ontario L4G 3W8, (416) 773-1511.

continued on page 58



"When you said these were heavy-duty joysticks... you weren't kidding!"

**Moorshead Publications
Order Form**

Subscriptions:

Please complete reverse side of order form to start or renew a subscription.

Back Issues: \$4.00 each; Ontario residents add 7% sales tax. Please circle issues desired.

1977	February					July
1978	April	May	September	November		December
1979	February		March	April	May	July
	August		September	October		November
1980	January	February	May	June	November	December
1981	January	February	March	April	June	July
	August	September	October	November		December
1982	January	March		April	May	June
	July	August	September	October	November	December
1983	January	February	March	April	May	June
	August	September	October	November		December
1984	January	February	March	April	May	June
	July	August	October	November		December
1985	January	February	March	April	May	June
	July	August		September		

On the following items please add \$1.00 for postage and handling plus 7% Ontario provincial sales tax.

Special Publications:

ITEM	QTY	AMOUNT
Electronic Circuit Design \$3.95	\$
Projects Book No. 2 \$3.95	\$
Personal Computer Guide \$3.95	\$
50 Top Projects \$4.95	\$
Your First Computer \$3.95	\$
Computers in Small Business \$3.95	\$

Binders: Electronics Today; Computing Now!
 Moorshead Publications
\$9.75 each plus 7% P.S.T.

**BOOKSHELF
ORDER FORM**

Code (e.g. BP12)	Title (Short-form is O.K.)	Price
.....	\$
.....	\$
.....	\$
.....	\$
.....	\$

**SOFTWARE
ORDER FORM**

.....	\$
.....	\$
.....	\$
Sub Total	\$
Tax (Ontario Residents)	\$
Postage	\$
Total Enclosed	\$

Orders from the Bookshelf are tax exempt. Please add \$1.00 for postage. Remember to put your name and address on reverse side. See over for mailing details.

Do you currently subscribe to Electronics Today Yes No Computing Now! Yes No Computers in Education Yes No Software Now Yes No

BE SURE OF YOUR ISSUE EACH MONTH. SUBSCRIBE TODAY.



BOOKS, BACK ISSUES, SPECIAL PUBLICATIONS, BINDERS — SEE OVER

Moorshead Publications

Suite 601, Overlea Blvd., Toronto, Ontario M4H 1B1.

MERCHANDISE ORDER Please fill out form overleaf

SUBSCRIPTIONS: NEW SUBSCRIPTION RENEWAL

Electronics Today

One year (12 issues) \$22.95 Two years (24 issues) \$37.95.

Computing Now!

One year (12 issues) \$22.95 Two years (24 issues) \$37.95

Computers in Education

One year (10 issues) \$25.00 Two years (20 issues) \$45.00

Software Now!

One year (12 issues) \$19.95 Two years (24 issues) \$34.95

Outside Canada (US Dollars)

For U.S. please add \$3.00 per year other countries add \$5 per year

NAME _____

ADDRESS _____

TOWN/CITY _____ PROVINCE/STATE _____

CODE _____ DATE _____

POSTAL CODE _____

Cheque enclosed DO NOT send cash

Mastercard Account No. _____

Visa Account No. _____

American Express Account No. _____

Expiry Date _____

Signature _____

THE ELECTRONICS TODAY RADIO DISGUISER/MAGAZINE BINDER



When you're on a secret surveillance mission, you can't very well stick your walkie-talkie up to your ear and send a report when you're surrounded by bikers. The Electronics Today Radio Disguiser/Magazine Binder lets you look real cool while you talk to headquarters.

When you get home, you can then use it to store 12 issues of Electronics Today without cutting or punching. Available with Moorshead Publications or Electronics Today imprint (please specify).

You'll be the best-read, best-disguised surveillance officer in the district, and your magazines copies will be organized for easy future reference. Oh, yes, one more thing. When you're on a stake-out, don't forget to take off your hat.

Binders are \$9.75 each; Ontario residents please add 7% sales tax. Send to:

Binder,
Moorshead Publications,
 Suite 601, 25 Overlea Blvd.,
 Toronto, Ontario M4H 1B1

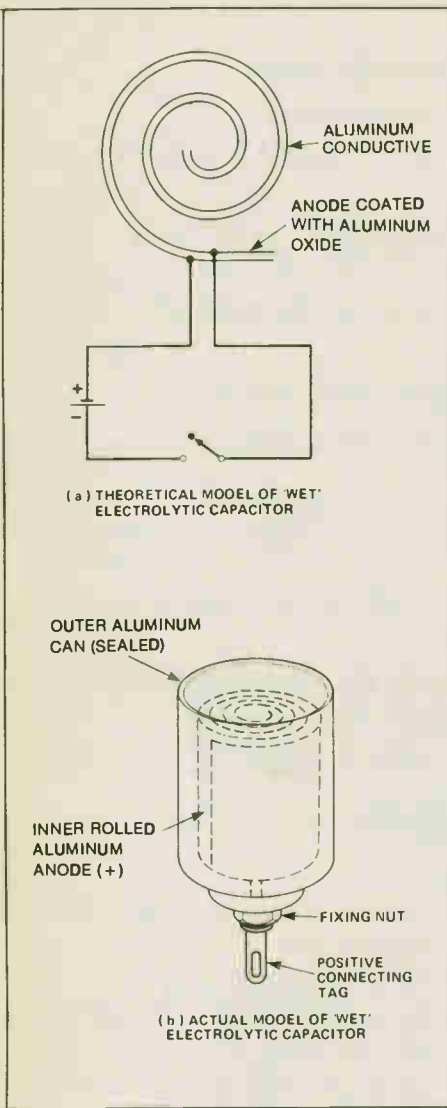

Fig. 7 A theoretical (a) and an actual representation (b) of a wet capacitor. The nut provides a negative connection to the chassis.

limited to around 35V. The tolerance of tantalum bead capacitors is typically $\pm 20\%$ and values from 0uF to 100uF are available.

Aluminum types also exist that use an electrolyte, with no tissue paper layers for it to soak into. These are called *wet* capacitors and Fig. 7 shows the device in its theoretical form (a) and actual form (b). Here, the inner rolled up aluminum foil is oxidized by the electrolyte and as such is the anode plate.

The aluminum can in which this is contained acts as the cathode plate and is filled with the electrolyte. The positive connection comes through the insulator in the can's bottom, while the fixing nut on the bottom of the can provides the negative connection. These electrolytics are generally quite bulky (typically 100mm high and 35mm in diameter) and are usually used to

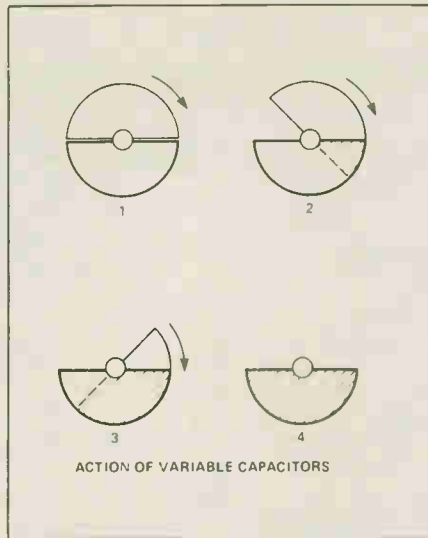

Fig. 8 Adjusting a varied capacitor: as the area of overlap increases, so the capacitance varies from 0 to maximum.

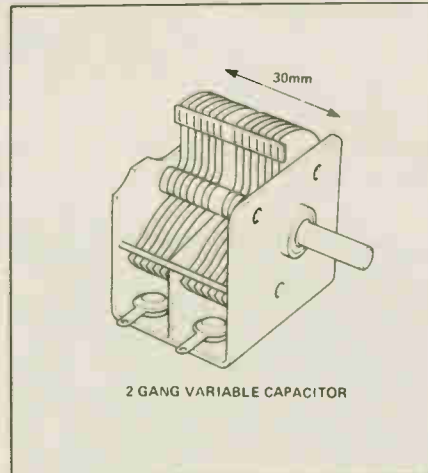

Fig. 9 A dual-ganged capacitor with two controls and multiple plates.

smooth power supplies and as such have high voltage and capacitance ratings. Tolerances typically run at $+80\%$ - 20% . In summing electrolytics, they give us high capacitance and voltage values in physically small packages. On the down side, they have a very wide tolerance range, must only be used with DC supplies, and have a tendency for the electrolyte to dry out in high temperatures, affecting their action adversely.

Variable Capacitors

Variable capacitors are non-electrolytic and take two forms: preset and manually variable.

Manually variable capacitors are commonly used in the tuning sections of radios. As we know, capacitance can be varied by altering the overlapping area of the two

Computers In Small Business

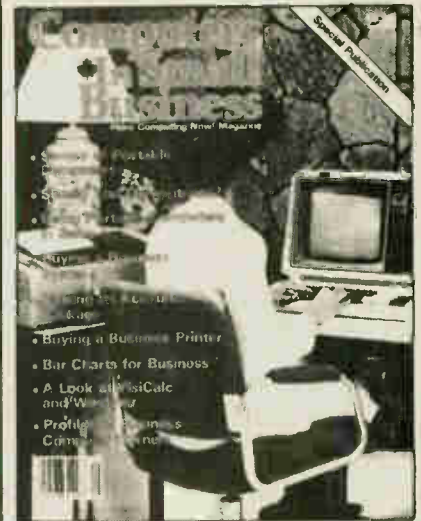

Small companies across Canada are hungry for knowledge about the microcomputer revolution. Many of them believe that they alone are ignorant about what is going on and what equipment is available.

This Special publication is addressed exclusively to this market. The articles comprise reprints of the very best material already published in *Computing Now!* magazine together with several specially commissioned features to form a well balanced publication. We believe this Special is of real use to the hundreds of thousands of small companies on the verge of buying a micro-computer.

**First Published
March 1984**

\$3.95 plus \$1.00 postage and handling. Ontario Residents add 7% PST. For a copy call (416) 423-3262 or write:

**Moorshead Publications
25 Overlea Boulevard,
Suite 601,
Toronto, Ontario, M4H 1B1**

Table 1
Attributes and applications of different capacitors

Type	Properties	Applications
Paper	Cheap, general purpose capacitors with a reasonable capacitance to size ratio.	General purpose.
Plastic:		
Polystyrene	High insulation resistance; low losses; small.	General purpose and charge storage; Filters.
Polycarbonate	Miniature; self healing.	Miniature general purpose.
Ceramic:		
Low permittivity	Low dissipation	Low voltage applications
Medium permittivity	High capacitance to size ratio.	
High permittivity	Large capacitance to size ratio; voltage and temperature sensitive.	Temperature correction components
Mica	Highly stable, low dissipation	General purpose.
Electrolytic:		
Aluminum	Polarised devices; very large capacitance to size ratio; limited life and temperature range.	Smoothing circuits; General purpose.
Tantalum	Small, expensive, polarised, highly reliable.	Where reliability and/or size is a priority.
Variable:		
Manual	Variable within certain limits.	Tuning circuits.
Preset	Variable within certain limits.	Tuning circuits.

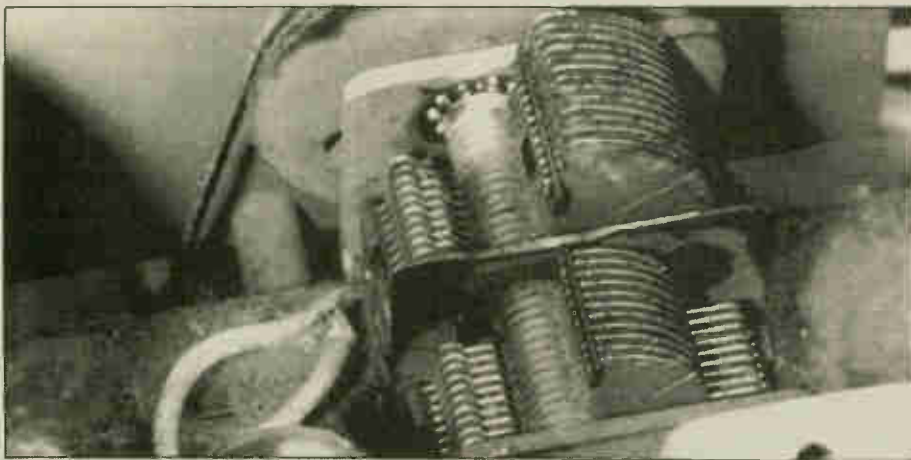

Fig. 10 A variable tuning capacitor from a RCA Victor model VR-41 radio, circa 1940.



Fig. 11 A preset trimmer with six conductive plates.

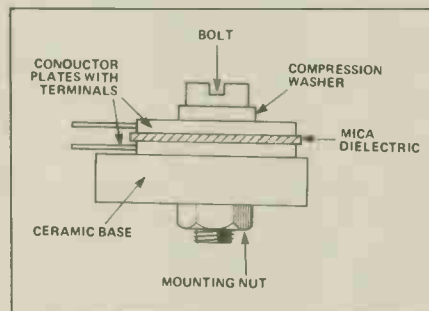

Fig. 12 The construction of a compression preset trimmer.

plates or by altering the thickness of the dielectric between them. Manually variable capacitors work by varying the area of the overlapping plates. Fig. 8 is a graphic representation of how this works. One of two semicircular plates is fixed to the central spindle. Rotating the spindle moves the one plate over the other.

In reality, more than two plates, more commonly known as vanes, are used, as in Fig. 9. This is a dual ganged variable capacitor, which means that the front and back sections are separate, so that they can be possibly used for different wavebands of a radio. For example, the front section of this one is variable from 10 to 208pF, and the rear section goes from 8pF5 to 176pF. The variable capacitor shown in Fig. 10 is from an early 1940s RCA radio.

Miniature preset trimmer capacitors come in various forms. Those which are used in small portable AM radios for example, may have as many as four separate tuning sections. Other types such as the one in Fig. 11 have six conductive plates attached to one spindle (screw).

Compression trimmers work by altering the thickness of the dielectric between the plates by compressing it to different depths. Fig. 12 illustrates the make-up of such a preset capacitor.

We have now covered the most common types of capacitor which you are likely to encounter; Table 1 lists the characteristics and uses of these types. ■

Audio Frequency Signal Generator

Using a dedicated IC, a signal generator giving a choice of three signal sources is not expensive to build.

By David Silvester

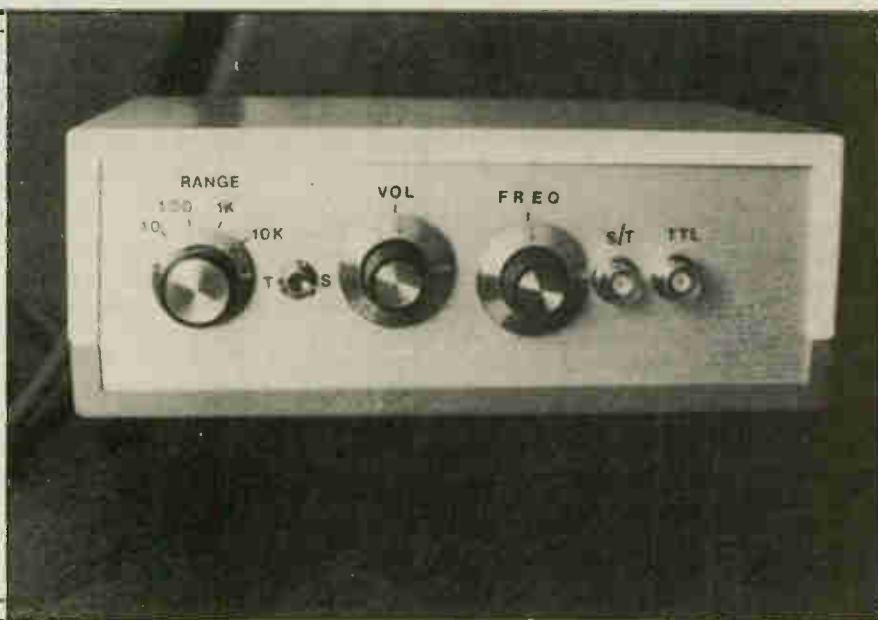

After the purchase of a multimeter one of the most useful pieces of test equipment to construct is an audio frequency signal generator. The signal generator described here provides two simultaneous outputs, a TTL compatible source running from 0 to +5V and a second providing either sine or triangular wave outputs symmetrical around zero volts.

All three waveforms may be used for amplifier testing, the triangular waveform being especially suitable for examining crossover distortion in class B amplifiers. A 'volume control' is provided for the sine and triangle waveforms while the TTL waveform is fixed. If the constructor requires a low output power a separate attenuator will need to be provided.

Now that dedicated waveform generator chips are available, and providing no sophisticated requirements have to be met, a signal source can be built for a reasonable price. A frequency range of 10 to 100,000 Hz was chosen although the frequency range of the 8038 waveform generator IC used in the project is 0.001 Hz to 300kHz, with output voltages related to the supply voltage. The sine wave is derived from a triangular waveform by the use of a non-

linear network within the IC and consequently is more distorted than the output from a pure sine wave generator. This distortion of about 0.5% appears as blips on the sine wave peaks but although this distortion is too high to enable the generator to be used for audio power amplifier distortion testing, it is most likely that it will be used as a signal source for amplifier repairs. In this case where the fault causes only half of the waveform to be amplified, the small amount of distortion produced by the signal generator can be ignored.

Circuit Description

Figure 1 shows the full circuit diagram of the signal generator. IC1 is the ICL8038 waveform generator chip that is the heart of the whole unit, it produces the basic three waveforms in the following manner. An external capacitor C1 to C5, selected by SW1 and connected to pin 10 of IC1 is charged and discharged by two current sources whose charge and discharge currents are selected by the resistance of R4 and R5. During the charge cycle the voltage across the capacitor increases linearly with time, and falls linearly with time during discharge. In addition two voltage com-

parators monitor the voltage across the capacitor and switch from charge to discharge at 2/3 supply voltage and from discharge to charge at 1/3 supply voltage. The voltage across the capacitor is a triangular wave with equal rise and fall times if R4 and R5 are of the same value. This voltage is sent via a buffer amplifier to the triangle wave output pin 3. There is no reason why the charge and discharge times need be the same and the waveform generator can be used to produce sawtooth waveforms of varying rise and fall times.

The switching of the two current sources gives a useful signal to provide the square wave output. However the IC's output is an open collector transistor and needs a resistor connected between IC1 pin 9 and the positive supply. The output voltage will vary between the lowest supply voltage (-12V) to the voltage of the positive power supply, +12V in our case. We cannot directly connect the resistor from the IC to the 5V supply as the output will still be from -12 to +5 volts. R1, R2, R3, D1, Q2, and the +5 volt regulator IC5 are used to provide level shifting to give the TTL compatibility above zero volts. Diode D1 provides protection for the transistor when

the output of IC1 pin 9 is at -12V , since by conducting it will hold the base only 0V_6 below zero while damage to the transistor will not occur until the base-emitter voltage exceeds -5V . The sine wave signal as stated earlier is derived from the triangular wave output and the circuit includes R6, R7, RV2, and RV3 to allow alterations to the non-linear elements in the IC to reduce the distortion to its lowest value. An oscilloscope is an asset in setting up the sine distortion pots and with the completed signal generator makes a highly efficient fault diagnosis setup. However if one is not available the two potentiometers may be set to their mid point with only a small residual distortion being left on the sine wave.

The sine or triangular wave output is selected by SW2, but as IC1's output is of high impedance at this point a 100k potentiometer is used as a volume control and is followed by a unity gain buffer with high input impedance (IC2). The 100R resistor R8 is connected between the output of IC2 and the output socket to provide some protection against accidental overloads. The switch SW1 selects a range of capacitors from $2.2\mu\text{F}$ to 220pF to provide the five decade ranges needed. An extra range of 1 to 10Hz was included in the prototype. To give complete frequency coverage a second control signal to the current sources sharing the capacitors is provided by RV1, and Q1 and the output from IC1 pin 7. The linearly varying voltage from RV1 produces a linear frequency change from all of the outputs. With the system shown all of the decade ranges can be covered in full with some overlap to allow for component tolerances.

The power supply unit relies on easily available 78L and 79L integrated circuit regulators. The 120VAC input is transformed to $15\text{-}0\text{-}15\text{V}$ by Q1, rectified by BR1 and smoothed by capacitors C9 and C10. The regulator chips are fed from these capacitors and give outputs of $+12\text{V}$, $+5\text{V}$ and -12V being followed by further capacitors C6, C7 and C8 to give additional smoothing.

Construction

As all of the components are mounted on the single PCB, construction is extremely simple (Fig. 2). The two integrated circuit sockets should be mounted first as these aid in locating the position of the other components. Do not insert the ICs at this stage. Note that the transformer is a PC mounting type. If a suitable transformer cannot be found, a standard open frame type such as one from the Hammond 166 series can be wired to the PC. A suitable substitute is the 166 F30 available from Electro Sonic, 1100 Gordon Baker Rd, Willowdale Ont., M2H 3B3, (416) 494-1555. The two potentiometers have their leads bent to lower their bodies towards the board and ensure that the mounting nuts are beyond the board edge (Fig. 3).

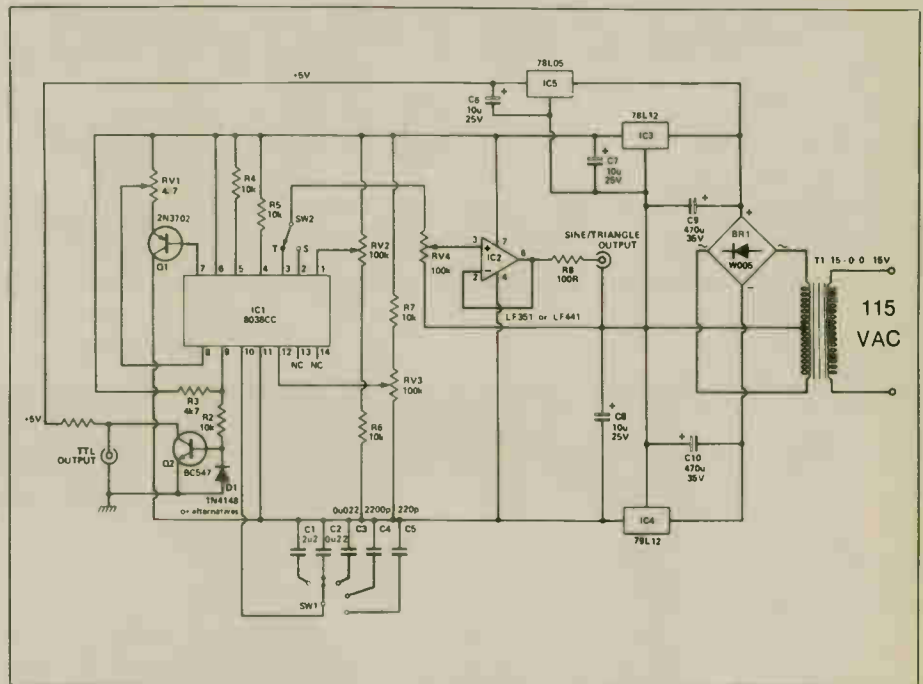

Fig. 1 The circuit of the signal generator. The heart of the design is the 8038 signal generator chip.

PARTS LIST

Resistors

R1,3	4.7k
R2,4,5,6,7	10k
R8	100R

Potentiometers

RV1	4.7k Lin pot
RV2,3	100k skeleton preset
RV4	100k Lin pot

Capacitors

C1	2.2uF
C2	0.022uF polyester
C3	0.022uF polyester electro or polyester
C4	2200pF polycarbonate
C5	220pF polycarbonate
C6,7,8	10uF 25V tantalum bead

C9,10	470uF 35V electro
-------	----------------------

Semiconductors

IC1	8038CC
IC2	LF351 or LF441
IC3	78L12
IC4	79L12
IC5	78L05
Br1	W005 Motorola MDA202 or similar 1A, 200V bridge rectifier
Q1	2N3702
Q2	2N5818
D1	1N4148, 1N914 or 1N916 diode

Miscellaneous

T1	Transformer 15-0-15V 200mA PCB mounting
SW1	1 by 12 way rotary switch
SW2	Miniature single pole changeover
BNC sockets; Verobox 202; knobs x 3; AC cable and grommet:	

Testing

Connect the AC to the PCB but ensure that IC1 and IC2 are not inserted. Check the voltages at the output of the three regulator ICs. After checking this, turn off the power supply and allow the voltage to fall to zero

before inserting IC1 and IC2. The output may now be examined on an oscilloscope if this is available and RV2 and RV3 rotated to obtain minimum distortion. If an oscilloscope is not available then these two resistors should be set to mid-point.

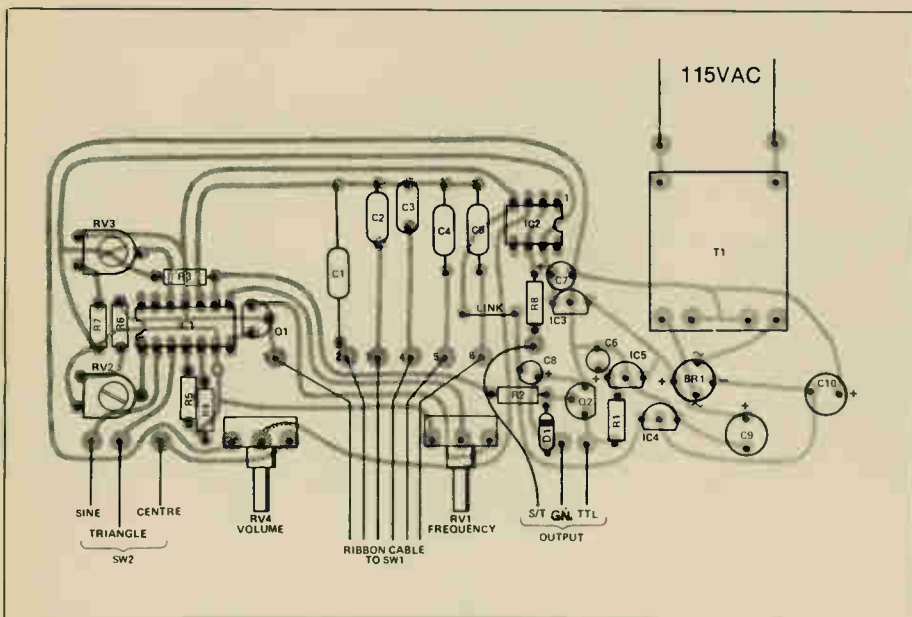

Fig. 2 The PCB overlay. Note that IC1 and IC2 should not be inserted until testing has commenced.

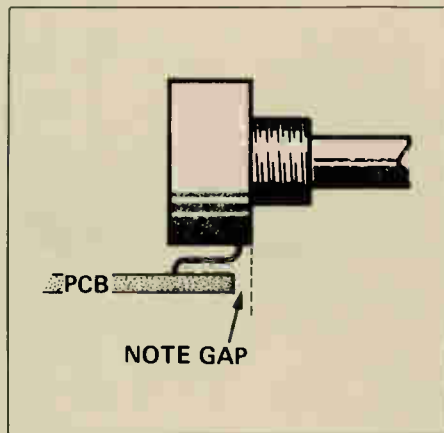
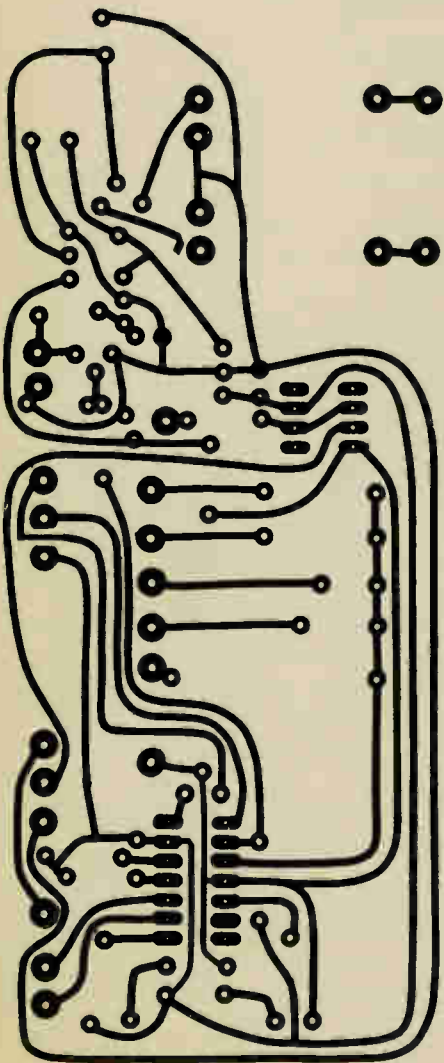

Fig. 3 The pots should be bent slightly forward to bring the panel nuts clear of the edge of the PCB.

**INTRODUCING:
THE NEW STANDARD
FOR IBM PC/XT
COMPATIBILITY**
The ACS-1000 Super Computer



- 1 Megabyte On-Board Memory
- Built-in Disk Controller
 - up to 4 Floppies
 - SASI Hard Disk Interface
- 54 KB User Definable ROM
- Switchable: 4.77 or 8 MHZ
- Built-in Multifunction Board
 - Parallel Printer Port
 - 2 Serial Ports
 - Time-of-day Clock

**Seize Control of Your
Hardware Destiny**

If you are using board level microcomputers you can have greater power, versatility and reliability by using the ACS-1000 single board SuperComputer.

The ACS-1000 is compatible with both software and hardware designed for the IBM PC/XT. It even has the same mounting holes and the same power supply connections. The difference is that the ACS-1000 offers a much higher level of integration and costs less than \$600 when ordered in quantity.

Save your Expansion Slots for true expansion. Disk Controllers, I/O ports and extensive memory are already built-in, simplifying production and freeing the 6 expansion slots to take on specialized work of your process control, CAD/ CAM or office automation applications. There's even a special port for a low cost piggyback modem.

See for yourself. We are offering a system evaluation kit for \$995.00. The 256K system includes bios, documentation, and an XT compatible power supply.

Special introductory offer on peripherals and chips.

Shugart SA 455 Floppy Drives \$185.00,
IBM Compatible cases \$80.00, 130 Watt
Power Supplies \$220.00, Keyboard
\$200.00, Chips 64K \$3.00, 256K \$14.00.

To order call 604-888-2606 or write:

Soltech Industries Inc.
9274 - 194th Street
Surrey, B.C. V3T 4W2

High Speed Probe



The Beckman LP25 Digital Logic Probe measures DTL, TTL, CMOS, NMOS and other logic levels at speeds up to 25MHz; it will detect pulses of 30ns duration. It features a pulse memory for single pulse detection, a tone output, overvoltage protection, and a coil cord. It retails for \$59.95. Contact Lenbrook Electronics, 111 Esna Park Drive, Unit 1, Markham, Ontario L3R 1H2, (416) 477-7722.

Circle No. 51 on Reader Service Card.

Laser Trainer

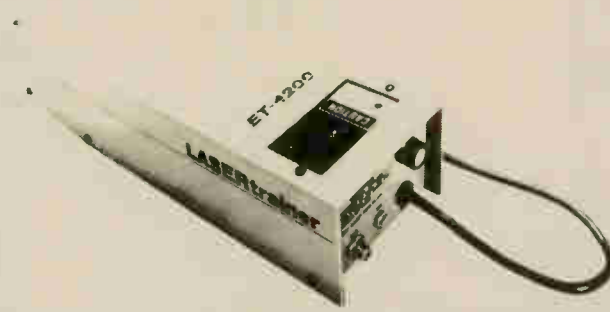

Heathkit/Zenith Educational Systems has introduced the first Laser Training System geared toward industry personnel, students, hobbyists and anyone interested in laser technology. The system includes a 400-page course and a parts package complete with lenses, filters, optical cables, and 15 experiments. The laser is a

low-power Class II Helium Neon type, emitting less than 1mW for safety. Rats. We thought we could use it to vaporize the neighbour's cats when they sing at night. At Heathkit Electronic Centres across Canada, or contact the Heath Company, 1020 Islington Ave., Dept. 3100, Toronto, Ontario M8Z 5Z3, (416) 232-2686.

Circle No. 50 on Reader Service Card.

Precision Capacitors



Philips is introducing a series of metal foil/polypropylene film precision capacitors for filtering, tuning and timing circuits which offer a higher resistance to heat shock during soldering than metal foil capacitors with a polystyrene dielectric. This eliminates the need for spacers, allowing automatic insertion on double-sided PCBs. Values range from 47 to 62,000 pF and voltages are 63V (460 series), 160V (461 series) and 250V (462 series). For more information, contact Elcoma Division, Philips Electronics Ltd., 601 Milner Avenue, Scarborough, Ontario M1B 1M8, (416) 292-5161.

Circle No. 49 on Reader Service Card.

DOES YOUR DIGITAL CAPACITANCE METER DO THIS?

FULL 4 DIGIT 0.5 INCH LCD DISPLAY COMPLETELY AUTORANGING WITH 10 RANGE MANUAL CAPABILITY

- AND THIS**
RANGE OF 0.0 pF to 1 FARAD (999.9 mF)
0.5% BASIC ACCURACY UP TO 100 uF
- AND THIS**
READS DIELECTRIC ABSORPTION
- AND THIS**
EXTENDED PSEUDO 5 DIGIT
RESOLUTION ON SOME RANGES ONLY
- AND THIS**
ABILITY TO ZERO LARGE CAPACITANCE
VALUES UP TO 99.99 uF
- AND THIS**
CALCULATES TRUE CAPACITANCE
IF CAPACITOR IS LEAKY
- AND THIS**
DIODE CLAMP AND FUSED
PROTECTED INPUT.
DISCHARGE RESISTOR IN OFF
POSITION AT TERMINAL INPUTS.
POWERED BY 9V BATTERY

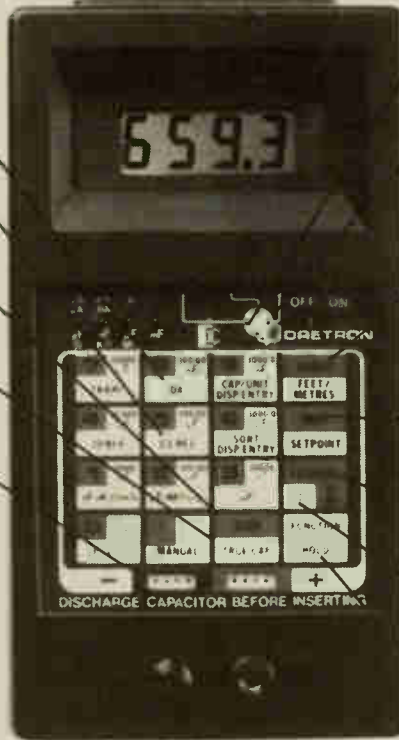

- AND THIS**
IDENTIFIES TRANSISTORS (NPN, PNP)
AND THEIR LEADS (E, B, C, ETC.)
- AND THIS**
TESTS ZENER DIODES AND RECTIFIERS.
UP TO 20V ZENER WITH AC ADAPTOR,
ZENER VOLTAGE WITH 9V BATTERY
DEPENDS ON ITS CONDITION
- AND THIS**
AUTOMATICALLY CALCULATES LENGTHS
OF CABLES IN FEET, METRES, MILES,
KILOMETRES (THEORETICAL RANGE
OF 9,999 MILES)
- AND THIS**
ABILITY TO SORT CAPACITORS IN
MANY DIFFERENT MODES
- AND THIS**
ABILITY TO READ LEAKY CAPACITANCE
(INSULATION RESISTANCE OR CURRENT)
- AND THIS**
CALCULATES TIME CONSTANTS WITH
USER DEFINED RESISTANCE VALUES
- AND THIS**
HOLD FUNCTION FREEZES DISPLAY

ONE YEAR PARTS & LABOUR WARRANTY

FOR ONLY THIS



MODEL MC300

Approx. Size
7" x 4" x 1 1/4"

DAETRON
935 THE QUEENSWAY
BOX 641
TORONTO ONTARIO M8Z 5Y9
(416) 255-9701

DEALER ENQUIRIES INVITED

MADE IN CANADA

PLEASE SEND ME _____

____ (QUANTITY) MC300(s) @ \$149.95 \$ _____

CARRYING CASE \$19.95 \$ _____

AC ADAPTOR \$11.00 \$ _____

ONTARIO RESIDENTS ADD 7% PST \$ _____

SHIPPING AND HANDLING @ 4.45 per instrument \$ _____

TOTAL \$ _____

I ENCLOSE CHEQUE MONEY ORDER BILL MY VISA

VISA CARD NO. _____

EXPIRY DATE _____ SIGNATURE _____

NAME _____

ADDRESS _____

CITY _____ PROV. _____ POSTAL CODE _____

1736 Avenue Rd.,
Toronto, Ontario M5M 3Y7
(416) 787-1448

QL

Sinclair's Breakthrough Computer... 32 Bit Power At the Lowest Price Ever



Gladstone's New Low Price
blows away all competition!

\$599⁹⁵

- Cross-Canada warranty service by AABEX
- 7-Day Money Back Guarantee.

- Includes Four Software Programs

Here are some of the incredible features of the Sinclair QL:

The Sinclair QL revolutionizes the computer revolution. It offers the utmost in performance, speed and power at the remarkably low price of only \$599.95.

The QL is a full-size computer designed around the most powerful and advanced microprocessor yet created for the personal computer: the Motorola 68008. With 128K RAM, expandable to 640K. High resolution color or black and white display, on either monitor or TV. Two RS-232C serial interfaces. Joystick cursor control.

The QL also comes with all the software you need to get started right away doing useful work. Wordprocessing, Spreadsheet, Graphics Database management. A powerful set of programs as sophisticated and as easy to use as any on the market.

Two Powerful Processors: 32-bit main processor (68008), and Intel 8049 to control keyboard, sound, and RS232.

New Operating System: In addition to conventional DOS commands, the 32K ROM (expandable) provides single-user multi-tasking, allowing you to run several programs individually and simultaneously. It also allows up to twenty independent windows to be viewed.

Fully expandable memory: The QL comes with 128K and is fully expandable up to 640K.

Professional keyboard: Full size QWERTY keyboard with 64 keys including shift, function and four separate cursor control keys.

Two built-in microdrives: Sinclair's cartridge tape storage system provides high capacity data

storage at a fraction the cost of floppy disk. Each stores up to 100K, easily and quickly accessible. Up to six more microdrives can be added externally.

Sinclair SuperBASIC: Adds new features to BASIC to allow the full power of the QL to be exploited. 'Procedure' facility allows code to be written in clearly-defined blocks. 'Extendability' allows new procedures to be added. 'Constant execution speed' allows long programs to run much faster than other BASICS.

Your QL is supplied complete with everything you need to start computing immediately: cables, power supply, blank Microdrive cartridges, comprehensive instruction and programming manual, and complete guides to the software.

Call 416-787-1448 to Order — Credit Cards Welcome — Mail Order Form on Page 63

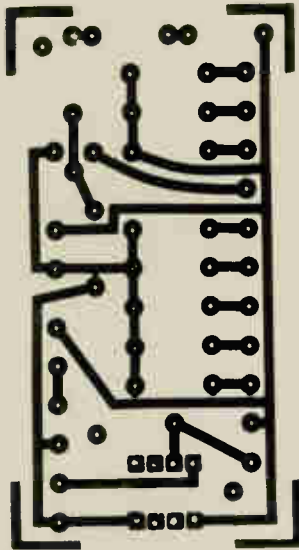

The PCB for the Battery checker.

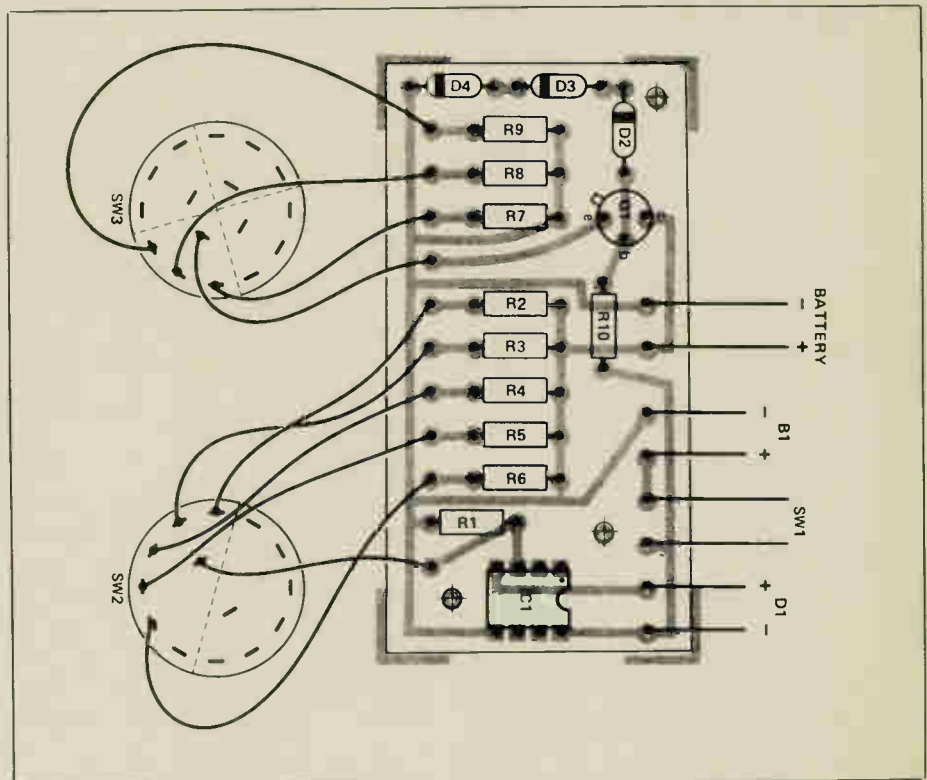

Fig. 3 The PCB layout. Use an IC socket to protect the 8211. The battery under test is connected via leads to a jack socket on the rear of the case.

AMAZING SCIENTIFIC and ELECTRONICS DEVICES

PLANS — All Parts Available in Stock.

- LC5 BURNING CUTTING CO2 LASER \$20.00
- RUB3 RUBY LASER RAY PISTOL 20.00
- BTC5 1.5 MILLION VOLT TESLA COIL 15.00
- IOG1K ION RAY GUN 109.50
- GRA1 - GRAVITY GENERATOR 10.00
- MAGNETIC CANNON/PROJECTOR 10.00
- LRG3 SOLID STATE LASER RIFLE 10.00

KITS — includes Plans and Parts

- LHC2K SIMULATED RED/GRN/YEL LIGHT LASER 34.50
- BTC3K 250,000 VOLT TESLA COIL 159.50
- IOG1K ION RAY GUN 109.50
- PSP3K PHASOR SHOCK WAVE PISTOL 49.50
- STG1K - STUN/PARALYZING GUN 39.50
- INF1K INFINITY TRANSMITTER 134.50
- MFT1K 2-3 MILE RANGE FM VOICE XMTR 49.50

ASSEMBLED AND TESTED PRODUCTS

- LGU30 RED 1MW PORTABLE HENE LASER 315.00
- TCL30 SOLID STATE TESLA COIL 35KV 74.50
- IPG50 POCKET PAIN FIELD GENERATOR 64.50
- BLS10 BLASTER DEFENSE WEAPON 89.50
- ITM10 - 100KV SHOCK AND STUN GUN 99.50
- PPF10 PHASOR PAIN FIELD PORTABLE 249.50
- SNP20 SECURITY PHONE LISTNER 99.50

• CATALOG CONTAINING DESCRIPTIONS OF ABOVE PLUS HUNDREDS MORE AVAILABLE FOR \$1.00 OR INCLUDED FREE WITH ALL ABOVE ORDERS.

PLEASE INCLUDE \$3.00 PH ON ALL KITS AND PRODUCTS PLANS ARE POSTAGE PAID. SEND CHECK, MO, VISA, MC IN US FUNDS.

INFORMATION UNLIMITED

P.O. Box 715, DEPT. ET, AMHERST, NH 03031

If D1 does switch on, try connecting a fresh battery to the input of the unit with SW2 and SW3 set at appropriate positions. This should, of course, result in D1 switching off while the battery is connected. If you should inadvertently connect a battery to the unit with SW2 at the wrong voltage setting this will not result in any damage to the checker provided the battery has a nominal voltage of 9 volts or less.

The load current used depends on the capacity of the battery you are testing. 1.5 volt cells are capable of quite high load currents and should be tested with SW3 in the 'high' position, as should high capacity 9 volt batteries and types that are really just comprised of series connected 1.5 volt cells. Medium sized 9 volt batteries require a 'medium' load current, and small 216-types require a 'low' load current setting.

Battery checking is perhaps more of an art than a science, and things are not always straightforward. I have two calculators which run from regular size 9 volt batteries, one an LCD type which requires very little current and the other a LED type which consumes a moderately high current. When the battery in the LCD calculator seems to be failing it does in fact seem to be perfectly satisfactory when subjected to any accepted form of battery checking, and will happily power the LED calculator for months. One might expect an almost exhausted battery from the LED calculator to power the low current LCD type for some time before failing completely, but not the

other way round. The cause of this paradox seems to be that the display circuit of the LCD calculator is very voltage conscious, and fails to operate properly once the battery voltage has fallen slightly due to normal ageing, even though there is still plenty of power left in the battery. The moral of the story is that when testing batteries, where possible, you should take into account the requirements of the equipment they are used to power. Some circuits require reasonably fresh batteries in order to function well, others will operate from batteries which, by most standards, are flat. Although with the current high cost of batteries it is tempting to squeeze every last bit of power from them, it is not a good idea to use virtually exhausted cells which could leak and ruin expensive electronics. ■

1736 Avenue Rd.,
Toronto, Ontario M5M 3Y7
(416) 787-1448

QL

The Software

The 4 Programs, Included with your QL

Spectacular Hi-Resolution Color!
Actual screen shot QL Graphics

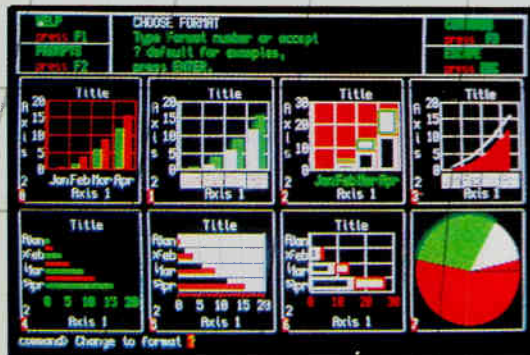

WORDPROCESSING

QL Quill is a total word processing package featuring: on-screen, step-by-step HELP menus, word wrap, full delete options, including cut-and-paste; wide view documents; boldface; superscript, subscript, underlining; hyphenations; overwrites; and will combine with data from other QL programs.

SPREADSHEET

QL Abacus provides instantaneous 'what if' spreadsheet manipulation functions featuring: single stroke assignable function keys; spreadsheet linkage; multiple-windows; text justification; scroll windows, and single name reference to rows, columns and cells.

DATABASE MANAGEMENT

QL Archive is an extremely sophisticated yet easy to use filing system featuring: 84 single command words for queries, cross-references and file searches; easy statistical and accounting calculations; screen editor for report formats, and complete HELP menus.

GRAPHICS

QL Easel produces spectacular color graphics. The program features: design handling and scaling either automatically or under user-control; text addition or deletion; nine graph styles; data manipulation and evaluation using command math functions and formulas, and complete HELP menus.

Select More QL Software Here

LANGUAGES & UTILITIES

QL ASSEMBLER. Converts M68000 assembly language sources files into QL-compatible binary files. Includes multi-tasking full screen editor which can run simultaneously with SuperBASIC **\$99.95**

QL MONITOR. Machine Code monitor. **\$69.95**

QL TOOLKIT Over 70 programs and extensions to SuperBASIC. includes print spooling, improved file access (full random input/output command), job control (allows management of multi-tasking) and SuperBASIC screen editor. **\$74.95**

for HOME, EDUCATION & BUSINESS

Q-STAR Spelling check and text editing program with 28,000 word capacity, including 4000 words of your own choice. Works with any QL file including the Word Processor supplied with the QL. **\$99.95**

DBASE MASTER. 9 separate filing programs to build and maintain lists of all descriptions. Written in QL Database. Includes Mailing List (record and select by 15 categories), inventory control, stamp collection, sports record, teacher's helper, etc. **\$74.95.**

SUNDIAL. 15-year calendar, appointment scheduler and daily diary. Up to 20 events each day can be stored, and accessed by searching on date, time, and name — or combination of the three. Bonus on-screen calculator. **\$79.95**

QL TOUCH 'N' GO Learn touch typing. Unique approach designed to give you mastery over the QWERTY keyboard in 24 hours. **\$74.95**

QL HOME FINANCE **\$74.95**

QL GARDENER. Garden design for the amateur or professional. **\$54.95**

BCPL. QL compiler ideal for systems programming, writing utilities, games, and applications. Generated native 68000 code. Easy QDOS interface. Link separately compiled segments. Can be linked with Pascal or Assembler. **\$149.95**

LISP. Features turtle graphics for exploring the language of artificial intelligence. Structure editor; pretty printer; garbage collector and tracer. Full screen editor. **\$149.95**

PASCAL. True single pass compiler producing native 68000 code meeting ISO 7185 standard. Direct addressing of full QL address space. Key routines on ROM for speed and convenience. **\$199.95**

PACK 116. Programs and routines for science and maths including permutations, combinations, capacitance, inductance, frequency, gaussian circuits, power supply circuits, and about 100 more **\$79.95**

Q-CAD. Computer Aided Design for the QL. Complete resident graphics library as well as user definable shapes, symbols, forms, formulas; and tables which can be scaled, rescaled, moved, saved, recalled, modified. Compare with other CAD systems 5 times more expensive. **\$99.95**

Q-CALL. Communications software for use with Hayes or equivalent 300 or 1200 baud modem. Will handle telephone connections, and manage file transfer. Ideal for use with Compuserve and other data services. Gets you online now! **\$79.95**

Q-FONT. Total printer control to use the "hidden" fonts in your Centronics or Epson or compatible printer. Also provide "hi-res" screen dumps to your printer. **\$54.95**

CANADIAN INCOME TAX GUIDE — 1985 **\$79.95**

QL CHESS. Developed by PSION. Features high resolution display, animated 3-D graphics, 28

C. Powerful QL implementation including full screen editor. **\$229.95**

THE PROGRAMMER. Program generator; you specify the input and the output . . . it writes the program. Uses cursor control and a few simple commands to generate fully written, tested and working program which can be stored and recalled. **\$99.95**

QDOS BOSS. Examine and change any sector of data on a microdrive cartridge. Print or display on screen in hex or ascii. DOS utility "shell" simplifies QDOS functions and commands. **\$79.95**

levels of play from novice to champion. Opening book of nearly 4000 moves, HINT and TAKE-BACK functions, and the option to play a human opponent or the computer. **\$84.95**

QL DECISION MAKER. Set up a decision tree to help evaluate the costs and results of decisions. Complex 'what if' questions are dealt with rapidly and graphically. **\$110.00**

QL PROJECT PLANNER. Divides complex activities into critically important stages to help in the planning and monitoring. When you decide on a starting time, it tells you when each activity must start and finish and when the project will be completed. **\$110.00**

QL ENTREPRENEUR. Uses a 'what if' format to help develop a workable business plan. Break-even point. Cash flow forecast. Balance sheet and profit and loss statement. Builds your skills and techniques. **\$110.00**

HARDWARE EXPANSIONS

Coming soon are 256K and 512K memory expansion boards and a disk drive interface.

Call 416-787-1448 to Order —

Credit Cards Welcome —

Mail Order Form on Page 63

Circle No. 24 on Reader Service Card

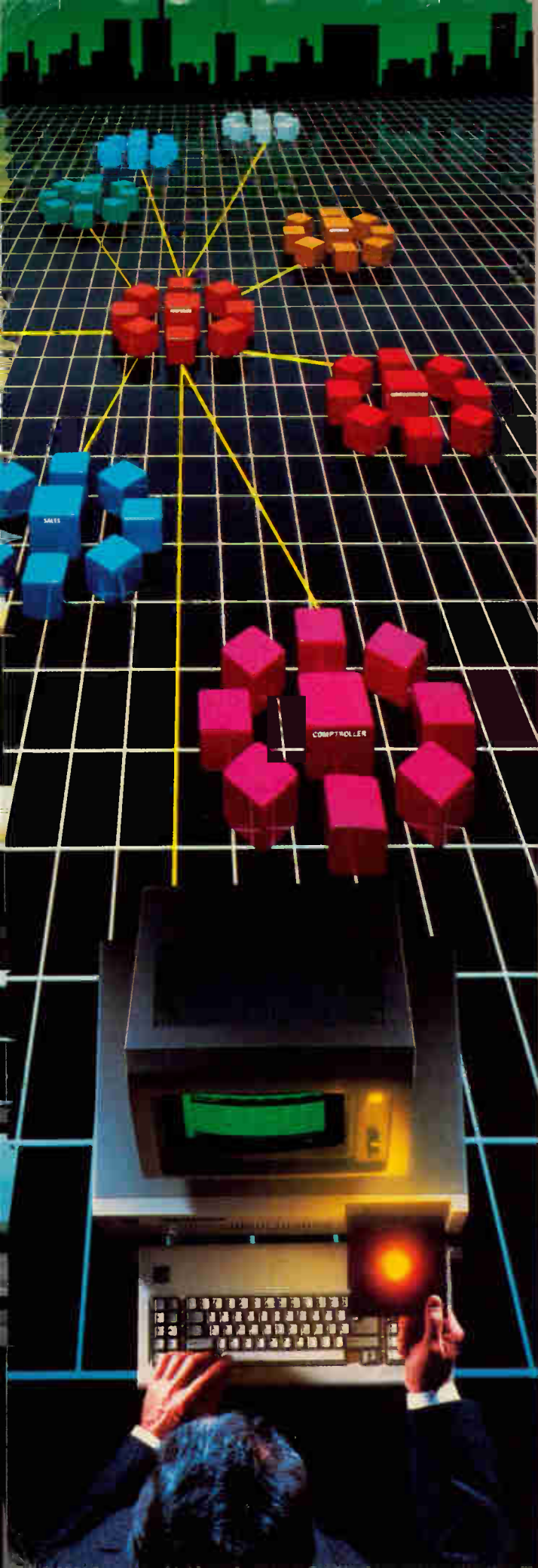

We've Put a Local Area Network on a Disk

Corporate Information Sharing. It's been described as the key to increasing a company's productivity. It's also why large networks of PC's are becoming more and more common in the workplace...in spite of the fact that they're costly, difficult to install, and incompatible with much existing software.

Finally, there's a solution to this corporate dilemma. Its name is LANLink™

A Software-Driven LAN That Uses Standard, RS-232 Ports. A major breakthrough in local area networks, LANLink™ uses your computers' existing serial ports and runs under PC-DOS.

Because all of the intelligence the network requires is on the server and satellite diskettes, expensive network interface boards aren't required.

A Powerful Network That's Cost-Conscious. If you've been pricing board-driven LAN's, you already know that they can cost over \$1,000 per workstation. LANLink™ is different.

Boasting a data transfer rate in excess of 100,000 BPS, LANLink™ is compatible with a wide range of programs. And because special boards aren't required, installation costs are one-third that of a traditional network.

A Network Designed the Way Business Works. With LANLink™ you're able to customize your network along departmental lines using a data-sharing hierarchy and password-protected access.

Get Started With LANLink™ TODAY. Call The Software Link TODAY for complete details and the authorized dealer nearest you. The LANLink™ Starter Kit, priced at \$745, comes complete with network software for both a server and a satellite computer. For a limited time, 50 feet of RS-232 cable will be included free of charge.

LANLink™ is immediately available and comes with a money-back guarantee. VISA, MC, AMEX accepted.

Circle No. 25 on Reader Service Card

LANLink™



THE SOFTWARE LINK, INC.

Developers of MultiLink™ and MultiLink Advanced™

400 Esna Park Drive, Suite 18, Toronto (Markham), Ont. L3R 3K2

CALL: 416/477-5480

Dealer Inquiries Invited

MultiLink, MultiLink Advanced & LANLink are trademarks of The Software Link, Inc. PC-DOS is a trademark of IBM Corp.

RS232C Chip

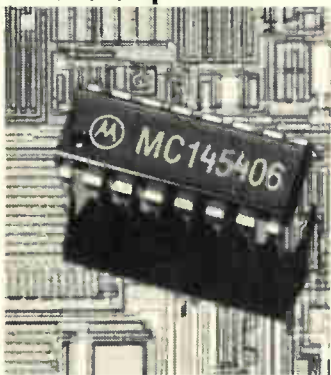

The Motorola MC145406 is a silicon-gate CMOS IC that provides both driver and receiver; TTL logic signals are level-shifted to the RS232 format at the output, and RS232 input signals are converted to TTL. Hysteresis in the receivers aids in the reception of noisy signals. From Motorola dealers, or contact Motorola Semiconductors, MOS Logic and Analog Integrated Circuits Division, PO Box 6000, Austin, Texas 78762.

Circle No. 48 on Reader Service Card.

Interview

Electronics Today was fortunate in being able to interview Rodney J. Packham, president of Packham and Stuffem, a company which has had an enormous influence on the computer and electronics industry.

ET: Could you tell us something about your profession?

Rodney: Of course. We're the people who fit the foam packing around computers and peripherals and test equipment.

ET: Tell us more about it.

Rodney: Well, it wasn't easy when we first started. We just fit hunks of foam into the box, but it was too easy for people to put everything back into the box if they wanted to. Then we tried foam peanuts. They're not bad, because they spray all over the room when you take the product out, but people with patience could still get them back in.

We decided on a high-tech approach. We started making foam packing inserts with up to 37 pieces, each piece made to tolerances of a millionth of an inch. That worked.

ET: What motivated all this?

Rodney: You know where the warranty says "must be returned in original box"? Well, this way it's impossible for people to ever do it, and returns are down enormously. We have it worked out for computers, for instance, so that you have to insert the body, the keyboard, the power cord, and the manual in exactly the right slots all at the same time or it won't go in the box.

ET: Any plans for the future?

Rodney: We're trying to eliminate precision manufacture by using expanding foam: as soon as you slide it out of the box, a chemical is released that expands the packing by 20 percent.

ET: Best of luck in your endeavours.

Rodney: Thank you.

Users of electronic typewriters will soon be able to access Telecom Canada's Teletex network with an add-on module, the TexCom 2400, containing a screen, memory, software, disk drive and 2400-baud modem. A letter quality document can be sent anywhere from one terminal to another in about 10 seconds, but 40 times faster than Telex. The unit will retail this fall for about \$3950. Hmmm. That's about ten times what an electronic typewriter costs, or about what a compatible with the works costs. For more information: Telecom Canada, 770-410 Laurier Avenue W., Ottawa, Ontario (613) 560-3030.

Circle No. 47 on Reader Service Card.

The Heath Company is offering two new educational courses, 'Computer Servicing — Peripherals' and 'Computer Servicing — Maintenance'. They're the latest additions to the Heathkit/Zenith computer servicing series. Required hardware is the EWS-100 Microcomputer Trainer. For a catalog or more information, contact the Heath Company, 1020 Islington Avenue, Dept. 3100, Toronto, Ontario M8Z 5Z3, (416) 232-2686.

Circle No. 46 on Reader Service Card.

The I&CS Seminar/Show is featuring sensors and transducers in industrial control. There'll be shows, exhibits and sensors covering both hardware and data acquisition techniques. It'll be held December 4-6, 1985, at the Carlton Place Hotel, 33 Carlson Court, Toronto, Ontario M9W 6H5. The hotel is (416) 675-1234, and the show people are: I&CS Seminars, Box G, 59 Water St., Hingham, MA 02043, (617) 749-1122. 'I'm going to Toronto, dear, to look at thermistors.' Uh huh.

A newly formed Canadian company, Revelations Research of Mississauga, Ontario, has purchased a Control Data Cyber 205 supercomputer, and plans to use it 'to conduct detailed research into fifth generation or artificial intelligence that will allow the development of a computer system capable of simulating the thought functions of the human brain through the use of neural network arrays.' Holy Moses. Does Isaac Asimov know about this?

Someone said that magazine editors could be replaced by computers; when the time comes here at ET, let's hope the boss buys a Revelations Research and not a ZX81.

There's more than meets the eye to a telephone line sense relay, me lad. You need piles of isolation, lots of sensitivity, and no disturbing the line balance while you're at it. If you'd like to know when a receiver has gone off-hook, the Elec-Trol TLSIA18A10 Telephone Line Sense Relay is placed in series with the line and operates a dry reed switch when the loop exceeds 18mA. There's 1500V isolation and 63dB balance provided. It's from Zentronics outlets, or contact them at 8 Tiibury Court, Brampton, Ontario L6T 3T4, (416) 451-9600.

Circle No. 45 on Reader Service Card.

Macintosh Digitizer



GTCO Corporation has a digitizer for the Macintosh computer which they call the Macintizer. Not bad. Most companies call their new products the CGHK45-234-T083-N. It consists of a pad and a stylus; the stylus position is detected electromagnetically, eliminating preventative maintenance from dirt or contamination. A mouse with crosshairs is also available. It works with MacDraw, MacPaint, and all other Macintosh software because its cable goes in place of the Mac's mouse. From Interworld Electronics and Computer Industries Ltd., 1442 Pemberton Ave., North Vancouver, BC V7P 2S1, (604) 984-4171.

Circle No. 44 on Reader Service Card.

sinclair

QL

Order Form



- 32-bit processor
- 128K Ram
- Two built-in microdrives
- Software included
- Hires color
- National warranty service by AABEX
- New low price!

\$599.95

- Monitors & Printers for QL
- 14" Hitachi RGB Monitor. Bright seven color display. Up to 1500 characters. \$549.00
 - JIL 12" Green Screen Monitor \$149.95
 - Centronics GLP Printer. Compact size. 132 columns. Near letter quality dot matrix. \$399.95
 - Smith Corona D200 Printer. 120 cps. 2K buffer. Series & parallel interface. \$699.95

ORDER FORM · MAIL TO
Gladstone Electronics, 1736 Avenue Rd,
Toronto, Ontario M5M 3Y7

Please send	Each	Total
— Sinclair QL Computer including manual-power supply-4 software titles	\$599.95	_____
— Hitachi RGB Monitor	549.95	_____
— Cable for Hitachi monitor	29.95	_____
— JIL Green Screen Monitor	149.95	_____
— Cable for JIL monitor	9.95	_____
— Centronics GLP Printer	399.95	_____
— Smith Corona D200 Printer	699.95	_____
— Cable for above printers	39.95	_____
QL Software		
— QL Assembler	99.95	_____
— QL Monitor	74.95	_____
— QL Toolkit	74.95	_____
— BCPL	149.95	_____
— LISP	149.95	_____
— PASCAL	199.95	_____
— C Language	229.95	_____
— QL Programmer	99.95	_____
— QDOS Boss	79.95	_____
— Q-Star	99.95	_____
— DBASE Master	74.95	_____
— Sundial	79.95	_____
— QL Touch 'N' Go	74.95	_____
— QL Home Finance	74.95	_____
— QL Gardener	54.95	_____
— Pack 116	79.95	_____
— Q-CAD	99.95	_____
— Q-Call	79.95	_____
— Q-Font	54.95	_____
— Can. Income Tax	79.95	_____
— QL Chess	84.95	_____
— QL Decision Maker	110.00	_____
— QL Project Planner	110.00	_____
— QL Entrepreneur	110.00	_____
— Shipping (per order)		\$15.00
— Ont. residents add 7% PST		_____
TOTAL		

Enclosed is: Charge to: Cheque Money Order Visa Mastercard

Card # _____ Expiry _____
Signature _____
Name _____
Address _____
City _____ Prov. _____
Telephone _____ Code _____

CREDIT CARD ORDERS: Call (416) 787-1448
Gladstone Electronics
1736 Avenue Rd., Toronto, Ontario M5M 3Y7

The **BEST** is still "made in West Germany"

HAMEG model **HM203-5**

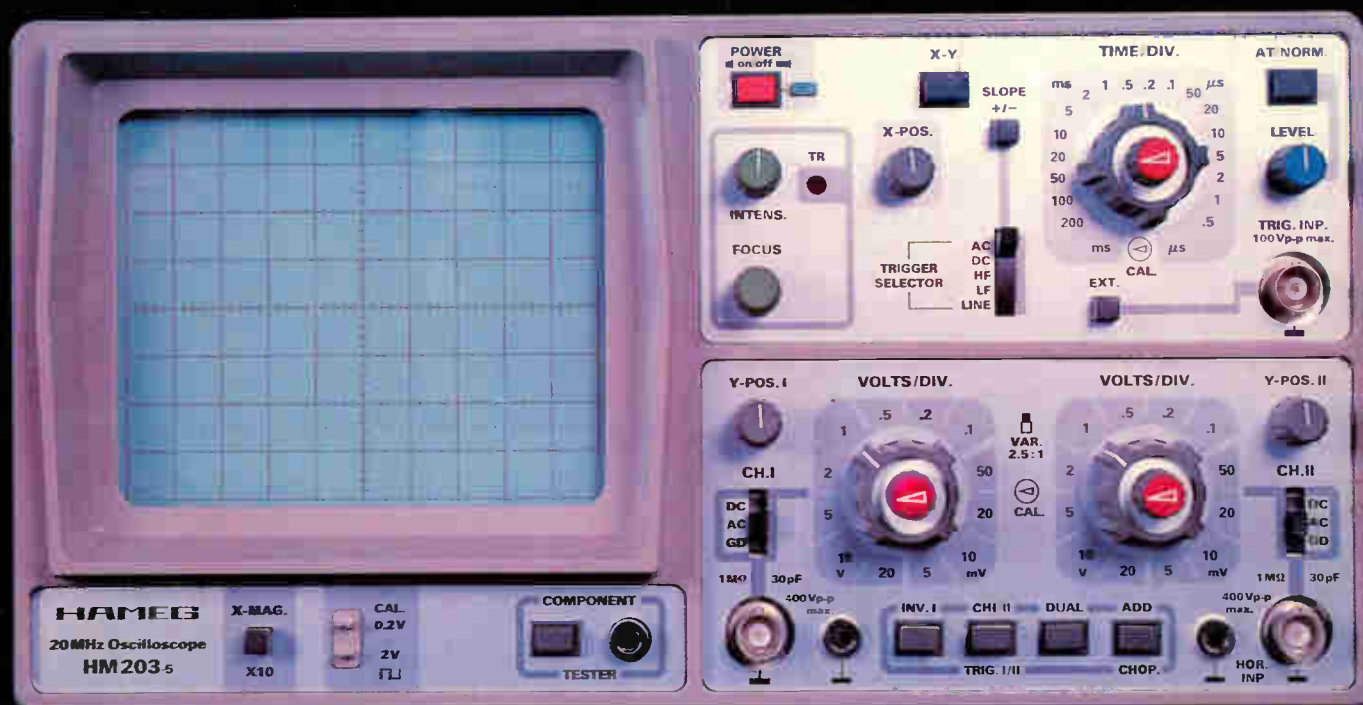

The 20MHz Oscilloscope that outsells all others in Western Europe. The model **HM203-5** is available complete with two switchable (X1-X10) probes. This CSA approved Oscilloscope is covered by a **two year** parts and labour warranty.

Immediate delivery from Stock
All major credit cards accepted.

\$770⁰⁰*

F.O.B. Downsview, Ont. FST Incl'd.

for the complete line of HAMEG instruments write or phone

HAMEG GmbH
West Germany is represented
and distributed in Canada by

BCS
ELECTRONICS
LIMITED

980 Alness St. Unit 7,
Downsview, Ontario
M3J 2S2
(416) 661-5585
TELEX 065-28169
Mon-Fri 8-5 pm, Sat 10-1 pm

*Price subject to change