

Electronics & Technology Today

\$2.95
MM70924

Canada's Magazine for High-Tech Discovery

May 1988



Pseudo Echo Unit Capacitance Meter



Toshiba T5100 386 Laptop



511477#MAR 88* ET34*

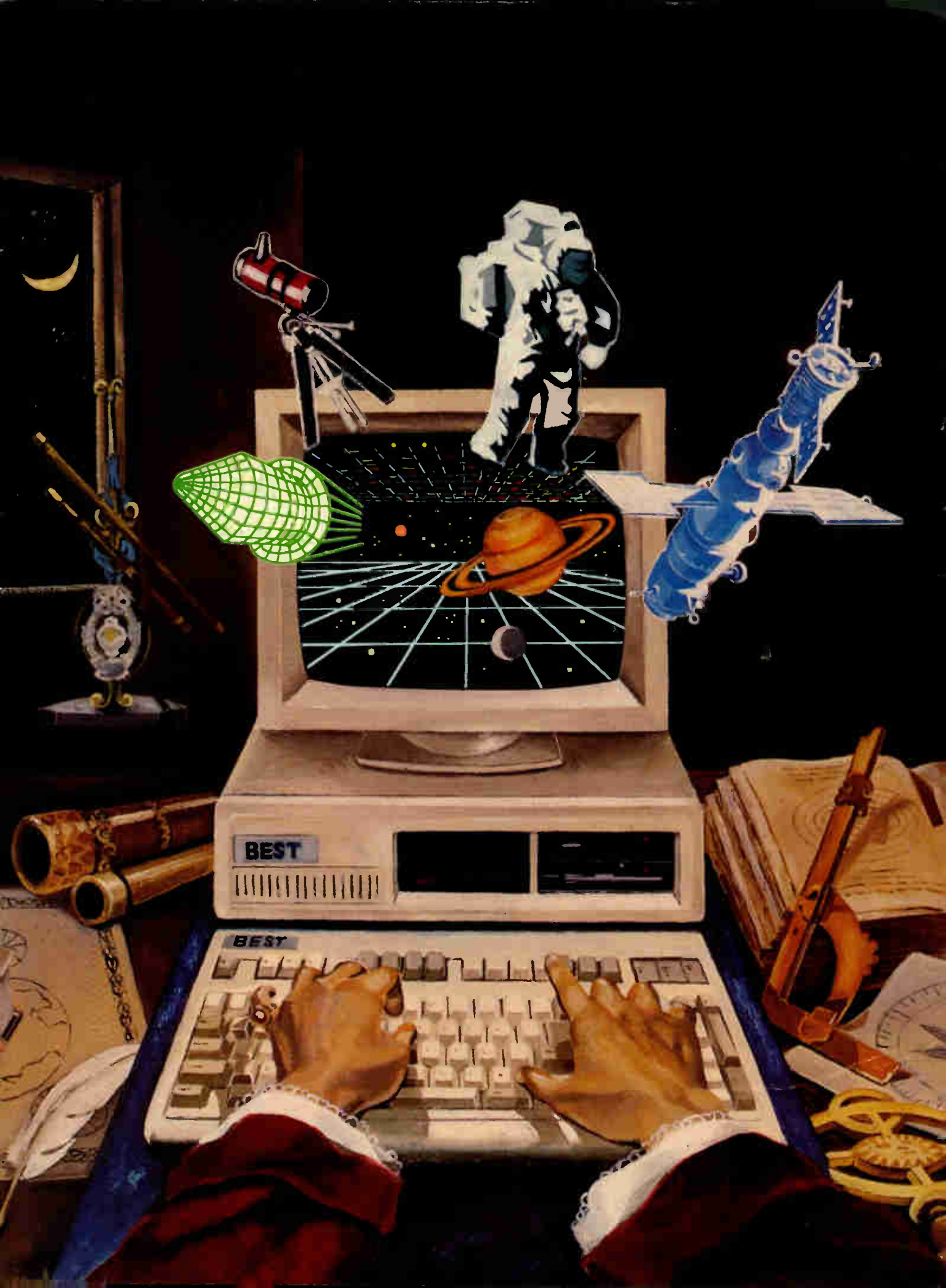

Just suppose Galileo... ● ● ●

...met Best Systems Corporation

Once Galileo had invented the telescope in 1592, he went on to become the first man to discover the rings of Saturn. If he had met Best Systems Corporation, he might have been the first to calculate the rotations and distances of far planets, while simultaneously organizing his complex observations and managing his daily entries. He could have then published his scientific findings with startling clarity using word processing for technical writing, manuals and documentation. For solving mathematical problems, he might choose the optional 80387 math co-processor. Imagine what Galileo could have achieved with Best.

Of course time moved too swiftly for Galileo to really meet Best Systems, but the time is right for you.

Whether you are exploring the possibilities of one Best System, or networking many, Best will show you how to integrate our micro-computer products into your universe.

Best can provide you with systems that allow you to utilize CAD/CAM, to design ASIC chips, printed circuit board layouts, schematics and diagrams. As well, Best Systems can be used for process control applications. Our MS DOS, UNIX and OS/2 compatible systems are designed and manufactured in Canada with pride.

For further information contact Best at (416) 620-7400. Don't wait, your Best discoveries are ahead of you.

The logo consists of the word "BEST" in a bold, sans-serif font, enclosed within a dark rectangular box.

BEST SYSTEMS CORPORATION OF CANADA INC.
DESIGNED AND MANUFACTURED IN CANADA WITH PRIDE

VANCOUVER 604 942 9121 EDMONTON 403 424 8845 CALGARY 403 233 2180 SASKATOON 306 664 8887

TORONTO 416 363 BEST OTTAWA 613 235 BEST MONTREAL 514 694 2417

MS DOS, OS/2 is a registered trademark of Microsoft Canada Inc. UNIX is a registered trademark of AT&T. XT and AT are registered trademarks of IBM Canada Ltd.

Circle No. 1 on Reader Service Card

Toshiba has just given the portable laptop

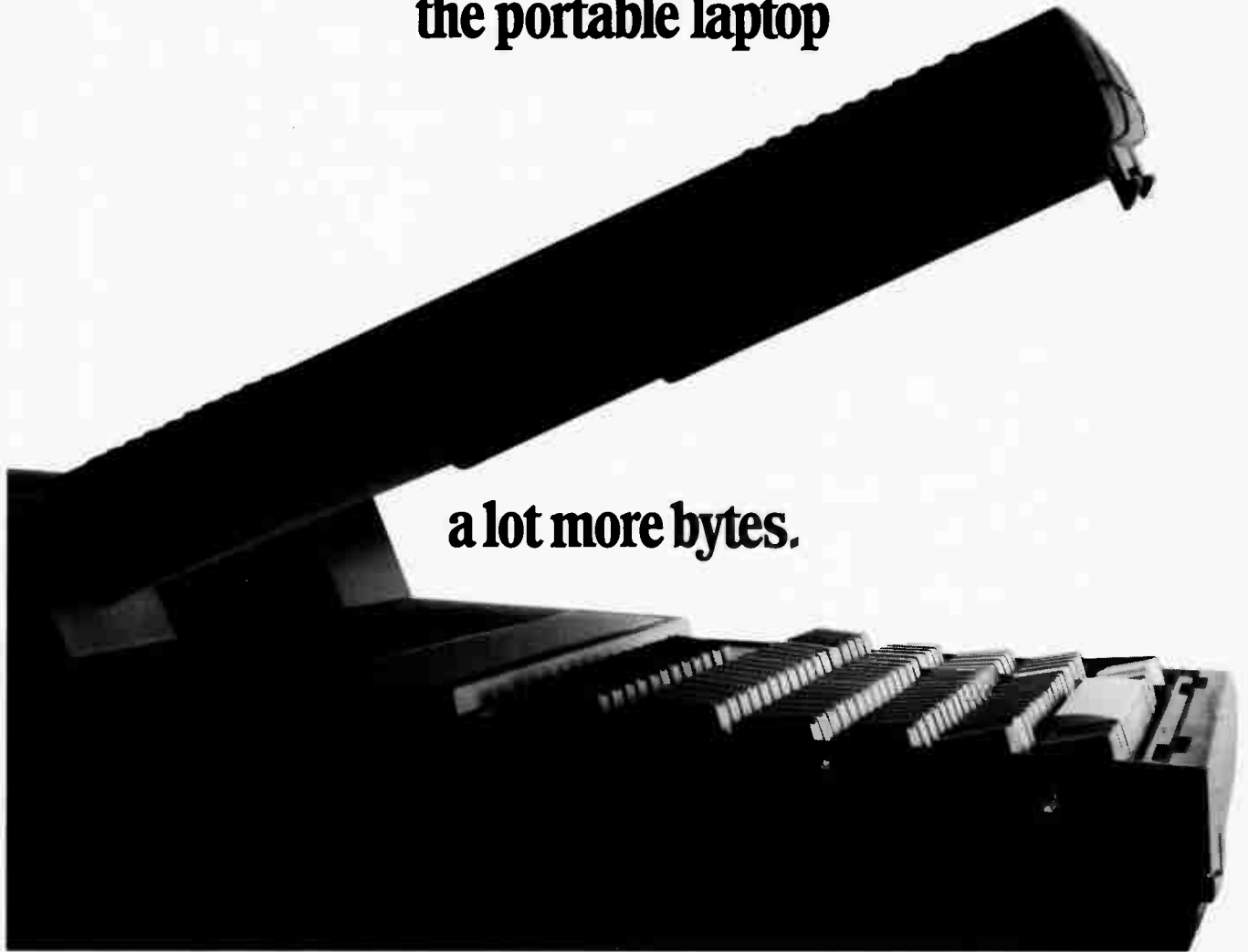

a lot more bytes.

Introducing the exciting new Toshiba T3200.

The portable laptop computer designed to take a big bite out of the desktop AT market.

While you're chewing over that data, consider some other major features of the T3200. It's a portable laptop that comes standard with one and one-half internal IBM*-compatible slots for hardware expansion and a fast 40-megabyte internal hard disk drive.

The T3200 moves fast too, with an 80286 microprocessor running at 12MHz. It's also very easy to read, with a superb Gas Plasma screen which is EGA (Enhanced Graphics Adapter) compatible. And it has

even more bytes with the standard one megabyte of RAM, upgradable to four megabytes. There's also a separate numeric keypad within the full standard keyboard, for real ease of use. And with all this, there's the added advantage of true portability.

To learn more about the multi-purpose T3200, place a call to your authorized Toshiba re-seller, or call Toshiba direct at 1-800-387-5645. Ask for a demonstration. Once you've had a taste of the new T3200, you'll be spoiled for any other PC, desktop or portable.

The best keep getting better!



TOSHIBA

WE MEAN BUSINESS
INFORMATION SYSTEMS DIVISION

Circle No. 2 on Reader Service Card

*IBM is a registered trademark of
International Business Machines Corporation.

Electronics & Technology Today

Canada's Magazine for High-Tech Discovery

Volume 12, Number 5

May 1988

FEATURES

- The Scientists Tell Me** 9
David Dempster's regular look at the world of science.
- Uninterrupted Power Supplies** 14
The theory, plus a mini-review of the Power Control UPS.
- A Visit to Trebas** 18
Canada's school for the recording arts.
- Electrochemical Computers** 30
Dr. T. Shah looks at chemical and optical computers.
- Microprocessors, Part 3** 50
Continuing our course on the workings of the CPU.

TECHNOLOGY

- A Unique Shockmount for Electronics** 28
Helical springs isolate delicate equipment.
- Toshiba T5100 Review** 46
Mainframe power in your lap with a 386 portable.

PROJECTS

- Pseudo Echo Unit Project** 36
An simple and ingenious approach to echo.
- Capacitance Meter** 57
Build this accurate, easy-to-make unit.

INFORMATION

- For Your Information..... 6
- Classifieds 12
- Next Month 42
- Win a Computer 26
- Software..... 33,44
- Books 34
- Order Form 41
- Subscriptions 42
- Market Place 48
- Advertiser's Index..... 62

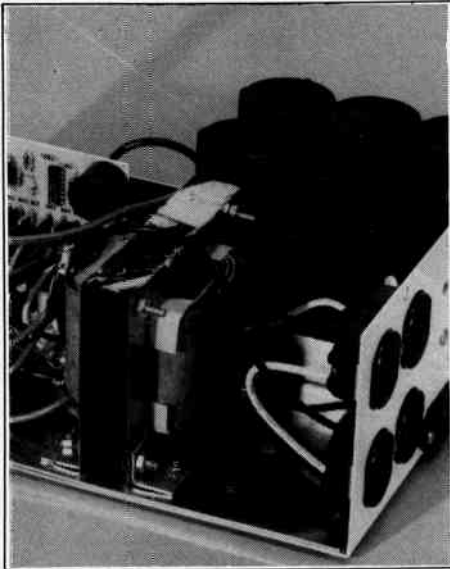

Page 16



Page 46

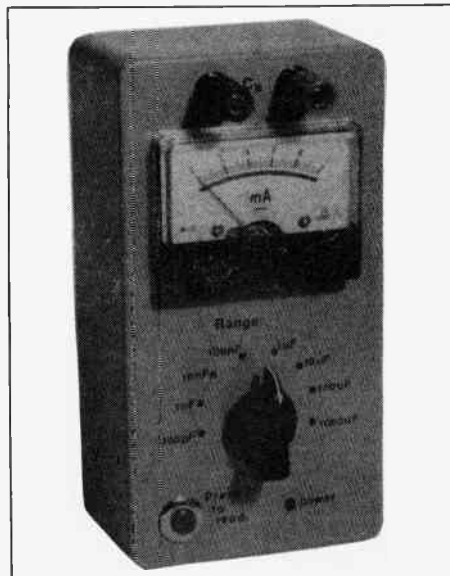

Page 57



Our Cover

The Power Control ME-400 UPS lights itself up with a floodlight; see page 14. The Toshiba T5100 powerhouse laptop is reviewed on page 46. Photos by Bill Markwick

FOR YOUR INFORMATION

Counting Photons

If you need to measure light right down to the last photon, the Infrared Time-Correlated Single-Photon System from Edinburgh Instruments is said to achieve a new level of noise performance. The low-noise photomultiplier system is intended for decay-time measurements up to 950nm, essential in the field of semiconductor research in the technologies of gallium arsenide and silicon. The system gives 400 counts/second noise when cooled to -30 degrees C. For more information, contact Edinburgh Instruments Ltd., 431 Boler Road, Suite 147, London, Ontario N6K 2K8, (519) 471-3612.

Circle No. 3 on Reader Service Card

Programmable Resistance Standard

Using a high-resolution A/D converter under microprocessor control, the Valhalla 2724A provides 10 million resistance values from 1000 microohms to 11 gigohms. For ATE engineers requiring an IEEE-488 simulated resistive thermal device, the 2724A can simulate the ohmic value with an accuracy of 7 ppm. Other features include short term stability to 2 ppm, 2/4 terminal operation and IEEE-488 compatibility. Valhalla Scientific is represented in Canada by Duncan Instruments, 121 Milvan Drive, Toronto, Ontario M9L 1Z8, (416) 749-4448.

Circle No. 4 on Reader Service Card

Elementary, My Dear CPU

The Toronto police force has become the first organization outside Britain to sign a contract for HOLMES, a computer system used in the UK for compiling and transmitting information. The Toronto force will have a central computer to link 18 divisions and more than 20 specialized units, including mounted and marine. Police at an unlimited number of terminals will be able to key in information and seek relevant detail from the central computer, consult indexes and record action taken. The system uses UNISYS (Burroughs) B25 computer workstations.

Tandy Acquires Grid

The Tandy Corporation (Radio Shack) and Grid Systems Corporation have signed a definitive agreement for the acquisition of Grid, which will become a wholly-owned subsidiary of Tandy. Grid Systems, manufacturers of battery-operated laptop computers, software and peripherals, is headquartered in California, with sales offices in Canada and Europe. Grid will continue to market under its current name, and will benefit from Tandy's materials sourcing, nationwide service and financial strength.

The Eye's Software

A biomedical engineer at the University of Southern California has developed a theoretical approach to explain how the eye alerts the brain to objects in motion. Vasilis Z. Marmarelis said that we need to develop an understanding of how the eye works as a detector and processor of visual information if we are going to communicate the skill of sight to robots. His theory is that specialized retinal neurons code the information for transmission to the brain. These neurons, called bipolar cells because they both receive and transmit, compose one of the retina's middle layers. They receive electrical signals from the retina's outer layer of photoreceptor and horizontal cells and send them to its innermost layer, composed of amacrine and ganglion cells. The ganglion cells, in turn, transmit the signals through the optic nerve to the brain.

A mathematical model of how the cells transform visual information in space and time is being developed. The next step would be a computer simulation of that process. The ultimate step would be to design an electronic device that would give robots motion-perception skills.

Color Videophone

The Ricoh Company of Tokyo is experimenting with a prototype device that can send and receive color images as well as voice over conventional phone lines. It permits transmission and reception of charts, drawings, photos and other graphic aids. The price and availability have not been determined. The device transmits color images in one to four seconds, as fast or faster than comparable black and white machines currently available. The technology is made possible by advanced data compression techniques.

Other companies have also developed black and white still-picture phones. These have been available in Japan since 1986, and sales are expected to increase with the adoption of compatibility standards. Ricoh hopes that color standards will be in place before they market the new color picture phone.

Continued on page 12

Electronics & Technology Today

Electronics & Technology Today is published 12 times a year by:
Moorshead Publications Ltd.
1300 Don Mills Road,
North York, Toronto,
Ontario M3B 3M8
(416) 445-5600
FAX: (416) 445-8149

Editor: William Markwick
Director of Production: Papu Leynes
Art Direction: Kevan Anson
Circulation Manager: Sharon Cernecca
Advertising Manager: Douglas Lawson

President: H.W. Moorshead
Publisher &
Executive Vice-President: V.K. Marskell
Vice-President - Sales: A. Wheeler
Vice-President - Finance: B. Shankman
Production: Catherine Dalziel
Naznin Sunderji
Accounts: P. Dunphy
Reader Services: S. Campbell
R. Cree
Advertising Services: H. Brooks

Newsstand Distribution: Master Media,
Oakville, Ontario

Subscriptions:
\$22.95 (one year), \$37.95 (two years).
Please specify if subscription is new or a
renewal.

Outside Canada (US Dollars). U.S.A. add
\$3.00 per year. Other countries add \$5.00
per year.

Postal Information:
Second Class Mail Registration No. 3955.
Mailing address for subscription orders,
undeliverable copies and change of
address notice is:
Electronics & Technology Today,
1300 Don Mills Rd.,
North York, Toronto,
Ontario M3B 3M8.

Printed by Heritage Press Ltd.,
Mississauga, Ontario ISSN 07038984

Moorshead Publications also publishes
Pets Magazine, Computing Now!,
Computers In Education, Business
Computer News and Government
Purchasing Guide.

Circulation independently audited by
MURPHY & MURPHY Chartered
Accountants.

TECMAR VGA

a subsidiary of Rexon, Inc.

- . VGA and EGA hardware register compatible
- . All 17 modes of VGA supported
- . Turbo BIOS - increases speed by 50%
- . Works on analogue (VGA) Monitors (VGA modes)
 - . Multiscan monitors (800x600 high resolution)
 - . EGA monitors (EGA Mode)
- . Supports dual monitor configurations
- . Great for CAD
- . Provides the best upgrade path for future software

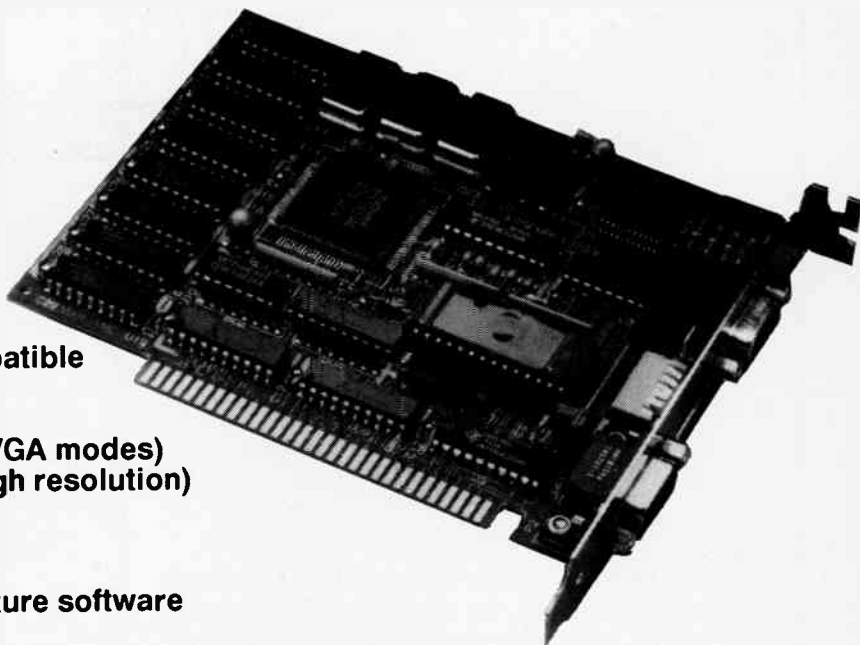

SEE WHAT VGA CAN DO FOR YOU

Tecmar VGA Combos

Four outstanding VGA Combos to choose from

LIST

1TECVOM Tecmar VGA with Tatung Omniscan 1795

This Combo allows the use of all the features of the Tecmar VGA card including VGA, EGA, and high resolution 800x600 with many software packages.

1TECV93 Tecmar VGA with Tatung CM1293 VGA Monitor 1295

This combo is for the budget minded user who wants to have his cake and eat it too. The CM1293 Visual Pro monitor is an analog 12" monitor for VGA. It will support all VGA modes of the Tecmar card and all lower resolution analog modes supported by Tecmar software. This includes ACAD at 640x480, 640x350. Imagine all this for a dealer cost about the same as an EGA board and monitor.

1TECV02 Tecmar VGA with Sony CPD1302 1995

This combo uses the famous CPD1302 with the best VGA card in the industry. The CPD1302 will support all features offered by the Tecmar card. This combo is not for everyone, only for those who want the best.

1TECV03 Tecmar VGA with Sony CPD1303 1895

The newly introduced CPD1303 also supports all features offered by the Tecmar VGA card, but at a lower price than the 1302.



Data Systems Ltd.

Sales to Resellers

HEAD OFFICE:
GUELPH
(519) 837-2444

BRANCHES:
Vancouver
(604) 875-9344

Calgary
(403) 229-1535

Winnipeg
(204) 475-7825

Toronto
(416) 454-2940

Montreal
(514) 849-4171

Halifax
(902) 423-6152



AT LAST!

A REMOTE CONTROL
TESTER THAT MAKES
REPAIRS QUICK
and PROFITABLE!

Celtron-1

Celtron-1 is a 'universal' tester that **INSTANTLY** verifies operation of infrared and ultrasonic remote control transmitters!

It's feature packed:

- Quick 'go/no go' LED'S
- AUTO-OFF for extra battery life
- Scope/Frequency Test & Jack
- 1 year warranty

Celtron-1 is great for TV, Audio, Video and Satellite TV shops, as well as for Cable TV technicians and retail counter salespeople.

Save time and money servicing ...use Celtron-1

CableServ Electronics Ltd.

18 Dufflaw Road, Toronto, Ontario M6A 2W1
(416)789-4581

Circle No. 6 on Reader Service Card

SUPERCONDUCTIVITY KITS

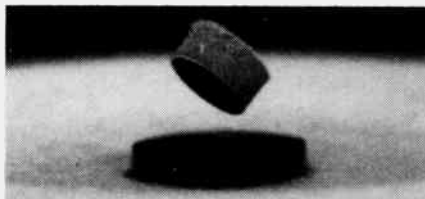

CS Technologies, the first Canadian supplier of commercially available and improved high temperature ceramic superconductors, is now offering two basic kits to experimenters, students and educators for use in high schools and colleges.

The first is a demonstration kit which includes a prefabricated and environmentally protected superconductive disc, rare earth magnet, plastic tweezers, cryogenic display platform and wire loop. The only additional material required is inexpensive and readily available liquid nitrogen to cool the disc for demonstrating the Meissner effect of magnetic levitation.

The second is a do-it-yourself superconductor fabrication kit which includes all the materials in the demonstration kit plus 10 grams of high-grade yttrium-barium-copper powder, a mortar and pestle, crucible, gloves, spoon, mask and a pill die for compressing the material into 1/2-inch discs.

In order to fabricate these superconducting discs, the experimenter needs the following facilities that are usually found in the school laboratory or shop: a kiln for several 12-hour cycles at 950 degrees celcius to fire the superconducting material and a vise for operating the pill die.

Both kits come with complete instructions and bibliography. Video cassettes are also available covering a wide range of topics in this exciting new field.

Prices for the demonstration and fabrication kits are \$40 and \$200 respectively + PST and shipping.

CS TECHNOLOGIES

21 Sumner Street, Kanata, Ontario.
K2L 2P3 (613) 836-4617

Circle No. 7 on Reader Service Card

More meter for your money!



HC-5010EC MULTITESTER

Basic accuracy 0.1%/0.25%; Buzzer for continuity check; Temp. to 1300°C; Conductance and capacitance; TR gain; Ten AC/DC volt ranges plus current and resistance.

\$109.50

Plus \$5 for shipping & handling.
Carrying case: Add \$10.

MODEL HC-775

Autorange digital multimeter with 5 DC voltage ranges, 200mV to 1000 VDC, 4 AC voltage ranges, 2V to 750VAC plus AC/DC current and resistance 0.1 ohm to 2 Meg. ohm. Max. 10 amp overload protection.

\$74.50

Plus \$5 for shipping & handling.
Carrying case: Add \$10.

VALUE PLUS!

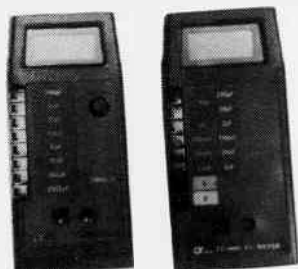

CAPACITANCE METER

MODEL DM 6023

Features nine capacitance ranges from 0.1pF to 20,000uF. .5% accuracy. Supplied with 9V battery, test clips and spare fuse.

\$109.50

Plus \$5 shipping & handling.
Carrying case: Add \$10.

LC METER

MODEL LC 6043

Five inductance ranges from 1uH to 20H. Six capacitance ranges from 1pF to 200uF. 1% accuracy. Supplied with 9V battery, test clips and spare fuse.

\$149.50

Plus \$5 for shipping & handling.
Carrying case: Add \$10.



Order by phone or mail. Credit card, money order, cert. cheque or C.O.D.
Ontario residents add 7% P.S.T.



KB ELECTRONICS

355 Iroquois Shore Road, Oakville, Ontario L6H 1M3
Tel: (416) 842-6888 • Telex: 06-982396 KBELOKVL

Circle No. 8 on Reader Service Card

NEW: SURFACE MOUNT COMPONENT KITS



- PROTOTYPING
- EXPERIMENTING
- SMT TRAINING
- TEACHING
- REPAIRING

Design now with the state-of-the-art surface mount chip components. Complete, low priced, conveniently packaged chip resistor and capacitor kits.

Chip resistor kit CR-1 contains:

710 resistors composed of 10 resistors of every 20% values from 10 ohms to 2M2 ohms (65 values + jumper), plus a bonus of 10 additional resistors in 1K, 10K, 100K, 1M and 0ohm jumpers.

Chip capacitor kit CC-1 contains:

285 capacitors composed of 5 chip capacitors of every 20% values from 10 pF to 220nF (53 values), plus a bonus of 5 additional capacitors in 100pF, 1nF, 10nF and 100nF.

Each kit sells for \$89.95 post-paid. Order by phone or mail. VISA, money order or certified cheque. Ontario residents add 7% sales tax. Please allow 4 weeks for delivery. Linear and digital surface mount kits available soon.

INLY SYSTEMS INTERNATIONAL LTD.

1090 Cummings Avenue, Gloucester, Ontario, K1J 7S2
Tel: (613) 744-8307

Circle No. 9 on Reader Service Card

THE SCIENTISTS TELL ME

By David P. Dempster

Scientists Learn How Complex Materials "Relax"

There's a group of scientists doing research at the University of California, Santa Barbara, who get excited about relaxation, but they don't mean "taking it easy." Rather, Richard Palmer, Daniel Stein and Peter Wolynes are referring to a mysterious property that glass, molasses, a number of vital biological reactions, polymers, and even

certain types of computational problems share. The property that is shared is known as slow or extended relaxation. It describes the unusually sluggish way in which such systems respond to external changes, or perturbations.

Palmer is a physicist from Duke University, Stein teaches theoretical physics and does research at the University of Arizona. Wolynes is a chemist at the University of Illinois, Urbana-Champaign. For more than 6 months they have coordinated a program in "Relaxation and Reaction Kinetics" at the university's Institute for Theoretical Physics which has brought together top scientists from around the world to exchange information and views, argue about and analyze this phenomenon.

The discovery of slow relaxation dates back to the 1800s, when the famous mathematician Karl Gauss measured the way in which a silk thread stretches when placed under constant tension.

The current surge of interest has come from a growing conviction that such behavior is a manifestation of a fundamental characteristic of complex materials that scientists do not yet fully understand, the coordinators explain. Generally, systems that exhibit slow relaxation are characterized by an uneasy mixture of order and disorder. That makes them much more challenging than the simpler systems that theoretical scientists have dealt with until recently.

Glasses are a prime example. In materials like crystals and metals,

the location of atoms is highly ordered. In glasses, however, the atoms are scattered about randomly. In a very real sense, glass is a liquid frozen in time. Glass flows but with extreme slowness, and the rate at which it flows is characteristic of extended relaxation.

"People have begun to realize that systems of this sort represent a fundamentally new kind of thermodynamical system: a system with many degrees of freedom and with disorder built in. You can't use the old techniques that worked so well for crystals, ferromagnets, superconductors and similar, generally ordered systems. As a result, they require a new type of statistical mechanics to describe adequately," Stein explains.

Boiling water is a typical "phase change." Scientists have used phase changes of this sort to explain everything from the origin of life to the evolution of the universe. But glasses, and other systems that exhibit slow relaxation, appear to embody a qualitatively different type of phase change, one in which the change occurs gradually and partially rather than abruptly and completely.

The scientists think they have a general idea of what is going on. It is analogous to a crowd leaving a theatre after the movie is over. The people filing down the aisles act as barriers to other people trying to get out. Similarly, as the atoms in glass or molasses try to flow in response to gravity, they keep getting in each other's way.

Prior to the program, a large num-

ber of apparently conflicting models had been proposed to explain this behaviour. The participants now realize that there is considerably more commonality between the various approaches than people had realized, the organizers report. In fact, a new model that incorporates elements of three early theories has been constructed.

Where do we go with all this knowledge? The researchers say that as such concepts are increasingly refined, they are being applied to such diverse areas as superconductivity, neural networks, combinatorial optimization problems (like airline scheduling), pattern recognition, and the origin of the genetic code.

So You Want Fast — Here's Fast

Researchers at Los Alamos National Laboratory, Los Alamos, New Mexico, are really speeding things up. Using a specially modified accelerator, they have pushed tiny particles to speeds of 50 kilometers per second.

The extreme velocity, nearly 112,000 miles per hour, is 50 times faster than a bullet fired from a high-powered rifle, and researchers say the limit has not been reached.

"I'm confident that we'll see 100 kilometers a second because we're still improving the equipment," said Paul Keaton, leader of the project team of scientists and technicians from Los Alamos and Science Applications International Corp.

The 50-km-a-second speed was

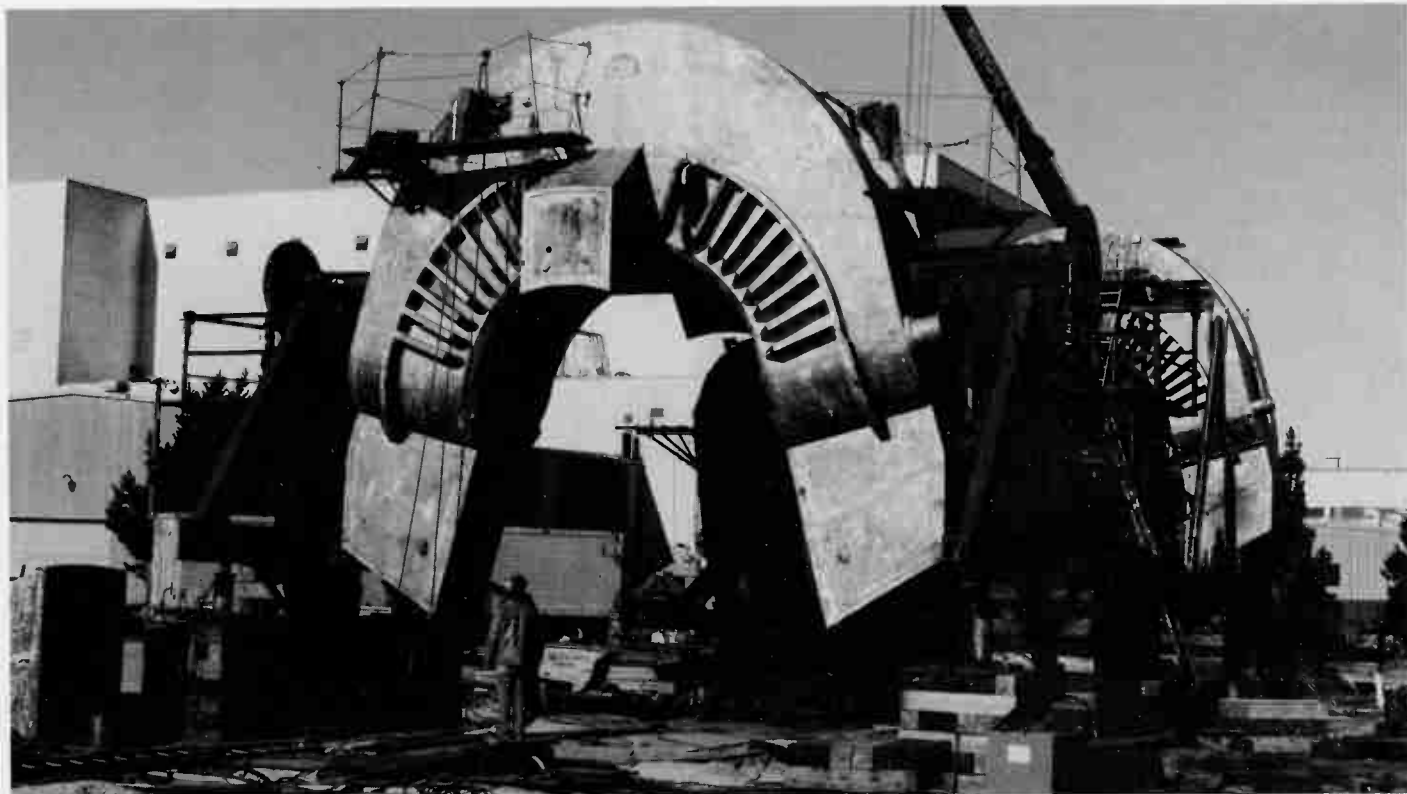

The Scientists Tell Me...

recently reached at the Lab's Ion Beam Facility on a Van de Graaff accelerator that was modified for the hypervelocity impact research project.

The milestone was achieved with iron particles the size of individual particles in a cloud of cigarette smoke, each weighing less than two trillionth of a gram.

The research which has applications in space science and defence, is designed to validate existing computer codes developed to describe what happens when particles travelling at high speeds hit something. Experimental verification of the codes for particles of this mass and velocity was previously impossible.

The particles are charged and accelerated to speeds up to one-half kilometer per second, about as fast as a 22-calibre rifle bullet, by a particle source injector that was built by the research team. They are then injected into the Van de Graaff for the final acceleration.

The two-story Van de Graaff is an electrostatic accelerator that uses high voltage and a long vacuum tube to accelerate charged particles. In the recent tests, the potential voltage was set at 5 million volts. It will be set higher when the equipment is refined, allowing the particles to be accelerated to higher speeds.

The research project will focus on a physical phenomenon called momentum enhancement, which occurs when hypervelocity particles strike a surface. Material from the target is ejected on impact, boosting the momentum already imparted to the target by the impacting particle. Sensitive techniques to measure the added momentum, which depends on such factors as particle size and velocity, angle of impact and target material, will be developed at the facility, Keaton said.

"We'll be working on technical developments, such as improving the particle injection mechanism, the target chamber and all the electronics, and scientific research involving impact dynamics and measurements," he said.

The momentum of speeding particles is determined by applying conservation-of-energy formulas to precise measurements of the charge and time of flight in the vacuum. The results obtained at Los Alamos so far agree with earlier findings at less powerful accelerators at universities in Germany and England.

Although the particles are travelling at extreme velocities, stopping them is not difficult because of their small mass. That doesn't mean that the particles don't have any effect on the target, however.

"Such 'cosmic dust' or micro-meteorites in space could create problems for a space station with a 20-year lifetime by slowing it slightly

or pitting exterior surfaces, including windows," said Keaton, "The work here will help researchers understand the physical mechanisms involved in such high-velocity impacts."

Taking Off the Fat With Home Computers

Here's a project that should make a lot of people happy. Some day in the not too distant future, volunteers in diet studies may be able to weigh and record electronically what they eat at home, and then send the data over a computer to a laboratory for analysis, according to a scientist with the U.S. Department of Agriculture.

"If we can gather more precise data, then we should have a more accurate picture of whether people are getting the nutrients they need to stay healthy and fit," says Mary J. Kretsch, a research nutritional scientist with the USDA's Agricultural Research Service.

With a new system Kretsch and colleagues have developed, volunteers record their food intake in their own homes on a portable computer. The computer is linked to an electronic scale which weighs the food, and to a barcode reader, similar to ones at supermarket checkout counters, which records the food's identity. The data can then be transmitted over the telephone to the research laboratory.

"Thousands of pieces of data are taken in a diet study," says Kretsch. "This new system will help volunteers record data immediately and send it to researchers. Volunteers will use special barcodes from a new barcode catalogue developed by Kretsch and colleagues to record the identity of most common foods, such as frozen and canned foods, fresh fruits, vegetables and meats. So far 21 volunteers in two pilot tests have already learned how to use the electronic package.

The system uses USDA's nutrient composition database, which can accurately calculate about 36 nutrients in a given food item. "The system is one of the major advances in determining dietary patterns in more than 40 years," states Kretsch, who is located at USDA's Western Human Nutrition Research Center in San Francisco.

She says the system may reduce chances of volunteers failing to record snacks and other foods they eat, and will also make it cheaper, faster and easier for researchers to detect unhealthy diet trends. At times in earlier studies some data on meals would be missing. Volunteers may have forgotten to write in food diaries what they had eaten, or may not have remembered every item in face-to-face interviews.



USDA scientist Mary Kretsch (left) instructs dietary study volunteer in the operation of computerized food scales

Introducing a giant among flashlights...

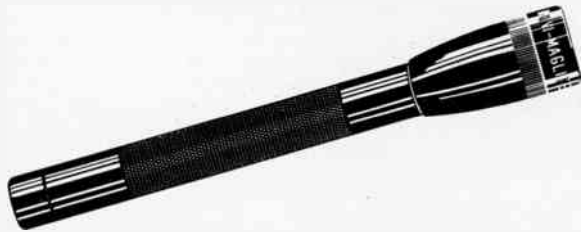

The Mini-Mag Lite® AAA flashlight

Unparalleled for superior quality and innovation.

- Only 5 inches long
- Available in a rainbow of colours
- Anodized aluminum with knurled grip
- Adjustable beam, from a spot to a flood
- Spare bulb in tail cap
- Water resistant
- Limited lifetime warranty

For information on Mag-Lite® flashlights and accessories, call ECG Canada Inc.

ECG CANADA INC.

A North American Philips Company
1928 St. Regis Blvd., Dorval, Qc H9P 1H6 (514) 685-5800
Fax: (514) 685-5804

Circle No. 11 on Reader Service Card

Featuring the newest line of Instrument Cases from Hammond



New 1598 plastic instrument cases are the latest in our line of plastic and diecast boxes. Don't pay for expensive tooling, we have the lowest prices on volume under 20,000 pieces. We'll also do your custom punching and screening. Send for FREE brochure or contact us for volume pricing.

HAMMOND MANUFACTURING™
394 Eoinburgh Rd. N.
Guelph, Ontario
N1H 1E5

Telephone:
(519) 822-2950
(416) 456-3770
Telex: 089-56523

Circle No. 12 on Reader Service Card

COMPUTER PARTS GALORE

316 COLLEGE ST. TORONTO M5T 1S3
SALES, SERVICE: 1-416-928-2161
FAX: 1-416-924-0292
TOLL FREE ORDERS: 1-800-387-1385
BBS: 1-416-366-2069
ENVOY100 ID: CPG

286 SYSTEMS

286 PREMIUM SYSTEM #1

MACH-12 12 Mhz 286 MOTHERBOARD
DESIGNED AND PRODUCED IN THE U.S.A.
-POACH ZYMOS VLSI CHIPSET
-640K (100ns) DRAM
-AWARD BIOS w/ SETUP/SPEED SWITCH IN ROM
-8 Slots 6-16 Bit 2-8 Bit
-Clock Calender

FULL SIZE AT FLIP TOP CASE

5060 "TACTILE" KEYBOARD
230W CSA POWER SUPPLY
PARALLEL AND SERIAL PORTS
CGA or MGA VIDEO ADAPTER
16 BIT HARD/FLOPPY DRIVE CONTROLLER
1.2 MEG and 360K FLOPPY DRIVES
8 DISK SET OF SYSTEMWARE SOFTWARE

1 YEAR PARTS/LABOR WARRANTY

only **\$1899.95**

286 PREMIUM SYSTEM #2

Same system as Premium #1 except with
BABY AT Wonderboard
-6/10 Mhz 01 WS, 12 Mhz, 1 WS.
-Zymos VLSI CHIPSET
-Clock Calender
-8 Slots 6-16 Bit 2-8 Bit

only **\$1799.95**

UPGRADES ADD TO BASIC PRICE

Upgrade to RT-101 Keytronics Keyboard	\$29.95
System without 360K floppy drive	less \$120.00
Hi-Res TTL 12" Monitor	\$129.95
EGA Video Adapter Upgrade	\$140.00
ATI EGA/WONDER Upgrade	\$250.00
GOLDSTAR EGA 13" Monitor	\$595.00
Upgrade to RLL Hdisk Controller	\$45.00
20 Meg 60ms Hdisk Seagate/Miniscrbe	\$339.95
42 Meg 38ms Hdisk Seagate ST251	\$675.00
44 Meg 28ms Hdisk Mini-scribe 3053	\$899.95
72 Meg 28ms Hdisk Mini-scribe 6085	\$1325.95
72 Meg 28ms Hdisk Micropoles 1335	\$1249.95
MSDOS 3.30 Special price with Systems only	\$129.95
3 Meg Extended/Expanded Ram Ok	\$249.95
80287 8	\$425.00
80287-10	\$550.00

8088 SYSTEMS

Latest clone technology. 100% compatible. Fully tested and Burned-in.

BASIC 8088 SYSTEMS INCLUDE:

640K Ram on 8 slot Motherboard
2 - DSDD 360K floppy and controller
AT/XT 5160 Tactile keyboard
Monographic Video Adapter
12" Amber Hi-Res TTL Monitor
Clock / Cal, Serial, Parallel, Game Ports
8 Slot XT/AT STYLE Flip-Top Case
180W CSA Power Supply
ONE YEAR PARTS/LABOR WARRANTY
6 free disks of Public Domain Systemware

Motherboard options.

(1) 4.77 Mhz Std.	\$1075.95
(2) 8 / 4.77 Mhz 2 Layer Pcb	\$1099.95
(3) 10 / 4.77 Mhz 2 Layer Pcb	\$1125.95
(4) BABY AT 8 / 10 Mhz	\$1599.95

ADD TO BASIC SYSTEM PRICE

20 Meg Hdisk with Controller	\$439.95
30 Meg RLL Hdisk w/ Controller	\$489.95
Upgrade to EGA Card w/256k	\$140.00
Upgrade to EGA monitor	\$460.00
8087 5Mhz	\$199.95
8087 8Mhz	\$299.95
MS-DOS 3.30 with system	\$129.95

PRINTERS & PLOTTERS

ROLAND PR1012 120 cps NLO w/cable	\$309.95
ROLAND PR1112 180 cps NLO w/cable	\$369.95
ROLAND PR1212 180 cps NLO w/cable	\$575.95
ROLAND PR1215 180 cps NLO W Carr w/cable	\$725.95
ROLAND PR2017 17 cps Daisy Wheel w/cable	\$949.95
ROLAND PR 2022 22 cps Daisy Wheel w/cable	\$855.95
ROLAND DXY-880 Plotter w/cable	\$1249.95
ROLAND DXY-990 8 pen Plotter w/cable	\$2449.95
HOUSTON INSTR. DMP-52MP w/cable	\$7499.95
NEC 890 POSTSCRIPT Laser Printer	\$5449.95
Centronics PAGEPRINTER 8 Laser Printer	\$1995.95
- HP Laserjet + Emulation 8 ppm	

DRIVES and CONTROLLERS

PANASONIC JU455 DSDD 360K	\$134.95
PANASONIC JU364 DSDD 3.5" 720K	\$134.95
JU364 3.5" Drive with Mounting Kit	\$154.95
PANASONIC JU475 1.2M AT Drive	\$174.95
CHINON 3.5" DSDD 720K Floppy Kit	\$149.95
CHINON 3.5" 1.4 Meg Floppy Drive	\$189.95
XT 20 Meg Hdisk w/ M-F-M controller/cables	\$439.95
XT 30 Meg Hdisk w/RLL Controller/cables	\$489.95
XT M-F-M Hdisk Controller (w/cables)	\$119.95
XT RLL Hdisk Controller (w/cables)	\$149.95
20M Hdisk 60ms Seagate/Miniscrbe	\$339.95
30M RLL Hdisk 55ms Seagate/Miniscrbe	\$379.95
AT 42M 38ms 1/2 hgt Seagate ST-251	\$674.95
AT 44M 28ms 1/2 hgt Miniscrbe 3053	\$899.95
AT 62M 38ms RLL Hdisk Seagate ST-277	\$859.95
AT 72M 28ms Full hgt Miniscrbe 6085	\$1324.95
AT 72M 25ms Full hgt Micropoles 1335	\$1249.95
AT 16 Bit WD-WA2 Hard/Floppy Controller	\$239.95
AT 16 Bit WD-RA2 Hard/Floppy RLL Contrler	\$314.95
AT 16 Bit Low-Profile Hard/Floppy Controller for XT case sizes	\$259.95
AT Adaptec 2372 Hard/Floppy RLL Controller features 160 interleave for max. performance	\$359.95

POINTING DEVICES

LOGITEC Serial Mouse w/software	\$114.95
LOGITEC Bus Mouse w/software	\$129.95
LOGITEC Bus Publisher Mouse	
PC PAINTBRUSH & First Publisher included	\$199.95
LOGITEC 2 Button Mouse	\$89.95
MOUSE PAD Optional for LOGITEC	\$14.95
GRAVVIS JOYSTICK adjustable tension Pistol grip with 3 Buttons	\$49.95
KURTA ISONE 8.5 x 11 Digitizer Tablet	\$595.95
KURTA ISONE 12 x 12 Digitizer Tablet	\$695.95
KURTA ISONE 12 x 17 Digitizer Tablet	\$1155.95
KURTA 1 Switch Corded Pen for ISONE Tablet	\$109.95
KURTA 2 Switch Corded Pen for ISONE Tablet	\$195.95
KURTA 3 Switch Cordless Pen for ISONE Tablet	\$195.95
KURTA 4 Button Corded Cursor for ISONE Tablet	\$149.95
KURTA 4 Button Cordless Cursor for ISONE Tablet	\$195.95

MAIL ORDERS: We take VISA, M.C., AMEX. Cheques (2Weeks for non-certified) C.O.D. \$4.00 extra. Min. Order \$25.00. Delivery & handling 5% (min \$5.00) for surface del. Heavy items may cost more. Premium del. service of your choice, extra cost. All prices are subject to prior sale. All prices are subject to change without notice. RMA needed for returns. 20% restocking fee on returned merchandise.

MODEMS and FAX CARDS

GVC 1200/300B Int. w/software	\$149.95
GVC 1200/300B Ext. w/software	\$169.95
GVC 2400/1200/300B Int. w/software	\$309.95
GVC 2400/1200/300B Ext. w/software	\$349.95

GVC modems are 100% Hayes compatible and include manual/software 2 yr. warranty.

ASHER PC FAX by QUADRAM

*4800 baud *Scanner compatible
*TSR Software Included

\$695.95

MONITORS

PACKARD BELL Hi-Res 12" TTL Amber	\$139.95
PACKARD BELL Hi-Res 12" TTL Green	\$149.95
AMDEK 410 Hi-Res 12" TTL Amber	\$265.95
SAMSUNG 14" Flat Screen TTL Amb	\$224.95
XTRON 14" Flat Screen TTL Paper White or Amber	\$269.95
THOMPSON 14" RGB Monitor "VCR compatible"	\$499.95
GOLSTAR EGA 13" Monitor .31" dot pitch, Dual-Scan 15 7-22 Khz	\$624.95
NEC MULTISYNCH-2 14" VGA Monitor	\$949.95
NEC MULTISYNCH-4 14" VGA Monitor	\$1850.00
NEC MULTISYNCH XL 20" CAD-CAM Monitor	\$3895.95

Uninterruptible Power Supply

Great new power supplies to keep things going when the going gets tough. Automatic switch-over, internal battery and will run up to 250 (400) watts for 10-15 minutes while you save your work. The units have 85% efficiency, 5ms switch-over, light, buzzer, 2 AC outlets and full transient filtering.

UPS-250W	\$449.95
UPS-400W	\$549.95

Lisp for the Mac

Texas Instruments has introduced the micro-Explorer workstation, consisting of TI's processor peripheral plugged into a Macintosh computer. The combination becomes a powerful AI computer, allowing advanced symbolic processing techniques. The processor is compatible with the Explorer family of AI software. Systems

start at \$14,995 (US), including a Mac, 40M disk, a total of six megabytes of memory, and software. Versions are available for those who already have a Mac. For more information, contact Texas Instruments Inc., Data Systems Group, PO Box 181153 DSG-179, Austin, Texas (512) 527-3500.

Circle No. 13 on Reader Service Card

The Return of Analog?

Today's digital technology may be unable to deliver the signal processing speeds required to realize one of tomorrow's electronic dreams: a global computer network with virtually instantaneous exchange of information. However, researcher John Choma Jr of the University of Southern California has redesigned an old-fashioned analog circuit that economically processes signals hundreds of times faster than either digital or traditional analog circuit, something like winning a race with a horse that's long been out to pasture.

Analog circuits can process signals up to 7 billion times a second, but were largely displaced by digital techniques because they suffer from loss of signal quality, high power dissipation and large size. Now that digital circuitry is running into a speed barrier, the industry is taking another look at analog. Unfortunately, analog research is in a shambles, with nearly all present designers having been trained in digital techniques.

Professor Choma redesigned a conventional

analog processor to reduce power consumption and increase speed. The key to the design is an innovative feedback scheme that uses additional transistors to effectively cancel the charge stored in the signal processing transistors. The new circuit will use more chip area, but this is not a problem since far less transistors will be required than for the equivalent digital circuitry. Professor Choma acknowledges that there is an extra manufacturing cost inherent in maintaining the signal quality in analog circuits, and he is conferring with representatives of the IC industry towards solving the problem.

Pathetic Pirates

In a recently filed lawsuit, Business Recovery Systems, a Colorado software manufacturer, alleged that a Rochester firm had illegally copied their disaster recovery planning software and documentation. The U.S. Marshal's office executed a seizure order and discovered the illegal copies.

The reason that they went ahead with legal proceedings is this: the Rochester firm borrowed the software, then returned it; unfortunately they left attached to it a routing memo, which read "Have copy of book and disk. It can be sent back."

Fastest Transistor

IBM scientists at the Yorktown Heights, NY, research facility have made and designed a transistor that has a 7 picosecond switching time, about twice as fast as the previous record for silicon. This makes silicon a match for gallium arsenide; the fastest gallium arsenide transistor to date has a switching time of 5 picoseconds.

The silicon transistor's speed was made possible by ultra-thin (tenth-micron) lines, and cooling the unit with liquid nitrogen. IBM points out that many complex problems must be solved before entire chips can be made that take full advantage of the small size and great speed of the new transistors.

More on Speed

The entire world of technology and hi-tech manufacturing seems to be obsessed with speed. People pay thousands of dollars for equipment to shave a few seconds off the operating time of their computers. Each month we receive press releases touting the fastest semiconductor ever made.

But do we really need this speed? Do we really need to shave a few seconds off?

Well, yes. The problem is human nature: we don't really need the computed results all that fast, but we hate waiting and looking at a blank screen while the computer cogitates. And, of course, you can't tear yourself away to go and get a coffee because you think you might miss something.

So here's the way to make the world's fastest computer, bank machine, or what have you: give the user something to do in the meantime. When AutoCAD regenerates your drawing, something which takes an eternity at least, the screen would pop up a tiny video game for you to shoot down Martians or something. Bank teller machines would play Trivial Pursuit while waiting to find out that the network is down. Police computers would give you a game of Marble Madness before telling you to pay \$200 or go directly to jail.

Classifieds
Where Buyers Find Sellers

FOR \$10 plus \$3.00 postage (Que. 9% tax.) one of the following 100-fuses A.G.C. 1/4" x 1-1/4" 1/8A to 50A (specify) 100-Jumbo red diffused LED T-1 3/4 (5mm) 12 Mini-switches d.p.d.t. Free flyer and sample with S.A.S.E. Parts and services on all Marconi Radio HF-VHF-UHF. **COM-O-PAC INC.** 2264 Montee Gagnon, Blainville, P.O. J7E 4H5.

COMPUTER and Electronic components at reasonable prices. Send \$2.00 for 1988 Catalogues and be on mailing list for one year of 'Bargain Flyers.' **M.O. ENTERPRISES**, Box 2066, Bramalea, Ontario, L6T 3S3.

SURPLUS Electronic Test Equipment, Bargain prices, Guaranteed. List \$2. refundable with purchase. **ALLIED INDUSTRIAL ELECTRONICS**, Box 401, Pointe-Claire Dorval Que. H9R 4P3 514-631-6941.

Designers, Engineers, hobbyists: Looking for that hard-to-find circuit? Try search on bibliographic data base. Thousands of practical circuits from dozens of journals. Many scientific applications. Ask for manual. **CIRCUIT SEARCH**. P.O. Box 268, Breslau, Ontario N0B 1M0

ORIGINAL TRI-MODE parts \$89.95, SB3 Parts \$69.95, Notch Filters \$39.95, Catalogues \$1.00, GENIE, Box 522, Montreal, PQ, H3S 2V3

CABLE TV DESCRAMBLING TECHNIQUES. 56 pages. \$13.95. Channel 3 notch filter \$39.95. Amazing see-in-the dark infra-red night view kit \$295.00. SCA background music kit \$49.95. Catalogues \$1.00. **OCTE(J)**, Box 173, Montreal, PQ., H3X 3T4. (514) 739-9328.

AMAZING SCIENTIFIC & ELECTRONIC PRODUCTS

- PLANS**—Build Yourself — All Parts Available In Stock
- LC7—BURNING CUTTING CO. LASER \$ 20.00
 - RUB4—PORTABLE LASER RAY PISTOL 20.00
 - TCC1—3 SEPARATE TESLA COIL
 - PLANS TO 1.5 MEV 20.00
 - IDG1—IDN RAY GUN 10.00
 - GRA1—GRAVITY GENERATOR 10.00
 - EML1—ELECTRO MAGNET COIL GUN/LAUNCHER ... 6.00

- KITS**
- MFBK—FM VOICE TRANSMITTER 3 MI RANGE 49.50
 - VWPM7K—TELEPHONE TRANSMITTER 3 MI RANGE ... 39.50
 - BTC3K—250.00 VOLT 10-14" SPARK TESLA COIL ... 199.50
 - LHC2K—SIMULATED MULTICOLOR LASER 39.50
 - BLS1K—100,000 WATT BLASTER DEFENSE DEVICE ... 99.50
 - ITM1K—100,000 VOLT 20" AFFECTIVE RANGE INTIMIDATOR 99.50
 - PSP4K—TIME VARIANT SHOCK WAVE PISTOL 99.50
 - PTG1K—SPECTACULAR PLASMA TORNADO GENERATOR 149.50
 - MVP1K SEE IN DARK KIT 199.50

- ASSEMBLED**
- PTW1K—SPECIAL EFFECT VISUAL PLASMA GENERATOR FOR GLOBES/NEON TUBING ETC. 99.50
 - BTC10—50,000 VOLT—WORLD'S SMALLEST TESLA COIL 49.50
 - LGU40—1MW HeNe VISIBLE RED LASER GUN 249.50
 - TA20 AUTO TELEPHONE RECORDING DEVICE 24.50
 - GPV10—SEE IN TOTAL DARKNESS IR VIEWER 349.50
 - LIST 10—SNOOPER PHONE INFINITY TRANSMITTER ... 199.50
 - IPG70—INVISIBLE PAIN FIELD GENERATOR—MULTI MODE 74.50

● CATALOG CONTAINING DESCRIPTIONS OF ABOVE PLUS HUNDREDS MORE AVAILABLE FOR \$1.00 OR INCLUDED FREE WITH ALL ABOVE ORDERS.

PLEASE INCLUDE \$3.00 PH DN ALL KITS AND PRODUCTS. PLANS ARE POSTAGE PAID. SEND CHECK, MD, VISA, MC IN US FUNDS.

INFORMATION UNLIMITED
P.O. BOX 716, DEPT. ET AMHERST, NH 03031

Circle No. 14 on Reader Service Card

For Advertising Information Call:
(416) 445-5600 Or Fax:
416-445-8149

Now from NRI comes the first course of its kind . . . anywhere!

Learn to use, program, and service today's digital electronic music equipment as you build your own computer-controlled music center



Now NRI puts you at the heart of the most exciting application of digital technology to date! With NRI's new at-home training in Electronic Music Technology, you get hands-on experience with the equipment that's revolutionizing the music industry—Atari ST Series computer with built-in MIDI ports, Casio CZ101 digital synthesizer with advanced MIDI capabilities, and ingenious MIDI software that links computer keyboard to synthesizer keyboard—all yours to train with and keep.

This year, over \$1.5 billion worth of digital electronic music instruments—keyboards, guitars, drum machines, and related equipment—will be sold in the U.S. alone. Who's buying this new-tech equipment? Not just progressive musicians and professional recording technicians, but also thousands of people who have never touched a musical instrument before. And there's good reason why.

Something called MIDI (Musical Instrument Digital Interface) has suddenly transformed musical instruments into the ultimate computer peripherals . . . and opened up a whole new world of opportunity for the person who knows how to use, program, and service this extraordinary new digital equipment.

Now NRI's breakthrough Electronic Music Technology course puts you at the forefront of this booming new technology with exclusive hands-on training built around a MIDI-equipped computer, MIDI synthesizer, and MIDI software you keep.

Dynamic New Technology Opens Up New Career Opportunities for You

The opportunities are unlimited for the person who's trained to take advantage of today's electronic music phenomenon. Now you can prepare for a high-paying career as a studio technician,

sound engineer, recording engineer, or road technician . . . even start your own new-age business providing one-stop sales and service for musicians, technicians, and general consumers alike. Or simply unleash your own musical creativity with the breakthrough training and equipment only NRI gives you.

Only NRI Gives You an Atari ST Computer, Casio Synthesizer, and Innovative MIDI Software You Train With and Keep

The Atari ST Series computer included in your course becomes the heart of your own computer-controlled music center. With its tremendous power, superior graphics capabilities, and built-in MIDI interface, the 16/32-bit Atari ST has almost overnight become the computer of choice for today's most knowledgeable electronic musicians.

The Casio CZ101 digital synthesizer, also included in your training, is the perfect complement to your Atari ST. The polyphonic, multitimbral CZ101—which stores up to 32 voices internally—"communicates" with your ST computer through MIDI, bringing life to virtually any sound you can imagine.

Plus, you get ingeniously designed MIDI software that opens up amazing new creative and technical possibilities . . . you actually build your own 4-input audio mixer/amplifier . . . and you test the electronic circuits at the core of today's new-tech equipment with the hand-held digital multimeter included in your course.

No previous experience necessary—in electronics or music!

No matter what your background, NRI gives you the skills you need

to take advantage of today's opportunities in electronic music technology.

With your experienced NRI instructor always available to help, you master the basics of electronic theory step by step, gaining the full understanding of electronics that's now so essential for technicians and musicians alike. You move on to analyze sound generation techniques, digital logic, microprocessor fundamentals, and sampling and recording techniques . . . ultimately getting first-hand experience with today's explosive new technology as you explore MIDI, waveshaping, patching, sequencing, mixing, special effects, and much more.

Plus, even if you've never been involved with music before, NRI gives you enough basic training in music theory and musical notation to appreciate the creative potential and far-reaching applications of today's electronic music equipment.

Send Today for Your FREE Catalog

For all the details about NRI's innovative new training, send the coupon today. You'll receive a complete catalog describing NRI's Electronic Music Technology course plus NRI courses in other high-tech, in-demand electronics fields.

If the coupon is missing, write to NRI School of Electronics, McGraw-Hill Continuing Education Center, 3939 Wisconsin Avenue, Washington, DC 20016.

NRI School of Electronics

McGraw-Hill Continuing Education Center
330 Progress Avenue, Scarborough, Ontario M1P 2Z5
Main Office: 3939 Wisconsin Avenue, NW, Washington, DC 20016

CHECK ONE FREE CATALOG ONLY

- Electronic Music Technology Computers and Microprocessors
 TV/Video/Audio Servicing Basic Electronics

Name _____ (Please Print) _____ Age _____

Street _____ Telephone _____

City/Prov./Code _____
We'll give you tomorrow. Member of Private Career Education Council 11-058

Uninterruptible Power Sources for Computer Installations

Total protection from power-supply disturbances for sensitive equipment and data.

By Dr. H. Virani

To most people, mains-borne electricity is a mysterious servant that responds instantly to their command. They insert a plug, turn a switch and receive instant light, heat and power for most of the things taken for granted in our daily lives. Even those of us who use sophisticated electronic equipment or instrumentation computers whether large or small, always assume it will be there, in unlimited quantities at our beck and call.

In the past, before the advent of the computers and other "real time" equipment on which we have become so dependent, it did not matter too much if there was a short break in the supply or that the power line was "noisy" or not exactly of the magnitude really required to obtain maximum reliability and efficiency from the equipment it was running. However, any user who has experienced any of these mains-borne-electricity-related problems, and has paid the cost in downtime, program errors, loss of data, production losses or equipment damage, will know only too well the frustration, time lost and ultimate monetary loss when this occurs.

An uninterruptible power supply (UPS) system is a device which is placed between the user's equipment input and the power-source output to act as a reserve source of energy in the event of a complete power failure.

But first we must establish the need for such equipment and having done so, select the appropriate product to meet the particular demands, of its application and environment. The user is buying insurance and therefore must make sure that when a claim is made the policy is a good one and provides for what it is intended, without hidden causes or conditions. The question is simply: Can I afford to be without my equipment? It does not matter if it is for a few milliseconds or some hours, the answer is the same in both cases (Fig. 1).

UPS Technology

There are basically two types of systems available to provide the reserve energy source: rotary and static UPSs. In addition there are two types of operating principles when considering each system: "outline" and "offline". Each type has its own advantages and disadvantages and these are outlined in the following sections.

Rotary Power Sources

The rotary power source (Fig. 2) is in essence an AC electric motor driven from the mains powerline or a rectifier supplied DC motor, shaft connected to an AC diesel generator which supplies power to the load.

Early systems incorporated a mains-failure detection circuit which triggered a start up sequence for the diesel engine, providing full power from the AC generator about 10-15s later. Later systems incorporated no-break flywheel systems, which attempted to maintain the generator speed for the 10-15s start-up time required for the engine, but suffered from poor frequency stability during the auxiliary-generator start-up period. Refinements have since been made to these systems, and the more recent types use rectified DC to drive a solid-state inverter. The inverter output, which is more reliable, powers a synchronous motor generator set which in turn supplies the load. These systems have been used in many computer mainframe applications where power levels from 50 to 500 KVA are required.

In general, rotary uninterruptible power sources (UPS) systems are initially less expensive than static UPS in larger installations, but when considered in terms of performance, reliability, and maintenance they have proved to be less than satisfactory. Input power line noise isolation is poor, as there is capacitive and inductive coupling between the input windings of the motor and the output generator windings; the output voltage regulation capability is highly dependent on the input voltage remaining on or near nominal, and the "ride-through" capability over many line cycles, claimed from stored energy in the flywheel and rotating parts, is highly dependent on "dynamic braking" as the motor generator at power failure is still connected to the power source, and the attempts to feed the input and output simultaneously.

Static Power Sources

The first totally static power sources were introduced in the early 1960s, and as the same suggests, they have no moving parts (except cooling fans, when fitted). These originally very large devices used solid-state technology and in their basic form rectified the incoming AC power line into DC,

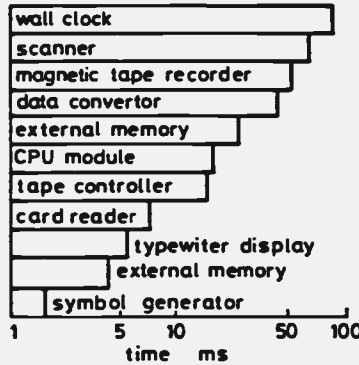

Figure 1

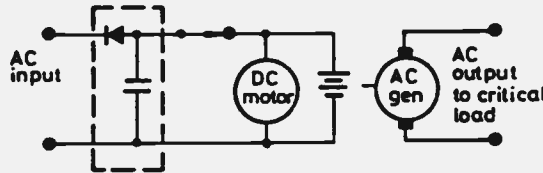

Figure 2

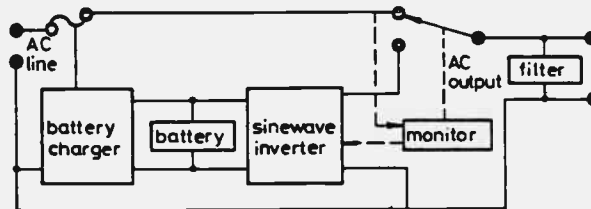

Figure 3

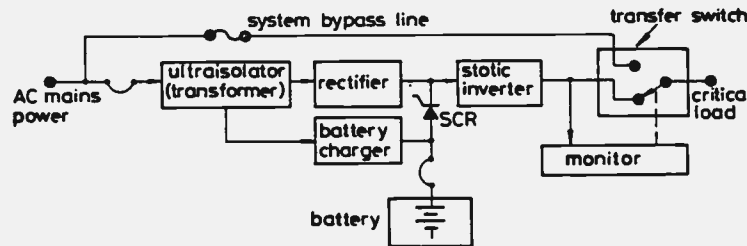

Figure 4

which in turn fed a solid-state inverter which changed the DC back into AC at the desired voltage and frequency, thus supplying the load. In the event of a main power failure a bank of batteries supplied the DC power to drive the inverter; the amount of time the load could be supported thus depended on the battery capacity and the load characteristics.

The batteries could be recharged by an external source when the mains power was restored or it could be a part of the UPS system function. A DC generator (with associated control circuits) could also be connected to the inverter to provide power after the batteries were exhausted.

From this basic system many techniques have been developed in the way in which they operate, and the three most common are referred to as:

- Continuous
- Forward transfer
- Reverse transfer

The continuous or online system, as the name implies, is always the final source of power for the load. The input of the uninterruptible power source is connected directly to the normal power line and the load receives power from the inverter output.

In contrast, the forward-transfer, or "offline" system (Fig. 3) is only connected to the load to provide AC power when it senses a fluctuation or interruption on the mains powerline.

The output of a reverse-transfer system, like that of the continuous online uninterruptible power sources, is normally connected to the load, but the load can be switched to a back up source — usually the mains power line — under certain circumstances. The online reverse-transfer system (Fig. 4) is that most commonly used in computer and other sensitive equipment applications, as it provides complete protection against all types of power line problems because:

- the input/output is isolated through the internal DC line and so removes all incoming power-line noise disturbances.
- serious voltage variations at the input will result in the internal batteries supporting the inverter-input direct voltage, and so the inverter output voltage will remain stable to the load, in the event of a complete mains failure the batteries will support the system.
- the output frequency from the inverter will always be within preset

Uninterruptible Power Sources

limits as the inverter output frequency is controlled by an internal oscillator.

- other input-output protection can be easily incorporated within the design (over voltage, over currents, etc.)

- it provides for switching to an alternative power source in the event of a system malfunction or failure.

Solid-State Switches

The faster operation of the solid-state switch is especially important in applications where the load is sensitive to step load changes or voltage transients, and so it is generally preferred in computer applications.

However, the user should decide whether this feature is essential as the difference in cost between the two can be significant; there are other more general considerations which should also be taken into account, such as the type of inverter design used and its dynamic response characteristics.

UPS Operating Modes

There are three modes of operation for any UPS system: operate, emergency and recovery. In the reverse-transfer

system most commonly used in computer applications as previously described, the modes occur as follows. In the "operate" mode as in the continuous system, the unit acts as a buffer between the mains power source and the load.

The rectifier and charger provide current to the inverter and simultaneously maintain the batteries at their full rated charge. The emergency phase begins when the mains power fails or is interrupted. As the drop in line power causes the output of the rectifier to decrease, the battery reservoir compensates for the decrease, and so the input DC to the inverter remains constant, thus keeping the inverter output into the load constant. The drop in the voltage at the AC input to the rectifier causes the battery reservoir to reverse-bias a rectifier diode and prevent battery current flowing back through the charger. The batteries support the inverter until the mains power is restored.

The length of time the inverter can be supported depends on the capacity of the battery and the size and the

characteristics of the load. The "recovery" mode begins when the mains power returns to normal. At this time the rectifier and charger output is restored and begins to drive the inverter, taking over from the battery while at the same time starting to recharge the batteries. When the batteries are fully recharged the system returns to the "operate mode".

Generally speaking, a correctly sized charger will allow a complete recharge of the batteries within 10-16 h.

UPS System Element

The characteristics of each of the elements of the UPS systems can have definite effects on the overall system performance and while they are of prime concern to the systems designer, the potential user should be aware of them. The elements concerned are as follows:

- rectifier
- charger
- inverter
- transfer switch
- status monitors
- alarms



The Power Control ME-400 UPS

*A Mini review
of a UPS*

By Bill Markwick

The rectifier should be capable of powering the fully loaded inverter continuously with minimum specified input voltage and should allow 120-150% of normal load to be applied for short durations (10s) with input voltages as low as 10% below normal. The rectifier should have input protection and be 85-90% efficient. The battery charger should be separately protected and have good efficiency.

The inverter determines the ultimate quality of the power that drives the load.

There are a number of concepts which have been developed, each type having certain characteristics which bear directly on its suitability for various applications. The type of inverter fitted into the UPS could be one of the most important factors considered as it is the most critical section of the complete system, and, should it fail, the UPS is instantly out of operation.

The purpose of the inverter is to change the direct voltage from the rectifier or the battery to pulsating DC, which in turn can be shaped and fil-

tered to produce a sinusoidal voltage that meets the requirements of the load. This voltage must be of stable amplitude and frequency, contain a low percentage of distortion and be a clean wave form. The most commonly used inverter types are the ferroresonant inverter, the pulsewidth inverter and the quasi-squarewave inverter. Whichever type is used, it should have adequate input protection (fused and low voltage cutoff), be capable of providing the full rated power over various power factors, and have good static and dynamic regulation characteristics. The inverter output frequency in normal operation is synchronized with the mains supply and is kept within close limits when in the "emergency" mode. Harmonic distortion should be kept as low as possible in any condition of load and line.

The type of transfer switch required should be selected depending on the characteristics of the load to be supplied. Many systems feature internal and external alarms and functional status indicators, using lamps or LEDs on a flow-diagram principle. There appears to be great merit in such visual

indication of correct or incorrect operation, as fault location and rectification is much faster and easier. Modular techniques are also widely available and contribute to ease of service and repair.

Conclusion

In the end, however, the requirements of each uninterruptible power sources system should be evaluated individually, because site and load requirements are seldom the same.

Initially, each individual load at the site should be analyzed to establish which are critical, which are essential and which are nonessential. Critical loads must have reliable power to prevent damage or dangerous operating conditions. Essential loads, must operate acceptably during short or prolonged mains power failure. Categorizing the loads and their profiles makes it easy to determine what needs protection, and installing a suitable, correctly specified uninterruptible power sources system will ensure that the insurance policy, when needed, will pay out. ■

In our Uninterruptible Power Supply article on the preceding pages, Dr. Virani discussed the theory and selection of the devices. Here's a look at an actual UPS, the Canadian-made ME-400 by Power Control Incorporated of Toronto. It's a small metal cabinet measuring about 4" by 9" by 12"; on the front is a power switch and status LEDs, and on the back are four power outlets and a line cord.

The unit to be protected from power interruption is plugged into the back of the ME-400, which is itself plugged into a standard outlet. Up to three more pieces of equipment can be added to the rear outlets as long as the total power drain does not exceed 400 watts. Surge and spike protection is built-in and the unit is totally silent when the AC is on.

In the event of a power failure, the ME-400 takes over, sounding an alarm beeper and giving you ten minutes (at the full 400W) to save your files and power down. When the AC is restored, the ME-400 goes into the charge mode, reaching a full charge in four hours.

The ME-400 costs \$1000. Optional equipment includes another battery pack to extend the operating time to 20 minutes.

In Use

We tried the ME-400 with a variety of small and large computers (and, of course, the light bulb on the cover). We tried switching a power bar on and off as well as yanking the plug out of the wall; there was never so much as a glitch from the computers, and we could power them down successfully every time. The output waveform did cause small lines to roll down the monitor screen, though they didn't interfere with operation in any way. Interestingly, these lines did not appear with the plasma screen of the Toshiba laptop computer.

When the power is cut, there's a slight hum from the unit as the oscillator takes over, followed by a regular beeping from the alarm. The change-over occurs in less than 2 milliseconds, enough to cause a tiny flicker from the light bulb that we had plugged in, but not enough to disturb any computers

that we tried. The red LED comes on to let you know that you're in the battery-supported mode.

When the power is restored, the green LED lets you know that the AC is back and the batteries are charging.

Inside

The ME-400 battery pack consists of six maintenance-free gel-type cells. Beside it is space for a second pack, which gives you the ME-410, with 20 minutes of time. The battery output is switched by a bank of transistors to produce a squarewave, which is then stepped to line voltage level by the hefty transformer. This transformer also serves to charge the battery when the AC is restored. An external alarm can be connected. The output is protected with a 4A circuit breaker, and everything is CSA approved.

There are also models with 800, 1200 and 1500 watts output, with duration dependent on battery configuration. Other uses include backing up electronic telephone systems and instrumentation. ■

Circle No. 42 on Reader Service Card

A Visit to Trebas

*A look at the Canadian institute for training in
the recording arts.*

By Bill Markwick



In the late 70s, David P. Leonard was working in the music and recording business in Montreal, managing artists, studios and recording labels. He asked himself, as did many in the Canadian industry, why many major artists immediately headed south to the US for the production of records and soundtracks. After all, he reasoned, we have the very best of state-of-art equipment and facilities here in Canada. The answer had to be the lack of trained support personnel: the engineers, technicians and producers that have to work with the artists in a proper blend of technology and art.

Since he had worked in developing technical and management training for various major industries both in the US and Canada, and as a communications consultant, David decided to open a training school to turn out the people he felt the recording industry needed, and so in 1979 he opened the Trebas Institute of Recording Arts in Montreal, the first of five locations. The name, of course, is from treble-and-bass, "spanning the spectrum of music and audio technology".

There are now campuses located in Montreal, Ottawa, Toronto, Vancouver, and Los Angeles. A Canadian-owned school teaching recording engineers in LA is an interesting reversal on the situation mentioned above.

Toronto

The Toronto division of Trebas is located in a large renovated house downtown at the corner of Dundas and Berkeley streets, in an area that's an eclectic mixture of Edwardian houses, rebuilt office buildings and the occasional factory. The first floor of Trebas consists of offices and a few classrooms, renovated not in the usual white-space-and-tracklights, but subdued colors with much of the original woodwork intact.

The second floor has more classrooms and the third has a large elegant student lounge ("probably the only student lounge with a Jacuzzi"). There's a small library, well-stocked with material relevant to recording and the physics of music. In the basement is the small 16-track recording studio and workshop. The studio, while it has everything needed to demonstrate the basics, is not used for training in full-scale sessions; in this case Trebas rents blocks of time at major 24-track studios in the area.

The atmosphere is friendly, busy.

The equipment is first-rate, including some advances in recording and recording studio technology which we'll come back to shortly.

The Course

The Trebas course consists of four terms which can be completed in less than two years on a full-time basis. Each term is at least ten hours per week of supervised instruction over fifteen weeks, with the entire program being at least 600 hours in length. The student puts in two to four hours of personal study for each hour of personal instruction. Part-time courses are also available, letting students complete the entire program with less than the full course load at one time. The graduation certificate requires a C average, corresponding to 70-79%.

First Year

The first year consists of twenty topics. A random sampling of these: Communications Principles, Music Theory, Ear Training, Record Producing, Sound and Recording, Multi-track Recording, En-

vironmental Acoustics, Management, and Industry Professionals Seminars.

The theoretical instruction and workshop practice is bolstered by the guest lectures and seminars. Guest lecturers have included recording-industry "stars" like Tom Dowd (Rod Stewart), Bill Porter (Roy Orbison, Everlys, Presley), and Phil Ramone (everybody). There are also lecturers from the technology side of the industry, speaking on hardware, acoustics, etc.

Second Year

There are many more topics in the second year, grouped into three areas as Record Producing, Engineering Technology and Management. The recent prominence of the computer in electronic music is covered in electronic-music labs, with explanations of how the basic building blocks of the synthesizer work, plus the ubiquitous MIDI interface system. Malcolm Cecil of the Record Plant, who has produced, engineered and performed on numerous hit records of major artists like Stevie Wonder, has

been appointed instructional specialist to design a number of courses for Trebas, including Computers in the Music Industry. Other important topics include The Visual and

Aural Image, Video and Audio Systems Analysis Arranging and Orchestration, Contracts, Copyright, Digital Audio Engineering, Video Recording, Managing, Accounting, Record Distribution and many others.

There is also emphasis on hands-on electronics, at least at the level you'd need for studio work. I don't think I ever met anyone working in a studio who didn't at least understand the basics of amplifiers, power supply wiring, grounding, etc. Even the Top Brass could solder up a 25-pair cable if they had to.

The Studio

Up to 1985, Trebas staff found themselves renting recording studio facilities to the tune of 4,000 hours per year. They decided that if they designed and built a small studio in their building, they could reduce rental time and provide an in-depth student involvement at the same time. The students prepared the budget, constructed the room, installed the equipment, tested the acoustics and outlined management of the studio (similar arrangements have been made for the other Trebas sites).

The internal facilities are used to familiarize students with the basics of the console routing, tape machine operation, microphones, and so forth. The teaching



A view of the studio control room, showing the electronic keyboards, console and audio/video monitors. (Inset) The reflection-free zone created by the special panel, which was designed and patented by Dr Peter D'Antonio.

A Vist to Trebas

of large-scale recording sessions is still done at rented 24-track facilities.

The tape machine is a Tascam 16-track with 1" tape, an economical format that can be used to demonstrate almost all the functions of multi-track recording. The console is a Soundcraft, a flexible unit with most of the features required for most studio work. The monitors are KEF units mounted in the acoustical corners of the room; this placement allows performance equal to that of much larger speakers.

The space for the actual recording area was limited, and one of the big

problems in miking a small space is the harshness of the reflections, something that will be familiar to anyone who's made a hollow, boomy home recording. One of the usual cures is to line the room with absorbent material, but this is bulky and often causes a muffled, bass-heavy sound. Trebas used a unique, patented wall panel designed by Dr Peter D'Antonio to produce a reflection-free zone on one wall. The panel consists of a number of horizontal baffles arranged in a precisely-calculated pattern; the acoustic cancellations produced by the panel's phasing gives the effect of a much larger

room without objectionable tampering with the frequency spectrum. I spent only a short time in the studio, but the bounce effect from voice and handclaps was very smooth and lacked that oppressive, disorienting feeling that often happens with absorbent rooms (the feeling that your voice stops two inches from your nose).

In the control room, the studs to hold the panelling have been installed on varying centres to minimize resonance, and certain panels have been left flexible to absorb bass energy. There's the usual complement of video equipment, monitors and electronic keyboards. Despite the standard array of electronic modules, MIDI hookups and computers, the Trebas staff emphasized that they also concentrate on teaching proper miking and EQ of acoustic sources. After all, acoustic guitar players don't want their guitars to sound like a Marshall amp eight feet wide. Well, they do, actually, but only for a giggle. Mixers and engineers have to be able to get a natural acoustic sound when required.

Employment

On the positive side for those thinking of a career in the recording arts is the fact that the media have created a demand that no one would have thought possible 20 years ago. There's an apparently endless lineup of records, videos, commercials, films and TV work. Needless to say, to be a good mixer takes far more these days than a good ear for bass, mids and highs; the technology is getting more sophisticated all the time. On the negative side is the fact that the industry is seen as glamorous (which it is, I suppose) and good AV people become subculture stars. This draws an enormous number of applicants for a limited number of positions that have a fairly low turnover rate. To be fair to the new applicant, it's entirely possible that you may have to be a tape jockey for a long time until it's your turn in the control room spotlight.

But then again, I'll bet that last somewhat negative comment won't mean a thing to the determined. If you feel cut out for AV production and you want an efficient way to absorb the new art and technology, Trebas is well worth investigating.

Locations:

Montreal: (514) 845-4141
Ottawa: (613) 232-7104
Toronto: (416) 966-3066
Vancouver: (604) 872-2666
Los Angeles: (213) 467-6800

Take Your First Step Toward A Career In The Music Business



- Highly selective, two-year training program
- Five campuses throughout North America
- Current theory mixed with practical hands-on training
- Modern state-of-the-art 24-track recording studios
- All classes taught by qualified, working professionals
- Financial assistance available for eligible applicants
- Job placement assistance
- Fully accredited by the accrediting commission of CNCE (USA)



CNCE

Educational Programs Accredited by the Council for Noncollegiate Continuing Education
A national accrediting agency listed by the U.S. Secretary of Education

TREBAS INSTITUTE OF RECORDING ARTS

6602 Sunset Blvd.
Hollywood, CA
U.S.A. 90028
(213) 467-6800

305 - 112 E. 3rd Avenue
Vancouver, B.C.
Canada V5T 1C8
(604) 872-2666

410 Dundas St. East
Toronto, Ontario
Canada M5A 2A8
(416) 966-3066

290 Nepean Street
Ottawa, Ontario
Canada K1R 5G3
(613) 232-7104

1435 Bleury, #301
Montreal, Quebec
Canada H3A 2H7
(514) 845-4141

NEW PRODUCTS



150MHz Signal Generator

B&K announces the new Model 2005 RF Signal Generator, capable of a frequency range from 100kHz to 150MHz fundamental frequencies, and up to 450MHz on harmonics. The output level is 100mv with a 20dB level control. An internal amplitude modulation control at 1kHz is continuously variable from 0 to 100%, plus external modulation capability is provided. B&K is represented in Canada by Atlas Electronics, 50 Wingold Ave., Toronto, Ontario M6B 1P7, (416) 789-7761.

Circle No. 16 on Reader Service Card

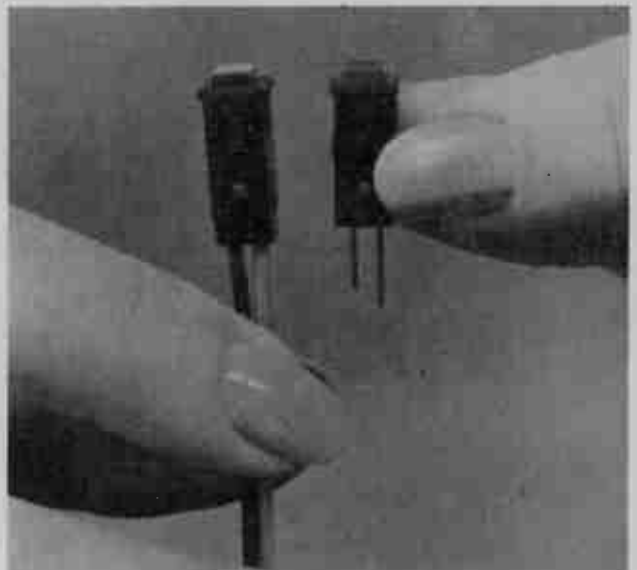

Square, Snap-in LED

Square, snap-in LEDs are now available from Dialight dealers. The 559 Series Square LED Indicators are suitable for a wide variety of applications, and provide wide-angle visibility because of the shape. No additional hardware is required; the LEDs mount in .218" holes on .300" centres. The red, yellow or green units are mounted in black housings. The name of a local supplier can be obtained from Dialight Corporation, 1913 Atlantic Avenue, Manasquan, NJ 08736, (201) 223-9400.

Circle No. 17 on Reader Service Card



Handheld MS-DOS

Paravant introduces the RHC-88, a 4.5 pound MS-DOS computer with military-standard ruggedness for use in even the harshest environments. The processor is 8088/8086 compatible; the operating system is MS-DOS 3.2 in 128K of ROM. Main memory is 512K of RAM expandable to 1MB. Programs are stored in 192K of program-mable ROM. The 5" by 2.75" LCD screen provides a 16 line by 42 character text mode and a 256 by 128 pixel graphics mode. Data is transferred in and out with a high-speed optical port. The unit is powered by NiCads, C-cells or an AC adapter. Many other options are available. The RHC-88 lists at \$3995 (US). Contact Paravant Computer Systems, 7800 Technology Drive, Melbourne, Florida 32904, (305) 727-3672.

Circle No. 18 on Reader Service Card



Telecom Catalog

Hewlett-Packard announces a new catalog with information on more than 90 test instruments for operators, users and manufacturers of telecommunications or datacommunications equipment. Contents include test gear for digital/analog testing, various types of transmission, microwave and satellite, cellular radio and more. The catalog, number 5954-6926U, is available without charge from HP. Hewlett-Packard Canada Ltd., 6877 Goreway Drive, Mississauga, Ontario L4V 1M8, (416) 678-9430.

Circle No. 19 on Reader Service Card

PC Logic Analyzer

Turn your PC, AT or compatible into a logic analyzer with the Techmatron Pc/La. This is a plug-in card available in two models, a 50MHz state and timing version with 32 channels and a 100MHz timing with 50MHz state analysis. The menu-driven interface has pop-up menus and a Help key. More channels can be added with plug-in cards. The basic unit is \$2,495 (Canadian, FST out). Contact Techmatron Instruments Inc., Suite 111, 833 The Queensway, Toronto, Ontario M8Z 5Z1, (416) 251-6671.

Circle No. 20 on Reader Service Card



Opto Measuring Equipment

A new line of seven measuring instruments and systems designed for R&D and testing has been introduced by Avantest America, Inc., represented in Canada by Allan Crawford Associates. The new line includes instruments for basic measurements of wavelength of light emitted by laser diodes and LEDs, as well as equipment used for high-precision and high-speed measurement. The complete line focuses on the growing applications of optoelectronics in communications, information processing, audio, medical and industrial equipment. For more information, contact Allan Crawford Associates Ltd., 5835 Coopers Avenue, Mississauga, Ontario, L4Z 1Y2 (416) 890-2010.

Circle No. 21 on Reader Service Card



Interference Filter

The Model 6515 notch filter from the Microwave Filter Company eliminates broadband transmitter sideband interference to VHF receivers at the same site. The unit is installed at the output of the transmitter; notch frequency is 47.005, with other frequencies available. Notch depth is 112dB minimum. Power handling is 10kW CW. For more information, contact MicroWave Filter Co., 6743 Kinne St., East Syracuse, NY 13057, (315) 437-3953.

Circle No. 22 on Reader Service Card

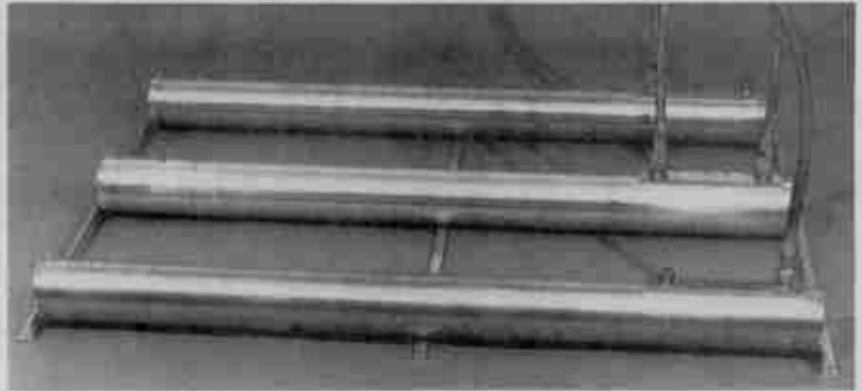

Function Generators

Brunelle Instruments has been appointed the exclusive Canadian sales representative for the Newtronics company. Eight different models of high quality Newtronics function generators are available, and the most popular model, the 200 series, features high frequency setting accuracy, external frequency measurements to 100MHz, environment compensated response analyzing, and precision start/stop. For more information, contact Brunelle Instruments Inc., 73 6th Range S., St Elie d'Orford, Quebec J0B 2S0, (819) 563-9096.

Circle No. 23 on Reader Service Card



Data Recorder

TEAC announces two portable data recorders, the 14-channel model XR-5000 and the 21 channel XR-7000. Both recorders feature a large CRT display that has user-selectable modes for bargraph or waveform configuration. ID information such as title or timecode can be recorded and played back to identify recording conditions. A standard VHS cassette tape is used to provide up to 5 hours and 44 minutes of recording time. Since these recorders feature the Group 1 x 2 recording format, a frequency response of DC-40kHz is standard. For more information, contact Metermaster Division of R.H. Nichols Co. Ltd., 80 Vinyl Court, Woodbridge, Ontario L4L 4A3, (416) 851-8871.

Circle No. 24 on Reader Service Card

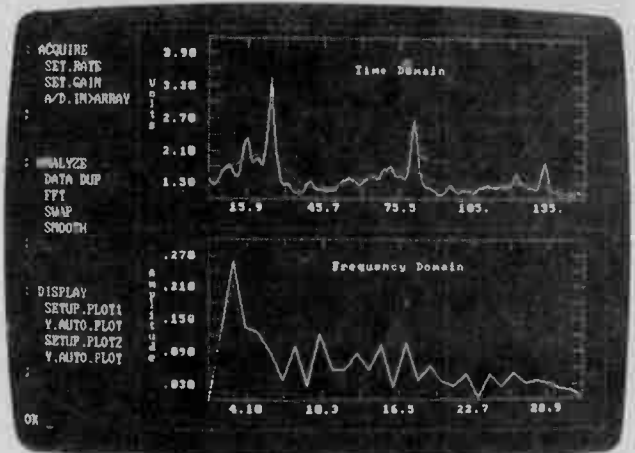

Technical Software

The Asyst 2.0 software for PCs and ATs is designed for technicians and engineers who need to capture and process scientific and engineering data. Functions include FFT and frequency analysis, curve fitting, smoothing and filtering, differentiation, and integration. There are statistical functions, matrix mathematics and numeric analysis. Input can be A/D, D/A, GPIB/IEEE-488, etc. Contact Asyst Software Technologies, 100 Corporate Woods, Rochester, NY 14623, (716) 272-0070.

Circle No. 25 on Reader Service Card

New Products

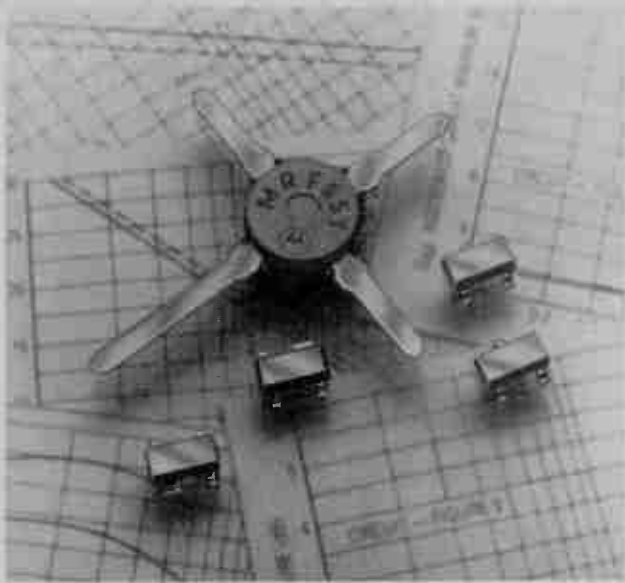

Low Noise RF Transistor

Motorola has introduced the MRF951 Series of small signal transistors, with low-noise NPN bipolars available in a variety of packages, including surface mount. Having a current bandwidth of 8GHz, these devices have high associated gain (12.5dB typ. at 2GHz) and a low noise figure (1.2dB typ. at 1GHz and 1.7dB typ. at 2GHz). At local Motorola dealers, or contact Motorola Semiconductor Products, PO Box 52073, Phoenix, Arizona 85072, (602) 244-3818.

Circle No. 26 on Reader Service Card

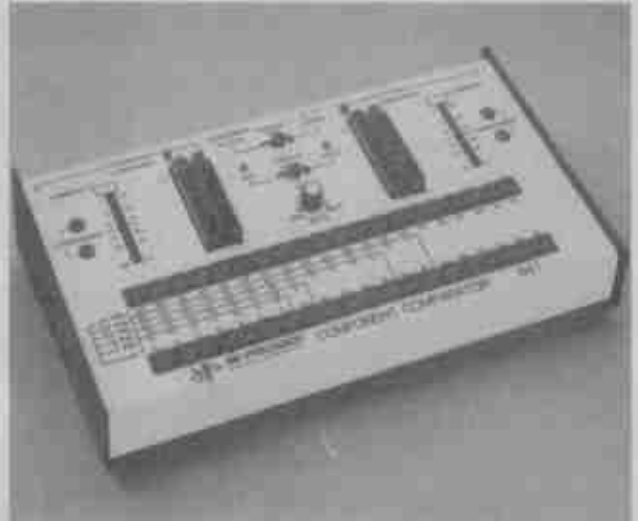

Component Tester

B&K introduces the Model 541 component tester, with the capability of testing ICs up to 40 pins. It generates a test signal to check resistors, capacitors, inductors, diodes, and other components. The VI curve is output for display on any oscilloscope. Two channels allow comparing an unknown component with a good one, and the output can be switched between channels for direct comparison. Two 40-pin ZIF sockets test the impedance signature of IC pins from 8-pin to 40-pin. The 541 also tests in-circuit. Atlas Electronics, 50 Wingold Avenue, Toronto, Ontario M6B 1P7, (416) 789-7761.

Circle No. 27 on Reader Service Card



Dustless Vacuuming

The Dust-Witch 2000 delivers both blowing and vacuuming action from the same nozzle, dislodging dust and pulling it up at the same time. Dust doesn't blow around and settle elsewhere, as in aerosol dusting-off sprays. The nozzle fits any commercial or household vacuum, and is ideal for removing dust from delicate equipment, miniatures, etc. The blowing power is variable down to zero. \$33.65 from Garnet Projects, PO Box 30241, Stn. B, Calgary, Alberta T2M 4P1, (403) 250-5429.

Circle No. 28 on Reader Service Card

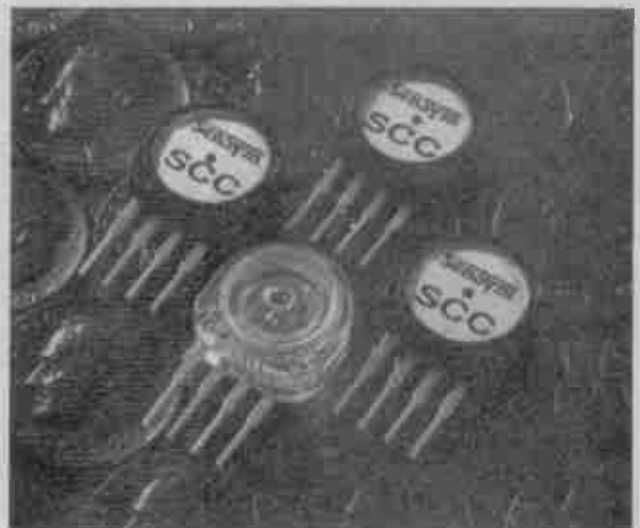

Pressure Sensors

If you're looking for small, solid-state pressure sensors, the SCC series from Sensym features low-cost, temperature stable units. Three devices are available from 0-5PSI to 0-30PSI. The devices are packaged in a four-pin SIP. Combined linearity, hysteresis and repeatability is less than 0.5% FSO. The price is under \$10 (US) in single quantities. For more information on sensors, contact Sensym Inc., 1255 Reamwood Avenue, Sunnyvale, California 94089, (408) 744-1500.

Circle No. 29 on Reader Service Card

Super VHS Recorder

JVC announces the Super VHS HR-S7000 videocassette recorder. With a horizontal resolution of over 400 lines, the new format exceeds the quality of the broadcast signal. Super VHS does this by recording the luminance signal in a broader and higher carrier frequency band, from 3.4-4.4MHz to 5.4MHz-7MHz. The broadening of the bandwidth from 1MHz to 1.6MHz and the use of a nonlinear sub-emphasis has resulted in improvements to the signal to noise ratio. Audio dynamic range is better than 90dB. The HR-S7000 also features automatic switching to standard VHS when required during recording or playback. At JVC video dealers, or contact JVC Canada Inc., 21 Finchdene Sq., Scarborough, Ontario M1X 1A7.

Circle No. 30 on Reader Service Card



Low Ohms Meter

Megger has just introduced a new portable low resistance ohmmeter, the D203 to its Ducter product line. The new model automatically compensates for thermal EMF effects, both constant and varying. This means that readings are faster and more accurate, since there is no need to wait for thermal stability. The eight full-scale ranges, from 199.9 micro-ohms to 1999 ohms, give resolution down to 0.1 micro-ohm on a 3 1/2 digit LCD. The Ducter D203 can be operated on 120VAC or via internal rechargeable batteries. Contact Metermaster Division of R.H. Nichols, 80 Vinyl Court, Woodbridge, Ontario L4L 4A3, (416) 851-8871.

Circle No. 31 on Reader Service Card

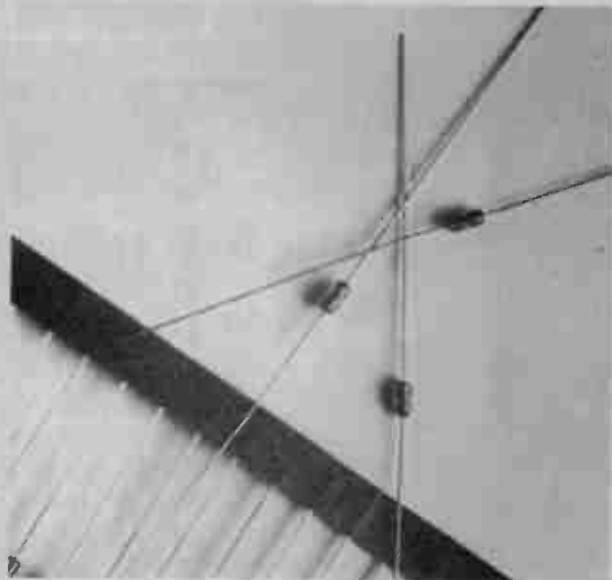

NTC Thermistors

Fenwal Electronics announces the release of its interchangeable, curve-matched NTC thermistors, the Uni-Chip Series II. These are low-cost, hermetically sealed, glass-encapsulated units. They are designed to cover the full temperature range of 0 to 100 degrees C, continuous use. Five standard values from 10k to 100k ohms are offered. Contact Fenwal Electronics/American Power Devices Sales and Applications, 450 Fortune Blvd, Milford, Mass. 01757, (617) 478-5255.

Circle No. 32 on Reader Service Card

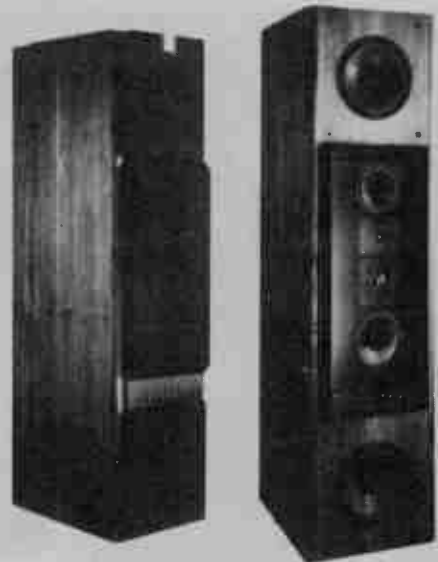

Powered Speakers

For those who just can't get them large enough or loud enough, Altec Lansing is offering the Model 550, a pair of six-foot speakers with five amplifiers each, for a total of 1400 watts. A remote control allows adjustment of the ten amplifiers to suit room acoustics. For \$18,000 (US) a pair, you can really make the dog howl or break the lease. At Altec dealers, or contact Altec Lansing Consumer Products, Milford, Pennsylvania 18337.

Circle No. 33 on Reader Service Card

SECOND ANNUAL

MOORSHEAD PUBLICATIONS

Subscribe Now over \$10,000 in the latest computer products and save up to 58% off

YOUR CHANCE TO WIN THE LATEST IN COMPUTER TECHNOLOGY FROM TOSHIBA. ALL YOU HAVE TO DO IS ENTER!

Celebrate MOORSHEAD PUBLICATIONS Anniversary as Canada's No.1 publisher of computer and electronics magazines by entering our ANNIVERSARY SWEEPSTAKES! You could become the lucky winner of the Toshiba products shown here worth over \$10,000... no purchase necessary... **ALL YOU HAVE TO DO IS ENTER!**

HOW THE SWEEPSTAKES WORK

There are two ways of entering: take out a new subscription, or renew one, to any of the participating magazines, before May 10th, 1988 and your name will be entered for the draw if you use an official entry form OR if you write (boldly and clearly) the word "SWEEPSTAKES" on other cards or forms.

If you wish to enter without subscribing you may use the Official Entry Form on this page; photocopies are NOT acceptable. Only one entry per envelope is acceptable. On May 15th, 1988, a random draw will be made from qualifying entrants. The first entrant

drawn to answer a time limited skill testing question correctly will be declared the winner.*

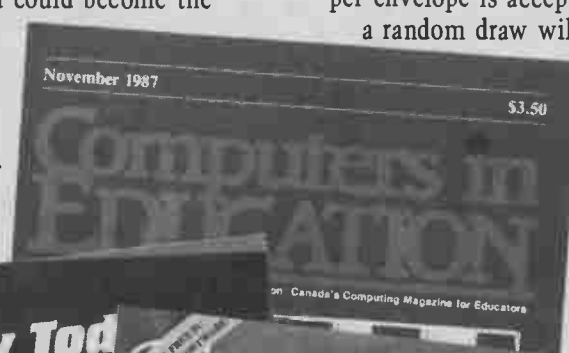
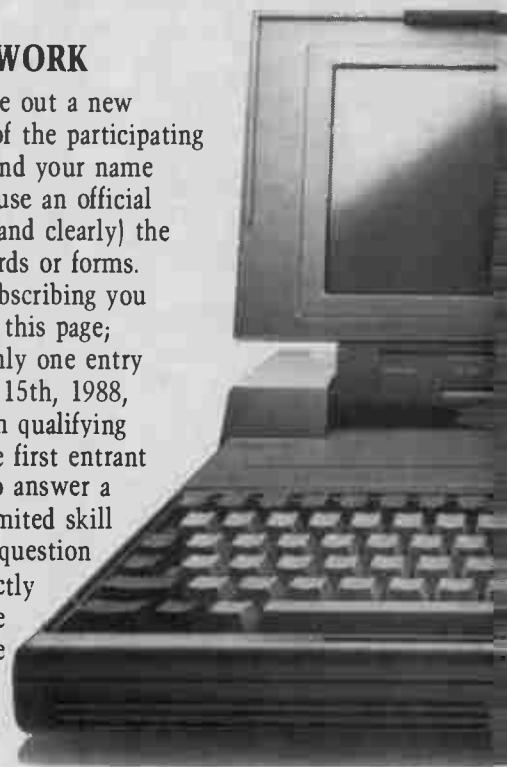

THESE GREAT PRODUCTS FROM TOSHIBA COULD BE YOURS!

If you're the lucky winner of our ANNIVERSARY SWEEPSTAKES, we'll arrange for you to receive at your home or office the products shown; a total value of over \$10,000! Simply by subscribing to (these publications) you have the chance to win the very latest in computer technology with the quality and reliability you've come to expect from Toshiba. You'll be able to conduct professional business transactions and computerize your business or home as never before!

TOSHIBA
WE MEAN BUSINESS
INFORMATION SYSTEMS DIVISION

ANNIVERSARY SWEEPSTAKES

Now and Win!

Computer technology from Toshiba in your subscription!



THE INCREDIBLE T3100...

All the power of the top of the line desktop in a package only 3' high when closed and only 14 pounds. Small enough to take anywhere!

Featuring a Gas Plasma screen, the T3100 provides outstanding resolution. At 640 by 400 pixels, it's ideally suited for graphics. A memory capability of 640 KB, expandable to 2.6MB with the addition of a single memory card.

And it's fast. With an 80286-2 micro-processor it's more powerful than a full-sized IBM PC-AT Desktop*.

Full IBM compatibility; a
10MB internal hard disk;
a 720KB floppy disk;
and an 81 key
full sized
keyboard.

THE NEW PAGELASER 12

Laser printer quality with a whole lot more.

Outstanding full-page print quality and graphics, with its resolution of 300 dots/inch. And at 12 pages/minute it's incredibly fast.

Long product life at 600,000. It holds up to 750 sheets, more paper than any other.

Up to 2MB of memory and a 16-digit English-Language panel display. A high duty cycle of 10,000 pages/month. It comes standard with many features including Serial and Parallel RS232 Interfaces.

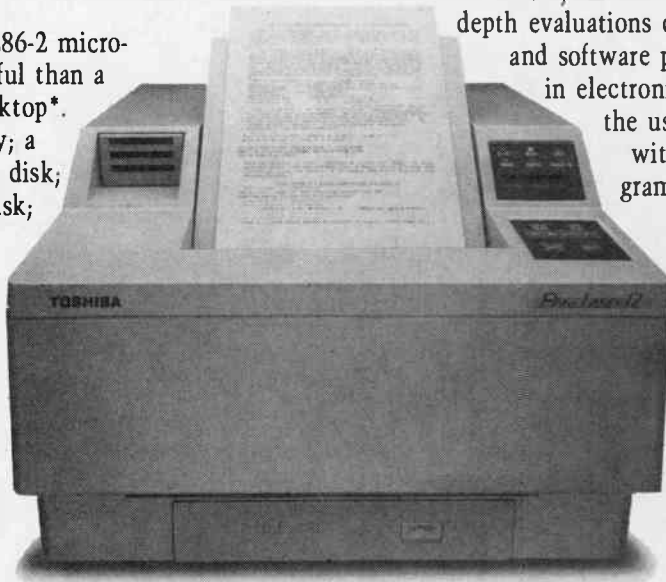

**MAKE THE MOST OUT OF YOUR
TOSHIBA SYSTEM WITH THE
MAGAZINES OF THE MOORSHEAD
GROUP... COMPUTING NOW!
ELECTRONICS & TECHNOLOGY TODAY,
COMPUTERS IN EDUCATION.**

Enter your subscription(s) and receive in-depth evaluations of computers, peripherals, and software plus the latest happenings in electronics & technology. Expand the use of your microcomputer with probing articles on programming break-throughs and important news that will increase your "computer consciousness"! You will find applications and innovations you can use directly on any computer and keep abreast of the newest developments in microcomputing!
Closing dates for entries
May 10th, 1988.

**SECOND
ANNUAL**

OFFICIAL ENTRY FORM MOORSHEAD PUBLICATIONS ANNIVERSARY SWEEPSTAKES

Yes, enter my name in the ANNIVERSARY SWEEPSTAKES for \$10,000 in TOSHIBA products, start my subscription to Computing Now!, Electronics & Technology Today, Computers in Education for the term checked below as a saving of up to 58% on the newsstand rates.

One Year for \$19.97 Two Years for \$36.97

NO, I don't wish to subscribe now, but tell me if I've won

MOORSHEAD PUBLICATIONS ANNIVERSARY SWEEPSTAKES

Name _____ Company _____

Address _____

City _____ Province _____ Postal Code _____

Check one:

Payment enclosed Charge my: American Express Visa MasterCard.

Card No. _____ Expiry Date _____

Special subscription rates are for ANNIVERSARY SWEEPSTAKES only. (Savings are up to 21% off regular subscription rates)
Moorshead Publications, 1300 Don Mills Road, North York (Toronto), Ontario M3B 3M8 Tel: (416) 445-5600 Fax: 416-445-8149

*IBM PC-AT is a registered trademark of International Business Machines Corporation.

*Employees and their families of Moorshead Publications and Toshiba Canada are not eligible to enter.

Unique Shockmounting for Electronics

Helical wire rope isolators conquer shock and vibration to protect shipboard electronics.

By Aeroflex Laboratories, Inc.

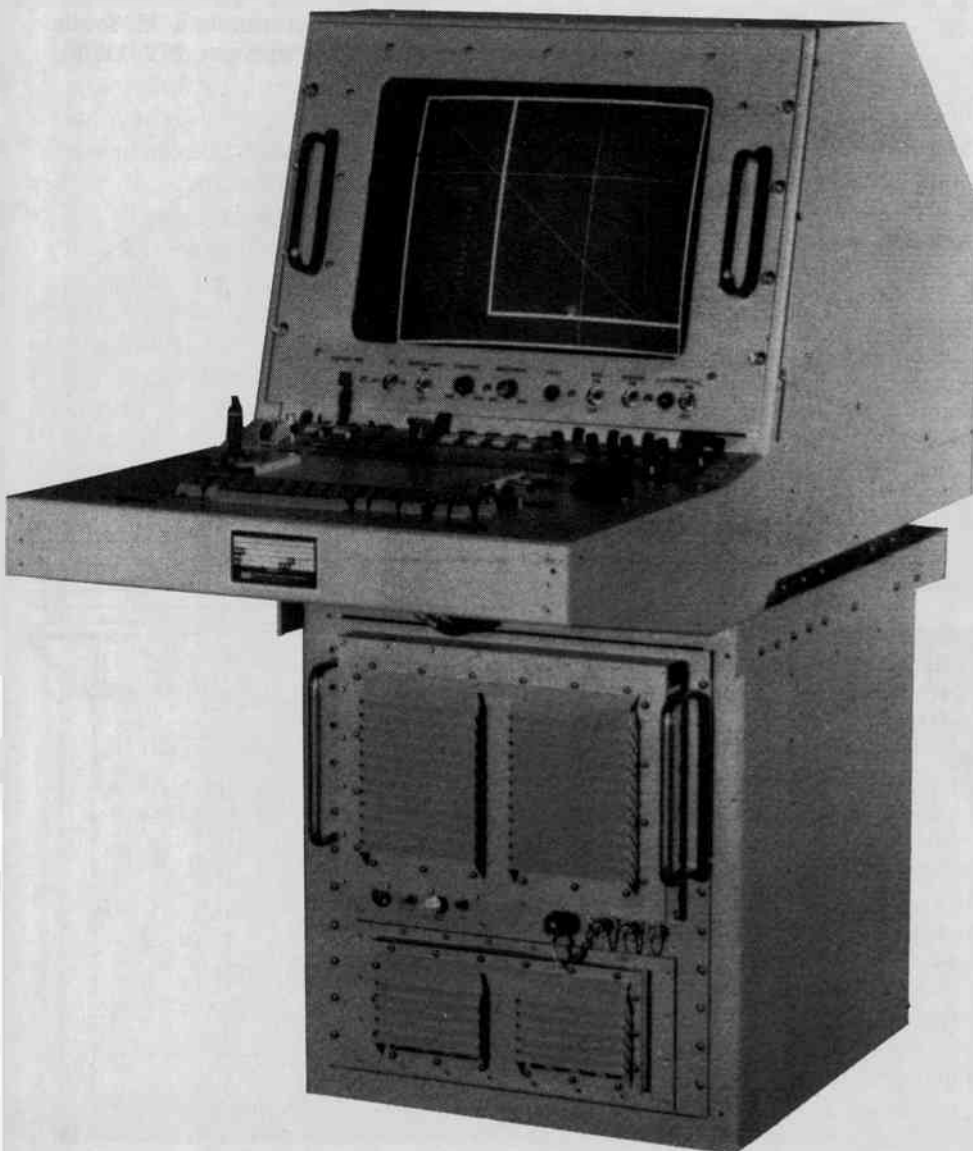

Delicate shipboard electronics must survive and operate throughout the entire range of environments that the ship will see, ranging from the heat and humidity of equatorial regions to the cold, snow and ice of the polar regions. Simultaneously, the equipment must cope with the inevitable and constant vibration that accompanies a ship underway. In addition, on fighting ships, it must withstand the shock and vibration conditions that occur during combat. The trend today is to design in helical wire rope isolators to conquer shock and vibration, thus providing life of ship protection for electronic packages.

A case in point: Computing Devices Company, a division of Control Data Corporation in Ottawa, Canada, supplies military electronic equipment to Canadian and American forces. One such piece of equipment is known under the acronym SHINPADS, or Ship Integrated Processing and Display System. Located in the operations center of a combat ship, SHINPADS displays various types of navigational and tactical information.

Cooperating with Aeroflex International of Plainview, NY, Computing Devices Company has designed and developed a vibration isolation system for a particularly sensitive part of the SHINPADS system. In the past, the most widely used tactic against both vibration and shock was simply to make the equipment more rugged mechanically — bigger, stronger, heavier. Ruggedizing equipment has been the traditional approach to coping with naval shock, and an engineering objective was to make equipment so rugged that shock isolation was unnecessary. Today, engineers look at the shock problems a little differently. Shock and vibration isolation systems are becoming better functionally and they are better engineered; they are more predictable and thus, they become a more acceptable part of a system design. Additionally, the use of isolators allows the use of commercial equipment, at considerably lower cost.

SHINPADS Requirement

The operator's console of SHINPADS weighs approximately 520 lb. (236 kg) and consists of an electronics package, a computer-style keyboard, and a cathode ray tube terminal. According to Mr. Douglas R. Watson, Computing Device's mechanical design engineer on

the SHINPADS project, only the upper half of the console is protected with vibration isolators.

Mr. Watson notes, "The most sensitive components of the system are the keyboard and the video display, which weigh about 270 lb. (123 kg) together. This portion is mounted on four helical isolators oriented front to back. Because the center of gravity of the equipment is not located midway between the front and back, two different helical isolators were selected. For the front, we chose a firmer isolator, and for the rear, we use the somewhat softer isolator."

This firmer CB1380 series of isolators use 3/8 inch (9.5 mm) diameter wire rope and the softer CB1280 series use 1/4 inch (6.25 mm) diameter wire rope.

Shock/Vibration Underway

Mechanical shock experienced onboard a ship can tear an electronic cabinet off of its mounting bolts, severing electrical cables. Electronics can be destroyed if not protected from the forces of direct contact explosions, underwater detonations, and the firing of the ship's own weapons and missiles.

Naval designers are responsible for assuring that a fighting ship and its electronic equipment will meet the vibrations and shocks it will see in service. Equipment received from the original manufacturer, and sometimes from other government, agencies, must be verified that it can pass the shock tests that have been established.

While the damaging effects of vibration are well recognized, a significant amount can be designed out to minimize sensitivity to fundamental driving frequencies. Sensitive electronic equipment is effectively protected and isolated by using vibration dampers.

Ship vibration is caused primarily by the propulsion system (except for resonances that may be excited by shocks), and different type ships have different characteristics frequency ranges. Destroyer type ships, for example, experience vibrations in the range from 5 to 15 Hertz, while an aircraft carrier may see 5 to 25 Hertz, and a submarine 5 to 50 Hertz. Vibration onboard ship is not considered much of an operational problem once the sensitive equipment has been identified and properly isolated.

In Action

Helical isolators are stable mounting assemblies of high quality standard performed wire rope held between rugged metal retainers. Wound in the form of a helix, each isolating element has specific response characteristics determined by the diameter of the wire rope, the number of strands, the cable length, the cable twist or lay, and the number of cables per section. Inherent damping is provided by flexure hysteresis, i.e., the rubbing and sliding friction between the strands of wire rope.

The unique design of the helical coil isolators can cope with high energy shocks of extremely short duration — 0 to 50 milliseconds — and respond to them over a longer time period — 40 to 80 milliseconds. They also smooth out random and steady state vibrations over a wide range. An unusual feature of isolators is their ability to absorb high energy inputs along the vertical, horizontal, and lateral axes (X, Y, and Z) simultaneously, creating a total-surround cushioning "envelope" that protects delicate equipment. In other installations, the isolators routinely attenuate 200 G's peak shock to less than 20 Gs.

Additional isolator characteristics include:

- **Very wide load range:** Larger isolating mounts can be attached to almost any equipment or enclosure regardless of weight. The static load rating of the largest

helical isolator regularly manufactured exceeds 15,000 lb. (6,800 kg).

- **Compact, low-profile envelope:** Ability to attenuate heavy shock loadings with minimum deflection permits helical isolators where space is at a premium, an advantage in new equipment and sometimes a necessity when replacing other isolating media that have failed in service.

- **Three axis solution:** Equipment can move in any direction — vertically, horizontally, and laterally.

- **Positioning no problem:** The isolators can be loaded in compression, tension, shear, or roll in base mount, center of gravity mount, or inclined off axis mount. They can be located anywhere in an isolating system. In the compression/roll attitude, the available stroke of the isolator can exceed its height.

- **Excellent environmental resistance:** the isolators are made of stainless steel and aluminum alloys. Their performance is unaffected by temperature. They function from -400 to 700 F (-240 to 370 C) and resist ozone, oil, grease, sand, salt spray, and organic solvents. Resistance to environmental attack means that helical isolators require no maintenance and usually will outlast the equipment they isolate. They can be painted to match the equipment.

For additional information on vibration isolators, contact Aeroflex Laboratories Incorporated, 35 South Service Road, Plainview, NY 11803, (516) 694-6700.

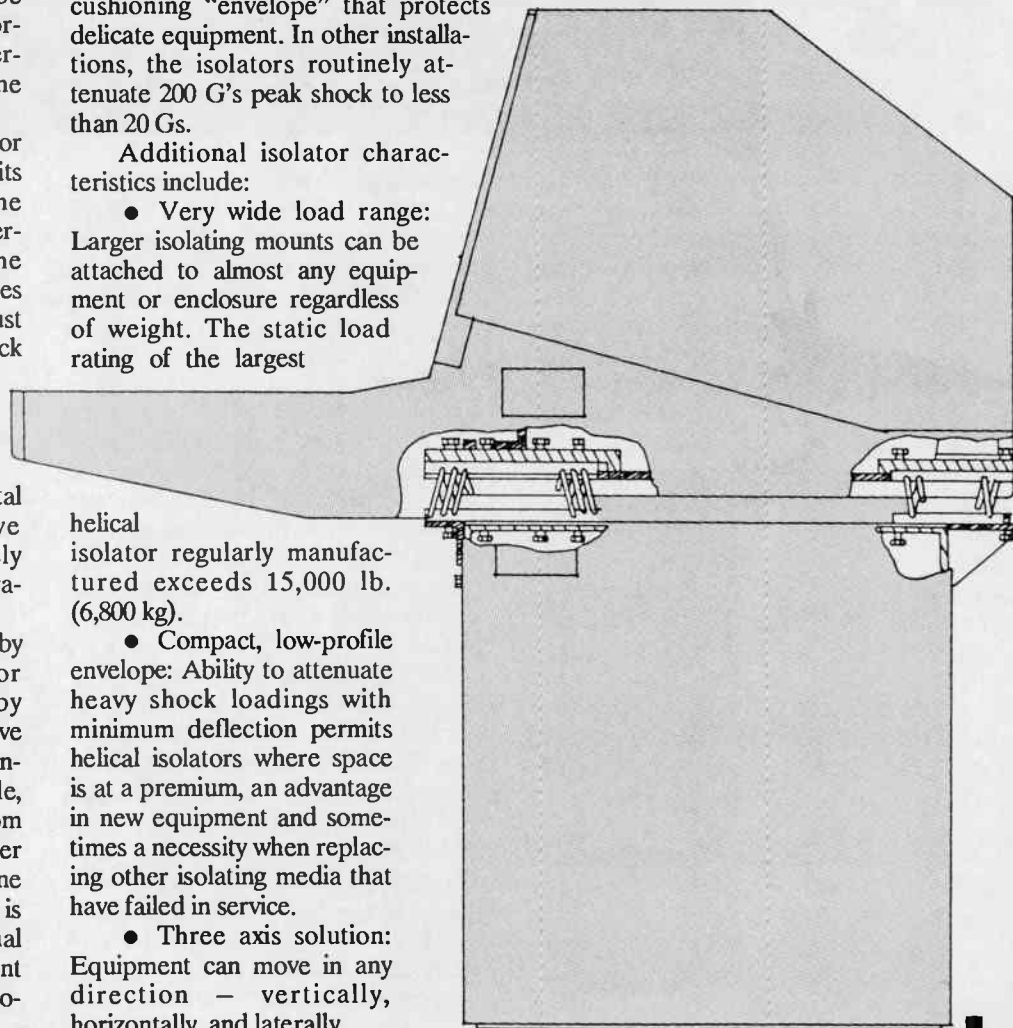



Optical and Electrochemical Computers

By K. Tahir Shah

The year 1900 is a landmark in the history of science and technology. Two unrelated developments announced that the years were to change later in the course of history. On one hand, Max Planck, a professor at Berlin University announced his fundamental discover of quantum physics. Not far from there at Gottingen, David Hilbert, a professor of mathematics, was busy building a new foundation of mathematics. At the International Congress of Mathematicians of 1900, he outlined a series of unsolved problems. The Hilbert's 23rd problem (in the list) later on lead a British mathematician Alan Turing to device a universal computing model, now known as the Turing machine. All computers of today are based on the Turing machine principle. The discovery of quantum physics eventually lead to the development of the laser. Both of these discoveries have changed our way of living on this planet. Now it seems that there is possibility of merging the two technologies to build optical computing machines.

On the other hand, studies on theoretical models of computation suggest an alternative to the Turing machine principle, i.e., computing

machines which are not sequential and can operate conceptually in a different manner. They may possibly be made computationally similar to the brain and can be built using biochemical substances.

Progress

The progress in VIS has reached a stage now that we begin to wonder if it can further be reduced in size and improved in performance. Furthermore, there are other limitations such as bounds on VIS density and its linewidth, the speed of electrons in the semiconductor (the electrons in semiconductors can not travel faster than a certain speed), the inefficiency of sequential machines for pattern recognition and similar tasks. It is known, for instance, that there are tasks which can be performed by a parallel machine more efficiently than a powerful single CPU machine. Given these limitations, what are the alternatives? What other kind of computing machines are possible to design based on either new computing principles or new physical switching mechanism? There are some other physical processes known to exist

which can be used for information processing, such as the use of coherent light (laser) instead of electrons (electrical current) or chemicals.

In 1969, Abraham Smoke from the Massachusetts Institute of Technology predicted the existence of an optical bristle device which was observed in 1976 by N.C. Venkatesan et al., of Bell Laboratories. Since then researchers continue to look for materials which can eventually be utilized to build an optical computer.

Some five years ago I read that a commercial organization was planning to design and build a functional molecular electronics computing device. The news was quite exciting to me at the moment because only a year earlier I was involved in research on the computational aspect of self-organized systems. According to officials of the same company, such a device was considered feasible and a prototype was expected to be complete within five years. Although there have been no serious developments in electrochemical computing since then, some later studies suggested that it may be possible to develop chemical computers eventually. Certainly, it is

something which we will not see in the next few years.

Development

The development of computing machines started with the search for a theoretical computation model applicable universally to all machines which are to be the (physical) embodiment of such model. These machines approximate their operational behavior as closely as possible to the one suggested by the computation model. As mentioned above all digital electronic computers are modeled on an ideal machine called Turing machine (named after Alan Turing). From the operational point of view it is strictly a sequential machine, i.e., it does only one thing at a time whether it be reading or writing. A further generalization of this machine by John von Neumann (to include memory) played the fundamental role in the development of digital computers. In fact, von Neumann designed and built the first computer. When we refer to the computation model for electronic computers we mean the von Neumann-Turing computation model or briefly Turing machine.

On the physical side, all computing machines depend on some kind of switching mechanism at their fundamental operational level. In today's digital electronics this is achieved by the gates consisting of transistors. These gates represent Boolean operation of an algebra invented by George Boole in the nineteenth century. His work is also considered as foundational in mathematical logic, the human thought process and what is now called the science of artificial intelligence. It was the first attempt to formalize human thought process. At the level lower than Boolean gates, in an hierarchy of processes, transistors (electronic tubes in the early days of computing) or similar devices are used to control the flow of current. In an on-and-off device, the current is either passed through this device or not at all. This is achieved by using a controlled threshold mechanism. In principle, it is not necessary to use electrical current. Something else like, light can also be used to achieve switching operation.

There are other known alternatives to the electronic switching which are subject of current active research. These are laser based optical gates and

the biochemical gates. Using lasers instead of electrical current does not require any change in the computation model for optical computers, i.e., they will be Turing machines and all programming theories will remain valid as they are for electronic computers. However, this is not the case with bio-chemical computers. The biochemical computation model falls outside this because of the adaptive nature of enzymes which are to be used as the basic switches. These two new and promising technologies are in the process of emergence. The optical computer technology is ahead of the bio-chip because no theoretical studies are involved. In the long run perhaps both will be competing technologies along with the digital electronics.

Many years ago researchers at the Heriot-Watt University (UK) have demonstrated experimentally how to

are about a thousand times faster. One expects, therefore, an optical computer to be about 1000 times faster than the fastest electronic computer.

Switching Principle

The switching principle is based on the existence of a nonlinear refractive index of certain materials. Any variation in the intensity of a laser beam results in changes in the index of refraction. If the laser beam is shone on a crystal at an appropriate angle, then a small variation in its intensity (near the threshold value) can switch the transmission state, i.e., from a no-transmission to a transmission state. Many stable states of transmission are known to exist in materials such as diamonds. In such a material there are many "on" states at different values of the laser intensity. No doubt this could lead to a multi-state (instead of only binary state) machine. Optical computers will not only be faster but there will also be a tremendous increase in the address-

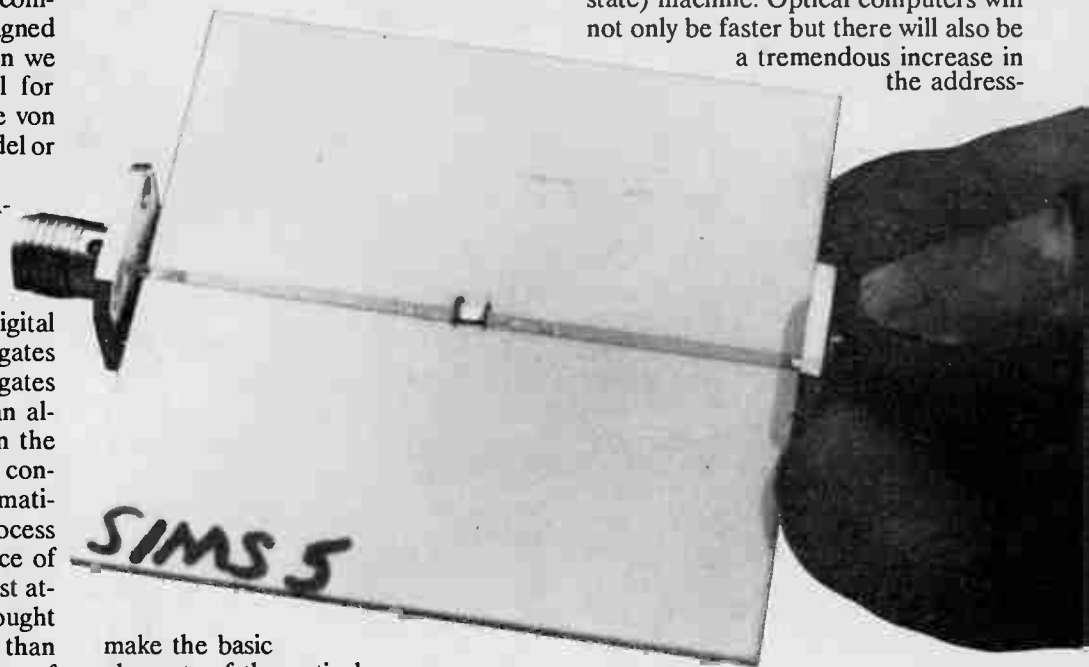

make the basic elements of the optical data processing machine. S. Desmond Smith and his collaborators constructed a logical gate consisting of a variable intensity laser beam and a crystalline material having nonlinear refractive index. They called the new optical switch a "transphaser", which is an entity equivalent to the transistor in electronics. Because the speed of light is much greater than those of the electrons in a semiconductor material, the typical switching time of an optical device is of the order of picoseconds as compared to electronic switching time of nanoseconds, i.e., the optical switches

ing space for the same bus lines. A transphaser is not only a binary but an N-ary stable device where N can be greater than two. Moreover, many frequencies of a laser can operate simultaneously on the same crystal without interfering with each other. This is certainly not possible in electronics.

Earlier I mentioned a commercial bio-chemical computer project. Their plan was to build a molecular electronic switch array with special proteins called "oriented antigen monolayers" (OAM), "monoclonal antibody" (MA), and "pep

Optical and Electrochemical Computers

ptide interface" (PI) as their basic ingredients. The final completed structure, called a Moleton, is like an electronic active element, i.e., a transistor or semiconductor impurity junction. An enzyme reacts with chemicals floating in the biological soup to produce the final component of the computer system, including a lead compound which is to act as the entry or exit point of any information addressed to the computer. In this type of computer the information is not stored in binary form but in ternary form, with on, off, and not defined states. Since a full technical report is not available, it is not clear to me how three stable states are possible.

Although such a configuration was proposed by a US company in 1982 and claimed that in five years time a working prototype will be available, it is not known whether any electrochemical machine of this type is being tested anywhere in the world at the present time. In my opinion, there are some very serious theoretical issues which are to be solved before any attempts to build such a computing machine. The most fundamental issue is that there is no such model of computation which fits into the way human and animal information processing system (essentially electrochemical) works.

The fundamental issue of a biochemical computer is not silicon versus carbon, although there is a possibility of developing a chip on carbon which can be relatively faster. The basic issue is whether a biological or chemical computer made of organic material should be or should not be of von Neumann-Turing type, i.e., should they be like electronic digital computers or not. There are many reasons why a chemical computer should be based on a computational model other than the Turing machine. For example, all communication in the endocrine and the nervous system utilizes lock-and-key mechanism. In both of these systems, chemical messengers (hormones and neurotransmitters) are released from one cell, travel through the extracellular medium and then bind to receptors on the surface of the receiving cell to modify its activity. If

the chemical messenger does not fit properly at the receptor end, it is unable to come close enough to trigger any activity by the receiving cell. The shape based specificity is a form of tactile pattern recognition. A similar task, if performed by an electronic digital machine, would require an enormous number of switching processes. Although protein enzymes are much slower switches than transistors, (typically 0.1 millisecond as compared to nanosecond) they are better suited for tasks where sequential processing is not the answer, such as



adaptive process control, pattern recognition etc. Enzymes have the virtue of being adaptable switches and with trial-and-error evolutionary approach they can reach an optimal configuration. The evolution process proceeds through the variation of amino acid sequences in the enzyme which is followed by selection and propagation of the best performing sequences. The question is can we program such machines to perform only assigned tasks. Michael Conrad of Wayne State University has studied this problem in great depth. We shall go into some details since his results on the design principles for a molecular computer are of fundamental importance. His main result is what he called a tradeoff principle.

Conrad's Tradeoff Principle

A system can not at the same time be effectively programmable, amenable to evolution by variation and selection, and computationally efficient.

Let me explain. In computation theory there is a thesis known as the Church-Turing thesis which states that any effectively computable function is computable by a formal process involving simple operation on strings of symbols. A computer program is a rule

that generates such a process. For a von Neumann-Turing computer such programming languages do exist and are defined by a finite, discrete base set of symbolic primitives. It is always possible to write a program in a language that directly maps the structure of the machine and the state of each component. This is called structural programmability and is the basis of all other forms of programmability.

The Conrad's Tradeoff principle suggests that an alternative domain of computing is possible (in principle) where programmability is exchanged for efficiency and adaptability. Biological systems, as the product of evolution must operate in this alternative domain.

Enzyme-driven computing in biological systems depends on complex and intricate process of self-organization and self-maintenance. Creating such a self-organized system with a support and repair system in clearly not feasible at the present time. To exploit the efficiency-adaptability side of the tradeoff relation, there are at least four approaches according to Michael Conrad:

Building a virtual machine on the top of a von Neumann-Turing machine.

Constructing electronic devices to embody the desired dynamical principles to the greatest extent possible.

Culturing existing organisms to perform useful information processing function. This may come into conflict with the evolutionary goals of the organism itself.

Construction of enzyme driven simple devices for the task where the lifetime of the device is not a major concern.

Whether or not it is possible to develop chemical computers depends on the fact that there is an urgent need to do so, plus available science and technology. There are some applications where biocomputers can be far more efficient than the digital electronic computers. Initially there is some potential for simple bio-chemical sensors which could be used as testing ground for further development eventually leading to chemical computers. ■

HIGH TECH PORTFOLIO

FREE CATALOG

Send for your free catalog of Test & Measurement products including oscilloscopes, digital multimeters, frequency counters/timers, digital thermometers, accessories, coax adapter connectors and cables, and IEEE-488 hardware and software.

Special Offers to June 30, 1988

Quality Test & Measurement Products via

JETSTOCK
A Service from Alan Crawford Associates Ltd.



Circle No. 70 on Reader Service Card

Easy1 PC Drawing Tablet

An exciting new concept and technology

Easy1 PC is a pressure-sensitive, 1024 x 1024 pixel tablet, for desktop publishing, presentation systems, design, art, animation, CAD, and touch control applications. It allows the user to draw or trace directly into the computer with an ordinary pen or pencil on paper. Easy1 PC is designed to run on any IBM PC/XT/AT or compatible computer using the most popular graphics software. Dealer Inquiries invited.

Anakin Research, Inc.,
100 Westmore Drive, Unit 11C,
Rexdale, Ontario, Canada M9V
5C3 Tel: (416) 744-4246 FAX 416-
744-4248



Circle No. 71 on Reader Service Card

Panther Phones

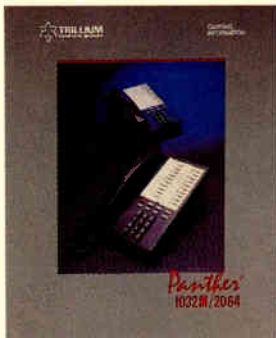

Trillium Telephone Systems Inc. has researched what features will be important in the future, and has developed the Panther family of key telephone systems to keep up with changing requirements.

Panther systems are available in a variety of configurations starting with the 3-line, 6 station 306 system right on up to the 2064 with 20 lines and 64 stations. Many options are available to enhance these Panther systems including the Call Data Recorder, Power Fail Transfer and an Off Premises Extension/Data Interface.

Circle No. 72 on Reader Service Card

Gestetner



The Gestetner 2150Z Zoom Copier is one of many products offered by Gestetner Office Systems. It features 77 settings for reductions and enlargements, high volume copying at 50 copies per minute, and an information message display that tells you everything from copying instructions to maintenance.

Gestetner Office Systems serves the business world through its comprehensive line of photocopiers, stencil and offset duplicators, ancillary equipment and supplies. Gestetner is represented in Canada by 20 branches in major centers as well as a dealer network.

Circle No. 73 on Reader Service Card

Receive instant information on these
High-Tech products. Use the enclosed
Reader Service Card.

AT&T POWER PROTECTION SYSTEMS

3, 5 AND 10 KVA POWER LINE CONDITIONER

THE LOWEST COST SOLUTION FOR SENSITIVE ELECTRONIC EQUIPMENT.

AT&T PLC

The AT&T PLC power line conditioner is an electronically controlled multitap transformer which continuously monitors the output voltage and selects the correct tap on the input side that will maintain that regulated output. Tap switching is automatic, electronic and completely transparent to the load. The secondary is isolated from the primary and an electrostatic field provides additional filtering.

Personal Computer Associates Inc., Unit 6, 676 Monarch Ave., Ajax, Ontario L1S 4S2. Tel: (416) 427-6612 or FAX 416-427-0934.

Circle No. 74 on Reader Service Card

CURTIS

Curtis Computer Accessories

One Stop Shopping For Innovative Accessories

Curtis Computer Accessories

Personal Computer Associates Inc. carry a wide variety of accessories from Curtis Manufacturing. Included in the lineup are: telephone line equipment surge protectors, monitor extension cables, printer cables, printer sharing switches, disk filters, a computer tool kit, power bars and line surge protectors, printer stands, monitor stands, computer stands and much more.

Personal Computer Associates Inc., Unit 6, 676 Monarch Ave., Ajax, Ontario L1S 4S2. Tel: (416) 427-6612 or FAX 416-427-0934.

Circle No. 75 on Reader Service Card

welcome to form processing!

FORMPERFECT

Form Filing Software

Formulator Software Inc. of Montreal, Quebec, offers you FORMPERFECT, an innovative form filling software program. With FORMPERFECT, any preprinted form is filled-in on a PC. The typewriter is no longer necessary, or as effective, for this function. FORMPERFECT has a database interface for sharing data with other software packages; eliminating the need for re-keying information. FORMPERFECT includes a spreadsheet-style calculator which takes care of any mathematical computations on a form. The formula's can be set up in advance thereby speeding up the filling-in process. Montreal: (514) 738-7461. Toronto: (416) 283-2973. FAX 514-733-2166.

Circle No. 76 on Reader Service Card

Best AVX-386



Best Systems Corporation's AVX-386 is a 32-bit MS-DOS, UNIX, and OS/2 compatible computer featuring Phoenix BIOS. Microprocessor speed is software selectable between 16 MHz or 8 MHz. Other standard features include: one 1.2MB and one 380KB floppy diskette drive; 2MB RAM (up to 8MB optional); one serial interface; parallel interface and game/joystick port; AT compatible real time clock/calendar with battery backup; and hardware reset switch. Also included are ten expansion slots: 6 IBM AT compatible and 4 IBM PC compatible. The power supply is a 200W running on 90 to 132 VAC at 50/60Hz or 198 to 265 VAC at 50 to 60Hz. A switched and fused auxiliary power connector is also supplied.

Best Systems Corporation of Canada Inc., 401 The West Mall, Suite 1110, Etobicoke, Ontario, Canada M9C 5J5. Tel: (416) 620-7400 FAX (416) 620-5005.

Circle No. 77 on Reader Service Card

EASY ORDER CATALOGUE

Honeywell Bull Express

NO TWIDDLING!

Honeywell Bull Express turns the waiting time into working time.

Whatever you need for your computer system - from printers and terminals, to commodity software and micros, to ribbons, diskettes, tapes, UPS, modems, acoustic covers, furniture, and other assorted accessories - call Honeywell Bull Express. Whether you have Honeywell Bull equipment or not.

We'll deliver the goods fast. In most cases, by the very next day.

To place an order, or order a catalogue, call:

1-800-268-5557

In Toronto: 298-4500

Honeywell Bull Express

Honeywell Bull Limited

Circle No. 78 on Reader Service Card



Presenting the Desktop Publishing Training Solution - Always there when you need it.

The Ventura Software Self-Paced Training Package provides video taped (VHS) private instructions on the Ventura Desktop Publishing Software.

FEATURES

- Two VHS Video Tapes
- Student guide
- Course diskette

Available from the Honeywell Bull Express or Authorized Reseller

To order call:

1-800-268-5557

In Toronto: 298-4500

Honeywell Bull Express

Honeywell Bull Limited

Circle No. 79 on Reader Service Card

THE LATEST IN TECHNOLOGY 80386 SYSTEM

Jaba JB-386

SPECIAL FEATURES INCLUDE:

- Powerful 80386 microprocessor operating at 16.5 MHz at 100 MHz
- 2MB static column RAM
- IBM-PC parallel standard printer adaptor
- 1.2MB floppy drive
- 2MB of RAM
- one 32-bit RAM expansion slot
- five 16-bit and three 8-bit slots
- seven DMA channels
- and a socket for an optional 80387 co-processor.

Jaba Systems Inc., 170 Esna Park Drive, Unit 9, Markham, Ontario L3R 1E3. Tel: (416) 477-6363, FAX 416-477-6891.

Jaba JB-386

Jaba JB-386 employs Canadian made true 32-bit 80386-16 or 80386-22 MHz system board with Phoenix BIOS and 2MB 80NS static column RAM on board, full compatibility with MS-DOS, OS/2, ZENIX, UNIX, applications. Other standard features include monochrome graphics adaptor capable of displaying 720 x 348 pixels in its text and graphics modes; IBM-PC parallel standard printer adaptor; 1.2MB floppy drive; and 2MB of RAM; one 32-bit RAM expansion slot, five 16-bit and three 8-bit slots; seven DMA channels; and a socket for an optional 80387 co-processor.

Jaba Systems Inc., 170 Esna Park Drive, Unit 9, Markham, Ontario L3R 1E3. Tel: (416) 477-6363, FAX 416-477-6891.

Circle No. 80 on Reader Service Card

SPECIALLY MADE FOR XT, MINI AT AND MINI 386 SYSTEMS

Jaba SXM SERIES

SPECIAL FEATURES INCLUDE:

- Power good detector (PG) in PCB connection with IBM AT system
- Surge (SB) filter
- 400 WATT (500 VA) (400 W)
- Short circuit protection
- 100% burn-in with individual test reports

Jaba Systems Inc., 170 Esna Park Drive, Unit 9, Markham, Ontario L3R 1E3. Tel: (416) 477-6363, FAX 416-477-6891.

Jaba Switching PSUs

The SXM series of switching power supplies from Jaba Systems offer good power detection, 100% compatible with IBM AT signal, also equipped with good overload and short circuit protection, especially designed for PC/XT/Mini AT-286 and AT-386 systems. Available in three configurations, 180W, 200W and 230W, the SXMs are equipped with low noise DC cooling fans and EMI/RFI filters. Ripple and noise is less than 1% peak-to-peak. All Jaba power supplies are 100% burned in with individual tests reports. Also available are SBM, SQM, SEM series of power supplies.

Jaba Systems Inc., 170 Esna Park Drive, Unit 9, Markham, Ontario L3R 1E3. Tel: (416) 477-6363, FAX 416-477-6891.

Circle No. 81 on Reader Service Card

GIVES YOU THE EDGE IN LASER PRINTER PAPER

LASEREDGE PRO™

LASEREDGE ECONO™

Trans Art Supplies

720 King Street West, Toronto, Ontario M5V 2T3
(416) 363-6156

- The look and feel of photographic paper without the cost.
- Super white, high resolution, semi-gloss finish for quality typesetting and copying. Does not bleed when waxed for artwork.
- Laseredge papers are ideal for use with all laser printers and laser copiers.

Circle No. 82 on Reader Service Card

CONVERT YOUR LASER PRINTER OR COPIER OUTPUT INTO MULTI-COLOUR IMAGES

60 colours available including 14 foils in matte and gloss finishes.

Use OMNICROM to convert black and white text and graphics into colour.

OMNICROM uses dry sheets of colour. No mixing of inks or solvents.

Make colour overlays and overheads, laminate and bind with OMNICROM.

Fast, economical and easy to use

OMNICROM

Distributed by **TRANS ART SUPPLIES** 720 King St. W., Toronto, Ontario M5V 2T3 (416) 363-6156



Circle No. 83 on Reader Service Card

Integrated Publishing System Approach

The Corel 386 Personal Computer processes 3 million instructions per second, comparable to mainframe processing speeds. The Corel 386 is 2 to 3 times faster than 8MHz 80286-based personal computers and runs virtually all software designed for IBM compatible PCs or ATs. With the Corel S800 WORM (Write Once Read Multiple) drive providing 800 megabytes of optical disk capacity, the system is ideal for archiving and replicating large data or image files. Provides a complete audit trail. Available from **COREL SYSTEMS CORPORATION**.



Circle No. 84 on Reader Service Card

OKIDATA Microline 393

The Workhorse of 24-pin dot matrix printers.

Fast. Rugged. Multi-Talented. And engineered to out-perform all others in its class - with ease.

Print perfect letter quality documents quickly and quietly. Choose from four fast printing speeds and meet those impossible deadlines. Command the 393 to unload and park continuous form paper when switching to single sheets - it handles the paper so you don't have to! The 393 is compatible with the most popular software and comes with a personality modules that lets you upgrade to new technology.



Circle No. 85 on Reader Service Card



SAK DATA PRODUCTS LTD.

CD 1920 Color Monitor

Sak Data Products Ltd. has introduced the CD 1920 color monitor from Monitem Corporation. This 19.6 inch color monitor displays flicker-free ultra sharp images on a raster of 1280 x 1024 pixels. RGB inputs and a horizontal scan rate range of 14 to 72 KHz make the CD 1920 compatible with all of the popular video graphics controllers including Monitem's own Viking 10 and Viking 20 controller cards. An efficient design means that the CD 1920's takes up less than two-thirds the space than that of comparable monitors, and the unit also features a convenient tilt and swivel base.



Circle No. 86 on Reader Service Card

Viking For the Mac

Sak Data Products Ltd. has introduced the long awaited Viking series of 19" monitors for the Apple Macintosh computer. Based on Monitem's best-selling PC compatible Viking 1, the Viking SE and Viking II allow users of the Macintosh SE and Macintosh II respectively to experience the crisp flicker-free display familiar to Viking 1 users. The paper-white, 1280 x 960 screen displays two full pages with detailed readable characters formed from square pixels. The powerful controller installs into the Macintosh and avoids processor wait states that slow down screen updating. The Viking Video System series features an interchangeability of the display monitor between the Mac SE/II, IBM PC/XT/AT and PS/2 controllers; all of which are available separately.



Circle No. 88 on Reader Service Card

Microframe 386

Sak Data Products Ltd. has introduced the Microframe 386 from Monolithic Systems Corp. The Microframe 386 provides high performance 80386 processing power, at 16 MHz or 20 MHz operation, and AT compatibility. Using VLSI technology, the Microframe 386 is able to implement this powerful full 32-bit AT compatible computer on the smaller XT-size motherboard resulting in fewer parts, less power consumption and greater reliability. Mounting holes are provided for both XT and AT chassis standards. Other features include a socket for an optional 80387 math co-processor, full 32-bit zero wait state memory, six AT and two XT expansion slots and capacity for up to 8 MB of on-board RAM.

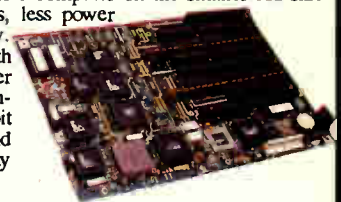

Circle No. 87 on Reader Service Card

Monitem Viking Graphic Display Systems

Sak Data Products Ltd. has introduced the Viking PRT Graphic Display System from Monitem Corp. The Viking PRT features a 19-inch portrait mode monitor and a high-speed graphics controller designed for the IBM PC/XT/AT and PS/2 Model 30 based workstations. Crystal clear, flicker-free images are displayed on the paper white phosphor with square pixels. Using a raster of 900 x 1280 pixels, the Viking PRT is the first publishing-resolution display system for desktop publishing of tabloids, broadsheets and other publications. Bundled GEM and Windows drivers allow the Viking PRT user to display true WYSIWYG documents created with Aldus PC PageMaker, Xerox's Ventura Publisher and other DTP software.



Circle No. 89 on Reader Service Card



Watch Your CAD Designs Soar!! CCS Designer... the complete PC CAD package for only \$99.95 Special Introductory Offer! CCS Designer from compu-CARE Inc. is designed for use with or without a mouse and is capable of running on IBM PC/XT/AT or compatibles with 512K of RAM. Useful applications include: architectural and mechanical design, organizational charts, business graphics and many more. Dealer inquiries welcome
compu-CARE Inc.
 3355 Georgia St., Richmond, B.C. V7E 2R5 (604) 275-4143

Circle No. 90 on Reader Service Card



VIP
 The VIP card from ATI Technologies offers VGA compatibility in all seventeen modes. It supports a variety of monitor types including IBM PS/2 analog, MultiSynch, EGA, RGB, TTL, and the internal monitors of the IBM PC Portable and Compaq Portable. Other features include: high resolution icon operating environment support for Windows and GEM; high resolution support for desktop publishing and CAD applications; and 132 column support for terminal emulation applications, spread sheets, word processing and accounting.

Circle No. 91 on Reader Service Card

Commodore Products



Commodore Business Machines Limited is a leading Canadian manufacturer of a wide range of personal computers for home, school and business applications. Commodore's line includes the powerful Amiga 2000, Amiga 500, and 64C computers. Their line of IBM XT compatible computers, including the PC 20-III, gives Commodore a competitive machine for the popular MS-DOS market. As well, Commodore supplies a broad selection of peripheral devices. Commodore markets its products through over 300 dealers and independent retail outlets across Canada.

Circle No. 92 on Reader Service Card



Toshiba T5100
 Toshiba knows how to package power. And Toshiba proves it again with the T5100 386 Laptop Portable computer. Based on the state-of-the-art 80386 microprocessor, running at 16 MHz, the T5100 is the ultimate in portable computer performance. And for even more power, you can plug in an 80387 co-processor. Richly featured, the T5100 includes a very fast 40MB hard disk drive, a PS/2 compatible 3.5" floppy disk drive, 2MB of RAM and more! Because of its compact size, the T5100 sets up in a mere 1 1/4 square feet of work space and weighs only 15 pounds.

Circle No. 93 on Reader Service Card

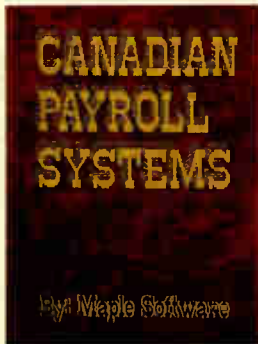

Maple Software
 38 Inniswood Dr.,
 Scarborough,
 Ontario
 M1R 1E5
 Tel: (416) 757-1729

WordPerfect 5.0

WordPerfect Corporation's WordPerfect 5.0 for IBM PCs and compatibles offers integration of text and graphics for designing newsletters, reports, and other documents. Other features include: Style definition for combining a series of codes that specify the format of text in your document; a Preview feature for displaying an entire page of text and graphics at once; alternate keyboard formats; absolute measurements for printing; flexible font capabilities and more.

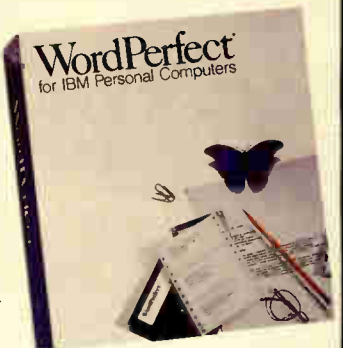

Circle No. 95 on Reader Service Card

Payroll The Pay-Calc Series

Avoid the growing complexity of those "do everything for everyone" programs. Choose one that has been tailored to accurately meet your specific payroll needs. Capability, accuracy and an unmatched ease of installation and use is backed by a 60-day full refund policy. Salary, commission plus 4-6 hourly rates for up to 200 employees' Cheques, T4s, and extensive reporting. It's fully menu-driven. This package is MS/PC DOS compatible.
 PC-3: Accountants & companies with branch offices. Multiple companies co-resident on hard disk.
 PC-4: Manufacturing. Multiple pay scales, unions, benefits, court-ordered deductions, etc.
 PC-5: General business. Our most popular version. Very versatile - Quebec version under development.
 PC-6: Restaurants and services.
 PC-7: The anatomy of Payroll. A highly tutorial-oriented version of PC-5 for students and educators, also now under development. Also, PC-2 for Apple, DOS 3.3.

Circle No. 94 on Reader Service Card

If you are looking for people who want to hear about High-Tech products... we already found them!
For advertising information call (416)445-5600 FAX 416-445-8149

MOORSHEAD PUBLICATIONS
 1300 Don Mills Road, North York, Toronto, Ontario M3B 3M8

WILDERNESS TOURS CANADA'S PREMIER RAFTING COMPANY



Enjoy a safe natural adventure among friends. We specialize in 2 day all-inclusive whitewater rafting packages on the Ottawa River, 90 minutes west of the Nation's Capital. No experience is necessary for what will be the highlight of your summer.

CALL FOR RESERVATIONS **1-800-267-9166**
 BOX 89, BEACHBURG, ONTARIO K0J 1C0

Circle No. 43 on Reader Service Card

THE NEW 65/9028 VT ANSI VIDEO TERMINAL BOARD!

★ FROM LINGER ENTERPRISES ★

A second generation, low cost, high performance, mini sized, single board for making your own RS232 Video Terminal. This highly versatile board can be used as a stand alone video terminal, or without a keyboard, as a video console. VT100, VT52 Compatible.

FEATURES:

- ★ Uses the new CRT9128 Video Controller driven by a 6502A CPU
- ★ On-Screen Non-Volatile Configuration
- ★ 10 Terminal Modes: ANSI, H19, ADM-5, WYSE 50, TVI-920, KT-7, HAZ-1500, ADDS 60, QUME-101, and Datapoint 8200
- ★ Supports IBM PC/XT, and Parallel ASCII Keyboards
- ★ Supports standard 15.75 kHz (Horiz.)
- ★ Composite or Split Video (50/60 Hz)
- ★ 25 X 80 Format with Non-Scrolling User Row
- ★ Jump or Smooth Scroll
- ★ RS-232 at 16 Baud Rates from 50 to 19,200
- ★ On Board Printer Port
- ★ Wide and Thin Line Graphics
- ★ Normal and Reverse Screen Attributes
- ★ Cumulative Character Attributes: De-Inten, Reverse, Underline and Blank
- ★ 10 Programmable Function Keys and Answerback message
- ★ 5 X 8 Character Matrix or 7 X 9 for IBM Monitors
- ★ Mini Size: 6.5 X 5 inches
- ★ Low Power: 5VDC @ .7A, ± 12VDC @ 20mA.

MICRO SIZE!

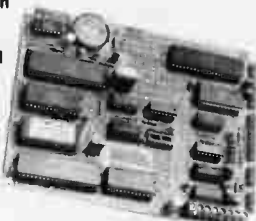

\$79⁹⁵

FULL KIT

w/100 Page Manual
 ADD \$40 FOR A&T

OPTIONAL EPROM FOR
 PC/XT STYLE SERIAL
 KEYBOARD: \$15

SOURCE DISKETTE:
 PC/XT FORMAT
 5 1/4 IN. \$15

Digital Research Computers

P.O. BOX 381450 • DUNCANVILLE, TX 75138 • (214) 225-2309

Call or write for a free catalog on Z-80 or 6809 Single Board Computers, SS-50 Boards, and other S-100 products.

TERMS: Add \$3.00 postage. We pay balance. Orders under \$15 add 75¢ handling. No C.O.D. We accept Visa and MasterCard. Texas Res. add 6-1/4% Tax. Foreign orders (except Canada) add 20% P & H. Orders over \$50 add 85¢ for insurance.

Circle No. 35 on Reader Service Card

SAMS FOR THE edge ON TECHNOLOGY

Written for radio listeners, ham radio listeners and ham radio operators, this guide can also be used by shortwave, FM broadcast and scanner listeners. The latest antenna designs and construction practices are covered.

Topics discussed include:

- low cost, easy to erect designs.
- constructing effective antennas and home-brewing your own.
- proper testing procedures.
- types of bands including indoor, outdoor and mobile antennas.

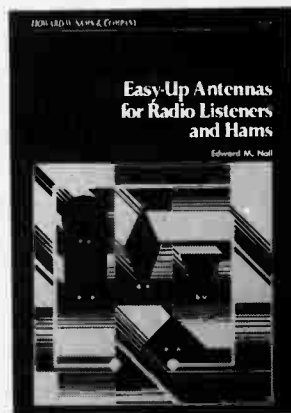

Easy Up Antennas for Radio Listeners and Hams, Edward M. Noll, \$26.95, 672-22495-1, 224 pages

Available at bookstores everywhere or order from:

☐ Copp Clark Pitman Ltd.
 2775 Matheson Blvd. East
 Mississauga, Ontario
 L4W 4P7
 (416) 238-6074

Circle No. 36 on Reader Service Card

BABANI book offer

Exclusively available in Canada from
Moorshead Publications.

EXCELLENT
GIFT!

NEW RELEASE

BP195: AN INTRODUCTION TO SATELLITE TELEVISION \$15.00

For the absolute beginner or anyone thinking about purchasing a satellite TV system, the story is told as simply as such a complex one can be in the main text.

BP:53 PRACTICAL ELECTRONIC CALCULATIONS AND FORMULAE \$11.75

A book that bridges the gap between complicated technical theory and the 'cut and try' method. A good reference book.

BP 174: MORE ADVANCED ELECTRONIC MUSIC PROJECTS \$12.00

Complementing Book BP74, "Electronic Music Projects", BP174 provides more advanced projects, such as a flanger, a phaser, mini-chrous and ring modulators, percussion synths, etc. Each project has an introduction circuit diagram and constructional notes.

BP 113: 30 SOLDERLESS BREADBOARD PROJECTS-BOOK 2 R.A. Penfold \$9.00

A companion to BP107. Describes a variety of projects that can be built on plug-in breadboards using CMOS logic IC's. Each project contains a schematics, parts list and operational notes.

BP92: ELECTRONICS SIMPLIFIED - CRYSTAL SET CONSTRUCTION \$5.25

This is a book written especially for those who wish to participate in the intricacies of electronics.

BP192 \$8.00

More Advanced Power Supply Projects, by Robert Penfold. A companion to BP76, this book covers switched mode supplies, precision regulators, tracking regulators, computer-controlled supplies, etc.

BP197: AN INTRODUCTION TO THE AMSTRAD PCs \$20.00

Recently introduced to Canada, the Amstrad PC is an MS-DOS computer for general and business use. This book explains all you need to know to start computing.

BP:150 AN INTRO TO PROGRAMMING THE SINCLAIR QL \$7.80

Helps the reader make the best use of the Sinclair QL's almost unlimited range of features. Complements the manufacturer's handbook.

BP48: ELECTRONIC PROJECTS FOR BEGINNERS \$7.80

F.G. Rayer, T. Eng. (CEI), Assoc.IERE Another book written by the very experienced author — Mr. F.G. Rayer — and in it the newcomer to electronics, will find a wide range of easily made projects. Also, there are a considerable number of actual components and wiring layouts, to aid the beginner.

BP136: SECRETS OF THE COMMODORE 64 \$5.85

This book is intended as a beginner's guide to the Commodore 64.

BP155: INTERNATIONAL RADIO STATIONS GUIDE \$9.00

An invaluable aid in helping all those who have a radio receiver to obtain the maximum entertainment value and enjoyment from their sets.

BP130: MICRO INTERFACING CIRCUITS - BOOK 1 \$9.00

Aimed at those who have some previous knowledge of electronics, but not necessarily an extensive one, the basis of the book is to help the individual understand the principles of interfacing circuits to microprocessor equipment.

BP51: ELECTRONIC MUSIC AND CREATIVE TAPE RECORDING \$5.85

This book sets out to show how Electronic Music can be made at home with the simplest and most inexpensive equipment.

BP222: SOLID STATE SHORT WAVE RECEIVER FOR BEGINNERS R.A. Penfold \$7.80

In this book, R.A. Penfold has designed and developed several modern solid state short wave receiver circuits that will give a fairly high level of performance, despite the fact that they use only relatively few and inexpensive components.

BP110: HOW TO GET YOUR ELECTRONIC PROJECTS WORKING R.A. Penfold

We have all built projects from magazines and books that they don't work. This book aims to help you overcome these problems by introducing you to the many of the common faults that can occur when building up projects.

BP74: ELECTRONIC MUSIC PROJECTS R.A. Penfold \$10.00

Although one of the more recent branches of amateur electronics, electronic music has now become extremely popular and there are many projects which fall into this category. The purpose of this book is to provide the constructor with a number of practical circuits for the less complex items of electronic music equipment, including such things as a Fuxx Box, Waa-Waa Pedal, Sustain Unit, Reverberation and Phaser-Units, Tremelo Generator etc.

BP 234: TRANSISTOR SELECTOR GUIDE \$15.00

Listings of British, European and eastern transistor characteristics make it easy to find replacements by part number or by specifications. Devices are also grouped by voltage, current, power, etc., Includes surface-mount conversions.

BP50: IC LM3900 PROJECTS \$4.25

The purpose of this book is to introduce the LM3900 to the Technician, Experimenter and Hobbyist. It provides the groundwork for both simple and more advanced uses and is considerably more than just a collection of simple circuits or projects.

BP233: ELECTRONIC HOBBYIST HANDBOOK \$15.00

A single source of easily located information: colour codes, pinouts, basic circuits, symbols, etc.

BP101: HOW TO IDENTIFY UNMARKED IC's \$1.95

An unusual and fascinating chart that is highly recommended to all those interested in electronics and which will hopefully pay for itself many times over, by enabling the reader to use IC's that might otherwise have been scrapped.

BP121: HOW TO DESIGN AND YOUR OWN PCB's

The purpose of this book is to familiarise you with the practical aspects of printed circuit board design and construction.

BP180: ELECTRONIC CIRCUITS FOR THE COMPUTER CONTROL OF MODEL RAILWAYS \$9.00

Shows how home computers can easily be applied to the control of model railroads and other quite sophisticated control. A variety of projects are discussed as well as circuits for train position sensing, signal and electric points control etc.

BP185: ELECTRONIC SYNTHESIZER CONSTRUCTION \$9.00

With this book a relative beginner should be able to build, with the minimum of difficulty and at a reasonably low cost, a worthwhile monophonic synthesiser and also learn a great deal about electronic music synthesis in the process.

BP115: THE PRE-COMPUTER BOOK \$5.85

Aimed at the absolute beginner with no knowledge of computing, this entirely non-technical discussion of computer bits and pieces and programming is written mainly for those who do not possess a microcomputer but either intend to one day own one or simply wish to know something about them.

BP72: A MICROPROCESSOR PRIMER \$5.25

In an attempt to give painless approach to computing, this inexpensive book will start by designing a simple computer and then the shortcomings of this simple machine will be discussed and the reader is shown how these can be overcome. A glossary of microprocessor terms is at the end of the book.

BP78: PRACTICAL COMPUTER EXPERIMENTS \$5.25

The aim of this book is to enable the reader to simply and inexpensively construct and examine the operation of a number of basic computer circuit elements and it is hoped gain a fuller understanding of how the mysterious computer "chip" works.

BP88: AN INTRODUCTION TO BASIC Programming Techniques \$5.85

This book is based on the authors own experience in learning BASIC and also in helping others, mostly beginners to programming, to understand the language.

BP42: 50 SIMPLE L.E.D. CIRCUITS \$5.85

Contains 50 interesting and useful circuits and applications, covering many different branches of electronics, using one of the most inexpensive and freely available components.

BP85: INTERNATIONAL TRANSISTOR EQUIVALENTS GUIDE \$9.00

This book is designed to help the user find possible substitutes for a popular user-oriented selection of modern transistors and includes devices produced by over 100 manufacturers.

BP140: DIGITAL IC EQUIVALENTS AND PIN CONNECTIONS \$15.00

Shows equivalents and pin connections of a popular user orientated selection of Digital Integrated Circuits. Includes European, American and Japanese devices.

BP131: MICRO INTERFACING CIRCUITS - BOOK 2 \$9.00

Intended to carry on from Book 1, this book deals with practical applications beyond the parallel and serial interface. "Real world" interfacing such as sound and speech generators, temperature and optical sensors, and motor controls are discussed using practical circuit descriptions.

BP100: AN INTRODUCTION TO VIDEO \$5.85

This is a book for the person who has just, or is about to buy or rent some video equipment but is not sure what it is all about.

BP125: 25 SIMPLE AMATEUR BAND AERIALS \$5.85

This book describes how to build 25 amateur band aerials. The designs start with the simple dipole and proceed to beam, triangle and even a mini-rhombic.

BP138: SIMPLE INDOOR AND WINDOW AERIALS \$7.00

People living in apartments who would like to improve shortwave listening can benefit from these instructions on optimising the indoor aerial.

BP141: LINEAR IC EQUIVALENTS AND PIN CONNECTIONS ADRIAN MICHAELS \$23.80

Find equivalents and cross-references for both popular and unusual integrated circuits. Shows details of functions, manufacturer, country of origin, pinouts, etc., includes National, Motorola, Fairchild, Harris, Motorola, Intersil, Philips ADC, AMD, SGS, Teledyne, and many other European, American, and Japanese brands.

BP156: AN INTRODUCTION TO QL MACHINE CODE \$10.00

The powerful Sinclair QL microcomputer has some outstanding capabilities in terms of its internal structure. With a 32-bit architecture, the QL has a large address range, advanced instructions which include multiplication and division. These features give the budding machine code programmer a good start at advanced programming methods. This book assumes no previous knowledge of either the 68008 or machine code programming.

TEMPORARILY
OUT OF PRINT

TEMPORARILY
OUT OF PRINT

BP7: RADIO AND ELECTRONICS COLOUR CODE AND DATA CHART

\$3.00

Opens out to Wall Chart approximately 584 x 457 mm. Includes many Radio & Electronics Colour Codes in use in UK, USA, Europe and Japan. Covers Resistors, Capacitors, Transformers, Field Coils, Fuses Battery Leads etc.

BP144: FURTHER PRACTICAL ELECTRONICS CALCULATIONS AND FORMULAE

This book covers electronics calculations familiar to the hobbyist. Fuller explanation to the library of all interested in electronics be amateur, professional or student.

ELEMENTS OF ELECTRONICS - AN ON-GOING SERIES

F.A. WILSON, C.G.I.A., C.ENG., BP82: BOOK 1. THE SIMPLE ELECTRONIC CIRCUIT AND COMPONENTS

\$11.70

BP77: BOOK 4 MICROPROCESSING SYSTEMS AND CIRCUITS

\$11.80

Although written especially for readers with no more than ordinary arithmetical skills, the use of mathematics is not avoided, and all the mathematics required is taught as the reader progresses.

Each book is a complete treatise of a particular branch of the subject and therefore, can be used on its own with one proviso, that the later books do not duplicate material from their predecessors, thus a working knowledge of the subjects covered by the earlier books is assumed.

BOOK 1. This book contains all the fundamental theory necessary to lead to a full understanding of the simple electronic circuit and its main components.

BOOK 2. This book continues with alternating current theory without which there can be no comprehension of speech, music, radio, television or even the electricity utilities.

BOOK 3. Follows on semiconductor technology, leading up to transistors and integrated circuits.

BOOK 4 A complete description of the internal workings of micro-processor.

BOOK 5 A book covering the whole communication scene.

BP180: ELECTRONIC CIRCUITS FOR THE COMPUTER CONTROL OF MODEL RAILWAYS

\$9.00

The projects in this book consists of various types of controller, including a high quality pulse type, as well as circuits for train position sensing, signal and electronic points control and many more.

BP194: MODERN OPTO DEVICE PROJECTS

\$9.00

This book provides a number of practical designs for beginners and experienced project builders. These projects utilize a range of modern opto-electric devices, including such things as fibre optics, ultra bright LEDs and passive IR detectors.

BP37: 50 PROJECTS USING RELAYS, SCR'S & TRIACS

\$7.80

F.G. RAYER, T.Eng.(CEI), Assoc. IERE Relays, silicon controlled rectifiers (SCR's) and bi-directional triodes (TRIACS) have a wide range of applications in electronics today. This book gives tried and practical working circuits which should present the minimum of difficulty for the enthusiast to construct. In most of the circuits there is a wide latitude in component values and types, allowing easy modification of circuits or ready adaptation of them to individual needs.

BP147: AN INTRODUCTION TO 8502 MACHINE CODE

\$10.00

The popular 8502 microprocessor is used in many home computers; this is a guide to beginning assembly language.

BP225: A PRACTICAL INTRODUCTION TO DIGITAL ICs

\$7.00

This book deals mainly with TTL type chips such as the 7400 series. Simple projects and a complete practical construction of a Logic Test Circuit Set are included as well as details for a more complicated Digital Counter Timer project.

BP47: MOBILE DISCOTHEQUE HANDBOOK

\$7.80

Divided into six parts, this book covers such areas of mobile "disco" as: Basic Electricity, Audio, Ancillary Equipment, Cables and Plugs, Loudspeakers, and Lighting. All the information has been considerably subdivided for quick and easy reference.

BP59: SECOND BOOK OF CMOS IC PROJECTS

\$7.80

This book carries on from its predecessor and provides a further selection of useful circuits, mainly of a simple nature, the book will be well within the capabilities of the beginner and more advanced constructor.

BP71: ELECTRONIC HOUSEHOLD PROJECTS

\$7.00

R.A. PENFOLD

Some of the most useful and popular electronic construction projects are those that can be used in or around the home. The circuits range from such things as '2 Tone Door Buzzer' Intercom, through Smoke or Gas Detectors to Baby and Freezer Alarms.

BP44: IC 555 PROJECTS

\$10.00

E.A. PARR, B.Sc., C.Eng., M.I.E.E. Every so often a device appears that is so useful that one wonders how life went on before without it. The 555 timer is such a device included in this book are Basic and General Circuits, Motor Car and Model Railway Circuits, Alarms and Noise Makers as well as a section on the 556, 558 and 559 timers.

BP82: ELECTRONIC PROJECTS USING SOLAR CELLS

\$7.80

A collection of simple circuits which have applications in and around the home using the energy of the sun to power them. The book deals with practical solar power supplies including voltage doubler and tripler circuits, as well as a number of projects.

BP95: MODEL RAILWAY PROJECTS

\$7.80

Electronic projects for model railways are fairly recent and have made possible an amazing degree of realism. The projects covered include controllers, signals and sound effects: striboard layouts are provided for each project.

BP93: ELECTRONIC TIMER PROJECTS

\$7.80

Windscreen wiper delay, darkroom timer and metronome projects are included. Some of the more complex circuits are made up from simpler sub-circuits which are dealt with individually.

BP94: ELECTRONIC PROJECTS FOR CARS AND BOATS

\$7.80

R.A. PENFOLD

Projects, fifteen in all, which use a 12V supply are the basis of this book. Included are projects on Windscreen Wiper Control, Courtesy Light Delay, Battery Monitor, Cassette Power Supply, Lights Timer, Vehicle Immobiliser, Gas and Smoke Alarm, Depth Warning and Shaver Inverter.

BP49: POPULAR ELECTRONIC PROJECTS

\$10.00

R.A. PENFOLD

Includes a collection of the most popular types of circuits and projects which, we feel sure, will provide a number of designs to interest most electronics constructors. The projects selected cover a very wide range and are divided into four basic types. Radio Projects, Audio Projects, Household Projects and Test Equipment.

BP84: DIGITAL IC PROJECTS

\$7.80

F.G. RAYER, T.Eng.(CEI), Assoc. IERE This book contains both simple and more advanced projects and it is hoped that these will be found of help to the reader developing a knowledge of the workings of digital circuits, to help the newcomer to the hobby the author has included a number of board layouts and wiring diagrams. Also the more ambitious projects can be build and tested section by section and this should help avoid or correct faults that could otherwise be troublesome. An ideal book for both beginner and more advanced enthusiast alike.

BP90: MINI-MATRIX BOARD PROJECTS

\$7.80

R.A. PENFOLD

Twenty useful projects which can all be built on a 24 x 10 hole matrix board with copper strips. Includes Door-buzzer, Low-voltage Alarm, AM Radio, Signal Generator, projector Timer, Guitar Headphone Amp. Transistor Checker and more.

BP103: MULTI-CIRCUIT BOARD PROJECTS

\$7.80

R.A. PENFOLD

This book allows the reader to build 21 fairly simple electronic projects, all of which may be constructed on the same printed circuit board. Wherever possible, the same components have been used in each design so that with a relatively small number of components and hence low cost, it is possible to make any one of the projects or by re-using the components and P.C.B. all of the projects.

BP107: 30 SOLDERLESS BREADBOARD PROJECTS - BOOK 1

\$9.00

R.A. PENFOLD

A "Solderless Breadboard" is simply a special board on which electronic circuits can be built and tested. The components used are just plugged in and unplugged as desired. The 30 projects featured in this book have been specially designed to be built on a 'Verobloc' breadboard. Wherever possible the components used are common to several projects, hence with only a modest number of reasonably inexpensive components it is possible to build, in turn, every project shown.

BP127: HOW TO DESIGN ELECTRONIC PROJECTS

\$9.00

Although information on stand circuit blocks is available, there is less information on combining these circuit parts together. This title does just that Practical examples are used and each is analysed to show what each does and how to apply this to other designs.

BP122: AUDIO AMPLIFIER CONSTRUCTION

\$8.75

A wide circuits is given, from low noise microphone and tape head preamps to a 100W MOSFET type. There is also the circuit for 12V bridge amp giving 18W. Circuit board or striboard layout are included. Most of the circuits are well within the capabilities for even those with limited experience.

BP108: MODERN ON AMP PROJECTS

\$7.80

R.A. PENFOLD

Features a wide range of constructional projects which make use of op-amps including low-noise, low distortion, ultra-high input impedance, high slew-rate and high output current types.

BP98: POPULAR ELECTRONIC CIRCUITS, BOOK 2

\$9.00

R.A. PENFOLD

70 plus circuits based on modern components aimed at those with some experience.

BP179: ELECTRONIC CIRCUITS FOR THE COMPUTER CONTROL OF ROBOTS

The main stumbling block would-be robot builders would be the electronics to control the robot to the purpose of this book explain and provide some very simple electronic circuits which bridge the gap.

BP32: HOW TO BUILD YOUR OWN METAL & TREASURE LOCATORS

\$7.80

Several fascinating applications with complete electronic and practical details on the simple, and inexpensive construction of Heterodyne Metal Locators.

BP106: CROSS-REFERENCES EUROPEAN AMERICAN AND JAPANESE DIODE PART NUMBERS.

\$7.00

Besides rectifier diodes, it includes Zeners, LEDs, Diacs, Triacs, SCRs, OCIs, photodiodes and display diodes.

BP68: HOW TO USE OP AMPS

\$11.80

E.A. PARR A designer's guide covering several op amps, serving as a source book of circuits and a reference book for design calculations. The approach has been made as nonmathematical as possible.

BP65: SINGLE IC PROJECTS

\$6.00

R.A. PENFOLD

There is now a vast range of ICs available to the amateur market, the majority of which are not necessarily designed for use in a single application and can offer unlimited possibilities. All the projects contained in this book are simple to construct and are based on a single IC. A few projects employ one or two transistors in addition to an IC but in most cases the IC is the only active device used.

BP118: PRACTICAL ELECTRONIC BUILDING BLOCKS - BOOK 2

\$7.80

R.A. PENFOLD

This sequel to BP117 is written to help the reader create and experiment with his own circuits by combining standard type circuit building blocks. Circuits concerned with generating signals were covered in Book 1, this one deals with processing signals. Amplifiers and filters account for most of the book but comparators, Schmitt triggers and other circuits are covered.

ORDER BY TELEPHONE (416) 445-5600 OR FAX: 416-445-8149 OR WRITE TO: MOORSHEAD PUBLICATIONS 1300 DON MILLS RD., NORTH YORK, ON., M3B 3M8

TEMPORARILY OUT OF PRINT

TEMPORARILY OUT OF PRINT

Pseudo Echo Unit

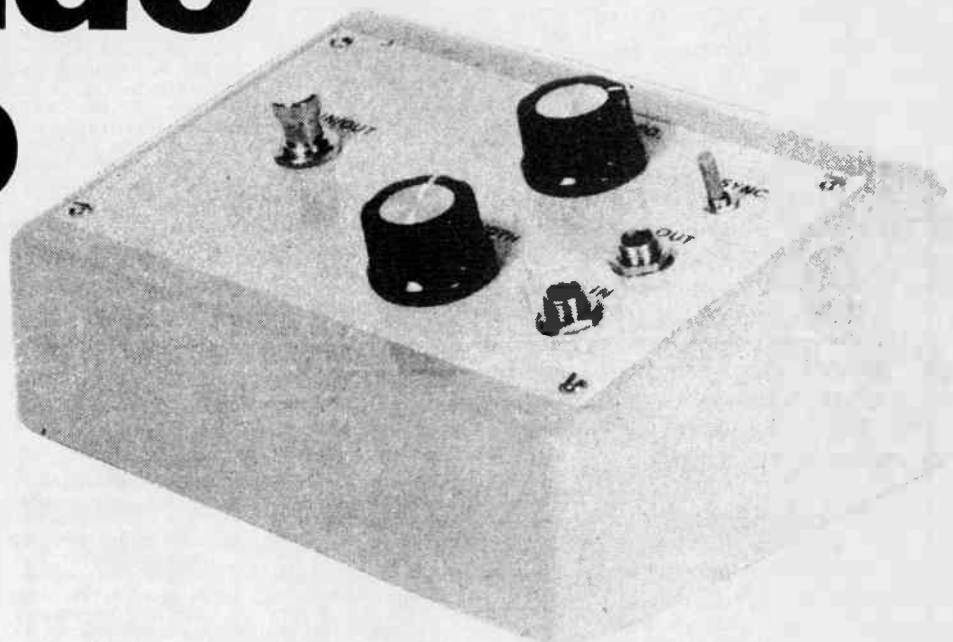

Produce realistic echo effects at a realistic price.

By Robert Penfold

This device is really a form of tremolo unit, but when used with an instrument (such as a guitar) which has a fast attack and slow decay, it provides an effect which is much more like an echo effect than a conventional tremolo type. The unit differs from a standard tremolo rather than the more usual sinewave or triangular signal.

The effect of a normal tremolo unit is much the same as manually varying the volume up and down at a rate of (typically) a couple of times per

second, and this effect can be generated manually via a swell pedal. The effect of this unit is to switch the signal on and off with no in-between state. This can be used as a rather harsh and extreme form of tremolo, but it is probably most effective when used on a suitable signal to give a pseudo echo effect.

The waveform of Fig. 1 shows how this effect is obtained. The input signal must be a type having a fast attack with a much slower decay time if the right

effect is to be produced. The output from an electric guitar is in this category, and synthesizers and most other electronic instruments can provide a suitable signal.

The effect of the unit is to chop up the signal into short bursts, and the output from the unit is therefore a series of signal bursts that start at a high level and gradually decay. The sound this gives is very much the same as if a short burst of signal were to be fed into an echo effects unit.



Fig. 1. (above). A combination of the signal's natural decay and the chopping effect of the unit gives an echo effect.

Fig. 2. (right). The waveform of (a) is the result of a simple chopping process; (b) is the result of incorporating zero switching in the process.

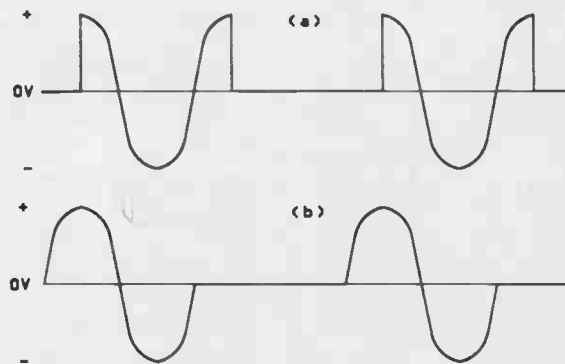

There are limitations to this way of doing things, and the main one is that it only works properly with a signal that has a suitable envelope shape, and which remains essentially the same throughout its duration. With most instruments there is no problem in either case, but the obvious exception is a voice signal which is unsuitable in both cases.

Another problem, and one which is most troublesome when using a low modulation frequency, is that of the start of a note occurring during an "off" period. This can seriously effect the timing of the music, and by eliminating the important attack period of the signal it can drastically alter its sound.

The Pseudo Echo Unit described here has a simple synchronization facility which can be switched in when using low modulation frequencies, so that the unit is forced to commence an "on" phase at the start of each new note. This seems to totally eliminate the "of" period problem.

Zero Switching

A third problem with this very harsh form of amplitude modulation is that it tends to produce "click" sounds as the signal is gated on and off. This happens because the unit will usually switch the signal on or off when it is not at zero volts. This gives a sudden change from whatever level the signals happens to have at instant of switching, to the zero

volts level. Under worse case conditions a waveform of the type shown in Fig. 2a is obtained, where the signal switches from its peak level to zero volts of each transition of the signal gate.

There are ways of reducing or eliminating the problem, and in this circuit zero point switching is used. This is very effective indeed and it permits quite high switching frequencies to be used without any significant switching glitches being generated at all.

The method used is very simple in essence, and it avoids the switching glitches by synchronizing the modulation signal with the input signal in such a way that the signal gate only switches state as the input signal passes through 0V. This gives an output signal of the type shown in Fig 2b, with only sets of complete half cycles present.

System Operation

The block diagram of Fig. 3 shows the general arrangement used in Pseudo Echo Unit. A buffer stage is used at the input of the unit, and the main signal path is through the sample and hold circuit to the output socket.

The sample and hold circuit is a form of signal gate, and it allows the input signal to pass straight through to the output when it is supplied with a "high" control signal. Switching the control input "low" blocks the signal

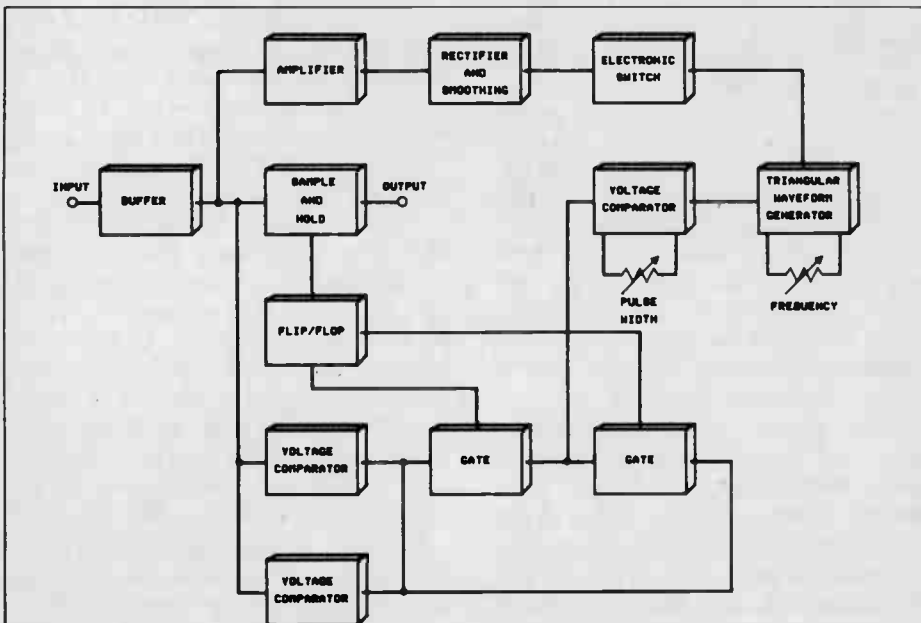

Fig. 3. The block diagram for the Pseudo Echo Unit.

PARTS LIST

Resistors

R1 R2, R15.....	100k
R3, R10, R16,	
R17, R18, R22	
R23.....	10k
R4, R5, R11, R12	4k7
R6, R9.....	1M
R7, R8, R21	2k2
R13.....	220k
R14.....	47k
R19, R20.....	15k
All 1/4 W 5% carbon	

Potentiometer

VR1.....	47k lin
VR2.....	1M lin
VR3	100k sub-min hor. preset

Capacitors

C1, C5	100u radial elect. 10V
C2, C6	470n polyester
C3.....	10n polyester
C4.....	10u radial elect. 25V
C7, C9	2u2 radial elect.
C8.....	1u radial elect. 63V

Semiconductors

D1 to D8.....	IN4148
silicon signal diode	
TR1	2N5818 npn silicon
IC1 LF351	bifet op amp
IC2	4016BE
CMOS analogue switch	
IC3 CA3140E	MOS op amp
IC4	4001BE CMOS
quad 2-input NOR gate	
IC5,7	1458 dual op amp
IC6,8	741C op amp

Miscellaneous

SK1.....	Standard jack
with DPDT switch contacts	
SK2	Standard jack socket
S1	locking pushbutton switch
S2	Part of SK1
S3	Miniature SPST
toggle switch	

Case, sloping front type about 165 x 70 x 125mm; printed circuit board; two controls knobs; B1, 9V; six 1.5V size cells in plastic holder; battery connector (9V type); 8-pin DIP socket (6); 14-pin DIP sockets (2); pins, wire, solder, etc.

Pseudo Echo Unit

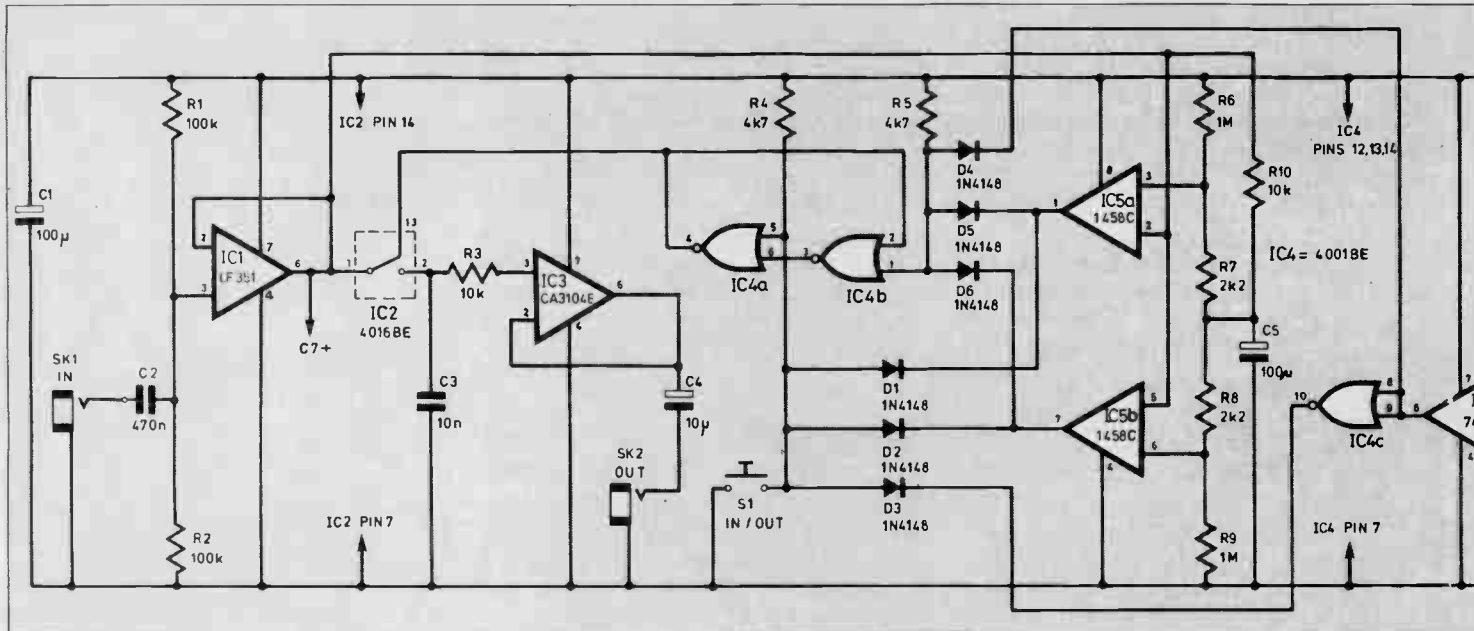

Fig. 4. The main circuit diagram for the Pseudo Echo Unit.

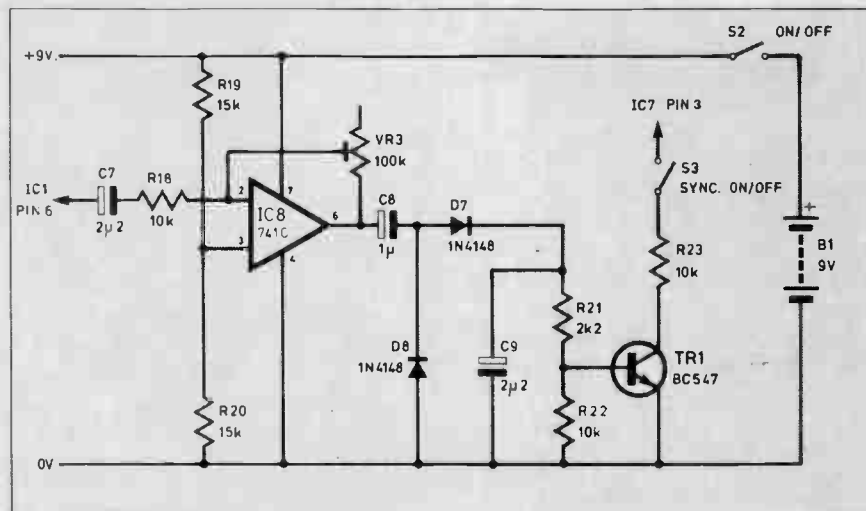

Fig. 5. Circuit diagram for the synchronization stage.

path, and the output is maintained at whatever level it happened to have at the instant when the signal was cut off. It is important that the output is not simply allowed to drift as this could result in unwanted "clicks" and other noises on the output signal.

The modulation signal is generated by a triangular waveform generator which feeds into a voltage comparator. The other input of the comparator is fed from a variable reference voltage, and this combination constitutes a conventional variable pulse generator.

The output signal can be continuously varied from narrow positive "needle" pulses through a 1 to 1 squarewave and on to the point where

narrow negative pulses are produced. In terms of the modulation effect, this can be varied from the point where the signal is switched off for the vast majority of the time and is only gated on for short bursts, through to a setting where the signal is almost continuously switched on and is only blanked out for very short periods.

The pulsed modulation signal is fed to the sample and hold circuit via some control circuitry which must prevent changes in the signal from taking effect until the input signal passes through zero volts. Two voltage comparators monitor the output from the buffer amplifier, and they are arranged in such a way that they both provide a high output level only when

the signal is very close to the 0V level. The voltage comparator outputs, together with the modulation signal, are fed to the inputs of two logic gate circuits.

A simple S/R (set/reset) flip/flop provides the control signal for the sample and hold circuit. The flip/flop must be supplied with a high input signal to its "set" input in order to switch on the sample and hold circuit, and a high input level is then needed at the "reset" input in order to take the sample and hold circuit back to the "hold" mode.

The gates provide these input signals, and the one feeding the set input is configured in such a way that it provides the set pulse when all three inputs go high, and the voltage comparators detect that the signal is close to the 0V level.

Once switched on, the sample and hold circuit remains in this state until the flip/flop is reset, and the second gate is designed to provide the reset pulse when the outputs of the comparators are both high, but the modulation signal is low. Thus, when the output of the pulse generator goes low the signal path is broken but not until the voltage comparators detect that the signal is close to the 0V level.

Some of the output signal from the buffer stage is fed to an amplified signal is rectified and smoothed. This gives a DC signal that is roughly proportional to the amplitude of the input signal. For the synchronization to

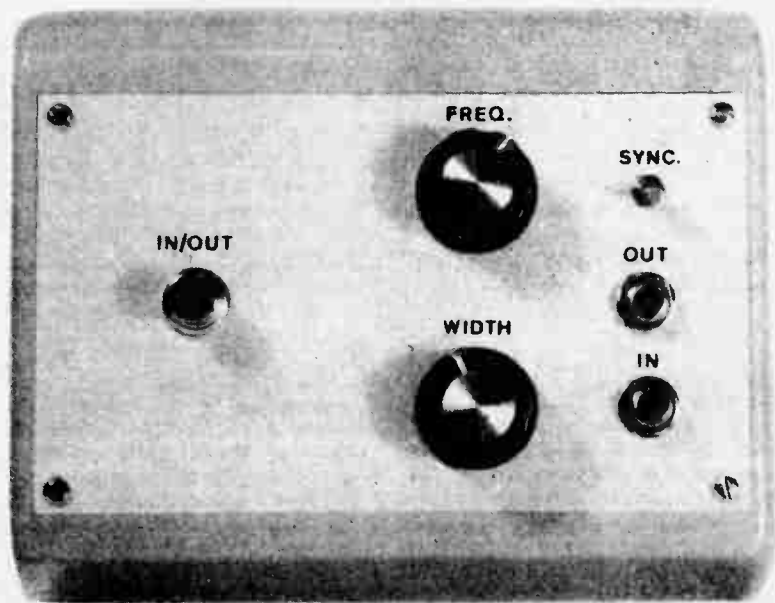
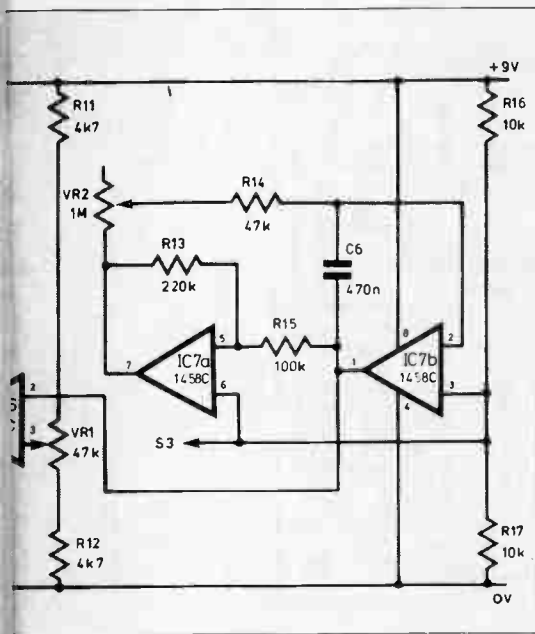

The finished echo unit, showing the footswitch mounted on the far left of the front panel.

work properly the input signal must be a type which has a fast attack time with a reasonably rapid initial decay characteristic. Guitars and signals with form, and the electronic switch is turned on briefly each time a note is played. The switch is connected to the biasing circuit of the triangular

waveform generator, and it has the effect of forcing the start of a new cycle each time the switch is closed, thus giving the required synchronization effect.

Circuit Operation

The main circuit diagram for the

Pseudo Echo Unit appears in Fig. 4, but the synchronization circuit is shown separately in Fig. 5.

The buffer amplifier (IC3) at the output ensures that there is no significant discharging of capacitor C3 during the "hold" periods. The CA3140E specified for the IC3 posi-

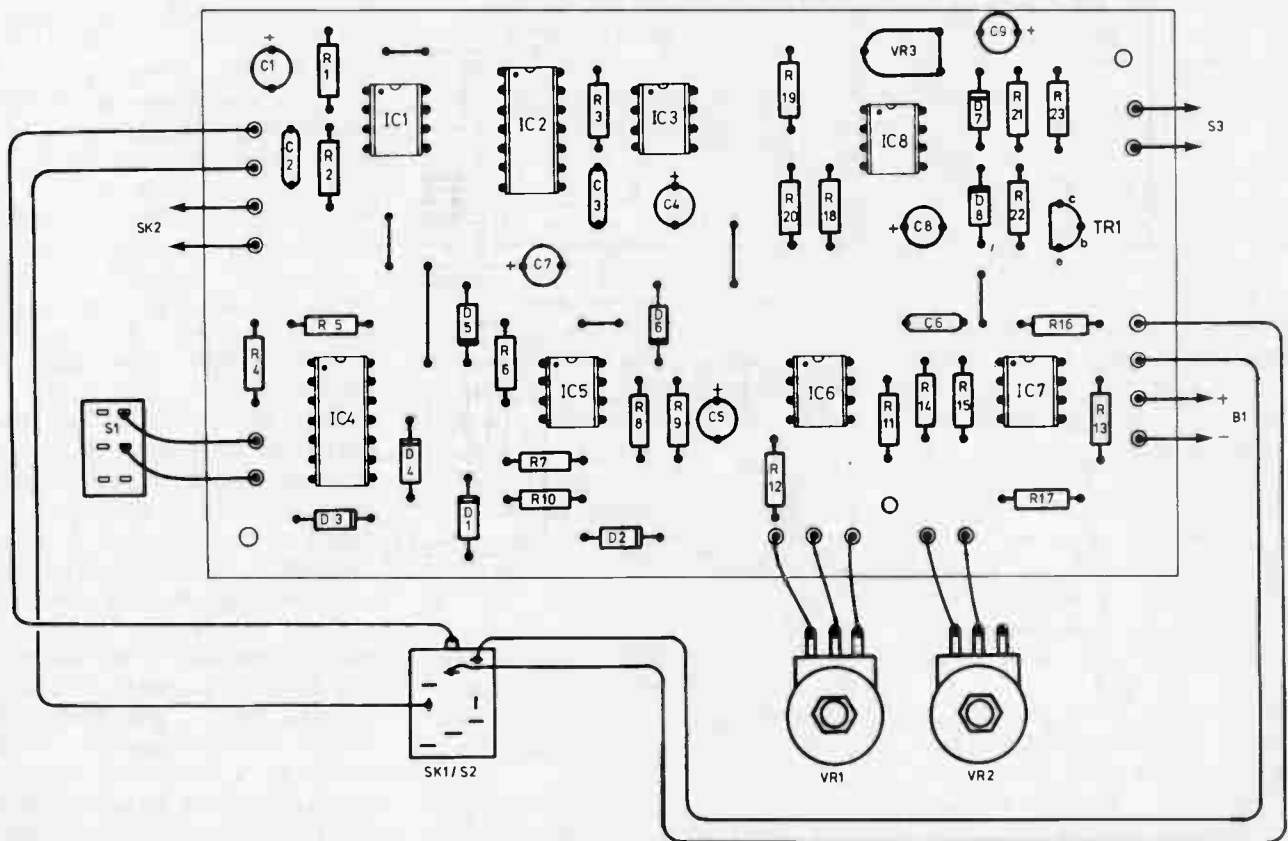

Fig. 6. The printed circuit board component layout and interwiring details for the case-mounted components.

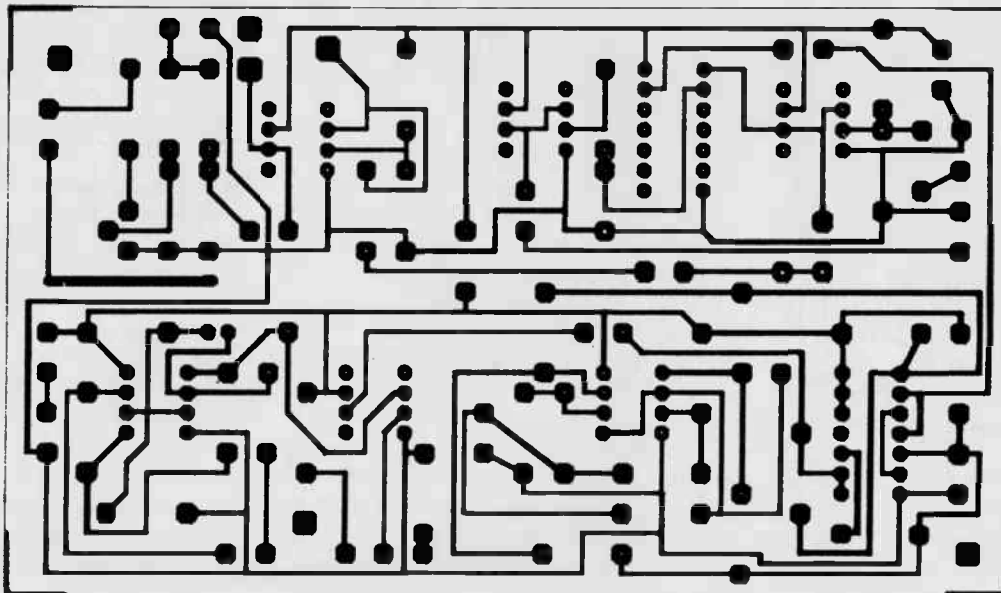

Fig. 7. Full size printed circuit board foil pattern.

tion is a MOS input type which gives an input impedance of over one million megohms. Note that there are actually four switches in IC2, but in this circuit only one is used and there are no connections to the other three.

The triangular waveform generator is based on IC7, and the two operational amplifiers in this device are connected as a conventional oscillator of the Schmitt trigger/Miller integrator type. Potentiometer VR2 provides a frequency range of about 0.5Hz to 10Hz. IC6 is the voltage comparator, with VR1 providing the variable reference voltage and acting as the pulse width control.

IC5 provides the two operational amplifiers which act as the voltage comparators in the zero crossing detector circuit. Resistors R6 to R10 and capacitor C5 provide two reference voltages just marginally either side of the "0 volt" level. Of course, it is not strictly accurate to call this circuit a zero crossing detector, as it is actually detecting the signal crossing through the quiescent bias voltage, which is about half the supply voltage and not 0V.

The flip/flop is a conventional CMOS R/S type which is formed from two cross coupled 2-input NOR gates (IC4a and IC4b). The two gates are simple 3-input AND types, each formed from a pullup resistor and three diodes. However, the one which

drives the reset input of the flip/flop is driven from the pulse generator by way of IC4c which is connected to operate as an inverter. This gives the desired action with the reset pulse being produced when the output of the pulse generator is "low" (and the output of the inverter is "high"). Closing switch S1 holds the flip/flop in the "set" state, and therefore switches out the effect. Note that one gate of IC4 is left unused.

Sync Circuit

Turning our attention to the synchronization circuit, Fig. 5, the amplifier stage is based on IC8, and this is a standard inverting mode amplifier circuit. The preset Gain control VR3 must be adjusted so that the electronic switch is only just activated on the initial peak of each note. Diodes D7 and D8 rectify the output from IC8, and C9 is the smoothing capacitor.

This circuit has a suitably fast attack time, and it also has a fairly rapid decay so that the electronic switch is not held in the "on" state for an excessive time. Transistor TR1 is used as the electronic switch, and is a simple common emitter type which pulls the bias voltage in the oscillator circuit lower when activated.

Switch S3 enables transistor TR1 to be switched out of circuit so that the synchronization can be disabled (which can be beneficial when using

high modulation frequencies).

Construction

The component layout and full size printed circuit board foil master pattern for the Pseudo Echo Unit is shown in Fig. 6 and Fig. 7.

Construction of the board is not difficult provided miniature printed circuit mounting capacitors are used (larger types could be very awkward to fit into place). Make sure that all the electrolytic capacitors and semiconductors are fitted the right way around and do not overlook any of the six link wires.

IC2, IC3, and IC4 are all MOS types, and consequently require the standard antistatic handling precautions to be taken. In particular, use integrated circuit holders for these devices, and do not fit them into the holders until construction of the unit is otherwise complete. At this stage only pins are fitted to the board at the points where connections to off-board components will eventually be made.

One of the smaller types of sloping-front case is ideal for this project, and the front panel should be arranged with switch S1 at one end of the panel, and the sockets and other controls towards the opposite end. Switch S1 should be a heavy duty push button switch of the push-to-make – push-to-break type, so that it can be operated by foot. It is for this reason that it should be mounted well clear of the

other front panel mounted components (so that they do not impede operation of this "foot switch").

The completed printed circuit board is mounted on the base panel of the case using the normal mounting pillars or screws plus spacers. It is then wired up to the front panel mounted components, see Fig. 6, and there is no need for any of this wiring to be screened, but it should be kept reasonably short and direct. In Fig. 6 it has been assumed that on/off switch S2 will be a set of make contacts on the input socket SK1. A socket with a single set of make contacts is unlikely to be obtainable, and it is therefore necessary to use two contacts of a socket having DPDT types.

With this method of switching the unit is automatically switched on when a plug is inserted into SK1, and switched off again when the plug is removed. This is common practice with musical effects units, but obvious-

ly an ordinary socket and a separate on/off switch can be fitted if preferred.

In Use

If the synchronization feature is ignored initially, the unit can be tested without setting up VR3. The output from socket SK2 is coupled to the amplifier, mixer, or whatever via a standard screened jack lead. As explained previously, the unit is automatically switched on when a signal source is connected to input-socket SK1, and switched off again when the plug is removed.

The effect is not one of the most subtle ones and it should be very apparent on any input signal. A little experimentation with the Frequency and Pulse Width controls will soon reveal the range of sounds that can be produced. The unit will work satisfactorily with a wide range of input levels, but it is not suitable for use with very low level sources such as microphones and some

guitar pickups unless a suitable preamplifier is added ahead of the unit. Inputs of up to about 6 volts peak to peak can be accommodated before clipping and serious distortion occurs.

It is really only worthwhile using the synchronization facility when the Frequency control is set for quite low modulation frequencies. At high modulation frequencies it is likely to have no noticeable effect, and could be counterproductive by elongating the initial modulation cycle (although you may prefer things this way).

In order to give the preset gain control VR3 the correct setting, start with this component fully backed off (set fully counterclockwise) and then advance it very gradually while playing notes into the unit. Adjust it just far enough to produce the synchronization effect. Remember, the synchronization will only work on signals that have an envelope with an initial transient to switch on transistor TR1. ■

Electronics & Technology Today

Canada's Magazine for High-tech Discovery

Order Form

CLIP OR COPY
AND MAIL

Subscriptions: Please complete bottom half to start or renew subscription.

SOFTWARE — Order Form

.....	\$
.....	\$
.....	\$
Sub Total	\$
Tax (Ontario Residents)	\$
Postage	\$
Total Enclosed	\$

BOOKSHELF — Order Form

Code (e.g. BP12)	Title Short-form is O.K.)	Price
.....
.....	\$
.....	\$
.....	\$
.....	\$

SPECIAL PUBLICATIONS

ITEM	QTY	AMOUNT
Book of Computer Music \$4.95	\$
Project Book No. 3 \$3.95	\$

BINDERS

ITEM	QTY	AMOUNT
Moorshead Publications, \$9.75 each. Ontario residents add 7% P.S.T.	\$

BACK ISSUES

\$4.00 each. Ontario residents add 7% P.S.T. Some issues may be out of stock, please call the reader service department at (416) 445-5600 or enclose a self-addressed, stamped envelope for a complete list of available issues.

Orders from the Bookshelf are tax exempt. Please add \$1.00 for postage. Ontario residents add 7% P.S.T. for Specials and Software.

NEXT MONTH IN

Electronics & Technology Today

Canada's Magazine for High-tech Discovery

Build a Programmable Thermostat!

No need to put up with the limitations of commercial setback thermostats. Build this and control it with pushbuttons and a digital display.

A Users Guide to Thermistors

How thermistors work and how to use them for measuring and controlling temperature.

The Evolution of Intelligence

Dr. T. Shah looks at some definitions of human intelligence as it applies to computer programming and Artificial Intelligence.

For advertising or subscriptions
please call (416) 445-5600 Fax: 416-445-8149

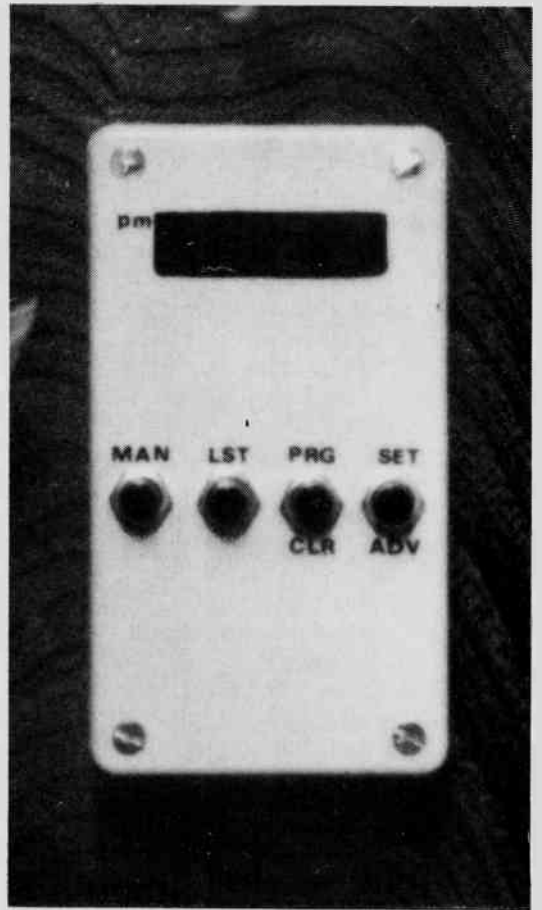

**BE SURE OF YOUR ISSUE
EACH MONTH.
SUBSCRIBE TODAY.**



Bonus!

Subscribe today and receive a sampler disk filled with great public domain software programs (IBM PC/MS DOS format only). This disk contains great games like Pango and Pitfall, as well as a fantastic Chess program and some great DOS utilities. See what you've been missing!

**Regular value: \$19.95
Time Limited Offer**

Moorshead Publications

1300 Don Mills Rd., North York, Toronto, Ont. M3B 3M8

SUBSCRIPTIONS: NEW SUBSCRIPTION RENEWAL

Electronics & Technology Today

One year (12 issues) \$22.95 Two years (24 issues) \$37.95

Computing Now!

One year (12 issues) \$22.95 Two years (24 issues) \$37.95

Computers in Education

One year (10 issues) \$25.00 Two years (20 issues) \$45.00

Outside Canada (US Dollars)

For U.S. please add \$3.00 per year Other countries add \$5.00 per year

NAME _____

ADDRESS _____

TOWN/CITY _____ PROVINCE/STATE _____

CODE _____ DATE _____

POSTAL CODE _____

Cheque enclosed DO NOT send cash

MasterCard Account No. _____

Visa Account No. _____

American Express Account No. _____

Expiry Date _____

Signature _____

See comgraph'88

Write Your Own Ticket To: Canada's Only Electronic Desktop Publishing Show and Conference.

It could be your first step towards electronically designing your own newsletter, producing your own product brochure or standardizing your corporate communications. It will be your *only* opportunity to compare and evaluate over 100 major exhibitors. Each featuring the latest in desktop publishing products and services.

Join us at comgraph'88
Tuesday, May 17, 11 am - 6 pm
Wednesday, May 18, 11 am - 8 pm
& Thursday, May 19, 11 am - 4 pm
**Metro Toronto
Convention Centre**

Conference produced by
The Electronic Desktop Publishing
Association. For information
on how to register contact the
EDPA Hotline, (416) 855-1777.

SAVE \$5
WITH THIS PASS

NAME _____

TITLE _____

COMPANY _____

ADDRESS _____

PHONE _____

Write your own ticket or attach your
business card and bring to the show.
Admission to the comgraph'88 show
without this pass — \$10.
Your Discounted Admission to Comgraph
is Compliments of

**Moorshead
Publications**

comgraph'88

Where Creativity Meets Technology

Tuesday 17, 11 am - 6 pm
Wednesday 18, 11 am - 8 pm
Thursday 19, 11 am - 4 pm
May 1988
Metro Toronto
Convention
Centre

Show produced by
communications 2000 inc.
For information on how to
exhibit contact Jim Annan, 239-3043.

Show sponsored by
The Electronic Desktop Publishing Association.
Co-sponsored by
The Society of Graphic Designers of Canada,
The Canadian Corporate Reprographic Management Association,
and The Canadian Business Forms Distributors Association.

Almost Free PC Volume 31

NINJA This is a fast martial arts game that lets you pit your skill against a neverending supply of well trained adversaries. Use function keys to move your "Ninja". Colour Graphics Card, EGA or compatible display required.

DDUP Use DDUP to eliminate the needless duplication of files that invariably plague most hard drives. DDUP will find and let you delete duplicates of files you never new you had!

DIRLABEL is a simple utility that saves you from having to hand-write disk labels. Feed standard 1 x 3-1/2 inch labels through your printer and start *DIRLABELING* your floppies.

MADNESS If you thought you were going crazy, you haven't played Madness. MADNESS is an adventure game for the mind. Enter a land of shadows and mirrors, a land where reality is little more than a hazy concept. Enter the land of MADNESS and try to find your sanity.

PM is a handy co-resident phone message utility. PM makes it easy to answer the phone while you are fine tuning a spreadsheet or composing a letter. Just pop PM onto your screen and enter the particulars of each call. PM inserts the correct date and time and appends each message to an ASCII text file. This message file can later be printed at the operator's convenience.

RUSHHR is one of the strangest games ever created. Play traffic computer by juggling the timing of a series of traffic lights in a busy downtown core. You control the number of cars that are able to get through each light. Learn what it takes to create an efficient system and see what happens when traffic jams occur. Traffic will never be the same!

SPEED performs a detailed system speed test - similar to the "SI" test provided on the Norton Utilities, only better. SPEED provides a wealth of statistics for many register and memory operations such as arithmetic calculations and block memory reads and writes.

FREECCELL is an unusual solitaire game — you can see all of the cards from the beginning of the game. Great graphics!

HDSENTRY is a resident utility that intercepts destructive calls to hard drives. Run HDSENTRY before trying public domain software of dubious origin. It tries to prevent Trojan software from destroying the data on your hard drive.

INDEXER is a flexible index generator. Create a text file with all keywords required in the index and indexer will generate an index file containing all keywords and page numbers. The user can specify which page is to be treated as page "1" and can also tell the program how to determine page breaks (either with form feed characters or with a fixed number of lines per page.

\$19.95

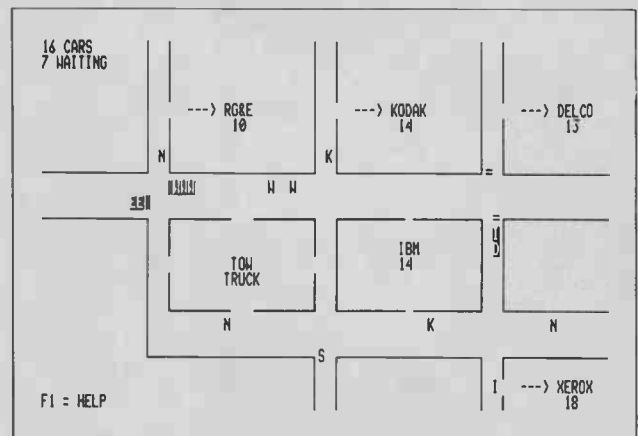
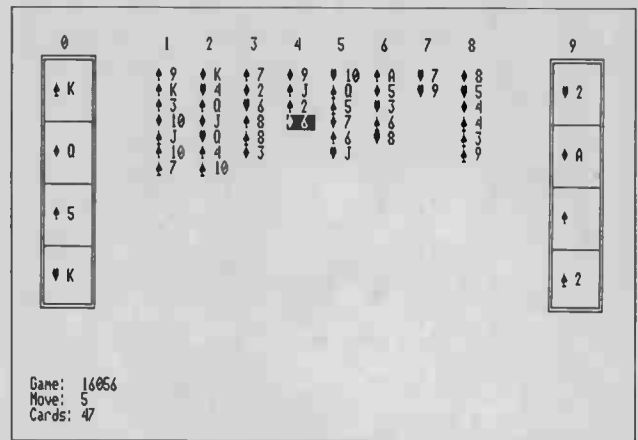

Only \$19.95 each

Ontario residents please add 7% P.S.T.
All orders: add \$1.50 for postage and shipping

Moorshead Publications

1300 Don Mills Road
North York, (Toronto)
Ontario M3B 3M8

or

Phone: (416) 445-5600

Fax: (416) 445-8149

Visa, MasterCard, American Express orders welcome

The programs contained on this disk have been downloaded by modem from a variety of sources in both Canada and the USA. All programs are believed to be in the public domain. Some programs contain messages from the author requesting the user pay a registration fee. Payment of such fees is entirely optional, however users may be entitled to telephone support, free software upgrades and printed manuals if they register. If you decide to register for any of the software contained on this disk, please contact the author of the program before registering. For a complete description of other Almost Free PC Software and SuperDisks, check the latest edition of Moorshead Publications Software Catalogue. If you don't have it, you can get it by writing or calling us. Naturally, its free!

IF YOU WANT TO LEARN PC SERVICING, YOU MUST GET INTO A MICROCOMPUTER!

MOST POWERFUL
COMPUTER OFFERED
IN HOME STUDY
COURSES!

Learn PC Servicing By Building Your Own (PC-XT Turbo) Desk-Top Computer!

NTS "Home-Study" training gets you right down into the heart of computer circuitry. Learn how microprocessors function, how they operate and are used to solve problems. Your programme includes a wide variety of tests and projects you perform as you build your own PC-XT-Turbo, circuit board by circuit board unit by unit.

Hands-On Training With Your (100% IBM Compatible) PC-XT Turbo Puts You At The Leading Edge of Technology!

This remarkable desk-top Micro-computer is the most powerful and versatile ever offered in any home study course and it's yours to keep.

- IBM is a Registered Trademark of IBM Corporation.
- All Diploma Programmes 100% tax deductible.
- Monthly payment Plan available.

PHONE FOR FREE
COLOUR CATALOGUE
842-8383



Advanced features of this PC-XT Turbo include:

- 16 Bit 8088 microprocessor for IBM compatibility
- 640K Ram for high speed performance
- 8 expansion slots
- 135 watt power supply
- Dual 360K double density floppy disk drives
- Colour graphics/printer adapter card
- Operating system included: MS-DOS with GW Basic
- 4.77 MHz - 8MHz "Turbo".

NTS
TRAINING THE WORLD FOR THE 21ST CENTURY

National Technical Schools
517 Bohemia Cres, Oakville, Ontario
L6J 2K7 (416) 842-8383

Toshiba T5100 Review

A powerful but compact 386 computer enters the laptop market.

By Bill Markwick

Intel's 80386 32-bit CPU has caused quite an upheaval in the computer market. Using the new OS2 operating system, and downwardly compatible with MS-DOS, it has everybody who's tried a 386 wishing they could upgrade the old PC, XT or AT (or compatibles). Besides enormous memory capability and flexibility, its speed is enough for all but the most power-hungry.

The Toshiba line of laptop computers now includes an 80386 computer, the T5100, housed in a 12" by 14" (30.5 by 35.5cm) gray case. In the lid is a 640 by 400 pixel plasma display, 7.5" by 6", that lights up in bright orange. The keyboard has a full-size, 82-key unit with the ten function keys across the top; all the functions of the 101-key AT style keyboard are available with a special shift key. To further reduce the width, the separate numeric pad isn't there; the numeric functions take over a section of the regular alphabetic keys when the Num Lock key is pressed.

On the right side is a 3.5" microfloppy drive, on both sides miniscule, quiet fans; on the inside is a 40 megabyte hard drive with a 29ms access time.

The first impression of the T5100 is one of solidity and precise construction. The weight, at 15 pounds, is a tad hefty; not bad for short trips, but quite a pull on the arm if you have to lug it around an airport. The next surprise is that there is no battery, only an AC line cord and power supply that automati-

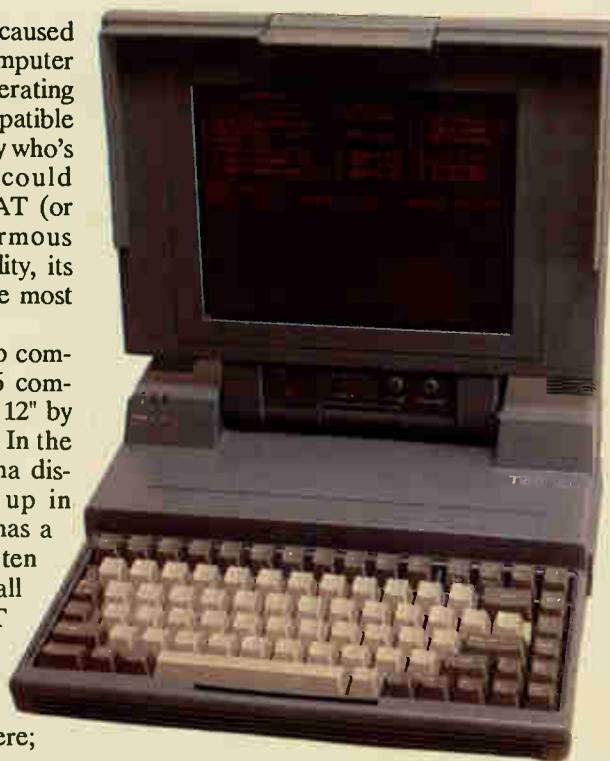

cally sets itself to the voltage of whatever country you happen to be in. With a power consumption of about 70 watts, I suppose batteries wouldn't go very far, perhaps half an hour, and this may be the reason that Toshiba went with mains-only. Besides, airlines frown on the use of electronic equipment on aircraft in case it interferes with something and you end up in Hamilton instead of Paris.

The T5100 has an elegant fabric carrying case, with a pocket for the manuals and line cord. The computer itself has no carrying handle on the front

where you'd expect it, though one does pull out from the rear and tilt down as a stand. This also uncovers the auxiliary connectors.

A Quick Tour

Switching on the power almost instantly brings up crisp orange lettering on a black background to inform you that the computer is under the control of MS-DOS version 3.2, though it's PS-2 ready. This screen is driven by a video card that emulates the IBM Enhanced Graphics Adapter (and also the CGA), and provides four shades of gray; a utility called XCHAD is included to adapt various colors to this gray scale for best contrast, something you'll appreciate if you've ever tried to read white-on-light-blue on a monochrome monitor.

There are controls for brightness and contrast. They seem to work best at maximum when you're in a bright office, though you might want to turn the brightness down in a dimly lit room. Glare is not really a problem because you can tilt the display to suit lighting conditions. On the case beside the lid hinge are the power indicator and disk drive lights, which, oddly, are labelled L and R.

On the rear panel, under the carrying handle/tilt bail lives a 9-pin D-connector serial port, a 25-pin parallel port which can be switched to accept a 5.25" external floppy drive, a 9-pin RGB monitor output connector and an expansion port which is designed for Toshiba products such as a modem, a memory card with another 2MB, or the

5-slot expansion unit which allows you to use IBM-compatible cards externally. A DIP switch allows you to configure a number of parameters such as Extended Memory on/off, 512K/640K and so on.

On the left is the parallel port/disk port switch and a DIN connector in case you want to use an external keyboard.

Tryout

Toshiba didn't send us any software except for DOS and a demo program with remarkably good animation; if you're used to the slow build of PC or even AT animation, the T5100 version will make you think you're watching a movie.

We loaded WordStar version 3, WordStar version 4, and AutoCAD (AutoCAD on a laptop!). Immediately we discovered that WordStar 3 doesn't like the EGA mode; although it runs properly, it won't exit without making a mess of the screen. This is not a fault of the Toshiba, but of WordStar 3 (this has been fixed in version 4). A quick cure for fans of good old Whiz-Com who lust after a laptop is to put WS in a batch file and follow it with MODE CO80. This will restore sanity whenever you exit (MODE.COM is from the DOS utility disk).

WordStar version 4 was much more interesting in terms of the hi-res EGA. It's possible to use WSCHANGE to

patch WS for 43 lines (of 80 columns) instead of 25. This lets you see almost all of a full page of text. The T5100 screen was more than up to the task of displaying the much smaller lettering.

AutoCAD loaded much faster than my Best Mark IV, which has an excellent hard drive, an 8MHz 8086 and an 8087 math coprocessor (load time was 5 seconds to the main menu versus 25 for the 8086). After I loaded in the ubiquitous Columbia shuttle, regeneration times were 10 seconds for the T5100 and 11 seconds for the Best. With a much more complex drawing with lots of text, the 8087 edged out the T5100 58 seconds to 62. In other words, the T5100 without a math chip is as fast at AutoCAD as a Turbo 8086 with a math chip. I've used a 386 with a math chip, and AutoCAD regenerates so fast that at first you think something's gone wrong.

The plasma display was really impressive with AutoCAD despite the fact that it's smaller than my hi-res monitor's 8 by 10" screen. In fact, the screen pixels are so precise, I soon came to prefer it. And, of course, who could argue with almost instant operation?

Other Features

Should you discover some software which doesn't like the 16MHz clock speed, you can use a software switch to set the clock to 8MHz. This is done by pressing the special Fn key and the

PgDn key. This FN can also be used to change the character display to a double row of dots, or to change the output to the external RGB socket. It also changes the number of pixels in a row from 350 to 400, and will also simulate keys not present on the keyboard, such as right CTRL and right ALT.

The TEST3 program supplied with the DOS utilities is one of the most comprehensive and easiest to use diagnostic/setup programs I've used. You can easily configure the memory for either the Lotus-Intel-Microsoft standard or for expanded memory, set the display gray scale brightness, select the video type, and much more, all done from a full-screen menu. There are all the usual diagnostic routines for the screen, memory, drives, and printer.

For optional equipment, you have a choice of a 5.25" external floppy drive, an expansion interface, a modem, two more megs of RAM, a Floppy Link for connecting to the drive of an existing computer and more.

As to complaints, I can only nit-pick. I'd really like a handle on the front, and the lid release is too easy to trip.

You would expect a computer of this complexity and small size to cost, and it does. The suggested list price at the moment is \$11,499. The price of the math chip option depends on the going price for the Intel 80387; at the moment it'll add about \$1400 to the total. ■

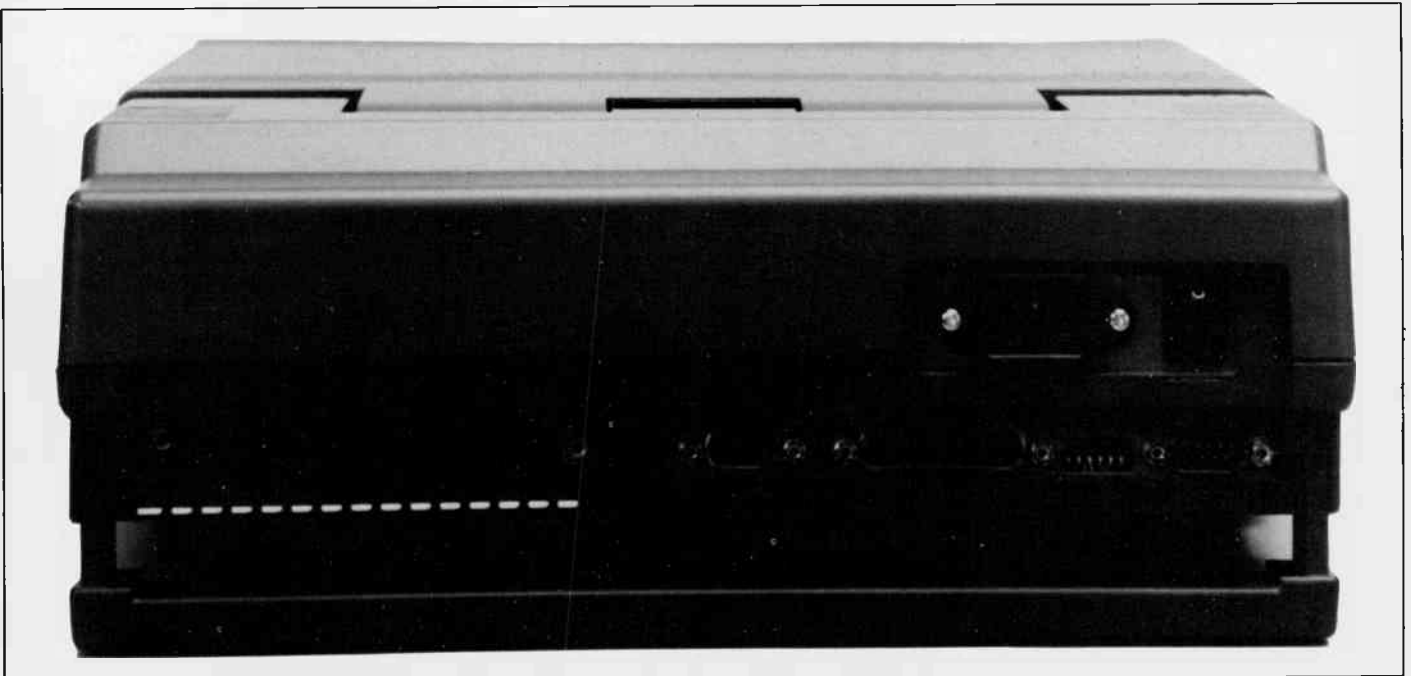

The T5100 handle/stand pulls down to reveal a serial port, a printer/disk port, an RGB monitor connector, and an expansion port.

K.E.M.

Stand alone TTL-IC tester

- Useful test-equipment for Lab and workshop.
- Can test 135 kind 74xx series (LS, S, ALS, HC) TTL-IC in a 0.5 sec.
- Z80 one board computer with all software in 32K EP-Rom.
- Complete Kit (without case) \$245.00

Voice (speech) recognition 5CH (Max. 20CH) Control SW Kit

- Can control 5 relays on/off with your voice
- State-of-the-art special 60 pin LSI control
- With additional circuit can extend more 15CH.
- Complete Kit with 5 Relays \$149.00

Digital Capacitance Meter Kit

- 3 digit large size LED display 6V/9V battery operation.
- Wide range 10pF to 999uF, Accuracy 2%
- Complete Kit (without case) \$ 39.00

Max 500MHz, 8-digit Frequency Counter Kit

- 10Hz to 500MHz, 6 combination measurements
- Up to 10MHz 30mV, 10MHz to 500MHz 100mV, Accuracy 0.005%
- Complete Kit (without case) \$145.00

Frequency Counter Adapter for your multi-meter

- Change your multi-meter into handy frequency counter.
- 5Hz to 200KHz, with optional pre-scaler. Max. 200 MHz.
- Accuracy 1%, sensitivity 100mV
- Comes with X'tal Calibrator Unit
- Complete Kit (without case) \$ 45.00

200MHz Universal Pre-Scaler Kit

- 200MHz 80mV, 1/100, 1/1000 divider
- Complete Kit (without case) \$ 29.00

600MHz Universal Pre-Scaler Kit

- 10Hz - 600MHz - 50mV, 1/100 divider
- Complete kit with metal case \$ 78.00

12CH (Max 32CH) Remote-Control Switch Kit

- Special function 1-chip CPU control
- A-type. Infrared Tx, Rx. Max. distance 40 feet.
- B-type. Wireless FM, Tx, Rx. Max. distance 300 feet.
- Complete Kit — A-type \$87.00 B-Type \$145.00

Stepping motor driver kit comes with mini motor

- Good for drive small motor. Max. 12V 1.2A, 3000pps.
- Manual or computer control are selectable.
- Special price \$ 68.00

High Speed EP-Rom erasing Lamp Kit.

- High intensity type. Erase 20pcs Rom in 5 to 10 minutes.
- Also, P.C. Board exposing UV Lamp sold by K.E.M.
- 1 set with timer \$ 41.98

AD-PCM method solid state tapeless recorder.

- Recording time 16 sec (can expand 32 sec) with 256K x 2 D-Ram controlled by new technological 60 pin LSI
- 500mW audio Amp and MIC Amp built-in.
- Assembled & tested \$ 75.00

AD-PCM S-Ram (or EP-Rom) Tapeless Recorder

- High quality sound (much better than telephone line) and low noise.
- Good for industrial applications i.e. emergency and hazard announcement.
- Please call for price and spec.

Only K.E.M. original almighty SUPER EP-ROM TOASTER can support 1 Mega bits EP-Rom programmer, 1-chip CPU programmer & EP-Rom emulator adapter units.

Features:

- Program 2716 to 27512 including CMOS and A versions in super high speed.
- Can Program 32 pin type/One Megabit EP-Rom with optional adapter unit KEM-904.
- Can Program 1-chip CPU with optional adapter units KEM-903A (8741/48/49) or KEM-903B, KEM 903B (8751, 87051).
- Also with an optional EP-Rom unit KEM-902 this programmer becomes a powerful development tool.



Super EP-Rom Toaster
KEM-901SP for IBM \$195.00
KEM-901 for Apple \$195.00

1 Mega bits EP-Rom
Programmer adapter unit
KEM-904 \$145

1-chip CPU Programmer Unit
KEM-903A \$145

KEM-903B \$195.00

EP-Rom Emulator adapter unit
KEM-902 (Max.256K) \$130

Intel HEX or Motorola, format - Binary format convert software.
(to Program from C-compiler, Assembler etc. into EP-Rom) \$ 50

\$6.00 for shipping. Plus PST for B.C. residents. Plus C.O.D. fee, if required. Sorry we have no facility for credit cards and do not accept invoice orders.

K.E.M. Electronics Ltd.

Mail to Box 69126 Station(K), Vancouver, B.C. V5K 4W4
Office 879E. Hastings Vancouver (604) 251-1514

DO DREAMS COME TRUE?

SALES MANAGEMENT TRAINEES AND SALES REPS

Dreams can come true if you "Get Active"

Our remuneration and benefits package is well above average. Our Managers and Sales Representatives have unlimited earnings potential! If you dream of the "good life", we can help you realize that goal.

Due to our accelerated expansion program, we have immediate openings for qualified candidates to be trained to manage our branches. Our comprehensive training program will teach you all that is necessary to run them.

The entrepreneurial spirit lives on at Active Electronics. Active is one of the fastest growing electronic retailer/MRO distributors in North America. We plan on opening new branches from coast to coast, and need management trainees and sales reps to help us grow. This is a once in a lifetime opportunity that will appeal to the person who would like the next best thing to running one's own business!

If you are an above average person, with a great deal of ambition and drive, prior experience in sales, telemarketing, we would like to hear from you!

Forward your resume to:

Hank Boyer, General Manager
Active Electronics
237 Hymus Boulevard
Pointe Claire, PQ H9R 5C7

Active

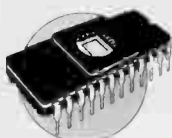

Next Month: COMPUTING NOW! DIRECTORY of IBM AND MACINTOSH PRODUCTS

Finding just the right software or peripherals for your computer is not an easy matter. Next month, however, it's going to become a little bit easier, with the publication of our third annual directory of computer products... the *only* Canadian publication of its kind!

This year... with weird new accessories popping up almost minute by minute... we've narrowed our focus. We'll be looking at all the latest goodies for the top two micromputer systems... the IBM and its many compatibles, and Apple's increasingly popular Macintosh.

It'll be a thick book... months in the making... with a cast of thousands... thousands of neat things you can do for your micro. Don't miss it.

For Group Rates or Subscriptions, call:
(416)445-5600 voice
(416)445-8149 FAX
(Advertising information: David Stone.)



Coverage will include: word processors, desktop publishing, data managers, spreadsheets, project managers, graphics, communications, utilities, languages, games, display adapters, memory expansions, I/O interfaces, monitors, printers, modems, mice, disk drives... and more!

Is your Computer Lonely? Get CB-CHAT Computer Conferencing!

EntreNet Systems opens your window on the world with our computer conferencing services for the home and business.

Have 'Keyboard Conversations' World-wide.

Now you can have 'real-time' conferences with folks around the world on CB-CHAT.

- It's a lot like CB-Radio, except that whatever you type is sent across the world to somebody else's screen.
- Have multi-way conferences or private conversations
- It's anonymous, it's fun!

Trade Ideas and Software via our Bulletin Boards and Forums

- Meet people via the Personals board.
- Exchange jokes, debate politics, discuss small business, stocks, travel, wines, entertainment.

- Join one of our public 'Forums' on Atari, IBM, Commodore, Apple, and Tandy computers. Trade public domain software, ask questions, get information.

- Businesses and organizations can create their own private or public international forums.

Other Services

- Play our increasing selection of multi-user games!
- Communicate across the miles with our variety of electronic mail services.
- We also can provide customized mail/database services for your organization.

World-wide access via the iNet systems

- CB-CHAT is exclusively available via iNet in America and Telecom Canada's iNet 2000 information management services. Here's why you should get iNet:

- CB-CHAT is just one of the many databases, computer and electronic mail services you can access via the iNet systems, such as Dialog, Infoglobe, Marketfax, Compuserve, The Source, etc.

- You can make a local phone call from any city or rural area in North America to access an iNet services via networks such as TeleNet, Datapac, etc. iNet and iNet 2000 are accessible via international networks at greater cost.

- We will arrange iNet accounts for you, your friends and associates, exempt from the normal \$100 US\$ to \$50 CDN\$ normally applied to iNet subscription.

To sign up:

Send your name and complete address to us or phone us at EntreNet Systems. We'll send you an official iNet application form and get you started!

EntreNet Systems

775 Ridgewood Ave.,
Ottawa, ON. K1V 6M8 Canada
613-737-7327 (voice)



EntreNet
Systems

Introducing Microprocessors Part 3

The process of fetching, decoding and executing the sequence of instructions which constitutes a program.

By Mike Tooley

Learning Objectives

The general learning objectives for Part 3 are that readers should be able to:

(a) Understand and use a subset of the instruction set of any common 8-bit microprocessor.

(b) Describe, using appropriate diagrams, the microprocessor instruction fetch/execute cycle.

(c) Understand the facilities provided by a monitor program.

The specific objectives for this part are as follows:

2.2 Instruction Sets

2.2.1 Explain what is meant by the terms instruction and instruction set.

2.2.2 Explain the form in which instructions are stored and presented to the microprocessor for execution.

2.2.3 Categorize instructions in the following groups:

data transfer
arithmetic and logical
test, branch and control

2.2.4 Examine the following modes of addressing:

implied
immediate
absolute.

2.2.5 Examine a subset of the instruction set of any common 8-bit microprocessor and identify the types of instruction for data movement (transfer), control, and arithmetic.

2.3 Fetch-Execute Cycle

2.3.1 Explain each stage of the fetch-execute cycle.

2.3.2 Explain the function of the Program Counter, Instruction Register and Instruction Decoder during the fetch-execute cycle.

2.3.3 Draw a timing diagram showing the state of the read, write (or read/write), and bus lines at each stage of the fetch-execute cycle for a representative 8-bit microprocessor.

2.3.4 Draw a timing diagram to show the movement of data during each stage of the fetch-execute cycle.

2.4 Monitor Programs

2.4.1 Use a monitor program.

Instruction and Instruction Sets

The individual commands contained within a microprocessor program are called instructions. Clearly, if a microprocessor is to be capable of performing a variety of operations, a range of different instructions must be available. Some of these will be concerned with moving data from place to place and are aptly known as "data-transfer" instructions. Others are used to perform "arithmetic and logic" functions. A third type of instruction is needed to control the overall flow of the program. Such instructions form part of the "test, branch and control" group.

The microprocessor keeps track of its progress through a series of instruc-

tions by regularly updating its Instruction Pointer (or Program Counter). This sixteen bit register effectively points to the address of the next instruction to be fetched in the sequence of execution.

A simple IMP program (expressed in hexadecimal format) might take the form:

```
3E
01 First instruction (two bytes)
06
02 Second instruction (two bytes)
02
80 Third instruction (one byte)
```

The five byte program contains three instructions. The first two take up two bytes each whilst the last instruction only requires a single byte. The hexadecimal representation is compact but not very explicit and readers might be forgiven for wondering what the program actually does. Furthermore, writing anything other than the shortest of programs in hexadecimal format is clearly going to be a rather tedious process.

In practice we make use of a mnemonic shorthand for writing our instructions rather than resorting to hexadecimal code. However, even programming in hexadecimal is one step removed from the binary codes that the microprocessor actually requires (readers may be unaware that the first generation of computer programmers actually wrote their code

in binary!).

As far as the microprocessor is concerned, each instruction comprises an individual binary code (the operation code) which may be followed by one or more further bytes (which constitute and operand). The operand qualifies the instruction in some way and typically may be used to form an address at which data is to be stored or from which data is to be fetched. Clearly, if we are dealing with an operand which it used to denote a 16-bit address, it will require two bytes. IMP knows how many bytes to take as an operand since it is implicit in the operation code which it will have previously decoded.

Assembly language

We have already stated that IMP responds to instructions presented in binary form and that a form of shorthand is used to simplify the task of writing a program. This shorthand is known as "assembly language" and it provides us with a means of expressing our programs in terms of a set of mnemonics.

Assembly language is a low-level language which is (relatively) easy for humans to learn and remember and which can quite easily be translated into the binary code required by a microprocessor. The function of translating mnemonic assembly code into binary code is performed by a utility program known as an "assembler". Some assemblers produce intermediate programs in hexadecimal format which are then translated into binary code for final loading into program memory.

Unfortunately, each microprocessor family has its own dialect of assembly language. This makes it difficult (if not impossible) to transfer programs written in assembly language from one microprocessor to another. High level languages, such as BASIC or PASCAL, are much more "portable" since, with a few changes, they can usually be modified to run on a wide variety of machines.

Happily, IMP's assembly language is reasonably conventional. The following instructions (and their hexadecimal equivalents) constitute a small subset of IMP's instruction set. For convenience we have divided these instructions into the three major groups associated with "data transfer", "arithmetic and logic", and "test, branch, and control"

Notes

(a) Mnemonics are used as follows:

LD = Load
 ADD = ADD
 SUB = SUBtract
 INC = INCrement
 DEC = DECrement
 JP = JumP
 Z = Zero
 NZ = Non-Zero

(b) n and xx represents an immediate data byte (values ranging from 00H to FFH)

(c) nn represents a two byte address (values ranging from 0000H to FFFFH)

(d) ll represents the low byte of an address (values ranging from 00H to FFH)

Readers should note that the general format used for IMP's data transfer instructions involves a destination followed by a source and that these are separated by a comma. As an example, the instruction LD A, B specifies A as the destination and B as the source. It is also important to note that the load instructions do NOT involve the destruction of the source byte; data is effectively copied from source to destination where it replaces whatever was there before the instruc-

Function	Instruction	
	Mnemonic form	Hexadecimal form
Data transfer		
Immediate data to accumulator	LD A,n	3E xx
Immediate data to B register	LD B,n	06 xx
Memory to accumulator	LD A,(nn)	3A ll hh
Accumulator to memory	LD (nn),A	32 ll hh
Accumulator to register B	LD B,A	47
Register B to accumulator	LD A,B	78
Immediate data to HL register pair	LD HL,nn	21
Memory (pointed to by HL register) to accumulator	LD A,(HL)	7E
Accumulator to memory (pointed by HL register)	LD (HL),A	77
Arithmetic and logic		
Add register A to register B	ADD B	80
Subtract register B from register A	SUB B	90
Increment register A	INC A	3C
Increment register B	INC B	04
Increment register HL	INC HL	23
Decrement register A	DEC A	3D
Decrement register B	DEC B	05
Decrement register HL	DEC HL	2B
Test, branch and control		
Jump unconditionally to specified IP address	JP nn	C3 ll hh
Jump to specified IP address if zero flag is set	JP Z,nn	CA ll hh
Jump to specified IP address if zero flag is reset	JP NZ,nn	C2 ll hh

Introducing Microprocessors, Part 3

tion was executed.

Finally, the meaning of the brackets shown in instructions such as LD A, (HL) are taken to mean "address pointed to by" or "memory location given by". Thus LD, A, (HL) means "load the accumulator with the data found at the address pointed to by the HL register pair". This may sound a little wordy but, in order to avoid confusion, it is important to be quite precise.

Addressing modes

The different ways of locating the data to be used by a microprocessor instruction are referred to as "addressing modes". Three commonly used addressing modes are known as "implied", "immediate", and "absolute".

In the "implied" addressing mode another register pair is used to hold the address of the location being accessed. In IMP's case, the instruction LD A, (HL) is an example of this mode. In the "immediate" mode of addressing the data to be used is contained within the instruction itself (i.e. the data in question immediately follows the operation code). The instruction LD A, n is an example drawn from IMP's set. In the "absolute" mode of addressing, the address at which the data is located forms part of the instruction. This mode is exemplified by IMP's LD A, (nn) instruction.

A number of other (more complex) addressing modes exist. These, however, are not really appropriate to an introductory level module and will be left for readers to explore in the event that they continue with studies at a higher level. For the moment, it is merely necessary for readers to be able to recognize and distinguish between the three modes previously mentioned. The following table summarizes these modes of addressing and includes examples from IMP's instruction set:

Problem 3.1

(a) IMP - encounters the hexadecimal values 3E and 00 which appear as successive bytes in a program instruction. What action do they produce?

(b) IMP is performing the assembly

language instruction SUB B. If the A register contains the 14H before the instruction was performed and 0AH after the instruction is executed, determine the contents of register B.

(c) A single-byte IMP instruction expressed in binary (MSB first) takes the form 00101011. What action does the instruction perform?

(d) It is necessary to load the HL register pair with 3C02H. What IMP

events each of which is known as a "fetch-execute" cycle. The fetch-execute cycle involves the following stages:

(a) Fetching the instruction from memory and placing it in the microprocessor's Instruction Register.

(b) Decoding the instruction (using the Instruction Decoder) and determining what subsequent action is required.

(c) If necessary, fetching more data.

(d) Executing the instruction.

This process is illustrated by the flowchart shown in Fig. 3.1.

Addressing mode	Data located . . .	Example
Implied	. . . at an address pointed to by other CPU registers	LD A, (HL)
Absolute	. . . at an address specified in the instruction	LD A, (nn)
Immediate	. . . in the instruction itself	LD A, n

language instruction is required?

(e) What hexadecimal code is used to represent the instruction in (d)?

(f) What addressing mode is used in the instruction LD A, FFH?

(g) To which group or class of instructions does the instruction LD A, (HL) belong?

The Fetch-Execute Cycle

The operation of a microprocessor is based upon a continuous sequence of

Timing diagrams

Timing diagrams show the relationship between control signals and the data and addresses which appears on the microprocessor buses. Fig. 3.2 shows a typical timing diagram which illustrates the sequences of events when IMP performs the instruction LD A, 3F. This fetch-execute sequence occupies just two complete machine cycles. During the first machine cycle, IMP fetches the operation code and decodes it. On the second machine cycle, IMP fetches the data byte (3FH) and copies it into the accumulator.

Read and write operations

When performing memory read or write operations IMP performs different tasks on the first and second half-cycle of the clock. During the first half cycle of the clock signal (i.e. when the clock line is high) IMP places a valid memory address on the address bus and selects either a read or write operation by taking the R/W line high or low respectively. Data exchanges then take place during the second half of the clock cycle (i.e. when the clock line goes low), the direction of data movement (i.e. to or from IMP) being determined by the previously set condition on the R/W line.

A read cycle (Fig. 3.3) can be used to transfer a byte of data from an address in ROM, RAM, or I/O to one of the IMP's internal registers. A write cycle (Fig. 3.3b), on the other hand, is used to transfer a byte of data from one of the IMP's internal registers to either

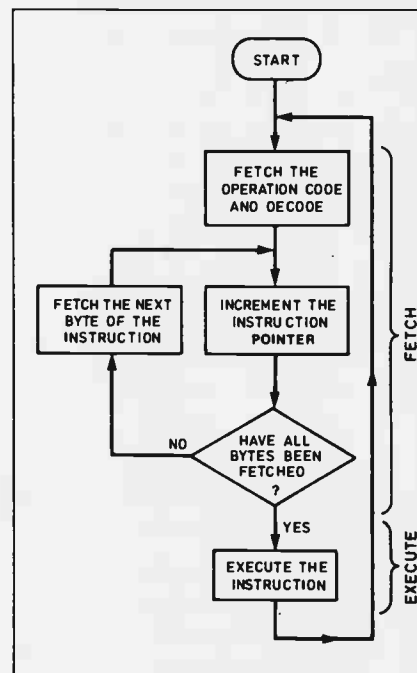

Fig. 3.1. Flowchart for the fetch-execute cycle.

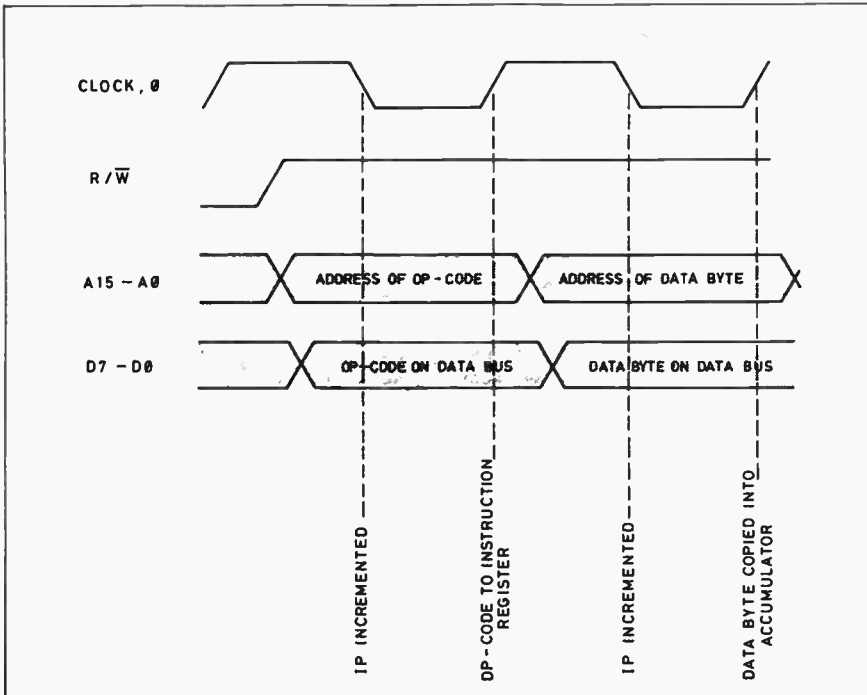

Fig. 3.2. Simplified timing diagram for a fetch-execute cycle.

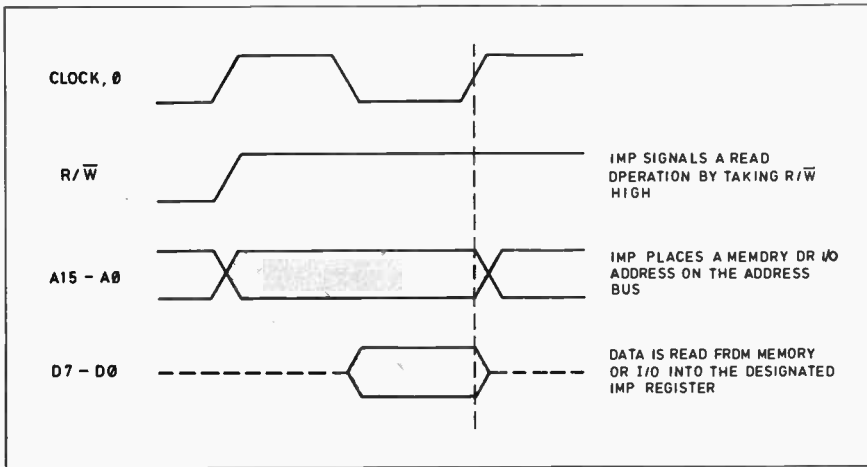

Fig. 3.3a. Simplified timing diagram for a read cycle.

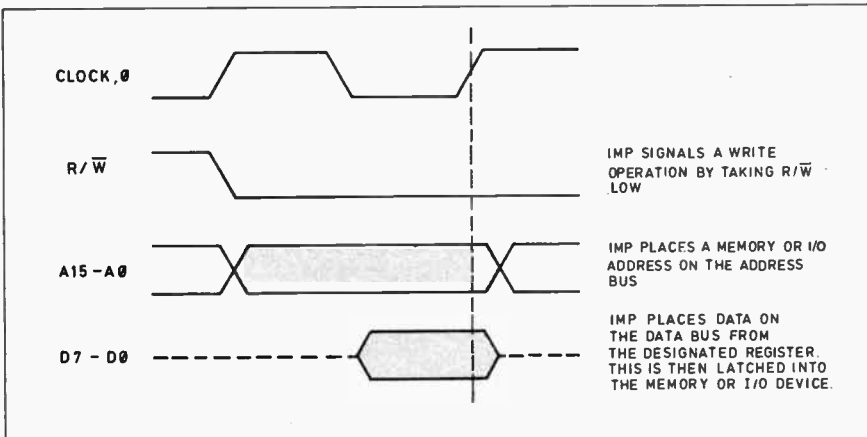

Fig. 3.3b. Simplified timing diagram for a write cycle.

RAM or I/O. Note that, whilst it is possible to undertake a write operation to an address in ROM there is little point in doing so as this would, by definition, have no effect on the contents of the address location in question.

Example 1

Now, let's consider a simple example. Suppose that we wish to add together two bytes of data stored in RAM as part of IMP's program. This task will involve three instructions. The first will load the first operand (in this case a byte of immediate data) into the accumulator (A). The second will load the second byte of data into the B register. Finally, the third instruction will add the contents of the A and B registers and deposit the result back into the accumulator.

We shall assume that the program starts at a hexadecimal address of 1000. Written in assembly language mnemonics, the program looks like this:

```
LD A, 01
LD B, 02
ADD A, B
```

The hexadecimal representation of the program is as follows:

```
3E 01 First instruction
06 02 Second instruction
80 Third instruction
```

Readers will probably have spotted that this program is identical to that which we introduced earlier. Note how each of the two load instructions is followed by the respective data to be loaded. Within IMP's memory, the program will thus take the form:

At the start of the program, the Instruction Pointer will be set to 1000H whilst, at the end, it will have reached 1005H. Execution of the program involves the following steps:

1. Fetching and decoding the first instruction (see Fig. 3.4a).

IMP places the contents of its Instruction Pointer (1000H) onto the address bus and takes the R/W line high. The byte returned on the data bus (3EH) is read during the second half of the clock cycle and passed into the instruction register.

2. Executing the first instruction (see Fig. 3.4b).

IMP executes the first instruction which involves copying the next byte (i.e. that which follows the operation code, 3EH) into the accumulator, IMP also updates the Instruction Pointer so

Introducing Microprocessors, Part 3

that it points to the address of the next instruction byte at 1002H.

3. Fetching and decoding the second instruction (see Fig. 3.4c)

IMP places the contents of its Instruction Pointer (1002H) onto the address bus and takes the R/W line high. The byte returned on the data bus (06H) is read during the second half of the clock cycle and passed into the instruction register.

4. Executing the second instruction (see Fig. 3.4d).

IMP executes the second instruction which involves copying the next byte (i.e. that which follows the operation code, 06H) into the B register. IMP also updates the Instruction Pointer so that it points to the address of the next instruction byte at 1004H.

5. Fetching the third instruction (see Fig. 3.4e)

IMP places the contents of its Instruction Pointer (1004H) onto the address bus and takes the R/W line high. The byte returned on the data bus (80H) is read during the second half of the clock cycle and passed into the instruction register.

6. Executing the third instruction (see Fig. 3.4f).

IMP executes the third instruction which involves passing the contents of the A and B registers into the ALU and adding the two bytes together. The result is then passed back into the accumulator (replacing the byte that was originally present). Also note that the byte present in the B register has remained unchanged. IMP also updates the Instruction Pointer so that it points to the address of the next instruction byte at 1005H.

Example 2

Now, as a further example, suppose that we wish to copy a byte of data from an address in ROM (G04EH) to an address in RAM (2AB0H). This task would obviously involve two instructions; a read operation followed by a write operation. We shall again assume that the program again starts at a hexadecimal address of 100H. The program would be written in assembly language as follows:

```
LD A, (C04EH)
```

```
LD (2AB0), A
```

The hexadecimal machine code corresponding to these two instructions is given below:

```
3A 4E C0
```

32 B0 2A

The program thus comprises six bytes. Each operation code byte is followed by a two byte address (in low-byte/high-byte order). Within IMP's memory, the program will thus take the form:

At the start of the program, the Instruction Pointer will be set to 100H whilst, at the end, it will have reached 1006H. The execution of the program involves the following four steps:

1. Fetching and decoding the first instruction (see Fig. 3.5a).

IMP places the contents of its Instruction Pointer onto the address bus and takes the R/W line high. The byte returned on the data bus (3AH) is read during the second half of the clock cycle

and passed into the instruction register.

2. Executing the first instruction (see Fig. 3.5b).

IMP executes the first instruction which involves reading the next two bytes (4EH and C0H) and using them to form an address (C04EH) which is then placed on the address bus. The data present at C04H is then copied into the accumulator during a further read operation. IMP again updates the Instruction Pointer so that it ends up pointing to the address of the next instruction byte at 1003H.

3. Fetching the second instruction (see Fig. 3.5c).

IMP places the contents of its Instruction Pointer (1003H) onto the address bus and takes the R/W line high.

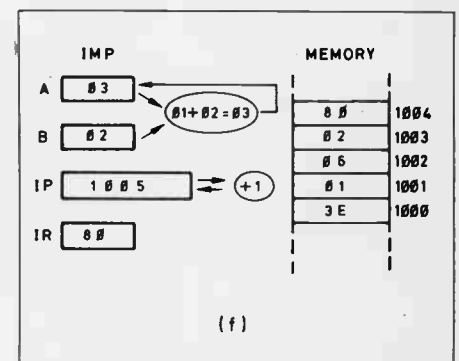
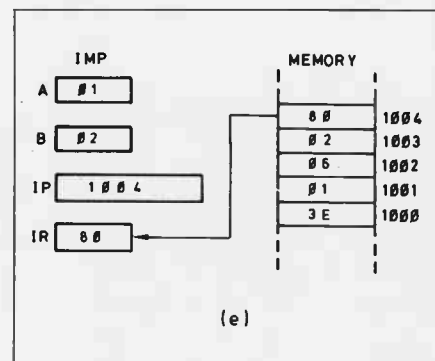
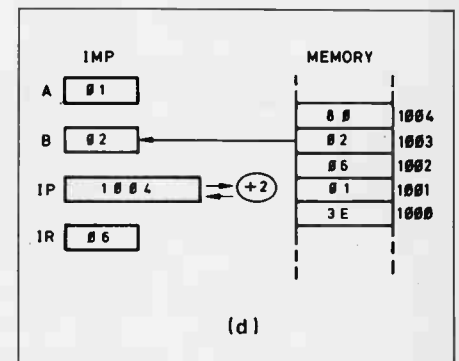
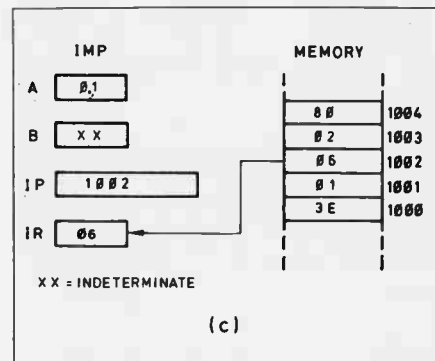
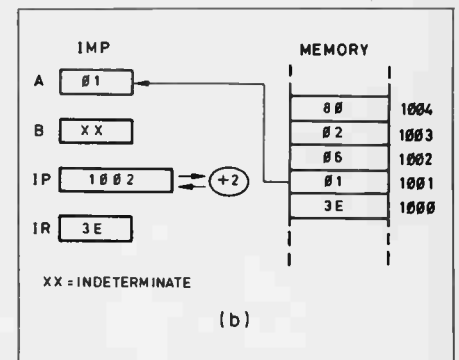
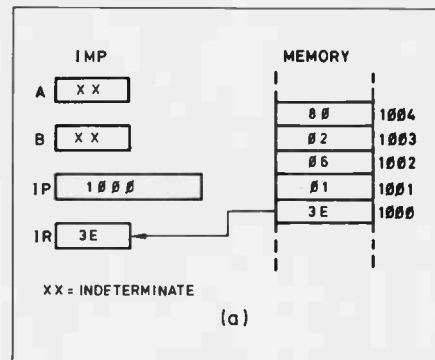

Fig. 3.4. Flow of data between IMP and memory in Example 1.

Address (hex)	Byte (hex)	Function
1000	3A	Operation code for LD A,(nn)
1001	4E	Low byte of address operand
1002	C0	High byte of address operand
1003	32	Operation code for LD (nn),A
1004	B0	Low byte of address operand
1005	2A	High byte of address operand

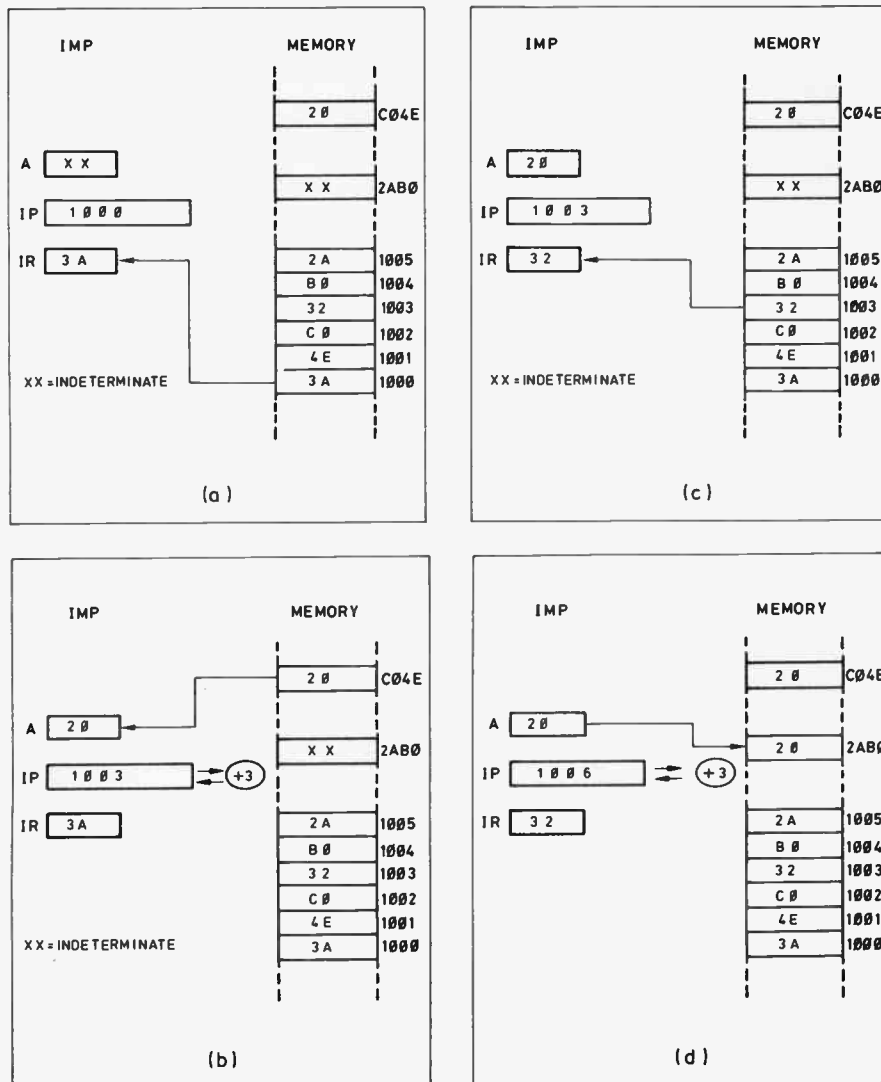

Fig. 3.5. Flow of data between IMP and memory in Example 2.

MACHINE CYCLE	M1	M2	M3	M4
TYPE OF CYCLE	MEMORY READ (OP-CODE FETCH)	MEMORY READ	MEMORY READ	MEMORY WRITE (EXECUTE)
ADDRESS BUS	IP (LOCATION OF OP-CODE BYTE)	IP+1 (LOCATION OF SECOND INSTRUCTION BYTE)	IP+2 (LOCATION OF THIRD INSTRUCTION BYTE)	ADDRESS ASSEMBLED FROM DATA READ DURING M2 & M3
DATA BUS				

Fig. 3.6. Table for Problem 3.2.

The byte returned on the data bus (32H) is read during the second half of the clock cycle and passed into the instruction register.

4. Executing the second instruction (see Fig. 3.5d).

IMP executes the second instruction which involves reading the next two bytes (B0H and 2AH) and using them to form an address (2AB0H) which is then placed on the address bus. The data present in the accumulator is then written to address 2AB0H during a final write operation. IMP also updates its Instruction Pointer so that it ends up pointing to the address of the next instruction byte at 1006H. Readers should now be getting a feel for the way in which IMP operates. In particular, the following should be noted:

(a) instructions may comprise one, two, three (or more) bytes.

(b) instructions comprise an operation code which may be followed by a further byte or bytes which constitutes an operand.

(c) instructions may involve further read and/or write operations, not just fetching (i.e. reading) the instruction itself.

Problem 3.2

Fig. 3.6 shows the sequence of operations which occur during the fetch-execute cycle associated with the instruction LD (2E00), A. Given that the accumulator contains 7FH immediately before the instruction is executed, complete the table showing the byte present on the data bus at each stage of the fetch-execute cycle.

Problem 3.3.

Write simple assembly language programs (using only the given subset of IMP's instruction set) which will:

(a) add 1 to the data stored in memory location 3E00H,

(b) exchange the data bytes present at memory locations 3E00H and 3E01H.

Monitor Programs

Monitor programs provide us with a variety of useful facilities which can not only aid our understanding of the operation of a microprocessor but also allow us to enter, test and debug simple programs. A typical monitor program comprises about 2K of code and provides the user with the means to:

Introducing Microprocessors, Part 3

(a) display the contents of a given block of memory in hexadecimal and ASCII (see note 1) format

(b) modify or edit hexadecimal bytes in memory

(c) display the contents of the CPU registers

(d) modify the contents of the CPU registers

(e) disassemble a given block of memory into assembly language mnemonics

(f) insert breakpoints (see note 2) into a program

(g) execute a program from a given start address until a breakpoint is encountered

(h) trace the execution of a program with a continuous display of the CPU registers and memory contents as each instruction is executed.

Notes:

1. ASCII stands for "American Standard Code for Information Interchange". The ASCII code is commonly used for representing alphanumeric characters (i.e. letters, numbers and punctuation) within a microprocessor system. Each character is represented by a single byte (i.e. 8 bits). Since the standard ASCII code uses seven bits, the leading (i.e. most significant) bit is either ignored or used to distinguish special graphic characters or tokenized keywords.

2. A breakpoint is a code (usually a single byte) inserted into a program during testing or debugging which, when encountered during the course of a program, suspends execution and returns control to the monitor program. This facility allows the user to examine the state of the system when a certain point is reached in the program.

Glossary for Part Three

Address modes

The various methods of specifying an address as part of an instruction.

Assembly program

A program which translates assembly language statements into the binary code machine code which is directly executable by the microprocessor.

Assembly language

Assembly language is a machine-oriented low-level programming language as distinct from human-oriented high-level languages. An assembly lan-

guage program is normally written as a series of statements using mnemonics. It is then translated into machine code by an assembler program.

Decrement

Programming instruction which decreases the contents of a register or storage location.

Execute (cycle)

The last part of the fetch-execute cycle during which the operation specified by the instruction is actually performed.

Fetch (cycle)

The first part of the fetch-execute cycle during which the instruction is fetched from program memory. The first part of the instruction to be fetched is the operation code.

Increment

Programming instruction which increases the contents of a register or storage location.

Instruction cycle

The total group of instructions that can be executed by a given microprocessor. This information provides the programmer with the basic information necessary to produce a working program.

Machine language

Binary coded language (often represented in hexadecimal) that is directly understood by the microprocessor. All other programming languages must be translated into binary code before they can be executed by the microprocessor.

Mnemonic code

Mnemonic codes are a form of shorthand which helps the programmer remember the function of a particular microprocessor instruction.

Operation code (op-code)

The first part of a machine-language instruction which specifies the operation to be performed.

Answers to Problems

3.1 (a) load the accumulator with immediate data of 00H

(b) 0AH

(c) DEC HL

(d) LD HL, 3C02

(e) 21 02 3C

(f) immediate

(g) data transfer

3.2 See Fig. 3.7

3.3 (a) Any of the following would be acceptable:

LD A, (3E00)

LD B, 1

ADD A, B

LD (3E00), A

or LD A, (3E00)

INC A

LD (3E00), A

or LD HL, 3E00

LD A, (HL)

INC A

LD (HL), A

or LD HL, 3E00

LD B, 1

LD A, (HL)

ADD A, B

LD (HL), A

3.4 One possible solution would be:

LD A, (3E00)

LD B, A

LD A, (3E01)

LD (3E00), A

LD A, B

LD (3E01) A

Please Note

We apologise for a couple of errors which unfortunately appeared in Part 1. Under Addition (page 597) the second paragraph set an example and we then added two completely different numbers - please disregard the second paragraph.

Finally, the answer to Problem 1.14(a) should have been 00000101; the MSB was wrong.

MACHINE CYCLE	M1	M2	M3	M4
TYPE OF CYCLE	MEMORY READ (OP-CODE FETCH)	MEMORY READ	MEMORY READ	MEMORY WRITE (EXECUTE)
ADDRESS BUS	1P (LOCATION OF OP-CODE BYTE)	1P+1 (LOCATION OF SECOND INSTRUCTION BYTE)	1P+2 (LOCATION OF THIRD INSTRUCTION BYTE)	ADDRESS ASSEMBLED FROM DATA READ DURING M2 & M3
DATA BUS	32 (OP-CODE)	00 (LOW BYTE OF ADDRESS OPERAND)	2E (HIGH BYTE OF ADDRESS OPERAND)	7F (BYTE FROM ACCUMULATOR)

Fig. 3.7. Answer to Problem 3.2.

Capacitance Meter

*An easy-to-use test meter that will check values from 100p to 1000uF.
Invaluable for checking unmarked capacitors.*

By Andy Flind

A multimeter, which will measure resistance directly on suitable ranges. This is only right, considering that the resistor is the most frequently used component in many circuits. The next most common item is the capacitor however, and by contrast, it is generally quite difficult to check the value of one of these. The generally accepted method is with a capacitance bridge, but few hobbyists seem to possess one. Probably because a good bridge is expensive. Also, a certain amount of experience is often required to operate it. Obviously, a need exists for a simple, inexpensive capacitance measuring instrument.

The Capacitance Meter described here is as simple to use as a voltmeter. The capacitor is placed across the terminals, a suitable range selected, and the value can be read on pressing a button. Should it be out of range the meter will read zero or full scale, indicating the direction of range switching needed.

Despite its simplicity it offers ranges from 100pF to 1000uF, greater than most previous designs. At one extreme it can measure the few picofarads between tracks on stripboard, at the other the actual value of a 470uF electrolytic can be indicated. Despite their enormous tolerance factors these still appear as "timing" capacitors in some projects.

How It Works

Although simple to use, the instrument's operation is moderately complex and requires some explanation. The block diagram for the Capacitance Meter is shown in Fig. 1.

The capacitor being checked, C_x , is connected as the timing element in a simple oscillator circuit built around 7555 timer.

During positive half-cycles of oscillation, capacitor C is charged through resistor R . Whilst the output is negative this capacitor is discharged through the timer's own discharge transistor. The maximum voltage reached across C therefore depends on the length of the charge periods, which in turn depend upon the value of C_x .

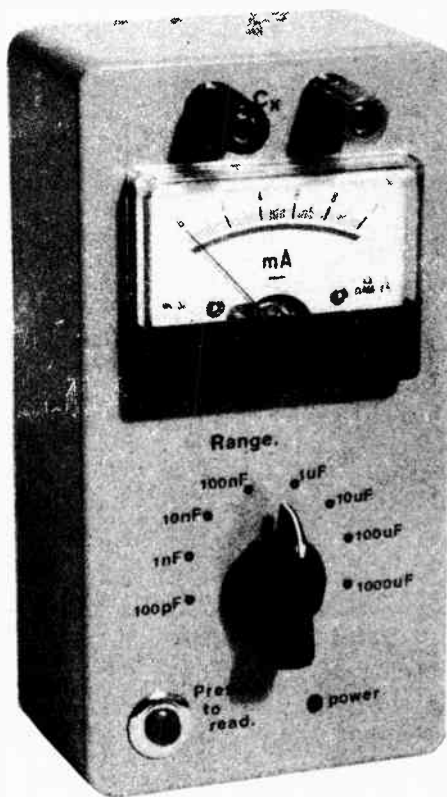

The rate of rise of voltage across C is in fact exponential, but as full scale corresponds to only about a fifth of the supply voltage the voltage reached is practically linear with time. The maximum value is detected, and with suitable values of C and R gives a direct indication of the value of C_x .

Where C_x is above, say, 100uF the frequency of oscillation is low, a few hertz at most. Greater speed would require too much current for the intended battery operation.

A low frequency rules out any form of "averaging" output circuit though, as this would take an unreasonably long time to settle. Instead, a sample-hold technique is used. The peak detector follows the voltage on C as it rises, then remains at the maximum value reached.

A second oscillator drives circuitry that periodically reads and stores the detected voltage before resetting it. The

meter indicates the currently stored voltage. The frequency at which this happens is about 1Hz; the meter can be seen "stepping" and should reach a stable reading within two or three cycles, regardless of the range in use.

Circuit Description

The full circuit diagram for the Capacitance Meter appears in Fig. 2. The oscillator follows the simplest possible arrangement, C_x , the capacitor "under test" being connected between ground and IC1 pins 2 and 6, with a single feedback resistor from the output, the value of which is selected by "Range" switch S1a.

The lowest resistor value required for the 100uF and 1000uF ranges, is 100 ohms. IC1's output cannot provide enough current for this so transistors TR1 to TR4 buffer it. The coupled collectors of TR3, TR4 follow pin 3, but provide greater current.

While positive, they also charge capacitor C1 through the resistor selected by S1b. Whilst they are negative C1 is discharged rapidly through IC1 pin 7, behind which lurks the chip's "discharge" transistor.

If the voltage on C1 exceeds that on capacitor C2, IC2, through TR5, pulls C2 up to match it. Initially there is a discharge path across C2 so it will retain the highest voltage reached.

Sample-holding is implemented through IC3, a CMOS 4016B "quad analogue switch". Switches IC3c and IC3d are connected as an astable oscillator, the frequency being set by capacitor C5 and resistor R21 to about 1Hz.

There are two outputs, appearing across resistors R17 and R22, which go positive alternately. As they do so, they pulse the two remaining switches IC3a and IC3b for brief periods set by R18, C4 and R16, C3. When IC3a is closed, the voltage on capacitor C2 is transferred to capacitor C6; when IC3b closes resistor R15 leaks some charge from C2. Between each "read" and "discharge" pulse there is plenty of time for C2 to

Capacitance Meter

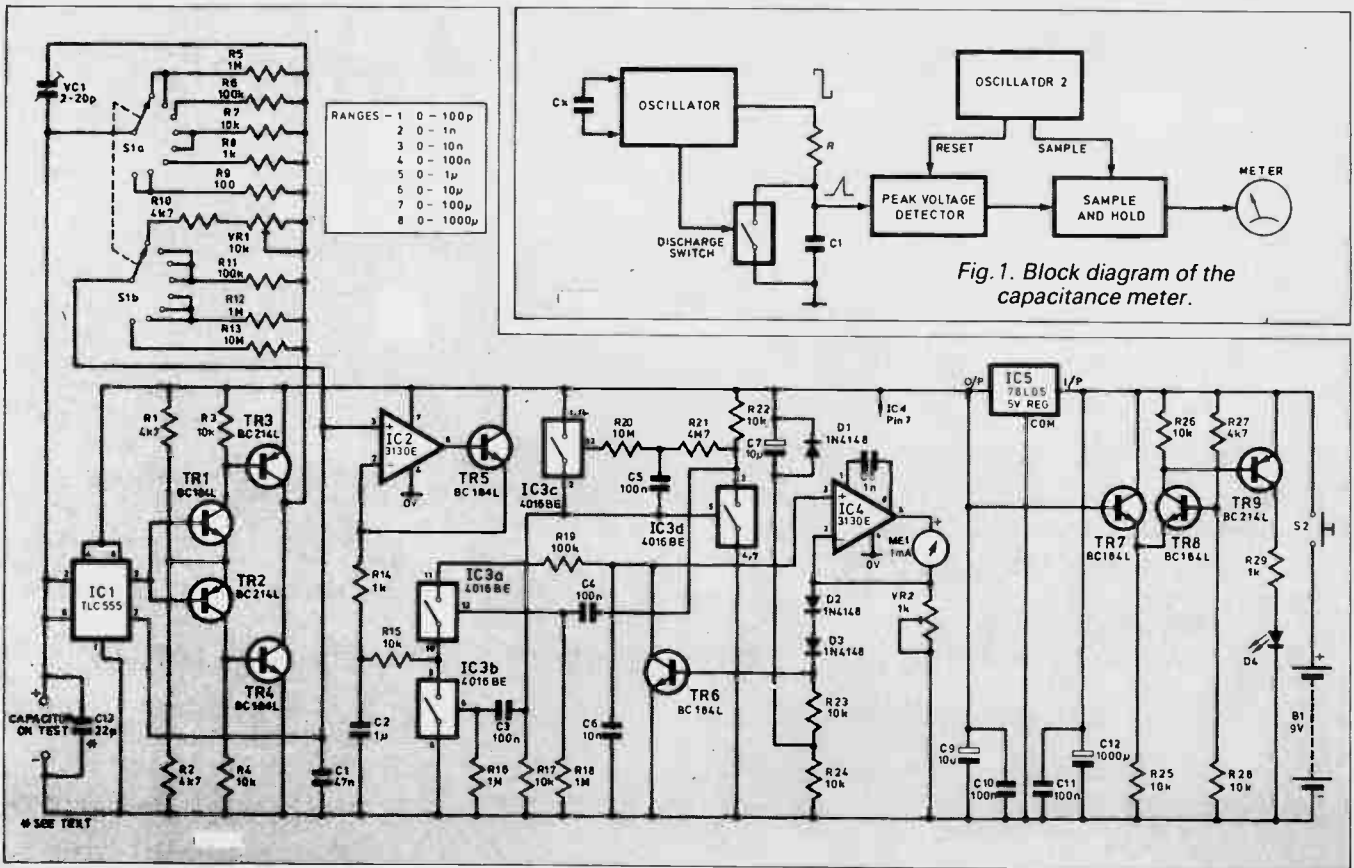

Fig 1. Complete circuit diagram for the Capacitance Meter.

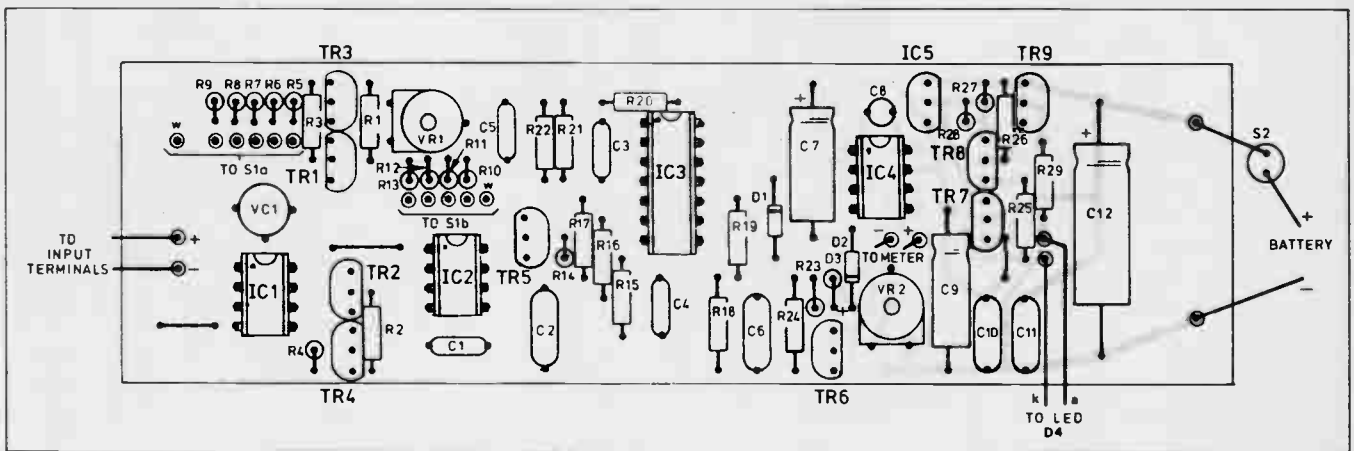

Fig 2. Printed circuit board component layout, interwiring details to case mounted components and full size underside copper foil master pattern.

regain the peak value from C1, at even the slowest operating speed.

A simple voltage-to-current arrangement for displaying the voltage from capacitor C6 on the meter, is made up by the components around IC4. Transistor TR6 is a clamp circuit for limiting the maximum input.

In the course of design it was found that on powering up, the meter drove hard to full scale. The cause seemed to be some form of breakthrough occurring in IC3 as the supply voltage first appeared across this chip. As push-button operation was intended, and the sight of the meter being overdriven each time was disconcerting, a cure was provided by capacitor C7, which operates the clamp briefly as power is applied.

A stable supply voltage is necessary, this being provided by the 5V regulator IC5. Transistors TR7 to TR9 compare the battery voltage against the regulated supply and drive LED D4. So long as the battery is healthy the LED is lit, but it extinguishes sharply at around 7.5V.

Low Values

The difficulty of measuring large capacitors has been mentioned but at the other end, the 0 to 100pF scale presents its own problems. This is likely to be very useful to radio enthusiasts, so it should be as accurate as possible.

During breadboarding, it was found that the meter would not zero on this range due to stray input capacitance, probably including that of IC1. The solution was the use of the variable capacitor VC1, which can be adjusted to neutralize the strays. When the complete instrument was assembled however, the imbalance had swung the other way.

The range-switch wiring was contributing too much neutralizing capacitance on its own. A 22pF polystyrene capacitor was placed directly across the input, which allowed zero adjustment with VC1 as before.

There remains some nonlinearity across this range, about five per cent of scale, which is probably unavoidable in a simple meter of this type. Options for dealing with this will be described in the setting-up procedure.

Construction

Before commencing construction, care should be taken to set that the board is

clean. Parts of this circuit operate at very high impedance where leakage can cause substantial errors, so it's worth giving it a wipe with a solvent cleaner and washing one's hands before assembly to prevent any risk of contamination by skin oils, etc.

All the components including the range selection resistors are assembled on a single printed circuit board. The component layout and full size copper foil master pattern being shown in Fig. 3.

In some places components are quite closely packed, so care and a fine-tipped iron are called for. In general it's best to fit components in order of physical height, as this makes for easier handling and less problems keeping them in place while soldering. "Height order" for this project begins with three links, followed by fifteen horizontally mounted resistors.

Sockets are recommended for IC1 to IC4 as this both protects them and aids testing. These ICs should not be plugged in yet. The two variable resistors VR1 and VR3 were "cermets" on the prototype; these are recommended, but standard subminiature types can be used, the board is designed to accommodate either.

When the board is assembled, some testing can be carried out before fitting in the case and wiring to the range switch. A long lead should be connected to the "meter" points (it can be shortened later) and the light emitting diode D4 fitted on about 8cm of lead.

Ribbon cable is suggested for all connections, for neatness and reliability. Temporary leads can be soldered to the battery points for testing.

If the board is now powered with just the LED connected, this should light. Following an initial surge as the electrolytics charge, the consumption should be around 11mA, most of which will be drawn by the LED.

A potential of 5V should appear across capacitor C9, indicating correct operation of IC5. If the facility is available (bench power supply, etc), the supply voltage can be reduced until the LED extinguishes, this should happen about 7 to 7.5V.

If all appears well, the meter can be connected and IC4 plugged in. With potentiometer VR2 set midway, as the board is powered the meter will probably "twitch".

The meter circuit's input can be accessed through pin 11 on IC3's socket

PARTS LIST

Resistors

R1,2,10,27	4k7
R3,4,7,15,17,22		
R23,24,25,26,28	10k
R5,12,16,18	1M
R6,11,19	100k
R8,14,29	1k
R9	100
R13, 20	10M
R21	4M7
All 0.6 W 1% metal film		

Potentiometers

VR1	10k cermet trim, horizontal
VR2 1k Cermet trim

Capacitors

C1	47n polyester
C2	1u polyester
C3,4,5,10,11	100n polyester
C6	10n polyester
C7,9	...	10u axial elect, 25V
C8	1n ceramic
C12	100u axial elec. 10V
C13	22p polystyrene, to fit across input (see text)	
VC1	2-20p trimmer
Assorted 1% values for calibration; 10n, 100p-, values below 100p, see text.		

Semiconductors

D1,2,3	1N4148
D4	red LED.
TR1,4,5	..	2N3904 npn silicon
TR2,3,6,7,8,9	..	2N3905 pnp silicon
IC1	7555 CMOS timer
IC2, IC4	3130 CMOS op-amp
IC3	4016B CMOS quad analog switch
IC5	78L05 5V 100mA voltage regulator

Miscellaneous

Case, plastic box 150mm x 80 mm x 50mm; PCB, IC sockets 8-pin, 14-pin; S1, miniature shaft assembly, 2-pole 9-way; S2, push-button switch — "press to make"; ME1, 1mA FSD meter; red and black terminal posts; multi-coloured ribbon cable; 9V battery and connector.

(fourth one up, right-hand side). If this is touched with one hand, touching positive supply with the other should cause

Capacitance Meter

the meter to rise, possibly to the stop, while touching negative should cause it

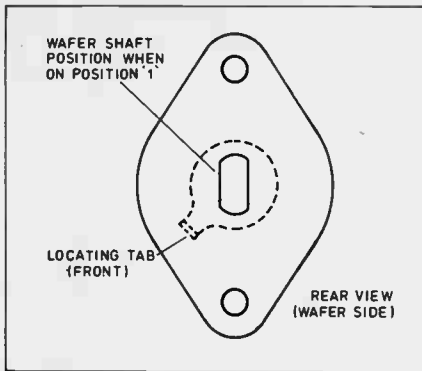

Fig. 3. Position of the range switch shaft assembly prior to fitting the contact wafer.

to fall. It should hold at random points when the input is open circuit, reading whatever voltage is retained by C6.

If this test is successful, IC3 can be plugged in and the board powered again. This time the meter should read zero but a very slight pulsing may be visible at about 1Hz, which may increase when the top of capacitor C2 is touched.

Touching the positive supply with the other hand at the same time should cause the meter to rise but it should return to zero when released, in steps at about 1Hz. Next, IC2 can be inserted after which touching the right-hand side of capacitor C1 with one hand and positive supply with the other

should cause the meter reading to rise, and C1 with *negative* a fall to zero.

Range Switch

Further testing requires the use of the range switch, so assembly and wiring of S1 should be completed. The ranges provided on the meter require more than one component value to be switchable, so a 2-pole 8-way switch is needed. A "miniature Make-switch" assembly is used as a suitable wafer is available.

The correct assembly and wiring of this is not obvious, so it will be described in detail. The parts required are a "Shaft Assembly" and a "2-pole 9-way" wafer, preferably "break-before-make". A point to note is that the wafer contacts are delicate and may catch and bend if the rotor is carelessly turned before assembly. While they can be straightened again, a watch-maker's skill is called for..

The first step is to remove the nut, lock washer and locating tab from the shaft assembly bush. Adjust the stop to No. 8 and replace the other components with the locating tab facing forwards. Cut the shaft to suit the knob and check that there are indeed eight positions.

Rotate the switch spindle counterclockwise (to position 1), then turn over so that the wafer side is uppermost and the locating tab is lower left, as shown in Fig. 4. Next take the wafer, which has contacts and a rotating centre on each side. It will be seen that one of the removing poles is in one piece, with a single wiping contact, while the other is in two parts with two wipers.

With this latter side facing away from the switch, turn carefully to the position shown in Fig. 5 and fit to the shaft. When wired as shown, the assembly will now provide the two 8-way switches required.

Two separate lengths of multi-colored ribbon cable with five and six-ways are used to connect the board to the switch, one for each section. These should be 18cm long, and are soldered first to the board, then to the switch.

On the prototype this was done before assembly into the case, the switch being held in a small vice. The links between contacts are made from insulated wire to avoid risk of shorts.

Case

Detailed case drilling dimensions are given in Fig. 6 as some of the internal clearances are small. The board and

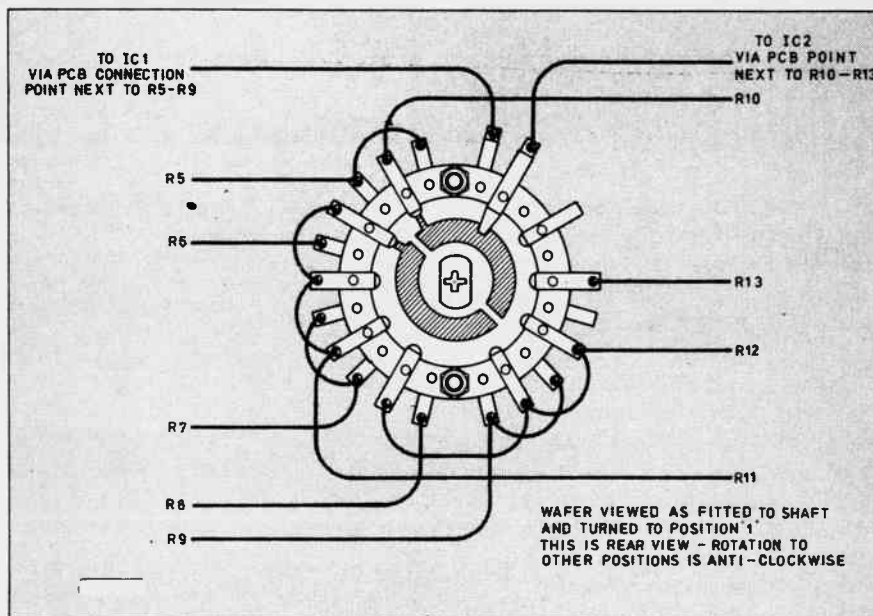

Fig. 4. Interwiring details for the range switch S1. The switch should be wired to the circuit board using 6-way and 5-way multicoloured ribbon cable.

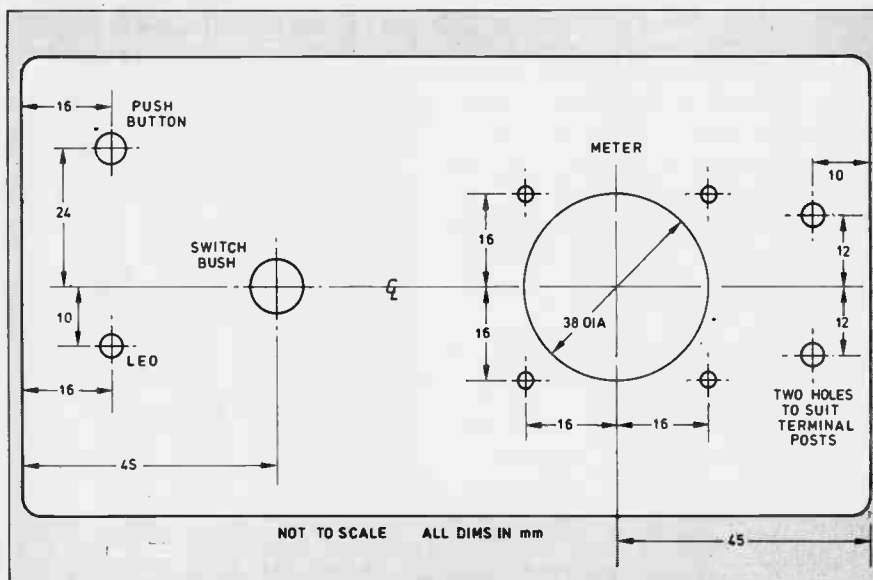

Fig. 5. Case drilling details.

other components are mounted in the case as shown in the photographs, all connections save those to the power supply being made with ribbon cable. The wiring to the circuit board is shown in Fig. 3.

All the wiring passes under the board and the use of ribbon cable makes it easier to lie flat. It should all be long enough to allow the board to be pulled out for access beside the case during calibration.

Red and black input terminals are provided for Cx ("capacitor under test"), with the black being connected to the negative supply side of the input, indicating polarity of electrolytic testing. A 22pF polystyrene capacitor (C13) should be connected directly across them.

Calibration

For calibration only, bypass the push-button so that the supply is on continuously while the battery is fitted. A simple short across the button terminals will accomplish this.

Calibration is carried out with suitable test capacitors, 1 per cent silvered mica or polystyrene types being ideal. Begin by connecting a 10nF capacitor across the terminals and switching to the 10nF range. Adjust VR2 for a full scale reading.

This is the only calibration needed for all ranges save 100pF. For this, first connect a 100pF capacitor and adjust VR1 for full scale. Then connect a 10pF and adjust VC1 for 10 per cent scale. Repeat this procedure until the reading is correct at both points.

When calibrated in this way the prototype exhibited some non-linearity on this range, from 20 per cent to 90 percent the readings were a little high. If the lower adjustment was carried out at 22pF instead of 10pF the accuracy improved, but below 22pF the readings became so inaccurate that the ability to indicate values below 10pF was virtually lost.

A slightly better solution was to adjust for "best compromise", but best of all is to calibrate as before, then, with the

help of suitable values of silvered mica, mark the cardinal points for this range separately on the meter scale. Quite outstanding accuracy for such a simple meter can be obtained in this way.

Conclusion

This instrument should prove invaluable in any workshop. It's far quicker and simpler to use than a bridge, and quite accurate enough for most purposes.

The true value of large electrolytic can be easily checked, useful where tolerances can be as much as -20 per cent to +50 per cent. At the other end of the scale, the capacitance between adjacent stripboard copper tacks, ribbon wires and the cores and screens of shielded cables can be measured.

In between it will cope with all those capacitors whose markings are ambiguous or have rubbed off, and with trimmers of uncertain origin and span. Even the effects of temperature on ceramics can be observed. In short, most constructors will soon wonder how they ever managed without it. ■

BCS ELECTRONICS LIMITED

1ST ANNUAL TEST EQUIPMENT TRADE IN SALE

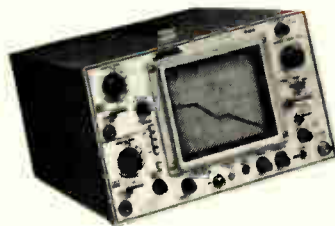

If these problems describe the test instruments you are presently using, then bring or send them to BCS Electronics for big trade-in savings. Any make, any model, trade in units do not have to be in working order. **Save up to \$252.00.**

Wide selection to choose from — sample savings below:

UNIT	LIST PRICE	SALE PRICE	EQUIVALENT TRADE-IN	YOU PAY
HAMEG 203-6	\$ 999.00	\$ 950.00	\$ 51.00	\$ 899.00
HAMEG 806	2365.00	2245.00	132.00	2113.00
ARI 160H	145.00	138.00	13.00	125.00
ARI 700T	315.00	295.00	19.00	276.00
DIGELEC 805	1795.00	1690.00	72.00	1618.00
OPTO 8010S	839.00	789.00	47.00	742.00



980 Atness St. Unit 7,
Downsview, Ontario,
M3J 2S2
(416) 661-5585
TELEX 065-28169

Drop in and see us soon. Sale on while stock lasts or until Saturday 4th June, 1988.

Store hours daily — 9.00 a.m. — 5:00 p.m.

Saturdays during the Trade-in sale 9.00 a.m. — 1:00 p.m.

Phone us for items not listed. One equivalent trade-in unit per purchase only. PST extra.

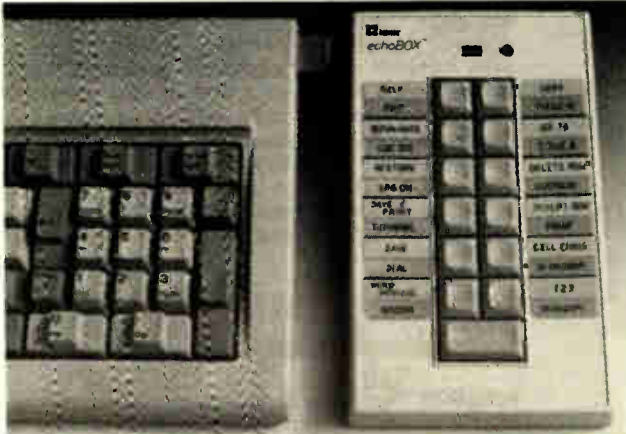

Auxiliary Keyboard

The Smart keypad is a small box which connects between the keyboard and the PC or compatible. It has 12 keys plus a shift key, and can store 24 commands in nonvolatile memory, sending them to the screen when required just as if they had been typed. The keypad eliminates the need for software macros that take up valuable RAM and may cause memory management conflicts. Available as the Model 10X for the PC (up to 950 keystrokes) and the 10A for the AT (up to 650 keystrokes). The entered commands can be changed any number of times. Inmar Inc., 1223 Peoples Avenue, Troy, NY 12180, (518) 271-6692.

Circle No. 37 on Reader Service Card



New Power MOSFET

The Power MOS IV line from APT is a series of high-voltage (to 600V), high current (to 22A) MOSFETS. The on-resistance is as low as 0.2 ohms, making them ideal for high-voltage power switching applications. The gate capacitance is as low as 800pF, reducing drive requirements. Contact Advanced Power Technology, 405 S.W. Columbia St., Bend, Oregon 97702, (382)-8028.

Circle No. 38 on Reader Service Card

**Uninterruptible
Computer Power System**

Power Control
Computer Standby Power System

Complete Power Protection for Serious Computers

The new *Power Control SPS* protects against Power Failures, BrownOuts, Surges, Sags and Impulses. Emergency AC Power is automatically generated from the enclosed heavy duty batteries, while audible, visual and remote alarms alert the operator. Power is conditioned with surge suppressors and line filters, providing a continuous, computer grade electrical supply.

- Superior Technical Specifications
- Available up to 1200 watt
- Load Transfer in less than 2 milliseconds
- Surge and Spike Protection up to 300 joules
- Battery Recharge within 4 hours
- Very Quiet Operation
- Audible and Visual Alarm Indicators
- Remote Alarm Contacts
- 12 Months Unconditional Warranty
- Manufacturing and Service in Canada

Power Control Inc.
12 - 175 Torvork Drive Toronto Canada M9L 2Y7
Phone: 416 747-6644 FAX: 416 747-9070

**NOW CSA
APPROVED**

Circle No. 39 on Reader Service Card

Advertiser's Index

Active Components	48
Allan Crawford Associates	Insert
Anakin Research Inc.	Insert
ATI Technologies	Insert
BCS Electronics Ltd.	61
Best Systems Corporation of Canada Ltd.	2, 3, Insert
CableServ Electronics Ltd.	8
Canada Remote Systems	64
Comgraph	43
Commodore Business Machines	Insert
Compu-Care	Insert
Computer Parts Galore	11
Copp Clark Pitman Ltd.	33
Corel Systems Corporation	Insert
CS Technologies	8
Digital Research Computers	33
ECG Canada Inc.	11
EMJ Data Systems	7
EntreNet Systems	49
Gestetner Inc.	Insert
Hammond Manufacturing Co. Ltd.	11
Honeywell Bull Canada	Insert
Information Unlimited	12
Inly Systems International Ltd.	8
Jaba Systems	Insert
Kaientai Electronic Merchants	48
KB Electronics	8
Logiciel Formulator Software Inc.	Insert
Maple Software	Insert
McGraw Hill	13
National Technical Schools	45
Okidata	Insert
Personal Computers	Insert
Power Control Inc.	62
Sak Data	Insert
Taylor Electronic Designs	Product Card
Toshiba Information Systems	4, 63, Insert
Transart Supplies	Insert
Trebus Institute of Recording Arts	20
Trillium Telephone Systems	Insert
Wilderness Tours	33
WordPerfect Corporation	Insert

**For Advertising Information
Call (416) 445-5600 Fax: 416-445-8149**

Busy office workers explain why they love their new desktop laser printer from Toshiba.

It can emulate just about everyone. HP Laserjet 500 Plus, IBM, Toshiba P351, Qume, Diablo.

You name it!

At 12 pages per minute, it prints faster than others, at a lower cost per page. Price/performance ratio is outstanding!

With up to 2 MB of memory and a 16-digit English-language panel display, it's powerful and user friendly.

At 600,000 sheets (extendable to 1.2 million sheets) its product life is many times longer than others.

It can hold more paper—750 sheets. You can add an envelope feeder.

Better paper handling.

Its resolution of 300 dots per inch provides outstanding full-page print quality and graphics.

With a duty cycle of 25,000 pages, it does more work in a month than others.

It comes standard with many features including Serial and Parallel RS232 Interfaces.



The Toshiba Desktop PageLaser 12.

The latest advanced technology from Toshiba's 110-year heritage of quality. Contact your Authorized Toshiba Re-Seller, or call toll free, 1-800-387-5645 and get more information. Your office workers will really appreciate it.

TOSHIBA

WE MEAN BUSINESS

INFORMATION SYSTEMS DIVISION

Circle No. 40 on Reader Service Card

Get the Courier HST™ 9600-bps modem. Then watch the rest of the world play catch-up.



USRobotics new high speed technology delivers over 1,000 characters/second on more dial-up phone lines. For less than \$1,100.

The new Courier HST (High Speed Technology) dial-up modem combines four great ideas that add up to a new standard for personal computer data communications.

It's full-duplex, with high speed (9600-bps) and low speed (300-bps) channels—automatically assigning the high speed channel direction. This asymmetrical solution avoids the problems of echo-cancelling technology or inefficient half-duplex schemes.

The most powerful data signalling technique—Trellis Encoded Modulation—lets Courier HST achieve maximum speed over a much wider range of phone line conditions than other 9600-bps modems.

A unique error- and flow-control method allows Courier HST to send up to 1,100 characters a second over long distance phone connections.

It's familiar as any 2400- and 1200-bps modem. Same features, commands and, in most cases, the same software. In fact, Courier HST automatically falls back to 2400, 1200 and 300-bps, connecting you with nearly all modems.

High speed. High accuracy. High value. And a two-year parts and service warranty. Get the USRobotics Courier HST, priced at \$1,029. And watch the rest of the world play catch-up.

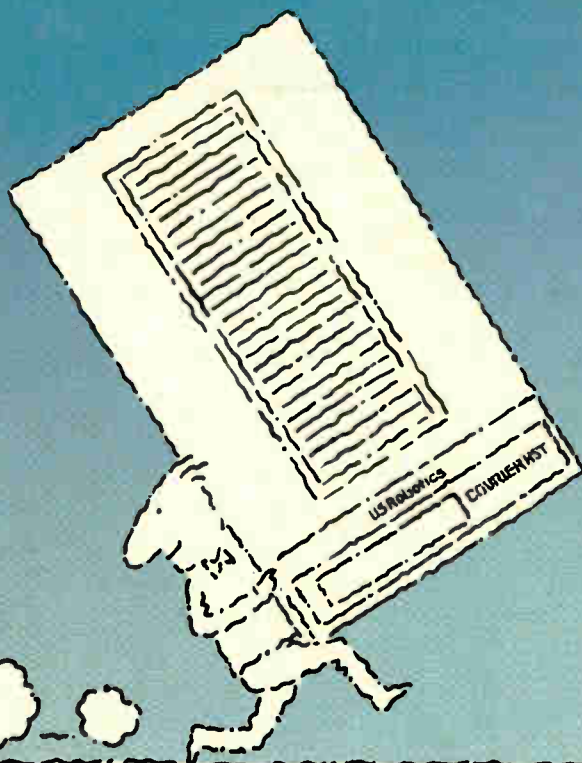

CRS CANADA
REMOTE
SYSTEMS

4198 Dundas St. W.
Suite 311
Toronto, Ont. M8X 1Y6
1-(416)-231-2383
1-800-268-2705

Circle No. 41 on Reader Service Card