

August  
20 CENTS

1920

# QST

A MAGAZINE DEVOTED EXCLUSIVELY TO THE WIRELESS AMATEUR



# THE A. R. CO. VARIABLE CONDENSER

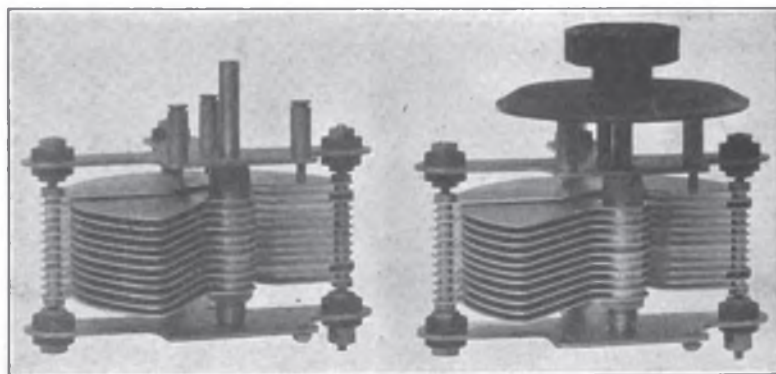

THE NEW "A. R. CO." VARIABLE CONDENSER

illustrated above is made in two capacities—.001 mfd. and .0005 mfd. and is supplied unmounted only but with dial and knob if desired. The rotary plates are rounded on one end affording straight line capacity. The dial is of moulded composition, scale in white—0—100. Bakelite Knob. We can guarantee this condenser in every way as to quality, reliability and satisfaction. The low price is decidedly an innovation.

Capacity	PRICES :	With Knob and Dial
.0005 mfd.	Unmounted \$5.00	\$6.00
.001 mfd.	6.25	7.25

POSTAGE 10 CENTS

---

**A.R.Co. Amplifying Transformer - \$5.00**

---

*We take pleasure in announcing a branch store located at 15 Temple Street, Portland, Maine, under the management of Mr. H. W. Castner.*

**ATLANTIC RADIO COMPANY**  
Incorporated

**88 BROAD STREET  
BOSTON 9, MASS.**

Branch  
**15 TEMPLE STREET  
PORTLAND, MAINE**

621.36305  
Q5  
v. 4

THE OFFICIAL ORGAN OF THE A.R.R.L.

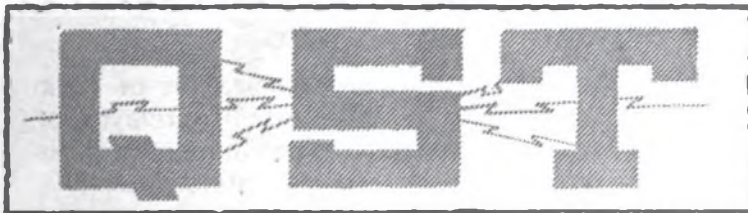

AUGUST, 1920

VOLUME IV

No. 1

# CONTENTS

6-26-35 ES

The A.R.R.L. QSS Tests	5
A Ham on the Telephone	Tewpieye 6
Navy Receiving Equipment (Part II, Concluded)	L. C. F. Horle 8
An Efficient and Flexible Receiving Set	A. L. Groves 10
Our Radio Dime Museum	D. A. Hoffman 13
The New York Radio Central Station	14
Old "WCC", Cape Cod	"An Old Timer" 17
Code Instruction Tables	17
Some Characteristics of the Underground System	18
A New Type of Variable	19
A Boardwalk Roller-Chair Radiophone	20
Clapp-Eastham 1/2 Kilowatt Hytone Transmitting Panel	20
Editorials	21
The Operating Department	23
Who's Who in Amateur Wireless	31
QST's Directory of Calls	33
Amateur Radio Stations	35
With the Affiliated Clubs	38
Amateur Radio in Holland	Seefred Bros. 40
Strays	41
The Heterogeneroplodynatron	Herbert Richter 44
Radio Communications by the Amateurs	46
Concerts de 2AB	53
Calls Heard	54

*Engineering Library*

QST is published monthly by The American Radio Relay League, Inc., at Hartford, Conn. Kenneth B. Warner (Secretary, A. R. R. L.), Manager and Editor.  
 Subscription price, \$2.00 per year, anywhere. Single Copies, 20 Cents.  
 Entered as second-class matter May 29, 1919, at the post office at Hartford, Connecticut, under the Act of March 3, 1879.  
 Copyright, 1920, by The American Radio Relay League, Inc.  
 Title registered at United States Patent Office.

THE AMERICAN RADIO RELAY LEAGUE, Inc.  
HARTFORD, CONN.

JUL 20 1920 R. G. S.

898661

# THE AMERICAN RADIO RELAY LEAGUE

INCORPORATED

"A national non-commercial organization of radio amateurs, bonded for the more effective relaying of friendly messages between their stations, for legislative protection, and for scientific growth."

## OFFICERS

**President**  
**HIRAM PERCY MAXIM**  
Hartford, Conn.

**Vice President**  
**CHAS. A. SERVICE, JR.**  
Bala, Pa.

**Traffic Manager**  
**J. O. SMITH**  
73 Hillside Ave.  
Rockville Centre, L. I.

**Treasurer**  
**A. A. HEBERT**  
Nutley, N. J.

**Secretary**  
**K. B. WARNER**  
Hartford, Conn.

## DIRECTORS

**A. E. BESSEY**  
Sunnyvale, Calif.  
**V. F. CAMP**  
Brightwaters, L. I.  
**J. M. CLAYTON**  
Little Rock, Ark.  
**J. C. COOPER, JR.**  
Jacksonville, Fla.  
**F. M. CORLETT**  
Dallas, Tex.  
**W. T. FRASER**  
Buffalo, N. Y.

**W. T. GRAVELY**  
Danville, Va.  
**F. H. HAMILTON**  
Indianapolis  
**A. A. HEBERT**  
Nutley, N. J.  
**HIRAM PERCY MAXIM**  
Hartford, Conn.  
**C. R. RUNYON, JR.**  
Yonkers, N. Y.

**C. A. SERVICE, JR.**  
Bala, Pa.  
**J. O. SMITH**  
Rockville Centre, L. I.  
**H. L. STANLEY**  
Babylon, L. I.  
**C. H. STEWART**  
St. David's, Pa.  
**K. B. WARNER**  
Hartford, Conn.  
**M. B. WEST**  
Waukegan, Ill.

## OPERATING DEPARTMENT

**TRAFFIC MANAGER**  
J. O. Smith

**ATLANTIC DIVISION**  
Manager  
Chas. A. Service, Jr.  
Bala, Pa.

**Asst. Mgr., Central Sec.**  
John DiBlasi  
88 Sinclair Ave.  
Flushing, L. I.

**Asst. Mgr., Southern Sec.**  
Chas. H. Stewart  
St. David's, Pa.

**EAST GULF DIVISION**  
Manager  
J. C. Cooper, Jr.  
Atlantic Natl. Bank Bldg.  
Jacksonville, Fla.

**CENTRAL DIVISION**  
Manager  
R. H. G. Mathews  
1816 Carmen Ave.  
Chicago

**Assistant Manager**  
Chas. H. Zeller  
4782 N. Maplewood Ave.  
Chicago

**WEST GULF DIVISION**  
Manager  
Frank M. Corlett,  
- 1101 East Eighth St.  
Dallas, Tex.

**ALASKAN DIVISION**  
Manager  
Theodore A. Stocking  
Ketchikan, Alaska

**ROCKY MOUNTAIN DIV.**  
Manager  
M. S. Andelt  
Richfield, Utah

**PACIFIC DIVISION**  
Manager  
A. E. Bessey,  
Sunnyvale, Calif.

**Assistant Manager**  
E. G. Arnold  
181 No. 17th St.,  
San Jose, Calif.

**ST. LAWRENCE DIVISION**  
Manager  
Albert J. Lorimer  
243 Mackay St.  
Montreal, Que.

**ONTARIO DIVISION**  
Manager  
A. H. Keith Russell  
852 Markham St.  
Toronto, Ont.

**NEW ENGLAND DIV.**  
Manager  
Guy R. Entwistle  
187 Sutherland Road  
Brookline, Mass.

**ROANOKE DIVISION**  
Manager  
W. T. Gravelly  
854 Main St.  
Danville, Va.

**DELTA DIVISION**  
Manager  
John M. Clayton  
1801 Welch St.  
Little Rock, Ark.

**MIDWEST DIVISION**  
Manager  
L. A. Benson  
4942 Wiesehan Ave.  
St. Louis

**DAKOTA DIVISION**  
Manager  
Russell H. Pray  
Valley City, N. D.

**NORTHWESTERN DIV.**  
Acting Manager,  
Royal Mumford  
Vancouver, Wash.

Address General Correspondence to Executive Headquarters, Hartford, Conn.



## The A.R.R.L. QSS Tests

The Bureau Tests End and the League Tests Begin.

**A**S this article is written, the A.R.R.L. Fading Tests are beginning all over the country, and we have every reason to feel that they will be as interesting and as successful in the securing of valuable data as were the co-operative Bureau of Standards A.R.R.L. tests.

Readers who are not familiar with the tests are referred to the opening articles in the two preceding issues of QST, where complete details are announced. In each A.R.R.L. Division transmissions by well known stations have been arranged, and a form for checking the variation of audibility is given. The Division Managers have appointed Fading Analysts for each section, and a uniform system of tabulating and studying the data has been adopted.

If we all pull together on these tests, much of scientific value should be accomplished. It is hoped that every A.R.R.L. man will feel it a duty to participate and aid in this important work. All stations are requested to keep their transmitting at a minimum during the time of these tests in their territory.

It is believed that experience in the conduct of these tests will show that the system being followed can be improved, so that rather than continue this first series indefinitely it has been thot advisable to announce Aug. 31st as the concluding date. Referring then to the schedule published in last month's QST, all schedules for dates after Aug. 31st are hereby cancelled. Division Managers will arrange for the broadcasting within their division, at the proper time, of any portions of their schedules not published in full up to Aug. 31st in the July issue.

There are two corrections in the New England Division schedule as published. Aug. 14th for 1PG, read 1PY, Westerly, R. I. Aug. 28th, for 1WR, read 1AK, Fall River, Mass. 1KAY is Portland Me.

Now a word to the recorders. Make curves on as many transmitters as you can, but if the schedules call for transmitting on each test night by stations in adjoining divisions and you can get either one at will, pick out the one to which you will regularly devote your attention and record it every possible test night at that time. That is, do not switch your recording to a new station every night—it is more important to have regular reports on the same transmitter, so that variations from normal reception may be noted. The recording form calls for a check-mark in the proper square. This works very satisfactorily where the swinging is gradual, but some stations fade so rapidly as to go thru most of their cycle during the transmitting of one group of letters. In such cases it is suggested that numerous small dots be tallied (possibly one per letter, even), to be connected by a curve immediately after the schedule. Another important thing is that a record on a station whose signals are extremely loud thruout the transmission will not show fading and will therefore be without value. If a station is regularly received with intensity 9, reduce filament current or cut out a stage of amplification. This will reduce the strength to a value where changes in audibility will be readily noticed. But be sure to note on the record that this has been done and also, if possible, note during the QST call the strength with the set in normal order.

Because progress in the Bureau of Standards tests showed that some rearrangement of the station network would add greatly to their value, the tests were terminated on July 17th. This was in accordance with the original scheme. Improvements in the methods of transmitting and recording are under consideration, and these will make it possible to plan future tests very satisfactorily. The network laid out for these first tests by our Operating Department

Engineering Laboratory

has worked to perfect satisfaction, and some remarkably fine work has been done by the participating stations. These men should feel that a difficult task has been well performed, and the Bureau wishes to thank them sincerely for their efforts.

As soon as the Bureau completes the tabulating of the data and draws conclusions therefrom, they will be announced thru the A.R.R.L. So far, the indications are that the phenomena are caused by reflection or refraction of the waves, as has long been believed by many. Perhaps the most striking feature of the tests is that no cases of fading revolving around the transmitter have been observed, as was expected by many of us, but inverse curves have been noted both on opposite sides of the transmitter and, more important, on the same side of the transmitter at different distances. This last feature is intimately bound up with what is being called "progressive fading", the occurrence of certain phenomena successively along the curve at different points in the same general line from the transmitter. The Bureau cites as an instance, a particular part of a curve on the signals of 2JU which began at Hartford with the letter A; at Bristol, Conn., with the letter B; at Laconia, N. H., with the letter G; and at Boston with the letter H. It is believed that a study of the distances, time factor, and phase relations in such instances will make it possible to determine the location of the reflecting media, if such exist, which caused the phenomena. From this we may hope to learn the nature of the medium, and so progress to methods for overcoming the fading evil.

The Bureau is of the opinion that the so-called changes of received wave length, as reported in QST by correspondents, are

largely receiving circuit effects. A regenerative receiver is very critical as to filament temperature and a small change in this factor causes marked tuning effects. These can be compensated for by readjusting the set, the operator receiving the impression that the incoming wave has changed. Another important thing is that the adjustment of a regenerative set that is best for strong signals is not the same as the best adjustment for weak signals of the same wave length, and as it is virtually impossible to tell whether a particular adjustment of such a set is a tuning or regenerating adjustment, the operator is easily deceived into the belief that the wave length has changed. This would not occur in non-regenerative receivers, but the latter do not have the needed sensitiveness. It is believed possible, however, for a transmitter emitting a band of wave lengths to fade out on one wave length at a particular receiving point and simultaneously swing in on another wave, for the reason that two different frequencies when reflected or refracted by the same conducting mass or surface, do not interfere subtractively at the same point. Mr. Frank Conrad, of 8XK, has suggested that a sending station with two "humps" sufficiently far apart could send to a receiving set tuned to both waves with a very good chance of unbroken reception, and supporting this theory is the observation that, so far as known, it is not possible to recover the signals of a fading C.W. (or modulated C.W.) station by retuning.

All in all, the QSS Tests are proving immensely interesting and promise to develop information on short wave transmission problems which will prove of the highest value to us amateurs. Watch QST for further information.

## A Ham On The Telephone

By Tewpieye

2PI makes his debut in QST with a good one. Ever imagine what radio nomenclature must sound like to the uninitiated? This is a story about just that.—Editor.

**M**R. JAMES BARNEY was an ardent "ham" and lover, and often wavered in his fidelity between the two extremes. When in the equally captivating presence of one the other was generally completely obliterated, but he occasionally inoculated sentimentality into the ether by rather obvious code MSG's to his other affinity via the A. R. R. L. One afternoon, following a futile endeavor to raise some easily imposed-upon station who would accept his MSG

which according to cable count would have made its recipient a millionaire, he finally resorted to the telephone.

Now Mr. Barney was a resident of a New York apartment house and consequently suffered all their advantages and equally enjoyed their manifold discomforts. He frantically oscillated the unoffending phone hook, yelled profanely into the transmitter and placed his receiver in proximity to the mouthpiece without raising the slightest satisfying squeak, before he

ultimately replaced the damaged phone stand, and carefully noting that the receiver was NOT on the hook, made his fuming way to the real estate office, in the building. He was there informed that service was NIL, owing to the absence of an operator, and that in all probability it would continue so for an indefinite period. Sensing a chance to make the maximum of money with the minimum of work, James offered his able self in the temporary capacity of switchboard operator. Needless to say he was immediately accepted.

After settling himself with all possible comfort in the operator's chair his first act officially was to remove the caps from the receivers. Making a serious pretext of tightening some perfectly firm binding posts he savagely jammed a plug into Central.

"Number please?"

"QSD", in an interrogative tone.

"Number please".

"QSD QSD P-S-E".

"Do you want information?"

"No—no". Then comprehending that all operators did not necessarily come under genus radio, James condescended to the explanatory—

"QSD what time have you?"

"Four twenty-five."

"OK Thanks old man, call you later." Crash, and the plug returned to its place.

After painfully setting his watch, the erstwhile operator, paying not the least attention to the frantic dropping of a paltry dozen or so annunciators, again plugged Central and gave her the number of his lady love. There then ensued a beautiful half-hour conversation, interrupted but once when Mr. Barney smothered the persistent buzzer with his cap.

As soon as this conversation reached the ultimate of its many endings, James again experimented with his apparatus ere he felt competent to answer the now innumerable calls. He jammed in half of the party plugs and leaned heavily on as many trunk buttons and anxiously awaited the result.

The inevitable happened. Half the population of the house answered with a confused "Hello hello".

James, not quite expecting this, was at a loss as how to reply, but his radio intelligence soon came to his rescue.

"Testing-testing — de-de-de-dah," he bawled into the transmitter, and desperately yanked the plugs.

Having at last determined which were the party jacks by the above conclusive tests, he cautiously proceeded to answer calls.

"Hello, hello, O.K. now, shoot."

"Connect me with the real-estate office, please".

"Sorry but they piped down about an hour ago."

"They what?"

"Piped down, layed off, closed shop" explained the sophisticated James. "I'll take an MSG for them though."

"Oh they are closed—Well this is important. Will you please give them a message as soon as they open?"

"QSR".

"What?"

"Sure thing, I'll relay the message. Shoot".

"Well, just tell them that the people below are making an awful noise. It's some sort of a telegraph affair, and their wires come right down outside of our windows. Our wash-woman was almost killed when she hung clothes on it last Monday. We can't sleep at all nights when it is buzzing, and our lights get dim and it is impossible to read. Also sparks fly from the ceiling in the dining room".

"Yes mam, that's outrageous. I shall report it and see that it is stopped." Mr. Barney made a mental reservation to replace his kick-back-preventer the next time he saw his set.

"Well", he soliloquized, it's sure lucky I got in on this. Gee, supposin' it had got to the office MIM. Ye Gods! Maybe there's some more of them flying around."

He plugged in on the apartment below his.

"Hello, this is the office speaking. Are there any complaints you wish to file this month, Mrs. Jackson?"

"Why, nothing in particular, only our lights went out last night and haven't been on since."

"Oh yes, well—er-er-the er-power company shut off the juice last night, Mrs. Jackson, but it will be on tonight."

Behold another mental resolution: to replace the fuses borrowed from the meter on the floor below.

"Well, now, I sure did nip that in the bud."

BUZZ, BUZZ, BUZZ.

"Hello-hello-hello-hel-l-l-l-oo. One, two, three, four, five, go ahead".

"Connect me with Mr. Stone's apartment, please, I've been trying to get you for the last half hour."

"Yes mam", and he shoved the plug into the handiest jack while he searched the list for Mr. Stone.

(Concluded on page 43)

**Coming Soon**

An analysis of the QSS reports in the "Bustands"—A. R. R. L. tests; a paper on the performance of our stations in these tests, by Mr. S. Kruse; some dope on the use of spark coils as a source of modulated plate potential for C.W. telegraphy; a cheap and easily-made rectifier which will give 350 watts d.c. for C.W. Watch for these articles.

## Navy Receiving Equipment

By L. C. F. Horle

Part II—Concluded

Presented at meeting of the Radio Club of America, Columbia University, March 26, 1920

Under the able direction of Prof. Hazeltine, who was then connected with the Navy Dept. in a consulting capacity, much research was done before the actual design was started and the various developments of this research were incorporated in the SE-1420 receiver.

In the design of this receiver effort was made to secure wide wave length range, high selectivity, freedom from local interference, stability in regenerative amplification, simplicity of operation, compactness, durability, and cheapness of construction.

In conformity with established practice, both tuned circuits have inductance coils provided with taps, six in number, and continuously variable air condensers giving overlapping wave length ranges from 260 meters up to 6,000 meters when the capacity of the antenna is .0004, and up to 7500 meters when the capacity is .0009 microfarad. The practice of sectionalizing and disconnecting the unused portions of the windings to avoid "resonant coils" has been abandoned, the windings being now made continuous and merely short-circuited at the proper taps. This completely eliminates "resonant coils" and allows of a simple and rugged construction. The arrangement is such that the coupling between the short-circuited and the active portions of the coils is loose, so that little loss is introduced.

The chief factor contributing toward high selectivity in this receiver is the choice of a higher ratio of inductance to

capacity than has hitherto been customary; the antenna condenser having a capacity of .0015 microfarad, and the secondary condenser of .00075 microfarad, whereas the type SE-1220 and other receivers of similar wave length range had capacities of .005 and .003 microfarad respectively. Compactness and proper distribution of

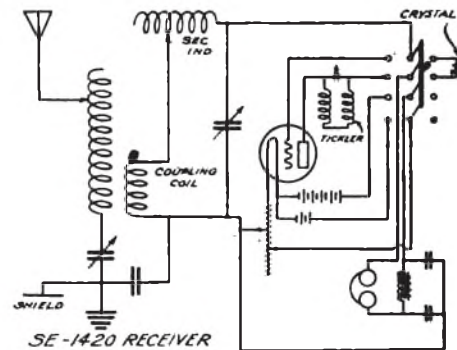

winding spaces are secured by reducing the size of the Litz wire used to 20 strands of No. 38 wire and by winding the successive taps in increasing numbers of banks.

Interference from short-wave nearby stations and from transmitting apparatus in close proximity to the receiver is eliminated by the use of grounded sheet-copper shielding completely enclosing and separating the antenna and secondary circuits. To completely eliminate capacity coupling,

the coupling coil is provided with a novel electro-static shield consisting of an additional winding placed over it, the capacity current in this winding inducing in the coupling coil voltage which exactly neutralizes that resulting from capacity current in the coupling coil. The coupling coil is placed in the secondary circuit instead of in the antenna circuit chiefly for the purpose of obtaining sufficient coupling without the use of taps to secure the low wave lengths, as the inductance of the antenna would otherwise prevent this. To secure complete stability in regenerative amplification, the stopp-

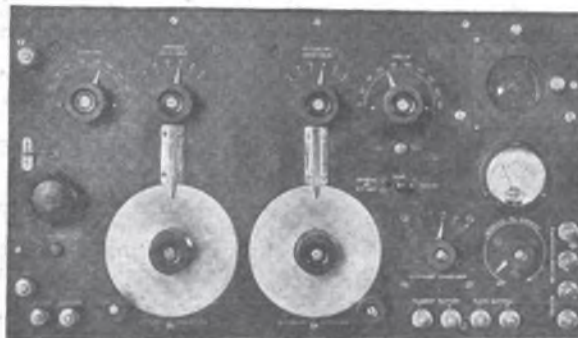

Fig. 3.  
Panel View, SE-1420.



ing condenser and grid leak are discarded, and the grid is connected through the secondary inductance to a point on the filament rheostat selected to give a negative grid potential or "bias" of about 1.3 volts with a Type SE-1444 tube, and about 2.2 volts with a Type CW-933 tube.

Oscillation control over the entire wave length range with both types of tubes above mentioned necessitates a large tickler, and in order to avoid resonant effects from this tickler at the shortest wave lengths, it is made in the form of a variometer, having a stationary part wound alongside of the secondary inductance coil, and allowing the plate circuit to be tuned.

The difficulty which frequently arises in short wave heterodyne reception from the capacity between the operator's hand and the secondary circuit (which may change the note sufficiently to make it inaudible) is eliminated by the use of an audio frequency choke coil and telephone condenser which prevents radio-frequency current from reaching the telephones.

The receiver permits the use of either the crystal or the vacuum tube detector, and contains within itself the receptacle and controls for the latter. The terminals of the secondary circuit are brought out for connection to a radio-frequency amplifier when the crystal-audion switch is thrown to the left. The standard auxiliaries, such as the filament ammeter, test buzzer, push button, etc., are clearly shown in the photograph, Fig. 3. The construction is simplified and cheapened by the introduction of unit assemblies, enabling the separate elements of the apparatus to be assembled independently instead of being built into a single panel.

Following the design of the SE-1420 receiver came the need for a radio compass receiver of greater selectivity and sensibility than had been available previously. The use of unilateral operation has been abandoned because of the difficulty in securing reliable bearings with the personnel available for operating the equipment. The possibility of using radio frequency amplification for this type of radio reception was investigated but it seemed evident while this investigation was being made that high power audio-frequency amplification would best meet the service needs, particularly since there was evidence at hand indicating that greater precision of bearing determination could be made if reception was done with the tube in oscillation. On the basis of this data the SE-1440 receiver was designed.

A series of amplifiers has been developed at the Radio Laboratory that should meet the needs of the service very satisfactorily.

They are designed (1) to supply moderately high audio-frequency amplifications where conditions are such that an ordinary antenna is available, or (2) to supply high audio-frequency amplifications where low antenna or loop reception is to be done over a great range in wave lengths, or (3) to supply high radio and audio-frequency amplification where extremely high amplifications are necessary and where the range in wave lengths is not greater than three to one.

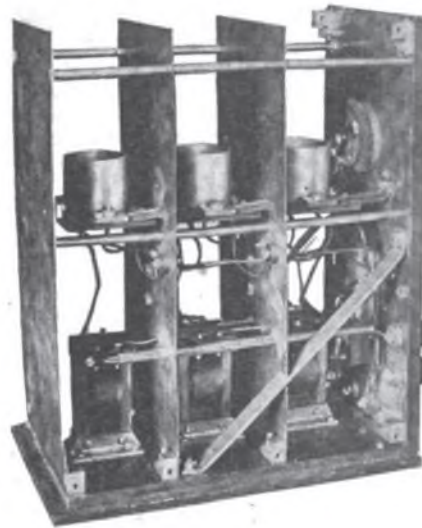

Fig. 4.  
Three Step Audio Amplifier  
(Electrically Shielded). SE-1599.

For use under conditions specified in (1), the SE-1600-A amplifiers are well suited. These amplifiers use two of the SE-1444 or CW-933 (Western Electric "J") tubes in connection with the two audio-frequency transformers.

The SE-1600-A uses iron core transformers. The coils of the transformers are machine wound with No. 44 copper wire. The layers are insulated from each other by means of paper and the whole coil impregnated with wax. The primary consists of 3900 turns and the secondary of 12,000 turns, the ratio being somewhat greater than three to one. The core is built up of 5-mil silicon steel. Three telephone jacks are provided by means of which the telephones may be connected in the plate circuit of the detector tube or in the plate circuit of either of the amplifier tubes.

For use under conditions outlined in (2) the SE-1599 amplifier has been designed. (Fig. 4). This amplifier consists of three amplifying tubes and three

amplifying transformers of the audio-frequency type. The whole device is thoroughly shielded and every means adopted to make it free of disturbance due to interactions in itself or between it and other apparatus. It is designed to meet the need for very high amplifications where a wide range in wave lengths is essential. As such it is suited for operation with receivers supplied with "audion control boxes" or with receivers equipped with vacuum tube detectors. A two point telephone switch provides for cutting out the last stage of amplification when necessary. Further control of the amplification may be accomplished by adjusting the filament rheostat.

For use under the conditions outlined in (3) the SE-1611, SE-1613, SE-1615, and SE-1617 amplifiers have been designed. These amplifiers are of the radio-audio-frequency type and employ six SE-1444 tubes. Iron core transformers are used for both the radio and audio frequency amplifications. The radio frequency transformers are the only major details in which these amplifiers differ from one another, each amplifier having its transformer designed for maximum amplification over a definite range of wavelengths.

The ranges of these amplifiers are approximately as follows:

SE-1611	400 to 1000 meters
SE-1613	1000 to 3000 meters
SE-1615	3000 to 10000 meters
SE-1617	6000 to 20000 meters

In addition to the above series of amplifiers there have been several types of amplifiers designed for special applications. The most interesting of these is, perhaps, the SE-1493. This amplifier consists of 4 tubes and three radio-frequency transformers having a range of 400 to 1,000 meters. The last tube of the series acts as a detector. It is designed to meet the need for radio-frequency amplification of this range where audio-frequency amplification in the form of the SE-1600 is already available and requires no "audion control box" for its operation.

This covers in general the trend of Navy Receiver development and illustrates the variety of apparatus required to meet the growing need of the service for special designs and purposes. No attempt has been made to emphasize the tremendous efforts necessary to perfect each detail under pressure of war conditions but the results of the work well justified this careful development.

## An Efficient and Flexible Receiving Set

By A. L. Groves

We all know that Mr. Groves has done some exceptionally good receiving work, and in this article he describes the set with which he does it, in such a manner that anyone may duplicate his results. Mr. Groves is an exponent of the "three-coil" circuit for short waves as well as long, but attention is particularly directed to the fact that for the reception of short waves the third coil is NOT a tickler, but instead forms the inductance for an Armstrong tuned-plate-circuit hook-up, a method which most of us have found superior to the tickler for amateur work. The diameter of the coils described by Mr. Groves was chosen after experimenting with every diameter from one inch to fifteen inches, and gave the best results. We are fortunate in having this pioneer work already done for us. This dope can be depended on.—Editor.

**A**S numerous amateurs have expressed a desire to know what kind of a set I use in obtaining results referred to in some of my previous articles in QST, I here present a full plan of my set, showing location of instrument, exact wiring methods, etc.

As will be noted, the set presents nothing radically new, unless we take into consideration the extreme simplicity of the whole layout, and this to a great extent accounts for the working efficiency of the set, for a set cannot work at greatest efficiency when hampered by unnecessary instruments and instruments placed on the panel in such a position that long leads and numerous crosses occur. The audion is a very sensitive instrument and every inch of unnecessary wire, every unnecessary switchpoint or other instrument, has its effect on it. These little things

might not amount to very much taken separately, but collectively they amount to much, and no pains should be spared to have as few instruments as possible, wired with heavy wire as directly as possible.

Fig. 1 represents a set 20 by 20 inches front panel, and 10 inches deep. The depth may be only 8 inches, depending upon the size of A and B Batteries used.

The switches 1, 9 and 10 are one inch switch blades. Condensers 3 and 13 are Illinois 13 plate condensers. Condenser 12 may be either 13, 23, or 43 plate, depending upon the maximum wave desired to receive from, using the DeForest honey-comb coils. If the 13 plate condenser is used, waves up to and including that of WII (formerly NFF) on 13,600 meters may be tuned to. A 23-plate one will just about take in NSS on 16,900 meters,

while the 48 plate one will tune to about 20,000 meters. DeForest claims 25,000, but if you get 20,000 you will do well. In fact, under actual working conditions all of the DeForest coils have lower minimum and maximum waves than those listed in their catalogue. Coil L-600 deviates from their figures to a greater extent than any other. They claim from 4,000 to 12,000 meters with it, while its working range is approximately 2,200 to 8,600 meters.

the Parkin, selected for its small size and simplicity.

The grid leak must be variable and is of the switch-lever-pencil-mark type.

Point 6 is the junction point of the plate circuit, stopping condenser, and receivers. The condenser used is the DeForest fixed condenser of .002 Mfds., and from this point a regular lamp cord is run to the point where it is desired to attach the receivers.

The coil mounting, 7, is the regular DeForest 3-coil mounting, preferably the ULC-400.

While the DeForest Honeycombs are excellent for long wave work, they are not suitable for best results on the short waves, and at the time of writing this article a new type of coil called the Duo-Lateral Coil has just made its appearance. I hardly believe these coils will prove any more efficient on short waves than the honeycombs, as I wound three coils of this type by hand back in April on 2 1/4-inch cylinders and while it was not expected that the hand-wound coils would show anything startling, a comparison between them and hand-wound honeycomb coils failed to show enough to warrant further experimenting with them, on the short waves at least.

For amateur waves, or we may say for waves below 600 meters, nothing brought out to date is more efficient (under actual working conditions) than the old time straight single layered coils.

The only previous objections to them was the inefficiency of the transformer, when made in the regular primary-secondary loose coupler style with its sliders and taps, dead-end effects and clumsy couplings, etc. The loose coupler had its day in the days of crystal detectors, but it has no place in the modern tube set of today.

Fortunately it is an easy matter to build coils of the correct size to fit the DeForest Mounting for short wave work, which are used in exactly the same manner as the regular coils, thereby doing away with the dead-end effects, taps, sliders, etc., and at the same time producing a most efficient set. A little experimenting by each individual to produce the exact number of turns in each coil is necessary, but once the correct values are determined the results obtained will more than pay you for the little trouble and care you have taken.

The best coils to use are composed of Bakelite tubing 5 1/4 inches inside diameter with 1/8 inch wall, giving an outside diameter of 5 3/4 inches. 1/8 inch Bakelite sheeting is secured to make the bands on which to mount the coils on the regular DeForest

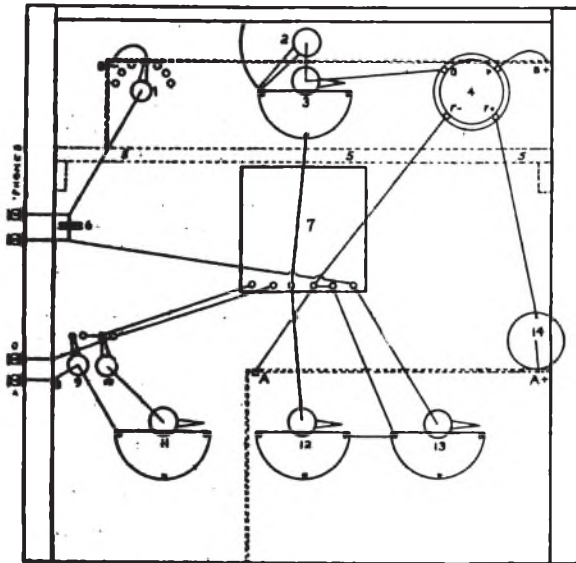

1. B. Battery Switch.
2. Variable Grid Leak.
3. Grid Condenser.
4. Audion Socket.
5. Shelf for B. Battery.
6. Fixed Condenser.
7. DeForest 3-Coil Mounting.
8. Aerial and Ground Connections.
- 9-10. Series-Parallel Switch.
11. Primary Condenser.
12. Secondary Condenser.
13. Plate Condenser.
14. Rheostat.

Dotted lines at top, B. Battery.  
Dotted lines at bottom, A. Battery.

The primary condenser, 4, should have a maximum capacity of at least .0015 mfd. and may be either the DeForest, Clapp-Eastham balanced or other standard condensers designed for panel mounting.

Switches 9 and 10 throw the primary condenser in series with the aerial when both are thrown to the left as shown. If 9 is moved to the right, leaving 10 to the left the aerial is cut straight through and the condenser cut out. If both 9 and 10 are thrown to the right the condenser is connected in parallel to the primary coil. This simple arrangement will be found more efficient than the usual 4-blade 8-point switches used for this purpose.

The rheostat, 14, used by the writer is

Plugs, which can be taken from your unused DeForest shortwave coils.

The tubing is purchased in lengths ranging from 1 to 1½ inches wide if you wish to make the set from 200 to 600 meters from these coils, or if for short waves only, 200-300 meters, they may all be 1 inch wide.

20 turns of No. 22 SCC wire are wound on the first coil, which will give a minimum wave of approximately 200 meters when used in the secondary.

25 turns are wound on the next coil, and 30 on the next. These three coils will cover practically the entire amateur field

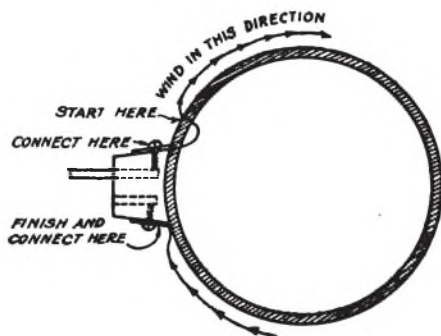

of waves with efficiency in the secondary circuit. In winding the coils it may be well to remember that on a cylinder of this size, 20 turns approximately equals 200 meters, 35 turns 300 meters, 50 turns 400 meters, 65 turns 500 meters, and 80 turns 600 meters, with the secondary condenser close around zero capacity. As the necessary number of turns increases, wider cylinders and finer wire are used. The 600 meter secondary requires the 1¼ inch cylinder wound with No. 30 SCC wire and this coil will give excellent results up to and including 800 meters. I leave it to the individual to wind as few or as many coils as desired.

For the plate coil, in most cases, one of the unused secondaries can be used. This depends somewhat upon the character of bulb used. The average Class 2 Marconi V.T., using three or four 22½ volt B Batteries requires a coil of 15 turns for the plate coil on 200 meters and one of 35 turns for 600 meters. In tuning on short waves it must be remembered the inductive feedback from the plate coil is undesirable; consequently the plate coil is swung wide open, as far as it will go and the plate coil tuning accomplished by the plate condenser thirteen.

The winding of the primary coil or coils will probably cause the average amateur the greatest difficulty, as no idea can be given here as to just what size these should be. Not less than 10 turns should be used. Most amateurs will be able to

judge about what size to start on by the number of turns they already use for a given wave, then after a start is obtained the rest is easy. Perhaps the best plan would be to wind the coils for 10, 15, 20, 25, 30 and 35 turns right at the start (6 coils in all); then you will be practically sure to have sufficient coils for primary secondary and plate for all the amateur waves. After these other coils are wound as needed and while this method may seem a little clumsy to some or too much work to others, I do not believe there has yet been brought out anything that will equal them under actual working conditions, and the advantage you have in working out the exact number of turns, size wire spacing, etc., for each coil to bring the set up exactly to your individual requirements is not to be overlooked and will in itself add much to the efficiency of the set.

The coils are all wound in the same direction and with as large size wire as the number of turns necessary on a certain width cylinder will allow. They are held facing you as in Fig. 2. The wire is started on the side towards you and wound to the right. After the correct number of turns have been wound on, and the end of wire made fast, it is mounted on the plug by the Bakelite band in the regular DeForest manner, care being taken that in all coils the end of wire where you started winding is connected to the plug and the last end of wire where you stopped is connected to the socket. This can be conveniently done by simply bringing the ends of wire to the metal plate and screws which holds the Bakelite band, as these screws connect firmly to the plug and socket, respectively.

After the correct sizes have been determined the leads may be soldered to the plugs in the regular manner if desired.

Be very careful to wind all coils in the same direction and to connect to the plug in the same manner.

Using a set exactly as described, amateur signals are being received on a 30 foot aerial the first week in July in twilight at distances ranging from 125 to 200 miles with an average audibility loud enough to be heard with the receiver held at arm length, while many are loud enough to be heard over the entire room. Only a single Marconi Class 2 bulb is used.

(Editor's Note: Mr. Groves is now using a filament hot-wire ammeter, with two-point switch in the filament circuit not shown. The switch cuts on and off the filament current once the rheostat is properly adjusted, and also turns it through the ammeter when desired, saving the meter and the drain on the battery when the meter is not desired.)

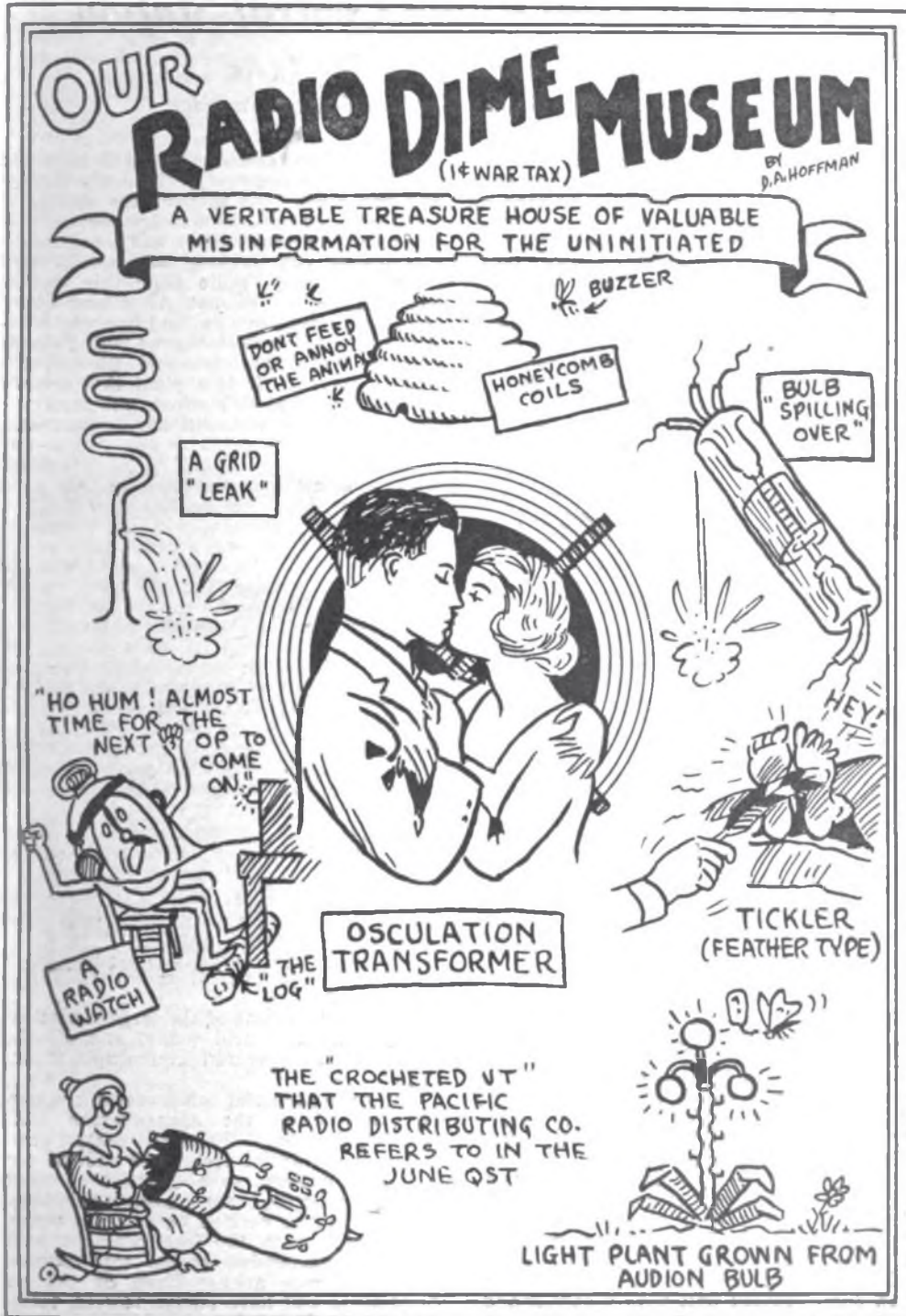

## The New York Radio Central Station

*Super Powered Radio Station To Be  
Erected By The Radio Corporation of America*

**F**OR more than two decades the wonders of wireless have so unceasingly intrigued the public imagination that it would appear little remained to be accomplished in developments of revolutionary character. Yet, once again, it is disclosed that a startling conception in wireless communication has been quietly brought to a point of realization. On the north shore of Long Island, near New York, the Radio Corporation of America is about to begin construction of a super-powered radio station that will simultaneously send to and receive mes-

operate simultaneously and will transmit and receive messages continuously during day and night. As soon as the station is completed, immediate message service will be established with France and Germany to supplement the existing commercial circuits; ultimately, radio from this station will connect up Buenos Aires and other points in South America, and two-way communication will be established with Poland, Sweden, Italy, Denmark and other European countries. It is a plant that dwarfs all existing wireless stations into insignificance; a single unit will have power and



sages from five nations of other continents.

The new and great medium of far-reaching economic and political influence will bear the name of New York Radio Central Station, the steel towers of which will arise on a 6,400-acre tract, comprising nearly ten square miles of land lying east of Port Jefferson, with a long frontage on Long Island Sound. The preliminary engineering studies have been completed, contracts for all the construction material are being let, and the J. G. White Engineering Co. is immediately taking the big job in hand.

There will be five complete transmitters, each one a duplex unit with a corresponding receiving station located nearby. All five transmitters and the five receivers will

range the equivalent of the largest wireless stations in the world today, and all the units may be operated in multiple if desired.

The form of aerial construction is a new departure using the Alexanderson multiple-tuned system. From the central power house six aerial spans will radiate out in a star pattern, to a distance of more than one mile from the center. This huge antenna will be carried on self-supporting steel towers, each 400 feet in height, with the wires suspended at the top between 150-foot across arms. Each of the six T-antennae will have twelve towers, forming, so to speak, the spokes of a giant wheel fashioned out of seventy-two miniature re-

plicas of the famous Eiffel Tower in France. Five of these antennae will be used for regular service while the sixth is reserved for emergency operation.

The apparatus and system which will be installed for each of the five units will be the same as that at present in the New Brunswick station. Every exacting requirement of commercial radio message service will be satisfied in the apparatus of circuits with which the station will be equipped. The generation of the energy will be effected by Alexanderson alternators constructed by the General Electric Company. This machine is the concrete expression of an ideal which electrical engineers have held for many years, for it represents a perfected generator of high frequency electrical oscillations constructed along the lines of the ordinary power house dynamo. The problems solved by Alexanderson, chief engineer of the Radio Corporation, were thought insurmountable. Because the transmission of radio signals requires alternating currents of frequencies a thousand times or more in excess of those used in power engineering, it was considered beyond the range of practicability to obtain such currents from a dynamo. In the Alexanderson alternator equipment, the new station will have a source of energy as reliable as the power dynamo, yet creating a steady stream of electromagnetic oscillations. So efficient and reliable has the Alexanderson 200-kilowatt alternator installed at New Brunswick proven itself, that leading radio experts of Europe have made special trips of investigation to the United States to view its performance; now this already famous single machine is to be duplicated and installed in the New York Radio Central Station; but this time there will be two 200-kilowatt machines for each transmitting station—ten in all. The achievement, from a radio engineering standpoint has nothing approaching a parallel: ten alternators, 2000-kilowatts, 3000 horse power—an astounding force to concentrate in realization of a dream to transmit messages over the world to all points of the compass from a single source!

A great saving in power is effected by the use of the Alexanderson multiple-tuned antenna. In fact, for the same power input formerly used for a single station, six times the effectiveness at a distance is obtained. In other words the same effect at a distance with 200-kilowatts input is obtained as would be obtained from the old type of antenna with 1200-kilowatts input. This new type of antenna is the equivalent of six independent radiators, all operating in unison at the same wave length, and for the complete station with its five antennae units, the power required will be less than 20 per cent. of that formerly necessary.

The project however, contemplates additional possibilities. To illustrate: in many cases, but one-half of a single spoke of the antenna system may be utilized for communication service to a certain point. On this basis the Long Island Station will ultimately permit simultaneous transmissions to a maximum number of ten points in the world, thus doubling the communication facilities originally planned.

The receiving aerials are of a new type, designed for operation with the improved Weagant system of stray elimination, which, by a combination of opposed electrical circuits, nullifies the effects of atmospheric electricity and makes possible uninterrupted reception from foreign countries under all weather conditions. We understand the Weagant system has been greatly improved since its announcement, and that Dr. Alexanderson has chosen it as the best available circuit for this work. The receiving units are located only eighteen miles from the multiplex transmitting equipment, instead of following the former practice of establishing one transmitter and one receiver in one locality and restricting the service of the circuit to one overseas destination.

The arrangements for distant control of the New York Radio Central Station follow the same policy of concentration. In Broad Street, the heart of New York's financial district, the company's public telegraph office is being re-equipped to handle the new station's traffic along with the radiograms which are now received for England, Norway, Hawaii and Japan. Thus messages for any of the five additional countries reached by the new station will be received in the New York City office and dispatched direct from a series of operators' keys and relays which will operate the transmitting apparatus out on Long Island. Messages from overseas will ultimately be received in the same manner, receipt and delivery of the actual messages being effected by the customary messenger boy service direct to the home or office of the patron.

It is expected eventually to install apparatus for high speed transmission and reception, photographic tape recording being used for the latter. This will be under the supervision of a trained staff of operators, along with which there will be the usual staff of expert Morse operators, who will work those circuits over which high speed transmissions is not taking place.

Countless details of technical interest and engineering importance are embraced in the specifications for the station, due to the combined personnel of the Radio Corporation and the General Electric Company, an arrangement made possible by the recent merger effected by these interests and the absorption of the Marconi Wireless Telegraph Company of America.

# Old "WCC" Cape Cod

GENERAL VIEW OF THE OSCILLATORY CIRCUITS

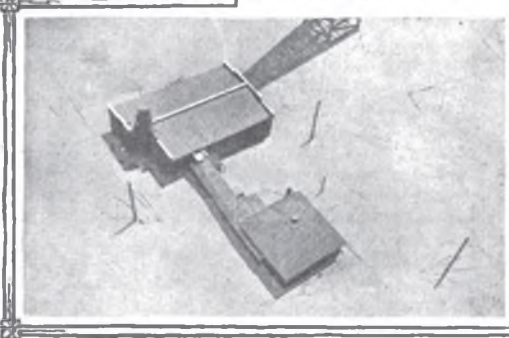
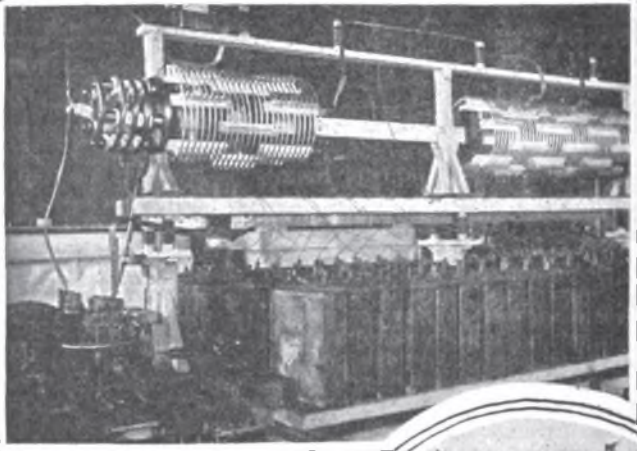

LOOKING DOWN ON THE POWER HOUSE & RADIO ROOM FROM THE TOP OF ONE OF THE TOWERS

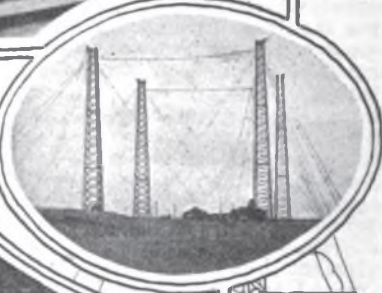

THE FOUR WOODEN TOWERS

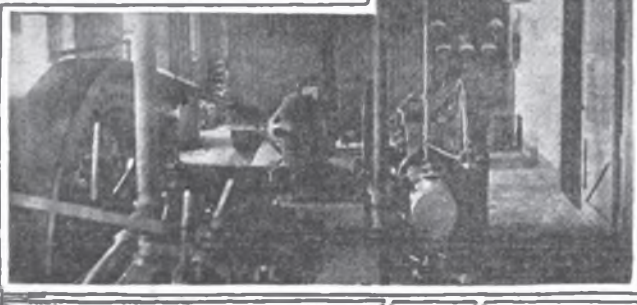

THE POWER-HOUSE INTERIOR



THE SPARK-GAP PHOTOGRAPHED BY ITS OWN LIGHT





# Old "WCC," Cape Cod

By "An Old Timer"

**M**ANY will remember the low note of Marconi's old South Wellfleet station which is now but history, the station having been torn down and nothing but the sands of Cape Cod remaining to tell of the radio days of the famous old station.

The several photographs will give an idea of the station and the equipment of the times before the war. There were four wooden towers 200 feet high, set at the corners of a square about 300 feet on a side, with the power house and radio room in the center of the square. Instead of a ground a counterpoise of wires on poles about fifteen feet above the earth was used. Transmission was by Wheatstone tape or hand, at will. In the engine room was a 50 h. p. oil engine belted to a Westinghouse alternator, 60 cycles, 1100 volts, a small D. C. generator for excitation and to charge the storage battery; and the two transformers which stepped the voltage up to 22,000. An unusual feature of the station was that the key, instead of breaking the primary circuit, broke this high-tension

circuit. From the transformers the current passed through two air-core chokes to the high tension room, then through oil chokes, to the automatic key, which had blowers to quench the arc, thence to air chokes, and on to the condenser, gap, and oscillation transformer.

There was a Western Union office at this station and the traffic was received in the day and punched on a tape, and at 9:30 P. M. we would start to send, stopping every fifteen minutes for five minutes. At the end of the schedule we would wait fifteen minutes and then repeat until we had run the tape three times. When traffic was heavy it would take us until nearly daylight to finish. On a clear cold night the writer has heard the spark while walking on the beach five miles from the station.

Farewell to old WCC is the wish of  
**ONE OF ITS OLD MANAGERS.**

(In an early issue we will have a similar story on old SA of 1904, the early Naval station in Puerto Rico.—Ed.)

## Code Instruction Tables

**S**EVERAL of the Affiliated Clubs have asked for a wiring diagram for a good code-practice table. We present here a most ingenious and versatile hook-up, devised at one of the flying fields during the war and adopted as a standard at Air Service schools.

In this circuit the buzzer or other source of musical frequency is permitted to oper-

ate continuously, the keys controlling merely the connection to the head-sets. All the apparatus shown at the left-hand side of the diagram is located at the head of the table, where sits the instructor. C is a 1 mfd. paper condenser, for insulation purposes. R is an adjustable resistance for controlling the strength of the signals, and may consist of three 500-ohm carbon

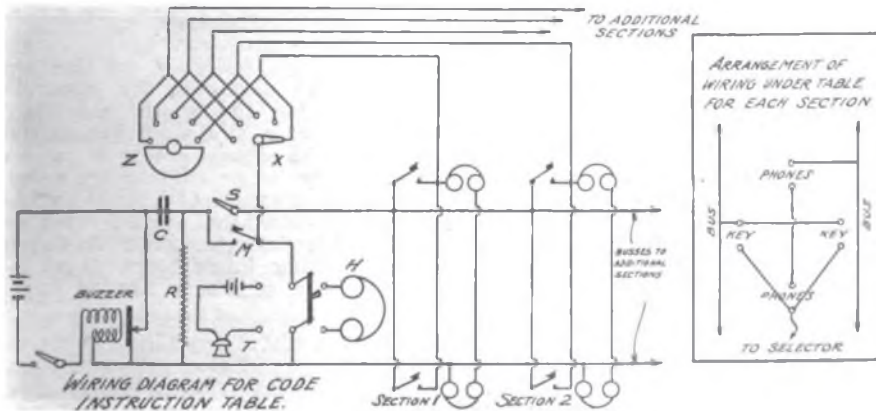

rods in series, with means for cutting out one or more. Switch S controls the continuous note to the bus lines, M is the master key H the instructor's head-set, and T a microphone and battery for speech when necessary. The remainder of the table is divided into sections, preferably by wood rails about three inches high, and each section consists of apparatus for two students, who sit facing each other and whose apparatus is interconnected. From each section another wire runs back to the instructor's table and is connected to a point on each of two switches, one X, a selector switch, and the other Z, a short-circuiting switch, the rotary member of which consists of semi-circle of metal capable of shorting all the points when revolved.

In operation, the switch Z is turned to short-circuit all these leads, switch S opened, and the instructor may then transmit to the whole table by means of the key M, the keys in the individual sections being out of the circuit. Opening switch Z and closing switch S, the circuit is so arranged that the two students in each section may have inter-communication, without interference with other sections. Furthermore, by manipulating the switch X, the instructor may listen in on the work of any section, and correct errors or give advice by switching in his microphone, all without disturbing the work of the other sections.

The insert in the figure shows the wiring necessary for each section, and will be seen to be extremely simple.

This circuit works excellently, and the advantage of providing inter-communication between many groups of students with individual instruction, as well as the simpler problem of transmission by the instructor to the whole table, can not be overestimated. If desired, one or two additional transmitting units can be connected in parallel across the busses, tuned to different pitches, and operated by assistant instructors. This will give practice in reading thru interference which is of the highest value and will render a most life-like imitation of the condition of the "air" on 200 meters on an average night.

### **SOME CHARACTERISTICS OF THE UNDERGROUND SYSTEM**

"The underground system for long wave reception, using optimum length wires, gives roughly the same signal strength as an average 100-foot antenna; while for short wave lengths the signal strength is a function of the wave length, and it may

be said that the shorter the wave length, the weaker the signal. This may be attributed to the skin effect of radio frequency current with reference to the penetrating qualities of such current thru a partial conductor. For a wave length of 600 meters, the signal strength as received by the underground system, is approximately one-twelfth as strong as a signal received with the overhead antenna. For efficient reception on short wave lengths, it requires an amplifier using three stages of radio-frequency, which gives a signal that is approximately of the same strength as that of a signal received on the overhead antenna unamplified.

"The underground system has excellent directional qualities. Using two wires in the direction of the transmitting station, the maximum signal is obtained; while using two wires which lie in a direction which is at right angles to the transmitting station, the minimum signal is obtained, and in many cases is not heard. It is possible that the operator on watch can, at any time, ascertain the approximate direction from which the signals are coming by means of using various combinations of wires. A good stand-by tune, by which the operator can hear all stations, is obtained by the use of two wires at right angles to each other, namely an east-and-north combination, and so on.

"It is very essential in this system that all wires be perfectly insulated; wires that are grounded bring in more strays altho when wires have been perfectly grounded, the stray ratio is still equal to and often better than that of the regular antenna. However, to obtain the best results from the system, the wires should be clear of all grounds.

"For short wave lengths it is highly essential that the optimum length of wire for each wave length be used. Altho by means of high amplification the proper signal strength may be obtained, for efficient results the optimum length should be used.

"There is a tendency on the part of operators to disparage the ground wire system during the winter months when strays are at a minimum, because of the fact that the signals are so much weaker than they are on an antenna with the same degree of amplification, but during the summer months the ground wire system demonstrates its superiority. In the matter of eliminating interference from nearby stations it is, of course, always superior."

Abstracts from "The Use of Ground Wires at Remote Control Stations," by A. Hoyt Taylor and A. Crossley, Proc. I. R. E., June, 1920.

## A New Type of Variable

**T**HE Connecticut Telephone & Electric Co. have produced a condenser which is entirely different from anything now on the market, both in design and in results obtained in operation.

This is a very convenient instrument, being extremely compact, stable and free from mechanical fluctuations, of very low effective resistance, and simple in design. Figure 1 illustrates the construction, an exterior view of the condenser being shown elsewhere in this issue.

It consists essentially of two plates, B and D. B is fixed, and not only forms one plate of the condenser, but at the same time is a support for the entire unit. The plate D is free to move to and from B. The surface of B is covered by a thin washer of mica C, and the plate D has secured to its underside a block of insulating material which supports the guide rod and the screw. This guide is slotted at either end and passes over pins. This latter arrangement prevents the plate D from rotating when the nut is screwed down upon the shaft. A spring placed upon the screw operates to open the plates when the nut is unscrewed on the shaft. The variation of capacity, then, is obtained by merely screwing the nut upwards and downwards upon the shaft, which moves the plate D to and from B. The thread on this shaft is selected, however, so that the entire range of capacity is secured by one turn of the nut, although the scale may be loosened and secured in some other preferred position.

The outside dimensions of the Connecticut condenser are 2 1/8" diameter and 1 3/8" height to the dial, the required capacity being obtained within this small space by

the use of an extremely thin dielectric—a sheet of mica .0005" thick—for the upper values; while, on the other hand, the presence of the mica, when the plates are considerably separated, hardly affects the capacity, the air dielectric then being the main factor. The result is that this condenser has a very high capacity at the upper end of the scale, and a correspondingly low capacity at the lower end, the

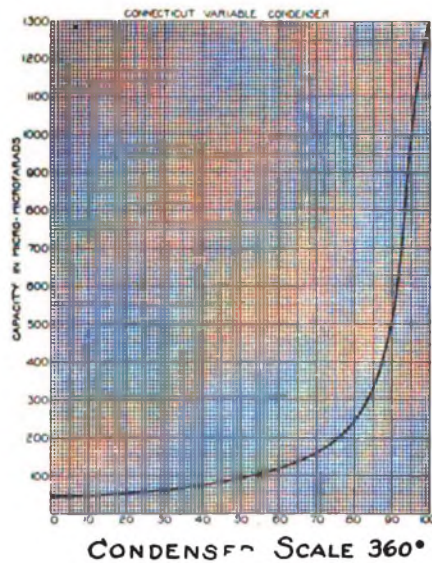

Fig. 2

whole being distributed over a scale length of 360 degrees. Fig. 2 is a typical calibration curve, in which this effect is clearly shown. The presence of the mica becomes evident only at the upper end of the scale, the sharp upward bend of the curve being caused by it. At any adjustment capacity is inversely proportional to

$$\frac{M}{K} + A,$$

where M is the thickness of the mica, K the dielectric constant of the mica, and A the distance from the outer surface of the mica to the movable plate.

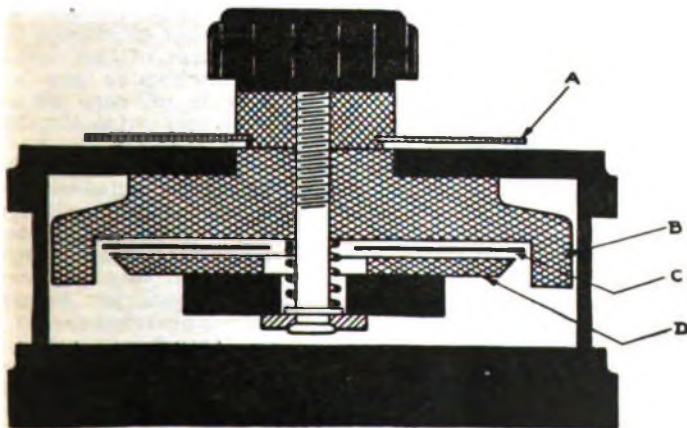

Fig. 1

### A BOARDWALK ROLLER-CHAIR RADIOPHONE

One can now find a genuine radio novelty on the boardwalk at the famous seashore resort, Asbury Park, N. J. Great excitement was caused recently when a roller chair containing three passengers and a wireless telephone and telegraph receiving apparatus made its appearance on the boardwalk.



As can be seen from the picture, the passengers are thoroughly enjoying this innovation introduced by W. Harold Warren, who some time ago demonstrated that it is possible to receive wireless telephone and telegraph signals within a steel and concrete bank vault with both inner and outer doors closed and with no external connections with the receiving apparatus. This equipment now makes it possible for a man to enjoy himself in a wheel chair on the Asbury Park boardwalk and at the same time have his New York office talk to him by radiophone or for his wife to get a land line connection with the New York radiophone station and say "Where are you, John?"

The apparatus is very compact and consists of a loop, a detector, and an amplifier. The loop is of the flat type and measures eighteen inches on each side. The cross supports and protecting frame are made of white pine lattice  $\frac{1}{4}$ -inch thick by  $1\frac{1}{4}$  or  $1\frac{1}{2}$  inches wide. Each of the cross supports is  $25\frac{1}{2}$ " long. Commencing  $3\frac{1}{2}$  inches from the center, saw cuts  $\frac{1}{2}$ -inch apart are made on both edges on each of the four legs, in which No. 26 S. C. C. wire is tightly wound, making a double web. Leads are taken from the ends to the detector circuit. No coils are used, tuning being accomplished solely with the variable condenser. There are 18 turns on each side of the loop and approximately 90 feet of wire is used. This size of loop is most effective for wave lengths from 300 to 500 meters, but good results have been obtained on wavelengths up to 800 meters.

### CLAPP-EASTHAM 1-2 KILOWATT HYTONE TRANSMITTING PANEL

The demand for an amateur spark transmitting panel at a moderate price was taken into consideration when this set was designed.

The instruments are mounted on a half-inch Bakelite panel  $16" \times 24"$ . The panel is suitably engraved, and high tension binding posts are mounted in the upper right hand corner for antenna and ground connection. The Hytone rotary quenched gap

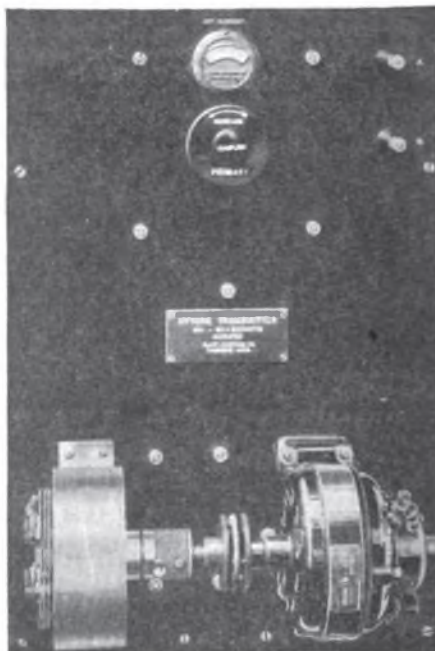

and motor are mounted on the front of the panel, as well as the knobs to change the coupling and primary turns of the oscillation transformer. The Hytone gap has been redesigned and is of cast aluminum, which provides a very attractive finish when machined.

In the rear of the panel are mounted the transformer, Dubilier mica condenser, and oscillation transformer. The oscillation transformer is constructed entirely of Bakelite and nickel-plated copper strip. Three are five turns in the primary and ten turns in the secondary. Adjustment of the secondary is provided for by a clip. All connections are of copper braid, which provides against undue resistance and loss of efficiency. With an antenna of 10 ohms resistance, this set is said to be capable of over 5 amperes output.



### The Ultimate Receptor

**T**HERE are too many thuminjigs, dingwhackers, and rettysnitches on a modern amateur receiving set. With all the various features to adjust, it takes too much precious relay time to shift from one wave to another, however slightly removed, and again secure the optimum adjustment all around. On an average set there are at least four adjustments to be made, and there may be seven or eight. Too many. Life is fleeting and we need improvement to better present consumption of "man-hours-per-message", as our grouchy friend, The Old Man, puts it.

Understand us, we do not wish for a minute to disparage the splendid tuned-plate-circuit regenerative tuners we have now. They are the best receiving sets we have ever had and our present good work is largely possible because of them. But can't our manufacturers whittle down the number of necessary adjustments and retain the good features of selectivity and high regeneration and so increase their value in relay work?

For a long time we've had in our mind's eye a picture of this Ultimate Receptor. A compact cabinet; a panel with just two large easy-turning knobs; one marked "Tuning" and arranged for calibration in wave lengths; the other to control "Regeneration". Wouldn't it be a great time-saver! Why, it takes a man a season to learn how to get the most out of our present sets, and it takes an expert a half minute to make a shift of wave length and get all the variable elements in their optimum adjustment again. Consider the set we have in mind. One element would control the tuning; properly tuned, there would remain only to adjust the regeneration to the critical value. (We are sure the regenerative feature is vital and must never be dropped, and that it is not possible to satisfactorily combine it with the frequency-adjusting member.)

Now for the principles—what shall they be? There is the single-tuned-circuit arrangement, a relic of the single-slide tuner days, and those who worked with the small Western Electric telephone sets dur-

ing the war know that they performed well. But they do not very well lend themselves to regeneration, nor do they seem selective enough. Mr. R. E. Thompson has recently patented a mono-control arrangement for commercial ranges which employs (with a crystal detector) a secondary inductance whose winding is so widely spaced that the distributed capacity is to all practical intents nil. Such a circuit, then, should act with true aperiodicity, make feasible a fixed coupling of such magnitude that the transfer of energy would be efficient and almost without reaction, and, it seems to us, should be capable of satisfactory regeneration when used with an audion detector—particularly since the range of wave lengths may be quite small. With the aerial circuit range adjustable by a variometer or series condenser, we would have it.

Something along this line is needed. Can't we have it, Mr. Manufacturer? The first man that comes along with it will gather in the berries.

### The Great American Noise-Maker

**S**URE, you guessed it—we mean the spark coil, the poor, sadly abused squeak box. But if you think this is another knock at that long-suffering piece of equipment, you are wrong. We've been accused of that too often. A certain man who owns a spark coil because he can't get alternating juice and who thinks we are unjustly hard on the coils, nearly beat us up recently over just that.

It isn't the coils themselves. They are perfectly respectable in proper hands, and although their potentialities in hands of other types give us the wooly willies we have all beheld the tragedy of a "rich" ham bursting into the game with a shiny new kilowatt transformer, and not a man of us but knows that he will cause X times as much clatter as any coil set in existence, the factor X being a number with seventeen more ciphers on it than our printer owns.

This must be admitted in common justice. It is because the coil is cheap and hence the starting equipment of so many

beginners who are nightly a source of provocation, that it has been brought into the Night Court. Very often when we sit trying to find a hole in the smother it is these gentry who are mutilating the air with flivver-boxes, and generally by the time an amateur reaches the "transformer stage" he has progressed to the point where he does not impose upon the rights of others. The result is that generally we see only the trouble the coilers make.

Now the Editor started out these many years ago with a gas engine coil, and he didn't know the code, and he hadn't heard of law and order in amateur affairs, and he had no idea how much racket he was making. So we know just how the game goes, and it seems to us, fellows, that condemnation is not our proper attitude towards the offending operators of spark coils. Thank your particular lucky-piece that it isn't a kilowatt, and go help your friend of the broomstick tuner and potato detector to get better. He probably knows much more than you did when you'd been in the game only that long, and he is the very material from which star A.R.R.L. stations are eventually made. Now that the hot weather is on and some of us DX men haven't much to do, why not give some time to visiting these coil stations, see what they have, and help them to get the best results out of their sets. That means adjusting the coils to a good clear tone and a good sharp tune, which will give them their best range and yet minimize their disturbance.

And haven't you realized that if these Juniors in the game only could hear the things you do, there would be more co-operation? We know one city where the local club made up a bunch of regenerative receivers and audion panels and sold them at cost—a very low figure—to the J.O.'s. The result was almost miraculous. Where bedlam had reigned supreme, all was as it should be. The beginners found that the older men were willing to help them, they could hear what the older men heard, co-operation entered too, and there was much less temptation to pound the key just to stir up something to listen to.

Here's another idea. Take these coil men out to your station, one at a time, set them down at the key, and tell them to go to it. Most of the time they haven't any idea what you are nightly up against but listening in on your set will show them. Let them start working somebody and then have a squeak box start nearby with the typical display of superfluous signals, adjusting the vibrator, useless talk at one word per minute, and a wave as broad as Texas. A sense of appreciation will dawn on them.

Remember, their right to the air is as

inviolable as ours. The situation demands co-operation. "Tolerance", as the Old Man says—tolerance, and education. Give the boxers a lift—it will pay.

### Club Affiliations

EVERY month sees an increase in the number of stable organizations affiliated with the A.R.R.L. In this way we are building up a fine structure that will stand the amateur in good stead whenever any matter arises that requires concerted effort for its conclusion.

These are the live-wire clubs, the far-seeing clubs, who are interested in the handling of relay traffic and who perceive the value of organization for all things. Let us repeat that in affiliating with the A.R.R.L. a society in nowise loses its independence or merges its identity. The A.R.R.L. does not seek that. Our sole aim is the creation of a complete fabric covering the amateur world, whereby, through co-operative effort, we may always enjoy the pursuit of citizen radio, progress in knowledge, and increase the efficacy of our traffic handling. The bond is a moral one—as it properly should be.

Clubs, if you think as the A.R.R.L. thinks on matters concerning the amateur, communicate with us on the subject of affiliation.

### Radio Jobs

THE current issue of "Electrical Merchandising", a magazine devoted to the retail electrical supply trade, contains several articles pointing out to electrical jobbers and dealers the value of stocking a line of radio apparatus and cashing in on the ever-increasing demand for supplies and equipment. Most of these articles stress the importance of securing the services of a live young amateur to head the new department. The A.R.R.L. has them.

It looks to us like there is going to be a good demand for radio salesmen with enough executive ability to take hold of such a proposition and make a go of it. He'll have to be a business man, or he can get nowhere; and, just equally as important, he must know his radio in order that he may give sound advice to customers. The peculiar combination of these two qualities is worth money in the radio business today, and we believe that those inclined that way can with profit prepare themselves for some good positions in work that never grows uninteresting.



# THE OPERATING DEPARTMENT

J. O. SMITH  
Rockville Centre, L. I.  
TRAFFIC MANAGER.



**R**EPORTS from several of the Divisions have not been received this month up to press-time. Although indications are that business there is much as usual and the failure to render reports is probably due to the fact that this is the height of the vacation season, it is very desirable that we have accounts of the divisional progress as usual.

In the past month the effect of strays has been felt to a considerably greater degree than heretofore this summer, and is reflected in the reports. At that, however, the volume of traffic handled seems to be in the neighborhood of fifty per cent. of the winter normal, and this is considered a splendid showing in view of the fact that this is the first summer in which we have made a really determined effort to keep routes open and things moving. With the experience gained this summer, and the technical improvements which will doubtless occur, we feel that there will never again be occasion for slackening relay activities in the summer months.

Traffic is being handled with absolute ease over territories where daylight routes are in operation, and the Traffic Manager wishes to again bring to the attention of the personnel the desirability of formulating short-jump routes with the stations within daylight range of each other. Station owners who are persevering in their operation through these months are finding the game well worth while, with only the long distance stations cut off from them, and with the increasing perfection of our routes, the summer handling of traffic is gradually reaching the efficiency of winter operation over the whole country.

Reports from the Division Manager follow:

## PACIFIC DIVISION A. E. Bessey, Manager

The situation for the summer is pretty bad, although we are keeping the routes open much better than any other summer before. The Bay district is all going fine and the stations are getting tuned up in great shape, more amateurs than ever doing long distance work, even under the adverse condition of the summer QRN. The routings through the north and south

are only reliable through 6EJ, who is keeping his hands full handling the relay work. He certainly has a wonderful location, as he is still going strong both north and south and is practically the only reliable route either way. At this particular time a good many of the stations are taking their vacations and there is not much work being done. There have been some tests made with 7CU, which worked very satisfactorily. We have a few new stations that are coming into prominence now. 6BJ of Burlington who is burning the air for fair, and promises to be a wonderful long distance station. He is heard in San Diego very QSA. The southern amateurs are heard here occasionally but are not at all reliable. 6AB of Healdsburg is doing nice work. 6OH of Ukiah is also doing splendid work. His spark is heard all over. The Bay section hears 6JI very good but up to the present time have not heard of any one working him.

We have this month a report from A. E. Banks, 6IY, of San Diego, which we have long wanted as we have been unable to get any report from San Diego lately. The last month has witnessed an aggravating increase in QRN which together with QRM from an almost constant arc and high power spark has made long distance work difficult. Communication has been carried on, however, with Los Angeles, Long Beach, Laguna Beach, and Del Mar, and a good number of messages have been relayed through stations 6JD, 6EM, 6SK, 6IF and 6MZ by our local operators. The following stations are using from one to two step amplifiers and are competent to handle traffic in San Diego: 6XZ, 6JI, 6TW, 6IZ, 6IY, 6MZ.

While northern stations are very QSA at all times it has been difficult to get answers from them, the reason no doubt being local QRM. This has been the case particularly with the Los Angeles stations and it is understood that the interference in that city has increased to such an extent that traffic has been steadily interfered with. It is believed that if some earnest individual made a survey of some of the high powered spark stations as well as the arc with a 200 meter wave meter he would be able to suggest grounding certain un-

grounded guy wires, etc., which are causing disturbances among amateur circles. There seems no reason for such an abundance of harmonics unless something such as the above is needed.

6EJ of Walnut Grove reports: A new member was added to the route here, a Mr. Adams of Stockton, 6KM, who joined the ARRL, thus giving us a member in Stockton who has a capable spark. 6GR of Sacramento has been successful in long distance work this month, clearing 7CU on several occasions. 6EJ and 6AK are clearing both north and south including Fresno, very well. All local routes in good order.

6DP of Santa Cruz reports route open to the south and has worked many of the Bay County stations. The boys in Santa Cruz are all getting nicely equipped and will soon be on the job for relay work. A. L. Munzig, of Redlands, Calif., is just securing a special license and we feel sure that this will open up the southern route so that we will be able to work through very nicely. He is an old timer and a commercial man so that he will have no difficulty in handling traffic.

There is a great wave of club organization at the present time which we feel sure will make it very interesting for winter work. All the Clubs seem very favorable towards affiliating with the ARRL and as soon as we get banded together and start working for a common interest believe that we will have better co-operation on relay work.

#### WEST GULF DIVISION F. M. Corlett, Manager

Radio activities throughout this division, as far as relay work is concerned, seem to be pretty much at a standstill. Old Man Static is right on the job with both feet and usually keeps a brick or two on his key to be sure that we don't handle anything.

District Superintendent White of Northern Texas and Tilley of Southern Texas have been endeavoring to work out a daytime schedule for Trunk Line "F" in order to keep it open all summer; some tests were run and all indications were that it would be an easy matter to handle traffic with ease IF the Stations IN LINE COULD BE DEPENDED UPON TO BE ON THE JOB ON SCHEDULE.

District Superintendent White, of Northern Texas District is spending his honeymoon in Colorado but sends in a brief report. He expects to be back in Texas shortly and invites correspondence from prospective as well as station owners. Address him at District Headquarters, Box 322, Ennis, Texas. He reports some ten stations under construction in the upper Panhandle of Texas. These stations will

help us on our swing westward next winter. Why not get lined up for some day-light tests NOW, as soon as the stations are ready, and see if we can't work WEST this Summer? Assistant District Superintendent Martin, of Amarillo, is doing some good work along the organization line, a club is being organized in Amarillo and it really seems that our dreams of an amateur radio station in the Texas Panhandle to help bridge some long jumps west will soon be a reality.

The Waco Hertzian Society has secured permanent meeting places at Hills Business College, and a club station will be erected there. In a recent parade in Waco the A. R. R. L. as well as the Waco Club was represented by an elaborately decorated automobile which created much interest among the spectators.

District Superintendent Tilley, of Southern Texas District, has a rather meager report to make. Radio in his district is about dead for the Summer it seems. A number of stations are taking advantage of the lull and are putting their stations up in first class condition. Tilley, 5ZU, is rebuilding his antenna system, putting in 70' masts; other improvements are a quenched gap, regenerative receiver, and an elaborate ground system. You fellows with good stations in Southern Texas get in touch with Tilley and let's see if a day-light schedule can not be arranged.

District Superintendent of New Mexico, Louis Falconi, is evidently so busy getting all fixed up for the coming season that we very seldom hear from him by mail and of course the jump is entirely too long to hear from him by radio. We understand that all that good receiving work he was doing last winter was on a straight loose-coupler and a couple of "lamps" and that he is now putting in a regenerative receiver and all the fixings. We wonder what he will do this winter. Let us hear from you, Falconi.

No further developments in the Oklahoma District as yet.

#### ATLANTIC DIVISION Chas. A. Service, Jr., Manager

Hot weather has brought most of the relay work to a standstill in this Division with the exception of daylight routes in operation between some of the larger cities. QRN is so intense most of the time that there is no chance of getting MSG traffic through except by the short jump method, although DX stations may be heard and worked on the few favorable nights with surprising ease, considering the time of year.

The Bureau of Standards QSS tests continue to hold the interest of the amateurs and by the time this report is published the A.R.R.L. Division tests of a similar nature



will be in full swing and, it is hoped, will be as successful. The Division Manager urges all amateurs capable of receiving these tests regularly to send in results as requested in the June and July issues of QST.

We note that the Navy Department is taking a greater interest in amateurs as indicated by the QST's which the various Navy Stations are sending for the benefit of the amateurs in New York, Philadelphia, the West Coast and elsewhere. The Navy realizes there is undoubtedly a good field for recruiting radio operators in this way and at the same time, to promote friendly feeling on both sides and a consequent cutting down of amateur QRM on the higher tunes.

The Division Manager has an accurately calibrated receiving set and has made measurements of local and long distance amateurs in his Division during the spring and early summer months and has found there is a universal tendency everywhere to cut down wave length within legal limits, and to pay some attention to decrement. This may be attributed to several causes:

1. The higher degree of skill and technical knowledge of the general amateur world.
2. The use of wave meters and the influence of A.R.R.L. and local associations' propaganda and assistance to junior members.
3. The knowledge that long distance work can be done on 200 meters with proper adjustments of transmitters and the use of amplifiers at receiving stations.

This is fine business and should be continued.

Reports from different sections of the Division are as follows:

Mr. Hornung, District Superintendent for New York, reports that the Y. M. C. A. Radio Club has been keeping a continuous watch and has been copying the QSS signals sent by the Bureau of Standards. New life has been injected into the Y. M. C. A. Radio Club. They are now printing a two-page semi-monthly bulletin called the Loud Speaker. In addition to this, they also have formed a free code and theory class for club members. Clubs throughout the country should take this movement up and help the ARRL by becoming affiliated. Traffic in and around New York has been pretty dull, due to excessive QRM and QRN.

Mr. Goette, District Superintendent for Brooklyn also reports that traffic has fallen off due to the coming summer season; very little western traffic is coming through. It is impossible, due to heavy static, to work any distant 3rd or 8th district stations.

The Radio Traffic Association of Brooklyn closed their last meeting of the season with a membership just falling short a

trifle under one hundred members. The first meeting of next season will be held in October.

According to advice received from the Bureau of Standards, the fading tests, so far, have been very successful. These tests are now known throughout this district and very little interference is being experienced from stations other than the official transmitters. As yet, Station 9LC has not been heard but the others have been coming through very good.

Mr. Spangenberg reports very little traffic in Northern New Jersey.

2QR (Robinson Bros. of Keyport, N. J.) has just been assigned to the traffic department of the ARRL. Mr. Frye has just appointed Mr. H. J. Hemphill 3DT as an official ARRL station in Atlantic City.

A peculiar condition exists between certain shore stations in Atlantic City and vicinity, it being possible to get daylight signals from stations on Long Island and New York vicinity. This is very encouraging and may result in a daylight route from New York to Philadelphia and vicinity. With the help of Mr. Smith (2ZL) and several others, a series of tests will be arranged in view of completing this route.

A series of tests have been carried on between Mr. R. C. Ehrhardt (8CE) near Scranton, Pa., and the station of the District Superintendent in an endeavor to connect Scranton with Philadelphia and vicinity. It is hoped that such a connection will be made in the near future although very little consistent traffic work has been done to date.

Stations which deserve the credit for having carried on the bulk of the traffic during the past month are: 3EH, 3MU, 3BA, 3FB, 3DT, 3NB.

The District Superintendent is pleased to report that the amateurs in this district have uniformly observed the request of Bureau of Standards to stand by during test hours. Very successful recording work is being done by the recording stations in this district. The spirit shown has been of the best and every station stands ready to do anything that will be of aid in bringing these tests to a successful conclusion.

The non-delivery of certain traffic has been called to the attention of the District Superintendent. Such cases were reported as long as three or four months ago. Test messages were sent and but 30 per cent. of this traffic ever reached its destination. The points of non-delivery were Philadelphia and New York City, chiefly the latter. The conditions in Philadelphia have been improved and the cause of non-delivery traced. But delivery in New York City has proven uncertain and unreliable. This is no doubt the fault of the smaller stations to whose hands the traffic was entrusted. Care has been taken to forward

traffic to prominent and reliable stations in that vicinity and addresses have been repeated and sent with care, but the results have been no better. I believe this matter should be brought up in meetings of local Radio Clubs and the importance of delivery impressed upon the members, especially the owners of the SMALLER STATIONS who, in most cases, are asked to assume the responsibility of delivery. It is fine work to transmit messages hundreds of miles and accomplish all kinds of DX work but the little fellow who delivers the message deserves EQUAL CREDIT in my estimation. Let's give the credit he rightly deserves together with some encouragement and perhaps the coming winter will see more traffic reach its final resting place, especially in the larger cities.

The District Superintendent for Eastern Pennsylvania has the following to report:  
**Condition of Trunk Lines and Branch Lines in Eastern Pennsylvania District:**

(a) Trunk Line B—Northern route, no station has yet been found to replace 3GX in Reading. The Pottsville station is not yet in commission.

(b) Trunk Line B—Southern route. No further progress.

(c) Trunk Line D—Stations 3DH and 3EE, the connecting links to the northward on this route, have not been active recently, and traffic for New York has been handled by long jumps. Southward, satisfactory communication with 3BE has been established through 3ZA station; 3BE has, as far as known, no outlet to the south.

(d) Branch Line No. 1. Station 8CE at Scranton has been very active, and has succeeded in handling some traffic through 3NB. This may provide a temporary method of routing traffic to the northeast part of Pennsylvania, until the shorter jumps are in working order.

**Conditions Around Philadelphia:**

3ZA station has recently been put in full commission, and has handled considerable traffic from Philadelphia by means of long jumps.

The District Superintendent for Central Pennsylvania reports that—

Conditions in the Central Pennsylvania District have not changed to any extent since the last report was made. Efforts to locate relay stations between Milton and Pittsburgh have so far failed. No reply has been received, to date, from the radio club in Harrisburg concerning prospective relay stations at that point.

Owing to the fact that the location, which was rented in order to get this station in operation at once, was sold and that he was forced to vacate, station 8BQ is out of commission again as far as his 1 k.w. is concerned. The power service is very poor and does not allow the use of this transmitter. However, he has in-

stalled an Amrad 100 watt transmitter for the present with which it is expected to reach Danville, who can connect up with Pottsville when required. This will provide an excellent chance to test the possibility and worth of 'short jumps on low power', which is very strongly in favor. Plans are being made to have a permanent and efficient station in operation by fall, if not sooner, in order to connect up with Pittsburgh, providing this long jump is necessary.

We hear from Mr. Devinney, Superintendent for Western Pennsylvania, that relay work in this district has fallen off about fifty per cent. in the last month, due mostly to warm weather and some very bad storms. The number of messages handled will run in the neighborhood of 300.

The chief interest just now seems to lie in fixing the sets up for next fall and experimenting with the CW which, he believes, will be the only thing as soon as the bulb situation gets straightened out.

**Line up of Branch Line No. 2:**

Uniontown, R. M. Sincock, J. McKinley, 8MT.

Pittsburg, B. P. Williams, 8EN.

Pittsburg, R. M. Carson, 8RQ.

Pittsburg, Wm. H. Raring, 8LH.

Monaca, J. E. Ahrend, 8DV.

New Castle, R. J. McConnell, 8ADF.

Greenville, P. A. Riley, 8CH.

Meadville, V. L. Wise, 8GN (out for the summer).

Cambridge Springs, D. M. Lord, 8WY.

Erie, The Summit Radio Club, 8UG.

There is a station at Washington, Pa., located in the High School that has been handling all messages in that locality but they change operators every term as the set belongs to the High School and of course the operators come and go, and on that account they have been left out.

Mr. Devinney's appointment of Burton P. Williams, 3220 Orleans Avenue, Pittsburgh, as his traffic assistant has been approved.

The District Superintendent for Maryland reports that radio is very dull in his vicinity with the exception of the QSS tests, which have been recorded regularly by a number of Baltimore stations. 9LC is the only station which has not been heard so far. It is interesting to note that results of Baltimore stations have so far checked with Washington stations, 40 miles away, while stations in Philadelphia get different curves than 3NB of Vineland, 45 miles away.

Stations in and around Baltimore have tried to connect with Philadelphia during June, but so far 3HG has been the only one to reach Philadelphia (3HJ) and work for any length of time. 3NB is received QSA in Baltimore and if the next season finds it impossible for Philadelphia stations

to work Baltimore direct, this may be used as an alternate route.

No report has been received from the District Superintendent of Delaware. Philadelphia and Wilmington are in communication day and night and there is little delay in the exchange of traffic. Unfortunately there is no southern outlet for Wilmington.

#### ONTARIO DIVISION

A. H. K. Russell, Manager

The past month has been bad for wireless relay work in this division. The heat has got in its deadly work and amateurs have been spending little time at their apparatus in consequence.

The Wireless Association of Ontario recently received a communication from the Naval Department of Canada, which has control of all radio matters, to the effect that the tests conducted throughout the winter of last year with a view to allowing an increase of wavelength to amateurs had proved unfavorable. In consequence for the present the fifty meter restriction stands for Canadian amateurs. The Department adds, however, that they do not regard these tests as final and will conduct more with the closing of navigation this coming fall.

This decision of the Naval Department emphasizes what has been preached by all the leading amateurs in this Division, i.e., that C.W. transmission is the only solution for the amateur in Ontario, compelled to work on so short a wave.

Considerable progress has been made by several experimenters in Toronto during the last few months in the development of C.W. transmission sets for amateur work, and it is almost certain that by the fall there will be several medium powered C.W. transmitters in operation in Toronto and vicinity, with prospects of a larger station being operated as well. In any case there is not the slightest doubt but that communication will be easily maintained by C. W. with the "8" stations to the south and west of us.

#### NORTHWESTERN DIVISION

Royal Mumford, Acting Manager  
Vancouver, Wash.

The long dreaded summer season of static and high tension induction now drowns out the distant stations and handicaps our work with those near by. Yet we continue to battle with these unfavorable conditions for the supremacy of the air. It is hard to listen to static that drowns out everything for hours at a time. But all things come to him who waits. Occasionally signals do manage to break through. Here, "sixes" as far south as San Diego are picked once in a while when static relaxes

its intensity. And "sevens" are heard at least as far south as Los Angeles.

Right here it may not be out of place to mention a little observation on my part regarding static and LD signals. If you listen in closely just before dark you hear little static and signals—well just wait for them. Often the LD start coming in fine as early as 7 o'clock. They usually make themselves heard sometime between 7 and 9. A minute after you hear one, they are coming in by the dozens. The best part of it is that static usually waits until after the LD signals have been traveling great for about half an hour or more!! Here we have a good half hour of LD opportunities, but everybody is hamming around locally, and the business stays on the hook. Now why can't we give up a little of our local conversation and take advantage of our LD Opportunities? This 2:30 A. M. stunt is all right but why not snap out of it, as some are doing, and clear our business ahead of the static? We can't do this every night of course. The static isn't always so accommodating, and LD doesn't always come in so well, but if we all watch and take advantage of conditions when possible, it will help out wonderfully.

Relay traffic north and south keeps moving, often slow to be sure, but perseverance always wins. Stick-to-it-iveness has been developed to the n'th degree. The relayers who put traffic through these days deserve all the more credit for their service in spite of present handicaps. On the whole relay work has actually been increasing during the last month. In Seattle 7AD, 7BK, and 7AN are evidently determined to stick to the job all summer. In Tacoma 7BC has recently connected south direct. However, 7CE handles most of the traffic. Here we have also 7CF whose spark is easy to read through static. At Vancouver, Wash., 7CU has handled over 80 messages during the past month.

In Portland considerable interest has been shown in relay work lately, in spite of the poor radio weather. 7CR and 7BP are on the job nearly every night and work north and south consistently. Most of the traffic south now goes through Ukiah, California. 7ED and 7DS are doing nearly as good work and may be depended on to give better account of themselves when conditions become more favorable. One commendable feature of Portland is the absolute control of spark coil amateurs by the Northwestern Radio Association of that city. Mr. White in charge of the work reports that the city is divided up into a number of districts over each one of which an assistant is put in charge. It is up to this assistant to run down every spark coil in his territory and pay each offender a personal visit. The youngsters are fast becoming well informed regarding the Gov-

ernment Radio Laws and regulations. And what is more they are invited to attend the meetings of the N.R.A. At these meetings they are given opportunity to learn as much about radio as they are willing to assimilate. This practice not only eliminates the law violations from the "squeak-box", but also interests all amateurs in long distance work.

Considerable interest is shown in the line up of relay stations to the east, but the stations in the eastern part of the division are noticeably scattering. The mountainous condition of the country makes even short jumps of 50 or 100 miles just about as hard to cover as 500. Disappointment is expressed by a number of anxious amateurs of this locality in their inability to do much work outside of town. At the same time hope is expressed that the A. R. R. L. can line up something, so that the use of their stations can be made worth while. This is exactly what we are going to do for these fellows. A number of new stations are going up, and old stations are being improved. Next winter will show unprecedented activity in Montana and Idaho.

Mr. R. S. Dawes, Box 663, Bozeman, Montana, has been appointed District Superintendent of Montana. He reports that wireless work in the state is almost at a standstill as most amateurs have closed their stations on account of static and storms. At the first opening weather he will be right on the job, and ready to get things started the right way.

The Electrical Engineering department of the Montana State College, Bozeman, Montana, has been organizing Radio Clubs through the local High Schools all over the state. Their station 7XB has been transmitting college news and giving code practice QST's on 425 meters. We will learn the results of their efforts as soon as things open up next fall.

In Silverton, Ore., 7CW continues working north and south with ease. Mr. DeGuire has been appointed District Superintendent for the state of Oregon and will give us a report next month.

Mr. Woodworth, 7CC, has been appointed District Superintendent, Moscow, Idaho. Mr. Teed, 7FT, Kuna, Idaho, has been appointed District Superintendent for Southern Idaho. We will be glad to have their reports in the next issue.

Mr. L. E. O'Brien, 7EV, Assistant Division Manager, 709 South 10th Street, Tacoma, Wash., reports an attempt was made to form eastern route "A" but due to lack of stations operating this summer, work has been suspended until the fall season opens up. Experimental CW has taken quite a hold in Tacoma and Seattle. With a single bulb transmission of speech has been heard several miles. A recent addition to the

radio field is BF1 with a powerful CW set. He claims he is 80 miles south of Tacoma (?) but is too bashful to give his name or whereabouts.

Recent tests from Tacoma to San Francisco Bay stations reveal the fact that QRN is still going on and we take our hat off to the "ops" who have the patience and perseverance to put a message through during these times. Up to date 250 messages have been handled through Tacoma for all points. Communication south is usually effected through 7CU, Vancouver; 7CR, Portland; and 7CW, Silverton, Ore. 7YS is still reaching the 6th district stations and Rev. Ruth is to be commended on the efficiency of his set. 7CE was appointed traffic clearing station in Tacoma. Route all messages south via 7CE. This will insure better results in clearing up traffic.

Puget Sound Navy Radio puts out a bulletin for amateurs and can be secured gratis by writing to District Communication Superintendent, Navy Yard, Bremerton, Wash.

#### ROANOKE DIVISION W. T. Gravely, Manager

Although the hot weather and static are now bearing down on us with fury, the stations in this Division continue to operate nightly, with a fair degree of success. It is really remarkable how signals are holding up through the heated term, and it is to be hoped that these conditions may last all through the summer months.

Of special interest in this Division are the Fading Tests which are being conducted for the Bureau of Standards, and I feel sure that when the data has all been collected it will afford material for reflection for days to come.

The A. R. R. L. has a formidable task before it in the QSS Tests, which are being held during July and August, but with the consistent co-operation of the amateurs throughout the entire country much valuable data will be available and well worth the time and energy expended.

Outside of the Seaboard District (Eastern Virginia), the Division remains unorganized, but tremendous efforts are being made to effect well defined lines, and to create new stations where they are most needed. It is a long weary road to travel, and will necessitate lots of hard work, but we will eventually be there.

I would like to hear from one or two stations in Eastern North Carolina, who will undertake the organization of that District, and who will co-operate with the other District Superintendents in forming lines. You Eastern Carolina fellows come on and help out. Let's hear from you immediately.

I will also ask that the stations in South-

ern West Virginia communicate with Mr. Jno. F. Wohlford, and let him know that he may count on their co-operation in the formation of lines through West Virginia, in conjunction with Mr. A. G. Heck, the District Superintendent for Northern West Virginia. It is very gratifying to note the increased activity in the Northwest Virginia District. Mr. Wohlford has rendered me a detailed report on the progress he is making in lining up prospects in various points where stations will count in our routes, and I extend him my thanks for his splendid efforts.

3HO, Blair, writes that he has to dismantle his set, but expects to operate the High School station in Richmond (3U11), so the League will still have a station there to count on.

Reports have reached me to the effect that a 1 K. W. station is being erected by the Lynchburg Cotton Mills at Lynchburg, Va., and a similar station at Greensboro, N. C. for the private use of the Company, but efforts will be made, on my part, to have the operators co-operate with the ARRL, and assist in the relay work. (Lynchburg please take notice). Mr. J. R. Wikle, formerly 4DM of Atlanta, Ga., is doing the construction.

L. C. Herndon, Superintendent for Eastern Virginia, reports that so far, no new stations have been located in the Eastern Division, but there are hopes that sooner or later a station will be opened in Fredericksburg and one in Petersburg, in which case there is no doubt that daylight communication between Norfolk and Richmond is assured.

The problem of decreasing the interference from the local Navy Station, NAM is being handled through official channels and it is hoped that in the near future the station will be retuned and the decrement lowered. There are also several commercial stations under construction or being planned along the Atlantic Coast, and as soon as these are opened the biggest part of commercial traffic will be handled through these stations, thereby greatly decreasing the amount of business NAM will have to handle. This will be of inestimable benefit to local relay stations.

All of the relay stations in this vicinity are equipped with amplifiers and regenerative receivers, and are getting excellent results, long distance amateurs coming in steadily, and as soon as our transmitters are gotten into shape, it will be hard to find a series of more efficient stations. The Norfolk Police Dept. has installed a .6 Telefunken transmitter (Call 3ZC) and the Norfolk Radio school a 1 k. w. Independent set (Call 3YD). The latter station is accessible to the Hampton Roads Radio Association, and although no long distance relaying has as yet been done by these sta-

tions, it is hoped that shortly they will be added to the list of efficient relay stations in the vicinity of Hampton Roads.

T. C. White, City Manager for Norfolk, advises there is but little to report this month due largely to the adverse weather we have been having in this district; also on account of two of the best stations, 3HO and 3FG, having had transformer trouble.

Station 3EN has been busy Tuesday, Thursday and Saturday evenings with the Bureau of Standards QSS tests and aside from that, has handled several relay messages to distant points, longest distance being 1HAA, Mr. Vermilya at Marion, Mass., who said 3EN QSA very. Worked NSF several times, he using phone and CW both. We are very anxious to have Mr. Blair, 3HO, of Richmond, Va., hurry the installation of his equipment in order that a possible connection in daylight may be made. It is believed with his station in good working order, that we can connect with his station, he in turn with 4CC, and then on down the line. North of us there are no stations nearer than Washington, D. C., and it is exceedingly difficult to work those stations at night, much less in daylight, and we would like very much to hear of any stations intermediate in order that daylight communication may be established North of here.

#### CENTRAL DIVISION

R. H. G. Mathews, Manager

During the past month traffic work has been carried on with fair satisfaction considering the handicaps of static and poor transmission due to the summer weather. No difficulty has been experienced in handling messages between Chicago and the East and especially good work has been done by the Ohio stations. Transmission has been very indifferent South and West although fair results have been obtained on Northbound messages due to the operation of the Shore route of Mr. Burhop.

Interest has been aroused in the fading tests being held by the Bureau of Standards and those proposed by the League and it is hoped that these tests will have the effect of reviving some of the missing interest in the southern and western parts of the Division.

Plans are on foot for a Central Division Convention to be held in Chicago the first week of September, this convention being open to all radio men in the Division and to include the usual banquet and meetings as well as individual good times. Mention of this Convention is made elsewhere in this issue.

The Chicago Executive Council has proposed and put into effect traffic rules governing local and long distance work in Chicago and accordingly the Division Manager wishes to notify all stations outside of Chi-

Chicago that this city is not open for long distance traffic prior to 9:00 P. M. Central Standard Time or 10:00 P. M. Chicago daylight saving time. The only exceptions to this rule will be special tests and messages of extreme urgency, in which case permission will be given for operation prior to that time by the Chicago City Manager. By eliminating long distance work prior to the set time, and correspondingly limiting local work after this time it is believed that better co-operation can be secured between the local and long distance stations of the city and the Division Manager requests the co-operation of other long distance stations in the Division in maintaining this rule. It is requested that messages for Chicago or for relay through Chicago be held until 9:00 P. M. Central Time and that in order to further the work of the Chicago Executive Council no attempts be made to forward such messages earlier unless these messages are of extreme urgency.

Because of the pressure of other business Mr. K. A. Duerk, District Superintendent of Western Ohio, has been forced to suspend his activities during the summer months and Mr. and Mrs. Charles Candler of 8ER, who have been doing such excellent relay work unofficially, have been appointed acting District Superintendents for Western Ohio, this appointment holding until further notice. In this connection the Division Manager wishes to express his appreciation to Mr. and Mrs. Candler for their splendid co-operation during the past relay season and for their present work along the lines of summer relay work.

#### MIDWEST DIVISION L. A. Benson, Manager

Very little traffic has been handled in this section the past month due to the fact that QRN has been terrific. Several early morning tests were tried out with little success.

J. G. O'Rourke, District Superintendent Eastern Nebraska, reports that at last interest in radio matters and particularly in our A. R. R. L. is beginning to revive in his district. It is a rather slow revival at present but by Fall intrastate traffic routes will begin to assume a permanent shape. Mr. Karl V. Nyquist, of 9AFX, Stromberg, deserves great credit. Hardly a morning passes without 9AFX on the job. He is taking great interest in the counties surrounding his station. Mr. Parmele, of Plattsmouth, is still improving the efficiency of his outfit and by next month will prove a valuable asset to the district.

Efficient relay stations are operating in the following towns: Wahoo, Norfolk, Wayne, and Oakland. According to recent reports a former A. R. R. L. man of Colorado is locating in Omaha. Mr. E. Anderson of 9EW is fast coming to the front.

Between June 11th and 20th, over 125 messages were handled between the Cadet Encampment at Valley and two Omaha stations. The station at Valley was installed for the purpose by the Assistant District Superintendent, Mr. Fred Bullis. 9SC and Fort Omaha WII handled the Omaha end.

Several radiophone tests have been conducted by Mr. O'Rourke and he takes great pleasure in reporting that he has been heard by 9AFX while transmitting on one Western Electric tube. 9AFX is 96 miles from Omaha.

Mr. H. L. Owens, District Superintendent, Eastern Kansas, reports that he is working under difficulties trying to establish day light routes east through his state. However, he expects to have one open through 9RY of Topeka in the near future. He has several excellent routes through 5BT of Blackwell, Okla., and west through 9NX or 9BW of Wichita and 9AEG of Eldorado, thence to 9LR of Anthony. They are all good for relay work at nearly any hour during the day. 9LR of Anthony, Kansas, is going to be a strong number in relay work this coming season. His signals are very QSA here on a short wave regenerative set using only one bulb.

Q. M. Shultise of Wichita (9NX), advises that he will not be with us this coming season. We regret this very much as he was prominent in relay circles. Robt. Pirtle, 9SZ of Council Grove will soon have his station in operation and will work alternate to 9EL.

J. A. Wanek, District Superintendent, Western Nebraska, reports that there are very few good stations in his territory and has very little grounds to work on at present. However, a contemplated rearrangement of the division line through the state of Nebraska will give him more territory, and a few good stations. He is lining up several good routes west and expects to have them perfect in the near future.

P. A. Stover, District Superintendent, Iowa, is still working hard with his CW modulated and is reported as being heard QSA at exceptionally long distances. He reports his territory a trifle dull at present due to so many of the best relay men being on their summer vacation. Mr. Stover is very busy himself but expects to devote more time to A. R. R. L. matters in Fall.

G. S. Turner, District Superintendent, Western Missouri, is spending his vacation in Chicago and will be unable to give his report this month. He states, however, that things are going along nicely and that he will have one big report for next issue.

J. A. Fritz, District Superintendent, Eastern Missouri, reports that he is still busy trying to establish an efficient daylight route to Kansas City. He has located a good station in Jefferson City and is also

(Concluded on page 32)



WHO'S WHO  
IN AMATEUR WIRELESS



**WM. E. WOODS**

We take pleasure in presenting the owner of 9LC, commonly known in amateur circles as "Bill" Woods, age 26, of St. Louis. We cannot improve on Mr. Woods' own account of his experiences, so present the whole works:

Started wireless as hobby at age of 14, while in short trousers. Purchased complete outfit from w.k. New York mail-order firm at \$11.50 per outfit. Erected aerial which was humdinger, but after listening to various sounds for three weeks with aid of the 75-ohm receiver decided to follow other pursuits and sold outfit to guy next door for \$4.50. After thinking over deal, decided to again embark, which did, this at cost of \$15. New apparatus was mainly electrolytic interrupter; immediately burned out house meter and three chandeliers of apartment above us at total cost of \$35 to male parent. These marvelous results firmly imbedded idea in my mind



**H. J. BURHOP.**

The above is the best picture we could get of Mr. Burhop of 9ZL, Manitowoc, Wisconsin, and we think his call letters will be sufficient introduction.

Mr. Burhop was born at Sheboygan, Wisconsin, in 1889, and jumped into the radio game with both feet in 1913. As evidence of the fact that his jumping was effective, we have the fact that he had a 1 k.w. station with the call of 9RW in 1915 with which he did some good long distance work, for those times. He went into the service in 1916, and after a year of commercial work joined the Navy at the outbreak of the War, naturally getting into the radio service. He was stationed at various land stations on the Great Lakes, as well as helping beat the kaiser on the U. S. S. Gopher, which the inhabitants of Chicago will remember as the super-dreadnaught which protected them from the vicious onslaughts of the Hun.

**WM. E. WOODS**

that wireless was an interesting study but needed great improvement before becoming practical, so constructed laboratory in back yard by remodeling coal shed; purchased  $\frac{1}{4}$  k. w. Blitzen transformer and, after bumming from high school for most of winter term, succeeded in working Racine, Wis., using two-slide tuner and galena to get him on. Got letter from Racine to verify the marvelous fact and on strength of this persuaded father that was a genius and had to have  $\frac{1}{2}$  k.w. at once. Installed this in house for convenience's sake, as disliked idea of going through back yard to bed at 2 a. m. through the snow. First night of operations, mother and father simultaneously noted very queer effects in chandeliers of various rooms and firmly requested I move back to "laboratory" with all possible speed. This was done, and began working distance at once, winter of 1914. Been at it ever since against wishes of whole family and neighbors. Got all information by reading radio periodicals and still have first little blue-covered QST, from which I gained much knowledge. I give the following issues all credit for what I know today, and have already begun to teach 2-year son the code while wife and small daughter look on in utmost disgust. Now have close to a thousand dollars invested in radio "junk" and still on the look-out for something new, planning on a "real set" this fall just as I have done twelve times previously. It's great stuff, and I'll sit up until after 4 a. m. ANY good night to prove the assertion.

**OPERATING DEPARTMENT**

(Concluded from page 30)

getting the members of the Jefferson City Radio Club interested in the A. R. R. L. and they expect to affiliate with us soon.

The Division Manager requests all stations in the western half of Iowa, Kansas and Nebraska who are interested in relay work to get in communication with him at once.

**ST. LAWRENCE DIVISION**

**A. J. Lorimer, Manager**

After the unfavorable report last month the present outlook is specially encouraging. We have traffic coming through now over two distinct routes. Both routes are over fairly long jumps, perhaps a little too long for good summer work; nevertheless traffic has been getting through with fair regularity.

3Z, Farnham, Que., has been working 1FV near Portland, Me., quite consistently and affords a good outlet to the New England Division. 3Z has also been QSO with 1HAA (Marion, Mass.).

**H. J. BURHOP**

Burhop was released from the Navy along with the rest of us and for a time did telegraphing out in Iowa but re-enlisted on condition that he should be stationed at Manitowoc where he could carry on his work as District Superintendent of Wisconsin, which appointment he has held since 1916. He was not satisfied with the amount of traffic at NTY and so he erected 9ZL at Manitowoc on February 1st and has been running 9ZN a good race ever since.

Burhop's specialty is summer daylight communication and the operation of his Lake Shore Route shows what he is doing long these lines.

The Division Manager, from 2BF, has been getting some traffic through via 8BB at Plattsburg, N. Y., and also handled a few direct to 2TF, Schenectady, N. Y.

An old time Montreal Amateur, Mr. Gladden, has opened up a fine station at Ottawa, Ont., call letters 3GT, giving us an outlet to the Capital City and one leg of the Montreal-Toronto route covered.

**DAKOTA DIVISION**

**R. H. Pray, Manager**

There is very little being done in the relay field at present due to the excessive amount of electrical storms and the fact that many stations are out of commission for reconstruction.

Mr. Boyd Phelps, Traffic Manager of the Minnesota Wireless Association has been appointed assistant to the Division Manager under the title of "Supervisor of Summer Relay in the Dakota Division", term to expire October 15th. It is generally acknowledged that it is always difficult to reach the Twin Cities and his special commission is to establish routes in all directions in reliable relaying distances. Everyone is asked to co-operate with him as far as possible. He can be reached by mail in care of the Minnesota Wireless Association, 416 Court House, Minneapolis, or by radio, 9ZT.

Mr. James Schultz, who has been Superintendent of the Southern Minnesota District, has resigned because of lack of time to look after ARRL matters properly, and Mr. Phelps will for the present assume the duties of District Superintendent in addition to his own.

Mr. J. A. Gjelhaug, 9ZC, Northern Minnesota District Superintendent, reported some correspondence with H. Clark of the Manitoba University, Winnipeg, and that Mr. Clark is getting a regenerative receiver and will soon be in the relay game.



## QST'S DIRECTORY OF CALLS

### FIRST DISTRICT

G. A. F. Werner	12 Pratt St., Allston, Mass.	1SK
A. A. Stockellburg	54 Hano St., Allston, Mass.	1SL
Wm. E. A. Dodge	25 Sargeant Ave., Beverly, Mass.	1SN
S. M. Zartarian	211 Fayerweather St., Cambridge (Correction)	1SP
Saymond Sorenson	340 Beechwood Ave., Bridgeport, Conn.	1SQ
Samuel S. Frizzell	Washington St., Duxbury, Mass.	1UD
Allan C. Lawson	10 Dikeman St., Waterbury, Conn.	1UJ
J. H. Washburn, Jr.	9 Wesley St., Somerville, Mass.	1UK
E. L. Shepard	76 Pine St., Bath, Me.	1UL
Jerome Richardson	County Road, Ipswich, Mass.	1UM
W. H. Cook	184 Main St., Pittsfield, Maine	1UO
Bert J. Atwell	25 Poltoma St., Pittsfield, Me.	1UP
H. W. Caatner	441 Congress St., Portland, Me.	1UQ
John R. Walker	140 Water St., Guilford, Mass.	1UX
John Hardy	Foster St., Littleton, Mass.	1UZ
Sands A. DenFish	113 High St., Mystic, Conn.	1VB
L. A. Morrow	104 Charles River Road, Cambridge, Mass.	1VC
Wilbur S. Wellington	15 Lunda St., Waltham, Mass.	1VD
H. B. Prescott	110 Crescent St., Portsmouth, N. H.	1VE
R. McK. Strickland	384 Orchard St., New Haven, Conn.	1VG
F. X. LaFrance	93 Warren Ave., Pawtucket, R. I.	1VH
L. W. Sayward	87 Hamden Circle, Wollaston, Mass.	1VI
E. M. Goddard	17 Constance St., Maplewood, Mass.	1VJ
Wm. Rosenbloom	108 Thornton St., Revere, Mass.	1VK

### SECOND DISTRICT

A. A. LeMay	1117 Hutton St., Troy, N. Y.	2FA
Harold Cohn	546 W. 146th St., New York	2FB
Fred Clayton	607 Emory St., Asbury Park, N. J.	2FC
A. S. Brower	19 South Clinton St., Poughkeepsie, N. Y.	2FF
H. D. Schadler	190 South St., Jersey City, N. J.	2FH
Frederick A. Girard	Magnolia St., Montvale, N. J.	2FJ
R. W. Freture	439a McDonough St., Brooklyn	2FK
F. McCarlin, Jr.	524 Paige St., Schenectady, N. Y.	2FM
V. H. Schmitt	158 Catherine St., Elizabeth, N. J.	2FN
W. S. Blanchard	401 Westervelt Ave., New Brighton, N. Y.	2FO
Harold Peiler	321 East 90th St., New York	2FP
Jos. Pignone	2065 Anthony Ave., New York	2FQ
H. L. Stanley	Prospect St., Babylon, N. Y.	2FS
W. E. Murray	521 North James St., Peekskill, N. Y.	2FT
Chas. I. Herts	501 West 144th St., New York	2FU
N. S. Conover	132 Milligan Place, South Orange, N. J.	2FV
C. V. Macpherson	590 West 172d St., New York	2FW
R. V. D. Gedney	Center Ave., Little Falls, N. J.	2FX
F. Frimerman	334 East 100th St., New York	2FZ

### THIRD DISTRICT

Wilbur Clark	919 South 51st St., West Philadelphia	3HZ
H. L. Strang	2020 First St., N. W. Washington	3IL
Milton Bergey	121 North Mill Road, Ashboarne, Pa.	3IM
Leonard S. Wall	Elkins Park, Pa.	3JI
J. E. Krone	2908 West Ave., Newport News, Va.	3JK
Merritt E. Gregory	61 Ridgedale Ave., Morristown, N. J.	3JL
Walter L. Henry	3 Park Ave., South Richmond, Va.	3JT
J. D. Simpson, Jr.	600 West 25th St., South Richmond, Va.	3JY
Robt. E. Linthicum	2013 Benning Rd., N. E. Washington	3KM
Harold Nielsen, Jr.	3751 Frankford Ave., Holmesburg, Philadelphia	3MN
Walter Rau	2085 East Kingston St., Philadelphia	3OW
Frank Olson	1943 Harlan St., Philadelphia	3PE
Jay V. Hoyt	Delaware, N. J.	3VU
Howard S. Frasier	5714 Hazel Ave., Philadelphia	3WI
N. Hamilton	4427 Sanson St., Philadelphia	3WW

### FOURTH DISTRICT

H. E. Martin	915 7th St., Miami, Fla.	4BH
Winford W. Brown	214 7th St., Miami, Fla.	4BI
Samuel Misher	Route B, Miami, Fla.	4BR
Maurice D. Clark	1924 Swift St., Jacksonville, Fla.	4BP
W. E. Wood	809 Palm Ave., Miami, Fla.	4BS
Don W. Moore	78 Filer Ave., Miami, Fla.	4CJ
Wm. A. Marsh	135 Bayside Park, Miami, Fla.	4DE

### FIFTH DISTRICT

Lloyd B. Quinby	2204 Brazos St., Houston, Tex.	5CA
Chas. B. Galloway	1516 Arch St., Little Rock, Arkansas	5CB
Frank M. Corlett	1101 East Eighth St., Dallas, Texas	5CC
Clyde B. Mosteller	Box 404, Pilot Point, Texas	5CD
Holmes Richter	116 North Willow St., Dallas, Texas	5CE
T. B. Ansell	927 North Marsalis Ave., Dallas, Texas	5CF
Marion Apple	407 North Tennessee St., McKinney, Texas	5CG
Arthur H. Holt	Kountze, Texas	5CH
M. B. Patterson	Frost, Texas	5CI
Ernest Albert Rodenhouse	2738 Judson St., Shreveport, La.	5CJ
Earl Sellers	Lucedale, Miss.	5CK
James F. Burnes	501 East Grand Ave., Marshall, Texas	5CL

C. E. Noll  
C. R. Granberry  
Fred James Maretz, Jr.  
A. W. Walton  
Gerald Mora  
E. L. Durbin  
Wm. Hardeman  
James Milton Peck  
L. B. Sartain  
Harvey W. Smith  
R. W. Goddard  
College of Agr. & Mec. Arts  
Howard Hughes, Jr.  
Joseph Moran

804 North Oregon St., El Paso, Texas  
711 West 7th St., Austin, Texas  
700 Stuart St., Houston, Texas  
1328 West Park Place, Oklahoma City, Okla.  
1601 21st St., Galveston, Texas  
139 Riverside Ave., Little Rock, Arkansas  
Box 427, Waco, Texas  
510 Monroe St., Little Rock, Arkansas  
South Pittsburg, Tenn.  
114 South Arno St., Albuquerque, New Mexico  
State College, New Mexico  
State College, New Mexico  
3921 Yoakum Boulevard, Houston, Texas  
429 South First St., Clarksville, Tenn.

5CM  
5CN  
5CO  
5CP  
5CQ  
5CR  
5CS  
5CT  
5CU  
5CV  
5CW  
5CX  
5CY  
5CZ

O. Schwendt  
C. Scruggs  
C. Stine  
J. B. Taylor  
C. W. Tilden  
H. F. Topping  
R. A. Tulp  
H. C. Seefred  
L. F. Seefred  
Dr. L. E. Waters  
H. White  
S. K. Whitehead  
C. G. Widing  
E. A. Williamson  
H. E. Wright  
Ed. S. Carter  
J. V. Wise  
N. Yale  
G. G. Mackey  
L. T. Delimlow  
H. A. Duvall and C. Esler

## SIXTH DISTRICT

1046 Blackstone Ave., Fresno, Cal.  
1178 E. 47th St., Los Angeles, Cal.  
1226 West 30th St., Los Angeles, Cal.  
111 Gaven St., San Francisco, Cal.  
1635 Waltman Ave., Los Angeles, Cal.  
222 West Richmond Ave., Richmond, Cal.  
1225 Sycamore Ave., Highland Park, Los Angeles, Cal.  
343 South Fremont Ave., Los Angeles, Cal.  
343 South Fremont Ave., Los Angeles, Cal.  
Suite 7, Mitchell Bldg., Anaheim, Cal.  
822 East 4th St., Santa Ana, Cal.  
138 North Bixel St., Los Angeles, Cal.  
904 East 42nd St., Los Angeles, Cal.  
2101 Stockton Blvd., Sacramento, Cal.  
315 Alvarado Court, Pomona, Cal.  
7105 1/2 Franklin Ave., Hollywood, Cal.  
Walnut-Grove, Cal.  
637 North 43rd St., Los Angeles, Cal.  
1526 Crenshaw Blvd., Los Angeles, Cal.  
426 1st Ave., San Diego, Cal.  
4965 Wadsworth St., Los Angeles, Cal.

6DT  
6DU  
6DV  
6DW  
6DX  
6DY  
6DZ  
6EA  
6EB  
6EC  
6ED  
6EE  
6EF  
6EG  
6EH  
6EI  
6EJ  
6EK  
6EL  
6EM  
6EN

C. F. Kennedy  
C. A. Hoffman  
F. F. Taylor  
W. K. Bert  
E. O. Robbins  
E. A. Scharf  
Miss Winifred E. Dow  
A. F. Liffrig  
H. G. Reichert  
R. J. Alexander  
C. J. Kennison  
N. G. Carleton  
C. R. Capehart

## SEVENTH DISTRICT

Kelso, Wash.  
618 Sunset Ave., Seattle  
227 No. Millern, Burley, Idaho  
1924 Ninth Ave., Seattle  
300 Fir St., Olympia, Wash.  
6320 22d Ave., Seattle  
2329 So. K St., Tacoma  
Creston, Mont.  
318 No. L St., Tacoma  
5046 So. K St., Tacoma  
1521 Alturas St., Boise, Ida.  
1067 E. Burnside, Portland, Ore.  
6814 So. Yakima, Tacoma

7BV  
7BW  
7BX  
7BY  
7BZ  
7CA  
7CB  
7CD  
7CE  
7CF  
7CG  
7CI  
7CJ

## EIGHTH DISTRICT

W. S. Burkhart, Jr.  
Asbury G. Wilson, Jr.  
Wm. C. Giles  
Russell M. Blair  
M. Fay McDowell  
Jordan Ross  
Albert G. Heek  
Chas. S. McCain  
Wm. Morris Stormer  
Abe I. Frankel  
Prescott G. Schlotterbeck  
Sidney S. Greenwood  
Thos. Myers, Jr.  
Clarence M. Minnis  
Burton P. Williams  
Wm. H. Griffiths  
Lyle H. B. Peer  
Wayne A. Copeland  
Roland F. Belyea  
Frederick O. Lee  
Allan L. Machesney  
H. S. Burns

Cherry Hill, Reading, Ohio (Correction)  
400 Hampton St., Wilkingsburg, Pa. (Correction)  
508 E. North Ave., Pittsburgh, Pa.  
3930 Ivanhoe Ave., Norwood, Ohio  
612 Mithoff St., Columbus, Ohio  
92 Hobart St., Rochester, N. Y.  
301 Highland St., Mannington, W. Va.  
Moraine Park, Dayton, Ohio  
9 1/2 Cleveland Pl., Jamestown, N. Y.  
207 Bannington St., Rochester, N. Y.  
1907 Washtenaw Ave., Ann Arbor, Mich.  
237 Augustine St., Rochester, N. Y.  
41 Michigan Ave., Buffalo, N. Y.  
740 Walbridge Ave., Toledo, Ohio  
3220 Orleans St., Pittsburgh, Pa.  
491 Locust Ave., Washington, Pa.  
409 Davis St., Elmira, N. Y.  
51 Center St., Warsaw, N. Y.  
50 Washington St., Warsaw, N. Y.  
R.F.D. No. 3, Seneca, N. Y.  
3414 Parkview Ave., Pittsburgh, Pa.  
111 W. John St., Martinsburg, W. Va.

8DI  
8BX  
8EA  
8EB  
8EC  
8EE  
8EF  
8EG  
8EH  
8EI  
8EJ  
8EK  
8EL  
8EM  
8EN  
8EO  
8EP  
8EQ  
8ES  
8ET  
8EW  
8EY

Virgil Jackson McElroy  
John Hay S. Lawson  
E. H. Giddings  
Harold DeRos Jones  
Kenneth O. McBride  
James C. Hyde  
Charles Ring Davis  
Lucas Tylekens, Jr.  
Everett C. Smith  
Nille Edison Nofrey

## NINTH DISTRICT

315 N. Pleasant St., Independence, Mo.  
Box 350—RR 1, Mt. Washington, Mo.  
414 North Broad St., Lanark, Ill.  
3900 Harriet Ave., Apt. 5, Minneapolis, Minn.  
812 S. Delaware St., Independence, Mo.  
703 E. Hyde Park Ave., St. Joseph, Mo.  
623 Obion St., Hockman, Kentucky  
104 S. White Ave., Kansas City, Mo.  
Weedman, Illinois  
Borden, Indiana

9GA  
9GB  
9GC  
9GD  
9GE  
9GF  
9GG  
9GH  
9GI  
9GJ



### 2JU, WOODHAVEN, L. I.

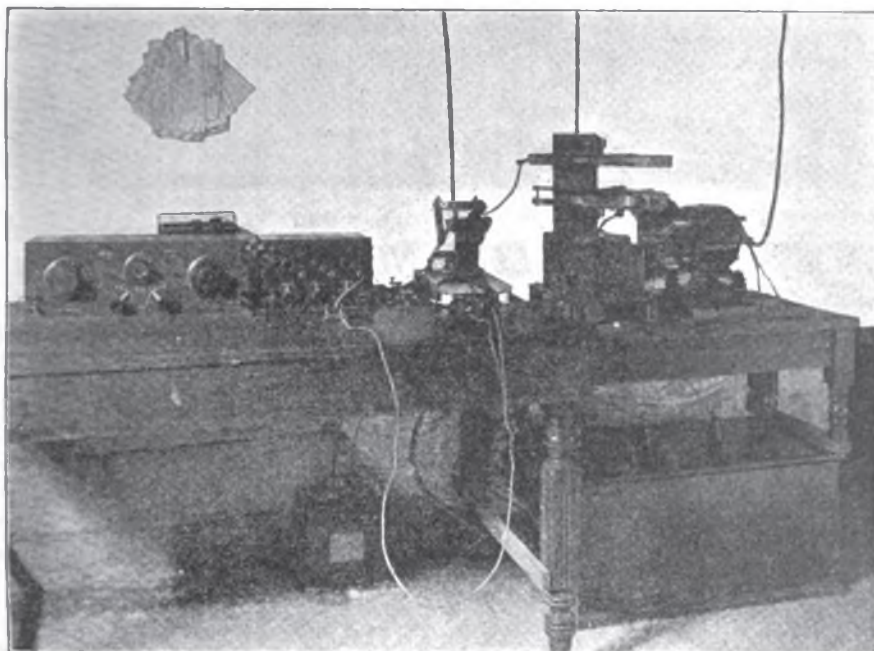

2JU is the call of the A. R. R. L. District Superintendent for Brooklyn, Mr. Clifford J. Goette, and is very well known throughout the eastern half of the country.

The extreme simplicity of this station is striking, but in our estimation this is an essential in a good relay station. In other words, this station looks very much as one would imagine it would, from hearing it on the air.

The transformer, under the table, is one of the old 30,000 volt United Wireless open-core "coffins" which a number of prominent relay stations have used with excellent performance. In a compact group on the transmitting table are a Grebe synchronous rotary, two .014 mfd.

Dubilier mica condensers in series giving a net capacity of .007 mfd., and the familiar pancake O. T. Note that the arrangement is such as to make the closed-circuit leads extremely short. Mr. Goette states this type of gap seems to be very efficient with the open-core transformer and he expects to break records next winter.

The receiver consists of a Grebe regenerative tuner and Grebe tube equipment—detector and two-step—and Baldwin phones. Except for the key and change-over switch, also an old United, there is nothing else on the table. The influence of a little commercial experience is certainly seen in this station—things are business-like and arranged for the efficient handling of traffic.



### 5HA, ALEXANDRIA, LA.

5HA, the station of Mr. F. B. Beuhler, Alexandria, La., seems to be an exceptionally well-ordered station. Everything is conveniently arranged and well installed—the kind of a relay station we like to see.

The photo is so clear that very little explanation is necessary. The transmitter consists of a  $\frac{1}{2}$  k.w. Thordarson transformer, Dubilier mica condenser, Hy-Rad rotary gap (mounted vertically to shorten the leads), pancake oscillation transformer, and a thermo-couple type of antenna cur-

rent meter. The receiver for short waves is a Paragon regenerative, with deForest variables; while a 15-unit deForest set employing honeycombs is used for all waves above 600 meters—to our mind a splendid arrangement. A two-stage amplifier is available for use on either receiver. No trouble is had copying arcs and sparks on both sides of the water, and many DX amateurs are heard with fine audibility.

5HA puts 5.2 amperes in the aerial, and should be an important relay station next fall.

### 7CC, MOSCOW, IDAHO

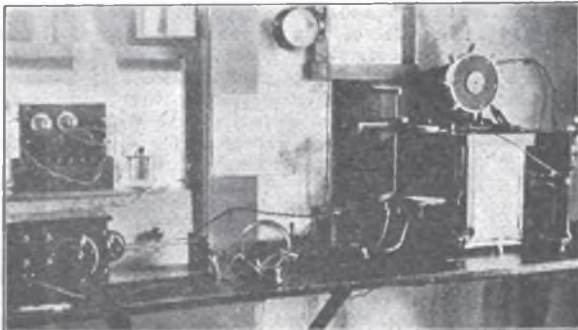

This western station is an important link in our route to the northwestern coast. It is operated by the District Superintendent, Mr. Rupert E. Kempf. Thordarson transformer, rack condenser, Hy-Rad gap, Murdock switch, and Adams-Morgan oscillation transformer will be noted on the transmitting side. Antenna reading is 8.4 amps., with 8 inches coupling, and communication has been had with 9JE, 6EA, 6BR, 6BQ, 6ZA, etc., while the record transmission is to 9CA and 9EE.

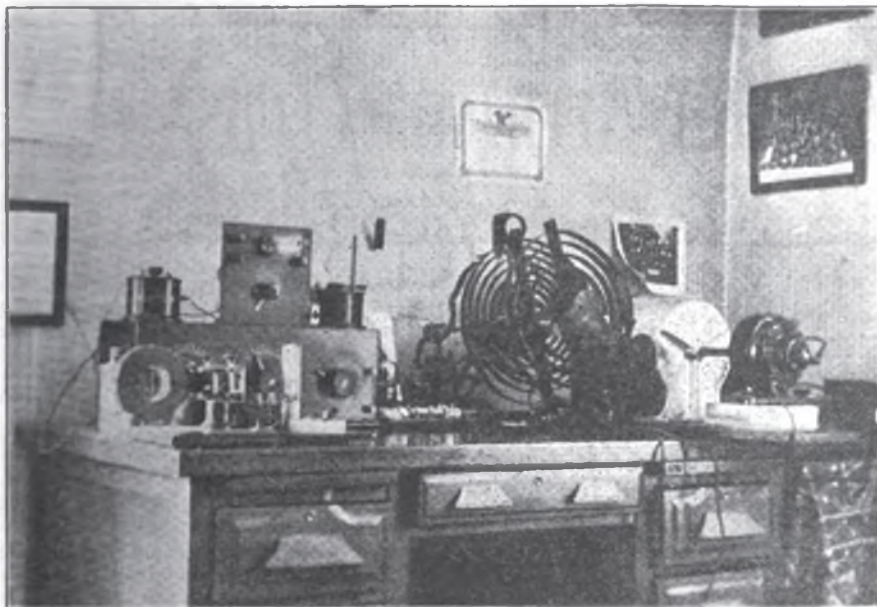

### **1AK, FALL RIVER, MASS.**

This is the station of the A. R. R. L. Superintendent for Lower Massachusetts and Rhode Island, Mr. Harold C. Bowen, which has done excellent work this season.

Transmitter consists of an Acme  $\frac{1}{2}$  k.w. transformer, seven sections of Murdock condenser, a Benwood rotary, and a Thor-darson oscillation transformer. Antenna current of 3.2 amperes is obtained with six inches between the O.T. windings. For short waves, the receiver is a Paragon, with Wireless Specialty Apparatus Co., two-step amplifier. An Eaton oscillator and honeycomb coils are used for long waves, with the amplifier so connected to a small key switch that in one operation the aerial and amplifier can be switched from the short wave set to the long wave receiver.

The antenna consists of six phosphor-bronze wires, 50 feet high and 50 feet long, with a rat-tail joining a phosphor-bronze rope for a lead-in. For a ground, a counterpoise the size of the aerial is used, buried in the ground directly under the aerial, besides grounding onto all the pipes in the cellar.

The receiving record for this station on short waves is 5ZA, Roswell, N. M. Practically all the high powered arc stations have been copied, most of them several feet from the phones. The sending record is Capleville, Tenn., 1100 miles, where the signals were reported QSA with a single bulb and loose-coupler hook-up.

### **A BRITISH AMATEUR**

This is Mr. George W. Hall, a QST enthusiast, at his station at Wigan, England, and we'll say he has quite a receiving set. In fact, he has three of them, covering all waves up to 25,000 meters. The long wave set and amplifiers are not shown in this photo—they are on a separate table on the



left. He uses S. G. Brown reed type receivers (British) and on this aerial hears Carnarvon, Horsea, Nauen, Nantes, Eiffel Tower, etc., all over the house. Can't you hear 8ER too, O.M.?



**T**HE Chicago Executive Council composed of the officers of the Chicago clubs affiliated with the A.R.R.L. (the organization of which is explained in an article entitled "Radio Club Organization" in the March QST), have adopted QRM regulations for their city as published below, and all Chicago amateurs are being governed accordingly. All amateurs should particularly note that Chicago is not open for long distance work prior to 10 p. m., except on special occasions such as tests or messages of extreme urgency, in which case special authority for such work will be granted by the City Manager.

The following rules and regulations have been adopted for the control of amateur radio traffic in the city of Chicago. Same to be effective on and after Monday, July 12th, 1920, applying to all amateurs who are members of either of the three radio associations,—Progressive, South Side or Ravenswood—or members of the American Radio Relay League.

Operating hours:  
 6 A. M. to 7 P. M.—Free air.  
 7 P. M. to 10 P. M.—Local Traffic Only.  
 10 P. M. to 6 A. M.—Long Distance Traffic Only.

From 6 A. M. to 7 P. M. amateurs can test, tune or transmit locally or to long distance stations without interruption.

7 P. M. to 10 P. M. is given over to local traffic only and no one will be permitted to test or tune during that period. If during that period a long distance station calls you, it will be your duty to inform him to QRX until 10 P. M., or have some other station inform him, as it will be made known that the city of Chicago is not open for long distance traffic before 10 P. M.

10 P. M. to 6 A. M. will be given for long distance traffic only. During this period no one will be permitted to test, tune or carry on local traffic.

Amateurs located on the north side will be known as either local or long distance stations to amateurs on the south side, and vice versa.

Traffic chiefs will be appointed in each section of the city who will be required to keep a complete log and who will determine which station has priority rights whenever two or more stations conflict.

Under no circumstances will a member of any of the three above named clubs be permitted to communicate with so-called outlaws or unlicensed amateurs. Members will endeavor to locate such stations and make a report to the traffic chief who will in turn report to the City Manager. The City Manager will endeavor to persuade such outlaws to become bonafide members of clubs. In failure of this such outlaws will be turned over to the Radio Inspector for action.

Any violator of the above rules and regulations will be fined not less than 25 cents for the first offense, and accordingly for each offense thereafter.

Remember, fellow amateurs, this is all for your own good and it is the aim of the Chicago amateurs to make this city one of the most efficient in the world.

If there are any questions that are not clear, I would be pleased to answer them if you will write me a letter stating your question.

F. H. SCHNELL,  
 Chicago City Manager,  
 2220 Roscoe Street,  
 Phone Lakeview 2221,  
 Radio 9AH.

#### THE CENTRAL DIVISION CONVENTION

The officers of the Central Division have hated to see any part of the country "put it over on them," and it is quite evident that this has been done in the holding of Conventions, as witness those held in Boston and Philadelphia. There is one thing that can be done by the Central Division, however, and that is to hold a Convention which will be ahead of those already held in both quantity and quality if not in date, and accordingly the Central Division Manager is planning on the holding of a Convention of all amateurs of the Central Division, whether League members or not, this assembly to be held in Chicago during the first week in September. There will be a banquet and meeting on the order of those in Boston and Philadelphia, and in addition the Chicago Executive Council will provide for the entertainment of visitors. This Convention will afford an excellent opportunity for the Western and Central Western Amateurs to get together, and attendance, if at all possible, is strong-

ly urged. Chicago has approximately 500 amateurs and present plans are for each visitor to be taken care of by one Chicago man. There will be sight-seeing tours of the city, both daylight and dark, and the Chicago Executive Council is assuring all visitors of the "time of their lives".

The Chicago Executive Council is acting as "Committee on Arrangements", and accordingly radio men wishing to attend the Convention should get into touch with this Council in order to secure reservations. Such communications may be addressed either to the Chicago City Manager, Mr. F. H. Schnell, 2220 Roscoe Street, or to the Central Division Manager, Mr. R. H. G. Mathews, 1316 Carmen Avenue.

#### WASHINGTON RADIO CLUB

The Washington Radio Club (D. C.) has adopted QRM regulations looking to the improvement of conditions for long distance work after 10 P. M., and has distributed a circular containing the regulations among the local amateurs.

#### ESSEX COUNTY RADIO ASSOCIATION

This organization (application for affiliation received) was formed in Salem, Mass., three years before the war and increased steadily until the outbreak of war, when most of its members enlisted. It was re-organized in the fall of 1919 and has the

largest membership ever, and enthusiasm proportionately great. A strong organization for the whole of Essex County, Mass., is their aim, and Lynn and vicinity have already merged with them as a section. They are a wide-awake outfit, well deserving of amateur support, and their president, Mr. F. Clifford Estey, 22 Oakland Street, Salem, would like to hear from interested amateurs in Haverhill, Lawrence, and Newburyport.

#### RADIO CLUB OF TACOMA

The Radio Club of Tacoma, Washington, recently voted to become affiliated with the A. R. R. L. This club was first organized in October, 1915, with eighteen members, expanding rapidly until the outbreak of war. Resuming again a year and a half ago, it has outstripped its former progress and is a live-wire and hustling organization, numbering within its body all the prominent radio men in that vicinity. Its Executive Board consists of Lester E. O'Brien, President, District Superintendent of the A. R. R. L.; Geo. Miller, Vice President; Neville Benoint, Secretary; Leslie Lunan, Assistant Secretary and Press Agent; Merritt Cookingham, Treasurer; Chas. Dow and H. F. Campbell, representing the membership at large. A very good photograph of the club is reproduced below. The club would appreciate exchange

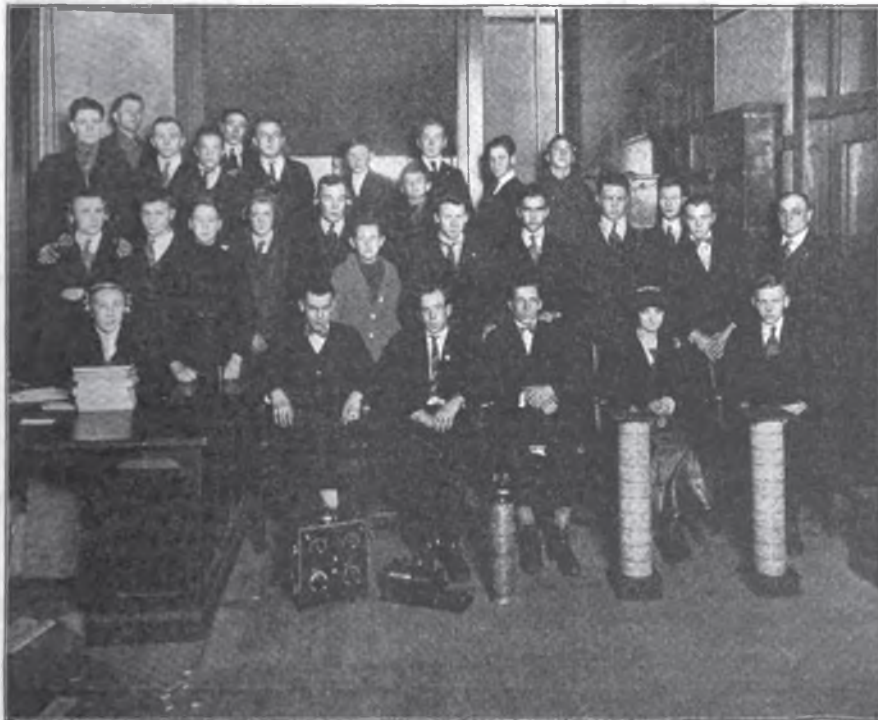

The Radio Club of Tacoma

of papers from other organizations. The secretary's address is 5040 South L Street, Tacoma.

#### RADIO TRAFFIC ASSOCIATION Brooklyn, N. Y.

At the regular meeting of the Radio Traffic Association held at Brownes Business College, Brooklyn, N. Y., on June 4th, 1920, the following officers were elected:

Mr. Walram S. Browne, Chairman.

Dr. Dewitt L. Parker, 1st Vice Chairman.

Mr. Joseph LeClair, 2nd Vice Chairman.

Mr. Frank A. Maher, Corresponding Secretary.

Mr. Albert R. Heydon, Recording Secretary.

Mr. F. William Boettcher, Financial Secretary.

Mr. John P. Holder, Treasurer.

Mr. Clifford J. Goette, Traffic Manager.

Mr. Ernest K. Seyd, Editor, "Radio Traffic Bulletin".

Mr. Charles F. Jacobs, Associate Editor.

The above officers constitute the Board of Directors of the Association to serve a term of one year beginning July 1st, 1920.

Our present membership numbers eighty-six and includes the majority of foremost amateurs of the Metropolitan District. Amateurs desirous of joining are invited to communicate with the Corresponding Secretary at 4903 Sixth Avenue, Brooklyn, N. Y. Communications by radio should be routed via 2JU (Clifford J. Goette, Traffic Manager).

#### E. O. & W. P. R. A. A.

The Eastern Ohio and Western Pennsylvania Radio Amateurs' Association was formed and started off with a splendid "get-together" convention of amateurs in New Castle, Pa., early in May. Rev. A. J. Manning, of 8DA, and Prof. H. W. Harmon, of 8YV, Grove City, Pa., gave interesting talks. In the election of officers, Rev. Manning was elected President, and R. J. McConnell, 8ADF, New Castle, Secretary. A club should prosper in their territory, and they have our best wishes for success.

#### RADIO CLUB OF BROOKLYN

The Prospect Radio Club, Brooklyn, N. Y., announces that it has changed its name to the Radio Club of Brooklyn, under which name it is now incorporated under the laws of New York.

The club has thirty-odd members, all having first-grade amateur licenses. Meetings are held every other Friday night at 4 Fuller Place in rooms kindly loaned the

club by Mr. Warren Benson. This organization has been in existence over three years and kept active during the war by having weekly code practice meetings and lectures on theory and practice. Three members of the club have radio telephones, and several concerts have been given.

The club also has a social end—rather a unique feature in a radio club. Last October it celebrated its third anniversary with a dinner, and since then has had several stag parties. The first real radio dance in Brooklyn was held by this organization on April 30th at the Apollo Studio. The social feature has created an atmosphere of brotherhood which has served to tighten the bonds of the Great Radio Fraternity.

#### AMATEUR RADIO IN HOLLAND By SEEFRED BROS.

**M**R. G. ROES, of Dordrecht, Holland, has given us some interesting information on Dutch amateur radio work, for the readers of the QST.

Mr. Roes tells us that Holland is as free a country as ours, but nevertheless transmitting is strictly prohibited. Without the privilege of operating a sending station, wireless would lose seventy-five per cent. of its attraction for an American amateur, but his Dutch colleague is only allowed to receive (a few semi-official experimental stations excepted) and even receiving stations have not always been permitted.

Before 1913, one was not allowed to operate any radio instrument, but after that time objections to receiving were removed. When the great war broke out in August, 1914, every station had to be dismantled. Although Holland had no part in the war, the authorities seemed to be very much afraid of radio, so even receiving apparatus was barred. In September, 1917, they were again permitted, and one could erect aerials of any size. A year later, Mr. Roes was the first amateur to receive the high powered American stations. With a single Dutch-made vacuum tube he heard NSS, NWW, NDD, and NFF. Shortly afterwards several reports came in from other amateurs who heard those stations, and at this writing every amateur is hearing them.

In long-distance short-wave work, Dutch amateurs have almost no experience

It will be interesting to learn that, up to 1916, audions were almost unknown in Holland. Mr. Roes bought a de-Forest T-tube when in New York in November, 1916; it remained the only V.T. in Holland until March, 1918, when Dutch-made vacuum tubes were put on the market by two or three firms, "Philips" tubes being the best

(Concluded on page 43)





After that NSF-9ZN chess game, we won't be surprised when we hear of poker-by-radio. We suppose it's only a question of time until some bright lad will get up a code for matching pennies and shooting craps over the air.

Who has a good system for keeping a log? We would like to hear something on this subject.

A card to stations over 500 miles whom you hear will certainly be appreciated and will do more toward causing that particular station to improve his outfit than any other thing—it will create a genuine desire to get the maximum out of his apparatus. Do it.

After looking over the average monthly collection of current radio literature, we feel that we are continuing to be sincerely flattered every month. But there is only one A.R.R.L. and only one QST.

By the way, the A.R.R.L. fading tests are going to show the maximum transmitting range of some of our stations—in summer, at that.

Does it hurt to put the B battery through the filament of a tube? Goddard of North Dakota says it does. Any echoes?

Comply with the radio laws! Do you know that the Navy Dept. keeps a log of amateur activities so as to have data to show against us if it is ever needed? Keep down on 200 and whet up that wave—it will carry just as far—farther, even.

At the last meeting of our Board of Direction, Mr. C. R. Runyon, jr., of 2ZS, tendered his resignation as a Director on account of press of other duties—he has quit the radio game. We are sorry to see 2ZS out, but will not be at all surprised when the little bug bites him again.

Seefred Bros., 6EA, Los Angeles, have been copied many times this past season at an amateur station in Honolulu, Hawaii, a distance of 2100 miles. Our congratulations! The Honolulu station reports audibility of signals about 7, using an 8-stage amplifier. Now for some Atlantic Coast station to get through to the Azores, about the same distance. East-bound ship opera-

tors, keep an ear out for some of us, will you?

We are pleased to see that the manufacturers of valves have recognized the amateur demand that a tube intended for detection be a soft tube with some residual gas. It's what we want.

The Alexanderson multi-tuned aerial has resulted in an immense improvement in the efficiency of high-powered stations. It should prove almost equally suitable for our work. Is any amateur experimenting with this system on 200 meters? If so, let us hear from you.

It pays to have your picture in "Who's Who". A lady in Wyoming or somewhere has fallen in love with Charlie Service's likeness. QST in the role of match-maker—we never even dreamed it!

They tell us nearly every member of the Radio Traffic Association of Brooklyn is wondering if his own particular Sweetie isn't the authoress of that recent letter in their Bulletin, signed "Helen", bitterly complaining about how nutty radio makes a chap.

Who's the recent new-comer in the long wave arcs? Bordeaux, we wonder? He seems never to sign.

Press dispatches from London tell of a wireless concert at the Chelmsford Marconi station, when Madame Melba sang selections in English, French, and Italian, her voice being heard, full and mellow, at Berlin, Paris, The Hague, Christiania, Warsaw, etc., over a radius of a thousand miles.

The Department of Commerce advises that preparation of the List of Radio Stations of the U. S. began on July 1st. It is not expected that it will be ready for distribution until some time in August or possibly September. It will contain Government, commercial, and amateur stations, and will be distributed by the Superintendent of Documents, as heretofore. The price cannot be determined until it is completed and the cost is known.

Dan Cupid has installed a radio set. On June 17th a girl in Detroit and a "gob" on

the U. S. S. Birmingham, 1000 miles off the Californian coast, were married by radio. The young lady and her friends gathered in the church in Detroit; the minister telephoned the bride's side of the argument to a telegraph office where it went by Western Union to NAJ, Great Lakes Ill., thence by radio to the Birmingham in mid-ocean. After so long a time a uniformed messenger came to the church with the other half of the ceremony, upon reading which the clergyman declared the business complete, and the bride and her friends began the usual celebration. Next!

That list of calls heard on a 3-foot loop in Indianapolis, reported in June QST, is good work. Mr. Lowe has favored us with the hook-up, shown herewith; the loop is coupled to tuner circuits using tickler feed-back. The loop was located in a room 55 feet above street level, and consisted of five turns of No. 12 d.c. wire wound on a frame three feet square, with the turns spaced  $\frac{3}{4}$ -inch apart. During winter the

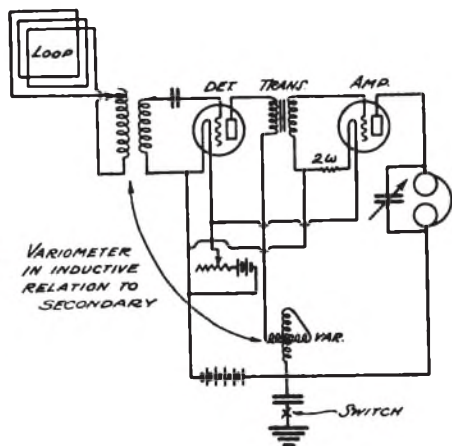

audibility of received signals varied from 60 to 800, 1AW being received with an audibility of 400 on numerous occasions. The directional effect was of course very marked, and resulted in quite a reduction in local QRM.

The R. T. A. (Brooklyn) report the disappearance of one of their prominent members, rumor having it that he hitched up seventeen bulbs in an amplifier and a piece of static came along and knocked him flat.

The Atlantic Radio Company, Inc., have established a new branch store at 15 Temple Street, Portland, Maine. The branch will be under the management of Mr. H. W. Castner, who is a well known radio man in this area. This is the first branch store to be established by this pro-

gressive organization but others are looked for in a comparatively short time.

The Editor refuses to answer inquiries as to why the June QST had the cover it did.

The Boy Scouts of America are co-operating with the Navy Dept. in collecting addresses of amateur station owners. The Navy broadcasts from NAH, details of which were published in QST for October last, are particularly for the Boy Scouts. The information sheets mentioned in that article are being handled by the Scouts as a matter of public service. Any amateur interested can get full particulars from the nearest Scout headquarters or by addressing Armstrong Perry, Seascout Radio Commodore, B. S. A., 200 Fifth Avenue, New York.

Applicants for commercial radio license are now tested on their sending as well as their receiving. Transmissions by an applicant will be received by the examiner and also graphically recorded on a tape recorder. For first-grade commercial license, applicant must transmit satisfactorily for five minutes at 20 words per minute; and for second-grade commercial, at 12 per minute. We are glad to see this; experience has proved that just because a man can receive 20 per is no reason why he can send stuff at that speed that anybody else can read. It should materially improve the standard of the fists we hear on 600. Many of them need improvement.

#### THE HAM'S PSALM

QST is my Bible,

I shall not want another.

It maketh me to lie down after midnite,

It leatheth me to sleep on my instrument table.

It wirelesseth my soul.

It leatheth me into paths of sleeplessness for the relay's sake.

Yea, tho I monkey with my junk dangerously I fear no annihilation,

For thy "Don'ts" and thy "Warners", they comfort me.

Thou preparest a contest in the presence of mine enemy hams;

Thou anointest my dome with transformer oil.

My bulb, she spilleth over.

Surely Insomnia and Relayitis shall follow me all the days of my life and I shall dwell in my radio shack forever. AMEN.

HAROLD HUSTON,  
San Fernando, Cal.

Errata in the article on "Constructing a 500-volt Rectifier Transformer for C. W. Work," in the June QST. Mr. Muns, the author, advises that to give the following secondary voltages, the stated number

of turns should be wound on each section of the secondary:

350	volts—	1300	turns
400	"	1480	"
450	"	1660	"
500	"	1850	"

Mr. R. H. G. Mathews extends a warm invitation to all radio men visiting Chicago during the coming Central Division Convention to make 9ZN their headquarters during their stay. A register of visitors and their stopping places will be kept, with bulletins of the various activities.

This is the pet hook-up of Mr. A. T. Hovey, of 1FT. Although a critical circuit, Mr. Hovey states it will amply repay the effort needed in familiarizing oneself with it, and is operative on either arc or spark from 200 to 20,000 meters. Condensers 2 and 4 are adjusted for regenerat-

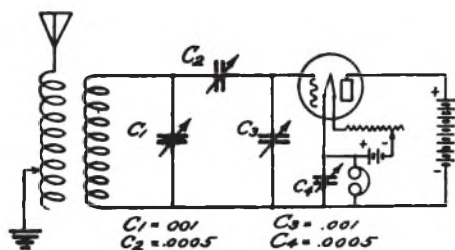

ing spark stations, condenser 3 not being used except on very close stations. Although regenerative adjustments will also serve to cause oscillation, condenser 3 is used for this purpose, with finer adjustments for undamped signals secured by condensers 2 and 4 the same as for sparks.

New publications received. "Super Range Receiver", by M. B. Sleeper. No. 4 of a series of pamphlets on Radio and Model Engineering, published by General Apparatus Co. 4 pp., 8 1/2" x 11". Complete directions and detail drawings for the construction of a tickler feed-back receiver to cover 6000 to 20,000 meters on antennas of .00045 to .001 mfd., employing Mr. Sleeper's well known system of unit panels. Good reliable dope.

**WOULDN'T IT BE WONDERFUL—**

If we smokers didn't always run out of matches about 1 a. m.?

If some of these radiophone operators would lose their false teeth for one night?

If Pacific Coast amateurs would quit knocking San Diego receiving stations when the latter have the big Poulsen arc at NPL to contend with all night long?

If printing presses didn't break down or

something happen, so that QST could arrive everywhere by the fifth of the month?

If somebody would lend NRH a decremeter?

**AMATEUR RADIO IN HOLLAND**  
(Concluded from page 40)

of them. He has sent us a small catalog describing these tubes. At the present time you can buy there any make of receiving tube you like. In 1916 the "Nederlandsche Vereeninging voor Radiotelegrafie" (Dutch Association for Wireless Telegraphy) was founded, having, in 1920, about 1500 members. The population of Holland is approximately six million.

Mr. Roes reports that a number of Netherlands amateurs are copying the Dutch stations at Tjililin (PKI) and Malabar (PKX), in the Dutch East Indies, on simple equipment. The distance is about 11,000 km., so that this represents very excellent work.

**A HAM ON THE TELEPHONE**  
(Concluded from page 7)

"Hello." This from a male voice.

"Is this Mr. Stone?"

"Nope, wrong apartment."

"Well, what IS the matter with that operator?"

"Wish the deuce I knew. I'd like to lay my hands on him for one minute. He's been raising h— with our phone."

At this the irrepressible Mr. Barney could no longer restrain himself and yelled

"De-de-de-dut-de-dut".

"There he is now!" Both voices.

"Well, cut out that QRM and I'll try to get the right party for you". James, of course.

"What?" cried the exasperated women, and the supposed Mr. Stone gently replaced his receiver.

"I sed QRX and I'll——"

"I'm a what?"

"Say, how do you get that way? I didn't say you were anything. I said QRX —" at this juncture the annunciators recommenced their vigorous rattling. James continued, "Say, I can't get you through this QRM. Better give me that on buzzer, Old Man".

"OLD MAN, SIR!! I'm going to complain to the company". CRASH!!!

That was enough for James. He gave a single hopeless glance at the dancing annunciators and ran. Then his common sense returning he did likewise. He carefully erased the record of his thirty-five cent call, and placing the headband of the phones in his pocket he again, with a dignified gait, made his exit.

## The Heterogeneroplidynatron

By Herbert Richter

WE cussed the static, we did, Gonzl and I, whilst discussing the relative merits of various Corn Cures for warts on ears. Nothing doing on spark, so I threw the old contraption on arc, and "tout de suite" here was our old reliable, NSS, working away fine thru the static, about thirty-five per. "Too fast for me", thot I, and just then my partner Gonzl voiced the same sentiments. (Here's your chance, deForest: Thot transference works better with an audion oscillating two feet away; make a recorder.) Some one tapped at the door; I opened it, and in walked our janitor, Mr. Nicodemus Bolsch.

"Vel, can I see your vireless today?" he asked trepidously, "You know you said I could come up vunce some time and you would learn me all the things about it." "Sure, Old Man, sure," I answered, "Sit down and we will show you a thing or two about the old station; sit down."

I got the extra pair of phones and jammed them down over Bolsch's ears, at the same time pulling out, with the headband guaranteed never to catch a hair, nineteen of his remaining fourscore hairs and ten. "Now listen, Nicky, do you hear that in your receiver?" "Ja, ja, that visling sound, ja." "Well, that's station PDQ—you know every station has three letters for its name? Sure. Ours? Sure, ours here is, is—now what it it, Gonzl? Oh yes, to be sure, POZ. Now, you still hear that visling sound? Well, as I said, that's station PDQ over in northeastern Argentina; they're going to give a wireless concert. They give one every day. You know they can send music by wireless. Sh—sh—they'll begin in a minute now—here we are—", and with that Gonzl furiously worked the young variable under the table, and the concert was being given.

His fist soon got stiff, so he suggested we try something else. "All zu viel ist ungesund", he said, "As a German would say. You understand German, Nicky? Is that right? Well, what do you know about that, Pard; Nicky here can speak German. Say, is QRM still sending press? Let's see—".

Here he cut out some inductance and put in some more condenser, and here was NSS again, this time on a lower tone. "There now," I remarked, "That's station QRM over in Carnarvon, Iceland, sending—Iceland? Ja, ja, you're right, Bolsch, it's right up northeast there, just straight south of the North Pole. They are send-

ing the world's news to Greenland now; guess I'll take down what they are sending." With that I stabbed a piece of paper and wrote down what they were sending (NSS was going thirty-five per, and twenty was absolutely the fastest I could handle then.) I wrote down news at least three weeks old, reading off as I wrote down; it was interesting; poor Bolsch "Bit". "It must be interesting ven you can understand vunce vat dey are saying", he averred. Gonzl just winked, and I winked back; that's all we did, Gonzl and I.



"Now, Herr Bolsch, would like to hear some commercial messages? Let's tune in QRA, what say, Pard?"; this from Gonzl. "Sure, might as well; you hear something interesting once in a while." And soon we had NDD sending about ten words per minute and repeating, ready to put you to sleep. "Say, by Jupiter! but they're going some; guess you'd better take this down, Gonzl; too fast for me." Gonzl nonchalantly took a piece of paper, and here is what he wrote down: "Hr Vladivostokski Pr 41768 9/14 8:14½ Jan. 23—O U Nutshellopski, Noncomposmentis Street, Lunaville, U. S. Asked Lina for you; she says yes; Come at once. (Signed) Ike Amblotski." "There, that's all. Say, read that, Nicky, and—what? can't read? Well, hear me read it: Sent from Vladivostokski, No. 41768 9/14, at fourteen one half minutes after eight, January 23rd, 1920, to Mr. O. U. Nutshellopaki who lives on Noncomposmentis Street in Lunaville—but say, Nicky, did you notice how long it took the message to get here? Just a minute and a half! Going some, eh, Nicky? Well, you know these wireless waves travel just 300,000,000 millimeters per second; quite some speed, eh? Oh, yes, the message. The message is: I asked Lina for you; she says Yes, I am yours. Come right away quick; she

is waiting. The fellow who signed it was Mr. Ike Amblotski. There, that's all. Pretty nice, eh? Bet Mr. Nutshellopski is happy, eh?" "He, he, he," interpolated Bolsch, "do dey efen get married by vireless, hey? He, he, he." "Sure", I told him, "and any time you want to get married, just let us know, Nicky, and we'll do it for you by wireless. What? Oh, married once, that's enough, eh? Well, maybe you're right there, Nicky. But say, Bolsch, guess we'd better show you some of the separate instruments, since you've now heard the message themselves. You'd like to see them, not? Sure, that so."

"Well, this is a deForest three-element oscillating vacuum valve radio detector (I pointed to the good old Audion, at the same time allowing a little blue glow to appear.) When you heat that filament, electrons fly off—you know what an electron is, don't you? Never saw one? Well! You know this word, look here, Nicky, e-l-e-c-t-r-o-n.

"Elek', you know," explained Gonzl', means 'little', and 'trones' means 'chunk', so you see 'elektron' means 'little chunk, and that's what the electrons are, Nicky." "You see," I went on, "When you heat that filament, it gets too hot for them there and they fly off to that cold metal plate—see them fly? Ja, ja, right dere in dat blue part; see them chasing each other?" And finally Bolsch was convinced that he saw what no man ever saw before: an electron. "But dey are pretty small" he told us, "and vot is dis?" Here he pointed to our forty volt storage battery, "That? Oh, that's just our source of high potential current, which we use once in a while. But it only gives us a little over forty million microvolts, but then that's about as much as we generally need."

"Well," Gonzl went on, "This three element oscillating deForest vacuum valve radio detector you know can be made to



wiggle over a million times a second, so that—Did I count them? No, not I alone, but my partner here and I have done it together by—How? Oh, it's not so hard;

there are several way of doing it, but we do it by means of some katabolical and metabolicalmathematical curves in connection with some metaphysical formulae. You understand, not? Not very well? Well, the next time we do it again we'll let you know about it, so you can come and help us; then you'll understand it all right." "Sure", I broke in, "We are making some new hyperbolical curves (our old ones broke) and then when we are thru we'll try again."

A 200 watt globular Mazda without a base lay on the table; we had stuck some tinfoil on it in a high frequency experiment. Bolsch pointed at and touched it—"Look out, look out, Bolsch," Gonzl quickly called out, "That's our Hetero-genero-plio-dynatron." "Ha? I tot it vos a tree-lemon os-os-osculating—vot did you called it?" "No, Nicky", I solemnly told him, "That is no vacuum valve as you suppose; it is our Hetero-genero-plio-dynatron, and it is somewhat dangerous to use it."

The Hon. Janitor backed up two feet.

"You see, it radiates waves of extremely short wave length—". "Extremely short," emphasized Gonzl. I went on: "Extremely short waves which may become quite harmful unless properly applied."

Bolsch was five feet away by this time.

"The danger, you see" (this from Gonzl) "Lies in the fact that most people know not how to use them." We followed him up here. "All short wave lengths become dangerous, Nicky, you know. But these however, are quite useful—." "Quite useful," I broke in this time. "Quite useful in treating certain diseases, especially such as pediculosis, and even more so if such treatment must be done by night. Ever have pediculosis, Nicky?" "N-n-no." "Well, anyway, would not advise you to use these extremely short wave lengths until you are thoroly acquainted with their dangerous properties."

Bolach was two feet from the door by this time; we followed him up.

"Gonzl and I", I told him, "Have made a thoro study of this instrument and how to use it. Should you ever have use for this instrument, just call on us and we will show you how to use it. But look out for those extremely short wave lengths—".

Bolsch was outside of the door and had closed it; the Hetero-genero-plio-dynatron had done its work.

I flung myself into a chair; Gonzl simply stood and stared at me, then burst out laughing: "Guess we'll show him the Transmitter next time, if—Saprastieffel, we missed NAA time sigs altogether."

# Radio Communications by the Amateurs

THE PUBLISHERS OF QST ASSUME NO RESPONSIBILITY FOR THE STATEMENTS MADE HEREIN BY CORRESPONDENTS



## REPLY TO MR. WASHINGTON'S LETTER

141 E. Fourth Street,  
Waukegan, Ills., June 28, 1920

Editor, QST:

I must take issue with Mr. Washington in his criticism of the article by me published in the April number of QST. From a strictly technical standpoint there may be errors in the way some of the terms are used but insofar as I am able to judge, the matter in my article conforms strictly to the well known and generally accepted principles governing radio transmission.

In the first instance, maximum voltage is intended. An antenna radiates most effectively when operated at a voltage just under the brushing point and this in no way is contrary to the formula for determining the "radiation resistance", as in all cases with a given transmitter (which for the purposes of this letter will include antenna and ground as well as the instruments) it will be found that the ammeter reading is at maximum when this condition is attained. In one experiment where difficulty in transmission was encountered a long antenna was erected. This was then turned carefully and results both as to radiation and signal strength at distant stations noted. Then this antenna was shortened by cutting off ten feet at a time till the antenna brushed so badly that shortening it further was obviously of no advantage. Each time the antenna was shortened the radiation as shown by the radio frequency ammeter increased, slowly at first and very much more rapidly as the brushing point was approached. When "brush" was first noticed a slight decrease in radiation was experienced and also a considerable increase in decrement. A further decrease in length resulted in a decided decrease in radiation and a decrement beyond the legal limit. Both radiation and decrement were better as the antenna was shortened and the betterment increased much more rapidly as the brushing point was approached. This was also true to a much more noticeable degree in the signal strength at distant stations. In these experiments a five K.W. 500 cycle transmitter was used.

Mr. Washington does not seem to take into consideration that in spark transmis-

sion, the energy per impulse (or per spark) and not the average value as shown by the radio frequency ammeter is what "makes the noise in the receiver". With a given power input it is certainly obvious that with equally efficient apparatus, each wave train at a low spark frequency will contain a proportionately greater amount of energy that when the same power is distributed among a greater number of wave trains in the same space of time. A tone can be no louder than the individual impulses of which it is composed, so the number of watts radiated have very little to do with signal strength except as they are in direct proportion to the effectiveness of the adjustments of the one particular transmitter on which the measurements are made.

As to radiation resistance. Quoting from pages 81 and 82 of the Circular of the Bureau of Standards No. 74, "The amount of power radiated depends UPON THE FORM OF THE ANTENNA, is proportional to the square of the current flowing in the current antinode of the antenna, and inversely proportional to the square of the wave length of the oscillation. Since the dissipation of power is proportional to the square of the current, it may be considered to be caused by an equivalent or effective resistance which is called the radiation resistance of the antenna. Thus the radiation resistance of an antenna is that resistance which if inserted at the antinode of current in the antenna would dissipate the same power as that radiated by the antenna." May I point out that while the power radiated may be expressed by the formula quoted in Mr. Washington's letter it is DETERMINED BY THE SHAPE OF THE ANTENNA and it does not necessarily follow that increasing the number of wires in an antenna will increase the "radiation resistance"? In fact, actual experience shows that the opposite is quite often the case.

What Mr. Washington says concerning the effect of the charge of the conductor, etc., as to brushing, is correct insofar as it applies to the apparatus and the leads connecting it, but insofar as the antenna itself is concerned it is not of so great importance. When an antenna brushes it commences at the open end and as the power or voltage is increased the brush ex-

tends further and further towards the transmitter. In many cases the leads to the transmitter will brush badly without any very great increase in decrement or falling off in signal strength and at the same time no brush effect can be detected on the antenna itself. But as soon as brush is noted on the wires of the antenna a decided decrease in signal strength will result and with it will be a fall of radiation and an increase in the decrement. It would logically follow that there is a limit to the power that an antenna will radiate and that this limit is the brushing point, as is well known to those familiar with the operation of high power arc transmitters.

Again quoting from the Bureau of Standards Circular No. 74, page 124, "On account of the skin effect, the series resistance in a condenser increases to some extent with the frequency." My experience with short wave transmission indicates to me beyond question that it does so increase and, as the shorter waves are used, increases "enormously". All amateurs are familiar with this difficulty in one form or another. A one K.W. transmitter can be operated on 600 meters with leads in the closed circuit so small that if they were used on 200 meters would decrease the efficiency of the set to such a point as to render it inoperative according to amateur standards. In my article, "ohmic resistance" was purposely used in distinction to "dielectric hysteresis," which in favor of the amateur does decrease as the frequency increases.

Mr. Washington's comparison of the results attained with his two transmitters is not convincing to me and I believe to the majority of the leading amateurs. Frankly, I'd like to see that 60 cycle set of his. All amateurs know the vast difference in range attained by different individuals with practically the same apparatus too well to form conclusions from such a test. However, the article in question was not intended to discuss the relative efficiency of 500 cycle quenched transmitters as compared to 60 cycle transmitters but rather to help each one get the best results from the apparatus he has. And the instructions and principles therein if carefully followed will not fail to achieve that result.

I believe that Mr. Washington will agree that it is an extremely difficult matter to write a non-technical article of the nature of the one in question and not leave oneself open to some criticism from a purely technical standpoint. The selection of proper terms in which to convey one's meaning is difficult indeed, as, for instance, the use of "ohmic resistance", to express the resistance in the conducting portions of a condenser. And I hope the apparently personal nature of this communication will be taken in the proper spirit,

as no personal criticism of Mr. Washington or the opinions he expresses in his letter is intended or implied.

Very truly yours,

M. B. WEST.

QSP T. O. M.

Dear Eddy:

The Old Man seems to have overlooked one of the troubles of a modern radio bug. Perhaps he has as yet not tried to hook up a radiophone and make it work. He has something coming and we all want to hear about it when it does come. Friend Kitty will be drowned, the old pipe stem will be gnashed in two and some new cuss words such as Uggerdam and Wuffcoises will see publication for the first time.

Say, I wonder who this here Old Man is anyhow. I had a buddie in the army who knew a guy who heard somebody say he suspected the Old Man was one of those big station owners somewhere in Indiana or Illinois or maybe Oregon or Tennessee. Well, I have my suspicions it must be Illinois(e) judging from all the local QRM and things he writes about. But then we have that right here in Ohio too. Up in Cleveland furinstance is about the best place to try out new ideas on barrage receivers and selective tuners I could imagine. Why up there there's so many hams who read the code off the charts on the wall as they go that it makes the old timers groan and wonder when the curfew will ring so they can get a whack beyond the city's walls with their own sets.

But one night while I was up there I started hearing some honest t' gosh radiophone stations working. Oh boy it was great. It took me just about no time to run down the station owners and begin getting details.

It looked easy. Just a small power bulb, a motor, a simple-looking generator and a few trimmings.

Back down at Akron in the spring another ham and I tried it out. We had everything we thot we needed and more too. Four kinds of bulbs, batteries, motors, generators, condensers, choke coils, tuning coils and meters. But would the darned collection get down to business and turn out sweet music? It would not. We coaxed, pleaded, tickled, oscillated, grid leaked, modulated, tuned, swore and everything. The best sound we could get was "Gr-wow-gr-whiz-s-s-s-woof-woof" or something like that. But after a while we got results—we did. We blew up a meter, a bulb and several condensers. This wasn't the result we were after but we'll try again this coming winter and then when it finally does get going we can give the laugh accompanied by sweet music of the Victrola to the next duck in Akron or Cleveland who

first starts dabbling with radiophone.

In the meantime we wonder what the Old Man is doing. We'd ask you, Eddy, to slip us his name and address, only of course yuh mustn't shortcircuit the golden egg party at the market price that commodity holds at present. Cummon, OM, write us a article on Rotten Radiophones. —DAH.

#### COURTESY DEMANDS IT

July 8, 1920.

Editor, QST:

I agree with you that an article in QST carries considerable prominence which somewhat compensates the writer for his labors. But this does not pay for the postage used in answering inquiries. I have received about thirty letters asking about the C.W. transformer described in your June issue and only one of them sent a stamped envelope.

Wouldn't it be in order to enclose a stamped and addressed envelope if an answer is expected?

Yours truly,  
ROBERT MUNN.

(Mr. Munn is right. The least we should do, in requesting others to accommodate us with helpful information, is to enclose a stamped envelope for reply. Let us do so.—Editor).

#### AN OPEN LETTER TO S. W. DEAN Koko Head Hawaii

Marion, Mass.

Dear Dean:

After reading all the compliments you gave me in our July issue of QST, I feel it a duty to write and thank you, and also to incidentally tell the World more about our little Rotary that quenched.

Before I do break into this detailed description of the cute little Rotary, however, I must pause and reflect upon past memories which the name Dean recalls. I don't recall the name of the son of this Mr. Dean whom I refer to now and here's hoping you've not the Son. . . . In years gone by this Mr. Dean took occasion to cut our telegraph line five or six times where it ran through his yard. Our "Board of Directors" held a meeting! Next night at 1 A. M. we made all arrangements and put the line in via the cable route under his property. The following night some rough boys tied a heavin' line on Mr. Dean's front porch railing and the railing left the porch. The Chester Hill Telegraph Co. could not be interfered with, if they had a hang their line on a Sky-Hook to get through.

Another Dean, the latest, is my next door neighbor. He's a Dean of some skirts' High School somewhere around here, and I have a smashing desire to soak his stove

pipe silk hat down over his ears. When he walks by my radio station, you'd swear he had a ram-rod the full length of his back, and that his neck was made of the hardest steel. He's the nearest approach to six o'clock I ever saw. But, poor feller, I don't know's I blame him. His cause of worry is well established, for his little dinky electric light service is hooked up in multiple with my wireless shed, and we are both trying to bust the little one KVA step-down transformer that the lighting company so generously installed. When I slap the Key down and give the ol' United transformer all she'll take, she takes the biggest part of all there is on the line. To be exact, the voltage drops from 110 to 72. This is kinder tough on the dean's electric lights. To stand in the street and watch 'em, you'd say someone was trying to work a blinker signal.

The Dean's got a telephone. So have I. They are hooked in multiple too. As soon as operations begin on my key, the bell rings. No, not from a kick back, but 'cause said Dean is turning the crank. Being slightly interested in whether he's calling the cops or the Dept. of Commerce, and realizing that the telephone line is mine as much as his, I take the hook down am treated to the following: "Hello. Is this the electric light company?" "Yes." "That Man Vermilya's at it again. Now if I can't have electric lights that don't shimmy up and down every time that 'ohm chaser' takes a notion to squeeze all the juice out of my 'lectric light wires, I might as well have candles." Then I hear old Kill-joy Supt. of the lighting company pipe up: "Well, you See, Dean, we had Vermilya on a separate transformer but he blew it up. We are going to put him off by himself just as soon as we can get around to it." Then the Dean—"Well, for the love of mud, cut him off, can'tja? He's a pest." Here I hang up and call 2JU. No further interest develops for me. So now, my friend, I want to tell you all about that cute little quenched gap we had in the form of a rotary.

You are quite right—it was supposed to be a little trigger arrangement, just as you said. Only the bomfoozled thing wouldn't trig! We pulled and yanked at that trigger for a year or more and the only thing it shot off was the index finger on my left mit and the same thing on another feller's right hand. The only one that fooled it was Hammond—he got his coat tail in it one day and while he lost the tail very suddenly, still he had the satisfaction of bending several of the copper studs, which we failed to do with our fingers.

This rotary was driven by a 50 horsepower motor, and so geared that it ran twenty-one hundred a minute. The trigger disc was eight feet in diameter, with forty-



eight copper studs on the outside edge. It sounded like the end of the world when it was running. It never ran over one hour, and by that time you could cook eggs on on the thrust bearings. The whole outfit was more or less of a Man-killing installation, any way. Connected to this rotary we had two, one-hundred-and-fifty K.W. 5,000 Volt D.C. Generators, three hundred K. W. total. If your main condenser, or the trigger condenser, broke down (and they did quite regularly,) it shorted these generators. Before the fuse and breakers blew, the machine "flashed over". Of all the shower of Sparks, Hot lead, Copper, Smoke, racket, and general riot, it was hard to beat the combination. We expected any minute to see the roof cave in on us.

Things are diferent now though, Dean—we've got all those past killers out in the lot, positively junk. The ol' quenched rotary's got a wire hooked on it and it's helping out the ground capacity. We've got two-hundred K.W. Alexanderson alternators there now, and there's not a place in the shack that you can lose your fingers or coat tails.

Don't suppose you'd like to believe it, but it's a fact—We've got one man here that went to put a fuse in on the 5,000 volt circuit one day and while standing on the iron frame work which was grounded to one side of the machine and ten feet above the cement floor, he got the full voltage 5,800 right thru between his feet and one hand. It flashed the machine over and threw him ten feet to the floor. Of course he talked about the "Blue Bells" for a week—completely lost—but today he's just as good as ever.

Today the only things that have any worries here are the bugs that fly into the Horn Gap which is on top of the alternator. This makes a flash and good-bye Mr. Bug. But there's no danger. The voltage of the alternator is only about 110. The flash cannot be heard, due to the frequency which runs as high as 27,000 cycles.

Some good-natured alternator attendant has tied a piece of cheese on this horn gap to catch these bugs, as he puts it. He claims that's what Alexanderson put it there for. Well I guess I'll go back to the Bakery and loaf.

C U L.

"VN"

#### TO THE OLD MAN AND OTHERS

I have noted the apparently frantic attempts of many of the fellows to bring their radiation up, especially to the much to be desired (?) ten amperes on 1 KW on 200 meters. In the first place, I am going to be a knocker, and say that in general it can't be done,—not on 1 KW anyway. (Chorus of howls to the contrary heard, and all stations will pls QRT, and QRX.)

Now, in the first place what does the amperage determine? Apparently, it determines the power output. Yes, I admit that it does, but the wave length used also determines a few things. Suppose we take a purely hypothetical case of a station as follows:

Antenna—4 wires 50 feet long  
T type,  
20 meters high at each end  
Leadin 55 feet long

Now suppose we are radiating 6 amperes on 200 meters from this antenna, with a decrement which will be somewhere near .2, at least. How much power are we actually putting in this antenna??? (The chorus of howlers are not so ready with their answers, I notice.) Well, if we take the following little simple formula, we can get an idea of how much we are getting:—

$$P = I^2 \times R$$

Where P is power in watts

R is radiation resistance in ohms

I is radiation in amperes.

Substituting,

$$P = 35 \times 16, \text{ for example}$$

$$= 456 \text{ watts in the antenna}$$

Where did the 16 come from, you ask?

Well, that is the hazy ghost of an animal known as "radiation resistance", which we get from the formula:—

$$R = \frac{H^2}{\lambda^2} \times 1600$$

where

H = Height in meters of antenna

$\lambda$  = Wavelength in meters of radiated wave

R = Radiation resistance in ohms.

Using the data given in the case of the antenna described above, we have

$$R = \frac{20^2}{200^2} \times 1600$$

hence R is 16 ohms.

Now I admit that this formula is not a very definite one, and that it is very liable to error, but it will be found accurate enough for almost all ordinary results. I will state in passing that a better method to get the radiation resistance is with a vacuum tube oscillator, by the "substitution method", where we set the oscillator going on the desired wave, and get the maximum radiation on the antenna; now switch the oscillator over to a circuit containing a big variable condenser and a variable, non-inductive phantom antenna resistance, and "juggle" the variable condenser until the maximum radiation is obtained with the resistance cut out. Now cut in resistance until the ammeter on the oscillator shows just the same amount of current flowing in the condenser circuit as was flowing in the antenna. Now find the resistance of the antenna resistance.

on a Wheatstone Bridge, and you have the radiation resistance of the antenna.

Suppose we have the radiation resistance of the antenna as above, it may be substituted for the R on the equation given.

Well, now who claims that they have a station whose overall efficiency is 45%? That's a pretty good station, I must say. Of course, I admit that it is possible. Well, now where is our 10 amperes?? Under the same conditions, as were given above:—

$$\begin{aligned} P &= 10^2 \times 16 \\ &= 100 \times 16 \\ &= 1600 \text{ watts, in the antenna} \end{aligned}$$

Naturally, no well behaved station can radiate this on 1KW transformer primary input, and still be within the law. Do you get me??

It seems, therefore that the statements of some of these people who are claiming that they get these wonderful radiations on 200 meters are sadly mistaken in something. I will leave you fellows to figure out what. As a general rule, however, the chief liar around a radio station is the ammeter which is used in the antenna. Most everyone is using a hot wire instrument, and a greater liar never lived, especially when used on the extremely high frequencies used for Relay work. Of course, a good thermo-junction type of meter is what should be used, as it is designed to work on all frequencies, but in most cases an amplifier, storage battery, or a couple of new tubes must be bought before you spend any money on a new ammeter, especially when the old one you made from a disabled alarm clock still works.

As far as the efficiency of a set goes it can also be easily seen, incidentally, from the above formula, why a higher antenna is so much better than a low one when transmitting. Suppose we raise the antenna 10 meters, then our radiation resistance, as shown, is, substituting:

$$\begin{aligned} R &= \frac{30^2}{200^2} \times 1600 \\ &= 36 \text{ ohms} \end{aligned}$$

$$\text{hence } P = 36 \times 36 = 1296 \text{ watts.}$$

If the power was kept the same we would have a lessened radiation with a high antenna, of course, instead of a raised amount of power.

The efficiency (?) of the average set is a thing that I hate to speak of. As a general thing the set is operated at a efficiency of something less than zero, tho it's more than that in some cases. The old Telefunken ship sets were rated as 0.5, and 1.5 "T.K.", literally "Telefunken Kilowatt", which meant 0.5 and 1.5 kilowatts in the antenna, respectively. The power transformers and motor gener-

ators were rated at a full one kilowatt, in the case of the 0.5 TK set, showing that they figured a total efficiency of 50%. Who is the amateur who claims his set is as efficient as a Telefunken used to be? It's lucky for the power companies, and for many house supply circuits that the U. S. Law states "No private station . . . . shall use . . . . a transformer input exceeding one kilowatt, etc." If it were not for this, I am sure that the regulations which the power companies have been adopting in various places would be quite strict, to say the least. The transformer input being limited to 1KW, it is up to the fellows to get all they can on this much power, and most of the transformers used by the amateurs are woefully inefficient. Judging as a general thing, I should state that an average of 25% is more like the efficiency of most of our sets, than even 50%, while more than 50% is surely unusual (tube sets excepted). Even with an efficiency of 75% overall, much more than 6.5 real amperes on 1 KW on 200 meters is pretty good, so where has the Old Man and his 10 amperes gone? Of course, I admit that some of you fellows 'way off a thousand miles from a radio inspector may do it, and the special stations will be able to get 10 amperes and even more than that on waves over 200 and with practically unlimited power authorized, but as far as the most of us getting 10 amperes, or anything like it,— well, just forget, and be satisfied with 5. CUL NM 73 OM.

"Prof. Bugs".

#### PERTINENT COMMENT

2712 Fremont Ave. So.,  
Minneapolis, Minn.

Editor, QST:

The American Radio Relay League, Inc.  
Hartford, Conn.

Dear Sir:—

In reply to an article entitled "Why is an Amateur?" which appeared in the December issue of QST, I am sending you my ideas on the subject.

In these days of supersensitive receivers many operators are able to work remarkable distances. But what is the result? Some eastern amateur has a message for some one in the west. Instead of trying short relays he burns up about an hour's worth of ether trying to raise some station in the middle west. After raising a station he finds that communication is poor but does he try and shoot the message thru some closer station? Most assuredly not. He would rather repeat his message a dozen times and work a thousand miles than shoot the message a few hundred on the first crack. That is

one of the earmarks of a "ham" and yet most amateur operators are guilty of this.

Another great fault is calling after having once raised a station. One call is sufficient under most circumstances but most amateurs call half-a-dozen times, make a few de's and then drag out their call, probably so some other amateur may get their call and then send them a postal.

It is surprising how many amateurs are ignorant of the conventional signals. Learn your International Signals and use them. Don't think because you have a list of them hanging on the wall and know QRM, QRN, QRS and QST, that is all there is to it. While most amateurs can work fairly fast and know a little about how to adjust their sets, when it comes to handling traffic in an expeditious manner, they are nil.

Most amateur stations where work is handled correctly are owned and operated by men who have done commercial or government work and should not be classed as amateurs but as radio operators. I believe that if an operator is an amateur call him an amateur, it sounds better than "ham", but, if he knows the game call him a radio operator.

Yours truly,  
R. J. Engler,  
Formerly, Chief Electrician (R) U.S.N.

**BLINKING LIGHTS**

Baldwin Park, Cal.

Editor, QST:

Among the Editorials for April, I notice one about the Power Companies. What you say about "buying out the company" is right to the point, and being much in the same boat as 8JQ, I tried out a stunt that does away with "blinking the lights." I might as well say that the light bill will take an awful jump, but even this has one good point, namely, the discouraging of unnecessary sending.

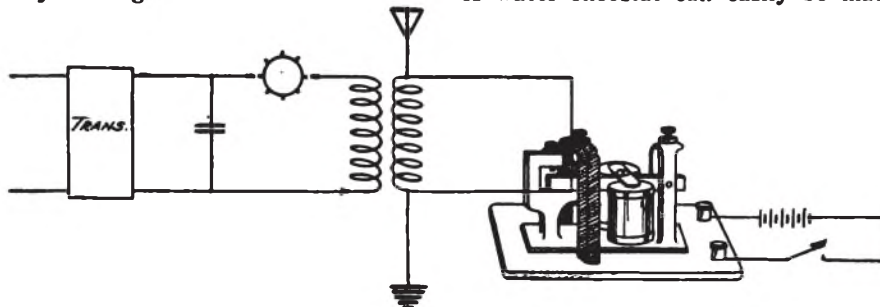

The idea is to let the juice run into the transformer all the time while sending, a switch being placed near the key to turn it on and off. The signals are made by opening and closing a shunt placed around the secondary of the oscillation transformer.

I have tried this out and it really works fine, and there is no blinking of the lights except when the power is turned on or off.

Everyone has an old telegraph sounder in the "junk box" and nothing better could be wanted. Mount a good sized contact on the lever about three-fourths of an inch from the free end. In the one I made, I made an entire new lever out of fibre, but I believe the metal one will do just as well.

Now cut out a yoke (fibre or bakelite) that will fit over the sounder and on which a contact may be mounted so as to make contact with the one on the lever when the lever is up. After the yoke is mounted adjust the contacts and adjusting screws so as to give as much up and down play to the lever as possible. Connect the ends of the secondary of the oscillation transformer to the contacts, using large size wire. Now connect up a battery in series with your key and the sounder, and there you are.

Start the transmitter and notice whether or not the current arcs across the points when the lever is down. If it does, it will be necessary to place the sounder in a bath of light oil.

I would like to hear from any one who tries this stunt out.

Yours truly,  
M. F. ROSS,  
6IS.

(Editor's Note: Another, and perhaps an easier method, is to shunt the key in the power circuit with a resistance of such value that the greater portion of the normal current flows through the transformer continually, and yet not sufficient in potential to cause sparking in the secondary circuit. The key then makes and breaks only the small additional current necessary to bring the current to normal, and blinking will be almost unnoticeable. A water rheostat can easily be made for

this purpose—two electrodes in a slightly acidulated solution, with the resistance variable by adjusting the spacing between the electrodes

Such expedients are recommended only where the blinking is caused by working off a line which is so heavily loaded that

any intermittent load will cause noticeable voltage fluctuations, and where the trouble cannot be remedied by simply getting an independent power supply for the radio set. The most common cause of blinking is a poor power factor—drawing excessive amps. off the line in an effort to put in the desired number of watts. Restoration of the power factor is the best remedy—see an article by Mr. Mathews on page 5 of last December's QST, entitled "Transmitter Resonance".)

#### FOR 200 METER OPERATION

Danville, Va.

Editor, QST:

For simplicity of design and ease of construction, don't you think the accompanying diagram commends itself? Try it and see.

Primary and Secondary on the same tube, say, one that is 3", 3½" or 4" in diameter—Primary wound with No. 24 SCC wire, number of turns depending upon the size of aerials; Secondary wound with 80 turns No. 26 SCC wire, and tapped at 40th, 50th, 60th, 70th and 80th turns; Plate Coil 2½" in diameter, 100 turns No. 26 SCC wire, tapped at 40th, 50th, 60th, 70th, 80th, 90th, and 100th turns. Small variable condensers across Secondary, and Plate Coil, as shown.

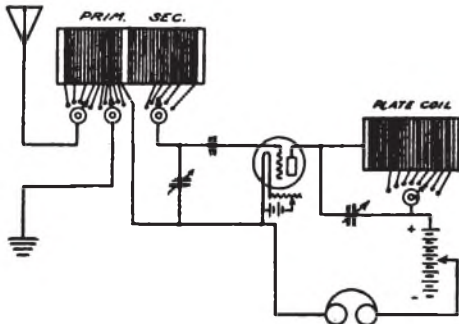

There is nothing new in the design, but its simplicity should be refreshing.

Ordinarily, the primary should be wound with from 25 to 50 turns, tapped each turn for the first four, then every fourth turn.

The circuit will oscillate on any wave length, and with proper sized coils, the Foreign Stations may be received.

This set will appeal to those who are wrestling with the construction of complicated apparatus, and who are not equipped for the job.

Yours truly,  
W. T. Gravely.

(Note—A series condenser in the antenna lead will increase the ease of tuning to short waves.—Editor.)

#### TELEPHONE INDUCTION

June 17, 1920.

Editor, QST:

Does any amateur know of some method that will stop the effects of induction from a transmitter going into the telephone mains without using the third wire system, one of the wires being grounded. The third wire has been tested out at this station and although it cuts a lot of the induction out, the neighbors still complain that they cannot use their phone.

It will certainly be disappointing to me if I cannot stop this trouble as I have just put my station into real working condition and, getting seven amperes out on the antenna now, would make an ideal relaying station this winter.

Well, OM, here's hoping that things come through OK. Thanks and 73.

Yours very truly,

E. G. CUNNINGHAM.  
9AP.

#### ATTENTION CLUBS!

2043 North Twelfth Street,  
Philadelphia.

Editor, QST:

It is desired by the officers of The Third Amateur District Convention to have all amateur organizations in the Third District communicate with them through their Secretary or President. Much work can be accomplished if this will be done promptly. It is planned that these organizations shall be communicated with in reference to the next meeting to be held in January or February, next, in Philadelphia. There is plenty of time to think this matter over during the summer, but when the fall once starts in, much will have to be done to get things started. Let us, therefore, have the names of all amateur associations, so that we can index them for use later on. We advise amateurs to organize everywhere and if possible to get in affiliation with the A. R. R. League. If only five or ten fellows unite to form a club or association it is better than nothing at all. Much splendid work can be accomplished by this union of mutually inclined wireless enthusiasts. QST will keep you informed as to what is going on relative to our Convention. Let us know, however, in the meantime, who you are and where you are.

GORDON M. CHRISTINE, M. D.,  
President Third District Amateur Convention.

(This movement has the hearty approval of A.R.R.L. Headquarters, and Third District clubs are requested to communicate with Dr. Christine with the view of co-operating in making the next convention even more successful than was the first one.—Editor).

## XAJ—SOME STATION!

234 Vine Street,  
Milton, Pa.

Editor, QST:

QST writers, etc., have given us many a fine article on "Short Leads in Your Transmitter." I am a short lead fiend myself, but please explain this one.

About a year and a quarter ago I happened one day to be wandering down the streets of old Tampico, Mexico, in vain search of booze. I neared the old cathedral (everything is "old" down there, you know). Somehow, something did not look just right for a cathedral. Sure enough, there was a 'T' type strung between the two domes, or wat you call 'em. And she had some neat little porcelain insulators on each wire end.

"At last", I thot, "a Mex ham to handle our MSG's that way out", and at once decided to look him over. After some back-alley stuff I found myself in a large room with a two-year-old auto-shooter smiling in my face and a husky Mexican in the outfield. It didn't take me long to assure my friend that I was a perfectly harmless and lonesome human. (I didn't have the heart to beat it.). After considerable explaining that I did not have time to see the President and seven or eight other high-brows to obtain required passes and the like, we established fairly good understanding that I was a "Radio-Girl" myself and was there to pay him a friendly visit and not running a counter-revolution.

Naturally the first thing I asked him his name, his standing, and if he owned the mass of junk hung on the walls and elsewhere. His name I can't write on this mill, but he said he was Chief Operator, Junior Operator, etc. In fact, he was everything. "The station", he put it, "belongs to the government today, but tomorrow h— knows who."

So this was XAJ, whom we copied in the States on one bulb and across the gulf on galena.

Here is where the jolt comes in. The transmitter was an old Telefunken. He said 2 KW, but my limit on German from the name plate on the transformer told me he lied by  $1\frac{1}{2}$  KW. I am sure he did. Even at 2 KW, with the leads he had I wondered how old kid NDH, lying a mile away, could hear him even with his old two steps. Oh Boy, that half KW covered no less than a hundred square feet of wall space and the same on the floor (I forgot to look on the ceiling), and leads of anything from bell-wire on up, but mostly the former. And enough of it to make 1AW

a twenty-seven wire aerial and a counter-poise too. Mixed up and twisted together and then some. His antenna lead was approximately three times as long as his antenna. I'll give him credit, though, that his ground lead was fairly short (he installed it, he said) but it was not due to his efforts—it was merely the handiest one.

Sorry, but he just would not allow me to photograph the set, or I would send you one to convince you that someone is wrong on this LEAD question. Can any of the gang account for it? Across the gulf of galena and in the States on one tube, with a mile of bell-wire in your oscillatory circuit! I can't.

GN and CUL 73.

HERBERT M. WALLEZE, 8BQ,

Traffic Asst., Cent. Pa. Dist.,

Ex-WCUI (now on the bottom)

Ex-KTE (should have been ten years ago).

---



---

**CONCERTS de 2AB**

Amateurs in the vicinity of New York were recently treated to a concert of dance music transmitted by radiophone from Station 2AB for the benefit of the Radio Club of Brooklyn, some fifteen miles away, where loud speakers were placed in the hall and the radio music received as loud as an orchestra which furnished the alternate dance numbers.

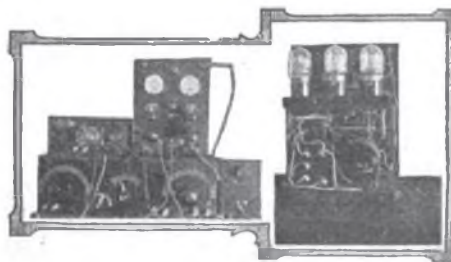

Our photograph shows the apparatus, which was all constructed by its owner, Mr. Morton W. Sterns. This set delivers about 15 watts to the aerial, and has done remarkable work for this power having been reported in every state this side of the Mississippi River and has made two records in excess of 1300 miles.

2AB is sending out regular concerts on Friday evenings at 8 and Sunday mornings at 11 o'clock, and would be glad to have reports from stations over 100 miles distant.

## CALLS HEARD

**T**HE Editor has received a number of letters recently, expressing disappointment that the writers lists of Calls Heard have not appeared in QST. We want to tell you fellows how that happens. All lists are filed as received, and periodically certain of them are taken off for publication. We have only two pages we can allot in QST to this department, and we do not believe that the quantity used for one issue has ever been one percent of the amount we have regularly on hand. The lists in our office right now would be sufficient to fill several thousand pages in QST! With such a quantity to labor thru the best we can do is to see that the selections published in each issue embrace reports from every section of the country—it is manifestly impossible to publish them all at once. We will do our best to present all the interesting lists. Be assured of our cordial appreciation of your kindness in reporting.

On account of the vast quantity of calls reported we must ask your co-operation in the following.

- (1) List the calls on a separate sheet of paper—do not embody them in a letter.
- (2) Arrange by districts from 1 to 9, and alphabetically thru each district; and run them across the page, not down a column.
- (3) Put parentheses around calls of stations also worked.
- (4) Omit initial or other unauthorized calls.
- (5) State the period covered by your report.

**1AW, HARTFORD, June 1—July 10**  
(1AE), (1AZ), (1CE), (1CK), (1CM), (1DQ), (1FH), (1FQ), (1FV), (1GY), (1MX), (1SN), (1SZ), (1TS), (1AES), (1BBH), (1BBL), (1FAQ), (1HAA), (1NAQ), (1TAZ), (1VAD), (1VAK), (2AO), (2BK), (2FS), (2GR), (2JU), (2OM), (2TF), (2YM), (2XJ), (2ZV), (3EN), (3EV), (3HJ), (3KM), (3NB), (3ZA), (3ZW), (NSF), (8BB), (8BP), (8CB), (8DA), (8ER), (8IK), (8WY), (8XK), (9ZN).

**8EJ, ANN ARBOR, MICH.**  
1AT, 1AW, 1AZ, 1RN, 2BM, 2DA, 2IL, 2IR, 2LO, 2XG, 2YH, 2ZM, 2ZS, 2ZV, 3AA (Can.), (3AR Can.), (3BP), (3DH Can.), (3DM (Can.)), (3DR), (3EG (Can.)), (3NE), (3NC), (3XF), (3XP), (4BZ), (5BT), (5ED), (5YA), (5YE), (5ZO), (8AA), (8AAI), (8AB), (8ABP), (8AG), (8AH), (8AI), (8AL), (8AM), (8AMN), (8AO), (8AP), (8AS), (8ASF), (8AT), (8BA), (8BG), (8BO), (8BP), (8BR), (8CB), (8CF), (8CH), (8DA), (8DC), (8DE), (8DF), (8DI), (8DO), (8DV), (8EN), (8EO), (8ER), (8EX), (8FD), (8FI), (8FS), (8FX), (8GC), (8GE), (8GN), (8GQ), (8GR), (8GY), (8GZ), (8IE), (8IH), (8IK), (8IR), (8KA), (8KB), (8KE), (8KK), (8KV), (8JJ), (8LA), (8LE), (8LS), (8LU), (8MT), (8MY), (8OZ), (8PF), (8PX), (8RA), (8RM), (8RN), (8SF), (8TN), (8UW), (8VE), (8VP), (8VR), (8WI), (8WY), (8XC), (8XI), (8XK), (8XU), (8YF), (8ZL), (8ZV), (8ZW), (9AK), (9AP), (9AU), (9CA), (9CE), (9EE), (9EV), (9FG), (9FH), (9HA), (9HJ), (9HN),

(9HR), (9HW), (9IT), (9KF), (9KM), (9KV), (9LC), (9LF), (9MH), (9MK), (9NQ), (9QJ), (9RP), (9UG), (9YA), (9YB), (9ZC), (9ZJ), (9ZL), (9ZN), (9ZT).

**1ES, BROOKLINE, MASS.**  
1AW, 1CM, 1FQ, 1HAA, 1TS, 1YB, 1ZA, 2BK, 2BM, 2BO, 2GR, 2JE, 2JU, 2LO, 2OA, 2EB, 2TF, 2VA, 2XH, 2XX, 2YM, 3BZ, 3DH, 3EN, 3EV, 3EY, 3FG, 3GX, 3HJ, 3KM, 3NB, 3NV, 3ZA, 5CW, 8ABG, 8CB, 8DA, 8DC, 8DI, 8DY, 8EN, 8ER, 8EV, 8FO, 8GB, 8HW, 8LA, 8MT, 8NL, 8PG, 8RQ, 8RS, 8VM, 8WY, 8XK, 8XU, 8YV, 9MH, 9ZN.

**9LR, ANTHONY, KANSAS**  
4AG, (5AA), 5AC, 5AL, (5AO), 5AP, 5BB, 5BM, (5BO), 5BZ, (5CD), 5CP, (5DO), (5EA), 5ED, 5EE, 5EO, 5EW, 5FL, 5FW, 5HB, 5LL, 5SB, (5YA), 5YE, (5ZA), 5ZC, 5ZG, (5ZL), 5ZN, 5ZO, (5ZU), 5ZW, (5ZV), 6GQ, 6ZA, 8AA, 8DA, 8ER, 8GQ, 8RS, (9ACV), 9AJ, (9AK), 9AU, 9BR, (9BY), 9CA, 9CI, (9CN), 9EE, 9EL, 9FL, (9FP), (9FU), 9GK, 9GM, 9GU, 9HA, 9HB, (9HI), (9HN), 9HT, (9IF), 9IV, 9JB, 9JD, (9JE), (9JN), 9JT, 9KA, 9KO, (9KV), (9LC), (9LF), 9LQ, (9MK), (9NE), 9NQ, 9OT, (9OV), 9PL, 9QM, (9RP), 9SD, 9SV, 9UG, 9WL, 9WU, 9XM, 9YO, 9ZA, (9ZC), 9ZH, 9ZJ, (9ZL), 9ZN, 9ZQ, 9ZS, (9ZT), (9ZU), 9ZV, 9ZX.

**6DH, FRESNO, CALIF.**  
5AC, 5ZA, 6AB, 6AC, 6AD, 6AE, 6AG, 6AK, 6KM, 6AT, 6AY, 6BH, 6BQ, 6BR, 6BS, 6EE, 6CM, 6CO, 6CQ, 6CV, 6DP, 6DY, 6EA, 6EB, 6EF, 6EJ, 6EL, 6EM, 6EN, 6ER, 6FE, 6FS, 6FU, 6GE, 6GH, 6GI, 6GQ, 6HM, 6HH, 6HZ, 6IF, 6IQ, 6JD, 6JE, 6JK, 6JM, 6JQ, 6JS, 6KP, 6KU, 6LE, 6MH, 6MZ, 6NL, 6ZA, 7BB, 7CC, 7CK, 7CW, 7CU, 7DF, 7VA, 7YS, 7YB, 7ZB.

**9FG, GOSHEN, IND.**  
1AW, 2ZS, 3ZR, 4AE, 4AE, 4AL, 5BT, 5YA, 'YE, 5ZL, 8AA, 8AK, 8BP, (8DA), 8DI, 8EA, 8EB, 8FI, 8FS, 8HA, 8HD, 8IC, 8IF, 8IK, 8LA, 8ER, 8MB, 8NI, 8NZ, 8RK, 8XI, 8ZY, 9AA, 9AJ, 9AP, 9AU, 9AW, 9BA, 9BG, 9BR, 9BY, 9CA, (9CI), (9DF), 9EE, 9ER, 9FD, 9FN, 9FW, 9GD, 9GS, 9HD, 9HJ, 9HN, 9IP, 9JW, 9KO, 9LF, 9LQ, 9MH, 9MV, 9PA, 9PR, 9PW, 9XM, 9YA, 9ZJ, 9ZL, 9ZN, 9ZQ.

**8NB, ROCHESTER, N. Y.**  
1AK, 1AW, 1TS, 2DA, 2FH, 2IR, 2JU, 2NR, 2QE, 2RM, 2ZL, 2ZM, 2ZR, 3EV, 3GX, 3NB, 3NH, 3NV, 8AA, 8BB, 8BG, 8BH, 8BV, 8CH, 8CB, 8CO, 8DA, 8EG, 8EN, 8ER, 8FO, 8GA, 8GS, 8HH, 8IK, 8KI, 8KP, 8KW, 8MU, 8MZ, 8NG, 8NL, 8PG, 8PP, 8QJ, 8SH, 8VM, 8XA, 8XK, 8XU, 8ZM, 8ABG, 8RBG, 9AU, 9GB, 9LQ, 9MS, 9NB, 9XH, 9ZJ, 9ZN.

**6ED, SANTA ANA, CALIF.**  
5AC, 5ZA, (6AE), (6AH), (6AK), 6AM, 6AN, (6AT), (6AY), 6BF, 6BH, (6BQ), (6BR), 6BS, 6BU, 6CC, 6CM, (6CO), 6CP, 6CV, (6DA), 6DF, 6DP, 6DX, (6DY), (6EA), (6EB), (6EC), 6EF, (6EI), (6EJ), (6EK), (6EN), 6ER, 6EX, (6EZ), 6FA, 6FD, 6FN, 6FS, 6FT, 6FU, 6FY, 6GC, 6GH, 6GI, 6GM, 6GQ, (6HH), 6HO, 6HU, 6HY, (6IF), (6IL), (6IY), (6JD), (6JI), (6JK), 6JM, 6JR, 6JV, (6KA), (6KE), (6KH), 6KL, (6KP), 6LC, 6LQ, (6MN), (6MZ), 6NB, (6NY), 7AD, 7DK, (7CC), 7ZB, 7YB, 7CU, 7CW.

**9ZT, MINNEAPOLIS, (Feb. 1st—April 15th)**  
9AAH, 9AAN, 9AB, 9AC, (9ACV), (9AD), 9AE, 9AG, 9AI, (9AJ), 9AN, 9AS, 9AT, 9AU, 9AV, 9AX, 9BG, (9BR), (9BT), 9BU, (9CA), 9CC, (9CE), 9CH, 9CN, 9CS, 9CT, 9CV, (9CW), 9CY, 9DB, 9DC, 9DD, 9DL, 9DN, 9DO, 9DT, 9DU, 9EA, (9EE), 9EK, (9EL), 9ET, 9EX, (9FB), 9FG, 9FI, 9FK, 9FL, (9FP), 9FQ, 9FT, 9FU, 9FZ, 9GA,

(9GC), 9GG, 9GH, (9GK), (9GM), (9HI), (9HN), (9HQ), (9HT), 9HW, 9HY, 9IF, 9IJ, 9IL, 9IP, 9IR, 9IT, 9IX, 9JA, 9JE, 9JI, 9JJ, 9JL, (9JN), 9JQ, 9JT, 9KG, 9KI, (9KM), (9KO), 9KR, 9KV, 9KW, (9LC), 9LF, (9LH), (9LR), 9LT, 9LY, 9MC, (9MH), 9MM, 9MS, (9MX), 9NG, 9NO, (9NQ), (9NX), (9OB), (9OE), 9OG, (9OV), 9PF, 9ZA, 9ZK, (9ZG), 9ZL, 9ZU, 9DH, 9EM, 9ET, 2XB, 2XG, 1AW.

**8ER, ST. MARY'S, O., May 18—June 21.**  
1AK, (1AW), 1FW, 1HAA, 2BM, 2EJ, 2GR, 2JU, 2TF, 2UE, 2VM, 2ZM, 2ZV, 2BZ, 3EN, (3HJ), (3NB), 3ZW, 4AE, 4BZ, 4YA, 4YB, (5DA), (5DA), (5YH), 5ZG, 5ZL, 8ADO, 8BJ, 8BP, (8CB), (8DA), 8DV, 8EJ, 8FD, 8FY, 8GS, (8IK), 8IN, 8RS, 8UO, (8WY), (8XA), 8XB, 8XK, 8YV, 8ZV, 8ZW, 9AF, (9AU), 9BW, (9CA), 9DF, 9GX, 9IX, (9JN), 9KV, 9LM, 9MH, 9UK, 9UM, 9UU, (9ZC), 9ZL, (9ZN), 9ZX, (NSF), XAs. The following were heard in daytime on June 6, 7 and 8: 1AW, 8DA, 9ZN, NSF.

**3EN, NORFOLK, during June.**  
1AW, (2BM), 2GR, 2JU, (2RK), 2TF, 2ZM, (3BZ), (3DH), 3HJ, 3IB, (3KM), 3NB, (3ZA), (3ZW), (NSF, fone & CW), (4CC), 8BP, 8DA, 8DI, 8ER, 8LA, 8WY, (8XK, spk and CW), (8ZW), 9ZN, and 9ZW.

**3HJ, HAVERFORD, PA, June**  
(1AW), 1BM, (1CE), 1DU, 1FAQ, 1FV, (1SN), (1TS), 2AJJ, (2ANN), 2BR, (dalite), (2CT), (2ME), (2NP), (2OA), 2RK, 3DG, (3DK), (3EN), (3HG), 3IH (cw), (3JR), (3KE), 3QC, (3XF), NSF, (3ABG), (3ER), 3IN, (3JU), (3NI), (3RQ), (3VX), (8ZW), 9HR.

**9ZC, BAUDETTE, MINN.**  
2XG, 5AL, 5BT, 5DO, 5TU, 5ZA, 5ZC, 5ZG, 7CC, 7ME, 8AA, 8DA, (8ER), 8FI, 8MQ, 8XK, (9AK), 9AO, 9AW, (9AU), (9AJ), 9BT, (9CS), 9DA, 9AF, (9DH), 9DR, 9DT, (9EE), 9EX, 9EY, 9FA, 9FT, (9FZ), (9GC), 9HA, (9HN), 9HT, (9HW), 9HT, 9IX, 9JA, 9JB, 9JE, 9JR, (9KI), (9KF), (9KV), (9LC), 9LU, 9LW, 9MH, ex 9MK, (9PI), 9RP, 9TU, 9UG, 9WW, ex 9XN, 9YA, ex 9YG, (9ZN), (9ZJ), (9ZL), (9ZU), (9ZV) and (RCW of the Radio Cub of Winnipeg, Man)

**6CR, LOS ANGELES.**  
5ZA, 6AE, 6AK, 6BJ, 6BN, 6BQ, 6BR, 6CP, 6CQ, 6CS, 6DK, 6DP, 6DS, 6DY, 6EJ, 6EX, 6FE, 6FI, 6GE, 6GK, 6GQ, 6HH, 6IY, 6JI, 6JK, 6KC, 6KM, 6KZ, 6MZ, 6OH, 6QU, 6UM, 6XZ, 6ZA, 6ZE, 7CC.

**2KV, BRONXVILLE, N. Y. Mar. 1—June 30.**  
1AE, 1AS, 1AW, 1BB, 1CK (Daylight), 1CM, 1DL, 1DQ, 1DR, 1DY, 1FAA, 1HAA, 1HH, 1HT, 1HW, 1JA, 1JAP, 1LD, 1NC, 1OAL, 1RN, 1RZ (Daylight), 1TS, 2AJW, 2BM, 2DA, 2FG, 2TF, 2SZ (Daylight), 3AW, 3BE, 3BZ, 3CT, 3CK, 3CV, 3DH, 3DO, 3DR, 3DS, 3EE, 3EH, 3EN, 3EV, 3EW, 3EZ, 3FB, 3FG, 3FR, 3FW, 3GI, 3GO, 3GV, 3GX, 3HG, 3HJ, 3IF, 3KM, 3NB, 3NS, 3NV, 3OA, 3OB, 3OF, 3OU, 3RK, 3SB, 3SF, 3SJ, 3UE, 3UG, 3VA, 3VN, 3WF, 3ZA, NSF, 4AO, 4AT, 5BS, 5DA, 5GA, 8AJ, 8AS, 8BB, 8BO, 8BQ, 8CB, 8CE, 8CT, 8DA, 8DD, 8DK, 8DR, 8DW, 8DY, 8EL, 8EN, 8ER, 8GB, 8GI, 8HH, 8HP, 8IB, 8KZ, 8MQ, 8MT, 8NI, 8OT, 8PG, 8RS, 8SS, 8SW, 8WY, 8XK, 8ZM, 9CA, 9CC, 9DD, 9FZ, 9HA, 9IK, 9IT, 9KV, 9ZM, 9ZN, 9ZO, 9ZV. Canadian 2BF.

**8IK, ASHLAND, OHIO.**  
5AL, 5ZL, 5ZC, 5DO, 4AG, 4AA, 3BZ, 3CC, 3CH, 2DA, 2ZS, 2ZM, 2ZL, 2IR, 2JU, 2WB, 2CS, 2ZP, 2WP, 1AZ, 1AW, 1AK, 9's and 8's too numerous to mention.

**8LF, CRAFTON, PA.**  
(Indoor aerial, one 40 ft.-wire, May.), 1AK, 1AW, 1TS, 1HAA, 2BG, 2BM, 2BW, 2DR, 2OA, 2QR, 2TF, 2ZL (spark and Mod.), 3BE, 3ED, 3EN, 3EV, 3FG, 3HJ, 3NV, 3PK, 3ZW, 4YA, 8BP, 8CB (Spark and Mod.), 8DA, 8DI, 8DZ, 8ER, 8FD, 8GC, 8HG, 8HP, 8LA, 8RS, 8TG, 8TI, 8TT, 8WY, 9AFX, 9AMN, 9BP, 9FW, 9HR, 9JN.

(9PI), 9PN, 9PS, 9PV, 9PY, 9QE, (9QV), 9QY, 9RB, 9RF, 9RG, 9RK, (9RP), (9RV), (9RY), 9SC, 9SR, (9SS), (9SY), 9TA, 9TQ, (9UG), 9UK, 9UQ, 9VR, 9WD, 9WW, 9XA, 9XN, 9YA, 9YN, 9YO, 9YV, 9ZA, (9ZC), 9ZJ, 9ZN, 9ZP, (9ZQ), (9ZU), (9ZV), (9ZX), 9AE, 8AL, 8BB, 8BP, 8BV, 8CB, 8CD, 8CI, 8DA, 8DC, 8EA, 8EN (Heard at noon April 5th), 8ER, 8FH, 8FI, 8FP, 8GA, 8GB, 8HA, 8HH, 8IF, 8JB, (8JJ), 8MB, 8NB, 8NC, 8ND, 8NF, (8NZ), 8PJ, 8PL, 8PV, 8QI, (8QJ), 8RH, 8RS, 8SS, (8WY), (8XA), 8XD, 8YO, 8ZG, 5AG, (5AL), 5BB, 5BG, 5BM, 5BO, (5BT), 5CP, 5DA, 5DG, 5DO, 5ED, (5EJ), 5EW, 5NA, 5YA, 5YE.

**1AAU, PROVIDENCE, R. I.**  
1AE, 1AW, 1CK, 1CM, 1FQ, 1GAI, 1HAA, 1JP, 1NR, 2BM, 2BK, 2DA, 2EV, 2GR, 2IT, 2JU, 2LO, 2RM, 2TO, 2VA, 2XH, 3BB, 3BH, 3EN, 3EV, 3GK, 3HJ, 3NB, 3ZA, 8BB, 8BQ, 8DY, 8EN, 8EV, 8FC, 8GI, 8H, 8IK, 8KX, 8LA, 8MT, 8PF, 8WY, 8XU, 8ZV and NSF.

**1TS, BRISTOL, CONN., May 18—June 20.**  
(1AAT), (1ABJ), 1AE, (1AK), 1AS, (1AW), (1AY) spark, mod. c. w. & fone, 1BAV, (1BB), (1BBL), (1BG), 1BM, 1CAO, 1CC, 1CE, (1CK), (1CM), (1CZ), (1DAB), 1DAL, (1DQ), 1DR, (1DY), (1EAV), (1ED), (1EK), 1EP, 1FQ, (1FV), 1FW, (1GAI), (1GP), (1GY), (1HAA), 1IL, (1IS), 1IW, (1KAY), (1KAZ), (1NAQ), (1NAT), 1QN, (1OP), spark, mod. c. w. & fone, (1RV), (1RZ), (1SAS), 1SAZ, 1SE, (1SN), (1SZ), 1TX, 1UAF, 1WP, (1YB); 2ABM, (2ANN), 2BA, (2BK), 2BM, 2CL, 2CM, 2CS, 2DR, 2EV, 2FB, 2FG, (2GR), (2JE), (2JU), 2LO, 2ME, (2OA), 2OM, 2PL, 2QR, spark, c. w. & fone, 2QV, (2RB), 2RM, 2RU, 2SZ, (2TF), 2TS, 2VA, 2XJ, c. w. & fone, 2ZE, 2ZL mod. c. w. 2ZM spark, straight & mod. c. w., 2AIM, (2AJD); 3AN, 3AQ, 3BZ, 3DH, DR, 3DS, 3EN, 3EV, 3FB, 3FG, 3FN, 3GV, (3HJ), 3MU, (3NV), 3OB, 3PR, (3NB), 3ZA, 3ZV, 3ABG, (3BB), 3BP, 3BQ, 3BV, 3CB, 3CD, (3DA), 3DI, 3DY, 3EN, 3ER, 3FW, 3GB, 3GQ, 3GS, 3HA, (3HP), 3IN, 3JY, 3KZ, 3LA, 3LJ, 3MM, 3NI, 3QJ, 3SH, 3TT, (3WY), 3XK spark, mod. c. w. & fone, 3XU, (8ZW), 9AU, 9HR, 9ZN.

**9LU, MORRISON, ILL.**  
"NSF", 2ZS, 2ZM, 3BZ, 3EN, 3HJ, 3NV, 3NZ, 4BC, 5AO, 1BT, 5CP, 5DO, 5YA, 5ZL, 5ZP, 5ZW, 8AA, 8AM, 8CB, 8CI, 8DA, 8DE, 8DG, 8DR, 8DS, 8EN, 8ER, 8FH, (8FI), 8GB, 8CJ, 8HD, 8HH, 8IA, 8IF, 8IK, 8IU, 8IS, 8JL, 8JO, 8KP, 8LA, 8LH, 8LS, 8MY, 8NF, 8NI, 8NT, 8NZ, 8PP, (8QJ), 8RA, 8RY, 8RS, 8ZS, 8XA, 8XK, 9AJ, 9AF, 9AK, 9AT, 9AX, 9AU, 9AW, 9BA, 9BE, 9BR, 9BP, (9BY), (9CA), 9CE, 9CN, (9CS), 9CW, 9DR, (9DC), (9DT), 9EE, 9EQ, 9ET, (9EZ), 9FA, 9FG, 9FU, 9FZ, 9GA, (9GM), (9GC), (9GR), 9GF, 9GS, 9GP, 9GX, 9HN, 9HA, 9HJ, (9HK), 9HT, 9HD, 9HI, 9HW, 9HR, 9HM, (9IA), (9IX), 9IJ, 9IT, 9ID, 9JT, (9JN), 9KF, 9KK, (9KI), (9KY), 9KV, 9KQ, 9KL, 9KK, 9KM, 9LC, 9LV, (9LF), 9LR, 9LK, 9LA, 9LX, 9LI, 9LO, (9MS), 9ME, 9MT, (9MN), (9NQ), (9NV), 9NY, 9NX, 9NE, 9OK, 9OE, (9PZ), (9PI), 9PV, (9QI), 9QJ, 9QQ, 9RK, 9RP, 9SJ, 9SS, 9SC, 9SU, 9UW, 9UK, (9UG), 9VA, 9WD, 9XM, 9YA, 9YB, 9YO, 9ZJ, 9ZN, 9ZS, 9ZU, 9ZT, 9ZL, 9ZK, 9ZG, 9AAV, 9ABN, 9ACN, 9AFB, (9AFF), 9NNA.

**9QJ, ST. LOUIS, May 15—June 15.**  
3EN, 4BZ, 4AZ, 5AC, 5AL, 1OA, 5YA, 5ZA, (8ER), (8DA), 8DI, (8LA), 8MI, (9AU), (9CA), (9CE), (9EL), (9OS), (9HM), (9HM), (9KM), (9MH).

**2TF, SCHENECTADY, April 27—June 10.**  
Stations worked: 1AK, 1CK, 1DR, 1DQ, 1DY, 1FV, 1SN, 1TS, 1VB, 1KAY, 1HAA, 2BK, 2GR, 2JE, 2PL, 2UE, 3AK, 3HJ, 3JR, 3NB, 3NC, 3NV, 3ABG, 3BB, 3CB, 3CE, 3DA, 3DV, 3EN, 3WY, 3MT, 3XU. Canadian 2AS and 2BF.

**6CO, SAN JOSE, CALIF.**  
(6BQ), (6CM), (6CS), (6DA), (6DH), (6EA), (6EB), (6EB), (6EJ), (6EK), (6EN), (6ER), (6EZ), (6FD), (6FE), (6FU), (6GH), (6GI), (6HH), 6HK, (6HZ), (6JD), (6JL), (6JM), (6OH), 6ZA, (6CC), (6CH), (6CR), (6CU), (6CW), (6DK), (6ZE), (6YS).

## Have You Ordered Yours Yet ?



Now ready for distribution—the new A. R. R. L. Emblem, officially adopted as the device of the League, as told Editorially in the July issue of QST.

Every member of the A. R. R. L. wants an Emblem. Wear this to let the fellows know that you are an amateur—it is fast becoming the universal means of identification. When you see this pin on a man, you know he's all right—he's an amateur; more than that, a brother member of the A. R. R. L.

In extra-heavy rolled gold and black enamel, three-quarters of an inch high. Furnished with either pin or screw-button (lapel) mounting. In ordering specify which you desire.

\$1.50 - - Postpaid

SECRETARY, AMERICAN RADIO RELAY LEAGUE,  
61 Waverly Building, Hartford, Conn.

## BARGAINS IN BAKELITE TUBING !

Bakelite Tubing is the ideal material for winding your receiving tuners, inductances for C.W., etc. It does not warp or shrink or change its form, and is the best possible insulator for purposes of this nature. We have been fortunate in securing a supply of this tubing which we can offer at the following low prices, postage prepaid:

No.	Outside Diam.	Inside Diam.	Price Per Foot
1	2 1/4"	2"	\$1.50
2	3 1/4"	3 1/8"	2.50
3	3 1/4"	3 1/8"	1.00
4	5 1/8"	5"	1.50

This tubing is in natural finish (brown), and comes in 3-foot lengths. Lengths of 1 foot or more supplied without extra charge, but add 25 cents cutting-off charge for each separate piece desired under 1 foot in length.

C. D. TUSKA CO., :: :: :: Hartford, Conn.

## Come to Headquarters for Wireless Books

When you want the books that really teach—the kind that meet the requirements of engineers—amateurs—Radio schools & Government departments come to us.

### Another New One. PRACTICAL AMATEUR WIRELESS STATIONS

An Experience Book Containing the Best Suggestions of Thirty-Three Experimenters on Building, Installing and Operating Experimental Stations for Radio Communication. Compiled by the Editor of THE WIRELESS AGE. 136 Pages. Paper. Price 75c. Profusely Illustrated.

### Practical Wireless Telegraphy

By E. E. Bucher  
Cloth, 852 Pages,  
340 Illustrations.  
Price \$2.25

### How To Pass U. S. Govt. Wireless License Examinations

By E. E. Bucher  
Paper, 96 Pages,  
Fully Illustrated.  
Price 75c.

SAVE A year's subscription to THE WIRELESS AGE may be included with book order at only \$1.50 additional. Regular price \$2.00.

50c (Postage on subscriptions outside U. S. 50c extra.)  
WIRELESS PRESS, Inc., 328 Broadway, New York

### Vacuum Tubes in Wireless Communication

By E. E. Bucher  
Cloth, 184 Pages,  
Fully Illustrated.  
Price \$2.25

### How To Conduct A Radio Club

By E. E. Bucher  
148 Pages, Fully Illustrated.  
Price 75c.