

*Eugene*

20¢

OCTOBER  
1920

# QST

MAGAZINE DEVOTED EXCLUSIVELY TO THE WIRELESS AMATEUR



"DX" OPERATOR WORKING THRU LOCAL QRM WITH THE AID OF A BALANCING LOOP.

THE AMERICAN RADIO RECEPTION  
RADIOGRAM

D.A. Hoffman

# "C-W" EQUIPMENT

THE APPROACHING RADIO SEASON WILL BE ESPECIALLY INTERESTING DUE TO THE RAPID INCREASE IN THE NUMBER OF CONTINUOUS WAVE STATIONS INSTALLED BY HUNDREDS OF AMATEURS THROUGHOUT THE COUNTRY. THE FLEXIBILITY OF A "C-W" TRANSMITTER—USED AS A TELEPHONE, BUZZER-MODULATOR, OR "C-W"—TOGETHER WITH THE EXTRAORDINARY TRANSMITTING RANGE AVAILABLE, BIDS FAIR TO REVOLUTIONIZE THE WHOLE AMATEUR RADIO FIELD.

IF YOU ARE DESIROUS OF KEEPING IN PACE WITH RADIO PROGRESS YOU WILL BE INTERESTED IN HIGH GRADE CONTINUOUS WAVE EQUIPMENT!

## MOTOR-GENERATOR SET

Direct coupled, 4-bearing unit. Drive motor of induction type operating on 110 volt, Single phase Alternating Current. Compound wound D.C. Generator, 48 Commutator Bars. Output: 500 Volts, 175-200 Watts, continuous. Set mounted on substantial oak base and furnished complete with Field Rheostat regulating output voltage. Delivery: Oct. 1, 1920.

**Price: F.O.B. Boston, \$130.00**

## D. C. GENERATOR

Output: 500 Volts, 175-200 Watts. Delivery: Oct. 1, 1920.

**Price: \$70.00**

## SPECIAL S.P.A.C. MOTOR

Operates on 110 Volts, 60 Cycle, Alternating Current. Rated at  $\frac{1}{4}$  H.P., but guaranteed to develop  $\frac{1}{2}$  H.P. continuously. Draws 4.5. Amperes, 1750 R.P.M.

**Price: \$27.50**

150 M.A. Regulating Impedance.....	\$7.00
Modulation Transformer.....	\$7.00
C.W. Inductance—Type 182 Correct for Electro magnetic Circuit. Range: 200-325 M.....	\$10.00
C.W. Inductance—Type 181 Correct for Colpitts Capacity Feed Back Circuit. Range: 200-325 M..	\$7.50
C.W. Inductance—Type 183 Correct for Grid Tickler Feed Back. Range: 200-325 M.....	\$12.50
Filter—Type 170. Consists of two 1 Mfd. Condensers and two iron core chokes; mounted in box with hard rubber panel. Guaranteed for a potential of 750 Volts.....	\$16.00

WE WILL BE PLEASED TO SUPPLY ANY INFORMATION CONCERNING "C-W" WHICH YOU MAY REQUIRE.

"Bulletin 14"—108 pages—over 100 illustrations—sent upon receipt of ten cents. A Rebate Certificate good for 10 cents on first dollar order is inclosed.

## ATLANTIC RADIO CO.

INCORPORATED

MAIN OFFICE:  
100 N. BROAD STREET  
BOSTON, MASS.

PORTLAND BRANCH:  
15 TEMPLE STREET  
PORTLAND, ME.

THE OFFICIAL ORGAN OF THE A.R.R.L.



OCTOBER, 1920

VOLUME IV

No. 3

# CONTENTS

Bulb Oscillators for Radio Transmission	L. A. Hazeltine	5
Radiotelephophone Personalities	"Tewpieye"	9
Notice re QSS Tests		11
Concerning Cages	Sumner B. Young	12
A Simple Radiophone Operating on "B" Batteries	F. S. Huddy	14
An Oil-Dielectric Transmitting Condenser	L. A. Bartholomew	15
A Paper on QRM	John F. Gray	16
A New Variable of Radical Design		20
Editorials		21
The Operating Department		23
With the Affiliated Clubs—The Chicago Convention		31
Amateur Radio Stations		35
Another C.W. Problem Solved	J. O. Smith	38
Strays		39
The Junior Operator		41
Radio Communications by the Amateurs		42
Calls Heard		49

QST is published monthly by The American Radio Relay League, Inc., at Hartford, Conn. Kenneth B. Warner (Secretary, A. R. R. L.), Manager and Editor.

Subscription price, \$2.00 per year, anywhere. Single Copies, 20 Cents.

Entered as second-class matter May 29, 1919, at the post office of Hartford, Connecticut, under the Act of March 3, 1879.

Copyright, 1920, by The American Radio Relay League, Inc.  
Title registered at United States Patent Office.

THE AMERICAN RADIO RELAY LEAGUE, Inc.  
HARTFORD, CONN.

# THE AMERICAN RADIO RELAY LEAGUE

"A national non-commercial organization of radio amateurs, bonded for the more effective relaying of friendly messages between their stations, for legislative protection, and for scientific growth."

## OFFICERS

President  
HIRAM PERCY MAXIM  
Hartford, Conn.

Vice President  
CHAS. A. SERVICE, JR.  
Bala, Pa.

Traffic Manager  
F. H. SCHNELL  
61 Waverly Bldg.,  
Hartford, Conn.

Treasurer  
A. A. HEBERT  
Nutley, N. J.

Secretary  
K. B. WARNER  
Hartford, Conn.

## DIRECTORS

A. E. BESSEY  
Sunnyvale, Calif.  
V. F. CAMP  
Brightwaters, L. I.  
J. M. CLAYTON  
Little Rock, Ark.  
F. M. CORLETT  
Dallas, Tex.  
W. T. FRASER  
Buffalo, N. Y.  
W. T. GRAVELY  
Danville, Va.

F. F. HAMILTON  
Indianapolis  
A. A. HEBERT  
Nutley, N. J.  
HIRAM PERCY MAXIM  
Hartford, Conn.  
C. A. SERVICE, JR.  
Bala, Pa.  
J. O. SMITH  
Rockville Centre, L. I.

H. L. STANLEY  
Babylon, L. I.  
C. H. STEWART  
St. David's, Pa.  
K. B. WARNER  
Hartford, Conn.  
M. B. WEST  
Waukegan, Ill.  
F. H. SCHNELL  
Hartford, Conn.  
H. M. ANTHONY  
Muncie, Ind.

## OPERATING DEPARTMENT

TRAFFIC MANAGER  
F. H. Schnell

ATLANTIC DIVISION  
Manager  
Chas. A. Service, Jr.  
Bala, Pa.

Asst. Mgr., Central Sec.  
John DiBlasi  
83 Sinclair Ave.  
Flushing, L. I.

Ass. Mgr., Southern Sec.  
Chas. H. Stewart  
St. David's, Pa.

EAST GULF DIVISION  
Manager

CENTRAL DIVISION  
Manager  
R. H. G. Mathews  
1816 Carmen Ave.  
Chicago

Assistant Manager  
Chas. H. Zeller  
4782 N. Maplewood Ave.  
Chicago

WEST GULF DIVISION  
Manager  
Frank M. Corlett,  
1101 East Eighth St.  
Dallas, Tex.

ALASKAN DIVISION  
Manager  
Theodore A. Stockng  
Ketchikan, Alaska

ROCKY MOUNTAIN DIV.  
Manager  
M. S. Andelin  
Richfield, Utah

PACIFIC DIVISION  
Manager  
A. E. Bessey  
Sunnyvale, Calif.

Assistant Manager  
E. G. Arnold  
181 No. 17th St.  
San Jose, Calif.

ST. LAWRENCE DIVISION  
Manager  
Albert J. Lorimer  
243 Mackay St.  
Montreal, Que.

ONTARIO DIVISION  
Manager  
A. H. Keith Russell  
853 Markham St.  
Toronto, Ont.

NEW ENGLAND DIVISION  
Manager  
Guy R. Entwistle  
137 Sutherland Road  
Brookline, Mass.

ROANOKE DIVISION  
Manager  
W. T. Gravelly  
854 Main St.  
Danville, Va.

DELTA DIVISION  
Manager  
John M. Clayton  
1301 Welch St.  
Little Rock, Ark.

MIDWEST DIVISION  
Manager  
L. A. Benson  
4942 Wieschan Ave.  
St. Louis

DAKOTA DIVISION  
Manager  
Russell H. Pray  
Valley City, N. D.

NORTHWESTERN DIV.  
Acting Manager  
Royal Mumford  
518 Beech St.  
Vancouver, Wash.

## ADVISORY TECHNICAL COMMITTEE

C. S. BALLANTINE  
WM. C. BALLARD, Jr.  
FRANK CONRAD

MINTON CRONKHITE  
J. H. DELLINGER  
C. L. FARRAND

PAUL F. GODLEY  
L. A. HAZELTINE  
C. D. TUSKA

Address General Correspondence to Executive Headquarters, Hartford, Conn.





## **Bulb Oscillators for Radio Transmission**

*By L. A. Hazeltine*

Professor of Electrical Engineering, Stevens Institute of Technology

Presented at meeting of the Radio Club of America, Columbia University,  
April 30, 1920

### PART I.

#### **Valves as Rectifiers and as Oscillators**

The unilateral conductivity of certain vacuous or gaseous conductors permits their employment as electric valves to alternately open and close an electric circuit, analogously to the use of mechanical valves to alternately interrupt and permit the flow of air or steam. The simplest use of a valve is to convert an alternating or intermittent flow into a continuous flow; for this will be accomplished automatically by a valve which permits a flow only in one direction. Thus automatic valves are used in reciprocating air compressors to give a continuous discharge of air, although the motion of the piston is alternating; and similarly electric rectifiers (such as the arc rectifier, the Tungar rectifier, the Fleming valve, etc.) act as automatic valves to convert an alternating current into a direct current.

The reverse operation, the conversion of a continuous flow into an alternating flow, can be automatically accomplished only by a valve which is inherently unstable; otherwise a positive (non-automatic) control of the valve is required, either by an independent means having the desired frequency or by the alternating flow produced. The mouth-piece of a wind musical instrument and the ordinary arc oscillator are examples of mechanical and electric valves which produce oscillations by their inherent instability. Bulbs having considerable gas, of either the two-electrode or the three-electrode types, may be electrically unstable and so can act in this manner as electric oscillators, as has been found with some audions without the normal feedback; also the dynatron, a particular form of three-electrode bulb, acts as an oscillator by reason of instability. Oscillators

having a positive valve control, however, are those in which we are here particularly interested, especially self-excited oscillators whose valve action is controlled by the alternating flow produced, as exemplified by the steam engine and by the ordinary three-electrode bulb oscillator (audion, pliotron, etc.). In the steam engine the valves, which admit steam to alternate ends of the cylinder and so convert the continuous flow in the steam line into the alternating motion of the piston, are themselves controlled by this motion. Similarly in the three-electrode bulb oscillator the grid whose varying potential periodically interrupts the plate current and so converts the direct-current power supplied to the plate circuit into alternating-current power, is itself controlled in potential by this alternating current. Instead of this electrostatic valve control, self-excited oscillators may have electromagnetic valve control, which has been practically applied in various ways.

#### **Electrostatically Controlled Oscillator**

This paper will refer specifically to the electrostatically controlled oscillator, employing a bulb with three electrodes: the cathode, in the form of a filament heated to incandescence; the anode, often in the form of a plate; and the control electrode, usually in the form of a grid interposed between the filament and the plate. Electrons emitted by the filament by virtue of its temperature leave the immediate neighborhood of the filament at a rate depending on the combined effect of the plate potential and the grid potential, and constitute the "space current". In all ordinary bulbs the effect of a given potential at the grid exceeds by several times the effect of an equal potential at the plate, but this is

not essential. In other words, the "amplification constant" of the bulb (defined as the quotient of the change in plate potential required to cause a given small change in space current, divided by the change in grid potential to give an equal effect) is usually above 5, but could be less than unity without prohibiting oscillation. When the grid is negative it tends to prevent

ence to the separately excited oscillator of Fig. 1a. The "exciter" may be an alternating current generator having a rectangular voltage wave or it may be a periodically operated reversing switch connected to a battery. In combination with the "grid bias" it causes the grid potential to be alternately slightly positive and highly negative, as represented by the wave  $e_g$ ,

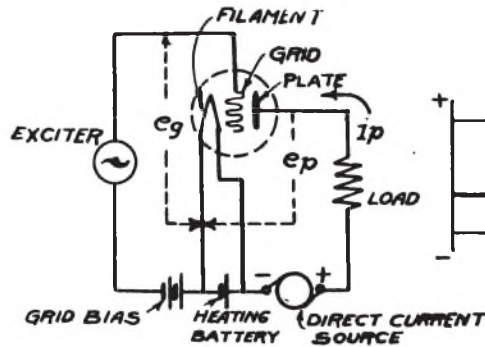

-FIG. 1a.-

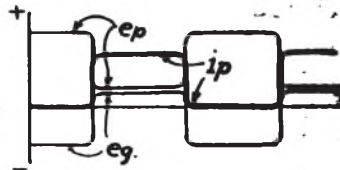

-FIG. 1b.-

electrons from leaving the filament, and if sufficiently negative will reduce the space current to zero, thus opening the electric circuits through the bulb. On the other hand, when the grid is positive, it will tend to draw more electrons from the filament, thus raising the space current and providing relatively low-resistance paths through the bulb. When the grid is negative, practically no electrons reach it, though electrons may pass through it to the plate; and even when the grid is positive, fewer electrons usually reach it than reach the

Fig. 1b. The highly negative grid potential interrupts the plate current entirely, while the slightly positive grid potential permits the plate current to flow readily, as indicated by the wave  $i_p$ . The grid current (not shown) will vary similarly to the plate current, but will be smaller. The plate potential (in this figure) will be equal to the voltage of the "direct-current source" when the plate current is zero, and will fall to a low value when the plate current flows (that is, when most of the

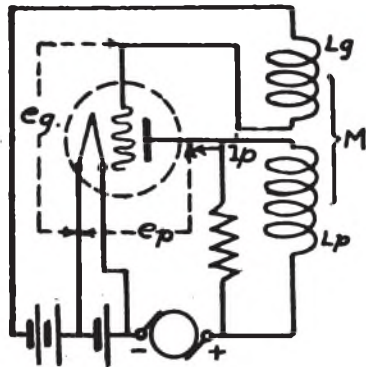

-FIG. 2a.-

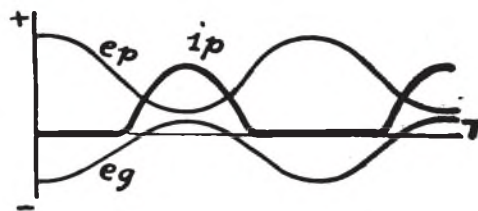

-FIG. 2b.-

plate, on account of its smaller surface. Thus the space current is made up of the plate current and the grid current, the latter normally being zero or relatively small.

The physical action in a bulb oscillator may be most simply examined by refer-

ence to the separately excited oscillator of Fig. 1a. The "exciter" may be an alternating current generator having a rectangular voltage wave or it may be a periodically operated reversing switch connected to a battery. In combination with the "grid bias" it causes the grid potential to be alternately slightly positive and highly negative, as represented by the wave  $e_g$ ,

oscillators by proper polarity connections. Conditions in Fig. 1 are simple and ideal. Each of the operating currents and voltages has only two different values during a cycle—the open-circuit value and the closed-circuit value. The internal losses in the bulb will be small, for current flows only when the corresponding potential is low.

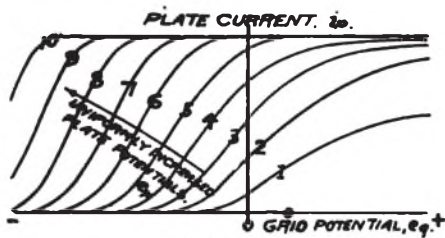

- FIG. 3 -

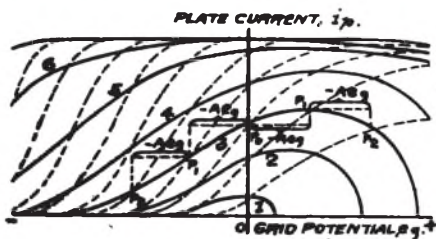

- FIG. 4 -

Let us try to obtain the results of Fig. 1 in a self-excited oscillator by connecting the primary of a transformer across the load and the secondary in the grid circuit, as in Fig. 2a. If it were possible to have a transformer without exciting current, so that it would transform voltage but would not affect the currents in the circuits, and if all inductive and capacity effects were absent, then the waves of Fig. 1b could theoretically be obtained, though even then the frequency would be indeterminate. As a matter of fact, the transformer must take exciting current and the circuit parts must have capacity; so the simple results attained by positive valve control in Fig. 1 cannot now occur. Instead, we shall have the following conditions to satisfy: first, the variation in grid potential must be in phase with the variation in plate potential, due to assumed close coupling of the transformer coils; secondly, the current must vary in phase with the two potentials, since these determine the current by their combined action; and thirdly, the relation of plate current to plate potential must be that fixed by the impedance of the plate circuit external to the bulb. The last two conditions together show that the external plate circuit must act like a pure resistance, inasmuch as its current and voltage must be in phase. Therefore an oscillation can

occur only at that frequency which will make the capacity and inductance associated with the plate circuit resonant with one another and hence non-inductive in their combination. Usually in practice, the capacity and inductance are effectively in parallel and are sharply tuned, causing the plate potential, and thence the grid potential, to be almost free from harmonics, as represented by the sine wave curves  $e_p$  and  $e_g$ , Fig. 2b. The plate current will then be zero while the grid is highly negative and will roughly follow the potentials during the remainder of the cycle, as represented by the wave  $i_p$  of the same figure. The grid current will vary in the same general way, but with a longer zero interval.

Thus it is seen that the ordinary self-excited oscillator cannot have sharp opening and closing of the circuits through the bulb; but instead the valve action serves to gradually change the resistance of the plate circuit. Such valve action is analogous to the slow opening and closing of the valves of a steam engine, resulting in "wire-drawing", or gradual throttling, and is undesirable for the same reason—loss in energy in the resistance (friction) interposed. Later in this paper will be shown (Fig. 11) a circuit devised and used by the author for giving sharp valve action in bulbs. As is well known the corresponding result in steam engines is one of the main advantages of the Corliss valve.

For simplicity's sake, the load resistance has been shown in Fig. 1 and 2 directly in the plate circuit and so will carry both direct and alternating currents having the same order of magnitude. In practice, oscillators are arranged, by the use of transformers or sharply tuned circuits or both (Fig. 9 and 10), to have a path of low resistance for the direct plate current and of suitably high effective resistance for the alternating plate current. The oscil-

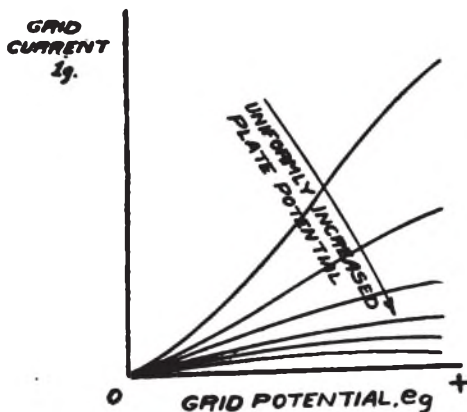

- FIG. 5 -



lator can then serve to convert the direct-current power of the plate generator or battery into alternating-current power with an efficiency that compares favorably with that of other electrical converting apparatus of like power rating. The grid-bias

potential for various constant plate potentials.

It is convenient to plot curves showing the relation between the plate current and the grid potential, taking into account such variations in plate potential as occur during oscillation. These are called derived characteristics. Under ordinary conditions the changes in plate potential bear a constant ratio to the changes in grid potential, represented by (n) in the equation below (which is not, of course, the usual amplification constant):—

$$\frac{\delta e_p}{\delta e_g} = n = \text{constant},$$

$\delta e_p$  and  $\delta e_g$  normally having opposite signs in order that power shall be given out from the plate circuit. The derived characteristic curves for this condition are shown by the full lines of Fig. 4, which are obtained from the normal characteristic curves reproduced from Fig. 3 and shown dotted. To plot one of these curves—say P,P,P,—the increment  $\delta e_p$  in plate potential between the successive dotted curves is divided by

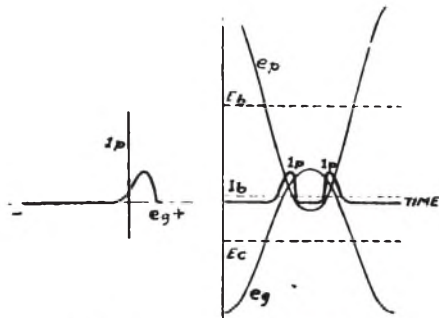

- FIG 6a - - FIG 6b -  
- REPRESENTING UNDERLOAD -

battery shown in Fig. 1 and 2 is a sink, not a source, of power, and is usually replaced by a resistance (R, Fig. 9 and 10) in which the grid direct current will cause a like voltage drop. The plate generator and this bias resistance are shunted by condensers to afford low-impedance paths for the alternating parts of the plate and grid currents respectively.

**Characteristic Curves**

The details of the action of a bulb oscillator may be determined as described below from the characteristic curves, in which the plate and grid currents are plotted against the grid potential for constant values of the plate potential. Fig. 3 shows a family of "mutual characteristic curves" of plate current and grid potential, the numbers on the curves representing

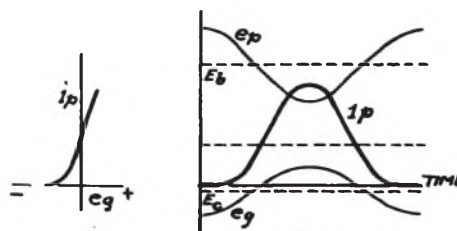

- FIG. 8a - - FIG. 8b -  
- REPRESENTING OVERLOAD -

the constant n, to give the corresponding decrement ( $-\delta e_g$ ) in grid potential. Then starting from any point on one of the dotted curves, lay off  $\delta e_g$  horizontally, and draw a vertical line to the succeeding dotted curve. This gives one point on the new derived curve. In a similar manner other points on the new curve may be obtained. There will evidently be a different family of such derived characteristic curves for every value of n.

Derived grid characteristic curves may be constructed by a similar process from the normal family of curves in Fig. 5.

In Fig. 6a, 7a and 8a are shown derived mutual characteristic curves, which are fixed for a given bulb by the alternating and direct components of the plate and grid potentials. Assuming sinusoidal variation of these potentials, their waves may be plotted as  $e_p$  and  $e_g$ , Fig. 6b, 7b and 8b, and thence the waves of plate current,  $i_p$ , may be plotted by reference to the characteristic curves. Similarly the wave of grid current could be plotted, if desired, by reference to derived grid characteristic

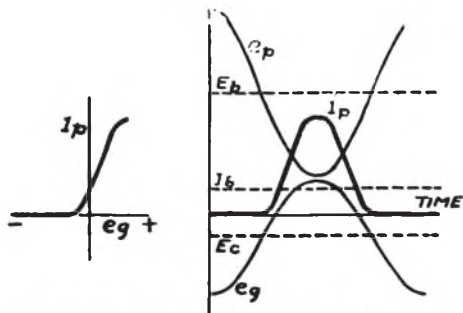

- FIG. 7a - - FIG. 7b -  
REPRESENTING NORMAL LOAD.

the relative plate potentials, which are constant for each curve. The "grid characteristic curves" of Fig. 5 are less important but are needed for a complete analysis; the grid current is plotted against grid

(Continued on page 30)



## Radiotelephotophone Personalities

By "Tewpieye"

This is the wildest story that has drifted into the QST Factory in many a day. QRM from these radiophones did it, we guess.—Editor.

**H**EN Muller (2BH, maybe you know him), while more or less a facetious individual, occasionally shows indications of at least mediocre intellect. During one of these rare manifestations we simultaneously came on an idea, which upon the manufacture of our next model will revolutionize the world! The name of the instrument, **RADIOPHOTOSELENOSCILLATORIOPHONE**, is self explanatory. The idea of transmitting a photo or living image via land-line is old and to quite an extent perfected. However, the principles which are applied to such telegraphy must be abandoned when similiar attempts are made by radio. The solution, of sending images thru an application of wireless, was discovered, as above stated, thru joint and exhaustive experiments on the part of Hen and myself. Our principle, briefly, is something on the order of the Goldschmidt Alternator, whereby we stepped up the frequency of our city lighting juice. The main variation from that commendable apparatus was seen in an auxiliary machine which in an entirely different manner reduced the already short wavelengths to those of light. These extremely rapid oscillations were superimposed upon still shorter waves (different degrees of the Ultra Violet), which we employed as carrier wave. The latter were generated by a two-stage application of the general principle. It is obvious that by tuning to the various frequencies of the carrier wave, an analogy to radio is found, and interference from other Radiophotoselenoscillatoriophone stations would be lessened.

We constructed a number of these machines and loaned one of each to certain amateurs on Washington Heights, giving them full instructions, and arranged, as a practical test, to have them all in operation at a set time on a given evening.

Hen arrived early, bringing me a stock of Bock Panatelas and we commenced tuning our rather complicated receiving apparatus. It might be mentioned that reception was accomplished by an application of the heterodyne idea, and its success on waves of such extreme shortness necessitated the Nth degree of delicacy.

The power company had recently installed our special ten K.W. lines with which we operated our receiving mechanism, and I examined the connections,

preparatory to opening up. Suddenly I gave a start.

"For the love of Mike, Hen! You hooked this darn thing up with annunciator wire!!!"

"Well it's the only stuff I could find around,—and it'll announce the photos! Hi!"

When Hen starts that foolishness 'tis best to pay him no attention, so I glared my disapproval and continued the investigation.



I reached forward and grasped the hundred amp switch.

Looking at my watch I noted that it lacked but a minute of the time when the prearranged stations would be operating. I reached forward and grasped the hundred-amp switch. 2BH backed away (he always does when he fears something may happen), and I threw in the juice to our four alternators.

As the machines gathered speed I sat transfixed, gazing first at the bell wire, then at the ammeter which was slowly climbing. Ten, twenty, twenty-five, and finally wavered about thirty!

"Wow!" yelled Hen, "That's a regular electric stove—ha—ought to increase our receiving range. Ha ha! Get that? Stove range—he he!!!"

He ducked, but I was too busy to chuck anything his way.

I tuned down to a couple of millionths of a centimeter and the platinum screen before us commenced to glow. Then changing colors it took on the appearance

of a radio station! The scene varied thru all the hues of the rainbow and continued to be unstable. This was no doubt due to the unsteadiness of this very short wave. However, I made mental note that the still shorter carrier wave was stable.

It worked! Before us was a perfect view of an uptodate radio shack.

As the shade graduated from a bright vermilion to a glaring green Hen could not resist the temptation to remark,

"Hey, Jack, you ought to call this a Chamelionograph!"

I growled ominously and he ceased his childish prattle.

On one side of the set we were regarding was a large gas-range, announcing the fact that the station was situated at no great remoteness from the kitchen. It was easy to recognize the long countenance which glared at the audion before him, so we had no need to recourse to the printed 2ABP on the wall. We centered our attention on the operator. He turned uneasily toward the stove which was continuously spattering him and his with the superfluities of frying frankfurters.

"Say", commented Hen, "I'll bet those doggone dogs make some QRM, what say?"

I continued my policy of saying nothing.

The canines in question began to sputter a little wildly and radio operator, Don Plumb, glanced fearfully about for a fire-extinguisher when suddenly the "picture" faded.

I was at a loss to explain this occurrence, but Hen brusquely took the key.

"2ABP de 2BH—sa om sum of tt grease spattered on the lens in front of the selenium cells—wipe it off—HI—AR K"

Sure enough, as the picture returned we beheld 2ABP rag in hand. The dogs were then conveyed in the direction of the dining-room and we QSY'd a few thousandths of an centimeter lower.

Another station came into "focus" and we interested ourselves with 2LM. A huge sheaf of radiograms adorned a hook above a one inch spark-coil which was sputtering profusely. An oscillation-transformer lay in discard on a shelf, while a wave-meter reposed permanently in the waste-basket. As the operator was industriously engaged we put on the phones. We were greeted with the last of a long series of 3DH's followed by an extensive array of 2LM's. As I turned off the bulbs Hen muttered, "I thought so!", and we changed scenes.

As I tuned in I lit a Bock Panatela and smoked vigorously to nullify the odor of melted wax which now emanated from my annunciator wire in quantity. The ammeter wended its slow but sure way towards the forty mark!

The image now kaleidoscoped to the compact fone-set of 2AB. We beheld its

owner, M. B. Sterns, in a very peculiar position. Tho it was past eight and full time for his concert, he was meandering around the room on hands and knees! He first protruded his head in a waste-paper-basket, then extracting it with difficulty, he crawled about the shack in the most amazing manner!

Hen suddenly left the room, returning a moment later with the telephone book. "Here you be, Jack; Matteawan one two six eight."



"Sterns just shimmied under the bed!"

"What are you talking about? Come here and watch this. It's good. Sterns just shimmied under the bed!"

"That's just it, you can't let the poor guy suffer like that. Matteawan one two six eight; that's Bellevue; call 'em up and tell 'em to send some men with a van up there!"

I admit 2AB's actions did look rather queer, but averred that we had better await developments, for if sane he might resent such drastic procedure.

Sterns finally emerged feet first from under his bed, a small shiny thing grasped triumphantly in his hand. He rose to his feet and advancing to his phonograph started the show. He had been hunting needles!

I threw the phone book at Hen and tuned in our next station.

What closely resembled a shaving mug took the place of Stern's shack. A thin cloud of steam wavered above this radio monstrosity, and flickered green and blue. The "mug" must have been very close to the lens of the apparatus for nought else of the station appeared. Suddenly an enormous hand took the handle, and the cup disappeared disclosing to view a respectable audion control cabinet. The mug re-appeared half emptied of its contents. Hen's brow raised and I prepared myself

for some facetious remark.

"Home brew", he suggested.

The mug repeated the disappearing act and when it again returned the guiding hand held a Mecca cigarette. Light dawned upon me. It was merely 2OK, friend Oscar, and his eternal cup of cocoa! This beverage finally left the scene for good and we gravely watched the maneuvers of the cigarette. 2OK threw in his transmitting switch, sent a few explanatory (?) V's, and placed a book on his key. Having first donned rubber gloves he grasped the coffin nail with a pair of pliers and held it in the spark!!

As Johnson, 2OK, consumes a box of butts per evening, I've sent in my dollar to the National Anti-Tobacco League. It may help to reduce QRM!

Above the operating table stood the redeeming feature of his shack, an A.R.R.L. certificate, heavily framed. Hen noticing this grew excited and dancing on one foot proclaimed,

"Hey, that's a frame up—Ha ha he he!"

Hen, with the skill of long experience dodged "Vacuum Tubes in Wireless Communication", which I accompanied with the remark that the pun was the lowest form of humor.

As 2OK commenced to relite his cigarette, I again QSY'd and my last glimpse of his station was of an O.T. in beautiful discard under his desk.

At this juncture, Hen howled as he came in contact with an incandescent bell wire and I cast a mournful glance at the ammeter. FORTY-FIVE amps! MIM!



2QV was likewise condemned to the "galley".

As a couple of wash-tubs "faded" into existence on the photo screen I thought we had returned to 2ABP but the sight of a huge Dubilier condenser disclosed that 2QV was likewise condemned to the "galley".

"Say, his set has a rather tubby appearance! Haw haw!" chirped Hen.

I looked threateningly at a copy of "Practical Wireless Telegraphy", and he sobered down.

A mass of machinery operating a break-in-system was the next most ostentatious instrument in the shack. An oscillation transformer stood to the left and I noted the proximity of the primary to its better half. Under the table reposed a Packard transformer and next to it a galvanized garbage-can.

Henry backed to the door and yelled:

"Say these guys who are stranded in the kitchen would make good aeri-als! Haw, haw; get that? Stranded!"

I contemplated murder and was seriously considering how I might hook 2BH to the ten K.W. line when a peculiar looking instrument in 2QV's shack attracted my attention. It was a large, well-worn clamp, affixed to the table, just one side of the key. Its use was obvious. When friend DePalma desired to test he merely swung the clamp around 'til the key was closed. It remained there until the termination of the test, incidentally a period of about one half hour. I looked in vain for a time clock operating this unique contrivance, set for about eleven P.M.

I tuned a little closer and the cook-stove came into focus.

"Say", quoted the irrepressible Hen, "I'll bet that's a BAKELITE stove, and by the way, with that right next to him he ought to have quite a transmitting range! Haw he \_\_\_\_\_!!!"

I threw everything within reach and as Hen jumped he slipped in a pool of molten wax, which, since eight o'clock, had been accumulating in puddles beneath the annunciator wire. As he fell, he grabbed my light extension. My last impression before the wire snapped and darkness prevailed was the scale of the ammeter. Fifty-six amps!

The glowing bell wire sparked fitfully in the dark. A little ball of white formed on one and quickly enlarging dropped to the floor in a blinding display of pyrotechnics. The alternators, with a final whine, came to a standstill and the fused wire cooled to a dull red.

### NOTICE

On Tuesday and Thursday nights during October, between 10 and 11 p.m. Eastern Standard Time, the A.R.R.L. will conduct another series of Fading Tests for the Bureau of Standards. Stations in northeastern quarter of country will be engaged in recording—details later. All stations are requested to confine their transmitting to a minimum during these periods, to prevent interfering with the recording.



## Concerning Cages

By Sumner B. Young, 1AE

**C**AGE antennae are seldom used by amateurs because their merits are not popularly known, and because a flat-top aerial of conventional design is easier and cheaper to erect. However, the cage has electrical and mechanical advantages which should make it popular with Relayers who desire extreme ranges, and it should prove valuable where space to erect an aerial is limited, or where high winds must be withstood. Anybody can build a cage; care and patience are alone essential.

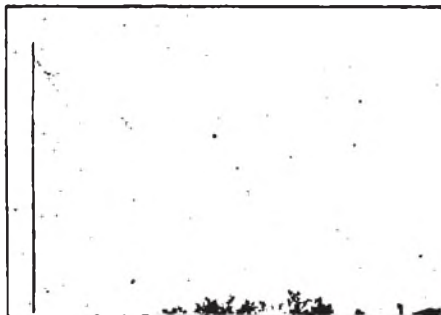

4-wire cage used at 1AE Mar. 20—June 24, 1920.

It is generally conceded that the flat-top has electrical shortcomings. Radio frequency currents traversing it flow mostly in the two outside wires, just as these currents would tend to run along the edges of a flat copper ribbon. The losses incurred are small, but they are of importance where excellence is sought. Sway-guys, which must be fastened to the ends of the spreaders, not only add weight, but more losses, for they offer four possible leakage paths to earth, blocked only by insulation which is never absolute.

Still more obvious are disadvantages of a mechanical nature. The spreaders of a large transmitting aerial are long and heavy, yet they add nothing to the electrical capacity of the antenna, and are always a menace, for they offer considerable surface to wind and sleet. Their contribution to the insulation scheme is negligible.

The circular shape of the cage is advantageous. Due to it, every wire gets its proper share of the load when high frequency currents are flowing through the cage. The heavy metal rings not only help to maintain this equal current distribution, but also increase the electrical capacity of the antenna system. Further-

more, long lead-ins may often be avoided, for the cage takes up little space and can be brought closer to the operating room. Sway-guys are eliminated, for the wind whistles through a cage instead of tossing it around.

The diagrams give specifications for a cage well suited to amateur requirements. In building it, the following procedure can be followed to advantage:

1. Bend the rings to shape by hammering them around a circle of heavy spikes driven into a wooden framework shaped like the spokes of a wheel. Wrap the joints and solder.

2. With a file mark the places on the rings where the aerial wires are to be fastened.

3. Cut the aerial wires to proper lengths, allowing a few extra feet, and coil them separately.

4. Solder one end of each aerial wire to the first ring.

5. Select a clear spot in the back yard. Fasten this ring securely to the side of the house so that it will remain in a vertical position and will not slide around even if considerable pull is exerted on it.

6. About 65 feet away, set up a post, and fasten to it a large board parallel to the side of the house to which the ring is fastened. Draw a two-foot circle on this board, and drive screweyes into it, spacing them sixty degrees apart around the cir-



10-wire cage to be used at 1AE this winter.

cumference.

7. Uncoil the antenna wires, fasten the free ends to the proper screweyes, and adjust to equal tension.

8. Tie in the rings, using short lengths of #16 bare copper wire.

9. Solder the tying-in wires to the aerial wires and to the rings. Use jumpers



where good electrical connection is doubtful. Apply the solder at the ENDS of the tying-in wires so that the aerial wires will not be stiffened where they meet the rings, and rendered liable to breakage.

This soldering takes time and care for the rings absorb a great deal of heat. A soldering-iron weighing at least three pounds must be used.

The cost of the cage described above will be about fifteen dollars. This figure can be greatly reduced by using galvanized iron instead of copper separator rings. However, iron is heavier, and the joints between the wires and the rings are somewhat subject to corrosion. Wooden separators such as bicycle rims and cross-arm arrangements will serve, but they are cumbersome, and put the cage at the mercy of the wind. They do not become part of the aerial itself, nor do they assist in distributing current equally between the wires of the cage.

If possible, install the cage so that a long lead-in is unnecessary. If this cannot be done, it will pay to build a miniature cage about six inches in diameter to take its place. Cables are poor radiators, and often poor conductors. It is significant that the down leads from the flat-top to the outdoor tuning inductances of the Alexanderson multiple-tuned antenna at

from March 28th, 1920, until the station was closed for the summer on the 24th of June. A conservative estimate, based on

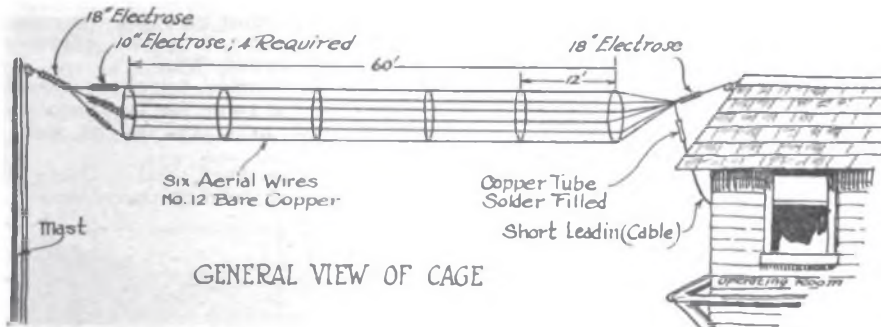
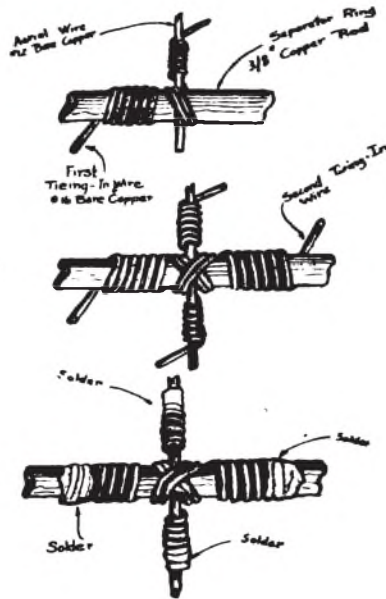

Marion, Mass., are cages, and it is presumed that this construction is duplicated at other high-powered stations of the Radio Corporation of America.

The photographs show two cages which

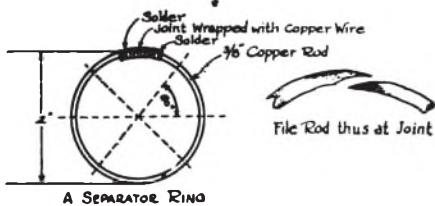

were built by the author and used at 1AE. The smaller consists of four wires 55 feet long, and has galvanized iron rings 18 inches in diameter. This was in service

our Log Book, is that it added 100 miles to the station's range. The other cage is of equal length, but has ten #14 wires spaced 36 degrees apart around three-foot copper rings. It received its initial tests on August 23rd, and a 10% increase in the reading of the hot wire meter noted. This cage was built in two sections which were joined together after they had been hoisted to the roof.

During the coming season, the author's business will keep him away from home a great deal, yet he hopes to "sit in" Saturdays and keep folks from forgetting the sound of his spark. Perhaps "The Old Man" will call him some night and describe a cage he has invented to shut up the radio pests he rants at.

## A Simple Radiophone Operating On "B" Batteries

By F. S. Huddy, III

**T**HE following is a description of my wireless telephone outfit. Enough data are given to make it easy for the average experimenter to make and work it. Many improvements will at once suggest themselves to the person constructing the outfit. Let it be said here that it is not a high-powered set. It will not send 1000 miles on 5 watts and is not meant for long distance traffic. It is, however, easily made and with 100 volts on the plate will transmit 5 miles with a good antenna. The type of tube to be used is left to the judgment of the maker. The writer is using a Western Electric VT-1—a receiving bulb.

Various tubes have been used. Almost any tube that will oscillate with 50 volts on the plate will do. The Marconi class II tubes work fine if the voltage of 500 is obtainable. As every experimenter has

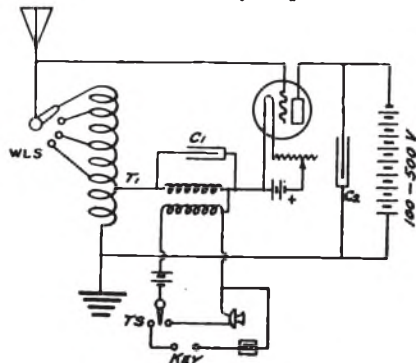

not this voltage at his disposal, the W. E. or Audiotron is more practical as they will oscillate and radiate at a much lower voltage.

The following materials will be needed:

- 1—11 ohm battery rheostat
- 1 local battery 'phone transmitter
- 1 large rotary switch
- 1 small rotary switch
- 1 high frequency buzzer
- 1 knife switch
- 1 Ford spark coil
- 1 2-mfd. telephone condenser
- 1 VT socket
- 1 wood or bakelite panel 12" x 12"
- 6 switch points
- 8 binding posts
- 1 lb. bell wire
- 1 condenser, .005 mfd. or variable

A glance at the drawings will show how the instruments are mounted. The small switch to the right of the microphone changes from buzzer to talking circuit, and

in its center position opens the battery circuit. A key is connected to the binding posts in the lower right hand corner of the panel. By shortening the buzzer and connecting a long flexible cord to the key binding posts, an extension microphone may be connected in, which is convenient to place in front of a phonograph.

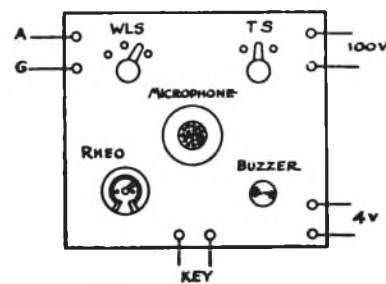

The tuning inductance consists of 53 turns of No. 18 bell wire wound on a tube  $5\frac{1}{4}$  inches in diameter.

Starting from the bottom, taps are taken at 20, 39, 43, 48, and 53 turns. T, is the tap taken at 20 turns.

The others run to switch points of the wavelength switch WLS.

C<sub>1</sub> is a 2-mfd. telephone condenser, while C<sub>2</sub> has a value for best results in my set of .005 mfd. and might well be a variable.

MT is the Ford coil. Uncle Henry makes good modulation transformers. The

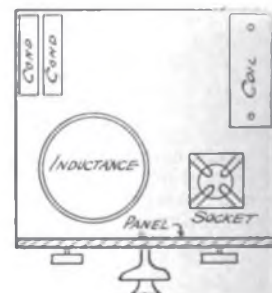

one I used transmitted the speech perfectly and without distortion. Switch TS is used to change from the microphone to the buzzer.

The buzzer is connected in series with the battery and key.

Anyone interested in the construction of this little outfit and who does not understand my description, is invited to write me at my residence at No. 204 Bowen St., Providence, R. I.

## An Oil-Dielectric Transmitting Condenser

By L. A. Bartholomew, 6LC.

**H**ERE is some firsthand dope on a condenser that will not "blow" when needed most. It is of the oil dielectric type, quite simple to construct; but expensive, as everybody finds out who makes any kind of a transmitting condenser. This one takes 70,000 volts to puncture; that is, the condenser will puncture if the voltage is allowed to build up to that figure. This does no harm whatever. A bubble rises to the top, and the condenser is ready for the next shot. The losses, also, are very small.

The material needed:

- 2 Bakelite end pieces,  $\frac{1}{2}$ " x 14" x 14".
- 38 Aluminum plates, No. 16 gauge, 10" x 13".
- 152 Spacers, round brass tubing,  $\frac{1}{4}$ " O.D. and  $\frac{1}{8}$ " I.D.,  $\frac{1}{8}$ " long.
- 8 Spacers, ditto except  $\frac{3}{8}$ " long.
- 8 Round Brass Rods,  $\frac{1}{2}$ " diam., 21  $\frac{1}{2}$ " long, threaded 8-32 for 1  $\frac{1}{2}$ " on each end.
- 16 Hex. Nuts, 8-32, and washers.

Tank and Oil.

The Bakelite end pieces carry the eight rods, on which, separated accurately by the spacers, the aluminum plates are mounted in two sets, the longest dimension of alternate plates being at right angles. The drilling of the plates and the end pieces is the first step, and the dimensions are given in Fig. 1 and 2, respectively.

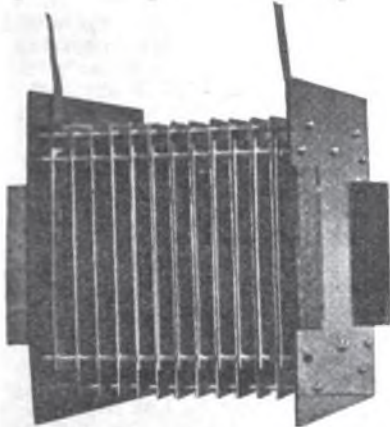

The 8 supporting rods are then put thru one end-piece, with washers and nuts behind, and the piece laid flat on the bench with the rods in a vertical position. Put short spacers on one set of four rods, and long spacers on the other set of four rods. Put on two plates (automatically at right angles to each other), and then another

set of spacers, this time long ones on all 8 rods. Then another set of plates, etc. When half the plates are on, connect on the terminals to the center plates, which is done to make the current path as short as possible. These terminals should be at least 1 inch in width, and preferably 2 inches. Then put on the rest of the plates, finishing with the remaining set of short

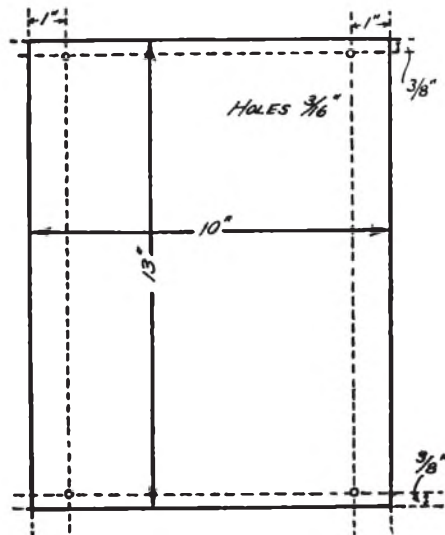

FIG. 1

spacers, and finally the other end piece. Fasten the ends with hexagon nuts, and draw up tight.

Make a tank of galvanized iron and put the whole affair in. Fill with Mineral Seal or any good high-flash transformer oil. Above all things, use heavy metal for the plates—No. 16 gauge aluminum is the best. I used scrap stuff, which was very low in price—the new stuff is expensive. These plates must be spaced at least  $\frac{1}{4}$ " apart, and  $\frac{1}{8}$ " is better. This design gives  $\frac{1}{8}$ " spacing. Use oil perfectly free from moisture, and let the condenser stand at least 24 hours before using, to let the air bubbles rise.

In drilling the plates, stack 19 plates in each stack and clamp to the bench in any convenient manner, and drill the four holes right thru the pile. This insures alignment. A  $\frac{1}{8}$ " hole is about right. Place one plate of each pile on a Bakelite end piece in the same way they will be when assembled, and drill the end pieces thru the holes in the plates, using them as templates.

The dielectric constant of Transil oil is about 2.1, so it takes quite a large condenser to get any great capacity. The value of the condenser here described is about .007 mfd. A photograph of a similar condenser is shown, but having but 25 plates, 8" x 10", and a capacity of about .003 mfd., being designed for high voltage and high tone. With it I get 9 amperes in the aerial with a 1200-per-s.c. spark rate, and on 600 per sec. and less power, 6 amps. The larger condenser here described (38 plates—007 mfd) is in use at 6ER, where the antenna current is 9 amperes on 1 KW at a spark frequency of 500 per sec. The best 6ER could do with a glass condenser was about 6 amps. 6HS and 6PI are also using the oil type of condenser.

I hope that this information will help any amateur who is having trouble with condensers that "blow".

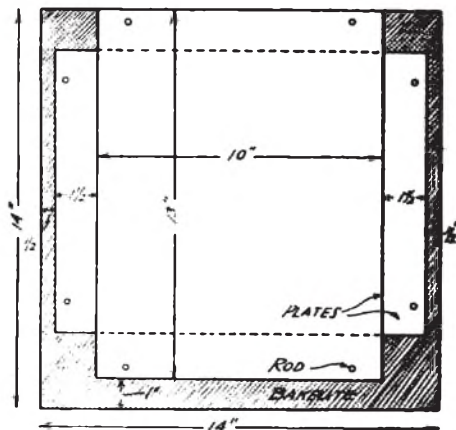

FIG. 2.

## A Paper on QRM

By John F. Gray, 6MZ

Presented before the Sunset Radio Club, San Diego, Cal.

We hail this article as the best we have ever seen on this important topic. It is a most vital one, to clubs and individuals alike. We have talked much of co-operation, and we reiterate that it alone can lessen our difficulties. In this splendid paper Mr. Gray defines the practical methods in which this co-operation can be applied. With all the earnestness there is in us, we commend these principles to the individual amateurs of the country.—Editor.

**O**UT of any hundred radio club meetings, or out of any hundred issues of radio magazines, you will find it hard to find a meeting or an issue that does not contain some discussion of the QRM question. And no matter how much we talk or write about it, the QRM situation seems to stay pretty much the same.

All radio communication is more or less affected by interference, but the situation is particularly bad in amateur work. When you come to think about it, this is not so very surprising. Nobody expects very good service out of a six-party telephone. So why should we expect to talk to whom-ever we please, whenever we please, on the several-hundred-party-line of two hundred meters? When you look at it that way, I sometimes wonder that we ever succeed in talking to each other at all.

You cannot hope to do away with QRM so long as radio apparatus of anything like the present type continues to be used—that is, you cannot hope to do away with it unless you are going to restrict the use of the air to two stations a night, two stations

an hour, or something on that order. All you can hope to do is to try to hold down unnecessary and avoidable interference to the point where a fellow doesn't feel like breaking up his set with an axe and taking to drink—if there were any drink to take to. That's what I am trying to get at here, but just how far I shall get remains to be seen.

As heard from 6MZ, the San Diego District seems particularly fortunate in this matter. This may be partly because we are out of the range of the spark coils, but I do not think it is entirely so. For the stations we work in town are able to copy us pretty much any time they answer a call. You fellows in town may think the situation is bad, but San Diego cannot be put in the same class with Los Angeles, where some suburban stations are not able to reach town through the QRM barrage for weeks at a time. It is said to be even worse in some of the eastern cities.

All the same, whether we are to be considered good or bad as cities run, there is no doubt that we can stand a lot of improvement.



There are any number of classes of QRM. There is the hard boiled kind—the fellow who hogs the whole air whenever he has a mind to, and thinks QRT was invented just to make him laugh. I have never heard him in the San Diego air, I am glad to say, but if he ever is heard we all know what to do with him—turn him in to the radio inspector—do it quick, and don't mince words about it. I wish the rest of the classes were as easy to deal with as he is.

And there is the bone-head kind. He isn't quite as easy to deal with as the hard boiled because the poor fellow was born that way; he may mean all right but he just could not help it. When you bawl him out, he feels awfully bad about it usually, apologizes all over the place, promises never again—and then goes right back and goes at it just as bad as ever.

His specialty is calling without listening for more than thirty seconds or, even worse, just throwing in his switch and pounding away on the key without ever bothering to listen at all. It never seems to get into his brain that it takes at least three minutes to really find out if the air is clear. He doesn't realize that the station he is calling may be copying someone whom he, himself, cannot hear at all; or if he does hear him he does not realize that the station he wants to call is the one that is being worked, because he does not have the sense to wait to hear a few call letters and learn who is working whom. He has other specialties in the same class but that is the worst one. San Diego is free from him, but I hear him once in a while. A little more listening would save a lot of wasted juice and a lot of hard feelings too.

Then there is the fellow whose speed limit for receiving is about three words a minute. You tell him QRT, QRW, QRX please, and he comes right back at you with "Your signals are fine and strong, old man—I have put my coupling two inches closer, how do I come in now?" All spelled out without a single abbreviation. More often than not he is ashamed of his bad copying and will not let on what the trouble is when you are talking to him. There is no crime in asking for QRS, but this fellow would rather let you QTA till you get a sore arm, or until you finally do discover his secret and hand him the code at a speed where he can take it in.

On the other hand, there is the high speed artist and the fancy fist fiend, or both combined in one. There is a fellow near San Diego (he is not a member of the

Club, though) who sends a hash of dots and dashes that sometimes could not be read by the best operator licensed. Being used to it, I can make a pretty good job of copying him on his good days, and I often get a lot of fun out of listening to him chewing the fat with some poor guy who is hearing him for the first time. If it was not for the call letters you would never know they were talking to each other, as neither of them are saying anything to do with what the other has just said. This sort of thing is not QRM itself, but it is the cause of a whole lot of it because it ties up the air with a lot of stuff that might as well go unsaid, or if they are trying to say something that requires an answer, it causes one or more QTA's that need never have been given.

And we have the station with the wave like a barn door that comes in equally well anywhere you want to tune your receiver. There are a number of them in San Diego, in fact they are about the only serious cause of complaint that there is here. Theoretically every amateur station, or nearly every one, is tuned on two hundred meters. Practically there is enough variation between most stations to enable fairly successful tuning out of interference, provided the interfering stations have sharp waves. You cannot tune out a broad wave because it comes in just as well one

place as it does another. If one transmitter is tuned to a hundred and ninety-five meters, and transmits a wave of that length only, and another transmitter is tuned to two hundred meters, and transmits a wave of that length only, you can tune your receiver to hear only one of them, if it is selective enough. But if one of these transmitters has just as strong a wave on one hundred and ninety-five meters as it does on two hundred there is no way for it to be tuned out, and the other station still heard.

Some time ago I tuned in a report to the chairman of the QRM committee on the subject of broad waves. The report had scarcely been mailed before the two stations most complained of had changed their broad waves to exceedingly sharp ones, and a station that I had given a fine boost went and came out with a wave that was QSA through one hundred and eighty degrees of the series condenser. What I am driving at is that it is hard to lodge a complaint against any particular station, because we amateurs fool with our sets so much that what is the truth about somebody's wave one week will be the reverse

**Mr. Kruse's Paper on the Bureau of Standards—A.R.R.L. Fading Tests unfortunately could not be made ready for publication in this issue. Watch for it IN THE NEXT ISSUE.**

the next. There is a station in town that is pretty sharp right now, but two or three weeks ago I copied him QRK on two thousand meters, believe it or not as you like. It took a pretty close coupling to get him but he came in all right.

All that can be asked is that we bear in mind to keep our quenching good and our couplings loose. Just because the hot wire ammeter reads higher, the closer you put the coupling, is too much temptation for some fellows—they reason that the more amperes they radiate the more noise they must make in the air. They do not or will not realize that the high ammeter reading given by close coupling simply means that they are radiating a whole lot of different waves no one of which is of any great power, but the sum of all of them makes the wire in the ammeter fine and hot. They are getting the amperes into the aerial all right but it does not mean anything because they are throwing them away in waves they do not want. Keep your coupling loose enough for there to be just one wave radiated and what energy does get into the aerial will be concentrated in one wave, not spread out all over the air causing nothing but QRM.

As to quenching. I notice that a good many of the fellows are making the discovery that the lower their spark rate is the more energy they can get into their ammeter. That is all right as far as it goes but some of them are going at it the wrong way. When they want a lower spark frequency they simply slow down their gap motors. This will get by for an experiment but it does not get by as a permanent proposition. Remember that the first duty of your rotary gap is to quench the oscillations in your primary circuit and to open this circuit so that it will not absorb back the oscillations in the aerial circuit. Just giving a high spark rate and a musical note is not the main purpose of the rotary. Once two or three oscillations have been given to the aerial circuit, the usefulness of the primary circuit is ended and you want to get rid of it—to quench it as soon as possible. So, when you have decided on the spark rate that gives the best radiation, and that gives the tone that suits your taste best, the thing to do is to speed up the motor again for all it will take and cut down the number of electrodes in the motor to the number that will give the frequency you are after. There is no such thing as too high speed for a gap motor.

Another thing that causes a lot of trouble is the use of full power for talking to a man in the same town. There used to be a great deal of this in San Diego although the fellows are learning better ways now. A number of times I have had to give up trying to get radiograms from the north for the rest of the evening just because

some amateurs in town were talking about the weather or kidding each other about their girls on full one-half K.W. When you want to chew the fat with the man in the next block cut down the input with a magnetic shunt or a rheostat to the point where he can just get you QRK. Or if you haven't got either of these loosen up the coupling to get the same result. A hinged oscillation transformer is a help in this method, and if a little QRM spoils the reception of the man in the next block do not begin to lose your temper and give her full power. It does not hurt to QTA, "Did it rain much over your way tonight?"

In talking about spark frequency there is one thing I might have added. Although there is not much doubt that a low tone gives better results on two hundred meters in most cases, this is not always so and it seems too bad that everyone in San Diego is taking up a low note. When stations have widely differing tones it is possible to do some selective tuning by what is called the group frequency method, by a variable condenser across the phones. And even if you cannot tune one out it is still fairly easy to read either a high or a low tone transmitter even when both are coming in at the same signal strength. The fellow who is content to stick with a high tone may not be able to break all the long distance records but he will be able to get his messages through most ordinary QRM, and day in and day out that is what you are trying to do. Average amateur work is down within a radius of a hundred miles or less.

One thing that can be given attention is the habit that some men have of making a string of unnecessary signals. One KA is what the law requires, three or four KA's are a violation of the law as well as a waste of valuable time. And when you have once established communication with a station there is no need of calling him the three full times, unless some exceptional condition makes it necessary. The same thing applies to calling a very near-by station, when you are fairly certain that he is on duty. Try him with a single call first and if that does not raise him the three repetitions can be used. And do not fill up the body of the message with a bunch of periods, dashes, and HI's. That does not mean to leave them out altogether if you like to use them but it does mean not to put them between every other word the way some operators do. Also I see no reason for signing off with your call letters at the end of every message. The man you are talking to knows who you are and as long as you are QRW it is nobody's business. When you give your sign-off with the SK, it means something because it tells men who are standing by what stations are clear for new business.

This about covers the matter of the QRM that we can all get together to stop in our every day sending. It leaves two big questions that are now being considered by nearly every radio club in the country as well as by the American Radio Relay League itself.

One is the question of different classes of amateur wave lengths. And one is the question of a division of the time for Relay League messages. They are both subjects which should be seriously considered but I think it is better that they should be freely discussed by the Club at some time rather than be gone into at great length in a paper.

There are two general classes of amateur stations: those that by reason of their low power do most of their communication within a radius of twenty-five or fifty miles or less, and those from a quarter to one K.W. that do inter-city and genuine long distance work. The big fellows need every bit of two hundred meters both because a longer wave length carries further, and because they need as much condenser as possible to use the power available. The smaller fellows cannot by any chance work much over fifty miles or so, nor can they use .007 or .01 microfarads. They use the two hundred meter wave mainly because the law allows them to and not for any particular good that they get out of it. They would do exactly as well on a hundred and fifty meters, in fact they would do even better because they would be able to keep on working when a high power station in the same town was transmitting, and not be drowned out as they are now. At the same time the QRM for the larger transmitters would be reduced by one-half or even more. I cannot see that such an assignment of wave lengths would do anybody any harm. Of course we would not expect the law to be changed or anything like that but it does seem that some agreement would be arrived at among the members of the clubs, between the various nearby clubs, and possibly throughout the whole country, by which some such assignment of wave lengths could be brought about. Let's think it over.

Then as to the division of time for Relay League work. I am one of those people who believe that the biggest thing in amateur radio is the handling of messages. It is the most instructive part of amateur work—in the long run it is the most interesting, and it is certainly our very best advertisement.

When a man is a really good League operator he is fully trained to be a first grade commercial operator, if ever he should want to be one. In fact in most commercial work where they have cast-iron rules about unnecessary signals and conversations, not to speak of their high power

sets, it is easy sailing compared to amateur relaying. To see the way a good relay station gets its messages off the pin in the face of all the difficulties with which we have to contend would make a commercial sit up and take notice. If it had not been for the training furnished by relay work, the country would have been hard up for radio operators in the war.

Then again—sooner or later a fellow gets tired of just chewing fat with anyone who will answer a CQ. When you know all about the sets of everybody to whom you talk and when they have heard all about yours, you begin to wonder what to talk about next. I am not trying to say that it is not good fun to pass the time of day with somebody in the next town or in the next block for that matter, for if we all felt that way about it we might as well join the Marconi service and get it over with. All I do mean is that we need something to keep us on the job and to keep up our interest. Relay work furnishes just this.

As to advertisement for amateur radio, about the only way we can keep the public informed that we exist and that we are doing serious and valuable work in the art of radio communication is by furnishing a sure-shot relay service,—not child's play, but something on a par with the commercial companies. And if we want to stay in existence we shall need every bit of advertising we can get. Every time they talk about a new radio act in Washington, it means danger for the amateurs.

When a station has a message to handle he should have the right to ask any station who is simply conversing to QRT, and what is more that station ought to be made to do it. There should be one, or better, two periods per day set aside for the exclusive handling of relay messages. To avoid confusion, certain stations should be designated to do relay work in regular order, two at a time, one to handle traffic and one to stand by to help if necessary. If we do something like this we shall be able to clear all San Diego traffic, North and South, in at most two hours out of the twenty-four. As it is now, San Diego is on the black list of the Pacific Coast Manager of the A.R.R.L. as having rotten service. \* As it should be, situated as we are, we should have the best service on the Coast.

To make such an arrangement worth while we should have an agreement with the Los Angeles club so that they can receive our traffic when we are ready to send, and so that we can do the same for them. I am sure they would be glad to do something along this line.

\* San Diego was on the black list perhaps, but it is no longer. The co-operation there is most admirable now, and we know they have a hard struggle working through NPL's arc.

—Editor.



## A New Variable of Radical Design

**T**HE Parkin Mfg. Co. have developed a new type of variable condenser of radical and interesting design, which is the most compact, practical, variable condenser that we have seen. It has a maximum capacity of .001 mfd., and the size of the unit is only 3" diameter by  $\frac{1}{4}$ " thick.

Some of the advantages claimed for this condenser are that it has a lower minimum capacity than the average air condenser, as the large number of plates in proximity to each other in the zero position have been eliminated; it is practically unbreakable, there being no plates to get bent and short circuited; it is absolutely balanced, and requires only one hole in the panel for mounting.

Another great advantage is that two or

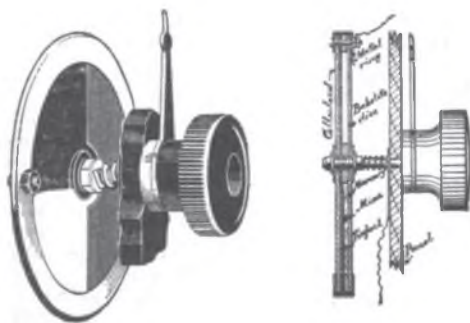

more units may be mounted on the same shaft, giving a proportionally higher capacity while taking up hardly any more space.

From the sectional drawing illustrating the construction it will be noted that three discs are used, one of fibre, one of mica, and one of celluloid, the mica disc being in the middle. Between the celluloid and mica disc there is a semi-circular tinfoil plate which forms one of the condenser plates. The fibre and mica discs are separated  $\frac{1}{8}$ ", at the periphery by a soft rubber insulating washer, and at the centre by a metal washer which also serves to make contact with the mercury with which the lower half of the space is filled. A brass eye fastens all the discs together at the centre and makes contact with the metal washer. A metal ring fastens the discs together at the periphery and makes contact with the tinfoil plate. This ring is clamped on with a pressure of five tons making the escape of the mercury impossible.

Connection is made from one side of the circuit to a soldering lug on the shaft, and from the other side, by a flexible wire, to the terminal on the ring provided for this purpose. If preferred this contact may be

made by a strip of spring brass mounted on the back of the panel and bearing against the ring.

From the above it will be clear that the tinfoil plate constitutes one of the condenser plates, the other plate comprising the body of mercury confined in the chamber between the mica dielectric disc and the fibre housing disc.

Since the weight of the mercury causes it to always remain in the lower half of its chamber, that is, in a substantially stationary position, while the tinfoil plate will rotate with the condenser, it follows that by the rotation of the instrument the semi-circular tinfoil plate may be brought into full or partial registration with the fixed semi-circular mercury plate or placed completely out of registration with it, thus varying the capacity of the condenser in accordance with the areas in register.

The transparent celluloid cover allows the operation of the condenser to be seen, and facilitates the original setting in the zero position.

These condensers, the manufacturers state, after having been thrown around a room, have been tested out and found to function perfectly.

They should fill the long-felt want for a rugged, low priced variable condenser.

### THE DIRECTORY OF CALLS

**T**HE long-looked-for Department of Commerce's List of Radio Stations of the United States is now promised for delivery early in October, and QST is therefore omitting the two pages of calls which have been appearing each month, as they would be calls contained in the government list in all probability. As soon as this list appears we will resume, taking up the lists where the Government edition stops.

The new list is to be published in two parts this year: one part to contain government, commercial, and special stations, and the other the amateur stations. The sale price cannot be determined until the cost of publication is known, but it is expected that the figure will not exceed fifteen cents for each list, possibly but ten cents for the amateur list.

Remittances for these lists should be sent to the Superintendent of Documents, Government Printing Office, Washington, D. C. Let us take this opportunity to say that that is also the correct address from which to obtain copies of the Radio Laws and Regulations of the United States (containing the list of "Q" abbreviations), the price of which is fifteen cents.





### The Chicago Convention

**A**MATEUR Radio saw its high water mark at Chicago on September 2, 3 and 4, 1920, when the Central Division held its first Convention. It was strictly an A.R.R.L. affair given by the Ravenswood Radio Association, South Side Radio Association and the Progressive Radio Association of Chicago in true A.R.R.L. style. From the meeting of visitors at the different railroad stations with automobiles, to the taking them back to the stations, everything moved with that snap and precision which is characteristic of the energetic mid-west. It was impossible to determine the number of amateurs present on the three different days, but between three and four hundred is a fair guess.

It was a great treat to see the different fellows, with their call letters and their names on the blue and gold badges. Most of them we all hear in the air here in the eastern half of the country. They looked very different than we expected, as is always the case. Locomotive engineers, telephone experts, electric light men, Catholic priests, insurance men, business men and students were among the interesting personnel. Their ages impressed us also. Mr. Bookwalter, who came up from Springfield, Ohio, was a young enthusiast of eighty-four summers, and QCP, whose examination papers at the Radio Inspector's office are kept on exhibit as an example of a perfect examination paper, was in short trousers and boasted of fourteen summers. They were everything in between and the great average seemed to be around twenty-four.

At the meetings, of which there were three, as reported elsewhere in this issue, it was also a great treat to hear the views of the different fellows whose names are so well known to us. The peppy spirit of general co-operation as voiced by residents of the First, Second, Third, Fourth, Fifth, Eighth and Ninth Radio Districts made one feel that we were actually the one big family we talk about in our QST, and the technical meetings made it very plain that we certainly have the identical prob-

lems on our minds, no matter where we live. The Fellowship Meeting, the final effort, was an exhibition of that curious brotherly spirit that animates us amateurs. The "stunts" that Brother Mathews pulled off made the banquet partake of the qualities of a big friendly party, where everybody simply loosened up and had a jolly good time. We know we did and we are willing to make it a pretty big red apple that everybody else did also.

The Convention out-convented anything yet pulled off in Amateur Radio, and the rest of the country is under obligations to the fellows in the Central Division for setting the standard of what can be done and giving us a living illustration of the magnitudes involved in our A.R.R.L. We lift our hats to you, Mr. Mathews, Manager of the Central Division and leader of this greatest of all Amateur Radio Conventions, Mr. Schnell, Chairman of the Executive Council of the three Radio Clubs, and Radio Inspector Kolster of the Ninth District, Chairman of the Trial Board of the Executive Council and all around good friend of the Amateur. We hope you will try your hands next year and we look forward with the greatest pleasure to being present.

### An Anniversary

**A** year ago this month, thru concerted amateur effort, the wartime restrictions on amateur transmission were removed and we amateurs picked up the threads of our operation where we had dropped them to go into uniform. A year ago we were a band of young hopefuls, dusting off old apparatus because it was close at hand, eager to get on the air but brimful of service-gained ideas, and filled with the resolution that Amateur Radio should be made a greater thing than ever before. How well those dreams have been realized! What vast progress in our activities this one tiny year has seen!

Our relaying network has been built up to a better-operating machine than ever before; the quality of our stations as judged by their performance is incom-

parably superior; we have played a prominent part in the effort to determine the cause of the elusive QSS; one of our number has been heard in Hawaii and almost every other amateur record has been repeatedly smashed; we have held a number of the most enthusiastically successful conventions; we of the A.R.R.L. have been officially recognized by several departments of our government as the Amateur Standard-Bearer; and, perhaps greatest of all, we have witnessed the introduction of Amateur Vacuum Tube Transmission. A marvelous year it has been. And the future? Gentlemen, we have repeatedly declined to prophesy anything connected with amateur affairs, for things happen much too swiftly with us amateurs to make it safe. We do not hesitate to venture, however, that the achievements of the coming winter will make last "season" look like the vacuum in an audion, which is our idea of nothing. Coast to coast? Why not? The Azores? Who can say? Great improvements in our equipment and methods—new developments? Unquestionably!

It's a great year for us which is now opening up, fellows. Get the old junk in shape and give 'er the juice—the gang is on the air.

### Romance

SOME of the old timers complain that there is no romance in tube transmission—it has no individuality or traditional associations like the old spark, they say. Right they are, to a certain extent—the tube work is new, most buzzer notes sound alike, and indeed there is a certain stalwart and hearty attraction about the old nonsink rotary, noisy and inefficient as it is. We have had them with us for years; all our good work has been with them, and there is romance in their wailing old note. But we do believe that they will have to give way to the more efficient tube set, and it seems to us that the talk of romance is merely the last argument of the dwindling members of the Old Guard. As for Romance, what can equal the Romance of getting something out of these little bulbs that have nothing in them?

### Our Advisory Technical Committee

THIS Fall will see the launching of our Board of Direction's "Technical Committee" idea. Our President, it may be remembered, was requested by the Board to invite certain gentlemen to become members of an A.R.R.L. Advisory Technical Committee. These gentlemen were the leading radio engineers of the

country and of Amateur Radio. They signified their pleasure in accepting the invitation and at the last meeting of the Board in New York their functions were discussed and decided upon. They will be supplied with certain data and their interpretation of this in terms applicable to amateur radio engineering will be requested. In time all of the great problems at which we now must guess or at most proceed into by purely empirical methods, we hope to see put down in precise and exact form and the laws that govern them we shall expect to have set forth. We shall make it a point to see that the language and methods employed are clear and distinct and susceptible of practical use by the average well informed amateur. We expect great results. We all know how we would like real authoritative advice on many of our problems. This plan of our Board of Direction aims to get this advice, and incidentally to elevate the technical standards of Amateur Radio generally. More later, on this interesting subject.

### Canadian Relaying

SHORTLY before the summer strays got really bad, regular communication between Canadian and United States amateurs was just getting into its stride for the first time. Reports from Detroit and Buffalo show that the Canadians were being heard well there, and in the St. Lawrence Division Montreal was QS0 8BB and 2TF, and Farnham (Quebec) was occasionally working 1FV and 1HAA.

With the coming of summer navigation in the St. Lawrence Valley, the Canadian amateurs reverted to their original 50 meters—which is perhaps just as well this first summer, for they will come back with renewed vim when the longer wave length is again permitted this winter, and then we shall see the result of the pioneering of the past late spring. The outlook for the regular handling of Canadian traffic is most encouraging; the Canadians are now busy getting their sets in shape, and we expect to see all our hopes for international relaying realized this coming winter.



# THE OPERATING DEPARTMENT

J. O. SMITH  
Rockville Centre, L. I.  
TRAFFIC MANAGER.



**A**S this is being written the turning point in amateur radio has been reached and the great increase in activity incident to the coming of cooler weather has begun.

The past summer marked a new era in our affairs. Never before had we consistently tried summer operation, and in the effort to maintain communication through strays and summer absorption many of our stations were increased to an efficiency which would not otherwise have been obtained. Many new DX sparks are heard on the air, as a result of this same summer persistency.

The reports show that in every territory strays are decreasing and interest is higher than ever before. Our organization is in excellent condition and we are well equipped as we now enter what will doubtless be the greatest winter Amateur Radio has ever known.

The reports in detail follow:

## NEW ENGLAND DIVISION Guy R. Entwistle, Manager

Two new assignments have been made in this division. Philip F. Robinson, 149 Hollis Avenue, Braintree, Mass., has been appointed Assistant Division Manager and Leon G. Pollard of 194 South Willard Street, Burlington, Vt., has been appointed District Superintendent of Northern Vermont. 1CK is well known in the first district as an efficient relay man, being an important link in the trunk line through New England. Pollard undertakes a real proposition in developing virgin territory in his section. He will also have the Canadian situation to handle. He reports the University of Vermont as ready to help out with relay work this Fall.

Below is a reorganization outline of the division:

Manager, G. R. Entwistle, 18 Boylston Street, Boston, Mass., 1AL.

Asst. D. M., Northern Section. H. W. Castner, 15 Temple Street, Portland, Maine, 1UQ.

D. S., D. F. Alexander, 209 Elm Street, Bangor, Maine, 1BK.

D. S., A. Ralph Tabbot, 10A Bar Harbor, Me.

D. S., Dartmouth Wireless Club, Hanover, N. H., 1YB.

D. S., Leon G. Pollard, 194 South Willard Street, Burlington, Vt.

This section adjoins Canada and will look after connections with our Canadian brothers.

Assistant District Manager, Philip F. Robinson, 149 Hollis Avenue, Braintree, Mass., 1CK.

D. S., Henry R. McLean, 342 Union Avenue, Laconia, N. H., 1CM.

D. S., Lee A. Bates, 8 Moen Street, Worcester, Mass., 1GY.

D. S., Wilbur H. Hardy, 776 Hale Street, Beverly Farms, Mass., 1BH.

City Manager, Lester Pulley, 33 Porter Street, Melrose, Mass., 1DR.

This section, known as the Eastern section, has the greatest density of amateurs in the district. Includes lower N. H., Eastern Mass. and Rhode Island.

Assistant Division Manager, Donald Mix, 40 Stearns Street, Bristol, Conn., 1TS.

D. S., Harold C. Bowen, 168 Belmont Street, Fall River, Mass., 1AK.

D. S., Homer E. Nichols, 513 Pequonock Street, Bridgeport, Conn., 1BM.

This section includes Western Mass., Conn., and lower Vermont. Connections to the second district trunk line will be arranged through this section, which will be known as the Western section.

Prospective relay men will pick out their nearest District Superintendent and inform him of their intentions if they wish assignments as official relay stations.

There will be many gatherings of amateur wireless men this coming season. To the chairman of the committees on arranging speakers for these meetings, the writer would like to suggest the following. Why not have these meetings on Saturday evening as far as possible. This will give speakers coming from out-of-town a chance to accommodate these clubs without interfering with their regular work which must still be done since greenbacks have long ago replaced clamshells for money. Relay officials are glad to come and contribute whatever little they may to the entertainment of the evening. It is much better to be able to lie in bed the morning after.



Portland, Me., has started the ball rolling on conventions. On the 15th of September, Mr. H. W. Castner, A.D.M., arranged a very successful meeting at which the following prominent radio men were speakers: Radio Inspector, H. C. Gawler, K. B. Warner, Hiram Percy Maxim. 1UQ presided. In October, the date to be announced later, Mr. Bates of Worcester will entertain the relay men of New England at Worcester, Mass. Watch other columns of this issue for details. Let's all go and make it a success.

1TS, Mix, writes that radio matters are at their ebb in his section during August. Vacations, exceptionally fierce QRN, and local thunderstorms are the reason. Springfield is again on the map in the person of 1JQ, Mr. McLean, who has QSO-ed 1AW. Providence also is coming strong with 1AAU, Mr. Learned, who is equipped with a modulated C-W set and works 1AW and 1QP, Reinartz of South Manchester, Conn. 1FQ expects his C-W set going soon, as does 1TS. District Superintendent Nichols has installed a counterpoise ground system and two stage amplifier. 1TS has a three step. 1BBL, Mr. David Moore of Farmington, Conn., has been appointed an official station.

Castner reports increased activity in his section. He anticipates even greater activity than last Winter. 1FV, Rahma W. Pratt, is holding down the key at present with great success. (We sincerely hope we understand this properly). 1FB, Cumming, is in on the DX. I have appointed A. Ralph Tabbot, 10A, as D. S. for Bar Harbor District.

Robinson says he expects to be heard both on C-W and 500 cycle set by Sept. 1st. The DX stuff has been holding up remarkably well and some of the new C-W sets are coming in fine. 2FS comes in QSA. 1AR has a C-W. 1HA, Lloyd Greene, of Cambridge, is also heard occasionally on C-W. 1FR of New Bedford is heard up this way.

Our old friend 1HAA down the Cape is still at it. With unlimited power supply on the power end and a seasoned fist he manages to keep his message hook clear. If you can't clear it pass it to 1HAA. He is installing one of those new Grebe gaps, (must have got in early with Ponzi). His antenna is almost a duplicate of 1AW—a trifle higher and more wires. Got 2000 feet in antenna and 5000 feet in counterpoise ground. Expects to do some work this Fall. We'll say so. 1HAA has been heard in St. John's Harbor.

#### ROANOKE DIVISION W. T. Gravely, Manager

In summing up the activities over the Division for the past month, there has been

a decided curtailing in active operation, but I learn, from many sources, that great preparations are being made for the Fall and Winter months. New stations will be budding forth, and marked improvements will be noted in the old stations. Also, continuous wave sets are beginning to make themselves heard here and there, which shows that the fellows are busy, and are ever working for increased efficiency in their stations.

The QSS tests in this division were a complete failure, due, mainly, to the lack of recording stations. The transmitting stations were heard, and their sparks went out on normal radiation, but reports were so few that the data isn't worth reporting. Mr. Groves, Fading Analyst for the Division, will cover the ground in his report to QST, so I shall refrain from making further comments.

It is with a great deal of satisfaction that I am able to report the organization of North Carolina, which is under way. Mr. Bunker, District Superintendent, is working hard to open up routes, in short jumps, from Danville to Atlanta, in conjunction with the other District Superintendents. He is also working on the Eastern and Western Routes, and is meeting with a great deal of success.

We are now assured of a good station at New Bern, N. C., and another at Wilmington, so it seems that the coast line, from Norfolk on down, is an assured fact.

Unless it becomes necessary to change plans, the main Southern Route, starting at Washington, will be as follows; Washington, Fredericksburg, Richmond, Lynchburg, Danville, Greensboro, Charlotte, and thence to the South, with alternative, through Lynchburg (or Roanoke), Winston, Greensboro and Charlotte.

I have had letters from Mr. Rothlinger of Wilmington, and Mr. Parker of New Bern, and they both tell me that they will bend their efforts to assist us in the perfection of the organization. These two gentlemen may be relied upon, I am sure, to assist in every way possible, and to take part in the activities.

Mr. Herndon, Eastern Virginia District Superintendent, writes that activities in his section have been limited, due to the hot weather, and the almost daily thunder storms. He says that information has been received to the effect that the second hump from NAM on 200 meters is caused by re-radiation from the towers, and plans have been drawn up for a complete re-arrangement of the antenna system, and that when this has been done, it is hoped that the interference from this course will come to an end—it has long been a serious handicap to relay operations in his vicinity.

Report has come from Mr. A. G. Heck,



Mannington, W. Va., District Superintendent, to the effect that radio operations have been at a stand-still in his District during the past two months, but that he expects at least three new first class stations in his vicinity for the fall and winter operations. He also states that 8ZW has been taking a course in VT operation, and expected to have a CW set, and phone, by Sept. 1st. (Go to it 8ZW—I hope the Aerial Ammeter will flutter for you). Will the serious amateurs all over West Virginia get in touch with the manager, so as to enable him to work out definite lines.

When this is published radio weather will be wonderfully improved, so let's all pull together, and round out a wonderful winter season.

3BZ will ring in a CW set, too, if he doesn't burn up all the tubes and meters to be found before he secures one millionth of an ampere radiation. The little bottles have a great deal in them, so friend Stanley says, but—it is as hard to get the juice out of them, as it is to get spirits out of an empty corn whisky bottle.

#### DAKOTA DIVISION R. H. Pray, Manager

Because of the fact that there was practically no radio work being done in this Division last month there were no reports from the Districts and consequently none was sent in from this Division. But amateur radio is beginning to take a new lease of life and there will, no doubt, be a full report next month.

The Fading tests in this Division were almost a complete failure, due, I think, to the fact that there was not enough interest. Although the transmitting stations were on nearly as scheduled, there were no recording stations and no reports. Of course there were some of the tests during which the static was too bad for recording of any kind but there were also some that were very good for radio work considering the time of year. But as amateur radio, as practiced by most, is merely a form of recreation we can understand how when a certain WW called for a canoe ride by moon light radio absolutely has no attraction at all. However, I hope that in any future tests this division may at least do as well as our neighboring Divisions.

There have been several new appointments in this Division and to give every one a better idea of the men now in office we present the complete list.

Division Manager, R. H. Pray, 813 Fifth Avenue, Valley City, No. Dakota, Radio 9ZX.

District of Northern Minnesota, J. A. Gjelhaug, Baudette, Minn., Supt., Radio 9ZC.

City Manager of Duluth, Wm. D. Wag-

ner, 123 W. 4th Street, Duluth, Minn., Radio 9EA.

District of Southern Minnesota, Boyd Phelps, Care Minnesota Wireless Assn., Room 416 Courthouse, Minneapolis, Supt., Radio 9ZT.

District of North Dakota, E. S. Leavenworth, Ellendale, No. Dakota, Supt., Radio 9WU.

City Manager of Fargo, Bert Wick, 207 Broadway, Fargo, No. Dakota, Radio 9AEJ.

District of South Dakota, Harold Larson, Viborg, South Dakota, Supt., Radio 9KG.

Mr. Boyd Phelps is also acting as Assistant Division Manager until October 15.

There is a determined effort being made to get Trunk Line A in shape to handle traffic regularly. There seems to be an outline for the route in working order at present, which is at least enough to start with and can be filled in as stations appear. The station of Mr. Bridges in Superior being the connection with the Central Division, it would run to 9ZC, 9ZX, and connect with the Northwestern Division through 7IM, the station of Mr. R. J. Simms at Billings, Montana. The relays as stated are rather long, being 225 miles from 9ZC to 9ZX, and approximately 600 miles to 7IM, but all of the stations in the order named have been working together through very bad strays during the month of August so that they should be able to handle traffic without difficulty with the coming of cooler weather. If 7IM gets out to the west as well as he does to the east trunk Line A seems sure of success. Work on trunk line G. from North Dakota to Houston, Texas, will begin as soon as there are enough stations to make it seem feasible. It is hoped that this route can be extended to Winnipeg at an early date.

Mr. J. A. Gjelhaug, 9ZC, Superintendent of the Northern Minnesota District reports increased activity in his territory and prospects of stations to fill in the trunk line early in the fall. There is another Winnipeg station being constructed, call 4AJ, which promises to be able to handle the relaying in that territory.

Mr. Larson, 9KG, Superintendent of South Dakota reports very little doing except in Sioux Falls.

Mr. Boyd Phelps, Supervisor of Summer Relay, and Superintendent of the Southern Minnesota District, has been working very hard at routes from the Twin Cities but owing to the fact that the amateurs in the Division have not had any interest in the summer work he has been unable to form any permanent routes so far. Now that the radio conditions are improving it may be possible to get more results, so will all the members of the A.R.R.L. and any amateurs who are interested please write Mr. Phelps, in care of the Minnesota Wireless Assn., 416 Courthouse, Minneapolis.

A system for monthly reports has been worked out for the division which includes all members and if carried out will prove a means by which the relaying and other amateur work can be put way above standard. The success of this plan depends entirely upon the individual as unless everyone sends in a report each month the data gathered will not be sufficient to obtain the full benefit. Each member should send in a report of the officer of his territory, either City Manager, Assistant District Superintendent or District Superintendent on or before the 12th of the month. This should include all activities and observations in amateur radio during the past month and a list of stations REGULARLY heard and worked. The reason for this is that by giving a list of stations worked regularly it will be possible to make use of it for forming and completing routes. The list of stations heard regularly is asked for so that if any two stations are hearing each other regularly but never communicating it would be possible to arrange a schedule for these stations and thus help on the routes. PLEASE, EVERY ONE NOTICE and send in your report not later than the TWELFTH OF EACH MONTH.

Now that school has started and the many vacation activities outside of radio have ended it is hoped that all station owners will write their District Superintendents about their station and what they will or hope to do in relaying. Do not think that your station is not big enough to be considered on routes as the Manager has worked stations over 100 miles distant which were using Ford spark coil units and six volt storage batteries for transmitters, and this was and is still being done regularly. SO please write your District Superintendent at once. If you are in doubt as to which district you are in write to the Division Manager.

---

**NORTHWESTERN DIVISION**  
Royal Mumford, Acting Manager

---

Either the winter relay season begins in August or there is no such a thing as season in amateur activities on the Pacific Coast. This is the unanimous verdict of all who have listened in consistently for the last month.

In the Northwestern Division we notice a marked diminution of static; but the number of relay stations is far below the normal. A couple of hours of solid grinding static and a few unsuccessful attempts at long distance work seem to dishearten many an amateur to such an extent that he leaves his aerial grounded for days at a time. But all this noise and bluff of old man QRN are only occasional outbursts, as of uncontrollable fits of anger which

wear themselves out in due course of time. All through the summer there have not been more than two days a week on an average when the static did not slack up a bit some time during the night. The only requirement, then, for summer long distance work is for two DX men to be on the job at that time.

During the month of August some of the hottest days of the year were followed by wonderful nights when signals pounded in with winter-like intensity and their reception was marred only by more or less intermittent static. In fact on the very hottest day of the year for Portland and vicinity the first relay traffic for months was handled with Los Angeles direct. From 7CU at Vancouver, Wash., communication has been maintained with Los Angeles direct two or three times a week during the entire month of August. A.R.R.L. traffic has been handled in both directions. Great credit is due the Los Angeles stations for they are bothered a great deal more with static than we who are farther north.

Not only Los Angeles but San Francisco, and Santa Ana and Long Beach, all farther south, have been worked from here; and in connecting with San Diego the results were surprisingly successful for the time of the year.

In Portland, Ore., preparations are well under way for any amount of A.R.R.L. work this winter. New stations are appearing and most of the old gang of last winter are on the job regularly. We are glad to hear the spark of 7BR again. He is sure to do his share of long distance work. 7ZI of ex-7DK fame has his new set ready for business and is making himself heard in all directions. He has recently connected with California stations 500 miles away and soon expects to break his records of last season. Most of the traffic is at present handled by 7DS, 7DP, and 7BP, all of whom work north to Seattle and both 7DP and 7BP work Ukiah, Calif., successfully. 7CR has recently made some satisfactory tests with the forestry service stations on Mount Hood.

In Seattle the relayers are all looking forward to the QRN-less season this winter and are planning on more extensive participation in A.R.R.L. work. The same is true of Tacoma and Lacey, Wash. In this locality we have four stations which are to be especially commended on their consistent performance this summer, 7AD, 7BK, 7CE, and 7YS. And lest we forget their good work in the coming of the winter season and the multiplicity of relay stations, let me say that but for the work of these faithful few relay work in their locality would have been practically dead. We are highly pleased with our first attempt to stick to the job all summer.

Amateurs in this division were startled to hear the spark of 5BR of Vancouver, B. C., which is the first Canadian station, so far as we know, that has connected with any of our "sevens". Mr. Wood is back at 6KL Oakland, California now. While at 5BR he worked stations in Seattle, Portland, and Vancouver, Wash. He reports increasing activity among the Canadian amateurs.

Olfan De Guire, 7CW, District Superintendent, Silverton, Oregon, has been doing excellent work this summer. He handles any number of messages from Seattle south and keeps the business moving with but little delay.

In Everett, Washington, we have a new spark 7FV which is QSA here. We are sure he will make a good relay station as soon as he is on the job regularly.

Our Division Manager, Mr. Hertz, better known as 7ZB to all who have heard his spark, has been away in Alaska with plenty of time to make plans for the coming season. He is back in our midst again now, and we will be glad to see him on active duty for the A.R.R.L.

In the Eastern section of this Division R. Earl Dawes, Box 663, Bozeman, Montana, has taken right hold of the work. With his assistants he is planning to put Montana on the map this winter and will start in as soon as the QRN subsides. The outlook for fall and winter is very good. The following have been appointed District Superintendents: Mr. L. L. Stanley, 7DJ, 320 State Street, Helena, Mont.; Mr. Grey, 7FL, care Grey Machine Shops, Butte, Mont.; Mr. Winfred Slausen, 7ZG, Bearcreek, Mont.; and Mr. Everett Cutting, at Bozeman, Mont., will assist Mr. Dawes in his work.

Currie N. Teed, District Superintendent, Kuna, Idaho, reports that little activity has been shown by local amateurs during the past month. Dry hot weather and unusually frequent electrical storms have caused a great deal of trouble, static often for days at a time being audible anywhere in the room. Considering the conditions in his locality one must admit that he is doing mighty good summer work and his efforts are appreciated.

#### PACIFIC DIVISION

A. E. Bessey, Manager

The radio situation on the Coast is very favorable for the summer time. Traffic has been going through in great shape. Never in the history of radio has traffic been handled in the summer time as this year. All the stations have been putting in high grade apparatus and amplifiers and getting their sets tuned so that they are getting through on LD work in fine shape.

In my report for the Bay District, will

say that we have many good long distance amateurs who are reaching out in handling traffic. At the present time, 6BN seems to be doing the best work both North and South. He is handling messages direct with San Diego 6JI. His best station to work with in Los Angeles seems to be 6KP, 6EX, and 6EP. Many others are doing good long distance work.

It has been impossible for us to get through to the East during the summer owing to the fact that 6ZA is on a boat and his station is closed for the summer. The only routing there through the South, which is rather unsatisfactory, is through Arizona, but there are many new stations opening up in Arizona and one new special station at Yuma, so that we feel sure that this winter we will be able to work through the East without any trouble.

We have the promise of a good station to be set up in El Centro, California, within a short time which will help in bridging the gap to Arizona. It is to be hoped the San Diego district will be of valuable assistance in handling traffic to the East. At present, San Diego is being fitted to handle relay traffic at 6EN, 6IY, 6IZ and 6JI. Mr. Milton Jackson has been appointed District Superintendent for San Diego.

Fresno is showing great interest in radio at the present time and although their conditions seem to be rather peculiar as they seem to be in a pocket and it was rather hard for them to get out, I think they can work up the valley to Sacramento; also to Los Angeles and San Diego. Their sets are getting more efficient all the time and feel sure by winter they will be doing good work.

Routing to Los Angeles from the bay district or North, can go through either 6BN, 6EP, 6EX, 6FS or 6UM. All can go through to the South. 6BR at the present time is out of commission on account of installing a new transmitter set and will be working soon under a special license, calling wave 200, working wave 375 meters, 150 meters for local work.

Would appreciate very much if all stations that feel they can do LD work would drop a card to 6BR as we wish to get our traffic stations lined up for this winter.

#### WEST GULF DIVISION

Frank M. Corlett, Manager

Reports from the various Superintendents throughout the Division show that interest and activities that have been lacking to some extent are again making their appearance. This is indeed encouraging.

District Superintendent W. H. Tilley, 5ZU, Austin, Texas, makes the most interesting report for this month that has been made since he assumed control of that District. Austin will be well represented



by 5ZU, 5BO, 5EJ and two or three more now in course of construction. 5ZU is now maintaining a daylight schedule every hour on the hour.

5ZN, Mr. Ed. Nettleton, of Eagle Pass, Texas, is making some extensive repairs on his station and will be with us with a dependable station which will open up things to the border. He is an old timer in the radio game, having been at it for years. He states that he will be ready for daylight tests immediately providing he does not QRM the Army station at Del Rio too much. If more of our members were more considerate of the Government stations we would be better off.

Mr. E. A. Sahn of New Braunfels is now in the air and says he will be glad to help us open up the way to San Antonio and judging from the strength of his signals now we ought to be assured of a real relay station in that town. San Antonio will be with us soon as we are promised a dependable station there about the middle of September through the effort of one of the old timers back from the war.

Mr. A. P. Daniels, 5AO, Houston, Texas, has been appointed Assistant District Superintendent and assigned the HOUSTON, TEXAS, TERRITORY. His report is interesting. Through the splendid co-operation of the Houston Chronicle and the Houston Radio Club fine results are being obtained in his territory. The paper is liberal with space and has a regular Radio Column every Sunday devoted to the Houston Club. Communications from out-of-town amateurs are invited. So far many smaller towns have been heard from and the station owners helped through the co-operation of the Houston Club members. Mr. H. E. Worthington is City Manager of Houston, his call being 5ZV. The Houston Club has a membership of 60.

5EO, Mr. John Whitworth, of Freeport, Texas, is making great improvements in his station and will have a reliable station there that will stand most any kind of a Texas storm.

Efforts are being made to get someone interested enough in Beaumont to enter the game but so far no results.

In Houston the following stations are equipped for relay work: 5AO, 5ZV, 5ZT, 5FL, 5ET, 5DX, 5HE, 5ZW. 5ZW and 5AO have maintained a daylight schedule twice daily all Summer for which they deserve great credit. The Radio Inspector is due in Houston soon and many are getting ready to take the examinations.

5YA, College Station, Texas, is erecting steel towers and the A.R.R.L. is assured of a good station there soon. From the ground they covered with 30 foot antennae last winter there is no telling what they will do this winter.

Mr. Raymond L. White, 5AP, District

Superintendent of the Northern Texas District, has returned from his vacation and in less than an hour or so was heard in the air again. Due to the intensity of atmospheric disturbances very little relay work is being done at night but at intervals we hear some good fellow-member tussling with old man static trying to hand a few messages over in short jumps and numerous "QTA's" are heard. The Assistant District Superintendents are taking advantage of the occasion and are putting over some commendable organization work. Among those deserving mention are Henry M. Harris of the Waco, Texas, Territory, and Martin, 5IF, of the Amarillo, Texas, Territory. No doubt 5IF will relieve the now congested condition westward and will grow into prominence as 5ZA has on our way westward; it will also reduce the long jump somewhat. A City Manager is to be appointed for Amarillo proper, which looks good toward minimizing interference. Keep the good work up, Martin, we are with you.

Harris at Waco has been assigned the call 5GJ. He has assisted in getting a station underway at Stamford, Texas, which will be right in line west from Waco and should make a good relay point. If someone would just come forward with a relay station at Sweetwater or Lubbock, the route west to Roswell would be a certainty, static or no static. 9RY is heard at Amarillo quite frequently and 9BW and 9LR have been heard often in Dallas and vicinity lately.

The district of Oklahoma again begins to look promising. Mr. Lawin G. Dill, 234 South Broadway, Oklahoma City, was in Dallas recently and called on the Division Manager. Mr. Dill stated that he would have a 1KW in first class working order shortly. Mr. Walton of Oklahoma City will also have his station working regular. Mr. Dill stated. This will give the A.R.R.L. two stations in the central part of Oklahoma. With 5BT at Blackwell and 5DO of Perry, 5BM at Muskogee, and several other stations that we know of, Oklahoma should be with us in the relay game very shortly. The Division Manager is working under a handicap regarding Oklahoma. The Oklahoma stations have never been received at headquarters with any great signal strength and for this reason the District Manager has not been able to determine which station owner would make the best District Superintendent for Oklahoma. I am going to put it up to the Oklahoma station owners to suggest which man they think would make the ideal District Superintendent for Oklahoma. In making your suggestions remember it is the policy of the League to select only those which are best fitted for relay work from the point of view of radio equipment, reliability of operation,

and the time he is willing to devote to relay work. Oklahoma should by all means have a District Superintendent to take charge of the relay activities and assist in getting Trunk Line "F" working from Dallas to the Northern boundary of this Division. Let every amateur in Oklahoma offer a suggestion.

**ONTARIO DIVISION**  
A. H. K. Russell, Manager

August has been marked by a profound deadness in amateur wireless, due to the holidays and to the fact that a great number of amateurs are on commercial work on the Lakes. However, with the coming of the fall wireless should again come into its own, and be bigger and better than ever.

The report for August must be of necessity brief, for the District Superintendents have omitted to make reports for the month, probably due to lack of material. However, the Superintendent in Western Ontario, Mr. Carter, advises that prospects never looked better for a successful season in his district and the same information comes from the secretary of the Club operating in affiliation with the A.R.R.L. in Northern Ontario.

So far as Toronto district is concerned it is hoped that there will be at least one and probably two medium powered C.W. transmitters in operation, with which it is hoped to establish steady C.W. communication with "8" stations. In any case a reliable outlet for Ontario traffic for the winter should be available through Niagara Falls, N. Y.

**ATLANTIC DIVISION**  
Chas. A. Service, Jr., Manager

The past month, being a vacation month, is probably the most inactive month of the year from a radio standpoint, in spite of the fact that the actual work done by those who have remained at home has been greater than ever before. Stations that in former years were only heard during the winter months have been heard frequently throughout the summer season, and with the advances that will no doubt be made during the coming winter season it is believed that more actual relay work will be accomplished than ever before.

The report of the Traffic Assistant for the Central Pennsylvania District, Mr. Herbert M. Walleze, who is acting as District Superintendent during the continued absence from home of Mr. Cawley, shows that conditions in that section of the State are dull, but that there is considerable activity in remodelling and improving stations. Among others that are improving their sta-

tions is 3ABD at Danville, Pa., which is one of the stations that we are depending upon this coming winter to fill in on the gap between Reading and Milton on Trunk Line B.

Unfortunately the Eastern Pennsylvania District is without the assistance of a District Superintendent since the resignation of Mr. Ferris, but the question of filling this vacancy will receive early attention. We had hoped by this time to have received definite information from Mr. C. M. Jackson, of Pottsville, that his transmitting set was in operating condition, as a station at this point could be of considerable aid in bridging the gap between Reading and Danville or Milton. The last information received from Mr. Jackson in April last indicated that he was about to install his transmitter, but since nothing further has been heard from him by the former District Superintendent. Station 3HJ at Haverford, Penna., has been doing good relay work in this District, and can probably be counted upon in the future. Station 3ZS again is in operation, after some necessary repairs to the spark gap, but so far the set has not been properly adjusted to work on the lower wave length of 200 meters, but it is hoped that this difficulty will be overcome shortly.

Mr. C. S. Horn, Superintendent for Delaware, has returned from a commercial trip to Holland and Belgium. He states that he has not yet been able to get his station in operation at Rehoboth as he expected, and, as the summer is about over, it is not likely that he will accomplish much at this point this season. He states that he has information which leads him to believe that a new station will be set up somewhere half way between Wilmington and Baltimore, and that he will endeavor to give what assistance he can in making this proposed station an efficient one for relay work between Wilmington and Baltimore. Station 3OB at Wilmington, Del., has been doing some good work during the summer, and has extended his range to some distance, which is promising for the coming season.

Mr. Duvall, Superintendent, Eastern Maryland, reports that he has been in touch with Washington station owners, and that in conjunction with them every effort will be made to establish reliable communication between Baltimore and Washington in the near future. The vacancy in the office of District Superintendent for the District of Columbia will no doubt be filled within a short time, as this matter is now being given attention, and when this is accomplished better results can be looked for. Mr. Duvall gives in detail in his report data relative to Baltimore and Washington stations, and in addition to this survey Mr. Duvall is sending out a questionnaire to

station owners in that vicinity with a view to obtaining all the data possible on the equipment of these stations. Taken as a whole Mr. Duvall's report indicates renewed interest on his part, and we have hopes that with hearty co-operation on the part of Wilmington, Baltimore and Washington stations the difficulty of communication in this section may be overcome in the near future. It will certainly be a satisfaction if this can be accomplished.

#### MIDWEST DIVISION

L. A. Benson, Manager

The Division Manager is glad to report that keen interest in both Relay and League work is now being shown by all District Superintendents and Assistants. Several District Superintendents have recently returned from their vacation and are at it hard getting things lined up. Distant stations are beginning to roll in like old times, the weather is getting colder, and everything points to the fact that a big season is before us.

J. A. Fritz (9KO), District Superintendent, Eastern Mo., has appointed Mr. J. Giesecke, 15 Fairmont Place, Jefferson City, Mo., (9AJN), as Assistant District Superintendent, Eastern Mo. This will prove a valuable station in handling traffic to Kansas City from St. Louis.

G. Turner (9DU), has just returned from the west coast where he had the pleasure of meeting Seefred Bros., 6EA. Mr. Turner is trying to locate a good reliable station in Denver where he states there are none at present. He says 9ZF has sold his station and decided to quit the game; this leaves practically no long distance station in Denver.

J. G. O'Rourke, District Superintendent, Eastern Nebraska, reports all his routes working perfectly and several new ones now under way. He has just returned from a tour through the state and reports interest lacking in the following towns: Norfolk, Freemont and York. Any stations in these towns kindly report to the District Superintendent.

P. A. Stover (9JA), District Superintendent, Iowa, has given up CW and is getting his spark set in trim. Mr. Stover wants all stations located in the extreme western portion of Iowa to kindly get in touch with him at once.

H. L. Owens (9EL), District Superintendent, Kansas, has recently returned from his vacation and is unable to give his report in time for this issue. However, he wishes all stations in his respective territory to communicate with him regarding appointments on several western routes through the state.

#### BULB OSCILLATORS FOR RADIO TRANSMISSION

(Continued from page 8)

curves. From these waves the losses and output of the oscillator may be determined

Thus by assuming various values for the potentials and plotting first the appropriate characteristic curves and then the waves, the behavior of an oscillator under all possible adjustments and loads may be examined. Usually such a process is far too laborious for a general numerical investigation, but is useful for a qualitative study.

As a matter of fact, the curves of Fig. 6, 7 and 8 have been so chosen as to represent underload, normal load and overload, respectively, of a bulb oscillator with fixed supply voltage  $E_s$ , fixed grid bias resistance  $R_g$ , and fixed ratio  $n$  of alternating plate voltage to alternating grid voltage. With the light-load conditions of Fig. 6 (corresponding to a low antenna resistance in Fig. 9 and 10), the alternating and direct components of plate current are relatively small, while the alternating components of the potentials are high. The minimum of plate potential is then slightly negative, causing all of the space current to flow to the grid for an interval and giving a sharp dip to zero in the plate current curve. This does not harm the bulb, but the output is much below that attainable from the bulb. With the normal-load conditions of Fig. 7, the potentials vary over narrower ranges and never permit an excessive grid current; so the plate current has little or no dip and is higher than before. With the heavy-load conditions of Fig. 8 (corresponding to a high antenna resistance in Fig. 9 and 10), the potentials vary over still narrower ranges and the minimum plate potential is much higher. This greatly increases the loss at the plate and will overheat the bulb, though the power output is not greatly different from that in Fig. 7.

The direct voltage (bias) and the alternating voltage (excitation) of the grid circuit are chosen with a view to giving high output and high efficiency, but are not highly critical in adjustment. The best ratio ( $n$ ) of alternating plate voltage to alternating grid voltage has sometimes been considered to be equal to half the amplification constant of the bulb, this corresponding to an external (load) resistance in the plate circuit equal to the internal resistance\*. But considerably higher grid voltages may be desirable.

On the whole, the proper load, bias voltage, and excitation voltage of a bulb oscillator, as well as the heating current and the plate generator voltage, are best determined by direct test. These quantities are all constants of the bulb and do

(Continued on page 37)





**W**E take pleasure in announcing the affiliation of the following societies, which was completed at the last meeting of our Board of Direction:

- Plattsburgh Wireless Club, Plattsburgh, N. Y.
- Radio Club of Paterson High School, Paterson, N. J.
- St. Louis Radio Assn., St. Louis, Mo.
- Connecticut Valley Radio Club, Springfield, Mass.
- Yates Radio Club, Penn Yan, N. Y.
- The Summit Radio Club, Erie, Pa.
- Troy YMCA Radio Club, Troy, N. Y.
- Rochester Radio Club, Rochester, N. Y.
- Central Maine Radio Club, Waterville, Me.
- Pomona Radio Assn., Pomona, Calif.
- Radio Club of Syracuse, Syracuse, N. Y.
- Crescent Radio Club, Clearfield, Pa.
- Bethlehem Radio Assn., Bethlehem, Pa.
- Marietta Radio League, Marietta, Ohio.
- Miami Radio Club, Miami, Fla.
- Radio Club of Tacoma, Tacoma, Wash.
- Columbus Radio Club, Columbus, Ohio.
- Baltimore Radio Assn., Baltimore, Md.
- Ann Arbor Radio Assn., Ann Arbor, Mich.
- Radio Club of Burlington, Burlington, Iowa.
- Galesburg Radio Assn., Galesburg, Ill.
- Radio Club of Washington, Washington, D. C.
- Radio Research Club of New York City, New York, N. Y.
- Wireless Assn. of Atlantic City, Atlantic City, N. J.
- Southern California Radio Assn., Los Angeles, Calif.
- Radio Club of Glen Ridge, Glen Ridge, N. J.
- Essex County Radio Assn., Salem, Mass.
- Cass Radio Club, Detroit, Mich.
- Framingham Radio Club, Framingham, Mass.
- Oshkosh Radio Club, Oshkosh, Wis.
- Utah Radio Assn., Salt Lake City, Utah.
- Radio Engineering Society, Pittsburgh, Pa.
- Eastern Ohio & Western Penna. Radio Amateurs Assn., Newcastle, Pa.
- Sunset Radio Club, San Diego, Calif.
- Springfield Radio Assn., Springfield, Mass.
- Central Michigan Wirelless Assn., Lansing, Mich.

The number of organizations now affiliated with the A.R.R.L. totals 85—all of

them live wires. This number includes most of the radio associations of prominence, and marks our progress toward the formation of a network of local organizations which will bind us all close together in matters which concern Amateur Radio. The A.R.R.L. Secretary will be glad to hear from clubs who think as the A.R.R.L. does on amateur affairs.

**THE CHICAGO CONVENTION**

The greatest meeting of amateurs ever held occurred in the convention of the A.R.R.L. Central Division at Chicago, Sept. 2d, 3d, and 4th. It was great in many ways. It was marked by enthusiasm of the highest pitch; the interest and value of the sessions were the best ever; and it was the first time in our history that amateurs from many miles have gathered for a three-day discussion of their affairs.

As most of us know, there is in existence in Chicago an organization known as the Chicago Executive Council, comprised of



Edgewater Beach Hotel, Scene of the Convention.

the officers of the three prominent clubs there—the Ravenswood, the South Side, and the Progressive, all affiliated with the A.R.R.L.—with the Chicago City Manager, Mr. F. H. Schnell, as Chairman. This board meets whenever desirable, and administers all amateur affairs in the city. The co-operation is wonderful, and they are doing great things in the reduction of QRM, etc. It was this organization which, at the instigation of Mr. Mathews, the Division Manager, arranged and engineered the convention. They did a most splendid

job of it, and we cannot better describe it than by saying that it was done in typical Central Division style—than which there is none more thanwhicher.

The beautiful Edgewater Beach Hotel, on Sheridan Road, was the scene of the activities. 9ZN is located on the northern end of the hotel grounds, and of course was the center of interest. The weather thruout was ideal, and contributed to the pep of the meeting. On the first day the visitors were registered at 9ZN, and thruout the day, and the next as well, many of us met for the first time men whose sparks we have known for long. It was a continuous session of greetings and the formation of new friendships—absolutely F.B. for all of us.

Inspector C. C. Kolster, incidentally Chairman of the Trial Board of the Executive Council, who discussed the relations of his office to the amateurs and complimented the local men on their methods. Mr. W. L. Holst, President of the Ravenswood Radio Assn, described the formation and growth of that club, and the results that are now being secured by all the local clubs thru co-operation.

The forenoon of the second day most of the visitors journeyed by auto to NAJ, Great Lakes, where they inspected the radio training school, ate navy chow for lunch, and otherwise enjoyed themselves, thru the courtesy of Mr. West, Lt. Comdr. McCauley, and Lt. Arney. An impromptu indoor baseball game was played on the



### THE CHICAGO EXECUTIVE COUNCIL

to whom credit for the success of the Convention is due.

First row, left to right: F. H. Schnell, Chicago City Manager; C. C. Kolster, Radio Inspector 9th District Department of Commerce; R. H. G. Mathews, Central Division Manager. Second row, left to right: G. A. FitzSimons, Traffic Assistant to the Division Manager; S. Wnorski, Ravenswood Radio Association; W. Holst, President Ravenswood Radio Association; M. Romborg, President South Side Radio Association; J. Novak, South Side Radio Association; B. Stolte, South Side Radio Association; J. Sholtes, Ravenswood Radio Association; N. Wunderlich, Ravenswood Radio Association.

In the evening the first meeting was held, in the Black Cat room of the hotel. This was a general business meeting of the Central Division, presided over by the able Mr. Mathews, and "Co-operation" was the keynote. It is probable that never before was this subject so thoroly discussed in all its aspects—and very good it was, too, for our very existence as amateurs depends on this. Mr. Maxim, our President, was the first speaker, and discussed our affairs from the national standpoint, urging co-operation in all our activities. Mr. M. B. West (old 8AEZ) was next, and discussed the probable trend of legislation and the desirability of co-operating with the government branches. Mr. F. F. Hamilton, 9ZJ, also spoke briefly on the same subject. Mr. K. B. Warner, A.R.R.L. Secretary, spoke on a few phases of co-operation, particularly with our QST and in the improvement of operating efficiency. Mr. Schnell, City Manager, outlined the "Chicago Plan" and its method of functioning, and was followed by Radio

grounds adjoining 9ZN, in the afternoon, and in the evening a technical meeting was held at the hotel. This was a REGULAR hamfest, and like all the other meetings, was 1:30 a.m. breaking up, only this one was more so. Mr. Maxim gave an extremely interesting talk on the sound values of various "noises"—pointing out the requirements in radio development to produce the most sound from a given amount of energy. Mr. H. E. Rawson had on exhibit a variety of British apparatus, including a 6-stage radio frequency amplifier and some power bulbs, and described them and his recent trip to England in most entertaining fashion. Ye Ed urged the adoption of radio-frequency amplification, better quenching in our rotary gaps, and unburdened himself on the subject of C.W. Mr. Montraville Wood, of Berwyn, Ill., inventor of the "submarine ear", a device for the auto-steering of torpedoes by sound waves emanating from the enemy ship, made an interesting demonstration of his device. A lamp was caused to light when



The Banquet, on the night of Sept. 4.

certain words were spoken near the sensitive diaphragm, yet it was insensible to other words. It was also caused to operate by a part of the audience clapping hands in unison, and a startling conclusion was reached when Mr. Wood switched in a small "cannon" which exploded with a deafening roar the next time the hand-clapping occurred. After a ten minute intermission, Mr. L. C. Young spoke on the work at NSF, using a C.W. transmitter and a multiple-tuned antenna; Mr. J. H. Miller delivered a paper on radio measuring instruments and their uses, particularly pointing out the superiority of the thermo-couple type of meter; Mr. T. B. Lambert, of Lambert & Associates, described an early invention for obtaining

ing wave length, with a synchronized receiver; Mr. F. S. McCullough, of the Glenn L. Martin Company, displayed his new 75-watt tube and described some of the work in tube transmission done at GMA, now 8ZC; and Mr. M. B. West, pioneer in amateur spark work, gave a valuable talk on the design of amateur transmitters, particularly the steps necessary to obtain a lower decrement in spark sets to comply with the probable requirements of new legislation.

Those who were sufficiently active to get up on time the next morning, made an auto trip over the boulevard system of Chicago, stopping to inspect a few amateur stations, and in the afternoon the radio field events were staged in the grounds surrounding 9ZN. There were



The Gang, photographed while visiting Great Lakes.



hookups to trace out and correct, and jamming contests in which the contestants copied signals on a small hand loop fitted with a crystal detector and phones. Several hundred dollars worth of apparatus was awarded as prizes to the winners.

On the night of the last day occurred the best time of all, the banquet, where good fellowship reigned supreme. It was held in the beautiful Colonial Room of the Edgewater Beach. Most of the local men had their O.W.'s with them, and "bright the lamps shone o'er fair women and brave men". It was a brilliant assembly of the best radio men in the central states, and was heartily enjoyed by everyone. Music every seven minutes provided the necessary urge for dancing, and made anything like a "speech" impossible. Brief remarks were made by Messrs. Maxim, Holst, and Warner, the latter presenting for its first public inspection the Sacred and Venerable Wouff Hong. It was peculiarly appropriate that this should first occur in the home Division of The Old Man. Suggestions as to the method of employing the Wouff Hong were called for, but the best that could be obtained was to "hook 'er to yer bulb". (Yep, the whole Tresco outfit was there.) So many interesting things occurred during the banquet that we must make the description short or there will not be anything else in this QST. D. F. Tainsh, Ravenswood jazz hound, gave a demonstration of his art by accompanying the orchestra on an impromptu xylophone constructed of tumblers with various levels of water therein, plus an empty cigar box and a serving tray. Prominent amateurs stood up and were identified by call letters. A letter from the Old Man was received by special messenger, commenting on the meeting as only the Old Man could, and expressing regret that he could not be present. A questionnaire, the craziest thing that could be imagined, and reproduced below, the product of the disordered brain of Joe J. Novak, was filled out by the guests, prizes to be awarded the best answers. A very cursory inspection of the results showed that one of these was so much superior to the others as to merit some extra Grand Prize, and Mr. H. H. Peterson was formally presented with one brand-new E. I. Co. Tesla Coil in recognition of his achievement. The committee had scored all the antique shops for a Roller Shade Condenser, but none were to be had. QRM contests, the guests copying signals picked up on a small aerial and put out thru a loud-speaker, were held, and prizes are being distributed to the winners.

The Executive Council has commenced the publication of a monthly sheet entitled the "Grid Leak", and the first issue was out as a Convention Bulletin and con-

tained all the news. It is a live, peppy sheet, and will do much good.

It was a wonderful meeting—one which did much for the cause of Amateur Radio. It stands as the high water mark of amateur achievement to date, and the next crowd to improve upon it will have SOME job on their hands. We make our best bow to the Chicago Executive Council. Too much credit cannot be given the Central Division Manager, the indefatigable Mr. Mathews. He was everywhere at once, seeing that everyone was happy, and at the meetings he proved a most capable Chairman and Toastmaster.

#### SIDELIGHTS ON THE CONVENTION

The oldest amateur present was Mr. F. M. Bookwalter, of Springfield, Ohio, 84 years young; his enthusiasm was the peer of anyone's. The youngest member attending was Mr. J. R. Miller, 9CP of Hammond, Ind., aged 14. 9CP has a first-class station, has passed his 20-word test, and is prominent in relaying in the Chicago district.

It passed the comprehension of one amateur present at the technical session that a priest could be a radio bug. Approaching Rev. A. J. Manning, he inquired: "Mister, are you interested in wireless?" We'll say 8DA is—rather!

W. H. Kirwan and the Iowa delegation were present with bells. On the rear of their car was a large sign with the Davenport slogan: "Hook 'er to yer bulb!"

Did you see Matty's bulletin board at 9ZN—a sheet of bakelite only worth about \$25. If any of you fellows get a Paragon with some chalked announcement on the inside of the panel about "Grand Banquet to-night", you'll know how it happened.

Did you meet the representative of the Wooden Audiotron Co.?

St. Louis, altho not in the Central Division, was represented by a delegation of about ten men. Yes, Bill was there.

Now for Novak's questionnaire. The questions were as follows:

If Marconi wasn't a Frenchman and yet the inventor of wireless put yes here.....but if DeForest invented the Armstrong system draw the symbol of a variable condenser here..... Do the electrons flow from the plate to the grid? If not how do they flow? From.....to..... If the high voltage on your grid should be positive, put NO here..... and if it should be negative, answer in the negative here..... If a non-synchronous spark transmitter produces undamped waves, put the symbol for a generator here.....and if you think that the polarity of your ground lead is positive, answer in the negative..... Has an undamped set a decrement.....what is it.....

(Concluded on page 37)



### 1HAA, MARION, MASS.

Ent: "Who is this guy 1HAA?"

Wistle: "I don't know, but the call sounds vermilya."

With which VN once again breaks into our pages. Yes, Irving Vermilya—who doesn't get enough radio working all day at the Marion transatlantic station and so has to pound brass on 200 at night.

1HAA has made a most enviable reputation and is counted one of our strongest eastern stations for the coming winter. We present here several views of his equipment.

The aerial is perhaps the most interesting. It is slanting flat-top, but like 1AW's it is nearer a fan than a flat-top. Two 100-foot poles, 54 ft. apart, support the upper ends of 20 No. 14 bare copper wires, which are spaced  $2\frac{1}{2}$  feet apart across a cable which in turn is carefully insulated at both ends. These 20 wires are 97 ft. long and terminate on a wooden spreader supported by a low pole set 62 feet back of a line connecting the two main poles. The spacing at the bottom spreader is 1 ft., and from there a 19-foot lead-in runs to the set.

1HAA uses a counterpoise, consisting of 50 wires covering an area of 50 ft. wide and 100 ft. long, supported 4 ft. above the ground by 20-inch insulators on each of the four corners, and carefully insulated from all grass or ground. This

seems to us a most excellent arrangement.

The transmitter comprises a 30,000 volt United Wireless "coffin", a Grebe synchronous rotary (alho this photo shows an old Marconi ship rotary), a "doctored" Clapp-Eastham O.T., and a condenser consisting of 36 Marconi jars of .001 mfd. each, in series multiple, giving a capacity of .01 mfd.

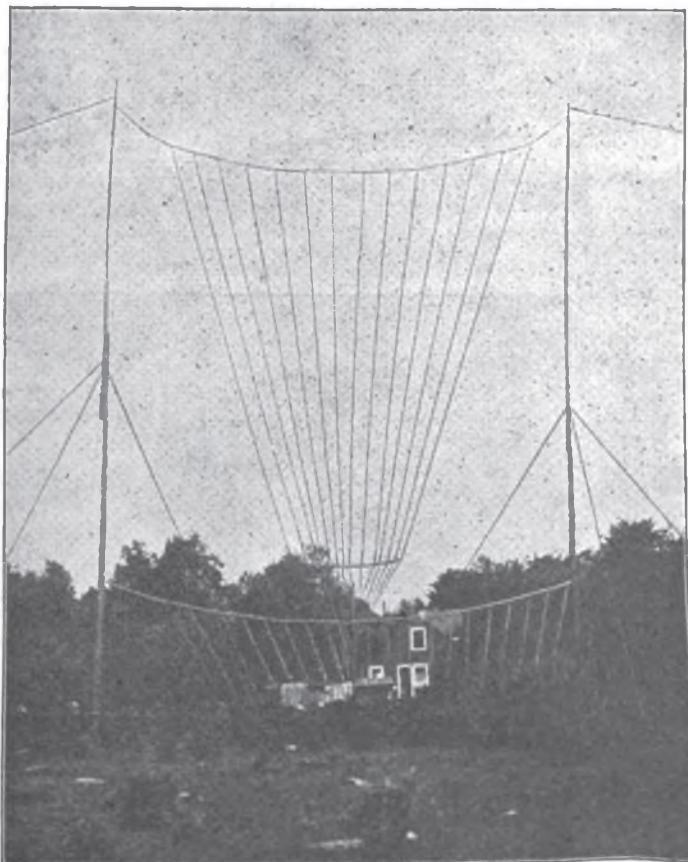





The receiving set consists of a Grebe CR-1, using a Marconi hard tube as a detector (Hey!), and a 2-step amplifier made by Hammond, using the same kind of tubes.

This station's operator is addicted to the use of the bug. When you hear a bunch of hash and all you can make out is the "1", log it as 1HAA—a good call for a Funny-Man.

### 5ZP NEW ORLEANS

(Photo on next page)

This station is owned and operated by Hubert E. de Ben, and is located at 1044 City Park Avenue, New Orleans, Louisiana. The sigs of 5ZP have been heard in twenty states.

The aerial is an inverted "L" type, 40 feet high and 50 feet long of five number fourteen wires. With the present high grade apparatus used by the average amateur, excellent results can be obtained with a small aerial.

The ground consists of galvanized wire netting buried six inches in the ground directly beneath the aerial. Connections are also made to the water pipe and several small lengths of pipe driven in the ground.

Two regenerative sets are used for receiving. One is used for wave lengths from 170 to 450

and the other is employed for a detector. The transmitter consists of a Winger  $\frac{1}{2}$  KW transformer (only four miles from NAT), Grebe rotary spark gap, Dubilier and Klitzen condensers, Thordarson oscil-

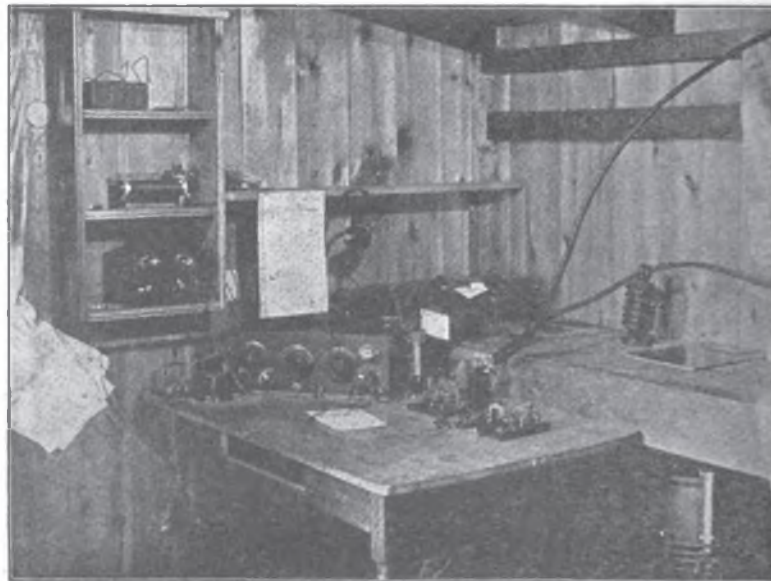



lation transformer, Westinghouse ammeter, etc. The transformer, protective-device, fuseblocks, etc., are under the table. The radiation on 250 meters with a decrement of .10 is 5 amperes.

Actual work has been carried on with

the following stations:

NSF, Anacostia, D.C., northeast, 1000 miles.  
 3EN, Norfolk, Va., northeast, 970 miles.  
 5ZA, Roswell, N. Mex., west, 950 miles.  
 9KM, Peoria, Ill., north, 800 miles.

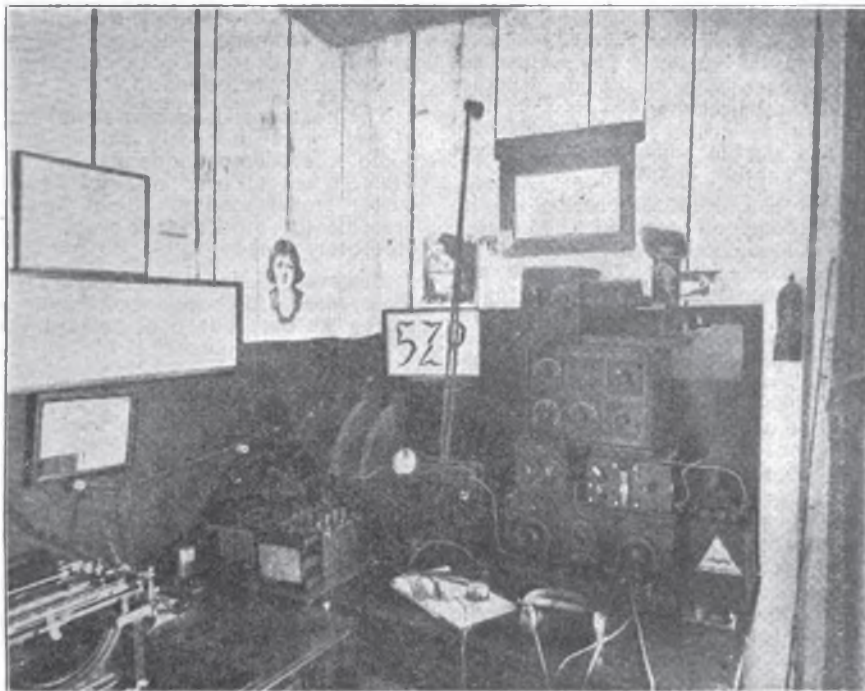

**THE CHICAGO CONVENTION**  
 (Concluded from page 34)

If you think that you are correct this far answer NO.....and if you believe that you have missed some, put NO here.....  
 If you know that you are as foolish as the bird that wrote this, write NO.....and if not write NO anyway.  
 If QST is published in Hartford, Mass., don't answer the next question but tell us what the call of Arlington is here..... If you prefer to have Naval control of radio amateurs, write the word NO.....and if not, fill in the last question with your initials.  
 Now that you are near the end, go back and write YES in place of the first and third where you have written NO. If you don't know what we mean answer in the affirmative.....  
 How many licensed amateurs do you think are in Chicago?.....  
 If you are so good that you have gotten all the above answered correctly thereby winning the first second or third prize, do you agree to appropriate one dollar for this honor?..... Write YES.

Mr. C. W. Patch, of 5 Villa St., Dubuque, Iowa, has favored us with a set of eleven photographs which he took at the Convention. We regret that space does not permit us to publish all of them. Anyone desiring prints of these photo-

**BULB OSCILLATORS**  
 (Continued from page 30)

not depend on the wave-length or other characteristics of the load. When no data of the oscillating circuit is available, the r.m.s. value of the plate alternating voltage ( $E_p$ ) may be assumed one half of the plate generator voltage ( $E_b$ ) and the efficiency may be assumed 50%; the bias resistance ( $R_c$ ) and grid alternating voltage ( $E_g$ ) should be made adjustable, the probable values being assumed, using Table II as a guide.

\*The relation between these resistances is determined wholly by the voltage ratio, ( $n$ ); for any change in the external plate resistance would be followed by a corresponding change in the internal resistance, the latter not behaving as a constant in a self-excited oscillator under varying load.

(To be continued)

graphs, all of which are very good, can secure them from Mr. Patch at 12 1/2c each, plus postage.

## Another C.W. Problem Solved

By J. O. Smith, 2ZL.

**A**N issue of QST not far removed from hence contained a story of the development of amateur C.W. transmission in which the author, Mr. H. L. Stanley, made several references to the writer. The writer has not as yet been able to decide whether these remarks were intended as a compliment or a brick, but, as long as our friend Stanley has started something, we might as well add another chapter.

After we had finally succeeded in injecting that ampere or so of C.W. juice, energy, or whatever the blamed stuff is, into an antenna, every Tom, Dick and Harry and a couple of hundred cousins of theirs, all of them, collectively and individually, took the greatest possible delight in very politely informing us, because they thought we would like to know, don't you know, that while the C.W. signals were fine, could be read through QRM, QRN and all the other Q's don't you know, they swung badly, oh yes, very, very much.

Bless all and sundry of their dear hearts, we knew they swung. We positively knew it. We knew it only too dingbusted well. Just imagine—here we were actually doing something that everybody doubted could be done because all the F. A.'s in the radio universe agreed C.W. transmission on short wave lengths was impossible, because it would swing so badly that no one at the receiving end would be able to follow it.

Well, anyway, friend Stanley, in his wise way, one day suggested that he had access to some radio experts and he would try and find out what caused our dinky signals to swing. "Try" was good, because nobody knew. So we started out ourselves to solve the universal problem of swinging C.W. signals on midget wave lengths.

For once in our lives, 2FS and the writer agreed. We agreed that the swing was due to a change in wave length or frequency or something, but we weren't quite sure what.

It was concluded, however, that in some way a change occurred somewhere in the antenna or ground system and we, accordingly, tried transmission under different conditions of weather, to see if we could blame it on the antenna. We decided that we could. We found that on calm nights the signals were much steadier than on windy nights when the antenna was shimmying. So, presto!, quick, like that, the great idea came to us, that if we could

have a stationary antenna, we could avoid changes of capacity, etc., consequently changes of everything else touchin' on and appertainin' thereto. The signals would be readable without the receiving operator spraining both wrists in turning knobs, etc., in trying to keep them in.

The next day the writer bought a pound of bell wire and some carpet tacks and made a stationary antenna in the attic. Then, when all was set and ready, the writer transmitted to friend Stanley and breathlessly awaited the reply, "Signals absolutely steady, QSA, no swing".

However, the next time the transmission took place, 2FS reported "your signals swung at first but O.K. toward the last. What did you change?"

That was a hard one, as nothing had been changed. The same thing happened occasionally afterward on various periods of transmission and finally the writer got rather hot about it and opened the window of the operating room for air. As he did so, he heard a steam train of the Long Island Railroad disappearing in the distance. Evidently the train had in some way affected those C.W. signals although the railroad is four blocks away. When the next train came along the result was that no swing took place. We were stumped.

The the writer recalled a journey he once made in the southwest. The train had been bumping and jolting along over the rails in terrible fashion for two or three hours. All at once it settled down and ran along so smoothly that the writer remarked to the conductor that they must have put in new rails on that particular stretch of track, or something. "Oh, no", said he "we ran off the rails back there a ways and we are now running on the ties."

Could it be possible that the same thing had happened to that second Long Island train?

But no, it finally developed that a heavy freight train would cause enough vibration to shake up the bell-wire antenna and a passenger train wouldn't. So the next day the indoor antenna was nailed fast for keeps and whether they now run on the rails or ties makes no difference, the signals do not swing any more.

And so it came to pass that another great engineering problem was solved and given to a breathless, waiting world—at a cost of sixty-five cents.



The Editor would like to have the address of Mr. Gilbert E. Mears.

Bill Woods was telling us about an amateur in Wood River, Ill., who operates a 2-inch spark coil and two sections of Amrad quenched gap from the magneto current of his Ford. All he has to do is to crank up the Henry, and he has his own power plant, and can get any note he wants. This takes the platinum gridleak.

Have any of our experimenters who have worked with Oudin and Tesla coils ever obtained those slow-moving "balls of fire" which are like ball lightning?

Radio Inspector H. C. Gawler, First District, announces that during the school term, September to June, amateurs may appear at the Custom House, Boston, Mass. for examination for amateur operator's license on any day of the business week except Thursday. Thursday is reserved for examinations for first grade commercial operator's license.

To Sept. 9th 1350 licenses were issued for amateur transmitters in the First District, the last call issued being 1FBV.

Harry J. Spruance, formerly of Montreal, Que., will confer a favor upon Lester M. Spangenberg, 25 So. 4th St., Lake View Heights, Paterson, N. J., if he will communicate with him. Last April Mr. Spruance advised 2ZM that his small phone set had been heard in Montreal, the letter being forwarded to 2ZM thru QST, and Mr. Spangenberg desires further light.

The East Side Y.M.C.A., 153 East 86th St., New York, announce the inauguration of a course in the Theory and Operation of Vacuum Tubes, under the direction of Mr. Elmer H. Lewis. The course consists of a series of lectures and laboratory experiments which cover this interesting subject in all its phases, embracing thirty-six class sessions of 2 hours each, 7:30 to 9:30 p.m. on Monday, Wednesday, and Friday of each week, the students being entitled, without extra charge, to all the privileges of the Y.M.C.A. The vacuum tube is playing a most important part in modern

radio, and a thorough course in this fascinating work will be of inestimable value and interest to live amateurs, to licensed operators, and to the more advanced experimenter. We are very glad to see the action of the Y.M.C.A. in establishing this course, and sincerely hope it will meet with an enthusiastic reception.

There must be something to the business of running a rotary gap at synchronous speed. Many amateurs report that when varying gap speed in a variable speed motor, there is an adjustment which can be held for a few minutes which will greatly increase the radiation for its duration. Interesting possibilities here. It has been suggested that the occasional falling in phase which would occur in normal operation in many cases, might account for some of the swinging of our signals.

Mr. A. L. Groves advises us that two Marconi Class II bulbs connected with all elements in parallel, and used as a detector, will give somewhat stronger signals than a single tube. This is because the characteristic curve of tubes in parallel is steeper than of an individual tube. This would make a cheap amplifier as the only additional expense would be the double drain on the A Battery.

New operator at 9QJ, St. Louis. Mr. and Mrs. F. W. Forshey announce the birth of their son Leo Hadley Forshey on Aug. 30th. Congratulations, Fritz!

'Nother radio romance. B. P. Williams, 8EN, Pittsburgh, met, courted, and won as his bride Miss Marian Carson, of Springdale, Pa., sister of R. M. Carson, 8RQ, official A.R.R.L. operator on Trunk Line B in Pennsylvania. This lady has forsaken the musical comedy stage to marry a radio bug and doesn't know what an awful thing she has done—but she probably will this winter. The newspapers featured the story so that on their trip they were pretty well known by the hotel clerks, and 8EN mentions that it "sort of QRM-ed the party." Hi, Brother!

Mr. Arthur Batcheller, formerly of the Massachusetts Radio & Telegraph School,



is now Chief Radio Inspector for the Port of New York, Col. Krumm having resigned his position to connect himself with the International Radio Telegraph Co., of New York.

Is anybody doing anything in the way of transmitting on a loop? The Editor wants some dope on the subject, please.

You fellows who want a little set to work around town—there is no excuse for going to all the trouble and expense of rigging up a complete set. A small buzzer is all you need: key and battery on the input, and aerial and ground to the armature and stationary electrode, being careful to eliminate the resistance of the windings from the aerial circuit.

Mr. Theophilus Johnson, Jr., ("Ted" to his intimates), Chief Radio Aide, U.S.N. Radio Advisor to Commander S. C. Hooper, Executive Officer in Charge, Director and Past Vice-President of the Radio Club of America, was recently married to Miss Hebe Helen Mattson, of Chicago. Mr. Johnson is an old-time amateur, his principal fad in the olden days being to connect up a three-slide tuner in a manner no one else could follow in a diagram. He had an important part in the organization of the radio aircraft service of the Navy during the war, and is the author of a very interesting paper entitled "Naval Aircraft Radio", recently presented before the I.R.E. We understand Mr. Johnson will have an important position in the radio section of the General Electric Co. He certainly has our good wishes.

Well, fellows, that "Grand Central Station" at New York surely got enough publicity in the August magazines, didn't it?

The AudioTron Sales Co. announce the completion of negotiations whereby the AudioTron is now regularly licensed by the Radio Corp. of America as well as by DeForest, for all amateur uses. The AudioTron was first marketed in 1915 and has had a long hard legal battle ever since. The familiar two-filament tube has been hand-made, and with increasing demand new models are being prepared, to be of the single filament type mounted on the standard 4-prong base. In October this company contemplates marketing a gas content detector tube known as the AudioTron, a high vacuum tube for amplifier work to be known as the AmpliTron, and a 5-watt oscillator which will be called the OscilTron.

"Eureka" wants to know where 7I got his oscillating rheostat

Lou Pacent points out that his new trade-mark is a Hertzian oscillator and not a wedding ring, and he hopes nobody will mistake his advertising for that of a mail order jewelry house.

9AIK suggests the use of old phonograph "needles" as switch lever stops. Drill a hole a little smaller than the needle, and force them in.

New books received: "Wireless Telegraphy and Telephony", by H. M. Dowsett, M.I.E.E. 331 pp., 8½ x 5½, published by The Wireless Press, London and New York, 1920. A typically British textbook, designed to act as a connecting link between the elementary text and the advanced treatise, and in particular to meet the demand for book which can be used in sequence to Hawkhead & Dowsett's "Handbook". Particularly good chapters on atomic theory, and exceptionally complete chapters are devoted to the accurate measurement of voltage, current, resistance, capacity, inductance, frequency, dielectric strength, and decrement, and it will no doubt be of value to American readers in search of data on these subjects. The price is \$3.50.

WOULDN'T IT BE WONDERFUL—

If 3RW didn't start every conversation with "QSA OM"?

If Ma could find her paraffine, now that she wants it?

If we could get all the apparatus we wanted by merely walking down town and paying for it? (From a North Dakota ham.)

If my dad would let me stay up at night as long as I want to? (Yep, Lil' Willie)

If the traction companies would supply us with 550 D.C.?

If NPL's arc was on Mt. Ararat with Noah's?

If John Barleycorn had a set? (He used to be good at sending out fits!)

If the O.M.'s cat got a bath?

If "wireless" was really what the name implies?

If 1SZ should forget to test his transmitter after 8 o'clock some night?

If NAF wasn't the training station for all the ham ops in the Navy?

David L. Moore, 1BBL, Farmington, Conn., gave to the world thru the Associated Press its first news of the S-5 accident, having copied the SOS of the S.S. General Goethals. It is said that naval officers at the Philadelphia Yard obtained their first knowledge of the accident when asked for information on the subject by the A. P.



Conducted by *Guy R. Entwistle*

**SPARK GAPS**

**T**HE proper selection of the spark gap for the primary circuit may decide the success or failure of the transmitting set.

Its function is to permit the condenser to become properly charged at one instant, and at the next instant release this energy for the creation of wireless waves. It also determines the amount of coupling that can be used with any particular installation. Thus we see it not only governs the character (broadness or sharpness) of the emitted wave but also its strength to a certain extent.

In general amateur practice we find three common types. The plain gap, the rotary, (synchronous and non-synchronous) and the quenched gap. The first type is used with spark coils and low powered transformers. It usually is made from two flat surfaces supported horizontally with a variable adjustment for sparking distances. Zinc, nicked steel, aluminum, or copper can be used.

A more common type is the non-synchronous or plain rotary.

Mechanically it consists of a rotor on which are fastened at equal spaced intervals, studs or electrodes. This is set in motion by any small motor of suitable size and speed. The connecting shaft must be well insulated if the rotor is all-metal. In some cases the rotor is made of bakelite or hard rubber which eliminates any necessity of shaft insulation.

Common spark frequencies used in radio are from 120 to 1000.

By frequency we mean the number of times PER SECOND anything occurs.

Hence when we say a rotary gap gives us a spark frequency of 300 we mean 300 complete sparks have occurred in that second and each spark represents a COMPLETE DISCHARGE of the condenser in the primary circuit. Also, each complete discharge of our condenser creates a separate wave train of oscillations. Therefore spark frequency and wave train frequency are one and the same. The tone in our receivers is

governed entirely by the spark frequency at the sending station.

Below is a table that will be found helpful in selecting the proper frequency, or number of studs for any motor of a given speed.

Before starting on our search let us refer to last month's article in which the subjects of high and low spark frequency were discussed. In general a resonant type transformer works best with a low spark frequency, while the non-resonant type lends itself to higher frequencies. Low frequency is around 200-400 while anything up to 1000 can be taken as high. 600 or 700 is the usual upper limit among amateurs.

R.P.M.	Low		High	
	Studs	Spark Note	Studs	Spark Note
1200	14	280	28	560
1800	10	300	20	600
2400	8	320	16	640
3600	4	240	8	480

Example—If the motor goes around 1800 R.P.M. and you have a resonance type transformer which works well around 300 for a spark frequency turn to first column and on the same line with 1800 in this column will be found 10 in the second column. Hence we need ten studs on the rotor at this speed, 1800 R.P.M., to develop the required frequency at the gap. Bear in mind this frequency we are now discussing has nothing whatsoever to do with the wave length. OSCILLATION frequency is the deciding factor in this latter case.

The two groups of figures will be found to be near 600 and 300 respectively, in all cases in the table. Departure from the table will not harm in most cases, provided the amateur bears in mind the connecting relation on which it is made; namely, SPARK FREQUENCY=R.P.S. x STUDS. R.P.S. can be found by dividing the REV. PER MIN by 60.

For a higher spark frequency, say 600, and the same motor speed, 1800 R.P.M., the second group of figures shows we need 20 studs on the rotor. Notice that twice the spark frequency requires just twice the number of studs for a motor of con-  
(Concluded on page 48)

# Radio Communications by the Amateurs

THE PUBLISHERS OF QST ASSUME NO RESPONSIBILITY FOR THE STATEMENTS MADE HEREIN BY CORRESPONDENTS.



## MORE CRITICISM OF "PROF. BUGS"

2637 Garfield Street, N. W.,  
Washington, D. C.,  
August 19, 1920.

Editor, QST:

In the August number of QST in the unsigned article "To the Old Man and Others" several erroneous statements were made.

The first of these is that the watts input to an antenna is

$P$  equals  $I^2 R$

"where  $R$  is the radiation resistance."

This is incorrect. The value  $R$  given in this equation is not the radiation resistance but the total antenna resistance. This total resistance is composed of the radiation resistance, the ohmic resistance of the ground connection, and the antenna wires, and finally the resistance due to the defective dielectrics in the field of the antenna. It is this total resistance that is measured by the substitution method which is mentioned at the bottom of page 49. The method most emphatically does not measure the radiation resistance; in fact there is at present no good method of measuring this value.

Radiation resistance may be calculated by means of the formula

$$R = \frac{H^2 1600}{\lambda^3}$$

but the statement that the formula "is accurate enough for all ordinary results" is anything but correct. The formula is a very poor makeshift which we use for lack of anything better.

Furthermore it is incorrectly used here. The height  $H$  is not the full height of the antenna but the height of the center of capacity, a distance which is considerably smaller than the antenna height unless the top is very large in proportion to the lead. In amateur antennas the top is not much longer than the lead. As the term enters into the equation in the second power the value of radiation resistance obtained by "Prof. Bugs" is very much too large.

The radiation resistance is here of only passing interest since "Prof. Bugs" is concerned with the current that may be expected in the antenna of a one kilowatt transmitter, and this current is limited by

the total resistance, not the radiation resistance alone. It is the total resistance, then, that should be considered.

The total resistance of the antenna may be conveniently measured by adding series resistance to the antenna circuit till the current is halved, when the added resistance equals the antenna resistance. The regular spark set may be used for this purpose but the coupling should be loosened considerably. Precautions to be observed are that the series resistance is correct at the operating wave (very few resistances are correct at 200 meters) and that the antenna meter is correctly calibrated. Most amateur meters are very badly off—anywhere from 5% to 50%—at 200 meters.

The method of adding series resistance may also be used with an oscillator but the oscillator must be one which has its own tuned circuit which is coupled very loosely to the antenna so that only a very small part of the possible output of the tube appears in the antenna. The ideal condition is that no appreciable change be produced in the current in the closed oscillatory circuit when it is placed in resonance with the antenna circuit. With an oscillator of any ordinary size this means that the antenna current will be quite small so that a thermo element and galvanometer will be needed to measure it. Such a combination is normally a current squared instrument, hence the deflection with half current will be  $\frac{1}{4}$  that of the full current.

Where the substitution method proposed in the article under discussion is to be used, a precaution must be observed which the writer of the article probably had in mind but did not emphasize. Both the substitution method and the series resistance method depend upon the assumption that the e.m.f. produced in the circuit under measurement remains constant. This condition is easy to meet in the series resistance method. In the substitution method the only sure way to obtain the same e.m.f. in the dummy circuit as in the antenna circuit is to use the same coil, first as the antenna coupling inductance and then as the dummy inductance, the oscillator or spark set primary coil being kept at the same distance as before. In case an antenna loading inductance is used it must of course be used at the same position in the dummy circuit.



Measured by the substitution method the antenna at 1AW has a resistance of 5 ohms at the operating wave length, the radiation resistance being a part of this. A current of ten amperes in this antenna would represent an input of  $10 \times 10 \times 5 = 500$  watts.

This is a large, but not impossible, input for a one kilowatt set—always assuming that it is possible to build a 200 meter, 60 cycle set which will have an input of one kilowatt. Like Mr. West, I would like to see such a set.

"Prof. Bugs" states that the value of the resistance used in the dummy circuit may be measured on a Wheatstone bridge. This is correct only if the measurement is made at the operating frequency, the bridge is one designed for radio frequent measurements and the resistance used as a standard is correct at these frequencies. As stated before, very few resistance boxes are even approximately correct at 200 meters.

S. Kruse.

**ELIMINATING BLINKING**

3483 West 98th St.,  
Cleveland, Ohio,  
August 16, 1920.

Editor, QST:

I noticed in the August edition an article on light blinking. I am using a simple hook-up which completely does away with this trouble. A separate set of contacts must be placed at the rear of the key, one on the base and one on the lever and hooked up according to the diagram.

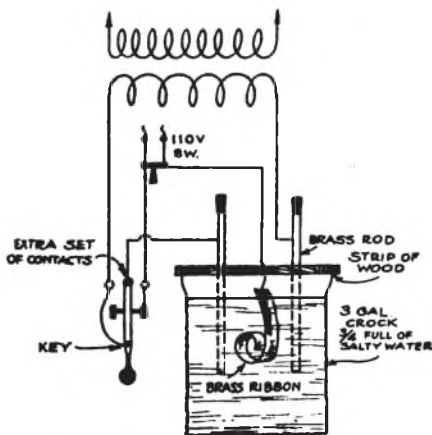

Procure a three or four gallon crock, fill it three-fourths full of salty water. Cut a strip of wood a little longer than the diameter of the crock, drill two holes three inches from the ends and slip some brass tubes or rods in these. Have them fit snugly so they can be adjusted. Have the wire connecting the brass ribbon hang over

the wood strip so it can be slid back and forth for adjustment. With this hook-up the transformer voltage can be regulated and also the light blinking stopped.

Yours truly,  
Arthur Schulder, 8AGB.

**SIMPLE RADIOPHONES**

251 Union Ave.,  
Rutherford, N. J.,  
New Jersey,

Editor, QST:

Most of the articles one sees in the electrical publications on Radio Phone Transmitting Sets have to do with the use of a generator or rectified A. C. to deliver the plate current, but the price of these instruments and their scarcity makes it impossible for most of us to get them, although most amateurs would like to have a Phone Set working.

A few weeks ago I hit upon the idea of using "B" batteries and getting the desired voltage in that way. I am using 5 standard "B" batteries delivering 110 volts to the plate of the vacuum tube. I use a very simple feedback circuit, the center connection on the secondary running to the filament. This circuit has been published many times so I will not give it again. I put up the set mostly to work with fellow amateurs in my own town. It worked fine, voice QSA on galena within a radius of two miles. A few nights later I was working with a friend when an amateur in Montclair called me and said he was getting me fine. That is about 7 miles from Rutherford. I was very much surprised and pleased to know my signals were carrying that far.

A few days ago 2WB in Bay Ridge, Brooklyn, put up a similar phone using 150 volts on his plate circuit. He is about 20 miles distant and I get him very QSA here, coming in at times almost as loud as another amateur in New York City using three tubes and radiating over 1 amp. 2WP gets me very good using a two step amplifier, signals being heard on the second floor.

It only took me about an hour to rig up this set, and I think it would pay any amateur to try it. I can use it with buzzer modulated, voice modulated, and straight CW. A small hot wire ammeter reading from zero to point five is needed in the ground lead so as to know the best adjustment. I am radiating 100 milliamperes on 325 meters.

I hope this will be of interest and help more amateurs to get CW sets working—we need them badly for local work.

If anyone hears 2MW, please let me know, as I would like to get the range of this set.

Very truly yours,  
Harry B. Wattson.

#### FOURTH DISTRICT PEP

105 Vineville, Ave.,  
Macon, Ga.,

Editor, QST:

I noticed a few days ago in the July "Strays" that it might be wonderful for the 4th district to show a little more pep. Ain't it the truth, OM? Things have looked pretty bad during the last season and seemed to get worse instead of better.

During last spring, I was one of the operators at 4YA, Ga. Tech. in Atlanta, and I had a pretty good chance to get a line on southern conditions. Here is how it looks to me. We can take messages from the northern and north-western stations (if they will repeat enough for us to copy them through the din) but when these messages get to Atlanta they have to stop or else go forward through Mr. Burleson's department. Even then, when two or three messages come back marked "Party Unknown", it gets a little bit discouraging.

I have often wondered just what kind of an opinion Mrs. 8ER and several of the others have formed about us fellows down here. Don't expect that it is anything complimentary but it just couldn't be helped. We have a pretty good come-back at them, though, that just about evens up the score. One of our Atlanta men sent several messages to his mother who was very sick in a northern hospital and not one of them ever got through to her. We would give the message to some station and then hear it forwarded to the next man about ten days later. That was the last we could ever hear from them and out of about six messages sent, not one was delivered. Looks like the 4th district wasn't the only one having hard luck so don't "ride" us all the time.

Here is something else we have been wondering about. Haven't seen a division report from the East Gulf since April. Don't know why but we are not quite dead down here and even if you don't have much to print about us, I think you will hear from the East Gulf Division as soon as the weather gets better and we can begin to open up with a little DX work. We are still on the job down here in spite of the "static" and you will probably hear from us every time we get even a few minutes clear weather.

Our main trouble since the re-opening has been no route South of Atlanta. Friend 4AG in Athens, less than 80 miles from Atlanta, could sometimes work 4AT and 4AO in Florida with some success but we at 4YA never could get through to them. I understand 4AO has sold his set and is not with us now but expects to get back in the game again next fall. It is not very often that we can work from Atlanta to Athens either. We consider conditions unusually good when we can do steady work over this short distance although both of us can do

DX work right along. 4AE at Jackson has not been on the job as his work carried him to another town, but I think he will be back again too. It will be a great loss if we have to lose both 4AE and 4AO too.

Just a few weeks ago I worked 4YB, K. of C. in Savannah, and then exchanged messages with 4BQ in Rome. Neither of these stations came in very QSA but think we can work both easily from Atlanta with better weather. Both of these should prove very valuable in relay work.

Have never gotten 4AN in Boston, Ga., good except the night before I left Atlanta about three weeks ago. Tried hard to raise him then but he failed to get me.

There is a good station going up in Macon now, 4DA, and it should prove to be another valuable link in the relay chain. We would have heard from this station before if he had not been requested like some of our Northern friends to "just about buy the power company."

We should be able to "go west" easily from Atlanta as we were able to work 5YE, University of Mississippi, for some time and exchanged several messages with them. 5XA, Auburn, Ala., also began to come in good just before we had to close down in Atlanta but on account of extremely heavy static we could not work them more than just exchanging signals.

It would seem that with the stations we had this spring and with the number of good stations increasing during the summer that we should get busy and make our arrangements now for work next fall so we will be ready to work as soon as the air "clears up".

Say OM, here's a good one. One of our Atlanta members made a business trip up east a short time ago and while there called on a few amateurs in Boston and New York. During the conversation at a station near Boston, the owner complained of not hearing 8's and 9's and other DX stations. The man from the south looked the set over, changed a few connections, rigged up a grid leak, did a little more to the set and in a few minutes had Mrs. 8ER and some of her neighbors on the line. The northern man was of course delighted but as his visitor started to leave, innocently asked him when the south was going to wake up in the radio game. Hi Hi. Can anybody tell one that will beat this?

Just wanted to let you know that we were still on the map and trying to do a little work so will QRT now. 73.

Yours truly,

E. H. Merritt.

#### AN AMATEUR DID IT

Editor, QST:

Chicago.

An instance when amateur radio was put to practical use occurred about 7:40 P. M., June 10th.

U. S. Mail Plane No. 206, having been delayed in leaving Cleveland for Chicago, was due to arrive at Maywood Field about dusk. The following request was broadcasted from plane when near Chicago:

"QST U. S. Plane No. 206.

"QST U. S. Plane No. 206.

Any station hearing these signals please notify Maywood Field of the Aerial Mail Service that 206 is coming into Chicago. Please phone Maywood Aerial Mail Field."

This message was phoned as soon as possible, although some delay was experienced on account of difficulty in obtaining telephone number.

The newspapers of next day reporting the incident stated that message was received at several amateur stations but gave Great Lakes Radio Station credit for service rendered.

Attached you will find letter from Post Office Department acknowledging receipt of message and confirming facts as outlined above.

An indoor aerial was used for reception of message at my station.

Yours truly,  
W. J. McGuffage,  
6120 Evans Avenue.

Mr. W. J. McGuffage, June 26, 1920.  
6120 Evans Avenue,  
Chicago, Ills.

Dear Sir:

Receipt is acknowledged of your letter of the 16th inst., regarding wireless message received by you from United States Mail Plane No. 206, at your radio receiving station, on June 10th, and in which you ask confirmation of telephone message that yours was the first information to reach this field regarding the arrival of this plane. In this connection, I beg to advise you that departure of ships from one field for another are always telegraphed promptly when ships leaves field. The departure of plnae 206, on the 10th instant, was reported from Cleveland in the usual manner. The Chicago station is not equipped to receive wireless messages and the exact time of arrival of this ship could not have been communicated direct to this field. I desire to thank you, therefore, for the service rendered in that instance.

Respectfully,  
A. R. Dunphy,  
Manager.

**ULTRA-ULTRAUDION.**

East Orange, N. Y.,  
March 11, 1920.

Editor, QST:

I am enclosing a simple circuit that works great.

I feel sure that the many readers of QST will be "tickled to death" with the results obtained by using it.

It is an adaption of the Ultra-Audion circuit. The Ultra-Audion hook-up is all right, but—I've added another variometer, V1, which increases its efficiency by at least 50%.

Trouble with the straight Ultra-Audion is that the degree of regeneration obtained is not readily controlled. By varying the coupling in the variometer I've added, ANY DEGREE of amplification can be obtained. And it's got them all stopped for radio phone reception!

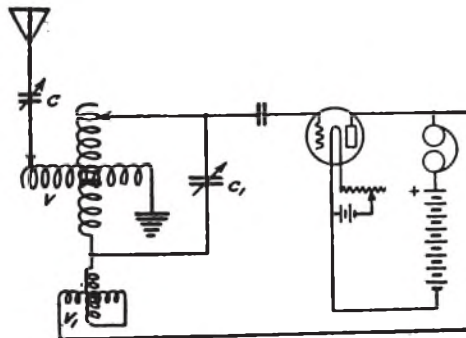

V is a tapped variometer, Sears Roebuck, SCR-54.

V1 is an untapped variometer wound with very heavy wire, preferably Litz.

C is a 43-plate variable condenser.

C1 is a 23-plate variable condenser.

G.C. is, of course, the grid condenser.

I trust that this will find space in an early issue of your magazine and wish QST abundant success.

Very cordially yours,  
G. N. Garrison.

**ON REDUCING INTERFERENCE**

San Francisco, Cal.

Editor, QST:

A great deal of complaint has been noticed from the amateur field at large, and especially from those situated in the near vicinity of the 600 meter shore stations, that these stations cause untold trouble due to "broad" (?) waves. Possibly with the old 60 cycle non-synchronous set, or a straight gap set in use this would be perfectly logical, but how many ever gave a moment's thought to the fact that this apparent broadness might be due to a broadly tuning receiver? Not many, I warrant. It is perfectly ridiculous to claim that a naval or commercial station using a modern 500 cycle quenched gap transmitter is, or can be emitting a broad wave, if it is properly tuned and, as the decrement of such stations often is as low as 0.03, which is really extremely sharp, and it is believed that this is only the natural antenna decrement, due to its resistance, rather than to any decrement due to a re-



action between the circuits. If interference is caused on waves differing from the operating wave of the receiver, it is really self-evident that it is the fault of the receiver itself, and not that of the transmitting equipment. (This is aimed particularly at the ones who claim that NAH and NPG have broad waves on quenched sets).

Now, with proper adjustment, the receiver can be adjusted so that there is no interference possible, provided the undesired wave is really of one single frequency (wave-length) and has no bad harmonics. The accompanying diagram shows a circuit by which this may be accomplished.

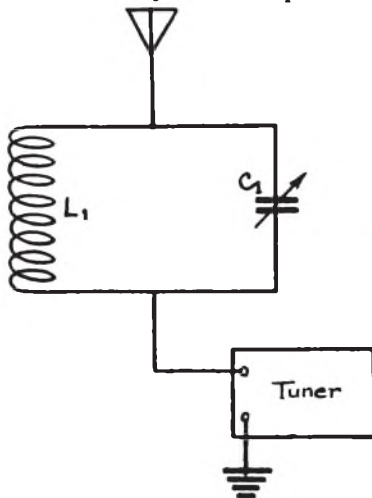

The cut represents a regular receiver, which may be of any common type, regenerative or otherwise, which is indicated by TUNER. The inserted series circuit is the thing that does the trick, and it does not have to be adjusted or fooled with, once it is connected and adjusted properly.

This circuit, called variously a "bug", "trap" or "filter circuit", is nothing more or less than a combination of capacity and inductance, represented by  $L_1$  and  $C_1$ , connected as shown, in the antenna lead of the receiver. This circuit, as can be readily seen, consists of a simple tuned circuit, the wave-length of which depends entirely on the values of the inductance and capacity connected across it. **THIS MUST BE TUNED TO THE WAVE OF THE SIGNAL IT IS DESIRED TO ELIMINATE IN THE RECEIVER.** At first glance, this seems strange, and unusual, but its explanation is as follows; if we have a tuned circuit, composed of capacity and inductance, this circuit will have practically zero resistance to any current of a frequency different than that the circuit is tuned to (i.e. its natural period), but to its own frequency the resistance will be infinity, or in other words no current will pass through

it at all. Now if such a circuit is connected in series with the antenna of a receiver, all the oscillations of different frequency than that the circuit is tuned to will pass through it freely, and will excite the tuner in the usual manner; if, however, oscillations of the frequency of the series circuit impinge on the antenna, and travel down the lead into the receiver, meeting with infinite resistance, they will be stopped, and the interference eliminated.

Practically, the inductance  $L_1$  and the capacity  $C_1$  may be almost anything within reasonable limits, provided the wave-length of the undesired station is known, as it generally is. The inductance may be a simple coil of wire without taps, on a cardboard tube, and the condenser may be a standard variable of any well known type, or the old long-forgotten tuning coil may be dragged out of the dust in the garret, and connected in circuit with a small fixed condenser. For 600 meters or thereabouts, if no old material is available, however, the "trap" may be constructed as follows:— take a cardboard tube, say 3" in diameter, and wind about 45 or 50 turns of No. 20 wire on it. Shellac, or paraffine, or otherwise secure the wire in place. Now connect a variable condenser across it, and connect a crystal detector across the terminals of the inductance, with a pair of telephones in series, in the manner which you ordinarily connect the detector in a wavemeter. Now excite the trap with a buzzer driven wavemeter, and tune to the wave wanted. Now disconnect the phones, and detector, and connect the trap in the antenna lead as shown, and lo! the QRM has vanished. For other wavelengths other coils must be used, or a honey-comb coil, or in fact any inductance and capacity which will tune to the undesired wave-length will be all that is needed. Never use too large a condenser, however, but rather use a larger inductance. It is not desirable to exceed 0.003 capacity at most in the condenser.

Different traps may be made, and connected in series, if more than one station is interfering with reception at any one location, and if properly constructed, so that no extraneous inductances or capacity are introduced into the trap (always use the shortest possible leads) there will be no loss of the desired signals, or leakage of the undesired signals into the receiver, although a difference in the adjustments in the tuner primary circuits will in practically all cases result.

Yours truly,

D. B.

(Note: We certainly cannot agree with our correspondent's statement that interference from naval or commercial stations is generally due to imperfections in the receiving equipment. How does he account for this interference when obtained on a

modern short wave regenerative receiver, which tunes sharper than any other tuners we know?

We believe it is true that there will be no interference on 200 meters from a quenched transmitter on 600 meters when the latter is properly adjusted. The trouble is that they are often improperly adjusted. Some of these sets have arrangements for wave-changing which do not perform all the necessary actions, such as coupling corrections, that last shade of fine tuning necessary in a quenched set, etc. These are supposed to be done by hand, and often aren't. Others of these stations seem to have been tuned by people who were far from knowing their business. In others the inspector's tuning has been disturbed. At any rate we know beyond question that some of these stations have been causing unwarranted interference on amateur waves. Chicago amateurs recently complained officially regarding NAJ, we understand, and upon investigation it was discovered that on its three short waves the decrement of this station exceeded the legal .2. NRH was similarly found to have a decrement of .237, due to mistuning, and was corrected to .065. At NAM, a 5k.w. 500 cycle set, the trouble is from another source. The authorities are co-operating and investigating the trouble. We understand a strong wave is radiated by that station on almost exactly 200 meters, although the decrement is but .04, and exists as about 10% of the total radiation on 600 meters, and about 8% on 952 meters. It has been discovered here that the trouble is due to re-radiation from the towers, and steps to correct this are now being taken.

We suggest that clubs in localities experiencing unwarranted interference from Navy stations take up the matter with the Naval Communications Service, Washington—we know they will gladly co-operate.

Regarding our correspondent's QRM eliminator, we believe it will work in the case of forced oscillations where the transmitting station is very sharply tuned, but like all other devices of this kind it is ineffective against the components of the interfering energy which represent other than its resonant frequency—it is helpless in the case of a broad wave. We can hope, however, that it will be of much help to amateurs troubled by forced oscillations from a nearby powerful station.—Editor.)

#### BLINKING LIGHTS

Cambridge, Mass.,  
August 21, 1920.

Editor, QST:

We have read with interest the communication in the August QST from Mr. M. E. Ross on blinking lights and wish to say from a manufacturers standpoint this method is unsatisfactory as radio transfor-

mers are not designed to stand a continuous load. If they were their costs would be considerably greater.

The most satisfactory way to eliminate blinking lights to have a double contact key which when down closes the circuit into the transformer and when up closes the circuit through the resistance of sufficient value to draw an equal amount of current. The reason for using resistance instead of an inductance is to eliminate arcing at the key.

By the above method blinking lights are eliminated by making the "blink continuous."

Very truly yours,

ACME APPARATUS COMPANY,

per C. F. Cairns.

(Note: Readers are requested to see a letter entitled "Eliminating Blinking", in this section.—Ed.)

#### LOG SYSTEM

34 Hobart Avenue,  
Summit, N. J.

Dear Eddy:

In the last issue of QST I noticed that you wanted to hear from some of us boys on the subject of keeping a good log. I won't guarantee that it is a good one, but it certainly works great at my station.

A note book is kept with 8 ruled divisions; they are labeled; Date, Time, Call, Working, Amplitude, Secondary Adjustment, Primary adjustment, and Amplification, respectively. When a station over 100 miles is heard these divisions are filled out accordingly. At the end of the month these records are all gone over and all new stations heard that month are listed individually on a card about the size of an ordinary post card. The stations call is placed in large letters at the upper left-hand corner. These cards are ruled the same as the note book with the exception that there are only five divisions labeled Date, Time, Working, Amplitude and Amplification respectively. The adjustment is placed in the upper right-hand corner. These cards are then filed according to districts and alphabetically in each district. A complete personal record and adjustment of every DX station heard is then always on hand.

When a fellow wants to know if I have heard his call, one look at the records will find out whether he has been heard or not. The complete data can then be sent to the station, without the least bit of trouble.

It also comes in handy when listening for a certain station. By means of the adjustment record the exact adjustment of the receiver can be ascertained and there is no need of constantly tuning over a wide range of wave lengths.

I have been using this system for quite a while now and I find it a great help.

Yours truly, I. R. Groves, 2DK.

### THAT UNKNOWN PHONE SET

Camp Lewis, Wash.

Editor, QST:

I saw in your last issue an article about a phone set 80 miles south of Tacoma with call PF1. This is a misunderstanding. That set is about 18 miles south of Tacoma and the call is CL1. CL-one...? It is the radio phone set of the 59th Regiment, 31st Brigade, C. A. C. I am at CL2, the brigade station, 31st Brigade Headquarters Detachment. We also have BI4 of the 14th Balloon Co., also a radiophone. BI4 and CL1 have SCR-67 Western Elec. sets. We have two E-10-bis French sets at CL2 and one E-3-bis French radiophone, and some W.E. sets on the way. Our sets are for field work up to 12 miles and work fine for that distance but no good for long distance. The SCR-67's are good for 60 miles to a similar set, but with good aerial and good weather can be stretched to about 300 miles. We have a spark set here at CL2 and are waiting for condenser and short-wave receptor. Then we are going to talk with amateurs.

Yours in the ether,

Neville R. Benoit, 7BC.

### MORE ABOUT XAJ

Mt. Morris, Ill.,  
August 17, 1920.

Editor, QST:

Just read 8BQ's letter on XAJ, Tampico. Was down there myself about the middle of May and noted some queer happenings. We were leaving the Panuca River, still in sight of land, and I had some traffic for him. Called him twice, the second time on about one-half k.w. Couldn't get him at all, but was hearing NAT and NAY through some fairly heavy static. Was called by another ship who said QSQ—XAJ. I then called him again on one-half k.w. and he came in then roaring. He said he had answered both times before. My set and antenna were O. K. as evidenced by NAT on carborundum, also by test. Now why?

Yours,

E. R. Tilden,

### THE JUNIOR OPERATOR

(Concluded from page 41)

stant speed. The same effect can be produced by doubling the speed and using the same number of studs.

It will be noted that the DIAMETER of the rotor has nothing to do with the number of sparks we get per second, or the frequency. It has, however, an important bearing on the efficiency of the gap. In general, the larger the diameter of the rotor the better. Mechanical difficulties prevent most of us from increasing our rotor size indefinitely.

The amateur will be well repaid for any labor along this direction. The reason is as follows: When the moving electrode, or stud, approaches the stationary stud, the spark jumps to meet it. At the next instant the two studs are opposite and an instant later are becoming separated. During all this time the primary circuit is virtually closed and the energy surging back and forth. At one time it is being passed over to the secondary and at the next moment is being passed back to the primary. This is against all principles of efficiency. Once it has been passed over to the secondary it should remain there until it has been converted into radiation. Hence we see the necessity of shortening the time interval at which our two electrodes are in use. Or, in other words, shortening the life of "spark" in the primary.

The next question is, how can we do this? Without going into mathematical details which are out of place here, the answer is to increase the DIAMETER of your ROTARY. 1AW has a rotor around two feet in diameter. NAA's is around FIVE feet. Those who know what is meant by LINEAR VELOCITY will understand the importance of a large diameter.

Another important item in the design of a rotary is the proper shape of the studs. The sparking surface should be narrow. Both stationary and moving electrodes (Studs) should be mounted horizontally, similar to the blades of a water wheel. This helps in shortening the life of the spark.

In practice it is impossible for the amateur to send out a single wave with a rotary and still accomplish any distance. But the Government has fixed the strength of the other waves not to exceed TEN per cent of the energy of that in the main wave.

It is due to this FEED BACK from primary to secondary that we have to use such LOOSE coupling. This means a loss of energy for our antenna circuit. Thus we see the type of gap used governs the amount of coupling used. This in turn determines the amount of energy we succeed in passing over into the antenna which, as we know, determines the distance to which we transmit.

One of the disadvantages of the rotary is that it makes much noise. This can be overcome by enclosing it in a box packed with felt or any other material that will absorb the vibration.

Many manufacturers advertising in QST offer complete rotors and stators which will make a good rotary for the amateur.

The synchronous gap will be taken up next month.



# CALLS HEARD

On account of the vast quantity of calls reported we must ask your co-operation in the following.

- (1) List the calls on a separate sheet of paper—do not embody them in a letter.
- (2) Arrange by districts from 1 to 9, and alphabetically thru each district; and run them across the page, not down a column.
- (3) Put parentheses around calls of stations also worked.
- (4) Omit initial or other unauthorized calls.
- (5) State the period covered by your report.

**1AAC, FRAMINGHAM, MASS.**  
 1AW, 1BM, 1FQ, 1FT, 1QP, 1RZ, 1SZ, 1TS, 1YB, 1KAY, 1PAM, 2AD, 2BB, 2BH, 2CK, 2DA, 2DC, 2EW, 2BK, 2GE, 2GU, 2JE, 2JP, 2JU, 2GM, 2LL, 2MEK, 2OA, 2OM, 2RG, 2RL, 2RR, 2SJ, 2TO, 2TN, 2WN, 2XJ (spark and tel.), 2YN, 2ZL, 2ZA, 2ZC, 2CF, 2CV, 2DH, 2EV, 2EW, 2HJ, 2NN, 2ZM, 4AL, 4LF, 8DA, 8BU, 8BP, 8IN, 8JU, 8EN, 8XU, 8WY, 8NN, 9AU, 9ZN.

**8MT, UNIONTOWN, PA.**  
 1AN, 1AU, (1AW), 1CC, 1GB, 1GR, 1HAA, 1IZ, 1NC, 1RN, (1YB), 2AE, 2BM, (2BK), 2BN, (2CS), 2CH, (2DA), 2EF, 2ET, 2GC, 2GL, 2IK, 2JA, 2JE, 2JM, 2JU, 2KM, 2NB, 2XJ Telephone, 2RB, 2ST, 2VA, (2XX) Telephone, 2ZS, 2ZL, 2BH, 2BT, (2BZ), 2DZ, 2EA, 2EF, 2EI, (2EN), (2EW), 2GA, 2GO, 2GX, (2HJ), 2IB, (2MU), 2MV, (2NB), 2NK, 2NV, 2PC, (2ZA), 2ZM, 4AE, 4AL, 4AN, 4AM, 4AT, 4CC, 4DD, 4DO, 4EJ, 4YA, (4YB), 5DA, 5AN, 5AQ, 5HQ, 5KA, 5GZ, 5AAM, (5ACP), 5AP, 5AJ, 5AZV, (5BB), (5BP), (5BQ), 5CH, (5DA), 5DC, (5DH), (5DI), (5DR), (5DS), 5DU, (5DV), 5EC, (5EF), (5EN), (5EO), (5ER), (5EJ), (5FD), (5FS, 5GA, (5GC), 5GJ, 5GP, 5GQ, 5HA, 5IF, 5IK, (5IN), 5INN, (5JQ), (5JJ), (5LA), (5LJ), 5MD, 5NP, 5OC, 5OL, (5OJ), (5PW), (5QG), (5RS), (5SP), 5VC, (5VQ), 5WA, 5WG, (5WB Telephone), (5WY), 8XA, (8XK Telephone), (8XU), (8YI), 8RQ, 8GS, 8FO, 8NG, 8ZNC, 8WB, 9FG, 9KV, (9OJ), 9TR, (9ZL), 9HR.

**8NB, ROCHESTER, N. Y., May.**  
 1AE, 1AS, 1AW, 1BU, 1CE, 1CK, 1CV, 1DQ, 1FW, 1GB, 1KA, 1KT, 1RZ, 1TS, 1YB, 2AA, 2AS, 2BB, 2BK, 2BM, 2DA, 2DR, 2EF, 2EH, 2GE, 2GR, 2JE, 2JU, 2KM, 2ME, 2OA, 2OR, 2QV, 2RB, 2TF, 2UE, 2WB, 2XJ, 2ZL, 2AN, 2BA, 2BE, 2BH, 2EV, 2FX, 2GO, 2GX, 2HJ, 2HR, 2HV, 2JR, 2KM, 2MK, 2NB, 2NP, 2NV, 2SQ, NSF, 4AG, 8AA, 8AJ, 8BB, 8BG, 8BM, 8BP, 8BQ, 8BU, 8CB, 8CC, 8CE, 8DA, 8DE, 8DI, 8DV, 8DZ, 8ED, 8EN, 8ER, 8FI, 8FO, 8FT, 8GQ, 8HH, 8IK, 8IL, 8JU, 8KW, 8LA, 8LW, 8MC, 8MT, 8MI, 8NF, 8NI, 8PA, 8PR, 8QJ, 8RC, 8RQ, 8RS, 8SH, 8TF, 8WY, 8XA, 8XK, 8XU, 8YV, 8ZM, 8ZW, 8AAN, 8ABG, 8CS, 8FG, 8MS, 9ZN.

**1AW, HARTFORD, Aug. 9-28.**  
 (1AS), (1CK), 1CM, 1FB, 1FV, (1JQ), (1QP), (1TS), (1BBH), (1BBL), 1FAQ, (1HAA), (1NAQ), 1VAD, 2BG, (2DA), (2DN), (2EF), (2JU), 2JL, 2JN, 2MB, (2NF), 2ND, 2OM, 2PV, (2TF), 3BE, 3BG, 3BZ, 3EH, 3HJ, (3LG), 3NB, (3OB), 3ZW, 3AD, (3BV), 3CH, (3DI, 3DY, (3EN), (3GS), 3IK, 3MT, 3NI, 3SH, (3WY), (3XK), 3ZC, 3ZW, 3ZY, 3HR, (NSF).

**2YM, NEW YORK, August**  
 1AS, 1AW, 1CM, 1DQ, 1FH, 1FV, 1TS, 1HAA, 3BG, 3BL, 3EN, 3FG, 3FD, 3GV, 3GX, 3HJ, 3JK,

3ND, 3RW, 3VV, 3ZA, 3ACS, 4BZ, 8BV, 8DA, 8DI, 8ER, 8LX, 8MI, 8NI, 8QO, 8ZW, 9ZN.

**3GX, READING, PA., Aug. 28 to Sept. 8.**  
 1AW, 1BM, (1DQ), (1PY), (1RZ), (1SZ), (1HAA), (2BK), (2GR), (2JU), 2JZ, (2NF), 2TF, 2WB, (2BZ), 3DL, 3EZ, 3FG, (3HG), (3HJ), (3KN), (3NB), 3RS, 3VV, 3ZW, (3ADH), 3AOF, 4CP, 4DM, 8CV, 8DV, 8EN, (8EV), 8GL, 8HG, 8JS, 8LX, 8MT, (8NI), 8QM, 8RU, 8SH, 8UO, 8XK.

**H. POLLOCK, PAWTUCKET, R. I., August.**  
 1AW, 1ES, 1CK, 1HAA, 1SZ, 1TS, 1VAD, 2OA, 2RK, 2RM, 3HB, 3HJ, 3KM, NSF, 8ER, 8HD, 8QM, 8XD, 9ZN.

**2MN, BELMAR, N. J., June 11 to Sept. 5.**  
 1AW, 1BBZ, 1BQ, 1CB, 1CZ, 1DQ, 1DY, 1FAQ, 1FV, 1FW, 1GAO, 1HAA, (1HO), 1IN, 1RZ, 1TS, 1VA, 2BZ, 2CZ, 2GO, 2HJ, 3VV, 3BV, 3DI, 3ER, 3QM, 3QV, 3WY, 3XK, 9AU.

**1RY, CHATHAM, MASS., Aug. 30 and Sept. 4.**  
 1AS, 1AW, 1CM, 1CZ, 1DQ, 1DY, 1ES, 1GAO, 1HAA, 1RZ, 1SZ, 2BG, 2BK, 2CT, 2DN, 2EL, 2JU, 2ME, 2MN, 2NF, 2OM, 2TS, 2WB, 2WZ, 2YM, 2ZL, 3BG, 3EN, 3JS, 3SH, 3XK.

**8ME, BEAVER, PA., Past Year.**  
 1AW, 2DA, 2ZS, 2ZV, 8AL, 8AO, 8ACI, 8BP, 8BV, 8DI, 8DK, 8ER, 8II, 8IK, 8MB, 8MM, 8TI, 8VM, 8XA, 8XU, 8ZW, 8ZX, 9CS, 9DV, 9ER, 9HD, 9HR, 9KF, 9ZJ, 9ZL, 9ZN.

**CANADIAN 5BR, VANCOUVER, B. C., July 10 to Aug. 9.**  
 (5AR), (5BK), (5BG), 5BJ, 6DP, 6FE, 6OH, 7AD, 7AH, (7BK), 7BU, 7CE, (7CU), 7CW, 7DA, 7DP, (7DS), 7FL, 7GR, 7IN, 7JM, 7NS, 7YB.

**7CU, VANCOUVER, WASH., August.**  
 (5BR), (6AS), (6AV), (6AR), (6BJ), (6BN), (6BQ), (6BR), (6CO), (6DK), (6DY), (6EA), (6EB), (6EJ), (6EP), (6EX), (6FS), (6GF), (6GR), (6IF), (6II), (6JD), (6JI), (6JM), (6JN), (6OC), (6OH), (6PQ), (6QR), (6SR), (6TC), (6ZE), (7AD), (7AN), (7BK), (7CE), (7CW), (7IN).

**1TS, BRISTOL, CONN., July 20 to Sept. 1.**  
 1AAU, C.W., 1AG, 1AK, 1AS, (1AW), 1AY C.W. and fone, 1BAY C.W. and fone, (1BBL), 1BL, 1BM, 1CK, (1CM), 1CZ, 1DBU C.W., (QST vs. QRA?), 1DQ, 1DR, 1EAV, 1EK, 1FAQ, 1FB, (1FBK) spk. and C.W., 1FQ, 1FV, 1GAO, (1GJ), 1GY, 1HAA, 1IAO, 1JQ, 1MJ, (1NAT), 1OAL, (1QP) C.W. and fone, 1RZ, 1SN, (1SZ), 1UAW, 1XD C.W. and fone, 1XE, 1ZC, 2AJD, 2AJW, 2AMZ, 2BG, 2BH, 2BK, 2CE, 2CT, 2DA, 2DI, 2DN, 2EL, 2GR, 2HN, 2JN, 2JU, 2JZ, 2MJ, 2NB, 2ND, 2NF, 2NV, 2OA, 2OM, 2PE, 2PL, 2PZ, 2QR spk. and fone, 2RK, 2RM, 2SH, 2TF, 2VA, 2WB, 2WG, 2XJ fone, 2XO, 2YM, 2ZL C.W. and fone, 2ZM spk., C.W. and fone; 3BG, 3BZ, 3DS, 3EH, 3EV, 3FB, 3FG, 3FN, 3FR, 3GX, 3HJ, 3HZ, 3MU, 3NB, 3OB, 3SJ, 3VV, 3ZA, 3ZS, 3ZW, 3BH, 3BP, 3BV, 3CG, 3DA, 3DI, 3DV, 3DY, 3EN, 3EW, 3FC, 3FW, 3FX, 3GS, 3GY, 3IK, 3IN, 3JS, 3JU, 3MQ, 3MT, 3NI, 3OY, 3QM, 3SH, 3VU, 3WY, 3XK C.W., 3YV, 3ZW, 3ZX, 3ZY, 9AP, 9AW, 9HE, 9ME, 9ZJ, 9ZN. ...

**8AD, BUFFALO, July 1 to Aug. 31.**  
 1AW, 1CK, 1ES, 1FV, 1NA, 1XJ, 2AJW, 2CT, (2EH), 2JZ, (2JU), 2ND, 2NF, (2RK), 2TF, (2WB), 2FG, (3HJ), 3NB, 3NC, 3OB, 3ZW, 4GT, 8AJN, 8BW, 8CV, 8CH, 8CF, 8CB, 8DA, (8DI), (8DF), 8ER, 8EN, 8GY, 8GB, 8HS, 8LX, 8LF, 8MT, (8NI), 8RS, 8SH, 8XK, NSF, 9AD, 9ALS, 9ASH, 9HE, 9ZN.

(Concluded on page 52)



“FR

Signal  
becom

LICENSED UNDER ARMSTRONG AND MARCONI PATENTS

## AND HERE IT IS-

### Greatest Improvement In Modern Radio

Do you remember the super service of the old original Paragon RA-6 amplifying short wave receiver? This new set surpasses it in every respect

*and the original RA-6 was the only one of its kind*

150% improvement over the old original Paragon, away ahead of all other receivers and excels the most service-able set on the market today.

Startling surprises in store for you if you will send for special bulletin describing this set.

Remember the old Paragon—this one beats it and all others by miles—our special bulletin tells you how. Send for it—it's free.

AND TH

*The above set will be on exhibition at ou*

Our word of honor to y

## Continental Rad

J. DI BLASI, Secretary  
DEPT. B,2,

Sole Distrib  
6 W

**NOTHING TO SOMETHING"**

**will do it—**

**h this new Paragon RA-10**

actual tests are inaudible with any other type of receiver,  
readable. "*Coming from Nothing and amplifying to Something.*"

**the Paragon RA-TEN**

**Here are the 150% Pointers**

A Wave Length range of 160 to 1,000 meters.

24% more sensitive and selective than the RA-6.

All amplification obtained without change of spark tone.

Objectionable effect of change in note entirely eliminated.

Coupling has scale of 180° instead of 90°, giving wider range of coupling.

Controls on all adjustments fitted with vernier attachments permitting of very fine tuning and control.

No dead end losses.

Cabinet of quartered oak; overall size 20<sup>5</sup>/<sub>8</sub>x8x7<sup>1</sup>/<sub>2</sub>"; white filled engraving, bakelite panel, knobs and dials.

Every set sealed before leaving factory, which is a guarantee for two years.

A super product of Adams Morgan Co.'s unapproachable engineers.

**15.00**

**the Electrical Show, Oct. 6 to 16, inclusive**

**warranty. Let us prove it.**

**Ad Electric Corp.**

**170n RA-10  
EET**

**J. STANTLEY, Treasurer  
NEW YORK**



**90X, LOUISVILLE, KY, July 1 to Aug. 31.**  
(NSF), 1AK, 1XJ, 2IL, 2XL (phone), 3BK, 3BQ, 3BZ, 3EA, 3VW, 4AE, 4KK, 5DA, 5YH, 5YS, 5ZG, 8AL, 8BP, 8CF, 8CU, 8DA, 8DH, 8DI, 8DR, 8DV, 8DX, 8DY, 8DZ, 8EF, 8 ER, 8GB, 8GR, 8IE, 8IK, 8IN, 8JJ, 8KN, 8LF, 8MC, 8MI, 8MT, 8NI, 8NL, 8NY, 8PP, 8RC, 8XK (I.C.W.) 8XL, 8YQ, 8YV, 8ZW, 8ZY, 8ZZ, 9AP, 9AT, 9ABL, 9ALS, 9BW, 9FL, (9HR), 9HW, 9IN, 9IT, 9KO, 9KU, 9LC, 9MH, 9MS, 9MT, 9NC, 9NQ, 9NZ, 9OJ, 9QJ, 9RM, 9WC, 9WK, 9WV, 9ZC, 9ZJ, 9ZL, 9ZN, 9ZO, 9ZR, 9ZX.

**1ES, BROOKLINE, MASS., August.**  
1AAU, 1AK, 1AW, 1BBL, 1BM, 1CBJ, 1CM, 1EK, 1FB, 1FQ, 1FV, 1GY, 1HAA, 1IAO, 1NAQ, 1OE, 1RZ, 1SZ, 1TS, 2AER, 2AJW, 2AMZ, 2BG, 2BK, 2BM, 2CE, 2CT, 2DA, 2DN, 2EL, 2GR, 2HN, 2JN, 2JU, 2JZ, 2NF, 2OA, 2OM, 2OU, 2PL, 2PV, 2RK, 2TF, 2VA, 2WZ, 2YM, 2ZM, 3BG, 3BZ, 3EN, 3EH, 3FB, 3FG, 3FR, 3GV, 3GX, 3HJ, 3HX, 3KM, 3MU, 3NB, 3ND, 3OB, 3PS, 3VV, 3ZA, 3ZW, 4CM, 4AD, 4BO, 4BP, 4BV, 4CF, 4DA, 4DI, 4DV, 4DY, 4EN, 4ER, 4GB, 4GS, 4GW, 4IK, 4LF, 4LR, 4LX, 4MI, 4MT, 4NI, 4QM, 4SH, 4WY, 4XK, 4YV, 4ZW, 4ZY, 4ZJ, 4ZL, 4ZN.

**8LF, CRAFTON, PA., August.**  
1AW, 1AW, 1AAJ, 1CB, 1XD (phone), 1FB, (1FV), 1HAA, 1RK, 1UB, 2BG, 2BK, 2BM, 2DR, 2EF, 2EL, 2GN, (2JZ), (2NF), 2RK, 2TF, 2TS, 2WB, 2XJ (phone), (3AAP), 3BG, 3BZ, 3CZ, 3DC, 3DN, 3DS, 3FG, 3GX, 3HL, 3HJ, 3KM, 3NB, 3NU, (3VV), 3WN, 4FB, 5YH, 8ADE, 8AFL, (8BV), 8CB, (8CF), 8DA, 8DE, (8DI), 8ER, (8FD), 8GB, 8HD, 8IK, 8ZV, 8ZY, 9AD, 9AT, 9GB, 9GX, 9SH, 9ZJ, 9ZN.

**CANADIAN SFE, PANANEE, ONT., Aug. 1 to 23.**  
1AR, 1AS, 1AW, 1BAY, 1BL, 1BM, 1GR, 1GY, 1HAA, 1NA, 1QP, 1RZ, 1SL, 1SZ, 2BG, 2BK, 2DN, 2EF, 2EL, 2FS, 2FJ, 2JU, 2JZ, 2NF, 2PL, 2QR, 2RK, 2TS, 2WB, 2XF, 2XX, 2ZL, 3HJ, 3OB, 3ZA, 3AD, 3BO, 3BP, 3BV, 3CE, 3CI, 3DA, 3DF, 3DI, 3EN, 3ER, 3FD, 3FM, 3FN, 3GB, 3HA, 3HF, 3NI, 3RN, 3SH, 3WY, 3XK, 3YV, 3ZJ, 3ZW, 3ZY, 3ZN.

**2CT, BRONX, N. Y. C.**  
(1AW), (1FV), (1HAA), 2TF, 3BG, 3BK, (3BZ), 3GX, (3HJ), (3KM), (3NB), 3NC, (3ND), (3VV), 3BK, 3BV, 3CB, 3CH, 3DA, 3DV, 3LF, 3MT, 3TD, 3XB, 3XK, 3ZW, NSF, 1DQ.

**3VV, NORFOLK, VA., July 15th to Aug. 15th.**  
(1AW), 1FV, 1PZ, 1RV, 2AAP, 2BK, 2CA, 2CE, 2CM, (2CT), 2EL, 2FG, 2HR, 2HW, 2JA, (2JU), 2JZ, 2NF, 2RK, 2TT, 3BA, 3BG, 3BL, (3BZ), 3CZ, 3GK, 3GR, 3HE, (3HJ), 3HR, (3JK), 3KM, 3LG, 3MU, 3NB, 3PS, (3QQ), 3RK, 3VA, 3VP, 3XI, 3YK, 3YM, 3ZA, 3ZL, 5YH, 5YS, 7JF, 8BK, 8CF, 8DA, 8DI, 8DR, 8ER, 8GP, 8GR, (8IK), 8LA, 8PK.

8VV, 8YK, (8YV), 8ZW, 8ZY, 9ALS, 9CM, 9DG, 9GB, 9GX, 9HF, 9PM, 9RW, 9ZF, 9ZN, (NSF).

**9AHC, ELLENDALE, N. D.**  
On one wire, one variometer for tuner, and galena:  
9ADZ, 9BW, 9JN, 9LW, 9PI, 9XN, 9YG, 9ZN, 9ZX.

**1NY, BELMONT, MASS., June 25 to Aug. 25**  
2BG, 2BK, 2DN, 2EL, 2GR, 2JE, 2JZ, 2NF, 2RK, 2SH, 2YM, 3BZ, 3HJ, 3NB, 3ND, 3VV, 3VW, 3DA, 3DV, 3LF, 3XK, NSF.

**8ZY, DEFIANCE, OHIO, July 20 to Aug. 24.**  
NSF, 1AW, (2BK), 2EL, (2GR), 2RK, 2ZL, (3BZ), 3HJ, 3ND, 3LG, 3AO, (5YH), (5YS), 3AIM, (3BP), (3CF), 3CV, 3CD, (3DA), 3DC, 3DI, 3DF, 3DH, 3DV, (3EN), (3FI), (3GB), (3GS), 3GY, 3HJ, (3IK), 3IN, (3JJ), (3JU), 3NI, 3QJ, 3QO, 3SH, (3UO), (3WY), (3XA), (3XK), 3ZW, 3AAF, (3ALS), 3AE, (3AP), (3AX), (3HB), (3IT), 3KO, (3LR), (3NQ), 3PW, (3ZN), 3ZJ, 3ZL.

**3AAR, NORTH GLENSIDE, PA., On Crystal.**  
1AW, 1HAA, 2NF, 2WB, 3BG, 3BO, (3BK), 3DR, 3EH, 3EN, 3FG, 3GH, 3GO, 3HJ, (3LH), 3MX, 3NB, 3NY, (3OT), (3PB), 3PG, 3PS, 3PW, 3QH, 3QQ, (3RU), 3RW, (3UF), 3VV, 3ZS, 3ZW, 3ABV, 3BV, 3ML, 3NI, 3SH, 3YV, 3ZW.

**8TY, JAMESTOWN, N. Y., Aug. 1 to 21.**  
1AS, 1AW, 2AJW, 2BG, 2BK, 2CT, 2EL, 2JZ, 2NF, 2QR, 2UE, 3BZ, 3EN, 3FR, 3HG, 3HJ, (V. 2SA), 3NO, 3VV, 3ACN, 3ALJ, 3BP, 3EV, 3CI, 3CV, 3DA, 3EN, 3FL, 3GB, 3GS, 3IK, 3IN, 3JU, 3LA, 3LX, 3ML, 3MT, 3NI, 3QM, 3BQ, 3SH, 3WY, 3XK, 3YV, 3ZW, 9ZN, NSF.

**9ZY, LA CROSSE, WISC., July 10 to Aug. 21.**  
5DW, 5ED, 5YH, 5ZZ, 8BP, 8BV, 8CF, 8DI, 8ER, 8FI, 8KV, 8XK, 8YV, 8ZY, 9AB, 9AU, 9AEK, 9AEH, 9AEQ, 9BW, 9CA, 9CS, 9EL, 9FS, 9GN, 9HR, 9KI, 9KO, 9LC, 9LR, 9NQ, 9OR, 9PB, 9PN, 9VR, 9ZC, 9ZJ, 9ZL, 9ZN, 9ZT, 9ZW, 9ZX.

**9AEU, DAVID CITY, NEBR., June 16 to Aug. 19.**  
5AL, 5AO, 5BT, 5CD, (5YH), 5ZL, 5ZP, 5ZV, 3CF, 3DC, 3ER, 3GB, 3IK, 3RB, 3AT, 3AU, 3BR, 3CA, (3EL), 3EW, (3FP), (3HT), (3IF), (3KO), (3LR), 3NQ, 3OX, 3QJ, 3QM, 3RY, 3SC, 3SY, 3VE, (3WI), 3YD, 3YO, 3YP, 3ZN, (3AEG), (3AEQ), (3AFX), 3AJN, 3AJS, 3AJX, 3AJY, 3ALO, (3ANF).

**2DX, SUMMIT, N. J.**  
1AW, 1BH, 1DN, 1JN, 1LY, 1QN, 1TS, 1HAA, 1RZ, 1GY, 1OA, 1BBL, 1CCL, 1CK, 1DA, 2CG, 2QR, 2ADJ (fone), 3HJ, 3BB, 3EW, 3BE, 3CK, 3CV, 3ZA, 3ZS, 3MS, 3LZ, 3LY, 3EN, 3HG, 3KM, 3AU, 3BO, 3DA, 3DW, 3ER, 3EN, 3GB, 3HF, 3MT, 3NS, 3WG, 3WY, 3XK, 9ZN.

## Oscillation Transformers

TELEFUNKEN PANCAKE TYPE

Double "A" Quality.

Bulletin C-105 on Request

### Radio Equipment Company

1525 N. Fawn Street, PHILADELPHIA, PA.

