

# QUEST

Devoted Exclusively to  
**CITIZEN RADIO**  
Published by the  
**AMERICAN RADIO RELAY LEAGUE**

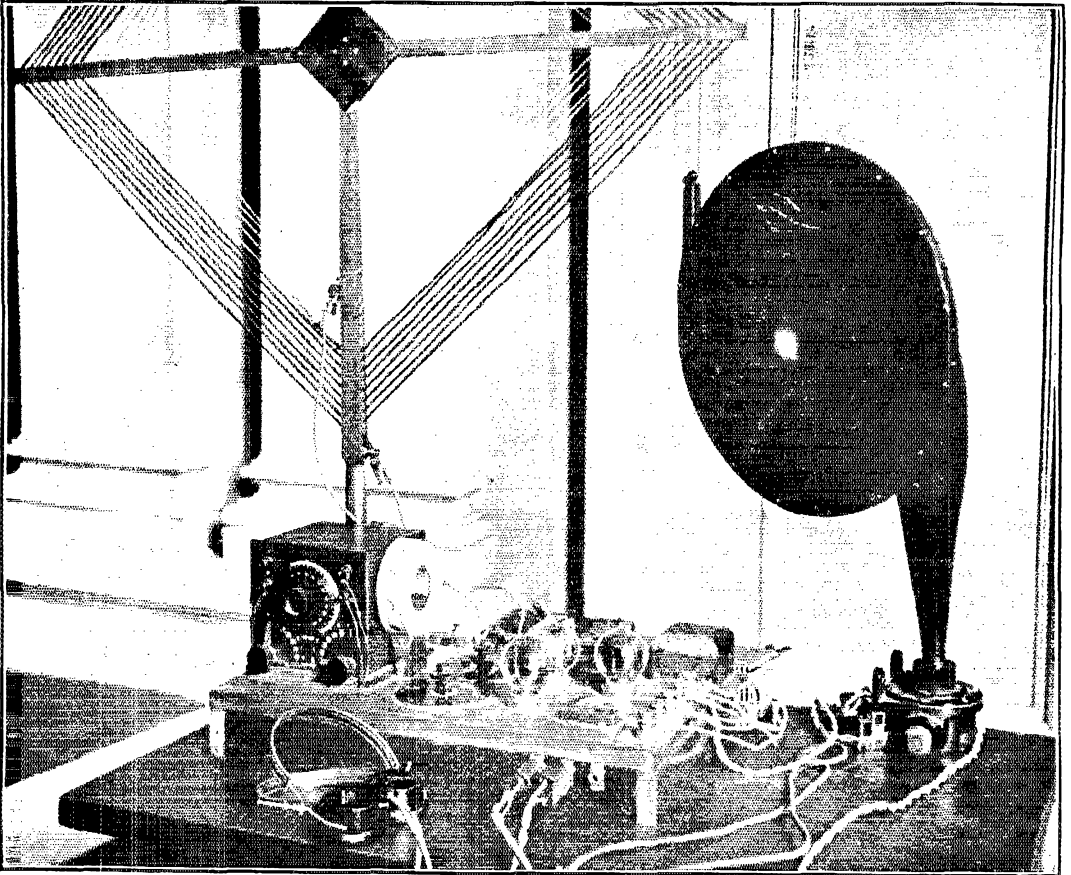

The Armstrong Super-Regenerator—This Issue.

**AUGUST '22**

**20¢**



Medal and  
Diploma  
received at  
World's  
Columbian  
Exposition,  
Chicago, 1893



TRADE  
**ELECTROSE**  
MARK  
REG. U.S. PAT. OFF. & FOREIGN COUNTRIES  
INSULATION  
MADE IN AMERICA  
Louis Steinberger's Patents



Medal and  
Diploma  
received at  
World's  
Fair,  
St. Louis,  
1904



**ELECTROSE**

ADJUSTABLE  
AIR-GAP ARC INSULATORS  
Radio Frequencies Radio Telegraph  
Radio Telephony X-Ray Apparatus  
Damped or Sustained Voltages

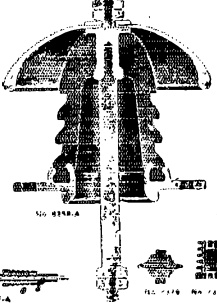

"ELECTROSE" is made in a number of grades for various requirements, each grade possessing special characteristics.  
Insulators and insulating parts and devices of special sizes and forms, designed and made to order.  
SOLE MANUFACTURERS

**ELECTROSE MFG. CO.**

60-82 Washington St. 27-37 York St.  
66-67 Front St. 1-23 Flint St.  
Brooklyn, N. Y., America

# RAC-3 AUDION

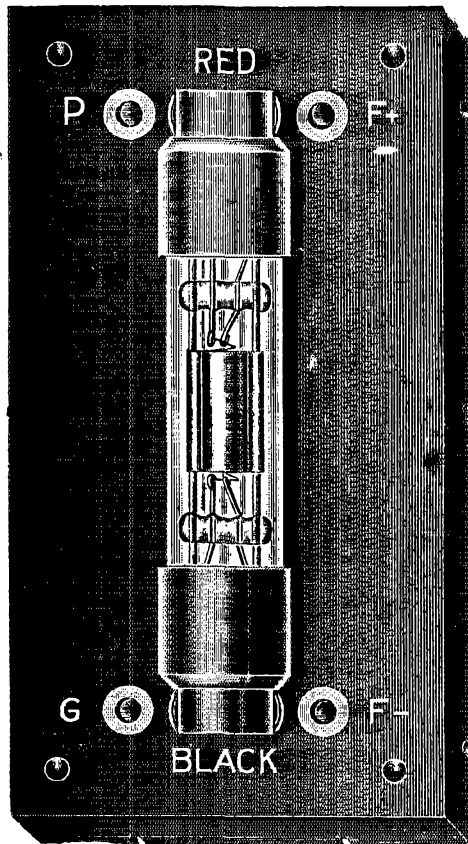

Price  
AUDION  
and  
Receptacle  
\$4.50

AUDION  
FREQUENCY  
AMPLIFIER  
  
RADIO  
FREQUENCY  
AMPLIFIER  
  
AUDION  
OSCILLATOR

Full Size

## FIRST UNIVERSAL AUDION

Manufactured under DeForest Patents No. 841,887 and No. 879,582

# Radio Audion Company

90 Oakland Avenue,

Jersey City, New Jersey

RAC-3 Audions are interchangeable without necessitating critical readjustments.

RAC-3 Audions are not critical to A or B battery adjustments.

Low battery consumption. Filament current 0.8 amp. at 4 volts, maximum. Plate voltage 2 to 22 volts.

Clear signals and great sensitiveness on long distance reception.

Perfect oscillation for use in regenerative circuits.

Small size. Rigid construction. Non-microphonic. No tube noises due to mechanical vibration.

Maximum insulation between filament plate and grid terminals resulting from new type of tube and receptacle.

Maximum direct mechanical contact between audion leads and receptacle clips.

Audion base caps and Receptacle block moulded Grade A Condensite.

Receptacle block is designed to permit built-up panel construction for amplifier panel. Circuit connections may be made from front, back or sides.

### NOTICE

This tube is not sold or purchased to be used as a detector of wireless waves. Any use or sale of it for such use renders the vendor or user liable to prosecution for infringement of patent. This tube is sold for use in tandem with another device acting as a detector for the purpose of amplifying either radio or audio frequency currents or as a generator of high frequency electrical oscillations.

After November 7th, 1922 the RAC-3 Audion will be available as a Detector and no longer limited for use in tandem with another device as a detector.

ALWAYS MENTION QST WHEN WRITING TO ADVERTISERS

# Condensite

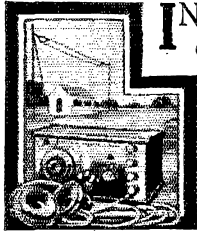

**I**NSULATION is rarely subjected to more trying conditions than in radio. The high potentials used in sending, the varying climatic conditions, from the cold of the arctic to the heat of the equator, from the dryness of the desert to the saturated air of the tropics; the rough usage encountered at the hands of the unskilled, the remoteness from means of repair and replacement; all these and numberless other trying conditions make it imperative that for radio work the best insulation should always be used.

Condensite is the name of the insulation which will withstand these conditions, and which possesses all the properties essential to radio insulation.

Upon request we will send the list of radio manufacturers who make their equipment of Condensite.

*Condensite Company of America*

Bloomfield, N. J.



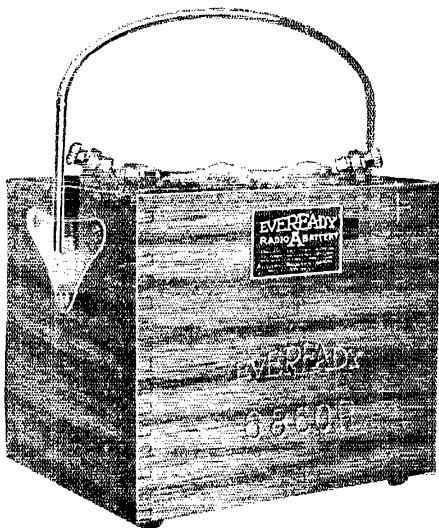

**Eveready "A" Batteries**  
 —hardwood box, mahogany finish  
 —convenient handle, nickel plated  
 —rubber feet protect the table  
 —insulated top prevents short circuits  
 —packed vent caps prevent spilling

No. 6860—90 Amp. Hrs.—45 Lbs.—\$18.00  
 No. 6880—110 Amp. Hrs.—52 Lbs.—\$20.00

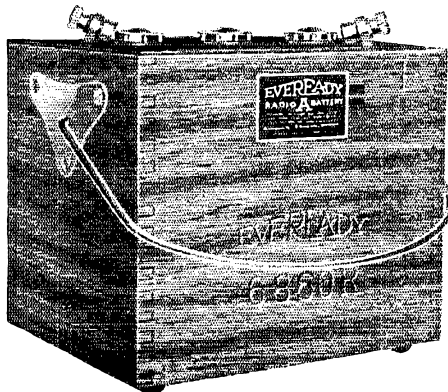

**Eveready "B" Battery No. 766**  
 Equipped with 5 positive voltage taps ranging from 16½ to 22½ volts. Fahnestock Spring Clip Binding Posts—an exclusive Eveready feature. Price \$3.00

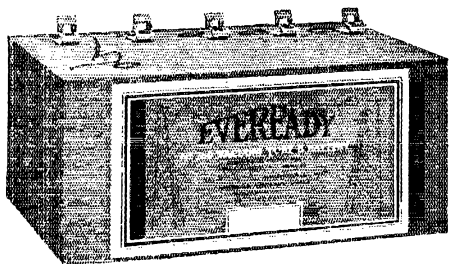

**Eveready "B" Battery No. 774**  
 Equipped with 6 positive voltage taps at 4½ volt intervals ranging from 18 to 43 volts. Fahnestock Spring Clip Binding Posts—an exclusive Eveready feature. Price \$5.00

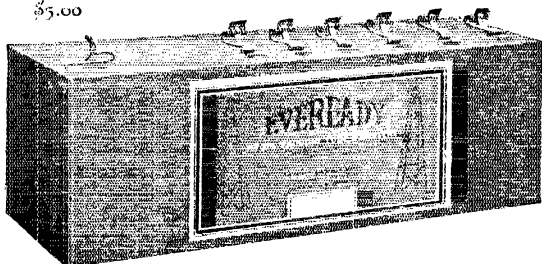

**For Better Results  
 USE**

**EVEREADY**

**"A" and "B" BATTERIES**  
*with your radio set*

For sale by the better radio supply dealers everywhere

Send today for descriptive booklets

**NATIONAL CARBON COMPANY, Inc.**  
 Long Island City, N. Y.

Atlanta Chicago Cleveland  
 Kansas City San Francisco

# ATWATER KENT RADIO APPARATUS

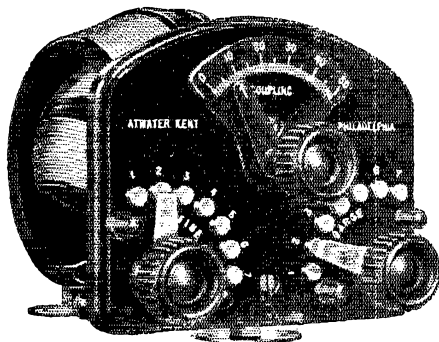

Variocoupler With Panel

A UNIQUE design developed in the Atwater Kent Radio laboratories and manufactured complete in this plant.

The unusual design and finish of this unit will appeal to every radio enthusiast who appreciates quality. New units are constantly being added to the Atwater Kent line.

Before buying new stock, write for latest literature.

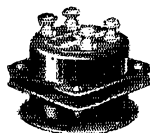

TRANSFORMER

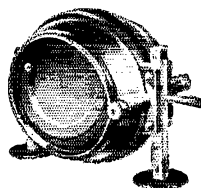

VARIOMETER



RHEOSTAT

ATWATER KENT MANUFACTURING COMPANY  
4945 Stenton Avenue      Radio Department      Philadelphia, Pa.

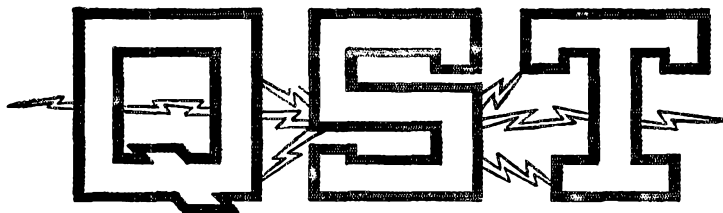

# The Official Organ of the A.R.R.L.

VOLUME VI

AUGUST, 1922

No. 1

This Month's Cover—The Armstrong Super-Regenerator.	Photo copyright by Ewing Galloway, N. Y. <i>K. B. Warner and Boyd Phelps</i>	7
More on Super-Regeneration		7
An Amplifier Howl		"LQ" 10
The S-Tube Rectifier	<i>Howard J. Tyzzer</i>	11
"Amateur Interference"	"BG" of 2FZ	13
Wave Traps	<i>Boyd Phelps</i>	15
Operation of the Low Power C.W. Transmitter	<i>A. M. Young</i>	16
Coils for C.W. Reception	<i>A. L. Groves</i>	18
The Application of Measuring Instruments to Radio	<i>John H. Miller</i>	20
"Un Poste Amateur SAB"	<i>Lloyd Jacquet</i>	22
Book Review		23
A Single Circuit Receiver	<i>L. W. Austin</i>	24
New Apparatus		24
Editorials		27
The Operating Department		30
International Amateur Radio		39
With Our Radiophone Listeners		41
With the Affiliated Clubs		45
Who's Who in Amateur Wireless— <i>Clyde E. Darr, Harvey Mitchell Anthony</i>		48
Calls Heard		49
"Strays"		55
Radio Communications by the Amateurs		57
Classified Advertisements		116
Index of Advertisers		119

QST is published monthly by The American Radio Relay League, Inc., at Hartford, Conn. Kenneth B. Warner (Secretary, A.R.R.L.), Editor and Business Manager. Edwin C. Adams, Advertising Manager.

Subscription price in United States, Possessions, and Canada, \$2.00 per year. Foreign \$2.50. Single Copies, 20 cents.

Entered as second-class matter May 29, 1919, at the post office of Hartford, Connecticut, under the Act of March 3, 1879.

Copyright, 1922, by The American Radio Relay League, Inc.

Title registered at United States Patent Office.

THE AMERICAN RADIO RELAY LEAGUE, Inc.  
HARTFORD, CONN

# THE AMERICAN RADIO RELAY LEAGUE

"A national non-commercial organization of radio amateurs, bonded for the more effective relaying of friendly messages between their stations, for legislative protection, for orderly operating, and for the practical improvement of short-wave Radio Communication."

## OFFICERS

*President*  
HIRAM PERCY MAXIM  
Hartford, Conn.

*Vice President*  
CHAS. H. STEWART  
St. David's Pa.

*Traffic Manager*  
F. H. SCHNELL  
1045 Main St.  
Hartford, Conn.

*Treasurer*  
A. A. HEBERT  
Nutley, N. J.  
*Secretary*  
K. B. WARNER  
Hartford, Conn.

## DIRECTORS

H. M. ANTHONY  
Muncie, Ind.

H. A. BEALE, Jr.  
Parksburg, Pa.

A. E. BESSEY  
Sunnyvale, Calif.

V. F. CAMP  
Brightwaters, L. I.

F. M. CORLETT  
Dallas, Tex.

C. E. DARR  
Detroit, Mich.

W. C. C. DUNCAN  
Toronto, Ontario

A. A. HEBERT  
Nutley, N. J.

F. A. HILL  
Savannah, Ga.

DR. A. E. KENNELLY  
Cambridge, Mass.

S. KRUSE  
Cambridge, Mass.

H. P. MAXIM  
Hartford, Conn.

F. H. SCHNELL  
Hartford, Conn.

C. A. SERVICE, Jr.  
Hartford, Conn.

C. H. STEWART  
St. David's Pa.

K. B. WARNER  
Hartford, Conn.

M. B. WEST  
Waukegan, Ills.

## OPERATING DEPARTMENT

ATLANTIC DIVISION  
Manager  
Chas. H. Stewart  
St. David's, Pa.  
Asst. Mgr., Northern Sec.  
C. J. Goette

1624 Hamilton Ave.  
Woodhaven, L. I.

Asst. Mgr., Southern Sec.  
Edw. B. Duvall  
3909 Cottage Ave.,  
Baltimore, Md.

EAST GULF DIVISION  
Manager

B. W. Benning  
50 Whiteford St.,  
Atlanta, Ga.

Assistant Manager  
W. B. Pope  
197 Dearing St.,  
Athens, Ga.

CENTRAL DIVISION  
Manager

R. H. G. Mathews  
332 S. Michigan Ave.,  
Chicago

Assistant Manager  
L. A. Pease  
2256 W. 24th St.  
Chicago

ALASKAN DIVISION  
Manager

Koy Anderson, 71T  
P. O. Box 206  
Ketchikan, Alaska

WEST GULF DIVISION  
Manager

Frank M. Corlett  
1101 East Eighth St.,  
Dallas, Tex.

PACIFIC DIVISION  
Manager

J. Vance Wise  
Walnut Grove, Cal.

QUEBEC DIVISION  
Manager

Albert J. Lorimer  
Farnham, Que.

ONTARIO DIVISION  
Manager

A. H. Keith Russell  
11 Pinewood Ave.,  
Toronto, Ont.

DAKOTA DIVISION  
Manager

N. H. Jensen  
Box 894, Sioux Falls, So. Dak.

NEW ENGLAND DIVISION  
Manager

Philip F. Robinson  
149 Hollis Ave.,  
Braintree, Mass.

MARITIME DIVISION  
K. S. Rogers

Prince Edward Island

ROANOKE DIVISION  
Manager

W. T. Gravely  
854 Main St.,  
Danville, Va.

DELTA DIVISION  
Manager

John M. Clayton  
1301 Welch St.,  
Little Rock, Ark.

Assistant Manager  
Hubert E. deHen  
1044 City Park Ave.,  
New Orleans

WINNIPEG DIVISION  
Acting Manager

J. H. Gjelhaug  
Baudette, Minn.

ROCKY MOUNTAIN DIV.  
Manager

M. S. Andelin  
Richfield, Utah.

MIDWEST DIVISION  
Manager

L. A. Benson  
4942 Wiesehan Ave.,  
St. Louis.

NORTHWESTERN DIV.  
Manager

Howard F. Mason  
3335 33d Ave., So.,  
Seattle, Wash.

## ADVISORY TECHNICAL COMMITTEE

C. S. BALLANTINE  
WM. C. BALLARD, Jr.  
LEROY M. E. GLAUSING  
FRANK CONRAD  
LEO C. YOUNG

MINTON CRONKHITE  
J. H. DELLINGER  
C. L. FARRAND  
PAUL F. GODLEY  
F. C. BLAKE

L. A. HAZELTINE  
C. D. TUSKA  
R. H. G. MATHEWS  
J. O. SMITH  
S. KRUSE

Address General Correspondence to Executive Headquarters, Hartford, Conn.

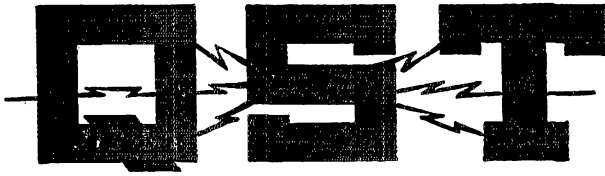

A Magazine Devoted Exclusively to the Radio Amateur

## More on Super-Regeneration

By K. B. Warner and Boyd Phelps

ON June 28th Mr. E. H. Armstrong delivered another address on his latest invention before a meeting of the Radio Club of America which packed and overflowed from the lecture hall at Columbia University, New York City. A crowd hungrier for information we never saw. Every square foot of space was occupied by a radio ham of some sort endowed with a worried look, flapping ears, a craning neck and a pencil and paper. They simply ate up every word Mr. Armstrong uttered and watched in rapt admiration as he demonstrated his latest development.

His talk was based mainly on his original paper before the I. R. E. which was reviewed in the last *QST*, but it was simplified and some purely theoretical discussions omitted and some actual wiring diagrams and circuit constants supplied for the practical amateur. We will not consume space in reporting that part of his lecture which duplicated his I. R. E. paper, and the reader is referred to the article on "Super-Regeneration" in our issue for July. We will confine ourselves in the present article to the presentation of what new information we gleaned from the second address.

The recommended "variation frequency" is now a little clearer: for phone and I.C.W.

it should be practically above audibility, say 12,000 to 15,000 cycles; for spark, the same, if the natural note is to be preserved, or an audio frequency may be used with increase in strength if one does not mind having the tone changed into a peculiar hard twang; and for C.W. telegraphy

it may be either a super-audible frequency used in connection with a separate heterodyne for beat reception or the variation frequency itself may be audible, say 500 to 1000 cycles, thereby modulating the incoming C.W. but giving every signal exactly the same tone, which is hardly feasible where normal QRM prevails.

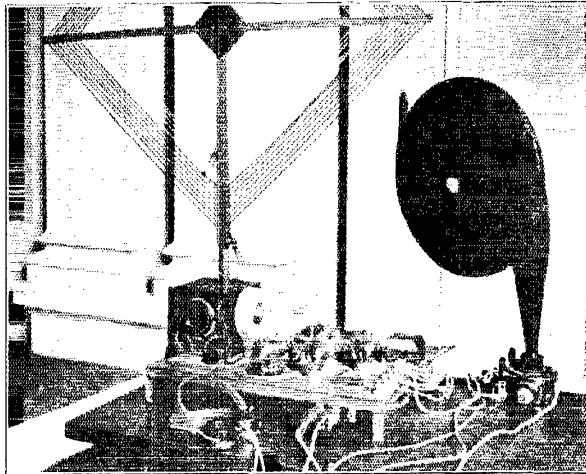

Major Armstrong presented the diagram shown in Fig. 1 of our last article and discussed it briefly, recommending big air-core inductances of about 2 henries as preferable to iron-core windings for the audio oscillator. Now a large part of the attendance at this meeting was made up of broadcast listeners and it seemed that the greatest interest of the evening attached to the arrangement that worked best for telephony. Accordingly the diagram of Fig. 2 of our last article was shown as a circuit more suited for phone reception. This is the scheme wherein the first tube is both the regenerative amplifier and the detector, with the phones in its output cir-

cuit, while coupled to it is the super-audible oscillator which produces a variation of the positive resistance of the first tube. The speaker pointed out, however, that better results could be had by performing the detection in the second tube or oscillator, which led him to our Fig. 4 of last month, wherein the phones are in the plate circuit of the oscillator. This is the circuit of the future, Mr. Armstrong said, altho this diagram shows only the fundamental parts and some auxiliary apparatus is necessary to make it a practical device. The practical circuit shown in the diagram herewith is the result, and is an outgrowth of Fig. 4 of our July article.

This is a two-tube circuit plus an extra amplifier, the first tube being the regenerative amplifier, the second acting both as oscillator and as detector, and the third as an ordinary audio amplifier. It is this

cy circuits out of resonance with the incoming wave. As the radio circuits of valve R offer considerable impedance to the super-audible oscillations of valve O, a rather considerable power is necessary in the latter, and both R and O were 5-watt Western Electric power tubes with 90 volts on their plates.

Now if no audio-frequency amplifier is to be used, the phones may be connected across the fixed .005-mfd. condenser in the output circuit of the second tube. The amount of energy developed by the oscillator at the variation frequency, however, is sufficient to completely paralyze an audio amplifier if impressed on its grid, and a low-pass filter is necessary between the detector-oscillator and the amplifier to keep out the 12,000-cycle component and yet pass the signal frequency. Any form of such filter is satisfactory, the arrangement

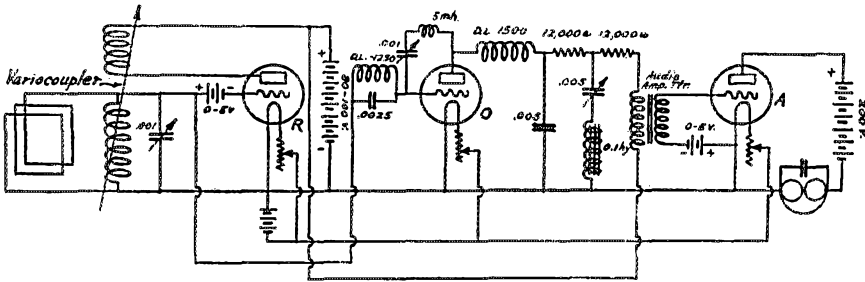

set which is shown in our photograph. Note the collector loop, which has a dozen turns 3 ft. square. The vario-coupler was provided so that the plate circuit might be back-coupled for regeneration by means of the tickler, and was an ordinary Grebe coupler with the rotor wound with double the usual number of turns for the tickler. Except for the lead running to the input circuit of the oscillator tube O, this first tube R is seen to be the familiar regenerative arrangement. The oscillator is tuned in both circuits to a super-audible frequency and to attain this has a 1250-turn duo-lateral coil shunted by a mica condenser of .0025 mfd. in its grid circuit, and a DL-1500 in its plate circuit. The two duo-laterals are not electromagnetically coupled but, instead, the two circuits are statically coupled by means of the condenser C, a variable of .001 mfd. maximum, having in series with it a small inductance of 5 millihenries. This is a choke-coil and should be located close to the condenser C, which controls the amplitude of oscillations generated in the valve O. The small choke coil has little effect on the feed-back at the variation frequency but serves primarily to keep changes in the feed-back condenser from throwing the radio frequen-

cy circuits out of resonance with the incoming wave. As the radio circuits of valve R offer considerable impedance to the super-audible oscillations of valve O, a rather considerable power is necessary in the latter, and both R and O were 5-watt Western Electric power tubes with 90 volts on their plates. Now if no audio-frequency amplifier is to be used, the phones may be connected across the fixed .005-mfd. condenser in the output circuit of the second tube. The amount of energy developed by the oscillator at the variation frequency, however, is sufficient to completely paralyze an audio amplifier if impressed on its grid, and a low-pass filter is necessary between the detector-oscillator and the amplifier to keep out the 12,000-cycle component and yet pass the signal frequency. Any form of such filter is satisfactory, the arrangement

shown in the diagram consisting of two 12,000-ohm Lavite resistances, an air variable of .005-mfd. maximum and an iron-cored inductance of 0.1 henry being merely a make-shift built up of pieces of equipment Mr. Armstrong had at hand. The variable condenser is tuned to eliminate the variation frequency in the amplifier by providing a shunt path across the primary of the amplifying transformer of low impedance at the frequency to which it is tuned. The amplifier valve was a Western Electric telephone repeater with 200 volts on its plate. An *additional* 200 volts is not essential; it might as well be supplied from an additional 110 volts and then connected to the same 90-volt battery that supplies the other tubes.

Hard tubes were used exclusively, it being impossible to maintain a stable adjustment with soft tubes. The grid of the first tube had a negative bias of 3 volts; this was merely to make the operation occur on the proper part of the characteristic curve and might as well have been attained by tapping off a different plate voltage for that tube, if any more convenient.

On test, this set picked up vocal selections from WJZ on its small loop and de-

livered them very QSA thru a loud-speaker connected in place of the phones. We had no idea of the amount of energy present, however, until Mr. Armstrong plugged in the phones instead of the horn. It almost tore up the phones; they clicked and rattled and the diaframs hammered on the magnets so hard that it sounded like a Western Union sounder instead of a lady doing her best to sing.

We found ourselves regretting that Mr. Armstrong was confining himself chiefly to a circuit best adapted to phone reception. He had another set-up ready for demonstration, embodying his "Case 3" where both the positive and negative resistances are varied simultaneously, and this was the arrangement which he had previously recommended as giving the best results in the hands of a patient amateur.

This is the scheme of Fig. 3 of our July article, wherein the first tube not only is the regenerative amplifier but has a second feed-back coupling whereby it generates its own variation frequency, and the second tube is the detector. This set was demonstrated, and proved a whizz. It seems to us that it's the set for us amateurs. It is simpler to arrange as far as apparatus is concerned, and the mind of a ham will immediately turn to the ease with which an old honeycomb-foil mounting can be worked in to provide for the variation-frequency coupling, using coils for the super-audible frequencies and plugging in small iron-cored transformers or big condensers across big honeycomb coils when the audible frequencies are to be used—a most versatile circuit, one which can be changed easily for any frequency, involves both kinds of variation, and is designated by Mr. Armstrong as the one which gives by far the best results. In fact, if the variation frequency is above audibility the separate detector is unnecessary—the phones can be placed in the circuit of the first tube. The arrangement is then reduced to a single-tube affair but equal. Mr. Armstrong stated, to a 6-tube super-heterodyne.

First it was demonstrated with two tubes, the variation being at audio frequency. The signals were estimated as representing an energy between 100,000 and 1,000,000 times that evident from the same signal in an ordinary regenerative detector and two-step audio amplifier. Then the detector was disconnected and all the functions performed on one tube, a phonograph record

from WJZ being audible all over the hall. A weak, high-pitched squeal was audible, presumably being the variation frequency, well within the limits of audibility. A second tube was then added, as an audio frequency amplifier of the detected signal, and the racket was very QSA. The phones were connected instead of the loud speaker, to give an idea of "what was there," and honestly it was a crime to put that much stuff into a pair of cans—it was enough to ruin them and to us seemed quite as loud as the other set had been with its three tubes. This we took as evidence of the correctness of the dope that the lower the frequency of the variation the greater the regenerative amplification and that audibility is sacrificed for quality in the super-audible variation employed for phone reception in the set illustrated in our drawings this month.

We regret that we have no constructional data respecting this two-tube set of July's Fig. 3 which worked so well for Mr. Armstrong, yet there seems but little needed. It appears to us as being the best yet for us telegraphing amateurs. And for C.W. telegraphy it seems to us that instead of using a super-audible frequency and a separate heterodyne we might use some moderately high-pitched frequency, say around 5,000 cycles, giving the immensely greater amplification that the lower frequency provides, and still heterodyne it separately with

the selectivity provided thereby and the ability to read different C.W. signals with different notes.

Mr. Armstrong does not recommend the use of the super-regenerator on an aerial. He says that signals will be as loud on a loop as on an antenna, as in any event they build up towards infinity and are limited only by the tube characteristics. Use on an antenna furthermore is inadvisable because when improperly adjusted the set radiates very strongly.

We mentioned last month that we thought the super-regenerator was a first-power amplifier. It seems it is even better than that. Ordinary radio amplification falls off rapidly as the wave length shortens, and the big advantage of the super-heterodyne is that it maintains constant amplification regardless of the shortness of wave. But the super-regenerator amplifies *inversely* as the *square* of the wave length and works better the shorter the wave length, for example giving 16 times the response on 50 meters that it will on 200 meters, and is essentially a short

## Watch Next QST

for an announcement that will interest you immensely and give you an opportunity you have long awaited. Don't fail to read this—in our September issue.

wave device. In fact its upper limit of efficient action is about a thousand meters.

Now at first glance the diagram looks complicated but the operation is much simpler than might be supposed. The oscillator after once being adjusted requires no changes over a considerable band of wave lengths so the variable condensers in the middle portion of the diagram play no part in tuning in the DX station. In fact, after their correct capacity has been determined, equivalent fixed condensers may be substituted. The secret of best operation is to learn the meaning of certain sounds which indicate a poor adjustment in a part of the circuit. These indications are indescribable but, according to Mr. Armstrong, when "gotten onto," make the operation of a super-regenerative set as easy as the ordinary regenerative circuit with which we are all familiar.

### A Contest for QST Readers Who Build Their Own

Now, fellows, we want some dope on super-regeneration from *you!* Mr. Armstrong says he has done practically nothing with it in the reception of DX telegraphy and in fact hardly knows just what system to recommend for that. We know several amateurs who have been experimenting with various of the hook-ups for some days at this writing and the results have been far from satisfactory. Yet we *know* it will work, because we have seen it and heard it.

Every amateur in the country will be interested in the new method and thousands of A.R.R.L. members will be starting their experiments immediately. A most interesting field of possibilities is spread before us: using variometers in plate tuning instead of tickler couplings, buzzers or choppers to furnish the audio variation frequency instead of an audio-oscillating audion, adaptation to Reinartz tuner arrangements to simplify tuning and regeneration—no end. So QST hereby announces a contest for articles on the subject, and will give prizes totaling \$100 for the best ones, as follows:

First Prize.....	\$50.00
Second Price.....	\$25.00
Third Prize.....	\$15.00
Fourth Prize.....	\$10.00

We're going to make the rules very simple, as it is results we are after.

1. The idea is to secure practical articles on super-regeneration, for publication in QST. For this purpose we will receive manuscripts up to noon of Oct. 1, 1922, addressed to QST at Hartford,

Conn., and a committee of judges consisting of Messrs. C. A. Service, Jr., Boyd Phelps, and K. B. Warner, of the QST staff, will determine the winners and make the announcement in QST for November, at which time the prizes will be paid.

2. Manuscripts must describe a practical adaptation of the principle of super-regeneration to the use of the practical telegraphing relaying amateur, for the receipt of both spark and C.W. telegraph signals. Good phone reception is not especially sought. The manuscript must contain detailed constructional data for the building of a successful set, of the successful working of which in DX amateur work evidence must be produced. The manuscript must be typewritten or in legible handwriting, with circuit diagrams on separate sheets, and must be accompanied by good clear photographs showing actual arrangement, etc. All manuscripts submitted shall become the property of QST. That sounds easy, doesn't it? You're going to try it anyway, for your own information, and because it's something great that you can't afford to miss, and here's a chance to pick up a substantial prize at the same time by telling QST about it for the rest of our A.R.R.L. gang. Give it a whirl, fellows, and let's have your articles in hand by the first of October sure. Good luck!

## An Amplifier Howl

By "LQ"

**J**UST after winding the alarm clock I made the mistake of tuning on the filaments for a nightcap "listen in".

Some bird was just saying "I get you all over the room with this 3 step amplifier."

Oh shux! Isn't that a fine thing to run into after a hard day?

Here was 3NUT bragging because he could copy 3XYZ, who is ten miles from him and has been heard 'way out in the Pacific Ocean. Most anyone could copy 3XYZ's "ether buster" at that distance with a detector made of a rusty darning needle and a piece of Lehigh coal.

On second that that is not correct; 3NUT could not do it and none of his kind could do it either. They never hear anything that comes in at less than 5,000 audibility. Also I have implied that 3NUT was *copying* the signals. That was wrong; his tribe simply sit before the apparatus all evening listening to the local stuff bellow and roar and make no use of the key at all save to brag about the infernal racket the receiver is making.

(Concluded on page 15)



# The S-Tube Rectifier

A Paper Presented by *Howard J. Tyzzer\** at meeting of Radio Club of America, Columbia University, March 31, 1922

THE various tubes about to be described make use of gaseous conduction. Due perhaps to the somewhat limited knowledge concerning this type of conduction, gaseous tubes have often been considered unreliable and inconsistent. However, our knowledge of the electron theory in its present state of completeness enables us to predict and account for many of the phenomena which have proved baffling heretofore.

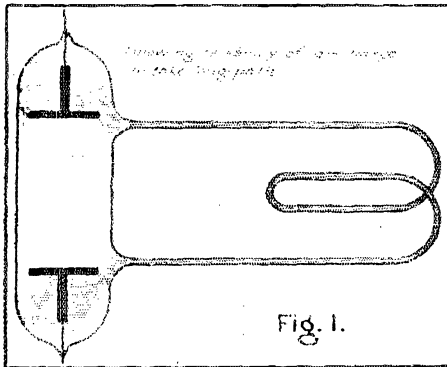

One of these phenomena, or perhaps it might better be called a principle of gaseous conduction, is responsible for a new group of useful devices. Mr. C. G. Smith, who has investigated this principle and invented the devices resulting from it, has termed it the "Short Path Principle".

If two electrodes are placed in a tube of gas at fairly low pressure and connected to a source of moderately high voltage, there will be a current discharge between them. Seemingly strange to relate, the bulk of the discharge tends to follow a long path as from the sides and backs of the electrodes rather than the shorter path lying directly between them. (Fig. 1). An analysis of this conduction, based on the electron theory, offers an explanation for this.

Pure gaseous conduction is a result of bombardment of the gas atoms by the free electrons in the gas. In other words in any gas there are a few free electrons which are not associated with any particular atom. When an electric field is applied to the gas, these free electrons are attracted

by the positive electrode; and if their path is uninterrupted, they travel toward it with rapidly increasing velocity. Generally the path of the electron is more or less obstructed, depending upon the gas pressure, as an electron cannot travel any great distance without colliding with an atom. If the electron has attained sufficient velocity, it will disrupt the atom by dislodging from it another electron, thus leaving a positive ion. To have sufficient velocity to ionize, the electron must travel through a certain potential drop or voltage difference. This is known as the "ionizing potential", and is a value which varies with different gases. At atmospheric pressure the atoms in a gas are fairly close together, and an electron cannot travel any great distance without colliding with one of them. Hence for ionization at atmospheric pressure, the potential gradient between electrodes must be steep or the voltage between electrodes must be high to impart, in the short path between atoms, sufficient velocity to the electron to ionize. As the pressure is reduced, the mean free path between atoms is increased, and inasmuch as the free electron can travel through a greater distance without danger of collision, the voltage between electrodes may be correspondingly less for ionization.

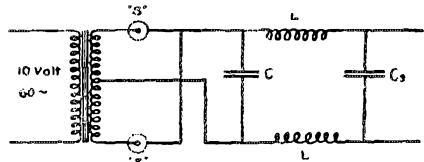

Fig. 2

If the electrodes in a gas at low pressure are placed close together, so that the distance between them is small as compared with the mean free path, it is conceivable that an electron would probably pass through the entire distance between electrodes without encountering an atom. If this is true, there will be no ionization and hence no conduction, providing all the paths are kept short.

A tube was constructed in accordance with this theory, and this was found to be true.

By applying a radial magnetic field, it was found possible to force the electrons to take a longer curved path, collide with

\*Radio Engineer, American Radio & Research Corp.

atoms, ionize them and so cause conduction. The point at which conduction began was quite pronounced; hence the device made a capital relay.

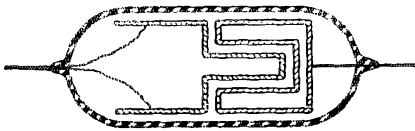

Fig. 3.

By shaping the electrodes as shown in Fig. 3, the magnetic field necessary for conduction when the inside electrode is positive, or the anode, is less than when the outside is made positive. Fig. 4 shows the reason for this; the magnetic field necessary to cause an electron to entirely miss the positive electrode is much less in "A" than in "B". Hence the device rectifies by the application of a permanent magnetic field of proper strength. Fig. 6 shows the tube with the permanent magnet in place. Two collars made of soft iron are used in conjunction with the magnet to obtain even distribution of magnetic flux throughout the active portion of the tube.

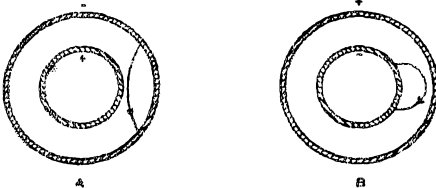

Fig. 4

It was in this tube that a discovery was made which placed gaseous conduction in an entirely different plane. Previous to this time difficulty had been experienced due to gradually diminishing gas pressure, gas being absorbed by the electrodes. This was the only apparent limitation to the life of the tube. Evidently the positive ions approached the negative electrodes with such a high velocity that they embedded themselves below the electrode surface. Here they combined with an electron and became an atom of gas again held in captivity by the cathode. This theory was evolved by Mr. Smith, and in proof of it a tube was constructed in which the cathode, or negative electrode, was molten tin. In this tube the gas pressure remained practically constant over long periods of operation. Provision was made whereby the surface of the molten tin could be observed through a microscope, and tiny bubbles of the collected gas could actually be observed bursting out at the surface of the electrode. Different materials were used in the cathode, and finally it was found that carbon, due presumably to its

porosity, allowed the imprisoned gas to escape, thus keeping the pressure constant. Tubes of this type were operated for several thousand hours continuously without any noticeable change. Although a thoroughly practical proposition in this form, the desirability of eliminating the magnet was apparent, and further research work was conducted with this objective in mind.

As a result of this investigation and

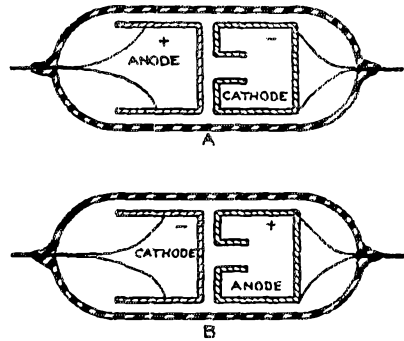

Fig. 5

work, a tube was devised in which the conduction was entirely dependent upon the static field created by the electrodes. A schematic cross-section view of the electrodes is shown in Fig. 5. The anode is just a plain flat electrode as before, but the cathode is cup-shaped with a small tube-like opening, as illustrated. Free electrons are drawn from all parts of the cup through this opening to the anode. In doing so they traverse a long path, collide with

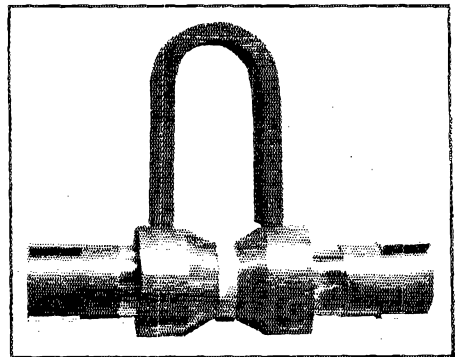

Fig. 6

atoms, and ionize them. The action is cumulative and hence the tube conducts.

When the cup is made positive, the action is quite different. Positive ions in the cup being much larger in bulk are less mobile, and but comparatively few of them wander sluggishly out through the opening to the cathode or negative elec-

trode. In fact the positive ions form a sort of cloud at the end of the tube inside the cup and tend to neutralize the negative static field created by the cathode. The movement of the positive ions is so sluggish and the number which reach the cathode so few that the current conduction is less than one-half of one per cent of the normal current carrying capacity when the polarity is reversed. The device is therefore a perfect rectifier for all practical purposes.

Fig. 8 shows a detailed cross-section of the tube that is being placed on the market. It will be noted that the tube is fitted with a screw base which utilizes the ordinary incandescent lamp socket, thus simplifying installation problems. The cup and active surface of the anode is carbon and the gas used is helium at about 12 mm. pressure. The size of this particular tube is more evident in Fig. 7. It is made for supplying D.C. plate potentials for 5-watt vacuum tubes. They are rated at 20 watts each, normal current being 50 milliamperes.

The tube has a practically constant drop of 150 volts, and will stand 2000 volts in the

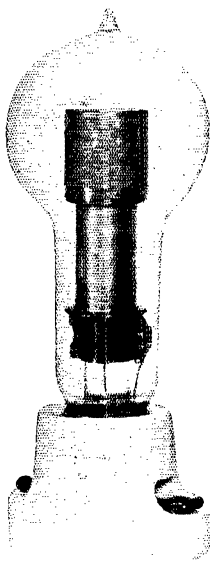

Fig. 7

reverse direction. Fifty milliamperes is a very conservative rating and is based on continuous duty. Two rectifier tubes, one in each side of the line as in Fig. 2, will supply sufficient current for one 50-watt Radiotron. This, of course, is an overload on the tubes and is not recommended except for intermittent use. It is, however, the sort of test that the tubes are subjected to before leaving the factory. Tubes will operate in series for higher voltage and in parallel for higher currents, if a stabilizing resistance is used with each tube. The life of the tube is practically indefinite and can only be terminated by mechanical breakage or subjecting it to several times normal current, thus overheating it.

It has been shown where, by application of the "Short Path Principle", gaseous conduction has been successfully controlled. Moreover it is to be expected that where the controlling energy is less than the energy controlled there are possibilities of an amplifier and oscillator. This is true with the "S" Tube and already laboratory models of amplifiers, oscillators, and even detectors have been constructed so we can see that the rectifier is but a forerunner of many useful devices.

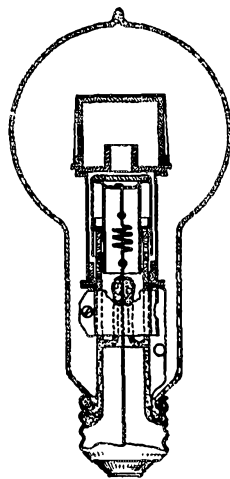

Fig. 8.

## "Amateur Interference"

By "BG" of 2FZ

The following story so exactly illustrates a scene which has been occurring all over the country that we reproduce it from "The Modulator," the Second District's peppy little magazine, with the kind permission of the publishers. Read it carefully, fellows, and watch your chance to do as "BG" did and set the fan listeners right when they make unjust charges of QRM from amateurs.—Ed.

IT'S about time something was done about it. You know what I mean. All this gab about making amateurs stop sending with their buzzing code outfits. Go down to any radio store and listen to a bunch of WJZ hounds discussing the radio situation. Ugggh—here are people who don't know the difference between a vario-coupler and an aerial switch voicing their opinion that amateur transmission should be stopped, absolutely tabooed! Its a goldarned shame, fellows, and I'll tell you

why I think so. For four months I had been answering the questions that came to the Radio Department of the New York ———. During that time it was my sweet lot to answer about 25,000 of them, mebbe more, but that's about right. Can you imagine telling steen million people how far they can hear with their three inch spider web coil and the detector described on April 31st? Or why can't I hear the music in Hoshkosh with my \$3.95 set? Well, man, I was doing that sort of thing

until I couldn't sleep at all—but that's wandering. I want to say that quite a number of letters complained of interference from "amateurs," but in nine cases out of ten the set used was a dinky \$15 crystal outfit or some darnphool single circuit tube set, put out by people who ought to know better. Practically all such letters came from Brooklyn—a certain section of Brooklyn in particular that is not a million miles from Bayridge. There was never a complaint from a man with a decent variometer or honeycomb set. As far as he was concerned, no other station than WJZ existed.

One letter in particular made me boil; that is, it made me boil more than usual. It came from a man living only a short distance from where I do, in the Bronx. That

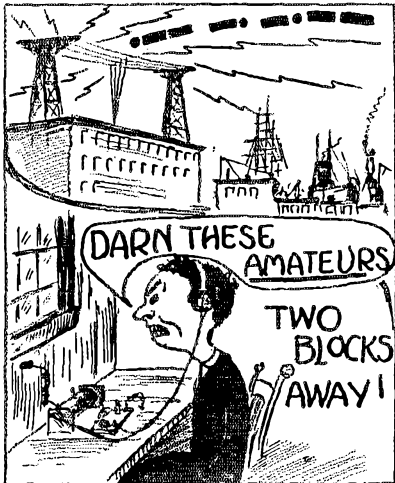

msg certainly was a cuckoo. The fellow wanted to know why in h— amateurs couldn't stay on their legal wave length of 200 meters and how it was they jammed the concerts so, and couldn't the G— advocate the stopping of all amateur buzzing outfits during the evening, etc.? He didn't say what kind of a set he had, but he didn't have to. I always knew. Now here's the funny part. When I got home that night, I found an uncle of mine waiting for me with his flivver. Oh, I had to come right along with him after eating supper. One of his friends had bought a "wireless" (grrrrr), and he was having lots of trouble with it, and I had to go over and see what the matter was. Well, I went, but I requested that my position on the paper be kept a secret. Can you imagine how I felt when the fliv, after a few minutes travel, stopped at a house whose number was the very same as that in the aforementioned letter? I knew what I was in for.

After going through the formalities of

introduction—"My nephew knows something about wireless"—I was ushered into the radio "room." Ye shades of Maxwell and Hertz! A single tapered coil suspended between two one-foot rules for support, a Fada crystal detector—the only decent thing in the place—a fixed condenser, one like you see in pictures of Faraday's lab., and a pair of unknown receivers. The aerial was a single straggly wire coming from gawdnose where, the ground a nearby steampipe. It was high concert time, so Mr. X sat down, jabbed the galena for a minute, and then sprang up, offering me the phones with a sickly smile.

"Listen to those d— amateurs," he bellowed, "why the devil can't they stop sending while the music plays?"

I never moved a muscle in my face, but silently accepted the cans and listened.

"—off astoria now with—"

I pounded the table, and sure enough, the crystal came back, stronger than before. There was silence for a moment, and I heard a snatch of music, but then came the roaring spark again, so loud he could be heard all over the room.

"—KUVS, KUVS, KUVS de KUSM, KUSM r ok will chase bootleggers up westchester creek send police launches. k"

I smiled quietly to myself. Amateurs! The dampfoole. I pretended not to hear what I had already read that day, and while the others were discussing prohibitive legislation against amateurs, I played with the coil switch. Said lever might just as well have been absent. When the cop tub shut up I managed, with the galena, to get WJZ in pretty well, but in about two minutes WNY opens up calling some boat with 6 rush messages. He gets him, and reels off those 6 in one shot. I assure you WNY comes in very well in the Bronx, even on a crystal, and Mr. X was prompted to further vocal explosions and further dissertation on the amateur and his ultimate destination. I surrendered the phones, took a deep breath, and then began my own little lecture on the infernal cussedness of some broadcast listeners. Believe me, bo, I spared no feelings. I had been fed up on all that stuff, and it was a grand chance to say my say. When I got done, Mr. X sheepishly asked me what I thought was a good set. I took him over to friend Matty's, and showed him the real set, the amplifier, and the loud talker. He said not a word.

About a week later, there was another letter from Mr. X. Oh, but how different! He wanted to apologize for what he had said in his previous letter, and that he had never realized what amateur radio was. He invited me—I was still unknown—to come and hear his new set work. I went, and when I told Mr. X who I was, he just sat down in a chair and gasped. Anyway, I saw the set. It certainly was a cuckoo,

but this time of a different genus. A beautiful —, a husky 6-60, and a magnavox. The man certainly spent a lot of money, methinks. When I asked him how the new set was working, he said, "Oh, the piano was worth it."

### AN AMPLIFIER HOWL

(Concluded from page 10)

They refer to this as operating. This howl does not seem to be getting

anywhere in particular but it does give me the chance to ask this question. What possible advantage has a hollow roaring signal of 50,000 audibility when mixed with machine-gun bursts, boiler shop choruses and occasional excellent imitations of a pig under a gate? Why is it not better to have a signal of audibility 15 without orchestral accompaniment?

I suppose it is a matter of taste. Some folks don't care for a meal at home but can enjoy it in a jazz cafe.

## Wave Traps

By Boyd Phelps

THE use of wave or frequency traps is by no means new. They have been used for several years in various ways but curious enough do not seem to be in general use in amateur stations as interference eliminators. In congested radio communities where interference is bad from wave lengths differing more or less from the listening wave due to "forced oscillations", the introduction of a wave trap in the antenna circuit will in most cases completely eliminate the interference. A brief review therefore may not be out of place.

A wave trap is a very simple affair consisting of a coil and a variable condenser in shunt and connected in series with the aerial lead to the receiving set, as shown in the accompanying figure. Its function is to weed out or trap any wave it may be tuned. By taking care to keep the resistance of this circuit low it will not decrease the signal strength of other waves above or below the wave to which the trap is tuned. The size of the coil depends on the waves it is desired to eliminate. For eliminating amateur waves the equivalent of a 35 turn honeycomb coil is about right, while for 360 meters one of 75 turns will do. The variable condenser may be any standard make of rugged construction. A large condenser will enable one trap to cover a wider band of wave lengths than will a small one.

A handy arrangement after preliminary experimenting is thru with is to put the coil and condenser in a small cabinet to match the rest of the set and run the antenna lead thru the trap before entering the receiving set but with a switch to short out the trap when not in use. It is not desirable to put it in the receiving cabinet or to place it in such a position on the table that there will be appreciable coupling between the coil in the trap and the inductances in the tuner.

The operation is very simple. If while listening on 200 meters a local station

should start up on 360 or 375 meters simply open the shorting switch on the wave trap and turn the condenser until the interfering station drops out. Tuning a trap is just the opposite from any other circuit as the signal vanishes at one setting but is heard on all other points of the scale. Unfortunately the introduction of the trap into the antenna circuit changes the wave length of the antenna circuit necessitating retuning

the primary slightly. The trap when once adjusted, however, is not affected by changes in the tuning of the receiving set. An interfering station once cut out by the trap will never be heard again as long as the trap adjustment and transmitting wave remain constant.

It is entirely feasible to use several traps in series to eliminate stations on as many wave lengths. When listening on 360 meters to a concert one trap may

be tuned to eliminate the shorter amateur waves while another may be tuned higher to eliminate commercial interference. Signals from nearby powerful stations that can be heard with the antenna disconnected can not be entirely eliminated with a wave trap unless the receiver is in addition suitably shielded.

The unused half of the condenser dial may be used to mark the call letters of local stations that have been found to interfere so that as soon as the characteristic tone of one of these is heard starting up, the trap may be instantly tuned to the position marked and very little of the message lost that is being copied, whereas it might otherwise be impossible to work thru the interference.

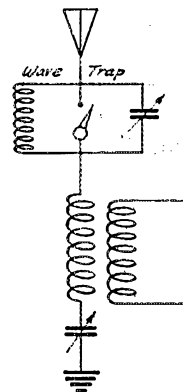

# Operation of the Low Power C. W. Transmitter

By A. M. Young, 3BEC

**D**URING the past year there have been tremendous changes in amateur radio of which the most important to the amateur himself perhaps is the advent of the C.W. transmitter. Old hams and new hams alike have run the gauntlet and have gotten rid of their old spark sets. Every night we hear the piping call of some new C.W. whose owner had at one time a crashing spark. Most of these new-born C.W. sets consist of the so-called 5-watt and 50-watt tubes and it is for the benefit of these aspiring bugs that this article has been written.

## The Antenna

The most important part of the C.W. set is, in my opinion, the antenna system. What is said here about the antenna is gleaned only from my own experience and I do not pretend to understand the mysterious things told by Mr. West in QST. The most important thing about the antenna is to have the center of capacity as high as possible. On the height of the antenna depends the ability of the set to "reach out." I have tried many times lowering or raising the antenna and sending with it that way with the result that, although the antenna current is often lowered by raising the antenna, my signals were reported much more QSA when it was at the greatest height. Another thing is to have the antenna used at the wave length on which it gives the best radiation, that is, oscillating at its natural period, as explained by Mr. West in the April QST. To do this and still keep the wave length at 200 meters, it is often necessary to shorten the antenna somewhat. If the amount that must be cut off is small, it will be found by making cages for antenna and ground leads (if they are more than ten feet long) and so decreasing the inductance at a point where current is the highest, that the fundamental wave length is slightly decreased. Another way to cut-down the natural period is to insert a condenser somewhere in the antenna system, preferably near the center of inductance or the balancing point of the whole. This will be found to have more effect on the wave length.

It should be noted also that, although as a rule high capacity in the antenna is desirable, there must be a limit to this also, since generally it can be secured only at the expense of effective height, which has been shown above to be so desirable; and further because of the decreased electro-

static field by comparison with an antenna of less capacity and greater height.

Also remember that a carefully adjusted and tuned antenna is far more desirable than one that is merely very large.

## The Ground

Perhaps even more important than the antenna is the ground. There are many ways of getting a ground and choice depends mostly on the conditions surrounding the station. A counterpoise is the easiest and most efficient way of getting a good ground, although an earth ground in some places where the soil is particularly moist, can be made so as to be almost as efficient as a counterpoise. A Round's round ground or a symmetrical arrangement of buried plates or wires will be found best. If a counterpoise is used it

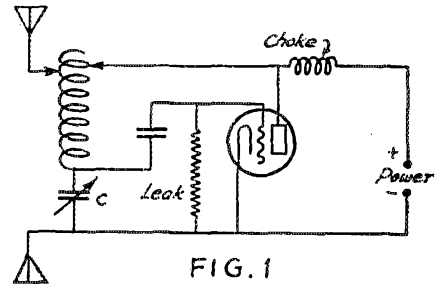

should cover an area equal to or greater than that of the antenna, and should be made in as nearly the same shape as the antenna as possible. The wires should be suspended about 10 feet above the ground and not more.

An ordinary ground tuned to work in conjunction with a counterpoise is desirable. This was originally described in the pages of QST by 2BML. No increase in radiation will be noticed, however, unless the ground used is of reasonably low resistance.

## The Plate Supply

The plates of the oscillator tubes may be supplied through a generator or a transformer. A generator is bulky, noisy, expensive and liable to break down and is therefore not as popular as the simpler, cheaper and more convenient transformer. The simplest way of using a transformer for plate supply is to use it without a rectifier, supplying the tubes with straight A.C. The advantages of this method are that it does not necessitate rectifiers or filters in

any form and that only one winding of the transformer is used. Its disadvantages are that it draws a D. C. load from the transformer that is apt to play tricks with the power factor, and that it causes local QRM which is worse than a spark transmitter due to the broadening of the wave. Furthermore, almost twice the ordinary plate voltage is required to give the normal output on account of the fact that the tube is in operation only during one half of the cycle. Another method of using a transformer is with the so-called "self-rectifier system". This is almost the same as the straight A.C. method except that the tubes are connected up in twos or multiples of two so that one group is in operation while the other is idle. With this method no rectifiers are needed but filters must be used if a pure D.C. output is desired. The best method is to use a large closed-core choke in series with the common lead. At first thought, the self-rectifier system might seem the best of all, but such is not the case as there is a great deal of power loss and inefficiency in the idle tube.

The third and best method of plate supply lies in the use of rectifiers. The cost here is greater than in the methods before mentioned, but when proper filters are used there are many advantages. Not only does it lessen local QRM to a minimum but the signals emitted are of a constant frequency and intensity which enables beat receiving to be used to full efficiency. Electrolytic rectifiers are most used and are cheaper than any other. Articles have appeared in QST many times, so I will not try to say

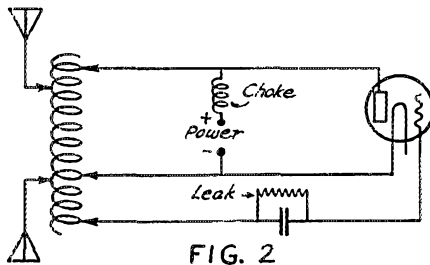

FIG. 2

anything more about them. Tube rectifiers are more expensive but are cleaner and more compact.

**Filters**

A very important thing about plate supply is filters. The owner of the ordinary C.W. telegraph station has an idea that they are not necessary except for phone. This is not true, however. In the first place filters smooth out the plate supply and thereby put less strain on the tubes; secondly, they enable beat reception to be used to its full advantage; and third, they reduce local QRM to a minimum. Consequently, it may be easily seen that filters

are of utmost importance. Rectified A.C. may be filtered in three ways. First of all, we may use a large coil in series with one lead of the plate supply as suggested by the Radio Corporation. The use of a large choke like this will generally cut down the supply voltage and slightly reduce the output and allowance should be made for this drop. Secondly, a large capacity of about 38 microfarads may be used across the supply as suggested by the well-known manufacturer of an electrolytic condenser. Or we may use a combination of the two, as is generally done. When using paper condensers it should be remembered that

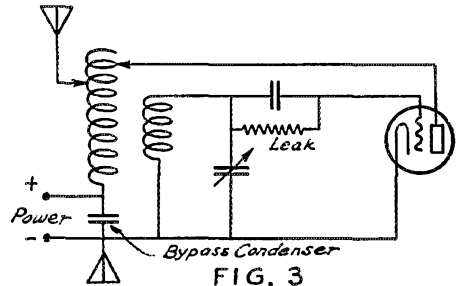

FIG. 3

radio frequency from the oscillator circuit should be kept out of them. To do this, a small choke can be placed in each lead to the condensers.

A very important thing about plate supply which is often overlooked when used with the reversed feedback circuit is the radio frequency by-pass condenser and choke. When series supply is used the condenser should be glass or mica of about .002 mfd. capacity and should be put across the supply so that it forms a part of the oscillating circuit. When parallel supply is used, a radio frequency choke tuned to the working wave must be placed in series with one leg of the supply and a blocking or insulating condenser placed between plate and helix. Were it not for this condenser the supply would be shorted.

**Oscillatory Circuits**

The most discussed part of the C.W. transmitter is the oscillating circuit. Although, to the uninitiated, it might seem that there were a great number of the hookups, there are fundamentally but two. They are the capacity and inductive feedback. Practically all others are but modifications of these. The outstanding capacity feedback circuit is the Colpitts (see Fig. 1). There the parallel plate supply is used and a tuned choke must be in series with one leg of the supply. It should be noted also that the grid leak must be connected between grid and filament in order that the high voltage will not pass through it. C must be of .001 mfd. capacity and must not only be continuously variable but must stand full plate voltage. The Colpitts cir-

cuit is rather undesirable in that it does not tune well below 200 meters and that it gives only about  $\frac{1}{2}$  of the output that the Hartley or 1DH circuit will give.

The Hartley circuit (Fig. 2) is a widely used inductive feedback circuit. The Radio Corporation and the 1DH reversed feedback circuits are modifications of the Hartley circuit. The latter (Fig. 3) is perhaps the most popular of all the circuits in that it is easier to tune, and gives greater antenna

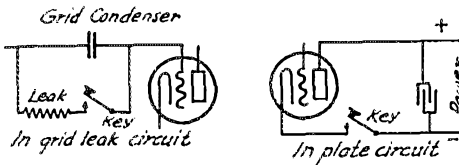

FIG. 4

current than any other. A further advantage is that tuning below 200 meters can be done without decrease.

#### Keying

Keying can be done in many ways, all of which have their disadvantages. However, the following are the most used methods. Keying is done: first, in the antenna circuit; second, in the plate circuit; third, in the primary of the plate transformer when a special transformer for filament lighting is used; fourth, in the grid leak circuit; fifth, by detuning.

Keying in the ground or antenna circuits should always be avoided. This is mainly because, when the key is up, the full plate current is kept on the tubes and in most

cases the circuit stops oscillating, and dead-ly effects result due to the great increase in plate current. Furthermore, there is more current consumed and all the other apparatus, as well as the tubes, heats up quickly. Keying by detuning has the same disadvantages with the added fact that energy is emitted while the key is up. This causes additional QRM and confusion for the receiving operator, and is illegal.

Thus, we are left only the plate and grid leak circuit keying. See Fig. 4. Of these two, the plate circuit keying is the best, but when high voltages are used for plate supply it is almost impossible to break the circuit instantaneously, due to the arc that forms between the key contacts. This can be overcome by the use of a relay, but this is cumbersome and complicates the operation of the set. Keying in the primary of the plate transformer is an ideal method, but in most stations the same transformer is used for filament and plate supply so this method cannot be used.

With grid leak circuit keying all is F. B. except for the fact that, when the key is up, the circuit howls at an audible frequency and makes a confusing backwash for nearby receiving stations. I know no method of eliminating this except by lowering the plate voltage.

In conclusion it might be said that what is true in the case of the spark transmitter is also true in the case of the C.W. transmitter. That is, the only way successful results may be had is: first, by using a low resistance and well proportioned antenna; second, by using efficient apparatus; and third, by careful tuning for maximum efficiency.

## Coils for C. W. Reception

By A. L. Groves, 3B1D

ALL too many amateurs seem to be misled by the natural advantages of C.W. signals and think that because they hear many of them with ordinary instruments it is not worth the trouble or expense to have receiving apparatus especially designed to take advantage of the benefits of C.W. It is my observation that most receiving sets give C.W. signals only half a chance and that they are heard in spite of the tuner rather than because of it.

To my mind variometers sets are undesirable for C.W. reception because in such work they are far from selective and because such signals are hard to pick up and hold on them. Similarly, altho C.W. may be received fairly well on simplified circuits, such arrangements do not give the continuous waves a fair show. My idea of

a receiver which will have special advantages for C.W. is one in which the ratio of the capacity to the inductance in the secondary circuit may be varied at will, where the selectivity afforded by a nice adjustment of the coupling is utilized, where a slight amount of direct inductive feedback may be employed between the plate and secondary circuit in addition to tuning the plate circuit, and wherein the plate circuit is tuned by a shunt condenser across a coil rather than by means of a variometer, and employing the same principles of selective ratio of inductance to capacity in this plate tuning arrangement as in the secondary circuit. A selection of the proper ratio of capacity to inductance in the secondary circuit makes for ease of tuning in C.W. signals and a similar arrangement in the plate circuit makes it much easier



to control the regeneration or oscillation than by means of a variometer wherein it is chiefly the inductance which is varied. Altho of course excessive capacity across the secondary reduces signal strength somewhat, our old theory to the effect that any capacity is undesirable must be revised, as I venture to say that in actual practice a certain amount of capacity is really beneficial to signal strength and certainly makes for selectivity in tuning.

In an article in QST for January 1922, I described a set embodying these principles and in this article I wish to give some additional specification for the construction of the single-layered coils for short waves which are particularly desirable in such a set. I have since constructed another set for myself on a panel a little larger so as to include an additional 43 plate condenser for a long wave secondary and a two point switch for changing to either condenser as desired, which set with honeycomb coils on the long waves will cover up to about 25,000 meters and yet not reduce the efficiency on the short waves in the least.

The reader is referred to the article described on page 9 of January QST entitled "Some Ideas on Short Wave C.W. Reception" for details concerning the actual set. The purpose of this article is to present my latest views on coils for use there-in.

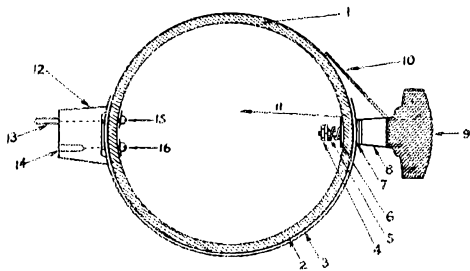

- |                                     |                      |
|-------------------------------------|----------------------|
| 1 Bakelite Tube 3" dia.             | 9 Knob               |
| 2 Wire                              | 10 Sw Lever          |
| 3 1/4" Bakelite sheet covering wire | 11 Wire to Aerial    |
| 4 Nuts                              | 12 Remler plug       |
| 5 Spring                            | 13 Plug              |
| 6 Washer                            | 14 Socket            |
| 7 Bakelite Washers                  | 15                   |
| 8 Gasket                            | 16 Connecting Screws |

After experimenting with a good many coils of various dimensions and windings, I have adopted for best results single-layered coils wound on bakelite tubing 2 3/4" inside diameter by 3" outside diameter, drilled in the center with holes to take the regular Remler panel plug and with the ends of the winding connected inside the cylinder direct to the screws that hold the plug to the tube. The winding is then covered with 1/64" bakelite sheeting which is held in place by the plug and screwed tight to the tube. Rather contrary to

theory, enameled wire is used thruout on the coils.

For the tuned plate circuit a condenser of not over the 23-plate size should

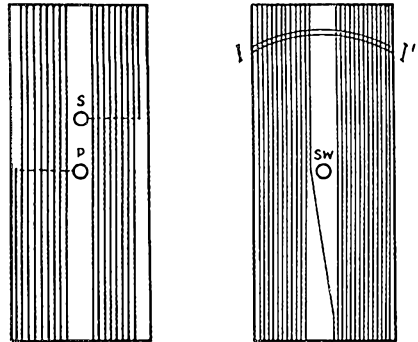

be used, and the plate coils have been designed for this size condenser. The smallest plate coil is wound on a cylinder of the 3" bakelite tubing 1 1/4" long, with 28 turns of No. 20 enameled wire. This about fills the cylinder after allowing for the space skipped in the center for the plug screws to go thru. With practically all tubes and a 23-plate condenser in shunt, this coil will tune the plate circuit for waves from about 170 to 350 meters. Another plate coil should be made with a tube 1 3/4" long wound with about 42 turns of No. 20 enamel which will give a minimum wave of about 225 meters in the plate circuit and a maximum of about 500.

In the secondary circuit for amateur wave lengths, and in fact all waves up to 600 meters, the secondary should not be over seven plates of the ordinary style of variable. The first size of secondary coil we need will be one composed of 56 turns of No. 20 enameled wire on a cylinder 2 1/4" long, which with the 7-plate condenser gives a wave length range of about 175 to 360 meters. Now a little consideration will show that a tube 2 1/4" long is about as large as most of us would care to have, and as the longer the wave the more permissible the use of finer wire, I have stopped short at the 2 1/4" cylinder for several reasons and have built up the wave lengths for the higher ranges by using finer wire on this same length of cylinder. If we wind this same cylinder with 65 turns of No. 21 enameled wire, the wave length range with the seven plate condenser will be almost exactly 200 meters to slightly in excess of 400 meters. Similarly, 74 turns of No. 22 wire gives a range of approximately 225 to 460 meters; 83 turns of No. 23 wire a minimum of about 260 meters; 92 turns of No. 24 wire a minimum of about 290 meters; 101 turns of No. 25 wire a minimum of about 320 meters; and 116 turns of No. 26 wire a

minimum of about 350 meters and a maximum well over 600 meters; and so it goes.

For best results in juggling the ratio of capacity and inductance for maximum selectivity it is desirable to have all of these coils, but they are not all necessary by any means. For ordinary purposes I find a secondary coil of 56 turns and another of about 106 turns (minimum wave 340 meters) all that is necessary for a wave length range of from 175 to 600 meters.

The 42-turn coil described for the plate circuit may often be used in the secondary for higher selectivity and has a maximum wave length of about 270 meters when shunted by the 7-plate condenser, its minimum being somewhere around 135 meters. Even the 28 turn coil may be used in the secondary for extra selectivity, when sometimes the 43 plate condenser is brought into use in the secondary. I have found no fixed rule to follow and the choice of capacity to inductance ratio is left to each individual as the occasion arises. Coils of this type may be wound to give wave lengths of 1500 to 1600 meters with high efficiency, after which it is advisable to use regular honeycomb or duolateral type coils, altho as a matter of fact the latter type of coils may be used down to 600 meters with good efficiency.

The primary circuit should have a variable inductance operated in series with a

condenser of .0015 micro-farads capacity or larger, which means at least a 67-plate variety. For this purpose one of the regular 28-turn plate coils has an extra hole drilled on the side opposite the plug hole in which a switch lever is arranged as shown in these figures. This should be a spring-blade switch with the tip of the lever filed slightly pointed rather than round, so as to make contact with but one turn at a time. It is insulated from the winding by two bakelite washers. The tip of the lever describes an arc across the windings scraping thru the insulation and making firm contact with any turn desired by turning the knob. The small losses in such a primary are not noticeable and are more than offset by the ability to select the correct turn without changing primary coils.

Extension handles should be fitted to the various controls and in my experience are better than shields behind the panel.

I am fully convinced that a set with coils made closely along the above lines will give a decidedly better account of itself on C.W. signals than any variometer set ever made and at the same time hold its own on spark signals as well, with certainly equal strength and greater selectivity. However, it is not suited for those who know little or nothing about tuning a radio set or to those who haven't the patience to learn how to use it—it's appeal will be to the *amateur*.

## The Application of Measuring Instruments to Radio

By John H. Miller \*

**I**N writing a few words on the application of electrical measuring instruments to radio in its various phases, my thoughts go back to the early days when such a thing as a meter on a transmitter was rarely seen, and the receiving sets of course simply did not need them.

After we learned not to connect a spark coil direct to the aerial, and found out what an oscillation transformer looked like, tuning of a transmitting set was frequently done with a small lamp located above the spirals. We changed the positions of the various clips until the lamp lit up satisfactorily and hoped that our transmitter was in tune and radiating a maximum amount of energy. Today we find a radiation ammeter on almost every transmitter, whether it be of the spark, arc or vacuum tube type.

It was recognized very early that when we wanted to measure current at a high frequency, ordinary electro magnetic instruments were practically valueless, since impedance became a determining factor in the readings and varied along with the frequency. Pure resistance necessarily had to be used if frequency variations were to be eliminated and about the only thing that a current in a pure resistance does is to heat it up. Heat then became a medium through which we could measure current of any frequency. Going further, we know that heat causes most metals to expand and this mechanical expansion we can cause to move an indicator over a scale graduated in amperes. Many ingenious methods have been used to magnify the slight expansion of the hot metal strip, but they are all essentially lever systems which increase the amount of motion until it is indicated on the scale of the instrument as amperes. This type of instrument

\*Chief Electrical Engineer, Jewell Electrical Instrument Company.

has been highly developed by the Germans, and before the War practically all of the expansion type of hot wire meters were imported. A hot wire meter, while very valuable when nothing else was available, has a number of faults which we must recognize if we are to take such an instrument at its face value. It is frequently sluggish, and the pointer quite often refuses to return to zero due to the permanent set of the expansion element. As the expansion element takes a permanent set and we return the pointer to zero by means of its adjustment, the ratios of the lever system are sometimes changed and we get a false reading when we again use it. The actual expansion of the metal strip is very small, usually only a few thousandths of an inch.

In multiplying this expansion so that the pointer moves over several inches of scale we introduce a great many factors which are usually somewhat variable. The net result of these facts is that the expansion type of hot wire meter is liable to have glaring inaccuracies and to be unreliable.

Another way in which we can utilize the heat developed in a resistance wire to indicate amperes on a scale, is to attach a thermo-couple, formed of two dissimilar metals, to the heating wire and measure the thermo-electric voltage generated on a standard D'Arsonval type of meter. The instrument which measures the direct current thermo-electric voltage may then be calibrated to read amperes flowing through the heater wire itself. This type of instrument is now being manufactured by the majority of reputable American instrument manufacturers and is the type of instrument which should be used on the transmitting panel of a radio set. Many tests have shown it to be consistent in its readings, to have practically negligible zero shift and to be quite accurate under widely varying conditions of service. The only factors that must be watched in an instrument of this sort are the design of the thermo-couple itself, the connecting leads and the position of the terminals. The permanent magnet type of direct current instrument which is used to read the slight thermo-electric voltage developed is a type of instrument which has been in use for years and has practically no inherent errors. The circuit going into the instrument through the resistance and out again should be in as straight a line as possible, so that these instruments are

made in the majority of cases for side connection. The design of the thermo-couple entails considerable investigation so that proper metals and proper methods of mounting may be used to give accuracy and long life in service. Where a thermo couple instrument and an expansion type of instrument are checked against each other it is fairly safe to say that the thermo couple instrument will be far more accurate than the other.

Leaving the high frequency meter we find that all large sets of course have their power instruments which are of ordinary commercial types. With spark and arc transmitters these measurements are not so vital as they are on the vacuum tube type. Every vacuum tube transmitter

should have a meter arranged to measure the filament supply of every bulb as well as the direct current voltage applied to the plate. In addition to these, a low reading ammeter, reading the current in the plate circuit, will be found to be valuable in controlling the output of the tube.

Turning to the receiving sets, direct current ammeters of small size are quite valuable in controlling the action of vacuum tube receivers and a meter

should always be used to measure the filament supply and operate it at its optimum value. If the filament current is too high the life of the bulb will be considerably reduced and if it is too low the efficiency will at once go down. The correct value of the filament supply is usually specified by the manufacturer of the tube and its value should be adhered to. Where bulbs intended to work on a fixed value of plate voltage are used it is well to be able to measure this value of plate voltage so that the conditions as specified by the maker may be reproduced. If you prefer bulbs of the gaseous type, with variable filament current and plate voltage values, instruments will usually enable you to duplicate previous settings quickly and without the time that would be lost experimenting to obtain the proper values.

It should be noted when voltmeters are used to measure plate voltage that high resistance is desirable, since some voltmeters are of such low resistance that they will use considerably more current than will a battery of tubes.

In research work values of plate current, filament current, and their respective voltages are always included as necessary data when tests on tubes are made, with the

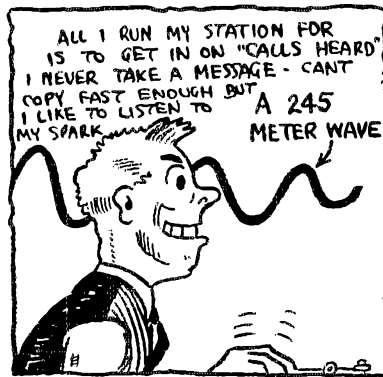

results that today our data on the characteristics of vacuum tubes of all sorts is quantitative rather than qualitative. A great deal of what we know in radio today is due to the fact that measurements have been made which have shown us the way to improvement and the actual reason for such changes as experience has shown beneficial.

In using electrical measuring instruments of any type, care should be taken in handling them and they should be protected from vibration and shocks. The moving element of an instrument is fitted with very fine hardened steel pivots, sharply pointed, resting on sapphire bearings. The actual bearing surface is very small, being a small circle about one thousandth of an inch in diameter. Such a small bearing is necessary to reduce frictional errors to a minimum, and if properly made and not damaged by rough handling will last for many years. Calculations show that the unit pressure in a bearing of this sort is of the order of several tons per square inch. Dropping an instrument usually flattens a pivot or cracks off the point, resulting in fractional errors. Consider an electrical instrument as a logical

assembly of mechanical parts, working on the principle of a motor, but with a moving element built as light and rugged as possible to give us accurate, reliable and consistent readings. Modern instruments will stand a remarkable amount of rough handling, considering the delicacy of their construction, but if the best results are desired, they should be treated with same care and consideration that is given a fine clock or any other delicate piece of machinery.

With these thoughts in mind it is believed that any amateur will find more interest in his work if he is able to measure the electrical quantities which he is using and that the results will justify the use of instruments wherever possible.

(Editor's Note: We have copy of a Bureau of Standards report on two Jewell thermo-couple meters which were first tested on 60 cycle current and showed an accuracy well within 1% of full scale deflection, and were then tested on a frequency of 311,000 cycles (wave length 965 meters) and showed no measurable change of reading with frequency, when in either vertical or horizontal position. This is an excellent showing.)

## "Un Poste Amateur 8AB"

By Lloyd Jacquet, 2KT

"... 8AB, you say? Why all the fuss? That's right here in the good ol' U. S., and only a few hundred miles, at that!"

The fuss, O.M. (and O.W.) is because this particular "8" station is not located in the U. S. at all, but is niched somewhere in Nice, which is in the southern corner of France, which is in Europe, as you all

We could feature him on the front page if we wanted to, because he's just as much of a ham as any other Radio Relayist, and the fact that the French Government recognized the fact and granted him a license makes it only more apparent.

Therefore let me introduce to you the owner and operator of this station *d'outre-mer*, Mr. Leon Deloy, who is not totally unknown to us American amateurs. Mr. Deloy has been in the U.S. and understands the condition here pretty well. He was stationed at Washington, D. C., during the War, with the French Delegation or something, and managed to learn a whole lot about American radio laws and amateurs. He is, in fact, "one of us."

Mr. Deloy can claim credit for being the first amateur operator controlling an amateur transmitting set in France. The set, or rather, sets which Mr. Deloy used in his experiments—for he was only allowed an experimental license—were heard in Aberdeen, Scotland, a distance of 1700 kilometers (1060 mile approximately), and has carried on communication with station 2FQ, of Mr. Burnham in London, a distance of 1100 kilometers (700 miles approximately).

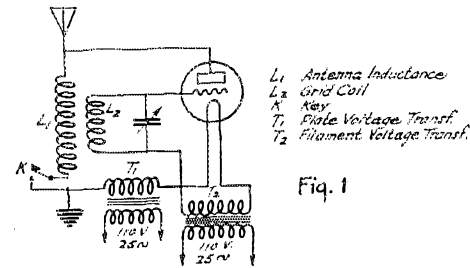

Fig. 1

know. This particular station's call is "8AB", and in order not to get him confused with the chap that operates his own 8AB up in Michigan, we'll call this new fellow "8AB France."

Oh yes, this is an honest to goodness station, with a transmitter an' everything.

The antenna system at 8AB-France is not very elaborate. In fact, it was put up in a great hurry and left that way, so anxious was Mr. Deloy to make immediate use of the newly issued license. You don't get those things everyday in Europe.

The system consists essentially of an umbrella type antenna with three phosphor bronze wires about 75 feet long at an average height of 60 feet. The lead-in is about 30 feet long. The antenna was originally designed for reception purposes, and its resistance is perhaps a bit high for C.W. work.

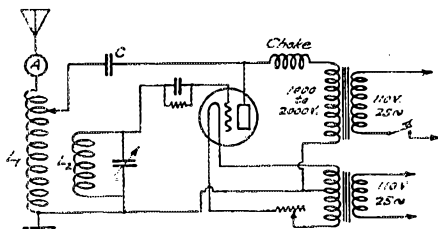

Fig. 2

It was in November 1921 that the first experiments were carried on with a vacuum tube transmitter. This transmitter consisted of an ordinary receiving tube, with 250 volts from a transformer placed on the plate. Distances of 6, then 15 miles were covered with this set. A wave length of 1580 meters was used in the experiments, so that the antenna current must have been pretty good. The wave length was cut down to 960 later, then to 725, and finally to 525, where it is at present. The diagram of connections used is shown in Fig. 1. Fair success attended these trials, and Mr. Deloy got ambitious. A 1-watt transmitter was not to satisfy him.

Two, then four tubes in parallel were pressed into service, and 500 volts A.C. instead of 250 was put on the plates of the tubes. The range was increased from 15 to about 25 miles, and communication was established with Antibes.

More improvements were made. This 4-watt tube set, if it can be called that, was junked and replaced by two 50-watt tubes. 2000 volts were impressed on the plates. The circuit was redesigned, and the one whose connections are shown in Fig. 2 was put into operation. Better ground connections were made and transmission was once again resumed.

In March, 1922, with an antenna current of 2.5 amperes, the signals from this set were picked up at Bonifacio, 300 kilometers away. Then, after looking over every connection carefully, by improving the ground, and changing the wave length to 360 meters, the antenna current jumped up to 3, and then 4 amperes.

About a week later, Amiens reported

reception of signals. It is 800 kilometers (500 miles) away. This was a great day for 8AB. Later on, it was learned that these sigs had been copied in London. Tests were conducted between 8AB in France and 2FQ in London, and communication between the two countries successfully carried on.

Since then, records have been made. On April 8, 1922, the signals were heard at Aberdeen, 1700 kilometers out. 2OM, a London amateur, and 2CV had established communication also, so that regular work could be carried on.

Today 8AB-France makes use of two 250-watt tubes, connected in parallel. The antenna current is about 5 amperes. Experiments are going on, and it may be possible that some American amateur will log him on this side. Then it is only a step! We will soon be forwarding "with love" messages to our nice feminine acquaintances of 1918-19 via the A.R.R.L.

## Book Review

"Radio Telephony for Amateurs," by Stuart Ballantine. David McKay Company, Philadelphia; 296 pages, 8 1/4 x 5 1/2; \$1.50.

For the first time since we took this job at A.R.R.L. headquarters we have read a radio text book complete from cover to cover. Perhaps the main reason why we have read Mr. Ballantine's new book is that it is not at all about radio telephony, and we have no idea why that title was chosen for it unless it was because of the popular interest in telephony.

This is a practical book for the practical amateur and it takes us back to the days of Morgan and Edelman. It is by long odds the most interesting book from the standpoint of the amateur that has appeared in years. After a noble preface in which the author considerably twists the tail of the English Language in spite of his apology in that connection, he reviews the principles of radio telephony and of the audion in his first two chapters. These chapters are the most compact review of fundamentals which we recall seeing, and knowing Mr. Ballantine as we do we are certain that it must have been a terribly hard job for him to be so brief and to the point! Likewise there is hardly any math in the book, which again must have been a trial to Mr. Ballantine. We recall with undiminished amazement an interdepartmental radio meeting held at the Bureau of Standards which we attended as an Air Service representative, and where the subject under discussion was receiving loops and the voltage to be expected thereon from a signal. Mr. Ballantine grabbed a piece of chalk and plunged into the discussion, evolving on the blackboard a most fearsome formula with at least two dozen

(Continued on page 38)

## A Single Circuit Receiver

By L. W. Austin †

ON account of the sharpness of tuning of continuous waves, it is sometimes difficult to pick up the signals with the usual two-circuit receivers, if the settings are not exactly known. This is especially true of short wave reception, where even under the best conditions it is easy to pass over the resonance point with-

reception. To this the antenna and ground (or terminals of the loop) are connected through two condensers  $C_1$ ,  $C_2$ , the capacities of which are so small that the regular setting of the condenser  $C$  is hardly changed by the presence of the antenna, but at the same time the full strength of signal is obtained. These capacities may amount to

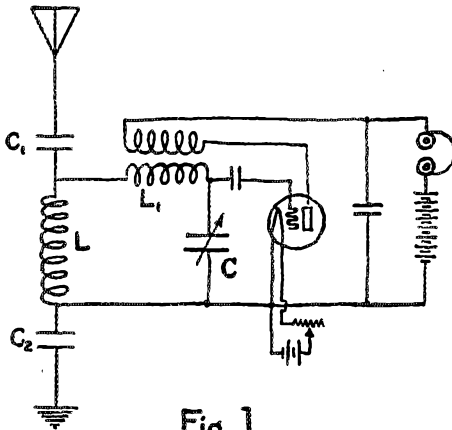

Fig. 1

out noticing it. If the usual single-circuit receiver be used, the problem becomes much easier, but frequently the interference of other stations is troublesome.

Several years ago I devised a simple type of circuit for picking up long wave stations which has been found to be especially adapted to short wave work\*. The circuit in its simplest form is shown in Fig. 1.

Here  $L$ ,  $L_1$ ,  $C$  is the usual regenerative or oscillating secondary used in electron tube

†U. S. Naval Radio Research Laboratory, Bureau of Standards.

\*L. C. Young of the Aircraft Naval Radio Laboratory has recently independently developed a similar circuit.

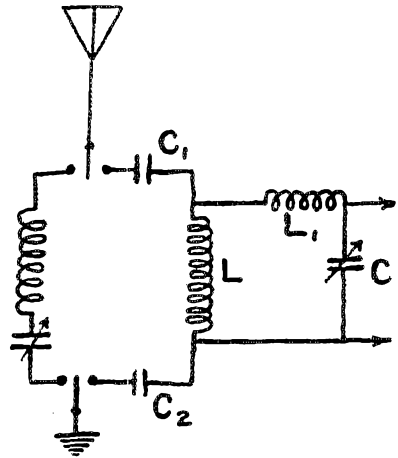

Fig 2

a few degrees on a 0.001 microfarad condenser, more or less, depending on the size of the antenna and whether the received signal is continuous wave or not. With this arrangement the antenna becomes merely a collector and takes practically no part in the tuning. The sharpness of tuning of such a circuit is far better than that of the usual single circuit receiver, but if after the station is picked up it is desired to use double tuning, it is easy to connect the antenna and ground to the primary by means of a double-pole double-throw switch as in Fig. 2.

## New Apparatus

**T**HOS. P. GIBLIN, inventor of the honeycomb coil and the duo-lateral inductance, seems to have gone them one better in the production of a new type of coil illustrated herein.

In the early efforts to wind compact inductances the great trouble was the increase in distributed capacity when a multi-layered coil was attempted. The honey-

comb winding greatly reduced this by crossing the wires of adjacent layers at right angles, and the duo-lateral made a further reduction by staggering the layers to avoid the honeycomb effect. This was a practical solution of the capacity problem, which exists mainly between layers, but it left much to be desired in the way of inductance as it required the spacing of

the turns in the same layer. In the new coil Mr. Giblin winds cotton yarn into the inductance, in the form of a lattice winding

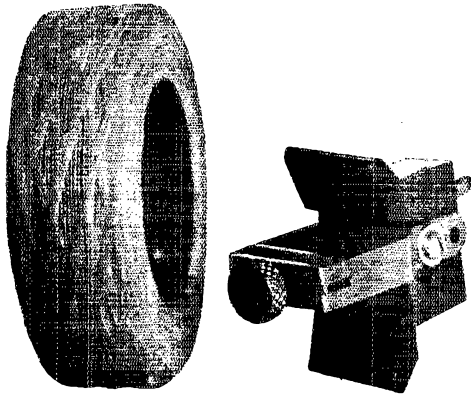

the same as in a honeycomb coil, but while the yarn is being wound lattice the wire is also going into the coil, the wire however going in parallel turns in each layer just the same as in spool-winding with the turns close together, the cotton yarn separating the layers. Thus by having the turns parallel and close, maximum inductance is secured, and by separating the layers by the yarn the distributed capacity is kept down. Furthermore, by a peculiar stunt in the winding the spacing between layers increases slightly on that side of the coil where the potential between layers is greatest, decreasing conversely on the opposite side, giving maximum copper space and maximum insulation in a given volume.

The result is a coil which seems to have more pure inductance, less distributed capacity, lower r.f. resistance, and lower natural wave length for its inductance than any of its predecessors.

**Some New Meters**

The Jewell Electrical Instrument Co. of Chicago has brought out two new instruments of unusual value to the radio art.

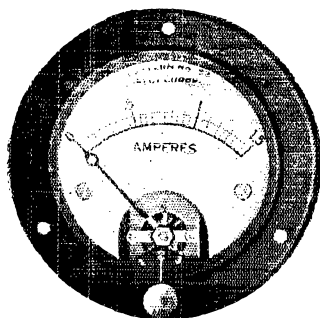

The small round instrument is a combination filament ammeter made for reading the current in any one of three tubes of a receiving set, thus taking the place of

three meters and offering a measurement of filament control in a compact space. It

has a switching arrangement that connects the meter across any of three 1.5 ampere self-contained shunts without opening the main circuit or interfering in any way with the operation of the set.

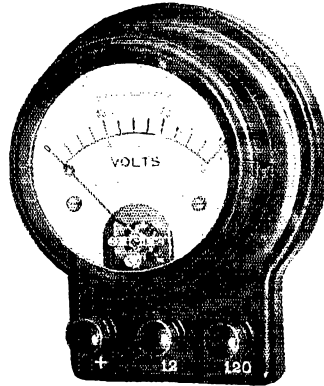

The other cut shows a front-connected combination instrument for checking the voltage of the "A" and "B" battery. The usual range is 0 - 12 - 120 volts but several others are made. With such an instrument the operator is enabled to watch his batteries to tell when approaching discharge so they may be either recharged or replaced.

has a switching arrangement that connects the meter across any of three 1.5 ampere self-contained shunts without opening the main circuit or interfering in any way with the operation of the set.

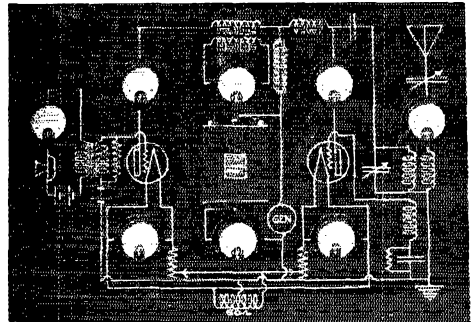

A novel panel showing how meters should be arranged in a C.W. circuit was exhibited at the Chicago Radio Show recently and attracted considerable attention. A photo of this panel is reproduced and the diagram is one that is recommended by many.

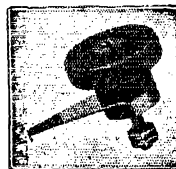

The new Klaus rotary switch made in Eureka, Ill., involves a new principle. There are no moving parts on the entire assembly except the knob and blade. The shaft and collar remain stationary thus insuring positive connections to be soldered directly to the shaft without danger of twisting off, which is a feature not found in others on the market.

The Artisan Mfg. Co. of Cincinnati send us the appended illustration of a small lathe developed by them—not a toy but a real husky accurate powerful lathe in condensed size.

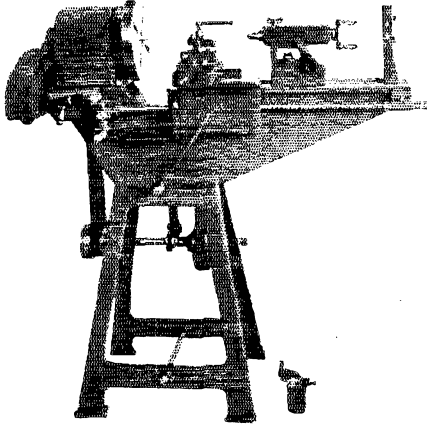

It takes 24" between centers, swings a full 11" over the bed and 16" over the gap in the bed, and has a remarkable range of speeds and thread feeds. By means of a back gear any one of six speeds is instantly available. The quick-change gear box enables the operator to chase S.A.E. standard threads from 8 to 224 per inch. Power is obtained from a ½ h.p. electric motor mounted on the rear and belted direct to the countershaft below.

With this machine the amateur can make almost everything that goes into his apparatus, not only saving considerably in its cost but gaining experience in machine work and enjoying the pride of knowing that his instruments are the result of his own design and workmanship thruout.

The price without the motor is \$139.00. The manufacturer will be glad to furnish additional information to interested amateurs.

The H. H. Eby Manufacturing Co., of Philadelphia, has brought out a new binding-post called the "Ace" which is a considerable improvement to their already well



known line of binding-posts. This new one has a nickel-plated brass base, heavily knurled to prevent turning when mounted, and has a hole drilled thru the neck large enough to take a #15 bare wire. It is nicely set off with a ½ inch insulated knob on the top.

### A New Variocoupler

The Queens Radio Company of Winfield, L. I., have a new vario-coupler that is quite interesting. It is supported by an aluminum frame designed for table or panel mounting and though the instrument is very light in weight it is of rugged construction. Taps are brought out so that variation down to a single turn can be obtained in the primary. This together with the 180°

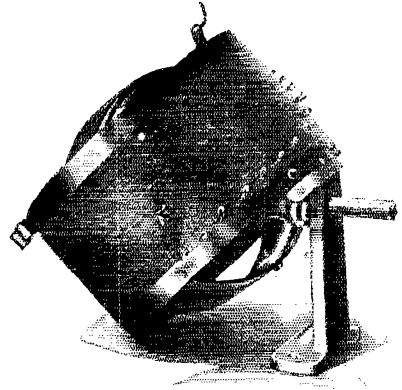

coupling variation and silk covered wire results in a neat and efficient instrument.

A new loud-speaker, appropriately called the "Adapt-O-Phone", has just been placed on the market by a Detroit maker of radio products.

The Adapt-O-Phone uses the regular head set. The receivers are held in position against the manifold by set screws and are protected from injury by soft rubber sleeves. It is quite attractive in appearance. The base is of mahogany; the manifold is heavily plated and polished, and the horn is japanned.

With the increasing custom of sending out concerts, bulletins, sermons and other messages of general interest, the need of a satisfactory, low-priced loud speaker is wide-spread; and the Adapt-O-Phone should meet with popularity.

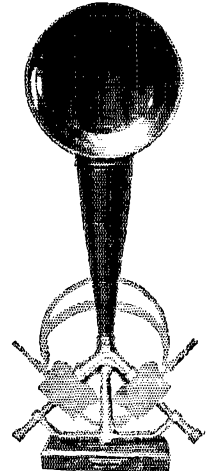

### RADIO FREQUENCY AMPLIFICATION

Our next issue will contain an important article on R.F. amplification on short waves—be sure to get your copy.



# EDITORIALS

## of the AMERICAN RADIO RELAY LEAGUE



### Exhibition Epidemics

WE thought amateur radio was going *some* when five radio districts held A.R.R.L. Conventions in one year, culminating in the biggest of all, the National Convention last September, where hams of every race, creed and polarity were attracted to Chicago and put over the completest foregathering of DX hounds and short time brass pounders from Coast to Coast the country had ever seen. And everybody said it was a whizz. The thing, though, that put it across, the common urge that brought men from California, New York, Canada and Texas, was not the desire to see new apparatus, not a burning thirst for knowledge and new circuits, nor yet because they wanted to advertise or sell anything, but because they were amateurs and had inside them that feeling of good fellowship and freemasonry that starts a hamfest at 2 a.m. or makes a fellow spend the price of a 250-watt tube set to come half way across the continent to argue about it. Some of us cant exactly explain why we are amateurs nor why we do some things in the name of amateur radio, but one and all, we're glad we are and do, and that's what counts. However, the rest of the world who has never learned the code or burnt the midnight Mazda or mended a busted oil condenser or seen a favorite filament part company, who believes the glassy stare and deaf ear hereditary, looks for something tangible as a reason for the amateurs interest and concludes that it all lies in the fascination of shiny apparatus and loud sigs, which is only natural, since that's what charms the rest of the world.

So far so good. Every amateur or A.R.R.L. Convention has been a big success, every one has shown apparatus and the latest spell-binding loud speaker, and with little or no organization or effort has come off financially to the good. What more natural than that those gentlemen who like to amuse, instruct or elevate the public—for profit—should view this as a most lucrative field for them to conquer; add to this the sudden interest in radiophone broadcasting, the birth of thousands of novice listeners and the tremendous attendance at the Second District Radio Show last March, and you have the stage all set

for showmen, exposition promoters, manufacturers-jobbers-dealers associations and what-nots to jump in and introduce the curious public to a mystifying, stupendous, alluring, educating, magnificent, inspiring conglomeration of radio shows, exhibitions, expositions and conventions such as the country has never seen before—and will probably see a lot more of. Some of these have been successes and have given as well as taken, but how many have been nothing more than schemes for making money quickly with the least possible outlay at the expense of the novice and general public? Or of advertising cheap apparatus of inferior construction which they can't sell an amateur but can fool a novice with? Or of promoting stock-selling companies with promises of phenomenal dividends? Judging by those we have seen or read about recently, the quality is inversely proportional to the increase in numbers and the land is just about overrun with them now. In each morning's mail we get a notice of a radio exposition in some out of the way place, where we will be given the privilege of renting a booth absolutely free for \$100, an opportunity we cannot afford to overlook! Fellows, how long will the public fall for this stuff, how long will it enjoy looking at cheap crystal apparatus with a 1000-mile receiving record or listening to loud-but-not-clear-speakers blaring forth some drunken refrain or examining with interest a booth completely equipped with a table and porch furniture? Just about one season more and then we'll settle back to a couple of big classics each year here and there around the country, like the automobile and electric shows, for the novice, and the amateur conventions for us ether-walloping hams.

But while things are adjusting themselves and the showmen are getting discouraged and the novices wiser we are faced by a new situation which has arisen largely because no convention is entirely successful without our backing and support and the people running them know it and are trying hard to win us over. It takes amateur pep and enthusiasm and incidentally amateur knowledge of what is what in radio, which the promoters have a highly negative degree, to make a "go" of any such affair; consequently we are asked to be a member of the Advisory Committee

or the Technical Committee or the something-committee or to co-operate as a club or as City Manager of the A.R.R.L. or District Superintendent, which will mean only a small amount of work and a lot of prominent advertising for the amateurs or the local club or the A.R.R.L. Such arguments may sound very plausible on the surface, but the fact is, fellows, that we amateurs are the leaders in radio in every community and if we don't approve of the show the whole town will know it and it will fall flat. No wonder the promoters want our backing!

The A.R.R.L. as we've said many times before, is non-commercial and uninterested in any schemes, movements or propaganda connected with money making except where the good of the amateur will directly and positively be served, and any company coming to us with a plan for the advancement of amateur radio in which it is one for the amateur and two for the company is gently but firmly shown the error of its ways and invited to go—elsewhere. And you'd be surprised what a number of such concerns want us to run contests or lend them assistance or backing in some profitable movement, always being sure, of course, to impress upon us the great benefit it will be in advertising the amateur and his value to the community.

Time was we might have fallen for this when some of the newspapers of the country were running their propaganda against "the American small boy" or the "kid with the coil" in an effort to put us out of business; those were the days when we needed to show the world the falsity of these statements even if the other fellow did not lose by it himself. But when people come to us now, asking our help in putting over radio shows that are not shows or in advertising their products which will not sell on merit alone, we not only sidestep it but advise our members to do the same, quick.

Don't get the idea we are against all radio shows or opposed to lending a hand where really needed; there are shows where an amateur club or an individual can help tremendously towards making it a success and in showing the public what radio really is, but these are few and far between and they need to be examined with a twenty-diameter microscope before passing muster. If you feel sure the people running the affair are OK and will put on something really worth while and there is an actual need for a radio show, go to it and help them all you can for it will help the cause of amateur radio too, but remember, it is the policy of the League to have no connection with *any* such commercial enterprise either as an organization or through its Operating Department, and if you hold a position in the latter we ask you not to jeopardize the prestige and good name of

the League by allowing yourself to be connected with a radio show in your official capacity except where it is part of an A.R.R.L. District Convention run by amateurs.

—C.A.S.

## San Diego

THERE'S a situation in San Diego that is a shame to California and that rates an immediate and vigorous clean-up. Perhaps our readers have noted in the Pacific Division operating report mention from time to time of certain stations there being blacklisted and in this month's report the casual statement that "the war is still on in San Diego."

The question involved is a basic one—whether or not the desires of the majority of the amateurs in a restricted community shall govern what they do. We say they shall. Wherever the Chicago Plan of co-operative division of working hours is employed this question has arisen. In every place but San Diego County the few who would be inconvenienced by such arrangements have given way for the greatest good to the greatest number. Indeed it is something we amateurs *have* to do. In bygone days all the air all night long was free for all but ever since we resumed after the Armistice there have been so many of us, of such diverse interests, that a division of the hours has been imperative. Of course the possession of a government transmitting license is on its face authorization to go ahead and transmit, but it is unwritten law in amateur circles that the desires of the majority shall govern such things and more than one Radio Inspector has told the amateurs of his district that such agreements, openly arrived at, shall be respected and that malicious violation shall be considered as grounds for the revocation of a license.

Now the Western States have the Pacific Plan, arrived at and adopted in convention assembled, and we know it is pretty generally respected along the coast. We consider it a fine thing. But in San Diego there is a little group of willful men who are running amuck and telling the squinteyed world that they won't be bound by the Pacific Plan or anything else, that they will transmit when they damwellplease, and that A.R.R.L. traffic will not move into or out of San Diego until the A.R.R.L. comes to them. A miniature war has been the result and of course there is no local co-operation, no progress, practically no relaying. Such situations have a leader, of course, and in this case it seems a man is peeved because he cannot dominate local activity and so he goes loco and succeeds in collecting a few ill-advised disciples with him. The Sixth District Radio Inspector in more than one endeavor to settle the racket

has been openly insulted and his authority scoffed. Our traffic manager in a recent visit to San Diego only confirmed in every detail our feeling that right resides with the peaceable San Diego amateurs and the A.R.R.L. has thrown its weight on the side of law and order and thru its Operating Department officials will sustain the rights of the majority of the amateurs to insist upon the observance of the Pacific Plan and orderly operating.

The situation in San Diego differs from the occasional little unpleasantnesses which arise when a co-operative plan is put into effect only in that in San Diego there are several of the bolsheviks instead of one. The result of course is inevitable—the job will merely take a little longer.

—K.B.W.

### A Great Trip

**A**NOTHER one of those fine things has been done which we of the A.R.R.L. pull off every once in a while. It is Fred Schnell's trip to the West Coast. It forged another link in the great chain of brotherhood which binds us together, and it adds a fresh inspiration to our new friends who are just entering radio. Our Board of Direction at its last meeting counted up the dollars and figured that we had enough to send our Traffic Manager out to the Northwestern Division Convention in Seattle, and also to have him swing down through Tacoma, Portland, San Francisco, Los Angeles and San Diego. Nobody from Headquarters had ever attempted this before, for the very good reason that it costs a pretty good stiff sum of money. But we have been itching to go just the same, and to mix up with the fellows on the West Coast and to show them that we were the same kind of good sports that they were. And then the great day came, and the Board gave the word and Fred fired a few things into a grip and beat it for the train. He swung around the whole big circle and he is just back. His story of the royal welcome he received and the good old A.R.R.L. spirit that was rampant makes a fellow's heart expand. Certainly, fellows, we have an organization and a spirit to be proud of, and that we have managed our affairs so successfully that we are able to send one of our officers across the continent and back is tremendously satisfactory to think of.

This is an almighty big country, and mens' interest urge them in widely different directions. But we radio people seem to have absolutely identical interests and thoughts, no matter where we are located. We are as one in promoting this fine American spirit of radio brotherhood, and as we welcome Fred Schnell, our Traffic Manager, back to his desk here in the office, we give thanks that there is at least one organ-

ization which stands shoulder to shoulder with a solid front on the matters of altruism, co-operation and good fellowship. We are sorry for those who have not felt this fine thing and had it enter their hearts.

—H.P.M.

### Your Pen In Hand

**S**AY, Old Mans, our QST is in need of articles for publication—interesting accounts of what to do to improve some phase of practical amateur communication.

QST of course is a rather unusual publication. It has never been on the open market in competition with other magazines for the acquisition of manuscripts. Professional writers can't write the kind of material we want for our pages. QST has always been filled with the product of practical amateurs describing something of more or less vital interest in short-wave two-way operation, and, owned as it is by the cream of the amateur field which makes up our A.R.R.L., the gang has always gladly written in to the Quist Factory with their accounts and contributed them for the good of the game. That same A.R.R.L. spirit which is evident in our work on the air has characterized the creation of QST's articles and has made for the A.R.R.L. organ a reputation for reliability and practical amateur value in its articles not touched by any magazine.

But it looks like a change is in the air now, and it's one more thing to be charged up to the broadcasting craze. The A.R.R.L. fellows who have the dope have gone into the radio business and either are too busy to write up what they know or are hoping to market it and get rich. The result is that, altho we continue to have good material, we haven't near the quantity from which to select which we would like, QST isn't nearly as helpful and entertaining as it could be if we had these other things, and we must be missing much that is new and important. In recent weeks we've been on the trail of three different fellows, well known amateurs, who have been doing valuable experimenting with radio frequency amplification and getting promising results. We asked them for an account of it for QST. Did we get it? We did not; one of them is already in business and the other two have one foot in and hope to climb in definitely soon, and their dope is secret and will form the basis for two more radio manufacturing companies. Because there is a chance to manufacture the thing and sell it to the novice public, QST misses a good article which by all the standards of last year would have come rolling in to us for the delectation of our crowd and the prestige of its author. Where is the author of a recent good an-

(Concluded on page 62)

# The Operating Department

F. H. SCHNELL, Traffic Manager  
1045 Main St., Hartford, Conn.

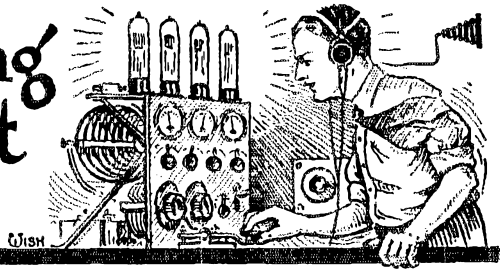

**M**ANY stations are inactive at this time of the year and the usual cry is let forth, "QRN and hot weather with the many stations off the job," etc. Those are things that cannot be helped, but there is no reason on earth why more effort cannot be put to wards operation during the summer months. Listen, fellows, that old QRN-cry and all that hot weather stuff is the bunk. The reason the least bit of QRN discourages you is because it has been pounded into

a bit discouraging at first, but if you will think of all that we have gone through since we first started up you will take heart.

The same fellows are not on the job every night in the month, but most of them are quite consistent and come on three or four nights for a couple of hours. Give it a whirl, fellows, and just because you do not reach out a thousand miles the first time you try, don't be a quitter.

Location has a great deal to do with sta-

## Message Traffic Report By Divisions

JUNE

DIVISION	C.W.			Spark			Total		
	Stns.	Mgs.	M.P.S.	Stns.	Mgs.	M.P.S.	Stns.	Mgs.	M.P.S.
Atlantic	11	410	37	1	22	22	12	432	36
Central	8	680	85	14	617	44	22	1297	65
Dakota	15	183	12	9	264	29	24	447	19
New England	18	1073	60	11	584	53	29	1657	57
Northwestern	3	25	8	13	525	40	16	550	21
Ontario	3	47	16	2	28	14	5	75	15
Pacific	13	372	28	16	505	32	29	877	29
Roanoke	21	552	26	6	69	11	27	621	23
Vancouver	1	12	12	4	67	17	5	79	16
West Gulf	2	100	50	4	180	45	6	280	47
Winnipeg	1	6	6	0	0	0	1	6	6
Total	96	3460	36	80	2861	38	176	6321	36
C.W. Messages, 3460—55%									
Spark Messages, 2861—45%									
Total, 6321									

your head for many years that summer work is impossible. It started when our standard of operation was much lower than it is now, before we had C.W. and all that. Times have changed yet you go on thinking that nothing can be done. Get the idea out of your head and try it for a couple of weeks every month. True, there are nights when nothing can be done. We have those nights right in mid-winter and most of you stick them out, but during the summer you toss up the sponge. And again we have excellent nights during the summer, but of course, not as many as during the winter.

Dust off that old set of yours and sit in for a couple of hours several nights in the week. You will learn that there are hundreds of stations working right along just as though there were no QRN. It may be

and perhaps it is true that no work can be done in the south and southwest, but for other parts of the country this does not hold true.

For the first time the C.W. message traffic is higher than the spark traffic. Is it because C.W. gets through QRN better? Form your own opinions and let's not argue about it. Time alone will reward the best system. We only want to say one more thing with respect to the monthly traffic reports and that is this: we do believe that a great many of the spark messages which have to cover distances of several hundred miles are relayed three or four times and a message over the same route via C.W. would make it in two jumps providing stations were available. In that way we think the spark total is higher because it requires more relays,

whereas with C.W. it covers the distance in fewer jumps thereby cutting down the total. *Ad captandum vulgus!*

So much, for that, yet we find it a pleasure to report the traffic honors this month to a spark station—get 'em while you can.

\*\*\*\*\*  
W. E. HECKMAN, 1AA  
Auburndale, Mass.  
302 messages  
New England Division  
\*\*\*\*\*

Forms for reporting the message traffic handled by all official relay stations have been distributed. A cut of the new form appears. The form is to be used in report-

<b>AMERICAN RADIO RELAY LEAGUE</b>			
OPERATING DEPARTMENT			
OFFICIAL RELAY STATION _____		C.W. SPARK _____	
MONTH _____			
MESSAGES:	RECEIVED _____	SENT _____	TOTAL _____
REMARKS:			
SIGNED _____			

ing messages received and messages sent with space for listing schedules and other activities of the station. These cards are to be sent to your district superintendent.

**TRAFFIC REPORT**

Atlantic Division—C.W.: 3ZO, 115; 2FC, 80; 3BNU, 67; 8CKM, 32; 2ARS, 27; 8CON, 22; 8BIL, 20; 3ANY, 14; 3HG, 12; 3ALL, 11; 3WF, 10; total 410. Spark: 3AC, 22.

Central Division—C.W.: Michigan, 216; 9UU, 97; Northern Ind., 72; 9CA, 71; 9DHZ, 35; 9DDY, 29; 8ZAG, 23; 8AQT-8AXB, 24; 8FT, 14; 8BEN, 12; 9BLC, 8; 9CP, 6; 9YB, 3; 8BOG, 2; total, 617. Spark: 8FT, 293; 8ZO, 175; Michigan, 124; 9CP, 50; Northern Ind., 23; 9YB, 11; 8BOG, 2; 9GU, 2; total, 680.

Dakota Division—C.W.: 9XI, 35; 9BBF, 25; 9BR, 25; 9AOR, 20; 9PI, 12; 9YAJ, 10; 9BAV, 10; 9ATW, 9; 9BAF, 8; 9ASF, 8; 9AIF, 5; 9ZC, 5; 9TI, 6; 9AUA, 3; 9GV, 2; total, 183. Spark: 9AVZ, 48; 9YAK, 45; 9BOF, 43; 9AIF, 36; 9BRI, 33; 9FX, 28; 9ZC, 15; 9AUA, 14; 9AUL, 2; total, 264.

New England Division—C.W.: 1ASF, 159; 1AYU, 135; 1BKQ, 108; 1AWB, 90; 1PM, 79; 1QP, 75; 1AZW, 57; 1IV, 54; 1BDI, 52; 1BNT, 10; 1UL, 47; 1COT, 46; 1AKG, 42; 1BDV, 35; 1CBJ, 18; 1OZ, 14; 1BK, 7; 1BRQ, 7; total 1073. Spark: 1AA, 302; 1FM, 58; 1BRQ, 49; 1BLE, 36; 1DY, 36; 1CAJ, 32; 1AKG, 20; 1AOK, 15; 1CKT, 14; 1WQ, 12; 1CIB, 10; total, 584.

Northwestern Division—C.W.: 7QE, 12; 7BS, 9; 7OZ, 4; total, 25. Spark: 7BK,

116; 7NC, 104; 7HI, 91; 7GE, 78; 7MF, 35; 7FR, 33; 7BG, 18; 7BZ, 16; 7IB, 14; 7IW, 14; 7IM, 12; 7ZJ, 7; 7MH, 7; total, 525.

Ontario Divisions—C.W.: 9AL, 36; 3FO, 8; 3CZ, 3; total, 47. Spark: 3GX, 16; 3DS, 12; total, 28.

Pacific Division—C.W.: 6ZZ, 86; 6ZX, 61; 6KA, 56; 6JD, 45; 6EN, 42; 6EU, 26; 6ALU, 15; 6FT, 10; 6BRT, 9; 6BJC, 8; 6EA-6EB, 7; 6AGH, 4; 6PI, 3; total, 372. Spark: 6AJR, 131; 6GR, 190; 6HP, 56; 6OD, 54; 6ALD, 36; 6AAK, 54; 6KE, 40; 6OM, 19; 6BJX, 11; 6IU, 9; 6AQX, 9; 6APF, 8; 6BDZ, 8; 6BAJ, 7; 6GP, 2; 6WR, 2; total, 505.

Roanoke Division—C.W.: 3IW, 144; 4GH, 68; 3BLF, 64; 8AMD, 52; 3TJ, 22; 3BZ, 22; 4DC, 24; 3BIJ, 21; 4BX, 20; 3ZZ, 19; 4DS, 19; 8SP, 14; 3AEV, 14; 4ID, 11; 3BHL, 8; 4GX, 8; 3BNE, 6; 4EN, 5; 3ACZ, 5; 8CAY, 4; 3BVB, 2; total, 552. Spark: 3AOV, 22; 8BDB, 16; 3ACK, 10; 3BVC, 8; 8WD, 8; 8BAZ, 5; total, 69.

Vancouver Division—C.W.: 5BQ, 12, total, 12. Spark: 9BD, 52; 5CN, 6; 5AX, 5; 5DO, 4; total, 67.

West Gulf Division—C.W.: WRR, 80; 5ZAT, 20; total, 100. Spark: 5TC, 121; 5QI, 43; 5SF, 12; 5LB, 4; total, 180.

Winnipeg Division—C.W.: 4BV, 6; Spark: nil.

**ATLANTIC DIVISION**

**C. H. Stewart, Mgr.**

For the past three months the reports from the Atlantic Division have been lacking from these columns, for which there have been several causes. The Division Manager must largely accept the blame himself for this situation, because he is the responsible one, and if the reports were not received promptly, it was his place to go after them. However, having been away from home in connection with the League legislative matters he was unable to find time to properly conduct his correspondence; then the advent of the radiophone broadcasting for a while seemed to have a very discouraging effect upon the personnel of the Division, due to many of our traffic officers getting into the commercial game on account of its apparent attractions, and, as a final contributing cause, it became necessary, under the instructions of the Traffic Manager, to set about upon a reorganization of the Division, which has taken considerable time and thought on the part of the Division Manager. The Manager has found out one benefit which has arisen because of the lack of reports in this column, and that is that he has obtained a knowledge of a number whose interest in A.R.R.L. work is evidenced by the complaints of no reports, and wherever possible he intends to utilize the service of these fellows in the new traffic

organization. After the reorganization is completed it will be up to the station owners to see that their message-handled reports are sent in regularly and promptly immediately after the 15th of each month to their District Supt. if they wish them to appear in the Division's summary. In a short time headquarters at Hartford will be furnished with a complete list of District Superintendents and City Managers, with the territory covered by each, so that if any station owner is uninformed as to the proper one to whom his report should be sent, he can obtain the information from headquarters by giving the name of the county or city in which he is located, upon application to Hartford.

A few words regarding the new Atlantic Division organization will be of interest. The Division, as in the past, will be divided into two Sections, the Northern Section comprising the States of New York and New Jersey, and the Southern Section the States of Penna., Del., Md., and the Dist. of Columbia. The detail work of these Sections will be handled by two Executive Assistants, working in conjunction with and under the guidance of the Division Manager. These Executive Assistants will act for the Division Manager in the territory assigned them, and among other things will be responsible for the monthly traffic report from their respective sections; will make appointments of official relay stations, subject to approval of the Division Manager; have complete charge of all special relays and tests; look after club affiliations; have charge of membership records of his Section, and conduct all correspondence of a routine nature with clubs, official stations and League members in his Section as were formerly handled by the Manager.

There will be two Assistant Division Managers in the State of New York, New Jersey and Pennsylvania, and one each in Delaware, Maryland and the Dist. of Columbia. They will have general charge of League affairs in the territory assigned to them, and will report to the Executive Assistant on all matters of detail relating to operation, and make recommendations to the Division Manager regarding appointments of traffic officials.

There will be 16 Dist. Supts. in New York; 8 in New Jersey; 12 in Penna.; 3 in Delaware; 5 in Maryland and 1 in the Dist. of Columbia, and these will report to their respective Ass't Div. Managers. Under the new organization proposed by the Traffic Manager, there will also be a City Manager for each city with a population of 25,000 or over. City Managers may be recommended for appointment by the Dist. Supts. They will report directly to the Ass't Division Manager, but must cooperate with their respective Dist. Supt. in the advancement of the interests of the League. The following cities rate City

Managers under the population requirement above mentioned:

N. Y. CITY: Manhattan borough, Bronx borough, Brooklyn borough, Queens borough, Richmond borough.

NEW YORK STATE: Albany, Amsterdam, Auburn, Binghamton, Buffalo, Elmira, Jamestown, Kingston, Mt. Vernon, New Rochelle, Newburgh, Niagara Falls, Poughkeepsie, Rochester, Rome, Schenectady, Syracuse, Troy, Utica, Watertown, Yonkers.

NEW JERSEY: Atlantic City, Bayonne, Camden, Clifton, E. Orange, Elizabeth, Hoboken, Irvington, Jersey City, Kearny, Montclair, New Brunswick, Newark, Orange, Passaic, Paterson, Perth Amboy, Plainfield, Trenton, West Hoboken, West New York.

PENNSYLVANIA: Allentown, Altoona, Bethlehem, Chester, Easton, Erie, Harrisburg, Hazelton, Johnstown, Lancaster, McKeesport, New Castle, Norristown, Philadelphia, Pittsburgh, Reading, Scranton, Wilkes-Barre, Williamsport, York.

DELAWARE: Willington.

MARYLAND: Baltimore, Cumberland, Hagerstown.

It will be seen that there are a number of new offices to be filled, as there will be 7 additional Ass't Division Managers; about 30 new Dist. Supts., and 70 City Managers, and the Division Manager will be glad to hear from any of those interested in the work of the League who feel that they are qualified for any of these appointments, stating their qualifications as fully as possible. Some appointments have already been made, and, of course, it will be impossible to appoint all those who will apply, but those who are really interested in the work should not be backward about offering their services and assistance. Remember, fellows, what you do is for the good of amateur radio, and not for the glorification of any individual. Come on in and help us make the Atlantic Division the best and most efficient Division of the League. We have the operators and the stations, and there is no reason why, when our new organization is completed, we should not be at the head of the list.

There has unfortunately been a lack of systematic reports of messages handled during the last couple of months. However, the following data has drifted into the Division Manager. For instance in Baltimore the bulk of the traffic has been handled by 3AJD (42), 3HG (43), 3AC (25), 3ZN, 3XAA and 3SQ (15), 3GZ, 3BUC, 3UC and 3WF. In Philadelphia the reports are lacking owing to the resignation of the Dist. Supt., and the fact that Mr. Rau (3FM) has only recently been appointed Ass't Division Manager for Eastern Penna., and has not had time to get his organization completed. Some good work has been done by 3AIC, and also by 3TA. In the Central part of Pennsylvania,

the State College Station SXE has been doing some good relay work. The reports from Western Pennsylvania are lacking. In the Dist. of Columbia, 3ZY has recently gone into the commercial game, and the good work previously done by his station will be missed. However, 3IW and 3ALN are carrying on in good shape, as well as 3KM and 3BAG; 3ALN handling the bulk of the messages, followed closely by 3IW.

#### WEST GULF DIVISION F. M. Corlett, Mgr.

If remodeling, rebuilding and generally improving transmitting and receiving apparatus counted as messages handled our report for this month would be a rip-snorting one. Such is not the case, however, and we will probably take last place in number of messages handled. Division Headquarters is in receipt of some brand new Official Relay Station Appointment Certificates and they are to be passed out to the stations handling and REPORTING each month the number of messages handled.

Monthly report of the New Mexico section has not been received and our report must reach Hartford by the first of each month so we can not include New Mexico stations in this report. North Texas section, South Texas section and Oklahoma section reports follow:

#### SOUTHERN TEXAS

Everyone seems to be at present content with listening in on the many really good broadcast programs from Houston. This is not discouraging because practically all of our good DX men in this section have expressed themselves as merely taking a vacation but will be very much in evidence as usual when the "season" opens up again.

Several stations are reported in operation in southwest Texas, working only in early morning hours; no traffic is reported. Asst. Chas. G. Clark at Laredo, briefly announces no traffic moving in those parts, but states that interest has not been lost. Every station is rebuilding.

Our average shortest relay jump is more than 200 miles and operators are seldom at their instruments for more than a half hour at a time, and they can hardly be blamed for who wants to sit-in and listen to a boiler factory for thirty minutes and hear not more than two stations in the air, and faint at that?

#### NORTH TEXAS

There has been a little reorganization taking place lately so please note: all assistants, from and including assistant district superintendents, are cancelled. The North Texas section is now divided into five districts to be known as first, second, third, fourth and fifth district. Please make your report to the following men: Arthur West, Box 90, Commerce, Texas (5ZAM)

superintendent of the first district which consists of all counties north and west of and including, Cook, Denton, Tarrant, Dallas, Kaufman, Vanzant, Wood, Upshure and Marion. Second District includes, Johnson, Ellis, Hill, McLennan, Bell, Falls, Limestone, Navarro, Nacogdoches, Shelby, Panola and Harrison counties. Until further notice men in this district will make their reports to the assistant division manager, Robert L. Clinkscales, 3913 Hamilton Ave., Dallas, Texas. Third District includes Hardeman, Foard, Knox, Haskell, Jones, Shackelford, Throckmorton, Baylor, Wilbarger, Wichita, Archer, Young, Stephens, Palopinto, Jack, Clay, Montague, Wise and Parker counties. This district will also make reports to the assistant division manager. C. B. Baxter, Box 176, Dublin, Texas (5IR) superintendent of the fourth district which includes, Taylor, Runnels, Coleman, Callahan, Eastland, Brown, Erath, Caommanche, Mills, Lampasas, Hamilton, Coryell, Bosque, Summer-ville, and Hood. Mr. J. L. Martin, 605 East Fourth St., Amarillo, Texas (5ZH) superintendent of the fifth district which consists of all counties north and west of and including the following: Andrews, Martin, Howard, Mitchell, Coke, Nolan, Fisher, Stonewall, King, Gottle and Childress.

A number of new stations have been installed and licenses issued as follows: 5ABJ, 5ABO, 5ABR, 5ACC, 5ACJ and 5ADP. Traffic for the west has been moving through 6ZZ.

There are only two really active stations in Ft. Worth at present, 5QI and 5TC. The traffic manager, Prof. Oba R. Garrett, of Fort Worth says that they have perfect co-operation between broadcasting stations, WBAP and WPA.

#### OKLAHOMA

Of course it is the same old story, but honestly, despite our best efforts we just couldn't locate a single station that has been doing any real work this month. We find more rebuilding and overhauling going on now than ever noticed before. In fact, 5ZZ, 5HK, 5LO, 5BY, 5ZG and 5ZM are completely out until masts, receivers, C.W.'s etc. are completed. This does not leave enough stations to even make day schedules, which accounts for our few messages this month.

#### ROANOKE DIVISION

W. T. Gravely, Mgr.

Despite static and other seasonal difficulties such as change of address and rebuilding of sets the traffic of this division is holding its own, all of which just goes to show what a little organization and genuine co-operation will do. Keep up the good work, fellows, and watch our smoke when the gang all hit their stride again.

Eastern Carolina now has a good dependable C.W. station in 4BX, with 20 watts. By working on regular schedule with 3BLF, Richmond, much traffic is cleared. 4KC is proving a big help in Asheville. 4MO and 4MW are reaching out and this gives Asheville five good DX stations. Traffic for Greensboro should be shot direct to 4DC or 4GX or to them thru 3BZ or 3AEV. Reliable daylight work is possible between these stations. 4ID is being reported QSA everywhere and will handle Salisbury and Charlotte stuff, also QSR to South Carolina and Georgia. 4LP of Shelby is also handling traffic.

With the above line-up in North Carolina, stations to the north of that state now have a more reliable outlet to the south and it becomes easier to bridge the uncertain gap between Virginia and Georgia.

West Virginia has fewer reliable stations than Virginia and North Carolina but it has the smoothest running organization in the division, due to the efforts of 8CHO. The fellows are co-operating to the limit. Being nearer to KDKA, relay work is being carried on with difficulty since the broadcasting listeners want all day and half the night. Emphasis is being placed on daylight work and this is already bearing fruit. 8AMD at Lewisburg is handling the bulk of the traffic. On daylight tests he has been heard as far as Danville, Va., and reports having heard 3BLF, Richmond, in daylight. Traffic has been handled between 8AMD and 3BZ in daylight, which, considering the distance, is F.B. 8CAY has also been heard in daylight in Danville.

One of the most encouraging happenings in Virginia is the revival of interest around Portsmouth. This section, formerly the most active part of the state, is coming back into its own. The following stations there have changed from spark to C.W.: 3ATZ, 3ACZ, 3BVB, 3BVC, and 3BNE. 3BVC and 3ACK using spark continue to do the same good work. 3IW is working all points and carries away the honors for having handled more messages than any other station. 3BIJ has increased power to 100 watts and 3BLF to 50 watts. 3MO is rebuilding for the winter and in the meanwhile operating at 3BIJ. 3TJ is still there with the goods. 3BLF is working on a regular schedule with 3ZO and 4BX, with the results shown in the traffic report. Two operators are now on duty at that station. 3HL is beginning to reach out. He is in daylight range of Roanoke and when 3CA and 3RF return, much traffic will go through these stations.

Traffic going north and south in this division pursues the following routes: Route No. 1—3IW, 3BHL, 3CA or 3RF or 3BIJ, 3HL, 3BZ or 3AEV, 4EN, 4DC or 4GX, 4ID, 4LP. Route No. 2—3IW, 3BLF or 3BIJ or 3TJ, 3ZZ, 3ATZ, 3ACZ, 3BVB, 3BVC, 3BNE, 4BX.

## NORTHWESTERN DIVISION

H. F. Mason, Mgr.

The reorganization work has been somewhat halted by the scarcity of reliable stations located to cover all of the division. But if every station will let it be known by sending in message reports that it is there and ready to represent its district, all will be well.

### MONTANA

H. E. Cutting, 7LY, A.D.M. First time in history no report received. How come, OM?? However, a summary follows: 7ZU has his antenna up again and is handling all traffic that goes east over the northern route. 7VZ continues a reliable station. Static has hit this state with full force and the present stations are so far apart that traffic suffers much delay. We need very badly, more good stations in Idaho, Montana and North Dakota.

### IDAHO

7YA and 7OT at Boise, and 7JF, 7ZM and 7WG in the northern part of the state are the principal stations handling traffic. Static is very severe and handicaps reception. Many unheard of stations are opening up, and every effort is being made to get the organization of this state on its feet for once.

### OREGON

Royal Mumford, A.D.M. The broadcasting craze is at its height, and relay work is slumping accordingly. 7IW at Eugene reports as follows: Old man static is hitting us hard. Signals are good and not much trouble is had in working any station that can be heard. Difficulty is experienced in working with Portland. Both 7IW and 7MF are on regularly. 7OZ has been issued a broadcasting license and is making the air hot for us with sweet (?) strains of jazz. At 7ZJ we find trouble in working through the heavy static, as might be expected. We note the increased use of C.W. and are contemplating installing it ourselves. GB, ole Spk.

No report received from Portland. At Salem, 7TJ is with us again, fellows, and we're mighty glad to hear the hole in the ether around Salem filled again. 7TJ is a reliable station working equally well in all directions.

### WASHINGTON SECTION

K. W. Weingarten, A.D.M. 7GE reports traffic moving with customary regularity. No trouble is had working either sixth district, Tacoma, Seattle, Vancouver or Grays Harbor stations.

SPOKANE: 7NL has reopened but not much traffic has been handled yet. 7QW is reaching out on C.W. and is the first consistent station that has been on in Spokane for sometime.

PULLMAN: If the summer weather didn't hit 7FI so hard it would be F.B. as



his spark is QSA throughout the division. 7ZS promises to be on during the summer months.

**TACOMA:** 7QE works east and south with good regularity on C.W. 7CE is tired of broadcasting and is coming back down on 200 handling traffic again. Welcome, ole top. 7BG and 7WM are holding down the spark. Pierce QRN is encountered from the electric smoke-prevention system in the stack at the Tacoma smelter. Can anyone help us out on this?

**OLYMPIA:** 7BZ is consistent on his spark.

**GRAYS HARBOR DISTRICT:** Walter Hemrich, D.S. Those doing work are 7KJ, 7NW and 7CU on spark and 7SC and 7NN on C.W. The Harbor is becoming quite a relay center.

**SEATTLE:** Traffic is being moved with its usual regularity by 7FR, 7NC and 7BK principally. During the recent radio show a set was installed at the club and A.R.R.L. booth, and quite a bunch of messages handled. Since our T.M. came out here and woke us all up to the fact that we are all about six months behind the times, the gang are all scratching their heads and looking around for the makin's of a C.W. set. 7BS will have his 50 watter going in a few days; 7IY a few weeks; 7BK in a few more weeks. 7FR undaunted still has faith in the "rock crusher." (By-the-way, Jones—WHAT'S YOUR CALL—T.M.) At Auburn, 7HI has done some very good work with stations to the eastward. With 300 watts and a sink gap he averages 150 miles per message and six messages per day. He works 7VZ when other stations are unable to hear 7VZ.

All stations north of Seattle are urged to get in touch with 7BG, the A.D.M., regarding appointments, etc., as this is a large territory without any good stations.

#### **PACIFIC DIVISION**

**J. V. Wise, Mgr.**

##### **DISTRICT A.**

Little activity in this district due to QRN. Nearly all stations have closed for the summer. 6ZZ has done a little work. 6ZD also on the job and has cleared many California stations. The southern route east is closed.

##### **DISTRICTS B. & C.**

A number of stations have shut down for the summer due to vacations and QRN. Plenty of the old timers still remain to care for all traffic. 6EN and 6KA are beating O.M. Static by R.F. and loop antennas. 6JD using one 5-watt tube is successful in clearing 6ZAC, 7YA and others. Our good old spark family although decreasing in number as time goes on is still holding down its end of the traffic. 6OD leads the sparks. 6EA and 6EB have both

changed to C.W. On a single 5-watt tube they have out-worked their sparks. The fellows around San Diego are still at war and little has been accomplished. 6ZB and 6TW are doing most of the work for this section. We still are looking forward to a time when harmony will exist in San Diego. (It won't take long.—T.M.)

##### **DIST. OF NORTHERN CALIF.**

We have few reports from the northern section of the state, thus the lumping of districts for this report. The district superintendent of District "G" is 6HP. A. E. Pooge, of Richmond, Calif. The Oakland city manager, 6EX. The fellows in general have been too slow in getting reports in, and it is necessary that they be more prompt in their reports to district superintendents. In San Francisco the majority of the work is handled by 6AWT, 6OO, 6ZE and 6ZW. 6ZE has one of the two 500-cycle sparks on this coast.

##### **DISTRICT OF CENTRAL CALIF.**

C.W. has bitten the central California stations. 6ZX, 6GF, 6AK, and 6KM have been C.W. for some time. 6AVM, 6GR, 6FH, 6GX and 6SU are building 10 watt tube sets. 6SG and 6ABX are also heard on C.W. Radio activities are increasing in this locality instead of decreasing as is general during the summer. C.W. stations outnumber spark stations in central California—the first locality in the west to boast of this fact. 6CC farther north is still a valuable aid to the route north.

##### **DISTRICT J.**

The only active station in Nevada is 6AJR and this old boy is on the job. While of little value east and west, he fills the bill north and south. 6AJR, by the way, will be a fifty watt tube set shortly.

##### **GENERAL**

A system of trunk lines is now being laid out. One of the "three flag trunks" starts at San Ysidro on the Mexican border and north via San Diego, Santa Barbara, Santa Cruz, San Francisco, Sacramento, and Colusa, north to the sevens. This line will be a daylight line as well as night.

The idea of these lines is to have L.D. reliable day routes and only stations of reliability will be picked. A network of trunk lines will enable a message to cover any place on the coast in daylight. Suggestions along these lines will be appreciated by the Manager.

##### **CENTRAL DIVISION**

**R. H. G. Mathews, Mgr.**

During June we have had the usual falling off in relay traffic but a few of the old stand-bys are still going. A remarkable feature of the summer work in the Central Division is that the spark transmitters

seem to be having less difficulty in getting messages across long distances through summer static than do the C.W. stations, and a universal cry seems to be going up in this part of the country for a rejuvenation of the old spark sets for summer work.

#### MICHIGAN

The 375-meter route, Detroit-Lansing-Grand Rapids—and all other points south and west from Grand Rapids—is in good shape now, making traffic an easy matter to get through. 8ZZ, 8ZAG and 8ZF maintain a daylight schedule. Traffic has taken a great slump in June, but 8ZAG is on every night 6:30 to 10:00 p.m. on 200 meters and 375 meters after 10 P.M. and will QSR in any direction. 8ZAG handles all traffic in Grand Rapids as there are no other DX transmitters there.

#### NORTHERN INDIANA

Reports for this month are very meager due to the fact that many of the stations have been off the air and that static for the past few weeks has been unusually severe. Only a few of the regular relay stations have been on and the few who have been in operation during the month have not sent in their reports to the district superintendents. All members of the Operating Department are doing exceptionally good organization work and are to be commended for it.

District No. 1: Routes in this district are as follows: East to west, 9ME, 9DAX, 9PC or (9II) to either 9HR or 9FS. From 9FS or 9HR to either 9AKD, 9CP, 9VL or 9AWZ. Going east read backward. North to south: SCP, SYN, 8NZ to either 9HR or 9FS, thence to 9CBA. Going north read backward. Messages going east or west may also be relayed from stations 9ME, 9DAX, 9II, 9PC to 9CBA, then to 9DTJ, 9CP, or 9AWZ. Going east read backward. Stations 9LB at Purdue and 9YQ at Culver will be placed on routes if they are in operation during the summer.

District No. 2: 9GU is closed for the summer, 9ACE is in trouble over his power supply; 9DCU has a 50 watt C.W. installation on but is not interested in handling traffic. 9FD is operating intermittently on his 50 watt C.W. and phone. 9BLC with a 10 watt C.W. is the most reliable of any of the stations here during the summer. 9YB has the usual summer complaint, no operators excepting the boss of the outfit and he never did graduate from the 10-word class.

#### ILLINOIS

Very little activity in Illinois during June. 9CA, 9DHZ, 9BTA, 9DDY and some others being the most active stations. An excellent report received from D.S. G. W. Bergman of 9CA, reading as follows: "9CA most active station this month, although

only on about two weeks. 9BTA failed to send in a report and may have handled in the excess of 70 msgs. but no report. Whatsamatter OM? 9BTA, the boy wonder on the 20 watt C.W., had a little bad luck and blew a couple of tubes. Gess it sorta dishearted the kid. Hi! 9BJT is the typical "Huckleberry Finn." Short pants, red hair and freckles all go together to make a darn fine fellow and a nice station. 9AJZ has been off for about a month. 9APB hasn't touched the spark set for two weeks. Can't seem to keep his thoughts away from C.W. F.B|OM. This district boasts of three new stations, 9CAE, 9CDZ, and 9CFL. 9BQW is doing excellent work with a small C.W. outfit and is getting across to St. Paul and Minneapolis particularly well. There are seven licensed stations in Rockford besides 9BQW: 9BRO, 9BPR, 9BNN, 9DEI, 9DJU, 9DVW and 9DQR."

#### NEW ENGLAND DIVISION

P. F. Robinson, Mgr.

F. H. Pierce, our A.D.M. for Maine, is taking a summer course at Columbia University, and has left. Linwood Hilton and Edward McShane in charge of A.R.R.L. work for the summer, a job which they are cleaning up in fine style. 1PM has been doing good work lately with his DeForest  $\frac{1}{2}$  KW Oscillation, having regular schedules with several other C.W. stations.

The following appointments have been made:

Perley Woodman, Dist. Supt., Androscoggin & Oxford Counties, Auburn, Me.

Delmont Parsons, Dist. Supt., Cumberland & York Counties, Portland, Me. (1AKY).

Edward Pomeroy, Dist. Supt., Sagadahoc, Lincoln & Knox Counties, Bath, Me. (1ACO).

Robert Dresser, Dist. Supt., Washington & Hancock Counties, Calais, Me. (1VT).

H. E. Nicholas, City Mgr., Bridgeport, Conn. (1BM).

Stalo Martino, Dist. Supt., N. H. County, Conn. (1AWB).

Perry Briggs, City Mgr., Hartford, Conn. (1BGF).

Waldo Heath, Dist. Supt., Northwestern Ct. (1QO).

Guy Phillips, City Mgr., New London, Conn. (1AYU).

Shepard, 1UL; Sever, 1FM, Newell, 1CIB; Mulligan, 1BJS, and Hill, 1BAS; have been appointed official relay stations on the Maine relay trunk line.

The broadcasting is still attracting a large number of our relay personnel and for that reason the message totals are small.

The C.W. stations are certainly coming

through now—nearly 50% more messages handled by C.W. than by spark this month, although 1AA, this month's high man, is far in the lead with his spark set on the messages-per-station count.

#### ONTARIO DIVISION A. H. K. Russell, Mgr.

Comparatively little is being done in relay work, although there is a lot more work being carried on here than last year and indications are that this fall will be the best yet for the division once we get the convention in Toronto on September 8th and 9th tucked away, and all the gang filled with the "up and at 'em" spirit. Everyone seems to be full of enthusiasm, and the affair should go with a bang, and right here the Ontario Division wants to invite every A.R.R.L. man to Toronto for September 8th and 9th.

Despite repeated messages, no report from western Ontario this month. The "old reliable" Cowan, however, comes through and reports 3GX the star performer of his district with the 25 cycle spark set from 8WO going strong. 3DS blew a 50 watt and relapsed to spark, on which he says he worked everyone within 500 miles. The fact remains, however, that he was QSA in Toronto with 10 watts C.W. and is yet to be heard from there on his spark set. He reports 9AL very QSA on voice in Kitchener. 3SB and others are still in the making. The D.M. had a visit from Byerlay of Ingersol who advises that Mackay has abandoned radio. We wonder how long his wife will keep that way. Byerlay has great plans laid down for 3GN, both C.W. and spark being installed.

Toronto had a temporary relapse in traffic handling due to considerable number of DX boys working at exams. 3JJ has two 250 watt tubes now. 3JI and 3JK are both heard now that exams are over. 9AL has done a couple of late tricks, and as a result reaped a harvest of postcards, and a blessing from the user of every single circuit tuner in town who was listening to the concerts. 3FO and 3GE are working on C.W. sets. 3CZ is still knocking them cold with his 50 watts C.W. Rogers in Newmarket has abandoned amateur radio for the commercial end and is now working for the Canadian Independent Telephone Company on their engineering staff—3BP surely is missed. The best news from Kingston is that Toronto and Montreal stations are both copied regularly there. If we can only get a good station established there our link between the two metropolises is forged. Donnelly says that there are no flies on 9AL. He copied him in Kingston on a screen door for an aerial. Tests are now being run between

Brockville, Kingston and Gananoque on voice, which is another good omen for the fall.

#### ALASKAN DIVISION Roy Anderson, Mgr.

Through the kindness of 7RK who was recently in Alaska a relay message to Alaska was planned and sent, as far as the writer knows, but due to the latter's inability to get his receiver in time no listening was done. It is planned to have other 7's broadcast Alaskan messages later on in the season.

7BJ (Vancouver) who is now in Chignik reports that 7UF, Ivar Wallin, is getting his set in shape. He also reports the following calls for the month of May, All about fifteen hundred miles from Chignik: 6KA, 7DP, 6ZI on C.W. and CL8 and 6ZQ spark on 375 meters.

On May 7th, 7IT (Ketchikan) heard 7SC calling 7NN. This was using a one-step with Westinghouse tuner and without any ground connection, C.W.

There are still nine members in the Alaskan Division.

#### DAKOTA DIVISION N. H. Jensen, Mgr.

The D.M. is convinced that traffic can be handled during the QRN period if a sufficient number of stations stay on the job. There are the occasional "good nights" when sigs reach out in good shape and daylight work is good at any time for short jumps. The "Schnell Special" from Hartford to Seattle was handled thru this division, 9ZN to 9YAK to 9PI.

#### SOUTH DAKOTA

In the southern part of the state traffic is being handled by 9YAK, 9BRI, 9BOG and 9AVZ. In the northern part 9ASF is starting things and reports that he now has his 100 watt set going. Has worked both coasts. 9DWL and 9BOR are both installing C.W. transmitters. Stations doing consistent work in the northern part are 9TI, 9PI, and 9DR.

#### NORTH DAKOTA

Several new C.W. stations are under construction in this district. The stations handling traffic regularly are 9WU, 9FX, 9YF and 9ABU.

#### NORTHERN MINNESOTA

Very little doing in Duluth on account of QRN and QRM from lake stations. 9BAF had his mast ruined by lightning and is out of commission temporarily. 9BAV is doing good work in handling traffic. Traffic is moving regularly north from the Twin Cities in steps to Brainerd. From there it goes on a regular daylight schedule via 9BAV to 9AOR, and 9AOR works 9ZC regularly every morning. A spark station has been located at Cohasset. This

town is between Duluth and Brainerd and may solve the last leg of the Twin Cities to Duluth daylight route. QRM from NUX is worse this year than ever on account of increased traffic on the Lakes. 9ZC reports that a good short jump route has been established thru the central part of the state to the Twin Cities.

#### SOUTHERN MINNESOTA

The talk about the Dakota Division Convention to be held in Minneapolis in the early part of September during State Fair Week, is overshadowing everything else. This promises to be a big event for A.R.R.L. members, and from present indications the attendance will be very large.

#### VANCOUVER DIVISION

W. D. Wood, Mgr.

Local activities have been very slack but there has been some station on the job in Vancouver nearly every night that can handle northbound traffic.

PRINCE RUPERT DISTRICT: Supt. J. Barnsley, 5AX, has been unable to reach down to Vancouver on his spark set even though tests were pre-arranged with 9BD and all the Vancouver amateurs. He is now planning on 50 watts of C.W. to be installed for this fall. There is no doubt now about our ability to QSR to Alaska this coming winter as 5AX is only a short, but difficult jump, to Ketchikan, Alaska. Barnsley copies messages sent to him "blind" by Vancouver stations.

In the interior the only news is that there is a broadcasting station at Nelsen, B.C., and will QSR on C.W., wave 440 meters.

To the south the sigs. still come roaring in from 6KA, 6JD, and 6EN in Los Angeles to the sevens farther up our way. Seattle traffic is handled chiefly thru 7BK, 7FR and 7SC in Aberdeen, Washington pounds thru on his C.W. Seattle spark stations QSS terribly at times in Vancouver and it is impossible to work them. The sixes come in up here like local stations, and 6ZI, 6AWT, 6GX, 6GF and dozens of others are heard regularly without QSS. All the above are on C.W.

5BR, the first western Canadian to "get across" will be back on the air soon with 10 watts of "C.Wat" and should reach out about as well as 5BQ.

5CN has the makings of a 50 watt tube set. 5BQ on C.W. and 9BD on spark are the only stations handling any DX traffic at all. B.C. bound messages should be routed thru them.

#### WINNIPEG DIVISION

J. A. Gjelhaug, Mgr.

4CB, Dist. Supt. of Saskatchewan, reports QRN very bad most nights and with

warm weather large numbers of radio bugs are very busy with other work and sports. A large number of receiving sets have been sold throughout the Province but very little doing in the line of building good strong transmitters.

Moose Jaw Senior Amateur Radio Assn. have placed an order for material for two 50 watt tube broadcasting and C.W. stations. 4EI, Moose Jaw, is making quite a hit with his 5 watt fone set around the city. 4BV was our best relay station this month.

Mr. W. W. Grant has resigned his position as Chief Radio Engineer of the Canadian Air Board and is now located at Calgary as president of the W. W. Grant Radio Ltd. and is operating Calgary Albertan Broadcasting station with the same success as he had at VAW. Mr. Grant writes that he has sent in application to A.R.R.L. and will be pleased to handle relay traffic between 10 and 11 P.M. This will give us a fine station in Alberta. Alberta now comes under the Vancouver Division and no doubt 9BD of Vancouver will have a reliable relay route working there soon.

4CB is all sold out and getting grey hairs trying to figure out the biggest transmitter and best receiving set he can get material to build, with available dough. We will get a trans-Canadian route going this fall or blow out some fair size tubes trying.

4BG of Winnipeg reports absolutely nothing doing in the line of relay work. 9YAF, of Pembina, N. D., not operating at this time, nothing coming in from the south.

Everybody is pulling hard for a trans-Canadian relay route by fall. Come on, fellows, and don't let there be any "stumbling block" in the Winnipeg Division. Saskatchewan relay stations have been doing good work and by fall they will surely be in fine shape with the many new and remodeled stations. Manitoba relay stations have been rather slow. Winnipeg should be the "hub" for Canadian relay, like Chicago is for the United States. The bulk of traffic will be to and from Winnipeg and all Canadian and United States amateurs are anxiously awaiting for a **FIRST CLASS RELAY STATION IN WINNIPEG**, the "hub" of Canada.

#### BOOK REVIEW

(Continued from page 23)

factors—it ran completely across a large room and had to continue on a second line. We are informed that this was merely typical of Ballantine, so our wonder is the greater at his book.

As the author himself says, in the third and succeeding chapters all mistaken at-

(Continued on page 40)



# INTERNATIONAL Amateur Radio

## News From South America

In a recent letter from Mr. W. H. Martin, "MB" on KDYL, he describes reception conditions around Montevideo (Uruguay) as the best he has ever experienced anywhere in the world. The American coastal stations south from WCC, WSA, WNY, WLC, WCY, etc., are copied there nearly every night during the winter. JOC, Chosi, Japan, on 600 meters, and KFS on 2400-meter arc have been heard. All of these things will support the claim of one of the operators at CWA, Cerrito, near Montevideo, that one night during early May he heard an American amateur working on phone signing 9ZN or 9ZM, he was unable to understand which. We dunno; it seems more likely to have been 9XM but X doesn't sound like Z. At any rate the DX is about 5100 miles, and CWA uses honeycombs and two steps of audio.

In the Argentine there is much amateur interest and activity now and the Radio Club Argentino of Buenos Aires, a member of the A. R. R. L., has firmly cemented the enthusiasts together, "of all and by all". They have a bunch of crack operators and are apparently unlimited as to power or wave length, two of their members having a 3-k.w. are working on about 2800 meters. They use radio amplification, at least for the longer waves, Mr. Martin saying that he copied the radio returns of the Dempsey-Carpentier fight last year at two different amateur stations there, each using seven stages of radio, detector and three audio.

In days to come when hams the wide world over are clearing their traffic across the seven seas, those of us here who know nothing but English will have the British Isles as our most likely place to work, some of us will pick on the French, and those of us who know Spanish will try Porto Rico, Brazil, and the Argentine.

## Baldwin Heard From

Capt. Norman Baldwin, Military Attache at the American Embassy, Peking, China, writes us that he is all for trying a Trans-Pacific stunt but fears the difficulties are almost insurmountable; a young war going on, refusal of the Chinese government to grant a license, an absolute lack of facilities

for constructing a transmitter, etc. But he knows a man there who has a friend who has some radio junk, and that spells possibilities. It's a mere 5000 miles from Peking to 6ZAC in Hawaii, and what's that to a couple of bottles?

Then there's Lt. G. H. Burgess, Wing Radio Officer somewhere in the Philippines. 'Chasay, George, got aning wkg yet?

## A Few in Mexico

Some news from Mexico was received in a recent letter from Harold T. Mapes, old-time A. R. R. L. member, now in Guanajuato, Gto. Radio is way behind there and most of the amateurs seem to keep under cover. One of the regulations for a government permit is that the apparatus shall not send or receive past the Mexican border. Hi! Mapes is applying for a permit and if the radio waves refuse to obey the Mexican law we may hear him up here yet.

## French "Calls Heard"

8AB, the station of Leon Deloy, of Nice, France, most active of the french amateurs, is now closed down for the summer and will resume in October. Tests for fall are being arranged with some American amateurs. 8AB reports the following British amateurs heard at Nice: 2FQ, 2OM, 2CV, 2ON, 2DM. Looks just like U. S. A. stuff, doesn't it?

"L'Audion", organ of the Radio Club of Italy, in its middle May issue commenced the monthly publication in English of a resume of radio activity in Italy. We appreciate this column very much, tho its English suggests what our own Italian might look like, and we hope it continues as a permanent feature.

We learn therein that an active correspondence is running between the Radio Club d'Italia, the Societe Francaise d'Etudes de T.S.F., and the Cercle Belge d'Etudes Radiotelegraphiques for the organization of the first international meeting of radio amateurs, to which end a commission composed of a representative from each of several European countries will meet soon in a preliminary meeting at Paris, whereupon invitation will be extended the radio clubs of all countries to participate.

### A Trip to Makapuu Point

(Under the above title the following article has reached us from the radio gang at the Submarine Base at Pearl Harbor, Hawaii, describing the reception of American amateur sigs)

It was a quickly arranged affair and reflects great credit upon Newton, the C.W. enthusiast, who called together the clan at the eleventh hour, secured a truck and loaded it with chow, blankets 'n' everythin'. Dave, the grid leak expert, took the wheel. He was in his happiest mood. Dave is the best driver on Oahu, bar none, and drove us to Makapuu in an hour and a half, the previous record being two hours.



After an interesting flight of rocky stairs we were ushered to an old wash-house where we put up a fifty foot field type of bamboo mast. A 4-wire flat-top inverted-L antenna was erected. Our C.W. receiver was made up of one Remler coupler, U.V.200 detector, and two-stage amplifier.

Loh, the speedy Chinaman, had prepared a real campfire dinner and plenty of java was on tap. Doc Bruneau kept the crowd in laughter all the while and drove home many good points for C.W. stuff. Chow was finished, an assortment of fags passed around and the gang started for the fun.

We just got in on the receiver for 6ZX, who was the first amateur to be heard on the island of Oahu. The next station was 6KY. Nothing more was heard until we shifted a U.V.200 for a VT. 6ZI came rolling through in good style. His signals were QSA and steady. 6ZB, 6TQ, 6EX, and 6ZAC came in thru the jam. Calls were hard to pick out as there were so many C.W. stations working. Harmonics from Heeia were bad. Rain and wind caused us to knock off the hunt for about an hour. 6ZG was picked up when we resumed and later he came through with some messages. 6ZZ was heard with good audibility, and 6ZG was picked up again. We camped on his wave and experimented on different types of bulbs. One VT and a U.V.200 gave the best results. 6ASJ was logged by the cook. Chas. L. Elvin, Oakland, Calif., was heard; he told about his set and gave his name; call letters were not heard. 6KI was heard and later Dave logged 5BG, which was the prize-winner of the hunt.

Next trip we will have a 30-watt C.W. set hooked up to an antenna between a couple of palm trees. Look out, 6ZI and 6ZG. Watta you say to a little record work? Malihini.

### New Radio Bill in England

On June 13th the Postmaster-General presented a bill in the House of Commons to amend the radio act of 1904 in a manner similar to the proposed changes in the United States. The bill gives the P.M.G. powers to make regulations as to conditions and restrictions on which licenses are to be granted, renewed, suspended or withdrawn; to refuse licenses to foreigners, to take control in cases of emergency, and to prevent interference with the radio communication by the generation of electric waves for other purposes. Full scope is left to inventive genius by allowing the erection of experimental stations; permission will be readily given for receiving stations, and transmitting stations of small power will be allowed with practically equal freedom when the applicants can show that they are serious students of radio. We have no information as to whether transmissions will be confined to experiments and the actual exchange of correspondence prohibited as at present.

### Porto Rico Radio News

Under the above name the Porto Rico Radio Club is publishing a mimeographed periodical which we follow with interest. It is edited and printed by U.S. 4JE, J. Agusty, whose station was recently described in QST. In Spanish of course, it is full of the Island's amateur news. Good luck, OM.

Porto Rico doesn't really belong in the *international* news any more than Hawaii does, and we don't want them to feel on the outside, but the establishment of amateur communication with them represents just the same problem as it does to lands where other flags are flying.

### BOOK REVIEW

(Continued from page 38)

tempts at a popular treatment have been frankly abandoned, which was necessary in order to get something said. Antennas, transmitters, sources of power, and receiving apparatus, are the general classifications—into the sub-divisions of which we cannot go. The author likes cages, knocks the Alexanderson multiple tuned antenna, advises amateur C.W. transmission on the fundamental wave length of the aerial, raps aerial insulators having high capacity to ground, boosts the master oscillator and gives some good dope on it, also upholds the Meissner circuit as the best for C.W. transmission, raps A.C. on the plate, tells how

(Continued on page 44)

# With Our Radiophone LISTENERS

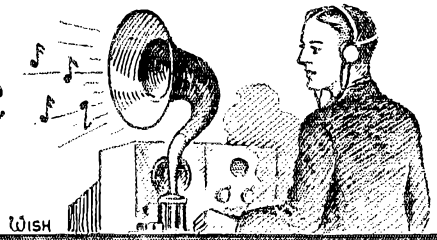

### The Boom in England

Popular interest in broadcasts is very evident now in the British Isles and we presume the British hams will come in for their share of troubles. However, the authorities are profiting by the experiences of the American administration and taking steps to avoid confusion as much as possible. The country will be divided into eight areas centering upon London, Car-

the various manufacturers as to whom should be permitted to operate the stations and at this writing the only broadcasting which is taking place is sent out by the Marconi station near Chelmsford, using a quarter kilowatt, and series of tests sent out by Marconi House and the firm of Burndept Ltd.

The impression is gaining ground in this country that there will be an immense

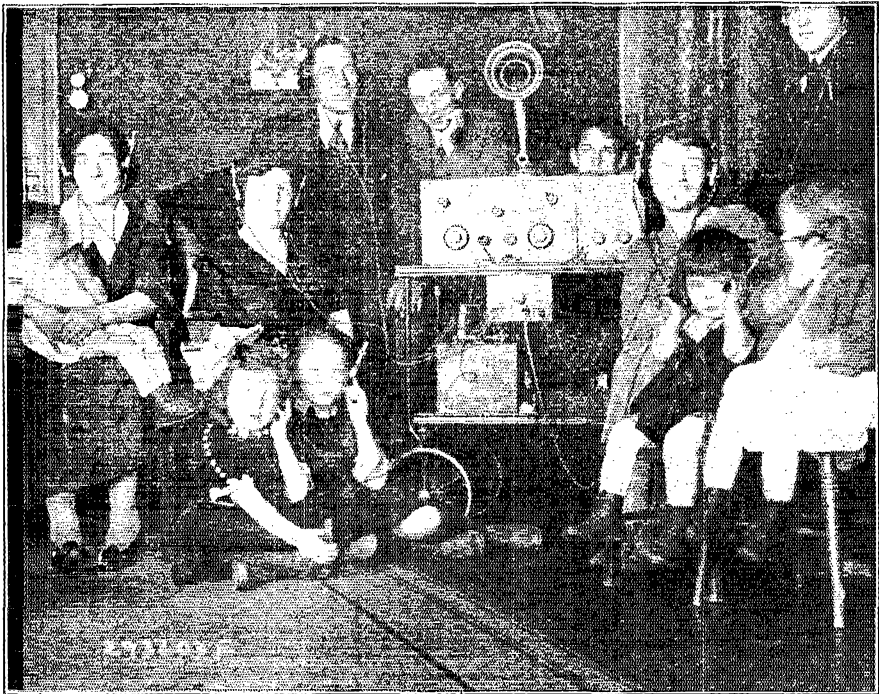

A Radio Family—Every One of Them Is Hard Hit  
 --Photo by Underwood & Underwood.

diff. Plymouth, Birmingham, Manchester, Newcastle, Aberdeen, and Glasgow or Edinburgh, with a permission granted to British bonafide manufacturers to erect a broadcasting station therein. The total number of B/C stations for the country will be eight. There seems to be considerable unpleasantness at present between

market in England for cheap American-made apparatus but we do not believe this is true. One of our correspondents informs us that the average radio man in England wants something good and his present idea is a two to four valve set costing from £30 to £80.

One of the interesting provisions intro-

duced by the P.M.G. in the new boom is the prohibition of the sale of receiving sets which can radiate or cause interference. It has been a pretty engineering job to design a set which would afford maximum regeneration on any normal antenna and yet be quite incapable of actual oscillation but it seems they have done it, and without the use of one-way repeaters. We need something of the sort in this country to reduce the horrible cat-calling on 360. An English amateur aptly quotes from "The Pied Piper:"

*"And even spoiled the women's chats  
By drowning their speaking  
With shrieking and squeaking  
In fifty different sharps and flats".*

which includes the antenna system. This circuit determines the frequency and wave length of the radiated energy and can be closely adjusted by means of a variometer. The 250-watt tubes amplify the modulated radio frequency energy.

In addition to the regular broadcasting schedule, WSB has introduced several novel features. A class for radio novices is held each Saturday morning and complete receiving sets are built while the class take notes preparatory to constructing similar sets for themselves. The Journal also maintains a radio truck completely equipped with a receiver and magnavox which gives at fresco concerts in the city parks and adjacent cities, received from WSB.

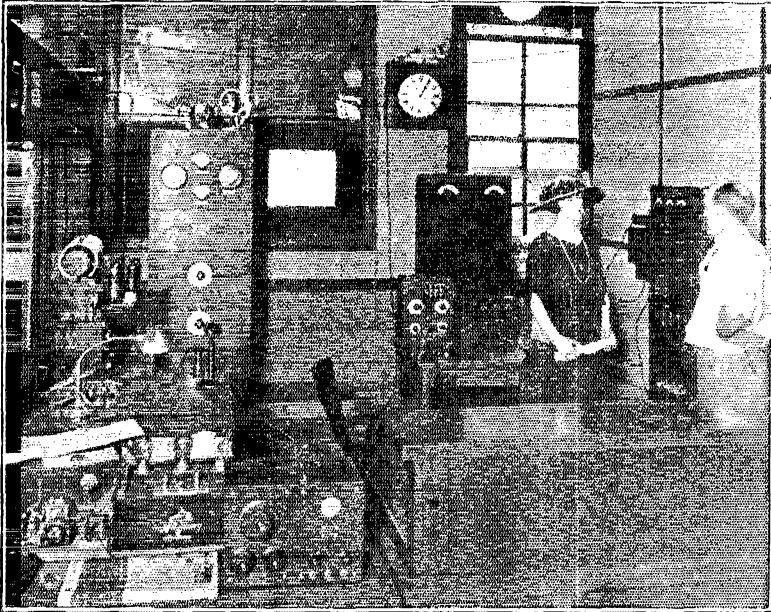

WSB, The Atlanta Journal, Atlanta, Ga.

One of the most powerful broadcasting stations in the south is WSB, the station of the Atlanta (Ga.) Journal. This station uses four 250-watt power tubes and one 50-watt tube. These tubes have an oxide-coated filament that insures maximum electron emission with minimum expenditure of filament circuit power. The tubes are mounted in the upper part of the framework back of the control panel and with adequate ventilation. The filament current of 6.25 amperes per tube is supplied from a constant potential generator mounted on the same shaft with a five and one-half horsepower motor which also drives the high voltage direct current generator delivering 1.25 amperes at 1,600 volts.

The oscillator comprises a tuned circuit

Music is broadcasted every Tuesday and Thursday from 7 to 8 p.m. from BT3, the Army station at Camp Lewis, Wash.

#### Care of the Storage Battery

As storage batteries are used in practically every radio station, sending or receiving, in the country, a few words about their care may not be amiss. By improper care a storage battery may be easily ruined.

Storage batteries are used as "plate" or "B" batteries, and for lighting the filament in which case they are known as "filament" or "A" batteries. Dry cells are the most common "B" batteries so it is the "A" battery with which we are mostly concerned although what we say applies to both types to quite an extent. At this



point it might be well to repeat the warning, "Don't confuse the "A" and "B" battery connections," as one or more tube filaments are sure to "blow."

In the first place, there are many makes to choose from and many design principles of more or less merit. We welcome the interest taken in this field by the storage battery manufacturers in designing a battery especially for our use when we formerly used auto batteries. The trouble with auto batteries was that they were designed to deliver very heavy currents for short periods and required frequent charging. In addition to the usual precautions in the design and manufacture of a storage battery the "A" battery should have thick plates. Thin plates with much exposed plate surface produce the heavy current required for auto starting but thick plates give more uniform current over a longer period between recharges and contribute to a longer life. In choosing the battery to buy, much must be taken for granted as one cannot even see what he is actually buying, so a great deal must be left to previous experience and the reputation of the manufacturer. We endeavor in selecting our advertisers to pick only those we believe have products of value to the amateur. More on the best make of battery to choose can hardly be said.

All "A" batteries commonly used deliver very close to six volts and have three cells of varying size depending upon the ampere-hour capacity at which they are rated. The ampere-hour rating is a measure of the quantity of electrical energy that can be stored in the battery. For example, a 60 A.H. battery after fully charged should deliver one ampere for 60 hours before being completely discharged, or 6 amperes for 10 hours. An older battery will not have as long a discharge life. When short-circuited a storage battery may deliver several hundred amperes for a short time but the battery will be practically ruined. All batteries have a normal charge and discharge rate (in amperes) and to exceed this means permanent damage and a shortening of the life.

The large and small sizes of "A" batteries have their merits and it is somewhat of a compromise to pick the size desired. From the above it will be seen that a battery of large ampere-hour capacity will run the tubes longer than a smaller battery. If the battery is not charged at home it means it will not have to be lugged to a battery charging station as often but on the other hand the larger sizes are quite heavy so it is a compromise. When charged at home the larger sizes are better as the station operation is not interrupted as often by recharging the battery, but of course the large ones cost more. In figuring out the time the set will operate

on a fully charged battery, an approximate idea can be gained by considering the detector and amplifier tubes to consume one ampere each. Thus a detector and two-step amplifier will decrease the total charge by three ampere-hours for each hour the set is operated, so a 60 A.H. battery should run the set about twenty hours.

Storage battery manufacturers furnish data with their batteries which should be carefully followed out. The only reliable method to determine the degree of discharge is by measuring the specific gravity of the electrolyte. Discharging is a chemical process in which the acid enters the plates while charging drives the acid out of the plates into the solution, for the current passing thru the battery on charge is in the opposite direction to discharge.

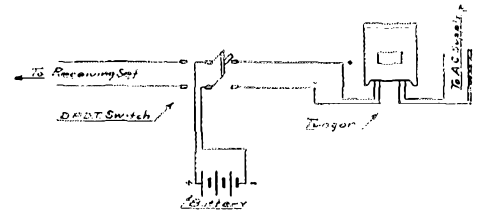

Consequently the specific gravity (the ratio of the weight of the electrolyte to the same volume of pure water) gets higher as charging progresses until all the acid is driven into solution. A storage battery, therefore, must not be left discharged as the acid in the plates will rapidly destroy them. Even a fully charged battery can not be left unused more than a few months without "sulphation" of the plates. A hydrometer-syringe should be purchased from an auto accessory store (for about a dollar) and tab kept on the readings according to the directions for that particular battery. The electrolyte should be kept well above the top of the plates but as the water and not the acid evaporates, only pure water is to be added to fill the cells. In case of loss of some of the electrolyte due to a cracked jar or spillage the solution may be weaker than usual. Acid had best be added by the man at the battery service station as there are numerous precautions necessary to protect the battery—and the eyesight.

This brings us to the subject of battery chargers. Of these, too, there are many brands. The magnetic and gaseous tube types are the most common of which the latter is somewhat more generally used, probably because of better organized sales or advertising forces. Of course if direct current is available the battery can be connected directly to the house wiring circuit thru a suitable resistance as a lamp bank of several carbon lamps, but as in the greatest number of cases only alter-

nating current is available, some form of rectifier must be used.

Eight hours is about the shortest time in which a battery can be completely charged if it is empty to begin with. Therefore to divide the ampere-hour capacity by eight will give the approximate maximum current that can be put into the battery without damage to the plates. It is well to keep below this figure by prolonging the charge or not letting the battery go completely dead. The habit of letting a battery go dead is bad practice as it has the exasperating practice of going dead quite suddenly in the middle of important DX reception and a long period of charging is necessary to bring it up. The time required for the two and three-ampere rectifiers to charge the battery is about the same length of time as the set is used, which means the charger will be going all day long if the operator listens all night long. The larger chargers are especially recommended for the batteries of higher ampere-hour rating.

The single bulb rectifier uses only half of the alternating current cycle. "Full wave" rectification can be obtained with two bulbs but it is somewhat more complicated. At first thought it would seem that "half-wave" rectification would have low efficiency—not over 50%. Further consideration, however, will reveal the fact that on the half cycle when no current is flowing thru the bulb, no energy is being taken from the line, except a small amount exciting the transformer and heating the filament. The efficiency, as a matter of fact, is in the neighborhood of 75%. Most of the transformers used in rectifiers are known as "auto-transformers" as they have no separate secondary but a part of the primary coil acts also as a secondary. Thus a circuit can be traced from the power supply to the storage battery terminals and may be the cause of trouble should the battery be accidentally grounded while charging. This danger is especially liable to happen with a single circuit tuner and may burn out the vacuum tubes and do damage to the receiver and rectifier. A double-pole double-throw battery knife switch therefore should be wired in such a way that the battery terminals connect to the blades of the switch and the clips in one position of the switch connect the battery to the rectifier and in the other position the battery is connected to the proper terminals of the receiving set. As the switch cannot be in both positions at the same time the accidental possibility of a pyrotechnic is eliminated. Sometimes it is possible to read signals thru the loud hum of the battery charging but for safety's sake it is desirable to connect a well insulated condenser in series with the ground. If this is sufficiently large, say .01 micro-

farads, it will not change the wave length appreciably, and will insulate the set from the ground.

The above has just touched on the subject of storage batteries but should be some guide to the beginner who hardly knows his battery. For the experimenter who likes to build things it is suggested he design a battery-charging rectifier along the lines given in the data in the June issue. Such a rectifier can be made for a few cents and possibly operate from the filament terminals of the C.W. transformer found in many stations. QST will be glad to learn how this works out. —B. P.

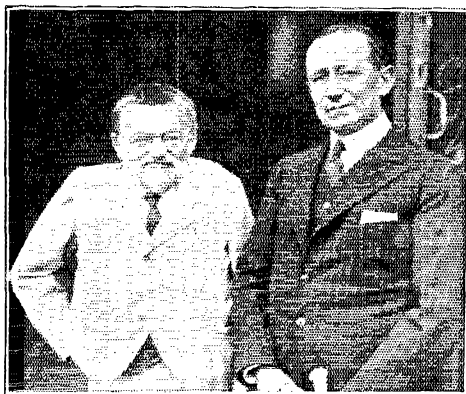

—Photo by Underwood

In the above are shown two men about whom a great deal can be said. Dr. Steinmetz, on the left, is the Chief Consulting Engineer of the General Electric Co. Almost everything he writes keeps the college boys who study E.E. awake many a night. His keen insight into electrical engineering problems has placed him in the "electrical wizard" class. Senator Guglielmo Marconi we have heard a great deal about for several years and he is often called the father of wireless. The photograph shows him on the steps of Steinmetz's laboratory at Schenectady, N. Y., during a recent visit to this country to see what trouble he started when he invented wireless.

## BOOK REVIEW

(Continued from page 40)

to build 50 henry chokes, boosts the Reinartz tuner skyhigh for C.W., recommends soft tubes for amplifiers for maximum results, and prays for the return of the day when we shall have decent detector tubes on the amateur market. Complete wiring diagrams with constants are given for any number of C.W. transmitting arrangements,

(Continued on page 47)

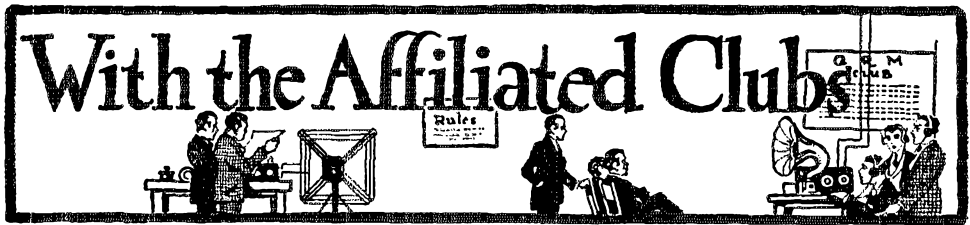

### The Northwestern Division A.R.R.L. Radio Convention and Show

During the week of June 5th to June 10th, a Radio Show and Convention were held under the auspices of the Seattle Radio Association and the Totem Radio Club in Seattle. All during the week hams were coming from every part of the 7th District to see the show and to attend the convention and banquet of the Northwestern Division of the A.R.R.L.

chairman could not be elected. For the purpose of doing business and getting the members of the council together, H. L. Jones, 7FR, was elected temporary chairman, and he was voted the power to call a meeting of all club representatives, and in council assembled permanent officers are to be elected for the coming year.

Plans will be made for the next convention and banquet, and instead of having several smaller ones each year there will



The real activities started Saturday morning, June 10th about 9:30, when Howard Mason who was chairman of the convention called the gang together in the auditorium of one of the large department stores. Mason told the bunch what the purpose of the convention was and asked for suggestions regarding the formation of the 7th District Executive Radio Council. Much talk took place pro and con, and by unanimous vote it was decided to form the 7th District Executive Radio Council. Two committees were appointed: one on resolutions and another on organization. These committees convened during lunch and prepared subjects to be voted on during the afternoon session. The convention was called to order again at 1:30 p.m. and the proposed scheme of forming the council was adopted unanimously. The Council is to take representatives from all clubs in the 7th District for the purpose of self-government. Representatives from Portland failed to attend and a permanent

be just the one big affair similar to the one held annually in the First, Second, Third and Fourth Districts.

The "Radio Amplifier," the monthly organ of the Totem Radio Club, was proposed as the official organ of the Council. Since officers were not elected, the decision as to whether or not it will be adopted must be made later.

H. R. Marriot, of the Naval Service, opened the technical session with a paper on the elimination of "mush" from Naval stations. He was given a good round of applause by the gang. Mr. Libby, chairman of the Seattle chapter of the I.R.E., spoke on "Frequency Traps" and pencil and paper were in evidence as much information was being obtained. Dr. Burglund was the next speaker, during which time he demonstrated his amplifier.

A jamming contest was the next thing on the program, and first-prize, a silver loving cup, was won by J. W. Holcombe, 7KP.

About 5:30, Mason closed the convention in order to give the visiting hams a chance to look over the radio show at Dreamland.

#### The Radio Show

About forty exhibitors displayed their wares in Dreamland. We saw the usual line of fancy baskets rigged up with radio sets that would receive 1000 miles; radio sets in canes, fishing poles and razor cases. One of the most popular forms was the "radio garter" on which was mounted a receiver using a crystal detector. Nearly everybody asked for a demonstration or two and the young lady who wore the garter was busy practically all of the time giving demonstrations. The gang appointed a committee to inspect the set more carefully and in detail. Said committee failed to report and it is not known whether or not the inspection was made.

The Totem Radio Club and the A.R.R.L. combined in one booth. A small spark set was in operation with the call letters 7AFV, and messages for delivery to all parts of the U.S. were accepted by the hundreds from the public as the show was going on.

The radio-controlled car was the most remarkable piece of equipment at the show. It was constructed in less than three weeks time by Kenneth Field of Seattle. An effort had been made to have Professor Glavin and his radio controlled car at the show, but it seemed that the gang could not afford the insurance of \$25,000.00, so they just said, "Bygawd we'll make one of our own," and make it they did. It performed as well as the car constructed by Professor Glavin, but instead of a spiral being used for an antenna a horizontal loop about 18" square served as a collector and it looked less cumbersome.

#### The Banquet

Carousing around the show made the gang hungry and everybody was anxious to start for the banquet.

This was held in the L. C. Smith Building, Seattle's 41-story sky-scraper. About 7 o'clock the gang started getting together and about 7:30 eats were being served. Jones, 7FR, thought his consomme was tea and he loaded it up with three lumps of sugar. This soon got around to the various tables and at the expense of Jones everyone had a good laugh. About 100 people attended the banquet. Toastmaster Mason made the address of welcome and introduced the speakers: Traffic Manager F. H. Schnell, Commander Mathes; Mr. Murray; W. D. Wood, 9BD of Vancouver; Bidner, 7HQ; Jones, 7FR; and Hagen, 7ON.

After much persuasion on the part of Mr. Otto M. Nicholson, 7KM rendered a very touching little song composed by himself. Along about midnight there was a

general hamfest, and for the fourth time Manning's Waffle Shop was captured by the gang 30 strong.

Everyone who attended it will remember the Northwestern Convention as one of the bright spots in amateur radio, because everyone had a grand time. Even when the party broke up at two in the morning regrets were passed around.

#### Champaign County Radio Association

The Champaign County Radio Association with headquarters in Urbana, Illinois, had a big banquet on November 21, 1921, since which time they have met on an average of once a month, the program usually consisting of talks by some member of the University faculty or student body who has had considerable experience.

The big event of the year was the part that the association took in the electrical show put on by the Electrical Engineering Society, a student organization of the E.E. Department of the University of Illinois. The radio exhibit consisted of a display of the University apparatus, the radio equipment of the R.O.T.C. unit of the Signal Corps stationed there, and an assortment of home made apparatus.

As an advertising stunt a baby carriage was equipped with a receiver and Magnavox and paraded the streets in the afternoon and serenaded the sororities in the evening. The transmitter consisted of a deForest midget radiophone supplied by a Signal Corps power unit which was placed in the automobile of a club member and followed several blocks behind the baby carriage to supply it with music.

#### Hey! Affiliated Clubs! ! ! !

This department wants some news of activities. What's the matter, has the broadcasting knocked you out? Don't let the summer static close up your club meetings. Keep them going and tell us what you are doing. We want Affiliated club news and we want it now! Are you going to supply it or not? We are not mind readers—you must send it in, and be sure and get it here by the FIRST of the month.

#### South Carolina Radio Association

A "high jinx stag" was given by the members of the Southern California Radio Association on June 24th. It was well attended by the older members who enjoyed some of the stunts. Major Dillon, sixth district Radio Inspector, and F. H. Schnell, A.R.R.L. Traffic Manager, made addresses. Major Mott came over from Avalon. Oh Boy! How we wish we could imitate Chairman Benjamin in this department! (They know how to put on a jinx on the Pacific Coast—T.M.)

### Mon-Yough Radio Association

At a semi-monthly meeting of the Mon-Yough Radio Association, held Thursday evening, June 1st, in the club rooms, 326 Fourth Avenue, McKeesport, Pa., the following officers were elected. The new officers will assume their duties July 1st, for a term of one year. Vice-Pres., John Hunter, Duquesne, Pa.; Asst. Secy-Treas., Emil Klob, McKeesport, Pa.; Technical Committee: Donald Willard, Chairman, Elizabeth, Pa., Albert G. Moore, Wilmerding, Pa., H. F. Kelso, Dravosburg, Pa.; Membership Committee: Walter Step, Chairman, McKeesport, Pa., Albert G. Moore, Wilmerding, Pa., Harry W. Wallis, McKeesport, Pa.

Two classes of membership are available, junior and senior, and the membership fee and dues are very normal. Radio fans are urged to investigate and consider the advantages of affiliating with this association, which meets regularly the first and third Thursday of each month at 8:00 o'clock P.M. These meetings do much to educate the members into the mysteries of radio telephony and telegraphy.

Information may be obtained by addressing a post card to the Association at the above address.

### Chester County Radio Association

New officers were elected at the annual banquet which was held on June 20th. Seventy-six members were present and all enjoyed the splendid music furnished by the orchestra. The new officers are: H. A. Beale, jr., President; J. Ira Laird, vice-president; David Logan, Secretary; Chas. K. Hallowell, treasurer. Directors, Thomas

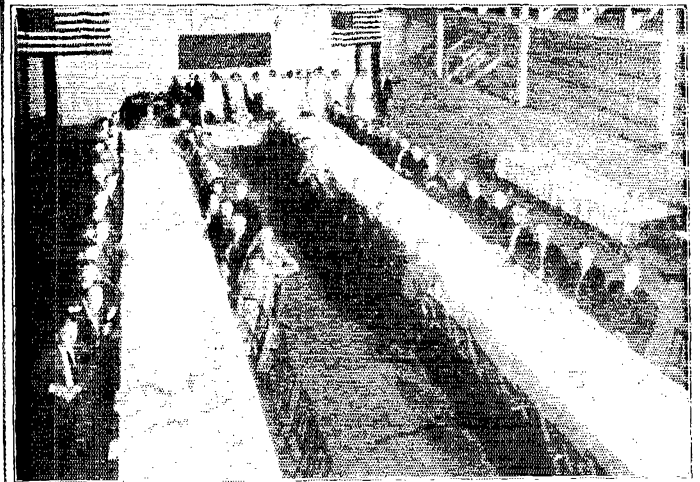

Appleby, Virgil Kauffman, John Evans, jr., Miss A. Bertha Hilton, and Professor Lloyd M. Knoll. Addresses were made by Prof. Knoll, Mr. Appleby, Mr. J. C. Randall (1ANQ), and Chas. H. Stewart, vice-president of the A.R.R.L. A year book was given to each member of the association.

### BOOK REVIEW

(Continued from page 44)

designed in every case for two 5-watt tubes, two 50-watters, or two 250-watters. The author concludes with his Appendix B in which he advises his readers to become affiliated with their local radio club where they will come in contact with kindred spirits and to make it their business to become a member of the American Radio Relay League, to which he graciously devotes several pages.

A few minor errors and a few statements on which we would beg leave to differ with the author do not detract from the value of this book, which we unhesitatingly recommend to every amateur.

"Radio for Everybody," by Austin C. Lescarboura, managing editor, "Scientific American," published by the Scientific American Publishing Company, New York; 334 pages, 5 x 7 $\frac{3}{8}$ , \$1.50.

"Radio for Everybody" was the first of the popular radio texts to reach the market. The author obviously has studied his reader

to find out what he needs to know, and we must consider this book the best all-around informative text for the new-comer in the game. It is frankly designed for the layman and takes particularly intelligent care in the development of its logic. Most of the new texts have the fault of introducing electrical symbols in radio circuit diagrams with little or no explanation of what they mean, but Mr. Lescarboura has taken care first to show line sketches of the pieces of apparatus so that a mental picture will be formed by the reader of the appearance of the pieces of apparatus in question and then he leads them into the use of the conventional symbols that take their place. As he introduces each new piece of apparatus and its function, he shows not only wiring diagrams that illustrate the use of the new piece of apparatus in the more complicated circuits, but he also presents photographs that show its actual appearance. When the author has completed the elements of radio, he handles in turn radiophone broadcasting, dot and dash

(Concluded on page 54)

# Who's Who in AMATEUR WIRELESS



**HARVEY MITCHELL ANTHONY**

This enterprising gentleman may not look like a ham but we are afraid such is the case. Tho thirty-one years of age he is a consulting electrical engineer, Professor of Applied Electrical Engineering of the Muncie (Indiana) Senior High School, and Director of Industrial Education.

During the war he was Officer-in-Charge of the Naval Aviation Radio training at Washington, D. C., and established schools for aviation radio training at Harvard University, Cambridge, and Pensacola, Florida. He was formerly in charge of advanced radio training at the Great Lakes Naval Training Station and had approximately 7000 men under his instruction.

Mr. Anthony is a graduate of Harvard University, Post-Graduate of Columbia University, graduate of Hawley Institute of Steam and Electrical Engineering of Boston, and graduate of New York Electrici-

*(Concluded on page 63)*



**CLYDE E. DARR**

Clyde Eldon Darr was born in the Ninth District—Illinois to be more definite—but adopted the Eighth District as his field of endeavor. His earliest efforts in wireless consisted of operating a string telephone between two tin cans. He then had a neighborhood telegraph circuit of hay wire and from thence passed thru the stages of the spark coil and the transformer on into C.W.

He was known before the war as 8AJD. After the war he developed 8CB until it was heard 2,600 miles. Upon obtaining a special license he was turned loose with the call 8ZZ. 8ZZ was the first station in Detroit to broadcast music to the public. The C.W. has been heard in the Azores, Cuba, Honduras, Panama, and up to 2,900 miles.

Mr. Darr is wholly interested in radio work, especially C.W., and does all possible

*(Concluded on page 54)*

# Calls Heard



## HEARD DURING JUNE Unless Otherwise Specified

**Heard By 6AX While Operating KKEI (One Tube)**  
 April 20 (100 miles west of San Francisco) 9PS, 8WR (QSA), April 21 (Latitude 36°45' Longitude 128°) 6VK, 6BV, 6BCD, 7NN, 7NW, 6DR, 6OO, 6KU, 6TU, 6IB, 6ASU, 6AAK, 6BEQ, 6CC, 6AK, 6FT, April 22 (Lat. 30°45' north, Long. 182°05' west) 6ZI, 7JD, April 24 (Lat. 27°47' N. Long. 136° W.) 6AQU, 6AIN, 6BCD, 6GR, 6KU, 7MF, 6AJR, 6AGP, 8VQ (QSA), 7ZK, 6AKT, 6AAK, 7KT, 7QE, 6GU, 7NN, 7TO, 6AWT, 7FR, Can. 9BD, 6BES, 4BF, 7DP, April 27 (Lat. 40°50', Long. 142°) 7HD, 7SC, 6GU, 6CC, 6ZI, 6IM, 6AQU, 6ZAC, 6ATV, 6KA, 6AWT, 7TO, 6IB, 7NN, April 28 (1115 miles E. of San Francisco) 6KC, 7MF, 6VK, 6EA, 6AAK, 7ZU, 9WD (QSA), 6KA, 7SC, 7DP, 6TU, 6IM, 6UP, May 1 (Lat. 51°05' N. Long. 154°15' W.) 7BH, 7BK, 7SC, 6EX, Can. 9DB, 6AJR, 9WU, Can. 5AK, 7NN, 6IB, 6PJ, May 3 (Lat. 52°49' N. Long. 152°10') (2000 miles from San Francisco) Can. 9BD, 6TU, 6AQU, 6TI (QSA and very steady), 6HP, Can. 5AK, 7FI, 7SC, 7BK, 7MF, May 5 (Lat. 53°50', Long. 152°) 6PK, 6ZI, 6AQU, 6BES, 6ZAC, 9AYU, May 9 (Lat. 52°45' N. Long. 158°10' W.) 8KA, (QSA), May 10 Lat. 52° Long. 161°) 6IB, 6ZI, 6AJR, May 11 (180 miles S.E. Unimak Pass) 6KA, 6KC, 6KE, 6AAK, 6BAK, 6BES, one 8 station but too QRZ, May 13 (in Bering Sea, 50 miles N. of Unimak Pass) C.W.: 6ZI, 6ZAC, May 15 (in Bering Sea) C.W.: 6AGH, 6BES, 6XAD.

**Can. 9AL, Toronto (2 Hours With Reinartz Tuner And One-Step)**  
 Spark: 20M, 8BRL, 9AFX, 9AMT, 9CP.  
 C.W.: 1CXB, 1EI, 1OT, (2BNZ), (2BQU), 2FP, 3OT, (3ZO), 3ZZ, 4DQ, 4GH, 4MW, 5XC, 8ACF, 8AQO, 8AQV, 8AQZ, (8AVD), 8AWP, 8AYB, 8BEO, 8BKE, 8BQU, 8CE, 8CKO, 8KH, 8SE, 8VY, (8ZB), (9AIX), 9AJA, 9CBA, 9DR, 9EI, 9ZJ.

**Can. 3GG, Timmins, Northern Ontario, Can.**  
 1HX, 1YK, 1ACU, 1AWB, 1AYV, 1BDI, 1BKQ, 1CJH, 2FP, 2KL, 2AWF, 2BQH, 2CUA, 3AL, 3BG, 3HG, 3HV, 3HW, 3BNU, 4ED, 3GY, 3KH, 3NB, 3SZ, 3ADI, 3AFC, 3AIM, 3AMM, 3ANF, 3AQO, 3AQZ, 3ARI, 3ASV, 3ASM, 3AWM, 3AWP, 3BDO, 3BEF, 3BEO, 3BFC, 3BHK, 3BIL, 3BUM, 3BZF, 3CAZ, 3CCX, 3CJH, 3CPX, 9IO, 9AIX, 9ARK, 9BHK, 9BUD, 9CBA.

**Can. 2DC & 2DE, Montreal, Que. (One Value)**  
 Spark: 1ADC, 3AD, 2BN, 2FP, 20M.  
 C.W.: -AZM, 1AZW, 1BDC, 1BES, 1BEI, 1BHT, 1BKQ, 1BQI, 1BTR, 1BUA, 1BWJ, 1CHJ, 1CIK, 1CJA, 1CN, 1HX, 1PM, 1PR, 1RD, 1XAD (phone), 1XG, 1XX, 1XZ, 1YK, 2AGL, 2AXK, 2AYV, 2BBX, 2BN, 2BRB, 2BEH, 2BG, 2BLP, 2BQH, 2BQU, 2CBL, 2CBN, 2CWE, 2FS, 2NZ, 2XM, 3BG, 3FUP, 3BVC, 3CH, 3ZO, 3ACF, 3ADG, 3ALO, 3AMM, 3AQO, 3AVD, 3AVT, 3BDU, 3BJS, 3BXT, 3CCX, 3CJH, 3CPX, 3JU, 3VQ, 3XU, 3XV, 9BCQ, 9UC.

**1AZX, Burlington, Vermont, (Loop and One-Step)**  
 Spark: 1AA, 1AKQ, 1BRQ, 1BVB, 1DY, 1GM, 1LZ, 1RV, 1SN, 1WQ, 2AAF, 2EL, 2FP, 2KK, 2MN, 2OM, 2RM, 2TF, 2WI, 3BFU, 3CN, 3II, 8EO, 8FC, 9AAW.  
 C.W.: 1ACS, 1ACU, 1ADL, 1AJP, 1AKG, 1ALW, 1ANQ, 1AR, 1ASF, 1AUN, 1AZD, 1AZW, 1BDI, 1BDU, 1BDV, 1BES, 1BGF, 1BJS, 1BQ, 1BLN, 1BQE, 1BQI, 1BVE, 1BWJ, 1CBP, 1CCZ, 1CDO, 1CHJ, 1CIK, 1CJA, 1CJH, 1CNE, 1CNR, 1CPN, 1CTJ, 1CVE, 1CZZ, 1GV, 1HX, 1JQ, 1KC.

1PM, 1PR, 1QN, 1XG, 1XM, 1XX, 1XZ, 1YK, 2AFP, 2AJP, 2AJA, 2AWF, 2AWL, 2AYV, 2BCF, 2BDM, 2BEH, 2BFX, 2BG, 2BLP, 2BML, 2BNZ, 2BQA, 2BQH fone & C.W., 2BQU, 2BRC, 2BUM, 2CRF, 2CBG, 2CES, 2CIM, 2CWE, 2FP, 1C.W. & C.W., 2KL, 2KV, 2NZ, 2OP, 2SQ, 2TS, 2UD, 2ADX, 2AJD, 2ALN, 2ANJ, 2AVY, 2ATZ, 2BPU, 2BIJ, 2BLF, 2BNU, 2BZ, 2CBM, 2CW, 2FS, 2HB, 2HG, 2IW, 2TA, 2WF, 2XW, 2ZO, 4BQ, 4BX, 4BY, 4GL, 8ACF, 8AGO, 8AHR, 8AIG, 8AMM, 8AMQ, 8APT, 8AQO 1C.W., 8AQV, 8AQZ, 8AVD, 8AVH, 8AVL, 8AXB, 8BBD, 8BDO, 8BDU, 8BEO, 8BFX, 8BIL, 8BLX, 8BOG, 8BSY, 8BXH, 8BXT, 8CCX, 8CJH, 8CJV, 8CKO, 8CNB, 8CPX, 8HM, 8IP, 8JU, 8KG, 8KH, 8NB, 8SE, 8SP, 8UC, 8UK, 8VQ, 8VY, 8XE, 8XV, 8ZAE, 8ZZ, 9AIX, 9CBA, 9DQG, 9IO, 9QC, 9UU, 9WA.

### 1CBO, Concord, N. H.

1EE, 1ES, 1GV, 1HK, 1HX, 1II, 1IV, 1KC, 1OE, 1PH, 1QP, 1TK, 1TR, 1UJ, 1XX, 1ACA, 1ACU, 1ADL, (1AIO), 1AKG, 1AMQ, 1ANQ, 1ASF, 1AWB, 1AWL, 1AYZ, 1AZW, 1BES, 1BHF, 1BKA, 1BKP, 1BKQ, 1BQR, 1BRG, 1BRQ, 1CBP, 1CHJ, 1CHW, (1CIK), 1CNE, 1CPN, 1CVE, 2BG, 2CZ, 2DA, 2DI, 2FP, 2FS, 2FZ, 2HJ, 2HV, 2HW, 2JW, 2NZ, 2OM, 2RM, 2SZ, 2TF, 2TP, 2TS, 2UA, 2UD, 2VH, 2WB, 2ABM, 2ABS, 2ACD, 2ACW, 2AFP, 2AJP, 2AJS, 2AJA, 2ALW, 2AMF, 2ANJ, 2ANM, 2ANZ, 2AUD, 2AUZ, 2AVF, 2AWF, 2AYF, 2AYV, 2AYZ, 2BFH, 2BEM, 2BFB, 2BIG, 2BJO, 2BLP, 2BNW, 2BNZ, 2BML, 2BQH, 2BQU, 2BRC, 2BTW, 2BUM, 2BXP, 2BYS, 2CBG, 2CBW, 2CBY, 2CES, 2CIM, 2CWE, 2CKK, 2CNZ, 2CMV, 2XJ, 2YE, 3BQ, 3CM, 3DT, 3EM, 3FS, 3IW, 3OF, 3PB, 3PS, 3SD, 3SH, 3TA, 3UH, 3ADX, 3AEV, 3AFB, 3AGC, 3ALE, 3ATG, 3ATZ, 3AUD, 3AUW, 3BFU, 3BIJ, 3BIT, 3BLF, 3BNU, 3BUP, 3CAN, 3CBM, 3XW, 3ZO, 4BX, 4GL, 8BO, 8EO, 8HJ, 8HM, 8IB, 8JL, 8KG, 8KH, 8LX, 8MP, 8NB, 8OW, 8QB, 8TB, 8UC, 8UP, 8UR, 8UZ, 8VQ, 8VR, 8VY, 8ACF, 8AFD, 8AHR, 8AIM, 8AJO, 8AMM, 8AMQ, 8AOX, 8AQV, 8AQZ, 8ARI, 8AUV, 8AVD, 8AVL, 8AVT, 8AWP, 8AXB, 8BBD, 8BCD, 8BDO, 8BDU, 8BEO, 8BIB, 8BKE, 8BPL, 8BPD, 8BUT, 8BUX, 8BVR, 8BXH, 8BXT, 8BZY, 8CAZ, 8CCX, 8CID, 8CJH, 8CKM, 8CPX, 8CQL, 8CON, 8XE, 8YD, 8YE, 8ZB, 9EI, 9UU, 9AAP, 9AIX, 9AJH, 9CBA, 9XI, 9ZN, BY4, Can. 3BV.

**1ACU, Preston D. Baldwin, Groton Long Point, Ct.**  
 C.W.: (1ES), 1HK, (1IV), (1OZ), (1PR), (1QP), (1VQ), (1XX), (1AGH), 1AIP, 1ANQ, (1ASF), 1AYZ, 1AZO, 1AZW, 1BKA, 1BKQ, (1BKP), (1BQE), (1BUL), (1BVA), (1CBP), (1CCZ), (1CJA), (1CNE), (1CPZ), (1CQW), 1CRE, 1CVE, (2BG), 2FP, (2HJ), 2HV, (2NZ), (2RY), 2TS, (2VH), 2WB, (2ABS), 2ACD, (2AJF), 2AOG, 2AQL, (2AYF), (2AYV), 2BDG, 2BDU, 2BEM, 2BFZ, 2BGI, (2BLP), 2BML, (2BQH), (2BQU), (2BRB), (2BRC), (2BTW), 2BUM, (2BYC), (2CAH), (2CBG), 2CCO, 2CCU, (2CDK), (2CEI), (2CES), 2CIM, 2CRU, 2CWE, (3AS), 3BG, 3CC, 3DT, 3FS, 3TA, 3VW, 3ADX, 3ALJ, 3AUW, (3BFU), 3BHL, 3BLF, 3BNU, 3CBM, 4BQ, 4BY, 4DC, 4LP, 8AN, 8KL, 8MP, (8OW), 8UC, 8UK, 8VQ, 8ACF, 8AIM, 8AVD, 8AVL, 8AVT, (8BBD), 8BDO, 8BEO, 8BKE, 8BLX, 8BRW, 8CAY, 8CBL, 8CJH, 8CKM, 8CKO, 9HW, 9IO, 9VV, 9BED, 9BHD, 9BSG, (WUBA), (WUC) Can. 9AL.  
 Spark: (1AYU), (1AZK), (1BVB), (2CY), 2FP, 2DI, 2RM, 2AAF, (2ABM), (2BRI), (3FP), 3BFU, 8BN, 8EW, 8JL, 8BAZ, 8CIG, 9CP.

### 1ES, Brookline, Mass.

Spark: 1BJS, (1BRQ), 2AAF, 2DN, 2FP, 2OM, 2RM, 8EW, 8TC.







8CXM, 8KH, 8OM, 8OW, 8SE, 8SP, 8UC, 8UD, 8AAW, 8AOG, 8BLC, 8BSG, 8CBA, 8DUC, 8DXE, 8DZY, 9EL

Spark: 2FP, 2OM, (4BD), (4EZ), 4GM, 4HS, 5TU, (8ASZ), 8BR, (8EO), 8JT, 8VQ, 9ALP, 9AMK, 9APS, 9LF, 9LFR, 9OX.

4BX, Wilmington, N. C.

C.W.: (1GV), (1HX), 1IX, 1KC, 1QP, 1XG, (1XM), 1XZ, 1AQW, 1AWB, 1AZW, 1BBW, 1BES, 1BKU, (1CCZ), 1CHJ, 1CNR, 1CNS, 1CVE, 1CXA, 2AD, 2BG, 2CB, 2CR, 2FP, 2PX, 2FZ, 2NZ, 2RB, 2RY, 2SQ, 2UD, 2WB, 2AAB, (2ACD), 2AFP, (2BEH) 2BIY, 2BFX, 2BQH, 2BNZ, 2BRC, 2BXP, 2CAL, (2CBG), 2CCD, 2CES, (3AB), 3BG, 3BV, (3BZ), 3CG, 3DT, (3FS), 3HJ, 3HI, 3HL, 3IJ, 3IW, 3LR, (3OT), 3PB, 3QV, 3RV, 3TJ, 3VW, 3WF, 3XW, 3YV, 3ZO, 3ZZ, 3AAB, 3AEV, 3ALN, 3AQH, 3ATG, 3AVY, 3BPU, 3BGT, 3BHL (3BJ), (3BLF), 3BMU, 3CAL, 3CBK, 3CBM, 4BQ, 4BY, (4DC), 4EB, 4GH, 4GL, (4ID), (4LP), 4MW, 4SH, 4ZB, 5FV, 5PY, 5AAM, 5BQ, 5DY, 5EA, 5HJ, 5HM, 5HV, 5JL, 5JU, 5KH, 5KJ, 5LB, 5NB, (5QB), 5SP, 5TC, 5UC, 5UK, 5UU, 5UY, 5VQ, 5VY, 5YD, 5ZR, 5ACF, 5AGD, 5AGO, (5AHR), 5AIO, 5AMM, 5ANB, 5APT, 5AQV, 5AQZ, 5ARD, 5ASV, 5AVD, 5AVH, 5AWM, 5AXB, 5AXC, 5AXX, 5AYO, 5BBB, 5BDU, (5BEF), 5BFX, 5BKE, 5BPL, 5BQU, 5BRL, 5CAW, 5CAY, 5CCD, (5CEI), 5CJH, 5CKO, 5CQL, 5CTJ, 5EOM, 5WUB, 5ZAE, 5AE, 9EL, 9LF, 9OK, 9SM, 9UT, 9WH, 9AAP, 9AIK, 9AJA, 9AKX, 9AWH, 9AXF, 9CBB, 9DGG, 9DGC, 9DKP.

Spark: 1AW, 2EH, 2FP, 2OM, 2WB, 3GZ, 3ACK, 3BVC, 3BL, 3CX, 4FD, 4FP, 4GM, 4GN, 4HS, 4YA, 5TC, 5UC, 5VO, 5ZO, 9HF, 9AAW, 9DHz.

4KL, Atlanta, Ga. (Reinartz Tuner With One-Step)

C.W.: 1BKC, 1XZ, 2FP, 2CES, 2OE, 3ALN, 3BLF, 3HNM, 3BPU, 3BZB, 3IW, 3ZZ, 4BK, 4RX, 4BF, 4JHW, 4KC, 4KO, 4LP, 4GS, 4ID, 5EK, 5FV, 5GM, 5KC, 5LA, 5LJ, 5XR, 7ZO, 8ALV, 8AZF, 8AC, 8AGC, 8CC, 8AMM, 8AQO, 8AIO, 8AXC, 8BEF, 8BO, 8BD, 8BFX, 8BZ, 8BKE, 8CC, 8EX, 8IX, 8PN, 8QO, 8SP, 8UC, 8WM, 8WP, 8XJ, 8XH, 8YD, 8ZAC, 8ZZ, 9AIX, 9AO, 9AUD, 9ARZ, 9AWA, 9ANT, 9AIQ, 9ARK, 9BGQ, 9BX, 9DIO, 9DZZ, 9DIZ, 9DZQ, 9DGP, 9EL, 9GY, 9IQ, 9IO, 9LX, 9OX, 9UU, 9YI.

Spark: 8AN, 8BAZ, 8EA, 9AAW, 9DGP, 9DHz, 9LF, 9OX, 9UH.

5GP, Anniston, Ala.

Spark: 5ABY, (5BP), (5ON), 5TU, (5VV), 9ACB, 9APS, 9DQ, 9DS, 9LE.

C.W.: 2FP, 3HJ, 3RLF, 4BQ, 4DC, 4EB, 4GU, 4ID, 4LP, 4MW, 4QT, 4ZB, 5ACE, 5DO, 5EK, 5FO, 5FV, 5HO, 5JB, 5KC, 5KU, 5LA, 5LJ, 5MA, 5NS, 5SP, 5ALI, 5AOV, 5AXB, 5ROD, 5BDU, 5BKE, 5RNI, 5RXH, 5UC, 5ZZ, 9ABB, 9AIX, 9AOG, 9ARK, 9BHD, 9BLC, 9BOA, 9BSG, 9BU, 9BUG, 9CFI, 9DUN, 9EI, 9IO, 9LK, 9UU.

5TC, Box 1157, Ft. Worth, Texas.

C.W.: 1ZE, 2OM, 3FS, 4BQ, 4EH, 4GU, 4ZB, 5JB, 5DO, (5OB), (5VA), 5ZA, 5ZAY, (5NS), (5JL), 6BES, 6KA, 6KY, 6XAD, 6ZAC, 6ZZ, 6ZU, 8BKE, 8VR, 8UC, 8VY, 9ARK, (9AOG), 9AZA, 9AIX, 9ASF, 9AMB, 9BSG, 9DUG, 9ZAC.

Spark: (5AO), 5ABY, (5HZ), (5MK), (5EH), (5TU), (5TG), (5UE), 5XA, (5ZAF), (5ZAK), (9ABV), (9APK), (9ARG), 9CW, 9DUY, 9DZY, 9ZAK.

5AR, Bay Minette, Ala.

Spark: 4BI, 4BQ, 4EL, 4FD, 4FN, 4GN, 4GU, 4NG, 5AA, 5ABY, 5ACY, 5EK, 5IR, 5TU, 9ACB, 9DLX, 9TCB.

C.W.: 2BLE, 4BF, 4BQ, 4DC, 4DK, 4ID, 4IN, 4KD, 4LP, 4MW, 5AAM, 5EK, 5FK, 5FO, 5JR, 5KC, 5LJ, 5SP, 5UK, 5AWU, 5AXB, 5BDE, 5CKE, 5DKE, 5LX, 5SM, 5UC, 5ZZ, 9AOG, 9BSG, 9BSZ, 9CAP, 9CBA, 9DGG, 9DSD, 9DXN, 9EI, 9AIX, 9QY, 9RO, 9UU.

5XAC, Conway, Arkansas

Spark: 5ABY, 5NC, (5QA), 5RA, (5SM), 5TU, (5WW), (5XAB), 9AMK, (9DZY), 9LF.

C.W.: 4GH, 4MW, 5SA, (5CB), 5DA, (5ED), 5FO, 5FV, (5JS), 5MA, 5OL, (5PS), 5SL, (5SP),

(5WK), (5XAB), 5KS, 5UE, (9AIX), (9AOG), 9AJA, 9BQW, 9DR, 9OX, 9UU, 9YAJ.

5DO, Memphis, Tenn. (One Tube)

2YI, 2NZ, 3BLE, 3LN, 3BQ, 1BZ, 4EH, 4FL, 4GL, 4LP, 4ZB, 4ZC, 5FV, 5HB, (5JB), (5KC), 5SP, 5ZAT, 5ACF, 5ACQ, 5AN, 5ANB, 5AIO, 5AIM, 5AOK, 5AVT, 5AXB, 5BDO, 5BDU, 5BJD, 5BO, 5BSQ, 5BXF, 5CAY, 5JL, 5JU, (5UC), 5UK, 5VQ, 5VY, 5XJ, 5ZZ, 9AIG, 9AIX, 9AIY, 9AJG, 9AMW, (9AOG), 9ARK, 9ATN, 9AUA, 9AXU, 9AW, 9BCT, 9BDL, 9BEM, 9BHD, 9BLO, 9BQW, 9BSG, 9BZI, 9CAN, (9CFI), 9CHA, 9BDL, 9DOW, (9DGG), 9DR, 9DUG, 9DUN, (9DXN), 9DZQ, 9EI, 9HW, 9IO, 9JG, 9JZ, 9PI, 9UC, 9UU, 9WA, 9WU, 9XE, 9YAJ, 9ZAC.

5KN, Port Arthur, Tex.

Spark: (5ACR), 5ABY, (5BV), 5JI, 5TU, 9ACB, 9ZV.

C.W.: 4BQ, 4GL, 5ACF, 5AHL, 5DO, 5EK, 5FO, 5IR, (5JB), 5JL, 5KC, 5LJ, 5LO, (5PB), 5RA, 5UD, 5VI, 5ZA, (5ZAT) 9RA?, 8HDU, 8UC, 8UMR, 8YO, 9AL, 9AIX, 9AOG, 9AON, 9ASL, 9BJB, 9BSG, 9DR, 9DCR, 9DXN, 9HT, 9JR, 9UU, 9ZAC. Crds. Ansd.

6ZD, Phoenix, Arizona

C.W.: 4GL, 5DO, 5EK, 5NT, 5IE, 5GI, 5PJ, 5WU, 5ZA, 6AK, 6CH, 6EN, 6JD, 6KA, 6GY, 6GD, 6GH, 6IB, 6KC, 6KU, 6NN, 6NX, 6TW, 6XH, 6XAD, 6ZA, 6ZAC, 6ZAE, 6ZAF, 6ZAL, 6ZB, 6ZF, 6ZG, 6ZN, 6ZI, 6ZT, 6ZU, 6ZZ, 6ZX, 6AAK, 6AAT, 6AKW, 6ASJ, 6AUV, 6AWT, 6BKB, 6DP, 6NF, 6NL, 6OZ, 6XF, 6ZU, 6AGZ, 6BRL, 6XV, 9AAW, 9AEG, 9ALG, 9AOG, 9AJS, 9AMB, 9ARJ, 9ARJ, 9BD, 9BJI, 9BSG, 9DTH, 9DTM, 9DVA, 9DXN, 9DZJ, 9XM, 9XAG, 9YAE, 9YAK, 9ZAC.

Spark: 5HK, 5IF, 5XD, 5XB, 5XM, 5XQ, 5CP, 6FH, 6GT, 6GD, 6HY, 6IC, 6IV, 6KE, 6LK, 6OD, 6OM, 6AH, 6AGK, 6AHF, 6AHQ, 6AIN, 6AID, 6AJH, 6AJR, 6AKL, 6AMN, 6ARK, 6AVD, 6AWK, 6BAJ, 6BPZ, 6BMP, 6ZAM, 6AWK, 6BAJ, 6BPZ, 6BMP, 6ZAM, 6BS, 6CB, 6CK, 6GJ, 6GT, 6HF, 6IM, 6IN, 6JD, 6KB, 6LK, 6MP, 6NP, 6OF, 6OT, 6TF, 6TJ, 6VY, 6YA, 6YJ, 6YS, 6ZA, 6ZM, 6ZO, 6ZH, 6ZS, 6ZV, 6ZU, 9AEG, 9AQG, 9AYU.

6AFO, San Francisco, Calif. (Detector Only)

6AK, 6CV, 6DA, 6DP, (6EB), 6EF, 6EN, 6ER, 6FH, 6FK, 6FT, 6GD, 6GE, 6GI, 6GP, 6GR (voice), 6GT, 6GY, 6HE, 6HK, 6HY, (6IC), 6IU, (6IS), 6IV, 6JC, 6JD (C.W.), 6KA, (6KC), 6KT, 6KY, 6LJ, 6LO, 6MH, 6MN, 6MZ, 6OD, 6OH, 6OL, 6PJ, (6AAT), 6PO, 6PP, (6QR), 6SK, 6UO, 6WE, 6WG, 6WL, 6WR, 6ZA, 6ZB, 6ZU, 6ZX, 6AAK, (6ARW), 6ABG, 6ABX, 6ACR, 6ACR, 6ACY, 6ADL, 6AEL, 6AEZ, 6AFD, 6AFH, (6AFN), 6AFX, (6AGF), 6AHI (voice), 6AHP, 6AHQ, 6AIB, 6AHU, 6AIF, 6AIN, 6AIO, 6AII, 6AII, 6AII, 6AII, 6AIX, 6ALD, 6ALU, 6ANQ, 6APO, 6AOY, 6AOZ, 6AQY, 6ARU, 6AOX, 6ATG, 6AUE, 6AVD, 6AVY, 6AWV, 6BOW, 6BEM, 6BNE, 6XAF, 6BR, 6BH, 6BK, (6ED), 6GA, (6HF), 6IN, 6IU, 6IW, 6KB, 6KE, 6KG, 6KJ, (6MP), 6NN (C.W.), 6OF, 6OZ, 6SC, 6SN, 6TL, 6TO, 6YA, 6YJ, (6ZJ), 6ZM, 6ZT, 6ZU, 6ZV.

6IV, 342 Main St., Riverside, Calif.

(Every District Except First)

Spark: 5BY, 5HK, 5IF, 5OF, 5XD, 5XU, 5YQ, (5ZA), 5ZH, 5ZT, 5ZZ, 6AH, (6AK), 6AR, (6AS), 6BM, (6BV), 6BW, 6CC, 6CH, 6CO, 6CP, 6CV, 6CZ, (6DA), 6DF, 6DM, (6DP), 6DW, 6DY, 6EA, 6EB, 6EN, 6EP, 6ER, (6EX), 6FF, (6FH), 6FK, 6FN, 6FT, (6GF), 6GI, 6GH, (6GM), 6GP, 6GR, (6GT), 6GX, (6HG), 6HK, (6HP), 6HY, (6IR), (6IC), 6IK, 6IM, 6IS, 6JC, 6JW, (6JY), 6KA, 6KC, 6KE, 6KM, 6KP, 6LC, (6LU), (6MH), (6NC), (6NL), (6OD), (6OL), (6OH), 6OT, (6PJ), (6PO), (6PR), 6PW, 6QD, (6QK), (6QR), 6QS, 6QY, 6RS, 6SJ, 6SK, (6ST), 6TC, (6TF), (6TO), (6TU), (6TV), 6UO, 6UP, 6UW, 6VE, 6VI, (6VK), 6VM, (6VX), (6VZ), 6WG, 6WO, 6WZ, 6XG, (6XH), 6XU, (6ZB), 6ZD, 6ZE, 6ZI, (6ZJ), 6ZK, 6ZM, 6ZQ, 6ZR, (6ZU), (6ZX), (6ZZ), 6ZAA, 6ZAE, 6ZAL, 6ZAM), (6AAH), (6AAK), (6AAU), 6ABG, (6ABK), (6ABM), 6ABP, (6ABU), 6ABW, (6ABX), 6ACR, 6ACY, 6ADA, 6ADF,

6ADL 6ADW, 6AEA, (6AEH), 6AEI, 6AEW, 6AEB, 6AEZ, 6AFD, 6AFN, 6AFW, (6AGE), (6AGP), (6AHA), 6AHP, (6AHP), (6AHQ), (6AHV), 6AIA, (6AIB), 6AID, (6AIF), 6AIG, 6AIN, (6AIO), 6AIP, 6AII, 6AIT, (6AUI), (6AJH), (6AJR), 6AJT, 6AJW, 6AKL, 6AKT, (6ALA), (6ALD), (6ALP), 6ALU, (6ALV), 6AMK, 6AMN, 6AMZ, 6ANG, 6ANI, 6ANP, (6AOE), (6AOR), (6AOW), 6APE, 6APO, 6APP, 6APY, 6AQT, (6AQU), 6AQY, 6ARD, (6ARK), (6ARU), 6ARW, (6ASB), 6ATE, 6ATF, 6ATG, (6ATH), (6ATQ), 6ATU, 6ATV, 6AUC, 6AUD, 6AUI, 6AUV, (6AVB), 6AVC, 6AVD, (6AVR), 6AVS, (6AVV), 6AWD, 6AWF, 6AWH, 6AWX, (6BAJ), 6BAK, 6BAP, 6BAZ, 6BBC, 6BBD, (6BBO), (6BBT), (6BCB), 6BCJ, 6BDS, 6BDW, 6BEA, 6BEM, (6BFE), 6BFF, 6BGJ, (6BGH), 6BGL, 6BHK, 6BIN, 6BIP, 6BJD, 6BJU, 6BJV, 6BJY, 6BNN, 7BB, 7BC, (7BH), 7BJ, 7BK, 7BP, 7BR, (7CK), 7CN, 7CW, 7FI, 7GD, (7GJ), 7HF, 7IN, (7IW), 7JD, 7JW, 7KB, 7KE, 7LN, 7LY, (7MF), 7MO, 7MP, 7MU, 7NF, 7NN, (7OT), (7OZ), 7QF, 7RY, 7TJ, (7TO), (7VO), 7WA, 7WG, 7XA, 7XH, 7YA, 7YG, 7YJ, 7YS, 7ZB, 7ZG, 7ZJ, (7ZK), 7ZM, 7ZO, (7ZP), 7ZS, 7ZT, 7ZU, 7ZY, 8AMZ, 8BE, 8HT, 8NR, 8PS, 8WU, 9AEG, 9AEY, 9AQE, 9DWP, 9DZE, 9YAL, 9ZX, CL8.

C.W.: 2FF, 2FP, 3LP, 4BQ, 5XU, (5ZA), 5ZAK, (6AK), 6CU, 6DF, 6DM, 6EA, 6EB, 6EC, 6EF, 6EN, (6FH), 6FT, 6GD, 6GX, 6GY, 6JD, 6JX, 6KA, 6KH, 6KU, 6KY, 6LV, 6MN, 6NX, 6NY, 6OO, 6PE, 6PI, 6PT, 6RM, 6RR, 6TW, 6VM, 6VT, 6WV, 6WZ, 6XS, 6XAD, 6XAF, 6XAQ, 6XAS, 6ZA, 6ZB, 6ZE, (6ZF), 6ZG, 6ZI, 6ZN, 6ZQ, 6ZR, 6ZS, 6ZW, 6ZX, (6ZZ), 6ZAD, 6ZAF, 6AAG, 6AAT, 6ACB, 6ADA, 6AEH, 6AGU, (6AGP), 6AIB, 6AIF, 6AIO, 6AII, 6AKW, (6ALE), 6ALU, 6ALV, 6AMZ, (6AOZ), 6AQA, 6ARB, 6ASC, 6ASV, 6ATG, 6ATP, 6AUI, 6AVD, 6AVI, 6AVY, 6AWP, (6AWT), 6AVV, 6BAF, 6BCD, 6BCR, 6BEG, 6BEO, 6BES, 6BJC, (6BKA), 6BKX, 6BLA, 6BQC, 6BQQ, 6BQT, 7CS, 7DP, 7FG, 7FT, 7LN, (7MF), 7MW, 7QT, 7RM, 7TQ, 7XF, 7XG, 7XZ, 7ZU, 8AGZ, 8AMM, 8BUM, 8XV, 8ZG, 8HP, 8HT, 8KP, 8NT, 8NX, 8PI, 8PS, 8WD, 8WU, 9AEG, 9AJA, 9ALG, 9AMB, 9AWL, 9AWT, 9AYU, 9BAZ, 9BBF, 9BEX, 9BJL, 9DTH, 9DTM, 9DUC, 9DVA, 9XG, 9XM, 9XAQ, 9ZY, 9ZAC, 9ZAF, 9ZAK, CL8, AGI, MFI, PX.

Phones: 5OF, 6KU, 6VM, 6WV, 6AAT, 6AOL, 6ZF, 6ZN.

6LV, San Mateo, Cal.

C.W.: (6AK), 6BJ, 6CU, 6EA, 6EF, 6EN, 6FH, 6FT, (6GD), 6GX, (6JL), (6JJ), 6KA, (6KU), 6NX, 6PI, 6RR, 6TW, (6AAT), 6AAG, 6ABX, 6ACH, 6AKW, 6ALU, 6ANR, 6AVR, 6AWV, 6AWP, 6BAK, 6BCD, (6BIR), 6BE, 6ZA, 6ZB, 6ZG, 6ZE, 6ZN, 6ZS, (6ZX), 6ZAC, (7QT), 7MF, 7SC, 7DP, 7ZM, 7ZU, 9AMB, 9AYU, 9DTE, 9ZAF, 9VAA.

Spark: 6AR, 6CC, 6DA, 6DP, 6EB, 6FH, (6GR), 6GT, 6HY, (6IB), 6IV, 6KC, (6KE), 6MH, 6OD, 6OL, 6PJ, 6PO, 6TI, 6TU, 6TV, 6VX, 6AAH, 6AAK, 6AAU, 6ABM, 6ABW, 6ABX, 6ACR, 6AEI, (6AEY), 6AKP, 6AHQ, 6AIN, 6AJH, (6AJR), 6ALA, 6ALD, 6AMI, (6AMK), 6AMW, 6APP, 6APY, 6ARK, 6ARS, 6ATP, 6ATF, 6AVR, 6AUJ, 6AWH, 6GZ, 7BK, 7KE, 7NW, 7MF.

Totem Radio Club, Seattle, Wash.

With 1500 foot Beverage wire pointed east, regen receiver and one step A. F. amplifier. All C.W. and over 1000 miles

Friday, June 23: 5FO, 6KA, 6NX, 9AMB, 9AOS, 9APW, 9ASE, 9BSG, 9DU, 9LN.

Saturday, June 24: 5FO, 8AW, 8UC, 8ZZ, 9APW, 9AUA, 9AUT, 9AUI, 9BH, 9BS, 9BSG, 9DR, 9PI, 9UU.

8BIL, Warren, Pa.

C.W.: 1ACU, 1ADD, 1AJP, 1AKG, 1ASF, (1AWB), (1AZD), (1BAS), 1BCF, 1BDI, 1BGF, (1BKJ), (1BLN), (1BVR), 1BXA, (1CCZ), (1CHJ), 1CPN, 1CVE, 1HX, 1KC, (1ON), 1PR, 1XM, 1XX, 2ACD, 2AFP, 2AIO, 2AJF, 2ANM, 2AUI, 2AWF, 2AWX, 2AXK, 2BEH, (2BG), 2BGW, 2BJO, 2BPL, 2BNZ, 2BQU, 2BRB, 2BRZ, (2CBG), 2CBT, (2CES), (2CMS), 2CNZ, (2COL), (2FP), 2FZ, (2KL), 2MJ, 2NZ, 2OF, (2SQ), 2UD, (8ADX), 8AFB, 8AGC, 8ATS, 8AJD, 8ALN, (8ANJ),

8BFU, (8BG), (8BIJ), 8BJY, 8BLF, (8BNU), 8BRW, 8BUV, 8BZ, (8CBM), 8CCC, 8DM, 8DT, 8FS, 8HG, 8HL, 8IL, (8IW), 8OT, 8US, (8VW), 8WF, (8ZO), 8ZZ, 4BQ, 4BX, 4DC, 4DQ, 4EB, 4ID, 4LP, (4MW), 5FV, 5JL, 5PC, 8ACF, 8ADN, 8AGZ, (8AHK), 8AHR, (8AIO), 8ALB, (8AM), 8AMM, 8AMQ, 8AN, 8AQZ, 8AQF, (8AQV), 8ARD, (8ARI), 8ASM, 8ASV, 8AUF, (8AVD), 8AVH, (8AVL), 8AWT, 8AWM, 8AWP, (8AWT), 8AWX, (8AXB), 8BAF, 8BED, 8BCE, (8BDB), (8BDC), 8BD, 8BDU, (8BEF), (8BEK), 8BEO, 8BFX, 8BGF, 8BGG, 8BJS, 8BKE, 8BQU, 8BRQ, (8BRT), (8BRW), 8BRZ, 8BV, 8BVT, 8VY, (8BXH), 8BZF, 8BZY, 8CAY, 8CAZ, 8CCX, (8CEI), 8CFP, 8CJH, 8CJY, 8CKM, (8CKO), (8CSL), 8DV, (8JL), 8JU, 8KH, 8HJ, 8HM, 8MP, 8OW, 8QC, (8SP), 8UC, 8UK, (8VQ), (8VY), 8XE, (8ZZ), (9AUI), 9AIX, 9AJA, 9AJH, (9AOG), 9ARK, 9AUA, (9BLC), 9BQU, (9BSG), 9CBA, 9DKP, 9DWY, 9EI, 9FK, (9GL), 9IO, 9OX, 9RO, (9UC), 9US, (9UU).

8BNH, Akron, Ohio—1 Tube

C.W.: 1ACU, 1ADD, 1ANQ, 1AWB, 1AZW, 1BGF, 1BKQ, 1BWJ, 1CHJ, 1CNE, 1CNR, 1HX, 1PR, 1QP, 1RD, 1YK, 2AWF, 2AYF, 2BDU, 2BEH, 2BFZ, 2BLP, 2BNZ, 2BQH, 2BQU, 2BRB, 2BRC, 2BXP, 2CRT, 2CBW, 2CC, 2CCD, 2CES, 2CFT, 2FZ, 2NZ, 2TS, 3ADX, 3AEV, 3AFB, 3AHT, 3AJD, 3BG, 3BGQ, 3BIJ, 3BJY, 3BLF, 3BLU, 3BNU, 3BRW, 3BZ, 3CBM, 3FS, 3HG, 3IW, 3VW, 4BQ, 4DC, 4LP, 4MW, 4FV, 5ACF, 5ADG, 5AIO, 5AM, 5AMM, 5AN, 5ANB, 8AQZ, 8AVH, 8AVL, 8AVT, 8AWM, 8AWP, 8AWT, 8AWX, 8AXB, 8AZH, 8BBD, 8BDB, 8BDO, 8BDU, 8BEF, 8BEO, 8BFR, 8BGG, 8BIL, 8BJS, 8BKM, 8BNO, 8BO, 8BOP, 8BRM, 8BRT, 8BRZ, 8BUX, 8BVK, 8BVR, 8BXC, 8BXF, 8BXT, 8BZF, 8CAY, 8CAZ, 8CJH, 8CCX, 8CFP, 8CJH, 8CJY, 8CKM, 8CKO, 8CON, 8COO, 8CTP, 8CVY, 8CYE, 8JS, 8JU, 8KG, 8LJ, 8LT, 8OW, 8PD, 8QB, 8RJ, 8SP, 8UC, 8UB, 8VQ, 8VY, 8XE, 8ZAE, 8ZZ, 9ALS, 9ARK, 9BHD, 9CBA, 9EI, 9UU, 9WW, Can. 9BV, 9AL.

8ZO, 1375 Franklin Ave., Columbus, Ohio

Spark: 1AW, 1AZK, 1ARY, 1BOQ, 1EL, 1LZ, 1YB, 1YD, 2AAB, 2AAF, 2DN, 2EL, 2FP, 2OM, 2SZ, 2TF, 2WB, 2XQ, 2AAF, 3ABB, 3ABL, 3AOV, 3AWE, 3AWT, 3BFU, 3BGT, 3BVC, 3FP, 3HJ, 3LE, 3WF, 3HI, 4BT, 4CX, 4EZ, 4FD, 4FP, 4GM, 4GN, 4GU, 4HS, 4YA, 6PJ, 6JD, 5JF, 5MO, 5PE, 5PY, 5RZ, 5TC, 6TU, 6XA, 5ZAA, 5ZAB, 6ZU, 6BL, 8AEQ, 8AER, 8APB, 8AFD, 8AGP, 8AGW, 8AHE, 8AHP, 8AHQ, 8AHY, 8AIB, 8AIT, 8AIZ, 8AJX, 8AMT, 8ANW, 8AOE, 8AR, 8ARK, 8ARS, 8ASL, 8ATU, 8AUX, 8AUY, 8AVG, 8AWQ, 8AXN, 8AXR, 8AYC, 8AYM, 8AZF, 8AZH, 8BAH, 8BAZ, 8BBY, 8BCO, 8BDV, 8BEP, 8BFY, 8BGU, 8BHO, 8BIT, 8BIV, 8BNA, 8BPG, 8BQA, 8BSI, 8BWD, 8BXC, 8BXX, 8BYN, 8BYP, 8CDZ, 8CER, 8CPA, 8CGF, 8CGM, 8CGZ, 8CH, 8CJZ, 8CKV, 8CP, 8COP, 8CQL, 8CTD, 8CUA, 8EA, 8EB, 8EO, 8EW, 8FT, 8JJ, 8KE, 8KH, 8KY, 8LQ, 8NG, 8NZ, 8PT, 8RQ, 8TC, 8TK, 8UC, 8UN, 8VE, 8VH, 8VI, 8VQ, 8WD, 8WO, 8WS, 8WU, 8WZ, 8XAE, 8XE, 8YAA, 8YAE, 8YJ, 8YN, 8YU, 8YV, 8ZA, 8ZAE, 8ZN, 8ZQ, 9AAW, 9ACR, 9AES, 9AFK, 9AGG, 9AGR, 9AHK, 9AIP, 9AIR, 9AJH, 9AKE, 9ALP, 9AMT, 9APK, 9APS, 9AQE, 9ARG, 9ARR, 9AVX, 9AWU, 9AXK, 9AYH, 9AYW, 9AZA, 9AZE, 9BAK, 9BEN, 9BHD, 9BHV, 9BOT, 9CA, 9CEN, 9CP, 9DCX, 9DCZ, 9DDZ, 9DEL, 9DEV, 9DGG, 9DGV, 9DGX, 9DHQ, 9DHZ, 9DKK, 9DMJ, 9DNQ, 9DNZ, 9DOT, 9DRM, 9DSO, 9DTN, 9DUU, 9DXC, 9DXT, 9DZJ, 9DZU, 9DZY, 9EP, 9FK, 9FS, 9FY, 9GU, 9GX, 9HR, 9HT, 9KI, 9LF, 9MC, 9OX, 9PE, 9PW, 9QC, 9RC, 9SN, 9ST, 9UH, 9US, 9UU, 9VL, 9VZ, 9WB, 9WT, 9WX, 9WY, 9XI, 9XT, 9YAC, 9YAJ, 9YAK, 9YB, 9YC, 9YJ, 9YM, 9YO, 9YQ, 9YU, 9ZC, 9ZH, 9ZJ, 9ZN, 9ZT, 9ZV.

C.W.: 1ADD, 1AJP, 1ARY, 1ASF, 1BDC, 1BDI, 1BGF, 1BQK, 1CCZ, 1CNA, 1CNE, 1CNR, 1CPN, 1DH, 1GV, 1HX, 1KC, 1MO, 1PR, 1QP, 1SQ, 1XAD, 1XE, 1XM, 1XX, 1XZ, 1YK, 1YZ, 1ZE, 2AFP, 2AWF, 2AWL, 2AXK, 2AYV, 2BEH, 2BFZ, 2BML, 2BQU, 2BRB, 2BTJ, 2BUA, 2BUM, 2BUQ, 2BXP, 2BYS, 2CBG, 2CCD, 2CFT, 2EH, 2FP, 2FZ, 2HW, 2KJ, 2KP, 2LO, 2NZ, 2SQ, 2TS, 2WR, 2XB, 2XQ, 2ZK, 2ZL, 3AAY, 3ADL, 3AFB, 3ALN, 3AMK,

3ANJ, 2AWH, 3BEC, 3BGT, 3BGX, 3BHY, 3BLF, 3BNU, 3BVC, 3BZ, 3BZH, 3CA, 3CAY, 3CBM, 3CC, 3CCC, 3DS, 3FP, 3HG, 3IL, 3IW, 3NZ, 3QV, 3SY, 3XA, 3XW, 3ZO, 3ZZ, 4BF, 4BQ, 4BX, 4BY, 4CA, 4DC, 4EB, 4EH, 4EL, 4FS, 4GH, 4GL, 4GX, 4ID, 4JH, 4KC, 4LP, 4XA, 4XD, 4YA, 4ZA, 4ZC, 4ZE, 4ZH, 5AA, 5AAM, 5ABM, 5ACE, 5DA, 5DO, 5EK, 5FV, 5HB, 5IR, 5JR, 5KC, 5KU, 5LJ, 5OH, 5RL, 5XA, 5XV, 5YG, 5ZA, 5ZC, 5ZO, 5ZX, 6BO, 6BR, 6EN, 6KA, 6TV, 6XAD, 6ZF, 6ZZ, 7MI, 7ZG, 8ABV, 8ACF, 8ADG, 8AFY, 8AGO, 8AHR, 8AIM, 8AIO, 8AJM, 8AJV, 8AJX, 8ALB, 8AM, 8AMC, 8AMD, 8AMK, 8AMM, 8AMQ, 8ANB, 8AOL, 8APT, 8AQA, 8AQF, 8AQO, 8AQZ, 8ASM, 8ASV, 8ASZ, 8ATU, 8AVH, 8AVL, 8AVM, 8AVU, 8AVW, 8AWM, 8AMP, 8AMR, 8AWX, 8AXB, 8AXC, 8AZH, 8BAS, 8BRAZ, 8BBD, 8BCL, 8BCO, 8BDB, 8BDE, 8BDG, 8BDO, 8BDU, 8BEF, 8BEI, 8BEN, 8BEX, 8BFX, 8BIL, 8BIS, 8BIT, 8BJS, 8BKE, 8BKM, 8BKN, 8BLC, 8BLV, 8BLX, 8BME, 8BMW, 8BO, 8BOG, 8BPJ, 8BPU, 8BQF, 8BQU, 8BRZ, 8BU, 8BUN, 8BUX, 8BVR, 8BXK, 8BYC, 8BYD, 8BZF, 8BZL, 8CAB, 8CAY, 8CAZ, 8CBC, 8CBJ, 8CBK, 8CEI, 8CFP, 8CGX, 8CGZ, 8CIA, 8CIS, 8CJH, 8CJX, 8CKO, 8CLD, 8CML, 8CON, 8CQL, 8CSH, 8CWP, 8CWS, 8CYO, 8DV, 8EA, 8HJ, 8JU, 8KH, 8KS, 8MP, 8NB, 8OZ, 8PT, 8QB, 8SE, 8TO, 8UC, 8UE, 8UF, 8UK, 8UZ, 8VJ, 8VQ, 8VY, 8WA, 8WR, 8XAE, 8XAK, 8XB, 8XE, 8XI, 8XK, 8XR, 8XV, 8XZ, 8YD, 8YK, 8YM, 8YS, 8YU, 8YK, 8ZAE, 8ZAG, 8ZE, 8ZF, 8ZG, 8ZH, 8ZK, 8ZL, 8ZM, 8ZN, 8ZY, 8ZZ, 9AAP, 9ABV, 9AFU, 9AIX, 9AIV, 9AJA, 9AJH, 9ALS, 9AMM, 9AMO, 9AMR, 9AMT, 9AMZ, 9AOG, 9APS, 9APZ, 9ARG, 9ARK, 9ASM, 9AUA, 9AWK, 9BBA, 9BBF, 9BDB, 9BED, 9BFG, 9BHD, 9BLC, 9BMF, 9BRL, 9BSG, 9BTA, 9BVP, 9CBA, 9DAA, 9DAX, 9DFB, 9DGG, 9DIO, 9DKP, 9DKY, 9DSM, 9DTA, 9DV, 9DYN, 9DZQ, 9EI, 9FZ, 9HM, 9II, 9IO, 9KP, 9LQ, 9OX, 9PC, 9PF, 9UB, 9UC, 9UH, 9UN, 9US, 9UI, 9WA, 9XI, 9XM, 9YAF, 9YAJ, 9YC, 9ZAC, 9ZAF, 9ZG, 9ZL, 9ZX.

Canadian—Spark: 2GX, 3JL—C.W.: 9AL.

8AXB—8AQT, 347 W. McMillan St., Cincinnati, Ohio. (All C.W.)

(1CNR), 1HX, 1XM, 1XZ), (2AFP), 2ALN, 2AYV, 2BNX, 2CCD, 2FP, 2NZ, 3AW, (3BLF), 3CA, (3IW), 3LR, 3QV, (3ZN), 4BQ, (4GH), (4GL), 4LP, 5ARM, (5DA), 5EK, 5ND, (5LJ), (5ZAT), 5ADN, 5AIO, (8BEF), (8BIL), 8BKE, 8BLW, (8BO), 8BXH, (8BZF), (8CJY), (8CKO), (8DV), (8MP), (8PT), 8RV, (8UE), (8UK), 8VV, 8XE, (9AAP), (9AIV), 9AJA, (9AJH), 9AOG, 9APM, (9ARJ), 9ARK, (9BCR), (9BLC), (9BOP), (9DGG), 9DIO, 9DKY, 9PF, (9UC), (9UU), 9WA, (9WU), (9XI), 9YAJ.

SAGF, Ann Arbor, Mich.

C.W.: 1AWB, 2AFP, 2BNZ, 2OE, 3BEH, 3BNQ, 3BUP, 3BZ, 3IW, 3KL, 3OT, 3ZO, 4DM, 4GX, 5FV, 5SP, 5ACF, 5AEG, 5AFY, 5AM, 5AMM, 5AN, 5ANB, 5AOV, 5APT, 5AQC, 5ARR, 5ASM, (5ASZ), 5AVD, 5AVH, 5BAZ (QRA7), 5BEF, 5BFG, 5BO, (5BOB), 5BRQ, 5BRT, 5BVR, 5BWA, 5BWK, 5BZF (8BZY), 5CAB, 5CAN, 5CAZ, 5CJH, 5CKO, 5CSP, 5CTN, (8EA), 8HJ, 8IO (fone), (8MP), 8OW, 8PT, 8SP, 8UC, 8VQ, 8VY, 8YG, 8ZAG, 8ZZ (fone), 9AIX, 9AJA, 9AL, 9ARK, 9AJH, 9BSG, 9BHD, 9CBA, 9DBL, 9DR, 9DYN, 9CFS, 9LZ, 9SL, 9UC, 9US.

Spark: 8AIZ, 8ALV, 8AO, 8ASL, (8BAV), 8BZF, (8BZY), 8CP, (8CZO), 8CER, 8DSD, 8EO, 8LF, 8MZ, 8PB, 8TC, 8UE, 9AAW, 9CF, 9DWM, 9DXS, 9DXT, 9LF.

8ANV, Wilkinsburg, Pa.

C.W.: 1ADL, 1BDZ, 1BKQ, 1CNE, 1XA, 1XM, 2AZ, 2AFJ, 2AFP, 2BEH, 2BGF, 2BIG, 2BGI, 2BEP, 2BNU, 2CBG, 2FP, 2KL, 2NZ, 2OE, 2XZ, 3AW, 3AP, 3ALS, 3AFD, 3BNU, 3BLF, 3CIK, 3CHJ, 3CBM, 3CES, 3IW, 3LR, 3ZO, 4GL, 4ZB, 5ZB, 5AYL, 5ACF, 5ALN, 5AMU, 5APT, 5AMQ, 5AOV, 5AMN, 5AWM, 5AJT, 5ALD, 5AMZ, 5ADJ, 5AIM, 5AXC, 5ASM, 5AN, 5AMY, 5AGT, 5AMT, 5AVS, 5AVH, 5ADN, 5AUX, 5IAO, 5AVH, 5AHG, 8TX, 8BFX, 8BZF, 8BEF, 8BZY, 8BYR, 8BYJ, 8BRT, 8BKH, 8BXT, 8BRW, 8BNU, 8BOM, 8BOF,

8BPV, 8BAH, 8BDI, 8BJS, 8BDU, 8BO, 8BIB, 8BDO, 8BIF, 8BCF, 8BIL, 8CEJ, 8CJY, 8CTP, 8CCX, 8CPH, 8CJK, 8CN, 8CKM, 8CKN, 8CJH, 8CHS, 8CVY, 8CHY, 8CFI, 8CKI, 8CTF, 8CJY, 8CNM, 8CRO, 8CQ, 8DV, 8DH, 8EN, 8EO, 8HM, 8HJ, 8JU, 8KY, 8KM, 8KU, 8KG, 8LY, 8MP, 8PD, 8RQ, 8SE, 8TF, 8UE, 8UC, 8UQ, 8VQ, 8XG, 8ZX, 8ZZ, 9ACM, 9AAU, 9AF, 9BA, 9BUD, 9CKP, 9CBU, 9CKM, 9DGG, 9DSO, 9IE, 9IO, 9UU, 9XU, 9XL.

9UU, Chicago, Ill. (All C.W.)

(1HX), 1QP, (1XM), (1ANQ), (1AZW), (1BKQ), (1CCZ), 1CV, (2FP), (2NZ), (2AJF), 2AFP, (2AWF), (2AYV), (2BEB), 2BEH, (2BFX), 2BNZ, 2CCD, 3BZ, 3CC, 3FS, (3HG), (3HL), (3IW), 3LR, (3ZO), 3AFB, 3ALN, (3BIT), (3BLF), 4BQ, 4DC, 4GL, 4ID, (4JR), 4LP, (4ZB), (5DA), 5FO, (5FV), (5KC), (5LJ), 5ZAT, (8AN), (8AM), (8BO), (8DV), 8EA, (8GV), 8HJ, (8JL), 8JU, (8JY), 8KH, 8LX, (8MP), (8OW), (8PD), (8QB), (8RJ), 8SE, (8SP), (8TO), (8UC), (8UE), (8UK), 8VQ, (8VY), 8WA, 8XE, (8YD), (8ZB), (8Z), (8ZAE), (8ZAG), (8ABP), (8ACF), (8ADN), (8AGO), 8AIO, 8AMM, (8ANB), (8APT), (8AQF), (8AQZ), 8ARD, (8ASM), (8AVT), (8AWM), (8AXB), (8AXC), 8AXK, 8AZH, (8BAS), (8BDO), (8BDU), (8BEF), (8BEI), (8BEN), (8BEX), (8BFX), (8BIL), (8BIS), 8BKE, (8BQU), (8BRK), (8BXH), (8BYE), (8CAB), 8CAY, (8CAZ), 8CFP, (8CGM), (8CGX), (8CKO), 8CLD, 8CMM, (8CON), (8CWS), (9DR), (9EI), (9FK), (9HW), (9IO), (9LQ), (9OX), (9PF), 9PL, (9FN), (9QY), 9UC, (9VE), (9WA), (9XI), (9YI), (9AAP), (9ACB), 9AIF, (9AIV), (9AMB), (9APW), (9ARK), (9ARZ), (9AUA), (9BRF), (9BCT), (9BHD), (9BLO), (9RMD), (9BSG), (9CBA), (9BLC), (9BVB), (9DGF), (9DEK), (9DGG), (9DGG), (9DIO), (9DTN), (9DWW), 9DZQ, Canadians (8BP), (8CZ), 9AL.

9BHM and 9DTC, Naperville, Ill. (All C.W.)

1HX, 1IX, 1QP, 1XZ, 1AFP, 1BKQ, 1CNE, 2NZ, 2AWF, 2AYV, 2BEH, 2BGK, 2BXP, 2CCD, 3BB, 3IW, 3LR, 3QV, 3AIS, 3LF, 4BC, 4BQ, 4HY, 4ID, 4LP, 4ZB, 5EK, 5FO, 5FV, 5HB, 5JR, 5MA, 5UN, 5VG, 5AMB, 5ZAT, 5AM, 8AN, 8BH, 8BO, 8CH, 8EA, 8GK, 8GY, 8IR, 8JQ, 8JU, 8JL, 8MP, 8OW, 8SP, 8TO, 8UC, 8UE, 8UK, 8VQ, 8VY, 8ZQ, 8ZZ, 8ACF, 8AGO, 8AHR, 8AIG, 8AIM, 8AIO, 8AMM, 8AMQ, 8ANB, 8AOV, 8APW, 8AQF, 8AQO, 8AQZ, 8ARD, 8ASM, 8ASZ, 8AVH, 8AVT, 8AWM, 8AWT, 8AXB, 8AXC, 8AZH, 8BAU, 8BDO, 8BED, 8BEF, 8BEI, 8BEN, 8BFX, 8BGD, 8BGG, 8BIL, 8BKE, 8BMM, 8BPL, 8BRC, 8BRW, 8BUX, 8BWK, 8BXF, 8BXH, 8BZF, 8CAG, 8CAZ, 8CBR, 8CKM, 8CID, 8CJH, 8CLD, 8CML, 8CTN, 8ZAG, Canadians 8BP, 9AL.

9DR, 1830 Stevens, Minneapolis, Minn.

C.W.: 2FP, (5FO), (5J), 5QC, 5SP, 8AUB, 8AXB, (8AM), 8AIO, 8AQZ, 8BFX, 8BVR, 8BKE, 8BRW, (8CAZ), 8JL, 8LB, 8UC, 8XV, 8ZZ, (8VY), (8ZA), 9AIV, (9ATN), 9AJH, 9ALX, 9AMU, 9AOR, 9ALS, (9AOG), (9ARZ), (9ASF), (9AAP), (9BTT), 9BHD, 9BUD, (9BKP), 9BBB, (9BAF), (9BKJ), (9BTT), (9BKB), (9BQW), (9BSG), (9BBF), (9CP), (9CFI), (9CBA), 9DXK, 9DBL, (9BVB), (9DIO), 9EW, 9OO, (9PN), (9QE), (9QF), 9RO, (9UU), 9VE, (9YAJ), 9YAK, 9YT, 9ZAC, 9ZX.

Spark: 8AZF, 9AAW, 9ANU, 9AYW, (9AXU), 9AAR, 9DSM, 9DZY, 9LF, 9SN, (9XT), (9ZC).

9APK, Chicago (1 Tube)

Spark: (2FP), (3ARN), 3BG, (3GN), 5HK, (5JF), (5TC), 8AHE, (8AFD), (8ASL), 8ASZ, 8AUX, (8AWU), (8AXN), 8AZF, (8BAH), (8BAZ), (8BBU), 8BO, 8DV, 8EA, (8EW), 3FI, 3FS, 3FT, 8JK, 8KY, (8CJH), 8NZ, 8VQ, (8UC), (8WD), 8YN, (8ZO), 8TK, (9ABV), (9ACW), 9AIF, 9AMT, (9ANP), (9APS), 9ASK, (9AUA), 9AUM, 9AZA, (9BGD), 9BKP, 9BHM, 9CS, (9DAG), 9DEL, 9DGV, (9DGV), 9DHD, 9DIO, (9DOT), 9DTN, 9DXT, 9FP, (9FK), (9NQ), (9OX), 9PD, (9UH), (9XI), 9XT, 9YAJ, 9YB.

C.W.: 1ADL, 1ARY, 1ASF, 1AZW, 1BKQ, 1YB, (2FP), 2BEH, 3AMK, 3BG, 5OL, 6JD, 6PD, 6KA, 6BES (QRA7), 8ADG, 8ADR, 8AIO, 8AM, 8AMM, 8APT, 8AQO, 8AQV, 8AVD, 8AWM, 8AXB, 8AXC,

8BEF, (8BEI), 8BEN, 8BIL, 8BIS, (8BLW), 8BO, 8BOG, 8BUX, 8CAY, 8CAZ, 8CFD, 8CEI, 8CKK, 8CKM, 8CKO, 8CFS, 8EA, 8GY, 8SP, 8TO, (8UE-EX-8AGK) 8WQ, 8YD, 9AAP, 9AFU, 9AIF, 9AOG, 9APW, 9ARK, 9AUA, 9AUL, 9BBA, (9BLC), (9BTA), (9CBA), 9CCS, 9DFB, 9DIO, 9DR, 9DUN, 9DWY, 9FZ, 9IO, 9PN, 9UH, 9WA, (9XI), 9YAJ, 9ZL.

**9CHJ, Eastmoreland Place, Joplin, Mo.**

C.W. 2FP, 2BQ, 4ZB, 5DO, 5EK, 5FO, 5FV, 5JB, 5JL, 5LJ, 5OI, 5SP, 5VI, 5YG, 5ZAK, 5ZAT, 5ZG, 6KA, 6EN, 6AIO, 6AN, 6AQO, 6AWM, 6BO, 6JL, 6MP, 6VY, 9ABV, 9AIX, 9AMB, (9AOG), 9ATU, 9AUA, 9AVM, 9AVN, 9BBE, 9BED, 9BGH, 9BHD, 9BIB, 9BSG, 9CBA, 9CCS, 9CFI, 9DBL, 9DIO, 9DPL, 9DR, 9DTA, 9DUN, 9DXN, 9EL, 9UU, 9YAJ.

Spark: 5IR, 5LB, 5NS, 5TU, 8EA, 9AAW, 9ACB, 9ANO, 9APN, 9APS, 9AVG, 9AVK, 9BLW, 9BME, 9BPK, 9DJB, 9DMJ, 9DRW, 9DSD, 9DZY, 9HT, 9LF, 9OX, 9RR, (9RY), 9WS, 9YAK.

Daylight: C.W.: 9DUN, 9CCS, 9BIB. Spark: 9AVK, 9BLW, 9RR, 9RY.

**9AHC Ellendale, N. Dak. (One Tube)**

C.W.: 2FP, 5EK, 5FO, 5SP, 5ZAT, 6KA, 7LU, 8AIO, 8AM, 8AUV, 8AQV, 8AQZ, 8ASV, 8AXB, 8BDO, 8BDU, 8BEF, 8BY, 8CAZ, 8CBJ, 8JL, 8JQ, 8JU, 8KH, 8MP, 8UC, 8UK, 8UZ, 8ZZ, 8ZL, 9AIX, 9AJH, 9AKX, 9AMB, 9AOG, 9AOL, 9APW, 9ASF, 9AUA, 9AVM, 9BAF, 9BAV, 9BBF, 9BCT, 9BED, 9BGH, 9BHD, 9BVG, 9BSG, 9BXA, 9CBA, 9CFI, 9DBV, 9DCW, 9DIO, 9DR, 9DUL, 9DUN, 9DZQ, 9DUZ, 9EW, 9GK, 9HJ, 9LN, 9PN, 9QE, 9UC, 9UU, 9WA, 9XL, 9YAJ, 9YV, 9YL, 9ZAE.

Spark: 5UC, 9AAW, 9ABV, 9ACB, 9AGK, 9AIF, 9AJH, 9AKX, 9ANP, 9AUL, 9BOF, 9BRI, 9CP, 9DPB, 9DUG, 9DZY, 9FX, 9LF, 9YAK.

**9AOG, Lawrence, Kansas**

C.W.: 1BKQ, 2FP, 2NZ, 4BQ, 4GL, 4ZR, 5ACF, (5DO), 5EK, 5GY, (5FO), 5FV, 5HO, (5JB), (5JI), 5LJ, 5OI, 5SP, 5VI, 5YG, 5ZAK, (5ZAT), (5ZG), 6EN, 6KA, (8AIO), (8AN), (8AUV), 8AQO, 8AQZ, (8AWM), 8AXB, (8AXC), 8BEF, 8BFX, (8BIL), (8BO), (8BGO), 8BUX, (8BVR), 8CMI, (8GY), 8IB, 8JL, 8KG, 8KH, (8MP), (8SE), 8UC, 8VQ, (8VY), 8XE, 8XJ, (9ABV), 9AEP, (9AIX), (9AJH), (9AMB), (9AMI), 9AN, (9APW), 9ATU, (9AUA), 9AVM, (9AVN), (9BAF), 9BAP, (9BBE), (8BFF), 9BCT, 9BED, 9BGH, 9BHD, 9BIV, 9BVB, (9BIB), 9BMD, (9BQW), (9BSG), 9RUD, 9CBA, 9CBB, (9CCS), 9CCV, (9CFI), (9DBL), (9DCF), (9DCW), 9DIO, (9DPL), (9DR), (9DRQ), (9DTA), 9DTS, (9DUN), (9DWY), 9DXN, (9ED), 9EO, (9FK), 9JG, (9JR), (9MX), (9SJ), 9SL, 9UU, (9VE), (9WA), (9YAJ), (9ZAC), 9ZAF, 9ZH.

Spark: 4GP, 5IR, 5JI, (5LB), 5NS, 5TC, 5TU, 8BAZ, 8EA, (8FW), 9AAW, (9ABV), (9ACB), 9AEG, 9AJH, 9ANO), 9APK, 9APN, (9APS), 9ARG, 9AVH, 9AVK, 9AVW, (9BGI), (9BHN), 9BKK, 9BLW, (9BME), (9BSZ), (9BSZ), (9BPK), (9CHT), 9DGV, 9DHY, 9DHz, (9DJB), 9DJX, 9DKK, 9DMJ, 9DPB, (9DRQ), (9DRW), 9DSD, (9DSN), 9DSZ, (9DVF), (9DZY), (9FK), (9HI), (9HT), 9KA, 9LF, 9OX, 9PW, (9RR), 9RY, 9UH, (9WS), 9XT, (9YAK), (9YU), 9ZH, 9ZV.

Daylite: C.W.: 9ABV, 9AVM, (9BIB), (9CCS), 9CCV, 9CFI, (9DPL), (9DRQ), (9DTA), 9DTS, (9DUN), (9SI), 9ZH. Spark: (9ABV), 9AEG, (9ANO), 9AVK, (9BHN), 9BKK, 9BLW, (9BME), 9DHY, (9DJB), (9DRQ), (9DRW), (9DSN), (9HI), (9RR), 9RY, (9YU), 9ZH.

handled in a manner which makes us regard the book as excellent for the layman.

**"Radio Phone Receiving—A Practical Book for Everybody"**, by a group of authors, with an introduction by Prof. Michael I. Pupin; the VanNostrand Company, New York; 179 pages, 4½x7½, \$1.50.

For sheer information of value, "Radio-phone Receiving" surpasses all the new books that have come to our attention. Each of its chapters is written by an expert on that subject, and altho the question of correlation between the various topics may arise, they are treated in an undeniably high-class manner and the book will come closer to interesting the practical amateur than any of the new-comers in its field. Dr. A. N. Goldsmith contributes an excellent chapter on "How Radio Telephoning is Accomplished," which is followed by "Tuning the Simple Receiving Circuit" by Erich Hausmann of the Polytechnic Institute of Brooklyn. Frank E. Canavaci, of the same institution, treats on "Receiving by Crystal Detectors," while "The Vacuum Tube" and how it works is ably handled by Prof. John H. Morecroft of Columbia University and author of one of our best radio texts. "Amplifying the Music or Speech" is the topic of a chapter by Robert B. Gibson and Paul C. Hoernel of the A. T. & T. Research Laboratories, while the difficult subject of "Regenerative and Heterodyne Reception" is concisely and intelligently explained by Prof. L. A. Hazeltine of Steven's Institute of Technology. John V. L. Hogan concludes the book with a chapter on "Radio Telephone Broadcasting."

Each chapter has been handled by a specialist in its topic. The book is copiously illustrated with drawings and excellent photographs, and it is with all most interesting.

K.B.W.

**CLYDE E. DARR**

(Concluded from page 48)

to help it along. In addition to his fine C.W. set he has a wife and young son but friend wife says he would sell the boy's shoes for a hunk of galena. He admits his principal interest is keeping the wolf from the doors of the unscrupulous manufacturers by biting and buying from the early enticing advertisements. He has a commercial license for decorative purposes and is President of the Detroit Radio Assn., Assistant Manager of the Central Division, A.R.R.L., member of our Board of Direction, and Associate Member of the Institute of Radio Engineers. But we believe the job he likes best is making the covers for QST.

**BOOK REVIEW**

(Concluded from page 47)

broadcasting, receiving equipment and its operation, amplification, learning the code and transmitting, phone and C.W. transmitters, various applications of radio, and the construction of simple receiving sets for broadcast programs. All of these are

# Strays



Rumor has it that broadcasting stations along the Atlantic Coast are preparing their patrons to listen for them on wave lengths about 1100 after the new radio bill is passed. Word is passing around amateur circles that the Department of Commerce has decided to put all broadcast stations near the coast on the higher range of wave lengths. We don't know how true this is, but we have always felt that as many as possible of the broadcasting stations should operate in that immediate vicinity.

M. B. West, author of many articles in QST and famous as pre-war SAEZ, has resigned as Expert Radio Aide, U.S.N., and is now with the Chicago Radio Laboratory.

L. R. Schmitt has resigned as Radio Inspector of the Ninth District to become the Chicago Sorsinc manager and has been succeeded at Chicago by E. A. Beane, late assistant inspector of the Second District.

We understand that rights under the Armstrong Super-Regenerative patent are for sale but with no takers as yet. Corporations comprising the "big five" are said to be staying off it because its acquisition by them would only revive public talk about monopolies, etc. A. H. Grebe & Co. recently called a conference of Armstrong license-holders at which the probable effect of the new invention was considered, and we are informed that a move is on foot to raise a pool of \$150,000 among the manufacturers licensed under the original Armstrong regenerative patents to secure for themselves rights under the Super patent, their contributions to the pool to constitute advance royalties on their own manufacture.

Ellery W. Stone is back from China and now managing the radio department of the Pacific States Electric Co. in San Francisco.

No more "A-P" tubes for a while, we hear. These tubes were being manufactured on an agreement with the Radio Corporation, we are told, which permitted the manufacture of a certain number. This quota now being used up, the factory is idle, but will resume in November when the Fleming patents expire. After Novem-

ber the "evacuated chamber" idea is public property and deForest licensees under the third-element patent will be free to GA. The Meyers R.A.Co. tube will then be sold as a detector as well as amplifier, too.

Traffic Manager Schnell to Commissioner Carlson at hearing on the Chicago radio ordinance: "Do you know what static is?"

C. C.: "Yes, it's the charge of electricity that stays on an aerial after you've received a signal".

Mr. H. C. Forbes, formerly Chief Operator at 9XI and assistant to Prof. Jansky at the U. of Minn., has accepted a position as Assistant Physicist in the radio laboratory of the Bureau of Standards.

Needed inventions—  
Automatic "DX card" printer.  
Folding 100-ft. masts.  
Vest pocket grounds.  
Endless storage batteries.  
—"Kick Backs".

This is how Governor John M. Parker felt about the Governors-President Relay after reading the report in the May QST: "I am glad to know that Louisiana's message was safely relayed and made such an excellent record."

4GL says the QRN is so bad in Georgia that they run A.C. motors off of it!

At the recent joint meeting of the I.R.E. and the A.I.E.E. at which Senatore Marconi was scheduled to speak at 8 p.m., a large number of the members arrived in plenty of time but the novice public was earlier and completely filled the hall and all approaches.

Mr. Robt. F. Gowen, 2XX, formerly Chief Engineer for DeForest, has been installing radiophones in Canton, China, assisted (?) by eight Chinese and one interpreter. Eighteen stations scattered in the most inaccessible places were installed and are now being operated (?) while friend Gowen is returning by way of the Suez.

The Federal 226-W amplifying transformer works best connected as follows:

P-1 to plate, P-2 to filament, S-1 to filament, and S-2 to the grid of the tube.

Hooray! As per our request the Department of Commerce informs us that the list of experimental, technical and training schools, and special amateur stations will be published in the new call book of "Amateur Radio Stations of the United States" which is now being printed, and that their street addresses will be given also.

The call 6ZE was printed by mistake for 6ZF over a list of "Calls Heard" in April issue.

Charles A. Service, Jr., has resumed his old love as assistant A.R.R.L. Secretary at the headquarters office, relieving Mr. R. L. Northrop, resigned. Everyone is delighted to have him back in the amateur world where he belongs.

"Radio Topics," founded originally by the Chicago Executive Radio Council as an outgrowth of "The Grid-Leak," its official organ, is no longer controlled by the Council and is making a bid for popular favor as a radiophone magazine.

In May QST, page 41, appears a statement that the license of 6HH was revoked by the Department of Commerce. This should have read "cancelled because of failure of the owner to apply for renewal."—T.M.

M. B. Sleeper uses a radiophone like a dictaphone. He was caught broadcasting like this: "The super-regeneration comma . . ."

**Wanted:** An American manufacturer who will put out a combination C.W. wave-meter and oscillator for separate heterodyning, for short-wave C.W. work.

We were happy to have Prof. Goddard, 5ZJ, from the New Mexico State College, drop in to visit QST, 1AW, and 1BGF here in Hartford.

9DXI, in Marinette, Wis., is all wrathed up on being reported in Kansas City on phone when he has only a spark set. On the contrary we say it is fine work.

At the request of Inspector Redfern of the Seventh Radio District, the Totem Radio Club appointed Sheldon G. Hagen as Deputy Inspector. He receives \$1 per year and has direct supervision over all amateur radio in Seattle and vicinity.

R. H. McMann is now president of the Second District Executive Council and A. A. Hebert, A.R.R.L. treasurer and director, is vice-president.

Prof. F. C. Blake of the Physics Dept. of Ohio State University, author of the

illuminating article in the June QST on Power Factor, has kindly consented to act as a member of our A.R.R.L. Advisory Technical Committee.

Mr. John diBlasi has resigned his connection with the Continental Radio & Electric Corp. and is now president of the Queens Radio Co., Inc. of Winfield, L. I. Mr. R. H. McMann has joined the forces of the Continental Radio & Electric Corp.

In Canada with the reopening of navigation the 50 meter restriction resumed as regards spark transmitters but the authorities have granted C.W. stations the privilege of using 200 meters the year around. Not a boost to C.W. in Canada, is it?

We note with interest that the phone stations in the vicinity of New York have gotten together and decided amongst themselves a working schedule so as not to interfere with each other. Their Inter-Companies Radio Broadcasting Committee is following the examples of many executive radio councils formed by amateurs several years ago. A suggestion has been made, however, that instead of having continuous broadcasting from eight in the morning until midnight every day and night in the week that it would help amateur affairs if all the stations would broadcast together for an hour or so and get it out of their systems all at once. Imagine the racket!

More reports have come in on hearing and working 6BO. The real 6BO says that reports indicate the chap using his call is around Pittsburgh, Pa. Swing your loops, gang, and send us your dope. We'll do the rest.

We read in a catalogue, "Most long distance DX stations use D.C. current."

"Oh, Galena, why are you so sensitive?"—East Gulf Radiogram.

We are looking forward with anticipation to the publication of the Bureau of Standards' report on the Bustands—A.R. R.L. Fading Tests which were participated in by so many of our members. We are advised that the report is nearing completion and now awaits the conclusion of the statistical analysis.

#### Clear as Pittsburgh

Reporting Mr. Marconi's speech in N.Y.C. before the I.R.E. and the A.I.E.E., the "Radio Dealer" in its June issue, says that Marconi eliminates static in the following manner: "To overcome static interference, he explained, he first determines the strength of the signal sent by means of a measuring apparatus and then makes the signal strength equal to that of the distant transmitting station."

# Radio Communications by the Amateurs

The Publishers of QST assume no responsibility for statements made herein by correspondents.



## QRM With Broadcasts

Hartford, Conn.,  
June 21, 1922.

Commissioner of Navigation,  
Department of Commerce,  
Washington, D. C.

Dear Sir:

Will you please be good enough to favor us with an answer to the following hypothetical question:

Is a Radio Inspector empowered to close down or to suspend or revoke the license of a duly licensed amateur transmitting station whose radiated wave complies with all the requirements of the law, because such station interferes locally with the reception of broadcast programs by stations in its immediate vicinity?

If your answer to the above is in the affirmative, will you kindly cite the regulation authorizing such action?

Your courtesy in the above matter will be highly appreciated by

Sincerely yours,  
American Radio Relay League, Inc.  
K. B. Warner, Secretary.

Department of Commerce,  
Bureau of Navigation,  
Washington, June 27, 1922.

Mr. K. B. Warner, Sec.,  
American Radio Relay League,  
Hartford, Conn.

Sir:

The Bureau has received your letter of the 21st instant asking if a Radio Inspector is empowered to close down or to suspend the license of a duly licensed amateur station where the radiated wave complies with all of the requirements of the law, because such station interferes locally with the reception of broadcast programs by stations in the vicinity.

Only the Secretary of Commerce has authority to suspend or revoke a license for cause and in this case such cause may be covered by Section 5, Act of August 13, 1912.

Respectfully,  
D. B. Carson, Commissioner.

(Sec. 5 of the 1912 law provides that every license shall prescribe that the operator thereof shall not willfully or maliciously interfere with any other radio communication, and that such interference shall be deemed a misdemeanor and shall be punishable

by fine or imprisonment or both. We believe that the words "any other radio communication" probably would be interpreted as referring to point-to-point radio communication. It is further to be noted that one of the Radio Inspectors has made a statement to the effect that there is no reason why listeners to broadcasts on 360 meters should experience interference from legally-adjusted 200-meter transmitters and that if they do have such interference because of the poor design of their receiving equipment, their recourse is to the dealer who sold them the "simplified" set.—Ed.)

## They're Orf Again!

Pacific States Electric Co.,  
San Francisco, Cal.,  
July 2, 1922.

Editor, QST:

It seems that Old Man Power Factor is not to lie decently interred after the funeral services in his honor at the last National Convention of the A.R.R.L. As one of the two contestants who debated the subject on that memorable evening at the Chicago Convention, I should like to be heard once more, promising hereafter to hold my peace.

The whole gist of this matter is that in a freely oscillating circuit, or in a forced oscillating circuit tuned to resonance with the impressed frequency, the inductive and

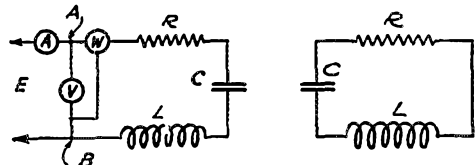

Fig. 1

Fig. 2

capacitive reactances are equal in value and opposite in sign, the impedance is virtually limited to the resistance, but the power factor, as brought out by the Board appointed to consider the Bureau of Standards' telegram at the Chicago Convention, is neither zero nor unity but is indeterminate. Let us see why.

In Fig. 1, the inductive and capacitive reactances are tuned to resonance with the impressed frequency, in which case—of course—the inductive and capacitive reactances are equal in value and opposite in sign. We say the power factor of the

circuit is unity but we mean the power factor only with respect to the points *A* and *B*.

Power factor is defined as the ratio  $\frac{P}{EI}$ ,

where *P* is the average power dissipated in the elements *R*, *L* and *C* of the total impedance of the circuit, *E* is the effective value of the alternating electromotive force impressed across the two end points (*AB*) of the elements *R*, *L* and *C*, and *I* is the effective value of the current entering and leaving the network at the two end points (*AB*). That the term *power factor* can be applied to the network of resistance, capacity and inductance in series, as in Fig. 1, does not mean that the term refers to the network of these three elements except and only with respect to the two points at which the potential is applied to the three elements in question and at which the current enters and leaves the network.

With unity power factor, the current is in phase with the potential. This very definition in itself proves that we cannot consider the power factor of a circuit, comprising the three elements *R*, *L* and *C*, as a whole except with reference to the two points between which these three elements are connected, because *within* the network the current leads the potential across *C* and lags behind the potential across *L*.

In any A.C. circuit comprising a resistance, an inductance and a capacitance in series, of either audio or radio frequency, resonant or non-resonant, the power factor across the inductance (if resistanceless) is always zero, the power factor across the condenser (if perfect) is also always zero, and that across the resistance is always unity. In the circuit of Fig. 1, we speak of the power factor of the circuit *A*, *R*, *C*, *L*, *B*, as being unity, when resonant, but it is significant that we include the points *A* and *B* in the network and that we really are considering the power factor only at these two points.

We live and learn. It will be recalled that in Mr. West's original paper, he advocated the improvement of the power factor of certain radio circuits or of the elements therein in order that associated circuits could be most efficiently coupled thereto. It was my contention that since in a freely oscillating circuit, or in a forced oscillating circuit tuned to resonance with the impressed frequency, the same conditions always obtain in that the inductive and capacitive reactances are always equal in value and opposite in sign and that the impedance, with certain limitation, is always that of the resistance of the circuit. (True, the decrement or resistance factor of the circuit can be reduced—with consequent increase in efficiency—by a judicious choice of inductance, capacitance and resistance values, but in any case the

two reactances will always be equal and opposite, and whether the circuit is resonant or not the individual power factors of the inductance, capacitance and resistance will always be zero, zero and unity, respectively.)

Now in my earlier contributions on this subject, I made the mistake of considering that because one loosely speaks of the *network* shown in Fig. 1 as having unity power factor, the same term can be applied to the typical radio circuit—the freely oscillating discharge circuit of a condenser shown in Fig. 2—inasmuch as the same conditions obtain, insofar as the equality of the two reactances is concerned. But, and this is significant, in Fig. 2 there are not two points of reference—as the points *A* and *B* of Fig. 1—where we can consider the potential applied to the *whole* network and the current entering and leaving it.

Those of you who will recall the mild (and not so mild, either) form of inquisition to which Mr. West and I were subjected at the Chicago Convention, will remember that this point was clearly demonstrated by the Board appointed to consider the Bureau of Standards' telegram. The diagrams and questions of the Board were intended to show the impossibility of measuring power factor in an oscillating, closed network. The point is that the power factor of the complete radio circuit is *not zero*, as stated by Prof. Blake, but *indeterminate*.

One can measure the power factor of any one of the elements, or any two of the network, but not of the whole. I quote herewith from a letter to me from the Bureau of Standards under date of November 16, 1921:

"Now consider a simple oscillatory circuit. The individual power factors of the condenser, inductance and resistance are explicit, and are approximately zero, zero and one, respectively. The power factor of the combination of any two of three elements is likewise unambiguous. *The power factor of the whole circuit is indeterminate*, because there is no e.m.f. associated with the whole circuit, or more rigorously, the e.m.f. associated with the whole circuit is zero. For this is what is meant by the term 'oscillatory circuit,' a circuit in which a damped alternating current will flow, following a transient electromagnetic disturbance, with no external e.m.f. acting."

It is not my intention to reply in detail to Prof. Blake's paper except to point out that he has *not* measured the power factor of either of the two radio circuits in question but simply that across the inductance or the capacitance in each case. The inductance having resistance and the condenser not being a perfect one, we should expect their respective power factors to be not far from the value of 0.00031 calculated by Prof. Blake.



I refuse to believe, however, that the spark gap will show a potential of "only slightly less than 21,200 volts" when a current of 117 amperes is flowing across the gap. The voltage named only obtains across the gap when the current is *not* flowing. I think the Professor will find that the potential across the gap drops to 5 or 6 volts when it is virtually short circuited in the ionized condition of spark discharge.

Referring to the quotation from Prof. Morecroft's excellent book given in the footnote at the end of Prof. Blake's paper, (the italics are mine):

"It must be such *circuits* that Prof. Morecroft has in mind where he says in his text book on radio communication 'in some *parts* of efficient radio circuits the power factor may be as small as 0.005.'"

It does not appear that the quotation supports Prof. Blake's contention for obviously Prof. Morecroft is speaking only of *parts* of circuits, not of *complete* circuits.

The subject of power factor in a freely oscillating circuit, or in a forced oscillating circuit tuned to resonance with the impressed frequency, then, can be dismissed with the statement that the power factor of the complete circuit is neither unity nor zero but is indeterminate, although conditions in such a circuit resemble those of Fig. 1—in which the power factor is loosely said to be unity, in reality only at the points *AB*—in that the inductive and capacitive reactances of such a circuit are equal in value and opposite in sign.

Sincerely yours,  
Ellery W. Stone.

### What American Means

Nicoya, Costa Rica, 31 May 1922.

Editor of QST—

My dear friend, Mr. Robert Sincock, at the end of a letter he was said me: "Your plan is rather unique and I hope that it works out as you have planned it. You have my best wishes along that line and I would suggest that you write to some magazine such as the one published at Hartford, Conn U.S.A. by the American Radio Relay League. It is called "Q.S.T." and is the best that you can get. If you state your plans to the Editor who is a friend of mine, I am sure that he would be glad to give the School a boost."

Mr. Sincock he was express so, because I was state him the follow words:—"Do you no wonder that I can not write very well in american. In fact, the american translation is more familiar for me than those grammatical knowledges that are indispensables for write very well; in spanish the grammatical forms are all diffeents. In Costa Rica there are two are and spark wireless Stations in the atlantic cost called: Limon and Colorado. In the center of the country there are also some ones,

but these are amateur private sets: my station is one of them, installed in my School, and it is the must very far station from capital city.

I wish to have a largest receiving and transmitter set, but in this country there are not those indispensables materials for to make the instruments. I heard Limon, Colon, and Colorado only. In my School where I am Director, a Section or Department for install a STATION by the spontaneous contributions of ours american friends or amateurs, I have established, and I think to stablish other likes in the nearness of this town. In Costa Rica there are not matters and not anywhere obtain them. For this reason, I was directed to various amateurs of your country in order to obtain some busy instruments or apparatus, and so, will can to install a more regular transmitter and receiving set to teach my poor fellows who are fondness in the radio field, and to call this Department of contributions or obsequious: "THE HALL OF OURS AMERICAN FRIENDS"—You lives in the must great Nation where no only the Greatness and Progress of your own dear country are purposed, but all of the world, and I think or I have the belief, that we must cultivate a very true affect and help us in all, making from North to South Poles, a vast country which its Monarch will be the Brother Lovingness and its laws the Sentiments of Heart. So please help us with any of the instruments or magazines I number here: a audion (amplifier, detector or oscillion), or variables condensers or a loose coupler, or honey comb coils, or a hot ammeter, or a meter, or a little dynamo or motor, or a thordarson transformer, or a oscilation transformer, or a amplifying transformer, or a loud-speaker, or phones, or variometer, or multi-point switch, or materials and instructions for to make some instrument suggest for you, or Radio News, or Q.S.T., or Wireless Age, or a rotary gap, or all you wish. All or that all you do not use, will be great thing for me."

Now, my dear sir, you understand why Mr. Sincock told me that? Do you wish to welcome my entreatly and to interest and friend your for help us? Do you please with glad and spontaneously help us in some form? I am very overtrust by knightly of your.

With my very best wishes to you personally and your universally readed Q.S.T., I am,

Very truly yours,

H. Vega O,  
(Director of R.T.1).

Address:

Mr. Higinio Vega Orozco.  
Nicoya, Guanacaste.  
Costa Rica, C.A.  
Escuela Radio Tristan

Editor's Note: Fellows, here is a chance to show what it means to live in America. We ask you just to imagine that Costa Rica was the head and center of radio and we here were unable to buy apparatus; study the letter of our radio brother in Costa Rica in that spirit, and let your conscience be your guide.

Every amateur we ever met has a graveyard with scads of apparatus that never will be used again by him. Could it possibly be put to any better use than in helping the cause of amateur radio in a country where eager amateurs exist without any apparatus at all? The reward of brotherly action in this case will be found in the place Costa Rica can take in A.R.R.L. affairs in the years which are quickly descending upon us.—K.B.W.

### The Helping Hand

Anthony, Kansas

Editor, QST:

The June issue of QST arrived today and I have glanced over the most of it and have read thoroughly the editorial page. As one of the novices referred to I am very much in sympathy with your attitude as expressed. I wonder if you would like a history of my case—it must be typical of a good many today:

A long time ago I thought some about jumping into the wireless game but at that time the learning of the code appeared big as a mountain, none of my pals were interested and I didn't suppose there was anyone close to whom I could talk, so I dropped it. That was perhaps eight or ten years ago.

This spring, along in April I would guess, I passed the house of a friend that I knew had built a receiving set. I had known it for quite a while but had not had sufficient interest to make a trip down to his house to see it, but that morning I was there so I stopped. He was listening in and handed me the receivers and I heard Hutchinson broadcasting market reports. That gave me the bug. I realized that I knew very little and would have to start at the bottom so I bought every magazine I could find and built a crude crystal set. It worked. I built a little better one, I helped three other fellows build sets, learning a lot by doing it. Then I started a tube set, single circuit, of course. I use it to experiment on—tear it up and make it over. As I said, I bought every magazine that I saw on the news stands, then one day I saw the March issue of QST at a friend's, I looked it over and liked it. The first article that I ever read clear through in QST was "Getting Started Listening." The description of the Reinartz tuner appealed to me but the talk at the end about choke coils was above my head. Later I saw the May issue. I read the

article by H. J. Goddard in regard to his tuner and I understood enough about it by then to ask questions so I wrote him. He answered with a mighty helpful letter and has been helping me ever since. He suggested that I subscribe for QST; I had thought about it but just hadn't done it—now I have and I am mighty pleased.

That is how I got the bug, and I've got it so bad I couldn't quit if I wanted to—I will go on and learn the code and get a transmitter. Now, the point of it all is this, I am a novice, pure and simple—I doubt if I would ever have gotten interested in radio if it had not been for the phone and broadcasting—will I be any less valuable to the League because I got started that way? I hope not. Which makes me say, *Do not let QST become one of the "popular" news-stand type of magazines but, also, do not condemn the novices—help them all you can because part of them will become amateurs and the more you help the novice, the sooner he will become an amateur.* Actual plans for building receivers help a great deal, for instance, those in the March and May issues. The more they go into detail the better. What does one have to know and do to get a license? I see advertisements of books that claim to prepare one for the examination but the advertisements aren't in QST, they are in magazines that I have lost faith in. They may be good or they may be trash and I haven't any money to waste. Could you spare a page each issue for a department of that sort? Sure the most of your subscribers would laugh at you but tell them why you run it and get them to help with suggestions—they might think it was fun.

Thanks for reading all this—I feel a lot better with all that load off my chest, whether you get any good out of it or not.

Yours very truly,

H. C. Barrett.

One glance at the above letter will tell any A.R.R.L. "ham" that Mr. Barrett is no longer a novice, but has graduated and has become one of us. We welcome you, O. M. And say, about that amateur spirit that 9ZX showed toward you—you'll find it everywhere in the A.R.R.L.

Are you any less valuable an amateur because you started as a radiophone novice? Absolutely no! Every one of us had to start at the very bottom. QST wants its readers to remember that. We thank you for your message to us and know that you are right. We are trying to help the novice thru our department entitled "With our Radiophone Listeners," as that is where our "Junior Operators" commence their experiences nowadays. The editor has been considerably puzzled, however, to receive

numerous letters from A.R.R.L. members protesting the existence of this department either because they regard it as a rather pitiful bid on QST's part for the interest of the broadcast listener, or because they think it very uninteresting and feel that the space should be given to articles. The answer to these is to be found in an examination of Mr. Barrett's letter. The phone broadcast listener is a potential A.R.R.L. man and should be encouraged. Personally, broadcast reception does not interest us because we do not think that the quality of the programs is good enough nor can it compare in fascination with amateur long distance, but our policy toward the novice listener shall ever be a broad one in the realization that the helping hand of the A.R.R.L. will lead to Amateurdom those of the new comers who are able to climb. Our members are urged to pursue the policy outlined in our June editorial.

The books to which Mr. Barrett refers relate to the examination for *commercial* license, and some of them are quite helpful in that direction. The requirements for an amateur operator's license, however, are not nearly as severe. They require the ability to send and receive the continental code at a speed of ten words per minute and only a moderate amount of theoretical knowledge of the action and adjustment of apparatus.

We intend that our department for the novice shall be utilitarian, and not filled merely with glittering generalities and pretty pictures. In fact, we have half a notion, as time goes on, to change its name to "The Junior Operator." Suggestions for this department will be cordially appreciated.

—Editor.

### The Beverage Wire

71Y, Vashon, Wash.

Editor, QST:

The Beverage wire, it seems, is a piece of apparatus on which there is very little accurate data available. The Totem Radio Club of Seattle has undertaken to make a thoro test of the antenna, with the data as follows.

The first experiment was to find the most effective length and for different heights. The first antenna erected was 630 ft. long and 2 ft. above ground, insulated with porcelain tubes wired to poles. With no resistance at the far end the natural wave length was about 250 meters. That is, it was the wave at which the primary and secondary of a 3-circuit tuner was at best resonance. By adding resistance of 200 ohms the resonant wave length dropped to 220 meters, then with 50 ohms more, to about 212 meters. An increase beyond 250 ohms seemed to broaden the tuning in the primary. Sigs could be heard

with equal ease with any amount of inductance in the primary but were not nearly as QSA as when the primary and secondary were in true resonance. In this last condition the primary seemed to function aperiodically. But the results obtained were not nearly as good as with a regular antenna.

It was then raised to about 12 ft. height. the resonant wave length with 300 ohms was then down to 208 meters without broadening tuning. Results were same as with lower wire—not as good as regular antenna. The QRN and QRM were just as bad and no very great directive effect was noticed. This was on June 22d. (Direction of all our antennas was 2 degrees south of east pointing east.)

On June 23 we increased the length to exactly 1350 ft. with average height of 10 ft. With approximately 450 ohms resistance the resonant wave length was around 210 meters. With this arrangement we began to get results. About 6 p.m. we heard some nine calling SBK on C.W., very QRZ tho as it was still daylight. At 10 p.m. we started watches of one hour, one man logging and another tuning so as to make no mistakes. Altho bad, the QRN was not as bad as on the regular antenna. 7GE, 7FG, 7IW, all sparks, broke things up pretty badly for quite a while. (Hi!—guess here is where I junk my old spark). This antenna began to show some of the characteristics that a Beverage wire is supposed to have. It was directional. It was better by far than the regular aeriels. It reduced QRN considerably. To really show its directional qualities take a map of the U.S. and draw a line across it in the direction of the aerial, place pins on locations of stations logged, and it can be seen that not many more than 15° or 20° on either side were heard. We heard a few sixes to the south but one queer thing was that they were not any more QSA than the nines, due to directivity of the antenna. The following stations were logged, sparks in italics: 5FO, 6KA, 6NX, 6ZI, 6GY, 6FT, 6AWT, 7FQ, 7QW, 7GE, 7AAB, 7IN, 7ZV, 7BN, 7NA, 9BSG, 9DU, 9AMB, 9LN, 9AOS, 9APW, 9ASE. Most of these were very QRK.

On June 24th we increased the length of the wire to 1600 ft., same height; a resistance of 200 ohms placed the resonant wave length about 200 meters. The QRN this day did not seem nearly as bad; it was pretty fair radio weather. We reduced the length again to 1350 ft. with 450 ohms and the QRN again was real bad, so we immediately increased to 1600 ft. with 200 ohms, where it was again reduced. We held watches from 9 p.m. to 3 a.m. The DX stations logged were all C.W.: Too many 6's and 7's, 5FO, 8AW, 8ZZ, 8UC, 9DR, 9BSG, 9PI, 9APW, 9BS, 9AUT,

9BH, 9AUU, 9UU, 9AUA. From midnight to 3 a.m. arc mush from NPZ was very bad from 200 meters up.

To my mind these are pretty good records, as summer time and its static do not make ideal receiving weather. Also the location was in one of the dead spots of Seattle for DX but the only place with sufficient room.

All of these stations were heard on a 3-circuit tuner using a variocoupler and two variometers, Radiotron detector, and one step of audio amplification. Two stages made it so we could hear some of the nines all over the tent but QRN was then so bad that one step was easier to read. The resistance at the far end was a 16-candle power carbon lamp and a 200-ohm potentiometer.

Yours truly,  
D. A. Cutler, 71Y,  
Totem Radio Club.

### "Of, By and For"

Radio 3AGL,  
Reading, Pa.

Dear Eddy:

Ever since receiving my copy of the June QST I have felt so relieved that I am forced to write you my appreciation.

I was overjoyed to find that QST remains an amateur magazine and has not changed into a "broadcast" magazine. All of the fellows I know feel the same way about it. They all hope that QST will remain as it is at present and not do what "\_\_\_\_\_ " did. In one month it changed from a fairly good amateur magazine into a 100% radiophone broadcasting magazine.

I have no doubt that QST will remain the magazine that it is now, popularly known among wise amateurs as "the only magazine."

Sincerely yours,  
Fred G. DeLong.

### Soldering to Pipes

3 Charles St.,  
Bangor, Maine.

Editor, QST:

In the March number the statement was made that the ground could not be soldered to a cold water pipe. I have soldered three or four every day for three years.

First, clean the galvanized iron pipe, then tin it with a hot iron, using Nacorrode soldering paste, then wind 8 or 10 turns of copper wire that has been well scraped. Apply more paste and a little solder and with a hot iron it will surprise you how pretty that solder will flow over the wire and hold it to the pipe. The only secret is a hot iron and a well tinned place on the pipe. The top of the pipe is the easiest to tin and solder. Use a ground clip on the

bottom of the pipe if you want to just hold the wire tight.

Very truly yours,  
Abbott C. Smith.

### YOUR PEN IN HAND

(Concluded from page 29)

tenna article in QST? In Cuba putting up a broadcasting station. Where's Kruse? Somewhere in Mexico. Where's West? In charge of somebody's laboratory where all these bases for articles are now commercial secrets. Where's Higgy? Making binding posts or something back in Columbus and too busy to write. Dammit, we could name a hundred cases just like that.

Now your QST, as a non-commercial magazine which is not designed for profit and run co-operatively by its A.R.R.L. owners, has never paid for its articles, nor do we see why those among us able to contribute something for the common good should expect remuneration—it isn't amateurish, it isn't A.R.R.L. We're perfectly willing to establish the practice if anyone can show us the logic of putting out that money and leaving our A.R.R.L. treasury with just that much less to use for things of common good; but we do not think it would help in a situation where the trouble seems to be that the chaps with the cold dope either think they are too busy to write about it or want to keep it under cover to launch on the unsuspecting market next fall.

This is a genuine call for help. We need articles. We want A.R.R.L. members to recall their duty to help keep QST absolutely in the lead as the incarnation of a community of amateur interest and the vehicle for the presentation to the amateur world of the things that count in 200-meter work. Whadyamean you're too busy selling radio stuff to knock off an hour and write up that new circuit? Wheredjaget the idea that to describe that new gadget would scoop all your sales next winter? Is that A.R.R.L. spirit? No, but it's a trend in the direction in which we begged our fellows not to go in a recent editorial.

Let's not commercialize QST and fill it with a lot of useless generalities, which is the only kind of stuff that folks who aren't real amateurs can write. That means that YOU who read these lines must take stock of yourself and do your bit. What can you write an article about? Wouldn't it give you a little warm feeling to see your article in QST, and wouldn't you have a feeling of boosting the game along if you helped? You know it; and don't think that because you understand a thing well it must be known already to everybody else and hence isn't a fit subject for an article; please give us a chance to be the judge on that. And if after a careful self-

A.R.R.L.  
Ontario  
Division

Wireless  
Association  
of  
Ontario

# ALL ABOARD FOR CANADA

## A.R.R.L. MEN

### COME

#### AND MEET YOUR CANADIAN BROTHERS

#### AT THE FIRST

## CANADIAN NATIONAL RADIO CONVENTION and EXHIBITION

### September 8 and 9, 1922

AT THE

PRINCE GEORGE HOTEL  
TORONTO, CANADA

DURING THE LAST TWO DAYS OF CANADA'S GREAT  
ANNUAL NATIONAL EXHIBITION

Write for

Booth Reservations to

W. C. C. DUNCAN  
196 Ellsworth Ave.,  
Toronto

Write for

Accommodation Reservations to

E. J. BOWERS  
37 Lowther Ave.,  
Toronto

It is requested that delegations report their expected hour of arrival in Toronto to E. J. Bowers, Chairman, Reservation Committee.

Banquet tickets for Saturday evening will be \$3.50 including Admission to All Sessions of the Convention.

Wireless  
Association  
of  
Ontario

A.R.R.L.  
Ontario  
Division

inventory you decide that you don't know a blooming thing to write about, at least drop the editor a line and tell him that so-and-so has a darb of a Super and that whoosit has a new kind of a mast that knocks 'em all dead—so that we can go after them.

Your pen in hand, O.M.—and thanks!  
—K.B.W.

#### HARVEY MITCHELL ANTHONY

*(Concluded from page 48)*

cal Institute of New York City. A few of the societies he belongs to are: U.S. Naval Institute, Fellow of the American Association for the Advancement of Science, British and French associations for the advancement of science, French Physical Society, Certified Member of the American

Association of Engineers, American Institute of Electrical Engineers, Institute of Radio Engineers, American Chemical Society, American Electro-chemical Society, Western Society of Engineers, Honorary Member of the National Association of Stationary Engineers, American Society for Municipal Improvements, Society of Industrial Engineers, Indiana Engineering Society, and a few pages more. He has been elected to the State Board of Examination and registration of professional engineers for the term 1921-24. The thing that puzzles us is how he could be an amateur and attain all these honors. Yet he is an amateur and in recognition of his prominence in this field his fellow amateurs recently re-elected him to the Board of Direction of our A.R.R.L.

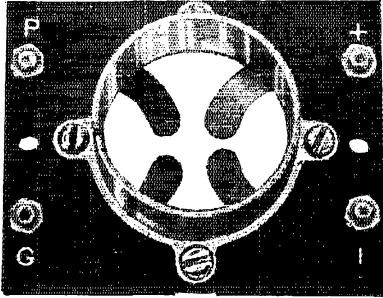

**VACUUM TUBE SOCKET**  
Type SA Style No. 166

Attractive, rugged and perfect in all details. Phosphor bronze contact springs. Heat proof composition base. Price \$1.00.

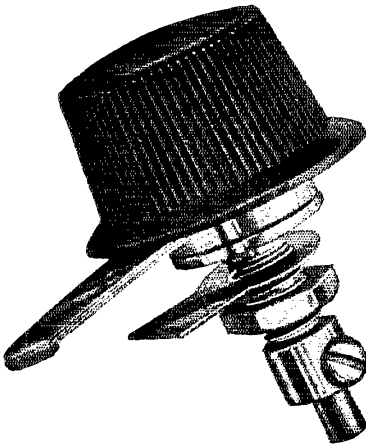

**INDUCTANCE SWITCH**  
Type SC Style No. 167

The best switch at the best price, featuring a laminated phosphor bronze contact arm. Price \$0.50.

*Special Discounts to Dealers.*

**THE RADIO ELECTRIC CO.**  
*Manufacturers and Jobbers in*  
**RADIO EQUIPMENT**  
1427-29 LIBERTY AVENUE  
PITTSBURGH, PA.

# TUSKA

Market Reports



# RADIO

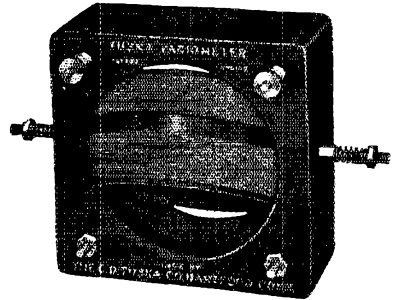

**Tuska Variometer Type 200**

The Tuska Variometer was the first moulded Variometer on the market; not only first to arrive, but first in quality.

All TUSKA RADIO follows this example. The name Tuska is a standard. Insist on Tuska Sets and Tuska Parts.

*Send 5c for Tuska Catalog No. 3*

**The C. D. Tuska Company**  
11 Bartholomew Ave., Hartford, Conn.

# BURGESS

## "B" BATTERIES

BURGESS "B" Batteries assure clear receiving, increase the efficiency of any receiving set, and they are cheapest in hours of service.

BURGESS "B" Batteries are sold by every progressive Radio Dealer and Jobber. "Look for the Black and White Stripes."

A postal card from you brings full information by return mail. Why not write to us today? (Dept. D)

### BURGESS BATTERY CO.

*Offices and Warehouses:*

CHICAGO	NEW YORK	BOSTON
111 W. Monroe St.	50 Church St.	136 Federal St.
MADISON	KANSAS CITY	ST. PAUL
Wisconsin	2109 Grand Ave.	2362 University Ave.

*In Canada: BURGESS BATTERIES, Ltd.  
Winnipeg, Toronto and Montreal*

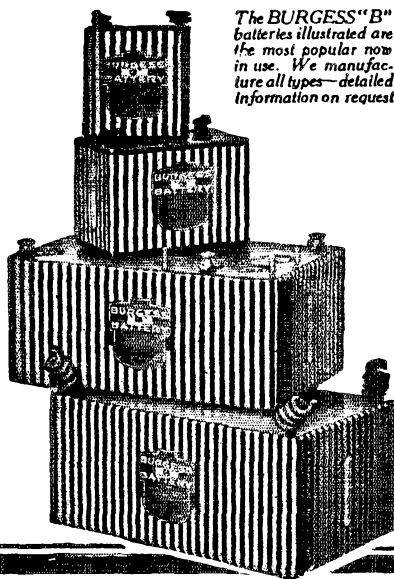

*The BURGESS "B" batteries illustrated are the most popular now in use. We manufacture all types—detailed information on request*

**OVER 300,000 SOLD—WHY?**

**"ASK ANY RADIO ENGINEER"**

Price \$12.00 F.O.B. N.Y. City

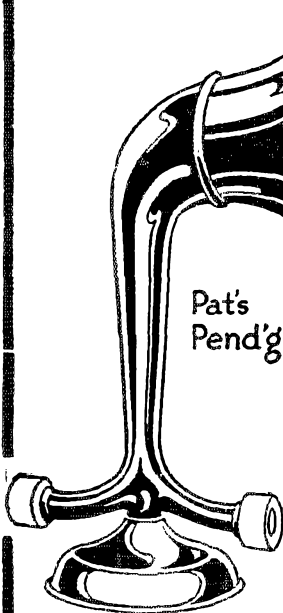

# INTRODUCING THE KING "AM-PLI-TONE" A RADIO SURPRISE

*Listen to the Concerts, News and Dance  
with a KING "AM-PLI-TONE."*

Just slip your head phones on the "AM-PLI-TONE" and you and your friends will be SURPRISED.

Polished Cast Aluminum Body with Nickel Plated Base and Horn. No sheet Metal is used, the "Tinny" Sound is Left Out. The VOLUME is DOUBLED because TWO head phones are blended into one POWERFUL tone.

A big hit—a big seller and immediate deliveries. Dealers and distributors what more can you ask? Write today for territory—KING "AM-PLI-TONE"

82 Church St., New York City

NOTICE: All infringers of this device will be vigorously prosecuted.

KQV—Pittsburgh Pa.—BROADCASTING STATIONS—Washington, D. C.—WMU

## Dependable Radio Equipment

All orders with remittance promptly delivered, Post or Express paid. Always a large and varied stock of most modern and reliable Radio Equipment and Parts.

Immediate Deliveries on all Items Listed



Stromberg-Carlson  
No. 2-A Headset  
\$7.50

Aeriola Senior Westinghouse Receiver.....	\$65.00
Aeriola Grand Westinghouse Receiver.....	325.00
DeForest Radiohome Set DT 700, less Batteries, Bulbs and Headset.....	36.00
DeForest 2-Stage Amplifier DT 300, less Bulbs and Batteries .....	35.00
Simplex Variometers.....	5.00
King Amplitone Horns.....	12.00
Holtzer-Cabot Headset.....	7.50
UV 201 Radiotron Amplifier Bulbs, each.....	6.50
No. 766 Eveready VT Batteries, each.....	3.00
Gould 6-volt, 60-80 Ampere Storage Batteries.....	19.00

Enclose Certified Check or P. O. Money Order with Orders

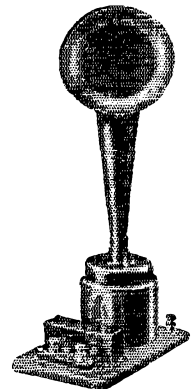

R3 Magnavox  
Loud Speaker  
\$45.00

## DOUBLEDAY-HILL ELECTRIC CO.

WASHINGTON, D. C. — DEALERS WRITE FOR DISCOUNTS — PITTSBURGH, PA.



# AMPLIFICATION

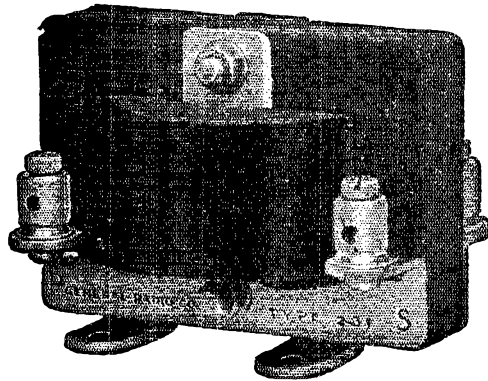

What do you KNOW about the amplifying transformer you purchase? Do not guess or take the other fellow's word for it; KNOW.

Does it have the correct impedances, the proper core and the best windings to give maximum amplification with a minimum of distortion over a suitable frequency range?

The General Radio Type 231-A Amplifying Transformer is correctly designed for best results with the Radiotron UV-201 tube. General Radio guarantee and service stand behind it.

The constants of the transformer are as follows:

	Primary	Secondary
Direct current resistance.....	1,100 ohms	5,500 ohms
A. C. resistance @ 1,000 cycles.....	11,000 ohms	130,000 ohms
Reactance @ 1,000 cycles.....	66,000 ohms	700,000 ohms

**PRICE, COMPLETELY MOUNTED, \$5.00**

*Send for Free Radio Bulletin 911-Q*

## GENERAL RADIO CO.

MASSACHUSETTS AVENUE AND WINDSOR STREET

CAMBRIDGE 39, MASSACHUSETTS

*Standardize on General Radio Equipment Throughout*

Do not confuse the products of the GENERAL RADIO CO. with those of other concerns using the words "General Radio." The General Radio Co. has been manufacturing radio and scientific instruments for many years. It has no affiliation with any other company.

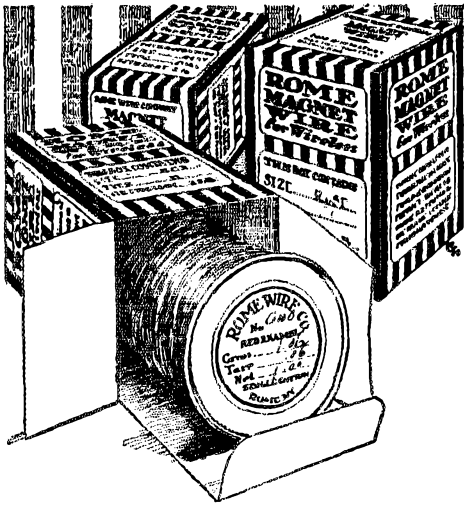

For satisfaction  
Demand Rome Blue  
and White Package  
or Label.

# ROME RADIO WIRE

## Magnet Wire

Best Quality Plain Enamel Covered; Enamel—and Single or Double Cotton Covered; Single or Double Cotton Covered.

All sizes; ¼-lb. to 40-lb. packages.

## Antenna Wire

Best Quality Solid or Stranded Copper Antenna Wire, plain or tinned; put up in lengths of 100-ft. and 150-ft. or on 24" reels of 200-lbs.

At Your Dealer's

**ROME  
WIRE COMPANY**  
ROME, N.Y. . . . . BUFFALO, N.Y.

DISTRICT SALES OFFICES

NEW YORK . . . 50 Church Street. CHICAGO . . . 14 E. Jackson Blvd.  
DETROIT . . . 25 Pershing Street

LOS ANGELES . . . 7 G. Pomerooy, 336 Aruze Street

2067-L

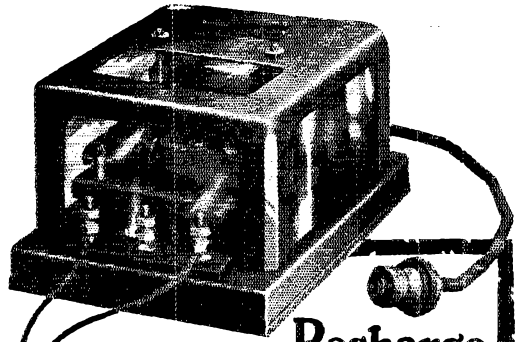

## Recharge Your Battery at Home

Charges both A and B Radio Batteries

Don't be without the use of your Radio Receiving Set while your battery is being charged. Get a Valley Charger and charge your battery right at home.

Attach the Charger to your home lamp socket—attach the clips to the battery terminals and you will get a quick, tapering charge which just exactly charges your battery, but cannot overcharge it or harm it in any way.

Will charge the A 6 volt battery at a 5 ampere rate, and the B 22½ volt battery at the required ½ ampere rate. 45 volt B batteries may be connected in parallel so that they can also be charged.

SATISFACTION GUARANTEED.

If your local distributor cannot supply you, write direct to  
**VALLEY ELECTRIC COMPANY,**  
Department Q, ST. LOUIS.

----- Mail the Coupon -----  
Valley Electric Co., Dept. Q, St. Louis, Mo.

Gentlemen: I am enclosing money order (or check) for \$18.00, for which send me a Valley Battery Charger with five-panel glass display case and indicator. If not satisfactory, I will return it and get my money.

Name \_\_\_\_\_

Address \_\_\_\_\_

**\$18.00**

F.O.B. St. Louis

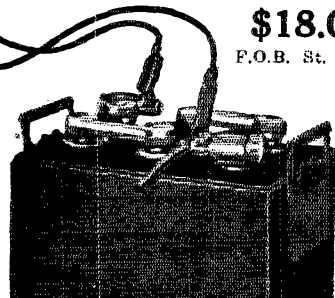

Why Should I Use a

# Weston

## Filament Voltmeter

### On My Receiving Set?

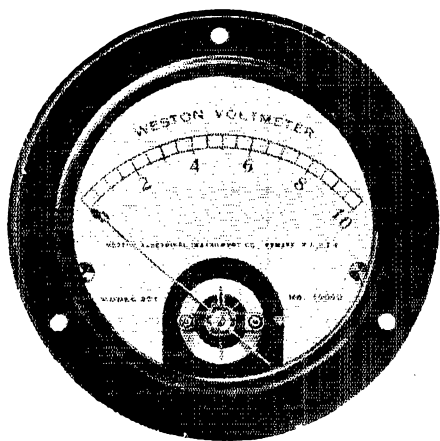

**Here's the Answer:**

1. It simplifies tuning by eliminating guesswork as to tube adjustments;
2. Filament voltage control increases the life of the tube from two to three times;
3. The Weston Filament Voltmeter is accurate and can be relied upon for duplication of results.

*All this means*

## Better Reception!

*Buy it from your dealer, or from us direct if he cannot supply you.*

*Write us for Radio Circular J.*

### Weston Electrical Instrument Company

158 Weston Avenue, Waverly Park, Newark, N. J.

Branch Offices in all Principal Cities

*Protect  
your VT's*

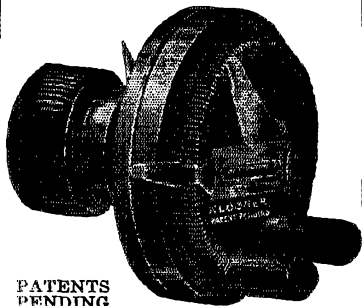

PATENTS  
PENDING

# KLOSSNER *Vernier* RHEOSTAT

EVERY TUBE you have de-  
serves a Klossner Vernier  
Rheostat. The Klossner *WIRE  
WOUND* feature produces a  
low starting current preventing  
sudden strain and thereby  
prolonging the life of the tube.

The Klossner provides mi-  
crometer adjustment for your  
critical detector tubes. One  
single knob controls both the  
rough and vernier adjustments.  
It is unsurpassed for loudest  
reception of telephone and C.W.  
and is essential for detector  
tubes of radio frequency am-  
plification. Awarded the New  
York Evening Mail's Certifi-  
cate of Excellence. Insist on  
the genuine—made only by the  
originators. Look for the name  
"Klossner" moulded on the base.  
The cost is no more than for  
other Rheostats without these  
exclusive features. At your  
dealer or send for interesting  
literature. Klossner Improved  
Apparatus Co., Dept. Q, 2024  
Boston Road, New York City.

*Dealers: This is the fast-  
est moving rheostat on the  
market. It is stocked by  
all leading jobbers. Get  
your supply from them.*

**One Single Knob  
No Sudden Strain  
\$1.50**

# Warren Radio Loop

NO  
A  
E  
R  
I  
A  
L

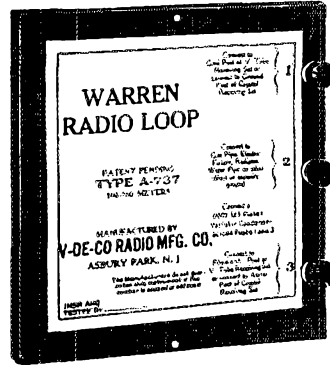

LESS  
S  
T  
A  
T  
I  
C

If Dad says—

"NO AERIAL ON THIS HOUSE"  
don't allow his QRM to worry you but  
purchase a

## WARREN RADIO LOOP

The LOOP that made the Radio Roller Chair  
famous on the Boardwalk at Asbury Park, N. J.  
Is just the thing for an apartment or den.  
Is light in weight and easily portable.  
Is produced under a new principle of winding.  
Is wholly enclosed, thereby protecting the winding.  
Is used in place of an outside aerial.  
Is adapted for receiving in moving vehicles.  
Takes the "tic" from static.  
Eliminates all danger from lightning.  
Can be used with any receiving instrument.  
Can be used without tuner.

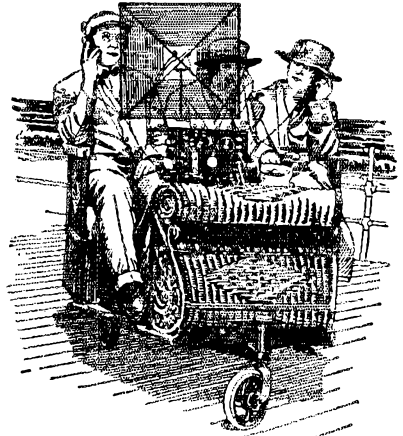

This picture of the Radio Roller Chair showing the  
Warren Radio LOOP was used as cover design on  
"Wireless Age" and "Radio News" and featured  
in many other magazines and newspapers in the  
United States.

Send your order through your dealer or direct to  
us with his name.

Type-A-737 (300-700 meters).....\$10.00  
Type-A-7236 (175-1000 meters)..... 12.00

## V-DE-CO RADIO MFG. CO.

DEPT. R, ASBURY PARK, N. J.

Send for Bulletin—No. A101

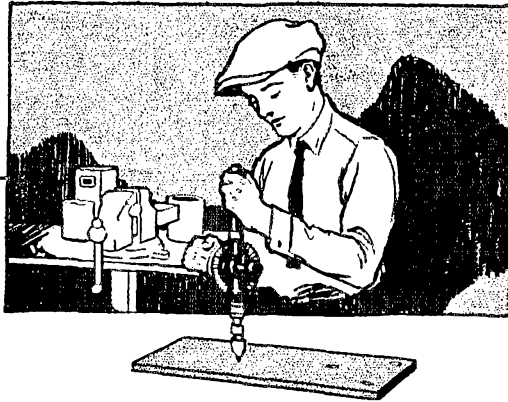

## Ask About Formica!

**F**ORMICA is known by the satisfaction it has given those who use and know radio insulation.

They will tell you it is the best insulating material—water-proof, warp-proof, splendidly finished in natural brown color or black—and absolutely efficient in its insulation effect.

Don't believe that all radio insulating materials are alike. There is a difference in the scientifically prepared and chosen fibre base from which Formica is made. There is a difference in the uniform excellence of the binder. In Formica it is always the same and always right. Formica processes are controlled with the utmost accuracy to produce an "always-good" product. Good manufacturing has made Formica the most popular of all radio insulating materials.

It is approved by the navy and signal corps. Insist on it.

*DEALERS: Our greatly enlarged plant is now in full operation. We are shipping twice as much Formica as we were a few weeks ago. There is no reason now why you can't handle the best radio insulating material—and benefit by the unusual co-operation the company gives its dealers.*

### THE FORMICA INSULATION COMPANY

4620 Spring Grove Avenue,

Cincinnati, O.

#### SALES OFFICES

50 Church Street, New York, N. Y.  
9 South Clinton Street, Chicago, Ill.  
414 France Building, Cleveland, Ohio.  
1642 Granite Building, Rochester, N. Y.  
415 Ohio Building, Toledo, Ohio.

422 First Avenue, Pittsburgh, Pa.  
Sheldon Building, San Francisco, Cal.  
932 Real Estate Trust Bldg., Philadelphia, Pa.  
321 Title Building, Baltimore, Md.

# FORMICA

Made from Anhydrous Redmanol Resins  
**SHEETS TUBES RODS**

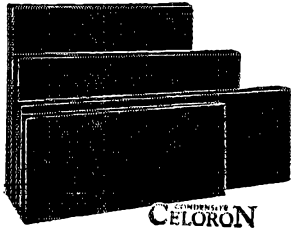

## RADIO PANELS AND PARTS

Start your set right. Pay particular attention to "insulation." Get a good panel and dependable parts. To make sure that you do get them look for the dealer displaying this sign:

CONDENSITE  
**CELORON**

### RADIO PANEL SERVICE

Condensite Celoron panels and parts are right. You can bank on them, for this strong, handsome, waterproof material (approved by the Navy Department, Department of Engineering) is extremely high in surface and volume resistivity and dielectric strength. It machines readily, engraves without "feathering," and takes a beautiful natural finish—polished or dull. This is why it is so widely used for panels, tube bases, mountings, variable condenser endplates, tubes, dials, knobs, handles, bushings, etc. We can machine all of these parts to your specifications.

Send today for our Radio Panel Guide

Are you an enthusiast? This Guide describes our panels in detail—tells how they are made and what they cost.

Are you a radio dealer? Learn about Celoron Radio Panel Service and how easily and profitably it enables you to supply your customers with panels and parts fully machined and engraved to their specifications. Write for our Special Dealer's Proposition today.

## Diamond State Fibre Co.,

Bridgeport (near Philadelphia) Pa.  
Branch Factory and Warehouse, Chicago

Offices in principal cities  
In Canada, Diamond State Fibre Co., of  
Canada, Ltd., Toronto

## HOMCHARGE YOUR BATTERY for A Nickel

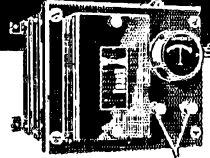

No mess, trouble, dirt—no moving of batteries—loss of time—no effort on your part—no technical or professional knowledge needed.

## THE HOMCHARGER

successfully meets all charging conditions, and is the only rectifier combining the following essential Hom-charging features.

1. Self polarizing. Connect battery either way and it will always charge. No danger of reverse charging, ruined battery or burnt out Rectifier.
2. No delicate bulbs to break or burn out. Only one moving and two wearing parts. These are replaceable as a unit, after thousands of hours use, at small cost. Cannot be injured by rough handling.
3. Operation stops and consumption of current ceases immediately upon disconnecting battery.
4. The only charger costing less than \$100.00 that will fully charge a battery over night. Gives battery a taper charge—exactly as recommended by battery manufacturers. Guaranteed not to harm your battery even though left connected indefinitely.
5. Highest efficiency of any three or six cell charger made.
6. No danger of fire. Approved by the Underwriters.

### ATTENTION MOTORISTS

Will charge your auto battery as well as radio battery. Send for Bulletin No. 58 for further information.

For sale by all radio, electrical and accessory dealers or shipped express prepaid for purchase price.....\$18.50  
\$20 West of the Rockies

### The Automatic Electrical Devices Co.

127 West Third St., Cincinnati, Ohio.  
Branch offices: New York, Chicago, Pittsburgh, Los Angeles, New Orleans, Detroit, Philadelphia, Baltimore, Dallas, Kansas City, St. Louis.

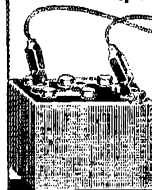

*Largest Manufacturers  
of Rectifiers in the World*

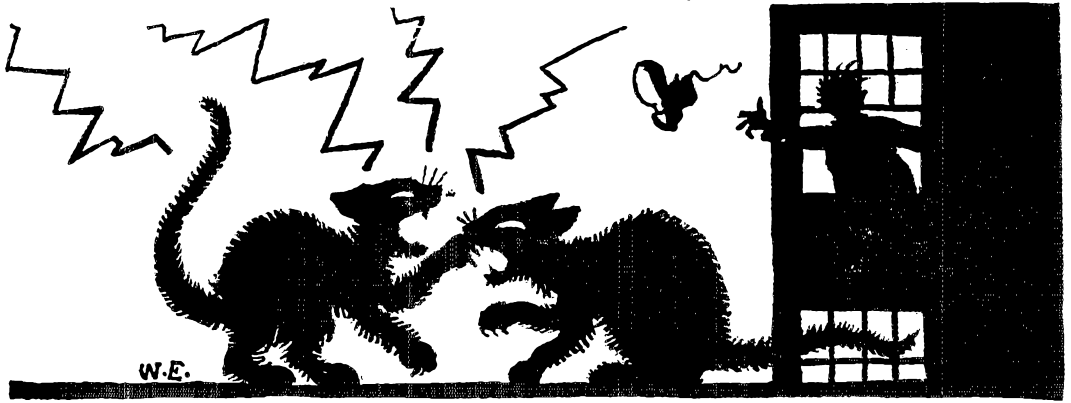

## “Stop those back fence concerts”

**T**HE yowls of a prowling Tommy are as mere love-songs beside the ear-splitting howls of a perturbed radio set (and you'll be surprised how often one gets perturbed without the calming influence of the proper Amplifying Transformer).

Most any transformer can amplify sound, but it will also amplify the stray fields which produce howling and distortion. It takes the Acme Amplifying Transformer with its specially constructed iron core and coil to put an end to the “back-fence” concerts. Only when you add the Acme do you get the realistic tone and volume so markedly absent in the ordinary radio receiving set.

The Acme Radio Frequency Transformer greatly increases the range of any receiving set, either vacuum tube or crystal detector type. The Acme

Audio Frequency Transformer produces not only volume, but reality of tone. It is indispensable to the satisfactory operation of loud speaking devices. The combination of one or more stages of Acme Radio and Audio Frequency Transformers assures the maximum of range, of volume and of reality in tone.

The Acme Apparatus Company, pioneer radio engineers and manufacturers have perfected not only Radio and Audio Frequency Transformers as well as other receiver units and sets, but are recognized as the foremost manufacturers of Transmitting Apparatus for amateur purposes. Sold only at the best radio stores. The Acme Apparatus Company, Cambridge, Mass., U.S.A. New York Sales Office, 1270 Broadway.

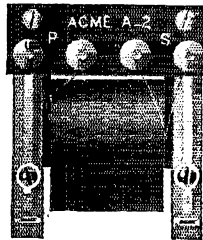

Type A-2 Acme Amplifying Transformer  
Price \$5 (East of Rocky Mts.)

# ACME

*for amplification*

# QUALITY PARAGON PERFORMANCE

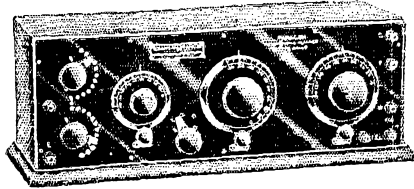

Paragon RA-10	:::	:::	:::	\$75.00
		160-1000 METERS		
Paragon RA-Special	:::	:::	:::	\$50.00
		160-500 METERS		
Paragon DA-2	:::	:::	:::	\$65.00
		DET. AND 2-STAGE		

Enclose certified check or P.O. money order. Include postage.

IMMEDIATE SHIPMENT  
"EVERYTHING IN RADIO"

"We Give You Real Service"

**A. V. GREGORY**

42 BROAD STREET  
RED BANK, N. J.

2KL

2KL

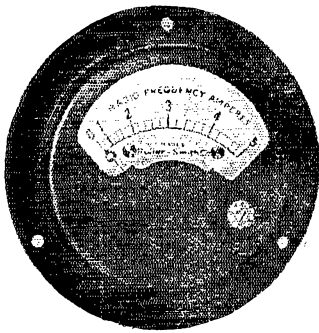

How Many  
Amperes  
Are You  
Radiating?

A Roller-Smith type TAW Thermal Ammeter will tell you accurately and it will continue doing so. These little 3 1/2" instruments have demonstrated their reliability in the Government service. You can't make a mistake when you use them. Bulletin No. AG-10 is yours for the asking. Send for it. This Bulletin also describes a most complete line of ammeters and voltmeters for all radio work.

**ROLLER-SMITH COMPANY**  
16 PARK PLACE, NEW YORK

Offices in principal cities in U. S. and Canada

"East and West, the Globe is Best"

## GLOBE RADIO HEAD PHONES



Highly sensitive  
Matched receivers  
Natural in tone  
Each receiver tested  
by radio  
Lightweight (11 oz.)  
Comfortable to wear  
Will not distort signals, when amplified  
Articulation perfect

2200 ohms List price only \$9.00

There are many types of head sets on the market but not too many good ones. The GLOBE RADIO HEAD SET incorporates a knowledge of acoustics based on nearly fifteen years of experience in making high grade sound producing and receiving instruments. It embodies correct design with the best of materials. The Globe Phones are for those who discriminate.

Ask about the Globe Antenna Attachment Plug for connecting your radio set to your electric light circuit.

Buy from your local dealer, or write us direct.

**GLOBE PHONE MFG. COMPANY**

Earl C. Hanson, Technical Radio Expert  
READING, MASSACHUSETTS, U. S. A.



# Armstrong Uses Pacent Radio Essentials in His New Super-Regenerative Circuit

**W**HEN Major Edwin H. Armstrong recently demonstrated his new super-regenerative receiver before the Institute of Radio Engineers, he was able to receive from the famous WJZ station at Newark (25 miles distant) by the use of three vacuum tubes, although only a small loop aerial was used in the steel framed building of the Engineering Societies, New York City. The program was reproduced with such great volume that it filled the lecture hall and corridors.

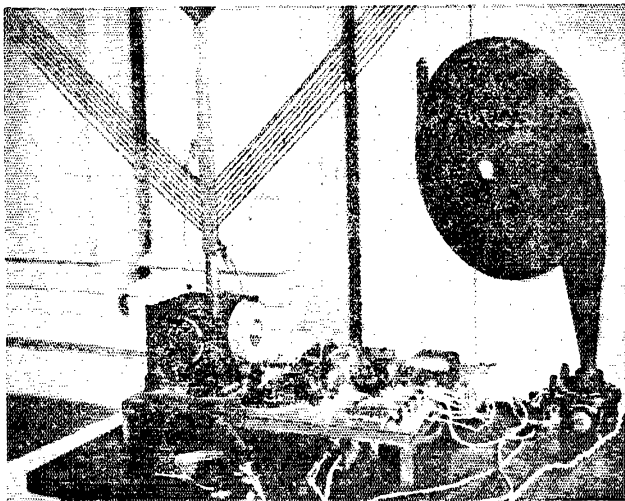

In his precision radio work, Major Armstrong chose his equipment with the greatest care and with a keen sense of engineering values. **PACENT** Radio Essentials were selected by Major Armstrong because they were of correct design and constructed with honest materials.

## ARMSTRONG CHOSE

**Pacent Duo-Lateral Coils**, as the best suitable inductances for the auxiliary frequency circuits. Duo-Lateral Coils are the last word in inductances.

**Pacent Universal Plugs**, because of the perfect, constant contact they produce, which is absolutely essential in any radio receivers employing extremely high amplification.

**Pacent Multijack**, because, aided by the Pacent Universal Plugs, they allow him to make perfect contacts and to rapidly change connections.

**Dubilier Micadons**, because they have constant capacity and entirely eliminate the noises caused by paper condensers. Dubilier condensers are essential for steady, continuous operation.

**Pacent Radio Jacks**, because they were designed especially for radio and they form perfect contact with Pacent Universal Plugs.

**Pacent Duo-Lateral Coil Receptacles and Plugs**, because of their convenience and the perfect electrical contact they form.

Let Pacent Products help you to build up the efficiency of your radio equipment.

**Don't Improvise—Pacentize**

*See the local Pacent Distributor or send for bulletins.*



**PACENT ELECTRIC COMPANY**  
INCORPORATED  
150 Nassau Street, NEW YORK

Member Radio Section, Associated Mfrs.  
Electrical Supplies

Branches:  
PHILADELPHIA, PA.  
Bourse Bldg.  
CHICAGO, ILL.  
33 So. Clinton St.  
WASHINGTON, D. C.  
Munsey Bldg.

TRADE **ESCO** MARK

**HIGH VOLTAGE MOTOR-GENERATORS STAND PRE-EMINENT  
IN WIRELESS FIELD**

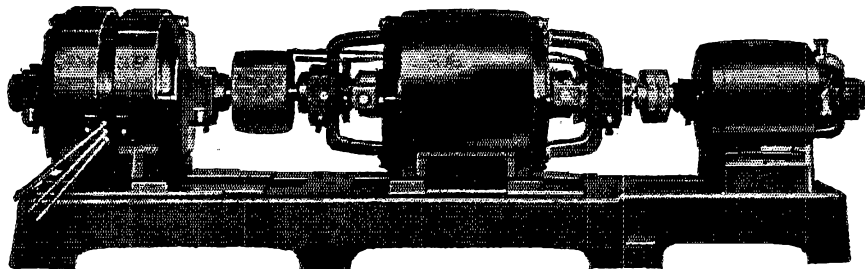

USED BY LEADING EDUCATIONAL INSTITUTIONS, U. S. GOV'T. RESEARCH LAB'YS,  
NEWSPAPERS, DEP'T STORES, ETC.

**ESCO**

Manufactures over 200 different combinations of windings for wireless and develops special apparatus  
for special requirements. Send us your problems  
Write for Bulletin 237—Complete Information

**MOTORS—DYNAMOTORS—GENERATORS—MOTOR-GENERATORS**

SOLD BY PRINCIPAL DEALERS EVERYWHERE

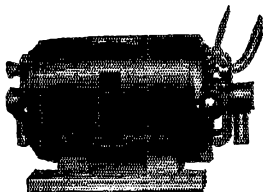

**ELECTRIC SPECIALTY CO.**

215 SOUTH STREET

**STAMFORD, CONN., U.S.A.**

## **QST QRX for the following:**

We represent all the leading manufacturers and can make immediate delivery on most anything in the **RADIO LINE** of TODAY.  
A trial of our **SERVICE** will convince you.

**SERVICE—OUR WATCHWORD**

Send 5c for a copy of our catalog

**ANTHRACITE RADIO SHOP**

P. O. Box 3, Scranton, Penna.



**EINSTEIN**

Has the dope on **RELATIVITY**  
We have the dope on **RADIO**

Longer Distance. Clearer Signals. Thru more interference. Non-infringing apparatus. Are you from "Missouri?" Write us today!

**Scientific Engineering Association**

817 MAIN STREET,

CINCINNATI, OHIO

To Get the Most from Your  
Radio Set Use "A" and "B"

# WESTINGHOUSE

⚡ RADIO ⚡

# BATTERIES

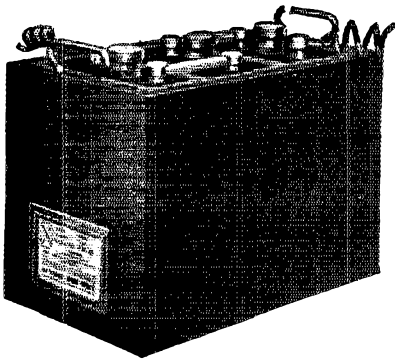

The Westinghouse "A" is a special radio battery, made with a heavy plate and separator to insure long life. It furnishes just the type of strong, steady, constant current of low voltage that radio reception needs. It will stand continuous use without getting "tired."

The Westinghouse "B" is the best answer yet found for "B" battery problems. With occasional recharging it will be constantly full of energy and will last indefinitely.

It is noiseless, clarifies the signals, does not polarize. Its adjustable contact gives adjustable voltage by which you can take the howl out of your vacuum tube.

*"The Best Westinghouse  
can build."*

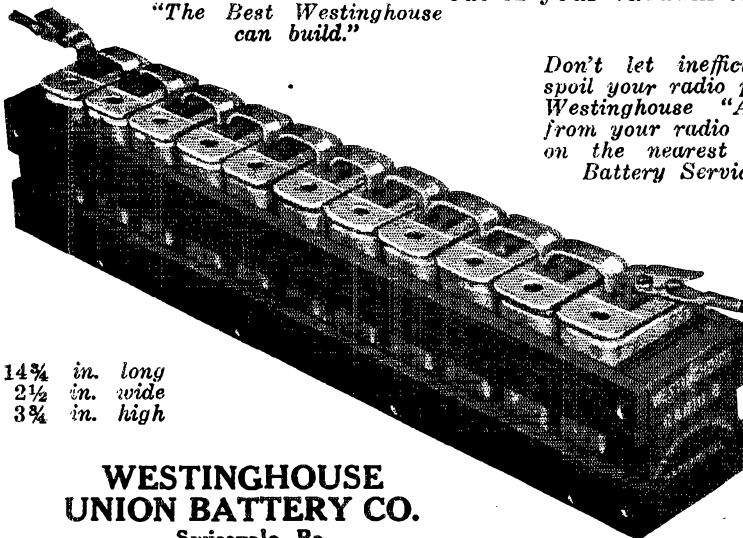

*Don't let inefficient batteries  
spoil your radio pleasure. Get  
Westinghouse "A" and "B"  
from your radio dealer or call  
on the nearest Westinghouse  
Battery Service Station.*

14  $\frac{3}{4}$  in. long  
2  $\frac{1}{2}$  in. wide  
3  $\frac{3}{4}$  in. high

**WESTINGHOUSE  
UNION BATTERY CO.**  
Swissvale, Pa.

# ELWOOD RADIO HEADSETS

The seventeen years of practical experience in the making of telephones and receivers by this company, assures you of good design and workmanship.

Elwood headsets meet the exacting demands of all purchasers of radio units and parts. Both receivers operate in unison, insuring clear, harmonious and uninterrupted reproduction. Our absolute guarantee of the ohmage capacity of these headsets is your safeguard.



Receivers have metal case, highly finished. Headbands have sanitary fabric covering, fully adjustable. Complete set packed in attractive carton.

We are also manufacturers of Binding Posts, Contact Points, Jacks and Plugs for Radio Work.

**ELWOOD ELECTRIC CO. INC.**

Formerly Liddell Electric Mfg. Co.

2-4 Randall Avenue, Bridgeport, Conn.

## THE NEW 'WHITE' ADJUSTABLE VERNIER CONDENSER

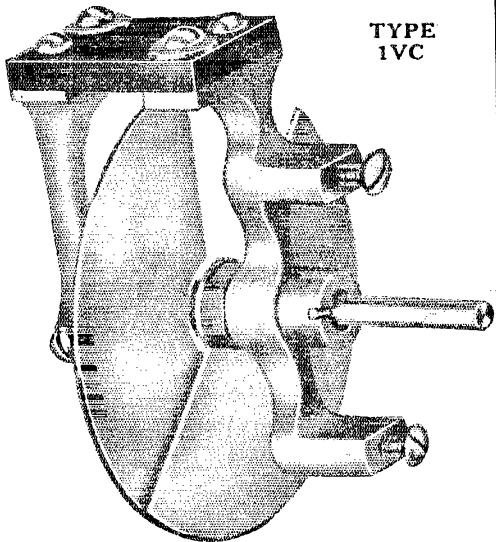

TYPE  
1VC

A NECESSITY FOR SHARP TUNING  
Positively noiseless. Highest grade, mechanically and electrically. Exclusive features.

PRICE, post paid.....\$2.50

**THE O. C. WHITE COMPANY**

Makers of Adjustable Electric Fixtures

15-21 Hermon St. Worcester, Mass.

## BRACH vacuum LIGHTNING ARRESTER

Not only since radio has become popular has the Brach Arrester been demonstrating its superiority, but for the past 16 years it has been used by the principal railroad and telegraph companies, by fire alarm systems, by the U. S. Army and others.

The Brach Vacuum Lightning Arrester stands like a sentinel, day and night, guarding your radio and home against interference and destruction—does it automatically, requiring no switching or other attention. Both indoor and outdoor types.

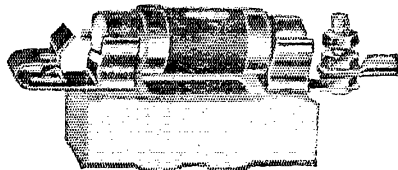

Listed by the Underwriters' Laboratories.

**L. S. BRACH MFG. CO.,**  
**NEWARK, NEW JERSEY**  
16 Years Specialists in Lightning Protective Apparatus

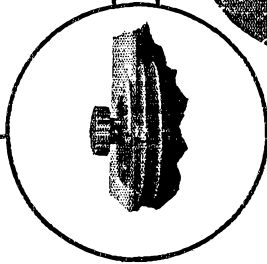
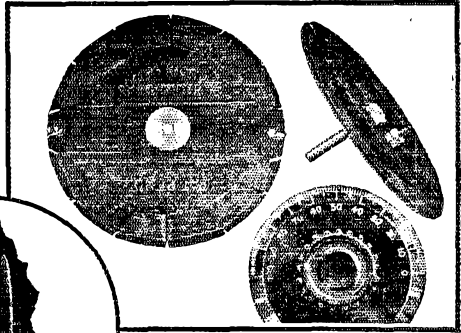
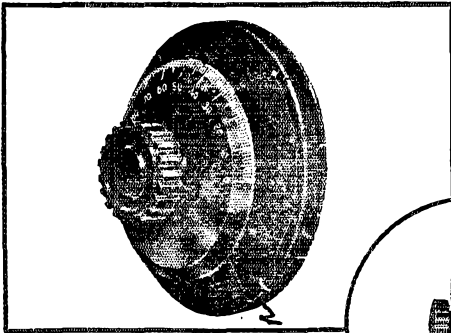

**A New Type Variometer  
Rogers Receiving Radiometer  
Smaller Simpler  
Less Costly Better**

The tuning efficiency and sharpness is greatly improved because the dielectric material is reduced to the absolute minimum—no wood, parafine, shellac, or varnish is used.

The Rogers Receiving Radiometer takes up but a fraction of the space required for ordinary variometers—it measures but 4" in diameter by 1" in depth.

Only one supporting bushing is used for the entire assembly; this bushing is also used for the electrical contact between the two inductors.

For long distance, short wave sets, two Rogers Receiving Radiometers will give as good as, if not better results than any other type of installation.

Can be used in any part of the circuit in which the ordinary ball type variometer can be used.

Price \$4.00 each, without dial and knob—about the cost of ordinary variometers.

**A Radiometer Hook Up**

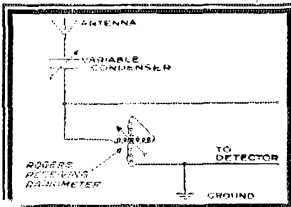

If your dealer cannot supply you, send us his name and money order or check for the number of Radiometers you need and we will see that they are delivered to you at once through him.

**DEALERS:** Write for our proposition and quantity discounts on Rogers Receiving Radiometers.

**Get Our New Illustrated  
Dealer Catalog  
Hommel's Encyclopedia  
of Radio Apparatus**

It contains what is probably the most complete list of Radio equipment and supplies ever published.

The products of over 40 leading manufacturers are illustrated by more than 150 large size illustrations.

This Catalogue is indispensable to every Radio Dealer—write for your copy, mentioning QST.

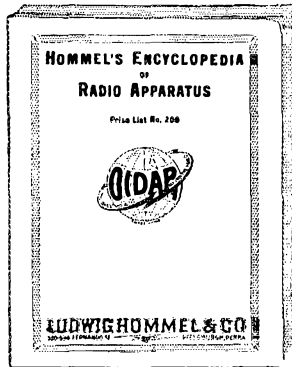

**DISTRIBUTORS FOR**

Radio Corp. of Amer. (Westinghouse, Gen'l Electric) Murdock, Fada, Remler, Frost, Brandes, Patent, General Radio, Radio Service, Baldwin, Signal, Acme, Rhamstine, Kellogg, Holtzer-Cabot, Connecticut, Burgess, Hipco, Brach, Homcharger, Chelsea, Arkay, Clapp-Eastham and other leading manufacturers.

**LUDWIG HOMMEL & CO**  
530-534 FERNANDO ST. ———— PITTSBURGH, PENNA

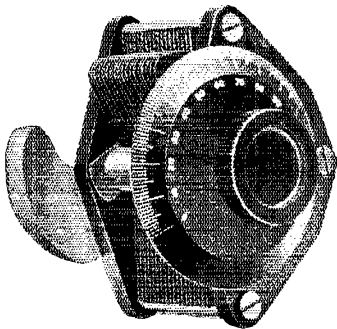

#3 Price \$4.75

## CHELSEA Variable Condenser (DIE-CAST TYPE)

No. 1—.0011 m.f. mounted .....	\$5.00
No. 2—.0006 m.f. mounted .....	4.50
No. 3—.0011 m.f. unmounted .....	4.75
No. 3a—.0011 m.f. unmounted, without dial .....	4.35
No. 4—.0006 m.f. unmounted .....	4.25
No. 4a—.0006 m.f. unmounted, without dial .....	3.85

Top, bottom and knob are genuine bakelite, shaft of steel running in bronze bearings, adjustable tension on movable plates, large bakelite dial reading in hundredths, high capacity, amply separated and accurately spaced plates. Unmounted types will fit any panel and are equipped with counterweight.

Guaranteed for circuits up to 1,000 volts.

### Amplifying Transformer No. 50

The Chelsea Amplifying Transformer gives the highest amplification possible and at the same time will not squeal, howl, or in any way cause noisy circuits. It is beautiful in design and embodies electrical characteristics unequalled by any. Guaranteed for all circuits up to 500 volts with a high safety factor.

It will not fail in service.

Purchase Chelsea Radio Equipment from your dealer. If he does not carry it send to us.

Write for our new \$6 catalog.

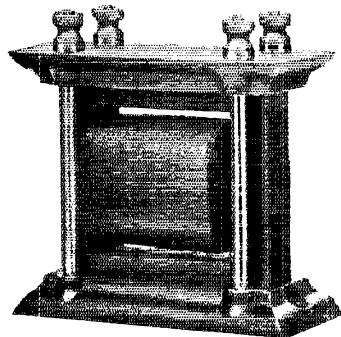

Price \$4.50

**CHELSEA RADIO CO., 150 FIFTH ST., CHELSEA, MASS.**  
Manufacturers of Radio Apparatus and Moulders of Bakelite and Condensite

## AMATEURS EXPERIMENTERS DEALERS

We can make quick delivery on all material listed in our latest price list. A 2c stamp will bring it to you.

### PANELS

1/8" .....	\$0.02	per sq. inch
3/16" .....	.02 1/2	per sq. inch
1/4" .....	.03	per sq. inch

## Pittsburgh Radio and Appliance Co., Inc.

"PITTSBURGH'S RADIO SHOP"

Desk B, 112 Diamond St.,

Pittsburgh, Pa.

—THE BEST PRACTICAL BOOK APPEARING IN YEARS—

## "Radio Telephony for Amateurs"

By STUART BALLANTINE

Not especially about radio telephony, but mostly about C.W. transmission and modern reception. New and reliable dope on aeriels, the design of C.W. circuits, modulation methods, master oscillators, super-heterodynes, radio frequency amplification, chokes and filters, etc. A book which every amateur should have and which we unhesitatingly recommend—see the Book Review this month. A cloth-bound book of 296 pages with more new dope than has appeared for years, for the small price of \$1.50 postpaid. Send for yours today, O.M.

**QST BOOK DEPARTMENT, 1045 Main St., Hartford, Conn.**

WITH the completion of our splendid new factory at Richmond Hill, N. Y., the Grebe high standard of quality will be maintained — and the production quadrupled!

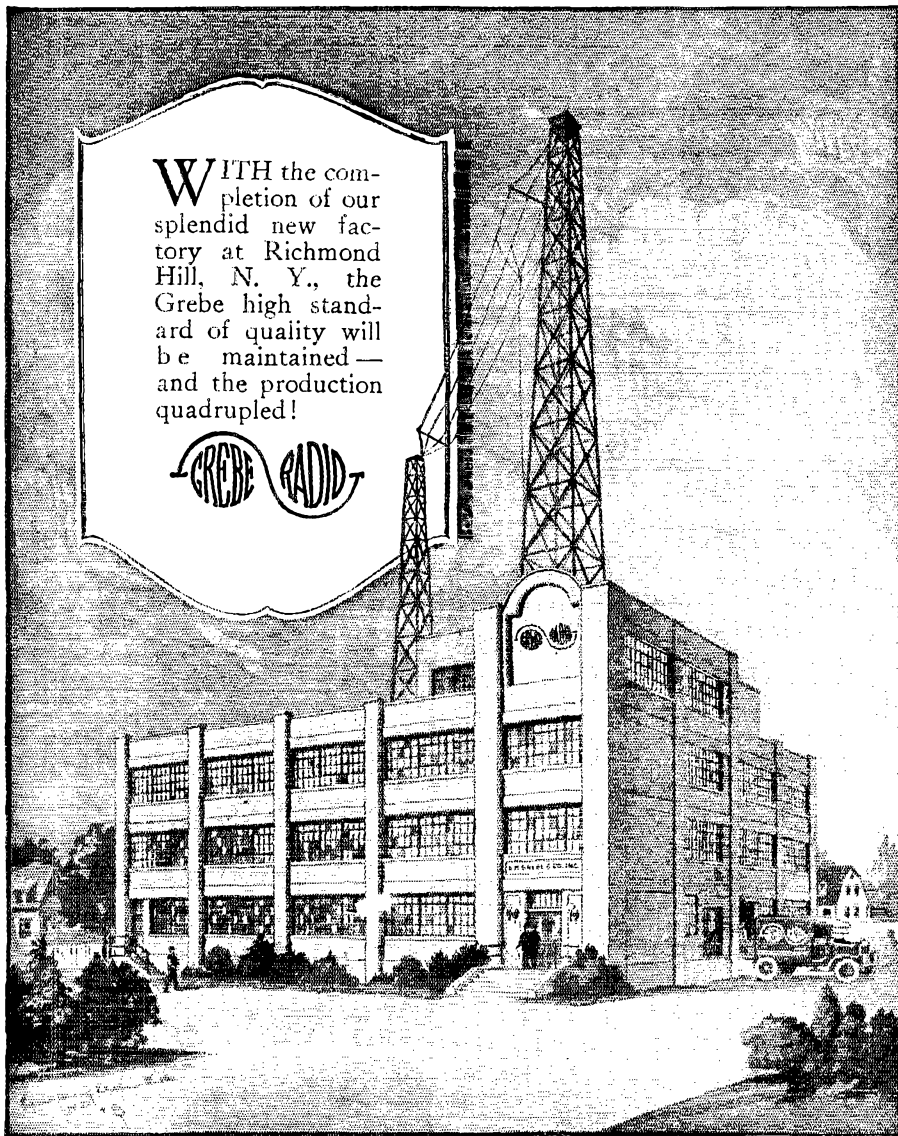

# EVERYTHING Radio!

“Sa Om”

We have complete stocks of C.W. and spark transmitting apparatus, parts and supplies.

The Famous Grebe Receivers are our specialty.

We carry only the best in amateur Radio Equipment.

Order from your dealer.



Trade Mark  
Registered

## PHILADELPHIA WIRELESS SALES CORP.

*Formerly Philadelphia School of Wireless Telegraphy*

1533 PINE STREET,

PHILADELPHIA, PA.

### RTS

### Switch Lever

The attention of jobbers and dealers is especially called to the RTS Bushing Lever. It has many improved features.

The knob is of the well known Marconi type, 1 3/4 inches in diameter. The spring lever of nickel bronze has ground ends, insuring smooth and positive adjustment. It has a 3/4-inch bushing and lock-nut for panel assembly. A guide bushing under the knob is an important feature as it raises the lever to the proper height for all switch points.

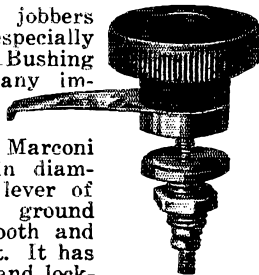

Retails at .....60c

#### AMATEURS

Amateurs will find the RTS Switch Lever on sale at their dealers' but if he hasn't it in stock, we will supply you direct.

#### Discounts to Dealers and Jobbers

Dealers and Jobbers: Write us today for special quotations and discounts on all RTS equipment.

### RADIO TESTING STATION

DEPT. Q-8, 25 STURGIS ST.  
BINGHAMTON, NEW YORK

## RADIOIST

↓ WE ARE NOW ↓  
L LOCATED IN OUR L  
O NEW HOME AND CAN O  
O PROMISE OUR USUAL O  
K SERVICE K

ORDERS SHIPPED SAME DAY  
THEY ARE RECEIVED

A complete stock of parts and  
finished apparatus.

## ROSE RADIO SUPPLY

Pioneers in the Radio Field  
129 CAMP ST., NEW ORLEANS

Send 10c for latest catalogue



# Ask to See This New Radio "B" Battery

Ask also to see the Willard All - Rubber Radio "A" Battery—a 6-volt battery built especially for Radio reception.

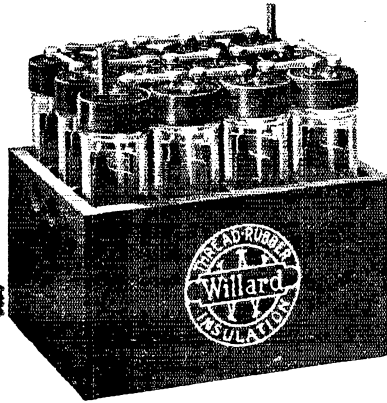

Ask your dealer or your nearest Willard Service Station to show you this specially designed 24-volt rechargeable Radio "B" Battery. Note the leak-proof glass jars—hard rubber screw-on covers—special Radio "B" plates—Threaded Rubber Insulation.

These features considered, it is not surprising that the Willard Radio "B" Battery has such a *remarkable ability to hold its voltage*, or that it is so noise-free and trouble-proof.

WILLARD STORAGE BATTERY COMPANY, CLEVELAND, OHIO  
*Made in Canada by the Willard Storage Battery Company of Canada, Limited, Toronto, Ontario*

WILLARD  
THREADED  
RUBBER  
BATTERY  
Willard



Tel.  
Back Bay  
5 9 6 4

# EASTERN RADIO

## INSTITUTE

899 BOYLSTON ST.  
BOSTON, MASS.



*"RADIO today is commanding the interest of more people than any other industry! Splendid opportunities are NOW available for those who are alive enough to see the possibilities. My fifteen years experience in Radio tells you that FORTUNES will be made within the next five years for those who train themselves now and take advantage of the present opportunities.*

The EASTERN RADIO INSTITUTE is the OLDEST, LARGEST and BEST EQUIPPED Radio School in New England. THOUSANDS of satisfied graduates tell our story best!

Day and Evening classes. Start any Monday.

REMEMBER:—Our ORGANIZATION with YEARS OF PHENOMENAL EXPERIENCE and SUCCESS is behind EVERY man who enrolls!

"Ask any man in Radio—he will tell you!"

Our illustrated prospectus for the asking.

F. D. PITTS, Director.

# RAYMOND RADIO CORPORATION

Manufacturers To the Radio Industries

V. T. Sockets  
Rheostats  
(Plain And Vernier)  
Variable Condensers  
Etc.

Executive Offices:  
309 Lafayette St.,  
New York City  
Works:  
Farmingdale, L. I.

Control Panel Units  
Crystal Detector Sets  
Vacuum Tube Sets  
Storage B Batteries  
Etc.

## RADIO GENERATORS FOR C.W.

Equipped with ball bearings. 42 segments in commutator. Speed 1725, Volts, no load, 500;

Capacity 125 watis.....\$30.00  
Parts for above except wire..... 14.00

All F.O.B. Canton. Stock Delivery

### The Electric Motor & Engineering Co.

2d Street, S. W., and B. & O. R. R.

CANTON, OHIO

# For this Broadcasting Receiver thousands have been waiting

**E**VER since broadcasting became the vogue, there has been a demand for a receiver which would fill a whole room with music of perfect tone quality but which would be so simple that anyone could tune in by moving a single lever.

This ideal has at last been realized in the Aeriola Grand—the supreme achievement of present-day radio.

When you hear the voice and the music that come from the Aeriola Grand it is as if the lecturer or singer at the broadcasting station were in your presence. The whole family listens and marvels.

The Aeriola Grand stands unrivaled not only as a radio receiver but as a piece of cabinet work.

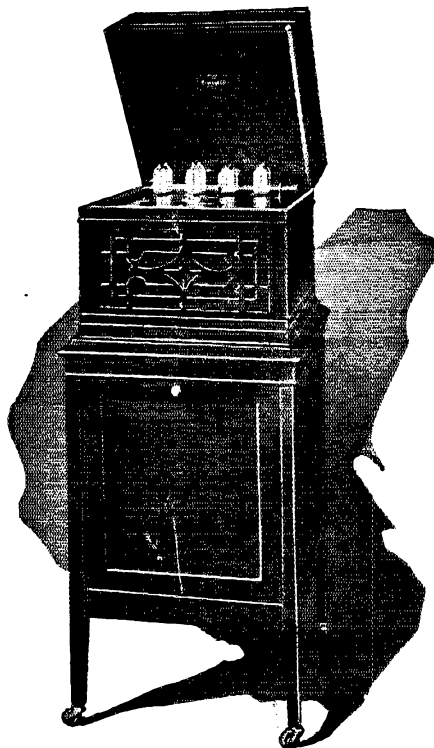

## PRICES

- Complete with mahogany stand, storage battery, battery charger, antenna equipment and all accessories ..... \$409.50
- Without stand, storage battery, charger and receiving antenna equipment ..... 325.00
- With stand, but without storage battery, charger and antenna.. 350.00
- Mahogany stand only..... 35.00

**See the Aeriola Grand at your  
nearest dealer**

Before you buy any receiver, secure a copy of the book "Radio Enters the Home". Contains the real story of radio and will help you to get the most out of this new art. 128 pages—over 200 illustrations—35c a copy. At your dealer or write direct to

### *What the guests heard at the Jacksons' Aeriola Grand Party*

- Baseball scores
- Dance Music
- Songs by a great ballad singer
- Lecture on the "Wedding Ring, Past and Present."
- A story by a famous author
- Chamber music by a noted string quartet
- The whole opera "Cavalleria Rusticana" with explanations.
- News of the day
- Weather forecast for the following day.

**Radio**  **Corporation**  
*of America*

233 BROADWAY ~ NEW YORK CITY

Sales Dept., Suite 2068

233 Broadway  
New York, N. Y.

District Office  
10 So. La Salle St.  
Chicago, Ill.

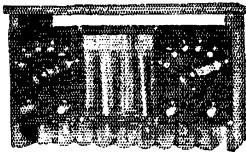

# Storage Batteries

designed for

# RADIO



## KICO "B" BATTERY

## KICO "A" BATTERY

### FACTS ABOUT KICO STORAGE "B" BATTERIES—

1. Not an ACID "B" Battery.
2. They eliminate noises caused from "Bs" that are rapidly deteriorating.
3. The switch control allows single cell variations from 12 volts up. (A critical plate adjustment is essential on your detector bulb for C.W. and Radiophone reception.)
4. Rechargeable from your 110 volt A.C. line in connection with the rectifier supplied with each battery.
5. Will last from three to six months on a single charge while in the detector plate circuit.
6. NOT an experiment. All batteries are sold with the privilege of receiving your money back if unsatisfied.
7. Neat, Efficient and Compact.
8. Unlimited life.

		Plain	With Panels
16 cell	22 volts	\$6.50	
24 cell	32 volts	8.00	\$12.00
36 cell	48 volts	10.00	14.00
50 cell	68 volts	12.00	17.00
78 cell	100 volts	18.00	21.00
108 cell	145 volts	21.00	28.00

*Literature gladly furnished.*

**KIMLEY ELECTRIC CO., 290 Winslow Ave., BUFFALO, N. Y.**

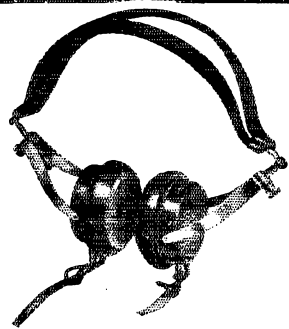

## Stromberg-Carlson RADIO HEAD SET

Brings in the long distance tones with accuracy and distinctness.

They give the fullest measure of enjoyment because of the quality of the tones. Convenient and comfortable. The construction of the Stromberg-Carlson Head Set allows simultaneous use by two observers. Price \$7.50 each f.o.b. Rochester, including two head set receivers, head band and forked 5-foot cord.

Send for our Free Bulletin No. 1030-Q, describing the No. 2-A Radio Head Set and other superior apparatus of our manufacture.

STROMBERG-CARLSON  
TELEPHONE MFG. CO.  
ROCHESTER, NEW YORK

## KEYSTONE FILAMENT RHEOSTAT

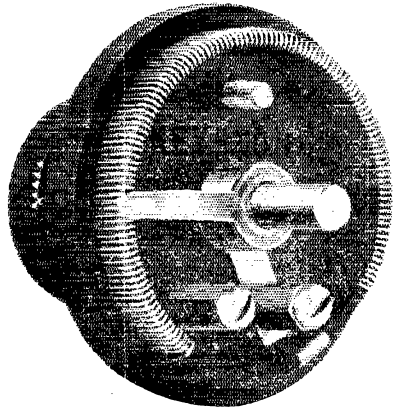

Resistance 6 Ohms.  
Carrying Cap. 1 1/4 Amps.  
Base, moulded Bakelite.  
2 1/4 In. Diameter.  
All metal parts, made of brass, and nickel plated.  
Large Knob, with polished pointer.

**List Price \$1.00**

Manufactured By  
**Keystone Radio Company**  
Dept. Q, Greenville, Penn.

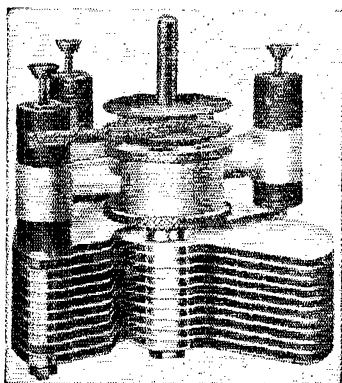

## A Better Variable Air Condenser Because it is Made Better

Smooth control, sharp tuning, and permanent, rugged mechanical qualities are the points that distinguish BETTER variable air condensers from all others. COTOCO Condensers have established a reputation for low electrical losses and precise mechanical construction.

The best way to be sure to get best results is to  
**Buy your Radio Supplies by the name**

# Cotoco

TRADE MARK REG. U. S. PAT. OFF.

### Our Other Specialties

Amplifying Transformers

— for Audio Frequency

— for Radio Frequency

Honeycomb Coils

This name means **RELIABILITY**—means built to the specifications of Radio specialists—means better results for you.

If your dealer cannot supply you, send us his name and we will take care of you.

*Write for Folders*

**COTO-COIL COMPANY**  
87 Willard Ave., Providence, R. I.

# THE THORDARSON AUDIO FREQUENCY AMPLIFYING TRANSFORMER

is now standard with many well known manufacturers  
That should be sufficient guarantee that it is right

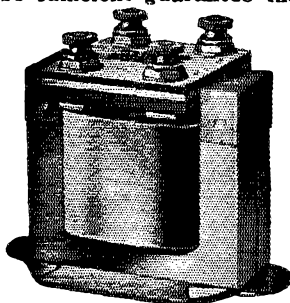

**SHELL  
TYPE**

**PRICE  
\$4.50**

Each transformer supplied fully mounted in an ingenious, nicked frame with substantial terminals mounted on a bakelite terminal board.

The terminal board is on the top, the only logical place for a terminal board. The transformer is wound with silk covered wire.

BACKED BY THE "GOLD MEDAL" LINE  
PRICE, AS ILLUSTRATED . . . . . \$4.50

## Thordarson Electric Mfg. Co.

500 WEST HURON ST. COR. KINGSBURY,

CHICAGO

## Try REYNOLDS RADIO Service

(Old)  
**9ZAF**

from DENVER  
Immediate Delivery

(New)  
**KLZ**

<p><b>"ESCO" Motor Generators</b></p> <p>400 V.—100 Watt . . . . . \$65.00</p> <p>500 V.—100 Watt . . . . . 68.00</p> <p>1000 V.—500 Watt . . . . . 185.00</p> <p style="text-align: center;">Above Price F.O.B. Stamford</p>	<p style="text-align: center;"><b>CLAPP-EASTHAM</b></p> <p>H R Receiver . . . . . \$40.00</p> <p>HZ 2-step Amplifier . . . . . 40.00</p> <p>R3 MAGNAVOX . . . . . 45.00</p>
---	---

**REYNOLDS RADIO Co., Inc.** Distributors 1543 Glenarm St. Denver, Colo.

**MANUFACTURERS**

**JOBBERS**

**DEALERS**

PLACE YOUR FALL ORDERS  
FOR

**EBY BINDING  
POSTS**

**N O W**



COMMANDER "H"    ENSIGN "H"    SERGEANT "SS"    BUDDY

OTE:—TO SATISFY THE TREMENDOUS DEMANDS FOR EBY POSTS WE WANT RESPONSIBLE DEALERS EVERYWHERE TO CARRY THEM.

JOBBERS: WRITE FOR BULLETIN 10 ALSO LATEST DISCOUNTS. DELIVERIES FROM STOCK.

THE H. H. EBY MANUFACTURING CO.,    PHILADELPHIA, PA.

# "Chi-Rad" Apparatus

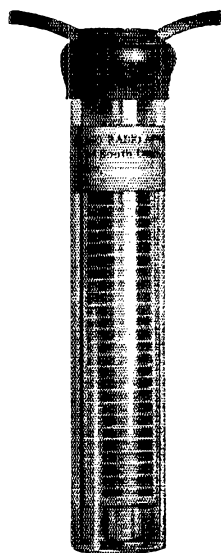

## New Storage "B" Battery

A real storage "B" Battery for your Radio Set at a price every Amateur and Experimenter can afford to pay. Can be used on receiving apparatus as source of plate potential on both Detector and Amplifier tubes. Ideal as source of energy on small Radio Telephones or C.W. Transmitters.

Simple and easy to re-charge from your lamp socket and will last for years with ordinary use.

Price per cell \$0.50  
Add PP on  $\frac{1}{2}$  lb.  
per cell.

### SPECIFICATIONS:

Cut shows cell one half natural size.

Voltage per cell 2 volts.

Pasted Plates—ready formed for initial charge.

High Ampere Hour capacity—will operate one detector tube 1000 hours with one charge.

Shipped dry with simple directions for preparing the electrolyte.

**Mahogany Tray for holding ten cells \$1.00 extra**

**Dealers:—Get our discounts on this new Battery—your customers will want them!**

### REMOVAL NOTICE

We have moved to 415 South Dearborn Street where we have opened a High-Grade Ground Floor Salesroom. With greatly increased space we will carry every make of good Radio Apparatus and will endeavor to have

**"The Finest Radio Retail Salesroom in Chicago"**

**CHICAGO RADIO APPARATUS CO., Inc.**

**415 South Dearborn Street,**

**Chicago, Ill.**

## Dependable Radio Supplies

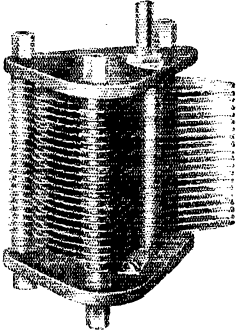

### Benwood Variable Condenser

Note the improved stationary plate design—this condenser has the greatest capacity for over-all size of any variable condenser made. Single bearing, wiping contact assures positive connections. Heavy aluminum plates will not bend or buckle. Solid Bakelite ends. 43 plate, .0011 Mfd. Each .....\$4.50

### Send for Catalog

You can **DEPEND** on "Benwood" parts or sets. Send 10c in stamps for the Benwood catalog and price list, also complete catalog and price list of DeForest Radio Equipment.

### Dealers

We manufacture high grade radio supplies in our own factory and have stock ready to ship. Write or wire for our liberal dealers' discounts. New price and discount sheet just issued.

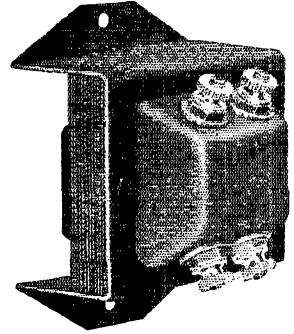

### Benwood Audio Transformer

Completely sheathed in metal—gives full 4 to 1 amplification without howling or squealing. Base is 2 5/8" x 3 3/8", height only 2 inches—ideal for either base or panel mounting. Core is best laminated steel giving highest transference of energy. Each .....\$4.50

The **BENWOOD** Co. INC.  
RADIO

"WORLD-WIDE MAIL ORDER SERVICE"

1114 OLIVE STREET,

ST. LOUIS, MO.

## Long Distance Radio Receiver

Completely assembled but not wired.

An opportunity to get this set at one third of its value—A new departure from ordinary receiver design. Wave length range from 200 to 600 meters.

Highly efficient for phone reception.

### ITEMIZED LIST OF PARTS

- 1 hard rubber panel—9" x 14" x 3/8" thick
- 2 23 plate condensers.
- 1 Vernier 3 plate condenser
- 1 Klosner rheostat
- 1 Vacuum tube socket
- 1 Switch
- 6 Contacts and 2 stops
- 1 Grid condenser and grid leak
- 2 hard rubber dials
- 2 Knobs and pointers
- 1 Hard rubber tube
- 3 Inductance coils
- 8 binding posts

Sufficient #14 tinned copper wire to wire up set.

Vacuum tube phones A and B batteries not included. Above mounted in a hardwood oak finished cabinet.

**PRICE \$24.00**

Information service for customers

**S. W. MILLS**

**2510 GRAND CONCOURSE, NEW YORK**

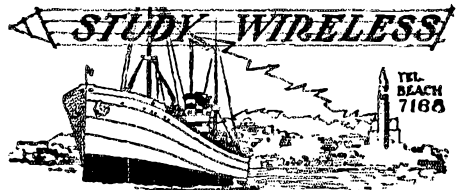

## POSITIONS SECURED!

95% of the graduates of this school are now successfully employed and a good paying position is ready for every student completing our course. Both land and sea jobs open.

This school holds a record for qualification of First Class and First Grade Operators.

*Send for 44 page Catalog Free*

We take this occasion to congratulate

**Mr. Theodore J. McElroy**

a graduate of this school  
on the great honor of winning the  
**WORLD'S RADIO RECEIVING  
CHAMPIONSHIP**

**MASSACHUSETTS RADIO and  
TELEGRAPH SCHOOL, Inc.**

**18 Boylston St. Boston, Mass.**

Formerly Boston School of Telegraphy, Est. 1903



# FROST RADIO PLUGS and JACKS

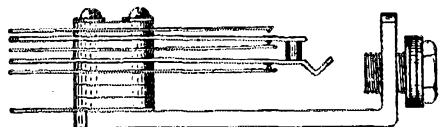

No. 136—Jack only, \$1.25

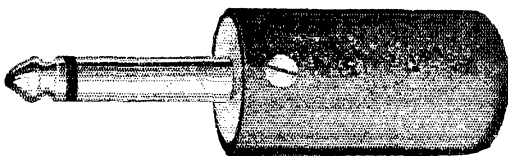

No. 137—Plug, \$1.25

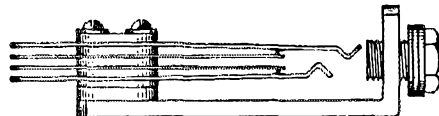

No. 131—Jack only, \$0.90



No. 132—Plug, \$1.00

Buy Plugs and Jacks designed for radio use. FROST RADIO PLUGS AND JACKS are the smallest, neatest and most perfectly finished. Terminals are "spread" and tinned, making the soldering of wires a Pleasure. Two-color Posters ready for distribution.

Attractive proposition for Jobbers and Dealers.

Made in all types, both plain and filament control, and interchangeable with any Standard Plug. We are ready to give immediate deliveries from stock, and can furnish any quantity up to ten thousand within a week after receipt of order.

## Frost Fones—A Quality Achievement

WE HAVE A  
COMPLETE  
PRICE LIST  
AVAILABLE  
FOR  
DISTRIBUTION

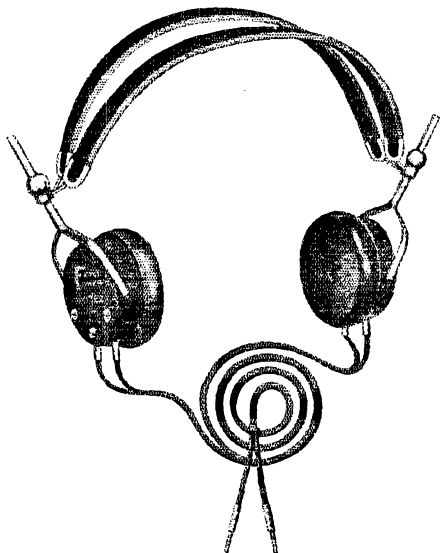

SEND  
FOR  
YOUR  
COPY

Frost Fone No. 162 \$5.00

For the price, it's the best buy on the market. Test 'em out with your pet and be convinced. Prompt deliveries, and attractive Dealer discounts. Write for full information.

We solicit Dealer inquiries for all standard Radio materials.

**THE WIRELESS MFG. CO., CANTON, OHIO**

EXCLUSIVELY WHOLESALE

# TELMACO

## TELMACOPHONE

*The Greatest Value  
On The Market*

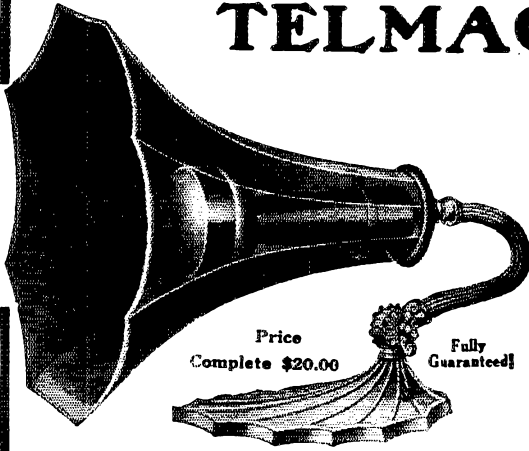

Price  
Complete \$20.00 Fully  
Guaranteed!

DEALERS: We are distributors for nearly all standard lines. Full discounts on the Telmacophone. Write for proposition on our complete line.

The BEST Evidence of the merit of the Telmacophone is the enormous demand for this loud speaker. Inverted horn, reflected tone. Equal to any other horn twice its length. Designed and perfected by expert acousticians.

Complete in every detail. No extras to buy. Nothing to get out of order.

Do not be satisfied with an inferior substitute. Insist on the best for your money—the Telmacophone.

Price complete \$20.00 Fully Guaranteed.

Radio Division,  
**TELEPHONE MAINTENANCE CO.**  
20 S. Wells Street, Dept. D. Chicago, Illinois

## For REAL Service

Mail your orders to us. We can supply you with the BEST at the BEST PRICES. Shipments made within 24 hours after receipt of order.

CATALOGUE  
22  
AT YOUR  
SERVICE

### THE SERVICE RADIO EQUIPMENT CO.

Designers—Manufacturers—Distributors

225 SUPERIOR ST.,

TOLEDO, OHIO



## Radio Frequency Transformers

Type RT-1, for the amateur and broadcasting range, 175-500 meters.

(Patent Pending)

**\$6.00**

*Will work on all tubes.*

The only completely shielded iron-core R. F. Transformer.

**RASLA SALES CORPORATION**

10 EAST 43d ST.,

NEW YORK CITY

National Distributors for Radio Service Laboratories, Inc.



# PARAGON

THE

## Pioneer

- 1915 First regenerative receiver ever manufactured bore the name PARAGON.
- 1916 First Trans-continental Amateur Reception (California from New York; not pre-arranged) effected with a PARAGON Type RA-6 Receiver.
- 1916 First Trans-continental Amateur Transmission (New York to California; not pre-arranged) effected by PARAGON designed transmitter.
- 1917-1918 PARAGON acknowledged supreme on Western Front.
- 1921 First Trans-Atlantic Amateur Reception effected with PARAGON receiving equipment, at which time 27 different amateurs scattered thruout the Eastern section of the United States registered signals at Ardrossan, Scotland—3500 miles.

*THERE'S A REASON!*

## The Adams-Morgan Company

*Manufacturers*

UPPER MONTCLAIR, N. J.

Most  
Sensitive  
  
Better  
Than A  
Regenerative  
Set



Use With  
Indoor  
Loop Aerial  
  
Reduce  
Static and  
Interference

MU-RAD TYPE MA-12

## THE VERY FINEST RADIO RECEIVING SET

A three stage radio frequency amplifier and detector set developed with the deliberate idea of producing a receiver of superior sensitiveness. Direct comparison with the best sets proves the astounding accomplishment of our engineers. Many times more sensitive than a regenerative tuner and far easier to operate. This set on a 1½ foot square indoor coil aerial will bring in the radio programs several times louder than a regenerative tuner and a 40 foot antenna. May be used with Radiotrons or A.P. Tubes. The most highly developed set on the market. Very reasonably priced.

### BEST IN APPEARANCE AND PERFORMANCE

Enclosed in handsome, highly polished mahogany cabinet with Radion panel. All connections in the rear. Thoroughly tested and covered by an absolute money back guarantee of satisfaction. Write for Bulletin #13.

### DIMENSIONS

6" Deep  
19" Long  
6½" High

\$128

### DEALERS WRITE FOR PROPOSITION

The demand for this remarkable set will be tremendous everywhere. A simple demonstration of its extreme sensitiveness will bring all the orders you can handle. Get our proposition. Ask for Bulletin #13.

## MU-RAD LABORATORIES, INC.

800 FIFTH AVENUE,

ASBURY PARK, N. J.

## WHITEHOUSE GRID LEAK

an efficient, constant, interchangeable and compact "Grid Leak."

*Not affected by Dampness, or Temperature because of the sealed GLASS TUBE*

**Splendid Proposition to Dealers**



Designed to fit any standard base, made in the following resistance values: 0.5; 1.0; 1.5; 2.0; 2.5; 3.

**Price - - 70c Each**  
(Other values to order)

Every one tested and guaranteed. If your dealer does not carry them, send postal money order.

**WHITEHOUSE RADIO & MFG. CO.**

311 - 89th Street

Woodhaven, Long Island,

New York



\$8.50

### Complete Enjoyment of Radio Telephony

is only possible with a Telephone of the very highest standard of efficiency.

### Everett Double Radio Phones

have satisfied the most exacting Critics

**Supersensitive—Clear—Light**

**Mechanically Perfect—Moderately priced**

**AT ALL DEALERS**

*Everett Electric Corp.*

320 BROADWAY,

NEW YORK

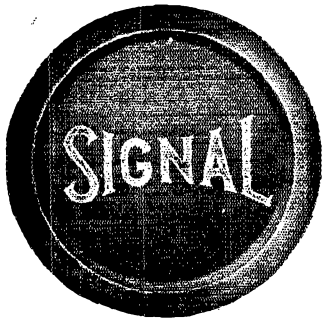

# IT IS TIME TO THINK OF SERVICE

It is time to look further than the mere equipment when you buy radio supplies, whether you're in Radio for profit or pleasure.

SIGNAL Radio Apparatus is built entirely in SIGNAL factories, from improved designs by our own radio engineers, working in our own laboratories.

Bear in mind that SIGNAL Equipment is not, nor will it ever be "side-line" material.

Back of every SIGNAL Product is this reputable company, with a record of years of development in Radio.

As a part of the Service offered beginners, advanced amateurs and serious experimenters on Radio we maintain a complete engineering service department, upon which our friends are at liberty to call at any time regarding their Radio problems, and to aid them in getting the best results at all times from their apparatus.

When you see this name "SIGNAL" on wireless and radio equipment, you may confidently expect real radio service on your problems.

## SIGNAL BACK MOUNTED VARIABLE CONDENSER

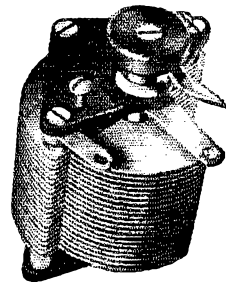

One of the SIGNAL line, produced to meet the requirements for a condenser for panel mounting. Comes in three models, so built as to permit mounting on panels from  $\frac{1}{8}$  to  $\frac{3}{8}$  inches in thickness. Machine screws are furnished for fastening the instrument to the panel; it is only necessary to drill three holes. Each instrument furnished with metal scale calibrated to 180 degrees. Knob and pointer are removable. Construction is very rigid, the material in the aluminum plates being .026" thick. The bearing plates are  $\frac{3}{16}$ " black Formica.

When you specify "SIGNAL" you specify "SERVICE"

## SIGNAL ELECTRIC MANUFACTURING COMPANY

Menominee, Michigan

Use this request-coupon to secure latest SIGNAL Bulletins. Fill out and mail today  Put your radio problems up to us.

### COUPON

Send me the new Signal Wireless Bulletin W.

Name .....

Company .....

City .....

State .....

QST

# DEALERS GET SPECIAL PROPOSITION

Send to KLAUS—"Radio Headquarters" for special discount lists and bulletins on apparatus and equipment. Our service department offers dealers assistance and advice on radio problems. We distribute "tested" apparatus. We know the equipment we send you is right. We want all Agents and Dealers to get our special proposition on the best lines of apparatus made.

Get our Prices on these lines of apparatus

Acme  
Adams-Morgan  
Baldwin  
Brandes  
Westinghouse

Clapp-Eastham  
DeForest  
Jewell  
Federal  
Radio Corporation

Grebe  
Moorhead  
Murdock  
Pacnet

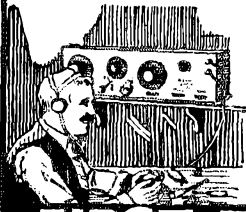

Write today to---

**KLAUS RADIO CO.**

Dept. 100

Eureka,

Illinois



**FIRST TESTED THEN SOLD**

## McTIGHE ALKALINE STORAGE "B" BATTERY

for **RADIO OUTFITS**

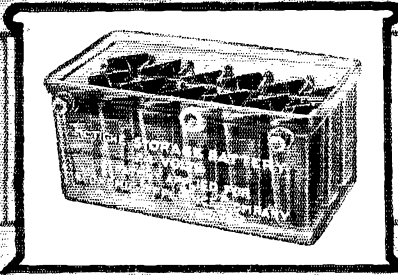

This month the McTighe Storage "B" Battery makes its appearance in an attractive oblong glass container of the unit construction type. It is the most satisfactory 22 volt "B" Battery -- is inexpensive -- noiseless -- cannot be damaged by short circuit, overcharging, standing idle or unchanged. Can be fully charged from any light socket for less than one cent.

The McTighe Rectifier is cheap, simple, durable and effective, and should be used when charging the McTighe "B" Battery.

Battery \$5.00; Rectifier \$1.50; Rubber Filler 25c  
F. O. B. Irwin, Pa. Discount to Dealers

**ECONOMIC APPLIANCE CO.**  
IRWIN, PENNA.

Our Radio Department is conducted by electrical engineers, which assure you dependable and highly efficient Radio equipment, either in complete sets or separate units, such as Head Receivers, Variocouplers, Variometers, Cabinets, Detectors, Antennas, Rotary Spark Gaps, Sliders, Panels, Dials, Knobs, Condensers, Grid Leaks, Contacts, Galena Crystals, etc. We especially recommend our popular Receiving Set, RESODON, which is one of the most desirable outfits for the home, club, etc. This set comes in a beautiful mahogany finished cabinet. Write for literature.

**R.E.S.**  
RADIO ELECTRIC SERVICE



**PAUL G. NIEHOFF & CO., Inc.**  
Electrical Laboratories and Manufacturers  
238 E. OHIO ST., CHICAGO, ILLINOIS

## AGENTS

Wanted in every city and town to sell radio apparatus. Good commissions. A few stocking agencies open to reliable parties.

**DELANCEY, FELCH & CO.**  
"Delfelco Service"

11 MEETING STREET  
PAWTUCKET, RHODE ISLAND

# ADJUST YOUR RADIO BATTERY

*-Then Forget About It!*



Once you have tuned your vacuum tube properly, the Prest-O-Lite Radio Battery holds it there. Continual adjustments to meet current variations are done away with. The new Prest-O-Lite Radio Battery is a "chip of the old block." Though specially adapted to furnish the steady, uniform rate of discharge required for the vacuum tube, it embodies the same principles that have made Prest-O-Lite Automobile Batteries so popular.

It is a product of the same precision laboratories. It has the same long life. Its plates are Prest-O-Plates.

Buy a battery that you KNOW is right.

## *Prest-O-Lite* RADIO "A" BATTERY

**THE PREST-O-LITE COMPANY, Inc.**

Carbide & Carbon Bldg., 30 East 42nd St., N. Y.

Eighth and Brannan Streets, San Francisco, Calif. In Canada: Prest-O-Lite Co. of Canada, Ltd., Toronto  
ALWAYS MENTION QST WHEN WRITING TO ADVERTISERS

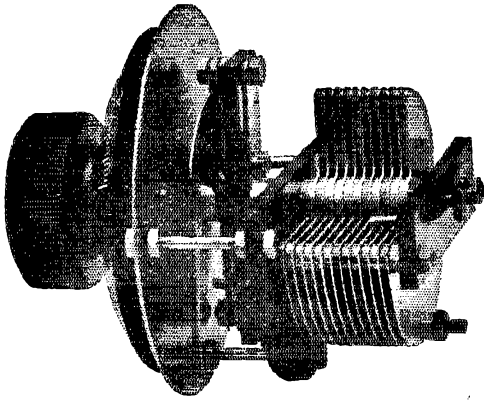

# POSACO

RADIO INSTRUMENTS OF  
**QUALITY**

INTRODUCING OUR NEW  
**Vernier Condenser**  
with **Single**  
**Knob Control**

PATENT APPLIED FOR  
Must be seen and tried to acquire a full appreciation of its fine tuning qualities.

Especially adapted to the new Armstrong Super-Regenerative circuit in which variable condensers play an important part and in which fine adjustments are absolutely essential.

Constructed with the same high standard of quality in materials, workmanship and design as our regular variable condenser. There is built in all POSACO Variable Condensers a 4½" round metal shield. Rotary plates cannot turn on shaft even should nut become loose.

The POSACO VERNIER condenser is made in three capacities:—.001045, .000545, .000295 Mfd. and the regular variable condenser in four capacities:—.001, .0005, .00025, .000045 Mfd.

ASK YOUR DEALER OR WRITE DIRECT FOR CIRCULAR AND PRICE LIST  
JOBBERs AND DEALERS WRITE FOR PROPOSITION

**THE C. D. POTTER COMPANY,** STAMFORD, CONN.  
U. S. A.

**The World's Standard for  
Perfect Broadcast-Reception**



The Dictograph Radio Head Set has made a new world's standard for Radio reception. The same scientific skill that has made the Dictograph and the Acousticon for the Deaf world-famous as accurate and super-sensitive sound receiving instruments, now produces the Dictograph Radio Head Set, Type R-1, 3000 Ohms, for all types receiving sets, sells for \$12.00. The cost is a trifle more—but Dictograph quality is worth more. "On sale at all dependable Radio Merchants."

**DICTOGRAPH PRODUCTS CORPORATION**  
Executive Offices 220 West 42nd St., N. Y. C.

**NEW FREE BOOKLET**

entitled

**Bradleystat**  
REGISTERED U.S. PAT. OFF.  
**PERFECT FILAMENT CONTROL**

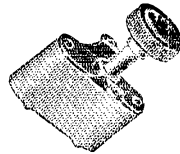

Bradleystats  
for sale by  
Radio Dealers

**\$1.85**

P. P. 10c extra

Radio enthusiasts everywhere are sending for this up-to-the-minute booklet on the simplest and most accurate method of vacuum tube control. You should have a copy to keep up-to-date in radio. Does away with wire-wound, troublesome filament rheostats.

**Allen-Bradley Co.**  
Electric Controlling Apparatus  
277 Greenfield Av.,  
Milwaukee, Wis.

*Manufacturers of graphite  
rheostats for 20 years.*



# Giblin-Remler INDUCTANCE COILS

INTERCHANGEABLE WITH ALL COIL MOUNTINGS

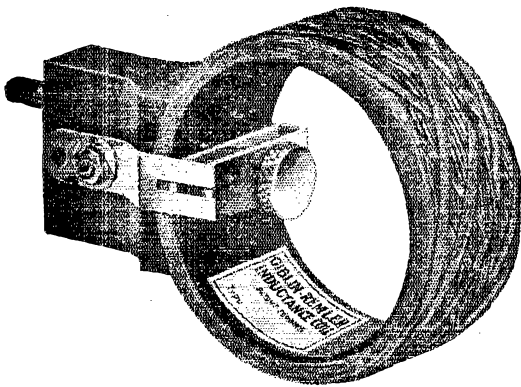

The new Giblin-Remler Coil has achieved a remarkable success. Placed on the market thirty days ago, it has already achieved enthusiastic response from all sections of the country.

Thomas P. Giblin, in designing the Giblin-Remler Coil has built an inductance coil that is infinitely superior in every respect to both the Honeycomb and Duo-Lateral Coils of which he is also the originator.

The Giblin-Remler Coil is equally effective on all wave lengths—the self capacity is far less than any previous compact inductance—this gives selectivity and sharp tuning for a given coil which is of special advantage to the amateur who usually has an antenna of low capacity. The high frequency resistance is also lower than any previous type.

Giblin-Remler Inductance Coils are patentable—they are manufactured by patented machinery. This protects you and insures your receiving the genuine Giblin-Remler Coils.

Type and Number of Turns, Mounted	Price, Mounted	Type and Number of Turns, Unmounted	Price, Unmounted	Inductance in Millihenrys at 1000 cycles Accuracy 1/4 %	Natural Wave Length in Meters, Accuracy 1/4 %	Distributed Capacity, in micro-microfarads, Accuracy 1 %	Wave Length Range in Meters using Condenser of .00004 mfd. min.		High Frequency Resistance in Ohms at Wave Length shown.
							Min.	Max.	
RG 20M 1.50	RG 20U .70	.030	39	14.3	63	334		1.1	
RG 25M 1.50	RG 25U .70	.041	47	15.2	75	389		1.5	
RG 35M 1.50	RG 35U .70	.083	87	25.4	128	550		3.5	
RG 50M 1.60	RG 50U .80	.169	114	21.6	185	785		8.8	
RG 75M 1.65	RG 75U .85	.377	163	19.8	266	1170		28.3	
RG 100M 1.70	RG 100U .90	.666	217	19.9	358	1550		80.3	
								4.4	
								12.1	
								28.3	
								6.2	
								12.6	
RG 150M 1.75	RG 150U .95	1.503	281	14.8	512	2320		1000	
RG 200M 1.80	RG 200U 1.00	2.68	374	14.7	690	3110	69.8	2000	
RG 250M 1.90	RG 250U 1.10	4.20	424	12.1	860	3880		5000	
RG 300M 2.00	RG 300U 1.20	6.11	494	11.2	1030	4680		10000	
RG 400M 2.10	RG 400U 1.30	11.04	618	9.7	1380	6300			
RG 500M 2.30	RG 500U 1.50	17.50	747	9.0	1730	7900			
								7.1	
								12.5	
								19.9	
								29.3	
								54.6	
								93.1	
								34.9	
RG 600M 2.40	RG 600U 1.60	29.2	1024	10.1	2260	10250		2000	
RG 750M 2.65	RG 750U 1.85	39.0	1249	11.3	2690	11850	111	5000	
RG1000M 3.40	RG1000U 2.50	71.6	1620	10.3	3570	16000		10000	
RG1250M 3.80	RG1250U 2.90	108.0	1930	9.7	4380	19700			
RG1500M 4.40	RG1500U 3.50	159.8	2300	9.3	5300	23800			

These tests have been made by Robert F. Field of Cruft High Tension Electrical Laboratory, Harvard University, Cambridge, Mass.

If you cannot secure Giblin-Remler Inductance Coils from your dealer send to us direct. Order now as these coils will help you get truly wonderful results from your set.

**REMLER**  
Radio Mfg. Co.

E. T. CUNNINGHAM  
General Manager

248 First Street  
San Francisco, Calif.

154 W. Lake Street  
Chicago, Ill.

# REMLER

APPARATUS THAT RADIATES QUALITY

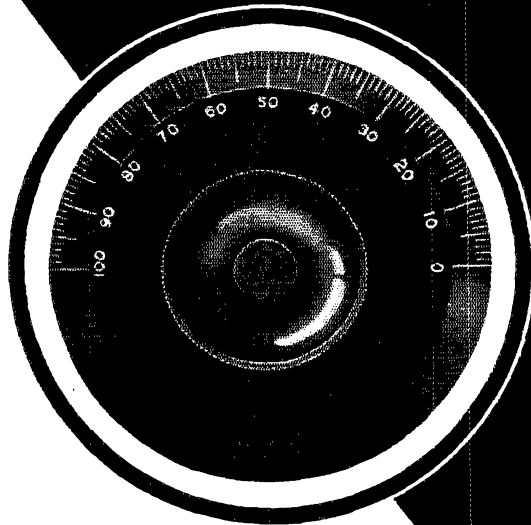

3 inch  
Bakelite  
**DIAL**  
with knob  
and bushing  
Type No. 100

**75c**

In ordering  
please specify  
 $\frac{7}{8}$ " or  $\frac{1}{2}$ "  
shaft.

The dial and  
knob are both  
of molded  
bakelite will  
not warp or  
discolor.

## Buy REMLER Quality

Here is a Remler Dial molded from genuine bakelite that will meet your most exacting requirements for accuracy and good looks.

This Remler 3-inch bevel-edged dial will not warp or discolor—it has a highly polished surface—the engraving is filled with white enamel which will not wear off—the 100 division scale is arranged for clockwise rotation.

The knob made from molded bakelite is  $1\frac{3}{8}$  inches in diameter—the bushing is drilled for  $\frac{7}{8}$  or  $\frac{1}{2}$  inch shaft, the set screw passing through both knob and bushing. The remarkable quality built in this Remler item—the extreme care used in manufacturing insures a dial that is absolutely true running at all times.

## REMLER RADIO MFG. COMPANY

248 FIRST STREET  
San Francisco, Cal.

E. T. CUNNINGHAM  
General Manager

154 W. LAKE STREET  
Chicago, Ill.

# CUNNINGHAM

## TUBES

*make clear  
reception possible*

for any type of

### Home Receiving Set

Cunningham Detector Tubes are the result of a national demand for tubes that meet the latest and most exacting requirements for all makes of home receiving sets. These quality tubes are manufactured in the great General Electric Laboratories.

When you buy Cunningham Tubes you KNOW that the reputation of one of the world's greatest scientific laboratories is behind them—you KNOW that the highest human and manufacturing skill is combined to insure clearness of reception of all radio messages.

Ask your dealer for further information about Cunningham Detector Tubes or write direct to us.

Type C-300

\$5.00

#### PATENT NOTICE

Cunningham tubes are covered by patents dated 11-7-06, 1-15-07, 2-18-08, and others issued and pending. Licensed only for amateur or experimental uses in radio communication. Any other use will be an infringement.



Trading as

**AUDIOTRON MFG. CO.**

248 First Street  
San Francisco, Cal.

154 W. Lake Street  
Chicago, Illinois



The trade mark  
GE is the guar-  
antee of the  
quality of these  
Each tube is  
built to most rig-  
id specifications.



ALWAYS MENTION Q S T WHEN WRITING TO ADVERTISERS

# RHAMSTINE\*

MODEL B

Amplifying

Transformer

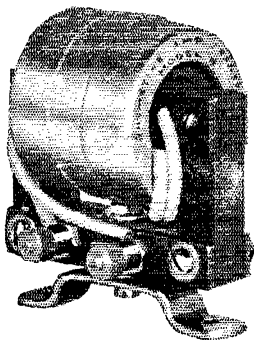

**\$4.00**

Postage and Packing 10c.

Ever since its introduction sixteen months ago, the Rhamstine\* Amplifying Transformer has steadily gained in favor until today it holds an enviable position with manufacturers and builders of radio sets. Now comes a new model—the same good quality in the Transformer but with a shielded coil—a metal casing plated and highly polished; a distinctive improvement which will satisfy the most exacting demands.

The Model B is a guaranteed product. The list price is \$4.00. You may pay more but it is difficult to get a Transformer that is better. Immediate deliveries.

### THE RHAMSTINE\* MODEL A TRANSFORMER

The original Rhamstine\* Transformer, now called the model A is of course still produced. Substantiating our belief that it is the equal of any transformer on the market, many letters have been received paying tribute to its excellent amplifying powers. The price is \$3.50, postage and packing 10c.

*Complete circulars upon request.*

Manufactured By **J. THOS. RHAMSTINE\***

2152 E. Larned Street,

\*Maker of Radio Products

Detroit, Mich.

## 10c. Charges Radio & Auto Batteries AT HOME WITH AN F-F Booster

\$15

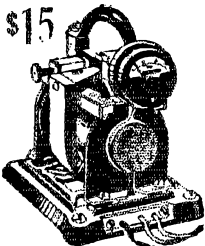

They Charge Automatically Operating Unattended. Leave Battery where it is, without even disconnecting it: Screw Plug in Lamp Socket, Snap Clips on Battery Terminals; Turn Switch & Battery will be Charged in the Morning. Is it not gratifying to feel that Your Radio Batteries will never fail & You are Always Ready to Receive Radiophone Broadcast Music Speech & News never having to be careful of or have to tell Friends that

CHARGE YOUR RADIO Your Batteries are dead? F-F BATTERY BOOSTERS are Complete Compact Self-Contained Portable Full Wave Automatic Magnetic Rectifying Charging Units for 105-125 Volt 60 Cycle A.C. No Skill is Required. Infusible Carbon Rectifying Brushes Maintain Uninterrupted Service. They Save You 90c. a Charge & Last a Lifetime. **REDUCED PRICES:**  
 Type 6 charges Radio "A" 6 volt Battery At 6 amperes \$15  
 Type B charges Radio "B" Batteries Up to 100 volts \$15  
 Type A-B charges Both Your "A & B" Radio Batteries \$20  
 Type 12 charges 12 volt Battery At 5 amperes \$15  
 Type 166 charges 6 volt Battery At 12 amperes \$24  
 Type 1612 charges 12 volt Battery at 7 amperes \$24  
 Type 1626 is a Combination of Both Type 166 & 1612 \$36  
 All types but Recharge Auto Batteries. The largest type are for heavy Batteries, or Where Time is limited. Shipping Weights 11 to 15 lbs. Purchase from Dealer, or Mail Check for Prompt Shipment. If via Parcel Post add Postage & Insurance Charges. Or have us ship C.O.D. Other F-F Battery Boosters charge Batteries from Farm Lighting Plants & D.C. Circuits & For GROUP CHARGING use our 12 Battery & Ampere Full Wave Automatic ROTARY Rectifier Described in FREE Bulletin No. 31A Order Now or Write Immediately for \$1

**The France Mfg. Co. OFFICES & WORKS CLEVELAND, OHIO, U.S.A.**

Canadian Representative: Battery Service & Sales Co., Hamilton, Ontario, Can.

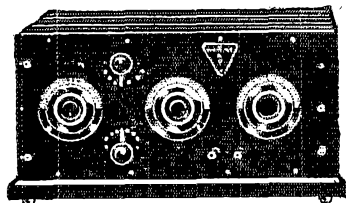

## HORNE Radio Production

80

Important and Essential Radio Devices

A Complete Line Distributed Nationally

Horne Manufacturing Co.



Sales and Executive Offices  
 30 Church St.  
 N. Y. City

Two Factories in Jersey City N. J.

## 14 YEARS OF KNOWING HOW

If experience means anything to you, the fact that Murdock Receivers have been delivering satisfaction on a "money-back" basis for 14 years will influence your choice. Those years of experience have finally resulted in the No. 56 Murdock Headset which combines rugged strength with clear distinct reproduction of voice and music. Each ear piece is "Murdock Moulded" into one durable unit, capable of protecting the delicate adjustments through years of rough use. The improved signal corps type headband adds the feature of comfort.

Go to your dealer and examine Murdock Phones before you buy. Compare their durable construction. Test their sensitiveness. Convince yourself that there are no other phones so good at so low a price. And then, *after you have* bought, the 14-day trial offer assures you of satisfaction with your purchase.

PRICES—2000 OHM \$5.00—3000 OHM \$6.00

# MURDOCK PHONES

WM. J. MURDOCK CO.

343 Carter St.,  
Chelsea, Mass.



## SEA HORN Loud Speakers Nature's Perfect AMPLIFIER

Extremely Loud and  
Very Distinct

Three Sizes

11 to 12 $\frac{3}{4}$ " high \$8  
13 to 14 $\frac{3}{4}$ " high 12  
15 to 16" high 15  
Horns are mounted  
on mahogany finish-  
ed base as shown  
and fitted with  
phone clamps.

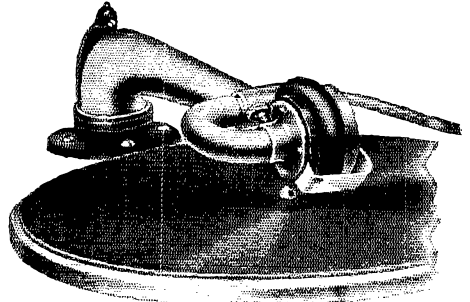
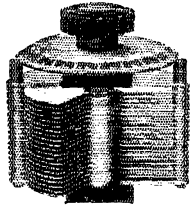

No. 51 Phone Clamp

Makes the phonograph a loud speaker.  
For Edison—Victor—Columbia Brun-  
swick and Oro-Tone. Attached in a mo-  
ment.

Price each .....\$1.50

### VARIABLE CONDENSERS

Precision made. Rigid con-  
struction. No loose bear-  
ings.

Price without dials:

43 plate.....\$4.00  
23 plate..... 3.50  
13 plate..... 3.25  
3" dials..... .85

### TUBE SOCKETS

Hand made of hard  
fibre—unbreakable.

The best socket made.  
May be used as either  
base or panel mount-  
ing.

Price each.....\$1.00

SEND FOR FOLDER—DEALERS WANTED

**THE ORO-TONE CO.**

1010 GEORGE STREET, CHICAGO, ILLS.

If **QUALITY** counts, bear in mind that **ACE** equipment speaks for itself. An Ace type **TRU** Concert Receptor can be placed in your parlor, and is in a class with your piano or finest phonograph.

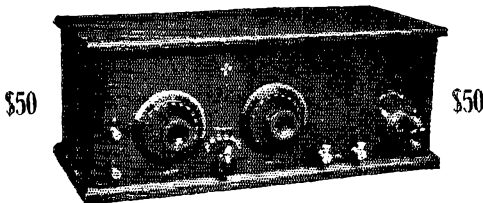

Licensed under Armstrong Patent No. 1,113,149

For electrical efficiency we claim our **TRU** to be equal or superior to any similar equipment now on the market.

A very important point to be considered in purchasing a Concert Receiver is the proposed change of wave lengths of broadcasting stations. The majority of Radio receivers now on the market would be worthless should this change be effected. Our receiver is arranged for immediate adaption to this change by even a most inexperienced person.

Better investigate—we have literature for the asking.

**THE PRECISION EQUIPMENT CO.**  
2437-39 Gilbert Ave., Cincinnati, Ohio

# HERE

## RADIO CITIZENS

Complete stocks carried for immediate shipment of the following apparatus:

Grebe Murdock  
DeForest Adams-Morgan  
Acme Radio Corporation  
C. Brandes, Inc.  
Federal Telephone & Tele-  
graph Co.

**FREE** BULLETINS  
PRICE LIST

Get the new lowest prices on apparatus and supplies. Bulletins and price lists mailed **FREE** on your request. Send for them today.

**Nash Electrical Service Co.**  
Marshall, Ill.

# RADIO APPARATUS

Distributors of Reliable Radio Apparatus to Schools, Colleges, Radio Clubs and Experimenters all over the World!



**"PITTSO"**

Specializing on "RADIO CORPORATION'S" Products

**"PITTSO"**

Now has three Stores. Send us your orders!

The present tremendous demand for Radio Apparatus has practically made it impossible for us to render our usual SERVICE. Reasonably prompt delivery, however, can be made on the items listed

## AMPLIFYING TRANSFORMERS

No. P-1 General Radio, semi-mounted.....	\$5.00
No. 50 Chelsea, semi-mounted.....	4.50
No. A-2 Acme, semi-mounted.....	5.00

## ANTENNA WIRE

"Pittsco" #14 hard drawn copper, (80 ft. per lb.) per lb.....	.40
500 ft. (Special value).....	2.25
"Pittsco" 7 strand #22 tinned copper, per ft.....	.01
500 ft. ....	4.00
1000 ft. ....	7.50
"Pittsco" 7 strand #20 Phosphor bronze per ft.....	.02
500 ft. ....	7.50

## ANTENNA INSULATORS

No. P-1 Electrose Ball insulator.....	.35
No. P-2 Electrose 4 inch strain insulator.....	.45
No. P-3 Electrose 10 inch strain insulator.....	.75

## "A" BATTERIES (Storage Batteries)

Yale 6 volt 60 Ampere-hours.....	18.00
Yale 6 volt 80 Ampere-hour.....	21.00
Yale 6 volt 100 Ampere-hour.....	25.00

Note—These batteries are shipped carefully crated and fully charged ready for use.

## "A" BATTERY RECTIFIERS

No. P-1 Tungar, 5 ampere type, complete with bulb.....	28.00
No. P-2 Tungar, 2 ampere type, complete with bulb.....	18.00
No. P-3 F. F. Battery Booster, 5 ampere type.....	15.00

## "B" BATTERIES

No. 763 Eveready, 22.5 Volt, small size.....	1.75
No. 766 Eveready, 22.5 Volt, large size 16½ to 22½ Volts.....	3.00
No. 774 Eveready, 43 Volt, large size Variable.....	5.00

## CRYSTAL RECEIVING SETS

Aeriola Jr. Westinghouse, complete with telephones.....	25.00
Everyman DeForest, complete with telephones.....	25.00

## CONDENSERS (Variable)

No. 1 Chelsea fully mounted, .001 Mf.....	5.00
No. 2 Chelsea fully mounted, .0005 Mf.....	4.50
No. 3 Chelsea unmounted with dial .001 Mf.....	4.75
No. 4 Chelsea unmounted with dial .0005 Mf.....	4.25
No. 367 Murdock fully mounted .001 Mf.....	4.50
No. 368 Murdock fully mounted .0005 Mf.....	4.00
No. 3660 Murdock unmounted without knob and dial .001 Mf.....	4.00
No. 3680 Murdock unmounted without knob and dial .0005 Mf.....	3.25

## TELEPHONES

No. 56 Murdock 2000 ohms.....	5.00
No. 56 Murdock 3000 ohms.....	6.00
No. 2A Stromberg Carlson 2000 ohms.....	7.50
No. P-1 Holtzer-Cabot 2200 ohms.....	8.00

Let "PITTSO" fill your orders for any of the above items. Our SERVICE on these at the present time will please you!

## PITTS RADIO STORES, INC.

12 PARK SQUARE, BOSTON, MASS.

Woolworth Bldg.,  
Providence, R. I.

3 Stores

276 Worthington St.  
Springfield, Mass.

# Receive Radio From Your Electric Light Wires



## THE SUPER-ANTENNA NOW AVAILABLE TO PUBLIC

THIS unit is the original design developed by the country's foremost engineers, for radio reception over the electric lighting circuits. Outside antenna is unnecessary.

This unit does away with the dangers of stringing antenna over power and lighting wires, where great danger results when storms or other causes result in the antenna touching a live wire. The "Super-Antenna" also eliminates the troubles and dangers incident to the erection of the antenna.

### No Outside Aerial Necessary

You just insert the plug in any electric light socket and connect binding post to your receiving set. The "Super-Antenna" is shock proof, will not blow fuses, and will not damage a receiving set in any way. Imitators will probably attempt to duplicate this epoch making invention, but during the many months of development of this unit, all practical circuits were protected, and it will prove expensive to experiment with imitations.

No power current is used when operating with a "Super-Antenna." It operates on any electrical circuits from 32 to 120 volts, D.C. or A.C. The light plug can be turned either "ON" or "OFF".

Order today Orders for "Super-Antenna" are being received from everywhere. Dealers are ordering them by the hundreds, but if you cannot get a "Super-Antenna" at your Radio dealers send check or money order for \$2.80 and it will be shipped postpaid anywhere east of the Rocky Mountains, add 25c for extra carrying charges west of Rocky Mountains. Order today and the unit will be shipped immediately.

# \$2.80

**SUPER-ANTENNA COMPANY,**

Dept. 88, Quincy, Ills.

## Wireless Amateurs Attention!

If you want service, order from us. We carry a large stock of High Grade Wireless Apparatus of our own and other manufacturers.

### SPECIAL!

- Vacuum Tube Sockets.....\$1.25
- Rheostats ..... 1.25
- 22 1/2 Volt "B" Batteries..... 1.50
- Rasco Dials ..... .60
- Rubber Binding Posts..... .20
- Tested Galena ..... .40
- Lateral Wound Coils. All Sizes

SEND 5c FOR OUR NEW PRICE LIST

**J. M. PAQUIN,**  
THE ELECTRICAL SHOP

787 Queen St. West, Toronto, Ont.

# NOVO "B" BATTERIES FOR RADIO

22 1/2 - 45 & 105 VOLTS

**NOISELESS  
DEPENDABLE  
GUARANTEED**

**ASK YOUR DEALER**

NOVO MANUFACTURING CO.

424-438 W. 33rd ST.  
NEW YORK

531 SO. DEARBORN ST., CHICAGO.

## AMATEUR RADIO CALL BOOK

Loose Leaf System, Amateur, Special, Experimental, Technical, Telephone Broadcasting, etc., kept to date monthly.

Postal Card for Particulars.

CITIZENS RADIO SERVICE BUREAU  
416 S. Dearborn St., Chicago

*Who's Who and What's What  
in Radio Communication*

# SHIP OWNERS RADIO SERVICE INC.

80 Washington Street, New York City

**Radio Distributors**



# Type "Q" Receiver

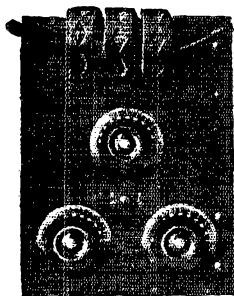

**AN IDEAL RECEIVING SET FOR LONG  
AND SHORT WAVE AND RADIO  
TELEPHONE RECEPTION**

This set is the most flexible receiving set on the market. With the use of the various sizes of Honeycomb Coils everything in the range of radio telegraph and telephone reception from 200 to 25,000 meters is brought into your home. Consists of a three coil mounting, and three Variable Condensers of proper capacity. Tuning extremely sharp. Remler dials.

Price without Detector . . . . . \$35.00

## Duck's New Radio Catalog No. 16

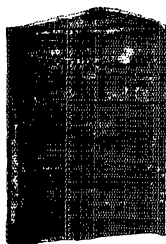

Send 25c in coin carefully wrapped today for copy of the greatest radio catalog ever put between the pages of two covers.

### *275 Pages--A Catalog DeLuxe*

Never in the history of radio was such a catalog printed. The radio data and diagrams embracing upwards of fifty pages, gives the experimenter more valuable and up-to-date information than will be found in many books selling for \$2.00, and \$1.00 could be spent for a dozen different radio catalogs before you could gather together the comprehensive listing of worth while radio goods found in this catalog.

A brief summary of the radio goods listed in this catalog:

The entire radio catalog of the Radio Corporation, with a wealth of scientific and technical data on C.W. transmitting sets, and all the diagrams for the assembling of these sets; the complete Remler catalog, which embraces 25 pages, the Westinghouse, Firth, Murdock, Federal, DeForest, Clapp-Eastham, Brandes, Connecticut Company, Thordarson, Turney, Magnavox Company catalogs, the best products of Adams-Morgan, Signal and countless other manufacturers, including our own complete line of radio apparatus, and many individual items and parts used in radio work today.

Send 25c in coin, (carefully wrapped) for the new catalog. The great cost of this elaborate catalog prohibits distribution on any other basis.

## The William B. Duck Company

243-245 Superior Street,

Toledo, Ohio

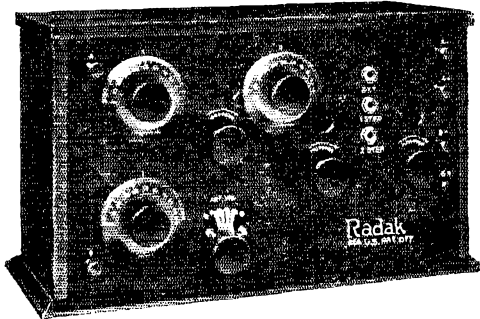

*Type R Z Radak Receiving Set,  
Clapp-Eastham's newest achievement  
(Licensed under Armstrong U. S. Pat. 1,113,149)*

# Radak

(Trade Mark Reg. U. S. Patent Office)

## Means Simplified Radio

**C**LAPP-EASTHAM'S long career in engineering and manufacturing has been devoted to Radio exclusively. In all those years its single aim has been to make Radio simple and easy for the novice. In the Type RZ Radak Receiving Set shown above the very highest development of this aim has been realized.

This new set brings in signals, message and music with amazing clearness and loudness, responding to wave lengths as great as 3,000 meters. Especially when used with the Radak Electro Ampliphone, the effects obtained are unsurpassed by any set made today, whatever the price.

Combines features of the Clapp-Eastham Type HR Regenerative Receiver with two stages of amplification in one cabinet. Extremely simple to operate.

### SPECIFICATIONS

**Cabinet:** Solid mahogany, dull finish. Hinged cover. Compartment for B battery.

**Panel:** Condensite, dull finish black; white lettering.

**Dials:** Indestructible metal, black with white lettering.

**Binding Posts:** Hard rubber composition. **Condensers:** Balanced type, built as a Vernier; two rotary, three stationary plates.

**Antenna Inductance:** Wound on formica tube.

**Pate Inductance:** Wound on molded ball. **Switch:** Fan blade.

**Rheostat:** Clapp-Eastham type H400.

**Circuit:** Single circuit regenerative.

**Price:** \$100, complete as above.

Ask to see this unusual set at the store where you usually buy electrical goods. If the dealer does not carry the Clapp-Eastham line, he may obtain same through his jobber.

Newest catalogue complete with the most up-to-date sets as well as other radio equipment sent you for 6c.

## Clapp-Eastham Co.

105 MAIN STREET, CAMBRIDGE, MASS.

*Oldest, Largest Manufacturers of Radio Equipment Exclusively. Established 1906*

## The Original-At The New Price

50 cents each add parcel post charges for less than one pound to your zone

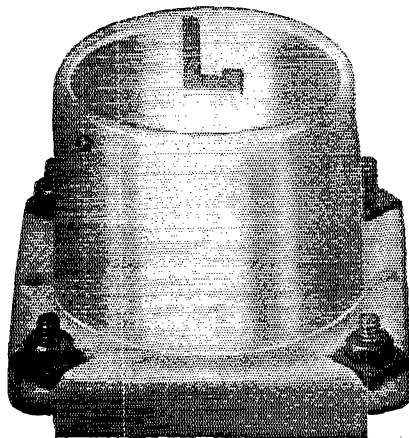

The original socket with the concealed bayonet slot.

*The old adage: "Imitation is the sincerest form of flattery" still holds!*

Ask Your Dealer or Write Direct to:  
**JOY KELSEY CORPORATION**  
4021 West Kinzie St., Chicago, Illinois



Send 10c for Sample  
Copy

Suite 10  
11 St. Sacrament Street,  
Montreal

# Radio Sets and Parts

DIRECT FROM

## Distributor

TO

## User

\* \* \* \* \*

NORTH STAR RECEIVER, Guaranteed to receive the larger broadcasting stations up to 100 miles, complete with tube; phones; "A" and "B" batteries and aerial, ready to install. .	\$63.00
NORTH STAR AMPLIFIER, designed to match the above receiver, complete with 2 tubes and 2 "B" Batteries (this amplifier hooked up to the above receiver will give you a range of more than 500 miles).....	50.00
HARKO V. T. RECEIVERS.....	14.00
HARKO TWO STAGE AMPLIFIERS.....	17.50
LAWSAM BABY CRYSTAL SETS (Complete).....	17.50
NORTH STAR VARIOMETERS.....	3.85
NORTH STAR VARIO-COUPERS.....	4.35
NORTH STAR VARIABLE CONDENSERS, 11 plate.....	2.10
NORTH STAR VARIABLE CONDENSERS, 23 plate.....	2.40
NORTH STAR VARIABLE CONDENSERS, 36 plate.....	2.85
NORTH STAR VARIABLE CONDENSERS, 43 plate.....	3.85
NORTH STAR UNBREAKABLE DIALS, 3".....	.65
NORTH STAR UNBREAKABLE DIALS 3 1/2".....	.85
NORTH STAR SWITCH SETS (with points).....	.75
NORTH STAR SINGLE TUBE SOCKETS.....	.75
NORTH STAR DOUBLE TUBE SOCKETS.....	1.40
NORTH STAR RHEOSTATS.....	1.10
NORTH STAR PHONE OR GRID CONDENSERS, EACH.....	.22
NOVO "B" BATTERIES, 22 1/2 volt, large, variable.....	1.85
NOVO "B" BATTERIES, 22 1/2 volt, small, variable.....	1.25
RED STAR HEAD PHONES, 2000 OHMS, GUARANTEED....	5.00
DETECTOR TUBES (tested).....	4.25
AMPLIFIER TUBES (tested).....	5.25

\* \* \* \* \*

NO CATALOG ISSUED—ORDER DIRECT FROM THIS LIST. ENCLOSE CHECK, DRAFT OR M. O. ALL ITEMS GUARANTEED AS REPRESENTED OR YOUR MONEY REFUNDED. GOODS SHIPPED DAY ORDER IS RECEIVED.

**MINNESOTA RADIO SALES CORPORATION**

210 PALACE BUILDING

MINNEAPOLIS,

MINNESOTA,

U. S. A.

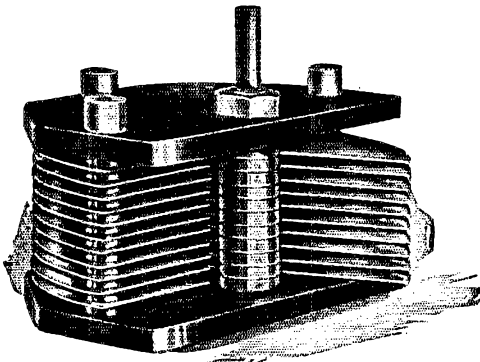

MAXIMUM  EFFICIENCY  
**VARIABLE CONDENSER**

The "MAXEFF" Variable Condenser, insulated with the best material known, providing the highest resistance path possible between the two sets of plates, constructed with accurately machined metal bearings with a double locking device giving absolute permanency of adjustment, assures maximum electrical efficiency with maximum mechanical ruggedness.

The "MAXEFF" Variable Condenser is so manufactured that the use of inferior moulded and shellac compounds for end plates or metal with small insulating washers which have great losses and low breakdown voltages, have been entirely eliminated.

The "MAXEFF" Variable Condenser will improve the operating efficiency of any receiver and will provide a variable capacity unit that may be relied upon.

Various sizes are supplied as follows:

- 3 plate Vernier ..... \$2.00
- 11 plate .00025 mfd. .... 3.15
- 21 plate .0005 mfd. .... 3.50
- 43 plate .001 mfd. .... 4.50

**THE HIGGY-AVERY CO.**  
 Manufacturers

**1199-1205 FRANKLIN AVENUE  
 COLUMBUS, OHIO**

If your Radio Dealer cannot furnish you with "MAXEFF" Condensers send us your order with remittance and we will supply you Postpaid.



**"RED-HEADS"**  
**THE LAST WORD IN  
 RADIO RECEIVERS**  
 at your dealers or  
 send direct to  
**The Newman-Stern Co.**  
 CLEVELAND, OHIO.



Always insist upon getting  
**NAA ARLINGTON**  
 TESTED  
**RADIO CRYSTALS**  
 The original Tested Minerals  
 Galena, Silicon or Goldite 25c  
 Mounted in Brass Cup 40c  
**THE NEWMAN-STERN CO.,**  
 Cleveland, O.



When you see the name  
**Teagle** on a radio instru-  
 ment you know that it is  
 a **BETTER** piece of ap-  
 paratus. Send for cata-  
 log. Teagle Radio Di-  
 vision of

**THE NEWMAN-STERN CO - CLEVELAND, OHIO**

**B K U M A** Trade  
 Mark  
 Reg't'n **Y R L S B U G**  
 Ap. For

**MEMORIZE CODE**  
 Almost Instantly  
**ATTENTATIVE BEGINNERS**  
 Who Use  
**DODGE ONE DOLLAR  
 RADIO SHORT CUT  
 DO ARRIVE**

WILLIAM N. ADLER (2BGC),  
 576 East 143 St., New York.  
**MEMORIZED CODE IN 40 MINUTES QUALIFIED  
 FOR LICENSE AFTER TWO WEEKS PRACTICE.**

J. ROBERT ZIEGLER (8A10),  
 129 Dauphin St., Lancaster, Pa.  
**MEMORIZED CODE IN 80 MINUTES QUALIFIED  
 FOR LICENSE AFTER ONE WEEK PRACTICE.**

**INVESTIGATE**  
 C. K. DODGE, Box 210, MAMARONECK, N. Y.

**J-RAY**  
**Receiving Apparatus**

SEND FOR BULLETINS

**J-RAY MFG. CO.**

1618 Chestnut St., St. Louis, Mo.



Model K400  
 Loud speaking receiver. Thoro-  
 phone is attached to the bottom of  
 the base and is concealed from  
 view yet easily accessible.

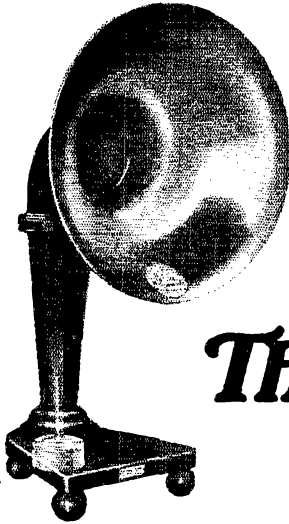

Model 501  
 This beautiful instrument gives you the de-  
 sired volume, and tone of exquisite quality and  
 musical excellence.

**\$35.00**  
**Complete**

# REAL MUSICAL REPRODUCTION

## THOROPHONE

(THUNDERPHONE)  
 TRADE MARK REG. U.S. PAT. OFFICE

Will bring the best popular  
 orchestras and most renowned  
 soloists into your home.

The THOROPHONE is more than a loud speaker, it is a *real musical instrument*. If you have never heard the THOROPHONE its clear, beautiful and satisfying tone will astonish you. Produced by America's oldest manufacturers of loud speaking telephones, it is based on principles which have been proven successful by years of actual use.

The THOROPHONE makes Radio a real means of musical enjoyment, not merely an interesting novelty. After you have once heard this real musical instrument no other loud speaker will satisfy you.

The THOROPHONE requires better than the average receiving set to give best results, but give it the power and you will be astonished at its musical qualities.

### WINKLER-REICHMANN CO.

4801 So. Morgan St.,

Chicago, Ill.

**THOROPHONE LOUD SPEAKING RECEIVER**—controlled mica diaphragm, carefully designed sound box, nickel plated throughout. Does not use up your storage battery. Simply connect it in place of one of your head receivers.

**THOROPHONE model K-400** ..... \$20.00  
**Phonograph Adapter, Model 350** ..... .40

**CONCERT HORN**—a beautiful instrument, highly ornamental in any home. Base and tone arm are of mahogany finish wood, the neck of heavy metal and the bell of extra heavy spun aluminum. Has great brilliancy **WITHOUT METALLIC TONE.**  
**CONCERT HORN model H300** ..... \$15.00

Height, 25 inches.

*DEALERS—We have a REAL loud speaker and a REAL proposition for you.*

Dept. Q

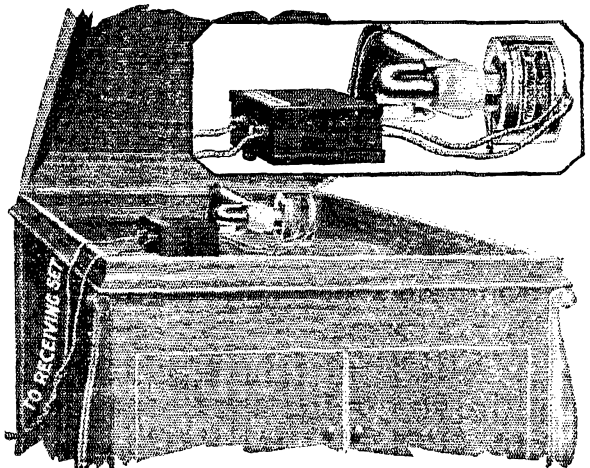

Those desiring to use their own phonographs can do so by attaching our adapter with Thorophone direct to phonograph tone arm.

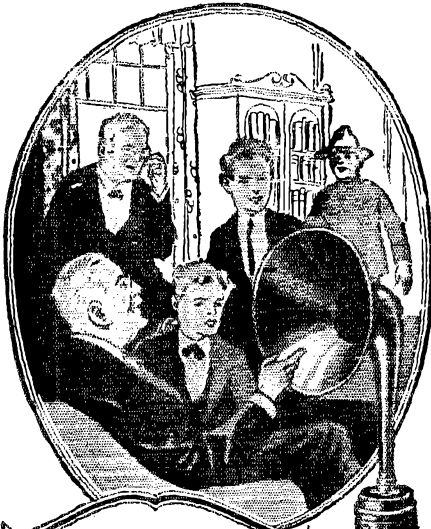

*We are entering upon  
a Wireless Telephony Age*

WHO can foresee, even one year hence, the wonderful development of the radio programs broadcasted daily from central stations?

To enjoy these programs at their best—and share the enjoyment with family and friends—equip your receiving set with the **MAGNAVOX RADIO**

Without a Magnavox Radio no wireless receiving set is complete. It makes it possible to hear all that is in the air as if it were being played by your phonograph.

*Any radio dealer will demonstrate for you, or write to us for descriptive booklet and name of nearest dealer.*

**The Magnavox Co.**  
Oakland, California  
N. Y. Office: 370 Seventh Ave.  
Penn. Terminal Bldg.



*"Radio brings it  
MAGNAVOX tells it"*

# JEFFERSON

## Amplifying Transformers

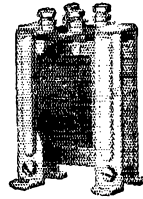

No. 45

BY ACTUAL TEST JEFFERSON Amplifying Transformers have proven superior to anything now on the market. Try them and note the improvement, the absence of distortion and the clearness of tone.

FURNISHED IN TWO TYPES, either mounted or unmounted. Wound with No. 40 and No. 44 wire on a core of highest grade 36 gauge Silicon steel.

Send for Radio Bulletin

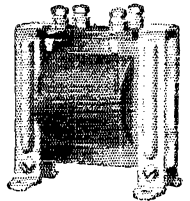

No. 41

REASONABLY PROMPT DELIVERIES

## Jefferson Electric Mfg. Co.

425 S. Green St., CHICAGO

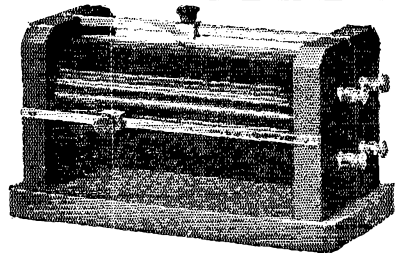

**LAMB TUNING COILS.** Two Nickel sliders and rods; four nickel binding posts. Coil contains about  $\frac{1}{2}$  #222 enameled magnet wire. Mounted in hard wood ends and base. Price \$3.00.

$\frac{1}{4}$ " Sliders—Brass 20c; Nickel 25c.

$\frac{1}{4}$ " Slider Rods—Brass 15c.; Nickel 20c.

Crystal Detectors, nickel plated on Mahogany Base, \$1.00.

Crystal Detectors, glass case and fibre base, \$1.25.

Contact Points, threaded with nuts—20c dozen

Compo. cap, Nickel base Binding Posts—7c each.

Plain Nickel Binding Posts—3 $\frac{1}{2}$ c each.

**IMMEDIATE DELIVERIES**

Liberal discounts to dealers

**F. JOS. LAMB COMPANY**

1938 Franklin St., Detroit, Michigan

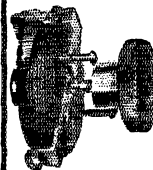

\$1.75

**JENKINS VERNIER RHEOSTAT** Indispensable for adjustment on Radio Frequency and Detector Tubes. Patent instant cut-off switch. Write for folder.

Liberal discounts to dealers and jobbers.

**J.E. Jenkins** Not Inc.  
59 E. Van Buren St.  
CHICAGO

# CONDENSERS

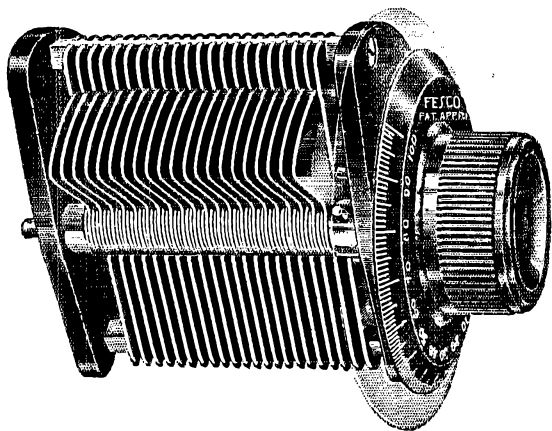

3 Plate.....	\$2.25
11 Plate.....	3.25
23 Plate.....	4.00
43 Plate.....	4.75

Add 75c to above list for condenser with dial.

### CAPACITY

3 Plate vernier..	.00004
11 Plate.....	.00025
23 Plate.....	.0005
43 Plate.....	.001

Each condenser is equipped with ground shield which eliminates all hand capacity losses. No accumulated error due to poorly cut spacing washers.

## BAKELITE **DIALS** BAKELITE

Furnished in either 3/16 or 1/4 inch shaft sizes. 3" outside diameter with large and clear numerals. 0-100 degrees.  
Price .....\$1.10

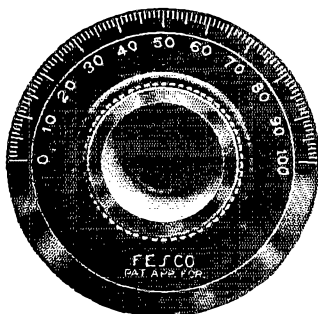

This dial is made of genuine bakelite and is guaranteed not to warp. The knob is knurled to prevent slipping of fingers.  
Price .....\$1.10

## STERN & COMPANY, Inc.

308 Asylum St.,

Hartford, Conn.

Catalog 10c.

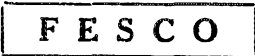

Dealers Propositions  
Entertained

## Bound Volume V of QST

The July issue concluded QST's fifth volume, which is now available in bound form. Unlike previous years, this volume is too bulky to bind in a single book and so is appearing in two equal sections. Uniform in appearance with preceding volumes, handsomely bound in red cloth with gold leaf imprinting.

This is the way to keep QST fresh and handy for immediate reference. The issues of the past year are a priceless storehouse of practical information for the telegraphing amateur. They are important enough to you to keep in bound form for the years to come.

*In two sections, Part I and Part II*  
 \$5.00 Postage Prepaid  
 Either section for \$2.50 postpaid

QST, 1045 Main St., Hartford, Conn.



**When Your Tube Goes "Pst"**

and you're out five dollars,—that's the time to make a note to protect your new tube with

### RADECO Safety Fuse

a tiny device that makes burning out the filament, even by an accidental short absolutely impossible. Good on any standard tube.

**1/4 for \$1**  
 Buy from your dealer or direct by mail.

*When ordering, specify exactly what tube, fuses are wanted for.*

**RADIO EQUIPMENT CO.**  
 630 Washington St. Boston, Mass.



*American Electric*  
 HIGH EFFICIENCY  
 TELEPHONES  
 "Army and Navy" and Swedish-American Types

*American Electric*  
 COMPANY  
 CHICAGO, U.S.A.

For 30 Years Makers of Good Telephones



**SOUTHERN RADIO CORPORATION**  
 Radio Engineers and Jobbers  
 905 Realty Building, Charlotte, N. C.

**Best of Everything in Radio Apparatus and Parts**

Send Stamp for Catalog "Q"

**J. H. BUNNELL & CO.**  
 32 Park Place, New York



**THE HARTFORD BATTERY MFG. CO.**  
 Dept. R. MILLDALE, CONN.

**RAY-DI-CO**

Radio Supplies for Service and Satisfaction  
 Write, wire or phone us for prices and information

**RAY-DI-CO Organization**  
 1547D N. WELLS ST., CHICAGO, ILL.

**OLIVER S. EVERETT**  
 MAKER OF  
**SPECIAL RADIO EQUIPMENT**  
 Quotations Furnished Upon Receipt of Specifications  
 83 OTIS STREET, MEDFORD, MASS.



# DeForest Radio Apparatus

IS

Designed by A.R.R.L. Men --- Tested by A.R.R.L. Men  
Suitable for A.R.R.L. Men

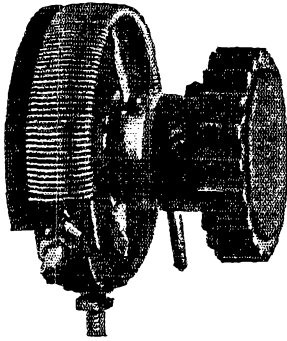

Rheostat F-500—Diameter 2", depth back of panel  $\frac{7}{8}$ ", knob diameter  $1\frac{1}{2}$ ", knob depth in front of panel  $\frac{1}{8}$ ", shaft  $\frac{1}{4}$ ", resistance 6 ohms, for panels up to  $\frac{3}{8}$ ".

Receptacle R - 500 — Base  $2\frac{1}{4}$ " square, height overall  $1\frac{1}{8}$ ", phosphor bronze springs #26 gauge, marked plus, minus, G and P on both sides of base. Takes all tubes except Myers, 50 watt and 250 watt trans.

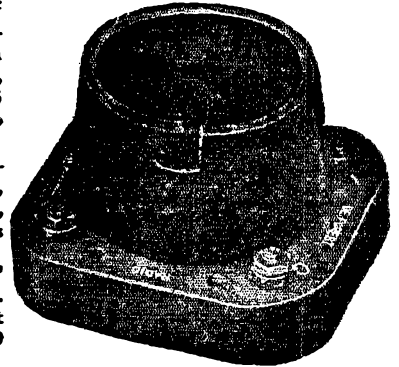

The dependability and excellence of design of DeForest Parts is well-known to the readers of QST. DeForest rheostats, receptacles, grid leaks, condensers, coil mountings, honeycombs and amplifying transformers are still made for those who build their own.

DX work requires parts of highest efficiency. Use DeForest Parts and hear stations in every district.



*"Famous for Dependability"*

## FROM CAT WHISKERS UP—

We can supply everything that's best in Radio. 1 or 101 of any article to user or dealer. Same day shipments.

*Inquiries are welcome*



DISTRIBUTORS  
Wholesale and Retail  
WESTINGHOUSE MURDOCK  
RADIO CORPORATION  
BRANDES, FEDERAL, DEFOREST  
and many others

AT EAST PITTSBURGH, PA.—NEXT DOOR TO KDKA

## Be Ready for the Fall "DX" Season Build Your Own Receiver

- B & K VARIOMETERS have a spring plunger bearing of our own design which gives perfect contact with rotor shaft. Shaft  $\frac{1}{8}$ " ..... postpaid \$5.50
- B & K VARIO-COUPLER. Primary 50 turns #18 wire tapped every five turns. Rotor wound with 30 turns #18. Shaft  $\frac{1}{8}$ " ..... postpaid 5.00
- COMBINATION NO. 50 consists of 2 variometers, 1 vario-coupler described above, complete with dials, 1 FADA inductance switch, 10 contact points, 2 switch stops, 6 nickel binding posts, 9 feet nickel connecting wire. All ready to mount on your own panel ..... postpaid 18.00

Write for bulletin No. 1

**BONDUAUX & KNIGHTS**  
1115 KELLY STREET, BRONX, N. Y.

# CLASSIFIED ADVERTISEMENTS

Six cents per word per insertion, in advance. Name and address must be counted. Each initial counts as one word. Copy must be received by the 10th of month for succeeding month's issue.

**SELLING OUT** Complete receiver, modeled after Grebe CR6 with 2 step amplifier, in finest portable cabinet, \$70.00. Photo for 6c stamps. Barrett, 3150 Central Ave., Indianapolis, Indiana.

**FOR SALE:** Magnavox, never used, \$40. 1½" spark coil, \$3.50. Short wave receiver. V. Bloomquist, 510 Sherman, So. Bend, Ind.

**FOR SALE OR TRADE** 1 Navy type loose coupler, 1 DeForest type P500 Audion Ultra-Audion Cabinet, 1 Variometer, never used. What have U? Make offer. Albert H. Buch, Tawas City, Mich.

8JL's 100 watt C.W. set complete \$100. Receiver complete \$125. L. N. Chatterton, 12409 Woodside, Cleveland, O.

**ATTENTION:** Dictograph Headsets and one Klossner rheostat for \$9.00. Offer good for thirty days only. Amplifier Tube & Phons Condenser \$6.50. Klossner Vernier Rheostat \$1.35. "GA" Phone Condensers, Grid Condensers thirty cents; Grid Leak & Condenser forty cents. Cash with order. Twelve hour service. C. K. Radio Company, Lyons, Kansas.

**FOR SALE:** Regenerative and 2 stage amp. Roy Conibear, Amboy, Ill.

**FOR SALE:** Grebe detector and two step type R.O.R.D. Auto filament control, in A-1 condition. price \$45. A. S. DeFrees, Hartford, Mich.

**BUY A SET** of these, hear 6's. Variocoupler & two variometers complete \$11. The East End Radio Supply, 12302 St. Clair, Cleveland, O.

**FOR SALE:** Here is a complete spark set for only \$35. ½ KW Thordarson transformer, Dubilier condensers, good OT, all good as new, Menominee rotary gap used but good, Protective Condensers, Giannetta, 54 Boerum Ave., Flushing, N. Y.

**BARGAIN:** ½ KW Acme transformer, Dubilier condenser, good condition, together \$18.00. M. Genthner, 101 Homer St., Newton, Mass.

**1AA 1KW SPARK** for sale—heard 28 states—Mounted Packard Transformer, .007 Dubilier, 110v non-synchronous rotary. Also .004 Dubilier. Make offer! Wallace Heckman, Auburndale, Mass.

**EDISON B BATTERY ELEMENTS.** Make your own. Can be recharged and lasts for years. 200 ampere hour A batteries, guarantee \$35.00. Harry Morrell, 52 Goffe St., New Haven, Conn.

**NEW CLAPP-EASTHAM HR** set with HZ two step amplifier, \$68.00. Complete set of parts for single circuit tuner with detector and two step, \$25.00. R. Ireton, Saginaw, Mich.

**25 WATT C.W.** and phone set including motor generator, 5 tubes, new, used less than 20 hours, cost over \$250, sell \$175.00 cash. Box 152, Mahwah, N. J.

**TELEFUNKEN** and Crocker-Wheeler motor generators ½ KVA 500 cycle \$75. Fine for your tube set. Henry Kienzie, 501 East 84th Street, New York.

**FIRST MONEY TAKES** Westinghouse RC regenerative tuner and two step amplifier, \$100; 4 DeForest rheostats, \$1 each; 4 RCA Radio Frequency amplifying transformers, \$6 each; 8000 RPM 110 volt Motor, \$15; 1/8 HP 10 volt D.C. motor-generator, \$20; Wagner 5 ampere battery charger, \$10; 2 RCA Potentiometers, \$1.50 each; 2 latest type .001 MF variable condensers, \$4.50 each; \$25 for 6 Radiotron 201, 1 Radiotron 200 and 1 ER detector, all used but in good condition. Further details on request. A. R. Leinbach, 137 Walnut St., Reading, Pa.

10 Watt C.W. with Tubes, \$45.00. 8CQH, Daryl McClung, 1221-9Ave. Huntington, W. Va.

**BARGAINS:** As Long As They Last. DeForest DT-800 two-stage Amplifiers, \$22.75 each; Cabinet Type Vacuum Tube Detectors with Condenser and Variocoupler Tuning, \$20 each; approved 100-ampere 600-volt 5-inch break Ground Switches, \$2.25 each. Sent postpaid on receipt of price, or parcel post collect on receipt of order. Ludwig Hommel & Company, 530 Fernando St., Pittsburgh, Pa.

**600 WATT Spark transmitter**, Panel mounted \$30. John Naratil, Palmerton, Pa.

**ALL NEW 3 Weston 0-1.5 Thermo-Ammeters** \$10 each also one 0-1 and one 0-2. One Weston Thermo Galvanometer 0-100 for wavemeter—\$9. Two ammeters 0-2½ and 0-5 Weston—\$5. One 50 Watt Radiotron and one Kenotron—\$15 each. Four 201 Radiotrons—\$5. One 27-350 Volt Dynamotor—\$22. One Eldredge hot wire meter 0-1—\$4. One General Radio hot wire meter used 0-2½—\$4. Philip Orelin, 54 Cook St., Brooklyn, N. Y.

**BARGAIN, Never used—Clapp-Eastham HR Receiver** \$33.00; HZ Amplifier \$30.00; Magnavox R-3, \$40.00; Harco Senior Receiver \$12.50; Stromberg Carlson Phones \$6.00; All guaranteed. Willis L. Otto, Cambridge, Ill.

**TESTED GALENA CRYSTALS** From our own Mines shaped, and tested at the mine in best standard hookup—direct to user. A real crystal—not a pinhead. Twenty-five cents postpaid, five for \$1.00 to group buyers. Ozark Crystal Co., Box 1, Morrellton, Mo.

**RADIO SUPPLIES—Murdock and Federal** Phones, Antenna Wire, Insulators, Radiotron Tubes, VT Controls, Eveready B Batteries, Etc. 5% off list prices, postpaid. Everything brand new and in perfect condition. Send Stamps for List. Wesley Robinson, Jr., St. Mary's Georgia.

**PRINTING FOR AMATEUR STATIONS**—post cards, blanks, letterheads, etc. Send stamp for samples and prices. ORC Press 1711 Estes Ave., Chicago.

**EDGEWISE COPPER .033x.295x3¼"** diameter 50 turns \$3.50 postpaid. Radio Specialties Co., Connellsville, Pa.

**FOR SALE—Clapp-Eastham H.R. Receiver** \$30.00; R3 Magnavox \$35.00. Western Electric Loud-Speaker, \$150.00; Kent Variometer, \$7.00; Burrows Rogers, Cainsville, Missouri.

**FOR SALE:** One Clapp-Eastham HR regenerative receiver, \$30.00; One Grebe detector RORH, \$13.00; One five dial Omnigraph with dials, \$12.00; Two AP detector tubes \$4.00 each; One radiotron UV200, \$4.00; all above articles new. One Paragon RA-6 like new, \$40.00; One Amrad type D Wavemeter, \$6.00; One Bunnell 2 inch spark coil, \$5.00; One Benwood large oscillation transformer, \$7.00. R. A. Saeger, Ankona, Fla.

**FOR SALE:** 160 to 600 meter regenerative set, with detector control, mounted in cabinet. Formica panel. Very simple tuning. Can tune to higher wave lengths by obtaining additional coils. Without batteries, tube or phones, \$30. O. E. Scholen, Stanwood, Wash.

**CHEAP!** Radio apparatus standard makes 50% off; Corona typewriter and carrying case, cost \$55.00, sell \$35.00; Davis double barrel hammerless 12 gauge shotgun, cost \$97.50, sell \$35.00; no second hand junk, C. L. Somers, Dresden, Tenn.

**BUILD YOUR OWN WIRELESS Telephone and Musical Receiver, Don't Wait for a Set.** We hear Chicago, 900 miles. Fine on good nights. Pittsburgh, Newark and New York come in Good and Loud—You Can Do the Same on a Single Bulb. There is Radio Music in the air each evening, and the living voices of the artists can be reproduced in your own home and enjoyed by you and your friends. Are you satisfied with your receiving set or would you like to build one that will receive over 6,000 miles on a single bulb and quit experimenting? One that will be equal to any regardless of claims and price—with which you can hear Honolulu, California, German, South American, French and English stations and practically all of the high powerful foreign and domestic stations, as well as amateur stations as far west as New Mexico, and the phone and music. Anyone can assemble this outfit and wire it up, and the

# SOMERVILLE

PRODUCTS LEND DISTINCTION TO THE CUSTOM-BUILT SET.

THEY HAVE STOOD THE TEST OF COMPETITION SINCE 1917.

DESIGN DETAIL AND QUALITY OF MATERIAL COUPLED WITH FAIR PRICE AND TRUTHFUL ADVERTISING ARE PRIME FACTORS IN ESTABLISHING POPULARITY.

"OLD TIME" AMATEURS INSIST ON GETTING PRODUCTS MADE BY AN ESTABLISHED RADIO COMPANY.

THEY HELP TO STABILIZE RADIO BY ENCOURAGING ORIGINATORS AND SHUNNING IMITATORS.

WHETHER YOU BUY FROM A DEALER OR BY MAIL, FROM SOMERVILLE RADIO STORES, 43 CORNHILL, BOSTON,

SPECIFY

# SOMERVILLE

## ROCKY MOUNTAIN CRYSTALS

More sensitive than Galena.

EACH CRYSTAL TONE TESTED

Mounted 35c, Unmounted 20c, postpaid  
Manufacturers, Jobbers, Dealers, Clubs  
apply for special trade prices.

Rocky Mountain Radio Products, Inc.  
9 CHURCH ST., NEW YORK, N. Y.

remarkable ranges that may be obtained will surprise you. Why not make a set up to date and efficient? Don't experiment with unknown circuits. We will promptly mail you our sample diagram of a complete short and long wave receiver, 175 to 20,000 meters, together with complete instructions for wiring and assembling, price of each part and where they can be bought, leaving nothing to guess about, on receipt of fifty cents in coin or stamps. Here is a diagram no one can afford to be without. Virginia Novelty Company, Desk A, Martinsburg, West Va.

LOOK! SAVE \$2.50! 16 Spring Key Switches, take the place of plug and two filament control jacks, with hookup, \$1.50. 50,000 ohm Lavite Resistances for radio frequency amplifiers, 40c. W. E. Signal Corps Grid Condensers, 40c. 3550 ohm coils, 6 oz., No. 40 copper wire, 60c. Western Instrument Repair, 314 N. Fairfield, Chicago, Ill.

INVENTORS: Protect your invention through A. M. Wilson, Inc., Washington, D. C. Over 20 years of efficient, expert, confidential service. Skilled in Radio-Electrical, Chemical, and Mechanical fields. Our 1922 illustrated Booklet, giving much necessary and very useful information which every inventor should know, will be sent free upon request. Prompt and careful attention. Highest references. Moderate fees. Send sketch or model for our careful opinion and preliminary advice. Write today to A. M. Wilson, Inc., 310-16 Victor Building, Washington, D. C. (Successor to business established in 1891 by A. M. Wilson).

ALWAYS MENTION Q S T WHEN WRITING TO ADVERTISERS

## Prepared Radio Measurements

With  
Self Computing Charts

by *Ralph R. Butcher*

A new WIRELESS PRESS book. Published as a real help to amateur radio. Obviates the necessity of long and involved mathematical calculations. A ruler or transparent triangle takes the place of intricate figuring and the results will be correct every time.

PRICE \$2.00

### The WIRELESS AGE

*The magazine that meets  
all your expectations.*

When its new you find it in the AGE. Every step in radio progress is fully and carefully described. You miss a lot of good things unless you read the AGE. \$2.50 per year, Postage outside U. S. 50c.

### SPECIAL OFFER ONLY

Prepared Radio ... Measurements	&	The ... Wireless Age ... 1 Year	\$4.00 Outside U. S. 50c. Extra
---------------------------------------	---	--	---------------------------------------

WIRELESS PRESS, INC.

328 Broadway, New York

## WRITE US FOR RIGHT PRICES

The best of apparatus and supplies at reasonable prices. We sell direct to the amateur, Grebe, Murdock, DeForest, Acme, Baldwin, Jewell, Brandes and other high grade lines. Tell us your needs and let us quote prices and delivery.

*Write to Us Today*

Garber Radio Electric Co.  
Metamora, Ill

### "WorkRite Radio Parts WorkRite"

They are standard everywhere. WorkRite Variocouplers, Variometers, Switch Parts, Hydrometers, Binding Posts, Rheostats, etc. Write for catalog.

THE WORKRITE MFG. CO., Cleveland, O.

## TWELVE 250 WATT Transmitting Tubes

for immediate delivery

Price \$110.00

STAR-TELEGRAM

FORT WORTH, TEXAS

## Our New Price List is Ready. Get Your Copy

Immediate deliveries on  
 Radio Corporation  
 Magnavox  
 Grebe  
 Amrad  
 Clapp-Eastham  
 Tuska  
 Formica  
 Thordarson  
 Remler  
 Cunningham  
 Frost  
 Federal  
 & Others

### Detroit Electric Co.

113-115 E. Jefferson Ave.

DETROIT, MICH.

## CONTRACT WORK WANTED

LET COLUMBIA MAKE SOME OF THE PARTS OR ASSEMBLIES ENTERING INTO THE CONSTRUCTION OF YOUR PRODUCTS

Our equipment available for your work is composed of:

Automatic Screw Machines  
 Hand Screw Machines  
 Milling Machines  
 Gear Cutting Machines  
 Thread Milling Machines  
 Punch Presses, Drill Presses  
 Polishing, Buffing, Plating and Japaning, Wood Working, Hydraulic Equipment for pressing and forming Plastic Materials.

SUBMIT SAMPLES OR BLUE PRINTS AND GET OUR FIGURES ON QUANTITY PRODUCTION

### Columbia Graphophone Mfg. Co.

Bridgeport, Conn.

75c  
EA.



### KELLOGG V-T SOCKET

*the durable socket*

Kellogg molded lamp sockets fit all standard four prong based vacuum tubes. Extra heavy solid base  $\frac{7}{8}$  inches thick. Four German silver springs with rounded ends firmly

held in position in deep grooves, cannot touch mounting surface. Double end nickel plated binding posts. Connections can be made under the socket as well as above. A practically indestructible construction. 75c each, postpaid.

#### COMPLETE RADIO EQUIPMENT

The item above is merely a sample of the excellent line of radio equipment that is handled by the Apex Radio Company, Inc. All orders for sockets or other standard equipment will be filled the day received. Send two cent stamp for our new price bulletin.

APEX RADIO CO., Inc. 1105 W 69th St. Chicago, Illinois

## "NEWRAD"

The Mark of satisfaction  
 Immediate Shipment

Variocouplers .....	\$6.50
Variometers .....	6.50
V.T. Sockets .....	.75
Rheostats .....	1.50
Amplifying Trans. ....	5.00
Dials .....	1.10
Phones—All Makes	
Magnavox .....	45.00
Switch Points .....	.03
Switch Levers .....	.65
Plugs, Jacks—Federal	
Binding Posts .....	.12
Insulators—All Types	
Condensers .....	4.50

We handle all leading makes of equipment.

### The New York Radio Laboratories

Manufacturers, Jobbers, Dealers

ACKERMAN BLDG., BINGHAMTON, N. Y.

### Vacuum Tube Detector \$5.50

Including complete cabinet with all instruments wired ready for use.

#### DETECTOR AND TWO STAGE AMPLIFIER \$22.50

With transformers and all other instruments in cabinet, ready for operation. This equipment is of high quality, and distances of as high as 3000 miles have been obtained with ease.

#### BATTERIES AND TUBES EXTRA

2000 Ohm receivers \$5.00  
 SUPERIOR CRYSTAL RECEIVING SET \$4.75

Attractive dealers proposition

STEINMETZ WIRELESS MFG. CO.,  
 5706 PENN AVENUE, PITTSBURGH, PA.

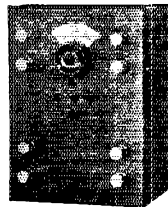

### SPECIAL PRICES THIS MONTH

On Grebe, Clapp-Eastham and Amrad Sets

### MASSEY RADIO COMPANY

The Radio Store, Winchester, Va.

YOU

who build your own should use my coils for that new single circuit tuner you are building. 150-3000 meters, special winding on impregnated cardboard tube. Rotor inside for regeneration. Price \$5, immediate delivery.

GEO. F. MARTIN

### RADIO PANEL SHOP

1103 S. 3rd St., Evansville, Indiana

—FOR YOUR CONVENIENCE—

# QST'S INDEX OF ADVERTISERS IN THIS ISSUE

Acme Apparatus Co., The.....	73	Magnavox Co., The.....	112
Adams-Morgan Co., The.....	93	Massachusetts Radio & Telegraph School, Inc.....	90
Allen-Bradley Co.....	98	Massey Radio Co.....	118
American Electric Co.....	114	Mills, S. W.....	90
American Radio & Research Corp.....	4th Cover	Minnesota Radio Sales Corporation.....	109
Anthracite Radio Shop.....	76	Mu-Rad Laboratories, Inc.....	94
Apex Radio Co., Inc.....	118	Murdock Col., Wm. J.....	103
Atwater-Kent Mfg. Co.....	4	Nash Electrical Service Co.....	104
Audiotron Mfg. Co.....	101	National Carbon Co. (Eveready Battery).....	3
Automatic Electrical Devices Co.....	72	Newman-Stern Co., The.....	110
Benwood Co., Inc., The.....	90	New York Radio Laboratories, The.....	118
Bonduaux & Knights.....	115	Niehoff & Co., Inc., Paul G.....	96
Brach Mfg. Co., L. S.....	78	Novo Mfg. Co.....	106
Bunnell & Co., J. H.....	114	Ogden Wireless Laboratories, The.....	120
Burgess Battery Co.....	66	Oro-Tone Company, The.....	104
Canadian Radio Convention & Nat'l Exhibition.....	63	Pacent Electric Co., Inc.....	75
Canadian Wireless.....	108	Paquin, J. M.....	106
Chelsea Radio Co.....	80	Philadelphia Wireless Sales Corp.....	82
Chicago Radio Apparatus Co., Inc.....	89	Pitts Radio Stores, Inc.....	105
Citizens Radio Service Bureau.....	106	Pittsburgh Radio & Appliance Co., Inc.....	80
Clapp-Eastham Co.....	108	Potter Co., The C. D.....	98
Classified Advertisements.....	116-117	Precision Equipment Co., The.....	104
Columbia Graphophone Mfg. Company.....	118	Prest-O-Lite Co., Inc., The.....	97
Condensite Company of America.....	2	QST Book Department.....	80
Connecticut Telephone & Electric Co.....	3d Cover	QST Bound Volume V.....	114
Coto-Coil Company.....	87	Radio Audion Co.....	1
DeForest Radio Tel. & Tel. Co.....	115	Radio Corporation of America.....	85
Delancey, Felch & Co.....	98	Radio Electric Co., The.....	64
Detroit Electric Co.....	118	Radio Equipment Co.....	114
Diamond State Fibre Co.....	72	Radio Panel Shop.....	118
Dictograph Products Corp.....	98	Radio Testing Station.....	82
Dodge, C. K.....	110	Rasla Sales Corporation.....	92
Doubleday-Hill Electric Co.....	66	Raymond Radio Corp.....	84
Duck Co., The Wm. B.....	107	Ray-Di-Co Organization.....	114
Eastern Radio Institute.....	84	Remler Radio Mfg. Co.....	99-100
Eby Mfg. Co., The H. H.....	88	Reynolds Radio Co., Inc.....	88
Economic Appliance Co.....	96	Rhamstine, J. Thos.....	102
Electric Motor & Engineering Co., The.....	84	Rocky Mountain Radio Products, Inc.....	117
Electric Specialty Co.....	76	Roller-Smith Co.....	74
Electrose Mfg. Co.....	2nd Cover	Rome Wire Co.....	68
Elwood Electric Co., Inc.....	78	Rose Radio Supply.....	82
Everett Electric Corp.....	94	Scientific Engineering Association.....	76
Everett, Oliver S.....	114	Service Radio Equipment Co., Inc.....	92
Firth, John & Co., Inc.....	120	Ship Owners Radio Service, Inc.....	106
Formica Insulation Co., The.....	71	Shotton Radio Mfg. Co., The.....	120
France Mfg. Co., The.....	102	Signal Electric Mfg. Co.....	95
Franklin Radio Mfg. Co.....	120	Somerville Radio Laboratory.....	117
Garber Radio Electric Co.....	117	Southern Radio Corporation.....	114
General Radio Co.....	67	Standard Assembling Co.....	120
Globe Phone Mfg. Co.....	74	Star-Telegram.....	117
Grebe & Co., A. H.....	81	Steinmetz Wireless Mfg. Co.....	118
Gregory, A. V.....	74	Stern & Company, Inc.....	113
Hartford Battery Mfg. Co., The.....	114	Stromberg-Carlson Telephone Mfg. Co.....	86
Higgy-Avery Co., The.....	110	Super-Antenna Company.....	106
Hommel & Co., Ludwig.....	79	Telephone Maintenance Co.....	92
Horne Mfg. Co.....	102	Thordarson Electric Mfg. Co.....	89
J-Ray Mfg. Co.....	110	Tuska Co., The C. D.....	64
Jefferson Electric Mfg. Co.....	112	United Electric Stores Co.....	115
Jenkins, J. E.....	112	Valley Electric Co.....	68
Joy-Kelsey Corporation.....	108	Ve-De-Co Radio Mfg. Co.....	70
Keystone Radio Company.....	86	Westinghouse Union Battery Co.....	77
Kimley Electric Co.....	86	Weston Electrical Instrument Co.....	69
King "Am-Phi-Tone".....	66	White Co., The O. C.....	78
Klaus Radio Co.....	96	Whitehouse Radio & Mfg. Co.....	94
Klein Radio & Elec. Supply Co., The.....	120	Willard Storage Battery Co.....	88
Klosner Improved Apparatus Co.....	70	Winkler-Reichmann Co.....	111
Lamb Co., F. Jos.....	112-120	Wireless Mfg. Co.....	91
		Wireless Press, Inc.....	117
		Witherbee Storage Battery Co., Inc.....	120
		WorkRite Mfg. Co., The.....	117

ALWAYS MENTION QST WHEN WRITING TO ADVERTISERS

## Wire Your Own—

and save 25%  
on high-grade  
assembled sets

Standard radio instruments are completely machine assembled in our splendidly equipped factory. The wiring, however, is left for you to do. By buying Standard instruments, you can get correctly assembled handsome radio instruments and at the same time save 25% or more of the cost by doing the wiring yourself. Our new 12-page folder now coming off the press, explains the Standard Plan in detail and illustrates Standard instruments in actual colors. Send 5c for your copy today in time to save money before your next purchase.

**The STANDARD Plan**  
"assembled—but not wired"

**Standard Assembling Co.**  
19 Bridge St., New York City

## "SHRAMCO PRODUCTS"

Amateurs: Send 5c in stamps today for our new Catalogue L showing complete line of parts, raw materials and high grade apparatus.

Dealers: Write for our attractive proposition.

**The Shotton Radio Mfg. Co.,**  
INCORPORATED  
8 Market St., Albany, N. Y.



## Firco Radio Apparatus

For sale by all prominent dealers

**JOHN FIRTH & CO., Inc.**

Pioneers since 1901

709 Sixth Avenue, New York

## Send Us Your Orders For

Variable Condensers, Variometers, Variocouplers, Loose Couplers, Tuning Coils, Amplifying Transformers, Sliders, Switches, Switch Points, Binding Posts, etc.

We are large manufacturers. Gorton machine engraving or manufacturing special parts to order.

**F. JOS. LAMB COMPANY**  
1938 Franklin St., Detroit, Michigan

## FRANKLIN VARIOMETER

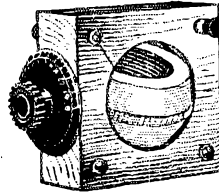

Made of selected hardwood. Permanent contacts assure smoothness of operation, unsurpassed by any other make.

PRICE \$4.50

Sample sent prepaid \$3.50

Dealers write for Discounts.

**FRANKLIN RADIO MFG. CO.**  
711 Penn Ave., Wilkensburg, Pa.

## The OGDEN WIRELESS LABORATORIES

### THE O.W.L. RHEOSTAT

Patents pendings

An instrument of real Value, NO THERMO-ACTION resulting in distortion because all parts are made of the same resistance alloy throughout.

PRICE - - \$1.00

1012 Ogden Ave., New York City

## WITHERBEE

### RADIO A BATTERIES

Built Right Since 1903

**WITHERBEE STORAGE BATTERY COMPANY, INC.**

234 W. 55th Street, New York

## RADIO REALITIES

Our price list, mailed Free on request. Contains complete lists of reliable Radio Sets and parts—every article carrying our guarantee. Mail orders given prompt attention.

Write today—Special Terms for Dealers

**THE KLEIN RADIO & ELECTRICAL SUPPLY CO.**

48 Fulton St. and 84 Park Place NEW YORK, N. Y.

# CONNECTICUT RADIO

## Buy for Performance

It's results that count with the radio enthusiast. The device that gives results is the one that's worth its price.

Measure Variable Condensers by performance and your choice will be CONNECTICUT.

Not only compactness and stability, but sensitiveness, finer ad-

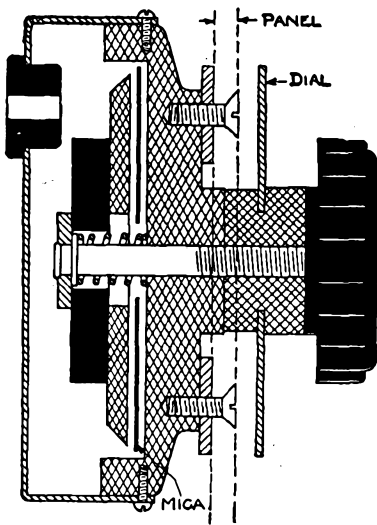

Cross section view of panel type condenser

justments, stronger signals, a greater working range — all these are yours with the CONNECTICUT Variable Condenser.

The novel construction of this condenser is shown in the accompanying cut, which illustrates the new panel type mounting.

Your dealer has the CONNECTICUT Variable Condenser, or can get it for you.



*The Recognized Symbol of Superior Performance*

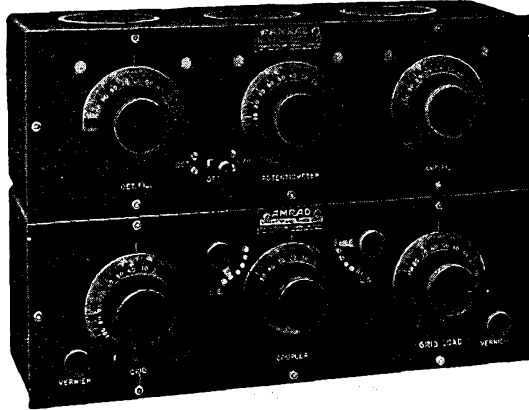

**Amrad Short Wave Receiver, including  
Tuner 2596, price \$55.00 and Detector  
2-Stage Amplifier 2634, price \$65.00.**

**Encased in solid mahogany cabinets**

## Why This Amrad Set Performs

Amrad BASKETBALLS—Variometers and Vario-Coupler—incorporating the exclusive basketweave windings, are employed in the Tuner.

Amrad Ampliformers, avoiding conventional, leaky lap joints and thus assuring maximum signal strength without distortion, are used in the Detector 2-Stage Amplifier.

These two features of design, plus many years of radio manufacturing experience, have produced the highly sensitive and efficient Amrad Receiver. Yet the price is no greater, and more often less, than any first-class quality receiving equipment available today.

*Bulletin L, mailed upon request, describes this Amrad Receiver in detail. Bulletin O describes the BASKETBALLS and Bulletin N, the Ampliformers. Have you read these bulletins? Order from your nearest dealer's. If he does not stock Amrad at present, place your order, and he will get it for you quickly. Look for the green and yellow Amrad labels in the best stores.*

## AMERICAN RADIO AND RESEARCH CORPORATION

General Offices, Works and Laboratory, 205 College Avenue  
MEDFORD HILLSIDE, MASS.

New York District Office  
13 Park Row

(4 miles north of Boston)

Chicago District Office  
218 So. State St.