

Which Will You
Judge By—
Results or
Unproved Claims?



Type R-A-10 Receiver Licensed Under Armstrong Patents D-A-2 Detector-Amplifier

- Also Manufacturers
of
- PARAGON
 - Radio Telephone Transmitters
 - V. T. Control Units
 - Rheostats
 - Potentiometers
 - V. T. Sockets
 - Amplifier
 - Transformers
 - Detectors
 - Control Dials
 - Amplifiers
 - Receivers
 - Switches
 - Variometers

Paragon Stands on its Record

In 1915 the *first* regenerative receiver, Paragon, was manufactured.

In 1916 Paragon effected the *first* transcontinental reception (not prearranged) from New York to California.

In 1917-18 Paragon receivers, due to greater sensitivity and selectivity, proved superior to all others in interception of enemy signals by the U. S. Army and Navy.

In 1921 Paragon effected the *first* transatlantic amateur reception, registering signals from 27 American amateur stations at Ardrossan, Scotland, a distance of 3500 miles.

In 1922 Paragon Products are a safe investment in a market in which it is difficult to judge values.

Paragon needs no extravagant claims; but we guarantee our customers this:—that Paragon Products are reasonable in price, sound in design and thorough in workmanship.

If your dealer does not sell Paragon Products, send for catalogue (free) and we will supply you promptly.

ADAMS-MORGAN CO., 4 Alvin Ave., Upper Montclair, N. J.

PARAGON
Reg. U. S. Pat. Off.
RADIO PRODUCTS



The ideal combination for VT control without the use of jacks or plugs.

We are the inventors and sole manufacturers of the famous Klosner Vernier Rheostat Model 100 still being sold for \$1.50.

Write for interesting literature on the "Amplitrol" and the Klosner Rheostats. Ask for Booklet OE.

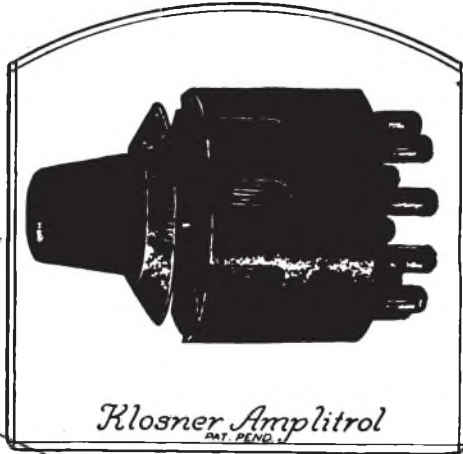

Klosner Amplitrol
PAT. PEND.

THE long looked for has at last arrived. The new Klosner "Amplitrol" fills that long felt radio want—that of controlling the vacuum tube circuit without the use of jacks, plugs or any additional switches. A real radio necessity. Each of your amplifier tubes deserves one. No more plugging in from one stage to the next. Simply attach your phones or loud speaker to binding posts and turn on any stage at will.

The "Amplitrol" not only adjusts the filament to its maximum efficiency, but it automatically controls the plate circuit at the same time, thus eliminating an extra operation. Unlike an automatic filament control, the "Amplitrol" does not put a sudden strain on your filament. It provides a gradual current increase for the filament, thus prolonging its life.

Made of moulded condensite. Contacts of phosphor bronze. Exposed metal parts highly nickel plated. New style tapered knob, and dial correctly numbered in white lettering. Price \$4.00.

What the "Amplitrol" is to the amplifying tube, so the Klosner Rheostat is to the detector tube. The new improved Rheostat Model 200, embodies some vast changes and improvements. These are too numerous to list, but your inspection will immediately win your approval. The "Amplitrol" and the new improved Klosner Rheostat are the ideal combination for your vacuum tubes. Klosner Rheostat Model 200, Price \$1.80.

The "Amplitrol" and the Rheostat do not employ the graphite disc principle, but that of wire wound. This feature insures perfect contact at all times, making tuning quicker and louder and giving greater range. See them at your dealers or write for literature.

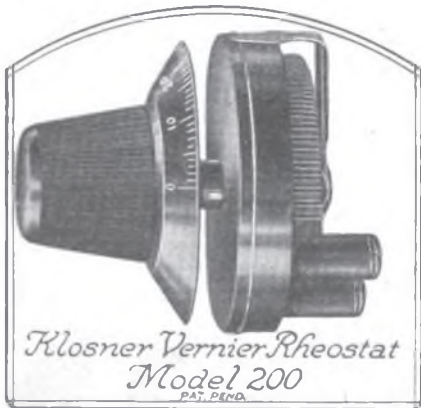

Klosner Vernier Rheostat
Model 200
PAT. PEND.

Klosner Improved Apparatus Co.,
2024 Boston Road
New York City

Here's the Fada Receiver!

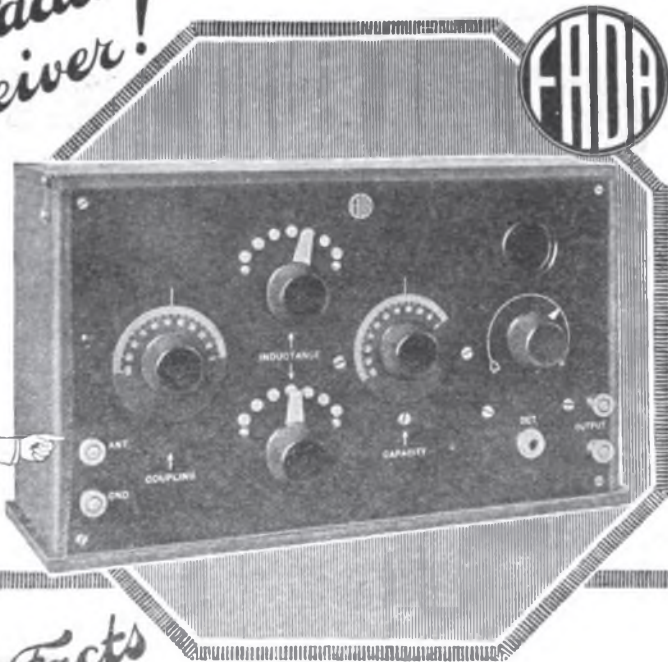

and There's the Facts about it.

THE FADA HANDBOOK
of
FADA-FACTS



The new Fada handbook will be sent to you upon receipt of 5c to cover postage. It's a How-To-Do-It book and you should have it

An Ideal Home Entertainer

The Fada receiver, a result of the same perfection in design and construction that distinguishes all Fada products, is gaining popularity as an ideal home entertainer.

When it's radio time in your home, you can sit back in your favorite chair, among the family circle, and command at your fingers' touch the talent of such noted artists as May Peterson, Percy Grainger, or Mme. Margaret Namara.

You marvel that their voices can come into your home with such depth of emotion and true personality. Music is an inspiration to everyone, it brings joy and happiness to all.

With a Fada radio receiver, music can be made part of your daily recreation. And after the musical program there is broadcasted a digest of important world events. A Fada receiver keeps you a jump ahead of tomorrow's newspapers.

Frank A. D. Andrea
1581-E Jerome Ave. New York City

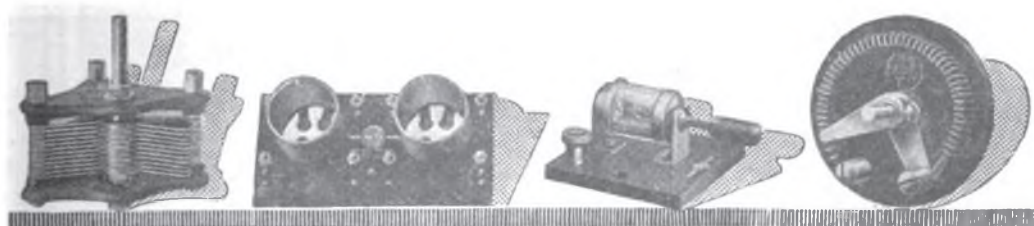

ALWAYS MENTION QST WHEN WRITING TO ADVERTISERS

3

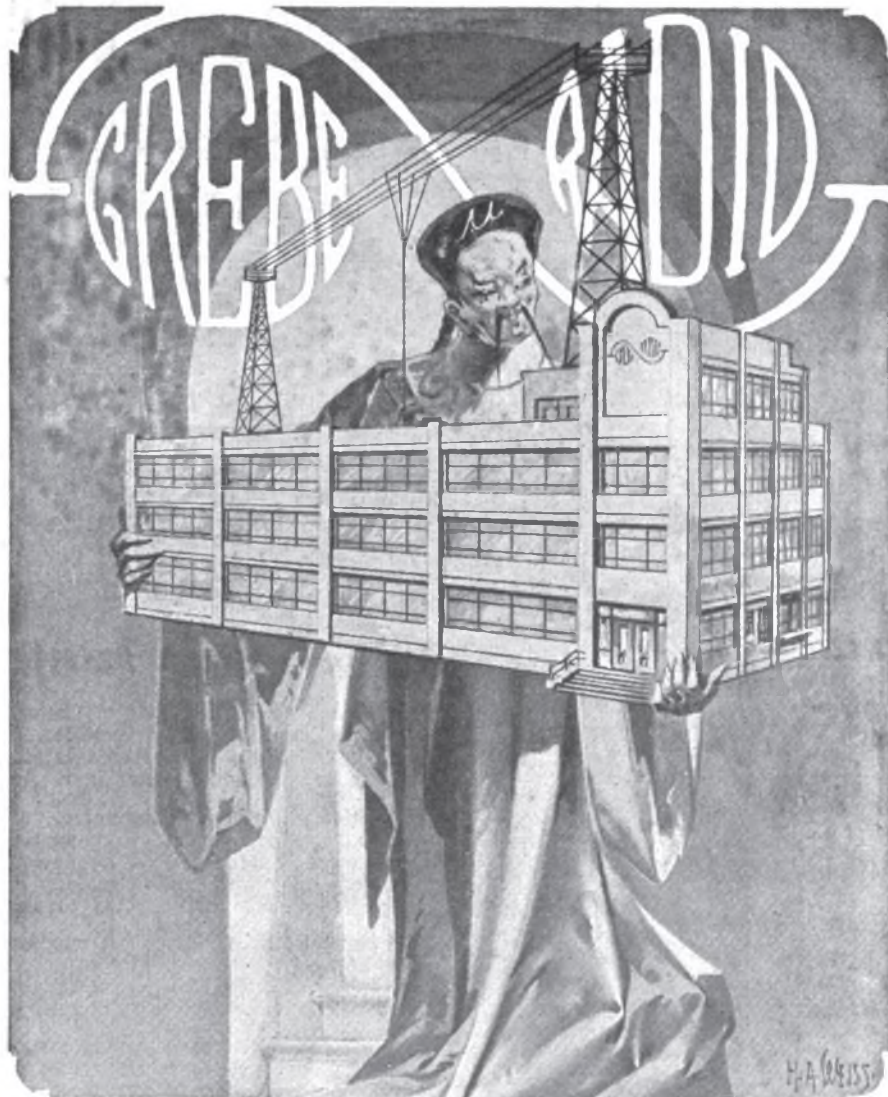

"TREASURES OF GOLD AND JADE
 SAID LAO TZU, DESERVE A
 PROPER DWELLING!"
 "GREBE RADIO IS NOW HOUSED IN A
 MANNER BEFITTING ITS EXCELLENCE."
Doctor Wu

QST

The Official Organ of the A.R.R.L.

VOLUME VI

OCTOBER, 1922

No. 3

Electric Wave-Filters		7
The A.R.R.L. Transatlantics, 1922	<i>F. H. Schnell</i>	11
Some Further Improvements in My Tuner	<i>John L. Reinartz</i>	12
Radio Amplification with the Reinartz Tuner		14
Simple Audio Regeneration		15
Another Month of Super-Regeneration	<i>K. B. Warner</i>	16
A 122-Foot Tower	<i>Leroy Moffett, jr.</i>	18
New Books Received		20
QST Subscription Contest		21
Multi-Stage Amplifiers	<i>M. C. Batsel</i>	25
Break-In for C.W.	<i>"Beep"</i>	28
"And the Land Shall Be Visited by Plague and Pestilence"	<i>"The Prophet"</i>	30
Amplifier Operation from A.C. Supply	<i>P. D. Lowell</i>	32
A Week in Baltimore with Portable Station 30I	<i>John Evans, jr.</i>	35
A Calibrated External Heterodyne and Wave Meter	<i>A. A. Learned</i>	37
High-Power Vacuum Tubes		37
"SA" in 1904	<i>"An Old Timer"</i>	38
Death of James L. Autry		40
Tube Supply from A. C.		40
Editorials		41
The Operating Department		44
International Amateur Radio		55
Who's Who in Amateur Wireless— <i>Winifred Dow, M. Adaire Garmhausen</i>		58
The Junior Operator		60
Amateur Radio Stations— <i>4BQ, A Holland Station, 9AUU, 8BO</i>		62
With the Affiliated Clubs		65
"Strays"		66
Calls Heard		69
Power Factor Applied to Radio Condensers	<i>Paul G. Watson</i>	74
Radio Communications by the Amateurs		77

Q S T is published monthly by The American Radio Relay League, Inc., at Hartford, Conn. Kenneth B. Warner (Secretary, A. R. R. L.), Editor and Business Manager. Edwin C. Adams, Advertising Manager.

Subscription price in United States, Possessions, and Canada, \$2.00 per year. Foreign \$2.50. Single Copies, 20 cents.

Entered as second-class matter May 29, 1919, at the Post Office at Connecticut, under the Act of March 3, 1879. Acceptance for mailing at special rate of postage provided for in Section 1103, Act of October 3, 1917, authorized September 8, 1922.

Copyright, 1922, by The American Radio Relay League, Inc. Title registered at United States Patent Office.

THE AMERICAN RADIO RELAY LEAGUE, Inc.
HARTFORD, CONN.

THE AMERICAN RADIO RELAY LEAGUE

"A national non-commercial organization of radio amateurs, bonded for the more effective relaying of friendly messages between their stations, for legislative protection, for orderly operating, and for the practical improvement of short-wave Radio Communication."

OFFICERS

President
HIRAM PERCY MAXIM
Hartford, Conn.

Vice President
CHAS. H. STEWART
St. David's, Pa.

Traffic Manager
F. H. SCHNELL
1045 Main St.
Hartford, Conn.

Treasurer
A. A. HEBERT
Nutley, N. J.

Secretary
K. B. WARNER
Hartford, Conn.

DIRECTORS

H. M. ANTHONY
Muncie, Ind.

H. A. BEALE, Jr.
Parkesburg, Pa.

A. E. HESSEY
Sunnyvale, Calif.

V. F. CAMP
Brightwaters, L. I.

F. M. CORLETT
Dallas, Tex.

C. E. DARR
Detroit, Mich.

W. C. C. DUNCAN
Toronto, Ontario

A. A. HEBERT
Nutley, N. J.

DR. A. E. KENNELLY
Cambridge, Mass.

S. KRUSE
Cambridge, Mass.

H. P. MAXIM
Hartford, Conn.

F. H. SCHNELL
Hartford, Conn.

C. A. SERVICE, Jr.
Hartford, Conn.

C. H. STEWART
St. David's, Pa.

K. B. WARNER
Hartford, Conn.

M. B. WEST
Waukegan, Ills.

OPERATING DEPARTMENT

ATLANTIC DIVISION
Manager
Chas. H. Stewart
St. David's, Pa.

EAST GULF DIVISION
Manager
B. W. Benning
50 Whiteford St.,
Atlanta, Ga.

CENTRAL DIVISION
Manager
R. H. G. Mathews
332 S. Michigan Ave.,
Chicago

ALASKAN DIVISION
Manager
Roy Anderson, 71T
P. O. Box 206
Ketchikan, Alaska

WEST GULF DIVISION
Manager
Frank M. Corlett
1101 East Eighth St.
Dallas, Tex.

PACIFIC DIVISION
Manager
J. Vance Wise
Walnut Grove, Cal.

HAWAIIAN DIVISION
Manager
C. J. Dow
Wailuku, Maui, T. H.

QUEBEC DIVISION
Manager
Albert J. Lorimer
Farnham, Que.

ONTARIO DIVISION
Manager
A. H. Keith Russell
11 Pinewood Ave.,
Toronto, Ont.

VANCOUVER DIVISION
Manager
J. T. North, Jr.,
Barron Hotel
Vancouver, B. C.

DAKOTA DIVISION
Manager
N. H. Jensen
Box 894, Sioux Falls, So. Dak.

NEW ENGLAND DIVISION
Manager
Philip F. Robinson
149 Hollis Ave.,
Braintree, Mass.

MARITIME DIVISION
Manager
K. S. Rogers
Prince Edward Island

ROANOKE DIVISION
Manager
W. T. Gravely
854 Main St.,
Danville, Va.

DELTA DIVISION
Manager
John M. Clayton
1301 Welch St.,
Little Rock, Ark.

WINNIPEG DIVISION
Acting Manager
J. H. Gjelhaug
Baudette, Minn.

ROCKY MOUNTAIN DIV.
Manager
Norman R. Hood
1022 S. Ash St.,
Casper, Wyo.

MIDWEST DIVISION
Manager
G. S. TURNER
124 Pearl St.,
Independence, Mo.

NORTHWESTERN DIV.
Manager
Howard F. Mason
3335 33d Ave. So.,
Seattle, Wash.

ADVISORY TECHNICAL COMMITTEE

C. S. BALLANTINE
WM. C. BALLARD, Jr.
LEROY M. E. CLAUSING
FRANK CONRAD
LEO C. YOUNG

MINTON CRONKHITE
J. H. DELLINGER
C. L. FARRAND
PAUL F. GODLEY
F. C. BLAKE
MELVILLE EASTHAM

L. A. HAZELTINE
C. D. TUSKA
R. H. G. MATHEWS
J. O. SMITH
S. KRUSE

Address General Correspondence to Executive Headquarters, Hartford, Conn.



A Magazine Devoted Exclusively to the Radio Amateur

Electric Wave-Filters

Electric wave-filters are one of the means which have made possible some of the recent advances in communication engineering. They were invented by Dr. G. A. Campbell of the American Telephone and Telegraph Company and have been widely used in the communication systems developed by the research engineers and scientists of this company and the Western Electric Company. A demonstration of their use was recently given by Dr. Frank B. Jewett, Vice President of the Western Electric Company, before the New York Telephone Society. In response to our request, Dr. Jewett has supplied our readers with the following discussion of filters.—Editor.

THE electric wave-filter is to-day a very important part of our communications systems. We use it in ordinary wire telephony, in carrier-current systems, in multiplex telegraphy or telephony, and in radio telephone and telegraph systems.

A filter is an electric circuit, or artificial transmission line, built up of coils and condensers and so designed as to transmit all the frequencies (wave lengths) within a certain range, but to fail completely to transmit those without this range. By its use, therefore, we may select signals of any desired wave length from other signals which are very close in wave length. It offers, therefore, a more refined method of selecting than the ordinary tuned circuit with which the radio amateur is familiar.

The principles which underlie the operation of filters are simple and easily understood. The actual design, however, of a

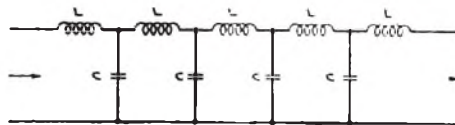

FIG 1

filter to transmit a specified range of frequencies (i.e. all wave lengths within a certain range) can only be accomplished by one who is willing and able to attack the subject with highly mathematical tools.

The simplest form of filter is shown in Fig. 1. It is essentially an artificial transmission line and contains resistance and inductance in series and capacity in shunt. It may be constructed of inductance coils and condensers, the resistance being an inevitable part of the inductance coils. The resistance is not desirable for it weakens the currents which we wish to transmit.

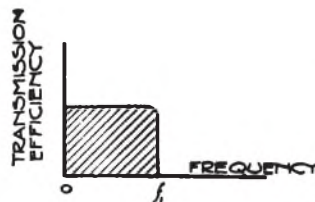

FIG 2

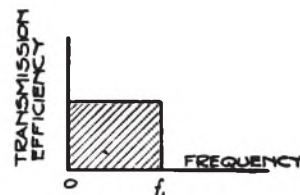

FIG 3

The currents which we do not wish to transmit are eliminated or suppressed by the action of the inductances and capacities, which is to be described.

This particular type of filter is a "low-pass filter" because it will transmit only frequencies below a certain definite limit which depends upon the values of inductance coils and condensers. That such a combination of inductances and capacities will not transmit high frequencies efficiently is immediately obvious. An inductance coil offers greater impedance the higher the frequency of the voltage which is impressed upon it. It would appear then that high frequencies would be choked by the action of the series inductances. On the other hand, a condenser offers smaller impedance the higher the frequency of the

voltage impressed upon it. The higher the frequency of the current which is flowing in the filter, the smaller becomes the impedance of the shunt condensers, and hence the more effectively do these condensers act as by-passes for the current. Inductances and condensers therefore work together to prevent high-frequency currents from reaching the distant end of the oscillator.

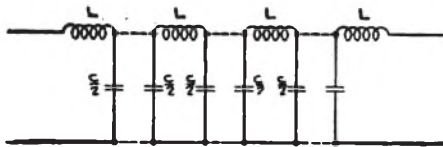

FIG. 4

This much is obvious as to the action of filters. It is not obvious, however, that such a combination of inductances and capacities will operate to transmit with practically equal efficiency all currents of frequency below a certain definite limit, and then fail completely to transmit frequencies higher than this limit. This conclusion can be reached by mathematical study, which is beyond the scope of this discussion, or may be tested by experiment. If one performs the experiment of determining the transmission efficiency of the filter with reference to the frequency of the current which is to be transmitted, results may be plotted as shown in Fig. 2.

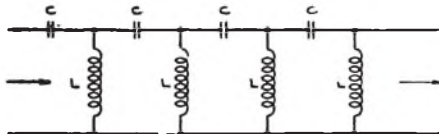

FIG. 5

As one increases the frequency of the current supplied to one end of the filter, there is no change in transmission efficiency until some frequency f_1 is reached. At that frequency there is an abrupt decrease in efficiency. The more nearly the coils are pure inductances, i.e., free from resistance, the more nearly will this graph of transmission efficiency become a rectangular figure like that of Fig. 3.

Although the mathematical analysis of the circuit is beyond the scope of our present discussion, a simple rule may be given for determining the value of f_1 , the "cut-off frequency" of the filter. Let us sketch the filter as in Fig. 4 as if it were made up of a number of consecutive sections, each formed by inductance and two condensers, connected as shown by the dotted lines. Each of the sections consists of an inductance and a capacity in series.

Such a circuit is resonant, i.e., tuned to a certain frequency, and this frequency, which is the resonant frequency of the section, is the "cut-off frequency" of the filter. Its value may be readily determined by the following formula:

$$f_1 = \frac{1}{2\pi\sqrt{\frac{LC}{4}}}$$

where L is the inductance and C the capacity of the coils and condensers shown in Fig. 1. In the tuned circuit of Fig. 4 the capacity is $C/4$ because there are two condensers in series, each of value $C/2$.

Another equally simple type of filter is the "high-pass filter" which is shown in Fig. 5. Here the elements of the filter which were discussed earlier are interchanged so that currents which are being transmitted through the filter meet the series impedance of the condensers, while the inductance coils offer shunts or by-passes for these currents.

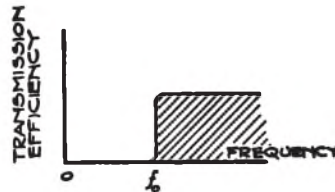

FIG. 6

Obviously enough, such a filter will not transmit a direct current, that is, a current of zero frequency. As the frequency is increased, however, the impedance which the capacity elements offer becomes less. On the other hand the impedance of the inductance coil increases as the frequency rises, with the result that these coils become less effective as by-passes and so divert less of the current if the frequency is high than if it is low.

For such a filter there is the same sort of abrupt change in transmission efficiency

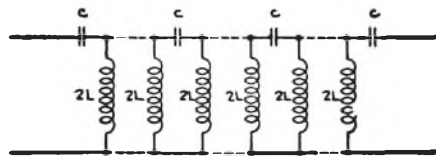

FIG. 7

as the frequency is increased. The characteristic relation is shown in Fig. 6, where f_1 represents the cut-off frequency. This cut-off frequency may be determined in a manner analogous to that pursued in the former case. We first redraw the filter circuit as a series of consecutive sections,

each formed by a condenser and two inductances. If connections between these sections are made as indicated by the dotted line, the circuit of Fig. 7 is identical with that of Fig. 5. The cut-off frequency f_c is the resonance or frequency to which each section tunes and this is given by the formula

$$f_c = \frac{1}{2\pi\sqrt{4LC}}$$

If the inductance, L of Fig. 5 is replaced by two parallel inductances as in Fig. 7, then each inductance must be twice as large. The series circuit formed by a section of the filter of Fig. 7 then consists of two inductances in series with a condenser, the total inductance being $4L$.

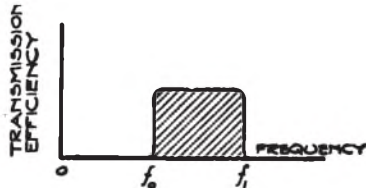

FIG. 8

If it is desired to transmit only currents whose frequencies lie within a narrow band, this may be accomplished by using a low-pass and a high-pass filter in series. The resultant characteristic would then be that of Fig. 8 and only those currents lying between frequency f_0 and f_1 would be transmitted. Instead, however, of arranging a high-pass and a low-pass filter in series, it is possible to arrange a filter which has in series the series elements of both types of filters and has in shunt the shunt elements of both types. We then obtain the "band pass filter" of Fig. 9.

This filter is the general case from which the other filters may be derived. Dr. Campbell invented the general type of filter. From this invention he derived some 10 or 12 other types, of which the filters previously described are two. In this general type of filter there are involved four elements for which values are to be assigned;

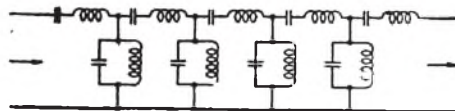

FIG. 9

namely, the series inductance and series capacity, and the shunt inductance and shunt capacity. There are then four variables in the circuit which must be considered when it comes to the design of a filter to accomplish a desired end. The de-

signer must determine the proper values for these four variables by equations which involve the conditions which he desires to meet. Suppose, for example, that he wishes to design a filter which will transmit between two frequencies and have the transmission characteristics shown in Fig. 9. He then has two conditions to meet, and

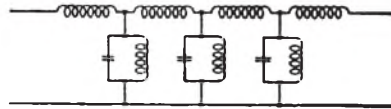

FIG. 10

four things to vary. He has more variables than he needs. In general he also has to meet in his design a requirement as to the impedance which the filter offers to frequencies within the transmission range. This is necessary because the filter is required to work between two parts of a transmission circuit and should have a proper value of impedance. This makes a total of three conditions to be met and four variables, i.e., one more variable than is needed.

It is therefore possible to design a filter of a desired impedance to transmit a desired band of frequencies with only three of the circuit elements which are shown in the general type of filter of Fig. 9. It makes no difference, so far as concerns the calculation, which element is omitted. We may make a band pass filter by omitting the series condenser as in Fig. 10, or by omitting the shunt capacity as in Fig. 11, or by omitting the series inductance as in

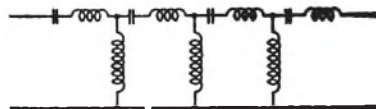

FIG. 11

Fig. 12, or the shunt inductance as in Fig. 13, and have all four filters equivalent so far as impedance is concerned and so far as the range of frequencies which they will transmit. A choice is then made between the four possible designs of Figs. 10, 11, 12, and 13 on the basis of convenience and cost. For example, one of these four designs might require a very large inductance or a very large capacity which would be difficult and costly to construct, and would occupy too much space for convenience. By studying the possible designs and the conditions for use, the designer makes his selection from the different types of filters which will transmit the same band of frequencies.

At present it is interesting to know what really happens when the designer omits

one of the circuit elements of the general type of filter shown in Fig. 9. There are four variables in this filter and in general it will transmit two bands of frequencies and have a transmission characteristic like that of Fig. 14. By the proper choice of the four elements these two bands may be made to overlap one another or become "confluent" as Dr. Campbell originally called them. The four element filter then has the characteristic shown in Fig. 8 and is really equivalent to a low-pass filter and a high-pass filter in series. On the other hand, if one of the elements is omitted, one of the transmission bands is displaced or "relegated to infinity."

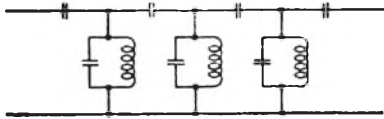

FIG. 12

By means of band filters, it becomes possible to separate in accordance with frequency. We are thus enabled to transmit a number of messages simultaneously over the same telephone circuit, or through the ether, and to separate these messages at the receiving station; for example, in the multiplex telegraph system, known as the carrier current system, there are transmitted over the same pair of wires simultaneously, 10 telegraph messages which are carried by currents of ten different frequencies, all somewhat above those of the voice range; two ordinary telegraph messages, carried by direct currents, i.e., zero frequency currents; and an ordinary telephone conversation. This multiplex telegraph system is in operation between many of the important cities of the country. In every case the separation of the different messages is accomplished by means of wave filters which select a single band of frequencies for transmission to the apparatus to which they are connected and fail completely to transmit all the other messages

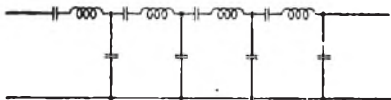

FIG. 13

which may be simultaneously received.

Filters are also used for similar purposes in the multiplex carrier current system of telephony. In this system the same pair of wires serves to transmit simultaneously five distinct telephone conversations, each carried by a different high fre-

quency current, the ordinary telephone conversation, and two telegraph messages.

Filters also permit the operation of a radio telephone station as part of a combined telephone and telegraph system. In this multiplex system of telegraphy and telephony, the telegraph signal is supplied by using an alternating current of 6,000 cycles and arranging to interrupt this current with a key, in the same manner as in ordinary telegraphy a steady current from a battery is interrupted and controlled by a key. As often, then, as a telegraphic dot or dash is to be transmitted, there is sent out from the key a current of 6,000 cycles. This current is added to the complex current from a telephone transmitter which is converting sound waves into electric waves. These two currents together modulate the high frequency radio current.

At the distant receiving station the radio signal is detected, i.e., the modulated radio wave which is received is demodulated. The result is the same mixture of telephone speech and telegraphic signals as is used at the sending station to modulate the radio-frequency, or carrier wave. It is a mixture, however, which is readily separated by the use of filters of the type which has just been described. The detected current at the receiving station is passed into

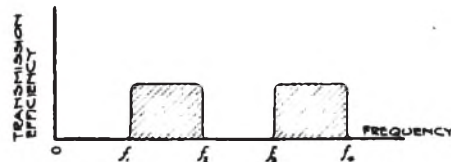

FIG. 14

two filters, one designed to transmit alternating telegraphic currents, and the other only telephonic currents. The filter for transmitting the telephonic currents and discriminating against the telegraphic signals, is designed to allow to pass through itself all alternating currents of which the frequencies are not greater than about 3,000 cycles; i.e., all the frequencies essential to intelligible and natural human speech. This filter, of course, excludes the telegraphic current which is of 6,000 cycles frequency. The other filter transmits only currents of 6,000 cycles or frequencies very close to 6,000.

In the demonstration of this system of combined radio telephony and telegraphy, a radio transmitting set was installed at one side of the auditorium and a receiving set at the other. Transmission took place between two small loop antennae. The circuit at each end was arranged with jacks so that a telephone receiver could be plugged in and an observer could listen to whatever was passing through the circuit

at that particular point. The receiver which was used was not the ordinary head receiver, but instead was a complete equipment of loud speaking telephone receivers such as was used in the Armistice Day Exercises at Arlington, New York and San Francisco. The whole audience was, therefore, able to hear whatever was passing through each part of the circuit. They could

hear the speech wave from the transmitter, or the 6,000 cycle telegraph signal, or the combination of the two; then at the receiving set they could hear the combinations of telegraphy and speech which resulted from the detection of the radio wave; then at the other side of the filters they could hear the speech or telegraph signal depending upon the filter whose output they were observing.

The A.R.R.L. Transatlantics, 1922

By F. H. Schnell, Traffic Manager

FELLOWS, we're going to have some more trans-ocean tests. Our A.R.R.L. Operating Department will conduct the third series of Trans-Atlantic Tests with the co-operation of the English, French, and Dutch amateurs, in December of this year. While no definite dates for the final tests have been decided upon, pending suggestions from England, France and Holland, the probable dates are December 12th to December 31st, inclusive.

During the first ten days of the tests American and Canadian Amateurs will transmit signals for reception in England, France and Holland. The best American transmitters, as determined by reception reports from the European amateurs, will be selected to broadcast the result of the re-

transmitting periods, preliminary tests will be held from October 25th to November 3rd, inclusive.

Instead of requiring each transmitter desiring to participate in the finals to file an entry blank for preliminary tests as was done last year, we have adopted a scheme that will give every transmitter a chance to participate in the preliminary tests—by dividing two and one-half hours (9:30 P.M. to 12:00 midnight) into ten periods of 15 minutes each, during each of which 15-minute periods every test night every transmitter in each inspection district is entitled to transmit. All other districts are to copy signals from stations transmitting.

To qualify for an individual schedule and code letters during the final tests, a trans-

Trans-Atlantic Preliminary Test Schedule by Inspection Districts

P. M.	Oct. 25	Oct. 26	Oct. 27	Oct. 28	Oct. 29	Oct. 30	Oct. 31	Nov. 1	Nov. 2	Nov. 3
9:30-9:45	C	1	2	3	4	5	6	7	8	9
9:45-10:00	1	2	3	4	5	6	7	8	9	C
10:00-10:15	2	3	4	5	6	7	8	9	C	1
10:15-10:30	3	4	5	6	7	8	9	C	1	2
10:30-10:45	4	5	6	7	8	9	C	1	2	3
10:45-11:00	5	6	7	8	9	C	1	2	3	4
11:00-11:15	6	7	8	9	C	1	2	3	4	5
11:15-11:30	7	8	9	C	1	2	3	4	5	6
11:30-11:45	8	9	C	1	2	3	4	5	6	7
11:45-12:00	9	C	1	2	3	4	5	6	7	8

"C" Represents Canadian Amateurs. Time given is Central Standard.

ception of signals transmitted by English and French amateurs during the last ten days of the tests, the same as MUU and WII did for us last year.

We will transmit from 7:00 P.M. of one day to 1:00 A.M. the following morning, during the first ten days, and we will listen from 8:00 P.M. of one day until 2:00 A.M. the following morning in the second ten-day period.

That is the tentative plan for the final tests.

Preliminary Tests

For the purpose of determining the transmitters that are to be allotted individual

mitter must show documentary evidence that its signals have been copied at a distance of at least 1200 air-line miles during the preliminary tests. This evidence may be in the form of a post card received from a receiving station located at least 1200 air-line miles from the transmitter.

It may happen that one of our best transmitters is out of commission during the preliminary tests so that it would be quite impossible to produce a record card. In this event, an operator may file application for entry in the final tests by sending in at least two records showing that signals from his transmitter have been copied at a dis-

tance of at least 1200 air-line miles during the months of September or October.

The schedule for the preliminary tests is given in Central Standard Time, which is one hour behind eastern time, one hour ahead of mountain time, and two hours ahead of Pacific time.

Here's what to do during the preliminary tests:

Transmit your own call letters according to the preliminary test schedule for exactly 15 minutes. Start promptly and do not overlap. If you are located in the 5th District you will transmit from 10:45 P.M. to 11:00 P.M. on October 25th; from 10:30 P.M. to 10:45 P.M. on October 26th, and so on through the ten nights. Carry on your regular League traffic until 9:30 P.M., then QRX for the tests. Do not transmit tests at any other time than that shown on the schedule.

While one entire district is transmitting all stations in the other districts are to copy as many stations as possible. After the tests

each night, each receiving station should send a confirming record to every station that was heard at a distance of 1200 air-line miles or over. We will need all the receiving practice we can get before the final tests, as we hope to copy signals from English and French amateur transmitters.

Any station which can show at least one record of 1200 air-line miles or better during the preliminary tests or as mentioned previously, and desires to enter in the final tests, shall furnish the following information when making application for entry:

Complete name and address of owner and station; call letters; type of transmitter (spark, C.W., I.C.W., A.C.C.W.); wavelength; complete description of antenna with ground or counterpoise; power input; and antenna current.

Entries will be received up to noon of November 15th, 1922, but not later. Send your entry to F. H. Schnell, A.R.R.L., Traffic Manager, 1045 Main Street, Hartford, Conn.

Some Further Improvements in My Tuner

By John L. Reinartz, 1QP

TO make a thing better and more efficient from the amateur's viewpoint is always in order. With the gradual passing of the spark transmitter passes the broad wave, and this has made it possible for me to follow up some early experiments which had indicated that the very good points of the tuning circuit I evolved could be made even better if spark transmission ceased to be.

Our detector tubes are potential-operated and perform best when they have the greatest voltage variation delivered to the grid. This can be accomplished only by the elimination of shunting capacity across the grid circuit inductance. For best results the tuning should not be by means of a variable condenser across the secondary but rather by means of a large variable inductance. Therefore I advise those who have made a tuner following the design in March 1922 QST to remove the inductance in the set and make up and connect in its place a coil made as follows:

On a 3-inch-diameter tube wind 30 turns of No. 18 magnet wire, and insert at one end a revolving portion of 20 turns of No. 13 magnet wire wound on a standard tickler or vario-coupler rotor form, with the two windings connected in series so that tuning may be done by the variometer thus

formed. The antenna is connected to the bottom or starting point of the stator, and taps brought out every turn for ten turns and connected to ground as shown in the diagram, thereby providing the untuned antenna circuit as described in my previous tuners.

It will be noted that the plate inductance has been eliminated—it is not necessary

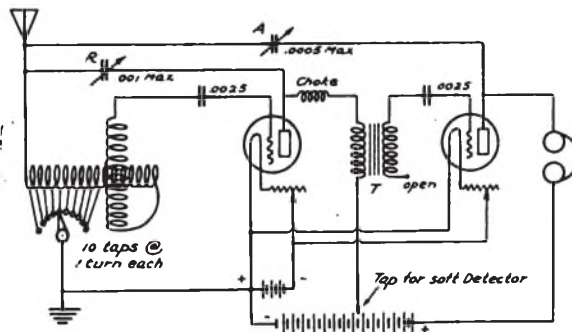

when the circuit is used as shown. In fact, even in the condenser-tuned circuit shown in QST for last March the plate inductance may be done away with if the spider-web coil is rewound with No. 18 wire so as to lower the resistance.

The above paragraph contemplates an

average amateur aerial. If a big aerial is used it will be desirable to wind a separate coil of 10 turns and place it at the bottom of the vario-coupler and connect into the plate circuit as was done in the March diagram.

The wave-length range of the set described is approximately 150 to 350 meters. If it is desirable to embrace the broadcast wave of 360 meters, a few more turns should be wound on the rotor. The grid condenser is a fixed mica of .0025 or .003 mfd. R is the regeneration-control condenser, a 43-plate variable.

Users will find this new circuit even better than my other two and I recommend it for use on 200 meters, at which it will function equal in audibility to any tuner made yet retaining the same ease of adjustment embodied in the other types. It seems to be so extremely conserving of voltages, however, that the detector grid is often paralyzed by spark stations within twenty miles, and if the builder is likely to have much nearby spark QRM the condenser-tuned model is preferable, simply because it delivers less voltage to the grid. Where spark interference is not bad, however, the new set will perform several times better.

I also wish to present an idea in audio-frequency regeneration shown in the amplifier circuit in this diagram. Audio-frequency energy is fed back capacitatively to the antenna circuit by a 23-plate variable condenser, A, from the anode of the amplifier, in much the same manner as condenser R controls the radio-frequency regeneration. The other necessary changes are the insertion of a mica grid condenser of .0025 or .003 mfd. in the lead to the amplifier grid and the omission of any connection from the low-potential terminal of the secondary winding of transformer T.

The main disadvantage of this circuit is that it is awfully rough on a pair of Baldies. It is easily equal to a two-stage audio amplifier at adjustments of condenser A which preserve the natural tone of the telegraph signal or which reproduce phone signals without noticeable distortion, yet by increasing the capacity of condenser A the tube will approach audible oscillation and an incoming telegraph signal may be made to "trigger it off" on its "howl-frequency" with an audibility which is little short of terrific. This action can be controlled exactly as desired by condenser A; if advanced too far the set will howl continually; at low values there is no tendency to howl but only undistorted audio-amplification; at some intermediate value the trig-

ger-effect is easily found. This feature is particularly helpful in C.W. reception, as the beat note of an incoming signal can be adjusted to equal the "howl-frequency" and thus disproportionately amplified, interfering signals on adjacent frequencies being pushed down into relative insignificance. The signals produced by this trigger-action are sharp and clean and without "whiskers."

I use an ordinary Acme amplifying transformer, a U.V. 200 detector with 16 volts on the plate, and a VT-1 amplifier with 90 volts.

I wish to take this opportunity to express my thanks to the hundreds of amateurs who have written their appreciation of the remarkable results obtained with the older types of tuners described by me, and I hope they will find their reward in better results from this newer type.

Editor's Note: It is impossible for us to keep up with this man Reinartz. Since preparing the foregoing for publication he has dropped around with another "trigger circuit" that knocks its predecessors cold.

Fig. 2 shows the arrangement, and just for old time's sake we have shown the March Reinartz tuner with condenser tuning, but minus the plate inductance which may be omitted if the other coil is wound with No. 18 wire or larger. R is the re-

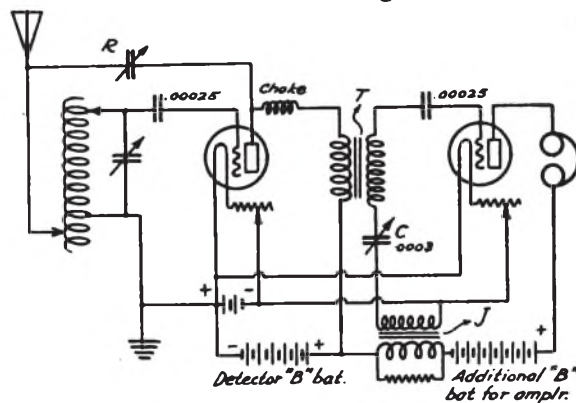

FIG. 2

generation control. Again we have a detector and a one-stage amplifier coupled by the audio transformer T. The secondary circuit of the amplifier contains the tricks, in the form of a second audio transformer, J, whose primary is in the plate circuit of the amplifier in series with the amplifier "B" battery and preferably located between the detector tap and the negative terminal of the additional "B" battery for the amplifier, as shown. The secondaries of the two amplifying transformers are in series with a small air variable condenser, C, say 7

plates, and with the completion of the circuit back to filament we have coupled the plate and grid circuits thru the transformers so that the tube will howl at an audio frequency, except that its tendency to do so may be controlled nicely by the throttle-condenser C.

This circuit, it should be noted, is *not* an audio regenerator. It is entirely valueless for phone reception. It is a sensitive audio oscillator which is "triggered off" by incoming signals, particularly C.W. signals. As a trigger circuit it is much better than Fig. 1 above, and the note or tone may also be controlled by the condensers. It is not critical as to type of tube, almost any kind working well in the amplifier. For transformer T Mr. Reinartz uses a Coto-Coil and for J a Jeffries. The primary impedance of J is too high, apparently, for this purpose, and results are greatly improved by shunting it with a leak of 2000 to 4000 ohms.

This arrangement gives terrific signals. Watch out for your ears in trying it.

We might as well convert this section of the magazine into a Reinartz Symposium. Several more interesting items respecting this very useful little tuner have come to hand and are presented hereinafter.

K.B.W.

Radio Amplification with the Reinartz Tuner

RECENTLY we mentioned that the Reinartz tuner had hit England and that its construction was described in detail in the May 13th issue of *The Wireless World and Review*. In the July 8th issue of the same magazine Mr. G. G. Blake gives a description of his own Reinartz set

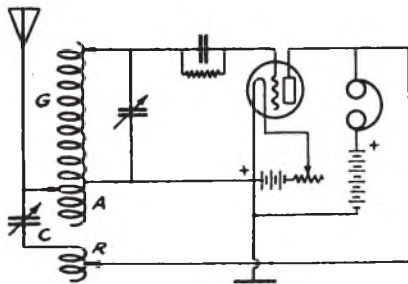

Fig. 1

to which he has added one stage of radio frequency amplification with great benefits. Mr. Blake says:

"It is one of the most selective tuners with which I have experimented, and almost entirely prevents jamming. I have listened

in amongst the shipping on an openly tuned set and heard several ships jamming one another, and have then changed over to the Reinartz Tuner and been able to separate them quite easily and hear the signals from any one of them without the least interference.

"Against this advantage of great selectivity, and the fact that it reduces atmospheric interference to a minimum, this set reduces the signal strength to about two-thirds of its original value, so that al-

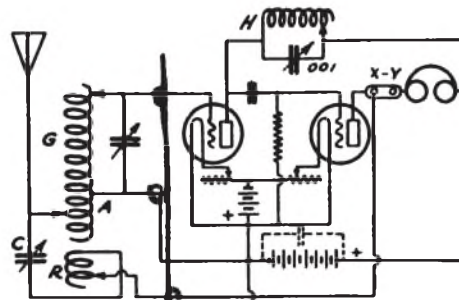

Fig. 2

though it is excellent for receiving loud signals or telephony from a powerful broadcasting station, it is of little use in picking up the weak telephony from amateur stations. To overcome this defect I have added one stage of H.F. amplification which has very greatly increased the strength of weak signals and telephony.

"Fig. 1 shows the ordinary single valve connections for a Reinartz Tuner. As this has already been fully described, the diagram needs no further explanation. It will be remembered that the grid inductance, aerial inductance, and magnetic reactance R are all wound on one former (and in the same direction).

"Fig. 2 shows the addition of one stage of H. F. amplification. This set is intended for the reception of telephony from the broadcasting stations and amateur short wave transmissions; its range is therefore anything from just below 180 meters up to 650 meters, and the number ofappings on the inductance is reduced to a minimum. All are wound with No. 22 double-cotton-covered wire on a 3 in. former. The grid inductance G has threeappings, one 20 turns from the point where the earth wire is attached to the inductance, one at the 35th turn, and the last one which is the end of the inductance is 50 turns from the earth.

"The portion of the inductance below the earth terminal marked A on the diagram is shown with an adjustable connection to the aerial. I find, however, in practice that a fixed 10 turns serves every purpose, as the aerial circuit functions aperiodically.

"Now, with regard to the magnetic component of the reactance circuit. In order to conform strictly to the Reinartz plan, R should be wound on the same former as G and A, except that owing to the addition of the second valve, the direction of its winding must be reversed. I have tried it wound in this way with a fixed 40 turns and obtained quite good results; but I have found it decidedly better to wind it on a separate former a little smaller in diameter than that used for the inductance, and fix it permanently just inside the aerial portion of the inductance. The best position which will suit all wave lengths is arrived at after the set has been assembled by setting the variable reactance condenser C, which should have a capacity of at least 0.001 mfd., at the midway point of its scale, and then introducing the reactance coil until reaction just occurs. After this, reactance is regulated entirely by altering the capacity of C.

"High frequency amplification is obtained by means of auto-transformer coupling. It will be seen that the plate circuit of the first valve contains an inductance H, tuned by the variable condenser (capacity 0.001). The inductance H is wound with 36 turns of double-cotton-covered copper wire, 16 gauge, on a 3 in. former. It is shown adjustable on the diagram, but in practice a fixed coil of 36 turns will cover the entire range of wave lengths for which this tuner is intended. This inductance H should be arranged at right angles to the grid inductance and as far as possible from it to avoid induction effects.

"Two terminals X and Y are shorted by a copper connector, and when it is desired to use the set in conjunction with an audio-frequency amplifier the connector is removed and X and Y are connected to the terminals of the amplifier's input transformer. It will be noted that the high resistance telephones are left connected in order that they may act as an impedance.

"The simplest method of tuning in a station is to buzz a wavemeter to approximately the required wave length, and having set the reactance condenser C just over half in, tune with the secondary condenser and the auto-transformer condenser simultaneously until the buzzer is most loudly heard in the telephones. It will be found that there is only one very sharp point on the scale of each condenser for each wave length. The signals are then brought up to the loudest possible value by varying the capacity of the reactance condenser C. Having tuned in the wavemeter its buzzer is stopped, and a very little further variation of the other two condensers brings in the signals from the distant station."

It surprises us to discover the Reinartz tuner favorably commented upon for its sharpness of tuning. Personally we have not found it so, particularly when some-

thing like 10 turns is included in the antenna circuit as advocated by Mr. Blake. In fact, we use ours ordinarily with either 1 or 2 turns in the aerial circuit and the tuning, while much better than the ordinary so-called single-circuit tuner, does not compare in sharpness with a three-circuit tuner. Nor have we ever been particularly entranced with the action of the Reinartz set in the reception of telephony; our chief endorsement of it is in the reception of C.W. telegraph signals where its smoothness and ease of adjustment are such as to make possible the handling of A.R.R.L. relay traffic on C.W. with even greater ease than ever spark traffic was handled on a three-circuit tuner.

But for whatever purpose the many builders of Reinartz tuners use them, we believe this simple explanation of the addition of a stage of radio-frequency amplification will be interesting and helpful.
—K.B.W.

Simple Audio Regeneration

NOW comes one John L. Reinartz who, being duly sworn, deposes and says that he knows an easy method to double the strength of signals received on a Reinartz tuner.

It does all of that, and it is easy. Altho the method probably is applicable to almost any kind of tuner, its special application is to the Reinartz because in that tuner the audio and radio circuits are separated. The idea is to introduce a little audio regeneration—see the diagram.

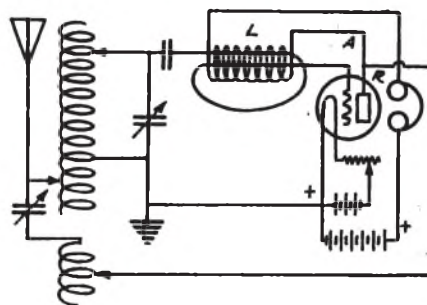

The anode-voltage supply in the Reinartz tuner is in shunt to the radio regeneration circuit—from the anode one connection R leads to the tickler inductance and reaction condenser, while another connection A supplies the energy from the B battery, in series with which are the telephones. This phone circuit thru A is an audio circuit, and into this path is introduced an air-core winding L, of considerable inductance. It may be the secondary from a small spark-coil or some similar winding of many turns. Such windings generally are of fine wire, involving considerable resist-

ance, but coils with resistance as high as 2000 ohms have been used with excellent results.

Thru this inductance L the audible telephone currents flow. If then this coil be brought in inductive relation to the grid lead, audio regeneration will occur. The grid lead may be threaded thru the center of the coil with improved results. If it be wound thru the coil for two or three turns, still better effects generally are obtained. In other words, the coil L is the primary of an audio-frequency feedback transformer, the secondary of which is formed by the turn or two of grid lead which is threaded thru it. Too much reactance can not be used in the grid circuit, as it is primarily concerned in conveying

the radio-frequent impulses to the grid, but the number of turns can be determined easily by experiment—it is that number that gives the loudest signals without distortion and without affecting the control of the radio-frequency circuits.

This is only one of many valuable little stunts which may be done on the remarkable Reinartz tuner. To such of our readers as have not been impressed by it heretofore we again commend it for C.W. reception and refer all hands to the description in QST for March, 1922.

K.B.W.

(Altho this article was written prior to Mr. Reinartz' on pages 12-13, it describes a tested method and we decided to present it too.)

Another Month of Super-Regeneration

By K. B. Warner

ANOTHER month of experimenting with the fascinating business of super-regeneration has passed. In close touch with amateur work the country over, as we are, we cannot feel that the progress has been particularly satisfying. Very promising results have been got in certain directions, tho, and at least we are able to prophesy that in another month we will have news. QST's contest for the best descriptions of super-regenerative sets closes October 1st and we have enough reports in hand to justify us in saying that our prizes will be well awarded and, what is more, that directions for getting real results will be available then.

Over most of the country success has been rare. The average super set is a reproduction of Mr. Armstrong's "Case II" set described at the R.C.A. meeting and frankly intended for broadcast reception. Perhaps it should not be particularly surprising that it brings in concerts very QSA over jumps of about 25 miles and is a dismal failure in DX. Occasionally a skillful operator will get a DX fone on it but no DX sparks are reported. Long distance amateur C.W. is copied, to be sure, but it seems in spite of the super effect rather than because of it. This particular arrangement so far has proved entirely unsatisfactory for amateur work and in our opinion is not worth while, even with the improvements described in two articles in September QST, except for the remote chance that it may lead to some helpful discovery.

It goes without saying that we amateurs don't want to waste money with a super arrangement which is expensive, noisy and critical, when our simpler regenerative sets are superior. However, if we can improve our present sets so that the super effect is

obtainable therein, particularly if this can be done with small effort and in a controllable manner, that is "something else again." *The one-tube super is making good!* This is especially gratifying because it means that our present tuning arrangements may be retained, methods with which we are already fully familiar, and the only additional equipment needed is some means for generating the "variation frequency" and introducing it into the circuit. Such sets are in operation today on regular amateur aerials, and in at least a couple of cases are bringing in the DX to beat the cars. The one-tube circuit is the most promising by any odds.

There is certainly opportunity for experiment here. Bearing in mind that the idea is to supply the regenerative amplifier with a second or "variation" frequency, numerous schemes present themselves to mind. In his first and second cases, Mr. Armstrong uses a separate tube to generate the variation frequency; on page 25 of September QST a circuit was suggested employing a buzzer or chopper for this purpose; one experimenter we know is using a separate oscillator tube connected to an ordinary iron-core audio-frequency amplifying transformer whose secondary is connected in the detector grid circuit with a by-pass condenser across it; and at least one chap is making the "souper" work with not a single piece of extra equipment! He has his tickler tightly coupled and turns on the filament current; as the rheostat is advanced a click is heard as the tube goes into oscillation; the rheostat is turned further and a second click is heard, accompanied by a squeal, the squeal which by this time is recognized as one of the accompaniments of most super arrangements. Indeed in this

case it is a true super-effect, for this set with no loop nor aerial and using only a 2½-inch coil has brought in DX amateur CW in New England from as far as the 4th and 9th Districts. It is very interesting to consider what is taking place in this set. For some reason the tube howls, a condition normally extremely obnoxious. We don't know whether the frequency is determined by the inductance of the phones with their shunt capacity or whether it is because the grid leak is too high a resistance for the grid condenser used; at any rate when the tube is "crowded" it squeals. This squeal constitutes a second or variation frequency in that circuit, and it produces the super-regenerative effect just as nicely as if it had been elaborately generated in a separate oscillator and painstakingly introduced into the detector circuit thru a vernier coupling control. By adjustment of the rheostat the audibility of the squeal may be reduced to where it is not bothersome, and after the first few hours it is hardly noticed. The use of a separate detector coupled to the first tube by a radio-frequency pick-up coil should eliminate it entirely but it has not been considered worth the effort.

The efforts of most experimenters with the one-tube circuit have been in the direction of giving the tube a second frequency by introducing coupled "variation-frequency circuits" into the grid and plate leads. This is done with the usual honeycomb coils and big condensers. Instead of tuning condensers across each honeycomb better results are had by shunting a single large variable across both coils as shown in the diagram herewith. How the radio frequency currents find their way to filament is a mystery, but they do. This circuit acts very much like our ordinary regenerative with a stage or two of R.F.A. ahead of it; it brings in signals inaudible on a two-stage A.F. amplifier, brings in weak signals much better, and doesn't amplify very strong signals as much as A.F.; tube noises are almost nil; and static audibility, on an aerial, increases with the signal amplification and not like it would on A.F. amplification. The adjustment of the variation-frequency circuit can remain undisturbed over the entire amateur band.

Mr. A. L. Groves, 3BID, originator of this arrangement, says that with the variation condenser at low values the set acts like an ordinary regenerator preceded by just a little radio-frequency amplification—it is sharp, perfectly quiet, and will receive spark, phone, or C.W. equally well. Increasing the variation condenser, the tickler coupling, and the capacity across the tickler, the amplification increases rapidly, sparks getting louder and louder, becoming scratchy and finally disappearing altogether; phones become louder, at length to

jumble up and disappear, and only the C.W. telegraphy is left, and it may be brought up to an audibility limited only by the tube and a practical limit set by the static obtaining at the moment. With increasing amplification the broadness of tuning increases markedly, but as only C.W. is received at such adjustments this is no handicap. And in spite of such amplification Mr. Groves insists that its DX is better than its QSA—he is copying dozens of DX C.W. stations in daylight on a Meyers tube with 90 volts on the plate. 3BID says he is never going back to the plain regenerator—which is the biggest boost we have as yet heard for the Armstrong Souper.

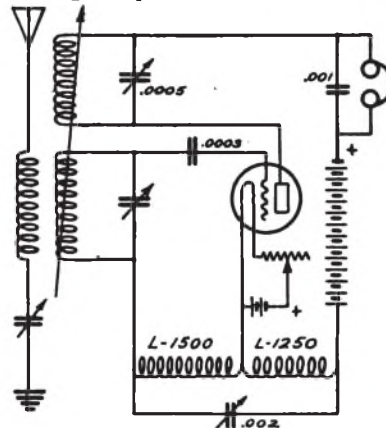

Incidentally, we dislike to believe that the effect of super-regeneration is attributable to variation in the resistances of the circuits. To our mind it is much more logical to consider that the variation frequency shifts the locus of tube action to a different point on the characteristic curve or to an entirely different curve, or both.

Consider the familiar "Case II," where the positive resistance of the grid circuit is said to vary at variation frequency. In this case the variation frequency is present as an A.C. voltage of a second frequency, impressed upon the grid of the regenerative amplifier. As we see it, this variation-frequency voltage actually displaces the axis of grid oscillation from its normal point and varies it between two other points on the curve, where, for example, the tube may first be permitted to oscillate and create an undistorted amplification, and then be shifted either to a point on a bend in the curve where rectification takes place and where oscillation is choked out because the energy is insufficient to overcome the circuit losses, or even to a negative region where the plate current is completely cut off. The rapid variation between these two conditions would serve to amplify without uncontrolled oscillation in a manner otherwise as explained by Mr. Arm-

strong. Examination of this theory will show that the proper bias for the grid of the regenerative amplifier is a value midway between the point of best detection and the amplification point that can be reached by the available variation-frequency amplitude, and will show the necessity of using tubes of a type capable of performing this shifting of grid biases without permitting the grid to become positive with respect to the filament.

In "Case I," where the negative resistance of the plate circuit is said to be varied, it would seem that on the contrary what happens is a variation of the plate voltage at variation frequency. This plate voltage variation is introduced by the plate circuit of the oscillator tube, and is capable of varying the potential on the plate of the regenerative amplifier between, say, twice its normal value and zero. The result is that the regenerative amplifier shifts, at variation frequency, to totally different characteristic curves, and the effect is much as in the previous case—for example, the action might shift between a point on a bend in the curve, automatically providing rectification thru distortion, and where the energy is not sufficient to overcome the losses in the circuit and permit oscillation, and another point well in the straight portion

of the curve where undistorted amplification and free oscillation are permitted.

All this may be exactly what is contemplated in the explanations of the variation of resistances, but we cannot satisfy ourselves that the supper effect can be obtained by a resistance effect entirely diassociated from changes in the grid-voltage-plate-current characteristics of the tube. In fact we see no manner of analyzing the problem that can escape the fact that the regenerative amplifier also does the detection, which, it goes without saying, is at marked variance with Mr. Armstrong's explanation.

"Case III," where both the positive and negative resistances are said to be varied, unravels into a combination of shifting grid axes and impressed plate voltages which shift in value. We confess an inability to visualize the plate current in such a circuit.

Mr. Boyd Phelps, assistant editor of *QST*, shares the writer's guilt in this new conception of the action of super-regeneration. The whole thing probably will come out in the wash some day.

Next month we will announce the winners in our Super-Regeneration contest and present the First Prize manuscript. We believe it will be a very valuable article to the amateur.

A 122-Foot Tower

By LeRoy Moffett, jr., 5ZAV ex-5HK

I BELIEVE one of the most necessary parts of a DX station is the antenna system. It will be found that most well-known DX stations have a properly designed antenna system.

One of the most important considerations is to have a higher center of capacity and this means a high support for the antenna. Altho self-supporting towers for this purpose cost more than guyed masts, I believe they are better in the long run because of the area necessary to guy a good mast and because of the energy absorption by the guy wires.

The tower described in this article has a square base 20 ft. on a side, the corners resting on concrete pillars. These concrete pillars are about 9 ft. deep in the ground, 4 ft. square at their bases tapering to about 18 inches at the top, and each one has a 6-inch pipe about 8 ft. long imbedded in it and protruding about 9 in. above the concrete. Three or four holes are drilled in the top of each 6-in. pipe to pass lag-bolts for fastening down the legs of the tower.

The actual construction of the tower is of 5x5-34' fir timbers originally intended for making oil derricks but ideal for our purpose. Their actual dimensions were 4 1/2 x

4 1/2 by 34 1/2 to 35 ft. long. They should be given one or two heavy coats of good paint.

The top pole should be a good straight timber free from knots. Starting about 10 ft. above the bottom the corners are knocked off by means of a draw-knife, making it octagonal in cross-section. A pulley should be securely fastened to its top.

The timbers in the tower construction are fastened together by means of 5/8-in. bolts 10 inches long at the bottom of each

joint and by a U-piece clamped around the top of joint, as shown in the detail sketches. The lap at each joint is 3 1/2 ft. A set of four cross-pieces is necessary at each joint, and these are the same 4 1/2 x 4 1/2 material. These four pieces should be 12 ft. long for the first set and 5 ft. long for the second. At the top of the tower proper

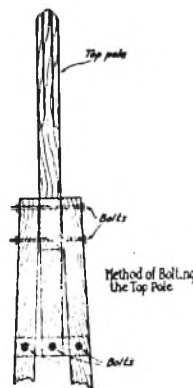

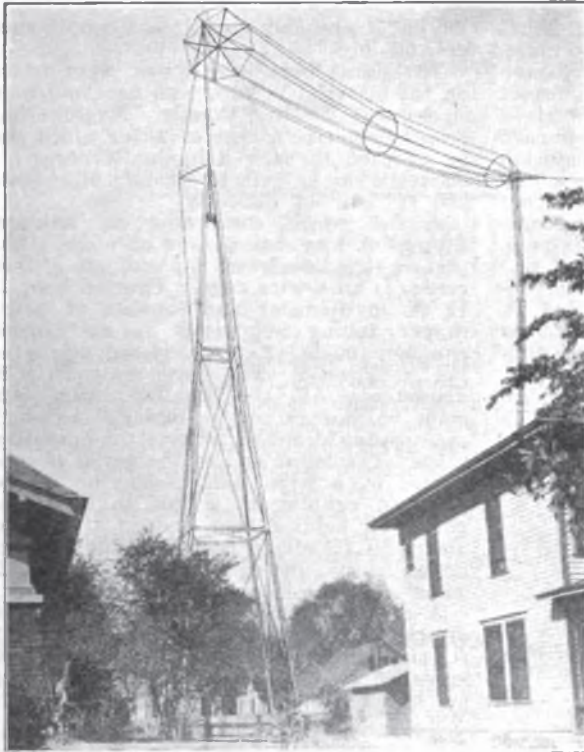

By comparing the photo and the working drawing an excellent idea of the construction of this tower may be gained.

the four corner timbers are held together by means of 15-in. bolts passing thru one of the timbers, then a block, and then thru the adjacent timber. About 7 ft. below the tower top a footing for bolting the bottom of the top-pole is constructed by bolting 4½x4½ blocks to the legs.

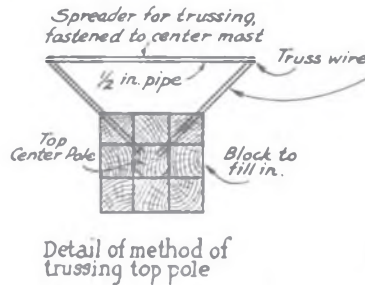

The following is the procedure observed by us in the erection of this tower. First a 34-ft. stick was set up as a temporary gin-pole, by which a 65-ft. section was raised consisting of the bottom and intermediate sticks forming one corner of the tower. This 65-ft. section was then firmly guyed and in turn used as a gin-pole for raising a 96-ft. section comprising one entire side-member of the tower. (The 34-ft. gin-pole was then taken down). The 96-ft. section was then guyed and a 12-ft. cross-piece bolted between it and the 65-ft. section at the first joint. The other two 96-ft. sections were next raised, each being set on its individual base, the lag-bolts screwed in to hold it firm to the pipe bases, each guyed at the top, and the 12-ft. and 5-ft. cross-pieces run across to the adjoining sections and bolted up.

We now have up three 96-ft. sticks and one 65-ft. stick, with four 12-ft. cross-pieces and four 5-ft. cross-pieces in place, and are now ready to string the brace wires. These are made by twisting four strands of No. 10 galvanized wire together, but a good cable may be used. Sixteen of these about 40 ft. long are needed, also two about 16 ft. long and two more about 8 ft. long, all fitted with husky turn-buckles. Each panel in the bottom two sections is trussed by stretching these cables cornerwise between the two adjacent poles of each section, and the shorter cables are run diagonally across to opposite sticks at the 34-ft. and 65-ft. levels, parallel to the ground, to keep the tower from twisting out of square.

The top stick of the fourth side of the tower is now ready to be put in place. This is done by attaching the block and tackle at the 96-ft. height, taking hold of

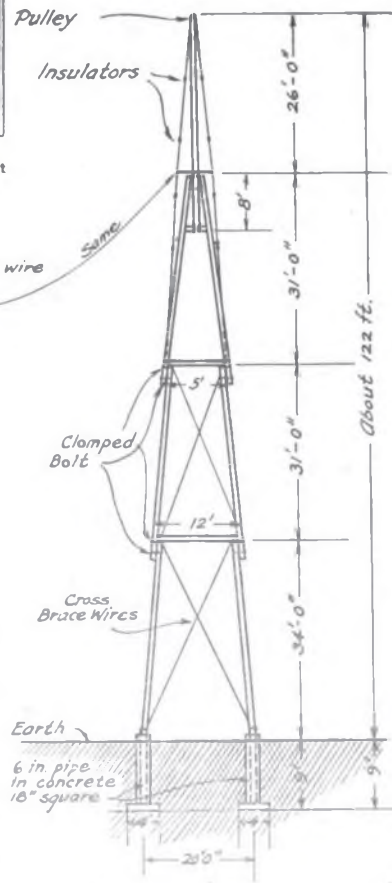

the stick a little above its center, and hoisting it to position, where it is bolted in place. No brace cables are necessary in this top section. This completes the four sides of the tower. The tops of the sticks are held together by running 15-inch bolts from each timber thru 1-ft. blocks of the 5x5 material, as shown in the detail sketch, in such a way as to provide a square top about 14 inches on a side with a square hole in its center about 5x5 thru which the top-mast can pass. All four sides are securely bolted in this manner. The four short cross-pieces previously referred to are then placed 7 ft. below this and a fifth piece bolted across two of these so that the bottom of the top-mast can be fastened in place.

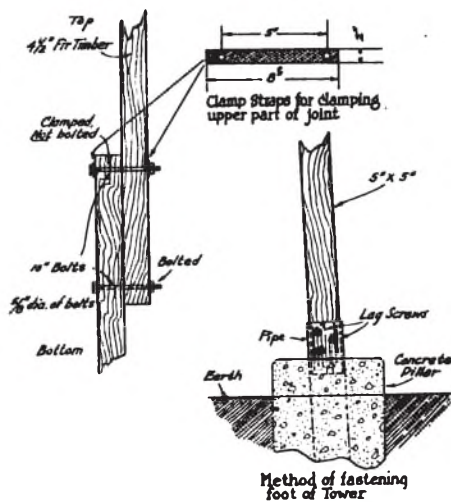

Now we are ready to raise the top piece. Fasten the tackle to it and raise it up inside the tower to the 96-ft. level and temporarily fasten it in place with a few feet protruding thru the hole in the top of the tower while the truss wires are put in place. There are two of these cables, fastened to the top of the top-mast and brought in to the 65-ft. level, trussed out from the top-pole on a frame of 1/2-inch pipe so as to form the two corners of a square on the side away from the pull of the antenna. The tackle is then attached lower down on the top-mast and it is hoisted up in place and fastened in its final setting and the truss wires tightened up. These should be well broken up with strain insulators. Flexible quarter-inch cable is used for the aerial halyard. The top-mast can be easily let down if trouble is experienced with the pulley, etc.

To put up a tower of this kind requires the services of two laborers and one man to superintend the job and do the climbing. The timbers in it cost \$4.30 each. At present I haven't the complete cost of the

job but it probably runs into a couple hundred dollars.

The dimensions here given were based on the material in hand and need not necessarily be followed exactly. My idea has been to describe a type of tower which can be adapted to each individual's needs. I believe it can be built to a height of at least 150 ft. without difficulty.

A few words concerning my antenna equipment may not be out of place. The present one, designed for use on a Z-license, is an 8-wire cage. The top hoop is 11 ft. in diameter and consists of 1/4-in. copper tubing supported by an 8-point spreader made of four crossed sticks of 1 1/2 x 3/4 wood. The lower hoop is 3 ft. diameter. All the smaller hoops are made of 3/8-inch copper tubing. A 7-inch cage lead-in drops directly to the operating room. The lower end of the aerial is supported by a wire, well broken up by insulators, running to a tree in the front yard and holding that end of the aerial about 60 ft. above ground. The over-all aerial length, including lead-in, is 140 ft. (For special-license station—Ed.)

A counterpoise of 17 wires is suspended directly under the aerial at a height of 9 ft. above ground, supported from a 14-ft. spreader at the station end and fanning out to a spread of 40 ft. at the far end.

New Books Received

"Elements of Radio Telephony," by Wm. C. Ballard, Jr., Asst. Prof. of Electrical Engineering, Cornell University; 132 pp., 5 x 7 1/2; McGraw-Hill Book Co., Inc., New York; \$1.50.

An elementary little volume written on the tide of popular interest in broadcasts to tell in simplified form what happens when messages are sent and received, what the apparatus is like which produces these effects, how it operates, and what apparatus is necessary. The accomplished amateur already knows most of the things said in this book but we should remember that it wasn't written for us. For the novice it is excellent. It will let him know what happens in his apparatus when he turns the knobs and will answer his growing technical questions as he progresses towards amateurdom.

"How to Retail Radio," by the Editors of "Electrical Merchandising," 226 pp. 5 1/2 x 8 inches; McGraw-Hill Book Co., Inc., New York.

All about how to sell radio apparatus to folks who don't know anything about it, even if you don't know anything about it yourself. The authors take themselves seriously, however, and altho as amateurs (Continued on page 29)



WELL, well, well, Brethren and Cistern, did you read last month about QST's Subscription Contest? We're conducting a REAL one. We want more folks to know about us and our A.R.R.L. and we're making it immensely interesting for our amateur members who will help us get them. In our September issue we told the story in all its hair-raising details, about how we are knocking all previous subscription-contest records for a row of stupid-degenerators by offering a whole string of

50 PRIZES TOTALLING \$2000.00

The contest runs for quite a spell so if you haven't climbed on the band-wagon yet there is still plenty of time to ride to glory with us and share in the fun. We figure that our ten thousand A.R.R.L. members who know all about QST are capable of forming themselves into a squadron of subscription-takers which will put your eye out. As material for these ten thousand men to work on we have a field of a couple of million radio fans who are interested in radio and blindly floundering around trying to find a radio magazine which will do something besides show them pretty rotogravure pictures of broadcast entertainers—a magazine which tells them something interesting—all primed waiting for one of our gang to present a copy of QST for inspection and take their subscription for a year or two. With the opening of the fall season and the return of cool weather this is a most propitious time for a contest and we think thousands of subscriptions can be got for the asking.

Of course it goes without saying that we can't afford to give away all this money unless we get the subscriptions but we know they can be got and so we're perfectly willing to set aside so much from each sub the same as if it were commission to a regular agent, and apply the fund thereby created to the purchase of prizes for the fellows who do the work for us—A.R.R.L. co-operation.

HERE'S THE DOPE

What do you need for your station? Whatever it is, QST proposes to buy it for you. We're going to buy \$2000 worth of

America's best radio apparatus from QST's advertisers and give it to the winners in our contest. We don't know what it's going to be—it's going to be what YOU want. We're not going to offer a transmitting set as first prize and a receiving set for second prize because the fellow who wins first prize may need a receiver badly and not need a transmitter at all—we're going to let *him* be the picker. Whatever he wants is his. In other words, the \$2000 in prizes will be awarded in the form of any desired radio apparatus selected from the catalogue of QST's happy family of advertisers. The distribution is as follows:

Grand First Prize, \$300 worth of apparatus			
2d Prize	\$200	"	"
3d Prize	\$150	"	"
4th Prize	\$100	"	"
5th Prize	\$100	"	"
6th Prize	\$100	"	"
7th Prize	\$75	"	"
8th Prize	\$75	"	"
9th Prize	\$75	"	"
10th Prize	\$75	"	"
11th Prize	\$50	"	"
12th Prize	\$50	"	"
13th Prize	\$50	"	"
14th Prize	\$50	"	"
15th Prize	\$50	"	"
16th Prize	\$25	"	"
17th Prize	\$25	"	"
18th Prize	\$25	"	"
19th Prize	\$25	"	"
20th Prize	\$25	"	"
21st Prize	\$25	"	"
22d Prize	\$25	"	"
23d Prize	\$25	"	"
24th Prize	\$25	"	"
25th Prize	\$25	"	"
26th Prize	\$10	"	"
27th Prize	\$10	"	"
28th Prize	\$10	"	"
29th Prize	\$10	"	"
30th Prize	\$10	"	"
31st Prize	\$10	"	"
32d Prize	\$10	"	"
33d Prize	\$10	"	"
34th Prize	\$10	"	"
35th Prize	\$10	"	"
36th Prize	\$10	"	"

37th Prize	\$10	worth	of	apparatus
38th Prize	\$10	"	"	"
39th Prize	\$10	"	"	"
40th Prize	\$10	"	"	"
41st Prize	\$10	"	"	"
42d Prize	\$10	"	"	"
43d Prize	\$10	"	"	"
44th Prize	\$10	"	"	"
45th Prize	\$10	"	"	"
46th Prize	\$10	"	"	"
47th Prize	\$10	"	"	"
48th Prize	\$10	"	"	"
49th Prize	\$10	"	"	"
50th Prize	\$10	"	"	"
	\$2000			

Say, O.M., what would you do if you were told you could have \$300 worth of new apparatus? We're going to be real mean and tempt you. Do you know that \$300 will buy you everything you can think

big hundred dollars, and a hundred dollars means a pile of apparatus when a fellow makes up a list of what he needs—it isn't many of us who can drop casually into a supply store and buy a hundred dollars worth of apparatus whenever the fancy strikes us. Yet nothing will give *QST* greater pleasure than to send \$100-worth of equipment to you—stuff of your own picking. By the way, O.M., how'd you like to have a nice lil C.W. set with four 5-watt tubes—you know, perfectly capable of covering from 6ZAC to French 8AB under the right conditions—how'd you like that? Parts for a mighty nice one, including tubes and meters, for a hundred washers. Even if you won tenth prize and wanted such a C.W. set, the \$75 tenth prize is still enough to buy almost everything necessary.

What do you think of super-regeneration? Or have you your doubts about this radio-frequency amplification stuff? Would

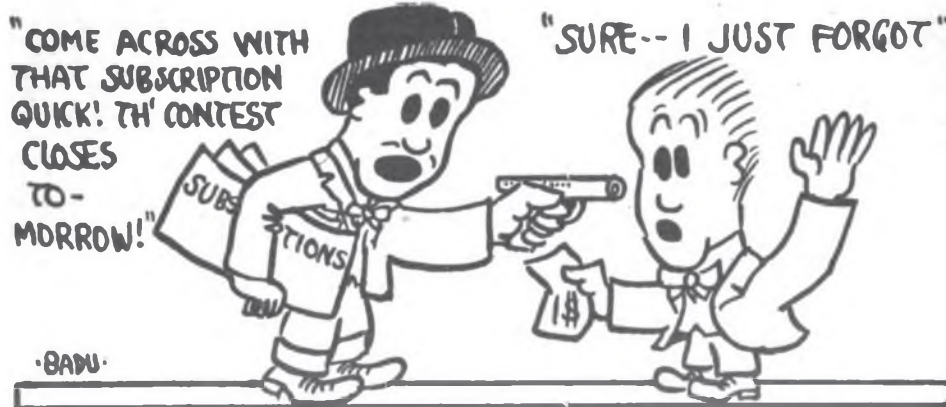

of for a 100-watt C.W. set—tubes, sockets, motor-generator, transformer, meters, everything from soup to nuts? Or, supposing you have an A1 transmitter, stop a min and consider that a super-heterodyne wouldn't make a bad receiver for this next winter and reflect upon the fact that \$300 will buy everything that the human mind can devise in the way of parts for rigging up a real one! Or suppose you are a laboratory hound but need the jack for some real meters and precision instruments—some real condensers and some inductance standards and a capacity meter and things that you dream of but don't know when you're going to get—*QST* is perfectly willing to hand them to you on a silver platter for a little hard work on your part. Think of the third prize, even—if you need anything in ordinary receiving equipment, for example, that will buy you the finest short-wave regenerative tuner in America and add a bang-up good two-step amplifier to the bargain. Suppose you didn't win anything higher than sixth prize, it's a whole

you like to try them and see for yourself? Costs money to experiment—unless you let *QST* buy your stuff for you. Just think—even down to the fifteenth prize the amount is \$50.00!

You see, fellows, it's you chaps who are practical amateurs to whom we are making this offer—you're the folks who need apparatus and at the same time you're the ones who can get out and tell the world about *QST*. Do you get our idea? We're not offering you a nice pretty rotary gap for a prize when mebbe you junked the spark a year ago—we're letting you DO YOUR OWN PICKING—but by heavens if you want a spark set all you have to do is hump a little and we'll send you a Type E transformer and a made-to-order he-gap on a big synchronous motor and a condenser that will hold the beast and an oscillation transformer out of 1-inch copper pipe and a barrel of porcelain insulators for an antenna—just let your imagination run riot: you can't think of anything we won't get for you if you'll do your part.

Even if you live in a little village and your possibilities are extremely limited, we're offering a total of FIFTY prizes and surely there's lots of room for you. Even those last prizes are worth \$10 and that means that for a very small effort on your



DON'T MISS LINING UP EVERYBODY AT THE CLUB

part you can have the makings of a step of amplification or that meter you've wanted, or a couple more tubes, or a REAL pair of phones—doesn't make any difference to us.

MINIMA

Now about those "threshold minima"—of course we have to require a minimum number of subs to qualify for the various prizes, as we can't afford to let some bird walk away with our \$2000 for ten subscriptions. The First Prize goes to the contestant turning in the greatest number of subscriptions, the Second Prize to the one with the second greatest number, and so on down to the Fiftieth Prize, BUT—In order to be eligible for the Grand First Prize of \$300 you must turn in at least 500 subscriptions.

In order to be eligible for the Second Prize of \$200 you must turn in at least 400 subscriptions.

In order to be eligible for the Third Prize of \$150 you must turn in at least 300 subscriptions.

In order to be eligible for Fourth, Fifth or Sixth Prize of \$100 each, you must turn in at least 200 subs.

To be eligible for any of the four \$75 Prizes, Seventh to Tenth inclusive, you must turn in at least 150 subs.

For any of the five \$50 Prizes, Eleventh to Fifteenth inclusive, you must turn in at least 100 subs.

To be eligible for any of the \$25 Prizes, of which there are ten from the Sixteenth to Twenty-fifth inclusive, you must turn in at least 50 subscriptions.

To be eligible for any of the twenty-five \$10 Prizes, numbered from Twenty-sixth to Fiftieth, inclusive, you must turn in at least 25 subscriptions.

In our previous subscription contests our Main Prize has been \$50. Just think—in this one the prize values even down to the Fifteenth Prize are as high as \$50.00! If we offered merely the last 36 prizes listed, this would be better than any of our previous contests, but we've added 14 bigger prizes running into real money for the men who mean business.

Now let's put all of these ideas into the form of regulations to govern the contest:

RULES OF THE CONTEST

(1) This contest is open to any member of the A.R.R.L., but only to members. Entries will be received only from individuals.

(2) The contest opened September 1st and will close at midnight on November 10, 1922. To be fair to contestants in the western states, subscriptions addressed to us may be placed in the mails in your town up to midnight of that date—the cancelling stamp of your post-office will be the guide. Subscriptions filed in the mails after midnight of Nov. 10th will not be counted.

(3) Fifty prizes totalling \$2000.00 in value will be awarded as hereinbefore described, subdivided as we have listed; and in order to qualify for any prize listed the minimum number of subscriptions specified therefor must be turned in. The right is reserved to withhold any prizes not qualified for by the submission of the specified minimum of subs.

(4) Only full-year subscriptions at \$2.00 each will be received in this contest. They may be new subscribers, renewals, or



MAKE IT BE YOUR NAME THAT THE EDITOR PUTS ON THIS ORDER

extensions of existing subscriptions. Full amount must accompany the filing of all subscriptions.

(5) To enroll in this contest, submit your name and address to the Contest Manager, QST Subscription Contest, 1045 Main St., Hartford, Conn. You will be sent immediately a few sample copies of QST and a supply of special subscription blanks. All subscriptions must be filed on these special blanks, which must bear your name in order that proper credit can be given you. Try to anticipate your needs for further blanks by requesting them sufficiently in advance, but if you run short WIRE US.

(6) The prize winners will be announced in *QST* for December. The value of the prizes will be awarded the respective winners in the form of any apparatus, equipment, supplies or parts which they may select from the catalogs or advertisements of any *QST* advertisers, and will be delivered without expense to contestants. If a contestant desires apparatus valued in excess of the prize won, *QST* will purchase it for him if he will deposit the difference in value with us.

Fellows, this thing is a cinch! The country is lousy with folks wildly interested in radio and you ought to get subscriptions from every one you meet in not more than two minutes. Every aerial marks at least one prospect! *QST* will do these folks worlds of good, because they're looking for



something nowadays that will answer their questions and not merely amuse them with pretty pictures, yet they've never been told about *QST*. That's all you have to do. Every little village has a hundred or more of them and in the cities they run into the tens of thousands—really! You've seen hundreds of single-wire aerials as you go about your home-town, haven't you? Put some sample copies under your arm, your sub blanks in your pocket, and armed with your best smile you drop around and see these folks. Presto! a subscriber—just like that! You don't have to know them—you're not limited to your personal friends—your prospects have a sign hanging outside the house right now—every aerial means a ten-to-one shot for a sub.

Then think of the crowds around the radio supply stores at noon—go get 'em! And the membership of your radio club, which is many times what it was when we held our previous contests—line 'em up; your amateur friends—get them to help you, solicit their own renewals to *QST*. Do you know that the winner of the First Prize in our last contest lived in a very small

town and won first honors by taking subscriptions from all his friends *over the air*? You can do that too. Why, when we ran our last dinky little contest it was a hard job to sell subscriptions; of course every radio amateur would subscribe but you had to dig to find folks outside the amateur class who were interested; once in a while you would find that your doctor or minister had a streak of wireless interest but it was rare. To-day? Shucks, there're MILLIONS of them!

QST's idea in this contest is to provide intensely interesting possibilities for the contestant in every kind of locality and particularly appealing incentives for real workers. Have you spare time which you would like to turn into radio-cash? Here's your chance. Are you out of work and yet wild to get some new stuff for this winter? Oh boy, here's your meat! In fact, daggone it, we aim to make this contest so interesting that it's worth any ham's time to take a week off and do nothing but work for us—it's awfully hard to earn \$300 in a week any other way. If you're serious about this thing you can think of dozens of ideas which will help you: you're not necessarily limited to your own home town; borrow the family fivver some day and chase over to the near-by towns and go over them with a fine-tooth comb too, and don't miss any aerials on the drive over; and what's the matter with a little ad in your home-town newspaper, if you mean business?; there's no limit to the possibilities!

IT'S NOT TOO LATE

The announcement of this contest is just out as we write these lines. Each mail shows that about a dozen more fellows have decided they'd like to have *QST* help outfit their station for this winter. Is your name entered as a contestant, O.M.? If not, it's high time you got in on the swim. Here's the chance of a lifetime. Don't let it get by you. It isn't too late, because there are plenty of prizes and actually millions of prospects, and the contest doesn't end until November 10th. We believe that any man who reads these lines can go out and get a hundred subscriptions in a few hours. Honest, it's just that easy—try it.

Man, dear, this is the chance of a young lifetime. It isn't every day in the year that somebody offers to buy you whatever you want for your station, yet—we repeat it—we WANT to. All you have to do is hump a little. Drop a postal at once to the Contest Manager and ask to be enrolled and to send you some special subscription blanks PDQ first-class mail and meanwhile start lining up your friends. You'll be sorry if you miss this opportunity. Can we send the blanks?

CONTEST MANAGER,

**QST Subscription Contest
1045 MAIN ST., HARTFORD, CONN.**

Multi-Stage Amplifiers

By M. C. Batsel*

A Paper Presented before the Radio Club of America,
Columbia University, New York

SEVERAL methods of coupling the successive tubes of multi-stage amplifiers will be discussed. The uses of each type including the useful frequency range will be mentioned.

When considering the design of an amplifier the first thing to be determined is the type of tube to use. A complete set of plate-current—grid-voltage and grid-current—grid-voltage curves for different plate voltages should be obtained, also the internal plate-filament circuit impedance vs. plate voltage obtained. From these curves the plate battery voltage and negative grid voltage necessary for the proper operation of the tube as an amplifier can be obtained.

Figure 1 shows some curves of an amplifier tube. The grid must have a sufficient negative D.C. voltage applied to it to insure that the maximum amplitude of A.C. voltage to be applied to the grid will not cause the tube to take grid current. Sufficient plate voltage must be used to produce a fairly straight plate-current—grid-voltage characteristic but must not be so high as to produce saturation.

Resistance Coupling

The resistance type of coupling between tubes will be considered first. Resistance coupling has much to recommend it when amplification absolutely without distortion is necessary. The value of resistance coupling in this connection is due to the fact that the amplification is independent of the frequency. This is true at least for all audio frequencies if the coupling condensers are properly proportioned.

A resistance-coupled amplifier circuit is shown in Fig. 2.

Tubes to be used in resistance-coupled amplifiers should have a reasonably high voltage-amplification factor. A high voltage-amplification factor means a high internal plate-to-filament resistance; this requires a high value of coupling resistance and in turn a higher plate voltage. Due to the number of batteries required the plate voltage that it is practical to use usually determines the amplification factor and impedance of the tubes used in designs for general use. A coupling resistance equal to the resistance of the tube plate-to-filament circuit or possibly as much as 100% higher is satisfactory. The grid resistances are necessary in order to maintain the grid at a fixed D.C. voltage with

respect to the filament. The resistance will also tend to relieve the grid of any positive charge that might be accumulated by leakage from the plate battery thru the coupling condenser.

The voltage amplification per stage of resistance coupling is equal to $\frac{1}{2}$ the voltage-amplification constant of the tube when the coupling resistance is equal to the impedance of the tube. The resistance would have to be 10 times the impedance of the tube to give 90% of the voltage amplification factor. It is obvious that the plate circuit battery voltage would be out of reason

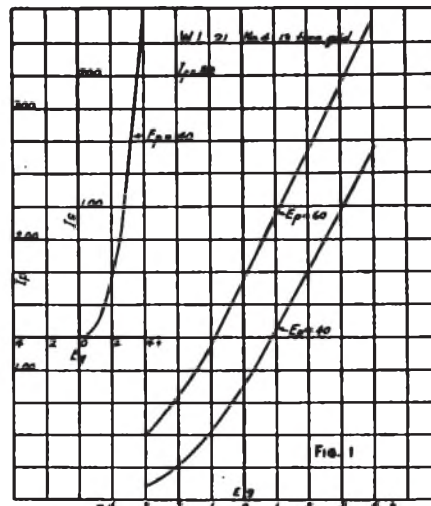

Fig. 1

if such a value of resistance were used.

The plate voltage must be sufficient to produce a linear relation between grid voltage and plate current.

Choke-Coil Coupling

Figure 3 shows a circuit using choke-coils or reactances for coupling between stages. The circuit is the same as shown for the resistance coupling, the resistance being replaced by reactances. The reactance can be so designed that the D.C. resistance is practically negligible and the A.C. impedance very high for even very low frequencies. A choke-coil having an inductance of 50 to 75 henrys can be designed so that the efficiency is not impaired at the high audio frequencies by the capacity of the coil. It is an advantage to use an open-core choke coil in order that the

*Engineer, Westinghouse Elec. & Mfg. Co.

coil can be made small and compact without saturating the iron of the core. By using sectionalized windings it is possible to keep the natural period of the winding entirely above the audible range even when the inductance is as high as 75 henrys.

The amplification is 90% of the voltage-amplification factor of the tube when the reactance is twice the impedance of the tube.

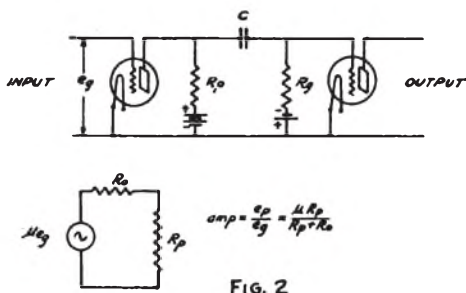

FIG. 2

Choke coils can be designed for use at radio frequencies and by keeping the distributed capacity at a minimum it is possible to obtain amplification over a considerable frequency range even below 1000 meters wave length.

Transformer Coupling

Coupling by means of transformers is desirable in many audio frequency amplifiers and is to be preferred for radio frequency. One advantage is that the voltage can be stepped up in the transformer. It is desirable when using transformers, as will be shown later, to employ tubes having a low impedance. While low-impedance tubes have a relatively low voltage-amplification factor it is possible to realize a greater total amplification per stage using transformers than by any other means.

Figure 4 shows a transformer connected in a circuit and the equivalent circuit of a transformer and tubes. As a transformer is intended to be used to step up the voltage it is necessary to make the step-up ratio as high as possible. If the secondary is first taken into consideration it is obvious that a great many turns are desirable in the secondary winding. The limiting factor is the highest frequency to be amplified. The resonant frequency of the secondary winding may be made the geometric mean of the frequency band to be amplified. If the range is 100 to 10,000 cycles the resonant frequency may be 1000 cycles. The equivalent circuit of the transformer and tube may then be represented by that of a parallel resonant circuit. "C" is the combined capacity of the winding and grid-to-filament capacity of the tube multiplied by the square of the ratio of transformation. The reactance of this circuit at the lower frequency is that of the inductance alone. With increasing frequency the re-

actance increases and reaches a very high value, acting as a resistance at resonance, and then decreases again and finally at higher frequencies its value is practically that of the equivalent capacity. In order to explain the action of a transformer so designed that the secondary is resonant, the variation in the A.C. voltage across a coil having an inductance equal to the inductance of the transformer primary when a constant voltage of varying frequency is impressed upon the grid of the first amplifier tube will be shown. The tube may be considered as a generator having an impedance R. The voltage generated will therefore divide between the resistance R. and the reactance ωL of the transformer primary. At low frequencies ωL is small and most of the voltage generated is lost as RI drop in R., the internal plate-filament resistance. As the frequency is increased ωL increases and when ωL is twice the R., the RI drop in R. is less than 10% of the voltage generated. It is obvious then that no matter how great the reactance may be made the voltage across the reactance cannot be greater than μe_g .

The addition of the secondary winding and connections to the tube only affects the impedance of the primary as would the addition of the equivalent capacity C. The reactance then becomes.

$$X_p = \frac{L_p \omega}{1 - L_p C \omega^2}$$

While the capacity causes the reactances of the winding to increase to a great value and then to decrease again as the frequency is increased, the increase above the value for which there is practically no RI

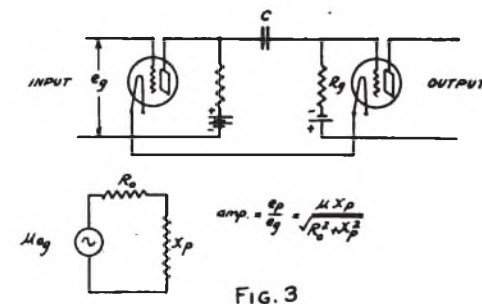

FIG. 3

drop in R. can not change the voltage across the primary winding. The secondary voltage is equal to the voltage across the primary multiplied by the ratio of turns.

Transformers can be designed to give very little variation in amplification for different frequencies or to be sharply resonant. The secondary winding can be the same in either case. If the primary inductance is sufficiently high to produce little RI drop in R. at low frequency and

the secondary winding is not resonant at a frequency so low that the reactance decreases too rapidly as the frequency is increased, the amplification-against-frequency curve is as shown in Figure 5, Curve 1. The second curve (2) shows the effect of decreasing the number of primary turns.

By decreasing the primary turns still further, the peak is made sharper and the maximum amplification greater because the step-up ratio is increased if the primary

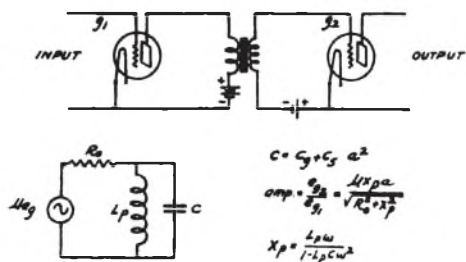

FIG. 4

turns are decreased while the secondary turns remain constant. It is desired to emphasize the fact that the resonance effect is only due to the transformers being connected to a generator having a high internal impedance. If the tube plate-filament resistance could be zero, no peak could be obtained. The only currents supplied to the transformer are the magnetizing current and a load current that is delivered to a capacitive load. If the internal plate-filament impedance of the tube is decreased the effect on the variation of amplification with frequency is the same as the effect of increasing the number of primary turns.

The secondary voltage is practically equal to the voltage across the primary multiplied by the ratio of transformation. If the transformer is well designed there is no leakage and therefore no chance of series resonance. The resistance of the windings, core losses, and dielectric losses modify the above statements slightly. Transformers afford a practical method of coupling tubes for cascade. It is not practical to use more than two or at most three stages of audio-frequency amplification. The last step may consist of a power tube if a powerful loud-speaker is used. For signals weaker than can be received with audio amplifiers, radio frequency should be used.

Radio Frequency Amplification

The greatest obstacle to be overcome in the design of a radio-frequency amplifier is the self-oscillations set up when a radio-frequency amplifier is connected to a tuned circuit, the oscillations being due to feed-

back thru the inter-electrode capacities. Other feed-backs may be effectively eliminated. If a transformer is used the amplifier will tend to oscillate at a frequency at which the transformer behaves as an inductance. The inductance in the plate circuit then gives rise to regeneration as in the well known regenerative tuned-plate circuit. The nature of the feed-back has been explained by Miller, Ballantine and others. Figure 6 shows the equivalent circuit of a tube with its inter-electrode capacities, also a diagram of the phase relations of the plate current and various voltages acting in the circuits.

Starting with I_p we may draw $R_p I_p$ representing the RI drop in the plate circuit. 90° ahead of this voltage we may draw $X_p I_p$ representing the voltage across the reactance X_p . The sum of these voltages is in phase with e_g . e_p is equal and opposite to $I_p X_p$ and causes a current to flow through C_m , the capacity between plate and grid. This current flows to the filament thru the circuit connected between grid and filament when the tube is connected to a tuned loop. At resonance the grid and filament circuit is of the nature of a resistance, being a parallel resonant circuit. C_m is very small and the current thru C_m will be a current leading the voltage e_p in phase by nearly 90° since the impedance of C_m is very great. The voltage drop over the resonant grid circuit, which behaves as an effective resistance, will be in phase with e_g and therefore tend to regenerate or sustain oscillation. Only when the plate circuit reactance is inductive can the feed-back occur in the proper phase to regenerate.

The voltage e_p is 180° out of phase with

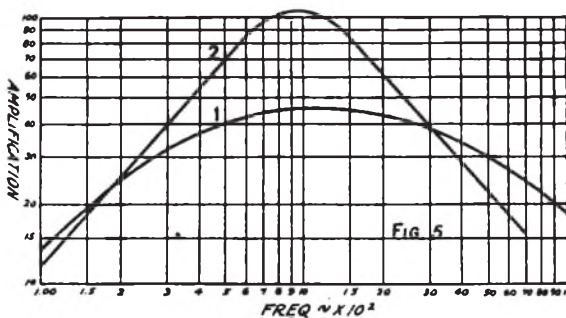

FIG. 5

μe_g when the impedance X_p is replaced by resistance and in that case it is not possible to induce a voltage in the grid circuit thru C_m that would be in phase with the original voltage e_g .

Transformers for wave lengths below 1000 meters must be designed so as to keep the distributed capacity of the windings themselves and between primary and

secondary windings at a minimum value. We have found iron cores to be useful even at a wave length of 300 meters. The iron must be thin and the laminations well insulated. The permeability of the iron is

a loss as the impedance of the transformer primary may be such that the phase of the plate voltage with respect to the grid voltage may never be right for regeneration.

It is interesting to note that the regenerative action can occur only in the tube connected to the tuned loop circuit provided all the transformers are similar. The feedback occurs at a frequency for which the transformer behaves as an inductance and when a resistance or its equivalent is connected between the grid and filament.

Radio-frequency amplification has not been widely used by amateurs because it is very difficult to secure amplification on 200 meters. For wave lengths from 250 meters and upward radio-frequency amplification is entirely practical. For the reception of broadcasted entertainment a loud speaker is usually desired if vacuum tubes are used and audio-frequency amplification is necessary for the operation of a loud-speaker. It is not practical to use more than 3 or 4 vacuum tubes requiring considerable current for filament heating, as the storage battery would be very expensive to purchase and to maintain. For this reason radio-frequency amplification has not come into general use, the regenerative circuit with audio-frequency amplification usually being used instead.

There are many places where the use of a loop or coil aerial is desirable or necessary and then radio-frequency amplification is necessary. This is true in a great many congested districts and apartment houses.

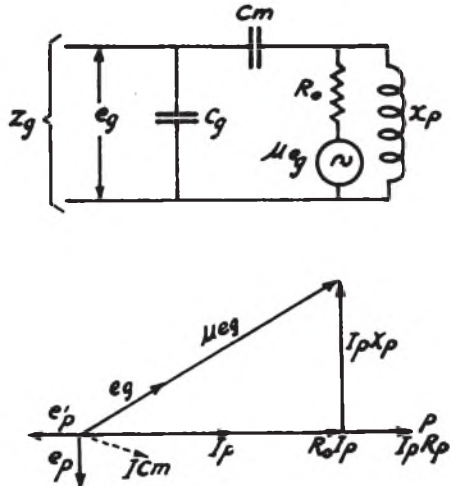

FIG. 6

of some advantage as the primary and secondary windings can be located farther apart than they could be in air for the same coupling or flux linkage. The losses in the iron core are a benefit rather than

Break-In for C. W.

By "BeeP"

WHY don't more of you fellows use some form of break-in system? With C.W. it works out beautifully! Most of the old objections to it are removed and because of its many advantages and ease of operation it is lots of fun.

Not a million nights ago a station which we shall designate as A* called "CQ" and announced that he had traffic going south. Before he finished calling, station B* answered and told him "QRV." A immediately broke to B and started with the message. When he got about half-way thru the message B had local interference so he sent one dash which stopped A and then said "... QRM." Both operators remained quiet until the QRM stopped, neither changing his tuning. Presently B gave the last word he received correctly followed by "K," and A continued from that word. Several messages were exchanged in somewhat the same manner, breaking at times due to doubtful reception

of a word. For a third station to keep track of both transmitting stations required acrobatic tuning manoeuvres which only a Reinartz tuner could hope to do.

From the above incidents selected from many a few of the advantages of break-in will be seen. Actual use will make them even more apparent. A receiving station in doubt about a word will not need to worry and perhaps miss other words and when his turn comes, call, sign, and ask for a repeat starting at such-and-such place and ending with a certain other word, but instead breaks as soon as the word has been sent and it is immediately repeated. This saves lots of time and laborious calling, lessens interference, and because of the ease of breaking on words that might otherwise be guessed at, more accurate messages result and more of them are delivered to the correct address.

Now there are many methods of operating a successful break-in system. Some amateurs who have trouble with their

transmitter paralyzing their detector tube have been able to use a small loop in the secondary circuit to balance out this energy. All kinds of double-contact keys have been devised which when connected in the ground circuit act also as a switch for connecting the receiving set to the aerial when in the "up-position." However, as most amateurs find a long low wire best for receiving it is natural to find that the most common break-in used is accomplished by simply listening with the receiving set on this other aerial. This works very nicely except when listening close to the transmitting wave.

The receiving aerial should be at right angles to the transmitting aerial to pick up the least energy. Where the receiving aerial is close to the transmitting aerial or lead-in it may be found that the antenna current jumps when the receiving set is tuned to the same wave. The thing to remember in this connection is that antenna current and radiation are not the same thing. In every case we have investigated, the station was weaker at a distant station when the antenna current was increased in this manner, showing it to be a matter of absorption and not useful radiation.

Once again the Reinartz tuner is of great value as in it the antenna circuit is aperiodic and not tuned to the transmitting wave under any ordinary conditions; hence on a separate wire for break-in work it does not affect the transmitter nor cause heavy currents in the receiver. It was stated in the July issue that it was thought the Reinartz tuner would make an excellent combination with the Beverage wire. This has been tried out on a short wire at 1HX and found to be the correct dope and, furthermore, because the wire runs away from the transmitting aerial and is not directional towards the transmitter, no trouble is experienced in receiving on any wave, even on the same wave as the transmitter.

The foregoing are a few suggestions as to how breaking-in can be done. In some cases where the energy absorbed in the coils of the receiving set from the transmitter is sufficient to render the detector inoperative, the aerial and ground leads may be reversed so that the incoming energy absorbed in the receiving aerial is of such phase relation as to buck the energy induced in the coils of the set, thus allowing receiving to be successfully done closer to the transmitting wave. A heavier grid leak will make the "come-back" of the tube less sluggish. There are probably several other kinds used not mentioned above. If so, *QST* will be glad to hear about it. We believe it is worth while and it surely adds a lot to the enjoyment of traffic handling.

*Call furnished on request.

NEW BOOKS RECEIVED

(Continued from page 20)

we have never appreciated the desirability of introducing modern merchandising methods in the electrical supply house where we buy our stuff and are perfectly content if the lad behind the counter can tell us what it's made of and who made it and discuss it with us as a fellow-ham, we admit that if this book by its good advice improves the perfectly horrible retail radio conditions to be found in every town, its authors rate recognition in our Hall of Fame.

It is the only book of its kind we have seen and the experience of its authors makes it authoritative anyway. It gives comprehensive advice on policies, financing, equipment, stock, advertising, selling and demonstrating, installing, speeding sales, record-keeping, etc. The authors recognize the amateur to the extent of advising radio stores to fit up a "clubroom" with a reading table, blackboard, lots of chalk, and some chairs, where hams can congregate and chew the old sock. "The amateur is a very powerful factor in the building of a radio retail business and his good will is something which must be fostered at all hazards." 9SP must've told'em that.

"*Radio for the Amateur*," by A. H. Packer and R. R. Haugh; 207 pp. 5 x 7½; Goodheart-Willcox Co., Inc., Chicago.

We object to the title of this book. The authors have made the mistake of considering the wireless newcomer an amateur. In fact so elementary is this book, so much does it resemble a text for a kindergarten, that it might be entitled "Radio for the Dumb-bell." It consumes 207 pages in leading its readers up to vacuum tubes. Nevertheless it has its very distinct place in the economy of things—in fact, judging by most of the novice listeners we've seen, we'd say this book is exactly their speed. In the most elementary of styles it explains everything about simple reception and transmission and does it as well as one-syllable words will permit. The drawings are just as simple, and most of the steps are illustrated and explained by well-chosen hydraulic analogies. Anybody who cannot gather the fundamentals of radio after reading this book should quit trying and get a job somewhere as a radio expert.

"*The ABC of Vacuum Tubes*," by E. H. Lewis, radio instructor, East Side Y.M.C.A., New York; 132 pp., 5 x 7½; Norman W. Henley Pub. Co., N.Y.C., \$1.00.

Exactly what its title implies: an elementary and practical book on the theory and operation of vacuum tubes as detectors and amplifiers, explaining non-mathematically the fundamental principles upon which all V.T. circuits are based. In our obser-

vation most practical amateurs are sadly deficient in tube theory; this little book will fill that need. It is one of the few recent "novice books" which are likewise of interest to the amateur field. The author presents some excellent characteristic curves in explaining his theory, and practical A.R.R.L. members who get a headache whenever the charcoalistic-curve is mentioned would do well to secure this book and enjoy the

pleasant sensation of being posted. The book is likewise an admirable supplement to the reading of the novice who has mastered his texts on generalities—V.T. theory is the next step.

Ho hum; not much doing this month. Wish somebody would write something about *amateur* radio.

K.B.W.

"And the Land Shall Be Visited by Plague and Pestilence"

By "The Prophet"

IN a village in the land which the Great God Antennius, God of Radio, thru his earthly agents, the Department of Commerce, hath named the Eighth District, there dwelt certain youths of the Tribe of the Patriarch, known as The Old Man, and of the Young Squirt, and the Worshipers of the Almighty Wouff-Hong and the terrible Retty-Snitch, who at an early age did suffer sorely from the visitations of that dread insect, the Radio Bug. And, verily, the disease did spread until several of the wisest and fairest (?) of the young men of the country-side had fallen victims. The antics of the stricken were amusing, tho terrible, to watch. They did suddenly seem possessed of the devil, for, verily, they rushed about with wonderful speed; they raised poles of fearful altitude and construction in their back yards; they did dig up the family flower garden and sink therein awesome quantities of all the metals which man, in his cunning, hath discovered; they begged from their sires pieces of gold and silver wherewith to purchase more junk, neither was paper scorned; they did make all manner of evil noise, yea, even unto the early hours of the morning. And the neighbors and kin of these youths gnashed their teeth and said unto them, "Now, wherefore makest thou such awful screechings and buzzings and sputterings and howls thruout the night watches? Verily, thóu must, indeed, be possessed of the devil!"

But, verily, the bite of the Radio Bug is deep and in spite of prosecutions and tortures these youths did prosper mightily until, finally, they builded unto themselves mighty sets of great power. The youth who aforetimes squeaked upon a squeak box now hammereth right lustily upon the key of a C.W. set and calleth all of his friends, yea, even unto the Sixth District, and doth handle many messages of great import. He maketh new records and smasheth old ones. He joineth clubs of other bugs and there absorbeth and giveth

off much wisdom. He sitteth up at night and poundeth his key and weareth the cans, yea, even unto the fourth watch. He taketh great pride in his set, which is right. He expandeth his chest and saith unto all who pass by, "Lo, look upon me. I am a bug."



The God of QRM

And as it is in this village, so is it all over this land.

But, lo, time passeth unto the space of about two years after the European eruption and the Great God Antennius, God of Radio, did look unto his Traffic Manager and spake unto him thusly, "Look upon these Amateurs. Verily, they do think they are the whole cheese. Now will I show to them the error of their ways and, may-

hap, lead them to better. I will send unto them a great plague and I will not allow one Bug to escape."

Then did he sit him down to meditate. Suddenly he sprang high in the air and cracked his heels together thrice and shouted, "Eureka!" which meaneth in the Grecian tongue—"Now will I fix these amateurs," for verily he had concocted a wicked scheme—the *Radio Phone*.

So it came to pass that in the space of a few weeks the minds of men became flooded with the whispers of the Great Antennius and the first broadcasting station did open up. But what sayeth the prophets? "It never rains but it poureth." And truly it is spoken, for in the space of a few moons there were scores of these obnoxious despoilers of the ether in operation and then did some wise persons among the Gentiles invent the science of Radio. Then an avalanche started and, verily, the multitudes did purchase sets, yea, the butcher, the baker, the candlestick maker, and those in authority and friends of those in authority. And it came to pass in those days that the air was filled with all manner of sounds and screeches and grunts and growls and howls and squeaks and roars and scratches and fizzes, in addition to the already over-sufficient confusion caused by the traffic handled by the men of commerce and the Amateurs. And, since the sets used by the would-be listeners were mostly of doubtful vintage, they got the benefit of all this babble. Then, even as the Great Antennius had planned, they did rise up in their wrath and ignorance and blame it all on the Amateurs. And they sent runners and messengers to the consuls and præfects and all those in authority and demanded that all Amateurs be forthwith fed to the Royal Menagerie. Yea, verily, if an Amateur ventured only to pound upon his key he was to be thrown into the dungeons. For the Listeners-to-Music reasoned thusly, "Now wherefore are these Amateurs who have sprung up in such alarming numbers since we invented Radio? And whyfore does their wireless interfere with our Radio? For is it not of more import that we listen to the outpourings of the stations that do broadcast than that they relay messages and improve upon their sets? For what know we of these dah-de-dahs, anyway?" And, verily, some in their ignorance, did even try to silence the men of commerce and the ships upon the great waters. Then they sat them down and wrote again to their friends in the Courts of the Law and implored them to cause all Amateurs

to be beheaded or at least imprisoned.

Then were the Amateurs in a sad plight, even as the Great Antennius had intended. It became an act of great courage to transmit at all, for if they did so, were they not certain to be invited to a neck-tie party? Verily, the handling of traffic became more and more difficult since many Amateurs had given up in disgust and others had turned traitor and joined the ranks of the Listeners-to-Music (?). With the exception of a few men of brave and strong heart and possessed of shot guns, transmitting became almost a lost art.

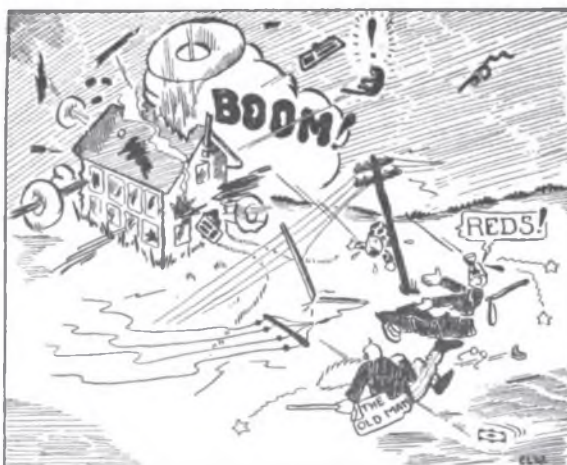

"... all manner of evil noise, yea, even unto the early hours of the morning."

Then spake the Great Antennius again to his Traffic Manager and said unto him, "Verily, I now believe the Amateurs have learned the lesson that I intended them to learn, to wit—that they do not compose the whole of the cheese. Therefore will I strengthen their hearts and cause them to fight against this great plague which is upon them and to regulate it to its proper place; since, verily, it doth now appear to me that it is possible for the Radio Phone to be of some use to the world. Therefore I will not allow it to be crushed entirely."

Then the whispers of the Great Antennius, God of Radio, filled the hearts of the Amateurs, who took heart, verily, and were strong as of yore. They did drag out their hereditary weapons, the Ancient Wouff-Hong, the Terrible Retty-Snitch and T.O.M.'s Kat, yea, it is even told to the prophet that some of the more bellicose gentry among the dwellers in the Land of the Eighth District even employed the lethal weapon known as the "forty-five." The battle was indeed terrible for doth not the Wouff-Hong smite grievously, and

biteth not the Retty-Snitch deep, and doth not the Kat of T.O.M. scratch most woefully? And many men fell on both sides and for a time the Amateurs did not prosper since they were few in number against the great host of the Amalekites arrayed against them.

Then again spake the Great Antennius, God of Radio, unto his Traffic Manager and said unto him, "Put thou it into the hearts of mine earthly agents, the Department of Commerce, to help these struggling Amateurs against this plague which I in my folly have laid upon them, by laws which shall wisely and justly control these broadcasting stations. Put thou it also into the hearts of the Amateurs that they must refrain from pounding upon their keys during the first watch of the night since it is evident that the listeners, it mattereth not how nutty, must also have their time."

And it was so. The earthly agents of

the Great Antennius did wisely and justly control the Broadcasting Stations and the Amateurs did stand by (and some even enjoy the concerts) during the first watch and then after most of the listeners were tucked in their beds, traffic flowed as usual during the rest of the night watches; although there still remained some misguided persons on both sides who stubbornly maintained that the ether belongeth entirely to them. But the Great and Terrible Wouff-Hong that squelcheth all things evil will surely squelch them in time—so wherefore worry? And as runneth the prophecy from NAA in the noontide watch—"The indications are for generally fair weather throughout the United States except for scattered thunder storms in some portions."

Mors omnia vincit—which meaneth in the language of the Ancient Men of Latium, "Long live Amateur Radio!"

Amplifier Operation from A.C. Supply

By P. D. Lowell*

For years we have been looking forward to the day when we could operate our tube equipment from the A.C. home-lighting supply. Early attempts in this direction were not very encouraging, the residual hum imposing a severe handicap on reception. Recently, however, considerable progress has been made towards a solution and it is safe to assume that the day of its perfection is not far removed. In this article, reprinted from the July issue of the Journal of the American Institute of Electrical Engineers with the kind permission of the Institute, Mr. Lowell describes the most recent progress in America in this direction.—Editor.

ELECTRON tube amplifiers now form an important part of practically all radio receiving sets, except the most simple types. Such amplifiers are in fact necessary to receive distant stations, or when using coil antennas. For good operation, amplifier tubes require for the filament a source of voltage of very constant value (usually about 6 volts) and for the plate a source of voltage of from 40 to perhaps 300 volts. The filament voltage is usually supplied by storage cells, and the plate voltage by dry cells. The maintenance of these cells in operating condition, especially the storage cells, is often a source of much difficulty and annoyance. The storage cells are necessarily bulky and heavy, require constant attention to maintain proper charge and density of electrolyte, give off injurious acid or other fumes, and are subject to considerable variations of voltage during the period of discharge. The development of an amplifier which can be supplied from the ordinary 110-volt, a-c. lighting mains is of considerable practical importance, since it would eliminate the practical difficulties of maintaining storage

*Associate Physicist, Bureau of Standards.

cells. The amplifier using such a-c. supply has the important advantages of reliability, convenience, and cheapness both in first cost and operating cost.

Such an amplifier using five stages of amplification has been developed at the Bureau of Standards. There are three

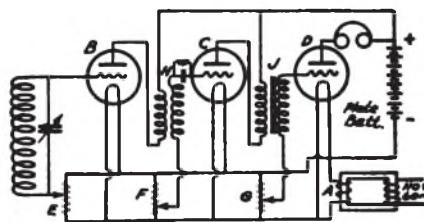

Fig. 1 Two-Stage Amplifier Circuit, using Tube Detector

stages of radio-frequency amplification and two stages of audio-frequency amplification. It is the purpose of this note to describe briefly this amplifier.

The first arrangement tried consisted of one radio-frequency stage of amplification, detector and one audio-frequency stage.

The filaments of the three tubes were lighted by 6 volts supplied by a step-down transformer, the primary of which was connected to the 110-volt, 60-cycle power mains. The circuit is shown in Fig. 1.

In Fig. 1, the filament lighting transformer is shown at *A*, supplying voltage for the filaments of electron tubes *B*, *C* and *D*. The amplifier input circuit is connected to the grid of tube *B* and to the slider of the balancing resistance *E*, the latter having a resistance of 200 ohms and being connected across the filament line. A radio-frequency transformer is shown at *H*, a balancing resistance at *F*, an audio-frequency transformer at *J*, and another balancing resistance at *G*. The purpose of the balancing resistances *E*, *F*, *G*, is to keep the normal voltage of the grids at a steady value with respect to the average voltage of the electrical midpoint of the filament and thus to eliminate the hum which variations of the grid voltage would cause. These balancing resistances are adjusted until the hum is eliminated. Reception was accomplished with this circuit but there was considerable 60-cycle hum present in spite of the beneficial effect of the balancing resistances.

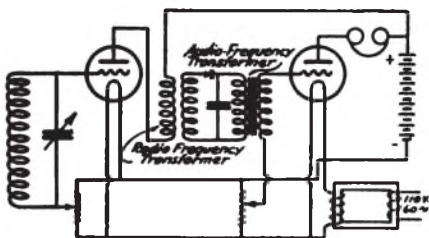

Fig. 2—Two-Stage Amplifier using Crystal Detector

The employment of a crystal detector in place of the electron tube detector reduced the 60-cycle hum very considerably. This circuit is shown in Fig. 2.

When an electron tube is used as the detector, there is impressed on both the plate and the filament a 60-cycle a-c. voltage which, although small, becomes very objectionable when amplified by one or two stages of audio-frequency amplification. When the crystal detector is used, no 60-cycle voltage is supplied to the detector circuit. The radio-frequency transformer whose output is delivered to the detector circuit prevents the passage in any appreciable amount of 60-cycle current supplied to the radio-frequency stage, and such voltages are not present in the crystal detector circuit and do not reach the input of the audio-frequency stage.

The employment of a crystal detector may at first seem objectionable, since with the crystal as ordinarily used it is rather difficult to find a point of good sensitivity.

But tests on this amplifier showed that careful adjustment of the crystal detector was not necessary because the radio-frequency amplification preceding the detector usually gave sufficient signal strength so that a point of sufficient sensitivity could be easily found.

This circuit gave quite good results. The 60-cycle hum was practically eliminated and the crystal detector gave almost as good rectification as the tube detector.

It was found that better amplifying

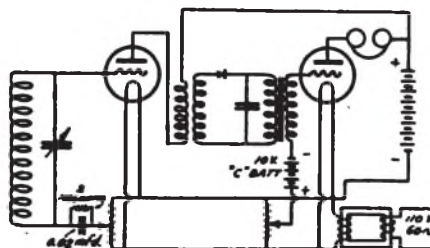

Fig. 3 Two-Stage Amplifier using Crystal Detector, with grid condenser for radio stages and grid battery for audio stages.

action could be obtained by inserting condensers of about 0.02 microfarad capacity, shunted by 2-megohm grid leak resistances, in the grid circuits, in series with the sliders of the balancing resistances. The grid condensers and grid leak resistances allow the grids to assume a normal voltage which is more favorable for amplifying purposes. The leak resistances allow any accumulated charge on the grids to leak off to the filaments. Still better amplification and quieter operation was produced by replacing the series grid condenser and leak in the audio stage with a 10 volt battery giving a negative charge to the grid. A battery of dry cells was used for this purpose; since only an extremely small current is required, the life of the dry cells is practically their shelf life. This gave a circuit as shown in Fig. 3.

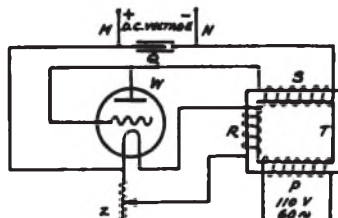

Fig. 4 Rectification Circuit for Plate Voltage Supply.

Alternating current rectified by means of a gas-filled two-element rectifier tube (a "Tungar" tube) was tried as a source of filament power but the residual hum was much greater than when unrectified alter-

nating current was used. This is because of the fact that during rectification, the wave form becomes distorted and it becomes impossible to stabilize the grid voltage by means of the balancing resistances.

In the above mentioned tests, a plate battery was used for convenience, but this was replaced by alternating current which had been rectified by means of an electron tube and smoothed out with condensers of large capacity. The rectification circuit for the plate voltage supply is shown in Fig. 4.

In Fig. 4 the primary *P* of the transformer *T* is connected to the power mains, and winding *R* gives 8 volts for the filament of the rectifier tube *W*. Winding *S* gives 300 volts which is rectified by the tube *W*

The final circuit is shown in Fig. 5, and includes three stages of radio-frequency amplification, galena crystal detector, two stages of audio-frequency amplification, loud-speaking reproducer, and the necessary power transformer and rectifying circuits.

This final circuit gives good amplification, with a slight residual hum which is not great enough to be objectionable when receiving signals of ordinary readable strength. The residual hum is of course more objectionable when extremely weak signals are being received. Radio telephone music and conversation are clearly reproduced.

The amplifier was operated under normal conditions using the usual sources of direct-

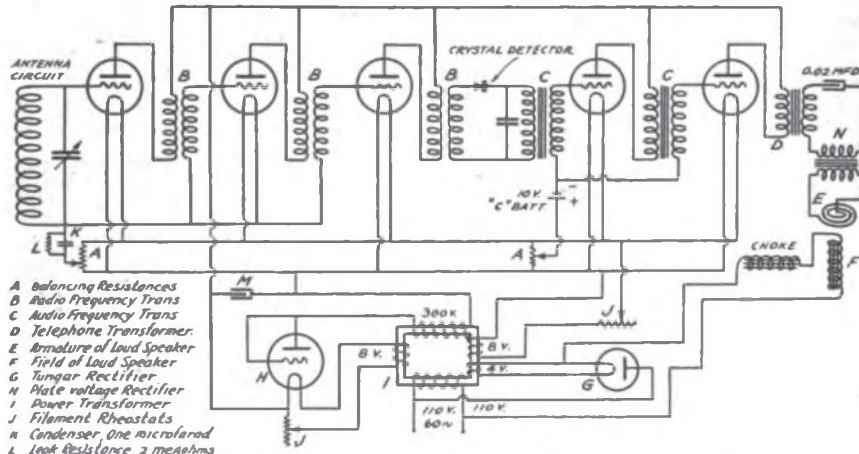

Fig 5 Final Complete Circuit of Five-Stage Amplifier using Crystal Detector Using 60 cycle alternating current to supply power for the filaments and plates.

and smoothed out by the condenser *Q*, which has about 10 microfarads capacity. This gives at terminals *M* and *N* a high-voltage direct current which is quite suitable for use on the plates of the amplifier tubes. Rheostat *Z* varies the brilliancy of the filament of the rectifier tube and, simultaneously, the voltage for the plates.

The use of a loud-speaking telephone receiver such as the "Magnavox" was made possible by applying to the field coil of the loud speaker an alternating current rectified by a "Tungar" rectifier tube. The impedance of the field coil was sufficient to smooth out the pulsating current to such an extent that the hum was not annoying. It was also advantageous to couple the loud-speaking reproducer circuit to the plate circuit of the last amplifier tube by means of a one-to-one ratio telephone transformer with a 0.02-microfarad condenser in series with the telephone circuit. This helped considerably to reduce the residual hum in the telephones.

current supply, and then switched over to alternating-current supply. This comparative test showed the a-c. supply to give as good amplification as the d-c. supply.

For the reception of damped waves, the amplifier as constructed operated most satisfactorily for frequencies from 400 kilocycles to 1500 kilocycles per second (750 to 200 meters). This frequency range was determined by the working range of the radio-frequency transformers used. By using suitable radio-frequency transformers, it is expected that the amplifier will be effective for the reception of damped waves for frequencies as low as 30 kilocycles (10,000 meters). This amplifier has also been found effective for the reception of undamped waves, when used with a separate heterodyne.

The special transformer with five windings and the rectifier tube were assembled in one box, and the amplifier tubes and amplifier transformers and other apparatus were assembled in a separate box. This

was done to avoid having the amplifier immediately adjacent to the special transformer, from which it would pick up considerable 60-cycle hum. The assembled rectifier unit measured about 8 in. by 8 in. by 9 in. and weighed about 21 pounds. The assembled amplifier unit measured

about 8 in. by 11 in. by 14 in. and weighed about 21 pounds.

Mr. F. W. Dunmore was a co-worker and participated in the development of this instrument. The author wishes to acknowledge his indebtedness to Mr. R. S. Ould for helpful suggestions in preparing this paper.

A Week in Baltimore With Portable Station 3OI

By John Evans, jr., 3AQQ

At the June meeting of the Chester County Radio Association, Yours Truly was resting easy after making a report that the association had at the present time over 125 members and was growing. Then out of a clear sky the meeting was informed that 3OI was to go to Baltimore for the week of June 10-15th inclusive, to be placed in the Fifth Regiment Armory under the auspices of the Maryland Radio Association for participation in the Export and Import Exposition to be held there on those dates.

Several days later a phone message from headquarters took me to Parkesburg and after two weeks of work which included painting, scrubbing, wiring, testing, etc., portable station 3OI hit the roads for Baltimore, at 10:10 A.M. Saturday, July 8th. Four miles of dusty road put a coat of tan on the sturdy shack. Everything went well until Nottingham, Pa., was slightly in the distance, then the engine on the truck refused to percolate. We found the gasoline feed to the carburetor broken completely off. The sun was shining brightly and, take it or leave it, it was some walk up the pike to the nearest garage. After three precious hours of tinkering we started off again.

It might be well to mention right here that the truck from the ground to the top of the shack measures 13 feet 6 inches, which necessitated careful watch on limbs of trees and other things overhead. At Gilpin Falls, Md., we encountered a covered bridge, which took off a piece of our roof. Everything went fairly well but of course slowly until we landed in Baltimore about 12:30 A.M. Sunday.

Our directions were anything but specific and after traveling up and down Charles and Gay Streets several times, we found a haven in the Central Police Station, where a pay-telephone was our only hope. After making a dozen calls I found it was impossible to get the truck into the Armory that night. Then after making a round of the city and looking over fifteen or more garages we finally found one to accommodate her height and parked her for the night. The driver and I then found a hotel and hit the hay for a much needed rest.

In the morning on going to the Armory we were cordially met by the Third District Council President, Mr. E. R. Bateman, who was so anxious to see 3OI again and get her in the booth that we had to go to the garage at once and bring her around to the Armory. More hard luck awaited us. We found that the clearance of the Armory door was not sufficient for her to get in. Since a cottage on wheels will not shrink as easily as a radio man's pocketbook, it was necessary for us to get riggers to remove the house from the chassis and put it in position on the Armory floor. This feat took practically all day Sunday.

On Monday morning I took up the task of putting the batteries and other paraphernalia together, also had the house cleaned inside and outside. Monday seemed to speed along and when the Exposition opened at 7:00 P.M. everything was in readiness and the crowd eagerly awaited the first selection from our radiophone transmitter.

I will state here that the Hall was well supplied with radio receiving apparatus. All of the stations excepting one were equipped with Magnavox reproducing devices, and the other one had a real Western Electric loud speaker that barked a message that was echoed and re-echoed throughout the Armory.

The transmitting equipment in 3OI includes a 20-watt DeForest transmitter which is used for key work and a special two 5-watt tube radiophone transmitter (3ZO-built) employing the Appleby-Heising modulating scheme. This set was driven by either 420 volts storage battery or a 500 volt motor generator, and was the set which was used practically all of the time we were in Baltimore.

The interest of the crowd seemed to center about 3OI—no doubt because it is something the public rarely sees—a radio broadcasting station in full operation; also because of the careful designing of the apparatus and the well-arranged interior of the station. In order to estimate the number of visitors who came into the station, on Friday night we asked them to sign their names in a book. This book is now in

possession of 3ZO and contains the names of 485 persons. It is easily estimated that a like number came in who did not sign, and by using the Bertillon system we figure that approximately 1500 people looked thru the windows. We couldn't stop to count the finger prints. Taking it all in all a conservative estimate for the week's attendance at 3OI is between 5000 and 6000 persons. In fact the promoter of the exposition gave us quite a boost when he stated that never in his thirty years of experience along this line had he seen an exhibit attract as many people as did 3OI.

The following special features were broadcasted from the station: On Tuesday

Intermingled with these features, many of the latest Victrola records were broadcasted.

During the week, at about supper hour, I listened to many of the amateurs around Baltimore communicating by CW telegraph. Three of these, 3FE, 3APT and 3XAA, were worked. Many reports came to our booth that our concerts were being received with a great deal of pleasure in Baltimore proper. Many of the Baltimore skeptics stated it would be impossible for the concerts to be heard in the city, as the Fifth Regiment Armory is nothing more than a large metallic screen. The supports for its large cylindrical roof are steel

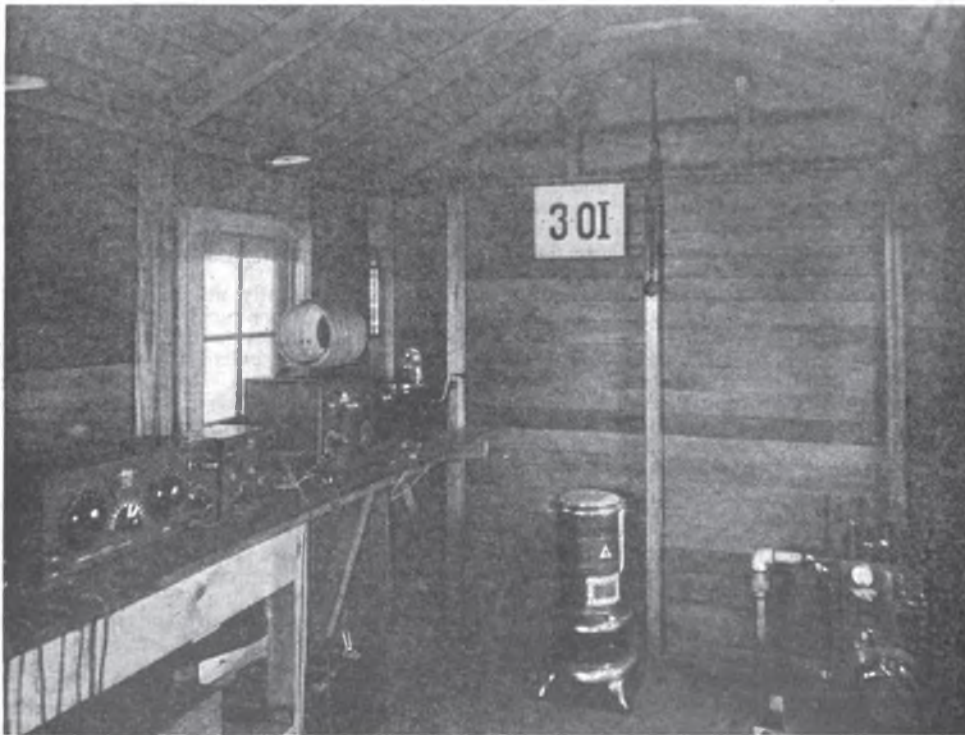

Mobile Station 3OI from the entrance

night, Mr. H. A. Beale, Jr., of Parkesburg, Pa., gave a very interesting lecture on "Radio Development." On Thursday night, Mayor Broening of Baltimore pleased the crowd with an exceptionally splendid address on "Baltimore." On Saturday, the Mexican Consul addressed the crowd assembled around the loud speakers. Every afternoon and evening, the audience was held spellbound by strains from a harmonica played by the champion harmonica player of the world, Mr. William H. Burks. Selections on the harmonica were given also by Mr. Alonzo Parks, a brilliant player.

I-beams and the roof itself is of tin. But we got along very well, no hitches or delays being incurred.

On Sunday morning, we were at the Armory about 7:30, ready to load the cabin on the truck and light out for home, but only to find that no one can work in Baltimore on Sunday without a permit and ever since I have been wondering how all these radio fans get their apparatus built. Anyway, Mr. Bateman and myself went downtown to the General Police Inspector and got a special permit. At 3:45 P.M. we were on our way home. With the exception of

a lost fan belt and being stopped by a motorcycle officer who asked where our mirror was, the trip was uneventful and we arrived in Parkesburg at 1:00 A.M. Monday.

I wish to express my deep gratefulness to Messrs. E. R. Bateman, Emile Boucher, Winters Jones and Hughie Jones, for the great favors and assistance they rendered me during my stay in Baltimore.

A Calibrated External Heterodyne and Wave Meter

By Alpha A. Learned, IAAU

CONTINUOUS wave signals are usually received by allowing the detector tube to oscillate at a frequency nearly the same as that of the incoming signal, thus producing beats of an audible frequency which are rectified by the detector tube. The production of beats, called heterodyning, can be accomplished by using a non-oscillating detector bulb or a crystal, and having a separate oscillating bulb to act as the heterodyne. When the external heterodyne is used with an ordinary three-circuit regenerative set, neither increased sensitivity nor ease of adjustment is gained, altho the device is valuable as a wave-meter for all incoming C.W. signals. However, with a radio frequency amplifier set using iron core transformers the ease of adjustment obtained with the external heterodyne is amazing—as practically all

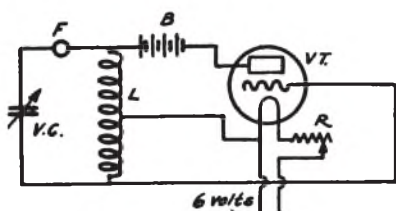

V.C.—Variable Cond max. capacity 0.00025 mfd.
L—40 turns No. 20 wire on 3/2" diameter tube, with top in the center.
B—Small, 22 1/2 volt "B" battery.
V.T.—Amplifier tube.
R—Rheostat.
F—Flashlamp bulb.

the amateur C.W. signals can be heard on a single adjustment of the receiving tuner, only the heterodyne dial being turned to pick out the desired signal.

The figure shows a diagram of connections and gives specifications for an external heterodyne having a wave length range of 130 to 400 meters. As can be seen, it is nothing but a miniature transmitting set. The variable condenser dial, rheostat knob, flashlamp bulb and two binding posts for the filament battery can be mounted on a panel about 9 inches long by 6 inches high with the V.T., inductance and B battery in the rear.

The flashlamp bulb is used as a resonance indicator when calibrating the instrument and also when measuring the wave length of any transmitting set. (Its presence has no effect on the operation as a heterodyne.) A standard wave-meter and a C.W. transmitting set are required for calibration. Connect a flashlamp bulb in series with the coil of the standard wave-meter and measure the wave length of the transmitting set. Then place the heterodyne near the transmitting helix and turn the variable condenser until the flashlamp lights, marking the resonance point and the wave length on the unengraved portion of the dial. This same thing should be done at intervals of ten meters, until the entire wave length range is covered. A "Somerville" dial is recommended, as the wave lengths can be carefully marked upon it in ink with a neat appearance. The variable condenser should be of a high grade with no loose bearings and a "Karlows" or other type of vernier movement should be attached. A detector bulb will often work as well as an amplifier, and with some tubes the B battery can be as low as two or three volts. A filament switch on the panel is convenient for a rapid change from C.W. to spark reception.

The position of the instrument is not important, as generally any place within two or three feet of the receiving set is OK.

The writer constructed one of these devices about a year ago, and through constant use in DX reception with a radio frequency amplifier set it has proven itself indispensable.

High-Power Vacuum Tubes

THE development of vacuum tubes of high power has now reached the point where even such devices as the Alexanderson alternator have a serious competitor. The research laboratory of the General Electric Co. has produced a tube capable of developing 20 kilowatts, as the result of some years of development work by W. C. White and H. J. Nolte, and in England the Mullard company is said to

(Concluded on page 39)

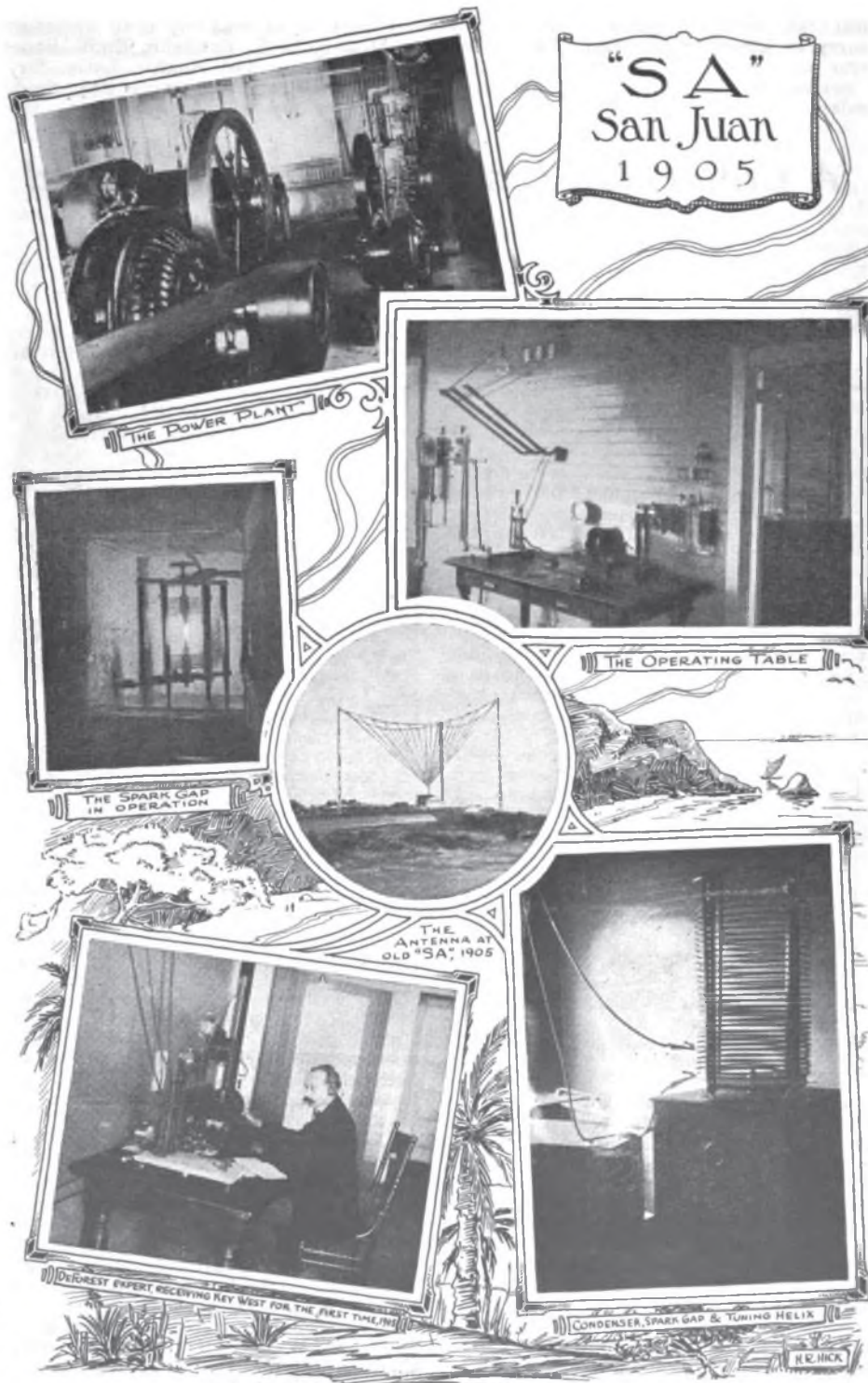

A Pioneer In High-Powered Stations— “SA” in 1904 By “An Old Timer”

IN December, 1903, while Electrical Engineer at the U. S. Naval Station at San Juan, Puerto Rico, Rear Admiral A. Dunlap instructed me to install a 3KW. Slaby-Arco set near the city of San Juan, on a high bluff overlooking the sea, to operate with a similar station of the Navy's at Culebra, an island near the eastern end of Puerto Rico, and ships at sea. We got busy with the old tape and coherer set, and felt as if we were on top of the world when we got the station going—the first installation on the island.

Then about February, 1904, I was handed an order reading “Locate a high power wireless station in the island of Puerto Rico”, and was told not to come back until I had found a good place. We made arrangements so the station work would go on, and started out to locate the “monster station” of those days. This was to be a 35KW. DeForest outfit, to communicate with similar stations at Guantanamo, Key West, Colon, and perhaps with New York direct. About a mile from the small radio station was an old Spanish fortification with a moat, located on the famous Spanish military road from San Juan to Ponce. The moat was perpetually damp and appealed to me as a good ground, and after surveying the location it met with the Admiral's approval and work commenced. It was a grand sight to see the 210 foot towers being erected, and the street was crowded with people watching the work. The towers were 300 feet apart in a triangle, with the operating house in the center. We made arrangements with the local lighting company to supply 110-volt 60-cycle power, and got busy setting up the apparatus. The antenna was in three fans of 15 wires each, 300 feet long, one fan being used with a loop connection for receiving, and the other two running to an anchor gap, leads from which went to the helix and a three-foot switch hung on the wall. We made this switch to protect the receiving set. Leads from this set ran to the regular DeForest change-over switch and then to the receiving set, which was the old three-slide tuner, electrolytic responder, with head phones. This was all new to us, as we had been using only the coherer. Later DeForest installed a pancake tuner with five coils, which was an improvement. The transmitter consisted of a 35KW. transformer; chokes, a condenser formed by three earthen vats about six by three by two feet containing glass plates and lead foil immersed in oil; a

straight spark gap in a wood box about three feet square, fitted with radiating discs, a hand adjusting wheel, and a small blower; a solenoid-operated relay key operating under oil; and the tuning helix, which was about five feet high, made of half-inch copper tubing.

When we first started up the lighting company had so much trouble from surges that they cut off, so the Navy had to build a power plant of their own. There was another delay, but by November, 1904, we were running. In October, 1905, a DeForest man arrived to start the testing and by December the plant was in good condition. If I recall aright, the call letters were:

San Juan—SA
Guantanamo—SI
Colon—SL
Key West—RD

and these four stations were the first high powered long distance stations of the U. S. Navy.

Then the fun began. Each station had a regular schedule. We would send D's for half an hour, then SI would, then SL, then RD. Sometimes we would hear each other, but more often it would be static, and before we got communication established we broke all the ten commandments with a few radio commandments added. We often got DF, the old DeForest station at Manhattan Beach, near New York, and one night were surprised to hear a high-pitched note signing BO, which kept us all guessing until we learned it was the Fessenden station at Brant Rock, Mass.

No doubt many of the old-time men will be glad to see the accompanying photos of this station. Here's luck to old SA, now NAU.

HIGH-POWERED VACUUM TUBES

(Concluded from page 37)

have successfully operated a 75-kilowatt tube made of quartz.

The G. E. tube is of very modest dimensions for its power, apparently being only some 20 inches in length by 3 inches diameter. It has a large and very rugged filament many times the diameter and length of ordinary power tubes, a cylindrical grid surrounding the filament, and a cylindrical anode about 1½ inches diameter by 8 inches long. Instead of supporting the anode within the tube as one of the customary electrodes, it is itself sealed into one end of the 3-inch glass tube, thru the other end of which the grid

and filament leads enter. Thus the plate forms a part of the outside wall of the tube, and it is accordingly easy to water-cool it for the safe carrying of large amounts of energy. Ten such tubes may be operated in parallel, generating 200 kilowatts of h.f. energy, which is ample for trans-atlantic telegraphy. They are ordinarily operated on about 20,000 volts D. C., obtained by stepping up A.C., rectifying by kenotrons, and filtering.



Tests looking towards the use of these high-powered tubes in commercial trans-ocean work are already under way at Radio Central, WQK. At present only the carrier wave is being radiated, while detailed antenna measurements are being made in the collection of data in this new work. It seems still to be quite a trick to parallel a group of these big tubes and secure high efficiency.

It is commonly believed that outfits of this kind will displace the complicated and more expensive alternators and results already obtained indicate that single valves of outputs as high as a thousand kilowatts are by no means impossible. *K.B.W.*

Death of James L. Autry

WITH heavy heart it is our painful duty to record the passing from this life of James L. Autry, pre-war 5ED and post-war 5AB-5ZX, at Houston, Tex., on August 31st.

Jimmie Autry was a peach in every respect and dearly beloved by a multitude of friends. He was a real old-timer in amateur radio, having been the very first A.R.R.L. member in Houston, a pre-war District Supt. of Texas, and founder of the

Houston Radio Club. Altho not very active as an amateur the past two years, Houston amateurs still considered him one of them at all times. He was in bed at the time of the last local ham-fest but got up long enough to come down and see the banquet table and meet the out-of-town hams.

Altho but 23 years of age he had risen to heights in the business world, being vice-president of the American Petroleum Co. and a director in the Fidelity Trust Co. of Houston.

In his school life he had been equally prominent, having graduated with honors from Rice Institute, Houston. For two years he managed the student newspaper, *The Thresher*; served as a member of the honor council in 1919-20 and as chairman of the council 1919-21, a member of the student's council for the same period, and was a member of the Congressional Club and of the Engineering Society.

Because of a most lovable personality and splendid character, Jimmy Autry had the admiration of friends uncounted. He was a member of that Mississippi Valley gang comprising pre-war stations 9IK, 9LQ, 9EP, 9NN, 9JT, 5BV and 5ED, who before the war made green ink famous in amateur correspondence. It is hard to think that old 5ED is no more.

Houston papers state that Autry was a member of the Ku Klux Klan and received the honor of their burial service, which has been established as the most beautiful service ever held at a grave in Houston.

Tube Supply from A.C.

WE seem slowly but surely progressing towards the ability to operate the filaments and anodes of our receiving audions from the alternating current house mains without trouble from 60-cycle gurgles. The French have experimented in this direction for many years and a recent issue of "L'Onde Electrique" described an interesting amateur installation of M. Ritz which is giving good account of itself.

The hook-up is shown in our diagram, where one tube, R, acts as a rectifier to supply the detector, D, which is connected to the aerial with the customary three-coil circuit in which P, S, and T are the primary, secondary and tickler, respectively. X is a transformer with three secondaries, one of 4 volts for the rectifier filament, one of 110 volts for the plate supply, and another of 4 volts with a center tap for the detector filament. Valve R rectifies the 110 volts and stores the energy in condenser C, which is of 4 mfd. The objectional feature encountered in all systems of supply from A.C. sources is the residual hum and to best neutralize this a filter arrangement should

(Concluded on page 59)

EDITORIALS

de AMERICAN RADIO RELAY LEAGUE



Girding Up Our Loins

WE hope we're not going to have to scrap to retain a place in the ether for amateur operation. The outlook for peace gets gloomy every once in a while but we still hope that things will run smoothly this winter.

This is the third time we've had a heart-to-heart on this subject. We amateurs must not let ourselves be crowded out of existence by a horde of listeners-in. Our important work must not cease completely because there are broadcasts. There's not the slightest doubt that we must share the air but "sharing" means part for each of us. On the reaction we've got afraid to transmit—afraid some influential voice will call us on the telephone and complain. Say! Things are coming to a pretty pass. We're *expected* to transmit. Our government licenses us for that purpose and feels that it is worth while because it means progress to the art and an army of skilled operators in time of national emergency. Do you realize that because an uninformed public has thoughtlessly protested and because we've been anxious to play fair, we're *slipping*? If we don't get on the air soon and stay there with determination we are liable to find the novice listeners completely in possession of the air and resenting a single peep out of us. Let us not wait until it is too late.

Certainly novices complain against amateur transmission. They don't know any better. They think the air ought to be quiet for them all night long. They don't know that QRM is the rule rather than the exception in radio. The whole matter is summed up in three words—"They don't know."

But must we therefore *quit*? We'll answer: We must *share* but we must not *quit*. Again we counsel a local understanding—an agreement between all classes of radio enthusiasts in each community—with a specified division time such as 10 P.M., before which the air shall be quiet for listening and after which U. S. Licensed Amateur Transmitting Stations shall G.A. Something of this sort is very desirable in correcting the impression that it is a crime to operate a transmitter. A.R.R.L. members are again urged to deal

with utmost kindness and patience with newcomers in the game, to endeavor to make them see the light, to go out of their way to favor them, to give them the benefit of every doubt, to observe all the courtesies of the ether, to QRX as one amateur to another, and to play the game thruout as an A.R.R.L. thoroughbred should—but flatly to decline to shut up shop completely in their favor. When there are complaints tell the listeners in a nice way that you have already given them the biggest share of the evening and that now you have some work of your own to do and want to use some of the air yourself.

Be more than reasonable, but be firm. We're going to have lots to do this winter.
K.B.W.

Sectional Organs

HAVE you an amateur magazine published by your radio club, executive council, district or division? If you haven't you don't know what you are missing. If you have, what are you doing to help it along? Do you know that an editor of an amateur publication has one of the hardest jobs in the radio world and that most editors complain that they either have to write most of the stuff themselves or continually wallop someone over the head for an article? Let's see if it is really worth while.

In the first place, most local or sectional papers start as the organ of the executive council or radio club and perhaps are but a few mimeographed sheets stapled together. They tell of the meetings of the club or clubs in the vicinity, what they are doing, what happened at the last meeting and what is going to happen at the next, and possibly the details of a contest of some sort or membership drive. This goes a long way in holding the clubs together but an even greater service to amateur radio can be rendered by making known and helping to enforce the periods of listening, local work, and DX; propounding the true A.R.R.L. standards and ideals; and furnishing a vehicle for the expression of sentiment and opinion for amateurs in that section of the country. In some places these publications print parts of the reports of their Division Manager showing where prog-

ress is being made and where stations or appointments are needed and in several cases inestimable service has been rendered to the League by publishing late bulletins or schedules of special tests and relays. Then, too, some of the best papers presented at club meetings can be reprinted, thus reaching a greater number of persons and forming a handy reference for those who heard the lecture but could not carry away all the data presented. The dealers in the vicinity are glad to advertise in the publication when it is shown that it is a true amateur publication and backed by the "hams," so this will contribute to the financial support as will a department of classified advertisements. The above are a few of the ways in which a "sectional organ" can serve the amateurs in its community—from which it appears it has a definite place in local affairs.

All this is very well and good as long as it remains an *amateur* publication but just as soon as the editor and a few more see the possibility of making some money, *watch out!* The fellows that control the publication *must* be amateurs and *must* be directly responsible to the amateur gang by virtue of having been elected by members of their local club or clubs or by general election in the section of the country served by the publication, as with *QST*. When those directly in charge of the magazine think they can break away from the gang to put money in their own pockets, and that surely the rest will be willing to pay five or ten cents more for each issue and that the amateurs will still give their whole-hearted support and donate contributions just the same, they have made one of the biggest mistakes of their lives. The first thing that follows such a procedure is the decreasing of amateur interest and the increasing of subscription and advertising rates to bring in more money in the get-rich-quick scheme. If such a magazine does not perish it changes policy and soon becomes known as a broadcaster's magazine, in which crowded field it may thrive during the peak of the craze, but passes beyond our notice. We see such magazines displayed among others on the news stand in front of our office building and perhaps pause to wonder what the amateurs in the locality where it is published think of it and then passing on up to our office we find the answer in the morning's mail. One of these letters we published in June *QST*.

Nope, we believe that to make a go of a club publication the time must be donated by the staff and if it expands to take in some of the surrounding country it will mean more hard-working amateurs on the staff. To such a gang we extend the right hand of fellowship and wish them luck and hope they may unearth some latent local talent. We greatly enjoy reading copies

of their efforts that drift in to this office. We fear no competition for we feel they are really a part of us. Just as there is a need for city councils or legislatures and a Congress, so also is there a need for local or sectional publications and *QST*. If such editors wish permission to reprint extracts or whole articles from *QST* all they need do is write us, and if we should wish at some time to reprint an article we liked we would expect the same courtesy, always, of course, giving credit to the source.

But what we started to say was, these editors need help and if you can be of service to them *do so*, for you are giving amateur radio a lift.

B.P.

Why Not G.M.T.?

WHENEVER in the past our A.R.R.L. has conducted a relay or test of national interest to radio amateurs, Eastern Standard Time has been used. Why shouldn't we adopt Greenwich Mean Time as the standard in all our relays and even in our everyday practice of traffic handling? Why shouldn't we have one standard of time by which we all may be governed alike and a time which we can adopt officially in our radio work?

Such a system would simplify matters considerably and there wouldn't be that doubt of accuracy which enters your mind if you live out in Wyoming and come to the point of converting Eastern Standard Time to Mountain Daylight Saving Time. All that would be eliminated because it only would be necessary to make one adjustment in your mind which would hold true for every part of the country.

More important is the adoption of a standard time of international recognition as we approach international amateur radio communication with European amateurs. Greenwich Mean Time is known the world over and is the one standard of time recognized by every civilized country.

G.M.T. divides the 360 degrees of the rotation of the earth into twenty-four periods (hours) of fifteen degrees longitude each. Starting at Greenwich, England, which is reckoned as 0 degrees and moving westward, for every 15 degrees of longitude the time is reckoned as one hour west of Greenwich. Thirty degrees is 2 hours west; 45 degrees, 3 hours west; and so on through the 360 degrees of longitude.

The matter of converting your local standard time to Greenwich Mean Time is a simple process if you will bear in mind the difference in time between the two. Eastern Standard Time is five hours earlier than Greenwich Mean Time. When it is 12:00 noon in Washington, D. C., or any other place having 75th Meridian Time, it is 1700 G.M.T. Thus it will be seen that 1700

G.M.T. is 11:00 A.M. Central Standard Time, 10:00 A.M. Mountain Standard Time, and 9:00 A.M. Pacific Standard Time.

G.M.T. uses the complete 24 hours of the day without regard for A.M. or P.M. While it is rather difficult to purchase a clock with a 24-hour face, it would be well to take a spare clock and set it for G.M.T. and use it in recording all radio communications. With our ordinary clocks we would read time direct until 12:00 noon, but since G.M.T. makes no distinction between A.M. and P.M. the hours after twelve noon would be added to twelve to give correct G.M.T. Three o'clock morning would be written 0800 and three o'clock afternoon would be written 1500.

In keeping a log G.M.T. would be invaluable for at least one good reason. Suppose you heard a signal from a great distance and suppose the transmitting station wished an absolute verification of the record. Just see what a simple matter it would be to compare the logs of two or three dozen stations all keeping the same standard of time. It would make no difference if the recording stations were located all over the face of the earth—the time would be the same. No effort would be wasted in converting the time of a given meridian to that of another; the only factor that would have to be kept straight would be the date, which we all do now.

How many times has it happened that you receive a card from a distant Second District station informing you that your signals were heard October 4th, 3:19 A.M.? What does it mean to you? Not a thing unless you know that 3:19 A.M. means 3:19 A.M. E.S.T. or 3:19 Eastern Daylight Saving Time. Even then there is confusion sometimes because a number of operators forget that a new day begins at midnight. As a matter of fact you may not have been operating at 3:19 A.M. on October 4th, but perhaps you were operating at 3:19 A.M. on October 5th, and of course you write to the operator from whom you received the card and learn that he meant 3:19 A.M. E.S.T., October 5th. All that would be done away with. There would be no A.M. or P.M. or E.S.T. or Central Daylight Saving Time to confuse you. There would be one standard of time by which we all would be governed and keep our records accordingly.

It looks pretty good for our use, doesn't it?

F.H.S.

Thanks

NOBLE has been the response to our plea "Your Pen in Hand." We knew the stuff was there. The numerous valuable responses will do much to make our QST a better magazine for us all. We extend our hearty thanks to the fellows who are helping us.

This shows all the clearer that there is a world of good dope available. How about the rest of you? No doubt you read QST and we hope you get helpful suggestions from it. Do you realize that this magazine is co-operative and that you find valuable things in it because some other amateur wrote us about something he knew about? Are you doing your share as an A.R.R.L. member? Say, what do you know that's new and interesting?

And you chaps who've promised to write articles for us—we want to tell you about a fellow who died not so long ago. When he appeared before Saint Peter the good saint asked him what good he'd ever done on earth, and he replied "Oh, I was a good A.R.R.L. member and wrote articles for QST."

St. Peter beamed. "Step right into the elevator, please."

The good A.R.R.L. man smiled broadly, stepped into the elevator, and as the door clicked behind him asked:

"How soon does she go up, Pete?"

St. Peter smiled grimly.

"It doesn't go up—it goes down. You only promised to write those articles for QST!"

Is it necessary for us to say anything more?

Thanks.

K.B.W.

What Would You Do Without QST?

THE heading on this editorial suggests an awful state of affairs, doesn't it?

What would you and all the rest of our A.R.R.L. and the telegraphing amateur fraternity do if there wasn't any QST? We hate to think of it.

Did it ever occur to you, O.M., that you are directly and vitally concerned in keeping QST alive and coming to you regularly each month? It costs a great big piece of jack every month to get QST into your hands, so much that your yearly dues are not even a drop in the bucket. And we haven't any "angel" to back us up with coin. No, QST like every other magazine is dependent on its advertising. We have the interest of our readers always before us and do our very best to print only advertising that is worthy of your patronage. And that patronage, the thing which makes QST possible must be supplied by you!

You can find everything in reputable radio apparatus "from soup to nuts" in QST. Make QST your exclusive buying guide, get good stuff, and keep your magazine alive.

And don't forget, O.M., to mention QST when you write to advertisers. It tells them that you are an amateur of good judgment and that QST is worthy of their support as well.

E.C.A.

The Operating Department

F. H. SCHNELL, Traffic Manager
1045 Main St., Hartford, Conn.



NOT many months ago the Roanoke Division, comprising the states of North Carolina, Virginia, and West Virginia, was barely holding its own with some of the larger divisions in traffic handling. Today it's a different story and by continued hard work in organization, W. T. Gravely, Manager of this division, with the cooperation of every man under his supervision, has given the larger divisions something to think about. When a division the size of the Roanoke can turn in a traffic report of 1615 messages for

month. Every man is bubbling over with enthusiasm and is eager to make his division the best in the country.

We suggest to those of you who are having trouble getting your reports in on time, get in touch with 3BZ and get his method of operation. It's a winner.

The A.R.R.L. is proud of every man in the Roanoke Division. We congratulate you all.

C. J. Dow, of 6ZAC fame, has been appointed temporary manager of the Hawaiian Division.

Message Traffic Report By Divisions AUGUST

Division	Stns.	C.W. Mgs.	M.P.S.	Stns.	SPARK Mgs.	M.P.S.	Stns.	TOTAL Mgs.	M.P.S.
Atlantic	27	844	31	7	499	71	34	1343	40
Central	27	1101	41	23	1418	62	50	2519	50
Dakota	7	257	37	3	16	5	10	273	27
Delta	3	58	19	2	21	11	5	79	16
East Gulf	11	256	23	3	56	18	14	312	22
Midwest	11	469	43	2	24	12	13	493	38
New England	25	1216	49	3	106	35	28	1322	47
Northwestern	3	51	17	9	216	24	12	267	22
Ontario	4	50	12	0	0	0	4	50	12
Pacific	19	323	17	20	822	41	39	1145	36
Roanoke	33	1510	46	2	105	53	35	1615	46
Rocky Mtn.	2	30	15	2	5	3	4	35	9
Vancouver	3	19	6	5	101	20	8	120	15
West Gulf	11	220	20	15	433	28	26	653	25
Winnipeg	0	0	0	1	2	2	1	2	2
Total,	186	6404	34	97	3824	40	283	10228	36
C.W. Messages,	6404—63%								
Spark Messages,	3824—37%								
Total,	10228								

the month of August—there's a reason. That reason is organization and cooperation. Even during the best winter months Roanoke stations did well to roll up a total of four or five hundred messages.

Several months ago it appeared as though broadcasting was going to put a crimp in amateur traffic. Did those amateurs throw up the sponge and quit? They did not. They went right out and took the broadcast listeners into their clubs and converted a great number of them into telegraphers and A.R.R.L. men. Several of them even handled messages and reported them this

L. A. Benson, because of business pressure, had to resign and in his place we have George S. Turner, 9ZAD of Independence, Mo., as the manager of the Midwest Division, elected by a popular vote of the members thereof.

Individual traffic honors for the month again go to a spark:

```

*****
**                                     **
**      F. B. Ostman, 20M             **
**      Ridgewood, N. J.            **
**      Atlantic Division            **
**      408 messages                 **
*****
    
```

TRAFFIC REPORT

Roanoke Division—C.W.: 4BX, 166; 3MK, 142; 3BLF, 132; 4MW, 129; 8AMD, 101; 4GH, 93; 3IW, 70; 8AFD, 70; 3TJ, 60; 4DC, 53; 4LP, 50; 8SP, 49; 3BMN, 46; 4GX, 35; 3ZZ, 34; 8BDB, 35; 4KC, 32; 3BVC, 28; 3BVL, 25; 8BKE, 24; 4ID, 22; 3BIJ, 20; 4NT, 18; 3BZ, 16; 3CA, 12; 3ATZ, 10; 8BPU, 9; 8AQV, 7; 3MO, 6; 3AAU, 7; 4NV, 4; 8CAY, 3; 3AEV, 2; total 1510. Spark: 8BDA, 53; 4IE, 52; total 105.

Atlantic Division—C.W.: 3ZO, 109; 2BNZ, 80; 2ALY, 74; 2AFP, 67; 8ACF, 52; 3DT, 45; 8AIO, 41; 8BIL, 40; 3FS, 33; 8CKM, 32; 2BDG, 30; 2CDR, 28; 3WF, 27; 8CON, 26; 2BG, 26; 2BEM, 24; 8AOL, 21; 3ANJ, 20; 8BTR, 15; 2AJA, 8; 8ARI, 8; 3AWH, 6; 8ZQ, 5; 3EM, 5; 8AKW, 5; 8OW, 7; 2RZ, 1; total 844. Spark: 2OM, 408; 2BQZ, 26; 3FP, 22; 2ARB, 16; 8VE, 18; 3CS, 6; 3BTP, 3; total 499.

Dakota Division—C.W.: 9DR, 75; 9AUA, 67; 9APW, 34; 9AVZ, 33; 9BAF, 33; 9BAV, 10; 9EA, 5; total 257. Spark: 9AYW, 4; 9ZC, 8; total 16.

Rocky Mountain Division—7LU, 21; 7ZO, 9; total 30. Spark: 7ZV, 3; 7DH, 2; total 5.

Pacific Division—C.W.: 6BQC, 52; 6KA, 45; 6FH, 35; 6CU, 35; 6PI, 28; 6FT, 20; 6EN, 19; 6ALU, 16; 6BJC, 15; 6ZX, 11; 6JD, 10; 6BF, 8; 6ASP, 8; 6ZB, 6; 6BRT, 6; 6EC, 5; 6AQA, 2; 6AGH, 2; 6KY, 2; total 323. Spark: 6GR, 157; 6HP, 102; 6UP, 83; 6HC, 72; 6OD, 64; 6OL, 48; 6ASC, 43; 6FH, 32; 6ABW, 32; 6KE, 25; 6ALD, 24; 6AJH, 29; 6GT, 22; 6ANX, 16; 6IV, 14; 6ABX, 15; 6AVR, 13; 6ZB, 12; 6BPZ, 5; 6ASN, 4; total 822.

Central Division—C.W.: 8CGN, 190; 8FT, 141; 9OX, 105; 9BDB, 74; 8UC, 59; 8ZAG, 58; 9EI, 57; 8BVO, 57; 8CAB, 47; 8CGX, 39; 8ANB, 37; 8CMI, 28; 8CWC, 21; 8ZAF, 20; 8BEK, 19; 8CYT, 16; 8BEF, 15; 9DCR, 11; 8AKP, 10; 8CLD, 10; 8BAH, 5; 8AHY, 3; 8YR, 3; 8CZG, 2; 8TT, 2; 8AIB, 2; 9CBA, 70; total 1101. Spark: 8ZO, 344; 9ZN, 204; 8AIZ, 192; 8AUX, 169; 8AYY, 80; 8FT, 71; 8AIB, 63; 8AHY, 48; 8UC, 41; 8NR, 38; 8AUA, 33; 9MC, 28; 8CMI, 21; 8TT, 21; 8EB, 18; 8BEK, 13; 8ANW, 11; 8DHZ, 10; 8BXC, 8; 8BAH, 8; 8ALK, 7; 8CGX, 6; 9OX, 5; total, 1418.

Ontario Division—C.W.: 9AL, 20; 3JI, 17; 3JK, 12; 3FC, 1; total 50.

Delta Division—C.W.: 5DO, 30; 5WO, 16; 5NV, 12; total 58. Spark: 5ZL, 14; 5XAC, 7; total 21.

Northwestern Division—C.W.: 7OT, 41; 7UU, 8; 7IY, 2; total 51. Spark: 7BK, 86; 7GE, 42; 7IY, 31; 7AW, 25; 7BG, 17; 7JF, 6; 7FD, 5; 7PQ, 3; 7AT, 1; total 216.

East Gulf Division—C.W.: 4KF, 62; 4IV, 40; 4HW, 40; 4MN, 31; 4FQ, 24; 4EG, 22; 4AU, 20; 4KU, 5; 4EH, 5; 4BQ, 5; 4HZ, 2;

total 256. Spark: 4BI, 28; 4HS, 25; 4EZ, 3; total 56;

Vancouver Division—C.W.: 5BR, 7; 5BQ, 6; 5CT, 6; total 19. Spark: 9BD, 74; 5BR, 10; 3EC, 7; 5DO, 6; 5CD, 4; total 101.

West Gulf Division—C.W.: 5QI, 39; 5ZAY, 36; 5QS, 30; 5AE, 26; 5NS, 20; 5XV, 18; 5ZAT, 15; 5IR, 15; 5ZM, 8; 5OC, 7; 5DW, 6; total 220. Spark: 5TU, 86; 5TP, 61; 5ACU, 40; 5PE, 40; 5IR, 40; 5ZAE, 30; 5NS, 25; 5QI, 19; 5RW, 15; 5TH, 13; 5ACQ, 10; 5HC, 10; 5UG, 10; 5CM, 8; 5IC, 26; total 433.

Midwest Division—C.W.: 9AOG, 109; 9FK, 86; 9BGH, 82; 9JA, 53; 9AML, 29; 9BZI, 30; 9AMU, 20; 9BSG, 17; 9ARZ, 17; 9DKY, 10; 9BWE, 16; total 469. Spark: 9BMN, 16; 9DNC, 8; total 24.

New England Division—C.W.: 1CMK, 135; 1ACU, 122; 1BKQ, 112; 1BDV, 100; 1BVB, 94; 1CHJ, 89; 1CBP, 76; 1BAS, 55; 1IV, 53; 1AWB, 46; 1AJU, 40; 1BDU, 25; 1VT, 22; 1ABS, 18; 1AYU, 21; 1BQK, 18; 1ASF, 20; 1CK, 14; 1SC, 13; 1BRQ, 3; 1OZ, 3; 1QP, 2; 1ANQ, 111; 1HX, 14; 1BGF, 10; total 1216.

ATLANTIC DIVISION

Chas. H. Stewart, Mgr.

Because of reorganization no reports were received from Western New York or Eastern New York. Better get busy, fellows, or you will be dragging along through the good weather without reports. Sweep the cob-webs off your sets and show the rest of the country that you can handle traffic with the best of them. We want to see some big totals from New York, so hop to it. Appointments are being made as rapidly as suitable stations show themselves and there are plenty of vacancies to be filled.

PENNSYLVANIA: Thomas reports that his reorganization is just about completed and his stations will be in action immediately. 8AGR, 8VH, 8AHE, and 8CMB are pegging along every night. 8EK gains a good operator in 8BIL who attends State College this season. 8ZD has his district (No. 9) all completed. F.B. Owing to many changes in appointments, Rau, of Eastern Penn., lacks reports. 8ARI will be out of the game this year. 8BIQ boasts a new C.W. outfit. 8ZQ is increasing his power to 100 watts.

Heads up, men! The division manager has received a number of complaints from stations regarding reports for the Atlantic Division. The fault does not rest with the division manager. Our monthly report is made up from reports sent in by the individual stations through the district superintendents and assistant division managers. When an individual station fails to report to his district superintendent the fault rests with the station and not the division manager. Official Relay Stations have been

provided with forms for reporting message traffic and stations failing to report regularly will be dropped. There is considerably more traffic being handled than our traffic report shows but where are those reports? Remember this, there are many vacancies to be filled in the Atlantic Division and we want good stations in those vacancies. If you are in doubt as to whom you should write for appointment, consult this directory and be governed accordingly. Let's see how many of you are willing to lend a helping hand.

Division Manager, Chas. H. Stewart, St. David's, Penna. 3ZS.

Asst. D. M. Maryland, G. E. Deichmann, Jr., Park Heights and Bancroft Ave., Baltimore, Md. 3HG.

A. D. M. Northern N. J., R. S. Johnson, Red Bank, N. J. 2AWL.

A. D. M. Eastern New York, Dr. E. A. Cyriax, 219 E. 71st St., NYC. 2DI.

A. D. M. Western New York, A. H. Benzee, Jr., 196 Keystone Ave., Buffalo, N. Y. 8FE.

A. D. M. Eastern Penn., J. F. Rau, 2085 E. Kingston St., Philadelphia, Pa. 3FM.

A. D. M. Western Penn., W. K. Thomas, 17 Emerson Ave., Crafton, Pa. 8LF.

CENTRAL DIVISION R. H. G. Mathews, Mgr.

(Detailed report received too late to be included in this issue of QST.—F. H. S.)

DAKOTA DIVISION N. H. Jensen, Mgr.

This division has lost, by removal, one of its most faithful A.R.R.L. workers, to-wit: J. F. Carpenter, 9DX-9XI, of Minneapolis, who has recently moved to Denver, Colorado. "Carp" was city manager for Minneapolis for several years and did excellent work in organizing for the handling of traffic through Minneapolis. The Rocky Mountain Division has gained a valuable member. "Carp" reports that he will be pushing the key at 9ZAF this fall.

MINNESOTA: Traffic is still light, but has picked up somewhat since the last report. A real station is being erected at Superior and will be operated jointly by Bridges, Hagen and Kellar this winter. 200 foot towers are being built and a special building is being constructed to house the apparatus. The equipment will consist of a "knock-em-dead" 1k.w. transmitter, a C.W. transmitter of at least 100 watts and an ultra modern receiver using 3 stages of both R.F. and A.F. amplification. Traffic in this district is moving regularly from the Twin Cities to Brainerd directly and not in steps as reported in the August QST. It moves on regular schedule at ten P.M. every night from 9AUA to 9BAV. 9BAV has made arrangements with other

amateurs in that city to handle traffic only after 9:30 P.M. in order to have a listening period before that time.

9DR, 9AUA and 9APW are doing exceptionally good summer work. No other report of activities received.

NORTH DAKOTA: 9DOC has discarded his spark transmitter and is installing a 200 watt C.W. 9AEJ has been appointed City Manager of Fargo.

SOUTH DAKOTA: 9AVZ, the "young squirt," (otherwise termed "the sleeping marvel,") appears to have been the only active station in this district during the past month, judging from traffic cards received. With 50 watts he has consistently worked 5's, 7's and a number of 9's. 9YAK will be on the air with both spark and C.W. this fall and winter.

DELTA DIVISION J. M. Clayton, Mgr.

With the approach of fall we find radio activities increasing throughout the division. Many stations, having completed their remodeling program, are back on the air and handling a good bit of traffic.

ARKANSAS: 5ZL has had his license re-issued and is giving the ether more than its share out Lil Rock way. 5XAC is putting up a new shack and two 80 foot poles to be used in connection with a real C.W. set. 5WF, while trying out his 20 watt C.W. transmitter, was unfortunate enough to blow out two tubes besides the 500 volt generator. 5ZAZ is still in the hospital as the result of a motorcycle smash. New stations in the Arkansas, all C.W., are as follows: 5AAC, 5AEH, 5FB, 5AFQ, and 5YM.

LOUISIANA: 5KC, at Plaquemine has junked his gravel smasher in favor of a 10 watt C.W. set which has been reaching out unusually well. 5ZAP, 5LA, and 5UK of New Orleans do DX work whenever QRM and the weather conditions permit.

MISSISSIPPI: 5ZAU will remain out of commission until a new Dubilier arrives from the factory. No other stations heard from.

TENNESSEE: Mr. W. W. Rodgers, 5RZ, of Memphis, has been appointed district superintendent of the western section of Tennessee, which district will be known as District No. 1. Mr. Rodgers is an active member of the A.R.R.L. and will soon do some effective work in his district. Mr. S. W. Wilkinson, 5WS of Knoxville, has been appointed district superintendent of the eastern section of the state and his district will be known as District No. 2. Mr. Wilkinson is a live wire and says that he intends to make his district the leading one of the Delta Division. Mr. Chas. Cowan, 5WO, has been appointed city manager of Knoxville to succeed Mr. Wilkinson. 5WO has a 15 watt C.W. transmitter and is doing good work. 5WS is rebuilding his

set. 5HL is beginning to reach out to a few points. 5MB is using 20 watts of C.W., but doesn't seem to reach out. Mr. Wm. Landoline, 5MO, has been appointed city manager of Memphis, Tenn. 5IK and 5OZ will be on the ether soon. 5NV, 5BW and 5LJ report that they have been doing some good DX work lately but failed to send in a report of messages handled. How cum? 5RZ has had trouble with condensers and C.W. transformers. 5DA has not operated during the month.

EAST GULF DIVISION B. W. Benning, Mgr.

FLORIDA: District No. 1: Although activities have been on the decline this month, all of the DX men are overhauling their sets and preparing for a real season's work. 4ZE finds that the lure of the DX work and message traffic is too strong for him. He is taking the old set back to the farm and reconnecting it to a lonesome leadin and tuning her up. 4BP has erected a respectable mast and installed a well behaved gap. 4EZ has been doing a little work with his spark set this month, but the major portion of his time has been spent on improving his station in general. 4HZ is getting a nice ammeter reading with his C.W. set but is having difficulty in reaching out consistently. He'll get there soon and traffic will go through Jacksonville in fine style.

Districts No. 2, 3, and 4 can report no prominent activities, but we are assured by the dist. supt. of each district, that the DX stations will be on the job when the winter season rolls around.

SOUTH CAROLINA: The division manager wants to inform the world that South Carolina is going strong in the relay game. Mr. G. W. Etheredge, Jr., acting manager, dropped the following bomb shell on the division manager in the form of a report: 4FQ is reaching all over the country and handling traffic like an old timer. 4LA is on the air with a 10 watt C.W. set and is adding 10 more to it. 4EG is using C.W. and is putting the old traffic through in fine style. Not only is he working the northern stations but is beginning to put messages through to the Georgia, Florida and North Carolina stations. This is FB and it looks like our long hoped for relay routes are beginning to get into shape. 4JK is helping put the old state on the map by reaching out and handling traffic. Although we have no detailed report on 4JK's activities, the D.M. is pleased to say that Atlantic stations are in constant communication with him and that his sigs pound through in fine style.

GEORGIA: District No. 1: 4BQ has been off the air so long that we were afraid his new pile driving C.W. set had gathered so much dust that it wouldn't work when he tried it, but it is not the case. When

4BQ returned from his vacation in Maine and opened up on that 500 watt baby, the air around north Ga. was shattered for fair. (Honest, man, it's a crime to allow such a thing to be turned loose in the ether—B. W. B.) 4IV is leading the rest of the stations that have reported. We are glad to have you with us, 4IV, and long may you wave. 4MN is doing some fine work and has a regular daylight schedule with 4IV.

District No. 2: We know that stations in this district are handling traffic by the armfull but somehow it seems like pulling teeth to get a report through on time. What about it, you city managers and official stations?? Are you mailing your reports in on the 22nd??? In Atlanta the following stations are on the air nightly and handling traffic: 4BI, 4HS, 4KF, 4AU, 4HW, 4KU and 4EH. Although there is very little time to handle traffic until after midnight, quite a bit is being put through in spite of the continuous broadcast schedule of three local stations. 4AU is using a temporary 2 wire antenna with counterpoise, but is reaching out and doing the work. 4BI's old rock crushing spark is still burning up galena for the local broadcast listeners and is making life miserable for the whole town. (Sincerely we pray that he will junk it—B. W. B.) and 4HS has found that the only time he can work his spark set is in the early morning and is usually found about 4 A.M. pounding away in free air. Verily, the boy has brains.

District No. 3: NO REPORT. We know, however, that 4BY is overhauling his C.W. set for the winter and that 4GL is oiling up the old bug key. They will be there O.K. regardless of what happens.

ALABAMA: NO REPORT!!! WHAT ABOUT IT MAC????? Report from station 5ZAS in Birmingham states that said station will be on the air shortly with 50 watt C.W. and 1 K.W. spark. With the C.W. they should be able to break through the barrier that has always existed between Ga. and Ala. We are looking for them to do some real work when every thing is ready. Say, you fellows in Montgomery and Mobile, let's hear from you once in a while. Has static and broadcast music completely wrecked you?? Come on, let's get busy and do something.

MIDWEST DIVISION

The Midwest Division needs considerable overhauling in several spots. There are any number of real good relay stations that represent some of the most valuable links in our main East and West traffic routes. These should be worked up to the point where transcontinental traffic may go through every night when the weather is favorable. There should be no delay even though some of the jumps to the coast represent many hundreds of miles. A con-

certed effort on the part of every Official Relay Station in the Midwest Division will bring about the desired routes that can be relied upon for this class of traffic.

IOWA: An increase of amateur work is noticed in Iowa. Most of the fellows have gotten over the fear of QR'ing broadcasting and are returning to their sets with a renewed vigor. Practically every route in Iowa has been kept open the entire month through the good work of 9BSG, 9ARZ, 9FK, 9BGH, 9BZI, 9AMI, 9DKY, 9AEQ, and 9JA. 2FP and 6KA have been

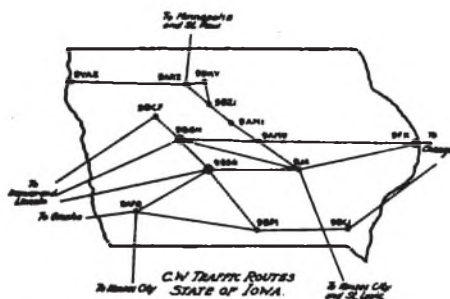

copied regularly by nearly every station. The map shows the routes through Iowa that are in operation day and night and every station is doing its best to move traffic within twenty four hours. 9FK has worked over 200 miles in daylight and is on the job every morning after midnight.

NEBRASKA: Omaha stations 9HG, 9DPB, and 9DSM continue to keep the hooks clear in all directions. 9YU has established communication with Texas and South Dakota stations and offers a good outlet for all westbound traffic. The station is in operation practically all day and is in daylight range of Omaha. 9DNC and 9AYS handle all traffic for Lincoln with the assistance of 9BWJ and 9BSQ. QRN seems to be on the decline and more stations are on the job preparing for a banner year.

KANSAS: Nothing heard from this state except for a report from 9AOG who leads in message traffic for his state. 9QO is breaking out and will do his share of relaying with the others.

MISSOURI: QRN and the heat prevent work in this state. The majority of the fellows has spent but little time on radio. 9YM will be back as per usual with the cooler weather. Interest in broadcasting seems to be decreasing and the old gang will be back stronger than ever this year. Most of them have had their fill of canned jazz and the dot and dash will be the order of the day.

As a result of the election in the Midwest Division, Mr. George S. Turner, 124 Pearl St., Independence, Mo. was appointed manager of the Midwest Division. C. Himoe ran a very close second having received but a few less votes than the 132 of

Turner. Turner is an old timer at amateur radio and we feel that the Midwest Division A.R.R.L. members have made a selection that they will not regret—all of you are duty bound to get behind Turner and push the division up to the top.

NEW ENGLAND DIVISION P. F. Robinson, Mgr.

This has been a big month for C.W.; the total traffic handled through C.W. stations being over ten times that handled by spark sets during the same period.

MAINE: Very few reports were received from this district this month, 1BAS, 1BRQ and 1BJS being the busiest stations with 1BAS (C.W.) leading in traffic handled. 1FB's summer station at Prouts Neck, Maine, (Spk. es C.W.) has been doing very good work but as Cumming is on his vacation he has neglected to report.

NEW HAMPSHIRE—VERMONT: No reports have been received from these sections of the division for some time and the division manager would appreciate any suggestions and recommendations leading to the appointment of A.R.R.L. personnel in these sections who will give us some reports for QST.

MASSACHUSETTS: McLean (1JQ) reports that all activities in the western part of the state are being handled by 1CMK and 1CHJ. So many new C.W. stations are popping up everywhere that the traffic per station is small and it is very hard to get complete reports from the newcomers. The old spark transformers are rapidly getting new secondaries put on them for C.W. and the way it looks now there will be no spark sets left (except as curios) by next year. 1BKQ (20 watts) has been reported in Colon, Panama Canal Zone. 1BQK is also doing fine work with his two five watt bottles. 1SC, one of the "spark hounds," also has a C.W. set he admits FB for DX but says it's hard to raise fellows with it. 1CNI, another spark artist, has been doing some good work and is handling a bunch of traffic but evidently is too busy to turn in a report to help out the spark percentage.

RHODE ISLAND: This is another of the heretofore reportless sections. Mr. Donald B. Fancher, 1BVB, has just been appointed A. D. M. so in the future some good peppy reports should be turned in. 1CDM has a good spark set in operation but as it blinks the lights and bothers the broadcasters he has to QRX at dusk. 1CBP and 1BVB are both doing good work with 10 watt C.W. sets. 1BVB gets on about 11:30 every night and is on until about 3:00 A.M. We understand that very soon there will be a Mrs. 1BVB to handle traffic before the OM gets on the job. FB. OM.

CONNECTICUT: 1QP reports that after trying every kind of antennae ever heard of and a few others besides, he

has returned to the good old fashioned flat-top or an imitation of it made up of small cages in flat-top form. 1TS is back on the job again and sure is welcome. What is the matter with Hartford, the home of the QST factory? Is 1AW listening to the broadcasts all the time? Why doesn't 1HX lay off that cootie and send in a report, also how about 1MO and 1BHW? Let's have report from everyone who handles one or more messages per month. (OK—1BHW and 1MO—will send a report every month—but give us a chance to get going. You want QST on time, don't you? Your patience in that respect has been rewarded—QST is out on time, likewise reports will be forthcoming as soon as we can spare the time from QST to rig up an antenna.—KBW ea FHS) Sa, 1QP when ya goin ta b on fr tt msg I got fr ya? —1HX.

NORTHWESTERN DIVISION
H. F. Mason, Mgr.

Conditions are rapidly approaching those of winter. Many of the stations that have been off the air this summer and whom we thought had given up the ghost, are blossoming out with C.W. sets of every description. (F.B.—T.M.)

IDAHO: 7WG reports static on the decline, but no messages handled. 7ZM is deep in broadcasting. There are a few stations in Northern Idaho at present. A. R.R.L. members in this vicinity please write and send prompt reports to W. J. Sutherlin, NezPerce, Idaho. 7JF seems to be handling traffic on spark in spite of the static. He has been appointed D. S. for that district. 7JD has been appointed D. S. for Central Idaho district. 7CK, and all other A.R.R.L. men in this district, please get in touch with you D. S. 7LN is the new D. S. for southern Idaho. No relaying is being done as the QRN is very heavy, and all stations are spark. Hi! However, 7LN with 100 watts, and 7CG with 50 watts of C.W., will hold down this end of the state this fall and winter. 7OT has his new 100 watter on the air, and 7YA will soon blossom out with 150 watts of C.W. The spark has been discarded at 7OI and all messages that were handled at 7OT through the heavy static that has been encountered the last month, were handled on C.W. All C.W. stations, especially those in Montana, Wyoming, and 9's, are requested to please write A.D.M. Bliss, 417 Bannock Street, Boise, Idaho, 7OT, and get in line for shovelling traffic over the Northern Route east this winter.

OREGON: 7IW, 7MF, and 7OZ handled most of the traffic, a considerable portion of which is relay traffic between Washington, Oregon and California. 7MF has worked 9WU of Denver on one 5 watter. Someone is wanted around Medford or Roseburg

to take traffic, as that district seems dead. 7BH has sold out and entered the game of matrimony. (Congrats, OM.) 7TJ is on at times, but is not handling much traffic. Everyone in Portland seems to be on a vacation, or else dead to the radio world.

(Come on, fellows, kick through with those message reports, and let the rest of the gang know you're not dead—D.M.)

WASHINGTON: Traffic has been moving with fair regularity over this section of the division the past month. C.W. is leading the way in cutting through the QRN. There are still a number of districts in the state which have no Dist. Supts. Some of these districts have no stations, and from the looks of things, will not have for some time. Districts 4, 5, 8, and 10 are still without Supts. No doubt these appointments can be filled before long. Mr. Robt. Waskey, 7UU of Seattle, has been appointed D.S. for district No. 7, comprising the counties of King, Kitsap, Snohomish, and Island. Most of the traffic in and out of Seattle is going through 7BK. 7FR has been off the air for some time, putting up a new antenna. The C.W. bug has bitten hard in Seattle; many of the gang are putting in sets, or already have them. Among them are 7BK, 7FD, 7IM, 7IB, and 7PQ. 7IY has been doing some good receiving. With a variometer set and a 1500 foot Beverage wire, (which, by the way is nothing more than #14 iron wire, common hay-wire) has logged every district except the first (come on, 1AW). His log includes 14-8's, 25-9's, and 5-4's. At present, 8AQO of Syracuse, N. Y., is testing with him, and if signals remain consistent over the period of two weeks, arrangements will be made to shoot traffic through on schedule all winter.

L. C. Maybee reports as follows: The summer season has started on the decline, nights are much longer, there is a grand old feeling of those winter nights on the air, and QRN is seldom very bad. Taken as a whole, this summer has been a remarkable one from the radio viewpoint. The C.W.'s have pounded through, and sparks have held an audibility that crowds the winter average. QSS has been more marked, but practically all the reliable winter sparks have held up during the summer. Traffic north, south, and west goes through fine, but the eastern work has become nil. 7TH is getting into the game with 10 watts C.W. 7ZS reports that he is having trouble hooking up with anyone, as they don't listen on 375. He is also having a hard time getting lined up with an eastern station to put his eastern traffic through. 7FI is off the job for the summer. Spokane is dead again. 7QE is out on a camping trip with his flivver. He will have some dope as to relay stations that are scattered around the state: 7AW has come into the relay game and is doing good work.

ONTARIO DIVISION
A. H. K. Russell, Mgr.

Despite vacation time, Ontario division stations took a hitch in their trousers this month and lots of good hard constructive work was done. Those relayers who went on vacations took their receivers with them and did some work for calls heard.

District No. 1: 3BV has a 50 watter going and 3NB has been copied in Toronto on tests with C.W. 3TA in Tillsonburg is putting in 5 watts C.W. 3MN has left London and moved to Windsor. 3ABX is about to burst forth with 20 watts of C.W. 3XN in London is working on 10 watts.

Gowan reports that 3BA has been appointed Deputy Radio Inspector for Brantford. Gowan, despite his convictions that broadcasting is all wrong, has gone the way of all flesh and is installing a broadcasting station for a Kitchener paper. Nothing doing in relaying though. Toronto has been decidedly lively. 3JI, 3JK, and 3FC are back from the holidays and are handling traffic nightly. 3FO and 3GE are back on spark, louder than ever. 3GE reports he is installing 50 watts C.W. 9AL is also rebuilding but will be on again soon. 3HE and others in Kingston are planning for a good relay route through there, and report Queens University has lots of power available there (C.W.) if they can be prevailed upon to use it for relay work. 3HE is taking a flier in the business end of radio.

PACIFIC DIVISION
J. V. Wise, Mgr.

Hereafter all districts will be known by number instead of letter as used at present.

This change is necessary to keep all divisions as near alike as possible. District A is District 1; B, 2; and so on down the line.

The appointment of stations to their respective trunk lines will be started the first part of October, also at this time the traffic check cards will be distributed to trunk stations only. The number of stations that are out for the summer is the reason for the delay in above work.

District No. 2: Little traffic being handled due to heavy QRN encountered in the south. Aside from this, many stations are under repair, while the operators and owners

of others are enjoying their summer vacations. 6AJH and 6AVR are now adding a tube set to their equipment. The following stations made a traffic report: 6ZB, 6AJH, 6EG, 6GT, 6IV, 6AVR and 6ANX. This is a splendid showing over the last few months, and the old San Diego gang are coming into their place in line again.

District No. 3: A total of twenty stations reported this month with a combined total of 524 messages. We may note here that C.W. stations greatly outnumber spark. Excellent results have been obtained by 6EN and 6JD from radio frequency amplifiers and

loops. Work has been made possible through QRN and QRM that was laughed at when mentioned a few seasons ago. The winter will find several 100 watt tube plants going full blast, and of course, the present gang.

District No. 7: Work has fallen off due to several of the old reliables taking to sea for the summer. 6ABU, 6ASJ and 6ASN are holding down the C.W. end of things, while 6HP and 6AOA are two good reliable spark stations, the latter the well known old QRM factory that made 6ZZ famous. We



hope he keeps up its former work. 6IK and 6DR have C.W. equipment, so two sparks have gone the way of the many old timers—the junk heap.

District No. 8: The fellows in this district and particularly the gang in Sacramento have paid no attention to QRN this summer. You will find two or three on the job every night from 7:00 P.M. until 2:00 A.M. 6FH deserves considerable credit for sticking to a tube set which for some time was not equal to his concert buster, but he has his old spark beat many ways now. 6GR, the hard boiled spark owl, is heard with his 20 watt tube set and he is talking about adding two more tubes. 6LO and 6GX have gone into C.W. 6ZX is now a 30 watt C.W. instead of 20. Due to the central location of this district, traffic is handled direct to the north and south borders of the country. The summer QRN has not cut these ranges down, although the east route remains closed via the north and central routes.

District No. 9: 6CC and 6TC are the only stations working in this district; both are spark and continue to lead in the amount of traffic going north.

ROANOKE DIVISION W. T. Gravelly, Mgr.

While the report of last month for this division showed a wonderful increase in traffic handled and improvements in conditions all over the division, this month's report will chronicle an even more astounding development which might well go down in history as the remarkable awakening of the Roanoke Division. Our message report shows an increase of over 200% in the last two months. The cooperation of the entire personnel and the fine spirit shown on all sides is the reason for this fine showing in the midst of the worst part of the radio season. The proportion of C.W. to spark messages was ample proof of the ability of C.W. to overcome QRN.

Virginia and North Carolina are neck and neck in traffic handled, with West Virginia coming steadily upward. The completion of daylight schedules and conversion of BL's are the outstanding features of the month.

Fellows, your division manager is proud of you for the wonderful work done during the two worst months of the year. We led the whole United States in C.W. traffic last month and next month we will surely have over 2000. This is certainly wonderful when it is considered that several months ago 500 was considered a good month's work. You have ability to operate under the most adverse circumstances and we know that the coming season will see the Roanoke Division leading the country as it has done for the past two months.

WEST VIRGINIA: Conditions in this state are rapidly becoming normal again

and A.D.M. Heck reports that next month will show a great increase in traffic.

District No. 1: 8AFD leads with 8SP close behind him in traffic handling. 8BPU and 8AQV are also handling traffic in this section.

No. 2: No report. Let the A. D. M. know that you are still alive and kicking.

No. 3: 8CAY helps the total out with a few messages.

No. 4: 8AMD leads West Virginia. He was operating at Camp Greenbriar assisted by 5RL. While there he did considerable missionary work for the A.R.R.L. He is a confirmed traffic hound.

No. 5: 8BDB is very active, likewise 8BKD. 8ABW will be back soon.

No. 6: 8BDA, the super spark station is going strong. 8WD and 8BAZ have combined their forces in making this station THE spark station of the state. They report their signals reaching out in QRN and are out after C.W. scalps. The erection of this station has renewed the C.W.—spark war in West Virginia which will be watched with interest.

NORTH CAROLINA: Wonderful spirit shown in this state and the ability of the operators has worked wonders for the traffic report.

District No. 1: 4GX and 4DC were the only active stations. 4EN is back in the air but too late to get his name on this month's traffic report. 4NV has been appointed an official relay station and contributes to this month's total. With 4CX and 4EN back in the game together with 4NV this district will be one of the most active in the future.

No. 2: D. S. Jackson is especially active in his district and is a live worker and A. R.R.L. booster. Majority of the stations are located at Asheville with others at Shelby and Brevard. Asheville stations are on continually from 8 P.M. to 4 A.M. every night. 4IE, 4MW, 4GH, 4KC and 4LP and ADS are all active as the traffic report will show. 4LP with one 5 watt tube is getting some remarkable distances in daylight.

No. 3: 4ID is the lone member of his division at present. Charlotte still remains dead to the world as far as relay work is concerned.

No. 4: 4BX maintains schedules in all directions with two operators and is very active. 4EA is going strong. B. L. Haiiut, at Wilson, N. C., is a new comer with the significant initials B. L., meaning broadcast listener, which he was up to a month ago. His conversion to the real game and the erection of 4NT and the 18 messages handled shows what a B. L. can do after once seeing the light. Welcome, OM, and more power to you.

VIRGINIA: Daylight work and the de-

velopment of new schedules are the features of the month. Strange to say there was not a single spark traffic report in the state. This month it is 100% C.W. Some monthly reports are missing and A.D.M. Wohlford wishes to emphasize strongly the necessity for a complete report from every district, if the state is to be represented in its true light. Reports should reach him not later than the 18th of the month.

District No. 1: 3MK is doing the majority of the work using 100 watts. 3BVC with 20 watts is also active. 3ZZ is busy with 100 ft. masts getting fixed to open up the new 500 watt set. 3ATZ, 3ACK, 3BNE, and 3ACZ are all overhauling.

No. 2: More stations are being added in this district and the fellows are getting on the job in earnest. The howl of the B.L.'s has been overcome and peace reigns. 3TJ has a regular daylight schedule with 3MK on Sunday and is also working Petersburg daylight. 3AWW and 3BNM are active in Petersburg.

No. 3: 3BVL is coming along. 3MO is back on the air and will turn in a large report next month. 3BIJ is still in the running.

No. 4: 3BLF is now working 100 watts and handling traffic consistently. He has the only station in the district and is anxious to locate others.

No. 5: 3IW is off on a naval cruise next month—we will miss his traffic. He did well this month.

No. 6: 3BHL is out of the States, consequently, no report.

No. 7: No report. There are three or four stations in this district that can be lined up to handle traffic and we need them badly. Get together, fellows and put your District on the map.

No. 8: Mr. C. M. Owen, Box 119, South Boston, Va., will take over the district at once and any stations not lined up there will please get in touch with him. Lynchburg please notice. His call is 3APR, using 10 watt C.W. Next month's traffic report will show his work. 3BZ and 3AEV are working as much as conditions will permit.

No. 9: 3HL is working C. W. and getting out some, but very little traffic is being handled.

No. 10: 3AOV is taking his vacation in the west.

ROCKY MOUNTAIN DIVISION
N. R. Hood, Mgr.

It is with great pleasure that I submit for the approval of the members of this division my first monthly report as Division Manager. The division has been in a chaotic condition and only by hard work on the part of all of the members of the division will it ever again resemble a good healthy

A.R.R.L. organization. Our chance lies in the time between now and the opening of the fall season, and during that time, if we get our shoulders to the wheel and by the time the QRN drops from our phones, we can have the entire division personnel lined up, and in working order for the winter rush. The advent of C.W. in this part of the country has been a great boon to our game in general. The QRN entirely blots out all spark signals from any distance, and had it not been for the little bottles, our traffic report would be almost nil. The routes throughout the entire division will be revised. All outstanding appointments, such as office appointments, and official relay station appointments, are hereby cancelled. In order to retain your station as an Official Relay Station, the individual stations should, at once, get in touch with the A.D.M. for their state, sending in the old certificates and new ones will be issued. We will consider the official stations in the division from now on, as our organization proper for the handling of special relays, tests, etc., so those of you who are official stations will do yourselves and the League justice by sending your certificate to your A.D.M. at once. If you hold office in this division send in your appointment certificates to the A.D.M. for your state, for new certificate. In the event that you are no longer to hold office you will be notified to that effect. Some of the division personnel have already been changed, and the change was made because those who were in office failed to do their part. It takes just a few hours work a month on the part of the division official to make things hum and just a few minutes work on the part of the individual station owners. The division manager is looking at you all alike, that is, you will do your part until he is shown different, and then changes that are necessary surely will be made. The A.R.R.L. has made it easy now for each station to report its traffic, so please use those cards to forward your report to the A.D.M. or Dist. Supt. When you run out of cards notify your Dist. Supt. or A.D.M. in time so that you will have a card on hand for next report and they will be forthcoming. The division personnel now stands as follows:

A.D.M. for Colorado: R. C. Schryver, 2111 So. Franklin St., Denver

A.D.M. for Wyoming: F. N. Mitchell, Box 575, Greybull, Wyo.

A.D.M. for Utah: Elliot Johnson, Ephraim, Utah

Dist. Supt. Colo.: Philip Laskowitz, c/o Reynolds Radio, Denver

Dist. Supt. Utah: Evan Seegmiller, Richfield, Utah

The A.D.M.s have their eyes open for good men. Great things will come of amateur radio this winter so you who are am-

bitious and get busy will be on the official ship. We need several Dist. Supts. and City Managers, and they will be picked within the next few weeks, so get busy and let your A.D.M. know what you can do and the extent of your ambitions so that we may get our new men. The A.D.M. of your state will handle this entirely so what he says regarding appointments in his state will be final. The certificates will be issued from the division manager's office.

The new routes will be made up as soon as the D.M. can get a check on the good stations. It would help if the relay stations in the division would notify the A.D.M. what stations they work best so that we may work up the most logical routes. Those who can work on a schedule are especially wanted. Just sit down and write your A.D.M. a letter, explaining what you have done, what you can do with your station, and what you would like to see done in the division as we are here to please the majority and to work together toward one end—the advancement of amateur radio and the A.R.R.L.

COLORADO: Traffic through Colorado has shown an awful slump due to stations not reporting their traffic. There is no excuse now as the cards have been mailed for the purpose of sending reports in to either your Dist. Supt. or the A.D.M., of the traffic handled.

Stations 9BXA, 9DVJ, 9BUN, 9XAQ, 9AYU, 9AMB, 9DTE, 9BXQ, 9DUC, 9DHI, 9BJL, 9XAI, 9DTH, 9AWL, 9DTM and 9DVA are all in operation in Colorado and with the addition of the stations that always open up when the season becomes good, Colorado will have a bumper season this winter. Stations 9XAI and 9XAQ are schools and are of course closed through the summer season. 9XAQ has been a good station in the past and we are anxiously waiting the opening of the station again.

9DUC has arrived in Denver from Chicago where he has been giving the radio activities the once over and will soon split the air with his set. 9AWL is rebuilding from aerial to ground. 9DHI reports sigs. QSA on his Reinartz and is ready for traffic. 9DTE has two "fifty watters" about ready to split the phone diaphragms. We will bend our efforts this year more than ever to the establishing of routes, on which we will have our most reliable and consistent operators and a place on them will be worth having if you really want to relay, or if you really have the interests of the League at heart.

WYOMING: 7DH has 10 watts C.W. and phone on a ranch in the mountains and has a 32 volt lighting system from which he will run his motor generator set. 7ZV, another one of our old timers and who had the prize spark set in Wyoming, has turned up his toes and quit his spark,

but has a neat 20 watt C.W. and phone. 7AFW is a new comer among us. He is working 10 watts C.W. and is QSA at Casper in daylight. 7GK sends no report of the activities down his way.

UTAH: Utah is rapidly getting ready for the winter rush. 6ATQ and 6ATH are each installing 10 watt C.W. sets and 6BNJ is putting in five watts. All the old gang with their rock crushers and C.W. sets are ready and traffic is moving a bit now. QRN has been unusually heavy this season, only three nites which could be called good nites, throughout the entire month.

Mr. Evan Seegmiller has been retained as Dist. Supt. for District No. 2, which includes Provo and all the territory south thereof. Any Utah station who is or thinks that he is qualified to be an official relay station, get in touch with the A.D.M. so that the new routes can be made up at once. We need a Dist. Supt. for District No. 1, the territory north of Provo, so put up your man, gang. This must be done at once as we feel the need of him already. Utah stations please get in touch with the A.D.M. as soon as possible. Address 6ATH, Ephraim, Utah.

VANCOUVER DIVISION

W. D. Wood, Mgr.

5CN has just raised a beautiful specimen of a 90 ft. B.C. toothpick and will be going strong with 50 watts C.W. 5AK is open for traffic. There are several stations in P.R. that will make themselves heard before long. 5CX now has a 15 watt C.W. set built for him at Vancouver by 5BR. 1200 miles was covered the first night with this set when tried out at 5BR, and only ONE VT-2 was used at the time. We are still waiting for a good transmitter and relay station for Victoria. 5CT is getting out fairly well on 5 watts C.W. He is increasing power and remodeling. Present indications point to a very good relay season and when the time comes for a Trans-Canada Relay test the Vancouver Division will be QRV-GA. At Calgary, Alberta, we now have CFCN, with 100 watts of C.W. on 275 meters. CFCN is handling traffic with 9BD on schedule. Among the Vancouver amateurs there are 5DO, 5EC, 5DK, 5CJ, and 5CD who are on at various times, but don't get very far.

How about that Trans-Canada Test, you easterners?

WEST GULF DIVISION

F. M. Corlett, Mgr.

El Paso Texas, and the nine counties immediately east have been re-assigned to SOUTH TEXAS SECTION. This District has been under the supervision of the New Mexico Asst. Div. Manager for some time on account of communication difficulties be-

tween Houston, Texas, and El Paso. This, however, has been overcome and the re-assignment to south Texas was deemed advisable. A dist. supt. for this district, which will be known as District No. 4, South Texas, will be announced next month.

District Superintendent appointments for Oklahoma are:

No. 1. Northwest Oklahoma: Chas. E. Whartenby, 5ZM, 801 West Oak St., Enid, Oklahoma.

No. 2. Northeast Oklahoma: C. M. Selby, 5BM, 1163 Locust Street, Muskogee, Oklahoma.

No. 3. Southeast Oklahoma: J. Wayne Cargile, 5KE, 209 Second St., McAlester, Oklahoma.

No. 4. Southwest Oklahoma: Donah. H. Boyette, 5DS, 111 North 7th Street, Lawton, Oklahoma.

Members having transmitting stations that desire to secure official relay station appointments should communicate with the dist. supt. of their district. There are a few stations in Oklahoma that are not members of the A.R.R.L. To these we extend a cordial invitation to join as relay work is really radio pleasure.

We are glad to welcome one of the old timers, Roy. W. Layton, back in active relay work. Roy Layton is in charge of 5AEJ, an excellent amateur station owned by the Allison Motors, Corsicana Texas, and he has been selected as district superintendent for district No. 2, north Texas. A number of official relay station appointments have been issued. No report has been received from assistant division manager, Louis Falconi, of New Mexico section this month.

SOUTHERN TEXAS: Prospects for a splendid relay season were never better than they are at present in this portion of the state. There has been an early cool spell which has added to the already increasing interest in relay work. Practically all stations in the vicinity of Houston will be using single circuit tuners for C.W. reception for they have already proven themselves to be just what the DX relay man has wanted. [?—Ed.] The reorganization of the traffic department has done much already toward a very successful system of operating and is already showing the result of a chain of higher class stations. Southern Texas has been divided into four districts as follows: No. 1 is east Texas, and is supervised by Harvey C. Sundstrom, 5AAU, district superintendent, 1716 Lubbock St., Houston, Texas, and application for official relay station appointments for east Texas should be addressed to him. No. 2 is designated as Central Texas and is handled by E. A. Sahn, New Braunfels, 5YK. No. 3 is known as West Texas, and comprises that portion of the state from Bexar county to the Rio Grande; 5ZAE, L. D. Wall, 216 Pereida St. at San Antonio has been ap-

pointed dist. supt. No. 4 will be known as Far West Texas, and will be composed of nine counties adjoining El Paso. Dist. Supt. for that portion not yet named. Radio clubs and isolated individual stations are requested to correspond with their dist. supt. nearest in order that all traffic routes may be completed at the opening of the relay season. The requirements for obtaining an official relay station appointment are: A station that will be kept in constant working condition (not torn down from time to time, rebuilding, enlarging, etc.) and operated at least a few hours daily to clear traffic; a dependable operator who will try to keep his hook clear; and a member of the A.R.R.L. If you can qualify to the above three cardinal requirements, your district superintendent would like to get in touch with you at once.

5AE, 5XV, 5HZ, and 5OC are the busiest stations at the present writing. In central Texas, 5CG gives promise of an excellent relay point; the station is located on top of the Cotton Exchange and is operated by Marion Apple, formerly of McKinney. 5QA and 5ZU are among the few central stations in operation.

West Texas report is short but interesting. 5ACU leads with 5ZAE a close second, and 5HC as a good third. 5ZAK has moved back to Camp Travis and is building a new shack and everything. Practically all traffic in this district has been handled on an "early morning plan." Laredo is still in the game though heavily handicapped this month by electrical storms daily. 5MT and 5ZAN both building better sets, as usual.

Far West Texas is coming on nicely with renewed life at El Paso. Some good C.W. sigs. from there have been coming east in fine shape.

OKLAHOMA: 5ZAT is constructing a self-supporting mast 130 feet high, which when completed will give Okla. City two of the highest amateur masts in the southwest. 5ADQ is installing a 100 watt C.W. 5ZG has completely rebuilt everything and will be going strong again with the 100 watter. 5BM is having quite a time getting things arranged for winter work. 5LB seems to be getting out in fine shape now. In our North West Dist. No. 1 we are going to rely almost entirely upon 5ZM as he appears to be the only operator who will be on every nite. 5PU and 5ZZ will be on part of the time. 5XT will handle traffic when WKY is not in operation.

NORTH TEXAS: Traffic in this section seems to have picked up a little over last month's report, as there is still a great deal of rebuilding and broadcast listening which seems to have the lead at present. 5ZH will open a route west to the coast working spark and C.W. on 200 and 375-meters. C.W. will probably solve the prob-

(Concluded on page 57)



British Relay League Formed

We note with pleasure in *The Wireless World & Radio Review* that Mr. Y. W. P. Evans, Hon. Secretary of the Manchester (England) Wireless Society, has obtained permission from the Postmaster-General to form a British Wireless Relay League and solicits correspondence with British amateurs with a view of forming such a League as early as possible. Heretofore we have understood the P. M. G. has been of the view that amateur relaying must be prohibited because it was a kind of competition with the telegraphs, which in Britain are owned by the government; and this attitude has hitherto held to such an extent that only testing has been permitted to British amateurs. The present authorization must be interpreted as a most pleasant indication of the growth of liberal views in radio matters abroad.

The A.R.R.L. has been in correspondence with the gentlemen proposing the formation of the B.W.R.L. and hopes to be able to cooperate with them as a sister organization in trans-atlantic relay activities. Best o' luck!

Need for an International Language

The A.R.R.L. is continuing its examination of the possibilities of an international artificial language for official adoption for use in international amateur communication. Members who are informed on the subject are requested to write the Secretary and present any helpful suggestions that occur to them, particularly whatever arguments they may be able to advance in favor of any certain language for this purpose and data on the extent to which the said language is organized thruout the world.

Esperanto is a favorite at the present writing but its opponents charge that it is very difficult to express oneself in the semi-technical conversation of amateur radio in that language, which they contrast with the possibilities of Ido, another such language which seems to have many boosters. The Secretary will be glad to hear from the disciples of these respective languages.

England Transmitting This Winter
The Manchester Wireless Society expects

to have a 1 k.w tube transmitter in active operation thruout the coming winter for the special purpose of testing with American amateurs. The antenna is already erected. This station is Britain's main hope in the "west-bound" Transatlantics announced elsewhere in this issue.

Coursey with Dubilier

Mr. Philip R. Coursey, late assistant editor of *The Wireless World & Radio Review* and manager of the British arrangements in the Transatlantic Tests of last winter, is now attached to the Dubilier Condenser Co., Ltd., as technical expert, with offices in London.

British Broadcasting

At last a definite scheme seems to have been agreed upon in Great Britain for the handling of the broadcasting problem. Articles of association have been prepared for an organization known as the British Broadcasting Company, to be owned by the manufacturers desirous of participating in broadcasting and to which any bona-fide British manufacturer is allowed to become a member. The arrangements are awaiting the approval of the Postmaster-General at this writing.

The license fee for broadcast-receiving stations is being increased from \$2.25 to \$4.50 per annum, the amount of the increase to be turned over to the Broadcasting Company to apply towards the expenses of operation, and a further contribution will be paid by the manufacturers as a percentage on each set sold by them. Profits of the broadcasting company are to be limited to 7½% per annum.

No foreign-made wireless apparatus is to be allowed in Britain for a period of two years. They are differentiating in the licenses between broadcast receivers and true experimental or amateur receivers. The former must be of such a design that they cannot tune below 300 meters or above 500 meters, must be absolutely incapable of radiation, and, we understand, are prohibited the use of the single-circuit tuner.

There will be eight transmitting stations, situated in London, Birmingham, Cardiff, Manchester, Glasgow, Aberdeen, Plymouth, and Newcastle, all run on different wave

lengths, and of sufficient power to be heard anywhere in the country with a three or four-tube set. Daily broadcasts from 5 o'clock to 11 P.M. are contemplated.

French Letter

Dr. Pierre Corret, frequently mentioned in our columns as the editor of *La T.S.F. Moderne*, organ of the *Societe Francaise d'Etude de Telegraphie et de Telephonie Sans Fil*, of which society he is also the vice-president, very graciously has agreed to



Here is Dr. Corret at a receiving station which he constructed in the French army during the war. In 1914 and 1915 he was in a little village in the Vosges. No tubes were available and he had to make use of cardboard tubes for the coils, odd bits of wire for the windings, wood rulers for the sliders, and he had even to make his square holes with a half-round file! In spite of which, however, this set worked very well and copied German messages which the headquarters set could not pick up.

give us a summary of interesting French amateur news from time to time. We present his first letter with pleasure:

"I will send you herewith the information which may interest readers of *QST* on the subject of the development of amateur radio on this side of the Atlantic.

"The most interesting thing at this moment is the preparation of the new law on radio. To tell the truth, there never was a truly legal definition of reception. Ten years ago when I published the first amateur manual in France, they presumed merely to absolutely prohibit receiving, and this by the simple decision of the Under-Secretary of State for Post and Telegraph, altho a law would have been necessary. Then there were a whole series of decrees, just as illegal as the Under-Secretary's of the State. These decrees no longer prohibited reception but presumed to compel the amateurs to request an authorization and to pay a tax. Finally, during these later years, they have prepared a law according to which it is not necessary to request authority but it is necessary to make a declaration and to pay a tax.

"The progress in ten years is evident as tending towards legality and liberty; first the simple decision of the Under-Secretary of State prohibiting reception; then the decrees prescribing the request for authority, and finally a law asking nothing more than a declaration.

"In addition, the juridical sub-commission entrusted with preparing this law submitted the project to the principal manufacturers or constructors and to the amateur societies, in order to have their advice on the subject. Such a thing as this had never been seen here before and shows that they are beginning to consider the amateur in France as no longer a negligible quantity. This communication on the other hand had the effect of showing the juridical sub-commission that it was not easy to regulate receiving and the commission has, it seems, abandoned for the present the idea of framing a law. On account of the probable progress in the science of radio it is going to issue provisional decrees.

"But I ask how can these be legal, and above all how they can be applied or enforced, for, up until now, never a one of the decrees were ever enforced! What will it be now when any one can receive at home on a loop without anyone knowing anything about it! The new law or the new decrees will be enforced no more than the others were and we will therefore come little by little to the inevitable normal turn of evolution; unrestricted and free receiving and regulated transmitting. But for this we must let the old administrative routine have time to adapt themselves to new conditions!

"We complain in France, but conditions in Switzerland are a lot worse! The general administration of telegraphs there has just put out some absolutely grotesque decrees regarding tests which might be made thru radio telegraphy. And yet "Free Switzerland" is commonly mentioned in Europe as almost equal to "Free America"! Those who wish to make a receiving test must ask for authority 15 days in advance. Such authority is subject to a tax of 10 francs when the entry is made. An official of the telegraph administration is present at the test and watches to see that the reception of signals is made within the prescribed limits. It is forbidden the tester, as well as his assistant, to listen to or copy signals heard during the course of a test and to give their meaning to a third person. It is likewise forbidden to make use of loud speakers or any kind of automatic recorder. All this is to avoid divulging telegrams which any amateur might receive at home

on a loop without the telegraphing administration being able to stop him listening!

"The free Americans might well laugh at the assinities of poor old Europe!

I read with interest in the June QST your little article on page 32 entitled "Circuits." Besides the four hookups mentioned, Colpitts, Hartley, Meissner and the Reversed

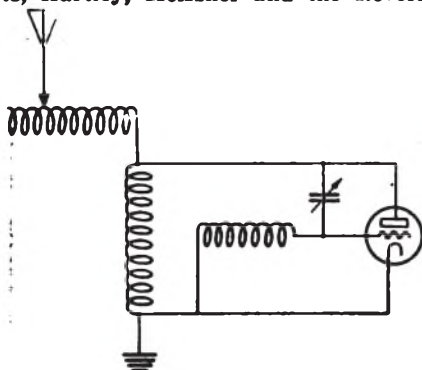

Feedback, the French army uses another hookup with electrostatic coupling between the grid and plate, which may be shown as follows, using a diagram similar to yours.

"You ask me as to my opinion of the value of Esperanto for transatlantic communication between the amateurs of America and Europe. I am convinced that it is very convenient and easy to understand. I needed only 20 days to learn it well enough to correspond with Esperantists speaking 30 different languages, and some months to speak it with men of many different languages in the International Congress of Esperanto.

"I am certain that for telegraphing communication one month would be sufficient for the intelligent American, and even less if they already know a foreign language.

"Before Esperanto there were many international languages proposed. Idiom Neutral is one of them. But this remains only a project and is not practical. In the same way, after Esperanto have come many other projects of different individuals who have always found "something better." The most noted is Ido, which got a lot of publicity and made a lot of noise, but did not collect many experts. It is easy to make up a new language the same as it would be easy to make a "better" Morse code. But what would be the use if each one had his own "better" code? The important matter is that all have the same. The same holds true for an international language. Esperanto shows itself very good and now has many experts throughout the world. Without doubt another language just as good could be made up or even "better," but the only important thing is that everyone speaks the same language!

"I think the adoption of Esperanto is a

necessary consequence to the development of radio communication and particularly that of radio telephony, where understanding must be immediate. The idea is coming to all the world.

"On the subject of transatlantic transmission tests with French amateurs next winter, I don't see hardly anyone but Mr. Deloy, 8AB, who can possibly be ready. Perhaps there are other stations in Great Britain and in Holland, but it seems to me that perhaps it might be a bit premature to silence all the American transmitting stations in order to hear only a few European stations. But I am convinced, as you are, that if it doesn't come off this winter it surely will the next."

THE OPERATING DEPARTMENT

(Concluded from page 54)

lem of working A.R.R.L. traffic through broadcasting hours. 5QS has been reported by 8HJ. 5DW has just completed a very efficient C.W. set, 5IC is reaching out with his new C.W. set using the 9DDY circuit radiating one-half ampere and has worked 150 miles; also has been heard by 9DZR and 9DUG on his one-half K.W. spark. 5AAR is doing some fine work with 100 watt C.W. 5QI has just completed a new C.W. 20 watts, and has worked 7LU.

We are sorry to lose one of our best official relay stations, Mr. Ruch A. Hall, 5PE, who is now at Ringgold, La. (Clayton note). 5CM is using a 1 K.W. spark and gives promise of being a good relay station. 5TH of Paris has a new C.W. going now and welcomes traffic that way.

WINNIPEG DIVISION

J. H. Gjelhaug, Mgr.

J. E. Maynard reports very little doing this month. 4CB is rebuilding and will have 100 watts C.W. 4EZ is also building a good C.W. set. 4GB of Saskatoon is now going strong using 4CB's old 15 watt C.W.

H. D. Clark says there is something stirring and that there will be something doing before long. Winnipeg amateur stations are getting their heads together and we look for some good stations there by winter.



Who's Who in AMATEUR WIRELESS



WINIFRED DOW



M. ADAIRE GARMHAUSEN

Ahh! At last! The Ladies' Number of Hooshoo! You know, gang, we have been wondering all this time what these Y.L.'s look like and now after years of pestering we have got them to come across with enough dope to introduce themselves. Both of 'em did it at about the same time and it was such a shock that the editor immediately thereafter took a couple of days' vacation and his assistant decided to get married! Not that it directly affected us thusly (apologies) but the relief was terrific and we heaved a sigh not unlike that of a power tube when the tip is knocked off. Modest as the present-day girls are, we gleaned the following data which we present with a pride equal to that of unearthing a new method of reception.

Miss Winifred Dow, otherwise known as 7CB, is without doubt the most prominent feminine operator west of the Mississippi River. We didn't dare ask her how old she was so we will have to draw our own conclusions from her statement that she was born in Tacoma on July 15, 1902. She claims she is "just a plain ham like the rest of the boys—and girls," but we think different. As evidence that she's a regular fellow, however, we must report that she has been caught at 1 o'clock in the morning up to her elbows in a tank of oil fixing a punctured condenser so as to get back on the air!

Starting in radio in 1916 she thinks she has not progressed any but again we think she is spoofing us. We know that she has been a staunch booster of amateur radio and a member of our A.R.R.L. for five years, and for the last several years she has served as A.R.R.L. District Superintendent. Miss Dow has been secretary of the Radio Club of Tacoma for two years. In the Washington's Birthday Relay last year in which hun-

dreds of the best amateurs all over the country participated and seventy-eight prizes were given, 7CB took second prize. But the following incident shows she is a true amateur and in a way that will make some of you who profess to be amateurs blush for shame. Miss Dow, like many other amateurs, was offered a position in a broadcasting station. For two months she was broadcaster and radio editor of the "Tacoma Ledger" but because it kept her away from her own set nights, she gave up the job, and, in her own words, is "happy to be a ham again instead of an editor or broadcaster." *Here is an amateur!*

Miss Marion Adaire Garmhausen hardly needs any introduction as most of us have heard of her in one way or another. She admits she was born May 28, 1899, but swears she does not look a day over sixteen. Being a telegraph operator by trade, she went to wireless school just after the war and found a *QST* somebody had left lying about (careless!). Our budding Y. L. says she was struck by the spirit of the organization and wrote Mr. Duvall, whose name she found in the magazine, for further particulars. His reply harmonized exactly with the spirit of the magazine.

When she put in her first set the reigning forces offered her every discouragement known to mankind, so she retired to her shell. Her articles in July, 1920 *QST* ("How to Build a Wireless Station") and May, 1921 ("Breaking Out") tell in her own words of her experiences in getting started, so any attempt on our part to repeat the tales of woe would at best be infringing on her original masterpieces. 3BCK (for that is her call) remained in her shell until the organization of "The Radio Condenser," sometime Third District organ, when the remorseful crowd invited her to join them. And she was not merely decorative, either—she was of real help on the "Condenser;" and she likewise was an active force in the planning and management of the hugely successful Third and Fourth District Convention in Washington last February.

However, they say she doesn't often venture out thusly. No ham has ever laid eyes on her station, despite sundry pleadings, and she swears "no ham ever shall until I get darn good and ready to let him." Ain't it like a woman! She admits her room "looks more like a blacksmith's shop than a young lady's 'boojwar,'" and in view of all of this discouragement we have given up hopes of having a photo of 3BCK in our "Amateur Radio Stations" department.

In spite of all her modesty we find that Miss Garmhausen holds two certificates in electrical engineering and is working for the last one necessary to get a diploma. We know she has been an ardent booster of the League and always will be, and it is her ambition some day to have to move to some place where her set will be able to fill a necessary place in A.R.R.L. relays.

Vivent les hamettes!

BeeP.

TUBE SUPPLY FROM A.C.

(Concluded from page 40)

be formed with the inductances which in connection with an appropriate capacity in the storage condenser absorbs a maximum of the residual A.C. component. The article in "L'Onde Electrique" gave no exact details on how this was accomplished but suggested that at F in the figure there be two inductances of 1500 turns, one in each side of the circuit, arranged to buck each other on the same closed iron core.

An apparently vital part of the arrangement is that M. Ritz used for his aerial a spare wire in the overhead supply system, presumably like the topmost lightning-protection wire in a transmission line rather than the common or neutral feeder, which aerial wire is in inductive relation to the "live" wires and the coupling between which probably helps to balance out the A.C. component. Still, we see no reason why it should not work as well on aerials not associated with the A.C. supply. As to results, numerous long-wave C.W. stations are copied with the A.C. hum entirely negligible, while the hum is heard weakly in the non-oscillating regenerative adjustment for

spark or phone reception; no short-wave work is reported.

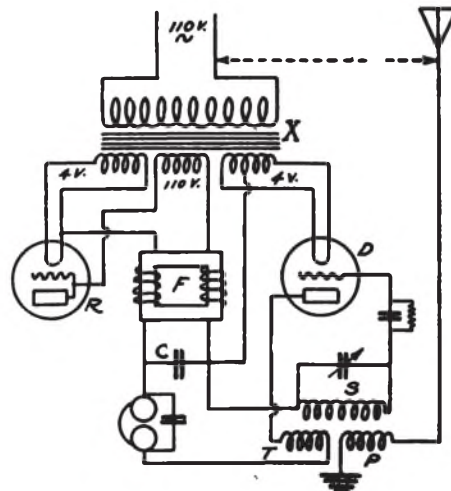

Are any of our readers having success with any such system?

—K.B.W.

The Junior Operator



(A department formerly known as "With Our Radio Phone Listeners.")

How to Tune a Three Circuit Tuner

ALL single-tuned-circuit receivers have the inherent characteristic of tuning rather broadly and may also prove a nuisance to the community because of the strong waves they may cause to be radiated. In congested areas where interference is bad the three-circuit tuner is very much to be recommended but because of its more difficult adjustments it takes some time to be able to get the most out of the tuner, especially when it is left to the operator without the help of a friend.

The ordinary three-circuit regenerative receiver has four adjustments that require attention: the series condenser in the antenna lead, the vario-coupler adjustments (taps and coupling), the grid variometer or secondary condenser, and the plate variometer. The latter controls the regeneration while the first three control the wave length and selectivity.

Either a variable condenser shunted across the secondary of the vario-coupler or a variometer in series with the grid serves to tune the secondary circuit, while the antenna series condenser with the primary coil of the vario-coupler tunes the aerial circuit. For the best signal strength it is imperative that these two circuits be adjusted to exactly the same wave length. Even when so adjusted a nearby station on a wave differing considerably from the wave to which the set is tuned may be picked up very strongly so an additional adjustment known as coupling is provided which regulates the transfer of energy from one coil to the other. Loosening the coupling slightly decreases the energy transferred but greatly increases the sharpness or selectivity so that interference is greatly minimized. This is the big advantage of the three-circuit tuner over the simplified types.

With the set operating normally and with loose coupling it will be noticed that as the plate variometer is turned there is a point at which a click or dull thud is heard. Below this point the phone, spark, and I.C.W. stations are best copied, as above this point the set is oscillating, which is the condition necessary for the reception of C.W. telegraph signals. When the tuning of the secondary circuit is changed the

point at which oscillation occurs in the adjustment of the plate variometer will change correspondingly.

Now with the coupling fairly tight and the secondary tuned to approximately the desired wave (which may be known by previous experience or by calibration from a buzzer-excited wave-meter), the plate circuit is gradually brought into resonance with the secondary circuit by turning the plate variometer slowly. Just before resonance is reached the tube "flops over" into oscillation. With the set oscillating the aerial circuit is then tuned to resonance. When the series condenser knob is turned it will be found that the set stops oscillating at a certain point but as the knob is turned farther it starts again. This is because the aerial when tuned to resonance with the oscillating set absorbs energy and, the detector tube being a weak oscillator, energy cannot be supplied as fast as the aerial circuit absorbs it, so the oscillations are stopped. Set the condenser at about the middle of this space where oscillations do not occur and turn the plate variometer until the set oscillates again. Continue with the series condenser as before and it will be found that only over a very small part of the scale are the oscillations stopped. This should be narrowed down to a degree or so. When this adjustment is obtained all the circuits are in resonance and at the best possible tuning for that wave in the reception of spark, I.C.W., and phone.

Continuous wave signals may be received by turning the plate variometer further to the right or loosening the coupling. If the signals are loud the latter adjustment is recommended as the sharpness of tuning is increased and spark interference to a much greater extent eliminated. In attempting to find a station tight coupling is generally used, but in working, very loose coupling is desirable.

Dispensing with resonance for the moment, the variation in the plate circuit of the detector depends mainly upon the variation of the grid voltage. The secondary circuit of the receiving set may be a coil of several turns shunted by a very large condenser or it may be a much larger coil shunted by a very small condenser. The variometer tuned secondary circuit is

the type where the inductance is large and the capacity only that present in the coils themselves, known as distributed capacity. With this type of set the voltage variations on the grid are considerable and a strong signal results. The honeycomb receiver in which the secondary is tuned with a shunt variable condenser decreases the grid to filament voltage somewhat when this capacity is made large but makes a "stiffer" circuit not so liable to be affected by oscillations of another frequency. Therefore, with the secondary tuned with a variable condenser, for the best signal strength the capacity should be kept low, but if the signals are loud and the interference bad a smaller coil and more shunt capacity is to be recommended.

These are merely suggestions to the beginner who has been told by amateurs to junk his two circuit tuner and get a three circuit tuner and who, after having purchased one, finds difficulty in getting equal results.

B.P.

Construction Pamphlets

The third of a series of pamphlets put out by the Department of Commerce, Bureau of Standards, in the form of Letter Circular LC 48 describes the operation and construction of a detector unit. Circular No. 120 describes the construction of a single-circuit tuner and Circular No. 121 tells how to make a two-circuit tuner. Any of these may be obtained for five cents in cash from the Supt. of Documents, Govt. Printing Office, Washington, D. C.

Hydrometer Readings

In an article in this department three months ago the factors to consider in the choice of the battery were considered, so a little talk on the use of the hydrometer may be appropriate at this time. Most radio bugs know that it is necessary to use a hydrometer to test a storage battery but some do not know exactly how to go about this simple job, and as a result of improper care of their battery, its life may be considerably shortened.

The electrolyte in the common lead cell is a mixture of sulphuric acid and chemically pure water. The specific gravity of this electrolyte is the ratio of its weight to the weight of an equal volume of water. The specific gravity of water then is taken as a standard and is 1.000, while sulphuric acid being nearly twice as heavy has a specific gravity of nearly twice as much, depending on its purity. It should be apparent that specific gravities between these two limits could be obtained by various proportions of acid and water. The correct mixture varies with the type of duty desired and with the manufacturer. What concerns us chiefly is the fact that the

specific gravity in any given battery varies with the degree of charge or discharge and that this is about the easiest way to determine the exact condition of the battery. Almost any good electrical textbook devotes a chapter to electro-chemistry where the reader may learn more about the exact chemical combinations that go on in the cells, but suffice it to say here that discharge is a chemical action in which acid enters the plates of the battery, and charging is the reverse process of driving the acid out of the plates into the electrolyte. The electrolyte is therefore "stronger" or has a greater specific gravity when the battery is fully charged, and as discharge progresses the specific gravity falls off accordingly.

So far we have barely mentioned the instrument that is to do the testing—the hydrometer. The most convenient form is known as a hydrometer-syringe, which includes a container for the hydrometer float and a rubber bulb for raising the electrolyte up into the glass chamber with the float. The hydrometer has a graduated scale on the inside of the tube reading from 1.150 to 1.300. A fully charged cell will register about 1.250 to 1.280 and a completely discharged cell about 1.150. On many hydrometers these two points are plainly marked with a red line.

The important thing to remember in the care of the battery is not to let it completely discharge as it is much better to put it on charge when the specific gravity falls to 1.185 than to wait until it is completely exhausted. A discharged battery must not be left in that condition as the acid in the plates quickly destroys them by what is known as sulphation.

Hydrometer tests are made as follows: (1) remove vent plugs from top of cell, (2) force the air out of hydrometer by compressing the rubber bulb, (3) insert the rubber tube of syringe thru vent hole into the electrolyte, (4) release the bulb and draw up a sufficient amount of the electrolyte into the glass tube to float the hydrometer, (5) note the point on the hydrometer scale which appears level with the top of the electrolyte when the hydrometer floats freely, touching neither top, bottom, nor sides, (6) force the electrolyte back into the cell from which it was removed.

If possible, readings should be made without lifting the rubber tube out of the cell as destructive dripping is thus eliminated. It is also advisable to rinse the syringe out with water or it will badly mar any material it comes in contact with due to the residual acid.

With ordinary use, only water needs be added, as the acid does not evaporate. Hydrometer readings must be taken before water has been added, as a thorough mixing

(Concluded on page 68)

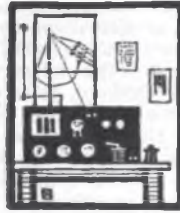

Amateur Radio Stations



4BQ, Rome, Ga.

Although 4BQ was described in this department some time ago when spark sets were the berries we cannot refrain from giving credit to the C.W. set of Mr. G. L. Hight, recently completed, as there are many points in arrangement and design that will undoubtedly form a valuable guide to others about to graduate to the larger tube sets.

The antenna is an eight wire cage 90-ft. long, spread on 8½-ft. hoops and running almost vertically to the top of a 125-ft. mast. The mast is built up of two 23-ft. lengths of 2-inch pipe welded together and reinforced at the joint with a 4-ft. piece of shafting turned to a driving fit; all this on top of an 85-ft. steel tower. A counterpoise of 18 wires 50-ft. long and 50-ft. wide at the end caused a doubling of antenna current and is tuned to the ground circuit which in itself consists of almost every metal object imaginable driven or buried in the premises.

The spark set consists of a Thordarson 25,000 volt 1 k.w. transformer, heavy pancake type oscillation transformer with 6 inches coupling, Dubilier condenser of .01-mfd. capacity, and a home-made synchronous rotary running at 1800 r.p.m. but with twelve teeth spaced at intervals of a sixteenth of the circumference and every fourth space left open. The open spaces are adjusted to come at the zero point of the A.C. wave, resulting in a peculiar note easily read thru QRM and QRN. This set has a record of 1500 miles.

Up until the last month or so, the C.W. set of 4BQ has consisted of four five-watt tubes and put out 4½ amperes. This set has been heard in every state in the United States on C.W. and I.C.W. and is at present running down a report of having been heard QSA by 6ZAC in Honolulu.

The set which we take great pleasure in presenting is No. 3, which has just been completed and is shown in the accompanying photo. This set consists of two 250-watt tubes using the "sure fire" circuit modified slightly to place the filaments at ground potential. There are three separate plate currents available: No. 1 is 500

stepped up to 2500 volts, No. 2 is 2000 volts of D.C. supplied by a 1500-watt motor-generator, and No. 3 is 2500 volts of rectified A.C. This latter supply includes an electrolytic rectifier with 42-cells in each leg, and a choke coil in the positive lead

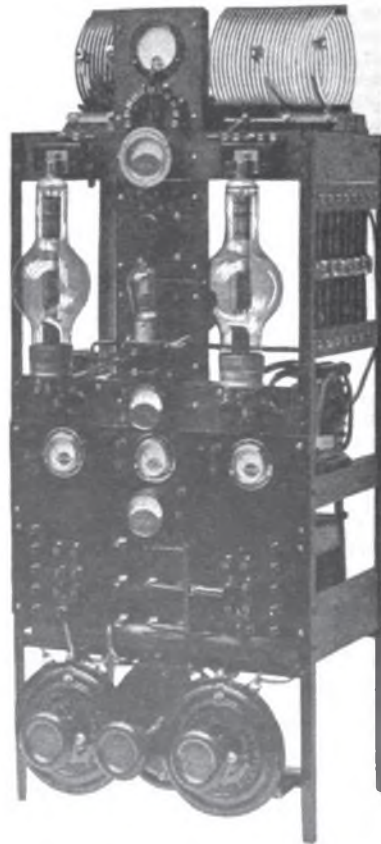

of 10-henries, followed by a 3-mfd. condenser shunted across the line. The filaments of the tubes are excited from two separate transformers with their center taps joined in common. A 42-ohm rheostat in the

primary of each transformer gives very smooth filament control. Separate filament voltmeters and rheostats for each tube are plainly seen in the illustration.

For telephone work this set employs Heising modulation with a 5-watt voice amplifier using 300-volts on the plate. This reduced voltage is secured from the main

It is found that much higher efficiency can be obtained by carefully adjusting the filament voltage of each tube separately. The whole set is very rigidly constructed of angle iron and asbestos wood.

Mr. Hight prefers the Paragon RA-10 to all other receivers for traffic work. Because of ill health he has been hampered

in construction work but we hope he will be with us regularly with his big tube set which, from the preliminary tests, promises to do some wonderful DX this winter.

4BQ certainly ought to have a splendid chance of getting over to Europe in our Transatlantic Tests this coming December.

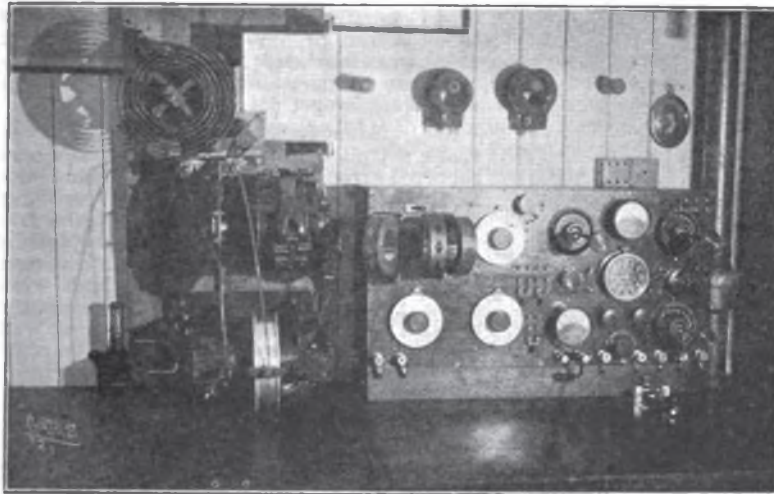

potential by the insertion of a series of high resistance rods varying from 50 to 80,000 ohms. The meter directly under the 5-watt tube reads up to 50 milliamperes and shows the current being drawn by the amplifying tube. The meter just above the triple-pole double-throw switch reads up to 3,000 volts for the plate circuit of the large tubes. The meter at the extreme top is a thermo-ammeter reading up to 15 amperes. Below this is a switch controlling the turns of the tickler coil, under which is the main plate milliammeter. The double-pole double-throw switch at the left bottom of the panel throws the plates from direct current to 500-cycle A.C. The triple-pole double-throw switch in the center of the lower panel is used to cut out the filter system and constant-current choke when the 500-cycle plate supply is used. The double-pole double-throw switch at the right switches the modulating circuit from buzzer to microphone or from one microphone to another. All meters have switches to cut them out or short circuit them for protection when C.W. or I.C.W. is used. Switches are also provided so that either tube can be operated separately for lower power. A separate small filament-lighting transformer is also used for the voice amplifier tube.

A Holland Station

One of our foreign members, Mr. W. H. Moorrees of Dordrecht, Holland, has sent us a photograph and short description of his station which may prove of interest, although transmission by amateurs is strictly forbidden there.

The set consists of honeycomb coils and a one-step amplifier using Telefunken vacuum tubes. The phones and condensers look familiar. There is a set in the center designed for ship reception that works very nicely. To the right of this set may be

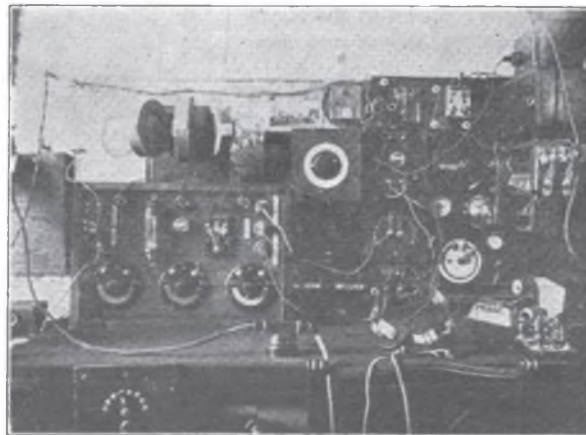

seen the one step amplifier and the aerial tuning inductance. The antenna is 165 ft. long, averaging 24-ft. high, and of two wires spaced 4 ft.

The long-wave set daily picks up NSS and phone from Chelmsford, England, and Paris, France, while the best record for the short wave set was made during the transatlantic tests when 1BCG was copied several nights.

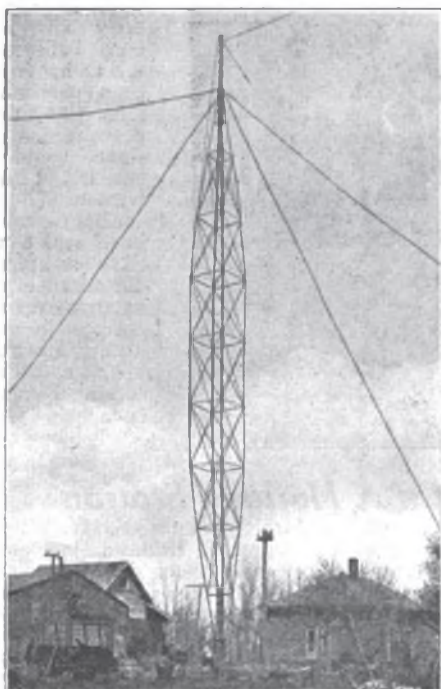

9AUU's Tower

The tower shown in the above photograph is one of the supports of the aerial at 9AUU, the station of Harry Long at Aneta, N. D. It has a total height of 75 feet, and was built before the War at a total cost of \$17.00.

At its base it is built up around an 8 x 8 fir timber, and at the top there is a 6 x 6 fir timber. The main construction is of 2 x 2 x 1/4 angle-iron, braced with 1-inch angle-iron. It is supported by four guys of 1/2-inch messenger cable.

8BO, Detroit

Remember in the story in the report on the "Governors-President Relay" how 8BO with a single 5-watt tube grabbed the Montana and North Dakota messages from 9WU in Ellendale, N. D., on the last night, shot these msgs. with the one from Michigan direct to 4GL, and blew the only 5-watt tube on the premises just after the last msg. was finished? This historic tube is shown in the photo and is suitably done up with black crepe.

8BO formerly had a good high-grade spark set putting out $C\frac{1}{2}$ amperes and was reported from 40 states, 5ZA being the farthest west. The C.W. set has long superseded the old spark. All of the DX records were made with the one tube during the nine months it held up. It was reported QSA from 41 states, the farthest west being Loleta, Cal., and heard consistently at 6XAD. The most unusual record was made when 8ALU in Pittsburgh, Pa., reported the C.W. QSA on a crystal detector.

The "sure-fire" circuit is used with 600-volts of rectified A.C. and 135-milliamperes, putting out 1.7 "thermo-couple" amperes from one 5-watt tube. A Robertson-Detroit chopper is used giving a 500-cycle note and one ampere in the antenna. The chopper is used in series with the grid leak and passes about 45-milliamperes. No trouble is experienced raising stations with the chopper—especially spark—and all stations worked on the chopper are also raised with it. On average nights the range seems to be about 1/4 of the range of the straight C.W. The best work on I.C.W. has been

(Concluded on page 68)

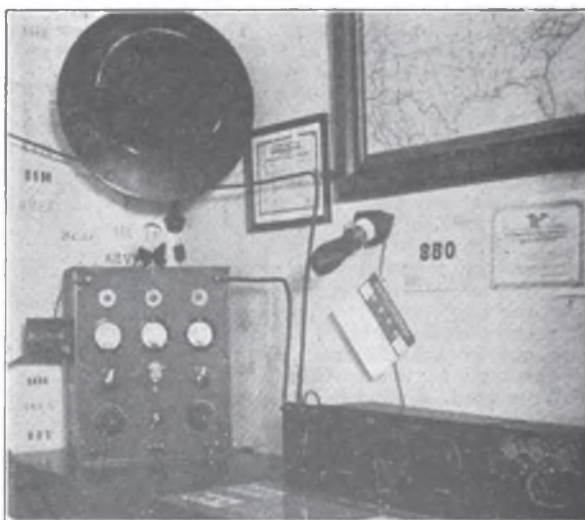



British Columbia Radio Association

During the Vancouver exhibition the B. C. R. A. made things lively for the local boys by installing the equipment of 5BR at the show using the call letters 5GY. Messages for the Pacific Coast were accepted and relayed for the visitors. Dozens of new members were secured and many questions pertaining to radio were answered by the men in charge of the booth.

Atlanta Radio Club

New officers of the A. R. C. are: C. Bell, president; P. C. Bangs, 1st vice president; R. Le Craw, 2nd vice president; H. L. Reid, secretary; and P. Hook, treasurer. The club is a bureau of the chamber of commerce and meetings are held every other Wednesday evening at the town hall. Discussion is taking place to determine how the telegraphing amateur may operate his station before midnight since the broadcasting stations have monopolized the air the whole evening.

Egyptian Radio Bugs

In the Egyptian Radio Broadcaster appeared an announcement that the E. R. B. was affiliated with the A.R.R.L. Probably this came about because the E. R. B. had filed application for affiliation and was under the impression that they could use the name of the A.R.R.L. Upon calling this to the attention of the editor of the Broadcaster such announcement was discontinued. The application is pending final action by our Board of Direction.

Cleveland Radio Association

At a recent meeting of the C. R. A. new officers were elected as follows: E. H. Poad, president; W. D. Bumstead, vice president; A. G. Peoples, recording secretary; F. Neubauer, financial secretary; H. H. Hurd, treasurer; E. I. Deighan, chairman of advisory committee; and F. M. Murphy, traffic manager. A radio show will be held in connection with the Electrical League later in the fall. Club meetings are held every second and fourth Friday in the new Public Hall. The C. R. A. conducts a radio page in two of the Sunday newspapers. The radio inspector has provided the traffic manager with notification blanks consisting of a blue notice for first failure to observe the traffic regulations, and a pink slip for the second offense which

means action by the radio inspector. This will eliminate the criticism that was heaped on Cleveland amateurs last year and the radio inspector promises whatever action is necessary to give Cleveland good clean operation. Up to this writing no one has received the "pink ticket."

Fourth District Convention

Having learned how to do it, the Fourth District will have a convention to be put over by its own members in February. It will be remembered that the Third District combined with the Fourth District last February and gave us one of the best conventions in amateur radio. Committees have been appointed to take charge of the convention. Charlotte, North Carolina will be the scene of the gathering and the tentative program is given herewith. We want to see every "ham" this side of the Rockies turn out for the affair.

FOURTH DISTRICT RADIO CONVENTION TO BE HELD AT CHARLOTTE, NORTH CAROLINA

OFFICERS

Chairman: F. A. Hill, 4GL, 1223 East Duffy St., Savannah, Ga.
Sec'y. & Treas.: John E. Hodge, 4BY, 143 Bull St., Savannah, Ga.
Entertainments, Hotels & Trans.: Fred Laxton, 4XD, Charlotte, N. C.; F. L. Bunker, 4CE, Charlotte, N. C.
Welcome: J. H. Robertson, 4ID, Box No. 8, Salisbury, N. C.
Publicity: B. W. Benning, 4XC, 50 Whiteford Ave., Atlanta, Ga.; W. E. Pope, 4AG, 197 Dearing St., Athens, Ga.
Technical: H. E. Bussey, 4AI, Gen. Electric Co., Atlanta, Ga.; A. J. Funk, 4XB, Savannah High School, Savannah, Ga. One other member to be selected by Chairman.
Exhibits: John Fox, 4EU, Travis Ave., Charlotte, N. C.
Stunts and Contests: W. T. Gravely, 3BZ, Gravely Bros., Danville, Va.

STATE CHAIRMEN

Georgia: W. B. Pope, 4AG, 197 Dearing St., Athens, Ga.
Alabama: V. C. McIlwaine, 5XA, Auburn Polytechnic Inst., Auburn, Ala.
Florida: L. W. McClung, 4BF, 1601 Bonnevista, St. Petersburg, Fla.
No. Carolina: Jimmy Morehead, 4CC, 215 Eugene Ave., Greensboro, N. C.
Virginia: Allen Clark, 3AEV, Danville, Va.
Tennessee: W. C. Hutcheson, 5DA, Wind Rock, Tenn.
So. Carolina: George Wrigley, 4HR, 311 E. Park Ave., Greenville, S. C.
Maryland: E. R. Bateman, 3APT, 1217 W. Lafayette Ave., Baltimore, Md.

TENTATIVE PROGRAM

February—some date—not to infringe on 3rd Dist. Convention.

(Concluded on page 68)

Strays



In connection with the reports of the Second Trans-Atlantic Tests last winter several mentions have been made of radio phone stations WQL and WQM which were heard by British amateurs. As previously announced, the Department of Commerce advise that these call letters were not assigned to active radio phone stations. Mr. Philip R. Coursey, who managed the British arrangements in these tests, however, is insistent that there is no room for mistake in the reports made, since many different amateurs in different parts of the British Isles sent in separate reports thereupon. Some had heard only one side of the conversation while others reported hearing the two talking together. We can only conclude that the call letters were used without authority by some unknown stations.

And now some enterprising firm has brought out a cotton clothes-line which has a stranded copper center concealed within it, for use on the roofs of landlords who object to antennas. Even a few clothes may be flown on it for disguise.

Has anyone had any difficulty in making tubes oscillate in parallel because the length of the circuit leads varied for each tube? It is often an important point and we would especially like to know if anyone has had this trouble. In one case at hand, three tubes were being paralleled and the grid-circuit wire was run to first one grid, then another, and finally to the third. Oscillations were obtained with great difficulty, efficiency was low, and grid current abnormal. Then separate grid wires were provided for each tube and bunched to the circuit lead so as to provide the same length of path to all grids. With no further changes the antenna current was tripled and the tubes oscillated readily with cool plates. The plate leads were similarly treated and a slight additional increase obtained.

Filament circuits should be carefully arranged too, but here more particularly in order that the voltage drop may be the same across each filament.

Dog-gone this fellow Reinartz; he keeps bringing out better tuners faster than we can make them.

An epidemic of these "endless-chain" prayers and good-luck letters has hit amateur radio, promising no burnt-out tubes all winter if the recipient will QSR a copy to nine other people but threatening dire calamity if ignored. These things are an awful nuisance, a relic of the days of witchcraft and black superstition, and they throw a burden of millions of extra letters on an already-groaning postal service. Let's keep them out of amateur radio, fellows. Ignore them; we have enough troubles already.

520, Cliff Vick, of Houston, has taken unto himself a bride, and has hearty congratulations and best wishes from the gang.

Mr. Harvey Mitchell Anthony, A.R.R.L. Director and old time amateur, was married on August ninth to Miss Ruth Emerson Leffler. We wonder if this was the result of the write-up in "Who's Who" which appeared in the August number? If so, it's fast work, we'll say, but we wish them all the luck in the world anyhow.

At the recent Pageant of Progress Exposition in Chicago Mr. T. R. McElroy again held his own in the speed contest against three other speed demons. Although he did not copy faster than his previous record of 56½ words per minute, he grabbed off 55-1/10 words per minute perfect copy, which was considered by a committee to be better than his previous record which had four errors.

Radio Exams. in Fourth District.

Radio Inspector Van Nostrand informs us that examinations will be given in the Fourth District according to the following schedule: Florida—Tampa, Sept. 29; Sanford, Oct. 2; Jacksonville, Oct. 4; Georgia—Savannah, Oct. 9; Macon, Oct. 12; Atlanta, Oct. 14 (amateur only); Oct. 16 (commercial only); South Carolina—Greenville, Oct. 21; Columbia, Oct. 24; Charlestown, Oct. 27; North Carolina—Wilmington, Oct. 31; Raleigh, Nov. 2.

From the Radio Globe: "Radio Editor:—I have an Aeriola, Jr., receiver for hearing the music and one of my friends tells me that the wave lengths of this receiver only

last three months, when they will have to be renewed. Please tell me where can I buy wave lengths and what are the best kind to buy?" Maybe some of the gang in Iowa have some extra ones.

It is rumored that Hamo Wright, the gink with the magnetic fingers, has gone in partnership with C.W. Duzzit, the mesco buzzer chauffeur, and renew burnt out tubes by filling them with lightning bugs. To us it looks like the QRN would be fierce!

3JX came home a few nights ago and proceeded to listen in but on hearing no signals lifted the top of his new receiving set and was greeted by a mass of copper drippings, burnt coils, over-roasted spaghetti, and other reminders of last year's furnace. He promptly spit on the cat and started figuring on a new set but this time he probably will fuse the storage battery circuit.

Wouldn't it be Wonderful—

If tomato cans were made of phosphor bronze?

If friend A. L. Groves would drop in on us some night when we're having trouble with our three-coil circuit?

If every ham knew the difference between 200 and 360 meters?

If second-hand spark equipment was really worth as much as some birds still think it is? (From a CW ham.)

If 5FT were audible everywhere 4 ft. from the phones?

The American Radio Relay League has two new competitors. 5ABA traced a money order and found it being held for the "Mexican Radio Relay League." The hottest one to reach us bore the address of the "American Radiator Relay League." Golly, but its hard enough moving msgs. in this hot weather without being asked to deliver radiators all over the country.

Which reminds us of a radio engineer who used a radiator for a ground at his home but on putting in a transmitter was in doubt about the aerial and ground connections, not knowing which was the best radiator.

8BCL (a broadcast listener?) has discovered a prohibition grid leak. He used two small wires in a glass of water and gets much more antenna current than without.

Hon. R. B. Howell, a member of Secretary Hoover's recent radio-telephony conference, has been nominated as Republican candidate for senator in the Nebraska primaries. Mr. Howell is an exponent of public ownership, a reformer with the courage of his convictions, a representative of the people, and possessed of very firm

views on radio. Mr. Howell, if elected, will be an important factor in the radio deliberations of the Senate.

The personnel of the office of the First District Radio Inspector has been increased and additional funds placed at his disposal, enabling a much better covering of the district this coming year. The same improvement we trust is occurring in the other districts.

When pipes driven in the ground are used for an earth connection is frequently made to them by filling the end of the pipe with lead or solder. Such metals contract when cold, however, and it has been suggested that linotype metal be used, which will expand on cooling and make a tight joint. This can be obtained from most printers for about ten cents a pound.

Regarding the problem of when to use a by-pass condenser in a C.W. set and when not to, the general rule is that when the power supply comes in series with the tube and the inductance a by-pass condenser should be put across the supply, but when parallel supply is used, bridged across from plate to filament, the by-pass condenser should be omitted, else it will permit the r.f. oscillations to leak by instead of going thru the inductance. In fact the condensers in the filter will permit this improper by-passing, and it should be eliminated in the case of parallel supply by inserting a radio-frequency choke in the supply lead near the plate.

Speaking of low wave lengths, one bug in Hartford reports waves as low as 50 micro-centimeters in his C.W. set. This happens every time he lights the tubes. As the proposed new law will not allow amateurs to use waves below 150 meters he is afraid he cannot light his tubes.

Most people use an individual rheostat on each tube and when the battery voltage changes slightly or when first listening in they adjust each rheostat. J. H. Miller suggests a master rheostat in the battery circuit. After the proportion of current in each tube is correctly adjusted only the master rheostat is shifted to take care of battery voltage variations.

Why do we go to great pains and considerable expense to get the very best insulating material for the panel of a set and then put sheet metal behind it as a capacity shield? Someone has asked why not use metal panels in the first place, with insulating bushings of hard fibre for control shafts, with binding posts on the rear of the cabinet and with switches sub-mounted on small insulating panels inside the cabinet? In fact the insulating bushings are not often necessary, as a large

hole may be drilled in the metal panel thru which a shaft for a condenser, etc., will pass freely with no need for support at the panel.

This is something to think about. We have seen such a set with an aluminum panel having a crackled black enamel finish and it really looks very handsome as well as providing excellent shielding from hand capacity.

If there is any chance of Marconi's reflected short wave transmission system making broadcasting any more secret, we're heartily in favor of it.

Rumors are thick these days of new R.C.A. tubes. We hear that a new model detector tube is being tested now at Radio Central, where heretofore 5-watt U.V.202's have been used altogether for reception. Marconi and a few select other guests inspected the new tubes but when questioned later about them said "they must remain quiet."

Neither does QST intend to be an amateur magazine in summer and a broadcast magazine in winter.

As a consequence of the demand for performance tests on radio receiving sets by non-technical dealers, the Bureau of Standards has drawn up an outline of tests which are to be carried out by the Electrical Testing Laboratories of New York in co-operation with the National Retail Dry Goods Assn. The tests are most comprehensive.

In place of a spark coil set for local work it seems that a key in the ground lead of the receiving set works f.b. and at the same time furnishes one of the best break-in systems. The coupling to the aerial circuit should be as close as possible up to the point where the oscillations stop. If an amplifier tube is used in place of the detector tube and more plate battery added the range may be increased several miles. The wave must be kept below 200 meters and the station licensed. Some of the owners of "broadcast receivers" getting bitten by the amateur bug may find this a convenient and surely inexpensive way to start in the ham game.

8BO, DETROIT, MICH.

(Concluded from page 64)

to 1XZ, 4FT, and 9AOG. Recently the power has been increased by the addition of another tube but no better distance has been covered.

Due to the antenna being walled in on the north and west by a row of trees and on the south and east by buildings, a satisfactory picture of the antenna system could

not be obtained. The antenna is a 6-wire inverted L, 45 ft. long, 66 ft. high at the lead-in end and 45 ft. high at the free end. The ground system consists of a buried counterpoise, driven pipe, and the city water system. The counterpoise consists of nine wires 30 ft. long, under the middle portion of the flat top. It being impossible to extend the counterpoise any farther at either end, a loading coil is used in the counterpoise lead.

The receiver consists of one of the first Grebe CR-3 receivers and is used with two steps of audio amplification.

HYDROMETER READINGS

(Concluded from page 61)

of water and acid around the plates and insulators takes considerable time and a correct reading cannot be obtained until total diffusion has taken place. The important thing to remember is, *use the hydrometer regularly and avoid total discharge of the battery.*

B. P.

WITH THE AFFILIATED CLUBS

(Concluded from page 65)

Thursday Noon—Assembly of delegates—Auto ride.
Thursday Night 8:30 P. M.—Informal meeting of delegates—"gabfest."
Friday, 10:00 A. M.—Convention opens—runs until Midnight.
Saturday, 10:00 A. M.—Final Convention Session.
Saturday Night—Banquet.

Houston Radio Club

An agreement with broadcast stations has been reached whereby broadcasting is given free air from 7:00 P.M. to 7:15 P.M. and from 8:00 P.M. to 10:00 P.M. Local amateur transmission is permitted until 10:00 P.M. providing it does not QRM the broadcasting. Outside of the hours 7:00 P.M. to 10:00 P.M. amateur traffic will be handled exclusively.

New England Radio Executive Council

The Boston Radio Executive Council has been changed to the New England Radio Executive Council with H. W. Castner, chairman, 727 Boylston St., Boston, Mass.

The annual New England Convention for 1922 will be held in connection with the coming radio exhibition in Boston. Amateur Day will be set aside the last day of the exhibition. Tickets will be sold only to A.R.R.L. members according to the present plan. Of interest to all relay men will be a traffic meeting and banquet in addition to other events of interest.

Next Month in QST

we will present the winning article in our contest for the best adaption of Armstrong Super-Regeneration to the requirements of A.R.R.L. relaying. Some real dope, O.M.—don't miss it.

Calls Heard



HEARD DURING AUGUST Unless Otherwise Specified

3JE, Toronto, Can.
 C.W.: 1ANQ, 1AWB, 1BKQ, 1GV, 2AWF, 2AYZ, 2BLP, 2CBG, 2BNZ, 2KL, 2OM, 2RM, 2ALN, 2AQR, 2BLF, 2BJY, 2BZ, 2CC, 2SM, 2TJ, 2IW, 2RX, 2EA, 2NK, 2ZO, 2ES, 2HX, 2AGR, 2AMD, 2APT, 2ATU, 2BFX, 2BPL, 2BRC, 2CGX, 2CKO, 2CDZ, 2DA, 2FT, 2KG, 2UE, 2ZZ, 2APS, 2ADX, 2BS, 2BRL, 2BSG, 2DFB, 2DKY, 2XL.
 Spark: 2HJ, 2ZO, 2UC, 2ZN.

9BD, Barron Hotel, Vancouver, B. C. (1 tube)
 C.W.: 5QI, 5JL, 5AAT, 5AWT, 5ASJ, 5APW, 5ABX, 5AK, 5BA, 5BUM, 5FH, 5GR, 5FT, 5KA, 5KU, 5GH, 5NX, 5BES, 5BOE, 5BCJ, 5ZX, 5ZF, 5AGF, 5AEA, 5TY, 5OE, 5MF, 5TU, 5NA, 5XC, 5TW, 5QW, 5OZ, 5WM, 5ZB, 5TS, 5YR, 5AXR, 5AMB, 5AQU, 5NC, 5PI, 5DA, 5ZAF, Can. 4BV, 5CT.
 Spark: 5ANG, 5GR, 5AMZ, 5IC, 5VX, 5TU, 5BB, 5BK, 5AEA, 5VE, 5KJ, 5KM, 5VX, 5TO, 5ZK.

Can. 3HE, Kingston, Ont.
 1ASC, 1AIQ, 1AGF, 1AJP, 1BKQ, 1BES, 1BGF, 1CMK, 1CPN, 1FB, 1UH, 2AWF, 2AFP, 2ACT, 2ANM, 2BMR, 2BKQ, 2BG, 2CBG, 2CGJ, 2CC, 2FP, 2HU, 2KL, 2TS, 2VA, 2ANO, 2BJO, 2BJY, 2BNU, 2BLF, 2CBM, 2CC, 2GW, 2LP, 2LR, 2MK, 2SM, 2TJ, 2TN, 2VW, 2XW fone, 2WF, 2ZO, 2AU, 2BX, 2BQ, 2EH, 2GK, 2MW, 2FV, 2AQO fone, 2AB, 2AMZ, 2AN, 2AIX, 2APT, 2ZWP fone, 2ATU, 2AFD, 2AVR, 2ASZ, 2BEF, 2BFM, 2BJY, 2BPH, 2BDB, 2BJU, 2BRW, 2BSO, 2BRF, 2BWA, 2BPH, 2BDY, 2BFX, 2BDO, 2CCX vy QSA, 2CLI, 2CGQ, 2CJY, 2CAX, 2CPX, 2CGN, 2CEI, 2CUV, 2HJ, 2KG, 2IFY, 2IFD, 2JV, 2SB, 2SL, 2UE, 2UK, 2ZQ, 2ZZ, 2AAP, 2AJA, 2AON, 2AQM, 2AXF, 2AWF, 2APS, 2AJH, 2BGH, 2BCF, 2BJV, 2BRL, 2CJA, 2DUY, 2DOP, 2IL, 2US, 2XL, Can. 2CZ, 2KO, 2NE, 2AL.

1ES, Brookline, Mass.
 Spark: (1CDM), 2AAF, 2AHU, (2ARY), (2BSC), 2CT, 2DN, 2FP, 2NF, 2OM, 2XA, 2AHK, 2HT, 2QN, 2AXN, 2BDA, 2BO, 2IL, 2UC, 2ZO, 2ZN.

C.W.: (1ABS), 1ACS, 1ACU, (1AGI), 1AIC, (1AJP), (1ANQ), 1ATJ, (1AWB), 1AZW, (1BAS), 1BDI, (1BDV), 1BES, (1BKQ), 1BLN, 1BSZ, (1CEC), 1CHJ, 1CLW, (1CMK), (1CMP), (1CPN), 1CPO, (1FB), (1GV), 1HK, (1ON), 1PY, (2ACT), 2ACY, 2ADL, (2AFP), 2AJA, (2ANM), 2AQH, (2AUZ), 2AWF, 2AWH, 2AYF, 2AYZ, 2BDG, (2BGI), (2BGW), 2BML, 2BMR, (2BNZ), (2BQD), 2BQH, 2BQU, (2BRB), (2BRC), (2BUM), (2CBG), (2CBW), 2CBY, (2CCA), 2CES, 2CGJ, (2CXZ), 2FP, 2GK, 2HW, (2IG), 2KL, 2NF, 2NZ, (2RM), 2TS, (2UD), (2VA), 2VH, (2XAJ), 2ADX, 2AEV, (2AFB), 2AGN, 2AHK, 2AIS, 2ALN, 2ANJ, 2ANO, 2APR, 2AQR, 2ATF, 2ATZ, (2AWH), 2BGT, 2BHM, 2BIT, (2BJY), 2BLF, (2BNU), 2BOB, 2BUP, 2BZ, (2CAN), (2CBM), 2CC, (2CDK), 2CG, (2DT), (2FS), 2GP, 2HD, 2IL, 2IW, 2KD, 2KG, 2LP, 2LR, 2MK, 2QV, 2SM, 2TN, 2VW, (2WF), 2ZO, 2ZW, 2DC, 2EA, 2EY, 2GH, 2HW, 2LP, 2MW, 2NT, 2FV, 2QI, 2AB, 2ACF, 2ACH, 2ADH, 2ADN, 2AEC, 2AFD, 2AFY, 2AGR, 2AIG, 2AIO, 2ALT, 2AMQ, 2AN, 2ANB, 2AND, 2AQB, 2APT, 2AQU, (2ARD), 2ASV, (2ASZ), (2ATU), (2AVD), (2AWT), 2AXN, 2BDB, 2BDO, (2BEF), (2BPH), 2BFM, 2BJC, 2BKE, (2BKH), 2BKN, 2BMM, 2BNJ, 2BO, 2BOZ, 2BPH, 2BPL, 2BQF,

2BRC, 2BRM, (2BRT), 2BRW, 2BSJ, 2BSH, 2BVR, (2BVT), (2BWA), 2BZJ, 2CAU, 2CDZ, 2CEF, 2CGN, 2CJH, 2CJY, 2CKO, 2CLI, 2CLW, 2CMI, 2CNW, 2CON, (2CPX), 2CUR, (2CUV), 2CYT, 2EH, 2FT, 2HH, 2HJ, 2KG, 2KH, (2ND), 2NV, 2OW, 2PD, 2PT, (2QB), 2SB, 2SE, 2SL, 2UE, 2UK, 2VY, 2WA, 2WI, 2WR, 2XE, 2ZAE, 2ZM, 2ZQ, 2ZZ, 2AAP, 2AJH, 2ALW, 2AON, 2AQU, 2AFS, 2AXF, 2AWF, 2BAA, 2BLC, 2BRL, 2BZL, 2CBA, 2CJA, 2DEK, 2DGO, 2DTJ, 2DUG, 2EI, 2FW, 2II, 2LZ, 2OX, 2UC, 2UH, 2WC, 2XL, Canadians (2JI), 2JK, 2KO.

1BJS, Nobleboro, Me.
 Spark: 1AA, (1ACO), (1ADC), 1AMD, (1AMQ), 1APT, 1AXD, 1AZK, 1BDT, 1BDV, 1BJN, 1BOE, 1BPF, (1BPZ), 1BRI, (1BRQ), 1BUB, 1BVB, (1BVG), 1BZN, 1CE, 1CED, 1CDN, 1CHG, 1CK, 1CKI, 1CPJ, 1DY, 1EZ, 1FB, (1FS), 1GW, 1HO, (1LZ), 1OE, 1OR, 1SC, 1SE, 1SN, 1TS, 1XM, 2AAF, 2ACW, 2AD, 2AER, 2AHU, 2ARY, 2AWF, 2AX, 2BER, 2BJG, 2BPF, 2DN, 2EL, 2PP, 2JG, 2MN, 2NF, 2OM, 2RM, 2SQ, 2ACY, 2AHK, 2AJD, 2AXN, 2AXQ, 2FS, 2UC, 2XE, Canadian 2BS.

C.W.: 1ABS, 1ACU, 1ADN, 1ADR, 1AG, 1AGH, 1AGI, 1AHZ, 1AJO, 1AJU, 1ANQ, 1AR, 1ASF, 1AUN, 1AWB, 1AWO, 1AZD, 1AZW, (1BAS), 1BBM, 1BCF, 1BDS, 1BDU, 1BDV, 1BEC, 1BES, 1BGT, 1BHR, 1BKA fone, 1BKG, 1BNT, 1BQ, 1BVR, 1CBH, 1CCZ, 1CDO, 1CFI, 1CHJ, 1CJH, 1CK, 1CKE, 1CLZ, 1CMK, 1CMP, 1CNE, 1CNE, 1COT, 1CPN, 1FB, 1GV, 1HK, 1HX, 1IV, 1JT, 1KC, 1PT, 1QN, 1QP, 1RD, 1SC, 1SD, (1UL), 1UJ, (1VT), 1XM, 1XX, 1YK, 2FI, 2ANM, 2AWF, 2AWH, 2AWS, 2BDG, 2BML, 2BQU, 2CBC, 2CBG, 2CDR, 2CES, 2CNZ, 2DA, 2FP, 2GK, 2HW, 2NZ, 2TS, 2UD, 2XAJ fone, 2D fone, 2AJD, 2BLF, 2BNU, 2BRW, 2BZ, 2CC, 2FB, 2HJ, 2IJ, 2IL, 2OT, 2VW, 2WF, 2XW fone, 2EA, 2AB, 2ACP, 2ADN, 2AFD, 2AJH, 2ATI, 2BOE, 2CGN, 2CID, 2CJH, 2FT, 2XE, 2ZZ.

1SC, Scituate, Mass. (18 inch loop on Aug. 27)
 Spark: 1CM, 1DY, 1OR, 1AAE, 1ACO, 1ADC, 1AKG, 2AX, 2FP, 2NF, 2OM, 2AJE, 2BG, 2OK, 2RW, 2ACY, 2ARM, 2BEI, 2AJT, 2BDA, 2BVM.

C.W.: 1CK, 1ES, 1FB, 1GV, 1SD, 1UH, 1AAW, 1ACU, 1ADC, 1AGI, 1AGK, 1AJU, 1ANT, 1ASJ, 1AWF, 1AZL, 1BCF, 1BGF, 1BKQ, 1BNT, 1BQ, 1BWJ, 1CDO, 1CHJ, 1CKE, 1CNE, 1CPO, 1CSO, 2AS, 2BG, 2FF, 2FP, 2FZ, 2HW, 2KL, 2PC, 2RM, 2VA, 2AEQ, 2ANM, 2AWF, 2AYF, 2AZY, 2BDW, 2BQD, 2BQU, 2BRB, 2BRC, 2BTW, 2BUM, 2CBG, 2CBW, 2CGJ, 2CKU, 2CPD, 2BA, 2BD, 2BZ, 2CC, 2DT, 2FS, 2KD, 2MO, 2MK, 2TT, 2TO, 2VW, 2ALN, 2APR, 2AWF, 2BAT, 2BL, 2BIT, 2BJY, 2BNU, 2BSJ, 2BUT, 2BVG, 2CDK, 2BZ, 2EA, 2FT, 2GH, 2GX, 2LP, 2DO, 2PX, 2AB, 2BN, 2DV, 2EH, 2FT, 2HJ, 2OW, 2SB, 2SP, 2SL, 2UE, 2UO, 2VY, 2WR, 2ZW, 2ACF, 2ADH, 2ADT, 2AFD, 2AFL, 2AFN, 2AIF, 2ALT, 2APT, (2ASZ), 2BDB, 2BEF, 2BEX, (2BFM), 2BFX, 2BJC, 2BJV, 2BKE, 2BKN, 2BPI, 2BRQ, 2BRT, 2BSH, 2BSS, 2BTR, 2BUR, 2BVT, 2BXH, 2CAK, 2CAY, 2CDX, 2CEF, 2CJH, 2CJY, 2CON, 2ZAE, 2CV, 2II, 2KR, 2XL, 2AON, 2APW, 2ARZ, 2ASZ, 2AXF, 2BCF, 2BCT, 2BJV, 2CJA, 2CJJ, 2DAE, 2DFB, 2DPL, 2DTJ, 2YAJ, 2ZAF, Can. 2JI, (2JK), 2AL.

1QS, Bridgeport, Conn. (1 tube)
 Spark: 1AA, 1AZK, 1AOK, 1ADC, 1AMQ, 1BJS, 1BVB, 1CHQ, 1CHX, 1CK, 1FS, 1LZ, 2AAF, 2AFD, 2AD, 2EL, 2DN, 2OM, 2QN, 2RM, 2FP, 2NF, 2NP, 2GE, 2FP, 2HJ, 2RW, 2BEI, 2BUC, 2ANW, 2AYM, 2AXN, 2DY, 2ZO, 2HG, 2KG, 2EW, 2BDA, 2TC, 2UC, 2CP, 2UH, 2ZN.

C.W.: 1AAP, 1ABS, 1AHZ, 1AIQ, 1AJU, 1AJL, 1ANQ, 1AOL, 1AWB, 1ATJ, 1AZW, 1BKQ, 1BDV, 1BTE, 1BNT, 1BGF, 1BES, 1CCZ, 1CNE, 1CEC, 1COT, 1CQW, 1CMK, 1CMP, 1ES, 1CK, 1FS, 1FB, 1IL, 1IL, 1EH, 1PQ, 1SD, 1VQ, 1XM, 1QN, 1XP, 1VT, 1RD, 1GV, 2AWF, 2AVE, 2AYF, 2ANM, 2ACT, 2AFP, 2AYZ, 2AGA, 2BQH, 2BML, 2BNM, 2BEC, 2BQU, 2BGL, 2BDG, 2BUM, 2BGM, 2CBG, 2COX, 2CBC, 2KL, 2BG, 2HW, 2FP, 2CC, 2NZ, 2EH, 2RM, 2VV, 2TS, 2ATJ, 2AJO, 2ANO, 2ATP, 2AFB, 2AWH, 2ADX, 2ALN, 2BMT, 2BLF, 2BJY, 2BVL, 2BNU, 2BRW, 2BIJ, 2BSP, 2BUC, 2BUP, 2BVA, 2BFG, 2BUY, 2BVC, 2MK, 2BP, 2KO, 2FS, 2WF, 2VW, 2LP, 2BZ, 2LR, 2DT, 2SM, 2DC, 4EA, 4EX, 4MW, 4MK, 4NT, 4LP, 4NV, 4BY, 4TI, 5AAM, 8AQO fone, 8ASM, 8AFD, 8ALD, 8AWP fone, 8AVY, 8APT, 8AMM, 8APH, 8ARD, 8AND, 8ASV, 8ASZ, 8ALT, 8AFV, 8AVL, 8ADH, 8BDA, 8BMK, 8BWA, 8BJV, 8BPH, 8BDU, 8BVT, 8BRM, 8BNJ, 8BCF, 8BRT, 8BJS, 8BEF, 8BDO, 8BWZ, 8BFM, 8BGV, 8BKE, 8BPH, 8CQX, 8CGX, 8CBC, 8CAZ, 8CID, 8CDZ, 8CJY, 8CUU, 8CKM, 8CFN, 8CGN, 8CCX, 8DAK, 8ZAE, 8ZAG, 8AB, 8AN, 8CF, 8KG, 8UZ, 8XE, 8HJ, 8SB, 8RC, 8LG, 8QD, 8UE, 8FT, 8JY, 8YD, 8SC, 8EA, 8QB, 8JD, 8WI, 8UK, 8ZO, 8ZZ, 9AAP, 9AWF, 9APW, 9AJH, 9AJJ, 9AMI, 9DFB, 9DTJ, 9EI, 9LQ, 9NU, 9OX, 9LZ.

1ABS, North Perry, Maine

C.W.: 1AAO, 1ACU, 1AGI, 1AIG, 1AJL, 1AJP, 1AJU, 1AKG, 1ARG, 1ASF, 1AZL, 1AZW, 1(1BAS), 1BDI, 1(BDV), 1BES, 1BLN, 1BNT, 1BRQ, 1CDO, 1CDD, 1CEC, 1(CFI), 1CHJ, 1CKE fone, 1(CMK), 1CMP, 1CNE, 1CNR, 1(CPO), 1CPN, 1CQW, 1CSO, 1AR, 1(ES), 1FX, 1(GV), 1HK, 1IL, 1IL, 1SD, 1SK, 1SQ, 1SV, 1KG, 1LE, 1(VT), 2ACD, 2ADL, 2AGC, 2AJW, 2ANM, 2AUZ, 2AVE, 2AVH, 2AWF, 2AWH, 2BGM, 2BMR, 2CBG, 2CGJ, 2BG, 2FP, 2GK, 2HW, 2KL, 2LP, 2LT, 2NZ, 2RM, 2RY, (2TS), 2VA, 2UD, 2AAY, 2ADX, 2ALN, 2BIT, 2BJY, 2BJW, 2(BNU), 2BTT, 2(CAN), 2CBM, 2CDK, 2CRJ, 2FR, 2IW, 2MK, 2TJ, 2TN, 2VW, 2XW fone, 2(ZO), 2ZW, 4BX, (4NT), 4QH, 8AQB, 8APT, 8AQO fone, 8ATU, 8AVL, 8BDV, (8BEF), 8BFM, 8BIP, 8BJO, 8BNJ, 8BNU, 8BRQ, 8BSS, 8BUA, 8BUR, 8BUV, 8BXF, 8CID, 8CJH, 8CKO, 8COI, 8(CUU), 8CUV, 8FP, 8SB, 8SL, 8VY, 8WR, (8Z), 8ZZ, 9AJA, 9AVF, 9AUZ, 9AWF, 9BHD, 9DTJ, 9Cans, 1(AL), 9AL.

Spark: 1ACO, 1(BJS), 1GM, 2BY, 2OM, 9ZN.

2CAD and 2ACY, Bayonne, N. J., (1 Tube)

C.W.: 1ES, 1FW, 1GV, 1RH, 1SD, 1XM, 1ACU, 1AGF, 1AGH, 1AGI, 1AIO, 1AJU, 1ANQ, 1AWB, 1AWZ, 1BDI, 1BES, 1BKQ, 1BQK, 1BVA, 1BYN, 1CEC, 1CHJ, 1CMK, 1CNE, 1CPN, 2HW, 2ANM, 2AWF, 2CGJ, 2BZ, 2CC, 2DT, 2FS, 2IR, 2IW, 2LP, 2LR, 2MK, 2OT, 2ZO, 2VW, 2AAO, 2AFB, 2VW, 2AAE, 2AFB, 2ALM, 2AQR, 2BLF, 2BNU, 2BRF, 2GDK, 2FB, 2BX, 2EA, 2GL, 2GO, 2NT, 2AB, 2DO, 2EK, 2FV, 2LJ, 2QI, 2EN, 2CN, 2EH, 2FT, 2HJ, 2JD, 2KG, 2KH, 2LT, 2OW, 2SB, 2SE, 2UC, 2UE, 2VC, 2VY, 2WI, 2WR, 2XJ, 2ZN, 2ZZ, 2AFD, 2AFY, 2ALT, 2AMD, 2AMQ, 2AOD, 2APT, 2AQF, 2AQO, 2ARD, 2ALV, 2AWB, 2AWZ, 2BDB, 2BDO, 2BDU, 2BEF, 2BFM, 2BFX, 2BOX, 2BRM, 2BRQ, 2BRW, 2BSS, 2CDZ, 2CEI, 2CFZ, 2CJH, 2CKM, 2CKO, 2CPX, 2CUR, 2DAK, 2ZAE, 2ZAG, 2CP, 2EI, 2HW, 2NU, 2OX, 2UH, 2UU, 2AIX, 2AJH, 2AWF, 2ALT, 2APR, 2APS, 2AXF, 2BED, 2BLC, 2BSG, 2BSO, 2BYA, 2DFB, 2DSM, 2CBA, 2CJA.

Spark: 3HJ, 9CP, 9UH, 9ZN.

2CJX, Ridgfield Park, N. J.

Spark: 1AKG, 1AMD, 1BGF, 1BPZ, 1BVH, 1BVS, 1CHJ, 1CHQ, 1CMK, 1CNI, 1DY, 1(GM), 1(ILZ), 1OJ, 1(BY), 2APB, 2(ACY), 2(RW), 2(AEO), 2AIB, 2APB, 2AQG, 2ARD, 2AVJ, 2AXN, 2BDA, 2BQA, 2DY, 2RL, 2RQ, 2TC, 2TT, 2UC, 2VQ, 2ZD, 2AFO, 2ARK, 2DZ, 2ZN.

C.W.: 1AAO, 1ABS, 1(AJP), 1AKG, 1AZW, 1BAS, 1BCF, 1BDI, 1BES, 1BKQ, 1BNT, 1BQT, 1BSP, 1CCZ, 1COT, 1CFI, 1CGZ, 1CHJ, 1CLT, 1COL, 1CPN, 1FB, 1HK, 1HX, 1JG, 1PY, 1QP, 1RD, 1TT, 1UH, 1XX, 1YK, 2AAW, 2AFB, 2ALN,

2ATZ, 2AUU, 2AWH, 2AYU, 2BG, 2BIJ, 2BNU, 2BP, 2BVC, 2BZ, 2CG, 2JJ, 2MK, 2OT, 2OW, 2TJ, 2VW, 2ZZ, 2AU, 2BB, 2BQ, 2DC, 2JK, 2UK, 2AB, 2ACF, 2ADH, 2AFD, 2AK, 2AMM, 2AMQ, 2AOL, 2APS, 2APT, 2AQO, 2ASM, 2ATU, 2AUL, 2AVD, 2BBD, 2BDU, 2BFM, 2BJS, 2BNU, 2BNY, 2BPS, 2BWA, 2CAF, 2CCX, 2CCZ, 2CDO, 2CEF, 2CGH, 2CID, 2CJH, 2CJM, 2QB, 2SB, 2SP, 2CTP, 2CUU, 2LJ, 2MW, 2NB, 2QB, 2SB, 2SP, 2UK, 2UZ, 2WR, 2XE, 2ZAF, 2ZAG, 2ZZ, 2AAF, 2ALD, 2AMI, 2HW, 2IO, 2VY.

2BWV, Richmond Hill, L. I.

C.W.: 1ES, 1FB, 1GV, 1HK, 1HX, 1IV, 1JT, 1PR, 1QN, 1RD, 1SC, 1SD, 1VT, 1XM, 1XP, 1ABY, 1ABS, 1ACS, 1ACU, 1ACH, 1AGI, 1AIP, 1AIQ, 1AJP (fone), 1AJU, 1AKG, 1AWB, 1AYZ, 1AZW, 1BAS, 1BCF, 1BDI, 1BES, 1BGF, 1BKQ, 1BNT, 1BQA, 1BQK, 1BQW, 1BVR, 1BWJ, 1CCZ, 1CEC, 1CFI, 1CHJ, 1CHW, 1CJA, 1CMK, 1CMP, 1CNE, 1CNR, 1CPN, 1CPO, 1CSO, 2AA, 2BZ, 2A, 2CC, 2DM, 2DT, 2FR, 2FS, 2HL, 2IK, 2IW, 2LP, 2LR, 2MK, 2OD, 2OT, 2RE, 2SM, 2TJ, 2TN, 2VS, 2VW, 2WF, 2ZM, 2AAO, 2AHK, 2AJB, 2AJD, 2AKA, 2ALN, 2ANJ, 2APR, 2AQR, 2ASY, 2ATZ, 2AWF, 2BGT, 2BHM, 2BIJ, 2BIT, 2BJY, 2BLF, 2BNU, 2BUP, 2BVC, 2BVL, 2AU, 2CQ, 2DC, 2DS, 2EA, 2EB, 2EX, 2GH, 2GK, 2HW, 2KC, 2LP, 2MK, 2MW, 2NT, 2NV, 2DO, 2QI, 2ABM, 2AN, 2DV, 2EH, 2FT, 2HJ, 2KG, 2KH, 2LT, 2PD, 2QB, 2SB, 2SE, 2SL, 2SP, 2UC, 2UE, 2UK, 2WR, 2ZN, 2ZZ, 2ACF, 2ACO, 2ADN, 2AEC, 2AFD, 2AFY, 2AKP, 2ALD, 2AMD, 2AMM, 2AMQ, 2ANK, 2ANO, 2APH, 2APT, 2AQO, 2ARD, 2ASV, 2ASZ, 2ATU, 2AVL, 2AVR, 2BCF, 2BDB, 2BDU, 2BEF, 2BEK, 2BFH, 2BFM, 2BFX, 2BGV, 2BJC, 2BJS, 2BKE, 2BKM, 2BNU, 2BOX, 2BPL, 2BPH, 2BRC, 2BRM, 2BRQ, 2BRT, 2BSJ, 2BSS, 2BST, 2BTR, 2BVL, 2BVR, 2BVT, 2BWA, 2BXH, 2CAZ, 2CCX, 2CDZ, 2CEI, 2CFB, 2CGX, 2CJH, 2CJY, 2CKM, 2CKO, 2CKX, 2CPX, 2CQX, 2ZAE, 2ZAG, 2AAP, 2AJA, 2AJP, 2AMI, 2AON, 2ARZ, 2AWF, 2BCF, 2BDB, 2BGH, 2BLC, 2BYA, 2CJA, 2CJJ, 2DEK, 2DSG, 2DTJ, 2HW, 2IL, 2IQ, 2KR, 2LQ, 2Canadian, 2KO, 2AL.

Spark: 1GM, 1AVA, 1BVB, 1CDM, 2ACY, 2AWF, 2BVC, 2EO, 2UC, 2APB, 2BDA, 2BRL, 2UH, 2ZN.

2TC at Pensacola, Fla.

C.W.: 2BEH, 4MW, 5DO, 5ES, 5HB, 2AFY, 2BKE, 2BSS, 2CDZ, 2BU, 2IO, 2OX, 2XZ, 2AJA, 2AON, 2AZA, 2BSG, 2CBA, 2DUG.

Spark: 4GM, 2UH.

3MB, Reading, Pa., (one tube)

Spark: 1AMD, 2OM, 2ABR, 2(AQR), 2HJ, 2NF, 2BI, 2AIB, 2AJT, 2ANW, 2AYM, 2BDA, 2EO, 2RQ, 2TC, 2ZN.

C.W.: 1AIC, 1AJL, 1AWB, 1BK, 1BKQ, 1CKE, 1CPN, 1CHJ, 1FB, 1HK, 1QN, 1XP, 2AWF, 2AWH, 2AWZ, 2CBG, 2COX, 2FP, 2RM, 2VA, 2WB, 2(AAY), 2AKL, 2ALN, 2AWH, 2BLF, 2BLR, 2(BIT), 2(BNU), 2BRW, 2BVA, 2BVC, 2BW, 2CA, 2CM, 2(DM), 2CBM, 2(FR), 2FS, 2IW, 2MK, 2TN, 2ZO, 2BQ, 2DC, 2EA, 2EB, 2GH, 2HW, 2NV, 2AQU, 2ASZ, 2AWM, 2(AVL), 2AMZ, 2(AFD), 2ARD, 2(APT), 2ATU, 2AB, 2ABV, 2AMF, 2BDO, 2BOX, 2BFM, 2BOZ, 2BCF, 2BJS, 2BRW, 2BKE, 2BPL, 2BFX, 2BVA, 2BWA, 2CJH, 2CDZ, 2CGX, 2CKM, 2CPX, 2CTP, 2CGM, 2CEI, 2CID, 2CCX, 2CKO, 2FT, 2IFC, 2IFY, 2KG, 2OW, 2SR, 2SP, 2UK, 2VE, 2ZAG, 2ZZ, 2AAP, 2AJH, 2ARR, 2AXF, 2BDB, 2BEH, 2BFB, 2BSG, 2BYA, 2DTJ, 2EI, 2GL, 2IO, 2LQ, 2NU.

3ZO, Parkesburg, Pa.

C.W.: 1FB, 1GV, 1IL, 1SC, 1(XM), 1(ABS), 1AJP, 1ANQ, 1(AWB), 1AZW, 1BBW, 1(BKQ), 1CCZ, 1CGQ, 1CPO, 2BG, 2(GK), 2HW, 2NZ, 2(RM), 2(RY), 2TS, 2UD, 2ZL, 2AFP, 2ANM, 2AUZ, 2AWE, 2BEG, 2BEH, 2BFZ, 2BIR, 2BQD, 2BRB, 2CHH, 2(CG), 2(DM), 2(FS), 2(GC), 2(JW), 2LP, 2MA, 2OT, 2QV, 2SM, 2VW, 2WF, 2AAO, 2(AAY), 2(BAW), 2(ADP), 2(ADJ), 2(ALN), 2(ANJ), 2(ATF), 2AVC, 2(AWF), 2AWH, 2BEI, 2BIF, 2(BIT), 2(BL), 2BMJ, 2(BNU), 2(BRW), 2(BTY), 2BVA, 2CBM, 2BX, 2EA, 2NT, 2BC, 2BF, 2FT, 2HJ, 2KG, 2KH, 2NB, 2PD, 2(RPT), 2TC, 2UC, 2UE, 2(XJ), 2(YD),

(8ZN), 8ZR, (8ZZ), 8AER, 8AFD, 8AKP, 8AMQ, 8APT, 8AQO, 8ASV, 8ASZ, 8BDB, 8BEF, 8BFH, 8BPM, (8BFX), 8BEK, 8BPL, 8BRC, 8BRM, 8BSJ, 8BSS, 8BVR, 8BWA, 8BKH, 8CAU, 8CAZ, 8XL, 8AOU, 8ARR, 8AXF, 8BDH, 8BJV, 8BSG, 8CCX, 8CEF, 8CJA, 8CJH, 8ZAE, 8AF, 8FK, 8IO, 8XL, 8AOU, 8ARR, 8AXF, 8BHD, 8BJV, 8BSG.

3BGN and 3BIS, Cape May, N. J. (One Tube)
 Spark: 1AW, 1GM, 2AD, 2ARB, 2FP, 2NF, 2OM, 3CN, 3CT, 3AQO.

C.W.: 1ACS, 1ACW, 1AGJ, 1AIQ, 1AJU, 1AJW, 1AKG, 1ANT, 1ANQ, 1ARJ, 1AWB, 1AWZ, 1AZO, 1BCF, 1BHL, 1BJW, 1BKO, 1BKQ, 1BTJ, 1BVA, 1CEC, 1CHI, 1CHO, 1CMK, 1CNR, 1CPN, 1CPR, 1CSO, 1GV, 1HK, 1HX, 1IV, 1PR, 1PY, 1SC, 1TS, 2ACF, 2AFP, 2AGC, 2AJW, 2AMF, 2AWF, 2AWZ, 2AYQ, 2BEH, 2BIR, 2BML, 2BMR, 2BQU, 2BRB, 2BTW, 2BUM, 2CCU, 2CH, 2CEH, 2CFE, 2CKL, 2GK, 2JW, 2KL, 2NF, 2RY, 2TH, 2TP, 2TS, 2AFB, 2AIS, 2AQR, 2AWF, 2AWH, 2AWM, 2AYF, 2BEB, 2BIJ, 2BLF, 2BML, 2BNU, 2BTY, 2BQU, 2BV, 2BVA, 2BVG, 2BZ, 2CC, 2CF, 2CN, 2CV, 2DT, 2FP, 2OT, 2QN, 2TJ, 2TM, 2TN, 2WF, 2ZO, 2ZW, 4BX, 4BY, 4EA, 4EL, 4NT, 8ACF, 8AQ, 8AQO, 8ASZ, 8ATU, 8AVL, 8AWM, 8AWZ, 8AXN, 8BCZ, 8BDB, 8BDU, 8BEF, 8BPM, 8BNU, 8BRT, 8BTJ, 8BUM, 8CID, 8HJ, 8MF, 8SB, 8SF, 8SL, 8UE, 8XE, 8ZQ, 8ZZ, 8ADH, 8AGI, 8AMI, 8ARS, 8AWF, 8BDH, 8BTJ, 8SM, 8PW.

4KF, Atlanta, Ga.

C.W.: 9AAN, 9AJH, 9APS, 9AXF, 9BHI, 9BLC, 9BRL, 9SM, 9BWK, 9CFI, 9CKM, 9DFB, 9DKY, 9DZM, 9EI, 9FD, 9FN, 9GL, 9GZ, 9KEE, 9KJP, 9LQ, 9NU, 9XL, 9ABB, 9ANB, 9ASZ, 9AP, 9BDO, 9IFY, 9KY, 9YBK, 9XJ, 9ZP, 9AE, 9DA, 9DI, 9ES, 9HB, 9KP, 9LA, 9QI, 9BQ, 9BX, 9CR, 9HW, 9KB, 9NW, 9NI, 9OD, 9HJ.

4NT, Wilson, N. C.

C.W.: (1ABS), (1FB), (2AWF), 2BJO, (2BQU), (2CAN), (2CES), (2CFI), (2CBG), (3FS), (3MC), (3OD), (3TN), (3VW), (3ANJ), (3BIT), (3BLF), 3BOB, (3BVA), (3BVL), (3CAL), (4BX), (4DC), (4FT), (4JK), (4KC), (4GH), (4LT), (8FT), (8HT), (8UO), 8ZZ, (8AFD), (8DKE), 9APS.

5AR, Bay Minette, Ala.

Spark: 5BJ, 5MO, 5SM, 5TU, 5ZL, 8BDA, 9AZF, 9BED, 9BM, 9BMN, 9BGN, 9DMJ, 9DZY, 9IR, 9OK, 9SM, 9UE, 9US.
 C.W.: 3BIJ, 3BLF, 3IO, 3LP, 3LR, 3TJ, 4AIP, 4BQ, 4BX, 4DAI, 4DL, 4DS, 4EA, 4EB, 4GL, 4HW, 4ID, 4JY, 4KF, 4LP, 4MN, 4NES, 4NT, 5ADE, 5AE, 5DI, 5DO, 5DY, 5EK, 5ES, 5HK, 5KU, 5LA, 5LJ, 5NT, 5NV, 5PX, 5QI, 5AB, 5ANB, 5BAZ, 5BDO, 5BEF, 5BFX, 5BGN, 5BKE, 5BWA, 5CDN, 5CGN, 5CKM, 5CWE, 5DAK, 5DLO, 5FT, 5IFY, 5RT, 5STY, 5UE, 5YD, 5ZN, 9AEP, 9AJA, 9AOG, 9AON, 9APS, 9ARR, 9AXF, 9BD, 9BED, 9BIZ, 9BRL, 9BSG, 9BTJ, 9BDY, 9BZI, 9CFI, 9CR, 9DAR, 9DGG, 9DKH, 9DSM, 9DWK, 9DXM, 9EI, 9EJ, 9KFN, 9NU, 9OX, 9SI, 9TRP, 9WC, 9ZAC.

5GP, Anniston, Ala.

Spark: 4FD, 4GN, 5MO, 5SM, 5TU, 5UD, (5VV), 5ZL, 8BDA, 8UC, 9ACB, 9AYY, 9DMJ, 9DZY, 9OX.

C.W.: 2FP, 3BLF, 3HL, 3TJ, 4AU, 4BQ, 4BY, 4EA, 4EB, 4EH, 4EN, 4FT, 4GH, 4JH, 4JK, 4KC, 4KF, 4LJ, 4LP, 4MW, 4NY, 4OD, 4ZF, 5AAM, 5ADE, 5AE, 5BA, 5BR, 5DI, 5DK, 5DO, 5DY, 5EK, 5EO, 5ES, 5FV, 5GH, 5HB, 5HL, 5HZ, 5IR, 5LA, 5NV, 5PX, 5QI, 5RJ, 5SZ, 5UN, 5XAD, 5XY, 5ZAP, 5ZAY, 5ZT, 6KA, 8AFD, 8AFY, 8ANB, 8AXB, 8BDO, 8BDU, 8BFM, 8BFX, 8BJA, 8BKE, 8BNU, 8BVR, 8BWA, 8CDZ, 8CGX, 8CJH, 8CKO, 8CNG, 8CNZ, 8DAK, 8FT, 8IF, 8KH, 8SB, 8SP, 8UC, 8UE, 8UK, 8VY, 8WR, 8XJ, 8ZAE, 8ZZ, 9AAP, 9ABV, 9AJH, 9AMI, 9AOG, 9AON, 9AOU, 9AOV, 9APH, 9APS, 9AQM, 9ARR, 9ARS, 9ASL, 9AWF, 9AWH, 9AXB, 9BCF, 9BDB, 9BEH, 9BGH, 9BHD, 9BHI, 9BRK, 9BRL, 9BSG, 9CFL, 9CIE, 9CJT, 9CJP, 9CP, 9DEK, 9DGG, 9DKY, 9DEI, 9DBL, 9DSM, 9DTJ, 9DU, 9DUG, 9DWN, 9DXD, 9DXN,

9DYN, 9EI, 9EJ, 9II, 9IO, 9JD, 9LM, 9LQ, 9LZ, 9NU, 9OX, 9PF, 9UU, 9WS, 9XAJ, 9XL.

5DI, 2209 Azle Ave., Ft. Worth, Texas

C.W.: 4AU, 4BQ, 4CF, 5AE, 5BN, 5BQ, 5DO, 5DY, 5EK, 5FV, (5HB), (5HJ), 5IR, 5JL, (5LA), 5NK, (5NS), 5NV, (5RB), (5RJ), 5UK, (5VA), (5ZA), 5AAW, 5ZAW, 7LU, 8BV, 8SB, 8SL, (8WR), 8ZQ, 9AMI, (9AMK), (9AOG), (9AON), 9APS, 9AVN, 9ZZ, 8AXT, 8BFX, (8BWA), (8DR), 9DO, (9NU), 9PW, 9XL, (9ZE), (9AV), 9AIX, (9AMB), 9AMG, (9AYS), 9BBD, 9BDE, (9BHD), (9BJB), (9BJU), (9BSG), (9BZI), 9BZW, 9CCJ, 9CCS, (9CJJ), 9CQX, 9DKY, (9DSM), (9DTJ), (9DTM), (9DUG), 9DXN, 9ZAC.

Spark: (5NS), (5OE), (5TU), (5ABY), 5AEJ.

5ES, Montgomery, Ala.

(3ALN), (3BZ), (3BLF), 4AF, 4BL, 4EB, (4KF), 4KC, 4KU, 4LP, 4MW, (5CZ), (5DO), (5LAL), 5VN, (5XR), (5ACX), 8AB, (8FB), (8FT), (8KH), (8UE), (8ZN), (8ZO), (8ANB), 8BKE, 8BAF, (8CDZ), (8CJY), (8CKO), 9DW, 9AON, 9APS, (9AJH), 9API, (9DFB), 9DZY.

6ASN, Berkeley, Cal.

Spark: 6GR, 6FH, 6HC, 6KL, 6OD, 6OL, 6TG, 6CC, 6AAK, 6AHF, 6AHG, 6AHP, 6APY, 6AVF, 6BTB, 7BK, Can. 9BD.

C.W.: 6BF, 6EB, 6EN, 6FH, 6GR, 6KA, 6KU, 6NX, 6RD, 6ND, 6ZN, 6ABQ, 6AOV, 6BCJ, 6BEG, 6BES, 6BIR, 6BJX, 6BMD, 6BQY, 6BTB, 6BZY,

6BQC, Los Angeles, Cal.

C.W.: (6AK), (6BF), (6FH), (6GR), (6GX), (6GY), (6IK), (6KU), (6LO), 6NX, 6OH, (6RD), (6ZA), (6ZB), (6ZF), (6ZO), (6ZS), (6ZXY), (6ZZ), 6AAT, (6ABQ), (6AGJ), (6AOK), (6AOZ), (6AQW), (6ARB), (6ASJ), (6AWT), 6BCJ, (6BHK), (6BJY), 6BQF, (6BQL), 6BUM, (7LU), (7MF), (7NA), (7OT), (7OZ), 7SC, (7AEA) QRA? (9AJA) QRA? (9AMB).

Spark: (6HC), 6GR, 6IC, 6TU, 6ZU, (6AAK), 6AKL, 6AMK, (6AUD), (6BJU).

Radio 6BSQ, Box 1298, Nogales, Ariz., Detector Only

Spark: 5EW, 5FO, 5GO, 5HK, 5HM, 5IF, 5IR, 5TM, 5IS, 5MJ, 5OF, 5QS, 5RA, 5SG, 5TG, 5XA, 5XB, 5XF, 5XI, 5XJ, 5XD, 5XU, 5YM, 5YQ, 5ZA, 5ZAD, 5ZAE, 5ZAG, 5ZAK, 5ZJ, 5ZR, 6AAA, 6AH, 6AAH, 6AAK, 6ABM, 6ACK, 6ACY, 6AEC, 6AEH, 6AEZ, 6AHV, 6AIF, 6AKZ, 6AMN, 6AMT, 6APP, 6AQA, 6ATG, 6AUL, 6ATQ, 6BBH, 6BS, 6VM, 6EA, 6AJH, 6EB, 6EL, 6FK, 6GI, 6GT, 6IV, 6KC, 6IS, 6LC, 6SJ, 6TG, 6TV, 6ZAL, 6ZAM, 6ZAR, 6ZB, 6ZE, 6ZR, 6ZU, 6ZZ, 7YA, 7ZM, 7ZO, 7ZF, 7ZV, 9APN, 9AQE, 9BBA, 9DSD, 9NR, 9YAE.

C.W.: 2NZ, 3FS, 4GL, 4BY, 4CB, 4XB, 4ZC, 5KP, 5CI, 5AA, 5EO, 5FV, 5IC, 5NK, 5PU, 5ZA, 5YL, 5XJ, 5ZAF, 5ZAK, 5ZAN, 5ZU, 6AAG, 6AAV, 6ALV, 6ASV, 6AUL, 6BLA, 6CU, 6EB, 6ES, 6LD, 6MT, 6XAG, 6XAD, 6XV, 6XZ, 6ZA, 6ZB, 6ZF, 6ZE, 6ZAF, 6AIF, 7LN, 8XV, 8BOE, 8BDU, 8AGZ, 9AMB, 9AAU, 9AQR, 9ARJ, 9AYZ, 9AIG, 9AYS, 9AWL, 9BBB, 9BIR, 9BJI, 9BOM, 9BOW, 9BSG, 9DCF, 9DTM, 9DZJ, 9FM, 9NX, 9PI, 9PS, 9WD, 9VZ, 9WU, 9XAG, 9XM, 9ZAE, 9ZE.

7ATH, Monroe, Wash.

Spark: 6ABX, 6AJR, 6ALA, 6ALU, 6AQA, 6ARK, 6ARS, 6ATU, 6CC, 6GF, 6RR, 6TU, 7AEA, 7BH, 7BK, 7CU, 7EY, 7FI, 7FQ, 7GE, 7GF, 7HD, 7HI, 7IC, 7IH, 7IW, 7IY, 7JD, 7JF, 7JW, 7KJ, 7KS, 7MF, 7MU, 7NR, 7NL, 7NN, 7NX, 7NZ, 7OE, 7OH, 7OW, 7RC, 7SA, 7TJ, 7TO, 7TW, 7VE, 7VF, 7VZ, 7WG, 7WR, 7ZK, Canadian 9BD.

C.W.: 5LA, 6AAT, 6AIV, 6AK, 6ALU, 6AMZ, 6ARB, 6ARC, 6ASJ, 6AW, 6AWT, 6BCD, 6BCJ, 6BEG, 6BOE, 6BQC, 6BZG, 6CJ, 6EN, 6FH, 6FT, 6GR, 6KA, 6KU, 6LF, 6NX, 6PI, 6RD, 6RM, 6RR, 6TV, 6VM, 6XAD, 6XE, 6ZE, 6ZF, 6ZI, 6ZO, 6ZX, 7ACK, 7AEA, 7AFW, 7AGX, 7AW, 7BK, 7BQ, 7BS, 7DP, 7FL, 7HS, 7IY, 7LR, 7LU, 7MF, 7NA, 7NJ, 7NN, 7OT, 7OZ, 7QE, 7QW, 7RN, 7SC, 7SY, 7TN, 7YA, 7ZB, 7ZI, 9AJA, 9AYU, 9DTM, BT3, Canadian 4BV, 5CT.

73G, Aberdeen, Wash.

Spark: Can. 9EC, 5DO, 9BD, 6AAK, 6ABM, 6ABU, 6ABW, 6ABX, 6AEH, 6AIH, 6AJH, 6AJE, 6AKT, 6AIA, 6ALW, 6AMK, 6AMZ, 6ANG, 6AQU, 6AR, 6ARK, 6ARS, 6AS, 6ATV, 6AVB, 6AVM, 6AWH, 6BAX, 6BB, 6BIU, 6BNE, 6BNT, 6CC, 6FE, 6GF, 6GP, 6GR, 6GT, 6HC, 6HP, 6LB, 6IC, 6KM, 6OD, 6OL, 6TC, 6TU, 6VA, 6VX, 6ZU, 7ADL, 7AEA, 7AGI, 7BB, 7BG, 7BK, 7BZ, 7CH, 7CE, 7EY, 7FI, 7FQ, 7GE, 7IN, 7IW, 7IY, 7JF, 7JW, 7KE, 7KS, 7MU, 7MY, 7MZ, 7OF, 7OH, 7OT, 7OW, 7PQ, 7TJ, 7TO, 7TW, 7VE, 7VF, 7WG, 7ZK, 7ZP, 7ZS.

C.W.: Can. 5CT, 5QI, 5ZA, 6AAT, 6AGR, 6AOT, 6AQW, 6ARB, 6ASJ, 6AWP, 6AWT, 6BES, 6BF, 6BHK, 6BJY, 6BMD, 6BMN, 6BPZ, 6BQC, 6BQL, 6BSA, 6BTB, 6EA, 6EN, 6FH, 6FT, 6GR, 6GX, 6IK, 6KA, 6KM, 6KU, 6LV, 6NI, 6RR, 6WK, 6XH, 6ZF, 6ZG, 6ZZ, 7AEA, 7AGF, 7FR, 7LB, 7NA, 7OE, 7OT, 7OZ, 7QB, 7QW, 7RN, 7MF, 7ZO, 9IN, 9BSG, 9DUG, 9Q3.

8BEP, Defiance, Ohio

Spark: 2AWF, 2FP, 2OM, 2ACY, 2BVC, 2FP, 4BI, 4GN, 5ZL, (8AGP), 8AFK, (8AIT), (8AIZ), (8AVX), 8AWM, (8AXN), 8AYO, (8BDA), (8BTJ), (8CAU), 8AWM, (8AXN), 8AYC, (8BDA), (8BTJ), (8CTI), 8EA, 8EW, 8KG, 8KY, 8OL, (8RQ), (8TK), 8UC, (8VH), 8VS, (8WU), (8WZ), (8ZO), (8ZY), 9AAW, (9AFK), 9AIP, 9AMQ, 9AMT, 9APW, 9ARR, 9AZA, 9AZF, 9BMM, 9CP, 9DJB, (9DMJ), 9DSB, 9DTN, 9DXT, 9DZY, Can: 3GN, 3GX, 3BP.

C.W.: 1CGJ, 1ANE, 1ANQ, 1XM, 2AFP, 2ARF, 2AWF, 2BEE, 2BJO, 2BML, 2CBG, 2FP, 2KL, 2NZ, 2AW, 2AIP, 2ANJ, 2APD, 2AQR, 2BZF, 2BNU, 2BVC, 2BZ, 2CB, 2CBM, 2IW, 2KO, 2LP, 2LW, 2TJ, 2VW, 2BJ, 2BQ, 4BX, (4EA), 4EH, 4ZF, 5EK, 5QI, 8AG, 8AM, 8ACF, 8ACH, (8ADT), 8AFP, (8AFY), 8AIM, 8AIO, 8AMD, 8ANB, 8APB, 8APG, 8APT, 8AQQ, 8ASV, (8ASZ), 8ATI, 8ATU, 8AUW, 8AXN, (8BAS), 8BDB, 8BDO, 8BDU, 8BDY, 8BFM, 8BSS, 8BKE, (8BKI), 8BPL, 8BQN, 8BRM, 8BWA, (8CAG), 8CAY, 8CAZ, 8CBU, 8CCX, 8CFX, 8CFN, 8CJH, 8CKM, 8CKO, 8CKX, (8CMI), 8CVJ, 8CKM, 8DAK, (8FT), 8JD, 8LQ, 8OW, 8UC, 8UE, 8UK, 8UZ, 8WI, 8XJ, 8ZAE, 8ZAG, 8ZO, (8ZY), 8ZZ, 9AAP, 9AIK, 9AIU, 9AJH, 9AJP, 9AMI, 9AON, 9APS, 9AUA, 9BGH, 9BN, 9BSG, 9BWS, (9CBA), 9CCS, (9CNV), (9DFB), 9DJB, 9DKH, 9DSM, 9DRB, 9DTJ, 9DXN, 9EJ, 9GL, 9LZ, (9UC), 9UU, 9WR, 9YQ.

8BKN, Cambridge, O. (1 Tube)

C.W.: 1ACS, 1AJU, 1ANQ, 1AUN, 1AZU, 1BHQ, 1CBK, 1CHJ, 1CPN, 1CQU, 1FB, 1ND, 2AMF, 2ARV, 2AUZ, 2AUV, 2AWF, 2AYZ, 2BES, 2BJO, 2BJY, 2BNZ, 2BQE, 2BQU, 2BRB, 2CBG, 2CGI, 2EH, 2KL, 2MM, 2TN, 2TP, 2AEV, 2ALN, (2ANO), 2AQA, 2AQR, 2ATU, (2AWH), 2BIJ, (2BLF), 2BLT, 2BNU, 2BZ, 2CA, 2CBM, 2CC, 2CI, 2IU, 2LJ, 2LR, 2MK, 2OD, 2GS, 2SM, 2TJ, 2VW, 2VZ, 2XW fone, 2ZAF, 2ZB, 4BX, 4DS, 4EB, 4EN, 4FT, 4GH, 4KC, 4NT, 5AAM, 5EK, 5QI, 5UK, (5ACF), 8ACH, (8AER), 8AES, (8AFD), 8AFT, 8AFY, 8AIO, (8AKP), 8AMD, 8AMH, 8AMM, 8AMQ, 8ANX, 8ANJ, 8ATU, 8AU, 8AXN, 8BDB, 8BEF, 8BF, 8BFM, 8BFX, 8BIQ, 8BJV, 8BNU, (8BQC), 8BOX, 8BQP, 8BRM, 8BUE, 8BXF, 8CAY, 8CBC, (8CDZ), 8CFP, (8CGN), 8CIY, 8CJH, 8CKO, (8CMI), 8CMM, 8CTP, 8CYS, 8EH, 8FT, 8LT, 8NB, 8ON, 8PD, 8PH, 8PT, 8SB, 8SL, 8TC, 8UE, 8UK, 8VE, 8VQ, 8ZAE, 8ZAG, 8ZG, 8ZZ, 9AAP, 9AJH, (9AKD), 9AON, 9ARF, 9ARZ, 9AU, 9BJV, 9BLC, 9BLD, 9BSG, 9BTT, 9BZI, 9CJA, 9DEK, 9DFB, 9DIK, 9DRR, 9DTJ, 9DXN, 9HU, 9II, Canadian 9AL.

Spark: 2ARD, 2OM, 2ALU, (8AVO), 8BDA, 8BMR, (8BQC), (8CBC), (8CJZ), 8EW, 8RQ, 8XJ, (8ZO), 8ZY, 9AZA.

8CZN, Cleveland, Ohio (Reinartz and 1 Tube)

Spark: 2FP, 2OM, 2HJ, 4FD, 4HS, 9CP, 9KI, 9OX, 9UH, 9ZN, 9AMK, 9AZA, 9BMN, 9DMJ, 9DTN, 9DWM, 9DXT, 9DZY.

C.W.: 1ES, 1GV, 1HK, 1ON, 1QN, 1SC, 1UH, 1XM C.W. & I.C.W., 1XP, 1XX, 1ACS, 1ACU, 1AGH, 1AGI, 1AIQ, 1AJU, 1AMI, 1ANQ, 1AU, 1AUZ, 1AWB, 1AZW, 1BDV, 1BKQ, 1BNT, 1BQI, 1BQK, 1BQT, 1CHJ, 1CME, 1CNE, 1CPN, 1CPO,

1CQU, 1CZA, 2BG, 2EH, 2FP, 2GK, 2IG, 2KI, 2KY, 2TS, 2UD, 2AWF, 2BDG, 2BIR, 2BML, 2BMR, 2BNC, 2BQH, 2BQU, 2BRB, 2BRC, 2BUM, 2BYU, 2CBG, 2CFI, 2CGJ, 2CKN, 2CPD, 2BZ, 2CA, 2FS, 2HL, 2LP, 2MK, 2TJ, 2TN, 2ZO, 2ZW, 2AAY, 2ALN, 2ANJ, 2AQP, 2AQR, 2AUU, 2AWH, 2BAC, 2BHC, 2BIJ, 2BIT, 2BJY, 2BLF, 2BNU, 2BQU, 2BRA, 2BVL, 2BWQ, 2AU, 2BQ, 2BX, 2BZ, 2DC, 2DS, 2EA, 2EB, 2EH, 2EK, 2GH, 2GX, 2ID, 2JK, 2KC, 2KF, 2LP, 2MW, 2NT, 2OD, 2QT, 2ZT, 2DA, 2DG, 2DI, 2DO, 2HB, 2JL, 2NV, 2QL, 2AAM, 2ADE, 2ALD, 2CP, 2DR, 2EI, 2FK, 2GR, 2II, 2LQ, 2LZ, 2NU, 2PF, 2RK, 2UH, 2WC Dahite, 2WU, 2AVY, 2AAP, 2AAT, 2AJH, 2ALB, 2AMI, 2AOU, 2APW, 2ARM, 2ARK, 2ARR, 2AWF, 2AXF, 2AY, 2AYS, 2BDE, 2BED, 2BEH, 2BES, 2BFG, 2BHI, 2BLC, 2BRL, 2BSG, 2BYA, 2BZI, 2CAS, 2CCB, 2CGD, 2CKT, 2CJA, 2CJJ, 2CNY, 2CYT, 2DBV, 2DCB, 2DEK, 2DFB, 2DGX, 2DKM, 2DKS, 2DKY, 2DTJ, 2DTN, 2DIM, 2DQU, 2DUG, 2DVA, 2DVR, 2DVW, 2DWE, 2DXN, 2DYT, 2DZW, 2YAJ.

8ASL, Fredonia, N. Y.

Spark: 1ADC, 1KV, 2AAF, 2AHU, 2AJE, (2ARB), 2BSC, 2DN, 2FP, 2OM, (2NF), 2RM, 2AJD, 2AWF, 2AC, 2BVC, 2FP, 2HJ, 2RW, 4FB, (8AEO), (8AHS), 8AIB, (8AII), (8AIZ), 8AJT, 8APE, 8AUX, (8AXQ), (8AYM), 8BDA, 8BGT, 8BLF, (8BQA), 8BQC, 8BRL, (8BXC), (8BYF), 8CBC, 8CEB, 8CMY, 8CP, 8CSD, (8CUG), 8EO, 8EW, 8FE, 8KG, 8NZ, (8OI), (8RQ), (8TC), 8TT, 8UC, 8VH, 8VQ, (8WO), 8ZD, (8ZO), 9AFK, 9AIR, 9ARR, 9CP, 9DEN, (9DWM), 9DZY, 9JX, 9LF, 9MC, 9ZN, Can. (8BA).

C.W.: 1ACS, 1AGH, 1AGI, 1AIQ, 1AJU, 1ANQ, 1AR, 1AWB, 1AZD, 1AZM, 1BES, 1BKQ, 1BQI, 1CCX, 1CCZ, 1CFI, 1CHJ, 1CK, 1CL, 1CLW, 1CNE, 1FB, 1HK, 1II, 1PY, 1QN, 1QV, 2AFP, 2ANJ, 2AUZ, 2AWF, 2BG, 2BJO, 2BML, 2BNZ, 2BQ, 2BQU, 2BUM, 2CBC, 2CBG, 2CES, 2CGI, 2FP, 2GK, 2HW, 2KL, 2NZ, 2TS, 2UD, 2AFB, 2AJD, 2ANJ, 2AQR, 2AXY, 2BIJ, 2BIT, 2BLF, 2BNU, 2BVC, 2BVL, 2BX, 2CBM, 2CC, 2IW, 2OK, 2OT, 2QV, 2SM, 2TJ, 2TN, 2VW, 2WF, 2BQ, 4BX, 4DC, 4EA, 4EB, 4KC, 4LJ, 4LF, 4NV, 8ACF, 8ADR, 8AFD, 8AFL, 8AGR, 8AIO, 8ALT, 8AM, 8AMM, 8ANB, 8ANO, 8ANZ, 8APT, 8APW fone, 8AQO, 8ARD, 8ASZ, 8ATU, 8AWN, 8AWY, 8AWZ, (8AYB), 8BDB, 8BDM, 8BDU, 8BFM, 8BJS, 8BJV, 8BKH, (8BNU), 8BRC, 8BRQ, 8BRT, 8BWA, 8BWB, 8BXH, 8BZF, 8CAZ, 8CBJ, 8CCX, 8CDZ, 8CEF, 8CGN, 8CID, 8CJH, 8CKM, 8CKO, 8COI, 8CTN, 8CUU, 8CUV, 8CYT, 8GH, 8HJ, 8KG fone, 8KH, 8LT, 8NB, (8ND), 8OW, 8QB, 8SB, 8SP, 8UB, 8UC, 8UE, 8UK, 8WA, 8XE, 8ZAE, 8ZN, 8ZX, 8ZZ, 9AAP, 9AON, 9AJH, 9BDB, 9BSG, 9BYA, 9BZI, 9DEK, 9DFB, 9DTJ, 9EI, 9UH, Can. (7JI), (8KP), 3SP, (3XX), 9AL.

8AAU, Canton, Ohio

Spark: 1ALY, 1AKG, 1AZK, 1NF, 2AJE, 2FP, 2GP, 2OM, 2RM, 2ACY, 2BNU, 3GU, 3HJ, 4FD, 5BI, 5IO, 5PY, 5AEG, 5AY, 5APM, 5ANW, 5ASL, 5AIB, 5AQO, 5AZF, 5AIX, 5AUX, 5AXN, 5AX, 5BDZ, 5BAY, 5BAZ, 5BNH, 5BNU, 5BNV, 5BDA, 5BRL, 5BQF, 5CLO, 5CDV, 5CFZ, 5CCT, 5CSD, 5EA, 5EB, 5EK, 5EO, 5EW, 5JP, 5JX, 5OI, 5RK, 5SE, 5TC, 5TT, 5UC, 5UD, 5OE, 5XE, 5ZO, 5ZY, 9AIW, 9AIR, 9AMK, 9AIX, 9AAR, 9APB, 9AJA, 9AAW, 9ACB, 9AZA, 9BXC, 9BZX, 9BCT, 9CFP, 9CCJ, 9CP, 9DXT, 9DEN, 9DZ, 9DTN, 9DZY, 9JB, 9JX, 9LF, 9LQ, 9OX, 9QC, 9UH, 9WA, 9WD, 9ZN.

C.W.: 1AYZ, 1AZW, 1AMK, 1ACS, 1AGI, 1AMQ, 1ACH, 1AKA, 1AWB, 1AWW, 1BWY, 1BND, 1BKQ, 1BGF, 1BXQ, 1BWZ, 1CQM, 1CJN, 1CME, 1CQU, 1CAZ, 1CGO, 1CIK, 1CM, 1FB, 1GV, 1HW, 1PQ, 1PK, 1VQ, 1XM, 1XP, 1XZ, 1ZX, 2AWF, 2AFB, 2AAW, 2AMH, 2AFP, 2AUZ, 2AFD, 2AUY, 2AWP, 2BNZ, 2BQH, 2BEH, 2BBX, 2BRC, 2BMQ, 2BFX, 2BQU, 2BOB, 2BVC, 2BDU, 2BDF, 2BVI, 2BVH, 2BQ, 2CDG, 2CBW, 2CBG, 2CDN, 2FP, 2GK, 2HW, 2KL, 2MK, 2NZ, 2OT, 2RU, 2VA, 2VW, 2ZO, 2AVY, 2ATJ, 2ANJ, 2ALN, 2ADY, 2ADN, 2BZV, 2BHM, 2BRW, 2BIJ, 2BLF, 2BDF, 2BNO, 2BJY, 2BNU, 2BGT, 2BZF, 2BVL, 2BY, 2BZ, 2CBM, 2CCC, 2CC, 2FS, 2HJ, 2IL, 2IW, 2JK, 2LP, 2LR, 2MK, 2OD, 2OW, 2PB, 2TJ, 2VW, 2WF, 2XW (fone), 2ZO, 4AW, 4BQ, 4BX, 4BY.

4CU, 4DC, 4EA, 4EN, 4GH, 4GK, 4GL, 4GS, 4GX, 4ID, 4IE, 4KA, 4KC, 4KF, 4LP, 4MN, 4NT, 4NV, 4UK, 4DO, 4ES, 4FV, 4NB, 4ND, 4NM, 4OD, 4QI, 4UK, 4US, 4ZK, 4ZAC, 4EN, 4GA, 4FM, 4NF, 4ZL, 4ABU, 4ABZ, 4ACF, 4ADN, 4ADP, 4ADY, 4AEG, 4AFD, 4AFY, 4AGK, 4AGO, 4AHR, 4AIZ, 4AJP, 4AKP, 4ALB, 4ALF, 4ALY, 4AMD, 4AMH, 4AMM, 4AMQ, 4ANB, 4AND, 4AMW, 4APT, 4APY, 4AQO, 4AQR, 4AQZ, 4ARD, 4ASF, 4ASV, 4ASY, 4ASZ, 4ATT, 4ATU, 4ATZ, 4AUM, 4AVM, 4AVT, 4AWK, 4AWM, 4AWP, 4AWT, 4AWV, 4AWY, 4AWZ, 4AXC, 4AXN, 4AZF, 4AB, 4BBN, 4BBU, 4BDB, 4BDO, 4BDU, 4BEF, 4BEO, 4BFX, 4BFR, 4BGF, 4BGZ, 4BHT, 4BJU, 4BJV, 4BKE, 4BKN, 4BKU, 4BLR, 4BNH, 4BNJ, 4BNO, 4BNT, 4BOC, 4BOX, 4BOZ, 4BPH, 4BPL, 4BPU, 4BQC, 4BQF, 4BRQ, 4BRM, 4BSS, 4BUM, 4BUS, 4BVM, 4BVR, 4BVT, 4BWA, 4BWC, 4BXC, 4BXF, 4BXI, 4BXH, 4BZK, 4BZO, 4BZV, 4BZY, 4BF, 4MB, 4BO, 4BU, 4CAY, 4CAZ, 4CBC, 4CBF, 4CBX, 4CCO, 4CCX, 4CDE, 4CDZ, 4CEF, 4CGM, 4CGN, 4CGX, 4CHJ, 4CIZ, 4CJH, 4CKF, 4CKM, 4CKO, 4CMI, 4CMO, 4CON, 4CQU, 4CTJ, 4CUR, 4CUV, 4CUD, 4CYT, 4CG, 4DAK, 4DRG, 4DA, 4DV, 4EA, 4EI, 4EF, 4ES, 4FS, 4FT, 4GV, 4HJ, 4HM, 4HP, 4HU, 4JD, 4JQ, 4JP, 4JU, 4KG, 4KY, 4LO, 4LT, 4ML, 4NB, 4OW, 4PD, 4PT, 4QC, 4SE, 4SE, 4SL, 4ST, 4ST, 4STY, 4UC, 4UE, 4UF, 4UK, 4VE, 4VY, 4WI, 4XE, 4XJ, 4XV, 4ZAE, 4ZAG, 4ZK, 4ZN, 4ZP, 4ZQ, 4ZK, 4ZZ, 4AUA, 4AAW, 4ADI, 4AEP, 4AZA, 4AJP, 4AJH, 4AAP, 4AKB, 4AKF, 4AGN, 4AON, 4ABV, 4AMK, 4ARZ, 4AJU, 4AMT, 4ARP, 4AY, 4AJA, 4ARK, 4AOK, 4AIM, 4AFN, 4ADH, 4AN, 4BSG, 4BCT, 4BED, 4BUD, 4BDB, 4BLC, 4BRL, 4BAA, 4BJR, 4BCF, 4BZX, 4BZI, 4BLG, 4BIU, 4BYA, 4FG, 4BDG, 4BDS, 4BEE, 4BB, 4CGK, 4CFI, 4CBA, 4CRM, 4CG, 4CR, 4DCG, 4DXN, 4DKP, 4DIO, 4DRD, 4DXT, 4DEK, 4DFB, 4DAX, 4DSM, 4DEJ, 4DWK, 4DFB, 4DUG, 4DGE, 4DVF, 4DVN, 4DXN, 4DC, 4DB, 4EI, 4FW, 4GL, 4HW, 4II, 4IO, 4LQ, 4LZ, 4KA, 4ML, 4NU, 4PV, 4UH, 4US, 4UU, 4UR, 4WS, 4XA, 4XD, 4XF, 4XL, 4ZB, 4ZL, Canadian 2BG, 2AL.

SATU & SBBD, Rochester, N. Y.

C.W.: 1AGH, 1AGI, 1APN, 1AIP, (1AWB), (1AJP), (1AZW), (1BES), (1BKQ), (1BGF), (1BRB), (1BDI), (1BQK), (1CMK), (1CH), (1CPN), (1ES), (1FB), (1GV), (1GN), (1HX), (1JT), (1SC), (1XM), (2AWF), (2AWH), (2AZM), (2BC), (2BEH), (2BFZ), (2BML), (2BQ), (2BUM), (2CC), (2CES), (2CBG), (2CBM), (2CGJ), (2CKN), (2CXZ), (3AFB), (3ALN), (3ANJ), (3AQR), (3AWH), (3AL), (3BG), (3BJY), (3BLE), (3BUP), (3BVC), (3BV), (3BNU), (3CBM), (3CHG), (3FR), (3FS), (3LP), (3VW), (3ZO), (3ZW), (4BG), (4AAM), (4AB), (4ACF), (4ANB), (4APT), (4AVD), (4ARD), (4AFY), (4AMD), (4AQO), (4ASV), (4BEF), (4BRQ), (4BRM), (4BPH), (4BTR), (4BWA), (4CDZ), (4CEL), (4CCX), (4CID), (4CNW), (4CKO), (4HM), (4KH), (4QB), (4UE), (4UK), (4WR), (4XE), (4ZX), (4ZQ), (4ZZ), (4AAP), (4AIX), (4AJH), (4BZI), (4CJA), (4DR), (4DTJ), (4HJ), (4UC).

Spark: 1AA, 2FP, 2NF, 2OM, 2AMZ, 2VC, 2ZN.

9BJV, Minneapolis, Minn.

C.W.: 2FP, 2BQD, (3JI), 3BLF, 4MW, (5DI), 5DO, 5EK, (5JL), 5LJ, 5NV, (5PX), (5QI), 5ZI, 6CF, 6FZ, 6XH, (7LU), (8AB), 8EH, 8FT, 8SB, 8UE, 8XE, 8ZZ, (8VY), (8KH), 8AFD, 8AIC, (8AFY), 8ALT, (8ADT), 8AMQ, 8ANB, (8APT), (8ASZ), 8ATU, 8AWA, (8AXN), (8BCY), 8BDO, (8BEF), (8BFM), (8BFH), 8BGM, (8BKE), 8BOM, 8BOT, 8BOX, 8BJV, 8BRT, 8BUM, (8BWA), (8CAK), 8CDZ, 8CGN, 8CKO, 8CUR, (8DAK), 8ZAG, 8AAP, (8ABV), 8ACS, 8AEP, (8AIU), 8AIX, (8AIY), 8AIP, 8AJA, (8AJH), (8AMB), 8AMI, 8AMN, 8AMT, 8AMU, 8ANQ, 8AOG, (8AON), 8AOS, (8AOU), 8APS, 8AJF, (8ARZ), 8AVZ, 8AWF, (8AXF), (8AYS), (8BAA), (8BAF), 8TB, (8FD), (8BCF), (8BGH), (8BLC), (8BLG), 8BKO, (8BFQ), (8BQW), 8BRL, 8BSG, (8BXT), (8BYA), (8BZI), 8CAJ, 8CCJ, 8CCS, 8CKK, (8CI), (8CFI), (8CMJ), 8DBL, (8DAX), 8DEH, 8DEK, 8DGN, (8DGG), 8DFB, (8DKY), (8DOF), (8DQ), (8DQM), 8DTJ, (8DTM), 8JX, (8DWW), 8DHW, 8DXE, 8DXN, (8DZQ), 8DWY, (8DZW), (8DSM), 8ZAC, 8EI, 8HW, (8II), 8JA, (8MF), 8NX, (8FK), 8LQ, 8LN, 8FF, 8LZ, 8PL, (8PW), 8NU, 8OX, (8UC), 8US, 8UH, 8WR.

(9WC), 9XL, 9CP, (9YF), (9XT), (9YAJ), (9DUG).

9MF, St. Cloud, Minn. (1 Tube)

C.W.: 2FP, 3ZO, 4BQ, 4BZ, 4CR, 4EB, 4KF, 4MW, 5DI, 5DO, 5FV, 5JL, 5LA, 5NV, 5PX, 5QI, 5EJ, 5UK, 6BOE, 6KA, 7LU, 7ZO, 8ACF, 8AFY, 8AMQ, 8ANB, 8APT, 8AQO, 8ASZ, 8BAH, 8BEF, 8BFH, 8BFM, 8BFX, 8BKE, 8BOX, 8BPA, 8BRQ, (8BVR), 8BWA, 8CDZ, 8CGM, 8CGN, 8ZGX, 8AB, 8AN, 8BO, 8FT, 8KG, (8SB), 8SL, 8UC, 8UM, 8UR, 8VY, 8WR, 8XJ, 8ZZ, 9AAP, (9ABV), 9AEP, 9AIU, 9AIY, 9AJA, 9AJH, 9AJP, 9AKB, 9ALB, 9AMB, 9AMI, 9ANQ, 9AON, (9AOR), (9OU), 9APS, 9APW, 9AQM, 9ARZ, (9AYS), 9AUA, 9AUS, 9AVZ, 9AWF, 9AXF, 9AYA, (9AYS), 9BAA, (9ABF), 9BBF, 9BCF, 9BED, (9BFG), 9BFQ, 9BIC, 9BJH, (9BJV), 9BKJ, 9BKO, 9BKP, 9BQW, 9BSG, (9BTT), 9BXT, 9BZI, 9CBA, 9CCS, 9CCV, 9CFL, 9CJA, 9CJI, 9CJJ, 9CKM, 9CQM, 9DBL, (9DGE), 9DGG, 9DIW, 9DJM, 9DJX, 9DNT, 9DPL, (9DQE), 9DQM, 9DSM, 9DSW, 9DTJ, 9DTM, 9DUG, 9DWW, 9XN, 9DZQ, 9DZK, 9DZW, 9ZAC, 9ZAF, 9AL, 9CP, 9DR, 9EI, 9FK, 9IL, 9JA, 9LQ, 9LZ, 9NU, 9NX, 9OX, 9PI, 9PS, 9PW, (9QE), 9UH, 9WD, 9XL, (9XT), 9YF, Can. 3JI, (4BV).

Spark: 5ZAW, 5TU, 5ZL, 7AAB, 8BDA, 8BDU, 8BOO, 8BO, 8UC, 8ZO, 8ZY, (9ABM), 9ABV, 9ACL, (9AES), 9AFK, 9AHZ, 9AMK, (9AMQ), 9AMT, 9APN, 9ASL, 9ASN, (9AZA), (9AZP), 9BJP, 9BMN, (9BSZ), 9BUP, 9BWS, 9CKL, (9CFP), 9CTW, 9DEH, 9DJE, 9DMJ, 9DRW, 9DTN, 9DUG, 9DWK, 9DXT, 9YAK, 9CF, 9DK, (9FK), 9GP, 9HG, 9JA, 9KA, (9LF), 9MC, 9NQ, 9PD, 9SY, (9TB), 9TV, 9UH, (9VL), 9WX, (9XT), 9ZC, 9ZN.

9ZN, Chicago, Ill.

Spark: (2FP), (2OM), (3HJ), 4BI, 4FD, (4HS), (5BW), (5ZL), 5AAW, (8BO), (8CH), 8CK, (8EA), 8EW, (8FT), 8HG, 8JJ, (8KJ), (8NZ), (8SB), (8UC), (8VH), (8ZK), (8ZO), (8ZY), (8AIZ), (8AVO), (8AXN), (8BBU), (8BDA), (8BIB), (8BKZ), (8CMI), (8DTA), 9FT, (9LF), (9NQ), (9OX), (9PD), (9TW), (9UH), (9UL), (9ACF), 9AIP, (9AMK), (9AMQ), (9AMT), 9ARK, (9AZA), (9BEL), (9BMN), (9CMO), (9DAG), (9DTN), 9DWM, (9DZY).

C.W.: 1XM, 1AZW, 1BGF, 1BKQ, 1CMK, (2FP), (2CC), (2KL), (2NZ), (2AFP), 2AWF, 2BML, 2BNZ, (2BRB), 2CJP, 2CKL, 2BL, 2BZ, 2LJ, 2LR, 2MK, (2IW), 2WF, 3ZO, 3ZW, 3BF, (3ALN), 3AQR, 3AUI, 3BIT, 3BNU, 3BLF, 4BI, 4BQ, (4CF), (4DC), 4DS, 4EA, 4KF, 4LP, 4MW, (5BW), 5DI, 5DO, 5HB, (5JL), (5ZA), 5ADE, 6KA, 7ZU, 8AB, 8AM, 8AN, 8AX, (8EB), (8EH), 8DX, 8FA, 8HH, (8KH), 8KG, 8ML, 8QL, (8SB), 8SL, 8UE, 8UZ, 8WA, 8XE, 8ZQ, 8ZX, 8ZZ, (8APT), (8ADN), (8ASJ), (8AKP), 8AIV, 8ACF, 8ASZ, 8AMM, 8ASU, 8ATU, (8AXN), 8AK, 8BXA, (8BDA), 8BRQ, 8BBU, 8BFX, 8BFM, 8BDU, 8BKE, 8BWA, 8BET, (8BEF), 8BS, 8BGT, 8BCF, 8BPL, 8BVR, (8BTL), (8CBJ), 8CCX, 8CJH, 8CKO, 8CDZ, 8CPX, (8CMI), (8CGM), (8CGN), 8CAZ, 8CJX, 8DAK, 8ZAG, (8DR), 8GV, (8EI), 8NU, 8JA, (8IO), (8OX), 8LQ, (8UH), 8XM, (9AVA), (9AIV), 9ABV, 9AMI, 9AON, (9APW), 9AIR, 9AJS, (9AWF), 9APE, 9AOG, 9ASL, (9AAP), (9APS), 9AVZ, 9ACY, 9ASW, 9AQM, 9BHL, 9BFG, 9BJV, 9BGH, 9BLC, (9BSG), 9BSR, 9BRL, (9BZI), 9CAS, 9CJJ, 9CEE, 9CJI, (9DSG), (9DFB), 9DJB, 9DGG, 9DWK, 9DTJ, (9ZAC), Canadian C.W.: 3KO, 3JH, 3AL.

9DZZ, Milwaukee, Wis.

Spark: 5TU, 8AIT, 8BDA, 8BLA, 8EO, 8EW, 8TC, 8UC, 8VR, 8ZY, 9AAW, 9AIR, 9AMK, 9AUI, 9AZA, 9BMN, 9CP, 9DAY, 9DWM, 9DZY, 9GX, 9JA, 9KI, 9LF, 9MC, 9NY, 9OF, 9OX, 9QC, 9UH, 9VL, 9ZB, 9ZN.

C.W.: 1AJP, 1AJU, 1AWB, 1AZW, 1BRR, 1BTA, 1CJH, 1CPN, 1CQW, 1GV, 1QN, 1VW, 2AFP, 2AWF, 2AYZ, 2AZY, 2BEH, 2BFG, 2BJO, 2BQU, 2BRB, 2CH, 2CKL, (2FP readable 50 ft. fm Magnavox), 2GK, 2HO, 2NZ, 2TS, 2UD, 2AFB, 2AFD, 3AJ, 3ALN, 3ANO, 3AQR, 3AUA, 3AUI, 3BEP, 3BFG, 3BLE, 3BNU, 3BRW, 3BVA, 3BWF, 3BZ, 3CA, 3CBM, 3CC, 3FM, 3FS, 3HL, 3IW, 3KO, 3LH, 3LP, 3MK, 3TJ, 3TN, 2VW, 3WF, 3ZW.

(Concluded on page 76)

Power Factor Applied to Radio Condensers

By Paul G. Watson, 3BV

MANY amateurs have constructed condensers very carefully, only to find that on completion they did not have the capacity that was desired. This is particularly true of transmitting condensers for spark sets. It is with these partial failures in mind that this article is written, and since many of these troubles center around the "power factor" of the condenser, it has been taken up from that viewpoint. The points where the losses occur will be brought out, and the reasons why the actual capacity and the effective capacity are sometimes different.

The "power factor" is the center of this set of calculations, and for the benefit of those who are not familiar with this expression, a brief explanation follows. Power factor is the cosine of the phase angle, of an alternating current. The phase angle is the angle falling between voltage amplitude and current amplitude in the same alternation. The sine curve which is commonly used to represent alternating current variation is the voltage curve, the current curve being of slightly different form, and say lagging behind the voltage rise and fall. This lag is expressed in terms of the angle falling between these two curves, the cosine functions being the power factor. Power factor in A.C. circuits is expressed in terms of the power as follows:

$$\text{Power Factor} = \frac{\text{Watts}}{\text{Volts} \times \text{Amps.}}$$

The watts are the actual power consumed, while the denominator is the product of volts and amperes in the same circuit. The factor will vary greatly in this case depending on the nature of the load.

Power losses in radio condensers can come from a great number of sources, but generally these losses can be classed under some of the cases taken up here. Losses may be due to dielectric imperfection, plate resistance, lead resistance, brush discharge, and by dielectric absorption.

The first case to be considered will be the loss due to ordinary conduction, or otherwise dielectric imperfection, and known as leakage. This loss in most cases is negligible at high frequencies, but at low frequencies it adds materially to the phase difference. The effect on the circuit is that of placing a resistance in parallel with the capacity. The effect is shown in Fig. 1 by vectors and a diagram. The current divides between the two branches. I_r , the current through the resistance, is in phase with the applied E (effective electro-

motive force) and the current through the condenser, I_c , leads E by 90° . The resulting I (current) leads the E by an angle which is less than 90° by the phase difference ψ . In Fig. 1 it can be seen that

$$\tan \psi = \frac{1}{R\omega C}$$

where R = insulation resistance

$$\omega = 2\pi f$$

C = capacity in microfarads

f = frequency.

The extent of this effect at low frequency is best shown by assuming a condenser having a capacity of .01 mfd., an insulation resistance of 10 megohms, and a frequency of 60 cycles. In this case

$$\text{Power Factor} = \frac{1}{(10)^6 \cdot 377 (10)^{-8}} = .027$$

From this it can be seen that 2.7% of the current flows by conduction rather than electrical displacement. At frequencies higher, say 10,000 cycles, this loss would

SHUNT RESISTANCE

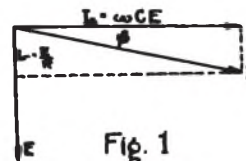
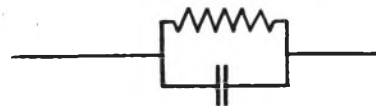

Fig. 1

drop to .00016 or .016%, which is negligible. For this reason, in radio work, unless the dielectric is extremely poor, this loss can be neglected.

The next case to be considered is the case of resistance in series with the capacity. This resistance can come from poor contacts, lead wire resistance, resistance of the plates themselves, or by poor connections to the plates. This resistance affects the circuit quite differently from the previous case where the resistance was in parallel.

In Fig. 2 is an elementary diagram and a vector diagram of the effect of this action. The E , across the resistance is in phase with the current I while E_c lags 90° behind I . The power factor taken from Fig. 2 is as follows:

Power Factor = $r\omega C$.
 r = resistance in ohms.

If $r = 1$ ohm, $C = .01$ mfd., the power factor at 60 cycles is $3.8(10)^{-4}$ which is negligible. If however the frequency is raised to 1,000,000, corresponding to a 300 meter wave length, the power factor of this condenser becomes .063 or a loss of 6.3% energy at the resistance. This is a very large loss and would upset calculations if not considered.

In the foregoing example r was assumed to be 1 ohm. It is sometimes more than this in some condensers, especially the ordinary paper kind, but in most others a high series resistance indicates a defect.

As the frequency increases, "skin effect" causes a slight increase in resistance. On this account, the power factor increases in proportion to a power of the frequency which is slightly greater than one.

The dielectric absorption loss manifests itself in the following manner. When a current is fed into the condenser, the instantaneous charge is followed by a small and decreasing flow of current. This current is the current which, for clearness' sake, we will assume is actually absorbed in the dielectric. In the discharge cycle the reverse to the charging takes place, i.e., the initial discharge is followed by a small current flow, which is gradually decreasing in value. This phenomenon is known as "electrical viscosity." The energy which causes the small current to flow is loss, and manifests itself in the form of heat in the condenser. Absorption is expressed in the terms of resistance, the most convenient being to assume the absorption as a series resistance, and is known as the "equivalent resistance" of the condenser. Such a condenser is calculated according to the data in Fig. 2 with the power factor equal to $r\omega C$. This resistance is constant at a given frequency, but varies with the frequency. The exact laws governing this variation have not been determined, but for approximate calculations the power factor can be assumed to be constant, r varying inversely with f or in direct proportion to wave length. This fact is taken from $r\omega C$ being constant in value. Most condensers in radio circuits have a constant power factor over the radio frequency range.

A condenser operated in air under a high tension ionizes the air near the edges of its plates, for example a Leyden jar. At extreme voltages this ionization takes the form of a blue discharge, most noticeable at the corners or on a projecting point. The power factor in circuits of this nature is influenced by this discharge which is quite large in comparison to absorption and resistance losses. In his research work Dr. Austin found the power factor of a Leyden jar to be constant up to 10,000 volts, from 10,000 to 22,000 volts the increase was about as the square of E and above

this figure, it was at a still higher ratio, increasing to the fourth power of E . With the exceptions of the Leyden jar and the compressed air condenser, the power factor is not a voltage function. Where solid dielectric is used, power factor depends largely on absorption and resistance. If the power factor increases with frequency, it is a sure sign of series resistance. At frequencies of 250,000 to 300,000 the effect of series resistance is often present due to the use of tin foil for plates.

A few formulas for condenser calculations follow. A careful study of some of

SERIES RESISTANCE

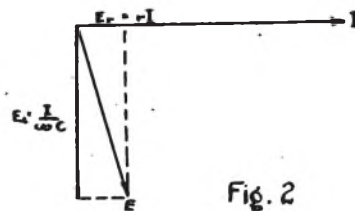
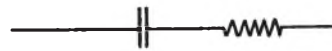

Fig. 2

these may show the direct cause of failure of the transmitting condenser to function properly.

Power input in a condenser—

$$P = .5 \times 10^{-4} NCE_e^2$$

P = Power in watts

C = Capacity in Mfds.

N = Number of charges per second

E_e = Volts (maximum)

This formula can be expressed in other forms: $P = 10^{-4} f CE_e^2$, where f = cycles per second; $P = 10^{-4} NCE_e^2$, where E = effective voltage of the A.C. circuit; or $P = 2 \times 10^{-4} f CE_e^2$.

Total power loss in a condenser is expressed in the following formula:

$$P = \omega CE^2 \sin \psi$$

where P = Power loss in watts.

The effective resistance of a condenser is expressed as follows:

$$r = \psi \times \frac{.001}{C} \times \frac{\lambda}{1000} \times .154$$

r in ohms

C = micromicrofarads

λ = in meters

While some of the preceding formulas may seem complicated to the casual observer, it will be found that simple substitution of numerical values for letters and performance of the indicated mathematical operation is about all that is needed in most cases.

Application of some or all of these formulae to condensers, especially those of

higher power, will result in the improvement of conditions, particularly if trouble has previously been experienced.

As previously mentioned series resistance is common, from long leads to the condenser, poor or dirty contacts, and the use of tin foil, where long plates are used. Parallel resistance comes from poor oil in the condenser, the presence of dirt in the oil, defective dielectric sheets, dust on the connections, and likewise moisture.

The writer has visited many amateur stations, in almost all sections of the country, and has noticed that the defects mentioned here existed in many of them.

CALLS HEARD

(Continued from page 75)

4AU, 4BQ, 4BX, 4BZ, 4CR, 4DS, 4EA, 4EB, 4EX, 4FW, 4GH, 4GX, 4HW, 4KF, 4LP, 4MW, 4NT, 4NV, 5AAM, 5DI, 5DO, 5FV, 5HL, 5IR, 5JL, 5LA, 5LJ, 5NV, 5QI, 5TV, 5UN, 5VA, 5VI, 5AB, 5ABA, 5ABR, 5ACF, 5ACH, 5AFD, 5AFT, 5AFY, 5AHL, 5AIG, 5AIM, 5AIO, 5AKH, 5ALE, 5ALT, 5AMD, 5AMK, 5AMM, 5AMQ, 5ANB, 5ANX, 5APT, 5AQF, 5AQO, 5ARB, 5ARD, 5ASM, 5ASV, 5ASZ, 5ATR, 5ATU, 5AUA, 5AVD, 5AWM, 5AWT, 5AWZ, 5AXE, 5AXM, 5AXN, 5AYN, 5BAH, 5BAQ, 5BAX, 5BCF, 5BCJ, 5BDB, 5BDD, 5BDO, 5BDU, 5BDY, 5BEF, 5BEH, 5BFM, 5BFX, 5BGG, 5BHE, 5BJE, 5BJS, 5BJV, 5KE, 5KEM, 5KEN, 5BKS, 5BKU, 5BNJ, 5BNQ, 5BNU, 5BNW, 5BO, 5BOX, 5BPA, 5BPL, 5BQF, 5BQY, 5BRC, 5BRF, 5BRM, 5BRN, 5BRQ, 5BRT, 5BRW, 5BSF, 5BSJ, 5BTU, 5BUM, 5BVR, 5BVT, 5BWA, 5BWB, 5BXA, 5CAB, 5CAG, 5CAT, 5CAZ, 5CBJ, 5CBX, 5CCX, 5CDZ, 5CEI, 5CF, 5CFB, 5CGM, 5CGN, 5CGX, 5CL, 5CID, 5CIZ, 5CJH, 5CKM, 5CKO, 5CNW, 5COI, 5COO, 5CPD, 5CPO, 5CPX, 5CTL, 5CTW, 5CUR, 5CYV, 5DA, 5DAK, 5DCF, 5DM, 5DQF, 5DWE, 5DZW, 5FT, 5HJ, 5HM, 5IB, 5IE, 5KG, 5KH, 5LT, 5MR, 5NB, 5NV, 5WR, 5OW, 5PD, 5QE, 5RT, 5SB, 5SE, 5SL, 5SP, 5UC, 5UE, 5UK, 5UZ, 5VE, 5VQ, 5VY, 5XE, 5YM, 5ZA, 5ZAE, 5ZAG, 5ZN, 5ZQ, 5ZR, 5ZK, 5ZZ, 9ABV, 9ABY, 9AHS, 9AIX, 9AJH, 9AJP, 9AKB, 9AKD, 9ALB, 9AMI, 9AMU, 9ANF, 9ANW, 9AON, 9AOU, 9APS, 9APW, 9AQM, 9AQJ, 9ARK, 9ARZ, 9ASN, 9ATC, 9AUA, 9AUS, 9AUV, 9AWF, 9AWH, 9AWW, 9AXF, 9AXR, 9AXU, 9AYS, 9BAA, 9BAC, 9BAD, 9BAF, 9BAS, 9BCF, 9BCG, 9BDA, 9BDB, 9BDC, 9BHG, 9BGW, 9BHD, 9BIZ, 9BJR, 9BKO, 9BLC, 9BLG, 9BQW, 9BSD, 9BSG, 9BSM, 9BWA, 9BWR, 9BYA, 9BYZ, 9BZI, 9CBA, 9CBB, 9CCS, 9CCV, 9CDJ, 9CFI, 9CGJ, 9CJA, 9CJH, 9CJJ, 9CKM, 9CMV, 9CP, 9CPJ, 9CPY, 9CQM, 9CR, 9CX, 9DBL, 9BDV, 9DCG, 9DCR, 9DEK, 9DFB, 9DFW, 9DGE, 9DIM, 9DJM, 9DJQ, 9DKH, 9KY, 9DME, 9DNT, 9DQE, 9DQU, 9DR, 9DSG, 9DSM, 9DTJ, 9DUD, 9DUG, 9DVW.

9DR 1830 Stevens, Minneapolis, Minn.

2FP, 4BV, 4KF, 4MW, 5AA, 5AAR, (5DI), 5DO, 5DIH, 5EK, 5HB, 5MV, 5QI, 5RJ, 5UK, 5ZA, 5ZAW, 5ZAY, (5EA), 7LU, (5AB), 8AQ, 8EH, 8FT, 8IE, 8MQ, 8UC, 8UE, 8VE, 8VY, (8WR), 8ZO, 8ZZ, 8ADN, 8AFY, 8AIZ, 8AFT, 8APW, (8ASV), 8ASY, 8ATU, 8BDO, (8BEF), 8BFT, 8BGO, (8BOX), 8BPL, 8BRQ, (8BRT), 8BVT, 8BWA, 8BXH, 8CGN, 8CJH, 8DAK, 8ZWN, (9FK), (9HG), (9JA), (9NU), (9NX), (9OX), (9XL), (9XT), (9ZC), (9ZN), (9AAP), (9ABD), (9AIX), (9AMB), (9AMI), (9AON), (9APS), (9ATU), (9BAF), (9BCF), (9BGH), (9BKJ), (9BQW), (9BMN), (9BSG), (9BTT), (9CCS), (9CFI), (9DBL), (9DFB), (9DKY), (9DOF), (9DPV), (9DSM), (9DYZ), (9YAZ), (9YAK), (9ZAC), Can. 3KO.

9DEK, No. Judson, Ind.

C.W.: 1ADL, 1ANQ, 1AZW, 1BGF, 1BKQ, 1HX, 2AFP, 2AWF, 2BML, 2BNZ, 2CGU, 2FP, 2OM, 2NZ, 2VA, (2AA), 2AEV, 2ALN, 2AQR, 2BIJ, 2BIT.

3BLF, 3BZ, 3CC, 3FS, (3QJ), 3ZO, 4BQ, 4BY, 4GH, 4GL, 4JH, 4KC, 4LP, 4MW, 5DA, 5EK, 5FV, 5HW, 5LJ, 5TC, 5ACF, (5AFD), 5AIO, 5AMD, (5ANB), (5APT), (5ASV), 5ATU, 5AXB, (5BCY), (5BDU), 5BEF, (5BEX), (5BFX), (5BGO), 5BIL, 5BKE, (5BOX), (5BRM), (5BVR), (5BWA), (5CAK), 5CAZ, (5CGX), 5CKO, (5CVY), (5CXW), (5AM), 5HJ, (5NB), (5SB), 5SP, (5ZZ), (9AAP), (9AFN), (9AIX), (9AIY), (9AJH), (9ARK), (9ARR), (9ASN), (9AYA), (9BDB), (9BED), (9BLC), (9BTA), (9BZI), (9CAH), (9CGK), (9CJA), (9DBL), (9DDY), (9DGE), (9DNC), (9DRR), (9FO), (9IO), (9II), (9PA), (9UC), 9UU, (9OX), (9YAJ).

Spark: 2FP, 2OM, 3HU, 3AIB, 3AIZ, (9AAW), (9AMK), (9AOY), (9AXY), (9AYY), (9BDP), (9BMN), (9OX), Fone (9DTJ), QRA PSE.

9ZN's "FJ" at 5723 Winthrop Ave., Chicago. (Loop & 3 Audio)

Spark: 2FP, 2OM, 3HJ, 5ZL, 8BO, 8EA, 8EB, 8FT, 8KJ, 8TT, 8UC, 8ZO, 8AIZ, 8BU, 8BDA, 8CYU, 8FK, 8LF, 8FU, 8NQ, 8PD, 8UH, 8VL, 8YB, 8AZA, 8BDS, 8BMN, 8DJN, 8DMJ, 8DZL, 8DZY.

C.W.: 1FB, 1AJP, 1AWD, 1AZW, 1BDI, 1BKQ, 1CKW, 2FP, 2AWF, 2BRB, 2CHG, 2CKL, 2CA, 2FS, 2LP, 2ZO, 2ZW, 3AYW, 3BIT, 3BLF, 3BNU, 4AF, 4BX, 4EX, 4JK, 4KF, 4LP, 4MW, 4ZF, 5EK, 5ES, 5DI, 5DO, 5JL, 5LJ, 5QI, 5UK, 6KA, 6AWT, 7LU, 7ZU, 8AN, 8RM, 8CF, 8FT, 8HH, 8HJ, 8KG, 8PD, 8SB, 8UK, 8WA, 8XE, 8XJ, 8ZO, 8ZQ, 8ZZ, 8AFD, 8ADW, 8AWM, 8AQO, 8AWB, 8ASZ, 8AWT, 8APW, 8ARD, 8AOB, 8ANB, 8AWP, 8APT, 8AMQ, 8ACF, 8ATU, 8BPM, 8BWA, 8BRW, 8BRT, 8BXH, 8BJS, 8BEF, 8BS, 8BEX, 8BFX, 8BXA, 8BRM, 8BRC, 8BKE, 8BOX, 8BRQ, 8BYE, 8BVR, 8BNU, 8BXH, 8CAX, 8CUU, 8CKO, 8CAK, 8CGN, 8CJH, 8CBX, 8DR, 8FK, 8II, 8IO, 8JA, 8LQ, 8UH, 8AMI, 8AAP, 8ABV, 8AJP, 8AOG, 8AYS, 8AIU, 8AQM, 8ARZ, 8AOU, 8ARR, 8ARK, 8BSG, 8BGH, 8BLC, 8BZI, 8BED, 8BJV, 8BGW, 8BST, 8BEH, 8CJJ, 8CCV, 8CJA, 8DQE, 8DFB, 8DBL, 8DUG, 8DTJ, 8DEK, 8DPL, 8DZQ, 8DGE. Canadian C. W.: 3JI, 3KO, 4BV.



Radio Communications by the Amateurs

The Publishers of QST assume no responsibility for statements made herein by correspondents.



Long-Wave Reception

Brooke, Va.

Editor, QST—

Kindly allow me to make the following reply to "A Novice" concerning his letter on page 54, September QST.

Taking each question in turn as presented in this letter I will state that, first of all, distance does not in any way depend upon the number of amplifiers used and a single tube will give just as great a distance as detector and any number of stages of audio amplification, as the signals cannot be amplified until they have been rectified by the detector tube and thereby made audible.

As to the coils "sweating." Very few real amateurs ever find any factory-made instruments ideal for their purpose and almost without exception some changes for the better have to be made to suit each individual requirement before best results are possible. The regular fibre bands of the honeycomb coils were replaced by specially treated "bakelite" bands to good advantage by the writer.

As I have always pointed out there is nothing "novel" about the hook-ups I have published in QST and I do not recommend "novel" hook-ups. However unless a set is properly constructed as to capacity and inductance effect and so arranged that leads are of a minimum length, a great variation in condenser readings for the same wave length will surely result and it should be the object of all builders to construct their sets in such a way that the condenser reading with any given coil for any given station will be as high as possible. This indicates that stray capacity and leads have been reduced to a minimum. If said set is so constructed there will be absolutely no variation in the size of coils required for any certain wave the year around and the condenser reading for that wave will remain the same. Knowing the habits of amateurs in planning sets more for looks than for actual operating results, necessitating different values of coils and condenser capacities, my readings previously given have always been a compromise between a poorly arranged set and one correctly arranged and from all accounts the compromise given by me tallies with the average amateur's figures. As a matter of fact regarding the size of coil for NAA or other stations op-

erating near his wave, HC or DL-750 coil is the proper secondary coil to use for maximum signal strength on a correctly designed set the year around. The coils are standard all right and the trouble is not with the coils but with the sets they are used on. Out of a great number of coils I have personally tested none of them vary to any extent that could account for the differences noted by "A Novice." One exception has been noticed and this was with a HC-1500 coil. This coil was stamped L-1500 but the coil was exactly L-1250 in value; therefore the discrepancy was evidently in labeling instead of winding.

Regarding reception. In the first place I have never recommended .001 mfd. condenser for the primary circuit. The value of coils in inductance makes it practically a necessity to use condensers of larger values on long wave work, and the larger the aerial the larger the condenser should be. This accounts in part for the lack of "pep" shown when primary is tuned.

However, this does not account for the big trouble these days. When my first article on H.C. coils was written we had NSS operating on 16,900 meters, MUU on 14,000 meters, WII, then an "N" station, on 13,600, POZ on 12,600, OUI on 10,000 and NDD on about 9,800. There were a few others at considerable distances operating above 10,000 meters occasionally but these were the principal ones.

Consider the difference today. Practically every station with DX aspirations operates above 10,000 meters and the number is growing continually, not only in foreign lands but right here at home. There is NDD, WSO, WII, WKQ (and several more sisters) NSS, NPL, KIE, KET, LY, YN, POZ, LCM and many more, all with one exception operating between about 10,000 and 17,000 meters. This represents a difference in frequency of about 12,000 cycles, a difference approximately equal to the difference in frequencies between 200 meters and 202 meters.

Now if anyone can even hope to get results from distant stations who operate on waves between 10,000 and 17,000 meters with all the present nearby stations going at full blast, which they do practically all the time, he is due a sad disappointment. Not only are results from distant stations impossible but the nearby stations hetero-

dyne themselves so badly that it is even impossible to tune these in with any degree of success. Therefore the experience of "A Novice" in getting NAA much louder than NSS is nothing at all new but really the rule to all operating in the east, and if results are to be had at all you must hike out to parts where the QRM is dimmed by distance or else take special precautions in erecting loops, long directional wires, etc., as is done by the high power stations themselves. Results from ordinary amateur aeri-als are absolutely impossible at present.

The primary will have little effect on tuning when you are being heterodyned off the map. The same applies to short wave phone reception mentioned by "A Novice" where many phones going at the same time will heterodyne each other badly and cause poor results, and this is doubled and more when the receiver happens to be so located that it also picks up the heterodyne harmonic effects of the nearer high-power stations.

Receiving the high-power stations with a separate heterodyne is theoretically the best but the difference in actual practice is very slight and not enough to justify the burning of another tube.

Home-made coils, if properly made, will not only work better but look better than the usual small honeycombs for short wave lengths. As to the matter of tubes, no one with a practical knowledge of long wave work would ever think of securing high amplification under the best of conditions on long waves with a soft tube. Hard amplifier tubes are absolutely necessary for long wave detection.

However, I would advise "A Novice" and everyone else interested in long wave reception that reception at present above 10,000 meters is practically impossible with the average amateur aeri-als so far as obtaining good DX results goes. Before the days of C.W. transmitters spark stations in Europe, the Pacific Coast and Hawaii have been almost regularly copied on a crystal detector, which today is quite impossible due to the high power C.W. stations and their general blanket effect. Also the few C.W. stations that first made their appearance on the Pacific Coast and in Europe, such as OUI and KSS, could easily be copied on a crystal detector and a chopper. Try this now'days and see how far you get.

Should the experimenter happen to catch a time when all of the high power C.W. stations within 500 miles of him are closed down, then he will be able to receive Europe, Hawaii and perhaps greater DX, with as much ease as of old, but it looks like this condition will never again prevail. However no one should have much trouble receiving from "LY" at the present time. He is up on 23,400 meters by himself and does not share in the general heterodyne

effect and QRM between 10,000 and 17,000 meters. Also good results can still be had from FL who uses 6,700 meters approximately. When WSO and NDD are quiet, fair results can be obtained from LCM and POZ. OUI has moved up to about 14,000 meters so we no longer get him with any degree of success. Dozens of new ones have sprung up. Some I know nothing of, as it has been many a day since I operated a set above 10,000 meters due to the general failure of these waves to give results under present conditions and the greater interest of the short waves.

I thank you for indulging these explanations, and hope they will serve to clear up some of the mysteries of long wave reception as it exists today.

With best "73" to all, I am,

Sincerely,

A. L. Groves, 3BID.

Winnipeg Heard From

Canadian 4CE,
33 Rosewarne Ave., St. Vital, Man.
Editor, QST—

In all of the copies I have received of QST there has not been any correspondence from Winnipeg, so it is about time you had some. There is nothing very exciting going on up here on account of the summer weather and the usual QRN. At the time of writing there is an organization of "real hams and broadcast listeners" getting under way. The radio craze is just as bad here as it is in any other place, and the gang that turned up at the first meeting of the club gave every evidence that the organization will be a success. As soon as the club or association (we haven't decided which it is to be) gets things moving, you fellows in the States will hear more of the "Peg" than you heard last winter.

As our power up here is limited to ¼ K.W. and also to 180 meters (C.W. 200), any hopes of doing very much DX work are very small. Still you never can tell. Wonder how many of you hams listen for any of our sigs, eh? Perhaps you get them but don't bother to answer. There are a bunch of ½ K.W. stations here, good ones too, that could handle traffic in proper style, if we can connect. C.W. is the only thing to get distance, we know, but what the Samhill are you going to do if you haven't got the shekles? Keep the old "rock crusher" on the job, that's all. There are hopes of one or two tube sets that will be in operation this winter. Yes, things are starting to show a little life here.

If any of you fellows in the States pick up our sigs, drop us a card; then we can tell what we can and cannot do. Most of the work is done after the broadcasting stations close down. That is after 10 P.M.

Yours truly,

Vincent Thomas.

Here's Where Radio Counts

Sandy Falls,
c/o Northern Canada Power, Ltd.,
Timmins, New Ontario, Canada.

Mr. A. H. Keith Russell,
Manager Ontario Division,
Toronto, Ont.

Dear Mr. Russell:

I have been going to write you for so long now that it has got to be a habit of letting the job be crowded out, so here goes.

Just want to tell you that I am back in the woods of Northern Ontario, in the Temagami Forest Reserve, Lat. 48 and Long. 81, on the Mettagami River in the Porcupine gold area. Have been fussing around an old wireless set for over a year on the receiving end, and have a couple of small transmitters as well. Was absolutely alone up this end of the world until a few months ago. No one worried much about radio at all. No other "ham" within 150 miles (Marshall of Temagami). Used to read your reports every month in QST and sigh with loneliness, then shove the wireless set off the table and build a better one. Have drifted all the well-worn route from the loose-coupler galena combination up to the two step and Reinartz, and wake up now every other night in a cold sweat about the "super regen" stuff—then get out of bed about 4 A.M. to put out the cat and fuss around in my shirt tail just to see who of the boys are still working.

Well, as I say, I got lonely, so began starting something in the local papers—little talks, etc., to see if there was anyone around here who would have the nerve to squeak up and say he was a "ham." Lordy! Lordy!—one guy wrote and said he was the real quill—and only SEVEN miles away! Fancy that and me a-pining back here amongst the balsams and spruce with a broken heart in one hand and a QST in the other. Consequently, I thereupon immediately proceeded in as decorous manner as possible to his domicile and upon seeing him, fell on his neck and wept with joy. I don't remember much else but folks tell me we had to be blasted apart after three days in order to give us sustenance. From then on things have progressed. I had found a kindred soul only SEVEN miles away, so the following day found me chopping an old dilapidated water closet box out of the ice, and hacking up the copper tank into a fifty foot strip for an O.T. Dug up a coil, key, condenser, gap etc., and cut loose. Nix! I prostituted the northern ether at 45° below for a week and all the wolves died within five miles of this camp. It was a riot! There must be something wrong. It looked as if I must be pounding right over my man seven miles away and going clear down to Texas—but no cards came. Then my aerial pole

blew down and did not have the heart to put it up again. Just tied it to an out-house at the far end, and went to the key—and poked away as usual to keep me from going "bluey." Two days later my ham drops a card to me that I was very QSA "just around where WNY comes in good"!!!

Oh me, Oh my—and my aerial five feet from the ground?!

So it went on—from that on up to a decent coil, interrupter, quarter K.W. quenched gap, R.F. meter, pushing out seven tenths of an amp or so, and tuning around 180 meters—you know how it goes. Went ahead and kept up the propaganda work and have about half a dozen with receivers all round me with a couple talking transmitter every time I get close enough to 'em. Have pushed the receiving end of the thing fairly hard myself, tried all the fool circuits that I ever saw or dreamt about, until I have chopped half a mile of perfectly good wire into little pieces. The nights find me fussing around with three or four receivers of different types, a bushel basket full of Groves, spider, D.L. coils, fil. voltmeters, milli. amm., verniers, and the cats pyjamas of a wave-meter that set me back a shade over a hundred fish alone. I am about 550 dead north of Toronto, yet I can honestly say I have never logged a CANADIAN HAM. Yet the walls here are plastered to the ceiling with cards from U.S. hams verifying reception. How come? As for radio-phone stuff, I rake in about a dozen U.S. stations ranging from KDKA to WHAF and 3XW.

WJZ pushed one of my letters to them into the New York Globe—the Pittsburgh Post followed suit—then nine magazines quoted it, Bruce Barton in the "American" magazine also, and the last I heard it had rambled into the "Radio Broadcast" advertisement which was selling an "Easy Home Radio Course" by Maj. Gen. Squier. Incidentally I might say that I was shoveling mail around from under my feet for ten days—all from girls in the U.S. wanting to marry me or asking delicate questions utterly remote from radio.

Oh, how I raved to be single again,—just for TEN WICKED MINUTES!!! Well, let's go. What I started out in the first place to tell you was that I am going to put in ten or twenty watts C.W. Should be all set by Nov. 1st—in fact I have everything all ready such as the more important items like diagrams of circuit, newer dope which cans the diagrams, and so forth. All I need now to get ready are a few tubes, choke coils, meters, inductance, motor generator and one or two other odds and ends too trivial to mention. Well, all joking aside, I think you will find me on the mat along with the rest of the gang with ten or twenty watts and about 500 volts some-

where around the date above stated, sooner by Heck if the gods are kind enough to assist me in the amassing of sufficient toadskins to buy the junk.

Best of 73s from your truly,
M. J. Caveney,
Can. 3GG.

Full-Wave Self Rectification

Norfolk, Va.

Editor, QST—

Having just received the August copy of QST and having just absorbed the contents of Mr. A. M. Young's article on the "Operation of the Low Power C.W. Transmitter," I wish to take some exceptions to some of his statements concerning the efficiency of the self-rectification circuit. I am using this circuit with two fifty watters and am getting very good results. He says in his article that there is a great loss of power due to the fact that one of the tubes is idle while the other one is in operation, and I have also read another article in one of the back issues, written by some one connected with 1XM, that in some of their tests they found there was a negative potential applied to the tube which was not in operation during each half cycle, further killing it, the whole effect being a loss of power. From my own tests here, with one tube in the circuit, and the other one taken out of the socket, my antenna current on 200 meters was 2.25 amps and with the two tubes operating was 4 amps. Now how come, where is that "loss of power"? Have tried other circuits, all except the reversed feedback, and have found that none of them gave me the results that the self rectification circuit gives, and hope to try the reversed feedback circuit soon. I also had trouble with the keying and found that the remedy was to shunt the key with a one mfd. condenser, when using the key in series with the grid leak.

Respectfully,
3MK.

Ether vs. Magnetic Field

P. O. Box 278,
Livingston, Mont.

Editor, QST—

According to Webster, energy is "the power by which anything acts effectively to move or change other things or accomplish any result." This, together with other definitions easily shown, implies that energy is inseparable from matter. It is difficult or impossible to consider energy in any other way. Therefore we think of kinetic energy as a result of matter in motion, and potential energy as a property of matter under stress.

Light and other electromagnetic phenomena, such as the waves used in radio telegraphy and telephony, are indisputably forms of energy, and, according to the above generally accepted meaning of the

word "energy," must be results of some form of matter in motion. Science has long accepted this as a fact, and many have been the attempts to determine the form of matter essential to the observed results. As a composite result of these long-continued efforts the students of physics the world over have accepted, with reservations here and there, what is called the hypothetical ether. This is supposed to be a form of matter, more or less uniformly distributed thruout the universe, very different from all forms with which we are familiar. In fact, in order to meet the requirements as a transmitter of electromagnetic waves without interference with other physical activities, it must be widely different, and we are therefore fully justified in assuming that such is really the case.

If we think of the ether as we do of the forms of matter immediately familiar to us, we soon find difficulties in our attempts to co-ordinate it with electromagnetic energy and other forms of energy. Probably the chief objection to the hypothetical ether has resulted from just such mistaken view of the subject.

It has been stated that no such thing as this hypothetical ether can exist, because it calls for diametrically opposite properties. That is, if we think of it as we do ordinary matter, it must be throughout at the same time both extremely tenuous and extremely dense. Fortunately it is not necessary to think of the ether in this way.

The absolute need for a medium of some kind to account for various physical phenomena, including magnetism, electricity, propagation of electromagnetic waves, and gravitation has stimulated analytical mental effort so largely that we have several worthy results. None of these can be said to be wholly correct; but collectively they give us a fair basis for discussion.

In his efforts to understand the phenomena of gravitation, Le Sage, of Geneva, published during the year 1818 an hypothesis which is given in the Encyclopedia Brittanica as follows:—

"Le Sage supposed that the universe was thronged with exceedingly small particles moving with very great velocities. These particles he called ultra-mundane corpuscles, because they came to us from regions far beyond the solar system. He assumed that these were so penetrating that they could pass through masses as large as the sun or earth without being absorbed to more than a very small extent. There is, however, some absorption, and if bodies are made up of the same kind of atoms, whose dimensions are small compared with the distances between them, the absorption will be proportional to the mass of the body."

In this way with further argument, Le Sage accounted for gravitation as a push

rather than a pull, or attraction as we are wont to express it.

If we give to Le Sage's corpuscles the additional properties of infinite or nearly infinite elasticity, motion in all directions with the speed of light, and inability to penetrate each other, we may find food for interesting speculation of a nature that might possibly give new and more definite information regarding the construction of the necessary medium conveniently called the ether.

With these additional properties Le Sage's corpuscles could not possess weight, possibly could not accomplish friction, and could not unite with each other alone to form masses. They might possibly be capable of forming various combinations with minute particles of some other unknown form of matter, to form atoms such as are cognizant to us. Thus, without much stretch of the imagination, Le Sage's corpuscles might become modern electrons under conditions as yet undemonstrated. Thus constituted and situated these particles might form the whole of a universal magnetic field, in conformity with Dr. Steinmetz' recently published theory. ["Popular Radio," page 161, July, 1922.—Ed.] Even if this be true or partly true, the writer can feel no need for abandoning the old name of the interstellar medium and all of our preconceived ideas regarding such medium.

If we accept, at least for the time being, these suppositions, we can reasonably deny some of the objections to the ether as advanced by those who think of it in terms of ordinary matter only. *Such a medium could easily be the great storehouse of the energy of the Universe.*

Any disturbance of the heterogeneous movements of the particles, which, as a whole, amount to homogeneity, could become evident as some form of energy known to us. Without some disturbance we could not be conscious of the presence of such matter.

Possibly we have two great divisions of matter; one form consisting of some such medium as that here assumed; the other possibly consisting of different minute particles likewise as yet not positively known to us. The former, for convenience, we might name negative matter. This we can reasonably assume to be unlimited in quantity. The latter, necessarily limited in quantity, we might name positive matter. Matter of which we are cognizant may consist of forms resulting from various combinations of these two primitive forms. This seems not largely at variance with modern views concerning the probable electrical constitution of tangible matter.

Objections may be offered to Le Sage's theory as well as to the suggestions and modifications of Le Sage's views given herein. In fact, "Clerk Maxwell (article

'Atom,' Enc. Brit., 9th ed.) pointed out that this transference of momentum from the ultra-mundane corpuscles to the body through which they passed involved the loss of kinetic energy by the corpuscles, and if the loss of momentum were large enough to account for the gravitational attraction, the loss of kinetic energy would be so large that if converted into heat it would be sufficient to keep the body white hot. We need not, however, suppose that this energy is converted into heat...."

Here again the physicist is thinking in terms pertaining to known forms of matter only. However, Maxwell's mental grasp of these subjects has probably never been surpassed, and it behooves us to give his considerations and conclusions very careful attention.

In further reference to Maxwell's views, the following quotation from page 353, vol. 17, Enc. Brit., 11th ed., may be found to have bearings on the subjects discussed. "In 1873 James Clerk Maxwell published his classical 'Treatise on Electricity and Magnetism,' in which Faraday's ideas were translated into a mathematical form. Maxwell explained electrical and magnetic forces, not by the action at a distance assumed by earlier mathematicians, but by stresses in a medium filling all space, and possessing qualities like those attributed to the old luminiferous ether. In particular, he found that the calculated velocity with which it transmitted electromagnetic disturbances was equal to the observed velocity of light; hence he was led to believe, not only that his medium and the ether were one and the same, but, further, that light itself was an electromagnetic phenomenon. Since the experimental confirmation of Maxwell's views by H. R. Hertz in 1888 (Weid. Ann., 1888, 34, 155, 551, 609; and later vols.) they have commanded universal assent, and his methods are adopted in all modern works on electricity and magnetism."

Maxwell does not here state that his medium is simply a universal magnetic field, and that it is material in constitution; but, by inference, it may be that we are justified in assuming that such was his opinion. He does not claim that there is no such thing as the ether. He simply, modestly, and in otherwise seemly manner states that: "He was led to believe, not only that his medium and the ether were one and the same, but, further, that light itself was an electromagnetic phenomenon." Hertz' subsequent undeniable demonstration gives to Maxwell's views on these subjects a stability that cannot be safely denied.

The results of these labors of Maxwell and Hertz cannot be considered except as among the most signal achievements to be found in the annals of science.

From the foregoing considerations, as well as others that may not be convenient-

ly recorded at this time, it appears to the writer that there must be and really is a medium of some kind filling all so-called space, conveniently named the ether; that such medium is electromagnetic in character; that it may in reality be simply a universal magnetic field; that a magnetic field is a thing of substance; and that we need not abandon the old and convenient name applied to this medium nor all of our preconceived ideas on the subject.

Cordially yours,
James E. Stuart, M.D.

(Editor's Note: By comparison with this subject the discussion on power factor which raged in *QST's* columns over a year was child's play. That makes this all the more interesting. Dr. Steinmetz has discredited the theory of the hypothetical ether and substituted in its place an equally hypothetical universal magnetic field. A.R.R.L. members who are familiar with the subject are invited to express themselves. There are some of us who feel we just cannot get along without our ether, and object to having it ruthlessly eliminated. Dr. Stuart takes up the cudgels in defence of our present conceptions. Our columns are open to anyone desirous of expanding Dr. Steinmetz' concept in reply.)

Misrepresentation

Indianapolis, Ind.

Editor, *QST*—

Just finished reading your article entitled "Your Pen In Hand," so I am going to do my bit. The article I am going to write is one which deserves the support of every A.R.R.L. man.

I have been connected as chief engineer to a well-known radio company in the Hoosier state and was attached to a branch office to render whatever assistance I could to the manager. The first duty I had to perform was to accompany him and give a demonstration to a body of about one hundred and fifty farmers. After the set was in operation and WWJ was coming in strong, one of the natives asked the manager to get some other station. And how did he do it? He walked over to the set and gave the dial one complete turn, which brought it back to the same position, and replied "All you have to do is turn the dial to the desired transmitting station." When he had turned the dial he said "This is WGY"—yet in reality it was still WWJ. He did this several times, naming KDKA, KYW, WSB, WEAU, and in fact nearly all the leading stations. All this time I was standing by. Then 8ZZ started calling 8ZY and the manager turned to the audience and said, "Is there anyone here who understands code?" Of course no one did. So he said, "That is a boat in the Atlantic Ocean." And he even went so far as to

state, when KDKA was broadcasting Arlington time, that it was POZ sending time.

Now, men, let's rise up and drive birds of this feather from good old Radio. This man had never seen a set until six months ago. He is killing radio and making enemies for us, we who are ever ready to lend every available assistance to the beginner. Altho this matter hasn't hurt us yet, it is going to. I lost my position fighting this misrepresentation. But after operating three years in the commercial game and owning an amateur station for nine years, there's no one going to ruin the greatest game in the world if I can stop him.

Yours sincerely,
A Fighter for Radio
(Late of the 6th District.)

(This is a matter, fellow A.R.R.L. members, in which we can be of service to our art. Let each of us do his best to discourage misrepresentation in radio. If we had been the writer of the above letter we would have been strongly tempted to tell the assembled farmers just what particular variety of liar this radio "expert" was. Let's make the other fellow play the game straight too.—Ed.)

Re Canadian Aluminum

Lisnadil, Ava Road,
Brantford, Ont.

Editor, *QST*—

The Canadian associate company of the Aluminum Co. of America is the Northern Aluminum Co., Ltd., Bank of Hamilton Bldg., Toronto. In a communication from them dated Aug. 5th they quote flat sheet aluminum 1/16 in. thick, at 40¢ per lb., f.o.b. Toronto works. Delivery is within approximately two weeks from receipt of order.

This material weighs .892 lbs. to the square foot, and is made up of aluminum 98 to 99% pure.

Hoping this will be of some value to the fraternity,

Yours sincerely,
Stephen M. Jones, 3CT.

More Beverage Results

Vashon, Wash., 8/15/22.

Editor, *QST*—

Herewith is a list of C.W. stations copied at my station on a 1500 ft. Beverage wire (galvanized iron—hi!), home-made Paragon set, and 2-step A.F. amplifier. Have heard all districts but the first.

The use of Beverage wire reduces the number of controls of a 3-circuit tuner to the grid and plate variometers, as there are no changes in the open circuit after the right amount of inductance is found, and no change in coupling is necessary—

use quite tight. I get better results with the 3-circuit than with a Reinartz and with no more controls either.

Yours truly,
D. A. Cutler, 7IY.

Calls Heard July 16 to Aug. 14, all C.W.

2FP, 3BLF, 4BV, Can., 4EX, 4KF, 4MW (QRA?), 5AE, 5DI, 5DO, 5QI, 5LA, 5JL, 5ZG, 6ALU, 6ARC, 6APW, 6ARB, 6BQZ, 6BQC, 6EN, 6GR, 6KA, 6NX, 6RR, 6ZF, 6ZAF, 6ZX, 7AEA, 7DD, 7LU, 7MF 7NA, 7OZ, 7SY, 8ACF, 8AFY, 8ALT, 8AQO, 8BEF, 8CPX, 8OW, 8SB, 8UE, 8ZAG, 8ZZ, 9AMA, 9AMB, 9AMI, 9ABV, 9AJA, 9AOZ, 9APW, 9AVZ, 9AYS, 9AON, 9AUA, 9BFG, 9BGH, 9BAF, 9BCU, 9BSG, 9BZI, 9DR, 9DTM, 9ZAC.

Ammeters vs. Voltmeters

3661 Michigan Ave.,
Chicago, Ill.

Editor, QST:

In the endeavor to control our vacuum tubes properly, it seems to be admitted that instruments are of value. As to the use of voltmeter and ammeter, however, we find some difference of opinion.

It seems logical to use a voltmeter for control of transmitting tubes, because here we wish to work our filament at the maximum temperature, so that we can get the most out of the tubes. Tubes cost money and we are after amperes in the aerial and know that the higher we can work the filament consistent with a reasonable life, the better. It is quite evident that by working at constant voltage we maintain a more nearly constant current density in the filament over its entire life than by working with constant current.

However, it does not seem that the same facts apply in the case of receiving tubes. Here we do not necessarily wish to work at the highest filament temperature possible because we are not looking necessarily for maximum filament emission. What we really do when we use instruments on receiving tubes is to note the point of best operation, provided that it is under the tube rating, and simply duplicate these values each time the current is turned on. For this reason it would seem that either current or voltage control could be used because the instrument would be used more to duplicate the previous setting than to actually work the tube at any definite point given by the manufacturer.

Now, since this is the case, it would seem that an ammeter were really the better instrument to use, since the ammeter always records what is going through the tube, whereas the voltmeter records the voltage at the terminals of the socket and poor contact due to dirty terminals on the tube may quite possibly cause an increase in voltage

on the instrument where it really does not apply on the tube itself.

I have been using current control on the receiving tubes in my set, on both detectors and amplifiers and it certainly seems to be the proper sort of control. I should like to hear from others in this regard, as it certainly seems that vacuum tube operation requires the use of either constant current or constant potential or something to be kept constant in line with ordinary engineering principles.

Yours very truly,
R. O. Miles

Northern Lights

West Chester, Pa.

Editor, QST:

I hope you can grant me a line or two in your valued paper to say a word in connection with the letter from the Westinghouse Elect. & Mfg. Co., by O. W. Horn, in a recent issue of QST.

I would like to draw Mr. Horn's attention to the logs of coast stations in Alaska. He says the "Northern Lights" do not affect radio. I agree with him. They *don't* affect it, *they put it out of business*, from the volume of static that rolls in. I have taken ships up to Alaska and experienced very heavy static, just like the Gulf of Mexico in summer. Several nights this past spring I have seen the "Lights" and on these evenings the static "boiled." This latter case was in New York City.

Yours sincerely,
Paul G. Watson, 3BV.
214 West Barnard St.

Storage B Batteries

Kansas City,

Editor, QST:

About every now and then there is an article in different magazines on "how to make a storage B battery," but when we try to make 'em it's a different proposition. At least we gain a lot of knowledge in "can'ts" from following the writers' instructions even if we don't get any B bats made.

The trouble with plain lead strips is they won't "form" and they won't charge, and they last about one hour. The trouble with Edison cells is they are hard to get, expensive and require weeks of labor. The trouble with making them out of prepared lead plates is one that we have all experienced. The positive plates simply will not cut up without crumbling to pieces.

Get your test tubes, assemble them in a rack, then get a bunch of *negative* storage battery plates. Used ones, if in good condition, will do. Cut them up into strips just wide enough to go in the test tubes and connect together with lead strips. Give them about a 12 or 15 hour charge at a 1

amp. rate, and your plates are "formed." The negative plates can be cut with tinsnips without crumbling, and when "formed" work as well as when one uses positive plates instead.

The 72 volt storage battery at 9DRQ has been in operation for 4 months and gives highly satisfactory service on the two tubes used. My bulbs are on an average of 4 hours per night, and it was 3 months before this battery needed recharging, which I did with a chemical rectifier.

A word as to connecting the strips. Pure lead connectors must be used, as solid wire solder easily breaks at the connection. Cut your lead plates clean on the end to be connected and apply a hot (soldering) iron at the side, and the plate and connecting strip will make a solid, clean connection. It is hard at first to do this but the knack is soon acquired.

Above all, care for this battery just as you would your A battery.

J. Olsen, 9DRQ.

P.S. This 72 volt battery cost me a little more than a 22 volt battery of the dry cell type and has already outlived one set of these.



LIGHTNING ARRESTER

APPROVED by Underwriters' Laboratories, latest Code. Carbon block type (not vacuum type) using a brown glazed porcelain case which can be installed inside or outdoors. Carbon block arresters have been standard in Railway signal and telephone protection for over 20 years. Ask your dealer or write us for special circular.

PRICE \$1.10

Jewell Electrical Instrument Co.
1650 Walnut St., Chicago

The Triple Test Transformer

What does it mean to you?

In a market glutted with new radio products, some well made, some poorly and cheaply constructed, a few articles stand out prominently from the rest because the manufacturer employs highly competent engineers, the best of material and skilled workmanship. The RADIO SERVICE LABORATORIES goes a step further and submits each individual transformer to its famous triple test before shipping same to the jobber, dealer and ultimate user.

The Triple Test

First—Test of Windings.

The bobbins when wound and sealed are tested for continuity of winding and for shorts and leaks.

Second—Test of Inductance of Windings.

After assembly of the bobbin within the container a careful test is made of the inductance of the primary and secondary windings and the mutual inductance of the windings to insure the consumer against any wrong connections or hasty, careless construction.

Third—Test for Amplification.

After the iron core is assembled and the transformer sealed, each transformer is given an actual circuit test in a radio amplifier; the gain in signal strength being noted over that of the detector tube alone and required to meet the gain of our standard laboratory model.

The Result

is a Radio Frequency Transformer that increases the strength of Radio signals or waves before they are applied to the detector tube where they are made audible—

"Louder Signals with less noise
Greater Range with same equipment."

RADIO SERVICE LABORATORIES Transformers by actual test are superior to any domestic or foreign make in the market. For sale at any electrical shop or store where Radio supplies are sold.

Special circular sent on request by the

Rasla Sales Corporation

National Distributors

Dept. B, 10 East 43d St., N. Y. City



The only completely shielded iron core

Burgess, the *Radio* Battery —construction fully patented

When you buy a Burgess "B" Battery you get more than long life, noiselessness, high capacity, and moderate price. You get also Burgess special construction, perfected by wireless specialists and fully patented! This exclusive *radio* construction is found in no other battery on the market today.

What does this mean to users of radio batteries? It means clear receiving. It means lowest cost per hour of service. It means long shelf life and highest current capacity. It means that Burgess "B" Batteries are the best *radio* batteries it is possible to produce. Don't take our word for it—ask any *radio* engineer.

Leading manufacturers of radio equipment specify "Burgess." Burgess "B" Batteries are handled by all progressive jobbers and dealers. "Look for the Black and White Stripes." If your dealer doesn't handle Burgess "B," just address:

BURGESS BATTERY COMPANY Engineers — Dry Batteries — Manufacturers

Offices and Warehouses at:

CHICAGO, ILL., 111 W. Monroe St. NEW YORK, N. Y., 50 Church St. BOSTON, MASS., 136 Federal St.
ST. PAUL, MINN., 2362 University Ave. KANSAS CITY, MO., 2109 Grand Ave. MADISON, WIS., Main & Brearly Sts.

In Canada: BURGESS BATTERIES, Ltd.
Winnipeg, Toronto, Montreal

BURGESS "B" BATTERIES

"ASK ANY RADIO ENGINEER"

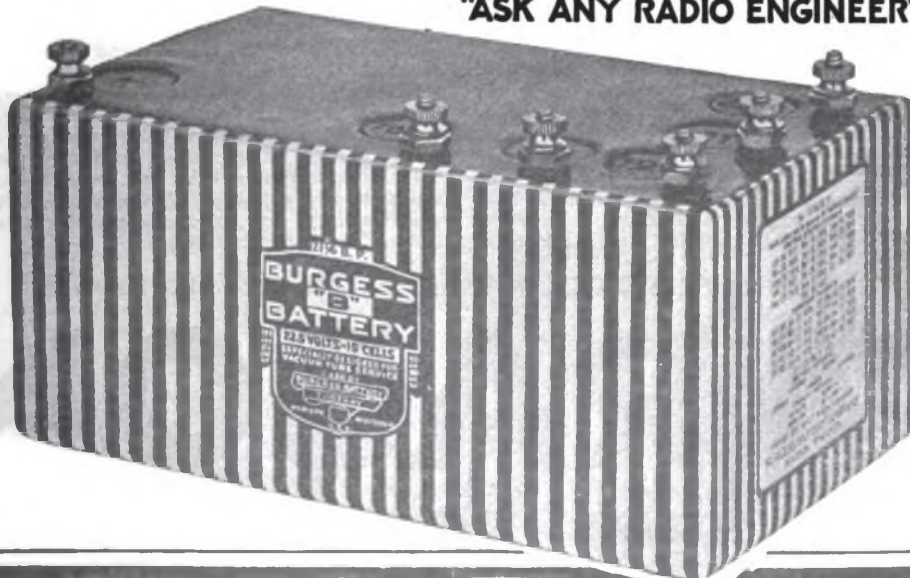

ALWAYS MENTION Q S T WHEN WRITING TO ADVERTISERS

85

Distortion Kills Music

The Curves Show Why

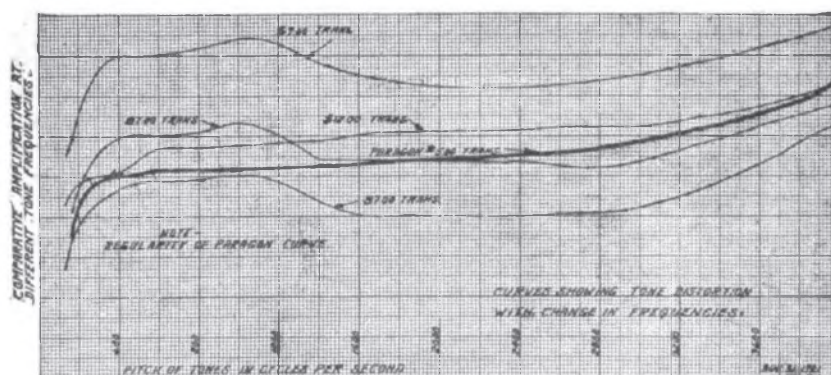

Curves Showing Tone Distortion with Change in Frequencies

Unless the Amplifier Transformer favors *all tones in exactly the same manner*, distortion will result. Notwithstanding their high prices some of the transformers whose curves are

shown above are totally unsuited to radio-phone reception. When you build use PARAGON, the same as is used in the Famous Paragon DA-2 Amplifier.

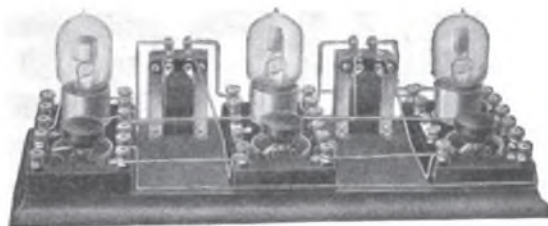

A Home-Built Paragon Amplifier

This illustration shows PARAGON VT Controls (Price \$6.00) and the PARAGON Amplifier Transformer (Price \$5.00) built into a Detector two step unit. The combination gives you a handsome high-grade instrument, low in price but highly efficient and absolutely without distortion.

PARAGON VT Controls (Patented) may be used to control vacuum tubes wherever they are used as detector, oscillator, trans-

mitter, and in cascade for radio and audio frequency amplifiers. An extremely useful and good looking unit. Comprises standard socket, famous PARAGON rheostat, grid condenser, provision for grid leak and all necessary circuit terminals. If your dealer does not stock these Paragon Products, we will see that you are promptly supplied. Write for booklet which will tell you the many uses for this efficient and compact mounting.

ADAMS-MORGAN CO., 4 Alvin Ave., Upper Montclair, New Jersey

PARAGON

Reg. U. S. Pat. Off.

RADIO PRODUCTS



“A Little Knowledge
Is a Dangerous Thing”

AND that's the truth which applies to the business of making Radio equipment. It is something to think about when you buy Head Sets.

There are two kinds of manufacturers of Radio head sets—those who know little or nothing of telephone design—and concentrate their efforts in quick production regardless of quality. And then there are those who know the business through years of experience and who place *scientific design and quality* above everything else. So this is a plea for the good of the industry — and for your protection.

Specifically — these Automatic Electric Head Sets have been developed by telephone engineers who've devoted more than



This is the high grade plug that comes attached, when desired, to Automatic Electric Head Sets. It will take care of any kind of cord terminals, will fit any kind of jack and will accommodate two head sets. With this plug attached to our head set you can be sure the head set is properly "poled."

thirty years of effort to the designing of better telephone apparatus. The time spent in the perfecting of this improved receiver is shown by the remarkable results which are produced under all conditions.

It has many distinctive features which prove its superior effectiveness. The powerful single pole electro-magnet and complete soft iron magnetic path—assure perfect clearness of both weak and loud signals. No distortion or foreign noises — whether used with crystal, V. T. detectors or multi-stage amplifiers.

If your dealer handles Radio equipment of the finest quality he is familiar with the Automatic Electric Head Sets. Ask him.

If your dealer cannot supply you, we will send you a complete Head Set, postpaid, for \$10.00 — with plug attached \$11.50.

Automatic Electric Company

ENGINEERS, DESIGNERS & MANUFACTURERS OF THE AUTOMATIC TELEPHONE IN USE THE WORLD OVER
HOME OFFICE AND FACTORY: CHICAGO, U. S. A.

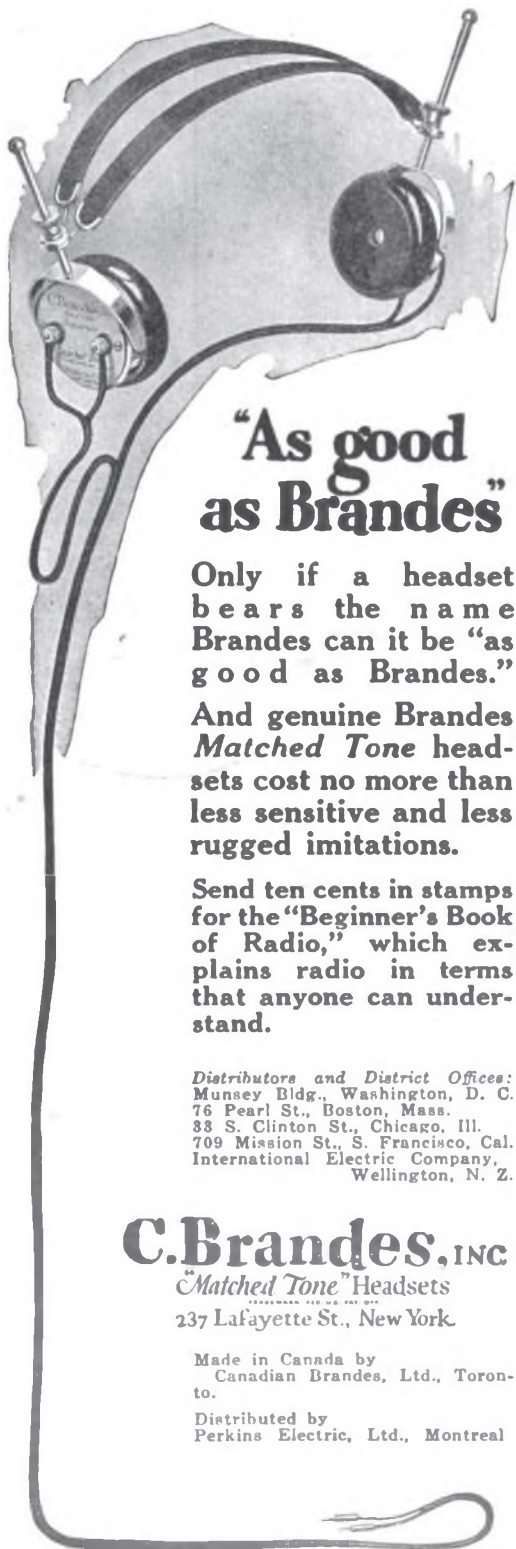

**"As good
as Brandes"**

Only if a headset bears the name Brandes can it be "as good as Brandes."

And genuine Brandes *Matched Tone* headsets cost no more than less sensitive and less rugged imitations.

Send ten cents in stamps for the "Beginner's Book of Radio," which explains radio in terms that anyone can understand.

Distributors and District Offices:
 Munsey Bldg., Washington, D. C.
 76 Pearl St., Boston, Mass.
 33 S. Clinton St., Chicago, Ill.
 709 Mission St., S. Francisco, Cal.
 International Electric Company,
 Wellington, N. Z.

C.Brandes, INC
"Matched Tone" Headsets
 237 Lafayette St., New York

Made in Canada by
 Canadian Brandes, Ltd., Toronto.

Distributed by
 Perkins Electric, Ltd., Montreal

THORDARSON

Out With Another Winner

A

VERNIER RHEOSTAT

With Individual Knobs for Rough and Vernier Adjustment. Greatly Improves Your Filament Control.



The smallest vernier rheostat on the market. Only 2 1/8" in diameter. Has ample radiating surface. Fool proof spring contacts.

Price \$1.50

Buy One and Convince Yourself

Send for our radio folder

**THORDARSON
ELECTRIC MFG. CO.**

502 W. HURON ST.
 CHICAGO, ILL.

RESULT OF 14 YEARS EXPERIENCE
 88

ALWAYS MENTION Q S T WHEN WRITING TO ADVERTISERS

ATWATER

KENT

2-STAGE AMPLIFIER

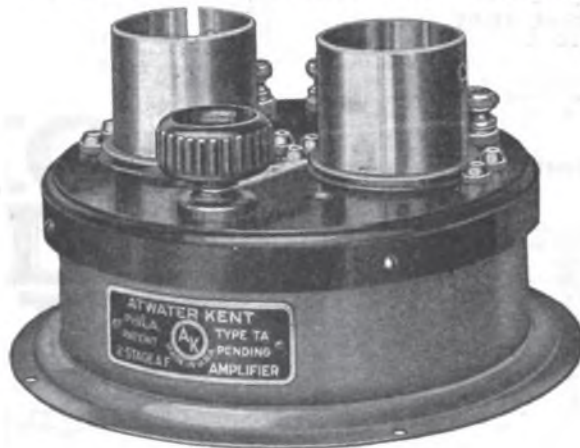

Price \$16⁰⁰

THE OUTSTANDING *Advantages* OF THIS INSTRUMENT *are*

- § Excellence of reproduction.
- § Amplification regulation by small steps.
- § A complete instrument in itself.
- § Compactness
- § Regulation entirely by knob, no jacks to equip.
- § Transformers protected by steel housing.
- § Short wiring connections eliminate capacity effect.
- § Hermetically sealed, absolutely no moisture troubles.

THE LOW PRICE IS MADE POSSIBLE AS A RESULT OF
20 YEARS' EXPERIENCE IN QUANTITY MANUFACTURE
OF SCIENTIFIC ELECTRICAL INSTRUMENTS

An Excellent Merchandising Proposition

ATWATER KENT MANUFACTURING COMPANY

4945 STENTON AVE.

Radio Department

PHILADELPHIA, PA.

ALWAYS MENTION Q S T WHEN WRITING TO ADVERTISERS

89

Radak

Trade Mark Reg. U. S. Pat. Off.
Parts that are leaders in their lines

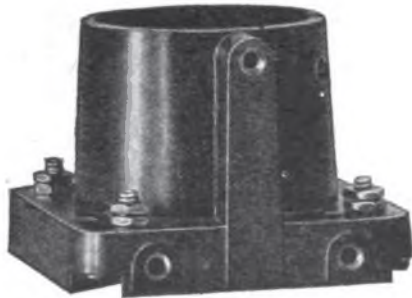

Type H T

RADAK UNIVERSAL TUBE SOCKET

Moulded In One Piece

Made of condensite, without the usual objectionable metal tube. Designed to mount easily on back of panel, requiring neither shelf nor brackets. Quickly screwed to any flat surface. Binding posts on base. Also holes outside each contact spring for using soldered connections. Fills a great need of the amateur.

PRICE COMPLETE \$1

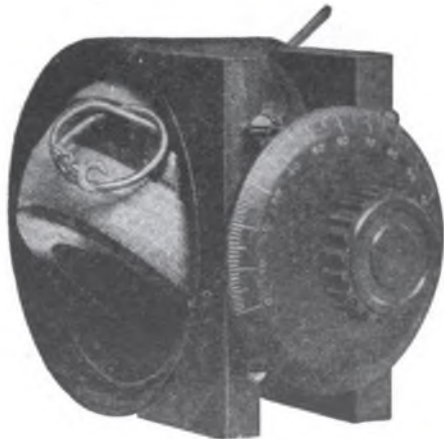

Type H.R.V.

RADAK VARIOMETER

Cuts Down Dielectric Losses

Ball of hollow moulded hard rubber; outer shell of bakelite. Inner winding firm on ball. Outer winding formed in section of sphere. Clearance small, giving wide range of wave-length. Dielectric material reduced to minimum. Unusually long inductance range for size of instrument. May be rotated continuously without breaking contact. Furnished with 3 in. dial and knob.

PRICE, COMPLETE \$6.50

Each of the parts shown separately here is one good reason why Radak Receiving Sets are giving such satisfaction. Each embodies the long experience of the Clapp-Eastham Company, and is a unit used in Radak Sets. Sold separately for the benefit of amateurs who construct their own sets. A Radio Catalog showing other parts, as well as the latest Radak Receiving Sets, 8¢.

CLAPP-EASTHAM COMPANY

105 MAIN STREET, CAMBRIDGE, MASS.
Oldest and Largest Makers of Radio Equipment
Exclusively
Established 1908

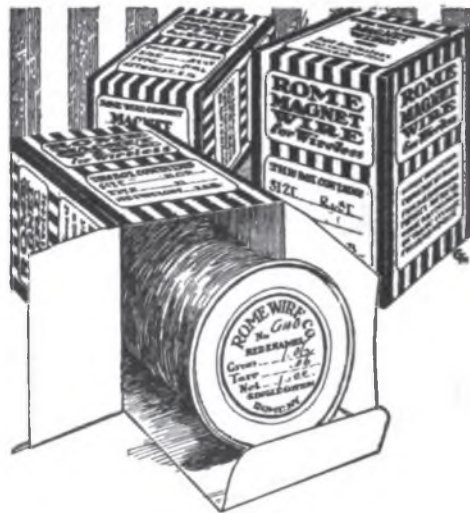

For satisfaction
Demand Rome Blue
and White Package
or Label.

ROME RADIO WIRE

Magnet Wire

Best Quality Plain Enamel Covered; Enamel—and Single or Double Cotton Covered; Single or Double Cotton Covered.

All sizes; ¼-lb. to 40-lb. packages.

Antenna Wire

Best Quality Solid or Stranded Copper Antenna Wire, plain or tinned; put up in lengths of 100-ft. and 150-ft. or on 24" reels of 200-lbs.

At Your Dealer's

ROME WIRE COMPANY

ROME, N.Y. BUFFALO, N.Y.
DISTRICT SALES OFFICES,
NEW YORK . . . 50 Church Street . . . CHICAGO . . . 14 E. Jackson Blvd.
DETROIT . . . 25 Pershing Street
LOS ANGELES . . . J. G. Power, 136 Arden Street

2067-L



“Why the menagerie?”

YOU wouldn't stand for a young menagerie howling around the house. Why permit your radio set to act that way? It's unnecessary. For just five dollars you can add an Acme Audio Frequency Transformer to your set. This ends the howling and distortion so prevalent in the ordinary detector unit and at the same time it greatly increases the volume of incoming sound. Music and the human voice assume their natural tones. No more thin, squeaky voices and tiny elfin wails.

You will also want the Acme Radio Frequency amplifying Transformer. You can use it with either a vacuum tube or a crystal detector set. It greatly increases the distance over which you can receive broadcasting programs. Just the same price as the Acme Audio Frequency

Transformer. Two stages of Acme Audio Frequency Amplification with two stages of Acme Radio Frequency Amplification will give you maximum range, volume and certainty of natural tone. Your set is incomplete without them.

The Acme Apparatus Company (pioneer transformer and radio engineers and manufacturers) also make detector units, detector and two stage amplifying units, the Acme Clear Speaker, the Acme phone, also C. W. and spark transmitting apparatus. Acme Apparatus is for sale at radio, electrical and department stores. If one is not close at hand, send money direct. Ask also for interesting and instructive book on Transformers. The Acme Apparatus Company, Cambridge, Mass., U. S. A. New York Sales Office, 1270 Broadway.



Type A-2 Acme Amplifying Transformer
Price \$5 (East of Rocky Mts.)

ACME

for amplification



11 Miles of
MANHATTAN
Headsets

IF ALL the Manhattan Radio Headsets that have been manufactured and sold since the first one was produced on March 20th, 1922, were placed side by side, they would stretch in an unbroken line eleven miles long.

This means quantity production—and quantity production assures you of four things:

1. **Uniform Quality of Product.** Quantity production demands absolute uniform quality of raw materials. Only the very best materials are uniform in quality.
2. **Rigidly Tested Product.** Quantity production necessitates rigid tests at every stage of manufacture. Rejection of a finished headset is costly.
3. **A Correctly Designed Product.** The proper design of the Manhattan Headset and the use of special tools, only possible in quantity production, enable us to add refinements and extra features at no increased manufacturing cost.
4. **A Quality Product at a Quantity Price.** Quantity production cuts labor costs.

This enables us to offer Quality Headsets at a Quantity Price.

Manhattan Radio Headsets are on sale by all reliable radio dealers. If he hasn't them in stock he will get them for you.

MANHATTAN
ELECTRICAL SUPPLY CO., INC.

NEW YORK
17 Park Place
ST LOUIS, MO.
1108 Pine St.

CHICAGO, ILL.
114 So. Wells St.
SAN FRANCISCO
604 Mission St.

No. 2500
2000 ohm
\$6.00



NO. 2501
3000 ohm
\$7.00

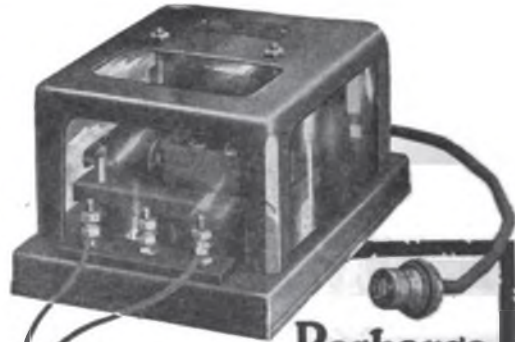

Recharge Your Battery at Home

Charges both A and B Radio Batteries

Don't be without the use of your Radio Receiving Set while your battery is being charged. Get a **Valley Charger** and charge your battery right at home.

Attach the Charger to your home lamp socket—attach the clips to the battery terminals and you will get a quick, tapering charge which just exactly charges your battery, but cannot overcharge it or harm it in any way.

Will charge the A 6 volt battery at a 5 ampere rate, and the B 22½ volt battery at the required ½ ampere rate. 45 volt B batteries may be connected in parallel so that they can also be charged.

SATISFACTION GUARANTEED.

If your local distributor cannot supply you, write direct to
VALLEY ELECTRIC COMPANY,
Department Q, ST. LOUIS.

----- Mail the Coupon -----
Valley Electric Co., Dept. Q, St. Louis, Mo.

Gentlemen: I am enclosing money order (or check) for \$18.00, for which send me a Valley Battery Charger with five-panel glass display case and indicator. If not satisfactory, I will return it and get my money.

Name _____

Address _____

\$18.00

F.O.B. St. Louis





Scene from the Opera "Faust"



The New
Star in
the Radio
World

MOMENTOUS events in the arts and sciences are the result of rising above out-worn principles, independent of the tools of mediocrity. Beginning where others have been content to finish, a forward-looking group of radio engineers, comprising the Mu-Rad Laboratories, have designed and successfully constructed radio apparatus which is as advanced as the twenty-one-jewel watch is over the key-winder. Prices of this apparatus insure that great numbers will benefit from their achievements. Descriptive literature upon request.



MU-RAD
LABORATORIES
INCORPORATED
ASBURY PARK
NEW JERSEY

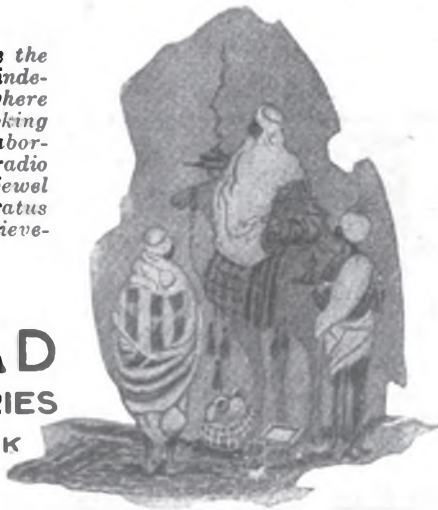

ALWAYS MENTION Q S T WHEN WRITING TO ADVERTISERS

93

THE day in and day out efficiency of this inexpensive De Forest Radiohome Receiver with its range up to 100 miles is just a straw that shows which way the wind blows. Anything marked De Forest lives up to the reputation of that great name.



Na-ald
Small Space
V. T. Socket

35c each, 3 for \$1.00. Moulded genuine condensite. Requires but small space for mounting. Readily accessible binding posts. No excess metal to interfere with efficiency. Unaffected by heat of bulbs or soldering iron. Phosphor bronze contacts. Nickel plated brass binding screws. Slash cut slot. Price possible because of large production.

Special proposition to dealers and jobbers.

ALDEN-NAPIER CO.
Dept., M.
52 Willow St. SPRINGFIELD, MASS.

"EURACO" PRODUCTS
(Guaranteed)
Compact — Interchangeable
Most Efficient — Accurate:

60 Cents per Unit



60 Cents per Unit

Mica Condensers — Grid Leaks Mountings:
Interesting Proposition for Dealers
EUROPEAN RADIO CO.
1342 East 22nd Street. Brooklyn, N. Y.

**"The
Watch
Dog
of the
TUBE"**

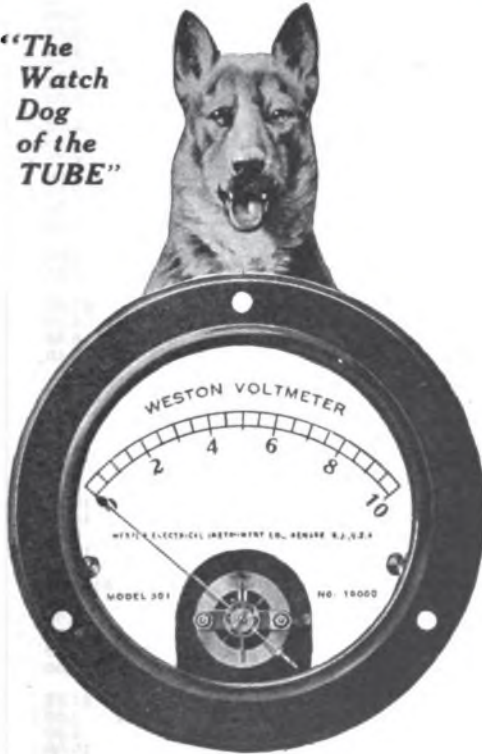

Weston Filament Voltmeter

***One of a Group of
important Weston
Radio instruments
described in Circular J***

Essential-- for GOOD Reception

Gives you your proper voltage instantly—thus greatly simplifies exact tuning. Saves its cost over and over by eliminating hazardous guesswork and making it possible to get doubled or trebled life out of each tube. A premature tube "burn-out" is practically an unknown occurrence with a Weston Voltmeter—if you use it properly.

Your dealer can supply you, or if he cannot, we will. Don't take a substitute if you want best results. Write for Radio Circular J.

Weston Electrical Instrument Co.

158 Weston Ave.,

Newark, N. J.

Makers of Electrical Instruments since 1888

WESTON



"THE SUN NEVER SETS ON THE WESTON"

"STANDARD" The World Over

ELECTRICAL INSTRUMENTS

*An Indicating
Instrument for
Every Individual
Need and Industrial
Purpose*

ALWAYS MENTION Q S T WHEN WRITING TO ADVERTISERS

95

SEE US AT THE RADIO SHOW

BOSTON, OCTOBER 30—NOVEMBER 4th—Spaces 51-52

Mail orders filled promptly on any standard set or part and Satisfaction Guaranteed.

COMPLETE SETS	
Grebe CR3	\$65.00
Grebe CR5	60.00
Grebe CR8	60.00
Grebe CR9	130.00
Grebe CR10	315.00
Nermco De Luxe	147.50
Nermco Standard	137.50
Aeriola Grand	325.00
Aeriola Senior	65.00
Westinghouse R C	132.50
General Electric	150.00
Wireless Specialty Radio-Audio Amp.	160.00
STORAGE BATTERIES	
Westinghouse 5 plate 84AH	\$18.00
Westinghouse 9 Plate 108AH	24.00
Westinghouse 13 Plate 162AH	33.50
Yale 60 A-H	18.00
Yale 80 A-H	21.00
Yale 100 A-H	25.00

RHEOSTATS	
Bradleystat	\$1.85
General Radio	2.25
Fada	.75
Federal	1.10
Cutler Hammer	1.00
Cutler Hammer Vern.	1.50
Klosser Vern.	1.50
Nermco	1.00

DIALS	
Electrose 4"	\$1.50
Se Ar De	1.25
Nermco 3" Frosted	.75
Nermco Rheostat Dial	.60

TRANSFORMERS—AUDIO FREQUENCY	
Acme A-2a	\$5.00
Federal 226-W	7.00
Radio Corp. UV 712	7.00
Nermco A-9	5.50
General Radio	5.00
TRANSFORMERS—RADIO FREQUENCY	
Acme R-2 1st	5.00
Acme R-3 2nd	5.00
Acme R-4 3rd	5.00
Excel	4.50

AMPLIFIER UNITS	
Grebe R.O.R.K.	\$55.00
Westinghouse D A	70.00
Westinghouse Senior (1½ volt dry cell) with tubes	65.00
Remler #333	9.00
Acme Y-2	13.00
Federal Jr. 2 St.	29.00

SOCKETS	
Se Ar De	\$1.25
Kellogg	.75
Federal	1.00
Murdock	1.00
Paragon	1.00
General Radio	1.25

CONDENSERS—Waltham "built like a watch"	
3 Plate Vern	\$1.75
13 Plate .0025	3.50
17 Plate .0004	3.75
21 Plate .0005	4.00
41 Plate .001	4.75
21 Plate with vern.	6.00
41 Plate with vern.	7.00
12 Plate Nermco .00025	4.00
20 Plate Nermco .005	4.25
38 Plate Nermco .001	4.75
General Radio #247A	6.00
General Radio #247B	3.75
General Radio #247E	5.50
General Radio #247F	3.25

VARIOMETERS	
Se Ar De #146	8.00
Remler #500	6.50

VARIOCOUPERS	
Se Ar De #166	\$5.50
Se Ar De #148	5.50
Se Ar De #167	5.50
Remler #503	5.40

PHONES	
Murdock 56/2000	\$5.00
Murdock 56/3000	6.00
Murdock 57-3000	7.50
Brandes Superior	8.00
Brandes Navy	14.00
Holtzer Cabot	8.00
Federal 2200	8.00
Federal 3200	10.50
Kellogg 2400	12.00
Globe	9.00
Baldwin, C. E. F. or G	16.00

LOUDSPEAKERS	
Western Electric	\$161.00
Magnavox R-3	45.00
Phonophone	14.00
Voclarion	6.50
Vocarola	30.00
Baldwin C Ualt	8.00

BURGESS B BATTERIES	
#4156 22½ Volt	\$1.75
#2156 B P	3.00
#5106 B P 45 Volt	5.00
#2756 113 Volts	15.00

VACUUM TUBES	
UV 200	\$5.00
UV 201	6.50
WD II	8.00
Audiotron 2 Fil	6.00
Myers R. A. C. 3	5.00

STORAGE B BATTERIES	
Westinghouse 22 Volt	\$6.75
Westinghouse Large 22 Volt	14.00

POTENTIOMETERS	
General Radio 400 ohm	\$3.00
Radio Corporation 200 ohm	2.00
Federal	1.50

JAMES H. JONES, 94 Massachusetts Ave., Boston, 17, Mass.
WHOLESALE RADIO APPARATUS RETAIL

BESCO

VARIABLE CONDENSERS

43 Plate	-	-	\$2.95
23 Plate	-	-	2.45

WE GUARANTEE SATISFACTION
OR MONEY REFUNDED.

ORDER TODAY **9CUX**
RADIO-WEAC

BAINES ELECTRIC SERVICE CO.
24 So. 8 St., Terre Haute, Ind.

The Opportunity of Today
RADIO

AN INTERESTING OCCUPATION THAT TAKES YOU TO ALL PARTS OF THE WORLD. RECEIVE INSTRUCTIVE AND AMBITIOUS TRAINING. EFFICIENT OUR COURSE BEARING INTERESTING AND EFFECTIVE. SPECIAL SPARK AND TUBE DAY AND EVENING CLASSES. SEND TEN CENTS IN STAMPS TO US.

COMMERCIAL RADIO INSTITUTE
10 EAST CENTER STREET • BALTIMORE, MD.

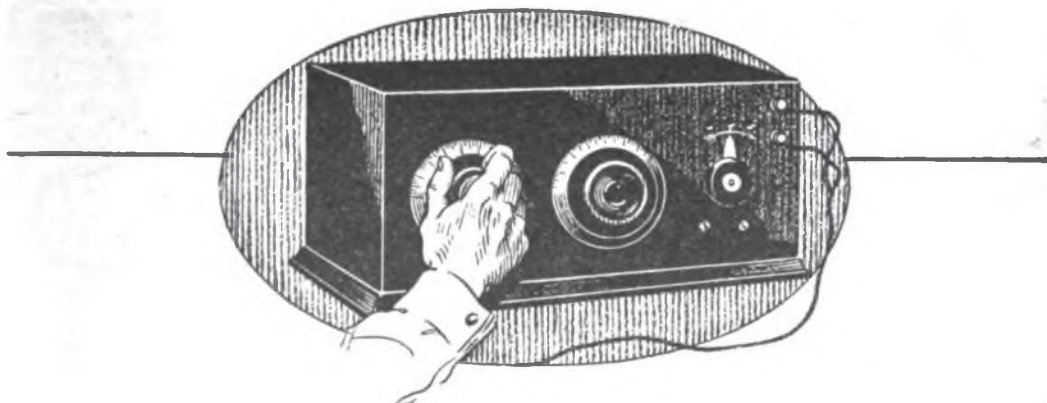

You can get the best insulation now!

ANY dealer can get Formica quickly now so there is no longer any need to use an insulation in which you have less confidence.

Our large capacity makes it possible for us to keep fully abreast of the large radio demand—and to serve all of our customers promptly.

When you insist on Formica you get an insulation that is approved by the navy and signal corps—and one that is known by the makers of the finest radio apparatus as being leak-proof, warp-proof, and remarkably uniform in insulating quality.

Formica works well with ordinary tools. You can produce a perfect panel, and all you need is a drill. It has a wonderfully attractive finish and holds it during a long life. Dampness, fumes, chemicals, do not injure Formica. It is almost immune to conditions.

That is why it is the most popular of all radio insulating materials.

DEALERS: We have many valuable dealer helps. Store cards, folders, plates for advertising. Call on us for co-operation.

THE FORMICA INSULATION COMPANY
4620 Spring Grove Ave.
Cincinnati, Ohio

SALES OFFICES

50 Church Street, New York, N. Y.
9 South Clinton St., Chicago, Ill.
415 Ohio Building, Toledo, Ohio

414 Finance Bldg., Cleveland, Ohio
1642 Granite Bldg., Rochester, N. Y.
318 Title Bldg., Baltimore, Md.

422 First Avenue, Pittsburgh, Pa.
1210 Arch Street, Philadelphia, Pa.
Sheldon Bldg., San Francisco, Cal.

FORMICA

A Laminated Phenolic Condensation Product
SHEETS TUBES RODS

ALWAYS MENTION Q S T WHEN WRITING TO ADVERTISERS

97

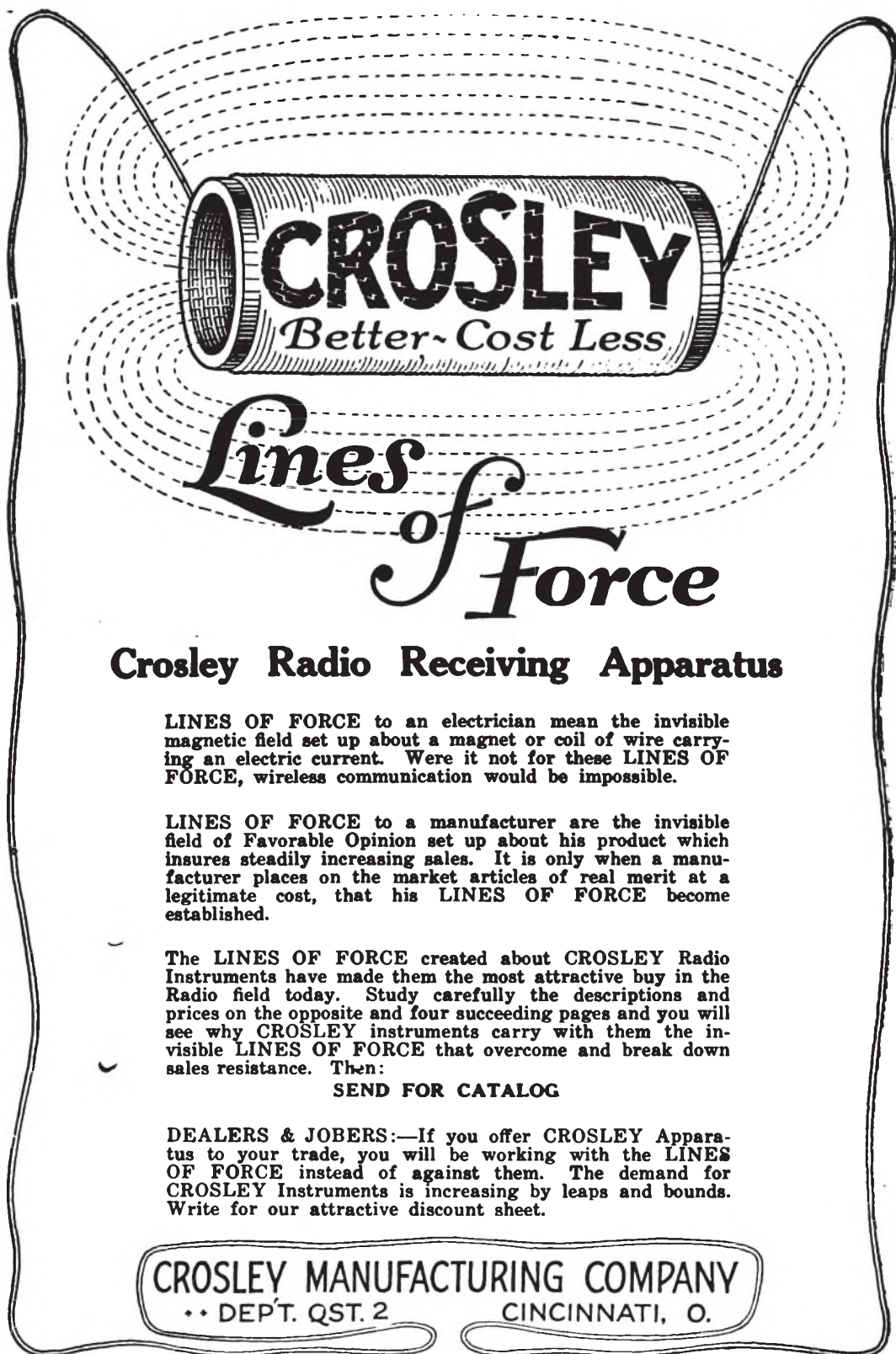

Crosley Radio Receiving Apparatus

LINES OF FORCE to an electrician mean the invisible magnetic field set up about a magnet or coil of wire carrying an electric current. Were it not for these **LINES OF FORCE**, wireless communication would be impossible.

LINES OF FORCE to a manufacturer are the invisible field of Favorable Opinion set up about his product which insures steadily increasing sales. It is only when a manufacturer places on the market articles of real merit at a legitimate cost, that his **LINES OF FORCE** become established.

The **LINES OF FORCE** created about **CROSLEY** Radio Instruments have made them the most attractive buy in the Radio field today. Study carefully the descriptions and prices on the opposite and four succeeding pages and you will see why **CROSLEY** instruments carry with them the invisible **LINES OF FORCE** that overcome and break down sales resistance. Then:

SEND FOR CATALOG

DEALERS & JOBERS:—If you offer **CROSLEY** Apparatus to your trade, you will be working with the **LINES OF FORCE** instead of against them. The demand for **CROSLEY** Instruments is increasing by leaps and bounds. Write for our attractive discount sheet.

CROSLEY MANUFACTURING COMPANY

•• DEPT. QST. 2

CINCINNATI, O.

CROSLEY RADIO APPARATUS has been recognized as the standard of value at a moderate cost. Our efficient staff of engineers has simplified these instruments so that they can be installed and operated by a novice.

CROSLEY

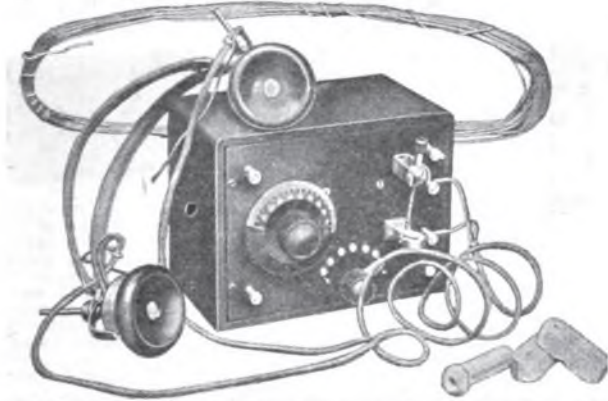

CROSLEY CRYSTAL RECEIVER MODEL 1. Complete with head phones, antenna and insulators, ready to install without additional equipment. Will receive wave lengths from 200 to 600 meters and has a range of 25 or 30 miles. It has been known to receive up to 200 miles. Beginners in Radio will find this a very efficient unit. It can be used with any of our special units to increase the range and volume.
Price \$25.00



CROSLEY AUDION DETECTOR UNIT. While this unit may be used with practically any type of tuner, we recommend it especially in combination with the **CROSLEY CRYSTAL RECEIVER MODEL 1.** It is designed to be operated with almost any crystal detector set. It will increase the range of a crystal outfit to about a hundred miles. One user in Minnesota hears Pittsburgh and Schenectady. The Combination is equivalent to our **HARKO SENIOR MODEL V.**
Price without tubes, batteries or phones \$7.50

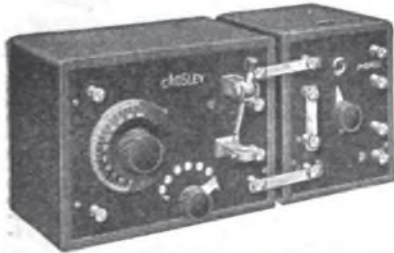

Showing the **CROSLEY CRYSTAL RECEIVER MODEL 1** attached to a **CROSLEY AUDION DETECTOR UNIT.** This arrangement changes the principle from Crystal to Audion and the detector stand must be eliminated from the remainder of the circuit. The accompanying photograph shows how this is accomplished by the simple connection of the binding posts. The upper and lower posts are connected, as are the middle posts on the left side of the detector unit. "A" and "B" batteries and one detector tube are needed in the operation of the outfit.



CROSLEY HARKO SENIOR MODEL V is a combination of the two units opposite in one cabinet. It makes a very neat and compact arrangement of a combination tuner and audion detector. We are confident that you will find nothing better on the market at any price. Price without tubes, batteries or phones..... \$20.00



CROSLEY RADIO FREQUENCY TUNED AMPLIFIER. This unit can be used with practically any type of Audion Detector Outfit, and is especially recommended for use with a combination of crystal receiver and audion detector, or **HARKO SENIOR MODEL V.** It is the feature of all of our larger units.

Being of our own design, we are proud of it. The R. F. T. A. not only amplifies the signals before they reach the detector, enabling it to work more efficiently, but also makes sharper tuning possible and eliminates interference to a wonderful degree. Will add at least six times the volume and range. Price..... \$18.00



Showing a combination of the **CROSLEY CRYSTAL RECEIVER MODEL 1,** the **CROSLEY AUDION DETECTOR UNIT** and a **CROSLEY RADIO FREQUENCY TUNED AMPLIFIER.** It is equivalent to the **CROSLEY RECEIVER MODEL VI** shown on the next page. See that description.

Dealers and Jobbers everywhere. If your dealer does not handle **CROSLEY** instruments write us direct.

Write for Catalog

CROSLEY MANUFACTURING CO.
DEPT. QST 2
CINCINNATI, OHIO

CROSLEY

A wire from the house top to a nearby tree or building for antenna. A connection to the radiator or water pipes for a ground. Connect these to a CROSLEY set and you are ready to receive music, news reports, sermons and what not by the turn of a dial.

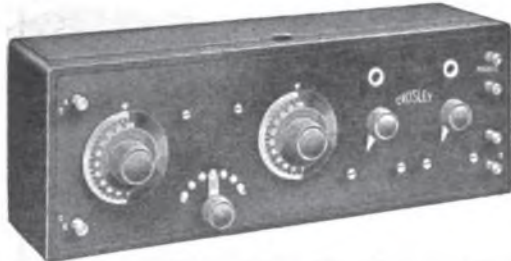

CROSLEY RECEIVER MODEL VI. This set consists of one stage of Tuned Radio Frequency Amplification and Audion Detector. It is normally for use with head phones but is especially recommended for use with any type of loud speaker. Additional amplification is unnecessary if head phones and horn are used in receiving local stations. It is equivalent to the combinations opposite and on the preceding page. Price without tubes, batteries or phones.....\$30.00



Showing a combination of the CROSLEY HARKO SENIOR, MODEL V and R. F. T. A. UNIT. This combination is made simply by connecting the binding posts directly across. An amplifier tube is used in the HARKO SENIOR UNIT with the grid leak and condenser bridged or short circuited. The detector tube is then placed in the radio frequency tuner. Thus this new unit contains the radio frequency tuner and the detector tube and its control.



CROSLEY TWO-STAGE AUDIO FREQUENCY AMPLIFIER. With this unit, two stages of audio frequency amplification can be added to any type of radio apparatus. Can be used in conjunction with the CROSLEY CRYSTAL RECEIVER MODEL I and CROSLEY AUDION

DETECTOR UNIT, CROSLEY HARKO SENIOR MODEL V, CROSLEY R. F. T. A. or CROSLEY RECEIVER MODEL VI. This unit increases the volume about one hundred times. Designed to match up uniformly with the above mentioned units. Without tubes, batteries or phones.....\$25.00



CROSLEY HARKO SENIOR MODEL V AND TWO-STEP AMPLIFIER. The working qualities of each of this combination have been described separately. This combination is not only equal in efficiency but the total cost of the separate units is lower than that of any other three-tube outfit. The controls are simple and are very limited in number requiring very little skill in accurate adjustment.



CROSLEY RECEIVER MODEL VI AND TWO-STAGE AMPLIFIER. This combination is equivalent to the CROSLEY RECEIVER MODEL X shown on the next page. With this combination, ship and shore stations on the Atlantic Coast easily are copied in Cincinnati, while radio telephone concerts and voice from Pittsburgh, Detroit, Chicago, Newark, N. J. and many other broadcasting stations are easily picked up.

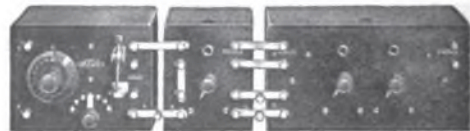

CROSLEY CRYSTAL RECEIVER MODEL I, AUDION DETECTOR AND TWO-STEP AMPLIFIER. This combination is the same as the HARKO SENIOR and TWO STEP AMPLIFIER hooked together. It is exceptionally efficient in the reception of signals broadcasted on the average wave length.



CROSLEY CRYSTAL RECEIVER MODEL I, AUDION DETECTOR, R. F. T. A. UNIT AND TWO-STEP AMPLIFIER. These various units hooked up, provide the same receiving instrument as the CROSLEY RECEIVER NO. X shown on next page.

Dealers and Jobbers Everywhere. If your dealer does not handle Crosley instruments, write us direct.

Write for Catalog

CROSLEY MANUFACTURING CO.
DEPT. QST 2 CINCINNATI, OHIO

CROSLY INSTRUMENTS not only incorporate every refinement of detail in the mechanical features but we are offering you beautiful pieces of furniture as well. Glance over the cabinets on this page and see for yourself.

CROSLY



Showing a combination of the CROSLY HARKO SENIOR MODEL V, a CROSLY R. F. T. A. UNIT and the CROSLY TWO-STAGE AMPLIFIER. It is equivalent to the CROSLY RECEIVER MODEL X and the combination on the preceding page. The High Efficiency and low cost of this combination make it one of the most popular instruments on the market to-day.

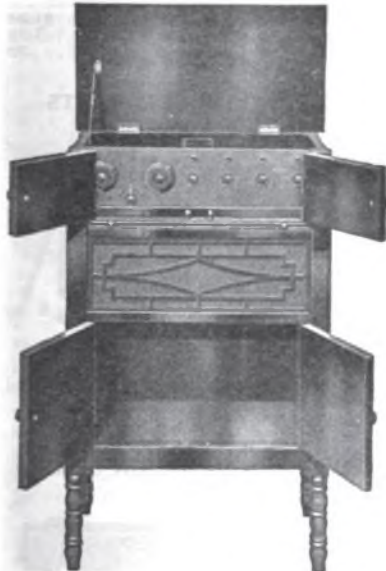
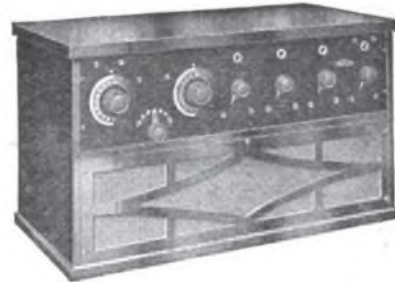

CROSLY RECEIVER MODEL XX. Crosley Receiver Model XX is the CROSLY RECEIVER MODEL XV in an upright cabinet. A hinged lid when raised, allows the operator access to every part of the receiving apparatus. The doors, both upper and lower are also hinged. Directly under the receiving apparatus is a highly finished board that slips in and out, forming a desk for the person operating the instrument. Wires lead from the binding posts on the receiving set to the batteries in the lower compartment. Music received on this instrument will be heard throughout a large room and often throughout an entire house, the latter feature depending upon the power of the broadcasting station. Mahogany finished. Without tubes, Batteries or Phones.....\$100.00

CROSLY RECEIVER MODEL XV. This receiving set is the same as CROSLY RECEIVER MODEL X., with the addition of a special sound resonating chamber for use as a loud speaker in connection with a pair of head phones. The addition of this sound resonating chamber is a feature that appeals to many persons. With it, every person in a room is usually permitted to hear the music or signals that are being received. Often it will be found that the entire house is filled with music broadcasted. Mahogany finished cabinet without tubes, batteries or phones.....\$70.00

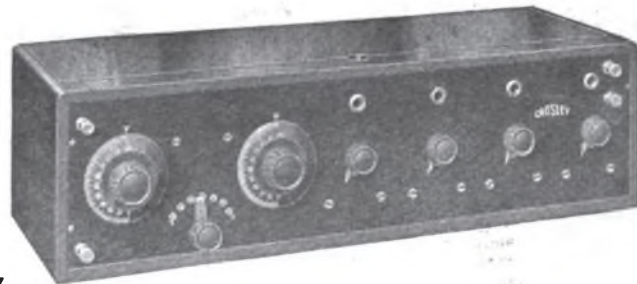

CROSLY RECEIVER MODEL X is a combination of MODEL VI and the TWO-STAGE AMPLIFIER in one cabinet. In placing this Receiver on the market, we are offering you a unit whose range, volume and selectivity is remarkable. Nothing can compare with it at twice the price. Developed in the CROSLY Laboratories, this unit is absolutely the last word in Radio Receiving Apparatus. Used with head phones and loud speaker, it will bring in distant stations all over the house. Price without phones, batteries or tubes\$55.00

If your dealer does not handle CROSLY instruments, write us direct.

Write for Catalog

CROSLY MANUFACTURING CO.
DEPT. QST 2

CINCINNATI, OHIO

ALWAYS MENTION Q S T WHEN WRITING TO ADVERTISERS

101

CROSLEY

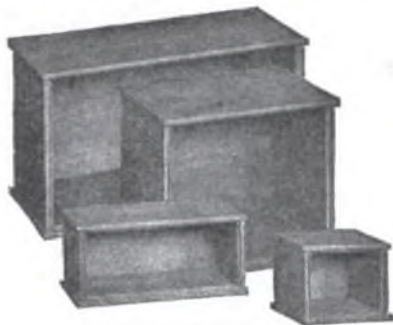

CROSLEY RADIO CABINETS

Realizing the demand for stock cabinets for those who build their own sets, we have developed a line of cabinets that are neat in design, attractive in appearance and finish and of the best workmanship. The CROSLEY RADIO CABINETS are made of hard wood, mahogany finish. Live dealers handle them—prices and sizes in our catalog.

CROSLEY SHELTRAN

Incorporated in the design of the CROSLEY SHELTRAN, are all the characteristics, so essential and necessary to obtain the maximum amplification from the modern vacuum tubes used in radio work. These tubes, with their high amplification constant, operate most effectively at large fluctuations of the grid potential. The CROSLEY SHELTRAN is designed to accomplish these results and tests have shown that the design is correct to insure maximum efficiency. Completely shielded—9 to 1 ratio. Better—Costs Less—\$4.00

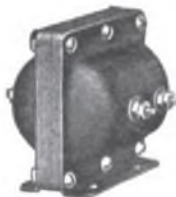

CROSLEY BINDING POSTS

These are made in three sizes— $\frac{3}{8}$ " diameter, $\frac{1}{2}$ " diameter and $\frac{1}{2}$ " diameter. They are all of the same design, however, as shown in the illustration.

No. 1.....	5¢	each
No. 2.....	7½¢	each
No. 3.....	10¢	each

CROSLEY MAGFON

No Radio station is complete without this MAGFON. A built-in horn amplifies signals, voice or music. With it head phones are unnecessary except on weak signals. Any make of watch case receiver can be used with the CROSLEY MAGFON by simply inserting it in the back of the cabinet. Mahogany finished \$10.00.



CROSLEY RADIO PARTS shown on these pages are the personification of economy and efficiency. The fact that they are endorsed and used by the best Radio Men in the country should be sufficient testimonial.

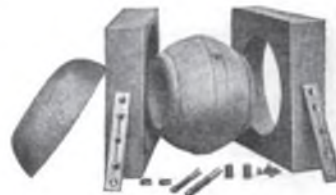

CROSLEY VARIOMETER PARTS

These variometer parts are made in our own large wood working plant on special automatic machinery, which enables to not only offer them to you at a price reduction, but to make each part accurately. Each Variometer set consists of two stators, one rotor and the necessary hardware shown in the illustration. Made of poplar wood, well shellaced.....\$1.50 Made of Mahogany..... 1.75 Winding form extra30

CROSLEY VARIO-COUPLER PARTS

The CROSLEY VARIO-COUPLER is made with the same accuracy as the CROSLEY VARIOMETER, and is designed to function perfectly with it. Each Vario-Coupler set consists of a formica tube, rotor and the necessary hardware for complete assembly.



Complete as shown in illustration, ready for assembly—\$1.50. Also furnished completely wound and assembled complete with knob and dial "Better—Costs Less"—\$3.00.

CROSLEY CRYSTAL DETECTOR STAND

This unit is especially well constructed, neatly mounted on black base covered on green felt. All parts are bright nickel finish, complete with mounted crystal, binding posts, etc., manufactured under the following patents: "Patented January 21, 1908; November 17, 1908; June 15, 1909; September 7, 1909; July 21, 1914; September 8, 1914; November 24, 1914; April 27, 1915; January 23, 1917. Licensed for amateur, experimental or entertainment purposes only. Any other use will constitute an infringement.—\$2.50.

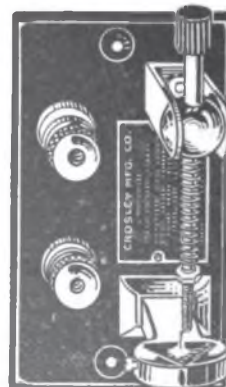

Write for Catalog

Dealers and Jobbers Who Handle Crosley Apparatus, handle the best

CROSLEY MANUFACTURING CO.
DEPT. QST 2
CINCINNATI, OHIO

CROSLY RADIO PARTS are manufactured from the best materials money can buy and are the acme of quality. We draw your especial attention to the **CROSLY** patent **BOOK-TYPE VARIABLE CONDENSER** which impartial tests show to have less resistance than any other condenser on the market.

CROSLY

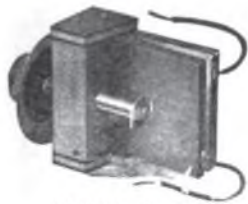

MODEL A

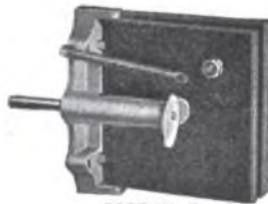

MODEL B

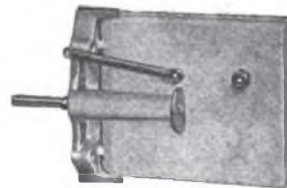

MODEL C

CROSLY VARIABLE CONDENSERS

The **CROSLY VARIABLE CONDENSERS** are undoubtedly one of the most radical improvements in radio during the past few years. By using it, louder signals are obtained as it not only is simple and easy to tune, but also has less internal resistance and no body capacity effect.

Model A, .0005 Mfd. (Wood Frame).....	\$1.25
Model B, as Illustrated, .0005 Mfd.....	\$1.75
Model C, .001 Mfd. (Porcelain Plates).....	\$2.25

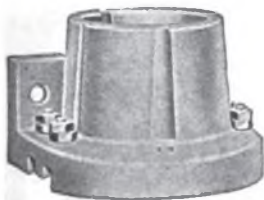

CROSLY V-T SOCKET

This socket has been pronounced by many radio engineers the best socket on the market. Ever since its announcement, its success has been phenomenal. Although the success has been largely due

to the price, its real popularity is based on its high quality efficiency service and practical unbreakability. Patents Pending. Beware of Imitators.

Made of porcelain for base, or panel mounting—\$0.50.

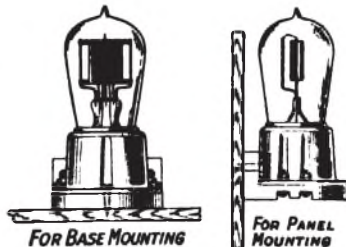

FOR BASE MOUNTING

FOR PANEL MOUNTING

Patent Applied For

CROSLY KNOB AND DIAL



Attractive and inexpensive, **CROSLY KNOBS** and **DIALS** are extremely well made for all required purposes. The dials are made of solid hard rubber 2 1/2 in. diameter, with the letters and figures stamped into them and white enameled.

Furnished Standard for 1/4" shaft or 3/8" shaft, optional—\$0.40.

CROSLY RHEOSTAT

This rheostat permits exceptionally accurate and delicate variations of the filament current. With it the best possible results are received from expensive vacuum tubes. Unique construction allows the **CROSLY RHEOSTAT** to be mounted on a panel of any thickness up to and including 3/8 inch. A special grade of non-corrosive wire forms the resistance and results in highly efficient service. Furnished complete with newly designed tapering knob, pointer, etc.—"Better—Cost Less"—\$0.60.



CROSLY R. F. A. T.

The **CROSLY RADIO FREQUENCY AMPLIFYING TUNER** is a new unit which takes the place of the Radio Frequency Amplifying Transformer and is much better. It makes possible sharp and efficient tuning over a broad band of wave lengths from 200 to 600 meters. The **Crosley R. F. A. T.** solves the radio frequency problem. With Instructions—\$4.00.



CROSLY TAP SWITCH



The unique construction of **CROSLY TAP SWITCHES** assures a constant tension and eliminates all possibility of the switch loosening and developing a faulty contact on the taps. A stationary washer of our own design has a soldering lug which makes possible a bus wire connection. All **CROSLY TAP SWITCHES** are furnished with a newly designed tapered knob and nickel-plated switch arm and bushing.

Price each complete.....30 cents.
Switch Taps for the above made of brass, nickel-plated and complete with brass nut, 2 1/2 cents each.

Write for Catalog

Dealers and Jobbers Who Handle Crosley Apparatus, handle the best

CROSLY MANUFACTURING CO.
DEPT. QST 2
CINCINNATI, OHIO

ALWAYS MENTION Q S T WHEN WRITING TO ADVERTISERS



No muss, trouble, dirt—no moving of batteries—loss of time—no technical or professional knowledge needed. May be used right in your living room.

THE
RADIO
HOMCHARGER
DE LUXE

charges your "A" or "B" battery over night and is the only rectifier on the market combining the following essential HOMCHARGING features:

- 1—Simplicity itself—attach to any lamp socket and connect battery.
- 2—Self-polarizing. Battery may be connected either way and will always charge.
- 3—Fully automatic in operation—gives taper charge—cannot overcharge or injure your battery.
- 4—Safe. All parts entirely enclosed. No danger from fire. APPROVED BY UNDERWRITERS EVERYWHERE.
- 5—Constructed of the best material—genuine Bakelite Panel, Jewell Ammeter, closed Core Silicon Steel Transformer. No castings used, only the best stampings throughout. UNQUALIFIEDLY GUARANTEED.
- 6—No delicate bulbs to break or burn out. Only one moving and two wearing parts, replaceable as a unit, at small cost.

AN ORNAMENT FOR YOUR
LIVING ROOM

Beauty has been combined with utility in the NEW RADIO HOMCHARGER DE LUXE. The body is beautifully finished in mahogany and gold. Equipped with rubber feet, it cannot mar polished surfaces. It harmonizes with the finest living room.

Furnished complete. No extras to buy. Price, \$18.50 at all good dealers, or shipped prepaid upon receipt of purchase price.

Booklet illustrating the NEW RADIO HOMCHARGER DE LUXE in actual colors is FREE for the asking. Send for your copy today.

DEALERS—JOBBER: Over 150,000 HOMCHARGERS will be sold this fall and winter. Send for "HOMCHARGER Business Builders" and Discounts and see how you can get your share of this business.

The Automatic Electrical
Devices Company

127 West Third St. - CINCINNATI, O.

Largest Manufacturers of Vibrating Rectifiers
in the World



SEE A FOR WALL MOUNTING

OVER 50,000 IN USE

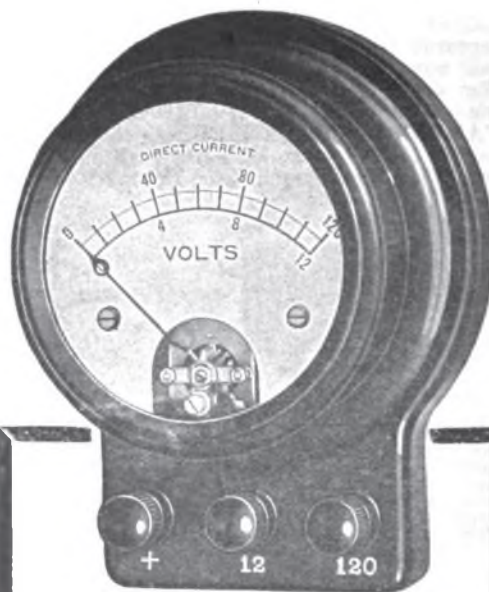

A-B
BATTERY TESTER

The Jewell A-B Battery tester fills a need for a low priced but accurate portable instrument for checking battery voltages. Double readings 0-12-120 volts is the range usually supplied, which takes care of the "A" battery under all conditions and the "B" battery up to the highest commonly used for receiving.

PRICE \$10.00

We were the first to supply a complete line of miniature radio instruments of uniform size. Ask your dealer or write to us for complete radio circular.

Jewell Electrical Instrument Co.

1650 Walnut Street, Chicago



Na-ald
De Luxe
V. T. Socket

Contact strips of laminated Phosphor bronze press firmly against contact pins, regardless of variation in length. No open current trouble possible. Socket moulded from genuine Condensite. Practically unbreakable. Special protected slot, with exterior reinforcement. Unaffected by heat of bulbs or soldering iron. All excess metal eliminated, aiding reception. May be used for 5 Watt power tube. Highest quality throughout. Price 75c.

Special proposition to dealers and jobbers.

ALDEN-NAPIER CO.

Dept., M.

52 Willow St. SPRINGFIELD, MASS.

VACUUM TUBES CUNNINGHAM

*Built
To Give Maximum
Efficiency*

VACUUM tubes are used for two distinct individual purposes in a receiving set—as DETECTORS and as AMPLIFIERS. The qualifications of a tube for these two uses are so different that for maximum efficiency tubes of entirely different design must be used.

This point was one of the chief considerations of the research engineers who designed Cunningham tubes in the great laboratories of the General Electric Company. After years of research and experimental work, the Cunningham C-300, a SUPER-SENSITIVE DETECTOR, and the Cunningham C-301, a DISTORTIONLESS AMPLIFIER, were developed. These two tubes, now nationally recognized as standards for all types of receiving sets, are responsible for the highly perfected results obtainable in radio phone reception.

Amplifies As It Detects

TYPE C-300
GAS CONTENT
DETECTOR
\$5.00

TYPE C-301
HIGH VACUUM
AMPLIFIER
\$6.50



248 First Street
San Francisco, Calif.

PATENT NOTICE
Cunningham tubes are covered by patents dated 11-7-05, 1-15-07, 2-18-08 and others issued and pending. Licensed only for amateur or experimental uses in radio communication. Any other use will be an infringement.



The trade mark GE is the guarantee of these quality tubes. Each tube is carefully inspected and tested before leaving the G. E. factory.

E. J. Cunningham

Trading as
AUDIOTRON MFG. COMPANY

154 West Lake Street
Chicago, Illinois

ALWAYS MENTION Q S T WHEN WRITING TO ADVERTISERS

105

REMLER

Giblin-Remler Inductance Coils

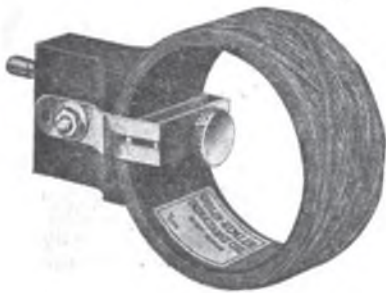

Ideal For Reception On All Wave Lengths

It is well known among radio engineers that the most efficient receiving sets are those designed so that all of the turns of wire in their inductance coils are in constant use, regardless of the wave length being received. This factor limits the wave length range of the most efficient sets for Radiophone reception.

Maximum efficiency is obtained for any given range of wave lengths in either single circuit or coupled circuit receivers by using Giblin-Remler Coils, shunted by variable condensers. Any desired range of wave lengths is at the operator's disposal by merely changing the size of the coils used in the coil mounting.

This operation does not require the connecting of any wires and is as simple and quick as inserting a telephone plug in a jack. If variable condensers of .001 micro-farads capacity are used, four sets of Giblin-Remler Coils (of sizes determined from the table) will cover the entire range of wave lengths between 128 and 23,800 meters.

Send 10c for new 40 page Remler Catalogue just off the press containing circuit diagrams for Remler Apparatus and other useful information including a table of inductance, capacity and wave length.

Maximum Inductance and Minimum Distributed Capacity

Type and Number of Turns, Mounted	Price, Mounted	Type and Number of Turns, Unmounted	Price, Unmounted	Inductance in Millihenries Accuracy 1/2%	Wave Length in Meters Accuracy 1/2%	Distributed Capacity in micro-microfarads Accuracy 1/2%	Wave Length Range in Meters using Condenser of .001 max. and .00004 min. mfd.		High Frequency Resistance in Ohms at Wave Length Shown					
							Min.	Max.	200	500	1000	2000		
RC 20M 1.50	RC 20U .70	.030	.030	39	14.3	63	334							
RC 25M 1.50	RC 25U .70	.041	.041	47	18.2	78	389							
RC 35M 1.50	RC 35U .70	.063	.063	87	25.4	128	560							
RC 50M 1.50	RC 50U .90	.109	.109	114	21.6	185	785							
RC 75M 1.85	RC 75U .95	.177	.177	183	19.8	298	1178							
RC 100M 1.70	RC 100U .90	.246	.246	217	19.9	358	1550							
RC 150M 1.75	RC 150U .95	1.503	1.503	281	14.8	512	2330	1000	2000	5000	10000			
RC 200M 1.50	RC 200U 1.00	2.26	2.26	374	14.7	690	3110	69.5	23.5	7.1				
RC 250M 1.50	RC 250U 1.10	4.20	4.20	434	12.1	890	3580		50.5	12.5				
RC 300M 2.00	RC 300U 1.20	6.11	6.11	494	11.2	1030	4480		67.5	19.9				
RC 400M 2.10	RC 400U 1.30	11.04	11.04	618	9.7	1380	6300		141	29.3	13.9			
RC 500M 2.30	RC 500U 1.50	17.50	17.50	747	9.0	1730	7900			54.8	22.3			
										93.1	34.9			
RC 800M 2.40	RC 800U 1.80	29.2	29.2	1024	10.1	2280	10250	2000	5000	10000	20000			
RC 750M 2.65	RC 750U 1.85	30.6	30.6	1249	11.3	2580	11850		111	43.8				
RC 1000M 3.40	RC 1000U 2.50	71.6	71.6	1620	10.3	3570	16000			84				
RC 1250M 3.80	RC 1250U 2.90	108.0	108.0	1930	9.7	4380	19700			123				
RC 1500M 4.40	RC 1500U 3.50	159.8	159.8	2306	9.3	5300	23600							

This table compiled by Robert F. Field of Cruik High Tension Electrical Laboratory Harvard University, Cambridge, Mass.

REMLER RADIO MANUFACTURING COMPANY

248 First Street, San Francisco, Cal.

154 W. Lake Street, Chicago, Ill.

REMLER



Remler No. 42 Bakelite Panel Plug
Price 60c

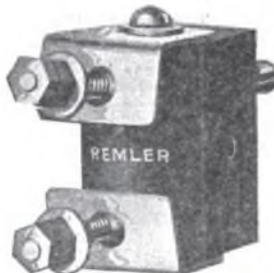

Remler No. 43 Bakelite Coupling Plug
Price 90c

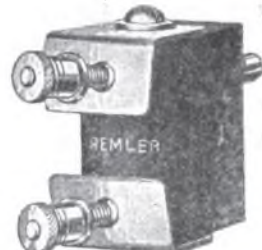

Remler No. 46 Bakelite Coupling Plug
Price \$1.00

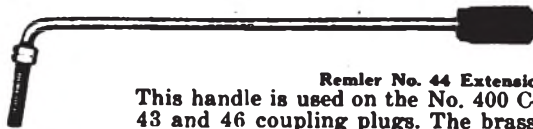

Remler No. 44 Extension Handle
This handle is used on the No. 400 Coil Mounting and fits No. 43 and 46 coupling plugs. The brass rod is nickel plated and fitted with moulded insulating handle. Two hexagon nuts provided for locking on plug. Length 5 1/4".
Price 30c

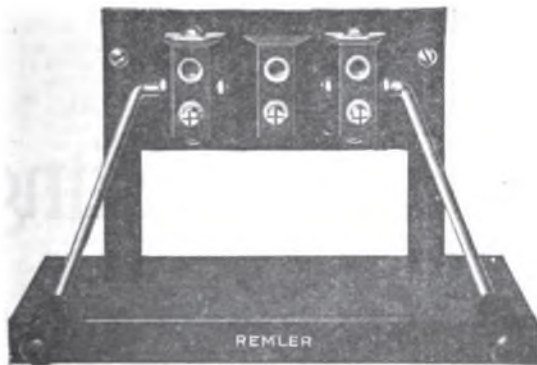

Remler No. 400 3 Coil Mounting
The Remler No. 400 3 Coil Mounting is specially designed for the Giblin-Remler Inductance Coils, but is equipped with standard coil plugs and permits the use of any standard inductance coil. Bakelite Panel and Base.
Price \$7.50

Specify Remler-- It Radiates Quality

The Remler All BAKELITE 3 coil mounting is undoubtedly the most efficient coil mounting on the market. The special shape of the Plugs allows a coupling range from zero to 90 degrees. The use of the long, insulated handles for adjusting coupling keeps the operator's hands away from the coils and minimizes body capacity effects.

For those who desire to build their own sets Remler high quality BAKELITE panel and coupling plugs and Extension Handles are sold unmounted as listed above.

Send 10c for new 40-page Remler Catalogue just off press, containing circuit diagrams for Remler Apparatus and other useful information, including a table of inductance, capacity and wave length.

REMLER RADIO MFG. COMPANY

248 First Street, San Francisco, Cal.

154 W. Lake Street, Chicago, Ill.

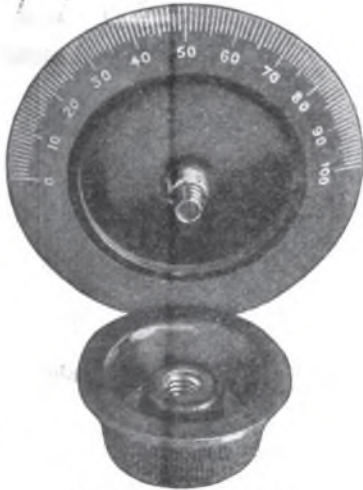

Patented June 20, 1922.

The Only Knob and Dial Without a Set-screw

The unsightly and troublesome SET-SCREW is at last eliminated. No more splitting the head of the set-screw or stripping of threads, perhaps ruining the dial.

To mount the TAIT-KNOB-AND-DIAL simply hold the dial with one hand and screw on the knob with the other; a few seconds does it. No tools are necessary. When fastened it is self centering and self aligning.

This beautiful patterned KNOB-AND-DIAL is made of the best grade of BAKELITE.

To those building their own sets—Don't fail to use this dial, it is REVOLUTIONARY in its field and is the PEER of all KNOBS-AND-DIALS. If your dealer has none write

us, and we will refer you to one who has.

Dealers—If your Jobber is not stocked up write us and we will refer you likewise.

Price—4"\$1.50
Price—3"\$1.00

We Sell Strictly to Manufacturers and Jobbers—whom we invite to write us for samples and discounts.

TAIT KNOB & DIAL COMPANY

Incorporated

11 East 42nd Street. Dept. Q. New York

Phone Murray Hill 0341

Used and Recommended by
the Largest Radio Concerns



BUY IT IN CARTONS



TRANSFORMER ENGINEERS SINCE 1911
ARE MANUFACTURERS

of
TRANSFORMERS
INDUCTANCES
& CHOKE COILS

for
RADIO

72½ Francis Ave., Hartford, Conn.

EISEMANN

WITHIN the last few months many concerns have engaged in the manufacture of radio parts, and the market has become flooded with apparatus of varied design and wide price range.

Obviously, greater discrimination must be practised by the buyer of radio materials.

Is not the guarantee of a responsible Corporation a factor to be considered? For twelve years the Eisemann trademark has been recognized in the automotive industry, as an assurance of quality and dependability. The same high standards are maintained in the manufacture of radio parts.



Audio Frequency Amplifying Transformer

This part used as an intervalve unit in a cascade amplifying outfit, utilizes to the highest degree amplifying properties of all makes of vacuum tubes. Maximum amplification within the tube limits is made possible and distortion of the signal is eliminated. The ratio is nine to one.

Highest degree of insulation of the primary and secondary windings is assured by the vacuum impregnating process in manufacture.

Price each \$6.00



Head Set

The Eisemann Head Phone will faithfully reproduce all broadcasted musical and spoken sounds. It is of simple design, yet rugged and sturdy of construction. The set is unequalled for quality of tone and balance of the receivers.

Specifications:

- Receiver case—aluminum.
- Coils—wound with highest grade enamelled insulated copper wire.
- Resistance—2,200 Ohms.
- Magnets—High percentage tungsten steel—permanent.
- Diaphragm—Rust-proof.
- Cord—Six foot.
- Head Band—Approved spring wire—self-adjusting sliding rod type.

Price complete—\$8.00



Vacuum Tube Socket

The contact points or fingers are supported by a single piece, tempered steel spring of proper tension. The four terminals are insulated from this spring by Bakelite insulation.

The socket is an all-metal, non-breakable type with provisions for table or panel mountings.

Price each 50c

Send for Folders describing Eisemann Radio Equipment.

RADIO DIVISION
EISEMANN MAGNETO CORPORATION

William N. Shaw, President

32 - 33rd Street, Brooklyn, N. Y.

DETROIT

CHICAGO

MAGNAVOX

brings City Entertainment
and Education
to the
Farm

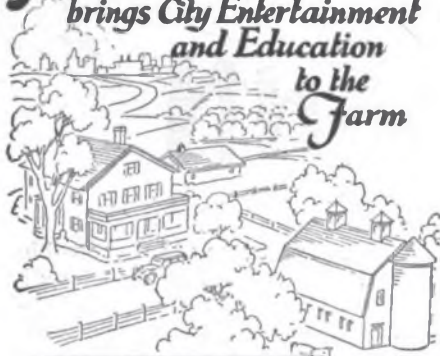

*How Science has bridged
with wireless the miles
between city and country*

Without a Magnavox Radio no wireless receiving set is complete. It makes it possible to hear all that is in the air as if it were being played by your phonograph.

- R-2 Magnavox Radio with 18-inch horn . . . \$85.00
- R-3 Magnavox Radio with 14-inch horn . . . \$45.00
- Model C Magnavox Power Amplifier
 - 2 stage AC2-C . . . \$80.00
 - 3-stage AC3-C . . . 110.00

Any radio dealer will demonstrate for you, or write to us for descriptive booklet and name of nearest dealer.

The Magnavox Co.
Oakland, California
Office: 370 Seventh Ave.

Radio brings it
MAGNAVOX
tells it

John G. Rieger, Radio Editor of **Buffalo Evening News**



Price
\$1.85
P. P. 10c

says
"The first time I used a Bradleystat, I could scarcely conceal my joy. It gave better adjustment than any vernier arrangement I had previously tried, and all in one movement of a knob."

Allen-Bradley Co.
Electric Controlling Apparatus
277 Greenfield Av.
Milwaukee, Wisconsin

Bradleystat
REGISTERED U. S. PAT. OFF.
PERFECT FILAMENT CONTROL

BOSTON RADIO EXPOSITION

AND

N. E. AMATEUR CONVENTION

MECHANICS BUILDING

Entire Week Oct. 30-Nov. 4

Covers New England with
One Exposition

SPACE AVAILABLE NOW

Executive Offices:
5 Park Square, Boston, Mass.

Broadcasting a Message of Radio Reliability

Cotoco

TRADE MARK REG. U. S. PAT. OFF.

Buy by this Name and You Buy Right

COTO-COIL CO. is not a mushroom growth in the Radio Field. We were winding electrical coils long before the radio boom. We are here to stay. Our products are right to hold their own in any comparison for quality. Electrically correct and mechanically accurate. Even the Cotoco Dial is a better product—practically unbreakable, with metal insert to assure smooth action.

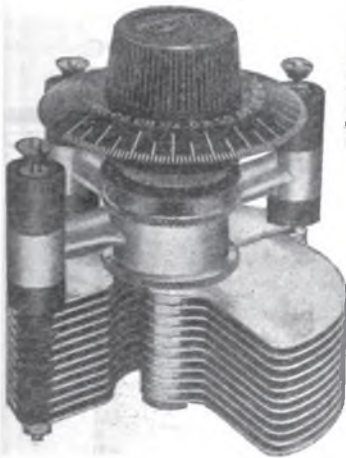

COTOCO VARIABLE AIR CONDENSER
Scientifically correct for minimum of electrical losses. A fine machine product that is as superior as it looks.

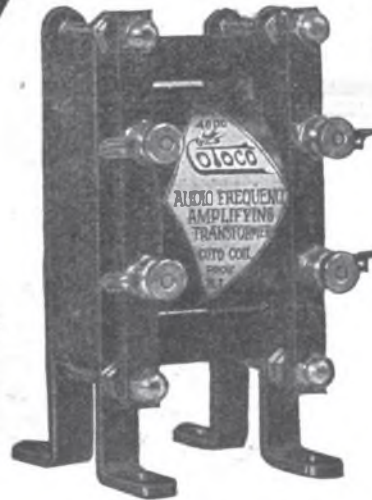

COTOCO AMPLIFYING TRANSFORMER FOR AUDIO FREQUENCY

The perfected protection against distortion in headphones or loud speaker. Stable audibility over a wide range of frequencies.

COTOCO HONEYCOMB INDUCTANCE COIL
Yet to find its equal as a compact, neat and remarkably efficient inductance unit. The original and still the best.

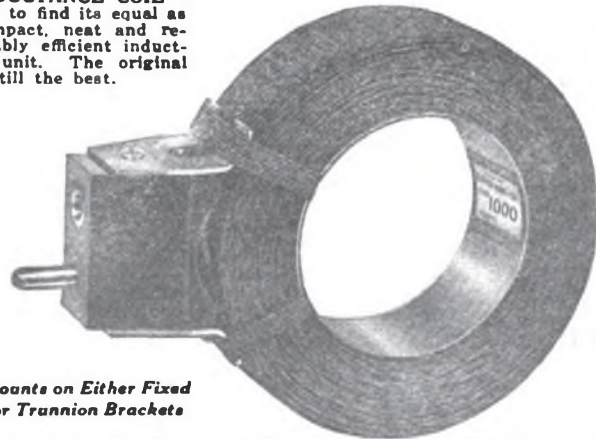

Mounts on Either Fixed or Trunnion Brackets

Send Us Your Dealer's Name

if he does not carry Cotoco Products. We will mail you **FREE** Connection Diagrams for Loop Aerial set and see that he can supply you.

COTO-COIL CO.
87 Willard Ave.,
Providence, R. I.

ALWAYS MENTION Q S T WHEN WRITING TO ADVERTISERS

111

INTERNATIONAL AND ANNUAL

CHICAGO RADIO SHOW

AT THE COLISEUM CHICAGO ILLINOIS

SATURDAY TO SATURDAY
OCT. 14TH TO OCT. 21ST

THE PUBLIC WILL MEET THE MANUFACTURER THE PUBLIC WILL MEET

IN
THE LARGEST STREET-FLOOR EXPOSITION BUILDING
IN THE UNITED STATES

A COMPREHENSIVE PROSPECTUS NOW READY
WRITE FOR IT

BUSINESS OFFICE
549 McCORMICK BLDG.
PHONE WABASH 1844

LAMB QUALITY APPARATUS



—Price \$60.00—

Our Improved Detector-2 Stage Amplifier Unit

Maximum amplification with minimum distortion. The result of concentrated research work, in our laboratory. Really a beautiful piece of apparatus. Interesting literature on request. Discounts to Dealers.

F. JOS. LAMB COMPANY

1938 Frankin Street,
Detroit, Mich.



RADIO CLUB PINS

An emblem made to order for your Club will work wonders—Write today for free 52 page catalog showing Radio emblems, class rings and pins. Samples loaned to officers.

METAL ARTS CO., INC.
7753 South Ave., Rochester, N. Y.

Dec. 1937

WITHERBEE

RADIO A BATTERIES
Built Right Since 1903
WITHERBEE STORAGE BATTERY COMPANY, INC.
234 W. 55th Street, New York

RADIO FREQUENCY

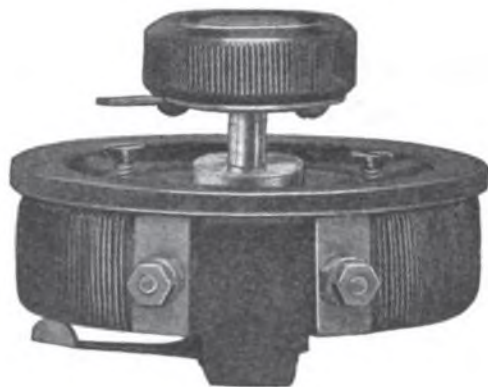

Radio frequency amplification will be the popular method of reception for A.R.R.L. operators this winter. This method of reception necessitates the careful adjustment of grid potentials. This can best be done by carefully constructed potentiometers. It is essential that something more than a variable high resistance be used. The contact must be smooth so as to eliminate noises; the base must be of a high insulating, non-absorptive substance; and the resistance high to prevent a rapid battery discharge.

The General Radio Company Type 214-A, 400-ohm potentiometer was constructed for just this service. Many of the original experiments on radio frequency amplification and super-regeneration were conducted using this very potentiometer.

Can you get at critical points on the curve of your detector tube? You can if you use one of these potentiometers in your plate circuit.

The construction of these potentiometers is similar to that of our Type 214 rheostats that have met with your approval for many years. They are all made in two styles of mounting, 214B for front-of-panel, and 214A for back-of-panel. Ask to see them at your local dealers.

Type 214A 2 ohm—2.5 amp. Rheostat.....	\$2.25
Type 214A 7 ohm—1.5 amp. Rheostat.....	2.25
Type 214A 400 ohm Potentiometer.....	3.00
Type 214B 2 ohm—2.5 amp. Rheostat.....	2.25
Type 214B 7 ohm—1.5 amp. Rheostat.....	2.25
Type 214B 400 ohm Potentiometer.....	3.00

Send for Free Radio Bulletin 911-Q

GENERAL RADIO CO.

MASSACHUSETTS AVENUE AND WINDSOR STREET
CAMBRIDGE 39, MASSACHUSETTS

Standardize on General Radio Equipment Throughout

Do not confuse the products of the GENERAL RADIO CO. with those of other concerns using the words "General Radio." The General Radio Co. has been manufacturing radio and scientific instruments for many years. It has no affiliation with any other company.

"She's A Beaut!"



*In performance
and workmanship*

3 Radio Detector and two audio at \$125.00 for use on loop and \$150.00 for loop or plain antenna work. Extreme distance. Unsurpassed clearness. We have a complete QUALITY line. "Nuff sed."

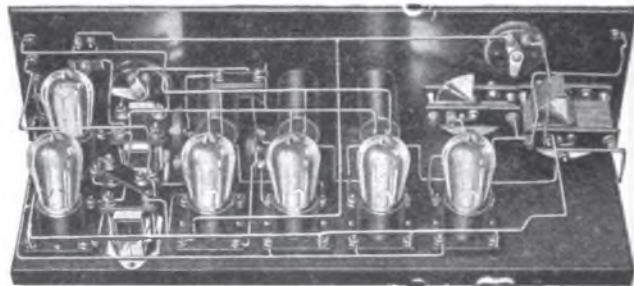

Scientific Engineering Assn.

817 Main St.,

Cincinnati, Ohio

THE NEW ROBERTSON-DETROIT CHOPPER

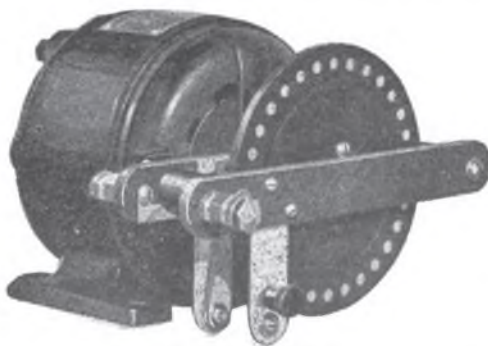

Patent Applied for
Robertson-Detroit Choppers now in use from New Jersey to California. Over 25 in Detroit alone. Among others—8B0, 8ZZ, 8KH, 8BA, 8IZ, 8XAE, 8GR, and WWJ.

PRICE F.O.B. DETROIT \$35.00

ANNOUNCEMENT OF OUR SYNCHRONOUS RECTIFIER IN THE NEAR FUTURE

ROBERTSON CLOCK & INSTRUMENT CO.

409 EAST CONGRESS STREET,

DETROIT, MICHIGAN

The result of over a year's continuous experimental work to improve upon our old model.

Bakelite Wheel five inches in diameter, mechanically perfect, varying less than one thousandth inch (.001") in thickness over entire circumference, runs dead true, no vibration of brushes. Thirty large contact inserts.

Brushes of brush copper and phosphor bronze, long and flexible with tension adjustable while Chopper is running.

Supporting structure of Bakelite and brass. Well built and strong.

Motor: Westinghouse one twelfth (1/12) H.P. either A.C. or D.C. RPM practically 1800 with Chopper.

AMATEUR RADIO CALL BOOK

Loose Leaf System, Amateur, Special, Experimental, Technical, Telephone Broadcasting, etc., kept to date monthly.

Postal Card for Particulars.

CITIZENS RADIO SERVICE BUREAU
416 S. Dearborn St., Chicago

*Who's Who and What's What
in Radio Communication*

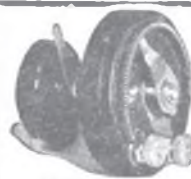

\$1.25

UNIVOX FILAMENT RHEOSTAT

Honestly made—Honestly priced
Bulletin R gives complete data
Splendid discount to the trade

Walter R. Horning, Inc.
Mfrs. 'UNIVOX' Radio Units
Cleveland, O., U. S. A.



Run-down batteries need not be the reason for missing any broadcast programs

No Concerts Missed Because of Run-Down Batteries

With a Tungar Battery Charger you can easily keep your batteries up to full voltage. It enables you to recharge batteries from any a-c. lighting circuit at your convenience and at a minimum cost. The battery doesn't have to be taken out of the house. "B" storage batteries, also, can be charged by means of a simple, inexpensive attachment.

The Tungar Battery Charger requires no attention while operating and is so designed that there isn't the slightest danger of injuring the battery. And its first cost is very low.

Tungar has kept other people's storage batteries in condition for years—why not yours? Of course, it is equally good for your automobile battery.

Our new booklet on the application of Tungars to radio batteries will interest you. Send to us for booklet B-3640, if your dealer cannot supply you.



Tungar Battery Charger—saves disappointments and annoyance

Tungar
BATTERY CHARGER

General  Electric
General Office Schenectady, N.Y. **Company** Sales Offices in all large cities. 35-A '27

ALWAYS MENTION Q S T WHEN WRITING TO ADVERTISERS

115

Digitized by Google

"All-American" Transformers Radio and Audio Frequency

Radio and Audio frequency are day by day becoming more and more important. The days of sets with detector only, are gone.

To get the best results you must use the best transformers. "All-American" Radio and Audio Frequency Transformers have given the best results to thousands of radio fans in all parts of the country and will give you the same results as soon as you try them.

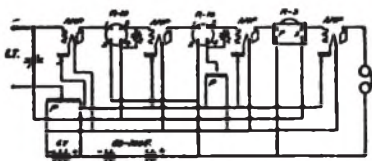

Try the hook-up illustrated above, but be sure to use "All-American" Transformers or you will not be satisfied.



"All-American" Radio Frequency
Type R. 10.....\$4.50



"All-American" Audio Frequency
Type R. 2.....\$4.25
Type R. 3..... 4.50

Ask your dealer.

RAULAND MFG. CO.
35 So. Dearborn St., Chicago, Ill.

KQV—Pittsburgh Pa.—BROADCASTING STATIONS—Washington, D. C.—WMU

Dependable Radio Equipment

All orders with remittance promptly delivered, Post or Express paid. Always a large and varied stock of most modern and reliable Radio Equipment and Parts.

Immediate Deliveries on all Items Listed



Stromberg-Carlson
No. 2-A Headset
\$7.50

Aerola Senior Westinghouse Receiver.....	\$65.00
Aerola Grand Westinghouse Receiver.....	\$25.00
DeForest Radiohome Set DT 700, less Batteries, Bulbs and Headset.....	\$6.00
DeForest 2-stage Amplifier DT 800, less Bulbs and Batteries	\$5.00
Simplex Variometers	6.00
King Amplitone Horns	12.00
Hotzer-Cabot Headset	8.00
UV 200 Radiotron Detector Bulbs.....	5.00
UV 201 Radiotron Amplifier Bulbs, each.....	6.50
No. 766 Eveready VT Batteries, each.....	3.00
Gould 6-volt, 60-80 Ampere Storage Batteries....	19.00

Enclose Certified Check or P. O. Money Order with Orders



R3 Magnavox
Loud Speaker
\$45.00

DOUBLEDAY-HILL ELECTRIC CO.

WASHINGTON, D. C. — DEALERS WRITE FOR DISCOUNT — PITTSBURGH, PA.

RADIO REALITIES

Our price list, mailed FREE on request. Contains complete lists of reliable Radio Sets and parts—every article carrying our guarantee. Mail orders given prompt attention.

Write today—Special Terms for Dealers

**THE KLEIN RADIO & ELECTRICAL
SUPPLY CO.**

48 Fulton St. and 34 Park Place NEW YORK, N. Y.

JOY-KELSEY CORPORATION

Manufacturers

RADIO EQUIPMENT

4021 West Kinzie St. Chicago Ill.

The Only Authentic Book on the Construction
and Operation of
**“The Armstrong Super-Regenerative
Circuit”**

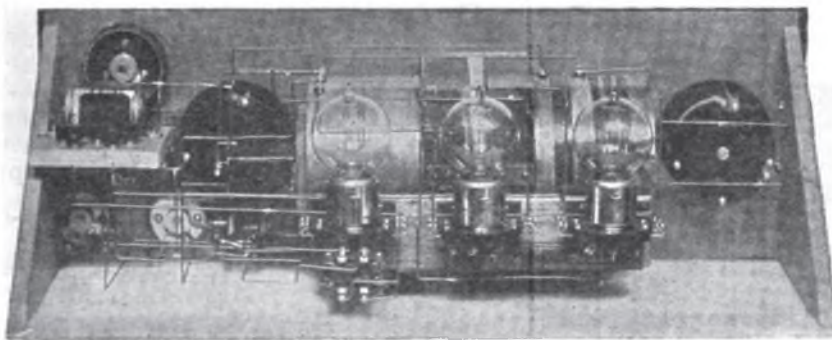

This set built by the author, George J. Eltz, Jr. E. E., A. I. E. E.

Described fully in 52 pages—including 21 Photographs and Hook-Ups, in simple non-technical radio language.

Complete Description of Each of the Three Circuits Invented by
MAJOR E. H. ARMSTRONG, E. E.

How to Change a Regenerative Circuit to a Super-Regenerative
Circuit

Price \$1.00 Per Copy Mailed or at your Dealer (Do Not Send Stamps)

RADIO DIRECTORY and PUBLISHING CO.

45 VESEY STREET

(Room 105)

NEW YORK CITY

NOTICE *The second edition of the AMATEUR RADIO CALL BOOK is now ready. Mailed to you on receipt of \$1.00. (Do not send stamps)*



PRICE \$3.50

**THE NEW IMPROVED
WIRELESS B BATTERY**
REFILLABLE VARIABLE
NOISELESS IN OPERATION

The Switch Makes It 100 p.c. Perfect

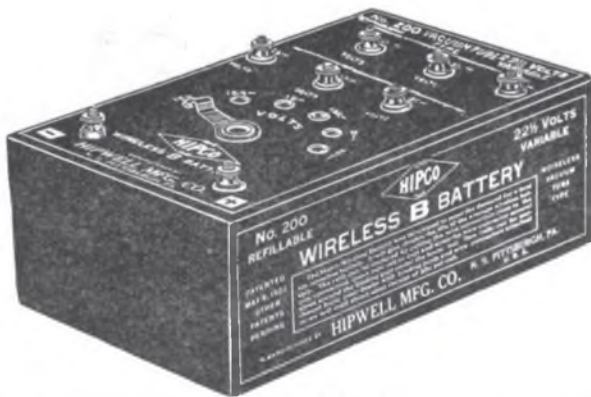

Must be seen to be appreciated. It has all the features that made last year's B Battery the phenomenal success. Ask for catalogue describing our full line of B Batteries and other Radio Supplies.

For sale at all radio supply dealers.

HIPWELL MFG. CO
N. S. PITTSBURGH, PA.



Send
for these
Bulletins

No. AG-10. 3 1/4" ammeters, milli-ammeters, voltmeters, milli-voltmeters and thermal ammeters for all receiving and transmitting sets.

No. AG-20. Telephone receivers.

No. AG-810. Medium and large size ammeters, milli-ammeters, voltmeters, milli-voltmeters and current squared meters for all receiving and transmitting sets.

Distributors write for attractive proposition.

ROLLER-SMITH COMPANY
16 PARK PLACE, NEW YORK
Offices in Principal Cities in U. S. and Canada

THE AMERTRAN



**A BROAD BAND
AUDIO FRE-
QUENCY SUPER
AMPLIFYING
TRANSFORMER**

This transformer has been recently developed in response to critical and exacting demands of discriminating radio engineers and progressive amateurs.

Highest amplification constant over broadest band of frequencies—Absolutely without distortion or resonance peaks.

Our Amplification Chart gladly sent on request—It tells the story!

LIST PRICE—\$7.00 F. O. B. NEWARK OR
GET IT FROM YOUR DEALER

The American Transformer Co.
Makers of Radio Transformers Since 1901
Dept. Q, NEWARK, N. J.



"Comin' In Great!"

At Last! —

High Efficiency Receivers at a *Down-to-Earth* Price

ELEVEN years in the manufacture of delicate electrical units and apparatus—eleven years concentrated in the production of one line of equipment—all electrical, *means* something in accumulated experience and facilities.

That's the answer to how we have been able to place on the market this super-sensitive radio head set for \$6.00.



All the high-priced qualities. Sensitiveness—balance—natural voice pitch—no scratching. Light weight, aluminum case—solid horse shoe magnet—no laminations—bus-bar connections—no loose wires.

Light diaphragm, set to thousandth-of-an-inch accuracy from magnet poles. Clean cut, rugged design throughout. Comfortable on the head—good to look at. Compare them with other makes irrespective of price and you'll be convinced they're quick sellers.

Write for exceptional dealer proposition, name of our nearest local factory representative and for list of Basco Radio Products.



\$6.00

Put up in attractive orange-colored cartons.

Briggs & Stratton Co.
Milwaukee PRODUCT Wisconsin

\$6.00 (2000 Ohm)

\$7.50 (3000 Ohm)

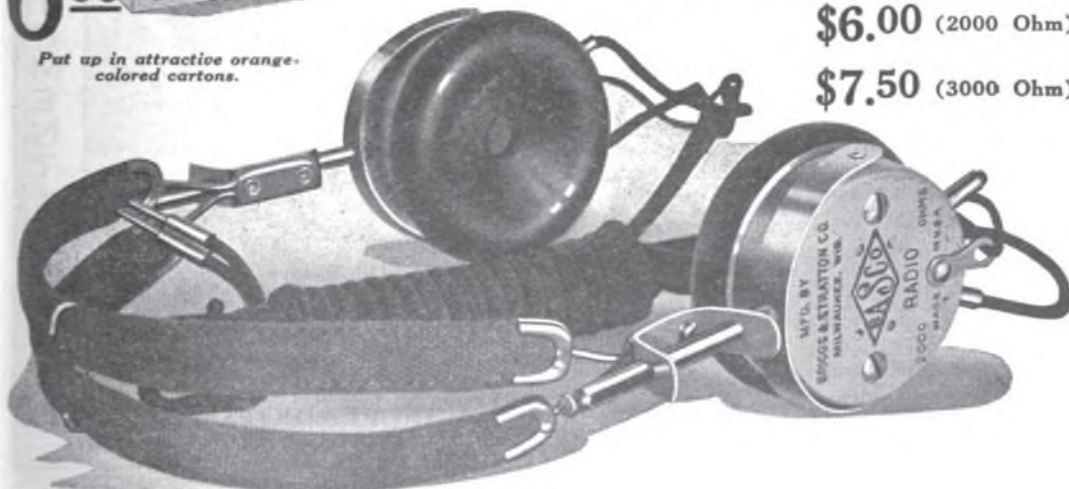

ALWAYS MENTION Q S T WHEN WRITING TO ADVERTISERS

119

POSACO RADIO

QUALITY AND EFFICIENCY VERNIER CONDENSER WITH SINGLE KNOB CONTROL

Especially Adapted to the New Armstrong Super-Regenerative Circuits in which Variable Condensers Play an Important Part and in which fine adjustments are Absolutely Essential

There Is Built in all POSACO Variable Condensers a 4 1/2" Round Metal Shield. Rotary Plates Cannot Turn on Shaft.

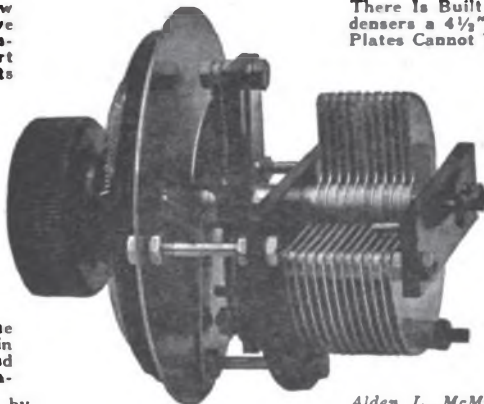

- B-1 .001045 MFD. \$7.50
- B-2 .000545 MFD. \$7.00
- B-3 .000295 MFD. \$6.50

- A-1 .001 MFD. \$4.50
- A-2 .0005 MFD. \$4.00
- A-3 .00025 MFD. \$3.50
- A-4 .000045 MFD. \$3.00

Constructed With the Same High Standard of Quality in Materials, Workmanship and Design As Our Regular Variable.

Ask Your Dealer or Write for Circular. Jobbers and Dealers Write for Proposition Increase Year Sales

Manufactured by

Alden L. McMurtry, Licensee

THE C. D. POTTER CO.,

Stamford, Connecticut

POSACO RADIO



MARVELOUS MUSIC OF THE AIR

Beautiful concerts, instructive lectures, stories, the day's news—all radio entertainment comes true and clear with the

Stromberg-Carlson Radio Head Set

Unexcelled in tone; extremely sensitive. Forked cord permits simultaneous use by two observers. A perfected instrument.

You may order Stromberg-Carlson Radio Head Set and other apparatus from your dealer—or send for Bulletin No. 1029Q and order direct.



Stromberg-Carlson
Telephone Mfg. Co.
Rochester, N. Y. Price \$7.50

THE LATEST  **IN RADIO**

I M M E D I A T E



S H I P M E N T

No. 410 Rotary Switch Lever:
Double brass Lever, heavily nickel plated. 1 3/4 in. Radius. Can't work loose. Absolutely the BEST on the market today. Fully Guaranteed. Money back if not satisfied.

List Price \$1.00. Send for sample
Manufactured By
VIRGINIA RADIO CORPORATION
CHARLOTTESVILLE, VIRGINIA

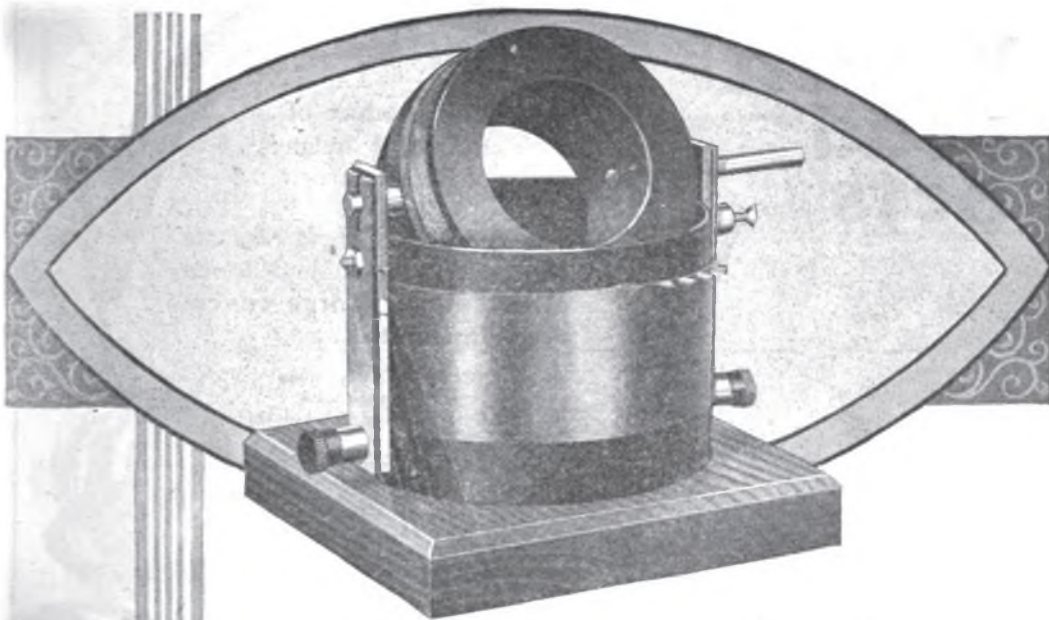

The Thoroughbred Vario-Coupler

An essential to every worth while radio set

IT IS an interesting thing to observe that A. Frederick Collins, Inventor of the wireless telephone, in "The Radio Amateur's Handbook" (Thomas Y. Crowell Co., New York) places the vario-coupler first in the list of parts essential to a successful regenerative receiving set. This only serves to emphasize the importance of a proper vario-coupler as essential to every set.

The Thoroughbred Vario-Coupler because of its exclusive features is chosen by experienced amateurs to complete their sets. The Thoroughbred Vario-Coupler is of the all-moulded type which reduces losses and is not subject to dampness. The first seven taps on the primary are tapped one turn at a time and the last seven, a tap at each seven turns. The user is thus able to **TUNE IN ONE TURN AT A TIME**—a feature not found on any other vario-coupler.

The amateur can use it with base on a table or he can mount it on a panel merely by removing this base.

The secondary of the Thoroughbred Vario-Coupler is wound with fine wire in order that it may be used for plate and tickler, thus doing away with the need for a variometer. On the average aerial it has a wave length of 200 to 700 meters. You can buy it at good radio and electrical stores for \$5.00.

The Thoroughbred Vario-Coupler is but one of fifteen radio products manufactured by the Marshall-Gerken Company in their new and larger plant at Toledo, Ohio.

Write for interesting literature.

THE MARSHALL - GERKEN COMPANY

Jackson and North 12th Streets,

Toledo, Ohio

Thoroughbred Apparatus

ALWAYS MENTION Q S T WHEN WRITING TO ADVERTISERS

121

Digitized by Google

Warren Head Sets



Specialists in Head Sets
and Loud Speakers

—The product of a
successful designer
of Receivers

All WARREN Head Sets are
thoroughly tested and toned
alike. A guarantee covers
every instrument.

Case—solid aluminum
Cap—hard rubber
All parts highly nickel-plated

We will gladly refund
your money if, after
2 weeks' trial, you
are not thoroughly
satisfied.

Ask your Jobber—
or write us



WARREN RADIO PHONE MFG CO. Inc
WARREN, RHODE ISLAND, U.S.A.



ATTENTION RADIO AMATEURS

EBY BINDING POSTS

GUARANTEE POSITIVE CONNECTIONS
DEMAND THEM OF YOUR DEALER



COMMANDER "H" ENSIGN "H"

SERGEANT SS BUDDY

To satisfy the tremendous demands for EBY posts, we have arranged with responsible dealers everywhere to carry a complete stock. Don't take a substitute. Insist on an EBY post.

THE H. H. EBY MANUFACTURING COMPANY, PHILADELPHIA, PA.

35c. Each

3 for \$1.00

Na-ald Genuine Condensite Dial

The dial that runs true.

Numerals engraved on bevel
and knob so shaped that fingers
do not hide them.

Thin edge with clear graduation to make
accurate reading easy. Concealed set screw
in metal insert. Will not warp or chip.
Finish and enamel permanent.

Low price with this quality possible only
through quantity production.

Special dealer and jobber proposition. An opportunity.

ALDEN-NAPIER CO.

52 Willow St. Dept. M SPRINGFIELD, MASS.

122



HOWARD VERNIER RHEOSTATS

Base made of special heat-
resisting composition. Total
resistance 6.8 Ohms. Carrying
capacity 1.5 Amperes. Diameter
of base 2 1/2 inches. All sliding
contacts without vernier
adjustment \$1.10. Order
now.

TESTED EQUIPMENT

Write, wire or call for our list of tested radio
apparatus

APEX RADIO COMPANY, Inc.

1105 W. 69th Street, Dept. Q, Chicago, Illinois

ALWAYS MENTION Q S T WHEN WRITING TO ADVERTISERS

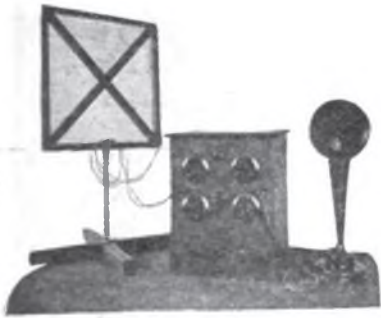

Complete Super-Regenerative Receiver

Look for this display box at your RADIO dealers. It contains everything necessary for the construction of a three-tube super-regenerative receiver, as designed and recommended by Kenneth Harkness.

\$75

Harkness booklet free with each order.

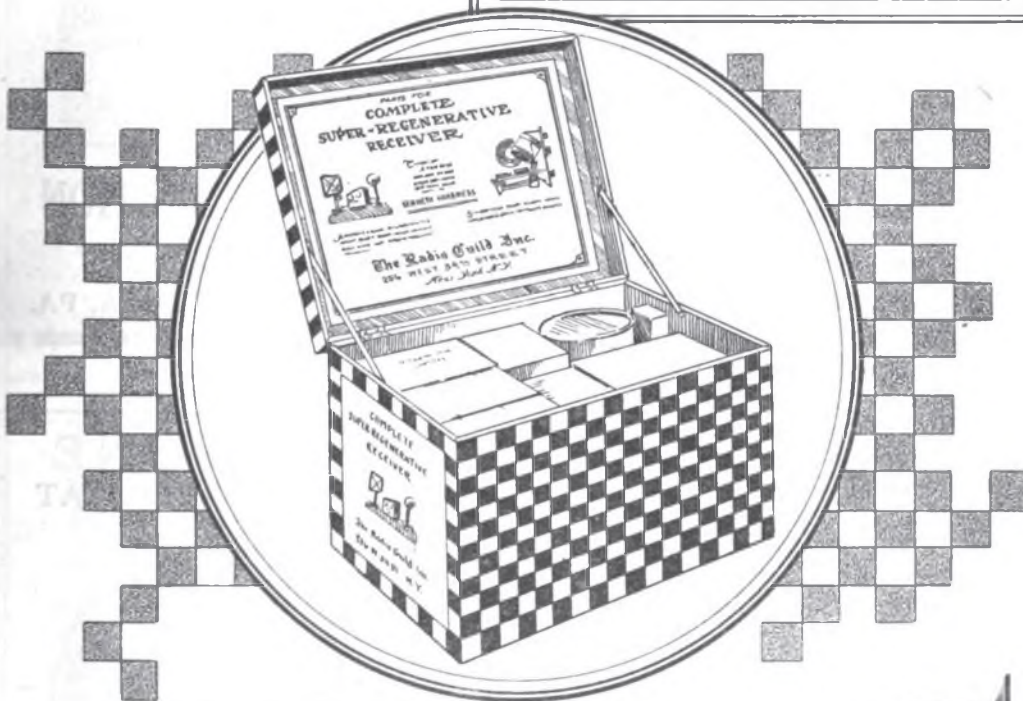

Kenneth Harkness' new, improved booklet on Super-Regeneration 2d Edition

Showing 25 wiring diagrams, mechanical drawings and photos illustrating the theory and construction of three different sets actually constructed by the author.

50c

Special discounts to dealers.

The Radio Guild, Inc.

256 W. 34th St.,

New York

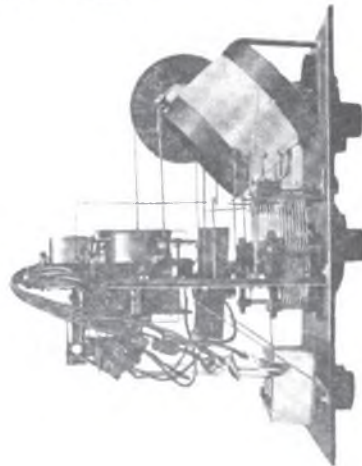

ATTENTION MR. AMATEUR!



Trade Mark
Registered

We have a complete stock of the old line Radio Companies' experimental and measuring instruments and parts.

The famous Grebe Receivers and Amplifiers are our specialty.

We are the official Radio Corporation Distributors.

Have your dealer order from us.

PHILADELPHIA WIRELESS SALES CORPORATION

Formerly Philadelphia School of Wireless Telegraphy

1533 PINE STREET

PHILADELPHIA, PA.

AUDIO FREQUENCY AMPLIFIER



MOUNTED TYPE M

Silicon Steel Cores; Shell Design—Bakelite Terminal Board; Ratio—9 to 1; Insulation test 1500 Volts.

Mounted Type M—\$5.00

Semi Mounted Type SM—\$4.50

Unmounted Type UM—\$4.00

Discount 10% for cash with order

Designed by *Packard* Engineers—

a quality name in Radio.

THE STANDARD TRANSFORMER CO.
Warren, Ohio

KEYSTONE FILAMENT RHEOSTAT

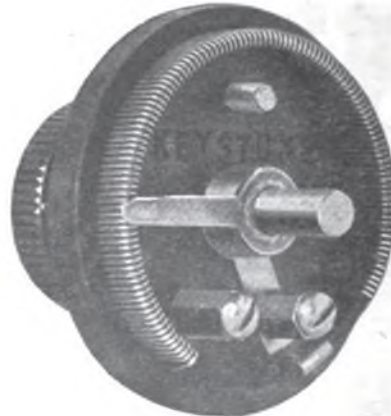

Resistance 6 Ohms.

Carrying Cap. 1 1/4 Amps.

Base, moulded Bakelite.

2 1/4 In. Diameter.

All metal parts, made of brass, and nickel plated.

Large Knob, with polished pointer.

List Price \$1.00

Manufactured By

Keystone Radio Company

Dept. Q, Greenville, Penn.



Eveready "A" Batteries
 —hardwood box, mahogany finish
 —convenient handle, nickel plated
 —rubber feet protect the table
 —insulated top prevents short circuits
 —packed vent caps prevent spilling

No. 6860—90 Amp. Hrs.—45 Lbs.—\$18.00
 No. 6880—110 Amp. Hrs.—52 Lbs.—\$20.00

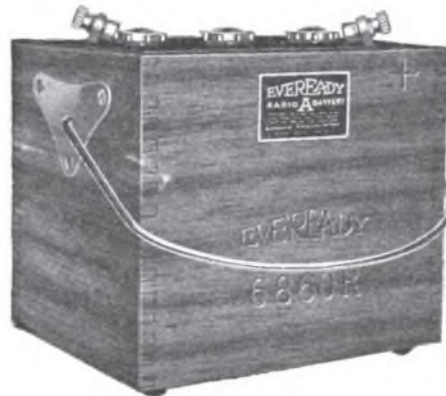

Eveready "B" Battery No. 766
 Equipped with 5 positive voltage taps ranging from 16½ to 22½ volts. Fahnestock Spring Clip Binding Posts—an exclusive Eveready feature. Price \$3.00



Eveready "B" Battery No. 774
 Equipped with 6 positive voltage taps at 4½ volt intervals ranging from 18 to 43 volts. Fahnestock Spring Clip Binding Posts—an exclusive Eveready feature. Price \$5.00



**For Better Results
 USE**

EVEREADY

"A" and "B" BATTERIES

with your radio set

For sale by the better radio supply dealers everywhere

Send today for descriptive booklets

NATIONAL CARBON COMPANY, Inc.

Long Island City, N. Y.

Atlanta Chicago Cleveland

Kansas City San Francisco

Make Your Own Receiving Set

With These Parts

The National variometer and variocoupler are specially designed for the reception of wavelengths between 150 and 650 meters. Two of the variometers and the variocoupler make a regenerative receiver that will bring in loud, clear and properly tuned signals. Make your own set and save 40 to 50%

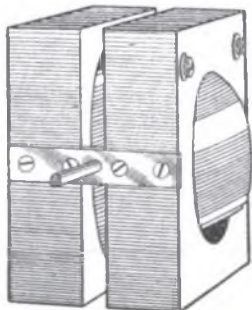

NATIONAL VARIOMETER
Complete Postpaid \$4.00

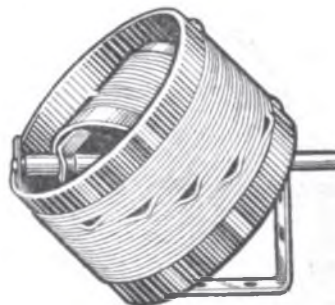

NATIONAL VARIOCOUPLER
Complete Postpaid \$3.50

VARIOMETER

Beautifully finished, substantially built and absolutely accurate in every detail. Minimum clearance between Rotor and Stator insures highest degree of efficiency. Especially adapted for the reception of concerts, lectures and other forms of broadcasting. Each, postpaid,..... **\$4.00**

VARIO-COUPLER

This 180° coupler permits the sharp tuning necessary to get distant stations. Wound especially to get the best results on amateur wavelength broadcasting. Positive contacts throughout. Neat in appearance, efficient in operation. Each, postpaid,..... **\$3.50**

VARIOMETER PARTS—At Factory Prices

For the amateur who wants to wind his own variometer, we furnish the wooden parts and all necessary wire, screws, hardware, etc.

Wood Rotors—4" diameter, 2" wide, 90c
grooved for windings, postpaid, each
Wood Stators—4 1/4" square, with slots for bearing plates, postpaid, \$1.00
per pair.....

Wire, etc.—complete set of all wire, screws and hardware needed to wind and assemble the complete variometer as shown in illustration above, postpaid, per set..... 70c

DEALERS, JOBBERS: ATTENTION

We manufacture these variometers and variocouplers in our own factory and have good stock ready for immediate shipment. Write for our very attractive prices.

NATIONAL RADIO CO., INC., 1302 S. VAN DEVENTER, ST. LOUIS, MISSOURI

WIS-WIN SWITCHES

We build switches de luxe at a price within reason. Special phosphor-bronze spring washer concealed in the bushing, with tension properly adjusted at the factory, insures firm contact at all times. No WIS-WIN switch need be taken apart to mount. Each switch adjusted, and enclosed in box with template for drilling holes for switch points.

Dealers: We can make prompt deliveries now, and have an attractive proposition.

Manufacturers: We are equipped to build switches according to your requirements. Improve the quality of your sets by using WIS-WIN switches.



No. 750 1 1/4" radius
No. 752 1" radius
Price 55 Cents Each

Willis Switch & Instrument Co.
8 Kingsbury St. JAMESTOWN, N. Y.

Circular S-1, describing our line: V-blade, Series-parallel, concealed B-Battery, Inductance, etc., sent free upon request.

If you cannot obtain Wis-Win switches from your dealer we will ship postpaid on receipt of money order.

JOBBERS AND DEALERS BIG MONEY IN RTS Radio Equipment

The demand for RTS Equipment has become so great that for two or three months we have been behind on orders. But now, with our greatly enlarged plant, we are able to supply standard and special equipment to dealers and jobbers in any quantity.

We show here one article that has proven exceedingly popular:

RTS CONDENSERS



The RTS Condensers shown above are standard in type and among the leaders in the industry. They eliminate howling, clear up phone speech and make the tubes perform perfectly. Furnished with mountings complete, ready for connections. Every condenser is thoroughly tested. They are made in three capacities.

Grid Condenser .0005 M. F. Retail at.....30c
Grid Condenser and Leak, combined Retail at...45c
Phone Condenser .0013 M. F. Retail at.....30c

JOBBERS AND DEALERS OPPORTUNITY
Now is the time to cash in big profits! Amateurs in all parts of the country are demanding RTS equipment and Specialties. Write today for price lists and liberal discounts to the trade.

RADIO TESTING STATION
Dept. Q-10 25 Sturgis Street
Binghamton, New York

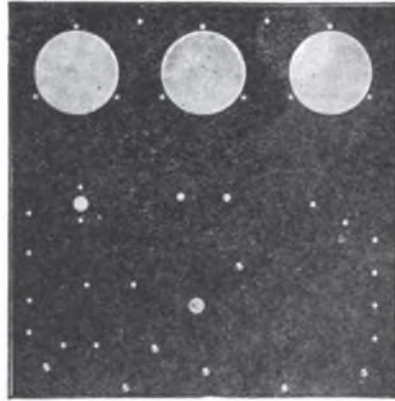

CONDENSITE CELORON

Sets a New Standard in Radio Panels and Parts

This strong, handsome, jet-black, insulating material gives you a surface and volume resistivity greater than you will ever need, and a beauty that will make your set the envy of your friends. It is the ideal material for making radio panels because it is highly dielectric, machines readily, engraves with clean cut characters and can be finished with a high, natural polish or a rich, dull, mat surface.

If you want the highest type panel you can obtain—a panel made from a material approved by the Navy Department Bureau of Engineering—a panel that will give you continued satisfactory service—insist upon a Condensite Celoron Panel.

Make Your Next Panel of Condensite Celoron

If your local radio dealer cannot supply you with a genuine Condensite Celoron Panel get in touch with us direct. We'll see that you are supplied.

An Opportunity for Radio Dealers

Condensite Celoron Radio Panels offer a sales opportunity unequalled to the live wire dealer who is keen on building business on a quality basis. Write us today for our special Dealers Proposition and let us give you all of the facts.

Diamond State Fibre Company
Bridgeport (near Philadelphia), Pa.
Branch Factory and Warehouse, Chicago

Offices in principal Cities.
In Canada: Diamond State Fibre Co., of Canada, Ltd., Toronto.

Order NOW For Fall

DISTRIBUTORS FOR
Radio Corp. of Amer.
 Westinghouse
 General Electric

Frost	Kellogg
Remler	Acme
Fada	Homcharger
Murdock	Signal
General Radio	Pacent
Brandes	Rham-tine
Baldwin	Connecticut
Burgess	Arkay
Hipco	Radio Service
Chelsea	Tuska
Holtzer-Cabot	

Clapp-Eatsman
 and other
 leading manufacturers

When vacation time is over and the days get shorter, Radio is going to take its place again in filling up the long, chilly evenings both in the city and on the farm. There will be big demands for both parts and complete sets. Will your stocks be up-to-date and able to take care of all this trade?

Now is the time to put your stock in order for Fall, not at the last moment, when we are rushed with orders and deliveries may not be so prompt. Order Now. Today. Our new, illustrated Catalog No. 200T will help you. Send for it.

WHOLESALE ONLY



LUDWIG HOMMEL & CO
 530-534 FERNANDO ST.  PITTSBURGH, PENNA

McTIGHE ALKALINE STORAGE "B" BATTERY

for RADIO OUTFITS



The McTighe Storage "B" Battery is the most satisfactory for radio use. It gives 22 volts, is in-expensive--noiseless--cannot be damaged by short circuit, overcharging, standing idle or un-charged. Can be fully charged from any light socket for less than one cent. Is furnished in an oblong glass case which nests neatly. The McTighe Rectifier is cheap, simple, durable, and effective, and should be used when charging the McTighe "B" Battery.

Battery \$5.00, Rectifier \$1.50, Rubber Filler 25c
 F. O. B. Irwin, Pa.

Discount to Dealers Address Dept. Q Prompt shipments

ECONOMIC APPLIANCE CO.
 IRWIN, PENNA.

Agent for the



COLUMBIA RADIO SUPPLY CO.
 808 19th St. N. W.
 Washington, D. C.

DX RADIO FREQUENCY TRANSFORMER

Be up to date, use R.F. Amplification and coil aerial. The secret of long distance reception. We know it is superior, prove it for yourself. Free folder on principles of radio frequency amplification with pictorial diagram.

DX 1—170-450 meters \$8
 DX S—400-1200 meters \$8
 DX 2—900-3000 meters \$8
 Plug-in socket mounting \$1

Dealers Write



American Electric
 HIGH EFFICIENCY
 TELEPHONES

"Army and Navy" and
 Swedish-American Types

American Electric
 COMPANY

CHICAGO, U. S. A.

For 30 Years Makers of Good Telephones



The A. C. AMPLIFIER for the AERIOLA SR.

AERIOLA AMPLIFIER

*Model AC, complete with
2 WD11-A vacuum tubes
(without batteries) \$68.00*

*Vocarola Loud-Speaker
Model LV.....\$30.00*



*This symbol of quality
is your protection.*

*Before buying radio ap-
paratus, always consult
the book "Radio Enters
the Home." Price 35 cents
by mail.*

The Aeriola Sr., simplest and most efficient of all single-tube receiving sets, becomes still more efficient with the new model A C amplifier.

No storage battery is required. With only two dry cells, two tubes, and a 45-volt plate battery the model A C amplifier greatly increases the Aeriola Sr.'s range of reception. Used with the Vocarola loud-speaker, the amplifier connected with an Aeriola, Sr., fills a whole room with concerts received over distances of ten to thirty miles.

Anybody can make the simple connections required, including mother and the girls.

Because there are no storage batteries to charge, because both the Aeriola Sr. and this new model A C amplifier are so light and handy the combination is ideal for Boy Scouts and for campers.

Radio  **Corporation**
of America

Sales Department, Suite 2068
233 Broadway,
New York City

District Office
10 South LaSalle Street
Chicago, Ill.

KING Rheo-Socket

Another RADIO SURPRISE

Price \$3, f. o. b. New York City

Compact, increased efficiency, shorter connections, less wiring — brings in stations you never heard before. Make this a part of your up-to-date set.

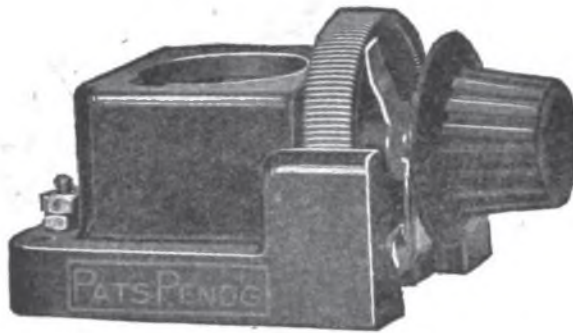

A high grade article in Red Bakelite with Phosphor-Bronze Contacts and Alloy Resistance Wire.

For Base or Panel Mounting

KING AM-PLI-TONE

82 CHURCH STREET

NEW YORK

Mfra. of the Famous KING AM-PLI-TONE

Jobbers, wire or write for proposition

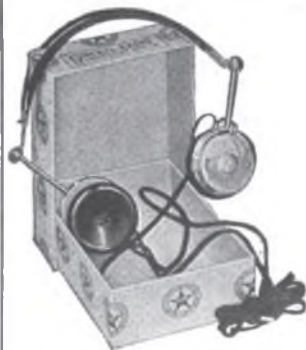

Red Star Head Phones

Why take a chance with your receiving set by using poor head phones, for after all your radio receiving set is no better than your head phones.

Red Star head phones speak up sharp and clear. Light in weight, they fit the head comfortably and do not tire; they are easily adjusted over the ears.

Protect your receiving set, by buying good head phones—ask your dealer to show you Red Star phones. You will be surprised at the results you will attain.

Monocoil 2000 ohm—\$5.00

Long-distance 3200 Ohm—\$8.00

Including head band and 6 ft. cord.

General Radio Equipment Co.
1133 Diversey Pkway., Chicago



Leadership Established!

During the last two years, this school has set up new New England records for

- (a) Number of graduates
- (b) Average of marks
- (c) Average length of time required.

In qualifying for a First Class Commercial Operators' license.

This clearly established leadership in New England places our school among the foremost in the country.

Send for our New Catalog Free

MASSACHUSETTS RADIO and TELEGRAPH SCHOOL, Inc.
18 Boylston St. Boston, Mass.

Formerly Boston School of Telegraphy. Est. 1908

Wimco Announces

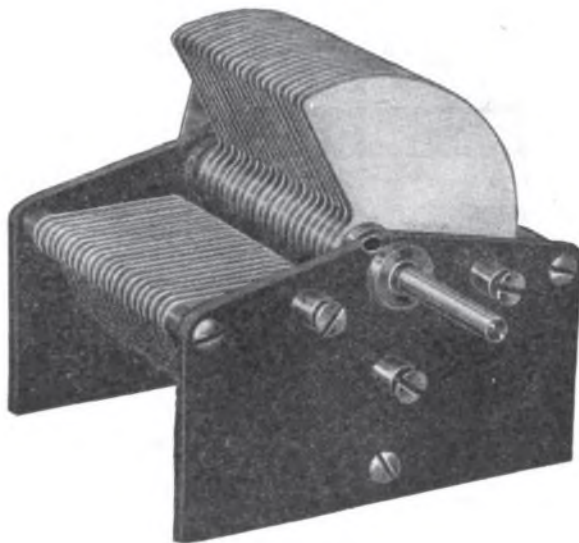

THE WIMCO VARIABLE CONDENSER

After months of experimentation to produce a really good Variable Condenser, we take pleasure in introducing to the trade The WIMCO Variable Condenser, which will be furnished in 43, 23 and 3 plate type. Tests conducted by the Washington Radio Laboratory show that The WIMCO Variable Condenser of the 43 plate type has a resistance, at maximum capacity, of but .018 ohms, and the capacity at zero on the scale is but 15 micro-microfarads. These values, we believe, are lower than in any other condenser manufactured for general amateur use.

The WIMCO Variable Condenser is now in production and your orders will have our best attention.

We have a very attractive proposition for the Jobber, and solicit your inquiries. Write for complete price list and discount sheet.

THE WIRELESS MANUFACTURING CO.
CANTON, OHIO

Manufacturers — Distributors

GIBLIN Audio Frequency Amplifying Transformer

Designed for use with standard amplifying tubes.
Maximum amplification without noise and distortion.
May be placed in any position without pre-magnetic coupling or squealing.

C
O
M
P
A
C
T

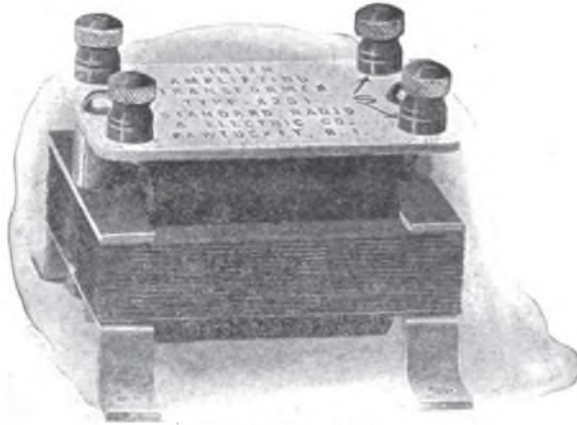

E
F
F
I
C
I
E
N
T

Mounted Type A 201

LIST PRICE **Mounted \$4.50** **Unmounted \$3.50**

Liberal Discounts Allowed

Also Giblin "Radioear" Vacuum Tube Receiver with one tuning control knob and two stages of amplification. List Price, \$50.00.

Giblin "Radioear" Crystal Receiving Set. List Price \$20.00.

STANDARD RADIO AND ELECTRIC COMPANY
Pawtucket, R. I.

BACK MOUNTED INDUCTANCE SWITCH

Use
The
Best

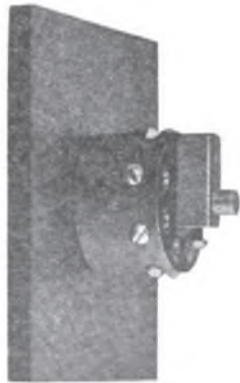

Forget
The
Rest

Pat. Appl'd For

In our new Back Mounted Inductance Switch we have the very latest and improved switch. Body is made of Fibre, with Bakelite Knob, and all other parts Brass. It insures perfect connection and eliminates short circuiting. Saves Labor and Time in putting set together. Saves drilling of numerous holes and does away with switch points and lever on front of panel. It is one compact unit all ready to put on panel.

LIST PRICE \$1.25, PARCEL POST PREPAID

Send Circular for this and Other

"RACCO PRODUCTIONS"

RADIO CONSTRUCTION CO.

42 Maverick Square, East Boston, Mass.

1898—1923

**25 Years Experience
In Head Phone Equipment
YOUR GUARANTEE**

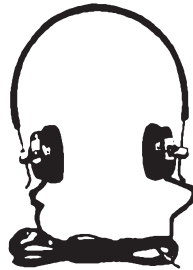

You will be delighted at the clear, distinct, ring of the message received over the Leich Radio head phones. This company began making head sets in 1898—thus the refinements and improvements of years of actual service tests are incorporated into the Leich head phones.

The head band is light—both ear phones fit evenly and firmly, and can be worn for hours without discomfort—the band can be adjusted by the thumb nut, and remains fixed—no readjustment necessary.

No. 1-D-1500 ohms \$7.00
No. 1-B-2000 ohms 7.50
No. 1-C-3000 ohms 10.00

Complete with head band and 6 ft. cord.

Ask your dealer—if he cannot supply write us.

LEICH ELECTRIC COMPANY
GENOA, ILLINOIS

AT LAST QUALITY at the RIGHT PRICE

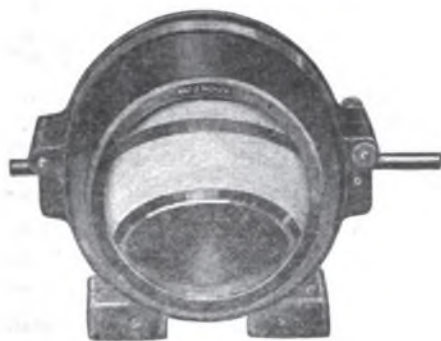

R.P.C. Condensite molded Variometer. Wave length 150 to 500 meters. Heavy Brass Bearings 1/4" Shaft. Not Only Electrically Perfect But Mechanically Right.

Variometer Price - - \$6.00
Vario Coupler - - \$6.50

Something different in Dials. Has large tapering knob which will not cramp the hands. Heavy brass insert bearing insuring perfect fit and alignment. Semi-circle slot for stop pins. Large clear lettering. Easily read. Made for 3/16" and 1/4" shafts. State size when ordering.

Price - - \$1.00

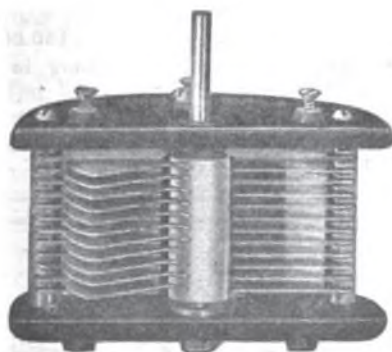

The method of casting both the Rotary and Stationary Plates as solid units, guarantees perfect contact at all times, insuring accuracy in assembly and capacity. Made with specially heavy plates. Pivoted on friction spring which makes a smooth movement with minimum resistance while exerting a counter balancing effect on rotary plates. Special pillars allow either table or panel mounting. We draw your attention to the extremely low price of this particular class of Condenser.

23 Plate .0005 M.F.D. - Price \$3.00

If your dealer cannot supply you we will ship you postpaid on your order with remittance.

Catalogue on Request.

Special Dealers Proposition.

RADIO PRODUCTS COMPANY

WESTPORT, CONNECTICUT

ALWAYS MENTION Q S T WHEN WRITING TO ADVERTISERS

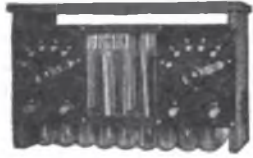

Storage Batteries

designed for

RADIO



KICO "B" BATTERY

KICO "A" BATTERY

FACTS ABOUT KICO STORAGE "B" BATTERIES—

1. Alkaline type.
2. They eliminate noises caused from "Bs" that are rapidly deteriorating.
3. The switch control allows single cell variations from 12 volts up. (A critical plate adjustment is essential on your detector bulb for C.W. and Radiophone reception.)
4. Rechargeable from your 110 Volt A.C. line in connection with the rectifier supplied with each battery.
5. Will last from three to six months on a single charge while in the detector plate circuit.
6. NOT an experiment. All batteries sold with the privilege of receiving your money back if unsatisfied within a 90 day trial.
7. Neat, Efficient and Compact.
8. Unlimited life.

	Plain	With Panels
16 cell 22 volts	\$6.50	
24 cell 32 volts	8.00	\$12.00
36 cell 48 volts	10.00	14.00
50 cell 68 volts	12.00	17.00
78 cell 100 volts	16.00	21.00
108 cell 145 volts	21.00	26.00

Literature gladly furnished.

KIMLEY ELECTRIC CO., 1355 Fillmore Ave., BUFFALO, N. Y.

Try REYNOLDS RADIO Service

from DENVER

9ZAF

KLZ

Clapp-Eastham H R Receiver . . . \$40.00
 Kennedy Type 281 Receiver . . . 80.00
 Kennedy Type 220 Receiver . . . 125.00
 Kennedy Type 110 Receiver . . . 250.00

Grebe CR5 Receiver \$80.00
 Grebe CR8 Receiver 80.00
 Grebe CR9 Receiver 130.00

Accessories, Supplies—Everything in Radio

Send 15c for our new RADIO GUIDE—Refunded on first order amounting to \$5.

REYNOLDS RADIO CO. INC. **1534 Glenarm St., DENVER, Colo.**
 LARGEST DISTRIBUTORS OF RADIO APPARATUS IN THE WEST

"SHRAMCO PRODUCTS"

Amateurs: Send 5c in stamps today for our new Catalogue L showing complete line of parts, raw materials and high grade apparatus.

Dealers: Write for our attractive proposition.

The Shotton Radio Mfg. Co.,
 INCORPORATED
 8 Market St., Albany, N. Y.



SOUTHERN RADIO CORPORATION
 Radio Engineers and Jobbers
 905 Realty Building, Charlotte, N. C.

At Last! *The Perfect* Radio Loud Speaker *for the Home*

THERE is no other Loud Speaker like the DICTOGRAPH—made expressly for home use by the makers of world-famous Dictograph products—standard everywhere for the finest, most accurate and most sensitive sound-transmission and loud-speaking devices. No other organization in existence has the facilities, the skill, the experience of the Dictograph Products Corporation for producing a perfect Loud Speaker.

DICTOGRAPH Radio LOUD SPEAKER

Years of experience in producing the marvelously sensitive "Acousticon" for the Deaf, the Detective Dictograph and the Dictograph System of Loud-Speaking Telephones have made possible this wonderful Radio Loud Speaker that reproduces every sound—singing, speaking, instrumental music—in crystal-clear, natural tones, full volume, and **FREE FROM DISTORTION AND NOISE.**

The Dictograph Radio Loud Speaker gives perfect results with any vacuum tube receiving set. No alterations; no extra batteries—you simply plug in and listen. The handsome appearance of this quality instrument harmonizes with any home.

Ask for a **FREE DEMONSTRATION** of the Dictograph Radio Loud Speaker at any reliable radio shop. Get DICTOGRAPH quality and still save money.



List Price
\$20

Complete with 5 ft. flexible cord.
A beautiful instrument! Finely constructed, richly finished. Its handsome appearance harmonizes with any home. Highly burnished, French lacquered, eleven inch spun copper bell horn attached to die cast black enamel tone arm, finished with nickel trimmings. Cabinet 6x6 inches base, 4 inches high, of solid, ebony-finished hardwood, mounted upon rubber knobs. Furnished complete with 5 ft. flexible cord. No extra batteries required.



3000
Ohms

Price
\$12.00

DICTOGRAPH Radio HEAD SET

The Best Head Set at any Price

The Dictograph Radio Head Set has established a standard of quality impossible to secure in any other head set. Its use on any receiving set, crystal detector or vacuum tube, improves reception immeasurably.

3000 ohms resistance. Price \$12.—the best Head Set in the world at any price. Regularly furnished as Standard Equipment with the Leading Receiving Sets made.

Dealers: Order through your jobber or write for names of authorized distributors.

Dictograph Products Corporation

220 West 42d Street,

Branches in all principal cities

New York City

SOUTHWESTERN AMATEURS

We are about to pass out of the long hot summer and hit the pace once again for a real winter of hi-pressure wireless activity. We wonder if you have ever stopped to think of the service that might be rendered you by this store.

We are thoroughly capable, being the oldest exclusive radio store in the Southwest, and have six licensed operators at your service. We are proud of that. Give us a trial.

THE SOUTHWEST RADIO SUPPLY COMPANY

1812 Main Street,

Dallas, Texas

"Pioneers in Radio"



DONGAN

RADIO FREQUENCY TRANSFORMERS

are unexcelled for radio frequency amplification. The adjustable silicon core, (a patented feature) enables accurate tuning of the grid and plate circuit to the frequency of the incoming signals.—**THE PEER OF THEM ALL.**

DONGAN

AMPLIFYING TRANSFORMERS

embody the DONGAN standard of high grade workmanship throughout. Scientifically constructed. — Reasonable in price—Neat in appearance. Manufactured in ratios of 8-1 and 3½-1.

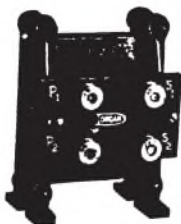

Manufactured By

DONGAN ELECTRIC MFG. COMPANY

2983-2993 Franklin St.
DETROIT, MICH.

—Western Distributors—

SIERRA ELECTRIC COMPANY

801-804 Roberts Bldg., Los Angeles, Calif.
515 Market St., San Francisco, Calif.

"Superlative" Amplification

You Can Increase Your Range

Eliminate Howling and Distortion

Bring out the full clear tone in volume

No. 41

WITH

JEFFERSON Amplifying Transformers

Furnished in two types either mounted or unmounted. Coils specially wound with No. 40 and No. 44 wire on a core of the finest rolled Silicon steel.

SEND FOR RADIO BULLETIN

PROMPT DELIVERIES

Jefferson Electric Mfg. Co.

425 S. Green Street,

Chicago

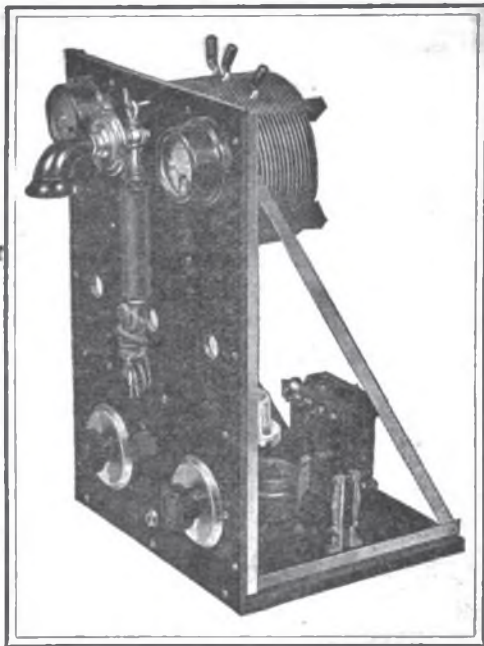

**The BENWOOD
CW Transmitter**

Simple, compact, up-to-the-minute construction--incorporating all the improvements made possible by our years of experimenting and it gets results!

1500 Miles With CW!

1100 Miles Voice!

**Music Heard 40 Feet From Phones by
Stations in 300 to 400 Mile Radius**

THESE are actual results obtained by our testing station WEB using the Benwood CW Transmitter shown herewith. You can get just as good results with it. This high-class set is just the thing for your broadcasting and DX work—using CW, ICW, Modulated Buzzer or Voice Transmission. An ideal set for the local radio club or the more progressive amateur. Think of the range this set will give you! If centrally located, you will be heard in almost every state in the Union. It is manufactured exclusively by and for the Benwood Co. and combines the best in material, workmanship and design.

Radiates 1½ to 3 Amps on Average Antenna

We guarantee that this outfit will radiate 1½ amperes on the average amateur antenna when assembled in accordance with our instructions. It will radiate 2 to 3 amperes when used with an antenna whose fundamental wave length is 225 to 275 meters. That is why you can get such wonderful results. The set comes to you completely assembled with all parts mounted on panel, as shown, but not wired. Full instructions and wiring diagrams are furnished. You can wire it and start sending in less than an hour after you receive it. The outfit is complete with motor generator minus tubes, and consists of the following: Panel 12x18x½, angle supports, hardwood base, 3 tube sockets, 1 power rheostat, 1 80 watt filament trans., 1 modulation trans., 1 CW inductance, 1 hand transmitter, 1 0-3 Radiation meter, 1 0-500 milliammeter, 1 21 plate condenser, 1 43 plate condenser, 1 tapped condenser, 1 L300 choke coil, 1 2000 volt filter condenser, 1 10,000 ohm grid leak, plug and jack connection for microphone buzzer and CW, 1 600 volt 220 watt motor-generator. Boxed for shipment, \$350.00 f. o. b. St. Louis, Mo.

CATALOG: Send 10¢ in stamps for the Benwood catalog and price list, also complete catalog and price list of DeForest radio equipment.

DEALERS: We manufacture a complete line of radio apparatus. We have stock on hand and ready to ship. Write or wire for our attractive proposition. New price list just issued.



1114 OLIVE STREET

ST. LOUIS, MO.

ALWAYS MENTION Q S T WHEN WRITING TO ADVERTISERS

137

**The
Standard Idea
Assembled - But
Not Wired**

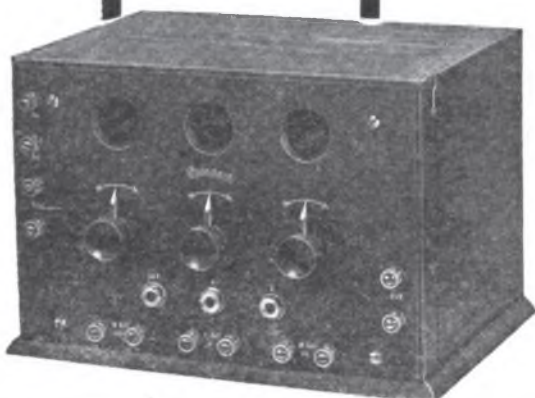

BUY your radio instruments in this new way—*this cheaper way*. Adopt the popular STANDARD IDEA and purchase high-grade instruments, including our Detector and Two-Stage Amplifier and our Multiple Wave Tuner, completely assembled — *but not wired*. You do the wiring yourself, according to simple directions, and save at least 20% in cost.

The wiring of instruments is the most expensive operation in our factory but when you do the job in your spare time you eliminate this costly hand labor and enable us to sell you the instrument at a great reduction. Thousands of fans are now following the STANDARD IDEA.

Ask us today for literature and prices and information regarding our offer to send any instrument for inspection on receipt of 1/3rd the purchase price.

Standard Assembling Co.
6 Stone St. NEW YORK, N. Y.

"East and West, the Globe is Best"

**GLOBE
RADIO HEAD PHONES**



Highly sensitive
Matched receivers
Natural in tone
Each receiver tested
by radio
Lightweight (11 oz.)
Comfortable to wear
Will not distort signals, when amplified
Articulation perfect

2200 ohms List price only \$9.00

There are many types of head sets on the market but not too many good ones. The GLOBE RADIO HEAD SET incorporates a knowledge of acoustics based on nearly fifteen years of experience in making high grade sound producing and receiving instruments. It embodies correct design with the best of materials. The Globe Phones are for those who discriminate.

Ask about the Globe Antenna Attachment Plug for connecting your radio set to your electric light circuit.

Buy from your local dealer, or write us direct.

GLOBE PHONE MFG. COMPANY

Earl C. Hanson, Technical Radio Expert
READING, MASSACHUSETTS, U. S. A.

**2nd DISTRICT
OPS!**

Have you seen the 2nd. District magazine?

Do you know what your friends are doing?

Are you interested in club doings and real "How to Make It" articles?

IF SO, you had better subscribe NOW to

THE MODULATOR

It's only a dollar a year, or ten cents a copy. Published every month by

The Executive Radio Council,
2nd District

120 Liberty St., New York, N. Y.

Condensite



INSULATION is rarely subjected to more trying conditions than in radio. The high potentials used in sending, the varying climatic conditions, from the cold of the arctic to the heat of the equator, from the dryness of the desert to the saturated air of the tropics; the rough usage encountered at the hands of the unskilled, the remoteness from means of repair and replacement; all these and numberless other trying conditions make it imperative that for radio work the best insulation should always be used.

Condensite is the name of the insulation which will withstand these conditions, and which possesses all the properties essential to radio insulation.

Upon request we will send the list of radio manufacturers who make their equipment of Condensite.

Condensite Company of America
Bloomfield, N. J.

RHAMSTINE*

RADIO FREQUENCY TRANSFORMER

The Rhamstine* Radio Frequency Transformer brings to the radio enthusiast a highly efficient unit, handsome in appearance, convenient in mounting and wiring and surprisingly modestly priced.

The Type 1 R.F. Transformer has a range of 200 to 500 meters—giving best results at the present broadcasting wave lengths. The transformer is fixed in the base with bayonet mounting, so instant changes of transformers for other wave lengths can be made.

In quality and performance, it leaves nothing to be desired; and its price makes it first choice in the field.



Pat. Apd. For

\$4.50
Postage 10c

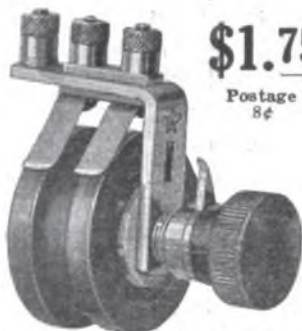

\$1.75
Postage 8c

Carbon Element POTENTIOMETER

A Potentiometer in the circuit of a radio frequency set is necessary if full results are to be attained; and the Rhamstine* Carbon Element Potentiometer gives, we believe, a more uniform variation of potential than any other. It has all the advantages of the usual carbon element, yet it is unbreakable. Made for panel mounting.

Send Today for Descriptive Folder

J. THOS. RHAMSTINE*

2152 East Larned Street,

Detroit, Mich.

*Maker of Radio Products

Pat. Apd. For

For REAL Service

Mail your orders to us. We can supply you with the BEST at the BEST PRICES. Shipments made within 24 hours after receipt of order.

CATALOGUE
\$22
AT YOUR
SERVICE

THE SERVICE RADIO EQUIPMENT CO.

Designers—Manufacturers—Distributors

225 SUPERIOR ST.,

TOLEDO, OHIO

Our Radio Department is conducted by electrical engineers, which assure you dependable and highly efficient Radio equipment, either in complete sets or separate units, such as Head Receivers, Variocouplers, Variometers, Cabinets, Detectors, Antennas, Rotary Spark Gaps, Sliders, Panels, Dials, Knobs, Condensers, Grid Leaks, Contacts, Galena Crystals, etc. We especially recommend our popular Receiving Set, RESODON, which is one of the most desirable outfits for the home, club, etc. This set comes in a beautiful mahogany finished cabinet. Write for literature.



PAUL G. NIEHOFF & CO., Inc.
Electrical Laboratories and Manufacturers
238 E. OHIG ST., CHICAGO, ILLINOIS



ATTENTION RADIOTICS

IF YOU USE AMPLIFYING TUBES you can make your Victor talking machine a RADIO LOUD SPEAKER, with a "BEEKO" Radio-Phone attachment.

Sample by mail, 40c.

Liberal discount in quantities

J. H. BUNNELL & CO.

32 Park Place, Department Q New York



HEAD TELEPHONES

INCREASE THE EFFICIENCY OF YOUR SET

By Equipping It With

Federal PARTS

Federal Head Telephones

have earned their great popularity. Made by a company that knows how; of best materials adapted to this use; being light in weight and carefully MATCHED IN TONE They most perfectly reproduce RADIO SIGNALS.

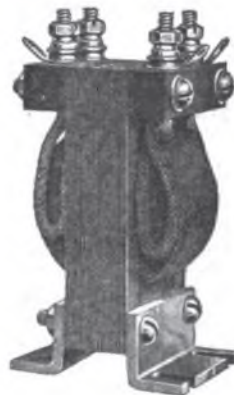

No. 226-W

AUDIO FREQUENCY TRANSFORMER

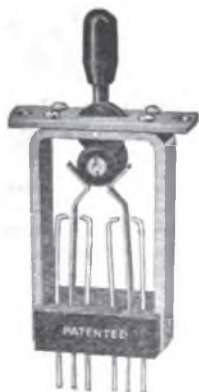

ANTI-CAPACITY SWITCH

THE GOOD DX WEATHER

WILL SOON BE HERE. Don't forget to add the NO. 226-W AUDIO-FREQUENCY TRANSFORMER TO YOUR SET. You will be pleased with the result.

You will need other parts such as ANTI-CAPACITY SWITCHES, VACUUM TUBE SOCKETS, RHEOSTATS, POTENTIOMETERS, CONDENSERS, JACKS, PLUGS, KNOBS and DIALS, GRID LEAKS, Etc.

For Best Results Be Sure You Get

GENUINE Federal



No. 5 TELEPHONE SHUNTING CONDENSER

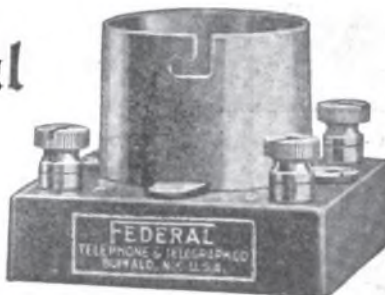

No. 16 V. T. SOCKET

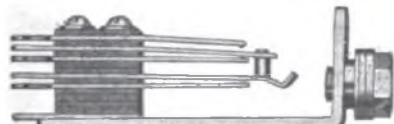

No. 1438-W FILAMENT CONTROL JACK



No. 15 PLUG

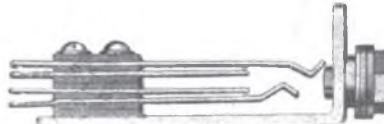

No. 1423-W DOUBLE CIRCUIT JACK

Federal Telephone and Telegraph Company
BUFFALO, N. Y.

WRITE FOR BULLETIN No. 115-W and No. 119-W.

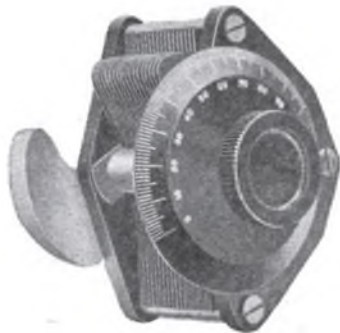

#3 Price \$4.75

CHELSEA Variable Condenser

(DIE-CAST TYPE)

No. 1—.0011 m.f. mounted.....	\$5.00
No. 2—.0008 m.f. mounted.....	4.50
No. 3—.0011 m.f. unmounted.....	4.75
No. 3a—.0011 m.f. unmounted, without dial.....	4.35
No. 4—.0008 m.f. unmounted.....	4.25
No. 4a—.0008 m.f. unmounted, without dial.....	3.85

Top, bottom and knob are genuine bakelite, shaft of steel running in bronze bearings, adjustable tension on movable plates, large bakelite dial reading in hundredths, high capacity, amply separated and accurately spaced plates. Unmounted types will fit any panel and are equipped with counterweight.

Guaranteed for circuits up to 1,000 volts.

Amplifying Transformer No. 50

The Chelsea Amplifying Transformer gives the highest amplification possible and at the same time will not squeal, howl, or in any way cause noisy circuits. It is beautiful in design and embodies electrical characteristics unequalled by any. Guaranteed for all circuits up to 500 volts with a high safety factor.

It will not fail in service.

Purchase Chelsea Radio Equipment from your dealer. If he does not carry it send to us.

Write for our new \$8 catalog.

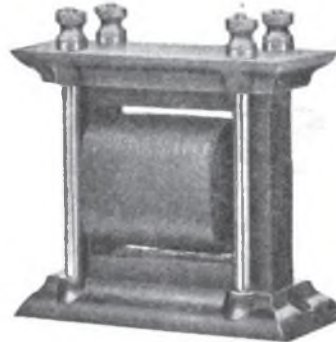

Price \$4.50

CHELSEA RADIO CO., 150 FIFTH ST., CHELSEA, MASS.
Manufacturers of Radio Apparatus and Moulders of Bakelite and Condensers

SIMPLEX—that's your safeguard



VARIOMETER PANEL VARIOMETER PANEL



DETECTOR PANEL AMPLIFIER PANEL
Also Unmounted Variometers & Variocouplers

Simplex Panel Units make it possible to try out any different hook-ups without disassembling panels. These highly perfected units eliminate much of the uncertainty of success in receiving radio broadcasts because they have been designed by men having years of experience in radio activities. Get them from your dealer.

SIMPLEX RADIO CO.

113-15 RIDGE AVE., PHILA., PA.



\$8.50

Complete Enjoyment of Radio Telephony

is only possible with a Telephone of the very highest standard of efficiency.

Everett Double Radio Phones

have satisfied the most exacting Critics

Supersensitive—Clear—Light

Mechanically Perfect—Moderately priced

AT ALL DEALERS

Everett Electric Corp.

320 BROADWAY, NEW YORK

WESTINGHOUSE

RADIO

⚡ BATTERIES ⚡

Eliminate all Battery Troubles from Radio Sets

The Westinghouse "A" Battery is a full capacity, low voltage, slow discharge, long-life storage battery built exclusively for radio work.

For "B" battery requirements Westinghouse has perfected a baby storage battery. No more throwing away exhausted cells. No more continuous "B" battery expense.

The Westinghouse "B" is a permanent battery. It never has to be replaced. It will discharge its load with constant, steady voltage. Then it can easily be recharged. It gives continuous service to the point of exhaustion without growing "scratchy." If your vacuum tube is inclined to be noisy you can adjust the contact on the Westinghouse "B" to take off the exact voltage the V. T. requires.

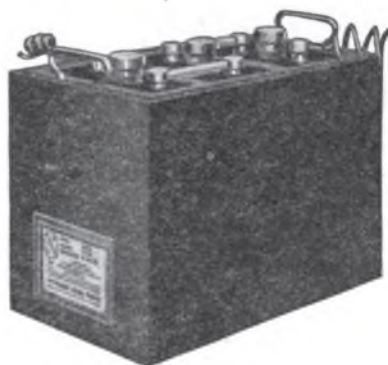

Get a Westinghouse "A" and "B" from your dealer or the nearest Westinghouse Battery Service Station and eliminate all your radio battery troubles.

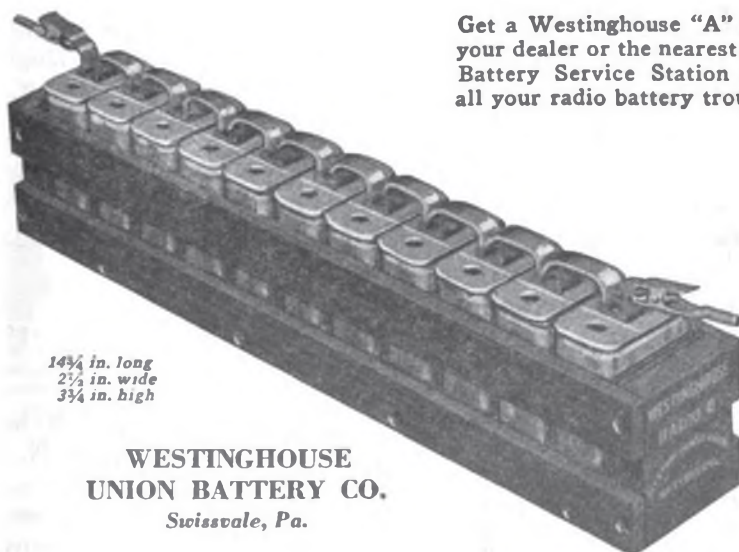

14 $\frac{3}{4}$ in. long
2 $\frac{1}{2}$ in. wide
3 $\frac{3}{4}$ in. high

WESTINGHOUSE
UNION BATTERY CO.
Swissvale, Pa.

*"The best
Westinghouse
can build."*

RADIO "A" & "B" STORAGE BATTERIES CHARGED AT HOME

FOR A FEW CENTS, FROM ANY 100 to 130 Volt 60 Cycle LAMP SOCKET, WITH AN **F-F RADIO RECTIFIER**

It Charges All 6 Volt RADIO "A & B" & Auto Batteries; & RADIO "B" Storage Batteries Up to 120 Volts. It has Unlimited LIFE at Constant EFFICIENCY, with Nothing to Slop over, Burn Out, or cause trouble and It Will Charge a Dead Battery. They Charge Automatically, Operating Unattended. Leave Battery where it is, without even disconnecting it; Screw Plug in Lamp Socket, Snap Clips on Battery Terminals; Turn Switch & Battery will be Charged in the morning. Is it not gratifying to feel that Your Radio Batteries will never fail & You are always Ready to Receive Radiophone Broadcast Music, Speech & News; never having to be careful of or to have to tell Friends that Your Batteries are

They Also Charge AUTO BATTERIES.

\$20

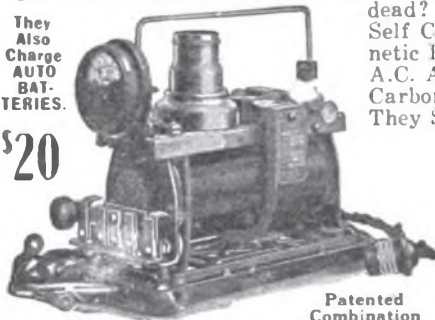

Patented Combination

dead? F-F BATTERY BOOSTERS are Complete Compact Self Contained Portably Handy Full Wave Automatic Magnetic Rectifying Charging Units, for 100 to 130 Volt 60 Cycle A.C. Also For Other Cycles. No Skill is Required. Infusible Carbon Rectifying Brushes Maintain Uninterrupted Service. They Save You 75¢ a Charge & Last a Lifetime. POPULAR PRICES:

Type 6 for 6 Volt "A" Battery, Charging at 6 Amperes \$15
 Type B Charges Radio "B" Batteries Up to 120 Volts \$15
 Type "A-B" Combination Radio Rectifier for Charging 6 Volt "A" & Auto Storage Batteries and Up to 120 Volts of "B" Storage Battery \$20
 Type 12 for 12 Volt Battery, Charging at 5 Amperes \$15
 Type 166 for 6 Volt Battery, Charging at 12 Amperes \$20
 Type 1612 Charges 12 volt Battery at 7 amperes \$20
 Type 1626 is a Combination of Both Type 166 & 1612 \$28

Eventually You Will Buy An F-F Rectifier. Why Not Now? It Costs You Less To Buy a Booster Than To Be Without One All Types But B charge Auto Batteries. The Larger Types are for heavy Batteries, or Where Time is limited. Shipping-Weights Complete With AMMETER & BATTERY CLIPS 11 to 15 lbs. Purchase from Dealer, or Mail Check for Prompt Shipment. If via Parcel Post add Postage & Insurance Charges. Or have us ship C.O.D. Other F-F Battery Boosters charge Batteries from Farm Lighting Plants & D.C. Circuits & For GROUP CHARGING use our 12 Battery 8 Ampere Full Wave Automatic ROTARY Rectifier described in FREE Bulletin No. 31A. ORDER Now or WRITE Immediately for FREE BOOSTER Bulletin No. 31.

THE FRANCE MANUFACTURING COMPANY OFFICES & WORKS CLEVELAND, OHIO, U.S.A.

Canadian Representative: Battery Service & Sales Co. Hamilton, Ontario, Canada.

PANEL SERVICE

We offer to the amateur and dealer

REAL PANEL SERVICE.

Our panels are cut to your order. Only genuine Condensite and Formica used.

1/8" per square inch \$0.02
 3/16" per square inch .02 1/2
 1/4" per square inch .03

We also carry a complete line of radio essentials. Dealers will find it profitable to have our latest price list and discount sheet.

PITTSBURGH RADIO AND APPLIANCE CO., Inc.

"Pittsburgh's Radio Shop"

Desk B

112 Diamond St., Pittsburgh, Pa.

BRACH

VACUUM LIGHTNING ARRESTER

The Wise Amateur Radio Operator Guides by the Judgment of the Experienced Engineer—He Depends Upon the BRACH Lightning Arrester.

The Brach Arrester robs lightning and static of its terrors and nullifies interference with reception of signals and voice currents.



Outdoor Type—\$3



Indoor Type \$2.50

L. S. BRACH MFG. CO.
 Newark, N. J.

Makers Of Solderall Mends Wires.

16 Years Specialists in Lightning Protective Apparatus.
 COAST REPRESENTATIVES— Pacific States Elec. Co., San Francisco, Los Angeles, Oakland, Seattle, Portland, Spokane.



Means RADIO Satisfaction

Radio equipment—whether you construct your own apparatus or buy the “custom-made” outfit—must be **made right**, or you cannot expect lasting satisfaction.

SIGNAL parts and sets are the product of a plant and an organization whose experience in making Radio equipment dates back to the earliest days of “wireless.”

There is seasoned knowledge and experienced handicraft built into every item of the SIGNAL line. Each piece will give you the service you have a right to expect.

Ask for SIGNAL when you want Radio parts or Radio sets and insure yourself against that “most embarrassing moment” when something goes wrong, just as you expect to entertain your friends.

For sale by dealers everywhere. Accept no substitutes.



We this month reproduce a picture of the **Signal Back Mounted Variable Condenser** because you cannot be told too often nor too much about it. Just one item of the Signal Line, it is quality through and through, built to be banged around more than the ordinary type condenser. We build Signal Condensers in three models to permit mounting on panels from $\frac{1}{8}$ to $\frac{3}{8}$ inches thick. Each instrument has metal scale calibrated to 180°. Knob and pointer are removable. The material in the aluminum plates is thicker than usual.

For convenience use this coupon; get it off to us today.

SIGNAL
Electric Mfg. Co.
1915 Broadway
Menominee, Michigan
33 So. Clinton St., Chicago
(1856A.)

COUPON

Send me the new Signal Wireless Bulletin W.

Name

Company

City

State QST



Stands for

Dependable Radio Equipment

TELMACOPHONE

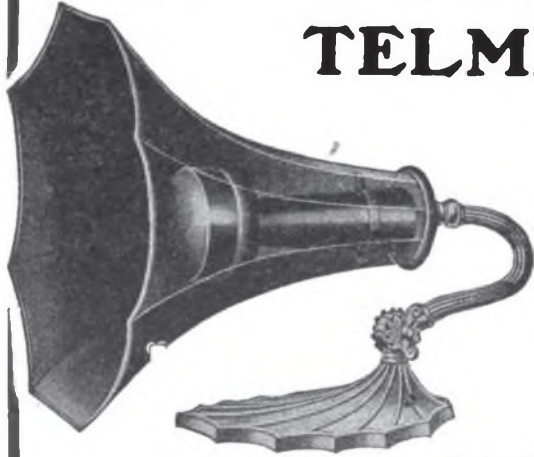

A Telmaco product for Which We Are Having A Phenomenal Demand.

Scientifically Constructed.

Unreservedly Guaranteed.

Reasonably Priced.

Complete with Type C. Baldwin Unit Attached—**\$20.00.**

DEALERS: We are distributors for nearly all standard lines. Full discounts on the Telmacophone. Write for proposition on our complete line.

Radio Division

TELEPHONE MAINTENANCE CO.

20 S. Wells Street,

Dept. D.

Chicago, Illinois

ARE YOU PREPARED?

We can supply you with anything on the market for that C.W. set you are going to use.

C us about CW

Catalog 5c

Anthracite Radio Shop

P. O. Box 3 Scranton, Penna.

**CHASLYN PATENTED
"SINK-OR-SWIM"
BALL BATTERY TESTER** \$1.00

Specific gravity shown instantly by floating or sinking of colored balls. Accurate — Simple — Won't break if dropped. Tester, Water Filler and Depth Gauge—*All for a Dollar Bill.* Send One Dollar and your dealer's name and address and set will be mailed you.

The Chaslyn Co.
4317 Kenmore Ave., Chicago



Green—Live
White—Night
Red—Dead

The **O.W.L. WIRELESS LABORATORIES**

THE O.W.L. RHEOSTAT

Patents pendings

An instrument of real Value, NO THERMO-ACTION resulting in distortion because all parts are made of the same resistance alloy throughout.

PRICE - - \$1.00

1012 Ogden Ave.,

New York City



The Willard Radio "B" Battery with glass jars and Threaded Rubber Insulation is the most practical insurance against leakage noises and leakage losses.

Why Gamble on "B" Batteries?

You're careful in soldering connections. You spend good money for additional stages of amplification. You give special attention to insulation of aerial and lead-in.

If you've gone that far, you simply can't afford to take a chance on having a leaky "B" Battery spoil it all with a bombardment of leakage noises. *You can't afford anything less than a leak-proof Willard "B" Battery.*

Every cell of a Willard "B" Battery is an individual glass jar. Jars are well-spaced to prevent leakage from cell to cell. Threaded Rubber Insulation protects the plates and thus guards against inside leaks.

Because of the leakproof feature Willard "B" Batteries are unusually quiet and hold their charge for long periods.

Ask your radio dealer or the nearest Willard Service Station to show you the Willard 6-volt Radio "A" Battery and the Willard 24-volt Radio "B" Battery.

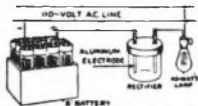

This rectifier will keep your "B" Battery charged at a cost of a few cents a month

**WILLARD STORAGE BATTERY COMPANY
CLEVELAND, O.**

Made in Canada by the

Willard Storage Battery Company of Canada, Limited,
Toronto, Ontario

Willard THREADED RUBBER BATTERY

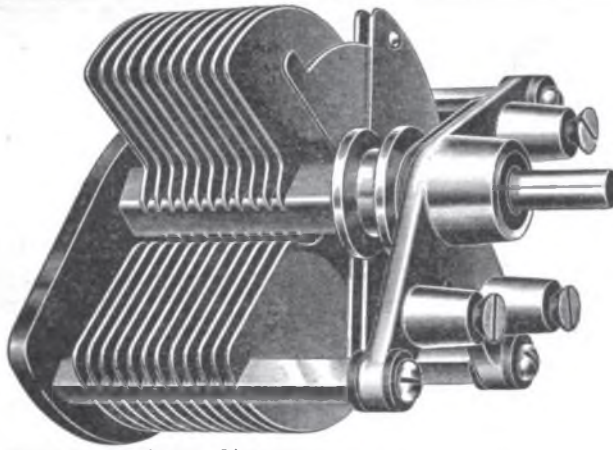

THE SEXTON CONDENSER

With Vernier control entirely eliminates the necessity for delicate tuning of a receiving set.

The single knob and dial control makes it possible for anyone to obtain desired results.

Alden L. McMurtry Licensee

PRICE—43 PLATE	\$7.00
PRICE—23 PLATE	6.50
PRICE—11 PLATE	6.00

Complete information upon request. Send Postal Card stating type of Receiving Set.

HARTFORD INSTRUMENT CO., Inc.

252 ASYLUM STREET,

HARTFORD, CONN.

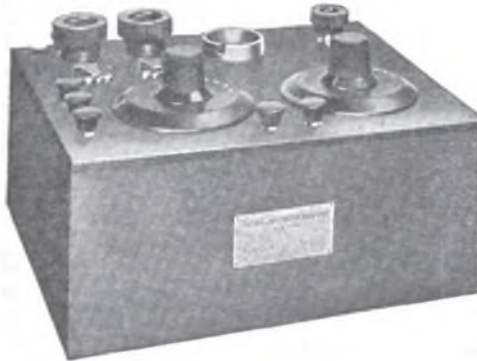

Type C & W No. 12

Manufactured By

The Cutting & Washington Radio Corp.

An ideal receiver for telephone, C.W. and spark reception.

Descriptive literature sent on request.

We handle a complete line of parts and equipment, May we serve you?

"NEWRAD"

The mark of satisfaction.

The New York Radio Laboratories

Manufacturers, Jobbers and Dealers

Dept. C. BINGHAMTON, N. Y.

Dealers:--

Your success depends on good discounts and prompt deliveries. We can assure you of both.

WE ARE JOBBERS FOR

Grebe Receiving Sets
Murdock Products
Baldwin Phones
Federal, Fada and
Radio Shop Products.

Write for Our Special Proposition "A"

**THE RADIO SHOP
— OF NEWARK —**

**41 South Orange Ave.
NEWARK, N. J.**



MURDOCK RADIO

WHEN men everywhere *insist* on Murdock apparatus, we realize that *quality* manufacture has imposed on us a *quantity* obligation, sometimes hard to meet.

Examine Murdock apparatus at your dealer's.

There are no other phones so good at so low a price. *After you have bought*, a 14 day trial privilege assures satisfaction with your purchase.

WM. J. MURDOCK COMPANY

343 Washington Avenue,
1270 Broadway,
509 Mission St.,

Chelsea, Mass.
New York City
San Francisco, Cal.

No. 56—2000 Ohm—\$5.00
No. 56—3000 Ohm—\$6.00

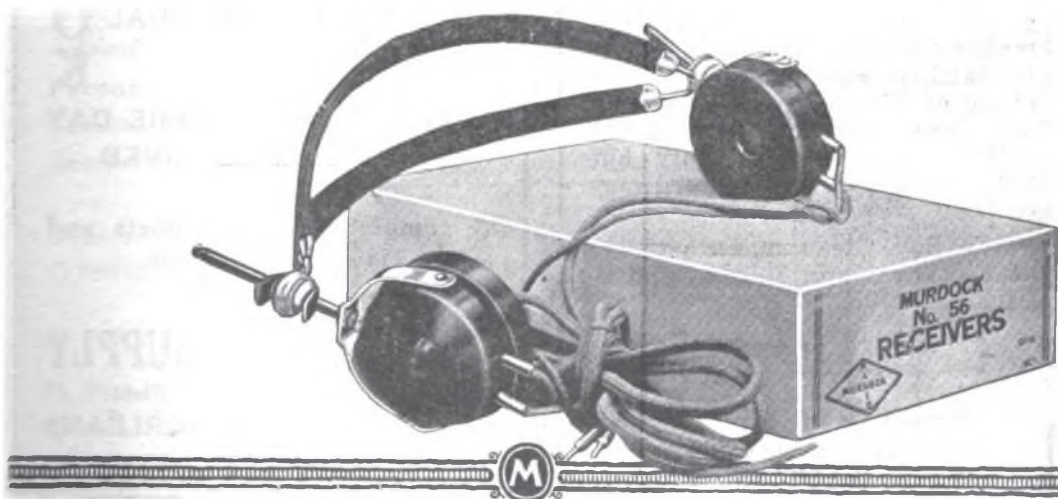

ALWAYS MENTION QST WHEN WRITING TO ADVERTISERS

149

Trade

E S C O

Mark

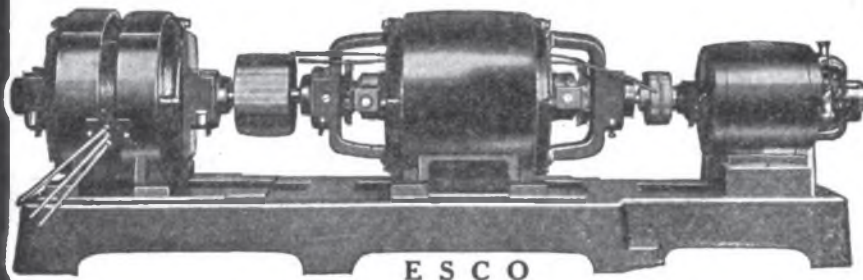

The things that have endured for ages were made of quality—the cheap things have passed on—and are forgotten.

High Voltage Motor-Generators stand pre-eminent.—Used by Leading Educational Institutions—U. S. Army & Navy Academies—Research Labs.—Newspapers—Department Stores & Broadcasting Stations.

Bulletin 237 Lists Over 200 Combinations.

Special Apparatus Developed for Special Requirements.

MOTORS — DYNAMOTORS — GENERATORS —
MOTOR-GENERATORS

Sold By Principal Dealers Everywhere

ELECTRIC SPECIALTY CO.

215 SOUTH STREET, STAMFORD, CONN., U. S. A.



WHAT'S IN YOUR PHONES ?

It is an electrical principle that the greatest effect will be produced in a magnet when there are the greatest number of ampere turns within a given space.

It is this magnetic effect, and not the resistance caused by the great length of fine wire, that makes for sensitivity in receivers. Remember, when making a purchase of Elwood Head Sets, you are obtaining receivers, with not only full ohmage capacity but with this scientific standard correctly worked out.

We have been manufacturers of Electrical and Radio apparatus since 1905.

ELWOOD ELECTRIC CO. INC.

2-4 Randall Ave., Bridgeport, Ct.

We make 3 different types in 2000 and 3000 ohm sets.

RADIOIST

↓ WE ARE NOW ↓
L LOCATED IN OUR L
O NEW HOME AND CAN O
O PROMISE OUR USUAL O
K SERVICE K

**ORDERS SHIPPED SAME DAY
THEY ARE RECEIVED**

**A complete stock of parts and
finished apparatus.**

ROSE RADIO SUPPLY

Pioneers in the Radio Field
129 CAMP ST., NEW ORLEANS

Send 10c for latest catalogue

RADIO MERCHANDISE

F. D. PITTS CO.

Incorporated

219 COLUMBUS AVENUE, BOSTON, MASS., U.S.A.

Announces a change of Policy

WHOLESALE ONLY



DISTRIBUTORS FOR

A. H. Grebe & Co. (New England)	Frank A. D. Andrea
Radio Corporation of America	Herbert H. Frost
General Electric Company	Electrose Mfg. Company
Westinghouse Electric & Mfg. Co.	Signal Electric Mfg. Co.
Wireless Specialty Apparatus Co.	General Radio Company
Magnavox Company	American Radio & Research Corp.
Clapp-Eastham Company	John Firth and Company
Western Electric Company	General Apparatus Co.
Acme Apparatus Company	C. D. Tuska Company
DeForest Radio Tel. & Tel. Co.	American Eveready Works
Federal Tel. & Tel. Company	Wireless Press
Wm. J. Murdock Company	Mu-Rad Laboratories
Adams Morgan Company	Dubilier Condenser Company
Pacent Electric Company	Weston Electrical Instrument Co.
Chelsea Radio Company	And Others
Remler Radio Mfg. Company	

Dealers are urged to send for our latest stock sheets, listing desirable radio merchandise for immediate delivery at attractive discounts.

The retail and mail order business formerly conducted by the F. D. Pitts Co. at 12 Park Square, Boston; Providence, R. I. and Springfield, Mass., is now operated by the "Pitts Radio Stores, Inc." at the same addresses.

DAYTON Radio Products

A complete and meritorious line of Radio parts with every article guaranteed for accuracy and its capacity in Micro-farads. Sold only thru legitimate Jobbers, Dealers and Manufacturers. Variable and Vernier Condensers are made of hard aluminum plates mounted on Bakelite Panels; furnished with either square or round panels.

Type 3 P. C. Vernier with Knob.....	Price \$2.00
Type 9 P. C. Condenser Cap. .0003 Mf.	Price 3.35
Type 17 P. C. Condenser Cap. .0005 Mf.	Price 3.95
Type 31 P. C. Condenser Cap. .001 Mf.	Price 4.80
Type 45 P. C. Condenser Cap. .0015 Mf.	Price 5.65
Condensers with Vernier attached 80c extra	
Variometers Bakelite Tube Type.....	Price 4.50
Variometers Moulded Bakelite.....	Price 7.50
Vario-Couplers Bakelite Tube Type.....	Price 5.00
Vario-Coupler Moulded Bakelite.....	Price 8.00
Genuine Bakelite Knobs and Dials 3"	Price 1.00
Genuine Bakelite Knobs 1/4-1/2	Price .35
Rubber Insulating Tubing (10 ft. Packages)	.45

Jobbers, Dealers and Manufacturers Write for Catalog No. 2 and Discounts

THE A-C ELECTRICAL MFG. CO.
Dayton, Ohio

Makers of Electrical Devices for Over 20 Years

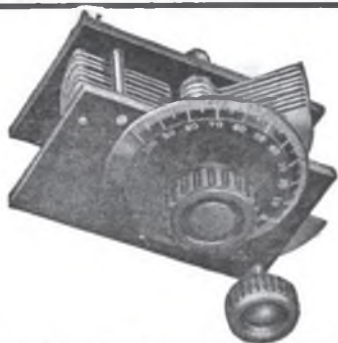

Dayton Variable Condenser with Vernier Attached

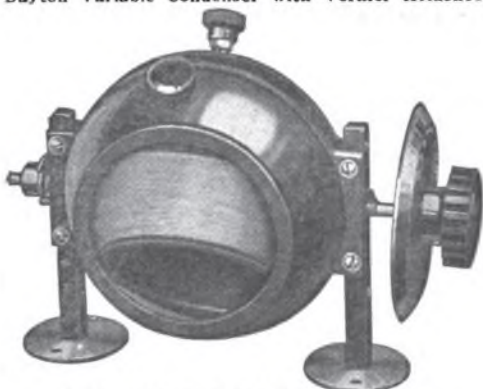

Dayton Moulded Bakelite Variometer

Super-Regenerative Circuit necessary parts and supplies AT ATTRACTIVE PRICES

Blueprint with details.....	\$.35
V. T. Sockets, 90c; Rheostats.....	.90
3" Bakelite Dials 75c; 4".....	1.15
.0005 Plate Condenser.....	3.55
.001 Plate Condenser.....	4.55
Triple Coil Mountings.....	4.75
Double Coil Mountings.....	3.55
Single Coil Mountings.....	.55
.005 Fixed Condenser.....	.95
.001 Phone Condenser.....	.35
.00025 Grid Condenser.....	.35
.00025 Grid Condenser & Leak.....	.45
1250 Coils, \$3.20; 1500.....	3.70
25 & 35 Coils, \$1.45; 400.....	1.85
Ever. B. Batt. 22 1/4, \$2.70; 45V.....	4.50
Manhattan 2000 Ohm Headsets.....	5.55
Brandes, \$785; American.....	7.65
Variometers or Variocouplers.....	3.80
Murad or DX Radio Freq. Trans.....	5.70
Thordarson Audio Transf.....	4.20
R3 Magnavox.....	42.50
Acme Choke Coil O. I.....	3.35
Wilcox 4 bulb Radio Frequency bakelite panel, white dials.....	80.00
R C Westinghouse 2 step.....	126.00
Cutting & Washington 2 step.....	118.00

All Standard makes on a money back guarantee. Prepaid anywhere in the U. S. when check accompanies order.

Standard Radio Supply Co.
1258 Park Place,
152
Detroit

ALWAYS MENTION Q S T WHEN WRITING TO ADVERTISERS

HERE

RADIO CITIZENS

Complete stocks carried for immediate shipment of the following apparatus:

Grebe Murdock
DeForest Adams-Morgan
Acme Radio Corporation
C. Brandes, Inc.
Federal Telephone & Telegraph Co.

FREE BULLETINS PRICE LIST

Get the new lowest prices on apparatus and supplies. Bulletins and price lists mailed FREE on your request. Send for them today.

Nash Electrical Service Co.
Marshall, Ill.

'RED-HEADS'

A Triumph in Radio Receiver Design



3000 ohms, complete with cord and military head-band.

—NOW
\$6.50

At the new price of \$6.50 per pair, "Red Heads" represent today's biggest value in radio headsets

SPECIFICATIONS

EACH "Red Head" receiver is wound to 1500 ohms (3000 ohms per pair) with highest quality electrolytic copper on accurately ground pole pieces attached to the best magnet steel procurable for the purpose. Machine-finished aluminum backs with strain posts and nicked binding posts. Ear caps of scientific design, moulded from our special red-brown composition, comfortably fitting the ear. High quality, fully adjustable military type head-band with seamless tape binding. Green mercerized cord. Careful workmanship and distinctive appearance. *Fully guaranteed.*

IT'S A FACT THAT

"RED-HEAD" 'Phones at \$6.50 are the lowest priced, high-grade, 3000-ohm, aluminum cup receivers on the market. The new price is possible only because of greatly increased production and cleverly improved facilities. Not one iota of quality has been sacrificed.

The same super-sensitive, clear-toned "Red-Head" Receivers—tested and approved for seven years by the critical amateur fraternity—originally priced at \$12.50 and then \$8.00—are now available at the markedly reduced list price of \$6.50.

"RED HEADS" WILL BE THE POPULAR RECEIVERS THIS SEASON

For sensitiveness, for mechanical perfection and for durability, "Red Heads" easily surpass any 'phones ever offered at anything like the \$6.50 price. Their genuine merit has created a country-wide demand for "Red Heads." The new low price will vastly increase their popularity everywhere. At your dealer's, or sent direct on receipt of price.

Newman-
Stern
Bldg.

The Newman-Stern Co

Cleveland,
Ohio

N.B.

Have you observed how the Teagle line of radio products is coming to the front? "Demonstrated merit" is the reason. We are the producers of Teagle Rheostats, Sockets, Condensers, Detectors, Crystal Receivers, Adaptaphones, etc. Like Newman-Stern "Red Heads," they give the utmost for the money and the maximum of satisfaction. They must. For like our "Red Heads," they're fully guaranteed.

Teagle

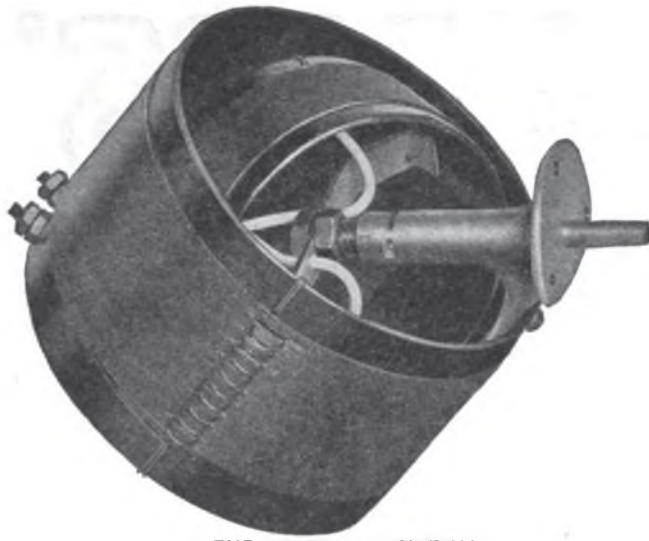

LORAIN

The only coupler especially designed for Perfect Panel mounting. A few distinctive features are:—Formica tubing—No. 22 DSC wire—one piece 1/4" brass shaft, runs true with panel. NO WOBBLE. Flexible leads to rotor—Rigid, easily cleaned taps—Excellent workmanship and finish—Price \$5.50. For complete description send for circular C2.

THE PERFECT MOUNTING
PAT. PEND.

If your dealer cannot supply you—order direct and send us his name. Dealers write for discounts.

LORAIN RADIO SUPPLY CO., Lorain, Ohio

THE NEW 'WHITE' ADJUSTABLE VERNIER CONDENSER

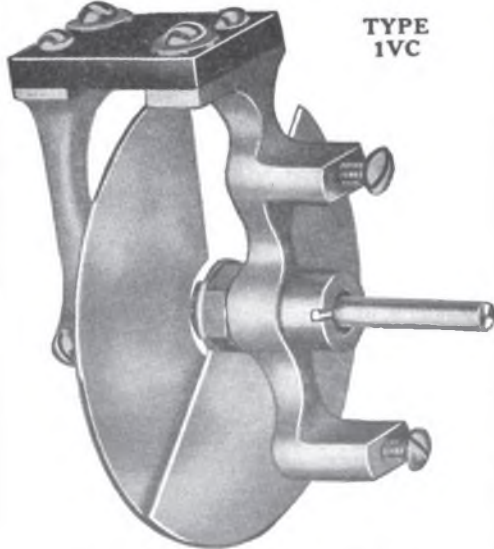

TYPE
1VC

A NECESSITY FOR SHARP TUNING
Positively noiseless. Highest grade, mechanically and electrically. Exclusive features.

PRICE, at your Dealers or Post Paid.....\$2.50

THE O. C. WHITE COMPANY

Makers of Adjustable Electric Fixtures
15-21 Hermon St., Worcester, Mass.



World Batteries FOR

Radio or Automobile
SAVE YOU 50%

Buy direct from factory.
Pay only one profit.
Highest quality made—
lowest prices.

WRITTEN TWO-YEAR GUARANTEE

Automobile Prices
6 Volt, 11 Plate \$12.50
Ford, Chev., Mitch.,
Hup., Grant, Elgin,
Vellie, Saxon.
6 Volt, 13 Plate \$14.50
Overland, Buick, Reo,
Paige, Hudson, Nash,
Stude. and Dort.
12 Volt, 7 Plate \$18.00
Maxwell, Dodge, Regal,
Frank., Briscoe,
and Crow-Elkhart.
Give year and model
of car

We defy price competition,
a glance at the prices below
will convince you that the
World Battery is the best
buy on the market. Batteries
shipped immediately. Express
C.O.D. Begin now to get 100%
battery service at one-half
cost. Mail your order today.

Radio Prices
6 Volt, 40 Amps \$8.50
6 " 60 " 10.00
6 " 80 " 12.50
6 " 100 " 14.50

World Battery Co.,

60 E. Roosevelt Road
Dept. Q, Chicago, Ill.



BUILD YOUR RADIO
Build Your Own At Home
Complete Standard Parts
for Long Distance Radio
Outfits. We do all machine
work; you do the hand work;
we tell you how. Immediate
delivery. Also complete Radio
Sets—all sizes at bargain
prices. Write now for our big
bargain catalog.

SAVE MONEY
4759 Calumet Avenue
Colonial Radio Equipment Co. Dept. 12, Chicago, Ill.



B & B W400

IT HAS a voltage step-up of 4—uniform over the *entire* audio frequency range. Remarkable freedom from *distortion* or “howl.” Compact construction and convenient terminals. Designed and made by a house of long standing in the electrical trade, specializing in transformers, whose reputation would not permit offering a transformer before developing it to a point of demonstrated superiority.

TEST IT yourself. Compare the B & B with any transformer at any price. Put it in the same circuit, on the same signal, using a 4P.D.T. switch for quick change. You will find a quality of signal and a range of operation which you have never been able to get.

We will pay You \$2.50 to test this remarkable Transformer

HERE IS a *real* audio frequency transformer. Three of the leading electrical testing laboratories have proven its marked superiority. Its outstanding merit appears not only in the tabulated figures of its definite characteristics, but is very evident in the improved quality of signals received.

THE PRICE of this great little transformer is \$7.00. Its *value* is greater. Cut out and mail the coupon below with \$4.50 and you will receive one B & B transformer postpaid. This pays you \$2.50 for testing and proving its superiority.

Not more than two transformers will be sold to one person on this basis. The regular price is \$7.00. Order, test, prove the unequalled quality of B & B transformers, and you will always use them, because they do give better results.

Every B & B W400 audio frequency transformer is sold with the maker's money-back guarantee. If not found superior in quality, it may be returned and full price paid will be refunded.

Sold only by the better class of dealers.

BETTS & BETTS
CORPORATION

645 West 43rd St., New York

Makers of B & B Variometers, V. T. Sockets and Receiving Apparatus

Betts & Betts Corporation,
645 West 43rd St.,
New York City

Enclosed find.....for $\left\{ \begin{array}{l} \$4.50 \\ \$9.00 \end{array} \right\}$ for which
please send me postpaid $\left\{ \begin{array}{l} \text{one} \\ \text{two} \end{array} \right\}$ \$7.00 B & B W400 audio frequency transformer, the difference being allowed to me for testing. In case I do not find the transformer to be of superior quality and entirely satisfactory I am to have the privilege of returning to you within 10 days and having my money refunded.

Name

Street

City & State.....

Please write plainly. Money should be sent by P. O. money order. Stamps not accepted.

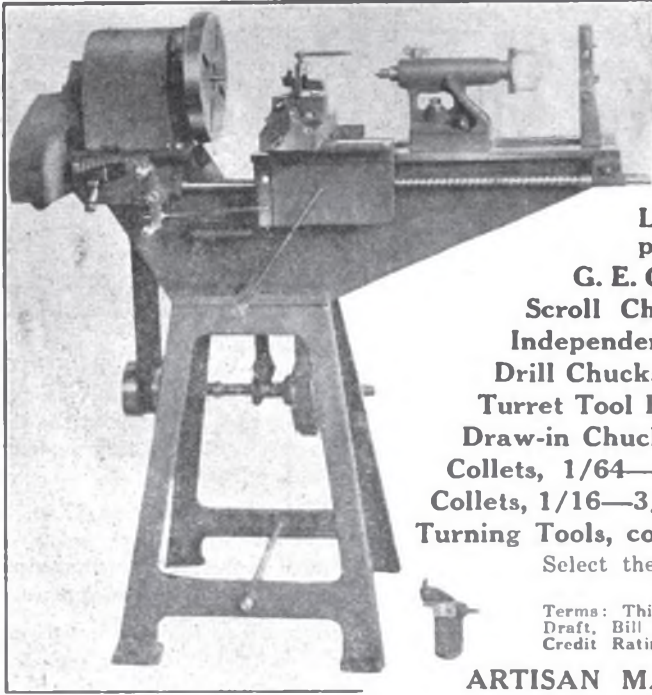

THE ARTISAN 11" x 24" GAP LATHE

(See description in
August QST)

For making Radio Parts;
The Solution of the Slow
Delivery Problem.

Prices—F.O.B. Cincinnati

Lathe, completely equip-
ped \$139.00

G. E. Co. 1/2 H.P. Motor \$40.00

Scroll Chucks fitted . . . 16.00 up.

Independent Chucks fitted 20.00 up.

Drill Chucks fitted 5.00 up.

Turret Tool Post, complete . . 26.00

Draw-in Chuck, complete . . . 18.00

Collets, 1/64—1/2" cap. 3.00 ea.

Collets, 1/16—3/4" cap. 4.00 ea.

Turning Tools, complete 1.80 ea.

Select the Equipment needed for your
Work

Terms: Third cash with order, balance eight
Draft, Bill of Lading attached, in absence of
Credit Rating.

ARTISAN MANUFACTURING CO.
Station "N," Cincinnati, Ohio

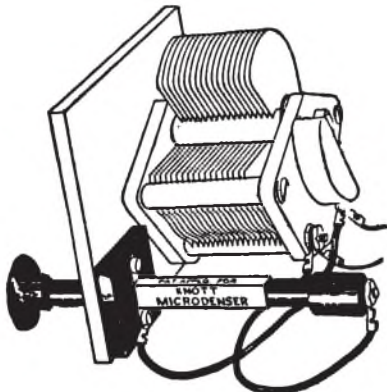

(Trade Mark Registered)

Showing how you connect to Condenser
Tune in that message or music you have been
losing. Tune out that interference. Bring it in
and clear it up.

Tune your condenser to the whistle and then
bring in the messages with this Micro.
Buy it of your dealer, or send us \$2.75 and
we will mail you one complete with connecting
wires and wrench-screw driver.

Knott Sure Ground. Radio Name Plates. Patent
Dial. Rheostat. Quodcoil. Cincoil. Microstat.
Send 2 cent stamp for Circulars.
Jobbers write for our proposition. It will please
you.



1 Ellery St., South Boston, Mass.

NOVO "B" BATTERIES FOR RADIO

22½ - 45 & 105 VOLTS



NOISELESS
DEPENDABLE
GUARANTEED

ASK YOUR DEALER

NOVO MANUFACTURING CO.
424-436 W. 33rd ST.
NEW YORK

531 SO. DEARBORN ST., CHICAGO.



It Pays To Buy
Where You See
This Sign

Mr. Dealer:—If you are a
progressive merchant you
will be interested in this
sign. Write us.

SHIP OWNERS RADIO SERVICE, INC.
Wholesale Distributors 80 Washington St., N. Y.

Baldwin Radio Products are Standard



VARIOCOUPLER

\$5.50

formerly
\$8.00

Patents Applied for



VARIOMETER

\$5.00

formerly
\$7.00



**BALDWIN
RADIO FREQUENCY
TRANSFORMER**

\$3.50

KNOWN the world over for efficiency.

Made in accordance with the best engineering practices of the radio art.

They never fail to bring in the **MUSIC** and they are **Positively** Guaranteed, Electrically and Mechanically to function properly.

Make your own set with Baldwin parts. Ask your dealer. Write for catalogue "E" free.

Dealers Write for Liberal Discounts

**BALDWIN RADIO ELECTRICAL
MANUFACTURING CO., Inc.**

684 BERGEN ST.,

BROOKLYN, N. Y.

10% OFF

Besides the articles listed below, which are quoted at 10% below the regular list price, we can also supply you with any piece of radio apparatus, including sets, at the same discount. Write for our price before buying.

PHONES

Baldwins, all types	\$15.00
Murdock No. 55, 2000 OHM	4.50
Murdock No. 55, 3000 OHM	5.50
Murdock No. 56, 2000 OHM	5.00
Murdock No. 56, 3000 OHM	5.50
Brandes Superior	6.75
Federal, 2200 OHM	6.75

TUBES

VT-1 Western Elec. Co.	\$7.50
VT-2 Western Elec. Co.	8.50
U-V-200	4.50
U-V-201	5.75

TRANSFORMERS

DX Radio Frequency	\$7.75
DX Radio Frequency Holder75
Acme Audio	4.50
Thordarson	3.85
Federal	6.25

VARIOMETERS

Atwater Kent	\$6.75
Atwater Kent Variocoupler	6.75
Black Moulded Variocoupler	4.50
Black Moulded Variometer	4.50
3-inch Dials	40-50- .60
4-inch Dials	40-50-75- 1.00

Every article we sell at these reduced prices is a standard product. Write us about your needs, you'll find we are the lowest in price.

We Prepay Postage

CUT RATE RADIO CO.

P. O. Box 472

DEPT. R. NEWARK, N. J.



MICRODENSER

The friendly feeling which the Radio Public is displaying toward the MICRODENSER is no doubt prompted in part, by its novel design.

But the deeper, more significant phase is the profound admiration for its fine tuning qualities, selectivity and permanent adjustments.

PRICE \$7.50

Complete with Dial & Knob

THE FIRST VARIABLE DIELECTRIC CONDENSER WITH A VERNIER ADJUSTMENT.

RaFone Variometers, \$3.80

Variocouplers \$3.80

R. S. TYPE FIXED CONDENSERS

.001 Phone Condenser

.00025 Grid Condenser

.00025 Grid Leak Condenser

detachable

THE RADIO SHOP

Dept. B

242 W. Adams Ave., Detroit.
Canadian Distributors Potvin, Herbert & Potvin,
Windsor, Ont.

Buy Your Radio Receiving Set at Manufacturers' Cost

Buy your Radio Supplies at a large discount below the list or retail price. If a saving of \$15.00 to \$140.00 on a Radio Receiving Set or if a saving of 25% to 40% on Radio Supplies interests you, write or telegraph us today.

KING RADIO MFG. CO.

521 Penn Ave., Wilkinsburg, Pa.

Armstrong Super Regenerative Circuit

Complete blue-print and descriptive matter \$0.25
400 turn Honey-comb Coils (unmounted) 1.00
1250 turn Honey-comb Coils (unmounted) 2.40
1500 turn Honey-comb Coils (unmounted) 2.80

Add \$1.00 to above prices for mounted coils. We can also supply the necessary choke coils and 12,000 ohm resistances used in this circuit.

Dealers write for Discounts

FRANKLIN RADIO MFG. CO.

711 Penn Ave., Wilkinsburg, Pa.

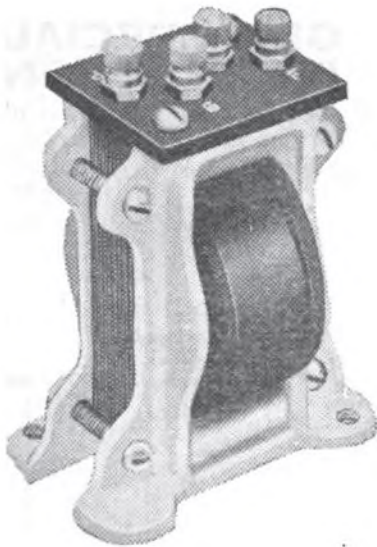

PRICE \$6.00

The 3YQ safely meets the exceptional demands of the new Armstrong Super-Regenerative Circuit.

3 Y Q Transformers are not built for incredible and needless voltage amplification—they are built for efficient amplification. 3 Y Q Transformers are leak-proof because no impregnating compounds are used for insulation. They are wound with larger wire than any other Audio Frequency Transformer so that their impedance is correct without being made up largely of resistance. They work with any present day tube. They are electrically and mechanically

DISTORTION Can Be--Has Been ELIMINATED

*Experimenters and music lovers use
3 Y Q Transformers for
"Amplification without Distortion"*

Howling and distortion have been eliminated from Radio by the 3 Y Q Audio Frequency Transformer. New laws, new methods of construction, have been developed. Old ideas have been improved—some have been discarded—and as a result you can now secure Audio Frequency Amplification that is surprisingly efficient.

perfect, have no exposed wiring to break or short circuit, and they can't be connected incorrectly. And they are tested to stand 600 Volts A C, proving them ideal for power amplification.

Many amateurs and professional assemblers demand the 3 Y Q Transformer in preference to all others. You, too, want the best—and you can be sure of getting it by asking your dealer for the 3 Y Q. Remember the name, 3 Y Q, and the price, \$6.00.



Federal Institute
of
Radio Telegraphy
2nd & Federal Sts., Camden, N. J.

DEALERS GET SPECIAL PROPOSITION

Send to KLAUS—"Radio Headquarters" for special discount lists and bulletins on apparatus and equipment. Our service department offers dealers assistance and advice on radio problems. We distribute "tested" apparatus. We know the equipment we send you is right. We want all Agents and Dealers to get our special proposition on the best lines of apparatus made.

Get our Prices on these lines of apparatus

Acme
Adams-Morgan
Baldwin
Brandes
Westinghouse

Clapp-Eastham
DeForest
Jewell
Federal
Radio Corporation

Grebe
Moorhead
Murdock
Pacnet



Write today to---
KLAUS RADIO CO.
Dept. 100
Eureka, Illinois

FIRST TESTED THEN SOLD

Our New Price List is Ready. Get Your Copy

Immediate deliveries on
Radio Corporation
Magnavox
Grebe
Amrad
Clapp-Eastham
Tuska
Formica
Thordarson
Remler
Cunningham
Frost
Federal
& Others

Detroit Electric Co.

113-115 E. Jefferson Ave.

DETROIT,

MICH.

HYGRADE SPECIALS

Radiotron U. V. 200 Tubes.....	\$4.75
Radiotron U. V. 201 Tubes.....	5.75
2766 Eveready Variable B. Battery.....	2.25
45 Volt Cyclone Variable B. Battery.....	2.75
Electrose Insulators per dozen.....	2.00
7 Stranded Copper Aerial Wire 200 ft....	1.25
Arkay Loud Speakers.....	4.00
.001 M. F. Signal Variable Condensers (with dial & knob).....	4.50
Thordarson Amplifying Transformers.....	3.89
Acme Amplifying Transformers (Semi-Mounted).....	4.25
Federal Amplifying Transformers.....	6.25
Skinderviken Transmitter Buttons.....	.75
Murdock 256 Head Set 3000 ohm.....	5.75
Murdock 256 Head Set 2000 Ohm.....	4.75
Federal 2200 Ohm Head Set.....	7.25
Dictograph 3000 Ohm Head Set.....	9.95
Western Electric Head Set.....	12.50
Rheostats, Fada 90c—DeForest.....	1.05
MARKO STORAGE BATTERIES	
6 volt 30 amp. guaranteed 2 years.....	\$10.00
6 volt 60 amp. guaranteed 2 years.....	13.50
6 volt 80 amp. guaranteed 2 years.....	17.00
6 volt 100 amp. guaranteed 2 years.....	21.00
Homcharger, charge your own battery..	16.50
Above prices are F. O. B. New York	
HYGRADE ELECTRICAL NOVELTY CO.	
41 West 125th Street, New York, N. Y.	



It's easy, make your own
INDOOR COIL AERIAL
Drawing, R. F. amplifier circuit, chart and tables giving proper number of turns to put on coil for any wavelength. Complete data covering 0 to 24,000 meters on 3 large sheets \$1.00. Stamps not accepted
C. A. DAVIS & COMPANY
2371 Champlain St., Washington, D. C.

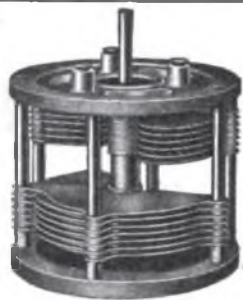

Mignon Condensers

Straight, Curve, Variable



Balanced TYPE "A"

Types "A" and "B"
BALANCED CONDENSERS
 "A" 8 STATORS and 6 ROTORS
 "B" 14 STATORS and 12 ROTORS
 Special Aluminum Plates
 FORMICA Inserts & Nickel Plated
 Terminal Posts, Diameter of Aluminum
 End Castings 4 1/8".
 Outside Dimensions Between End Cast-
 ings "A" 2 3/4" and "B" 3 1/2".
 1/4" Rotor Shafts.

As illustrated

"A" .0005 M.F. \$4.50
 "B" .0008 M.F. \$5.00



Types "B" and "C"

COUNTER BALANCED CONDENSERS

"B" 13 STATORS and 12 ROTORS
 "C" 23 STATORS and 22 ROTORS
 Special Aluminum Plates
 FORMICA Inserts and Nickel Plated
 Terminal Posts. Diameter of Aluminum
 End Castings 4 1/8 inches.
 Outside Dimensions Between End Cast-
 ings "B" 3 3/8" and "C" 4 1/2 inches, 1/4
 inch Rotor Shafts.

As illustrated

"B" .0008 M.F. \$5.00
 "C" .0017 M.F. \$6.00

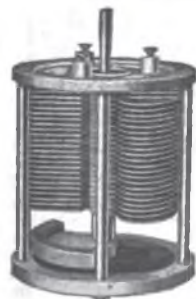

Counter Balanced
TYPE C

Vernier TYPE B Type "B"

COUNTER BALANCED

and with

VERNIER ADJUSTMENT

13 Stators, 12 Rotors and 1 Extra Heavy
 ROTOR VERNIER of Special Alumi-
 num.
 FORMICA Inserts & Nickel Plated Ter-
 minal Posts. Diameter of Aluminum
 End Castings 3 1/8".
 1/4" Rotor Shaft, 1/8" Vernier Shaft with
 8-32 thread.
 Outside Dimensions between
 the end Castings 3 3/8".

As illustrated

"B" .0008 M.F. \$6.50

Types 11, 23 & 43

VARIABLE CONDENSERS

No. 11— 6 STATORS and 5 ROTORS
 No. 23—12 STATORS and 11 ROTORS
 No. 43—22 STATORS and 21 ROTORS
 Special Aluminum Plates
 FORMICA Insulation and Nickel Plated
 Terminal Posts. Outside Diameter 4
 inches.

As illustrated

No. 11	No. 23	No. 43
.00047 M.F.	.00074 M.F.	.0015 M.F.
\$3.75	\$4.00	\$4.50

Authorized Sales Representatives

Western Radio Distributing Co.,
 114 L. C. Smith Bldg.,
 Seattle, Wash.

Detroit Electric
 Company
 113 E. Jefferson
 Ave.
 Detroit, Mich.

The Reynolds
 Radio Co.
 Denver, Colorado

McCarthy Bros.
 & Ford
 Buffalo, N. Y.

The Radio
 Engineering
 Sales Co.
 Cleveland, Ohio

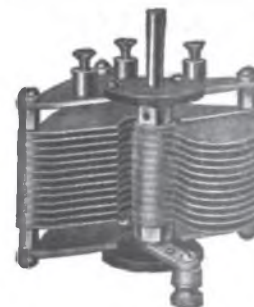

Variable
TYPE 23

ALWAYS MENTION QST WHEN WRITING TO ADVERTISERS

Trade Mark **BKUMA YRLSBUG** Reg. Ap. For
Attentive Beginners Who Use

Dodge One Dollar Radio Short Cut

DO ARRIVE

Items From Our Honor Roll

1BYB
Earle E. Lockwood, Norwalk, Conn.
9 Westport Ave.
Memorized Code in 40 Minutes

1BIC
D. O. Shepard, Plantsville, Conn.
262 Summit St.
Memorized code in few hours

1JX
Arthur J. Carlson, Waterbury, Conn.
Colonial Trust Co.
Memorized Code in One Hour

1CPH
Paul St. Jacques, Woonsocket, R. I.
272 Adams St.
Memorized Code in 2 Hours

Some Learned Code, Passed Exam, Won License All in One Week. Fact Reported to Enlighten Others Struggling With ABC Methods. Send ONE DIME for Honor Roll Dodge Short-Cut Beginners Now Licensed Operators—Covers Ten Radio Districts.

FOR EACH DIME OUR METHOD COSTS IT MAY SAVE DOLLARS

C. K. DODGE **Box 210** **MAMARONECK, N. Y.**

Vacuum Tube Detector \$5.50

Including complete cabinet with all instruments wired ready for use.

DETECTOR AND TWO STAGE AMPLIFIER \$22.50

With transformers and all other instruments in cabinet, ready for operation. This equipment is of high quality and distances of as high as 3000 miles have been obtained with ease.

BATTERIES AND TUBES EXTRA
2000 Ohm receivers \$5.00
SUPERIOR CRYSTAL RECEIVING SET \$4.75

Attractive Dealers proposition
STEINMETZ WIRELESS MFG. CO.
5706 PENN AVENUE, PITTSBURGH, PA.



DEALERS ONLY—

Write for Harry Alter's RADIO "POCKET-BOOK." A net price catalog of radio supplies published each month. Our wholesale prices hit bottom. The RADIO "POCKETBOOK" sent free to dealers only. Use your letterhead.

HARRY ALTER & CO.

126 N. MAY ST., CHICAGO

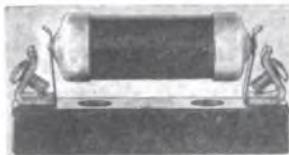

"BERKSHIRE" RADIO FREQUENCY AMPLIFYING COIL

IRON } 3 SIZES \$2.00 EACH
CORE } 150-700 METERS WITH BASE

CIRCULAR SHOWING CIRCUIT ON REQUEST

BERKSHIRE ELECTRIC CO.

Pittsfield, Mass.

SPECIAL RADIO EQUIPMENT

Prices Quoted Upon Receipt of Specifications
Machine work and panel drilling. Plans and diagrams made for special receiving and transmitting sets.

OLIVER S. EVERETT

83 Otis Street **MEDFORD, MASS.**

PRICE REDUCED

QST BOUND VOL. IV

Now Only \$3.50, postpaid

Aug. 1920-July 1921, inclusive

QST, 1045 Main St., HARTFORD, CONN.

—LOOSE-LEAF-LOG—

Ring Book Containing 50 Conventional Log Sheets and 50 Radiogram Blanks—Re-Fillers Very Reasonable

Postal Card for Sample Sheets and Photo.

CITIZENS RADIO SERVICE BUREAU
416 S. DEARBORN STREET, CHICAGO, ILL.



BUILD YOUR OWN. 50c instruction book for 20c on how to make eight classes receiving sets from two slide tuner to combined radio—audio frequency outfits. With every order you receive price list of parts illustrated in book. Buy direct from factory and save dollars. Both text book and catalog mailed for 20c.

Dept. 13. **RADIO PARTS MFG. CO.**
West Park Place, Detroit, Mich.

DUCK'S RADIO CATALOG No. 16 256 PAGES

Continuously since 1909 Duck's Radio Catalogs have never been equaled for completeness, and great wealth of radio data



Send 25c in coin carefully wrapped for your copy of this wonderful book, the most unusual and complete catalog ever put between two covers. Not sent otherwise. Enormous cost and tremendous demand prevent distribution at a less retainer.

Over 50 pages of latest hook-ups (wiring diagrams) and invaluable and up-to-date data and information on radio. Not only a catalog, but a wonderful textbook on radio.

Never in the history of radio has there been such a catalog. The radio data and diagrams embracing upward of 50 pages give the experimenter more valuable and up-to-date information than will be found in many textbooks selling for \$2; and \$1 could be spent for a dozen different radio catalogs before you could gather together the comprehensive listing of worth-while radio goods found in this great catalog.

Our new No. A650 Duck Rheostat (at right) has just the necessary amount of resistance to take care of the drop in voltage from the battery when fully charged to the battery at its minimum working voltage. The base is of moulded composition. The resistance element is wound on a black fibre strip, the element being securely fastened in a slot in the base. Contact arm is of phosphor bronze of the proper tension to insure perfect contact and smooth operation. Adjustable to any thickness panel up to 3/8 inch, 2 1/4 inches in diameter. An exceptional Rheostat at a most popular price. No A650 Duck Rheostat, \$1. Shipping weight 8 oz.

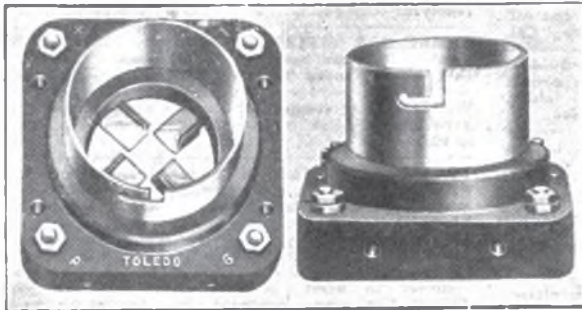
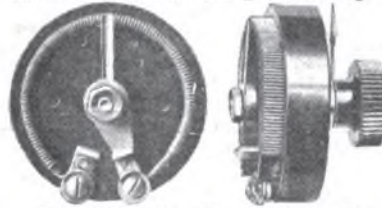

No. A666 Duck's Positive Contact Bakelite Tube Socket (at left) is beyond doubt the most advanced tube socket on the market today. To our knowledge there is no other type of tube socket that cannot be forcibly criticized from some angle. Either the receptacle does not easily accommodate the varying diameter of the bases of bulbs, or the notch on receptacle is not just right, or the receptacle is easily subjected to breakage, or connections are in an inconvenient place, or, and

most important of all, the type and style of the contacts do not insure positive, certain contact without considerable manipulation.

In our new socket all these defects in other bulbs are overcome.

No. A666 DUCK'S Bakelite Tube Socket, \$1. Shipping weight, 1/2 pound.

DUCK'S New Moulded Variometer

Our new moulded variometer (shown below) speaks for itself. For a comprehensive description of the design and radio thought back of our variometers, we invite your attention to our exhaustive description in catalog. In prettiness of design, compactness and lightness of weight, we have not seen any variometer that we believe compares with ours. The forms, unlike many others, positively will not warp.

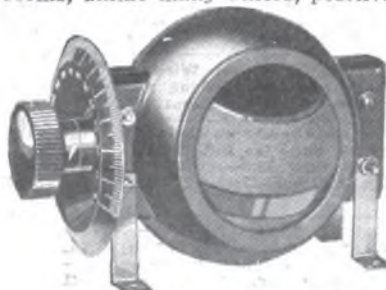

Duck's New Moulded Variometer

No. A900 plate variometer, with knob and dial, \$7.25

No. A901 grid variometer, with knob and dial, \$7.25

Note: If knob and dial are not desired deduct 75c.

**Duck's Products Have
Stood the Test of
Time
1909-1922**

There are many Duck products that completely dominate all competitive types.

The Largest Line in America — 62 Complete Instruments—58 parts.
Dealers

We want live, responsible dealers in every city and town in the United States, both for the sale of our extensive line of radio apparatus and all other worth-while lines of radio goods, on all of which we can quote attractive dealer's discounts. We can offer you facilities and advantages that no other radio house can offer.

The WILLIAM B. DUCK CO., 243-245 Superior Street, Toledo, Ohio

CLASSIFIED ADVERTISEMENTS

Six cents per word per insertion, in advance. Name and address must be counted. Each initial counts as one word. Copy must be received by the 10th of month for succeeding month's issue.

WEST COAST signals all over the room with 4GL radio frequency transformers. Range 200-600. Price \$3.15 each with circuit. Savannah Radio Shop, 1223 East Duffy St., Savannah, Ga.

WANTED 200 Watt Acme Power Trans. Have almost new 1/6 h.p., 220 volt motor; 1800 R.P.M.—\$18.00. Will swap. B. Ainsworth, 561 Grand St., B'klyn, N. Y.

USED RADIO and electrical books and correspondence courses bought, sold and exchanged. List free, Roy Anderson, Ketchikan, Alaska.

PRACTICALLY GIVEN AWAY new Magnavox \$40.00, short wave regenerative and two step amp. phones, B Batteries, tubes, 6V 80 Cooper Battery \$75.00. Bakelite enclosed gap with motor \$14.00. Murdock Variables \$3.00, Bauernfeind & Heid Co., Menasha, Wis.

STANDARD RADIO parts, 10% to 20% off list price. Tubes, headsets, condensers, couplers, in fact, practically everything in radio. Write for prices on any equipment desired. Buyright Co., P. O. Box No. 82 (Benson Station) Omaha, Nebr.

REGENERATIVE SETS below cost, variometers, variocoupler, detector, two stage amplifier, jack control, complete, \$45.00, Caverley, 4744 Winthrop Ave., Chl.

RADIO STORAGE BATTERIES, 2v-60a, \$6.50; 6v-40a, \$11.00; 6v-60a, \$13.00; 6v-80a, \$15.00. Mail orders filled on receipt of price. Send Stamp for folder, Lloyd E. Clark, 383 Broadway, Everett 40, Mass.

FOR SALE Regenerative Receiver with detector in 9"x14"x10" mahogany cabinet. Have heard every district with it. Includes 6 volt Exida battery and .001 condenser free. Sell for \$50.00. 1/4 K.W. Acme Transformer, Murdock Oscillation Transformer, Plate Glass Oil Condenser, Rotary Gap and Eldredge Ammeter, sell for \$25.00 or trade for CW apparatus, Wayman Davenport, Plainview, Texas.

FOR SALE Complete, twenty watt C.W. Transmitter, panel mounted, formerly 8PN Deceased. Write for list, W. W. Espey, Vandergrift, Pa.

FREE Vacuum tube socket given free with each Radiotron detector tube at \$5.00 or Amplifier tube at \$6.50. We have a complete line of standard apparatus at standard prices for immediate shipment. Twelve-hour service or money refunded. Florman Radio Laboratory, McPherson, Kansas.

FOR SALE 10 panel DeForest receiving set with 17 honeycomb coils but without bulbs or receivers or battery. First M.O. for \$100.00 takes it. J. P. Gillett, Rippey, Iowa, RDO 9BGH.

FEW GENUINE GERMAN TELEFUNKEN H. W. AMMETERS with scale reading 0-4 amps. Fitted with shunt for half scale reading and adjustment for temperature variations. Very accurate and sensitive. Brand new with original seals unbroken. Diameter 2 and 7/8 inches. While they last, \$3.50 each. Robert E. Goll, 1342 East 22nd St., Brooklyn, N. Y.

WANTED One secondary section for United Wireless Coffin Transformer and insulating tube covering primary. Paul Graeter, 987 McMullan St., Cincinnati, O.

DEALERS ATTENTION send for circular on the newest and fastest seller crystal set, imitation leather case, nickel fittings, retails for less than \$5.00. Harrison Manufacturing Co., 2529 Grand River, Detroit, Mich., Dept. D.

MAGNETIC Modulator, UP-1357, \$9.75. Direct current 220 volt, 1/4 H.P., General Electric motor, \$22.50; Microphone 323-W, \$2.50; CW Inductance, 19 turns No. 8 copper on grooved 5" bakelite tube, \$4.00, tickler 75c. additional. All items look and are good as new. Hathaway, 1575 Penn., Denver, Colo.

SELL: Reinartz Tuner and detector control, \$25.00. Write Harold Heiss, 9508 Columbia Ave., Cleveland, Ohio. 8CYZ.

FOR SALE: 1 1/2 K.W. Acme F-1 Transformer (new) \$20.00; 1 1/2 K.W. Clapp Eastham Transformer (new) \$15.00; 2 Magnavox Transmitters, (new) \$17.00 each; 2 Magnavox Tone Arms (new) \$23.00 each; 1 Robbins & Meyers Motor Generator, (new) D. C. Motor & 500 V Generator, 2 K.W., \$75.00. Hickson Electric Co., Inc., 36 South Ave., Rochester, N. Y.

SELL: 1/2 K.W. Blitron Transformer \$10.00; 1/2 moulded condenser \$4.00; Proudfoot Det. & 2 stage \$20.00. F. B. Heselton, Webb City, Mo.

A REAL radio frequency transformer for amateur use; beats anything on the market; range 200-600 meters; designed by 4GL; price \$3.15 each postpaid anywhere in U. S. Circuit with each transformer. Savannah Radio Shop, 1223 East Duffy St., Savannah, Ga.

FOR SALE: 2000 Mile Spark Transmitter, \$40 Complete. Will sell parts. Radio 60M.

TELEFUNKEN 1/2 KW 500 cycle ship set complete with motor generator, receiving set, spare parts. New \$250. An International four cylinder gasoline power unit AC or DC cost Navy \$100.00 With above set \$100 extra. Telefunken or Crocker Wheeler 500 cycle motor generators for tube sets, \$75.00. Henry Kianze, 4501 E. 84th St., New York.

1 K.W. Thordarson \$15, Hyrad Disc \$5, Special Rotary Quenched Gap \$20, Lightning Switch \$3. R. Kinney, 1808 Middlehurst Rd., Cleveland Heights, Ohio.

WANTED: Used 500 Watt 1000 Volt D. C. generator, state full particulars, price reasonable. Sell spark and receiving equipment. Roy Kuester, Menasha, Wis.

GREBE C. R. 8 \$72.00 Antenna wire, 7 strand No. 22 tinned, 70c. per hundred ft., Magnavox \$40.00. Sale this month, write Mack's Radio Shop, Ansonia, Conn.

WANT to buy second-hand receiving set—describe and give price. A. A. McTavish, McKinney, Tex., care Dr. Gould.

TWIN S. CRYSTALS, the Super Sensitive crystal sold with a money back guarantee. Pair 25c. 500 mile regenerative plan free. Nelson Mfg. Co., Interurban Bldg., Dallas, Texas.

TESTED GALENA CRYSTALS From our own Mines shaped and tested at the mine in best standard hookup—direct to user. A real crystal—not a pinhead. Twenty-five cents postpaid, five for \$1.00 to group buyers. Ozark Crystal Co., Box 1, Morrellton, Mo.

TRADE: Factory-mounted 2 K.W. Packard, like new, guaranteed. Want 1 K.W. Clapp-Eastham Transformer, Tesla Coil, Brown Phones or equipment equal value. All letters answered. H. Oge, Box 32, Boonville, Ind.

FOR SALE—Variometer set, 2 step, batteries, tubes. Excellent condition \$150. Small single circuit set \$50. Loud talker, \$15. 8BIP, Syracuse, N. Y.

FOR SALE—1/4 K.W. 27000 volt transformer, Clapp-Eastham coffin type, \$20.00. Herschel Powell, Romeo, Mich.

HOOK-UPS: Diagram of connections for detector and two-step amplifier to work with Reinartz tuner, for silver dime. John L. Reinartz, South Manchester, Conn.

SPECIAL—1/4 KW spark transmitter panel, mounted, \$20.00. Durant Rice, 1321 So. 35 Ave., Omaha, Neb.

—CW MUST SELL—DeForest OT3, 3 Radiotrons; UV 202; Federal Hand Microphone; worth \$130 for \$55.00. Esco DC motor generator 500 volt, 8U, Field Rhostat, worth \$110 for \$50, meters, filters, etc., Rhodes, 40 West 86th St., N. Y. C.

BATTERY CHARGERS: Best and cheapest battery charger on market \$15, new demonstrators \$13.75, absolutely guaranteed. Complete with ammeter, clips and cord. Oscar Ruf, 1480 Santa Clara St., Santa Clara, Calif.

4GL RADIO frequency transformers; DX, fones and 600 meters; \$3.15 each with circuit. Savannah Radio Shop, 1223 East Duffy St., Savannah, Ga.

2KF's—PARAGON 2-5-U—Transmitter, used six months. You know the brand and quality. Price \$35. H. D. Solvage, Irvington, N. J.

HONEYCOMB Coll Regenerative, including Coils and Radiotron Detector \$60.00. Box 208, Williamsport, Pa.

HERE'S A BARGAIN: Complete station (formerly 9UC) will be sold. Write for list. Everything must go and it's priced to sell. L. M. Smith, Salem, Wisc.

MAKE YOUR OWN Head Phones. Complete parts including Headband, Cases, Magnets, coils completely wound 2000 ohms, all ready for assembling with instructions \$3.50. South Hills Radio Co., 411 Charles St., Knoxville, Pittsburgh, Pa.

600 WATT, 1000 Volt Generator, speed 1750, \$60; 6 Volt, 40 Amp. Battery, \$6.00. Philip Stout, Knoxville, Tenn.

FOR SALE—1/2 KW spark transmitter complete, \$35. Will trade for receiving apparatus. A. G. Strauss, 828 N. 9th St., La Crosse, Wis.

AMRAD 6 volt spark coll, \$10.00. Gall Wade, Manitowoc, Wis.

MOTION PICTURE machine, complete with arc light, rheostat, film rewinder, etc., ready for use. Cost \$200. Sell for \$45 or trade for good 500 volt motor generator, 8CFB. H. E. Wallace, 7215 Whipple St., Swissvale, Pa.

CW TRANSFORMER for sale—For 5 watt tubes, 900V. secondary with midtap, 7.5 filament with midtap at 3.5v, 7.5v Kenotron filament 7.5v midtap 3.5v. Primary to operate on 110v, 60-cycle. Will operate 4-UV-202. Price \$20.00. Arthur L. Walsor, Cheaning, Mich.

SELL:—3000 Meter Loose Coupler, \$5.50; genuine two filament Audiotron, \$4.50; Cunningham Amplifier, \$3.00. Hayden Whitney, Jr., Concord, Mass.

INVENTORS: Protect your invention through A. M. Wilson, Inc., Washington, D. C. Over 20 years of efficient, expert, confidential service. Skilled in Radio-Electrical, Chemical, and Mechanical fields. Our 1922 Illustrated Booklet, giving much necessary and very useful information which every inventor should know, will be sent free upon request. Prompt and careful attention. Highest references. Moderate fees. Send sketch or model for our careful opinion and preliminary advice. Write today to A. M. Wilson, Inc., (Radio 3ARH) 310-18 Victor Building, Washington, D. C. (Successor to business established in 1891 by A. M. Wilson).

FOR SALE—1 BDC's CW, ICW and fone set consisting of two 50 watt tubes, motor gen., instruments, etc., \$175.00, all inquiries answered. Wm. E. Arnold, 183 Oliver St., Southbridge, Mass.

MUST SELL 1/2 KW Thordarson transformer, \$15.00; OT for same, \$5.00; .007 mf. glass plate condenser, \$6.00; one step amplifier, \$12.00; Regenerative receiver without bulb or battery, \$35.00. Raymond Winslow, 31 Paris St., Norway, Ma.

FOR SALE—New Magnavox R-3, \$40.00. Henry C. Winte, Chesaning, Mich.

GENERATOR WANTED, 50—100 watts, 500 volts, R. Young, 3 Glebe Rd., Toronto, Canada.

SELL—Regen. & Det. 2 step, \$55.00, complete 1/4 KW transmitter, 55 fones, \$3.50. Albert Woodruff, Glenwood, Ia.

BARGAIN: 1/4 KW spark set with motor rheostat, \$25. E. Squires, Wheaton, Ill.

FOR SALE—Regenerative Tuner, detector and three stage amplifier with two large Burgess "B's". All O.K. Details upon request. Price without tubes, \$90. Detector and 3 Western Electric Amplifier Tubes (not Signal Corps), \$125. Edgar Bell, 55 Harwood St., Pittsburgh, Pa.

OUR SPECIALS THIS MONTH: Forty-three plate variable \$2.50. Variocouplers wound with green Double Silk wire, \$3.75; Pennsylvania Storage Batteries, 6 volt, 80 amp., \$13.00. Eighteen months' guarantee. Only 100 to go at this price. Penna. Grove Radio School, Broad Theatre Bldg., Sales Department, Penna. Grove, N. J.

POST CARDS—Description of ur station with QRA. 500, \$3.50; 250, \$2.50, delivered. Samples on request. Donald J. Detwiler, 1120 Va. Ave., S. W. Washington, D. C.

ALWAYS MENTION QST WHEN WRITING TO ADVERTISERS

Cleveland Dulce-Tone Junior.

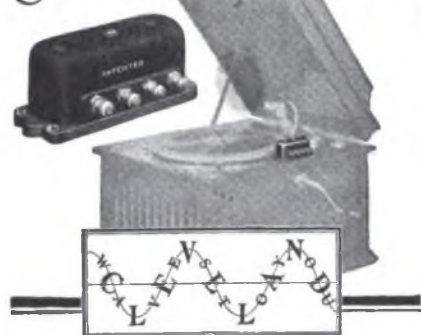

RADIO MUSIC PERFECTLY REPRODUCED THROUGH YOUR PHONOGRAPH

The Dulce-Tone Junior converts your phonograph into the finest of loud talkers without detracting in the least from its power to play phonograph records.

The radio music comes to you with cello-like sweetness, even more clearly than that reproduced from your records.

The Dulce-Tone Junior is adaptable to any phonographic instrument. When you consider that you are using the wonderful sound-box, tone-arm and even the needle which has been perfected only after years of experimenting, you can realize the **QUALITY** and **SWEETNESS** of the tone which is so faithfully reproduced through the Dulce-Tone Junior.

Any one can attach the Dulce-Tone Junior in a few minutes. To operate, simply swing the tone arm allowing the needle to rest on the small center element of the Dulce-Tone Junior. This ingenious instrument eliminates the necessity of numerous expensive head-phones when entertaining a roomfull of people—is a true economy.

The Dulce-Tone Junior is the instrument of the century—an instrument that will improve any radio set. Put one on your phonograph today and realize the possibilities of radio music for quality of tone.

RETAIL PRICE ONLY \$15.00
(\$17.50 West of the Rockies)

If your dealer does not handle the Dulce-Tone Junior, fill out the coupon below, mail it with one dollar and we will forward this wonder instrument to you C.O.D. at \$14.00.

The Cleveland Radio Mfg. Co

241 St. Claire Ave., N. E. Cleveland, Ohio
Sole Licensees under KAEHNI Circuit Inventions and Patent Applications

COUPON

The Cleveland Radio Mfg. Co.,
241 St. Claire Ave., N. E.,
Cleveland, Ohio.

Enclosed find one dollar for which send me a Dulce-Tone Junior (\$14.00 balance due C.O.D.) Send me your folder entitled "Waves to You Through Your Phonograph."

Name

Address

Town & State

Red Seal Battery Contest

Starts Nov. 1st. Closes Nov. 15th

ALL RADIO SETS INSTALLED FREE IN THE HOMES OF THE WINNERS ANYWHERE IN THE U. S. A.

1st Prize

This cabinet type complete Radio Receiving Set is one of the finest and most up-to-date sets on the market. It is designed and manufactured by the Colin B. Kennedy Company of San Francisco and St. Louis, makers of the finest type of radio receiving sets. The cabinet is walnut and stands 58 inches high—a masterpiece of cabinet making. The receiving set is regenerative, having an effective range from 175 to 25,000 meters—400 to 800 miles on "broadcasting." Contained within the cabinet are all batteries, Magnavox Loud Speaker with special horn, a Radio Homcharger De Luxe. Value complete, \$725.00.

2nd Prize

It consists of the Westinghouse R. C. Receiving Set, Western Electric Loud Speaker, "Tungar" Battery Charger, Storage Battery, 9 "B" Batteries, one Manhattan 2,000 ohm Headset, 3 vacuum tubes, 2 telephone plugs, and complete antenna equipment—a total value of \$408.50.



3rd Prize

A complete receiving outfit made up of the well known Grebe CR-9 Regenerative Receiver with 2 stage amplifier, Magnavox Loud Speaker, Storage Battery, a Radio Homcharger De Luxe, "B" Batteries, one Manhattan 2,000 ohm Headset, 3 vacuum tubes, 2 telephone plugs, and complete antenna equipment—a total value of \$256.50.

50 Other Prizes

To 50 other contestants, whose answers the judges decide are most meritorious, will be given one of the famous Manhattan 2,000 ohm Radio Headsets. These headsets are built with the precision of a watch and have great sensitiveness and high amplifying qualities.

Win this \$725.00 Radio Set FREE

Only a rich man could buy it
but a poor man may win it FREE

SIMPLY obtain a free "Red Seal Battery" contest blank between November 1st and November 15th from stores that show the Window Display pictured below. Each contest blank gives full simple instructions to help you write your answer and full rules of the Contest.

Red Seal Battery, Finish-the-Sentence Contest

The prizes will be awarded for the most appropriate answers for completing in your own way in not more than ten words, the following sentence: "The Red Seal Dry Battery is best (1) because it is the all-purpose battery and (2) because....."

Examples

Your answer may be descriptive of the Red Seal Dry Battery or it may describe some use. For example: "It never fails on land, air or sea." Another: "It never starts what it can't finish." Another: "It rings bells and buzzes buzzers."

Judges

The judges of the Contest are: Mr. Llew Soule, Editor of *Hardware Age*, New York; Mr. Howard A Lewis, Manager of *Electrical Merchandising*,

New York, and Mr. Joseph A. Richards, President, Joseph Richards Co., Inc., Advertising Agents, New York

Awarding the Prizes

Prizes will be awarded to those who conform to the rules of the Contest and whose answers, in the opinion of the judges, are most appropriate. In case two or more persons submit winning answers, prizes identical in character with those offered will be given to each successful contestant.

Announcing the Winners

As soon as possible after the judges have rendered their decision the names of the prize winning contestants will be announced in the *Saturday Evening Post*.

Contest Opens Nov. 1--Closes
Midnight Nov. 15.

All answers must be written only on contest blanks supplied by dealers displaying Red Seal Battery Contest window display. Send as many answers as you like to:

Red Seal Battery Contest

Manhattan Electrical Supply Co., Inc.
17 PARK PLACE
NEW YORK CITY, N. Y.



Look for this Window Display
in Dealers' Windows Nov. 1 to 15.
It identifies Dealers who will give
you free Contest Entry Blanks.





MANHATTAN

ELECTRICAL SUPPLY CO., INC. NEW YORK

Makers of the Famous Red Seal Dry Batteries
and Manhattan Head Sets



—FOR YOUR CONVENIENCE—
QST'S INDEX OF ADVERTISERS
 IN THIS ISSUE

A-C Electrical Mfg. Co., The	152	Keystone Radio Company	124
Aeae Apparatus Co., The	91	Kimley Electric Co.	134
Adams-Morgan Co., The	1-86	King "Am-Pli-Tone"	130
Alden-Nagler Co.	94-104-122	King Radio Mfg. Co.	158
Allen-Bradley Co.	110	Klaus Radio Co.	160
Alter & Co., Harry	162	Klein Radio & Elec. Supply Co., The	116
American Electric Co.	128	Klosner Improved Apparatus Co.	2
American Radio & Research Corp.	4th Cover	Knott Machine Co., E. R.	156
Andrea, F. A. D.	3	Lamb Co., F. Jos.	112
American Transformer Co., The	118	Leich Electric Co.	132
Anthracite Radio Shop	146	Lorain Radio Supply Co.	154
Apex Radio Co., Inc.	122	Magnavox Co., The	110
Artisan Mfg. Co.	156	Manhattan Elec. Sup. Co.	92-166
Atwater-Kent Mfg. Co.	89	Marshall-Gerken Co., The	121
Audiotron Mfg. Co.	105	Massachusetts Radio & Telegraph School, Inc.	130
Automatic Electrical Devices Co.	104	Metal Arts Co.	112
Automatic Electric Co.	87	Mignon Apparatus	161
Baldwin Radio Elec. Mfg. Co., Inc.	157	Modulator, The	133
Baines Electric Service Co.	96	Mu-Rad Laboratories, Inc.	93
Benwood Co., Inc., The	137	Murdock Co., Wm. J.	149
Berkshire Elec. Co.	162	Nash Electrical Service Co.	152
Betts & Betts Corp.	155	National Carbon Co. (Eveready Battery)	125
Boston Radio Exposition	110	National Radio Co., Inc.	126
Brach Mfg. Co., L. S.	144	Newman-Stern Co., The	153
Brandes, C. Inc.	88	New York Radio Laboratories, The	148
Briggs & Stratton Co.	119	Niehoff & Co., Inc. Paul G.	140
Bunnell & Co., J. H.	140	Novo Mfg. Co.	156
Burgess Battery Co.	85	Ogden Wireless Laboratories, The	146
Chaslyn Co., The	146	Pacent Electric Co., Inc.	2d Cover
Chelsea Radio Co.	142	Philadelphia Wireless Sales Corp.	124
Chicago Radio Show	112	Pitts Radio Stores, Inc.	151
Citizens Radio Service Bureau	114-162	Pittsburgh Radio & Appliance Co., Inc.	144
Clapp-Eastham Co.	90	Potter Co., The C. D.	120
Classified Advertisements	134	Radio Construction Co.	122
Cleveland Radio Mfg. Co.	165	Radio Corporation of America	121
Colonial Radio Equipment Co.	154	Radio Directory & Pub. Co.	117
Columbia Radio Sup. Co.	128	Radio Guild, Inc., The	123
Commercial Radio Institute	96	Radio Parts Mfg. Co.	162
Condensite Company of America	139	Radio Products Co.	133
Connecticut Telephone & Electric Co.	8d Cover	Radio Shop, The	158
Continental Radio & Elec. Corp.	168	Radio Shop of Newark, The	148
Copper Clad Steel Co.	108	Radio Testing Station	126
Coto-Coil Company	111	Rasia Sales Corporation	84
Crosley Mfg. Co.	98-99-100-101-102-103	Rauland Mfg. Co.	116
Cut Rate Radio Co.	158	Remler Radio Mfg. Co.	106-107
Davis & Co., C. A.	160	Reynolds Radio Co., Inc.	134
DeForest Radio Tel. & Tel. Co.	94	Rhamstine, J. Thos.	140
Detroit Electric Co.	160	Robertson Clock & Instrument Co.	114
Diamond State Fibre Co.	127	Roller-Smith Co.	118
Dictograph Products Corp.	135	Rome Wire Co.	90
Dodge, C. K.	162	Rose Radio Supply	150
Dongan Elec. Mfg. Co.	136	Scientific Engineering Association	114
Doubleday-Hill Electric Co.	115	Service Radio Equipment Co., Inc.	140
Duck Co., The Wm. B.	163	Ship Owners Radio Service, Inc.	156
Eby Mfg. Co., The H. H.	122	Shotton Radio Mfg. Co., The	134
Economic Appliance Co.	128	Signal Electric Mfg. Co.	145
Eisemann Magneto Corp.	109	Simplex Radio Co.	142
Electric Specialty Co.	150	Southern Radio Corporation	134
Elwood Electric Co., Inc.	150	Southwest Radio Supply Co., The	136
European Radio Co.	94	Standard Assembling Co.	138
Everett Electric Corp.	142	Standard Radio & Electric Co.	132
Everett, Oliver S.	162	Standard Radio Supply Co.	152
Federal Institute of Radio Tel.	159	Standard Transformer Co., The	124
Federal Tel. & Tel. Co.	141	States Co., The	108
Formica Insulation Co., The	97	Steinmetz Wireless Mfg. Co.	162
France Mfg. Co., The	144	Stromberg-Carlson Telephone Mfg. Co.	120
Franklin Radio Mfg. Co.	158	Tait Knob & Dial Co., Inc.	108
General Electric Co.	115	Telephone Maintenance Co.	146
General Radio Co.	113	Thordarson Electric Mfg. Co.	88
General Radio Equipment Co.	130	Tuex Supply Co.	162
Globe Phone Mfg. Co.	138	Valley Electric Co.	92
Grebe & Co., A. H.	4	Virginia Radio Corp.	120
Hartford Instrument Co.	148	Warren Radio Phone Mfg. Co., Inc.	122
Hipwell Mfg. Co.	118	Westinghouse Union Battery Co.	143
Hommel & Co., Ludwig	128	Weston Electrical Instrument Co.	95
Horning Inc., Walter R.	114	White Co., The O. C.	154
Hygrade Elec. Novelty Co.	160	Willard Storage Battery Co.	147
Jefferson Electric Mfg. Co.	136	Willis Switch & Instrument Co.	126
Jewell Electrical Inst. Co.	84-104	Wireless Mfg. Co.	131
Jones, James H.	96	Witherbee Storage Battery Co., Inc.	112
Joy-Kelsey Corporation	116	World Battery Co.	164

ALWAYS MENTION QST WHEN WRITING TO ADVERTISERS



CONTINENTAL

"New York's Leading Radio House"

The New Plug that Eliminates Screwdriver and Pliers



**MODEL UD-824
SINGLE**

PRICE - - \$1.75



**MODEL UD-825
DOUBLE
PRICE - - \$2.60**

RCA Telephone Plugs represent the greatest advance ever made in Plug design.

To connect the Head Telephone or other device to these Plugs just move the patented spring grip with the finger, insert the tips and let go. The harder you pull the harder it grips—yet instantly released by shifting the spring grip.

Model UD 824 is a miniature compared to other plugs. Model UD 825 is only slightly larger than the conventional single plug. This plug is invaluable for simultaneous Head Telephone and Loud-Speaker operation; or for two pair of Telephones.

A money order makes you the proud possessor of an RAC Telephone Plug!

2009-Q

"Modern Radio"—a new two hundred and eight page catalog of our wireless equipment, supplies, and apparatus sent for thirty-five cents.

CONTINENTAL RADIO AND ELECTRIC CORPN.

6 AND 15 WARREN STREET NEW YORK, U. S. A.
