

QST

DEVOTED ENTIRELY TO

AMATEUR RADIO

Published by the American Radio Relay League

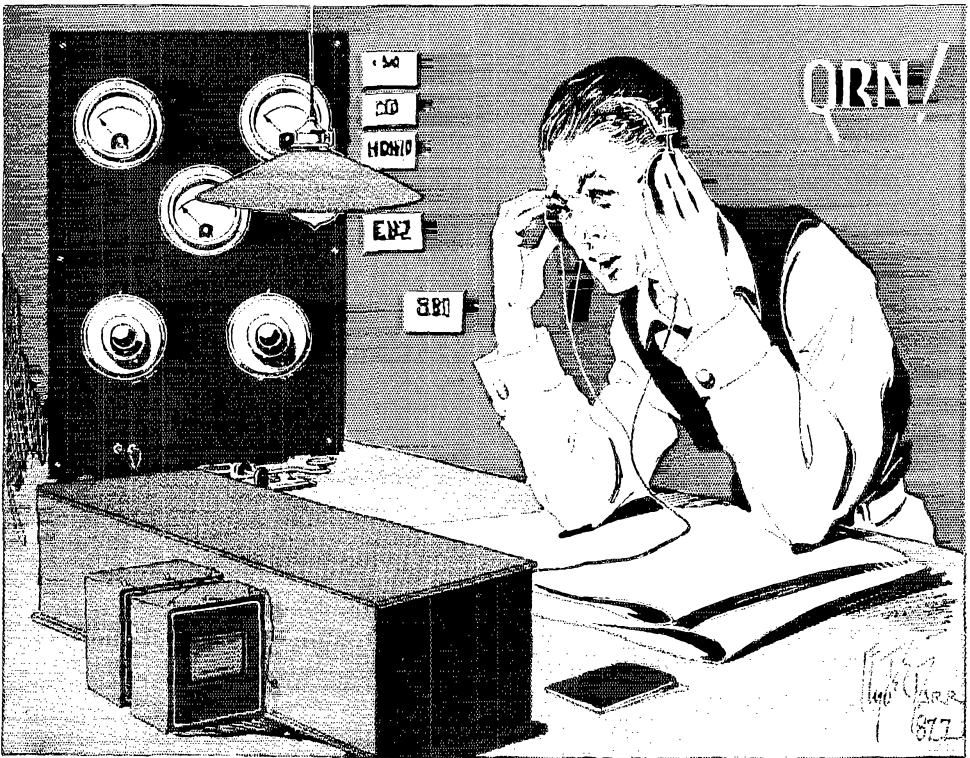

June
1927

25¢



Cunningham

RADIO TUBES



**CX
340**

**Price
\$2.25**

For Resistance and Impedance - coupled Audio Frequency Amplification.

The secret of success in resistance or impedance-coupled audio frequency amplification lies in the use of properly designed high mu tubes.

The New Cunningham CX-340 high mu tube brings to resistance and impedance-coupled audio frequency amplification, efficiency heretofore unattainable with previously existing types of tubes.

A new tube, for a new need, the CX-340 completes, for present needs, the Cunningham line of 16 Special Purpose Tubes. Each type of tube is designed to perform a definite and particular task in radio receivers.

Whenever a new type of tube is needed, Cunningham will produce it, but not before it is practical and has passed the laboratory stage of its development.

Consult your radio dealer. He will tell you the right combination of Cunningham Radio Tubes for your receiver.

CX 340 and fifteen other types in the orange and blue carton.

Operating Characteristics

Amplification factor (mu)	30
Filament Operating Voltage	5 volts
Filament Current Consumption25 amp.
Recommended Plate Voltage	135 to 180 volts
Plate Resistance (at 135 to 180 volts, under operating conditions; not at zero grid bias)	150,000 ohms
Recommended plate resistor (250,000 ohms)25 meg.
Recommended grid resistor (grid leak)	1 to 2 meg.
Recommended coupling (blocking) condenser005 to .05 mfd.
Plate and Grid Voltage values		
"B" volt.	Grid bias	Plate Resistor
135	volts neg.	megohms
180	1 to 1.5	.25
above 180	3	.25
	2 to 4.5	.5 to 1

E. T. CUNNINGHAM, Inc.
New York Chicago San Francisco





Dependability

From the far northern Ice Patrol Service to the tropic Radio Station, Faradon Capacitors have been generally accepted for exacting fixed electrostatic condenser needs.

The continued increasing use of Faradon Capacitors by Expert Amateurs and quality Equipment Manufacturers is most convincing evidence of Faradon dependability.

When planning new equipment remember that the twenty years experience of the Wireless Specialty Apparatus Company is at your service for fixed condenser needs. 868

Faradon

WIRELESS SPECIALTY APPARATUS CO.
Jamaica Plain, Boston, Mass., U. S. A.

Est. 1907

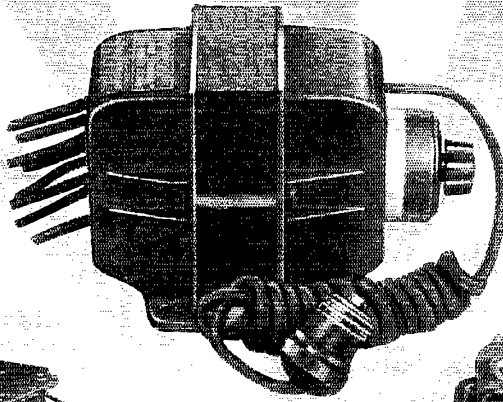

AmerTran Power Transformer
Type PF 52—\$18.00 Each

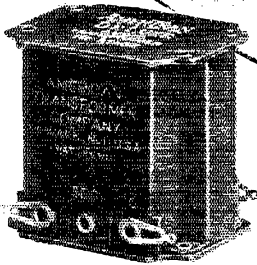

AmerTran
De Luxe Audio
Transformer
\$10.00 Each

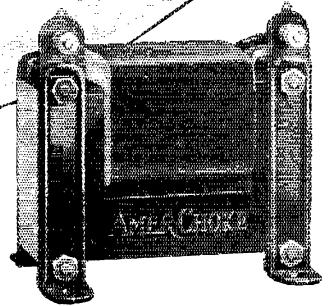

AmerChoke
Type 854
\$6.00 Each

The Quality of AmerTran

You wouldn't consider a cheaply built engine in a \$3,000 car—

Then why spend money for a good speaker and good tubes for reception apparatus and put into it poorly designed, inefficient audio transformers?

AmerTran DeLuxe transformers are so perfected that they cause tubes to amplify with all their natural fullness. Lesser transformers cannot equal the AmerTran DeLuxe for dependable volume and tone quality. Properly

installed, they result in uniform reception over the entire useful audible range.

There is no question about the AmerTran DeLuxe. Time and again it has proved to the satisfaction of engineers and laboratory workers that it is the truly outstanding audio transformer. Finest results with modern speakers and tubes are easily obtainable, and comparison will convince you that the AmerTran DeLuxe sets an entirely new standard of audio amplification.

Literature will be sent gladly on request describing the use of AmerTran Radio Products in the best of high voltage plate supplies.

The American Transformer Company
178 Emmet Street Newark, N. J.

"Transformer Builders for
Over 26 Years"

Section Communications Managers of THE COMMUNICATIONS DEPARTMENT, A. R. R. L.

Eastern Pennsylvania		8BQ	ATLANTIC DIVISION		
Maryland-Delaware-District of Columbia		5AB	H. M. Walleze	597 No. James St.	Hazleton
Southern New Jersey		3EH	A. B. Goodall	1824 Ingleside Terrace	Washington, D. C.
Western New York		8EJ	H. W. Densham	140 Washington St.	Collingswood
Western Pennsylvania		8KE	C. S. Taylor	598 Masten St.	Buffalo State College
			G. L. Crossley		
			CENTRAL DIVISION		
Illinois	9AAW		W. E. Schweltzer	4264 Hazel Ave.	Chicago
Indiana	9CQY		D. J. Angus	310 N. Illinois St.	Indianapolis
Kentucky	9ARU		D. A. Downard	118 No. Longworth Ave.	Louisville
Michigan	8ZZ		C. E. Darr	137 Hill Ave.	Highland Park, Detroit
Ohio	8BYN		H. C. Storck	694 Carpenter St.	Columbus
Wisconsin	9VD		C. N. Crapo	443 Newton Ave.	Milwaukee
			DAKOTA DIVISION		
North Dakota	9EFN		G. R. Moir	618 11th Street, South	Fargo
South Dakota	9BDW		F. J. Beck		Milbank
North Minnesota	9EGU		C. L. Barker		Hanning
South Minnesota	9RYA		D. F. Cottam	3538 Third Ave. So.	Minneapolis
			DELTA DIVISION		
Arkansas	5AIP		Leonard Clippard	2108 North Pierce St.	Little Rock
Louisiana	5UK		C. A. Freitag	129 Camp St.	New Orleans
Mississippi	5AKP		J. W. Gullett	1708 23rd Ave.	Meridian
Tennessee	4KM		L. K. Rush	4 Second St.	Bemis
			HUDSON DIVISION		
Eastern New York	2ADH-2AXR		Earle Peacor	Box 118	Yonkers
N. Y. C. & Long Island	2CWR		F. H. Mardon	117-11 140th St.,	So. Ozone Park, L. I.
North New Jersey	2WR		A. G. Wester, Jr.	50 Princeton St.	Maplewood
			MIDWEST DIVISION		
Iowa	9BKV		A. W. Kruse		Akron
Kansas	9DNG		F. S. McKeever	1317 Mich. St.	Lawrence
Missouri	9RR		L. B. Lazure	3010 Mercer St.	Kansas City
Nebraska	9BYG		C. B. Delhl	6605 Cedar St.	Omaha
			NEW ENGLAND DIVISION		
Connecticut	1BM		H. E. Nichols	32 Elmwood Ave.	Bridgeport
Maine	1BG		Frederick Best	13 E. Crescent St.	Augusta
Eastern Massachusetts	1BYL		R. S. Briggs	393 Ashmont St.	Dorchester
Western Massachusetts	1DB		A. H. Carr	30 Vassar St.	Worcester
New Hampshire	1ATJ		V. W. Hodge	227 Main St.	Claremont
Rhode Island	1BVB		D. B. Fancher	22 Summer St.	Westerly
Vermont	1AJG		C. T. Kerr		Poultney
			NORTHWESTERN DIVISION		
Alaska*	7DE		L. H. Machin	Box 452	Cordova
Idaho	7BT		Henry Fletcher	1610 N. 10 St.	Boise
Montana*	7AAT		O. W. Viers		Red Lodge
Oregon*	7IT		A. C. Dixon, Jr.	1350 East 38th St.	Portland
Washington*	7FD		Otto Johnson	4340 30th Ave. W.	Seattle
			PACIFIC DIVISION		
Hawaii	6BDL		John A. Lucas	Box 1142, Fort Shafter	Oahu
Nevada	6UD		C. H. Newcombe		Yerington
Los Angeles	6AM		D. C. Wallace	109 W. Third St.,	Long Beach Calif.
Santa Clara Valley	6NX		E. J. Quement	51 Pleasant St.,	San Jose
East Bay	6ZX		P. W. Denn	592 85th St.,	Oakland
San Francisco*	6VR		J. W. Patterson	1338 Fell St.,	San Francisco
Sacramento Valley	6CBS		C. F. Mason	2530 N. St.,	Sacramento
Arizona	6ANG		D. B. Lamb	229 W. First St.,	Mesa
Philippines	6IAU		Manuel L. Pellizaro	252 Galicia St.,	Manila
San Diego	6BQ		G. A. Sears	256 Bonair St.	La Jolla
			ROANOKE DIVISION		
North Carolina	4JR		R. S. Morris	413 S. Broad St.	Gastonia
Virginia	3CA		J. F. Wohlford	118 Cambridge Ave.	Roanoke
West Virginia	8BSU		C. S. Hoffman	128 Chantal Court	Wheeling
			ROCKY MOUNTAIN DIVISION		
Colorado	9CAA		C. R. Stedman	1641 Alhlon St.	Denver
Utah-Wyoming	6RM		Don C. McRae	214 Belvedere Apts.	Salt Lake City
			SOUTHEASTERN DIVISION		
Alabama	5AJP		A. D. Trum	217 Catoma St.	Montgomery
Florida	4QY		W. F. Grogan	Box 816	Fl. Myers
Georgia-South Carolina-Cuba-Porto Rico-Isle of Pine	4KU		H. L. Reid	11 Shadowlawn Ave.	Atlanta
			WEST GULF DIVISION		
Northern Texas	5AJT		W. B. Forrest, Jr.	502 Royal St.	Waxahachie
Oklahoma	5APG		K. M. Ehret	2904 N. Robinson St.	Oklahoma City
Southern Texas	5YE		E. A. Sahm	148 N. Academy St.	New Braunfels
			MARITIME DIVISION		
Newfoundland	5AR		Loyal Reid	Avalon House	St. Johns
New Brunswick	1BE		T. B. Lewis	7/2 N. B. Power Co.	St. John
Nova Scotia	1DD		W. C. Borrass	14 Sinclair St.	Barrmouth
Prince Edward Island	1BZ		F. W. Hyndman	25 Fitzroy St.	Charlottetown, P. E. I.
			ONTARIO DIVISION		
Ontario	9BJ		W. Y. Sloan	187 Close Ave.	Toronto
			QUEBEC DIVISION		
Quebec	2BE		Alex Reid	169 Logan Ave.	St. Lambert
			VANALTA DIVISION		
Alberta	4GT		A. H. Amussen	3123 18th St. W.	Calgary
British Columbia	5BJ		E. S. Brooks	c/o Forestry Dept. Radio Court House,	Vancouver
			PRAIRIE DIVISION		
Manitoba	4DF		F. E. Rutland, Jr.	552 St. John Ave.	Winnipeg
Saskatchewan	4FC		W. J. Pickering	514 19th St. W.	Prince Albert

*Temporary officials appointed to act until the membership of the Section concerned choose permanent SCMs by the nomination and election.

At last!

Dependable "B" and "C" Power

Ample Voltage—Self-Adjusting—Quiet

After two years of intensive development, Grebe has produced a power unit that is:

Durable—Designed and built for long, reliable service by a company that has made superior radio apparatus for over seventeen years. Its ample power reserve brings out the best tones in your set. "C" voltages automatically adjusted for changes in "B" voltages.

Quiet—No "motor-boating", hum, or noises from variable voltage contact adjustments. Shielded against outside impulses.

*Send for Booklet QE telling about
this new Grebe product*

*Type 671
for 5 and 6
tube receivers;
110 volts
60 cycles A.C.*

A. H. Grebe & Co., Inc., 109 W. 57th St., New York

Factory: Richmond Hill, N. Y.

Western Branch: 443 So. San Pedro St., Los Angeles, Cal.

The Oldest Exclusive Radio Manufacturer

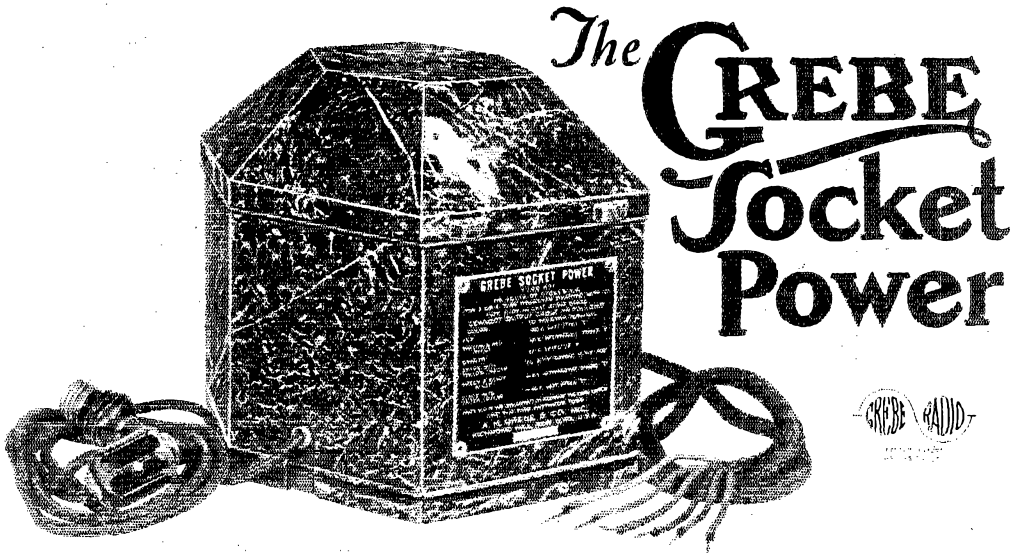

"Built for service ~ not to a price"

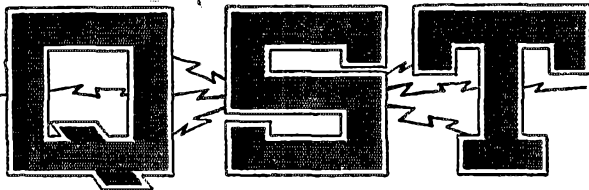

The Official Organ of the A.R.R.L.

VOLUME XI

JUNE, 1927

NUMBER 6

Editorials	7
Standard Frequency Transmissions	8
Official Wavelength Stations	8
New Short-Wave Receivers	9
The Dakota Division Convention	17
A Flexible Crystal Transmitter	Edward M. Glaser 17
Atlantic Division Convention	23
5-Meter Work at 2XM with Crystal Control	A. H. Turner 24
The Hudson Division Convention	26
Landmarks in the 1 1/2- to 5-meter Region	Robert S. Kruse 27
The Midwestern Division Convention	30
150 to 200 Meters	31
The Cheapest Bug	Joe Charpie 32
Notes on 5-Meter Tests	32
A 5-Meter Transmitter	W. H. Hoffman 33
Concerning A. R. R. L. Conventions	A. A. Hebert 35
A Device for Limiting Signal and Static Intensity	S. Young White 36
What Is the Input to Your Set?	Don C. Wallace 37
The New England Division Convention	38
Another Angle on R. F. Chokes	John H. Webb 39
A. R. R. L. Information Service Rules	39
Experimenters' Section	40
Radio Interference Ordinances Cannot Limit Transmitting Stations	48
Amateur Radio Stations	4TK-4QB, JAPY 44
I. A. R. U. News	46
Communications Department	50
Calls Heard	64
Hamads	92
QRAs	94
QST's Index of Advertisers	94

QST is published monthly by The American Radio Relay League, Inc., at Hartford, Conn., U. S. A.
Official Organ of the A.R.R.L. and the International Amateur Radio Union

Kenneth B. Warner (Secretary, A.R.R.L.),
Editor-in-Chief and Business Manager

F. Cheyney Beekley,
Managing Editor and Advertising Manager

Robert S. Kruse,
Technical Editor

Harold P. Westman,
Assistant Technical Editor

David H. Houghton,
Circulation Manager

Subscription rate in United States and Possessions, Canada, and all countries in the American Postal Union, \$2.50 per year, postpaid. Single copies, 25 cents. Foreign countries not in American Postal Union, \$3.00 per year, postpaid. Remittances should be by international postal or express money order or bank draft negotiable in the U. S. and for an equivalent amount in U. S. funds. Entered as second-class matter May 29, 1919, at the post office at Hartford, Connecticut, under the act of March 3, 1879. Acceptance for mailing at special rate of postage provided for in section 1103, Act of October 3, 1917, authorized September 8, 1922. Additional entry as second-class matter, acceptable at special rate of postage provided for above, at Springfield, Mass., authorized September 17, 1924.

Copyright 1927 by the American Radio Relay League, Inc., Title registered at United States Patent Office.

Member of the Radio Magazine Publishers' Association.

The American Radio Relay League

The American Radio Relay League, Inc., is a non-commercial association of radio amateurs, bonded for the promotion of interest in amateur radio communication and experimentation, for the relaying of messages by radio, for the advancement of the radio art and of the public welfare, for the representation of the radio amateur in legislative matters, and for the maintenance of fraternalism and a high standard of conduct.

It is an incorporated association without capital stock, chartered under the laws of Connecticut. Its affairs are governed by a Board of Directors, elected every two years by the general membership. The officers are elected or appointed by the Directors. The League is non-commercial and no one commercially engaged in the manufacture, sale or rental of radio apparatus is eligible to membership on its board.

"Of, by and for the amateur", it numbers within its ranks practically every worth-while amateur in the world and has a history of glorious achievement as the standard-bearer in amateur affairs.

Inquiries regarding membership are solicited. A bona fide interest in amateur radio is the only essential qualification; ownership of a transmitting station and knowledge of the code are not prerequisite. Correspondence should be addressed to the Secretary.

Directors

- | | | |
|-----------------------------------------------------------------------------------------------------------------------------------------------------------------------------------------------------------------------------------------------------------------------------------------------------------------------------------------------------------------------------------------------------------------------------------------------------------------------------|----------------------------------------------------------------------------------------------------------------------------------------------------------------------------------------------------------------------------------------------------------------------------------------------------------------------------------------------------------------------------------------------------------------------------------------------------------------------------------------------------------------------------------------------------------------------------------------------------------------------------|-----------------------------------------------------------------------------------------------------------------------------------------------------------------------------------------------------------------------------------------------------------------------------------------------------------------------------------------------------------------------------------------------------------------------------------------------------------------------------------------------------------------------------------------------|
| <p><i>President</i>
HIRAM PERCY MAXIM
Drawer 2102
Hartford, Conn.</p> <p><i>Vice-President</i>
CHARLES H. STEWART
St. David's, Pa.</p> <p><i>Canadian General Manager</i>
A. H. K. RUSSELL
5 Mail Bldg.
Toronto, Ont.</p> <p><i>Atlantic Division</i>
Dr. EUGENE C. WOODRUFF
234 W. Fairmount Ave.
State College, Pa.</p> <p><i>Central Division</i>
CLYDE E. DARR
137 Hill Ave., Highland Park,
Detroit, Mich.</p> | <p><i>Dakota Division</i>
C. M. JANSKY, JR.
Dept. of Elec. Eng., U. of M.
Minneapolis, Minn.</p> <p><i>Delta Division</i>
BENJ. F. PAINTER
424 Hamilton Nat'l Bank Bldg.
Chattanooga, Tenn.</p> <p><i>Hudson Division</i>
DR. LAWRENCE J. DUNN
480 East 19th St.
Brooklyn, N. Y.</p> <p><i>Midwest Division</i>
PORTER H. QUINBY
Box 134A, Route 6,
Omaha, Neb.</p> <p><i>New England Division</i>
DR. ELLIOTT A. WHITE
Dartmouth College
Hanover, N. H.</p> <p><i>Northwestern Division</i>
K. W. WEINGARTEN
3219 No. 24th St.,
Tacoma, Wash.</p> | <p><i>Pacific Division</i>
ALLEN H. BABCOCK
65 Market St.,
Southern Pacific Co.
San Francisco</p> <p><i>Roanoke Division</i>
W. TREDWAY GRAVELY
603 Main St.,
Danville, Va.</p> <p><i>Rocky Mountain Division</i>
PAUL M. SEGAL
c/o District Attorney
West Side Court Bldg.
Denver, Colo.</p> <p><i>Southeastern Division</i>
HARRY F. DOBBS
c/o Dobbs & Wey Co.,
Atlanta, Ga.</p> <p><i>West Gulf Division</i>
FRANK M. CORLETT
2615 Catherine St.,
Dallas, Tex.</p> |
|-----------------------------------------------------------------------------------------------------------------------------------------------------------------------------------------------------------------------------------------------------------------------------------------------------------------------------------------------------------------------------------------------------------------------------------------------------------------------------|----------------------------------------------------------------------------------------------------------------------------------------------------------------------------------------------------------------------------------------------------------------------------------------------------------------------------------------------------------------------------------------------------------------------------------------------------------------------------------------------------------------------------------------------------------------------------------------------------------------------------|-----------------------------------------------------------------------------------------------------------------------------------------------------------------------------------------------------------------------------------------------------------------------------------------------------------------------------------------------------------------------------------------------------------------------------------------------------------------------------------------------------------------------------------------------|

Officers

- President* HIRAM PERCY MAXIM, Hartford, Conn.
Vice-President CHAS. H. STEWART, St. David's, Pa.
Secretary KENNETH B. WARNER, Hartford, Conn.
Treasurer ARTHUR A. HEBERT, Hartford, Conn.
Communications Manager . . . F. EDWARD HANDY, Hartford, Conn.

Address General Correspondence to Executive Headquarters, Hartford, Conn.

EDITORIALS

ABOUT the time that amateur radio was so agitated recently with the fear that broadcasting was going to succeed in extending itself downward to 150 meters, losing our upper band for us, numerous letters were received at Headquarters from worried members who had one strange illusion in common—that the amateur had been “pushed off waveband after waveband”.

Nothing of the sort ever happened, but there is a thought in the discussion which it is very worth while to absorb and profit by.

Under the old 1912 law the amateur was handed the entire huge wave region below 200 meters. Did he use it? He did not. In the days before broadcasting the average amateur wavelength was about 240 meters—that is, before short waves were developed. We had just about succeeded in beating ourselves down into a beautifully concentrated mess on 200 meters flat when the desirability of shorter waves was discovered. Promptly we started segregating on certain other points below 200 meters but of course we did nothing to occupy all of the territory and by that time there were plenty of other radio interests who wanted short waves and the business of “allocation” commenced. However, even then we were allowed slices all through the territory and got just about the slices we asked for—in the face of the wishes of a lot of other interests.

To-day we are going through the same thing again—we sit around and howl about our fancied grievance in being “pushed off of” some imaginary wavelength while we continue to concentrate in terrible numbers on the 80- and 40-meter bands and neglect all of the others although urged every month to show some signs of life. We are the same fellows that QST had to use a club on a few years ago to get us into activity on 80 and 40. We are the same fellows who, a year or two from now, will be just as busy bragging about how “we amateurs” (meaning Phelps, Kruse, Douglas, Ducati, and a few others) “spent our time and money developing the five-meter band and now the commercial interests (sniff-sniff) want to take it away from us”.

The point in all of this is that it does not appear to us at Headquarters that we amateurs are making enough use of the 20-meter band. It is extremely valuable territory, of absolutely prodigious possibilities, and it will be most jealously sought after by commercial interests. There is going to be

a huge short-wave scrap about October and if we cannot at that time show a most full and complete use of this band and establish it as essential to our future welfare, we will have much difficulty in retaining it. It is summer now, the time when 20-meters can demonstrate its greatest usefulness, and if only we will display a little pep and make use of the wonderful possibilities of this wave, we will have a clean-cut case to present to the world. But it will take a whole lot more 20-meter stations than one can hear nowadays!

AMATEUR radio is all right. We have heard so many Old Timers the last year or so grumbling in disappointment about things that were the matter with the game that we have looked into it pretty thoroughly and it seems to us that it is all right. Our idea is that these things are complained about, not because conditions are worse, but because conditions are different. Of course they are different. As we have said so many times, there once was a time when radio amateurs had only one hook-up, the old standard arrangement for a spark station, and there was nothing to do with it but operate, and so in those days the brasspounder rose to great heights and message handling was a fine art. Those of us who lived in the game at that time can never think other than most highly and almost reverently of those “good old days”, but we must not allow ourselves to feel that any other form of amateur radio is worthless. To-day we have not only the brasspounder message-handler but the experimenter and also the “rag-chewer” who gets his fun out of personal contact with his friends all over the world. These three types of amateurs furthermore are distributed between five active amateur bands. A perfectly terrible condition, you say? Not at all—it’s merely different! Of course it is different—it is progress. Similarly it has introduced its new problems into our operation, giving us increased difficulty in maintaining contact with our fellows in the other bands, and emphasizing our need for some medium for keeping these diversified activities coordinated.

Here is where the A.R.R.L. comes into the picture. It becomes perfectly apparent that we have a greater need for our League now than we ever have had in the past. Our League coordinates the work of ama-

teurs in these various lines of activity and in all of these many bands. Through QST it binds us all together and develops loyalty to the organization in which we find our common meeting place and confidence in its works.

American amateur radio in its changed

circumstances and with no League would indeed be in a bad way. But we amateurs have our League, a blessed tie that binds, and thru it we are able to benefit by all the changes in our circumstances that spell progress.

K. B. W.

Standard Frequency Transmissions

THE Official Wavelength Station Committee of the Experimenters' Section, A.R.R.L. announces the following standard frequency schedules. The frequency values at 1XM and 9XL are based on the standards of the Bureau of Standards and have been checked by the Cruft Laboratory at Harvard University and by the Communications Laboratory of the Massachusetts Institute of Technology. While the accuracy of 1/10 of 1% is to be expected, no guarantee is made other than the one that transmission will be suspended if errors are found by the O.W.L.S. Committee.

Station 1XM is operated by the Communications Division, Massachusetts Institute of Technology and the M.I.T. Radio Society, Cambridge, Mass.

Station 9XL is connected with, and a part of, the "Gold Medal Station" at Anoka, Minnesota, full details of management and operation appearing in our March issue elsewhere in this issue.

In the following, "f" is the frequency in MEGACYCLES and the *approximate* wavelength in meters follows.

SCHEDULES

(Figures are frequencies in MEGACYCLES per sec.: approx. wavelengths in parentheses)

Friday Evening Schedules			Sunday Afternoon Schedules		
Eastern Standard Time for 1XM			Eastern Standard Time for 1XM		
Central Standard Time for 9XL			Central Standard Time for 9XL		
Time (PM)	Schedule A		Time (PM)	Schedule C	
	f	λ		f	λ
8:30	2.50 (85.7)	6.50 (46.1)	3:00	10.0 (30.0)	
8:42	3.60 (83.3)	6.75 (44.4)	3:12	12.0 (25.0)	
8:54	3.75 (80.0)	7.00 (42.8)	3:24	14.0 (21.4)	
9:06	3.90 (76.9)	7.25 (41.3)	3:36	14.5 (20.7)	
9:18	4.00 (75.0)	7.50 (40.0)	3:48	15.0 (20.0)	
9:30	5.70 (52.6)	7.75 (38.7)	4:00	15.5 (19.3)	
9:42	6.50 (46.1)	8.00 (37.5)	4:12	16.0 (18.7)	
9:54	7.00 (42.8)	8.25 (36.3)	4:24	18.0 (16.7)	
10:06	7.50 (40.0)	8.50 (35.3)	4:36	20.0 (15.0)	
10:18	8.00 (37.5)	8.75 (34.3)			
10:30	8.50 (35.3)	9.00 (33.3)			

Date	Schedule	Station
June 3,	A	9XL
June 12,	C	9XL
June 17,	B	9XL

DIVISION OF TIME

3 minutes—QST QST QST nu (Station call letters)
3 minutes—5 sec. dashes broken by station call letters every half minute.

1 minute—announcement of frequency in megacycles per second (8.75 megacycles per sec. is sent as "8 r 75 MC")

1 minute—announcement of next frequency in megacycles per second.

Special Notice—The continuation and possible extension of these transmissions depends entirely upon the response of the A.R.R.L. If you use the transmissions send a note to Experimenters' Section, A.R.R.L., Hartford, Conn.

R. S. K.

Official Wavelength Stations

THE Official Wavelength System furnishes a service cooperative with, but differing from, that of the Standard Frequency Stations 9XL and 1XM, which are also operated in accordance with plans made with the O.W.L.S. Committee. Contact with the O.W.L.S. is through Mr. D. C. Wallace, 6AM, who is also chairman of the committee. Mr. Wallace is at present checking up all O.W.L.S. to make sure that they are really indicating their wavelength (or frequency) at the end of each transmission—and are doing so with proper accuracy; which is to say 2%. They do this in the course of regular operation and do not send calibration schedules as do the S.F. stations.

The list is as follows:

1AAC, 1AVW, 1AWW, 1BHW, 1BZQ, 1CCW, 1CK, 1KP-NRRC, 1ZL, 1ZO, 2CLA, 2DS, 2MU, 2SZ, 2XI, 3APV, 3BE, 3XW, 4LK, 5AGN, 5AKN, 5EW, 5MN, 5OX, 5PH, 5SP, 5XBH, 5ZAV, 6AKW, 6AM, 6BB, 6BCP, 6BGM, 6BQB, 6CAE, 6CDN, 6CVO, 6LJ, 6SX, 6TI, 6TS, 6XAG, 6XAO, 6ZE, 6ZZH, 6ZV, 7AGL, 7BE, 7BU, 7GQ, 7NX, 7QK, 7XF, 7ZX, 8AA, 8APZ, 8BAU, 8BZT, 8EQ, 8GU, 8GZ, 8XC, 8ZG, 9AXQ, 9BCH, 9BGK, 9BMR, 9CPM, 9CXU, 9DXN, 9EGU, 9ELB, 9FF, 9IG, nc1AE, nc2BE, nc3CO, nc3NI, nc3FC, nc4BT, nc4FV, nc9AL, eg2OD, eg2SE, Ireland 5NJ, oa2CM and oa2AC. Crystal Controlled O.W.L.S.: NKF, 1AXA, 2BO, 2BRB, 2EF, 2WC, 4BY, 4XE, 6AOI, 6DLL, 8CMM, 8DAJ, 9AUG, 9BVH, 9UZ-NRRL, 9ZA, eg2NM, eg5LF and oa5BG.

Standard Frequency Stations: 1XM and 9XL.

New Short-Wave Receivers

IN the following there are presented several short-wave receivers that offer some distinct advantages for either 5- or 20-meter work. It happens that they were all devised for 5-meter work but the ideas used are not tied to that wavelength.

In looking over these receivers it must be noted that some of them use series-tuned input circuits and others use shunt-tuned

In theory, the shunt-tuning arrangement gives one a chance to "swamp out" the variations of tube capacity by putting them in parallel with a considerably larger tuning capacity. At 5 meters this is probably nothing more than a pleasant theory for one can not well use a condenser minimum that is large enough to give the effect and if one can not have the effect over the entire scale it isn't worth considering.

At Fig. 1B, we have one of the possible forms of series-tuned input circuit. Obviously this allows neither rotor nor stator to be grounded and they must accordingly be kept away from the hands and from metal panels to permit operation. On the other hand, this series arrangement obviously permits the use of more turns in L_1 (or else of a larger single turn) and that may be an advantage.

Another consideration apart from those just mentioned is that since the detector is to oscillate, it will be desirable to use some oscillation control which does not have too much tuning effect. As has been said many times, the resistance-control method usually has less tuning effect than the variable-condenser method—the old Weagant arrangement that most of us use. On the

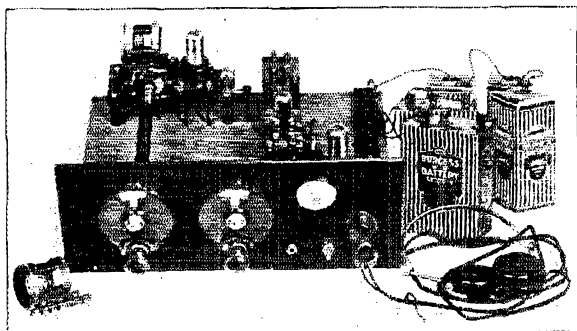

THE TUNER AS A WHOLE—THE LEFT DIAL DRIVES THE TUNING CONDENSER THRU THE EXTENSION SHAFT WHILE THE RIGHT ONE DRIVES THE REGENERATION CONTROL RESISTANCE WHICH IS MOUNTED ON THE PANEL. THE 2 STAGE AUDIO AMPLIFIER IS AT THE RIGHT OF THE SET

circuits. The respective advantages of these arrangements may be touched on briefly with advantage in understanding the receivers.

Referring to Fig. 1 we have at A the usual shunt-tuned or parallel-tuned arrangement in which the tuning condenser C_1 is connected across the capacity C_{gp} which latter capacity is composed of the capacity inside the tube and socket. The advantage of this arrangement is that the shape of the tuning curve can conveniently be set in advance by choosing the shape of the condenser plates, in fact that is what is done in broadcast receivers. With some ordinary care the receiver will not be off the correct curve a great deal when it has been made provided C_1 is not too small as compared to C_{gp} . The italicised part of the last sentence points out that in a 5-meter receiver the rule may fall down, and in fact it does somewhat tend to do just that. Another very real advantage of this arrangement is that the rotor of the condenser can be connected to the filament and grounded, permitting hand-capacity to be removed without extension tuning controls. This is a most convenient thing at 5 meters and enough to decide the choice of circuit if one intends to use a metal case or chassis.

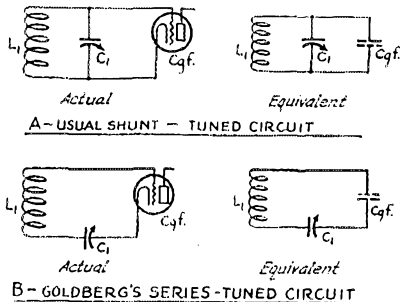

FIG. 1 SERIES AND SHUNT TO INPUT CIRCUITS

A is the usual input circuit with the tuning condenser in shunt or parallel to the capacity of tube and socket while B is a series arrangement. The grid leak and condenser have been omitted in both cases for simplicity. In the actual set, the grid leak would be connected across C_1 in the B circuit and therefore a small choke coil in series with it would be advisable. The A circuit requires a separate grid leak and condenser or else the filament return can be made to the slider of a potentiometer connected across the filament battery.

other hand, the condenser method tends to be a bit quieter and smoother. In any case it is easier to get satisfactory regen-

eration control when there is ample grid-circuit inductance to couple to, which again suggests the use of the series circuit in spite of its difficulties.

THE "NOISE LEVEL"

Those who have done much 20-meter work know that the "noise level" is much higher there than at 40 meters, and those who have proceeded to 5 meters know also that it rises rapidly below 20 meters. This has been the main stumbling block in 5 meter and 20 meter work, especially since Mr. Ford's cars "peak" at about 6.4 meters and others peak at various waves from 6 to 14. This constitutes another problem and a rather accidental partial solution of that problem is shown in one of the following tuners.

The following is then to be taken as showing three tuners each of which has combined these considerations in different ways, the results in each case being a practical 5-meter receiver whose principles are applicable to 20-meter work and to some degree to 40-meter work.

A 5-Meter Receiver With Series Tuning and Resistance Control of Regeneration

By Don. H. Mix*

IN the January, 1925, issue of QST, Mr. M. W. Goldberg, of St. Paul, Minnesota, touched upon a five meter receiving circuit which seemed sufficiently promising to warrant further development. During the

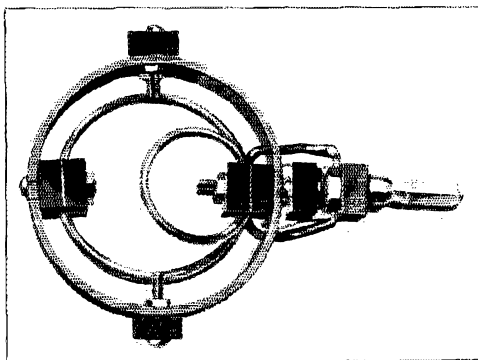

THE 4.65 TO 5.15 METER COIL SYSTEM

past year or two, several tuners have been constructed by the staff at 9XH-9EK for experimental work at wave-lengths within the five-meter band assigned to amateurs. Final form of the circuit is shown in Fig. 2.

* 9EK-9XH C. F. Burgess Lab. Inc., Madison, Wisconsin, also 4DM, "Burgess Isle," Fla.

The input circuit is series-tuned, to permit the use of a longer tuning inductance.

As in any receiving tuner, one of the first problems is to obtain a smooth tuning

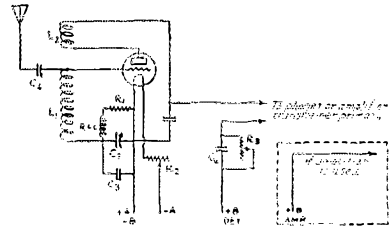

FIG. 2 CIRCUIT DIAGRAM

- L1 Tuned circuit inductance
- L2 Tickler or plate circuit inductance
- C2 Variable tuning condenser (about 23 picofarads)
- C3 Fixed air condenser (about 18 picofarads)
- C4 Antenna coupling condenser
- C5 Plate circuit by-pass condenser (500 pfd.)
- C6 Oscillation control by-pass condenser (1/2 ufd.)
- R1 Grid leak (10 megohms)
- R2 Filament rheostat (30 ohms)
- R3 Variable high resistance (100,000 ohms maximum)

curve. To know how to go about this one must first analyze the input circuit briefly.

It will be seen that, if the fixed capacity C3 is omitted, the variable capacity C2 and the internal capacity of the detector tube in series constitute the resultant capacity across the inductance L1. The curve of Fig. 2 illustrates the resulting capacity of such an arrangement. In this illustration, it is assumed that the capacity of the tube and socket, which remains constant, is 20 picofarads and that the tuning capacity C2 has a range of from 10 to 50 picofarads. This curve is obtained from the equation for the resultant capacity of two capacities in series,

$$C = \frac{C1 \times C2}{C1 + C2}$$

where C1 is the capacity of the tube and socket and C2 is the capacity of the variable C2.

An examination of the curve will show that, as the capacity of C2 increases toward the value of C1, the resulting capacity curve is very steep and curved, while as C2 increases above the value of C1, the resulting capacity curve approaches a straight line of moderate slope. From this it will be seen that it is very desirable to use only the upper part of such a capacity curve to secure a slow and even tuning control. This can be done by making the condenser in two parts of which 30 pfd. is fixed capacity and only 20 pfd. variable. Thus, if A-B of Fig. 3 is made a fixed capacity of about 30 picofarads and B-C is made as the tuning capacity of about 20 picofarads maximum, the variable capacity merely varies

the resultant capacity over the section B-C of the curve and the desirable tuning conditions are secured. The foregoing is merely an illustration and does not give the exact values for this receiver altho the actual values do not differ greatly from those given in the illustration.

Experience in work at longer wavelengths has shown that a tuning range of about 7,000 kilocycles for a tuning dial scale of 100 divisions per 180 degrees is permissible for convenient operation. As it is always desirable to provide an overlap on both sides of the assigned wavelength band, it is necessary for a five-meter tuner to cover a frequency range of about 13,000 kilocycles which means that a system of at least two plug-in inductances is necessary to cover the desired band under the conditions outlined above. In this receiver, two inductance coils are used. Coil No. 1 has a range of 4.6 to 5.15 meters or 6900 kilocycles while Coil No. 2 has a range of 5.03 to 5.6 meters or about 6000 kilocycles.

Measurements show that the internal capacity of the type UX-199 tube is about thirty percent lower than that of all others commonly used and for this reason is used in this receiver.¹

Control of oscillation is secured by means of a variable high resistance in the detector

DETAILS OF CONSTRUCTION

The baseboard is made of wood 15 1/4" x 12" x 3/8". It is mounted on strips of hardwood 3/8" x 5/8". This permits sub-base wiring of the audio amplifiers and prevents any possible warping of the baseboard.

The antenna coupling condenser, inductance coil mounting, tuning condenser with

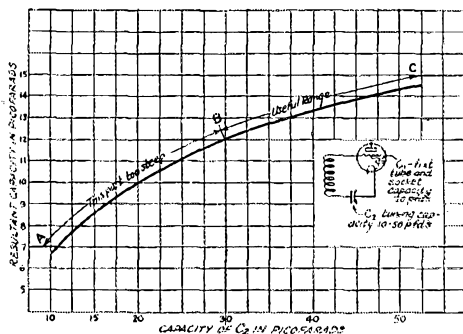

FIG. 3 CURVE SHOWING RESULTANT CAPACITY WHEN VARYING A CONDENSER IN SERIES WITH A 20 PFD. FIXED CONDENSER

The circuit diagram shows how this applies to the 5-meter tuner.

its accompanying shunted fixed air condenser, detector socket, grid leak mounting, and plate circuit by-pass condenser are mounted as a unit on a base 6 3/8" x 2 1/2" x 1/4" which, in turn, is supported on four hard rubber or wooden posts to secure the desired elevation above the baseboard. The fixed air condenser and the plate circuit by-pass condenser are mounted on the under side of the rubber base. This arrangement allows extremely short leads between the units of the tuned circuits which is highly important. Fig. 4 shows the details of the coil forms and the jack-strip into which they are plugged.

The tuning condenser is made from a General Radio "micro" type condenser. All but three rotary and two stationary plates are removed. The fixed air condenser shunting the variable may be from the removed plates using two rotary and two stationary plates. The spacing between the plates of the fixed condenser should remain the same as in the variable condenser. The tuning unit is mounted well back from the control panel to reduce any possible body capacity effects. An extension control shaft for the variable condenser is shown in Fig. 5.

THE COILS

The two coils are both wound on forms like those of Fig. 4. The form for Coil No. 1 differs from that for Coil No. 2 in that the wire hole marked X is omitted in Coil No. 1. Both coils are of No. 12 enameled wire wound to a 1 3/8" diameter. Coil No.

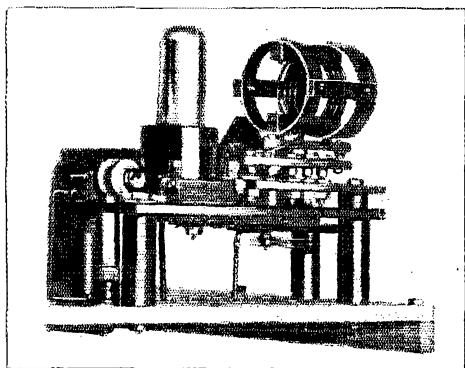

THE TUNING SYSTEM AS SEEN FROM THE BACK OF THE SET

Directly under the coil system is the fixed air condenser C₁, made of the extra plates taken from the tuning condenser C₂.

plate circuit. This form of control has a minimum tuning effect when changing the degree of regeneration. Care should be taken in selecting the variable resistance. Secure one in which the resistance varies smoothly and not in steps of several hundred ohms.

1--The UX112 oscillates more easily at 5 meters, however. It is a matter of personal choice.—Tech. Ed.

2 has four full turns while Coil No. 1 has three full turns and a small fourth turn which is drawn down to about $\frac{7}{8}$ " outside diameter and is supported only on the lower side (see photograph). This turn should be drawn down gradually from full size until the desired wavelength range is se-

are used throughout this assembly. The coil plugs may be obtained from General Radio Company.

In constructing a five-meter receiver, shortness of leads and firmness of all wiring and mounting of units are most important factors. The slightest shifting of

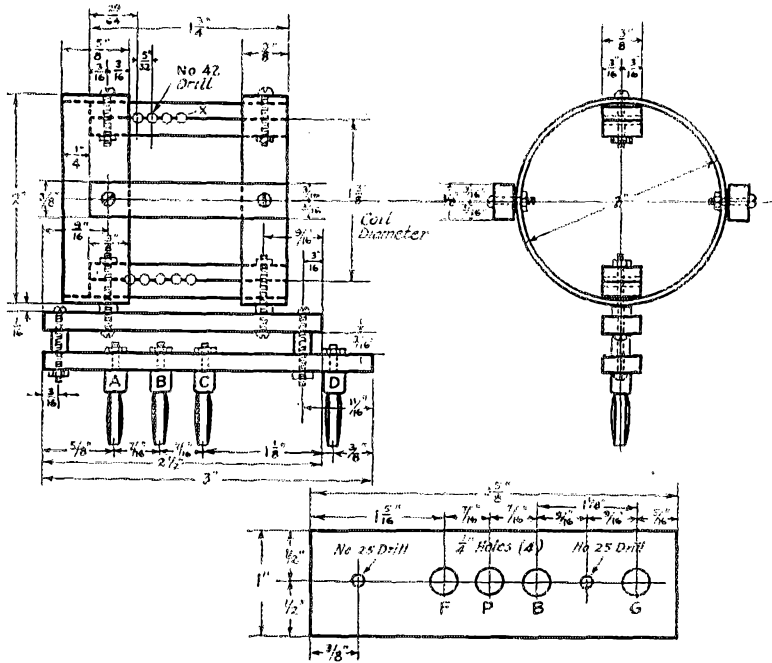
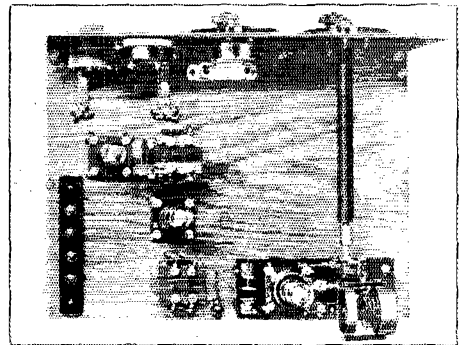

FIG. 4 COIL FORM AND JACK STRIP

A-B-C-D are General Radio spring plugs, F-P-B-G are drilled to take the corresponding jacks.

cured. A tickler winding of one turn of small magnet wire is wound on the projection of the left hand end supporting tube. This turn should be located about $\frac{3}{8}$ " from the tuned circuit winding.

While the inductance forms may appear to be difficult to construct, those shown in the photographs were made with only a hacksaw and a hand drill in a few hours time. The end supporting rings are first cut from bakelite tubing of 2" diameter. The circumference of each ring is then divided into four equal segments and the holes for the supporting strips located and drilled. The cross supporting strips are next cut to the required dimensions, the pairs matched and clamped in a vise, and the end screw holes drilled. The end screws are then inserted and the wire holes drill $\frac{5}{32}$ " apart with a No. 42 drill. The form is then assembled leaving off the upper pair. The wire coil is then inserted inside the support and clamped in place with the remaining strips. No. 256 machine screws



PLAIN VIEW OF THE SET

Just to the left of the tube socket is the antenna series condenser C, which consists of two discs of about $\frac{1}{2}$ " diameter, spaced to suit the antenna used.

wiring or location of units may make a signal unreadable. The detector tube should not be mounted in a flexible socket. If

microphonic noises are found to be objectionable, the entire receiver should be mounted on rubber sponges or other shock absorbing materials.

Under normal conditions, a B battery voltage of 90 has been found most satisfactory for the detector.

Several tests were made with this model and no difficulty was experienced in lo-

tuning. It is, of course, also much more sensitive.

The layout is given in the photograph and in the diagram of Fig. 7 and needs no great amount of comment.

The detector circuit is a simple oscillator circuit with a series tuning condenser C_1 , in this case a 1-bearing midget with a capacity of 135 μf . The tube is shunted by another midget C_2 of lower maximum and by turning this a few degrees the tuning range is shifted, after which another small band can be covered by C_2 . Since C_2 is the condenser used while tuning it is operated by a long extension shaft of fibre to minimize hand capacity effects.

The 5-meter inductance consists of one turn of soft copper tubing, the two halves of which are supported by the condensers. The leads from C_2 to the tube are of very small wire in order to keep the tube from picking up jars and vibrations. The tube is insulated by being mounted on a rubber sponge.

The type of tube used is immaterial, tho a hard high- μ detector tube seems to be the most sensitive. In any case a tube which has its elements rigidly supported is best by all means.

REGENERATION CONTROL

The regeneration control is effected thru a UX-199 used as a resistance. This is tube VT2. A little study will show that if the grid potentiometer of this tube is moved the plate resistance will vary. This feed-back control was used to obtain a fine adjustment of regeneration and to get away from the noises made by the usual resistance-control.² This arrangement seems to be much better than the usual resistance control and retains the advantage of not changing the tuning as the throttle condenser scheme does. The idea can be employed very nicely in the other amateur bands.

THE VARIATION-FREQUENCY OSCILLATOR

The sensitivity of the super-regenerative circuits depends on getting the detector so adjusted that it tends to oscillate and then in some fashion throwing it rapidly in and out of the oscillating condition by changing the grid or plate voltage at a high audio rate. Whenever the voltages are such that the tube wishes to oscillate it will amplify very strongly but before it can actually oscillate, the voltages are again changed and it is prevented from "flopping over."

In the circuit here shown the grid volt-

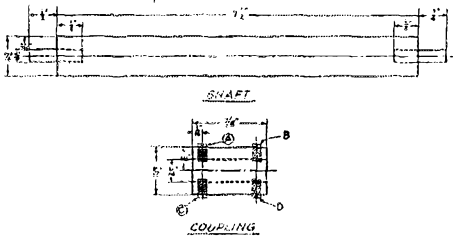

FIG. 5 EXTENSION SHAFT AND SHAFT COUPLING FOR TUNING CONDENSER

The shaft is of $\frac{5}{16}$ " round hard rubber with $\frac{1}{4}$ " round brass rod inserts. The coupling is of $\frac{1}{2}$ " round brass with 4 set screws A-B-C-D.

eating and holding signals of an audibility as low as R-2 or R-3. While experiments with this circuit were confined chiefly to

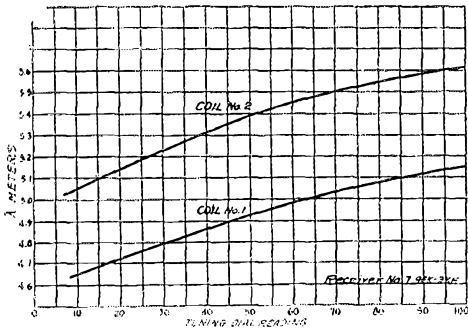

FIG. 6 THE TUNING CURVES OF THE SET AT 9EK-9XH

Warning—Very slight differences in construction will produce entirely different curves, hence these will not fit another tuner.

wavelengths in the vicinity of five meters, it was found that excellent results may be obtained at 20, 40, and 80 meters using larger capacities and inductances.

A Super-Regenerative 5-Meter Receiver

By Frank C. Jones**

THE 5-meter receiver used here is of the super-regenerative type and is much easier to handle on 5 meters than the ordinary set because of its broadness in

2. The condenser shunted around the control resistance in the receiver described by Mix is to cut down this very noise which is the main objection to this sort of control.—Tech. Ed.

**Experimenters' Section, 6AJF, 1715 Schiller Street, Alameda, California.

age is varied 12,000 times per second by the 12,000 cycle oscillator VT3, which is simply a tuned-grid oscillator made by putting a fixed shunt around one winding of a superheterodyne I.F. transformer to make a circuit resonant somewhere around 12 Kc. Some of the 12 Kc. power from the grid of this tube is fed to the grid of the detector

been settled since we still find that builders of superheterodynes for 40- and 80-meter c.w. work always give them up again—the wildly enthusiastic at first. We do not know just why this is so.

At 5 meters and at 20 meters our trusty oscillating detector-plus-audio jugs have been running into a new difficulty, that of

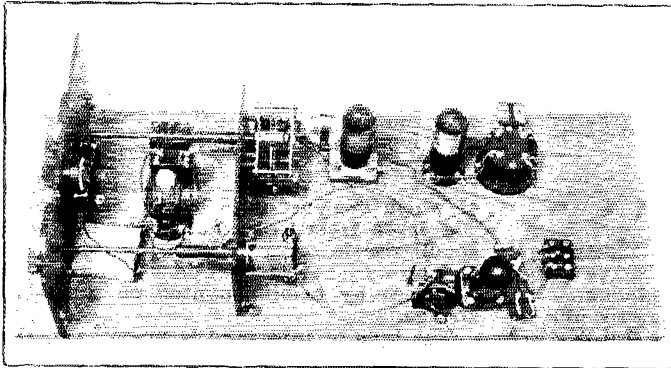

THE SUPER-REGENERATIVE RECEIVER WITH TUBE-RESISTANCE CONTROL OF DETECTOR REGENERATION

At the right front is the detector tube. At the right rear is the 12 Kc. oscillator and to the left of that the 100-meter oscillator with its tuning condenser. Nearest the panel is the regeneration control tube VT2 with its bypass condenser and the 4½-volt part of its battery. The 3-volt part of the battery is external and is connected to the terminal block which can be seen underneath the rearmost condenser shaft.

through the $1/10$ megohm resistance R and acts as an alternating C battery, swinging the detector tube in and out of the oscillating condition 12,000 times per second.

THE HETERODYNE

Since a super-regenerator does not make a beat note but acts simply as a highly sensitive detector, it is necessary to provide a heterodyne tube to create the beat note. The separate oscillator for heterodyning to an audio frequency works over a narrow band around 100 meters, one of its harmonics being used to beat against the incoming signal. The only important point about the oscillator is to use a *small* condenser for tuning it, so as to make it easier to find the harmonics and keep them in the 5-meter band. The condenser used here is a 3-plate receiving condenser with a vernier dial.

A Combined Superheterodyne and Detector-Audio 20-Meter and 5-Meter Receiver

By Robert S. Kruse, Technical Editor

AS every reader of *QST* knows the relative merits of the oscillating detector-plus-audio as against the superheterodyne have been argued about for several years. The question seems not to have

a terrific "noise background" made up of all sorts of electrical noises with the automobile contributing heavily by means of the unlicensed automatic transmitter it carries under the name of an ignition system. The Ford is the worst offender, because there are more of them and because it makes such a handful of sparks for each explosion. These affairs seem to "peak" at 6.4 meters but they are broad enough so that there is little escape from them anywhere below 25 meters—and none at all at 5 meters. In addition to this, the general awful hash of electrical noises in any large city made

life miserable for Phelps and myself whenever we tried to do 5-meter radio mapping around 2EB, and it was none too quiet around 10A, for Hartford has its fair share of industrial electrical loads.

OUR REASONING

Now we had always reasoned this way: If I am using an autodyne detector it does not matter where the noise comes from; as long as the confounded thing gets into the grid circuit it will jolt the grid and the tuned input circuit will oscillate *at its own rate* so that the noise will come right along with the signal regardless of the apparatus that follows after the detector. Therefore, I can't hope to get rid of this electrical noise and will simply have to swear and bear it. There remains only one question—what wavelength should I autodyne the 5- or 20-meter signal to?

Naturally (if that line of reasoning is correct as we believed it to be for the last year or so) there is only one answer; one should autodyne to the wave at which one can get the best amplification. That is to some such wavelength as 300,000 meters, which is to say 1000 cycles (which is an audio frequency). Then we will use an audio amplifier and amplify at the rate of 30-per-stage and in two stages will have

lots of signal and the whole thing will take only three tubes, the autodyne detector and two audio.

Now that is fine—except that the noise comes right along with the signal and when the signal is a “phone lifter” the noise is—our audibility meter only goes to 10,000 audibility!

THE WAY IT WORKED

When we took out the detector-2-step receiver and listened for the automatic 5-meter transmissions of 10A or 2EB they

read the signals. A year of this sort of thing becomes exceedingly monotonous and we would have dropped the whole busi-

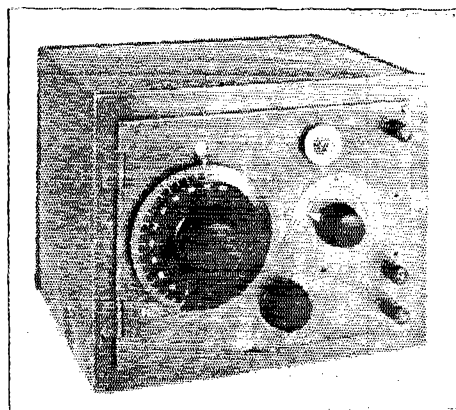

A COPPER-SHIELDED AUTODYNE DETECTOR 5-METER RECEIVER

Built by C. H. West of Stapleton, New York, 2CSM. The large dial operates the throttle regeneration control, the small knob operates a 5-pfd. tuning condenser which is shunted across the fixed capacity of the strap wiring. An exterior audio amplifier is used.

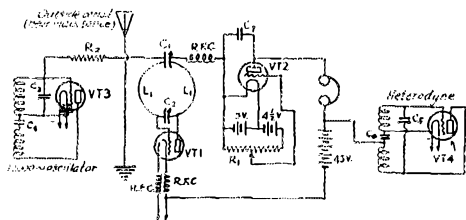

FIG. 7. CIRCUIT DIAGRAM OF THE SUPER-REGENERATIVE RECEIVER WITH TUBE-CONTROL OF REGENERATION

- VT1 Detector
- VT2 Regeneration control tube
- VT3 Variation-frequency tube oscillating steadily at 12 Kc.
- VT4 Heterodyne to create beat note. Tunable in neighborhood of 100 meters.

All batteries are common except the ones connected to VT2 which are separate dry cells.

- C1 135- μ fd. one-bearing midget condenser (tuning)
- C2 40- μ fd. of same type (band selector)
- C3 250- μ fd. fixed condenser tuning the grid cct. of VT3 to 12 Kc.
- C4 and C6 1,000- μ fd. bypass condensers
- C5 25- μ fd. tuning condenser for heterodyne

C1 and C5 are operated by fibre extension shafts as they are the active controls with which the set is operated.

C7 1-microfarad audio bypass condenser
 R, Potentiometer to control grid bias of VT2, thereby controlling its plate resistance, thence the plate voltage of VT1 and in turn the regeneration of that tube. This control need not be used much with a super-regen. hence the tuner is practically 2-control. R₁ has a resistance of 2000 ohms.

R₂ Coupling resistance connecting VT3 grid to the grid of VT1. (1/10 megohm).

L1 One 5-inch turn of copper tubing.

Note—the antenna merely runs near the inductance L₁ but does not connect to it. It could, of course be coupled to the inductance more closely but this is not necessary.

The chokes are basket weave, 30-40 turns of 5/8" diameter.

ness had not the signals at various times gotten themselves copied at remote points.

Finally it seemed to me that the one hope of the whole thing for us was somehow to improve the ratio $\frac{\text{signal}}{\text{noise}}$. If we

could not do that we were licked on the 5-meter game—and 20 is almost half as bad at times.

Looser antenna coupling did not do it, signal and noise went down together. The super-regenerator had been tried and while it gave good sensitivity the noise came up with the signal as far as these two cities are concerned.

The only remaining dodge seemed to be the superheterodyne, which according to our reasoning was no good because the noises were sure to heterodyne (or autodyne) to the intermediate frequency and come right thru with the signal.

THE WAY OUT

That is where we were wrong. I have found that the noise drops off in a ratio of almost 1000/1 when the noise is coming thru with the signal, the ratio being in audibilities, while the signal is a very little (3 times or so) better than before. This knocks one of our beliefs in the head but at the same time confirms one of our other beliefs, namely that the sensitivity of the c.w. super isn't enough above that of the ordinary arrangement to warrant the ex-

were lost beneath the fearful row that I have politely called “background” as soon as we got some 60 miles from the station. Repeatedly I drove from Hartford to New York listening with the utmost intentness at points 10 miles apart along the road and was unable to hear the signal of 2EB or 10A consistently, until within 45 miles of the station, and then only by exercise of the greatest concentration was it possible to

tra machinery at 40 or 80 meters *unless* one has a noise there that might be cured with the super. (I do not promise the cure at those waves.)

Now I will admit that this disconcerted me exceedingly because the "widest-open"

THE NUMBER OF I. F. STAGES

The next question was as to the proper number of I.F. stages. Since potentiometer control of the I. F. regeneration was to be used, it seemed reasonable that 3 would be no better than 2, and this proved to be

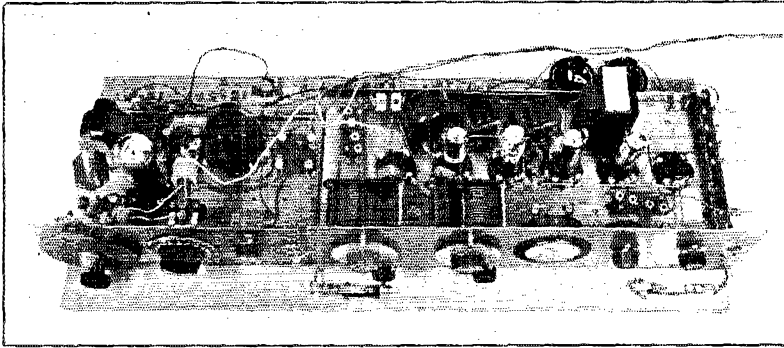

THE COMPARISON SET FOR TESTING THE SUPERHETERODYNE AGAINST THE AUTODYNE-PLUS-AUDIO

The unit at the left of the regular 5-meter receiver at 10A but the coils can be changed to operate at 20 meters. The unit at the right is a superheterodyne for broadcast waves (200-600) of which only the I. F. and audio parts are used, the tuning condensers not being in circuit.

With this tuner operating as a superheterodyne, 10A and 2EB at 5 meters have been copied easily at 5 miles without an antenna while the set was inside an automobile whose ignition system was in operation. With a 12-foot antenna the same thing was done with more difficulty at 50 miles from 10A. With the detector-plus audio this was impossible above 1 mile and the noise was severe. The whole thing could be hollid down to a superheterodyne occupying the left panel only. This would also do away with the external jacks and the baseboard, making the whole set about 10 inches long.

broadcast receivers, the ones first knocked cold by line leaks and amateur interference always seemed to be the supers. A little thought showed a possible explanation. We know that the oscillating detector is a much "stiffer" affair and considerably more stubborn about letting static and such things disturb it than is the non-oscillating detector. In our super the first detector was oscillating.

the case.

The next thing was to decide if the beat note was to be made by causing the second

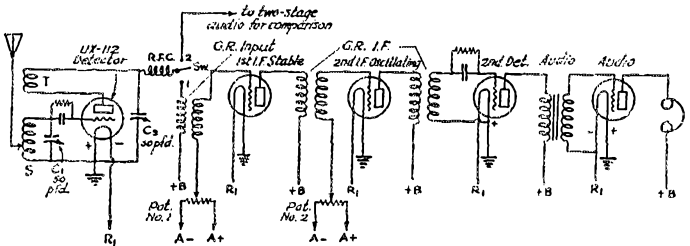

FIG. 3 THE SUPERHETERODYNE 5-AND 20-METER RECEIVER

S and T are the usual secondary and tickler coils, while C₁ and C₂ are the usual tuning and regeneration control condensers. Resistance control of the regeneration can of course be used if desired.

SW is the changeover switch, actually a plugging arrangement, which jumps the set to either audio amplification at 1000 cycles or to 2 stages of 30 Kc. amplification plus a 2nd detector and one audio.

All rheostats are in the negative lead as usual, the ground connections shown all actually going to the metal panel and base. The leads marked R₁ go to one rheostat while those marked R₂ go to another rheostat. This would not be necessary if the tubes were all alike.

While General Radio I.F. transformers are indicated they are not essential, nor is the particular combination shown necessary. Three transformers of the same type may be used.

AUTODYNE OR HETERODYNE

A few tests were made to compare an autodyne first detector with a heterodyne working on a non-oscillating first detector. It was a clear case—the autodyne was simpler, less open to noises and *vastly* more effective at different signal strengths (especially weak ones) because the strength of oscillation was controllable.

Fine! That saves at least a tube and one or two controls.

I.F. stage to oscillate or by using a separate heterodyne. I am not satisfied on this point as yet, but Phelps and I have both been using two I. F. stages of which each has a

separate potentiometer control and the first is stable while the second is oscillating weakly. The combination may not be the best but works very well.

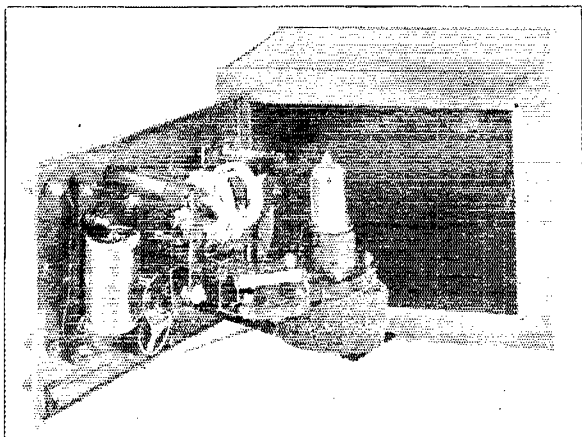

INTERIOR VIEW OF THE SHIELDED RECEIVER

In front of the r.f. choke coil may be seen the single vane of the widely spaced tuning condenser.

This accounts for 3 tubes. The second detector follows and since the noise coming thru is not bad we can stand one stage of audio with its nice high gain. This gives a 5-tube job which is about the nicest arrangement one can imagine in some regards—tho I will say nothing for the appearance of the present sample.

The Dakota Division Convention

THE Electrical Engineering Building of the University of Minnesota seems to be an ideal place to hold a convention and the response of the membership to this, the second Dakota Division Convention, held in Minneapolis on April 22-23, made the hearts of the convention committee feel good by the large attendance. The very fine program prepared showed unusual care and the way things were run almost made one feel that W. W. Swanson, 9XI, convention chairman, was a railroad man instead of a college student. There were so many good things it is hard to know just what to report. One of the big attractions was John L. Reinartz, 1QP-1XAM, who was radio operator for the Mc-Millan-Greenland expedition. Johnnie is always a good speaker and, while he was somewhat handicapped by the loss of his

beautiful lantern slides, his description of the voyage was most interesting; and we must not forget the other good talk he gave on practical amateur stations and operation.

Fred Schnell, former A.R.R.L. Traffic Manager and now Ambassador for the C. F. Burgess Laboratories, talked and demonstrated Don Mix's latest receiver which it is feared will relegate the "Schnell" Tuner to a thing of the past. Something new in a transmitter arrangement was demonstrated by W. H. Hoffman, 9EK, also of the Burgess Co., and we certainly have fallen hard for the neutralization of amplifiers.

With such good and well known traffic men as Cy Barker, D. F. Cottam, F. J. Beck and Communications Manager Handy, present, everybody learned all there was to know and there should be a marked improvement in our practices in the future.

Mr. Clough from Chicago showed himself familiar with the design and manufacture of coils and we were glad of the opportunity to meet him.

A. A. Hebert, A.R.R.L. representative, was prepared to give the delegates the latest information on radio legislation and if the silence during his speech was any indication of interest the information given must have made an impression.

Through the courtesy of the Electrical Engineers of the college an opportunity was offered to attend the Electrical Party given in the auditorium of the E. E. Building on Friday evening. There was a big attendance and most interesting electrical demonstrations.

All kinds of stunts were participated in by the fellows and the liars' contest brought some new ones to the delight of every one.

We reporters have to attend so many banquets that an extra one does not make much difference, but under the Toastmastership of L. V. Berkner, Chief Operator of 9XI, with the help of Wesley Barlow's Orchestra and a Humorist, whose name we did not learn but who seemed to know everybody, the assembly was put into a good mood. When Fred Schnell closed the entertainment with his inimitable recital of his trip aboard NRRL, there is no doubt that if a vote had been taken then it would have been unanimous that Prof. Jansky, Director of the Division, and all of his aides "put over" the best convention, and our sympathy goes to those who did not attend.

—A. A. H.

A Flexible Crystal Transmitter

By Edward M. Glaser*

THE transmitter to be described is about the tenth one of the crystal controlled type built for service at 2BRB and has proven itself very flexible and reliable. There are two separate units that make up the transmitter, the oscillator and the power amplifier. With a crystal, the frequency of which lies within the eighty-meter band, the power amplifier may be successfully operated in the 80-, 40- and 20-meter bands without the aid of any intermediate amplifier with very fine results.

THE OSCILLATOR

Almost any so-called "5 watter" will do but the 210 is to be preferred. The tube may be heated from the same filament transformer or generator, supplying the power amplifier, 203-A. Two small rheo-

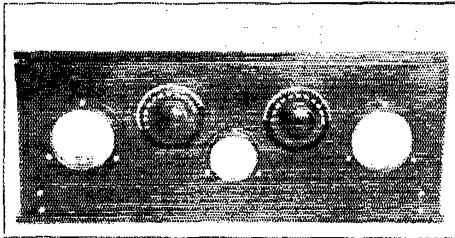

THE CRYSTAL OSCILLATOR IN ITS CABINET

stats, one in each leg, should be used, so as to preserve as nearly as possible the center-tap arrangement. The plate supply may be derived from the same source as that supplying the amplifier by inserting the proper resistance which will vary from 10,000 to 30,000 ohms depending upon a dozen or more things. A much better method, but somewhat more expensive, is to use a separate "high power B eliminator." A "dud" 50 watter serves as a rectifier tube being supplied from an Acme 75-watt power transformer which supplies 750 volts for the plate and 10 volts for the filament. A carbon pile rheostat is used in the primary of the transformer which cuts down the filament and also the plate voltage to any desired value and makes an extremely flexible unit with perfect control of oscillator input and, hence, output. A 216-B rectifier in any type of high voltage B eliminator with a primary rheostat will serve equally well. The eliminator should be capable of supplying at least 400 volts at 50 milliamperes, although the oscillator described requires but 300 volts at 30 milliamperes. If

the IR drop method thru plate resistances is used, the operator has almost no control over the oscillator input except by varying the C battery or by having tapped resistances with a suitable switch which, at best, can hardly be called flexible.

C BATTERY

I believe that a C battery is absolutely necessary for efficient operation, for most power, and for clean-cut keying, although it is possible to get the outfit working with grid leak resistances only. A resistance operates quite well on the oscillator as it runs steadily, but, since the C battery is needed for the amplifier, the oscillator might as well be plugged in on the same one. 45 volts is plenty of bias for the oscillator operating at 350-400 volts plate supply. The amplifier needs more, the value depending quite a bit upon the waveband being used in some cases. This might even be made an additional adjustment for changing wavelength, particularly if 20 meters is being used. It must be kept in mind that the more "C" bias used, the more r.f. power is needed to properly operate the power amplifier. At 1000 volts plate supply, the "C" bias will vary from 90 to 150 volts on 40 or 80 meters, but as much as 350 may be necessary to give the best results on 20 meters. Practically, however, not much over 200 volts need be used as good results have been obtained at 2BRB with that value. Additional bias will probably increase amplifier efficiency though. With 1800 plate volts on the amplifier, the "C" values just about double. Instead of a battery, a small motor-generator or dynamotor may be successfully used for "C" bias. Care must be taken, however, if the builder wants to use r.a.c. for this purpose. An ordinary B eliminator is useless! It must be remembered that the tube feeds d.c. energy into the source of "C" potential which will probably raise the voltage of an ordinary dry battery 10% or even more after operating for an hour or so. If a rectifier of the "eliminator" type is tried, a voltmeter connected across the output will show a very great increase in voltage when connected in the circuit and the key pressed.

Figure 2a shows the usual C battery connected between the grid and filament of the tube. The r.f. choke prevents the short-circuiting of the r.f. voltage being applied to the grid from the previous tube. The grid of the tube, being located between the plate and filament will be hit by some of the electrons traveling from the filament to the plate. These electrons unless they

*2BRB, 845 East 18th Street, Brooklyn, N. Y.

are leaked back to the filament will accumulate and make the grid negative in respect to the filament. A negative value may easily be reached which entirely cuts off the plate current. When the normal C battery is used, the electrons picked up by

tube. In practice, the leakage path is such that when the voltage gets to a very high value, it is able to cause a momentary discharge but as it builds up again in short order, this does not help matters materially.

This will cause input to the amplifier to drop to almost nil (especially if the cut-off point is reached where the tube blocks because of too much "C" bias) and will give a "swishy" note. A rectifier with a good regulation no doubt can be used very successfully. I haven't yet had the means of trying out such a rectifier. A single rectifier delivering 700 volts may, with suitable resistances, supply both "B" and "C" voltage.

It is advisable to put a 235-volt Mazda lamp in series with the plus lead of the "C" battery to protect the latter from a possible short-circuit via the crystal mounting or otherwise. This may also prove valuable as an indicator of resonance as it has at 2BRB on the 20-meter wave.

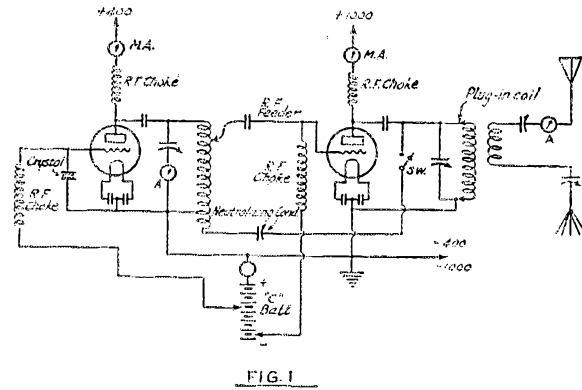

FIG. 1

the grid, leak back to filament thru it in the direction of arrow "c" and thus prevent any large accumulation. As the battery has a certain amount of resistance, referred to as its internal resistance, the flow of electrons (current) thru it causes a voltage drop across it which is added to the battery voltage. This results in a rise in the bias voltage but in this case it is not large enough to cause any trouble. In some amplifiers and most oscillating circuits, we use a resistance which leaks off the electrons at a given rate and there is always a mean number of the electrons on the grid to determine the negative bias. Under both of these conditions, the electrons may travel in either direction thru the bias arrangement, as shown by the arrows "b" and "c".

Figure 2b shows the bias obtained from a rectifier. The complete filter is omitted for clarity, a single condenser only, being shown. As indicated by the arrows, the electrons emitted by the filament, pass to the plate and thence through the r.f. choke to the grid. Any electrons picked up by the grid cannot get to the filament because they cannot pass from the plate of the Kenotron to its filament. This is shown by the direction of the arrows. The effect of adding electrons to the plate is to increase the voltage between the plate and filament of the rectifier tube. The effect is the same as though these electrons were supplied by the filament of the rectifier tube itself. From this we see that as the grid of the amplifier tube continues to pick up electrons which cannot get back to the filament, the bias voltage keeps getting higher and higher until it reaches a point where it completely blocks the amplifier

TUNING THE OSCILLATOR

The circuit is shown in Figure 1. A closed circuit ammeter which ought to be a good thermo-couple meter is used to indicate maximum output from the oscillator.

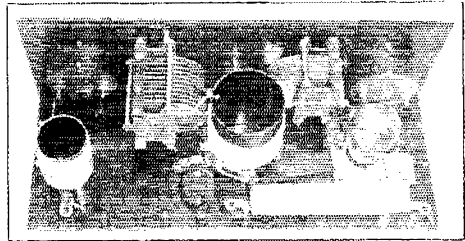

THE INSIDE VIEW OF THE CRYSTAL OSCILLATOR

The tuning condenser should simply be adjusted to the point of maximum current without causing any instability. This current will vary depending upon the amount of grid bias in use on the amplifier. It will be highest when the oscillator is operating by itself (without being hooked on to the amplifier). A meter with a 3-ampere maximum reading is most convenient. The filament of the UX-210 may be operated as low as 6.5 volts when the set is working properly which will materially increase the life of this tube. If the plate voltage can be decreased so that the amplifier will operate with 300 volts on the oscillator, about 22 volts grid bias should be used on the oscillator. A grid and plate r.f. choke are

essential. The plate circuit of the oscillator is tuned almost to the crystal frequency. The 210 generates the harmonics which are utilized directly by the power amplifier.

THE POWER AMPLIFIER

The amplifier is tuned to the wave band on which you want to work by simply tuning its plate circuit to this wave. The grid of the amplifier then picks up energy from the harmonics of the 210 to supply enough of its losses and to allow the amplifier to operate successfully on that frequency. It is possible to operate a UV-204-A directly from the oscillator on the first and second harmonics but it will probably not function properly on 20 meters unless an intermediate amplifier is used tuned to 40 meters. However, a 50-watter doesn't require as much power as the larger tube and will operate on 20 without the aid of an intermediate amplifier.

ADJUSTING THE P. A. ON 80 METERS

Plug in the 80-meter plate coil. Try putting the r.f. feeder one turn from the plate end of the oscillator coil. The nearer the plate, the more the power drawn from the oscillator up to a certain point where the power will decrease upon moving the clip nearer the plate. This point is usually about the last turn to the plate end of the inductance. Throw the neutralizing condenser in circuit and make sure it is connected to the low voltage side of the amplifier plate stopping condenser. (This will reduce the voltage across it and prevent a flashover.) Start with 90 volts C battery and about 500 volts on the plate. Start up the oscillator and light the amplifier tube. Keeping the key up, (if keyed in the plate circuit) wiggle the amplifier tuning condenser until an adjustment of the neutralizing condenser is reached where the wiggling causes no upsetting of the oscillator adjustment. This is the point of neutralization. You may never obtain perfect neutralization but it isn't necessary to get it perfect. A little movement of the oscillator millimeter is allowable when keying. Adjust the amplifier tuning condenser for the lowest plate current. Connect the antenna coil and tune the antenna circuit to resonance. Retune the amplifier slightly and also the neutralizing condenser if necessary. A slight adjustment may be needed due to feedback from the amplifier to the oscillator which is always present in some degree. Listen in on your receiver for some "squeaks" and see if they sound like C.C. Tune in a "squeak" from the oscillator and press the key. The amplitude should increase considerably. Tune around for some

"squeaks" that don't sound like C.C. (they will probably sound like a.c. or r.a.c. if present) while holding the key down. If these are present, the amplifier is oscillating which is not a healthy condition. Take your wavemeter and tune it to the oscillator. Press the key and hold it near the amplifier. It should be in resonance. If it is, the chances are that all is well. If self-oscillation is present, the amplifier will have to be rewired or at least some of the leads to and from the amplifier will have to be changed. If all seems OK, raise the input to normal by using about 150 volts "C" bias and 1000 on the plate. Everything should operate perfectly cool. If the tube heats,

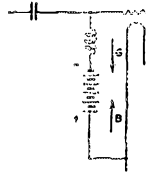

FIG 2A

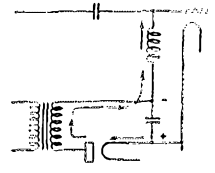

FIG 2B

something is wrong. Play around for a while and see if you can improve matters. You rarely hit it right the first time. The tube should take over 200 watts with ease and without getting red.

ON 40 METERS

Start with reducing voltage as before. Open the switch that disconnects the neutralizing condenser and insert 40 meter plate coil. Tune the plate condenser to the minimum plate current. Take the wave with a wavemeter. It should correspond to twice the crystal frequency. Test for C.C. by listening in on the receiver as before. Another test which usually works is to detune the plate condenser slightly and check the wave again. If it hasn't changed, the chances are that all's well. A slight detuning of the amplifier plate condenser should never shift the wavelength if the crystal oscillator is operating properly. When confident that everything is working as it should, increase power and tune the antenna to the 40-meter wave. You might need more C battery than on 80 meters.

ON 20 METERS

Do exactly as with the 40-meter wave but insert the 20-meter plate coil. Keep the input low because the efficiency on this wave will not be so good. To start with, use all the C battery available, raising the oscillator input as necessary to give suitable plate current to the amplifier. You may not get a low plate current dip as on 40 meters, or, at least, it won't be nearly as pronounced. Instead, you may get a dim peak on the lamp in series with the "C"

positive lead. This is the only apparent indication of resonance at 2BRB, as the amplifier oscillates over the entire scale except in this one small peak where it operates as it should. (A previous job which is now in use at 2PF does not have this peculiarity but operates exactly as on 40 meters, although it takes more power from the oscillator. The efficiency in each outfit happens to be about the same, however.) Self-oscillation with its consequential feedback is very likely to be present when trying 20 meters so be sure to proceed with caution. Test for self oscillation as already described. The r.f. chokes will be found to play an increasingly important part as the frequency goes up. If the amplifier refuses to cooperate with the oscillator, try different chokes.

PLATE SUPPLY

Some operators prefer a perfect d.c. note and some prefer some form of modulation. Raw a.c. on the amplifier is not as broad as with a self-excited outfit but is pretty

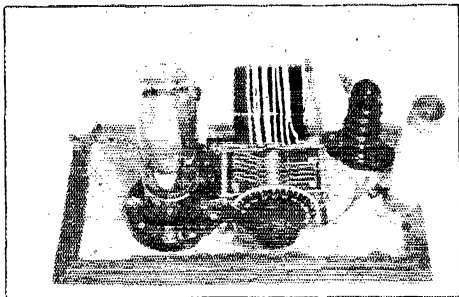

THE POWER AMPLIFIER TUBE AND ITS ASSOCIATED EQUIPMENT

poor. Unfiltered r.a.c. is good, broad, and steady. The author, however, prefers the pure d.c. note with buzzer modulation when desired, and also phone. The d.c. is very sharp, making it carry exceptionally well. It is key-clickless, if the proper precautions are followed. If the oscillator is run off the same supply as the amplifier, the regulation of the supply should be pretty good. That is, the voltage should not drop too greatly on pressing the key. If it does drop a great deal, the oscillator will be running at an overload when the key is up which is a poor condition to put up with and which may prove disastrous to the crystal and to the life of the 210.

KEYING

The amplifier tube is keyed by any method which will drop its plate current to ZERO immediately upon releasing the key. The author is not in favor of grid keying because the amplifier continues its work (to a smaller degree to be sure) upon releasing

the key and this prevents snappy, clean-cut, telegraphing. The amplifier may be successfully keyed in the plate lead giving clean-cut signals by a relay, using a keying filter (as described many times in *QST*) if necessary to stop clicks. Another method is to key the r.f. feeder, taking precautions to prevent the oscillator from being thrown out of adjustment too greatly, and seeing that the r.f. passing is kept below the point necessary to operate the amplifier. This is an absolutely clickless method of keying, and has been used at 2BRB for some time. Keying has a great deal to do with making the signals attractive and, in most cases, will make a crystal controlled transmitter stand out in a class by itself, easily recognizable, and beautiful to copy.

MODULATION

Chopper, buzzer, an audio tube oscillator, or phone are all easily adapted to the oscillator. To use a buzzer, chopper, or phone, simply connect the secondary of a modulation transformer in series with the C-battery lead on the oscillator and connect the chopper, buzzer, or microphone in series with a battery, rheostat, and the primary of the modulation transformer. See Fig. 3. Assuming a 6-volt battery to be used, the microphone may be connected in without any resistance, but a 20-ohm rheostat should be connected in series with the buzzer or chopper to prevent over-modulation which will stop the oscillator from oscillating. To get good modulation results, the oscillator must be set near (not on) the critical point or it won't get thru. The plate milliammeters on both the oscillator and amplifier should show a slight deflection upon modulating the carrier wave. Since the oscillator is controlled by the crystal, the modulation is not a frequency modulation but an amplitude, or power, modulation which is the ideal thing. The wave emitted is not noticeably broader than the pure c.w. and, thus, the interfering qualities of the familiar modulation methods are not present, and the neighbors are completely satisfied. The buzzer modulated signal is broad enough to permit raising the stations called more easily than if pure d.c. were used and yet does not interfere with other stations in the vicinity. The author is inclined to believe that the obvious attractiveness of the note is probably what attracts the called station, rather than the fact that the signals seem broader. At 2BRB, the most excellent reports are received both on the buzzing modulation and on phone although the pure d.c. is used about 60% of the time. The oscillator may function better when modulated if the "C" bias is reduced, as the modulation adds "C" bias to the C-battery and the combination may be too great.

THE ANTENNA

The choicest antenna at this station is an inverted L small cage with a fundamental wavelength of about 120 meters. This operates very successfully on all three bands. 2 or even 3 separate antennas may be used but a single 120-meter aerial is the most practical. Every kind of antenna in captivity with the exception of the multiple tuned type has been used at 2BRB but a single large antenna is at least as good as a lot of separate ones for the various wavelengths. With such an antenna system all that is required to change from one waveband to another (after the set is working properly) is to plug in the proper plate coil in the power amplifier, tune the amplifier plate condenser, and bring the antenna system into resonance by tuning the antenna or counterpoise series condenser (or both). This takes but a few seconds. It is usually also advisable to have a switch to cut out the neutralizing condenser on the 40- and 20-meter bands where it is not needed. In some instances, it may be necessary to increase power to the oscillator to operate the power amplifier successfully on 20 meters.

The 80-meter crystals used in this transmitter were purchased from the Scientific Radio Service, Mt. Rainier, Md., and were found very satisfactory. The mounting to be used with these crystals varies somewhat with the individual crystal. A very simple mounting may be made from two brass plates, the lower one anything larger than one inch square and the upper one not larger than $\frac{3}{4}$ of an inch square and not over a sixteenth inch thick. A round upper plate is very convenient. Both plates must be ground flat. Sandpapering them with very fine sandpaper or emery cloth on a flat surface will prove satisfactory. The upper plate need not cover the entire crystal. No spring at all should be used, the weight of the plate being plenty of pressure on the crystal. A very flexible and light pigtail connection to the upper plate is absolutely necessary. The latest addition at 2BRB (which is not shown in the photographs) is a three point switch connecting any one of three crystals (all in separate mountings) in circuit, thereby allowing three wavelengths in every band. This is a useful refinement.

R. F. CHOKES

Everybody I know uses a different type of r.f. choke and they all seem to work in their own way. I have tried many types but have found none better than the following: A thin bakelite or cardboard tube about an inch in diameter wound with about No. 32 d.c.c. wire for 8 inches. This will probably serve its purpose on all three

bands. At any rate, it is a fairly good guess for a starter and after you have the outfit "perking" anything may be tried and the best adopted.

INDUCTANCES

A very good oscillator plate coil may be made by winding $12\frac{1}{2}$ turns of No. 12 or 14 wire on a thin bakelite tube 3 inches in diameter. 10 turns are utilized in the plate circuit and $2\frac{1}{2}$ in the neutralizing circuit. The turns should be spaced twice the diameter of the wire. Two taps should be brought out one turn apart from the plate end of the coil for the r.f. feeder.

The amplifier coils are made of the plug-in type by fitting them with General Radio plugs. The coils should be made as follows:—

- 20 M—4 turns, spaced 3 times diameter of wire No. 6 or copper tubing. Wound on tube 2 inches in diameter.
- 40 M—6 turns spaced 3 times diameter No. 10. on tube 3 inches in diameter.
- 80 M—12 turns spaced 2 times diameter No. 12 on tube 3 inches in diameter.

A small piece of 5-10 turns of Hammarlund wound coil serves as an excellent antenna coil.

CONDENSERS

For oscillator tuning—any good 500 μ fd. receiving condenser. For amplifier tuning—double spaced 125 μ fd. to 250 μ fd. For neutralizing—250 μ fd. double spaced or better, triple spaced. Feeder—1000 to 8000 μ fd. Sangamo mica receiving condenser. A variable condenser here will give good control of r.f. output from

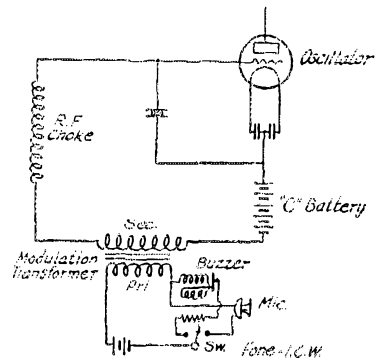

FIG. 3 MODULATING THE OSCILLATOR.

oscillator but is not necessary if other control is available. Filament by-pass—500 μ fd. (plus) installed right at the socket terminals—can be Sangamo receiving condensers. Plate blocking condensers—500 to 2000 μ fd. rated at least double the plate voltage to be applied.

LEADS

Leads should be as short as possible. Jam the parts together, but keep the coils 2 inches away from any object. All this cannot be emphasized too strongly. The leads must be extremely short to insure proper operation because this outfit must have a high over-all efficiency to be capable of "doing its stuff". In making up the oscillator and amplifier, beware of unallowable capacity effects. If any leads are too exposed, feedback from the amplifier to the oscillator may take place and cause considerable damage, especially to the crystal.

SHIELDING

In this particular transmitter, nothing will be gained by shielding if foregoing results are followed, but some losses will be introduced. Better not monkey with shielding unless you have nothing better to do.

HELPFUL HINTS

If separate filament transformers are used on the oscillator and amplifier, be sure to tie them together. Too much neutralizing condenser will make the oscillator plate current rise when keying. Too little, will make it fall. In coupling to the antenna circuit, start with tight coupling and gradually reduce it, always retuning the antenna and plate circuits as necessary, until the point is reached where the antenna current falls off rapidly. Avoid tight coupling. It may cause the condition known as "motor-boating" which will shatter the crystal. After having carefully tuned the amplifier to all wavebands, write down the condenser setting and "C" voltages, so that you will always be able to QSY without retuning. The coupling to the antenna may be left fixed if the coils are so made that each is self-adjusted. The correct coupling for each coil will be found only after careful measurements. A bakelite strip is connected to the condenser by two small brass angles. The jacks are set in this strip, one being connected directly to an angle by being set right in it. A small bakelite strip contains the two plugs. The bakelite tube is bolted to this strip in such a way as to give the correct coupling to the antenna coil when the plate coil is inserted in the jacks.

To compare this crystal controlled transmitter with a good self-excited transmitter, the author built a tuned grid-tuned plate outfit (which many local amateurs were raving over). This was tuned to the same wavelength as the crystal transmitter on each band by means of three sets of plug-in coils. Four switches enabled the operator to throw from one transmitter to the other. The antenna meter had to be moved to give fair readings because there was a difference of three feet in the antenna lead.

As near as could be guessed, the antenna currents on the 40- and 80-meter waves were about the same on both transmitters. The self-excited circuit gave a better output on 20 meters. (With an intermediate amplifier tuned to 40 meters, the crystal set gave about the same current on 20.) However, the reports from stations all over the country favored the crystal outfit overwhelmingly and even the 20-meter signal was reported better than that from the tuned grid-tuned plate transmitter, in spite of the lower output. The inputs in all cases were kept alike within a few percent. Comparisons were made under all kinds of conditions. The notes of both transmitters were as nearly alike as possible. All fairness in construction and operation was given each outfit. David Talley of 2PF made a series of similar tests with his crystal controlled transmitter versus his pet Hartley arrangement with the prompt junking of the Hartley!

As a concluding bit of advice, it is cheaper in the end to get an 80-meter crystal and do away with intermediate amplifiers than to buy a 160-meter crystal and use an intermediate. Keep the crystal and the mounting free from dirt. Keep the input to the oscillator down below 20 watts. The extra expense of the crystal and apparatus necessary for the oscillator will repay the operator in satisfaction in getting more distance, more traffic, more consistent communication with a particular station and, therefore, more enjoyment.

Atlantic Division Convention

AS announced in the May number of *QST*, the 2nd Annual Atlantic Division Convention will be held at the Fort Pitt Hotel, Pittsburgh, Pa., June 23-24-25. Now that we have received the program we can assure that there will be something "doing" every minute from 9 o'clock Thursday morning until the last minute Saturday night when the convention comes to a close with an initiation into the Pi Alpha Tau fraternity. Good lectures, speeches by prominent A.R.R.L. men, contests of many kinds, visits to interesting places and general hamfesting will be in order. The Golden Triangle Radio Association, the P.R.R. Central Region Gang and Pi Alpha Tau International Radio Fraternity are sponsoring the convention and it has the full sanction of Director Woodruff. For further information write Biddle Arthurs, Jr., General Chairman, 206 Stanwix St., Pittsburgh, Pa.

5-Meter Work at 2XM With Crystal Control

By A. H. Turner*

HAVING read in *QST* of the difficulties everyone was having in communicating over any great distances at 5 meters, I started last January with the construction of a 50-watt crystal-controlled set that was first put into operation at 6.66 meters on the sixth harmonic of a 40-meter crystal. The crystal is a rare and highly active little jewel which was kindly loaned to me by the owner of station 2BIG.

After getting this set all tuned up on one-quarter, three-quarters, and one and one-quarter wave antennas,¹ I offered my services to the Experimenters' Section of the A.R.R.L. and hurriedly added another tube in order to use the eighth harmonic of

The 40-meter tube and crystal, slightly eclipsed, are behind the crystal tank circuit meter; the crystal being in between the plates of the vertical vernier condenser.

I would not have used an SA-24 (low mu 203-A) if I had known of the new low-element-capacity tubes that are now available. Five-meter sending sets do not seem to be very fussy about their r.f. chokes. There are eight in the transmitter and all are the same and plenty good enough. On Eastman glass "M.Q." developer tubes. These are flat-bottomed, straight sided glass bottles (about 2½" x ½") I wound a single layer of No. 38 d.c.c. wire fastening the ends with the red wax from batteries. The bottoms of the tubes can

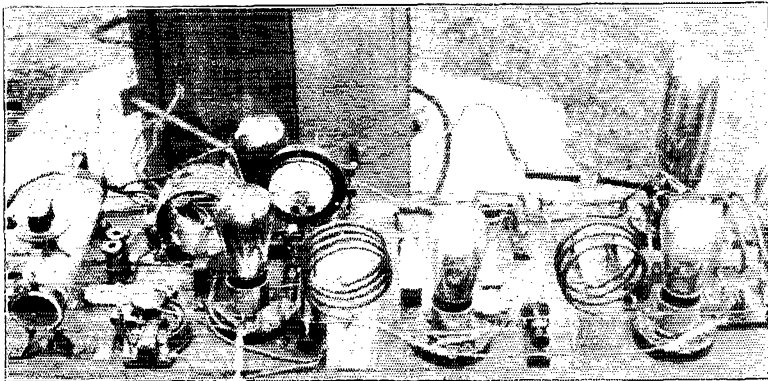

THE 5-METER CRYSTAL CONTROLLED TRANSMITTER
The arrangement of parts is explained by the text and diagram.

the crystal instead of the sixth and enter the February tests at 59,680 Kc. (Nearly enough, 5.025 meters—Tech. Ed.) The set operates on much the usual basis, doubling frequency in several stages and then amplifying the output of the last of the frequency-doubling stages. The circuit is shown in Fig. 1; the apparatus arrangement in a photograph.

In the picture of the transmitter, the progression of tubes is from the rear left along the front, and to the SA-24 at the rear right. Most of the radio frequency chokes, blocking and by-pass condensers and main inductances are visible. Inductive coupling is used between the last two tubes, but I believe conductive to be just as effective. There is considerable reaction in the successive circuits with either method.

be punched out first so that wooden mounting plugs can be inserted in both ends.

TRANSMITTING ANTENNAS

I have tried one-quarter, three-quarters, and one and one-quarter waves in tests with a friend in Schenectady.⁴ At this distance the latter two are superior to the quarter wave, and have not much difference between them.

1. These were not antennas such as those shown in the diagram but were current-fed against the tube filament. The antenna of the diagram can be regarded as a ½-wave voltage-fed affair. The line feeding it is tuned and has ¾ of a wave standing on each side, 1½ waves altogether. This puts a current maximum at the center where the line is current-fed and a voltage maximum at the end where the antenna is voltage-fed. To the 1½ waves on the feed line must be added the ½ wave on the antenna extension, making a total of two waves.—Tech. Ed.

*8AUX, 2105 Lancaster Ave., Wilmington, Delaware.

In spite of the fact that antennas are frequently operated at harmonics to raise the angle of radiation, it has often occurred to me that there must be partial neutralization of the opposite polarity radiation from such antennas. Professor Morecroft explains this on page 755 of his "Principles".

Therefore, to reduce the field and the dielectric losses of the lower end of the antenna, which was a one and one-quarter wave (third harmonic) one at this time and also to eliminate this theoretical and perhaps somewhat practical field neutralization I made a "Zeppelin antenna" out of it by running a three-quarter wave antenna from the filament up along side of it, thus leaving one-half wave at the top free. For some reason or other, the added capacity of the new wire did not make a shorter original antenna necessary. So now we have a tuned two-wire vertical transmission line three-quarters wave long feeding a one-half wave antenna at the top. And it certainly is some radiator. Effective resistance is probably about 100 ohms, as my antenna current of 0.6 ampere must represent nearly 40 watts. Curiously enough, all of the four current loops are equal within the accuracy of my measurements.

THE TESTS

The set just described was laboriously keyed "vvy test nu 2XM" during nearly all the schedules of February except those during which I listened for a chance "peep" from some other skeptic.

I cannot say that the tests as far as 2XM was concerned were a howling success, nor was the R.D. box filled with QSLs from Australia, but a friend near Schenectady, ten miles away, using the best of our 5-meter receivers, reported good audibility. The deep snow prevented any local scouting at that time.

Not to be discouraged by this lack of success, I improved the antenna and during the first three week-ends of April my co-worker Mr. F. G. Paterson has brought in some very interesting information.

His first trip was within a radius of twenty miles and immediately brought out the fact that 5-meter waves do not bend or fill in behind hills except at great distances. For instance, we have a hill a mile south of us and just over the crest of this hill the signal is not audible, but twenty miles to the north over open country the signal was of good strength.²

Laboring under the open country idea, Mr. Paterson drove his car the following

Sunday to the Mt. Whitcomb observation tower on the Mohawk Trail just above Hairpin Turn. The tower is fifty miles from here air line, but not quite visible as

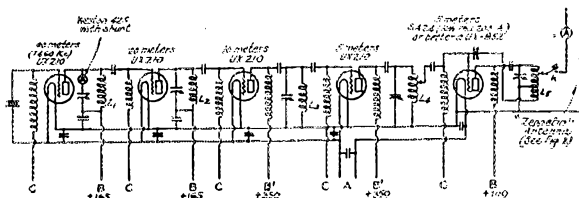

FIG. 1 THE CRYSTAL-CONTROLLED 5-METER TRANSMITTER

- A D. C. filament supply.
- C Adjustable grid bias voltages.
- To get a high percentage of harmonic power it is recommended that the first, second and third tuned circuits have high L and low C; for instance, if the coils are of 3/16" copper tubing wound to a 2 1/2" diameter with 1/4" spacing.
 - L₁ 8-10 turns.
 - L₂ 5-6 turns.
 - L₃ 3 turns (about all that can be used).
- To stiffen the last circuit and keep down the harmonics they are made with L₄ and L₅—2 turns each.
- All of the tuning condensers are made as shown in Fig. 3.

Berlin "Mountain" is in the line of sight. The 2XM signal was heard easily with a shaky portable antenna in a howling wind, even during the first five minutes of the test when I was letting the tube warm up with reduced power. We are 850 feet above sea level, ten miles north of Schenectady. To anyone knowing the heights and locations of the mountains mentioned we give this little trig problem to calculate the deviation angle of the wave. It must be less than ten degrees.

Last week-end, to do the job correctly, Patterson drove to Mt. Mansfield in the Green Mountains of northern Vermont. The road to the top not being open, he had to hike a few miles through snow. We would have selected Mt. Washington in the White Mountains if the railroad had been running.

Here at 150 miles air line, was 2XM's signal trickling through with good readability, with the same receiving equipment being shivered by the high wind. The ease with which this 50-watt signal reached both of these locations certainly changed my ideas of 5-meter attenuation.

Another attempt was not successful but

2. This is in direct contrast to the work away from 2CSM, 10A and 2EB whose signals "fill in" at very moderate distances behind hills; in fact rather more rapidly (in terms of miles) than would be the case for 80-meter work. It seems possible that the rather formidable hills about 2XM are quite capable of giving similar long distance screening at larger wavelengths. If this guess is correct the difference is simply in the size of the hills and it would be interesting to make a comparison against 80 and 160 meters as was done at New York and Hartford. This entire matter is commented on in a general review elsewhere in this issue.—Tech. Ed.

may indicate one of two things. Arriving at Burlington just before sunset, Patterson tried the receiver on a hill some two hundred feet high and with a good view of at least thirty or forty miles in this direction over Lake Champlain. Mt. Mc-

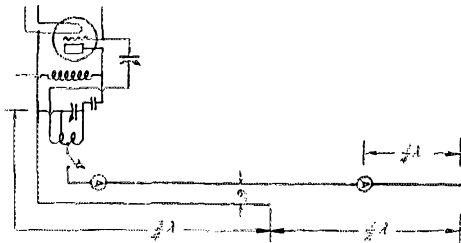

FIG. 2 ANTENNA SYSTEM AND METHOD OF COUPLING AND KEYING

This exact arrangement is NOT recommended for points near broadcast receivers. The location of 2XM permitted its use without harm to anyone.

Gregor or other hills in the neighborhood of Saratoga and Lake George were the probable obstacles in the line of sight, but these are nearly half way between the transmitter and receiver. Therefore it is more

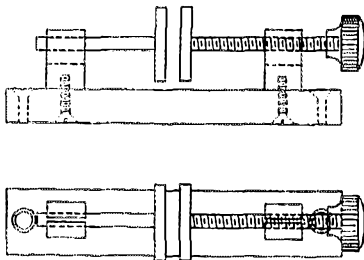

FIG. 3 TYPE OF TUNING CONDENSER USED

The plate diameter is about one inch. Where the voltage across the condenser is high, additional insulation is provided by mica glued to the surface of the disc.

probable that the lateness of the day caused the lack of reception rather than the intervening hills. The 50 and 150 mile receptions were in bright sunlight in early afternoon.³

The fact that we are shielded from the west and south by hills a mile away and nearly a hundred feet higher, suggests a possible explanation why 2EB and others were not heard here. But how stupid of me not to think of taking the receiver over to the top of the hill or to the top of our seventy-foot radio observation mast during the February tests! I was using the same receiver and had ideal receiving conditions, no wind, no interference, and tried several

3. See check with other work mentioned in the general 5-meter article in this issue.—Tech. Ed.

types and lengths of antennas, but heard not a "peep" at any time.

As Dr. A. H. Taylor has suggested, that the 5-meter signals must start off at a very low angle if it is to make use of the Heavyside layer, and perhaps the most innocent looking hill is a vital factor in real distance work. Ducati perhaps has no intervening hills when he put a signal across the Mediterranean.

It might be well for the 20-meter amateur to look at the neighboring topography.

So much for the slightly encouraging results. Incidentally, Patterson reports that he never heard a prettier signal at any wavelength, than the one of 2XM on approximately 5 meters.

The Hudson Division Convention

Hotel Pennsylvania, June 3d-4th

JUNE is one of the prettiest months in the year in New York City, and the convention committee, under the leadership of Director Lawrence J. Dunn, has decided that the second annual Hudson Division Convention will be held on the dates mentioned in the caption.

Those who were fortunate enough to attend last year's convention well know that Director Dunn will again give something worthwhile. While we are unable to print the whole program at this writing we can vouch that the best of speakers will be available, and the last event — the BANQUET—will be held June 4th at the Hotel Pennsylvania. Write David Talley, Sec'y Convention Committee, 2222 Avenue O, Brooklyn, New York, and tell him you are coming, as \$5.00 will cover all convention expense.

WELL KNOWN SAYINGS

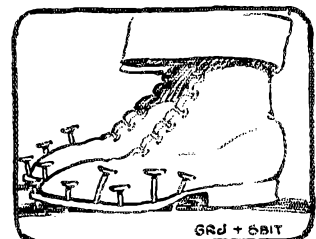

"COULDN'T RAISE A SOLE TONITE, OM"

Landmarks in the $\frac{1}{2}$ - to 5-Meter Region

By Robert S. Kruse, Technical Editor

STARTING to work with 5-meter transmitters or receivers gives one a peculiarly lost feeling as one's normal ideas of the size things must have are suddenly no good and everything must be found by cut and try. Of course, practice will develop the same sort of semi-instinct that most of us have about 40-meter work, but it is a great help to have a little advance information from someone who has "been there."

It is very helpful in this matter to forget all about kilocycles and megacycles for a bit and to think in the old-fashioned wavelengths. The length of the wave has a direct relation to the size of the coils and condensers and tubes—things one can see and take hold of. It is much less elusive than the frequency which has an inverse relation to these things and in addition to that involves time, which one cannot see or hear or taste or smell, and which one cannot even comprehend decently when it is being used in such small amounts as $1/60,000,000$ of one second.

Mark, that I do not say that the meter and the wavelength are forever to replace the megacycle in the 5-meter region; I merely say that the wavelength has the excellent virtue that thinking of it refreshes our failing perception of the good old formula.

$$\lambda = 59.6 \sqrt{LC}$$

Having gotten that firmly back in mind once more and having developed a sort of instinct with regard to 5-meter apparatus dimensions, we can drop back again to megacycles, though I will admit an utter lack of enthusiasm as to kilocycles which are perfectly hopeless as to awkwardness in 5-meter work.

OSCILLATORS

First of all—let us put together a few oscillators and see where they operate. It isn't necessary to do this for 20 meters, for it is a hopelessly out-of-date amateur who has not built such equipment. It isn't really necessary to repeat at 5 meters in view of the many oscillators of that sort shown in *QST* these past months. However, just to make the picture complete, Figure 1 shows a few sets of arrangements that will operate in the 5-meter region if the tube is a UX-210—which isn't the easiest sort of tube to pull down into that region.

Now let's refer to the family of oscillators shown in the photograph. The one at the top isn't all there, the socket should

be occupied by a UV-202 or a UX-210. This (with one particular tube) worked at 2.35 meters. The exact capacity of the Sangamo fixed condenser did not matter much, the wave being determined by the tube capacity and the inductance of the leads. Since the tube capacity is fixed the next move seemed to be to cut down the lead inductance and this was done by soldering the condenser directly to the tube pins for oscillator B, which then worked at 1.41 meters. Taking the base off this same tube and soldering to the lead-in wires dropped the wave to 1.23 meters and clipping a bit off these wires dropped the wave to .97. It seemed that the 202 could not be carried down any further, readily and that

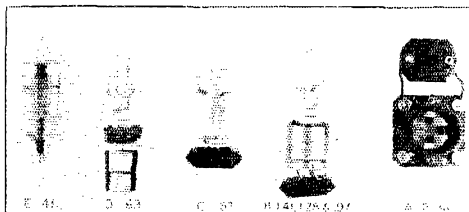

A GROUP OF OSCILLATORS AT 2EB. MADE UP TO SHOW HOW READILY EVEN OLD TUBES WILL GO BELOW THE 5- AND .77-METER BANDS

The wavelength for each is marked beside it. The tubes are UV-202 and UV-201. All operated without even an r.f. choke.

a smaller tube was needed next. (This isn't correct as will be shown a bit later.) Oscillator C was therefore made of an ancient UV-201. When connected as shown, this operated at .87 meters—which is still above the .77 band. For the moment, things did not look very hopeful. Reconsideration showed that the length of the leads inside the condenser itself could be decreased. This was first tried on the UV-202 and oscillator D resulted. This operated readily at .631 meters which is BELOW the .77-meter band!! That settles this business of not being able to get ordinary tubes down to that region. Just to see what can be done easily without special equipment the UV-201 was next equipped with a tiny condenser rolled up and put inside the stem of the tube as shown at E. This worked at .41 meters. The condenser in this case consisted of a piece of empire silk with tinfoil on each side, which is probably not a combination that would stand up long. However, the necessary capacity can be gotten with an air condenser easily enough

so that is a small difficulty. In one tube laboratory, 500-watt 5-meter tubes have been built in which the whole oscillatory circuit is *inside the tube* so that no r.f. troubles can occur at the lead-ins because the r.f. does not get to these places at all, the energy being taken out thru magnetic coupling thru the glass.

WHAT CAN BE DONE

It seems very hard to get rid of the idea that these things must be very strange and difficult. It is not so. A 5-meter oscillator usually gets into action with less fuss than an 80-meter one, while the extreme short-wave affairs—below one meter are the easiest of all, being so simple as to construction.

Perhaps this can be better appreciated when one mentions that a number of us have operated 500-watt tubes at .7 and .6 meters and that a *fifteen kilowatt* tube will operate at 5 meters during the June tests. This same tube can be (and has been) operated at .77 with good output.

CONCERNING CHOKE COILS

We have worried a good deal about choke coils for the 5-meter work. There is a strong suspicion that this was wasted effort. If the rest of the outfit is alright, it isn't hard to make it operate with almost any choke that looks reasonable for the wavelength. Of course it will not do to use an affair that is 3 or 4 inches in diameter and

rent readily and finally the capacity between turns had best be kept down as much as convenient. This can be done with spaced turns and it does not matter a great deal if the method of spacing is by use of a tube or on the Lorenz "basket-weave" basis. Of course if the tube is used it must have a reasonably low amount of solid material—in other words be as thin as is reasonable. Paper and celluloid tubes are flimsy but good. The 1" Hammarlund coils are excellent and I hope some enterprising manufacturer starts selling them in short lengths, especially as they also make good tuner coils for the ordinary amateur bands.

Now when one comes to the very short waves the choke problem becomes even simpler—a *perfectly straight piece of wire is enough!*

This may sound a bit silly but it is really quite reasonable. The reactance of any inductance goes up as the frequency goes up. At 5 meters we are able to use a tiny choke that would have no effect at all at 200 meters, and as we lower the wavelength—which is to say raise the frequency—still farther the X_L of even a plain wire rises so high that it becomes an effective choke. All of the oscillators in the photo will operate very well without a visible choke. It is not a delusion either—the r.f. does *not* arrive at the B supply in any noticeable amount while the plate lead of the tube is very active indeed.

One can go even further. At .4 meters a straight piece of wire is often a more effective choke than it is after it has been coiled up incorrectly, because the coiling has raised the capacity-bypass effect (distributed capacity) to an extent that more than makes up for the added inductance. A correctly-made coil does not do this, but just now I had rather not say just what the best .4- or .77-meter choke looks like—we have not got that question settled at 200 meters. However, just as we make 200-meter sets work with chokes that are probably not right, so also can we make oscillators work very decently at waves well down toward 1/3 of a meter—with standard tubes.

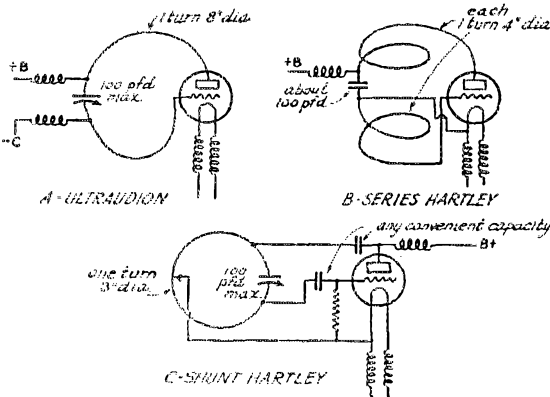

1 - 5 METER UX-210 ARRANGEMENTS, ALSO SUITED TO THE UX-852

WAVEMETERS

wound with wire somewhere in the twenties. Such a thing is simply a condenser at 5 meters and lets the 60,000,000 current flow right on thru—or rather it acts as a shunt condenser and prevents the oscillator from starting.

First off—the coil must certainly not be over an inch in diameter, somewhat smaller is still better. Next, it needs to be wound with as small wire as will handle the cur-

The wavemeter problem for the 5-meter band is settled, to our great relief, since General Radio has produced the type 458 meter. The range of this meter as supplied is from about 4 meters to about 6.5. It is convenient to extend the curve a bit in both directions after which one can make 2 larger coils to extend the range up to that of the type 358 meter (which leaves off at 14 meters) or some similar regular amateur meter. This will give good overlaps all the

way. Another convenient scheme is to make 2 extra coils for the 358, or finally one can make one coil for the 458 and one for

simply loosens one of the nuts on each spring plug and screws the two plugs in or out of the brass crossbar!!

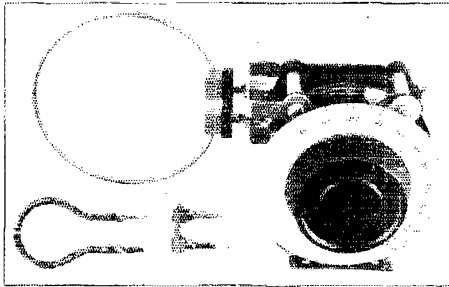

THE GENERAL RADIO 358 WAVEMETER WITH EXTENSION COILS

The normal coil has a range of about 4-6½ meters, the two extension coils cover 2-4 and 1-2 with good overlaps.

the 358. Following are coils that have been found handy for this sort of thing.

Extra Coils for the 358 meter to extend it down to the 458.

Sub-Sub-A coil

One 3" of ¼" edgewise copper cut away to leave a gap equal to distance between condenser posts.

Sub-A Coil

Two turns of same material with ends straightened to make parallel leads to condenser. Range of coil adjusted by cutting these leads. This coil does not overlap very far at the upper end but the 14-meter region is not used.

Extra coils for the 458 meter to extend it up to the 358.

A—Single-turn coils made up like the regular coil for the meter, with adjustment made by changing size of turn. Start with diameter equal to 1.3 times present coil diameter and adjust by trial.

B—Construction similar to Sub-A coil above.

One will find that such "trick" coils tend to give rather weird ranges because seemingly minor differences of construction make a large difference, hence all specifications above are simply starting points.

WAVEMETERS BELOW 4 METERS

The 458 wavemeter goes down below its normal range very neatly if provided with smaller coils as shown in one of the photos. The range of the three coils shown is such as to give good overlap. The intermediate coil is adjusted by cut, solder and try but the smallest "coil" is adjusted by a very much simpler scheme than cut-solder-and-try; one

CALIBRATION

With a 458 meter as a starter it is not hard to calibrate for the range of 1-15 meters, especially if a few points from 9XL or 1XM are used as fillers in the upper end of the region. By far the most helpful thing in this connection is an oscillator with a 201-A tube which has a 0-1½ mil meter in the grid circuit. This can be set to a known wave and then the 2nd, 3rd, 4th and even 5th harmonics found by the kick of the grid meter. Of course one must use decent care not to "slip a harmonic" and it is always well to check a point from the 2nd harmonic of one wave of the oscillator by putting the oscillator at a somewhat higher setting and checking from the 3rd harmonic. This is where it is handy to have the "fill-in" coils between the usual amateur meter and the 458. The "fill-in" coils can, of course, be calibrated easily enough from the usual meter, by using the process just suggested.

The oscillator itself need not be anything elaborate at all. The simplest thing in a series or shunt Hartley arrangement with

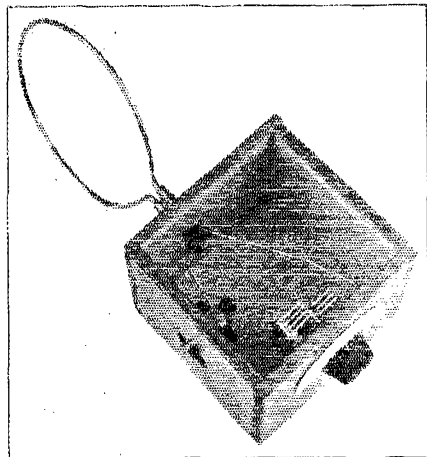

A 5-METER WAVEMETER BUILT BY C. H. WEST OF 2CSM

The condenser is a one-bearing soldered-brass "vernier" with a capacity somewhere below 50 pfd.

plenty of regeneration and with a condenser in the 250 pfd. region. With different coils this will go easily from 3 to 300 meters. A decent vernier dial is an absolute necessity and the thing should really have a metal panel that can be grounded. If that isn't possible one can at least ground the condenser. Naturally, the oscillator

needs no calibration; it is only being used to locate one frequency on the known wavemeter and to pass a harmonic of that frequency down to the new wavemeter.

LECHER WIRES

It is perfectly possible to base all this on Lecher wires, but I have no wish whatever to push their use. It is so pathetically easy to make minor errors that add up to a very bad result that one finds amateur Lecher wire work to check very badly in-

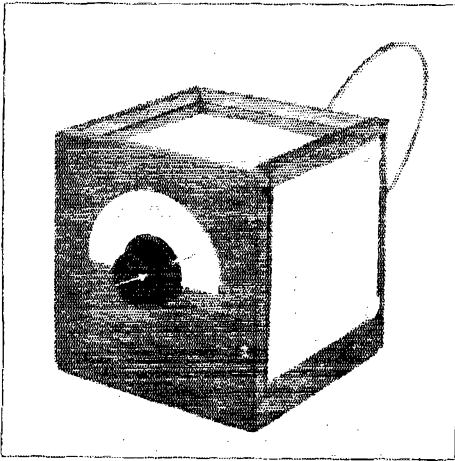

EXTERNAL VIEW OF THE WEST WAVEMETER. SHOWING SCALE AND CALIBRATION CURVE. WHICH LATTER WAS MADE FROM THE 358 METER AT 2EB

deed while calibrations made as suggested above check beautifully. Nevertheless, the Lecher wire (by the way the word does NOT contain a "T" sound but is given the soft "ch" pronunciation) has the advantage of being an affair that will easily give one the approximate location of things in unmistakable fashion, avoiding the chance of making bad errors when harmonic calibration is being done. It is just as well, therefore, to become familiar with the wires, especially as you may wish to feed an antenna with a pair of them in the so-called "Zeppelin" arrangement. Of that, more in another place.

Meanwhile, don't let anyone tell you that it is hard to make a tube operate at 5 meters or at "point seven seven".

The Midwestern Division Convention

THE central division of A.R.R.L. is called the *Midwestern* division and has just held a convention in the *eastern* half of the United States. Sounds all scrambled up, doesn't it? So it is, but the misfit

labels worried nobody at Ames, Iowa on the 15th and 16th of April; in fact there never could have been a convention in which there was less of worry and more of kindly feeling and friendship. It was enough to make a Kansas farmer feel homesick—and the Tech. Ed. of *QST* comes in that class.

It isn't the important folks at a convention that make a good convention—tho there were plenty of them present. The technical talks may be good (and they were certainly so at Ames) and it still isn't an A.R.R.L. convention. The apparatus shown may be the newest and the most interesting (we had 5-meter equipment, up-to-the-moment transmitters and fine laboratory displays) and even then it isn't an A.R.R.L. convention. The place may be excellently chosen (and Ames Aggie is splendid) and we still do not have a true A.R.R.L. convention.

It isn't until some hundreds of good fellows meet as friends and as co-workers and extend to each other the hand of fellowship and the grin of friendship that the thing is complete. Then it becomes a real A.R.R.L. convention, and by that standard the convention at Ames ranked about 300%. There were all the usual stunts, the usual meetings, the usual exhibits and a banquet at which there was FOOD, and I am certainly not competent to say if these things were all especially well done or if it just seemed so because of the superlative way in which all thought and worked together. The traffic organization, the Campus Radio Club, Alpha Sigma Delta, the faculty of the college, the Experimenters' Section men and the rest of us—just plain amateurs—all seemed entitled to talk together as intimate friends and we did just that, and came away feeling very much improved and elated and altogether pleased with life and with radio. After the talking and the prizes and the movies were all over and everyone had said goodbye all around we felt doubly happy because the convention hadn't kept things to itself but had chipped in and sent telegrams to the shut-ins of the Division who couldn't come, that is to say Max Colvin of 9WV, Earle Chambers of 9LN and M. A. McCollom of 9BQW.

A convention that produces that sort of feeling is of the sort that makes A.R.R.L. strong and the future bright.

—R. S. K.

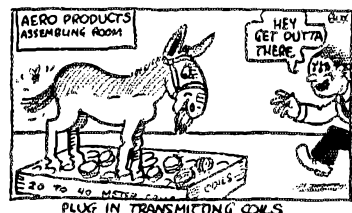

150-200 Meters

OUR last month's article on radio regulation was written while the Federal Radio Commission's hearings on broadcasting were still in session and before any announcement concerning the disposition of 150-200 meters was made. On April 5th the Commission issued its General Order No. 4, reading as follows:

In view of the manifest inconvenience to the listening public which would result from any immediate widening of the frequency band devoted to radio broadcasting, the Federal Radio Commission will not at this time allocate to broadcasting stations frequencies other than those between 550 and 1500 kilocycles (545.1 to 199.9 meters), except on specific request of such stations. It believes, however, that the band between 1500 and 2000 kilocycles (199.9 to 149.9 meters) should, so far as may be practicable, be held open for experimental work in broadcasting and allied forms of radio service, to the end that with the further development of the art, this band may be eventually made available for broadcasting, whether for the ear or the eye, if it shall prove particularly well adapted to such type of service to the public.

This answered the question as to the extension of the broadcasting band but was misinterpreted in many quarters as meaning that the amateurs had lost the 150-200-meter band. Newspaper accounts freely reported that the waves between 150 and 200 meters had been taken away from the amateur, set aside and reserved for television. Knowing that these reports were inaccurate we wrote to the Commission and under date of April 13th received the following letter from Commissioner Bellows:

Dear Mr. Warner:

Replying to your letter of April 7, the Federal Radio Commission certainly does not intend to stop or limit amateur operation in the frequency band between 1500 and 2000 kilocycles.

We do not, as a matter of fact, anticipate many requests for experimental broadcasting licenses within that band, but we feel that if broadcasters desire to experiment below 200 meters, and can show good reason why such experiments will be in the public interest, they should have an opportunity to do so.

I do not anticipate that there will for a long time be enough requests of this type to interfere in any way with the amateurs who are at present occupying this band, and our sole thought is that it is undesirable to "freeze" the situation to such a point that the possibilities of developing broadcasting transmission below 200 meters are permanently shut off.

Again on April 15th Commissioner Caldwell wrote us:

Answering yours of April 12th concerning the future of the 150-200 meter band, I feel sure that this is clearly explained in the letter which has already gone to you from Commissioner Bellows.

You can rest assured that it is not the plan of the Commission to interfere with the use of this band by amateurs but to preserve it for experimental use in a way which will mean most for the future development of the broadcasting art, both audible and visual.

Amateur radio, then, continues in the 150-200 band as before, except that the region is now "non-exclusive". Phone broad-

casting stations may be licensed in that band upon application, but it is hardly to be expected that any broadcaster will desire a wave in that band. The experimental radio-picture and television stations are to be licensed in that band, but it is inconceivable that there will be many of them in anything like the near future. So far we know of but one, the A. T. & T. station 3XN at Whippany, N. J., operating on 191 meters.

It seems to us that the Commission's action was the wisest possible, if we have to have somebody in our band with us. The hearings made it very plain that phone broadcasting did not need more territory but it is equally clear that it is felt that if the need ever comes for more channels, or for new territory for some new service like broadcast television, it should be in waves that adjoin the present broadcast band—which is to say, in our upper band. We're entitled to a little smile, too, we think, at another indication that the way to preserve a band for some future purpose is to let the amateur have it a while longer. However, it needs to be emphasized that the Commission is treating the amateur most courteously and considerately and is shooting perfectly squarely with the League. We do not believe that we shall feel any appreciable handicap in operation in our upper band for a long time to come.

—K.B.W.

Strays

SCFV had a defunct 50 wattter and after putting flexible leads between the filament prongs and the filament transformer so he could get a strangle hold on it, he tapped and banged it for half an hour until the two pieces of the busted filament came together and welded. He's still using it.

We have just looked over the first few issues of the "Static Sheet", a memographed affair put out by the Silver Gate Amateur Radio Club of San Diego, Calif. It contains a lot of interesting local gossip. FB!

QST could find space for a few good articles on amateur phone operation. Anybody got anything they'd be good enough to write up for the information of the gang?

The Cheapest Bug

By Joe Charpie*

OTHER homemade "bugs" have been written up in *QST* but I doubt if any of them could be made *much* more cheaply than this one. Of course it did cost a dime, because a dime had to be cut up to make the contacts, and there seems to be very little demand for the left-over parts of a cut-up dime.

The best thing about the bug is the vibrator which is a Gillette razor blade—really fine for the purpose. The main arm

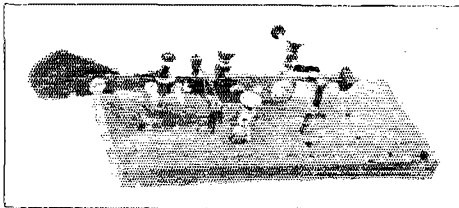

is of two pieces of brass strips laid together. A thru bolt at one end holds the handle—piece of an old rubber panel—and another thru-bolt at the other end holds the Gillette spring. Between these are two thru-bolts close together and between them the two

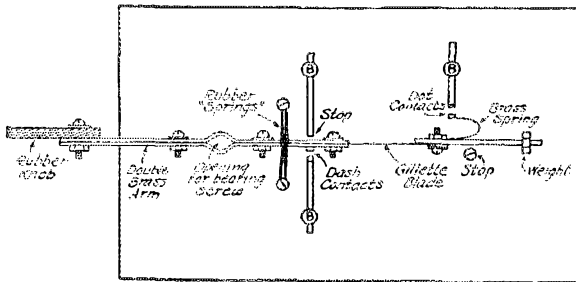

B-B-B- Binding Posts

strips are sprung apart so that a long wood screw can be put thru into the base, with enough washers under the arm to provide clearance. This isn't beautiful and probably something like the bearings and staff of an alarm-clock balance wheel might do better work but the present arrangement does very well. As to the "springs," they too are not quite standard, being rubber bands, but they work quite well after once being adjusted.

The dot arm is made of a short piece of heavy copper wire screwed to the free end of the Gillette blade and carrying both the dot contact and a weight (a nut or a small

coil of wire solder) to get down to the proper speed.

The bug has been in use at this station for some time and is quite satisfactory.

NOTES ON 5-METER TESTS

The 11th Commandment

Twenty six June days shalt thou devote to thy establish work and to the handling of traffic but the remaining four days thou shalt not give solely to these things but shalt in part give over to the transmitting and likewise the receiving of the waves which are five meters in length, and the days on which thou shalt do this are the 11th and 12th and also the 18th and 19th of the month of June which cometh after May but before July.

If it be that thou knowest not whereof I speak read then the 44th page of the May book of ye amateur's bible which is called *QST*. (But for Pete's sake don't use daylight saving time.)

Standard Time for the 5-Meter Tests

The schedule for the 5-meter tests did not stress the point that we will operate on Standard Time. Remember that the so-called "Daylight Saving" time is not at all general over the world and that we will ball things all up if we use it.

Read the schedule on page 44, of the May issue and translate it into your local STANDARD time, the kind the U. S. government and the railroad use for your region.

June 11 and 18 are the Test Dates

Now that the International Relay Tests are over we can all get a fair shot at the 5-meter tests. This issue outlines a number of new receivers, the past year's issues have outlined a lot of transmitters and page 44 of the May issue gave the schedule. That ought to leave us all lined up to make the thing a success. If you can do it let your transmitter run under automatic keying—or with another operator—and go out of the neighborhood to listen. If the transmitter overlaps a schedule or two, no violent harm is done.

*9CBJ, 2326 Nowland Ave., Indianapolis, Indiana.

A 5-Meter Transmitter

By W. H. Hoffman*

A reliable 3-to 5-meter transmitter of low power was described by this laboratory in *QST* for April, 1925. That transmitter was built up around a 5-watt tube and for experimental testing and measuring purpose has never failed to function properly as a persistent oscillator. It is still here at the laboratory in its original form.

During the last few months further tests have been conducted with some degree of success and it has been found desirable to

feed Colpitts. The inductance for the oscillatory circuit is of quarter-inch copper tubing. It is divided into two equal parts and the length of each part can be varied

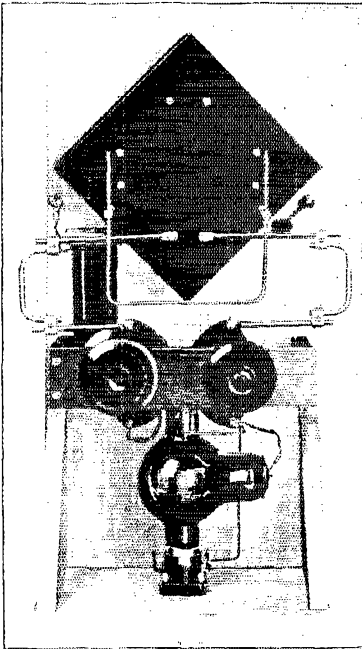

FRONT VIEW OF TRANSMITTER

At the top is the fixed feed condenser with the U-shaped antenna coupling coil mounted on it, and the two halves of the main inductance going off to either side. To the left of, and a bit below the feed condenser are the tubular resistors. Directly under the feed condenser is the mounting for the two tuning condensers and under that the UX-852 tube in its socket.

make use of higher powers. Our new transmitter uses a UX-852 Radiotron tube tho the DeForest H tube will operate satisfactorily in the same circuit.

The circuit arrangement is shown in Fig. 1 and will be recognized readily as series-

* C. F. Burgess Laboratories, Madison, Wisconsin, also radio station 9EK-9XH.

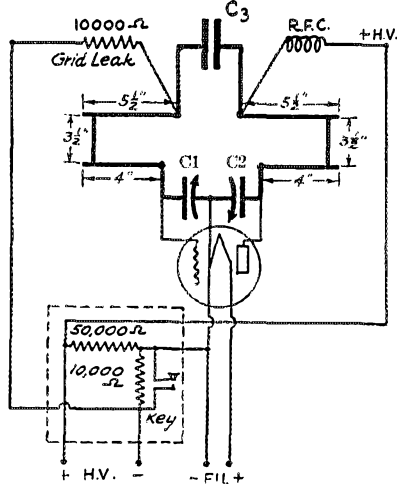

FIG. 1. THE CIRCUIT DIAGRAM OF THE TRANSMITTER

C1 and C2 are 3-plate variable condensers with the rotors tied together electrically but not mechanically. C3 is the fixed feed condenser whose construction is described in Fig. 2 and the text.

R.F.C. is the radio frequency choke coil which consists of 20 turns of No. 28 D.C.C. wire on a 5/8" rubber rod.

The grid leak and keying resistances are of the usual tubular variety.

by means of slides and binding posts as shown in the diagram and photographs. Between the two halves of the inductance there is the feed condenser C3 (stopping condenser or by-pass condenser) which is shown at the top in both the diagram and photographs. This is a fixed high-voltage air condenser consisting of 9 aluminum plates about 1/32" thick, 6 inches long and 4" wide, piled up as shown in the photographs and Fig. 2.

The tuning condenser C1-C2 has two sections. The plate and grid of the tube are each connected to the stationary plates of a variable air condenser. The two rotors are connected together and to the filament as shown in Figures 1 and 2. The two condensers are thus connected in series. They form the tuning capacity of the Colpitts oscillatory circuit and the two stators (which have already been connected to the grid and plate of the tube) are connected to the free ends of the tuning inductance.

The two tuning condensers are identical. Each consists of a variable air condenser having two stationary plates and one rotor plate. The plates are spaced $3/16"$ apart and have a radius of $1\ 7/8"$. By adjusting the inductances and the tuning condensers

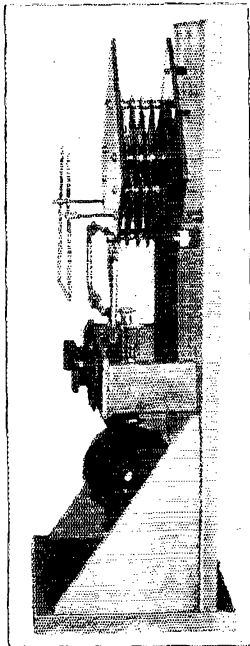

SIDE VIEW OF THE SET, SHOWING THE FEED CONDENSER CONSTRUCTION AND THE WAY IN WHICH THE ANTENNA-COUPLING COIL IS MOUNTED

the set can be operated at from 3 to $5\ 1/2$ meters.

The keying method used at 9EK-9XH is shown in the dotted lines in the circuit dia-

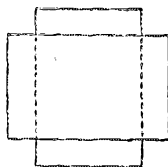
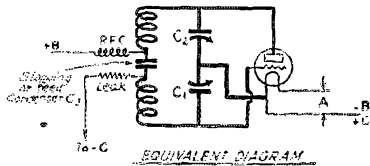

METHOD OF STACKING C_3 PLATES

FIG. 2--SIMPLIFIED DIAGRAM AND CONSTRUCTION OF FEED CONDENSER

gram of Fig. 1. The two resistances act as a potentiometer and when the key is up the grid receives a C bias due to the drop thru the 10,000 ohm resistance. Since this is

$1/6$ of the total resistance (10,000 plus 50,000) this bias is $1/6$ of the plate voltage which is enough to block the tube and stop the plate current almost completely. When the key is down this bias is shorted out and the tube has only the bias which appears across the grid leak as soon as the tube starts taking current and oscillating.

With 1500 volts applied to the plate the tube draws about 200 milliamperes but the efficiency of the circuit is good enough so that the plate becomes only a dull red and operation is stable. Running the plate voltage up to 2100 volts increases the plate current to about 400 mils and causes the plate to become quite hot but operation continues stable and the tube did not show any disastrous effects when so operated over a short period.

With 300 watts input the signals were observed on a 5-meter receiver at distances up to 15 miles. The note was somewhat bubbly but easily readable. No effort has been made to clear up this note which is believed to be due to vibration from the generator.

1.—The normal input to this tube is 75 milliamperes at 2000 volts, which is 150 watts. With 50% efficiency this will run the plate a very dull red. If the plate is running at a cherry color (which should not be exceeded) the dissipation is about 100 watts, the safe maximum. To keep down to this limit with an input as large as 300 watts calls for an efficiency of 66% and very careful adjustment. If that is obtained no harm is to be anticipated except a slight shortening of the filament life because of the tripled plate current. A more desirable adjustment might be one with a higher plate voltage and higher C bias but the same dissipation. The circuit here shown is in any case likely to give better filament life than the circuits such as the ultraudion in which the entire oscillatory current goes thru the tube capacity.—Tech Ed.

We Are Not Exclusive

Just because the 5-meter tests have been announced as from the "X" section don't for a moment think that we are "agin" having the rest of you in! Come right ahead; hurry thru the last year's QST file, make up the transmitter and receiver and then take a good quick look at page 44 of the May issue—which talks *Standard Time* and not daylight saving.

That's all, except to report in full by radio, wire and mail—to the "X" Section, of course.

A 15-Kilowatt 5-Meter Set

In the 5-meter tests for June there will be a 15-kilowatt set, a 5-kilowatt set, a couple of one kilowatt sets, at least two $1/2$ kilowatt affairs and about 10 of the 250-watt sort. Just the same—some UX-210 will probably make the record performance, provided the boss of the 210 doesn't get all mixed up and try to use daylight time. The schedule (page 44 of the May issue) is on U. S. Standard time wherever it concerns the U. S. A.

Concerning A. R. R. L. Conventions

By A. A. Hebert, Treasurer and Field Man

FOR the assistance of convention committees who may have the responsibility of conducting A.R.R.L. conventions, the following information is given which we hope will be helpful.

At the annual meeting of the Board of Directors of the League, held February 6, 1925, the following amendments to the By-Laws were enacted; this defines what constitutes an A.R.R.L. Convention, under what circumstances it may be held and to some extent how it shall be run:

"An American Radio Relay League convention is defined as a meeting of persons interested in amateur radio, of any regular American Radio Relay League Division, as specified in By-Law 4 hereof, when such meeting has been authorized and is conducted as hereinafter provided.

(By-Law 4 simply specifies the limits of the Divisions which can be found in the Communications Dept. page in the front of any QST.)

"Neither the name of the American Radio Relay League, nor the initial letters thereof, nor its emblem, shall be used in connection, or in advertising thereof, save such as above defined.

"Before such a convention is held, the parties desiring to conduct the same shall obtain the approval of the Executive Committee, which shall act with the advice and consent of the director of the division in which the convention is to be held. To this end there shall be submitted to the Executive Committee a statement setting forth the place and date of the proposed convention, the territory to be embraced and the particular purpose to be served thereby. The Executive Committee may call for any other information necessary to make its decision. The management and plans of every such convention shall be subject to the approval of the Director of the Division in which the convention is to be held."

From the above you will note that one of the first requirements is to write the Executive Committee, A.R.R.L., Hartford, Connecticut, and obtain its approval. The letter should give the following information:

.....Division Convention
Date.
Tentative Program.

COST

Of importance to any committee is the expense of staging a convention, so the fol-

lowing items have to be considered in estimating the cost:

- Cost of:
 - Banquet (determined from probable attendance).
 - Banquet Tickets.
 - Programs.
 - Printing first notice.
 - Postage on same.
 - Printing second notice (usually post-card).
 - Postage.
 - Badges.
 - Complimentary banquet tickets (given to prominent out-of-town speakers).
 - Signs and decorations if any.
 - Music, if any.

After the total estimated cost has been found, it should be divided by the probable attendance so as to obtain a unit cost. When that figure is known it is well to add to it an allowance of 25% to 40% to take care of unforeseen incidentals; but your total price for the convention should not exceed five dollars (\$5.00).

ATTENDANCE

One of the mistakes usually made by most committees is overestimating the attendance. A very simple rule may be followed which gives a fairly close estimate. Draw a circle of 150 miles radius from the convention city; plot within this circle all the cities having licensed amateur stations, and with the latest copy of the Government Amateur Callbook, count all licensed stations in each city, putting the number alongside the name in the circle. When this has been done for all cities, strike a total. Divide the total number by 2, and the result will be the probable attendance.

THE DIRECTORS' POSITION

In accordance with the By-Laws, it is necessary to submit your plans and program for the convention to your division director for his approval, as your plans develop. The committee in charge of a convention should bear in mind that the director is the ranking official in his division; he outranks all section communications managers and he should be asked to open and close the convention and to act as the Toastmaster at the Banquet; or to name or approve a suggestion as to who is to preside, such as the president or the club under whose auspices

(Continued on Page 36)

Device for Limiting Signal and Static Intensity

By S. Young White*

MOST operators handling commercial or amateur traffic find it necessary to limit the use of audio frequency amplification to a single stage for headphone reception, as with greater amplification the static crashes and local signals are of sufficient intensity to be deafening. Where a large proportion of signals is relatively weak, however, the higher degree of amplification materially assists in copying them. These diverse conditions can be reconciled by the use of a simple signal intensity limiting device which would pass on the weak signals without appreciable diminution, but would lower the intensity of static crashes and extremely loud signals to comfortable headphone volume.

After the necessity for such a device became apparent, a number of means sug-

gestion is kept at a low value by running the filament at two volts. The plate current value is quite low, as a $4\frac{1}{2}$ volt "C" unit is used for energizing the plate. It is placed as shown in order to allow grounding one phone lead. The input transformer has its primary connected in the output circuit of the last audio tube.

The device in action causes a peculiar sensation, since no signals are very loud, and some difficulty is experienced in recognizing local stations whose signals usually cause the phones to be hastily removed to prevent deafening. Extremely loud static crashes no longer paralyze the ear for several seconds, as they are reduced to a pleasant volume, and since the device does not block due to this cause one can start reading the signal immediately after the static crash has ceased instead of waiting for the ears to stop ringing.

After operating with this device for several days it is believed that it will become a fixture in the station, as one learns to rely on the tone to recognize local transmitters instead of the volume.

Speaking in terms audibility, a signal entering the device with an intensity of two will be heard with an intensity of two, but one entering with an intensity of ten will be heard as an R3 or R4 signal.

It is quite useful in hunting distant broadcast stations, altho above the cut-off point distortion begins, which can be removed by lowering the r.f. amplification in the usual way. For loud speaker use it may be followed by a stage or two of audio, which would allow signals of only a certain intensity to reach the speaker. This is not recommended, however, as more or less serious distortion usually occurs.

It is not known if the device is original with the writer, but it does not seem to be familiar to those in the game, so it is passed on as a helpful suggestion.

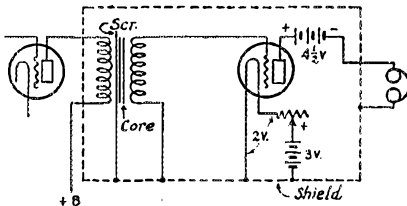

THE CIRCUIT ARRANGEMENT

The tube at the left may be the detector or a first audio tube. The device may be followed by more audio stages if desired. The shield and the interwinding screen Scr are not absolutely necessary. The latter may be a single layer of wire wound between primary and secondary and left open, only one end being connected to the shield. Usually some wire must be taken off the inside of the outer winding to permit the introduction of this shielding winding. A single turn of tinfoil may be used, the overlap being insulated with paper so a shorted turn does not result. Again, only one end of the foil is to be grounded.

gested themselves, and of these the most simple were thoroughly tested and a final design decided upon, which is extremely easy to duplicate.

The circuit is shown in Fig. 1, and is intended to follow two efficient stages of audio. Slightly more uniform signals result if the tube and all batteries are enclosed in a grounded shield, and shielded headphone cords be used, but the operation is excellent even without these precautions.

The tube is a UV or UX 199, whose emis-

(Concerning A.R.R.L. Conventions)

(Continued from Page 35)

the affair is held, the local or ranking S.C.M., etcetera.

Committees should also bear in mind that A.R.R.L. Headquarters stand ready to give a helping hand at all times, and will gladly furnish hints, sample copies of programs, etcetera, to further a successful convention.

* c/o Loftin-White Laboratories, No. 1 Union Square, New York, N. Y.

What Is the Input to Your Set?

By Don C. Wallace*

THERE is a system, as old as the hills, for determining input to a transmitter. I believe practically every amateur in the country can apply this system, and actually *know* what his input is. The beauty of it is that *no apparatus of any kind need be purchased*—or borrowed.

The reason for stressing this is, that we all do a great deal better work, if we know what is happening, all the time, rather than simply depending upon, "Your sigs R-6 FB", whatever that means. The scheme is very simple and to show how it works we will follow the process by which the power input to each of the component parts of 6AM was measured. As the tube is water cooled, and the plate supply a mercury arc, little about the set was according to usual amateur station arrangement, but the idea is illustrated just the same. For the usual amateur station the job is a simple one.

First, every electrical device in the house was turned off except a single 100-watt lamp. Now the watt-hour meter (the house meter owned by the light company) was watched. It was found that the aluminum disc of the meter took 50 seconds to revolve when the 100-watt lamp was running.

The filament of the transmitter (this was a surprise) revolved the meter in 12 seconds. There is a simple formula which will give us the watts consumed by the filament.

$$50/12::x/100$$

Where 50 seconds required to revolve the disk of the meter on a 100-watt lamp. Where 12 seconds required on the water cooled tube.

Where x is the wattage of the water cooled tube.

Where 100 is the known wattage of the lamp.

Figuring this out we find that the wattage of the filament is 417. That's a lot of watts for a filament, but it's worth it in steadiness, and consistency in output. As a matter of fact, however, much of this wattage here is consumed by the filament rheostat.

In the same way, another pleasant surprise came in measuring the wattage consumed by the "keep-alive" of the mercury arc. It came to 151 watts. Imagine this in comparison to the consumption of a chemical rectifier on high power, or even a motor on a sinc, or the filaments of a couple of large rectifier tubes.

Next, the usual power of the station was measured, and then low power, and then the

filament and mercury arc together. Logically enough, the filament at 417, and the mercury arc idle at 151; total 568 watts. Actually, the total as measured on the meter came to 555 watts, so that either the primary resistance of the filament transformer, or the idling wattage consumption of the arc, or both, drew a trifle less when both were running.

Of course we must estimate the losses caused by the transformers, wiring, and the various resistances within the set, used

Load	Seconds per meter disc revolution	Formula	Watts from line
100 Watt Lamp	50		100
Filament of Tube.	12	$50/12 \times 100$	417
Mercury Arc Idling	33	$50/33 \times 100$	151
Filament & Mercury Arc	9	$50/9 \times 100$	555
Plate input at Low Power + Mercury Arc + Filament	5	$50/5 \times 100$	1000
Low Power plate input only		1000-555	445
Plate input at Full Power + Mercury Arc + Filament	3	$50/3 \times 100$	1666
Full Power plate input only		1666-555	1111

Note—The input to any particular part of the set can be obtained by suitable subtractions, remembering that the power from the line does not all arrive at the device. One must subtract something for the loss in the transformers and wiring (5 or 10%) and something more for loss in the rectifier and filter (10 or 20%).

either to control the filament, or to keep the key from sparking, or to keep the high power tube from drawing too suddenly on the plate supply. These losses have been estimated at 10%, probably a fair figure in the case of this transmitter. In a like manner the rectifier, filter, and resistance loss (200 ohms resistance placed after the filter system) were estimated at 10%. The result of these figures is shown in the accompanying table, and will serve as a guide in making up suitable tables to apply to any other transmitter.

*6AM, 109 West Third St., Long Beach, Cal.

ANOTHER METHOD

If one does not wish to depend on a lamp as a standard one may instead use the "meter disc constant", which can be seen on the meter nameplate, or from inquiry to the light company or the makers of the meter. When asking anyone for this constant be sure to give them the make, type, serial number and current rating of the meter as well as telling them whether it is two or three wire. This "meter disc constant" will be given you as "watt hours per disc revolution." For some typical meters the constants are as follows: Westinghouse RA 5-ampere 2/3, Sangamo 5-ampere 5/24 while for some typical 10-ampere meters the constants are 5/6 and 5/12 for the three wire and two-wire meters respectively. Sometimes the constant will be given in terms of "watt seconds per disc revolution," which means that the number is 60 times as great for the same meters as in the examples above.

Supposing now that we use the Westing-

(Continued on Page 39)

The New England Division Convention

YES; it's all over but the memory, and that will live for months. With the largest registration of delegations ever noted from Maine, Boston, Providence, Worcester, Bridgeport, April 15 and 16 will stand as red letter dates of the fourth annual New England Division Convention



held at the Hotel Garde, Hartford, Conn. The good spirit of coopération was shown by the Hudson Division with delegations from the Hackensack, Brooklyn and Bronx Radio Clubs under the leadership of Director Dunn, Talley, Solotar and Oscanyan.

From the sound of the gavel at two o'clock, from Harold S. Johnson, 1HN, President of the Radio Transmitters' Association of Hartford, who sponsored the affair, until after midnight Saturday, every minute was filled with interesting meetings. The big traffic meeting was under the charge of Fred Best, 1BIG, who introduced Larry A. Jones, Assistant to the Communications Manager. This was Larry's first official appearance as a representative from headquarters and, while he may have felt shaky in the knees, he made a very good impression. Norman Miller, 1AWE, and Bronson Weed, 1BHM, two good traffic men led the discussions which clarified a number of traffic questions.

Our good Director, Doc. White, has not lost his power of expression and those illustrations of Ohm's law and the L/C ratio were well worth listening to.

Two very fine stunts were put on by the Eastern Massachusetts Amateur Radio Assn. and the Providence Radio Assn. Young and Maney of the Providence Gang certainly can sing radio parodies to popular tunes.

The trip to A.R.R.L. Headquarters, with A. A. Hebert as conductor, taxed the capacity of a big bus and the gang had to be taken in relays, actually necessitating three round trips. Other visits of interest were the ones to the Southern N. E. Tel. Exchange where there is a modern installation, as well as WITC, the Travellers broadcast station, where 1ANQ, chief engineer and ITS, operator, made every one welcomed.

The Army was represented by Capt. Ferriter and Lieuts. Boyden and Graves; the Navy by Comdr. MacGowan, Lieut. Russell and Ensign Wells. Their addresses explained fully the Army-Amateur net and the Naval Reserve Units.

Quartz crystals were interestingly covered by Prof. K. S. Van Dyke of Wesleyan University, and Harold Westman, Asst. Technical Editor, QST, also spoke on Crystal Control Transmission. R. B. Bourne, 1ANA, with his visual "Five Meter Stuff" and Boyd Phelps, 2EB, who might be called the Father of Short Waves, ended a most pleasant afternoon. The hotel chef then insisted that no convention would be complete without something to eat and so more than 200 strong men, Y.L.'s, O.W.'s and one or two R.W.'s sat to a most luscious Roast Vermont Turkey dinner. (Where were you, Vermont gang? We really missed you.)

With our worthy president, Mr. Maxim, presenting the Traffic Trophy to 1BIG and the distribution of prizes donated by 18 manufacturers, loyal supporters of QST, the two-days festivities came to an end. All aboard for Boston next year.—A.A.H.

Another Angle on the R. F. Choke

By John H. Webb*

BEING troubled with reports as to bad QSS on the signals of my 5-watt transmitter, I began to suspect that it was not QSS at all but something that happened inside the sending set.

After everything else had been changed, the r.f. choke coil came in for inspection. It had been wound on a cardboard tube and there was the possibility that this tube might have absorbed moisture. This was of course simple enough to check up. The coil was baked in an oven and when it was replaced in the set the antenna current was nearly doubled with no other change—but the next morning the same trouble was back again as the tube had absorbed moisture overnight.

To end the trouble forever, I got some scraps of celluloid from an auto top repair shop (free), a piece of suitable size was curled into a tube 3 inches in diameter sticking the ends, which were overlapped one-half inch, with a cement composed of a syrupy mixture of acetone and celluloid. (The celluloid dissolves in the acetone which can be procured at drug stores for about 10c an ounce. Two ounces are a plenty.) After the wire was wound on, the whole thing was coated with this cement, which makes it waterproof, and the resulting coil is fully as strong as that wound on cardboard tubes.

Celluloid can also be used to make "no loss" receiving coils. The method to use is as follows.

On a 3-inch cardboard tube, a smooth layer of ordinary wrapping twine is first wound. On this were laid four one-half inch strips of celluloid, (at right angles to the winding) spaced equidistant around the tube and held in place by a rubber band on each end of the tube.

Number 18 bare copper wire was used for the coils and before winding was stretched tightly to take out the curlicues. After this it was wound on the tube, tightly spaced with string. When the winding was completed, the spacing string was removed and a coat of the dissolved celluloid was carefully applied over the wire where it had the celluloid strips underneath, thus securely binding the wire to the strips.

After drying for one-half hour, the original layer of string was carefully pulled out leaving sufficient clearance to slip the completed, self-supporting, coil off the cardboard tube easily and without damage.

The coil can be mounted on bakelite strips fitted with plug and jack mounting or in any other way desired.

A.R.R.L. Information Service Rules

Please help us by observing the following rules:

1. Keep a copy of your questions and diagrams and mention that you did so.
2. Number the questions and make a paragraph of each one.
3. Make diagrams on separate sheets and fasten them to the letter.
4. Print your name and address (not merely your radio call) on your letter. Don't depend on the return address on the envelope as this is destroyed when the letter is opened.
5. Don't ask for a comparison of the various manufacturers' products.
6. Before writing, search your files of QST—the answer probably is there.
7. Address all questions to Information Service, American Radio Relay League, Inc., 1711 Park Street, Hartford, Conn.
8. It is not essential to enclose an envelope as long as you supply postage and **PRINT CLEARLY** your name and address on your letter.

What Is the Input to Your Set?

(Continued from Page 38)

house RA meter mentioned above and find that our own unknown load drives the disc through 26 revolutions in one minute. This means that the power consumed is 26 (2/3) watt hours in one minute or (60) 26 (2/3) watt hours in one hour which is to say that we are drawing 1040 watt hours per hour which of course means that the load is 1040 watts.

Watt meters are expensive. High voltage voltmeters are likewise expensive, and very few stations have either. Consequently, the methods explained here in a concrete case, should be welcome, and make for better operation.

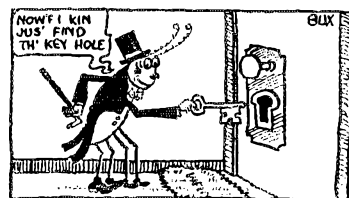

A "BUG" KEY

*4NE, 1843 Herschell St., Jacksonville, Fla.

Experimenters' Section Report

A GAIN, letters are being received asking what the "X section" "requirements" are. There are none, except an interest in the experimental side of radio. The reason for this informal "Section" of A.R.R.L. is the desire to secure contact between people working on the same problem and to pass on in the most useful way the results obtained from experimental radio work.

There are no special limits as to the nature of the work done tho there is a list of suggested problems and for the sake of simplicity all are asked to enroll, and to mark on this list the things they are interested in.

A transmitter is not necessary unless one happens to be working on that sort of problem. Neither are there any formal reports, tho the point of the whole thing is naturally lost if *QST* is not kept informed as to that which has happened.

That is all there is to it—but that has been worthwhile and has brought good material to *QST* and to amateur radio.

THE TELEVISION DEMONSTRATIONS

By this time it is no news to anyone in the section that the American Telegraph and Telephone Co., on April 7th gave a television demonstration at the Bell Telephone Laboratories, 463 West Street, New York City. The demonstration had at once great similarity to and considerable divergence from the classic one of C. Francis Jenkins which was the first—I believe—of all public demonstrations and which was first described in *QST*. It will be remembered that in the Jenkins scheme the object or person to be "transmitted" was brightly illuminated and then "looked at" by a telephoto cell which saw various parts of the object in rapid succession by reason of a rapidly rotating wheel with a spiral line of lenses set in it. So far the two schemes are essentially the same. The varying light that flickers into the photoelectric cell is now used in both systems, to modulate the e.m.f. of the cell, or its resistance, if one prefers to look at it that way. This modulation is suitably amplified and put on a radio or wire channel.

At the receiver there is a difference. In the Jenkins system the modulated energy received from the wire or radio channel was again amplified and imposed on a gaseous lamp—probably neon—which then emitted a light with a high frequency variable flicker and this flickering light was then spread on a screen by a second lens-wheel, whereupon one had the picture back again.

In the Bell Telephone system, the stream of received energy goes to a brush which is being spun over a circle of contacts by a synchronous motor, so that each little pulse of modulation (corresponding to one point of the original object) is shot into the correct wire to take it to the right part of the receiving "grid", on which the picture is to appear. This "grid" is a curious sort of glorified neon lamp which is best described by one of the accompanying photos. It is a long neon tube bent



DEMONSTRATION TELEVISION TRANSMITTER AT THE BELL TELEPHONE LABORATORIES

Seated before the "electric eye" is R. C. Mathes while at the control panel is J. W. Horton, both of whom contributed to the apparatus. Directly to the right is the synchronous motor which hustles the pickup around over the object to be transmitted. There appears to be some disagreement in the reports which variously say that the transmitting screen consists of a checkerboard of thermo-electric cells which are in turn connected to the "line" in a fashion similar to the operation of the various parts of the receiving grid, or else that a single cell operates thru a moving optical system as stated in the text. Facing the synchronous motor is H. M. Stoller who devised the synchronizing system. All Photos Courtesy Bell Telephone Laboratories, Inc.

back and forth on itself until it covers the whole area on which the picture is to appear. Behind it are hundreds of little metallic patches, each connected to one of the wires from the distributor. Whenever an impulse is shot into a wire it goes to one of these patches and in the tube there appears at that point a flash corresponding in intensity to the strength of the pulse. Since the entire screen is traversed in less than 1/16 of a second the eye sees the flashes all at once—that is the first one is still being seen when the last happens. Thus as far as the eye is concerned the whole screen is covered with a luminous picture which is being replaced 16 times per second by another luminous picture so that these images run together and the result is a moving image of the object at the sending end.

This description is crude because of brevity and because no very complete information has been given out.

The transmission, however, was acceptable over both the wire and radio channel, the radio channel being somewhat the better. The neon grid has been so called for convenience, tho the writer has no certainty that other gases were not present. It would seem to have the advantage of a greater possible illumination than can be gotten by spreading the light of a simpler lamp over the screen thru a moving optical system. It is quite likely that this is bad guess work and that later developments of the Jenkins arrangement may prove the opposite.

AMATEUR TELEPHOTOGRAPHY AND TELEVISION

Just enough correspondence on the subjects of television and telephotography arrives to keep the matter stirred up a bit. In order to secure some sort of fair opinion as to our proper procedure may we please

tributed to date. Surely there must be more logs in existence than that! Please send them to the Experimenter's Section A.R.R.L., 1711 Park Street, Hartford, Conn.

THE BRITISH TESTS

The tests from British 6CP which were made in January were very "thinly" received, probably because the notice was so excessively short that very few of our letters had time to reach the members. Again—if test schedules are sent to us for use in QST we must have at least 2 months notice. A test that is worth running internationally is worthy of some planning ahead. This is no special comment on City and Guild College, for the same thing is constantly being done by men right here in the United States who send test schedules for insertion in an issue of QST which is even at that moment being mailed out to the members.

AMPLIFIER MEASUREMENTS

In Wireless World for January and February, there ran a series of most interesting articles by R. L. Smith-Rose and H. A. Thomas on the procedure in measuring amplification in vacuum-tube systems. They are worth reading, as is much that appears in the publication mentioned.

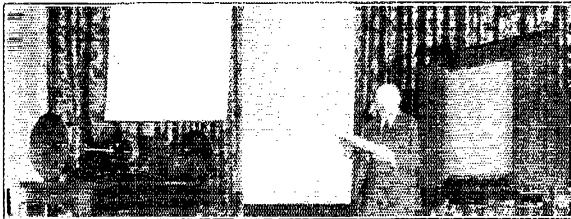

DR. HERBERT IVES LECTURING ON THE SYSTEM WITH AID OF SOME DEMONSTRATION APPARATUS

At the left is a laboratory form of the whirling lens-disc, such as was used in the Jenkins system and at least some forms of the Bell system. Over that is a map showing the radio television link from Whippany, N. J. to New York, also the wire link from Washington to New York. At the left is a neon-tube screen as described in the text.

THE SECTION REPORTS

The original idea of running a summary of the reports gotten from the section at our "inventory" has to some extent been given up. It seems more advisable to use the material so obtained in planning for the Section, also in articles. Needless to say, credit will be given when and where this is done. That it has not been done sooner is very much regretted, for some very fine material was received. It is not wasted, however.

hear from all those who would like to make some attempts at either. There are a number of Jenkins machines hither and yonder for the telephotography attempts and some summer tests may be most interesting. As to television, I have no suggestions and will welcome any.

DR. PICKARD'S OBSERVATIONS

For once it is necessary to confess that this section has made a "flop". A very long while ago the request was made that as many as possible provide for Dr. Pickard some quite limited observation on radio conditions from Feb. 6 on, for the wavelengths of 40, 20 and 80 meters. The idea was simply to classify as many evenings as possible during that time under some such system as

The subjects covered are very wide in range. From memory there are recalled worthwhile papers on antennas, 5-meter transmission, keying, bypass condensers, r.f. chokes, antennuation, field measurement, short-wave r.f. amplification, shielding, and portable transmitters. These will all be used.

THE .77-METER BAND

With the 5-meter job fairly under way there are signs that the .77-meter band will come alive soon. Various tubes from 199s to 15 kilowatt tubes are being operated at that wavelength and some are making preliminary stabs at an antenna. There is still some haziness as to the best receiver.

This should be a great wave for reflector work. Even at 5 meters reflectors are

- | | |
|-----------------------------|------------|
| Good | Excellent |
| Indifferent or more exactly | Good |
| Poor | Passable |
| | Poor |
| | Very Poor. |

Was this not hard enough? For some reason or other exactly TWO men have con-

big and clumsy but at .77 they are convenient enough.

THE 5-METER "CQ PARTY"

Particular attention is called to the 5-meter "CQ Party" which was announced on page 44 of the May issue. Note especially also that all schedules announced in this Section's work are on standard time. The so-called "daylight saving" time will not be used until it is adopted by the United States government, and even then it may not be suitable for international tests.

At present we are sure that there will be at least one 15-kilowatt and one 5-kilowatt 5-meter set in the test from Chicago, about 30 half- and quarter-kilowatt tubes at various points, the crystal-controlled job at 2XM with a new output end and a large number of 50- and 5-watt sets. ACD and 1ER can be counted on to represent Italy in their usual capable style. Australia also can be depended on and we will not be surprised to hear from other points. If any doubt exists as to the correctness of the time used by you it may be well to arrange matters so that you can get away from your own transmitter and listen while it is sending. This will permit extension of your transmitting time a slight time in both directions without "gumming" your reception too badly.

At another place in the magazine there is a discussion of receivers for the test.

REPORTS ON THE 5-METER TEST

On our past tests the main difficulty has been with slow reports. It will be a great help if they are made at once this time.

THE S. F. OBSERVATIONS ON 9XL AND 1XM

The observations on transmissions effects with 9XL and 1XM as the sending stations have begun to be highly interesting. Many exceptions to the skip-distance rules are noted as are also some remarkable "dead" spots for 9XL in the vicinity of Chicago. 1XM seems to go far better to the east (Europe) than to the west, also it goes well to the south. 9XL is getting over to the Pacific coast in great shape and both stations can be heard thru most of the Mississippi Valley.

Several hundred acknowledgments on our Standard Frequency transmissions have been received, of which quite a few are on the regular mimeographed record forms. Most of the others ask for record forms. Before we are done it is likely that we will have some excellent transmission information. More blanks for this work can be had for the asking.

SPECIAL S. F. SCHEDULES FOR AUSTRALIA

Chief Operator Hugh McCartney of 9XL has proposed some special S.F. schedules for a tie-in between our standards and those of the Wireless Institute of Australia. The plan will be talked over by Ross Hull of this outfit and Maxwell Howden of the W. I. of A. over their "private wire" this coming Sunday. If the schedule is sent we will be able to give details in July, QST.

MEGACYCLES AND METERS

Perhaps others have become a bit wearied of the kilocycle and wondered if it would not be more handy to talk about 30 meters than about 10,000 kilocycles. Dr. Pickard has been insisting that for such wavelengths one can talk frequency quite conveniently if one will only use megacycles instead of kilocycles, also that the megacycle stays good for the 5-meter and .77-meter bands where the kilocycle becomes preposterous.

Since some sort of a solution is needed, opinion is invited and as something definite to tie to there is submitted a chart received from G. P. Taylor of 9BAN, the location of which station does not appear on the letter. Mr. Taylor says, "The vertical set of

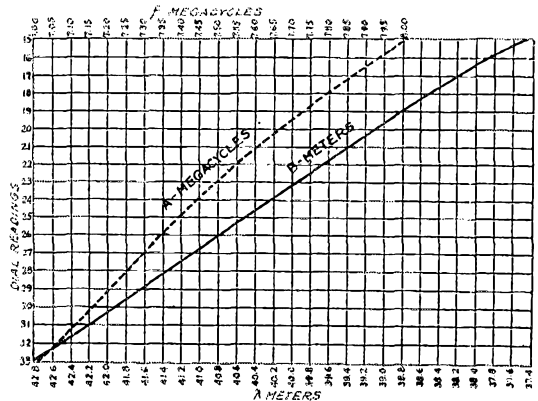

figures at the left are the degrees on my wavemeter dial. At the top are the megacycle readings 1/100 megacycle to the line of the chart. (In reproducing the chart only every tenth line has been used so that as it appears the readings are 1/20 m.c. per line.) At the bottom are the meters. "One curve is known from the calibration of the meter. In my case the m.c. curve was known first and the other was graphed from it. For instance, 28 on my dial was 7.25 m.c. which is 41.37 meters. A point is then put on the "28" line at approximately 41.37 meters etc.

"It is a handy chart and having it all on

one sheet simplifies it a good deal. It can be made for any desired band, of course. The accuracy naturally depends on the care with which you log standard frequency stations and make the curve itself."

Lest anyone go off on a tangent and suspect that this Section is in danger of slipping from standard terms to introduce new ones, attention is called to the fact that *opinion* has been asked for, also that we are the logical people first to consider this



CLOSEUP OF ONE OF THE RECEIVING "GRIDS" BEING PUMPED

At the right Dr. Herbert E. Ives, center H. D. Arnold, Director of Research and at the left E. B. Craft Executive Vice President of the Laboratories.

problem of terminology at 5 meters since we are the first people to do anything useful with 5 meters—and .77 meters.

The amateur of the A.R.R.L. has a good history of terms and symbols contributed to the art, and none of them have been done violently—the cooperation with the standards committees has always been excellent.

REFERENCES

From various sources in the Section, notes have been received calling attention to the following references.

Wireless World, September 22, 1926, Biography of Popoff, Russian radio pioneer.

Jahrbuch der Drahtlohen Telegraphie u. Telephonie, Eine Uhrsache der andernung des polarisationszustandes kurzer wellen, Korchenswesky, Dec. 1926.

I. R. E. convention paper (Jan. 1926 session). The Correlation of Radio Reception With Solar Reception With Solar Activity and Terrestrial Magnetism. Greenleaf W. Pickard (reprint available at 50c).

These are not intended to be late references but rather those that are of special interest at this moment.

—R. S. K.

Radio Interference Ordinances Cannot Limit Transmitting Stations

THAT a municipality has not authority to regulate Federally licensed radio stations and that municipal radio-interference ordinances can not be held ap-

plicable to them, was admitted by the City Council of Portland, Oregon, recently when it amended the Portland ordinance to exclude such stations from its provisions. The action of the council, which is regarded as extremely significant in determining the attitude of municipalities elsewhere, came as a result of an attack on the measure in the Federal Court by the American Radio Relay League, through its general counsel Paul M. Segal, of Denver, Colorado, our Director from the Rocky Mountain Division.

In spite of the fact that by revising the ordinance the city has refused to permit its legislation to be made the basis for a test suit involving the rights of a municipality to regulate federally-licensed radio transmitters, League officials regard the move as most important in establishing the rights of such stations.

Under the terms of the Portland ordinance, which was drawn up to suppress and regulate interference of all kinds to broadcast receiving sets in operation in the city, practically all types of high-frequency generating systems were subject to licensing, taxation and control. Apparatus so covered included violet-ray and X-ray machines and broadcast and amateur radio stations. The suit instituted by Mr. Segal on behalf of the 20,000 amateurs comprising the League sought to enjoin the enforcement of the ordinance as it applied to amateur and other Federally-licensed radio transmitters.

In seeking the injunction, Mr. Segal pointed out that the ordinance was unconstitutional in that it sought to control and regulate interstate commerce, power which is vested solely in the Federal Government; that the ordinance did not and could not establish a basis on which to judge a station for interference, and that the measure at times was in direct violation of the provisions of the license issued the amateur by the government. It was pointed out that in all instances where such conflict occurs the Federal provisions supersede local regulations.

On learning of the suit, the city authorities immediately drew up an amendment pertaining to broadcast, commercial and amateur stations in order that the ordinance as a whole might not be endangered. The amendment as passed provides that the terms of the ordinance shall not apply to radio stations, either broadcast, commercial or amateur, which are licensed by the government.

This amendment reduces the ordinance to a simple police measure designed to prevent the operation of static and X-ray machines during the hours of broadcast reception.

The situation brought out in the suit by the League is one which has been carefully

(Continued on Page 46)

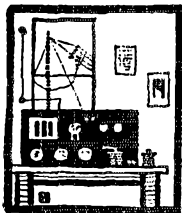

Amateur Radio Stations

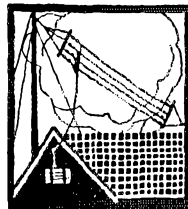

4TK-40B, Jacksonville, Fla.



ROBERT H. REID and Guy L. Carter are the owners and operators of this station which is located at 507 Duval Street. The operators have not concentrated their energy in any one direction and they are always ready to QSR, chew the rag or go after DX as the particular conditions may propose.

The initial transmitter used a five watt which was later replaced with a UX-210 with 500 volt, Kenotron rectified a.c. on the plate. The set was operated on 80 meters and is the panel-mounted one on the right.

Later, the 40-meter wave attracted attention and another transmitter was built. This set is on the table at the left and is keyed by relay from the operating table on which the receiver and 80-meter set is located.

A 203-A is used with 1500 volts, about 800-cycle, plate supply. Several forms of rectifiers were tried and were all discarded in turn. The generator is a 900-cycle machine being self-excited and coupled directly to a half horse Westinghouse motor running at 3450 r.p.m. under full load. This is slightly under the rated speed of the generator, thus the 800-cycle supply mentioned above. A storage battery is connected in the field circuit of the generator which boosts the output. The machine is located on the back porch for cooling and to keep its noise from getting into the receiver. The input to the tube is kept low and no effort is made to squeeze the last mil into

the antenna. This helps in the obtaining a steady note.

The antenna first used was a vertical Hertz working on its fundamental. The present one is a single wire inverted L with a vertical counterpoise working on the third harmonic. This gives somewhat better results. It is also used to receive on, being connected to the sets through a change-over switch of a Navy type using a pyrex stand-off insulator to carry the transmitting contacts. This switch controls the power to the transmitters and when they are turned on, it disconnects the "B" batteries from the receiver. There is, then, no danger of paralyzing the tubes and only a slight noise is heard in the phones. A small red pilot light next to the switch gives notice when either of the transmitters is in operation.

The wavemeter graph appears on the wall over the lamp and is on a generous scale which allows accurate readings. The wavemeter itself is in front of the 80-meter transmitter. This is an excellent feature as small curves are always getting misplaced and cannot be read rapidly and accurately at the same time.

This station has had its share of foreign contacts and while no attempts have been made to grab off huge chunks of traffic, it has made the B.P.L. and is an ORS and OBS. The operators are always ready to QSR or chew the sock at any time.

9APY, Berwyn, Ill.

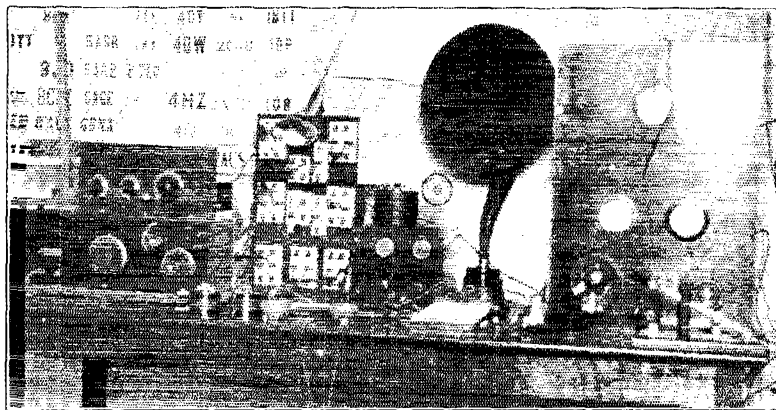

THIS station has two separate and distinct transmitters. One of these is a UX-210 in an inductively-coupled Hartley circuit and is used on the forty-meter band, while the other is a 203-A in the same sort of a circuit working on either 82 or 175 meters. Each transmitter is complete in itself; having its own meters, antenna-counterpoise system, coils, etcetera, and is worked from a switchboard.

The power is supplied from two sources. A 1 1/2-Kw. pole transformer delivers 550, 1100 or 2200 volts to a chemical rectifier or else 750 volts of r.a.c. may be obtained from an Acme transformer and a pair of "S" tubes. A common filter consisting of a total of four mikes and a 50-henry choke can be switched in or out of either of the two supply circuits.

The receiver uses R.E.L. coils and covers all the bands. Two stages of audio are used and an R-3 Magnovox allows nearly all signals to be copied without wearing fones. This is a considerable saving on the operator's hair. A "B" eliminator has worked out very successfully.

A General Radio wavemeter is in use to check not only the signal going out but also those being received. A complete log is kept with a card-indexed checking system for all stations heard or worked. Any call can be looked up in an instant and the number of times a station has been heard or worked seen at a glance. This necessitates a great deal of work but is very handy as a reference. Each call has its own card.

Traffic is the main idea at 9APY although DX is welcome when there is no traffic or for an occasional diversion. All U. S. districts and Canada have been worked with the 80-meter transmitter and reports from off the coast of Ireland and Portugal have been

received. Due to the fact that traffic is the mainstay, DX has been a bit stifled.

9APY is an O.R.S. as well as a member of the I.A.R.U. and R.C.C. He was acting ADM while 9AAW was away on a world tour and was DS No. 7 until the new traffic system was started.

Radio Interference Ordinances Cannot Limit Transmitting Stations

(Continued from Page 43)

studied by other municipalities for some time. The city of Atchison, Kansas, in 1923 drew up an interference ordinance, but upon opinion of the city attorney that municipal regulation of amateur communication was illegal, the measure was drawn up so as not to apply to such installations. A similar opinion has been rendered by the city attorney of Minneapolis with respect to an interference-prevention ordinance in that city, it being held that no such ordinance is applicable to stations licensed by Federal authority and operated under the terms of such licenses. Salem, Ore., which desired to adopt the Portland ordinance, adopted also the amendment so that it does not apply to licensed stations.

In view of these decisions, other cities will be slow in adopting ordinances improperly seeking to regulate licensed stations, in the opinion of the League's counsel. Director Segal, 9EEA, is by profession the prosecutor at Denver's West Side Court. His other hobby, however, is radio law, a field in which he is becoming recognized as an expert.

—A. L. B.



I.A.R.U. NEWS

ONCE again we would like to point out at the suggestion of nu3SJ that a large percentage of the QRM at the lower end of the U. S. 40-meter band is due to the fact that those amateurs assigned the band just below it insist upon starting at the lower end and tuning upward when searching for answers to their calls. It is therefore logical that the "nu" stations will flock to the bottom and even below the official limit so that they will be heard before the others. Try tuning from 42.8 meters down OMs and you'll make just as many QSOs without anywhere near the amount of QRM you run into at the 37.5 meter end of the scale.

WAC

Quite a large number of folks seem to have the opinion that it is only necessary to write in and tell us they have worked all continents to be eligible for membership in this club. This is not the whole story by

stations have qualified since the initial announcement which appeared in the April, 1926 QST. The list of members is as follows. nu6OI, nu6HM, nu1AAO, nc4GT, np4SA, nu9ZT, eb4YZ, nu9DNG, op3AA, nu2APV, op1AU, nu5ACL, nu5JF, eg2IT, eg5NJ, op1CW, fo1SR, nu1CMP, nu1CMX, eb4RS, nu7IT, nu1CH, sc9TC, nu5TW, nu6CTO, op1BD, nu9BSK, nu4TN, am2SE, eg5XY, sc2LD, ef8CS, nu2CRB, oa2SH, nu7VH, nu2MK, nu2AHM, nu2CYX, su2AK, su1BU, eg5SZ, nu5QL, nu8ALY, eg5MA, foA5X, nu6ALR, nu1VC, nu6VZ, nu6CCT, nu7EK, nj2PZ, nu4BL, hu9BHT, hu6ZAT, eg6TD and sc2AS.

Send in your cards OMS and join the ranks.

BELGIUM

We are very pleased to announce that the Réseau Belge is now the recognized Belgian Section of the International Amateur Radio Union. It is therefore advisable that all Belgian amateurs affiliate themselves with this organization so that their viewpoints and opinions may be made known to its officers and through them to the entire world. In this way the Belgian amateur may take his rightful position in the world of amateur radio.

The accompanying illustration shows the beautiful diploma that is given to each member. Every Belgian amateur should have one hanging in his shack.

AUSTRALIA

We received by radio thru nu9BJP, the following news from oa4RB. "Conditions have been very good for radio here lately. The U. S. stations start coming in as early as four in the afternoon. Many stations are audible over here, coming in with a strength of R8. Most of our stations are operating just below the forty-meter band.

"Not many of us are operating on 20-meters. A few are working in that region occasionally but no station is on that wave consistently. The "nu" stations are heard on 20 meters as early as 2 o'clock in the afternoon and the best time seems to be about five in the evening. Most signals are about R5 with a few R6. The European stations are heard best around four p.m. Many



MEMBERSHIP CERTIFICATE IN THE BELGIAN SECTION OF THE I.A.R.U.

any means. It is necessary that you send use the QSL cards acknowledging the *working* of your station by at least one station in every continent. These cards are examined and returned to you. If they are found to be satisfactory, the certificate will be forwarded and you are then a member of the WAC club. You are not a member until you have this certificate. This probably explains (at least to some extent) why so few

of these are heard, the loudest being eb4AU. Most of our stations when working in the twenty-meter band operate just a little above twenty-one meters."

S-W PRESS

These schedules of short-wave stations transmitting press reports of general interest have been supplied us by 9CVR.

Station	Location	Wavelength Frequency	Language	G.C.T.	Time P.S.T.	E.S.T.
NKF	Anacostia, D. C.	4915 Kc. 61 meters	English	0100	5.00pm	8.00pm
XDA	Mexico City, Mex.	8815 Kc. 34 meters	Spanish	0500	9.00pm	Midnight
NPM	Honolulu, T. H.	8565 Kc. 35 meters	English	0900	1.00am	4.00am
VIS	Sidney, Aust.	5875 Kc. 51 meters	English	1230	4.30am	7.30am
VAS	Louisburg, N. S.	5765 Kc. 52 meters	English	1230	4.30am	7.30am
WNU	New Orleans, La.,	7495 Kc. 40 meters 11532 Kc. 26 meters	English	1130 0530 1130 0530	3.30am 9.30pm 3.30am 9.30pm	6.30am 12.30pm 6.30am 12.30am

CHILE

nu6CKV was working sc2AS when all of a sudden, 2AS's signal started going to pieces. He told 6CKV to wait a couple of times and then said, "Big earthquake, GB". We believe this to be the first time anyone has heard of an earthquake on 40-meters.

DENMARK

The experimental station of the Telegraph Laboratory, Royal Technical College at Copenhagen signing ed7ZM is desirous of running some short-wave tests and would be pleased to hear from any American stations able to participate in them. The power used will be from 200 to 300 watts and the wave 44.2 meters. Those interested are requested to communicate with G. Bramslev at the above address.

BRITISH GUIANA

We have been informed by Arthur E. Gagan that the short-wave shBZL located at Georgetown, Demarara, British Guiana, is operated by operator Parker and himself, Superintendent of the longer wave BZL. The information contained in the April issue is erroneous in this respect.

JAMAICA

John F. Grinan, nj2PZ, states that he has been getting a large number of QSL cards addressed to nj2AC and nj2AR with the request that they be forwarded. He states that his is the only station in Jamaica and that these calls were probably used by stations that were unable to raise any so-called DX with their own calls. It is certainly too bad that so many stations have been worked

by these fake stations. The use of a fraudulent call is not only illegal but certainly not very sportsmanlike.

There will probably be no other stations operating in Jamaica in the near future as it took 2PZ all of two years to convince the authorities that it would be a perfectly proper thing to allow his station to be operated.

The next time you work any of these "Jamaica" stations, it would be good policy to ask for the correct QRA so that the QSL card won't be wasted.

JAPAN

JKZB is an experimental station which is controlled by Y. Imaoka on the research staff of the Tokyo Electric Company. The

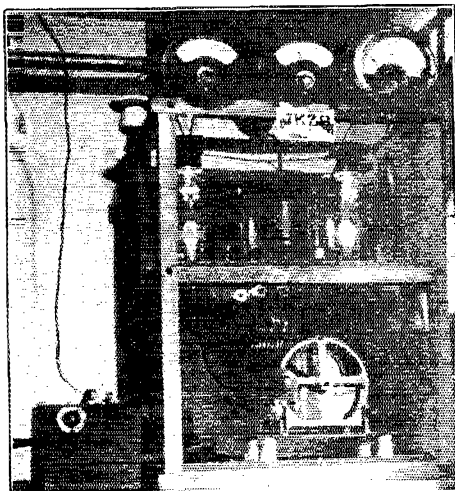

THE MAIN TRANSMITTER AT JKZB

station is located at Kawasaki, half way between Yokohama and Tokyo and two miles off Tokyo Bay.

The main transmitter uses two 250-watt

tubes which are similar to the UV-204 but made at the factory of Tokyo Electric Company. These tubes run at a cherry red color and the circuit is a Mesny using specially designed inductances. The plate supply is rectified a. c. obtained from full-wave keno-

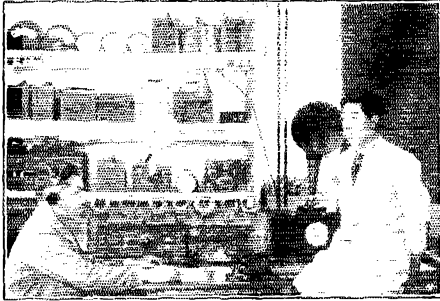

S. OSAKA AND Y. IMAOKO OF JKZB

tron rectifiers and smoothed by means of 5 microfarads of capacity and a 60-henry choke.

The transmitter and receiver are located in the same room and the transmitter is operated by means of remote control relays. Separate antennas are used for receiving and transmitting. The transmitting one is a vertical wire twenty-five meters long and the counterpoise is a radial system composed of five wires each eight meters long. The receiver is the usual regenerative detector plus a two-stage audio amplifier. A ground is used.

JKZB is in operation every Tuesday, Thursday and Friday from 0800 to 1300 G.C.T. On the first Saturday of each month, a 24-hour test is run, beginning at 0800 G.C.T. and continuing until the next day. A CQ is sent twenty and forty minutes past each hour. The wavelength used is 38 meters.

Mr. Imaoka is now traveling in Europe where he will be until the end of September when he is coming to the United States. He hopes to visit many amateur stations and will appreciate the aid of any amateurs who may assist him in his visits to these stations.

JKZB will be operated in his absence by S. Osaka who will be in charge of the station.

NEW HEBRIDES

HVW is located at Vila on the Island of Efate in the New Hebrides group. The New Hebrides are jointly governed by Great Britain and France and the radio laws of the group administered jointly by the British and French Resident Commissioners. Vila is the seat of the government and is located in about the center of the group. The

white population of the Islands is about 3,000 and the natives about 60,000.

HVW is the Condominium Government Radio Station and is the only one on the Islands. It is a 5 Kw. spark outfit. The short-wave set uses a single 201-A with 250 volts on the plate obtained from storage batteries. The input varies from five to seven watts depending upon the condition of the batteries. A series feed Hartley circuit is used, this giving the best results of those tried. The ham set is owned and run by F. H. Harvey who is the assistant op on the commercial outfit. He is the only amateur of the islands.

REPUBLIC OF SALVADOR

There is at present but one amateur radio station in this country. It is owned by J. Fred Mejia and signs ns1FMH. The government regulations do not allow the operation of transmitters and the only reason this station is in operation is because Mr. Mejia was the Chief of the Radio Division for a time and when withdrawing from that office requested a special license. As is the case in many countries, those who framed the laws covering radio operations knew nothing about the matter at all. It is expected

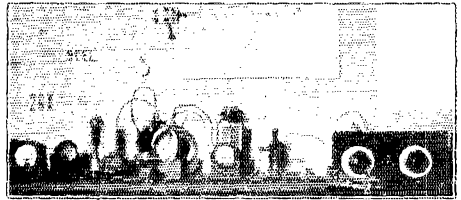

ns1FMH, SAN SALVADOR

that 1FMH will again be appointed to the position of Chief of Radio and he will endeavor to have the amateur recognized.

The transmitter uses a direct-coupled Hartley circuit. A fifty watt is employed and the plate supply is rectified and filtered a. c. The combination of a pair of "S" tubes and a brute-force filter result in a note that is almost pure d. c.

SGL

There are quite a few of the Swedish American Line boats that are equipped with short-wave c. w. sets. The S.S. Stockholm, SGL, is one of these.

The power is supplied from a 220-volt, 500-cycle alternator which is driven by a small de Laval steam turbine. The field of the alternator is supplied from a d. c. generator mounted on the same shaft. A separate 500-cycle motor-gen. takes care of the filaments of the four 250-watt tubes that are used. Two filaments are connected in series and the two sets are in parallel.

The plate-power is obtained from a step-

up transformer giving 3500 volts each side of the center tap. A full-wave gas filled rectifier tube is used. The filament of this rectifier takes 10 amperes at 2 volts and it will rectify 1 ampere at 3000 volts. The life is estimated at about 50 hours but will be considerably less if the voltage being rectified is increased above the rated value.

The Hartley circuit was used at first and trouble was had due to unsteadiness of the wave. The improved Meissner circuit as described on page 19 of the August, 1926, *QST* was then tried. This cleared up the trouble which was caused by the high internal capacity of the four 250 watters in parallel.

The normal ship's antenna is used. This is a "T" type one with a flat-top about 300 feet long. The lead-in which is 85 feet long connects to the flat portion at a point one third of the way from one end. A high harmonic of this antenna is used and a remarkable feature is that the most violent rolling of the ship seems to have no effect on either the frequency or signal strength. It is believed that if a fundamental antenna



A CORNER OF THE "STATIC ROOM" ON THE SGL

were used, the effects would be very pronounced. However, no direct comparison has been made and this is not known for certain.

The short-wave outfit proved more effective than did the 1850-meter wave and LGN (Bergen Radio, Norway) was able to copy the meteorological reports sent on the short wave when SGL was able to hear the long-wave acknowledgments. These reports were then sent on schedule and the QSLs obtained on the trip back. LGN has now put in a 33-meter transmitter and very consistent contact is had for the entire trip across and back.

QSL

Cards to amateurs in Belgium whose correct QRAs are not known should be sent to Reseau Belge, QSL Section, 11 Rue du Congrès, Bruxelles. This is the official QSL section of the Belgian section of the I.A.R.U.

We will appreciate being informed by all

other organizations giving QSL card service as to this fact and the correct address to which cards should be sent. Publication of such information should prove of benefit to all concerned.

SOME MORE NEW ONES

We have received from a large number of operators, both amateur and commercial, the following list of stations, the QRAs of which are not known to all. Although space does not permit our thanking each one individually, we appreciate receiving this information and are always glad to get such dope. Keep 'em coming.

- na7AAM—Radio, Yakutaga Beach, Alaska.
- nc5FS—Mackenzie River Delta, Arctic Coast, Northern Canada.
- ar8LHA—Lambert, Box 86, Beirut, Syria.
- acVPS—Gov't Radio Station, Hongkong, China.
- aq1DA—C. W. Liversidge, Kirkuk Palace Hotel, Kirkuk, Iraq.
- OX1—Nexpoli. Cantoel, Stradiux, Beluchastin, Balkan States.
- asRAO3—Mr. Golovstchikoff, Lab. of the Far Eastern University at Vladivostok, Siberia.
- eaGP—Giorg Priechedfried, Vienna 13, Zehetnergasse 20.
- e1ISE—Fauske, Norway.
- etTPAI—Wl. Wysocki, Nowowiejska 33, Warsaw, Poland.
- eaOHK—Austria Radio Co., Renggasse 14, Vienna 1, Austria.
- slCOS—Mr. Svensson, Apartago 611, Bogata, Colombia.

SHIPS

- SKA—M.S. Axel Johnson, Axel Johnson Co., Stockholm, Sweden.
- SGT—M.S. Suecia, Axel Johnson Co., Stockholm, Sweden.
- SFN—S.S. Louisa, Axel Johnson Co., Stockholm, Sweden.
- SKU—S.S. Hanoë, Messrs, Carlbom & Co., Hull, England.
- SBM—Swedish Warship Fylgia.
- xen1NL—Dutch Steamer, Kinderdyk. Formerly signed noNL. QSL to Wireless Operator, c/o Holland American Line, Market Street 120, San Francisco, Calif.
- DCZ—Sailing yacht, Vaterland. QSL to German Consulate General, 42 Broadway, New York City.
- nnM3Y—Capt. Pierce, U.S.M.C. VO1, Managua, Nicaragua.
- NEM3—Bar Point, Nicaragua. QSL to R. H. Jule, U.S.S. Denver, c/o Postmaster, New York City.
- KLE—S.S. Zacapa of the United Fruit S.S. Corp.

The Communications Department

F. E. Handy, Communications Manager
1711 Park St., Hartford, Conn.

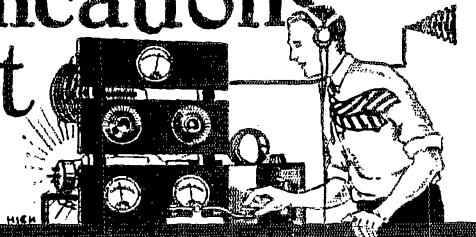

20-Meter Reports

THERE is so much activity on 20-meters now that we can hardly hope to cover more than some of the high points in the limited space available. Extracts from the best reports and suggestions received are included as usual for the information of everyone working on "20".

Glaser of 2BRB is at this writing engaged in making a comparison of horizontal and vertical reception at 20-meters. If possible, the effects of polarization of radio waves at this frequency and useful operating facts about various types of collectors will be determined as suggested last month. It is hoped that there will be information on this subject for this column from a variety of sources within the next month or two.

During the past month a number of additional stations in foreign countries have been heard and worked on "20" and probably many more will be on the shorter wavelengths by the time of the International Relay Party. nu1BUX (Fall River, Mass.) reports 20-meters FB for work at all times of day. foA3Z, foA5X and foA6N have all been heard many times on "20" and foA4F was worked for three quarters of an hour at about 3 pm EST April 13 by 1BUX. nu7BB-AP (Seattle, Wash.) using one UX210 with T.P.T.G. claims distinction by being the first "7" to work Mexico and Iceland on "20" the latter QSO taking place at 6 pm PST. 7BB reports traffic plentiful and he has been QSO all districts with 6 wats input in less than three weeks. nu9KV (Duluth, Minn.) worked oa4RB Apr. 13 and reports him steady and r6 from 2 am until 4 am CST at which time he went off the air. nu5AGQ (Ft. Worth, Texas) says he raises about everyone called on "20" getting reports averaging r6 from Newfoundland, Chile and Australia. A 203A running cool from a filtered "sync" working into 30 feet of tin drain pipe mounted vertically 15 feet from ground is used. oa4RB (20.3 meters) and oa2UK (just below him) have been worked, foreign QSOs being generally established about 8 hours earlier than on 40 meters. 20-meter Aussies come in best about midnight and Chilean stations (sc2AS and sc8AG) at 5 pm CST. nu8CMB (Cleveland, O) with one 7½ watter has worked eb, eg, ef, oh and all the U. S. and Canada. He put in a 250 watter and worked e1AY on "20" with this on April 5. nu8BAU (Columbus, O.) tells us that vs1AB (formerly am2SE) is on regularly on 23 meters at about 1100 GCT and would like to hook more U. S. 20-m stations. 8CWT has reports from all over and one night he worked oa7DX and oa7HL in succession.

nu6BUX (Pomona, Calif.) says he can QSY from 20 to 40 meters or vice versa in about 20 seconds. His antenna is a bent Hertzian type having a natural period of about 50 meters working slightly below the natural period fundamental for 40-meter work and loaded to 60-meters for 3rd harmonic 20-meter operation which he finds more efficient than 2nd harmonic operation. A S.P.D.T. switch has connected to one outside terminal a variable condenser, and to the other outer terminal the loading coil, the central post connecting directly to the antenna lead. The other terminals of the condenser and coil of course connect together and thru coupling coil and ammeter to counterpoise. For best results the clip connecting c.p. to load coil is usually disconnected when the radiator is tuned for 40-meter operation but this should not be necessary if the coupling of the load coil to other apparatus is kept low. T.G.T.P. circuit is used, the number of turns and setting of condensers being reduced for 20-m work.

nu5ACL (Dallas Texas) says more oh-stations were logged on "20" in one week than ever heard on

40- and 80-meters. The oa's pound thru about midnight CST. sc8AR is R7 daily about 6 pm CST. He has been QSO oz2AC and ef8CT and worked a ship signing deTC on 20.5 meters 1400 miles from the U. S. with one 201A and 110 v.d.c. from the ships supply. This station was unlicensed but will have license soon. 6VZ (Santa Monica, Calif.) worked au1CD Apr. 5 9 pm to 9.30 pm PST giving him a message for ef8JN. Fine steady R5 sigs both ways. ef8YOR has been worked twice on "20", the last time 6.45 pm to 7.30 pm PST May 1st. nc1CO also worked Apr. 19. nu8CFG worked eb4AX and oa2UK with one 210. nu2BSL worked eg5YX and eg5BY on 20—says its easy to raise 'em. nu4PX (Atlanta, Ga.) says, "20 sure is FB but you have not yet sung its praises loud enough from the standpoint of the fellow with low power or poor location—or both. I have a 7½ watter and a back yard full of high power lines—no chance for an outside antenna. My antenna and c.p. are each made of 15 feet of stranded electric light wire. The horizontal parts are about 11 feet each with ant. and c.p. separated about 7½ feet and in same room with transmitter. In three weeks on "20" I have worked all U. S. and Canadian districts with reports of R6 to R8 from France and Australia and what's better, perfect contacts thruout long QSOs." This letter speaks for itself.

nu7JF (Moscow, Idaho) reports copying eg2CX ef-8CT, ef-8CN, eb4WW, nj2PZ, su2AK, sc8AG, oz2AE, and oz2AC on "20" despite his QRM from a 60,000 volt transmission line. The following have been worked: 1UE 1BUX 1CAW 1RY 1CMX 1BYV 1AKZ 2IE 2QU 2CTQ 2AWX 2AOL 2TP 2APA 8AVM 3DS nc8NI nc8CS 4GS 4BQ 4WH 5APE 5APB 6DT 5APG 6's are too many, no 7's, 8ALY 8BOY 8AYA 8BJB 8ASB 8DKV 8CVQ 8BAU 8AVB 8CTD 8CMB 8DON 8AHC 9ALM 9EF 9DKC 9AHQ 9CJT 9ANZ 9AHU 9DGR 9A5 9BJP 9DIJ 9CJY 9ARL 9DGI 9CTO 9DPV 9CST 9EMB 9DKM oh6BDL oh6AG oh6CLJ. nu4JR (Gastonia, N. C.) in ten days (Apr. 3 to 13) worked the following 20-meter stations at various times: nu8CJ, 1MK, 1AHI, 1ALF, 9EIR, 2AQW, 9TM, 9AWB, 7GB, 6AJM, 5FS, 2AIU, 9CTO, 6CLN, 6BPM, 6KM, 9CHD, ef8CT, nc2AL, nc4FV, na7AAM, eg5BY, nu6BRQ (Oakland, Calif.) sends us a list of the most consistent 20-m stations he hears in the U. S. All cards QSLed in full and all sigs heard between 11.80 am and 4.30 pm PST: 2XAD, 3XT, 4HE, 5AGQ, 5ZA, 7AAE, 7FU, 7SY, 7ZM, 7TX, 7MP, 7BB, 7PV, 7AIJ, 8BAJ, 8AYA, 9BYL, 9EAE, 9BYC, 9CJY, 9EEW, 9NM, 9EA, eg2BOW (G. L. Brownson, Hale, Cheshire, Eng.) sends a list of calls heard on 20 meters via nu8BAG covering a period of Mar. 29 to Apr. 8: nu1CAW, 1CDP, 1BYV, 1BVL, 1AJM, 1ASU, 1AKZ, 1PM, 1BKP, 2AVG, 2AFG, 2WC, 2CTF, 2AHM, 3CFG, 4LZ, 4DM, 4WE, 8BAG, 8AHC, 8ASB, 8CLP, 8DRJ, 8ALY, 8BOX, 8XE, 8AXB, 8CWN, 9EF, 9AFB, NIDK, NKF, nc1AR, 3NP, ne8AF.

1NK (Revere, Mass.) finds 20-meters FB, the berries for DX and rag chewing. He just came down from 80-m a few days ago and worked the best DX yet with his 210. eb4AU and ef8CT report him R6 1NL and 2AWX handled some traffic from ef8CT to A.R.R.L. HQ on 20 meters but the tests arranged by R.E.F. were not planned with sufficient slack so we could notify the gang. nu9BPM reported his schedule with KFSX (Warrrior) when QSO 1MK on "20". 6CCR worked eudX and now says 9RA7 nu9KV tried some tests with oz2AC, keeping a schedule for that purpose. At 2 am CST the signals are steady and R8 at both ends. At 9 pm CST they are still R5 and readable without repeats under ordinary conditions. 9KV maintains that the U. S.

stations all QSS out gradually at about 11 pm CST daily as the ship distance increases after dark so that while it is still possible to conduct coast to coast work, stations in the central part of the country using antennas like the average ham cannot work any except the foreign 20-meter stations. SALG takes his 40-meter traffic down to 20- to QSR where conditions are better.

eg5YX (Mr. N. C. Smith, Crofttholme, 117 Chesterton Rd., Cambridge, Eng.) will be pleased to run daily schedules with any U. S. station who writes him during June for the purpose of studying weather effects. With 10 watts plate input he has worked 1BVU, 2GP, 4NH, 8AXA, 9EF, nc3QN, 1AQT, 1BUX, 1BYV, 1CAW, 1CMX, 1KA, 1RD, 1SW, 2AQW, 2AHM, 2TP, 4TV, 8ALY, 8AHC, nc1AM, SKU. With 2 watts input 8ALY, 4TV and 1RD were worked and with .24 watt input 1RD still reported R1-R2. SKU we learn is the tramp ship SS Hanau which has a transmitter on 22, 37, and 44 meters. oa4RB, oa7DX and oa2TM are heard on 20-meters in England 0600-0730 Greenwich. foA5X and stations in Japan and India are heard at 1700 while Brazilians start coming in at 2000 and the U. S. gang about 2200. The best time to work eg's is at this season 2200 to 0100 on 20 meters and from 2400 on for 40-meters, all times GCT.

nu8CCQ (Williamsport, Pa.) says "20 sure is the berries for DX. RCC, and real pleasure after one has been thru the QRM and QRN on 40 and 80 meters. I do wish to say that some of the 5-minute CQ's and calls are not as necessary as the gang think. I have neglected to log a number of stations because of their long calls without sines to identify them. I find it easy to raise stations on short CQ's and calls. If one doesn't use bk-in it is still possible to call again if a called station doesn't come back promptly. Slow sending is fine until QSO is made when I believe things can be speeded up to good advantage. For the benefit of those trying WE211D tubes—they won't work due to the chokes inside the tube itself." Calls worked and heard at 8CCQ—all QSL's answered: Sins wkd: 4FA, 5AMO, 6BD, 6KM, 6VZ, 7NY, 9BAF, 9BAD, 9CKI, 9CYB, 9DGA, 9DQB, nc1DX, nc5AU. Hrd: 5ANT, 5QL, 6FR, 6YR, 9AJI, 9BKM, 9CXL, 9FAG, 9FK, nc1AR, ne8AF, np4KD, ey5HS, ef8CT, ef8ZF, NIDK, 1BHS (New Bedford, Mass.) reports hearing plenty of 6's, oh, oz, sb, etc. He has worked ef8CT, ei1NO, oa7CW, oz2AC, eb4AU, sb1AD and nu4GN, 4BL, 4WH, 4CJ, 8CDP, 8ADH, 8DKA, 8CIL, 8DSY, 8CFL, 9MN, 9BBQ, 9DJO, 9CXL, 9CWN, 9AXB, 9ANZ, 9BJP, 9AOK, 9DAC, 9BYC, and 6CYG. 1BYV (Framingham Center, Mass.) says it's very easy to QSO DX on "20" because they're not DX any more on that wave but all like local. With his old UX210 he has worked all nu-districts, nc-1-3-4-5, ne, np, nd, nd, ef, eg, sb, em, ed, ei, su, sc, sb, oh and oz. 6BA reports thru 1BYV that oz2AC has been having the best U. S. A. QSO's ever using "20."

EXPEDITIONS

Mr. C. E. Himoe, 9ZE-ex9AOG, and Kenneth M. Gold, 1AAV, have been chosen as radio operators of the Schooners "Bowdoin" (WNP) and "Radio" (call not yet assigned) of this year's MacMillan Expedition. WNP goes into the Northland again for a 12 to 15 months stay while the "Radio" will go as far as Labrador returning in September. Half and quarter Kw. installations working on 20 and 40 meters will be used. The sailing date is now set as June 28. Be ready for traffic from WNP and her sister ship, gang.

The communications arrangements of the Wilkins Arctic Expedition seem to be working out very successfully. KFZG (Point Barrow) regularly works KFZH (near Fairbanks, Alaska) and KFZH is QSO many stations in the States and handling a good amount of the traffic by amateur radio. KFZH (6703 Kcs or 44.7 meters) keeps a daily schedule with 7BM-7DR (Aberdeen, Washington) at 11.45 pm PST which is set ahead to 12.30 am in case KFZH is QRW with KFZG. A message to Mr. Guy Jones of the North American Newspaper Alliance in New York came through in short order from Operator Mason of KFZG, travelling via 6CTX, 4FL, and 8CMM. Another message started on the same date, April 24, to Sec'y Warner of A.R.R.L. made equally good time coming via KFZG, KFZH, 7ABK, 7AAT, 9EEF, 2KX, 1AZW, 1NE. Some relay!

Mason (KFZG at Point Barrow) using a 201-A crystal controlled with 24 watts plate input, an antenna on a 80-foot flagpole, counterpoise fastened

to a shovel in a snowbank got Hemrich (KFZH at Fairbanks) 1500 miles away on his first call—sigs R4 and readable 24-hours per day. Although the Delco system at a mission will be pressed into service, the hand generator has worked nicely except that the prime movers sometimes walk away and make themselves scarce when there are messages to clear. Hi! DX-reception of hundreds of U. S. amateurs and dozens of foreigners is reported by Mason. Conditions at the northernmost tip of Alaska are FB. We hope to have some calls-heard and photographs to present next month. In the meantime, please keep your ears open for KFZG and KFZH in the vicinity of 45 meters wavelength. Maybe you can hook up direct. At any rate there will be interesting traffic coming down for QSR.

Instances showing the worthwhile side of amateur radio are cropping up all the time. 6BXC at Los Angeles recently handled a message which came via 6AMM and op1HR which was instrumental in sending money to a chap at Fort Nichols, P. I. in time so that he was able to catch the very next boat to the States without delay. FB, everybody.

eb4WW filed a message at 4.45 am April 29, giving it to 6CTX (operated by Granbacka of 2AHG) at 8.45 pm April 28. The message was addressed to oh6AXW and passed on to him at 9.30 pm Honolulu time, thus arriving at its destination 7½ hours before it was filed. Anybody want to send a message to yesterday? Wouldn't it be great if all our amateur relay traffic could go through like that! Let's each do our part to make it so, OM.

6BYH keeps a daily schedule with the yacht *Warrior*, KFSX, at 5.30 PST. The gang should watch for traffic from and for KFSX either direct or via coast stations QSO.

7AAT did some fast work in making the B. P. L. this month and last. While a bunch of schedules is responsible for most of the total, 32 messages were passed to 9BPM in one hour and forty minutes on one morning schedule. It was hot and heavy work at 80-per. Let's hear of more like it.

7ACN says he heard a certain call CQ 100 times without a break, sign three times, and then repeat the whole thing.—And there are others just as bad. Let's get over this rotten habit. It just gives others a poor impression of our operating ability, and doesn't do us a bit of good. Send your calls plainly and "mix 'em up" with a sine at frequent intervals, OM.

9DYD and 9LY are the originators of a unique organization known as the Bed Haters. To become a member all that is necessary is to QSO either of the two "Headquarters" stations after two AM CST. Neat little membership cards are furnished each member, showing that he is a real Bed Hater, and not an impostor. The organization numbers over 70 members. One ham in the eastern part of the country wrote in asking to be made an honorary member, as his mother wouldn't allow him to stay up after three AM EST. Hi!

A good marker for the Canadian 52.5 meter wave is WLW's short wave broadcast which is near 52 meters.

Why have so many of you fellows the idea that speed is more important than accuracy? Without accuracy, *nothing else counts!* Surely you realize that our main goal in putting through a message is—or should be—to get that message to the addressee in the same form in which it was originated. Let's get over this idea of seeing how rapidly we can transmit a message, and put more stress on how nearly *right* we can handle it. Accuracy, FIRST, then speed in handling and reliability in delivering will make our traffic work more nearly all we would like to see it.

Let's make it a rule, fellows, that whenever we accept a message from a foreigner, we will send a confirmation copy by mail to its destination, in addition to the usual method of QSR. After a message has bridged the gap into this country, it should certainly be able to go the rest of its way without unnecessary delay.

Say, Oscar, why do the YL ops like crystal control? That's easy, Rudolph. 'Tis so they'll have a permanent wave!

With the Route Managers

By Lawrence A. Jones*

CUSE all fish-hooks! When are you fellows going to come through with some letters? There were more than usual this month, but when you stop to think that there are seventy one of us Route Managers, the number of suggestions is still awfully small. It is still necessary for us to stagger blindly along with this page, and just trust to luck that we are giving you something you want.

Before you read this, you will have received a mimeographed list of all the RMs appointed so far, seventy one of 'em. This list ought to prove useful to all of you who are on the job. It will tell you whom to write to when you want to arrange a schedule with a certain section of the country. We will try to keep it up to date with a supplement from time to time, and here's hoping you hang on to the lists and use them.

Well, fellows, traffic is still dropping. Nearly every section shows a marked drop this month. QRN seems to have been worse than usual lately, and, of course, it is the main cause for the marked falling off in totals. We have a big job ahead of us to keep relaying up during the summer, but we can do it. Let's get right down to brass tacks now, and boost the gang along. Originate some good messages, arrange some early morning eighty meter schedules if QRN is too bad for evening operation on that wave, and try to persuade your fellows to operate at least one hour each day during the summer. This can be in the morning or any other time, but make it regular. You all know from experience that such operation will do wonders toward a traffic total. Come on, now, get busy, and let's see what we can do. JFI, RM of Tennessee says, "Schedules are not yet being kept very regularly, but I can see some improvement." That's the stuff, OM! Keep right after 'em, and the improvement will become more and more marked.

6RJ has resigned his position as CRM of the East Bay Section, to take up the duties of Assistant SCM. We are mighty sorry to lose him. 6APA becomes the new CRM for that section, and will carry on the good work where RJ left off. In his last report as RM, 6RJ gives us quite a bit of information. He says, "Many new opportunities have been afforded this month for lining up traffic routes. 6ANE, a new RM in the section has been making visits to Official Relay Stations, Radio Clubs, and sending out post cards inviting co-operation in traffic schedules, and has been personally responsible for many new reliable routes. New reports were secured at the Oakland Radio Club, whose members are planning to help increase our schedule total." FBI That ought to give some of you others some suggestions. You might try the same thing in your section that "Annie" has been doing in East Bay. 6RJ also tells us that the spring and summer slump is not likely to affect traffic handling and reporting in the East Bay Section, according to the present outlook. There you are, gang! If one section can do it, all the rest can.

6DL, RM of Alabama, sent out a form letter to all the ORS in his section asking for reports and dope on schedules. It is a dandy letter, and ought to bring forth something in the line of response. Harrison is to be congratulated.

1IT, CRM of Vermont, writes, "Old Vermont is just beginning to get into shape for traffic and the delivery of messages by radio. Many of the stations are coming up to the eighty meter band on purpose to see that local traffic can be handled. The RMs of Vermont are going to try to keep regular skeels between each other so as to provide a certain path of QSR over the state." That's the spirit! With the RMs at work like that, it won't be long before messages will travel through Vermont quickly and reliably.

9DLD, RM of Wisconsin, says, "Up to the present time I have not given much thought to what we ought to see in the Route Manager's Page in QST, but I hope that I may be able to offer some suggestions in the near future." Atta boy, we hope so too! He also says that Wisconsin amateurs are pushing "Tourist Traffic" this summer. That ought to offer a fine source for some of the messages we need so badly right now. The SCM of Wisconsin has created a new office, known as the Chief of Tour-

ist Traffic. That makes another suggestion for some of the other sections where tourists are more than plentiful in the summer. But please try to make the messages real ones,—not just the old "greetings by radio" affairs. The more interesting the text of a message, the more efficient will be the handling thereof. Now give us time to take a deep breath after that last, and we will be ready to continue.

6IW, RM of Southern Texas, says that he has been taking note of the conditions in his section, and finds that very few of the operators make use of the various routes. It seems that each operator tries to get his messages through direct, which often causes delay in the service. This is true, unfortunately, and it is one of the things we will have to buck against. Our work will not cease when we get good reliable routes in operation. Far from it! We'll have to devote our time then to getting the gang to make use of these routes, or they won't be worth a great deal. RM Cline also says, "My efforts next month will be toward linking up the different districts with reliable schedules." Good! We'd like to see the rest of you try that, too.

10C-BFT, RM of New Hampshire, writes, "Sorry that I haven't been able to get enough dope from the fellows for a bigger report. I expect a better showing next time, as I am writing to every ham and asking him for information." There you are. Several of you are now trying that stunt, and it ought to bring forth all the dope you need. It's really worth trying for those of you have trouble getting information from your gang. Evans also says that he has appointed IIP as an assistant RM, and that they are going to get together and dope out a plan for boosting New Hampshire traffic, etc. Good stuff, OM, and here's wishing you luck. Let us know how you come out.

9CZC, RM of Iowa, says, "Traffic activities have taken an awful slump. The QRN surely puts a wet blanket on our heretofore classy traffic organization." That's the fix most of us are in, and it's a pretty hard one to get out of. Naturally summer traffic will always be lighter than winter, but it is quite possible for us to so encourage the gang that the slump will be lighter than before. "Mac" is working hard, we know, and this will begin to show results before long. He is an ardent booster of early morning schedules on eighty meters. If QRN continues, it looks as though that idea, along with twenty meter traffic development will prove to be the best way out of traffic drops.

2QU, RM of Eastern New York, came through with that new traffic handling system of his. It has many good points, and if it can be put into use we'll tell you all about it in the near future. It's great to have the gang interested enough to think these things up. We're bound to get somewhere before long if all of you write in your ideas.

3CEB, the acting RM of Virginia, writes a nice letter telling what he has been doing. Glad to hear from you anytime, OM,—and all the rest of you too. 3CEB is working hard on schedules both within the state and between the state and outside points, and hopes to have some real routes to show for his work before long. Hope you do!

Reading over all the above paragraphs ought to give a lot of you fellows some new ideas on your job. That's the only way we'll ever get 'em. One or two fellows simply can't think of enough activities to keep all the RMs busy, and moreover, what is helpful in one section may not necessarily be helpful in another. Our job requires some study and exchange of ideas, and that is just what this page was started for.

Possibly the reason some of you haven't written is because you think you haven't any ideas that are worth-while. If you feel that way about it, why not just write a plain, ordinary, every-day letter telling us what you have been doing,—and the chances are ten to one that we'll be able to find something worth telling the gang about. Don't stop to think it over,—just take your pen and write.

The hook is about cleared for this month, now. Think all this stuff over, watch the conditions in your section, do whatever you think best toward improving them, and then tell us what you did. So long until July. 73 fm "LJ."

*Assistant to the Communications Manager.

ARMY-AMATEUR NOTES

SECOND CORPS AREA—8DME and 8CVJ have kept Net schedules with 8HJ. If AA stations don't keep their schedules, they will be replaced by new ones. 2ASE, the N.C.S. of Eastern N. Y. Net complains of lack of cooperation by the stations in his net. 2CVS is now alternate N.C.S. of the Bronx Net, in place of 2APV. Net schedules are being satisfactorily kept. 2ABC is the new alternate N.C.S. in the Manhattan Net. 2EV and 2CBC assist in keeping the schedules with 2SC. 2APD has been acting alternate N.C.S. in the Brooklyn-Statens Island Net, assisting 2EF in keeping schedules with 2SC. 2ARM and 2AVR are the only active Net

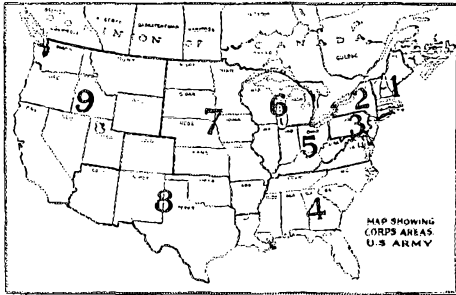

stations. 2DV is the new principal N.C.S. of the New Jersey Net, succeeding 2WR. 2OU has been doing excellent work arranging schedules. 2HW, N.C.S. of the N.J.N.G. Net kept schedules with 2SC.

FIFTH CORPS AREA—AA work in this area is almost at a stand-still. Any of the old gang wishing to get something started will kindly write to 8BYN giving latest dope on their stations, schedules, etc.

SEVENTH CORPS AREA—A number of stations have been appointed in Omaha, each one to control AA work in one state in the Area. The ones so far appointed are 9BGG, 9DUH, 9DFR, and 9AL. As fast as other state nets are put into action, other stations will be appointed to this staff.

All applicants for the AA system should apply to the Corps Area Signal Officer of the Corps Area in which the amateur resides. These are:

- 1st Corps Area—Army Base, Boston, Mass.
- 2nd " "—Governors Island, New York City.
- 3rd " "—Baltimore, Md.
- 4th " "—Atlanta, Ga.
- 5th " "—Fort Hayes, Columbus, Ohio.
- 6th " "—1819 West Pershing Road, Chicago Illinois.
- 7th " "—Fort Omaha, Omaha, Nebr.
- 8th " "—Fort Sam Houston, San Antonio, Texas.
- 9th " "—The Presidio, San Francisco, Calif.

Accompanying this column is a map showing the various Corps Areas. Civilians desiring to join the Officers Reserve Corps should apply to the Commanding General, of the Corps Area in which they reside.

OFFICIAL BROADCASTING STATIONS

(Changes and Additions
Local Standard Time)

9BWN (84.6) 10:30 pm Mon. (38.3) 10:30 pm Fri.; nc-4AF (20) 3 pm Sun. (39.5) 3:30 pm Sun.; nc-4CU (41.30) 8 and 10 pm Sun. 9BWN (88) 10:30 pm Mon. (40) 10:30 pm Fri.; 9EGA (38.65) 10:30 pm Wed.. KSO (405) (voice) 10:30 pm Mon. & Fri. 9JU, Tues. and Fri., 8 pm 415 meters.

The United Fruit Company's *Esparta*, EDO, is anxious to make schedules with amateurs. The short wave outfit uses a fifty watt tube with pure dc plate supply on about 22 meters. Mail should be sent care of the New York Times Radio Station 2UO, and addressed to the chief operator.

Gosh, gang! Why don't more of you use break-in? You simply don't know what you are missing. It's lots more fun than this business of calling each other two or three times every time we come back. Try it!

Did you hear of the ham who worked for two weeks on a twenty watt outfit and then discovered that two of the tubes were Kenotrons?—*QRM Bulletin*.

BRASS POUNDERS' LEAGUE

Call	Orig.	Del.	Rel.	Total
9CPM	29	47	394	470
3SM	72	176	216	464
8VZ	180	142	20	342
op-1AU	—	—	—	321
op-1HR	—	—	—	309
2AMJ	67	23	207	297
8CYK	186	68	43	297
8XE	34	29	209	272
1CRA	76	18	169	263
7AAT	152	—	104	256
9EK-XH	67	79	90	236
6AYC	31	4	200	235
8EU	27	36	164	227
9HWN	27	36	164	227
6DEY	187	16	14	217
6BJX	63	119	35	217
6ALH	41	—	171	212
8BAU	25	14	171	210
6AGG	103	14	91	208
8DBL	15	8	182	205
6BYY	80	122	—	202
1APL	23	32	143	198
8CMO	13	14	170	197
5ASR	15	4	177	196
1BJK	32	9	150	191
9AAU	60	25	93	178
6EJ	23	31	118	177
6BYH	25	11	140	176
9DTK	9	23	142	174
4DM	67	72	34	173
9ZK	57	24	86	167
6CTE	29	7	126	162
9BBS	22	61	74	157
6BVM	13	8	109	130
6ACG	45	20	86	151
9CMV	78	8	64	150
8AVK	29	19	100	148
8CEO	18	23	101	142
1OC	53	16	72	141
8CXL	—	—	141	141
5ALG	23	9	107	139
9COS	76	11	50	137
6CDZ	46	8	82	136
6ZBJ	19	18	99	136
9BQH	53	9	74	136
9CAA	16	16	104	136
1MK	36	51	48	135
6BGB	—	63	72	135
6CMT	4	17	112	133
1IP	19	19	94	132
6ABM	47	6	78	131
9CZC	1	2	128	131
7DA	24	4	102	130
7PN	28	21	104	153
8GI	5	12	112	129
9CIA	14	19	94	127
2ALP	19	32	74	125
9DWN	8	16	100	124
1DV	10	14	100	124
8AGO	51	21	50	122
9DOE	25	18	78	121
5AMO	27	14	80	121
9ROW	32	3	85	120
6AWQ	19	14	86	119
8DOQ	23	8	88	119
6CLQ	13	10	95	118
6BXI	6	—	112	118
8CNX	38	6	70	114
6BUX	12	16	86	114
6BYZ	26	14	68	108
9CN	20	60	23	108
1BFZ	25	14	68	107
1BIG	12	38	3	103
9DAE	8	12	83	103
6GW	2	50	50	102
3CFG	36	6	59	101
5FJ	14	4	83	101
6DEG	25	4	71	100
6BWW	27	60	13	100

9CPM, 3SM, and 8VZ take first honors as message pushers while op1AU and op1HR take fourth and fifth place this month with a pile of good traffic work. They are both in line and working for the Roberts cup we understand. It is certainly fine the way that the B. P. L. men are consistently operating and keeping that old bogey, the summer slump, from putting us effectively out of business. FBI

DIVISIONAL REPORTS

ATLANTIC DIVISION

DELAWARE-MARYLAND-DIST. OF COLUMBIA—SCM, A. B. Goodall, 3AB—Delaware: 3AIS is heard on 40 meters occasionally. Maryland: 3CGC continues to keep in touch with the rest of the bunch besides the PRR tests. 3CJ has been consistent in handling traffic on 80 meters. 3AEA reports activity in the near future. 3LL is putting in crystal control with kenotron rectifiers. 3AGL is trying hard to keep on the air. 3PS is operating on 40 and 20 meters.

Dist. of Col.: 3NR has changed over to a self-rectified circuit and finds it satisfactory. 3BWT had the misfortune to have his antenna come down during the month. 3GP, after experimenting to find the elusive antenna length of a Zeppelin antenna finally reports success with the result that the signals are rolling out. 3AB is active only on short schedules in the early evening. 3ASO has his crystal controlled fone and CW operating on 80 meters.

Traffic: 3GP 30, 3BWT 97, 3NR 56, 3AB 35, 3CAB 2, 3PS 17, 3CJ 13, 3CGC 6.

EASTERN PENNA—SCM, H. M. Wallace, 8BQ—3AIY, Chas. Hackenjos, 1181 West Indiana Ave., Phila. has been appointed RM for the city of Phila. We expect that the Phila. men will cooperate fully with 3AIY in an effort to bring your city up to the top in A.R.R.L. work. 20 meters seems to have taken its toll with some of the fellows. Originate traffic on 20 and let us make it a useful hand instead of another DX hunting ground. 3SM leads the high men, moved and married, all at once. FB and congrats. A new stick at 8EU's is the berries. How about some cooperation with RM Maneval? 3CMO is messing with 40 again. Traffic continues to rush thru 3AVK. 8BFE is still hunting his license. 3AIY is QRM'd by a local fone. DX is good on 40 for 8CDS, and 8AUV. No traffic on 20 for 3BFL. DX skeds on 40 brought 8VF quite a few. 3AY says local QRM will cost him his ORS yet. 3CJN keeps Allentown humming. 8BSZ has a new 50 watt rig perking. 9WH is Yling. A lot of work out 3AWT's total some. 3ADE is busting out on 20. Much overtime work raised hector with 3BQP, too. 3PY is collecting traffic on 80 now. 3HD wasn't on much. Business picked up for 8BIR. 8ADQ is planning an xtal rig. 3ZM sent some nice photos but not such a good report. 3NP is failing us of late. 3AVL could hit it up a little, too. Give us more NEWS. QSO your RMs for skeds, etc.

Traffic: 3SM 464, 8EU 227, 3CMO 197, 3AVK 148, 8ADQ 97, 3ADE 74, 3AWT 78, 3CJN 20, 3VF 25, 3BQP 25, 3HD 22, 3CDS 19, 3BFL 18, 8BIR 15, 3PY 15, 8BSZ 15, 3NP 12, 3AIY 12, 8BFE 12, 3ZM 8, 3AY 9, 8WH 7, 3AVL 5, 8AUV 4.

WESTERN PENNA—SCM, G. L. Crossley, 8XE—Traffic this month is very light some of the heavy traffic stations reporting light totals. Yet there are a couple of stations reporting higher totals this month than usual. There are a few stations going to 20 meters while a few are returning to the upper bands. The SCM visited the Erie Radio Club recently and had quite a talk with some of the gang there. It seems that the Erie fellows are having quite a time there with outside QSO mainly because of that locality being dead to a number of directions. They report Pittsburgh a bad locality for communications and QSS quite bad with stations in that direction and seldom having more than an R4 report. The reports show an increase by two of the junior section of the brass pounders—8CES and 8DJP each report an understudy. Congrats OM to you and the OW. 8CEO has finally been able to work out break-in and now has a set working on 160, 80, 40 and 20 using the same antenna and plug-in coils transmitter. 8CYP is now on 80 and says there is plenty of traffic for anyone looking for it. 8GK and 8AMR are on 20. 8AXM and 8CES are on 40. 8DBL is on with 2-210s on 20, 40 and 80 meters. 8HM has his station under construction but at present, is using a 5 watt portable on 40. 8DKS and 8CRK report poor weather, QRN and QRM too much for DX. 8GI is looking for schedules west. 8BRM says he has seen no activity since PRR days. 8BRC is building a new power plant and is installing crystal control on all of his sets. 8BW is building a new shack and putting in 250 watts. 8BBL and 8DNO are QRW school. 8DOQ blew his kenotron but is back on the air again. 8AGQ is off the air for repairs. 8ABW lost his mast in the wind and his rectifier burned out but will be back on the air very soon. 8CTC is a new

ham at Meadville. 8VE is on the 20 band exclusively. 8AJU is going back to the 80 band. 8JW is graduating from Swathmore, and will be on the air again after June. 8DFY tried xtal control but junked it in disgust. 8CWT is installing mercury arc. 8XE is still on the air looking for traffic. 8ARC is doing some test work for the Aluminum Co. on aluminum for rectifiers. 8AGO is busy with the convention publicity (I hear the Western Pa. gang is going to be well represented—SCM).

Traffic: 8XE 272, 8DBL 205, 8CEO 142, 8GI 129, 8AGO 122, 8DOQ 119, 8BRC 86, 8CWT 31, 8ABW 29, 8CYP 25, 8HM 17, 8BRM 16, 8DKS 15, 8ARC 15, 8VE 15, 8APC 10, 8GK 8, 8AJU 7, 8DNO 6, 8BBL 5.

WESTERN NEW YORK—SCM, C. S. Taylor, 8PJ—For the last couple of months, Western N. Y. has led the country in traffic. That shows what can be done if you all get busy. There has been a decided decrease in all reports this month which indicates nice weather, fish poles, and outdoor life which has tempted the majority. 8ABG worked on-2RY. 8ADE worked on-7DX and ef-8FJ on 20 meters. 8ADG has been trying out 20 and is all set for European tests. 8AKC is slated for Army ham post this summer. 8AHC worked Hawaii, Uruguay, eg. ab, sc, sb and others. 8AIL is off the air at present. 8ANX has a portable, call 8QU. 8APK has changed antenna system from 1 wire to 3 wire cage. 8AVJ is off the air most of the time on account of summer weather. 8AYB has cancelled all skeds on account of QRN. 8AYU has skeds with 8BMJ, 3AC, 8CRF, 8DKY. 8BAG worked XG, at sea, and many others locally and is now checking off-wave stations. 8BCM received a msg. from the Yacht XG. 8BFG is an ORS now, handling traffic. 8BGN worked on-2YJ. 8BLP is off building a new transmitter. 8BMJ works on 80 meters. 8BYE is on every morning from 9 until noon. 8CCR reports traffic slight. 8CDC blew his 50 watter. 8CDB handed two msgs. to England. 8CEG has been visiting in Washington. 8CNT worked 6TX. 8CVJ worked Colorado. 8CNX made the BPL again. 8CNH worked Italy and France. 8CYK made the BPL this month. 8DHX worked the west coast,—is trying out 20 meters. 8DME worked Calif. and Texas. 8DNE has skeds with 1BQD. 8DRJ worked io and sc. A business man tried to locate his mother in the west and after having sent several letters, telegrams, etc., finally tried amateur radio as a last resort and gave a msg. to 8GJ who got it into Calif., located the mother and received an answer by letter. FB, OM. 8HJ is still in the Army net. 8NT is busy at school. 8QB is one of the PRR 100 per cent. stations with skeds with 8ARC. 8TH and 8VN are back again with a new station.

Traffic: 8ABG 4, 8ADE 3, 8AHC 27, 8AKS 5, 8ANX 10, 8APK 22, 8AVJ 10, 8AYB 11, 8AYU 2, 8BAG 12, 8BCM 25, 8BFG 8, 8BGN 4, 8BMJ 47, 8CCR 3, 8CDC 18, 8CDB 94, 8CEG 6, 8CNT 17, 8CVJ 3, 8CNX 114, 8CNH 38, 8CYK 297, 8CXH 41, 8DME 17, 8DNE 31, 8DRJ 9, 8GJ 17, 8HJ 19, 8QB 19, 8TH 6.

SOUTHERN NEW JERSEY, SCM, H. W. Densham, 3EH—Well gang, the SCM certainly appreciates the activity and pep shown by this month's reports. I only wish I had the time and opportunity to get around to see each of you personally but I am with you in spirit, always. I hope before the summer is over that I will again be pounding brass. Drop in at my QRA and talk things over fellows. Always glad to see the gang and talk radio. 3CF came through with his usual total. EB-4AX and OA-2UK with ten watt. 3ZL, who lost his mast, reports having all the material for his new antenna outfit and will be back on the air soon. 3SJ (ADBS) had a fine time lately when he visited headquarters in Hartford. 3BWJ has gone back to 80 meters and says there is plenty of traffic there. He goes to West Point in June and the Neal note of 3BWJ will be greatly missed. 3UT says that 3BCO, 8AS and the rest of the Ocean City gang are giving him some real competition. 3CO reports a fine total but unfortunately has had to cancel his tlc skeds because of insufficient time. 3CBX reports a scarcity of tlc on 40 meters. Better get up on 80 OM. 3KJ is on 40 meters five and six days a week. 3BEI shoved a msg from headquarters through 2CDH to Marine headquarters in Washington, D. C. in twelve minutes. 3ALX reports that he will soon be home from college and will have his fifty on the air.

TRAFFIC: 3CFG 101, 3SJ 38, 3BWJ 81, 3UT 62, 3CO 41, 3CBX 6, 3KJ 11, 3BEI 9, 3OQ 11.

CENTRAL DIVISION

INDIANA—SCM, D. J. Angus, 9CYQ—9ASX is very active on 40. 9BBJ operates when he is home from Purdue. 9DDZ who lost his antenna during a wind storm, has a new one. 9BQH led Elkhart in the message totals. 9DVE is using a mercury-arc rectifier for plate supply. 9AUX bought a 30-watt Telefunken tube. 9ABP gets on the air twice a week now. 9CMV is the joint station of the hams attending the University at Lafayette. There are 6 other stations at Lafayette, this being the first time in radio history that Lafayette really woke up. 9BUZ has tuned plate and grid. 9BOX is working a 5 on 39 meters. 9CIZ is working a 5 on 87.5 meters. 9BWI is on crystal control. 9CHC is on 80 meters with a 7½ watt. 9BYT is on 40 meters.

The Indianapolis Radio Club awarded the traffic prize for the first quarter of 1927 to Joe Charpie, 9CBT. He handled the most traffic and won the prize of \$6 worth of radio transmitting equipment. 9AMI is in the hospital at South Bend and hopes to be out soon. 9RKJ is putting in a crystal. 9CEY is putting in a 50 watt to replace the one he blew. 9ASX wants schedules on 40 meters. 9DRS has a 50. 9EF and 9DIJ are on 20 meters. 9CP is QRW school but operates some. 9EJU reports 9AGR is on with 100 watts 80 meter CRAC. 9EG is on with 50 watts on 41 meters. Geo. Hoover and Powers are ready to go with 15 watts as soon as the papers come from Hoover. 9DDA is on with 100 watts fone and code on 80 meters. 9EJU is on both 40 and 179 meters.

Traffic: 9CMV 150, 9BQH 136, 9BUZ 61, 9CMJ 58, 9EBW 56, 9EGE 59, 9DPJ 37, 9CVX 37, 9CNC 26, 9BYO 6, 9DBA 26, 9AIN 23, 9EJU 3, 9ABW 12, 9ASX 18, 9CEY 9, 9BKJ 5, 9BBJ 20, 9DDZ 25, 9DVE 39, 9BYI 15, 9CRV 42, 9BOX 23, 9CYQ 25, 9CLO 24, 9BWI 15, 9AXH 11, 9DSC 8, 9ALH 6, 9AYO 12.

KENTUCKY—SCM, D. A. Downard, 9ARU—The summer slump is beginning to show up. Does anybody want to take the SCM fishing? 9ABR reports having worked oa-3ES and oa-5BW on 89 meters and has a sked with oa-3VP. New ORS please get in touch with 9ABR as he is the Route Mgr. for this Section and wants to know about your skeds, when you are on the air, etc. 9ALM adds France and China to his list of DX worked. 9ATV has changed the location of his station which makes it the third time in the last couple of months. 9BPB is still enjoying himself breaking mercury tubes. 9EI is also having a good time blowing fifties and plate transformers. 9JL of U. of Ky. has again come to life and will be on the air consistently, on 40 meters. Old 9LH is chief operator. 9BAZ worked all districts except the 2nd in a couple of hours and reports getting R3 and 9 from the West Coast. 9KZ is perking nicely on 77 meters. 9BWJ reports results from shorter leads on his new transmitter lots better than he expected. 9GC is still waiting on power. 9OX and 9WR have consolidated and moved to the city limits. 9HP says the total of foreign countries he has worked is now 37. 9ARU is still off the air rebuilding but will be back again shortly on 20, 40 and 80 meters.

Traffic: 9ALM 40, 9ABR 36, 9WR 18, 9OX 14, 9RWJ 12, 9ATV 12, 9KZ 10, 9BAZ 9, 9HP 9.

WISCONSIN—SCM, C. N. Crapo, 9VD—9EK manages to keep totals high by sticking to schedules. 9DTK is putting in resistance key thump filter. 9BEK bought 9DTK's old 250 watt so he will be on the air again soon. 9DLL arrived home from the Dakota Div. Convention OK, not only finding it reporting time but also loads of work. 9BWZ sends his first report and says he will always report regularly. 9SO sent a msg. from Ohio thru 9AHD for one of the ops and rec'd a reply in less than 4 min. from the op's house in a neighboring town. 9EGW's H tube passed out and he is now using a UV203A. 9DKA's transmitter was off for a while but he has a M.G. going now. 9AZN kept schedules with 9DTK, 9DXZ and 8ARE. 9BPW is moving his station and perhaps will have a new call. 9EEF operated at WRRS during the month. 9AGV kept schedules OK. 9CIB joined the Naval Reserve as 2nd class radio man and is now on 2 weeks cruise on USSC 412. 9BWO is still on 20, 40 and 80. 9EHM's transmitter is being completely overhauled. 9VD represented Wisconsin at the Dakota Div. Convention. 9BIB just returned from Minneapolis where he attended the Dakota Div. Convention. 9AIA was on 180 m. fone but came down to 40 meters two weeks ago. 9ARE had a booming month up here with about 53 QSOs will 22 different stations up on 175 meters fone.

Traffic: 9DTK 174, 9EK-XH 236, 9DLL 89, 9BWZ 79, 9SO 78, 9DLQ 43, 9EGW 32, 9DKA 31, 9AZN 32, 9BPW 29, 9EEF 27, 9AGV 24, 9CIB 21, 9BWO 13, 9SA 10, 9EHM 11, 9VD 9, 9EAN 8, 9CAV 8, 9AFZ

8, 9JM 6, 9BIB 6, 9AIA 4, 9ARE 4, 9AZY 4, 9CDT 3, 9COI 17.

OHIO—SCM, H. C. Storck, 8BYN—Well, gang, here's another report and for the beginning of summer, it sure is a humdinger. 8BAU turned in a good total this time. Keep it up, OM. 3BI-8CXL comes second. He reports 8AXS, 8CVE, 8CNI and 8BZT are all active stations in Dayton. 8DIH has been disappointed with schedules but comes in third. 8RN is going commercial again, on the tr. Yosemite. 8CQU turned in 70 but doesn't say anything about himself. 8BNW keeps a flock of schedules and says the hardest messages to QSR are the ones for OHIO. 8AKO is back on the Crib on the lake and will handle traffic thru 8HB there. 8DBM is very QRW—more time in about a month. 8GZ keeps a bunch of schedules but says "too blamed QRW for much work". 8BEV says he has been having a flock of tough luck with his TP-TG xmitter. 8ACY is off the air again until Jan. 1, 1928. 8BWW is using TP-TG circuit with a 250. 8CMB says 20 is FB for traffic if you look for it. 8DSY is working 'em all on 20 and keeps a lot of schedules. 8CFL is now working exclusively on 20 for the summer. 8AOE is on 40 now with Hertz. 8OQ is a good schedule station. 8ALU thinks he didn't do so good and is working out some reliable schedules. 8BFA is again on the Lakes and is taking a set with him. 8DDQ is sure out after traffic. 8BEM just got on the air again with a UX210 and is getting a kick from low power work. 8AVX just moved also and is going strong by this time. 8DIA visited Columbus and is now using voltage fed Hertz as the result.

8CCG says he can't be on regularly any more. 8CTD is a very regular station. 8AQU has dropped to 40 and says FB. 8ARW is on the 40 band every afternoon and night for traffic. 8AVJ turns in a total but says nothing about himself. 8DQZ says school work not so pressing just now. 8DMX also is afraid to say anything about himself. (Must be in love, OM.) Hi. 8AEU is working on 20 with an 80 meter Hertz and says FB. 8DHS nearly forgot his report, has to move his QRA, and overlooked the date on his license and lost it, with no hopes of getting one again because the RI says he would have to appear for examination. 8ADH has his troubles getting on the air as he classes everything else as more important than radio. 8AWX says his gang is QRW with plans for Central Division Convention in Youngstown in August. 8BKM went back up to 85 meters and is going to 160 soon. 8GL has been busy with school. 8CLR says YLs are taking his time and bad conditions on the air get him sore. Hi. 8BAH says his Junior Op. now knows the letter "M"—"da da." 8DEM has been very QRW with school. The SCM has been off practically all month, due to press of work and also lack of time to rebuild his rectifier. Allowance will be made for summer inactivity but don't presume too far, thinking to hold your ORS certificate on this account. Report even tho inactive. Get in touch with RM 8AU at once and line up some 20 meter schedules for this summer, gang. Any OHIO ORS who is consistently reported off-wave on any of the bands, will lose his certificate so suddenly, it will make his head swim. The SCM is always ready for schedules when real traffic is promised so don't forget that and also, will keep an ear open for the Ohio ORS every time 8BYN is on the air in case you fellows want to QSO. Would suggest that you call once and sign once, etc., so you will be easier to pick out. If you have break-in, tell that, so we'll QSO sooner.

Traffic: 8BAU 210, 8CXL 14, 8DIH 92, 8RN 92, 8CQU 70, 8BNW 61, 8AKO 60, 8DBM 57, 8GZ 52, 8BEV 50, 8ACY 46, 8BWW 45, 8CNB 42, 8DSY 41, 8CFL 38, 8AOE 28, 8OQ 22, 8ALU 21, 8BFA 19, 8DDQ 18, 8BHM 18, 8AVX 17, 8DIA 16, 8CCG 16, 8CTD 14, 8AQU 12, 8BYN 12, 8ARW 11, 8AYJ 11, 8DQZ 10, 8DMX 10, 8AEU 10, 8DHS 9, 8ADH 9, 8AWX 9, 8BKM 8, 8GL 6, 8DPF 5, 8BOP 5, 8BSC 3, 8AVR 2, 8PL 2, 8DAE 2, 8RJ 2, 8CLR 1.

MICHIGAN—SCM, C. E. Darr, 8ZZ—8DED has been appointed RM for Western Mich. 8CEP is the new RM for Eastern Mich. Please get QSO with them and make arrangements for traffic schedules and routes. An upper peninsula RM will be appointed soon. 8CYU is building a 100 watt fone set for 170-180 band and a duplicate of 2AHM's set for 80, 40 and 20 band. 8CIS takes traffic from the west coast on 40 at night and QSRs east on 20 in daylight. 8AWT is on 20 meters. 8AUB is on 20 part of the time. Grand Rapids has many new stations coming on the air and are planning a feed and hamfest in the near future. The RMs of Michigan are forming traffic routes thru the state. Every active station and ORS is needed. Won't you please help them, OMs? 8ACU has received his appointment as Army-Amateur Radio

Station. The Mich. hams had a May Pole Party at Monroe on May 8th. 8ZZ-8WT-8BEU and 8LU are working on 20 meters and reports are FB. 9CM is now on daily with crystal 88 meters and using one UX210. 8ZH will be ready for traffic schedules soon. 8JG is on about once a week now. SBPX with 8AUB's help, is going with TP-TG.

Traffic: 8AUB 33, 8AMS 4, 8PF 6, 8MM 4, 8ZH 14, 9CM 11, 8ACU 5, 9CSI 20, 8DFD 72, 8ZZ 24, 8SX 40, 8DOE 20, 8BPX 4, 8JG 7, 8DED 12.

ILLINOIS—SCM, W. E. Schweitzer, 9AAW—Traffic is still moving along merrily in Illinois. The drop in stations reporting has not taken place this year and Illinois is out to set a record this year. The main issue (with us) today is whether the Board's action on National Conventions is justified. Don't forget, gang, the cup of the CRTA is not won permanently yet. Let's have some real reports next month. 9AAE blew his mercury arc rectifier which he was using for high voltage rectification. 9AAW attended the Dakota Division Convention. He is trying a vertical Hertz but it doesn't perk. 9AFB is still using a 210. 9AFF has been sick for the past month. 9AHJ is working all U. S. districts consistently. 9AJM is doing good work converting KCLs to brass pounders. 9ALJ hopes the directors change their minds and hold national conventions. 9ALW is making plans for a new station. 9ALZ is pounding away on 20 meters. 9APY is going to put in a mercury arc rectifier or kenotrons. 9ARM reports no traffic. 9AXZ is putting in a 250 watter with a sink rectifier. 9AYB is still QRW at the Univ. of Illinois. 9BBA will be off because of school work. 9CHF expects to move to Calif. according to 9BIZ. 9BHM reports traffic east and west is good. 9BNA finally got up a new antenna. 9BPX is keeping about ten schedules. 9BRX reports 9CEB is operating on the lakes. 9BWL is going to Asheville, N. C. 9CDX is a new ham in the game. 9CEC is teaching Boy Scouts the code. 9CEH says QRN getting heavier. 9CIA says it is a job to QSR messages to foreign countries. 9CNB has moved to a new QRA. 9EAI has been sick. 9EGC took in the Dakota Div. Convention. 9EHK is busy driving a new car. 9ELR has spring fever. 9BL wishes Santa Claus would send some traffic his way. 9CN is working lots of DX on 20 meters. 9IZ blew his 5 watter. 9LY and 9MP are out to secure an ORS. 9MR was home during Easter vacation. 9NE is secretary of the Aurora radio club. Active radio clubs should send in their reports direct to Headquarters in Hartford. 9QD has a new generator and promises to show us all up now. 9RK reports that the station will operate on 40 meters for the summer. 9SK is now a member of the I Tappa Key Society. The SCM received two reports from stations who did not sign their calls to their report cards. Am not familiar with the handwriting of every station reporting so if your report is not in this month, remember this was you. 9VV has the old 50 perking again. 9PU is busy with college work.

Traffic: 9CIA 127, 9CN 108, 9APY 71, 9CEH 70, 9CNB 68, 9BPX 64, 9DXZ 54, 9MP 54, 9GF 49, 9CZL 49, 9DYD 40, 9AFB 40, 9SK 38, 9CPQ 38, 9BEN 32, 9DDE 27, 9BBA 24, 9AXZ 22, 9CSB 22, 9BL 19, 9CWC 19, 9DGA 18, 9KA 18, 9RK 17, 9BVP 16, 9ELR 14, 9PU 14, 9AHJ 14, 9VV 14, 9LY 18, 9DXG 11, 9CNP 10, 9EHK 11, 9QD 7, 9AFF 5, 9DLG 5, 9BWL 4, 9ALZ 4, 9AAW 3, 9BIZ 3, 9BNA 3, 9EAI 3, 9IZ 2, 9EGC 2, 9CDX 1.

DAKOTA DIVISION

NORTH DAKOTA—SCM, G. R. Moir, 9EFN—Your SCM would have been mighty glad to have met you all at the convention but unfortunately, business prevented.

9CRB is on the job with 2 ops and is going to tackle forty meters soon. 9EFN is headed back to 80 after having no luck on 40. 9DM is doing FB work with a 5'er. 9DYV has been QRW, hence no traffic this month. 9DKQ is getting out very well with a fifty. 9BJV reports the possibility of a new ham station at Valley City.

Traffic: 9DKQ 5, 9BJV 13, 9DM 32.

SOUTHERN MINNESOTA—SCM, D. F. Cottam. 9BYA—It is a pleasure to report that the Dakota Division Convention was very much of a success. On account of bad roads, the attendance was cut down some and we are very sorry to say that some who wished to come could not on that account. Every one there was very much pleased and expressed the hope that another Convention would be held soon in this Division. They said: "This Division puts on the best conventions in the country. More of them, please." Those of you who could not be to it

missed a lot when you didn't hear the speakers, Reinhartz, Schnell, Hoffman, Handy, Hebert, Clough and Jansky. Well, gang, we will have another convention and you may be sure you will hear men on a par with these.

Traffic this month is very good. 9CPM is back on the air with a 204A and plenty of voltage on the plate. 9COS is keeping 8 skeds and doing some very fine work. He says the convention was FB. He made the Ames, Iowa Convention at a total cost of 67½ plus registration and won a \$45 B eliminator. (Suppose he will use it for his high voltage supply—he will try anything). 9XI handles important traffic for QST and others. During the last four months, 9XI has worked 1247 stations, 425 of the total were foreigners. FB. 9EFK, although under a doctor's care, still pounds the key. 9DBC blew his jug and is busy repairing the whole layout. 9DAW keeps one sked, and works the whole country on 4 watts. 9BHZ is rebuilding for both 20 and 40, crystal controlled. 9BXX is now operating another B battery transmitter (he won it at the convention). 9DBW is busy but ops as much as he can. 9CIX has a new xmitter. 9EFO has a new xmitter and is getting out well. 9SF keeps one sked and works Australia and KDO. 9CHP wants sked any A.M. for Minneapolis traffic. 9LW is on with a 7½ watter and M.G. set. 9CCX has a new antenna and his G.M. is going again. 9BOI is QRW with school and isn't on much. 9AIR shipped his xmitter to the convention and he promises to have lots of traffic next month. 9DWO is at 9XL-9WI on S.F. transmission. 9XL was heard on 8500 Kc. in N.Z. at 4:30 in the afternoon. 9DEQ is on both 20 and 40 and is getting out FB. 9AQD keeps 4 skeds and is doing good work.

Traffic: 9CPM 470, 9COS 187, 9DGE 96, 9XI 91, 9EFK 67, 9DBC 34, 9DAW 29, 9RHZ 27, 9BXX 25, 9DBW 25, 9CIX 21, 9BYA 18, 9EFO 17, 9SF 10, 9GH 4, 9DHP 4, 9CCX 2, 9LW 4, 9AQD 10, 9DEQ 8.

NORTHERN MINNESOTA—SCM, C. L. Barker. 9EGU—Out of the 51 mssgs. handled by 9CWN this month, 24 of them were handled from on-6CXY. FB. 9KV is on 20 meters almost exclusively. 9CWA has been appointed Associated Press station. He says the BCLs blame him for a bad power leak. Hi. 9AOK now has a transmitter on 37.8 meters and one on 20 meters. 9EGU made a few long-needed alterations and has been appointed an official Associated Press station for emergency work. 9EGF says he will be on the Lakes in June. 9BRP is a new station in Virginia. 9ABV blew three plate blocking condensers this month. 9CTW says traffic is scarce and schedules are hard to get. 9EHO reports hearing 9BMX CQing on 20 meters at 9:30 pm. 9DKR handled a number of orders this month and says he has some new dope on a Hertz antenna system and driver system. 9BJD, a new ORS at Duluth, was not able to be on much due to moving. 9AKM says his transmitter is bothering but he can't find the trouble. 9BMX gets more enthusiastic about 20 meters all the time. 9BET has built a new tuner, transmitter and antenna system. 9BMR blew his old 50 watter but is on with a 201A until he gets a new bottle. 9DUV has a new transmitter all finished but can't raise a soul on 40 meters. 9EGN, an ex-ORS, has had his appointment renewed and works on both 20 and 40.

Traffic: 9CWN 51, 9KV 47, 9CWA 44, 9AOK 29, 9EGU 24, 9EGF 18, 9ABV 15, 9CTW 15, 9EHO 8, 9DKR 7, 9BJD 7, 9BVH 5, 9AKM 4, 9BMX 3, 9CTW 1.

SOUTH DAKOTA—SCM, F. J. Beck, 9BDW—9DWN was busy with track and school. 9BQW rolled up a big traffic total with a 201A. 9DGR works all bands now. 9DLX likes 20 very much. 9BKB has more time and keeps a few skeds. 9CKF worked a bunch of DX and was QSO DCZ. 9DB attended the Dakota Div. Convention and rebuilt his set. 9CZG says 20 meters is FB. 9DNS has been appointed ORS. 9BOT finds QRN bad on 80. 9TI is on occasionally. 9DID is back home again in Webster. 9CJS, 9NM, 9DIY and 9AGL were on a few times but handled no traffic. 9AGL reports that 9DDH will be on all waves. Several ORS have been cancelled. Remember the 10 message per month requirement.

Traffic: 9DWN 124, 9BOW 120, 9DGR 42, 9DLY 37, 9BKB 28, 9CKF 24, 9DB 15, 9CZG 18, 9DNS 15, 9BOT 8, 9TI 4.

DELTA DIVISION

ARKANSAS—Wm. L. Clippard, Jr., 5AIP—The recent flood in Arkansas covered a great portion of the state and several fellows' stations as well. Those on "top" did some mighty fine work. 5CK kept Havana informed and rivaled the WU when the wires went down. 5JB did the same for Hot Springs.

Sura FB, OMs. 5SI and 5AW handled many army and relief messages. 5ABI also did some excellent work. 5CK, 5JB, 5SI, 5ABI, 5AW and 5AIP together handled several thousand words of A.P. as well as the regular traffic. 5CJ had hard luck with his xmitter. 5HN is now on with 50-watt crystal. Let's keep the good work going, OMs, and have an even better report next time.

Traffic: 5SI 44, 5AIP 36, 5CK 34, 5AW 24, 5ABI 22.

LOUISIANA—SCM, C. A. Freitag, 5UK—5UT is a new station in New Orleans using 7½ watts with 500 volts RAC. 5QJ, due to his inability to give radio as much time as heretofore, feels it his duty to turn in his ORS certificate. However, he is always ready to help in handling traffic and otherwise. 5AEN has rebuilt his transmitter and is getting out well, having been QSO Australia and New Zealand several times with 7½ watts. 5UK has been going on some good work on 20 meters and has been QSO all U. S. Districts, Canada, Porto Rico and Honolulu, using 7½ watt tube with 500 volts RAC.

Traffic: 5PM 56, 5UK 23, 5EB 13, 5IE 7, 5WY 4, 5QJ 1.

MISSISSIPPI—SCM, J. W. Gullett, 5AKP—The outlook for this state is good. Some of the gang are moving to 20 meters and there is a good deal of interest shown for this time of the year down there. A Mississippi Valley Emergency Route will be working smoothly in the near future so we can have a dependable route from the Great Lakes to the Gulf of Mexico at all times and we will handle traffic on schedule and otherwise. The Miss. gang are standing by and are rendering all assistance possible in the flood sections. 5AKP is QSO New Orleans and Memphis regularly now morning and night. 5AUB is going upon 80 meters. 5AGS is QRV emergency flood work. 5ANP reports QRM from baseball. 5FQ is QSO the west coast regularly. 5QZ has come down to 40 meters with that 250 watt bottle. 5API has been running out of Cleveland and on the flood relief train and is on the road from 6:00 am until 11:30 pm. 5ARB is being rushed considerably by the YLs. 5AQU has gone down to 20 meters and reports it FB. 5AKP lost his antenna in a young storm a few days ago but has it up and going again.

Traffic: 5AKP 37, 5AUB 1, 5AGS 5, 5QQ 10, 5ANP 13, 5FQ 11, 5API 41, 5ARB 5, 5AQU 10.

TENNESSEE—SCM, L. K. Ruess, 4KM—Our Route Manager is making some progress with his work but he deserves more support from the ORS. 4FI has two transmitter on the air and uses both 20 and 40 meters. He also reports working 1MK. 4HL is preparing for the big relay as he has an assistant to help him keep a steady watch. He also reports 6BUR paid him a visit. 4FA leads with the traffic this month and was pulling for the 100 mark when ole man flu overtook him and threw him for a 29 msx. loss. 4KM and 4KX are still as busy as a worm in hot ashes, using both 20 and 40. 4KM has been out of the city for the last week or more. 4CU still pounds a bit and handled considerable press during the flood period. 4BU works 4FZ about 10 blocks away using a 204. FB, OM. 4DK is selling out.

Traffic: 4FA 71, 4FI 41, 4CU 35, 4HL 10, 4KM 10.

HUDSON DIVISION

NORTHERN NEW JERSEY—SCM, A. G. Wester, 2WR—Only 70% of the ORS reported this month and the SCM demands that those not reporting do so or they will have to forfeit their ORS certificates. Traffic is moving despite the increase of QRN and our traffic total is about the same as our winter average. 2CO, 2CJD, 2BAL, 2AQE, 2AFG and 2DV have made application for ORS. The job of RM is still open for some ORS that can handle the work of same and it is requested you write the SCM if you are fitted for the position. 2AVK, 2QI and 2ADL-2AZU have been appointed ORS and we welcome them to our fold. 2BAL, 2GX, 2AFG, 2CJD, 2BW, 2ADL, and a few others went to Hartford to the N. E. Div. Convention. A few of the ORS are now on 20 and report DX excellent at night. 2WR had a smashup with his car two days previous to N. E. Div. Convention which prevented him from going. The Hudson Division Convention will be held June 3 and 4 and on the afternoon of the 4th will be a traffic meeting at which all ORS are requested to attend. 2CW reports the activities of all Caldwell amateurs but his own. 3L. 2AT is down on 40 meters for the summer. 2DX has entered the rebuilding state. 2IS has conquered the west coast at last. 2QI bought a new flivver and does not find much time to operate. 2BIR works DX very consistently,

however he QSO'd oa-2BD. 2CP is now located in Fords where a new complete xmitter will be built. 2CGK and 2CXY are in the BCL business which keeps them very busy. 2ADL did not find much time to operate as he was visiting the amateurs of Hartford and Washington, D. C. 2ALM with a UX210 on 20 meters has been working many foreigners. 2ANB is very QRV school work. 2BQQ has been on the sick list which accounts for his sparse traffic report. 2BLM is another who is doing fine work on 20. 2KA is off due to a blown tube. 2AVK maintains a Monday night schedule with 3SJ. 2BBL is a newcomer in Woodcliff. 2CPD, with the aid of 2AG, has his xmitter crystal controlled. 2ARC reports efficiency was lowered when he installed a lightning switch. 2BAL is QRV for traffic on 80 and 20 meters. 2CO is having fine results with a Hertz antenna. 2KS has moved to Newark and lives under the shadows of the antennas of WAAM and WGCP which he cannot eliminate in his short-wave receiver. 2ALI, the traffic manager of the ARAEC, sent in a report of the activities of their members. 2AQE is getting his sister ready to be his 2nd operator. 2ASZ is now using a self-rectified system in his transmitter. 2CJD is experimenting with Hertz antennas. 2BW has a new 80 meter crystal which he will use in his 40 meter outfit. 2IE, with the help of 2CJD, has been cleaning up his chemical receiver.

Traffic: 2CW 28, 2AT 72, 2IS 72, 2EY 3, 2BIR 6, 2CP 14, 2ADL 58, 2ALM 6, 2ANB 4, 2KA 2, 2AVK 14, 2CPD 28, 2ARC 2, 2KS 2, 2GV 9, 2AQW 8, 2AGL 12, 2AFG 18, 2ANG 6, 2AOP 2, 2CO 25, 2BAL 4, 2AQE 8, 2ASZ 8, 2CJD 14.

NEW YORK CITY & LONG ISLAND—SCM, F. H. Mardon, 2CWR—There is a noticeable falling off in some boroughs this month but on an average a larger amount of stations are reporting. There is an increase in the activities of Richmond and the fellows there are requested to keep up the good work. Richmond has always been at the tail end of the list but this month, it gives Manhattan a tie in the stations reporting. Don't get spring fever so early, fellows, clean up that short-wave set for the time for good DX on the high frequencies is just approaching. The SCM is receiving complaints from fellows as to why their reports do not appear in the current QST along with the rest. If the reports arrive at the SCM's before or on the 23th, they go in, otherwise they do not and if the late reporter happens to be an ORS, he is not credited with reporting that month, three such late reports and his ORS automatically expires.

Manhattan: 2ANX is very busy and not on regularly. 2KR is leaving for Chicago but will be back with us in a few months. 2BCB is busy rebuilding xmitter with plug-in coils. 2AMJ still works everyone he hears and is soon coming on with xtal set. 2EV says traffic is hard to get and harder to get rid of. This is now in L. I.

Bronx: 2ALW is busy compiling dope of his 20 meter night reception experiments. 2AWU is very busy breaking in a new Op. 2CXY is busy rebuilding. He received a letter of congratulation from Gen. Saltzman for his fine work in Army-Amateur activities. 2BNL reports nothing new. 2ALP reports everything FB. 2ALL has installed a vol. feed Hertz. 2BBX is now using voltage feed Hertz on 20, 40, 80. 2APV will be back on 20 in about a week.

Brooklyn: 2AVR was not on much this month but reports a new station 2BAZ opened near him recently. 2AGX has moved to Phila. 2AVR has just completed a MO-PA circuit set which will be ready for the I.R.P. tests. 2CTY tried xtal control but says he is back on TP-TG to stay with a nice 80 meter crystal for sale. 2PF needs no applause—if he were not so busy, we would worry. 2APB-CCD still going strong. 2BRB is experimenting with 5 meters. 2WC is still hard at it, has a crystal controlled fone on 84.15 using a new and unique modulation scheme. 2BO reports nothing new but a Baby Girl. Congratulations, OM. 2AMI reports things going strong. 2ADZ is very busy, has made a few new skeds and is QRX for interborough traffic.

Long Island: 2AGU is doing fine work but having MG trouble. 2BSL reports 20 is FB. 2AJE says rag chewing FB on 20 but traffic BUM on that wave. 2CLG wants skeds for Sat. afternoon and Sunday as that is the only time he can get on the air. 2AV is back on the air with a new mast and is getting out FB. 2AJX is doing quite a lot of foreign msg. handling. 2AWX reports not on air much account of school. 2AIZ is making his last trip to sea and will soon be on the ham waves all the

time. 2AWQ now uses S tubes. 2AUE has been off the air for a month.

Richmond: 2AYH reports traffic slow. 2AKR reports a few tubes went west and is busy at school. 2CEP reports it hard to pick up traffic. 2ABO is waiting for some interborough traffic. 2CPG will soon be on with 150 watts. 2ABH is keeping up the good work. 2AEK is very QRW but finds time weekends to get on the air.

Traffic: Manhattan: 2ALS 11, 2EV 44, 2AMJ 297, 2BCE 27, 2KR 9, 2ANX 10. Bronx: 2BBX 98, 2ALL 11, 2ALP 125, 2BNL 4, 2AWU 52, 2CYX 89, 2ALW 1, 2ARD 9, Brooklyn: 2BO 49, 2WC 14, 2BRB 3, 2APB 20, 2PF 18, 2CTY 2, 2AVR 6, 2AMI 7, 2ADZ 32, Long Island: 2AWQ 37, 2AIZ 5, 2AWX 48, 2AYJ 45, 2AV 14, 2CLG 7, 2AJE 2, 2BSL 5, 2AGU 80, Richmond: 2AKK 3, 2ABH 26, 2ABO 6, 2CEP 7, 2AYH 8, 2AKR 12.

MIDWEST DIVISION

IOWA—SCM. A. W. Kruse. 9BKV—Traffic activities have taken a slump this month due to heavy QRN and warm weather. However, the ORS made a good showing in spite of QRN. 9CZC, the RM, is given credit for his consistent work in maintaining schedules and routes throughout the state. 9BWN tops the list again this month and has a schedule with on-3ES. 9CZC turned in his usual fine total and works schedules both morning and evening. 9DLR is QRW with track work and graduation activities. 9BKV is going down to 20 for the summer. 9DRA reports 20 meters FB and worked on-CTO. 9EHN has a handy fone on 80 meters. 9DEA is going to try a Hertz antenna. 9DVG is burning the ether with his UX210. 9CGY is hanging up wall paper, so not much traffic. 9CS is keeping daylight schedules on 41 meters. 9AED has a small transmitter at KMA using 500 volts of B batts. 9DAU won a Grebe CR18 at the convention. 9EJQ is very QRW and has no time for schedules. 9AHN has started up with a fever.

Traffic: 9BWN 227, 9CZC 131, 9DLR 92, 9BKV 63, 9DRA 40, 9EHN 32, 9DEA 24, 9DVG 23, 9DZW 16, 9CGY 10, 9CS 10, 9AED 7, 9DAU 2, 9EJQ 2, 9AHN 15.

KANSAS—SCM. F. S. McKeever. 9DNG—Kansas had an unusually fine month for traffic, it looks as if things were really started at last. 9HL is a new ORS and starts out with a splendid record. 9DNG and 9CCL attended the Midwest Division Convention. The former brought back a WE250 watter and will have it going shortly. 9AEK, 9CV and 9CET are all doing fine work. 9AEK hopes to get a WAC ticket soon. FB. 9CET tried a chem. rectifier but changed back to his sync. 9BGX, the RM, is going strong on 40 m. and reports one schedule with on-8AJL. 9KM reports DX and also traffic. 9HS is on regularly and doing good relay work. 9CFN has a new 50 watter and gets lots of R9s. 9DPW worked Australia and Africa this month. 9CKV dropped his QRH from 80 to 40 and his traffic dropped proportionately. Hi. 9DSR has QRM from spring fever. 9CNT and 9BUY are working all of the U. S. 9BII, 9CCS and 9AVM are QRW with school. 9BYQ sticks to 175 meters. 9COR worked Chile and ny-KKY. 9JU and 9DIH had a good time at the Dakota Div. Convention. 9JU arranged a sked with 9XI while there. 9LN and 9CLR are going steadily in Lawrence. 9BYN is a new station there who shows good promises for the future.

Traffic: 9DNG 37, 9HS 34, 9CNT 6, 9CCS 2, 9DSR 6, 9LN 25, 9BUY 14, 9COR 21, 9CKV 33, 9CFN 30, 9CET 27, 9BYQ 29, 9BGX 20, 9AEK 17, 9KM 45, 9DPW 13, 9HL 80, 9CV 8, 9CLR 5, 9JU 9.

MISSOURI—SCM. L. B. Laizure. 9RR—9ZK and 9DOE led the St. Louis gang for traffic totals this month. 9BEQ came third and 9DUD fourth. 9DOE worked ARCX near the South Pole and reports it will not be in port for two months. 9AEX is a new station in St. Louis. 9DZN worked 20 meters and complains of no traffic on that QRH. 9DUD worked the 40 meter band all month and put up a new mast. 9ZK says #511 ND on QSO with the RM on skeds. 9AJW-UI-BWR got going again with a new tube which 9AJW personally brought home, two others having been broken in the mail. 2 new stations are building there. 9CYC is on 20, 40 and 180 and reports quite a bit of traffic going thru. 9CVY is getting out well. 9NW replaced antenna and counterpoise with vertical Hertz with good results. 9BZM blew one 210 but the other does as well as both did before. 9DTQ is QRT waiting for power line to be run to his house but set in QRW with 4 201A tubes. 9BUW rebuilt the works for a 210. 9HY applied for ORS and says 9DTQ

got tired of waiting for a power line so hooked up 6 Ford coils to a 201A. EK9BZW is pounding brass at 9HY. The Joplin gang have been running a club for over two months and have classes in code and theory going. 9CBE will be back on the air as soon as he replaces the apparatus damaged by fire. 9RR had to abandon skeds on account of QRN and Job. 9ZD was tied up with illness but pounded brass vigorously. 9ACA also moved and had to QRT. 9ACA also moved and has not set up yet. 9TJ went to Oklahoma City. 9ZD Jr., 9BKK and 9BJC, our marine representatives, all sent back accounts of their experiences as commercial ops during the month. 9ADR and 9ACA are reorganizing the ham club along the lines of the St. Louis OBP. 9DQN is still pounding brass on low power.

Traffic: 9ZK 167, 9DOE 121, 9DUD 10, 9BEQ 46, 9DZN 2, 9AAU 178, 9AJW 37, 9CYC 5, 9DKG 2, 9DUD 10, 9DAE 103, 9CXU 3, 9BUE 5, 9BGO 46, 9CDF 6, 9ARA 46, 9RR 61, 9NW 18, 9BZM 2, 9HY 15.

NEBRASKA—SCM. C. B. Diehl. 9BYG—9AL is very busy and hasn't much time for radio. 9CNN reports business light. 9QY turns in a good total for first shot. 9EEW is doing well. 9DFR is busy with studies, etc. 9BYG is still GRX but expects to be on again shortly. 9EHW reports QRN bad for traffic work. 9ASD is still at it. 9AFR is reporting again. 9DI is going good. 9BOQ is busy and hasn't much time for radio. 9DAC is experimenting with 20. 9DUH reports traffic light. 9BBS is still on top of the pile. 9BQR is trying for 40 meters. 9EBL is having his rush season now so can't pound brass in his usual style.

The RM reports business light. Fetterman is having his rush season and hasn't much time to put in with this wor. Neilson is selling BCL sets. Craft uses 80 meters for traffic. 9QY laments his departed UX210. Cox operates irregularly on account of his work. Henry is studying for Annapolis. Crozier stays on 40 when he can be on. Williams cusses because there is not more action. Glade is back with us again and his QRA is now Grand Island. Bamer is going strong for this time of year and doing fine work. Magnuson is still busy with his crops. Miller experiments on 20 a good deal. Jones is busy and cannot operate as much as usual. Larimore sure pounds brass these days and turns in a beautiful total. Chesley tinkers with 40 meters and says he'll stay with it until he gets it. Cumming is busy and after his sickness, can't stand it to stay up all night any more.

Traffic: 9AL 30, 9CNN 10, 9QY 45, 9EEW 15, 9DFR 14, 9EHW 11, 9ASD 9, 9AFR 38, 9DI 93, 9DAC 11, 9DUH 26, 9BBS 202, 9BQR 3.

NEW ENGLAND DIVISION

CONNECTICUT—SCM. H. E. Nichols. 1BM—Our annual New England Convention at Hartford has passed into history but not its memories. Surely the spirit displayed by those present indicated the real A.R.R.L. brotherhood and everyone seemed inspired and enthused with it. Great credit is due the Hartford boys for the fine way things were handled and the banquet program was a treat long to be remembered. 1BJK and 1AOX are now army amateur stations and wish all amateurs in their vicinity would communicate with them at once if interested in this work. Those who attended the convention can more fully appreciate this call but these two stations will be glad to give further information upon request. 1BHM has been appointed Route Mgr. for the State and is desirous of getting assistants in all of the larger cities or towns who will help him form a network over his section to operate on schedule.

1MK is working on 20 meters but due to convention many of the ops were absent from the key, thus causing a little drop in traffic total. 1CTI reports quite a little activity in his Section. 1BCA gets home from college for the weekend. 1BMG went to Philadelphia and forgot to mail his report but sent it in through the kindness of 9AKW. 1BQH and 1TD are on the job and have plans for some real traffic totals. 1ZL has been getting out on 20 meters reporting contacts with England, Ireland and Canadian 4's with his famous little liver. 1ADW has been rebuilding and plans to try for a commercial ticket soon. 1OS, our YL operator, has applied for ORS as well as sending in a nice traffic total. We welcome her to our ranks. 1CKP and 1MY report the usual foreign DX. 1IV is using parts of his transmitter at WICC due to a recent fire and says they work very nicely in the b.c. transmitter.

Traffic: 1BJK 191, 1MK 135, 1BHM 51, 1AOX 58, 1BEZ 27, 1CTI 28, 1CJX 22, 1BCA 17, 1BMG 16, 1BQH 15, 1TD 9, 1BLF 8, 1ZL 8, 1BGO 6, 1ATG 4,

1ADW 4, 1ACD 2, 1CKP 4, 1DV 124, 1VB 61, 1BCG 56, 1OS 34, 1BYM 16.

RHODE ISLAND—SCM, D. B. Fancher, 1BVB—All our traffic work seems to center around four or five good stations. The rest are at a standstill. The RM reports that the gang in our Section don't seem interested in schedules. Fellows, this is the LAST warning. Unless your SCM has more support and a report of at least ten messages per month, he will have to cancel ORS appointments right and left. Last month, some of the reports arrived too late to be included. There is no excuse for the report being late as it only takes a day for your report to reach me via mail and if it is mailed on the 26th as it should be, it would arrive in time. Excuses will not be accepted unless they relate to sickness or something that cannot be helped.

Providence and Pawtucket: 1AMU is keeping schedules and pushing traffic. He also has time for DX. 1DP has resigned his ORS due to lack of operating time. 1CKB went to 80, and came back down to 40. 1AEL says no traffic. (What's the matter OM, haven't you ten people that you can send messages to? SCM). 1MO blew his S tubes and is rebuilding to see if he can do some local DX. 1AID is dropping to 20 meters to escape the QRM on 40. (We will miss you on 40 MU—SCM). 1BIL and 1AWE didn't report this month. There's just one more chance, OMS.

Westerly: 1AAP is building a 20 meter outfit and says that all work in the future will be done on low power. 1BVB is keeping schedules and moving some traffic. 1CUI is going and will QRV for traffic.

Newport: 1BQD, our RM, has a bunch of schedules and is working hard to put R. L. on the map. With a little cooperation, he will have things in shape for a good summer. Give him a lift, everybody! The Army-Amateur Stations are getting things in shape for the big doings of the Army and Navy here in May. As the whole thing will center around Newport and Southern Rhode Island, we are thinking that 1BQD and 1BVB will be kept busy.

Traffic: 1BQD 87, 1BVB 34, 1AMU 25, 1AID 12, 1EI 11, 1DP 4, 1CKB 8.

MAINE—SCM, Fred Best, 1BIG—The Old Guard is still on the job with two of the Pine Tree State gang in the BPL in spite of the spring slump. Three new RMs are on the job and their organization work is beginning to show its effect already. 1FP has gotten the northern and eastern portions of the state lined up in good shape. 1AUR has been appointed Chief RM and is looking after the central part of the state. 1COM is a newcomer but a hustler. A great many of the Maine gang are arranging their outfits for transmission and reception on 20, 40 and 80 meters, thus making good reliable contacts available for either day or night work. The Maine gang certainly has fine spirit and is cooperating with the RMs and SCM 100%. We look for a great summer in the traffic game. 1BFZ again led the SCM in traffic handled for the month by a slender margin. His good work is certainly appreciated at this time of year. FB, OMI 1AUR has schedules with 1QY, 1BIG, 1COM and 1BTQ; tying the central part of the state into a fine net. NIDK has been worked with very good results, also 1QY handled his usual good total. He is very much interested in A-A work and is lining up as many of the Maine gang for this work as possible. 1AIT has two new UX-210's and a pure d.c. note. 1IP and 1BIG are worked daily on schedule. 1BTQ handled a very fine total this month, and has schedules with 30K, 1APK, 1AUR and 1COM.

1AQL is away except for weekends, but turned in a good total. 1ACV has schedules with 1ALE and 1ABV and asks that the rest of the gang look for him on about 42 meters. 1FP, 1BFZ and 1AQL manage to keep Bangor on the air every night. 1CDX is moving and doesn't know what his future QRA will be. 1CFO is going great guns on the 20 meter band. 1IUU and 1ATV handled no traffic due to press of school work and business. 1BIG is getting things ready for the International Relay Tests, May 9 to 22. He hopes to do a little DX now after a busy winter with traffic.

Traffic: 1BFZ 107, 1BIG 108, 1AUR 77, 1QY 74, 1AIT 52, 1BTQ 43, 1AQL 31, 1ACV 21, 1FP 20, 1COM 18, 1CDX 4, 1CFO 3.

EASTERN MASS.—SCM, R. S. Briggs, 1BVI—Many of the Eastern Mass. gang met at the New England Convention at Hartford on April 15-16 and we surely did have a fine time. Next year, we meet at Boston, so save your shekels. This month, 1CRA leads our brass pounders again. FB, OMI He and 1OG are new QRS. 1UE, the RM, would like to hear from any who want information on schedules. Let's have your cooperation, OMs. 1ADL found traffic scarce. 1XM has its regular transmitter on

the air again using a tuned grid-tuned plate circuit with plug-in coils. 1AXA and 1AHV got a commercial ticket. 1BDV's family kept him on the jump hence not much radio. 1BDM and 1BVL are arranging 5-meter tests. 1BVL is on 20 meters using a UX-210. 1GA kept a fine schedule with eg-5RZ. 1GP was on 77 meters and handled a good deal of traffic. 1NK, 1ABA and 1ACA have been active on 20 meters. 1ABA hooked up with oz-2AC. 1NK QSO'd ef-8CT, eb-4AU and eb-4AX in daylight. 1ADM is still making a big noise on 20, working oa-5DX. 1RF took a message from eb-N83 and worked ek-4DKA. A new transmitter is being installed at 1AVY using an M.G. 1BMS worked Brazil, Holland and Austria and is still cleaning off spots after fooling with 1AAO at the N.E. Banquet. HI, 1IM says things are going slow. 1OG had some BCL QRM and changed his QRA. 1APK is fooling with trans-receiver outfit. 1NQ kept schedules with NIDK. 1XAW is on 20 meters every day. 1ACH kept a number of schedules on 78 meters. After trimming an old tree near his aerial, 1BZQ gets out better on 40 and 20. The tree is now timed to about 50 meters. HI, 1ALP is fixing up the ole flivver and hopes to visit some hams. 1KY is still at it on 77 meters. She brought a real live (CQ?) hound to the convention. 1BKV and 1AIR are on 20 meters. 1UE works on 20, 40 and 80 meters. 1YC is heard occasionally. 1BYX is a great boy for 20-meter work and puts Framingham on the map just like 1AAC used to. He and eg-5YX are arranging 5-meter schedules. 1OU is putting up a small set in Providence so he can use it while he is there.

Traffic: 1CRA 268, 1BZQ 89, 1ACA 86, 1UE 82, 1XM 70, 1ACH 65, 1ADL 56, 1GP 53, 1LM 51, 1KY 39, 1GA 32, 1NQ 30, 1ADM 15, 1AVY 15, 1NK 14, 1AHV 13, 1BKV 11, 1PB 11, 1OG 11, 1ABA 10, 1ON 9, 1AIR 9, 1AXA 8, 1BYV 8, 1APK 8, 1AAK 7, 1RF 4, 1VC 4, 1OU 4, 1BVI, 3, 1BMS 2, 1BDV 1.

NEW HAMPSHIRE—SCM, V. W. Hodge, 1ATJ—Traffic took a slump this month due to QRM from spring wx. 1AOQ had a bum finger and his station is closed for the annual overhauling. 1AVL is at N.H.U. but has a set going there. Our RM, 1OC, will be off until fall. He has been doing fine work as off-wave observer in addition to his other work. 1ASR reported by Western Union. 1P sent in a good total and has been doing good DX. Four new stations are reported as starting up. 1JN has applied for ORS. The SCM has joined the Benedicts and agrees with 1LM and 1BIG that married life is FB. HI. This is why he didn't have the pleasure of meeting the gang at the convention.

Traffic: 1OC 141, 1IP 132, 1AER 59, 1JN 23, 1ATJ 14, 1AOQ 11, 1ASR 10.

VERMONT—SCM, C. T. Kerr, 1AJG—Say, fellows, you sure are holding together fine in traffic handling through this spring. We had a fine message report for the time of the year. Thanks for sticking at the key. Got a letter from 1BIQ who mailed it in Santo Domingo. He is operating at KZAI and will touch West Indian ports. A fine report from old 1BDX says the old wreck is perking about so-so. 1BJP is having trouble with bad power leaks. 1BBJ churns them out FB. 1IT works regular schedules and turns in a nice RM report. 1BEG shoots around from 80 to 20 meters and handles traffic, too. 1AJG has gone nutty over fishing. HI.

Traffic: 1AJG 38, 1BEG 41, 1IT 61, 1BBJ 81, 1BJP 12, 1BDX 18.

WESTERN MASS.—SCM, D. B. Carr, 1DB—1AAL is handicapped by a badly burned hand but gives us a splendid total. 1AJM worked oz-2AC for over an hour at 11:30 pm on 20 meters. 1AZK received a message from es-2NM that travelled around the Philippines and California. 1AMS went to Schenectady, visited 2AHM and 2GK and says he also saw WGY. 1AMZ visited all the hams in Pittsfield when on his vacation. 1APL makes the BPL for the fourth time and the third time in succession. 1ARE is on both the 40 and 80 meter bands. 1ASU has kept a schedule with sb-1AC on 20 meters. 1AWW is an army monitor station and has been handling traffic in the army net. 1AZW has worked 11 countries with one UX-210. 1BIV is moving again but will be on the air again soon. 1BKQ is experimenting with crystal control. 1GR says being secretary of the new Radio Assn. keeps him very busy but still he has time to do ham work. 1WQ in Great Barrington will soon have a new ORS appointment. 1DB came to the aid of 1AAL when he couldn't use his hand and helped him handle traffic in some of his schedules. It seemed great to your SCM to work some of the gang. Drop me a card and say when you will work me. 1UM is using tuned grid and plate now with full wave rectification.

Traffic: 1AAL 87, 1AJM 8, 1AKZ 5, 1AMS 1, 1AMZ

3. 1APL 198, 1ARE 3, 1ASU 5, 1AWW 19, 1AZW 22, 1BIV 36, 1BKQ 3, 1EO 19, 1GR 7, 1DB 27, 1UM 5, 1AUO 11, 1WQ 22.

NORTHWESTERN DIVISION

WASHINGTON—SCM, Otto Johnson, 7FD—7EK is the star DX station of this state, wkg all continents consistently. 7DF is also doing real good DX, but handles more traffic. These two stations are the probable winners of "Foreign QSO" tests in May. 7RL has worked OZ on fone. 7XF is doing some real traffic work. 7FD worked JKZB this month. 7MP is signing off for the summer. 7TX and 7AM are doing good work on 20 meters. 7VL reports more traffic during last month. 7QB is joining the Forestry Service. 7GE is gradually getting started again. 7AIY moved into new QRAs, but will be going strong soon. 7AAE, 7PH, 7EH and several others are out for an ORS. Several others are going to be out an ORS ticket if they fail to report again. The traffic men are all to be congratulated on their good totals this month which are as follows:

Traffic: 7DF 87; 7ACB 48, 7VL 35, 7AM 33, 7RL 22, 7AAE 21, 7EK 21, 7MP 18, 7TX 16, 7GE 15, 7FD 4.

IDAHO—SCM, E. H. Fletcher, 7ST—What's the matter, fellows, no traffic since 7JF resigned as RM? Let's show 'em our stuff next month. 7QC rebuilt and worked Australia the first night. 7ACN is a new ORS. 7ABW is off part of the month because of illness. 7ST still spends his time at 7YA. 7YA rebuilt and tried 20 meters but found it not so good. Some 40 meter broadcasting was done over 7XT. Good stuff, gang. 7ACK still works. 7IO is on 20, 40 and 80. 7EJ pounds thru pretty good these days. 7GW turned in a nice list of off-wave stations this month. A new club called the Idaho Key Pushers was organized and the fellows are joining rapidly. It promises to be the starter for making new friendships.

Traffic: 7QC 24, 7ACN 20, 7ABW 6, 7ST 4, 7YA 3, 7ACK 2, 7IO 2, 7GW 1, 7EJ 1.

OREGON—SCM, A. C. Dixon, Jr., 7IT—At last the Portland gang has been able to work Europe. 7VQ on 50 watts worked Belgium and France and hears eg-6GT. It is far easier to work the Europeans from Eugene than from Portland but DX westward is the other way around. 7TM in Eugene works Europe right along. 7VQ uses some trick aerial and doesn't want to give it away. 7ABM handled messages for the mother of a young man sick in a S. F. hospital. 7AEK runs the sink rectifier once in a while. After turning in a FB report, 7SY thinks he is off radio for the YLs. 7ABH has a schedule with oh-6AJL every Fri. night. 7MF is now operating a portable station, 7ABM, at Corvallis, Ore. He will be on in Medford this summer with the call 7MF. 7BD worked Argentina on a UX210.

Traffic: 7AEK 3, 7SY 50, 7EO 2, 7ABM 39, 7ABH 26, 7JO 8, 7VQ 9.

MONTANA—SCM, O. W. Viers, 7AAT—7PU worked oa-5LF with a pair of 201-A tubes. We are sorry to say that this station is soon to be dismantled and moved to California. We wish you the best of luck and DX OM! 7DD is experimenting with higher power and says he has a dandy transmitter for sale. 7AGF announces that his station will soon be ready to go. 7AFM and 7QV are new ORS and desire some traffic work with the gang. 7CC works on 20 and 40 when he is off duty from KGFZ. 7AAQ, at Billings, just returned from Boston and is cooperating with the SCM in traffic work. He will soon be on the air with a 200 watt transmitter. 7AFP is QRW so does not get much time to push the key. 7CK has been having trouble with his filament generator for his DC transmitter. 7FL is very QRW at school but will be going strong when school is out. 7AAT-QT held down 7 daily schedules single handed and with a little coaxing of the 210s made the BPL.

Traffic: 7AAT-QT 256, 7PU 130, 7DD 33, 7AFM 8, 7CC 6

PACIFIC DIVISION

SAN FRANCISCO SECTION—SCM, J. W. Patterson, 6VR—6GW again leads the section in traffic

honors. 6RW better watch out for your traffic honors. 6RW will be off indefinitely until he gets his 1KW bottle back. 6BIA is another rising traffic station. 6CCR clicked with France on 20 meters getting a report of R.S. 6CLS is QRW getting ready for an auto tour of the U. S. A. so finds little time to be on 20 meters. 6WS is still keeping his bug warm. 6BAF did some fine work during the

month by handling a very important message when the telegraph lines were down. 6EF has resigned as R. M. due to business. (Your offer of cooperation is greatly appreciated as your good work of the past has been—SCM.) 6KW is operating on 20, 40 and 80 meters and keeps a regular schedule with NPA. 6CHE after a year's hard work, and his sync feeding his dynamite 50 pure dc when his filter condensers laid down on the job. Hi! 6DAW is back on the air with one of 6EX's dynamite so's using a Hartley Circuit. 6GE expects to be signing a 7 call in the near future. Best of luck in your new QRA. 6PN is keeping schedules with his home town, New York City. 6RH relayed one from oh-6EXY to nu-1AXR in four hours and has a fine report working 30 stations in the rather limited times he can be on. 6KJ reports DX just the same. 6VR has difficulty QSOing due to severe auto QRM being so bad at times the cans have to be removed.

Traffic: 6GW 102, 6BIA 67, 6CLS 65, 6VR 52, 6DAW 37, 6GE 23, 6RH 34, 6EJ 22, 6RW 22, 6CCR 21, 6KJ 16, 6WS 15, 6CHE 13, 6PN 9, 6BAF 4.

EAST BAY—SCM, F. W. Dann, 6ZX—Good dope this month as 16 ORS reported. Thanks gang. Effective May 1st, please forward your Form 1 to the recently appointed Assistant SCM, J. H. MacLafferty, Jr., 2901 Rawson St., Oakland. Those desiring appointments or information relative thereto, please write Mac. No fellows, Dann is not giving up the game but owing to business pressure along other lines, Mac was kind enough to offer his Assistance for the time being, and so in order to keep the East Bay Section going right along, 6RJ is representing the SCM in all League activities, whenever he is unable to be present, so when Mac speaks, it's the same as if it were the SCM fellows. Give Mac all the help you can. DANN is NOT quitting, and is still behind the East Bay League activities and backing MacLafferty 100 per cent. T. F. Babcock, 2624 Best Ave., Oakland, Calif., has been appointed as Chief Route Manager in 6RJ's place, so you confer with T. F. on anything pertaining to Routes, etc. 6ANE has been appointed in 6CCT's place. Fellows who were reporting to 6CCT will now report to Fisher, 6ANE. 6CZR, a new ORS with a 7½ watter, says the oh gang are flooding him with msgs. More power to you, OM. 6AYC is still high man, but the rest of you will get a chance now as he sailed on Dr. Parker's Yacht Idalia, KFVM, for the Antipodes the first of May. Watch for his traffic, everybody. Good Luck OM and 78. 6RJ is second with 6BGB third. 6RJ was the first station worked by KFSX Yacht Warrior on round the world cruise. Mac says DX F. B. with Zep Antenna and 1200 Volts B. Batts. 6CTX worked nine Aussies one night April 24th. 6BU will install a M. G. set soon. 6ALV says no changes and lots of QRM from Power Leaks. 6BRQ says DX pounds in on 20 meters but had a hard time getting down there. 6ANE is a new ORS using 400 volts B. Batts. in coupled Hartley. 6CMG has installed the old MOPA with two fifties and is on the forty meter band. 6AHW is working ea and oz consistently now. 6BER is back in the game again. 6BBJ has a new Lab but is QRW with 6CKC on the Ham Meter. 6CLZ QRW with studies. 6ZK has been off the air, but is coming back on again soon with battery Plate supply and Zep Antenna.

Traffic: 6AYC 235, 6RJ 177, 6BGB 135, 6GU 81, 6APA 39, 6CTX 87, 6AMI 36, 6RUZ 29, 6CAK 25, 6ALV 18, 6BRQ 13, 6ANE 13, 6CKC 12, 6CMG 5, 6BBJ 5, 6BER 3, 6AHW 1.

HAWAII—SCM, J. A. Lucas, oh-6BDL—6DEY, 6ACG and 6BWV made the BPL this month. 6AXW was out for a week, otherwise they might have made it as usual. 6DEY is a new station at Schofield Barracks. They have four operators working a fifty watter. Two operators take a shift each night. 6ACG is still going strong on 20 and 40 with not a sign of a let-up. Half the stations 6CXY worked are middle or east NU. 6BWV reports getting an R9-10 report from NA. 6CFQ is teaching a class of 15 the dits and dahs at 6BUC and doing some work from there. 6DCU blew his new transformer so is off for a time. 6AHH the possessor of the only crystal in OH has been unable to make it oscillate.

Traffic: 6DEY 217, 6ACG 151, 6BWV 100, 6CXY 86, 6AXW 82, 6BUC 56, 6BDL 30, 6DCU 17, 6AHH 16, 6CFQ 16.

ARIZONA—SCM, D. B. Lamb, 6ANO—Summer is here again and swimming is the new sport around here. 6DCQ reports nothing new around his station. 6BJF is still a hard boiled nite-owl. Stayed up several nights to enjoy the DX. 6CAP has been QRW with school work. 6CUW has rebuilt. 6AWH

is off due to moving his QRA. 6AZM is back with a transformer and Kenetrons. 6CDU has changed his QRA to Route 9, Phoenix, Ariz. 6BWS put in a 50 watt. 6X 9EH-9FJ is planning on putting in a WE 250. (FB OM). 6BJI is off the air due to change in QRA. 6CBEJ sold his 250 and now uses a 7.5 watt. 6ANO is back after locating the trouble in the xmtr.

Traffic: 6BWS 21, 6CDU 18, 6AZM 5, 6CAP 6, 6BJF 47, 6DCQ 12, 6CBEJ 6, 6ANO 57.

SANTA CLARA VALLEY—SCM, Frank J. Quement, 6NX—6BVY maintained his splendid contact with the Orient. 6BYH is a new "OO" and took lots of TRF from KFSX. 6CTE is a new ORS and made the BPL three months in a row—FB. RM-6BMW is QRW school and lining up skeds this month. 6CLP is increasing his power and 6BNH has a new xmtr working. 6CSX continues to handle OB trf via skeds. 6ACQ says trf has DX beaten by X miles. 6DDN keeps skeds with WYA in Long Island. 6BTJ and 6AJZ handled their usual amount of trf—reports EG-SXY good on 40. 6CJD is working on Hertz system—Hil 6AXZ and 6MP are worrying about finals—so ND radio. 6CEI lost his 50. 6AMM still maintains his PI connections. 6ZAT is a new "oo" and has a large supply of cards for the off wave boys. 6ZAT, 6NX, 6CKV, 6DFE, 6KG, 6CDW all worked France this month and all are members of the WAC club.

Traffic: 6BVY 202, 6BYH 176, 6CTE 162, 6BMW 31, 6CLP 40, 6BNH 23, 6CSX 18, 6ACQ 17, 6DDN 16, 6BTJ 16, 6AJZ 8, 6CJD 8, 6AZS 2, 6NX 3.

PHILIPPINE ISLANDS—SCM, M. I. Felizardo, op-1AU—This report by radio to QST from Manila, P. I. op-1AU via 6BVY, 3WE, 1BVB. Op-1HR still keeps so many schedules that his traffic stays high each month. The signal corps amateur station with its three or four operators sure handles traffic. The SCM's traffic has exceeded the 300 mark this time with nu-6BVY at the other end. A weekly sked is kept with el-LAIX, Norway. Op-1AT worked a new QRA at Selankor, Malaya. His traffic also shows marked increase. Op-1AH, a new QRA with a dfty, has reported he works nu and oz regularly.

Traffic: Op-1AU 821, op-1HR 309, op-IDL 61, op-1AT 42, op-1AH 7.

SACRAMENTO VALLEY—SCM, C. F. Mason, 6CBS—6CDK and 6FR, newly appointed ORS, take the honors for our Section this month, with their good message-handling work.

Traffic: 6FR 55, 6CKA 26, 6AVB 36, 6CDK 78, 6CGM 10.

NEVADA—SCM, C. B. Newcombe, 6UO—6ABM, our RM, works from 7 to 12 pm. daily. His appetite for traffic is wonderful. 6CDZ works on 38.7 from 7 to 8:30 am, noons and 5:30 to 7 pm daily. 6AJP is on the air again with a 201A with 250 volts in TP-TG circuit. 6GA is rebuilding and will be with us soon. 6CHG saw a new UX852 advertised in May QST and said "I'm sunk."

Traffic: 6ABM 181, 6CHG 47, 6CDZ 186, 6UO 4.

SAN DIEGO—SCM, G. A. Sears, 6BQ—Membership in the Silver Gate Amateur Radio Assn. is increasing rapidly as the date for the 6th Dist. Convention approaches. 6AJM has his hands full as program manager and is making excellent headway. Pitch in, OM, and give him every possible assistance. 6BXI leads in traffic handling this month for the whole Section. 6BYZ, RM of Orange Co., is making progress lining things up in fine shape. 6AJM works 20 meter skeds with se-2AR. 6AXU is trying 5 meters. 6SJ reports many stations refusing traffic. 6BAM says all's well since the power leak has departed. 6FP's new QRA is 408 Goldfinch St. 6CNK has Honolulu skeds now. 6LH has been sick since his trip to San Diego. 6HU is QRW finishing up school. 6ANC and 6KD own and operate station KGEN on 277.6. 6BFE looks for increased traffic this month. 6BXN finds some time to pound brass between his store and duties as Secy. SGARA. 6CTP still hangs up DX with his 201A. 6BAS is QRW lodge work. 6MB is back on the air again after several months' absence.

Traffic: 6BRI 118, 6BYZ 108, 6AJM 89, 6AXU 72, 6SJ 66, 6BAM 44, 6BQ 30, 6FP 29, 6CNK 27, 6LH 26, 6HU 14, 6ANC 12, 6BFE 11, 6BXN 9, 6CTP 3, 6BAS 8, 6AOY 15.

LOS ANGELES—SCM, L. E. Smith, 6BUR—As SCM this is my last report, fellows. Thanks for your fine consistent work, your cooperation and effort that has made our Section one of the very best. And also my wish that as time goes on, you will grow and prosper and become "the" Section. Three assist- and RMs have been appointed: 6ALZ, Whittier; 6AWQ, San Bernardino; and 6ZBJ in Santa Barbara.

These men are working under chief RM 6DDO and the hearty cooperation of all stations is asked. Traffic is much better this month than last, reflecting the work of the RMs and showing that coming summer doesn't kill ham radio. 6BJX again takes the traffic lead this month but ran a close race with 6ALH and 6AGG. 6BUX has a 15 second change from 40 to 20 meters. 6PF and 6CMT on the way home from the recent Whittier hamfest ran out of gas and pushed their hack 5 miles. Good DX. 6DEG just made it, an even hundred, but still enuf. 6ZBJ suggests that traffic for Santa Barbara from Los Angeles be given 6AHS from San Diego via 6AJM and from Oakland, Frisco via 6RJ. Messages between 6ACG and his YL created a husky traffic total. 6AWQ is sure putting San Bernardino on the radio map. 4TK and 6OR run a good sked. Since school is nearly out, 6RF, 6BXC, 6CT, 6CQA, 6DAQ, 6AIO, 6OF, 6BHR, 6CHT and others have decided it is time to start studying. Hi. 6CCO, 6AHS and 6ALZ are rebuilding. A power leak troubles 6PY. Several good schedules help traffic at 6CMW-6AJQ. 6BVO keeps Riverside on the map. After rebuilding, 6AHS has been doing fine DX. 6AKW wants schedules on 20 meters. Portable 6DFA operated by 6CYH in the Mohave Desert worked three Aussies, Japan and the east coast. 6AZT is looking for schedules. 6AM succeeded in working 8 countries on each of two Saturday nights. A Jr. op arrived at 6NW. Congrats. 6AE is running good traffic totals. A Hawaiian schedule helps 6CSW. 20 meters interests 6BXD. 6CMQ has been handling some of this YL traffic, too. Poor 6CQA, reports he is engaged now, also that his pipe makes him sick. 6CMY and 6BXC are consistent as ever. 6AHP is one of the loud ones on 20 meters. 6CCL keeps Fresno traffic moving. "What is that to be the first QSO of an 'eh' and 'nu' took place for 35 minutes Apr. 25 between eb-4WW and nu-6BAV."

Traffic: 6CMT 188, 6BJX 217, 6BUX 114, 6AGG 248, 6AWQ 119, 6ALH 212, 6ZBJ 186, 6DEG 100, 6BXC 37, 6ALZ 3, 6AHS 40, 6CCO 8, 6BVO 28, 6AJQ 62, 6PY 15, 6AKW 4, 6CYH 22, 6CHT 18, 6CZT 10, 6AM 91, 6NW 18, 6AE 86, 6CSW 96, 6BXD 6CMY 25, 6AHP 27, 6RF 18, 6OR 3, 6BVM 153, 6BAY 20.

ROANOKE DIVISION

NORTH CAROLINA—SCM, R. S. Morris, 4JR—Everybody seems to be having trouble this month. More reports are wanted from active non-ORS. on the 25th of the month. 4MI is having trouble with his wave jumping. 4NJ is experimenting with antennas. 4OH says he isn't QRW school so it must be YLs. 4EC has been experimenting a little on 20. 4OC is getting the foreigners on his crystal now. 4VQ hasn't been on much due to the illness of his mother. 4PP is still waiting for license renewal. 4BX reports things very dull. 4FV QSYd from 80 to 40 and says it is FB. 4DB has QRM from college work. 4SJ has been laid up with a bad shoulder. 4JR has at last gotten his MO-PA set on the air. 4TS has been working on 20 and says it's the berries.

Traffic: 4MI 43, 4EC 24, 4TS 22, 4JR 21, 4OH 18, 4DB 13, 4SJ 6, 4OC 8, 4VQ 4, 4NJ 3, 4BX 2, 4FV 1.

VIRGINIA—SCM, J. F. Wohlford, 3CA—The SCM would like to see all stations in this state have a copy of the Handbook which can be procured from HQ for one dollar. All matters pertaining to routes should be handled with the RM, Mr. Randolph Smith, 3CEB, 1208 Omohundra Ave., Norfolk, Va. All ham stations in and around Norfolk are requested to get in touch with Marion M. Causey, 3MK, at Norfolk, Va., handling matters locally and covering those stations at Newport News, Cape Henry, Portsmouth and other outlying points adjacent to Norfolk. 3RT blew his fifty watt, also his five watt. 3AHL handled important PRF traffic between points when the Cape Charles cable broke down. 3SZ, a newcomer, is getting along nicely. 3QF has regular schedules with el-1CR. 3FM is another newcomer doing good DX. 3ADD, another new station, is coming along slowly. 3NM added another five watt to his outfit. 3CEL reports 3TJ back on the air. 3BN and 3CH are still hammering brass. 3BZ reports all apparatus undergoing a change. 3BDZ is very QRW fixing up the family flivvers for the summer season. 3CA is waiting for a crystal. 3CKL has a good time on the track team from VPI as he gets to run around and call on the hams in points they visit.

Traffic: 3CKL 39, 3CEL 4, 3NM 9, 3GX 4, 3UX 14, 3KU 51, 3JT 8, 3TN 18, 3CEB 37, 3RT 10, 3AHL 11, 3SZ 26, 3QF 75, 3MK 32.

WEST VIRGINIA—SCM, C. S. Hoffman, 3BSU—Most of the activity this month has been done on 20

neters. SAUL was QSO sc-2AS, nh-BW (a commercial). SALG was QSO et-2CT and many stations on the west coast. SCDV and SACZ are very active on 30. SVZ reports keeping schedule for two years with 9DVT. FB, 8WK is building a 1-KW crystal controlled set, 600 cycle supply. 8BJB is having tube trouble. 8BNP is putting in a MO set. 8AWV and 8BJG are too QRW to show any activity this month. 4KF, ex-8ARN, visiting Wheeling and was initiated into the Pi Alpha Tau Radio Fraternity and promises to spread it down south. Well, gang, the SCM hopes to see you all at the Pittsburg Convention in June.

Traffic: 8VZ 342, 8ALG 139, 8DCM 33, 8BSU 2, 8CDV 4, 8UL 7, 8BJB 6, 8BJG 3.

ROCKY MOUNTAIN DIVISION

UTAH-WYOMING—SCM, D. C. McRae, 6RM—Things seem to be moving in good shape and the gang made a splendid showing this month considering the fine weather we have had which naturally puts somewhat of a kink in the time spent pounding brass. Wyoming stations put thru some fine work this time. 7DA made the BPL. TRX is going fine and turns in a better report this time than last. 7DA uses 300 volts of B battery on a 210. 6CLQ keeps four skeds daily except Sunday. 6CNX has been QRW this month but turns in a good report. 6AIK has moved up and is operating on 81.5 meters now. 6BTX still works on 80 but is putting up a new antenna so 40 can be used successfully too. 6CVA is still putting a few thru although reports that he is very busy and so has very little time for radio. 6RM is still on 20 with splendid results. 6RV has his remote control for his 21 meter outfit going in good shape now. 6ZT still continues to work out in fine shape. Well, gang, let's keep the good work going right thru the summer and make old man QRN and the policeman's malaria take a back seat.

Traffic: 7DA 130, TRX 18, 6CLQ 118, 6CNX 38, 6BAJ 39, 6RM 20, 6BTX 14, 6CVA 8, 6AIK 4, 6RV 43, 6ZT 10, 6BAJ 39.

COLORADO—SCM, C. R. Stedman, 9CAA—Denver stations are all active and the prospects are that they will remain so all summer. A number of new stations have sprung up in and near Denver as well as in other parts of the state and they are invited to send monthly reports to the SCM. 9BYC is spending a lot of time playing checkers and has also joined the National Guard. 9AOI has junked the old faithful snow factory (chemical rectifier) and now uses tube rectification. 9DUI left the state and is going to Radio School. 9CDE has been sick and while recovering handled a 104 word message from Minnesota to a passenger on a train going thru La Junta and delivered it. 9DVL is working out well on 40 and 80. 9EAE is also on 40 a little but most of his work is on 5 and 20. 9DSU is a new station at Florence. He reports 9AP is on 200 meters at Canyon City. 9CDW, 9DWZ and 9EEA are all on 40 meters. 9CAA is increasing power to go thru summer QRN. 9CNL and 9DSY are still with us. 9DSY is on 20 meters. 9CAW is trying to rejuvenate a dead tube so he can on some more. 9DGJ has a new H.V. transformer. 9BQO has a new transmitter working FB. 9CJY needs money and so is selling the B/C set. HI. 9DKM is trying to change his YL QRM to an additional Op. 9EAM is too QRW business to do much on the air. The YL at 9DBF will probably be on again soon, possibly with a new call. 9COC is getting on the air.

Traffic: 9CAA 136, 9DVL 59, 9CDE 27, 9EEA 24, 9CJY 23, 9CNL 18, 9DSU 14, 9DWZ 14, 9CDW 14, 9CAW 13, 9RQO 18, 9DKM 7, 9EAE 6, 9BYC 3, 9DGJ 3, 9DSY 3, 9QL 2, 9EAM 6.

SOUTHEASTERN DIVISION

ALABAMA—SCM, A. D. Trum, 5AJP—Alabama hams have had the privilege of relaying first hand information from the flood area of the Mississippi and lend a helping hand to humanity. Mobile and Montgomery hams especially are to be commended. 5DL is a fine boy nw working OA-5DX Sunday morning. 5AC was on a fever but is laid up now with the MUMPS in the Marine hospital, seizes his jaw is very QSA and radiates plenty. 5ASR is on consistently now and handles quite a bit of traffic. 5ADA is on the air with a 7.5 watter and a prettiest DC note. 5JY has been hunting foreigners this month and was tickled pink when he worked France with an R-6 report. 5AJP has been off the air this month. 5JP just got a new 210 and can't raise any DX. 5PI had to get more sleep or go coo-coo so he handled a little work this mo. 5ABS is rebuilding his chem. rect. this mo and promises to be on with a pure DC soon. 5VC is not active but hopes to be on again soon. 5QP is at Auburn and second op at 5DF. 5AIW is dormant. 5ETB is on regularly with a rebuilt panel xmitter getting

rud rept from everywhere. 5LX is working steadily on the new Frisco Line and is unable to give us much of his time. 5DT is nearing completion and will be on soon. 5DI paid Selma a visit and helped the bunch quite a bit while there. The 5EK-5AV schedule went west on acct. of the landlady going up on the light bill. 5AV now has 2-210's working harmoniously in conjunction with a Hertz Ant. 5NL is on consistently with a 15ty.

Traffic: 5ADA 23, 5NL 33, 5ASR 196, 5AV 27, 5DF 49, 5DL 43, 5AJP 7, 5JY 63, 5FT 18, 5JP 16, 5ABS 9.

FLORIDA—SCM, W. F. Grogan, 4QY—4BL and 4DM are closed for the summer. 4DD has received his commercial ticket. 4XE reported that a total of 24 ham stations are now in the 7th Dist. Naval Reserve. 4NE reports that between 12 and 15 stations are now active in Jacksonville. 4CK is making three transmitters, one for each band. 4OB says QRN sure has been bad and he can't remember it being as bad last year. We are very sorry to hear of the death of 4TK's father. 4LK (RL) is recovering from a bad case of vilitis. 4HY reports very good DX. 4OO was reported in England on 80. 4QY is handling all the traffic for KDWW, Yacht Fortuna, on regular daily schedule. The yacht is now on a fishing cruise in the Gulf. Fruit and supplies are ordered shipped from Northern points to KDWW by amateur radio. (FBI C. M.)

Traffic: 5ADA 23, 5NL 33, 5ASR 196, 5AV 27, 4NE 33, 4CK 32, 4BL 30, 4TK 9, 4OB 7, 4HY 4, 4OO 3, 4LK 14.

GEORGIA, SOUTH CAROLINA—SCM, H. L. Reid, 4KU—4JK who had appendicitis is down again with a double operation. 4EI is rebuilding and will have a knockout station going soon. 4EZ writes in for an ORS. 4AAM has been off this month rebuilding.

GEORGIA: OM Harrison at Augusta is about to get on with a new 352 and will be on the lookout for traffic. 4GY is old 4GE at Savannah. He's been a commercial for the last two years but is craving amateur traffic. 4KU is on 20 meters and likes it fb. 4SI is doing good work there also along with 4IO, 4RM, 4XC is getting on slowly but surely this time. He's married and settled now with a junior op. 4PJ is on and is putting Carrollton, Ga., on the map. 4GZ is doing nice work and is anxious to go the gang.

Traffic: 4KU 2, 4GY 1, 4EI 36, 4KZ 17, 4JK 14, 4KD 2.

PORTO RICO: 4KD is on with a 210 using 450 volts of Everready Layerbills. 4LZ is waiting for his 210. 4JE made a call at Ensenada but at WPR and not 4KD. 4SA is still alive and doing nice work.

WEST GULF DIVISION

SOUTHERN TEXAS—SCM, E. A. Sahn, 5YK—It seems that the summer slump is upon us as reports are a bit slow this time. We have a new reporting station—5AMG formerly of Marshall, Texas, now of Houston. Glad to have you OM. 5PK and 5EW are consolidating their stations so as to have more equipment. San Antonio is well represented by 5WP, 5HS, 5RR and 5HE. Most of the hams there are busy getting ready for the Hamfest, to be held July 15, 16 and 17. 5RR blew his fifty but is on with a 201-A. The RM is getting his schedules in shape quite well. We are anxious that everyone cooperate with him so that we can handle traffic with reasonable reliability. 5AUA worked KUGK for an hour one morning.

Traffic: 5HS 1, 5PK 20, 5EW 10, 5WP 2, 5AMG 5, 5AUA 4.

OKLAHOMA—SCM, K. M. Ehret, 5APG—Traffic sorta' took a slump this month. With school just about out, the "Gang" have been fishing and suffering from that disease called "Spring Fever." 5EJ blew his German 200 watter and is using a 7½ watter now. 5AMO is working Aussies and Zedders every morning. 5VM is off the air on account of his filament transformer up for repairs. 5ADX is going good now and working all districts although no foreign DX. 5ANY is on occasionally but is engaged in a \$15,000.00 building contract and is busy most of the time. 5VH uses UV-201-A and gets good DX. 5APC still works 'em on a 201-A and 90 volts "B" Battery. 5AIR is QRW YL's but handled 5 messages between dates. 5AN burnt out his M. G. and has lost hope in radio. 5AKM is constructing a special radio shack for his transmitter. 5ASK is still at Kow Kollege. 5DQ reports QSO with FQPM at Cammaroons Equatorial West Africa, says that makes 5 continents for him and only leaves one to go, which is Asia. 5AEQ has been reporting for several months and is in line

for an ORS appointment. 5ANL has been trying to get on 40 meters but gives up the ghost. 8SW handled AP news via 5CK and 5JB while Hot Springs, Arkansas was isolated during the flood. 5QL is O. B. S. for Oklahoma now although we believe he does the foreigners more good than he does our own Section. Hil 5AAV moved his station and is about ready for biz. 5APG is working on the construction of a new crystal controlled set.

TRAFFIC: 5ANL 15, 5DQ 14, 5AEP 6, 5APG 4, 5FP 101, 5AMO 121, 5AGN 6, 5AIR 5, 5SW 16, 5QL 1.

NORTHERN TEXAS—SCM, W. B. Forrest, 5AJT—There is no news this month; everyone seems to have been busy at different things. Of course, the usual DX went right on but no world records were broken.

Traffic: 5VU 41, 5AJJ 10, 5WW 4, 5ACL 8, 5AKN 16, 5RG 21.

CANADA

MARITIME DIVISION

NOVA SCOTIA—SCM, W. C. Borrett, 1DD—Things are looking up in this Section, especially in Cape Breton. 1DM comes into the DX column by working oa-21J. 1BR has worked ep, ex, ef and ei. 1BK and 1BT are two new CB stations to break forth in Sydney. 1DA is on regularly. 1CX has a new rectifier. 1DS is another NS station to come on this month. 1AR has been heard working a USA 2 station regularly. 1DD came forth once more with a triumph for the Division by working TUN-2 in Africa. He is now a member of the WAC club. The Murphy Radio Silver Cup for 1926 has been won by Frankie Clarke, of 1AI, for his excellent work during the past twelve months. He is a worthy successor to Joe Fassett of 1AR who won it in 1924 and 1925.

Traffic: 1DD 8, 1DM 12, 1DA 5.

NEW BRUNSWICK—SCM, T. B. Lacey, 1EI—1AD appears to be our star station this month, having worked 85 foreign stations, 15 countries, 5 continents and several islands and ships. 1AE had the misfortune to blow his rectifier tubes and has been operating with AC. 1AM has been keeping up experiments on 20 meters and has worked many foreigners in daylight. 1AQ has increased his power and is using an H tube. 1AX has been on intermittently and has made himself a bug to increase his traffic totals. 1CB, is a new station operating on 38 meters. 1EI is now operating at Mr. Frank Thorne's station 10-BO and using four five wattors on 40 and 80 meters. Receiving conditions have been extraordinary, foreign DX coming in daily, with foreign contacts exceptionally good and numerous stations worked. ARCX, LGN, DCZ are heard here nightly. Signals on the Canadian band 52.2 meters are very few and far between on Wed. nights. The NB gang are busy tuning up their lizzies to burn up the roads on the way to the Maritime Convention which promises to be a good one.

Traffic: 1AD 20, 1AK 24, 1AM 10, 1AQ 1, 1AX 7.

PRINCE EDWARD ISLAND—SCM, F. W. Hyndman, 1BZ—The SCM is on 20 meters. 1AP is on 20 at night and 42 at noon. 1CO QSO'd Germany, Brazil and other foreigners.

Traffic: 1CO 6, 1AP 4.

VANCOUVER DIVISION

BRITISH COLUMBIA—SCM, E. S. Brooks, 5BJ—Only two reports were received this month. Guess the gang spent all their money on easter eggs and forgot to save two cents for a postage stamp. The B.C.A.R.A. station tried out a Kenotron rectifier but results were poor. 5CT is now handling traffic on 80 and reports it a relief from the QRM on 40. 5AC turns in a good report of traffic for 14 days working.

Traffic: 5AC 28, 5CT 19.

ALBERTA—SCM, A. H. Asmussen, 4GT—Reports are slow this month. Guess the spring weather is to blame. The A.H.E.A. had a very successful meeting in Calgary. They now have club rooms and will soon have a HE xmitter on the air. 3DI, a new ham, is doing nice work. 4AF was late with his report. 4AH tops the list this month for tlc and if he keeps going, may be the big boy for DX. 4AL has made a record but not on much. 4DQ has made the best records for this section. Think this is the only Canadian section that can boast of a lady operator having real DX to her credit. 4CU blew his H tube but will soon be on with a 250 wattor. 4HM keeps plugging away with his remote control. 4BN is now a traveling salesman. 4BZ gets out good but does not report. 4DA, 4JJ, 4GL and 4GF are getting hot and we are looking for big things from them. 4DG

came all the way from Jasper to attend the AREA meeting. 4CL is QRW with exams. 4EB broke his wrist but not while using the key. 4AU expects to be going good very soon. 4IO changes from 20 to 40 or 80 with ease and says 20 is FB for DX. 4GT may move to Edmonton and join the Igloo Hut.

Traffic: 4AH 28, 4DQ 4, 4IO 4, 4DI 5, 4GT 5.

QUEBEC DIVISION

QUEBEC—SCM, Alex Reid, 2BE—The boys are making plans to hold a field day about the end of May. They hope for a large attendance as there will be a number of novel stunts pulled. Traffic has fallen off during the month, due to the fact that a great number of the boys have gone down to 20 meters, also several trying crystal control. 2FO is our star 20 meter station. 2BE and 2AL have moved to new QRAs and are back on the job as usual. 2HT has finished his new transmitter and receiver and has made a wonderful job. 2BB has moved to new quarters and reports good results using an indoor antenna. 2EV is silent, due to moving. 2AV is very active and is looking for skeds. 2AD is trying out all sorts of antennas. 2BH and 2AN are QRW at college. 2AU will be on at a new QRA soon. 2DO is receiving fine reports and is keeping a number of skeds. There will be three new hams on the air shortly. 2BV is having trouble from powerline interference. 2AK has Sunday morning schedules with New Jersey.

Traffic: 2AV 8, 2DO 7, 2BE 4, 2FO 12, 2BB 13, 2BG 7, 2AK 8, 2BV 5, 2AL 6.

ONTARIO DIVISION

ONTARIO—SCM, W. Y. Sloan, 9BJ—The effects of spring fever are certainly noticeable in the traffic totals this month. The early springlike weather seems to have the same demoralizing effect throughout the division.

Southern Dist.: 3CS heads the division for activity this month. 3IA has built a new xmitter using a UX210 in the tuned grid tuned plate circuit and hopes to be perking on 20 soon. 3LW has erected a new mast. 3CB is to be commended for his fine work in revising the Canadian calls for the Citizens Call Book. 3FU is silent this month. 3UD has moved again and will be off for a while.

Central Dist.: 9AL has two crystal controlled transmitters in operation spasmodically but reports no traffic this month. 9BJ put a message into Vancouver 10 minutes after it was filed. 3AZ reports operation on 20, 40, 52.5 and 80 meters. 3CJ works on 42.5 and 52.5 with his 202. 3EL has been active on 20 with an indoor antenna. 3BL has had the misfortune to be laid up for most of the month but is feeling better now. 3FC had schedules with eg-5HS and others, most of his work being done on 20. 3CT is down again on 40 while 3DC is crystal controlled using a 20 watt Mullard. 3DV is a new station in Hamilton and certainly looks promising. 3PG is getting out in great shape with his low-power B battery set. We are sorry to hear that 3BZ has been ill but understand that he will be back soon. 3AR is getting ready to take the big slide down to 20. 3RT has worked great DX on 40, having clicked with a station at Papeete, Tahiti. 3CC threatens to move from Hanover. 3CR will be attending school at Toronto this fall. 3CK, 3QS, 3GE, 9AG, 3PW, 3UR and 8MV are known to be on the air spasmodically and we would like to have a note from them on the 20th of each month.

Northern Dist.: 3GG who for years has been firmly planted up on the fone band, has gone down to 20 meters. 3HP clicked with two Frenchmen and two Australians during the past month. 3NI has the car greased up again and is stepping on the gas once more.

Traffic: 3CS 53, 3HP 37, 3JL 15, 3CJ 15, 3FC 13, 9BJ 13, 8L 6, 3CC 5, 3ET 6, 3CB 3, 3BR 2, 3BL 4, 3CR 1, 3AZ 1.

PRAIRIE DIVISION

SASKATCHEWAN—SCM, W. J. Pickering, 4FC—The Canadian band 52.5 meters is being used more than ever these days and is good for local work. 4AQ is using ACCW on 40. 4CB has been QSO oa-2YT. 4CP is trying to make ORS and is getting along fine. 4FA has moved down to 20 meters and says that it has the other bands skinned. 4FC has been QSO oa-5HG. Will those ORS who are not reporting, please do so in future and have their reports in by the 20th of each month reporting from the 15th of one month to the 15th of the next.

Traffic: 4AQ 10, 4CB 5, 4CP 8, 4FA 4, 4FC 2.

Correspondence

The Publishers of QST assume no responsibility for statements made herein by correspondents



QST Made

Box 17,
Weston, Mass.

Editor QST:

Perhaps you would be interested in hearing the story of the making of a ham entirely by QST.

To begin with, I have attained the ancient and honorable age of thirty-nine and my waist line is struggling to attain a diameter greater than my chest measure. I have been a B.C.L. since the pioneer days of KDKA and have built a number of sets for myself and my friends. I made a set with "Aero Coils", as described in QST, and have had a great deal of pleasure with it, listening on twenty, forty and eighty meters, having acquired a fairly good knowledge of the code. This, by the way, I started in to learn by means of the long-wave set also drawn out in QST.

When I received a copy of your Handbook, I immediately made up my mind that I must have a transmitter. The Handbook is so well written that it seemed to me that anyone could get results by following the instructions. Accordingly, I built the low power Hartley set, Christmas tree lights and all, including key-thump filter. I used materials advertised in QST and found out from your Information Service where I could purchase a three-henry choke. I built the transmitter very carefully with a wooden frame, bakelite panel, 12 by 18 inches, and enclosed it in glass so as to be dust-proof. The panel shows a plate current meter, a grid current meter, the antenna r.f. ammeter and two condenser dials. The inductances are R.E.L. as advertised in QST. They are mounted very carefully on bakelite brackets.

I studied very carefully the question of antennas in your Handbook and in back numbers of QST, finally deciding to put up a Zeppelin type. Two wires run from the transmitter up into the air for thirty-two feet where one is dead-ended and the other continues as a flat-top for one hundred and twenty feet.

And here comes the real thriller. After everything was ready and hooked up to a combination "B" eliminator and wet storage battery giving 530 volts for the plate of the 210 tube, Sunday night, I sat down to the receiver and picked up a CQ from

3UT. I called him and nearly fell out of my chair when he came back at me. He told me that my signals were very loud and steady. Now, how is that for real proof of the value of QST—putting up a transmitter according to directions and landing the very first call that is made with it!!

Right here, I wish to go on record with my appreciation of the kindness of 3UT in spending over half an hour with me sending slowly and clearly. Such courtesy on the part of an old-timer toward a rank beginner means a great deal to the future of ham radio.

My second QSO was with 8DMS, who spent considerable time with me. With every single QSO I have had up to date, the operators have wished me luck and have been most patient in transmitting to me. It is a wonderful spirit that is displayed by the gang and I am proud to become one of them.

I have occupied enough of your time with this long letter but I could not resist writing you thanking you for the help you have given me in getting started as a ham.

Yours truly,

—George W. Bailey, 1KH.

Standard Frequency Transmission

2522 Highland Avenue,
McKeesport, Pa.

Editor QST:

I wish to convey my thanks to the Experimenters' Section and particularly to the operators of station 1XM for their untiring efforts. I imagine that less than one out of ten acknowledge this valuable service. I intended to express my thanks last October and though I am bed-fast and have plenty of time, I have delayed all this time. I mention this to show that even a fellow with loads of time will neglect to write. This is due in large part, because it is not a two-sided QSO and the personal element is lacking.

It is not my purpose to dilate on the merits of this service, but I'll wager that there would be an awful howl if it were discontinued. I expect to use it again and I know another amateur who is relying on future transmissions when he gets the coils

for his wavemeter finished. In conclusion, let me state that I never knew exactly where 30 meters was or even 40. The wavelengths of commercial stations as announced in *QST* surely gave me a queer curve, for they must have been changed. It was a grand and glorious feeling when I calibrated my wavemeter from 1XM and really knew my wave.

Kindly forward the carbon copy to 1XM. No acknowledgment of this letter is necessary. The 1XM transmissions are plenty. With many thanks and 73, I am

Cordially yours,
—A. W. Drieling, M. D., SCGV.

Off Wave

355 McGill Street,
Montreal, Canada.

Editor *QST*:

I have comparatively recently graduated from being a B.C.L. into the Amateur end of the radio game. I wish to express my high appreciation of the officials of the League and the excellent periodical issued.

I have but one criticism to make and that is not of the A.R.R.L. but its members who persist in operating outside their waveband. As pointed out in *QST* many times, it is absolutely inexcusable and very discouraging for anyone working DX or taking important traffic from people entitled to use the band above or below those apportioned to the U. S. amateurs. Apparently, it is not an uncommon fault as I have quite a long list compiled from my log. Would not a suggestion of a cancelled license bring these fellows to their senses?

Sincerely yours,
—A. G. Brewer.

Amateur Phone

2945 Seyburn Avenue,
Detroit, Mich.

Editor *QST*:

Just for variety's sake, let's retreat from the old QSO-QSR battle-ground, for a time, and consider a new topic. The time is ripe for a general house-cleaning in amateur phone conditions. Briefly, the proposition is this: Make 150 to 175 meters the *only* phone band.

Like all other amateurs, we have watched the recent "Radio Bill" with keen interest and we believe that order and sane regulations are forthcoming. But, while the ball of red tape is being unwound, let us assist in this popular pastime.

The 80-meter band is too small and too important to be monopolized by phones. The very few credible phones on 80 would be super-quality on 150 to 175. As for the bulk of 80-meter phones, there are other

places we have wished they were, all of which are not in the 80-meter band! Then, too, with all our phone men together on the high band, our possession of it would be clinched.

The small broadcasters are clamoring for this high band. With the 150 to 175-meter band secured for *general* use, we could, if necessary, compromise and release the 175 to 200-meter band to them to hash up in their own sweet way.

It is entirely fitting that the amateur's suggestions in regard to the new system of things, be heeded just as much as are those of the commercial people and this is the time to make them. We wonder how other amateurs feel about this? If enough expressions on the subject could be priced loose to indicate the consensus of opinion, Headquarters could propose to the Radio Commission that a regulation to this be adopted.

We believe that concentration of amateur phones into the 150 to 175-meter band would safeguard our upper wave; would reduce QRM; would produce a broader, more cooperative field for the phone men; and would, by unifying this scattered element, strengthen all amateur radio. What sa OMs?

—V. Sherman, SBMW, SMX.
—H. Allport, SCBM.

Rag Chewing

111A-13th Street,
West New York, N. J.

Editor *QST*:

Although I have been a ham for six years and a subscriber to *QST* for nearly that long, this is my first letter to you. So you see, I've waited a long time to say this.

There have been several unfavorable comments on hams who are not very much enthused about handling messages and also those who *don't* QSL by card.

While I do not claim to be entirely guilty of this, it seems to me that a ham who has been pounding brass for six years continuously, handling his share of traffic the major part of the time and who has sent out over two-thousand QSL cards should get kind of tired of doing the same thing so long. Don't you think so?

I think a ham who can weather the passage of several years on the air and still have an active station ought to be credited for his endurance. How many real old-timers can boast of an active transmitter today? I'm afraid not very many.

I QSR quite often but I usually would like to QSO a ham who can chew the fat about things in general at a fair clip. There isn't a better way in which you new

beginners can improve your fists and copying than by handling messages. I'm sure there are more hams who hunt for messages every day than there are those who don't, so you see there is no reason for persecuting the few remaining rag-chewers.

So, have a heart, fellows, when you voice your opinions about others. Some hams don't go to school and the little time they have left to pound brass is just sufficient for a few QSOs. You can be sure the old timer has lost several hours of sleep trying to break traffic records during his earlier days also.

Yours faithfully,
—*Diran Sarkisian, 2BKR.*

Why Not?

1310 Queen Anne Avenue,
Seattle, Washn.

Editor, *QST*:

It seems that in every other issue of *QST* (or is it every issue) some fellow has to have his say about QSL cards. Being an amateur of the kind who gets a great kick out of the ether without putting one back into it, I have silently watched all of the comments on cards for the past few years.

I believe there is a definite place in Amateur Radio for QSL cards, so let's look at this thing from a sane and business-like standpoint.

We all know that it costs money to send cards, but we usually charge that up as a part of the game—a self-incurred expense; an act of our own free will. It is when some fellow in the next county accidentally listens-in on our sigs and sends us a card with a request that we "pse QSL" that we feel the pinch on the station's budget. When several cards like this arrive in every mail, it begins to hurt!

As a remedy for this, I'm going to suggest that we help each other out a bit on this expense—that we share it more evenly. If I want to send a card (and I have sent many), that's my business. But, I have no reason to feel that the other fellow *owes* me one in return. He may be one of the kind who consider QSL cards as pests—that's his business.

Now then, if we really want and expect a card in return, why can't we persuade the printer to make out cards on the double-folded Government postal stock—the kind with the return card attached, with George on one stamp and Martha on the other. On my half of the card, I can give the information which appears on my regular card, in fact, it will be just like my regular card. On the return card, spaces may be left for information I desire about the other station with a blank space in the center for his call letters. The other fellow takes just a minute to fill in the information I desire,

signs his call letters and drops it in the nearest mail-box, with no expense and very little effort on his part.

In this way, if we are really interested in obtaining a reply, we stand our rightful portion of the expense instead of burdening someone else with it.

Won't someone start the ball a-rolling and report their success with it?

Cordially,

—*F. T. McAllister.*

Re: Hollow Signals

4 Glenhurst Avenue,
London, N.W. 5,
England.

Editor, *QST*:

I see that 8BAD has raised the question of echo effects on signals received below 40 meters. It has interested me for some time past and I sometimes find it hard to read a station due to this phenomenon.

There seem to be two kinds of echo, one is where dots are distinctly doubled and sometimes tripled and the other is where signals just sound "hollow".

The 20-meter stations like WIK, 2XT, 2XS and 2XSA all have multiple dots and tails to dashes for about an hour or two 'round noon G.M.T. and I suppose it must be due to signals going right around the world a few times. This is quite feasible as the interval in the train is about 1/6th or 1/7th of a second which would be about the right time for a "once around". I understand that this trouble had to be overcome before the Beam services could be read sensibly. It is a curious thing that WLL hardly ever has the same trouble with his signals here and I suppose that it must be due to different directional properties of the aerial.

The other kind of echo is noticed here on nearby stations like F'W and also on WIK, but only at night on WIK. The signals don't sound chopped but just "echoy". The only thing that could give a second reflexion of the signal so quickly as to make no apparent break is something about the distance of the Heavyside Layer. If this is causing the reflection, it must be due to a sort of a diffused reflection from the Layer as apart from the other part of the signal that goes right into the layer and gets the DX. I used to think it was caused by low decrement aerials, but if you work out the resistance on a wave like forty meters, you will see at once that the energy could not persist long enough.

I am afraid the European countries do not give such a display of high power "ABC callers" as on the American side, but if anyone does notice this "double dot" effect

on European signals, I should like to have the details.

Hoping this explanation will be some help in the matter, I remain,

Yours sincerely,

—R. Pollock, eg5KU.

Grafting

30 State St.,
Cambridge 39, Mass.

Editor, QST:

"Being the secretary of the blank radio association I have been called upon to write and ask if you would kindly contribute to our club two of your blank blank and one of your blank blank? These parts are to be used in a new set for use in our club room."

The above is an actual quotation from a letter just received and it is typical of a perfect flood of letters that come into this office. These letters usually have a postscript at the bottom or in some cases a rubber stamp calling attention to the fact that they are A.R.R.L. members and by so doing leave the impression that because they are A.R.R.L. members they are entitled to beg.

Literally, we receive several thousand requests annually for donations of radio parts. Many of these are immediately turned down at the start because they are for some local fair or similar situation that should be taken care of by local merchants rather than by the manufacturers. Next comes the "poor boy" or "dying old man" personal requests. These too have to be turned down. The reason is pretty evident. First of all, it is unfortunate to have to state that many of these requests are not bona fide and second if manufacturers took it upon themselves to supply the needy with all their requirements the manufacturers would soon go bankrupt.

We then come to the third and most troublesome class, namely, the A.R.R.L. members. They are the most troublesome because the requests cannot be turned down in the same way that those of the first two classes can. The experimenters have done much to aid the development of radio and to popularize it. In recognition of this, most manufacturers have a policy of trying to help out the most worthy cases. The difficulty of the problem comes from the fact that it is impossible to discriminate between worthy and unworthy cases.

Take the above letter for example. How many members has the blank radio association? Perhaps it is just a group of three or four young men who desire to build a set which will be located in one of their homes. This is strictly a personal proposition and material should not be begged for. How do we know that there is an association at

all and that the individual is really asking for it in his own name?

As the manufacturer is being asked to go to his safe and take out the equivalent of \$5.00 to \$50.00 for these donations, it seems only fair that the person requesting them should supply the necessary information. When a solicitor comes in from the street and asks for a donation for his cause we analyze the worthiness of it before taking the money out of the safe. There is no more reason why the same careful analysis should not be made in the case of requests for apparatus. Apparatus represents cash just as much as that green medium of exchange which we call the dollar.

Another source of difficulty in deciding these cases is the large number of requests we get for donations for prizes to be given out at amateur meetings. These prizes do not go to the speediest operator or the one designing the best set but to the tallest or fattest or the one holding a lucky number.

The General Radio Company has been with the amateur for well over a decade and three of its officers were amateurs back in the dark ages long before there was such a thing as the "Radio Act of 1912". We are with the amateur through and through and it is only because of our personal interest in the amateur field that this letter is being written. We know that some of you may say at once we are getting grouchy in our old age, but this is not the intent of the letter. We want to help. We cannot help when we get such deluges of requests for free apparatus as we are now receiving. It is going to mean that we in common with other manufacturers are going to have to adopt a policy of saying "No" to every case unless the amateur can clean up the situation.

Here is our suggestion. Let all of these requests be turned into A.R.R.L. Headquarters. If the request contains sufficient information as to the size of the organization asking for the donation and it appears that the organization is doing good helpful work, then the A.R.R.L. Headquarters should mark the request as approved and forward it to the manufacturer in question. This approval would not bind the A.R.R.L. nor would it bind the manufacturer to make the donation but it would prove of tremendous help to the manufacturers in separating the chaff from the wheat. It would not be so much to A.R.R.L. Headquarters to pen up a card file for each club requesting a donation. This card could be filed under the club name and every time the club makes a request for a free donation the date and the name of the manufacturer involved could be written on the card. This would prevent clubs from getting into the grafter class and it would aid those clubs

making reasonable requests to get quick approval.

Do you not think it would be possible to help the manufacturers out in this respect?

Yours very truly,
GENERAL RADIO COMPANY
 By B. H. Richmond, Treasurer.

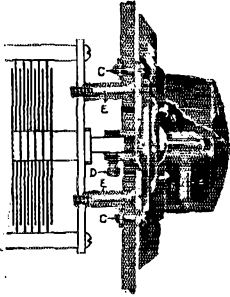

National Velvet-Vernier Dial Type A

The original, matchless, NATIONAL Velvet-Vernier Dial, used by thousands of satisfied Radio Amateurs and B. C. I.'s the world over.

Sold separately or mounted on the NATIONAL DX Condenser. For experimental or breadboard sets. Sold also attached to NATIONAL Transmitting Condensers.

Send for Price List 116-Q-6

NATIONAL COMPANY, Inc.
 W. A. Ready, Pres. Cambridge and Malden, Mass.

NATIONAL

RADIO PRODUCTS

HAMS!

Don't throw away your old tubes, receiving or transmitting. Send me your old tube and 39c and I will send you a Type UX201A, UX199 or UX120; or two old tubes and I will send you a Type UX112 or UX171. Your tubes don't have to light or oscillate, as long as they are not broken. No order for less than \$1.00 filled. Please include postage. New Jersey Radio Supply Co., 76 Springfield Ave., Newark, N. J.

Ad. Anriema, Inc.
 Manufacturers' Export Managers
 125 Broad Street, New York, N.Y.

Scientifically equipped to economically export dependable receiving and transmitting radio apparatus.

RADIO OPERATORS WANTED

THE EASTERN RADIO INSTITUTE can train you quickly and thoroughly because:

MODERN AND EFFICIENT METHODS
THOROUGH INSTRUCTION under staff of LICENSED COMMERCIAL OPERATORS
MODERN APPARATUS including SHORT WAVE TRANSMITTER

FOURTEEN years a RADIO SCHOOL
THE OLDEST, LARGEST and MOST SUCCESSFUL school in New England. **RECOMMENDED BY THE**

A. R. R. I.
 Day or Evening Classes Start Every Monday.

SPECIAL CODE CLASSES
Write for Illustrated Prospectus

EASTERN RADIO INSTITUTE
899 BOYLSTON STREET BOSTON, MASS.

Seventh Edition Just Off the Press

ROBISON'S MANUAL OF RADIO TELEGRAPHY AND TELEPHONY

Completely Revised and Up-to-Date
 Of the 6th edition of this book reviewed by QST it was said this is perhaps

"The Best Radio Book That Ever Came To This Desk"

The standard Navy book on radio originally prepared in 1907 by Lieutenant (last year Admiral and C-in-C of U. S. Fleet) S. S. Robison. The 6th edition and the present edition revised by Commander S. C. Hooper, U. S. Navy, late Radio Officer, U. S. Fleet.

Price \$5.50 postpaid (former edition sold for \$8.00)

Address: Secretary-Treasurer, U. S. Naval Institute, Annapolis, Md., U. S. A.

Announcing THE NEW WESTON 2 and 3 1/4 inch Diameter A. C. Panel Instruments

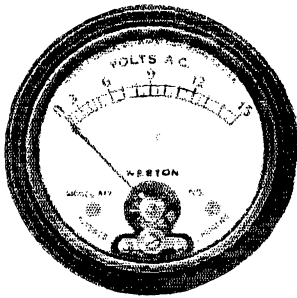

Model 517—2" diameter.

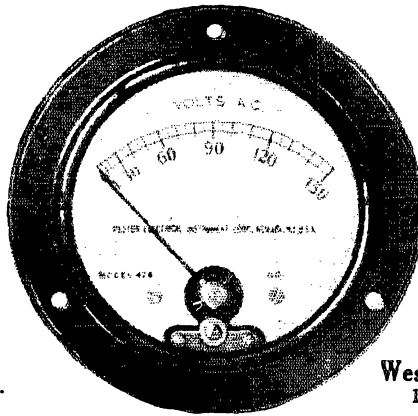

Model 476—3 1/4" diameter.

MINIATURE but reliable instruments are now available which can be used to solve your small panel problems—instruments that are accurate on any commercial frequency, that have an exceptionally high resistance with a low power consumption. Moreover they are moderately priced.

These instruments are made as Voltmeters, Ammeters and Milliammeters in both 2" and 3 1/4" sizes with flush-style cases for panel mounting.

Weston Electrical Instrument Corp.
158 Weston Avenue, Newark, N. J.

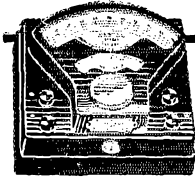

STANDARD THE WORLD OVER
WESTON
Pioneers since 1888



Send the **EASY** Way
With The Improved Martin

Reg. Trade Marks
Vibroplex
Bug
Lightning Bug

VIBROPLEX

For Continental or Morse Code
Adjustable to any speed
from 10
words per
minute—
up

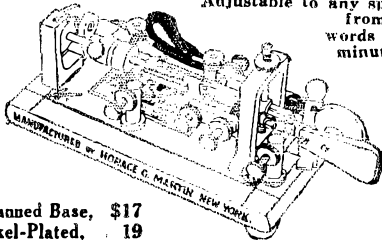

Japanned Base, \$17
Nickel-Plated, 19

Easy to learn and easy to operate. Simply press the lever—the Vibroplex does the rest. Adjustable to any speed from 10 words per minute up. Saves the arm, prevents cramp and improves sending 50 to 100%. Over 100,000 users. No station complete without this up-to-date BUG. Can be used in majority of DX circuits without relay.

Special Radio Model
Equipped with Extra Heavy, Specially Constructed Contact Points to break high current without use of relay. Sent anywhere on receipt of price. Money order or registered mail. **\$25.25**
Liberal allowance on old Vibroplex.

Insist on the Genuine Improved Martin Vibroplex. The Vibroplex Nameplate is your protection. Order N O W!

THE VIBROPLEX CO., Inc.
825 BROADWAY NEW YORK
Cable Address: "VIBROPLEX" New York

PARVOLT

Formerly Sangamo

WOUND CONDENSERS

Stand

the
Surges

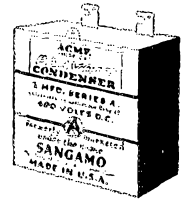

Capacities and prices

Series A 400 Volt Duty Mids.		Series B 500 Volt Duty
\$.85	.1	\$1.25
.95	.25	1.50
1.00	.5	2.00
1.25	1.0	2.50
2.25	2.0	3.50
3.00	3.0	6.00



We Recommend

Sangamo Mica Condensers

THE ACME WIRE COMPANY
New Haven Connecticut

Majestic

100% Electric "B"

Gives your radio Full Strength Permanent "B" Power

from the light socket

It does improve reception!

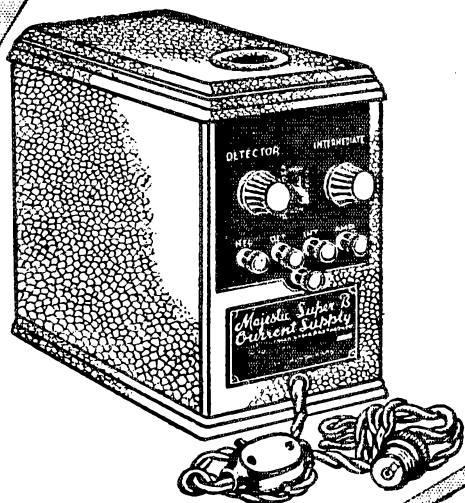

No
acids or
liquids--No
hum. Ask your
dealer to demonstrate

Majestic Standard-B

Capacity Nine
201-A tubes or
equivalent. 45
milliamperes at
135 volts.

\$26.50

West of Rockies
\$29.00

Raytheon Tube
\$4.50 Extra

MAJESTIC SUPER-B

Capacity 1 to 12
tubes, including
use of power tubes.
45 mils. of 150
volts.

\$29.00

West of Rockies \$31.50
(as illustrated)
Raytheon Tube \$4.50 Extra

Majestic Master-B

Positive control of
all output voltage
taps. For sets
having high cur-
rent draw or heavy
biasing batteries.
60 mils. at 150
volts.

\$31.50

West of Rockies
\$34.00

Raytheon Tube \$4.50 Extra

FULLY GUARANTEED—SOLD ON EASY TERMS

GRIGSBY-GRUNOW-HINDS CO. 4562 Armitage Ave., Chicago

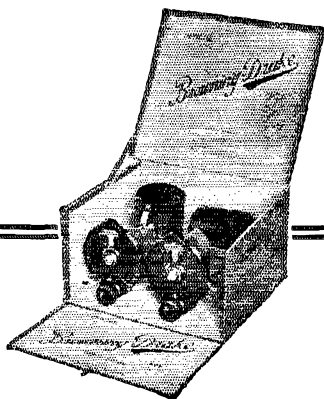

The Official Browning-Drake KIT SET

RADIO amateurs are interested only in those radio developments which have a real scientific background. The new official Browning-Drake assembly is based on the mathematical research on R. F. transformers and the experience of the past three years. The result is that more Browning-Drake Kits are sold than those designed for any other set.

Be sure you get the genuine Browning-Drake Corporation Kit, Foundation Unit, Neutralizer and Cartridge Resistance as well as the other approved parts of associate manufacturers.

Booklets containing complete constructional data are available for twenty-five cents. Get your parts TO-DAY and BUILD the official Browning-Drake Kit Set.

DEALERS:—Some of you amateurs are dealers. If so, we invite you to write for information on the new Browning-Drake opportunities.

BROWNING-DRAKE CORPORATION
BRIGHTON MASS.

BROWNING-DRAKE
RADIO

CARTER

NEW RESISTORS

FOR
Power Operated Sets

The advent of socket operated sets using A. C. current from the socket brought a new demand for resistance.

Carter Resistors are the answer to this demand and have met with instant success. Again Carter originality is displayed in these new products. See them at your dealers.



Send for illustrated folder of circuit suggestions.

Full Size
In Canada: Carter Radio Co., Ltd.

CARTER RADIO CO.

MEMBER
RMA

CHICAGO

HAMMARLUND

Low-Wave Receiving
Condensers and Coils

and Hammarlund Transmitting Condensers are built to standards of accuracy that professionals and advanced amateurs appreciate.

Their reputation is world-wide.

Back of them are 16 years of experience in manufacturing precision instruments for radio, telephone and telegraph use.

If your dealer can't supply you write us your needs.

HAMMARLUND MANUFACTURING CO.
424-438 W. 33rd Street, New York City

For Better Radio
Hammarlund
PRECISION
PRODUCTS



The Coils the thing!

that makes
Radio

From Microphone to Loud Speaker

No radio unit is any better than its coil for the coil is the vital part of all radio apparatus.

Coils in the microphone and all the way down the line to the loud speaker determine the volume, the selectivity, the distance, and, most important of all, the tone qualities. Coils cannot be too well made—the wire in them cannot be too good—the insulation cannot be too perfect.

The best radio apparatus in the world, made by the most successful radio manufacturers, is equipped with Dudlo layer wound coils. These manufacturers know from experience that it is *unprofitable* to attempt to wind their own coils and *unwise* to experiment on doubtful sources of supply for parts so highly specialized and so important as their coils.

By standardizing on Dudlo wire and coils, you can avoid all worry as far as these units are concerned.

Dudlo coils are wound to manufacturers' specifications. The Dudlo Engineering Laboratories are at the service of any radio manufacturer to assist in designing the proper coil for certain purposes—samples submitted without obligation.

DUDLO

DUDLO MANUFACTURING CORPORATION, FORT WAYNE, IND.

56 EARL STREET NEWARK, N. J. 160 NORTH LA SALLE STREET CHICAGO, ILL. 4153 BINGHAM AVE. ST. LOUIS, MO. 274 BRANNAN ST. SAN FRANCISCO, CALIFORNIA

SAY YOU SAW IT IN Q S T—IT IDENTIFIES YOU AND HELPS Q S T

for
REAL RECEPTION!



KINGSTON

"B" Battery Eliminator

Guaranteed to remove the battery nuisance and deliver clearer tone and increased volume. Provides three different voltages at the same time. Each tap adjustable over a wide range, making possible any desired voltage from 5 to 150, absolutely harmonizing "B" current supply to your set. Raytheon tube used as rectifier. No noise or vibration. Contains no acid or solution and will not get out of order. Operating cost negligible.

At Your Dealer's

Price, complete with Raytheon tube **\$35.00**

KOKOMO ELECTRIC COMPANY
KOKOMO, INDIANA

YAXLEY

APPROVED RADIO PRODUCTS

Automatic Power Control

You need no longer worry about the switching of your B eliminator or trickle charger or both. An Automatic Power Control will do all the extra switching for you. When you turn the switch on your set, the Automatic Power Control switches on the B eliminator and cuts out the trickle charger or does either. When you turn the set off, the Power Control is working automatically, surely and without fail turning off the B eliminator and trickle charger on.

No. 444—Automatic Power Control, Series "Type"—for use with sets having tubes with a current draw equal to or greater than 6 U. V. 199 type of tubes. Each, \$5.00
At your dealer's. If he cannot supply you, send his name with your order to

YAXLEY MFG. CO.
Dept. S 9 So. Clinton Street
Chicago, Ill.

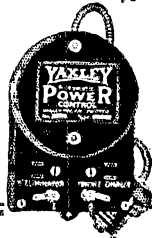

FROST-RADIO FROST-RADIO FROST-RADIO FROST-RADIO FROST-RADIO

FROST-RADIO FROST-RADIO FROST-RADIO FROST-RADIO FROST-RADIO

FROST-RADIO

FOR FINE CONTROL
of TONE and VOLUME

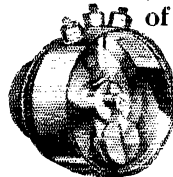

Frost-Radio Super Variable High Resistance Units give remarkably fine control of tone and volume through their smooth and noiseless operation. They are far ahead of wire wound types. Roller contact arm eliminates wear on resistance strip and insures long service. Furnished in two and three

terminal types and in resistances from 50,000 to 500,000 ohms List: \$1.25.

WONDERFULLY BETTER FOR EVERY SET

Frost Radio Metal Frame and Bakelite Rheostats are not only the smallest and most compact rheostats made, but they have velvety-smooth action and windings of finest Nichrome or Chromel A wire. Due to number of turns used these rheostats will keep cool under the heaviest load for which they are designed. Complete with Bakelite pointer knob. Resistances from 2 1/4 to 75 ohms. List: Metal Frame, 50c; Bakelite, 75c.

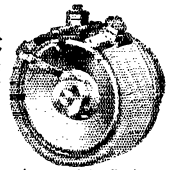

HERBERT H. FROST, Inc.
MAIN OFFICE and FACTORY
ELKHART, IND.

Chicago Philadelphia St. Paul
New York Pittsburgh New Orleans
Boston Washington, D. C. Los Angeles Buenos Aires
Argentina

FROST-RADIO FROST-RADIO FROST-RADIO FROST-RADIO FROST-RADIO

TRANSMITTING INDUCTANCES

REL

REL

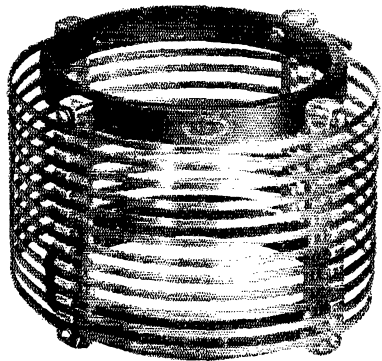
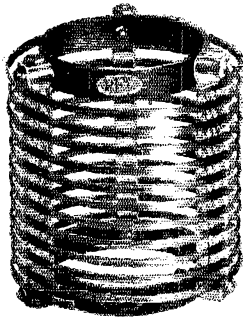
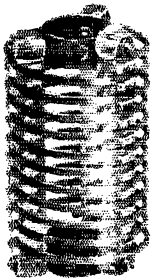

TYPE-S, 3" diameter, 6" long, 11 2/3 turns. Expressly designed for extreme short wave transmission (20 meters and less, however, can also be used on 40 meters).

TYPE-L, 5" diameter, 6" long, 11 2/3 turns. For 40, 80 and 150 meter wave bands (corresponding to the capacity shunted across the inductance).

TYPE-LL, 3" diameter, 6" long, 11 2/3 turns. Specially designed for transmitters operating above 200 meters (broadcast stations). A number of these units may be connected in series.

REL inductance units are so designed that each type may be telescoped in the next larger type. This will prove very practical where close coupling is desired.

Single units of either type S or L Price \$ 5.50
 Double units of either type S or L Price \$11.00

(Double units comprise one primary unit and one secondary unit with two 1/2" diameter by 15" long glass coupling rods.)

Single units of type LL Price \$11.00

Special designs of flatwise or edgewise wound inductances for broadcasting stations. Prices on application.

TRANSMITTING PLUG-IN INDUCTANCES

REL

REL

Those who may desire plug-in inductances for quick shifting will find the REL PLUG-IN UNITS just the desired thing. Flatwise wound on moulded glass. Designed to operate in all circuits up to and including 2 K.W.

Use a Transmitting Plug-in inductance and not a Revamped Receiving Plug-in Coil

Any of the above units supplied with plug-in arrangement at a \$1.10 extra charge. Base jacks supplied unmounted.

QST

PSE COPY NU

QRA

Better facilities—Better short wave apparatus—Better laboratory—Better 2XV—Better everything for everybody. Visit our showroom. Complete line of Short Wave Transmitters and Receivers.

RADIO ENGINEERING LABORATORIES

100 Wilbur Avenue

Long Island City, N. Y.

SAY YOU SAW IT IN QST—IT IDENTIFIES YOU AND HELPS QST

A VITROHM RESISTOR

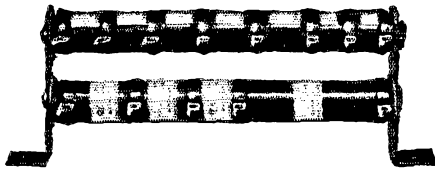

FOR
RAYTHEON and Q. R. S.
350 m.a. A B C Units

Vitrohm 507-62 is ready for immediate delivery to consumer, dealer, jobber and manufacturer.

This new Ward Leonard Resistor is wire-wound, with both resistance wire and terminal contacts protected by a fused-on coating of vitreous enamel. Special pre-aged resistance wire guarantees accuracy of rating when installed and permanence of this accuracy regardless of length of service.

Vitrohm 507-62

For all 350 m. a. Current Supply Units. 4760 ohms total resistance; tapped for -40, -22, -9, -4½, +22, +45, +67, +90, +135, +157 and +180 volts.

Approved by Raytheon and Q R S Laboratories

Price, with mounting brackets, \$8.75

Ward Leonard Electric Company
MOUNT VERNON NEW YORK

7135-8

High Frequency Design

Are you satisfied with the results obtained from your transmitter? Maximum output with a steady note requires careful design of circuit and apparatus. Don't envy the fellows who push their traffic thru consistently. Let us help YOU get in that class.

We will design and furnish all specifications for the MASTER OSCILLATOR-POWER AMPLIFIER circuit, either crystal controlled or otherwise, that will best fulfill your particular requirements. We have the equipment to solve all your problems.

Radio frequency chokes, frequency meters and other precision equipment designed to order. We can also supply oscillating POWER CRYSTALS to cover the amateur bands or ground to any specified frequency.

Prices furnished upon request. State your requirements in detail in order that we make accurate estimates.

CAPITOL RADIO ENGINEERING CO.
101 6th St., N. E. Washington, D. C.

Hoyt B ELIMINATOR VOLTMETER

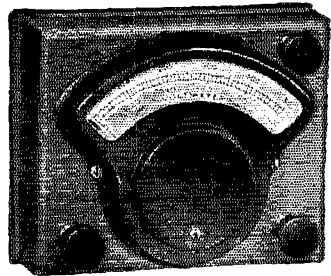

A new sensitive voltmeter, for regular Dealers' service work as well as for laboratory and precision measurements. Resistance 1,000 ohms per volt. Provided with two scales.—0-100 volts and 0-500 volts, covering the entire range of ordinary B-Eliminator and Power-Amplifier work. Prices, HOYT Standard B-Eliminator Voltmeter, 0-100 and 0-500 volts—\$28.00.

Supplied on special order with additional scale, either: —0-10 volts or 0-100 ma. at \$32.50.

Send for Price list Q-6

BURTON-ROGERS CO.

Sales Dept. for Hoyt Electrical Instrument Works
BOSTON, MASS.

90 Volt Power Unit \$12.75

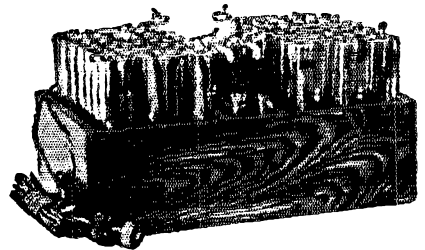

Hums, line noises, etc., positively impossible with this new advanced unit. Plug in and forget Non-acid and noiseless. All detector and intermediate voltages plainly marked. Simpler to hook-up than dry cells. Operates any type set 1 to 12 tubes.

Greater volume and clearness guaranteed. If not thoroughly satisfied, return after using 90 days for complete refund. Guaranteed further 2 years. For 110-120 volts A. C. 25 to 60 cycle current, 90 volts, \$12.75; 112½, \$15.25; 135, \$17.50; 157½, \$19.50; 180, \$24.00; 202½, \$26.00.

Also built for D. C. current 110 and 32 volts at only \$3.00 additional, any size above. Ample stocks—same day shipments. Simply say—ship C.O.D. or write for my interesting literature, testimonials, etc.

B. HAWLEY SMITH, 332 Washington Ave., Danbury, Conn., U. S. A.

AERO COIL

SUPER-SENSITIVE INDUCTANCE UNITS

The Perfect Inductances for All Low Wave Work

**FOR
RECEIVING**

AERO LOW WAVE TUNER KIT

Price \$12.50

Completely interchangeable. Adopted by experts and amateurs everywhere. Range 15 to 130 meters. Includes 3 coils and base mounting, covering U.S. bands, 20, 40 and 80 meters. You can increase or decrease the range of this

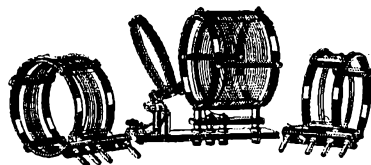

PRICE \$12.50

short wave tuner by securing the AERO Interchangeable Coils described below. All coils fit the same base and use the same condensers. Use Code No. INT-125 in ordering.

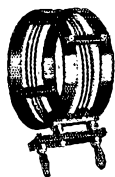

INTERCHANGEABLE Coil No. 0

Range 13 to 29.4 meters. This is the most efficient inductance for this low band. Code number INT-0.

Price \$4.00

INTERCHANGEABLE Coil No. 4

Range 125 to 250 meters. Fits same base supplied with low tuner kit. Code number INT-No. 4.

Price \$4.00

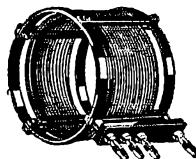

THE NEW AERO INTERCHANGEABLE COIL No. 5
Normal range 235 to 550 meters. However, by using .0001 Sangamo fixed condenser across the rotor and stator of the .00014 variable condenser, the maximum wave band of this coil is increased to 725 meters. This gives you coverage of the following bands: Airplane to Airplane, Land to Airplane, Ship to Shore (Great Lakes) Ship to Shore (Atlantic and Pacific Oceans). Code number INT-No. 5.

Price \$4.00

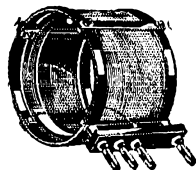

**FOR
TRANSMIT-
TING**

KEY 2040 KIT Price \$12.00
Kit contains 2 AERO Coils, 17 to 50 meters each, 1 AERO Antenna Coil Mounting Base, 1 AERO Grid Coil Mounting Base, 2 AERO Essential Choke Coils.

KEY 4080 KIT Price \$12.00
Kit contains 2 AERO Coils, 36 to 90 meters each, 1 AERO Antenna Coil Mounting Base, 1 AERO Grid Coil Mounting Base, 2 AERO Essential Choke Coils.

If you desire to have this set tune also 20 meters, simply buy two AERO 20 to 40 meter transmitting coils, which plug in the same mounting bases, and work efficiently with the above items.

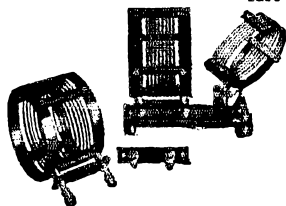
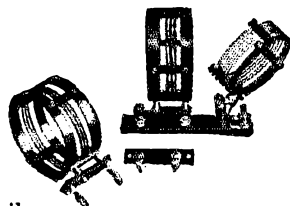

PLAN FOR D. X. RECORDS NOW!

Order these coils direct from us if your dealer hasn't them and start now for wonderful records. Specify code or key numbers when ordering. Or write at once for complete descriptive literature.

AERO PRODUCTS, Inc.

Dept. 16

1772 WILSON AVE., CHICAGO, ILL.

AERO PARTS

Transmitter coils (17 to 50 meters, Key 2040C and 36 to 90 meters, Key 4080C) \$4.00 ea.
Antenna Base, Key PRI-300, \$3.00 ea.
Grid Coil Base, Key GRID-100, \$1.00 ea.
Choke Coils, \$1.50 ea.



PRICES in this "AD" are CORRECT

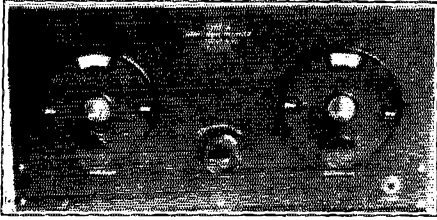

Fortunate purchase of parts enables us to sell you the Standard GROSS Short-wave receiver, regularly listed at \$55.00, for a ridiculously low figure.

GROSS plug-in coils, Hammarlund midline condensers, and other high-grade parts, are used in its construction. Every set shipped in perfect working order with iron-clad guarantee. Supplied with plug-in coil for any band you specify, 20, 40, 80 or 200 meters.

Extra coils \$3.00 each.

Remittance with Order — No C. O. D. Shipments

J. GROSS & COMPANY,

This offer only good while present stock lasts, after which they will again sell at the original price. Individual parts used list at over twice the figure at which we are offering this receiver. We guarantee it to equal or better the performance of any short wave receiver on the market.

GROSS short wave plug-in coils from 15 to 130 meters at \$11.50.

See our "ad" in May QST for our other apparatus.

Two Tube Short Wave Receiver **\$16.75**

Three Tube Receiver \$20.75

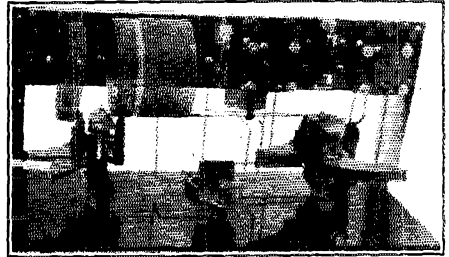

30 Park Place, N. Y. City

TOBE

Trade Mark Reg. U. S. Pat. Office

VERITAS RESISTORS



2 Watt—a New Size

We announce a new 2-watt Veritas Resistor, intended to replace old type resistors and grid leaks in which the resistance element is separately enclosed within a glass tube, and which are only 1/10 to 1/20 as able to carry current safely. In spite of much greater value, 2-watt Veritas Resistors sell for no more than the old style. They stand up in service, are accurate, changeless and can be soldered without damage.

The TOBE 5-watt Veritas Resistor is still part of the Veritas line. In addition we now present to the Radio Public a 10-watt resistor with all the excellent Veritas characteristics and suitable for use in large R-eliminators and Power-Supply units. Send for catalogue Q-6.

Tobe Deutschmann Co.

Engineers and Manufacturers of
Technical Apparatus
Cambridge, Massachusetts

Centralab Modu plug

GIVES old receivers the improved tone volume control of latest, best sets. Replaces present speaker plug. Tune in with dials. Then modulate to any degree on Modu Plug alone (between speaker and set).



Reduces interfering noises. Attaches without tools. Nothing else like it. Cord or Jack Type, \$2.50 at dealers, or mailed C. O. D.

Parts manufacturers for 69 makers of leading standard sets.

Central Radio Laboratories
20 Keefe Ave. Milwaukee, Wis.

Centralab

AC INSTRUMENTS

In the next thirty days we will offer you AC Buzz proof instruments, including wireless relays, learners outfits and telegraph school outfits. These instruments can be used on the ordinary 110 volt lighting circuit. Inquiries solicited.

ELECTRO MFG. CO.

Dept. C,

Box 582,

Fresno, Calif.

Cardwell



for the TWENTY METER BAND

—The New Cardwell Types T-199 & T-183

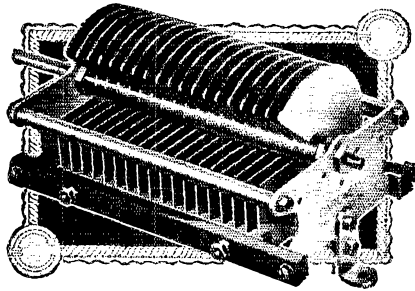

are ideal. Extra heavy construction, wider spacing and polished, round-edged plates assure the non-vibration and absolute freedom from losses which are positively essential at high frequencies. No other commercially built condenser is nearly as efficient at frequencies above 15000 KC. Use the right condenser anyway. Here is what they will stand.

TRANSMITTING CONDENSERS

Type	Price	Capacity (Mmfd.s.)	Airgap (Inches)	Spacing between adjacent plates	Plate Thickness	Length (Back of panel)
141-B	\$4.25	245	.030	.085	.025	2.375
123-B	5.00	480	.030	.085	.025	2.375
137-B	6.00	954	.030	.085	.025	3.000
164-B	7.00	217	.070	.165	.025	4.000
147-B	10.00	440	.070	.165	.025	5.875
157-R	12.00	217*	.070	.165	.025	5.875
T-199	10.00	230	.084	.208	.040	6.500
T-183	10.00	110	.171	.382	.040	6.500
166-B	70.00	297	.219	.502	.064	10.250

*—Double stator, capacity of each section.

CONSULT THIS CHART

Plate CW	Voltage Phone	UX171 or smaller	UX210 UV202 VT2	"H" Tube	UV203 UV203A 211D	UX852 UV204 UV204A	Up To 1kw	Higher Power
200	200	*	*	o	o			
500	500	*	*	o	o			
800	600		†	†	†	T199		
1000	800		†	†	†	T199	T199	
1500	1000			T199	T199	T183	T183	
2000				T199	T199	T183	166B	166B
3000	1500			T199	T183	166B	166B	166B
Higher	2000 Voltages					166B	Spec.	Spec.
						Spec.	Spec.	Spec.

*—Any Type of Cardwell Receiving Condenser.

o—Any Type "B" or "C" Cardwell Condenser.

†—Type 164B, 147B or 157B Cardwell Condenser.

‡—Mounting feet, 25c per pair, sold separately.

RECEIVING CONDENSERS

Type	Capacity Mmfd.s.	Price
191E	75	\$2.75
167E	140	4.00
168E	220	4.25
169E	340	4.75
192E	500	5.00

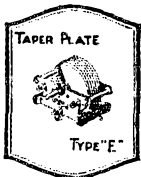

The Allen D. Cardwell Mfg. Corporation
81 Prospect Street
Brooklyn, N. Y.

Condensers

"THE STANDARD OF COMPARISON"
SAY YOU SAW IT IN QST—IT IDENTIFIES YOU AND HELPS QST

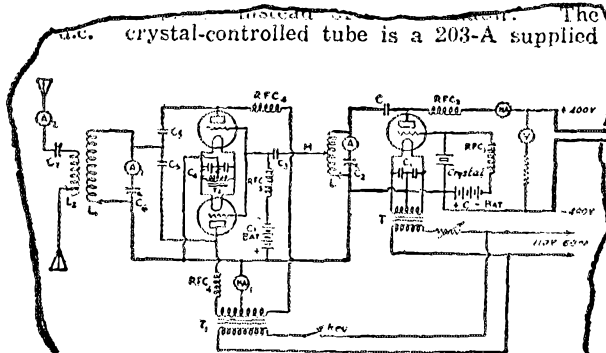
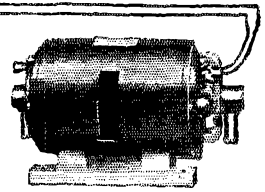

FIG. 1 THE COMPLETE CIRCUIT

with from 350 to 400 volts of pretty good "d.c." In 1MK's case the d.c. comes from a small Escro motor generator minus any filter. The crystal oscillates (yep it does)

Clipped from March 1927 Q. S. T.

This is item 4--It is a very good set for crystal control.



Bulletin 237E List over 500 combinations of generators, motor generators and dynamotors for Radio. If you have not a copy write for one.

P.S.--Have you a copy of Filter Facts?

ELECTRIC SPECIALTY COMPANY

Mark "ESCO" Trade

225 South Street

Stamford, Conn., U. S. A.

Manufacturers of Motors, Generators, Motor-Generators
Dynamotors and Rotary Converters, for Radio and Other Purposes

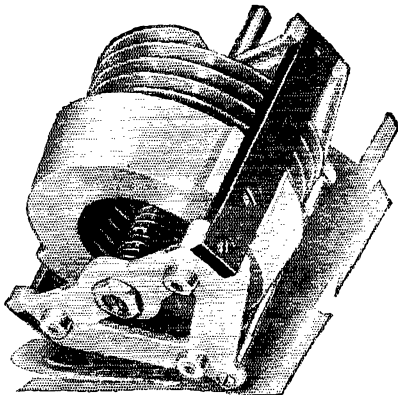

A truly remarkable capacity variation not approached by any other condenser. There is no crowding of stations on the dial and no hair-splitting adjustment to make, not even on the twenty-meter band. Think what wonderful reception is made possible with a condenser of .000350 mfd. capacity! Price, with special dial \$7.70 postpaid. Every amateur receiver will soon have them. GET YOURS NOW.

THE HELICON

RADIO CONDENSER CORPORATION
Peoria, Illinois

Transmitting Apparatus At Rock Bottom Prices

PROMPT — RELIABLE — MAIL ORDER SERVICE — WITH
THE 2MA MONEY BACK GUARANTEE

No. 12 Cooper enameled antenna wire \$2.90 100 ft. roll. Pyrex 7 1/2 inch strain insulators \$1.19. 12 inch Pyrex \$2.79. H.E.L. Transmitting inductances double units with coupling rods 40-80 meters \$8.95. Single unit \$4.65. New Aero Transmitting Coil Kit 40-80 or 20-50 Meter Coil Kits \$9.85. RCA LC-1803 10,000 volt condensers (for tuned grid and plate transmitters) \$2.95. New Ward Leonard Center-tapped with mountings 5000 ohms for 5 and 508 \$1.75. up to 250 watts sets \$2.59. Crescent lavite 5000 ohm leaks \$2.19. Heavy duty G.E. 5000 ohm leaks \$1.49. Sangamo .002 condensers \$.48 Paradon 3000 volt .002 \$2.29. All sizes of Jewell 3 inch Flush Mount Jewell Thermo-couple antenna ammeters \$3.69. Jewell Milliammeters. A.C. Voltmeters, D. C. Voltmeters \$6.00 each. Filter Condensers, Flechtme 2MFD 2000 volt \$5.19. 4 MFD 2000 volt \$8.60. Sangamo 1 MFD 1000 volt, \$1.60. 2 MFD \$2.15. 4 MFD \$3.65. A Few Left Thordarson Combined Plate & Filament Transformer for 7 1/2 watt set 650 volt plate winding 7 1/2 volt filament with center-tap. Special \$8.19. Thordarson Filament Transformers-Mounted with mid-tap. 80 watt (for 4 7 1/2 watters) \$6.05. 150 watt (for 4 50 watt tubes) \$7.90. 300 watt (for 250 watters) \$13.15. Thordarson Plate Transformers, 100 watt plate \$10.90. 450 watt plate \$14.90. R.F. Chokes \$3.90. Short Wave Receiver Specials Aero Short Wave Coil Kit \$9.45. R.E.L. Short Wave Kit \$3.69. Cardwell 7 plate S.L.V. \$2.45. 11 plate \$2.45. Special on Cardwell Transmitting Condensers. 43 plate \$4.95. Special T. Types, T-199, T-183B. \$3.95. rebuilt 23 plate \$3.25. Hammarlund Transmitting Condensers 23 plate \$3.75. 43 plate \$3.25. Any Other Parts Not Listed Here In Stock At Reduced-Low Prices.

RADIO 2MA

168 Washington St.

New York City

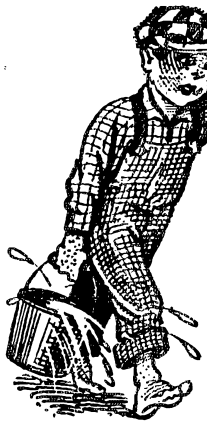

New!

You don't have to be
water boy to this
battery charger

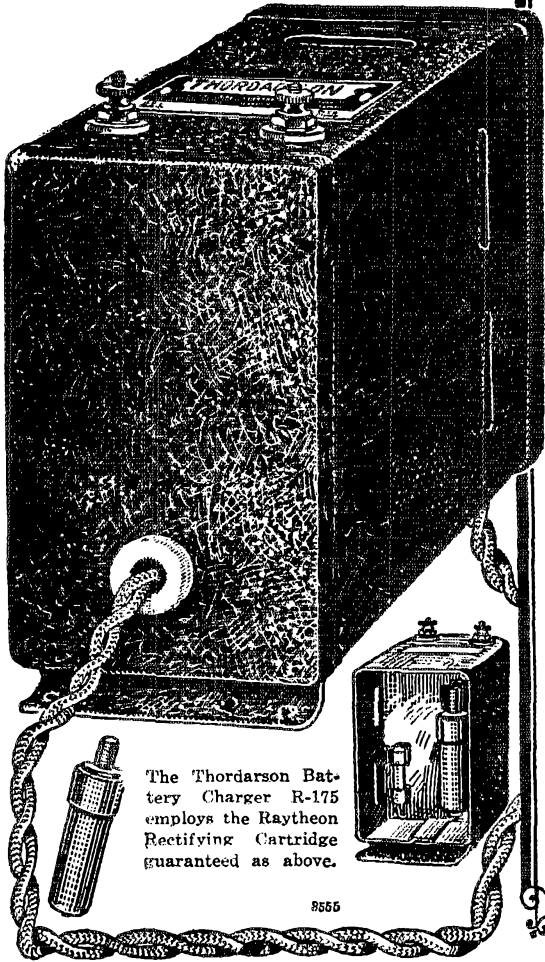

The Thordarson Battery Charger R-175 employs the Raytheon Rectifying Cartridge guaranteed as above.

8555

THORDARSON BATTERY CHARGER R-175

Radically new,—sound in principle,—proven in performance.

The Thordarson Battery Charger makes its bow as a welcome relief to the army of butlers to thirsty battery chargers.

DRY—As dry as they make 'em. In fact, the rectifying element is contained in a moisture proof cartridge.

SILENT—No vibrating parts. Current is rectified through a patented electro-chemical process.

SAFE—There is no hazard to rugs or woodwork for there is no acid to spill. The tubes of the set are safe even if turned on when charger is in operation.

COMPACT—Fits into battery compartment easily. Only 2 3/4" wide, 5 3/4" long and 4 3/4" high, overall.

EFFICIENT—This charger is always ready for service. No overhauling required. Rectifying element can be replaced in thirty seconds.

GUARANTEED—The rectifying unit is guaranteed for 1,000 hours full load operation, or approximately one year's normal service. The Transformer will last indefinitely.

Charging Rate—2 amperes

For Sale at Good Dealers Everywhere
or direct from the factory

Price Complete \$12.50

THORDARSON ELECTRIC MANUFACTURING CO.
Transformer Speciality Since 1895
WORLD'S OLDEST AND LARGEST EXCLUSIVE TRANSFORMER MAKERS
Turner and Kingsbury Streets — Chicago, Ill., U.S.A.

"B" Eliminator TESTING Problem Solved by

Sterling



Model R-415



TO GET full value from your "B" Eliminator you must *know* that your "B" Power is delivering the *right* amount of voltage to detector, amplifier and power tube.

Low resistance voltmeters suitable for testing batteries are worthless for testing "B" Eliminators. This specially designed High Resistance Sterling is accurate for both.

Whether this voltmeter is used in your business or for your own set, it is *essential* if you want the facts about any "B" Eliminator.

It is the Universal Voltmeter for the Amateur R-415

Sterling voltmeter meets the special needs of the amateur in a variety of ways—for testing the output of D. C. Generators, and for every other purpose calling for a *high resistance* voltmeter.

Never before has a laboratory instrument been available at a price so reasonable.

Sterling

R-415 VOLTMETER

A laboratory meter at the remarkably low price of **\$8.50**

Also Model R-417. A New 150v. Sterling A. C. Meter for Testing A. C. line current and all A. C. Circuits.....\$7.50

THE STERLING MFG. CO.
2831 Prospect Ave. Cleveland, O.

SHORT WAVE RECEIVER AND ONE STEP \$17.50

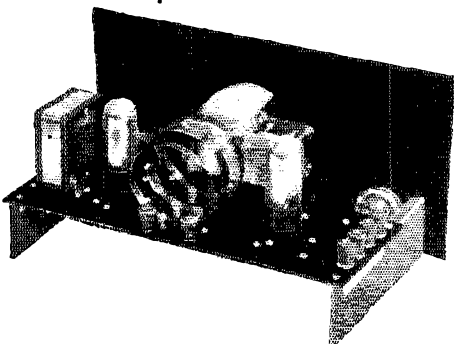

"The above receiver comes with a set of plug-in coils for the 40 meter band. Additional coils may be had for other waves. Vernier dial and smooth oscillation control makes set very efficient on short waves. We also make a transmitter to go with this at a very attractive price. Every thing we manufacture is positively guaranteed in every respect. Write for pamphlet of additional amateur items.

PARMATER PRODUCTS CO., Charlotte, Michigan

QST Oscillating Crystals

Prices for grinding POWER crystals for the various Amateur bands as follows:

150-170 Meter band	\$15.00
75-86 Meter band	\$25.00
37.5-42.5 Meter band	\$40.00

We will state the frequency of the crystal accurate to better than a tenth of one per-cent. All crystals guaranteed.

BROADCAST BAND

We will grind for you a crystal accurate to plus or minus 500 cycles of your assigned frequency for \$50.00 unmounted, or \$60.00 mounted. This crystal is our POWER type and is absolutely guaranteed. PROMPT DELIVERIES.

We grind crystals to any frequency between 40 and 10,000 kilocycles. Let us quote prices for your particular requirement.

"The Crystal Specialists"

SCIENTIFIC RADIO SERVICE

P. O. Box 86 Dept. K Mount Rainier, Maryland

A Laboratory Product **CRESCENT LAVITE RESISTANCES**
for Distortionless Amplification



Used in 50 big broadcasting stations, 12,000 48,000, 50,000 and 3,000 ohms. For distortionless amplification. Order a Crescent today at \$1.50. Special sizes made to order. Discounts to dealers.

Cresradio Corp., 166-32 Jamaica Ave., Jamaica, N. Y.

"JACOBS ANTENNA SPREADER"

Made in both 5 in. and 7 in. diameters
Patented Sept. 8, 1925; Sept. 7, 1926



Made of metal for erecting either 4, 6 or 8 wire Cage Antenna or counterpoise. R. T. Cole, 5ZAA writes "The Spreaders have given perfect satisfaction on my short wave transmitting antenna." Price \$6.00 per dozen; \$3.25 for a half dozen. Circular upon request.

CHARLES F. JACOBS, (2EM) 270 Park Place, Brooklyn, N. Y.

RAYTHEON MANUFACTURING COMPANY

MAKERS OF RELIABLE RECTIFIERS

KENDALL SQUARE BUILDING

CAMBRIDGE, MASS.

March 31, 1927

Aerovox Wireless Corporation
70 Washington Street
Brooklyn, New York

Gentlemen:

Attention of Mr. S. I. Cole

From time to time our laboratory has made careful and constructive tests on the condensers manufactured by your company for use with our type "B" rectifier in B-Power Supply Units, for use with the "BH" rectifier in B-Power Supply Units and in "A-B-C" Units using both the "BH" and "BA" 350 milliampere rectifier.

The performance of these condensers has been entirely satisfactory when used in these circuits and the actual measured capacitance has not varied from the rated value more than three percent.

The non-inductive type of construction used in your condensers is highly recommended for these circuits as our tests show filter circuits using this non-inductive type of capacitance to have greater efficiency for a given number of microfarads used.

Manufacturers of high quality B-Power Units have realized that an adequate safety factor in condenser construction is essential for continuous satisfactory service and your efforts to develop a high quality condenser will undoubtedly react to the mutual benefit of those now interested in the socket power field.

From the results of our tests we are glad to recommend your condensers to manufacturers interested in the development of quality B-Power Units.

Sincerely yours,

RAYTHEON MANUFACTURING COMPANY

By



D. E. Replogle
Sales Engineer

DER:AW

AEROVOX WIRELESS CORP.

70 Washington Street, Brooklyn, N. Y.

"AMATEUR SUPPLIES"

Attractive QSL Cards
\$3.50 per 500 up

Rectifier Elements and Rectifiers
Complete on Order

Filter for preventing BCL—QRM
\$5.00

LONG'S RADIO SHOP
2812 So. Main St. Los Angeles, Calif.

Kenotron Rectifying Tubes
(Type T.B.1.)
MFD. BY GENERAL ELEC. CO.

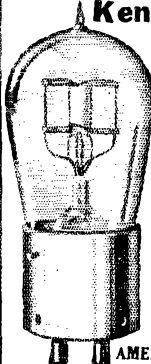

These rectifying tubes operate on a filament voltage from 8 to 10 Volts and draw 1 1/2 amps. They will safely stand an A.C. input voltage up to 750 Volts and pass plenty of current and voltage for the plate of the Transmitting Tubes.

They are also very efficient rectifiers for use in "B" Battery Eliminators.

**STANDARD BASE
NEW IN ORIGINAL CARTONS**

PRICE ONLY \$1.25 Ea.
AMERICAN SALES COMPANY, 21 Warren St., N.Y.C.

Become a Radio Operator
See The World. Earn a Good Income. Avoid Hard Work.
Learn in the Second Port U. S. A.

Radio Inspector located here. Opportunities for employment second to no other port. Most logical location in the U. S. A. to come for training.

Practically 100% of radio operators graduating on the Gulf during past four years trained by MR. CLEMMONS, Supervisor of instruction. All graduates placed to date.

Day and Night Classes, enroll anytime. Write for Circular.

Gulf Radio School 844 Howard Avenue,
New Orleans, La.



PACENT TRANSFORMERS

Used and specified by the leading radio engineers of the country.

PACENT Electric Co., Inc.
91 Seventh Ave., New York

To Our Readers Who Are Not A. R. R. L. Members

Wouldn't you like to become a member of the American Radio Relay League? We need you in this big organization of radio amateurs, the only amateur association that does things. From your reading of *QST* you have gained a knowledge of the nature of the League and what it does, and you have read its purposes as set forth on page 6 of every issue. We would like to have you become a full-fledged member and add your strength to ours in the things we are undertaking for Amateur Radio, and incidentally you will have the membership edition of *QST* delivered at your door each month. A convenient application form is printed below—clip it out and mail it today.

.....1927

American Radio Relay League,
Hartford, Conn., U. S. A.

Being genuinely interested in Amateur Radio, I hereby apply for membership in the American Radio Relay League, and enclose \$2.50 (\$3 in foreign countries) in payment of one year's dues. This entitles me to receive *QST* for the same period. Please begin my subscription with the issue. Mail my Certificate of Membership and send *QST* to the following name and address.

.....

.....

Station call, if any

Grade Operator's license, if any

Radio Clubs of which a member

Do you know a friend who is also interested in Amateur Radio, whose name you might give us so we may send him a sample copy of *QST*?.....

..... Thanks!
SAY YOU SAW IT IN QST—IT IDENTIFIES YOU AND HELPS QST

An accurately calibrated 5 meter wavemeter

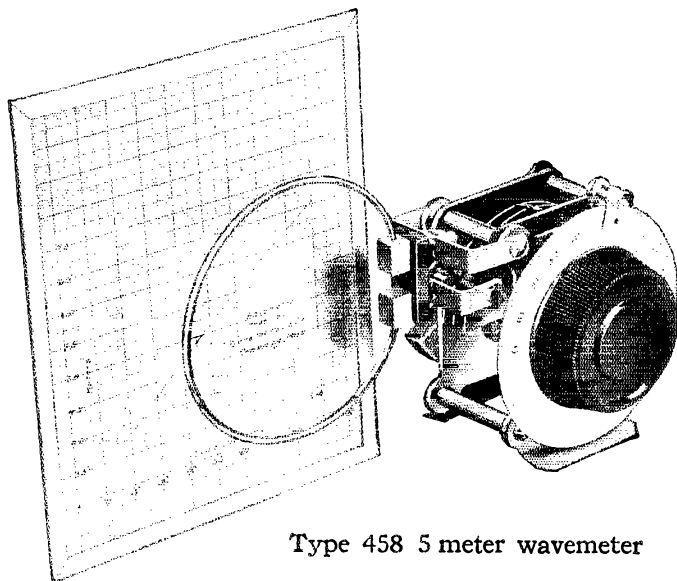

Type 458 5 meter wavemeter

The recent developments in transmission at 5 meters (60,000 k.c.) have made it imperative to use an accurate wavemeter.

The Type 458 wavemeter is supplied unmounted, having only brackets to support the condenser in an upright position. The condenser is of the usual soldered plate, metal end plate type, having a maximum capacitance of 50 MMF.

The coil consists of a single turn of 1/8" copper tubing, and is connected to the condenser by means of the convenient General Radio plugs. The coil is silver plated.

A four inch dial and indicator completes the wavemeter. It is found that the metal end plates so completely shield the condenser that hand capacity is not at all troublesome.

An individual calibration chart is supplied with each Type 458 Wavemeter.

Price, complete with calibration chart\$8.00

The Type 458 5-meter wavemeter as described above is obtainable from the General Radio factory only upon receipt of \$8.00 net, delivered post paid anywhere in the United States.

GENERAL RADIO CO.,

CAMBRIDGE, MASS.

GENERAL RADIO

A. R. R. L. MEMBERS ATTENTION!

You are not all located within shopping distance of a dealer stocking General Radio parts. Remember that we will deliver, post paid, anywhere in the United States, any of our radio parts on receipt of current catalog price.

Also if we can be of help to you in supplying technical information, we will welcome your correspondence. Have you a Bulletin No. 927 in your file? If not, a post card will bring it.

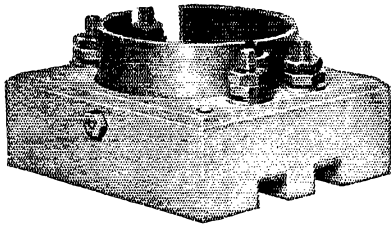

50 Watt Lowloss Socket

Maple treated base with brass airgap shell and heavy phosphor bronze springs. For UV 303A UV 217 and similar tubes. Price \$1.25

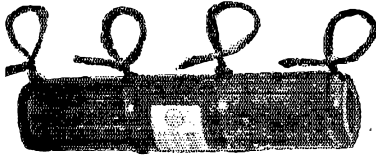

15,000 ohm Gridleak

Tapped at 5,000 and 10,000 ohms with 85 watt capacity. Price \$1.50.

5,000 ohm 85 watts	\$1.00
5,000 ohm W. L.	.75
10,000 ohm 150 watt.	1.50

UX210 TRANSFORMERS FILTER CHOKES

200 Watt Size—Plate winding for full wave rectification, supplying 1100 volts with center tap at 550 volts. Has two 7.5 volt filament windings for UX210 and UX216 B tubes. Price \$12.50

100 Watt Size—Plate winding for half wave rectification supplying 750 volts. With 100 henry choke system gives smooth RAC note. Has two 7.5 volt filament windings for UX210 and UX216 B tubes. Price \$9.50

50 henry 100 milliampere filter choke	\$5.50
100 henry 50 milliampere filter choke	\$5.00

UTILITY RADIO CO.

80 LESLIE STREET EAST ORANGE, N. J.



For the Raytheon BA 350 MA Tube

Better reception, with all batteries eliminated, now a fact with Raytheon's new BA 350 MA Tube, Dongan Transformer No. 3591 and Double Choke No. 3584.

Raytheon BA 350
MA Tube
\$7.50

Dongan No. 3591
Transformer
\$15.00

Dongan No. 3584
Double Choke
\$15.00

*Modernize your set. Im-
mediate delivery upon
receipt of check or money-
order.*

Dongan Electric Manufacturing Co.
2999-3001 Franklin St., Detroit, Mich.

TRANSFORMERS OF MERIT for FIFTEEN YEARS

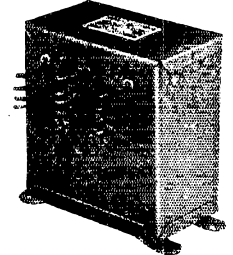
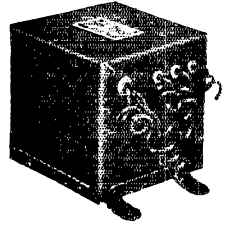

SET BUILDERS and SET OWNERS

WE Can Save You From 10 to 50 Percent
on all Standard National Parts and Accessories.

Send for Our Bulletin on Radio Parts;

ASSOCIATED SET BUILDERS
228 JELLIFF AVENUE NEWARK, N. J.

WANTED!

The business of "BAMPS" who are tired of so called "Bargains" and "GYN" apparatus. We carry only Standard Parts that have proven their worth. We can furnish all parts for a complete station that you will be proud to own. Send for catalog. Authorized Dealers for Carlwell, Amertran, etc.

AMATEUR SUPPLY CO.

44 Whittier Street, Rahway, N. J.

Make any Good Receiver
BETTER

**CC
TUBES**

C. E. Mfg. Co., Inc.
PROVIDENCE,
R. I.



Learn the Code at HOME This EASY Way COMPLETE course in Morse or Continental With the **TELEPLEX**

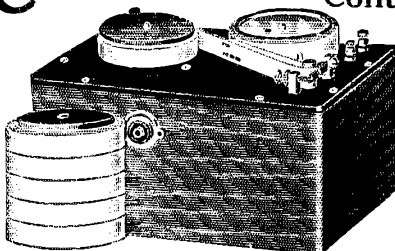

The only instrument that REPRODUCES actual sending of expert operators. Sends five times as many words with one roll of tape as any other instrument, and \$1.00 each. Extra rolls of tape from our unlimited stock, \$1.00 each. Special rolls of 450 words made to your order \$2.00. Not merely short, simple words—but exact messages, radio-grams, newspaper matter, etc. used in actual work. About fifty per cent. easier and figures that cannot be memorized. Teaches Morse or Continental in half the time. Positively improves ability of the best operators. Now in general use throughout the country. Users marvel at its sending. With or without key and sounder, or buzzer. Nothing else to buy. You miss the thrill of radio, unless you know the code. Write TODAY for particulars of this amazing instrument. A post card will do. DEALERS EVERYWHERE! Write for proposition.

TELEPLEX CO., 76 Cortlandt St., New York



Jewell Instruments Give Satisfaction

When you select Jewell Instruments for your transmitter or receiver your instrument problem is solved. Most amateurs use Jewell Instruments and they give unlimited satisfaction. They are properly designed and ruggedly constructed of best obtainable materials insuring high overload capacity with sustained accuracy.

Write for a copy of our radio instrument catalog No. 15-C which describes our instruments in detail.

Jewell Electrical Instrument Co.

1650 WALNUT ST., - - CHICAGO

"27 YEARS MAKING GOOD INSTRUMENTS"

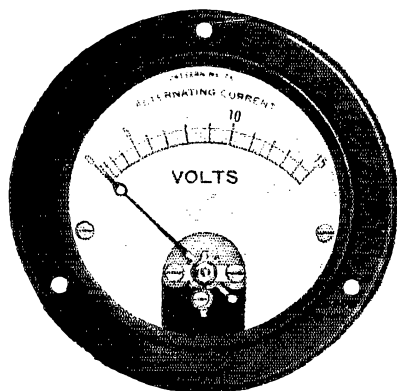

Pattern No. 74 Alternating Current Voltmeter is the standard of the amateur fraternity for controlling power tubes and is available in several ranges adaptable to your requirements. It is one of the famous Jewell trio of instruments for amateurs.

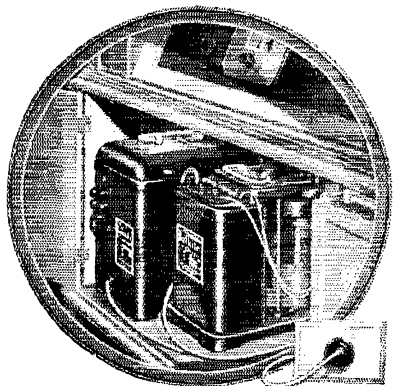

Now make your radio set a light socket receiver with Balkite "B" and the new Balkite Trickle and High-Rate Charger

Ask your radio dealer

FANSTEEL PRODUCTS CO., INC.
North Chicago, Ill.

New "Ham" Inductances

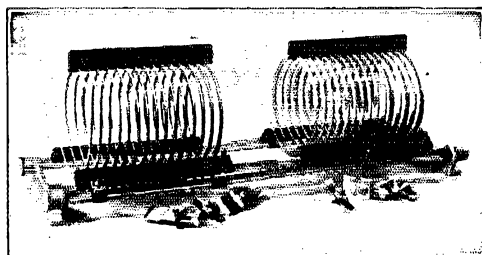

Designed to give peak efficiency on amateur wavelengths. Single coils and coupled types, with glass rods and end castings.

	Single Coil	Coupled Unit
Type 154 for 40-80-160 meters	\$5.50	\$12.50
Type 123 for 20-40-80 meters	\$4.75	\$11.00
Inductance clips EXTRA, each \$0.20	



Cut 1-2 Size

New Stand-off Insulators

Our own product, insulation equivalent to other similar types, but requiring much less mounting space. Brown glazed porcelain. Each \$0.20.

E. F. Johnson Co.
Waseca, Minnesota

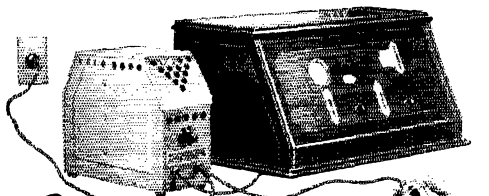

No batteries

Run this radio direct from house current outlet. Ordinary 110 volt 60 cycle domestic electricity transformed mechanically into smooth, quiet radio A, B and C power, as you use it. No more batteries to fuss with! No trickle chargers! Price \$50.00

Crosley receivers designed for use with this marvelous power supply, are the AC-7 (pictured above) a 6 tube table model at \$70 and the AC-7-C, a 6 tube console at \$95.00.

Write Dept. 18 for descriptive literature.

THE CROSLEY RADIO CORPORATION
Powel Crosley, Jr., Pres. Cincinnati, Ohio

**CROSLEY
RADIO**

Crosley manufactures radio receiving sets, which are licensed under Armstrong U. S. Patent, No. 1,113,149 or under patent applications of Radio Frequency Laboratories, Inc., and other patents issued and pending. Prices slightly higher west of the Rocky Mountains.



The
A.R.R.L.
Auto
Emblem

Spring is here! Decorate that new car—or the old one for that matter.

Will other hams know you when they meet you on the road this summer? Show 'em you're proud to be a ham. 5 x 2 1/2", heavily enameled in gold and black on sheet metal, holes top and bottom, 50c each, postpaid.

A. R. R. L. Members -- What about your friends?

You must have a friend or two who ought to be members of our A.R.R.L., but aren't. Will you give us their names, so that we may write to them and tell them about the League and bring them in with the rest of us? The A.R.R.L. needs every eligible radio enthusiast within its ranks, and you will be doing your part to help bring this about by recommending some friends to us. Many thanks.

American Radio Relay League,
Hartford, Conn.

.....1927

I wish to propose

Mr. of

Mr. of
Street & No. Place State

for membership in the A.R.R.L. I believe they would make good members. Please tell them the story.

.....
.....

THE SUPER SYNC

The Synchronous Rectifier That Can Be Filtered

When properly filtered the Super delivers a direct current which is often mistaken for battery plate supply. The Super will handle as high as 4000 volts giving practically full wave rectification.

The brushes on the Super are mounted in pairs ninety degrees apart and serve to conduct the current. These brushes run

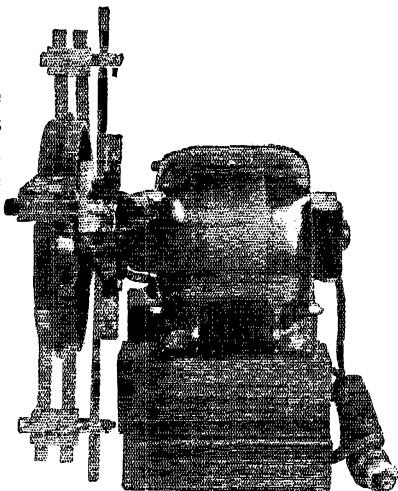

on a smooth surface the entire circumference of the commutator thus assuring a clean, smooth, contact.

The commutator is eight inches in diameter and is turned at a synchronous speed by a 1/4 H. P. synchronous motor.

On installing the Super you will find that it will increase the efficiency of the entire transmitter.

PAT. PENDING
PRICE \$75.00 F.O.B. ST. LOUIS, MO.

MARLO ELECTRIC CO., 5241 Botanical Ave., St. Louis, Mo., U.S.A.

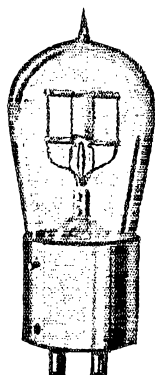

Navy Type CG-1162 5 WATTS PLIOTRONS

(MFD BY GENERAL ELECTRIC CO.) NEW, IN ORIGINAL CARTONS

Filament Voltage 7 1/2 Volts. Filament Current 1 3/4 Amps. Safe Plate Voltage 550 Volts. Plate Current 40 Milli-amps.

Also Used as Power Amplifying Tube.

ONLY \$1.00 EACH

UNITRON 2 1/2 AMPERE CHARGERS

With genuine Westinghouse Rectigon Bulb,

Reg. \$18.00
Our Price

\$8.95

6 AMP. \$12.95

ALL BRAND NEW
GUARANTEED

TUBES

Western Electric	
V. T-1	\$1.95
V. T-2	\$5.65
102-D—	
High Mu-40	\$5.50
Type UX201-A	.39
Type UX200-A	.49
Type UX112	.49
Type UX171	.49
Type UX213	\$1.75
Type UX216-B	1.29
Type UX210	2.95
B-Eliminator Rectifier — 80 Mils. \$1.00	
No order for these tubes under \$2.00 shipped.	

SELLING LIKE WILD FIRE TRANSMITTING FILTER CONDENSERS

2000 Volt
Guaranteed

Sold on a Money
Back Basis

1MFD	\$2.39
2 "	\$2.99
4 "	\$4.99

Roller Smith 0-1 Amp., \$3.95; 0-4 or 0-5 Amps., \$2.95; 0-250 Milli-ammeter, \$4.49; Weston Meters 0-150 volts, \$5.95. Learn-the-Code with one of our Code Practise Sets. Buzzer and Key mounted on mahogany baseboard, all wired ready to use. Reg. \$10.00; only, \$2.39.
Garod Pyrex low loss sockets for short wave transmitting tubes up to 7 1/2 watts49c

No C.O.D.—No Parcel Post Shipments. Send in your name for our Ham List. No Stamps. Send Certified Check, or Express or Money Order. References—Dun or Bradstreet, Federal Trust Co, Newark, N. J.

THE NEW JERSEY RADIO SUPPLY COMPANY
76 SPRINGFIELD AVE. NEWARK, N. J.

Dubilier 10-Mfd.—Tapped
400 Working Volt Filter
Condensers.
Only \$3.95

Why is the Karas Equamatic the most efficient receiver ever designed? Write us for full information.

KARAS ELECTRIC CO.,
1031 Association Bldg., CHICAGO

Wanted Your Old Western
Electric VT-1 or VT-2 Tubes

Will pay ten cents apiece
for every one you send,

2EK, 89 LEHIGH AVE., NEWARK, N. J.

HAM-ADS NOTICE

This department of *QST* is conducted as a service to members of the American Radio Relay League. Advertisements can be accepted only under the following conditions:

- (1) "Ham Ad" advertising will be accepted only from members of the American Radio Relay League.
- (2) The signature of the advertisement must be the name of the individual member or his officially assigned call.
- (3) Only one advertisement from an individual can be accepted for any issue of *QST*, and the advertisement must not exceed 100 words.
- (4) Advertising shall be of a nature of interest to radio amateurs or experimenters in their pursuit of the art.
- (5) No display of any character will be accepted, nor can any typographical arrangement, such as all or part capital letters, be used which would tend to make one advertisement stand out from the others.
- (6) The "Ham Ad" rate is 7c per word. Remittance for full amount must accompany copy.
- (7) Closing date: the 25th of second month preceding publication date.

THE life blood of your set—plate power. Powerful, permanent, infinitely superior to dry cells, lead-acid, Bs, B eliminators. Trouble-free, rugged, abuse proof, that's an Edison Steel-Alkaline Storage, B-Battery. Upset electrically welded pure nickel connectors insure absolute quiet. Lithium-Potassium solution (that's no lye). Complete, knock-down kits, parts, chargers. Glass tubes, shock-proof jars, peppy elements, pure nickel, anything you need. No. 12 solid copper enameled permanently perfect aerial wire \$1.00, 100 ft. Silicon steel laminations for that transformer 15c lb. Details, full price list. Frank Murphy, Radio 8ML, 4837 Rockwood Rd., Cleveland, Ohio.

25% to 35% discount to amateurs on receiving parts, no sets. Our weekly data sheets give you more dope than all the radio magazines together. 20 weeks' trial \$1.00, 52 weeks \$2.50. Over two pounds data, circuits, catalog, prepaid 25c. Fred Luther Kline, Kent, Ohio.

PURE aluminum and lead rectifier elements holes drilled brass screws and nuts, pair 1/16", 1 3/4" 13c, 1"x6" 15c 1 1/2"x6" 17c, 1 1/2"x8" 19c. Sheet aluminum 1/16" \$1.00 lead \$1.00 square foot all prepaid. Silicon transformer steel cut to order .014" 10 lb. 25c, 5 lb. 30c, less than 5 lb. 35c per lb., .022" thick 5c less per lb. Postage extra. Edgewise wound copper ribbon, 7 sizes, see Jan. *QST* 1/2" square copper wire better than copper tubing 50c lb. Postage extra. Air pocket insulators blue glazed porcelain 8" leakage path fine for transmitting, 4 for \$1.00 prepaid. Geo. Schulz, Calumet, Michigan.

THE Ensall radio laboratory six tube short wave receiver. Range 15 to 270 Meters. Operates on Loop Antenna. Excellent for summer reception with unusual DX. List price of inductances with circuit drawing, \$18.50. Parts list on request. Wiring charge on request. This popular receiver now being used by many amateur stations. We also are distributors for practically every make of radio apparatus. Build, also transmitters, receivers, wavemeters, inductances, etc. We employ your parts in any apparatus if desired. Quotations on request. Thos Ensall, (8BDN) 1208 Grandview Ave., Warren, Ohio.

I am not selling out. But I have a lot of stuff I don't need and want to sell. Write for list. 5ASU, Box 205, Montgomery, Ala.

STILL selling genuine brand new RCA 5 watters, model UV-202, only \$2.30. Also 150 watt filament transformers for either 5 or 50 watters unmounted at only \$5.50 prepaid. 9CYN and 9GF, Mitchell, 3520 Sheridan Rd., Chicago, Ill.

QSL hams: Highest grade, neat and original cards. Reasonable. Samples on request. INQ, 130 Cornell St., Rosindale, Mass.

RWJ RHEOSTATS are almost entirely free of heating. Only when used at the maximum capacity of 150 watts is there more than a slight tendency of the coil to get warm. The coil is taped to provide required regulation to all types of tubes and transformers. Both Primary and Secondary rheostats now \$3.00 postpaid. Both types permit balanced center-tap. Table-mounting series only. E. E. Hare, 9BWJ, Paintsville, Ky.

TRADE: Mounted Advance Sync Rectifier with spec insulators 10,000 volts, for good omnigraph. 5C11 Kenotron Rectifier and filter. Model ET3620. 160 mils. 400 volts, without tubes, \$30. D. T. Fernandez, 4517 N. Paulina St., Chicago, Ill.

400 V. 100 W. Esco coupled to 220 V. 3 ph. A C motor, \$25.00; 1000 V. 300 Watt Esco motor 110 V. single phase, \$95.00; 2000 V. 1000 Watt Westinghouse double commutator, \$275.00; 2500 V. 2 kilowatt Generator double commutator, coupled to three phase 220 V. 1750 Speed motor, 2500 Volt 600W. double commutator generator coupled to 110 to 220 volt single phase motors 1750 speed. Also many others. Imitd Western Electric condensers 50c. New 1/4 H. P. 110 Volt 3500 speed. Robbins & Myers alternating current motors \$8.50. Prices f. o. b. Chicago. James J. Smat, 1734 Grand Av., Chicago, Ill.

SELL-trade-4 tube (12-425 meter) receiver. Large 12 volt A, 1350 volt B power supply unit. Write Clinton Fozz, Greensburg, Ind.

SELL transformer 1 1/2 K. V. A. 1b. for welding. E. C. Easton, 34 North 11th St., Newark, N. J.

CROCKER-Wheeler 2 1/2 1500 volt 450 watt dynamotors New \$45.00 some at \$40.00. 1/2 KW 500 cycle transformers, new, \$12.50. Crocker-Wheeler 500 cycle motor generators 1/2 to 5 KW. Complete Navy transmitters, 1/2, 1, to 5 KW. Also portable pack sets, motor, gasoline or manual driven. Advise your requirements. Small Sagamo Watthour meters Navy design for battery service, \$12.50 new. Keeps accurate record of charge and discharge. Navy Wavemeters, leather case, current squared meter, three interchangeable coils, range 125-2500 meters, \$45.00. SE 1012 50-1000 meters, used, \$35.00. Edison 6v 75 ampere batteries. Navy keys 3/16" silver contacts, blinker \$2.00. Henry Kienzle 501 East 84th Street, New York.

PERFECT reproductions, any write-up from any past issue of *QST* or any other radio magazine. I have 'em all from 1908 to date. Send red stamp for price on write-up you want, or send 20 cents for sample "Rotten Old Man" pre-war *QST* story. 6LM, Box 177, El Monte, Los Angeles, Calif.

MOTOR generator wanted about 2000 volt 1000 watt; also new 204A. Sell 1500 volt Jewel meter, new, \$20.00. Gordon Brown, 192 South Goodman St., Rochester, N. Y.

CARTOONS for your station walls, call cards, etc. What do you want? Write IANE, Gildersleeve, Conn.

DODGE Radio Shortcut fixes signals in mind to stick. Kills hesitation. Cultivates speed. Produces results. 9BNT Anderson: "Instead of being stung again as I thought when first looked at Shortcut glad to say by using same raised my receiving speed from eight to twenty per in three evenings—method FB." Quarter coupon and reports progress made by 200 users, all licensed, 25c. Specimen reports each district on request. Shortcut with Appendix and Better Key Work, \$3.50. U. S. and Canada, elsewhere \$4.00. Reg. mail. None C. O. D. Send money order. Check may delay. C. K. Dodge, Mamaroneck, N. Y.

700 WATT transformers 1000-1500 volts each side \$14.00. 250 watt 550-700 volts each side \$10.00. Or any voltage you want. Room for filament winding. 50 watter type 211D Western Electric tube used but in perfect condition \$12.00. 9CES, F. Greben, 1927 S. Peoria St., Chicago, Ill.

HAMS: Get our Samples and Prices on Printed Call Cards made to order as YOU want them. 9APY HINDS, 19 S. Wells St., Chicago, Ill.

SELL—Bunnell Gold Bug \$8. cootie \$3. *QST* August 1920 to December 1926 \$15. FOR. H. Friend, Thornton High School, Calumet City, Illinois.

Two bits each and postage offered for *QST*s Jan., Feb., Mar., July, Aug., Sept., Oct., Nov., Dec., 1921. Jan., Mar., June, July, Sept., Oct., Nov., 1922. July, Aug., 1923. June, July, Aug., Oct. 1924. June, 1925 whoa: SLO, Box 162, Sta. B., Toledo, O.

FOR Sale—Long wave receiver with honeycombs; short wave receiver; low power transmitter; also accessories. Write for prices. J. H. Champlin, Maple Ave., Westley, R. I.

FOR sale—Xtal controlled xmitter with two Xtals, transformers, rectifier, filter, three UX210 tubes, meters, separate cabinets and brass panels for master and frequency doubler. Beautiful in appearance and works splendidly. Write 3AA1 for complete dope. John S. Arnold, Alexandria, Virginia.

SLEEPER serenaders 1927 model, cost \$125.00 for \$75.00 and Ops tables for a good looking shack, hard wood tops, mahogany stain legs and aprons, size 36x72; a good buy for \$15.50, direct from our factory. Need any kind of shack or home furniture OM? I've got it and the prices can't be beat. Ham dealer—Bill Ryder, Jr., Hibbing, Minnesota.

"COMPLETE" 100 watt transmitter with new tubes, motor-generator, four meters, etc. Also transceiver

in cabinet. These are bargains, also various other material. Write for list, and description of sets. ex-4MV, Charles T. Wycoff, Manchester, Okla."

FOR sale—parts for 500 cell Edison B battery, \$30.00. All inquiries answered. 2ADX, E. A. Turner, 4 Grosvenor Sq., Schenectady, N. Y.

EMERSON motor generator set. 200 watt, 500 volt full load. \$25.00. Fred Downing, Deepwater, Mo.

OMNIGRAPHs, Vibroplexes. Transmitters, Chokes, Meters, Transformers, 50 watters, 210s. "S" tubes, motor generators. CR18s, "H" tubes, Receivers, Sync Rectifiers, Natrometers, Wavemeters—bought, sold, exchanged. L. J. Ryan, 9CNS, Hannibal, Mo.

FOR sale. Some Meyer tubes. Cartridge-fuse type, never used. \$1.10 each. 2PH.

30H, 85MA, 250 ohm chokes \$2.75 postpaid. Write for list of "B" eliminator material. Will estimate on kits to build any outfit. Leitch, Park Drive, West Orange, N. J.

MUST sell immediately. Grebe CR8 and Kennedy Universal with amplifier. Make me an offer. 8DKE.

FOR sale. 2 Kellogg broadcasting microphones, new condition, \$55 each. Harold Dewing, St. Nicholas Hotel, Springfield, Illinois.

TRADE: 0-500 voltmeter for No. 54 0-150 0-6 volts meters 0-10 milliammeter. Schindler, 116 Rebecca, Scranton, Penn.

QSL cards, two colors, government post cards \$1.90 per hundred, white cards \$1.00, postage 10c. Free samples. SDTY, 257 Parker Ave., Buffalo, N. Y.

ALL Postpaid. R.E.L. Transmitting Inductances, double \$8.90; Single, \$4.85 R.E.L. mountings for "H" tubes, \$1.89. R.E.L. 50 watt sockets, \$1.89. R.E.L. Short Wave Receiving Coil Kits, \$3.75. R.E.L. Radio Frequency Chokes, \$1.00. Sangamo Filter Condensers, working voltage 1000 guaranteed, 4 mfd., \$3.65; 2 mfd., \$2.15. Allen Bradley "Radiostats," the big primary rheostats, \$6.29. Allen-Bradley "Radioleaks," 2000-30,000 ohm variable transmitting grid leaks, \$4.89. See my "Ham ads" in April and May "QST." Note new address, 3BMS, G. F. Hall, 535 West Horter St., Philadelphia, Pa.

WANTED: Used 208s or 203As. Elmer Gunther, Ft. Dodge, Iowa.

SELLING out. Write for list. Arthur Giesler, 212 F Street, LaPorte, Indiana.

ESCO 100 watt M. G. 110v D. C. motor. Sacrifice, \$20. IALN, 3 Milford St., Boston, Mass.

FILTER apparatus special this month. Chokes, condensers, and all types of transformers and transmitting apparatus at big discounts. 30 henry, 50 milliampere eliminator choke \$1.75. 2APJ, 643-5 West 171st Street, New York City.

YOU need our famous "Hamalog," the original ham catalog. A new supplement is now ready. Hams all tell us it's the best they ever saw. Big variety of the very best of transmitting and receiving apparatus. New inductances, as described elsewhere in this issue; all DeForest transmitting tubes—send us your order for immediate shipment; classy new condensers; Ward-Leonard grid leaks; for all tubes; Latest Citizen's Ham Call Book, 75 cents; A.R.R.L. Radio Amateurs Handbook \$1.00; New UX-852 75 watt short wave Radiotron in stock \$32.50. Don't forget to get that "Hamalog." E. F. Johnson, 9ADD, Waesca, Minnesota.

COMPLETE 250-watt 20-40 meter Transmitter: UV-204A tube; Jewell Meters; Cardwell Condensers, Thordarson Transformers; mounted; KFUH Circuit. Price Complete \$125.00. Price Griffith, 1109 Eighth Avenue, Forth Worth, Texas.

HEADQUARTERS for Hams—Immediate deliveries on Mueller 150-watt input tubes \$15.00. RCA 5-watters \$3.15. Tobe 5-mfd 2000-volt Condensers \$13.75. Aerovox 1-mfd 1500-volt Condensers \$1.75. Potter 2030-volt 1-mfd Condensers \$2.50; 1-mfd 2500-volt \$3.25. 15-Dial Omnigraph \$25.00. "Ham List" 4c. Romanyel Curtis, 1109 Eighth Avenue, Forth Worth, Texas.

CURTIS-Griffith 250-watt power-filament transformers 350-550 each side \$12.50. Thordarson power-filament transformers for 7.5-watters \$6.90. Thordarson power transformers 350-550 each side \$11.00; 1000-1500 each side \$16.00. Edgewood Inductance 6-inch, turn 12c; 4-inch, turn 10c. Aluminum square foot 85c; lead square foot 85c. Curtis-Griffith 30-henry 150-milliampere chokes \$12.00. National 23-plate 3000 volt transmitting condensers \$9.50. "Ham-List" 4c. James Radio Curtis, 5-A-Q-C, 1109 Eighth Avenue, Forth Worth, Texas.

SAY YOU SAW IT IN Q S T—IT IDENTIFIES YOU AND HELPS Q S T

PUREST virgin aluminum for chemical rectifiers, "R" eliminators, etc., mounting pillars for tuned plate-tuned grid transmitting circuit. Send for descriptive circulars. 2EM.

MUST sell transmitting and receiving apparatus at a sacrifice to go to school. What do you want? Leonard Kammeyer, 714 East Fourth St., Waterloo, Iowa.

FOR sale: Emerson motor generator (Benwood), rebuilt and belted giving 750 volts D. C. Complete with high voltage meter for sixty bucks. Also slightly used H tube, twelve bucks. R. E. Turner, 6TN, 1101 West 29th St., Los Angeles, California.

SELL complete transmitter or parts separately. RCA, Jewell, Acme, etc. Used less than five hours. Send for list. W. M. Hansen, Niles, Mich.

SPECIALS: Oscillation transformers for Hartley 20, 40, 80 meter bands, \$7.00; wavemeters for 15-210 meters, calibrated and graphed, \$10.00; B eliminators, \$18.00; short wave receivers, \$20.00. Stamp brings bargain list. Wanted: R. C. A. power unit ET3620 complete with tubes. Must be first class condition and cheap for cash. State full particulars. Roger Curran, Dundee, N. Y.

PILOT 17 plate condensers .75. REL coil kits \$3.83. C. O. D. SRNB, Waterville, Ohio.

JEWELL Meters, new, 25% discount. We stock Acme, Thordarson, National, Cardwell, General, Radio, Nathaniel Baldwin, Crescent Lavite, Lynch, Tobe Deutschmann, R. E. L., Allen Bradley, Yaxley, Philco, Signal, Bakelite, Samson, Raytheon, CeCo, Pyrex, R. C. A., Grimes RGS, Browning-Drake, Fleron, Branston, All-American, Ferranti, Aero Products, Acme Wire Products, Ward Leonard, Westinghouse, Eby, Victorcen, Lincoln, Precise, Hammarlund, and many others. We allow discounts to Hams, custom set builders and dealers only. Tell us what you want. A complete line of Ham and RCL apparatus. Specializing in the best parts only. No junk. Roy C. Stage, Wholesale Radio, Montgomery & Burt Sts., Syracuse, N. Y.

SET builders! Electrad Royalty variable resistances, 20 MA capacity, 0-10000 ohms, 60c. Well made 600 volt mica Bakelite fixed condensers .00025, 10c, .002, 15c .006, 20c. Radio 1NZ, 25 Sterling Rd., Waltham, Mass.

QRQ fluid makes glass drilling easier than brass. Year's supply \$1.00. Glass Panels drilled to order. 9BNR, Sorrento, Ill.

EVERYTHING for the ham: 1/16" sheet lead and aluminum \$1.00 per sq. ft. No. 12 "Dyrex" solid copper enameled wire, 1c ft. No. 10 "Dyrex" solid copper enameled wire 1 1/4c ft. A full stock of Acme and Thordarson transformers and choke coils, Jewell meters and all the rest of the stuff to make that short wave transmitter or receiver. Send for catalogue. "Dyrex for DX." E. J. Nicholson, SBIN, 1407 First North St., Syracuse, N. Y.

GENERATORS, new 275 volt d. c. will give up to 500 volts at 120 watts, \$5. 6 volt input dynamos output 400 at 200 watts, \$15. 1/2 kw and 1 kw 500 cycle motor generators 120 volts d. c. drive. Slightly used 500 cycle generators 200 watt \$10. 1/2 kw \$15. 200 watt 900 cycle \$10. 500 cycle large meters volt, watt, frequency and ammeters. Microphones \$1. 5000 ohm gridleaks 75c. Receivers CN113. 300 to 2500 meters \$12. Western Electric VT ones \$1.25. VT twos 3.00. Postage extra. R. Wood, 46-20 102 St., Corona, N. Y.

ACME 1/2 H chokes .5 amp \$4.50. Acme grid coils \$1.00. G. E. UP415 plate rejectors 2.00. Splitdorf phone condensers 10c W. E. 3A choke \$3.00. 400 volt Escro m. g. set 2 hearing \$27.00. Metal battery boxes \$1.50. Push button switches 15c. Magnavox 2 stage amplifier \$6.00. Kennedy speaker \$6.00. Marconi changeover switch, magnetic \$7.50. Lightning knife switch 50c. G. E. crystal tuner \$2.00. Condensers UC1803 95c. Acme 1 1/2 henry choke, dble, \$4.50. Magnetic modulator UT1367 \$5.00. 24" mahogany cabinets \$1.25. Silicon Steel laminations 20c lb. Send check \$5.00 will ship assorted parts. Must clean out. H. G. Pearce, 6DDO, 603 West 57th St., Los Angeles, Calif.

"POWER transformers—for 7.5 watters, Filament, 7.5V., Plate, 600V., center-tapped, \$5.75. For fifties, Filament, 15V., Plate, 1100V., center-tapped, \$8.00. Milliameters, 0-100, \$2.00. Rectifier Elements, Aluminum, Lead, pair, 1"x4", 7c; 1"x6", 10c. Wavemeters, calibrated, 15-170 Meters, Complete, \$4.00. QSL cards, \$1 per 100, highest quality, free samples. Orders filled immediately. Terms, C. O. D. or cash. Complete Radio Catalogue upon request. William Green, 207 Cathedral Parkway, NYC."

Q R A SECTION

50c straight with copy in following address form only:
CALL—NAME—ADDRESS.

- 1KH—George W. Bailey, Webster Road, Weston, Mass.
 - 1LC—Herman Sanborn, Beacon St., Shrewsbury, Mass.
 - 1LX—Randolph B. Reed, 298 Westford Street, Lowell, Mass.
 - 1ZK-1BWD—M. L. MacAdam, 274 S. Central Ave., Woblaston, Mass.
 - 3KP—4828 N. W. 16th St., Washington, D. C.
 - 3NN—Robert R. Achey, Quakertown, Penn.
 - 4DP—4828 N. W. 16th St., Washington, D. C.
 - 4ES—455 N. E. 28th St., Miami, Fla.
 - 4GY—R. R. Brewin, 1458 S. Gordon St., S. W., Atlanta, Ga.
 - 4NQ and Army Radio WUD, 1st op Otis T. Allen (AL) 2nd op A. W. Chambers (CW) Radio Station, Fort Benning, Georgia.
 - 4VB—Paul H. Merriman, Monteagle, Tenn.
 - 5KR—Vir N. James, 105 Carolina St., San Antonio, Texas.
 - 5JT—H. F. Page, 1401 Seventh St., New Orleans, La.
 - 6JIG—Joe A. Bowers, Box 37, El Centro, California.
 - 6SM—A. E. Ekdale (AE) and C. W. Seamans (CS), 159 S. El Molino Ave., Pasadena, Calif.
 - 7OK—S. W. Norman, R. F. D. No. 11, Box 267, Seattle, Washington.
 - 8DEF—Geo. M. Benas, 1801 Genesee St., Utica, N. Y.
 - 9AEU—Francis Walton, Browning, Illinois.
 - 9AHK—Leo A. Gizynski, 1803 S. 59th Ave., Cicero, Ill.
 - 9DEF—A. Maitland, Jr., 204 Walsig Bldg., Kansas City, Mo.
 - oa-2RX—Henry Olive St. John, 82 Gibbes St., Rockdale, New South Wales, Australia.
 - BD-8—Sgt. MacAdam, State Armory, Quincy, Mass.
 - eb4YZ—Andre Courtois, Hodimont-Verviers, Belgium.
- The following stations belong to members of the A.R.R.L. Headquarters gang. Mail for them should be addressed care A.R.R.L., Hartford, Conn. When operating 1MK they use personal signs as indicated.
- 1MK Headquarters IES A. A. Hebert "ah"
 - 1AL H. P. Westman "ws" IGO L. A. Jones "lj"
 - 1BAO R. S. Kruse "iq" 1KP L. NRRR F. Cheyney
 - 1BDI F. E. Handy "fh" Beekley "beek"
 - 1BHW K. B. Warner "kb" IOA R. S. Kruse "iq"
 - 1BUD A. L. Budlong "bud" ISZ C. C. Rodimon "er"

Model "N"
Vario Denser

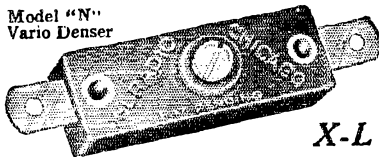

**Pep Up
Your Set
with
X-L Products**

Tune quickly—adjust accurately—eliminate distracting noises—get correct tube oscillation—with X-L VARIO DENSERS in your circuit.
Designers of all latest and best circuits specify and endorse.

MODEL "M"—Capacity range 1.8 to 20 micro-micro Farads. Micrometer adjustment assures correct oscillation control in all tuned radio frequency circuits. Neutrodyne, Roberts 2-tube, Browning-Drake, Silver's Knockout, Interflex Circuit, Quadtransformer, World's Record Super-9, B. T. Power-6, R. B. Lab. Circuit, etc.

Price \$1.00.

MODEL "G"—For Cackaday, Oliver Lodge X-Lifting White, Nookin Ultra-5 circuits. Filter and intermediate frequency tuning in super-heterodyne and positive grid bias in all sets. Capacity range, Model G-1 .0002 to .0001 Mfd. Model G-5 .0001 to .0005 Mfd. Model G-10 .0003 to .001 Mfd. Price each with grid leak clips \$1.50.

X-L PUSH POST—Push it down with your thumb, insert wire, remove pressure, wire is firmly held. Vibrations will not loosen, releases instantly. Price 15c.

Also in strips of 7 on black panel marked in white. Price \$1.50.

FREE wiring diagrams showing use of X-L units in the new **LIFTIN-WHITE** constant coupled radio frequency circuit, and in other popular hook-ups. Send for yours today.

X-L RADIO LABORATORIES, 2428 N. Lincoln Ave., CHICAGO, ILL.

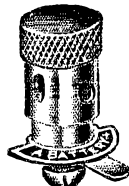

**X-L PUSH
POST**

FOR YOUR CONVENIENCE QST'S INDEX OF ADVERTISERS IN THIS ISSUE

Acme Wire Company	72
Aero Products, Inc.	79
Aerovox Wireless Corp.	85
Amateur Supply Co.	88
American Sales Co.	86
American Transformer Co.	2
A.R.R.L. Application Blank	86
A.R.R.L. Emblems	90
A.R.R.L. Handbook	3rd cover
A.R.R.L. Recommendation Blank	90
Associated Set Builders	88
Auriema, Inc., Ad.	71
Browning-Drake Corp.	74
Burgess Battery Company	4th cover
Hurton-Rogers Company	78
Capitol Radio Engineering Co.	78
Cariwell Mfg. Corp., Allen D.	81
Carter Radio Co.	74
C. E. Mfg. Company	88
Central Radio Labs.	80
Cesradio Corp.	84
Crosley Radio Corp.	90
Cumminsham, Inc., E. T.	2nd cover
Deutschmann Company, Tobe	80
Dongan Electric Mfg. Co.	88
Dudlo Mfg. Corp.	75
Eastern Radio Institute	71
Electric Specialty Co.	82
Electro Mfg. Company	80
Elkon Works, Inc.	95
Fansteel Products Co.	89
Frost, Inc., Herbert H.	76
General Radio Company	87
Grebe & Co., A. H.	4
Grishy-Grinow-Hinds Co.	82
Gross & Co., J.	93
Gulf Radio School	86
Hammarlund Mfg. Company	71
Helicon Radio Condenser Corp.	82
Jacobs, Chas. E.	84
Jewell Elec. Inst. Corp.	89
Johnson Co., E. E.	39
Karas Electric Co.	71
Kokomo Electric Co.	76
Long's Radio Shop	85
Marlo Electric Co.	91
National Company, Inc.	71
New Jersey Radio Supply Co.	71, 91
Parent Electric Co.	86
Parinater Products Co.	84
Radio Engineering Labs.	77
Scientific Radio Service	84
Smith, R. Hawley	78
Sterling Mfg. Company	84
Stromberg-Carlson Tel. Mfg. Co.	96
Teleplex Company	88
Thordarson Elec. Mfg. Co.	83
U. S. Naval Institute	71
Utility Radio Co.	88
Vibroplex Company	72
Ward Leonard Elec. Co.	78
Western Electrical Instrument Corp.	72
Wireless Specialty Apparatus Co.	1
X-L Radio Labs.	94
Taxley Mfg. Co.	76
ZEK	91
ZMA	82

REG. U.S. PAT. OFF.

THE **ELKON**

PRINCIPLE of RECTIFICATION

The Elkon rectifier, invented and developed by Samuei Ruben and the Elkon Works, Inc. is the first to make current rectification possible by means of a "BONE DRY" rectifying medium constructed entirely of **SOLID, IMMOVABLE, NON-FRAGILE** materials.

Now on the market for more than a year, doing duty in thousands of homes in the **ELKON TRICKLE CHARGER**, this rectifier, in actual use, has more than lived up to the expectations of those who conceived and developed it.

It has made possible, for the first time, rectification without **ACIDS, ALKALIS, TUBES, or MOVING PARTS.**

It is economical. It operates noiselessly. It does not cause interference. Short circuiting cannot harm it. It functions equally well in any position and under any extreme of climate.

Now in use in the Elkon Trickle Charger, the Elkon 3 Ampere Charger, and the Elkon "A" Power it is fast supplanting the old methods of current rectification.

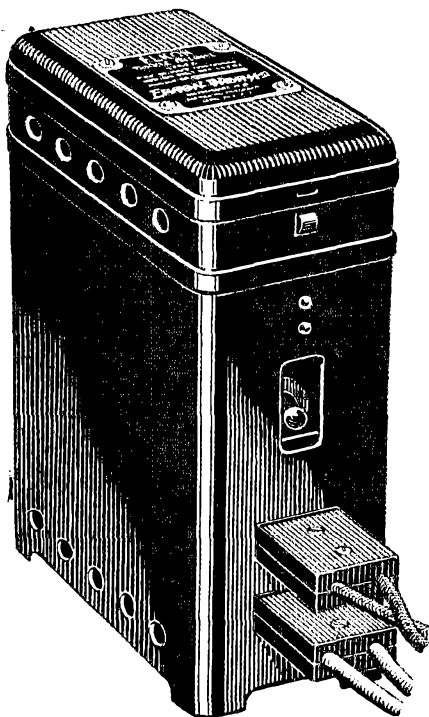

The Elkon Trickle Charger in which the Elkon Rectification principle was first made available to the public Jan. 1, 1926.

ELKON WORKS
Subsidiary of P. R. Mallory & Co. Inc.
Weehawken, N. J. Inc.

No. 501 Receiver, Treasure Chest. 5-tube; coils shielded; equipped with voltmeter; solid mahogany.

East of Rockies \$180
 Rockies and West \$192.50
 Canada \$225
 Without Accessories

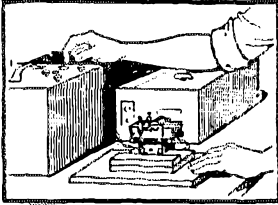
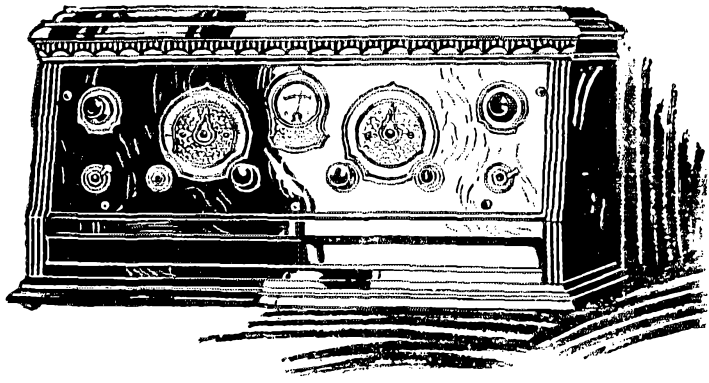

Test of Condensers for Electrical Characteristics

Permits synchronizing three condensers of like capacity on one shaft. Result—clear selectivity and pure tone quality.

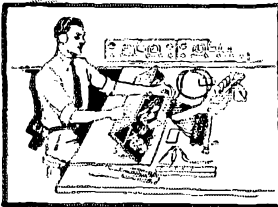

Test Against Oscillation

Adjustment completely neutralizes Receiver. Result—stability at all points on the dial and absence of the distortion which always accompanies radiation.

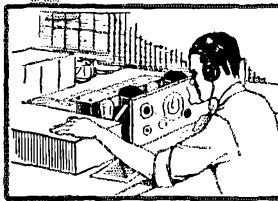

Test for Reception Over Complete Wave Band.

Individual calibration charts are prepared for each Receiver, indicating where every station may be received. Result—uniformity of tuning from 200 to 550 meters.

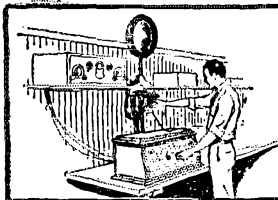

Final Test for General Efficiency.

The performance of each Receiver is checked against that of a laboratory model. Result—the unsurpassed Stromberg-Carlson tonal quality volume and musical range in every Receiver.

Major Tests

Which Insure Stromberg-Carlson Permanence of Value

The Stromberg-Carlson definition of "permanence of value" includes permanence of performance—obtained through the selection of high grade parts, the scientific matching and adjustment of those parts and the most rigid inspection of the results they give in every Stromberg-Carlson Receiver.

This comforting assurance of dependability is as valuable to the Stromberg-Carlson purchaser as is the knowledge that Stromberg-Carlson guarantees not to reduce prices—a policy which first gave meaning to the phrase "permanence of value in radio".

The Stromberg-Carlson Hour

Tuesday Evenings, 8 to 9, Eastern Daylight Saving Time, George Olsen and his Stromberg-Carlson Orchestra thru WJZ, WBZ-WBZA, KDKA, KYW.

Stromberg-Carlson Telephone Mfg. Co.
 Rochester, N. Y.

Stromberg-Carlson



Makers of voice transmission and voice reception apparatus for more than 30 years



To the Man Who Would Like to be an Amateur and Doesn't Know How to Start—to the New Recruit to Short-Wave Radio.

Here is a book written to order for you, to tell you how to do these things

It starts at the beginning and tells

what an amateur is,
what the League is,
what amateur radio is,
how to be an amateur,
how to learn the code,
how to understand what you hear,
how to get your licenses,
how to build a simple station,
how to build a better station,
how to operate your station,
how the A. R. R. L. works,
how to handle traffic,

and it winds up with an appendix filled with enough extra dope to keep you busy for the next ten years.

It has twice as many words as the average book, all of them directed right at you and your case.

The name of this book is
THE RADIO AMATEUR'S HANDBOOK
and the price is only \$1, postpaid

American Radio Relay League
1711 Park Street, Hartford, Conn.



Mark Twain said,

*“You can’t tell how far a frog can jump
by looking at him.”*

*You might make a guess, but it would be
only a guess, because the frog has no per-
formance record.*

Similarly, you can’t tell how long a battery will last by looking at it. With Burgess Batteries you don’t have to guess because they have a performance record. Outstanding in this performance record is the fact that thousands of radio amateurs have been using Burgess Batteries for years and years with entirely satisfactory results. When the time comes for you to purchase batteries—don’t guess—ask for the battery with the insurance of service.

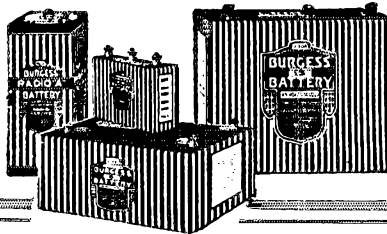

BURGESS RADIO BATTERIES
