

QST

DEVOTED ENTIRELY TO

AMATEUR RADIO

PUBLISHED SINCE 1915 BY THE AMERICAN RADIO RELAY LEAGUE INC.

Unparalleled Selectivity!
*A New Development—
The Acoustic Wave Filter*

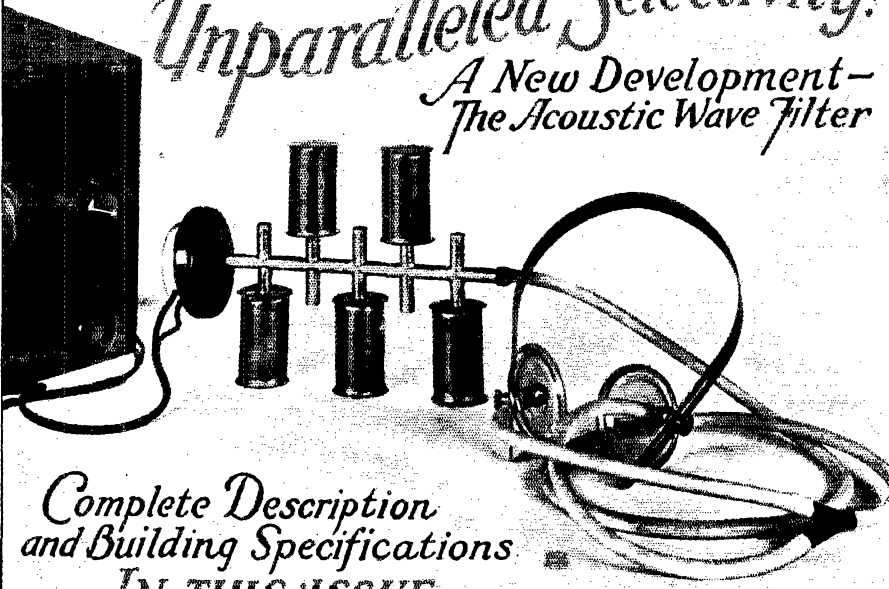

*Complete Description
and Building Specifications
IN THIS ISSUE*

AUGUST
1928

25^c

A NEW AMATEUR BAND WAVEMETER



TYPE 558 AMATEUR BAND WAVEMETER . . . PRICE \$20.00

The type 558 Wavemeter is designed to meet the requirements of the new amateur assignment. Five coils are provided covering the 5, 10, 20, 40 and 80 meter bands. The indicator is of the neon type. Each instrument is individually calibrated with an accuracy of $\frac{1}{4}$ of 1%.

GENERAL RADIO Co

Write for new Bulletin No. 930 with direct to consumer prices.

You will find many items of interest.

30 State St., Cambridge, Mass. 274 Brannan St., San Francisco, Calif.

DON'T MISS

"The Engineering History of Radio"

by

Donald McNicol

*Fellow A. I. E.E. Fellow I. R. E.
Past President of I. R. E.*

It is appearing serially in *Radio Engineering* beginning with the June 1928 issue

A new section covering COMMERCIAL DEVELOPMENTS now appears in each issue—It deals with aeroplane and train communication, talking movies, picture transmission, speech amplifiers, etc.

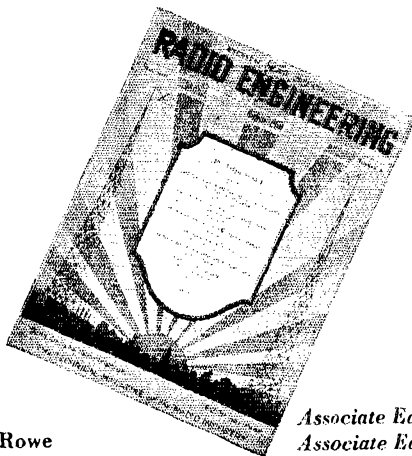

NOTE
—
The June and July numbers will be sent gratis to those using the coupon below in subscribing.

*Editor—M. L. Muhleman
Managing Editor—G. C. B. Rowe*

*Associate Editor—John F. Rider
Associate Editor—Austin C. Lescarboursa*

Some of the other articles in the June issue are:

- The Sulphide Rectifier** - - - - by Dr. H. Shoemaker
- Selecting a Band of Radio Frequencies** - by G. F. Lampkin
- Radio Set Power Supply** - - - - by George B. Crouse
- A. C. Tubes vs. Series Filament Operation** by W. P. Lear
- Mathematics of Radio** - - - - - by John Rider
- High Voltage D. C. Generators** - by J. H. Blankenbuehler

Radio Engineering is NOT sold on newsstands. If you are not a subscriber already, use the coupon below.

RADIO ENGINEERING, Inc.
52 Vanderbilt Ave., New York, N.Y.

NOTE—June and July issues will be mailed gratis to new subscribers so they will have the entire McNicol series.

Enclosed find { \$2.00 for 1 year } subscription to *Radio Engineering* to begin August 1928.
 { \$3.00 for 2 years }

Enclosed find twenty cents (20c) for which send sample copy of *Radio Engineering*.
(PLEASE PRINT NAME AND ADDRESS)

Name _____ Address _____
City _____ State _____

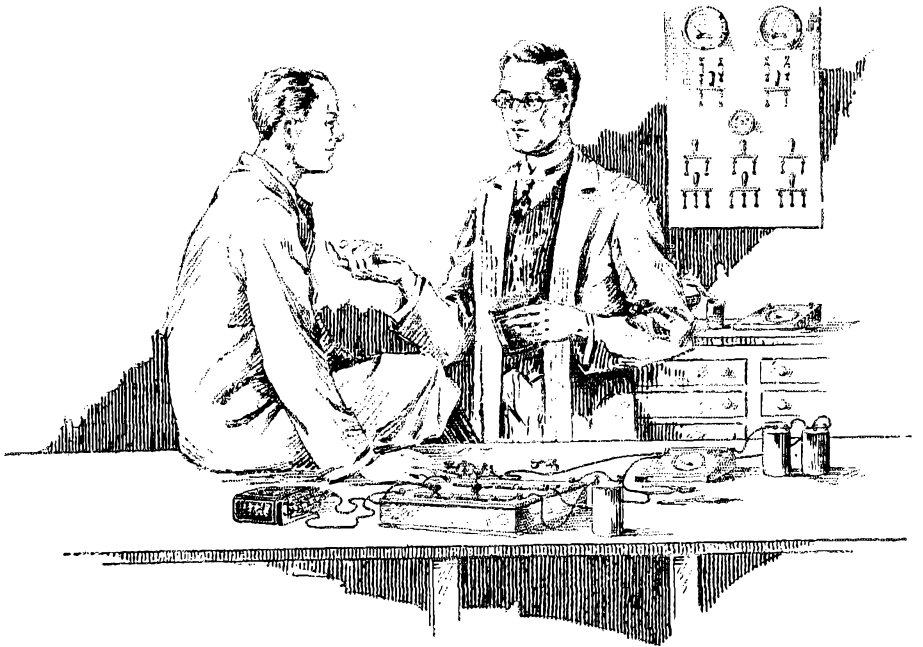

And by Laboratory Test

In leading electrical laboratories from coast to coast Faradon Capacitors have proven their reliability.

Their long life and dependability have won for Faradon acceptance by the quality radio manufacturers.

We will gladly cooperate with you on special equipment not covered by the more than 200 types of Faradon Capacitors ready for prompt delivery.

WIRELESS SPECIALTY APPARATUS CO.
JAMAICA PLAIN BOSTON, MASS., U.S.A.

Established 1907

Faradon

Electrostatic Condensers for All Purposes

Section Communications Managers of THE COMMUNICATIONS DEPARTMENT, A. R. R. L.

Eastern Pennsylvania 3QP
Maryland-Delaware-District of Columbia 3AIS
Southern New Jersey 3CQG
Western New York 3PI
Western Pennsylvania 3NE

Illinois 9APY
Indiana 9CVO
Kentucky 9ARU
Michigan 8CEP
Ohio 8BYN
Wisconsin 8VD

North Dakota* 9DM
South Dakota 9DB
North Minnesota 9EGU
South Minnesota 9BYA

Arkansas* 5ABI
Louisiana 5UK
Mississippi 5AKP
Tennessee 4KM

Eastern New York 2CNS
N. Y. C. & Long Island 2KR
North New Jersey 2WR

Iowa* 9DZW
Kansas 9DNG
Missouri 9RR
Nebraska 9RYG

Connecticut 1ZL
Maine 1BIJ
Eastern Massachusetts 1UB
Western Massachusetts 1UM
New Hampshire 1ATI
Rhode Island 1BYB
Vermont 1AJG

Alaska WWDN
Idaho 7ST-7ALD
Montana 7AA-7QT
Oregon 7PP
Washington 7FD

Hawaii 6CFQ
Nevada 6FO
Los Angeles 6AM
Santa Clara Valley 6NK
East Bay 6CZR
San Francisco 6VR
Sacramento Valley 6CBS
Arizona 6ANO
Philippines* 6LAT
San Diego 6BQ

North Carolina 4JR
Virginia 3CA
West Virginia 8HD

Colorado 9CAA
Utah-Wyoming 6BAJ

Alabama 5AJP
Florida 4LK
Georgia-South Carolina-Cuba-Porto Rico-Isle of 4KD

Northern Texas 5ANK
Oklahoma 5APG
Southern Texas 5TK
New Mexico 5TT

Newfoundland 8AR
New Brunswick 1BU
Nova Scotia 1DD
Prince Edward Island 1BZ

Ontario 9BJ

Quebec 2BE

Alberta 4HA
British Columbia 5BJ

Manitoba 4FY
Saskatchewan 4FO

ATLANTIC DIVISION

J. B. Morgan, 2nd 331 E. Willow Grove Ave. Chestnut Hill, Phila.
Dr. H. H. Layton 205 Washington St. Wilmington, Del.
M. J. Lotysh Box 49, RFD 1 Cambridge, N. J.
C. S. Taylor 538 Masten St. Buffalo
G. L. Crossley State College

CENTRAL DIVISION

Fred J. Hinds 3337 Oak Park Ave. Berwyn
D. J. Angus 240 N. Illinois St. Indianapolis
D. A. Downard 116 No. Longworth Ave. Louisville
Dallas Wise 9187 Falcon Ave. Detroit
H. C. Stork 694 Carpenter St. Columbus
C. N. Crapo 143 Newton Ave. Milwaukee

DAKOTA DIVISION

H. L. Sheets Brinsmade
F. J. Beck Milbank
C. L. Barker Henning
D. P. Cottam 2538 Third Ave. So. Minneapolis

DELTA DIVISION

H. E. Vette 5408 U St. Little Rock
C. A. Freetag 129 Camp St. New Orleans
J. W. Gullett 1708 23rd Ave. Meridian
L. K. Rush 4 Second St. Bemis

HUDSON DIVISION

F. M. Holbrook 2 Livingston Ave. White Plains
M. B. Kahn 617 W. 141st St. N. Y. C.
A. G. Wester, Jr. 50 Princeton St. Maplewood

MIDWEST DIVISION

H. W. Kerr Little Sioux
F. S. McKeever Lawrence
L. B. Lutzers Kansas City
C. B. Deitl 5605 Cedar St. Omaha

NEW ENGLAND DIVISION

C. A. Weldenhammer 33 Washington Place Bridgeport
Frederick Best 13 E. Crescent St. Augusta
E. L. Batley 39 Royal St. Wollaston
Dr. A. Tesser, 8 Schaffer St. Worcester
V. W. Hodze 227 Main St. Claremont
D. B. Fancher 942 Hobart St. Westery
C. T. Kerr 1 Poulmey

NORTHWESTERN DIVISION

W. R. Wilson U. S. LHT Fern Ketchikan
Henry Fletcher 1610 N. 10th St. Boise
O. W. Viers Red Lodge
R. H. Wright 210 Ross St. Portland
Otto Johnson 4340 30th Ave. W. Seattle

PACIFIC DIVISION

F. L. Fullaway 2714 Manoa Rd. Honolulu
C. B. Newcombe 109 W. Third St. Yerington
D. C. Wallace 252 Hancock Arc. Long Beach Calif.
P. J. Quement 366 62nd St. San Jose
J. Walter Frates 368 62nd St. Oakland
J. W. Patterson 400 Octavia St. Apt. 29 San Francisco
C. F. Mason 2530 N. St. Sacramento
D. R. Lamb 229 W. First St. Mesa
Jose E. Jimenez 835 San Fernando St. Manila
G. A. Sears 236 Bonair St. La Jolla

ROANOKE DIVISION

R. S. Morris 413 S. Broad St. Gastonia
J. F. Wohford 118 Cambridge Ave. Roanoke
C. S. Hoffman 128 Chantal Court Wheeling

ROCKY MOUNTAIN DIVISION

C. R. Stedman 1611 Abbot St. Denver
Parley N. James 430 "D" St. Salt Lake City

SOUTHEASTERN DIVISION

A. D. Trum 217 Catoma St. Montgomery
C. E. Froulkes 592 Spearing St. Jacksonville
H. L. Reid 11 Shadowlawn Ave. Atlanta

WEST GULF DIVISION

J. H. Robinson, Jr. 522 Cumberland St. Dallas
K. M. Ebrat 2994 N. Robinson St. Oklahoma City
E. A. Sahn 146 N. Academy St. New Braunfels
L. E. Radka Tucumcari

MARITIME DIVISION

Loyal Reid Avalon House St. John's
E. B. Lacey 20 N. St. Power Co. St. John
W. C. Horrett 14 Sinclair St. Dartmouth
P. W. Hyndman 25 Fitzroy St. Charlottetown, P. E. I.

ONTARIO DIVISION

W. Y. Sloan 167 Close Ave. Toronto

QUEBEC DIVISION

Alex Reid 169 Logan Ave. St. Lambert

VANALTA DIVISION

E. J. Taylor 16107-87th Ave. Edmonton
E. S. Brooks c/o Forestry Dept. Radio Court House, Vancouver

PRAIRIE DIVISION

D. R. Sinclair 205 Cambridge St. Winnipeg
W. J. Pickering 514 19th St. W. Prince Albert

*Temporary officials appointed to act until the membership of the Section concerned choose permanent SCMs by renomination and election.

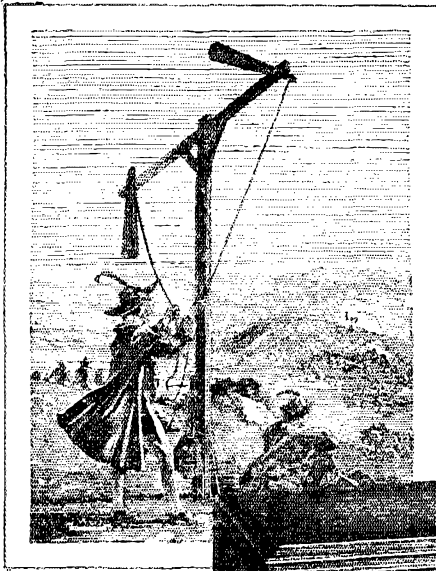

Shortly before the French Revolution Claude Chappe invented a semaphore telegraph system consisting of towers surmounted by movable arms. Messages could be conveyed in this manner in fifteen minutes. In August, 1794, the first line was completed between Paris and Lille and on September (at the news of the capture of the town of Orléans from the Austrians) was transmitted from Lille to Paris.

Get it Better with a Grebe

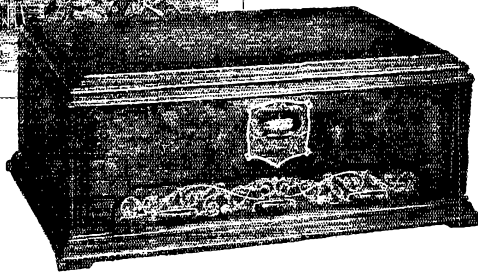

Progress in telegraph or radio—in each of the great inventions that has made this world a better place to live in—has resulted from years of research, tests and experiments.

It is only natural, then, that the Grebe Synchronphase A-C Six should be hailed as an outstanding development of radio science. A non-battery, alternating current receiver that represents *nineteen* years of painstaking effort to reach the utmost in radio reception.

These long years of development now give you a receiver of incomparable range and selectivity—with beautiful tone quality—

freedom from A-C hum—illuminated single dial and other new Grebe improvements which make possible better local and distance reception.

This new receiver is fully explained in Booklet Q, which will be sent upon request. Or better yet, hear the Grebe Synchronphase A-C Six today. You will then have a demonstration of what *nineteen* years of Grebe leadership has accomplished.

Other Grebe sets and equipment: Grebe Synchronphase Seven, Grebe Synchronphase Five, Grebe Natural Speaker (Illustrated), Grebe No. 1750 Speaker.



GREBE

TRADE MARK REG. U.S. PAT. OFF.

SYNCHROPHASE

A-C Six

RADIO

A. H. Grebe & Company, Inc., 109 West 57th Street, New York City

Factory: Richmond Hill, N. Y.

Western Branch: 443 So. San Pedro St., Los Angeles, Calif.

Makers of quality radio since 1909



QST



The Official Organ of the A.R.R.L.

VOLUME XII

AUGUST, 1928

NUMBER 8

Editorials	7
Overhauling the Transmitter for 1929	Ross A. Hull 9
Concerning Lunar Effects on Electromagnetic Waves	Greenleaf W. Picard 20
Following the "Southern Cross" to Brisbane	J. Walter Frates 21
Acoustic Wave Filters and Audio Frequency Selectivity	R. B. Bourne 23
Some More About Amateur Television	Harold P. Westman 30
Army-Amateur Activities in the Philippines	31
The 1928 International Relay Party	Louis R. Huber 33
Amateur Calls Changing	35
An Effective Antenna Tuning System	R. B. Bourne 36
28,000 Kilocycles—And How!	Harold P. Westman 37
Northwestern Division Convention	42
Standard Frequency Stations Needed	42
Filter Circuits	Clyde Farrar 43
Additional Notes on Iron Core Reactances	D. E. Reptogle 46
Rocky Mountain Division Convention	47
Central Division Convention (Ohio)	47
Communications Department	48
I.A.R.U. News	60
Calls Heard	61
Correspondence	62
Central Division Convention (Wisconsin)	82
Book Reviews and References	84
Atlantic Division Convention	88
Hamads	91
QRAs	93
Index of Advertisers	94

QST is published monthly by The American Radio Relay League, Inc., at Hartford, Conn., U. S. A. Official Organ of the A.R.R.L. and the International Amateur Radio Union

Kenneth B. Warner (Secretary, A.R.R.L.),
Editor-in-Chief and Business Manager

F. Cheyney Beekley,
Managing Editor and Advertising Manager

Harold P. Westman,
Technical Editor

Ross A. Hull,
Associate Technical Editor

David H. Houghton,
Circulation Manager

Subscription rate in United States and Possessions, Canada, and all countries in the American Postal Union, \$2.50 per year, postpaid. Single copies, 25 cents. Foreign countries not in American Postal Union, \$3.00 per year, postpaid. Remittances should be by international postal or express money order or bank draft negotiable in the U. S. and for an equivalent amount in U. S. funds. Entered as second-class matter May 29, 1919, at the post office at Hartford, Connecticut, under the act of March 3, 1879. Acceptance for mailing at special rate of postage provided for in section 1103, Act of October 3, 1917, authorized September 9, 1922. Additional entry as second-class matter, acceptable at special rate of postage provided for above, at Springfield, Mass., authorized September 17, 1924.

Copyright 1928 by the American Radio Relay League, Inc. Title registered at United States Patent Office.
Member of the Radio Magazine Publishers' Association.

The American Radio Relay League

The American Radio Relay League, Inc., is a non-commercial association of radio amateurs, bonded for the promotion of interest in amateur radio communication and experimentation, for the relaying of messages by radio, for the advancement of the radio art and of the public welfare, for the representation of the radio amateur in legislative matters, and for the maintenance of fraternalism and a high standard of conduct.

It is an incorporated association without capital stock, chartered under the laws of Connecticut. Its affairs are governed by a Board of Directors, elected every two years by the general membership. The officers are elected or appointed by the Directors. The League is non-commercial and no one commercially engaged in the manufacture, sale or rental of radio apparatus is eligible to membership on its board.

"Of, by and for the amateur", it numbers within its ranks practically every worth-while amateur in the world and has a history of glorious achievement as the standard-bearer in amateur affairs.

Inquiries regarding membership are solicited. A bona fide interest in amateur radio is the only essential qualification; ownership of a transmitting station and knowledge of the code are not prerequisite. Correspondence should be addressed to the Secretary.

Directors

President
HIRAM PERCY MAXIM
Drawer 2102,
Hartford, Conn.

Vice-President
CHARLES H. STEWART
St. David's, Pa.

Canadian General Manager
A. H. K. RUSSELL
5 Mail Bldg.,
Toronto, Ont.

Atlantic Division
DR. EUGENE C. WOODRUFF
224 W. Fairmount Ave.,
State College, Pa.

Central Division
CLYDE E. DARR
137 Hill Ave., Highland Park,
Detroit, Mich.

Dakota Division
C. M. JANSKY, JR.
Dept. of Elec. Eng., U. of M.,
Minneapolis, Minn.

Delta Division
BENJ. F. PAINTER
424 Hamilton Nat'l Bank Bldg.,
Chattanooga, Tenn.

Hudson Division
DR. LAWRENCE J. DUNN
480 East 19th St.,
Brooklyn, N. Y.

Midwest Division
PORTER H. QUINBY
817 Lauderman Building,
St. Louis, Mo.

New England Division
DR. ELLIOTT A. WHITE
Dartmouth College,
Hanover, N. H.

Northwestern Division
K. W. WEINGARTEN
8219 No. 24th St.,
Tacoma, Wash.

Pacific Division
ALLEN H. BABCOCK
65 Market St.,
Southern Pacific Co.,
San Francisco

Roanoke Division
W. TREDWAY GRAVELY
Box 245,
Danville, Va.

Rocky Mountain Division
PAUL M. SEGAL
Box 1771
Denver, Colo.

Southeastern Division
HARRY F. DOBBS
c/o Dobbs & Wey Co.,
245 Spring St., N. W.,
Atlanta, Ga.

West Gulf Division
FRANK M. CORLETT
2515 Catherine St.,
Dallas, Tex.

Officers

President HIRAM PERCY MAXIM, Hartford, Conn.
Vice-President CHAS. H. STEWART, St. David's, Pa.
Secretary KENNETH B. WARNER, Hartford, Conn.
Treasurer ARTHUR A. HEBERT, Hartford, Conn.
Communications Manager . . . F. EDWARD HANDY, Hartford, Conn.

EDITORIALS

EVERY month Ye Ed sits down to dash off a bit of running comment for this page. As the years roll by it becomes a record of our progress, for in it are recorded the high-lights of our changing status from month to month. Sometimes there is a sermon to preach, sometimes an opportunity to exult over an amateur accomplishment, sometimes a note of warning to sound, sometimes an opportunity to let loose and rollick in the sheer joy of being an amateur. Always it seems that those subjects which are "hottest" in the life of amateur radio at the moment are legitimate topics for editorial review.

To most of amateur radio the most important thing on the hook these days is the Washington Convention of 1927 and the effects which it will have upon amateur radio beginning in 1929. Now, in mid-summer, with half of the time gone by, seems a good moment to take stock of the situation. The world has had the Washington Convention for half a year. In half a year more its provisions go into effect. Already there are numerous signs that a busy radio world is at work adjusting itself to the new requirements. Thousands of changes, from drastic to trivial, are having to be made throughout the vast worldwide structure of radio, but already, bit by bit, things are dropping into their proper notches. It is possible now to get some sort of picture of the changing scene.

As we look it over carefully from the amateur standpoint, we find it quite reassuring. A few months ago we had grave doubts about some of the features which affected us, but no longer. We see now no reason to doubt that we shall be happy next year.

Promptly upon the ratification of the treaty by this country, our Federal Radio Commission started action and a really considerable amount of progress has been made, particularly in the short wave field which interests us. One of its actions in particular needs some explaining.

Our "40-meter" and "20-meter" bands now read 7,000-8,000 Kc. and 14,000-16,000 Kc., respectively. Next year they will read 7,000-7,300 Kc. and 14,000-14,400 Kc., respectively. What of the territory we lose, 7300-8,000 Kc. and 14,400-16,000 Kc.?—what is to become of it? It goes to fixed stations, and it contains some mighty valuable channels. Now it must be understood

that all around the world there is a mad race to get commercial short-wave stations established, a race taking on the proportions of a gold rush, for it must be remembered that there are only so many channels available and that priority in the right to use a frequency is to be established only by actually getting on the air and occupying it. These portions of our bands which we lose next year have never been assigned to amateurs in most countries and so are fully available in those countries for commercial occupation. Our country with its tremendous business enterprises is experiencing more of a demand for channels than any other country. If it waits until the end of the year to make assignments in these bands which then automatically become non-amateur bands, it will find them all claim-staked by other nations. What to do? The Commission has adopted what is about the only possible policy in the matter, the immediate issuing of construction permits to commercial firms in this country to occupy frequencies in these portions of our bands. It involves another sacrifice on our part insofar as it means that we will not have the exclusive occupancy of our bands until the end of the year. Twenty-one commercial channels have been assigned in the 7,300-8,000 Kc. territory and twenty-seven channels in the 14,400-16,000 Kc. band. There is one redeeming feature. The stations thus authorized will actually get into operation but slowly, and gradually, during the remaining months of the year. What will happen to us, then, will be to experience a gradually increasing number of interfering stations in "our" bands. It will be almost time for the change-over to the narrowed bands. It seems to us that this process of gradually reducing the effectiveness of our bands by the infiltration of commercial stations during the late months of the year actually may be much better and easier for us than to attempt to work with full width up to midnight of December 31st and immediately thereafter rearrange ourselves in the much narrower territory. There are two points in this for us: we must not now be alarmed when we hear an occasional United States commercial station working in those portions of the bands which will not be ours next year; and amateur rebuilding operations, particularly where they involve crystal con-

trol, should be based on a frequency which will be within next year's bands, and thus escape any such interference.

Preparations are going on around the world to move commercial stations that now exist in what will be next year's amateur bands, and because the outside territory is rapidly being occupied by new stations it is to be expected that all the proprietors of stations operating in the 7,000-7,300 and 14,000-14,400 Kc. bands will move as quickly as possible, as these bands must be given exclusively to amateur radio after the end of the year.

One early result to be expected of the assignment of commercial stations within the territory we are soon to lose is the movement of non-amateur "amateur" stations now operating in the low-frequency portions of our bands, to channels now designated as commercial and thus clear of our next year's bands—and under commercial licenses, too, not amateur!

It has been decided that our "80-meter" and "160-meter" bands, which it is internationally agreed may be shared with mobile and fixed services, will in this country be available throughout their extent to amateurs and will *not* be shared with commercial mobile and fixed services. This means that we will share these bands only with Army mobile stations and Naval aircraft. This is the same arrangement which we have had in effect for several years and which has caused no inconvenience to amateurs. There are, incidentally, sixteen channels in our "80-meter" band that will be used by naval aircraft, but at sea under circumstances where we may expect their operation to have but little effect on this most important band.

There are numerous other little signs of the activity of readjustment. Amateur calls are gradually being changed to accord with the provisions of the treaty. The British government is discussing the wavelengths to be made available to British amateurs. The Australian government is reported to be considering the continuation of the authority to Australian amateurs to use the 33-meter wave because Australia is so far away from congested localities that international interference would not result. Our government is considering a power reduction for American amateurs so that our occasional off-wave operation will be less likely to produce interference of commercial field strength. There is much discussion in amateur circles about the necessity of soliciting some regulations relating to the type of power supply which amateurs should use next year, so as to secure at least the abolition of the hated "raw a.c."

Some months ago we proposed a scheme for sub-dividing the "40-meter" and "20-meter" international amateur bands be-

tween various groups of nations, in the thought that some such plan was essential if international communication was to go on. We presented it as a suggestion for discussion. There seems to be considerable sentiment to the effect that such a plan is not essential, and it seems to us that any such optimism is a most healthy and wholesome sign. We ourselves are not yet prepared to adopt this view, and to us it still seems that some such cooperative plan is extremely desirable, and that the precision we must attain next year will make it something quite possible of realization. The growing sentiment seems to be, though, that we could well leave these bands internationally free-for-all, and that in a short time the natural readjustment of amateurs amongst various bands and the natural dividing of their operating hours by differences in time will result in a satisfactory situation. We don't know—we want to think it over some more.

Technically there is much to report. We were quite worried about this situation a few months ago. It seemed to us that the 1929 requirements were so severe that many stations would have to be junked and very extensive rebuilding undertaken. A few months of hard work on the problem now indicate that it will be possible to improve apparatus easily. That is a tremendous relief. For example we are very proud to be able to present in this issue an excellent article on the simple changes that may be made in self-excited transmitters to make them serviceable under 1929 conditions, and another article relating the construction of a simple gadget which may be affixed to an autodyne receiver and which, if the transmitters put forth "1929" signals, will give 1929 selectivity in reception. We feel very happy about this, for the self-excited oscillator is our simplest transmitter and the autodyne is our simplest receiver, both being in use in by far the majority of the amateur stations of the world. It may be said, in fact, that the presentation of these two articles constitutes one entirely adequate answer to the problem raised by the necessity for having better transmitters and better receivers in 1929. Of course we do not stop there. The A.R.R.L. Technical Development Program is now in full swing and is moving on to higher-powered transmitters, transmitters better than those which attain the results described in this month's article, the development of more selective receivers, the evolution of satisfactory amateur frequency-meters, the development of ten meters, etc. We now have every confidence that the technical difficulties will be overcome and that we are going to have just as much success and enjoyment from operation in 1929 as ever before—perhaps a lot

(Concluded on Page 19)

Overhauling the Transmitter for 1929

Some Modifications Which Permit Substantial Advances in Self-Excited Circuit Performance.

By Ross A. Hull*

Foreseeing the inevitable change in operating conditions in 1929 and appreciating the urgent need for modification and improvement of amateur equipment, the A.R.R.L. Board of Directors appropriated a sum from the League's surplus for the conduct of a program of investigation and development of amateur transmitters and receivers. This article embodies the conclusions resulting from the first phase of the program work—a study of self-excited transmitters. It is, we feel, one of the most important articles ever published for the radio amateur. Let every amateur study it most carefully, and apply its information, for it contains salvation for 1929.—Editor.

IN any undertaking, I suppose, half the battle, or at least an appreciable fraction of it, is in the determination of a method of attack—the drafting of a procedure and a policy. Anyway, in the instance of the A.R.R.L. Technical Development Program we found this to be true.

Of the several scores of possible fields of endeavor, we thought, there is at least one which we can delete. Hartleys, Colpitts and Tuned-grid tuned-plates have been in general use throughout the world for years, and amateurs, experimenters and scientists have sought con-

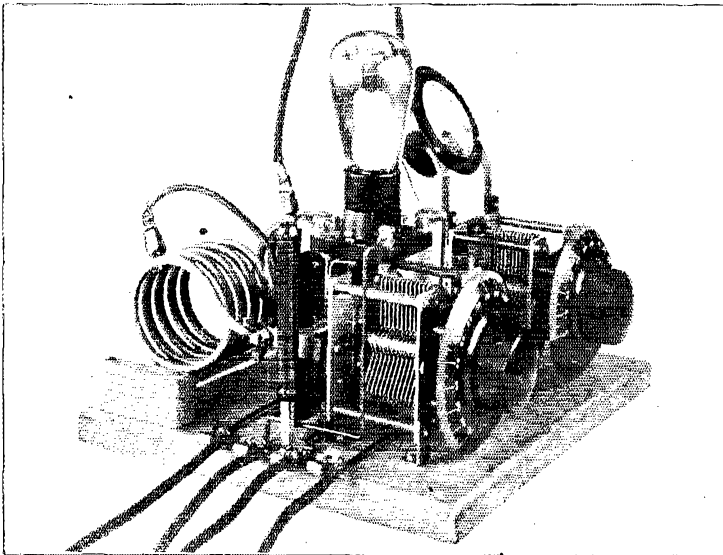

A SIMPLE TRANSMITTER WITH A "1929 TYPE" PERFORMANCE

Incorporating a Hartley circuit and differing only in the arrangement of its plate "tank", this transmitter, when carefully tuned, is capable of producing signals that are up to any reasonable standard which could be set for next year. The use of a High-C plate circuit results in unusually heavy circulating currents and, in consequence, particularly heavy conductor must be used for the coil and its leads to the tuning condenser. Except for the filament lead and on the antenna coil (where the currents are relatively low) clips for connections are absolutely banned.

There was, for example, the apparently simple question of whether the present-day self-excited circuits were worthy of any

stantly to improve them. And yet, we reflected, with all the developments and advances of recent times, if the world's crystal-controlled and oscillator-amplifier amateur transmitters could be taken off

*Associate Technical Editor, QST. In charge A.R.R.L. Technical Development Program.

the air to-morrow there would be about five truly constant frequency and unmodulated signals left. Most certainly, we decided, the self-excited circuits are the bunk. They have had six or seven years in which to prove their worth and in all that time they have succeeded in making a variety of horrible noises; let's forget them and break into some brand new territory.

But, as we have said at the start, de-

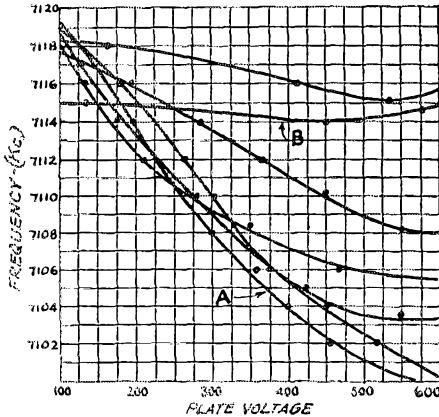

FIG 1. SHOWING WHY AN UNRECTIFIED OR IMPERFECTLY FILTERED PLATE SUPPLY CAN CAUSE A TRANSMITTER TO MONOPOLIZE WIDE SECTIONS OF THE BAND

From Curve A it can be seen that in a typical 1928 transmitter, poorly adjusted, the frequency "flutter" due to a "ripple" of 100 volts in the plate supply can be as high as 4 Kc., under which conditions the note is "hash". From Curve B—the performance of the same transmitter adjusted correctly—the "flutter" with a similar plate supply is seen to be negligible. In this case the note would be a "musical d.c."

decisions on such matters comprise at least a fraction of the battle—and even fractions of battles cannot be dismissed so simply. It is true, we reflected on second thought, that by far the majority of present-day amateur transmitters are built around self-excited circuits; it is true that such circuits have been the very foundation of world-wide amateur radio communication; it is true that the scrapping of self-excited circuits would mean the scrapping of about 90% of existing amateur transmitters. Is not, then, the self-excited circuit perhaps one of the biggest things in amateur radio we mused. Is it not deserving of the most detailed study and investigation possible, in the attempt to preserve it, even though it has done its work in such a noisy fashion throughout the years?—And so was written into the program of activities, at the head of what is now an elaborate document, a Problem One—"The Study of Present Day Self-Excited Circuits—The Possibilities, if any, of Their Use in 1929".

"Why, we might spend a month on the problem," said Perry Briggs, 1BGF (who was destined to do the study) "and then we might find that they always will mean swinging, chirping, rattles and mush!"

Little did we think at the time that it would be possible to make the statement that we now can make with complete confidence—that all standard self excited circuits can produce signals that will comply with any reasonable standard set for 1929 if only they are built and operated intelligently. But there is a lot hanging to those last four words. There is in fact this entire story.

TRANSMITTERS UNDER A MICROSCOPE

The first requirement in the study undertaken was, of course, a means of examining the performance of any type of transmitter in precise detail. It would not serve, we realized, to put the various transmitters on the air and ask QRK? QSB? QSSS? and then decide from the various FB's and QSA's received in reply that 1929 was a cinch. Instead, we had to provide for some electrical microscope through which we could examine and reduce to black and white the actual performance of any transmitter under any conceivable set of conditions. The most useful apparatus used in this work was an enlarged and modified version of the "Growler" (a shielded oscillator). Built within a large copper wash-boiler this oscillator was pro-

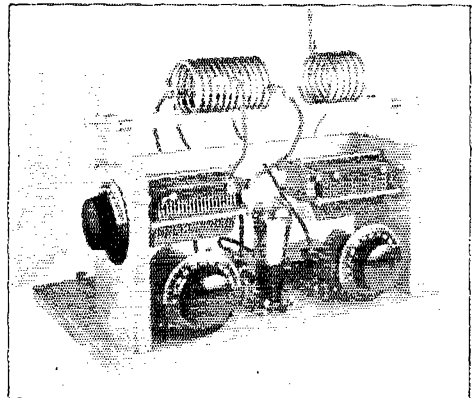

ONE OF THE "1928 TYPE" TRANSMITTERS RESPONSIBLE FOR SOME OF THE CURVES ON THESE PAGES

As an example of the use of long condenser leads and clips the arrangement is one to be avoided. The wide separation of the tube, the condensers and the coils does not permit the short stiff leads which are to play such an important part in obtaining a "1929" performance.

vided, in addition to the usual tuning control, with a vernier straight line frequency condenser giving a full scale tuning range

of about 28 Kc. The output of the oscillator was fed through a three-stage resistance-coupled audio-frequency amplifier to a loud speaker of high quality, so giving some hope of a reasonably flat audio frequency response curve. To provide for quantitative observation the oscillator was calibrated roughly on the major tuning dial and with a certain degree of precision on the vernier. The calibration curve for the latter control, incidentally, was obtained by

automatically doubly checked as the work proceeded. A third and even a fourth check was made possible by detuning the oscillators to musical octaves (2000 and 3000 cycles) as well as by 1000 cycles. Possessed with a "musical ear" and considerable patience, we thought, the amateur could well calibrate his 1929 frequency meter in this manner from one known point on the scale!

The purpose in providing and calibrating a vernier of this type was to supply a means of observing the swing or drift in the frequency output of any transmitter due to prearranged variations in plate voltage, filament voltage or antenna constants, and to measure it down to about 100 cycles. Fortunately, the "Boiler" proved highly satisfactory for this work, and during some hundreds of comparisons of circuits, transmitters and constants, it was run almost continuously for several weeks.

THE "BEST" CIRCUIT

A detailed study of the data obtained revealed in all its brilliance the fact (which we had so long thought true) that all standard self-excited circuits, irrespective of how carefully designed and built they may be, are equally and any time capable of producing truly wretched signals. And, conversely, that all such circuits, when correctly arranged and tuned, can be made to produce signals that are veritably above criticism. Along with this we can insist with limitless assurance that the performance of the various

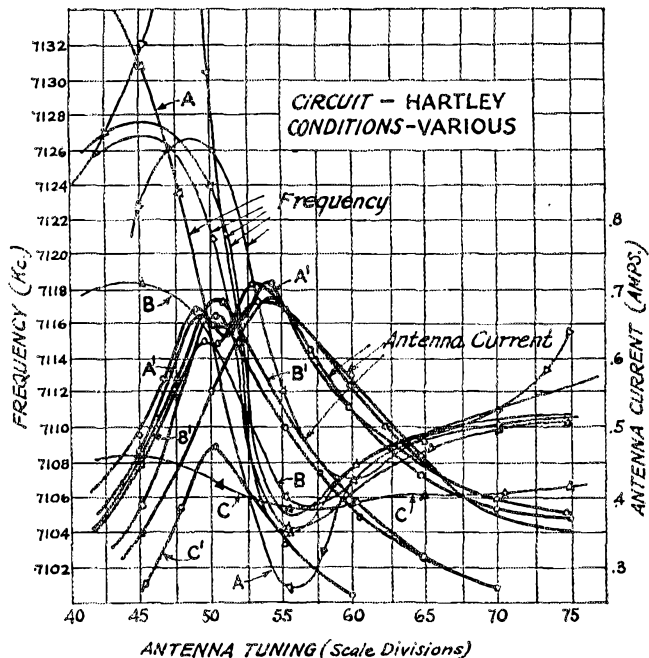

FIG. 2 A FAMILY OF ANTENNA TUNING-VS.-FREQUENCY CURVES OBTAINED WITH MISCELLANEOUS VALUES OF ANTENNA COUPLING IN A "1928 TYPE" TRANSMITTER

The splendid gain in frequency stability provided by loose antenna coupling can be seen by a comparison of Curves A, A' and B, B'. The former were plotted with "two-inch" antenna coupling and the latter with "five-inch" coupling. The dark lines indicate the variation of antenna current as the antenna is tuned up to and past resonance while the light lines show the change in frequency resulting.

the rather unusual method of checking the beats produced by the oscillator against a second radio frequency oscillator, directly with a one thousand cycle, electrically driven tuning fork supplying energy of that frequency to one of a pair of headphones. After adjusting the two r.f. oscillators to zero beat (the output of one being in the second headphone) the second r.f. oscillator was detuned until a one thousand cycle beat was obtained, first on one side and then on the other. At these two points, in turn, the oscillators were again set to zero beat and the detuning to one thousand cycles repeated, each point being

standard circuits actually is equivalent — that the Tuned-grid tuned-plate cannot be said to be "better" than the Hartley or the Hartley "better" than the Colpitts unless detailed qualifications be included in the statement. Which is, after all, merely a reiteration of QST's claim of all the years—that "that circuit is best with which you are most familiar."

THIS TUNING BUSINESS

And now, in all humility, let us ask to be pardoned if we appear excessively frank in the statement of some further deductions resulting from the study. We are con-

vinced, for instance, that if all amateur operators of the world, without any changes in their equipment, were to be displaced by a new generation of amateurs having a clear understanding of transmitter tuning,

before it ran into another station. It is not surprising that amateurs have been careful of everything except their signal; that with certain obvious exceptions the correct tuning of a transmitter was the result of accident rather than design. In 1929, as we have already suggested, it will not be essential for all transmitters to be rebuilt. It will, however, without the slightest doubt, be absolutely necessary for all amateurs to make it their business to learn the finer points of transmitter tuning; to learn exactly how to make their signals conform with the high standard to be required in 1929 and to provide the means of checking, within the station, the character of the signal being transmitted. For the success or failure of amateur radio in the future is to depend chiefly upon the personal element—the men behind the keys.

THE "1929" SIGNAL

At this stage it would be well perhaps to outline the specification of what is now considered to be the desirable 1929 signal, drawn up after close study of the requirements and since checked by experiment to determine its complete practicability. It should be understood that this specification does not cover the most desirable signal but rather that signal, attainable with even the most modest equipment that will permit its owner to identify himself as a sincere dyed-in-the-wool radio amateur.

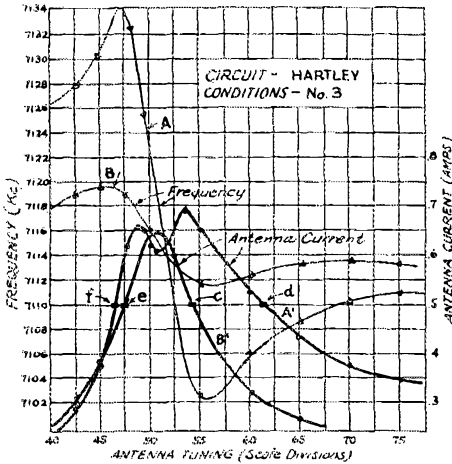

FIG. 3. INDICATING THE FREQUENCY CHANGES RESULTING FROM ANTENNA DETUNING IN A TYPICAL HARTLEY CIRCUIT

A change from "two-inch" to "four-inch" coupling in this case shows an avoidance of the "double resonance hump", with an insignificant sacrifice of antenna current, and a vast improvement in the frequency change. The necessity of detuning the antenna in one particular direction is shown clearly in these curves.

and the desire to put their knowledge into effect, completely satisfactory operation in the 1929 amateur bands would be inevitable. In short, and more abruptly, the chief ailments of present day amateur radio are the men pushing the keys. They have built their power supplies with one thing in mind—voltage; they have tuned their transmitters with just a single thought—antenna current—they have pounded out their CQ's for but one purpose—DX; and the signal, the very foundation of the whole game, has been left to splutter, wobble, creep and rattle across great slices of the bands because of some dizzy FB's and QSA's given, in most cases, with about as much sincerity as the pleasantries passed across the counter by a grocer's clerk to his customers. Whew!

Of course, there is not the slightest question that the condition has been a natural one. The amateur bands have been wide and it was not a tragedy if one station did swamp a couple of hundred kilocycles. The off-wave operation has been a relatively minor offense, for the fields beyond the fence were almost vacant. Further, a creepy-wobbly signal has been readable because it usually could wobble a long way

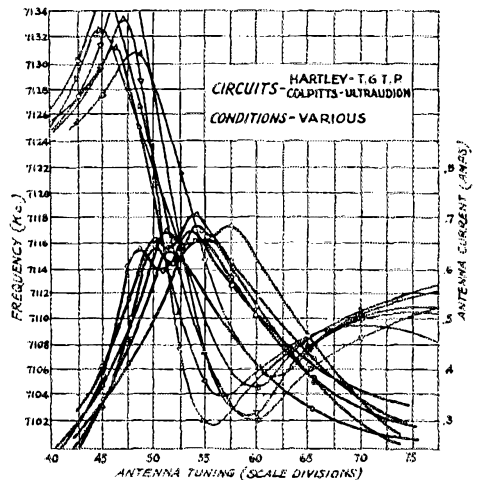

FIG. 4. SOME SIMILARLY POOR PERFORMANCES OBTAINED WITH FOUR DIFFERENT CIRCUITS

Selected average curves obtained with poorly adjusted Tuned-grid tuned-plate Hartley, Colpitts and Ultraudion circuits are shown.

The 1929 signal, in the first place, must be entirely within the limits of the band. Then, its frequency "flutter" due to ir-

regularities of plate supply must not exceed about 1/30 of 1% (approximately 250 cycles at 40 meters). *We'll say more on that later.* In addition, the frequency of the signal must be relatively constant. The signal must not "shimmy" as the antenna vibrates, it should not "chirp" as it is keyed, nor can it "creep" appreciably as the line voltage fluctuates or the tube heats. In short, the frequency of the first dot transmitted should be within 1/10 of 1% (about 750 cycles at 40 meters) of the hundredth dot, even if the plate has reddened or the line voltage drifted in the meantime. And at the end of a few hours of operation the frequency should not have strayed much farther.

MEASURING PERFORMANCE

An examination of these requirements showed clearly that we could, in our Laboratory, even with the limited facilities, determine just when a transmitter came

"pure d.c." produced by a transmitter emitting a single frequency (which incidentally is an extremely uncommon and rather undesirable note). (b) The "musical" note, resulting from a signal which is modulated by plate supply ripple in amplitude only (good crystal control transmitters with rippled plate supplies give them). And (c) the "mush" note, which is the outcome of a signal both "fluttered" in frequency

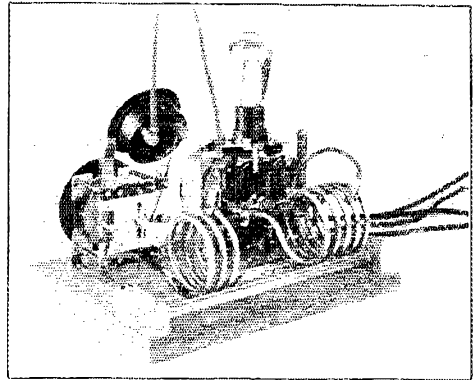

A REAR VIEW OF THE "1929 TYPE" LOW-POWERED HARTLEY

The tube socket being mounted on top of the plate tuning condenser, its plate and grid terminals are particularly convenient to the leads between the condenser and the coil on to which they are connected through the plate and grid condensers. And the left is the antenna tuning unit, consisting of a coil—which is moved along the glass rods for variation of antenna coupling—a condenser, and a thermocouple ammeter. The meter, though mounted on the condenser, must be insulated from it. The plate choke can be seen between the two variable condensers. Aside from their use in supporting the antenna coil, the glass rods also serve to prevent the plate coil from vibrating.

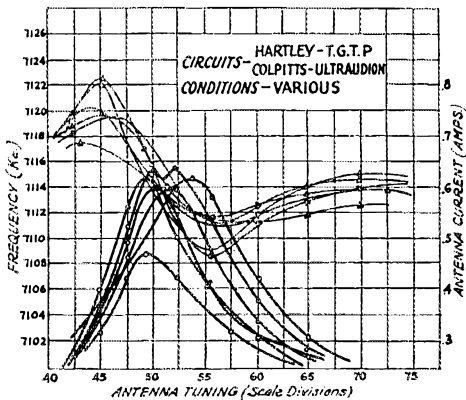

FIG. 5. CURVES TAKEN WITH THE SAME CIRCUITS RESPONSIBLE FOR FIG. 4 ADJUSTED TO GIVE THEIR BEST PERFORMANCE

Being representative of the capabilities of average present day self-excited transmitters, these and other similar curves are proving of great value to use in comparisons with those obtained with transmitters of modified or more advanced type.

up to the specification, and, if it did not, by just how much it failed. And so, at the outset, we built a transmitter with the closest possible electrical resemblance to the average low-powered amateur transmitter of the present day in order that we could plot in black and white the exact amounts by which it missed the mark under a variety of conditions.

Right here we must delve into a discussion of notes with the hope of clearing up some of the widespread misunderstanding which exists. First let us state that there are three distinct groups into which all notes can be divided. They are (a) the

and modulated in amplitude by the plate supply.

The important point is that note "a"—the "pure d.c.", occupies the least possible amount of territory, with note "b" coming next and occupying slightly more territory on account of the side-bands resulting from the modulation. Note "c", however, though obtained from the same plate supply that gave note "b", can well occupy ten times the territory, for the output "frequency" of the transmitter is buzzing across a whole band of frequencies.

Our first interest, therefore, was an actual measurement of the frequency change due to changes in plate voltage—that undesirable characteristic of self-excited transmitters which causes the frequency to "flutter" with any "ripple" in the plate supply.

Considerable difficulty was experienced in plotting the curves shown in Figure 1 for the reason that they were planned to

represent only the frequency changes caused by variation of plate voltage and not the further changes due to resulting plate temperature variations. Though a high degree of accuracy was not found possible, the curves nevertheless were sufficiently representative of average performance to be of great value. From Figure 1 it can be seen that the average transmitter, tuned in the average manner, and operated on the 7,000-7,300 Kc. ("40-meter") band, can have its output varied by at least 18 Kc. with a change in plate voltage from 100 to 500. In the "self-rectified" or "raw a.c. supplied" transmitter this means that during each half cycle, as the voltage climbs to maximum and drops to zero, the frequency swishes back and forth across a band of more than 18 Kc! Is it any wonder that so many signals are just splutters, blotting out wide sections of the band? Among the curves are some representing the performance of all the standard circuits and from this and other families of similar curves it has been shown definitely that similarly horrible performance can be obtained from all the circuits without difficulty. What is more interesting, however, is that the enormous improvement indicated by a comparison of curves "A" and "B" can be attained in any of the circuits merely by careful tuning—a

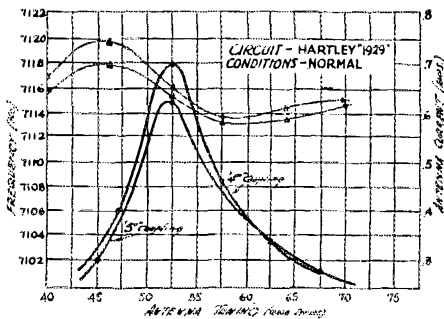

FIG. 6. IN WHICH IS SHOWN THE IMPROVEMENT RESULTING FROM THE USE OF A HIGH-C PLATE CIRCUIT

The antenna-tuning-vs.-frequency curves of the simple "1929-type" Hartley taken within two values of antenna coupling. Aside from their value in indicating the probable frequency response to antenna swaying, these and similar curves in Figs. 2, 3, 4 and 5 were found to be splendidly representative of the merit, in most other respects, of the circuits giving them. They were taken in large numbers and given detailed consideration for this reason.

reduction of the frequency "flutter" from 18,000 cycles to 600 cycles! With each curve the constants of the circuit were noted and from study of the conditions and the resulting curves a tuning procedure was evolved. But more of that anon.

SIGNALS WRECKED BY ANTENNA TUNING

Early in this work it became evident that one of the chief factors was antenna coupling and tuning. It was found that the performance changed radically as the antenna was tuned to resonance and beyond it, and that there were certain adjustments on one side of resonance or the other at which the desirable conditions were obtained. This check on previous observations led to a most detailed study on the influence of antenna coupling and tuning—a study which provided a most magnificent check on all our previous deductions. In a series of some scores of curves the antenna tuning was varied and plotted against the output frequency. At the same time antenna current was noted at each adjustment of antenna tuning and the resonance curve so obtained plotted on the same sheet. The process was then repeated at several values of antenna coupling to pro-

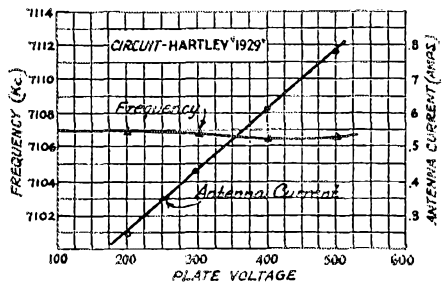

FIG. 7. DEMONSTRATING WHY "D.C." NOTES ARE NOT DIFFICULT TO OBTAIN WITH A HIGH-C PLATE CIRCUIT AND CORRECT TUNING

The "1929-type" transmitter under these particular conditions changed its frequency only 400 cycles when the plate supply was dropped 400 volts. Frequency "flutter" due to plate supply ripple was therefore extremely slight and a "d.c." note was obtained readily.

vide at least reasonably complete data for every circuit and transmitter under every practical combination of constants. Several typical curves obtained in this manner with a standard Hartley transmitter are shown in Figure 2. The values of antenna coupling are indicated in inches but it should be pointed out that, except under the particular conditions represented, these values are entirely meaningless. For us to say that your coupling should be 2 inches would be as futile as for us to suggest that you should use 30 degrees of a condenser when we did not know its maximum capacity. The precise measure of coupling (the "coefficient of coupling") involves considerations of the inductance of the two circuits and their mutual inductance and it was merely the impracticality of using this measure

1 "Some Light on Transmitter Tuning", QST, July, 1927.

that led us to employ inches for comparative work.

THE EFFECT OF COUPLING

The important though elementary fact to be found illustrated in these curves is that as the coupling is reduced the frequency change due to variations in antenna tuning is steadily lowered. Two extreme examples indicated by curves "A" and "B" show that a reduction in coupling from 2" to 5", though only resulting in a 5% drop in antenna current provided at least a 57% improvement in frequency stability. Carried to a still greater extreme, and at the expense of about half the antenna current, a condition could be obtained (Curves "C") where an improvement of about 92% resulted. It may seem strange that these and succeeding similar curves are taken so seriously and given so much consideration and for this reason it might be explained that aside from indicating the responsiveness of the circuit to movements of the antenna they were found to be surprisingly representative of the merit of the particular transmitter from all other aspects. Without a single exception the adjustments and constants which provided the best antenna-tuning-vs.-frequency-change curve also provided the best plate-voltage-vs.-frequency curve and the best performance in general. And a more recent detailed theoretical study has shown that this should have been the case.

A point of considerable interest and of the greatest importance is illustrated on the curves of Figure 3 representing the performance of a Hartley at two less extreme values of antenna coupling. Curves "A" in this case represent those of a typical amateur transmitter in which the antenna coupling is excessive. Two points of maximum antenna current are found and relatively serious frequency change is indicated. Curves "B" represent the conditions with a desirable value of coupling, showing a single point of maximum antenna current (not appreciably lower than that of "A") and a much improved frequency characteristic. The important point, however, is that resonance occurs right at the steepest point of the frequency curve and that at this point the frequency stability under operating conditions probably will be at its lowest value. Further, it can be seen that whereas detuning of the antenna to a higher wavelength than the oscillator will mean operation on a flatter portion of the frequency curve, detuning in the opposite direction could result in operation right at a sharp peak of the frequency curve (the upper peak of curve "A" for instance) and the possibility of a stable frequency so be made equally remote. In actual practice it was found that not only was the stability much im-

proved when the antenna was tuned to a higher wavelength (in this particular case) than the oscillator but also the note was vastly better. The latter condition resulting, of course, from an improved plate voltage vs. frequency curve. When the antenna was tuned to the points "c" and "d", under these conditions, the note was a pure "d.c." When it was tuned to points "e" or "f" (the antenna current being the same in each case) the note was heavily modulated and worthy only of the term "rac". At certain

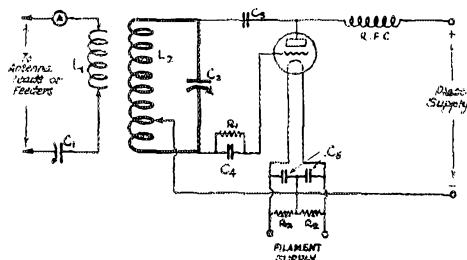

FIG. 3. THE SIMPLIFIED HARTLEY CIRCUIT OF THE "1929 TYPE" TRANSMITTER

- A—Thermocouple ammeter 0-1 amps.
- C1—500 μfd. receiver type variable condenser.
- C2—500 μfd. receiver type variable condenser of good quality.
- C3—500 μfd. fixed condensers.
- C4—250 μfd. fixed condenser.
- C5—2000 fd. fixed condensers.
- R1—10,000 ohm. gridleak.
- R2—50, 100 or 200 ohms fixed resistors or Christmas-Tree Lamps.
- R.R.C.—160 turns of No. 30 gauge D.C.C. wire on 3/4" diameter wooden rod.
- L1 and L2 for the various bands are described under the photograph of them.

values of antenna coupling this effect became much less marked, and at other values the "d.c." note was obtained on the reverse side of resonance. In quite the majority of runs, however, it was found essential to detune on one particular side of resonance in order to obtain the best note and the maximum frequency stability.

A COMPARISON OF CIRCUITS

Having made some preliminary studies of different circuits in regard to the variations of frequency caused by changes in plate voltage, and having been impressed by the similarity of their performance, a detailed comparison was undertaken at this stage. The various circuits were set up and in turn they were adjusted carefully to give their best performance. Then by tuning everything to resonance and by providing excessive grid excitation and antenna coupling they were each adjusted to give a series of poor performances. Scores of curves drawn from the data so obtained proved conclusively that the Hartley,

Tuned-grid tuned-plate, Colpitts and Ultraudion all were capable of producing equally poor frequency stability and note, and on the other hand, when they were adjusted correctly, that their maximum performance was definitely of the same order. In Figure 4 is reproduced a family of typically poor curves for the standard circuits. In all cases they represent similar input power and, as can be seen from the resonance curves, similar antenna current. Figure 5 is a selection of the best curves ob-

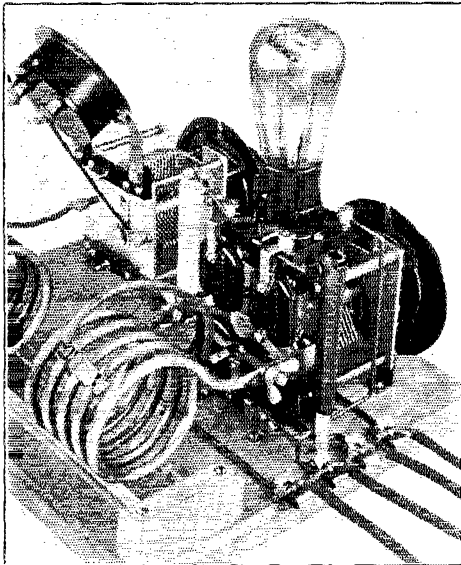

A "CLOSE-UP" SHOWING THE HEAVY "TANK" LEADS AND SOLID CONSTRUCTION

The plate and grid fixed condensers are mounted immediately under the tube socket. Below them are the two filament by-pass condensers and the center-tapped filament resistor. On the far side of the tube socket is the plate choke supported from the plate terminal. On the near side is the grid leak pushed over a wooden peg in the base-board. Heavy flexible wire is used for the filament lead to the inductance, a clip being permissible in this case on account of the low current to be passed by it. Relatively enormous currents flow in the coil-condenser circuit and in this case connections between the two must be made with wing nuts, or some similar device, in order to avoid serious losses.

tained with each circuit, input and output powers being held to the same value in each case. The latter curves, aside from their interest as proof that standard circuits are similar in their performance, were of great value to us in providing a statement of the best possible results that could be expected from present day self-excited amateur transmitters. With these curves we could make accurate compar-

isons of the improved performance resulting from modifications and refinements and so determine rapidly and definitely the relative merits of the various arrangements. The curves representing the performance of the "Transmitter With a 1929 Performance" are reproduced in Figures 6 & 7 to provide just such a comparison. From these curves it will be seen that the simple—in fact crude—rig illustrated in the photographs is capable of performing quite creditably. It has a frequency change when correctly tuned of but 6 Kc. as the antenna circuit is passed entirely through resonance. It will encounter a sudden 400-volt change of plate voltage and swing its frequency approximately 400 cycles. In consequence when operated from rectified and reasonably well filtered a.c. the "flutter" will be negligible and the output in consequence "musical". In fact, even when supplied from the unfiltered product of a motor-generator it is capable of turning out a note that can hardly be described as other than "d.c." *Always providing, of course, that it is tuned with extreme care in the manner to be outlined.*

And the circuit of this transmitter, disappointing though it may be, is nothing more than a simplified Hartley! Through all the work we had looked forward to the possibility of being able to insist that 1929 will not necessarily mean more complex or more expensive apparatus and even if we do anticipate some "raspberries" over the crudity of our sample transmitter we cannot disguise our pleasure at being able to state just that.

HIGH-C CIRCUITS

The feature of the transmitter which is directly responsible for its rather unusual performance is the plate oscillatory circuit, which is so proportioned as to have a preponderous of capacity. Such a circuit, having a low inductance-capacity ratio (to be described as a High-C circuit) has characteristics which make its use in the self-excited transmitter very desirable. A change from the inductance-capacity ratios in general present use to those indicated in Figure 8, for instance, resulted in a splendid improvement in the Antenna Tuning vs. Frequency curve (compare Figures 5 and 6); a distinct advance in the Plate Voltage vs. Frequency characteristic (compare Figures 1 and 7); and a corresponding improvement in the note. Of course, some minor disadvantages are involved.

In such High-C circuits, as the inductance is reduced and the capacity correspondingly increased, the circulating current mounts rapidly. Even with the UX-210 in the circuit of Figure 8, the radio-frequency current flowing through the plate coil and its condenser is of the order of 5 amperes, while with the larger

tubes, and similarly High-C plate circuits, currents as high as 16 or 18 amperes are to be expected. High currents such as these enormously exaggerate the weaknesses in the tuned circuits and for this reason, if self-excited circuits are to be operated successfully next year, the arrangement of the plate "tank" and the apparatus used in it will be matters of the greatest possible importance. If a typical wire or small strip inductance of the present day is used, the losses in it will mean a drastic reduction of power. If a poor condenser is asked to do duty it will introduce still further losses or, if the inductance is good enough to give it a chance, will end its useful life by burning up its insulation.

COIL AND CONDENSER VALUES

Of equal importance to the coil and condenser are the connections between them. Spindly leads between the coil and condenser with clips on them for adjustment of turns can cause a heavy loss of output power, even in a 7.5-watt transmitter, and usually will result in a greater loss of stability than the High-C circuit could hope to give. In the higher-powered transmitter the resistance of such leads and clips can well cause the circuit to be entirely inoperative. A successful High-C plate circuit will require the use of $\frac{1}{4}$ " copper tubing (or strip of similar surface area) for the coils of the transmitter of 50 watts or less, and at least $\frac{3}{8}$ " tubing or its equivalent for the higher powers. Then it will be necessary to determine the correct number of turns experimentally in order that the end turns may be screwed directly to the condenser terminals or to connecting strips. One satisfactory arrangement is that shown in the "close-up" of the transmitter. In this case "wing nuts" were fitted to the machine screws holding the inductance in order to facilitate changes from one band to another. In the case of the filament lead and other leads in the transmitter the currents are no higher than in the usual transmitter and consequently it is necessary to exercise only the ordinary care. The one redeeming feature of the "tank" condenser problem is that the voltages developed across a High-C circuit are much lower than in the circuits of the usual constants. For this reason good receiver-type condensers are satisfactory for transmitters operating with plate voltages of 1000 or less, while nothing more than "double spacing" should be necessary for transmitters employing the UX-852 or UV-204-A. It might be explained at this point that much higher capacities than those indicated in Figure 8 can be used if only heavy enough inductances and good enough condensers are used. Experiment with inductance-capacity ratios involving capacities as

high as 1000 μ fds. at 7100 and 14000 Kc. has indicated, however, that with the usual equipment available readily at the present time the losses involved with ratios higher

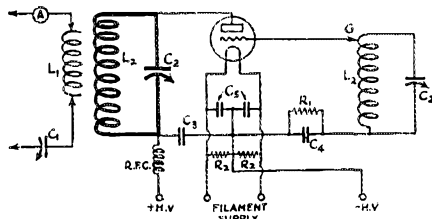

FIG. 9. SHOWING SIMILAR MODIFICATION OF THE TUNED-GRID TUNED-PLATE CIRCUITS. The grid clip "G" is provided to permit effective adjustment of grid excitation. The letters correspond to those of Fig. 8.

than that used in the transmitter illustrated are out of proportion to the increase in frequency stability afforded by them.

REBUILDING THE PLATE CIRCUIT

The modification of any present-day self-excited transmitter for operation with a High-C plate circuit is not a matter which should mean either appreciable expense or difficulty. In the transmitter used for work on all or several wave bands, a condenser of 500 μ fds. is suggested. For a transmitter which is to be operated exclusively on the 14,000-14,400 Kc. ("20-meter") and the 28,000-30,000 Kc. (10 meter) bands, a maximum capacity of 350 μ fds. should serve effectively. In the transmitter employing 1000 plate volts or less, a good receiver-type condenser should be satisfactory but it is suggested that it should not be considered above suspicion if trouble develops. In one of the experimental transmitters, fitted with a condenser of splendid reputation and operating with a single UX-210, a few hours of steady operation resulted in an invisible insulation breakdown which had the effect of reducing the output by about 50% and which caused the note to become a complete "hash". Under these conditions, obviously, all the careful tuning possible was of no avail. Another condenser of the same type, operated under similar conditions for several hours as a check, disappointed us by performing perfectly.

For the higher powered transmitters the use of two good transmitting condensers in parallel to give the suggested capacity values would serve but experimental work in progress at the moment (to be detailed in a future article) would seem to indicate the desirability of using an air-dielectric fixed condenser for the plate circuit, a small vernier being fitted for tuning. When

variable condensers are used, it must be remembered that the mere inclusion of a 500 μfd . size condenser in the set does not result in a High-C circuit unless the coils are so proportioned as to give the necessary frequency at the *upper end* of the condenser scale. For the 28,000-Kc. band the coil should be of such a size that about 200 μfd s. of the condenser are used; for the 14,000-Kc. band about 300 μfd s; for the 7,000-Kc. band about 400 μfd s; for

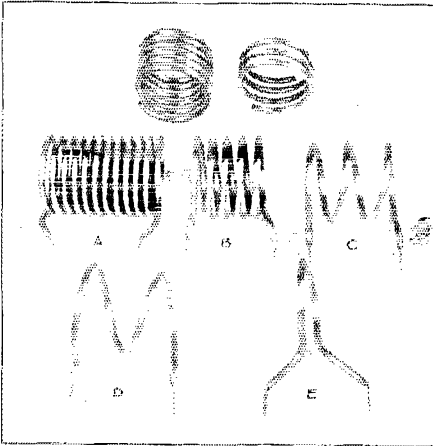

PLATE AND ANTENNA COILS FOR FIVE BANDS

Coils A, B, C, D and E are used for the 3,500-4,000 Kc. (80 meter), 7,000-7,300 Kc. ("40 meter"), 14,000-14,400 Kc. ("20 meter"), 28,000-30,000 Kc. (10 meter) and 56,000-60,000 Kc. (5 meter) bands, respectively. They have an inside diameter of $2\frac{1}{2}$ " and were made by winding the $\frac{1}{8}$ " soft copper tubing over a length of $2\frac{3}{4}$ " outside diameter iron water pipe by hand. To facilitate the winding process holes were first drilled in the pipe and the tubing, one end of the copper tubing being secured to the iron pipe with a machine screw before the winding was started. The ends of the coils are hammered flat and drilled to fit under the wing nuts which hold them to the condenser leads. Two antenna coils—to be seen above the plate coils—serve for use with coils A, B, C and D. Their size will be determined to some extent by the type and constants of the antenna.

the 3,500-Kc. band 450 μfd s., while for the 1715-Kc. band (on which frequency stability is not nearly so difficult to obtain) the same order of capacity is completely satisfactory. The coils shown in the photograph operate with just such capacities on the various bands in the particular transmitter for which they were wound. In the Tuned-grid tuned-plate or Colpitts circuit similar plate circuit constants are suitable.

THE PLATE SUPPLY

It is not possible to make a detailed discussion of the self-excited circuit performance without in some way considering the

problem of plate supply. At the same time, in view of the hundreds of thousands of words which have been written on the subject in *QST* and the Handbook, it is not thought necessary to give circuits or constructional details. If the transmitter is to be given any chance to perform in 1929 fashion, it is needless to say that the supply, if not generator or battery d.c. must be rectified and in some way filtered a.c. Further, the battery, generator, transformers, rectifiers and chokes must be capable of supplying or handling much greater currents than they will be asked to pass in actual operation, for if this is not so, the handicap of poor regulation will surely make the attainment of a 1929 signal more difficult.

There is also the same old problem of keying. Key clicks and sparking contacts will continue to be important, even if the transmitter is re-arranged and correctly tuned. In this case also, the incorporation of methods and the observation of precautions described in many *QST* articles and the Handbook will be necessary. A matter which will be of even greater importance with the 1929 self-excited transmitter is the elimination of antenna swaying and the vibration of the set or any of its radio frequency wiring. The modified arrangement and correct tuning admittedly will reduce the effect of these variations on the frequency but at the same time the character of the note will be so improved that these variations will be much more noticeable. With a 1928 transmitter in which the plate supply ripple "flutters" its frequency over a band of 15 or 20 Kcs., the effect of a swinging antenna or a vibrating lead is to a considerable extent lost in the mess. With an otherwise steady and "pure d.c." signal, however, any such weakness will protrude in all its infamy.

THE ESSENTIALS OF TUNING

And now, since the highlights of transmitter tuning have been so broadly scattered throughout this rambly screed, let us collect them in a simple statement of good procedure.

When the transmitter has been assembled, or re-assembled; when the antenna and its leads or feeders have been tightened or in some other way prevented from swaying; when it has been found that all leads or coils, and the transmitter itself, cannot vibrate; when the coils have been adjusted to give the desired frequency with the necessary value of capacity—then, and not until then, should the grid excitation be adjusted to give a plate current of about half the rated value with the antenna coil removed. In the Hartley this will mean adjustment of the filament clip in steps of about half an inch at a time, keeping mind,

for a rough guide, that the ratio of turns between the grid and filament clip and the turns between the plate and filament clip will be somewhere between 1 to 4 or 5. In the Tuned-grid tuned plate it will mean tuning of the grid circuit and the plate circuit and adjustment of the grid clip shown in Figure 9.

At this stage, when it is known definitely that the frequency is within the band, the antenna coil can be connected and coupled loosely to the plate coil. And loose coupling for the particular coils used in the Hartley transmitter illustrated is obtained with a spacing of *not less than five or six inches*. When the antenna has been tuned and the coupling increased to give the maximum antenna current, the value of that current should be noted mentally as something to avoid as one would the plague. Without delay the antenna coupling should be backed off until a point is reached at which the maximum current is about 85% of the previous value. And this reading should be recorded as something to be avoided with equivalent enthusiasm. At this stage the use of a "growler" (a shielded oscillator fitted with 'phones) or a receiver tuned to a weak harmonic becomes essential, for only by listening to the signal within the station is it practical to decide on which side of resonance the antenna is to be tuned to give the best note. Under practically all conditions, the correct adjustment will be obtained when the antenna is tuned to a lower frequency (a higher wavelength) than the oscillator but a comparison of the signal obtained in this way with that obtained on the other side of resonance will immediately indicate the desirable side. All that then remains is to detune the antenna on that side in order to give an antenna current of about 75% of the 85% peak value. *And this is the antenna current which should never be exceeded if the transmitter is to perform in the true 1929 manner.*

After a final check of the frequency, CQ's may now be pounded out in limited quantities and a QRK may be asked with a certain amount of confidence. If the reader has followed this story and put its suggestions into effect, he can expect a favorable report. It is conceivable, in fact, that the signal will inspire the answer "You have a 1929 signal, O.M." And, if he has previously listened to it himself in his own "Growler", he will know that he is entitled to believe it.

[As an extension of the subject of self-excited transmitters, the constructional

considerations involved in the modification of higher-powered transmitters will be discussed in the September QST.—Editor.]

Editorials

(Continued from Page 8)

more, because more of us are going to be knowing what we are doing than ever before! If we may throw in a free advertisement for the old mag, don't miss QST—we're going to have lots of hot stuff.

And so, taking things by and large, we feel a lot better. Everything looks pretty. In fact we insist upon being optimistic as anything. And in winding up this screed for the month we want to point out that a great deal of the activity around the world in the way of readjustment attests a recognition of the established position of amateur radio which is based upon the strength we have secured by virtue of being written into the international treaty as one of the classes of stations that always shall be provided for. Believe us, that is good! It looks to us like it may turn out that, having developed our technique to where we may operate happily in our limited facilities, it was really a blessing to us that this international conference came along and resulted in our international status being so definitely established. All we want to say is that any ham who wants to sell his station because "this is the last year of amateur radio" is just plumb foolish!

K. B. W.

Strays

The Radio Corp. station WIK, a useful marker in the vicinity of our "20-meter" band, was changed in frequency on June 24th to a new assignment at 13930 kc. (approximately 21.54 meters). A new E.C.A. station, WOP, is approaching completion and will be heard soon on 13900 kc.

9DPL, having read the recent newspaper report that Congress had changed the postal rate to permit other than government postal cards to be mailed with one cent postage, claims that this should surely result in QSL activity returning to normal.

The Headquarters Office of the Ninth District, Department of Commerce Radio Division, recently moved from the Federal Building to new quarters. Communications to the Supervisor of Radio in that district should now be addressed to 2022 The Engineering Building, Chicago, Ill.

Concerning Lunar Effects On Electromagnetic Waves

By Greenleaf W. Pickard*

READING the recent article by Mr. C. E. Paulson, entitled "Lunar Effects on Electromagnetic Waves," my first feeling was one of regret that the readings were not continued over a much longer period. For it can readily be shown that a cause and effect relation cannot be established by observations over so short an interval as thirty days, which is only one cycle of the alleged cause.

The moon's synodic period or lunar month is approximately 29.5 days, and differs but little from the period of solar rotation. It has already been established that one cause of reception changes is solar activity, which appears to center on certain areas of the sun's surface, which remain fixed in heliographic latitude and longitude for months and even years, and which usually contain sunspots. These active areas therefore rotate with the sun, and cross the central solar meridian at intervals of approximately 27.3 days. If on a particular day the full moon coincided with the earthward presentation of an active solar area, then a lunar month later full moon would come 2.2 days after the representation of the active area, and finally, in about 6.75 lunar months, or 199 days, full moon and active solar area would be in opposition. If both sun and moon cause reception changes, a minimum of over six months' observations would be required to disentangle the effects. I personally would wish at least two years' reception data before deciding that a lunar effect existed. As a matter of fact, I have before me over two years of continuous observations of night reception in the broadcast band, and in these data I find no lunar effect, although they show a high correlation with solar activity and terrestrial magnetism.

Unfortunately, I am not aware that anyone has yet taken systematic observations of 2XAF, or in fact of any particular high frequency transmitter, over a sufficient period to show the presence or absence of lunar effect, as a thing distinct from solar and magnetic elements. Although Mr. Paulson's single month of observations cannot in itself prove anything one way or the other, nevertheless it may be of interest to compare this with magnetic and solar activity, and also with another variety of night reception. In the figure, I have first replotted his graph of 2XAF (which had rather uneven time abscissa in the original) and un-

der it I have placed in descending order the diurnal range of the earth's horizontal magnetic field as measured at Cheltenham, Maryland, the Wolfer Provisional Sunspot Numbers and night reception at Newton Centre, Massachusetts, from WBBM at Chicago. The four curves appear to march together; if this be so, why give the moon any credit?

It is more difficult to discuss the purely physical side of the lunar hypothesis. But it might be well to call attention to the fact

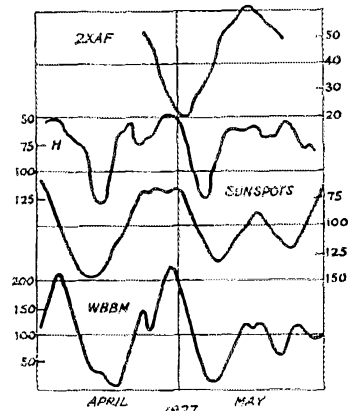

COMPARISON OF NIGHT RECEPTION FROM 2XAF, WBBM, DIURNAL RANGE OF H AND SUNSPOTS

that full moonlight has less than one hundred thousandth the intensity of sunlight, and is in addition but feebly polarized. This earth receives more polarized light in a day from the blue sky than it gets in years of moonlight. Even the solar corona (which is shining all the time, eclipse or no eclipse) is a stronger source of polarized light than the moon. And on grounds which are hard to summarize briefly, I do not think that moonlight, regardless of intensity or degree of polarization, can have any measurable effect upon radio transmission. Two sets of electromagnetic waves may pass simultaneously through the same space, but each is transmitted just as if the other did not exist. The only known way in which one radiation, such as light, may affect the transmission of another radiation, such as radio waves, is by producing a change in the medium, such as ionization. Sunlight does this for our atmosphere, and the effect is pronounced; moonlight at most would produce one thousandth of one per cent. of the solar effect.

*Consulting Engineer, Wireless Specialty Apparatus Company, Boston, Massachusetts.

Following the "Southern Cross" to Brisbane

By J. Walter Frates*

FOLLOWING in the tragic path of Captain Bill Erwin and Alvin Eichwaldt in the ill-fated "Dallas Spirit," the flight of the "Southern Cross," KHAB, from the Oakland Airport to Brisbane, Australia, across the untraveled airways of the broad Pacific, was not only the greatest feat in the history of aviation but also the final proof of the great value of short-wave radio communication for aviation and a great triumph for the amateur radio operators in all countries bordering on the Pacific.

Where the "Dallas Spirit," by its tragic tail-spin, left a question as to the reliability

Hawaii and Australia, Kingsford-Smith, Ulm, Captain Lyons and James Warner owe a debt of gratitude to that indomitable fraternity which is amateur radio, for they found that where there are land and people there is not always a commercial station but there is always an amateur. On that long breath-taking hop from Kausi in the Hawaiians to Suva in the Fijis, when daylight placed a limit to the range of the transmitter, lonely amateur operators at cable stations in some of the smaller isles watched over them and let the world know of their progress and well-being. Among these was Fanning Island 1AJ;



Photo Courtesy Associated Press

THE "SOUTHERN CROSS" BEFORE LEAVING THIS COUNTRY

of short-wave radio for exceptionally long distances, the "Southern Cross" continued and left not the slightest doubt, nor as to the ability of amateur operators and their equipment to hold them in constant hearing.

When commercial and "non-amateur" stations had either long since given up the ghost or were having difficulties on the Pacific Coast, amateurs in San Francisco and Oakland were still listening to the steady drone of the transmitter and comfortably copying positions until KHAB reported itself beyond the Loyalty Islands and within a few hundred miles of Brisbane, where daylight intervened and the burden of communication was taken up entirely by the enthusiastic Australian and New Zealand amateurs, some of whom had been copying the signals since the first night out of Oakland.

Although they received tremendously important and valuable assistance from commercial stations in the United States,

there were others whose calls we do not know.

KHAB carried three transmitters, a short-wave tuned-plate tuned-grid, made by Ralph Heintz, 6XBB, of San Francisco, a duplicate of the ones carried by the "Dallas Spirit" and by Captain Sir George Wilkins on his polar hop, and the same one the "Southern Cross" used on its endurance flights; a 600-meter rig; and an auxiliary distress arrangement. The short-wave transmitter was used mostly, although Warner, the operator, went to 600 at various times to get bearings from passing ships and shore stations. The short-wave transmitter utilized a 50-watt tube and was powered by wind-driven generators on the wings. It operated on 33.5 meters and the key was kept closed when the operator was not sending. Radio beacons were received on the plane but Warner had difficulty with them at various times.

San Francisco Bay amateurs made great plans to cover the flight on the night before the hop.

"Just stick by us," Smithy and Warner told us over the phone. "We'll try to make it interesting for you of the A.R.R.L." And they did.

As it passed out the Golden Gate, the "Southern Cross" QSO'ed 6ARD, a "non-amateur" station operated by the "San Francisco Examiner." Later it called 6AM and other coast amateurs but failed to hook. Throughout the day a steady watch was maintained from San Francisco and Oakland. 6IP and 6CZR copied the plane from 6OT, furnishing information to the general public. 6CKC, 6BFU, and 6JS did likewise for an Oakland newspaper. 6RJ furnished dope to a broadcasting station. 6ALX and 6CGM assisted the other A.R.R.L. operators. 6AHB was also part of the listening staff, as was 6EDK. In San Francisco 6ARD attended to the wants of its proprietors, and 6KW kept a watch for a press association.

Amateur operators did not copy messages addressed to 6ARD, the "San Francisco Examiner," or personal messages, in spite of the fact that they were sent "QST 6ARD de KHAB" and that it was an emergency case in which the general public was interested. In the early evening, after about an hour on 600 meters, KHAB returned on short waves and Warner sent a broadcast to all amateurs informing them that the "San Francisco Examiner" would prosecute all those giving out messages addressed to 6ARD, under previous contracts. Some time later the men on the plane must have realized the injustice of this and of their danger if every amateur shut off his receiver, for, with the statement, "the world deserves to know what is going on with the "Southern Cross", they began to send information about the progress of the flight under a general Q.S.T. non-addressed. The incident brought up an interesting question as to whether an SOS would be considered by the "Examiner" as its personal property, and, if every amateur shut off his set and 6ARD could not receive the distress call, whether previous contracts would benefit the airmen following its transmission.

From the twilight hours of the first evening, a constant watch was maintained at 6CZR by the writer and 6IP, with the assistance of 6EDK, 6AHH, 6BDO, and Earle Ennis, writer and experimenter, until the plane passed the Loyalty Islands and daylight put an end to further work. KHAB's signal strength varied from R4 to R7 and 8 during the entire flight. The greatest signal strength was recorded when the plane was nearing Honolulu and the sun was shining brightly on the Pacific Coast. The note was rougher than that of the "Dallas Spirit," particularly on the Kauai-Suva hop when the plane struck bad

weather and Smithy maneuvered it with inhuman skill to 10,000 feet. Bad swinging was also noticed. Reports from wire services in San Francisco indicated that amateur reports were beating those of "non-amateur" stations, Navy radio and the commercial companies. Some of the latter lost the signals entirely. However, 6KW continued to maintain his watch in San Francisco for the press services, and the plane's signals still droned into 6CZR.

Hawaiian amateurs also did excellent work. OH6CLJ, who was one of the men who worked on the Dole flight skeds, reported in to the 6CZR operators through 6DBM of San Francisco that he was copying the plane easily and would stand-by. He was asked to QST the arrival on 19 meters but the signals did not get across OH6DUD, Wheeler Field, also agreed to QST on 20 meters, as did oh6ADH, who handled a lot of traffic for the aviators after their arrival at Wheeler. Other Hawaiians cooperated.

In Alaska a number of amateurs were asked to QRX for the plane's signals and did so, among them na6ZZE at Bristol Bay and na7LY. Seventh-District amateurs scored at various times by furnishing perfect copy when copy in the Sixth District was patchy. A Seventh-District amateur did all operators a favor when he got into communication with a Nicaraguan station on the plane's wave and asked him to QRT as he was QRming the signals.

9CKF in South Dakota, inveterate long-distance sked man, got his information on the progress of the flight from oa5HG and other Aussies and Zedders who were watching over the welfare of the Aussie air men in their daring jump across the awe-inspiring waste of the Pacific. 6CIS and 6CBS of Sacramento followed the progress of the plane from 6CIS, but were bothered with QRM.

Amateur stations in Australia, New Zealand, Japan, China and other points were heard calling the plane at intervals during the flight, but failed to hook like the Americans and the Hawaiians, caused in all probability, by the fact that Warner was too busy with his own work to bother about QSO's and that he was not hearing well on account of motor and generator QRM.

In the not-far-distant future when aerial fleets will be making transcontinental and transoceanic passenger and freight flights and will carry on their radio communication on a short-wave band similar to the marine work on 600 meters, a great deal of the credit for the work will be due to the pioneering efforts of the amateur, who devoted his time and equipment unselfishly for the advancement of the art and without a pecuniary interest.

Acoustic Wave Filters and Audio Frequency Selectivity

By R. B. Bourne*

One of the greatest worries confronting the transmitting amateur is the great mutual interference which it is feared will obtain in the narrow bands next year. One of our crying needs, therefore, is a method for securing greater selectivity than we have ever known. The inherent principles of heterodyne reception are such as to produce interference in the telephones from any signals within an audible frequency difference from the desired signal, and we know no way of overcoming this fundamental difficulty by ordinary radio-frequency means. Electric band-pass filters may be used at "intermediate" or at audio frequencies to cut out unwanted signals. Their use at intermediate frequencies offers promise but of course involves the use of the superheterodyne. At audio frequencies the electric filter is quite expensive, bulky, and very likely to have considerable losses. This article describes another device to accomplish the same end—an acoustic band-pass filter. It is beautifully effective if the received signal is what it should be—and what it must be to survive next year. The filter described may be built by any amateur at trifling expense. It should be a part of every amateur's preparation to meet 1929 conditions. Its use will guarantee, we believe, the successful employment of the autodyne receiver next year. Taken in conjunction with Mr. Hull's article in this issue on transmitter adjustment, we feel encouraged to prophesy successful operation in 1929 with equipment differing but little from that of to-day.—Editor.

THE need for greatly increased selectivity in c.w. receivers becomes apparent immediately that serious thought is given to the problems confronting the transmitting amateur. In order to use satisfactorily the narrowed amateur transmission bands to be in effect at the first of next year, we must be able to crowd into those bands not only all the stations now operating within them but also foreign stations as well. It is with this nice problem in mind that the writer presents this paper.

Let me say at the start, however, that the success of the devices to be described in the following pages is bound up irrevocably with and is dependent entirely upon vital improvements in transmitters. As will be pointed out shortly, our transmitters, to utilize effectively the possible selectivity in receivers, will have to have a steady, pure wave. Just how steady and how pure this will have to be will be shown. Crystal-controlled d.c.-plate-supply transmitters will, of course,

be ideal.

To get a picture of the selectivity obtainable by the use of acoustic wave filters in conjunction with a good autodyne receiver, consider a receiver operating at say 7000 kcs. (40 meters), using a 50- μ fd. tuning condenser. Imagine we are receiving a signal from a local oscillator, B-battery supply and rigidly constructed. The note is pure and steady. We can probably

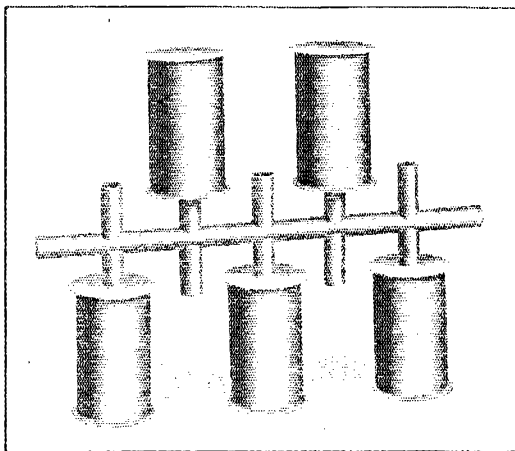

tune this signal in and out again on the other side of zero beat in say three degrees of our tuning condenser dial. This means that 1.5 degrees are used in changing the beat note from zero to say 10,000 cycles. Now suppose we have a vernier tuning condenser of such size that this range of 0 to 10,000 cycles is made to extend from zero to 100 degrees on the dial of the vernier. A cou-

sing wave filters can easily be made which will pass a band of audio frequencies of any desired width and with one particular filter in mind, our steady d.c. signal would be heard over but *three degrees of the vernier dial!* This would seem to indicate that some thirty other signals could

*1ANA, 221 Holcomb St., Hartford, Conn; Research Engineer, Maxim Silencer Co. Hartford.

be present in the range of the vernier, but it should be pointed out that, with the ordinary autodyne, a beat note of given pitch can be heard in two places on the tuning dial, so perhaps it would be more conservative to say that the selectivity has been increased to such an extent that fifteen times as many stations can be accommodated in a given band as at present. Such selectivity is undoubtedly desirable. It is useful, however, only if practically all

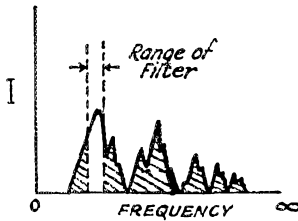

FIG. 1

the energy of the beat note is concentrated within the limits of the pass-band of the filter. The acoustic wave filter makes possible the reception of an R3 signal in the presence of an R8 signal differing in frequency only 100 cycles.

Consider Fig. 1. This shows the frequency spectrum of a steady but impure note plotted against intensity. Such a note is produced by the average indifferent plate supply. In case the frequency of the transmitter is wobbling, as well, Fig. 1 represents an instantaneous set of values which shift around as the transmitter wave shifts. With no filter in the audio end of the receiver, all these components register upon the ear, generally with the effect sometimes called "noise." Many of the components do not contribute to the "audibility" of the signal, since their effect is masked by other and more intense components. A considerable percentage of the energy sent out is thus unavailable, in any case, for the production of maximum signal strength. If, now, an audio-frequency filter is inserted in the output, so as to attenuate all frequencies excepting a very narrow band, we see, still referring to Fig. 1, that a large percentage of the total energy present is cut out and the net effect on the ear is a signal very much reduced in intensity, sounding not at all like the unfiltered signal. Only those components of the complex audio frequency which lie within the pass-band of the filter will get through. The shaded area represents the unavailable energy.

The solution of this difficulty immediately suggests itself. Let us put as much as possible of our energy in one frequency lump and tune our receiver so that this frequency falls within the pass-band of

the filter. Then we will have a state of things such as is shown in Fig. 2. Here, our pure note, excepting a few weak harmonics, is all nicely concentrated, and comes through the filter unattenuated. Excepting for slight resistance losses, which increase with the frequency, filters can be made to have zero attenuation within the pass-band.

Granting a pure wave, the filter will still be useless unless the beat note can be held within the pass-band of the filter. A "chirpy" note will swing across the band and only parts of the transmission can be heard. With both the impure note and the swinging and wobbling note, the apparent selectivity is not a bit improved since, with the former, we may tune into any set of components, there being several, and with the latter, we may catch the note on any part of its swing. The note must be pure and it must be steady. If perfect steadiness is not practical, then we may widen the width of the pass-band, to allow the note to do a little swinging. The selectivity will suffer, of course, in proportion to the increased width of the pass-band.

What filters can be employed to accomplish these results? Either electrical or acoustic wave filters. The former, to be effective for our purpose, turn out to be

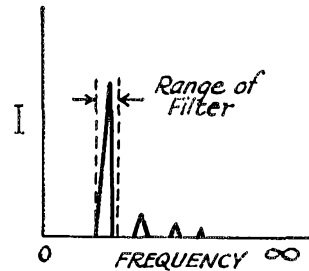

FIG. 2

expensive and cumbersome. Acoustic wave filters may be readily built by anyone capable of doing mechanical work such as is usually associated with the construction of a good receiver.

Many amateurs, when the word "filter" is mentioned, visualize a 30-henry choke coil and a condenser with as many microfarads as the pocket-book can afford. Electric wave filters, which were invented by Campbell,¹ are structures which have negligible transmission loss over a definite range or ranges of frequencies and have an appreciable transmission loss at all other frequencies. Such structures generally take the form of recurrent similar networks comprising series and shunt elements. The theory

1. U. S. Patent No. 1,227,118.

supposes either an infinite number of similar sections in cascade or a finite number of sections terminated in a structure the impedance of which is equal to the char-

acteristic impedance of the filter. From three to five sections are generally sufficient to give all the attenuation desired for frequencies it is desired to suppress. Terminating or inaugurating a filter improperly gives rise to reflection effects which disturb the operation of the structure. A filter is therefore designed to work out of and into a certain impedance.

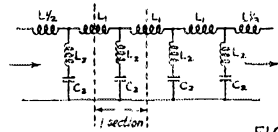

FIG. 3

Probably the simplest and most familiar filter is the "low-pass" type which passes currents from zero frequency (d.c.) up to a certain frequency called the "cut-off" frequency, and attenuates currents of all frequencies. A "band-pass" filter readily passes currents of all frequencies lying within the upper and lower limits of the band and bars all others.

G. W. Stewart² made a series of studies of the acoustic wave filter as an analogue of the electric wave filter. His theory assumed lumped constants and no progressive wave motion within the device. This means that the dimensions of the series and shunt elements comprising the filter are small, say a tenth, compared to the wavelength. With a given physical structure, the dimensions of which are small

observed and calculated values of the main band agree within the limits of observation (5%).

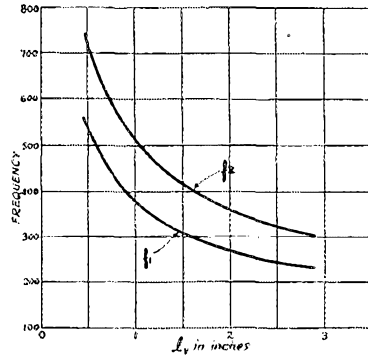

FIG. 5. SHOWING THE EFFECT OF L_v ON THE POSITION OF THE PASS-BAND IN THE FREQUENCY SPECTRUM

A picture of acoustic inductance and capacitance may be obtained by considering a bottle-like resonator. Again, assuming the dimensions of the resonator to be small compared to the wavelength of the sound, let us see what happens when an incident sound wave is impressed upon the neck of the resonator. The small plug of air in the neck moves back and forth more or less as a whole,

suffering little or no compression. The motion of this short column of air compresses and rarefies the air within the closed cavity. The compression is accomplished with little motion. Here, then, we have acoustic inductance in the neck and acoustic capacity in the closed cavity. We would expect such a system to oscillate when excited by a current of air blown across the mouth of the neck, and furthermore to oscillate at a frequency determined by the inductance of the neck and the capacity of the cavity. It does. A resonator exposed to a sound wave of its resonant frequency amplifies the intensity in the neck of the resonator.

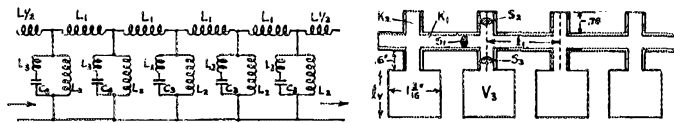

FIG. 4

compared to the wavelength of the sound dealt with, it is easy to see that this important relation soon fails to hold if the frequency increases very much. In other words, it is impossible to build an acoustic filter which is the exact analogue of its electrical counterpart because the constants—inductance and capacity—cease to be "lumped" and become distributed. A combination of electric lines would seem to resemble the acoustic filter. The theory underlying the principles of the acoustic

2. Phys. Rev. 20, 528—1922.

3. W. P. Mason, Bell System Tech. Journal, April, 1927.

A short tube open at both ends, then, acts as an inductance, while a small closed cavity acts as a capacitance, "short" and "small" being used in a comparative sense. We may have an acoustic inductance with-

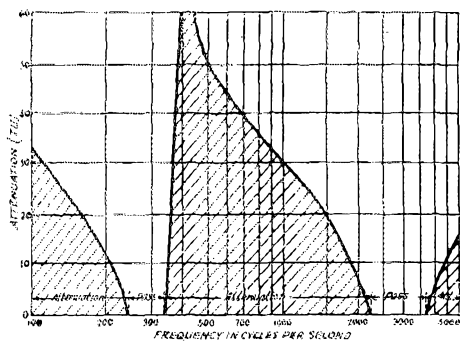

FIG. 6. CHARACTERISTICS FOR THE L-SECTION ACOUSTIC FILTER SHOWN IN FIG. 4

out appreciable capacity but not a capacity without inductance, since even a hole of the smallest conceivable length presents some inductance. By properly choosing an arrangement of tubes and cavities, we can build an acoustic wave filter with predetermined characteristics, insofar as the limits of theory permit.

We have now to establish the necessary formulae for acoustic inductance and capacity. Their derivation will not be given and we write simply:

$$\text{Acoustic Inductance} = L_s = \frac{l \times \rho}{S}$$

where l = length of tube (inches)
 ρ = density of air.
 S = cross sectional area of tube (sq. in.).

$$\text{Acoustic capacity} = C_s = \frac{V}{a^2 \rho}$$

where V = volume (cu. in.).
 a = velocity of sound (13,600 in./sec. at room temperature).

It happens that, in the formulae encountered, ρ cancels out so we need not worry about its value. This also means that barometric pressure does not affect the values of the cut-off frequencies. We introduce another term "conductivity", which is useful in simplifying formulae.

$$\text{Conductivity } K = \frac{\rho}{L_s} = \frac{S}{l} \text{ for a tube,}$$

and is equal to the diameter of a round hole in a thin plate, where that form of

coupling to a cavity is used. The length l of a tube must be corrected for the flaring out effect at the end of the tube and we use for this correction $\frac{\pi R}{2}$ where R is the

radius of the tube. In the case of tubes as side branches, we measure the length of the tube starting from the center of the main channel tube and not from its edge. No end correction is, of course, applied to a tube closed at one end.

Fig. 3 shows an electrical low-pass filter of four sections (T type) and its acoustic counterpart. We choose this type of low-pass filter rather than the simpler one in which there is no inductance in series with the shunt capacity since, if we try to make an acoustic capacity without an inductance in series with it, the question arises as to whether the capacity is in shunt or in series with the main channel inductance. Furthermore, this type of filter gives a sharper cut-off than one consisting of series inductances and shunt capacities.

Since these are low-pass filters the lower cut-off frequency $f_1 = 0$. For the electric filter the higher cut-off frequency is f_2 .

$$f_2 = \frac{1}{\pi} \sqrt{\frac{1}{C_2 (L_1 + 4L_2)}}$$

and for the acoustic filter

$$f_2 = \frac{a}{\pi} \sqrt{\frac{K_1}{V_2} \left(\frac{1}{1 + \frac{aK_1}{K_2}} \right)}$$

which formula is directly obtainable from the electric case by substituting the acoustic values therein.

While we may use a low-pass filter having a cut-off at say 500 cycles, with considerable success, a band-pass filter is more desirable. For the latter, we choose a network which is readily reproducible in the acoustic form. Fig. 4 shows both the electrical and acoustic filters. In this case, we have attenuation from 0 up to f_1 -- f_2 on up, there being no attenuation within the range $f_1 - f_2$.

For the electric filter, we have

$$f_1 = \frac{1}{2\pi} \sqrt{\frac{1}{C_3 (L_2 + L_3)}}$$

$$f_2 = \frac{1}{2\pi} \sqrt{\frac{L_1 + 4L_2}{C_3 (L_1 L_3 + L_1 L_2 + 4L_2 L_3)}}$$

and for the acoustic filter

$$f_1 = \frac{a}{2\pi} \sqrt{\frac{1}{V_3 \left(\frac{1}{K_2} + \frac{1}{K_3} \right)}}$$

$$f_2 = \frac{a}{2\pi} \sqrt{\frac{K_2}{V_3} \left[\frac{1 + \frac{4K_1}{K_2}}{1 + \frac{K_2}{K_3} + \frac{4K_1}{K_3}} \right]}$$

Inspecting these formulae, we see that both f_1 and f_2 vary inversely as the square root of the volume of the chamber V_3 . This means that we may shift the location of the pass-band by varying the length of the tubular chamber V_3 , as with a piston-like plug. Fig. 5 shows a plot of these two frequencies versus the length l , for the filter shown.

For the benefit of those interested, the appendix contains the derivation of some of these formulae. We will, at this point, go through the calculations involved in designing the particular band-pass filter shown in the illustration.

We chose, as a suitable size, brass tubing $\frac{3}{8}$ " outside diameter and $5/16$ " inside diameter. For the Volume V_3 , we use brass tubing $1\ 3/16$ " inside diameter. We make l_1 , the diameter in the main channel from section to section, 1.25 inches. $S_1 = .077$ sq. in. $R_1 = .166$ in. $l_v = 2.25$ in.

$$K_1 = \frac{S_1}{l_1} = \frac{.077}{1.25} = .0615$$

$$K_2 = \frac{S_2}{l_2} = \frac{.077}{.78 + \frac{\pi \times .156}{2} + \frac{.1}{16}} = \frac{.077}{.78 + .245 + .188} = .0635$$

$$K_3 = \frac{S_3}{l_3} = \frac{.077}{.6 + \frac{.3}{16} + \frac{\pi \times .156}{2}} = .0745$$

$$V_3 = \frac{\pi \left(\frac{3}{16}\right)^2}{4} \times l_v = 2.5 \text{ cu. in.}$$

$$\frac{a}{2\pi} = \frac{1130 \times 12}{2\pi} = 2160$$

substituting, we have

$$f_1 = 2160 \sqrt{2.5 \left(\frac{1}{.0635} + \frac{1}{.0745} \right)} = \sqrt{730} = 253 \text{ cycles/sec.}$$

$$f_2 = 2160 \sqrt{\frac{.0635}{2.5} \left[\frac{1 + \frac{4 \times .0615}{.0635}}{1 + \frac{.0635}{.0745} + \frac{4 \times .0615}{.0745}} \right]} = 2160 \sqrt{.0245338} \text{ cycles/sec.}$$

The observed values for f_1 and f_2 are 245 and 335 cycles, respectively, a close agreement.

In designing a filter of this type, the lower cut-off frequency may be assumed and the side-branch system designed for it, since the distance between sections in the main line does not affect this value. Once the dimensions of the side branches are

fixed, the upper cut-off may be determined by assuming the dimensions of the main channel. It simplifies the calculations to use the same size of tubing for the main channel as is used for the tubes involved in the side-branches. Of course many other arrangements of elements are pos-

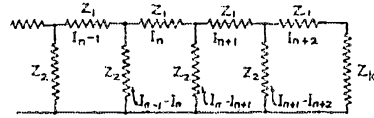

FIG. 7 (Appendix)

sible, and the reader, using the information contained herein and in the Appendix, may design any type of filter, being always careful not to exceed the limits imposed by the theory.

For our terminating impedance, we use the resistance of the rubber tube of the listening device, in this case a Dictaphone head-set. This will attenuate some of the higher frequencies, as well, so that the over-all effect is about as it should be. Since the filter is made in five sections, the maximum total attenuation in the stop-bands is very high, of the order of 60 TU. TU is the abbreviation for "transmission unit" and the number of TU's by which two power levels W_1 and W_2 are said to differ is given by the relation.

$$N_{TU} = 10 \log_{10} W_1/W_2$$

On this basis, 60 TU represents a loss in the ratio of a million to one, or an intensity ratio of a thousand to one. Within the transmitted band there will be some attenuation due to friction in the filter and in the stethoscope tubes. To make up for this, an additional stage of audio-frequency amplification is recommended.

The acoustic wave filter is not in any way presented as a static eliminator, but it will be noticed by those using the device that there is a material reduction in noise. Since the audio-frequency components of noise cover practically all frequencies, some of them will lie within the pass-bands of the filter.

The filter is inserted between a single telephone receiver and the stethoscope. If a loudspeaker is to be used after the filter, the whole arrangement must be sound-proofed by placing in a suitable box of ample dimensions; otherwise, sounds emerging from the open tubes of the side branches will affect the apparent performance.

CONSTRUCTING THE FILTER SHOWN

The band-pass filter described previously is very easily built, the only tools required being a hack-saw, files, hand drill, soldering iron, vise and possibly tin-snips. No lathe work is necessary. A blow-torch may be used.

Fig. 8 shows a sketch of the first section of the filter. All sections being similar, the work is greatly simplified. Saw off a piece of the $\frac{3}{8}$ -in. tubing $7\frac{1}{2}$ in. long and place in a vise. Starting $1\frac{1}{4}$ inches from one end, make prick-punch marks every $1\frac{1}{4}$ inches. These locate the holes through the main tube. Using a $\frac{5}{16}$ -in. drill, taking care to keep it at right angles to the axis of the main tube, drill right through. We now have the main tube complete, with two lines of holes.

We next make all the side-branch tubes. These are done one at a time. File the end of a long piece of tubing stock to fit the main tube. This is readily done with a $\frac{5}{16}$ -inch rat-tail file. When the fit is accomplished, saw off and trim five such pieces, measuring 0.6 in. from the bottom of the groove to the end. Make five others 0.78 in. long, measured from the bottom of the groove. Making the side tubes in this

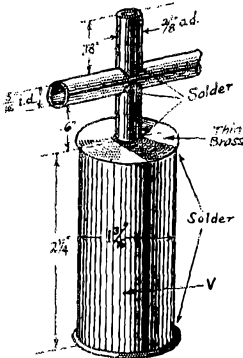

FIG. 8

manner reduces the possible wastage, since it is difficult to file a groove to fit and to dimensions at the same time.

Next, we solder the side tubes to the main tube, taking one of each size for the pair. The three tubes are soldered at the junction point simultaneously by holding in the vise, the jaws of the latter embracing the flat ends of the side tubes. Take care that no undue amount of solder runs into the main channel. When both tubes are in place, their axes should coincide. Proceeding in the same manner, solder on all the pairs of side tubes, protecting the soldered ones from the heat by wrapping with a wet cloth. On account of the diameter of the

cavity used, it is necessary to stagger the adjacent sections as shown in the photograph of the filter. Adjacent tubes on one side of the main tube thus will be alternately short and long.

Now cut out five discs of thin brass, $1\frac{3}{8}$ inch in diameter, and drill a $\frac{5}{16}$ -inch hole in the center. Solder one of these to each of the flat ends of the five 0.6-inch side tubes. Cut out five more discs with no hole to be used in closing the far end of the tube forming the volume V. These cavities are made from $1\text{-}3/16$ inch inside-diameter brass tubing $2\frac{1}{4}$ inches long. Solder these to the five discs previously attached, then solder on the plain discs at the ends of the large tubes, and the job is done.

If a higher range of frequencies is desired for the pass-band, make the length of the large tube (l_v) less than $2\frac{1}{4}$ inches. The relation between these frequencies and the length of the large tube has previously been given.

The filter becomes a low-pass filter if the open tubes be closed. It is an interesting experiment.

APPENDIX:

Referring to Fig. 7, we write, from Kirchoff's Laws,

$$I_n Z_1 + (I_n - I_{n+1}) Z_2 - (I_{n-1} - I_n) Z_2 = 0$$

collecting terms

$$I_n (Z_1 + 2Z_2) - (I_{n+1} + I_{n-1}) Z_2 = 0$$

$$\frac{Z_1 + 2Z_2}{Z_2} = \frac{I_{n+1}}{I_n} + \frac{I_{n-1}}{I_n} = \frac{1}{\frac{I_n}{I_{n+1}}} + \frac{I_{n-1}}{I_n}$$

Now the currents in successive stages change logarithmically, and satisfy the relation

$$\log \frac{I_n}{I_{n+1}} = P, \text{ or } \frac{I_n}{I_{n+1}} = e^P.$$

Where P is the propagation constant and equals by definition $A + jB$. The real part of this expression, A, is the attenuation constant, while B denotes the phase shift from section to section.

$$\therefore \frac{Z_1 + 2Z_2}{Z_2} = \frac{1}{e^P} + e^P = e^P + e^{-P}$$

$$1 + \frac{Z_1}{2Z_2} = \frac{e^P + e^{-P}}{2} \equiv \text{Cosh } P$$

Now Cosh P can never be less than + 1 nor greater than - 1. Therefore for values of $1 + \frac{Z_1}{2Z_2}$ which lie between + 1 and - 1, P is imaginary and A = 0. This means a "pass-band" and no attenuating. Equating,

$$1 + \frac{Z_1}{2Z_2} = +1 \text{ or } \frac{Z_1}{Z_2} = 0$$

$$1 + \frac{Z_1}{2Z_2} = -1 \text{ or } \frac{Z_1}{Z_2} = -4$$

These are the limits of no attenuation. Referring to the band-pass filter of Fig. 4,

$$Z_1 = j\omega L_1 \text{ and } Z_2 = \frac{1}{\frac{1}{j\omega L_2} + \frac{1}{j\omega L_3 + \frac{1}{j\omega C_3}}}$$

$$= \frac{j\omega L_2 - j\omega^3 L_2 L_3 C_3}{1 - \omega^2 L_3 C_3 - \omega^2 L_2 C_3}$$

$$\frac{Z_1}{Z_2} = \frac{j\omega L_1 - j\omega^3 L_1 L_3 C_3 - j\omega^3 L_1 L_2 C_3}{j\omega L_2 - j\omega^3 L_2 L_3 C_3}$$

$$= \frac{L_1 - \omega^2 C_3 (L_1 L_3 + L_1 L_2)}{L_2 - \omega^2 C_3 L_2 L_3}$$

Now, for $\frac{Z_1}{Z_2} = 0$, $L_1 = \omega_1^2 C_3 (L_1 L_3 + L_1 L_2)$ or

$$\omega_1^2 = \frac{1}{C_3 (L_2 + L_3)}, \text{ whence}$$

$$f_1 = \frac{\omega_1}{2\pi} = \frac{1}{2\pi} \sqrt{\frac{1}{C_3 (L_2 + L_3)}}$$

And, for $\frac{Z_1}{Z_2} = -4$, we have

$$L_1 - \omega_2^2 C_3 (L_1 L_3 + L_1 L_2) = 4\omega_2^2 C_3 L_2 L_3 - 4L_2$$

$$\text{whence } \omega_2^2 C_3 = \frac{L_1 + 4L_2}{L_1 L_3 + L_1 L_2 + 4L_2 L_3} \text{ and}$$

$$f_2 = \frac{1}{2\pi} \sqrt{\frac{L_1 + 4L_2}{C_3 (L_1 L_3 + L_1 L_2 + 4L_2 L_3)}}$$

Now, in the acoustic case,

$$L = \frac{\rho}{K} \text{ and } C = \frac{V}{a^2 \rho}$$

Substituting in the expression for f_1 , we have

$$f_1 = \frac{1}{2\pi} \sqrt{\frac{1}{V_3 \frac{\rho}{a^2} \left(\frac{\rho}{K_2} + \frac{\rho}{K_3} \right)}} = \frac{a}{2\pi} \sqrt{V_3 \left(\frac{1}{K_2} + \frac{1}{K_3} \right)}$$

Rearranging the expression for f_2 , we have

$$f_2 = \frac{1}{2\pi} \sqrt{\frac{L_1 \left(1 + \frac{4L_2}{L_1} \right)}{C_3 L_2 \left(L_3 + L_2 + \frac{4L_2 L_3}{L_1} \right)}}$$

$$= \frac{1}{2\pi} \sqrt{\frac{1 + \frac{4L_2}{L_1}}{C_3 L_2 \left(\frac{L_3}{L_2} + 1 + \frac{4L_3}{L_1} \right)}}$$

Substituting the acoustic values, we have

$$f_2 = \frac{1}{2\pi} \sqrt{\frac{1 + \frac{4K_1 \rho}{K_2 \rho}}{V_3 \frac{\rho}{a^2} \left(\frac{\rho}{K_3} + 1 + \frac{4K_1 \rho}{K_3 \rho} \right)}}$$

$$= \frac{a}{2\pi} \sqrt{\frac{K_2}{V_3} \left(\frac{1 + \frac{4K_1}{K_2}}{1 + \frac{K_2}{K_3} + \frac{4K_1}{K_3}} \right)}$$

Strays

The Jenkins Laboratories, 1519 Connecticut Ave., Washington, D. C., announce a series of television transmissions especially for A.R.R.L. members on each Monday night commencing July 2d. The transmissions begin at 8 P.M., Eastern Standard Time, and continue for one hour. The call is 3XK, the frequency 6420 Kc. (46.73 meters), 15 pictures per second, 48 lines per picture. In each transmission simple subjects will be sent the first five minutes, then more elaborate subjects for five minutes each, followed then by a picture story.

Mr. Jenkins calls the transmissions "broadcast motion pictures". Each subject will be preceded by a code announcement, and each picture will conclude with the word "End", which will mean, of course, to throw the switch back to the loudspeaker for next announcement. For the first several weeks only silhouettes will be transmitted; later halftone pictures will be broadcast. If sufficient interest is shown, transmissions will be increased to twice or three times a week. Amateurs receiving these transmissions are requested to advise the Jenkins Laboratories and A.R.R.L. Headquarters.

Some More About Amateur Television

By Harold P. Westman, Technical Editor

THE article that appeared on page 17 of the May, 1928, issue of *QST* gave a considerable amount of information pertinent to television reception equipment in general and touched to some extent upon the particular transmissions from WGY at Schenectady. Unfortunately, at the time it was written, we had no definite schedules on these transmissions and in spite of a footnote to this effect have received a large number of requests for additional information.

The present schedules from WGY are as follows:

Sunday—10:15 to 10:30 p.m. E.D.S.T.

Tuesday, Thursday and Friday—1:30 to 2:00 p.m. E.D.S.T. At such times as these schedules are run, announcements are made concerning the others and it is very probable that if any change is made in this schedule, those listening in will be informed to that effect. Transmission takes place on two frequencies, the regular broadcast frequency of 790 kc. and a higher frequency of 13,660 kc. (21.96 meters).

A 24-line picture is sent at the rate of 20 per second in these transmissions which means that if you have constructed a disc with 48 holes you must either cover up each alternate hole or lay that disc aside for use on the Jenkins transmissions mentioned elsewhere in this issue. The scanning disc should revolve at the rate of 1200 r.p.m.

Many seem to be having difficulty in laying out the spiral. There are three prime things to be considered in such a problem: the number of lines per picture, the proportions of the picture, i.e., square or rectangular, and the dimensions of the picture. The first two of these are important and if they are changed will result in inaccuracies in the picture or distortion. If the wrong number of holes is used, the results will be nil, whereas if the proportions are incorrect, the picture will appear to be stretched in one dimension and compressed in the other. From this we see that the number of holes *must* be correct and that the proportions may vary somewhat. The dimensions can vary considerably, for if the picture is made too large, the effect will be that of using a coarse screen in printing.

We know that there must be 24 holes, the proportions of the picture are approximately square and slight variations will not be extremely damaging. The size of the picture will depend upon the amount of illumination which one gets from the neon tube.

Suppose we want a picture of about 1" by 1". It will not be exactly square because the holes are to be an equal number of degrees of a circle apart rather than an equal linear distance apart. Start out with a disc of about 8 inches in diameter and draw a circle of about seven inches in diameter. Leaving the compass set at the radius of the circle, mark off equal divisions around the circumference of it. The circle will then be divided in six parts. Laying a rule across opposite points, draw lines through the center and across the entire disc. You will have three such lines. The arc of the circle between each adjacent pair of lines must then be subdivided to give three points. This can be done by "cut and try" and should not prove to be very difficult. After drawing straight lines through the opposite points, we have a circle divided into 24 triangular shaped pieces. The dividing lines are spaced an equal number of degrees apart.

The next thing to do is to mount the disc on its hub being sure that it is not mounted off center to the circle already inscribed. A way to check this is to prick-punch the center of the shaft and while it is being rotated by the motor, press the end of a drill against the punch mark. A small amount of metal will be cut off and the drill will find the center of the shaft. Using this as the center, the compass may be used to indicate how far off its proper position the disc may be.

Run the $\frac{1}{4}$ " shaft on which the disc is to be mounted through the hub so disc is to be mounted through the hub so that about an inch of it sticks out of the hub. Tie a piece of light string so that it will not slip around the shaft and with about half a turn around the shaft, make a loop in the end that will accommodate a lead pencil. The point of the pencil can then be made to trace a spiral as it is revolved around the shaft. The cord will be shorter after each full revolution by an amount approximately equal to the circumference of the shaft. If the disc is of metal and self supporting, the pencil can be held still and the disc and shaft revolved under it. This should result in greater accuracy as the inclination of the pencil can be made more constant. If the pencil is moved, see that it is as near to being perpendicular to the face of the disc as it can be held.

Now, measure the distance between two adjacent lines of the spiral with the com-

(Continued on Page 32)

Army-Amateur Activity in the Philippines*

The Story of op1HR

As originator of the plan of affiliation between the Signal Corps of the U. S. Army and the transmitting amateur, and as the Army-Amateur Liaison Agent during the first ten months of the Army-Amateur activities, Captain Tom C. Rives will long be remembered by League members. Though now stationed at Fort William McKinley, in the Philippine Islands, Captain Rives maintains the same interest in amateur work as this article, prepared by him with the coöperation of Captain Robert A. Willard and Lieut. G. A. Bicher, clearly indicates.—Editor.

AMATEUR Radio Station op1HR is owned and operated by the 12th Signal Company, Philippine Scouts, United States Army. The station was built and put into commission in March, 1925, by Lieutenant H. P. Roberts, Signal Corps, United States Army, and since that time has been operating with splendid success.

The station is located on top of what is known as Signal Hill in the Army Post of Fort William McKinley, Rizal, P. I., and is approximately five miles southeast of the city of Manila. The operating "shack" is at one end of what was originally built for a gun shed. The walls and floor are of rough planking and the whole place is open to any favorable or unfavorable breezes that may blow. During the typhoon season, when QRN usually is terrific, the rain and wind travel almost horizontally and it is naturally difficult to keep the station in any degree of dryness. The temperature, however, does not vary a great deal in these parts and is generally about eighty degrees in the shade.

Shortly after the station was installed, a daily schedule (Sundays excepted) was started with 6BJX, Ernest Knoch, Los Angeles, Cal., and this schedule was kept practically without interruptions until December, 1927, at which time Knoch informed us that due to business and ill health he was forced to give up the schedule. This was a sad blow to us as we had formed many pleasant associations with him. However, he is certainly to be complimented on the regularity with which he kept his schedules. During a 26-month period he handled approximately 8,000 messages averaging 25 words each—and he lost many hours sleep to do this for there is quite a time difference between the two stations and the schedule started at ten thirty at night Manila time. The following is quoted from a letter from the Commanding Officer, 12th Signal Company (P.S.), to Ernest Knoch: "If the officers of this Garrison and others who take advantage of your courtesy ever owed anyone a debt

of gratitude, they certainly owe it to you. You probably don't realize what it means to us over here to be able to get messages

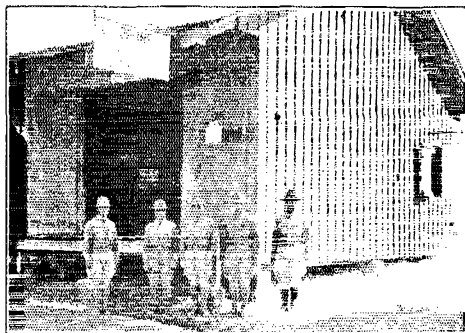

THE SHACK OF OPIHR

The Filipino operators to be heard at the key are, left to right, Pvt. Gallere and Bondad, Serjts. Cabiling and Balbuena, Mtr. Sgt. Maningas.

to the United States and obtain replies in a fraction of the time it takes by mail—speaking not only for myself but for all the others over here we certainly appreciate the service you are rendering us."

In December, 1927, when 6BJX gave up his schedule, over six hundred messages accumulated on the hook. Finally 6AMM, Bruce Stone, San Jose, Cal., stepped in and said he would take the traffic. By the third week in January the hook was clear and we have been able to keep it that way ever since. Most of these messages were Christmas greetings from the American personnel doing their bit in the islands. Many a mother's heart was gladdened by these messages and if the recording angel is on the job one more amateur will have a cushion seat when he arrives in Heaven.

The messages handled are not normally the "greetings-by radio" variety but are mostly honest-to-goodness messages that the Army personnel here send back to their relatives and friends in the United States. Op1HR also handles quite a few messages from low powered stations all over the

*Published by approval of the War Department.

islands and has regular schedules with stations in China and Hawaii. At the present

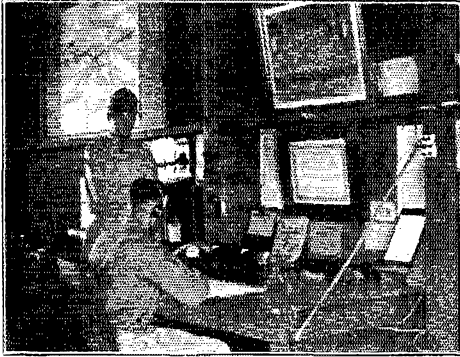

OPIHR AT FORT WILLIAM MCKINLEY IN THE PHILIPPINES

The operating table from which the T.G.T.P. transmitter is remotely controlled—note DX power switch control rod. Capt. Willard, Commanding Officer, 12th Signal Co., is standing behind Sgt. Balbuena.

time. op1HR handles the weather reports between the observatories in Shanghai and Manila.

All messages originating at op1HR are rigidly censored by the Commanding Officer of the 12th Signal Company to see that no message of a business or commercial na-



THE OPIHR PERSONNEL UNDER SOME LOCAL BANANA BUSHES—OR ARE THEY COCOANUTS?

ture, that may be construed as competing with commercial radio companies, is transmitted. This brings up points of an extremely tantalizing nature when the censorship of op1HR is applied to the relay traffic from other amateur stations

Op1HR is an Official Relay Station of the

A.R.R.L. and is a member of the WAC Club. As an emergency station (WUCD) in the Philippine Department Net, it works with such detachments of United States troops as are sent out on special missions throughout the islands. In case of emergency it can be operated by remote control from Fort Santiago (Department Headquarters), being directly connected by land line telephone and telegraph lines. For all this work two fifty-watt tubes in a tuned-grid tuned-plate circuit are used. The receiver is the conventional two-tube autodyne. The normal wavelength used is 39 meters.

All the members of the organization interested in the station are Filipinos with the exception of the commissioned officers, who are Americans. The present Commanding Officer, 12th Signal Company, is Captain Robert A. Willard, Signal Corps, United States Army. George A. Bicher, 2nd Lt., SC, U. S. Army, is the Officer in charge of the station.

The station is open every day from 4.00 p.m. (Manila Time) until midnight. Most of the traffic goes to the United States and, due to the regular schedules kept by such stations as 6BJX and 6AMM, there is little difficulty in clearing the hook. Approximately four hundred messages, averaging twenty-five words each, are handled each month.

Some More About Amateur Television

(Continued from Page 30)

pass or pair of dividers and locate an arc of the spiral between two of the radius lines that is the same length. Using the outermost point as the first hole, mark off the other 23 points along the spiral working towards the center.

If a metal disc is used, the holes can be drilled with a small drill. Holes should be just large enough to overlap and the size will be equal to the height of the picture divided by the number of holes. In this case it amounts to .036" and a No. 60 drill which is the smallest easily procurable and .040" in diameter should be used. If a hand drill is used, cut off the smooth shank of the drill so that it can be mounted in the chuck with only about $\frac{1}{4}$ " or $\frac{3}{8}$ " extending. This will save drills as it is very easy to snap them when they are so thin and extend very far out of the chuck.

From the information given above, it should be possible to lay out most any sort of a scanning disc and provided the work is carefully done, the results should be gratifying.

The 1928 International Relay Party

By Louis R. Huber*

THE logs are checked, the messages are counted, and the tallies have been set down. The Award Committee, in all its solemnity, has wielded the Wouff Hong and the Rettysnitch, and has adjourned. The International Relay Contest of February, 1928, is all done—but the shouting.

"The guests are met, the feast is set—
May'st hear the merry din"

Who won? 1ASF did, with a fifty-watt transmitter and *no extra operators*. He shouted the loudest, in those two glorious weeks last winter, in spite of the fact that a steam shovel nearly wrecked his transmitting antenna mast. There's no need to wish him more *power* by way of congratulation; in the first place, he doesn't need it, and in the second, he'll have it, just as soon as he chooses the Grand Prize.

Canadian 1AR led Canada, and by the rules gets Grand Prize number two. Among the next twenty-five, all of whom are United States amateurs, every district is represented. Some mighty fine prizes will go to the fellows in "the high twenty-five".

There are several interesting aspects of the contests which should be pointed out. In the first place, everyone enjoyed it tremendously, or else we can't believe the reports that were turned in. We're so impressed with the fun that the contest afforded that we believe the prizes are a secondary matter. Perhaps the idea was best expressed by R. M. Brown, of nIGREN, who said: "You may disqualify me for something I have not done or have done (though I have done my best to do everything as it should be) but you will not be able to take away the enjoyment I have had, and for that I thank you".

Another aspect which most surely is of great importance is the amount of good will and acquaintance stirred up between this continent and other lands. Why, bless us, if we don't think that working five "new" countries is not as good or better, in the line of diplomacy, than sending a delegation to the League of Nations. And it actually costs less!

A number of WAC certificates were awarded as a result of the contest. The number of QSL cards handled at headquarters for foreigners and NU-NC amateurs was tremendous.

Special mention must be given to 1ASF on the score of being the only NU or NC station to work Sweden, 6DHS takes the

honor for being the only one to work Argentine. 2AOL had Egypt all to himself; and 1KH took the Netherlands.

Now let's say a word about the participants outside the "nu" and "nc" classification. Their logs!! . . . and their message files!! Some of these are works of art; they deserve enshconement into some fine museum. British 5BY turned in a beautiful report that counts up to the figure of 573. He leads all others in Great Britain and elsewhere by hundreds. Second to him comes Belgian 4AU, with 486 points. Porto Rican 4SA is third with a score of 405. Australian 7CW comes fourth with 369; and New Zealand 3AR lands near our own level with 328. In each foreign country where an amateur took part, the station with the highest score will receive a prize.

Among the gleeful shouts of the prize-winners will be mingled weeping and the gnashing of the teeth of those who made so bold as to operate off-wave. 1IC might have been sixth in the United States, but he thought the grass across the fence grew greener. 2CRB might have been eighth, but he, too, strayed from the straight and narrow path. 8AXZ *might* be sporting some new apparatus as a reward for being fourteenth. 1AXA and 2CUQ were in the "big money", but watchful ears heard; accusing and irrefutable reports came in!! The rest who were disqualified for unfair play, although having scores too low for prizes, are:

1BW, 5KC, 1ALR, 2AVB, 2BFQ, 3AFW, 4EC, 9DPW, and 9AMN. All disqualifications have been made only after concrete and irrefragable proof has been presented. Official Observers' reports played a part; a special watch at 1MK was kept, and in each case the log of the offender was found to check with the accusation. But let us leave the Vale of Tears and gaze upon the calls of those who reached the Promised Land:

1ASF—305 nc1AR—105

2ALU—295	6AM—166
2TP—269	9EZ—162
8GZ—258	9DRD—149
1CMP—241	3HF—148
4FU—223	1WI—136
9DNG—213	1ABA—135
1BHS—209	1AZD—133
5WZ—202	7DF—133
8AHC—201	9ARA—131
4WE—195	9CK—126
4BI—169	5QL—123
3CKJ—168	8ADG—122
1KK—166	

* Assistant to the Communications Manager.

40C-121
5KG-117
3BMS-114
5AMO-106
9CRD-104
1MX-104
2CTV-104
3CFG-103
8DPA-102
1BGQ-99
4KN-99
9BQC-98
1RY-97
9BCJ-96
3DHX-98
1AQT-98
2ATK-92
nc9BZ-92
3KU-90
5ZAV-88
4OB-87
8AJN-85
2AOL-85
2GP-84
4SI-88
3DKX-81
5AUV-78
3AUV-78
1ACH-78
4CJ-72
1VS-69
6RQ-69
6RPC-68
1IH-66
9AOK-66
1KH-66
6BUX-66
8CFR-64
8ROX-62
9CPH-62
2BR-61
8PI-61
8DME-61
9DFZ-60
6BJL-60
nc2RE-60
6RZF-60
2GX-60
3WM-60
2AZ-60
nc1AM-59
1CJC-58
1CX-58
1ADM-56
2AZK-56
9ECZ-55
3QE-55
6AKW-54
6EC-54
8BCT-54
8AIR-58
2KX-58
3AG-52
3LW-51
9AVA-51
7MO-51
8BYN-51
8BHZ-50
9DWS-50
3CUG-49
6ID-49
6BHV-49
8CAU-49
1FI-48
1AWE-47
2JC-47
1AKZ-46
9LD-44
6UF-44
7GP-48
6AMM-48
nc8CS-48
6AJM-42
4TZ-42
1ZD-40
2KR-40
4JR-40
4QV-40
9CKF-39

3BNU-38
3DH-38
9CCJ-38
1CPB-38
1FS-38
2WC-37
1AVJ-37
9DGA-37
9DOE-37
9AKN-37
1ZL-37
9ASC-37
1LJ-36
1BHM-36
9CYA-35
1LX-34
1BAT-34
4OH-34
7EK-34
6JU-34
nc1AD-34
9RP-33
5EB-32
8CNH-31
8ASF-30
6BCH-29
8DKE-28
1BVL-28
1AAW-28
1EX-28
1RP-27
1BQD-27
2DX-26
2BCV-26
1ATJ-25
2AHG-25
9AED-25
4TO-25
1GV-25
8DED-28
3AKW-22
1PM-22
2BOX-22
8DJV-22
nc5GO-22
1AEF-22
6TJ-22
3PF-21
9CFN-21
2ALP-21
2BO-21
1CPJ-21
nc2AL-21
8KC-21
9NM-20
2ALW-19
9EFK-19
8DSN-19
6ABK-18
2JE-18
18Z-18
9BQE-18
2AWQ-18
9EFZ-18
2ZA-17
8AYU-17
1AUC-17
8CVJ-16
9BHS-16
6CXO-16
2BDC-16
2BW-16
7AFO-16
1ARC-16
8DNF-16
4NH-16
9CCV-16
7ABH-16
8ARO-15
9EFO-15
8BFG-15
1ZZ-15
2CH-15
9SO-15
9DMA-15
1ASU-15
6IH-15
2BKR-15
2LH-14

6CHL-14
1ASR-13
6BYH-13
2CHI-12
5GI-12
8CLA-12
4LX-12
2BBX-12
2AHO-12
7BM-12
8ATV-12
1BLS-12
4DB-12
9BRI-12
1AGE-11
6DHS-11
2BCH-11
5AGQ-11
1BTQ-11
3BUV-10
8CLP-10
9BOW-10
6RGO-10
8RV-10
9BPL-10
9EFW-10
8AUT-10
6CIS-10
9MN-10
8DHS-10
6CUH-10
3QV-10
4NL-10
8VE-9
6RG-9
3AIO-9
9ANZ-9
8WT-9
8RAZ-9
1BNS-9
3HH-9
9CZH-9
8GL-9
2JN-9
3FZ-9
9DBJ-9
2BDA-9
3LD-9
2BAV-8
6WB-8
1HO-7
9DCG-7
7IV-7
1ZV-7
1RIV-7
3CRT-7
7ACF-7
5ALA-6
6AOD-6
1AJM-6
8ANG-6
1ADW-6
6DQ-6
2BAC-6
4MI-6
8CDB-6
1ON-6
7VI-6
nc5CP-6
1WV-6
9AVP-5
8DAJ-5
2OL-5
9DIH-5
nc2CA-5
2CC-5
2CO-4
9DHP-4
6RRJ-4
9QS-4
2FN-4
9BOB-4
6CZK-4
4CK-4
7AEC-4
8AGQ-4
9BKJ-4
9ZA-3
9CDE-3

2AVZ-3
8AMS-3
9EJO-3
1TD-3
2ACY-3
6DDQ-3
8CJ-3
9HCA-3
7AAT-3
2RCB-3
2HR-3
1IA-3
2DR-3
1ATU-3

1FN-3
nc4AH-3
3CJ-3
5ABX-3
9DWE-3
8DDK-3
1AFB-3
8AKZ-3
9AFB-3
3SJ-3
9COS-3
7EO-3
4SV-3

8AMU-3
8DBM-3
9BI-3
1CKM-3
3BCD-3
nc4FV-3
7AKK-3
2CTQ-3
9BSH-3
6CHT-3
7AGB-1
9HI-1
2ATZ-1

Foreign Scores

EG
5BY-573
5ML-277
6RB-231
2NH-227
5MA-186
2VQ-182
5VL-94
5YX-71
6HP-64
2CX-62
5AD-56
6UW-53
2KE-52
5JW-47
5BD-45
5YK-48
6RW-23
6QB-22
6RB-16
2SC-10
6CI-7
6PP-5
2ZC-6
5YG-4
6LB-3
6GZ-1
2AX-1
6JK-1
6WY-1

4YN-10
3CA-9
7JK-7
3WH-7
5BY-4
3JJ-1
2NS-1

OZ

3AR-328
2AC-274
2BG-280
3AU-208
2EP-114
4AE-103
4AO-92
2AB-73
2AT-56
9AZ-40
3AJ-33
1AP-28
1AR-19
3AI-16
1AC-7
3CG-1

EF

8LN-169
8CP-84
8IX-58
8YNB-47
8FC-35
8LA-17
8YCC-13
8GYD-10
8FU-10
8FT-7
8JD-7
8LAP-7
8GRG-7

EB

4AU-486
4CB-232
4RS-119
4CO-34

OA

7CW-369
2SH-380
3WM-284
3HL-253
3CP-221
2DY-208
3LS-203
3VP-201
5HG-157
7CH-152
3KB-150
7LJ-144
2YJ-106
2MH-98
6SA-97
5CM-91
3LP-76
5XG-54
8DX-39
5WA-38
5WP-27
3JO-25
4AW-19
3XF-18
2XI-16
8GR-13
2RZ-10

ED

OIP-3*

EP

8AM-259
2CO-103
3FZ-90
1MA-1

EN

0 WIM-1
(zero WIM)

EO

12B-55
1ID-19

ES

2NX-3
EC
AA2-1

EK

4AAP-79
4XY-49

EW

H2-88

EE

EAR18-36

EJ

7DD-7

EI

1FP-253
1RK-116
1CR-102
1MA-87
1MG-23
1CE-4

EM

SMUV-4

FO

A8Z-162
A4X-75
A4L-39
A8V-27
A6U-24
A9A-23
A8C-22
A3M-10
A7U-7
1SR-5
A6R-4
A4M-2
A8D-3
A4V-1
A4E
A8Y
--1

OH

6BDL-20
6CLJ-18

SC

2AS-288
2AR-106
3AK-66
7AA-21

SU

1BU-53
1CG-6
1FC-6

*This station was a ship off the coast of N. J. and can not receive a prize on account of its commercial status.

SB	NN	NP
1AW—175	1NIC—120	4SA—405
1AK—152	NA	OO
2AX—105	7TO—87	1AJ—135
2AG—83	7MN—1	GEO—9
2IG—40	NH	FE
2AK—30	CA—4	1ES—1
2AS—27	NE	SA
2AZ—13	NL	DA9—3
7AB—1	GREN—208	FQ
NE	NM	PM—96
SAN—5	1N—133	EA
AI	9A—69	GP—121
2BG—19	NR	WY—40
AC	2FG—307	KY—10
1AX—12	2EA—112	KL—4
1CB—9	2AGS—75	
2FF—4		
AQ		
1LM—10		

The task of awarding the prizes is a large one. It has only begun at this writing. Choices have to be asked—they must go by mail. The winners highest in the list have the privilege of selecting the prize-group which they like best. We are doing our best to satisfy everyone and to make the awards fit the winners. We ask the prize-winners to have patience.

The list of prizes appeared on pages 33, 34, 35, and 44 of February, 1928, *QST*. Some very desirable groups have been made up from these donations. They range from twenty dollars up to \$350 or more. We are grateful for additional late donations for the contest from the following manufacturers:

Pacific Engineering Laboratory Co.	\$18.00
One set of 10 Pelco short wave receiving coils, including the set for the RF amplifier.	
Chicago Radio Apparatus Co., Inc.	\$7.50
One set of Chi-Rad short wave coils.	
Allen-Bradley Co.	\$6.50
One Radiostat variable resistance for transformer primary.	

Amateur Calls Changing

OFFICIALLY all Canadian amateur calls now begin with the letters "VE." Canadian amateur licenses are always dated to expire on the same day, annually—in April, if memory serves. When licenses were reissued this year they bore new calls, consisting of the letters "VE" followed by the numeral and letters of the old call. This is in accordance with a provision of the Washington Convention, obligatory the first of next year. Thus, for example, the station which we always re-

ferred to as nc9AL and which was really assigned 9AL for a call and which combined the letters "nc" with two other letters to make an amateur intermediate, is now licensed as VE9AL. Inasmuch as the first two letters indicate nationality, in accordance with a subdivision of the alphabet incorporated in the Washington Convention, the old intermediate "de" is supposed to be used. Canada has acted this early, however, only because present licenses will run until next Spring.

All of us in this country will have our calls changed too. The League has suggested that the calls of amateurs in continental United States begin with the letter "W" and those in distant territories and possessions with the letter "K". Such distinction is necessary in order to recognize a Hawaiian, an Alaskan, a Porto Rican, etc. This idea we believe will receive favorable consideration in Washington, and in fact it would seem that renewal licenses are now coming back with the letter "W" in front of the call; 1BDI for example is now W1BI. We imagine that it will be the Government's intention to amend the call on all renewals made from now on, and to change the calls of the rest of us by an order, later in the year, directing the prefixing of a letter ahead of existing calls.

Similar changes must be made by governments in every country by the end of the year. When this is done we say goodbye to the I.A.R.U. intermediates which have served us so faithfully and go back to the old standard intermediate "de", relic of the days before international DX. It seems to us that in the case of amateurs of two countries which have changed amateur calls so as to indicate nationality, the international intermediate may now be abandoned as an unnecessary encumbrance; "VE9AL de W1BDI" is fully informative. But the retention of the I.A.R.U. intermediates seems essential where the amateur call has not been changed by the government. Thus "8FN de W1BDI" is not explanatory, for 8FN may be French, U.S.A., Newfoundland or what-not. To call French 8FN it had still better be "8FN efnu W1BDI" until France changes too.

And let's not have any foolish business of prefixing "W" or "K" to calls until they are individually changed, or a proclamation is issued, by the Government. We must individually sign just what our licenses read until they are officially changed.

—K. B. W.

An Effective Antenna Tuning System

By R. B. Bourne*

MOST amateurs pay not the slightest attention to the problem of getting the most out of their receiving antennas. The vast majority of receivers are coupled to the antenna either through a very small condenser or by means of a coil of two or three turns. The degree of coupling is sometimes made variable but in neither case is the antenna tuned, by intention, at least.

What! another control! Yes, but it is not necessary to use it if not wanted. With a given antenna, say 100 feet in length, there will be certain groups of wavelengths for which the antenna is tuned, using either capacitive or inductive coupling. But what of the wavelengths in between? On these, there is a loss of signal strength because resonance potentials and currents are not possible.

In order to take advantage of a tuned receiving antenna, the writer, some three years ago, built into his autodyne receiver an antenna tuning arrangement, shown in schematic form in the accompanying drawing. With the switch S open, we have a conventional type of receiver familiar to everyone. C_2 is the antenna coupling condenser of 10 $\mu\text{f.}$ and $L_2 C_2$ the usual tuned grid circuit. $L_1 C_1$ is a wavemeter having a small coil and large condenser, the combination covering from 15 to 50 meters. The coil of this circuit is set at right angles to that of the grid circuit or at such an angle that the coupling between the two is at a minimum. With the switch S open, $L_1 C_1$ is a wavemeter loosely coupled to the tuner. This, in itself, justifies its presence in the receiver.

As an antenna tuner, the device is used in the following manner. The signal is tuned in with the switch S open. Closing the switch may have no effect or it may result in the detector stopping oscillating, depending on whether the wavemeter happens to be tuned correctly and depending also upon the wavelength. For certain wavelengths, tuning the wavemeter circuit has little or no effect on the signal. For others, however, the effect of properly adjusting the complete set is rather remarkable. Assuming we are on a wavelength the reception of signals on which can be improved, we find, upon varying C_1 , that for a certain range of capacities, the detector stops oscillating, C_1 is set so as to have a

value about midway in the "dead" space on its dial. Regeneration is increased until the signal appears again. If the regeneration control affects tuning, a readjustment of C_2 will have to be made. In any case, the coupling between the two LC circuits by means of C_3 is liable to affect the adjustment of the tuning condenser more or less, depending on the size of the coupling condenser. The gain in signal strength obtained in this manner, on waves

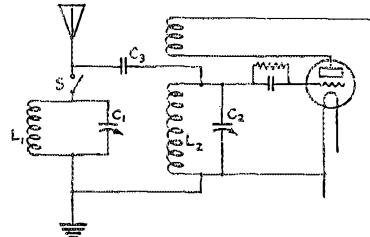

THE MANNER IN WHICH THE TUNING CIRCUIT IS CONNECTED WHEN USED IN CONJUNCTION WITH A RECEIVER EMPLOYING CAPACITIVE COUPLING BETWEEN THE ANTENNA AND GRID CIRCUITS

The station wavemeter or frequency meter may be used for $L_1 C_1$ and will show how much of a gain may be obtained in this manner.

susceptible to treatment, is worth while, and in some cases will approach the gain obtained by a stage of audio frequency amplification.

Another thing happens simultaneously. With the antenna in tune with the oscillating detector, energy is fed from the latter to the former, resulting in effect in a reduction of antenna resistance. This of course means increased selectivity. If the scheme is used ahead of a stage of r.f. amplification in which there is no reaction between amplifier and detector, only a moderate gain in signal strength is noted, since the effective resistance of the antenna has not been lowered.

Admittedly, there are several implied questions left unanswered, involving the impedance characteristics of coupled parallel tuned circuits, but even though they are not gone into at this time, the scheme outlined above is so effective, so simple and so cheap that it seems well worth while to present it.

*1ANA, 221 Holcomb St., Hartford, Conn.

28,000 Kilocycles—And How!

By Harold P. Westman, Technical Editor

IT is said that "History repeats itself". The one originally making this statement might have had amateur radio in mind, providing there was such a thing as amateur radio. The history of amateur radio has certainly been a cyclic affair.

Not many years ago, we were surprised and, perhaps, shocked to find that our theories regarding transmission were not as accurate as we had supposed. It was found that effective transmission could be had at frequencies of 3,000 kc. in spite of the great attenuation predicted for such "high" frequencies. A few pioneers, may their tribe increase, got vacuum tube transmitters to oscillate at these uncommon frequencies, coupled them to indifferent antennas and actually shamed the 1500 kc. equipment that had had some years in which to develop. And how folks did object to leaving their nice warm beds of accepted theories and "normally behaving" circuits to venture into the cold outdoors of newer realms. And, what would be the humorous part, if it were not so tragic, is

far as DX was concerned, it was decidedly superior. But, as in the 3500 kc. work, it was like pulling teeth to get enough stations to operate on that frequency to give it a fair trial and find out that it was worthwhile.

The next frequency to be attacked was 14,000 kc. and there were many who after a short trial announced in letters to us that it was useless as far as amateur operation was concerned. It was not as effective at night as was 7000 kc. which indicated it to be an inferior frequency for DX work. It was much more erratic in its behavior, signals were harder to copy due to swinging and fading. Antennas seemed too small to be able to have much effect. And yet, 14,000 kc. work is common today. A large number of amateurs use this band exclusively while a still larger number devote their time to operation in these two last named high frequency bands.

In March, the Federal Radio Commission opened the 28,000 to 30,000 kc. band to

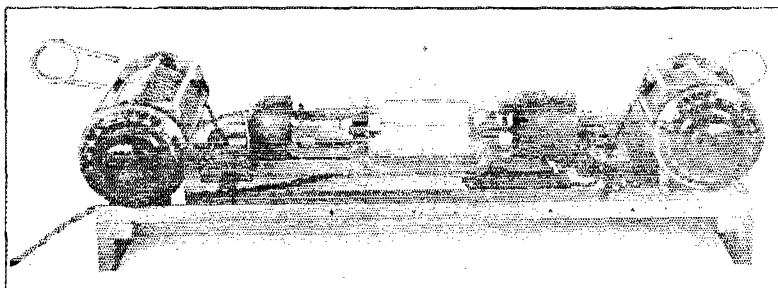

THE 28,000 KC. TRANSMITTER AT 1SZ

A 204-A is used in an Armstrong circuit. The plate coil and condenser are at the left and the grid tuning circuit at the right. The blocking condensers, by-pass condensers and grid leak are located behind and under the tube. The antenna was a Zepp employing a half wave vertical radiator, 16 feet long. The two feeders were each 8 feet in length. The receiver was described in the article "A Portable Receiver" appearing in the April, 1928, issue of QST. No contacts were established with the equipment.

that these newer realms became even more comfortable than the older. The tragic part is that it took months, months and months to get even a small minority in the swim. Of course, after a few important land marks had been pointed out and some momentum gained, it was impossible to keep the rest away from these "high" frequencies. And so 3000 and 3500 kc. work became a fact.

And History did repeat! A considerable time later, 7000 kc. was an accepted frequency for amateur operation. In fact, as

general amateur work. Since then, very little has been done by amateurs as a whole but, fortunately, it is not true that all amateurs sat back and waited for the other fellow to do it. There are probably between two and three dozen actively interested in the problem and it cannot be said that they have not made progress. They have done well considering the number of persons involved and the possibility that transmissions at this frequency may be at their best under conditions which we do not now associate with good operation.

Contrary to the opinions of many, it does not take special arrangements, equipment not available to amateurs or a superior understanding of radio to get a transmitter and receiver to operate at this frequency. The types of tubes used by these pioneers include 210's, 203-A's, 204-A's & 852's, and the circuit arrangements, Hartley, Armstrong, Colpitts, Ultra-audion and Mo-Pa. There seems to be as much diversity of opinion as to what constitutes the "best"

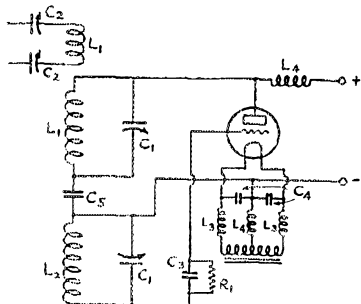

FIG. 1. THE SPLIT-COIL HARTLEY CIRCUIT ARRANGEMENT USED BY SALLY

L1—3 turns of $\frac{1}{4}$ -inch copper tubing, 3 inches in diameter.

L2—2 turns of $\frac{1}{4}$ -inch copper tubing 3 inches in diameter.

L3—25 turns of No. 20, 1 inch diameter.

L4—40 turns of No. 30 on 1 inch form. Double spacing is used.

C1—500 μ fd. variable condenser.

C2—100 μ fd. variable condenser.

C3—100 μ fd. fixed condenser.

C4—250 μ fd. fixed condenser.

C5—2000 μ fd. 3000-volt condenser.

R1—20,000 ohms.

It might be advisable to use series feed to the plate and take some of the work off the plate choke. The high voltage lead would then go to the junction of L1 and C5.

circuit arrangement as there is among those working in the 7000 and 14000 kc. bands which would lead one to believe that probably all of those circuits commonly used by amateurs give similar operation when properly adjusted.

In response to our requests, a number of experimenters has supplied us with accounts of the work they have done in this new band. While these do not by any means cover all the work that has been done, they give an insight into some of it and it is hoped that it will show others how simple it is to make their present equipment operate at 28,000 kc. We want to thank those who supplied the information that is given below.

SALLY

A considerable amount of work has been done by SALLY of Rochester, N. Y. He started in with a 203-A and after trying it in the split-coil Hartley, Colpitts and

Armstrong circuits that it was not doing as well as it might, particularly in regard to frequency stability which seemed to be poor on frequencies above 24,000 Kc.

The 203-A was swapped for an 852 and as might be expected the difficulties encountered were considerably reduced. The split-coil Hartley, single-coil Hartley Colpitts, Armstrong and Meissner circuits were tried. The split-coil Hartley and Colpitts were by far the best, the Armstrong a good third and the Hartley and Meissner circuits a very bad fourth and fifth. Some of the "five-meter circuits" were tried but did not perform nearly as well as the three better circuits mentioned above.

The split-coil Hartley was finally adopted because it could be tuned more easily without the tube going out of oscillation than could the Colpitts. With it, it is possible to rotate the grid tuning condenser over the entire range from 27,000 to 35,000 kc. independent of the plate condenser and still keep the tube oscillating.

Filament and center tap chokes should be used and care should be taken to obtain those of proper value as they can easily cause poor performance. Coupling between the two coils was not found to be critical.

Three types of antennas were tried, a $4\frac{1}{2}$ -wave horizontal voltage feed Hertz, 11 feet off the ground, a $3\frac{1}{2}$ -wave bent antenna consisting of a vertical wire 22.5 feet long and a horizontal wire 22.5 feet long and a vertical half-wave Zeppelin. All of these systems were fairly well in the clear.

Due to the scarcity of reports, very little positive information was obtained regarding the $4\frac{1}{2}$ - and $3\frac{1}{2}$ -wave systems. However, reports on the $\frac{1}{2}$ -wave Zepp were far more encouraging and signals were reported as being much louder and less bothered with fading than with the other two. It is interesting to know that when using the vertical antenna for the first time, good reports on signals were obtained from ef8CT and eg2BRG. For two months previous while using the other two systems no reports had ever been received from Europe.

As a check on these antenna systems, the three were interchanged at intervals during contacts with west coast stations. The vertical antenna gave by far the best signals at all times of the day tried and local stations reported signals nearly twice as loud with the vertical antenna as compared to the other systems.

The regular tuner used on the lower frequency bands was first employed but caused trouble due to the tuning effect of the regeneration control condenser, interference caused by automobiles, power leaks, etc., body capacity, lack of selectivity and feed back from phone cords. A tuner similar to the "Traffic Tuner" described in the April,

1927 issue of QST was constructed. The whole set was enclosed in a copper shield as are the batteries for the 199 type tubes employed. Tube base coils are used for all bands and due to their small fields, enclosing them in a shield did not affect the frequency ranges in the slightest. The internal capacities of the dry cell tubes are somewhat less than those of the larger tubes and this allows larger inductances and capacitances to be used in the tuning circuit.

8ALY has been in communication with 6UF, 6DVO, 6ANN, 5AUZ and two locals, 8AHK and 8CVO. During March and the early part of April, tests were made practically every week-end but as no reports were received nor any amateur signals heard, it was decided to run tests only on Sundays between 1520 and 2230 G.C.T.

On April 1st, contact was established with 6UF and 6DVO and since then, with the exception of one or two Sundays when no signals could be heard and even the harmonics from local stations were barely distinguishable, communication with the West Coast could be maintained with ease.

Signals from the West Coast start coming through at 1400 and usually fade out around 2230 G.C.T. No great deviation of signal strength was noticed during this period although signals were usually stronger and steadier between 2100 and 2200. Fading was apparent at all times

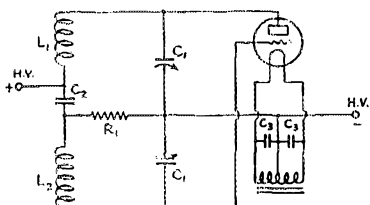

FIG. 2. 2JN USES THIS ARRANGEMENT OF THE COLPITTS CIRCUIT

- L1—5 turns of 1/4-inch copper tubing, 3 3/4 inches in diameter.
- L2—4 turns same as L1.
- C1—Cardwell type T183.
- C2—2000 μ fd., 10,000-volt fixed condenser.
- C3—2000 μ fd. fixed condensers.
- R1—9000 ohms.

but seldom bad enough to actually interrupt communication. 6UF was worked as many as 5 or 6 times on some Sundays during the test period and no difficulty was had in establishing contacts. The signals usually peaked at 2130 and were at times R8 to R9.

Signals from 5AUZ were not heard very often, they seemed to come through very well between 1930 and 2300 G.C.T. with practically no peaking of signals being no-

ticeable but with fading similar to that noticed on West Coast signals.

The most consistent and steady signal heard was that of HJG who can be heard between 1300 and 2300 G.C.T. never weaker than R3 and with very little fading.

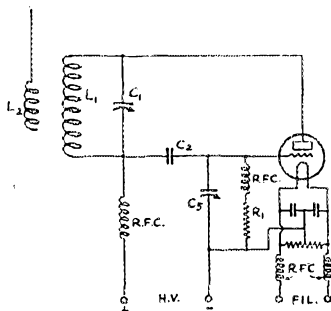

FIG. 3. THE ULTRA-AUDION AS USED BY 5AUZ

- The capacity, C3, is used to control feed back.
- L1—3 turns of copper tubing, spaced 3/8 inch and 3 1/2 inch in diameter.
- L2—4 turns same as L1. One end left open.
- C1—250 μ fd. receiving condenser double spaced. (Now about 60 μ fd.)
- C2—Faradon .0012 μ fd.
- C3—100 μ fd. midget.
- R1—16,000 ohms.
- RFC—150 turns of No. 30 on broom handle.

WIK is seldom heard and never better than R1. AGC was seldom heard but when the signal was picked up it seemed to fade very little.

2JN

Perhaps when it comes to DX, the palm should go to 2JN of Upper Montclair, N. J., who has been in communication with ef8CT four times, who has heard 8CT thirteen times when it was impossible to get in two way contact and who was heard by 8CT six times under similar conditions. He has also received reports from eg2NM, eg5YK and eg2NH. He has been in communication with 2ACN, 2AHO, 2AOL, 2AQB, 2BCI, 2BHA, 2BRB, 2GP, 2NM, 2SY, 2TP, 6ANN and 6UF. He has also been reported by three Second District stations whom he did not work.

2JN is using his regular 14,000 kc. transmitter for the 28,000 kc. work. The circuit is the familiar Hoffman arrangement of the Colpitts and it seems to work very well. An 852 is used with half-wave self-rectification.

The antenna is located in the attic of a two-story house and is about 1.5 feet beneath and parallel to the rafters. It is of the Zeppelin type, the radiating portion being 16 feet long and the feeders; 8 feet in length. The receiver employs a single stage of radio frequency amplification using a

UX-222, 199 type tubes are used for the detector and single stage of audio frequency amplification. This is the receiver used for the lower frequency bands and all that was necessary was to wind smaller coils for this new range. The regular coils were wound on tube bases but this smaller one is air-supported. The tuning range is from 24,000 to 35,000 kilocycles and the adjustment is not much more tricky than on the lower frequencies.

6UF

Another station that has given an excellent account of itself is 6UF at Knowles, Cal. With 100 watts input to a 203-A used as a neutralized power amplifier feeding a vertical Zeppelin antenna, reports were received from 5DQ, 8ALY and 9BNX. The signals were weak and always heard

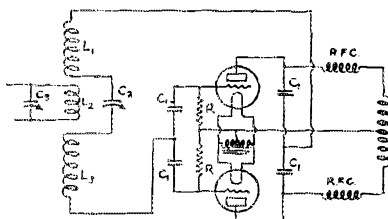

FIG. 4. FULL-WAVE SELF-RECTIFICATION IS USED BY 8EX WITH THIS REINARTZ CIRCUIT ARRANGEMENT

- L1, L2 and L3—4 turns of $\frac{1}{4}$ -inch copper tubing spaced $\frac{1}{2}$ inch and 3 inches in diameter.
 C1—Paradon 25 μ fd. condenser.
 C2—1000 μ fd. Cardwell double spaced to give about 250 μ fd.
 C3—250 μ fd. GR condenser.
 R—10,000 ohms each.
 R.F.C.—1 inch of No. 30 d.s.c. on 1 inch tube.

during the morning transmissions. Increasing the length of the feeders from $\frac{1}{4}$ to $\frac{3}{4}$ waves made practically no difference in the results. By substituting an 852 for the 203-A, an increase in output was obtained.

The radiating system was then changed so as to use a vertical antenna and horizontal counterpoise each of which were $\frac{1}{4}$ wave long. This system gave better results than those previously tried.

As a test, the 852 power amplifier was removed and the 210 which had been employed as the master oscillator was used to excite the antenna. With about 25 watts input, 8ALY was worked and he reported the signal as being the loudest ever heard from the west coast on any frequency. The 852 was then tried in place of the 210 and some very fine results were obtained. A goodly number of contacts were made with this arrangement. During the time that

6UF has been operating at this high frequency, communication has been established with 8AHK, 8ALY, 8CSR, 8EX, 6DBO and 2JN. Signals from 2EB, 2NM, 4GH and 8GK were heard in addition to the contacts mentioned above.

The receiver used in the standard affair employing capacitive control of regeneration. It is built on a 5" by 10" aluminum panel and is 6" deep. A 199 is used as a detector tube and a 201-A as the audio amplifier tube. Normally a 500-foot antenna is coupled to it but when there is trouble from a strong power leak near by, or the static is very bad, a short indoor antenna is used. No ground or counterpoise is connected and the antenna is tied to one end of the coupling coil, the other end of the coil being free. The direction in which the coil is wound seems to have considerable effect on the strength of the signals and the coil should be reversed to obtain the proper condition. Very tight coupling to the filament end of the grid inductance is necessary. No trouble is experienced due to "dead spots" over the 14, 28 and 56,000 kc. bands. Exceptionally fine signal strength is obtained, a point which all visitors to the station comment upon.

2GP

When 2GP of Richmond Hill, L. I., N.Y. became interested in this new band, he proceeded to cut down the size of the inductances in his 14,000 kc. transmitter and receiver and started in.

The transmitter is a shunt feed Hartley with 1000 volts on the plate of a 203-A which has seen service during the last 2 $\frac{1}{2}$ years on the other amateur bands. The input is about 200 watts.

The radiating system consists of a 58-foot Hertz with a single wire feeder about 30 feet long tapped about 18 feet from one end of the antenna. This is used against a 60-foot counterpoise resulting in a combination that would be difficult to analyze.

The receiver is the one used for the lower frequency bands for which Gross plug-in coils are provided. Capacitive control of regeneration is employed. For 28,000 kc., the secondary coil consists of two turns of No. 14 wire and is about 2" in diameter. The tickler coil is of 1" diameter and consists of 3 turns of the same wire, although d.c. is used and the winding is scrambled. G.R. plugs are connected to the ends of the coils and they may be fitted into the regular receptical used to hold the other coils of the receiver. The tuning condenser is rather large and covers a range of about 23,000 to 30,000 kc. The receiving antenna is about 70 feet long and 25 feet high. It is coupled by a small capacity to the grid of the detector tube. A single stage of audio amplification is used.

With this outfit 2GP worked 2AOL, 2BEV, 2BRB, 2BUO, 2EB, 2JN and 2NM. In addition to these stations worked, 2AQB, 2AVG, 2TP and ef8CT were heard and the signals of 2GP reported by ef8CT.

5AUZ

On Sunday morning, April 15th, 5AUZ in El Paso, Texas, decided that he would like to get going on the new band. Single turn inductances were substituted for the 8-turn affairs normally used for plate and grid tuning in the Armstrong circuit doing duty at 7,000 kc. The plate voltage on the 204-A was 1500 and the current about 150 mils. The plate coil showed lots of fire when given the well known "pencil test" and the next thing was to try and get the plate current down by adjusting the grid tuning condenser. However, it was found that this had no effect on either the plate current or the frequency which stayed at about 30,000 kc. regardless of the adjustments of either of the tuning condensers. About this time, a familiar odor was noticed and the blocking condenser was found to be dripping wax. The condenser was supposed to be good for 4 amperes so it was concluded that the circuit was not acting in true Armstrong fashion. A double-spaced Cardwell was substituting and the circuit acted more normally except for the fact that the plate current was still around 150 mils with no antenna connected.

The receiver is the same one used for the 7-and 14,000-kc. bands, employs a single UX-222 and is modeled after the one described by R. B. Bourne in the December, 1927 issue of QST. For the start, the antenna coil was moved over into the detector compartment and a two-turn coil was substituted for the 4-turn grid coil used for 14,000 kc. reception. All of these preparations took approximately 30 minutes. Upon listening in, 8ALY was heard working 6UF and 6ANN. Neither of the 6's could be heard and after these contacts had ended, 8ALY was called but did not answer. A long CQ was made to which 8ALY responded. A thoroughly satisfactory contact lasting for 30 minutes was made with good signal strength at both ends. Later on, 8AHK was worked although the fading was very bad. The regular 7000 kc. antenna was used and the antenna current, at the point where the ammeter was connected, was nil.

Since this work has been done a new transmitter has been constructed for this band, employing a single UX-210 in the ultra-audion circuit. The plate voltage is either 550 a.c. or 450 volts obtained from B batteries. When using the B battery, a slight amount of modulation supplied from an audio oscillator is employed so as to broaden the note for easier copying.

No two-way work has been done using this set but it has been reported several times by stations in the Eighth District. Using two UX-210's in parallel with a 5000-ohm grid-leak instead of the 15,000 ohm unit used with a single tube, the set will operate at a frequency of 50,000 kc.

When using the r.f. stage of the receiver, tuning becomes rather troublesome as 30,000 kc. signals are hard enough to find with a two control receiver. It has been found, though, that the 222 really gives some amplification at this frequency.

SEX

In Cleveland, Ohio, we find 8EX who uses a UX-210 in the Reinartz circuit shown herewith. With this he worked 6UF for about 15 minutes. Both signals were steady and about R6. The contact was re-established about 1 hour later and continued until 8EX blew a fuse. Later in the same day, ef8CT was logged about R4 but swinging badly. This was on Sunday, April 1st, and an R6, steady report was received from 6DBO who heard these signals at 7.45 p.m. P.S.T.

One week later contact was established with 6ANN at noon E.S.T. and while signal strengths were good fading was bad. The antenna system is a full-wave Zep with feeders just short of $\frac{1}{4}$ wave. A shunt condenser is used for tuning the feeders. The system goes straight out the attic window at a height of 32 feet to a 40-foot pole. The radiating portion is 31 feet long.

The tuner used is the same as employed for operation in the other bands. Capacitive control of regeneration is used and the 1500-kc. coil form was called upon to hold the winding of the 28,000-kc. coil. This is a 1" diameter coil of 3 turns of No. 14 antenna wire spaced $\frac{1}{4}$ ". The tickler is 4 turns of No. 22 d.c.c. wound on 2 fingers and soldered to the proper contacts. Very loose coupling to the antenna is needed in order that the set will oscillate and for this reason a new tuner will probably be built soon.

A crystal-controlled transmitter which was used for 14,000-kc. work has been modified to make it suitable for 28,000 kc. operation. It has not as yet been satisfactorily adjusted and gives about half the output that is obtained from the self excited set. However, it gives what seems from the experience already gained to be more important than power output and that is *frequency stability*.

5HE

When using an 852 in an ultra-audion circuit, 5HE of San Antonio, Texas, worked 1AQD at 12:30 P.M. and 2:30 P.M.

C.S.T. on April 29th. 1AQD is reported to be using 1000 volts on the plate of a UX-210.

The transmitter at 5HE was located within a foot of the lead-in bowls and the antenna was 32 feet long overall including that portion of it referred to as the counterpoise. The coupling coil was located 1.4 amperes. The set and counterpoise were 6 feet above ground making the top of the vertical antenna which was 24 feet long 30 feet above the ground. This is only a temporary installation in operation but a short time, which accounts for the small amount of work done.

ef8CT

We believe that ef8CT, Pierre Auschitzky, Villa Cyclamen, Arcachon, France is using two transmitting tubes, power unknown, in a push pull oscillating circuit. Current feed to a half wave antenna is used. It was hoped that more information concerning this station would be available but such has not proved to be the case.

MORE STATIONS NEEDED

While opinions regarding the equipment to be used in 28,000-kc. work are many and varied among those experimenters from whom we have received reports, there is an opinion to which there are no dissenters. It is perhaps best expressed by the following quotation taken from the report of 8ALY. It is, "Due to the *scarcity of stations* working in the 28,000 kc. channel it would not be safe to forecast results although communication with West Coast amateur stations has been fairly satisfactory." The italics are not due to 8ALY but are used to indicate the thought expressed by most of those involved.

Although it may seem to many that transmission at frequencies above 25,000 kc. will never be satisfactory for communication purposes, it must be remembered that work at 14,000 kc. was once thought impractical but that we now know that by picking the right time, season, radiator, etc. that excellent work can be done. It certainly seems from the results already obtained that 28,000 kc. holds some possibility and that it should be given a whirl. Why not put *your* outfit on this band during Sundays as are these others? All the previous changes outlined at the start of this article were successful so don't let's quit because we aren't sure that this won't be. We weren't sure of the others, either.

Let us see if we can't make "History repeat" once more!

Northwestern Division Convention

August 31. Sept. 1, Seattle, Washington

ALL ABOARD! for the Hotel Bergonian, Seattle, Washington, where the annual convention of this division will be held on the above dates, under the auspices of the Amateur Radio Club of Seattle.

Everybody is working hard to make this a *he* convention and the committee in charge extends a cordial invitation to all the radio amateurs in this division. If you attend we will feel repaid for the hard work.

A.R.R.L. Headquarters have promised to send Louis R. Huber, 9DOA, now Assistant to the Communications Manager in Hartford, and from what we hear he is a live wire.

Our program will be so arranged we know everyone will be satisfied. So write and let Ken Casey, 7ACB, 722 No. 74th St., Seattle, Washn., know that you will be present.

Standard Frequency Stations Needed

IT is with great regret that the O.W.L.S. Committee has learned that 1XM (Mass. Institute of Technology) will be unable to continue the transmission of Standard Frequency Schedules. Accordingly, volunteers are asked to transmit such schedules on the East Coast. A West Coast volunteer is also wanted. Such stations must have at least two operators trained in technically accurate frequency measurements and one or two assistants. The group or organization behind the transmissions must be well and favorably known to inspire public confidence in their accuracy. Power is not the prime requisite though 250 watts is desirable; a good and distinctive note and absolutely steady frequency are essential. Crystal control is not suitable because of the large number of frequencies to be covered. Transmissions will probably be in the 3.5, 7.0, 14.0, and 30 megacycle bands. Anyone interested please write K.V.R. Lansingh, nu6QX, in charge of O.W.L.S.-S.F., Box 731, Hollywood, Calif.

K.V.R.L.

Filter Circuits

By Clyde Farrar*

ALTHOUGH many discussions of filter circuits have appeared in print, most of the articles have presented the subject from a practical viewpoint only. This short article is an attempt to throw some light upon the actions taking place within the filter circuit.

The present high grade filter circuit usually consists of two inductances, called choke coils, across which are shunted 3 capacitances. In the majority of cases a double rectifier feeds into the filter circuit. The function of the filter is to attenuate all alternating current components of the complex wave applied to it and pass only the constant component. With the output of a double rectifier (i.e., full wave) feeding into such a filter circuit, the voltage *E* applied to the filter is a complex wave which may be expressed analytically by the following formula.

$$e = \frac{2}{\pi} E - \frac{4}{3\pi} E \cos 2\omega t - \frac{4}{15\pi} E \cos 4\omega t \dots \dots \dots \text{eq. 1}$$

Where *E* is equal to the maximum value of voltage and ω , the angular velocity, is equal to $2\pi f$. The current through the condenser *C*₁ (Fig. 1) will then be a complex wave, and for a double rectifier may be represented by the following formula.

$$i = .72 I \sin \omega t + .34 I \sin (2\omega t + 24) + .09 I \sin (3\omega t + 77) + .06 I \sin (4\omega t - 91) + .034 I \sin 5\omega t + \dots \dots \dots \text{eq. 2}$$

Where *I* is equal to the maximum value of current. The effective value of current may be determined if it is desired. However, we are interested only in the current through *C*₁ during the discharge period, since the function of *C*₁ is to store energy during that period the rectifier is passing current and to give up its store of energy during that period the current from the rectifier is zero, the assumption being that the filter will keep the current constant during that period the rectifier is passing current. From the well known equation for the discharge of a condenser through a load, the size of capacitance to be used to maintain constant, or nearly so, current may be obtained. Given the equation for the discharge current of a condenser equal to

$$i = \frac{E}{R} e^{-\frac{t}{RC}} \dots \dots \dots \text{eq. 3}$$

Where *R* is the resistance of load, *E*, the applied voltage, and *C* the capacitance of

the condenser. For *i* to remain sensibly constant

$$\frac{-t}{\epsilon R c}$$

must at all times be nearly equal to 1, or

$$\frac{-t}{RC}$$

must approach zero, since *t* is the time during which the condenser is discharging (for a double rectifier is approximately $\frac{1}{4}$ cycle) the product *RC* must be large. Therefore, for a given load resistance *RC*

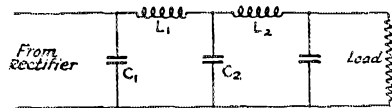

FIG. 1

has a certain minimum value, for constant current. In general, the greater the number of sections to the filter circuit the less

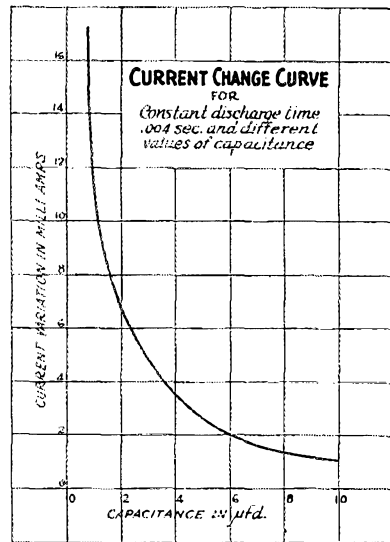

FIG. 2

may be the capacitance of *c*₁ and still obtain a pure direct current output.

A little consideration will show that the discharge current is fixed by the load and not by the size of condenser, therefore, the condenser current does not increase

*Department of Electrical Engineering, University of Idaho, Moscow, Idaho.

with an increase in capacitance. Consider formula 3. With a fixed applied voltage (the maximum voltage applied to the condenser) and fixed load resistance R, varying C only affects the time constant of the

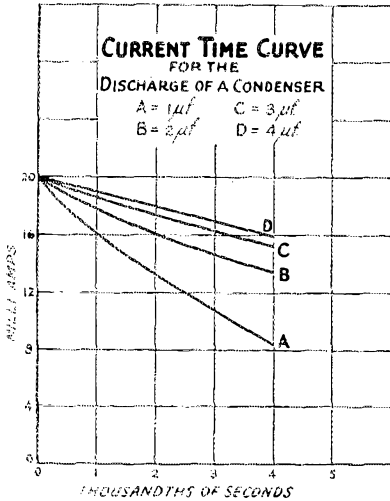

FIG. 3

current and has no effect upon the discharge current *i* except to maintain the current during discharge more nearly constant. Figure 2 shows the effect of increasing the value of *C*₁ holding the volt-

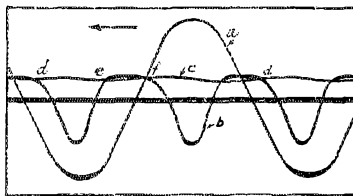

FIG. 4

age, load resistance, and discharge time varying from 0 to 4 thousandths of a second constant. Examination of Figure 2 shows that adding capacitance above 4 μfd. will charge the current variations only slightly. Figure 3 shows the relation between the current fluctuation and the capacitance *C*₁. From an examination of Figure 3 it can be seen that there is little to be gained by the addition of capacitance above 4 to F. Figure 4 shows an oscillograph of the line voltage (a), (b) the condenser current, and (c) the load current. The condenser is charging during the time d, e, and is discharging through the filter during the time

ef. It should be noted that the discharge current is sensibly constant during the discharge period. In the oscillogram for Figure 4 the load current has been reversed which gives the appearance of the load current fluctuating opposite to the condenser discharge current.

The capacitance *C*₂ in conjunction with inductance *L*₁ acts as a filter. The capacitance *C*₂ offers a low impedance to the alternating current while the inductance offers a high impedance to the alternating component. The capacitance does not act as a reservoir of electrical energy since it is assumed that at no time does the current and voltage at its terminals drop to zero, hence its sole function is to form in conjunction with inductance *L*₁ an attenuating network.

The capacitance of *C*₂ and the inductance of *L*₁ must be so proportioned that the product of $W^2L_1C_2$ is always greater than 4. Unless this condition is fulfilled no attenuation will take place.

Figure 5 is an oscillograph showing the applied 60-cycle line voltage (a), the condenser current through condenser *C*₂, and the load current (c).

If on applying a filter to connect a rectifier to a load and the voltage fluctuation

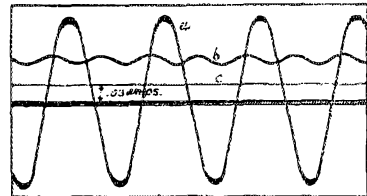

FIG. 5

of the output is too large, additional filter sections may be added. It should be kept in mind that the attenuation factors vary in geometrical progression with the number of sections. In many cases it is cheaper to add sections, than to add to the value of capacitances and inductances.

It is sometimes desirable to determine the percent voltage attenuation for each section of a multi-section filter, or it is desirable to determine the number of sections of a filter to affect a predetermined attenuation. In such cases use may be made of the exponential variation of attenuation. Namely:

$$i = e^{-mx} \dots \dots \dots \text{eq. 4}$$

Where *i* is the alternating current at the terminal section of the filter, *m* is equal to the number of filter sections. *X* is equal to the attenuation factor which is equal to

$$X = \cosh^{-1} \left(\frac{\omega^2 LC}{2} - 1 \right) \dots \dots \dots \text{eq. 5}$$

for a filter in which the resistance of the inductances is neglected and where the resistance of the inductances is considered

$$x = \text{Sinh}^{-1} \left\{ \frac{\sqrt{\frac{\omega^2 LC}{4}} \left[\pm \sqrt{\frac{R}{\omega L} + \left[1 - \frac{\omega^2 LC}{4} \left(1 + \frac{r^2}{\omega^2 L^2} \right) \right]^2}}{4} \right] \right\} \dots \text{eq. 6}$$

It should be noted that the attenuation need be calculated for the fundamental frequency and not for the multiple frequencies, since the attenuation constant is proportioned to the square of the frequency. For 60-cycle double rectification, the fundamental frequency is equal to 120.

Figure 6 shows the relation between the number of filter sections and the ratio of final to initial current at the terminal section of the filter. Curve A is a graph showing the variation in the terminal section for different numbers of filter sections. The resistance has been neglected for curve A, while curve B is based on formula 6. In general the simpler formula (5) may be used for all calculations. Knowing the allowable voltage fluctuations at the load terminals, the number of filter sections may be determined. It should be kept in mind that the attenuation is independent of the load current if the inductance of the choke coils remains constant. However, the inductance of the choke coils does not usually remain constant but decreases with an increase in load current.

The voltage fluctuation may be found by means of Ohm's Law, namely:

$$\Delta e = i Z \dots \text{eq. 7}$$

where Δe is the voltage fluctuation, i is the current flowing in the terminal section of the filter and Z is the impedance of the terminal section which is connected to the load. Or in the usual case, the impedance of the terminal condenser in which case the impedance is equal to

$$Z = \frac{1}{\omega C} \dots \text{eq. 8}$$

where w has the same meaning as before and c is equal to capacitance in farads.

The condenser C_2 has two functions to perform. In conjunction with L_2 it has to absorb the remaining ripple in the voltage wave and also to act as a source of variable current at a variable frequency to the load. Since a filter has essentially a two-way action (that is, reversing the directions of propagation of the wave does not alter the attenuation of the wave) the load current at variable current and frequency must originate at the terminals of the filter section.

Hence the capacitance is fixed by several considerations among which the more im-

portant are: (a) Have a low impedance to the load current; (b) to have sufficient capacitance to deliver the variable power to the load, (c) and to absorb the remaining ripple from the preceding sections. If a radio receiving set is the load, the power demand is then fixed by the audio frequency end of the set, since the a.c. power demand is small on the radio frequency end.

The capacitance of (C_2) must be sufficient so that the lower notes do not meet too high in impedance. If the impedance of the condenser is too high and the audio

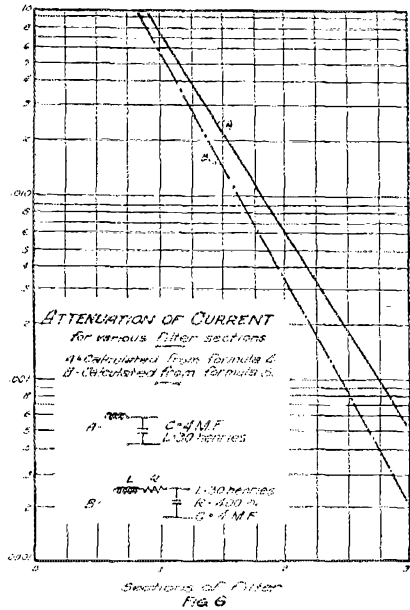

transformers are of high quality, motor boating may occur. This is explained by the fact that the amplifier, being able to pass and amplify the lower notes, the impedance of the condenser then acts as a coupling impedance which couples the output of one stage to the input of the other stage. This explains why motor boating may occur with the substitution of a high grade transformer for a low grade transformer. The remedy is obviously to increase the capacitance of C_2 . In general, if condition (a) is met, (b) will also be satisfied at the same time. The size of condenser C_2 to satisfy condition (c) is very easily met, and in most cases will be too small to satisfy conditions (a) and (b).

Figure 7 is an oscillogram which illustrates the function of the condenser C_2 when it is acting as a source of electric

(Continued on Page 47)

Additional Notes on Iron Core Reactances

By D. E. Replogle*

ALTHOUGH the derivation of the sign charts for filter reactors, simultaneously carrying direct and alternating current, which appeared in the April issue of QST, may have seemed rather involved, to some readers, the actual

case: In the design of a 165-milliamperere Raytheon operated power unit for supply filament and plate current for type 222 tubes, filament series connected, it was found that a 30-henry choke was required. The first point to be considered in the

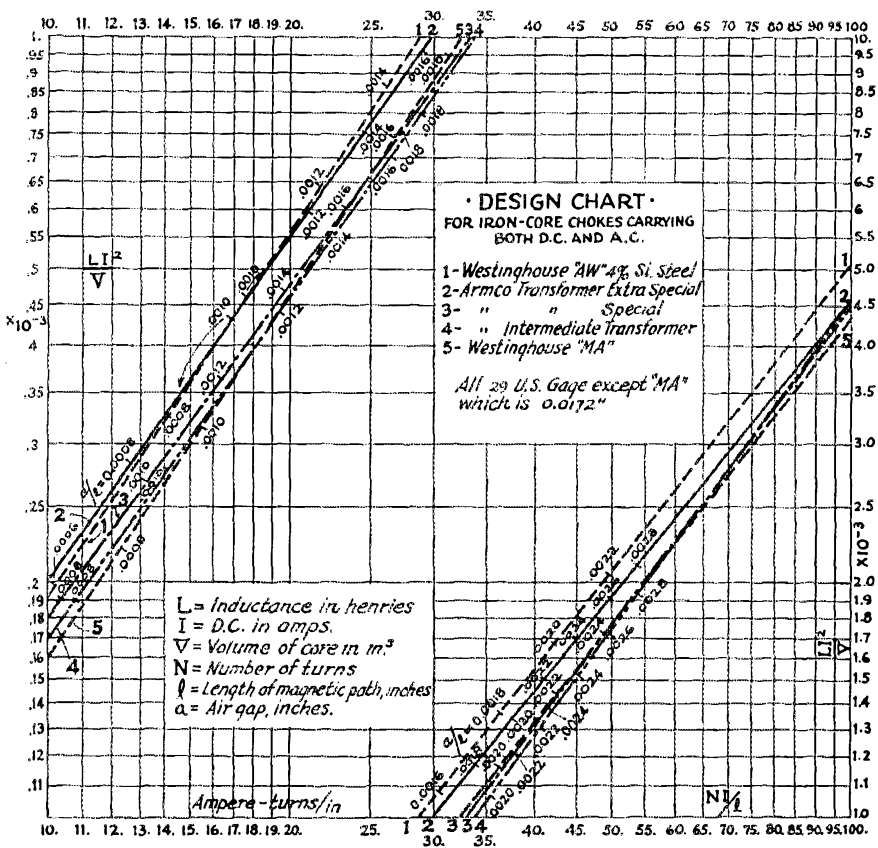

THE CURVES ARE REALLY CONTINUOUS BUT HAVE BEEN CLIPPED IN HALF TO MAKE THE CHART MORE CONVENIENT IN SIZE
 Use the curves on the left side for values between .1 and 1.0 and the right hand curves for values between 1.0 and 10.

process of designing a filter choke from the resulting charts is exceedingly simple.

As an example, let us review an actual

*Director, Raytheon Circuit Laboratories, Cambridge, Mass.

1. The Radio Amateur's Handbook has such a table. An allowance of somewhat less than 1000 circular mils per ampere was made in arriving at the size given.—Editor.

design of the choke was, naturally, the size of the wire necessary to carry 165 milliamperes without undue heating. This was ascertained from a wire table to be No. 28.¹

The size of the window space in the core which was to be used must be found so that the maximum number of turns

(Continued on Page 78)

Rocky Mountain Division Convention

August 24-25, Pueblo, Colorado

The place of assembly for the third annual Rocky Mountain Division Convention is Memorial Hall Council Chambers, located at Main and Grand Sts., Pueblo, Colorado. While our Division is one of the smaller ones our record of attendance is pretty close to 100%. So, we extend to you "hams" in this division and other sections a most cordial invitation to attend our affair, and help keep up our traditions. A.R.R.L. Headquarters is sending the new Assistant to the Communications Manager, Louis R. Huber, 9DOA, as official representative and as he is an old brass pounder you will all feel at home with him. Fellows, let's hear from you. Glen R. Glasscock, 2409 Pine St., Pueblo, Colorado.

Central Division Convention

August 17-18-19, Columbus, Ohio.

The Central Ohio Amateur Association are sponsoring this year's Ohio Section convention and the committee in charge is endeavoring to surpass all previous conventions. Some of the old timers will remember what Columbus staged five years ago. We are going to do our best to make you remember this one.

Mathews of old 9ZN will be with us; R. S. Kruse, formerly of A.R.R.L. Headquarters has promised to be present; Handy and Hebert of A.R.R.L. have been delegated to attend. We are also expecting some one from NKF. Plenty of good entertainment is being planned for the delegates.

A very cordial invitation is extended to all radio amateurs to attend our convention. All activities will take place at the Neil House. F. R. Gibb, Sec. & Treas., 150 Glencoe Road, Columbus, Ohio, will appreciate your advices that you will be present.

Strays

In connection with Don Wallace's article on page 38 of July *QST*, entitled "Becoming an Operator in 15 Minutes", attention is directed to the fact that the Radio Act of 1927 requires that every operator of a transmitting station must hold an operator's license issued by the Department of Commerce. As minimum requirements the applicant must demonstrate the ability to receive and transmit the code at ten words per minute. While believing it to be FB if the OW can operate the OM's station

when the latter is away from home, she must have a license and can't be permitted to operate until she can secure the license. The law must be borne in mind, and members are cautioned against permitting the operation of their stations by any unlicensed person, even under the supervision of a licensed operator. *QST* understands that Mrs. Wallace possesses an amateur operator's license.

Filter Circuits

(Continued from Page 45)

energy to operate the loud speaker of a radio receiving set. Curve (a) is a 60-cycle timing wave, curve (b) is the current through the loud speaker of an oscillating

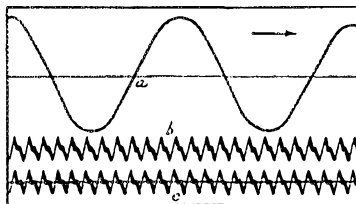
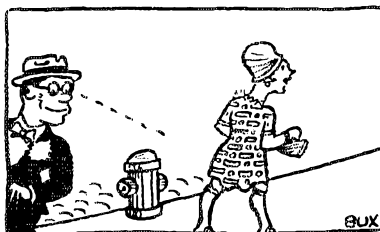

FIG. 7.

receiving set, and curve c is the condenser current. An examination of the curves show that (b) and (c) have the same shape which means that the loud speaker is obtaining alternating current from the condenser only.

In conclusion, the input condenser acts as a storage of current from the rectifier to maintain current through the filter during the blocking period of the rectifier. The total attenuation of the second condenser (in conjunction with the inductance to act as an attenuating network) is a function of the number of filter sections. The terminating capacitance acts as a reservoir and as such must have a capacitance sufficient to meet the power demands of the load.



FOLLOWING THE DOTS AND DASHES

The Communications Department

F. E. Handy, Communications Manager
1711 Park St., Hartford, Conn.

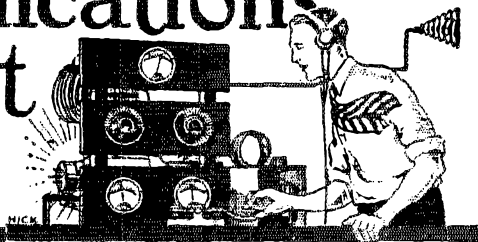

Operating Procedure That Gets Results

By Howard C. Storck*

EFFICIENCY is the key to satisfaction and success in any amateur radio station. The most efficient equipment is worth nothing unless we have an efficient operator who uses approved procedure. With efficient operating procedure as well as a good station results are assured. This article is a summing up of what has been observed to make for popularity and success in a number of good stations. It goes without saying that the well known rules of operating procedure which govern the Official Relay Stations are the ones to follow.

The first need for the traffic man is a bunch of good schedules and that means also, having a good wavemeter. There is a huge kick to be gotten out of good, snappy schedule work. If you don't believe it, try it. Have ONE wave in each band so when you get known, others will know where to look for you, and this helps a lot. Always work on that wave, unless you must QSY for QRM, and then try and standardize those waves for QSY only. If you have schedules—Be courteous—When you have them, keep them—don't disappoint the other fellow, and expect him to overlook it. Always try to have traffic for your schedules when possible. Do your best to originate good traffic. When working schedule and break-in, and the other fellow knows your style of operating, "R-K" is enough to let him know that you got the message OK, and is plenty snappy. Don't send "R" and then ask for fills. If you desire numerous fills, sometimes it is better to ask for QTA of entire text, or address, as it will save time at both ends. Be accurate—accuracy counts. Never give an OK on a message unless you are sure you have it right. Never take traffic unless you know you can be on the air in time to move it promptly. Never let a message, especially a delivery, die at your station. Mail it, if necessary, but send it on its way regardless. If a message has nearly reached its point of destination, all the more reason you should see it through. Keep your message file for three months at least, and don't forget to report to your SCM if you want to retain your ORS Certificate, whether you have traffic to report or not.

If you don't have schedules, or have traffic to move that your schedules don't handle use the directional CQ. If you CQ for traffic, specify it in some way. A good amateur tries to keep a good station on the air at all times, always tries to conduct himself and his station so as to reflect credit upon himself and the League, applies the Golden Rule at all times, always uses discretion in BCL troubles, tries to avoid key-thumps and interference, and NEVER tests when there is a chance of causing serious QRM. Use break-in but don't abuse it. It makes most amateurs sore to have another station breaking them all the time for foolishness. Have a good wavemeter, accurately calibrated. Keep it so by checking its calibration often. Keep a good log. The log will give the key to any station whether good, bad, or indifferent. These points of course apply to all classes of stations as well as to the traffic stations.

Next let's look at the man who is on for a good time rag-chewing, making friendly QSOs etc. Plain CQ should mean "ready for anything". CQ TEST for better just TEST when no assistance in tes-

ting is needed) should mean just that, and should not be answered unless the one answering can help. It should not be abused, but used where there is actual need of help by a station far away, for check etc. Don't CQ until the other fellow gives up in disgust and passes on. Nine-tenths of the CQ hounds never know how many have passed them up during a long CQ. Don't call and sign five or six times at beginning and end of every transmission when contact has been made. Never send R or OK unless you mean it, and never QSZ unless asked to. QRS gladly and don't get sore, and don't cover up with "QRM or QRN" when you mean QRS. It is no discredit to ask for QRS, as some seem to think. On the other hand, if you can stand more speed, for heaven's sake say "QRQ". On reporting signals, cut out the superfluous dope. "Ur RAC R8 wdi in Columbus, Ohio" tells the tale unless more is necessary for complete report, then say what you want to in the fewest possible words. Don't answer a directional CQ unless you want his traffic. Nothing makes a man with traffic more peeved than to CQ East and get an answer from a ham west of him who just wants a report on his signals or to chew the rag. Don't use a flock of dots to denote a mistake. Send and repeat the entire word, and don't, please DON'T take another's time sending or while thinking of more to say. Give the other fellow a chance. Use K, AR and SK properly, and when you say SK, mean it, and don't go back another time. Someone else may have been waiting for that SK and be calling you. Always thoroughly cover the dial after an SK. You will be surprised at the number of stations that will call you after an SK, especially when you are handling traffic. And lastly, don't make too much fuss saying GN. On signing off—"Gld qeo 73" is all that's necessary.

Here's a word for the DX hound (for we are all that at heart). Most of the foregoing is important but some special points must be kept in mind when working in the 40-meter territory (or on 20-meters) instead of with the traffic men on 80-meters. When CQing DX it is very helpful to specify about where you are going to listen by ending your call with "QRX 33 mx" or "QRX 45 mx" etc. This is no more than common courtesy. Also don't CQ or call too long. Sign your call letters often. Be sure you are within the limits of the band you are using. On no account trespass on other territory. Remember that the good must suffer with the bad. A very few outlaw stations can "queer the deal" for the rest. Be brutally frank if necessary in giving reports on signals. The other man will appreciate it if he is the right sort. If he isn't it's good for him to know the truth. Always QSL promptly if you don't QSL first. Many of these points can be applied to other activities on the air. A useful suggestion to foreign stations is that they differentiate between DX and the United States. This would help immensely. It is exasperating to listen to someone calling CQ DX, to call him, and to hear him go back at some other foreign station. Furthermore it would help immensely if foreign amateurs would refuse to work any nu station (with the exception of X stations) outside the U. S. amateur bands.

TRAFFIC BRIEF

NR7AD, way up in Big Port Walter, Alaska, says that one of his long-wave inductances serves as a nest for his pet hen. He reports two eggs in one day. Gee! Amateur radio surely is stimulating!

* B'Y.N. Section Communications Manager Ohio, 694 Carpenter St., Columbus, Ohio.

Another Bawling Out

By Rufus P. Turner, 1AY

THE writer is ready and willing to guarantee that no less than two-thirds of the readers would retort with heated pens should he state that close to sixty percent of the active amateurs are running amateur radio onto the rocks through sheer carelessness. Still he wishes to go on record as having made such a statement; and should he receive an abundance of those overwarmed epistles, he will conclude that we, as humans, are still prone to strike at the fellow who lays the cold facts before us, and gently pat the hypocrite who encourages us in our shiftless practices.

There is refuge in the realization that we are always forced by honor to seek the friend (for friend he is) who has brought the bare facts before our eyes, and confess that he was right after all. To prevent having to come to the writer later, then, study conditions before writing your letter. Unearth a few statistics, if you have them; if you have none, compile some by investigation and tabulation.

If, instead of issuing station licenses on application, the radio supervisors were able to visit each applicant and test installations for harmonics, poor keying, wobulation, etc, and issued a license only when the station measured up to requirements, we would have better stations, better operators and better amateur radio.

Some poor soul who reads the foregoing will conclude that the writer is favoring a movement to keep new fellows off the air. But such is not the case. No station deserves the right of the air if it cannot measure up to the requirements. Still further, no station is deserving of the right to stay on the air if it falls below the standard—no matter to what this drop in efficiency may be due.

There was a time, back in the so-called good old days, when a man might wire his home to his own satisfaction, and at the same time endanger his own life and the lives of others. Today he may wire his home if he be properly qualified, but that wiring must pass the city test. A man could drive a motor vehicle unmolested by the officers of the law, if we did not know the vehicle to be a menace in the hands of one unqualified to operate it. What a chaotic condition would result if everyone built an automobile and drove it around through the city as he desired.

The traffic situation of those imaginary streets, the wave bands, is getting more and more deplorable. Amateur radio must be improved. We would have fewer complaints and better conditions if we gave regular attention to holding our stations on a certain high level.

Even worse than the fellow who "slips on the air" with a poor station is the one who has been on the air for some time and whose station has run down to a mere nothing. The writer called on no small number of active amateurs just to get some dope for an article like this. It was not unusual for him to find many cases of bad keying, harmonic manufacture on a wholesale basis, and etc., but it was rather startling that so many of the owners of the carelessly-built, carelessly-operated stations should express the Oh-I-should-worry-I-get-out-just-the-same spirit.

We should care if our stations are falling below the standard. It is true that we are not visited by the supervisors often, but we should realize that we aren't doing amateur radio any good, if we don't care. The Authorities are watching. Other countries are listening in and determining the value of amateur radio by just what they hear when they sweep the wave bands. After concluding this article, tune your receiver to one of the popular bands, and count the number of carelessly-built, carelessly-operated stations. Compare that to the number of the better stations you would enjoy listening to all night. Then re-read the writer's statement, "Close to sixty percent of the active amateurs are running amateur radio onto the rocks through sheer carelessness."

Quoting Friend Warner (in one of his recent editorials): "We are again waving the old Redtysnitch . . . and now call upon every amateur to take stock of his station and clean house."

Now this article should not be concluded without some reminder that the amateur is left, to a great extent, on his honor when operating his station. At this time there are no police of the ether who scout our bands in search of law-breakers, particularly those who delight in working off-wave. And why should we have radio police? Has amateur radio

suffered such deterioration that off-wave operating has become a commonly accepted practice? Have we relegated the ethics of operating to the trash heap altogether?

The amateur who is giving his best to the art—the kind of fellow who is keeping amateur radio from going on the rocks—is the one who holds in high esteem the Radio Laws of the Country, and the regulations of the A.R.R.L. He has equal regard for certain unwritten laws of operating, and is ethical enough to observe and abide by them.

One fellow must not be expected to do all the work of making the amateur game attractive to newcomers. Each must do his bit. Raising the standards of amateur radio is a task requiring one-hundred percent support. Let every station owner inspect his apparatus and correct all faults; sharpening that wave, suppressing those harmonics, eliminating that key click adjusting the set within the proper bands, and so on.

Let's go fellows! For the sake of amateur radio, let's get together and dust out our shacks. Let's appoint ourselves committees of one to look into the betterment of the art.

A JOB WELL DONE

"Twentieth Century Limited" service in amateur radio has been inaugurated between New York City and Chicago. A small group of picked stations, organized by 3ZF, Route Manager of Eastern Pennsylvania, conducts nightly one of the finest relay trains on the continent. Headquarters messages have ridden on it upon several occasions—we know that the service is *par excellence*. 3ZF tells the story:

"Every evening except Sunday the express line functions. Its purpose is to speed up deliveries, promote good operating, and provide another means for the enjoyment of our hobby. No commercial interests are in any manner connected with this net. It is purely A.R.R.L. throughout. The schedules work like this:

11:00 p.m. EST 2BME sends to 3ZF (2BME via 1LL to NYC)

11:15 p.m. EST 3ZF sends to 8EU

11:30 p.m. EST 8EU sends to 9AIN

11:45 p.m. EST 9AIN sends to 9PU (9PU via 1LL to Chgo)

These schedules are for traffic going WEST from New York City. Immediately after completing this chain we all QRX in reverse order for traffic coming EAST from Chicago. This usually takes another hour. In this manner we can handle traffic swiftly and accurately by means of short RELIABLE jumps almost regardless of QRN, etc. Several hundred messages have been handled; and traffic is increasing practically every evening."

While there is seldom a break in the chain, the contiguity of the system is insured by *relief stations* that carry on when necessity calls:

2CP relieves 2BME

3QP relieves 3ZF

8AVK relieves 8EU

9AYO relieves 9AIN

9APY relieves 9PU

They are prepared to step into the place of the regular stations, using the *same* frequency. Once or twice the reliefs have been tried; they handled things as though there had been no change.

Side-lines to the express line are being established as fast as reliable stations can be linked together. Already one such system has been formed, and works beautifully.

9:30 p.m. EST 3SN sends to 8ADE

9:40 p.m. EST 8ADE sends to 3LC

9:50 p.m. EST 3LC sends to 3CFG

10:00 p.m. EST 3CFG sends to 3ZI

10:10 p.m. EST 3ZI sends to 3ZF

It is a real satisfaction to be a part of a system such as the "Twentieth Century Limited." To know that, night after night, and week after week, the fellows you work will be *right there* when you call; to know that you will pass messages swiftly and surely (no monkey business—just common sense operating); all this gives you a feeling something akin to the feeling you get from finding a good meal awaiting you every noon. There is no lost time; everybody is on the job—and consequently the work *never becomes tiring*, as it would if you had to spend four hours moving the same amount of traffic. Brasspounding of this sort is an art in itself.

—L. R. H.

IMK

Vacation time has cut down on the list of schedule-stations for this month. But we won't say that QRN and QRM are to blame, for traffic is handled regularly each night regardless of poorer conditions. The following list is up to date. (Eastern Standard Time)

1ACH (80) Mon. and Fri., 7:30 p.m. (to be replaced by 1KY about August first).
 1BIG (80) Mon. and Fri., 7:00 p.m.
 1BQD (80) Mon. and Fri., 9:00 p.m.
 1VB (80) Tues. and Fri., 7:45 p.m.
 VE2BR (40) Sun., 9:45 p.m.
 2BME (80) Sun., 11:45 p.m.; Mon. and Thurs., 7:15 p.m.; Tues., 7:30 p.m.; Fri., 9:30 p.m.
 2CTM (80) Mon. and Fri., 9:30 p.m.
 2ZS (80) Mon. and Thurs., 7:45 p.m.
 3QP (80) Mon. and Thurs., 9:45 p.m.
 4XE (80) Sun., 7:30 p.m.
 4IE (80) Thurs., 11:00 p.m.
 6BWH (40) Tues., 12:30 a.m.
 6CIS (40) Fri., 12:30 a.m.
 6EY (40) Wed., 12:30 a.m.
 6NK (40) Mon., 11:45 p.m.
 6ZD (40) Wed., 1:30 a.m.
 8AAG (80) Sun., 11:15 p.m.
 8DED (80) Tues. and Thurs., 9:30 p.m.
 8ZZ (80) Sun., 11:00 p.m.; Thurs., 9:00 p.m.
 VE9AL (80) Tues. and Fri., 7:15 p.m. (VE9AL on 52.5 m.)
 9OK (80) Sun. and Thurs., 11:30 p.m.
 9ENM (40) Mon. and Fri., 11:15 p.m.
 9APY (80) Tues., 9:00 p.m.

All the latest Official and Special Broadcasts are sent from IMK at the following times (E.S.T.):
 Sunday, Tuesday, and Thursday at 8:00 p.m. and midnight.

Monday and Friday at 8:00 p.m. and 10:00 p.m.

PERIODS OF GENERAL OPERATION have been arranged in order that everybody may have a chance to work HQ. Usually these general periods follow one of the OBC schedules. Here they are, listed under FORTY and EIGHTY meters:

EIGHTY METERS:

8:10 p.m.—9:00 p.m. on Sun., Mon., Tues., Thurs., and Fri. This general period follows the OBC, which is sent at 8:00 p.m.

10:00—11:00 p.m. on Tues. and Thurs.

12:00 p.m.—1:00 a.m., or later, on Sun. night (Mon. morn).

FORTY METERS:

10:10—11:00 p.m. on Sun., Mon., and Fri. This general period follows the 10:00 p.m. OBC.

12:00 p.m.—1:00 a.m., or later, on the following nights and a.m. of day following: Mon., Tues., Thurs., and Fri. This general period follows an OBC only on the nights of Tues. and Thurs.

IMK's QRH, as you surely know by this time, is 41.98 meters and 88.86 meters. Familiar signs are "RP" of Bob Parmenter, "OU" of Louis Huber, "FH" of Ed Handy, and "AH" of A. A. Hebert.

160-METER CODE PRACTICE

The volunteers have sent us their schedules of transmission, which will go into effect as soon as the beginners have been notified. The mimeographed material designed to enable the beginners to get on the right wavelength should be completed by the time this QST arrives. It will be sent to each beginner who has asked for it. Any new comers who wish to take advantage of these transmission are invited to write us. Please address "160 Meter Code Practice", Communications Dept., A.R.R.L., 1711 Park St., Hartford, Conn.

TRAFFIC BRIEFS

Uruguayan 1BU made the following comment in his report on the International Relay Contest: "Quite all signals on 20 meters are remarkably steady and quite a E6 to R8. FB. QSO are much more easy than on 40 meta., and only have little QRM produced by Ford cars. Fortunately Mr. Ford has now built the new Ford car, and for our pleasure he has forgotten the four transmitting coils."

The winners in a lot drawing contest held during the recent A.R.R.L. Convention at the Pennsylvania Hotel, New York City, were given a free flight in the Stinson-Detroit radio laboratory owned by the Pilot Radio Laboratories, Inc., of Brooklyn, N. Y. The winners, W. H. McCleary of Staten Island, Gerald Gerlach of Astoria, and J.

B. Knight of Brooklyn, were flown from Curtiss Field, Long Island, to Hartford, Connecticut. The flight was made in exactly fifty minutes, averaging about one hundred miles an hour.

The visiting amateurs were entertained by a tour of Hartford and an inspection of League headquarters. Before the return flight, A. A. Hebert, Treasurer and Field Man of the A.R.R.L., made an air inspection of Hartford in the Pilot plane.

Zeh Bouck, radio columnist of the New York Sun, was in charge of the plane's radio apparatus during the trip. Weather reports to the plane, en route, were transmitted by IMK.

The Coast Guard Cutter *Marion* is the boat that has been selected for the Greenland Oceanographic Expedition, which left Washington about mid-July. The call is NITB. The following periods will be devoted to amateur contact: On 24 meters: 8 to 8:30 a.m., noon to 12:30 p.m., and 4 to 4:30 p.m. E. S. T. On 36 meters: 5 p.m. to midnight E. S. T. Any traffic handled with NITB may be forwarded by wire collect to Coast Guard Headquarters, Washington, D. C.

The United States Department of Agriculture is organizing, with the help of 9APY and 9ASE, a monthly test net which functions among several cities in the eastern half of the country. Washington, Atlanta, Chicago, Kansas City, New York City, Pittsburg, and Detroit are connected by the co-operation of picked stations in each locality. The purpose of the net is to provide communication when the telegraph lines fall down on the job during storms, etc.

nc5AW, Whitehorse, Yukon, worked RAO8 at midnight P.S.T. the other night. RAO8 is the Radio Laboratory, University of Vladivostok, Siberia. RAO8 works on 20 meters every Sunday between 7000 and 8000 Greenwich.

Brass Pounders' League

Call	Orig.	Del.	Rel.	Total
op1HR	211	129	374	714
oh6BOE	127	79	494	700
8CDB	537	28	84	649
6ALX	42	54	234	330
1MK	124	92	104	320
6AMM	107	178	20	305
4CK	101	52	114	267
na7JR	199	54	93	255
3CKL	27	127	90	244
6IP	46	61	134	241
oh6CFQ	109	54	20	183
5JY	47	73	41	161
6ZX	—	109	10	110
7HP	16	51	28	95

Stations representing every U.S. district except the second and ninth and including also the outstanding stations in Alaska, in the Hawaiian and Philippine Islands are listed in our B.P.L. this month in spite of the advent of hot weather and the attractions of the great out-of-doors.

op1HR and oh6BOE head the list for outstanding meritorious performance. All these stations appearing in the Brass Pounders' League are noted for their consistent schedule-keeping and reliable message-handling amateur radio work. Special credit should be given the following stations responsible for over one hundred DELIVERIES in the message month: nu6AMM, op1HR, nu8CKL, nu6ZX. Deliveries count!

A total of 200 or more bona fide messages handled and counted in accordance with A.R.R.L. practice or just 50 or more deliveries will put you in line for a place in the B.P.L. Why not make more schedules with the reliable stations you hear and take steps to handle the traffic that will qualify you for B.P.L. membership also.

MORE TEN-METER TESTS

The second series of ten-meter tests will be held AUGUST 11-12, AUGUST 18-19, and AUGUST 25-26. We hope that every amateur who can possibly do so will get down on this new short-wave band (9.99 to 10.71 meters) and spend as much time as possible on ten-meters all day long on the dates named. Amateurs everywhere are invited to take part and report results, be they negative or otherwise.

All that is necessary to take part is to get on the air, transmitting or receiving or both. Information in this and past issues will enable you to get on ten meters without much difficulty if you are a new convert to the band of ten-meter experimenters whose results we have reported regularly in past issues.

A number of excellent contacts have been made on ten meters between points a thousand miles apart which indicate that this wavelength can be used for moderate distance work as well as for the trans-continental DX. The ten-meter reports received in the past month will appear (with a report of the August tests if possible) in our next issue.

Please report results to A.R.R.L. Headquarters by August 27 at the latest—just as soon as the last day of tests is over. It will be appreciated if a brief description of your equipment is included with logs and reports. Also we hope that a number will give their results using different types of antennas capable of radiating energy at different angles with the vertical—also provided with reflectors for directional radiation along definite lines from the transmitting station. An antenna with reflector wires mounted in a frame so that the whole business can be rotated would be ideal for this.

Whatever you use, OM, be sure to get in on the August ten-meter tests and let us know what you did. Let's go!

TRAFFIC BRIEFS

When the Marathon Swim was pulled off around Alameda Island, on the west coast, Sam Houston, 6BDO, donated the use of two short wave transmitters, one being located on Neptune Beach (San Francisco) and the other aboard a speedboat which followed the leading swimmers. The shore station was given the portable call 6AFZ; and the speedboat station was given the call 6SR. 6BDO and 6IP manned the shore station, while 6DTM, 6DCZ, and 6BDU went to sea. All went well except that 6DCZ got sea-sick and "spent half of the race looking longingly at the distant shore line He has since decided not to try for a commercial license as a seagoing brasspounder."

The efforts of all the boys were rewarded with complete success. The crowd on shore enjoyed the "hot" news from the speedboat, while another entirely separate attempt on the part of a newspaper to report the race was a complete failure. The newspaper outfit had hired a professional announcer, some extra entertainers, and had gotten a special limited commercial license. The barge on which their station rested got stuck in the mud; and they spent the afternoon yelling into the mike in vain.

Code was used entirely from the speedboat. 6DTM and 6BDU won congratulations on their steady fists in the presence of a bucking boat and flying spray.

Twenty meters seems to be the solution of summer difficulties for the brasspounder. Don C. Good, of 6AJM, keeps a wonderful schedule with oPIAD. In addition to his regular traffic work, he reports working eg, ef, eh, ee, eo, em, aj, op, np, nq, ny, oa, oz, fo, es, sa, oo, ne, and nu.

ELECTION NOTICE

To all A.R.R.L. Members residing in the Sections listed below: (The list gives the Sections, closing date for receipt of nominating petitions for Section Manager, the name of the present incumbent and the date of expiration of his term of office.) This notice supersedes previous notices. In a number of cases (*) when no valid nominating petitions have been received from A.R.R.L. Members residing in the

different Sections in response to our previous notices, the closing dates for receipt of nominating petitions are set ahead to the dates given herewith. In the absence of nominating petitions from Members of a Section, the present incumbent continues to hold his official position and carry on the work of the Section (†) subject, of course, to the filing of proper nominating petitions and the holding of an election by ballot or as may be necessary. Resignations are indicated by (**).

Section	Closing date for petitions specified of the present year on or before noon of the dates	Present S C M	Present term of office ends
Western N. Y. † *	July 28	C. S. Taylor, 8PJ	July 1
Indiana † *	July 28	D. J. Angus, 9CYQ	July 1
Kentucky † *	Aug. 28	D. A. Downard, 9ARU	Aug. 2
Ohio † *	July 28	H. C. Storck, 8BYN	July 1
North Dakota † *	July 28	H. L. Sheets, 9DM, Acting	
Northern Minnesota	Aug. 28	C. L. Barker, 9EGU	Oct. 2
Louisiana	Aug. 28	C. A. Preitag, 5UK	Oct. 2
Mississippi † *	July 28	J. W. Gullett, 5AKP	July 1
Tennessee	Aug. 28	L. K. Rush, 5KM	Oct. 2
Kansas † *	July 28	F. S. McKeever, 9DNG **	July 1
Maine † *	July 28	Frederick Best, 1BIG	July 1
Rhode Island † *	Aug. 28	D. B. Fancher, 1BVB **	Aug. 2
Vermont † *	July 28	C. T. Kerr, 1AJG	July 1
Idaho	Aug. 28	Henry Fletcher, 7ST	Oct. 2
Nevada	July 28	C. B. Newcombe	Sept. 15
Iowa	July 28	H. W. Kerr, 9DZW, Acting	
Arkansas	July 28	H. E. Velte, 5ABI, Acting	
No. Carolina	Aug. 28	R. S. Morris, 4JR	Oct. 2
West Virginia † *	Aug. 28	C. S. Hoffman, 8HD	Aug. 2
Colorado	Aug. 28	C. R. Stedman, 9CAA	Oct. 2
Alabama † *	July 28	A. D. Trum, 5AJF	July 1
Ga.-S. C.-Cuba-P. R.-Isle of Pines † *	Aug. 28	H. L. Reid, 4KU	Aug. 2
Oklahoma † *	July 28	K. M. Ehrret, 5APG	July 1
Southern Texas † *	July 28	E. A. Sahrn, 5YK	July 1
Utah-Wyoming † *	July 28	Parley N. James, 6BAJ, Acting	
Philippine † *	July 28	Jose E. Jimenez, oPIAT, Acting	

Newfoundland and Canada

Nominating petitions for Section Managers in Newfoundland and Canada should be addressed to Canadian General Manager, A. H. Keith Russell, VE9AL, 5 Mail Building, Toronto, Ont., Canada. To be valid, petitions must be filed with him on or before the closing dates named.

Newfoundland † *	Aug. 28	Loyal Reid, nc8AR	July 15
New Brunswick † *	Aug. 28	T. B. Lacey, nc1EI	Aug. 2
Nova Scotia † *	Aug. 28	W. C. Borrett, nc1DD	Aug. 2
P. E. I. † *	Aug. 28	F. W. Hyndman, nc1BZ	Aug. 2
Ontario	Aug. 28	W. Y. Sloan, nc9BJ	Oct. 2
Quebec	July 18	Alex Reid, nc 2BE	Sept. 15

1. You are hereby notified that an election for an A.R.R.L. Section Communications Manager, for the next two-year term of office is about to be held in each of these Sections in accordance with the provisions of By-laws 5, 6, 7 and 8.

2. The elections will take place in the different Sections immediately after the closing date for receipt of nominating petitions as given opposite the different Sections. The Ballots mailed from Headquarters will list the names of all eligible candidates nominated for the position by A.R.R.L. members residing in the Sections concerned.

3. Nominating petitions from the Sections named are hereby solicited. Five or more A.R.R.L. members residing in any Section have the privilege of nominating any member of the League in their Section as candidate for Section Manager. The following form for nomination is suggested:

(Place and date)

Communications Manager, A.R.R.L.
1711 Park St., Hartford, Conn.

We, the undersigned members of the A.R.R.L. residing in the.....Section of the.....Division hereby nominate.....as candidate for Section Communications Manager for this Section for the next two-year term of office.

(Five or more signatures of A.R.R.L. members are required.)

The candidate and five or more signers must be League members in good standing or the petition will be thrown out as invalid. The complete name, address, and station call of the candidate should be included. All such petitions must be filed at the

headquarters office of the League in Hartford, Conn., by noon of the closing date given for receipt of nominating petitions. There is no limit on the number of petitions that may be filed, but no member shall sign more than one such petition.

4. Members are urged to take initiative immediately, filing petitions for the officials of each Section listed above. This is your opportunity to put the man of your choice in office to carry on the work of the organization in your Section.

—F. E. Handy, Communications Manager.

ELECTION RESULTS

Valid petitions nominating a Section Manager for the New York City and Long Island Section of the Hudson Division were filed naming but one candidate for the office. As provided by our Constitution and By-Laws when but one candidate is named in one or more valid nominating petitions, that candidate shall be declared elected. Mr. Morton B. Kahn (2KR) is herewith declared elected for the next two year term of office in this Section.

In the Northern New Jersey Section of the Hudson Division, Mr. Arthur G. Wester Jr., 2WR, and Mr. Dallas C. Akers, 2BDC, were nominated. Election results: Mr. Akers, 75; Mr. Wester, 82. Mr. Wester has therefore been declared elected.

In the South Dakota Section of the Dakota Division, Mr. Rubert Olson, 9DES, and Mr. Dwight M. Pasek, 9DGR, were nominated. Election results: Mr. Olson 10; Mr. Pasek, 11. Mr. Pasek has therefore been declared elected.

DIVISIONAL REPORTS

ATLANTIC DIVISION

WESTERN NEW YORK—SCM, C. S. Taylor. 8PJ—With many operators on vacations now, the district comes through quite well. 8ADE keeps up schedules. 8AHC works OA and OZ and has schedules. 8AIL has a new 852 tube. 8AVS had hard luck with his antenna coming down. 8ARX is now handling traffic. 8AWG is now instructing at Boy Scout camp. 8BFG went to the Convention at State College. 8BLP states traffic had on account of QRN. 8BRD is now rebuilding his set. 8DBI at WHAM is doing good work on short waves. 8CNH delivered a message from an OH station. 8CNT worked WNP and has schedules with 8AXF and 8BPQ. 8CNX just put in a new 852 tube. 8CPC was QSO Calif. 5 times. He is now on the way to Europe and will return in September. 8CTL is now using an 852 tube and new recto bulbs. 8CVJ worked Italy and England. 8CYB has schedules and traffic. 8DBI worked NN, NJ and has schedules with 6DTP and 8BAU. 8DDL says ex8BNG has a new transmitter at Rochester. 8DDL will operate 8MU at Canandaigua Lake for the summer. 8DME handled a message for Hawaiian-Australian fliers. 8DSP says he had a fine time at State College and got pinched there for shooting off fire crackers. 8QB is ready for PRR work and traffic. 8PJ is now on the U.S.S. Reld on a Naval Reserve cruise with 8CAN. 8TH has a new Recto set in operation now, also doing work at Boy Scout camp. 8UII has gone to his summer home. 8CDB has a WAC certificate now. 8CDB is the leader for this Section in traffic this month. He made the BPL in grand style. 8DQP has but three messages. 8PI will attend Culver Summer school this year. 8UL has undergone an operation for appendicitis and will also go to Europe shortly.

Traffic: 8CDB 677, 8ARX 57, 8CPC 45, 8DSP 40, 8DII 38, 8DME 37, 8CYB 28, 8AHC 27, 8CNT 26, 8DDL 18, 8CTL 15, 8BFG 12, 8QB 12, 8BLP 9, 8TH 9, 8CVJ 6, 8DQP 3, 8ADE 1, 8CNH 1.

WESTERN PENNSYLVANIA—SCM, A. W. McAuly. 8CEO—There was a little mixup this month in reporting, some reports coming to me and the rest to Mr. Crossley and as I have to leave June 30 for my vacation, this report may be a little incomplete. We all want to thank Crossley and his gang of brasspounders for the excellent Convention they put on for the benefit of the Atlantic Division. Do not forget that Anderson, 8GL is still RM and will arrange schedules for you. His address is 416 Glen Ave., Ellwood City, Pa. A special appeal to Pittsburgh stations is made to get into the traffic game. 8CES says "bring on your skeds and traffic." He has a schedule with 8CHO but wants more.

SCFR, on the 20 and 40 meter bands, has been doing some real work. He has been keeping a daily schedule with 8AIB handling traffic for the Dyott Expedition. 8GL the RM, is on the air daily on 83 meters. 8CYP is experimenting with airplane radio. He will try to get on a plane from Rodgers Field soon. 8ARC has been keeping a schedule with nc4GG on 20 meters and picking off the DX. 8AGO has a portable call, 8PR. 8CEO will be off the air for two weeks on a vacation trip. 8DHU and 8CEO will visit 4JR, with whom a schedule has been held for over four years. 8DOQ says "nil here on account of spring fever and baseball." 8BGW has adopted the forty meter band for summer work. 8DOY is a new ham in New Castle. Welcome, OM. 8DWV is a new one in Ellwood City. Wonder if 8GI has been spreading brasspounding propaganda? 8BNR picked up a message from the crew of the wrecked dirigible Italia. 8CDS is back on the air now and is looking for traffic.

Traffic: 8CFR 121, 8GI 46, 8CEO 30, 8CYP 19, 8AGO 8, 8ARC 4, 8BGW 3, 8CDS 1.

MARYLAND-DELAWARE-DIST. of COLUMBIA—SOM, H. H. Layton. 8AIS—Quite a number of the gang are to be found on the 80 meter band. Let's have those reports, fellows, so we can put you on the active list.

Delaware: 8ALQ will be QRV traffic shortly. 8WJ has a new job with the local power company.

Maryland: 8BBW rebuilt his transmitter and hooked nu6UC right off the bat. 8AEI is QRV organizing Naval communication reserves.

D. of C.: 8GT at Boiling Field continues to be high traffic man of the entire Section. Reports bad QRM from power leak from landing lights. 8BWT is next but had the misfortune of losing his two masts in a hurricane. 8NR is back from Florida and promises a large traffic total next month. FB.

Traffic: Delaware: 8ALQ 4, 8WJ 2, 8AJH 1, 8AIS 2. Maryland: 8BBW 3, 8AEI 2. D. of C.: 8GT 35, 8NR 9.

SOUTHERN NEW JERSEY—SCM, M. J. Lotysh. 8CFG—The following stations are advised that their ORS appointments have been cancelled for failure to meet their ORS obligations fairly: 8VX, 8BTQ, 8CBX, 8BAY, 8ALX, 8BMZ, 8WB, 8SX, 8CFG never worked harder for traffic than this month, and his report still is rather lean. 8ARC is a very consistent station and is a good ORS prospect. 8ZI seems to be busy with Army-Amateur work. He worked 1MK on RM night. (LRH) 8IV still is pattering with fons and 20 meters. 8UT reports by his customary nice letter 8BSD kept a

sked with unINIC. 8CO resumed activity with nice total. 3ATJ and 3ARN are newcomers. Reports are requested from all active stations in the section, whether ORS or not. Watch your reports, gang, and if you need more time be sure to mail yours by midnight of the 27th. Later reports cannot be inserted. Let's start going again this month. 3CFG offers to double any other total in next month's report. Let's have competition. (FB, OMs, go to it.—LRH)

Traffic: 3CFG 81, 3ARC 16, 3ZI 15, 3IV 18, 3BBD 9, 3CO 10, 3UT 7, 3ARN 2, 3ATJ 5.

EASTERN PENNSYLVANIA—SCM, J. B. Morgan, 3QP—The nightly express service for traffic from New York to Chicago and return originated by 3ZF is working smoothly. Traffic seems to be plentiful over this channel although the majority of stations complain of lack of traffic. QRN and so forth. Notice the same gang reporting each month—hot weather or no. Where are the rest of you? A lot of appointments will be QSK next month if you don't show up.

Traffic: 3ZF 232, 3WJ 24, 3AFJ 32, 3LC 118, 3QP 71, 3AKB 124, 3HH 25, 3AVK 61, 3ADQ 88, 3CWO 9, 3DHT 34, 3ADE 38, 3AWO 2.

CENTRAL DIVISION

MICHIGAN—SCM, Dallas Wise, 8DJR who has been up at WOOD, Grand Rapids, will be home for the summer and will have 8BJJ on the air. 8BJQ of Flint has several schedules with other Mich. stations and finds them reliable. 8AAF is using a fifty with a current feed Hertz and gets out in great style. 8CU is one of the USDA net stations. 8BWR has been quite busy on 80 and handled quite a few with 8CEP on schedule. 8DED has been having QRM from baseball but still manages to lead Mich. for the month. 8DFB complains of 40 meters being dead at times. 8BRS is rebuilding and getting ready for the fall rush already. 8CEZ says not much doing on account of the bad QRN on 80. 9AYR has been silent on account of waiting for a couple of tube rectifiers. 9CSI has just graduated from high school and has a job so will not be able to be on during the daytime except Sundays. 8CNK turns in a nice total and says he is on about five hours a day. 8AUB wants another bigger and better QSO party next fall. 9CE works a schedule with 9CEX every other day. The Mich. 80 meter QSO party went over well and believe everyone that was on had a good time. 8DKX takes the honors for the most QSO's, having ten. 8DED and 8DEX were tied for the number of different stations worked, each having seven. Of the eight test messages started, seven were delivered that same night which shows the traffic can be handled FB if we just get out and try. 8WO, 8ZZ, 8CFY, 8CKZ, 8ALJ, 8BWR, 8AUB, 8AAF were some of the other fellows who helped make the party a live one.

Traffic: 8DJR 23, 8BJQ 9, 8AAF 11, 8BWR 65, 8DED 120, 8DFB 7, 8BRS 6, 8CKZ 4, 9CSI 21, 8CNK 75, 8AUB 22, 9CE 12, 8CEP 64.

INDIANA—SCM, D. J. Angus, 9CYQ—9AIN again leads Ind. for traffic handled. 9FAP is the short wave station at Fort Benjamin Harrison and now in operation day and night, handling traffic for the CMTC camp. Plenty of ops as hams are there from all over Ohio and Indiana. 9FTT is a new ham at Bloomington. 9EGE is enthusiastic about the state convention. 9ABW is remodeling. 9JP is the call of the Indianapolis Radio Club portable station. It is crystal controlled on 88.75 meters. 9FTW is the call of the new Richmond radio club station. 9EPH is a new ham at Springport. 9HKJ is putting in a new chemical rectifier. 9DBA has moved to Valparaiso for the summer. 9BYI is learning the bug. 9BIA is selling out for the 6th time. Don't think it will stick. 9EVA is putting up a new mast. 9FPF is putting in a 210. Elkhart and South Bend are going to have a hamfest on the 14th of July and expect the north end of the state to be there. 9RF QSO'd the west coast on 10 meters. 9ASX is going after a commercial. Indianapolis hams are very busy on the preparations for the coming convention July 28 and 29.

Traffic: 9AIN 132, 9EGE 85, 9EVA 10, 9FPF 1, 9FGC 6, 9FCG 17, 9EEY 18, 9ASX 19, 9BYI 5, 9RKJ, 7, 9CNC 14, 9CVX 19, 9CLO 10, 9BZZ 5, 9CRV 38, 9CYQ 15.

OHIO—SCM, H. C. STORCK, 8BYN—There is a wholesale slaughter of inactive ORS coming again soon and this is the last call to you sluggish ones. 8CQU takes the lead for OHIO this time. 8CMB comes next. 8DBM is third. 8GZ knocks down fourth. 8AMI will be on in Cleveland with his portable through the summer. 8DTN hopes to be on with a 50 watter soon. 8CPQ says traffic seems to be on the mend now. 8API deplores the "round the neighborhood" method of boosting traffic totals. 8CXD is still short his rectifier tubes. 8OQ reports as usual. 8BBR reports his schedules are short. 8SI has nothing to say for himself. 8BKM reports traffic on the down-grade. 8CSC sent greetings from the C. of C. to the Australia fliers. 8CSS says not much traffic on 40. 8DDK has been QRW. 8DSY bawls the fact that traffic is so scarce. 8DQZ leaves us until Sept. 8DJV works 13 hours per night. 8ADA worked 5JA on his 10 meter harmonic. 8CFL has been rebuilding. 8BAC, 8CNO and the SCM were on only a few days this month, the rest being used as vacation. All went east. 8AZO has been rebuilding. 8BQJ is experimenting with television. 8ARW is on the air again. 8CCO specializes in chewing the rag. Remember the Central Division Ohio State Convention, August 17, 18 and 19, O.M.A. A gang will be here from Hartford. Come and meet them. A big time is planned, best ever.

Traffic: 8CQU 95, 8CMB 75, 8DBM 61, 8GZ 46, 8AMI 42, 8DTN 36, 8CPQ 85, 8API 25, 8CXD 24, 8OQ 19, 8CNO 17, 8BRR 15, 8SI 18, 8BYN 12, 8BKM 12, 8CSC 10, 8CSS 2, 8DDK 6, 8DSY 5, 8DQZ 5, 8DJV 4, 8ADA 4, 8CFL 3, 8BAC 3, 8AZO 3, 8BQJ 2, 8ARW 1, 8CCO 1.

WISCONSIN—SCM, C. N. Crapo, 9VD—9DLD leads but he is handicapped because he can't QSY to any other band. 9SO has 10 meter set working but reports reception inconsistent. 9EMD's schedules work fine with 9FAW, 9BAW and 9DLD. 9FAW believes in Sunrise schedules. He has one with 9EMD and another with 9PFU. 9FSU is a newcomer in the game. 9DND keeps schedules with 9ASX, 9EVA and 9DNB between watches at the local power plant. 9BWZ is back on the air for the summer. 9BWO is on a vacation with a portable transmitter and receiver. 9CVI is at Great Lakes for two weeks. 9EWY wants an OBS appointment at Lacrosse. 9DCX gets a few messages through between thunder storms. 9VD has his 852 on the air on 40 and 80. 9BWN reports via amateur radio. 9BPW is using a new xmitter with tube base coils. 9EBT says there isn't much doing up his way. 9ARE just returned from Dodge Institute with a commercial ticket. 9BIB has a crystal set going on two bands. 9DEK is rebuilding. 9DJK says his shop is working overtime. 9BSS is always on the air. 9EEF is having lots of trouble with power leaks.

Traffic: 9DLD 114, 9SO 49, 9EMD 45, 9FAW 20, 9FSU 17, 9DND 16, 9BWO 11, 9CVI 9, 9EWY 6, 9DCX 6, 9BPW 5, 9EBT 5, 9ARE 5, 9BWZ 14.

ILLINOIS—SCM, F. J. Hinds, 9APY—Wish to thank the gang at this time for my election to the office of SCM for Illinois. Will endeavor to do my best and continue the good work for our retiring SCM, 9AAW. I also wish to announce the new RM who is to be 9DXZ. 9TQ is spending a week or two in New York. 9DLG is touring the west coast. 9GV is using a 250. 9EPG is building a portable transmitter for camp use. 9CNY blew the works. 9AAW says of his tubes, "Now they light and now they don't. Hi." 9EGX will attend the U. of Ill. this fall. 9BZO is taking a trip. 9EJO will have a transmitter at the fair grounds in August. 9RX for his traffic. 9CFW wants an ORS certificate. (How about the rest of you traffic fellows?). 9ANQ works with low power on 20. 9AAS is keeping some schedules with the BCLs. Hi. 9DSU gets out FB on 20 meters. 9PU has been on the air only 2 weeks this summer and gets R9 from oa-2VI. His schedules are FB. Traffic is slack at 9CKM. 9EYA is off to Michigan until school starts. Yls have the better of 9ALE. 9BLL and 9DEFA report things slow. DX is good on 40 at 9DCK. 9IZ has been in St. Louis on a trip. 9APY is trying to pacify the BCLs. 9ASE is taking charge of the USDA tests. 9BRX has a brand new Commercial ticket and hopes to go on the lakes soon. 9BNI can't amplify his new crystal. 9ACU is trying to get out on 10. 9KB is rebuilding. 9BNE is building two new transmitters. 9DXZ is on 20 and

40 now. 9CZL has been experimenting with 80 meter fone. 9AFA worked ALL his traffic with WNP. FB, OM. 9BHH works on 10 meters. 9AWX is back on 80 meters. 9CNB is now on 20. 9AQA's new baby girl will soon be reporting. 9DWP is rebuilding. 9DD5 is (QW) automobile QRX for a 250 watter. Ex-9EFS is now 5AXW) was in Chicago for a visit.

Traffic: 9CIA 83, 9PU 70, 9CZL 67, 9AFA 58, 9BJO 46, 9CNB 45, 9BZO 84, 9AAS 83, 9APY 27, 9DCQ 26, 9EPG 19, 9GUO 19, 9CUH 18, 9ABE 15, 9FCQ 15, 9BHH 12, 9DGA 12, 9BNI 12, 9BNI 10, 9CNU 10, 9ACU 8, 9AD 7, 9FCW 7, 9KB 7, 9ALK 6, 9BTK 6, 9GV 6, 9CKM 5, 9AEG 4, 9BEX 4, 9AHJ 2, 9BRX 2, 9IZ 2, 9AGG 1, 9ANQ 1, 9EYA 1.

DAKOTA DIVISION

SOUTHERN MINNESOTA—SCM—D. F. Cottam. 9BYA—Traffic looks pretty slim this month. Remember the UX210 and the 222 that could be yours if you keep up the traffic. 9COS is highest this month. He has been on a vacation, too. He has a coat of tan on him that makes him look like No. 12 enamel. 9DBW has been on a trip to Canada. 9FSN was with him. They visited several ham stations. 9BTW has been QSO SE and NN. 9EFK keeps one sked. He is very busy delivering groceries in his egg beater but hammers the brass evenings. 9ELA has been on 80. 9BYA had a blow up of apparatus in general and has been depressed ever since. The worst of it is 9BYA was handling the 9XI schedule with 1MK after 9XI's generator passed on and then the first blow up of all time had to wreck things. 9EFO keeps one schedule. 9EHO, a new reporting station, is doing some very nice work with a 20BA. 9AIR has been hamfesting all month, saw 22 stations and gathered a lot of info. The last Twin City radio club meeting of the season was held at the Univ. of Minn. where moving pictures of Twin City ham stations were shown. Everyone enjoyed them very much. Mr Sumner T. Young was master of operations from photographing to projecting. He is to be congratulated on his fine work in our interest.

Traffic: 9COS 40, 9DBW 18, 9BTW 15, 9EFK 18, 9ELA 11, 9BYA 11, 9EFO 7, 9EHO, 6, 9AIR 1.

NORTHERN MINNESOTA—SCM, C. L. Barker. 9EGU—CKI says he may go to sea. 9DPX, who was aloft as RJC, is back at St. Paul again operating his own station. 9EHI used a Hartley on 40 all month. 9ABV has been with the National Guard up at Devils Lake. 9CIW and 9BMR visited the SCM. 9CIW took a trip by car visiting the SCM and other hams enroute. 9BMR is too busy to be on but paid the SCM a visit while on a short camping trip at the lake.

Traffic: 9CKI 6, 9DPX 3, 9EHI 6, 9ABV 2, 9EGF 1.

NORTH DAKOTA—Acting SCM, Prof. H. L. Sheets, 9DM—9BVF is rebuilding. He went back to a one wire aerial and counterpoise and reports FB results. 9IK is attending the summer session at Valley City Normal. He reports a new station. 9FKY. 9BRR is plugging away as usual. 9DM is at the U. of Minn. working hard. A new ham has reported from Killden, N. D., but has not received his license yet.

SOUTH DAKOTA—SCM, F. J. Beck, 9DB—The gang are all rebuilding and getting ready for cooler weather. 9DIY has his C.C. set going OK. 9BOW was visited by 9DWN. 9DGR, 9DBZ and 9DKL visited the SCM. 9DLY is recovering from a broken leg. 9DB put in separate sets for 20 and 40 meters, new receivers, etc., and handled some traffic besides. 9DNS is quite active on 40.

Traffic: 9DB 31, 9DNS 6, 9BOW 3.

DELTA DIVISION

ARKANSAS—Acting SCM, H. E. Veltz, 5ABI—Well, fellows, I have been appointed your acting SCM until you have nominated and elected a regular SCM. We lost one of the best SCMs that Arkansas has ever had when 5AIP left us to become a ship op. 5BR has also left us to ship op. They both have their first class tickets. Sorry to have you go, OM's. Best of luck to you both. The R. I. paid us a visit and we were glad to have him come. Several of the fellows took the exams. We have two new

stations in Little Rock, 5BCZ and 5BDD. 5ANN is completely rebuilding and will be on 10, 20 and 40. 5ABI is the leader for this section in traffic. 5SI, the RM, will be on the air soon. 5AND has moved to Helena. 5SS expects to leave for Calif. soon and expects to set up out there if he does not go to sea. He reports some traffic. 5IQ says that he does not hear any stations on 10 and that 20 is FB but very erratic. 5AUU is back home and will be on soon. Let's try and have more traffic reports next month. ORS have not been reporting as they should. Come on, fellows, let's put Arkansas on the map.

Traffic: 5ABI 29, 5AQX 3, 5SS 5.

MISSISSIPPI—SCM, J. W. Gullett, 5AKP—6Q says that his UV-204 set his radio frequency choke on fire but he is going again with a new choke. 5API is going on a vacation. He is still sticking to the fone on 178 meters. 5AJJ is QRW. 5SS and 5AED had a schedule. 6BDZ is a new ham in Vicksburg. 5AGS and 5AQU will be in scout camp for the next eight weeks and will have a transmitter on the air using the call 5AGM. 5AKP is now rebuilding his transmitter, receiver, antenna and wavemeter. He has been QSO EG, EF and OA lately on 20 meters.

Traffic: 5AKP 73, 7FQ 12, 5API 5.

LOUISIANA—SCM, C. A. Freitag, 5UK—5IE has some difficulty with his xmitter. 5LD uses B batteries. 5BCM is a new station in Shreveport. 6AAY, 5HR, 5BJ and 5UK are still going strong on fone.

Traffic: 5ANC 11, 5NS 2, 5UK 7, 5BCM 6.

HUDSON DIVISION

EASTERN NEW YORK—SCM, F. M. Holbrook. 9CNS—the big event of the month was the meeting at White Plains of 42 hams and would-be hams from 18 towns of Westchester County. The meeting was enthusiastic. 2CVJ gave a talk on Television. 2APQ made the BCL with three to spare. This is a result of schedules. 2AYK handled traffic relating to GMD with NKF and 2BHV. 2AXX has daily schedules with 8BLP. 2QU was slowed down by illness and resetting transmitter. 2BKE finds his pure DC gets out consistently. 2ANV is erecting a new Zeppelin antenna with the help of 1AWQ who is contributing material. 2AWF is back from a camping vacation. 2BMP (old 2ABQ of spark days) is now on the air and says CW is FB. HI. 2ACY is Army-Amateur at Schenectady. He reports that his shack was visited this month by 8BQK, 2ATA, 2BGB and 2AGP. 2JE, formerly operator at NAN, is our newest ORS and is on every night. 2BJJ, who has won commercial first class license, has a new 852. 2ARS is starting up with a 210 REL set. 2MZ sends in her first traffic report. Her QRH is 39 meters. 2CTH will be temporarily QRT due to complete fading of his B battery. 2CNS shot a message via Quebec to an old Ontario friend of 20 years ago and received a pleased reply via ne2AC.

Traffic: 2APQ 103, 2AYK 64, 2AEX 32, 2QU 18, 2BKE 12, 2ANV 10, 2ACY 10, 2JE 7, 2BJJ 5, 2MZ 4, 2CTH 2, 2CNS 1.

NEW YORK CITY AND LONG ISLAND—SCM, M. B. Kahn, 2ER—Due to the change of SCM, no doubt many of the fellows were at a loss as to where to send their reports but I am not accepting that as an excuse from the ORS holders. This month's report was disgraceful and there is going to be a shake-up in the C. D. of the Section. There are over 40 ORS in this Section and some of the fellows haven't sent in a report for months. Others haven't even a transmitter on the air. In view of this condition, all ORS who haven't a perfect record are going to have their appointments cancelled. Those who think they can meet the requirements of an ORS are invited to send their applications to me. Only those who are positive that they can report their activities each and every month need apply. There are several appointments open for the right fellows as RMs and OBs so let's hear from the live wires of the Section who are interested.

Manhattan: 2AOJ-2BJU is on ten meters with a TP-TG circuit using a UX250 and is working fine DX. 2BGO is on the air every morning, except Mon. and Tuesday, from 2 a.m. until dawn. 2BCB is working Ausies quite consistently on 30 meters and informs us that 2TC is in China listening for Nu-2's 2DP worked many 7's last month but other DX was nil. 2ER has been trying to get some traffic on 80 meters but it seems that real messages are not to be had.

Bronx: 2BRX is the only Bronx station who took

the trouble to report. He kept a schedule with ARDI for eight successive nights.

Brooklyn: 2UI is the lone star in Brooklyn.

Long Island: 2BGK relayed a message from the "Italia" by long distance phone. He uses two 201A's with 300 volts RAC. 2GP has left for Europe and won't be back until Sept.

Traffic: Manhattan: 2KR 38, 2AOJ-2BJU 27, 2DP 9, 2BGO 6, 2BCB 5, Bronx: 2BBX 68, Brooklyn: 2UI 31, Long Island: 2BGK 14, 2GP 35.

NORTHERN NEW JERSEY—SCM, A. G. Wester, 2WR—2WR is on 40 again with a new plate transformer. 2CP has a fast express route working with the west and uses 2BME as an alternate. 2AT expects to put plenty of traffic into New York via 2KR, the SCM of N.Y. 2JC is quite due to remodeling of club rooms. 2KA is rebuilding. 2JG is QRV for any aeroplane test as he lives on the trans-continental Air Route. The YLs have 2AGM now that college days are over. 2BDF was busy with YMCA work. 2MD kept a schedule with sb-1AW. 2CTQ is using voltage polarized feeder for 20 now. 2CJX has been busy with business. 2BY is going to have several prominent YL operators call at her shack during the summer. Guess a few OMs will also be around. Hi, 2BBB has left to pay a visit to nc2BB at Montreal. 2AVK sent his report while enroute to Canada for a vacation. 2BAL is going back on 20 after a few days on 40. 2AOP expects a new flivver to give his signals a race. 2ADL has left for the sunny South, stopping off at 3ANV, enroute to WSB. 2ANB is vacationing in Calif. 2AOS is peddling Atwater Kent sets. 2AER is back from M.I.T. and will be heard on for the summer. 2ASZ is with us in a late report. 2ARB has had very fine contact with WNP and handles all their traffic. 2BME reported a good total direct to HQ—just in time.

Traffic: 2WR 1, 2AT 22, 2EY 1, 2JC 8, 2KA 6, 2JG 25, 2AGN 15, 2MD 24, 2CTQ 7, 2CJX 12, 2EY 3, 2BME 113, 2AVK 14, 2BAL 4, 2AOP 14, 2AOS 3, 2ADL 115, 2AER 8, 2AEB 2, 2ARB 22.

MIDWEST DIVISION

NEBRASKA—SCM, C. B. Diehl, 9RYG—9QY says that 20 meters is FB for summer. He keeps a nightly schedule with 6EEZ. 9RYG is still the maddest man in town. 9DVR is still at 'em. 9DI is on deck. 9CHB reports a ham picnic at Superior—8 hams and several YLs were present. Have a very fine report from 9EQF at Norfolk. 9EQF is the shining example for Nebraska ORS.

Traffic: 9EQF 28, 9DVR 9, 9QY 6, 9DI 4, 9CHB 4.

IOWA—Acting SCM, H. W. Kerr, 9DZW—First our apology to the Asst. C.M. for allowing the printer to place an "ex" before 9DOA. Our own "OU" connects with 9EHN from 1MK and invites QSU when you hear that sig. "QRW" comes from all sides—9EIW with "strawberries", 9BWN cable-testing and inspecting for the Bell Fone over the state. 9CS and 9CUX have asked for rain check till fall. Our RM visited a number of the gang on a vacation trip. 9BCA gets a big kick QSOing 6 countries and 8 continents in one night. 9EQJ worked three on 10 meters, continues 5 meter transmission from 2:30 to 3 pm. Sundays. 9DRA failed to report his 60 last month but leads this. 9CKQ had complete QSO with ed-DY Treviso, Italy, on 20 meters, also worked eg-5BY with 400 volts on his 210 bottle. The Acting SCM would like to hear from every Iowa Ham.

Traffic: 9DRA 76, 9EDW 66, 9BCA 49, 9EHN 41, 9CS 28, 9DZW 26, 9CZC 12, 9EIW 9, 9PB 8, 9EQJ 4.

KANSAS—SCM, F. S. McKeever, 9DNG—9CFN is in Canada on his vacation so was pretty much QRT this month. 9CWW takes the cake this time. He worked Japan and lacks only Africa for his WAC. 9CV and 9CET are still coming. 9HL let his skeds all go. 9DIH and 9DNG lost their antennas in recent storms. 9DNG wants to thank all Kansas ORS for their cooperation during the last two years. Besides this being his last report as SCM, he is dropping out of the game for the present at least. We understand that nominating petitions are being circulated for 9CET and 9JU. FB.

Traffic: 9CWW 16, 9CFN 14, 9CV 14, 9LN 12, 9HL 10, 9DNG 7, 9DIH 1, 9BHR 1.

MISSOURI—SCM, L. B. Lazure, 9RE—9BEU finally lined up some reliable skeds and traffic showed an increase over last month. 9ZK took second honors for traffic. 9BMU followed 9ZK with a good Chicago sked and some new equipment. 9BMU says

his set got soaked in the rain. 9DZN and 9BHI landed fair totals and installed a new 852 with good results. 9BHF works all bands and keeps a sked with 9AYK. He received his ORS this month. 9FTA is getting ready to operate. 9EVV is a new St. Louis station. 9AAO had his mast cut down by BCL friends but operated at another shack while temporarily QRT. 9DOE reports everything FB on WNX, his summer job. 9ADH escaped a tornado narrowly. 9BMS is rebuilding and hopes to be on by August. 9EUB applied for ORS. 9ASV was QRW rebuilding for 20 meters. 9BJA is getting all set for fall skeds. 9BFB-9FSI continues working on 180. 9DMT is on 20 and 40. 9CKS is home from college and getting QRV on 10 and 20 meters. 9DKG works on 20 meters mostly. 9ARA was heard a number of times by the SCM pounding brass. 9BUL handled quite a bit of traffic through QRM from blown condensers. 9FPX sends his first report. 9RR is rebuilding. 9BSB and 9EYP led in K.C. traffic. 9FIO, 9ENU, 9DOJ and 9RR QRX'd for USDA tests on the 23rd. 9DNG is moving. 9EMH and 9BUR handled a few. 9BKK is being operated by a YL sister while Bob is away, ship operating. 9EQC has a new transmitter and is QRV for traffic. 9FHV is a first time reporter. 9DQN has a good sked with 9CUE of Indianapolis. 9BSB keeps regular St. Louis skeds. 9RR has been QRW boosting the USNR campaign in this Section. The enlistment in the 9th district tripled in two months. The new ham club is going strong. 9EYP passed some hot dope to the SCM about commercial stations working under amateur licenses. FB, OM. More stations handled traffic in every part of the Section than last month, increases being registered in St. Louis, Kansas City and in the out-state stations.

Traffic: 9BEU 61, 9ZK 44, 9BMU 19, 9DZN 6, 9BHI 21, 9BHF 7, 9AAO 8, 9EUB 24, 9ASV 4, 9BJA 17, 9BFB 6, 9DMT 6, 9DKG 8, 9BUL 18, 9EPX 1, 9FTO 12, 9EMH 11, 9ENU 10, 9EYP 25, 9RR 3, 9BSB 48, 9DQN 19, 9EQC 10, 9FHV 2, 9RR 11.

NEW ENGLAND DIVISION

CONNECTICUT—SCM, C. A. Weidenhammer, 1ZL 1TD keeps a schedule three times a week with 1BI-1BQH in Boston. 1AMC handled some traffic with WNP and worked several European stations. OA and OZ stations were again worked by 1BJK who hopes to have an imposing traffic report next month. 1MK again leads in traffic. Operator Parmenter reports that five sixth district schedules for San Fran. traffic are being worked, and that two more for Los Angeles traffic are pending. 1BNS has planned an extensive building program for the summer months. A call for help in a Iowan's hour of bereavement was relayed by 1AMG. 1BI-1BQH states that his schedule with 1TD keeps him in touch very nicely with things at home. 1BGC worked New Zealand. The battery power supply at 1OS "went west." WIVE moved during the month. 1HM has built a very successful photo receiver. 1MC has been very active on 20. 1AFB reports work on 20 where QRN is nil. 1IV has joined the studio operating staff of the Nat'l Broadcasting Co. 1ZL handled traffic with Australia, New Zealand and South America. The SCM is getting an 80 meter transmitter ready for summer traffic work. 1RP is out for an ORS certificate. 1ASD has a job as a butcher. He states that he is a real "ham" now. Hi.

Traffic: 1MK 320, 1BQH-1BI 55, 1BNS 19, 1AMG 17, 1AMC 14, 1BJK 9, 1ZL 3, 1BGC 9, 1OS 8, 1VE 3, 1TD 49, 1ASD 13.

RHODE ISLAND—SCM, D. B. Fancher, 1BVB—With this report your SCM is resigning. Having accepted a position out of the state, 1BVB is moving and won't be able to look after the affairs of R. I. I want to take this opportunity to thank you boys for your cooperation in the past and ask you to give the next man the same. Good luck to you. 1BLS was too busy with school work this month to do much in radio. 1MO is whipping out to good DX. 1AWE has been having YL trouble this month. Hi. 1BQD says things are very quiet. 1BVR is getting ready to move to New London, Conn. Will see you on the air from there.

Traffic: 1BVB 34, 1BQD 19, 1BLS 14, 1MO 8, 1AWE 7.

EASTERN MASSACHUSETTS—SCM, E. L. Battey, IUE—IKY worked IMK on RM night. IVW had a visit from SCNO, YL, and 8BYN (SCM of Ohio). INQ knocks off the DX when he gets a chance to operate. IBVL is now working in Danvers. He, IUE, and others had a call from IAPL and a friend from New Bedford. IASI has a new 150 watt transmitter. ICRA is going to CMTC at Fort McKinley. IACH took a portable transmitter on a trip to Maine and N. H. with him and was able to keep in touch with home OK. A schedule was tried by IRF was not much success. 1KB, an old timer, sends in a report that he is just starting up again and having good luck. IAPK has just completed a new transmitter. Anyone up about 2AM should listen for IBQZ as he haunts the air at that hour. Don of IFL has a portable 15 watt station at Andover, Conn., call IBMM. IPB is going on a Naval Reserve Cruise for a couple of weeks. 1KH has worked 25 countries and 5 continents. "College boards" are over at IGP and we should hear more from him now. IBVL, IRY and IADM all worked fe-EGEZ. FB, ILM reported as usual but he says not many messages. IAHV and IAKS are both working at WCC now. IAAW sent in his report as usual. Want to wish you all a pleasant vacation if you have one, and hope you come back all QRV for 200 per month!!!

Traffic: IACH 49, IKY 42, IAKS 35, IASI 26, IAHV 24, ICRA 24, IRF 21, ILM 21, IBZQ 20, IRY 15, IFL 14, IAPK 14, 1KH 11, IUE 11, IAAW 10, IPB 7, IWV 8, INQ 7, IGP 5, IBVL 3.

WESTERN MASSACHUSETTS—SCM, Dr. J. A. Tessmer, IUM—The new SCM thanks the fellows (and the YL in Boston) for their good wishes. I never knew that I had so many friends in Hamdon. The gang should thank IDB for the leniency given to some of the ORS in Western Mass. While IAPL was burning up the roads with his murder-cycle and rebuilding his transmitter, and IAKZ was teaching code to the YL, IAJK spent two weeks on the ocean with the Naval Reserve. IBWY is on 40 meters for the summer. IBVR is on 38-39 meters. IWQ is leaving for Fort Monmouth Aug. 3rd. Everything is quiet at IAFQ these hot summer months. IASU QSO'd na7MN. IBKQ members had a shake warming party at IUM. The chariot race was won by IBCL Hegbert. Refreshments and prohibition drinks were served. IANI is back from NAD and Eagleboat.

Traffic: IASU 4, IBVR 5, IWQ 5, IUM 5, IAMZ 10, IAFQ 10, IAPL 14, IBWY 15, IANI 31.

MAINE—SCM, Fred Best, IBIG—Everybody enjoyed the Maine Convention held at Augusta July 13 and 14. Headquarters was well represented there. IANH turns in the best report this month. He has been a hard worker and in spite of many handicaps, manages to get his report in on time. That ORS is surely forthcoming and may you hold it always! IAQD turned in his third report and says that his ten meter rig is rebuilt and doing better than ever. He and IBIG had a schedule for about two weeks but nothing was heard. The Bar Harbor Radio Club gang are planning on buying a good frequency meter which is to be kept at IBGS and used to calibrate wazemeters which the gang will construct from time to time. FB, IAQL is rebuilding. IBAY reports IBAD, a new ham, located in Freeport, Me. We hope he's not too BAD. HI, IBIG and IALY put in fifteen days of active duty at NAD and report a wonderful time.

Traffic: IBIG 108, IANH 25, IAQD 4.

NEW HAMPSHIRE—SCM, V. W. Hodge, IATJ—The SCM is glad to hear the gang report in spite of few messages landed and summer QRM. IBFT sent in his usual good total and says he is using an 852. IAQO sent in a fine report. IIP worked California with an input of 4 watts and an indoor antenna. IAEF will be on with a portable set at his camp. IJN is on daily in spite of hot weather. Both IIP and IBFT are now enlisted in the Naval Reserve. IBST reports a lot of activity in Berlin. This is FB as we have always needed some reliable stations in the northern portion of this Section. IAUE is on in West Concord now. IAIP had tough luck and burned out his H tube.

Traffic: IBFT 85, IAQO 74, IAEF 19, IIP 5, IJN 2.

NORTHWESTERN DIVISION

ALASKA—SCM, W. B. Wilson, WWDN—Alaskan traffic is moving very lively. Schedules are kept with nu 7's and 6's every night. 7JR and 7HL seem to have the most punch if Seattle at 7FD (this report was sent by 7TO via 7TX to 7FD). Many stations are on in Alaska but do not report. 7TO will be glad to QSR your reports or they may be sent in through na7FD via 7TX, 7KO or 7LZ. The summer stations at the canneries are in full swing and can be heard on the air nightly.

We are well into our brief season of extreme activity with all our cannery stations hard at their summers work. Most of the operators this summer seem to be equipped with short wave sets personally owned. 7JR in the Bristol Bay region got busy among the Oriental employees and originated enough messages alone to entitle him to entry in the B.P.L. He handled most of these messages with op1HR and op1CM and hopes to make a better record for the month of July. 7HL at Taku Harbor did not originate many but his relays make the total add up. 7TO fell down on totals as most of the month was spent in Ketchikan. Also, short wave conditions were extremely bad with heavy atmospherics and local QRM. A route from 7TO to nuIMK is maintained via nu6CIS. A circular letter was sent all known stations in the district this month. It is hoped to get action soon relative to some ORS appointments. 7ABE at Iditarod and 7AER at St. George are consistent as usual with good totals for their isolated locations.

Traffic: 7JR 255, 7HL 140, 7AER 115, 7TO 56, 7ABE 56.

WASHINGTON—SCM, Otto Johnson, 7FD—This month is featured by an 80 meter station, 7KO who is doing real traffic work with few, if any, "bum" nights. Practically all traffic handled by Seattle stations was with Alaskan stations who are in the midst of the fishing season. The Seattle gang are QRW with plans for the coming Northwestern Division Convention to be held at the Hotel Bergonian on Aug. 31 and Sept. 1st. Full details will be found in QST and Key Clicks or may be had from any Seattle ham. Louis R. Huber, 9DOA, the Assistant to the C. M., will be the Headquarters representative. Activities in Eastern Washington have fallen off although Gray's Harbor seems to be showing signs of life.

Traffic: 7KO 66, 7LZ 44, 7BR 32, 7FD 22, 7TX 19, 7BM 18, 7OV 16, 7NO 16, 7AEV 10, 7AFQ 8, 7TJ 7, 7AGO 5, 7ACS 4, 7VL 4, 7AG 4.

MONTANA—SCM, O. W. Viers, 7AAT—7HP is knocking 'em dead on 40: He handled several death messages and worked Mexico. 7HT who has less time for radio comes in second. 7AAW snapped out of it and gave the SCM a surprise. FB, OM, 7DD handled a few and is still experimenting with crystal control. 7JC visited the SCM for several days. 7AAT-QT worked a few on a new Hertz tuned to 89.4.

Traffic: 7HP 95, 7HT 49, 7AAW 25, 7DD 21, 7AAT 6.

OREGON—SCM, R. H. Wright, 7PP—Some of the gang are rebuilding in anticipation of fall and winter activity. 7EZ, a new call but an old operator, is using a 7 1/2 w. bottle and getting out splendidly. 7LP is on the air again after a long period of inactivity. He is also using 7 1/2 watts. 7AJW, the Battleship Oregon, has been doing excellent DX on 40 meters. This station has an operating list of 30 licensed hams. 7UN is high traffic man this month. 7GQ is on intermittently. He works Alaska and moves traffic occasionally. 7ALK is on regularly. 7MF will be on at Medford during the summer, after a period of inactivity at Corvallis. 7PL now has 250 watts and is building a shielded grid receiver. 7PP is installing crystal control.

Traffic: 7UN 86, 7MF 31, 7PP 19, 7PL 9, 7ALK 21, 7GQ 8.

PACIFIC DIVISION

EAST BAY—SCM, J. Walter Frates, 6CZR—The fact that OM summer slump is more an excuse for the lazy rather than an actuality was demonstrated this month. Traffic men in the section were kept busy handling messages for those on vacation and for the local men at the Calif. Nat'l Guard Camp at San Luis Obispo. 6ALK had a great deal of enjoyment from the mountain of traffic sent out by 6SR and AV3 at the camp under the direction of 6BDO. He made the BPL both ways. 6IP ran him a close second and also made the BPL both ways.

6ZX, former SCM, also cut in on the Guard traffic and made the BPL with deliveries. 6EJ, a new ORS at Vallejo, did good traffic work through skeds with NA, OH, and OP. 6DKO did his usual amount of work with no sign of slackening. 6CZR spent his vacation visiting 6CIS and 6CBS in Sacramento and doing message handling with OH, op-1CM and ac-2CL. 6BNG is still battling away in fine shape. 6BPC at Vallejo is back on the air again for traffic work. 6RJ is keeping his station on all summer. He is QRW convention entertainment plans and copied KHAB, Southern Cross, for a BC station. 6CZR, 6IP, 6EDK, 6AHE, 6BDO and Earle Ennis did likewise for Bay newspapers and press associations. 6EDK has remote controlled his station in apt. house with Zepp antenna on roof and is reconstructing receiver to use shield grid tube. 6OT, Oakland Radio Club station, is still under reconstruction by 6BJW will be on the air by about the end of the month. 6EY reports reception of 2XV, Coast Guard's Greenland transmitter. He says they did not keep skeds given them in order to make QSO's. 6BZU handled a few. 6CTX is using raw AC until MG gets back from the east. 6DTM is having a lot of trouble getting his new 500 cycle power supply going. 6COL has managed to work am-8AB, gi-6MU, EF and EG and keep a watch on 10 at odd times. 6IM says he is ready for the coming convention. 6CGM has a bad power leak.

The Oakland Radio Club held an anniversary house-warming during the past month. Director Babcock, 6ZD, 6ALX, 6CZR, 6IP were among the speakers. W. W. Salisbury and Larry Marshall, teaching fellows in physics at U. of C., gave demonstration of their 10 meter transmitter. Entertainment and hot dogs were enjoyed. 6IT presided as president but turned the gavel over to secretary 6EDK who had charge of the program.

Traffic: 6ALX 380, 6IP 241, 6BDO 185, 6ZX 110, 6HJ 45, 6DKO 44, 6CZR 40, 6BNG 40, 6BPC 40, 6RJ 38, 6EDK 25, 6EY 18, 6BZU 17, 6CTX 15, 6DTM 10, 6COL 8, 6IM 6, 6CGM 4.

SANTA CLARA VALLEY—SCM, F. J. Quement, 6NX—6AMM was first in the delivered total for the country last month and it looks as if he will be first this month with 178 delivered messages. His new transmitter will soon be on the air. Heavy power leaks QRN slowed up the schedule. 6BVY, Lt. E. Beall, has just been appointed as commanding officer of the newly formed Volunteer Communication Reserve Section No. 3 of the USNR. 6NX, the SCM, has been appointed in a like capacity to command section No. 6 at San Jose. 6BMW noticed a drop in off-wave stations this month. Only two stations were heard off-wave and they were QSO's direct and told to raise their QRH. This is gratifying and shows the results of the good work done by OO stations. 6ALW says the bottom has dropped out of the 20 meter band and he is now up on 40 with an 80' Hertz. 6NX is building an SG receiver. 6BTJ has moved back into the Section again after a year in Nevada. 6ED is the station of Prof. Jeffers located at Mount Hamilton California. 6BHY and 6AJZ are QRW.

Traffic: 6AMM 305, 6BMW 56, 6ALW 9, 6NX 4, 6BTJ 3.

PHILIPPINES—Acting SCM, J. E. Jimenez, op1AT—The following report came in the form of two messages via op1HR and nu6HJ: "On writing this report, the *Salvager* is out on salvage work on stranded steamer stop have rendered great relief to distressed steamer's officers and crew as well as to their worried families and friends stop no communication after striking isolated reef as ship's engine room flooded with seawater and radio not equipped with emergency outfit stop op1AH did splendid delivery service.—six op1DR". A European traffic circuit was opened at 1DR through am8AB who keeps regular schedule with England and South Africa. Another message contains the report of op1HR: "Schedules are kept with the following stations at op9FB, Zamboanga oh6DEY, Schofield Barracks, Honolulu—ac8ZW Obayshanghai, China, nu6HJ, Vallejo, Calif., ac2AB, Warines, Tientsin, China; op1RC, Cavite Naval Radio School, Cavite, P. I., nu6AMM San Jose, Calif.—above stations on daily schedule except 6AMM do not QSO Sunday. . . . Traffic is handled through op1HR to following destinations: nu, oh, ai, ac, am, oz and locals."

Traffic: op1HR 714, op1DL 108, op1GZ 2, op1PW 80, (April-May) op1HR 686, op1DL 176, op1GZ 26, op1AT 3.

SAN DIEGO—SCM, G. A. Sears, 6BQ—6AJM again leads in traffic in spite of his PI schedule being cancelled temporarily on account of op1AD's moving. He expects to put in crystal for work on 20 and 10 meters. Don has worked all continents on both 20 and

40 meters. 6BF's UX210 gives him reports like a 1/4 KW. 6EC-XE reports traffic with nu1NIC diminishing on account of most of West Coast boys having returned. 6DNS, a new ORS, piled up a good total for a first month. He has 3 regular schedules. 6BYZ sends his reports in by radio. 6BGL sends his report in as usual. Why not fill out the ORS application. OM? 6QY has rebuilt his 21 meter transmitter and has mounted it all on plate glass. 6BZD lost half the plate in one of his rectobulbs. 6BAM says there will be a new bunch on the air at Santa Ana soon. He is helping several prepare for the examination. 6OX found time to handle a few this month. 6AKQ reports the end of his shore duty and will be at sea until October. 6DGW is changing to a motor generator again. 6BAG reports some traffic. 6FP says he's busy with power troubles again. 6BAS is experimenting with crystals at 6XJ. 6CNK says weather is too fine for radio now. 6BFE is completely rebuilding. Several reports received last month too late to be included. Reports must reach us no later than the 29th. Failure to send in reports for three months results in cancellation of ORS. The Naval Reserve Communications is showing a lot of activity. More applications are wanted. 6CXF and 6DNS are making the cruise to Honolulu this year. Those interested can get full particulars by calling or writing your SCM.

Traffic: 6AJM 92, 6BF 71, 6EC 69, 6DNS 58, 6BYZ 39, 6BQ 24, 6BGL 23, 6QY 16, 6BZD 14, 6BAM 19, 6OX 18, 6AKQ 11, 6DGW 11, 6BAG 11, 6FP 9, 6BAS 8, 6CNK 4.

HAWAII—SCM, F. L. Fullaway, oh6CFQ—6BOE has the high total for this month. Skeds with KNT, op1HR, op1CM, nu6DH, nu6DJ, nu6BF and nu7PP did it. He reports work on the ten meter band. Wants to QSO. His QRH 29 megacycles and he tests daily 0180 to 0380 PM HST. 6CFQ makes the BPL again. Handled a lot of fleet traffic. He keeps five skeds. 6DEY says its dead on 20. 6AVL is now on with 100 watts supplied by two VT4B's used for rectifiers. 6ALM is leaving to visit Calif. so will be off for the summer. 6DJU is still on the air. 6DCU handles all of 7AER's traffic for the mainland. It is routed from na7AER to oh6DCU to oh6CFQ to nu6HJ or 7ABK. 6DLR is now remote controlled with his transmitter in a pigeon loft. 6DPG is on 20 and 40 but says the passing Fords bother him, 6DQJ is back on again. 6CLJ has a vertical first harmonic Zepp fed from a 204 tube. Upon the arrival of the yachts, a dinner was given for the operators of WGDH and WGDI. Many hams attended and a FB time was had. WGDI left for the states so the op missed out. Bell of 6DEY left for the states on the transport. He will be on the air soon as a nu nine. 6DCU is joining the Army to go the West Point and will operate at 6DEY.

Traffic: 6BOE 700, 6CFQ 188, 6DEY 72, 6AVL 48, 6ALM 89, 6DJU 51, 6DE 26, 6DCU 17, 6DLR 15, 6DPG 11, 6DQJ 8, 6CLJ 7.

LOS ANGELES—SCM, D. C. Wallace, 6AM—6CQP has high total and would like a good sked with New York and one with Texas. 6ZBJ has charge of a YMCA boys' camp. 6AGR would have made the BPL this month if he had been able to keep his sked with WGDI but the ship was without a wave-meter and had a new QRH every night. 6BZR says his Rectobulbs are nearly purchased. 6CUH handled 36 messages in one week since school closed. He relayed a message from 9SK to oh6DJU in 20 minutes. 6OF QSR'd messages for S.S.P.Co. when storm in Owen's Valley took out all fine lines to Riverside. 6DGT reports that 6AKF has gone to sea. 6CHA is keeping some good schedules. 6IJ has ambitions to become an ORS and sends in a good report. 6DKV got R8 from oh6AVL five days in a line. 6DKX is building a screen grid receiver. 6APW is going to C.M.T.C. for a month. 6AWQ reports visits from 6AJI, 6JT, 6GT and 6AM's steno. 6ALG is having a great deal of trouble with QRM from leaky transformers. 6AEC sends in a good total. 6BXD has a new TP-TG transmitter job, using a vertical pipe antenna. 6COT handled messages from KNT. 6EEB's 310 quit oscillating. 6DEG made a pilgrimage to the "shrine of ham radio in Long Beach" and got exact dimensions of 6AM's copper shield grid layout. He says his Chinese copy of 6AM's receiver is the best yet. 6AKD handled a rush message for oo-1AJ to San Francisco. 6BJX enjoyed a fine time on his vacation. 6BVM was on 20 for a month. 6ALR will have his new set finished soon. 6CQM says 1MX reports him crystal controlled. 6BZC intends to get on strong again as school is out. 6DHR is in pursuit of a job for vacation. 6CMQ will be at 6CPQ on Balboa

Island most of summer. 6DPY worked 0h6DJU and 0p6DEY. Mrs. 6AM heard portable 6ZZA on schedule at Dayton, Ohio. 6AM was also QSO 9EF on 10 meters R8 and R9. 6DMG sends in a good report. 6ASM is in San Francisco now and is being kept in touch with Los Angeles by 6DGT of L.A. and 6DRR of S. F. 6PY is working with a portable. 6DQG. 6DKV reports that he and 6DLS and two new hams went to Mojave desert for 3 days and took a portable along but didn't have much luck. 6BJX went to Big Trees, Yosemite and back via Tioga Pass. He has also been elected Sec'y. of the Pasadena Short Wave Club. 6AKW is very busy with haying now. 6CAF worked 6AM on 80. 6BRO kept a schedule with portable 6AIV. 6AIO has been looking for a job. 6CNJ has been out of town. 6CZU, 6CBD, 6CZT, 6BSN, 6BUX and 6BGC all send in reports as usual. 6QL has at last "gone and done it"—made the WAC. Congratulations. He gives the Zepp antenna credit for making it.

Traffic: 6CQP 91, 6ZBJ 47, 6AGR 47, 6BZR 46, 6CUH 44, 6OF 43, 6DGT 42, 6CHA 40, 6UJ 38, 6DKV 28, 6DKX 26, 6QL 26, 6APW 26, 6AWQ 26, 6AIG 25, 6AEC 24, 6BXD 23, 6COT 22, 6EEB 20, 6DEG 16, 6AKD 16, 6BHX 13, 6BVM 11, 6ALR 10, 6CCU 10, 6BZC 9, 6DHR 9, 6CMQ 8, 6DPY 6, 6AM 5, 6DMG 5, 6ASM 5, 6PY 4, 6UKV 4, 6BJX 3, 6AKW 3, 6CAF 3, 6BRO 2, 6AIO 1.

SACRAMENTO VALLEY—SCM, C. F. Mason, 6CBS—6CBS helped 6ER change his set from Colpits to a TP and TG with self-rectification on two UX210's. 6DQG claims reception is better for him in early morning hours. 6DON has the most of his time to spend on radio now that high school is closed. 6CDK is on again using 281's for rectifier. 6LO is on with two 250's using Thordarson plate supply giving pure DC. 6CBS has his TP and TG going now.

Traffic: 6CIS 103, 6ER 12, 6DON 17, 6ATQ 7.

ARIZONA—SCM, D. B. Lamb, 6ANO—6HJF is still receiving cards from France. 6BWS's YL received a diamond ring for birthday. (Who bought it, OM? Hi.) 6EAA applied for ORS. 6DIR is going away on a vacation in Northern part of the state for the summer. 6BWS sent out 24 cards to stations working off wave. 6SW is installing a mercury arc rectifier. 6CAP reports that a dance will be given so that money may be raised to buy a 250 watter for 6EEL Radio Club. 6ANO is having trouble with line voltage. 6CDU works early in the mornings.

Traffic: 6BWS 76, 6CDU 32, 6BJF 4, 6ANO 26.

ROANOKE DIVISION

VIRGINIA—SCM, J. F. Wohlford, 3CA—3ASC is moving his station. 3EC is using 1500 volts on a 204A with fine reports. 3AG has been rebuilding. 3AAJ continues to step out on traffic lines. He is handicapped by having to operate WRVA. 3HZ continues to tinker with 20 and 40 meters. No success on 10 yet. 3CKL is still working his schedule with m1N1C. 3ALS seems to be getting out and handling traffic. 3ANV is off on account of sickness. 3RL was reported 400 miles on 80 meter phone on low power. 3KG will be on with AC supply as line has been completed to his place. 3BGS also has the AC now and will come up with chemical rectified supply. The radio club of Richmond had a big meeting at which Commander Fawell, USN, was principal speaker. He gave some very interesting dope on various frequency developments and also on the International conference in regards to frequencies, etc.

Traffic: 3CKL 24, 3ALS 29, 3AAJ 23, 3AG 9, 3EC 42, 3ANV 11, 3RL 3.

NORTH CAROLINA—SCM, R. S. Morris, 4JR—4OC reports his schedule working FB with 7p-PM. 4SJ won second prize in the N. C. Convention traffic contest. 4EA keeps a sked with 4EC who is now on the air at Wilmington and asks the gang please to note the change of QRA. 4AB says his schedules have gone to the dogs. 4JR is on only for schedules but promises more work soon. 4TO says he is going to apply for WAC as soon as he gets his cards from Africa and Asia. 4ADQ has QRM from power leak. 4AHI has trouble in getting a fixed condenser to stand up in his 9EK transmitter.

Traffic: 4OC 32, 4SJ 27, 4EA 23, 4AB 17, 4TO 14, 4EC 11, 4JR 6.

WEST VIRGINIA—SCM, C. S. Hoffman, Jr.—8HD—8CQJ leads with messages handled working so-2EA and oa-6HG. 8APN of Fairmont is a new ORS. 8DCM is on daily. 8DNN has several schedules. Morris and Stevens of ex-8BDA are reported to be on with 8BXD. 8DW worked a dozen European countries. 8HD-8AWM just returned from Yellowstone Park and other western points, having a splendid vacation trip.

Several of the gang reported going to State College Convention.

Traffic: 8CQL 44, 8APN 14, 8DCM 2.

ROCKY MOUNTAIN DIVISION

COLORADO—SCM, C. R. Stedman, 9CAA—9EAM, the old Brass Pounder, changed to a new QRA with the result that he has been off the air. 9DRV is going to Calif. and enjoy some visits with some sixes. 9DQJ had to cancel all his skeds and says he can't handle any traffic without them. 9CDE is on low power. 9CSR is planning a crystal-control outfit. 9DGJ claims his Ford is a good radio bug exterminator. Some of the Denver gang doubt the authority of the statement, however, as 9CAA seems to be successfully recovering from a badly sprained wrist and numerous bruises. 9CAA is active and ready to go as always. 5AAV is a Colorado visitor for the summer and is signing his portable 5ZZC and showing the Denver gang up on DX. 9ENM keeps schedules with 9CAW and 1MK. 6AIK at Ogden, Utah sent his report to the Colo. SCM this time.

Traffic: 9CAA 8, 9DGJ 1, 9BQO 2, 9CSR 27, 9CDE 3, 9DQJ 2, 9DRV 9, 9ENM 51, 9CAW 37, 6AIK 5.

UTAH-WYOMING—Acting SCM, Parley N. James, 6BAJ—6DPO is taking a vacation in Calif. 6BAJ keeps a schedule with 7VJ, who paid him a visit recently. 6RV has been on 20 this month. 6DYE has a dandy T.P.T.G. rig on 40.6 meters, using three 210's.

Traffic: 6BAJ 8, 6RV 29.

SOUTHEASTERN DIVISION

FLORIDA—SCM, C. E. Foulkes, 4LK—4ACV has a Jr. op. 4CK is in Washington, D. C. but handled quite a few messages before leaving. He made the BPL and leads all Florida by a large margin. Activity has been camping with 4ADB this month from the looks of this report. 4ACC comes in third with his total. 4BN has been experimenting with a portable transmitter on the beach. 4X has been rotten for 4AAO lately. 4LK has been working on the transmitter at NRRQ. Are the YLs QRMing 4TK? 4ACV has worked all continents.

Traffic: 4CK 267, 4ADB 52, 4ACC 44, 4BN 12, 4AAO 4, 4LK 2, 4TK 1, 4ACV 38.

GA-SC-CUBA-PORTO RICO—SCM, H. I. Reid, 4KU—Georgia. The Atlanta Radio Club has been revived and it is hoped that things will begin to move as in the days of old. 4RN will keep nightly skeds with 4SI starting July 1st when he clears for Europe. 4GY is using a 210 now. He retired his five watter after working el, oa, and fm with 400 volts on the plate.

Porto Rico: 4KD has heard 4PQ, 4AAG, 4ACL and 4AA in St. Thomas, V. I.

Traffic: 4RN 7, 4GY 6.

ALABAMA—SCM, A. D. Trum, 5AJP—Alabama hams are readjusting themselves and their sets for the new fourth district calls which are now being dished out in Alabama. 5JY is leading the State in traffic handling and consistent work. His father is now second op at JY. Kilpatrick of 5BBA has just finished rebuilding his transmitter. He thinks 20 meters is the berries. Good things, BBA. Bayne of 5ATS had the misfortune of losing his father this month. Alabama hams wish to express their deep sympathy in his hour of grief. 5ATJ is at Camp McClellan this month. He was on regularly while home and carried on some good traffic. A new ham is going on the air next door to him soon. 5ADA has been keeping sked with California regularly this month on 40. He is using a Hertz with a 210 back of it with 650 DC on the plates. 5UV is back on the air after his illness, ready for traffic and rag-chewing. 5AYL has been off the air most of this month and has been taking advantage of the hot days in rebuilding his set. He now has a 15 watt set on 20 meters. 5VW is on daily and 5JP pounds brass when he is not out with the YLs.

Now fellows when the new fourth district calls are issued out and we really get down to good work with them, lets all review the past of Alabama Amateur work with our dear old fifth district calls (which we are reluctant to relinquish) and make it a part of our daily amateur life to uphold our fine sending, rag chewing and traffic handling. I know as well as all of you, that we have the best gang in the world. Let's show them by giving me a fine report on your activity each month.

Traffic: 6JY 161, 5ADA 22, 5ATJ 9, 5AYL 7, 5ATS 5, 5BBA 4.

WEST GULF DIVISION

OKLAHOMA—SCM, K. M. Ehret, 5APG—On the morning of May 28th, 5AIR heard the "Italia" call CQ but couldn't raise him. 5BAG has been rebuilding the old xmitter and just as he had it about finished, a little cyclone wrecked his antenna again, and tore down the power lines. 5AYO built a new receiver which works quite well. 5VH says the weather is too hot—says lemonade and the hammock for him. 5HAZ has been using a 201A but has graduated into the 210 class finally. 5AMO left home before he had a chance to send in his traffic total but says it would have run around 150. 5AMO is too-dressing again down on an oil well in Texas. 5ZAV has ground several 80 meter crystals and hopes to be on July 4th with a real signal. 5QL is on his vacation which he is taking at home, improving his set. 5AAV is spending the summer in Denver and operating under the call 5ZZC. 5AFX is doing most of his work on 20 meters now. 5APG as well as 5QL heard the airplane "Southern Cross" several different mornings during the Pacific flight.

Traffic: 5AFX 10, 5APG 16, 5AIR 4, 5BAG 1, 5AYO 25, 5BAZ 19.

NORTHERN TEXAS—SCM, J. H. Robinson, 5AKN—We have two more stations reporting this month than last which shows an increase in activity. All the fellows report a lack of traffic. DX also seems to be scarce, as QRN is too heavy. Army-Amateur activity is picking up. 5BAM reports schedules with 5AMO and 5OH. 5BBF is building a Zepp antenna and says daylight work is good but night work is not. 5RJ is using crystal control on 40 meters. 5AHU is back from college. 5HY has gone to CMTC and is operating crystal control station 5AIN. 5JA has an 852 going on both 20 and 40 meters now. 5AEK is on 20 meters and wants an ORS. 5NW is on 20 meters. 5JD is putting a new 204A in his set. 5AQ is rebuilding. 5BG-5AKN is working on both 20 and 40 meters.

Traffic: 5BAM 38, 5BBF 24, 5RJ 16, 5AHU 9, 5HY 7, 5JA 6, 5AQ 6, 5JD 6, 5AEK 4, 5AKN 2, 5NW 2.

SOUTHERN TEXAS—E. A. Sahn, 5YK activity seems very good despite the merciless QRN of mid-summer in the Gulf area. Several new hams are on. Others are back who had quit for a while. 5HS is looking forward to the San Antonio Hamfest. 5ALA at Mirando says the weather is too hot to pound brass. 5EW reports that his brother M. J. got married and leaves him as the only op at 5EW at present. 5ATM says that he and 5ANK are both in Shreveport with a touring orchestra. 5LP, Melville Chun at Houston handled a message from Honolulu to Newark, N. J. He is putting in a new transmitter. 5MU, Irving Seligmann at Seguin is back after having been away at school. 5ATI at New Ulm, and 5BDP at Bishop, are newcomers. 5SR has become a commercial op. 5SY at El Campo, Texas says he has been heard in Paris. Our old friend and standby, L. D. Wall at San Antonio got married about a month ago.

TRAFFIC: 5EW 35, 5LP-5BBS 27, 5ATM 19, 5HS 2.

Canada

ONTARIO DIVISION

ONTARIO—SCM, W. Y. Sloan, VE9BJ—Central Dist: VE3BL reports that during the latter part of May, he visited many stations, among them 1MK. He is on the air nightly on 52.56 meters with his OBC and traffic schedules. VE3BK says that 40 meters is used and that Brazil has been worked. VE3BO uses a 210 on 40 and 52.5 meters with an input of about 16 watts. VE3DY is immersed in school exams but traffic has been handled. VE3CJ is very busy these days, also, but when he has more time, he will become Route Manager. 9BJ is now at the island for the summer. 9AL has been confining his work to schedules on 52.5 meters. 3FC has been handling traffic from out-post stations in the North on 52.56 meters with nightly schedules after 10:30 EST. 3AZ is away on radio work in Northern Ontario and won't be back again until Sept. VE3EH is a portable station with a good signal on 52.5 meters. VE3EF also is a portable on vacation in the North with a fine signal on 52.5 meters.

Eastern Dist: VE3VS is on the air again. 3HE is rebuilding and 3HO is off temporarily.

Southern Dist: 3CS is, as usual, the most active station in this district working on 10, 20 and 40 meters. Schedules are kept with many DX stations and the first EJ-NC contact was established by this station. VE3AQ is active on 40, 52.5 and 80 me-

ters. VE3BV is active on 52.5 meters. 3AD is going to Muskoka for the summer and may take a portable along. VE3AY has been active on 40 and 52.5 but has now to rebuild his chemical rectifier. VE3WG is still bothered by bad induction QRM and may have to move to get rid of it.

Northern Dist: VE3HP is the only reporting station and he has been doing good work on 52.5 meters.

Traffic: VE3FC 53, VE3HP 33, VE3EH 25, VE3AL 22, VE3BO 17, VE3BK 11, VE3VS 10, VE3DY 8, VE3EF 20, VE3CS 7, VE3AQ 4, VE3CB 2.

QUEBEC DIVISION

QUEBEC—SCM, Alex Reid, 2BE—Although we are in mid-summer with vacations, QRN etc., DX and traffic are holding their own and what is more encouraging, three new stations came on the air during the month. It certainly appeared like old times to hear eight stations of this division on during one evening. 2BW and 2AC have been appointed ORS. 2AC of Thetford Mines has translated the story of the A.R.R.L. into French and has also started a radio club. 2AP, our newest station, worked four districts the second night on. He is using one of the new 250 watt tubes. 2FY got his first DX during the month. 2AE is using a Belgian 60 watt and doing good work. 2AV is back at the key. We are sorry to report that 2BV is ill. 2AL and 2BR are still pounding away at DX and traffic. 2BE has a Friday and Saturday schedule with o2ZME on 20. 2BR hooked OZ during the month. 2CW is QRW training for the coming regatta. 2CA worked OA on 40 during the month. 2BG is still in the land. 2BB is the most consistent ham of the division and turns in a nice report. 2BH is rebuilding and increasing power. 2AQ is leaving for the Arctic for eighteen months.

VANALTA DIVISION

ALBERTA—SCM, E. J. Taylor, 4HA—4AH is asst. operator at station CJCA. 4CL is out of town. 4GT moved to a new locality. 4EP is busy on forty. 4FT is a new station. 4EI paid us a visit on his way to Seattle. 4CU is rigging up a new receiver. 4HM is still in England. 4FF is getting into twenty. 4HA is on twenty. Get behind the 52.5 band campaign to save this valuable channel for Wed. night all-Canadian gathering.

BRITISH COLUMBIA—SCM, E. S. Brooks, 5BJ—The B.C.A.R.A. clubhouse is coming along fine and the gang are hoping to have it finished for the convention. 5BR sends in a good total of relayed messages. 5CO says he followed KHAB most all the way across the Pacific as did a number of the Vancouver gang. 5CT has rebuilt again. 5AR has gone to Portland pro tem. 5RJ has quit the commercial end of radio and is now a moving picture projectionist. 5CF has been very sick lately and the gang are hoping for a speedy recovery. 5CP continues to build sets for the gang. 5AJ has returned from OA OZ districts. 5AD says he worked OO, OA, OZ, OH and AJ in one night on 40. FB. Traffic: 5BR 138, 5CJ 12, 5AD 12, 5CO 5.

PRAIRIE DIVISION

MANITOBA—SCM, D. B. Sinclair, 4FV—4EK still pounds away very consistently. 4DL took a vacation at Turtle Mountains with 4AR of Boissevain. Several contacts were made with a portable transmitter. 4NR now has a pure DC note. 4DB has a fifty perking FB. 4FV's new UX352 will be on the air soon. 4DI put up a vertical antenna. 4GQ still pounds away on 20. 4DJ gets out very nicely with a 210 in a Hartley. Our old friend 4DP is back from the mines. He is now using a fifty. 4HP has his official call at last. 4FN, 4DK is rebuilding so TP-TG all glass-mounted. 4CT was on 20 a little. 4GG managed to get on 20 once in a while. 4FO has a 250. 4BT will be on the air with his fifty in a few days. 4DW is still pounding away. Keep up the good work, fellows.

Traffic: 4EK 15, 4DL 9, 4NR 8, 4DB 5, 4FV 5, 4DI 4, 4GQ 3, 4DJ 2, 4DP 1, 4FN 10.

SASKATCHEWAN—SCM, W. J. Pickering, 4FC—4AI is a new station on the air operated by H. E. Broten of Meacham. Two 201A's are used in an MOPA circuit. 4FC is only on the air Wednesday nights. The Saskatoon gang is becoming active. There are quite a number of stations operating, and more coming up.

Traffic: 4FC 11, 4AI 8.



NEW CONSTITUTION PROPOSED

BY the time this issue gets into print, all National Section presidents and secretaries should have received copies of General Letter No. 10, sent out from I.A.R.U. headquarters recently. For the information of the general membership, it might be mentioned that this letter deals with a proposed new constitution for the Union, which will be voted on by all National Presidents and by the officers of the Union.

The Union started out with a membership composed of individuals. This was necessary, because in most countries there were no recognized amateur organizations to represent the amateurs there. However, during the past two years and more, strong national societies have sprung up in practically every country where amateur radio flourishes, and with this rise, the individual-membership feature of the Union constitution became increasingly unwieldy and burdensome.

Early in 1927 it was proposed to all the National Sections that the time had arrived when the Union should be converted into a union of *societies*, with one recognized amateur society or organization from each country being a member of the Union and representing the amateurs of its respective country in the Union. This suggestion met with approval, and the Executive Committee of the Union was instructed to prepare a new constitution to provide the machinery for such an organization.

The first proposal was prepared in the fall of 1927, and sent out for vote. Various objections were cited by most National Sections, however, and a revision was therefore made. It is this revision which is sent out under General Letter No. 10.

The basic objects and principles of the Union remain the same. Section I, of Article II, on membership, represents the heart of the new document, and reads as follows:

"The membership of the Union shall consist of the national amateur radio societies which, on the date of the adoption of these provisions, are recognized as sections of the Union under its previous Constitution, and

any additional national amateur radio societies which subsequently may be admitted to membership as provided below."

Most of the other changes are merely to conform to this, although there are alterations in the plan for locating the headquarters, etc.

It is believed that the new document takes care of all the objections that were cited against the first proposal, and that this new Constitution will, therefore, be favorably acted upon. All votes should be received by the first of September, and announcement of the result will be given in the next available issue of QST, with the new Constitution printed in full, if it is passed.

All National presidents and other Union officers are urged to return their votes as promptly as possible.

CHANGE IN THE DUTCH SECTION

The Dutch Section of the Union has been converted into a national amateur organization, complying with the new ideas regarding national sections, and is now known as the Nederlandsche vereeniging voor Internationaal Radio-amateurisme. The official "diamond" of the new organization is shown herewith, and represents another addition to what is now becoming a large family of such emblems. W. Tappenbeck, N. Doelenstaat 2-4, Amsterdam, is Hon. Secretary. Our best wishes go to the organization.



R.S.G.B. BECOMES BRITISH SECTION

As a result of a vote of the members of the British Section of the I.A.R.U., the Radio Society of Great Britain has been appointed the National Section for Great Britain. Capt. Ian Fraser is President, and H. Bevan Swift is Hon. Secretary. This move brings Great Britain into line under the new scheme of the Union.

The old Section, together with its officers, is automatically eliminated, but Union

(Continued on Page 78)

Calls Heard



eg-2BQH. G. G. E. Bennett, 26 Blenheim Park Road, Croydon, Surrey, England

20 meters

laac labt lack lacm lade ladm laef lafb lafd
 laff lafo lags lahi lakd labl lamu lana lanh
 laqt laaf lauu lasy lav laaz lbat lber lbea lbil
 lbms lbqd lbgq lbusu lbw lbwm lcof lehr leje lcjh
 lomb lcmf lepblada ide lei lfl lfn lia lij ljj
 lkh llc lml lmy lpd lqh lry lsi lts lvw lzz
 2abu 2adl 2afx 2ag 2ail 2ajb 2akl 2ann 2adg 2arb
 2asl 2atx 2aue 2auro 2aus 2avb 2azl 2azu 2bad 2bci
 2bec 2bew 2bhh 2bdr 2bev 2bfit 2bfz 2bg 2bgb
 2bha 2bjm 2bkp 2bot 2box 2bvz 2bw 2bxr 2ek 2etq
 2cuc 2ev 2fs 2gz 2hq 2ih 2ja 2ol 2ow 2pj 2ra 2aj
 2tp 2vi 2vn 2xad 2xar 2xas 2xo 2ahl 2ala 2anh
 2ani 2aog 2aok 2aum 2auh 2aw 2bfm 2bhc 2chk
 2ev 2im 2ku 2kl 2qv 2zf 2acv 2azf 2adb 2adm 2aek
 2av 2ef 2es 2dc 2hr 2io 2km 2nl 2pd 2rn 2sb 2acl
 2adp 2afb 2agq 2akp 2alz 2aot 2at 2atm 2ats 2ava
 2ayb 2bam 2bf 2bj 2dq 2dv 2eg 2gm 2hs 2ie 2ik
 2mq 2nb 2ns 2pt 2go 2gq 2rg 2ta 2uk 2yb 2va
 2acz 2agr 2aiq 2ajm 2ajk 2am 2am 2ax 2bx 2cy
 2bjh 2bz 2bvy 2bdf 2bhy 2che 2col 2cs 2cwl 2cxi
 2cyy 2cz 2dan 2dbd 2dep 2dev 2dgo 2dhd 2dlw
 2don 2ec 2ih 2jn 2m 2of 2uf 2vx 2wb 2xb 2xu
 2zzn 2aay 2abz 2acw 2aev 2afo 2ago 2ah 2aj
 2akk 2arq 2ef 2ek 2fe 2fa 2fi 2iv 2jh 2jm 2kn
 2nr 2os 2sp 2vj 2abw 2acm 2ada 2adg 2afe 2agq
 2agy 2ajk 2akz 2alu 2aov 2ash 2atl 2avp 2axa 2bxz
 2bcu 2bfv 2bjm 2bkg 2bc 2cc 2cc 2cl 2clp 2con
 2cpx 2cro 2csr 2scq 2evj 2ewt 2ezu 2dce 2dew 2div
 2dne 2dri 2dnn 2dod 2don 2dpp 2dpo 2dsa 2dsv
 2hx 2ig 2ilf 2imq 2ird 2re 2sp 2xm 2xao 2xcl 2xex
 2aix 2alz 2ana 2anq 2apl 2ara 2axx 2ayp 2ayv
 2axf 2axu 2abb 2bgq 2bjp 2bkz 2bmx 2bpl 2bvh
 2bwo 2bxl 2byo 2che 2cis 2ck 2erd 2en 2cnd
 2cwb 2czw 2dc 2db 2dbj 2dce 2dga 2djh 2dk 2dke
 2dku 2dmb 2dng 2dps 2dqe 2drg 2drd 2drr 2dsz
 2dnd 2ebp 2ecu 2ef 2efz 2ery 2ehd 2elo 2enr 2eny
 2eoh 2ern 2es 2esk 2ekt 2ely 2eyu 2ez 2fae 2fhw
 2fzv 2fzw 2fly 2hmm 2kv 2lo 2mi 2mt 2oj 2rf 2ax
 2uu 2vz 2dvw 2nq 2aj 2ik 2iv 2ll 2mn 2af-hval
 af-kol af-1b af-2k af-2kw af-2bl am-2ab as-rao8
 fe-suw fe-2vo fk-4ms fm-8rit fm-tun2 fo-a3c fo-a3z
 fo-a4o fo-ast fo-a7l fo-a7u fo-a8a fo-lar fo-ocdb
 na-7ady na-7aer na-7km na-7mn nb-be8 ne-lad ne-lar
 ne-lbr ne-lco ne-2al ne-2an ne-2ax ne-2bc ne-2ct
 ne-3cj ne-3cs ne-3fc ne-3gg ne-4ac ne-4aq ne-4ct
 ne-4ha ne-5au ne-5aw ne-5bl ne-5bn ne-og ne-8ae
 np-4ja np-4sa np-wgt nr-cto oa-2dy oa-2ly oa-2rc
 oa-2rz oa-2sh oa-2uk oa-2yl oa-2yj oa-3bk oa-3cp
 oa-3dc oa-3gr oa-3hl oa-3j oa-3k oa-3kr oa-3in
 oa-3tm oa-3vp oa-3wz oa-3xo oa-3yk oa-4rb oa-5bj
 oa-5bw oa-5by oa-5cm oa-5dx oa-5hg oa-5mb oa-5xz
 oa-6sa oa-7li oa-vfp oa-vis od-and od-anf od-ank
 oh-6adh oh-6alm oh-6avf oh-6crj oh-6dey oh-6dnd
 oh-npm op-lxr op-npo op-lap of-1fb of-1fe of-2ae
 of-2ag of-2bx of-2bz of-3au of-3aw of-3az of-4ae
 oz-4bm sb-lar sb-1lb sb-2ar sd-pjc sl-hjg xen-ocp.

On 40 meters

laao labd labz laej laez lanh lanx lazu lbba
 lbed lbl lbma lbqd lbad lcpj lgh lgw lpx lgz
 lih lmk lmo lmp lmr lmx lno lnh lsi lvs lvt
 lye laed 2aef 2aas 2afa 2afr 2agp 2ajb 2acs 2aoo
 2apl 2as 2aub 2auk 2aub 2avv 2axf 2azu 2baz 2bcb
 2bhi 2biv 2bv 2bkn 2blr 2blz 2bms 2bsc 2bvz 2bxr
 2edm 2chl 2emu 2ep 2es 2euc 2exl 2exm 2dp 2fm
 2fs 2zh 2zp 2ja 2ij 2kl 2kr 2me 2nj 2ov 2rk 2tr
 2uh 2uo 2vt 2vi 2vr 2aal 2abl 2abq 2ard 2adv 2aef
 2afw 2ajz 2alf 2anh 2as 2ard 2arp 2asg 2awf
 2bec 2bel 2bg 2bli 2bns 2bsd 2cei 2ehh 2eja 2ekl
 2ex 2ga 2na 2nd 2nr 2oh 2pf 2pe 2ql 2rb 2sl 2sz
 2ut 2vg 2wj 2aba 2acd 2acn 2adc 2aep 2ie 2gl
 2jm 2jn 2pk 2ox 2rn 2td 2to 2ud 2wm 2ans 2ae

5afi 5aif 5agp 5amo 5anh 5ank 5aqe 5arg 5ary
 5azm 5bam 5ga 5hz 5jc 5kg 5oa 5vx 5yb 5aoj 5avi
 6awa 6bfp 6bgw 6ppo 6ban 6bhz 6cub 6dev 6dgr
 6dd 6dpo 6dye 6kw 6xl 7ef 7ek 7ip 7vq 8aaw 8aaz
 8adu 8agz 8ahe 8air 8alo 8aps 8ath 8avl 8avs 8awu
 8axz 8ayo 8baf 8bad 8bal 8bc 8be 8bev 8bfg 8bpa
 8brf 8bth 8byn 8bd 8bcm 8ccw 8cft 8che 8chg 8ciw
 8cnh 8cmm 8enn 8enr 8enx 8cpr 8eqn 8esa 8eto
 8exk 8crg 8car 8dbi 8dc 8dcm 8dii 8din 8dkk 8dnf
 8dno 8dod 8dpa 8kq 8li 8qb 8qh 8uj 8avt 8ahq 8axh
 9aip 9alo 9aju 9acd 9aof 9arm 9aue 9aav 9avz 9axu
 9ban 9bpi 9bca 9bcg 9bcx 9bey 9bck 9bmm 9bpl
 9bah 9bwk 9bxr 9caj 9ccx 9ccb 9cec 9che 9cia 9cjh
 9clt 9coa 9cph 9cnd 9cet 9cya 9cye 9cyw 9db 9ddn
 9des 9dhr 9dng 9doq 9dra 9ds 9dso 9das 9dix 9dxz
 9dzw 9ebc 9ec 9ec 9eft 9ege 9ejo 9elb 9eiz 9enn
 9epg 9erh 9eta 9etz 9eul 9eva 9eyy 9ez 9fbf 9fbv
 9fdf 9fes 9fgp 9fhy 9fik 9fa 9lk 9um 9mt 9nr 9ny
 9st 9vw 9xl er3 ai-vwz fe-suw fm-8sar ne-2cd ne-3fc
 ne-4bm ng-lva nm-lz da-3ut da-5mb xen-ocq.

ec-2YD, Near Brno, Moravia, Czechoslovakia
20 Meters

1pd 2bfz 2evo 2alp 2tp 2czr 6bdo 6bnx 6cyy 6cdq
 7fa 7aj 9cn nc-1lq nc-1ly nc-2be ne-5aw fm-tun2
 fk-8ms sb-lah oa-2yi oa-4rb oa-6sg oz-4tm.

30 to 40 Meters

1blf 1anz 2blx 2ov 2bfz 2ain 2aqo 2amx 2afu
 2anh 2cn 2wk 2wl 2ae 2bbs 2ip 2er nc-1br fa-lae
 ac-lax ac-2ck ac-2ff ac-8ag ai-lsk nr-cto sb-lah
 sb-laz sb-lay sb-lid sb-2ax su-2ak su-loa oa-6sg
 oa-5wa oz-2ae oz-3az xen-sfv.

WSQ, Between Mosquito Inlet, Fla., and Kittery,
Maine. Operator Ed. Kampf

6bfz 6cgm 6bjh 6fh 6do 6dzl 6pw 6cpx 6wa 6avp
 6hzm 6dcq 6un 6am 6ma 6bc 6bp 6bau 6wa 6chq
 7aj 7abh 7m 7mx nq-2ac np-6cx ca-kl ea-ij ea-rc7
 eb-4ar eb-4au ed-7z ed-7jo ef-8ro ef-8br ef-8xf
 ef-8bc ef-8ct ef-8eo ef-8gl ef-8ih ef-8px ef-8wz ex-5by
 eg-5mq ef-6rw eg-6uo eg-6yg ei-1dy ei-1et ek-4nai
 ek-4jl en-ovim ep-1by ep-3gb ex-las ee-ear6 sa-2bx
 sb-lar sb-law sb-2az sb-1ib se-2as se-3ac so-ladd
 so-lbx oa-5qp oa-5dx oa-5hg oa-2ah oz-2ae oz-2bp
 oz-3az nidk wnp.

eh-4XS, Roger Parent, Dolhain, Belgium

1biv 1boe 1epc 1erd 1fn 1si 1no 1xr 2cty 2cs 2aoo
 2bjs 2et 2edm 2awq 2mb 2bey 2ev 2exl 2afz 2abl 2bel
 3qt 3bqz 3adp 3ge 3kdg 3ebt 3anh 3ard 3iw 3vh 3ei
 4agd 4acv 5fk 6ij 6gl 7ro 8ck 8dlu 9lrd nc-1br ne-8rg
 ne-ftt nq-5fl nr-2agx oa-awv su-2ak ai-dg sa-de3
 sc-2al sb-lca sb-laj sb-law sb-lax sb-1lb sb-lbr
 sb-1bz sb-1ea sb-1cg sb-1cm sb-1fb sb-1hd sb-2ad
 sb-2ag sb-2aj sb-2al sb-2as sb-2ay sb-2ax sb-2bg
 sb-2id sb-2ih sb-2is sb-2rd oa-7pm oa-7ex oz-3am
 oz-3az oz-4ac oz-4ao fq-ocya ag-1ril as-55ra au-1lrk5
 xen-ek xei-azt.

eu-RK1, Theodora Gauchman, Svobody St.,
Tatrosiarvi, U. S. S. R.

1qt 1amd 1apr 2arm 2eda 2ow 2auc 2ers 2aov 2al
 3cif 3aqz 3fa 4wl 4red 4rf 4aed 8ccs 9ez ac-2al ac-2ck
 sa-lax.

oz-2GO, Harold G. Fownes, 110 Riddiford St.,
Wellington, N. Z.
20 and 40 Meters

na-7alu nb-be8 ne-lac ne-lap ne-lar ne-lax ne-lbi
 ne-lbr ne-lco ne-lid ne-ldm ne-2am ne-2be ne-2bg
 ac-2fo ne-3ag ne-3bo ne-3bt ne-3cm ne-3dn ne-3el
 ne-3gg ne-3gn ne-3mp ne-3nj ne-3z ne-4ar ne-4bp
 ne-4cn ne-4eh ne-4ey ne-4gz ne-4gi ne-4hh ne-4hs

(Continued on Page 66)

Correspondence

The Publishers of QST assume no responsibility for statements made herein by correspondents.



A Souvenir

173 Albany Ave.,
Shreveport, La.

Editor, QST:

The enclosed is a relic of the Hearn household recently unearthed in the attic. You will recognize it as recalling the "swing around the country" taken by Mr. Marconi shortly after he had announced his invention of wireless telegraphy. He came to Shreveport when I was 17 years old. I attended the demonstration held in the old Opera House (long since torn down). His audience was jocularly skeptical of him, for it was unholy to communicate from one

inated by the International Radio Conference and it is only due to the valiant efforts of officials of the A.R.R.L. and others that we retain the privilege of operating our stations. Operation according to law is not only to our individual advantage but is our duty to our fellow amateurs and those who struggled so hard to have us recognized as a worthy class who deserved a place in the crowded spectrum. Promises were made or implied by those who saved us that our stations would be operated in accordance with the regulations set down by the Conference, and the great majority of them are. Off band operation whether wilful or accidental is carried on by only a very small percentage of the amateurs of the country, but every station which does so brings discredit on, and endangers the status of all the rest.

It is a truly laudable spirit which prompts us to protect our fellows who are guilty of such violations, but is it for the greatest good of the greatest numbers? We won what we did at the Conference only by a very small margin and it behooves us to guard well what we have earned. No other radio service would expect to carry on repeated operation in violations of its license without disciplinary action; and these other services demonstrated to the satisfaction of the powers that be that they have a greater right to the air than we amateurs.

I favor a much stricter application of the law to amateur stations than there is at present. It is to be assumed, if not from confidence in human nature alone at least in view of the difficulty of proving anything to the contrary, that all off-band operation is accidental and due to carelessness. I do not believe that the carelessness of a few should be permitted to endanger the status of the majority. I believe that a single repetition of off-band operation after a warning by a properly authorized station constitutes sufficient reason for suspension of the station's license, and further, I think it is the duty of the A.R.R.L. to report such violations to the Supervisor of Radio concerned.

The officials of the League got us what we have and we should back them up in helping the vast majority keep it against the carelessness of a few who have little regard for the rights of others.

—Harris Fahnestock, Jr., 1BBO.

Shreveport, La., March 27, 1909

You are cordially invited to attend a
Free Demonstration of Marconi Wireless Telegraph
and Exhibition of Marconi Wireless Instruments
Sending Messages Without Wire, Lighting
Electric Lights, Siren Blowing, Ringing Bells,
Railway Signals, Etc.
Grand Opera House
Monday, Tuesday and Wednesday Evenings,
March 29, 30, and 31, at 8:15
Special reserved seats for ladies

point to another without visible physical connection! In fact, I dare say that ninety-five per cent of the audience put him down as a trickster or sleight-of-hand performer. My reaction, however (as I was at a period where facing the "unknown" was intriguing), was that there must be something to this—if only I had the intelligence to understand it!

—Bradford Hearn, 5ANC.

Off-Band Operation

984 Memorial Drive
Cambridge, Mass.

Editor, QST:

Having read with interest the various communications in QST concerning the operation of amateur transmitters outside of the legal wavebands I am prompted to express my feelings in a somewhat different vein.

Last fall amateur radio was almost elim-

..the Modern Necessity for Electrical Radio...
MERSHON
CONDENSER
 the

The Mershon Condenser gives a *very large capacity* in a very small space. Is self-healing in case of puncture, and is unaffected by changes in temperature, or by moisture.



Expert radio amateurs used the Mershon Condenser for more than six years in their transmitting equipment. Today the Mershon Condenser is being widely used over the whole country in connection with electrical radio sets, whether new AC tubes are used, or battery sets are attached to house current thru the use of Eliminators.

Send for
 Your Free Copy
 of
 This Book....

The AMRAD Corporation
 Medford Hillside, Mass.

Please send a copy of your new book on the MERSHON CONDENSER, showing hook-ups and designs.

Name.....

Address.....

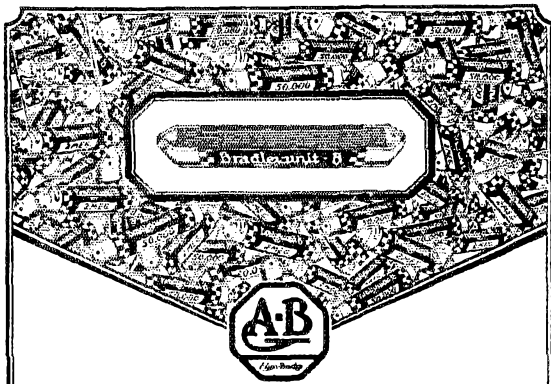

No Grid Leak Interference with the Bradleyunit-B Resistor

BRADLEYUNIT-B solid-molded resistors eliminate the noise and interference in radio circuits caused by inferior grid leaks. Oscillograph tests show the Bradleyunit-B to be remarkably quiet in operation.

The Bradleyunit-B Fixed Resistor is made of a special, uniform mixture, baked and solid-molded at high pressure. This creates a solid, uniform unit, providing a constant resistance regardless of voltage used.

Radio manufacturers are assured of an accurately calibrated resistor which will retain its initial rating indefinitely.

For Radio Manufacturers

These remarkable solid-molded resistors are practically unaffected by moisture, altho not depending on a glass enclosure for protection.

The Bradleyunit-B is furnished with or without tinned leads for soldering. Made in values from 500 ohms to 10 megohms.

Tapped Bradleyunit Resistors are also furnished to meet your specifications.

Allen-Bradley Co., 277 Greenfield Ave.
Milwaukee, Wis.

Allen-Bradley Resistors

741 47 Street,
Milwaukee, Wis.

Editor, QST:

I want to express my approval of the Editorial in the June QST on the use of amateur waves by commercial interests. One need only glance down the pages of a Call Book to see the many amateur calls assigned to stations whose real place is in a commercial band. Many of these stations communicate with amateurs and more do not. Among the latter are stations operated by oil companies, light and power companies and automobile manufacturers. Let's get these usurpers out of our bands. We are cramped enough for space ourselves and there are channels allotted for those services.

In regard to off-wave operation I think very highly of the idea of publishing off-wave station calls in QST. 9DSG is right when he says that an inaccurate wavemeter is just as inaccurate when used to check a received signal as when it is used to check the transmitter. Even so the off-wave list will be long enough if we just report the stations that are below NKF and NAA and above WIR and WIZ in the 80 and 40 meter bands.

So let's get all the commercials out of our bands and all the amateurs back into them.

—W. T. Schultrich, 9CDT.

Long Beach,
Cal.

Editor, QST:

We hear of freakish results—sometimes not so freakish—when a station QSO's with a fraction of a watt. It has also been fairly well established that a re-radiated wave from guy wires, gutter pipes adjacent to wiring etc. may have a fraction of a watt output.

A receiving set (which generates harmonics all of its own) can easily receive signals on its third harmonic, thus being sensitive to signals which might be the fourth harmonic of a transmitter.

Recently, the writer heard a fifth district station on 32 meters QSO a New Zealand station. Upon sending a card the five wrote me an unpleasant reply stating that he was on 40 meters. The next time this five was heard his statement was checked and truly he was on 40, but with a perfectly readable signal right on the New Zealander's wave. Quite possibly the signal was caused from re-radiation from the receiving antenna tuned to the NZ station.

I mention this example for the benefit of those wishing an "Outside the Band" list of calls heard.

—Don C. Wallace, 6AM.

CARDWELL CONDENSERS

The Test Of Time

HAS PROVEN THAT

Cardwell Condensers

are *BASICALLY RIGHT* ~

RUGGED ~

STRONG ~

FOR YEARS preferred over all others by the foremost Amateurs, Experimenters and Engineers. No gold plate, no funny doodads, but ALL condenser, built to last for the life of your installation and longer, and to give you the utmost in service and efficiency.



"BALANCET" (midget) CONDENSERS

High, Medium and Low Voltage
TRANSMITTING CONDENSERS
(Standard and to order)

RECEIVING CONDENSERS



"One for every tube and purpose"

LITERATURE UPON REQUEST

The Allen D. Cardwell
Manufacturing Corp.
81 Prospect Street
B'klyn, N. Y.

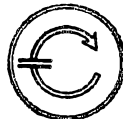

"THE STANDARD OF COMPARISON"

Is This Operating?

Lake Bay,
Alaska.

Editor, QST:

I am a long-suffering type of person and it has taken me a long while to get "haired-up" to the point of writing about some of this lid practice in the amateur bands.

In the first place, who was the crank that coined the idea that in calling a station you should send your own call once after pounding out the other fellow's call for ten minutes? Here at Lake Bay my apartment happens to be my office also. Recently I was listening to a sixth district station (call withheld, though he deserves worse) calling a nine. I counted the 9ARA's coming from this fellow's key—five, six, seven, eight, until finally I reached up above my desk and grabbed a counting machine I use on the job. When the six had ceased pounding his key, and I my counting machine, the figures showed that 139 consecutive 9ARA's had been transmitted before the six signed once.

Now, gentlemen, if that's operating I'm St. Peter's brother. Let's prepare a nice chopped-up razor-blade pudding for these fellows,

Evert Rodenhouse, 7ADP.

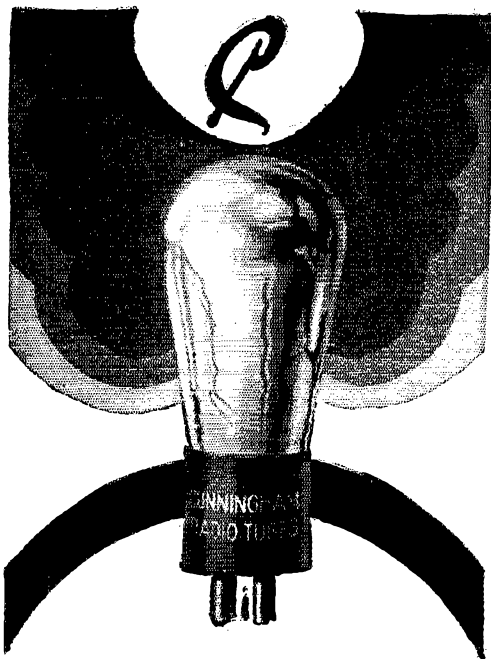

Increase Your Radio Enjoyment

By replacing each tube in your set with a *new* Cunningham Radio Tube you are sure of clear, resonant tone. You are virtually giving new life and energy to your radio, and you thereby increase your radio enjoyment.

Don't use old or inferior tubes with new ones—use new tubes throughout.

Look for the name **CUNNINGHAM**
on the Orange and Blue carton . . .

E. T. CUNNINGHAM, Inc.
New York Chicago San Francisco

Manufactured and sold under rights, patents and inventions owned and/or controlled by Radio Corporation of America.



Calls Heard

(Continued from Page 61)

nz-WUCG, Cpl. E. J. Day, Hdqtrs. Bty., 1st. C. A.,
Fort de Lesseps, C. Z.

(20 meters)

1bms 1atr 1fv 1vw 1b1k 1jj 1dy 1gh 1pd 2bxx 2gp
2aqs 2ag 2bbx 2buo 3ke 3aek 4dt 4acp 4acc 4ek 4bn
5aq 5uk 6uf 6eze 6esj 6avl 6dz 7ajj 8ess 8byn 8hc
8dod 8cpc 8adm 8gz 8bd 9eju 9fbw.

(40 meters)

1axx 1nu 2blr 2ama 2bla 2bwr 2uc 2xc 2ty 2uo
3anh 3au 3aim 4vh 4ch 4px 4acv 4hk 2erb 5ary 6afx
6ezz 6eex 6dzk 6dh 6lo 6ey 6ax 6ju 6app 6cwk 6dca
8do 8bta 8hr 8dtp 9dfj 9eco 9dop 9aez 9bz 9fsi 9heu
9aey wuan.

(23 meters)

nc-2ce np-4sa eg-5kl eg-5vl ei-1gw ef-8orm.

(33 meters)

nm-1rz nm-9a nn-1nnc nn-1nic nq-7cx nq-7cf nq-
5ea ns-1fmh nr-2ags eg-7cw ei-1dy sc-2ah se-2jm si-
cos oa-4nw oa-8dj oz-2ac ef-8btr op-1bj oh-6xx.

ed-7XX, H. Glistrup, Fredericiagade 10, Copenhagen,
Denmark.

(40 meters)

lakd lave laus lbhm lcrd lfs lic lom lrf lww
2aen 2agw 2ak 2auh 2bdh 2bf 2cei 2cwm 2cxn 2dp 2fz
2mx 3aal 3afa 3amx 3anh 3ayz 3ee 3ua 4abw 4aeb 8dts
8djf.

eg-5HS, M. F. J. Samuel, 16 Blenheim Rd., London,
N. W. 5, England.

(20 meters)

lahi lakm lavl lbsu 2aon 2bdr 2cuq 3bim 3hf 4hn
4io 4nl 5acl 5afb 5afx 5atm 5auz 5avs 5uxo 5ham
5bh 5dk 5dv 5pt 5rg 5sw 5ta 5uk 5yb 6adp 6axr
6ahs 6alw 6azs 6bgy 6hq 6bzf 6eel 6euc 6eyx 6czq
6dbo 6dev 6dhj 6dor 6fh 6ih 6ju 6of 6uf 7acs 7afo
7ago 7ajj 7ef 7ek 7fe 7if 7mo 7mx 8ccq 8cfl 8elp 8dd
8alz 8auu 8avp 8bjp 8bmx 8bnd 8bpl 8bqy 8che 8erd
9bdj 9djh 9dqu 9drd 9dpx 9erl 9ef 9efz 9ekw 9hm
9mn na-7ady na-7mn nc-2al nc-2be nc-3es nc-3fc nc-
4et nc-4dq nc-4fv nc-5aw nc-5cp nh-ca nr-2fg af-ko
ai-2kt ai-2kw aq-1lm as-o3ra fo-1sr fo-a3z fu-a4f fo-
a7n fo-a9a oa-2iy oa-2re oa-2rz oa-2sh oa-2uk oa-3bq

Frequency Precision

Attained by Using

REL Frequency Meters

A radically new type of frequency measuring instrument designed expressly for the new amateur bands effective January, 1929.

Quoting Hiram Percy Maxim, President A.R.R.L.:

"If somebody were to ask you the question, 'What is the big outstanding problem in amateur radio today?', what would you reply? It was asked me the other day. I had given the matter considerable thought, so I was ready with my reply. My answer was, 'Frequency precision'."

That's the problem, fellow amateurs, but are you going to do precision work without precision measuring equipment? Your new transmitter and your new receiver cannot be designed to operate within the new lawfully assigned bands unless you use an accurate frequency meter. Your old wavemeters are useless. Obsolete!! Why? In most cases the new 7000 to 7300 Kc. band (old 40 meter band) is crowded into 5 to 10 divisions on the dial. It won't be so many meters any more, but it will be so many kilocycles. You will eventually specify your QRH in frequency.

REL is again pioneering for the good and welfare of amateur radio. The new line of amateur frequency meters deserves the critical attention of everyone interested in amateur radio. REL is presently developing new transmitters, new receivers, new coils and condensers. Watch for their announcements in the coming issues of *QST*.

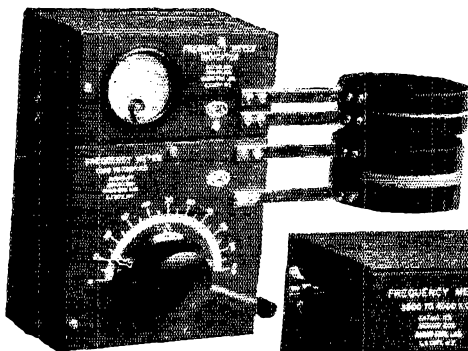

Illustrating how the 7000 to 7300 K.C. frequency meter is coupled to the external frequency meter indicator.

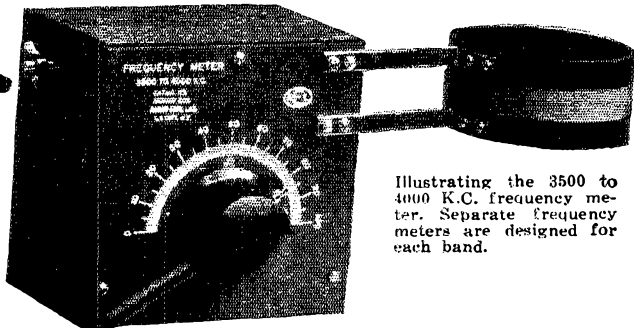

Illustrating the 3500 to 4000 K.C. frequency meter. Separate frequency meters are designed for each band.

ADVANCE DATA ON FREQUENCY METERS

Cat. No. 173 Frequency Meter, 3500 to 4000 K.C. (85 to 75 meters)	PRICE \$15.00
Cat. No. 177 Frequency Meter, 7000 to 7300 K.C. (42.8 to 41.0 meters)	PRICE \$15.00
Cat. No. 178 Frequency Meter, 14000 to 14400 K.C. (21.4 to 20.8 meters)	PRICE \$16.00
Cat. No. 179 Frequency Meter, 28000 to 30000 K.C. (10.7 to 10.0 meters)	PRICE \$15.00

Each frequency meter is individually calibrated from a Piezo crystal controlled standard. New Uniquely designed Coils and Condensers—Highly sensitive independent resonance indicator circuit. (Flashlight lamps, Neon tubes, hot wire meters, and galvanometers cannot be used to sharply indicate resonance on the new narrow amateur bands). Indicator produces no change of calibration. Large calibration curves allow accurate readings to within 1/10 of 1%.

Supplied with one original and one blueprint curve sheet.
 Cat. No. 180 Frequency Meter Indicator. PRICE \$16.00
 These are supplied with Weston milliamper meters and crystal rectifiers constituting the most sensitive resonance indicators known.

RADIO ENGINEERING LABORATORIES

100 Wilbur Avenue Long Island City, N. Y.

How to Select a Resistor

EVERY radio engineer is confronted by two important questions when he selects a resistor—"How accurate is it?" and "How long will it maintain its accuracy under the average load?" Until the resistor answers these two with perfect satisfaction, all other questions are unnecessary.

Here's how Hardwick, Field, Inc., answer them:

1. Har-field Resistors can be supplied to you as accurate as plus or minus 1%, if you wish.
2. Under average load conditions, all Har-field Resistors are guaranteed to maintain the accuracy your order specifies.

Har-field Resistors are made in either vitreous enamel or specially coated cement finish. Tell us about the resistor you want and let us send you a sample with prices. Write

HARDWICK, FIELD, INC.

SALES OFFICE
122 Greenwich St.
New York City



FACTORY
215 Emmett St.
Newark, N. J.

Model "N"
Vario Denser

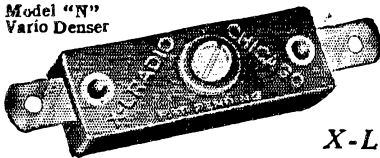

**Pep Up
Your Set
With
X-L Products**

Tune quickly—adjust accurately—eliminate distracting noises—get correct tube oscillation—with X-L VARIO DENSERS in your circuit.
Designers of all latest and best circuits specify and endorse.

MODEL "N"—Micrometer adjustment easily made, assures exact oscillation control in all tuned radio frequency circuits, Neutrodyne Roberts 2-tube, Browning-Drake, Silver's Knockout. Capacity range 1.8 to 20 Mfd. Price \$1.00.

MODEL "G"—Obtains the proper grid capacity on Cockaday circuits filter and intermediate frequency tuning in super-heterodyne and positive grid bias in all sets. Capacity range, Model G-1 .00002 to .0001 Mfd. Model G-5 .0001 to .0005 Mfd. Model G-10 .0003 to .001 Mfd. Price each with grid clips \$1.50.

X-L PUSH POST—NEW! Bakelite Insulated Push it down with your thumb, insert wire, remove pressure, wire is firmly held. Vibrations will not loosen, releases instantly. Price each 15c.

FREE—New up-to-date book of wiring diagrams, showing use of X-L units in all popular hookups, also the Goodwin Aperiodic Detector Circuit, applicable to any set; adds a stage without added tuning controls. Write today.



**X-L PUSH
POST**

X-L RADIO LABORATORIES,
Dept. D, 1224 Belmont Ave.,

Chicago, Illinois

A KICK

to your signals that shoots 'em clean across. A peculiar, keen cutting note that lifts 'em clear of the jam—sets you there. That's the Mercury Arc, Automatic Starting, Unlimited Power, Long Life, Trouble-Free. A Rectifier of unparalleled performance. Just write and your Rectifier problems are solved.

RECTIFIER ENGINEERING SERVICE
4837 Rockwood Rd., Radio BML, Cleveland, Ohio

oa-3ep oa-3dc oa-3gr oa-3hl oa-3jo oa-3tm oa-4nw
oa-4rb oa-5bw oa-5cm oa-5dx oa-5hg oa-5wh
oh-6alm oh-6avl oz-1fe oz-2ac oz-2ae oz-2bx oz-3aj
oz-4ae oz-4am sa-1c6 sa-1a9.

S.S. DROMORE CASTLE, New York City to Cape Town, South Africa, via 2CUF.
Operator Clyde Townsend, care the Union-Castle Mail Steamship Co., 26 Broadway, New York City.

New York to 500 miles South East.
1acy 1alb 1bqt 1gh 2asr 2axk 2bck 2bix 2box 2cgr
2rs 3adp 3aqz 3bel 3bns 3dcp 3mb 4ep 4bk 4dt
4el 4jd 4ky 4st 4tg 5aut 5as 6ajv 6ard 6ham 6amt
6ayb 6avs 6bta 6bc 6bpe 6brq 6th 6bwy 6cau 6ccw
6cjl 6cke 6csp 6csr 6dsa 6sp 6ahm 6bqe 6hsh 6cmq
6cwh 6dck 6dea ep-1aa fm-8parv ne-1ap ne-1ed ne-1im
ne-3gb.

500 to 1000 miles South East New York.
1bms 1cmt 1dms 1gd 1gh 1gw 1ig 1im 1acv 1auz
1ae 1bb1 2afr 2agu 2ama 2aub 2bck 2bdf 3adp 3afx
3ajd 3arq 3bz 3ec 3ekj 4arb 4ck 5st 5aq 5gb 5box
5ajj 5anc 5avw 5bok 5bqp 5cle 5cc 5cjl 5cqi 5cxc
5czr 5dtp 5kg 5kz 5th 5aez 5axj 5bbk 5bsh 5bzz
5ewy 5ds 5dxi 5ems 5enn 5fby 5fdz 5kz 5mn 5c-lae
5c-lap 5c-lar 5c-1eo 5c-2cw 5c-3ag 5c-3be 5c-3bk
5c-3cc 5c-3ej 5c-3dc 5c-3gn 5c-3rb 5c-3al 5n-2kr
5n-5ag 5n-1nic.

1000 to 2000 miles S. E. New York.
1ahx 1awm 1enz 1ex 1gh 1st 1ag 2ama 2aug 2bck
2bek 2buy 2cxl 2tr 2up 3adp 3afz 3bns 3bnu
3mv 3wm 4ac 4arb 4kw 4pa 4jt 4wm 5as 5ard 7ail
8app 8avp 8haf 8bcq 8brh 8cj 8cdt 8dmu 8ze 9ahj
9arm 9axx 9bv 9cd 9elb 9e2b 9ffj 9kz eb-4tm ee-earo
ef-8axq eg-2cc ep-1as ep-1bx ep-3am ne-3es nn-1nic
xc-51.

2000 to 2500 miles S. E. New York
1agz 1axq 1bed 1bw 1bwm 1cxl 1fj 1kh 1mk 1mx
2adb 2aem 2ans 2atz 2bdw 2ber 2ef 2euf 2dg 2hc 2kh
2ow 2qh 3adb 3adp 3ag 3anh 3aok 3ap 3bnu 3cdu
3ep 3cuq 3ee 3tm 4bl 4dt 4fs 4io 4pu 4ta 5afg 5ats 5ave
5awz 5jx 6auu 6adv 6ebp 6dfr 6dtl 6it 7aat 7aku
8adm 8ajv 8ano 8baf 8bc 8brh 8cj 8abz 8ant 8bq
9bkl 9dxx 9e2h 9bz dnc eb-4da eb-4fb eb-4rp eco
ee-2yd ee-ear4 ee-ear65 ef-8fs ef-8cl ef-8z ef-8gdb
ef-8lb ef-8rlt eg-2hj eg-2cc eg-2yy eg-2aw eg-5ms
eg-5lx eg-6dr eg-6hp eg-6rb eg-6rm eg-6wy ei-1gl
smua en-owy ep-1aa ep-1bv ep-1bx et-2ua eu-ora eu-
sfrm fm-8ags gw-14b ne-2bb ne-2bj ne-2bw ne-3bm
ne-8he.

2500 to 3000 miles S. E. New York.
1ary 1awm 1blf 2agw 2ama 2aaj 2ber 2bt 2bz
2ckk 2cut 2cuq 2kl 2mb 2uo 2wi 3aed 3dh 3ac 3hal
3cfw 3im 3pz as-4ap byz eb-4tm eb-4wx ed-7fr ed-7io
ed-7mt ed-7w ee-ear44 ef-8ak ef-8z ef-8gou ef-8fb
eg-1bx eg-2cc eg-2sc eg-6br eg-6rm ei-1gl en-0fp
gl-2it np-4as rku sefe sqcl sb-1v wix wip xuu.

3000 to 5000 miles S. E. New York.
1abz 1ajc 1aqi 1ary 1awm 1bqs 1bc 1clm 1dl 1ie
1mk 1nq 1ap 1wl 2apd 2azs 2bda 2bxr 2euf 2euj
2cxl 2eyx 2ezr 2dg 2efz 2gk 2gp 2je 2mq 2rs
2vd 2wl 3afx 3anf 3anh 3aq 3avv 3bmz 3bnu 3cw
3ua 4ek 4ea 4kl 5acl 6ads 7dr 8akc 8bu 8bf 8czg
8dbe 8dkt 8dme 8drz 8kq 8lj 8ve 9apv 9bz 9eaj 9erh
9fs 9fcp 9fk asra-03 asra-83 byz byb eb-4wx ef-8cc
ef-8fg eg-2cc eg-5xy fz fw-3 gbk gkt glq ne-1ad ne-1ak
ne-3zd oic oip poj ptm pjn rza sb-1ah sb-1aw sb-1d
sb-2ax sb-2az sb-3qaa skd su-1oa.

5000 to 6800 miles (Capetown) S. E. New York
1aao 1ajc 1aqa 1asr 1bav 1bvm 1bx 1em 1cm 1emx
1gh 1gw 1om 1pl 1wl 2afx 2aha 2ajb 2anh 2ari
2ass 2ate 2atq 2avh 2avp 2bav 2bdf 2bkf 2btq 2cz
2enn 2cxl 2eyz 2dg 2ih 2mb 2rs 2ty 2xo 2ahl 2alq
2auh 2bpl 2bno 2brc 3cc 3ein 3ekl 3ef 3pf 3wj 3wm
4aed 4aeb 4ar 4cc 4ck 4io 4mc 4pd 4td 4vl 5ayb 7by
8ab 8afq 8ajv 8akc 8at 8ayv 8bko 8box 8ccw 8ent
8ctx 8evo 8dem 8dod 8dpa 8dph 8dpo 8ez 8gz 8hc
8li 8lx 8yz 9ack 9avz 9brv 9bc 9caf 9civ 9ds 9de
9dng 9dvw 9ez 9eaj 9epg 9erh 9eve 9hi 9hj 9xi 9za
agb byz cfh eb-4rk ec-2aa ef-8ez ef-8fr ef-8fx ef-8y
eg-2kf eg-2nh eg-2od eg-2sc eg-5bl eg-5by eg-5ku eg-5lc
eg-5ml eg-5uh eg-5uw eg-5yk eg-5yx eg-6hp eg-6wi
ei-1cr ei-1dy ej-7dd en-0tz ep-1aa es-2nm fo-5ar
fo-5bk fo-5rd fo-5z2 fq-pm fwz fy gbj gkt gjz hva-1
jha jan kio kzt ne-1ap nn-4sa oodi pch pkh ptm
poj pepp perr sa-3de sb-1aa sb-1ah sb-1ai sb-1ar
sb-1aw sb-1bi sb-1bo sb-1cl sb-1dx sb-1id sb-2ah
sb-2aj sb-2ax sb-2ay sb-2az sb-5bf ec-7aa su-1fb
su-1na.

eg-6YL Miss. B. Dunn, Stock, Essex, England
(40 meters)

1bcb 1boi 1mk 1vs 1vt 2aad 2bih 2blj 3baa 3akb
3anh 3ec 4abz 4acv 4ck 4oo 5air 5ath 5afx 5avp

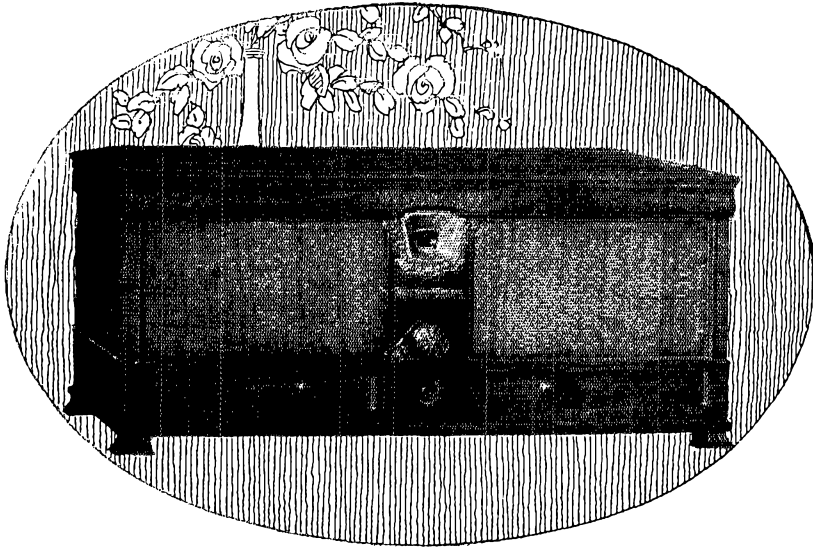

No. 635
 Stromberg-Carlson
 Treasure Chest.
 Price, less tubes \$185.
 Slightly higher prices
 Rockies and West,
 and Canada.

The New Stromberg-Carlson

THIS new Receiver marks the success of long experimentation by Stromberg-Carlson engineers in producing a Receiver having the convenience and simplicity of A. C. tubes and retaining all the glorious tone quality for which Stromberg-Carlsons have long been celebrated.

Handsome in cabinet work—a beautifully grained American Walnut; extremely sensitive; highly selective and producing fine volume over

the entire tuning range from 200 meters to 550 meters it provides a remarkable instrument at a very reasonable price.

As in other Stromberg-Carlsons provision is made for reproduction of phonograph records. It is totally shielded, tunes with a single selector [illuminated], is entirely self contained and operates from any 60-cycle A. C. house lighting circuit, using no batteries or liquids.

Listen to the Stromberg-Carlson Sextette Tuesday evenings at 8 o'clock Eastern Daylight Time, through the NBC and Associated Stations: WJZ, WBZ-WBZA, WJR, WSB, WBAL, WHAM, KDKA, WREN, WTMJ, WCCO, KYW, KWK, KOA, WBT, KVOO, WFAA, WOAI, WMC, WHAS, KPRC.

Every new Stromberg-Carlson has handy jack to facilitate playing Phonograph records.

STROMBERG-CARLSON TELEPHONE MANUFACTURING CO.
 ROCHESTER, N. Y.

Stromberg-Carlson

MAKERS OF VOICE TRANSMISSION AND VOICE RECEPTION APPARATUS FOR MORE THAN THIRTY YEARS

Say You Saw It In Q S T — It Identifies You and Helps Q S T

There Has Never Been Radio Like This Before

FANSTEEL Balkite Radio

IN CABINETS BY
Berkey & Gay

FANSTEEL PRODUCTS COMPANY, Inc.
NORTH CHICAGO, ILLINOIS

9cfg 9dck 9daz nc-3bm ne-8ae el-la2b xel-aww em-smus em-smzf em-sdk fk-lpq em-snm ep-1aa ep-3fz xep-1uu eu-ra8y fl-lta fm-8ags w8bs. nc-5aj ne-5at ne-5au nc-5cj ne-5dn nc-5ef ne-5fk ne-5go nc-5gt ne-5hp ne-5go ne-8ae ng-uf nj-2pz nm-9a nn-1nic np-4oi nq-2ac nq-2pt nq-3jt nq-5ev nq-7cx nr-2ea nr-2fg nr-cto ee-ear35 ed-7bl nq-11m ef-8tc op-1lg nc-8kp.

Graham G. Hall, 49 Studley Rd., Ivanhoe, Victoria, Australia

2 ayj 2rg 4rn 5rj 5ke 6ea 6al 6uk 6am 6bfp 7ar 8as 9dng 9dws 9efk 9cub 9apf 9apz 9avj oh-6bhl oh-6dud oo-bam oo-1aj oz-1an oz-2aj oz-2aq oz-2ay oz-2aw oz-3al oz-3av oz-3aw oz-3az oz-4aa oz-4ao op-1hr od-pkl aj-ltt af-hva eb-4ar eb-4ft ef-8la sc-3as.

Alfred Huppertsberg, Essen, Albrechtstrasse 26, Germany
32-45 Meters

laae laba labn lair lanz laq laqt lavk lavj lbvl lbbn leer lenz lhra lih lih lmv loo lazn 2atg 2aqz 2aub 2avw 2cer 2eug 2jc 2mb 2qt 2pa 2sm 2rfg 2rs 2sif 2ues 2vi 2wc 2vd 2xaf 2avv 2apx 2anh 2bh 2bf 2bh 2bu 2ca 2cb 2cc 2cd 2ce 2cf 2cg 2ch 2ci 2cj 2ck 2cl 2cm 2cn 2co 2cp 2cq 2cr 2cs 2ct 2cu 2cv 2cw 2cx 2cy 2cz 2da 2db 2dc 2dd 2de 2df 2dg 2dh 2di 2dj 2dk 2dl 2dm 2dn 2do 2dp 2dq 2dr 2ds 2dt 2du 2dv 2dw 2dx 2dy 2dz 2ea 2eb 2ec 2ed 2ee 2ef 2eg 2eh 2ei 2ej 2ek 2el 2em 2en 2eo 2ep 2eq 2er 2es 2et 2eu 2ev 2ew 2ex 2ey 2ez 2fa 2fb 2fc 2fd 2fe 2ff 2fg 2fh 2fi 2fj 2fk 2fl 2fm 2fn 2fo 2fp 2fq 2fr 2fs 2ft 2fu 2fv 2fw 2fx 2fy 2fz 2ga 2gb 2gc 2gd 2ge 2gf 2gg 2gh 2gi 2gj 2gk 2gl 2gm 2gn 2go 2gp 2gq 2gr 2gs 2gt 2gu 2gv 2gw 2gx 2gy 2gz 2ha 2hb 2hc 2hd 2he 2hf 2hg 2hh 2hi 2hj 2hk 2hl 2hm 2hn 2ho 2hp 2hq 2hr 2hs 2ht 2hu 2hv 2hw 2hx 2hy 2hz 2ia 2ib 2ic 2id 2ie 2if 2ig 2ih 2ii 2ij 2ik 2il 2im 2in 2io 2ip 2iq 2ir 2is 2it 2iu 2iv 2iw 2ix 2iy 2iz 2ja 2jb 2jc 2jd 2je 2jf 2jg 2jh 2ji 2jj 2jk 2jl 2jm 2jn 2jo 2jp 2jq 2jr 2js 2jt 2ju 2jv 2jw 2jx 2jy 2jz 2ka 2kb 2kc 2kd 2ke 2kf 2kg 2kh 2ki 2kj 2kl 2km 2kn 2ko 2kp 2kq 2kr 2ks 2kt 2ku 2kv 2kw 2kx 2ky 2kz 2la 2lb 2lc 2ld 2le 2lf 2lg 2lh 2li 2lj 2lk 2ll 2lm 2ln 2lo 2lp 2lq 2lr 2ls 2lt 2lu 2lv 2lw 2lx 2ly 2lz 2ma 2mb 2mc 2md 2me 2mf 2mg 2mh 2mi 2mj 2mk 2ml 2mm 2mn 2mo 2mp 2mq 2mr 2ms 2mt 2mu 2mv 2mw 2mx 2my 2mz 2na 2nb 2nc 2nd 2ne 2nf 2ng 2nh 2ni 2nj 2nk 2nl 2nm 2no 2np 2nq 2nr 2ns 2nt 2nu 2nv 2nw 2nx 2ny 2nz 2oa 2ob 2oc 2od 2oe 2of 2og 2oh 2oi 2oj 2ok 2ol 2om 2on 2oo 2op 2oq 2or 2os 2ot 2ou 2ov 2ow 2ox 2oy 2oz 2pa 2pb 2pc 2pd 2pe 2pf 2pg 2ph 2pi 2pj 2pk 2pl 2pm 2pn 2po 2pp 2pq 2pr 2ps 2pt 2pu 2pv 2pw 2px 2py 2pz 2qa 2qb 2qc 2qd 2qe 2qf 2qg 2qh 2qi 2qj 2qk 2ql 2qm 2qn 2qo 2qp 2qq 2qr 2qs 2qt 2qu 2qv 2qw 2qx 2qy 2qz 2ra 2rb 2rc 2rd 2re 2rf 2rg 2rh 2ri 2rj 2rk 2rl 2rm 2rn 2ro 2rp 2rq 2rr 2rs 2rt 2ru 2rv 2rw 2rx 2ry 2rz 2sa 2sb 2sc 2sd 2se 2sf 2sg 2sh 2si 2sj 2sk 2sl 2sm 2sn 2so 2sp 2sq 2sr 2ss 2st 2su 2sv 2sw 2sx 2sy 2sz 2ta 2tb 2tc 2td 2te 2tf 2tg 2th 2ti 2tj 2tk 2tl 2tm 2tn 2to 2tp 2tq 2tr 2ts 2tt 2tu 2tv 2tw 2tx 2ty 2tz 2ua 2ub 2uc 2ud 2ue 2uf 2ug 2uh 2ui 2uj 2uk 2ul 2um 2un 2uo 2up 2uq 2ur 2us 2ut 2uu 2uv 2uw 2ux 2uy 2uz 2va 2vb 2vc 2vd 2ve 2vf 2vg 2vh 2vi 2vj 2vk 2vl 2vm 2vn 2vo 2vp 2vq 2vr 2vs 2vt 2vu 2vv 2vw 2vx 2vy 2vz 2wa 2wb 2wc 2wd 2we 2wf 2wg 2wh 2wi 2wj 2wk 2wl 2wm 2wn 2wo 2wp 2wq 2wr 2ws 2wt 2wu 2wv 2ww 2wx 2wy 2wz 2xa 2xb 2xc 2xd 2xe 2xf 2xg 2xh 2xi 2xj 2xk 2xl 2xm 2xn 2xo 2xp 2xq 2xr 2xs 2xt 2xu 2xv 2xw 2xx 2xy 2xz 2ya 2yb 2yc 2yd 2ye 2yf 2yg 2yh 2yi 2yj 2yk 2yl 2ym 2yn 2yo 2yp 2yq 2yr 2ys 2yt 2yu 2yv 2yw 2yx 2yy 2yz 2za 2zb 2zc 2zd 2ze 2zf 2zg 2zh 2zi 2zj 2zk 2zl 2zm 2zn 2zo 2zp 2zq 2zr 2zs 2zt 2zu 2zv 2zw 2zx 2zy 2zz

G. M. Grening, Operator S.S. Christobal, KMD, Address nu-8CZQ

Heard between Port au Prince, Haiti, and Christobal, N. Z., middle of June

lckp 2apu 2bfu 2bxr 2exi 2dn 2lk 2aa 2aob 2arh 2auv 2auw 2ez 2ec 2ehi 2mk 2pf 2sm 2uc 2fc 2hk 2pd 2ro 2tk 2vl 2ac 2ag 2ah 2aj 2ak 2al 2am 2an 2ao 2ap 2aq 2ar 2as 2at 2au 2av 2aw 2ax 2ay 2az 2ba 2bb 2bc 2bd 2be 2bf 2bg 2bh 2bi 2bj 2bk 2bl 2bm 2bn 2bo 2bp 2bq 2br 2bs 2bt 2bu 2bv 2bw 2bx 2by 2bz 2ca 2cb 2cc 2cd 2ce 2cf 2cg 2ch 2ci 2cj 2ck 2cl 2cm 2cn 2co 2cp 2cq 2cr 2cs 2ct 2cu 2cv 2cw 2cx 2cy 2cz 2da 2db 2dc 2dd 2de 2df 2dg 2dh 2di 2dj 2dk 2dl 2dm 2dn 2do 2dp 2dq 2dr 2ds 2dt 2du 2dv 2dw 2dx 2dy 2dz 2ea 2eb 2ec 2ed 2ee 2ef 2eg 2eh 2ei 2ej 2ek 2el 2em 2en 2eo 2ep 2eq 2er 2es 2et 2eu 2ev 2ew 2ex 2ey 2ez 2fa 2fb 2fc 2fd 2fe 2ff 2fg 2fh 2fi 2fj 2fk 2fl 2fm 2fn 2fo 2fp 2fq 2fr 2fs 2ft 2fu 2fv 2fw 2fx 2fy 2fz 2ga 2gb 2gc 2gd 2ge 2gf 2gg 2gh 2gi 2gj 2gk 2gl 2gm 2gn 2go 2gp 2gq 2gr 2gs 2gt 2gu 2gv 2gw 2gx 2gy 2gz 2ha 2hb 2hc 2hd 2he 2hf 2hg 2hh 2hi 2hj 2hk 2hl 2hm 2hn 2ho 2hp 2hq 2hr 2hs 2ht 2hu 2hv 2hw 2hx 2hy 2hz 2ia 2ib 2ic 2id 2ie 2if 2ig 2ih 2ii 2ij 2ik 2il 2im 2in 2io 2ip 2iq 2ir 2is 2it 2iu 2iv 2iw 2ix 2iy 2iz 2ja 2jb 2jc 2jd 2je 2jf 2jg 2jh 2ji 2jj 2jk 2jl 2jm 2jn 2jo 2jp 2jq 2jr 2js 2jt 2ju 2jv 2jw 2jx 2jy 2jz 2ka 2kb 2kc 2kd 2ke 2kf 2kg 2kh 2ki 2kj 2kl 2km 2kn 2ko 2kp 2kq 2kr 2ks 2kt 2ku 2kv 2kw 2kx 2ky 2kz 2la 2lb 2lc 2ld 2le 2lf 2lg 2lh 2li 2lj 2lk 2ll 2lm 2ln 2lo 2lp 2lq 2lr 2ls 2lt 2lu 2lv 2lw 2lx 2ly 2lz 2ma 2mb 2mc 2md 2me 2mf 2mg 2mh 2mi 2mj 2mk 2ml 2mm 2mn 2mo 2mp 2mq 2mr 2ms 2mt 2mu 2mv 2mw 2mx 2my 2mz 2na 2nb 2nc 2nd 2ne 2nf 2ng 2nh 2ni 2nj 2nk 2nl 2nm 2no 2np 2nq 2nr 2ns 2nt 2nu 2nv 2nw 2nx 2ny 2nz 2oa 2ob 2oc 2od 2oe 2of 2og 2oh 2oi 2oj 2ok 2ol 2om 2on 2oo 2op 2oq 2or 2os 2ot 2ou 2ov 2ow 2ox 2oy 2oz 2pa 2pb 2pc 2pd 2pe 2pf 2pg 2ph 2pi 2pj 2pk 2pl 2pm 2pn 2po 2pp 2pq 2pr 2ps 2pt 2pu 2pv 2pw 2px 2py 2pz 2qa 2qb 2qc 2qd 2qe 2qf 2qg 2qh 2qi 2qj 2qk 2ql 2qm 2qn 2qo 2qp 2qq 2qr 2qs 2qt 2qu 2qv 2qw 2qx 2qy 2qz 2ra 2rb 2rc 2rd 2re 2rf 2rg 2rh 2ri 2rj 2rk 2rl 2rm 2rn 2ro 2rp 2rq 2rr 2rs 2rt 2ru 2rv 2rw 2rx 2ry 2rz 2sa 2sb 2sc 2sd 2se 2sf 2sg 2sh 2si 2sj 2sk 2sl 2sm 2sn 2so 2sp 2sq 2sr 2ss 2st 2su 2sv 2sw 2sx 2sy 2sz 2ta 2tb 2tc 2td 2te 2tf 2tg 2th 2ti 2tj 2tk 2tl 2tm 2tn 2to 2tp 2tq 2tr 2ts 2tt 2tu 2tv 2tw 2tx 2ty 2tz 2ua 2ub 2uc 2ud 2ue 2uf 2ug 2uh 2ui 2uj 2uk 2ul 2um 2un 2uo 2up 2uq 2ur 2us 2ut 2uu 2uv 2uw 2ux 2uy 2uz 2va 2vb 2vc 2vd 2ve 2vf 2vg 2vh 2vi 2vj 2vk 2vl 2vm 2vn 2vo 2vp 2vq 2vr 2vs 2vt 2vu 2vv 2vw 2vx 2vy 2vz 2wa 2wb 2wc 2wd 2we 2wf 2wg 2wh 2wi 2wj 2wk 2wl 2wm 2wn 2wo 2wp 2wq 2wr 2ws 2wt 2wu 2wv 2ww 2wx 2wy 2wz 2xa 2xb 2xc 2xd 2xe 2xf 2xg 2xh 2xi 2xj 2xk 2xl 2xm 2xn 2xo 2xp 2xq 2xr 2xs 2xt 2xu 2xv 2xw 2xx 2xy 2xz 2ya 2yb 2yc 2yd 2ye 2yf 2yg 2yh 2yi 2yj 2yk 2yl 2ym 2yn 2yo 2yp 2yq 2yr 2ys 2yt 2yu 2yv 2yw 2yx 2yy 2yz 2za 2zb 2zc 2zd 2ze 2zf 2zg 2zh 2zi 2zj 2zk 2zl 2zm 2zn 2zo 2zp 2zq 2zr 2zs 2zt 2zu 2zv 2zw 2zx 2zy 2zz

9DWE, John C. Bailey, 735 Middle Drive, Woodruff Place, Indianapolis, Ind.

20 Meters

laac lakz lamc lasu lawe laxp lbbm lbf lbw lmc lmf los lqv lrd lluz lxi lxp lxx lzz 2aiw 2oo 2vs 2xad 4aba 4sq 5air 5ba 5aat 5afn 5axr 6ahs 6amn 6ano 6avp 6ayi 6bf 6bp 6bo 6bt 6cbp 6cby 6cl 6cuz 6che 6col 6cpx 6csj 6cub 6cuz 6cuz 6cuz 6dgg 6dkg 6dmk 6dti 6dzt 6dor 6ea 6ef 6of 6oo 6pn 6uf 6xi 6zz 7abg 7abh 7acs 7add 7dp 7gr 7hx 7ne 7nr 7mv 7ur 7vh 7vq 7vz eb-4au ef-8fc ef-8fr ef-8orm eg-5ma ep-1aa fq-ocdl na-7ae na-7ke ne-1ad ne-1ar ne-1bt ne-1eo ne-1er ne-1dm ne-2al ne-2am ne-3mp ne-4bc ne-4dq ne-4gb ne-4gd ne-4gg ne-4ha ne-4hh ne-4mp ne-5ep ne-8ae ne-8wg nm-cyy nm-27a nm-9a nm-1ng nn-1nic np-4ags np-4je np-4sa np-6k nr-2fg ns-ceg sb-1aw sb-2ar sb-2az sc-3ae as-3ak se-1fb oh-6alm oh-6clj oh-6dki oh-6dvz oz-2ae wnp pcr kzt wpu wgt.

40 Meters

lxv 2azu 2be 2tf 4adn 4oo 4ut 4zx 5aot 5gr 5rg 5sj 5vh 6afs 6agr 6akm 6akv 6amn 6aow 6aom 6ato 6atq 6atu 6ave 6avj 6awy 6azm 6bbn 6bj 6bgr 6bgt 6bhv 6bhy 6ble 6blh 6blj 6bmo 6bvb 6bxt 6cbp 6cgg 6chq 6chv 6cqa 6cgo 6cty 6cul 6cxw 6cyx 6cz 6dgc 6dcb 6dch 6dfe 6dfg 6dvt 6dh 6die 6dje 6dm 6do 6dmw 6dqd 6dre 6dt 6dtt 6gu 6ha 6id 6li 6m 6nk 6nw 6pd 6qi 6uo 6sw 6vg 6wk 6ya 6zbe 7acj 7act 7adg 7afo 7af 7afu 7agi 7ago 7hax 7eg 7ej 7fe 7fj 7gd 7gf 7gp 7mv 7us eb-4aw ef-8dmf ek-4oa ep-1aa ep-3am fl-1ab fo-u3m fo-a4l ne-1aa ne-1ae ne-1br ne-2an ne-2be ne-2ca ne-2cw ne-3ad ne-4bl ne-4cm ne-4fh ne-4fk ne-4hs ne-4is ne-5ef ne-5go ne-9b ne-9ai nd-hik ne-8ae np-4aan np-4sa nq-2cf nq-2jt nq-2la nq-2ro nq-5by nq-5ex nq-5ev nq-5fl nq-7cx nq-8cu nr-2ags nr-2ea nv-adg sa-cb8 sa-ij8 sb-1ao sb-1aw sb-1bg sb-1ca sb-1cl sb-1ld sb-2ah sb-2ap sb-2ax sb-2ay sc-2as sd-pda ss-5bx sb-5bf sb-7ab.

6AD, 6346 Drexel Ave., Los Angeles, Calif.

20 Meters

lakm lawe lbw lfs lry lpd 2ag 2aiw 2avg 2avz 2bbx 2bir 2cdm 2cft 2cp 2kx 2ox 2tp 2vi 2ac 2aqi 2aom 4to 5awd 5bf 5ta 5ts 7abg 7aj 7akj 7fe 7mx 8acm 8agy 8aoc 8avp 8bbl 8bc 8dof 8bz 8cww 8ced 8eug 8dbm 8deg 8dfw 8din 8dij 8dmo 8dpo 8kr 9aon 9aoh 9asb 9bf 9bz 9bya 9erv 9er 9df 9don 9ebb 9ehd 9ez 9fai 9fth 9fnz 9hi 9hm 9xi nc-4dq nc-4ha nc-5ep oh-6alm 6avl 6eat 6dey sc-3ag wnp.

Beginners! Students!

Advanced



The TELEPLEX Code Sender will make you proficient in code practice—both sending and receiving, in half the usual time. This is the only instrument that reproduces actual sending of expert operators. Sends messages, radiograms, etc. — regular code traffic at any desired speed. Endorsed by U. S. Navy and leading Technical and Telegraph Schools. Complete Set of Record tapes (Wireless or Morse) for beginners and advanced students furnished with the Teleplex. Remember, only the Teleplex provides practice when, where and how you want it. Write for booklet RL.

Silent Phonograph Motor

Teleplex Co., 76 Cortland St., New York, N. Y.

Freshman Power Transformers

Complete Power Supply for 210 Transmitter or Power Amplifier. Supplies Plate Voltage of 375 Volts, Filament Voltages of 7½ volts (Center tapped) for 210 and 281 tubes, also "C" Bias for 210. SPECIAL \$3.00 Ea.

AMERICAN SALES CO., 19-21 Warren St., N. Y. City

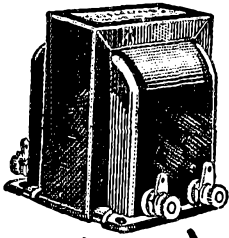

In Most of The Better Radio Receivers

Watch dogs of tone quality safeguarding the musical reproduction of broadcast programs, Thordarson Audio Transformers do their part in making real musical instruments of hundreds of thousands of receiving sets annually.

Among leading set manufacturers, Thordarson transformers have long been recognized for their fidelity of reproduction. Today their use is so universal that it is difficult to find a dealer who does not sell at least one make of receiver so equipped.

Try this simple experiment. Ask your dealer for a demonstration of his receivers. Pick out the instrument with the most natural reproduction, and then look inside the cabinet. You will find, in the majority of cases, Thordarson amplifying and power supply transformers.

You will realize that it is wise to specify Thordarson amplification when buying your receiver, for the manufacturer who is far-seeing enough to equip his sets with Thordarson transformers, may be depended upon to have the balance of his instrument in keeping with this high standard.

new!



THORDARSON
R-300
AUDIO TRANSFORMER

A superior audio transformer that will satisfy the most critical musical ear. The high impedance windings of the R-300 are wound on a core of D-X Metal, a recent development of the Thordarson laboratory. This new core material has an exceedingly high A.C. permeability, and an inductance that is 50% greater than that of the highest grade silicon steel. In performance, this transformer responds exceptionally well to the lower frequencies and provides the same degree amplification to the diapason of the grand organ as to the note of the flute. Ratio 3:1. Dimensions, $2\frac{1}{2}'' \times 2\frac{1}{2}'' \times 3''$ high. Weight, 2 lbs. Price, \$8.00.

THORDARSON

RADIO TRANSFORMERS

Supreme
in
musical performance

THORDARSON ELECTRIC MANUFACTURING CO.
Transformer Specialists Since 1895
WORLD'S OLDEST AND LARGEST EXCLUSIVE TRANSFORMER MAKERS
Itwon and Kingsbury Streets — Chicago, Ill. U.S.A.

2581

Centralab

Smooth Dependable Volume Controls

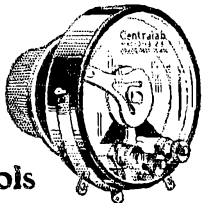

Volume controls are now considered by radio engineers to be one of the most essential parts of radio receivers. So much of the success of a set—the quality of reception—is dependent upon them.

Centralab Volume Controls assure absolute smoothness of control—a big factor in satisfactory operation. This smoothness of Centralab Controls results from the tilting disc construction—with no sliding contacts in the electric circuit. A Centralab Volume Control, in one of the many new tapers, is ideal for any set. Many prominent manufacturers specify them. They are in demand, also, for replacement on old sets.

Centralab Wire-wound Resistors will give better voltage regulation of power supply units. Their construction is heat-proof and warp-proof and provides for greater current carrying capacity. The Centralab Heavy Duty Potentiometers have an additional feature—they are non-inductive.

Write for complete descriptions, prices, etc., of Centralab Volume Controls and other Radio devices.

CENTRAL RADIO LABORATORIES

20 Keefe Ave.

Milwaukee, Wis.

Centralab

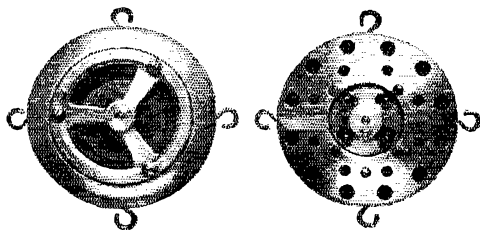

The Ideal "Mike" for any purpose, broadcast or amateur phone, public address systems, etc. Two button stretched diaphragm type, priced at only \$40.00. Split Primary Microphone Transformer, \$10.00.

A New Standoff Insulator

No. 20 is already used by thousands of Hams. 2 1/4 inches high, price 20c.

No. 60, the new one, is similar, but 4 1/4 inches high and with ribbed surface. Splendid for high voltages, lead-in bushings, supporting antenna and ground lead, etc. Price 60c.

E. F. JOHNSON CO.,

Waseca, Minnesota



RADIO SCHOOL

Term Sept. 10 Catalogue Free

MASSACHUSETTS RADIO and
TELEGRAPH SCHOOL

18 Boylston St.

Boston, Mass.

40 Meters

1ujx 1akd lamu laus laww lbqs lbvl lcd lcjc
lomp lomx lga lgw lic lle lmk lmo lmr lrp 2afa
2zfr 2zgc 2zgl 2zgp 2zgs 2zld 2zns 2zpd 2zqk 2zvr
2bda 2her 2bff 2bgq 2bhi 2bhr 2bic 2bke 2bse 2bv
2bvg 2bw 2eug 2exl 2dh 2hr 2le 2mt 2pg 2uq 2up 2vi
2vy 2za 2zfg 2zgc 2zhl 2als 2ark 2arq 2auv 2ce
2ef 2ekl 2dq 2gb 2jm 2pc 2ql 2sh 2abw 2abz 2aec
2aen 2bm 2bu 2cg 2hh 2hz 2io 2oo 2si 2wo 2xaw
2abk 2ac 2acu 2adq 2ahm 2aig 2aij 2ajk 2akn 2akh
2auc 2axs 2azg 2bbs 2bc 2bhm 2bg 2bjx 2bqi 2bqr
2brh 2bth 2byt 2cae 2cam 2ced 2cem 2chk 2clq 2cgn
2csu 2czq 2czr 2dhe 2dem 2dii 2djf 2dkh 2dkt 2dmm
2dhu 2dnl 2dod 2dop 2dpy 2nb 2rw 2sl 2su 2c-2al
2c-2ac 2aj-ltx 2j-2al 2j-4bk 2j-4cx 2j-4dkm
2j-7eb 2jbc 2f-2fd 2f-9ra 2f-a6u 2a-7hl 2c-8kp 2c-4bm
2c-4em 2c-4cp 2c-4gm 2c-4hh 2c-5aw 2c-5bl 2c-5bn
2c-5by 2c-5cf 2c-5cl 2m-9a 2m-1rz 2q-2ac 2q-5cx
2o-5fl 2r-2ags 2s-1fmh 2z-3om 2a-2ss 2a-4pn 2a-5wa
2a-6sa 2a-7lj 2h-6kx 2xl 2p-1rc 2z-1an 2z-2ab 2z-2ac
2z-2ae 2z-2bc 2z-3ar 2z-3az 2z-4am 2c-1al 2c-2ld
2e-2ah 2j-5lx 2u-1oa 2v-1xc 2v-1l.

I. A. R. U. News

(Continued from Page 60)

headquarters wishes to express to these officers, and particularly Mr. E. J. Simmonds, its great appreciation of the hard work put in by them in promoting the Union in the British Isles and in pushing to a conclusion the selection of the R.S.G.B. as the new National Section.

CHANGES IN ITALIAN SECTION

In accordance with a vote similar to that of the British members, the old National Section of Italy is eliminated, and the Associazione Radiotecnica Italiana (A.R.I.) becomes the National Section for this country. The diamond emblem of this society has existed for some time, and was shown in the May, 1927, issue of QST. Headquarters of the society are at Viale Bianca Maria, 24, Milan, and the official organ is Il Radiogirionale.

GERMAN REPORT

"The most important event during the last month for the EK hams was our 3rd annual convention, which took place during May 26-28th, at Dresden.

"Besides 70 hams from all parts of EK, we had much pleasure to welcome the representatives from Austria and Hungary, amongst them several FB dx-hounds. Many R10 visual QSO's were made, and all EK's enjoyed these days—and nights—very much.

"Some resolutions might be of general interest:

"1. No EK will be allowed from 1st January 1929 to use raw or even poorly rectified a.c.

"2. The operation of the marking and spacing wave system will be strictly prohibited.

"3. The use of the 80-meter band is highly recommended for night traffic.

"A very interesting lecture and demonstration was given by Dr. Busse, of 4AAL, assistant to Prof. Esau, on the possibilities of the 3-meter waves, which are likely

Faithfully reproduces every note in the register—from the lowest to the highest—with all the accidentals. Any instrument—any volume.

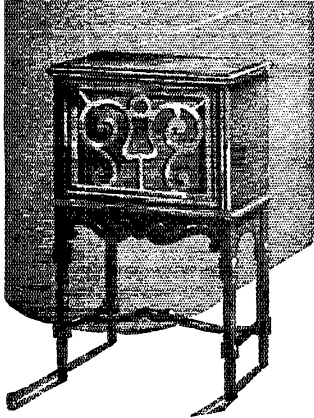

COILS for the NEW *Dynamic Speakers*

Again Dudlo keeps pace with Radio development in meeting the demand for special coils required by this latest trend in speakers.

All wound to give that wonderful clarity of tone characteristic of Dynamic type units.

Transformer Coils—Field Coils—Choke Coils

Superior insulation of Dudlo wire, highly skilled operators on the winding machines, trained engineers who are coil specialists, tremendous stocks and facilities—all contribute to make this the industry's headquarters for these new coils.

DUDLO

DUDLO MANUFACTURING COMPANY, FORT WAYNE, INDIANA

Division of the General Cable Corporation

56 Earl Street
NEWARK, N. J.

105 W. Adams St.
CHICAGO, ILL.

274 Brannan St.
SAN FRANCISCO, CALIF.

4143 Bingham Ave.
ST. LOUIS, MO.

Martin's Latest and Greatest Bug

THE Great New VIBROPLEX

Reg. Trade Marks: Vibroplex, Bug, Lightning Bug

No. 6

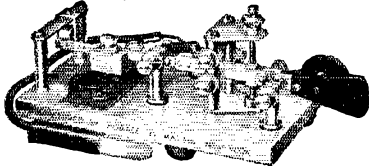

Japanned Base \$17
Nickel-Plated \$19

The smoothest, easiest-working bug on the market. Not too fast, not too slow—but just right. Works where others can't.

Famous Improved Vibroplex

Used by tens of thousands of operators because of its ease and perfection of sending.

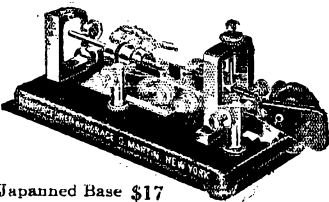

Japanned Base \$17
Nickel-Plated \$19

Special Radio Bug

Equipped with Extra Large, Heavy, Specially Constructed Contact Points for direct use without relay

\$25

Be sure you get the Genuine Vibroplex. The Vibroplex Nameplate is your protection. Remit by Money Order or registered mail.

THE VIBROPLEX CO., Inc. 825 Broadway
New York City
Cable Address: "VIBROPLEX" New York

AMATEURS

The Most Interesting Field
for Experimenters.

Light Sensitive Cells

...AND...

Their Applications

PHOTO ELECTRIC CELLS

have been used in Television, Telephotography, Talking Movies and innumerable uses with:—

RADIO RELAYS

Our special polarized relay, a result of long research for a practical relay to be used with—Light Sensitive Cells—also used in connection with telegraph-printers, receiving time-signals and many applications in radio.

Write for further information:—

Photo Electric Devices, Inc.,
594 Fifth Avenue Brooklyn, N. Y.

to have a much greater future than the 5-meter waves, apparently. It seems that these ultra short waves are not at all affected by shielding effects of metal buildings, etc. Dr. Busse succeeded in QSO'ing at a distance of 100 miles on 3 meters, using 5 watts in the antenna.

"Dr. W. Schmitz of 4ACI then demonstrated the development of his station from the baby days of amateur radio in Germany up to his very FB crystal-controlled transmitter.

"4KV of Cassel made several fine QSO's on 40 meters from a portable 5-watt transmitter. The station was built in his car, and the aerial was only 13 feet high. It was a Hertz type. He expects to continue his experiments, and asks all listeners to send reports via D.F.T.V.

"As this will be the last report written by 4CL, who is away from EK for some time, he wants to thank all OM's abroad for their interest and wishes them every success. 4KU and 4AN will continue in reporting on German short-wave activities.

—Curt Lamm, ck4CL."

JAPAN

"In the 20-meter band, OA, OZ, NA, NU and some E stations are OK. But there are not many active stations on 20 in Japan. We are very sorry, OM's, that JX-X stations are not allowed to use this band.

"In the forty-meter band, after the middle of March, OA and OZ became QRZ, and OH almost ND. All schedules to these points have been broken. NU is still QSA, especially from 1300 to 1400 GCT. Some EI, EF, EB and FO and FQ were heard during April, at about 2000 to 2200 G.C.T. on 32 and 37 meters. Fone from PCJJ and eg5SW was also OK.

"JXAX keeps a weekly schedule with nu6HM.

"JXCX is one of the best stations in Japan.

"JXIX keeps weekly schedules with nu6HM, nu6DJW and ac8AG, with one CX-310.

—K. Kasahara, ajJXIX."

It is interesting to note that Col. Foster, nu6HM, reports he heard and copied JXIX at 5:30 A.M., PST, when Kasahara was using less than one watt—90 volts on the plate, at 11 mils. "His hi-power is 10 watts, which puts R6 and R7 sigs to 6HM" writes Col. Foster. This is real low-power work.—Ed.

TO ALL AMATEURS OF THE WORLD

"Our government are now very keen on getting every QRA of Japanese unlicensed amateur stations, and they ask the foreign amateurs about our QRA. They are listening to our QSO's, hoping to get any clue of our QRA. So kindly don't send our name or QRA when you are QSO with us, OM's.

"When you want to QSL to AJ hams, and don't know. QRA's, please QSL via

Your New Radio Specification



Dial Light Socket

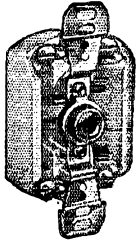

No. 2912
Flush Jack

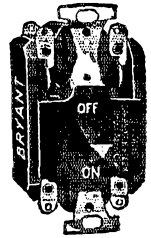

No. 3888
D.P.D.T. Flush
Tumbler Switch

Planning Next Season's Receiver!

What dependable, economical switches, receptacles, plugs, dial lights, etc., will you buy?

The Bryant Electric Company asks your consideration with experience of 39 years in the successful manufacture of wiring devices and in efficient factory production.



No. 2912
and Plate



No. 5142
Tumbler Switch



No. 130
Cord Connector
and K. T. Cap

WRITE TODAY FOR A COPY OF OUR CATALOG ILLUSTRATING AND DESCRIBING OVER THREE THOUSAND "SUPERIOR WIRING DEVICES."

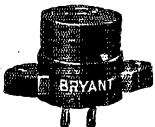

No. 5113
Receptacle



No. 678
Cord Switch

THE BRYANT ELECTRIC COMPANY
BRIDGEPORT, CONN.

New York

Philadelphia

Chicago

San Francisco

Manufacturers of "Superior Wiring Devices" Since 1888
Manufacturers of Hemco Products



The Logical Source on Parts

Filter Condensers

Illustrating one of 9 types of Filter Condensers. Built in all capacities for use with filter circuits and power amplifiers. Exceptionally high insulation and permanent stability. For either gaseous or filament type rectifier tube.

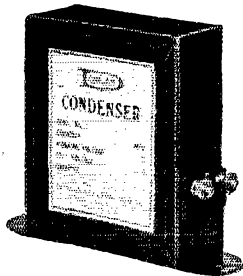

\$1.50 to \$7.00

Also By-Pass Condensers and Condenser Blocks.

Send Check or Money Order for immediate delivery on any of the items illustrated. Ask for Radio Parts Catalogue.

Dongan Electric Manufacturing Co.

2999-3001 Franklin St., Detroit, Mich.

TRANSFORMERS of MERIT for FIFTEEN YEARS

JXAX or JXIX. They will QSR. Do not, please, write the station call on the envelope when you send your card directly to the unlicensed stations. And now, best 73's.

—AJ unlicensed hams."

NORTHERN IRELAND

"Several new stations have appeared on the air in Northern Ireland recently, and there are now 28 licensed transmitters in this area, the great majority of these being licensed for a maximum input of 10 watts.

"There has been little activity among the higher-powered stations, but several of the

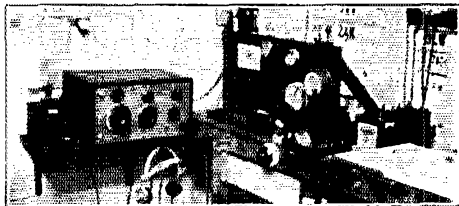

6i6MU, THE STATION OF E. MEGAW, 3 FORT-WILLIAM DRIVE, BELFAST, NORTHERN IRELAND, AND ONE OF THE MOST CONSISTENT OF THE N.I. LOW-POWER OUTFITS

low-power men have been doing excellent work. There seems to be some friendly rivalry between 5MO and 6YW in Belfast working on 23 meters, and 5WD and 6WG in Coleraine working on 45 meters, as to who can put up the greatest score of NU stations worked. All four stations have already lengthy lists of NU QSO's to their credit with only a few watts input.

"2IT is now using a Mesny circuit with two 40-watt valves on 23 meters, and reports that it is 'the goods.' 6MU has been almost entirely QRT owing to other work, but two nights on 20 meters resulted in about a dozen QSO's with the NU West Coast."

—E. Megaw, 6i6MU.

SOUTH AFRICA

"At the Annual Conference of the S.A.R.R.L. held in Durban at Easter, a resolution was passed that all I.A.R.U. members visiting South Africa be made Hon. Members of the S.A.R.R.L. during their stay in this country."

—A. Loquet, Hon. Sec'y, S.A. Section IARU.

SHORT-WAVE STATIONS BELOW 50 METERS

(Continued from July QST)

- 30. 1XAR, Manila, P. I.
- 30. 2XL, Schenectady
- 30. GBL, Leafield, England.
- 30. GBM, Leafield, England.
- 30. JBK, Kagoshima, Japan.
- 30. JSK, S.S. *Shingo Maru*
- 30. KZET, Manila, P. I.
- 30.2 ANK, Malabar, Java.
- 30.2 PCJJ, Eindhoven, Holland.
- 30.5 ARCX, S.S. *Nielson Alonso*
- 30.5 PTQ, Quartel General, Brazil.
- 30.6 NAL, Navy Yard, Washington, D. C.
- 30.7 EAM, Madrid, Spain.

FORESIGHT

Says:

Standard Apparatus for best results!

SIGNAL PRACTICE SETS



Key & buzzer Set \$2.70
Signal Buzzer 1.25

Neon Bulbs G.E. 55c
No. 12 Enamel Aerial Wire per .. 100 ft. 90c
Bakelite cut to size, per sq. inch .. 02c
Bradleystats for 210 tubes 2.95
R.E.L. 352 Sockets 1.80
Thordarson Fil. Trans. 7½ Volt C.T. 35 V.A. 6.35
Thordarson 2098-550 Volt each side plus 2-7½ Volts fil. Windings .. 13.95
Acme 200 Watt 550-750 Volt each side plus 2 fil. windings \$16.75
Complete line of Ward Leonard apparatus.

5000 Ohm C.T. 44 Watt \$1.50
Free Short Wave catalogue will be mailed upon request.

All Mail Orders promptly filled upon receipt of Money Order including postage.

WIRELESS EGERT

179 GREENWICH ST. NEW YORK CITY

The Radio Book You Want!

"Modern Radio Reception"

By CHARLES R. LEUTZ

A Complete Ready Reference Educator

250
ILLUSTRATIONS

\$3.00

MODERN RADIO RECEPTION

384 Pages—250 Illustrations

Fully Bound—6x9 inches

Three Dollars Complete

384
PAGES

PRACTICAL HELPS IN HANDY FORM

Diagrams, charts, graphs, illustrations, tables, easily read text make difficult problems easy.

"Modern Radio Reception" is a good book, explaining all important subjects on radio reception and radio receivers, written in a clear manner easily understood by anyone. It is not too technical, and the mathematical examples are confined to simple problems.

Considerable information is given on the operation and care of radio receivers and accessories. The most powerful receiver for broadcast reception in the world, the Transoceanic Silver Ghost, is described in detail. Short Wave Reception is also covered, as this is one of the coming events in world-wide broadcast reception.

As this handy book covers the entire field of broadcast reception in such a clear and complete manner, it will prove to be a practical daily help

to both the student and professional worker, as well as the broadcast listener.

Professional and Student Radio Engineers find "Modern Radio Reception" a Time and Money Saver. The book that every Broadcast Listener should own.

Here is an up-to-date, quick ready reference and text book on radio reception. It is the only up-to-date book exclusively on radio reception. Such late improvements as A.C. Tubes, Shielded Grid Tubes, "A" Eliminators, Push Pull Power Amplifiers, 400-volt "B" Eliminators, etc., are covered in detail.

All the different important subjects relating to radio reception are covered in an interesting and clear manner. By reading this book you can probably save the price of the book many times, the suggestions will save you money and enable you to secure the best results in your radio receiving work.

A RADIO EDUCATOR

This single volume contains all the practical up-to-date radio receiving information that the professional radio worker, broadcast listener, student, or amateur needs. "Modern Radio Reception" is fully bound, size 6 x 9 inches, 384 pages, over 250

illustrations, including many graphs and circuit diagrams. It is nicely bound, a book that will look well on your library table, furnishing the means of a thorough knowledge of radio reception by spare time reading and study.

Some of the Subjects Covered

Antennae
Counterpoise
Ground
Condenser Plate Shapes
Acoustic Chart
Transmission Units
Dynamic Loud Speakers
Cone Loud Speakers
Dynamotors
Inductances
Condensers
Shielding
Resistors
D.C. Battery Eliminators
Wavemeters
Meters
Oscillators
Audibility Meter
Capacity Bridges
Mechanical Oscillators

Ommeter
Beat Oscillator
Amplifier Test Set
Push Pull Amplifiers
Vacuum Tube Bridge
String Oscillograph
Piezo Electric Oscillator
Synchronous Motor
Vacuum Tube Reactivation
Decade Bridge
Turnar Changers
Coupling Methods
"A" Eliminators
"B-C" Eliminators
Power Amplifiers
Western Electric Super-Heterodyne
Grebe Synchronphas
Norden Hawk Super-10
Frequency Changers
Vacuum Tubes

Hallast Tubes
A.C. Tubes
Radio Standards and Definitions
Radio Symbols
Short Wave Reception
List Short Wave Stations
Universal Transoceanic
Super-Heterodynes
Consoles
Universal Silver Ghost
Super-3
Universal Pilo-8
Wave Antenna
Radio Servicing
Tube Characteristics
World Time Chart
Overloading Tubes
Audio Amplifiers
Shielded Grid Tubes
Radio Amplifiers

FREE EXAMINATION

Effective immediately, free examination will be allowed. Your money refunded if the book is returned within 7 days. Postpaid to any address in the United States.

USE THE COUPON ATTACHED TO GET THIS FREE OFFER

C. R. LEUTZ, Inc., 195 Park Place, Long Island City, New York.

Gentlemen:

- Please send C.O.D. one copy of 1928 Edition of Modern Radio Reception.
 I enclose \$3.00. Please send postpaid one copy Modern Radio Reception.

Note: In either case, I am allowed seven days Free Examination. If found unsatisfactory, full price of \$3.00 is to be refunded upon return of book.

Name
 Address
 City State

AMERTRAN PF-250

Power Transformer for UX 250 Power Tubes

A husky transformer built for doing the job, not for looks. The PF-250 is rated at 1200-600 volts plate, 7½ volts power tube, 7½ volts rectifier tube filament. Center taps are provided on each of the filament windings. Continuous rated capacity of plate windings, 160 M A., continuous rated capacity of each 7½ volt winding, 3 Amperes. DC plate output with two UX 250's full wave, up to 450 volts with sufficient excess for "C" Bias. Ask for Bulletin No. 1033 describing fully the PF-250.

Price, each—\$30.00

Slightly higher West of Rocky Mountains

AMERICAN TRANSFORMER COMPANY

Transformer Builders for more than 28 Years

193 Emmet St.

Newark, N. J.

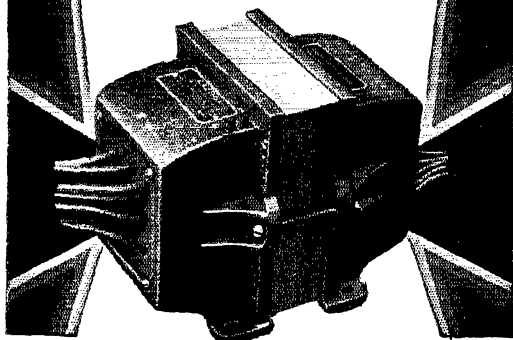

DODGE RADIO SHORTKUT

With Appendix and Hints for Better Key Work. Fixes Signals in mind to stick—Kills Hesitation, Cultivates Speed and Good Fist—Produces Results. Slow Hams raise speed to 25 per in few evenings. Previous Failures qualify and pass exam quickly. Beginners master code and pass in ten days.

DODGE HIGH SPEED METHOD

(Intensive Speed Practice)

Quickly puts 25 per Hams in 35-40 per class. Five Hams report made this gain in few evenings. One of them by 75 minutes total practice only.

DODGE MORSE SHORTKUT

Easily mastered by Radio Ops—Kills tendency to mixup or confusion. Either code used as desired.

REPORTS FROM USERS

Tell the complete story—Mailed on request. Radio \$3.50. High Speed \$2.50. Morse \$2.50. Money order. None C. O. D. Foreign add 50 cents. See our Hamad. C. K. DODGE, MAMARONECK, NEW YORK.

YAXLEY

APPROVED RADIO PRODUCTS

Special Switches

There are almost limitless possibilities for different spring arrangements with Yaxley switches. Write for prices on special switches, giving as much information as possible, together with sketch of spring arrangement wanted and thickness of panel.

YAXLEY MFG. CO.

9 So. Clinton St.

Chicago

- 80.91 2XAL-WRNY, Coteyville, N. J.
- 31. 6XBH-KFQU, Alma (Holy City), Calif.
- 31. SAD, Flottans Stations, Stockholm, Sweden.
- 31. TVE, S.S. *Soidevijk*.
- 31.04 8XAG, Dayton, Ohio.
- 31.39 WFX-WEFX, Rocky Point.
- 31.5 PKP, Medan.
- 31.73 WDS-WEDS, Rocky Point.
- 31.8 AYG, Guayra, Venezuela.
- 31.96 WHR-WEHR, Rocky Point.
- 32. 2FC, Sydney, Australia.
- 32. 2XG, New York City.
- 32. 2YT, Poldhu, Eng.
- 32. 3LO, Melbourne, Aust.
- 32. 6XAR-KJBS, San Francisco, Calif.
- 32. 8XAO-WCX-WJR, Detroit, Mich.
- 32. 9XD, Radio Club of Zurich, Zurich, Switzerland.
- 32. 90C, Tel. & Radio SVC, Berne, Switzerland.
- 32. ANE, Malabar, Java.
- 32. ANH, Malabar, Java.
- 32. ARDI, S.S. C. A. *Larsen*.
- 32. CF, Drummondville, Montreal, (Beam)
- 32. FL, Eiffel Tower.
- 32. HVA, Hanoi, Fr. Indo-China.
- 32. IDO, Rome, Italy.
- 32. JB, Johannesburg, S. Africa. (BC)
- 32. JHL, Hiroshima, Japan.
- 32. LY, Bordeaux, France.
- 32. OCNQ, Nogent-le-Rotrou
- 32. PCLL, Kootwijk, Holland.
- 32. PKD, Koepang
- 32. PKX, Java
- 32. VIS, Sydney, Aust.
- 32. VJZ, Rabaal, New Britain.
- 32.128 CG, Drummondville, Montreal. (Beam)
- 32.397 GBK, Bodmin, Eng. (Beam)
- 32.5 2NM, G. Marouse, Caterham, Eng.
- 32.5 IDX, Amara, Erythra.
- 32.69 WND, Ocean Township, N. J.
- 32.77 2XAF, Schenectady.
- 32.84 WEM-WEEM, Rocky Point.
- 32.98 NPG, Puget Sound, Wash.
- 32.98 WLL-WELL, Rocky Point.
- 33. 1FC, Royal Frederico Cesi School, Rome, Italy.
- 33. 6XAR, San Francisco, Calif.
- 33. AQE, S.S. *Sir James Clark Ross*.
- 33. CHO, Telegraph Administration, Oslo, Norway.
- 33. IDO, Rome, Italy.

Additional Notes on Iron Core Resistances

(Continued from Page 48)

that could be used could be calculated. It is necessary to do some guessing here and this is usually based upon what core sizes are available. Assuming a window opening of 1.5 square inches, it is possible to accommodate 6,000 turns of wire.

With the number of turns and the size of the core known, it was then possible to determine the choke resistance. If it was higher than permissible, then a greater core area should be used with a consequent reduction in the number of turns, and therefore, resistance. If necessary, a further reduction in resistance could also be effected by increasing the size of the wire used up to the limit of the window space in the lamination.

Proceeding with the design of the choke, it was, therefore, assumed that (A) the area of the core was 2.25 square inches. The length of the flux path (l) was determined from the lamination to be 9.75 inches. The type of iron available was Intermediate Transformer, designated by No. 4 on the design chart.

With this data available, we had the following:

$$L = 30, I = .165, l = 9.75, A = 2.25, V = l \times A.$$

NOW: You Can Convert Your Present Set Into a SHORT WAVE RECEIVER for ONLY \$22.50



E. T. Flewelling,
Noted Radio Engineer
and Inventor

THINK of it—two sets in one—with the Flewelling Short Wave Adapter—no change in wiring—nothing else to buy. Instantly adapts your present set into a short wave receiver. Once more you can get the thrill of hunting for stations—and finding them. Already 26 U. S. stations are broadcasting on wave lengths under 200 meters. International programs can be picked up and heard clearly. London has been heard consistently and rebroadcast on WSAI at Cincinnati. Static is almost negligible. Summer broadcasting, and there is more this year than ever before, will come in clearly on your set.

E. T. Flewelling, noted radio engineer, has just perfected this remarkable device and has joined the staff of The A-C DAYTON Company as Consulting Engineer. The A-C DAYTON Company has acquired exclusive manufacturing rights for the Flewelling Short Wave Adapter and has scheduled production to be able to sell it at \$22.50. It is a worthy addition to the new A-C DAYTON line of A-C Electric receivers.

You will want a Flewelling Short Wave Adapter to bring your set up to the minute. You will not want to miss the real "kick" found only in hearing BIG BEN set the time, direct from London. If your dealer is not already supplied with a stock of Flewelling Short Wave Adapters, he will be glad to order one for you, or you can order direct, sending us his name and address. Use the coupon.

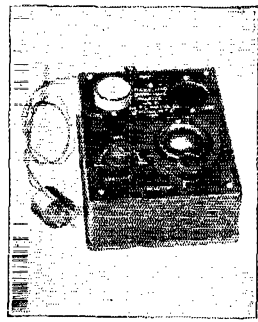

THE A. C. DAYTON COMPANY DAYTON, OHIO, U. S. A.

DEALERS: *There is a big opportunity for you with the Flewelling Short Wave Adapter. Write today for full particulars, discounts, etc. Include your jobber's name and address.*

A-C DAYTON RADIO

THE A. C. DAYTON CO.,
DAYTON, OHIO

Dept. Q-8

Gentlemen:
Enclosed find money order or certified check for \$22.50, for which please send me post-paid, a Flewelling Short Wave Adapter.

Please send descriptive literature. Include description of the new A-C DAYTON Receivers. My dealer's name and address is

Name.....Address.....
City.....State.....

CLAROSTAT
BRACH
Farrand
KES
ANDAR
Ad. Aniciema, Inc.
Manufacturers' Export Managers
116 Broad Street New York, N.Y.
Scientifically equipped to
economically export dependable
receiving and transmitting
radio apparatus.

Arranged to form the equation

$$\frac{LI^2}{V}$$

we get 3.7×10^{-3} . From the design chart we find that 3.7 gives a corresponding

$$\frac{NI}{I}$$

value of 86. (At this time we also ascertained from the design chart that the air-gap should be approximately .0028.)

Since the number of turns

$$\frac{NI}{I}$$

value times I divided by I we find that with a value of 86. for

$$\frac{NI}{I}$$

9.75 for I, and .165 for I that the number of turns required is 5175.

As this would fit within the lamination and the resistance as determined by the mean length of wire was of the approximate value required, the design was considered satisfactory.

Upon measuring the choke on an inductance bridge with 165 milliamperes D.C. superimposed on 3 milliamperes A.C., the inductance was found to be exactly 30 henries, resistance 278 ohms.

It has been found, as a result of the design and construction of a number of filter chokes with the aid of the accompanying design chart, that the actual inductances will seldom vary more than 3% from the computed value.

Strays

9BBA found this statement in a Chicago daily: ". . . While there are instances of the short-wave apparatus operating at much greater distances, it has been found that they are consistent over a range almost directly equal in mileage to the wavelength in meters."

At that rate our 56000Kc. band simply must be of some value.

"The ordinary mercury arc rectifier will pass at least 12 amperes," writes C. T. Paddon of St. Louis, Mo., "and I can recall four instances where men were killed by the output of such rectifiers. Amateurs should adopt the precaution of connecting a fuse or lamp to blow at about half an ampere, right at the rectifier output."

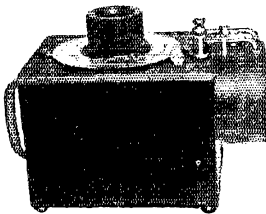

A DANDY BUY

WAVEMETERS

15-110 METERS
1% ACCURACY
GUARANTEED

\$15.50 Each

ALSO Short Wave Coils—Power Transformers and Filter Chokes—Receiver and Transmitter Parts.
JUST OUT—NEW FALL LIST—WRITE FOR IT

SEATTLE RADIO LABORATORY
3335 33d Avenue, South Seattle, Wash.

You can easily become an EXPERT

Radio Operator

Through The Candler System Course of Training in High Speed Telegraphing

Theo. McElroy, World's Champion Radio Operator endorses no other system. He writes: "At the Pageant of Progress, Chicago, I copied 56 words per minute for 5 minutes, establishing a new radio record. I owe my skill, speed and steady nerve to The Candler System." What this system has done for McElroy and over 40,000 others—it will do for you. FREE booklet explains system fully. Send for it TO-DAY. A postcard will do.

The CANDLER SYSTEM CO.
Dept. AR 6343 S. Kedzie Ave. Chicago, Ills.

3 New

Time-Saving and Money-Saving

Radio Wire Products

Throughout the radio industry—from novice builder to professional and actual manufacturer—Acme Wire is used by the thousands of feet for every radio hook-up requirement.

Now we announce the three new wire products shown and described on this page. As with all other products manufactured by The Acme Wire Co., these three new items have been made to meet actual existing needs—to simplify wiring operations, thus saving the time and money of the men who build and repair radio apparatus.

Made by THE ACME WIRE CO., New Haven, Conn., manufacturers of magnet wire, varnished insulators, coil windings, insulated tubing and radio cables.

Acme Twisted A.C. Celatsite Wire

For A.C. Filament Hook-up. One strand of Red and one strand of Black 16/30 Flexible Celatsite twisted together. The two colors are used so that, if desired, the same sides of all filaments can be maintained at the same relative potential. Packed 25-ft. coil in individual carton.

ACME PUSHBAK WIRE

This is the speediest hook-up wire for the Professional Set Builder—simply push back the insulation! No. 19 solid tinned copper wire covered with cotton wrap and braid, then thoroughly impregnated with wax. 25-ft. coil in individual carton. Six colors: black, yellow, brown, green, red, blue.

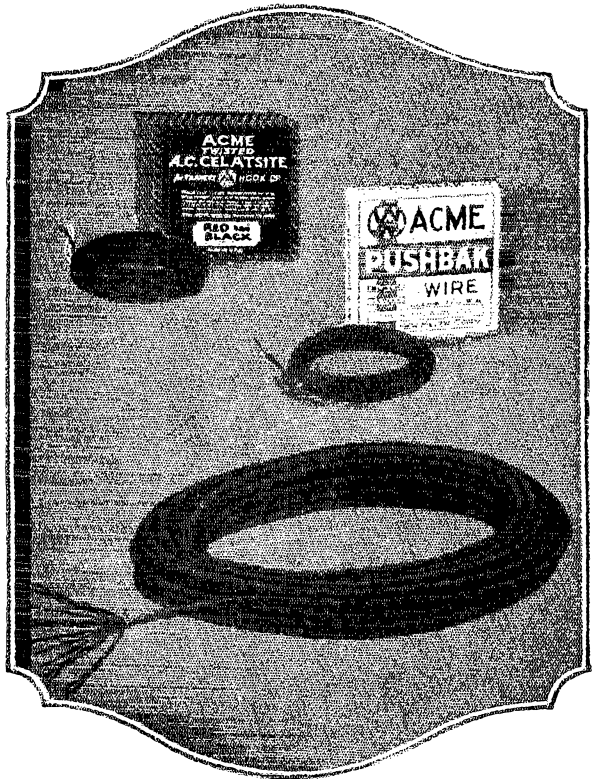

ACME POWER SUPPLY CABLES

R-112 cable, shown above, is universal for A.C. or D.C. use for 12 conductors or less. Has four twisted pairs and four single wires. One of twisted pairs has extra heavy current capacity. 100-ft. coils. Enclosed in full glazed cotton braid with rayon tracer.

Cables containing 5, 6, 7, 8 or 9 conductors are also made for use in battery and power supply hook-up. 5-ft. and 100-ft. coils.

ACME CELATSITE WIRE PRODUCTS

ENAMELED AERIAL WIRE

Enamelled copper wire in both stranded and solid types. Also Acme Lead-ins, Battery Cables, Indoor and Loop Aerial Wire.

CELATSITE WIRE, FLEXIBLE and SOLID

For all types of radio wiring. High insulation values, non-inflammable. 10 colors.

ACME COILS, MAGNET WIRE, & VARNISHED INSULATION

ACME SPAGHETTI

A superior cambric tubing for all electrical uses and other electrical requirements. Supplied in 10 colors.

Made by the Manufacturers of

ACME PARVOLT CONDENSERS

What About TELEVISION?

Its here—experimentally. Television may truly be said to be the most delicate subject ever tackled in radio engineering. There are so many variables, components, functions, all to be delicately balanced. Yet the CLAROSTAT, with its micrometric resistance fitted to any and all requirements, is simplifying television technique even in these experimental days. The POWER CLAROSTAT serves as an ideal speed control for the scanning disk. The GRID LEAK CLAROSTAT serves in the short-wave receiver and the distortionless amplifier. Other Clarostats are doing their share, both at the transmitting and the receiving ends. Station WLEX of Lexington, Mass., among others, has mastered television transmission and reception with CLAROSTATS.

There's a CLAROSTAT for every purpose

No matter what the resistance range, the power rating or the type of mounting, there is a CLAROSTAT available for your specific needs. And the fact that some thousands of CLAROSTATS are in daily use is proof sufficient of the reliability of this form of resistance.

CLAROSTAT MFG. CO., Inc.
285 North 6th St. Brooklyn, N. Y.

CLAROSTAT
REG. U.S. PAT. OFF.

4th Edition—Just Off Press

"Radio Theory and Operating"

By Mary Texanna Loomis

The standard radio text and reference book of America. Near 900 pages, over 700 illustrations, flexible binding.

PRICE \$3.50—Postage Paid

For sale by hundreds of bookdealers throughout America and many foreign countries. Or may be purchased direct from the publishers. Send check or money order to

LOOMIS PUBLISHING COMPANY
Dept. 5 Washington, D. C.

Send For New Radio Book--It's Free

New hook-ups. This book shows how to make short wave receivers and short wave adapters. How to use the new screen grid tube in D. C. and A. C. circuits. How to build power amplifiers, ABC eliminators. Up-to-the-minute information on all new radio developments. It's free. Send for copy to-day.

KARAS ELECTRIC COMPANY
4030JA N. Rockwell Street Chicago

Name

Street and Number

City and State

4030JA

The Central Division Convention

THE above convention, sponsored by the Milwaukee Radio Amateurs' Club was a huge success with some event of interest going on every minute. The city officially greeted the arriving delegates with "Welcome Central Div., A.R.R.L." displayed in letters three feet high on the municipal building. From the opening night, May 25, when the gang got together for a smoker and general hamfest, to the May Ball, Sunday evening, which officially closed the convention, the events were thoroughly enjoyed by hams and YLs alike. The highlights of the smoker were a lecture on ether waves by Rev. A. H. Poetker, Prof. of Physics, Marquette University, a thorough discussion of ham problems by K. B. Warner, Secretary A.R.R.L., Editor-in-Chief *QST*, and original selections sung to old tunes by the M-"RAC" Songbirds. Throughout the convention, interesting talks were interspersed with airplane rides from Maitland Field, trips to local amateur and broadcasting stations and visits to industrial plants.

After making several such trips, the gang met Saturday afternoon at the Milwaukee School of Engineering. First on the program was the demonstration of a large Tesla coil. This reminded us of the old "spark" days and was awe inspiring for some of the new hams present who had no memories of "spark" work to reassure them. S.C.M. Crapo presided at the meeting as at the previous meetings. Following a talk on "Communications" by the C.M. from Hartford, "Antenna Feed Systems" were explained in detail by D. J. Angus, Indiana S.C.M. and the organization of the Central Division was discussed by Central Division Director, Clyde E. Darr, 8ZZ. "Television" by H. R. Hartley, Transmission Engineer, Wisconsin Telephone Company illustrated by slides provoked many questions and the afternoon ended with a talk by W. C. Evans, Manager of KYW.

During the banquet the convention photo was made and a special entertainment program added to the fun. Following the awarding of prizes, George Turner, Senior Radio Inspector, 9th District, announced the results of the radio operators license examinations held Saturday morning and a large number of new hams were welcomed by acclaim. Toastmaster R. E. Knoff next introduced Major W. I. Razor, representing the Signal Corps. He was followed by Lieutenant-Commander R. H. G. Mathews C-V(S) USNR who spoke on behalf of the volunteer Naval Communication Reserve. Many other speakers helped to make the evening complete. This convention is one that will be remembered for a long time by everyone there. About two hundred A.R.R.L. members were present and all joined in expressing thanks to those of the M.R.A.C. who worked so hard to contribute

GREAT LOSS OF LIFE FEARED AT MONTPELIER

Boston, Nov. 5.—(AP)—New heights were reached today in the ever mounting toll of life and property lost in the worst storm and flood disaster that New England has experienced within memory, and although

overshadowing everything else in the storm stricken area was the message of L. A. Kelly which told of a man dead in the neighboring city of Davis, one of whose was reported to be the lieutenant-governor of the state, E. H. Jackson.

The message was sent out by Sturges DUD and was picked up by Arthur L. Kugh, an amateur operator at Washington, N. Y. who relayed it to the Associated Press.



Binghamton, N.Y. April 9, 1928

In
On the night of Nov. 4, 1927 I was the only person in the world with the flooded city of Montpelier and for 24 hours without a sleep my little Esco generator kept the Associated Press, United Press and U.S. Government in touch with L. J. Hunt (Associated Press correspondent at Montpelier) and my reception & reports from IBE Borer sent to all corners by the globe.

8370

Yours truly
A. L. Hunt
199 Court St.

ELECTRIC SPECIALTY COMPANY

TRADE "ESCO" MARK

South Street

Stamford, Conn.

Real DX means maximum miles per watt, and that is what ESCO" generators are built for



A New Simple Tube Checker

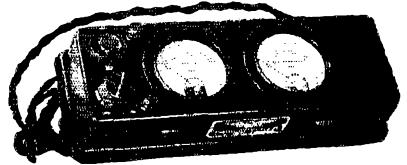

Pattern No. 150

Jewell has succeeded in developing a tube checker that is indeed simple. It is so simple that all that is required to prepare it for testing tubes is to plug the attached cord into a 110 volt 60 cycle outlet.

This new tube checker known as Pattern No. 150 is somewhat similar in appearance to other Jewell tube checkers which have earned an enviable reputation for accuracy and reliability, but differs in that all tubes can be tested without resorting to batteries of any kind. This is accomplished by incorporating transformer which furnishes the required voltages, making use of alternating current instead of the conventional A and B batteries.

All tubes can be tested from the WD-11 and 199 tubes up to the 210.

A five-prong socket is supplied with an adapter for 4-prong tubes and a rheostat enables adjusting the filament in conjunction with the 0-48 volt A.C. voltmeter. Plate current is read on a 0-15 milliammeter.

This new tube checker is described in our Form No. 2004. Write for a copy.

Jewell Electrical Instrument Co.

1650 Walnut St., Chicago

"28 YEARS MAKING GOOD INSTRUMENTS"

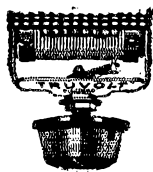

Pats. Pending

No
Guess
Work!

TRUVOLT

ALL-WIRE RESISTANCES

Truvolt Variable Fixed and Tapped Resistances are unusually accurate and dependable. Their unique design keeps them cool by direct contact with the air.

An exclusive feature of Truvolt Fixed Resistances is that the values can be changed and set at any point desired by the use of sliding clip taps.

In Truvolt Variable Resistances, the contact arm slides lengthwise over the turns of resistance wire; hence there is practically no wear on the resistance element. Their easy potentiometer control eliminates difficult calculation, and permits easy adjustment to tubes and line voltages. Electrad specializes in a full line of Controls for all Radio Purposes.

Write for Free Circular and Full Information.
Dept. T-8, 175 Varick St., New York

ELECTRAD

RADIO IN BRASIL

When in Brasil, apply to M. BARROS & CIA for anything you need in connection with radio.

M. BARROS & CIA

70 sob. Rua S. José 70 sob.

Postal Box 89

Rio de Janeiro

Telegraph address, Radioparte, Rio de Janeiro

Branch: Avenida S. João 4, S. Paulo, Brasil

AEROVOX Makers of high quality resistors and condensers that are Built Better — to endure.

Write for The Research Worker. A free monthly publication.

AEROVOX WIRELESS CORPORATION
68 Washington Street Brooklyn, N. Y.

ROBERT S. KRUSE

Consultant for Shortwave Devices

103 Meadowbrook Road,
West Hartford, Conn.

Telephone Hartford 45327

to the enjoyment. In making farewells many present were looking forward to another pleasant and profitable meeting at the next big Central Division Convention.

—F.E.H.

REFERENCES and BOOK REVIEWS

By R. S. Kruse

National Electrical Safety Code, Fourth Edition. Bureau of Standards Handbook No. 3, Published by Bureau of Standards, Department of Commerce and to be obtained at \$1 from Superintendent of Documents, Government Printing Office, Washington, D. C. (Specify fourth edition of Dec. 31, 1926.)

The major portion of this book is, as in the past, devoted to generation and distribution and need not be further discussed here. The radio provisions of Section 50, Part 3 are of direct A.R.R.L. interest, especially since the book has been adopted as standard by the American Engineering Standards Committee as of Nov. 15, 1927. It may therefore be expected to be the basis of many local rulings.

The radio rulings are on the whole sane. Low power stations being not given any requirements to follow, while the requirements for medium and high power are adjusted in a manner that seems rather reasonable until one begins to examine the definitions of low, medium and high power. It becomes clear that the committee should have had an amateur member present, or someone from the Radio Department who is familiar with the conditions under which amateur station (very much the most numerous of all transmitters) operate.

Consider these definitions, quoted from page 469.

"1-Low Power. Transmitting stations to which the power supplied is less than 100 watts and where the voltage of the power supplied is less than 400 volts.

2-Medium Power. Transmitting stations not classified as low power or high power.

3-High power. Transmitting stations to which the power supplied is greater than 100 watts or where the voltage of the power supplied is greater than 2000 volts."

Just what this means is a bit hazy. Amateur stations draw their power from 220-volt lines or 110-volt lines, therefore they are all low power as far as the line-voltage requirements go. The power taken from the line is likely to be either below 100 watts (making the station low power on that count too) or else between there and 1000 watts, making the station medium power. What seems incomprehensible is the thought that there may exist such a creature as a set with less than 1 kilowatt input, fed by a line with a voltage above 400, or even above 2000! Clearly the numerous amateur stations were (as usual) not being thought of and the relatively few commercial ones were being considered.

However—let us be thankful that the provisions are sane, even though the classification of stations seems rather muddled.

A Popular Guide to Radio, By B. Francis Dashiell. Published by the Williams & Wilkins Co., Baltimore. 285 pages, 101 illustrations with several photographic plates.

This reviewer must admit a certain community of spirit with Mr. Dashiell, for the Technical desks of QST are haunted constantly by the same sort of imps that follow one step behind any writer of a popular radio book, demanding that everything be made simple—no matter how abstruse it really may be.

QRD? This Summer

VACATION time—whether “roughing it” over mountain trails or taking it easy in a “cottage by the sea”—there is one form of entertainment which the transmitting fan now finds indispensable. And that’s the portable station,—keeping in touch with home, the world of sports, vacationing friends on other trails. Something to do when the camp supper is finished and the long evening is ahead.

And so, now is the time for those who have not already done so to get that Mobile License and check up on needed equipment. Is your portable station in complete order? How about the instruments? You’ll need at least two—a Radio Frequency Ammeter and a Filament Voltmeter. And Weston is prepared to make immediate delivery—by mail or express—if your dealer hasn’t just the size or range you need.

WESTON ELECTRICAL INSTRUMENT CORPORATION
602 Frelinghuysen Ave. Newark, N. J.

WESTON RADIO INSTRUMENTS

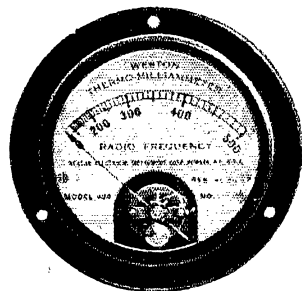

For example:—a 3-1/4 inch diameter, Weston Model 425 Ammeter and a Model 301 Voltmeter—D. C., of course, and an 8-volt range, probably. And the price only \$13.50 and \$8 respectively.

No other vacation “duffle” will give you so much pleasure at so little cost. And remember, that’s for Weston Instruments—good not only for your vacation, but for a life-time—and the highest quality and most dependable performance anywhere obtainable. Communicate direct with us if we can be of any service. We will give your request prompt attention.



NATIONAL

Velvet Vernier Dial type N for short wave work. A solid German Silver Dial with the original Velvet Vernier mechanism and a real vernier for closed reading to one tenth division. Price \$6.50. Send for Short Wave Bulletin. NATIONAL CO. INC., W. A. Ready Pres., Malden, Mass.

TRANSFORMERS

Guaranteed—Mounted—Complete

250 watt 550—700 each side	\$10.50
700 watt 1000—1500 each side	14.50
700 watt 2000—2500 each side	21.00
1 Kw 2000—2500 each side	30.00

Add \$2.00 for fil. winding
SCES F. GREBEN

1927 So. Peoria Street, Pilsen Sta., Chicago, Illinois

RADIO OPERATORS WANTED

THE EASTERN RADIO INSTITUTE can train you quickly and thoroughly because:

MODERN AND EFFICIENT METHODS
THOROUGH INSTRUCTION under staff of
LICENSED COMMERCIAL OPERATORS
MODERN APPARATUS including SHORT WAVE
TRANSMITTER

FIFTEEN years a RADIO SCHOOL
THE OLDEST, LARGEST and MOST SUCCESSFUL
school in New England. RECOMMENDED BY THE

A. R. R. L.

Day or Evening Classes Start Every Monday.

SPECIAL CODE CLASSES

Write for Illustrated Prospectus

EASTERN RADIO INSTITUTE

899 BOYLSTON STREET BOSTON, MASS.

QST OSCILLATING CRYSTALS AMATEUR BANDS

WE WISH TO ANNOUNCE:

1st.—That now, our crystals are capable of being used with as high a power tube as the 50 watt size.
2nd.—That we do not claim to grind the CHEAPEST crystals, but we do claim to grind only the best which is the cheapest in the long run.

3rd.—That we will ship the closest frequency crystal we have to your desired frequency, and that the frequency of the crystal will be stated ACCURATE to BETTER THAN A TENTH of 1%.

4th.—That all crystals are absolutely guaranteed in regard to output and frequency, and immediate shipment can be made on crystals in the amateur bands. Prices for grinding POWER CRYSTALS to oscillate in the various amateur bands are as follows:

1715 to 2000 Kilocycles	\$15.00
3500 to 4000 Kilocycles	\$25.00
7000 to 7300 Kilocycles	\$40.00

Note: The above prices are effective July 1st, 1928, to be in effect until November 1st, 1928. (Add \$10.00 to these prices if crystal is to be mounted in an excellent dust-proof power mounting.)

Broadcast Band—We will grind a crystal for you accurate to plus or minus 500 cycles of your assigned frequency for \$45.00 unmounted, \$55.00 mounted. Two day shipment and all crystals guaranteed.

Crystals ground to any frequency between 40 and 10,000 Kilocycles. We will be pleased to quote prices on your particular requirement.

SCIENTIFIC RADIO SERVICE, “The Crystal Specialists”

P. O. Box 86, Dept. “Z” Mount Rainier, Maryland

Where are your seven copies of QST for this year?

Certainly you need a binder for your 1928 copies as issued—

One-fifty each, post-paid



Note the wire fasteners. Unnecessary to mutilate copies. Opens and lies flat in any position.

A binder will keep your QSTs always together and protect them for future use. And it's a good-looking binder, too.

Q S T

1711 Park St., Hartford, Conn.

PACENT DUO-LATERAL COILS

FOR laboratories, experimenters, engineers and for special circuits, Pacent Duo-Lateral Coils are the accepted standard.

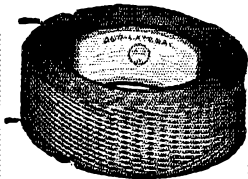

A complete line of all standard turn ratios are always in stock.

Write for information and prices

Pacent Electric Co., Inc.
91 Seventh Avenue, New York

BECOME A RADIO OPERATOR

See the World. Earn a Good Income.
Duties Light and Fascinating.

LEARN IN THE SECOND PORT U.S.A.

Radio Inspector located here. New Orleans supplies operators for the various Gulf ports. Most logical location in the U.S.A. to come to for training.

Nearly 100% of radio operators graduating on the Gulf during the past six years trained by Mr. Clemmons, Supervisor of Instruction. Start training now for fall runs.

Member of the A.R.R.L.—Call "5 G R"

Day and Night Classes—Enroll anytime—Write for circular.

GULF RADIO SCHOOL

844 Howard Ave.

New Orleans, La.

That the 'Popular Guide to Radio' has managed to stay in focus is materially to its credit. There are no perforations to the inventors or revolutionizers of radio; that noble chance for an outburst of adjectives has been replaced by the calm statement that 'Nobody actually invented radio.' From such a sane beginning, the book proceeds and one can find little fault with its general balance, unless indeed one may wish to complain that a good beginning must be followed by something else, and that the book therefore would have benefited vastly by a list of references concerning the many things that must be cut short when all of radio is to be swept over in less than 300 pages. This condensation has perhaps brought with it more inexactness in statement and terminology than the engineer may feel happy over, but it is to be remembered that the book is not aimed at him.

Methods, Formulas and Tables for the Calculation of Antenna Capacity, By Frederick W. Grover. Scientific Paper No. 568 of the Bureau of Standards, to be had at 20c from the Superintendent of Documents, Gov't Printing Office, Washington, D. C.

The first impression received from this very interesting 60-page discussion was that the formulae all related to multi-wire antennas such as are used on the longer waves where loaded antennas cannot well be avoided. However, second thought shows that the relatively brief discussion of the single vertical wire and single horizontal wire will serve most of the cases where such wires are utilized and that the analysis thereon becomes generally useful.

The Radiation Resistance and Energy Capacity of Half-Wave Antennas. By E. Green. E. W. & W. E., Feb., 1928.

A highly timely discussion, which will be read much less than it deserves.

Rotating Beacon Radio Transmitters. Papers from I. E. E. meeting. E. W. & W. E.

The Disturbance of the Electromagnetic Field by Buildings, etc. Reviewed in E. W. & W. E. for February, 1928. Original appearing in German in *Elektrische Nachricht Technik*, Nov., 1927.

Measurement of the Electromagnetic Field for the Purpose of Determining the Range of a Broadcasting Station. Abstracted in E. W. & W. E., Feb., 1928, with reference to original German article.

What is the Marconi Beam? J. Garrick Eisenberg, Radio, March, 1928.

Description of some of the equipment of the beam transmitters working between England and Australia. This can with profit be used as a practical illustration of the March QST article by Clapp and Chinn.

Belgian B-82, Radio, March, 1928, by E. A. Tubbs.

Description of an unusual antenna system adapted to 15-meter work.

Stabilization of Short-Wave Transmitters by Crystals. By J. Jammet L'Onde Electrique, January, 1928.

The title has not been translated literally but its significance is as stated and the following article, though not novel is worth reading.

A Remote Control Radio System Deluxe, by G. C. B. Rowe, Radio News, Feb., 1928.

Graphical Determination of Magnetic Fields, by A. R. Stevenson, Jr., and R. H. Park, General Electric Review, Feb., 1928.

Now— TELEVISION —and the accepted motor for it!



ON JUNE FOURTH through Station WLEX, Lexington, Mass., before a gathering of business and engineering leaders of the radio industry, a very successful demonstration of Television was held. The images were sent over the air and accurately received without the noise that had previously accompanied earlier experiments. The Baldor Motor illustrated above was responsible for the success of the Television demonstration. Many motors were tested but the Baldor Single Phase Motor with constant or adjustable varying speed gave, by far, the best results. It is the only approved motor.

Television requires a motor which will not spark; sparking distorts the received picture.

The Baldor Variable Speed Motor has no brushes, commutator or automatic switch, or any device that can spark.

Television requires a motor with little friction, so as to be able to follow the moving picture accurately.

The Baldor Motor is ball bearing, which means minimum friction, and is easy to keep accurate.

Television requires a very quiet receiver, so as not to transmit noises to the receiving set.

The Baldor Motor is quiet and humless.

Get the facts on this improved motor. Send for Bulletin No. 11.

INTERSTATE ELECTRIC CO.
4354 Duncan Avenue, St. Louis, Mo.

Distributors for the Baldor Variable Speed Motor

Television requires at the receiving end a motor which can be varied to suit.

The Baldor Motor is designed and built expressly for variable speed work. It is possible to vary the speed from 50 to 1100 r. p. m. in the 6 pole motor and 100 to 1700 r. p. m. in the 4 pole motor in gradual steps.



To Our Readers Who Are Not A. R. R. L. Members

Wouldn't you like to become a member of the American Radio Relay League? We need you in this big organization of radio amateurs, the only amateur association that does things. From your reading of *QST* you have gained a knowledge of the nature of the League and what it does, and you have read its purposes as set forth on page 6 of every issue. We would like to have you become a full-fledged member and add your strength to ours in the things we are undertaking for Amateur Radio, and incidentally you will have the membership edition of *QST* delivered at your door each month. A convenient application form is printed below—clip it out and mail it today.

American Radio Relay League,
Hartford, Conn., U. S. A.

Being genuinely interested in Amateur Radio, I hereby apply for membership in the American Radio Relay League, and enclose \$2.50 (\$3 in foreign countries) in payment of one year's dues. This entitles me to receive *QST* for the same period. Please

begin my subscription with the issue. Mail my Certificate of Membership and send *QST* to the following name and address.

.....

.....

Station call, if any

Grade Operator's license, if any

Radio Clubs of which a member

Do you know a friend who is also interested in Amateur Radio, whose name you might give us so we may send him a sample copy of *QST*?

..... Thanks!

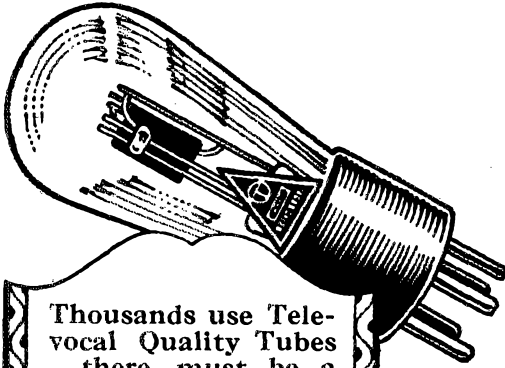

Thousands use Tele-
vocal Quality Tubes
—there must be a
difference! All
standard types. Ask
for them at your
dealers.

TELEVOCAL CORPORATION

Televocal Building
Dept. R-2, 588 12th Street
West New York, N. J.

Televocal
Quality Tubes

Transformers

and
Chokes

Of course Acme builds them—
Acme products are nationally
known.

Furnish us with your blue
prints and specifications for
prices.

We invite your inquiries.

Member R.M.A.

The Acme Electric & Mfg. Co.

Established in 1917

1653 Rockwell Ave., Cleveland, Ohio.



**'Round the World With New
Karas Short Wave Receiver**

Enjoy the thrills of hearing stations thousands of miles
away. Karas engineers have developed short wave equip-
ment to highest point. Easy to build. Easy to tune with
Karas Micrometric dials. 63 to 1 ratio. Uses Karas con-
densers built like a fine watch. Karas coils and audoa-
standard of the world. Send to-day for complete infor-
mation and construction blue print. Free.

KARAS ELECTRIC COMPANY

4030JB N. Rockwell Street, Chicago

Name

St. and No.

City and State

4030JB

Review of Radio Industry, by H. B. Richmond, Radio Engineering, Jan., 1928.

Low Mu Tubes as R. F. Amplifiers, by Nelson P. Case, E. E., Radio, Feb., 1928.

Characteristics of the Photo-electric Cell, by John P. Arnold, Radio, Feb., 1928.

Playing With a Photo-electric Cell, by Samuel G. McMenn, Radio, Feb., 1928.

Decreasing Radio Congestion by Wired Radio, by R. D. Duncan, Jr., Electrical World, Jan., 1928.

Low Frequency Transformer, by "Empiricist", Wireless World, Jan., 1928.

Short-Wave Direction Finding With Loop And Auxiliary Antenna at Large Distances. F. A. Fischer (in German) Zeitschrift fur Hochfrequenztechnik, Dec., 1927.

Concerning the Suitability of Short Waves for Direction Finding, by Day and Night, by F. Michelssen (in German) Zeitschrift fur Hochfrequenztechnik; Dec., 1927.

Recording of Radio Signals, Mario Santangeli (eiler) Revista Telegrafica, Jan., 1928.

Contours of 2LO (interesting field strength tests with account of means of measurements) R. H. Barfield, Wireless World, Jan. 4, 1928.

Short-Wave Echos (Geltow, Germany to Rio de Janeiro,) Wireless World, Jan., 1928.

The Movietone, by W. I. G. Page, Wireless World, Dec., 1927.

Experiments and Observations Concerning the Ionized Regions of the Atmosphere, by R. A. Heising, Proc. I. R. E., Jan., 1928.

A New Method for the Calibration of Ammeters at Radio Frequencies, by Herbert C. Hazel, Proc. I. R. E. Jan., 1928.

Automatic Volume Control for Radio Receiving Sets, by Harold A. Wheeler, Proc. I. R. E., Jan., 1928.

A Vacuum Tube-Voltmeter, by the Laboratory Staff, Radio Broadcast, Jan., 1928.

Atlantic Division Convention

State College, Pa., June 14, 15 and 16

IT has always been a matter of regret with this writer that strict necessity for conserving space in the magazine allows only a column for convention reports; this applies particularly to such conventions as the Third Annual Atlantic Division Convention, which was held at State College, Pa., on the dates mentioned, under the direction of G. L. Crossley, F. M. Gager, Director Woodruff and the operating staff of 8XE.

If you were not one of the lucky ones who attended, picture to yourself an ideal location among the Pennsylvania mountains, more than 1000 feet above sea-level, three

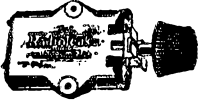

Bradley Leak, 2.95
absolutely noiseless and stepless, 2000 to 30,000 ohm resistance. List \$5, special \$2.95.

\$. Bradleystat No. E-210
Special1.60



Signal Buzzer Set International Code on Baseboard \$2.45
Belden braid ¼ inch wide, ft. .08
Myers \$5 4½ volt Det. or Amp tube, complete with mounting clips95

Thordarson Power Transformers
\$13 list—T-125, cap. 100 watt, secondary each side of neutral 350 and 550 volts, \$9.85.
\$18 list—T-126, cap. 450 watt, secondary each side of neutral 1000 and 1500 volts, \$13.95.
\$30 list—T-127, cap. 900 watt, secondary each side of neutral 1000 and 1500 volts, \$22.50.

LEEDS

The Home of RADIO

**45 VESEY STREET
NEW YORK**

**New York's Headquarters for
Transmitting Apparatus
When in Town Visit Our Store
Full Line of Acme -- Thordarson -- Jewell -- Flech-
theim -- General Radio -- Signal -- Bradley**

SPECIALS

Dubilier Mica Condenser, .002 cap. 8,000 working volt 1.95
General Radio 247D .001 cond. plain or with vernier 1.75
Dubilier cond. 1.7 mfd. 1,000v D.C. test; 650v. working voltage 1.35
Dubilier cond. .5 mfd. 1,000v D.C. working voltage .85
R.C.A.—U.V. 1716 Super Het. transformer 1.45
Ward Leonard Resistances; fits standard base receptacles; sizes 300—400—900—1200 and 2000 ohms .95
\$15. Imported German head sets; very sensitive 3.45
Honeycomb Coils unmounted, all sizes in stock at ½ price.
\$8 Signal Corp adjustable arm micro-transmitter for panel mounting 2.45
\$9. Dubilier condenser, 4mfd; 600 v. D. C. working type 303; limited quantity 2.25
R.E.T. Transmitting Inductances, per set. 3.80
Bristol 50 Henry choke 2.75
6.50 Acme .0005 enclosed condenser .95

Neon Glow Lamps, made by General Electric Co., type G.10, standard base, 101 uses, as illustrated in QST May issue page 1755

Flechtheim Condensers, all types 35% off list.

Pyrex Low-loss V.T. sockets, each 39c.

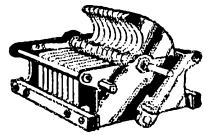

Cardwell con- 3.45
densers, double spaced for transmitting, .00025 cap.

No. 12 Enameled copper wire, any length, ft.\$1.01

No. 10 Enameled copper wire, any length, ft.01½

Genuine Bakelite Panel 10x14x¼1.50

Baldwin phones type C, pair 5.95



Ward Leonard Resistance \$4.75 list—6½ inch long—800-1000-1200-3000-6000-8000-11000 ohms; can be used for 2-50 watt tubes or less. \$1.45

Acme C. W. 30 Henry Choke \$18 list—150 M.A. single. \$14.40, also other sizes at special prices.
General Radio No. 358 Short Wave Meter, 14 to 225 meters, list \$22, special \$17.80

**MAIL ORDERS FILLED SAME DAY
10% Must Accompany All Orders**

35,000 COPIES

OF THE

Radio Amateur's Handbook

NOW IN USE

Regular Cover \$1.00 Bound in Leather Cloth \$2.00 Postpaid Anywhere

*If you haven't
a copy of The Radio
Amateur's Handbook you
are missing the greatest value
in radio today.*

**DO IT →
NOW**

AMERICAN RADIO RELAY LEAGUE,
HARTFORD, CONN.

Dear Sirs:

Enclosed find my \$..... Please send me postpaid (any where in the world) my.....copy of the Handbook.

Name

Addr

BUILD A DAVEN TELEVISION RECEIVER

Complete Essential Kit, \$60.00

THE first complete Kit. Furnished with either T-24, T-36 or T-48 Scanning Disk, Motor, Bushing, Rheostat, Daven Television Tube, 3 Complete Stages of Daven Television Amplification and Instructions for Building.

Daven Television Receiver Complete including Television Tube—\$100.00 (Less amplifier Tubes.)

Daven Television Apparatus

Daven Television Scanning Disks	Each	
24 apertures (T-24)	\$ 5.00
36 apertures (T-36)	7.50
48 apertures (T-48)	10.00
Daven Special Television Amplifier (3-T)	12.50
Daven Special Television Amplifier (4-T) for Two Hi-Mu tubes and two power tubes.	17.50
Daven Television Tubes—20 to 200 milliamperes Striking voltage 150.		
Plate 1½ x 1½	12.50
Daven Television Motor	25.00
Daven Bushing to fit ¼, 5/16 and 3/8 inch motor shafts	1.00
For 48 aperture disk	3.50
Daven Rheostat	3.50
Daven Television Photo Electric Cell 1½-inch bulb	20.00
Daven Television Photo Electric Cell 3-inch bulb	37.50
Daven Resisto Couplers:		
1st stage No. 421x D-421xx	
2nd stage No. 422x D-422xx	
3rd stage No. 423x D-423xx	
x Glastors are used for resistance	2.15
x Super Davonins in Plate and Glastors in Grid	4.85
Daven Mu-20 Tubes for Amplifier Stages	2.25
Daven AC-71 for output tubes in series with television lamps	3.50
Daven AC-10 (brighter illumination)	9.00

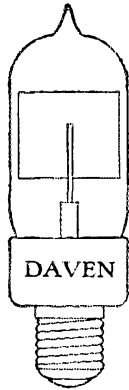

Write For Television Booklet

The Daven Corporation Amplification Specialists 169 Summit St., Newark, N.J.

days of perfect sunny, lazy Spring weather, the companionship of several hundred fellow-minded hams, college surroundings, plenty of tennis courts to play on "after hours", a charming hospitality which made everyone feel they owned the town and everything in it, perfect management, and a technical program which stands out as the best this writer has ever attended—and you can begin to get an idea of what it was like.

The morning and afternoon of the first day were given over to registration and hamming, but in the evening we got the first broadside in that A-1 technical program when Mr. V. D. Landon, of the Westinghouse Company, spoke on receiver characteristics and their measurement. While we are about it, we might as well mention the other technical speakers—it is a shame we cannot say more about each one, but lack of space forbids: Dr. Woodruff spoke on 10 meters and gave us a most effective picture of radio's place in the scientific world of frequencies, as well; Mr. F. W. Dunmore, of the Bureau of Standards, gave a fine illustrated talk on the latest thing in aircraft radio beacons; A. W. McAuly, 8CEO, gave us the dope on Kenotron rectifiers; Dr. J. O. Perrine, a most finished speaker, talked on transatlantic telephony, and also ran off some phonograph records that showed what happened when certain frequencies were eliminated from normal speech and music, over-modulation introduced, etc.; Miss E. M. Zandonini, 3CDQ, of the "Bustan" talked on crystal grinding and calibration, and Mr. Alfred Crossley, of the Naval Research Laboratory at Bellevue, D. C., gave a masterly talk on crystal control as applied to amateur sets. All the talks were excellently illustrated with slides and charts.

And we must not forget the lecture of Dr. Ulrich Franzhoff, 8DHU, of Germany, a stunt so cleverly made up and executed by the Oakmont gang that this writer, even though he had been forewarned that the estimable "doctor" was a fake, had serious doubts about it at times during the talk.

At the banquet, in addition to the speakers mentioned above, were Dean Sackett, of the School of Engineering, and Prof. C. L. Kinsloe, head of the Department of Electrical Engineering at State College, Handy and Budlong from A.R.R.L. headquarters, and Dr. Dunn from the Hudson Division—he mailed himself down by air-mail parcel post! After the banquet came the second drawing of prizes. The sessions were over after selecting Philadelphia as the city for the Fourth Atlantic Division Convention in 1929.

The committee which was responsible for this affair is most heartily to be congratulated; it was a fine job, and the Philadelphia crowd has a mighty high mark at which to aim.

—A. L. B.

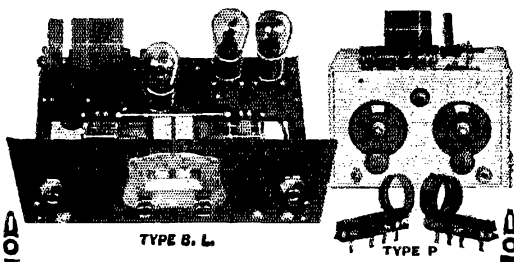

The Short Wave Set That Backs Its Claim

TYPE "P" S. W. Receiver—portable—embodying all the latest developments in H. F. design. Compact, quality job — size 6 in. x 9 in. Can be used on permanent or portable installations. Equally fine results on either S. W. broadcasting or code reception. Finest grade material throughout. Vernier dials, latest type small diameter low-loss coils. 3 plug-in coils supplied, covering 15 to 115 meters. Uses standard UX 201A or 199 Tubes

KIT
\$32.50

TYPE B. L. High grade S. W. Receiver for either S. W. Broadcasting or Code reception. Same as model "P", designed specially large for permanent installation. Drum dials. Both of these receivers will give fine results, receiving American stations in foreign countries

KIT
\$30.00

If you prefer to have these sets assembled, tested, and ready to operate, enclose \$7.60 extra to cover cost of work.

LOW WAVE LABORATORIES
37 Barclay St. New York City

We manufacture complete line of transmitting apparatus
ENCLOSE STAMP FOR CATALOG

HAM-ADS

ANNOUNCEMENT

Effective with the October, 1928, issue of QST the following changes will be made in the rules of this department. The Ham-Ad rate will be 15c per word. The restriction which has limited use of this column to members of the American Radio Relay League will be removed and advertising may be signed either by company name or by an individual. A special rate of 7c per word will apply to advertising which is obviously non-commercial in nature and which is placed and signed by an individual member of the American Radio Relay League. Please read carefully the following conditions under which advertising in these columns will be accepted.

(1) Advertising shall pertain to radio and shall be of nature of interest to radio amateurs or experimenters in their pursuit of the art.

(2) No display of any character will be accepted, nor can any special typographical arrangement, such as all or part capital letters, be used which would tend to make one advertisement stand out from the others.

(3) The Ham-Ad rate is 15c per word, except as noted in paragraph (6) below.

(4) Remittance in full must accompany copy. No cash or contract discount or agency commission will be allowed.

(5) Closing date for Ham-Ads is the 25th of the second month preceding publication date.

(6) A special rate of 7c per word will apply to advertising which, in our judgment, is obviously non-commercial in nature and is placed and signed by a member of the American Radio Relay League. Thus, advertising of bona fide surplus equipment owned, used and for sale by an individual or apparatus offered for exchange or advertising inquiring for special equipment, if by a member of the American Radio Relay League, takes the 7c rate. An attempt to deal in apparatus in quantity for profit, even if by an individual, is commercial and takes the 15c rate. Provisions of paragraphs (1), (2), (4) and (5) apply to all advertising in this column regardless of which rate may apply.

THE life blood of your set—plate power. Powerful permanent, infinitely superior to dry cells, lead-acid, Bs, B eliminators. Trouble-free, rugged, abuse proof, that's an Edison Steel-Alkaline Storage, B-battery. Upset electrically welded pure nickel connectors insure absolute quiet. Lithium-Potassium solution (that's no lye). Complete, knock-down kits, parts, chargers. Glass tubes, shock-proof jars, peppy elements, pure nickel, anything you need. No. 12 solid copper enameled permanently perfect aerial wire \$1.00, 100 ft. Silicon steel laminations for that transformer 15c lb. Details, full price list. Frank Murphy, Radio 8ML, 4837 Rockwood Rd., Cleveland, Ohio.

PURE aluminum and lead rectifier elements holes drilled brass screws and nuts, pair 1"x4" 13c, 1"x6" 15c, 1 1/2"x6" 17c, 1 1/2"x8" 19c. Sheet aluminum 1/16" \$1.00, lead \$1.00 square foot prepaid, \$1.00 or more. Silicon transformer steel cut to order .014" 10 lb. 25c, 5 lb. 30c, less than 5 lb. 35c lb. .022" 5c less per lb. Not cut 2-7" wide 15c lb., minimum 10 lb. postage extra. Edgewise wound copper ribbon 7 sizes see January QST. Air pocket and stand off insulators 25c each. 4 for \$1.00. Glazed porcelain 5 and 6 1/4" long prepaid on 4. Electrolytic condenser parts, \$1.50 prepaid. Geo. Schulz, Calumet, Michigan.

BULLETIN 66-E Lists the Ensell Radio Laboratory receivers, transmitters, wavemeters, etc. Item No. 69 and 68-A type receivers are the most modern types for amateur reception. Four and eight tubes respectively. We also make all types of apparatus for any radio purpose, including inductances, power transformers, rectifier units, filter chokes, high voltage variable condensers, plate reactors, etc. We build to order any apparatus using your parts if desired. Kit and blue print service on any power amateur station. Write for copy of Bulletin 66-E. Thos. Ensell, 1208 Grandview Ave., Warren, Ohio, SBDN.

IMAGINE an organization of radio "nuts" with over 3000 clients scattered throughout the world, hundreds of them hams, all of them radiowise—dealers, builders, experimenters. Over \$40,000 stock of high-grade receiving and transmitting parts only, no sets. Spend over \$5,000 yearly on our own experimenting, carry nothing until it passes our tests. 25c will bring prepaid over four pounds, catalog, circuits, data, etc. Weekly data sheets for experimenters and builders (more reliable data than all radio magazines together)—20 weeks \$1.00, 52 weeks—\$2.50. Full dealer's discounts to licensed hams, and radiowise builders. Fred Luther Kline, Established 1920, Kent, Ohio.

HAWLEY Edison element battery and parts standard for over five years. Look at our patent pending connector—no thin wire to drop off—contains 20 times more metal than regularly used. Heavy shock proof cells, fibre holders, etc. Everything for a rapid-fire "B" supply. Complete assembled 100 volt "B" \$10.00. Knock-down kits at still lower prices. Chargers that will charge in series up to 160 volts \$2.75 to \$4.00. Trickle B Charger for 90 to 150 volt "B" \$3.75. Special transmitter "B" batteries up to 6,000 milli-amp capacity, any voltage. Write for interesting literature, testimonials, etc. B. Hawley Smith, 360 Washington Ave., Danbury, Conn.

GENERAL Electric 12-350 volt, 143 ampere dynamo \$18. Westinghouse 10-350 volt .08 ampere \$20. Complete with effective filter, meter 0-500 volts, panel etc \$30. 500 cycle transformers \$12.50. 500 cycle generators and gasoline engine power units. 1500 volt motor generator for DC supply. Unusual machine \$150. Photographs, Henry Kienzle 501 East 84th Street, New York.

JEWELL Meters, new, 25% discount. We stock Hammarlund, Ward-Leonard, Acme, Thordarson, Pyrex, National, Cardwell, Baldwin, CeCo, Yaxley, Signal, Bakelite, Samson, Raytheon, RCA, Brownings-Drake, Fliron, Ferranti, REL, Aero, Eby, Victoreen, Silver-Marshall, Tryman, Tobe, Shield Grid Tubes, Carter, Budine, Clorostats, Air Chrome Speakers, Exponential Horns, Abox, Kingston, Marco, Ham Call Books, Keys, Relays, Buzzers, Exide, Philco, Westinghouse, Fritts, Newcombe-Hawley. Many other lines of Ham and HCL apparatus. Tell us what you want. Discounts to Hams, dealers and custom set builders only. Roy C. Stage, Montgomery & Hurt Sts., Syracuse, N. Y.

FOR sale—Two complete radio transmitters, one 500 watt master oscillator power amplifier, one 500 or 750 watt crystal control power amplifier, UV204, UV204A, UX852 tubes, numerous small parts and other equipment. Write for list and prices. 9KG, Paul Harris, Graham, Brothers, Evansville, Indiana.

LARGE 22 1/2 volt Rayovac batteries, 89c, RCA 50 watters, original cartons, \$12.00, REL 50c watt sockets, \$1.50, 6 months guaranteed new 210s also 281s each \$4.50, 6 months guaranteed 201As and 199s 79c. Readrite 2 meter tube checker, \$3.00, Resistometers 49c, RCA 585 rheostats 29c, other rheostats all sizes, 15c, Willard storage B batteries \$1.95, Kodak silent 2 1/2 amp. homecharger \$4.75, Bradley switches 29c, Federal transformers \$1.19, pure aluminum 1/16" thick, sq. ft. 80c, Electrad 5000 ohms, grid leak 50c, rubber panels 1c sq. inch Bakelite panels 2c sq. inch, Amateur Call Books 85c. Westinghouse four volt socket power \$6.25, six volt \$7.50, Brandes phones \$2.50. Free list, everything for hams. D.L. Marks, 125 Madison Ave., Albany, N. Y.

ENGRAVING—Finest workmanship on radio and laboratory apparatus panels. A. L. Woody, 19 S. Wells St., Chicago, Ill.

CURTIS-Griffith 250-watt power-filament transformers 350-550 each side \$10.50. Thordarson mounted transformers: 550-volts each side; two 7 1/2-volt filaments each \$20.00; Thordarson 350-550 power transformers mounted \$16.00; 1000-1500 power transformers \$22.00. Thordarson 650-volt power-filament transformers for 7 1/2-wattors \$6.90. Aluminum square foot 85c; Lead square foot 85c. Potter 2-mfd 1000-volt condensers \$2.75. "Ham-List" 4c. James Radio Curtis, 1109 Eighth Avenue, Fort Worth, Texas.

OMNIGRAPHS, teleplexes, condensers, transmitters, receivers, chokes, meters, transformers, crystals, 50 watters, supersyncs, S. Tubes, vibroplexes, electric and portable receivers. Phone transmitters. Bought, sold exchanged. L. J. Ryan, 9CNS, Hannibal, Mo.

ENGRAVING—finest workmanship on radio and laboratory apparatus panels. A. L. Woody, 19 S. Wells Street, Chicago, Ill.

HAVE sold 66 transformers made by G. E. Carry 1000W. 1100-2200-4400v. each side center tap. Guaranteed. Few

left, \$12. F. O. B. Detroit. "Ask the Ham who has one." F. G. Dawson, 5740 Woodrow, Detroit, Michigan.

WESTINGHOUSE 600 volt DC generator 110 AC motor set, good shape. Make cash offer. 6DTL.

TRANSFORMER supplies, 110-12 volt, center tapped, 150 watt filament transformers, mounted, \$6.50. Complete kit including blue print for above transformer, \$4.50. Shell type punched laminations of high silicon steel. Send for samples. Mounting castings, set 60c. Send for complete list of transformer construction material. R. B. Annis, 524 N. Oriental St., Indianapolis, Ind.

QSL cards, \$100 per hundred on plain cards, \$1.85 on government cards. Prompt service. 9BEU, 9032 Window Ave., St. Johns Sta., St. Louis, Missouri.

SELL—one Kennedy Universal receiver with amplifier. Forty dollars. W. L. Hyatt, 124 N. 8th St., St. Joseph, Missouri.

LOUDSPEAKER units rewound and remagnetized. \$1.50 to \$2.50 guaranteed. Quick service. A. B. Clark, Albia, Iowa.

QRH? Will your wave-meter meet the Nineteen-twenty-nine Amateur requirements? Let us calibrate your wave-meter, from standard frequency crystal Oscillators, to the greatest possible accuracy. We build Precision Wave-meters and Oscillators for Laboratory and Amateur use. Let us quote you prices on calibration, or on complete Wavemeters, built either on our plans or to your specifications. Write 9BVC, the Wave-meter specialist, Lutesville, Mo.

QSL cards, two color \$1.00 per hundred. Government cards \$1.90. Radiogram blanks. Stationery. Write for samples and other prices. 9CKA, Corwith, Iowa.

SELL—one h.p. 32 volt d.c. motor, \$15.00. REL short-wave tuner \$2.00. Four Westinghouse wet Bs \$6.00. Choke. RCA, UP1627, \$7.00, UP1653, \$5.00. Many other parts. Want: G. E. 24/1500 dynamotor. Wm. Hansen, Jr., Niles, Mich.

QSL cards: 100 two color, 95c, 150 government cards, \$2.50. Message blanks, stationery, etc. H. M. Selden, Cranesville, Penn.

HEADQUARTERS for hams:—Mueller 150-watt input tubes \$15.00. Complete 7½-watt transmitters: tube, transformer, rectifier, key, etc. 20-40 meters \$40.00. Receiver 20-40 meters and one step \$17.50. Aerovox 1000-volt 1-mfd Condensers \$1.75. Potter 2000-volt tested 1-mfd Condensers \$2.50; 2500-volt 1-mfd condensers \$3.25. ARRL Handbooks \$1.00. "Ham-List" 4c, Robert Curtis, 1109 Eighth Avenue, Fort Worth, Texas.

2500 Volt 1000 Watt Motorgenerator 110-220 Volt, AC drive \$225.00. 1500 Volt 750 Watt Motorgenerator 3-phase drive \$125.00. 1000 Volt 200 Watt Motorgenerator, 110 Volt AC drive \$75.00. 1000 Volt, 450 Watt with 10 Volt filament supply, 32 Volt drive \$150.00. 750 Volt 200 Watt motorgenerator 110 Volt AC drive \$45.00; 300 Watt \$65.00. 400 Volt generators \$8.50. Couplings \$1.75. ½ Hp. 1750 speed repulsion induction motors \$27.50; ¼ Hp. \$7.50. ¼ Hp. 3450 speed motors \$8.50. ¼ Hp. direct current motors \$6.50. Transformers 110-2200 Volt \$12.50. Also larger motors and generators. James Smat, 1734 Grand Ave., Chicago, Illinois.

2AUR Stolzenberger reports: Now copy 22 per. Quite an advance from 6 per where was anchored fast when heard about Dodge Radio Shortkut through QST. Expect to do 30 per with little further effort. Experimenter rather than traffic man and limited attention to operating. ORS

8BZP Walker reports: In the game since 1908. HRS taught many men code using old method. No more of that for me. Now use and recommend Dodge Radio Shortkut exclusively. Method \$3.50 United States—Elsewhere \$4.00. Money Order. C. K. Dodge, Mamaroneck, New York.

HAMS: Get our Samples and Prices on Printed Call Cards made to order as you want them—9APY, Hinds, 19 S. Wells St., Chicago, Ill.

TUBES, tubes, tubes, at reduced prices. Write for list. Write for my special agents proposition. Mac, Box 21, Seaford, N. Y.

TRANSFORMERS for plate and filament supply, to operate on 25, 40, 50, 60, and 500 cycle supply. Filter chokes and special purpose transformers you can't get elsewhere, built to your order. Specializing in the building of large plate and filament supply transformers and filter chokes. Nat G. Scott, New Albany, Mississippi.

MOTOR generator bargains almost new 750 Volt 200 Watt Robbins and Myers direct connected on iron base to 110 Volt 60 Cycle single phase alternating motor \$45.00. 400 Volt 100 Watt direct connected to 110 Volt 60 Cycle motor \$30.00. Three 400 Volt 100 Watt 3500 Speed

Western Electric generators with field resistance each \$9.50. Two 1/3 H.P. 110 Volt 3500 speed alternating current motors with coupling to direct connect to above generators or any machine having a 1/4 inch shaft each \$11.00. Also a few larger generators and motor generators. George H. Harris, 1911 Chicago Ave., Chicago, Ill.

POSTPAID and guaranteed brand new. Redrite panel mounting, flush type Milliammeters, 0-300 and 0-400 Mils. Either type, \$1.25. Redrite 0-15 A.C. Voltmeters, flush type, \$3.00. R.E.L. 2000 volt working voltage filter condensers, 1 Mfd., \$3.10; 2 Mfd., \$5.50. Sangamo .002 Mfd. 5000 volt tested fixed condensers, \$1.75. General Electric 5000 ohm Heavy Duty Gridleaks, \$1.25. R. E. L. 5000 volt working voltage .002 Mfd. fixed condensers, \$7.50. Other prices on request. G. F. Hall, 535 West Horter St., Philadelphia, Pa.

WE still have them, Navy five watters in original boxes. 7.5 volts filament 750 volts on plate \$1.30 each. The best and lowest priced power transformer on the market 750 each side of center tap for filament, 7.5 volt center tapped filament winding at only \$8.75. Shipping weight 10 pounds. Please include postage. COD if desired. E. P. Hufnagle, 879 South 18th St., Newark, N. J.

CRYSTALS with quality the first consideration. Sold subject your approval. Herb Hollister, 9DRD, Edwardsville, Kansas.

SELL—G. E. mercury arc, used but good condition, 9 bucks. 250-watt Curtis-Griffith power transformer, mounted; plate 550 each side center tap; filament 10 volts with center tap. 9 plunks. Grebe "ROCK" 2-stage amplifier, 10 berries. All in excellent condition. 5AQB, Box 11, Comanche, Texas.

WANT QSL cards that are different from anything you've ever seen? We print 'em. Write for samples. 5AHU, Box 46, Comanche, Texas.

TRANSFORMERS 1000-750 and 500 each side 250 watt unmounted \$8.00. 100 watt 325 each side with two 7½ volt windings \$5.50. 275 each side and 5 \$4.00. 12V-16 amp. \$7.00. Specials to order. Chokes, 250 mills 20 to 50 Henry adjustable core, \$7.50. 30 to 150 Henry 160 mills adjustable \$5.00. 30H, 100 mills \$2.00. 3 Henry one ampere, key thump, \$3.25. Send for list of materials and specifications. M. Leitch, Park Drive, West Orange, New Jersey.

WANT the latest ham doings? Then subscribe to Ham News! Six pages, bi-monthly. 25c for three months. 15917 Muirland, Detroit.

SELL—Acme TR-2 200 watt plate and filament supply transformer \$16.. Thordarson 80 Henry 150 M.A. choke #13. two R.C.A. 281 rectifying tubes \$5. each. 2 mfd. Tobe 600 Line condenser \$2.50, 4 mfd. same \$5. All guaranteed never used. William F. Fell, R.F.D. No. 1, Phoenixville, Pa.

DISCOUNTS to Amateurs—I can supply the following at regular dealer discounts—Aero Products, Jewell Meters, Ward Leonard Leaks, Signal Keys and Relays, Dubilier Blocking Condensers, REL Parts, Flechtheim Condensers, Thordarson Transformers, Amaco Condensers, Goodrich Panels. I specialize on ham equipment and stock many lines not mentioned here. A postcard brings prices and literature. R. N. Johnston, 66 E. Mill St., Akron, Ohio.

WANT G. E. 24-1500 dynamotor new or slightly used. 9NM.

SELLING out—250 watt transmitter with W.E. tube \$140. 50 watt transmitter with 203 es W. E. 50, \$75. Ham stuff. Robert Freeman, Box 124, Adel, Iowa.

WANTED: several new or used UV217 Metetrans. Write and give prices. 5ACL.

HAVE you bought your Master Radio Wavemeter yet? If not, why not? Join the ranks of thousands of satisfied users and enjoy the benefits of having a precisely calibrated Wavemeter! Only \$5.50 and \$8.50, but worth more. Four coil plug-in, 15-200 Meters. Send for full description. Specials: Raytheon Kino-lamps—\$12.00. GE Cooper-Hewitt neon lamps—95c; socket—20c. Scanning discs in stock. Dudlo-wound 50 Henry, 300 milliampere chokes—\$2.85. Fada power rheostats—40c. Dubilier .002, 6,000 Volt condensers—\$1.80. See June Ham-ad for Pure rectifier elements and copper tubing inductance. Send for free catalog. "Quick Service" William Harrison, 35 Ft. Washington Ave., New York City.

WE stock Tobe Deutschmann (Mueller) transmitting tubes. 250 watter \$81.75, 30 watter \$12.75, 8 watter \$5.10. These are now capacity short wave tubes. 6EX Recto-bulbs \$15.00, 50 watter \$20.00, Jewell \$7.50 meters \$5.50. Ant. meters \$9.50. 99.6% pure alcoa heavy aluminum 70c sq. ft., acme No. 12 enameled wire 95c 100 ft., 5000 volt Sangamo cond. \$1.50, extra large 82.2—35.7 crystals

NATIONAL TUBE REPAIRS

DURING our long period of experimentation and development, we have always maintained a money back guarantee and we have **SURVIVED**.

This means that we are putting honest effort into our Products and that we merit your orders.

We List and Price Repairs

W. E. 211	- -	\$16.50
W. E. 212	- -	40.00
U. V. 203A	- -	19.00
U. V. 204A	- -	75.00
U. V. 204	- -	50.00

(10% Discount on lot of 6 tubes, from above list)

These tubes are rebuilt using same type filament as they had originally; also the operating characteristics are maintained the same.

We purchase burnt out tubes of the above types.

SOLVE your rectifier troubles once and for all.

RECTOBULBS

3000 Volts and 250 Mils. **\$15 ea.**
Type 203 50 Watt Tube **\$20 ea.**

No charge for crating if cash accompanies order.

Our work guaranteed against defects of material and workmanship.

National Radio Tube Co.
3420 18th St., San Francisco, Calif.
(A Ham Institution)

FOR YOUR CONVENIENCE QST'S INDEX OF ADVERTISERS IN THIS ISSUE

A-C Dayton Company	79
Acme Electric & Mfg. Co.	88
Acme Wire Products	89
Aero Products, Inc.	3rd cover
Aerovox Wireless Corp.	84
Allen Bradley Company	70, 83
American Sales Company	70, 78
American Transformer Company	78
Amrad Corporation	63
Aurlima, Inc., Ad.	80
A.R.R.L. Handbook	89
A.R.R.L. Membership Blank	87
A.R.R.L. Special Offer	95
Barros & Cla., M.	84
Bryant Electric Co.	75
Burgess Battery Company	4th cover
Candler System Company	80
Cardwell Mfg. Corp., Allen D.	67
Central Radio Laboratories	72
Clarostat Mfg. Company	82
Crosley Radio Corporation	96
Cunningham, Inc., E. T.	66
Daven Corporation	90
Dodge, C.	78
Dongan Electric Mfg. Co.	76
Dudlo Mfg. Corporation	73
Eastern Radio Institute	85
Electrad, Inc.	84
Electric Specialty Company	83
Fansteel Products Company	76
Frost, Inc., Herbert H.	93
General Radio Company	2nd cover
Grebe & Company, Inc., A. H.	4
Gresham, F.	85
Gulf Radio School	86
Hardwick, Field, Inc.	88
Interstate Electric Co.	87
Jewell Electrical Instrument Co.	89
Johnson Company, E. E.	72
Karas Electric Company	82, 88
Kruse, Robert S.	81
Leads Radio Company	89
Leutz, Inc., C. B.	77
Loomis Publishing Company	82
Low Wave Laboratories	90
Massachusetts Radio & Telegraph School	72
National Company, Inc.	85
National Radio Tube Company	94
Paent Electric Company	86
Photo Electric Devices, Inc.	74
QST Binder	86
"Radio Engineering"	1
Radio Engineering Laboratories	67
Rectifier Engineering Service	68
Rooney, John T.	93
Scientific Radio Service	85
Seattle Radio Laboratory	80
Stromberg-Carlson Telephone Mfg. Co.	69
Telex Company	70
Televox Corporation	88
Thordarson Electric Mfg. Co.	71
Vibroplex Company	74
Waston Electrical Instrument Corp.	85
Wireless Eberl	78
Wireless Specialty Apparatus Co.	2
X-L Radio Laboratories	68
Yaxley Manufacturing Co.	78

You Have Until
AUGUST THIRTY-FIRST

To Take Advantage

**of the special offer
announced in the
July issue of QST.**

THE RADIO AMATEUR'S HANDBOOK

AND

a year's subscription to



FOR

\$3.00

Even if you are already a member of the League and a subscriber to QST, you may take advantage of this offer. Simply mention that fact and instead of entering it as a new subscription we will extend your present subscription for another year.



The American Radio Relay League

1711 Park Street, Hartford, Conn.

Replace your old radio!

Seven and a half million sets now obsolete

1928 Features

Few radios AT ANY PRICE combine ALL of these features.



Crosley Radios tune efficiently
Crosley Neutrodyne circuit is sharp, sensitive and selective.



Crosley Radios are shielded
Each element shielded from each other provides maximum selectivity.



Crosley Radios are very selective
In crowded districts you find a means of listening to ONE station at a time.



Crosley Radios have great volume
Volume may be increased to tremendous proportions without distortion.



Crosley Radios can be softened to a whisper
A positive volume control cuts down programs to a whisper.

Crosley Radios have illuminated dials

Your set has served you well *but you will not be satisfied with its strained stringy tones when you hear a new full toned power speaker Crosley set*

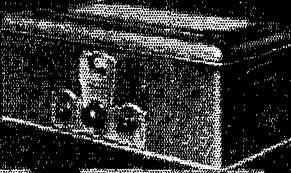

FIVE DAYS FREE TRIAL IN YOUR OWN HOME

Crosley originated the idea of a national policy of home demonstration. Compare a Crosley radio set with any other and you will choose the Crosley. If you have electric current in your home, your set should be a modern, AC electric receiver. A converted battery set is out of date. If you pay more than \$65.00 for a radio set, it should have two 121 output tubes, push-pull instead of one, eight tubes instead of seven. To be up-to-date, your new radio set should be designed to take and supply the current for a power or dynamic type of speaker. Crosley sets are so designed. Your set should be completely shielded and incorporate the highly sensitive, genuine, neutrodyne circuit. It should have a modern illuminated dial. An examination of Crosley radio sets will show you many other modern exclusive features.

\$25.00 NEW DYNAMIC CONE AMAZING SPEAKER!

The Dynacone is a new revolutionary speaker at a price less than many good magnetic speakers. Crosley manufacturing speed and straight line methods permit the extremely low price.

WHY PAY MORE THAN CROSLY PRICES?

We urge you to listen to a Crosley radio set, try it, put it to any test you can think of. No sets that approximate Crosley prices can compare in

performance. Why pay a high price for a set that can compare favorably with Crosley?

SIX TUBE GEMBOX AC ELECTRIC, \$65.00

Self-contained AC electric receiver. It utilizes two radio, detector, two audio and a rectifier tube—171 power output tube. Designed for use with the new Crosley Dynamic power speaker. Operates from 110 volts 60 cycle AC house lighting current.

Prices of Crosley receivers do not include tubes.

1928's greatest radio



8 tube SHOWBOX \$80

Genuine Neutrodyne, Newly perfected audio frequency system creates marvelous tone quality. Modern illuminated dial.



8 tube JEWELBOX \$95

Genuine Neutrodyne, Shaded coils, modern illuminated dial, highly selective and powerful.



6 tube BANDBOX \$55

An improved model of the 1927 receiver that led the world to better radio. Genuine Neutrodyne. The set you can safely buy where AC current is not available.



5 tube BANDBOX Jr. \$35

Operates entirely from dry cells and is especially designed where no electric current is available.



Improved MUSICONE \$15

The outstanding Magna 6 tube speaker available, still maintaining its leadership, today, as from its inception in 1925.

CROSLY



Crosley Radio Corporation
1000 Broadway, New York, N.Y.

Your name _____
Address _____
5 DAY FREE TRIAL COUPON

A New and Better SHORT WAVE RECEIVER

The Aero International Four

(Rear Panel
View)

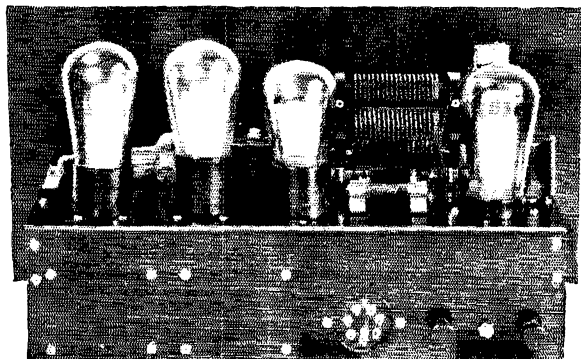

NOTICE

Your dealer can furnish you with complete parts for the Aero International Four in knockdown form. All parts, including cabinet, are enclosed in factory-sealed package, insuring perfect coordination between all units. If your dealer can't supply you, order direct from the factory.

These are the new Aero L. W. T. Coils used in the Aero International Four. Read about them below—then plan to build this superlative set at once!

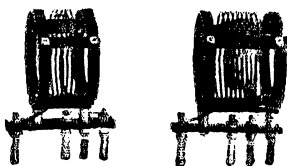

THE new Aero "International Four" Receiver marks a distinct milestone in radio progress. For the first time, radio frequency amplification on short waves has become a possibility. Sensitivity has been increased, control has been made far easier and receiver noises have been reduced considerably below their former level by development in the design of this receiver.

Newly designed parts have been incorporated throughout. The tuning condenser has no metal-on-metal bearing, so that the hissing noises formed by the variation in contact has been eliminated. New coils of a smaller diameter, having a much smaller external field, a better shape factor and improved efficiency are employed. The foundation unit with holes drilled for mounting every part, simplifies the construction of the set, and assures proper placement of the parts. The isolation of the antenna from the tuned stage means that swinging of the antenna will have no effect on tuning and variations in antenna lengths have little effect on the operation of the set.

The Aero "International Four" is to our knowledge the first short wave receiver of any kind designed peculiarly for reception of musical broadcast rather than code reception, and as such fills its place far better than the best of all-purpose outfits, although due to its ease of control and great sensitivity, it is superior to most all perfect short wave sets in any field.

Uses The Aero Coil L. W. T. 10 Kit

The new kit of coils illustrated above is the L. W. T. 10, price \$10.50. This is designed to go with special drilled and engraved foundation unit, in which mounting base is provided in drilled sub-panel. If you desire to furnish your own foundation unit, order the L.W.T. 11 Kit, price \$11.50. This kit includes mounting base.

The New Aero L. W. T. 12 Coils

This is the new Aero L. W. T. 12 kit. Consists of 3 new small diameter Aero Interchangeable Coils and base mounting with primary coil. Patented Aero construction provides 95% air dielectric and corresponding high efficiency. A pronounced improvement, even superior to our last season's coils. You should own this kit if you're interested in securing the best in short wave reception performance.



Write for Interesting Literature

Send today for complete descriptive literature on the Aero International Four. This completely illustrates and embodies a complete list of parts and special price list. You'll want to build and own this wonderful set. Write us for complete information at once!

AERO PRODUCTS Inc.

Dept. 16

1772 Wilson Ave.

Chicago, Ill.

For Your Own Information~



THE next time you buy Burgess Batteries for your radio set, take a pencil and mark the date on them the day you connect them to the set. Then you will know how long they last.

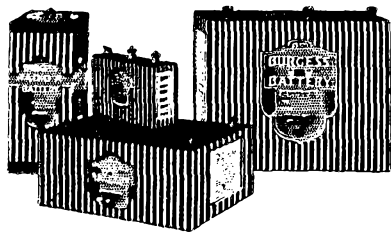

"Ask any Radio Engineer"

BURGESS BATTERY COMPANY

MADISON, WISCONSIN