

# **QST**

DEVOTED ENTIRELY TO

# **AMATEUR RADIO**

PUBLISHED SINCE 1915 BY THE AMERICAN RADIO RELAY LEAGUE INC.



**SEPTEMBER  
1928**

**25<sup>c</sup>**

# Precision...

## FOR THE AMATEUR TOO

Frequency standardization and the development of frequency standards has been a work of primary importance to the General Radio Company since its foundation. Paralleling the precision standards designed for commercial laboratories, low-priced instruments have been constantly produced to meet the increasingly rigid requirements of amateur radio. Three types of meters are now available for specific uses in the Amateur spectrum.



### TYPE 558 AMATEUR BAND WAVEMETER

The type 558 wavemeter is specifically designed for the new international amateur wavelength bands. The coils cover only the wavelength bands actually assigned for amateur use. This feature permits spreading each band over the entire condenser scale, resulting in great accuracy of setting. The guaranteed precision of this instrument is 0.25%, the same as that of the Type 224 Precision wavemeter costing ten times as much. Coils are provided for the 5, 10, 20, 40 and 80 meter bands. Mounted calibration charts are supplied with the instrument.

### TYPE 558 WAVEMETER

Price ..... \$20.00

### TYPE 358 AMATEUR WAVEMETER

The type 358 wavemeter covers a continuous range from 4 to 220 meters which includes five of the bands open to Amateurs, as well as the experimental and short-wave commercial bands. The greater range of this instrument does not permit as great an accuracy of calibration as is supplied with the 558, the calibration being good to 1%. A mounted calibration chart is provided.

### TYPE 358 AMATEUR WAVEMETER

Price ..... \$15.00

### TYPE 458 5 METER WAVEMETER

The type 458 wavemeter covers only the range from 4 to 6.5 meters and is designed for use by those experimenters who are working extensively in this region to the exclusion of other bands. The accuracy of calibration is 1%. A mounted calibration chart is supplied with each instrument.

### TYPE 458 WAVEMETER

Price ..... \$8.00

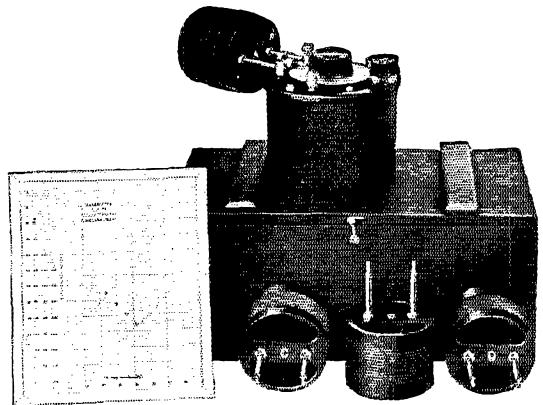

# GENERAL RADIO CO

Write for new Bulletin No. 930 with direct to consumer prices  
You will find many items of interest.

30 State St., Cambridge, Mass.

274 Brannan St., San Francisco, Calif.

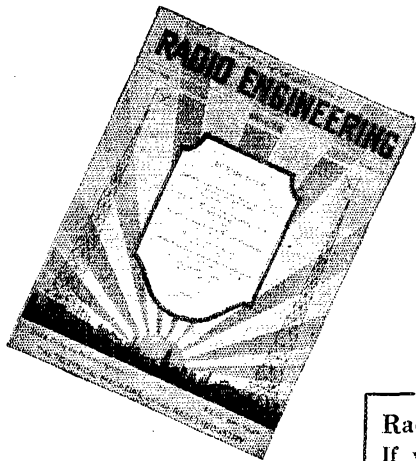

*Editor*  
**M. L. Muhleman**

*Managing Editor*  
**G. C. B. Rowe**

*Associate Editors*  
**John F. Rider**  
**Austin C. Lescarboursa**

Radio Engineering is NOT sold on newsstands.  
 If you are not already a subscriber use coupon below.

## Table of Contents for August

Manufacturing Procedure . . . . .	<i>By Howard Radcliff</i>
Research Methods . . . . .	<i>By Frank B. Jewett</i>
Picture Scanning With Natural Light	
The Design of the Tuned Double-Impedance Amplifier	
	<i>By Edward E. Hiler</i>
Application of the Four-Electrode Receiving Tube, Part II	
	<i>By Alan C. Rockwood and B. J. Thompson</i>
“A” Filters Using Dry Type High Capacity Condensers	
	<i>By P. E. Edelman, E. E.</i>
The Engineering Rise in Radio, Part III . . . . .	<i>By Donald McNicol</i>
The Mathematics of Radio, Part IX	<i>By John F. Rider, Assoc. Editor</i>

### Departments

Commercial Developments The Roma Radio Installation <i>By C. J. Pannill</i> Applications of the Photoelectric Cell in Industry, Part I <i>By Milton Bergstein, Ph. D.</i>	Fifth Annual Radio World's Fair News of the Industry Constructional Developments New Developments of the Month Buyers' Directory
--	--

**FOR YOUR CONVENIENCE IF YOU ARE INTERESTED**

RADIO ENGINEERING MAGAZINE, Inc.  
 52 Vanderbilt Avenue, New York, N. Y.

Enclosed find { \$2.00 for 1 year } subscription to Radio Engineering.  
 { \$3.00 for 2 years }

Enclosed find twenty cents (20c) for which send sample copy of Radio Engineering.

Name \_\_\_\_\_

Address \_\_\_\_\_

City \_\_\_\_\_ State \_\_\_\_\_

PLEASE PRINT NAME AND ADDRESS

*Please Check Your Classification*

- Manufacturer
- Dealer or Distributor
- Engineer
- Professional Builder
- Service Man
- Technician

Anything Else \_\_\_\_\_

# Your New Radio Specification

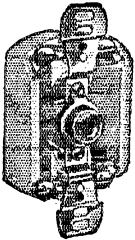

No. 2912  
Flush Jack



No. 2912  
and Plate



No. 130  
Cord Connector  
and K. T. Cap



No. 5113  
Receptacle



Dial Light  
Socket

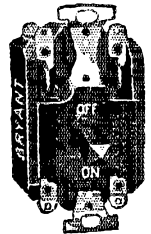

No. 3888  
D.P.D.T. Flush  
Tumbler Switch



No. 5142  
Tumbler Switch



No. 678  
Cord Switch

## Planning Next Season's Receiver!

What dependable, economical switches, receptacles, plugs, dial lights, etc., will you buy?

The Bryant Electric Company asks your consideration with experience of 39 years in the successful manufacture of wiring devices and in efficient factory production.

WRITE TODAY FOR A COPY OF  
OUR CATALOG ILLUSTRATING  
AND DESCRIBING OVER THREE  
THOUSAND "SUPERIOR WIRING  
DEVICES."



THE BRYANT ELECTRIC COMPANY  
BRIDGEPORT, CONN.

New York

Philadelphia

Chicago

San Francisco

Manufacturers of "Superior Wiring Devices" Since 1888  
Manufacturers of Hemco Products





# Even the Microscope Won't Tell You the Hidden Flaws

*that cause costly  
condenser  
break-down!*

SO minute are the imperfections that cause condenser break-down that even a microscope cannot be relied upon to find them. With the ACME PARVOLTS we employ scientific instruments to test the special papers and foils used in their construction.

It is only through eternal vigilance—through constantly testing and inspecting everything from raw materials to finished product that we are able to make condensers of such fine accuracy and dependability. This is the reason why ACME PARVOLT Condensers enjoy the reputation they do today.

When you realize that imperfectly made or inaccurately rated condensers break down under the sudden voltage surges common to electrified radio—that such break-downs can ruin many dollars worth of assembled parts—you must also appreciate why experts say "Play safe with PARVOLTS".

Made by THE ACME WIRE CO., New Haven, Conn., manufacturers of magnet and enameled wire, varnished insulations, coil windings, insulated tubing and radio cables.

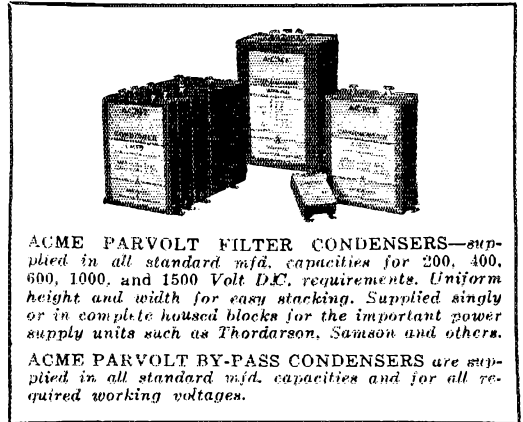
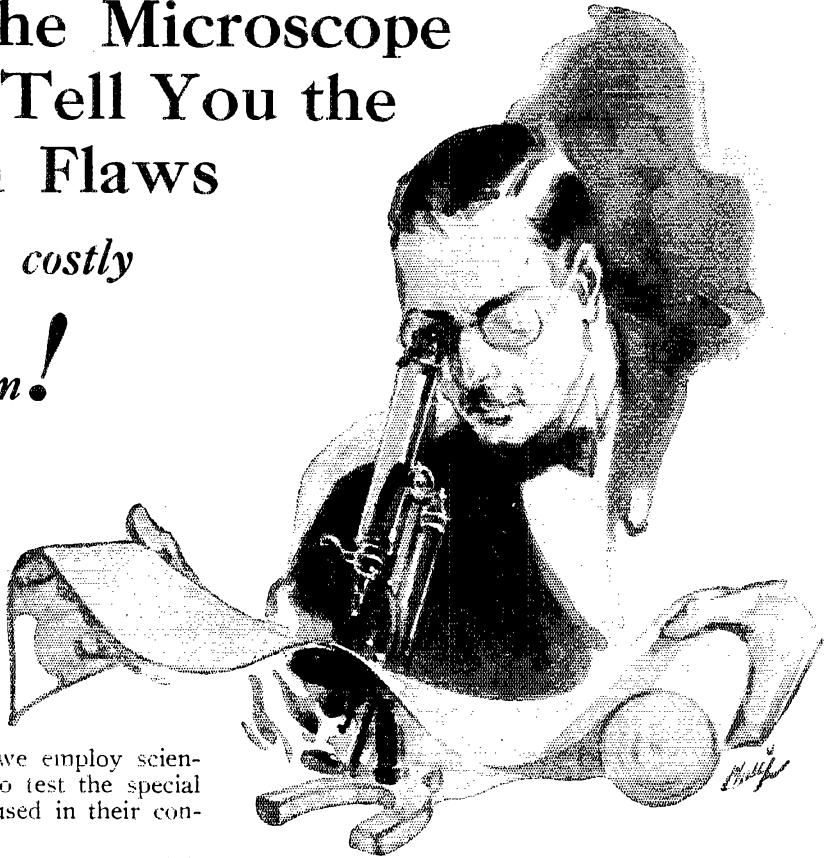

ACME PARVOLT FILTER CONDENSERS—supplied in all standard mfd. capacities for 200, 400, 600, 1000, and 1500 Volt D.C. requirements. Uniform height and width for easy stacking. Supplied singly or in complete housed blocks for the important power supply units such as Thordarson, Samson and others.

ACME PARVOLT BY-PASS CONDENSERS are supplied in all standard mfd. capacities and for all required working voltages.

## ACME PARVOLT CONDENSERS *Made by the Manufacturers of* ACME CELATSITE HOOK-UP WIRE

### ENAMELED AERIAL WIRE

*Enameled copper wire in both stranded and solid types. Also Acme Lead-ins, Battery Cables, Insulor and Loop Aerial Wire.*

### CELATSITE FLEXIBLE and SOLID

*For all types of radio wiring. High insulation value; non-inflammable. 10 colors.*

### ACME SPAGHETTI

*A superior synthetic tubing for all practical radio and other electrical requirements. Supplied in 10 colors.*

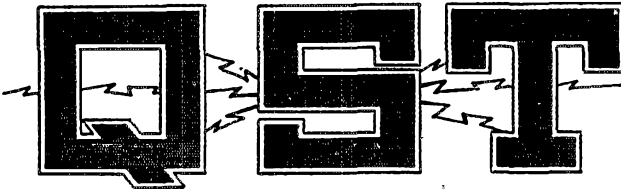

# The Official Organ of the A.R.R.L.

VOLUME XII

SEPTEMBER 1928

NUMBER 9

Editorials . . . . .	7
Standard Frequency Transmissions from 9XL . . . . .	8
The Oscillator-Amplifier Transmitter . . . . . <i>Ross A. Hull</i>	9
Radiovision . . . . . <i>Thornton P. Drabirst</i>	15
We Ought to Talk Frequency . . . . .	19
Opportunity . . . . . <i>Hiram Percy Maxim</i>	24
Pacific Division Convention . . . . .	24
Adapting Medium and High-Powered Self-Excited Transmitters to 1929 Service . . . . . <i>Ross A. Hull</i>	25
The UX-860 . . . . . <i>Harold P. Westman</i>	31
The Zepp . . . . . <i>James J. Lamb</i>	32
The Fifth Age . . . . . <i>W. A. Adams</i>	37
Synchronism . . . . . <i>C. Francis Jenkins</i>	38
Remodeling the Traffic Tuner for 1929 . . . . . <i>Harold P. Westman</i>	39
Washington Developments . . . . .	43
Experimenters' Section . . . . .	46
Mica Condensers for High Frequency . . . . . <i>Arthur M. Trogner</i>	47
Election Notices . . . . .	49
I. A. R. U. News . . . . .	50
Calls Heard . . . . .	51
Correspondence . . . . .	52
Book Reviews . . . . .	76
Financial Statement . . . . .	80
Indiana Central Division Convention . . . . .	80
New England Division Convention . . . . .	82
Ham Ads . . . . .	91
QRAs . . . . .	93

QST is published monthly by The American Radio Relay League, Inc., at Hartford, Conn., U. S. A.  
Official Organ of the A.R.R.L. and the International Amateur Radio Union

**Kenneth B. Warner** (Secretary, A.R.R.L.),  
Editor-in-Chief and Business Manager

**F. Cheyney Beekley,**  
Managing Editor and Advertising Manager

**Harold P. Westman,**  
Technical Editor

**Ross A. Hull,**  
Associate Technical Editor

**David H. Houghton,**  
Circulation Manager

Subscription rate in United States and Possessions, Canada, and all countries in the American Postal Union, \$2.50 per year, postpaid. Single copies, 25 cents. Foreign countries not in American Postal Union, \$3.00 per year, postpaid. Remittances should be by international postal or express money order or bank draft negotiable in the U. S. and for an equivalent amount in U. S. funds.

Entered as second-class matter May 22, 1919, at the post office at Hartford, Connecticut, under the act of March 3, 1879. Acceptance for mailing at special rate of postage provided for in section 1103, Act of October 3, 1917, authorized September 9, 1922. Additional entry as second-class matter, acceptable at special rate of postage provided for above, at Springfield, Mass., authorized September 17, 1924.

Copyright 1928 by the American Radio Relay League, Inc. Title registered at United States Patent Office.  
Member of the Radio Magazine Publishers' Association.

# The American Radio Relay League

The American Radio Relay League, Inc., is a non-commercial association of radio amateurs, bonded for the promotion of interest in amateur radio communication and experimentation, for the relaying of messages by radio, for the advancement of the radio art and of the public welfare, for the representation of the radio amateur in legislative matters, and for the maintenance of fraternalism and a high standard of conduct.

It is an incorporated association without capital stock, chartered under the laws of Connecticut. Its affairs are governed by a Board of Directors, elected every two years by the general membership. The officers are elected or appointed by the Directors. The League is non-commercial and no one commercially engaged in the manufacture, sale or rental of radio apparatus is eligible to membership on its board.

"Of, by and for the amateur", it numbers within its ranks practically every worth-while amateur in the world and has a history of glorious achievement as the standard-bearer in amateur affairs.

Inquiries regarding membership are solicited. A bona fide interest in amateur radio is the only essential qualification; ownership of a transmitting station and knowledge of the code are not prerequisite. Correspondence should be addressed to the Secretary.

## DIRECTORS

- |   |  |   |
|---|--|---|
| <i>President</i><br><b>HIRAM PERCY MAXIM</b><br>Drawer 2102,<br>Hartford, Conn.                           | <i>Dakota Division</i><br><b>C. M. JANSKY, JR.</b><br>Dept. of Elec. Eng., U. of M.,<br>Minneapolis, Minn. | <i>Pacific Division</i><br><b>ALLEN H. BABCOCK</b><br>65 Market St.,<br>Southern Pacific Co.,<br>San Francisco          |
| <i>Vice-President</i><br><b>CHARLES H. STEWART</b><br>St. David's, Pa.                                    | <i>Delta Division</i><br><b>BENJ. F. PAINTER</b><br>424 Hamilton Nat'l Bank Bldg.,<br>Chattanooga, Tenn.   | <i>Roanoke Division</i><br><b>W. TREDWAY GRAVELY</b><br>Box 245,<br>Danville, Va.                                       |
| <i>Canadian General Manager</i><br><b>A. H. K. RUSSELL</b><br>5 Mail Bldg.,<br>Toronto, Ont.              | <i>Hudson Division</i><br><b>DR. LAWRENCE J. DUNN</b><br>480 East 19th St.,<br>Brooklyn, N. Y.             | <i>Rocky Mountain Division</i><br><b>PAUL M. SEGAL</b><br>Box 1771<br>Denver, Colo.                                     |
| <i>Atlantic Division</i><br><b>DR. EUGENE C. WOODRUFF</b><br>234 W. Fairmount Ave.,<br>State College, Pa. | <i>Midwest Division</i><br><b>PORTER H. QUINBY</b><br>817 Lauderman Building,<br>St. Louis, Mo.            | <i>Southeastern Division</i><br><b>HARRY F. DOBBS</b><br>c/o Dobbs & Wey Co.,<br>245 Spring St., N. W.,<br>Atlanta, Ga. |
| <i>Central Division</i><br><b>CLYDE E. DARR</b><br>137 Hill Ave., Highland Park,<br>Detroit, Mich.        | <i>New England Division</i><br><b>DR. ELLIOTT A. WHITE</b><br>Dartmouth College,<br>Hanover, N. H.         | <i>West Gulf Division</i><br><b>FRANK M. CORLETT</b><br>2515 Catherine St.,<br>Dallas, Tex.                             |
|   | <i>Northwestern Division</i><br><b>K. W. WEINGARTEN</b><br>3219 No. 24th St.,<br>Tacoma, Wash.             |   |

## OFFICERS

- |   |   |
|---|---|
| <i>President</i> . . . . .              | <b>HIRAM PERCY MAXIM, Hartford, Conn.</b> |
| <i>Vice-President</i> . . . . .         | <b>CHAS. H. STEWART, St. David's, Pa.</b> |
| <i>Secretary</i> . . . . .              | <b>KENNETH B. WARNER, Hartford, Conn.</b> |
| <i>Treasurer</i> . . . . .              | <b>ARTHUR A. HEBERT, Hartford, Conn.</b>  |
| <i>Communications Manager</i> . . . . . | <b>F. EDWARD HANDY, Hartford, Conn.</b>   |

# EDITORIALS

**I**N the spring of 1927 the Radio Division, Department of Commerce, abandoned the issuing of Amateur Extra First Grade Radio Operator Licenses because of the apparent lack of amateur interest. In the several years that this type of licenses was available only about 150 of them were issued. Immediately it was abandoned, great disappointment was expressed by amateurs, and during the year the feeling grew in amateur circles that we had not properly appreciated this recognition of the amateur by the Department and that we desired its reinstatement. By the time our Board met this spring there was a definite desire in amateur ranks to secure its restoration, and our Board accordingly petitioned the Radio Division. Now we are happy to announce that this grade of license has been reinstated, new blanks have been engraved, and all of the offices of the Radio Division throughout the country are prepared to issue them to amateur applicants.

The offering of this superior grade of amateur operator's license is a stimulus to amateur proficiency and achievement, and something in which great pride can be taken by the holder. In earlier days the quite capable amateur could establish his proficiency by taking out a commercial license but there is to-day such a great difference between amateur equipment and commercial equipment, because of the now vast difference in wavelengths and methods, that it is only infrequently that an amateur is able to pass the commercial examination, and only after special study for that purpose. And even then it does not indicate particularly his greater proficiency as an amateur.

The new form of "ticket", on the brown form, is distinctively an amateur license, and the providing of it by the Division is a pretty recognition of amateur radio. To be eligible for this examination the applicant must have had at least two years' experience as a radio operator and must not have been penalized for violation of the radio laws—his record with the Radio Division must be clean. A speed of not less than 20 words per minute in Continental Morse receiving and transmitting must be attained, the same speed as for a commercial license. A special examination broader in scope than the regular amateur examination is given, with the requirement of 75% as a passing mark.

We wanted this grade of license restored. It has been done. It is now distinctly up to us to "patronize" it. Every amateur who can meet the requirements ought to

undertake to possess himself of one of these licenses at the earliest possible date. It becomes the distinguishing mark of the superior amateur. The Radio Division itself, and the military branches which offer appointments to amateurs, will inevitably recognize it as such. It is a spur to individual achievement, something of which we may rightfully be proud. Let us show our appreciation of the Division's kindness in restoring this special grade of license by giving them lots of "customers".

**T**HIS business of monitoring all transmissions from an amateur station, as is consistently recommended in Mr. Hull's series of transmitting articles, is a most useful and valuable idea. It is nothing short of strange that we went so many years without doing it. Its necessity is now perfectly apparent.

Most amateurs go along for years listening to every signal in the world except those from their own transmitter, which should be the first ones they listen to! This failure undoubtedly is responsible for the poor notes one hears on the air. It may be demonstrated easily to anyone's satisfaction that it is not possible to adjust any transmitter correctly, however good it is, by the use of meters alone. Adjustments for satisfactory output and for good efficiency are by no means sufficient, for in spite of these a good transmitter may still put out a signal of poor tone, chirping and creeping, infested with key clicks, and sensitive to every slight movement of the antenna. Yet all of these weaknesses are disclosed instantly by monitoring the transmission, so that one may know exactly what the signal sounds like to the distant station. When a monitor is used it becomes unnecessary to solicit numerous signal reports and attempt to secure some intelligent mean by discounting the over-enthusiastic ones and bolstering the ultra-conservative. What a tremendous amount of time and effort this saves, and what a vast amount of unnecessary interference it removes from the air! The only thing a distant receiver can report to the operator of a monitored transmitter which the latter does not already know about his signals is their audibility at the receiving station.

The 1929 station whose signal goes bad in quality or whose frequency begins to crawl, will be completely out of luck, lost in the mêlée. Monitoring prevents this, for it is instantly known to the transmitting opera-

tor. Every amateur who desires to be successful in 1929 must arrange to monitor his emissions.

**T**HE letter from Mr. Shaw, published in this month's "Correspondence," raises some interesting points. In addition to bringing us new technical difficulties, the Washington Convention presents us with some modifications in operating procedure and with several sets of entirely new abbreviations. Like the rest of the convention, these become effective on January 1st. In early issues *QST* will present all of this information which has an amateur application.

The changes in operating procedure itself are trivial and of course will be handled by our Communications Section in its codification of our *Rules & Regulations*. Then there are a simpler and much more sensible set of audibility signals, a brand new and much more extensive set of "Q" signals, and a rather extensive list of one-, two- and three-letter abbreviations. All of these have meanings internationally agreed and they are binding upon all classes of stations, so that we must adopt them and become familiar with them and drop our old abbreviations at the end of this year.

Amateur stations are neither stations of the "fixed service" nor of the "mobile serv-

ice". They are separately provided for as one of the classes of private experiment stations, and they have their own privileges and restrictions in the convention. All of this will be much better understood by studying a complete copy of the convention, which also includes, of course, all of the abbreviations and tables mentioned. Really a copy should be in every amateur "shack." A copy of the English translation of the document, known as "International Radiotelegraph Convention, Together With General Regulations and Supplementary Regulations Attached Thereto," may be obtained from the Superintendent of Documents, Government Printing Office, Washington, for twenty-five cents.

The prefix for a general call to all stations has been changed from "QST" to "CQ" and the former is now a blank in the international list of "Q" signals. That doesn't mean that *QST* is going to change its name, though. If some uncomplimentary meaning had been assigned the letters "QST", such as "You interfere with me—get out," we might have to. But now that *QST* is left blank in the international list, it becomes exclusively the name of a good amateur magazine.

—K. B. W.

## Standard Frequency Transmissions from 9XL

**S**TATION 9XL is a special station, comprising one of the three portions of the "Gold Medal Station", WCCO—9XL—9WI at Anoka, Minnesota. WCCO is operated as a broadcast station, 9XL purely as a standard frequency station and 9WI as a general amateur station, the three transmitters having independent equipment and antennas but a common power supply. Through arrangements made by K. V. R. Lansingh of the Official Wave Length Station Committee of the Experimenters' Section, A. R. R. L., 9XL is operated on schedules regularly announced in *QST*. The work of operating the station is done without charge by Chief Operator Hugh S. McCartney with the assistance of Lyall K. Smith and Ivan H. Anderson also on the staff of WCCO.

While no guarantee of accuracy is made on a gratis service, it is the aim of the staff to maintain an accuracy of 1/10 of 1%, which is materially better than can be held by most frequency meters. The frequencies are measured by means of standards which have been especially standard-

ized for this purpose by the Bureau of Standards.

A small percentage of tone modulation is employed so that the signal is distinctive and more quickly recognizable.

The fact that this service has been rendered in the past is no guarantee of its continuing indefinitely in the future. It depends upon whether the response received seems to warrant the amount of work and expense involved in maintaining this free service to all amateurs. If you take advantage of this service, please acknowledge that you are doing so by notifying the Experimenters' Section, A.R.R.L., 1711 Park Street, Hartford, Conn. You may use ordinary stationery or special blanks that may be obtained from the above address. A goodly number of these blanks has been gathered and as the number grows we will gradually gain a unique and accurate record of transmission phenomena possible with no other station.

### SCHEDULES

(Figures are frequencies in MEGACYCLES per second; approximate wavelength is given in parentheses.)

(Continued on Page 32)

# The Oscillator-Amplifier Transmitter

## A Practical Study of Its Suitability for 1929 Operation

By Ross A. Hull\*

The first activities on the A.R.R.L. Technical Development Program, in the examination of 1929 difficulties, have been studies of the possible methods of adapting present-day transmitters for 1929 service. The first resulting article, reporting the work on self-excited transmitters, appeared in the August, QST. The second phase of the work has been on master-oscillator-amplifier transmitters. In this article Mr. Hull, the director of the program, presents the results of this examination. Here is a real "1929 transmitter."—Editor.

**D**URING the last two years, in particular, master-oscillator-amplifier transmitters have been given brilliant and comprehensive treatment in QST. A study of the articles included in the appended bibliography would provide the amateur not only with a splendid idea of the operation of these circuits, but also with complete constructional details of several types of practical transmitters. In view of the existence of this material, we do not propose to treat the history of the circuits, the theory of their operation or even the reasons behind their peculiar effectiveness, unless such treatment is involved in the consideration of their application to the solution of next year's problems. The objectives in our examination of master-oscillator-amplifier transmitters were to study the conventional circuits; to build one into a transmitter in the way that the average amateur would build it; to tune it with the care that the average amateur would take, and then to measure its performance. In this way we hoped to be able to gain some idea of the relative desirability of oscillator-amplifier and self-excited circuits in a general way. Our objectives included also the construction of a somewhat refined transmitter; the precise tuning of its circuits, and the measurement of what would then be something approaching the best possible performance

that could be expected under normal conditions. These are the matters, therefore, to which we will give our attention.

### "OSCILLATOR-OSCILLATOR" TRANSMITTER

We recall, five or six years ago, the construction of an elaborate master-oscillator-

amplifier transmitter. We knew that such a transmitter would give steady signals of splendid character, and as a result we were not surprised to obtain some excellent reports during the first few QSO's. We recall as well, however, that shortly afterwards, the transmitter was started up with the oscillator accidentally disconnected. Behold! The antenna current

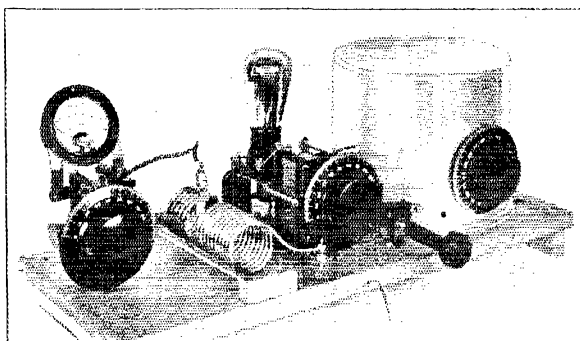

A LOW-POWERED OSCILLATOR-AMPLIFIER TRANSMITTER WITH A "1929 TYPE" PERFORMANCE

The frequency being set by a High-C oscillator within the aluminum container, and the amplifier being accurately neutralized, the antenna can be shaken to the ground and the frequency will remain practically constant. Differing from crystal-control practice, the oscillator is a tube similar to the amplifier operated well below its rating.

was there just the same. Eventually, we were able to tune the thing properly but we were surprised to find that with the slightest misadjustment the performance would drop to that of a self-excited transmitter. Since that time, the development of effective neutralizing systems has simplified the tuning business very greatly. It must be understood at the start that even in these enlightened days the use of a master-oscillator-amplifier transmitter does not spell the end of swinging and creeping frequencies—that its use does not in any way eliminate the necessity of careful and exact tuning.

The first transmitter built in the Laboratory for this study consisted of a UX-171 oscillator using the Colpitts circuit, and supplied from 135 volts of "B" bat-

\*Associate Technical Editor, QST. In charge A.R.R.L. Technical Development Program.

tery, driving a UX-210 amplifier powered by a 550-volt generator. It was, as our objective dictated, an average transmitter, built and tuned without any particular care. The oscillator was tuned to take 30 m.a. and the amplifier bias was adjusted until a plate current of 70 m.a. was obtained in normal operation. The amplifier

switched on the "Growler" and listened. To our surprise we found that the note was poor, that the frequency was creeping badly and that it responded to even slight vibration of the antenna. Further tuning adjustment was made with some considerable improvement in performance but it was not found possible to obtain the same

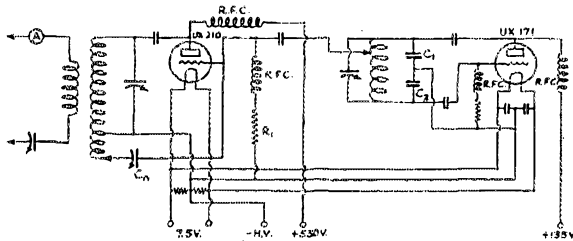
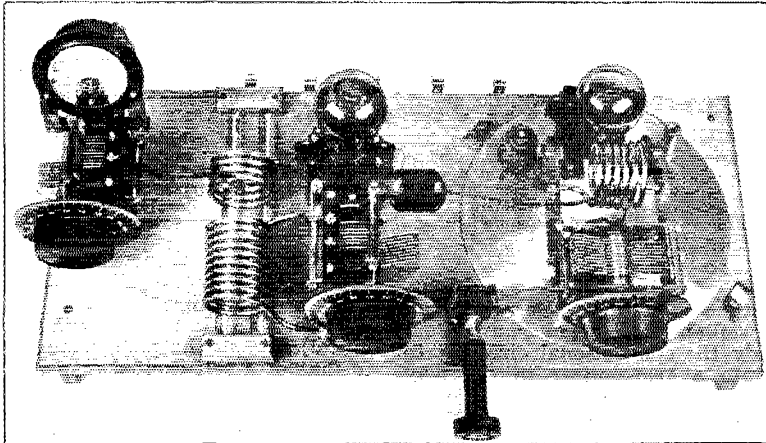

FIG. 1. THE CIRCUIT USED FOR PRELIMINARY EXPERIMENT

Heating of the fixed condensers C1 and C2 in the High-C oscillator tank caused serious creeping. Their use was avoided in the second transmitter by the employment of the Hartley circuit for the oscillator. Additional turns outside the amplifier plate tank were found necessary to make the neutralizing condenser Cn effective and for this reason the simple neutralizing scheme shown in Fig. 2 was adopted. The grid leak R1 in place of a bias battery proved dangerous in practice, the amplifier plate current rising to enormous values when the oscillator was detuned or when the amplifier grid excitation was removed in some other manner.

was neutralized with its plate supply disconnected by adjusting the neutralizing condenser until no energy could be

efficiency in the amplifier as that obtained in the self-excited oscillator described in last month's QST. Plotting of the antenna-tuning-vs.-frequency characteristics showed that it was considerably better than that of the self-excited transmitter but on the other hand the plate-voltage-vs.-frequency curve was extremely poor. An increase of the oscillator plate voltage to 300 resulted in an enormous improvement of the amplifier efficiency and measurement showed us that we had far surpassed the self-excited set in this regard. Under these conditions, however, the frequency creep was as much as 10 kc. per minute and the oscillator was therefore run alone until the cause of the trouble was found. A process of elimination placed the responsibility on the small fixed "bridge" condensers used across the oscillator inductance, which apparently were heating sufficiently to change their



THE TRANSMITTER WITH THE OSCILLATOR SHIELD REMOVED  
Mounted on an aluminum disk is the Hartley oscillator with a High-C tank. Over it fits the aluminum kettle. The amplifier unit, with a relatively Low-C plate tank, is mounted alongside the oscillator and between it and the antenna tuning unit. Glass rods are used to support the amplifier plate coil and the antenna coil, coupling between them being varied by sliding the latter along the rods. The neutralizing condenser—probably the most important control in the transmitter—is mounted between the oscillator and amplifier tuning condensers.

found in the amplifier tank with an indicating wavemeter. At this time, we

capacity appreciably. The replacement of these condensers with others of the air-



dielectric type or the change to a Hartley circuit, fitted with an ordinary variable condenser, immediately reduced the creepage to a low figure. The use of a UX-210 in place of the UX-171 resulted in still further improvement.

MORE TROUBLES

Other weaknesses in the performance were frequency wobbles due to vibration of the inductances and wiring, and violent frequency swings resulting from movements of the operator in the vicinity of the set. All of these matters were given consideration in the design and construction of the second master-oscillator-amplifier transmitter pictured and described on these pages. Summing up our experiences we decided that the term, "master-oscillator-amplifier" is not the synonym for constant frequency that it is so often thought to be—that the system is capable of producing extremely satisfactory signals, but that tuning plays just as much or more of a part than in the case of self-excited outfits.

In the second transmitter, a UX-210 was used as the oscillator in a Hartley circuit, so avoiding the necessity of fixed "bridge" condensers. The mounting of the inductance and the wiring were made more substantial and the unit was assembled on an aluminum disk over which an ordinary aluminum kettle could be inverted. The shield, so provided, was not intended to prevent undesired couplings between the oscillator and amplifier but merely to avoid the frequency changes due to body capacity variations. It proved thoroughly effective for this purpose though it was found necessary to drill holes around the bottom edge and at the top to provide ventilation. Before these holes were drilled serious frequency creeping was caused by the heating of the apparatus within the kettle.

THE OSCILLATOR TANK

A High-C tank was used for the oscillator, the values of inductance and capacity being of the order of those found desirable in our previous study of self-excited oscillators. The low power of the oscillator, however, made it possible to use inductances of 3/16" outside diameter copper tubing. With input power to the oscillator of 10 or 12 watts it was not found necessary to use heavier conductor or more effective contact than that provided by the

plugs and sockets shown in the photographs.

The amplifier, consisting of another UX-210 arranged in a conventional circuit, was mounted with its associate apparatus in a group just clear of the oscillator. In the plate circuit of this tube a High-C tank was avoided in order to permit a high degree of efficiency without the necessity of any particular refinement of its construc-

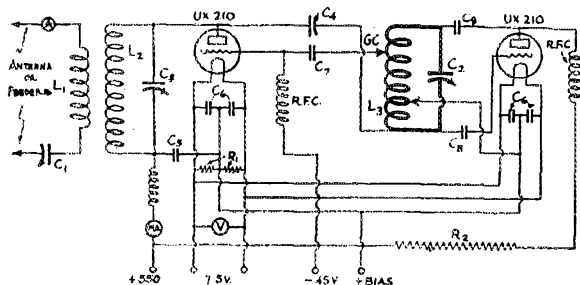

FIG. 2. THE CIRCUIT OF THE TRANSMITTER ILLUSTRATED ON THESE PAGES

- C1, C2—500- $\mu$ fd. receiver type variable condensers.
- C3—350- $\mu$ fd. ditto.
- C4—50- $\mu$ fd. midjet condenser.
- C5—2000- $\mu$ fd. fixed by-pass condenser.
- C6—1000- $\mu$ fd. filament by-pass condensers.
- C7—250- $\mu$ fd. coupling condenser.
- C8—250- $\mu$ fd. fixed oscillator grid condenser.
- C9—1000  $\mu$ fd. oscillator stopping condenser.
- R1—Center tap resistors—50- or 100-ohm resistors or Christmas tree lamps.
- R2—100-watt, 10,000-ohm grid leak used to drop plate voltage for oscillator.
- R.F.C.—Three sections each of 50 turns of 30 gauge d.c.c. wire wound in 3/4" plots in a 1" former and connected in series. The usual tubular chokes should be equally satisfactory.
- L1, L2 and L3 are illustrated and described elsewhere. Various keying methods were used satisfactorily though their relative effectiveness has not, as yet, been studied. For the time being, we suggest that one of the many effective schemes which has been described in QST be employed. The adjustment of the grid clip GC will not be found critical. Satisfactory operation probably will be obtained with one-quarter of the total turns between GC and the plate but experiment with other adjustments is desirable.

tion. In the case of a correctly neutralized amplifier tube, slight changes in the tube constants due to changes in the load or heating of the tube should have negligible effect on its performance and it is on account of this fact that a High-C amplifier plate tank is not particularly desirable. With amplifier plate inductances of the sizes shown in the photograph, the tank currents were not high enough to justify the use of heavier conductor than that used in the oscillator, nor the use of more elaborate connectors. In the antenna circuit, still lower currents are found and the same conductor was entirely suitable.

In this second transmitter, a change was made in the neutralizing method (as can be seen by a comparison of Figs. 1 and 2) since it was found possible in the second method to avoid the necessity of turns additional to those included in the tank cir-

cuit. This change, of course, considerably simplified the arrangement of the tank. The construction of the transmitter is quite conventional in all other respects and it

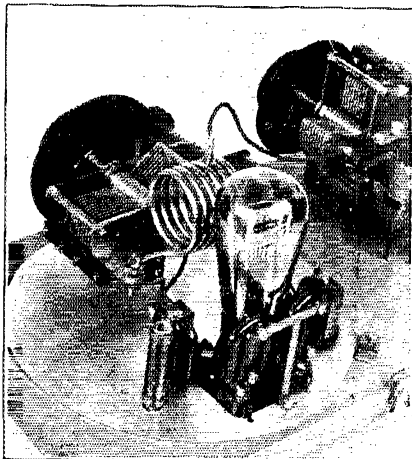

A "CLOSE-UP" OF THE OSCILLATOR UNIT

On the left of the tube is the grid leak and the grid condenser from which the combined connecting strip and coil mount is run to the variable condenser. A similar arrangement is used on the plate side of the tube. On the right side of the tube is the plate r.f. choke. The filament by-pass condensers can be seen mounted on the tube base in the immediate foreground.

should not be necessary to add to the information provided by the illustrations and diagrams.

#### THE ULTIMATE PERFORMANCE

We admit that the transmitter is a dizzy looking contraption but we must say that its performance was something very close to our idea of perfection, as soon as we had mastered its tuning. It could be left running with an automatic key for a couple of hours (monitored with a crystal oscillator) without a frequency drift of any serious proportion; it could have its plate voltage (both oscillator and amplifier) varied 10% with a frequency change that was only just observable; it could be "walked all over" with both hands without the monitor noticing it; it could give us a "pure musical d.c. note" with the simplest filter.

It performed so splendidly, as a matter of fact, that we dreamed that night of a world filled with master-oscillator-amplifier transmitters and Bourne acoustic filters. Truly it was a world of bliss!

But we cannot leave those statements without placing in juxtaposition the claims that tuning is even more important in master-oscillator-amplifier transmitters than in the self-excited sets and that the use of

a monitor or "Growler" for the work is of equivalent consequence.

#### THE TUNING PROCESS

In tuning the oscillator the same procedure will apply as that outlined for any self-excited transmitter. In tuning this oscillator with the aid of a monitor, we found it desirable to do the work with the plate supply filter disconnected. In this way it was more readily possible to decide upon

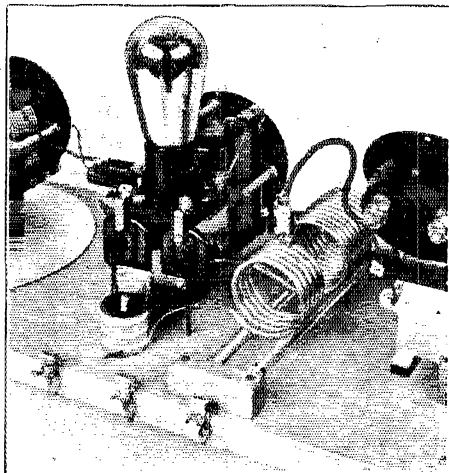

THE AMPLIFIER UNIT IN GREATER DETAIL

The height not being limited by any shield, the tube, in this case, is mounted in a convenient position on brackets extending from the tuning condenser. Under the tube base is the plate circuit by-pass condenser and dropped from it is the filament by-pass unit. Projecting to the left of the tube is the grid coupling condenser in the lead from the oscillator.

the adjustments giving the cleanest note than when a well-filtered plate supply was used. In the adjustment of this particular transmitter, the generator was run without any filter and the adjustment was considered satisfactory when the modulation of the note due to plate supply ripple had been reduced to the point where it could just be detected.

While tuning the oscillator, it is well to have the grid lead to the amplifier attached, but the amplifier should be run with its plate supply disconnected. Just as soon as the oscillator has been adjusted to give the cleanest and steadiest signal on the required frequency, with the input at about 10 watts, the preliminary neutralizing can then be undertaken. For this work, a two-turn coil connected to a flash lamp bulb should be coupled closely to the amplifier plate coil, and with the neutralizing condenser set at zero, the plate tuning condenser rotated until the maximum indication is obtained in the bulb. At this stage,

the neutralizing condenser should be adjusted until no such indication is obtained even after a slight readjustment has been made with the amplifier plate tuning condenser. The plate voltage to the amplifier can now be connected (the grid bias being at about 45 volts) and slight retuning of the amplifier plate tank can be made to reduce the amplifier plate current to the lowest value. Antenna coupling and tuning can now be effected, keeping in mind the fact that antenna coupling still plays the same important part in master-oscillator-amplifier transmitters as far as efficiency is concerned, and that it still has some influence over the performance as far as frequency stability is concerned. In short, when the coupling has been adjusted until maximum antenna or feeder current has been obtained, the coupling should be backed off until the antenna current is

rent other than that resulting from the loose coupling was not considered necessary.

If the tuning has been followed in the monitor, the signal will probably be clean

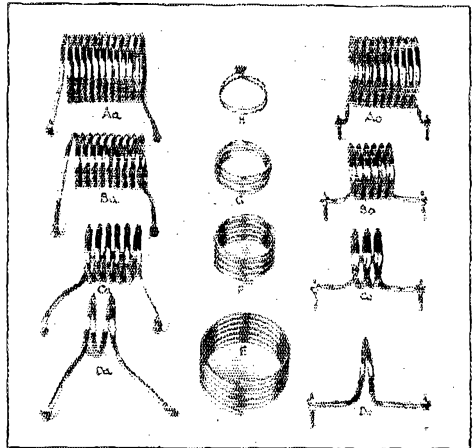

**OSCILLATOR, AMPLIFIER AND ANTENNA COILS FOR FOUR BANDS**

Made of 3/16" outside diameter copper tubing and wound by hand on a piece of iron pipe these coils serve for the four bands from 3,500 to 14,400 kc. in this particular transmitter. In a transmitter arranged differently some changes in the dimensions given may be necessary. Coils Aa and Ao are the amplifier and oscillator coils for the 3,500 kc. band. They have an internal diameter of 2 3/4". Coils Ba and Bo are for the 7000 kc. band, Ca and Co for 14000 kc., and Da, Do for 28,000 kc. For the last three bands the coils are wound to have an inside diameter of 1 3/4". Coil E is used in the antenna circuit for 3500 kc., F for 7000 and 14000 kc. and G for 28000 kc. The number of turns used can be seen on the illustration. Coil H, fitted with a flash-lamp bulb, is that used for the preliminary neutralizing process.

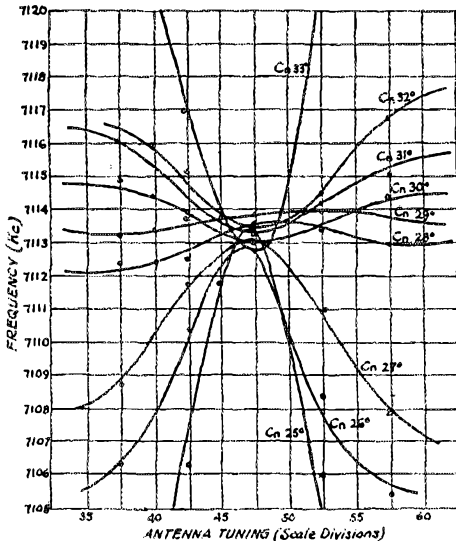

**FIG. 3. SHOWING THE EXTREME IMPORTANCE OF PRECISE NEUTRALIZATION**

In taking these curves the neutralizing capacity Cn was set at various values, denoted for convenience, by the dial readings. At each adjustment the Antenna-tuning-vs.-Frequency curve was plotted. It can be seen from curves Cn 27 or Cn 32 that misadjustments of two or three degrees on a 500 µfd. condenser can lower the performance almost to that of a self-excited transmitter. The correct adjustment in this particular case was somewhere between 29 and 30 degrees. With Cn at 29 the frequency swing was slightly upward while at 30 it was downward. If Cn could have been adjusted to about 29.3 the frequency change caused by tuning the antenna through resonance probably would have been not more than a few cycles and antenna swinging would then have had practically no influence on the frequency.

about 85% of its former value. Unlike the self-excited transmitters no noticeable improvement was effected by detuning the antenna and any sacrifice of antenna cur-

and extremely steady, but attention should be reverted to the neutralizing condenser for final adjustment. By listening to the transmitter with little or no plate-supply filter a magnificent final adjustment of neutralizing can be made. As the attainment of complete neutralization is approached, the character of the note will improve greatly, and at the exact point of neutralization it will be far superior to that obtained on either side. The point at which the note clears is, indeed, so well defined that we are now of the opinion that much more exact adjustment of neutralizing can be obtained by checking with the monitor than with any method so far attempted. We admit, however, that the method previously mentioned (or a similar one) is indispensable in providing the approximate adjustment, since the monitor method can be put into use only when the transmitter is operating in a somewhat normal fashion. In all of our experimental work we found

that the adjustment of neutralizing was of extreme importance. In every case, it can be said without exaggeration, a 10-degree movement of the 50- $\mu$ fd. neutralizing

one sixth of the amplifier input—the two tubes working on the same frequency—and unless the oscillator is being run well under its rating. This means that a UV-203-A or a UX-852 would be the only tubes suited for use as an oscillator controlling a tube of the latter type, while a UX-852 would be required to control a UV-204-A. It is not claimed, of course, that these combinations alone would prove satisfactory. It is merely suggested that under average conditions they would be very desirable.

In case this statement of master-oscillator and amplifier ratings would not appear to be checked by general crystal-control practice, it might be well to explain that conditions in the two instances are not by any means parallel. In the crystal-control transmitter the work of the oscillator is merely to supply sufficient excitation for the succeeding amplifier tube. In the case of the master oscillator (the term is used on account of its convenience but they are really both master oscillators) its work is to supply the amplifier excitation in a similar manner but to do the work without changing its frequency in accordance with any minor fluctuations of the load on it. In the crystal oscillator the crystal takes care of any such changes but in the master oscillator a stable frequency can be obtained in a practical manner only by making the energy drawn from it for amplifier excitation a fraction of the total radio frequency energy being developed.

We like the master-oscillator-amplifier transmitter. Its complications are minor; its tuning is straightforward; its performance, we'll tell the cross-eyed world is well-nigh supreme.

Recent QST articles treating the Oscillator-Amplifier Transmitter:

Master Oscillators and Power Amplifiers (Kruse) March, 1927

A Constant Frequency Transmitter (Hoffman) July, 1927

A Low-Power Master-Oscillator Transmitter (Dudley) Feb., 1928

Keying Master-Oscillator Circuits (Dudley) April, 1928

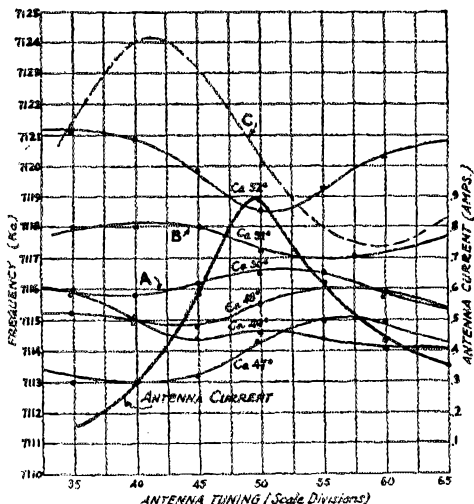

FIG. 4. GRAPHICAL INDICATION THAT DETUNING OF THE AMPLIFIER PLATE TANK ACTUALLY IMPAIRS PERFORMANCE

In this case the amplifier plate tank capacity  $C_a$  was set at various values and an Antenna-tuning-vs.-Frequency curve plotted for each. In Curve A the tank capacity was slightly below that required for resonance at the oscillator frequency, and the frequency swing was upward. In Curve B, taken with a condenser setting one degree higher, resonance clearly had then passed and the frequency swing was downward. It appears from the curves that a setting between 50 and 51 degrees would have produced that desirable condition in which antenna tuning has no appreciable effect on frequency. The dark curve is given to denote the antenna tuning adjustment at which the antenna circuit was in resonance with the amplifier plate tank. The dashed curve C was taken with the low-powered self-excited transmitter described in the August QST. It is given to provide a comparison of the performance of the two transmitters.

condenser spelled the difference between a 1928 and a 1929 type signal.

TRANSMITTERS OF HIGHER POWER

While the time set apart for this study of present-day master-oscillator-amplifier transmitters did not permit the construction of a higher-powered transmitter, we can see no reason why the same general ideals should not hold good. The choice of the oscillator and amplifier tubes will be a matter of greatest importance for it is certain, in our minds, that the complications involved in a master oscillator will not be justified unless the input of the oscillator, operating at normal efficiency, is at least



THE ONLY U.S. HAM WHO NEVER HRP A FOREIGN STATION

# Radiovision

By Thornton P. Dewhirst<sup>3</sup>

**O**F LATE there has been considerable publicity concerning radiovision or television and the reception of such signals by the amateur and experimenter. There has been but little information in a form suitable for the amateur and it is the object of this article to give some pointers on the problem and show some of the limitations of the art in its existing state.

First of all, do not expect too much from your radiovision investment. A picture of only slight detail is possible when reception is to be accomplished on the present broadcast set and the transmitter is to stay within the ordinary assigned channels of today. The use of present-day channels limits the number of lines drawn per picture to approximately 24. This means that the bust of a single person is about the limit of recognizable reproduction in half tone work and that possibly two moving figures in silhouette may be accomplished at the most. However, let us go into detail about the apparatus proper and return to this phase of the subject when we have acquired a little more data concerning the methods of transmission and reception.

By means of a revolving disc at the transmitter, the object is scanned by a spot of light, the reflection of which is picked up by a bank of photo-electric cells and these electrical impulses so generated are used to modulate the carrier wave. At the receiving end we have another disc revolving in synchronism and the radio signal is employed to illuminate a lamp which is viewed through the disc. The number of holes in the disc will determine the number of lines per picture and the speed of the disc will determine the number of pictures transmitted each second; both of these factors are set by the transmitter.

In the case of the 24-line picture as transmitted by WGY, there is not much that need be said. These pictures may be received on the standard broadcast receiver providing a good audio-frequency amplifier is being used and the radio frequency end is such that the full 10-kc. band is passed.

For reception of the 48-line pictures, the story is quite a bit different. Unless your present receiver uses a tuned r.f. amplifier with separate controls for each stage, and the audio amplifier will pass an extremely wide range of frequencies, it will be necessary to use a specially constructed set.

Let us take the case of a 24-line picture.

Consider that each line is divided up into 24 separate elementary portions which means that for the whole picture we have  $24 \times 24$  or 576 elementary areas that are being scanned by the beam of light. Now, if 20 pictures are being sent each second, each elementary area giving a large change in illumination compared with its

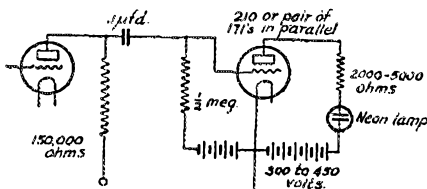

FIG. 1

immediate neighbors, the maximum frequency being transmitted will be  $576 \times 20 = 11,520$  impulses per second. These impulses are uni-directional and two pulses would be equivalent to one cycle, which means that the equivalent frequency is half of this value or 5,760 cycles per second. In actual transmission of half tones, the change of illumination will not occur abruptly nor will there be a change for each elementary area. This results in the highest frequency being still further lowered so that if the amplifier will pass frequencies up to 5000 cycles, it will be satisfactory for the job. When silhouettes are being transmitted, the changes in illumination are apt to be more rapid and abrupt, resulting in a larger band of frequencies that must be passed by the system. To compensate for this, when receiving (or transmitting) silhouettes, the amplifier does not have to have as excellent frequency response characteristics as when half tones are being received, because in silhouettes we are interested in but two values of illumination, light and dark; whereas in half tones, the various shades between these values must be considered.

A 36-line picture sent 10 times per second will require a band but slightly wider than the 24-line, 20-per-second transmission. However, since the number of times a second a picture must be repeated in order that the phenomenon of persistence of vision be obtained is also a function of the intensity of the illumination, it can be appreciated that in order to obtain a steady smooth image using the above speed, a light source of considerable intrinsic brilliancy will be required. The stronger the

<sup>3</sup>Radio Consultant, 4909 7th Street, N. W., Washington, D. C.

light, the fewer pictures per second necessary to obtain persistence of vision providing the speed is not reduced to a point where flicker is introduced. About 15 pictures per second is the slowest speed advisable.

A 48-line picture sent 15 times per second will require about 20 kes. for each side band or about four present-day channels. For this work, receivers must differ considerably from those employed for present-day broadcast reception. One stunt is to use four channels for this transmission, splitting the picture up into four parts, each of which is handled by a separate transmitter and receiver.

The best type of audio amplifier for the job will be a resistance-coupled affair. High mu tubes of the "240 type" may be employed and the plate resistors should be of about 150,000 ohms (somewhere between 100,000 and 250,000 ohms will be about right), the coupling condenser around .1  $\mu$ fd. and the grid leak,  $\frac{1}{2}$  megohms. These last two may be changed somewhat although it must be remembered that as the coupling condenser is made larger, the grid leak resistance must be reduced. If the condenser is too small, the low frequencies will not be amplified while if it is too large, the size will have to be reduced to a point where the amplification of all frequencies is lowered or the tube blocks. About 180 volts of B-battery will be needed for the amplifier.

In a stage of resistance-coupled amplification, the output signal is approximately 180 degrees out of phase in relation to the input signal. The number of stages needed does not then depend only upon the amount of gain necessary but also upon the fact that the image is to be a positive and not a negative one. Whether there shall be an odd or even number of stages will depend upon whether the transmission is of a negative or positive picture. When the correct number of stages has been found for a given transmission so that the picture received is a positive one, additional stages must be added in pairs so as to retain this phase relation. The grid bias should be adjusted with care. When receiving half tone pictures, adjust as for phone signals while if silhouettes are to be received, the bias should be slightly increased.

The use of the grid bias method of detection is to be recommended in preference to the leak and condenser system. While the sensitivity will be reduced, the amount of distortion will also be reduced, resulting in more satisfactory operation. Changing from one type of detection to the other will also cause a shift in the phase relation of the output. An r.f. choke may be needed between the plate circuit of the de-

detector and the grid circuit of the first amplifier to prevent the r.f. that gets by the detector from loading up the audio amplifier.

The neon lamp should have a plate or target that is as large as the picture we wish to reproduce. This is necessary since we want to look directly at the lamp through the holes in the disc. The use of small lamps is not recommended as there is considerable improvement in the use of a lamp with a plate or target of ample proportions (about  $1\frac{1}{2}$  inches square). These may be readily obtained and are well worth the additional expense entailed. It is connected in the plate circuit of the last stage of the amplifier. This stage may consist of a 210 or a pair of 171's in parallel. See Figure 1.

The resistance of the lamp before it is ignited is infinite but after it has been ignited, its resistance is quite low, varying from several thousand to ten or twenty thousand ohms depending upon the amount of current passing through it. The voltage drop across the lamp is constant, its resistance varying in inverse proportion to the current flowing through it while the illumination is proportional to the current flow. In testing a lamp by connecting it across a battery, a.c. line, etcetera, it is essential that a resistance of a few thousand ohms be connected in the circuit or the target is liable to volatilize and render the lamp inoperative for this particular type of work. The resistor will control the amount of current that can flow and prevent this sort of breakdown.

The radio frequency amplifier offers more of a problem than does the audio system. When the width of the side bands is not much greater than the present day broadcast channels, it is possible to take a tuned radio frequency amplifier (the stages being tunable separately) and by adjusting the circuits slightly off tune with each other, the width of the band can be increased although the gain is reduced.

A step further in this line is the method described by Dr. F. K. Vreeland in his paper which appeared in the March, 1928, issue of the Proceedings of the Institute of Radio Engineers. He uses two tuned circuits loosely coupled by either an inductance or capacitance so as to resolve all the resonance curves into one with flat top and steep sides. It is in effect an adjustable band-pass filter. Such filters may be used either before or after the untuned amplifier stages or they may be employed as the coupling devices between the amplifier tubes.

One may also use a double-detection receiver (superhet) and insert a fixed band-pass filter between the first detector and first intermediate frequency amplifier or

the filter may be inserted somewhere between that point and the second detector.

Synchronization is a problem of considerable magnitude and has not been solved to date. There have been many solutions offered but in the majority of cases, they have been too expensive for general adaptation. Present practise is to use a series or shunt wound motor and by means of a resistor in the field circuit or in series with the line, adjust the speed to the desired value.

To determine the required speed, multiply the number of pictures per second by sixty, the product being in r.p.m. If you already have a revolution counter it will help you arrive at approximately the correct speed although if you have not one, it is not necessary to get one as after several trials you will find the approximate settings of the resistors for a given speed. Assuming everything else in working shape, as you approach the correct speed, the image will appear, although in distorted shape. If the image is continuously traveling up or down it indicates that either the speed is incorrect or not constant. If the image remains stationary but is not properly framed, the receiving disc is out of phase with the transmitting disc. This may be corrected by moving the lamp to a different part of the disc, dropping the motor speed a fraction of a revolution if possible or rotating the field of the motor.

The size of the disc depends upon the number of holes and the width of the picture. The distance between the outermost hole and the center may be calculated by the following:

$$\text{distance} = \frac{\text{number of holes} \times \text{width of picture}}{2\pi}$$

$$\text{size of holes} = \frac{\text{height of picture}}{\text{number of holes}}$$

For best results the size of the picture should be determined by the size of the target in the neon lamp. Assuming a 1½ inch square target, a 24-line picture requires a disc with a radius of approximately six inches while a 48-line picture would call for a twelve inch radius.

In laying out the spiral one can make use of a piece of drill rod or dowel, the circumference of which is the same as the height of the picture. By placing it at the center of the disc with a piece of string or wire tied firmly to it, a marker fastened to this string about ¼" from the edge of the disc will inscribe the desired spiral as it is rotated about the center. In speaking of the spiral one might refer to the dis-

tance between holes as the separation of the holes and the height of the picture or distance between the first line and the last line as the offset of the spiral.

When using the disc method of transmission very little in the way of refinement seems possible due to the huge size of the disc if better pictures are to be achieved. Mechanical improvements must be made

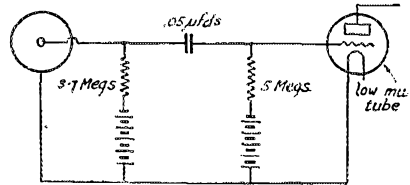

FIG. 2

and one method patented by Ramsey is to continue the spiral on around gradually approaching the center of the disc. Each complete turn of the spiral has its own lamp which in turn is operated from a separate transmitting channel or a switch is provided to light the individual lamps in succession. This produces a larger picture than a given disc could normally accommodate. If the spiral is of two complete turns, the separation of the holes will be twice the spiral offset and two lamps will be needed. The switching device causes irregularities in contact which is important in half tone work and the sparking produced causes radio interference to the receiver. This may be partially reduced by switching ahead of the output tube and providing an output tube for each lamp.

Jenkins uses a number of helices drilled in a cylinder, each helix being illuminated by an individual target in a multi-target lamp similar to the manner in which Ramsey illuminates several spirals on a disc. Jenkins places the multi-target lamp at the center of the cylinder and by the use of quartz rods conducts the light to the periphery of the cylinder with very little loss. The individual targets of the lamp are small and thus a given amount of energy will produce a large amount of illumination. It is confronted with the same drawbacks as regards switching as is the Ramsey system.

Ramsey's method produced a gradual narrowing of the width of the image as the spiral approaches the center of the disc while the other produces a fading out of the image at the edges. The first may be corrected by proper framing and providing that care is exercised at the transmitter, no distortion will be caused. In

the cylinder method, a lens will correct the difficulty to some extent.

The disc can be used for both transmitting and receiving at the same time by continuing the spiral a quarter turn more. For a 24-line picture, lay out six more

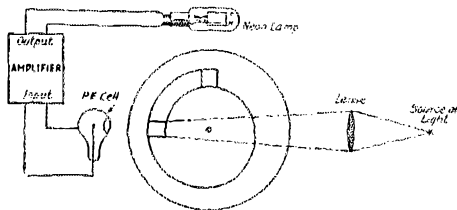

FIG. 3

holes after the full spiral has been made and for the 48-line disc there should be twelve additional holes. The picture is to be received one quarter of the circumference from the point where it is transmitted. A photo-electric cell (abbreviated P.E.) a light source and a few more stages of amplification will be needed. The number needed will depend upon the number of lines to the picture and the intensity of the light source. At least a 500-watt lamp on arc light should be employed. The arc should not be run from an alternating current source as the variations due to the a.c. (even 60 cycles) which are relatively slow will modulate the signal and cause trouble.

The connections to the P.E. cell are shown in Fig. 2. The resistance in series with the cell will vary between three and seven megs. It has been found advisable to use a low mu tube as the input tube which may be followed by high mu tubes in the rest of the amplifier. It would perhaps be best to start with silhouettes since then the P.E. cell may be adjusted at a value where the voltage is just below the point causing the cell to glow when the strongest light is on it for the longest time necessary. For half tone work, the cell must be worked down on its characteristic curve where a linear relationship exists between illumination and response. Under these conditions more amplification will be needed. Figure 3 shows the general arrangement for transmitting and receiving on the same disc. Try placing a key, small screw driver, fingers, etcetera in the lighted area and see the outline of these objects in the receiving area. Next, a photographic film, preferably a positive, may be tried.

After this has grown to be "old stuff" one can try putting the signal on a carrier wave to be picked up at a distance. With the 24-line picture the transmitter may be any good phone set. However, it must be good

and there should be no a.c. hum in the carrier and the complete audio spectrum to about 5000 cycles should be transmitted without much distortion. Few of the present-day amateur phones will pass this test and the first step toward this type of transmission should be a thorough housecleaning of the phone set. It is useless to attempt the work with a poor transmitter.

The disc with the extra holes may be used and the receiving area employed for monitoring the signal. After you have done satisfactory work with the 24-line pictures, you can try transmitting a 36- or 48-line one. This transmission and reception problem should keep you employed for some time.

The use of the cathode ray tube for the receiver is worthy of consideration since it opens up the possibility of real radiovision. In this tube, a stream of electrons may be moved in two directions at right angles to each other by means of either an electric field or a magnetic field. The window of the tube is covered with a fluorescent material and the electrons upon striking it cause it to glow. By means of proper values of current or voltage and frequency, the small spot of light can be made to completely cover the window. For radiovision work, the use of a material for coating the window that was not only fluorescent (emits light when exposed to certain rays) but also continues to glow for a short period after the ray has been removed would be of material assistance. This will help in causing the vision to persist and thus give the effect of greater illumination as far as this characteristic is concerned.

Radiovision for the home is still in the very distant future and this constant hoodwinking of the public should cease. The radio industry will benefit enormously when it does. When the elementary area used to build up our picture bears the same proportion to the whole picture that the individual particles of the emulsion of the moving picture bears to the total number of particles in the exposure and some method of transmitting each of the individual parts with ease and the problem of synchronism has been completely and simply solved, radiovision will be ready for the public. Today it is merely a plaything for the amateur and experimenter. It is an interesting field of experiment but one should not expect too much from his present day equipment.

### Strays

A certain ingenious fifth district amateur has trained his parrot to yell "CQ". He had an automatic CQ disk for his telegraph transmitter but his 'phone set was wanting



## We Ought to Talk Frequency

The Reasons Why, Including a Look at Our 1929 Bands

IT is time that amateur radio thought and spoke in terms of kilocycles instead of wavelength in meters. All of the rest of the world has changed. By the terms of the Washington Convention of 1927 the primary standard in all assignments to radio stations is to be frequency, and it will be in terms of frequency that all of our amateur assignments are made. The term wavelength is such an inconvenient one, and so far-fetched as far as concerns the physical appearance of anything in a station, that it seems the sooner we forget all about it the easier it will be for us to figure things out. Electricity in general got off on the wrong foot a good many years ago when it started talking about a current flowing from positive to negative, only to discover in more recent years that the motion which occurs is that of electrons moving from what we call negative to what we call positive. Everybody knows how much trouble that dual conception has caused. It seems to us that this business of wavelength in meters is equally left-handed.

There are a number of excellent reasons why the International Radiotelegraph Conference decided to express its allocations in terms of frequency instead of wavelength, and numerous very excellent reasons why we amateurs must now convert ourselves into thinking in terms of kilocycles. Let us examine a few of these reasons.

In the first place, talk about wavelength is "the bunk" because it is a thing that cannot very well be measured. When we talk about the length of our radiated waves we mean, for example, that if we had an oscillator going at about 7,500,000 cycles per second, and coupled to an antenna, and then if, Joshua-like, we could command those waves to stand still, and then if we could see them, and then if we had a nice steel tape-line whose accuracy we could rely absolutely upon, and then if we measured these waves and found that it were 131 feet and 3 inches from a point in one wave to exactly a similar point in another wave, then our transmitter would be operating upon approximately 40 meters! Now we can't see the waves, and we can't stop them and have the same conditions that apply when they are radiating, and we can't rely too much upon our measuring sticks. The one thing that the world does have absolutely accurately is time, and it also has the ability to count, and the one thing which may be said with precision about our circuit is the number of times per second which it oscillates. Is it not ridiculous that we continue

to talk in terms evolved from as far around the bush as wavelength in meters?

It is perfectly easy to think in terms of frequency and to see why this is logical. Consider the simple oscillating circuit of Figure 1 and imagine that the condenser, C, has been charged by impressing a voltage across it. Seeking to equalize the difference

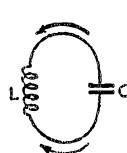

FIG. 1

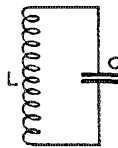

FIG. 2

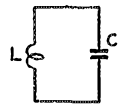

FIG. 3

in potential between the condenser plates, a current starts to flow, say in the direction of the heavy arrow. This current has to thread its way through the inductance, L, in which process it encounters electrical inertia because the inductance tends to prevent the flow of the current by taking up its power in the form of an electromagnetic field. Eventually all the power in the circuit exists in the form of these electromagnetic lines of force around the coil, instead of in the form of electrostatic lines of force in the condenser, as had been the case an instant before, and current flow ceases. But when the current through the coil ceases, the field around it collapses and the energy is returned to the circuit to proceed and charge the condenser, and in fact this same quality of inertia in the inductance now gives the current a "push," so that the condenser instead of merely having its charge neutralized, is now charged in the reverse of its original direction. The current now starts back in the direction of the light arrow and the same performance occurs again, this action continuing until the power is reduced below a certain critical value by losses from heating or radiation. This is simply the customary story of oscillation in an LC circuit, as is related in any radio textbook.

Now the one thing which is perfectly obvious about this procedure is that if the inductance L is a large inductance like that in Figure 2 it will take the current a longer time to thread its way through the circuit, and if the capacity C, as in Figure 2, is a large condenser, it will take a longer time for it to become charged. "Electricity" having a constant velocity, it is immediately apparent that this circuit is going to take a longer time to go through one complete

set of conditions (a cycle) than a circuit like Figure 3, in which both the inductance  $L$  and the capacity  $C$  are small. We have said in the past that the circuit of Figure 2 has a longer wavelength in meters than that of Figure 3 but we don't actually know how to express this left-handed measurement with any particular accuracy and the chief thing that we do know about Figure 2 is that it takes longer to oscillate, has a greater time-constant, oscillates more slowly, *has a lower frequency in cycles per second*. We can measure that because, from astronomy, we know exactly how long a second is. Is it not easier to deal with the more direct and obvious feature in the circuit, the rapidity with which it goes through its cycle?

Let us consider another example of the unreliability of attempting to deal in meters of wavelength. We say that the velocity of radio waves is 300,000 kilometers per second, the same as that of light. Obviously this velocity, divided by the frequency, should give the wavelength. Our circuit that oscillated 7,500,000 times per second comes out to have a wavelength of exactly 40 meters. And this is dead right if we know that the velocity is 300,000 kilometers per second. Unfortunately we don't know anything of the sort, even though that figure is frequently cited for this purpose. As a matter of fact, that figure is known to be somewhat incorrect and the latest scientific researches attribute to this figure the value of 299,820 kilometers per second. Our wavelength now turns out to be 39.98 meters! Which is right? Unfortunately we don't know. Some day science will set a still more accurate figure for the velocity of our waves, and then we will have still another measurement for our wavelength. All we can say to-day is that it is impossible for any small but dark reasons to give a wavelength accurately but that we are able to state our frequency with precision. For this reason the nations of the world have now agreed that the operating privilege to all radio stations will be stated primarily in terms of frequency, the approximate wavelength in meters to be stated as a secondary value, but with the frequency to be hewn to the line and letting the meters fall where they may.

There are other reasons why the terminology of wavelength is outgrown for us amateurs. Some of our 1929 bands are only a "meter" or so wide and any attempt to locate a wavelength within such bands is futile and meaningless unless it is carried out to the ten-thousandth part of a meter. It is easier to talk whole numbers in frequency. We know that we must learn greater precision for next year and that we must be able to recognize and discriminate between frequency differences of, say, 10,000

cycles (10 kilocycles) in our 40-meter band. Yet how can we deal in meters of wavelength with the two frequencies 7250 kilocycles and 7260 kilocycles when we think of them as being exactly the same thing, namely, "right around 41.3 meters"? Answer: we can't!

One more reason. Any intelligent examination of the capabilities of our various bands involves consideration of the number of stations which each will accommodate, which number varies with the frequency and in each case is to be expressed only in terms of width of channels, which again must be related to some percentage of the frequency. More about this later.

For these various reasons it is apparent that we amateurs ought now to abandon our outgrown wavelength nomenclature and get on the band-wagon and talk frequency. The standard way of doing this is to speak in terms of kilocycles per second, commonly called just kilocycles, and abbreviated "kc." A kilocycle is a thousand cycles, which is to say that the actual frequency of an oscillator is to be divided by 1,000 to give the frequency in kilocycles. For example, our 40-meter oscillator which we said oscillated 7,500,000 times per second has a frequency of 7,500 kilocycles per second or 7500 kc.

QST is going to lead the way in this. Frankly, we find ourselves unable to express 1929 thoughts lucidly in terms of wavelengths and we know that all of us simply must get around to talking frequency to be able to deal intelligently with next year's activities. QST therefore is going to talk frequency. We will follow such references with the approximate wavelength in meters, in parentheses, the wavelength being based on the velocity 300,000 kilometers per second. Since frequency is the primary standard and wavelength at best an approximation, the basing of the wavelength expression on 300,000 is near enough accurate and ever so much more convenient than the figure 299,820. That also is exactly the practice of the International Radiotelegraph Convention and of our own Federal Radio Commission and Radio Division, Department of Commerce. For the small sum of 5c (stamps not accepted) the Superintendent of Documents, Government Printing Office, Washington, will send you a copy of the "Kilocycle-Meter Convention Table," based on the figure 300,000, which was published on March 1st of this year. It is a large card, 13" by 23", containing 60 columns of figures, and its examination will provide a profitable pastime for nights when static is bad.

The Headquarters "gang" is now pretty generally thinking and talking in terms of kilocycles and we find it much more understandable and easy to deal with. The story is told that one of the later members of the Federal Radio Commission did not

know much about technical radio and, shortly before some extensive hearings were held, received some elementary instruction in the basic theory. Of course it was all in terms of kilocycles. At the hearings one of the speakers referred frequently to wavelength

each station might be permitted to deviate a certain small percentage on either side of its assigned frequency. Suppose the deviation is 0.1 percent; then let us assume that, in the commercial bands, there should be a space of one kilocycle on either side of

### AMATEUR FREQUENCY BANDS *assigned by The Washington Convention of 1927*

Kilocycles	Width in Kilocycles	Assignment	Approx. Meters on basis factor 3	Meters on basis factor 2.998	Harmonic family for centers of related portions		Amateur Purpose
					Kilocycles	Meters	
1715-2000	285	<i>Amateur, Mobile, point-to-point</i>	150 - 175	149.9 - 174.8	1775	168.92	<i>Domestic</i>
3500-4000	500	" "	75 - 85.7	74.96 - 85.66	3550	84.46	"
7000-7300	300	<i>Amateur Exclusively</i>	41.1 - 42.9	41.07 - 42.83	7100	42.23	<i>International Night</i>
14,000-14,400	400	" "	20.83 - 21.43	20.82 - 21.42	14,200	21.11	<i>International Day</i>
28,000-30,000	2000	<i>Amateur &amp; Experimental</i>	10.00 - 10.71	9.99 - 10.71	28,400	10.56	<i>Experimental</i>
56,000-60,000	4000	" "	5.00 - 5.36	4.997 - 5.354	56,800	5.28	"

FIG. 4

in meters. "What does he mean, wavelength?", said the member, leaning over towards a friend. "I never heard of it. Why doesn't he talk kilocycles?"

How much happier we'd all be if we had never heard of meters!

#### A LOOK AT OUR 1929 BANDS

Let us now examine the bands which will be available for amateur radio after the end of this year. Figure 4 shows the assignments, the width of each band in kilocycles, and the approximate location of each band in terms of wavelength in meters.

From this table, which band would you say was the "widest"? If we speak in terms of the number of stations which can be accommodated in any band we get quite a jolt when we discover that neither that band 4,000 kc. wide nor the one 2,000 kc. wide is the "widest." Even the best adjusted station occupies a little slice out of the spectrum and this "slice" is to be expressed as a percentage of its operating frequency, so that as we get into a higher-frequency band we find that the width of the channel required for a single station is greater, and that a wider band will not necessarily accommodate more stations. Let us make some attempt to determine this "channel width." The Navy Department has calculated it out for the Federal Radio Commission on the basis of the 1929 assignments. It commences by assuming that

this signal, to minimize the possibilities of interference. Understand that we amateurs aren't going to observe individual channels within our bands, but a consideration of the subject is useful in establishing the relative widths of our different bands. We find that on the basis just suggested the separation between channels in our "160-meter" band is 5.71 kc., 9.5 kc. in our "80-meter" band, 16.3 kc. in our "40-meter" band, 30.4 kc. in our "20-meter" band, and 60 kc. and 118 kc., respectively, in our two highest-frequency bands.

It is apparent that we need some new scale if we are to have an accurate gauge of the number of stations which can be accommodated in our various 1929 bands. This is supplied in Figure 5, which takes account of the fact that at double the frequency a signal occupies double the room in the spectrum. Now we are able to gauge the relative widths of our bands. We find that the "5-meter" and "10-meter" bands are the same in practical width, that the "20-meter" and "40-meter" bands are narrower than this but that our "80-meter" band is double this in width, and that our low-frequency band is our widest in point of number of stations that may be accommodated.

In Figure 5 the "40-meter, 20-meter and 5-meter" bands are shown extended by dotted lines to the extreme right-hand edge of the drawing. These are the former widths of

these bands, the territory which we are authorized to occupy during 1928, and thus the drawing shows graphically the extent of our losses at the Washington conference. There is a harmonic relation in this drawing. Any point on one line is the second harmonic of the point on the line immediately above it, the fourth harmonic of the corresponding point on the second line above it, etc. Thus our 1928 assignments were a true harmonic family, each higher-frequency band being of twice the width in kilocycles of the band which preceded it but each capable of accommodating the same number of stations, and with the additional feature, based upon the motto of the Third National Radio Conference that "Everybody should eat his own hash," that the harmonics of

international agreement is that it is available for mobile, point-to-point and amateur services, but the present disposition of our Commission is to make no assignment in it other than amateur, considering the extent to which our high-frequency allocations have been clipped. We use the band chiefly for telephony, to which it is open throughout its extent. It is an excellent short-distance telegraphy band and our Communications Department is planning the expansion of this work as a beginner's wave. It will probably also be available soon for television and picture transmission experiments. It is to be noted that the portion 1715-1750 kc. has no harmonic relation to any of our other bands. The frequency in this band which is the center

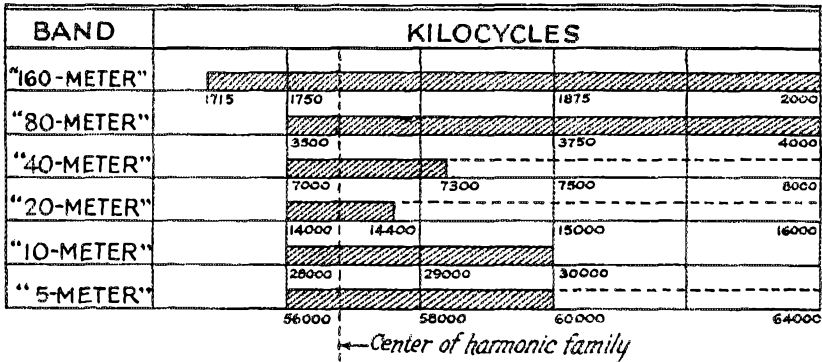

SHOWING RELATIVE WIDTHS OF 1929 AMATEUR BANDS  
FIG. 5

an amateur transmission could fall only within a higher-frequency amateur band. Only small portions of our 1929 bands are harmonically related to all of the others. The center of the harmonic portion is shown in figures in Figure 4 and is illustrated by the dotted line in Figure 5. From this it may be seen that if one wishes to have a crystal which, by harmonics, is capable of working in every amateur band, the crystal should have a frequency between 1750 kc. and 1800 kc. (166.7-171.4 meters); or, if the "160-meter" band is not desired, between 3500 kc. and 3600 kc. (83.3-85.7 meters).

We might now with profit look a little more carefully at each of our bands.

**1750-kc. band.** This band actually runs from 1715 to 2,000 kc. (175 to 150 meters). It contains about 60 commercial channels on the basis on which our Commission is now making commercial assignments. The

of the harmonically-related portion is 1775 kc.

**3500-kc. band.** This is our well-known "80-meter" band, 3500 to 4,000 kc. (85.7 to 75 meters). This band remains the same in 1929 as it is today. That is fortunate for us, for this is our traffic wave, the heart of our Communications Department, the backbone of the League. Most of our organized operating activities take place on it, and by far the bulk of our domestic communications. The Navy rates it as containing 52 commercial channels. The harmonic center is at 3550 kc. Telephony is permitted between 3500 and 3550 kc. (85.7 and 84.5 meters). The international agreement on this band is also that it is available for amateur, mobile, and fixed services. But the Federal Radio Commission, impressed with the necessity for our retaining it if our organized communication is not to perish, has decided that no

commercial mobile or fixed assignments will be made therein in this country. We retain in this band our old arrangement of the last several years with the government services, whereby we share this band with low-power Army, mobile stations working in daylight hours during the field training season, and with Naval aircraft while operating off-shore. The President has assigned to the Navy sixteen frequencies within this band for the use of Naval aircraft. The Navy has used frequencies here for many years and has not bothered us, so there is no reason to suspect that this means any additional inconvenience for us.

**7000-kc. band.** This is our million-dollar band, the center of the rumpus at Washington last fall, the one where we acquired the heartache and lost our shirt to Europe and Canada. Originally 7,000 to 8,000 kc., it will read next year 7,000 to 7,300 kc. (42.86 to 41.1 meters), with its harmonic center at 7,100 kc. It contains 18 commercial channels, viewed with envy and cupidity by a crass and vulgar commercial world. It is our chief international night band, and is open only to amateur telegraphy. Considering that we have nearly adequate privileges for domestic communication in the 3500-kc. band and are handicapped chiefly in our international bands, the League has proposed to the amateur societies of the world that the 7000-7300-kc. band be used in intra-continent work only for distances in excess of 1500 miles and that an informal and unofficial sub-division of the band be made for international working, whereunder amateurs of the United States would confine their transmissions to the portion from 7,000 to 7,150 kc., the remainder being partitioned amongst other groups of nations. This proposal is still pending.

**14,000-kc. band.** This band, once our joy and pride, extending from 14,000 to 16,000 kc. but never extensively occupied and held by amateurs, now reads 14,000 to 14,400 kc. (21.43 to 20.83 meters). Containing 13 commercial channels, it is our narrowest band in effective width, and as such dictates the center of the harmonically related portions of all of the bands, its center of course being at 14,200 kc. This is our daylight DX band, also used for super-DX at night. It is open only to telegraphy. In the same fashion as suggested for the 7,000 kc. band, the League has proposed the informal sub-division of this band amongst the amateur societies of the world, under which plan North American amateurs would confine their emissions to the portion 14,000-14,200 kc. This too is still pending.

**28,000-kc. band.** This is a new band extending from 28,000 to 30,000 kc. (10.71 to

10 meters) Although 2,000 kilocycles wide this band contains but 33 commercial channels and is therefore only of half the effective size of our "80-meter" band and just slightly larger than our "40-meter" and "20-meter" bands combined. The "harmonic center" is at 28,400 kc. The highest frequency regarded as being of commercial value is about 23,000 kc. and the value of this band is therefore questionable. Early experimenting has been fruitful, however, even over moderate distances, so that there is excellent reason for hoping that we shall be able to make this band of practical value to us before long. The international assignment is to "amateur and experimental," so that we may expect experiment stations of all descriptions to roam this band with us.

**56,000-kc. band.** This is what is left of the old "5-meter" band, now extending from 56,000 to 60,000 kc. (5.36 to 5 meters) and with its harmonic center at 56,800 kc. This also is "amateur and experimental" and perhaps a better term for it would be amateur experimental, as it has not yet been developed for practical communication. Much work has been done on it, by Kruse, Phelps, Douglass, Jones and others, and occasionally good signals have been heard at decent distances but with no reliability. This band and the 28,000 kc band are heaven for the experimenter, to whom we must look for methods which will eventually make them useful. 34 channels. The entire band is open for telephony work as well as telegraphy, and probably will be made available for amateur television and picture-transmission work.

As we conclude this informal analysis of our 1929 bands it seems all the more demonstrated to us that any proper appreciation of what we have and what we are doing next year must be in terms of frequency.

—K.B.W.

---

### Errata

The following corrections should be made in the Bourne article on Acoustic Wave Filters in August QST:

p. 25, second paragraph, first sentence, should read ". . . and attenuates currents of all other frequencies."

p. 26, next to last paragraph, last sentence, should read ". . . we have attenuation from 0 up to  $f_1$  and from  $f_1$  on up, . . ."

p. 27, third paragraph, for "diameter" read "distance."

## Opportunity

By Hiram Percy Maxim, President, American Radio Relay League

When I was a very small boy my father and I used to ponder at length over the problem: Is it the salt fish that makes the ocean salt, or is it the ocean that makes the salt fish salt?

There is a somewhat similar problem to-day but there is no joker in it. Is Amateur Radio what we amateurs have made it, or are we amateurs what Amateur Radio has made us?

Amateur Radio is one of the amazing products of this century. Where before has an amateur group been depended upon in great public emergencies? Where before has an amateur group been depended upon for communications by every kind of an exploring expedition that starts out? Where before has an amateur group been depended upon by a great railroad system for its communications in time of emergency? Where before has an amateur group been depended upon to carry a message from the President of the United States to an explorer in the polar regions? And where before has an amateur group led the way in an important field of scientific research?

The answer is: Nowhere. And hence the question: Is there something about Amateur Radio that carries us amateurs along with it and makes us what we are, or is it we amateurs who have made Amateur Radio the wonderful thing it has become?

I believe it is we amateurs. We built up a splendid organization, which gave us the tremendous advantage of being able to work as an efficiently coordinated whole, instead of a disorderly mob. And this brought us OPPORTUNITIES, which we never otherwise would have had.

And all the OPPORTUNITIES have not passed. Radio telegraphy brought broadcasting. The latter brought the talking moving picture. And then meanwhile amateur moving pictures came along. They have brought that latest marvel, full natural colored amateur motion pictures. Commercial full natural colored motion pictures will quickly come from these, and full natural colored talking moving pictures will follow it. And then will come radio television in full natural colors.

Amateurs are to have golden OPPORTUNITIES in all of them. And it leads one to wonder which of us, obscure to-day, are to shine with the lustre of a Lindbergh tomorrow.

Let's keep everlastingly at it, fellows.

### Pacific Division Convention

Oakland, California, October 11-12-13

**Y**ES fellows, the 9th annual convention of the Pacific Division is to be held at the Key Route Inn, 22nd & Broadway, Oakland, on the above dates and *some* program has been prepared. No dry technical talks, but of course there will be discussions. The big *motto* is a good time for every one with trips to Idora Park, where free rides on all concessions will be had; swimming, roller skating, etc., on one of the days—the next day at Lakeside Park where free picnic lunch will be served and where a number of stunts will take place.

A special trip will be made to San Francisco where the gang there will entertain the delegates.

The committee in charge is working hard to outclass all previous conventions but we will need your attendance to do this. Come one, come all—every one will be welcome.

Write S. G. Culver, the convention secretary, Box 549, Oakland, Calif., that you will be present.

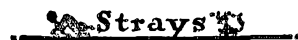
 **Strays**

Perhaps the simplest way to get a good musical note would be to paint the set with phonograph records dissolved in alcohol.

—SBWS

# Adapting Medium and High-Powered Self-Excited Transmitters for 1929 Service

Some Design, Constructional and Tuning Considerations Involved

By Ross A. Hull\*

As a sequel to "Overhauling the Transmitter for 1929," which appeared in the August QST, this article treats the particular modifications which are desirable in transmitters of medium or high power. It is assumed that the reader will have made a detailed study of the preceding article. If this is not so, a complete understanding of the present outline will be impossible.—Editor.

NO one will deny the existence of a belief, among radio amateurs, that a transmitter assembled neatly behind a shining panel and equipped with a fine array of meters and control knobs never works quite so well as did the same apparatus in its early life, spread in wild confusion across a table top. Nor can

sadly as the power was raised. For a week or more, the Laboratory was filled with odors of burning bakelite, hard rubber and wood, and at times whiffs of smoke drifted lazily across the tables—but in the end our pulse had returned to normal, for we had found that even 250-watt self-excited transmitters can be made to behave in a 1929

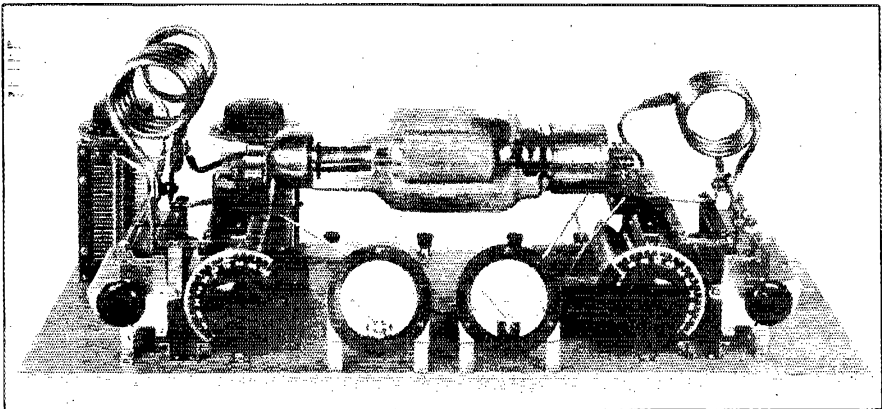

ONE TYPICAL HIGH-POWERED SELF-EXCITED TRANSMITTER WITH A "1929 TYPE" PERFORMANCE

Heavily built with conductors, resistors, condensers, transformers and chokes of ample proportions, provided with High-C grid and plate tanks, and tuned with extreme care, this transmitter behaved admirably both in the Laboratory and when later operated under average conditions. In two evenings, when five countries were "worked", the reports—whether we believed them or not—were all "d.c. crystal-control".

it be denied that there exists an equally fallacious belief to the effect that the circuits and values of a successful low-powered transmitter will not provide an equivalent performance when high power is used. We had built low-powered transmitters which provided a "1929 performance" but there was too much of the radio amateur in our make-up to allow us to approach the application of the same ideas to high-powered work without considerable concern. There was, it seems, that inborn fear that the performance of our transmitters would drop

manner with just the same treatment we had given the low-powered set.

The treatment, as we explained last month, consisted of installing High-C tuning circuits, making all conductors, condensers, resistors, transformers and chokes of ample proportions, and tuning with extreme care to keep the grid excitation at the most desirable value, the antenna coupling at the lowest practical point and the antenna detuned on the particular side of resonance which provided the cleanest signal.

The only serious problem, of course, was that involved in the use of the High-C circuits which we had found so effective

\*Associate Technical Editor. QST. In charge A.R.R.L. Technical Development Program.

in the low-powered transmitters. Calculation showed us that we could expect tank currents of the order of 18 amperes if we employed the capacity-inductance ratios of the low-powered sets, and much experimental work preceded the construction of

cannot be followed in any self-excited transmitter if a 1929-type performance is to be expected.

The circuit used is the tuned-grid tuned-plate, selected on account of its mechanical suitability for use with a long tube having its grid terminal at one end and its plate at the other. Other circuits could have been used but with this particular tube they would not have permitted the same simplicity of layout or directness of wiring.

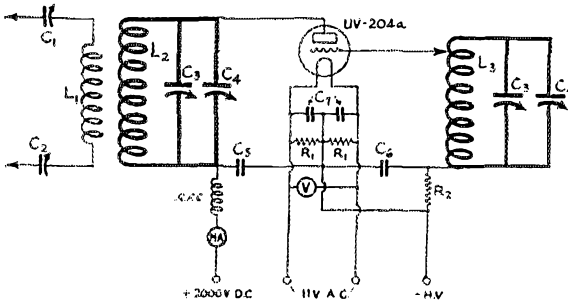

FIG. 1. THE CIRCUIT OF THE TRANSMITTER ILLUSTRATED

- C1, C2—440- $\mu$ fd. variable antenna or feeder tuning condensers.  
 C3—440- $\mu$ fd. variable condensers connected across the tuning condensers used to provide adjustable "lumped" capacity for the High-C circuits.  
 C4—330- or 250- $\mu$ fd. tuning condensers.  
 C5—100- $\mu$ fd. fixed by-pass condenser (5,000-volt rating).  
 C6—100- $\mu$ fd. fixed grid condenser (5,000-volt rating).  
 C7—2000- $\mu$ fd. fixed filament by-pass condensers (2,500 volt rating).  
 R1—100-ohm center tap resistors. A center-tapped filament transformer can be used instead.  
 R2—Heavy duty 10,000-ohm grid leak. Leaks rated at 75 watts or less usually will heat appreciably and cause frequency creeping.  
 R.F.C.—160 turns of 28 gauge D.C.C. wire on a  $\frac{3}{4}$ " diameter form.

This circuit was used in the transmitter under discussion in preference to the Hartley or Colpitts merely because of its particular adaptability to a tube having its grid terminal at one end and its plate at the other. Any one of the many satisfactory keying methods which have been described in QST can be used.

tank circuits in which the losses were low enough to be justified without question by the improvement in performance.

#### A TYPICAL TRANSMITTER

The final transmitter, built at the completion of the experimental work to provide a typical example of the manner in which the high-powered transmitter should be remodeled for 1929, is that illustrated in these pages. We will first describe it in detail and then proceed to a discussion of the manner in which the same principles could be applied to transmitters of other types.

A UV-204-A tube was selected for use in the "sample" transmitter since it is the largest tube readily available to the amateur and so is the tube most suited for use in a 1929-type high-powered outfit. A great many amateurs attempt to build a successful high-powered transmitter by using a UX-852 or similar tube running at four or five times its rated power but there is not the slightest question that this procedure

#### TANK CONDENSERS

The variable condensers throughout are of standard types. Many types of pie-plate, copper disk and copper tube condensers for the tank circuits were built, and still more designed, but considerations of compactness and simplicity invariably brought us back to the use of the standard types connected in parallel to give the necessary capacity. We admit, however, that there is a splendid field of endeavor in the evolution of cheap and effective "home-brew" fixed or adjustable tank condensers to be added in parallel with existing tuning condensers. The most important requirements will be the use of heavy copper sheet for the plates, and pyrex glass, high quality hard rubber or well dried wood for the insulation; the use of heavily-soldered connections to all plates, and the provision of some means of halving and quartering the capacity so that it may still be used on the highest frequency bands. In both the grid and plate circuits of this transmitter, a Cardwell Type 199 condenser is run in parallel with a Type 147B, the former used for tuning adjustment, having a maximum capacity of 330  $\mu$ fd., and the latter used as an adjustable lumped capacity, contributing 440  $\mu$ fd. The two feeder or antenna condensers are of the Type 147B. "Double-spaced" condensers are all that are necessary for the plate tank of a tube supplied with 2000 volts when a High-C circuit is used. Where plate voltages of the order of 500-1000 are used the spacing used in good receiver-type condensers is satisfactory. In the grid circuit the voltages are still lower but it was still found worth-while to use "double-spacing" where the plate voltage is of the order of 2000 volts.

#### INDUCTANCES OF UNUSUAL PROPORTIONS

The grid and antenna inductances are wound with  $\frac{1}{4}$ " copper tubing, this being of suitable size for the currents



flowing in the circuits in which they are connected. The plate coils, however, are of much heavier construction. Our first plate tank had an inductance of the same  $\frac{1}{4}$ " copper tubing as that for the grid and antenna coils, the temporary connections to the condensers being made with clips heavily soldered to cables of about the same diameter as the tubing.

long periods at higher power than the rating of the tube, for both of them, under such conditions, heat appreciably. Experiment with High-C circuits covering the widest practical range of values and dimensions has led us to recommend that plate and grid tanks similar to those of the transmitter under discussion be used in cases where the input power is between 100 and 400 watts.

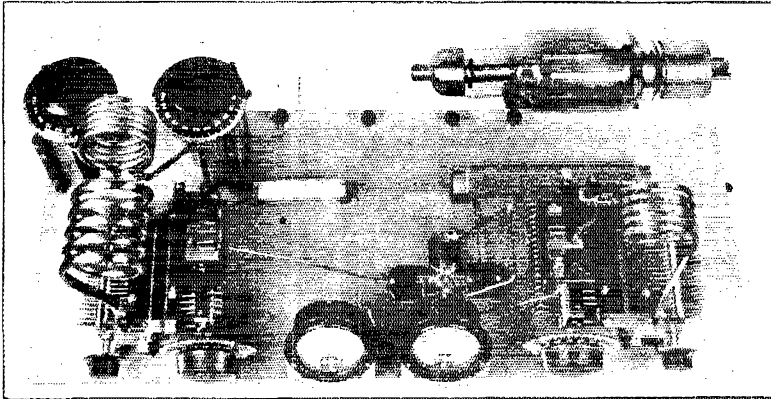

THE "250-WATT" TRANSMITTER AS SEEN FROM ABOVE

At the right is the grid unit comprising the tank circuit with its two variable condensers in parallel, and the heavy duty grid leak immediately behind them. Of the four fixed condensers arranged in a group, that on the right is the grid condenser. On the left of the group is the plate circuit by-pass condenser, the remaining two serving as the filament by-pass. On the left side of the transmitter is the High-C plate tank, with its unusually heavy inductance, and the antenna tuning unit. To the right of this plate unit the radio frequency choke can be seen.

After a run of a few minutes the conductors heated to the point where solder is liquid and the whole thing fell apart. The plate coils eventually decided upon as the mean of efficiency and clumsiness are of  $\frac{3}{8}$ " tubing, the ends, as in the case of the other coils being sweated into copper lugs of the type used in power switchboard wiring. The plate and grid coils are attached with machine screws and wing nuts to  $\frac{1}{2}$ " wide, copper strips which serve also as the connectors between the two variable condensers. The exact arrangement of this mounting can be seen in the photographs. The antenna coils are mounted in a somewhat similar fashion on brackets projecting from the two series condensers. The important points to observe are that the plate and grid coils are mounted directly on the condensers, so avoiding any long leads; that the connections between the coils and condensers are of heavy construction with large contact areas, and that the mountings are sufficiently substantial to avoid the possibility of vibration of the coils unless they are actually struck. It might be admitted that even the plate and grid coils of the present transmitter could be improved upon if the transmitter were to be operated for

For inputs greater than these it is suggested that  $\frac{1}{2}$ " outside diameter tubing or, preferably,  $\frac{3}{4}$ " wide, heavy copper strip, be used for the plate coil and  $\frac{3}{8}$ " tubing or  $\frac{1}{2}$ " strip for the grid. In all cases the leads to the tank condensers should be of similar conductor to that used in the inductance and some heavy clamping device should be used for the connections. *Clips simply will not serve the purpose.*

Further comment on the constructional details of the transmitter are hardly necessary for the minor points can well be gleaned from a study of the circuit diagram and the photographs. It can be said, however, that it is not suggested for one moment that the transmitter represents the acme of mechanical and electrical perfection. It is presented merely as an example of the simple modifications necessary to equip the amateur transmitter with High-C tanks, mechanically rigid construction and, as the outcome, the ability to produce signals of 1929 standard when tuned correctly.

#### REBUILDING EXISTING TRANSMITTERS

In quite the majority of present-day amateur transmitters, complete re-construction would not be necessary in order to modify them in accordance with the ideas set out

herein. In a Hartley transmitter employing a UX-582, for instance, the only important changes might well be in the mounting of the tube so that its grid and plate leads are convenient to the plate tank, the addi-

Aside from these matters, the attainment of a 1929 signal with the self-excited circuit will most certainly mean the dumping of a.c. or "self-rectified" plate supply and the installation of some form of rectifier or a generator. At the moment, sad to relate, the only truly practical rectifier for the UX-852 or UV-204-A is the mercury arc, but we are fortunate in being able to hint that it may not be long before this condition is effectively remedied. The filter system is still to be a problem but the improvement in the plate-voltage-vs.-frequency characteristic afforded by the use of High-C tanks will simplify the matter to a considerable degree. We dislike the idea of talking results and so leaving ourselves open to misunderstanding on the part of the more literal-minded readers, but in this connection we cannot refrain from mentioning that the transmitter illustrated on these pages, supplied from a mercury arc rectifier and equipped with a 2  $\mu$ f. condenser as its only filter, can produce a piercing "d.c." note on which modulation can be detected only by the hypercritical observer.

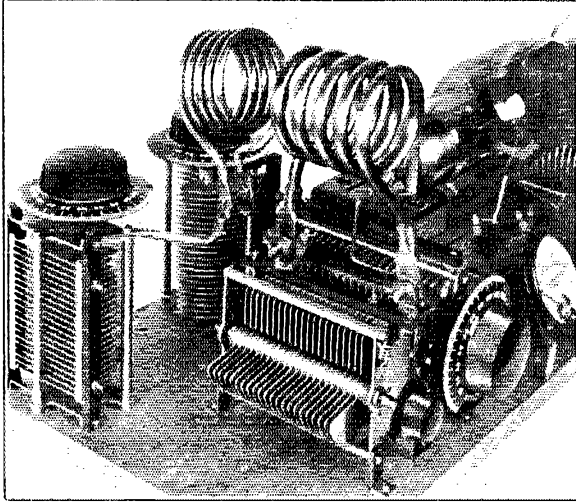

A "CLOSE-UP" OF THE PLATE TANK AND ANTENNA TUNING UNIT

In the immediate foreground is the 440- $\mu$ f. variable condenser providing "lumped" capacity, adjustable for the various frequency bands. Behind it, and connected in parallel with it, is the main tuning condenser. Heavy copper strip is used for all connections in the tank, the inductances being attached to the tank condensers with  $\frac{1}{4}$ " machine screws and wing nuts. Coupling between the plate and antenna coils is varied by swinging the latter on its mounting.

tion of a second variable condenser in parallel with the existing plate condenser, and the provision of a new set of plate coils with suitable heavy mounting and connections on the condensers.

In a Colpitts transmitter the same process would apply, the particularly important point in this case being to remember that the "bridge condensers" and the condenser joining the two coils in the "split Colpitts" all must be considered as tank condensers and so must not only be proportioned to give the required total capacity across the coil but should be of a high grade, air dielectric type. Small mica dielectric condensers could not be used effectively in these roles.

Of course, in all probability, the alterations also would involve a general clean-up of wiring, a stiffening of the antenna coil and its mounting, and some re-rigging of the antenna to avoid appreciable vibration or swinging. Then, it may mean installation of a separate filament transformer to avoid filament-voltage fluctuations during keying or the use of a separate power outlet for the filament supply if a filament transformer is being used and fluctuations still occur.

#### ADJUSTING FOR A 1929 PERFORMANCE

The tuning process for the high-powered transmitter is similar to that described last month for the low-powered set, the chief

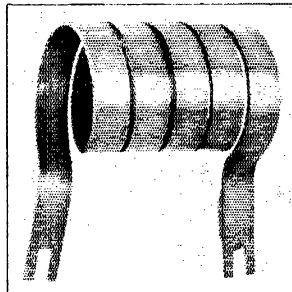

THE TYPE OF PLATE INDUCTANCE SUGGESTED FOR USE WITH INPUT POWERS GREATER THAN 400 WATTS

Built of  $\frac{1}{4}$ " thick copper strip  $\frac{3}{8}$ " wide, inductances of this type proved satisfactory in the High-C plate tank even at the highest possible input to the tube. Careful comparison with the  $\frac{3}{8}$ " copper tube inductances, however, revealed no improvement in performance that would justify their use with input powers less than 400 watts under normal conditions of efficiency. Rather, the scarcity and expense of the strip, and the difficulties entailed in winding it, made the tubing much to be preferred.

difference being in the observance of extreme care in avoiding contact with any

metal part of the set. The operator can be killed suddenly and very effectively by coming into contact with the transmitter in the right (or wrong, if you wish) manner.

In the tuned-grid tuned-plate circuit it is well first to set the plate condensers at

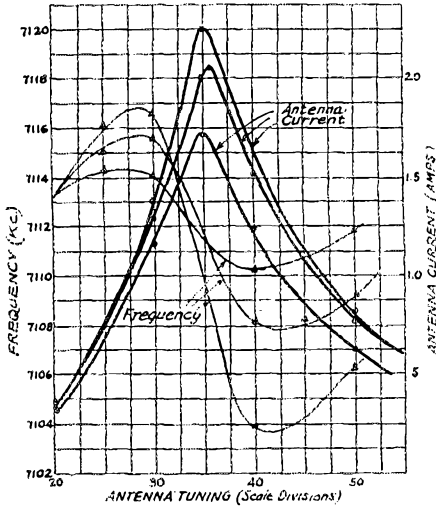
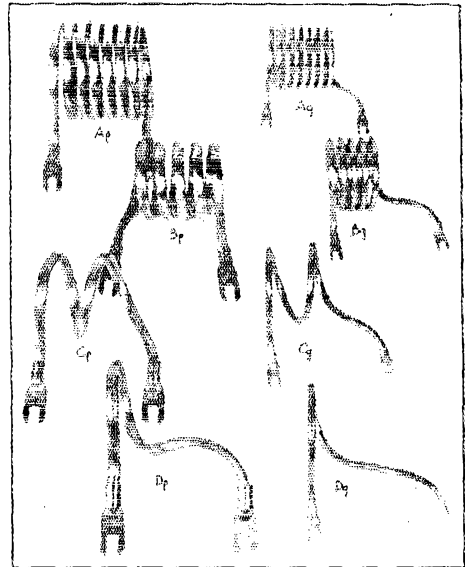

FIG. 2. ANTENNA-TUNING VS. FREQUENCY CURVES FOR THREE VALUES OF ANTENNA COUPLING

In addition to showing a performance similar to that of the low-powered transmitter described last month, these curves provide further indication of the splendid improvement in stability afforded by loose antenna coupling.

some estimated value with the grid tank condensers at zero. Then, with the antenna coil removed, the plate voltage (reduced to about 75% of the rating of the tube) can be applied, and the grid tank capacity increased slowly until the plate current dips and then rises to a value about 10% higher than the minimum. At this point the frequency should be checked, and if it is not within the band the process should be repeated until it is. At this stage the antenna coil can be coupled loosely and the antenna or feeder circuit tuned until maximum current is indicated. If the plate current at this point is still below the rating of the tube, when the voltage has been increased to normal, the grid capacity can be increased until it has climbed to the required value, at which time the antenna tuning should be readjusted. Each change in the constants of the grid circuit will mean changes in frequency and so continual checking with the frequency meter will be necessary. The antenna coupling can now be increased until maximum antenna current is obtained and immediately it should be reduced until the antenna current is about 85% of the maximum value. It is at this

stage that it is so essential to check the signal with a monitor or "Growler" in order to observe on which side of resonance the antenna should be detuned in order to obtain the cleanest signal and in order to permit that final polishing of all adjustments which is to mean the difference between a good 1928 and a 1929 performance. The monitor will be indispensable also in deciding upon the connections to the antenna coil. With symmetrical current-feed antenna systems the difference in note with the leads to the antenna coil connected one way or the other usually will not be marked but in the as-



GRID AND PLATE INDUCTANCES FOR FOUR FREQUENCY BANDS

For the 3500 kc. band Ap and Ag are the coils used, Ap being 3 1/2" inside diameter and Ag 2 3/4". Bp and Bg serve for the 7000 kc. band, Cp and Cg for 14000 kc., and Dp, Dg for 28000 kc. With the exception of coil Ap the coils are all 2 3/4" inside diameter. The plate coils are of 3/8" outside diameter copper tubing, and the grid coils of 1/4" tubing. All of them were wound by hand on pieces of iron pipe. This procedure is possible, however, only when the tubing is of the "soft drawn" grade.

symmetrical antenna feed systems such as the "Zeppelin," the vertical current-feed antenna or the "antenna-counterpoise" arrangement, many adjustments can be obtained with which one particular connection must be observed. In the transmitter under discussion with the particular antenna used the shrill "d.c." note gives place to a heavily modulated signal just as soon as the feeder connections are reversed.

The more we tune transmitters the more convinced do we become that the amateur transmitter can be tuned about as success-

fully by watching the meters alone as an automobile can be driven in heavy traffic by exclusive observance of the ammeter and

card size, 5½" wide x 3¼" high, may go thru the mails, in the United States and its possessions only, with only a 1-cent stamp affixed. When making up your QSL cards have them of the above dimensions (unless you use the government 1-cent card) and you will save 1c on each card. Private mailing cards of other sizes still take 2c each. Add this latest information to the rates already given on page 26 of the July, 1928, issue of QST and save yourself money.

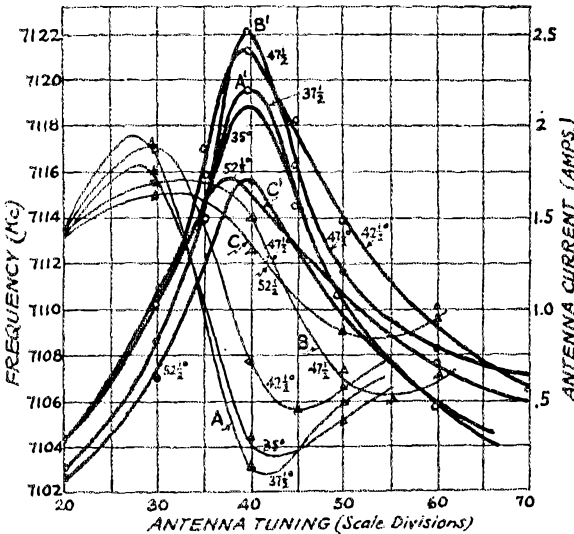
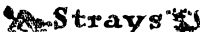

FIG. 2. PROVIDING SOME INDICATION OF THE INSTABILITY ACCOMPANYING LOW VALUES OF GRID EXCITATION

Curves A, A1 were taken with the grid condenser set at the value which gave minimum plate current. Serious frequency instability was noted and the curves could not be duplicated by rotating the antenna condenser in the opposite direction. Satisfactory stability could only be obtained by the use of extremely loose coupling. Curves B, B1 were taken with that value of grid excitation which gave the rated plate current for the tube under normal conditions. Much greater frequency stability is indicated and the frequency curve B could be checked and rechecked at any point. With still greater grid excitation curves C, C1 obtained. The rather flat frequency curve C, however, was accompanied with a considerable loss of output and serious heating of the tube. The adjustment was not one which could be used in practice. With this circuit the adjustment of grid "tuning" and antenna coupling are closely related. Low or high values of grid excitation require extremely loose antenna coupling to give satisfactory frequency stability whereas, with grid excitation of a particular order, the normal antenna coupling can be used and high efficiencies obtained. A study of the signal in the monitor can be depended upon to reveal this desirable value of grid excitation.

the oil gauge. We can see no more justification in the amateur operating his transmitter without being able to hear what his signal is doing than in the motorist driving his car without the ability to see where he is going. In fact we can foresee the possibility of the introduction of another crime in amateur radio punishable by Wouff Hong—that of operating a transmitter without monitoring it throughout every transmission. Why, broadcasting stations are put off the air for failing to do that very thing!



Save Postage!

Since July 1 private mailing cards, if they conform to standard government post-

SAA, on his new card, has replaced all the conventional dotted lines with the statement "Believe it or not! Your 'Pure d.c. Crystal-control signals' pounded in here R9 on ..... 19..." That's one more stunt that won't be novel any more.

Undesirous of climbing the high roof of a rickety barn to unhitch his old antenna, and anxious to make room for his new one, 1BZJ hit upon the idea of shooting it down with a "22" rifle. A single shot, it is said, sufficed.

YL—"And what's the furthest place you've ever reached with your radio?"

Ham—(Wondering whether she meant transmitting or receiving.) "Elucidate".

YL—(She must have been a bit dumb.) "Never heard of it."  
1BHB, 1ARA

6BWS has built a new 5 meter transmitter. The component parts comprise a filament meter, plate meter, grid meter, antenna meter and wavemeter. [We used that this month because we are to talk frequencies from now on.—Editor.]

Special Despatch to the Toronto *Globe*. (Extra special we'll say) Quebec,—

"Hidden in a shabby street here has been found what is described as the most powerful radio set in America, the machine being in the possession of a 21 year-old Russian. With this set Arsene Nelna is said to have been in communication with European Capitols for the last two years. The powerful radio is called a "Kolster Decremeter", and it is the last word in telegraphy and wireless telephony. With this machine, it is stated, Nelna has been talking to Paris, Petrograd, Berlin and London every day for several years. What these messages are may lead to startling discoveries."

Why, yes. The "Kolster Decremeter" may yet be the cause of another World War.

# The UX-860

## A Screen-Grid Power Tube

By Harold P. Westman, Technical Editor

**T**HE long line of radio tubes already available to the amateur and experimenter has recently had a new youngster of rather husky proportions ushered into its midst under the alphabetical-numerical cognomen of the UX-860. It being a "power" tube, there is no "CX" or Cunningham designation involved.

The UX-860 is a screen version of the 852. In cases where the 3.3  $\mu$ fd. grid-to-plate capacity of the 852 causes trouble, the 860 may be substituted and its reduction of this capacity to a value of .05  $\mu$ fd. should be very helpful. It is designed primarily for use as a radio frequency amplifier at frequencies greater than 3,000 kcs. The screen-grid does away with the necessity of neutralization although it by no means does away with the need for proper shielding of the external circuits.

While it may be used as an oscillator, it has no particular advantage over the 852 as such nor is it generally suitable for use as a modulator or audio frequency amplifier due to its high plate resistance.

This tube very much resembles the 852 in appearance. It is of the T type in which the plate and grid are supported on separate stems with their leads brought out through separate seals which insure low capacity and high insulation. The filament is supported on a third stem and its leads together with the lead from the screen grid are brought out through another seal. As in the 852, the filament leads terminate in a UX base, the screen-grid being connected to the grid terminal of this base.

A thoriated tungsten filament in the shape of a double helix is supported from a center rod and requires no springs. The plate is cylindrical with six fins or wings to dissipate heat. The screen is of close mesh and is interposed between the control grid and plate. It is as high as the tube and is supported by collars clamped to the filament and grid stems.

The filament should be operated at its rated voltage. Loss of emission may be occasioned by either overloading or underloading the filament. Loss of emission due to reduced filament voltage is due to too low a rate of diffusion of the active material to the surface of the filament. This is materially hastened by the application of abnormal plate voltage and high plate current.

As with the other tubes employing thoriated tungsten filaments, severe overload may cause a decrease in emission. Providing a

large amount of gas has not been liberated, the emission may be restored by disconnecting the plate and screen-grid voltages and operating the filament at normal voltage for ten minutes or more. The time required for reactivation may be decreased by raising the filament voltage to 12 volts.

The maximum plate dissipation either as an amplifier or oscillator should never exceed 100 watts. This corresponds to a cherry red color of the plate. Looking at

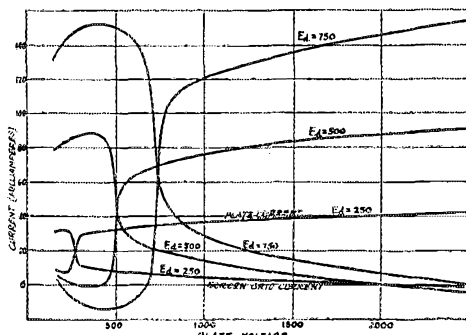

FIG. 1. SHOWING THE VARIATION OF BOTH SCREEN-GRID AND PLATE CURRENT WITH CHANGES IN PLATE VOLTAGE, CONTROL GRID VOLTAGE BEING ZERO AND FILAMENT VOLTAGE, 10.

the plate with the filament lighted is apt to be misleading because of the reflection of the light from the filament. It is best to turn the power supply to the tube off and note the plate color.

The screen voltage may be obtained from a separate source or from the plate supply system. The use of a separate source is not only expensive but does not offer as much safety as does the second method. If the plate voltage is removed and the screen voltage maintained, the screen current will increase considerably and overload that element, destroying it perhaps. On the other hand, if the screen voltage is obtained from the plate supply system, any changes in plate voltage will also result in a change in screen voltage and the ratio of the two will remain about the same, thus eliminating this danger.

If a resistance of approximately 100,000 ohms be placed between the positive terminal of the plate supply and the screen, the voltage on the screen will be of a satisfactory value. When using this method of

supply, the filament circuit should not be opened with the plate voltage on or the full plate voltage will be applied to the screen needlessly stressing the seal, etcetera. In all cases, the impedance between the screen and filament must be kept low by means of by-pass condensers. At no time should the screen dissipation exceed 10 watts which as in the case of the plate is indicated by a cherry red coloring.

Under normal operation, a bias of approximately 200 volts should be applied to the control grid. When a leak is substituted for battery bias, its value should be about

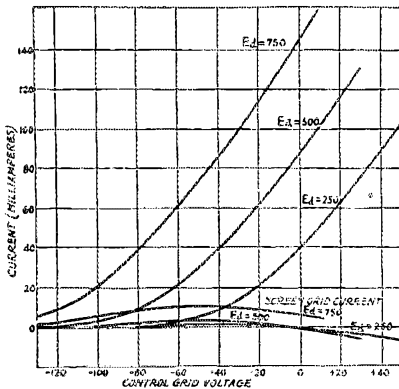

FIG. 2. EFFECT OF CONTROL GRID VOLTAGE UPON SCREEN-GRID AND PLATE CURRENT WITH 2000 VOLTS ON THE PLATE.

10,000 ohms. The value of bias is not critical and variations to suit particular circuit arrangements may be made. Both grid and plate leads are in the form of two conductors which should be twisted together. If only one of these conductors is used, excessive heating at the seal may result.

Some characteristics of the tube are given herewith:

- Filament voltage 10.
- Filament current 3.25 amperes.
- The following values are obtained with normal plate voltage (2000 volts) zero grid bias and normal screen voltage (500 volts);
- Plate current 70 milliamperes.
- Plate resistance 150,000 ohms.
- Mutual conductance 1.35 milliamperes/volt.
- Amplification factor 200.
- Approximate direct interelectrode capacities (I. E. E. definitions).
- Plate-to-grid (Filament and screen grounded) .05 mufds.
- Grid to filament and screen 8.5 "
- Plate to filament and screen 9.0 "
- Maximum operating plate voltages
- Modulated plate voltage d.c. 2,000. volts.
- Non-modulated plate voltage d.c. 3,000 volts.
- A.c. plate voltage (r.m.s.) 3,000. volts.

- Maximum plate current d.c. 100. mils.
- Maximum plate dissipation 100. watts.
- Maximum screen dissipation 10. watts.
- Nominal screen voltage 500. volts.

The filament voltage current characteristics are the same as for the 852 and are not given here. This curve may be found on page 21 of the May, 1927 issue.

This tube should be of interest to those operating crystal controlled transmitters or other types of oscillator-amplifier circuits at the higher frequencies where feedback is so damaging.

As with all other power transmitting tubes excepting the 852, the 860 may only be obtained directly from the Engineering Products Division, Radio Corporation of America, 233 Broadway, New York City, New York. To save you the trouble of telling us that the 210 and 250 are obtainable through dealers, we should like to point out that these types are now considered as being primarily amplifier tubes for broadcast receivers and not transmitting tubes exclusively.

Correction

An error was made in figure 1 in the article "Some More About the Family" by A. B. Chamberlain which appeared on page 29 of the July issue. The ordinates should be labelled "TU Loss" rather than "TU", thus indicating a loss of high frequency audio energy due to transmission over a bare circuit. This is compensated for by the equalizer which has opposite characteristics.

9XL Transmissions

(Continued from Page 8)

Friday Evening Schedules			Sunday Afternoon Schedules		
Central Standard Time			Central Standard Time		
Time (PM)	Schedule A	Schedule B	Time (PM)	Schedule C	
8:30	3.5 (85.7)	7.0 (42.9)	3:00	14.0 (21.4)	
8:42	3.75 (80.0)	7.2 (41.6)	3:12	14.2 (21.1)	
8:54	4.0 (75.0)	7.4 (40.5)	3:24	14.4 (20.8)	
9:06	8.5 (35.3)	7.6 (39.5)	3:36	15.0 (20.0)	
9:18	9.0 (33.3)	7.8 (38.4)	3:48	16.0 (18.7)	
9:30	9.5 (31.6)	8.0 (37.5)			

September	14-Schedule "A"	16-"C"	28-"B"	October	12-Schedule "A"	14-"C"	26-"B"
-----------	-----------------	--------	--------	---------	-----------------	--------	--------

DIVISION OF TIME

- 3 minutes—QST QST QST nu9XL.
- 3 minutes—5 second dashes broken every half minute to give station call letters.
- 1 minute—announcement of frequency in megacycles per second (8.75 megacycles is sent as "8r75 MC.")

If you use these transmissions please send a note to the Experimenters' Section, A.R.R.L., 1711 Park St., Hartford, Conn.

—H. P. W.

# The Zepp

## Facts and Figures for the Design of the Hertz Antenna with Two-Wire Voltage Feed

James J. Lamb\*

THE general principle of the two-wire feeder is as old as the theory of electric waves on wires. The Hertz antenna is as old as the theory of electric oscillations. Therefore this article is founded on ancient history, and anyone interested in digging deeper into the theory and mathematics of the thing may do so by looking up the chapter on electric waves on wires in Fleming<sup>1</sup>, (edition of 1910), or in Pierce's "Electric Oscillations And Electric Waves." The latter, by the way, covers the theory of feeders beautifully.

There are two types of antenna feed in general use among amateurs today, one being what is called "voltage" and the other "current". The names have not as much to do with the feeders themselves, as with the point at which they are connected to the antenna. The voltage feed system is coupled in some manner to the antenna at a voltage antinode (usually at one end) while the current feed type is coupled in some manner to the antenna at a current antinode, usually the center or an odd quarter wave from one end. The feeder systems are themselves of two general types, the first complex in design and suitable for one fixed frequency, the second wonderfully adaptable to amateur use.

The first system is that in which the output impedance matches the impedance of the feeder system thereby preventing wave reflection and standing waves on the feeder wires.<sup>2</sup> The second, is that in which the output terminals are open circuited, there being full reflection and consequently standing waves on the wires.<sup>3</sup> The second, when used as a voltage feeder, is the familiar Zeppelin, and the one in which we are interested.

The conventional case of two parallel wires with their output ends open circuited and with a non-reflective source of high-frequency sinusoidal E.M.F. at the input end is shown in Figure 1. In the case of the two parallel wires as used in amateur feed systems (the attenuation being negligible) we shall have maximum amplitude of current at G at a given frequency, (wavelength) when the length  $L$  of each of the wires is equivalent to an odd multiple of a quarter wavelength. The current at the ends of the wires will, of course, be

zero, and the voltage amplitude a maximum. There will be a phase difference of 90 degrees between the voltage and current at any point on either wire, due to full reflection, and the current at a given point on either wire will be 180 degrees out of phase with current at a similar point on the

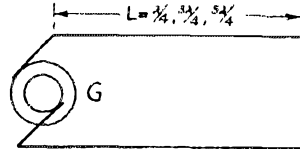

FIG. 1. TWO PARALLEL WIRES WITH THEIR OUTPUT ENDS OPEN CIRCUITED AND INPUT SUPPLIED WITH A HIGH FREQUENCY SINUSOIDAL E.M.F. FROM A NON-REFLECTING SOURCE G. EACH WIRE IS AN ODD MULTIPLE OF  $\frac{1}{4}$  WAVELENGTH LONG

other wire an equal distance from the source. The field about either wire will therefore cancel that of the other, and little or no electro-magnetic radiation will result.

If a wire equal in length to an even multiple of a quarter wavelength is now added to one side, as shown in Figure 2, the relation of forward to reflected waves remains the same as in the case of Figure 1, but the extension is a linear oscillator in free space, radiates electro-magnetic waves, and becomes an antenna. This is one way of explaining the theory of the two-wire volt-

1. Principles of Electric Wave Telegraphy and Telephony, by J. A. Fleming.

2. Matching the Transmission Line to the Antenna, by Walter Van B. Roberts, QST, Jan. 1928. The voltage and current are practically in phase, there being just sufficient potential difference between the input and output terminals to offset the drop in the line. A neon tube run along the length of such a feeder system should glow with practically constant brilliancy at all points indicating almost constant voltage distribution.

3. When there is a full reflection from the output terminals, the voltage and current are in phase quadrature, or 90 degrees out of phase with each other. Standing waves on the wires accompany reflection and are indicated by points of maximum and minimum voltage and current. The distance between two points of maximum current or voltage is  $\frac{1}{2}$  wavelength and the distance between a point of maximum current and one of maximum voltage is  $\frac{1}{4}$  wavelength. A neon lamp run along the wire will glow with the greatest brilliancy at a voltage antinode and will show no glow at a voltage node.

age feed or Zeppelin antenna. Now that we have the theory, we can tackle the actual design.

There are three essential requirements in the dimensions of a successful "Zepp", and these are:

(1) The feeder system must be such that each wire is equivalent in length to an odd multiple of one quarter of the wavelength being used. In other words, the feeder (both wires as a unit) must be tuned to the fundamental or an odd multiple of the fundamental of the wavelength being used.

(2) The antenna must have a length equivalent to an even multiple of one quarter wavelength.

(3) The feeder system must be electrically symmetrical.

Since the antenna or radiator is first erected and the feeder system suspended from it, we will now take up its design and construction.

#### THE LENGTH OF THE ANTENNA

The length of the antenna or radiator for a given frequency will not be the same for all conditions. If it runs close to the

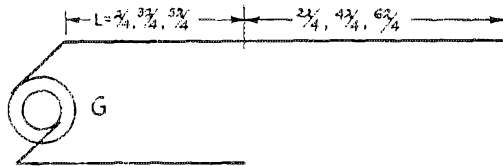

FIG. 2. WIRE OF LENGTH EQUAL TO AN EVEN MULTIPLE OF  $\frac{1}{4}$  WAVELENGTH ADDED TO ONE SIDE OF THE SYSTEM

In actual practice G is the antenna inductance and associated tuning apparatus.

ground, immediately over a tin roof, near a grounded gutter-pipe or lightning rod cable, its natural period (in terms of frequency) will be lower than that of the same antenna in the utopian state known as "free space". The antenna will not have to be very far "above ground", however, to become apparently quite free from the loading effect of capacity to ground and the length may therefore be calculated as for a radiator with zero inductive and capacitive loading in free space and later shortened as may be required. The lowest frequency at which an unloaded Hertz antenna may be operated is its fundamental. When so operated it is a "half wave", or its length is equivalent to one half the wavelength at which it is operated. Therefore, the shortest antenna length we may have is a half wave of the longest wavelength we are to use. The antenna may, of course,

be operated at frequencies which are harmonics of the fundamental frequency, or wavelengths which are  $\frac{1}{2}$ ,  $\frac{1}{4}$  or  $\frac{1}{6}$  of the fundamental wavelength. Let us suppose

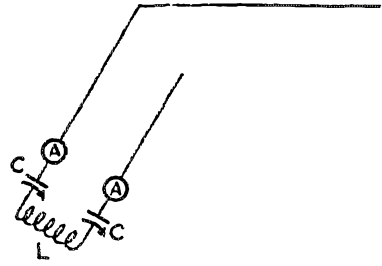

FIG. 3. SERIES TUNING OF THE FEEDER SYSTEM

that we wish to design an antenna to operate on the four amateur bands of 3,500-, 7,000-, 14,000- and 28,000-kc. (80, 40, 20- and 10 meters). The shortest antenna which may be used is a  $\frac{1}{2}$ -wave 80-meter radiator, although it could be made a  $\frac{1}{2}$ -wave 160-meter radiator and operated as a  $2/3$ -wave antenna on 80 meters. One meter is 3.28 feet, and the length of the  $\frac{1}{2}$ -wave 80-meter antenna is therefore  $\frac{1}{2} \times 3.28 \times 80$  or 131.2 feet. We make the antenna of this length to start with and later shorten it, if necessary, after giving it a check by the method to be described further on.

Having our radiator now prepared for suspension between heaven and earth, we are ready for the feeders.

#### DESIGN OF THE FEEDER SYSTEM

As stated before, the feeder system as a whole must be tuned to the fundamental or an odd multiple of the fundamental for the wavelength being used. In other words, the feeder system must be  $\frac{1}{2}$ -wave,  $3/2$ -wave,  $5/2$ -wave etc. The feeder system might be so constructed as to have each feeder wire exactly equivalent to an odd multiple of  $\frac{1}{4}$ -wave in length, allowance being made for the loading effect of the input inductance, but this would be a tedious process and would permit operation on one fixed frequency only. The amateur demands a system which is flexible in adjustment and which permits ready and rapid QSY from one band to another. The solution is, then, to have the system tunable, and moreover tunable in the station itself. This is provided in the two tuning arrangements shown in Figures 3 and 4. The series system is used when the natural wavelength of the feeder system including the antenna inductance is slightly above the fundamental or odd multiple of the fundamental of



the working wave. The parallel tuning arrangement is used when the natural wavelength of the feeder system including antenna inductance is above an even multiple of the working wave but less than an odd multiple. In other words, if the length of the feeder is such that the natural wave length of the feeder system is between  $2/2$  and  $2/2$  or between  $3/2$  and  $4/2$  wave etc., the series tuning arrangement is used. If this natural wavelength is between  $2/2$  and  $3/2$  or between  $4/2$  and  $5/2$  etc., the parallel arrangement is used. The series arrangement is used when it is possible to go down to the next odd  $1/2$  and the parallel when it is desirable to go up to the next odd  $1/2$ . Figure 5 shows some convenient feeder lengths and the system of tuning most satisfactory for each of the amateur bands.

It is interesting to note that there are some particular lengths which are such that it is impossible to get down to the next odd  $1/2$  wave by series tuning and just as impossible to go up by parallel tuning. Care should be taken in putting up the feeders not to hit upon such a length. This situation results when the feeders are of the order of 25 feet in length and it is desired to work on 20 meters. The jump to  $1/2$  wave is too much for series tuning. To go to  $3/2$  wave puts more than  $1/2$  wave in the antenna tank circuit when the parallel ar-

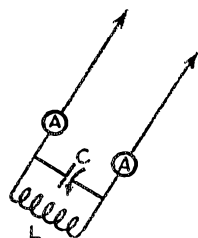

FIG. 4. PARALLEL TUNING OF THE FEEDER SYSTEM

angement is used, and very little energy transfer from the oscillator output to the feeder input is possible. Increasing the feeder length to 30 feet, however, permits parallel tuning on the 20-meter band while series tuning is used on the 40 meter band.

The lengths specified in the table shown in Figure 5 need not be exactly followed, a variation of a few feet one way or the other being permissible, particularly on the longer feeders.

There is one salient requirement in the feeder construction. It must be *symmetrical*. Each wire must be exactly the same length as the other. This is particularly

important when the system is to be operated on the higher frequencies where a foot is a considerable part of a wavelength, and an apparent slight degree of asymme-

APPROXIMATE LENGTH OF EACH WIRE, FEET	TUNING ARRANGEMENT FOR VARIOUS BANDS				
	1750 kc (160m)	3500 kc (80m)	7000 kc (40m)	14000 kc (20m)	28000 kc (10m)
120	SER	PAR	PAR	PAR	SER OR PAR
90	PAR	SER	SER	PAR	SER OR PAR
60	PAR	SER	PAR	PAR	SER OR PAR
40	(---)	PAR	SER	PAR	PAR.
30	(---)	(---)	PAR	PAR	SER OR PAR
15	(---)	(---)	SER	PAR	PAR.
6	(---)	(---)	(---)	PAR	SER.

SER - Series Tuning PAR - Parallel Tuning (---) - Not Recommended

FIG. 5. SOME SUGGESTED FEEDER LENGTHS AND RECOMMENDED TUNING METHOD FOR EACH OF THE AMATEUR BANDS

try would result in a comparatively great asymmetrical voltage and current distribution, causing a loss of a considerable amount of the non-radiating properties desired in the feeders.

The distance by which the wires should be separated is not critical in value, although there is an optimum value. They must be close enough together to give effective cancellation of their respective fields and far enough apart so that minute vibration with respect to each other will not cause proportionate variation in the inter-wire electro-static capacity of sufficient magnitude to cause, in turn, appreciable variation in the feeder tuning and consequent wobblulation of frequency. A value of separation which seems to meet these requirements satisfactorily is 10 to 12 inches.

Since, in most cases, the feeder system is suspended from one end of the antenna itself, all unnecessary weight should be eliminated. This means that the spreaders must be of the lightest obtainable material suitable for the job, and practically puts glass rods, towel bars and the like out of the question. Wooden spreaders in the form of  $1/4$ -inch dowels boiled in paraffin are quite satisfactory, or ready-treated pieces of "printer's furniture", which may be obtained in  $3/8$ " by  $3/8$ " by 3 foot strips from a printers' supply or job printing establishment, may be used. Spacers should be placed about every five feet and rigidly connected to the feeder wires.

The feeders should be made up of wire of the same gauge as that of the antenna wire, because the current at the antinodes in the feeders will be of the same order of value as at the current antinodes in the antenna. Number 12 enameled solid cop-

per wire is quite satisfactory both on this account and also because it possesses sufficient rigidity to prevent its whipping about in the wind as lighter wire would have a tendency to. If possible, the feeders should be supported on the side of the building, ridge-pole or mast at any con-

ficient at the point of maximum antenna current, (resonance) tighten the coupling between the feeder input and transmitter output coils, and repeat the tuning process. The feeder tuning condenser should not be so adjusted as to give maximum antenna current and plate input, but should be set at a point off resonance where the antenna current is about 85% of the maximum obtainable. This will give the stable operation, steady frequency and general all-around operating characteristics demanded of the antenna system for 1929 conditions.\*

If the series tuning arrangement is the one required, the process is the same, both tuning condensers being adjusted from maximum down simultaneously and kept "in step". The frequency should now be checked with a meter, and a slight readjustment made all around if the tuning of the feeder system has unduly upset the adjustment of the transmitter. The two feeder r.f. ammeters should now indicate approximately equal values of current. If the difference in the two readings is greater than about 10 percent, the length of our radiator is probably too great, and a process of pruning is in order.

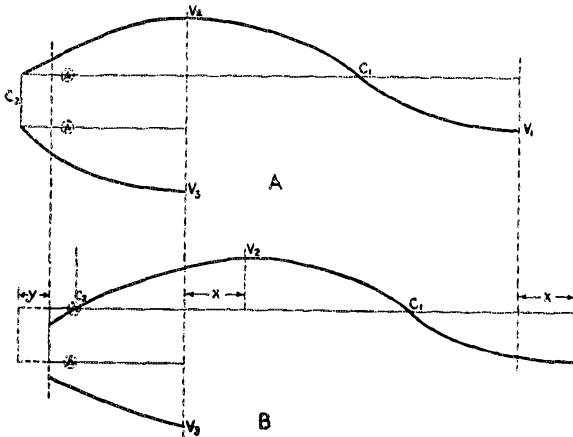

FIG. 6. A—Voltage distribution when the length of the antenna is proper for the frequency at which it is being operated. B—Voltage distribution when the length of the antenna is too great for the frequency at which it is being operated by the amount X. Voltages antinodes. (Loops), are indicated by V, current antinodes by C.

venient point by stand-off insulators, as this permits stretching the wires taut and also removes a proportionate amount of the load from the antenna, ropes and guys.

#### TUNING THE FEEDER SYSTEM

Our radiator now swings in the afore-said free space. The feeder system drops in a more or less graceful catenary to the lead-in bushing and thence to the antenna inductance with its associated tuning device. The transmitter is adjusted to the frequency which we intend to use and is "rarrin to go". But before we can get the desired amount of energy from the output circuit of the transmitter to the antenna, the feeder system must be tuned to do the job.

Take another look at the table of Figure 5, and note the tuning arrangement recommended for the length of feeder we are using at the frequency on which we are to work. Suppose it is the parallel type. Set the feeder tuning condenser at maximum capacity, (250- or 500- $\mu$ fd.). Turn on the filament and plate supply to the transmitter and step on the key. Swing the tuning condenser from maximum down until the antenna ammeter shows signs of life and the plate mills climb up to a satisfactory value. If the input is not suf-

#### CHECKING THE LENGTH OF THE ANTENNA

A short review of the voltage and current distribution in the feeders and antenna under the ideal and abnormal conditions may be in order. Figure 6 illustrates A, the voltage distribution when the length of the antenna is correct for the frequency at which we wish to operate; and B, the voltage distribution when the length of the antenna is too great for the frequency at which we wish to operate. There will always be voltage antinodes (loops) at  $V_1$  and  $V_3$  of both A and B, as these are the extreme ends of the whole system. This will always be true when there is a state of oscillation. A voltage antinode is also to be desired at a point directly opposite  $V_2$ , and this we have at  $V_2$  in A. In B, however, the antenna is too long for the fre-

(Continued on Page 36)

4. *Overhauling the Transmitter For 1929*, by Ross A. Hull, QST, Aug. 1928. It has been usually found that a better note, denoting more constant frequency, is obtained with the feeder circuit tuned below the resonance frequency or with the feeder tuning condenser set at a higher value of capacity than at resonance. Some exceptions have been noted however, the note being better in several cases with the tuning condenser set at a lower capacity value. This setting should be checked by listening to the signal via a monitor or shielded receiver.

## The Fifth Age

By W. A. Adams\*

I AM not going to sa that ham radio is the bunk, but when you buy a new fifty watt bottle after using a seven and a halfer fer a long time and then onli get one tenth amp less radiation it doesn't go over like a R 8 report in South Africa. Its all right fer these big boys like 6AM and 6HM to throw the cow's husband about radiation don't count fer nothing, but that kinda stuff just qsy's over my head. I am one o those kind a guys that try to watch the amp meter move until you almost see it going around in a circle. That no radiation is o.k., but me fer the big swing on the ammeter needle. Which all goes to prove that I was getting mighty disgusted when after buying a fifty I found to my pleasure that I was getting abt one amp wid a suction of 200 mills. I had onli been getting an amp and two wid 80 mills. Boy I was sure disgusted and I don't mean maybe.

When I am sore at my set I usually get out of the shack and walk around. So at this particular occasion I betook myself in the general direction of 6CLT.

"Sa om," I qsoed, "what do you do fer a amp meter that won't bedge?"

"What kind you got?" he came back.

"It is a Roller Smyth hot wire." I answers.

"Just set a candle under it," he sez, "and watch her budge. I'll go as far as to bet you get two tenths more."

"Aw. Cut the funny qrm. I just got a fifty and I get a tenth less than I got wid my seven and. I have tried every thing from cutting down the counterpoise to putting a couple thousand on the plate. I even put the R.F. chokes in backwards."

"Well," he comes back, "Budgel seems to get three amps out of his you better try—."

"Sh!" I breaks in, looking out of the window, "will you qso that neat pair of ground connections." We gazed with awe. "Sa, ain't that one hot mama. Here is where I am qrw right now." I jumps up busts out of the door and continues on my way. The mean YL was abt a half a block ahead of me and I aimed to keep that far behind until I found her qrd. About two blocks more and she speaks to a boy friend, and I'll be blessed if it isn't my old friend CBY. A hi does the trick and one minute more and I am qso the boy friend.

"Who in the world is that mama?" I sez.

jerking my head in the general direction of the fast disappearing YL. I knew that CBY was hogtied so no danger from any qrm.

"That's Helen," he comes back, "Don't you know her? She lives down in your neighborhood."

"I don't," I returned, "but I sure craves a qsp. Hw abt it?"

"Sure thing," he sez, "I will be over to your house tomorrow when she goes by. Anything to help another ham."

"Gee your anxious," I sed, "do you know her too well or have I been qrming you pretty bad?"

"Neither," he sez, but I was suspicious. Maybe that fifty was making more noise than I thought it was. Maybe 6HM was right after all. Nevertheless he was over to the shack next afternoon, and after he had exhausted every means of getting more radiation without putting in a killowatt, we qsy's to the front porch and the YL comes by. Everything was working to sked so far.

As the YL comes by he puts out a nice eq.

"Hello, Helen," he sez. Miss Helen turns around and we become qso. "Sa," he continues, "I want you to meet my good friend Bill or Annie as he is commonly known."

"Hello, Annie," she sez with a voice that sounds like crystal control. "I am very glad to meet you."

"Your not half as glad as I am," I says real truthfully. Then an idea pounds in like a ton of bricks, fer the om is abt as slow as a bug wid all the weights off. "Aren't those books awful heavy?"

"Well," she comes back, "they aren't very light."

"Let me carry them for you," I sez, "I was just going down to the store." I just remembered that my ma had asked me to get a can of prunes the day before, and gone after them herself.

She looks me over but I don't crack a smile, and she hands them over.

"Sure sorry you have to go so soon." I sez to CBY and I begins to walk off wid Helen. But I notices a smile around his lips, and so I looked around when we had gone two or three steps and I see him laughing fit to kill. Right off I confirms my suspicions that something is not so good

## Synchronism

By C. Francis Jenkins\*

**M**ANY of those who are receiving our transmissions of radio-movies are having difficulty in rotating their disc in synchronism with the transmitter disc so I should like to make a suggestion.

Your disc is probably already mounted upon a motor shaft and if you have another motor it may be left there. If, however, you have only the one motor, it will be necessary to mount the disc on some other shaft making sure that the bearings are well supported and not loose.

Next, cut from the rubber inner tube of an old automobile tire, a disc about one-

Don't use a rheostat in the driving motor circuit to control its speed; let it run at the speed for which it was designed as this will result in greater constancy. Most any size of motor will do providing it is not too small; a 1/20th, 1/16th or 1/8th horsepower motor revolving at about 1725 r.p.m. will work well with scanning discs up to 12 or 15 inches in diameter.

## Radio Set Tester

**I**N this day when the average radio receiver is operated from a variety of sources, employs tubes that differ widely in their characteristics and circuit arrangements that are vastly more complex than one would have thought practical a few years ago, the lot of the trouble shooter or repair man is certainly not one that is envied by many. Upon him devolves the problem of keeping the ultimate consumer happy and content with his purchase, for, even the best of sets fall heir to ills most of which are minor but many of which have possibilities of developing into problems of major importance. What is more valuable for the repair man than test

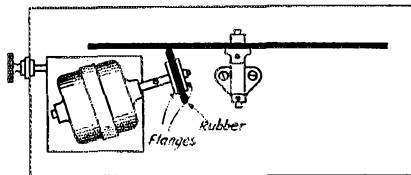

SHOWING THE GENERAL ARRANGEMENT OF DRIVING MOTOR AND SCANNING DISC.

The driving motor shaft should be at the same level as the shaft on which the disc is mounted so as to reduce slippage. The motor is mounted at an angle to the scanning disc so that it will usually be smaller than the breadth of the motor.

fourth the diameter of your scanning disc. For a 48-hole, 12-inch disc, a 3-inch rubber disc will be about right. Put this disc between a pair of 2-inch diameter flanges that are to be mounted on the motor shaft.

The motor should then be mounted on a board that can slide between guide strips on the platform that holds the scanning disc. The position of the motor should be such that in the case of a 1725 r.p.m. machine to drive a disc at 900 r.p.m., the friction wheel should touch the disc at a point about three inches from the center. Now, by means of a screw adjustment, the position of the motor board may be shifted so the correct speed is obtained. As the friction disc approaches the center of the scanning disc, the speed of the scanning disc will increase.

It is not advisable to use more than two friction discs cut from the average thickness of inner tubes and in most cases, one thickness will be best. Although the disc will chatter a bit at starting, it will be found quite simple to obtain and hold synchronism after the disc is up to its running speed.

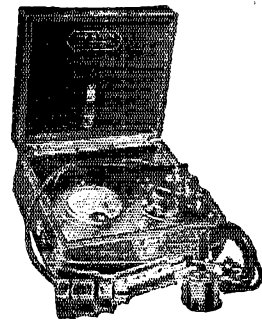

equipment which will allow him to put a set through its paces in the shortest amount of time? The diagnosing of trouble should be but incidental to the correcting of it.

The instrument shown in the illustration is a versatile device that may be used to check almost all parts of any modern receiver without the use of a great deal of thought or time on the part of the operator. It is equipped to measure direct voltages as high as 600 or less than a volt, regardless of whether they are obtained from

\* 1519 Connecticut Ave., Wash., D. C.

(Continued on Page 70)

## Remodeling the Traffic Tuner for 1929

Opening up the scale of the Autodyne not only for this year but for next year's conditions

By Harold P. Westman, Technical Editor.

IT should perhaps be stated at the outset that the receiver to be described is not the result of the organized "Technical Development Program" that is being prosecuted by the League. It is merely my own opinions as to some receiver characteristics that should be desirable for operation primarily in 1929 but with a thought towards making the set satisfactory for the remainder of this year. When the transition occurs, a comparatively small amount of work will allow the tuning ranges to be modified to meet the newer conditions.

We are at present doing practically all of our communicating within three bands: the 3500-, 7000- and 14000-kc. bands in which there are a total of 3500 kilocycles. What is left of these in 1929 will encompass but 1200 kilocycles and it behooves us to use all the territory open to us. Our 1750-kc. band will contain 285 kilocycles and while transmission over large distances when employing low-powered transmitters is not as good there as it is in the 3500-kc. region, it should be very satisfactory for distances not in excess of 250 miles or so. Traffic networks, where the distance between stations is small, could be established there and the reduction in the amount of interference encountered should help considerably in getting traffic through. Any receiver suitable for 1929 should, then, be capable of covering the 1750-kc. band as well as the other three more popular ones.

Our new 28000-kc. band has offered some possibilities, in that communication over comparatively short distances has been established. We would be very foolish not to make extensive tests to determine just how effective these frequencies are for our purposes. This gives us five bands that must be covered if we are to make ready for 1929 conditions. While it would be nice to cover also the 56000-kc. band, this does not seem to be thoroughly practical from a constructional point of view, and it would seem best to build a separate receiver (probably of the double-detection type) for this band.

The simplest method of constructing a receiver to cover all five bands would be to use a size of condenser that allowed that band to be covered which required the largest capacity range and let the other ranges fall where they may. However, there was de-

scribed in the April, 1927, issue of *QST*, under the heading of "A Traffic Tuner," a receiver that spread each band over practically the entire tuning dial scale. After handling such a set one simply hates to go back to receivers which resemble a New York subway. The subway gives you lots of space between trains but precious little within them; so does the average set treat the amateur bands.

As the name implies, the "Traffic Tuner" was primarily devised for the benefit of the traffic handler who must be capable of making and keeping schedules even though conditions be poor. This requires a set that spreads the particular band in

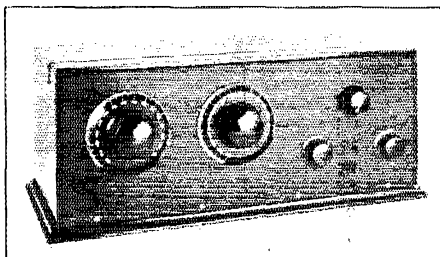

FIG. 1. ALL PRETTIED UP

which operation is desirable over a large portion of the tuning dial so that tuning, even with a comparatively fast motion dial which allows the band to be searched quickly will not be abrupt and critical. In the second place, the regeneration control must not have too great an effect upon the tuning. Thirdly, it should be possible to log signals and assuming that the signal frequency has not been changed to be able to go back and pick them up without wasting too much time. Sensitivity and stability must, of course, not be sacrificed.

A receiver built with these points in mind might answer many of our 1929 troubles and if it didn't, it would at least give us a start towards meeting them. That in itself is well worthwhile.

The older tuner employed a conventional type of tuning condenser which goes from minimum to maximum capacitance with a rotation of 180 degrees. In this one, a National "equicycle" condenser which is rotated

270 degrees to cover its range is used. A gain of 50% in dial space results.

The capacity change needed to cover the 1750-kc. band as indicated by the tables in the Handbook is several times that required

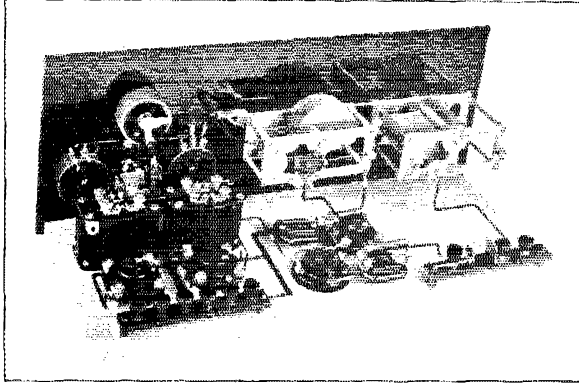

THE INNARDS.

The clip that is holding onto the tie rod of the tuning condenser is connected to the larger section. When both sections are to be used, it is clipped onto the machine screw supporting the smaller capacity section. The antenna tuning coil is not shown.

to tune across the 14000-kc. band. This makes the use of a single capacity range rather hopeless and two condensers of different ranges are necessary. Fortunately it is a simple matter to convert the National condenser for the job.

There are two types of National equi-cycle condensers. The older is the one which is built into the set while a photograph of the newer type is shown separately. The plate shape and spacer thickness is the same for both types so no trouble should be encountered from this angle. The main difference is in the type of frame used to support the plate assemblies.

In converting the unit for use in this receiver, the stator plates are removed as well as the rods on which they are mounted. It will not be necessary to take the frame apart for this operation unless the threading on the rods does not extend far enough to allow one end of the rod to be worked back through the insulating piece.

The rods removed may be cut in half and employed to support the two new stator assemblies or else they may be replaced by four 6/32 round headed brass machine screws about 1½ inches long. One of these

assemblies which will be used for the higher frequency bands employs a single stator plate and exposes one side of it to the first rotor plate. The spacing between these two plates is very important and it should be adjusted so that with the proper coil, it just covers the 14,000-kc. band with enough overlap to take care of capacity effects due to antenna coupling which may be changed and which shifts the tuning slightly. In the particular set being described, more overlap was allowed than is absolutely necessary so that there should be no great difficulty in duplicating the ranges even though the capacity effect of the wiring, etc., should differ by much in other sets. As a rough adjustment when reassembling the condenser, make this spacing the equivalent of the thickness of eight QST pages. The final adjustment will be made when the set is in operation.

The other section of the condenser may consist of a single plate or if double spacing is thought desirable two stator plates should be used. It is mounted on a pair of machine screws and placed between two of the rotor plates. For convenience in wir-

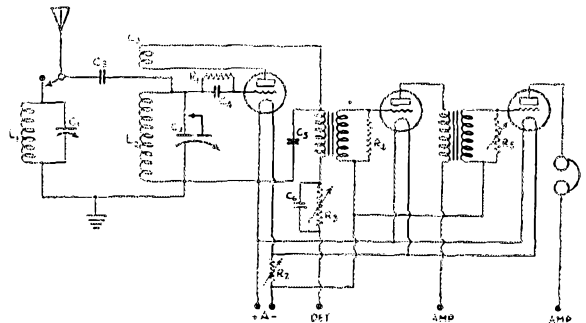

FIGURE 1. THE SCHEMATIC DIAGRAM OF THE SET.

- C1—550 mufd. variab'le.
- C2—Described in text.
- C3—Described in text.
- C4—100 mufds.
- C5—2000 mufds.
- C6—1 mufd.
- R1—7 megs.
- R2—10 ohms or more.
- R3—Frost 50,000-ohm variable.
- R4—1 to .25 megs.
- R5—Frost 500,000-ohm variable for volume control.
- L1 will vary to suit the antenna and L2 and L3 are described in the text.

ing, the smaller capacity section is assembled to the back of the unit and the other at the front nearest the panel and dial. The smaller section will be wired into

the circuit permanently while the larger section will be connected across it for the 1750-kc. band. A switch could be constructed for this change but would probably result in mechanical difficulties. To simplify matters, a piece of flexible wire was connected to the larger section stator plate and the clip on its end may be snapped onto the machine screw supporting the stator plate of the smaller section or onto the frame of the condenser thus grounding the larger section when it is not in use. It makes a workable and practical arrangement involving the use of no great amount of mechanical ability or equipment as might a more beautiful appearing switch. There is no need for its being operable from the front of the panel because it will need to be shifted only when it is desired to receive

signal strength. What is more important, it helps on the signal noise ration. A large tuning condenser is used and the coil should be of such dimensions that the antenna circuit will tune over the 1750-kc. band. Harmonic tuning will be employed for the higher

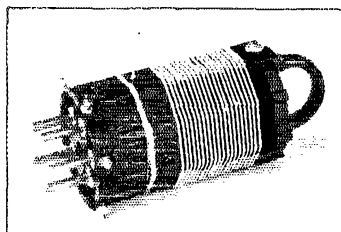

THE PILOT COIL FORM WITH THE 7000-KC. WINDING ON IT IS AT THE LEFT OF THE CONDENSER

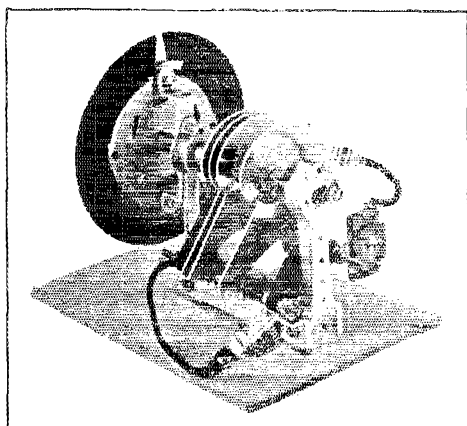

THE NEWER TYPE OF EQUICYCLE CONDENSER AND HOW IT IS CONVERTED FOR THE JOB.

It shows the larger capacity section as consisting of two stator and three rotor plates with double spacing. This section may consist of just one stator and two rotor plates with normal spacing. Neither is it necessary to remove the unused rotor plates.

on a different band and as it is necessary to change coils when making such a shift, no hardship is imposed by requiring that the clip also be changed.

The only other point to be discussed concerning the condenser is the use of the Hammarlund "neutralizing" condenser. This allows a band that is either above or below the U. S. bands to be covered so that, for instance, those foreigners working around 8330 kcs. may be received.

The circuit diagram is given in Fig. 1. It will be noted that the antenna circuit is tuned after the fashion described by R. R. Bourne on page 36 of the August issue. It allows the antenna tuning and coupling to be varied independently and if capacitive coupling is to be employed for the 1750-kc. band it is of great help in building up the

frequency bands and the coil will not have to be changed for them. No switching arrangement has been provided for disconnecting the tuning circuit other than the use of an extra binding post. If such is desired, it may be installed without a great deal of trouble. If a very long antenna is used, the tuning coil and condenser may be connected in series by connecting the coil across the two antenna binding posts.

The antenna coupling condenser consists of two small brass plates. One is somewhat larger than the other (it happened to be available and was not cut down) and the smaller is approximately  $\frac{1}{2}$  inch square and is soldered to a piece of heavy bus bent in the form of a "U", the sides of which pass under the head of a binding post. Spacing up to an inch and a quarter may be had. Coupling should be made loose and the two stage audio amplifier relied upon for obtaining good signal strength. The looser the coupling the less effect will the antenna tuning have upon the calibration of the tuning dial and the less need there will be for using the regeneration control.

The coils are wound on Pilot forms, one of which is shown next to the tuning condenser. When using such small tuning capacities, one really begins to appreciate the tuning effect the tickler coil has upon the circuit. In the 14,000-and 28,000-kc. bands, it is possible to shift the tuning very materially by changing the number of tickler turns by one, this with tickler coils of No. 30 s.s.c. wire. The tickler seems to give the smallest effect on loading the secondary circuit and detuning it when the least number of turns is employed. The coils were wound about  $\frac{1}{4}$  of an inch below the filament end of the secondary winding and the turns reduced one at a time until the circuit would not oscillate over the entire range of the tuning condenser. After the minimum number of turns was obtained,

the winding was shifted away from the secondary until the loosest coupling was obtained without causing the regeneration control to become cranky and irregular. The result is a smooth control of regeneration with very slight detuning effect. The use of a large coil with looser coupling causes greater detuning.

The use of a 2000-*unfd.* by-pass condenser between the battery side of the tickler coil and filament helps materially in the prob-

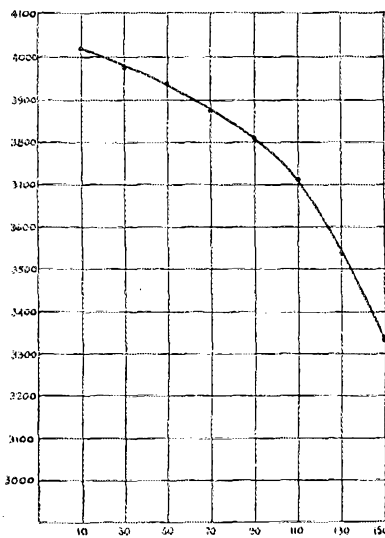

FIGURE 2. THE TUNING CURVE FOR THE 3500-KC. COIL.

It shows how the number of dial divisions for a given range will change depending upon the particular end of the scale being used.

lem of regeneration. A small condenser in this position makes it necessary to increase the size of the tickler coils with its accompanying troubles. As the size of the by-pass condenser is increased, it tends to by-pass more of the higher audio frequencies because it is in shunt of the primary of the audio transformer. While this may be damaging to quality in a broadcast receiver, it can be considered as an assistance in a set for receiving telegraph signals in that it tends to reduce the hissy background. It has little or no effect upon signals in the lower audio range to which they are usually heterodyned.

Dry cell tubes of the '99 type are used. Since they have been equipped with long terminal prongs that make decent contact, they are not half so troublesome and are first rate as oscillating detectors for high frequency work. Fringe howl has been cured as usual by shunting a .1 or .25 meg leak across the secondary of the first audio

transformer. The transformers are designed for music and so we are not discriminating against a large percentage of the signals on the air. Separate B leads are provided for the two audio amplifying tubes so that on nights when the static is very bad, the plate voltage to the first amplifier tube may be dropped to a volt or two and thus by its limiting action, one to one ratio between the signal and static can be obtained. This is a stunt that has been mentioned before in *QST* and was recently suggested again by Paul G. Watson of West Chester, Pa. The phone cords do not come to the panel at all and, therefore, won't always be getting in the way.

Coil sizes are as follows:

Band in kc.	Coil Range	Number Turns Sec. Tickler	Degrees to cover band	
			1928	1929
1500-2000	1895-2055	65.	9	106 40
3500-4000	3371-4027	46.25	5	116 116
7000-8000	6897-8000	16.25	4	133 21
	7940-9755	16.25	4	
14000-16000	13510-16300	7.25	4	114 11
	11760-13640	7.25	4	
28000-30000	27650-30380	2.25	3	40 40

The 6879-8000-kc. and the 11760-13640-kc. ranges are obtained with the shunt capacity in the circuit while the other ranges for the same coils are obtained without the shunt condenser. The value of this condenser is determined by shunting it across the tuning condenser and increasing its capacity until when with the tuning condenser at about 10 degrees, the frequency is slightly below that obtained when there is no shunt and the tuning condenser is set at 150 degrees. It would, perhaps, better be adjusted with the 14000-kc. coil which band is covered without the shunt capacity in the circuit.

The secondary coils are wound with No. 26 d. c. c. wire excepting in the case of the 1750-kc. coil which is wound with No. 30 s. c. c. which is used for the tickler coils. The ticklers are close wound and are spaced about  $\frac{1}{8}$ " from the filament end of the secondary windings. The 1750- and 3500-kc. coils are close wound while the spacing between turns of the 7000- and 14000-kc. coils is the diameter of the wire used. In the case of the 28000-kc. coil, it was found necessary to wind the secondary coil with about  $\frac{1}{4}$ " spacing between turns and then wind the tickler coil between the turns. If the tickler were wound below the secondary in the usual fashion, it would probably call for at least two or three more turns which would require that the number of secondary turns be reduced still further.

Fig. 2. gives a typical tuning curve. It happens to be for the 3500-kc. band but is similar for the other range. The thing to be pointed out is that the number of divisions of dial space to cover a band

(Continued on Page 68)



# Washington Developments

Commercial Assignments in Our Bands; Amateur Calls Changed; Amateur Extra First Class Operator's License Restored.

**W**E have previously mentioned in QST that 21 channels between 7300 and 8000 kc. (part of our present "40-meter" band) and 27 channels between 14000 and 14400 kc. (in our present "20-meter" band) have been assigned to commercial interests by our Federal Radio Commission, because these will not be amateur frequencies after January first and because United States stations will not get the use of them if they do not start now. Construction permits have been issued for the use of many of these channels and it is now expected that many of the stations will be in operation before the end of the year. This applies particularly to the Radio Corporation group. R.C.A. channels on which operation prior to January 1st is likely are: 7400, 7415, 7520, 7715, 14800, 14830, 14920, 15040, 15430, 15460, 15490, 15970 and 16000 kc. As these stations one by one come on the air we shall find our operating territory gradually reduced, but by the same token the foreign commercial stations now operating in the ranges 7000-7300 and 14000-14400 kc. will be moving out, for they must be clear of our 1929 bands by the first of the year.

### NEW AMATEUR CALLS

As anticipated in our August issue, page 35, the Radio Division of the Department of Commerce announces that, effective October 1, 1928, all amateur, experimental and training school station calls are changed by prefixing the existing call with a letter to indicate nationality, as required by the Washington Convention. The prefix for stations in continental United States is "W", while for those in distant territories and possessions it is "K", to permit distinguishing them from continental calls of the same district. Quoting from the *Radio Service Bulletin* for June 30th:

While the requirements of the convention are not actually effective until January 1, 1929, it has been deemed advisable to change the call signals effective October 1, next, as the Division desires to show the new signals in the annual list of Amateur Radio stations of the United States, edition June 30, 1928, rather than to change the calls effective January 1, 1929, and publish the new calls in the June 30, 1929, edition.

Therefore, beginning that date, all stations in the classes above named within the continental limits of the United States are hereby ordered to add to their call signals the letter "W", and those in Alaska, Hawaii, Porto Rico and the Virgin Islands, should add the letter "K". These letters should precede the call signal; for example, station 4ABC, if within the continental limits of this country, becomes W4ABC and, if in Porto Rico, becomes K4ABC.

It is important to note that the prefixes

"W" and "K" are *not to be used before October first*. On that date, however, their use commences, with the old intermediate "de" and the abandonment of "nu".

In passing, let us mention again that every amateur ought to subscribe to the *Radio Service Bulletin*. It contains much important information. It cost sbut 25c per year (stamps not accepted), from the Superintendent of Documents, U. S. Government Printing Office, Washington.

Aside from the fact that Canada is going to use the letters "VE", we have no reliable information on the prefixes that other countries will use for their amateur calls. As it does not seem likely that we will have a complete list before the year is out, we print below the international table of allocation of call signals from the Washington Convention. Nations are obliged to select some letter or letters from their assignment to use as a prefix to amateur calls, but we can not tell at this date what they will be. Where a nation is given all combinations beginning with a given letter, as in the case of "W" for the United States, that single letter will suffice; but where a letter is partitioned amongst several countries, like "Z", two letters will be necessary. One cannot say to-day, for example, whether New Zealand amateurs will use the prefix "ZK", "ZL" or "ZM". This list, therefore, is of no aid in making calls but will be helpful in determining the identity of calls heard.

Chile .....	CAA-CEZ
Canada .....	CFA-CKZ
Cuba .....	CLA-CMZ
Morocco .....	CNA-CNZ
Bolivia .....	CPA-CPZ
Portuguese colonies .....	CRA-CRZ
Portugal .....	CSA-CUZ
Roumania .....	CVA-CVZ
Uruguay .....	CWA-CXZ
Monaco .....	CZA-CZZ
Germany .....	D
Spain .....	EAA-EHZ
Irish Free State .....	EIA-EIZ
Liberia .....	EIA-ELZ
Esthonia .....	ESA-ESZ
Ethiopia .....	ETA-ETZ
France and colonies and protectorates .....	F
Great Britain .....	G
Hungary .....	HAA-HAZ
Switzerland .....	HBA-HBZ
Euador .....	HCA-HCZ
Republic of Haiti .....	HHA-HHZ
Dominican Republic .....	HIA-HIZ
Republic of Colombia .....	HJA-HKZ
Republic of Honduras .....	HRA-HRZ
Siam .....	HSA-HSZ
Italy and colonies .....	I
Japan .....	J
United States of America .....	K
Norway .....	LAA-LNZ
Argentine Republic .....	LOA-LVZ

Bulgaria	LZA-LZZ
Great Britain	M
United States of America	N
Peru	OAA-OBZ
Finland	OKA-OKZ
Czechoslovakia	ONA-OTZ
Belgium and colonies	OQA-OZZ
Denmark	PAA-PIZ
Netherlands	PJA-PJZ
Curacao	PKA-POZ
Dutch Indies	PPA-PYZ
Brazil	PZA-PZZ
Surinam	RAA-RQZ
U. S. S. R. ("Russia")	RVA-RVZ
Persia	RXA-RXZ
Republic of Panama	RYA-RYZ
Lithuania	SAA-SMZ
Sweden	SFA-SFZ
Poland	SUA-SUZ
Egypt	SVA-SZZ
Greece	TAA-TCZ
Turkey	TFA-TFZ
Iceland	TGA-TGZ
Guatemala	TIA-TIZ
Costa Rica	TSA-TSZ
Territory of the Saar Basin	UHA-UHZ
Hedjaz	UIZ-UKZ
Dutch Indies	ULA-ULZ
Luxemburg	UNA-UNZ
Kingdom of the Serbs, Croats and Slovenes	UOA-UOZ
Austria	VAA-VGZ
Canada	VHA-VMZ
Commonwealth of Australia	VOA-VOZ
Newfoundland	VPA-VSZ
British colonies and protectorates	VTA-VWZ
British Indies	W
United States of America	XAA-XFZ
Mexico	XGA-XUZ
China	YAA-YAZ
Afghanistan	YHA-YHZ
New Hebrides	YIA-YIZ
Iraq	YLA-YLZ
Latvia	YMA-YMZ
Free City of Danzig	YNA-YNZ
Nicaragua	YSA-YSZ
Republic of El Salvador	YVA-YVZ
Venezuela	ZAA-ZAZ
Albania	ZKA-ZMZ
New Zealand	ZPA-ZPZ
Paraguay	ZSA-ZUZ
Union of South Africa	

## EXTRA CLASS LICENCE RESTORED

Attention is here called to the kind restoration, by the Radio Division, of the Extra First Class Amateur Operator License. All Supervisors of Radio are now prepared to issue this license. For further particulars our editorial this month should be consulted.

## TELEVISION FREQUENCIES

It is expected that a generation order will issue from the Federal Radio Commission in the very near future, authorizing amateurs to experiment with picture transmission and television transmission within the frequency bands 1715-2000 kc. and 56,000-60,000 kc. (the "160-meter" and "5-meter" bands) but within these two bands only.

W4GP John McCaa  
 W4AHN Paul Brake  
 W4AHQ Vernon V. Story  
 W4AIN John L. Gauthen  
 W4JB Cecil L. Thomas  
 W4AAH Basil Payne  
 W4AHT Hardy D. Carl, jr.  
 W4AHW Francis M. Greebe  
 W4AHX Elmer McCurdy Prather

This has no reference to the frequencies used by broadcasting and experimental stations for popular consumption, but refers only to transmissions by amateurs themselves.

## THE GOVERNMENT CALL BOOK

Amateurs are not adequately supporting the very splendid call book, *List of Amateur Stations of the United States*, published annually by the government for the modest sum of twenty-five cents. Only about 5,000 copies are sold annually. With 17,000 amateurs in this country there should be bigger support. It costs the Radio Division over \$3,000 of their appropriation to have this list made available for popular sale, and unless there is more evidence that the list is in demand the Division may discontinue its publication.

The book will appear in September or October and will be complete to June 30th. It is accurate, and it deserves our support. The Radio Division having paid the entire cost of composition, the 25c charge represents only the cost of paper and handling. Orders should be addressed to the Superintendent of Documents, Government Printing Office, Washington, and remember that stamps aren't accepted. Last year some purchasers were erroneously advised that the supply was exhausted and their money was returned, but this year we are assured of an ample supply.

## CHANGES IN ALABAMA

On July 1st the Radio Division, for administrative convenience, transferred the state of Alabama from the Fifth District to the Fourth District, under Major Van Nostrand at Atlanta. This necessitated the changing of Alabama amateur calls from 5s to 4's. Applications were sent all amateurs early in June and 4th-district licenses, dated July 1, were issued as fast as applications came in, so that those who responded promptly will be correctly listed in the June-30th issue of the government call book. In many cases the same combinations of call letters were given the stations; in other cases two- or three-letter calls were given them according to what they had while in the Fifth District. Major Van Nostrand kindly supplies us with the following list of Fourth District calls in Alabama to July 9th:

1025 Fairmount St., Anniston  
 Auburn  
 41 W. Magnolia St., Auburn  
 Auburn  
 227 Magnolia St., Auburn  
 105 Vine St., Birmingham  
 4141 39th Ave., N., Birmingham  
 1400 N. 30th St., Birmingham  
 2721 Bessemer Blvd., Birmingham

- W4AIB George Woods Fahrubel
- W4AIE Leonard William Thomas
- W4AIM Hdqrs. Co. 3rd Bat., 167th Inf., Ala. Natl. Guard
- W4AX Joe Wheeler Clancy
- W4CD Alabama Natl. Guard, 106 Obsn. Sqdn., Air Corps
- W4DS William Alonzo Boon
- W4GG Edward Florian Herzog
- W4HI D. J. Connolly
- W4JY I. J. Jones
- W4MY Wendell H. Binkley
- W4OM Walter Martin Garrard
- W4RE H. L. Ansley
- W4VC M. B. Drennen
- W4AHZ Leonard C. Kron
- W4AIO Aubrey Whitney
- W4UV Julius Clarence Vessels
- W4AIA Arthur & Viola Hook
- W4ET Robt. L. Brackett
- W4AID Raymond N. Jones
- W4PAR Joseph E. McCormack
- W4RC Joseph E. McCormack
- W4ACX James I. Kelly
- W4AHY J. W. Hudgins
- W4MB Wilton H. Pollard
- W4SN Charles Forrest Striplin, Jr.
- W4AAS Thomas Joseph Peddy
- W4AAJ Chas. E. Emrich
- W4OA James Robertson
- W4WS Norman Sinclair Hurley
- W4AAQ Samuel Jefferson Bayne
- W4AHO Alexander D. Trum
- W4AHP Robert Edward Troy, Jr.
- W4AHR Andrew C. Kilpatrick
- W4AHS John Brown
- W4AIP Julian Maurice Gantt
- W4AN John Cravens Howell
- W4AHU Basil B. McGinty
- W4AHL Terry L. Geurrant
- W4AIL Henry W. Fulwider
- W4DJ William H. Dent
- W4FN Walter W. Merkle
- W4IA L. Tennett Lee, Jr.
- W4PAS R. B. Sommerville
- W4TH Karl William Bewig
- W4TI R. B. Sommerville
- W4VX Carroll M. W. Engelbert
- W4AIK Leslie B. Stanton
- W4AHV Ralph A. Owen
- W4AIC Earl Campbell Schrimsher
- 500 Miller Ave., Birmingham
- 115 Kate Ave., Birmingham
- 1800 2nd Ave., Birmingham
- 1316 17th St., S., Birmingham
- Roberts Field, Box 570, Birmingham
- 216 Pine St., N. West End, Birmingham
- 1007 Crescent Ave., Birmingham
- 1530 N. 20th St., Birmingham
- 1538 11th Ave., Birmingham
- 1400 30th St., N., Birmingham
- 1430 N. 12th Court, Birmingham
- 1428 N. 12 Ave., Birmingham
- 510 St. Charles Ave., Birmingham
- 1719 29th St., Ensley
- Fayette
- Fayetteville
- P. O. Box 127, Foley
- Ft. Morgan (Mail c/o United Fruit Co., Mobile)
- 903 S. 10th St., Gadsden
- 246 S. 5th St., Gadsden (Portable)
- 246 S. 5th St., Gadsden
- Hazen
- 104 Oakwood Ave., Huntsville
- 104 White St., Huntsville
- 724 E. Clinton St., Huntsville
- Lochapoka
- 55 S. Joachim St., Mobile
- 264 N. Conception St., Mobile
- 960 Marine St., Mobile
- 108 Cramer Ave., Montgomery
- 217 Catoma St., Montgomery
- 516 Cloverdale Road, Montgomery
- R.F.D. No. 4, Montgomery
- 1404 Church St., Montgomery
- 24 Capitol Parkway, Montgomery
- 5 Woodward Ave.
- River View
- 803 Lawrence St., Selma
- 515 Sylvan St., Selma
- 816 Union St., Selma
- 835 King St., Selma
- 232 Lamar St., Selma
- 111 Alabama St., Selma (Portable)
- 706 Broad St., Selma
- 111 Alabama St., Selma
- 1005 First Ave., Box 834, Selma
- 1024 15th St., Tuscaloosa
- 610 McClain Ave., Tuscaloosa
- 4838 6th Ave., Wylam

**SUPERVISOR KOLSTER COMMENDS US**

In the annual report of the Supervisor, First District, to the Radio Division, Supervisor of Radio Kolster comments as follows under the subject of "Interference":

"I wish to bring to the attention of the Division the splendid cooperation extended to this office by the amateurs who volunteered their services in connection with this investigation work".

We're proud of that.

**CAPTAIN HOOPER NOW D. N. C.**

Captain S. C. Hooper, in charge of the radio section, Bureau of Engineering, U. S. Navy, and lately assigned as Technical Advisor to the Federal Radio Commission, has been appointed Director of Naval Communications at Washington, relieving Capt. Thos. T. Craven, who has been promoted to Rear Admiral and transferred, we believe, to sea duty. Like Admiral Craven before him, Capt. Hooper is a splendid friend of the amateur. He has known us longer than any of his predecessors in that office. Although known to amateurs as one of the joint revisors of the well-known *Robison's*

*Manual*, he must be best known as one of our most helpful friends at the Washington international conference—see January *QST*. Our congratulations and best wishes to both officers!

—K. B. W.

**Strays**

If you substitute for the crystal a wave-meter or any tuned circuit, tuned to the same wavelength as the crystal, during the "tuning up" process, you will not be so apt to have a crystal "transmitter" and a broken crystal when it comes time to work the set. After all the preliminary adjustments have been made, the crystal can be put back in the circuit.—3CKL

A description of their line of uniform-size meters for transmitters, and some dope on the uses of various meters, is in the Weston Electrical Instrument Corp. new circular J. Better get one.

## Experimenters' Section

**T**HE members of the Experimenters' Section, together with the rest of the amateur fraternity, are faced with the big problem of meeting the more or less drastic change in operating conditions which the inauguration of the provisions of the International Radio Conference of 1927 will bring upon us January first of next year. We have never been licked by frequency restrictions before, and we are not going to be licked this time. It is quite obviously not only expedient but also necessary that the body of experimenting amateurs concentrate their activities on the technical phase of preparing to cope with the not far away situation, and that the Experimenters' Section as the organized body of these experimenting amateurs tackle those technical problems bearing most directly on the approaching situation.

### CONCENTRATING ON PROBLEMS TO MEET 1929 CONDITIONS

With this viewpoint in mind the list of X Section problems has been somewhat modified. While most of the old problems have been retained, the scope of several has been enlarged and several new problems have been added. Four problems have, for self evident reasons, been eliminated. The present list of problems is as follows:

#### THE ANTENNA CIRCUIT

- A10-Antennas and feeder systems.
- A12-Loop transmission and reception.
- A13-Underground antennas.

#### RECEPTION

- R12-Radio frequency amplifiers for amateur bands.
- R13-Methods of obtaining audio frequency selectivity.

#### TRANSMISSION

- T25-Radio frequency chokes for transmitters.
- T26-Keying methods.
- T27-Transmission and reception on 28,000 Kc., (10 meter), band including antenna systems.
- T30-Transmission and reception on frequencies above 56,000 Kc., (wavelengths below 5.357 meters).
- T33-Constant frequency transmitters.

Glancing over the list, it is seen that A10 has been enlarged to specifically include feeder systems, while A12 and A13 are as before. Receiving problem R12, while specifically mentioning radio frequency amplifiers, actually encompasses every type of receiver including the superheterodyne. R13 is a new addition, and one which is undoubtedly to prove of great value in adapting receivers to 1929 conditions.

The transmitting problems T25 and T26 are unchanged, while old problem T27, hav-

ing outlived its usefulness, has been replaced by new problem T27 made necessary by opening of the 28,000 kc. band. T28, portable Transmitters, has proven more the question of mechanical design in adapting a low power transmitter for portable use than a real experimental problem, and has therefore been eliminated. T30 and T31 have been combined as T30, while T32 has been enlarged to include all constant frequency transmitters as T33. General problems G12 and G13 are so obviously general in their nature and remote from the big problem before the amateur at this time that they have been eliminated.

Due to the wide scope of each problem and the desirability of having each experimenter concentrate to the greatest possible extent on the problems he may select, not more than TWO problems are to be chosen from the list by each member.

If at some future time, however, the experimenter should decide to substitute a different problem for one first chosen, he may do so by writing Headquarters, advising the change.

Experimenters at present enrolled for problems which have been discontinued on the new list should not drop their activities on these problems, but should continue to a conclusion and report on these problems as usual.

Outlines suggesting a method or methods of attack on the problems as well as a list of references of material are being prepared for each problem and will be sent to members enrolled for the respective problems as soon as the preparation is completed.

There is work to be done by every experimenting amateur now as never before, and new members for the Experimenters' Section are needed and wanted. All desiring to be enrolled should do so at once—just address the Experimenters' Section, American Radio Relay League, 1711 Park St., Hartford, Conn., and state that you wish to join the X Section.

—J. J. L.

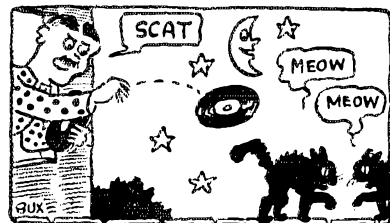

BROADCASTING RECORDS

# Mica Condensers For High Frequency

By Arthur M. Trogner\*

A recent article in *QST* gave some explanation of the necessity for symmetrical arrangement of condenser units when used in parallel in high frequency transmitting circuits. This is no new conception or principle, but, like a lot of other fundamental rules it is of such small moment in intermediate and low frequency circuits that it can usually

inductive reactance such small differences in physical circuit length may mean. This difference in inductive reactance will force most of the current to flow through the lower reactance path and very probably burn out that condenser. In the figures the different thicknesses of the dotted lines indicate (very approximately only) the proportion of the total current which will flow through each condenser in the various arrangements. If you are counting on using nearly the full current carrying capacity of each condenser in the combination, it is easy to see that burnt-out condensers will be the result. Adding more condensers in parallel such as 1 (b) and 1 (c) even though the physical lengths of the separate paths may be the same will not cure the trouble to any appreciable degree since the

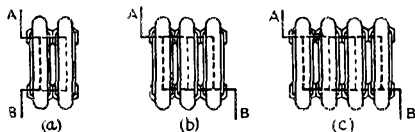
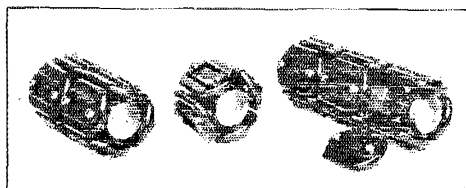

FIG. 1. THE THICKNESS OF THE DOTTED LINES THROUGH THE CONDENSERS SHOWS ROUGHLY HOW THE CURRENT WILL DISTRIBUTE ITSELF

be neglected there. In the high frequency field the effects of a neglect of this principle of symmetry will not be pleasant unless your pocket-book is well lined and you delight in making business for the small condenser makers.

What is meant by this symmetry can best be explained by first showing what *not* to do and why. Fig. 1 shows several common methods of connecting small fixed con-



GROUPS OF FOUR CONDENSERS MOUNTED IN PARALLEL SHOWING A SINGLE GROUP AS WELL AS TWO AND THREE GROUPS IN SERIES

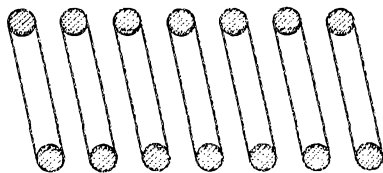

FIG. 2. SHOWING THE DISTRIBUTION OF THE CURRENT IN A COIL WOUND WITH ROUND CONDUCTOR

Of course, there will be some current flowing at the outer surface and even in the center but the percentage of the total current which flows along the inner surface will increase as the frequency is increased.

denser units in parallel when greater current carrying ability, greater capacity, or both are desired. It is obvious that the paths from "A" to "B" in 1 (a) are not the same length through both condensers. From your own work with high frequencies you know what an appreciable difference in

outside condensers will still carry most of the current for the same reason that high frequency currents are crowded to the surface of a conductor on which they are traveling. The inside condensers, or the inside of the wire, are paths of higher inductive reactance than the outside and radio frequency currents always travel in the path of least inductance even though this results in higher circuit resistance. Another example of this is shown in Fig. 2 which shows roughly the character of the current distribution in the conductor of a coil carrying high frequency current. The current is crowded to the inside surface of the wires since the outer surface of the turns, being cut by more lines of force, has a higher inductive reactance. This will be easy to see if you remember that the inner surfaces are cut by the flux which is inside the coil, whereas the outer surfaces are cut by this same flux plus the flux which distributes itself between the inner and outside surfaces of the wire. (See Morecroft, *Principles of Radio Communication*, page 125 first edition or page 156, second

\*Formerly at U. S. Naval Research Laboratory. Now with Wired Radio Inc., New York City.

edition.) This is one reason why coils wound with flat copper strip are so effective for high frequency work; there is not a lot of useless copper on the outside of each turn to cause eddy current losses.

This leads us to the right way to connect condensers in parallel. Put each condenser unit in a path of equal inductance. This is shown in Fig. 3 for various combinations. We have tried this out and know that it is worthwhile every time. With such arrangements, each con-

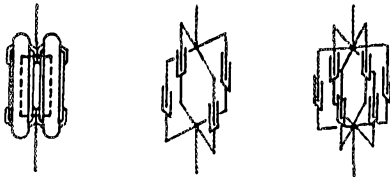
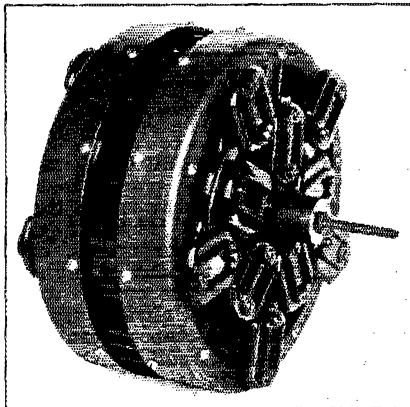

FIG. 3. HOW CONDENSERS SHOULD BE CONNECTED IN PARALLEL TO OBTAIN EQUAL DISTRIBUTION OF CURRENT THROUGH ALL THE UNITS

denser will carry its share of the load. Of course, each condenser in any parallel combination should be at least of the same rated capacity otherwise the difference in capacitive reactance thus form-



FOR THE 20-KW. TUBES

This group employs the same principles as do the smaller units although it has been necessary to change the mechanical arrangement somewhat. This unit has ten condensers in parallel with five sets in series. It is made up of 200 µfd. units which are built to stand a test voltage of 5,000 d.c. The total combination has a capacity of 400 µfd. and has been tested to 35 amperes at 18,000 kcs. It is only needed where 10- or 20-kw. water cooled tubes are being used.

ed will cause more current to flow through the larger capacities and might overload them. It might be well to point out here

that the usual difficulty with condensers at these high frequencies is not voltage breakdown but heating and failure of the dielectric.

In Fig. 4 is shown detail dimensions of standard parts which have been found very useful here at the Laboratory. These parts provide for 4 units in parallel and by using the ring fittings shown, such parallel units can be readily arranged with 2 or more sections in series where needed to take care

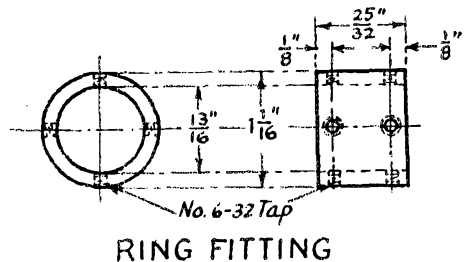
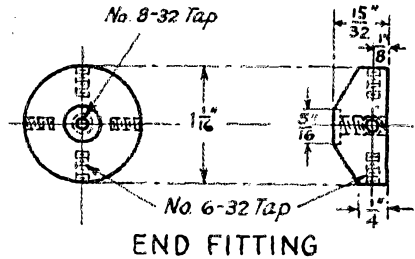

FIG. 4. DIMENSIONS OF THE MOUNTING UNITS TO CONNECT FOUR CONDENSERS IN PARALLEL

Connection to the rest of the circuit is made through 8 x 32 machine screws run into the threaded holes in the center of the end fittings. The ring fitting is employed to connect sets of four condensers in series. Several sets may be so connected making a solid mechanical as well as good electrical unit.

of high plate voltages, and the like. Fitting of similar construction are employed to mount six condensers in parallel.

It might be well to add a few words about choosing the proper kind of condenser units to use. One of the benefits to "Hamdom" from the coming of the BCL is the improvement in many radio parts available on the market. Among these are greatly improved small mica condensers. Originally intended mainly for use in receivers, it has been found that the better types, constructed of the best materials to rigid standards, are just the thing for use in high frequency transmitters. Notice that I did not say that all small mica condensers are good for transmitter work.

There are many makes of condensers on the market which are all right for use in receivers, but which will not stand up under the severe loads found in transmitters. The difficulty with most condensers of this type is that their internal losses are too high. Often this is true only when the condenser is passing appreciable currents which accounts for the fact that such condensers may be good low-loss units for receivers and yet fail in transmitter use.

A suggested set of rough specifications is given below. The units should be entirely enclosed to prevent accumulation of dust and moisture across and between the edges of the mica sheets. A complete water-tight enclosure is to be preferred since only a slight amount of moisture may cause a rapid rise in losses. Condensers should be capable of carrying the currents specified in the table below without exceeding an ultimate temperature rise of 10° C above surrounding temperature.

Capacity	R. F. amps. at 6000 Kcs.
.0002 to .00059 mfd.	3 amps.
.0006 to .00099 mfd.	4 amps.
.001 mfd. and larger	5 amps.

## ELECTION NOTICES

To All A.R.R.L. Members Residing in the Central, Hudson, New England, Northwestern (including Territory of Alaska), Roanoke, Rocky Mountain and West Gulf Divisions:

1. You are hereby notified that an election for an A.R.R.L. Director, for the term 1929-1930, is about to be held in each of the above Divisions, in accordance with the Constitution. Your attention is invited to Sec. 1 of Article IV of the Constitution, providing for the government of A.R.R.L. affairs by a Board of Directors; Sec. 2 of Article IV, defining their eligibility; and By-Laws, 14, 15, 16 and 17, providing for their nomination and election.

2. The election will take place during the month of November, 1928, on ballots which will be mailed from Headquarters in the first week of that month. The ballots for each Division will list the names of all eligible candidates nominated for the position by A.R.R.L. members residing in that Division.

3. Nominating petitions are hereby solicited. Ten or more A.R.R.L. members living in any Division have the privilege of nominating any member of the League

in their Division as a candidate for Director. The following form for nomination is suggested:

(Place and date)

Executive Committee,  
A.R.R.L. Headquarters,  
Hartford, Conn.

Gentlemen:

We, the undersigned members of the A.R.R.L. residing in the ..... Division, hereby nominate ..... of ..... as a candidate for Director from this Division for 1929-1930.

(Signatures)

The signers must be League members in good standing. The nominee must be a League member in good standing and must be without commercial radio connections. His complete name and address should be given. All such petitions must be filed at the headquarters office of the League in Hartford, Conn., by noon of the first day of November, 1928. There is no limit on the number of petitions that may be filed, but no member shall append his signature to more than one such petition.

4. Present Directors from these Divisions are as follows: Central, Mr. Clyde E. Darr, Detroit; Hudson, Dr. Lawrence J. Dunn, Brooklyn; New England, Dr. Elliott A. White, Hanover, N.H.; Northwestern, Mr. Karl W. Weingarten, Tacoma; Roanoke, Mr. W. Tredway Gravely, Danville, Va.; Rocky Mountain, Mr. Paul M. Segal, Denver; West Gulf, Mr. Frank M. Corlett, Dallas.

5. This is your opportunity to put the man of your choice in office as the representative of your Division. Members are urged to take the initiative and file nominating petitions immediately.

For the Board of Directors:

K. B. WARNER, Secretary.  
Hartford, Conn., 1 September, 1928.

### Strays

Reports have been circulating in amateur radio that the UV-203-A 50-watt tube is no longer available. The rumor is untrue. The tube is still available, but must be ordered direct from the R.C.A. in New York. Only the UX-852 and the UX-210 are available from dealers. All the other transmitting tubes are sold under a sales agreement, through the Engineering Products Division, Radio Corporation of America, 233 Broadway, New York. Requests for information on, and orders for all transmitting and power rectifying tubes other than the 852 and the 210 should be addressed to that division.



Conducted by A. L. Budlong

**A**S this report is being written, a number of replies have come in from Presidents of National Sections regarding the vote on the proposed new Constitution. It appears, so far, that the objections cited to the first proposal have been satisfactorily taken care of in the second proposal; we hope and believe that the new Constitution can be reported on as being adopted, in the next issue of QST. In addition to the QST notice, of course, more detailed written reports will be mailed promptly to all Section officers.

The editor of this department again wishes to urge upon the presidents and secretaries of all National Sections that they send in regularly each month some kind of a report for their respective sections. During the Summer it was to be expected that reports would fall off somewhat, but with the Fall approaching, there should begin a greater interest in amateur radio. See to it that your country is represented in this section of the magazine each month by sending in a short report to reach Union Headquarters not later than the 25th of each month.

Information is particularly requested from foreign countries regarding the attitude of their governments toward the new amateur wavebands. We want to know as soon as possible how much of these bands is going to be made available to you, what powers will be allowed, intermediates designated, etc. Please advise this office promptly when such information becomes definitely known.

#### ACTIVITY IN THE AZORES

In a letter to the I.A.R.U. editor, Mr. M. S. Killen, Hon. Sec'y. of the Western Union Radio Club, Horta, Fayal, Azores, states:

"Our club station, ep3MK, works on 45 meters, 80 watts input to a Hartley oscillator. Our club has just commenced working, but there is much interest, and we have already made contact with nu2UN and nu2NV. We want to let all NU stations know that we are anxious to QSO them."

#### BELGIUM

According to a letter from Mr. Paul de Neck, President of the Reseau Belge (Belgian I.A.R.U. Section) there has not been so much activity for the beginning of the summer due to the influx of a great many new members, all young in the noble art of transmitting, and a period of motoring, football, etc., on the part of the old-timers. His report, which follows, shows an encouraging amount of amateur work, however:

"eb4AU recently worked a Japanese unlicensed station on 20 meters, making the first EB-AJ contact. He also worked a Canadian ship anchored in Papeete harbor (Tahiti) and reports a QSO with VPG, a British station at Accra, on the Gold Coast of Africa.

"eb4FT, on regular schedule, worked a French ship bound for the West African coast practically every night up to the arrival of the ship at Port Gentil, in the Gabon, its port of destination.

"eb4AR is particularly interested in going after ships, and works lots of them.

"eb4OU, on 45 meters, puts out phone over the whole of Europe, with 100% readability, and recently received a report from Siberia commenting on the excellence of his phone quality. He is using a Belgian ham circuit, called the 'circuit Van Gasse', and with 45 watts input is one of the best phones in Europe.

"eb4FT has just informed us that he worked a new official short-wave station skVPC, on 32 meters. The QRA: Port Stanley, Falkland Islands.

—Paul de Neck, President, Reseau Belge."

#### CHILE

nu5APG, K. M. Ehret, at Oklahoma City, reports a recent QSO with that well-known Chilean station sc2AS, in which the latter stated that he was starting a new business further south and would definitely be off the air with the old set for at least two years, there being no electricity available at the new location. 2AS stated, however,

(Continued on Page 62)



# Calls Heard



Luis Greco Loprena, Calle Habana 7A, alta, Santiago de Cuba, Cuba  
(Heard during June)

1aba 1acm 1acu 1acy 1awd 1arb 1as 1bbe 1bc 1ber 1bbm 1cb 1cbg 1ch 1cmf 1cpi 1gw 1mx 1no 1qi 1rp 1tr 1vm 1vw 2alb 2apy 2arb 2bea 2bek 2bkg 2bkg 2bkg 2brx 2bxr 2bxr 2cf 2cv 2cxl 2dq 2kp 2la 2om 2pa 2pw 2ra 2tp 2ty 2ou 2xaf 2xc 2xs 3aep 3anh 3arx 3cc 3cya 3eg 3sh 3ts 3ut 4aa 4ab 4ck 4dq 4fe 4ha 4rr 4ud 4wo 5aba 5acn 5aep 5aff 5ax 5aug 5ain 5ani 5ag 5ar 5ary 5aw 5ayl 5ef 5ea 5en 5fi 5fl 5ky 5ie 5lac 5oa 5si 6am 6auk 6bcp 6byq 6bzs 6gy 6dov 6di 6gqg 6oiv 6wyk 7adx 7ail 7aip 7awm 7fc 8af 8ap 8ann 8avd 8axq 8azk 8bhn 8bho 8bhq 8bhr 8bvx 8byw 8ccl 8ccq 8clq 8nx 8euz 8exc 8xcl 8dgg 8dno 8el 9bal 9bec 9bo 9hg 9hsy 9hwj 9ocv 9cif 9cne 9cx 9cxc 9cys 9dce 9dkg 9ejw 9et 9evn 9fs 9iv 9pd 9e-9dkg nj-2pa nq-2ac nq-2kp nq-4bn nq-5cx nq-5cq nq-5ry sa-3wb se-2ab se-2om ue-3es. H. J. Conti, 15 Harbor Terrace Drive, Ite, N. Y. ne-1ad ne-1ax ne-2bb ne-3ai ne-3ar ne-3ay ne-3bm ne-3ce ne-3in ne-3mv ne-9am ne-9ax ne-9az velap velar velce velco veldq ve2br ve3bo ve3br ve3ch ne-8rg nj-2pa nm-9a nm-xia nm-1nic nq-2ef nq-2iq nq-5by nq-5ea nq-5fc nq-5fl nr-2ea na-1fmh ea-ep ea-eh ea-ky ea-4fx ef-7ly ee-are7 ef-8axq ef-8br ef-8cl ef-8er ef-8gdb ef-8gyd ef-8it ef-8pns ef-8rrm ef-8vu ef-8wb eg-2un eg-5dh eg-5lw eg-6bb eg-6by eg-6dp ei-lee ei-ldo ei-lmg ei-1mm ek-4abg en-0j2 ep-1ae ep-1ef ep-3am ep-3bz sb-1ah sb-1at sb-1bg sb-1ca sb-1fd sb-2bz se-2ah se-1mi se-2ea se-2jm su-1cg fe-sur fe-suw fm-8gkc fq-pm oa-8jk od-afv oh-6ajl. 70V; Don Newman, RFD 12, Box 632, Seattle, Wash.

(20 meters)

1agr 1ap 1atr 1aw 1aw 1ber 1bvl 1cki 1om 2ayj 2bc 2dk 2gr 2nj 2qv 3aql 3ae 3gr 3aek 4am 4ck 4dt 4dv 4gg 4pd 5aek 5ahx 5akp 5as 5ar 5ata 5ast 5at 5aw 5awp 5bbe 5bf 5bg 5bh 5bw 5em 5ie 5kj 5ql 5qo 5rg 5ta 5uk 5xd 5yb 5z 5zas 5zv 7aav 7abg 7aeb 7aet 7aev 7afo 7afu 7ajj 7ail 7aka 7akj 7alz 7ap 7akv 7avp 7awf 7axf 7azg 7bc 7box 7brh 7ccl 7ecp 7cmx 7cpc 7dcd 7djj 7dma 7dne 7nb 7nb 7ucl 7aid 7ajw 7ama 7any 7asx 7atg 7avo 7axl 7bxc 7bez 7bjp 7bqy 7bxx 7byo 7bzy 7cet 7cic 7erd 7ear 7euh 7exa 7cwa 7db 7dex 7dfy 7dgr 7dhp 7dih 7dix 7doo 7drd 7dvr 7dvv 7eag 7eaz 7eef 7efh 7eta 7euh 7exa 7eyl 7ez 7fhw 7fci 7fdt 7fhy 7gab 7gty 7hl 7na 7qy 7sx 7wk na-7ady na-7aer na-7am na-7nr ne-2ca ne-4gg ne-4ha ne-5bn velaw ve2br ve3es vedgg nj-2pz eg-2ur eg-5by eg-5ma eg-5ml eg-5vy ef-8fc ef-8fd ef-8orm oa-2uk oa-2yi oa-3bd oa-3xr oa-3ry oa-4bb oa-7lj oz-2ae oz-3aw oz-7mu oh-6alm oh-6avl oh-6elj oh-6dey oh-6dud oh-6eat sb-1aw se-2ab se-2as wnp voq.

E. J. Sahn, 265 E. 182nd St., New York City  
(20 meters)  
6bh 6by 6bza 6cxm 6cj 6esj 6czk 6xx 6xu 6zdd 7mx ee-ear9l ef-8fd eg-5by eg-6yv eg-4abn fe-1es fe-eez oa-2ac oa-3bd oz-2bg.

(40 meters)

ek-4yt ep-1cn ne-2av ne-3ay nq-5cx nq-5fc nq-5fl sb-1ah sb-1ld.  
ei-ITU, Dante Bstafi, Torino, Italy.  
1bgq 2ii 3az 3eg nn-1na nq-5cx sb-1bg sb-1as sb-1bs sb-1ar sb-1ah sb-1aw sb-1ca sb-2ad sb-7ab se-2ar su-1oa su-2ak oz-2za oz-2am oz-2aq oz-3az oz-2bg oz-4am oz-2ae oz-3ar fm-8rk fm-8jo fm-8ev fm-8gst fm-8hpg fq-pm fq-Ocya ft-nft.  
IBUX, D. H. Borden, Toulisset, Mass.  
(20 meters)

eh-4au ef-7gz xcd-0ij ee-ear70 ee-ear70 ef-8bf ef-8btr ef-8dmf ef-8eo ef-8est ef-8fr ef-8hip ef-8hpu

ef-8orm ef-8rrr ef-1m eg-2ay eg-2kf eg-2nh eg-2qv eg-2sc eg-2vq eg-5ls eg-5ml eg-5uw eg-5vl eg-6bd eg-6dr eg-6hf eg-6hp eg-6ig eg-6mi eg-6oh eg-6rb eg-6ta eg-6vp eg-6wi eg-6wt eg-6xp eg-6yv ei-idy ei-1kl ei-1gw ei-ipo ek-4abg ek-4ka en-Owr ep-1aa ep-1bk fe-eez fk-4ms fm-tun2, fq-8hpg nu-4agf np-4sa nq-2kp oy-lau sa-1c6 sb-1ah sb-1aw sb-1jb sb-2ab sb-2az se-2ah se-2ar se-3ac se-3cj su-1bx su-1ex oa-2hm oa-2jk oa-2rc oa-2rx oa-2ss oa-2yi oa-3bq oa-3my oa-3xo oa-4nw oa-6bj oa-7cw oa-7lj oz-2ae oz-2ae.

(40 meters)

ea-jh eb-4di eb-4fp eb-4ro ee-ear94 ef-8btr ef-8zb ei-1go ek-4uai ef-4uj ek-4vt em-smua ep-1ae ep-1bl ep-1bx ep-1by ep-1cn ep-3ag ep-3gt ep-3hp fq-ocya nj-2pa nm-9a nm-1nic nq-2ea nq-5ay nq-5by nq-5cx nq-5ea nq-5fl nq-pwal nr-2ags nr-2ea nr-4mwn oa-2bv oa-2ij oa-2kb oa-2rb oa-2wc oa-3hm oa-3hq oa-3jk oa-3pi oa-3wh oa-3xo oa-4pn oa-6bd oa-5hg oa-5fl oa-5jh oa-5vj oa-5ws oa-7cw oa-7dx oa-7lj oa-7wt oz-2ga oa-3ar oz-3au oz-3az oz-4am sa-bx2 sa-ca2 sa-de3 sa-dl9 sa-dq4 sb-1ah sb-1ak sb-1aq sb-1ca sb-1cn sb-1ld sb-2ad sb-2ah sb-2aj sb-2al sb-2bg sb-5ah sb-9af se-2ab se-cnag se-1em se-1mi se-2ah se-2jm so-1aa su-1fb su-1oa su-2ak.

Harold G. Fownes, 110 Riddiford St., Wellington, New Zealand.

1aal 1ayj 1anh 1cdx 1lbu 1com 1aur 1asr 1bjp 1aoo 1bat 1zl 1nq 1akz 1aww 1um 1bzi 1ajm 1vh 1nk 1ue 1cam 1asu 1bkp 1btv 1byv 1ry 1ajm 2bc 2bx 2kr 2al 2bp 2bxz 2bxt 2asb 2am 2ie 2haz 2bxr 2ate 2ahg 2agn 2at 2ad 2fc 2as 2as 2qo 2al 2aha 2awa 2awx 2qu 2apa 2ahm 2at 3ak 3bbw 3bnu 3atp 3aed 3apx 3ade 3ag 3wj 3ajh 3cix 3cp 3nf 3bnu 3aop 3ais 3efx 3ku 3akb 3ak 3aoc 3fg 3bg 3avm na-7abz na-7am na-7abe na-7aer na-7aam na-7to na-7hl ne-7ax ne-1ak ne-1ap ne-2ax ne-2bb ne-2w ne-3es ne-3dy ne-3el ne-3hp ne-3ni ne-3qn ne-3md ue-4aj ne-4fv ne-4g ne-4hm ne-4xt ne-4ac ne-5ad ne-5al ne-5a ne-5eo nm-1aa nm-9a np-4aan np-3jg np-4kd np-4ca nh-ca nx-1kl ac-2cp ac-8to ac-8na ag-67ra aj-jxex aq-1lm lq-1mdz on-1ad oh-tdju oh-6ch oh-6dl oh-6jk od-1pr sa-aas sa-dak sa-de8 sb-1aw sb-2aw sb-3qa fm-tun2 fo-a3c fo-a3z eb-4ax eb-4yz ed-7dd ef-8ix ef-8ct ef-8zf eg-5by eg-5hs eg-5yx eg-6wg eg-6ut eg-6cx ej-7dd en-Ogg ep-1bx ep-1bk ew-h2 ew-ab.

eg-5BZ, G. G. E. Bennett, 26 Blenheim Park Road, Croydon, Surrey, England  
(During May—On 20 Meters)

1abd 1adm 1adw 1aff 1akm 1aod 1aqt 1asf 1atr 1ber 1bed 1big 1bil 1bux 1bv 1bx 1cab 1cjh 1cmz 1de 1fn 1kh 1mx 1si 1ue 1uo 1vw 1xaw 2ag 2ago 2ain 2arb 2awq 2azi 2bbx 2bcw 2bdr 2bfq 2bfy 2bjm 2bmk 2bms 2bot 2bxr 2cdm 2ch 2ek 2ctq 2ff 2ih 2sb 2sj 2vk 2xad 2xg 3aal 3aih 3ann 3any 3aq 3bgq 3bjw 3chk 3db 3dg 3di 3dr 3wm 3zf 4aay 4acc 4ad 4ack 4af 4agr 4ek 4db 4dv 4io 4ll 4nl 4ow 4pd 4pl 4kn 4ry 4to 4wm 4fa 4adn 5ae 5afk 5aw 5ara 5ati 5auk 5avs 5ayb 5azu 5bbe 5bj 5dq 6dv 6gf 6he 6kg 6mq 6ns 6oo 6rg 6wz 6zav 6agr 6as 6ajm 6alw 6ard 6azs 6bqv 6bid 6bjh 6bkd 6boa 6bx 6bux 6bfz 6cdw 6cgm 6chq 6col 6evx 6cz 6cz 6db 6ddy 6dop 6dev 6dfs 6dhq 6djk 6dlw 6dom 6don 6dor 6drb 6dri 6ec 6ih 6jg 6jn 6kb 6pw 6gf 6uz 6w 6wb 6xi 6yo 6zdd 7aav 7acs 7acy 7aff 7afo 7ajj 7akj 7ako 7ek 7fe 7fh 7kt 7lt 7md 7mv 7mx 7nr 7of 7sf 7tj 7vq 8abh 8acm 8adg 8avp 8avp 8bhl 8bdp 8bn 8bey 8bg 8bkq 8byn 8cse 8ccl 8csw 8clt 8cm 8en 8epd 8ew 8oce 8dvw 8dvv 8dqk 8gz 8j 8k 8nb 9au 9aid 9aw 9ake 9alz

(Continued on Page 72)

# Correspondence

The Publishers of QST assume no responsibility for statements made herein by correspondents.



## For Next Year

136 High St.,  
Exeter, N. H.

Editor, *QST*:

What is to be done about it? Must the name of *QST* be changed after January 1st next? It is to be noted that "QST" is not included in the list of "Q" signals adopted by the Washington Convention and apparently "CQ" is to take its place (Article 9 bis, Par. 3). Won't the CQ hounds laugh if our magazine must be called "CQ".

Seriously, though, I hope that an article will soon be forthcoming dealing with the changes in operating procedure which must be made in accordance with the Convention. Much has been said about the new wavelengths, but very little about the other ways in which amateur operation will be affected. Of course most of the regulations apply to commercial work, but it would seem that, for the sake of uniformity, the amateurs should conform to them as far as possible.

For example, I don't suppose that the amateurs are bound to use the new set of audibility signals ("R" signals), running from 1 to 5, but it seems to me that they should do so, especially as I think that the new ones are better than the present ones running up to 9.

The new list of "Q" signals certainly looks different from the old one. It will take some time to get used to QRZ meaning "You are being called by—"; QRV "Send a series of V's"; QSR "The distress call received from—has been attended to by—"; etc. It is amusing to note, among the numerous miscellaneous abbreviations which have been authorized, that "OK" is officially recognized, meaning, "We are in agreement."

Probably the owners of amateur phones will have little occasion to send out SOS's, although perhaps some of them ought to do so, but they may wonder why the official radiophone distress call is "Mayday," until it is understood that this stands for the French "m'aider".

I am wondering if the amateurs will adopt "C" for Yes and "N" for No, or if such expressions as "Yep" will continue to hold their own. Do you think there would be any advantage in trying to establish a set of abbreviations especially suited to amateur use, just as the commercials have their "Z" signals? These might be special "Q's",

although there would be a disadvantage in mixing the official with the unofficial. We already have "73," so how about extending this plan? Thus, for example "71", might mean "Please send card" etc *ad infinitum*. A rather lengthy list might serve in emergencies, as for instance, when operators do not speak each other's language, but I am not enough of a DX man to speak with authority on such matters.

I am glad to see that national prefixes, rather than intermediates, are to be used hereafter. I have never cared for the intermediate plan and I guess we have all had the experience of listening to a long string of calls, only to find that the all-important intermediate was given carelessly or was lost in QRM or QSS. The prefixes ought to go far towards making station identification easier.

Into what class do amateur stations fall? They are "fixed" in that they are "permanently located and communicating with one or more stations similarly located," but in most ways their operation (except when working on schedule) seems to be more of the nature of that of mobile stations, as referred to in the Convention. Probably this is a matter of no importance, however.

I am sure that an article in *QST* on some of the points mentioned would be of interest to many of us.

—H. S. Shaw, 1RZ.

The reader is referred to the Editorial pages of this issue.—Editor.

## The "Splatter System"

[In which Dr. Hulburt, of Taylor and Hulburt fame, comments on the possibilities or impossibilities of the "Warner Splatter System."—Editor.]

Naval Research Laboratory,  
Anacostia, D. C.

Editor, *QST*:

In *QST* for July 1928, page 7, I read your captivating suggestion of the "Warner Splatter System" for the use of the 30 megacycle (10 meter) waves. This system, based on Meissner's 80-degree angle long distance experiment, contemplates directing these waves more or less vertically upward with the idea that they be splashed down from the skyward regions. From the descriptions which I have read about the overhead regions I wonder whether the wire-

# ELKON REPLACEMENT RECTIFIERS Are Saving Radio Fans MILLIONS of DOLLARS

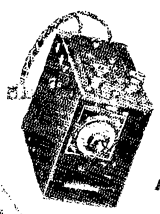

Type BNK for replacing the acid jars in Balkite Types N and R Trickle chargers

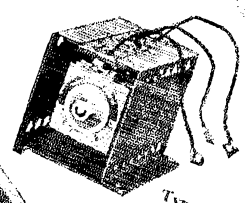

Type RJ for replacing the acid jars in Balkite Type J chargers

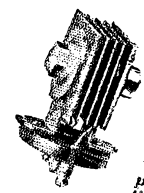

Type V-3 for replacing the rectifiers in 6 makes of Trickle chargers

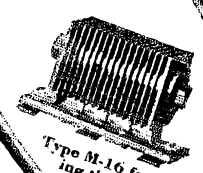

Type M-16 for replacing the rectifiers in 11 makes of "A" Eliminators and 3 Ampere chargers

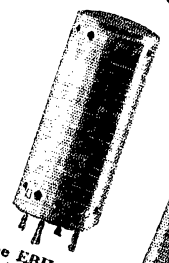

Type EBH for replacing the BH type tubes in "B" Eliminators

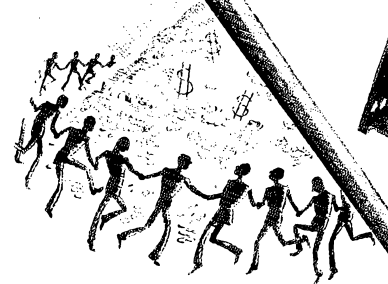

Millions of dollars are invested in radio chargers, eliminators, etc. which would be lost if it were not possible to replace the rectifying units when their life has been exhausted. All Elkon Rectifiers are replaceable.

### HOW TO TELL IF YOUR RECTIFIER NEEDS REPLACING?

If your trickle charger no longer keeps your storage battery up the way it did when it was new, you need a new rectifier.

If your set has not the same pep as it did when you installed your "A" Eliminator, you need a new rectifier.

*Do not void the Manufacturers' Guarantee on your Balkite Power Units*

The Elkon Replacement Units and those made by the Fansteel Products Company containing an Elkon Rectifier, are the only ones authorized for replacement of the acid jars in Balkite Power Units.

See your dealer today—there are thousands of hours of good reception left in your power units as soon as you have replaced your rectifier or acid jar with a new dry Elkon.

## ELKON, INC.

Port Chester, N. Y.

Division P. R. Mallory & Co., Inc.

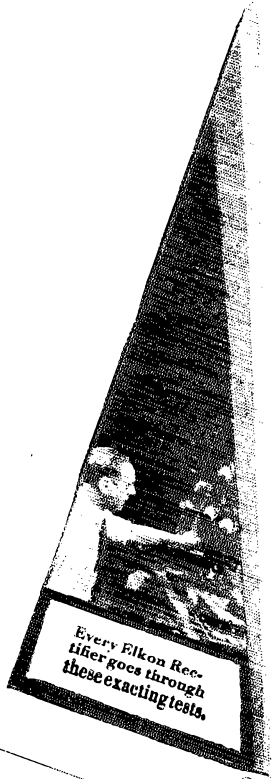

Every Elkon Rectifier goes through these exacting tests.

Say You Saw It In Q S T — It Identifies You and Helps Q S T

ELKON, Inc., Radio Department  
220 Fox Island Road, Port Chester, N. Y.  
Please send me complete information on the Elkon Radio Products.

Name.....  
Address.....

# Get into the COMMERCIAL RADIO FIELD where the MONEY IS

We've had hundreds tell us that they knew radio backwards and forwards. Yet they enrolled in our courses. And a few weeks after they started to learn radio the RIGHT way these same men told us that they never realized how much they had been missing right along.

Maybe you too have sufficient radio knowledge to build a few radio circuits. That isn't enough to make a real commercial success. What you really need is a course that takes you from the first elements of radio right through the most complex stages and gives you the practical knowledge you need for commercial work.

## RADIO INSTITUTE SPONSORED BY RCA, G-E AND WESTINGHOUSE

The Radio Institute of America is the world's oldest radio school, giving the finest and most comprehensive instruction obtainable. Our graduates are making real money—we'll send you copies of some of the letters they write us about their successes.

### STUDY AT HOME

Another feature of this course is that you can study at home—when you please and as long as you please. No need to give up your present employment. No time lost traveling back and forth to classes. Our new booklet tells how others—just like yourself—have won success in radio, and how you too can make this profession of fascinating brain-work your life career. You owe it to yourself to read this book through. If you will clip and mail the coupon, we'll send the book to you.



RADIO INSTITUTE OF AMERICA Dept. D-9  
326 Broadway, New York City

Please send me your booklet.

Name .....

Address .....

less waves will act as the system has suggested. To have any considerable splashing, or scattering, of the wave would require electron coagulations of rather high density—ten million or so per cubic centimeter (or a million, million ions)—whereas the usual electronic densities are probably a hundred times less. It is difficult to see any way in which such coagulations could occur under normal conditions, although they might possibly exist under unusual circumstances, as during wind storms in the high atmosphere, aurora displays, et cetera. On the whole, one cannot be quite certain yet of the meaning of Messner's experiment.

There is, however, a scattering of the 10-meter waves which unquestionably does exist—a scattering from the waves of the sea. Sea water has a very high refractive index for these waves (twice as high as the index of a diamond for light) and consequently is a very perfect reflector. It is like molten silver for light waves. If an observer had an eye sensitive to 10 meter waves and were situated aloft over a patch of the sea on which were falling a sheaf of the waves, he would see the water waves and ripples shimmering and scintillating very brilliantly in all directions with the 10-meter illumination. The same thing, but perhaps to a lesser extent, would be expected to be true of the facets and inequalities of the land. This type of scattering may be of importance in the 10-meter communication channels, such as filling in the skip zones, indicating storms at sea and the like.

—E. O. Hulburt.

## Danger

[The following letter from S. C. M. Sears, to an amateur in Los Angeles, is published to bring this subject to the attention of the membership, so that all members may be warned against accepting such offers. The Los Angeles amateur stated that there would be "something in it for the stations doing this work." Amateurs cannot accept compensation for their services in handling messages. See the article by Mr. Segal on page 13 of July QST.—Editor.]

LaJolla, Calif.,  
May 27, 1928.

Dear OM:

I am in receipt of your letter of the 25th with reference to lining up some San Diego amateur station to handle orders between the ..... Company, where you are employed, and the ..... Company of San Diego.

I am sorry, indeed, that I cannot do as you request. To handle such business, the stations involved would have to operate under a limited commercial license; such work not being permitted under an amateur license. Recently some of our stations have had to decline similar messages from other sources, as they do not care to jeopardize their licenses.

---

---

NEW  
*Console Model*  
A. C. TUBE  
Stromberg-Carlson

HERE is the wonderful Receiver you have dreamed of owning—a Receiver with the celebrated Stromberg-Carlson tone, at a price within the reach of everyone.

Not only the tone but its extreme sensitivity—its keen selectivity—its splendid workmanship tell you at once it is a Stromberg-Carlson.

This Receiver has a handy jack to facilitate playing records electrically through the wonderful audio system of the Receiver; thus making it possible to convert any standard phonograph into a high quality modern electrical reproducing instrument.

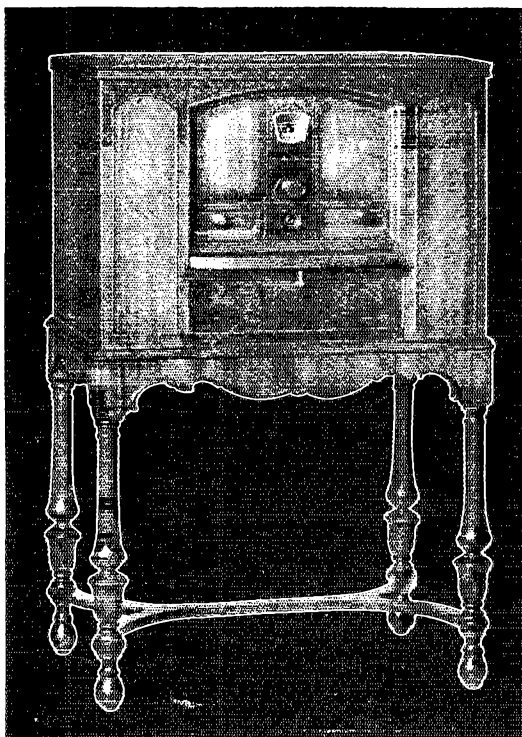

No. 656 Stromberg-Carlson Uses 5 UY-227 A.C., one UX-171 Output Tube, and one UX-280 RCA Tubes. Price, less Tubes and Speaker, \$245. Slightly higher Rockies and West and Canada.

The beautiful cabinet sets a new standard in radio. It is low, artistically designed, with two-toned Walnut panels and top of matched Walnut butts. A slide which may be used as a writing table acts as a cover to close the front.

STROMBERG-CARLSON TELEPHONE MFG. CO., ROCHESTER, NEW YORK

*The Stromberg-Carlson Sextette Friday Evenings at ten o'clock Eastern Daylight Time through the N B C and 22 Associated Stations*

# Stromberg-Carlson

MAKERS OF VOICE TRANSMISSION AND VOICE RECEPTION APPARATUS FOR MORE THAN 30 YEARS

# TONE

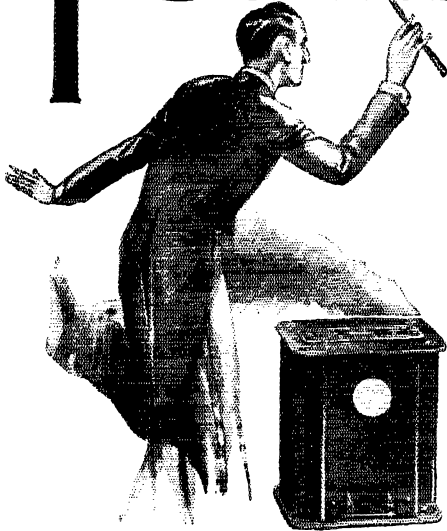

## Push-pull Transformers with impedances to match power tubes and dynamic speakers . . . .

Type "BX" Input Transformer has extremely high primary inductance. Secondary accurately divided. Price each, \$6.50

Type "GX-210" Output Transformer. Especially designed for push-pull amplifier using UX-210 or CX-310 tubes. Secondary connects directly to moving coil of dynamic speaker. Price each, \$6.50

Type "HX-171" Output Transformer. Same as above except impedance matches UX-171, CX-371, or UX-250, CX-350 tubes. Price each, \$6.50

# SANGAMO

## ELECTRIC COMPANY

SPRINGFIELD, ILLINOIS

Free circular giving audio hook-up and complete information on request.

I trust that you will understand my reasons for taking this stand, and hope that you will be able to effect some other arrangement that will prove satisfactory. The Boulevard Express Company maintain stations in Los Angeles and San Diego and might be in a position to help you out on this.

Yours very truly,

—G. A. Sears, Section Communications  
Chisholm 2CX. Members A.R.R.L.

## Why YL'S Become Amateurs

"Round Hills."  
So. Dartmouth, Mass.

Editor, QST:

I have been wondering if you and the other "hams" wouldn't be interested in hearing from a YL operator—since they seem to be rather scarce—and perhaps hearing how a YL became a "ham".

My husband, being the Radio Engineer for "The Round Hills Radio Corporation," had a transmitter and seemed to have such a lot of fun staying up all night operating it, that I began to think that I was missing a lot. So that—and the fact that I was afraid of becoming a "radio widow"—caused me to learn the code and become the YL operator at Station 1BHS.

I am not saying much about how the amateurs, whom I QSO'ed, had to suffer when I started (and I'm not so good yet) but I will say they were all perfectly great about sending slowly and repeating possibly a dozen times, and I would like to take this opportunity to thank them.

I wish some more YL's would get the "bug". I have attended two conventions: one in Boston and one in New York and only met two other YL operators. In Boston I was rather backward, but in New York I entered the contests with the rest and came back to Round Hills with four tubes and an aluminum shield.

—Helen Davis, YL at 1BHS.

## In Appreciation

Aboard S.S. Astoria, in port.  
Seattle, Washington.

Editor, QST:

Having just finished reading the excellent article by Mr. Boyden Sparkes in the *Saturday Evening Post* for July 21st, entitled "Some Attic Adventures," in which Mr. Sparkes has so ably caught the spirit of amateur radio and placed it before the public, it comes to me that we could show our appreciation of this in some way, such as by letters or station cards. The writer can recall no comprehensive article on this subject ever having been printed in the more popular non-radio magazines, and it seems that Mr. Sparkes is due a sincere vote of thanks from each of us. Many of our difficulties can be traced to lack of informa-

# CARDWELL CONDENSERS

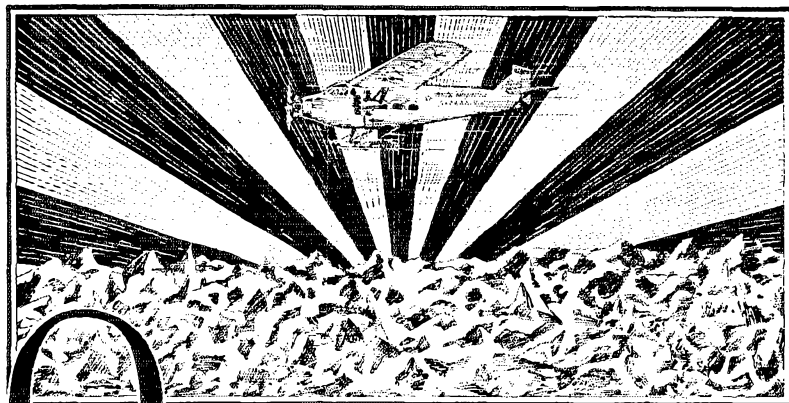

Over the top ~ ~ ~

**With Commander Byrd in 1926 !  
Into the Antarctic in 1928 !**



**M**ONTHS, sometimes years, are spent in preparing for Polar Expeditions. Every item of equipment from ship to footgear is considered, tested, viewed from every conceivable angle before being accepted as worthy to share responsibility for the safety of an expedition and its participants. No factor that human ingenuity can devise, making for success and security, is overlooked.

**DEPENDABILITY** in materials and equipment is of paramount importance in these, as in other ventures, where man is dependent upon things of his creation for his very life.

**VAST** and silent spaces, the Polar Regions. Vast, but to the listening ear not silent when vibrant with the all pervading voice of Radio.

**BYRD, DYOTT, MACMILLAN, STOLL-McCRACKEN**, are some of the names identified with expeditions placing their confidence in **CARDWELL CONDENSERS** for the equipment needed to keep them in touch with civilization, and possible succor when in desperate need of it.

**WHO** will say that the equipment selected for ventures like these is not **DELIBERATELY** and **WISELY CHOSEN?**



*Literature upon request*

**The Allen D. Cardwell Manufacturing Corp.**

81 Prospect Street, Brooklyn, N. Y.

**"The Standard of Comparison"**

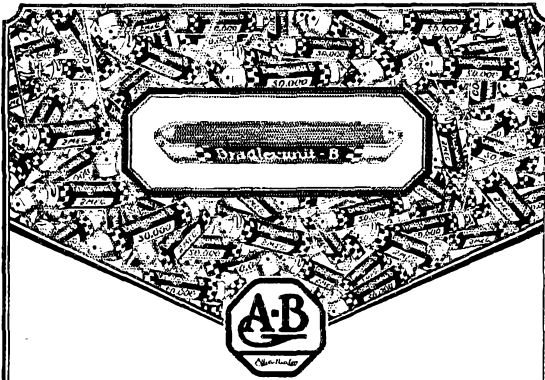

## No Grid Leak Interference with the Bradleyunit-B Resistor

**B**RADLEYUNIT-B solid-molded resistors eliminate the noise and interference in radio circuits caused by inferior grid leaks. Oscillograph tests show the Bradleyunit-B to be remarkably quiet in operation.

The Bradleyunit-B Fixed Resistor is made of a special, uniform mixture, baked and solid-molded at high pressure. This creates a solid, uniform unit, providing a constant resistance regardless of voltage used.

Radio manufacturers are assured of an accurately calibrated resistor which will retain its initial rating indefinitely.

### For Radio Manufacturers

These remarkable solid-molded resistors are practically unaffected by moisture, altho not depending on a glass enclosure for protection.

The Bradleyunit-B is furnished with or without tinned leads for soldering. Made in values from 500 ohms to 10 megohms.

Tapped Bradleyunit Resistors are also furnished to meet your specifications.

Allen-Bradley Co., 277 Greenfield Ave.  
Milwaukee, Wis.

## Allen-Bradley Resistors

tion on the part of the public, and truthful publicity of this kind will certainly go a long way toward establishing a better understanding of the radio amateurs of the world.

—Emry C. Stuedle, 6NW, KGEP, 5503 South Cimarron, Los Angeles, Calif.

“es” and “&”

4338 W. Fort St.,  
Detroit, Michigan.

Editor, *QST*:

Many of the fellows, in their correspondence and on QSL cards, write the abbreviated “and,” “es” instead of “&”. No doubt this is due to the general run of amateurs being unaware that “. . .” is the character for “&” in the American Morse code.

—J. O. Ellison, 8COW-8AGR.

### “Propaganda Cards”

66 Ingram Road,  
Thornton Heath,  
Surrey, England.

Editor, *QST*:

Probably many American hams have by now received a card from a British station which bears at the head an inscription which can only be read as a direct insult to the R. S. G. B.

Although, so far as we have been able to find out, the operator's only objection to the R. S. G. B. is that it does not give the same value for the money as the A. R. R. L., he does not join up and lend a hand with improving things, but tries his hardest to discourage other intending members from joining.

*QST* readers will realize that the T. & R. Bulletin, with its minute circulation as compared with *QST*, is neither so large nor so prolific in advertisements, but that it will grow if the R. S. G. B. is given support by the British hams, and not if they all cry off and do nothing whatever to support it.

Luckily there are not many such “hams” in Great Britain, but the existence of one or two is enough to cause anxiety to those who are looking forward to a British version of the A. R. R. L. as the ultimate outcome of the R. S. G. B., with a proportionate large membership.

We hope that stations seeing these propaganda cards will not treat them seriously, and will realize that they only express the sentiments of a very few unfortunates who have lost interest because they have been content to watch the work of others instead of doing their own bit.

—L. H. Thomas, eg6QB, D. W. Heightman, eg6DH, H. D. Price, eg6HP, H. Chisholm eg6CX. Members A.R.R.L.



# America's Most Sensational D. X. Receiver

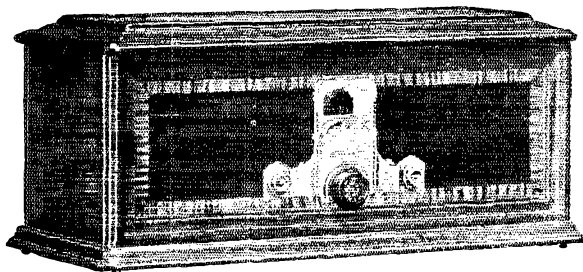

IN planning the F 11, Federal had but one goal — to produce, regardless of cost, the most sensationally performing radio receiver that skilled engineers could devise. Delicate hair-line tuning, together with an almost unbelievable distance range, attests to their success.

Antenna and ground operation with four stages of tuned radio frequency coupled with detector, and two stages of amplification will bring in even the weakest of radio impulses picked up by the antenna. Each unit of the set including the individual tubes, is completely shielded. The chassis is of sturdy all-metal construction — the cabinet of genuine mahogany.

This set may be had either for battery or for light socket operation with Federal's power-tube coupler which greatly enhances tonal quality and the efficiency of the set.

Prices, without tubes, for battery operation, \$250; for light socket operation, 60 cycle, \$360; 25 cycle, \$380. (Slightly higher west of Rockies.)

*The designated Federal retailer in your community will gladly demonstrate this phenomenal receiver, or you may write direct for complete specifications.*

**FEDERAL RADIO CORPORATION, BUFFALO, N. Y.**  
OPERATING BROADCAST STATION WGR AT BUFFALO  
Federal Ortho-sonic Radio, Ltd., Bridgeburg, Ont.

# Federal ORTHO-SONIC\* Radio

Licensed under patents owned and/or controlled by Radio Corporation of America, and in Canada by Canadian Radio Patents, Ltd.

\* Federal's fundamental exclusive development making possible Ortho-sonic reproduction is patented under U.S. Letters Patent No. 1,888,470

Say You Saw It In Q S T -- It Identifies You and Helps Q S T

# Radio Broadcast

announces a  
Series of Articles  
by  
Mr. Robert S. Kruse

RADIO BROADCAST wishes to announce that Mr. Robert S. Kruse, formerly Technical Editor of QST, will be a regular contributor to Radio Broadcast.

MR. KRUSE'S first article entitled "What About the 5-Meter Band?" appeared in the August issue. His second article entitled "Practical Work on 5-Meters" will appear in the September issue. Other articles on short-wave experiments, experiences and apparatus, written by Mr. Kruse will appear in future issues.

READERS OF QST can follow Mr. Kruse's experimental findings in the short-wave field by reading Radio Broadcast each month. Send one dollar NOW for the next four issues of Radio Broadcast containing articles by Mr. Kruse. This offer gives you the magazine at 25c per copy instead of 35c.

Radio Broadcast, Garden City, N. Y.

Radio Broadcast  
Garden City, N. Y.

Enclosed is \$1.00 for next four issues of Radio Broadcast containing articles by Mr. Kruse.

Name.....

Address.....

## Award of Honor

Anvik, Alaska,  
May 14, 1928.

Mr. Kenneth B. Warner:

It has been noted here, in Alaska, that while many bouquets were handed you after the Conference in Washington, and a few bricks were thrown, none of those substantial rewards were tendered you which are ordinarily so gratifying to the recipient and which testify to posterity of the gratitude of his contemporaries. It is, therefore, with great pleasure that I have to inform you, that the Bunkodyne, which you will find enclosed, has been awarded to you.

The Bunkodyne, as you are probably aware, is to the A.R.R.L. amateur what the Carnegie Peace Prize is to the prize fighter and the Pulitzer Medal is to the pacifist, the *ne plus ultra* of recognition.

The latest award was made to Mr. Everett Lasher, of TADY, Latouche, Alaska, who makes a specialty of routing his "nu" correspondence via England. Mr. Lasher has constructed his transmitter in

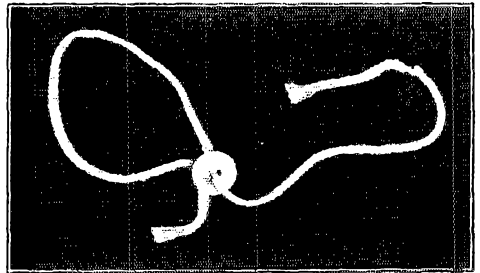

such a way that it can be used as a long distance pulmotor. He recently revived a 6 who lost consciousness during a CQ endurance test. Mr. Lasher's want of judgment was overlooked in view of the humanitarian impulse which led him to do what would otherwise have been reprehensible. At the time that the award was made, I made the mistake of informing him that it was the 347th award that had been made during the present year. On looking up the record, I find that in point of fact, it was the second award that has been made since the foundation, in 1923. The first award was made to Mr. Charles A. Service, Jr., for being good looking. No other names were considered at the time. Your name, therefore, in point of time is the third on the list; but in point of honor, as one who loves his fellow ham, it leads all the rest. Please accept my congratulations.

The Bunkodyne, as you probably know, is a perfect substitute for the rubber bands and shawl straps which are principally responsible for the decline in morals which is characteristic of the present generation. It consists, essentially, of a grid, an inductance and a condenser. The condenser, which is the tightening or binding element, is in the form of a loop which is passed through

# Radio Operators!

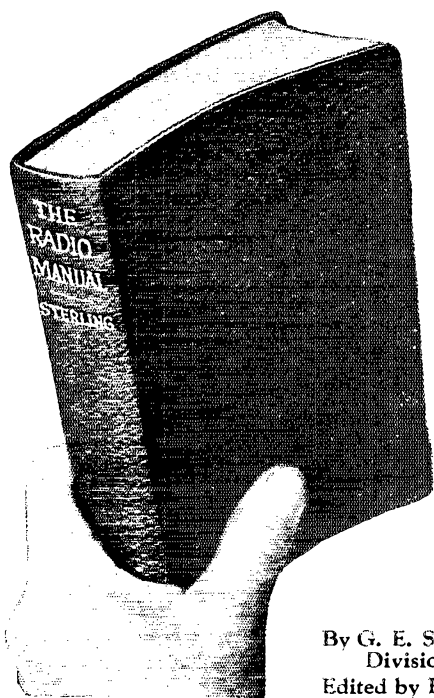

Are you prepared to use the new International "Q" signals which go into effect January 1, 1929? Do you know the correct procedure for obtaining a radio compass bearing as prescribed by the terms of the International Radio Telegraphic Convention, effective January 1, 1929?—the right procedure when distress communications are ended and silence is no longer necessary?—what to do when you hear from a radiotelephone station the spoken expression Mayday?

*These Questions and Thousands More  
Are Answered In*

## THE RADIO MANUAL

*A Complete Handbook of Principles, Methods,  
Apparatus for Students, Amateur and  
Commercial Operators, Inspectors*

By G. E. STERLING, Radio Inspector and Examining Officer, Radio Division, U. S. Dept. of Commerce.

Edited by ROBERT S. KRUSE, for five years Technical Editor of QST.

### Complete Preparation for Government License.

1. Elementary Electricity and Magnetism
2. Motors and Generators
3. Storage Batteries and Charging Circuits
4. Theory and Application of the Vacuum Tube
5. Fundamental Circuits Employed in Vacuum Tube Transmitters
6. Modulating Systems Employed in Radio Broadcasting
7. Wavemeters, Piezo-Electric Oscillators, Wave Traps and Field Strength Measuring Apparatus
8. Marine Vacuum Tube Transmitters including detailed description of Model ET-826

9. Radio Broadcasting Equipment including, for the first time in any text book, the complete equipment of Western Electric 5 Kilowatt broadcasting Transmitter used in over 75% of American broadcasting stations.
10. Arc Transmitters including description of Federal Marine 2 Kilowatt Arc Transmitter Type AM 4151; also models "K" and "Q"
11. Spark Transmitters including description of Navy Standard 2 Kilowatt Transmitter
12. Commercial Radio Receivers and Associated Apparatus

### 16 Chapters Covering

- including, for first time in any text book description and circuit diagram of Western Electric Superheterodyne Receiver Type 6004C
13. Marine and Aircraft Radio Beacons and Direction Finders.
14. The Development of Amateur Short Wave Apparatus. Complete details of construction, operation and licenses.
15. Radio Laws and Regulations of the U. S. and International Radio Telegraph Convention. Quotations of all important sections
16. Handling and Abstracting Traffic

## Examine It Free Special Price Now

"The Radio Manual" is now on the press and will be ready shortly. Over 900 pages bound in flexible Fabrikoid. Regular price after publication will be \$6.00. Orders received now will be accepted at the special advance price of \$4.95. Send no money now. Examine the book first. Pay or return in ten days.

### Order On This Coupon

D. VAN NOSTRAND CO., INC., 8 Warren St., N. Y.  
 Send me as soon as published THE RADIO MANUAL for examination. Within ten days after receipt I will either return the volume or send you \$4.95.—The special advance price.

Name .....

St. and Number ..... (QST 9-28)

City and State .....

# Don't Start the Season Blindly—

Radio over-hauling time is here! That means carefully going over last season's equipment—checking up every part of the set to make certain nothing will fail of proper performance. Particularly, you should check the calibration of your instruments. Much can happen to them unless they were scientifically designed and constructed in the beginning.

Doubtless you will need to make some replacements and we suggest that you give serious consideration to the instruments you select. Radio instruments vary widely in their design characteristics and in their ability to withstand the excessive strains and surges incident to the operation of your set.

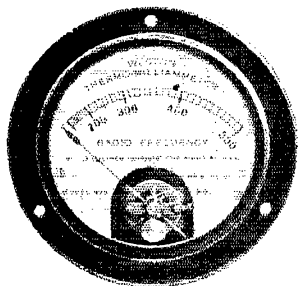

## Weston Thermo Milliammeters

For example, we call your attention to the following characteristics of Weston Thermo Milliammeters—Model 425:

They give definite assurance of your output, and accurate readings after hours of constant service.

Extra large over-loads will not burn out these meters.

Model 425 is ideal for short wave transmission, as it has a very low internal electrostatic capacity. For this reason it gives the true value of the current in the circuit, and does not disturb the constants of your transmitter.

Model 425 is also made as radiation ammeters in ranges from 1 to 20 amperes, having a safe over-load capacity of 50%.

Write for the new radio circular "J" just off the press.

**WESTON ELECTRICAL INSTRUMENT CORPORATION**

602 Frelinghuysen Ave., Newark, N. J.

# WESTON RADIO INSTRUMENTS

one of the two holes which form the grid, the other being reserved to receive the condenser in the event of the first hole being worn out. The grid is located in the middle of the inductance. The inductance and grid may be purchased from any mail order house or any dealer in second hand buttonholes. The condenser consists of a string of any desirable length, having a resistance one inch, more or less, from each end. The ends beyond the resistance are the filaments. One of these, F, is longer than the other, f. In operation, the letters, papers, million-dollar bills, etc. which it is desired to keep together having been placed in the loop of the condenser, the filament F is pulled steadily and firmly until the desired degree of compression has been attained. It will be found that it will release this compression, if it is desired to extract one or more of the papers or the bills. A gentle pull will effect this.

The Bunkodyne is a patented device. The award carries with it the privilege of manufacture and sale; subject, of course, to prosecution by the holders of the patent rights. It is not known who they are; but it can, doubtless, be found out by experiment.

In making the Bunkodyne award, it is customary to send with it case remittance of \$342,671.00, or as much of this amount as may be available from the interest accumulations on the original foundation investment of \$00.29; but in this instance, out of a delicate regard for your feelings, this feature is omitted.

Trusting that you will find great enjoyment in the use of the Bunkodyne and in the exercise of the privileges which accompany the award,

I am sincerely yours,  
*John W. Chapman, na7TE.*

P. S. Having discharged the responsible duties which have devolved upon me, I want to say that it would be a good thing for your critics to ponder upon what would have happened to us if you had *not* taken part in the conference at Washington.

## I. A. R. U. News

(Continued from Page 50)

that he would try to set up a transmitter with a 201A tube and a dry-cell plate supply.

We are sorry to see the old 2AS go off the air, but hope that some satisfactory QSO's are established with the baby set in the new location. Let us hear from you by mail, at least, OM.

## CHINA

Father E. Gherzi, S.J., in charge of the weather and seismic services at the Meteorological Observatory at Zi-ka-wei, near Shanghai, and already familiar to QST readers from his article on fading in the June issue, writes as follows:

# A NEW NOTE IN AUDIO AMPLIFICATION

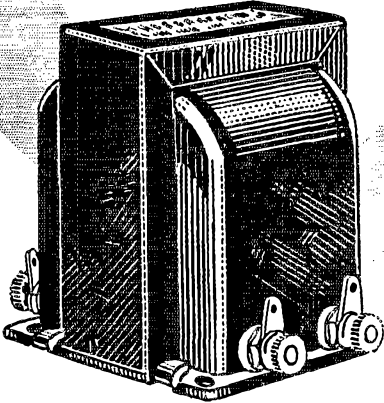

## THORDARSON R-300 AUDIO TRANSFORMER

**S**UPREME in musical performance, the new Thordarson R-300 Audio Transformer brings a greater realism to radio reproduction. Introducing a new core material, "DX-Metal" (a product of the Thordarson Laboratory), the amplification range has been extended still further into the lower register, so that even the deepest tones now may be reproduced with amazing fidelity.

The amplification curve of this transformer is practically a straight line from 30 cycles to 8,000 cycles. A high frequency cut-off is provided at 8,000 cycles to confine the amplification to useful frequencies only, and to eliminate undesirable scratch that may reach the audio transformer.

When you hear the R-300 you will appreciate the popularity of Thordarson transformers among the leading receiving set manufacturers. The R-300 retails for \$8.00.

**THORDARSON ELECTRIC MANUFACTURING CO.**  
*Transformer Specialists Since 1895*  
**WORLD'S OLDEST AND LARGEST EXCLUSIVE TRANSFORMER MAKERS**  
*Huron and Kingsbury Streets — Chicago, Ill. U.S.A.*

### Power Supply Transformers

These transformers supply full wave rectifiers using two UX-281 tubes, for power amplifiers using either 210 or 250 types power amplifying tubes as follows: T-2098 for two 210 power tubes, \$20.00; T-2900 for single 250 power tube, \$20.00; T-2950 for two 250 tubes, \$29.50.



### Double Choke Units

Consist of two 30 henry chokes in one case. T-2099 for use with power supply transformer T-2098, \$14; T-3099 for use with transformer T-2900, \$16; T-3100 for use with transformer T-2950, \$18.



### Power Compacts

A very efficient and compact form of power supply unit. Power transformer and filter chokes all in one case. Type R-171 for Raytheon rectifier and 171 type power tube, \$15.00; Type R-210 for UX-281 rectifier and 210 power tube, \$20.00; Type R-280 for UX-280 rectifier and 171 power tube, \$17.00.

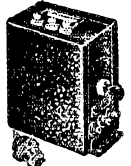

### Speaker Coupling Transformers

A complete line of transformers to couple either single or push-pull 171, 210 or 250 power tubes into either high impedance or dynamic speakers. Prices from \$6.00 to \$12.00.

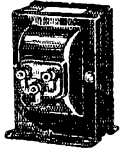

### Screen Grid Audio Coupler

The Thordarson Z-Coupler T-2909 is a special impedance unit designed to couple a screen grid tube in the audio amplifier into a power tube. Produces excellent base note reproduction and amplification vastly in excess of ordinary systems. Price, \$12.00.



**THORDARSON ELECTRIC MFG. CO.**  
500 W. Huron St., Chicago, Ill. 3883-F

Gentlemen: Please send me your constructional booklets on your power amplifiers. I am especially interested in amplifiers using.....tubes.

Name.....  
Street and No.....  
Town.....State.....

# Quality

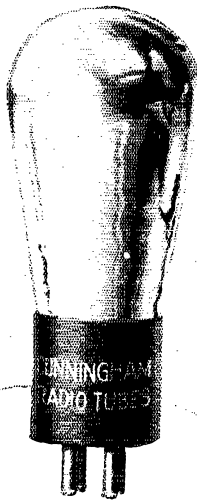

You can depend  
on their performance

because Cunningham  
Radio Tubes are guar-  
anteed against electrical  
and mechanical  
defects in construction.

Look for the Name  
Cunningham on the  
Orange and Blue  
Carton . . . . .

**E. T. Cunningham, Inc.**

New York Chicago  
San Francisco

Manufactured and sold under rights, patents  
and inventions owned and/or con-  
trolled by Radio Corporation  
of America.

# Cunningham

RADIO TUBES

"I think amateurs everywhere might be interested in knowing that I am sending every day at 0145, 0945, and 1215 GCT, on 23 meters, a weather bulletin giving meteorological observations from many stations in the Far East. As this sending is always done with the same power—220 watts—at a very exact hour, I would be indeed grateful to all hams who could try to listen in. The transmissions last about 15 minutes.

"I am sure that various official weather bureaus, for instance, along the Pacific Coast, would be glad to get these observations, and it would be another feather in the cap of the amateur if through this channel a scientific link could be established between the observatories on each side of the Pacific Ocean.

"The station is always operated by myself, QRH 23 meters, under the call ac8ZW. The note is fairly distinctive, being 500 cycles."

#### ENGLAND

May: "Most work during May has been done on 23 meters but conditions do not seem to have been as good as usual; at any rate, in the latter half of the month. 5ML's best QSO's were with the sixth and seventh US districts and the third, fourth and fifth Canadian and with OA, SC, SB, AI and fk2MS. Lately he has been listening on ten meters without hearing much so far. 2XV had consistent contact with the sixth and seventh with 75 watts until the middle of the month, when he too found conditions fall off. OA and OZ were also worked on 23, and a number of these boys seem to have left their old pet 30 meters for the lower band. Some interesting QSO's were had with nu111 and 2XV is looking forward to meeting him in person soon.

"5YK worked fk2MS and the usual sixes and sevens on 23; he has been trying phone on this wave, too, and also did some work with negative results on the 10-meter band. 5YX, who like 5YK is crystal controlled, worked two NU sevens and some fives on 32 meters during March and would like to know if any six heard him as he could not raise one. 5BQ is getting out EB on 23 and wants schedules with the NU fourth and NC. What offers, gang?

"2CB and 2CX are working South America on 23, but 2CB cannot seem to get decent contact with the States. He is one of the 'mangle brigade' using a hand generator for power supply. 6QB has worked heaps of sixth and seventh district stations, getting R6 from both on 23 meters with low power. He also hooked OA and nc4FB. 2NH ran a schedule with oz4AM for 39 days without a break! He is also investigating ten meters. 6BB works AS and SB on 45 meters as well as the U.S.A. 6PA has worked all over the States on 23 with a power unit of five watts. Good work, OM.

"6HP works OA on 23 but has difficulty with South America. 6CL has had some

# Unless You Are Checking Out Jan. 1...

YOU WILL REQUIRE A FREQUENCY  
METER TO OPERATE WITHIN THE LAW!

“PRECISION work requires precision measuring equipment,” says H. P. Maxim, Pres. A. R. R. L.

Old wavemeters will soon be useless. You can't operate with the new 7000-7300 Kc. band jammed into 5 or 10 divisions on the dial. Try to pick out 7275 Kc. on the dial of your present wavemeter. It can't be done! Kilocycles will supercede meters. QRH will be specified in frequency.

REL, anticipating the need of thousands of Amateurs, is producing the new frequency meters shown on this page, designed expressly for the new bands. Years of scientific research and engineering skill have made these meters superlative pieces of equipment, typical REL products.

## WRITE

for literature which completely describes the new meters and outlines the new operating requirements.

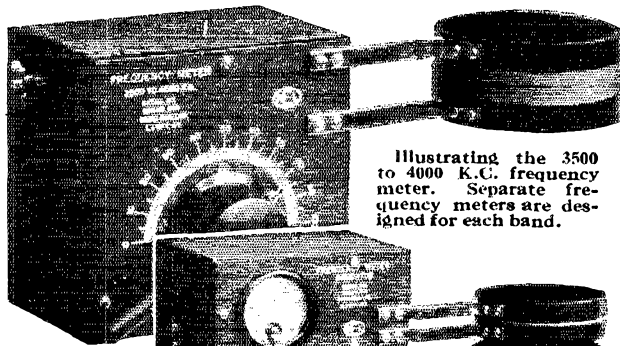

Illustrating the 3500 to 4000 K.C. frequency meter. Separate frequency meters are designed for each band.

Illustrating how the 7000 to 7300 K.C. frequency meter is coupled to the external frequency meter indicator.

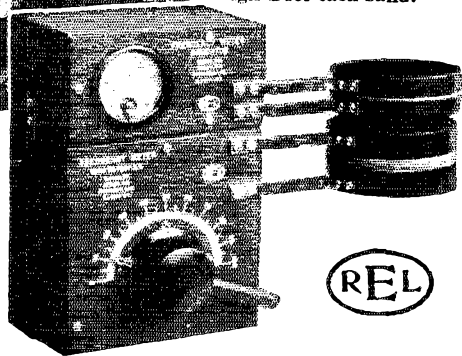

**RADIO ENGINEERING LABORATORIES**  
100 Wilbur Avenue Long Island City, New York

# NATIONAL TUBE REPAIRS

**C**UT down your operating cost—our rebuilt tubes accomplish this—their life is equal to new tubes and their performance will satisfy—send in your

## Burnt Out Tubes Now

### We List and Price Repairs

W. E. 211	- -	\$16.50
W. E. 212	- -	40.00
U. V. 203	- -	15.00
U. V. 203A	- -	19.00
U. V. 204A	- -	75.00
U. V. 204	- -	50.00

(10% Discount on lot of 6 tubes,  
from above list)

These tubes are rebuilt using same type filament as they had originally; also the operating characteristics are maintained the same.

We purchase burnt out tubes of the above types.

**SOLVE** your rectifier troubles once and for all.

### RECTOBULBS

3000 Volts and 250 Mils. **\$15 ea.**  
Type 203 50 Watt Tube **\$20 ea.**

No charge for crating if cash  
accompanies order.

Our work guaranteed against defects of material and workmanship.

**National Radio Tube Co.**  
3420 18th St., San Francisco, Calif.

(A Ham Institution)

interesting NU contacts early in the month but like everyone else is finding things dud just now. 5HS is very QRW but will be QRV again soon.

"The Third Annual Convention of the R.S.G.B. is to take place on the 28th and 29th of September, and any American hams over here on these dates will be welcomed. Further details as to programme are not yet available, but it is sure to be wonderful for everyone."

—K. E. Brian Jay, *eg2HJ*.

"June: The general impression this month is that the pet 23-metre band has been bad—at any rate, compared with previous months. It would seem by comparison with last year that this state of affairs will last until about next February, as far as super-DX is concerned.

"5YK worked NU fourth on phone and got R4 with 60 watts crystal. He could not raise either the sixth district or the Antipodes, both of which were weak. He is working on a ten-metre crystal set, employing a new principle. This station will be ready to go on 10.15 metres as soon as the license arrives.

"5YX has done nothing, being QRW with exams. 5BY has been going strong, however. 2XV found conditions rather poor, but in spite of this worked su2BT, sb2AJ, sb2AX and a few NU stations; also oa2RB on 32 metres, the others being on 23. Frequent QSO's were had with nullI to make various arrangements about his visit to England. 2XV will shortly be on the 8-to 10-metre band and reports will be welcome; the word TEN will be sent after each transmission to show it is not a harmonic. Operations will probably commence early in August.

"Other hams busy on ten metres are 2NH and 6QB, who also are to be found on 23 and 90. 2CX worked SB and SC, so is now WAC. Very FB OM. 2AX worked lots of NU's and SC and AQ on 23. 6WN cannot raise NU, so would welcome reports on his signals if any one hears them. 6CL on 23 was called by an NU four, but did not hear him. 6PA says NU is only local when conditions are good. 2CB worked OA, SC and NU first, on 23, but has difficulties with the States; he, too, would like reports.

"6RB worked the world on 23 in May, but has not had any luck in June.

"Many hams are rebuilding and getting set for next year, and 5YK's standard frequency transmissions are being found of the greatest value. 6QB with his standard R.S.G.B. wavemeter is pretty busy, too. Most of the British members are now preparing for the new Washington wavelengths, which may become effective any day now.

—K. E. Brian Jay, *eg2HJ*.

FRANCE

From a letter sent in by our old friend Leon Deloy, one of the past presidents of



# SM

## "ROUND THE WORLD" FOUR

### Just What the Name Implies!

The trimmest short wave set ever—that's the verdict everywhere on the new 730 S-M "Round-the-World" Four. It does everything you expect of a short-wave receiver—everything, even, that you expect of an S-M receiver. The Radio Broadcast Laboratory, in initial tests of the 730, received English 5SW daily on the speaker, during afternoon hours. 9BBW, receiving on the "Round-the-World" Four, worked in one evening stations in Germany, France, England and Italy. Low-power amateur code stations over the U. S. and Canada are received regularly on the 730. And for television work, it's ideal!

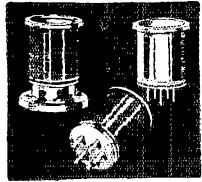
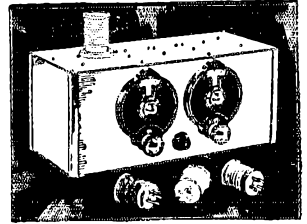

New S-M 131 Plug-In Coils (used in the 730) wound on moulded bakelite, fit any 5-prong tube sockets. Wound, \$1.25, or blank, \$0.50 each.

The "Round-the-World" Four is a complete four-tube regenerative, non-radiating short wave receiver kit with aluminum shielding cabinet. It has one screen grid r.f. stage, a regenerative, non-radiating detector, and two high-gain Clough audio stages. It tunes from 17.4 to 204 meters with four plug-in coils. The kit is \$51.00, complete with cabinet, four coils, and full instructions—ready for immediate shipment.

The 731 "Round the World" Adapter is the two-tube, r.f. amplifier and detector, less the two stage a.f. amplifier of the above set. With an adapter plug, it converts any set to long-distance short wave reception. Price, complete with cabinet and four coils (17.4 to 204 meters) \$36.00. The 732 "Round the World" Essential Kit contains the two tuning and tickler condensers, the four plug-in coils, coil socket, and three r.f. chokes, with full instructions for building a one, two, three or four tube short wave set. It costs but \$16.50 complete.

And it beats anything for getting out into the short-wave "Thrill Band." Choose the kit you prefer—and "step out!"

### 720 Screen Grid Six The Year's Biggest Value

This is the set that S-M gets squarely behind and tells you it's the biggest value in broadcast-band receivers to be found today. A man-sized recommendation!

Successor to the famous Shielded Grid Six that took the country by storm, the 720 is the kind of a set you can build in an evening, on its pierced metal chassis. When it's finished and you put it on the air—then the real surprise begins. Distant stations will come in, one after another, with local

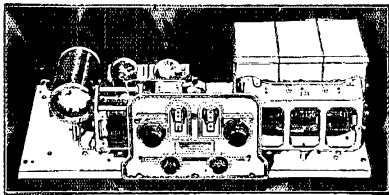

volume, and positive 10 kc. selectivity. As to tone, the 720's superiority is insured by the new 255 and 256 audios, as described at the right.

Look at the 720's features as you see them in the picture, and remember that S-M backs it to the limit—assures you that you can't get more actual radio elsewhere at twice the cost. Then note the prices: Custom-built complete in a beautiful two-tone brown metal shielding cabinet, \$102.00. Complete kit only \$72.50, with the same cabinet \$9.25 additional.

Better order now—such values spell scarcity!

Are you receiving the "The Radiobuilder" regularly? Every month it gives you all the earliest S-M news, operating hints and kinks. To S-M Authorized Service Stations, it comes free of charge, with all new constructional Data Sheets. If you build professionally, write us about the Service Station franchises.

**SILVER-MARSHALL, Inc.,** 858 W. JACKSON BLVD. CHICAGO, U. S. A.

### Audio Transformers Just Two Years in Advance

Radically new in principle, these transformers are the first to give freedom from the hysteretic distortion found in all other types. They combine decided advances in both tone and volume, as will be seen below. E is the two-stage curve for the large size transformers (S-M 225, 1st stage, and 226, 2d stage, \$9.00 each); D is that of the smaller ones (S-M 255 and 256, \$6.00 each). Note the marked advantage over A, B, and C—all standard eight and ten dollar transformers under equal conditions.

And you can have this finer performance in any set at less than average transformer costs!

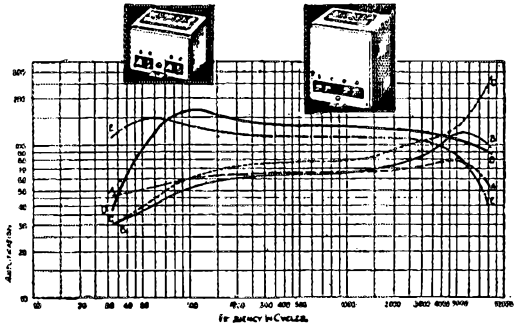

The S-M catalog describes all these products, as well as A and B Power Supplies, Power Amplifiers, Modulation Transformers, etc.

Silver-Marshall, Inc.  
858 W. Jackson Blvd., Chicago, U. S. A.  
...Send your complete catalog, with sample copy of the Radiobuilder.  
...For enclosed 10c, send five sample S-M Data Sheets.

Name.....  
Address.....

## A detailed treatment of vacuum tube circuit theory

If you have not yet seen this book you will certainly want to examine it, as it furnishes you with a dependable, up-to-the-minute discussion of thermionic vacuum tube circuits; places in your hands thoroughly developed conventions which may be used in solving obscure circuit problems with ease.

From elementary thermionic theory to the theory and design of amplifier circuits, the book covers each phase of the subject of vacuum tube circuits with detailed thoroughness.

### THEORY OF THERMIONIC VACUUM TUBE CIRCUITS

By LEO JAMES PETERS

Assistant Professor of Electrical Engineering, University of Wisconsin 226 pages, 6x9, 110 illustrations, \$3.00

The consistent aim throughout this reliable manual has been to furnish the reader with a firm grasp of fundamental theory and a familiarity with methods of attacking problems so that he can investigate systems and circuit arrangements other than those discussed in the book.

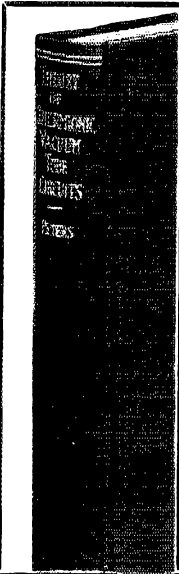

the R.E.F. (Reseau Emetteurs Francais) we learn that in a recent election a new president was appointed to this society, and is Mr. Reyt, Professor au Lycee, 24 Rue des Vaupulents, Orleans (Loiret) France. Mr. Reyt, who is well-known to all amateurs through his calls 8FD and 8YOR, was elected in May; Pierre Louis and Mr. Deloy become Honorary Presidents.

We extend our sincere congratulations to Mr. Reyt on his new appointment.

#### GERMANY

A card from ek4HX, contains this interesting information:

"I beg you to put a few lines in QST about QSL's for EK. Many NU amateurs send cards direct, but that is dangerous for us, and the cards often do not reach their destination. All cards for EK stations should be sent via DFTV, Berlin W57, Blumenthalstr. 19. Perhaps NU OM's don't know that all EK stations with a '4' and only two letters in the call-sign are unlicensed."

### McGraw-Hill FREE EXAMINATION COUPON

McGraw-Hill Book Co., Inc.,  
870 Seventh Avenue,  
New York, N. Y.

You may send me Peters' Theory of Thermionic Vacuum Tube Circuits, \$3.00, postpaid. I will either return the book, postage prepaid, in 10 days, or remit for it at that time.

Name .....  
St. & No. ....  
City .....  
State .....  
Name of Employer .....  
Official Position .....  
(Books sent on approval in the U.S. and Canada only)  
Q.S.T. S-1-28

### Remodeling the Traffic Tower

(Continued from Page 42)

depends upon the position of the band on the dial. To cover 500 kcs. starting at 3500 kcs. requires a dial rotation of from 134 to 18 degrees or 116 degrees. Now, if we start at 3350 kcs. or 147 degrees, we have to rotate the condenser only 72 degrees to get to 3850 kcs. Thus if we cut our coils so as to place the desired range at the lower dial readings, the maximum dial rotation will be obtained for a given band. Of course, at the lower range of the condenser, any changes in circuit capacity will have a larger effect upon calibration than at the higher capacity settings. With this in view and the thought that the minimum capacity across the coil due to the tube socket, wiring, etc., may vary to some extent in other receivers, no effort was made to squeeze the last dial division out of the ranges. He who is so inclined may do this; others will perhaps be satisfied with the ranges as they are. At any rate, it requires but little effort to add or subtract one turn, more or less, and you can suit yourself.

Well! So far we have a pretty decent 1928 affair but it isn't much of a world-beater for the 1929 conditions. By doing some more adjusting and shifting, we can make it into just as good a 1929 set as it is a 1928 one.

The shunt adjustable condenser can be dropped because there will be but five bands in all—and the smaller section of the tuning condenser will be employed for tuning on the 7000- and 14000-kc. bands while the two sections in parallel will be used for the 1750-, 3500- and 28000-kc. bands. Of course, they will both have to be reduced in capacity.

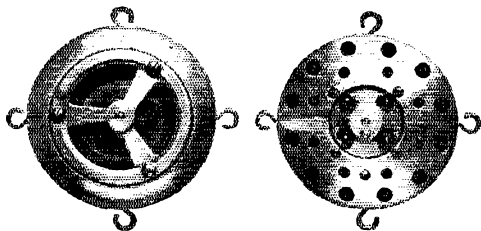

NEW—a low priced two button "mike", similar to cut, priced under \$15.00.  
Standard Broadcast Type, ideal for public address, etc., price \$40.00.

Send for further information. A new special bulletin on all short wave equipment is now ready.

E. F. JOHNSON COMPANY

Waseca, Minn.

### SPECIAL TO AMATEURS

Barawik's new shortwave dept. has everything that amateurs desire. The Barawik Radio Guide gives full details. Send for it.

### FREE RADIO GUIDE

**RADIO BARGAINS**  
Shows the latest wrinkles, newest developments in radio at startlingly low prices. Get the set you want here and save up to 50%. The best in parts, kits, complete factory-built sets and supplies. Orders filled same day received. Write for free Catalog and Guide NOW! Wholesale prices to dealers, set builders, agents.  
**BARAWIK CO., 119 Canal Sta., Chicago, U. S. A.**



## Replace Your Old Radio!

Few radios at any price combine ALL the following features which are so necessary to the fine radio reception you may have today. Crosley gives you them ALL at the world's lowest price.



**Crosley Radios tune efficiently**  
The Crosley neutrodyne circuit is sharp, sensitive and selective.

**Crosley Radios are shielded**  
Each element is shielded from each other. This improves the efficiency of the set. Stations close together are easily separated.

**Crosley Radios are selective**  
Where stations are crowded together you will appreciate the selective qualities of Crosley radio. You listen to ONE station at a time.

**Crosley Radios have volume**  
The volume of Crosley Radios is phenomenal for the slight amount of battery or AC current consumed. The volume may be increased tremendously without distortion.

**Crosley Radios can be softened to a whisper**  
The volume control of Crosley sets is so positive that the operator may cut any broadcast program down to a scarcely audible reception.

**Crosley Radios fit any kind of furniture**  
Outside cases of Crosley Radios are easily removed for installation into any type of console cabinet.

# New A C electric receivers replace old radio models

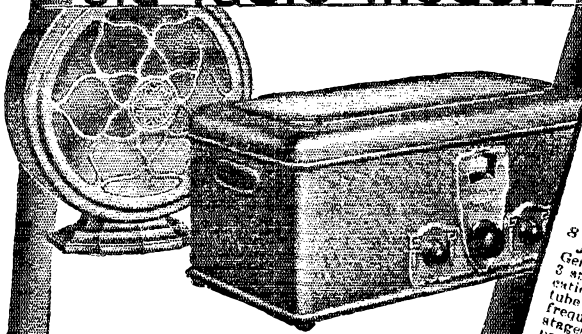

## Genuine 6 tube Neutrodyne Crosley GEMBOX \$65

Self-contained A C electric receiver. Utilizes two radio, detector, two power and a rectifier tube (171 power output tube). Operates from 110 volt 60 cycle A C home lighting current.

Try this amazing set. Prove to yourself on a 5 DAY FREE TRIAL IN YOUR OWN HOME that no radio that approximates Crosley price can compare in performance. Why pay higher price?

This wonderful little Gembox is designed to use the new and astounding dynamic.

### DYNACONE

the Crosley power speaker, which is radio's greatest development this year. A genuine dynamic speaker selling for \$25 equals ANY in pure realistic tone—unmatchable in price.

## 5 tube dry cell operated BANDBOX Jr. \$35.



Ideal set where recharging of storage battery is inconvenient



**Improved Musicone \$15**  
This Crosley achievement is the world's greatest in the field of magnetic type speakers.

## CROSLEY AC Electric Radio Sets unequalled values

Crosley A C Electric Radios operate on 25 to 40 and 60 cycles. Where A C 110 volt current is available they are perfect radio receivers. No better performance is obtainable. Cabinets are built at any price to make radio expensive, but for realistic, powerful reception Crosley receivers know no superior.



**3 tube A C Electric JEWELLOX \$55**  
Genuine neutrodyne 3 stages radio amplification — 52 detector tube — 3 stages detector frequency (last two power tubes) and 250 coil push — pull rectifier. Shielded and illuminated dial. Highly selective.



**5 tube AC Electric SHOWBOX \$50**  
Genuine neutrodyne 3 stages radio amplification detector 3 stages and (last two power tubes) and 250 coil push — pull rectifier.



**The 6 tube BANDBOX battery type \$55**  
The Bandbox is the radio replacement for electric current. It is available for AC receivers. Genuine neutrodyne, housed in a beautiful gold plated cabinet. This receiver can be converted for use from the power lines by means of a supply unit.

WHATEVER HAPPENS IN 1928 YOU'RE THERE WITH A CROSLEY

FREE TRIAL

Ask any Crosley dealer to hitch a new Crosley radio to your antenna. Test, try and prove in your own home (under the exact conditions you will enjoy your radio) the superior performance of Crosley sets. If you can't locate a near-by dealer, fill out the coupon below.

Mail this

# CROSLEY RADIO

The Crosley Radio Corporation  
Cincinnati, Ohio  
Powel Crosley, Jr., President  
Montana, Wyoming, Colorado, New Mexico and West prices slightly higher.  
Crosley Radio prices do not include tubes.

## COUPON

Dept. 18  
I cannot locate a Crosley dealer. Please arrange for FREE 5 DAY TRIAL in my own home of the Crosley Radio I have checked.  
Gembox ( ) Jewelbox ( )  
Showbox ( ) Bandbox ( )  
Bandbox Jr. ( ) Dynacone ( )  
Musicone ( )

Name .....  
Address .....

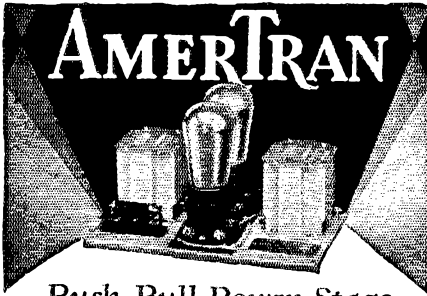

## AmerTran

### Push-Pull Power Stage for Dynamic Speakers

For best results, every dynamic type speaker should be preceded by a push-pull amplifier. This is particularly true because they reproduce frequencies as low as 30 cycles and the attendant hum from raw AC on the filaments of power tubes is greatly pronounced unless filtered out by a push-pull amplifier.

The AmerTran completely wired push-pull power stage has been specially designed for dynamic speakers. Consists of type 151 input and output transformers (200 for working out of 210 type tubes or 161 for 171 type tubes). Completely wired with sockets and resistances. Also available for cone type speakers and for both 210 and 171 tubes.

Licensed under Patents owned or controlled by R. C. A. and may be bought with tubes

**Price complete (without tubes) \$36.00.**  
(slightly higher west of Rocky Mountains)

Write us for hook-up of this remarkable instrument.

**AMERICAN TRANSFORMER COMPANY**

Transformer Builders for more than 28 Years

194 Emmet Street, Newark, N. J.

The distance between the plates in the smaller section should be increased until the 7000-ke. band is covered by a dial rotation of somewhat over 100 degrees. The spacing will be roughly equivalent to the thickness of 20 *QST* pages. In the other section, we can no longer use the capacity obtained by a single stator plate between two rotors and must shift the stator so that it is exposed to but one rotor plate. In this respect it will be similar to the smaller section although the spacing between the two plates will be less (about 10 *QST* pages).

We then get the following coil sizes and ranges:

Band in kcs.	Coil Range	Sec. Ticker	Turns	Degrees	Sections of	Part of
					Band	Condenser
1715-2000	1675-2055	77.	9	98	Both	
3500-4000	3279-4000	37.	6	120	Both	
7000-7300	6656-7316	26.25	5	118	Smaller	
14000-14400	13045-14460	9.25	4	60	Smaller	
28000-30000	27900-30800	2.75	3	45	Both	

The types of winding, size of wire, spacing of turns, etc., are the same for these coils as for the previously described ones. The same coils may be used with the necessary turns added or removed as the case may demand.

### Radio Set Tester

batteries or socket power devices. The various ranges are 600, 300, 60 and 8 volts and a resistance of 1,000 ohms per volt is had for all of them. Direct current ranges of 150 and 30 milliamperes are available for checking the plate current of the tubes as well as the output of various of the commonly used rectifiers.

For sets employing tubes similar to the UX-226 and UY-227, there is an a.c. voltmeter having ranges of 150, 8 and 4 volts. The four-volt range is used for checking the filament voltage for the tubes mentioned above, the eight-volt range will be convenient for ascertaining the voltage across the filaments of 171s, 210s and the various rectifier tubes now in use, while the highest range may be used to determine the line voltage which may vary considerably in some parts of the country.

It is possible to make measurements upon a tube under normal operating conditions employing for such tests the regular power supply to the set. It is also possible by means of a switch provided for that purpose to change the bias on the grid of a tube and by measurements of plate current to ascertain whether the tube is in good condition. A rotating switch is so arranged that measurements of the plate and filament voltage, plate current, bias, etcetera may be made in succession without moving any of the equipment excepting the switch.

A product of the Weston Electrical Instrument Corp. of Newark, N. J., this instrument is known as their Model 537, Radio Set Tester.

—H. P. W.

## Guaranteed to Stay Accurate

It is one thing to build a resistor that shows up well in a quick test, and decidedly another to give it a month's trial carrying the work-a-day load before testing it. The difference in accuracy can be (and often is) surprising.

Test Har-field Resistors for a month or a year. Day after day they will carry the load they were built to carry, and maintain the accuracy your order specifies. For Hardwick, Field, Inc. have built the accuracy into their resistors that enables them to honestly make their guarantee.

Har-field Resistors are made in two types of coating—the vitreous enamel or specially processed cement. They come in a wide range of values to suit every need, and large quantities of any type or size can be quickly supplied. Prices are low enough to demand consideration from every careful purchasing agent and individual.

Tell us about the resistor you want and we will gladly make up samples for you with prices.

**HARDWICK, FIELD, INC.**

SALES OFFICE  
122 Greenwich St.  
New York



FACTORY  
215 Emmett St.  
Newark, N. J.

# ..the Modern Necessity for Electrical Radio... the MERSHON CONDENSER

The Mershon Condenser gives a *very large capacity* in a very small space. Is self-healing in case of puncture, and is unaffected by changes in temperature, or by moisture.



Expert radio amateurs used the Mershon Condenser for more than six years in their transmitting equipment. Today the Mershon Condenser is being widely used over the whole country in connection with electrical radio sets, whether new AC tubes are used, or battery sets are attached to house current thru the use of Eliminators.

Send for  
Your Free Copy  
of  
This Book....

The AMRAD Corporation  
Medford Hillside, Mass.

Please send a copy of your new book on the MERSHON CONDENSER, showing hook-ups and designs.

Name.....

Address.....

## BUILD A DAVEN TELEVISION RECEIVER

The first complete kit furnished with either T-24, T-36 or T-48 Scanning Disk Motor, Bushing, Rheostat, Daven Television Tube, 3 Complete Stages of Daven Television Amplification and Instructions for Building. Daven Television Receiver, Complete, Including Television Tube—\$100.00 Less amplifier Tubes.

### DAVEN TELEVISION APPARATUS

Daven Television Scanning Disks	Each	
24 T-24	.....	\$ 6.00
36 T-36	.....	7.50
48 T-48	.....	10.00
Comb. Disc with 24, 36 and 48 Apertures	T-48	15.00
Daven Tele. Amp. T-3	.....	12.50
Daven Spec. Te. Amp. T-3 for 5 H1 Mu Tubes and 2 power Tubes	.....	17.50
17L 210, 250 Types	.....	17.50
Daven Telev. Neon Lamp 20 to 80 Milliamperes Striking Voltage	.....	12.50
100 Plate 1 1/2x1 1/2 each	.....	27.50
Daven Telev. Motor	.....	1.00
Daven Bushing to fit 1/2 inch 5-16 and 3/8 inch Motor Shafts	.....	3.50
Daven for 48 Aperture disc	.....	3.50
Daven Rheostat	.....	3.50
Daven Telev. Photo Elect. Cell 1 1/2 inch	.....	20.00
Daven Telev. Photo Elect. Cell 3 inch	.....	37.50
Daven Television Couplers	.....	
1st Stage No. 421x D-421xx	.....	2.15
2nd Stage No. 422x D-422xx	.....	4.65
3rd Stage No. 423x D-423xx	.....	9.00
x Glazors are used for Grid and Plate resistors	.....	2.25
xx Super Davolans in Plate and Glazors in Grid	.....	3.50
Daven AC 17 for output tubes in series with Television Lamp	.....	9.00
Daven AC 10 (for brighter illumination)	.....	2.25
Daven Mu 20 H1 Mu Tubes for Amp. Stages	.....	3.50
Daven Mu 6 Power Tube	.....	3.50

### THE DAVEN CORPORATION

AMPLIFICATION SPECIALISTS

170 Summit Street Newark, N. J.



## Calls Heard

(Continued from Page 51)

5anz 9ara 9asx 9avu 9axf 9aze 9bga 9bqz 9bmx 9bqy 9bwk 9efr 9ehe 9eok 9erd 9esr 9evd 9ekd 9dkc 9dmt 9dng 9del 9ef 9efy 9ehd 9eoh 9esh 9evq 9ez 9fei 9fbv 9pjd 9feg 9fzv 9fzv 9hm 9mt af-koj ai-2kt aj-jll am-3ab fe-2vo fessux fk-4ms fm-8ags fm-8ev fm-8jo fm-8rit fo-3sa na-7ady na-7aer na-7mn ne-ef ne-ca ne-lar ne-2be ne-2ca ne-3ap ne-3ej ne-3es ne-3fe ne-4dd qe-4fv ne-4ha ne-4hh ne-5au ne-5hn nm-27a np-wgt np-4agf np-4sa nq-2kp oa-2dy oa-2ij oa-2ly oa-2rc oa-2sh oa-2uk oa-2vi oa-3hd oa-3gr oa-3ij oa-3jk oa-3lp oa-3m oa-3vp oa-3xo oa-4lj oa-5bj oa-5bv oa-5by oa-5cm oa-5dx oa-5hg oa-5wh oa-7eh oa-7ew oa-7vp oa-7vs od-and od-anf od-6alm oh-6vl oh-6hvj oh-6hey oh-6khi oh-6kud oh-6dvz oh-6ndm oz-1ao oz-2ae oz-2bg oz-2bx oz-3at oz-3aw oz-3az oz-4ae oz-4am sb-2qj sb-1aw sb-1ib sc-3ac sc-3ej sl-hjo

(On 40 Meters.)

lagz lagw laje labk laux lanz laui lazt lasy laxq lbar lbdm lbed lbki lbja lboe left leiz lemf lemx lexi lgw lhb lie lkb lkm llt lmk lmr lmq lsi lvt lwb lye 2adl 2afa 2afw 2agw 2aib 2amh 2ans 2api 2apy 2aqj 2aqz 2avz 2axk 2ayk 2az 2azo 2bcy 2bdi 2bdh 2bek 2bgz 2bvg 2bhq 2bgz 2bhv 2bih 2blc 2bov 2bse 2btj 2bta 2btt 2bxj 2adm 2chu 2cot 2cad 2cwm 2xkl 2yxz 2dn 2dp 2dq 2fe 2gh 2gq 2ja 2je 2kl 2kr 2lx 2mb 2ps 2qc 2rk 2al 2uo 2vc 2vd 2wi 2xd 2aac 2aj 2an 2af 2afj 2afv 2afz 2axv 2ayb 2ajt 2amw 2anh 2aob 2ard 2arh 2arx 2ath 2atn 2ato 2aua 2auj 2auv 2auw 2bce 2bel 2bfg 2blp 2bn 2bns 2bt 2brf 2cfn 2hn 2ec 2er 2ez 2fg 2gr 2kd 2mb 2qt 2sz 2vz 2aba 2abz 2ac 2acv 2ada 2anf 2ano 2ant 2aeg 2hek 2aem 2ad 2af 2ag 2ah 2aj 2ak 2al 2am 2an 2ao 2ap 2aq 2ar 2as 2at 2au 2av 2aw 2ax 2ay 2az 2ba 2bb 2bc 2bd 2be 2bf 2bg 2bh 2bi 2bj 2bk 2bl 2bm 2bn 2bo 2bp 2bq 2br 2bs 2bt 2bu 2bv 2bw 2bx 2by 2bz 2ca 2cb 2cc 2cd 2ce 2cf 2cg 2ch 2ci 2cj 2ck 2cl 2cm 2cn 2co 2cp 2cq 2cr 2cs 2ct 2cu 2cv 2cw 2cx 2cy 2cz 2da 2db 2dc 2dd 2de 2df 2dg 2dh 2di 2dj 2dk 2dl 2dm 2dn 2do 2dp 2dq 2dr 2ds 2dt 2du 2dv 2dw 2dx 2dy 2dz 2ea 2eb 2ec 2ed 2ee 2ef 2eg 2eh 2ei 2ej 2ek 2el 2em 2en 2eo 2ep 2eq 2er 2es 2et 2eu 2ev 2ew 2ex 2ey 2ez 2fa 2fb 2fc 2fd 2fe 2ff 2fg 2fh 2fi 2fj 2fk 2fl 2fm 2fn 2fo 2fp 2fq 2fr 2fs 2ft 2fu 2fv 2fw 2fx 2fy 2fz 2ga 2gb 2gc 2gd 2ge 2gf 2gg 2gh 2gi 2gj 2gk 2gl 2gm 2gn 2go 2gp 2gq 2gr 2gs 2gt 2gu 2gv 2gw 2gx 2gy 2gz 2ha 2hb 2hc 2hd 2he 2hf 2hg 2hh 2hi 2hj 2hk 2hl 2hm 2hn 2ho 2hp 2hq 2hr 2hs 2ht 2hu 2hv 2hw 2hx 2hy 2hz 2ia 2ib 2ic 2id 2ie 2if 2ig 2ih 2ii 2ij 2ik 2il 2im 2in 2io 2ip 2iq 2ir 2is 2it 2iu 2iv 2iw 2ix 2iy 2iz 2ja 2jb 2jc 2jd 2je 2jf 2jg 2jh 2ji 2jj 2jk 2jl 2jm 2jn 2jo 2jp 2jq 2jr 2js 2jt 2ju 2jv 2jw 2jx 2jy 2jz 2ka 2kb 2kc 2kd 2ke 2kf 2kg 2kh 2ki 2kj 2kl 2km 2kn 2ko 2kp 2kq 2kr 2ks 2kt 2ku 2kv 2kw 2kx 2ky 2kz 2la 2lb 2lc 2ld 2le 2lf 2lg 2lh 2li 2lj 2lk 2ll 2lm 2ln 2lo 2lp 2lq 2lr 2ls 2lt 2lu 2lv 2lw 2lx 2ly 2lz 2ma 2mb 2mc 2md 2me 2mf 2mg 2mh 2mi 2mj 2mk 2ml 2mm 2mn 2mo 2mp 2mq 2mr 2ms 2mt 2mu 2mv 2mw 2mx 2my 2mz 2na 2nb 2nc 2nd 2ne 2nf 2ng 2nh 2ni 2nj 2nk 2nl 2nm 2no 2np 2nq 2nr 2ns 2nt 2nu 2nv 2nw 2nx 2ny 2nz 2oa 2ob 2oc 2od 2oe 2of 2og 2oh 2oi 2oj 2ok 2ol 2om 2on 2oo 2op 2oq 2or 2os 2ot 2ou 2ov 2ow 2ox 2oy 2oz 2pa 2pb 2pc 2pd 2pe 2pf 2pg 2ph 2pi 2pj 2pk 2pl 2pm 2pn 2po 2pp 2pq 2pr 2ps 2pt 2pu 2pv 2pw 2px 2py 2pz 2qa 2qb 2qc 2qd 2qe 2qf 2qg 2qh 2qi 2qj 2qk 2ql 2qm 2qn 2qo 2qp 2qq 2qr 2qs 2qt 2qu 2qv 2qw 2qx 2qy 2qz 2ra 2rb 2rc 2rd 2re 2rf 2rg 2rh 2ri 2rj 2rk 2rl 2rm 2rn 2ro 2rp 2rq 2rr 2rs 2rt 2ru 2rv 2rw 2rx 2ry 2rz 2sa 2sb 2sc 2sd 2se 2sf 2sg 2sh 2si 2sj 2sk 2sl 2sm 2sn 2so 2sp 2sq 2sr 2ss 2st 2su 2sv 2sw 2sx 2sy 2sz 2ta 2tb 2tc 2td 2te 2tf 2tg 2th 2ti 2tj 2tk 2tl 2tm 2tn 2to 2tp 2tq 2tr 2ts 2tt 2tu 2tv 2tw 2tx 2ty 2tz 2ua 2ub 2uc 2ud 2ue 2uf 2ug 2uh 2ui 2uj 2uk 2ul 2um 2un 2uo 2up 2uq 2ur 2us 2ut 2uu 2uv 2uw 2ux 2uy 2uz 2va 2vb 2vc 2vd 2ve 2vf 2vg 2vh 2vi 2vj 2vk 2vl 2vm 2vn 2vo 2vp 2vq 2vr 2vs 2vt 2vu 2vv 2vw 2vx 2vy 2vz 2wa 2wb 2wc 2wd 2we 2wf 2wg 2wh 2wi 2wj 2wk 2wl 2wm 2wn 2wo 2wp 2wq 2wr 2ws 2wt 2wu 2wv 2ww 2wx 2wy 2wz 2xa 2xb 2xc 2xd 2xe 2xf 2xg 2xh 2xi 2xj 2xk 2xl 2xm 2xn 2xo 2xp 2xq 2xr 2xs 2xt 2xu 2xv 2xw 2xx 2xy 2xz 2ya 2yb 2yc 2yd 2ye 2yf 2yg 2yh 2yi 2yj 2yk 2yl 2ym 2yn 2yo 2yp 2yq 2yr 2ys 2yt 2yu 2yv 2yw 2yx 2yy 2yz 2za 2zb 2zc 2zd 2ze 2zf 2zg 2zh 2zi 2zj 2zk 2zl 2zm 2zn 2zo 2zp 2zq 2zr 2zs 2zt 2zu 2zv 2zw 2zx 2zy 2zz

SAVS, Donald F. Byram, 43 River St., Homer, N. Y.

(20 Meters)

eh-4au ef-2eo ef-8et eg-5ml eg-5uw eg-5vl eg-6hp eg-6sk eg-6ut eg-6gb eg-6ht eg-6vp ei-1fl em-smuv em-smzf gi-2by gw-17c nr-cto.

(40 Meters)

eb-4wx eb-4ro ef-8gyd ef-8fc ef-8lx ef-8rbv ef-8hpq ef-8er ef-8orm ef-8xd ef-8ix ef-8st ef-8tr ef-8xf ef-8rm eg-2nn eg-1bx fm-8rit fm-8ags iq-pm en-ozf oa-3ls oa-3ep oa-3az oa-4am oh-6adh oh-6dey om-1z nm-9a nm-8a nn-1nic nn-2ac nn-3cx nn-2ags us-1fmh sb-1aw se-2ah.

eg-6WY, H. Almaxwell Whyte, Burtleigh, Church Road, Forest Hill, S.E.

ldi lauk lgx lbeb lbat lbfl lbz lcaw lbke lasu lejh lew 2blx 2aaj 2ejd 2afx 2bcw 2bha 2mg 2axx 2caq 3di 4fs 4adb 8axa 8auc 8br 8drj 9dbj 9asd 9ef.

SDDK, Hosea Decker, Delaware, Ohio

(Heard from April 18 to May 16)

oa-2dy oa-4ab oa-4nw oa-4lj oa-4ag fq-ocya eb-4au eb-4fp ef-8st ef-8fc ef-8hpq ef-8ix ef-8wb ei-1dy se-2ah sb-1aw sh-1id sb-2ag sb-2ak ne-8rg nm-1rz nm-9a nq-2jt nq-5ea nq-5cx nq-5fl nr-2ags nidk.

ef-8XD.

laac labd labt labv ladm laff laze laha laib lair lals lamu lapv laqj laqt lavk lauz laxq lbbe lbed lbft lbke lbix lbu lbux lejh lemp lemx lepe lcki ljaa lqj loh lom lmx 2aca 2adl 2aeb 2aco 2afw 2ahh 2aib 2afb 2akj 2ajg 2api 2ass 2atq 2atz 2awb 2aul 2avw

# Send For WESTERN RADIO New 1929 Catalog

Dealers and Set Builders

THE NEW 1929 Catalog is crammed full of the FINEST, NEWEST, Nationally known A.C. sets, consoles, cabinets, dynamic speakers, kits, PARTS, eliminators and accessories at LOWEST PRICES. Largest stock of radio parts. Prompt delivery.

Write for our FREE catalog WESTERN RADIO MFG. CO., 128W. Lake St., Dept. Q9, Chicago

FREE



The Big Friendly Radio House

# THE AMATEUR'S BOOKSHELF

Readers of *QST* appreciate the need for good radio books. What we consider to be the best standard text books are handled by A. R. R. L. Headquarters for the convenience of members of the league and readers of *QST*. Those listed below pretty well cover the requirements of the average amateur or experimenter.

The Radio Amateur's Handbook, by F. E. Handy, Communications Manager, A.R.R.L. Third edition. The standard text book and manual for transmitting amateurs. Contains immense quantity of data and information valuable to experimenters and all interested in any phase of radio. 256 pages, 297 illustrations .....	\$1.00
The Radio Amateur's Handbook, Cloth Bound Edition. Except for binding, identical with regular edition .....	2.00
Radio Telephony For Amateurs, by Stuart Ballantine. One of the most valuable books we know of for the amateur. Theory, construction, practice. <i>Not</i> particularly about telephony. Heartily recommended for every amateur. 296 pp., 5½x8¼ .....	2.00
Manual of Radio Telegraphy and Telephony, by Commander (now Admiral) S. S. Robison, U. S. N., published by the Naval Institute. "Ranks with the very best of all published radio matter . . . Not only worth its cost but is perhaps the best radio book that ever came to this desk."— <i>QST</i> Book Review. 895 pp., 6¼x10 .....	4.00
Experimental Radio, by Prof. R.R. Ramsey. Third Edition. A splendid manual for the student and experimenter describing in detail 117 experiments of particular value and interest to the amateur desiring a complete understanding of radio work.	2.75
Principles of Radio Communication, by Prof. J. H. Morecroft. An elaborate general textbook. 935 pp., 5¾x9 .....	7.50
Radio Engineering Principles, by Lauer & Brown. An excellent general textbook .....	3.50
Practical Radio Telegraphy, by Nilson & Hornung. 380 pages, 223 illustrations. A text for prospective commercial radio operators .....	3.00
Wireless Pictures and Television, by T. Thorne Baker. 188 pages, 99 illustrations. Completely and clearly presents the whole subject .....	2.50
Thermionic Vacuum Tube, by H. J. Van der Bijl .....	5.00
Radio Frequency Measurements, by Moulin .....	10.00
Prepared Radio Measurements, by R. R. Batcher .....	2.00
Elements of Radio Communication, by Ellery W. Stone .....	3.00
Radio Simplifier, by Kendell & Koehler, revised by J. M. Clayton .....	1.00
Ideas For The Radio Experimenter's Laboratory, by M. B. Sleeper ...	.25

Prices include postage

*Read 'em and learn!*

**AMERICAN RADIO RELAY LEAGUE, INC.**

1711 Park Street - - - - Hartford, Conn.

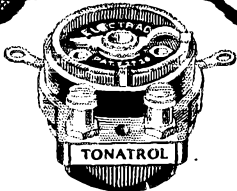

Exclusively Licensed by  
Technodyne Corporation  
under U. S. Patent Nos.  
1593658, 1034105, 1094104

## Control Your Volume!

A Complete  
Line of Volume  
Controls

# TONATROL

Observe this caution in building your receiver. Make sure you can control the volume smoothly and easily by incorporating Tonatrol in the circuit.

Tonatrols are the highest development in volume controls and are designed in types to meet the special requirements of all A. C. or conventional battery circuits. Also furnished with filament or power switch attached.

Electrad specializes in a full line of controls for all radio purposes. Write for FREE descriptive circulars.

Dept. T-9, 175 Varick St., New York

# ELECTRAD



Announces with Pride and Pleasure  
A New Condenser  
Trade Marked, Surgproof

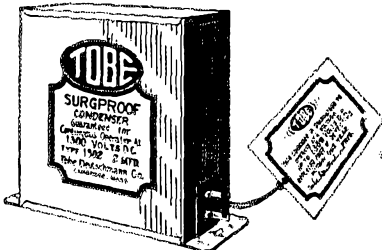

**SURGPROOF** Condensers carries an immediate replacement guarantee if defective within one year.

**SURGPROOF** Condensers have a safe working voltage of 1300 volts D.C. and are recommended for any high-voltage amplifier, using two UX 210 Power Tubes in Push Pull or the new 250 tubes.

Encased in a familiar Tobe Silvered Case 4 1/2" X 5 X 1 1/2".

Type 1302 2Mfd \$5.00. Type 1304 4Mfd. \$9.00

For Sale at Your Dealers.

**Tobe Deutschmann Company**  
Canton, Mass.

2az 2bad 2bay 2bbe 2bcc 2bck 2ber 2bdf 2bfg 2bgz  
2bgr 2bjg 2bif 2bse 2bke 2ein 2com 2erb 2eui 2exl  
2eyx 2fg 2ge 2hr 2dk 2mm 2rs 2up 2tt 2sz 2wi 2zz  
3aa 3aee 3afj 3aih 3anh 3ajh 3aqi 3aqm 3apm 3aod  
3aqz 3aoo 3bip 3efg 3ejn 3dh 3iz 3qw 3qe 3aby 3acv  
3ac 3aef 3aej 3aep 3aek 3f1 3ds 3hr 3ej 3eq 3ge 3ea  
3km 3me 3th 3tk 3td 3we 3aol 3aif 3ayl 3rg 3vx  
3yb 3adg 3ary 3aw 3axa 3awu 3baz 3bbs 3bfw 3bc  
3haf 3bjb 3hz 3bqr 3bou 3bto 3ecg 3elp 3enh 3ent  
3cpr 3cti 3dad 3dnf 3dod 3dsy 3ez 3ain 3ama 3bxi  
3ola 3erd 3uce 3cad 3ef 3erh 3ejo 3ecx 3ecz 3fpp  
3tm 3c-lad 3c-lby 3c-lbr 3c-lrr 3c-lze 3m-lr2 3m-  
3a 3q-2ac 3n-2ef 3q-2kp 3q-2iz 3q-2ro 3n-5em 3q-5ay  
3q-5by 3q-6cx 3q-5fc 3q-5fe 3q-5fl 3q-7ex 3n-1fmh 3z-  
3fr5.

ecRP19, Al Weirauch, Mestec Kravale

1awe 1by 1ckp 2cx1 3sz 3q-5fl 3a-de3 3b-lah 3b-  
lat 3b-lar 3b-laq 3b-law 3b-lbo 3b-lca 3b-lcg 3b-lid  
3b-2ac 3b-2ad 3b-2af 3b-2ay 3b-7ab 3c-lah 3c-lai 3c-2ab.  
(20 Meters)

1ads 1aff 1ry 2arb 3c-3ac.

eu-78RA, W. Nelenex, USSR, Leningrad 2 27

Sagorodny pr log 13

1bt 1mf 1om 2cuq 3b-2ad 3b-2ay 3c-2as 3f-1dy 3g-  
gm 3f-les 3m-8sr xed-7ach xed-7rl.

S.S. DROMORE CASTLE, New York City to Cape  
Town, South Africa, via ZCUP.

Operator Clyde Townsend, care the Union-Castle Mail  
Steamship Co., 26 Broadway, New York City.

Port Elizabeth to 5000 miles S. E. N. Y.

1aa 1aba 1awq 1aun 1bqz 1ckp 1no 1nq 1rp 1ut  
2apd 2ar 2ak 2atx 2aub 2axt 2bda 2bhr 2bke 2chb  
2cu2 2cx1 2cxr 2ig 2kl 2kp 2mu 2ty 2af 2api 2ard  
2bmc 2qe 2py 2au 2avk 4abz 4acv 4ob 4tk 4ut 4vh  
4we 5ayl 5uc 5avl 5awa 5ccw 5ue 5awa 5ek 5awu  
5bbs 5hzh 5bo 5byw 5cwh 5chi 5cx1 5dal 5eq 5xas  
5bhg 5bwo 5paj 5ecx 5eln 5erm 5fbv 5fhy 5ra 5fk  
5rbm 5a-rao3 5yc 5yb 5yz 5a-lh 5b-4co 5b-4di 5b-4f  
5c-ear28 5f-8ev 5f-8fd 5f-8fx 5f-8x 5f-80rm 5f-8vvd  
5f-8wb 5f-1fp 5n-ofp 5p-laa 5p-lae 5p-pju 5w-hb  
5k-3ms 5l 5o-2srb 5o-3fc 5o-3tt 5o-3tu 5o-4e 5o-4o  
5o-4v 5o-4bl 5o-4so 5o-4st 5o-4sr 5o-4a7 5o-4b  
5o-4g 5o-4h 5o-4i 5o-4j 5o-4k 5o-4l 5o-4m 5o-4n  
5q-8hpz 5q-ocya 5q-pm 5rb 5rb 5rb 5rb 5rb 5rb  
ido 1sf 1ku 1kzt 1gn 1odj 1od-3bk 1oh-6avl 1oh-6dy 1ohk  
1ox 1oz 1ph 1ppp 1pd 1pk 1pr 1ri 1ro 1za 1b-lad  
1b-laq 1b-lbt 1b-law 1b-lbo 1b-lca 1b-lcm 1b-lid  
1b-lno 1b-2ad 1b-3qa 1b-5bf 1b-7ab 1sv 1sof 1soh  
1swk 1wnb 1wua 1wv 1vkef 1vte.

5000 to 4000 Miles S. E. N. Y.

1aai 1bki 1ckp 1gw 1ro 1rp 1om 2apd 2aub 2avb  
2bdf 2bhr 2bts 2cu2 2ev 2iq 2am 2sm 2svk 2bbv 2bnu 2sj  
2vg 2aba 2abg 2hy 2nc 2vp 2ayl 2sz 2acz 2axd 2axz  
2bbs 2bky 2brh 2bvy 2chg 2ckg 2cmo 2cvg 2dps  
2drj 2fhy 2gz 2li 2ax 2ani 2cev 2er 2fgs 2bf 2by  
2c-ear28 2f-8wb 2k-4abm 2p-3am 2p-4z 2o-4b 2o-4cy  
2q-pm 2rb 2ra 2rt 2so 2gn 2na 2odj 2ph 2ra 2b-lah  
2b-laj 2b-lbz 2b-lc 2b-lcm 2b-lid 2b-2ad 2b-2ah 2b-2aj  
2b-2ar 2b-2ba 2b-5aa 2b-7ab 2u-1oa 2u 2sof 2sqbx 2pp  
2wz 2wnb.

4000 to 3000 Miles S. E. N. Y.

21abt 1ade 1age 1ajd 1alb 1amf 1anz 1au 1avf 1enz  
1enz 1ga 1ic 1jm 1kh 1kr 1lx 1mx 1pu 1rp 2afa  
2apd 2aq 2axw 2auo 2bav 2bda 2bfn 2bhr 2bkk 2buy  
2byv 2cot 2tw 2ty 2u2 2vi 2za 2aa 2aaj 2aoo  
2afj 2afx 2am 2aqm 2arx 2au 2auv 2ea 2ee 2nn  
2nr 2qe 2sz 2acc 2ac2 2ar 2at 2uq 2vh 2wm 2abi  
2auz 2awd 2ayd 2ayl 2bt 2fo 2kg 2lv 2ann 2aw  
2bht 2bdt 2bkh 2bky 2chg 2chz 2ent 2epd 2eu 2eq  
2af 2ak 2api 2bir 2ceb 2dku 2dmt 2dlj 2eln 2erh  
2fhm 2fz 2ag 2aj 2by 2by 2b-4di 2d-7rl 2c-ear65  
2c-ear 23 2f-8fj 2f-8pm 2g-6kd 2p-lae 2p-lbx 2p-lms  
2p-3am 2p-laa 2q-8hpz 2q-8kr 2gk 2ac 2hio 2c-4v 2kf  
2ze 2ppp 2pd 2pt 2a-e18 2a-a2z 2b-laa 2b-lah 2b-laj  
2b-lan 2b-lar 2b-law 2b-lbz 2b-lbt 2b-lca 2b-lcb  
2b-lcj 2b-lcn 2b-lid 2b-ltl 2b-2ag 2b-2aj 2b-2bf 2b-3qa  
2b-5aa 2b-5bf 2b-7ab 2c-2aa 2u-1fc 2shl 2sn 2sp  
2sq 2sq 2sup 2wgt 2wik 2wiz 2wjo 2wv.

3000 to 2000 Miles S. E. N. Y.

1adb 1afd 1any 1asu 1ax 1bcb 1bqt 1cio 1ckp 1enz  
1no 1 1u 1vt 2ail 2amt 2ans 2aqd 2as 2aup 2awq  
2bav 2bda 2bif 2bit 2bkk 2bts 2bxx 2byw 2ch 2exl  
2dr 2kl 2mb 2qu 2sm 2vc 2vi 2ahh 2an 2aob 2av  
2bj 2dl 2ff 2az 2sn 2wm 2ucd 2acn 2aep 2ch 2gr 2gal  
2agk 2ake 2akv 2ank 2bjb 2bpa 2btr 2ent 2ent  
2cvg 2dds 2dfb 2dhe 2dnf 2dps 2dpu 2sx 2uj 2xl  
2esb 2ef 2elb 2fax 2gmy 2uu 2uz 2a-h 2b-4bu 2b-4di  
2c-ear28 2f-8aa 2f-8af 2f-8btr 2f-8ed 2f-8hg 2f-8hdg  
2f-8il 2f-8ix 2f-8orm 2f-8rrr 2f-8wb 2g-5ma 2g-5v  
2i-las 2i-lbs 2i-ldy 2p-laa 2p-lbv 2p-lbf 2p-3am  
2p-3gb 2l-lab 2o-4bl 2q-ocya 2go 2gr 2gk 2hjo 2kav



Are YOU among the

35,000

who refer daily to a copy of the  
**Radio Amateur's Handbook**  
*for Guidance and Information?*

If Not, get a copy NOW

We believe that The Radio Amateur's Handbook, by F. E. Handy, Communications Manager, A.R.R.L. is the most valuable book which any amateur or experimenter could own. Its chapter headings will give an idea of the thoroughness with which the subject is covered. They are "What Is An Amateur?" "Getting Started", "Fundamentals", "How Radio Signals Are Sent and Received", "Building a Station—The Receiver", "The Transmitter", "Power Supply, Keying and Interference Elimination", "Antennas", "The Wavemeter—Radio Measurements", "The A.R.R.L. Communications Department", "Operating a Station", "The Experimenter".

These chapters each occupy from ten to forty pages—indicating that each subject is treated in a thorough manner. In addition there is an appendix containing a fund of useful data. Then there is an index, occupying six pages, by which the valuable information contained in the book is made available. This in a particularly important point and has been compiled and cross-indexed with great care and thought. Altogether the Book contains 256 pages of the most valuable radio information ever found between two covers.

The Radio Amateur's Handbook starts at the beginning and tells what an amateur is, what the League is, what amateur radio is, how to become an amateur, how to learn the code, how to understand what you hear, how to get your licenses, how to build a simple station, how to build a better station, how to operate your station, how the A.R.R.L. works, how to handle traffic, how to conduct experiments and make measurements, and a multitude of other things too numerous to mention.

Anyone who is at all interested in the technical side of radio can ill afford to be without The Radio Amateur's Handbook.

Regular Cover \$1.00      Postpaid Anywhere      Bound in Leather Cloth \$2.00

*If you haven't  
a copy of The Radio  
Amateur's Handbook you  
are missing the greatest value  
in radio today.*

**DO IT** →  
**NOW**

AMERICAN RADIO RELAY LEAGUE,  
HARTFORD, CONN.  
Dear Sirs:  
Enclosed find my \$..... Please send  
me postpaid (any where in the world)  
my..... copy of the Handbook.

Name .....

Address .....

.....

# Martin's Latest and Greatest Bug

## THE Great New VIBROPLEX

Reg. Trade Mark: Vibroplex, Bug, Lightning Bug

### No. 6

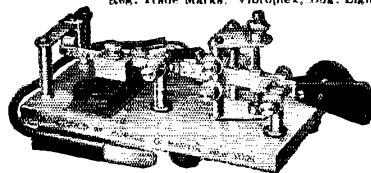

Japanned Base \$17  
Nickel-Plated \$19

The smoothest, easiest-working bug on the market. Not too fast, not too slow—but just right. Works where others can't.

### Famous Improved Vibroplex

Used by tens of thousands of operators because of its ease and perfection of sending.

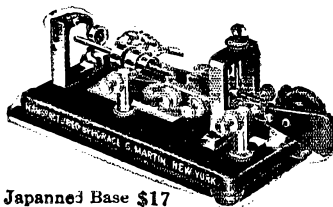

Japanned Base \$17  
Nickel-Plated \$19

### Special Radio Bug

Equipped with Extra Large, Heavy, Specially Constructed Contact Points for direct use without relay

**\$25**

Be sure you get the Genuine Vibroplex. The Vibroplex Name-plate is your protection. Remit by Money Order or registered mail.

**THE VIBROPLEX CO., Inc.** 825 Broadway  
Cable Address: "VIBROPLEX" New York

kfzq naa up-4ug nq-2cf oedj olq perr pts sb-lah sb-law sb-1ca sb-tid sb-2ah sb-2bf sb-9aa sb-prt su-loa wik wiz wmbt.

3000 to 1000 Miles S. E. N. Y.

lagg laip lbeb legn lckp lga lno lmq lpb lww  
2and 2ats 2ayq 2ayj 2az 2bbe 2bda 2bgz 2bhr 2bif  
2bjh 2bys 2bw 2cww 2cwm 2cwh 2cxl 2ia 2ie 2kw  
2ps 2vc 2vy 2aal 2afw 2afx 2agb 2ais 2ajh 2anh  
2bno 2cuj 2dh 2di 2ds 2uz 2vz 2vc 2acv 2acx 2aef 2af  
2av 2ej 2ea 2si 2ug 2adl 2ain 2awd 2ayl 2car 2aef  
2agy 2ajt 2ank 2apn 2axz 2bcy 2bch 2bct 2bhr 2cfc  
2chp 2civ 2cmo 2ent 2enz 2eus 2dch 2dsy 2li 2aid  
2bhz 2eos 2etz 2fax 2fep 2gq 2kb 2gb 2gj 2yy 2yz  
ee-ear28 ef-3brt ef-8wb eg-6q eg-2nak ee-2nf ef-1f  
gbr gkt naa ne-2bb nm-1f nm-8a oedj ohk pch perr  
sb-1id sb-3bf wik wiz will wmbt wsbs.

Cedric Serle, 1 Torrington St., Canterbury, ET,  
Victoria Australia  
(20 meters)

ladm laep lasf lasu lawe lcki lcmx lf lry lsw  
lez 2afx 2ags 2amn 2atx 2awf 2baa 2bow 2bay 2bge  
2bum 2cuq 2cuw 2gf 2np 2tp 2vc 2xad 2aib 2ani 2aw  
2cm 2hf 2ly 2dt 2io 2km 2ll 2nh 2ob 2px 2to 2wh  
2afb 2awd 2hf 2kg 2mx 2wz 2vz 2ay 2av 2aw 2ann  
2awp 2axz 2bau 2bax 2bzy 2bq 2by 2cby 2cft 2col  
2esj 2evy 2dan 2dco 2dce 2dor 2doe 2ej 2vz 2abm  
2fh 2si 2ane 2avp 2axa 2baf 2box 2btj 2bto 2cjm 2cip  
2dhp 2dhw 2dij 2jq 2xe 2ckp 2dbj 2dku 2drd 2eky  
2eq 2ez 2sd nc-3es nc-3fc up-4aa ef-2fd ep-lae eg-2nh  
eg-2hh ei-2xv eg-5by eg-5ma eg-5ml eg-5mq eg-5vy  
ei-1gw ei-2k ei-2kt ex-ra03 gi-6mu.  
(40 meters)

laxa lay laz lbgq lbhs lmx lwl lzg 2alu 2amn  
2evj 2cxl 2ib 2am 2fu 2lk 2oc 2u 2si 2ahx 2amo  
2ayv 2auz 2bj 2kc 2gl 2we 2rg 2agr 2akw 2alz 2am  
2aov 2avy 2awa 2bge 2bcn 2bhh 2bip 2bpc 2bzn 2cci  
2cxm 2cht 2cut 2dam 2dca 2dhh 2dju 2ea 2ec 2ya  
2ax 2iz 2ak 2ara 2ahc 2axz 2bq 2dhs 2gz 2pa 2sg  
2sh 2gg 2aok 2awa 2arn 2ase 2be 2bv 2bxb 2cau 2ehq  
2eic 2ek 2ekf 2ekp 2cmz 2eya 2dg 2dfz 2dga 2dhp  
2dng 2enp 2ez 2rp 2xi nc-5co eb-4ar eb-4ft ne-iar  
ne-9bz se-2as se-2ax se-lax se-2ck se-2al se-2f se-ljc  
se-2ff ac-8na ac-8rj ac-9as fe-egex fe-ze eo-1aj ea-2nm  
ef-8fc ef-8fd ef-8xd ef-8ep ef-8orm ef-8wb eg-6vy  
oh-6adh oh-6alm oh-6avl oh-6boe oh-6bud oh-6bdl  
oh-6bqe oh-6bhl oh-6dtz oh-6fx ai-2bg ai-1lm ei-1di  
ei-1fb ei-1fn ai-1sk ai-1lm ai-2by ai-3ba ai-4bk ai-4bv  
ai-4zz od-1jr od-2aj od-3bk od-4as od-6kl lf-3ms  
am-3ab en-0rz en-0fp ep-1bd ep-1az ep-1cm ep-1bi  
op-1rc ac-1hh as-3fa as-ra03 fo-a3q fo-a7l va-1vr  
ou-hum su-2bt su-loa xnu-6dh ardi na-wuj.  
eg-2BOQ, H. E. Bottle, 27 Stormont Rd., London  
S. W. 5, England  
(Heard during June 1928)

lahx laep lafd laff lah laqd laqt laf lawe lbo  
lbux lbvl lcmx lfa lia lij lkmp lmr lmx lnaa lom  
lry lsz lvy 2aj 2an 2ahf 2aks 2arb 2arx 2ate 2azk  
2bge 2bfa 2bkk 2bme 2bmk 2chd 2cxl 2fu 2mt 2po  
2adm 2aui 2bq 2aft 2lk 2aqq 2agy 2awg 2baz 2clp  
2enh 2ego 2eup 2dl 2duw 2ez 2a-1e6 sb-law sb-1ib  
sb-2ab sb-2at sb-2al sb-2ax sb-2az sb-2zh ac-3ac  
ac-3ej su-lex su-lna fe-egex fe-gm fe-les fm-tun2  
ne-lad ne-2bc.  
eg-6YL, Miss H. Dunn, Stock, Essex, England  
(40 meters)  
(Heard during June 1928)

laek 2ber 2bhr 2box 2es 2va 2cia 2dgs nb-bc3 ne-sae  
xed-7sch el-1ala el-1a13 el-1als el-1a2b el-1a2c xel-aww  
em-sbm em-sbk ep-lafc ep-lbv ep-1ca ep-1cn ep-1wz  
xep-1ms eu-4rb eu-9rb eu-19b eu-26ra eu-08ra eu-  
27ra eu-54ra eu-57ra eu-63ra eu-90ra eu-93ra eu-lskw  
eu-oskw eg-67ra ar-8fhh sa-dc3 sb-lah sb-2az.

## Book Reviews

By Harold P. Westman, Technical Editor

*Practical Television* by E. T. Larner with a foreword by John L. Baird, 175 pages, 97 figures and illustrations published by D. Van Nostrand Company, Inc., New York City, New York. Price \$3.75.

This book is apparently intended for general public consumption in that it treats the subject in that fashion commonly referred to as "popular". It gives

**Ad. Auriema, Inc.**  
Manufacturers' Export Managers  
116 Broad Street New York, N.Y.  
Scientifically equipped to economically export dependable receiving and transmitting radio apparatus.



## Jewell Radio Test Bench

The Jewell pattern No. 580 Radio Test Bench has been designed to provide, interconnected, all the instruments necessary to completely check the circuits and general working condition of radio receiving sets and accessories.

The testing panel is steel, black enameled, with all markings engraved directly in the steel and filled with white. The panel carries seven instruments, as follows: 0-7.5 volts D.C.; 0-75 volts D.C.; 0-150-300-750 volts D.C.; 800 ohms per volt; 0-15-150 D.C. milliamperes; 0-4-8-16 volts A.C.; 0-150-750 volts A.C., and 0-1.5-15 microfarads.

The panel is supplied with binding posts, so that all instruments can be used individually and with switches to cover all ranges. It is also supplied with a plug and cord so that all circuits in a radio set can be tested along with the tube, which may be placed in a socket in the panel. A pair of outlets are arranged to be connected to the 110-volt, 60 cycle, A.C. line, so that line voltage may be read and a set plugged into the outlets. Line voltage is also used for measuring the capacity of condensers.

Our descriptive circular Form No. 2004 describes this Radio Test Bench in detail. Write for a copy.

## Jewell Electrical Instrument Co.

1650 Walnut St., Chicago

"28 YEARS MAKING GOOD INSTRUMENTS"

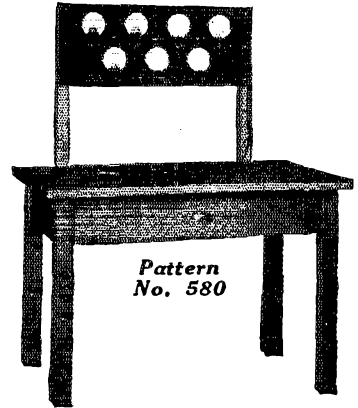

Pattern  
No. 580

### NEW SUPER COILS

TYPE 19—FOR 20-40-80 m. Receivers, celluloid supported, space-wound with No. 15 green s. c. wire, plug-in, two coil unit type. Plug in antenna coil. Extremely efficient, of low r. f. resistance, and small held.  
Type 19—Complete, with mounting .....\$2.50  
Type 19B—Extra coil for broadcast band .....\$2.50  
TYPE 15—Especially recommended for the Amateur, and Experimenter, same as type 19, except of single coil unit type. Range 15-220 m. Fine for low power transmitters, very flexible in its uses.  
Set of 3 coils, and mounting .....\$6.50

#### WAVEMETERS!

SRL TYPE 160 Range 15-110.  $\frac{1}{2}$  of 1% accuracy guaranteed .....\$15.50  
Crystal grinding a specialty—Consult SRL for your crystals. Out Now—New ball bulletins—Write for them—They're free.

### SEATTLE RADIO LABORATORY "Builders of Good Radio Equipment"

3335 33rd Ave. So. SEATTLE, WASH.

### RADIO OPERATORS WANTED

THE EASTERN RADIO INSTITUTE can train you quickly and thoroughly because:

MODERN AND EFFICIENT METHODS  
THOROUGH INSTRUCTION under staff of  
LICENSED COMMERCIAL OPERATORS  
MODERN APPARATUS including SHORT WAVE  
TRANSMITTER

FIFTEEN years a RADIO SCHOOL  
THE OLDEST, LARGEST and MOST SUCCESSFUL  
school in New England. RECOMMENDED BY THE  
A. R. R. L.

Day or Evening Classes Start Every Monday.

SPECIAL CODE CLASSES

Write for Illustrated Prospectus

EASTERN RADIO INSTITUTE

899 BOYLSTON STREET BOSTON, MASS.



## As Pioneers in TELEVISION

We invite correspondence from amateurs in regard to these new Raytheon Products, which are being used successfully in the Television broadcasting.

Kino-Lamp—the first Television Tube developed to work on all systems.

Foto-Cell—made in both hard vacuum and gas-filled extra sensitive types.

RAYTHEON MFG. CO.

Kendall Square Building  
CAMBRIDGE, MASS.





FANSTEEL  
**Balkite Radio**

IN CABINETS BY  
**Berkey & Gay**

FANSTEEL PRODUCTS COMPANY, Inc.  
 NORTH CHICAGO, ILLINOIS

a brief history of some of the many systems that have been devised for television, pointing out the principal manner in which they differ from each other. The more important difficulties confronting the experimenter and some of the methods evolved for their solution are also discussed. Elementary explanations of selenium and photo-electric cells as well as of the cathode ray tube are given. A generous portion of the book has been devoted to the methods of Baird including descriptions of his "Noctovisor" and "Phonovisor". Picture transmission is treated but incidentally, the author devoting practically all his space to television, that is, seeing at a distance. It is an interesting book through which the uninitiated may make his acquaintance with the subject in a not too technical manner.

*Bible Dramas* by William Ford Manley, 225 pages, published by Fleming H. Revell Company of New York City, New York.

There is but slight or no connection in the minds of most between radio and the Bible. It might, therefore, not be amiss to say that the reason for this review is that this series of *Bible Dramas* is published by arrangement with the National Broadcasting Company and covers a dozen stories prepared in such a manner as to make them suitable for radio presentation as well as for church or theatrical use.

The material has been so prepared that each story is complete in itself and although written primarily for radio presentation, makes interesting reading. It seems almost foolish to speak further concerning these when it is possible to get a vastly better and more accurate impression by listening in to one of the *Bible Dramas* as broadcast on Sunday nights over the N. B. C. Network of stations.

*Storage Batteries Simplified* by Victor W. Page, new revised edition, 258 pages, 112 figures, published by the Norman W. Henley Publishing Company of New York City, New York. Price \$2.00.

This book is not an advanced work on storage batteries but rather, a simplified version as the title suggests. It is apparently aimed at the garage man whose knowledge of electrical equipment and theory is meagre and whose radio knowledge is a negative quantity. The author has drawn profusely upon the installation and operating instructions supplied by various storage battery manufacturers. It should have but little appeal to the radio man and perhaps the second sentence in this paragraph goes further towards describing the book than do all the rest.

*Standard Time Conversion Chart.*

Perhaps many remember the "Time Slide Rule" described on page 42 of the September, 1927 issue of *QST*. This chart is very similar, though in somewhat more detail. The circle indicating geographical locations is divided up to show every 7.5 degrees and the names of the principal countries through which these meridians pass is given. The time is shown from midnight to noon to midnight with the hours running from 1 to 12 rather than from 1 to 24. This may cause some inconvenience but is easily corrected and so should not be very damaging. It is called, *Miscellaneous Publication No. 84* and may be obtained from the Superintendent of Documents, Government Printing Office, Washington, D. C. for 10 cents. No stamps or uncertified checks are accepted.

*Conversion chart. (Kilocycles to meters or vice-versa.)*

At this time when we are endeavoring to think and speak in kilocycles rather than meters, it is of utmost importance that we have some means of making this conversion with the least amount of effort. The Radio Division of the Department of Commerce, under whose jurisdiction the amateur is, are using the factor of 300,000 kilocycles per second in their conversions and this value will accordingly be used by *QST*. The Radio Division has had charts prepared covering values of from 10 to 29,990 in steps of 10 (the units may be either meters or kilocycles) and these may be obtained from the Superintendent of Documents, Government Printing Office, Washington, D. C. for 5 cents each. No stamps or uncertified checks are accepted.

New  
**REMLER**  
 Tone Triumph

Custom-Built Sets Use  
 Unique Audio-System

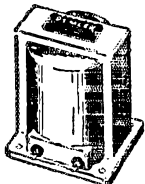

Almost everybody claims top quality. Now Remler makes good with a new, improved, and novel system of Audio-Transformers. Six new items meet every audio need.

Keep up with the progress of Radio. Learn what the Remler Audio System is and what it does. Write today for Bulletin No. 15.

Send For This

M-9 REMLER Division of GRAY & DANIELSON  
 MANUFACTURING CO., 260 First Street,  
 San Francisco, Calif

Please send me

- Literature about new parts.
- Bulletin Service for Professional Set Builders

NAME.....  
 ADDRESS.....  
 CITY.....STATE.....  
 Do you build and sell sets?

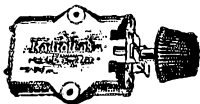

**Bradley Leak, absolutely noiseless and stepless, 2000 to 30,000 ohm resistance. List \$5, special \$2.95.**

44. Bradleystat No. B-210 Special .....1.60



Signal Buzzer Set International Code on Baseboard ..... \$2.45  
Belden braid 1/4 inch wide, ft. .08

47. Acme B-6--"B" eliminator transformer, 235 v. each side of centre tap. .... 2.45

Acme 500 w. plate transformer, 1000-1500-2000 each side of centre tap, 24.00.  
Acme B.H.-1 transformer, 255-510 each side of centre tap; also 2 ill. windings of 1 v. each side of centre tap. \$10.25.  
Acme C.W. 30 Henry choke, \$18 list — 150 M. A. single \$14.40; also other sizes at special prices.

# LEEDS

**The Home of RADIO**  
**45 VESEY STREET**  
**NEW YORK**

**New York's Headquarters for Transmitting Apparatus**

**When in Town Visit Our Store**

**Full Line of Acme -- Thordarson -- Jewell -- Flechtheim -- General Radio -- Signal -- Bradley**

### SPECIALS

- Dubilier Mica Condenser .002 cap. 6,000 working volt 1.95
- General Radio 247D .001 cond. plain or with vernier 1.75
- Dubilier cond. 1.7 mfd. 1,000v D.C. test; 650v working voltage 1.35
- Dubilier cond. .5 mfd. 1,000v D.C. working voltage .85
- R.C.A.—H.V. 1716 Super Het. transformer 1.45
- Ward Leonard Resistances; fits standard base receptacles; sizes 300—600—900—1200 and 2000 ohms .95
- \$15. Imported German head sets; very sensitive 3.45
- Honeycomb Coils unmounted, all sizes in stock at 1/2 price. \$8
- Signal Corp adjustable arm micro-transmitter for panel mounting 2.45
- \$9. Dubilier condenser, 4mfd; 600 v. D. C. working type .25
- 903; limited quantity 2.25
- R.E.L. Transmitting Inductances, per set. 8.80
- Bristol 50 Henry choke 2.75
- 6.50 Acme .0005 enclosed condenser .95

Neon Glow Lamps, made by General Electric Co., type G.10, standard base. 101 uses, as illustrated in QST May issue page 17 ..... .35

Flechtheim Condensers, all types 35% off list.

Pyrax Low-loss V.T. sockets, each 39c.

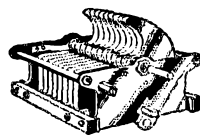

**Cardwell condensers, double spaced for transmitting, .00025 cap. 3.45**

No. 12 Enameled copper wire, any length, ft. ....\$0.1

No. 10 Enameled copper wire, any length, ft. .... .01%

Genuine Bakelite Panel 10x14 3/4 .....1.50

Radiwin phones type C, pair 5.95

Myers \$5 4 1/2 volt—Det. or Amp tube, complete with mounting clips ..... .95



**Ward Leonard Resistance**  
\$4.75 list—6 1/2 inch long—800-1000—1200—3000—6000—8000—11000 ohms; can be used for 2-50 watt tubes or less, \$1.45

Television disks as specified in QST special \$1.95.  
General Radio No. 358 Short Wave Meter, 14 to 225 meters, list \$22, special \$14.50.

**MAIL ORDERS FILLED SAME DAY**  
**10% Must Accompany All Orders**

## RADIO IN BRASIL

When in Brasil, apply to **M. BARROS & CIA** for anything you need in connection with radio.

### M. BARROS & CIA

70 sob. Rua S. José 70 sob.

Postal Box 89

Rio de Janeiro

Telegraph address, Radioparte, Rio de Janeiro

Branch: Avenida S. João 4, S. Paulo, Brasil

## DODGE RADIO SHORTKUT

With Appendix and Hints for Better Key Work. Fixes Signals in mind to stick—Kills Hesitation. Cultivates speed and Good Flat—Produces Results. Slow Hams raise speed to 25 per in few evenings. Previous Failures qualify and pass exam quickly. Beginners master code and pass in ten days.

### DODGE HIGH SPEED METHOD

(Intensive Speed Practice)  
Quickly puts 25 per Hams in 3-4 per class. Five Hams report made this gain in few evenings. One of them by 75 minutes total practice only.

### DODGE MORSE SHORTKUT

Easily mastered by Radio Ops—Kills tendency to mixup or confusion. Either code used as desired.

### REPORTS FROM USERS

Tell the complete story—Mailed on request. Radio \$3.50. High Speed \$2.50. Morse \$2.50. Money order. None C. O. D. Foreign add 50 cents. See our Hamad. G. K. DODGE, MAMARONECK, NEW YORK.

Eighth Edition Just Off the Press

## Robison's Manual of Radio Telegraphy and Telephony

Completely Revised in June, 1928, and Up-to-Date.

Of the 6th edition of this book reviewed by QST it was said this is perhaps

**"The Best Radio Book That Ever Came to This Desk"**

The standard Navy book on radio originally prepared in 1907 by Lieutenant (later Admiral and C-in-C of U. S. Fleet) S. S. Robison. The present edition revised by Captain S. C. Hooper, U. S. Navy, now Director of Naval Communications.

780 pp. Price \$4.00 postpaid. 6th edition sold for \$8.00; 7th edition sold for \$5.50

Address: Secretary-Treasurer, U.S. Naval Institute, Annapolis, Md., U.S.A.

# Consulting Engineers

For Short Wave and Trans-  
mitting Apparatus

We can furnish you with any type  
of Radio Experimental Apparatus  
you might require.

Communicate with us for further  
information. .

E G E R T  
SALES COMPANY

179 Greenwich St., N. Y. City

## Short Wave Converter Unit

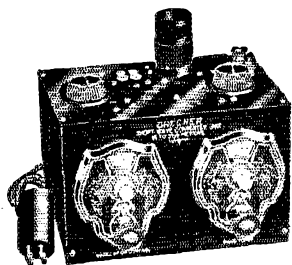

Complete  
\$22.50  
Special

Some of the best entertainment of the air is broadcast on the short waves by many powerful stations. There is no longer any reason why all should not receive these excellent programs from all over the world. The Dresner Short Wave Converter Unit is completely assembled. It efficiently covers a wave band of 15 to 550 meters, and makes reception easily obtainable for all. Offered at the special price of \$22.50—*complete ready to plug into your receiver in a few seconds.* If your dealer cannot supply you SEND MONEY ORDER DIRECT and we will ship P. P. prepaid. GUARANTEED.

DRESNER RADIO MFG. CORP.  
644 Southern Boulevard, New York City

## Financial Statement

BY order of the Board of Directors the following statement of the income and disbursements of the American Radio Relay League for the second quarter of 1928 is published for the information of the membership.

K. B. WARNER, Secretary.

STATEMENT OF REVENUE AND EXPENSES FOR  
THE THREE MONTHS ENDED JUNE 30, 1928.

REVENUE		
Advertising sales, QST .....	\$ 14,810.09	
Newsdealer sales, QST .....	9,906.36	
Handbook sales .....	3,464.26	
Handbook advertising sales ..	1,305.00	
Dues and subscriptions .....	7,949.40	
Back numbers, etc. ....	889.29	
Emblems .....	146.85	
Interest earned .....	392.35	
Cash discount earned .....	318.66	
		\$ 39,182.26
Deduct:		
Returns and allow- ances .....	\$4,309.27	
Less portion charged to reserve for news- stand returns ..	1,306.51	3,002.76
Discount 2% for cash .....	272.74	
Exchange and collection charges	16.45	3,291.95
Net Revenue .....		35,890.31
EXPENSES		
Publication expenses QST ....	11,124.47	
Publication expenses, Hand- book .....	1,521.99	
Salaries .....	14,056.25	
Forwarding expenses .....	565.24	
Telegraph, telephone and post- age .....	1,066.91	
Office supplies and general expenses .....	1,660.93	
Rent, light and heat .....	927.50	
Traveling expenses .....	1,728.72	
Depreciation of furniture and equipment .....	493.56	
Bad debts written off .....	62.14	
Communications Dept. field ex- penses .....	71.30	
Total Expenses .....		33,279.01
Net Gain from Operations		\$ 2,611.30

## Indiana Central Division Convention

YES Sir! The Hoosier boys know how to run conventions and the Indianapolis Radio Club, who sponsored this year's affair which was held on July 28-29, more than kept up the reputation.

Beginning early Saturday morning delegates began arriving from different parts of the state and the register showed several from neighboring states. The forenoon was spent in getting acquainted and by the time the afternoon session was ready to open every one was on a friendly basis. Promptly at 2 o'clock, Director Darr called the convention to order and welcomed the guests. Then followed some really good informative addresses by F. R. Finehout, 9CLO, on crystal grinding and with practical demonstration. D. J. Angus, the SCM, 9CYQ, understands crystal circuits

**VITROHM** Transmitting Grid Leaks and Rheostats now cover the entire line of transmitting tube circuits. ¶The prices on these amateur products are reduced materially. ¶Your dealer should stock Vitrohm Transmitting Products. ¶If you have difficulty in obtaining them, write us direct.

CATALOGUE NUMBER	PRODUCT	RESISTANCE	DISSIPATION	CURRENT	MAX. TUBE RATING	PRICE
507-2	Grid Leak*	5000 ohms	44 watts	90 m.a.	100 watts	\$2.00
507-3	Grid Leak*	5000 ohms	200 watts	200 m.a.	1000 watts	2.80
507-4	Grid Leak†	50,000 ohms	200 watts	60 m.a.	1000 watts	6.50
507-5	Grid Leak†	20,000 ohms	200 watts	100 m.a.	1000 watts	4.25
507-51	Grid Leak*	10,000 ohms	200 watts	135 m.a.	1000 watts	4.00
507-66	Grid Leak**	15,000 ohms	200 watts	120 m.a.	1000 watts	6.00
507-63	Rheostat†*	50 ohms	50 watts	1 amp.		5.50
507-59	Rheostat*†	20 ohms	80 watts	2 amp.		5.50
507-83	Rheostat*†	12.5 ohms	60 watts	2.2 amp.		5.50

\* Center-tapped

† DeForest P or R. C. A. 852 Tube  
De Forest H Tube

\*\* Steps at 5M—10M—15M

for R. C. A. 852 or DeForest P Tube

† For Primary Control

\*† Filament and Primary Control

## Ward Leonard Electric Company

37-41 South Street

Mount Vernon, N. Y.

### RADIO SCHOOL

Earn \$35 to \$50 Per Week

The rapid expansion of RADIO has created many new positions on land and sea. Enroll now. New term begins September 10th in both day and evening class. Send for free catalogue.

#### MASS. RADIO SCHOOL

18 Boylston Street, Boston  
Tel. Hancock 8184 Established 1905

### TELEVISION

although still in an experimental stage, has now advanced sufficiently to enable amateurs to build outfits that will give edifying results.

Write today for our price list of television apparatus.

Photo Electric Devices, Inc.  
594 Fifth Avenue Brooklyn, N. Y.

### QST OSCILLATING CRYSTALS AMATEUR BANDS

WE WISH TO ANNOUNCE:

1st.—That now, our crystals are capable of being used with as high a power tube as the 50 watt size.  
2nd.—That we do not claim to grind the CHEAPEST crystals, but we do claim to grind only the best which is the cheapest in the long run.

3rd.—That we will ship the closest frequency crystal we have to your desired frequency, and that the frequency of the crystal will be stated ACCURATE to BETTER THAN A TENTH of 1%.

4th.—That all crystals are absolutely guaranteed in regard to output and frequency, and immediate shipment can be made on crystals in the amateur bands. Prices for grinding POWER CRYSTALS to oscillate in the various amateur bands are as follows:

1715 to 2000 Kilocycles	\$15.00	Note: The above prices are effective July 1st, 1928, to be in effect until November 1st, 1928. (Add \$10.00 to these prices if crystal is to be mounted in an excellent dust-proof power mounting.)
3500 to 4000 Kilocycles	\$25.00	
7000 to 7300 Kilocycles	\$40.00	

Broadcast Band—We will grind a crystal for you accurate to plus or minus 500 cycles of your assigned frequency for \$45.00 unmounted, \$55.00 mounted. Two day shipment and all crystals guaranteed.

Crystals ground to any frequency between 40 and 10,000 Kilocycles. We will be pleased to quote prices on your particular requirement.

SCIENTIFIC RADIO SERVICE, "The Crystal Specialists"

P. O. Box 86, Dept. ZA

Mount Rainier, Maryland

## New Tone Brilliancy

with a Potter Condenser Block  
in your Power Amplifier. Rich,  
natural bass tones that possess a  
real thrill.

No.  
T2900  
where  
one 250  
Type  
Power  
Tube  
is used  
\$20.00



No.  
T2950  
where  
two 250  
Type  
Power  
Tubes  
are used  
\$22.50

Highly Efficient—Long Life  
The Choice of Leading  
Radio Engineers

Ask your dealer for full information

**POTTER MFG. CO.**  
North Chicago, Illinois

and showed the gang what he could do with that small xtal-control portable set. H. F. Weakley of the Esterline-Angus Co. gave a good talk on Radio Instruments. C. E. Dutton of the A. T. & T. gave us a new angle on chain broadcasting and made us realize the advance which has been made in that particular field of radio. The most interesting lecture of the two-day sessions was that given by R. J. Kryter of the Presto-Lite-Battery Co. The subject of Rectifiers and Filters was handled in a masterly way. A. A. Hebert, Treasurer-Fieldman, from A.R.R.L. Headquarters, discussed the 1929 problems with which we amateurs will be faced, and told us what was being done by Headquarters to help relieve the situation.

Former Division Manager R. H. G. Mathews, Lt-Commander, U.S.N.R., brought a naval personnel with him, and enrolled 22 of the delegates present into the Naval Reserve. Matty is certainly a worker and if he continues the same pace he will have the best Unit in the service.

When we speak of Banquets we always think of those night affairs which are scheduled for 7 o'clock in the evening and let every one starve until 8 o'clock, but this banquet was another departure from the conventional—it was held in the afternoon; a real Sunday afternoon dinner.

There were so many nice things that took place that space prevents mentioning everything, but we will say that the good prizes donated by the manufacturers had to be won. The closing of the affair took place shortly after the dinner but not before OM Burns had had a chance to regale us with his entertainers—they were good too—and we now know he has an eye for pulchritude.

—A. A. H.

## Beginners! Students!

Advanced



The TELEPLEX Code Sender will make you proficient in code practice—both sending and receiving, in half the usual time. This is the only instrument that reproduces actual sending of expert operators. Sends messages, radiograms, etc. — regular code traffic at any desired speed. Endorsed by U. S. Navy and leading Technical and Telegraph Schools. Complete Set of Instruction Tapes (Wireless or Morse) for beginners and advanced students furnished with the Teleplex. Remember, only the Teleplex provides practice when others and you want it. Write for booklet RL.

Silent  
Phonograph Motor

Teleplex Co., 76 Cortlandt St., New York, N. Y.

## The New England Division Convention

Held at Augusta, Maine.

THE Maine A.R.R.L. Convention held at Augusta, July 13 and 14 was acclaimed by those who attended the biggest and best affair of the kind ever held in the Section. The Convention Committee secured the full cooperation of many state and local agencies in "putting it over". Chairman L.A. Burleigh Jr. (IKE), Secretary Fred Best (IBIG) and Leslie Hall were responsible for the fine arrangements. For those who drove from all parts of New England and New York large banners and signs pointed the way to Ham Headquarters at the Augusta Y.M.C.A. and bid the delegates welcome.

The opening sessions were held in the Senate Chamber at the State Capitol. After the address of welcome by Mayor Mc-

**Hey,**  
I am—  
have u ordered ur copy of  
**Andy's  
Handbook?**

THE BEST \$1 YOU EVER SPENT!

PUBLISHED BY  
AMERICAN RADIO RELAY LEAGUE  
1711 PARK ST. HARTFORD, CONN.



# Synchronous Motors for Television

In addition to building reliable and satisfactory motor generators, "Esco" has had many years of experience in building *electric motors* for a great variety of applications.

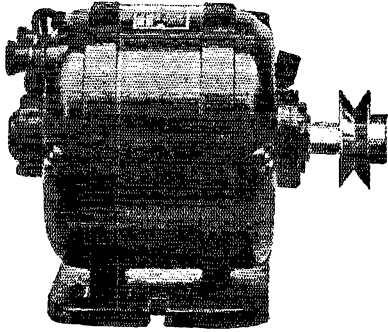

*Synchronous motors*, small, compact, reliable, self starting are now offered for **Television** equipment. They require no direct current for excitation, are quiet running and fully guaranteed.

Other types of motors suitable for Television may also be supplied.

Write us about your requirements.

## ELECTRIC SPECIALTY CO.

225 South St.

Trade "ESCO" Mark

Stamford, Conn.

4th Edition—Just Off Press

### "Radio Theory and Operating"

By Mary Texanna Loomis

The standard radio text and reference book of America. Near 900 pages, over 700 illustrations, flexible binding.

**PRICE \$3.50—Postage Paid**

For sale by hundreds of bookdealers throughout America and many foreign countries. Or may be purchased direct from the publishers. Send check or money order to

**LOOMIS PUBLISHING COMPANY**  
Dept. 5 Washington, D. C.

## Centralab

### Giant Power Rheostat

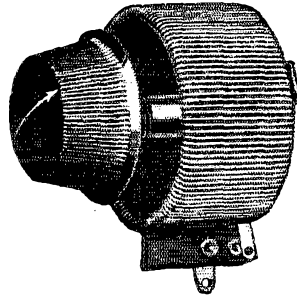

Small in diameter but large in capacity, this rheostat will safely carry any power load of 70 watts. Constructed of heat-proof materials throughout. No fibre to warp or burn out. Wire is wound on a steel core insulated with asbestos. Extra wide core assures large area for quick heat dissipation.

This unit is ideal for primary control of "AC" receivers or

"A" Power Units. It will keep the line at a constant workable average, keeping the secondary output well within rated limits. These units connected in series across the output of a Rectifier and Filter system for "B" Power will provide all necessary voltage taps.

These units can be used in any power circuit position without any danger of burning out—the capacity is only limited by the capacity of the wire.

Manufactured with either two or three terminals. Diameter 2"; Depth 1 1/4". Write for new Booklet on "Volume Controls and Voltage Controls—Their Use."

**CENTRAL RADIO LABORATORIES**

20 Keefe Avenue

Milwaukee, Wis.

# YAXLEY

APPROVED RADIO PRODUCTS

## Special Switches

There are almost limitless possibilities for different spring arrangements with Yaxley switches. Write for prices on special switches, giving as much information as possible, together with sketch of spring arrangement wanted and thickness of panel.

**YAXLEY MFG. CO.**

9 So. Clinton St.

Chicago





# AIR-KING

15-130 METERS  
\$12.50

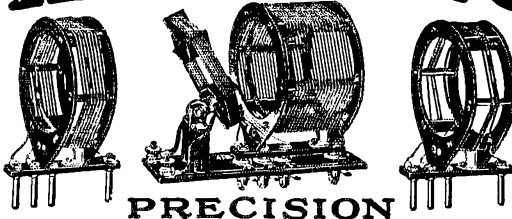

PATENTS

PRECISION

PENDING

SHORT WAVE PLUG-IN KIT

97% AIR DIELECTRIC  
GENUINE BAKELITE

The new Air-King Short Wave Kit consists of three plug-in coils, ranging from 15 to 130 meters (when tuned with a .00014 mfd. condenser), and a plug-in base, with variable primary, which is soldered with phosphor bronze flexible connections to permanent antenna-ground binding posts on the base. Each coil is accurately space-wound

on a bakelite squirrel cage form, with ribs threaded to lock each turn in place.

Friction holds the variable primary in any position it is put in. Double contact between coil prongs and the jacks in the base assure perfect connection at all times, from the moment of inserting coils.

Send for free booklet on hook-ups and descriptions of coils.

If Your Dealer Can't Supply You, Order Direct

MFD. by AIR-KING PRODUCTS CO.  
216-WALL ABOUT ST. BROOKLYN, N.Y., U.S.A.

## QUARTZ OSCILLATING CRYSTALS

Unconditionally Guaranteed

1 in. sections ground to 1% of your specified frequency at these prices:

40-75 meters	\$25.00
75-100 meters	17.50
100-200 meters	10.00
200-600 meters	15.00
Tested blanks, 2 to 5 mm thick	5.00

Sections of any practicable dimensions made to order.

Prompt Delivery

J. T. Rooney, B. Sc., 31 Calumet Bldg., Buffalo, N. Y.  
"Ten years crystallographic experience"



(ACTUAL SIZE)

500 to 5,000,000 ohms

distributed capacity and inductance, practically negligible. The most accurate and efficient resistance unit known to radio. Write for booklet B.

DAVEN CORPORATION

NEWARK, N. J.

## BECOME A RADIO OPERATOR

See the World. Earn a Good Income.  
Duties Light and Fascinating.

### LEARN IN THE SECOND PORT U.S.A.

Radio Inspector located here. New Orleans supplies operators for the various Gulf ports. Most logical location in the U.S.A. to come to for training.

Nearly 100% of radio operators graduating on the Gulf during the past six years trained by Mr. Clemmons, Supervisor of Instruction. Start training now for fall runs. Member of the A.R.R.L.—Call "5 G R" Day and Night Classes—Enroll anytime—Write for circular.

### GULF RADIO SCHOOL

844 Howard Ave.

New Orleans, La.

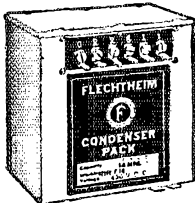

TYPE F14 - for 171  
Power Pack-450 D. C.

# FLECHTHEIM

## SUPERIOR CONDENSERS

Dear OM:

You will soon be busy again at work on your transmitter, or designing and building that new power pack you've had in mind. Flechtheim Superior Condensers have created an enviable name for themselves, for they are dependable and at the same time very reasonably priced. Complete line of By-pass, Filter, High Voltage, Transmitting and special condenser blocks for the 171, 210 and 250 power amplifier tubes. Write for catalog X Tnx, OM es pse QSL.

73's nu 2AFS, Chief Engineer.

Complete Line From 250 to 3000 V. D. C.

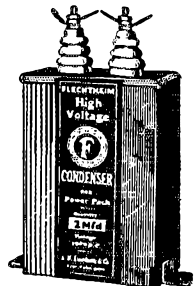

TYPE H200-650 D. C.

A. M. FLECHTHEIM & CO., Inc., Dept. QT, 136 Liberty St., N. Y. C.

# For Better TELEVISION

Just as CLAROSTAT has pioneered in super-reception, B-eliminators, socket-power receivers and quality amplification, so is it ready to pioneer in television. CLAROSTAT, with its precision resistance fitted to the exact needs, is ready to meet the ultra-critical requirements of television technique. It is for you to ask for CLAROSTAT engineering cooperation. Meanwhile, typical of what CLAROSTAT can do are the following:

## Neon Lamp Control

The Standard CLAROSTAT is indispensable for applying a critical voltage on the neon lamp for the desired contrast between light and shade. A satisfactory image, with sufficient detail, depends on proper direct-current voltage for normal glow, yet low enough to permit of ample contrast with increased brilliancy due to signal modulation.

## Scanning Disk Control

Positive synchronism of receiving and transmitting scanning disks is obtained by means of special Power Clarostat (100-watt rating). A push-button short-circuit resistance for momentary speeding up of motor to get into proper step with transmitter. This arrangement is standard practice in most television receivers.

WRITE for our literature and for any special data you may require.

CLAROSTAT MFG. CO., Inc.  
285 North 6th St., Brooklyn, N. Y.

**CLAROSTAT**  
REG. U.S. PAT. OFF.

## The Zepp

(Continued from Page 36)

quency by the amount X, which has the effect of shifting the voltage antinode  $V_2$  from a point directly opposite  $V_1$  along the wire away from the point directly opposite  $V_1$  by the same amount X. In order to maintain the whole system in resonance with the desired frequency it is necessary to so adjust the feeder tuning as to effect reduce the length of the feeder system by the amount Y. The current and voltage distribution in the two feeder wires is no longer symmetrical, and the two radio frequency ammeters A-A will not indicate equal values of current. We therefore shorten the length of the antenna by the amount X, and retune the feeder input circuit until the system is again in resonance. The two meters will now indicate approximately equal values of current, and the voltage and current distribution will be proper as shown in A.

There should be a current antinode (voltage node) at the center of the antenna inductance when the condition shown in A of Figure 6 prevails and this may be checked by touching the center turn with a neon lamp or point of a wooden-handled screw driver. There should be no glow from the lamp or spark from the screw driver.

In the actual process of adjustment, the antenna inductance and tuning condenser arrangement is connected to the input end of the feeders, as shown in Figure 7. The two ammeters are located equal distances from the top end of the feeder system, which also makes the distance from the antenna inductance and condensers to each meter equal. Therefore, when the current as indicated by the two meters is the same, there will be the proper distribution of voltage and current in the feeders and antenna. The length of the antenna, which we made a full  $\frac{1}{2}$  wavelength long in the first place, is cut off by about six inches at a cut until the difference in current as indicated by the two meters is not more than about ten percent. It should be remembered that the current as indicated by the meters may not be, and very probably is not, the maximum current in the feeders. The maximum current would only be indicated when the meters were located at current antinodes, which is not likely to occur in many cases. The importance of the readings of the two meters is not how much current they indicate, but the ratio of the currents at these two points opposite each other on the feeder system. If the distribution is perfectly symmetrical this ratio will be one to one, or both meters will read the same. The screw driver or neon lamp test on the center of the antenna inductance should indicate zero voltage at that point when the two meters indicate equal current, as mentioned above.

Figure 7 shows a suggested arrangement of the input end of the feeder system for

## PACENT DUO-LATERAL COILS

FOR laboratories, experimenters, engineers and for special circuits, Pacent Duo-Lateral Coils are the accepted standard.

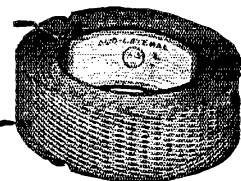

A complete line of all standard turn ratios are always in stock.

Write for information and prices

Pacent Electric Co., Inc.  
91 Seventh Avenue, New York

**H**ey, Ham—  
**H**ave u ordered ur copy of  
**andy's**  
**Handbook?**

THE BEST \$1 YOU EVER SPENT!

PUBLISHED BY  
AMERICAN RADIO RELAY LEAGUE  
1711 PARK ST. HARTFORD, CONN.

## FREE Wholesale Radio Catalog

Set Builders-Dealers! Save Money!

Send for the most complete book of nationally known Parts, Kits, Cabinets, Consoles, Speakers, Power Units, Sets, etc. All at lowest wholesale prices. Quick service on all your needs. Write now, it is FREE—

**SETBUILDERS SUPPLY CO.**

Dept. 16-1 Romberg Bldg. Madison and Market Sts. CHICAGO, ILL.



# UNI-RECTRON POWER AMPLIFIER



(IDEAL FOR USE WITH DYNAMIC SPEAKERS)

As the Uni-Rectron stands it is a super power amplifier, which can be used in connection with any radio set and loud speaker. Binding posts are provided for input to the Uni-Rectron and output to the speaker. Requires no batteries for its operation. It obtains its power from the 110 Volt, 60 Cycle alternating current lighting circuit of your house.

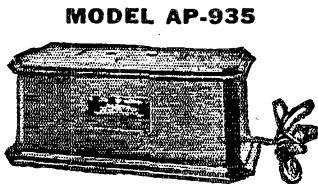

MODEL AP-935

whisper to the loudest crash of sound—R.C.A. Uni-Rectron amplifies each note at its true value. High and low notes are all treated alike.

The volume and quality delivered will be a revelation.

Also by removing the input and output transformers it can be used as a source of power for an oscillating or transmitting tube, furnishing power for all circuits, grid, plate and filament and is the cheapest form of Power Supply for Amateur Transmitting purposes ever offered. New.

LIST PRICE \$88.50  
(Without Tubes)

**Special \$19.75 EA.**

The UX-210 super power amplifying tube and the UX-216B or 281 rectifying tube are used with this amplifier, which cannot overload. From the faintest

SEND FOR OUR LISTS OF RADIO BARGAINS

**AMERICAN SALES CO., 19-21 Warren St., New York City**



## NATIONAL

Velvet Vernier Dial type N for short wave work. A solid German Silver Dial with the original Velvet Vernier mechanism and a real vernier for close reading to one tenth division. Price \$6.50. Send for Short Wave Bulletin

NATIONAL CO. INC., W. A. READY, PRES.  
MALDEN, MASS.

**AEROVOX** Makers of high quality resistors and condensers that are Built Better — to endure.

Write for The Research Worker. A free monthly publication.

**AEROVOX WIRELESS CORPORATION**  
68 Washington Street Brooklyn, N. Y.

## To Our Readers who are not A. R. R. L. members

Wouldn't you like to become a member of the American Radio Relay League? We need you in this big organization of radio amateurs, the only amateur association that does things. From your reading of *QST* you have gained a knowledge of the nature of the League and what it does, and you have read its purposes as set forth on page 6 of every issue. We would like to have you become a full-fledged member and add your strength to ours in the things we are undertaking for Amateur Radio. You will have the membership edition of *QST* delivered at your door each month. A convenient application form is printed below—clip it out and mail it today.

*A bona fide interest in radio is the only essential qualification for membership.*

American Radio Relay League,  
Hartford, Conn., U. S. A.

I hereby apply for membership in the American Radio Relay League, and enclose \$2.50 (\$3 in foreign countries) in payment of one year's dues. This entitles me to receive *QST* for the same period. Please begin my subscription with the ..... issue. Mail my Certificate of Membership and send *QST* to the following name and address.

.....

.....

Do you know a friend who is also interested in Amateur Radio, whose name you might give us so we may send him a sample copy of *QST*?

..... Thanks

# — QST nu9F O — CALL BOOK

Published March, June,

September,  
December



Single Copies  
U. S. and Canada  
\$1.00 Each  
(Foreign \$1.10)

Subscription  
**ONE YEAR**  
(4 Issues)

For \$3.25  
(Foreign \$3.50)

Amateur, Land and Ship Stations  
From 83 Countries

**Radio Amateur Call Book Inc.**

508 So. Dearborn St., Chicago, U. S. A.

the amateur station where quick QSY with a minimum of time and effort is desired. The connections between the antenna inductance and parallel tuning condenser should be "low loss" and with plenty of cross section to carry the tank current. The parallel tuning condenser should be

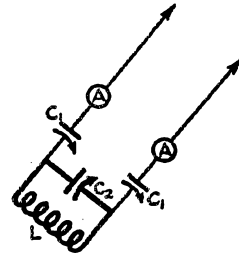

FIG. 7

capable of carrying the tank current without heating and should have a voltage rating approximately the same as that of the plate circuit tuning condenser of the transmitter. Its capacity may be around 250  $\mu$ fd. The series condensers may have a lower voltage rating but should be of the same quality, their capacity being also about 250  $\mu$ fd. maximum.  $L$  is the usual antenna inductance of about 5 to 10 turns. When the parallel tuning arrangement is being used, the two series condensers are set at maximum, and when the series tuning arrangement is being used, the parallel condenser is set at zero.

## Strays

Zero LB suggests that the cover designs by 8ZZ should be signed something like this:  
Darr! Darr! Darr did it  
Darr! Darr did it  
Darr! Darr did it

That General Radio plugs will screw into Sangamo fixed condensers is a point that should be of interest to anyone who wants to use plug-in condensers for any purpose.

—7MJ

FREE to You

### 1929 RADIO BOOK

New Hook-ups. This book shows how to make Short Wave Receivers and Short Wave Adapters. How to use the new screen grid tube in D. C. and A. C. Circuits. How to build Power Amplifiers, and ABC Eliminators. Up to the minute information on all new radio developments. Set Builders, Fans, Dealers, send for it today.

**KARAS ELECTRIC COMPANY**  
4030 JI-N. Rockwell St., Chicago, Ill.  
Please send me your free hook

Name.....  
Address.....  
City.....State.....  
4030-JI



Write for it!

You can easily become an **EXPERT**

## Radio Operator

Through The Candler System Course of Training in High Speed Telegraphing

Theo. McElroy, World's Champion Radio Operator endorses no other system. He writes: "At the Pageant of Progress, Chicago, I copied 56 words per minute for 5 minutes, establishing a new radio record. I owe my skill, speed and steady nerve to The Candler System." What this system has done for McElroy and over 40,000 others—it will do for you. FREE booklet explains system fully. Send for it TO-DAY. A postcard will do.

**The CANDLER SYSTEM CO.**  
Dept. AR 6343 S. Kedzie Ave. Chicago, Ills.



THE FIRST WOMAN TO DISAPPROVE OF RADIO AS A HOBBY

# Q T C

## Protection at Last Bunnell Combination Protector and Circuit Breaker or Plate Overload Relay

"Those Precious Bottles"—Secondaries of High Voltage Transformers, Choke Coils, Etc.

All can be protected from damage by an overload through the installation of a Bunnell Plate Overload Relay. Inserted in the negative "B" lead they will open the "B" supply instantly, if an excessive current is permitted to flow (as adjusted). The instrument is supplied with a vernier operating current adjustment, alarm contacts and manual reset. Number 10268—\$12.50 each—Schedule BB.

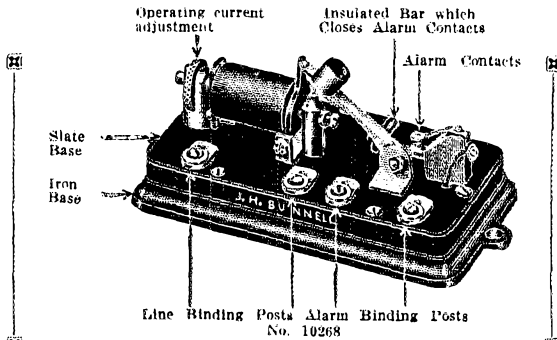

For those who prefer to have an additional set of contacts to break the 110 volt line at the same time we can supply our No. 10268-A, with additional contacts normally closed. They open only when the instrument trips.

SPECIFY IN EITHER CASE YOUR NORMAL OPERATING CURRENT SO THAT WE MAY SUPPLY THE CURRENT ADJUSTMENT RANGE.

No. 10268-A—\$16.50 each—Schedule BB.

**J. H. BUNNELL AND COMPANY, Inc.**  
Manufacturers of Telegraph & Radio Apparatus  
32 Park Place New York City

### SPECIAL TO AMATEURS

Barawik's new shortwavelept. has everything that amateurs desire. The Barawik Radio Guide gives full details. Send for it.

## FREE RADIO GUIDE

**RADIO BARGAINS**  
Shows the latest wrinkles, new developments in radio at startlingly low prices. Get the set you want here and save up to 50%. The best in parts kits, complete factory-built sets and supplies. Orders filled same day received. Write for free Catalog and Guide NOW! Wholesale prices to dealers, set builders, agents.  
**BARAWIK CO., 119 Canal St., Chicago, U. S. A.**



## A PUNCH

To your signals that puts em over. Batters down QRM, hurdles continents, lifts em clean over the ropes. Takes a mercury arc to do it. The rectifier of unlimited power, life and performance. Read what the gang says. Write now and your rectifier problems are solved.

**RECTIFIER ENGINEERING SERVICE**  
4837 Rockwood Road Radio 8ML Cleveland, Ohio

# The A.R.R.L. Diamond Is the Emblem of a Real Amateur!



The League Emblem comes in four different forms. Its use by Members is endorsed and encouraged by the League. Every Member should be proud to display the insignia of his organization in every possible way.

**THE PERSONAL EMBLEM.** A handsome creation in extra-heavy rolled gold and black enamel, 1/2" high, supplied in lapel button or pin-back style. There are still a few fellows who are hiding their light under a bushel. Wear your emblem, OM, and take your proper place in the radio fraternity. Either style emblem, \$1.00, postpaid.

**THE AUTOMOBILE EMBLEM.** Introduced only this spring, already more than 800 cars are proudly displaying the mark of the "Radio Rolls-Royce." 5 x 2 1/2", heavily enameled in gold and black on sheet metal, holes top and bottom, 50c each, postpaid.

**THE EMBLEM CUT.** A mounted printing electrotype, the same size as the lapel button, for use by Members in any type of printed matter, letterheads, cards, etc. \$1.00 each, postpaid.

**THE "JUMBO" EMBLEM.** You've taken care of yourself, your car and your printing. How about the shack wall or that 100-footer? Think of the attention this big gold-and-black enamel metal emblem will get! 19 x 8 1/4", same style as Automobile Emblem. \$1.25 each, postpaid.

Mail your order and remittance NOW to

**The American Radio Relay League : : Hartford, Conn.**

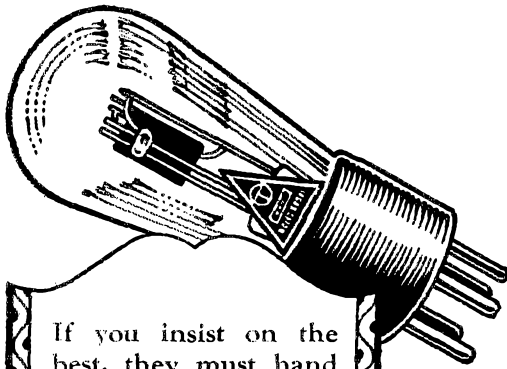

If you insist on the best, they must hand you Televocals. All standard types. Ask for them at your dealers.

**TELEVOCAL CORPORATION**

Televocals Building  
Dept. R-3, 588 12th Street  
West New York, N. J.

**Televocals**  
*Quality Tubes*



**Don't Forget**

That the A.R.R.L. Emblem is the badge of every real Amateur.

It is available in various sizes for button, pin, auto or radio-mast.

*"That ham may recognize ham—display the A.R.R.L. Emblem."*

American Radio Relay League, Hartford, Conn.

**TRANSFORMERS**

Guaranteed—Mounted—Complete

250 watt 550—700 each side.....	\$10.50
700 watt 1000—1500 each side.....	14.50
700 watt 2000—2500 each side.....	21.00
1 Kw 2000—2500 each side.....	30.00

Add \$2.00 for fil. winding

**SCES F. GREBEN**

1927 So. Peoria Street, Pilsen Sta., Chicago, Illinois

**ROBERT S. KRUSE**

Consultant for Shortwave Devices

103 Meadowbrook Road,  
West Hartford, Conn.

Telephone Hartford 45327

in ED. Anyhow I puts my best eq into getting acquainted, and before long we sound like two old maids at a ham convention. We walks on past the store, and neither one of us thinks anything about stopping. Our minds and my heart had qsyed liked someone had hanged a boarding house wash on my counterpoise.

Before either of us knew anything about it we were in front of her house and I was still holding on to her books.

"Sa," I sez, "would you get mad if I asked you something?"

"I don't know," she sez, "Go ahead and ask it."

I clears my throat, and like I was starting in to send one of those reliability msgs, I asks :

"I got a bid fer a frat dance and no date. Will you—Will you—er—go with me?"

She smiles sweetly or do I imagine it and sez:

"You will have to ask father."

That comes in R9 and sounds like bad qrn on a Saturday nite.

"Gee whiz. Holy condenser dials." I sez wondering what size shoe he wears. "When is he home?"

"Every evening," she sez. "He will be glad to see you."

"Yea;" I says, "just like he does a bill collector, and then he will be glad to see a bootblack." Just then her ma announces that if she expects to eat she had better get in and start to work.

I started walking home feeling as happy as a guy that has called an aussie and gets an R8 report only to find that he failed to get the last dot on the call. I had an idea what the qso with the old man would be like. I would step up sa hello and then provide the house with a new exit. A light bulb rose over my head. That was the reason CBY had laughed at me. He knew that I would get enough punishment to make up fer all the qrm I had ever caused him.

Anyway the next eve I goes over to the house per sked and asks for Helen. She takes me in hand and shoves me in a small room off the living room.

"Father," she sez, "I want you to meet Bill."

"Pleased to meet you," he sez between throwing out condensers, voltmeters, monkeywrenches and etc. out of a receiver that he had his head stuck in.

"Trouble?" I queries in a small meek voice.

"No. Not at all," he sez, "I am just taking my daily dozen."

"Oh." I sez and he immediately straightens up and I began a hurried search fer an exit.



"Do you know anything about a radio?" he asks.  
"Very little." I sez, "What is the matter?"

"This thing won't work worth a darn, and I got a bet with one of the boys down to the office that I hear better dx tonight than he does."

"Do you hear anything at all?" I asks.  
"Not a blankety blank thing." he returns.  
"Ah, that sounds easier." I sez and sticks my head in the cabinet. If I can only fix the set I thought to myself I sure will be in good wid the old man. I looked through the whole thing without seeing a thing wrong, and in moving around to get a better look I feels a loose wire wid my foot. One look and I saw that the B bat lead fer the R.F. tubes was nil here. So I hooked it up when he wasn't looking and then I put my head inside again. When he was looking again I pulled my head out of the set and sez:

"There, I'll bet the thing will work." I turned the switch and immediately the room was flooded with music. He looks at me like I was the radio congress kicking the hams off the air fer good.

"Your sure a wonder. How in the world did you do it?"

"Well," I sez thinking of Peck's theory, "the synchronating by pass condenser was fowled with the neutralizing oscillating hetrodyning frequency, and after unjoining the diaphragm it worked O.K. Now may I asked you a question? Can I—," but he had already plugged in the phones and was listening fer dx. He waved a hand at me. "Do anything you want. I have lost too much time now."

I walks out into the living room and announces that it is ok with the old man. So we qsy's to my leaping lena and dashes fer the dances.

About aussie time we return and the old man is as happy as a youngster with a new seven and a halfer. He has a list of W's as long as an unraveled filter condenser.

"Just wait until I tell the gang about this," he sez, "It sure will make 'em sit up and take notice." and he chuckles to himself in anticipation of the great time he will have.

"Sure is ok with me." I sez and bids Helen an affectionate goodbye using 88's as a standard.

On my way home I just began to wonder what CBY was so happy about. I will make him laugh up the other side of his face when I tell him about the hit I have made.

It is one month later. I have sold my tube fer twenty bucks, and my filter fer ten. Still I can't see just what the laugh of CBY's meant. Sure a funny thing. Guess it will be an unexplained mystery like the origination of static.

Oh, yes. I forgot to mention that CBY has a nice note with that new fifty of his.

# HAM-ADS

## ANNOUNCEMENT

Effective with the October, 1928, issue of QST the following changes will be made in the rules of this department. The Ham-Ad rate will be 15c per word. The restriction which has limited use of this column to members of the American Radio Relay League will be removed and advertising may be signed either by company name or by an individual. A special rate of 7c per word will apply to advertising which is obviously non-commercial in nature and which is placed and signed by an individual member of the American Radio Relay League. Please read carefully the following conditions under which advertising in these columns will be accepted.

(1) Advertising shall pertain to radio and shall be of nature of interest to radio amateurs or experimenters in their pursuit of the art.

(2) No display of any character will be accepted, nor can any special typographical arrangement, such as all or part capital letters, be used which would tend to make one advertisement stand out from the others.

(3) The Ham-Ad rate is 15c per word, except as noted in paragraph (6) below.

(4) Remittance in full must accompany copy. No cash or contract discount or agency commission, will be allowed.

(5) Closing date for Ham-Ads is the 25th of the second month preceding publication date.

(6) A special rate of 7c per word will apply to advertising which, in our judgment, is obviously non-commercial in nature and is placed and signed by a member of the American Radio Relay League. Thus, advertising of bona fide surplus equipment owned, used and for sale by an individual or apparatus offered for exchange or advertising inquiring for special equipment, if by a member of the American Radio Relay League, takes the 7c rate. An attempt to deal in apparatus in quantity for profit, even if by an individual, is commercial and takes the 15c rate. Provisions of paragraphs (1), (2), (4) and (5) apply to all advertising in this column regardless of which rate may apply.

POWER crystals tested 600 volts. New 80 meter band \$15.00, 40 meter band \$22.50. 9DRD, - Edwardsville, Kansas.

THE life blood of your set—plate power. Powerful permanent, infinitely superior to dry cells, lead-acid, Bs, B eliminators, Trouble-free, rugged, abuse proof, that's an Edison Steel-Alkaline Storage, B-battery. Upset electrically welded pure nickel connectors insure absolute quiet. Lithium-Potassium solution (that's no lye). Complete, knock-down kits, parts, chargers. Glass tubes, shock-proof jars, peppy elements, pure nickel, anything you need. No. 12 solid copper enameled permanently perfect aerial wire \$1.00, 100 ft. Silicon steel laminations for that transformer 15c lb. Details, full price list. Frank Murphy, Radio 8ML, 4837 Rockwood Rd., Cleveland, Ohio.

PURE aluminum and lead rectifier elements holes drilled brass screws and nuts, pair 1"x4" 13c, 1"x6" 15c, 1 1/2"x6" 17c, 1 1/2"x6" 19c. Sheet aluminum 1/16" \$1.00, lead \$1.00 square foot prepaid, \$1.00 or more. Silicon transformer steel cut to order .014" 10 lb. 25c, 5 lb. 30c, less than 5 lbs. 35c lb. .022" 5c less per lb. Not cut 2-7" wide 15c lb., minimum 10 lb. postage extra. Edge-wise wound copper ribbon 7 sizes see January QST. Air pocket and stand off insulators 25c each. 4 for \$1.00. Glazed porcelain 5 and 6 1/4" long prepaid on 4. Electrolytic condenser parts, \$1.50 prepaid. Geo. Schulz, Calumet, Michigan.

HAWLEY Edison element battery and parts standard for over five years. Look at our patent pending connector—no thin wire to drop off—contains 20 times more metal than regularly used. Heavy shock proof cells, fibre holders, etc. Everything for a rapid-fire "B" supply. Complete assembled 100 volt "B" \$10.00. Knock-down kits at still lower prices. Chargers that will

charge in series up to 160 volts \$2.75 to \$4.00. Trickle B Charger for 90 to 150 volt "B" \$3.75. Special transmitter "B" batteries up to 6,000 milli-amp capacity, any voltage. Write for interesting literature, testimonials, etc. B. Hawley Smith, 360 Washington Ave., Danbury, Conn.

FOR a number of years we have been supplying the highest quality apparatus to laboratories, universities, broadcast, experimental, marine and amateur stations. Building to order as well as standard items for any particular field of the art. Our long experience is your guarantee of quality. Merely state the items in which you are interested for literature covering same. Thos. Ensall, 1208 Grandview Ave., Warren, Ohio.

JEWELL Meters, new, 25% discount. We stock Hammarlund, Ward-Leonard, Acme, Thordarson, Pyrex, National, Cardwell, Baldwin, CeCo, Yaxley, Signal, Bakelite, Samson, Raytheon, RCA, Browning-Drake, Fleron, Ferranti, REL, Aero, Eby, Victoreon, Silver-Marshall, Tyrman, Tobe, Shield Grid Tubes, Carter, Bodine, Clarostats, Air Chrome Speakers, Exponential Horns, Abox, Kingston, Marco, Ham Call Books, Keys, Relays, Buzzers, Exide, Philco, Westinghouse, Fritts, Newcombe-Hawley. Many other lines of Ham and BCL apparatus. Tell us what you want. Discounts to Hams, dealers and custom set builders only. Roy C. Stage, Montgomery & Burt Sts., Syracuse, N. Y.

OMNIGRAPHS, teleplexes, condensers, crystals, transmitters, 50 watters, supersynses, S tubes, Vibroplexes, electric and portable receivers. Phone transmitters, motor generators, receivers chokes. Bought, sold, exchanged. L. J. Ryan, 9CNS, Hannibal, Mo.

FOR sale—complete station receiver DET and 2 step transmitter TP TG 15 watt panel mounted with meters, etc., \$100.00. 9JG, 3681 Rutger Street, St. Louis, Missouri.

SALE only—Grebe 18, new condition, fifty dollars. George H. Smith, Charleroi, Penn. 8ANC.

SELL or trade: Western Electric portable navy telephone transmitter and three tube receiver complete, \$40.00. RCA transmitter model ET-3619 Kenotron power unit model ET-3620 complete, \$60.00. Rectifier tubes, meters, coils, microphones. Real bargains. Write for bargain list. VE2AC, Box 221, Thetford Mines, Quebec, Canada.

LARGE 22½ volt Rayovac batteries, 89c. RCA 50 watters, original cartons, \$12.00, REL 50 watt sockets, \$1.50, 6 months guaranteed new 210s also 281s each \$4.50, 6 months guaranteed 201As and 199s 79c. Readrite 2 meter tube checker, \$3.00, Resistometers 49c. RCA 535 rheostats 29c. other rheostats all sizes, 15c, Willard storage B batteries \$1.95, Kodak silent 2½ amp. homecharger \$4.75. Bradley switches 29c. Federal transformers \$1.19, pure aluminum 1/16" thick, sq. ft. 30c, Electrad 5000 ohms, grid leak 50c, rubber panels 1c sq. inch Bakelite panels 2c sq. inch, Amateur Call Books 85c. Westinghouse four volt socket power \$6.25, six volt \$7.50, Brandes phones \$2.50. Free list, everything for hams. D.L. Marks, 125 Madison Ave., Albany, N. Y.

LOOK—9EYT selling out. Write for list! UX852 never used, \$27.50. Set Aero coils, \$6.00. 12 Jewell meters cheap. Complete transmitter and receiver, \$20.00. 9EYT Lincoln, Illinois.

QSL hams: Stock up in neat and reasonable cards now. Samples on request. Radio INQ, 206 Metropolitan Ave., Roslindale, Mass.

SELL—3 Coto-coil condensers: one each 23 plate, 17 plate, 33 plate; marble base key, 10 amp.; home-made relay, large single contacts: 2 WE VT2; 3 WE VT1s; Cootie key; Hammarlund SLF; 5 plate, 23 plate; Cardwell 43 plate; Baldwin type G. Make offer. M. B. Seyffert, Phoebus, Virginia.

SELL—new 203 (50 watter) \$15.00. Slightly used 203A, \$15.00. Both tubes guaranteed in good shape. L. B. Hallman, Jr., 608 S. Oates St., Dothan, Ala.

HAMS: Get ready for winter DX. Order your QSL cards now, with new intermediate. Satisfied hams everywhere. Highest quality work. Prompt service. If you need cards send stamp for samples and prices. 8CUX, Millington, Michigan.

FOR sale: the new 15 dial Omnigraph, with 32 dials, cost \$41. First best offer takes it. Prepaid. Write 8DII, 34 Howard Ave., Binghamton, N. Y.

FOR sale, No. 117 Jewell Service Test Set, complete with batteries. Cost \$90.00. Sell for \$55.00. Will service all kinds of sets and tubes. L. W. Van Slyck, Ironwood, Michigan.

FOR sale—Jewell No. 34 0-15 volt AC \$3.00; Jewell No. 33 0-300 mills d.c. \$3.00; Weston No. 301 0-800 mills d.c. \$3.50; 2 Jewells No. 64 0-8 amps TC \$4.00 each; Jewell

No. 53 0-8 volts d.c. \$2.50; General Radio hot-wire 0-7 amps. \$1.50. Also four Xtals SRS at different frequencies in 160 meter band at \$7.00 each. R. A. Donnelly, 2CPD, Brielle, N. J.

QRH? Will your wavemeter do next year? Does it cover the ten meter band? We'll rebuild it to meet the new requirements. We calibrate amateur wavemeters to an accuracy of one fourth of one per-cent. Two bucks for any band, three bands five bucks. All calibrations from standard frequency crystal oscillators. All work guaranteed. Higher degree of accuracy if desired. We build precision laboratory wavemeters and oscillators. Write for dope. Something new, center-tap kit for filament transformers. Ask us. QRX We can save you money on all standard radio apparatus. Write for prices. 9BVC, Lutesville, Mo.

SOMETHING for your notebook! Complete diagram and three page explanation RCA 200 watt, 500 cycle, ACW transmitter. See July hamad-price fifty cents. C. O. Slyfield, 8LA, Frankfort, Michigan.

WANTED—power filter and rectifier supply for 250 watt tube. C. J. McDonald, Dresser Junction, Wis.

Hams: Get our samples and prices on printed call cards made to order as you want them. 9APY Hinds, 19 S. Wells St., Chicago, Ill.

FOR sale or trade. Delco light plant 10 amp, 32 volts no batteries, in A1 condition. Worth \$65. Want 1000 MG set. Will pay difference. 6ARV, Earle L. Mallette, Box 269, Saratoga, Calif.

NEON tubes—General Electric type G10, \$1.00 each. Add postage. Radio 9AUB, 1231 South Meridian St., Indianapolis, Ind.

SELL low power xmitter, power supply and receiver. Cardwell, Aero, Thordarson, etc., parts. Fine for beginner. Almost new at less than half cost. 6CKS, Hurley, 1180 Mullen Ave., Los Angeles, Calif.

TRADE Conn. C melody saxophone and case for REL apparatus or GR type 358 wavemeter, Weston or Jewell meters, or what have you? C. E. Peterson, 2719 Price Ave., Cincinnati, Ohio.

SELL—Acme 150 watt filament transformer, \$7.50. 11V, 66 Vine St., Bridgeport, Conn.

CHOKES, 30H 100 M.A. \$2.00. 30H adjustable 160 M.A. \$6.00. 250 M.A. \$7.50. Transformers, 500 to 1000 each, side midtap, 250 watt \$8.00. 325-325-7½-7½ \$5.50. 275-275-5 \$4.00. Complete new lists and specifications ready. M. Leitch, Park Drive, West Orange, N. J.

AERO coils, REL transformers, grid leaks, chokes, xmitting tubes, and other items. New and of standard makes, priced low. Write for list. H. A. Carr, 1114 Monroe St., Vicksburg, Miss.

WANTED, 24-1500 or 32-500 volt dynamotor. 9CZL, Wisner, Neb.

QSL cards, 100 two colors, 85c. New enlarged line. Cartoons, radiograms, stationery, etc. H. M. Selden, Cranestville, Penn.

CURTIS says its DX time now! Thordarson mounted transformers: 550-volts each side, two 7½-volt filaments, each \$20.00; Thordarson 350-550 power transformer \$16.00; 1000-1500 power transformer \$22.00. Special Thordarson 650-volt power-filament transformers for 7½-watters \$6.90. Aluminum square foot 85c. Lead square foot 85c. Potter 2-Mfd tested 1000-volt condensers \$2.19. "Ham-List" 4c. James Radio Curtis, 5-A-Q-C, 1109 Eighth Avenue, Fort Worth, Texas.

HEADQUARTERS for hams:—Mueller 150-watt input tubes \$15.00, Aerovox 1,000-volt 1-mfd condensers \$1.29. New complete 7½-watt transmitters: tube, transformer, rectifier, key, etc., 20-40 meters \$40.00. Receivers 20-40 meters and one-step \$17.50. Potter 2000-volt tested 1-mfd Condensers \$2.50; 3500-volt 1-mfd condensers \$3.25. Amateur Callbooks \$1.00. "Ham-List" 4c. Robert Curtis, 1109 Eighth Avenue, Fort Worth, Texas.

COMPLETE 50-watt short wave transmitter with power supply, tube rectifier, wave meter and specially built receiver. This is a first class, complete, powerful transmitting and receiving station for which I have no further use because of business interests. Parts are finest obtainable, consisting of Acme, Thordarson, National, General Radio, Weston, RCA, etc., and cost over \$400. Will sell everything complete for \$150 cash and guarantee purchaser first class condition. List of parts on request. K. N. Ford, Apt. 3-J, 7010 Continental Ave., Forest Hills, Long Island, N. Y.

WESTINGHOUSE radio frequency ammeter. Type Cay. Range 0-10 amperes with protective shunt. Switchboard

mounted for the Federal Telegraph Company. Complete \$10. Saul Schiller, 1534 48th Street, Brooklyn, N. Y.

WANTED: Surplus parts laying around your shack for cash. State catalog numbers and condition. Write me for used parts bargains. Big stock and quick service. Radio 8LO, Toledo, Ohio.

QSL cards, two color \$1.00 per 100, Government \$1.90. Radiograms blanks, stationery. Write for other prices and samples. 9CKA, Corwith, Iowa.

SELL—eight tube Ultradyne with cabinet \$40.00. Also BT short wave coils \$8.75. Everything excellent condition. 9FPH, Brook, Indiana.

2500 Volt 1000 Watt Motorgenerator 110-220 Volt, AC drive \$225.00. 1500 Volt 750 Watt Motorgenerator 3-phase drive \$125.00. 1000 Volt 200 Watt Motorgenerator, 110 Volt AC drive \$75.00. 1000 Volt, 450 Watt with 10 Volt filament supply, 32 Volt drive \$150.00. 750 Volt 200 Watt motorgenerator 110 Volt AC drive \$45.00; 300 Watt \$65.00. 400 Volt generators \$8.50. Couplings \$1.75.  $\frac{1}{2}$  Hp. 1750 speed repulsion induction motors \$27.50;  $\frac{1}{4}$  Hp. \$7.50.  $\frac{1}{2}$  Hp. 8450 speed motors \$8.50.  $\frac{1}{4}$  Hp. direct current motors \$6.50. Transformers 110-2200 Volt \$12.50. Also larger motors and generators. James Smat, 1734 Grand Ave., Chicago, Illinois.

WANT good dynamotor, resistance amplifier and five to eight hundred volt generator. E. V. Casey, 712, Casey, Washington.

WANTED: 50, 75, 250 watt tubes, state condition and price. Also any other apparatus new or used. Will buy for cash all surplus or obsolete stock. Will exchange or trade apparatus. What do you need? Warren Waterman, 125 Madison Avenue, Albany, New York.

MOTORS for television experimenters, 100 volt universal with rheostat. Variable speed from 500 to 5000 revolutions. \$7.50 prepaid. Remittance with order. Samara, 41 South St., New York City.

TUBES X216B, \$2.00. X281, \$4.00. Combination power-filament transformers, \$15.00 up. New. Write for list. Mac, Box 21, Seaford, N. Y.

National (6EX) Rectobulbs rectify 3000 volts at 250 ma \$15.00, fifty watt \$20.00, tubes repaired. New RCA 852 tubes \$31.00. Extra large 82.2-85.7 crystals guaranteed for 600 volts \$17.50. Heavy 99.6% pure Alcoa aluminum 70c sq. ft. TB-1 GE neontrons handle 700 volts at 100 ma 95c (these have standard base and are new). 25% off to you on Rusco I. F. trans. and bandpass filters, Signal keys, Leuch relays, Jewell meters, Ward Leonard Leaks, Thordarson trans., and chokes, 35% off on Flechtheim filter condensers and Tube apparatus. Write for prices on anything you need. I will save you money and give you service. R. E. Henry, 9ARA, Butler, Mo.

GENUINE RCA tubes; UX200s, 65c, UX213s, \$2.50, UX216Bs, \$4.25. Bradleystats, 90c, E210s, \$1.50. RCA rheostats; PR53s, 75c, PR539, 50c. Crosley pups \$3.90. VT14s, \$1.50. TB1 rectifiers, \$1.30. Chokes: 50 Henry, 85 milliamperes, \$1.75, 80 Henry, 50 milliamperes, \$1.50. Mesco keys, \$1.00. X250s, \$7.00. 9ASV, Route B, Box 410, Joplin, Mo.

POSTPAID and guaranteed brand new. Readrite panel mounting flush type milliammeters, 0-300 and 0-400 Mils. Either type, \$1.25. Readrite 0-15 A.C. voltmeters, panel mounting, flush type, \$3.00. R.E.L. 2000 volt working voltage filter condensers, 1 Mfd., \$3.10; 2 Mfd., \$5.50. Sangamo .002 Mfd. 5000 volt tested condensers, \$2.00. General Electric 6000 ohm Heavy Duty Grid-leaks, \$1.25. Other prices on request. G. F. Hall, 535 West Horter St., Philadelphia, Pa.

PRECISION short wave 1AVU-built apparatus, transmitters, receivers, power-units, oscillators, wavemeters, etc. New precision Amateur wavemeter \$9.50 complete 10-100 meters. New 1AVU Silver DX Phantom receiver using UX-222, UX-210, and UX-201 for super DX work completely shielded. Precision apparatus built to order,  $\frac{1}{2}$  to 5 meter transmitters a specialty. Guaranteed products. 1AVU, H. O. Barschdorf, 171 No. Sumner St., Adams, Mass.

WANTED: 6V input dynamotor for 7 watt. Sell; transmitter supply unit, receiver, wavemeter, key. 8BJO, Dundee, N. Y.

HAVE sold 66 transformers made by G. E. Carry 1000W, 1100-2200-4400v. each side center tap. Guaranteed. Few left, \$12, P. O. B. Detroit. "Ask the Ham who has one." P. G. Dawson, 5740 Woodrow, Detroit, Michigan.

## Q R A SECTION

50c straight with copy in following address form only:

1BML—Curtis G. Docherty, 196 Congress Ave., Providence, R. I.

2BUO—Werner H. Olpe, 14 Brooklyn Ave., Jamaica, L. I., N. Y.

SDWX—Charles Rose, R. F. D. No. 6, Naples, N. Y.

spCB1—Carlos A. Braschi, P. O. Box 8, Lima, Peru.

The following stations belong to members of the A.R.R.L. Headquarters gang. Mail for them should be addressed care A.R.R.L., Hartford, Conn. When operating 1MK they use personal sines as indicated.

1MK	1BMM-FL G. D. Meserve
A.R.R.L. Headquarters	"dm"
R.B. Parmenter, Chief	1CEI-ISZ J. J. Lamb "jim"
Op "rp"	18UD A. L. Budlong "bud"
L. E. Huber "ou"	1ES A. A. Hebert "ah"
1AL H. P. Westman "ws"	1KP F. C. Beekley "beek"
1BHW K. B. Warner "kb"	1SZ C. C. Rodimon "rod"
1WBDI F. E. Handy "fh"	1PX C. G. Keneffick "ck"

## LESSEN STATIC TUNE MORE SHARPLY

Bring your set up to maximum sharpness with X-L Vario Densers

Practically all of the popular high grade circuits now use X-L products. Endorsed by leading radio engineers, designers and builders and used by members of the league everywhere. Broad and positive capacity range that assures exact oscillation control easily obtained with both Model "N" and Model "G" Vario Densers. Genuine Bakelite casing, dust and moisture proof. All metal parts phosphor bronze nickel plated. Only the best imported India latex used. Extreme micrometer capacity advance, exceptional accessibility in close quarters.



MODEL "N" VARIO DENSER

Model "N" has variable capacity adjustable from 1.8 to 20 micro-microfarads. Price each \$1.00. Model "G" with grid clips made in three variable capacity ranges, viz—Model G-1 .0002 to .0003 Mfd. Model G-2 .0003 to .0005 Mfd. Model G-10 .0003 to .001 Mfd. Price each \$1.50.

**New Bakelite Insulated X-L Push Post**  
The most perfect binding post made. Push down with thumb, insert wire, remove pressure, wire is held firmly. Plain in all standard makings. Also made in all metal design. Price each 15c. Strip of 7 on black panel with white markings, price \$1.50.



X-L PUSH POST

Write for free copy of new book of wiring diagrams showing use of X-L units in all leading circuits.

**X-L RADIO LABORATORIES,**  
Dept. D, 1224 Belmont Ave., Chicago, Illinois

THE BEST \$1 YOU EVER SPENT!

Ham—  
Have u ordered ur copy of  
Handy's  
Handy  
Handbook?

PUBLISHED BY  
AMERICAN RADIO RELAY LEAGUE  
1711 PARK ST. HARTFORD, CONN.

## Genuine Bakelite Panels

3/16" Thick, Color Black

38x43" reg. price \$29.00, Special at \$8.75 per panel

American Sales Co., 19-21 Warren St., N. Y. City



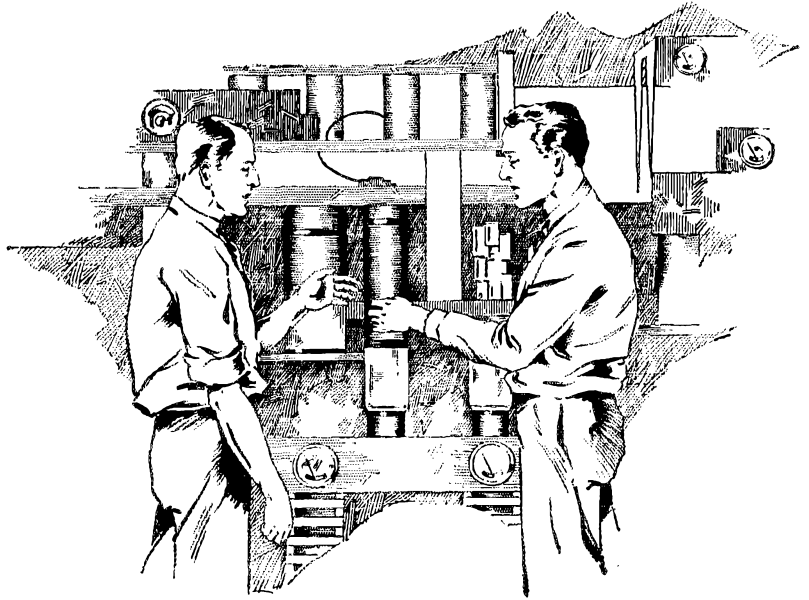

# In the Modern Broadcasting Station

In amateur transmitting and receiving sets as well as in quality radio receivers for home use, Faradon Capacitors play a very definite part in maintaining satisfactory service, meriting its widespread utilization.

More than twenty years of the application of electrical engineering skill combined with highest quality materials have made Faradon Capacitors the standard of electrostatic condenser long life and reliability.

Our engineers stand ready to cooperate on special equipment which cannot be taken care of by the more than 200 types of Faradon Capacitors ready for prompt delivery.

**WIRELESS SPECIALTY APPARATUS CO.**  
JAMAICA PLAIN BOSTON, MASS., U.S.A.

*Established 1907*

# *Faradon*

---

*Electrostatic Condensers for All Purposes*

---



*In the studio of station W E A F, New York, from which some of the most delightful programs are broadcast.*

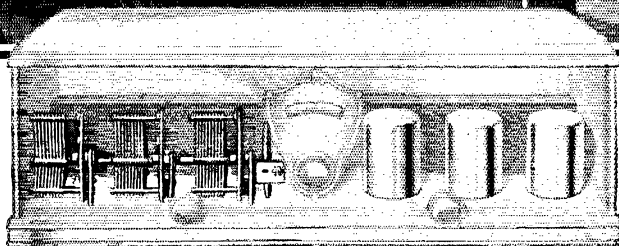

*Clearer reception, finer tuning, reduced interference with aluminum equipped receiving sets.*

## Reception as Fine as the Broadcast

**E**VERY DAY millions of families throughout the world are listening to delightful broadcast programs with a keener enjoyment because their radio sets are "Aluminum equipped."

Reception is made clearer, tuning made finer, interference reduced to the minimum by designers who have found that this wonderful metal meets the varied needs of radio so admirably.

Aluminum is the ideal radio metal because it combines high electrical conductivity, permanence, beauty and extreme lightness.

Leading radio manufacturers recognize its superiority. So, in many receiv-

ing sets you find aluminum shielding, aluminum condenser blades and frames, aluminum foil fixed condensers, chasses, sub-panels and cabinets.

When you see an aluminum equipped set you will know that its manufacturer has done everything he can to bring the true enjoyment of radio to you—to give you reception as fine as the broadcast.

Look for aluminum in the set you buy—if you build a set, by all means, use aluminum. We will be glad to send on request a copy of the booklet, "Aluminum For Radio," which explains in detail the many and varied radio uses to which this modern metal is adapted.

**ALUMINUM COMPANY OF AMERICA**  
ALUMINUM IN EVERY COMMERCIAL FORM

2439 Oliver Building  
Pittsburgh, Pa.



Offices in 19 Principal  
American Cities

# ALUMINUM

*The mark of Quality in Radio*

# Now a Perfected SHORT WAVE RECEIVER

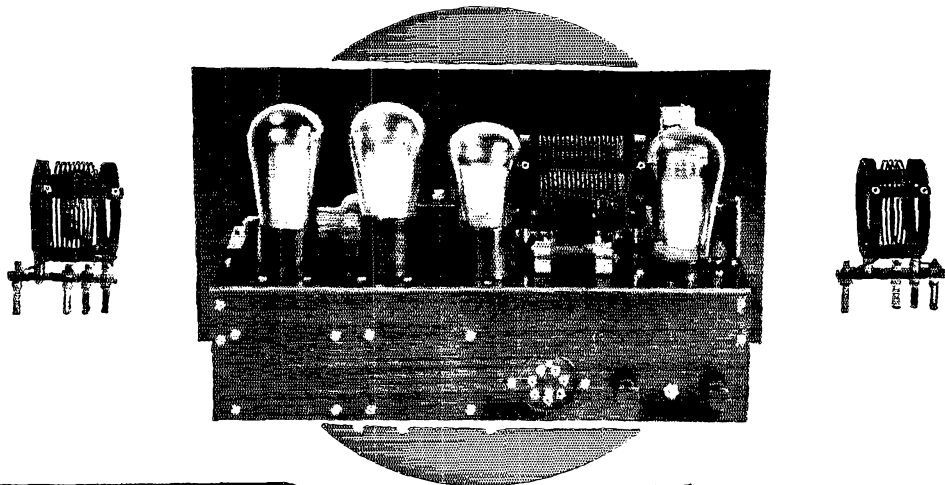

## The AERO INTERNATIONAL

Here is a receiver designed to work the greatest possible distance with the least possible tuning troubles, and which can be built for the most reasonable price compatible with the use of the finest parts throughout. No expensive and troublesome shielding is required, and only one coil need be replaced to QSY between bands.

Sensitivity has been increased, control has been made far easier and receiver noises have been reduced to a minimum. Newly designed parts have been incorporated throughout, including Aero Coils of a smaller diameter, having a much smaller external field, a better shape factor and improved efficiency. The tuning condenser has no metal-to-metal bearing to cause noises and the isolation of the antenna from the tuned stage means that swiveling of the antenna will have no effect on tuning.

### Order the Complete Kit

You can easily assemble the Aero International. All parts are supplied in one Kit, and the foundation unit comes with holes already drilled, assuring ease of construction and proper placement of all parts. Ask your dealer for the Aero Complete Kit No. 8. If he can't supply you, write direct to us, giving dealers name. The price of this Kit is \$55.30.

# AERO PRODUCTS

INCORPORATED

Dept. 368

4611 Ravenswood Ave.

Chicago, Ill.

### AERO COIL KITS

#### THE L. W. T. 10 KIT



If you wish to purchase only the Aero Coils for the Aero International, order the L. W. T. 10 Kit. The price is \$16.99. These coils are designed to be used with our foundation unit.

#### THE L. W. T. 11 KIT

If you prefer to furnish your own foundation unit for the Aero International, order the L. W. T. 11 Kit. The coils are the same as in the L. W. T. 10 Kit, but a mounting strip is provided. The price is \$11.56.



#### THE L. W. T. 12 KIT

Here are the newest Aero Coils. They are small in diameter, provide a much smaller external field, a better shape factor and improved efficiency. The Kit consists of three Aero Interchangeable coils and base mounting with Primary Coil. Price \$12.50.

# *Again* **BURGESS** *Contributes*

**Type PL 5728 High Potential  
Battery [108 volts, taps at 72  
and 108 volts]**

In keeping with its policy of assisting in the experimental development of the art of radio, Burgess Battery Company contributes a high potential battery particularly necessary for the successful operation of the receiver used in radiovision, television, and other methods of reception where there is the transference of an image, moving or stationary. In photo electric cell experiments, the PL is indispensable. Also can be used for airplane radio, plate supply.

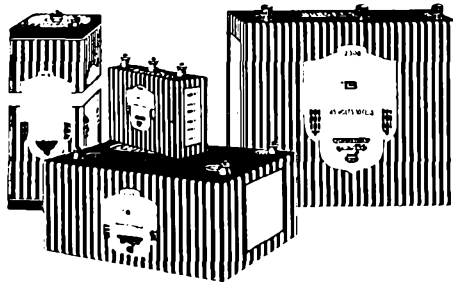
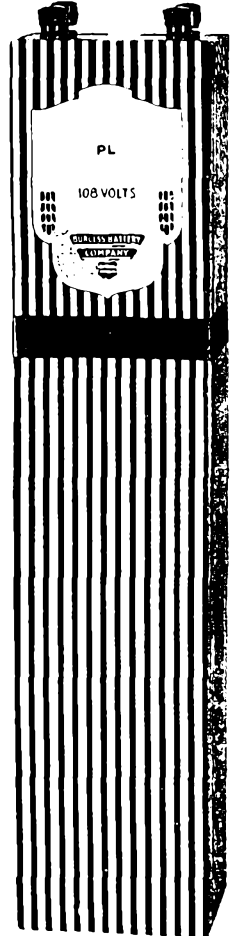
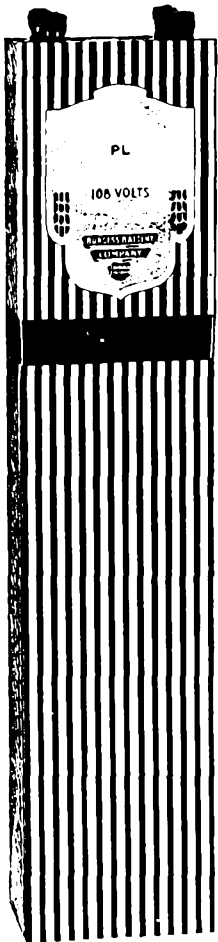

*"Ask any Radio Engineer"*

**BURGESS BATTERY COMPANY**  
**MADISON, WISCONSIN**



# The Communications Department

F. E. Handy, Communications Manager  
1711 Park St., Hartford, Conn.

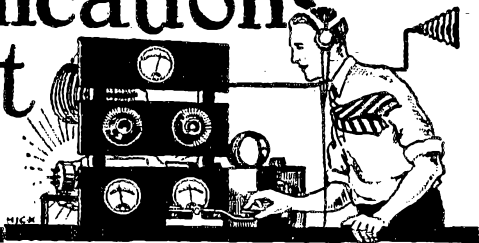

## Scandinavian-American Short-Wave Tests

**R**ADIOLYTTEREN of Copenhagen, Denmark, is sponsoring a QSO Contest which will take place between 0000 GMT Oct. 23 and 2400 GMT Oct. 30. Scandinavian amateurs (intermediates EL, EM, ED, and ES) will work between 20.8 and 21.4 meters and 43 and 47 meters. They will listen for North Americans in the 20- and 40-meter bands, and for South Americans in the 30-meter band. Prizes and certificates will be awarded by *RadioLytteren* in proportion to the number of points scored.

Each contact, to be valid, must include the sending and receiving of at least ten words. Working the same station twice will *not* give extra credit. Complete data of each QSO, including log and conversation exchanged (or messages, if any), must be mailed to A.R.R.L. headquarters (if you're on this side of the Atlantic) immediately after the test. November 10 is the closing date for receipt of reports from the U.S.; and November 30 is the closing date for reports from other American participants. A.R.R.L. will forward the reports to *RadioLytteren*.

Scandinavian contacts with Newfoundland, with Canadian first, second, and third inspection districts, and with U.S. first, second, third, fourth, and eighth inspection districts will count one point. Scandinavian contacts with Alaska, with Canadian fourth and fifth inspection districts, with U.S. fifth, sixth, seventh, and ninth inspection districts, and with Panama, Mexico and Central America will count two points. South American amateurs may claim three points each. Respective scores on the side of the Atlantic count the same in Scandinavia; that is, for example, if a Scandinavian works 6CIS, each station will get two points.

## Ten Meters

There is little to report until the results of our August tests are available. Interest in ten meter experimenting appears to be taking on more of an international character.

Phelps of 2EB has been reported a consistent R5 and R6 at 4LD (Sewanee, Tenn.—750 miles) and 1AQD (Livermore Falls, Maine—320 miles) being heard all day long on 10-meters even when 20-meter conditions were very poor. Many reports on 2EB have also come from Texas and all these reports seem to indicate that ten meters is not necessarily a trans-continental wave only.

Rus Sackers of 8DED heard 6DHS calling "CQ ten" on July first. Five minutes work got the 20-meter transmitter perking on ten meters and in less than a half hour a two-way 10-meter QSO was effected. 6DHS came in splendidly (better than on '20') and was worked several times during the afternoon. 8DED used a forty meter antenna on its fourth harmonic. Look for 8DED on ten meters every Sunday afternoon from one to four pm EST.

9EF (Hammond, Ind.) in addition to QSO's with 6AM, 6DHS and 6DZF has more recently worked 4JK and 9RGQ and been reported by 1BW and 1CGX. 9EF is working on a horizontal reflector and would be glad to make schedules with anyone. 9DBW will be on the air on ten meters every Sunday.

oa5HG has a receiver working on ten meters and will have the transmitter there shortly. oa2AC has a complete ten meter station and schedules with nu9EF at 1100 GCT each Sunday. If this doesn't work other

hours will be tried. ed7ZG is transmitting each Sunday 1400 to 1600 GCT on ten meters. oa4PN assures us through nu4RN and nu7AC that he is all set for ten meter tests and asks reports on his signals.

oh6CFQ and oh6DPG are running ten meter tests together and have worked across the island two-way a great number of times during July, improving the apparatus and signal strength as the tests progressed. oh6CFQ reports that "Several stations in the U.S. have been heard with good intensity. More interest is bound to develop and the next step will be two-way communication with the U.S.A. and the rest of the world on ten meters." Let's have that log of U.S. stations heard, OM.

The Victorian Section of the Wireless Institute of Australia will hold a ten meter competition from August first to December first. Stations in the Section that have announced their participation in the competition and tests are: 3WM 3CP 3KB 3KS 3GR 3VP 7CW 7CH 2BQ 3YX and 3LS. A silver cup will be presented to the amateur accomplishing the most on ten meters during the contest. Schedules of oa3CP: Tuesdays and Thursdays, 1000 to 1200 Greenwich; Fridays and Saturdays, 2400 to 0200 Greenwich, on exactly ten meters. Which 'nu' and 'oa' stations are going to be first to click for two-way work on ten meters?

The results so far attained (see last QST) indicate much ten meter success with simple modifications of existing station equipment and circuits. Summer and fall are ideal times for experimenting on ten meters because it is then that one can freely tinker with radiating systems without discomfort. Putting up a low ten-meter horizontal antenna in the open is not a hard job. Building an antenna with reflector wires for directional transmission is not as difficult as might be supposed—at least not for a ten-meter job. Constructing a framework for a ten meter reflector so that the angle as well as the line of propagation can be varied is a little harder. However, this is something that all of us in a position to do so should try if we possibly can. It is a job that can be tackled best at this season. A commercial 11-meter reflector was described in the Proceedings of the Institute of Radio Engineers for November 1927. We have a hunch that the chap who tries something of this kind will be able to break through consistently in spite of conditions that make signals from ordinary antennas pass out of the picture. All who take part in and report on our tests with whatever equipment they can muster and either positive or negative results—and especially those experimenters who run a series of well-planned tests with "different" types of antennas will be contributing substantially to the game.

## BYRD—WFA

Remember the first time amateur radio went north with MacMillan? Remember how every amateur was "on his toes" to work WNP? That was before we got down to eighty meters. It was quite an achievement to raise WNP in those days. But now the North Pole is just over the hill for us; and we're looking for more worlds to conquer. What's the answer—will we have to sit down and cry, as Alexander did? No—because Commander Richard E. Byrd is going to the South Pole!

With him will be four of our fellows, Lieut. M. P. Hanson, Lloyd V. Berkner, Howard F. Mason, and

Lloyd K. Grenlie, who will keep the outfit in touch with civilization. There will be several stations—some for planes, some for dog-sleds—one of which, operating at the base with 500 watts output, probably will be heard more than the rest. The various calls are as follows:

WFA—base  
 WFBT—supply ship *Samaon*  
 WFB—plane *Floyd Bennett*  
 WFC—Fairchild plane  
 WFD—advance base  
 WFE—advance base  
 WFF—Fokker plane  
 RPK—advance base

Nine channels below 100 meters have been assigned to the explorers: 91.3; 68.1; 53.1; 45.6; 34.06; 26.5; 22.8; 17.95; and 13.72. The fliers will use 34.06; 68.1; and 91.3 meters for communication with the base and with dog-sled parties. 600 meter sets also will be carried by the supply ship, the base, and the planes.

A crash-proof, forty pound portable transmitter and receiver will be carried in each plane. Motor-driven and perhaps wind-driven generators will go with the planes.

In our judgment, this expedition will carry with it all the interest that the first amateur radio equipped MacMillan expedition had. There is some interesting work ahead for us with the Byrd expedition.

L. R. H.



#### THE ROBERTS' CUPS

Won by nu6BJX and op1HR in consideration of their reliability in relaying traffic between the United States and the Philippine Islands. These trophies were presented by Lieut. Hadyn P. Roberts, and awarded under the auspices of A.R.R.L. for the 1927-1928 competition. Congratulations, 6BJX and 1HR. Attention is called to the fact that Lieut. Roberts has again offered two splendid trophies to be awarded in a 1928-1929 contest for amateur operators. The rules of the contest were announced on page 45 of June 1928 QST. No time is more appropriate than the present for all comers to get set at the start of the season to make a showing for the next award.

#### NITB

The Coast Guard Greenland Expedition now works with amateurs exclusively on 32 meters. A radio report from the Coast Cutter "Marion" just received through both 11C and 2WI gives credit to those stations which have assisted by schedule and general work. QRX for NITB, OM.

"NITB to ARRL Hartford Conn. (Aug. 3) Best amateurs with whom we have regular schedules are 11C at 7.30 pm EST; 2ANM at 8 pm; 2WI at 9 pm. Since leaving Halifax, we have also heard and worked the following stations: lab law 8dcc 2ab latv 1kl lart sayb 4ft 1mk. 73.—Marion Expedition."

## WSBS

The *Carnegie* of the Department of Terrestrial Magnetism has just re-established contact with the U.S.A. at this writing, working both 2AVB and 1MK on the night of July 29 from a point 300 miles east of Cape Farewell (half way between Iceland and Greenland). The expedition left Reykjavik on July 27. The TR (position report) handed 2AVB on the 29th was relayed and delivered by 3GP on the 30th. On August 3, "IJ" was again QSO 1MK and the hook was cleared both ways of a bunch of accumulated traffic. The schedules for the following days were rendered useless by local electrical storms in the U.S.A. 1ASD raised WSBS on the night of August 7 taking a good report for QST which we quote below. The *Carnegie* is now coming southward in mid-Atlantic QRD Barbados and Balboa. When you hear WSBS on 22.1, 33.2 or 45.6 meters give "LJ" a call and help with the traffic OM. Your reports on WSBS signals sent via ARRL will be appreciated, too.

From WSBS.

"Since my message of June 8, have visited Plymouth, England; Hamburg, Germany, and Reykjavik, Iceland. I was in London three days and dropped in on the R.S.G.B. office. Unable meet active hams in Hamburg as most are operating under cover. I found but one active station in Reykjavik, and this operator was away for the summer. Saw very nice commercial and broadcast layout there though. We are now off Grand Banks, Newfoundland and expect to arrive Barbados September 14. Had a good time and look at my first iceberg last night as we passed within 50 ft. of a big one. It was surprising to find one down here at this time of the year. From June 5 until a few days ago, we lost practically all contact with the U.S.A. NAA's was the only signal which followed us consistently and no NU hams were heard on any wavelength for two months. Contact with European stations was fairly good during that time. We put up a higher and longer antenna on July 5. Since contact with 1MK was last established, have experienced two more dead nights during both of which Aurora Borealis was observed. Have schedules with NKF, 1MK, 2AVB and ek-4AU. Other stations worked are: eg-6FB, ex-6PP, eg-6YL, ek-4YT, en-OGA and sb-11D. As we haven't time to QSO more than one or two stations per evening, we should appreciate all possible reports on our signals from hams. The work of the expedition is progressing nicely with magnetic, atmospheric, electric and oceanographic observations being made almost every day. The weather has been pretty cold most of the time although it was quite 'summery' in Reykjavik. See you next sked. 73. (sig) Larry Jones, operator, Yacht Carnegie."

## WNP

Nr. 916, July 6, via 2ARB (also copied on indoor antenna by 2KU) to A.R.R.L., Hartford, Conn.

"The last of the Arctic winter—so far as WNP was concerned—passed with the month of June. On June first, the Bowdoin "broke out" in a week only scattered pans filled the harbor and by the middle of the month, we had completely open water. Four stations handled nearly all our June messages. These were in order of messages handled, 9AFA, 2ARB, 3AKW and 3ANK. These four stations have kept daily schedules between four and six P.M. Eastern Standard Time and have been a big help to members of Rawson MacMillan Field Museum Expedition. Only one foreigner, Egyptian EGEZ was worked and very few U.S.A. stations were worked off schedule.

"When spring is in the air and the sky is blue outside, it is mighty hard to stay below decks in the hold of a little schooner pounding brass—not when there are canoes to paddle, dorys to sail, and there is plenty of blue water to sail them on.

"Message total for June was 189, the lowest I believe of any month since WNP left Wiscasset last year. Many members of expedition have been away on trips doing scientific work leaving few men here to send messages. The Bowdoin sails for home on August 20, will arrive in Sydney, Nova Scotia about September 1st and is due to dock Wiscasset, Maine on September 8.

"Following is a list of stations worked during June: 1 20 meters: 1azx 1ber 1sz 2acn 2ag 2arb 2bvg 2gp 2mu 2nj 2ol 2yi 2vk 3adm 3akw 3ank 3atq 3acn 3adg 3ahc 3azg 3btr 3eel 3ear 3eyd 3adn 3afa 3auu

9bqy 9bqy 9bqy 9bdc 9eah 9efk 9efv 9ejo 9fbw 9fhy 9if 9pu fe-egz. 40 meters: 3arc 8ccs stop. Best regards to all—Himoe.”

Nr. 1021, August 2, via 2BME to A.R.R.L., Hartford, Conn.

“Traffic running smoothly via sked with 2ARB, 3AKW and 9AFA stop 9AFA completed one year of good QSO on July 22nd. He is the only station who has worked us consistently throughout the year. The Bowdoin is being repaired for her homeward voyage. We will sail in three weeks.

“Message total for July was 237. Following stations worked during July, all on 20 meters: 1alb laze 1byz 1ay 1sz 1sl 2aer 2aio 2arb 2atr 2auo 2bkh 2com 2fu 2rr 2vi 3akw 3ank 3atq 3bjm 3chk 3sr 3qv 5ain 6dch 8ayo 8bfc 8hnl 8hop 8cfr 8ejm 8enh 8evg 8dlld 8dme 8dtn 8jg 8rd 9adn 9afa 9bcb 9bnx 9cvb 9ena 9gv ve4bt ve4gq stop Regards. Himoe.”

## About Disqualification

ICMP has been disqualified as a prize-winner in the International Relay Contest. Evidence received from several sources against him as an off-wave offender, after copy had been turned in, proved conclusively that he had no right to receive prizes. 40C is thus entitled to some of the good things donated by the manufacturers.

### TRAFFIC BRIEFS

Participants in the International Tests were protected against the likelihood of possible error by observers and from any protests made on the grounds of individual dislike or personal interest. The Award Committee established a rule that no disqualification would be made on a single complaint of off-wave operation.

The observers were mainly disinterested parties residing in the United States although some information received from participants in this and foreign countries proved of value in disclosing additional evidence. In weighing evidence, the source was given careful consideration before claims were allowed. It is interesting to note that there were complaints against a number of participants several times as large as the list of those actually disqualified which appeared in August QST. The marker stations NAA and WIZ were helpful to observers and participants alike.

We have it indirectly that IIC used crystal control during the International Tests. This makes it hard to understand the mass of evidence received from points all over the country resulting in his disqualification for off-wave work. ICMP also disqualified, claims to have used an “xtal” rig and suggests that “harmonics” may be blamed for some of the reports against him.

Though it is hard for us to find adequate explanation in this single word, it appears that the best of sets can misbehave. Recent complaints by amateurs against energy radiation from a high power commercial station QRMing several parts of our 3500-4000 kc. band in the east at the same time it worked on its regular frequency—also the points made in a letter appearing on page 64 of August QST—lead us to wonder if some of these transmitters were not operating simultaneously on two frequencies. This has been proved possible and perhaps practical in an I.R.E. paper.

Then again we can consider the possibility of re-radiation of energy on a new frequency from some point near the transmitting station, perhaps a rather remote possibility. Also it is a fact that some crystals can be made to oscillate at two different frequencies under certain conditions. If a crystal is near the edge of an amateur band then the change of frequency due to temperature changes in the crystal becomes important. On excellent authority we have it that this frequency variation is approximately one thousandth of one percent for each three tenths of a degree Centigrade (which is 250 cycles per degree C. at 7500 kc. and becomes kilocycles when the crystal gets nice and hot).

Independent reports from many unprejudiced and reliable observers leave no room for doubt in the justice of the disqualifications of the Award Committee. Very possibly some well meaning amateurs (due to carelessness in checking waves and a strong intention of operating exactly on the edge of the band) suffered the penalty with those guilty of purposely working off-wave. It is impossible to dis-

criminate between these. Both classes of operators hurt amateur radio. If any of the considerations in the paragraphs above can be considered an explanation of off-wave work, it seems to us that a monitor box and an accurate wavemeter in every amateur station is the answer.

—F. E. H.

### BRASS POUNDERS' LEAGUE

Call	Orig.	Del.	Rel.	Total
op1HR	186	102	472	760
6KV	384	159	...	543
6ALX	128	229	150	507
9EZ	220	220	10	450
3ZF	61	48	324	433
1MK	98	110	208	406
9PU	17	27	310	354
6AMM	72	201	22	295
op1DR	93	145	20	258
2BME	6	8	238	252
oh6CFQ	145	88	12	245
SHJ	31	191	14	236
na7HL	19	20	195	234
6BWS	18	1	212	231
7AM	63	65	80	208
na7JR	46	55	105	206
na7AER	51	55	70	176
6BTZ	53	57	11	121
6ADH	52	59	...	111
na7ABE	33	57	18	108
na7LY	67	61	22	105
1BIG	15	50	35	100
9AFA	44	55	...	99
6CZR	20	73	...	93
9BSS	27	52	4	83
6ZX	...	55	10	65

Omitted last month:

3ZF 63, 42, 127, 230. 6ADH 82, 2, 166.

Again op1HR leads! Special credit should be given the following stations responsible for over 100 deliveries in the message month: 6ALX, 9EZ, 6AMM, SHJ, 6KV, op1DR, 1MK, op1HR. Deliveries count! All stations appearing in the Brass Pounders' League are noted for their consistent schedule-keeping and reliable message-handling work in amateur radio.

A total of 200 or more bona fide messages handled and counted in accordance with A.R.R.L. practice or just 50 or more deliveries will put you in line for a place in the B.P.L. Why not make more schedules with the reliable stations you hear and take steps to handle the traffic that will qualify you for B.P.L. membership also.

### TRAFFIC BRIEFS

Alaskan traffic seems to go best through 6DFW, 6FA, or 6CLZ.

OZ2AG furnished the New Zealand press with dope on the *Southern Cross* during its flight over the Pacific.

VE2BE and OZ2ME handled messages of congratulation and regret respectively to Tunney and Heeney during the recent pugilistic encounter.

1AOF and 40C relayed a message from an African missionary to his wife at Cape Cod, Mass. fqPM was the African station. 2KR stood by to aid in case he was needed.

The “Twentieth Century Limited” route from New York City to Chicago has been greeted with approbation from all quarters. We have heard some talk of someone extending the line to the west coast. That will be a good job for the coming season. Whoever does it will surely deserve some credit, as there are fewer stations and longer distances along the way. Who will be the “western 3ZF”?

na7AD in Big Port Walter, Alaska, keeps us well supplied with news of that territory. He says that there are lots of hams up there at the various commercial stations. Ex-7BB is just two miles from 7AD through rock (and eight miles the usual way).

VGFO is the call for the short wave apparatus of the S.S. *Beothic* of the Canadian Government Arctic Expedition. Ross Smythe of VE2AQ is the operator. The outfit will be QRV amateur contact and virtually will depend upon the gang in emergencies.

Fermenting grain in the hold of a helpless ship nearly asphyxiated twenty men who were effecting salvage near the Philippine Islands. opIDR was on deck (literally and figuratively) and got medical instruction via amateur radio from a source 300 miles distant. All hands saved!!

Don Mix's airplane flight has suffered all the delays that are common to flights these days, and is now in fair prospect of leaving. The call will be KHAS, with crystal controlled signals on 20.26, 39.4, 40.52, 34.07, 68.14, and 76.8 meters. For other details see article on page 47 of July QST.

After a bum take-off which partly wrecked it, the Rockford-to-Stockholm plane is being rebuilt to start again. Call letters are KHAH; and the signals should come through on approximately 33 meters.

### 160 METERS

Mimeographed material for beginners who want to get started right on the 160 meter band has been prepared and will be sent to anyone requesting it. A list of volunteers, with their schedules of transmission, appears in the bulletin, telling just when and for whom to listen when you want code practice. In this issue of QST a special article, *The Traffic Tuner for 1929*, has been written purposely for the beginner. Get the joy of creating your own apparatus by building one of these!!

More volunteers are needed for the code practice transmissions. If you can keep one or two schedules reliably every week, we'll be more than glad to set you down in supplements to the 160 Meter Bulletin as one of the volunteers.

### THE U. S. NAVAL COMMUNICATION RESERVE IN FLORIDA

BY WM. JUSTICE LEE

CAPTAIN C. D. Stearns, U.S.N., then Commandant of the Seventh Naval District, began the organization of the Volunteer Communica-



tion Reserve in his district in February 1925. A Lieutenant in the Reserve was designated to take charge of this work. But one officer and two or three enlisted men were in this district in the Communication Reserve at that time. Slowly but steadily enrollment and appointments were made. By December 1927, the personnel had increased to 84 officers and men of whom 16 are Communication officers. The officer personnel also includes 3 medical officers and 2 supply corps officers whose principal work is in connection with Communication Reserve activities. All service is performed without pay.

Since its inception, the Communication Reserve has enrolled among its members, the owners and operators of 24 amateur radio transmitting and receiving stations located in the largest Florida cities and in many smaller cities. The Navy Department, through cooperation of the Department of Commerce, has assigned two stations of the Reserve radio personnel, navy call letters—NRRG-4XE at Orlando—NRRQ-4EZ at Jacksonville. The Headquarters of the 7th District Reserve are at Orlando, Fla., where 36 Communication Reservists are enrolled. The Navy Department has furnished uniforms to such Reservists as are located adjacent to a Unit Headquarters. Units have been enlisted at Orlando, Jacksonville, Ft. Myers,

and Tampa. Each unit has a commanding officer and a medical officer and reports by radio each Thursday night to the Master Control station in Orlando.

During the Miami hurricane (September 1926) Gifford Grange, 4HZ, Radioman USNR, of Jacksonville established the first direct communication with the stricken city, and handled messages through his amateur station calling for the assistance of the National Guard of Florida and the Red Cross. Radiograms from Naval District Headquarters at Key West are often handled for delivery to Reservists in Jacksonville, Tampa and other points. NRRG (Orlando) usually works NAR (Key West) three to five times a week and recently assisted in establishing contact between NAR and a Navy vessel at sea.

On Armistice Day, 11 November, 1927, the Orlando Unit of the Communication Reserve participated in the memorial parade, and its members turned out 100 per cent strong for the occasion. His Excellency John Martin, Governor of Florida was escorted by members of the Naval Reserve and Company K of the Florida National Guard.

The purpose of the Volunteer Communication Reserve is to enroll and train radio and telegraph operators in Navy methods and procedure. Commercial and amateur operators are enrolled, if found qualified. They receive news bulletins and written courses of instruction and are afforded an opportunity to become acquainted with expert radiomen in all parts of the United States. Each year a selected number of men have been afforded the opportunity of shore radio station duty with full pay for two weeks, and in some especially desirable instances, radiomen have been sent on summer cruises on board U. S. Navy Destroyers, where they have been assigned to stand radio watches at sea. Communication Reservists in addition to being trained in Navy Radio procedure, are also instructed to some extent in the Manual of Arms and infantry drill.

During the past two years, Captain Robert W. McNeely, USN, has been Commandant of the Seventh Naval District. His interest and cooperation at all times, has made possible the continued progress of the Volunteer Communication Reserve. This branch of the Seventh District Reserve is under the command of Lieutenant Commander Wm. Justice Lee, USNR, who has had charge of it since its inception in February 1925. He was originally qualified for aviation duty, general service, but transferred to Communication duty at his own request, on account of his interest in the Communication Reserve work.

Officers and men (in photo) of U.S. Naval Communication Reserve, Orlando, Fla. Armistice Day, Nov. 11, 1927. Note the following amateurs in uniform: 4BE, 4UA, 4ACR, 4WR, 4XE, 4ACR, 4ADB, 4TJ, and 4NU.

### TRAFFIC BRIEFS

SDME, of the Western New York Army-Armature Net, reports that SAFG, SAHK, SBEF, 8CVJ, SAHC and himself, all members of that net, have been handling messages by the hundreds for residents in that section of the country, the Finger Lakes region. The most noteworthy part of his letter states that all messages must contain substantial material that takes some thought to prepare, and is of interest to amateurs thru whose hands it passes. In other words, no rubber stamps are used.



MILLY AMPS AND MIKE ROW FARAD  
THE HAPPY THERMO COUPLE

8DMS and 1WV use 3"x5" cards to keep data on stations worked. These cards are filed in a little box under district numbers. Whenever the dope is wanted on dial settings, QRH, etc., it's all there and takes just a moment to find.

9APY sez that 9HW sez that there are two Costa Rican amateurs who QSO in nl but Espagnol. Good chance to brush up on your Spanish, OM. They are nr2AGS and nr2EA, both just above nnINIC. They are supposed to be on the air every night but Sunday from about 10 to 11 E.S.T.

Who got the news across to Germany first about the landing of the Bremen? Marconi? Naw—1AVJ did it five minutes after the AP let it out. ck4UAH was the lucky boy in Germany.

A unit of the Volunteer Communication Reserve, U. S. N. R., has been organized at Wilmington, Del. It meets each Tuesday evening to instruct men in code and theory. An interesting mimeographed bulletin is published from time to time. At present the headquarters station for the Fifth Section is 3AUU, which uses crystal control on 40 and 80 meters. Where 3AUU cannot be heard, 3AIS will be ready to accept traffic for 3AUU. The matter of men going on voluntary cruises of 15 days this coming summer was taken up at the monthly meeting of officers, and it was decided that men in any rating might take this cruise provided there are vacancies. The cruise will begin July 1st, and will include stops at Newport, R. I., and Boston, Mass. Men will be paid, and uniforms will be issued at no cost.

The organization of an employee amateur network has recently been started by members of the Hawthorne Club of the Western Electric Co. in Chicago. In their evening school they conduct one class per week which covers all phases of radio. Each day during noon hours, they conduct a code class. An attempt is being made to stimulate interest in amateur radio, and all employees of the A. T. & T. System who are amateurs are wanted in the network. So far stations in New York, Chicago, Atlanta, Philadelphia, New Zealand, and Ontario have joined. Regular schedules for the stations in the network are being arranged, and the employee amateurs, besides getting a lot of enjoyment out of the work, find opportunities to be of service in emergency work.

The Los Angeles Times published an item which should make some of you off-wavers get wise. Here it is: "SEWARD, (Alaska)—Government radio operators here today depaired of establishing satisfactory communication with the Wilkins expedition at Point Barrow. Numberless amateur radio stations overwhelmed the thirty-three meter wave used by the Wilkins transmitter and although the Seward station listened for three hours, it was not able to hear signals from the expedition."

From eg2ZC we hear that Great Britain's YL station, eg6YL, is very anxious to QSO NU. She is on 44.9 meters, as a rule, and has a ripply DC note.

8GZ-ZG and oa6SA have been keeping a snappy daily schedule. They work break-in, sending single and as fast as you like—weight up on bug. Can break each other by one dot. We ought to have more of this kind of stuff.

1FL and ne8AE carried on an excellent two-way phone QSO for an hour and a half one night. 8AE played three phonograph records, and signal strength was such that one of the records was audible twenty feet from the speaker at 1FL.

The Veteran Wireless Operator's Association will award two scholarships for attendance at the Radio Institute of America, donated by the Radiomarine Corporation of America, in addition to 2 already donated by A. H. Grebe. Awards will be made to those American born youths over eighteen who write the best essays on "Why the American Merchant Marine Needs Perfect Wireless Communication." Complete information may be obtained from James Maresca, Sec'y, Veteran Wireless Operator's Ass'n, Room 1889, Hotel Roosevelt, N. Y. C.

While a trans-Pacific liner was en route from Shanghai, according to the New York Sun, a Chinese station called them and sent the following service message: "Greetings of the Moonbeams and the Rose

Buds. May you enjoy never-ending prosperity and your union be blest with seven sons. Goodby, hello, and have you any messages for my station."—A polite way to say QTC, eh what?

From 1AJK: "Everyone I work says 'FB OB'. Now, I ask you, is it right to rub it in by saying, 'Fine business on th' beach'. It's rotten business—financially, anyway." Hil

Mr. Robert Langmuir, a BCL short wave convert of Englewood, N. J., reports hearing nx1XL calling nu8AXZ. He says 1XL was R3 dc.

The National Convention of the Photographers Assn. of America held at Louisville, Ky., was a success. As was announced by an official ARRL broadcast to League members, the Louisville ham originated messages to all photographers in the United States extending invitations to attend the convention. The results were even more than expected, and the boys in Louisville wish to take this means of thanking the stations at the receiving end for their delivery of the messages.

3ADE was asked by a Harrisburg lady to try to locate her brother in Newark, N. J., who had not been heard from in 23 years. She had tried the department of police in Newark, but had been unsuccessful. 3ADE got on the air and QST'd for QSO Newark. He worked 2CMC in Brooklyn, who located the man's name in the Newark phone directory. The man had changed his first name which explains the inability of the Police to locate him. A message was obtained from the man in question, and the family re-united. 3ADE says, "The people around Harrisburg thought it was something wonderful, but for us fellows, it was but another message to deliver which was minus an address."

6AAU, who went to Alaska last year as xna7ADJ, is going north again on S. S. Arctic, and will carry low power SW transmitter for ham work.

9CKF is conducting a series of phone tests with oa3AR. 9CKF uses 40 meter CW, and the Zedder uses 33 meter fone.

6CLZ has a sked with na7AER on 20 meters every Saturday, and keeps him in touch with relatives in Berkeley. 7AER is on St. George Island, in the middle of the Behring Sea. There are only four white people on the island, and mail from the outside arrives only once every six months, so amateur radio is the main and practically only means of outside news.

The Whittier Radio Club recently put on a fine A.R.R.L. meeting in Los Angeles. There were about 105 members present, and entertainment consisted of an excellent feed, music by a strictly ham orchestra, and several interesting talks. L. E. Smith, former SCM, presided over the meeting, and 6AM, the present SCM, was among the speakers. A message from Director Babcock was read, and Mr. H. B. Watson, engineer for the Federal Telegraph Co. gave an interesting talk on the duties of a commercial op.

Nu6AM and oa2YI had a QSY party the other day! They established QSO on 40-meter band at about 1010 GCT, and after working a while, both went down to the twenty-meter band. They worked there until things got a bit monotonous, and then 6AM shot up to 79 meters, leaving 2YI on 20. QSO was carried on in this fashion for a while, and then 6AM dropped back to his original 40-meter wave, and 2YI came back up to his original 32-meter location. All this was accomplished within an hour or so, and looks like it may be a record for QSYing at big DX. All sending was single, and signals were good on all waves. This was all overheard by 3CEI and reported to us.

#### COUNTING RUBBER STAMP MESSAGES

Because, now and again, stations fall back into the habit of originating quantities of the so-called 'rubber-stamp' messages with such texts as 'your card received will QST', 'greetings by radio' and the like, it becomes necessary to re-affirm our policy with respect to such messages. The history of our organization shows the demoralizing effect of an influx of such stereotyped messages in quantity. Because such messages mean little individually and because there is much labor and little pleasure in handling such messages the result has always been a decrease in the *delinery* column while the totals of originated

and relayed messages rise to unprecedented heights—that mean nothing at all. Because the net effect of encouraging rubber-stamp messages is to clog the hooks of traffic handling stations until these stations can no longer function, it was decided long ago to kill large quantities of such messages at their source delivering good messages promptly and not counting the rubber-stamps when figuring out totals for the report under the honor system. Several arguments in favor of "greeting" messages have much in their favor. These have been given in the Correspondence Department of QST during the last year. While there is nothing against and much in favor of handling individual friendly greeting messages which do have significance to the general public, it is necessary to maintain a firm policy with respect to counting rubber-stamp messages to further efficient traffic handling with a good percentage delivery in our national scheme of affairs.

The League's system for crediting points for messages handled is based on giving one credit each time a complete message is handled by amateur radio, i.e., one credit for each originated message, one credit for each delivered message and two credits for each relayed message (one credit for the work in receiving it and one for the work in transmitting it). Changes in this plan of crediting were considered and turned down by vote of the Section Managers late in 1927.

Obviously, a station in handling a rubber-stamp message has to exert only a small amount of effort in receiving the text and signature once. Then by handling the address to different points en group a large number of messages (?) can be received and transmitted in similar fashion with little expenditure of time and effort. The italicized statement regarding counting or not counting of rubber-stamps is herewith amplified to credit honest effort as it deserves while discouraging quantities of rubber-stamp messages. Every message handled by radio, complete with preamble, address, text and signature counts one—no partial messages shall be counted.

Example (showing a claimed and revised count on R.S. messages): A certain station takes an R.S. message to 10 addresses and relays it onward to another station claiming "relayed 20" for his work. This station shall be credited with "relayed 2", one for receiving 8 complete preamble, address, text, and signature, one for sending a complete message on its way. For receiving and relaying to three stations (requiring the complete message to be sent three times) a total of four might be justly claimed in the relayed column.

### 1MK

The following schedules are up to date:

1ACH (80) Sun., 7:45 p.m.; Thursday, 7:30 p.m.  
 1BIG (80) Mon. and Fri., 7:00 p.m.  
 1BQD (80) Mon. and Fri., 9:00 p.m.  
 1KY (80) Mon. and Fri., 7:30 p.m.  
 1UE (80) Tues., 9:45 p.m.  
 1VB (80) Tues. and Fri., 7:45 p.m.  
 VE2BR (40) Sun., 9:15 p.m.  
 2BME (80) Sun., 11:45 p.m.; Mon. and Thurs., 7:15 p.m.; Tues., 9:15 p.m.; Fri., 9:45 p.m.  
 2CTM (80) Mon. and Fri., 9:30 p.m.  
 3QP (80) Mon. and Thurs., 9:45 p.m.  
 3ZS (80) Mon. and Thurs., 7:45 p.m.  
 4IE (80) Thurs., 11:00 p.m.  
 4XE (80) Sun., 7:30 p.m.  
 6BWH (40) Tues., 12:30 a.m.  
 6CIS (40) Fri., 12:30 a.m.  
 6EY (40) Tues., 12:30 a.m.  
 6NX (40) Mon., 11:45 p.m.  
 6OJ (40) Mon., 1:00 a.m.  
 6ZD (40) Wed., 1:30 a.m.  
 8AAG (80) Sun., 11:15 p.m.  
 8CIG (80) Mon., Thurs., and Fri., 9:15 p.m.; Tues., 7:00 p.m.; Sun., 7:15 p.m.  
 8DED (80) Tues. and Thurs., 9:30 p.m.  
 8ZZ (80) Sun., 11:00 p.m.; Thurs., 9:00 p.m.  
 VE9AL (80) Tues. and Fri., 7:15 p.m. (VE9AL on 52.5 meters)  
 9APY (80) Tues., 9:00 p.m. (9APY on 40 meters)  
 9ENM (40) Mon. and Fri., 11:15 p.m.  
 9OX (80) Sun. and Thurs., 11:30 p.m.  
 WSBS (40) Sun., Mon., and Fri., 10:15 p.m.  
 All the latest OFFICIAL and SPECIAL BROADCASTS are sent simultaneously on 41.93 and 83.86 meters from 1MK at the following times (E.S.T.):  
 8:00 p.m.: Sun., Mon., Tues., Thurs., and Fri.  
 10:00 p.m.: Mon. and Fri.  
 Midnight: Sun., Tues., and Thurs.

PERIODS OF GENERAL OPERATION have been arranged in order that everybody may have a chance to work HQ. Usually these general periods follow one of the Official Broadcasts. They are listed under FORTY and EIGHTY meters:

EIGHTY METERS:  
 8:10 p.m.—9:00 p.m. on Sun., Mon., Tues., Thurs., and Fri. Official Broadcast sent preceding these general periods.

10:00—11:00 p.m. on Tues. and Thurs.  
 12:00—1:00 a.m. (or later) on Sun. night (Monday morning).

FORTY METERS:

10:10—11:00 p.m. on Sun., Mon., and Fri. Official Broadcast sent preceding these general periods.

12:00 p.m.—1:00 a.m. on the following nights (actually a.m. of day following): Mon., Tues., Thurs., and Fri. On Tues. and Thurs. the Official Broadcast precedes these periods.

1MK operates on 7150 kc. and 3575 kc. (41.93 and 83.86 meters). "RLP" is the usual sign, and belongs to Robert B. Parmenter, formerly of 9WR, now chief operator at 1MK. Other familiar signs are "GU" of Louie Huber, "FH" of F. E. Handy, and "AH" of A. A. Hebert.

### ELECTION RESULTS

Valid petitions nominating a single candidate as Section Manager were filed in a number of Sections on or before the closing dates that had been announced for receipt of such petitions. As provided by our Constitution and By-Laws, when but one candidate is named in one or more valid nominating petitions, this candidate shall be declared elected. Accordingly election certificates have been mailed to the following officials: (These officials will welcome your monthly activity reports.)

Section	Address
Indiana	D.J. Angus, 9CYQ, 310 Illinois St., Indianapolis
	J.W. Gullett, 5AKP, 1708 23rd Ave., Meridian
Ohio	H.C. Storck, 8BYN, 694 Carpenter St., Columbus
Iowa	H.W. Kerr, 9DZW, Little Sioux
No. Dak.	B.S. Warner, 3DYV, 303 Fourth Ave., Enderlin
Vermont	Clayton Paulette, 1IT, North Troy
Kansas	J.H. Amis, 9CET, 915 Lincoln Ave., Topeka
So. Texas	R.E. Franklin, 5OX, 1806 Valentine St., Houston

In the Maine Section of the New England Division, Mr. Grover C. Brown, 1AQL, 269 North Main St., Brewer, Maine and Mr. Frederick Best, 1BIG, 13 East Crescent St., Augusta, Maine were nominated. Election results: Mr. Brown, 19; Mr. Best, 36. Mr. Best has therefore been declared re-elected. At this writing elections are being held in the Oklahoma and Utah-Wyoming Sections by mail ballot, the results to be announced at a later date.

No valid nominating petitions were received from the following Sections before noon of July 28 so that the closing date for receipt of petitions was extended to noon of August 28: Western N.Y.; Nevada; Arkansas; Alabama; Philippines; Quebec. If necessary the closing date will be further extended but we expect to be able to declare a candidate elected in at least one of these Sections. Attention is called to the detailed notice on pages 51 and 52 of August QST soliciting nominating petitions from several Sections. Please get busy for your candidates where necessary.

—F.E.H.

### TRAFFIC BRIEFS

8DSP used to keep a daily schedule with ncIBI, and one of the messages he delivered was from 1BI to a relative in Sarnia, Ont. A four page letter of real appreciation and thanks from the addressee was DSP's reward for mailing the message. The following brief quotation will serve to show the spirit of the letter, "I am sure that you amateurs are making your worth felt in all parts of the country, and it is very generous of you folks. Your work is a very good thing for the public at large, and the people should be thankful for it. I for one, appreciate your good will and services."

An inner-organization has been formed among some of the members of the Radio Operators Club of Spokane, Wash., known as the Royal Order of Sevens. It will be noted that there are seven letters in the word Spokane, each of which represents one of the seven degrees through which the candidate

must pass. The Seven Degrees follow: First, (S), Seven QSL cards from seven districts or intermediates, to show that seven stations have been satisfactorily worked since the organization was formed. Second, (P), Promptness—seven messages must have been delivered to seven Spokane addresses within 24 hours of receipt. Third, (O), Oath—The oath of the R.O.S. must be memorized. Fourth, (K), Knowledge—Seven test questions must be satisfactorily answered to prove their knowledge of amateur radio. Fifth, (A), Activity—The station of the candidate must be on the air at least seven hours a week. Sixth, (N), Neatness—The station must be kept neat at all times, and all wiring neatly done. Seventh, (E), Entertainment—Suitable entertainment to be provided with the admission of each newcomer, the incoming member to be master of ceremonies for the evening.

-----  
 Papa, may I send a CQ?  
 Yes, my darling daughter,  
 Send three times and sign three times,  
 Like Hdqs. sez you oughter.—SABM  
 -----

2ALU's been working ARCX, now at the South Pole, and has been taking AQE's traffic via ARCX, since AQE is not allowed to QSO hams at present. ARCX is the Neilson Alonso, has d.c. and works on 37 meters.

ALU has also been working xekDCZ, Count Von-Luckner's ship en route to Germany. Several messages have been handled.

#### ARMY-AMATEUR NOTES

SECOND CORPS AREA: Work has been temporarily discontinued until October 1st, but 2SC, the net control station, will be on the air each Monday night at 10:00 p.m. E.S.T. on 77.8 meters.

THIRD CORPS AREA: SGI, 8AGO, and 8BPD maintained schedules with the C. S. during May. 3BN, 8RPD, 8EU, SCYP, SGI, 8BVO, and 8NP were on duty during June.

EIGHTH CORPS AREA: MAIN has moved to a new location at Fort Sam Houston, Texas, and should be found on both the 20 and 40 meter bands. Schedules have been made with Nat'l Guard nets in Colorado, Oklahoma, and Texas.

#### A. A. CONTEST SUCCESS

One of the reasons for the affiliation of the amateur station with the Signal Corps is for the purpose of better organization of Radio Nets which will function in emergencies, such as the recent New England floods, the Miami hurricane, the Mississippi Valley disaster, etc. With this in mind, a competition, open to all Army Amateur Stations in the Second Corps Area, was held some time ago. Ten valuable prizes were donated by some of the leading radio manufacturers, and the ten amateurs making the greatest number of points were given their choice of these awards, in the order of their standing.

The contest consisted of the transmission of a cipher, a code, and a clear message from 2SC, the Corps Area Net Control Station, located at Governors Island, N. Y. These messages were sent at 8:00, 10:10, and 11:00 P.M., respectively, and were repeated on the 17th and 19th of the month so that all stations would have a chance to copy them. The speed of all transmissions was between 15 and 20 words per minute.

The first message was in cipher, and had to be deciphered by means of a cipher disc, supplied to all A.A. stations. Each participant was required to send the answer to this message in cipher, to 2SC via his N.C.S. 25 points were allowed for the correct answer, 15 points for the reception of the cipher message, and 10 points for the correct translation.

The second message was a code affair, and a maximum of 15 points was credited for the correct reception of it.

The third one was a straight message which reported (fictitiously, of course) that an Army dirigible had crashed in the vicinity of the receiving amateur, and requested a brief story of what the amateur would do in the way of relief work in such an emergency. A maximum of twenty points was given for the best story, and many vivid and imaginative pieces of fiction resulted. We are sorry that there is not space enough to reproduce some of the prize-winners. The winner of the whole contest, 2EV, wrote one that all amateurs would do well to use as a guide in case of a similar emergency. A summary of the reports made it very evident that every amateur

station, whether he is an Army Amateur or not, should have some means of emergency communication in case of a failure of his power supply. This fact was forcibly brought out in the recent New England emergency. A small power battery transmitter is probably the most practical emergency set.

The ten prize-winners in the contest are here given in the order of their standing: 2EV, 2WZ, 2AFV, 8DME, 2AOP, 2BCB, 8CVJ, 2CZR, 2DV, and 2BCU.

#### TRAFFIC BRIEFS

A report comes to us of the good work done by 9CEF, Chicago, and 8EQ, Lima, Ohio. During the severe storm of March 30th, which isolated Lima from the rest of the world, CEF and EQ got together and furnished all kinds of news to the stricken city. 8EQ is an invalid, but in this case he was better fitted for the work most of the able-bodied in Lima. Fine work, OM's.

#### ROTTEN SENDING\*

In our beloved QST we find much sound advice, not the least of which is not to use rotten Morse.

If we analyze sending in an effort to find the reason for so much poor stuff we find that there are three major classes of operators. I have named these *Naturals*, *Unfortunates* and *Brainless Wonders*.

*Naturals* are the good senders. I call them *Naturals* because many of them became good senders in spite of a lack of systematic practice or much serious thought about sending.

*Unfortunates*, of whom there are not so many, are those who were at one time good senders but who have lost their 'grip'. They are only unfortunate, however, to the extent of the cost of a good semi-automatic key or 'bug': upon securing one of these animals an *Unfortunate* will move into another class. Which class he moves into is entirely dependent upon himself!

*Brainless Wonders* form that army of operators whose sending sounds like a combination of hail rattling on a tin roof and the mutterings of a stammering flivver. We can go further and divide this class into three sections:— (a) Jazz artists, (b) Combination specialists, and (c) Glass arms with St. Vitus' dance. All these belong to the class of *Brainless Wonders* as they never think what their sending sounds like to the fellow at the other end, who requires supernatural powers to assist him in deciphering the junk hurled at him by these birds.

You all know the Jazz artist. He is the pink who has a 'swing' to his sending. It 'swings' in more senses than one. It sounds as though he were trying to keep time with a punk jazz orchestra as Anvil Chorus. His CQ is dut—de dut dut—dut dut—da daah instead of dah dit dah dit—dah dah dit dah.

The Combination specialist thinks the receiving operator is an ardent and expert puzzle worker. He omits spaces; it is too much trouble to pause and get going again. "Mary died, come home" is rendered "Mary dil cog hog". If his transmission is questioned he curses the density of the ivory at the other end.

Last, but not least, the glass arm. He grabs the key and hangs on for dear life; probably he is afraid it will jump up and slap his face. He pumps away in a manner similar to the Volunteer Hose Company when the corner soft drinkery is ablaze. I can not describe the spittings and sputterings in the ether caused by these operators. Static is music by comparison.

Now all of this is so utterly unnecessary. A little consideration for the other fellow, a little careful, patient practice, and the ranks of the *Brainless Wonder* could be greatly thinned.

Why is it we never hear a young operator talk about how *well* he can send? It's always how fast. I have no objection to speed, but we must learn to walk before we can run. Get speed out of your heads, fellows! I have been telegraphing for twenty years, and there are more messages to be sent now than when I started, so there will always be plenty for you. Make it your ambition to send in such a way that the receiving operator will never have to 'break'. Speed will come naturally.

\*Abstract of address by H. T. Barker, SADE, given before Radio Assn. of Western New York.



**J. WALTER FRATES**

SCM East Bay, received his first ham license in December, 1926. His station, 6CZR, is run in the interests of traffic handling and rag-chewing. Mr. Frates is president of the Oakland Radio Club, and is a writer on the editorial staff of the *San Francisco Chronicle*, Oakland office. He is 25 years old, and has been married for six years. Yes, there is a young one, too.

**A. D. TRUM**

SCM Alabama, entered amateur radio in 1919. Trum's station, 5AJP holds many fine traffic and DX records to its credit. The SCM is an accountant for the Alabama State Highway Dept., and Associate Member, I.R.E. and has been both operator and announcer at WIBZ, Montgomery's municipal BC<sub>2</sub> station.



**BRUCE STONE** of 6AMM has been doing some exceptional schedule work with the Philippine Islands for the last three years. We're giving you his foto so you'll know him the next time you "see" him on the air. Bruce thinks it pays to mail messages when radio QSR is not possible within forty-eight hours, because he has received from appreciative addressees the following: "1 pr bedroom slippers; 1 Javanese table cover; 1 Panama hat; 2 bottles perfume; and other things such as erasers and calendars." Not bad, OM, not bad.



**FREDERICK M. HOLBROOK**

SCM Eastern New York Section, entered amateur radio in 1921, and his station, 2CNS, has been an ORS for the last four years. Mr. Holbrook is 53 years old, and earned his EE degree from Columbia University in 1897.



**EARLE F. PEACOX**

Peacox, former SCM of the Eastern New York Section entered the fifth stage of amateur radio last April. Well known as 2AJE in the spark days, Peacox has signed the following calls since 1923: 2ADD, 2ADH, 2CIL, 2DD, 2ALM, 2AXR and he is now "ep" at 2UO. In the past, Peacox has held several positions in the A.R.R.L., Publicity and Communications Depts., and a free-lance writer on various papers and magazines.



According to 9CZC, Route Manager of Iowa, the dots and dashes will be sent at approximately the same length during 1929. In the latest release (in which we learned the above) nothing was seen of a forecast on the probable length of spaces between the dots and dashes. If some of this does not improve we'll expect to hear some more rotten QSC.

The Ass't. C. M. had the pleasure of short-circuiting the output of 1MK's mercury arc with his left hand the other day. A thirty ampere fuse in the 220 volt side of the transformer was blown; and 1MK went off the air for fifteen minutes. Otherwise no damage was done except that a couple of fingers were burned slightly.

9WOP wrote in the other day with the following query: "I hev very often received Marconigrams from my Noot Broadcast Receiver. Inn fact, I gett them every nite. All of them are signed 'Kozack, the Otto Dreiwäsch.' Now, I have been unable to QSR on account of insufficient address. Who is this guy Dreiwäsch that sends so many Wireless Grams?" Please, oh, please, fellows, look up Dreiwäsch for us so that we may answer 9WOP's nice letter.

Tnx . . . tks . . . tku . . . yah, but wot do u sa in return? 1UE suggests DMI, meaning *don't mention it*. Now let's hear it on the air

On several occasions 5UK and 5ANC have been ready to handle emergency press or traffic following the severe winds and electrical storms that have swept that part of the country but have not been able to do useful work as the expected wire failure did not occur.

Here's a radiogram received at 1MK from one of the SCM's, whom we suspect to have entered the fifth (married) stage of radio existence: "Dear CM disregard my forthcoming letter concerning me, quitting radio and don't cancel my SCM or 1MK schedule or anything I will stick in ham game little longer."

9APY was eating dinner the other day when a lady from Clayton, Mo., to whom he had mailed a message a few days before, called him on the "far distant" thru his central operator, wanting to know if he would pay the \$1.75-for-three-minutes charge while she gave him a reply message !!!

Don Good of 6AJM maintains one of the most reliable schedules with the Philippine Island. The fellow at the other end is op1AD. 6BQ, SCM, says in a letter, referring to 6AJM: "His skeds are reliable and it is nothing unusual for the number of messages handled in one morning to run up anywhere from twenty to forty. Every message received by him is verified by mail as well as forwarded via radio. Incidentally it is proving quite costly as his postage bill runs rather high."

Lloyd of 8CFR reports re-establishing contact with the Dyott-Brazil expedition through 561AW on August 14. The expedition had not been heard from during the month before this date due to trouble with Indians and un-navigable rivers and it was a relief to many to hear that "all's well". 1ASD succeeded in hooking GMD direct on August 18 but had some trouble with QSS.

It seems practically certain that a strong parasitic in the vicinity of 43 meters—one which could be copied in England as readily as the within-band signal—was responsible for the evidence turned in from different quarters against 1CMP.



6RJ IS AN INSURANCE MAN



# DIVISIONAL REPORTS

## ATLANTIC DIVISION

**S**OUTHERN NEW JERSEY—SCM, M. J. Lotysh, 3CFG—3CFG again leads in spite of blowing up his transmitter. A new set is being planned with another 852 and a new plate supply ala 1929. 3ATJ had a chance to be famous. With his shack full of press reporters trying to get out news of Capt. Carranza's death, his lone 201A got cold feet. 3UT requests his ORS to be cancelled. Sorry to lose you, Walt. 3CO also rebuilding for next year. 3BWJ still complains of lack of operating time. 3BEI is off until fall. 3CO's ORS has been reinstated. 3ARN is an up and coming new station. With the next report, good weather will be coming on, so let's get back to work and turn in some real results.

Traffic: 3CFG 24, 3BWJ 6, 3ATJ 7, 3CO 2, 3ARN 3.

**WESTERN PENNSYLVANIA**—SCM, A. W. McAuly, 8CEO—Please note on page 3 of QST where you are supposed to report, fellows. 8BBL and 8BYS have combined and are now operating under the call of 8DNO. 8CFR reports that GMD has not been heard for three weeks. 8CNZ has moved again. 8BRM is busy with telephone work. 8GI and 8CYP were SCM visitors. 8CEO and 8DHU took a two weeks trip through the south, visiting several hams en route. The SCM would like to hear from a few stations with good wavemeters who would be interested on official observation work. Also those desiring to handle traffic and who do not now have an ORS.

Traffic: 8GI 38, 8CFR 25, 8CYP 21, 8CNZ 20, 8BRM 15, 8CEO 15, 8DNO 35.

**EASTERN PENNSYLVANIA**—SCM, J. B. Morgan, 3QP—This month's total of traffic is rather good. It is due to the large score run up by 3ZF in his Twentieth Century Limited express message service from N. Y. to Chicago. Try to route your western traffic over this channel, fellows, and watch the speedy work. Connecting channels can be seen by referring to page 49 of the August QST. 8EU will be located in Phila. in a short while and will take a trick at the key at 3ZF, with whom he will be associated. Good luck to you, Maneval. Things are rather slow at 3QP. 3AKB had some QRM in the shape of vacation—the BPL showed it. 3AVK and 3ADE were bothered with hot weather. Who wasn't? 3CDS complains of bad QSR on the part of some of our brethren. 3ADQ rebuilding again and says not to overlook the sign "EB" after his call, in which case the op will be his YL. FB, OL, 3AVL is rebuilding. 8CWO says this may be his last report if his college application is accepted. 8DHT still shooting the traffic. We welcome 8RDG to the ranks of the "Reporters" with a fair total for a starter. 8AWO took a S/W receiver to camp with him to keep his hand in. 8BQ is proud to say he has a new junior YL op. Congrats.

Traffic: 3ZF 433, 3QP 23, 3AKB 37, 3AVK 42, 3ADE 16, 3CDS 1, 3ADQ 28, 3CWO 9, 3DHT 69, 3BDG 15, 3AWO 7.

**MARYLAND-DELAWARE—DIST. OF COLUMBIA**—SCM, H. H. Layton, 3AIS—L. H. Ryan, 3WJ (Acting SCM)—Dr. Layton, our SCM, has gone on vacation for two weeks to Saginaw, Mich. via car and boat. Let's wish "Doc" a good time. Yes, he took the wife and Jr. op. The seashore and what not will keep 'em from the key, but don't forget, fellows, if you want your reports in this section of QST each month, you've got to send me the info. If you are rebuilding, etc., let us know. Will it be a big report next month—?

Del: 3AIS has been very active with his new crystal control set. 3WJ has been off the air to allow the paper hanger to change the room. 3ALQ reports weak signals.

Md.: 3BWJ is rebuilding and teaching the YL the dit dah. 3TR at the Naval Academy writes that he is joining our forces on the air with 75 watts, 2500 volts 25 cycle self rect.

D. of C.: Our old friend 3GT at Rolling Field still has the record on traffic. If you have traffic for the coast and points West, shoot it over to 3GT. 3KA, formerly 4CK of Miami, Fla., has taken up his new residence in Washington. He has applied for an ORS. Welcome, OT.

Traffic: Del: 3AIS 3, 3WJ 1. Md.: 3TR 6, 3BWJ 1. D. of C.: 3GT 30, 3KA 12.

**WESTERN NEW YORK**—SCM, C. S. Taylor, SPJ—The mid-summer reports this month are fair and much progress has taken place in the Syracuse section. A new club has been formed which will be known as the Syracuse Society of Transmitting Amateurs and solicit the membership of all small town stations around Syracuse. Their object is to give 100% service to the ARRL and their Secretary is H. C. Kaffer, 707 Wolf St., Syracuse, N. Y., who awaits your application and membership. 8AHC has worked oa. and oz. 8AIL will be at camp next month. 8AKZ worked 6ZZI but handled no traffic. 8ANX is off for the summer but will be on again about Sept. 8ARX handled 99 msgs. FB, OM. 8BCM has been off the air due to work. 8BFG handles some traffic. 8BMJ expects more traffic in Sept. 8BUM has been off the air due to bad transformer trouble. 8CDB worked all continents and na-7AEB. 8CNT worked 29 stations in six hours one day, but QRN killed good reception. 8CNX is rebuilding very slowly but may be ready by Sept. 8CRF is off until the fall season begins. 8CSW has been at Alfred Univ. for the summer but sneaks over to Cook Academy to get off a few msgs. now and then. 8CVJ will be off the air until Sept. 8CYB put out a few msgs this month. 8DDL says he has an R9 YL now so sigs have changed for a while. 8DHX lost his license and now works 8CIG. 8DII has been changing the transmitter and is going to have 1500 volts DC ready by Sept. 8DME worked Australia and Germany and handled other traffic. 8DNE is at camp but managed to handle traffic from there. 8DQP has been busy getting 8ALQ ready for fall work. 8DSP says things are not very lively at this time. ex8WU is operating a "2" station at Schenectady.

Traffic: 8AHC 8, 8AIL 5, 8ARX 99, 8BFG 8, 8BMJ 18, 8CDB 34, 8CNT 9, 8CVJ 1, 8CYB 20, 8DHX 18, 8DII 21, 8DME 17, 8DNE 25, 8DSP 69, ex8WU 1.

## CENTRAL DIVISION

**I**NDIANA—SCM, D. J. Angus, 9CYQ—9AIN leads the section in schedules by virtue of his activity on the "Twentieth Century Limited," N. Y.—Chgo Route. Beginners sit in with him nightly for code practice. 9EZ handled a bunch of msgs with portable stations connected with the Academy. 9EVA handled a stack and says he will build a 1929 xmitter. 9CRV comes next. 9FAP served duty for C.M.T.C. men for a while. 9BYI is the early bird—he arises daily at six for schedules. 9CNC worked OA on 20. 9FB tries 10 meters. 9ASX took a vacation. He reported a dandy hamfest of the South Bend and Elkhart gangs at Lake-of-the-Woods, on July 15. 9DSC and 9DXH bring up the rear.

Traffic: 9EZ 450, 9AIN 208, 9EVA 100, 9CRV 45, 9FAP 38, 9BYI 24, 9CNC 11, 9ASX 6, 9DSC 6, 9DXH 2.

**KENTUCKY**—SCM, D. A. Downard, 9ARU—9AWN has applied for ORS appt. 9BXX is a new ORS. 9FBU is still handling traffic. 9BGA says 20 meters is the berries. The golf bug hit 9ENR. 9AID got an R-7 report on 20 meters from oz-2AW. 9OX is busy with other work but keeps his skeds—so he says. 9FBV reports a QSL of his sigs from oa-3PJ as R8. We have a new OBS in 9BAN at Henderson. 9BWJ says he has joined the "Experimenters" Section and is going to be an inventor. Hi. 9AZY has a 210 perking on 40 meters. 9MN is putting in a new DC system on his transmitter. 9ATV has a new screened grid receiver that really works plus ultra. 9ARU will be on the air as soon as things start getting cool.

Traffic: 9OX 22, 9ATV 15, 9BAN 10, 9AZY 17, 9AID 11, 9MN 2.

**OHIO**—SCM, H. C. Storck, 8BYN—Some Ohio ORS are getting good totals for this time of year. 8CMB takes the lead this month with 88 messages. 8DBM follows closely with 74. 8DSY specializes on important traffic. 8DTN handled some traffic for WNP. 8CRI is runner-up for ORS. 8CNO has been having trouble with her set. 8CCS is in the hospital. 8CSS wants dope on VOQ. 8DMX says he can't hear any Ohio stations any more. 8BAC is still working on his new 20 meter outfit. 8AYO is keeping a schedule with se-2EA. 8DJV handled a love letter for 8DLD. Hi. 8DDK is installing xtal control. 8BBR says traffic has disappeared. 8ARW hasn't anything to say. 8BKM is on his honeymoon. 8CFL

operates mostly in the daytime. 8AZO admits being busy with the YLS. 8OQ blames the heat but—8AMI will be in Cleveland with his portable, 8ABE. 8BBH has whanged his QRH again. 8BOP will be off the air until October. 8DTC's Jr. op has been keeping the air loaded with noise. 8DIA is rebuilding. 8CNU has been very QRW. 8BNA is home for the summer. 8AVB is too QRW to do much. 8RN is still aboard KFNN. By the time this appears in QST, the convention will be over, and you fellows will be thinking of the coming radio season. Let's get some schedules lined up and ready to go, and try really to do things this winter. See if we can beat our BPL record of last winter.

Traffic: 8CMB 88, 8DBM 74, 8DSY 58, 8DTN 30, 8CRI 18, 8CNO 16, 8CSS 13, 8DMX 12, 8BAC 12, 8AYO 12, 8DJV 8, 8DDK 6, 8HRR 5, 8ARW 5, 8BKM 4, 8CFL 4, 8BAU 3, 8AZO 2, 8OQ 2, 8AMI 1.

ILLINOIS—SCM, F. J. Hinds, 9APY—There are a number of ORS applications which will receive attention very shortly. Traffic took a slight jump this month. 9BSH has been experimenting on 10 meters, will be on 20 and invites the gang to visit him and see the Air Field at Chanute Field, Rantoul, Ill. 9DXG is rebuilding a-la 1929. 9ANQ, 9CUH, 9UY and 9BER entertained 9DLQ, 9FVB, 9ERU, 9CHS, 9AEO and 9EYC at a hamfest. 9ASE is getting along in fine shape with the USDA net. 9IZ bought a Ford. 9DLG is visiting in Calif. 9AMN has been busy with 9RK's sister. Hi. 9QD is getting ready for a traffic boom. 9BRX worked WNP on 20 and has a commercial ticket now. 9ALK is rebuilding. 9EGX has a blown filter system. 9RTX is operating 9XN up at the 500 on an expedition. 9RX for him, gang, and QSR to Chicago. Wave is 38 meters. 2AMC has taken up his abode near 9CCZ and will be going with a "9" call soon. 9ACU is on 20 and 40. 9BZO is bursting out with a new set using a crystal. 9CNB has a new tube. 9PU says traffic buzzed there this month due to a TP-TG but the note is hard to get DC. 9DSU is moving to St. Louis. Sorry to lose you, OM. 9AAW is getting DC using UV-204 and recto bulbs in parallel on each side of cycle. 9FQS uses an 852 in TPTG. 9ANQ holding tests with ed-7ZG and ex-2NH on 10 meters. 9TQ is spending some time in Denver. 9AKB passed thru Chicago on her way to Yellowstone. 9FCW and 9CNY are on for traffic. Please send all reports to 9APY on the 25th. 9AFA's traffic was all with WNP.

Traffic: 9PU 354, 9APY 112, 9FQS 27, 9CIA 26, 9PHY 26, 9ASE 17, 9CNB 16, 9CNY 13, 9DSU 11, 9BTX 10, 9FCW 10, 9QD 10, 9CZT 9, 9ALK 6, 9CKM 5, 9EGX 5, 9CUH 4, 9ACU 3, 9BRX 3, 9CUO 3, 9AAW 2, 9AHJ 2, 9AHK 2, 9AMN 2, 9ANQ 1, 9BSH 1, 9BVP 1, 9ECR 4, 9AFA 99.

MICHIGAN—SCM, Dallas Wise, 8CEP—8CKZ has the set working remote control now even to the mercury arc and says it is FB. 9EQV reports a few even in the hot weather. Five of the fellows from Columbus, Ohio, visited 8BRS. They had quite a Hamfest. 8AUB says the station needs some repairs. 8BWR not doing much during the summer months but will be back strong in the fall. 8CU blew his plate transformer so is silent for the time being. 9CE reports the 20 and 40 meter signals very QRZ and QSS all during the month. 8ASO was up on the USS Dubuque during the USNR cruise and kept nightly schedules with his home station with 9ALM at the key. 8DKX will be at Camp Grayling and will be using the call 8DAA. 8AAF has a new op "Mildred". Congratulations, OM. The call 8CNK Lansing has been changed to 8BGV. 8BJQ now has a new power supply, 1500 rectified AC. 9CEX reports per usual. 8DED is busy playing baseball but still manages to turn in a fine total. The gang at Holland held a fine Hamfest Sunday, Aug. 5th. Fine work, fellows. 8ZZ is busy getting his mercury arc ready for the fall rush. 8WO is taking his first vacation. 9EMJ is moving to Detroit, and will be heard from there shortly. 8CEP is trying his hand at grinding his own crystals.

Traffic: 8CKZ 6, 9EQV 12, 8BRS 19, 8AUB 14, 9CE 17, 8ASO 14, 8DKX 29, 8BGV 64, 8BJQ 9, 9CEX 16, 8CEP 31, 8DED 102.

WISCONSIN—SCM, C. N. Crapo, 9VD—9DLL sends in a large summer total, due to fine cooperation on the part of operators keeping schedules. 9BSS has sent in a report at last. 9SO reports traffic handling difficult on 40 meters. 9EMD has schedules with 9FAW, 9DLL and 9BSS daily. 9DND keeps one schedule and is rebuilding the transmitter. 9BWO needs Asia for a WAC. 9BWZ has four schedules and keeps traffic moving his way. 9FTI-

9OT relays a few when his pole is up, but it's usually down. 9FAW is attending Camp Williams from Aug. 18 to Sept. 1st. 9DEK is rebuilding and will soon have an all-wave outfit. 9EWY is putting in a 75 watt mercury arc rectifier. 9CVI worked VE1DQ on 20 and keeps a schedule with 9DLL on 80. 9EFC is back on the air with 2 210's self-rectified on 40. 9ESM has re-designed his transmitter and receiver and is now on 20.5. 9DCX thinks his shack is too hot daytimes and is QRW service work. 9DTN is back on the air after 3 years vacation, but says too much QRW now. 9DJK is also installing a mercury arc. 9ERT says he originated 8 and only two of them were delivered. 9DZZ sends in his report just to help out his SCM. Thanks, OM. 9DNB says things are beginning to pick up on 40. 9AFZ gets on the air occasionally when he is in town. 9DLQ-9FVB is using a 210 at his summer residence. 9IB says ten msgs. are a bunch when you have no schedules. 9EYH is now at Troy Center using 5 201s with B battery plate supply. 9VD is on the air occasionally but has no schedules.

Traffic: 9DLL 164, 9BSS 83, 9SO 69, 9DND 64, 9EMD 49, 9BWO 37, 9BWZ 35, 9OT-9FTI 19, 9FAW 18, 9DEK 16, 9EWY 15, 9CVI 11, 9EFC 10, 9ESM 10, 9DCX 9, 9DTN 6, 9DJK 6, 9ERT 5, 9DZZ 5, 9DNB 4, 9AFZ 3, 9DLQ-9FVB 3, 9IB 2, 9EYH 1, 9VD4.

## DAKOTA DIVISION

SOUTHERN MINNESOTA—SCM, D. F. Cottam. 9BYA—The old traffic war horse 9COS is high again. He has had a large number of visitors but manages to handle traffic in his spare moments. 9DBW is on all three bands; and is on 10 every Sunday, too. He has done some nice DX work and has discovered that a V.F. Hertz 62 ft. long, hooked direct to plate coil, is the best antenna tried so far. 9BHZ has been away on a vacation, fishing, etc. 9BFO has been doing some changing in both transmitter and receiver. 9DBC says he is working most of the 24 hours. 9DMA is an official soda squirt this summer and with all the hot weather, he has been very QRW. 9BYA has just returned from a trip into the wilds of Canada. 9BKX is remodeling. 9DOP has been at the National Guard Camp and was also on a farm for awhile so used a portable for his traffic. 9ELA did all his traffic work the first week of the reporting month. He visited 9EGN. 9BTW has been very busy this month with a job and also building a permanent transmitter for 1929. 9EOH now has proper power to run a 208A bottle. 9UG paid him a visit of about two weeks. 9AIR has been on the sick list.

Traffic: 9COS 39, 9DBW 24, 9BHZ 4, 9BFO 1, 9DOP 27, 9ELA 13, 9BTW 11, 9EOH 8.

NORTHERN MINNESOTA—SCM, Cy. L. Barker. 9EGU—9AKM says it is too hot to stay inside and play with radio. 9EGU has received an appointment as Lieutenant (jg) C-V (S) USNR to take up duties as Section Commander of Minnesota, North Dakota and South Dakota for the Reserve. 9FTU is a new station at Two Harbors. He starts right out with schedules. 9CTW is getting radio fever again. 9BCT reports that the skip has gone on 20 meters so that he works many "locals." 9ABV works only in the early morning, but gets some DX at that. 9EHI and 9EGF are QRW non-radio-ly. 9EGF and 9BVH blew tubes. 9BBT may be on in August. 9EGN leads the Section in activity—FR for you, OM. 9CWA is "taking on" television movies. 9EHO still sticks to the set in spite of the warm weather calling him. 9DOQ at Duluth is another prospect for ORS appointment.

Traffic: 9EGN 41, 9CWA 10, 9EHO 6, 9FTU 5.

NORTH DAKOTA — Acting SCM, Prof. H. L. Sheets, 9DM—9CDO has been experimenting with a transceiver and took a trip to the Black Hills. 9BRR rebuilt his set and is building a new rig for 10 meter work. 9DYA bought a Marconi megger and manages to work a little with it. 9DM has to move so will be some time before he will be on the air. 9BVF is at CMTC and will not be on till fall. I wish to thank all the gang for the cooperation while I was acting SCM. I hope that the new SCM, 9BYV of Enderlin, will receive as much.

SOUTH DAKOTA—SCM, F. J. Beck, 9DB—9DNS was high traffic man in spite of an operation for appendicitis. 9DGR, the new SCM, says he hasn't found 10 meters yet. 9DB has been QRW with a

new receiver. 9FNN and 9FNM are new stations at Watertown. 9FOQ has been at Boy Scout Camp. 9CJS has a new QRA which promises to be much better. We wish to thank the members of the Section, especially the YMCA Radio Club of Sioux Falls for the hearty cooperation extended to the retiring SCM during his term of office.

Traffic: 9DB 13, 9DGR 14, 9DNS 18.

#### DELTA DIVISION

**L**OUISIANA—SCM, C. A. Freitag, 4UK—On July 3rd 5ANC entertained ten hams. The features of the evening were a "QRK" cake made by the OW and a symphony concert by 5AJK, who played "The CQ Hound"—one of his own compositions. Incidentally, each month the hams in New Orleans hold an informal meeting at 5GR, the Gulf Radio School. 5APA is on his seismograph part again around Plaquemine. 5KH blew his 50 watt and is now second op at 5BCM. 5AGJ runs KRMD. 5KZ has a YL. 5ANK moved to Shreveport. Reception is poor in this vicinity.

Traffic: 5ANC 13, 5BCM 14, 5UK 7.

ARKANSAS—Acting SCM, H. E. Velte, 5ABI—It seems that many of the fellows are taking advantage of the hot months to rebuild their stations. By fall, we expect to have a number of real stations on the air. 5RCZ, one of the new stations in L.R., reports his first traffic. FB, OM. 5HDD is using a pair of 210's with either rect. AC or MG as a plate supply and gets a real DC report. 5ANN is finishing up his transmitter and will be on soon with a pair of 250 tubes. 5HN has gone to 40 meters, and reports some traffic. 5ABI still continues to hammer out a few. 5PX is QRW. 5ABN has moved to Little Rock. 5SS has requested that his ORS appointment be cancelled as he is leaving to take up advanced aviation. 5IQ wants a ten meter partner for testing. 5ZAA traded 5ABN out of 5AUU's power supply. 5AUU is in the hospital with a bullet wound which he received while cleaning his .22 rifle. We wish you a speedy recovery, OM. Fellows, we are proud of the A.R.R.L. and let's make the A.R.R.L. proud of us. This can be done by giving your cooperation to the SCM so that we may have better reports in the future. Let's put the DELTA DIVISION on top.

Traffic: 5ABI 30, 5BCZ 14, 5HN 8.

MISSISSIPPI—SCM, J. W. Gullett, 5AKP—5AGS is silent at this time as he is one of the directors at the Boy Scout camp. We will lose him this fall and winter as he will go to college at Ga. Tech. 5AGV will take up his duties in the experimental laboratories of the RCA the first of Sept. where he will be employed as an electrical engineer. He has been the operator at 5YD for the last four years. We wish you well, OM. 5AQU is instructor in life saving at the Boy Scout Camp now so his transmitter is quiet for the time being. He is going off to college this fall and study dentistry. 5AJJ reports no traffic as he forgot to ground the frame of his motor-generator and blew it up. 5API is off on his vacation so reports no messages handled. 5AED says no traffic as he is rebuilding his entire layout for the narrowed wave bands of 1929. 5AEG is a new station at Vicksburg on the 40 meter band and he is using a UX-250 and says it is FB. 5FQ reports one message handled as he shot the transformer in real dead for the last three weeks so he hasn't his receiver. 5AKP says that 20 meters has been real dead for the last three weeks so he hasn't handled as much traffic as he usually handles.

Traffic: 5FQ 1, 5AKP 49.

#### HUDSON DIVISION

**E**ASTERN NEW YORK—SCM, F. M. Holbrook, 2CNS — Eleven stations report 226 messages. 2APQ has a new 44 foot mast and worked 14 G's in 4 days. 2MZ is on vacation. 2AYK reports traffic still fairly brisk even in this bad weather. 2ANM kept nightly schedule with cutter *Marion* NITB, in Labrador waters and delivered many coast guard messages via Western Union or mail. 2BKE reports 4RN now too deep in army work to keep us northern schedules. 2AUO has rebuilt shack and is back on the air. 2RJJ still uses an 852 but will use a 210 for 20 meters. 2ABY finds his new Zepp much better than fundamental antenna with counterpoise. 2AXX still scores. 2AGR with a 250 watt wants an ORS. 2ACY has worked EG, SV and FO. 2CWH is putting in crystal control. 2BOW will be off the air until Fall.

Traffic: 2APQ 73, 2AYK 71, 2ANM 83, 2BKE 15, 2AUO 11, 2JE 5, 2ABY 4, 2AXX 2, 2AGR 2, 2ACY 2, 2CNS 1, 2BJJ 7.

NEW YORK CITY & LONG ISLAND—SCM, M. B. Kahn, 2KR—Action is being taken by the SCM to clear the section of inactive ORS. By the time the next report is due, many who are indifferent to the meaning of an ORS certificate will no longer have valid tickets. It should be understood that monthly reports are necessary to the retention of an ORS appointment as the activity that is expected of every ORS. The new RMs are 2BGO for Manhattan, 2BBX for Bronx and 2AVB for Long Island. 2AVB has been the L. I. RM for some time but has received little or no cooperation from the L. I. Stations. The RM position for Staten Island is vacant and those who think they can qualify for the job are invited to send me this application.

Manhattan: 2ALU is going strong from his new QRA and expects to better his record of last winter. 3BVA and 4DX are the owners of 2ALU. 2BGO still keeps his nifty ham sheet "The Xmitter" going. Watch his smoke. 2AOJ is at the CMTC at Ft. Monmouth and expects to move to L. I. on his return. 2AFO is a new ORS and is very active. 2BCB is on quite consistently and doing fine work. 2BNL is still among those present. One of the few Old Timers who report consistently. 2AEE is a USNR station and expects to spend his vacation aboard a destroyer. 2KR is doing experimental work on airplane communication with 2AES.

Bronx: 2APV rates highest in traffic with 2CYX next. 2BBX, the new RM, is still the most consistent low power station and is using crystal now. 2AET reports nothing new. 2SF has a fine 210 500 cycle transmitter.

Brooklyn: 2PF is at Ft. Monmouth, N. J. for a vacation. 2UI is having trouble with a BCL's super-het receiver. 2BDM just got his MO-PA going now. 2AJL can't get many msgs. from the gang.

Long Island: 2AVB, the RM, is the only one to report. (You L. I. fellows better wake up, SCM).

Traffic: Manhattan: 2KR 29, 2AFO 21, 2AOJ 21, 2BCB 14, 2BGO 7, 2BNL 6, 2ALU 6, 2AEE 6. Bronx: 2APV 43, 2CYX 42, 2BBX 14, 2AET 9, 2SF. Brooklyn: 2PF 26, 2UI 5, 2BDM 2, 2AJL 1. Long Island: 2AVB 16.

NORTHERN NEW JERSEY—SCM, A. G. Wester, 2WR—Reports were received this month from amateurs who are not ORS and this is very FB as reports are welcomed from every ham that is on the air and handling traffic. 2WR is striving to put a 1929 signal on the air. 2CP is working nights in Red Bank which shoots all his skeds to pieces. 3KY is handling very little traffic. 2IC is on the air at irregular times. 2FC had a fine QSO with Chile. 2BDF is still very QRW at WMCA. 2MD maintained a very fine sked with WNP for 15 days. 2CJX was kept off the air due to heavy business pressure. 2BY, our YL ORS, has been visiting many stations during the summer. 2IS is busy as ever with WKBO. 2AVK just returned from Canada and is back on the air. 2BAL and 2GV have good contacts with South America. 2IX is at camp for a few weeks. 2AOP is back from vacation and will make the BPL regularly. 2BJT, the station of the Hackensack Radio Club, is on the air regularly on 40. 2AOS while vacationing in Vermont, used the portable call 1BAS. 2BME makes the BPL with a very fine report as a result of the famous "20th Century Limited Express Route." 2AOS will shortly change his QRA. 2ABC has put up a new mast and Hertz for 40 meter operation. 2BIH is receiving reports from across the pond.

Traffic: 2CP 13, 2EY 1, 2JG 13, 2FC 2, 2BDF 3, 2MD 32, 2BY 7, 2AVK 4, 2BAL 7, 2JX 3, 2AOP 2, 2BME 252, 2AOS 2, 2ABC 4.

#### MIDWEST DIVISION

**N**EBRASKA—SCM, C. B. Diehl, 9RYG—9CHB is dinkering with 50 watts. 9CDB is having a rush of business. 9BQR went to 50 meters. 9EQF is going to the Univ. at Lincoln and expects to assist 9ANZ this winter. Sympathies are extended to Mrs. 9EEW in her sickness. 9DFR works at WOW afternoons and has the whole morning to build a MO-PA set. 9DVR surely is giving them fits for this time of year; and is doing the work of the Chief as well as Asst. Observer. 9DI is in the midst of harvest and is QRW very. 9CHB is rebuilding with fifty watts on 40 meters; and expects to bust out

soon. 9CDB is having a big rush of business this time of year. 9BQR has finally got down to 20 and walks out right smart. Good for you Art, OB. 9CBK will be on the air any day now with 250.

Traffic: 9DVR 12, 9DI 6, 9CHB 14, 9CBK 2.

IOWA—SCM, H. W. Kerr, 9DZW—Thirteen stations reporting, seven ORS and 6 non-ORS, doubling the traffic of the corresponding month a year ago. FB. Prospects improved! 9BCA has daily skeds with CAB Marine Corps Stn. at Puerto Cabezas, Nic. and 9CZC QSO nz-ZAZ. 9DRA's best DX was oz-4AE while 9DZW gets his first EG. More reports of personal contacts than traffic briefs. The RM and SCM visited 9BKV, a great Ham-Chix-Fest it was, his heart is with us and he may QSU when he gets settled later. 9BCA has Friday sked with 1MK. 9EDW is keeping three daily skeds. 9BIP asks for club dope. Keep the SCM posted on traffic news and send the RM your skeds promptly.

Traffic: 9BCA 126, 9EHN 59, 9EDW 40, 9DRA 27, 9PB 12, 9EIW 11, 9DZW 11, 9FRZ 9, 9CKQ 7, 9CZC 1, 9FAR 1, 9DPL 1.

MISSOURI—SCM, L. B. Laizure, 9RR—9ARA plans a jaunt east in Sept. before school opens. 9BUL handled some interesting traffic for sea-going operators. 9BJA says skeds QRT temporarily for QRN. 9BFB-FSI work daily morning, noon and night on 178 meters if you can imagine being on that much. 9COY and 9FRG are frequent visitors at 9BFB. 9DMT moved the works and reports better DX. 9EPX did his part to boost traffic, by originating some and applied for ORS. 9CBC is working with 9ERM. 9BQS has not been going since the close of school. 9LI was off most of the time due to job QRM. 9ASV pounded brass regularly but traffic was scarce. 9DKG tried to get going on 10 meters. 9DAE says ND, too hot and no dope came in from the gang. 9DAE has joined the USNR. 9DOE is a prospective member. 9EUB had a few mags and much QRM from his new Ford. 9CRM is still off due to QRM. 9CDF reported by Western Union that he is still on the job and keeping sked with 9ERR. 9BEU led in reported traffic despite QRM from rebuilding and moving the station to cooler quarters, plus addition of crystal. 9ZK lost several bottles changing the stuff around but is holding on with some 210's and says he gets out just the same. 9DZN is trying to arrange skeds and handled some traffic. 9BMU also handled a few mags thru QRM from exams. 9BEQ and 9AOT remembered the SCM from Victoria, B.C. a stopping point on their western tour. Many thanks, OMs. 9DLB is closed for the summer. 9DUD has completed his new transmitter and is using a 204A. 9DOE sends in another long distance report from WNX. 9DQN had the misfortune to paralyze his 50 while trying 20 meters. 9BSB has installed crystal in his high power 210 layout. 9BUR is a benedict from last month. 9ZD and 9DQN acquired a flock of Edison A bats for filament supply. 9ENU, 9FTO and 9DOJ kept up USDA test work. 9RR was obliged to drop the same. 9LD and 9DEF are absent in N.Y.C. 9EQC led in traffic reported in K.C. with 9ENU second. The new club meetings are drawing a fine attendance. 9FIO has gone to the country for a vacation. 4HX has been a K.C. visitor recently and will probably stay with us this winter. Welcome, OM. 9BKK is reported moving to Iowa this fall and will be greatly missed here.

Traffic: 9DZN 8, 9RMU 4, 9BEU 21, 9ZK 13, 9ASV 5, 9EUB 5, 9DKG 3, 9EPX 19, 9DMT 4, 9BFB 4, 9BJA 15, 9BUL 18, 9ARA 27, 9EQC 35, 9ENU 22, 9RR 3.

#### NEW ENGLAND DIVISION

MAINE—SCM, Fred Best, 1BIG—Well, gang, ole Maine did herself proud in putting on the best Convention imaginable. 9AYU, 2EQ, 2BKC, 2BLO, ex-4CK as well as a great many of the gang from New Hampshire and eastern Mass. were present from outside the state. For the information to those who were not present, and haven't heard, Maine Conventions are to be a regular thing, and the Augusta gang are surely proud of having put the first one over in such grand style, under the able leadership of none other than 1KE. 1BIG led the Maine gang in messages handled this month. Come on, gang, it's surely a cinch to handle over one hundred. 1ANH, 1CDX and 1BAY have won their ORS appointments and Mr. and Mrs. 1AJC are next in line. They have an exceptional station; and it is unusual for an OM and an OW to each have an ORS certificate in the same family. Mrs. 1AJC got a

big kick out of working an-1NIC. 1BLT is a new ham located in Portland. 1CDX sent in a mighty fine total. 1BAY managed to squeeze out a few in spite of YLs and the hot weather. 1ANH is very busy selling Chevies but sent in his report just the same. We think you deserve special mention for the regularity with which you report each month. 1AQD has been appointed an Official Observer. He has a new General Radio wavemeter and hopes to make good use of it in checking up on off-wave stations. Louis, who is our ten meter pioneer, has been able to get a signal thru to 6CZK on that band. 1AQL reports that plans are well under way for the second Annual Maine Section, ARRL Convention to be held in Bangor, Maine, next year. It's a cinch that the ARRL is going forward by leaps and bounds in the Pine Tree State. Three new members of the Queen City Radio Club have been assigned their calls, namely 1KQ, 1AEN and 1AVQ. Congratulations, gang!! Now let's see you all go after an ORS.

Traffic: 1BIG 100, 1CDX 29, 1AJC 17, 1BAY 10, 1ANH 7, 1AQD 2, 1AQL 1.

CONNECTICUT—SCM, Carlton Weidenhammer, 1ZL—The SCM takes this opportunity to ask all ORS to report by the 26th surely as the reports must be forwarded to his summer address. 1AOI yearns for traffic. 1VR is as consistent as usual in his schedule with 1MK. 1TD says that he will be active in Sept. 1AMC has trouble hearing stations on 80. 1BI-BQH has returned to New Haven for his vacation. His schedule with 1TD will carry on as usual when he returns to Boston. 1RP made his first report as an ORS aspirant. He hopes to have a 250 watter soon. 1MK was the star traffic station again. "RP" reports a fine schedule with 60J in Hollywood. 1BGC is on 40 for the summer. 1AMG reports much activity in the Twin City Radio Club since the army was made its headquarters. 1ASD and a former "ham" are incorporating and pooling their apparatus. There should be big doings now, OM. 1AEB is working everything in Europe and environs on 20 and 40 and handling plenty of traffic to boot. 1BNS has torn down his apparatus and does not know when he will be on the air again. A 5 ton Mack truck smashed an Essex into 1ZL's Ford with the result that the SCM is not riding these days. His 80 meter station will be ready early in October. Traffic was handled with WNP this month. 1VE is rebuilding.

Traffic: 1AEB 60, 1ASD 3, 1AMG 7, 1BGC 6, 1MK 406, 1RP 22, 1BI-BQH 63, 1AMC 31, 1TD 22, 1VB 10, 1AOI 105, 1ZL 10.

WESTERN MASSACHUSETTS—SCM, Dr. J. A. Tessmer, 1UM—1AJK is moving up from the cellar and is going to use non-remote control. 1AMZ is QRW visiting local hams. 1ANI reports his 210 went west after an unsuccessful struggle with 1500 AC. 1ANI is spending the month of August at Fort Monmouth. 1ASU reports having handled a message to Tom Heeney from oz-2AC. 1UM thanks 1AWW for the congratulations received. 1BKQ is on the air at odd times, mostly in the daytime. 1BKF, a new Worcester ham, is on the air on 40, handling some traffic.

Traffic: 1BKQ 2, 1ASU 4, 1AWW 6, 1UM 8, 1AMZ 20.

VERMONT—SCM, Clayton Paulette, 1IT—Congrats from 1AJG, OM, and good luck to you. 1AJG wishes to thank all the hams for their fine cooperation during his administration as SCM and knows that they will give the same hand to 1IT. So saying CUL 73 as SCM, 1AJG is signing off but will be on the air in the fall again as usual. SK. Due to QRW the last three months reports will now follow. May: 1FN has a new Jr. op. Congrats, Forrest, OM. 1BEB has 2 skeds now. 1BD is moving back to Plainfield. 1EZ is rolling out FB and QRW skeds now FB, OM. 1CGX on 3 skeds turns out 302 mags. Sure FB, OM. 1ATU is on 20 most of the time. 1YD closed down till fall. 1BCK on AA stuff very FB. 1A00 trims 1CGX having 343 mags. WOW, FR. June: 1A00 rebuilding and on with 204A. 1CGX in New York till October. GL, OM. 1BCK only rolled 47 this time. How, OM? 1EZ on sked with 12. 1BJP is on with a new set and ready to sked again. July: 1FN is doing FB QSOing with hams on 35 meters. 1AJG saying so long OM's and GL. 1BCK is back home after doing some BCL repair work in Manchester, Vt. 1NH is on all three wave bands with 270 volts of B battery with 1 201A tube. 1EZ worked his first DX on 20 meters, hooking sb-2AL.

Traffic: May: 1FN 4, 1BEB 13, 1EZ 51, 1CGX 302,

1YD 26, 1BCK 185, 1AOO 343. June: 1AOO 89, 1CGX 157, 1BCK 47, 1EZ 12. July: 1BCK 19, 1NH 6, 1EZ 6.

**NEW HAMPSHIRE**—SCM, V. W. Hodge, 1ATJ—Nice weather and YLs are proving great attractions to most of the gang, 1IP being particularly hit. 1AOQ has been busy laying sewer pipes (For your underground antenna, OM?) 1BFT is busy getting his 852 to function properly. 1AVL is doing a little DX. 1ANS reports a bunch of traffic from the Maine Convention. N. H. was well represented at Augusta. 1AUy a new op at Meredith was a recent visitor at the SCMs. 1BST in Berlin is now ORS and ready for traffic.

Traffic: 1AOQ 50, 1BFT 23, 1ANS 20, 1IP 6, 1ATJ 5.

**EASTERN MASSACHUSETTS** — SCM, E. L. Battey, 1UE—1LM reports a traffic vacation. Hi. 1AGS is trying for a two-letter call so that the W prefix will not make his call too long. 1ADM worked oa-2RH. 1NV says 20 is nowhere near as good this summer as last. 1RY has now worked all continents and is waiting for a card from India. Good luck, OM. 1KH tried 80 and got an answer to every call for 3 consecutive days. FB. 1CMZ is married so not much doing for a while. 1KY took a trip down N.Y. state and visited 1MK enroute. 1UE blew another 210. 1NQ, 1FL and 1ON all sent in reports. 1WV, 1APK and 1AXA were all QRW vacations but are now back QRW ham radio. 1ACH and 1UE have schedules with 1MK. 1RL, 1AQ, 1ATG, 1ATO and others all went to Maine convention and had a great time. 1BZQ got the 20 meter set going which seems to be the berries. 1ASI is back to old reliable 50 watter. QRM is bad at 1ABA from his car. 1BBT sends in his first report. He will soon be an ORS. 1NK is still very interested in Naval Reserve work. 1BVL is now working in Danvers, and a couple of others expect to start a station there in the fall. 1SL has been at his summer home in Shirley.

Traffic: 1UE 27, 1ASI 35, 1ACH 32, 1BZQ 27, 1KH 20, 1LM 9, 1KY 9, 1ADM 10, 1RY 8, 1FL 8, 1BVL 8, 1AGS 7, 1APK 4, 1BBT 3, 1ABA 2, 1NK 1, 1WV 1, 1NV 1.

**RHODE ISLAND**—1BDQ says business and hot weather cause terrible QRM with radio. He will be going again in the fall. 1AWE is spending a vacation at Bar Harbor but will be back on the air by the time this report is in print. 1BLS's 210 went west and the receiver seems to be grieving over its loss as it also refuses to perk. Hi. 1MO reports not much traffic during the hot weather.

Traffic: 1AWE 6, 1MO 8.

#### NORTHWESTERN DIVISION

**ALASKA**—SCM, W. B. Wilson, WWDN—7SC, "The Voice of Alaska," reports working a YL opr. at ai-2GL on 40 meters, signals R4 steady. 7JR and 7HL were busy as usual with relay traffic. 7ABE and 7AER along with 7JR made the BPL this month. FB. Reports are late getting to QST mailed at the end of the month so request prompt reports not later than 25th via radio so final report can be mailed 26th when possible. There are several NA stations on the air frequently who are never heard from in reports, please let's hear from you. 7AER at St. George piled his totals up principally with the Schooner Morrissey and the Coast Guard Cutter UNALGA.

Traffic: 7HL 234, 7JR 206, 7AER 176, 7LY 150, 7TO 108, 7ABE 108, 7SC 50.

**MONTANA**—SCM, O. W. Viers, 7AAT—7HP is still the star station of the section even though his totals have dropped. 7AAW has been on a little and handled a few. 7DD says QRN is sure fine in Butte—it drowns everything out. Hi. The ORS appointments of 7EL and 7AFM have been temporarily cancelled as they are very busy during the summer time and don't get a chance to be on much. 7AJU belongs to the same list as he is still pounding brass at sea. 7AAT-QT hasn't had time to be on much due to so much work at the printing office. Please report, gang, or you'll be sorry.

Traffic: 7HP 52, 7AAW 23, 7DD 1, 7AAT 4.

**OREGON**—SCM, R. H. Wright, 7PP—Although some traffic has been handled, there has been a decided lack of activity reports, for the reason that nearly all of the ORS are on the inactive list due to vacations, rebuilding, etc. However, with the opening of the Northwest Division Convention and less QRN due to warm weather, this Section promises to

be "up and coming" for winter activity. 7PL is QRW but says he will keep his 250 warm for this winter. 7GQ just manages to operate his 75 watter enough to keep on the air.

Traffic: 7AKK 102, 7ALK 19, 7EH 13, 7MV 15, 7GQ 6.

**WASHINGTON**—SCM, Otto Johnson, 7FD—7AM used his portable station 7HE during a vacation trip and reports tourist traffic FB. (probably both automotive and radio). 7LZ handled quite a lot of traffic but forgot to report. 7AEV and 7ACB are trying for ORS. 7RL is going east and will sign 2PDQ or something soon. He will go into vacuum tube research work. 7BM is touring Calif. 7VL reports increasing activities in Spokane. 7UE, 7SG and 7VK are newcomers there. 7AFY and 7AGO are touring. 7VL is QRW with 7XAB. Tacoma is again waking up and some good work is being done. A large number of Seattle and Tacoma hams took in the Vancouver, B.C. ham convention and 7ACB brought back a 250 watt bottle as a prize won in a code contest. Seattle is all set for the big convention Aug. 31 and Sept. 1. A joint picnic of the Seattle and Tacoma clubs is to be held Aug. 12 at Lake Lucerne. This picnic will also serve to work up enthusiasm for the convention. Hi. 7OV has just finished rebuilding the station with special preparations for the coming 10 and 20 meter dx.

Traffic: 7AM 208, 7AEV 36, 7TX 29, 7VL 10, 7ACS 9, 7TJ 8, 7AGO 5, 7UI 5, 7AFQ 4, 7ACA 2, 7ACB 2.

#### PACIFIC DIVISION

**EAST BAY**—SCM, J. W. Frates, 6CZR—Traffic totals are going higher and higher in spite of the fact that the summer months are popularly believed to cause an annual slump. 6KV, the Calif. Nat'l Guard station at the summer camp in San Luis Obispo, poured a steady stream of live messages into the section. The station kept schedules with 6ALX and 6BTZ. 6ALX came second to 6KV. Both stations made the BPL. 6HJ is coming up rapidly as one of the star trans-oceanic traffic stations through his skeds with op-1HR, oh-6CFQ and na-7AER. 6SR reported the remainder of the Nat'l Guard Camp traffic. 6BTZ made the BPL two ways through his skeds with 6KV and other stations. 6CZR made the BPL for deliveries thru schedules with op-1CW and op-1PW, AC and NA, and is planning to be on 80 megacycles for the next tests. 6ZX again hit the BPL for deliveries with some of the 6KV traffic. 6BOY made his mark with a good traffic total. 6AWM has been hitting the ball on 40 meters instead of on 80 meters and has been working VOQ and other stations. 6IP blew his seven and a half watter but is back on the air again for a high total with 6CZR's prized UX-210. 6CLZ says that his messages total 924 words, and one of them was in Spanish. Hi. He has been working OA on 20 meters, as well as keeping NU skeds. 6EBA, a new man in the traffic game, did the proper thing and reported his totals right off. FB. 6RJ spent his vacation among the hams at Santa Cruz and Capitola boosting the coming convention. 6COL has been working WWEG in Alaska. 6AWF is still perking away in FB style. 6BPC is having good results with high power and says one benefit from living in the same town with NPG (both arc and CW) is that the BCLs never think of hams. 6EDK is again in the throes of rebuilding his model station. As OBS he sends out League QST's in FB shape with automatic tape machine while assisting the OW to tune in on the dinner dishes. 6EDR just raised an interest in traffic and is playing with receivers using plate detection. 6EY keeps a sked with 1MK. 6DDQ is doing FB work as RM of the northern part of the Section. 6CDA is having a fine time rebuilding with crystal control, frequency doublers, and power amplifiers. 6CGM blew his 50 and asks the gang not to tell the OW that he is buying an 852 until after he gets it installed. 6IT, chief observer, has rebuilt his receiver using stage of untuned shield grid r.f. and says he gets a volume increase equal to a couple of stages of audio. 6OT, the Oakland Radio Club station, is back on the air. 6BSB tries all circuits. 6DCZ has been bitten by the remote control bug and is putting everything out in the barn. 6BFO is going to use a 50 and a Colpits. 6CCT has been at Lake Tahoe operating his portable 6CDH. BAM of Tahiti was a recent visitor in this Section. The Central Calif. Radio Club is being reorganized after several months on inactive list and may have 6WW back on the air again. 6AYC is on the way around

the world with 6CLV as commercial operator on liner.

Traffic: 6KV 543, 6ALX 507, 6HJ 236, 6SR 148, 6BTZ 121, 6CZR 93, 6ZX 65, 6BOY 62, 6AWM 42, 6IP 37, 6CLZ 37, 6EBA 29, 6RJ 12, 6COL 9, 6AWF 7, 6BPC 6, 6EDK 5, 6EDR 4, 6EY 3.

LOS ANGELES—SCM, D. C. Wallace, 6AM—6ZBJ sends us some gossip: 6CMY is back on with a 20 meter set doing FB. 6AWY is back on again at Santa Maria and says he wants to be an ORS soon. 6CND got married so guess he is out for a while 6BHN is off and on—YLitis. 6EBV is a new ham in Santa Maria and is going to develop a FB fist, it seems. 6UJ is keeping some good schedules, and reports a visit from 6ZBJ which was not nearly long enough. 6UJ has good connections for delivery of traffic in Los Angeles and small towns nearby and any hams with traffic should hand him a call from 7:45 am to 9 am any day. 6AKD handled traffic from New Zealand college to U. S. C. Dental College through oz-2AX. 6CUH got reports of R7 and R8 from oz and oz. 6CHA has been off the air most of this month due to selling part of his station. 6OF reports QRN is getting worse up there in the mountains, and most of his traffic is handled on 40. 6AM is using 1/2 KW air cooled tube for a change. 6DKV handled a message from a tennis champ sending for money and answered message in 15 minutes. 6DKV in trying to get to the A.R.R.C. club meeting on time, ran over a cat and dog, and had to come on rim plus one headlight. 6BZR blew his 50 on Fri. the 13th and sent it on a round trip through 6EX. 6BRO expects to have a sked with 6AJM of San Diego as soon as he completes his building operations. 6DKX reports weather rotten, and very busy with regular work. 6AGR says DX is not so good. 6BVM hooked New Caledonia. 6DOW expects traffic to pick up soon. 6ABK has been on his vacation and says not much is doing there in summer, with the shack so hot and the ocean so cool. 6ALR is building a new set and also has spent some time on Television. 6CNJ just got back on for good and is looking for skeds. 6CBD says traffic is scarce there but he is trying to get a sked with 5PA for southern Calif. messages. 6DMG says things are not so good there. 6EEB declares the 20 meter band dead, 40 meters fair but not enough traffic to be found. 6DGT is completely tearing up the set and reports DX good but weather terrible. 6ASM wishes to thank 6DGT and 6AGG for their fine work in keeping him in touch with home while in San Francisco in June. 6DHR received a visit from 9DRV. The H. P. Radio Club tried sending code practice to its members while they slept but results observed were nil. 6CHT has been "promoted" from chief operator to announcer at KFQZ. 6DFG built new 85 meter phone transmitter aka QST with storage batts exclusively. The RCLs rave about the tone quality. 6BJX was going to the midsummer meeting of the Pasadena Short Wave Club the night he sent in his card. There was going to be a big mystery surprise, and eats to be served and prepared by Mrs. BXD, Mrs. BTM and YL 6HXA. 6COT has been off the air most of the month due to heavy QRM from work. 6BGC reports that Glendale is hatching several new hams and he heard about five from last ham exam. 6AKW is going to try some M.O. xmitter for fall set. 6CZT is very QRW with the radio business but hopes to have things arranged so he can get back in the fun soon. 6AEC has been making his station over. 6EAF wants a hookup with anyone 6AM to 7AM, 7 PM to 8:30 PM weekdays. 6BVT reports that the Eagle Rock Ether Splitters took a trip to the beach for four days this month with the portable transmitter and their best DX was Hawaii. 6CQA reports that the Artists Studios is using his set on location at Santa Barbara. When he gets it back in August he is installing it for airplane communication. 6DHU evidently had to choose between putting his time in on radio or a "hopped up" Ford and the Ford won. 6AIO is operating KFQZ now and doesn't have time to pound brass much. 6DPK will be on 20 and 40 meters soon after several months' inactivity. 6PY, 6SJ, and 6CMQ also report.

The A.R.R.C. announces that the Section banquet will be held in Los Angeles in September. 6AGR's station will be quiet while he is doing his stuff for the Nat'l Guard of Calif. as their radio sergeant, Aug. 4 to 18. 8SF is now in Calif. as 6CUI and proves a very fine operator for our section. The Long Beach radio club, the Associated Radio Amateurs, met with 24 present. A low power contest with the A.R.R.C. was discussed. The Foothill High Frequency Club is a new club just organized with H. W. Keiser as Pres., C. L. Sweeten, Vice-Pres., J. K.

Anderson, Sec. and Treas. 4ABR is traveling around the country with his folks, and dropped in to see us at Long Beach.

Traffic: 6ZBJ 131, 6UJ 88, 6AKD 70, 6CUH 63, 6CHA 52, 6OF 50, 6AM 32, 6DKV 31, 6BZR 30, 6BRO 27, 6DKX 22, 6AGR 22, 6BVM 19, 6DOW 16, 6ABK 12, 6ALR 10, 6CNJ 10, 6CBD 10, 6DMG 10, 6EEB 8, 6ASM 6, 6DGT 7, 6DHR 6, 6CHT 6, 6DEG 6, 6BJX 5, 6COT 4, 6BGC 2, 6AKW 2, 6CZT 1, 6AEC 1, 6EAF 1.

PHILIPPINES—Acting SCM, J. E. Jiminez, op1AT—Report received by radio from op1DR via 6AMM.—"op1DR kept a sked with am-3AB for European traffic and op1AH for Manila deliveries. All P.I. amateur station licenses and renewals are now being subjected to provisions of last Washington conference as regards wavelength allocations so 1DR is now operating on 41 meters."

Report received by radio from op1HR via 6AMM.—"Skeds are kept with op9PB, Zamboanga, at 5 pm daily, with ac-2ZW (Observatory, Shanghai, China), 6 pm daily, with nu-6HJ 6:30 pm daily, ac-2MO 7 pm daily, op-IRC (Radio School, Cavite) 8 pm daily, nu-6AMM 9:15 pm daily except Sun. We worked seDCXR at Galapagos Island and ne5CO, handling most traffic with 6AMM."

Traffic: op1HR 760, op1DR 258.

SAN DIEGO—SCM, G. A. Sears, 6BQ—6DNS leads the Section, besides being on USNR cruise to Honolulu. He reports a fine time on the Islands and was royally entertained by the OH gang. 6AJM has a new sked with op-1CM now and traffic is moving fast. 6BAS has 3 complete transmitters on the air now and is testing out 10 meters. 6BQ had temporary sked with op-1HR. 6BZD reports but little traffic on 20. 6BGL reports as usual. 6FP has sked cancelled. 6BFE blew two 210's. 6BAM has been sick but remodelled his shack. 6QY has a new YL in his family. 6AKZ has been on a vacation. 6CNK is getting ready for 10 meters. 6BWI has been working two jobs lately. 6AKQ is at sea for a couple of months and is inactive. 6DOB is in charge of a YL gang, Miss Florence Terrell being the chief op. there. This will be news to most of the gang. She signs "ET" and Lloyd Jones is "LU" when in town.

Traffic: 6DNS 32, 6AJM 25, 6BAS 18, 6BQ 15, 6BZD 10, 6FP 9, 6BGL 7, 6BFE 1, 6BAM 1.

SANTA CLARA VALLEY—SCM, F. J. Quement, 6NX—The usual run of traffic came through 6AMM this month. 201 delivered messages ought to put Bruce again in the lead over any ORS. A pair of 352's in a self-rectifying circuit will soon be placed for use in this PI circuit. 6BHY also continues to handle a nice bunch of traffic. 6BMW is on vacation this month. 6ALW will soon have an 852 on the 30,000 Kc. band. His traffic has been normal. 6BYH was too QRW during the month altho he managed to handle several messages. 6NX is building a SG receiver. 6BNH is also QRW. Let's have a 100% report next month.

Traffic: 6AMM 295, 6BHY 23, 6BMW 26, 6ALW 22, 6BYH 10, 6NX 6.

HAWAII—SCM, F. L. Fullaway, 6CFQ—The army gang are at summer camps so their traffic is light. The air seems dead. Some activity on ten. There is a large field on 10 meters. Who is going to be the first one to help put Hawaii on the map on ten meters? 6CFQ has the highest traffic total. Traffic for the yacht race personnel was handled every night with 6AIJ. 9DSE-6AWR-WGDJ quit the Pandora here and spent three weeks with 6CFQ. Two interesting skeds were kept with SIU and the submarine V3. 6DEY has been struggling with a xtal xmitter with no luck but turned in a good total. He kept a sked with xnu6CLV all the way from Cuba to Honolulu and still works him. 6CLV is QRD around the world on the Pres. Pierce. 6ADH still handles his share of traffic but is very QRW at RCA. 6DQQ hits the high spots on Maui. 6DCU only pounds when he gets leave as he is in the ARMY now. 6DJU took a fiver to camp with him and works nu easily. Uses 6EDJ as portable call. 6DPG is working on ten meters. Has an ultra audion and it WORKS. 6CLJ reports that 6AKP was elected pres. of the High school radio club with 6ALM as vice-pres. 6DTR is at camp Chemsig with portable call 6BBC. 6CFQ and nu6AWR-WGDJ sure caused a commotion amongst the commercial ops. They all want to become hams now. The ops from the British tramp *Saltencate*, the Swede *Buenos Aires*, and U.S. *Lur Line, City of Honolulu*, and others were shown around town and entertained at 6KQ and 6CFQ. Sure made

them interested in ham radio. nu6DNS, nu6PY and several other Naval Reservists were shown the town and pineapple cannery, also. 6DNS used a suit of 6CFQ's civies and went to a dance with him. Hi.

Traffic: 6CFQ 245, 6DEY 163, 6ADH 111, 6DQK 94, 6DCU 80, 6DJU 52, 6DDP 9, 6CLJ 9, 6DLR 3, 6BBC 37, 6EDJ 3, 6ADH (May-June) 166.

ARIZONA—SCM, D. B. Lamb, 6ANO—6BWS leads the state this month in traffic, making the BPL. His YL is leaving for Kansas until school starts so he will be on the air lots during the rest of the summer. 6EAA is a newly appointed ORS with 7½ watter on 40-20 meters. 6BJF has a steady job in Electrical shop so can't be on the air as much as during the past. 6AZM reports on air with a couple of 5/1 ratio transformers getting DC with master oscillator and 25 cycle current. 6ANO had a 50 watter go soft so now is on with a 7½ watter. 6SW is on the air with a DC note from soup recd. 6DGY is in Phoenix on his way from San Diego. 6DIB is on his summer vacation. 6DIE uses mercury arc and seems to be getting out OK. 6EFC bought 6BWS's bug key to improve his fist. 6CDU is leaving Aug. 5 for Army encampment and is taking his transmitter along for gov't work. 6BHC and 6CAP are on with AC. 6CPX is changing his call to 6CDY during the next year when he will attend the Univ. of Ariz, again. 6CBJ went to Wisconsin but no further report of him. Would 6AYU kindly write 6ANO. Have some DX cards for you, being 6AYU was my former portable call. Thanks, OM. The Bisbee Radio Club dance was a success so now they will soon have a 250 watter.

Traffic: 6BWS 231, 6BJF 4, 6EAA 4, 6AZM 2, 6ANO 8.

#### ROANOKE DIVISION

WEST VIRGINIA—SCM, C. S. Hoffman, 8HD—8APN handled the greatest number of messages with 8CLQ following a close second. 8APN reports very consistent QSO's with OA, OZ, NQ and EF. 8CLQ has schedules with 8GI and 9AIN, besides working OZs, SACZ and 8BJB are rebuilding. 8RPV and 8ASE are experimenting with television. 8VZ is still at 8SP. 8DNN is thinking about moving to Fairmont.

Traffic: 8APN 50, 8CLQ 40, 8BJB 16, 8HD 6.

VIRGINIA—SCM, J. F. Wohlford, 3CA—3KU expects to go to sea. 3AQY is using an MO-PA circuit and gets out well. 3II has gone in for television. 3JT and 3II are going strong at the new location. 3WM is operating at 3TN. 3TN has a sked with 3AEE, 3AUA, 3EC and 3AQY are on. 3KU is operating a vertical antenna 104 feet above the street. 3ALS is on 10, 20 and 40 meters. 3ASC is working the 20 meter band now. 3AAJ had QRM from the heat but did fairly well. He is trying out a new receiver. 3RL is putting in an MO-PA circuit. 3CFY expects to get on the air again. 3BZ worked se-2EA. 3CCL did some nice work in handling messages for sick folks via 9BRL and 9BGZ. We wish to extend our sympathies to 3BGS in the loss of his wife.

Traffic: 3CKL 71, 3EC 17, 3RL 3, 3AAJ 21, 3ALS 14, 3ASC 1.

NORTH CAROLINA—SCM, R. S. Morris, 4JR—4TS says very QRW. 4ADJ says too much hot weather for radio. 4AB, the RM asks for letters from traffic men. 4OC still has his fu-PM sked going strong. 4VH says QRX till cooler weather. 4TO took a trip to the beach. He stopped off at 4AB and 4JR long enough to say hello. 4JR had a very enjoyable visit from 8CEO with whom he has had a sked for four and a half years. 4OH just returned from a Florida trip.

Traffic: 4AB 124, 4TO 37, 4OC 23, 4JR 9, 4TS 6.

#### ROCKY MOUNTAIN DIVISION

COLORADO—SCM, C. R. Stedman, 9CAA—9ENM seems to be leading the state this time for the amount of activity. He is holding down 6 schedules and reports them working out in fine shape. 9FUY is a new station run by an old time op, Dick Chase. 9DQD is still off the air but will probably be on again soon. 9DRU is a new station in Delta, Colo. 9CDE says its vacation time and that it sort of curtails his ham radio. Hi. 9CAA says the vacuum in his mercury arc went bye and forgot to come back. 9CSR says he got reports from both ends of the earth but couldn't QSO. 9DWZ dropped us a

card saying that altho he is inactive at present, he has hopes for the future. 9CJY has left Denver to join Gen. Electric but says he is going to try and work back this way. 9BJN is the new president of the Associated Radio Operators of Denver. 9EAM is back on the air just as this report goes in. 9DKM has definitely and positively quit radio at least 20 times in the last two years, and the latest was he was off low power for life, and going on with 250 watts. The next day induction from the high voltage leads to the phone line rang all the phones in his block. 9ERN has moved to Denver and is on 20 and 40. 9BQO has a set all ready to go but his folks swiped his A batteries for the BC set.

Traffic: 9ENM 36, 9CAA 11, 9FUY 12, 9EAM 5, 9CDE 3, 9CSR 7.

UTAH-WYOMING—Acting SCM, F. N. James, 6BAJ—6RM reports that he is leaving us for good. He expects to be on the air in San Bernardino, Calif. by October 1st. In behalf of the gang, I wish to thank Don for the excellent work he has done as SCM. 6BAJ is contemplating rebuilding for 1929.

Traffic: 6BAJ 1.

#### SOUTHEASTERN DIVISION

ALABAMA—SCM, A. D. Trum, 4AHO—ex5ATP now 4AN is on the air for the summer handling quite some traffic and sending out fine sigs. ex5ADA now 4AIP is doing quite some experimental work and is laying low on traffic for a while. 5BBA now 4AHR is working on a new shack for his amateur work and hopes to have a fine xmitter going soon. 5ATS now 4AAQ was on his vacation this month. He hopes to make up for lost time next report. Ex5ATJ now 4AHP just returned from a CMTC camp and is just getting going good again. Ex5AXN now 4AAH had the flu for three weeks and spent all his time recuperating by pounding brass. 4VC ex5AS worked all districts in one hour. FB, 4AIC ex5BBP, who has just been on the air for a short time, is doing some worthwhile traffic work. Ex5AS now 4VC is still pounding brass and is a very consistent station. 4AHZ ex5ARG is on and invites QSO. 4RC ex5TB writes that he expects much activity in that section soon. 5QP has returned and will be on soon. Two new hams are coming in and 5AIW, 5VC, 5HM and 5QP are awaiting their new 4th district calls. 5AYL now 4ANY is doing his bit. He kept schedule with WUAG in Vancouver, Wash. 5JY is rebuilding this month for 1929 and will be back on with a better record than he has had in the past. 5AJJ now 4AHO is on once in a while when business permits.

Traffic: 4AIP 16, 4AIC 5, 4VC 15, 4AAH 16, 4AHP 6, 4AAQ 16, 4AHR 5, 4ANY 21, 4RC 8, 4AN 21.

FLORIDA—SCM, C. E. Ffolkes, 4LK—I am very glad to see the interest shown by the gang, who have remained behind the vacationists during these hot months. The SCM would be very glad to hear from any of the fellows in the section who have not reported before. 4ACC leads the gang this month and will be away during August. 4NE stays on 20 meters most of the time now. The 2nd op at 4ACV has moved to Tampa. Hope to hear from him over there. 4BN has been testing fone work on 80. 4TK sets R3 in OA. 4OB says that QRN is terrible. 20 meters is not so hot to 4HY. 4LK will be on regularly next month. The SCM received a visit from a live prospect in Tallahassee last week. Hope to see you on the air soon, OM.

Traffic: 4ACC 58, 4NE 10, 4ACV 22, 4BN 6, 4TK 2, 4OB 2.

#### WEST GULF DIVISION

NORTHERN TEXAS—SCM, J. H. Robinson, 5AKN—Some of you fellows forgot about your report this month so you're not mentioned. 5BBF reports good traffic and worked one Asiatic station. 5AHU reports good traffic. He has been keeping schedules. 5BAM still hears a few sigs. 5RJ wants a ham for president (of the USA) so that we will have more room in the 40 meter band. He is using his portable, 5VE, at Electra, Tex. 5HY has returned from the CMTC at San Antonio where he operated the 500-watt 500-cycle Army control station. 5AIN, 5AAE is working on 20, 40 and 10 meters and has a schedule with 5RJ. 5AKN is keeping a schedule with 9EMN. 5AKN's crystal control set gets through the summer QRN FB. 5JD is har-



vesting his corn crop. 5JA and 5NW have been on vacations. 5AQ goes golfing.

Traffic: 5BRF 39, 5AHU 18, 5BAM 16, 5RJ 15, 5HY 10, 5AAE 6, 5AKN 5BG 5, 5JD 4, 5JA 2, 5NW 1, 5AQ 1.

**OKLAHOMA—SCM, K. M. Ehret, 5APG—**We are on the last leg of summer now with prospects of a "hot" election between 5AMO and 5FJ running for the office of SCM. With a new SCM at the helm, there is reason to believe that you fellows will make 5YK, SCM of Southern Tex. and 5AKN of Northern Tex. dig to keep their hats in the ring. 5AZG of Fairview says that he would like to work more 5's. 5PA has been re-assigned to a new ham at Enid who is on with a 208A working in a TP-TG circuit. 5ANT has a new 5B2 and will soon be ready for more skeds during early morning hours for state work. 5FJ expects to be back from South America early in Sept. 5AMO is dressing tools for an oil well in Texas and says the pesky well blows salt water all over him during work hours and that he is fairly itching to get back to his transmitter. 5BAE has been away on a vacation but handled some traffic before leaving. 5AYO is doing consistent work. The SCM saw 5AJW with a flat tire on a highway about 30 miles from home but guesses that 5AJW got home OK as he is on the air now. 5AIR has been tootating a mean SAX during the summer dances. 5VH has his new transmitter about completed.

Traffic: 5APG 14, 5AZG 2, 5AYO 55, 5RAE 3.

**SOUTHERN TEXAS—SCM, E. A. Sahn, 5YK—**The summer slump seems to have hit for certain now. Many of the gang are away on vacation and then QRN, the Gulf variety, is at its best. 5EW, the Wilson brothers, say they have been unable to do very much because of broadcast activity. W.W. is operating KHMC at Harlingen and M.J. at KWWG in Brownville. 5PK is in the Japan seas and says that ship radio is the thing for him. 5ALA says he will go on again in a few days. The Radiofest of the San Antonio Radio Club was again a great success. The R.I. was there and examinations were given; stations were visited and a banquet was held. And now, gang, it is time for me to bid you farewell as far as being your SCM is concerned. My new duties as a school superintendent make it imperative that I drop some of my other duties. To continue to try and serve you would have been an injustice to both the amateurs and myself. It is with extreme regret that I had to take this step after serving you continuously since 1921 and as SCM since 1923. But you are fortunate in securing 5OX, Robert Franklin, 1806 Valentine St., Houston. He knows the amateur game and has been a prominent amateur for many years. It is my hope that you get behind him and cooperate with him in every way. I thank each and every one of you for the cooperation that you have given me.

## CANADA

### QUEBEC DIVISION

**QUEBEC—SCM, Alex. Reid, VE2BE—**The second annual picnic was held at St. Genevieve, Saturday afternoon, July 7th, and was the greatest get-together of transmitting hams and their friends ever held in this Division. There were 92 present; and judging by the comments received from the gang, everyone had a wonderful outing. The weather was ideal and with two movie cameras in action, the boys will be able to review the whole afternoon at one of our fall hamfests. In the Soft Ball game, the Everready team won by a score of 20 to 9 over the Burgess team. There were 37 prizes distributed during the afternoon to the winners of the running, three-legged, peanut, sack and walking races. Space is too limited to give the names of all the winners, but the OM from the South Shore was sure there in the sprints. Harry Sloan, as field director, and Chas. Archibald as official scorer deserve a great amount of praise for the efficient way in which the events were run off. The same goes for Mr. Burke, who had charge of the swimming pool, and Geo. Wendt, who had charge of the fruit stand. The ladies all agree that Harry Parker is the champion Tea brewer! The SCM wishes to thank the following who so kindly donated the prizes: Everready Battery Co., Can. Westinghouse Co., Electrica Ltd., Burgess Battery Co., G. C. Payette Co., W. T. Hawes Ltd., Alphy Blais and C. H. R. Bird. 2BH is going to the Arctic on the Beothic and will be glad to work hams in his spare time. Beothic call VYG, wave about 80.5.

Traffic: 2AC 29, 2BW 14, 2BR 22, 2BB 12, 2AL 3.

## ONTARIO DIVISION

**ONTARIO—SCM, W. Y. Sloan, 9BJ—**Central Dist.: 3DY has been keeping a sked with 3CJ; and his traffic has flourished as a result. 3CJ is on his annual vacation—all summer—at Bobcaygeon, Ontario, and he has his trust 210, etc., along with him. It is cooler these nights. "Bud" is getting traffic routes lined up throughout the Province while on vacation so that everything will be all set for fall weather. 3BP is on regularly on 52.5 meters despite the weather. 3CL has been licensed and is now on the air using a 201A in the transmitter to start with. He has already been reported as heard in Ottawa. 3BO has been keeping schedules both east and west. 9AL has departed for Stoney Lake. We believe that he has a portable set along. 3DC has been using 52.5 regularly and has received a report from England. 3DV is getting ready for the Fall. 3AI has a transmitter that still works—occasionally. 3BT was on all waves as usual. 3FC and 3BL went to Ottawa on the latter's motorcycle and were royally entertained by the fellows there. 3BL is going to do some survey work on reception conditions using a portable receiver and his motor-bike. His 210 still oscillates on 52.5 at every opportunity, and speeds the official broadcasts regularly every night at 9:30 EST.

Southern Dist.: 3CS has worked his 36th country. 20 meters is responsible, we believe. 3CB is using 40 and 80 when possible. 3CB paid a visit to Hamilton and had a very nice time with the fellows there. An old timer has turned up in Windsor and is operating under the call 3BV, mostly on 52.5. 3BV may be a great help in our prospective traffic net. 3AQ has been busy installing a station at the Armouries in his town. 3HB is a new station in London. Sarnia is not heard from very much. Wotsa matta? 3AY is preparing to make his 210 sit up and take notice.

Eastern Dist.: 3JW is now on the air and going strong on 52.5 with a fine punch. Jimmy is unfortunately blind and gets a great deal of pleasure from working his set. 9CC sends time signals from the Dominion Observatory daily on 52.6 meters from 2:55 to 3:00 pm EST.

Northern Dist.: 3ET and 3AR are on occasionally. 3ET keeps schedules with Toronto. 3EH is active in the Bush and rolled up a good traffic total working on schedule with Toronto. 3HP is keeping an OBS schedule and working with the out-post stations in the North Woods. All of this work is, of course, on 52.6 meters.

Traffic: VE3EH 62, VE3FC 47, VE3DY 25, VE3CJ 23, VE3BT 11, VE3CS 10, VE3BV 8, VE3AL 6, VE3BO 6, VE3BL 6, VE3AI 2, VE3CB 2, VE3AY 1.

## PRAIRIE DIVISION

**MANITOBA—SCM, D. B. Sinclair, VE4FV—**VE4BT has been the most active station in the section. He sold his 50 watter to VE3GQ and then worked oh6BQH and oh-3WH on a 210. VE4GQ is on 20 meters. VE4DJ has been working on 40 meters. VE4DP, VE4NR, VE4GI and VE4DK prefer the TPTG circuit; while VE4EK thinks the series Colpitts has no peer. VE4HF is the call of ex-4NR. VE4GG has a DC note. VE4DB and VE4FN are trying for DX. VE4FV worked Russia. VE4DW keeps his regular daily schedule with Winnipeg. FB, OM.

Traffic: VE4BT 10.

**SASKATCHEWAN—SCM, W. J. Pickering, VE4FC—**Two new ones are on the air—VE4AA and VE4AI at Yellow Grass and Meacham. 4AA has a Hartley, pushed by a 171 and wants to QSO other Sask. stations on 40. 4AI is using 2-201 A's in a MO-PA layout with B batteries and wants to meet the gang on 80. 4GR has had quite a number of visitors lately and very few QSO's or DX. 4FC has a new Flivver so isn't doing much brass-pounding. 4BL has gone to the U. S. for a while.

Traffic: 4AI 8, 4GR 3.

## LATE AND ADDITIONAL REPORTS . . . . .

9EKM has been very busy since graduation. 7TY is using a new 5 watter now. VE5BF has gone and married so that accounts for his absence from the key. 6CIS says his skeds with Alaska and the east are FB and help traffic. 6ATQ has rebuilt his receiver, using tube base coils, and it works FB.

Traffic: 9EKN 1, 7TY 20, 6CIS 103, 6WR 12, 6DON 17, 6ATQ 7.