

# QST

DEVOTED ENTIRELY TO

# AMATEUR RADIO

PUBLISHED SINCE 1915 BY THE AMERICAN RADIO RELAY LEAGUE INC.



**JANUARY**

**1929**

**25¢**

# 1929 IS HERE—

SO IS THE NEW 1929

## RADIO AMATEUR'S HANDBOOK

1929 means **NEW REQUIREMENTS**. The Handbook, the radio amateur's guiding light, is the most valuable help you can have in meeting these requirements.

Mr. Ross A. Hull, the director of the A. R. R. L. Technical Development Program, has collaborated with Mr. F. E. Handy, original author of the Handbook, so that the new book is completely overhauled and rewritten.

Much that was excellent practice in the past becomes obsolete under the new requirements. Even if you have previous Handbooks, you must secure a copy of the new one to keep abreast of the changing conditions.

The complete story of Amateur Radio, what it is all about, with sympathetic, elementary information for the beginner, all the way up to the complexities of the most modern gear and the profundities of the most involved traffic-handling procedure—all in 1929 viewpoint. Whoever you are, whatever your interest in amateur radio, you just can't get along without the New Handbook.

And the price is the same—\$1 postpaid anywhere

Just off the press

Send in your order now.

**AMERICAN RADIO RELAY LEAGUE, HARTFORD, Conn., U. S. A.**

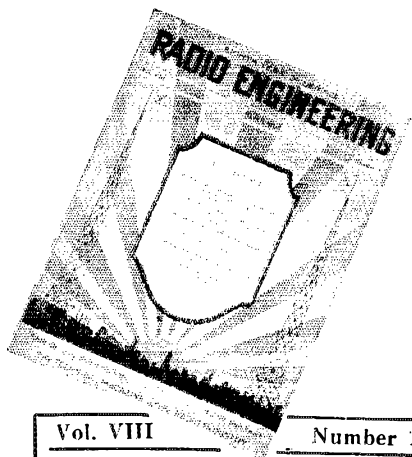

Vol. VIII

Number 12

**Contents**

- Grid Circuit Detection Distortion  
By J. R. Nelson
- The Industrial Laboratory  
By Zeh Bouck
- Corrugated Shipping Containers in  
the Radio Industry  
By J. D. Malcolmson
- Some Practical Data on Public  
Address Amplification  
By McMurdo Silver
- The Mathematics of Radio, Part  
XIII.....By John F. Rider,  
Associate Editor
- The Engineering Rise in Radio,  
Part VII, .. By Donald McNicol
- Radio Inspection  
By James E. Smith
- Constructing a Modulated Oscil-  
lator, By John B. Brennan, Jr.

**Departments**

- Constructional Developments
- News of the Industry
- New Developments of the Month
- Buyer's Directory

**- If -**  
You are interested in the  
Engineering develop-  
ments in Radio; if you are  
an engineer, a dealer,  
technician, custom set  
builder, or an advanced  
experimenter

**Read further and  
Use the Coupon**

**A** GREAT deal of material for the "radio contractor" will appear in Radio Engineering during the next few months. It will include articles dealing with the installation of speech amplifying systems for theatres and auditoriums, radio wiring for apartments, hospitals, etc., aeronautical installations, and the various commercial and industrial uses to which radio is being put. It'll be good. Don't miss it.

**Radio Engineering is NOT sold on newsstands  
(See coupon Below)**

BRYAN DAVIS PUBLISHING CO., Inc.  
52 Vanderbilt Avenue, New York, N. Y.

Enclosed find { \$2.00 for 1 year } subscription to Radio  
                  { \$3.00 for 2 years } Engineering.

Enclosed find twenty cents (20c) for which send sample copy  
of Radio Engineering.

Name .....

Address .....

City ..... State .....

**PLEASE PRINT NAME AND ADDRESS**

Please Check Your  
Classification

- Manufacturer
- Dealer or Distributor
- Engineer
- Professional Builder
- Service Man
- Technician

Anything Else.....

# The phantoms of music now become REALITY!



**I**NSTRUMENTS—golden notes—formerly lost to radio now come through broadcast receivers in full tonal beauty. No longer does the bass viol come in thinly on overtones alone—no more do the shrill notes of the piccolo at top register die away in a shrill, reedy absurdity. The modern radio has **TONE!**

Better broadcasting—better tubes—better speakers—but it has remained for Sangamo to build transformers to match these improvements. And particular attention is called to Sangamo Push-pull transformers! The Sangamo Push-pull Input Transformer has an extremely high primary inductance to secure faith-

ful amplification of low notes and an accurately divided secondary insures practically identical frequency characteristics. There are Sangamo Push-pull Output Transformers to match the impedance of the various type power tubes and special Output Transformers for dynamic speakers.

In the Sangamo line there are transformers which permit set builders and manufacturers to produce the real tone fidelity. Are you ready for us to send you the data?

## Sangamo Condensers

Molded in Bakelite—unchanging value under all conditions of service.

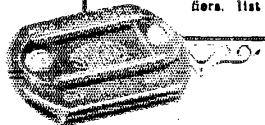

## Tone!

<b>"X" Line Transformers</b>	
Type AX straight audio amplification, list price	\$8.00
Type BX Push-pull input unit, list price	\$8.50
Type GX-171 Push-pull Output transformer, for 171 or 250 power output tubes for cone speaker, list price	\$8.50
Type DX, same as GX except for 210 and 112 power tubes, list price	\$8.50
Type IX Push-pull Output for 171 or 250 Power output tubes to match the impedance of moving coil of Dynamic loud speaker, list price	\$8.50
Type GX, same as DX except for 210 and 112 power tubes, list price	\$8.50
Type E output choke to match impedance of the various type power tubes, list price	\$3.00
<b>"A" Line Transformers</b>	
(Similar to "X" line but with special core metal to give slightly better curve)	
Type A straight audio amplification, list price	\$10.00
Type R Push-pull input transformer for all tubes, list price	\$12.00
Type G-171 Push-pull Output, for 171 or 250 type power tubes with cone speaker	\$12.00
Type D-210, same as G except for 210 and 112 power tubes	\$12.00
Type H-171, Push-pull Output for 171 or 250 power tubes for Dynamic speaker	\$12.00
Type G-210, same as type H except for 210 and 112 tubes, list price	\$12.00
Type F Plate Impedance for use as a choke to prevent oscillation and for impedance coupled amplifiers, list price	\$6.00

# SANGAMO

## ELECTRIC COMPANY

Springfield, Illinois

For 29 years preeminent manufacturers of electrical precision instruments



# Section Communications Managers of THE COMMUNICATIONS DEPARTMENT, A. R. R. L.

		<b>ATLANTIC DIVISION</b>	
Eastern Pennsylvania	W3QP	J. B. Morgan, 2nd	481 E. Willow Grove Ave. Chestnut Hill, Phila.
Maryland-Delaware-District of Columbia	W3AIS	Dr. H. H. Layton	895 Washington St.
Southern New Jersey	W3CFQ	M. J. Lofsky	Box 49, RFD 1
Western New York	W8PJ	C. S. Taylor	598 Masten St.
Western Pennsylvania	W8CP0	A. W. McAuley	309 Third St.
		<b>CENTRAL DIVISION</b>	
Illinois	W9APY	Fred J. Hinds	3337 Oak Park Blvd.
Indiana	W9CYQ	D. J. Angus	310 N. Illinois St.
Kentucky	W9BAZ	J. B. Wathen, III	Box 87, R. F. D. 1
Michigan	W8CEP	Dallas Wise	9187 Falcon Ave.
Ohio	W8BYN	H. C. Storek	494 Carpenter St.
Wisconsin	W9VD	C. N. Crapo	443 Newton Ave.
		<b>DAKOTA DIVISION</b>	
North Dakota	W9DYV	B. S. Warner	399 4th Ave.
South Dakota	W9DGR	D. M. Fuscik	782 Illinois St.
North Minnesota	W9BYH	Carl L. Jabs	1829 James St.
South Minnesota	W9BYA	D. F. Cottam	2538 Third Ave. So.
		<b>DELTA DIVISION</b>	
Arkansas	W5ABI	H. E. Vette	5408 U. St.
Louisiana	W5UK	C. A. Prestag	129 Camp St.
Mississippi	W5AKP	J. W. Gullett	1708 23rd Ave.
Tennessee	W5AFI	Polk Purdue	100 Radio Station WBAN Nashville
		<b>HUDSON DIVISION</b>	
Eastern New York	W2CNS	F. M. Holbrook	2 Livingston Ave.
N. Y. C. & Long Island	W2KR	M. B. Kahn	617 W. 141st St.
North New Jersey	W2WR	A. G. Wester, Jr.	50 Princeton St.
		<b>MIDWEST DIVISION</b>	
Iowa	W9DZW	H. W. Kerr	
Kansas	W9CET	J. H. Amis	915 Lincoln Ave.
Missouri	W9RR	L. B. Lazure	3010 Mercier St.
Nebraska	W9BYG	C. B. Deini	2605 Cedar St.
		<b>NEW ENGLAND DIVISION</b>	
Connecticut	W1ZL	C. A. Weidenhammer	33 Washington Place
Maine	W1BG	Frederick Best	13 E. Crescent St.
Eastern Massachusetts	W1FE	E. L. Battey	38 Royal St.
Western Massachusetts	W1UM	Dr. John A. Tessmer	8 Schaffner St.
New Hampshire	W1ATJ	V. W. Hodze	227 Main St.
Rhode Island	W1RCR	C. N. Kraus	92 Keene St.
Vermont	W1IT	Clayton Faulette	
		<b>NORTHWESTERN DIVISION</b>	
Alaska	W7WDN	W. B. Wilson	U. S. LHT Fern
Idaho	W7ACN-7JL	James L. Young	303 13th Ave. So.
Montana	W7AAT-7QT	O. W. Myers	
Oregon	W7FP	R. H. Wright	310 Ross St.
Washington	W7FD	Otto Johnson	1840 30th Ave. W.
		<b>PACIFIC DIVISION</b>	
Hawaii	K9CFQ	F. L. Fullaway	2714 Manoa Rd.
Nevada	W800	C. B. Newcomb	
Los Angeles	W8AM	D. C. Wallace	209 Pine Ave., Room 410
Santa Clara Valley	W8NX	F. J. Quement	252 Hanchett Ave.
East Bay	W8CZR	J. Walter Frates	368 62nd St.
San Francisco*	W80R	C. P. Banes	262 Castro St.
Sacramento Valley	W8CBS	C. F. Mason	2530 N. St.
Arizona	W8ANO	D. B. Lamb	229 W. First St.
Philippines*	00LAT	Jose F. Jimenez	835 San Fernando St.
San Diego	W8BQ	G. A. Sears	236 Bonair St.
		<b>ROANOKE DIVISION</b>	
North Carolina	W74SJ	Emm Schuelke	R. F. D. No. 1
Virginia	W7CA	J. E. Wohlford	118 Cambridge Ave.
West Virginia	W7ED	C. S. Hoffman	126 Chantal Court
		<b>ROCKY MOUNTAIN DIVISION</b>	
Colorado	W9CAA	C. R. Steidman	1641 Albion St.
Utah-Wyoming	W86AJ	Barley N. James	430 "D" St.,
		<b>SOUTHEASTERN DIVISION</b>	
Alabama	W4AHO	A. D. Trum	217 Catoma St.
Florida	W4LK	C. E. Foulkes	502 Shearing St.
Georgia-South Carolina-Cuba-Eerto Rico-Isle of W4RT		H. L. Reid	11 Shadownawn Ave.
		<b>WEST GULF DIVISION</b>	
Northern Texas	W5AKN	J. H. Robinson, Jr.	522 Cumberland St.
Oklahoma	W5AM0	Glenn Moran	763 Asp. Ave.
Southern Texas	W5OK	R. E. Franklin	1806 Valentine St.
New Mexico	W5IT	L. E. Radka	
		<b>MARITIME DIVISION</b>	
Newfoundland	VE8AR	Leval Reid	Avalon House
New Brunswick	VE1EI	T. B. Lacey	630 N. B. Power Co.
Nova Scotia	VE1DD	W. C. Horrett	14 Sinclair St.
Prince Edward Island	VE1BZ	F. W. Hyndman	25 Fitzroy St.
		<b>ONTARIO DIVISION</b>	
Ontario	VE3FC	E. C. Thompson	266 Queensdale Ave.
		<b>QUEBEC DIVISION</b>	
Quebec	VE2BE	Alex Reid	169 Logan Ave.
		<b>VANALTA DIVISION</b>	
Alberta	VE4HA	E. J. Taylor	10107-87th Ave.
British Columbia	VE5BJ	E. S. Brooks	2987 Camosun St.
		<b>PRAIRIE DIVISION</b>	
Manitoba	VE4FT	D. B. Sinclair	205 Cambridge St.
Saskatchewan	VE4FC	W. J. Pickering	514 19th St. W.
			Winnipeg Prince Albert

\*Temporary officials appointed to act until the membership of the Section concerned choose permanent SCMs by renomination and election.

# Parts For The Amateur Experimenter

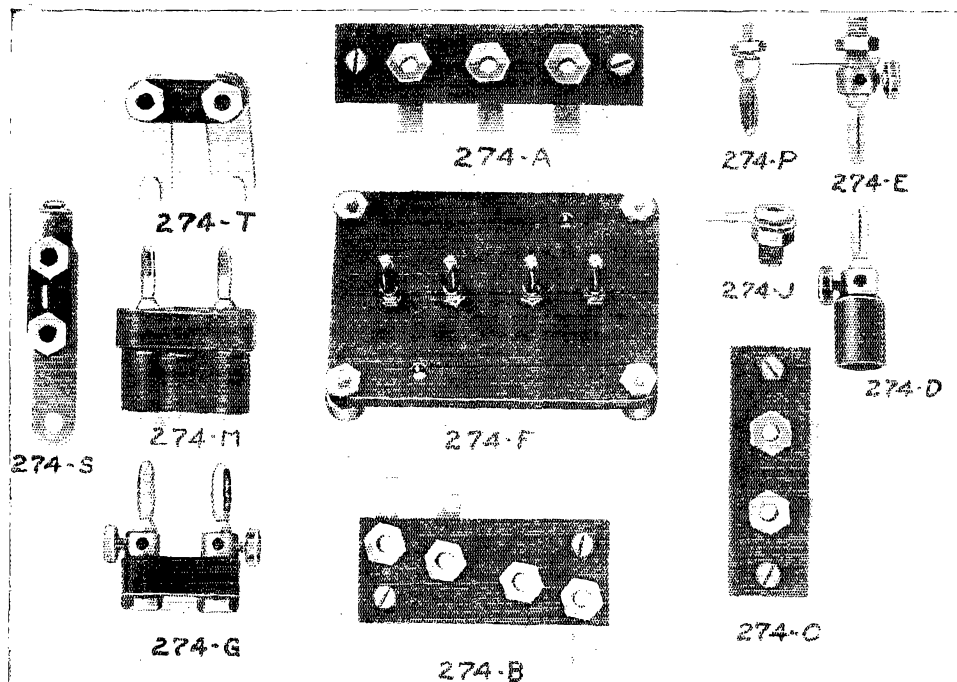

**T**HE experimenter will find the parts illustrated extremely useful. This group consists of jacks, plugs, transformer mounting bases, coil mounting bases and multiconnector plugs. These items will be found useful in comparing different methods of coupling either at radio or audio frequencies. They are especially adapted for use where the plug-in feature is desired.

## GENERAL RADIO CO.

*Bulletin No. 931 on Request*

30 STATE STREET  
CAMBRIDGE, MASS.

274 BRANNAN STREET  
SAN FRANCISCO, CALIF.



# QST



## The Official Organ of the A.R.R.L.

VOLUME XIII

JANUARY 1929

NUMBER 1

Editorials	7
Official Frequency Stations	8
Standard Frequency Transmission from W9XL	8
28,000-ke. Communications	Ross A. Hull 9
A Crystal Note Without a Crystal	17
Book Reviews	20
The Heterodyne Frequency Generator	21
Rotten Television	The Old Man 24
A Poor Man's M.O.P.A.	J. T. McCormick 25
The Total-Loss Receiver	Clair Foster 29
Experimenters' Section Report	31
Using Brass Tube Bases for Plug-In Coils	Morris F. Marx, Jr. 34
The Series Gap Condenser	Roy A. Jenkins 35
Antenna Systems--A Rehash	Harold P. Westman 36
Before the Guy-Wire Breaks	B. D. Virmani 40
A Unique Method of Control by Means of Sound Waves	Allen B. DuMont 41
Increasing Transmitting Antenna Efficiency	Stuart L. Scaton 43
A Filter for Street Car Noises	15
L. A. R. U. News	46
Calls Heard	47
Correspondence	48
The Pacific Division Convention	49
The West Gulf Division Convention	50
Communications Department	51
Election Results	74
Hamads	88
QRAs	98

QST is published monthly by The American Radio Relay League, Inc., at Hartford, Conn., U. S. A. Official Organ of the A.R.R.L. and the International Amateur Radio Union

Kenneth B. Warner (Secretary, A.R.R.L.),  
Editor-in-Chief and Business Manager

F. Cheyney Beekley,  
Managing Editor and Advertising Manager

Harold P. Westman,  
Technical Editor

Ross A. Hull,  
Associate Technical Editor

David H. Houghton,  
Circulation Manager

Subscription rate in United States and Possessions, Canada, and all countries in the American Postal Union, \$2.50 per year, postpaid. Single copies, 25 cents. Foreign countries not in American Postal Union, \$3.00 per year, postpaid. Remittances should be by international postal or express money order or bank draft negotiable in the U. S. and for an equivalent amount in U. S. funds. Entered as second-class matter May 29, 1919, at the post office at Hartford, Connecticut, under the act of March 3, 1879. Acceptance for mailing at special rate of postage provided for in section 1103, Act of October 3, 1917, authorized September 9, 1922. Additional entry as second-class matter, acceptable at special rate of postage provided for above, at Springfield, Mass., authorized September 17, 1924.

Copyright 1928 by the American Radio Relay League, Inc. Title registered at United States Patent Office.  
Member of the Radio Magazine Publishers' Association.

# The American Radio Relay League

The American Radio Relay League, Inc., is a non-commercial association of radio amateurs, bonded for the promotion of interest in amateur radio communication and experimentation, for the relaying of messages by radio, for the advancement of the radio art and of the public welfare, for the representation of the radio amateur in legislative matters, and for the maintenance of fraternalism and a high standard of conduct.

It is an incorporated association without capital stock, chartered under the laws of Connecticut. Its affairs are governed by a Board of Directors, elected every two years by the general membership. The officers are elected or appointed by the Directors. The League is non-commercial and no one commercially engaged in the manufacture, sale or rental of radio apparatus is eligible to membership on its board.

"Of, by and for the amateur", it numbers within its ranks practically every worth-while amateur in the world and has a history of glorious achievement as the standard-bearer in amateur affairs.

Inquiries regarding membership are solicited. A bona fide interest in amateur radio is the only essential qualification; ownership of a transmitting station and knowledge of the code are not prerequisite. Correspondence should be addressed to the Secretary.

## DIRECTORS

- |   |  |  |
|---|--|--|
| <p><i>President</i><br/><b>HIRAM PERCY MAXIM</b><br/>Drawer 2102,<br/>Hartford, Conn.</p> <p><i>Vice-President</i><br/><b>CHARLES H. STEWART</b><br/>St. David's, Pa.</p> <p><i>Canadian General Manager</i><br/><b>A. H. K. RUSSELL</b><br/>6 Mail Bldg.,<br/>Toronto, Ont.</p> <p><i>Atlantic Division</i><br/><b>DR. EUGENE C. WOODRUFF</b><br/>234 W. Fairmount Ave.,<br/>State College, Pa.</p> <p><i>Central Division</i><br/><b>CLYDE F. DARR</b><br/>187 Hill Ave., Highland Park,<br/>Detroit, Mich.</p> | <p><i>Dakota Division</i><br/><b>C. M. JANSKY, JR.</b><br/>Dept. of Elec. Eng., U. of M.,<br/>Minneapolis, Minn.</p> <p><i>Delta Division</i><br/><b>BENJ. F. PAINTER</b><br/>424 Hamilton Nat'l Bank Bldg.,<br/>Chattanooga, Tenn.</p> <p><i>Hudson Division</i><br/><b>DR. A. LAFAYETTE WALSH</b><br/>220 West 42d St.,<br/>New York City</p> <p><i>Midwest Division</i><br/><b>PORTER H. QUINBY</b><br/>817 Lauderman Building,<br/>St. Louis, Mo.</p> <p><i>New England Division</i><br/><b>FREDERICK BEST</b><br/>13 East Crescent St.,<br/>Augusta, Maine</p> <p><i>Northwestern Division</i><br/><b>K. W. WEINGARTEN</b><br/>8219 No. 24th St.,<br/>Tacoma, Wash.</p> | <p><i>Pacific Division</i><br/><b>ALLEN H. BABCOCK</b><br/>66 Market St.,<br/>Southern Pacific Co.,<br/>San Francisco</p> <p><i>Roanoke Division</i><br/><b>W. TREDWAY GRAVELY</b><br/>Box 245,<br/>Danville, Va.</p> <p><i>Rocky Mountain Division</i><br/><b>PAUL M. SEGAL</b><br/>Box 1771<br/>Denver, Colo.</p> <p><i>Southeastern Division</i><br/><b>HARRY F. DOBBS</b><br/>c/o Dobbs &amp; Wey Co.,<br/>245 Spring St., N. W.,<br/>Atlanta, Ga.</p> <p><i>West Gulf Division</i><br/><b>FRANK M. CORLETT</b><br/>2515 Catherine St.,<br/>Dallas, Tex.</p> |
|---|--|--|

## OFFICERS

- |   |   |
|---|---|
| <i>President</i> . . . . .              | <b>HIRAM PERCY MAXIM, Hartford, Conn.</b>   |
| <i>Vice-President</i> . . . . .         | <b>CHARLES H. STEWART, St. David's, Pa.</b> |
| <i>Secretary</i> . . . . .              | <b>KENNETH B. WARNER, Hartford, Conn.</b>   |
| <i>Treasurer</i> . . . . .              | <b>ARTHUR A. HEBERT, Hartford, Conn.</b>    |
| <i>Communications Manager</i> . . . . . | <b>F. EDWARD HANDY, Hartford, Conn.</b>     |

# EDITORIALS

---

**J**ANUARY 1, 1929, magic date, is upon us. A year of mingled hopes and fears, of bustling preparation, and now we enter the world of changed radio conditions to test the soundness of our ideas.

Now, on the eve of that event, we take stock of the situation. The world's greatest conference gave us, a year ago, the International Radiotelegraph Convention of 1927, a document in which stupidity and crass greed, and fear and lack of knowledge of us, won a partial victory over the stout support of a small group of enlightened and forward-looking nations. A place was chiseled for the amateur, international recognition obtained, and the amateur's name securely labelled to certain frequency bands, but for a time it seemed our wings had been effectively clipped. Not now, though, for our preparation has been thorough. We know that we retain ample privileges at 1750 and 3500 kc., a most interesting new territory at 28 megacycles, and although we are clipped at 7000 and 14000 kc., we already know that our technical development has kept abreast of the resulting difficulties and that the ways exist for us to continue to exact from amateur radio that full measure of enjoyment which for so many years has held us in thrall to it. We now know that we can make transmitters sufficiently stable and sharp, receivers sufficiently selective, and frequency-adjusting apparatus sufficiently accurate to guarantee contentment to every one of us. These technical improvements are matters that we ought to have attended to long ago. There will be a better brand of amateur radio next year. Perhaps we will find this convention, for all its difficulties, a blessing in disguise.

January 1st marks the dividing line between the old and the new in amateur radio. It is going to be very interesting, a few years from now, to look back on our 1928 emotions as recorded in *QST*, to see how we sweated and bled over these problems and with what unnecessary uneasiness we then viewed those opening months of 1929. When we look back then we are going to wonder how we ever got along in 1927 and 1928 with those crude methods which we once employed. We now enter the new days with our new methods, with the new spur to accomplishment and with enough things to do to keep us busy and excited for five years.

It is the duty of every amateur to prepare himself for the new life which exists on the other side of January 1. It is the

normal season for good resolutions, and they are certainly in order in amateur radio. *QST* has made a strenuous effort to be of the maximum service to amateurs during 1928. The individual amateur must now know that his transmitter is properly constructed and adjusted, he simply must be able to monitor his transmissions both for frequency and quality, and he must have improved the selectivity of his receiver. He must also have prepared his station to do some of its operating in the 3500-4000 kc. band, with arrangements for a quick shift to other bands, particularly the higher-frequency bands, when the spirit moves. With these simple preparations, with what unlimited eagerness may he look forward to his new world!

Of course all of the problems are not solved. The joy would go out of amateur radio if there were no more difficulties, no more objectives. As we enter 1929 we test our present ideas and we shall find out interesting things, both from a technical standpoint and in the field of human relations in operating. A.R.R.L. Headquarters feels that it has done about all that it can do to prepare the individual member for 1929. We have presented operating advice and technical information by the hundreds of pages, the very best data that could be advanced short of actually experiencing 1929. Now it is up to you fellows. We want you to write us and tell us of your experiences and of the technical gadgets and innovations which you find useful. There is a great shortage of *QST* material. During 1928 it has seemed that almost every member felt that he was lacking in the wisdom to make suggestions that would be useful in rebuilding the station. The greater portion of the material which we have published to prepare ourselves comes from the League's technical development program. We here do not know why you fellows have felt so bashful and backward about coming across with your own stories, which have always been the backbone of *QST*, whose contents have been largely the result of individual members' work, published and passed on for the information of all the other members. Now we need help and we call upon you to tell us of the interesting things you have done with your own station apparatus.

There is another field, too, in which Headquarters needs help. We enter 1929 with no cooperative arrangements with foreign amateurs, with every amateur

authorized, so far as his license gives him the privileges, to work on all the frequencies available to amateurs. The A.R.R.L. proposals of early this year, for a subdivision of the amateur international frequencies by continents, did not meet with any general endorsement. It was the view of many leading amateurs, both at home and abroad, that one could not lay down a workable plan in advance; that we would have to go into 1929 and actually experience it for a while. Then, with first-hand knowledge, plans for international cooperation between amateurs could be made. You readers are going to notice many things. You are going to see that if only so-and-so would use such frequencies, and another crowd some other frequencies, satisfactory work would be possible where otherwise it

isn't. You will decide that if only somebody could be induced to do something or other, vast improvements would result. The chief function of the International Amateur Radio Union, and its greatest value to us, is going to be in the negotiating of such agreements between the amateur societies of the world, to make possible that greater degree of felicity in amateur relations which comes only with mutual recognition and cooperation.

On both of these counts, then, the technical field and the operating field, A.R.R.L. Headquarters invites your comments and your contributions as we learn what 1929 is like.

Good luck!

K. H. W.

## Official Frequency Stations

**T**he Official Frequency Station system furnishes a service cooperative with but differing from that of the Standard Frequency Station, W9XL, which is also operated in accordance with plans made with the O.F.S. Committee.

The chief duties of the O.F.S. are to indicate the frequency of each transmission at its termination, to check the frequency of other transmissions when requested and to aid in the general work of keeping all amateurs within their assigned bands. The announcement of frequency at the end of each transmission will be in kilocycles and consist of four or five numerals without any punctuation whatever.

An accuracy of at least 0.5% is required of all O.F.S. and it is expected that they will check their frequency meters at least once every two months against a suitable standard or Standard Frequency transmissions from W9XL.

See page 68 of the November issue of QST.

The present list is as follows:

W6XAO-W6ZV, VE3FC, OZ2AC, W6AM, W1CK, W1AWW, W8EQ, W4XE, W5ZAV, W9EGU, W6ZH, W2MU, W4RY, W5SP, W7GQ, W2DS, W1BZQ, W6BGM-W6CVO, W9IG, W1ZL-W1AVW, W2CLA, W8GZ, W8ZG, W9BGK, EG2NM, VE9AL, W8APZ, W5OX, W1AAC, W8BZT, VE3CO, EG2OD, W6CAE, W9AXQ, W9CPM, W5EW, W1AXA, W9BGH, EG2SZ, W6BB, W8DAJ, W9AUG, VE2BE, W2BRS, VE4BT, OA-5BG, W4LK, EGG15NJ, W1CCW, W8BAU, W9UZ, W2EF, W6AKW, W6CDY-W6CRX, W6AYC, W6BRO, W6WN, W6BMW,

W6CMQ, W7AAT, W9AHQ, W9EFO, W6BAJ, EG5YK, W6BZU, W1BD, W5NW, OA7CW, W6EC-W6XE, W6QX, OA5LF, W6QL, W5BG, W2DC, W9BVC and W2UV.

—H. P. W.

## Standard Frequency Transmissions from W9XL

Schedules for January and February

Schedule "A"		Schedule "B"	
Central Standard Time (P.M.)	Frequency in kc.	Central Standard Time (P.M.)	Frequency in kc.
8:00	7,300	3:00	30,000
8:12	7,225	3:12	29,000
8:24	7,150	3:24	28,000
8:36	7,075	3:36	14,400
8:48	7,000	3:48	14,300
9:00	4,000	4:00	14,200
9:12	3,750	4:12	14,100
9:24	3,500	4:24	14,000

Division of Time

4 minutes—CQ CQ CQ de W9XL W9XL W9XL.

3 minutes—series of letter "d" with the dash about five seconds long and broken every half minute for station call letters.

1 minutes—frequency—kc.

4 minutes—time allowed to change to next frequency.

### DATES OF TRANSMISSION

January	Schedule	February	Schedule
6th	"B"	3d	"B"
11th	"A"	8th	"A"
25th	"A"	22d	"A"

All O.F.S. should use these transmissions to keep their frequency meters calibrations within the required limits of accuracy. It will be appreciated if you will send us a report on your reception of these signals.

See page 8 of the November issue of QST.

—H. P. W.

## The Status of 28,000-kc. Communication

A Review of Results Attained, a Discussion of Seeming Discrepancies With Present Theories and a Presentation of Some Practical Suggestions

By Ross A. Hull\*

**I**N addition to being of very considerable importance, the present development of the 28,000-kc. band is at once the most engaging and most baffling problem that the amateur has faced for many years. Of course any problem is, to the amateur, engaging if it is baffling but this one would seem to possess a rare combination of the expected and the unexpected which makes it of particular appeal to the imaginative or experimentally inclined individual. The possibilities of the new band have so far been exploited in only a fragmentary and superficial manner but at this stage it is considered that sufficient evidence has been accumulated to indicate many apparent discrepancies between practical performances and the predictions of scientists and engineers.

It is this condition which has prompted us to write of the work which has been accomplished in the hope of providing the incentive for a much larger group of amateurs to experiment in fields to be outlined. It is this condition, also, which has impelled us to place on record the performances which appear to be at variance with present theory, hoping earnestly that those scientists who have conducted the past brilliant researches in the characteristics of the upper atmosphere will be incited to come to our aid and level off the seeming incongruities with which we cannot help being concerned.

In March of last year the band of frequencies between 28,000 and 30,000 kc. was thrown open to the amateurs of this country. Before the end of that month several stations had become active and communication across the continent had been established. Many amateurs claimed imme-

diately that the new band was more satisfactory than any other. Amateurs familiar with the present theories of high-frequency transmission phenomena admired the enthusiasm of the leaders in this new exploration, felt pleased that the Kennelly-Heaviside "layer" should have come low enough to have permitted such an auspicious opening, but hinted knowingly that the "layer"

would soon rise to its normal heights, when contact would fail. That some such change in the equivalent layer height has taken place at intervals during the year is evident from an examination of the results which have been obtained. The extent of these

changes and their frequency, however, differ so from what one would have been led to expect from the present knowledge of the upper atmosphere that they are thought to constitute one of the discordant notes on which we hope to play at some length.

It must be admitted that the presentation of this estimate of the status of 28,000-kc. communication is handicapped seriously by the fact that it is based on the observations of amateurs only (whose activity in the daylight hours is, with very few exceptions, limited to the week-ends) and that these observations and reports of contact cover an unknown fraction of recent amateur activity throughout the world. In consequence, our data consist chiefly of smatterings of observations taken during the daylight hours of most week-ends during the last eight months. If we were more daring, or if it was not our object to present a strictly conservative report, we would hazard a guess at the possible performances during the entire period, hoping that we would not be overlooking some theory which presupposed a week-end trip on the part of the ionized regions to locations nearer earth.



W6UF

The station which participated with W1CCZ in the experimental work with high angle radiations described in the text. The transmitter comprises a UX-112 crystal oscillator, a UX-112 and two UX-210's as intermediate amplifiers, and a UX-252 as the final amplifier. The two last amplifiers both operate on the output frequency and the UX-252 is therefore neutralized. The receiver is of conventional type employing a UX-199 tube as detector and UX-201-A as amplifier.

\*Associate Technical Editor, QST. In charge A.R.R.L. Technical Development Program.

After the first successes in late March and early April, when communication was established across this continent, between the Atlantic coast and France, and from both the Atlantic and Pacific coasts to the middle-western States, it became evident that the equivalent layer must be lower, on the basis of present theories, than had been anticipated for that time of year. Furthermore it seemed apparent that the equivalent layer was maintaining this low position with unexpected consistency, for of the first seven week-ends since the opening of activity six of them had been known to provide conditions permitting satisfactory communication. Without making allowances for imperfections in transmission and reception equipment—which undoubtedly influenced the results—the general impression was created that communication on the new band, when both transmitter and receiver were in full daylight, was quite the equal of that on the 14,000-kc. band. Signal strengths in most cases were of a high order, though it was thought at the time the periods of severe fading were more frequent than on the lower-frequency band.

These results, together with the prediction that the equivalent layer probably would be at its lowest during the summer months,<sup>1</sup> led many to decide then and there that the 28,000-kc. band, presented to the amateur as interesting but worthless territory at the International Radiotelegraph Conference, was, in a considerable measure, the solution to our congestion problem. The free electrons in the upper atmosphere, however, were already starting on a vile move upwards to spite us.

During the months of May, June and July, when, if at any time, 28,000-kc. communication should have been successful, according to present ideas of the behaviour of the ionized regions, the contacts were wiped almost into oblivion. On only four week-ends of the thirteen in these three months was any communication reported. It is clear, however, that the satisfactory week-ends in this period were quite the equal or any in the previous period, R7 and R8 signals of particular steadiness being common even in contacts between the coasts and central States. Of course, we must admit a weakness in the evidence which leads us to deduce that the equivalent layer height was greater during the week-ends of May, June and July than during those of March and April. In the first place, it is certain that amateur activity is at its lowest ebb during the summer week-ends when vacations and automobile trips are of greater appeal than the contortions of a mere ionized atmosphere. Further, it is

conceivable that 28,000-kc. activity was at a lower ebb even than that on other frequency bands as the combined result of the psychological effect of the first successes and the temptations of the great outdoors. If only amateurs could be made to appreciate the significance of their efforts!

Early August gave indications of a return toward civilization on the part of both the amateurs and the free electrons, for at that time satisfactory contacts were reported in increasing numbers. And as the season progressed and the days became shorter, communication became even more satisfactory and more wide-spread, whereas, if the equivalent layer had behaved as current hypotheses would seem to dictate, it should have migrated to higher regions from which the 28,000-kc. signals would never have returned to earth.<sup>2</sup> During this period also, our concept of the performance in general may be distorted somewhat by the fact that the number of amateurs and their experimental activity was definitely on the increase. However, there should be some significance in the statement, based on reports received, that satisfactory communication over distances up to 100 miles and over 1,000 miles was established during all of the fifteen week-ends between that of August 12th, and that of the last reports to hand—November 18th.

Nor was this communication limited to the Northern Hemisphere. During September, for instance, the first Australian successes in communication across Australia and between Australia and New Zealand occurred at a period when communication in this country was being maintained, and when the first signals from the United States were being copied in New Zealand. Through October and November, to the week-end of our most recent reports, activity increased steadily and for every week-end the upper atmosphere continued to prove equal to all the demands that the 28,000-kc. band of frequencies made upon it. As the result of possible improvements in the apparatus used, or on account of still further changed conditions, communication during the seven week-ends ending November 18th, became definitely more consistent and more reliable. By this time contact had been established between England and both the Atlantic and Pacific Coasts, between Hawaii and both the Pacific Coast and the central States, and, on November 9th, between the Pacific Coast and New Zealand. The reports, though dealing more with new contacts made than with the reliability of any one of them, indicated that signals of the order of R7 and R8 were general over distances beyond the skip-distance, even from transmitters with an

1. A. Hoyt Taylor, *Proceedings of Institute of Radio Engineers*, August, 1926, makes one of many such predictions.

2. A. Hoyt Taylor, *Proceedings of the I.R.E.*, August, 1926, as one example.



input as low as 10 watts. Reports from the few amateurs who caught on to the idea that it was the characteristics of any one prolonged contact and not the news of the momentary first linking of some two stations which was of greatest importance, served to create the impression that whenever communication was established it was usually with signals of greater intensity and steadiness than those found on the 14,000-kc. band, and that fading, when not substantially absent, was at a very low period. At times, it would seem, the only audible fading was at such a low period that it could be detected only after prolonged contact, when the signals would have been observed to vary a point or two in audibility from one transmission to the next.

Since the development of the 28,000-kc. band was one of the activities in which the Technical Development Program was scheduled to take a part, we had been observing the progress of affairs with particular interest. Toward the end of October the results had wandered so far from our expectations that we made hurried plans to conduct a week of intensive observation, hoping that we would be in time to take advantage of the continued apparent abnormalities of the ionized regions and possibly to take observations during the expected period when they would return to the condition which we had come to regard as normal for that time of year. Our hopes in the case of the latter possibility were to be in vain! In general, we had been completely baffled by the consistency and effectiveness of the communication reported and we had found it impossible to reconcile the results with our interpretation of the current hypotheses regarding the conditions in the upper atmosphere. We were determined to see for ourselves how effective and how consistent communication could be and to make quite certain that the equivalent layer was not fooling us by breezing down to lower levels just for the week-ends. In addition we hoped to be able to duplicate and possibly check the experiments<sup>3</sup> of Meissner, conducted on 27,000 kc., in which, contrary to reasonable expectations, some higher angles of radiation were found to be much more effective than radiations at low angles or at the tangent of the earth's surface.

But in order to make clear this, to us, important objective it will be necessary to digress in order to discuss some of the present views concerning the nature of the ionized regions and the possible behavior of frequencies of the order of 28,000-kc. in them. We might point out at this moment that it would appear as though many ama-

teurs regard the problems of communication on the new band merely as those of the transmitter or receiver circuit. Some of their chief worries, it would seem, are whether the Hartley is better than the Ultraudion on that frequency and whether the tuned-grid tuned-plate can be made to oscillate with equivalent ease. It must be admitted that such considerations are properly a phase of the problem but it is certain that they do not compare either in interest or importance with that essential and elusive part of the communication system which extends a few hundred miles above our heads. In all earnestness we plead for a greater appreciation of this point on the part of amateurs engaged in experiment on the new band.

It is well known to all amateurs that long distance, high frequency communication is made possible by the existence of a condition of ionization in the atmosphere which produces a refraction or bending of the waves leaving the surface of the earth, causing them to come down again at distant

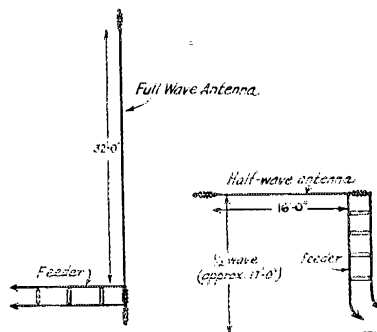

FIG. 1. TWO TYPES OF ANTENNAS WHICH SHOULD BE PARTICULARLY EFFECTIVE FOR OPERATION ON THE 28,000-KC. BAND

The antenna dimensions given were calculated for a frequency of 28,846 kc. No feeder lengths are provided since they will be dependent upon the location of the transmitter with respect to the antenna. They can be determined, however, by reference to the Sept. 1928 QST on page 35.

points, the locations of which are dependent upon the conditions in the ionized atmosphere and upon the frequency being used for the transmission. We will not attempt a detailed explanation of the influences by which the atmosphere is considered to be ionized, since this has already been treated in great detail in QST by Taylor and Hulburt and, more recently, by Rice. A brilliant array of more comprehensive articles on the subject is also available in other technical publications.<sup>4</sup> We might state, however, that the ionization responsible for the refraction can be considered as the

3. A. Meissner, *Proceedings of the I.R.E.*, November, 1927.

4. *Proc. I.R.E.*; *Bell. Tech. Journal*; *Physical Review*; and many foreign publications.

breaking up of neutral gas molecules of the upper atmosphere into their negative constituents—electrons—and their positive constituents—ions. The most important agency, causing this ionization or freeing of electrons is considered to be sunlight. In consequence the ionization experiences a daily variation due to the rotation of the earth and a seasonal change as a result of the inclination of the earth's axis to the orbit. A common miscon-



THE 28,000-KC. EQUIPMENT AT WICCC

The 28,000-kc. transmitter used for the tests is on the table at the right, above it being the feeder-tuning apparatus. Two UX-852 tubes, with their grids and plates connected, were used as rectifiers in the plate-supply system. A UX-204-A was operated as the oscillator. The main receiver, at the extreme left, employs a UX-222 in a stage of tuned radio frequency amplification. The apparatus at the upper center is an auxiliary 14,000-kc. and 7,000-kc. transmitter. This apparatus is located in a small shack about a quarter of a mile from the main WICCC station.

ception on the part of amateurs is that the ionization is in the form of a relatively thin layer which exists at 100, 120 or perhaps 400 miles above the earth's surface depending upon the time of the day or year. In actuality, it would seem, the ionization exists from the surface of the earth to the outermost limit of our atmosphere. The ionization is not, of course, constant, but extends upwards in an irregular gradient to a height of maximum intensity at, possibly, a point between 150 and 600 miles above the surface of the earth, after which it tapers off in another irregular gradient to the limit of the atmosphere. In order to avoid the complexities of reference to this gradient quantitatively the practice has been adopted in some scientific circles of speaking in terms of "the height of the layer"<sup>6</sup> or "the equivalent layer height." The gradient of ionization which would cause a 14,000-kc. wave to be bent in such a manner as first to reach the earth again at a distance of 1,000 miles would be termed "an equivalent height of so many miles," the term being intended to suggest that if a

5. We are inclined to think that the use of such terminology, though possibly convenient, is quite confusing. Amateurs need hardly be warned that the constant visualization of such "layers" is likely to result in false concepts.

reflecting medium was placed at the "so many" miles height, and that should the waves travel to and from it in straight lines, they would reach the earth for the first time at the same 1,000-mile point. In short, the "equivalent layer height" already mentioned many times in this paper refers to the height of an imaginary reflecting surface which would cause the same skip distance as that resulting from the particular ionization gradient being considered. The important thing is to avoid the temptation to think of the ionized regions as a "ceiling" of a definite height—instead to keep in mind the fact that any heights mentioned are only those of an imaginary equivalent reflector.

The gradient of the ionization or, more correctly, the gradient of the free electron density, is the factor actually responsible for the bending or refraction of the waves. The speed of travel of the waves is increased by an increase in the number of free electrons in their path and consequently when any two adjacent rays, for example, are projected into the regions of the atmosphere where free electrons exist in increasingly greater numbers, the higher of the two rays meets more free electrons than the lower. The higher ray therefore travels faster than the lower and the beam of rays is bent.<sup>6</sup> If the ray beam starts out at a low angle it possibly will be bent only slightly and will return to earth nearer and nearer to the transmitter until a critical angle is reached from which the beam will return at the nearest possible point to the transmitter. At some higher angles the beams are considered to be bent in such a manner as to go out into space without ever returning to earth.

Aside from the gradient of the free electron density, another factor enters into the process of refraction. It is the frequency of the transmitted signal. The degree of refraction is decreased as the frequency is increased and hence the angles of the radiated rays which are bent away from the earth and lost become lower as the frequency goes up. By making a number of assumptions it has been calculated<sup>7</sup> with an equivalent layer height of 100 miles (a "measured" average height over this country during several days in August, 1927) that on a frequency of about 20,000-kc. all rays radiated at angles greater than 10.8 degrees from the tangent of the earth's surface are bent off into space and wasted as far as long distance communication is concerned. Further, with the same equivalent layer height, and on the same assumptions, it has been shown that only the lowest rays would ever come to earth when a frequency of 26,090-kc. was used and that this, in con-

6. Rice, QST, July and August, 1927.

7. Taylor, Proc. I.R.E., August, 1926.

sequence, is the highest frequency on which communication could be had between two distant points on this earth. From this we would be led to expect communication with frequencies between 28,000- and 30,000-kc. only when the equivalent layer height was in the vicinity of about 75 miles and then only by utilizing the tangent ray or rays radiated at very small angles to it.

We realize fully that this has been but a pitifully crude and abbreviated statement of the generalities of some existing hypotheses but it will have served its purpose if it has indicated to amateurs not yet familiar with them these two facts—that they require an equivalent layer height of the order of 75 miles if reliable long-distance 30,000-kc. communication is to be had, and that they assume all rays radiated at angles greater than a few degrees above the tangent ray to be lost in space for all time. In reconciling these same hypotheses with the long studied performances on the lower frequencies, however, it would seem that the equivalent layer height must be assumed to be at least 100 miles in the summer days, except on rare occasions, and that its height at other seasons must be still greater. And measurements<sup>8</sup> of its height, taken in various ingenious fashions and on the basis of some assumptions, have tended to check these figures. As a result of which we felt justified in wondering whether the equivalent layer had been extraordinarily low during many portions of the last eight months, whether frequencies of the order of 30,000-kc. were refracted in just the manner that had been visualized or if the free electron density gradient (and perhaps the ionization gradient in general) differed in some strange fashion from the character which we understood to be in order.

The anticipated loss of all rays except those radiated at very low angles also concerned us greatly—as it has concerned many others—for the Meissner experiments had appeared to prove that the 27,270-kc. radiated at angles of 38 degrees and others at 80 degrees from the tangent ray were vastly superior to those of the low angles for communication between Nauen and Buenos Aires. Meissner's published results<sup>9</sup> were limited to the behavior of that frequency only over that particular distance and it was hoped in our week of experiment to see which, if any, of the upper angles were effective on 28,000-kc., and to discover whether the most effective angles for one distance were also the best for all other distances beyond the skip.

The station at which the experimental

8. Briet and Tuve, *Phys. Rev.*, Sept., 1926. Taylor and Hulbert, *Phys. Rev.*, Feb., 1926. R. A. Heising, *Proc. I.R.E.*, Jan., 1928. Dahl and Gebhardt, *Proc. I. R. E.*, March, 1928. Breit, Tuve and Dahl, *Proc. I.R.E.*, Sept., 1928. Schelling, *Proc. I.R.E.*, November, 1928.

work was conducted was W1CCZ at Wianno on Cape Cod. The apparatus and the special beam antenna<sup>10</sup> had been built some months previously at the summer home of Mr. E. C. Crossett for experiment on the 28,000-kc. band but activity had ceased when Mr. Crossett moved to his Chicago home in September. At our request the station was reopened and placed at our disposal for the test week.

The antenna system consisted of a horizontal fundamental Hertz antenna fed at one end through a tuned two-wire feeder



THE OPERATING SHACK AND ANTENNA AT W1CCZ

system. A reflector wire was located one-quarter wavelength behind this antenna and two other reflectors were supported one-half wavelength on either side of the antenna. At a point three quarter-waves in front of the antenna a single director was mounted, the whole arrangement being similar to the system suggested by Uda<sup>10</sup> and Yagi.<sup>11</sup> The mechanical arrangement of the system was such that it could be adjusted to any angle above the horizontal in either a westerly or easterly direction, the exact orientation being on a line running 14 degrees north of west, corresponding to the Great Circle between Wianno and Eastern Australia. The transmitter used to excite the antenna consisted of a UX-204-A tube arranged in a self-excited circuit and operated with an input of approximately 400 watts.

The chief difficulty in our way was that of obtaining observers who were free enough to give us their entire interest during the days of the test. We were extremely fortunate in finding two amateurs "on the air" who threw themselves into the work with apparently limitless enthusiasm and stood watch for us during almost the entire full daylight hours of the week. The amateurs were Mr. William Eitel of W6UF and Mr. Ivan O'Meara of ZL2AC. Without the co-operation of these two gentlemen our ob-

9. *QST*, October, 1928.

10. Uda, *Proc. I.R.E.*, May, 1927.

11. Yagi, *Proc. I.R.E.*, June, 1928.

jectives undoubtedly would not have been reached. We would place on record our appreciation of the splendid spirit and keen understanding shown by them.

Activities opened on November 1st at 2:00 p.m. E.S.T. It was planned to transmit for the first half hour of every hour of the week during which any communication conceivably could be possible. This first

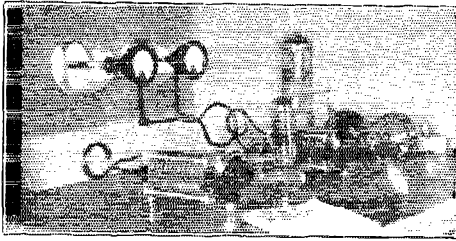

THE 23,000-KC. TRANSMITTER AT W6TS

*This station also was active in observing the special test transmissions and has played an important part in recent work with Reinartz of W1XAM, 1XAM and 6TS, it will be remembered, were pioneers in the activity on the old 40- and 80-meter bands.*

transmission was therefore of one-half hour duration. At the termination of the period W6UF was heard calling W1CCZ and soon afterwards communication was established with that station. The beam at this time was adjusted at an angle of 60 degrees to the horizontal facing west. W6UF at Los Gatos, Cal., reported the signals a steady R5 and, after being told the nature of the tests in progress, immediately agreed to stand by for the entire week. His signals were R5 with slight fading. Without delay the beam was adjusted to a sequence of angles between 30 degrees and the horizontal position and Eitel reported definite consequent changes in signal intensity. A further immediate observation on his part, and one of probable great significance was that fading was influenced definitely by the changes in beam angle. With the beam changed to 30 degrees to the horizontal, the signal strength was reported to have increased from R5 to R9 and the fading which was severe at some angles, was observed to have disappeared almost completely. Eitel picturesquely qualified the increase in signal strength at the 30-degree angle by stating "My father sitting in a chair six feet from me can hear signals distinctly at all times when angle is changed to 30 degrees."

As we afterwards discovered, O'Meara of ZL2AC at Gisborne, New Zealand, was listening to these same transmissions and, to our surprise, also reported that the 30-degree angle was greatly superior to any other. The signals were first heard by him at 7:45 a.m. New Zealand time (3:15 p.m.

E.S.T.) when they were reported R3 to R4 with slight fading. At about the same time O'Meara heard the harmonic of W1K at R4. During the progress of the test the signals from W1CCZ varied between R3 and R5 at various beam angles but increased whenever the 30-degree angle was used. A signal's strength of R6 to R7 was given for transmission at this angle. At the end of the first hour the W1K harmonic was reported to have faded to R1 while the signals from W1CCZ maintained a strength of between R5 and R7 until the transmitter was closed down at 6:00 p.m. E.S.T. (10:30 a.m. N.Z.T.)

Out of the kindness of our hearts we had made a schedule with W6UF for the following, days no earlier than noon E.S.T. (9 a.m. P.S.T.). Communication was again established at this time, W6UF's signals being R4. At this time the beam was adjusted at 60 degrees east (having been left at that angle after a previous test transmission) and the W1CCZ signals were reported R4 also. The beam was immediately changed to 30 degrees west, when the signal strength jumped to R8-R9 as on the previous day. ZL2AC also followed the transmissions on this second afternoon and apparently on all succeeding days, but unfortunately his full report on the remaining receptions has not, at this moment, been received.

Contact with W6UF was continued until 5 p.m. E.S.T. when the last of several attempts that day was made to communicate with the New Zealand station. ZL2AC was being heard at R4 by W6UF but no trace of his signals was evident at W1CCZ.

With the exception of one day, when Eitel was obliged to be away from his home, daily communication was maintained with him for the seven days. At no time were the signals from W1CCZ reported by him to be of an audibility of less than R8 when the beam angle was at 30 degrees. It would appear that the signals made their first appearance suddenly at almost full strength and, as darkness extended beyond the transmitter, disappeared with similar rapidity. The W1CCZ signals were first evident at Los Gatos at about 7:45 a.m. P.S.T. (10:45 a.m. E.S.T.) The signals from W6UF, however, were not heard at Wianno until 10:30 E.S.T. After this hour thoroughly consistent signals could be exchanged until about 6 p.m. E.S.T. when the W6UF signals usually would drop out. On only one afternoon did they disappear before this—at 5:35 p.m. E.S.T. The W1CCZ signals, though, did not drop out until between 6:30 and 6:45 p.m. E.S.T. when the beam was adjusted to the 30-degree angle. On the last evening of the test period, when the reflectors and director had been removed, the signals at W6UF went out almost an hour earlier. In general, the signals from W1CCZ could be received

across the continent approximately an hour earlier and an hour later than the signals of W6UF. The antenna used at W6UF was a full-wave "Zeppelin" fed Hertz operated at heights varying from 10 to 25 feet above ground.

Experiment, with different beam angles and with the director and some or all of the reflectors removed, was made, extending over almost the entire hours when communication was possible. Code letters were sent to designate the different settings of the beam and in this way Eitel selected the most effective setting without a knowledge of the angle. Many splendid checks were obtained of the improved signal intensity and greatly reduced fading at beam angles within a few degrees of 30 degree. In contrast to Meissner's results no particularly effective angles above this were evidenced. The removal of the director made it clear that it was of very slight benefit. Also, experiment in the removal of the side reflectors made it appear that they were not of appreciable importance. The rear reflector, it seemed, was performing most of the work by itself. When it also was removed, leaving the antenna system as a simple horizontal fundamental Hertz approximately one wavelength above ground, the signal strength immediately dropped from the normal R8-R9 to R4-R5 and fading became pronounced.

It is unfortunate that conditions were such that similar signals were received from stations using ordinary antennas during the entire week. It had been hoped that at some time of the test period the usual signals would disappear, so making it possible to determine whether or not the signals from the beam failed in the same manner.

As the result of our observations of the 28,000-kc. work in general and of this test week in particular we find our mind filled with what appear to be important questions—problems to which we have not, as yet, found any solutions. We feel that we might well state them in the hope that other experimenters will come forward with suggestions. They include:

(a) With the knowledge that 25 of the 36 week-ends including and preceding that of November 18th were satisfactory for communication in the 28,000-kc. band and that such communication was maintained on every day of the first week of November, are we to believe that the conditions in the upper atmosphere at those times were as unusual as present hypotheses would demand?

(b) If the conditions during the last nine months should be considered normal, why is it that such frequent and such satisfactory communication has been possible on the 28,000-kc. band when the hypotheses concern-

ing the behavior of such frequencies would not seem to permit it?

(c) Can we assume that the high-angle rays actually are increased in amplitude when a beam antenna, such as that used, is tilted at high angles?

(d) If this is so, and if the gradient of ionization in the atmosphere is such that only the lowest rays ever return to earth, why is it that the rays radiated at relatively high angles to the earth's tangent appear to be much more effective than those radi-

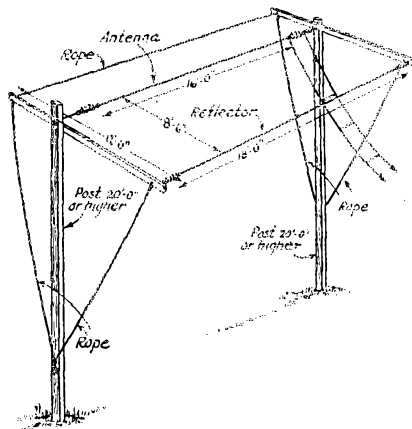

FIG. 2. ONE PRACTICAL ARRANGEMENT FOR AN ANTENNA AND ADJUSTABLE REFLECTOR

The cross pieces supporting the reflector wire could be pivoted on the upright poles with iron bolts. Then, by adjusting the tie ropes, the angle could be varied. If transmission in the opposite direction is to be attempted the reflector could be pulled over to the other side of the antenna by means of the ropes. The dimensions of the antenna and reflector are given in this case also for 28,846-kc.

ated at low angles? Why is it that the radiation at higher angles provides, at various distances, not only definitely higher signal intensities but also a marked reduction in fading and an increased period of reception during any one day?

As a further result of our observations we are able to present some odd suggestions regarding equipment and experimental possibilities which may be of interest to amateurs who are to undertake operation on the 28,000-kc. band. They are concerned chiefly with antennas which, it would seem, have a very important influence over the results obtained.

Vertical half-wave antennas suspended at heights above ground less than their length, and horizontal antennas at heights greater than one wavelength, it would appear, radiate strongly at low angles. In the light of our experience, therefore, they would not seem particularly effective on the 28,000-kc. band. Full-wave vertical antennas suspend-

ed near the ground and horizontal antennas strung at a height of one-half wavelength are considered to radiate strongly at angles between 20 and 40 degrees. They probably would be more satisfactory than simple antennas arranged in other fashions. The low heights make it possible that the antenna will be drastically screened in some loca-

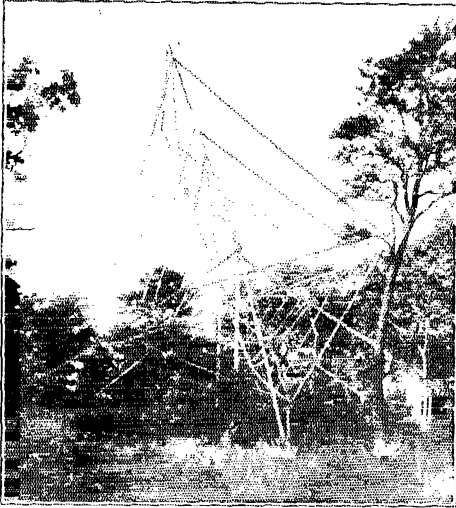

ANOTHER VIEW OF THE W1CCZ ANTENNA

tions and every endeavor should be made to erect it in an open area well clear of trees or buildings.

The experiences with the W1CCZ beam antenna have made it evident that any such system can be made much simpler than was first thought. In its most practical form the system would consist of a half-wave antenna mounted centrally between two reflector wires one wavelength apart. A quarter wave behind the antenna the third reflector would be mounted, the four wires being supported in some wooden structure which would permit the angle to be varied. The exact form of the supporting frame is not of particular importance and the amateur can be depended upon to design some assembly which is most suited to his facilities.

Another highly satisfactory and still simpler system would consist of a horizontal half-wave antenna with a single reflector wire behind it. The reflector could be tied into place with ropes and made adjustable in the manner shown in Figure 2.

The length of the antennas for a given frequency can be determined in the usual manner.<sup>12</sup> The reflector wire or wires should

be made approximately nine-eighths the length of the antenna.

The apparatus or circuit used in the transmitter itself need not differ from those used on the other high frequencies. Particular attention should be given to the tank-circuit constants, the plate supply system and the mechanical construction in accordance with what are at present considered good practices, and special care must be taken in the tuning adjustments if a clean and steady signal is to be obtained. It is, perhaps, more important on this band than on any other to maintain the input to the tube at or below the rated value.

The best modern practice for the lower-frequency bands can well be followed in the 28,000-ke. receiver also. The only possible necessary change, beyond that of the tuning-circuit constants, will be the detector plate voltage. In most receivers, an increase in this voltage over that used on other bands will be found necessary to provide a satisfactory condition of oscillation.

With a good 28,000-ke. transmitter and receiver and a suitable antenna (preferably one equipped with one or more adjustable reflectors) a magnificent field for communication and experiment is opened up to the amateur. The chief thing is to realize that communication can be expected only when the two stations are separated by a region of daylight and that contact is likely to fail completely at some times.

What is most needed at the present time is the complete and accurate record of performances obtained, particularly with regard to the date, times and consistency of prolonged and frequent contacts. Amateurs will therefore contribute definitely to the development of the band if they will make a practice of noting the details of such contacts and sending their observations to Headquarters. Another urgent need, of course, is some variation of existing hypotheses which will account for the results being obtained!

Some day, we believe, the new band will be found to comprise frequencies of untold worth.

### Strays

W9DJK suggests that the CQ parrot owned by a fifth district ham really ought to have an operator's license to avoid complications with the Radio Commission. If apprehended it is thought said parrot could ask for nothing better than solitary confinement on a diet of crackers and water.

Clipping from the humor column of the Duluth (Minn.) Herald:

"A professional radio operator seems to be one who connects with lost explorers after amateurs show him how."

## A Crystal Note Without a Crystal

By T. C. Cooper\*

**W**HO of you has listened to the commercial transmitter with its clean cut note and not wanted to duplicate it? Herewith follows a description of a master-oscillator power-amplifier transmitter operating in the 3500-kc. band at W1CGR, which has been developed to a point of reliable performance comparable with that of a commercial set-up, but within the means of the average amateur.

### NEUTRALIZATION VS. FREQUENCY DOUBLING

Although the overall efficiency may be increased by neutralizing the amplifier and operating the oscillator at the amplifier frequency, this method has been replaced with the slightly less efficient one of doubling the amplifier frequency, for the following reasons:

- A. Undesirable feed back eliminated under all conditions which makes possible the following items under "B" and "C".
- B. Frequency changes made easily without the necessity for additional adjustments.
- C. A steady, clean cut note with pure d.c. characteristics.
- D. A slight change of tube characteristics has negligible effect upon note and frequency, which may not be true when the usual pseudo bridge is employed.
- E. In order to duplicate the above by neutralizing the amplifier, elaborate shielding, additional windings and a neutralizing condenser are necessary.

Referring to the oscillator which operates in the 1750-kc. band (the amplifier operating in the 3500-kc. band) the schematic wiring diagram shows that a series feed split coil Hartley has been chosen. Other conventional self-excited circuits should work out satisfactorily. However, this one seems to lend itself to the application particularly well, in that its output is reasonably constant over a wide range of frequencies, with but a single control adjustment. The series feed is partly responsible for this convenience and, therefore, has been given preference over the more commonly used shunt feed.

It should be noted that the tank circuit is completed with a high grade mica condenser of .004  $\mu$ fd., located close to the tank inductance, and that it must carry the radio frequency current in this circuit which may be several amperes.

The position of all leads to the inductance

referred to is relatively as shown; this is equally true of the center-tapped resistances and by-pass condensers. The latter arrangement permits of short radio frequency return leads and accordingly, has been given preference over transformer center-tapped windings.

A strong second harmonic may be realized by choosing a high value of grid leak resistance in the order of 10,000 ohms or more,

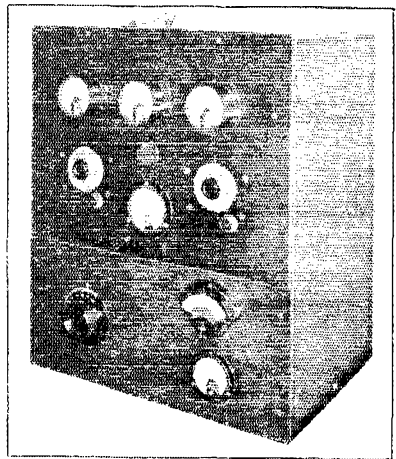

A GENERAL VIEW OF THE SET COMPLETELY ASSEMBLED.

The top, back and side covers may be removed to allow greater accessibility when it is necessary to work upon the equipment. When in place, as shown, they offer complete protection of the set against dust and dirt as well as mechanical injury. The lower portion of the panel carries the oscillator tank circuit condenser and the plate voltmeter and milliammeter. The upper panel carries the amplifier equipment. The three upper meters are for antenna current, plate voltage and plate current while the meter in the center is for filament voltage. The condensers control the frequency of the amplifier tank circuit and antenna system.

by reducing the number of turns in the grid circuit to a working minimum and increasing the plate turns to a working maximum. Incidentally, the note will also benefit.

Let's deviate from our description for a moment. Before one can raise the efficiency of any circuit, the losses must be reduced to that point where connections are connections and insulation is insulation.

For example, don't wire up a tank circuit with No. 18 wire when the inductance may be of 2/16-inch copper ribbon, for a chain is only as strong as its weakest link. Don't expect condenser bearings to stay clean and depend upon them for good contact forever.

\*W1CGR, original 2DR, 135 Dwight Road, Springfield, Mass.

It pays to brighten them up at regular intervals. Don't use a leaky socket or condenser with inferior insulation. Particular attention must be paid to similar points throughout the system.

The oscillator tube is a UX-210 and a plate current of 38 mills is obtained with a plate voltage of 500. Strong, stable oscillations are had at a frequency of 1750-kc.

The second harmonic may be readily heard in the 3500-kc. band by disconnecting the aerial and ground from the receiving set and moving it ten or twenty feet from the oscillator and also removing the transmitter amplifier tube from its socket, taking care to disconnect the coupling from the amplifier grid to the oscillator tank circuit.<sup>1</sup> This is the time to check the oscillator note and frequency, always remembering that you cannot expect the amplifier note to be any better than that of the oscillator.

#### OSCILLATOR POWER SUPPLY

After continual failure to realize a pure d.c. note with the conventional brute force filter, the circuit shown has been adopted. The reactors, radio frequency chokes and condenser values are not critical. A large capacity across the 216 rectifier tubes does, it is true, load them heavily, but equally true is the fact that the regulation is improved, a factor in obtaining constant oscillator frequency under varying loads imposed by the amplifier. The capacity across the rectifier may be reduced without much change in regulation but the percentage of a.c. ripple will be increased.

#### COUPLING CONDENSER

The .001  $\mu$ fd. coupling condenser between the grid of the amplifier and the tank circuit of the oscillator should be mica insulated to withstand both radio frequency voltages and the combined d.c. voltages of the oscillator plate supply and the amplifier grid bias. Its value is not particularly critical and may be decreased to .0008  $\mu$ fd. with equally good results. As the size is reduced, the tap from the amplifier grid should be moved nearer to the plate end of the oscillator tank coil.

#### AMPLIFIER

The amplifier 1750-kc. power input is developed across the choke, RFC, which is described in the data appearing under the schematic diagram. The by-pass condenser, C3, returning this grid circuit to the amplifier center tap is essential. If it is omitted, complete cut-off of the amplifier plate current is not possible with an open key when

a reasonable fixed bias is used. This results in the familiar back wave common to most master-oscillator power-amplifier transmitters even though neutralized. It is also important that the plate circuit return condenser, C2, not be omitted.

The 203-A amplifier tube is worked with an input of 80 watts since it has been determined that this represents an optimum use of the output of the oscillator previously described. A series feed plate supply has been chosen for the amplifier as for the oscillator. The amplifier grid is also highly biased and radiation of consequent tube harmonics suppressed by a selective coupled radiating system.

The position for optimum coupling under such conditions is surprisingly critical to that degree where small plus or minus values from the correct one may result in overheating of the amplifier tube, loss of useful radiation, shifting of frequency from a swinging radiating system or a change in note and other undesirable inherent reactions.

#### POWER TRANSFORMERS

One of the requisites for a steady note is good voltage regulation of the plate and filament supplies. The use of three transformers as shown in the diagram materially helps in realizing this condition.

#### RECTIFIER TUBES

UX-281 rectifier tubes are not rated to deliver their output at 1,000 volts; nevertheless, the particular stock tubes in use have continued to do so at an average of 80 milliamperes and show no signs of weakness after 700 hours of intermittent service.

#### RADIO FREQUENCY INDUCTANCES

The oscillator inductance is wound with soft copper strap 3/16-inches wide and 1/16-inch thick. The maximum diameter of the coil is 4 inches and the shape of the winding supports is hexagonal and not round. The spacing between the edges of the turns is 1/4-inch. The grid coil is of seven turns and the plate coil of twelve and a half turns. The spacing between the two coils is half an inch.

The amplifier plate coil is wound with thirteen turns of No. 12 soft drawn copper wire, each turn spaced three-eighths of an inch as measured between wire centers of adjacent turns. The maximum outside diameter is 3 1/2 inches.

The antenna coupling inductance consists of eight turns of No. 14 soft drawn copper, turns spaced 3/16 of an inch between wire centers of adjacent turns and with a maximum outside diameter of 5 1/4 inches.

It has not been found necessary to mount the various inductances at right angles to each other; however, it is good practice to

1. Better still, construct a monitor with which you can continue to check the character of the signals when the station is in operation. See page 17 of the October issue for further information on the construction of the monitor.—Tech. Editor.



have at least three inches of clear space around them and not include any metal objects in their concentrated fields.

**RADIO FREQUENCY CHOKES**

The radio frequency chokes, RFC, prevent radio frequency currents returning to ground through the power transformers or from taking the long path between the oscillator and amplifier. The jumper between the center tapped resistances of the radio frequency tubes serves to stabilize both circuits. This lead being at zero radio frequency potential does not effect the coupling but without it, undesired reactions may obtain.

**CONTROL ADJUSTMENTS**

There are three main adjustments nearly independent of each other and these may be carried out in the order given:

1. Oscillator frequency.
2. Amplifier tank circuit frequency.
3. Radiating system frequency.

**AMPLIFIER PLATE SUPPLY AND KEYING METHOD**

These items representing two closely associated circuits will be considered jointly. We will start by calling attention to the method of keying which has successfully passed tests wherein other methods have fallen short.

An electrified receiver with a minimum sensitivity of 10 microvolts-per-meter when operated in common with the transmitter 60-cycle supply failed to register interference. A three-circuit tuner located some 150 feet from the transmitter also was unable to detect the transmitter operation. Other electrified receivers in the immediate vicinity were likewise free from any transmitter interference.

Returning to the schematic, a reactor, X, is used to retard any sudden change of the amplifier plate current and a condenser, C4, absorbs keying surges. Only the amplifier current flows through the reactor and the current through the resistors, R2 and R3, does not affect it.

The pure d.c. of the oscillator should not be contaminated by an impure plate supply to the amplifier tube. Accordingly, the reader is urged to follow the schematic or its equivalent. It has been the writer's experience that interference to

neighboring broadcast receivers results even with selective receivers if a modulated supply and operation on 3500 kc. are employed.

The resistors, R2 and R3, as shown in the amplifier plate supply serves these purposes:

1. Improves regulation.
2. Protects the filter condensers from surges.

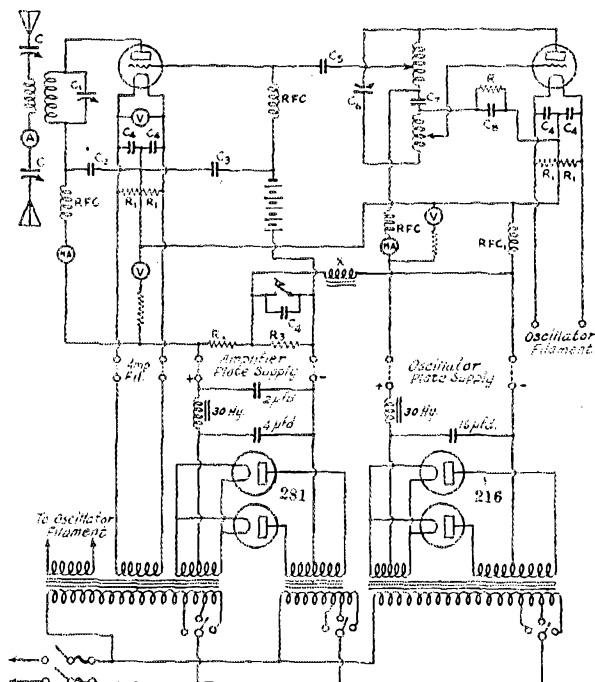

THE COMPLETE SCHEMATIC DIAGRAM OF THE TRANSMITTER AND POWER SUPPLY IS SHOWN ABOVE.

The connections between the power supply units and the transmitter are shown in dotted lines. No lines are shown for the oscillator filament due to its position in reference to the transformer winding feeding it. The inductances used for the oscillator tank, amplifier plate circuit and antenna circuit are described in full in the text. The radio frequency chokes, RFC, are small honeycomb coils 3/16-inch thick wound with No. 28 s.c.c. wire. The inside diameter is 1/2-inch and the outside diameter, 1 1/4-inch. If similar chokes are not available, all may be constructed as RFC1 is. This consists of a single layer of No. 26 d.c.c. wire on a 3-inch tube. The winding is 5 inches long. The constants of the filter circuit in the power supply are indicated on the drawing and the other constants of the transmitter are as follows:

- |               |                |                           |
|---------------|----------------|---------------------------|
| C.—500 µsf.   | C6—600 µsf.    | R2—30,000 to 50,000 ohms  |
| C1—250 µsf.   | C7—4,000 µsf.  | capable of dissipating 80 |
| C2—.01 µsf.   | C8—800 µsf.    | watts.                    |
| C3—1 µsf.     | R—10,000 ohms. | R3—10,000 ohms approx-    |
| C4—.2 µsf.    | R1—25 ohms.    | imately.                  |
| C5—1,000 µsf. |                |                           |
- X—30 henries capable of handling 100 mls. d.c.

3. Provides that part of the bias which may be readily shorted for keying.

From an examination of the keying method, it is apparent that the combined values of the bias battery and the IR drop

across the resistance,  $R_3$ , should be sufficient for complete cut-off of the amplifier tube plate current when the oscillator is operating and the key is open. When the key is closed, the amplifier plate current will not exceed 15 or 20 mils, assuming the radiating system to be detuned during this check.

Should the current exceed these values with the recommended "C" voltages, it is suggested that the coupling lead from the

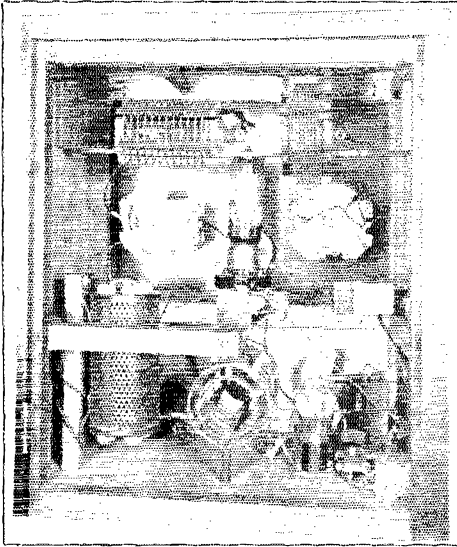

A REAR VIEW OF THE SET SHOWING THE GENERAL ARRANGEMENT OF THE VARIOUS PARTS

The oscillator tube and its accessory equipment is located at the lower right with the multiplier for the high voltage meter at the left. The amplifier tube is mounted on the framework in the center and the two tuning condensers are at its sides. Above the condensers and tube may be seen the amplifier and antenna inductances.

grid of the amplifier be moved away from the plate end of the tank coil just enough to bring about the correct conditions. Closing the key and resonating the radiating system should now increase the amplifier plate current to at least 70 or 80 mils and the oscillator plate current by about 2 mils. These values will vary somewhat with different antenna systems.

The writer will be pleased to answer questions pertaining to this article providing self-addressed stamped envelopes are included.

### Strays

The current and voltage in the keep-alive circuit of the mercury arc rectifier is usually kept down to the lowest possible value in order to reduce the heating of the tube at the point near the keep-alive arc itself. At

times this voltage may drop somewhat and the arc becomes extinguished. When the arc goes out, the current in the circuit drops to zero and the magnetic field around the choke in the keep-alive circuit collapses, inducing a voltage across the terminals of the choke. This voltage may, in many cases, be high enough to cause a break-down in the insulation of the choke or transformer which supplies this circuit. A way of preventing this voltage from doing any damage is to shunt the choke with a resistor of from 5,000 to 50,000 ohms.

## BOOK REVIEWS

By H. P. Westman, Technical Editor

**H**ANDBOOK of Chemistry and Physics by Hodgman and Lange. Thirteenth edition by the Chemical Rubber Publishing Co. of Cleveland, Ohio. Price \$5.00. 1196 pages with an index comprising 18 pages.

There are fifteen sections covering the following: Mathematical Tables, 144 pages, General Chemical Tables, 558 pages, Properties of matter 37, pages, Heat, 69 pages, Hygrometric and Barometric Tables, 9 pages, Sound, 5 pages, Electricity and Magnetism, 37 pages, Light 57 pages, Miscellaneous Tables, 27 pages, Definitions and Formulas, 53 pages, Laboratory Arts and Recipes, 3 pages, Photographic Formulas, 3 pages, Measures and Units, 116 pages, Wire Tables, 16 pages and Problems, 7 pages.

As may be seen, several of these sections are of direct interest to the radio experimenter and engineer. The mathematical tables include among other things, Algebraic Formulas, trigonometrical functions, differentials and integrals, analytical geometry, four and five place logarithms, natural sines, cosines, tangents and cotangents, hyperbolic functions, degrees-radians and a table giving the reciprocals, powers, and roots of numbers between 1 and 1000, together with the circumference and area of circles of their diameters. The section on mathematics may be obtained separately, the price being 75c.

*Principles of Mercury Arc Rectifiers and Their Circuits* by David Chandler Prince and Francis Brooke Vogdes. 225 pages and 155 figures. Published by McGraw-Hill Book Company, Inc. of New York City. Price \$3.00.

While primarily directed at the power engineer who must work with rectifiers, the book devotes a considerable amount of space to the fundamentals underlying the operation of mercury arc rectifiers. In addition it treats both the kneotron and tuncar tubes giving their principles of operation and their outstanding characteristics.

Well over half the book is devoted to power rectifier circuits employed with mercury arc rectifiers. Methods of attacking many of the problems met with in this work are outlined and the regulation of both single and poly-phase arrangements is treated extensively.

A chapter on the theory of the causes of arc-back brings out many interesting points which must be considered in the general operation of these units.

For the man who is interested in finding out more about mercury arc rectifiers, this book is of great interest particularly if his work is along standard electrical engineering lines.

# The Heterodyne Low Frequency Generator

By J. E. Smith\*

IT is to be conceded that the low frequency generator is an indispensable piece of apparatus about the radio laboratory. It is required to act as a source of alternating voltage, at any desired frequency in the audible range, in all measurements made on amplifiers, loud speakers, filters, microphone transmitters and many other pieces of apparatus used in radio practice. In fact, it can be used, in combination with a suitable amplifier, to supply an alternating voltage for any kind of measurement requiring such an e.m.f. Among these may be listed the following: operating the various types of low frequency bridges, measuring capacity, phase angle, power factor, resistance, *et cetera*. In making many of these measurements, special arrangements of apparatus are required but in all cases the low frequency generator is indispensable.

The low frequency generator which is in general use is a vacuum tube oscillator having a variable tuned circuit, the inductance and capacitance in this tuned circuit being so adjusted, according to the

formula  $f = \frac{159.2}{\sqrt{LC}}$  that the desired

frequency is generated directly. The large inductance used is generally fixed while the condenser consists of two parts, one variable in steps and the other, connected in shunt, continuously variable. The quantity of apparatus required and the expense involved is relatively considerable, at least it is considerable from the viewpoint of the average experimenter.

It is well known that an audio frequency beat note can be easily produced by the process of superimposing a high frequency oscillation upon another high frequency oscillation. The beat frequency produced is equal to the difference between the two high frequencies. However, in the most familiar case where such beat frequencies occur—in the oscillating receiver—the complete gamut of the audible range is passed over in almost a hair's breath movement of the condenser tuning dial. It is, therefore, impractical to use such a method for the production of audible frequencies without making some effort to choose the proper conditions. It is true that it might be possible to make the set-up operable by shunting a micro-condenser across the terminals of the principal condenser, but it will be found that this will not be a practical solution. If a slow motion gear train be used,

the ratio of this train will have to be so great that the effects of back-lash will certainly mask the very small motion that the main condenser is required to make.

The problem then, is to find the conditions

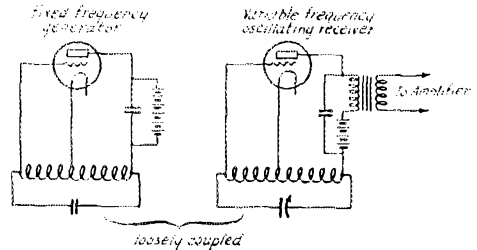

FIGURE 1. This is probably the simplest method of generating audio frequencies by means of beats. Although it is possible to generate both frequencies in a single tube, this usually results in bad dragging of both frequencies into step when the circuits are adjusted for low beat frequencies. Loose coupling between the two circuits should be employed in order to alleviate this condition.

under which the following requirements will be met:

- (A) It must be possible to continuously vary the frequency from zero to the required upper limit (generally the limit of audibility).
- (B) The variation of frequency, when caused by the turning of the dial, must be so accomplished that there is not an uncomfortably large change of frequency for a given amount of dial motion.
- (C) Sufficient power must be generated at any frequency in the range to satisfy the requirements of the tests being made.
- (D) The harmonic content of the output shall not be too large.

These are the main requirements. Any others that arise will be considered as they are met. The simple arrangement is illustrated in Figure 1. It consists of a generator of the ordinary type, on the left, having in its tuned circuit a fixed inductance and a fixed capacitance. Coupled to this is an oscillating receiver, shown on the right, having also fixed inductance but a variable capacitance. There is nothing new in this arrangement but we shall see that the important feature is the value of the constants employed. The method of arriving at them is as follows: Let  $F$  be the constant frequency of the generator at the left of Figure 1, and let  $f$  be the variable frequency of the generator on the

\*President, National Radio Institute, Washington, D.C.

right. The beat frequency,  $f_b$ , resulting from the combination of  $F$  and  $f$  is

$$f_b = F - f \quad (1)$$

whether  $F$  is greater or less than  $f$  makes no practical difference, but only makes a difference in the algebraic sign of  $f_b$ . The auditory response to  $f_b$  is the same whether its algebraic sign is plus or minus. With  $F$  constant, then,  $f$  must vary in the same amount as  $f_b$  varies. That is, if the beat frequency is to vary from zero to 20,000 cycles per second, then  $f$  must vary between  $F$  and  $F \pm 20,000$  cycles per second.

Let  $f_b$ , then, represent the total range of

tuning condenser dial and that the condenser we wish to use has a capacity ratio

$$\frac{C_2}{C_1} = r \quad (3)$$

where  $C_2$  is the maximum capacity of the condenser and  $C_1$  is the minimum. Substituting this relation in equation (2), in order to eliminate  $C_1$ , and solving for  $L$ , we obtain

$$L = \frac{k^2}{f_b^2 C_2} \left[ \sqrt{r} - 1 \right]^2 \quad (4)$$

Equation 4 gives the value of the inductance required in the oscillating receiver in order to make the limits of the beat frequency meet the limits of the movement of the tuning dial. Since  $f_2^2 = LC_2/k$ , Equation 4 may be put into the form

$$f_2 = \frac{f_b}{\sqrt{r} - 1} \quad (5)$$

It will be seen from this that since  $f_b$  is in the audible range, for  $f_2$  to be above audibility,  $r$  must have a value lying between 1 and 4. The lowest possible value that  $f_2$  may be permitted to have is the upper limit of audibility, which would require that  $r$  be equal to 4; in other words the capacity ratio of the variable condenser would be 4.

The frequency  $f_2$  is the lower frequency limit of the oscillating receiver. The upper limit is

$$f_1 = f_2 + f_b \quad (6)$$

To obtain the equation for the beat frequency at any setting of the variable condenser, let  $r'$  be the capacity ratio at that setting. That is, if  $C_2$  be the capacity at a given setting, then  $C_2/C_1 = r'$  at that setting. Then, since  $f_b$  is  $f_1 - f_2$ ,

$$f_b = \frac{k}{\sqrt{L} \frac{C_2}{r}} - \frac{k}{\sqrt{L} \frac{C_1}{r'}} = \frac{k}{\sqrt{LC_2}} \left[ \sqrt{r} - \sqrt{r'} \right] \quad (7)$$

From this equation, the calibration curve of the generator can be computed very closely, providing the values are measured accurately and the calculated curve may be used as a check on the experimental calibration.

In order to visualize the phenomena let us refer to Equation 1 which states that the beat frequency is equal to the difference between the frequencies of the two generators and that one of these frequencies is constant, (i.e., does not vary with the setting of the condenser) while the other does vary. The manner in which the oscillating

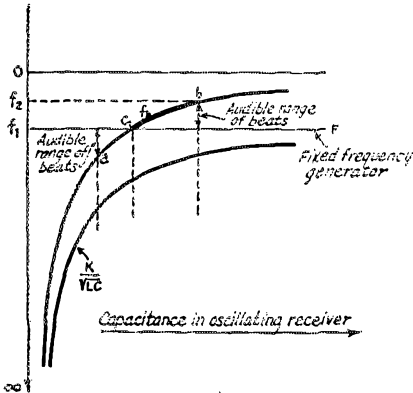

FIGURE 2. The two curves show the effect of changing the value of capacitance across the inductance of the variable frequency oscillator upon the frequency at which it is oscillating. The horizontal line  $F$ , is at the frequency of the fixed frequency oscillator which is also the value of  $f_1$ , the highest frequency of the oscillating receiver. Beats in the audible range are generated between the points marked  $a$  and  $b$  with zero beat at  $C_1$  where the curve crosses the fixed frequency line. It should be noted that a much larger change of capacity is required to run through the audible range of beats when the range of the variable frequency oscillator is lower than the fixed frequency. The shape of this curve also indicates why a high  $C$  circuit is more stable than one of low capacitance: the greater value of  $C$ , the flatter the curve gets and the less effect a given change in capacitance causes.

the beat frequency and let  $f_1$  and  $f_2$  be the upper and lower limits respectively of the frequency of the oscillating receiver. Assuming that the coupling between the two oscillators is very loose as is the case in actual practice, we write

$$f_b = f_1 - f_2 = \frac{k}{\sqrt{LC_1}} - \frac{k}{\sqrt{LC_2}} \quad (2)$$

In these formulas, the frequencies are in kilocycles per second, inductances in microhenries and capacitances in microfarads. The constant  $k$ , for these units is 159.2.

Now suppose it is desired to cover the whole range of  $f_b$  over 180 degrees of a

receiver varies is indicated by the curve in Figure 2 marked  $k/\sqrt{LC}$ . This curve is a hyperbola and lies completely below the axis of zero frequency; that is, it is algebraically negative with respect to the fixed frequency of the other oscillator because we are considering the beats as the difference between the two. However, it all sounds the same to the ear, so we need not worry whether the curve is above or below the axis.

It will be noted that this hyperbolic curve never reaches its axis of zero frequency; in fact we do not even wish it to enter the region of audible frequencies. But if we raise the curve to the position of the curve marked  $f_0$  in Figure 2, part of the curve will fall in the region of audible frequencies as far as the beat note between the two oscillators is concerned. This part of the curve lies between the points a and b. The two parts of this section of the curve that lie on either side of F are equal with respect to their frequency range; in other words at C, the beat frequency is zero and as we go in either direction on the curve away from C, the beat frequency rises until it reaches the limit of audibility at a and b. For the purpose of generating audible frequencies it is not necessary to use both halves of this section of the curve; furthermore, by using only one half of this section we are enabled to use a smaller capacity ratio. If we used both halves of the curve, we should have to have a capacity ratio 1.414 times as great and would cover the audible frequency band twice over the range of the condenser.

It will be noted, however, that as the curve is raised farther and farther, the part of it which comes into the audible range of beats becomes steeper and steeper. It is, therefore, advisable to raise it only as far as is required to bring its flattening top portion into the audible range. This means that it is advisable to have the fixed frequency, F, as low as possible and have a high C/L ratio in the tuned circuit.

Unfortunately, it is not possible to determine on a fixed frequency that is just above the audible range and obtain satisfactory operation. This is due to the fact that both of the oscillators employed generate harmonic frequencies as well as the fundamental frequencies desired. It is, therefore, possible to beat the second harmonic of the lower fundamental frequency against the fundamental of the higher frequency and get a beat note that may be in the audible range. For example, if we use 20 kc. as the lowest fixed frequency above audibility and vary the oscillating receiver from 20 to 40 kc. to obtain a beat frequency of from zero to 20 kc., we find that the second harmonic of the fixed frequency is 40 kc. and as the beat between the fundamental of the fixed frequency and the fundamental

of the variable frequency goes from zero to 20 kc., the beat between the second harmonic of the fixed frequency and the fundamental of the variable frequency goes from 20 kc. to zero. From this it will be seen that when turning the dial of the variable frequency generator, we will have in the output circuit two audible frequencies, one of which varies from zero to 20 kc. and the other (weaker but still good and audible) varying between 20 kc. and zero.

The tabulation below shows the beat frequencies generated by various combinations of harmonics and between harmonics and the fundamental frequencies involved. The first column headed, F, lists the fundamental frequency of the fixed oscillator. This value is varied between 40 and 120 kc. in 20-kc. steps. The second column, f, gives three values of the variable frequency which correspond to beats between it and F, or zero, ten and twenty kilocycles, the values of which appear in the third column. The other five columns give the beat frequency for various combinations of harmonics.

F	f	F-f	F-2f	2F-2f	2F-3f	2F-4f	4F-5f
40	40	0	40	0	40	40	40
	30	10	20	20	10	0	10
	20	20	0	40	20	40	60
60	60	0	60	0	60	60	60
	50	10	40	20	30	20	10
	40	20	20	40	0	20	40
80	80	0	80	0	80	80	80
	70	10	60	20	50	40	30
	60	20	40	40	20	0	20
100	100	0	100	0	100	100	100
	90	10	80	20	70	60	50
	80	20	60	40	40	20	0
120	120	0	120	0	120	120	120
	110	10	100	20	90	80	70
	100	20	80	40	60	40	20

The more desirable conditions are those in which no beats between the harmonics occur at a frequency of 20 kc. or lower. From the table it will be seen that as the value of F is raised, this condition is improved. Theoretically, no frequency can be obtained where no such beats are had but in practice, the frequency may be so chosen that these beats occur between harmonics that are remote from the fundamental frequency and are, therefore, of small enough energy not to result in an audible signal in the output circuit.

It will also be noted that the beat between the second harmonics of both oscillators as shown in the fourth column is always double the desired beat frequency. The only manner in which this can be overcome is to insert filters that allow only the fundamental frequency to pass and combine the output of the two oscillators in a common detector circuit. This materially complicates matters and unless a very pure output is required, it is not done. Its effect in the output is that of introducing some energy at the second harmonic of the desired audible frequency.

(Continued on Page 30)

## Rotten Television

By The Old Man

**S**AY, son, between you and me it's just about time somebody took a crack at all this hogwash that is permeating current literature concerning television. I've been following it all pretty closely, and getting hotter and hotter about it, and by garm I've got to get it off my chest. It's just too much for this old bird to swallow.

Last Fall I got together a pretty good television outfit. Nice discs, dandy motor, all the dingbats and doodads, and whatnot. I set it all up according to directions, and was ready to get what was to be got.

Now, judging by the articles and advertisements that are appearing by the score these days, I was all primed for the biggest thrill of my hoary and sinful career. In just a few minutes I was going to tune in on a television station, twiddle a few knobs, and see the pretty pictures.

Here's what happened. I tuned in the station. That part was easy, at least. No picture. Just a funny bunch of lines. Then I took a slant at what the directions say: "After tuning in on a television transmission, all that is necessary is to bring the drive motor into synchronism, and the picture will appear." Sounded easy, so I hove up and down on the motor rheostat a little. Not a darned picture. I gave it some more of the same medicine. Just exactly no difference at all. By this time I was beginning to smell a rat in that innocent looking sentence in the directions. "All that is necessary—"—eh? All that is necessary. There's the rub! For the rest of that broadcast I twiddled and jiggled and sweated and fumed, and only *once* toward the tail end did I hit synchronism.

I did hit it once. For about half a second, actually, I had the picture. It was a rotten picture. It flickered and it was fuzzy and foggy, and about the time I was wondering how and why they picked on a cow to televise, it suddenly dawned on me that it was a man's face I was looking at. Then I lost synchronism and my man disappeared in a maze of badly intoxicated lines. By the time that broadcast finished I had a brand new and extensive vocabulary. Kitty, having ventured too near during the festivities, had been spat upon copiously.

Since that time I have tried it some more. I bought all the synchronizing gadgets there are, but I'll be triple dad gormed if I can hold that picture in synchronism for more than a couple of seconds. It just isn't being done, and I'll bet my favorite corncob that nobody will ever do it for any longer period unless some public-spirited family

starts in to breed television synchronizers through eight or ten generations.

There is another nasty little habit that outfit of mine has. In the infrequent second or so I manage to hold it, a snake that has been stung in the snout with home-brew will often wander into the picture and all across the subject. I don't know what makes him, and I can't seem to control him. Sometimes he's there, and sometimes he isn't, and sometimes he brings his relations with him. I don't like snakes in what I see, but what am I going to do about it?

In these honeyed-up ads and articles, why don't they go ahead and tell the whole story? Why don't they say that there isn't a single practical synchronizing system available yet, and that getting your picture and holding it is about ten times as hard as holding a wobbly forty-meter d.c. signal by using a 67-plate tuning condenser with a sticky shaft and no vernier? Why don't they say that it takes a lot of practice and the fingers of a magician to hold a picture for about three microseconds? Why don't they tell us that the picture is only a little cuss about an inch square, and that the whole business looks like a fire scene in the movies?

Why don't they mention that the definition is rotten in the little pictures, and many times worse in the ones where you use a magnifying glass to get them bigger?

And why don't they explain that the only way we can get bigger pictures and better definition is by using enough modulation on the carrier to take up half the broadcast band, and that even if we had transmitters to send such stuff and receivers to receive it—which we haven't—the Federal Radio Corporation wouldn't let anybody have that much of the ether?

Why don't they say that television is crude, results are difficult to achieve, and that it is only a plaything for the experimenter who is satisfied with occasional bum results, and that it is distinctly not at the stage where John W. Public can buy an outfit and get anything remotely approaching a satisfactory picture?

Now, I'm all for progress. Don't get me wrong. I am sure that some day we will have really practical television. There are a lot of serious experimenters like Jenkins and Alexanderson working on it, and when you get people like that working on anything, something is bound to happen. The two big problems of cheap satisfactory synchronization and definition and size with limited ether space will be solved by some-

(Continued on Page 24)

# A Poor Man's M. O. P. A.

By J. T. McCormick\*

**M**OST of us have noticed that we are able to read a weak crystal-controlled signal through a comparatively strong signal of the more usual kind. The reason is no secret. The crystal fellow's dots and dashes are always at the same pitch and we recognize them instantly as belonging to the station we wish to copy.

We sigh for a crystal—but we're too poor. If only a fellow could build a self-excited oscillator as steady as a crystal, the world would be rosy indeed. We're so poor that we can't even afford the extra tube necessary for an oscillator-amplifier affair.

But wait! Perhaps *all* is not lost. If the crystal man's note sounded perfectly steady in the receiver, the little self-excited oscillator in the receiver must be as steady as the crystal signal to which we listened. Now we have something to work on. We merely need to find out why it is that every ham from Tecumseh to Tokio is able to build a steady receiver; then apply our new knowledge to the building of a transmitter. Looking over the situation, we find that the receiver works under conditions somewhat different from those found in the usual transmitter. In the receiver:

1. The tube runs perfectly cool.
2. There is very little load on the control circuit.
3. Regulation of the power supply is excellent.
4. The radio frequency load impedance is low.
5. Low "C" is used in the control tank.

Differences 4 and 5 are obviously in favor of the transmitter and it is apparent that the reasons for unsteadiness in thousands of self-excited transmitters must lie in 1, 2 and 3. We need not discuss No. 3 as nearly everyone is giving it proper consideration at present. Only 1 and 2 are left. Looks easy!

The receiving tube runs cool because we do not try to apply twice the rated plate voltage. Also, we use a high grid bias. Of course, we can't afford to make the transmitter dance to the same tune as the receiver in the matter of plate voltage because, after all, the receiver merely needs to oscillate, while the transmitter must deliver power to the antenna. Most of us can trim the voltage down a skinny bit with profit, though. Perhaps, the old 5,000-ohm grid leak will give us another ampere in the antenna, but we're after a chirpless note. Let's get one of those variable resistors that are supposed to be able to dissipate a lot

of power, and use it as a leak. We can protect it from radio frequency energy by shunting it with a condenser and putting a good choke in series with it. We can twist the knob to the left in a determined manner until the monitor says the note is chirpless.

No. 2 is not as easily disposed of, but we're going to tackle it. We usually think of the tank circuit as a load on the tube, but, conversely, the tube conductance is also a load on the tank. Imposing a load on a

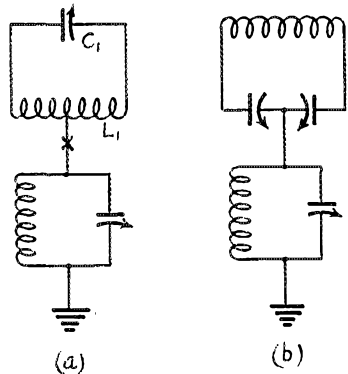

FIGURE 1

tuned circuit is equivalent to increasing the resistance of it. We want to keep the resistance of the tank circuit low because it controls the frequency of oscillation and we prefer that it be very partial to one particular frequency. Transmitting tubes usually have a very low plate impedance and the best we can do is to cut the plate voltage and increase the grid bias (this decreases the tube conductance) until the monitor gives its OK.

Now we reach the real stumbling block—the antenna. How in tunket are we going to take the antenna load, or at least part of it, off the control tank circuit? Let's try to couple the antenna to the tube, but not to the control circuit!

Figure 1 shows two ways of connecting two tuned circuits together electrically and yet permit them to be tuned independently. It is assumed that the voltage node of one circuit has been precisely located and the other circuit connected to this point. It is assumed also that there is no coupling between the two circuits other than the connection mentioned. (This is theory, not practice!) Adding a load to one circuit will not affect the other. If we can only persuade the tube to put r.f. "juice" through

\*W9BHR, 210 N. Knox Ave., Topeka, Kansas.

both circuits, we can couple the antenna to one and control oscillation with the other. Figure 2 shows two ways in which this might be done—only, they won't oscillate. That is; neither circuit will oscillate if both of the tanks are tuned to the same frequency.

I must leave the main line at this point

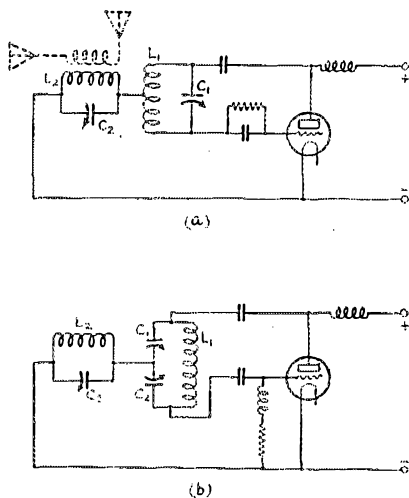

FIGURE 2

and do a little switching. We are in the habit of referring to all circuits which won't oscillate as non-oscillators. Actually, there are two breeds of the critters. There is the gentle animal which lacks sufficient feedback to produce self-oscillation. It is more or less harmless. However, there is also the vicious monster which actively fights oscillation. Remember when we hooked up the tickler backwards? That's one example. Figure 3 shows two more. If we try to force oscillations in these circuits by means of a driver tuned to their natural period, we find that the anti-oscillator circuit releases power from the tube to damp out the oscillations so forced. Because of this natural perversity, the circuits of Figure 3 will not only refuse to oscillate of their own accord, but also will stop the show if connected in the same tube circuit with a genuine oscillator. This, of course, is at resonance. In the case of non-resonance, the reactance of the anti-oscillator may be far enough out of phase not to affect oscillation. In that case, it does no harm. (Moral: Filament chokes *must not* be resonant!)

Now that we have reminded ourselves that there is such a thing as an anti-oscillator, let's keep it in mind and reconsider the circuits of Figure 2. First, we will take another look at Figure 1a. We decided that the two tank circuits could be tuned inde-

pendently—and they can. But it is also evident that whenever oscillation occurs in the L2C2 circuit, the point marker "X" must rise and fall in potential at radio frequencies. If we look upon the whole L1C1 circuit as being a mere lump of metal, we realize that it, too, must rise and fall in potential. Of course, L1 is an inductance and C1 is certainly a condenser and it is true that neither one nor both can be accurately considered as a mere lump of metal, but the "lump of metal" viewpoint is lucid and near enough to the truth for our purposes.

In Figure 2a, the r.f. output of the tube (if any) passes through both tuned circuits because they are connected in series with regard to this output. It is also plain that L2C2 is connected to what would normally be considered a voltage node in L1. However, if L2C2 reacts to the r.f. current passed through it by the tube (and it does) the "node" of L1 is no longer a node because it is part of the "lump of metal" affected by L2C2. That is; the voltage node is at the center of L1 as related to oscillations of L1C1. As related to the rest of the world in general, however, no such node exists, but there is one somewhere between the center and the grid end of L1. (Quick, Watson, the smelling salts! Mr. Einstein has fainted!)

About this time, we notice that the grid and plate of the tube in Figure 2a are also a part of the "lump of metal" and are, therefore, related to L2C2 in the anti-regenerative manner of Figure 3a. Now, L1C1 is a regenerative circuit simply because it is connected to the plate and grid in such a manner that the phase relationship between the plate and grid voltage is right to produce self-oscillation. When L1C1 is oscillating, the plate is negative at an instant when the grid is positive. On the other hand, looking at the plate and grid from L2C2, if, for some reason, oscillations are present in that circuit, the voltages impressed upon the plate and grid will be of the same polarity. These two circuits are in series across the output of the tube and if the output current was to flow through both of them, the voltages across L1C1 would at one instant make the plate positive and the grid negative. At the same instant the voltage across L2C2 would also tend to make the plate positive and at the same time it would apply a positive potential to the grid because the plate and grid are both tied to the same end of L2C2. Thus the voltage applied to the grid by the regenerative circuit will be 180 degrees out of phase with the voltage applied to it by the anti-regenerative circuit. This assumes that both circuits are tuned to the same frequency. If, then, at the same instant, one circuit tries to change the grid potential one volt and the other circuit makes a similar attempt, but



in the opposite direction, it is very clear that nothing is going to happen.

We can plainly see that we must give the oscillator an advantage over the anti-oscillator if we wish the thing to perk. This can be done by detuning the anti-oscillator circuit. Those of us who have used the Hartley (who hasn't?) know that the grid excitation would be too great if L1C1 were used alone with the filament tap connected to the center of L1 as it is. We know also that the plate turns would be too few—the r.f. output impedance would be too low. Use of the "anti" circuit would seem to correct this. We know that it can easily cancel all or any part of the grid excitation and we can make it whatever we like by proper detuning. Whatever reactance in proper phase to the r.f. component of the plate current is offered by the "anti" circuit when this adjustment is made represents the equivalent of additional plate turns.

Giving the circuit of Figure 2a an actual trial, we find most of our reasoning to be correct. It does oscillate. We can adjust the grid excitation by properly detuning the "anti" tank. Although the voltage across the "anti" tank is necessarily low to permit oscillation, we find that we can pick up plenty of power from it for the antenna because its reactance is lowered when the antenna load is added and it can be tuned closer to resonance as the load is increased. Touch the junction of L1 and L2 with a screw driver. The grid current leaps upward, but the beat note heard in the monitor changes only slightly. This indicates that we have been lucky enough to land somewhere near the "node" of L1.

There is but one thing wrong. The plate current is too high for the tube we are using. We are trying to duplicate receiver conditions in a transmitter and high plate current violates condition No. 1. Since the grid excitation is just right, the high plate current must be due to low output impedance. Trying to get more plate turns by increasing the reactance of L2C2 will only result in the stoppage of oscillation.

Obviously, we must compromise. The connection of L1 must be moved toward the grid end. This will place some of the antenna load on the control tank, but it can't be helped. We move the clip one turn. It is too much. The circuit is not as stable as before with regard to antenna changes and we cannot get enough plate current to represent a decent amount of input.

It occurs to us that we may be able to concoct from Figure 1 a circuit in which neither tank is an anti-oscillator. We actually accomplish this in Figure 4, which is simply a Hartley circuit with the addition of a separate output tank circuit inserted between the stopping condenser and the helix. Giving it a trial, we discover the

necessity of neutralization as shown by the dotted lines in order to prevent the thing from oscillating T. P. T. G. fashion. We find the output tank very difficult to adjust because every part of it is wild with body-capacity effect. Perhaps we could manage to put up with these irritations, but we also

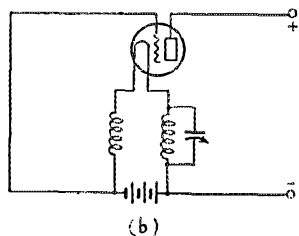
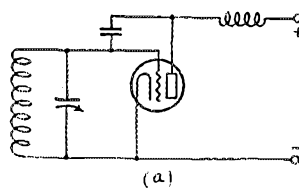

FIGURE 2

find that, at the higher frequencies, the antenna is considerably coupled to the oscillator tank by reason of capacity between the pick-up coil and the "lump of metal"—the output tank in this case. Chuck Figure 4 in the waste-paper basket; it is no good at amateur frequencies.

No, we won't give up. We found Figure 2a to be practical in every way except that it was necessary to move the clip on L1 a whole turn at a time in adjusting. Figure 2b is fundamentally the same as Figure 2a and is adjusted by means of nice smoothly-running condensers. Of course, two tuning condensers would be a nuisance so we must modify the circuit as shown in Figure 5. In this figure, a regular high-capacity condenser is used to tune the oscillator circuit and to provide as much "C" as good efficiency will allow. Two midget condensers are used to feed the output tank circuit. The maximum capacity of these midgets need be only just enough for this purpose. About 50  $\mu$ fd. each will be sufficient at 7,000-kc. and higher frequencies. The lower frequency bands will require larger condensers. The capacity, of course, may be as large as desired as long as one is still able to do the actual tuning with the regular tuning condenser.

A trial convinces us that Figure 5 is a really practical circuit and up to 1929 standards. There is but one disappointing fea-

ture. We find it necessary to decrease the capacity of the plate midget until the plate current is at a respectable value. This, naturally, puts some of the antenna load on the oscillator circuit, but, nevertheless, the circuit is still a boon to the fellow with a

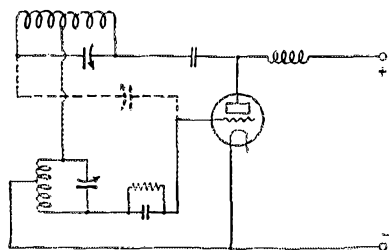

FIGURE 4

slim purse. In fact, I have installed it permanently—in a tin cracker box! Figure 6 shows the details.

I found the Ultraudion transmitter shown on pages 19, 21 and 22 of the September, 1927, *QST* and also on page 100 and 101 of the Handbook to be admirably adapted to "canning" and speedily revamped it to serve as the cracker box oscillator. The midget condenser that formerly served as the feedback control in the Ultraudion was removed, as were also the antenna windings from the plug-in coils. These coils should be clamped down with wing nuts, but I haven't as yet found time to do it. The two binding posts which formerly held the antenna leads now serve as connections to the two midgets, C2 and C3 of Figures 5 and 6, which are mounted on a piece of hard rubber covering a hole in the top of the can. A single binding post was added just behind the variable grid leak for the purpose of connection to the grid keying arrangement.

The cracker box rests on its back so that what was formerly the lid is now the front door, opening downward. All adjustments to the oscillator can easily be made through this door. Coils can be changed by first removing the tube. Removal of the tube is accomplished through a hole directly over it in the top of the can. This hole also provides ventilation. A slot cut in the right side of the can gives access to the binding posts for plate and filament supply. A smaller hole in the left side permits connection to the key binding post. These holes complete the ventilation scheme. The hole which admits the two midget condensers is cut in the top of the box near the rear. Connection to the midgets is easily made by removing tube and helix.

The output helix is mounted well above the top of the box in a horizontal position and at right angles to the oscillator helix. QSY of the output tank is accomplished by

means of a clip. The clip end of the coil is at the rear, the grounded end being placed to the front to avoid body-capacity effect. C4 of Figure 6 is mounted on the tin lugs soldered to the top of the box. The dial or knob of C4 needs no indicator as the adjustment is made entirely by observation of plate and grid meters and OK'd by the monitor. The antenna shown in Figure 6 happens to be what I am using at present. Any kind of an antenna can be used with any kind of coupling to the output tank.

Plate and grid current meters are mounted on the wall of the shack. These "meters" are merely indicators; this is a poor man's set. They consist of two cheap voltmeters shunted with potentiometers to keep them from going off scale.

The "canning" of the oscillator has proven quite effective. It is possible to move around the shack at will without changing the beat note in the monitor in the least. The hand may be moved all around the can without perceptible change. Actually touching the can produces a very slight, but noticeable, change of signal pitch. Bringing the hand near the "live" end of the output coil produces bad swinging as might be expected.

Here are some things to remember when tuning up Figure 6 for the first time: Antenna (and counterpoise, if any) should be disconnected and C4 turned to minimum capacity while the oscillator is being tuned to the desired frequency. C2 and C3 are both set at maximum capacity at the start. C3 will need no knob as it is always left at maximum setting. If plate current is in evidence after the power has been turned on and before the key is closed, the power

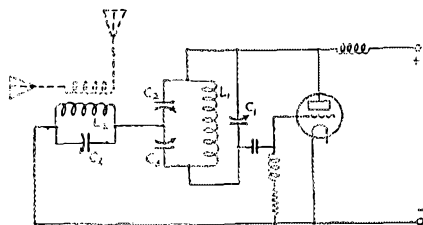

FIGURE 5

should be shut off and the filament voltage raised a bit. If, at the next trial, there is no indication of grid current after the key is closed, shut down and hunt for "bugs"—the thing isn't oscillating. When the oscillator is once perking at the desired frequency, the capacity of C4 should be slowly increased until the grid current nears the minimum value. If this point is passed and the needle suddenly flops to zero, C4 should be hastily readjusted. The capacity of C2 should be reduced, bit by bit, until the plate

(Continued on Page 78)

## The Total-Loss Receiver

By Clair Foster\*

**F**IRST let it be said that the "1929" receiver is all it was cracked up to be in the November issue of *QST*.

I had the pleasure of trying the finished model last summer at the home of K. B. Warner. The receiver I had been using in the East at W2QW was built from the article on page 25 of *QST* for December, 1927; and it was the best receiver I had ever owned. But with it last summer I could go over the 7,000-kc. band and find place after place so congested with stations that it was impossible to dig one out of the mess; while with the "1929" receiver I could hardly find a place where the QRM was so bad that I couldn't separate the signals enough to read individual stations. In fact if a feller didn't want to leave his noisy companions you could just grab him by the seat of his pants and pull him out.

The set's extreme selectivity was apparent. Really, the stations were so spread out that my suggestion would be to rig up a set of Midget condensers and their accompanying coils in a scheme like a turret lathe. Then all you'd need to do to drop from 8,000 to 7,500 kc. would be to swing the turret to the next notch; another push and she'd go from 7,500 to 7,000 kc., and so on. So when I built mine I had to take liberties with the original design. But merely to suit my individual needs; needing something reasonably selective that would find my old DX friends always on the same spot, and that would bring in faint signals loud enough to be read with the least amount of accompanying noise.

With only 3 plates in the midget condenser I soon had a whole flock of coils; and to cover the band I was so busy changing coils that I never had time to listen to anything. As stated in *QST*, 3 plates will be fine for 1929. In fact my idea of a good receiver for 1929 is just a large open-faced cuspidor to spit in when you get disgusted. With that and a nice easy chair and a package of Camels you're all set for a fine session of DX.

I kept sticking plates back into my condenser until I finally ended with 6 of the original 7, and with three coils 8, 10, and 12 turns, that cover, all with the same tickler, the realm of the consistent DX, the whole 7,000-kc. band and on up to 9,700-kc. Other coils go up to 14,000-kc. and below the 7,000-kc. band, but in these we aren't interested just now.

Instead of using the plug-in coils suggested in the article, each with its own tickler, I used a separate movable tickler,

as being more convenient to experiment with than trying to get just the right balance of coil and tickler on each individual form. Of course moving the tickler changed the frequency and could move stations as much as four degrees on the dial, but that didn't matter for the time being. After considerable experimentation with both tickler- and coil-turns a combination was finally arrived at that permitted the set to oscillate freely, smoothly and surely with all coils and with the tickler fixed in one position. The fixing

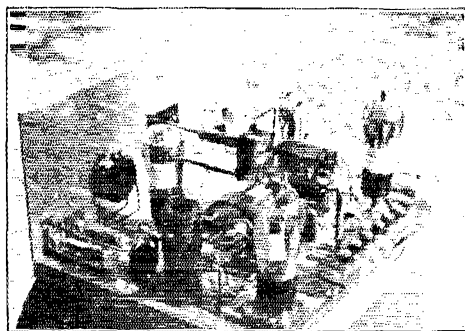

"IT SHOWS UP THE WOBBLY BIRDS—"

was done by a screw through a tapped hole in a hard wood dowel set firmly in the baseboard.

Then all coils were calibrated with one of those nice 200-dollar General Radio precision meters. So now when a feller asks for his QRH I can give it to him from the receiver very close to right.

The coils are wound on some of Ralph Heintz' favorite forms that I dug out of an old receiver. They are made of some dense, thin fibre, perfectly rigid, can't be distorted, and have two stiff pins that go down into phone-tip jacks fixed in a piece of bakelite elevated an inch from the baseboard. They have little notches sawed in them to take the turns of No. 18 enamelled wire with uniform spacing.

If I had another of these receivers to build I'd never use a metal panel. Too much trouble to get things insulated right when you are away off from civilization and can't get the right material for bushings. I'd use a bakelite panel, and then, if any hand-capacity effects appeared, dismount the stuff from panel and slip inside a sheet of aluminum or copper.

For the phone jacks and the shafts of the Frost variable resistances large holes

\*W6HM Carmel, California.

were drilled and bushed with fibre and sheet fibre washers used both sides of the panel. The tuning condenser is set 5 inches back from the panel on a piece of bakelite that cantilevers from a small aluminum bracket bolted to the back of the panel; its shaft lengthened and with the two sections joined by a piece of fibre tubing into which the shafts fit tightly so that the whole is rigid. In the panel a large hole was drilled



"PERFORMS EQUALLY WELL OVER THE WHOLE RANGE—"

for shaft clearance, over which on the inside a piece of bakelite was bolted. In this, a hole was drilled exactly the diameter of shaft, so that this condenser shaft, with a drop of light oil on it, turns smoothly with absolutely no play. General Radio 4-inch dials suit me better than any others.

The stock pointer-knob is good enough for the volume control because you seldom touch it; but for the 50,000-ohm Frost, the feedback control, the ordinary knob is too slippery and has too little projection. The feedback is under constant manipulation and it pays to find a knob that is easily handled. I got one from an old fashioned dial, put it in a lathe and scooped out a recess to clear the lock-nut of the Frost. With its fine, sharp milling it sure is a nice hunk of stuff to keep a firm but delicate touch on. If I had it to do over again I'd make the panel enough longer to take another G. R. dial for this purpose; for with a slow motion dial it is easier to keep on the edge of oscillation for faint signals, the kind in which I'm most interested.

In building this receiver it is well to bear in mind that she is a ticklish bird to get just right and that you will need a flock of gridleaks and fixed condensers; and that it is well to locate all fixed condensers so that

1. When the receiver in general, and the tickler in particular, are adjusted correctly we have found that the feedback control need hardly be touched in tuning over any one band. The use of but one tickler for several bands, in Col. Foster's receiver, probably is responsible.—Editor.

2. See page 7, August QST.—Editor.

they may be readily changed. In my set every condenser is so located that its contact screws may be easily reached with a screw driver. This requires more room than occupied by the receiver shown in the QST article but, to my way of thinking, a receiver works more surely and stably when the parts are not congested. The baseboard of mine is 14 inches long and 12 inches deep. In the accompanying photo the detector is the tube just back of the feedback control. The screen-grid tube just back of the detector is the antenna coupler.

An interesting circumstance arose at the completion of this receiver. Loud d.c. signals, or what I in my ignorance took to be d.c., appeared all over the dial with all coils, strong enough to blot out reasonably loud high frequency signals. It sounded as if some station were so close that the receiver was getting its "blanket." After several days of puzzlement it turned out that the QRM was from the long wave arcs of NPG and NPL, on 3,000 kc. (10,000 meters) or some such low frequency. Something in the receiver was tuned to the wave of these arc stations. The filter Ford-coil secondary, was the first thing suspected. Then the secondary of the audio transformer; then the primary. Tests proved that none of these was the culprit. Obviously there must be *something* in the set with capacity across it that was tuning it nicely to these arcs. Finally I happened to think of the little r.f. choke. Looking around, two fixed condensers in series were found that might tune it. The choke was shorted out and the arcs disappeared forthwith. This set didn't seem to need the choke, so it was left out.

Now, as to volume, my set has altogether too much when using the second audio stage, though some of the fellows who have been here seem to like it. An old UV-712 transformer was first used. This I think has a ratio of about 9-to-1. Then a General Radio 6-to-1 was tried. Still too much amplification to suit my particular ears. Then a Thorardson 2-to-1. Still too much. With the first audio the 2-to-1 wasn't so good as the same stage with the UV-712, so that transformer went back into the set. An extra phone jack was put in, and this first stage is all I ever use. With it I can get foA50 night after night R7 at the time when South African signals come in best. And this is on our West Coast, remember.

There is one thing this receiver surely does. It shows up the wobbly birds and the creepers; and a feller with a wide signal sure gets all the space the law allows. In this class is the majority of the commercial stations which by the grace of a complaisant Radio Commission gracelessly parked themselves right in the amateur band without waiting until Jan. 1, 1929.\*

(Continued on Page 30)

## Experimenters' Section Report

**I**N response to our request for additional men to enroll in Special Problem No. 66 covering the aluminum-lead electrolytic rectifier we received so many offers that we were unable to take advantage of them all. We are extremely sorry that it was necessary to turn so many down but the number of electrodes that were available limited the number of men who could be enrolled.

There have been approximately fifteen hundred aluminum electrodes distributed among twenty-three experimenters who are located in practically all parts of the country. They are as follows: W1CCD, W1MR, W2ATQ, W2BAI, W2BCW, W3CAB, W3KA, W4ABN, W4JL, W6CVM, W7AKK, W8ADB, W8CPQ, W8CSW, W8ZF, W9CKI, W9CRD, W9CV, W9EHD and W9FUG. The other three experimenters whose calls are not included are located in the second, eighth and ninth districts.

The voltages to be rectified vary between 110 and 3,000 and the number of cells in the various rectifiers between 12 and 110. Both the center tap and bridge methods are being employed.

It will, of course, be several months before there is anything like a complete report available on this work. During this time, these experimenters will operate their rectifiers in conjunction with their regular amateur transmission and will supply Headquarters with a complete report on the rectifier's operation each month. The final report representing the findings of all the experiments will appear in QST.

### The 7,000-kc. Zepp. for 3,500-kc. Operation,

By James J. Lamb\*

**I**T must by this time have become clearly apparent to every amateur that the present frequency assignments absolutely require a distribution of our communication between the bands according to the distance to be covered and the time of day at which the contact is to be made. In view of the congestion on the 7000-kc. band in particular, it is not only ridiculous but extremely inconsiderate to make use of this DX band in the crowded evening hours for purely domestic or local communication which has its proper place in the 3,500- and 1,750-kc. bands. We have a band suitable for every distance at the proper time of day, and we must so use these bands.

The transmitter may readily be tuned

to any band, or at least should be of the true 1929 type which is designed for operation on all of the assigned bands and there can be no valid objection to shifting from one band to another because the transmitter won't work on that band. The antenna system seems to present the apparent stumbling block, but, happily, this stumbling block is more apparent than real.

Most amateurs are limited in back yard space and accordingly in the length of antenna which may be erected. An informal survey of the situation shows that the great majority of amateurs must limit themselves to a 7000-kc. fundamental antenna system

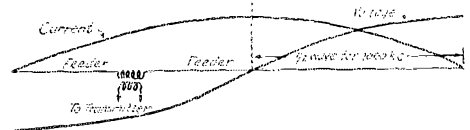

FIGURE 1. VOLTAGE AND CURRENT DISTRIBUTION ON A 7,000-KC. ZEPPELIN ANTENNA WHEN IT IS EXCITED AT 3,500 KC.

The radiator and feeder system have been "straightened out" in the interest of clarity. At the point where the antenna inductance is located, the current value is approximately 70% of its maximum and so is the voltage.

of the Zeppelin type, as most back yards permit a maximum antenna length of around 60 to 70 feet.<sup>1</sup> The problem is, then, to make the most of what we can have and see if this type of antenna cannot be worked on the 3,500-kc. band even though it may not be done with all the efficiency we desire.

The first consideration is to forget that the antenna is a Zepp. and consider it as an ordinary Hertz rig with part of it doubled back on itself. The feeders are no longer such, but are a more or less radiating portion of the antenna itself. With an "antenna" length of 65.5 feet (half wave for 42 meters), the feeders will usually be between 30 and 40 feet long. The total length of the whole system is therefore between 125 and 145 feet. This looks suspiciously like the length of a half-wave 3,500-kc. antenna—and it is. Why not try to excite it at 3500 kc. and see what happens? No sooner said than done—it works. Figure 1 shows a typical case, illustrating what happens to the voltage distribution in the erstwhile feeder and antenna portions of the system. The "antenna" now operates as a quarter-wave affair in more or less free space, while the feeders furnish the other necessary quarter

\* W1SZ-WICEL, A.R.R.L. Technical Information Service and Experimenters' Section.

1. The Zepp. QST, September, 1928. What Length Antenna? QST, October, 1928.

wave and do some radiating since the voltage and current distribution in them is not of the symmetrical nature required to give full cancellation. It may appear that the whole thing is pretty much of a makeshift rig, but do not be surprised if the results are 90 percent as good as those obtainable with a "regular" 3,500-kc. antenna system. Perhaps not so good, but still workable for that local traffic, and with no interference to the ham who has stayed up until four AX to work a little DX with the Aussies. Zedders and points west (or east, depending on the viewpoint).

Many other solutions of the problem will readily suggest themselves to the men using antennas of dimensions and types varying from the case here cited. There are several points to be borne in mind in studying out the best way of tuning the system and by giving proper attention to these points the

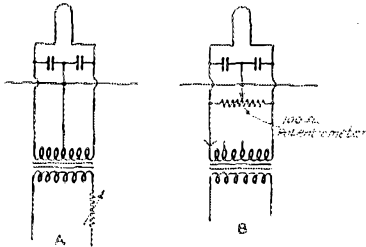

FIGURE 2

performance can be pretty well forecast. First, the antenna coupling coil must be located at a point not too far from a current loop. Otherwise it will be impossible to get satisfactory transfer of energy to the antenna. Such a point may be found anywhere between one-quarter and one-half wave from one of the extreme ends of the antenna. If the feeder system appears to be too short to place the antenna inductance over a quarter wave from one end (such as a feeder 15 feet long with an antenna length of around 65 feet), substitute a 50- or 60-foot wire hung up in the back yard as a counterpoise, and go ahead in the good old fashioned way. The second point is the total length of the feeders plus the "antenna." If this length figures up to less than one-half wave for the frequency on which operation is desired, the "dead ended" feeder wire may be loaded by connecting an inductance in series with it, or as an alternative, a piece of wire of the proper length to bring the total antenna length up to the required half wave may be strung out in the back yard and connected in place of the "dead ended" feeder wire. In either case, it will usually be most efficacious to locate the antenna tuning condenser in series with the "feeder" which connects to the erstwhile "antenna," since it is desir-

able to keep the current loop as close as possible to the inductance.

#### FULL-WAVE SELF-RECTIFICATION

How many of us have played around with a full-wave self-rectified transmitter and tried all the adjustment we could think of in order to get a decent note only to finally quit in disgust. We have usually ended up by blaming it on either an unbalanced plate transformer which supplied a higher voltage to one tube than to the other, or else, the blame was put on the tubes as being of sufficiently different characteristics to cause the trouble. To those who have had such trouble, the following from W9EGE of So. College St., Angola, Ind., should be of interest.

"I wish to submit to readers of *QST* some dope on improving the full-wave self-rectified transmitting circuit as used in either oscillator or amplifier. Although it is evident that this type of circuit in not eminently suitable for 1929, it will probably still be used in crystal controlled circuits.

"I have never seen this scheme in *QST* although it may be known to many. W9DZX and myself are operating our portable station, W9GCO, at Angola, Indiana. The transmitter employs full-wave self-rectification and it was found that a better note was to be had using one tube than when using two. After a time, we made it possible to monitor the emitted note, and found there were two waves when both tubes were employed. In this circuit, things like that usually happen when the tubes or wiring are out of balance.

"Place a midget variable condenser across each of the plate blocking condensers. Set these condensers at minimum and then rotate one towards maximum. If this should make the note worse, reset to minimum and try the same on the other condenser. This should improve the note. Set the condenser at the point giving the best results and try for a better balance by adjusting both condensers.

"This balances any difference in the tube capacities and, to some extent, in the wiring. It eliminated a large percentage of our a.c. reports and we hope it may do the same on other full-wave self-rectified transmitters."

—James W. Shaw, W9EGE

#### FILAMENT HEATING AND THE CENTER TAP

We are all familiar with the Xmas tree lamp method of getting a center tap for the makeshift filament lighting transformer. Likewise, we have all very probably assumed that the center-tapped transformer was the best that could be obtained and was the cheapest in the end. However, Abe Benesovitz, W9ADS, of 415 McKinley

Street, N. Hibbing, Minn., makes the comparison given below.

"In Figure 2a, we have the conventional filament heating arrangement for a medium power transmitter. The arrangement given in Figure 2b has the following advantages over it:

1. It is cheaper.
2. It gives a more accurate center tap.
3. It allows variation of the tapping point to put tone modulation on a "pure d.c." note.
4. It allows of a greater voltage range, permitting the use of foreign tubes such as Nuevron.
5. The filament voltage is adjustable without a primary rheostat.

"A comparison of the cost of each system shows the difference to be considerable. A 12-volt, 175 v.a. filament heating transformer with center tap will cost about \$15.00 and a suitable primary rheostat to regulate the secondary voltage will be about \$3.00 more, bringing the total to about \$18.00.

"On the other hand, one can obtain a 150-watt<sup>1</sup> toy electric train transformer adjustable for output voltages of from 5 to 20 for \$7.50. A 100-ohm potentiometer will cost \$1.50 which makes the total cost of the equipment \$9.00. From this we see that the method shown in Figure 2b is only about half as expensive for the chap who is running a medium or low power transmitter as is the other arrangement.

"These toy transformers are sufficiently well insulated to withstand a voltage of 2,000 between primary and secondary."

DISTRIBUTED COUPLING

"The design outlined below operates for no good technical reason but—it works. Like

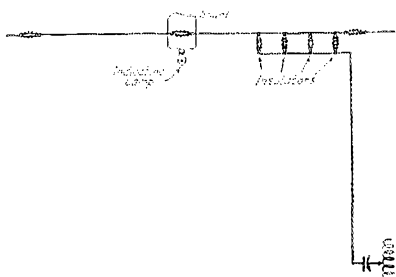

FIGURE 3

so many efficient amateur designs, it is the result of a wild idea and an idle afternoon.

2. Very probably the rating on the transformer holds only for the highest voltage and it will not be possible to get 150 v.a. at all taps. The maximum current output at any voltage will be approximately 7.5 amperes which make the unit suitable of handling up to a pair of 852's, 203-A's or even 204-A's.

—Technical Editor.

It is now in use in a number of middle western stations and performs very consistently.

"Why change an antenna unless something is to be gained?—a natural assumption! So—before going into the design of this job we will enumerate its advantages.

1. It will operate efficiently to within three or four meters on either side of the wave to which it is cut.
2. It is simple and inexpensive to build.

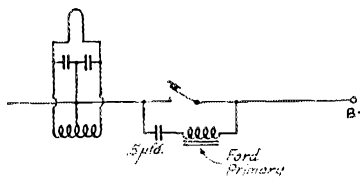

FIGURE 4

3. The radiating wire can be cut to the desired wave without any allowance for loading due to feeder wire, etc., and there is no critical point to be searched for.
4. The feeder can be any old length without loss of efficiency.

"This seems to be a lot of preamble for so simple a device. The antenna consists of a radiator cut to the desired length. Another wire one quarter the length of the radiator is run parallel to one end of the radiator and the lead is brought down from the outside end of the feeder wire. The drawing, Figure 3, will tell more than the description. The feeder wire is connected to the grid end of the oscillator inductance through a variable condenser, the setting of which is not at all critical."

—C. J. Paddon, c/o Electrical Research Prod. Inc., 250 West 57th Street, New York City, N. Y.

KEYING

David B. Terriere, W2BMG, of Hempstead, N. Y., suggests the keying filter shown in Figure 4. The key is located in the negative high voltage lead and a 0.5 μfd. condenser in series with the primary winding of a Ford spark coil (model T variety). The result, he claims, is not enough sparking to singe a flea's whiskers.

TUNING ARRANGEMENT

Charles A. Rudloff, W2ARQ, of Brooklyn, N. Y. C., suggests a simple arrangement for spreading out the tuning range that can be applied to most tuners. He shunts the regular large tuning condenser with a 5-plate, 15-μufd. midget condenser as shown in Figure 5. C1 is the regular tuning condenser and C is the midget. The

(Continued on Page 72)

## Using Brass Tube Bases for Plug-In Coils

By Morris F. Marx, Jr.\*

**M**ANY folks have a number of the old type brass tube bases around and would like to use them as mountings for tube base coils. I was in this position and solved the problem by using the old base as a mount to which is fastened the coil wound on a larger piece of tubing. Each coil requires a brass tube base, a piece of three-inch diameter Celeron tube 1 inch wide, (fiber, cardboard or bakelite could be substituted), a piece of heavy brass  $\frac{3}{4}$ -inch wide, 3 inches long, one 6-32 nut and a bolt,  $\frac{1}{2}$ -inch long.

The brass bases are first removed from the tubes. They may be either boiled or broiled off. I prefer boiling in water because holding over a flame to loosen the base will tarnish the brass. Either way will do the trick. If boiled in water, it will be necessary to twist the base until the lead wires break or else they may be loosened with a soldering iron. Scrape the paste out of the inside edge of the base and dry the base over a small flame. The last operation on this piece is to get the soldering iron good and hot and touch it to the tips of the prongs and fling the solder from the holes leaving them clear for the wire of the coils to pass through.

Now for the brass piece. I used heavy brass ribbon from an old home-made spark helix. It should be about 1/32-inch thick or more. Aluminum or some other springy metal may be substituted. 1/16-inch rectifier aluminum should fill the bill nicely. Little more need be said about this piece as Figure 2 shows the desired shape. The straight part, that which is bolted to the Celeron tube, should be left just long enough to accommodate the width of the tube. (1 $\frac{3}{8}$  will clear the 1" wide tubing very well.) Bend the piece so that it springs tightly into the tube base. It can be made to hold rigidly without soldering but if necessary, a little solder can be added.

The Celeron tube is fastened to the brass strip with a 6-32 nut and bolt. This hole will not always be in the center because in the larger coils, the secondary winding may take over half the coil form while the tickler with its small wire will need only  $\frac{3}{16}$ " or  $\frac{1}{4}$ ". An attempt should be made to get the bolt in a position (determined by the number of turns of the two windings) which will put it between the two windings. Figure 1 shows the idea in mind. The head of the 6-32 bolt gives just the desired space between windings. The brass piece is fastened to the inside of the coil form and not to the outside where the wire is.

Any reasonable sized wire may be used for the coils. Use your own pet combination. No. 18 d.c.c. for the secondary and No. 22 enamel covered for the tickler was used here because of no other reason than that these sizes were at hand. For the higher frequencies requiring only three or four turns, bare wire, space wound might be used to advantage for the secondary coil. In all cases, the wire for the tickler coil can be rather small and No. 24 is amply large enough. It is not necessary to employ a spaced winding for the tickler.

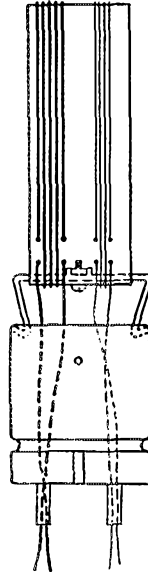

FIGURE 1  
THE MOUNTED  
COIL

*The head of the screw which holds the coil form to the metal piece is located between the two windings. The metal piece is so bent that it hooks into the ridge at the top of the base and may be soldered in place if this is deemed necessary.*

After winding the coils with about the correct number of turns, bring the leads out through the prongs as shown in Figure 1, leaving them extra long. (Be sure to have them skinned for a sufficient length.) Then, wrap the protruding ends temporarily around the prongs but don't solder them as yet. The coil is then put in the receiver; use an ordinary tube socket not of the cushion type. The chances are that the circuit will not oscillate, so, untwist the leads and take the base off the coil. Reverse either the secondary leads or the tickler leads but not both. Of course, it may be that you will guess correctly the first time but in spite of the law of averages, this rarely ever happens. Reassemble the coil and try again and if the tickler coil is of sufficient size, the circuit will oscillate. The number of turns on the secondary may then be juggled until the proper

number for the particular range to be covered is obtained. After the proper number of secondary turns has been found, the tickler coil can be adjusted for the smallest number of turns that will allow oscillation over the entire range of the tuning condenser.

\*W3CJ, 1424 Patterson Park Avenue, Baltimore, Md.

(Continued on Page 76)



# The Series Gap Condenser

By Roy A. Jenkins

**A**FTER reading the "Frequency Measurement Problem" in the October issue of *QST*, I thought I would provide myself with a series-gap condenser. However, when I looked over my supply, I found they were all of the spacing washer type (yes, 5 & 10 variety) and I couldn't figure out a way to insulate the stator plates without rebuilding the whole unit. The accompanying drawings show how the job was finally completed.

Figure 1A shows the brass end plates; the rotor being insulated from the stator by means of a hard rubber bushing. The end plates were cut as shown by the dotted lines there being sufficient material left to allow it to fit solidly on the new bakelite end plates to be provided.

The complete condenser assembly is shown in Figure 1D. The long bolts (8-32) are run through the four corner holes. If a nut is put on each side of the plate, no spacing washers will be required. It is a good idea to run the bolts toward the front as shown so as to provide mounting screws if the unit is to be mounted to a larger panel. Tighten the nuts up and be sure the distance between the four corners is the same. This insures correct alignment.

That's all there is to it for the work. I rebuilt mine in an evening and I'm not going to worry about touching condenser plates in my frequency meter any more.

## Strays

While W3NG was waiting for a train in the St. Louis terminal, he thought he'd get a copy of *QST*. He asked the S.Y.T. behind the news counter for one and after reviewing her wares she replied, "I'm sorry we haven't the Key West Tea but we have nearly all the New York society papers if they will do."

If it is desired to retain the plug-in coil feature for a low powered transmitter when High-C tanks are used it should be possible to obtain sufficient contact area by using two "G. R. Pins" instead of one for each connection between the coil and the condenser. It has been suggested that the ends of the tubing of the inductance be flattened for about an inch, two pins being inserted at each end. Two sockets, of course, replace each socket previously used.—W8A.X.A.

The trickle charger makes a splendid tube "pepper-up", says Herbert Hunt. The dud tube is first "flashed" across the secondary of the charger transformer for one minute and is then aged across the output of the rectifier for ten minutes.

On the cover of the September *QST*, much to the consternation of radio hounds the world over, we printed a portrait of the one and only original radio hound—the hound whose pre-eminence in amateur radio circles is unrivalled, unquestioned, unmistakable, unremitting and unprecedented. Though we have it on good authority that the animule is of pedigreed parentage we have to admit that its breed is as yet in doubt. Our search through "The Elementary Mathematics of Blooded Canines" and "Radio Hounds in Theory and Practice" failed to reveal any mention of the particular pink, orange and black breed which is characterized by slots up its legs and around its hips.

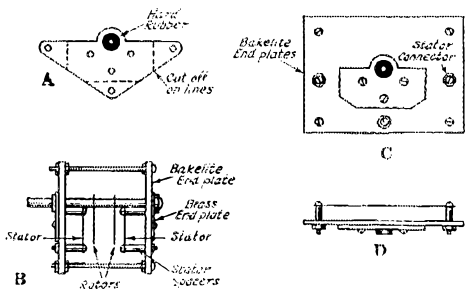

FIGURE 1

The two bakelite end plates are of generous proportions and the old brass end plates are mounted as shown in Figure 1B. A 1/2-inch clearance hole is drilled to pass the shaft and is plenty large enough to prevent trouble due to binding. The original holes in the brass plates for mounting are used to secure them to the bakelite. Be sure that the holes in both plates coincide or the job will be a fizzle. There are eleven holes in each plate and if both are drilled at the same time it will save much trouble.

All but two of the stator plates were removed and these are separated by three or four washers. It may be necessary to add some washers to take the place of the plates that were removed and allow the lock nut to tighten up properly.

Figure 1C shows how the stator plates were spaced from the bakelite ends. These spacers may be obtained from the Ford coils you took the filter condensers out of (the ones that blew up). Dry cell terminal caps are also of uniform thickness and may be used.

# Antenna Systems—A Rehash

By Harold P. Westman, Technical Editor

**I**N spite of all that has been written concerning antenna systems, we continue to hear many remarks to the effect that certain types of antenna systems cannot be made to operate. Upon investigation, it is usually found that the trouble lies entirely in the method employed to deliver the radio frequency energy to the radiating portion of the system.

Perhaps the simplest method of attack would be to start with the ordinary antenna and counterpoise systems which gave so little trouble from this point and which were universally employed by amateurs a few years ago. These antenna systems were invariably operated around their fundamental frequencies because the average back-yard was too small to allow the erection of an antenna large enough to be operated at a harmonic. Due to these same space requirements, the antenna and counterpoise were usually of about equal length and the center of the system was dragged into the operating room. The commonest method of coupling two radio circuits is by inserting a coil of wire in each and bringing the two coils into magnetic relation to each other. Thus general conditions tended to encourage an amateur to pick the proper coupling arrangement for this type of antenna system.

With the advent of higher frequency transmission, the next logical thing to do was to operate the old antenna at its second harmonic or with a full wave upon it. This probably caused the first trouble experienced with antenna feed methods and many amateurs tuned their transmitters to about double the frequency previously used and tried to feed energy into the full wave antenna in the fashion to which they had been accustomed. They soon learned to their sorrow that it was impossible to current feed a full-wave antenna by inserting a coupling coil at the center of the system and this is probably the main reason for all the talk we now hear about the impossibility of operating an antenna at its second harmonic. At the present time many antennas are being operated with a number of full waves upon them.

When these antennas were lengthened (or the frequency of the driver raised) so that operation was had on the third harmonic or with three half waves on the system, it could once more be current fed by means of a coil inserted at the center and from this was deduced that antennas could only be operated at odd harmonic frequencies.

When the frequencies of operation be-

came so high that what used to be the lead-in of the antenna could be used as a fundamental radiator, many of us began to worry about the absorption losses due to the fact that the greatest part of the radiator was located close to the station and its height above ground was small. The linear radiator or Hertzian antenna then came into its own and, whereas, we used to talk merely of coupling to an antenna, we now began to worry about two distinct types of coupling that had to be treated in different ways to be effective.

## SINGLE WIRE FEED LINES

With the advent of the Hertzian antenna, came the use of feed lines connecting the radiator with the driver. The single wire feed line became popular with amateurs

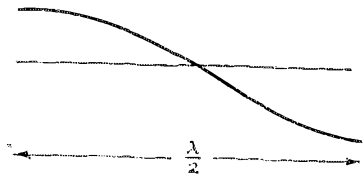

FIGURE 1. THE VOLTAGE DISTRIBUTION ALONG A HALF-WAVE LINEAR RADIATOR

For clarity, the current distribution is not shown but will be 90 degrees out of phase with the voltage. There will, therefore, be a current loop at the center of the system and current nodes at the ends of the wire.

and their neighbors. The next door broadcast listeners had many reasons for disliking these systems because they usually resulted in bad interference to him. He, in turn, interfered materially with the amount of operating that the amateur could do and no one was happy. To begin with, the radio frequency currents didn't always have the same viewpoint as regards what portion of the system was the radiator and what portion constituted the feeder as did the amateur. The system commonly acted as a grounded antenna operating on a harmonic of its fundamental. The distributed capacity between the secondary and primary of the filament heating transformer acted as a series condenser (not such a good one, either) to ground and the radio frequency currents in their search for a suitable ground at the other end of the 110-volt system, had a habit of wandering around the block and visiting the neighbors.

In the second place the "feed line" radiated, leaving absorption losses as high

as before. There was, therefore, no noticeable gain, and, in fact, many operators were unable to get near enough to suitable conditions to obtain even fair performance.

The point at which the end of the feed line was attached to the radiator received much attention and many operators quoted values that were, to them, just as sacred as was the (I think it was 59.2°) angle at which the inductances must be placed in order to build a workable neutrodyne receiver.

When we talk about current feed to an antenna, we mean that we are making the transfer of energy from one circuit to the other at comparatively high current values and low voltage. For this type of coupling, coils are inserted in both circuits and the large currents flowing through one coil sets up a strong magnetic field about it which link with the turns of the other coil. Current feed may, therefore, be considered as magnetic coupling. In the case of voltage feed, the transfer takes place at high voltage and low current and may be made directly or by means of a capacitance. In this case the coupling is by means of an electric field.

If it is our desire to employ magnetic coupling (current feed) it would be foolish to place the coupling coils at such points in the circuits where there is little current flowing. These coils should be inserted at the points of maximum current which, in the case of a half-wave radiator, will be the center of the wire. Those points of maximum current or potential are usually called current or voltage loops whereas points of zero current or voltage are referred to as current or voltage nodes. In these systems that have distributed capacitance and inductance, the voltage and current are 90 degrees out of phase and the point at which a current node appears will also be a voltage loop. Likewise, a voltage node and current loop are found at the same point. At resonance, whether at the fundamental of the radiator or at a harmonic, the ends of the wire are always at high potential (voltage loop) and zero current (current node). The center of the system may or may not be a point of zero current or zero voltage depending entirely upon its electrical length which determines the number of quarter waves that are impressed upon the system. The term "electrical length" is employed to indicate that the system is not entirely dependent upon its linear length but may be modified by the insertion of lumped inductance and capacitance.

Now, with the single wire, we are using voltage feed and the most desirable coupling point would be at the end of the radiator because this is a point at which there is a voltage loop. However, when the

coupling between the feed line and the radiator is so tight, the resonance period of one system affects the other and, as stated above, in many cases the two portions resolve themselves into a single unit. It is, for this reason, desirable to loosen the coupling between these two circuits and this may be done by attaching the feed line to a point nearer the center of the radiator. As the coupling between the circuits is reduced, the amount of energy transferred from one to the other is re-

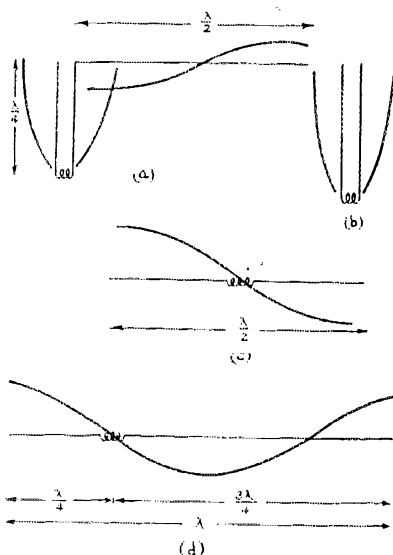

FIGURE 3

At a, we have the Zepplin antenna as it is commonly constructed, the voltage distribution being shown. B is the feeders alone and these are laid out straight in c. They are coupled to the driver, through a coil at the center of the system and the energy is transferred at high current values. At d is shown the entire Zepplin antenna laid out straight. It can be resolved into a full-wave antenna coupled by a current feed arrangement at one quarter of a wave from one end. The coupling coil is located at a voltage node which is also a current loop.

duced but this should be no more damaging than is the case where the antenna coupling is reduced in an antenna-counterpoise, current feed system.

Loosening the coupling allows a single peaked resonance curve to be obtained and this will help materially in obtaining a steady wave and good note. Adjustment for input to the antenna system as a whole is made at the transmitter by changing the position of the feed line where it is clipped on to the tank inductance. The farther the clip is from the filament tap (ground potential), the closer the coupling between the antenna system and the

driver and the more energy that is transferred. Here, too, the coupling may be made too tight and the feeder will affect the frequency at which the oscillator is operating.

Most amateurs have the impression that the small condenser commonly inserted in the feeder near the tank circuit end is used as a coupling device. It probably helps considerably when the feeder, radiator and ground through the filament lighting transformer are all combining to form the radiator, but in a system that is operating properly it is unnecessary unless the feed line happens to be of such length as to cause it to resonate at the transmission frequency. In this case, it is preferable to use a small inductance to detune the feeder as this will operate against the transmission of harmonic frequencies because the reactance of an inductance increases with frequency while the reactance of a capacitance decreases with frequency. The inductance, therefore, will offer a much greater reactance to frequencies higher than the transmission frequency than will the condenser which offers a lower reactance to harmonics than it does to the fundamental. If the feed line is in resonance there will be standing waves upon it and this will result in radiation.

In operation, the radiating portion of the system will have a standing wave upon it. This means that the voltage gradient along the wire is not constant but varies, in the case of a half wave radiator, from maximum at one end, through zero at the center to a maximum of the opposite polarity at the other end. This is shown in Figure 1 and should be quite familiar to most. If the radiator is located in a suitable position so that one can run a neon tube along side of it, it is possible to plot the curve shown by running the lamp along the wire at a distance from it to allow the lamp to just light. At the extremes, the lamp will be farthest from the wire and at the center it will be very close to the wire. In most cases, it will not be possible to get any response at the center point.

This distribution occurs because the system is so arranged as to length and its terminal equipment (in this case the terminals are open circuited) that there will be a full reflection of the wave from each end and the energy will pass back and forth along the wire until the losses due to radiation, wire resistance and absorption have completely dissipated it. The single wire voltage feeder should not have standing waves upon it but the voltage along the wire should be about the same at all points and the radiation from the line should be negligible because there is no large voltage drop across sections of it.

#### ZEPPELIN ANTENNA

The Zeppelin antenna is logically the next step in voltage feed systems. It allows maximum coupling to be obtained between the radiator and the feed line and by means of a second wire paralleling the feed wire, practically all radiation from this portion of the system is eliminated. In order that good transfer of energy be had from the feeder to the radiator, it is essential that there be a voltage loop at the point where the two connect. There-

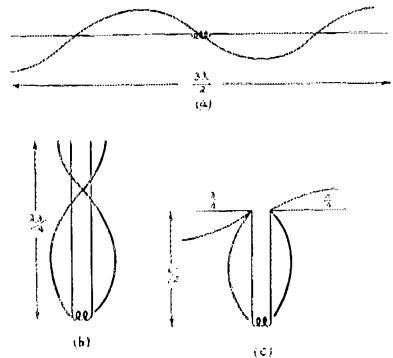

FIGURE 3. A THREE HALF-WAVE ANTENNA AND THE VOLTAGE DISTRIBUTION ALONG IT IS SHOWN AT A

A coupling coil is located at the center and current feed is employed. The system may be folded as at b and then the quarter wave sections at the top may be bent away from the vertical section as at c, resulting in a current feed from the driver to the feed line and current feed from the feed line to the half wave radiator that has been broken in the center to allow coupling at its point of maximum current.

fore, the electrical length of the feed system must be such that there will be a voltage loop at the ends of the system.

In Figure 2a, we have a Zeppelin antenna as it is commonly erected. The radiating portion is a half-wave long and the feed wires are a quarter-wave each. The inductance is inserted at the center of the feed system so as to couple it to the driver and from our previous remarks it will be seen that the energy is delivered to the feed system by means of current feed. The two condensers usually inserted in the line but not shown for greater clarity are employed to allow the feeders to be so adjusted that their electrical

1. It is realized that this method of indicating the polarity of the voltage on the feeder line is incorrect. If this feed line is laid out flat as in 2c, both voltage curves will be on the same side of the line indicating that the polarity of both wires is the same. This is not true and the voltage curve of the first wire in the feed line should be drawn on the other side of the line, putting both voltage curves to the right of their respective datum lines. Unfortunately, the habit of drawing these curves as shown is very strong and, perhaps, causes less confusion for the average reader than would the more correct portrayal.

length is proper for a voltage loop to be had at the ends of the wires.

If, as in Figure 2b, the radiator is disconnected, we have a folded or bent half-wave antenna which is current fed from the driver. Its radiating characteristics will be negligible because the two wires will be at equal and opposite voltages at any point along the line. The fact that it is a half wave, current fed antenna will be more apparent in Figure 2c in which the system is laid out flat with the two wires running away from each other. We may, therefore, consider the Zeppelin antenna as being a full-wave antenna being current fed one quarter-wave from one end and one half of the system being composed of a bent antenna system having very poor radiating characteristics. This is shown in Fig. 2d.

As in any current feed system, the length of the feed wires may be adjusted to any value that will give a current loop at the point of coupling to the driver. In practice, this means that the feed system must, if laid out straight, be an odd number of half waves long or, if one considers the length of the pair of wires, it must be an odd number of quarter waves long. These lengths will cause a voltage loop at the open end of the system and a current loop at the center of the system.

#### ANTENNA SIZE

What has probably been the largest stumbling block in the erection of a satisfactory Hertzian antenna has been the matter of just how long the radiator should be for a given frequency of transmission. Fortunately, quite a number of people have been interested in this and a comparison of the factors obtained by several workers appeared on page 49 of the October, 1928 issue of QST. From this, we obtain

$$L = \lambda \times 1.56$$

where  $L$  = Length of the radiator in feet  
 $\lambda$  = Fundamental wavelength

From this, one can predetermine the length of the radiator and, as the electrical length of the feed system is under the operator's immediate control, the problem of choosing suitable length systems should no longer be the bugbear it has been.

#### CURRENT FEED

If, in the Zeppelin antenna, we can current feed to the station end of the feed system and voltage feed from the feeders to the radiator, there is no reason why we can't current feed at both ends of the line. This will require a current loop at each end of the feed line and the line must

have upon it an even number of half waves. Because a current loop is required at the far end of the line, this system cannot be so easily divorced from the radiator as in the case of the Zeppelin. One cannot have a current loop at the end of a wire without having some place for the current to flow into. We can, therefore, get a better view of this system by considering it as a three half-wave antenna or an antenna being operated on its third harmonic, which is the same thing. Such an antenna is shown in Figure 3a. If as in 3b, we fold the antenna up and run both wires parallel for their entire length, we do not change the voltage distribution along the system but have, primarily, destroyed its ability to radiate. Next if the last quarter wave of each wire is run at right angles to the rest, we have Figure 3c which is the current feed antenna used by many amateurs.

#### SUMMARY

The large majority of amateurs has given up the use of single wire feed systems and are employing the two-wire systems because of the greater simplicity with which they can be adjusted for satisfactory operation. In the design of systems consisting of radiators fed by two-wire lines, there are several important points that must be considered and they are briefly reviewed below:

1. Voltage feed means the transfer of energy from one circuit to another at high voltage and low current.
2. Current feed means the transfer of energy from one circuit to another at high current and low voltage.
3. The coupling for voltage feed must occur at a point in the circuit that is at a voltage loop.
4. The coupling for current feed must occur at a point in the circuit that is at a current loop.
5. Our two-wire feed systems are current fed at the station end and they may be coupled either by current or voltage to the radiator.
6. In order to voltage feed the radiator, the two-wire line must be an odd number of quarter waves long.
7. In order to current feed the radiator, the two-wire line must be an even number of quarter waves long.
8. It is not necessary that the feed line be cut exactly to a given length because it can be loaded and adjusted at the station end.
9. The length of the radiator in feet may be found by multiplying the desired fundamental wavelength in meters by the factor 1.56.
10. The radiator will have a voltage loop at each end and must, therefore, be an even number of quarter waves long.

## Before the Guy-Wire Breaks

By B. D. Virmani\*

**T**HERE are many troubles that may be encountered in putting up a mast to support the antenna. For instance, on several occasions the halyard became entangled with the guy wires and could only be separated by laying the whole mast down on the ground again. In one case, after the halyard and guys were separated and the erecting proceedings started once more, the halyard slipped out of the groove in the pulley as soon as the mast reached a high angle above the ground. The halyard being caught very firmly between the pulley wheel and the pulley frame, there was no other alternative than to take the mast down once more and after putting the halyard back into the groove, do the hoisting job over again.

This is a great nuisance if one has to erect and pull down a mast two or three times in order to get the job done satisfactorily. One is sure to become short of both temper and breath and begin to feel that something is lacking which if supplied would overcome these difficulties. "Necessity is the mother of invention," and an urgent necessity was felt to remove this nuisance. After thinking the matter over for a while, a bright thought struck. If the mast can be raised without the halyard and it can be passed over the pulley after the mast is in place and tightened up, it will solve the problem.

In line with the above reasoning, a second pulley was fastened about four feet from the base of the mast and a piece of 7-22 copper wire was passed through this and run up over the upper pulley, the two ends being joined permanently together. This was all done while the mast was on the ground and the wire formed an endless "belt between the two pulleys.

After the mast had been erected and fixed firmly in place, one end of the halyard was tied to the antenna insulator, to the other end of which the antenna was attached. The other end of the halyard was twisted around the endless wire and the halyard was raised by pulling down the other side of the endless wire. The halyard, after passing over the groove of the pulley, was brought down to the base of the mast. It is important to tie the aerial wire to the aerial insulator and halyard. This puts weight on the halyard and helps to keep the other end of the halyard at an angle, so that it does not slip out of the groove of the pulley.

A number of aeriels was erected in this manner and the aerial wires were always pulled to the extreme limit so that they could not swing in the wind. One night when I was working a fellow ham on another continent, a heavy windstorm came up. Clang! went one of my guy wires at the top of the mast, as the guy-wire insulator broke. The mast bent in homage to the mighty power of the wind and the antenna trembled and sent a high

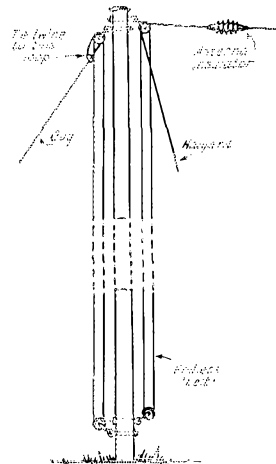

ILLUSTRATION OF PULLEYS, MAST, ET CETERA

frequency sine wave salute to the storm. That nice international QSO was interrupted. Yes, the whole installation was shaken from its very foundation and every tube, condenser and inductance asked, "How long will this storm continue?"

All was at peace after about eight hours. It was then morning and you could see the sun smiling in the horizon. This smile brought another problem of how to put a new guy at the top of the mast without lowering the mast. Much brain traffic was handled. Many books and journals were consulted including our great amateur Bible, *QST*. Many devices and tricks were tried, one of which was described in some back issue of *QST* under the heading, "When the Guy-Wire Breaks." But everything seemed to fail. Then a fresh gust of wind whispered, "Look sharp, take down the mast or it breaks," to which an immediate response was given.

While taking down the mast, I pondered

(Continued on Page 70)

\*AI-2KJ, c/o The Bharat Insurance Company, Ltd., Dera Ismail Khan, India.

# A Unique Method of Control by Means of Sound Waves

By Allen B. DuMont\*

**T**O start with it would be best to explain just what the title of the article means and that the "how to do it" will come in good time. The device in question may be employed to open or close an electrical circuit by means of sound waves of a given frequency. Likewise it can be arranged to close one circuit at the same time opening another circuit.

The sound of the sound waves which actuates the relay are, in this particular case, supplied by clapping the hands together cup-shape so as to produce a strong, low frequency vibration. Originally the need for the device was felt because of the nuisance of getting up to turn off the broadcast receiver when bedtime stories or the like started up but after working with the unit for some time it has been found that it may be advantageously employed in many other ways. For instance, if comparative measurements are being taken of two pieces of apparatus, an almost instantaneous change-over from one to the other can be accomplished without wires from any point within a radius of fifty feet by simply clapping your hands. Where it is inadvisable to locate the receiving and transmitting sets close together and a control circuit for the transmitter would entail considerable wiring, this device comes in very handy. The relay operates on as low a current as one milliampere which is supplied from a single dry cell and because it does not have to be reset, it is always ready for operation.

There are two major parts to the device; the sound operated, circuit breaker and the relay which it actuates. The relay in turn operates the contacts through which the external circuit (which is to be controlled) is operated.

The sound operated, circuit breaker consists of a copper tab resting upon two copper wires. This is shown in Figure 1 and is mounted on the long side wall of a cedar box 8 inches long, 3 inches high and 4 inches wide.

When a sound wave corresponding to the natural frequency of the side of the box strikes it, the box wall will vibrate. The tab which is light in weight will be knocked away from the wall of the box due to this vibration and will open the circuit between the two wires for a short interval of time. The frequency at which the box wall vibrates will depend upon its physical dimensions and can, therefore, be varied to suit

any particular requirements. With the dimensions given, response will be had at a low frequency and the relay can be operated by a clap of the hand.

The armature of the relay consists of a strip of phosphor bronze six inches long, one-quarter inch wide and a thirty-second inch thick. One end of it is mounted rigidly to a post and the other end has mounted

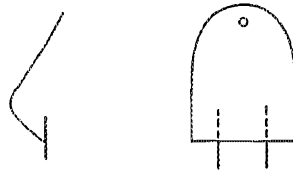

FIGURE 1. THE COPPER TAB THAT IS USED AS THE SOUND OPERATED CIRCUIT BREAKER

*It is bent as shown in the left view and its edge rests upon the two pieces of wire, thus completing the circuit through to the relay.*

upon it a piece of soft iron or steel that loses its magnetism quickly. The armature is mounted on a hard rubber base with a pair of 1,000-ohm telephone head set magnets as shown in Figure 2. A copper contact strip is mounted on, but insulated from, the armature and is connected to a binding post by means of a light piece of wire which will not interfere with the operation of the armature. Platinum contact points are mounted on each side of the armature and an additional contact is mounted on the side to which the copper contact strip is fastened. This contact consists of a piece of light flexible copper wire.

Let us assume that the switch is closed for 2-way operation and that the armature is moved over against the magnet "C" which closes the circuit between the contact "A" and the armature. This causes a current from the battery to flow through the magnet "C" and hold the armature in this position. Now, if the circuit breaker is disturbed by clapping your hands, the current flowing through the magnet is interrupted and the fact that the amount of residual magnetism in the soft iron piece at the end of the armature is small and it is holding its position against the tension of the phosphor bronze armature strip, results in its springing away from the magnet. It will move far enough to make contact between the armature and the contact "B". By this

\*446 Park St., Montclair, N. S.

time, the circuit breaker will be closed once more and the current from the battery will flow through the magnet "D", thus holding the armature in this position. From this it will be seen that the armature will be operated back and forth making a trip to the

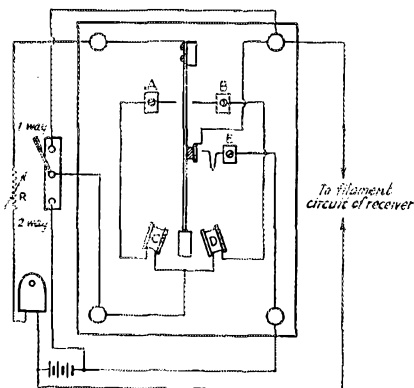

FIGURE 3. THE CIRCUIT IN WHICH THE RELAY IS OPERATED IS SHOWN ABOVE, AS WELL AS THE GENERAL CONSTRUCTIONAL LAYOUT OF THE UNIT

In the circuit shown the relay is operated from the "A" battery of the receiver which is being controlled. The resistor R is a 100-ohm potentiometer and is provided so that the device may be operated from the batteries of the receiver. It may also be used to vary the sensitivity of the relay and if its resistance is made great enough, the relay will act only to open the circuit which will have to be closed manually.

opposite position each time the circuit breaker is opened by a sound wave. It is unnecessary to reset the relay and it may be operated any number of times without receiving any attention.

If the switch is thrown to the "1-way" position and the armature moved against the magnet "D" the current will flow through the circuit breaker and armature to contact "B". From there it flows through the winding "D" and the "1-way" switch to the contacts "E" and back to the other terminal of the battery. When the circuit breaker is opened, the armature will spring away from the magnet "D" and even though it does close the contacts at "A" there will not be a complete circuit made through the magnet "C" to hold the armature in that position and the circuit will remain open until the armature is manually returned to the magnet "D".

This same effect may be had by increasing the value of the resistor R so that the current flowing through the magnet is just sufficient to hold the armature. When the current through the magnet is interrupted and the armature springs away, the field of the other magnet is not strong enough to attract the armature and it comes to rest between the two magnets.

Should it be necessary to turn one circuit off and another on, another copper contact strip may be mounted upon the armature and an additional contact point provided. These will, of course, be arranged on the side of the armature strip opposite to the contacts shown so that as one pair of contacts make, the other pair will break.

As the relay magnets have a resistance of 1,000 ohms and a potential of about 2 volts will give satisfactory operation, we see from Ohms law that a current of 2 milliamperes is required to operate it. This means that it can be operated for about six months on one set of dry cells or it can be operated from the radio battery with practically no noticeable decrease in its life.

The complete unit is contained in the cedar box mentioned previously. The circuit breaker is on the long side, the resistor is on the short side and the relay and switch are mounted on the cushions on the bottom of the box. The cushions are provided to prevent operation of the circuit breaker due to the vibrations of the armature spring. Cushions are also placed under the box to keep any jarring (hitting against the table when passing it) from operating the circuit breaker.

This relay has been in operation for a long time to turn on and off a broadcast receiver. When used for this purpose, it is advisable to place it at least four or five feet to one side of the loud speaker so that any exceedingly loud clapping or drumming that may be broadcast will not operate it. The average range over which the relay will work is about thirty feet but it can be adjusted to operate over fifty feet away. It is also being used to turn a transmitter on and off that is located across the room from the receiver. This eliminates the need for an extra pair of wires to allow the plate and filament voltages to be turned off and on. This device is hardly to be recommended as a means of keying but possibly some of our CQ hounds could use it to advantage to limber up their fists and at the same time stay on the air.

### Stays

Dr. Woodruff, our Atlantic Division director, has fitted up a dormitory at State College for those visiting hams who may want to stay over night. As it is located over the furnace room, he calls it the "smoke house" for hams.

Just to let you know of the progressive spirit of the amateur, we have recently received a request for a decalomania of the League emblem from a member who wanted to display it on the fuselage of his plane.



# Increasing Transmitting Antenna Efficiency

By Stuart L. Seaton\*

**M**ANY amateurs are so located that an ideal antenna system, free from trees, wires, houses, *et cetera*, is an impossibility. The purpose of this paper is to show a means of bettering the efficiency of the average single wire linear type antenna.

A short time ago some investigations were made to determine the best type of antenna to use with a portable receiver mounted in a truck. Many systems were tried, including short single wires, loops, and at last the resonant wave coil was found to be the best. It is just an inductance having a natural period equal to the wavelength or frequency one is interested in. Reinartz's Modulator is one and Tesla's high frequency transformer is one with both ends free.

Under ordinary conditions, a coil is not a good radiator or receiver of electro-magnetic energy, but for the very limited space that this antenna had to be put into it proved to be of much greater value than any other that was tried.

As an experiment a resonant wave coil was connected to a transmitter in place of the antenna. The good results, considering the size of the thing, were such a surprise that the idea of putting one at each end of a typical single wire antenna presented itself. This was tried and the transmitted wave was found to be quite a bit steadier, while the signal strength was several percent greater. In order to find out what was taking place in this antenna to cause such a change, a review was made of past antenna developments and it was found that Hertz had used almost the same thing when he added a metal plate to each end of the linear oscillator.

That the Hertz antenna, with plates, is more efficient than the linear oscillator may be seen this way: The distance effect of an antenna is almost directly proportional to the maximum average value of the current flowing in it, by the equation:

$$E_0 = 2\pi V_L \cdot \frac{\alpha L}{\lambda} \cdot \frac{I_0}{r}$$

and

$$M_0 = 2\pi \cdot \frac{\alpha L}{\lambda} \cdot \frac{I_0}{r}$$

Where:

$E_0$  = The electric field strength at or near the equatorial plane of the oscillator.

$M_0$  = The magnetic field strength at or near the equatorial plane of the oscillator.

$V_L$  = Velocity of propagation.

$\alpha$  = Form factor of antenna.

$L$  = Total length of the oscillator.

$\lambda$  = Wavelength.

$I_0$  = Current amplitude at current antinode.

$r$  = Distance from oscillator (much greater than one wavelength).

Interpreting this geometrically, if we plot the curve of current distribution by plotting the current values as ordinates at each current element and connecting the points thus obtained, (see Figure 1) the area (shaded in the figure) included by this curve and the oscillator, is equal to the total length, times the form factor, times the current value at the current antinode; or equal to the total length times the average current value, and is a measure of the amplitude of the electromagnetic field at distant points. That is, the current distribution curve is characteristic of the effect at remote distances.

The effective capacity of a linear oscillator is increased by the addition of conductors or plates at the ends (of a value relatively small as regards the effective wire capacity) hence the frequency will be lower than for a single wire of the same length. The difference is of course greater as the end pieces are relatively greater with regard to the wire capacity.

The greater the capacities of the attached end pieces are as compared to the effective wire capacity, the nearer does the minimum current amplitude at any point of

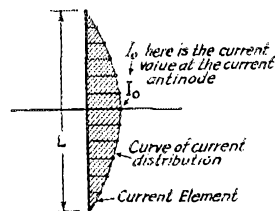

FIG. 1

NORMAL POTENTIAL AND CURRENT DISTRIBUTIONS ON A LINEAR ANTENNA

the wire approach the current amplitude at the antinode, i.e., the curve of current distribution approaches a straight line parallel to the oscillator, and the form factor approaches its maximum value, one.

The current amplitude at its antinode is

\*Washington Grove, Maryland.

determined by the potential amplitude at its antinode from the equation:

$$\frac{I_0}{V_0} = \sqrt{\frac{C^2}{L^2}}$$

where:

$I_0$  = Current amplitude at current antinode.

$V_0$  = Voltage amplitude at voltage antinode.

$C^2$  and  $L^2$  = Capacity and coefficient of self-induction, respectively, of the length of wire considered as a unit. The curves of current and potential distribution must be as shown in Figure 2.

As a matter of fact, the highest potential on the oscillator occurs at the end pieces. Hence, the current amplitude is much greater

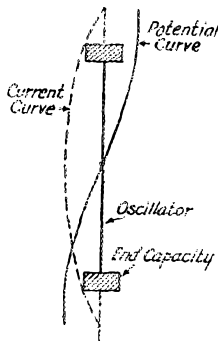

FIG. 2

MODIFICATION OF FIG. 1 BY END LOADING

er in relation to the maximum potential amplitude than it would be for a simple wire of the same length.

If the oscillator with the end pieces be reduced in total length to a value such as to give the same natural period as before and the distance effect measured, it is found to be in the neighborhood of 12 or 14 percent greater than that of the linear oscillator.

This is so provided that maximum potential amplitude is the same in both cases and the capacity of the end pieces is 8 to 10 percent of the effective wire capacity because the antenna with the end pieces has the advantage of its high current value at the current antinode and the high value of its form factor.

The above has been experimentally checked and there is no doubt about the increase in efficiency caused by the addition of a coil or plate of a value not exceeding 10 percent of the effective inductance or capacity, or both, of the antenna alone. It is readily seen why the addition of a plate or capacity helps the antenna: the coil has capacity, both distributed and effective ca-

capacity to ground, also it has greater inductance than the plate. In practice, these two characteristics combine to increase the average current value along the length of the antenna while keeping the potential amplitude at a high value. The coil may be thought of as a sponge, which, while not radiating much itself, causes a greater energy to flow along the antenna, hence increasing its effectiveness.

In the specific case of an antenna 60 feet long, with a natural period of 40 meters and a capacity of 0.0000532  $\mu$ f., the inductance was .00498 milli-H. This gives an LC ratio corresponding to nearly 40 meters. The addition of a coil consisting of 22 turns of 2½ inch dia. copper ribbon spaced about ¼ inch to each end of the system raised the inductance to 0.00528 milli-H. and the capacity to 0.0000563  $\mu$ f., and increased the wavelength about 5 meters.

The antenna length was increased a bit at each end to bring the fundamental to the same value as without the coils. Before any transmission tests were made, the resistance of both the antenna without coils and the antenna with coils was obtained over a range of ten meters above and below the intended operating point, to make sure that the antenna input would be constant, and also to make sure that neither antenna was working at an unfavorable wave due to a resistance "hump." The procedure of each test was to erect one of the antennas, get into communication with some station of a desirable location as regards distance, obtain a complete report on the signal, then take the first antenna down and put the other up (about 30 seconds work) and get a complete report on the second antenna. Contact was established alternately with each antenna and no indication was given the receiving station as to what might be expected as a result of the test.

It was observed that using the antenna without coils to establish communication was more difficult than when the one with coils was used.

Both at great distances and nearby, the signal from the antenna with coils was favored for steadiness and intensity, the increase in intensity being as high as 50 percent in some cases while the average increase taken from all the tests showed about 18 percent gain.

The antenna with plates or with spheres in place of the coils, of a value of about 10 percent of the linear antenna capacity, showed an increase in intensity of about 10 to 12 percent but the gain in steadiness seemed to be about the same as with the coils (due, no doubt, to the same capacity increase in both cases).

Several other antennas were tried at dif-

(Continued on Page 68)

## A Filter for Street Car Noises

**B**EFORE a convention of traction officials at San Diego there was presented a report by Mr. G. W. Shaon, Superintendent of Equipment of the San Diego Electric Railway Co., which report is of direct interest to all QST readers and in particular to those in any way connected with the operation of electric railways. The report cannot be reproduced in full here but is abstracted from a copy sent to us by Mr. D. C. Good of the Silver Gate Radio Association.

Experiments with various connections of the armatures, main series fields and commutating series fields of a car equipped with Westinghouse 514-A-3 motors suggested that a filter would be useful in suppressing that part of the interference which is caused by commutator sparks. This conclusion was drawn from the fact that in general those connections made the least noise in which there was a field winding between the trolley and any armature.

A filter was then built and tried at a time when there were not too many other cars nearby. This sectional filter seemed promising when tested on an isolated section of trolley wire within 3 feet of which was a 40-foot antenna connected to an Atwater-Kent receiver (3 r.f., detector and 2 audio) tuned to broadcast wavelengths. The filter was a single-section device consisting of an 8-microfarad electrolytic condenser and a 300- $\mu$ Hy. inductance.

To determine proper constants, a sectional multi-stage filter was built and so installed that the various units could be

interference which must accordingly be minimized by care in the maintenance of the contracting parts. It was also found that a car without filter created bad interference when anywhere on the section though it was at times as far as 1 1/2 miles from the receiver.

A filter design was now developed, such as is shown in the diagram but unfortunately it is not clear from the report and print if the condenser is electrolytic (and therefore self-repairing) nor is it clear whether the condenser has two sections of which each has a capacity of 2  $\mu$ fd. or whether the total capacity is 2  $\mu$ fd.

After a 90-day endurance run, the filter was again tested by comparing two cars, one of which carried the filter and both of which were operated over a 4-block stretch at the middle of which was located an observing post. This observing post employed a Radiola 26 receiver (6-tube superheterodyne with loop) to which a 50-foot antenna 75 feet from the trolley wire had been added. Both a loudspeaker and a plate milliammeter were used as output indicators. The filtered car increased the normal meter reading of 38 to a maximum of 40 and produced mild noise in the speaker which would not have interfered with anything but faint signals. The unfiltered car increased the reading to 100 and created a roar that made all reception impossible.

—R. S. K.

### Strays

If difficulty is experienced in coupling the coil of the frequency meter to that of the receiver in making a check by the click method, W2FD suggests that a belt made of flexible insulated wire be looped around the two coils. The belt acts as an untuned r. f. transmission line.

W1AD offers the following suggestion for the rectifier described by A. J. Haynes in December, 1927, QST:

"In making the high resistance shunts for the jars could not find anything available in the line of graphite except the flake, and this did not work at all. In looking around for something else found a graphite paint, namely 'Dixon's Silica Graphite Paint'.

"By coating a piece of drawing paper with a 'half and half' mixture of this paint and black India ink, a strip 1/4-inch wide by 2 inches long will give a resistance of approximately 1/2-megohm. In my rectifier, strips 1/2-inch wide by 2 1/2 inches long were used."

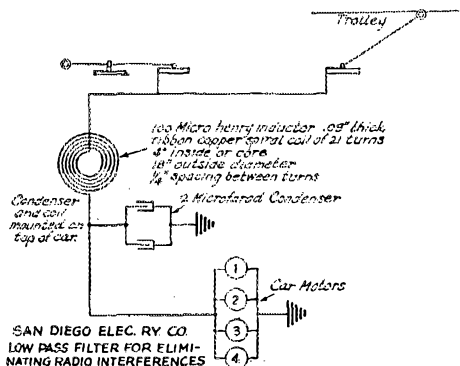

cut in and out separately. During tests with this filter it was found that the goodness of the filtration increased with the use of more sections, provided one considered the commutator interference, but that not much was done for the trolley-wheel spark



Conducted by A. L. Budlong

**A**S related in the previous issue, the new Union Constitution has finally been adopted, and the Union is now a union of amateur societies. National sections already in existence were listed in the editorial of the December issue, and mention was made of several countries where sections are being formed.

We again wish to extend an invitation to all amateur societies in countries where sections do not exist to file applications with the Secretary of the Union for admission to the I.A.R.U. Only one society can be recognized for each country concerned, and it is therefore necessary when submitting the application that all pertinent information concerning the society, its constitution, officers, membership, etc., be submitted at the same time. It may be mentioned here that the requirement of at least twenty-five members has been removed automatically under the new constitution. It is expected that in most countries from which applications will be received there will be more than twenty-five members, but it is conceivable that in a few cases where amateur radio is yet young and restrictions heavy, the membership will be below this figure. This fact is no bar to admission, however, providing the society making the application is truly the representative amateur organization for that country and providing it satisfies the requirements otherwise.

The Union is the international organization for the promotion of two-way private radio telegraphic communication. It is the desire of the Union officers to have as members one society from every country in the world where organized amateur radio exists. Information is slowly coming in from various countries regarding their new intermediate letters and other amateur regulations as laid down by their respective governments for 1929 operation. The Union wishes to urge again upon every member society and upon individual amateurs where sections do not exist to correspond with it immediately any definite information that is known concerning these

matters. As early as possible this year we want to publish a list of intermediates and other information. We can do it only with the cooperation of amateurs everywhere.

### Belgian Section Notes

By Paul de Neck, President Reseau Belge

With deep regret we record the resignation of our Hon. Secretary, Mr. Marcel Ocreman, eb4FU, and also of our "cash manager" Mr. Hunninck, eb4UA, both owing to business pressure. Mr. Ullrix, eb4OU, will take both jobs on his shoulders in the future.

Conditions for DX work have been very bad lately, and night after night it is impossible to work a distant station, or even to hear one of them—especially U. S. A. stations.

Our sailing training ship *L'Avenir* sailed November third for Martinique and from there to Tampa, Florida. Her call is XEB4WK with a pure d.c. note on about 32 meters, just above PCPP. All hams are cordially invited to work her when possible, and will be gladly received on board to have a look at the station, when the ship is in Tampa harbor. Please apply to the master, Captain Vandezande, or to the wireless operator, Mr. Vandelmans.

On telegraphy, good work has been done, despite the unfavorable conditions, by eb4DI and 4RS, who worked Japan lately, a most difficult QSO from here. 4BC, 4FP, 4AR and the usual DX gang are still going strong whenever conditions permit.

Our good ham 4AU, Mr. J. Mahieu, who won second place in the International contest, and who is well known by the W gang, has been severely ill for the last few months, but is now completely recovered. Phone amateurs are more and more turning to the Van Gasse circuit, and 4AI, 4VG, 4TO and others are receiving really good reports. 4OU got an FB report from a French military station, UF-2, situated in the middle of the Sahara, and puts on good press news to the above-mentioned sailing vessel XEB4WK.

(Continued on Page 22)

# Calls Heard



*A. G. Weynton, 1 Harcourt Flats, Brierley Street, Cremorne, Sydney, Australia*

*W2ATZ, Eric Palmer, Jr., en route to Rio de Janeiro, Brazil*

wlabz wlbk wlbux wlbx wlbs wlcnz wlefn wleq wlfz wlmc wlmk wliom wlxw wlxz w2acf w2apf w2axg w2axz w2bgo w2bpo w2co w2czr w2emg w2fa w2ns w2pa w2le w2wa w2wi w2wr w2ws w2bsj w3cki w8ckl w8hl w8kl w8lj w8mj w8ne w8pa w8qb w8qc w8z w5afz w5agc w5ain w5ark w5ax w5bj w5hj w5kh w5mx w5tx w6aak w6afs w6ahj w6aie w6akn w6am w6aov w6ard w6ard w6ayo w6avi w6awa w6aye w6bgb w6bih w6bjx w6bkg w6bp w6bpm w6bqh w6brk w6bv w6byz w6bws w6cdc w6cef w6cgm w6chl w6cka w6clj w6cmx w6cpo w6ctx w6cul w6cww w6czr w6dco w6dey w6dfm w6dhs w6dkv w6dkx w6diu w6dlh w6dqe w6dtl w6dud w6dyj w6dzk w6ebn w6ec w6edp w6eeo w6gm w6hk w6ir w6kq w6nq w6no w6vy w7ar w7agb w7aub w7bn w7bu w7iz w7jh w7mn w7tc w7tn w7wl w8bc w8bda w8bk w8br w8cft w8cxw w8ddk w8dgb w8dnn w8dpo w8ea w8lq w8mu w8xt w9abw w9am w9apf w9bb w9bc w9caf w9che w9cjh w9ckf w9cos w9cub w9cxa w9czf w9dbw w9dlh w9dec w9edc w9ef w9ejo w9eln w9fhe w9fem w9fxr w9kd w9xn eun3 nq-2co op-lad op-lhr op-lcm op-lpw.

wlabx wlaem wlabd wlaeq wlagw wlahx wlaas wlabd wlabt wlecz wlxv wlxm w2aby w2acd w2aei w2afr w2afz w2agw w2ain w2ajb w2akv w2ald w2alo w2alu w2apb w2azl w2azo w2baz w2bbx w2ccb w2bda w2beh w2bfo w2bfn w2bfy w2bgb w2bhr w2bit w2bjj w2bjk w2bjm w2bjr w2blx w2bmd w2bmg w2bot w2box w2boz w2bpu w2brb w2bvz w2bwr w2bxr w2cau w2cek w2ccd w2cla w2cqd w2cty w2cup w2cyr w2cw w2di w2fm w2fn w2fp w2hq w2ie w2iz w2jn w2ki w2kj w2ky w2lx w2ne w2qv w2rv w2sc w2ta w2ub w2uo w2vc w2vw w2ws w2wy w2wz w2xa w2xd w2xaf w2xht w2zet w3atj w3aua w3biu w3cjd w3hqz w3ee w3ag w3an w3xn w4aaq w4aar w4acc w4ahl w4ajl w4nkf w4xe w5had w5bdh w5om w5gr w5zav w6aak w6czz w5dsl w6dfr d6ceo w6eey w6eih w6oj w6xe w7aat w7abh w7lz w7fd w7er w7xf w8aau w8afz w8agy w8abc w8air w8ajt w8aly w8alo w8apo w8ahu w8bbp w8cub w8da w8dga w8hjb w8hjb w8blh w8cam w8caq w8cpc w8dnc w8dij w8dpo w8dys w8duw w8dyi w8dxc w8ea w8ez w8hb w8jp w8kr w8qv w8xe w8zce w9aaw w9abz w9aaf w9ahq w9aip w9aof w9apy w9aqx w9baz w9bbg w9bbo w9djp w9dr w9fam w9fdt w9fdy w9fdz w9fhe w9fff w9fhy w9fd w9fh w9ft w9fo w9fs w9fsu w9fsx w9fxm w9gau w9gce w9gcq w9xi w9xn.

*Graham C. Hall, 128 Milton Parade, Glen Gris S. E. 6, Victoria, Australia*

*S.S. Binnendijk of the Holland-American Line, J. Arends, Operator*

wlii wlom wlpk w2ag w2agn w2in w2pn w2ra w2tp w3ap w3arb w4tk w5ayo w5bad w5bj w5qa w6abg w6am w6ax w6bhz w6bnw w6chy w6dbm w6dq w6dr w6dwi w6eoo w6pw w6tn w8bhi w9acf w9adm w9brc w9bzc w9cjh w9cub w9den w9ef w9fa w9eln w9thv w9pu z1aj z1ab z1af z1fu z1fv z1ib z1ac z1ak z1aw z1az z1bc z1bz z1bg z1bo z1bp z1fb z1fg z1zg z1zgo z1zgp z13ab z13aw z13cm z13cp z14ac z14am z14ao k6bpg k6dju k6dad k6ekx k6kq op-lcm od-ljr oc-lpp oc-2mo ek-4aap ef-8orm g2lz.

wlcf walm w2bia w3dh w5ada w8dpo w9ara nn-lnc ea-tx eb-4dx eb-4uu eb-4ij ed-4lh ef-8am ef-8zed en-ovn gi-6wg ea-2ag ea-2nb et-1bk et-1cn sb-1cg sb-8ah oa-2aw oa-2ek oa-2hm oa-2rx oa-2tw oa-3cp oa-3gr oa-3hl oa-3jk oa-3kr oa-3vp oa-4pn oa-5cm oa-5jh oa-7ch oa-7lj z1zop z1zgo.

*10-meter band*  
oa-3cp oa-3my oa-3ks oa-3kb oa-8pm oa-8hq oa-6sa z1lan.

*WEDC ex WQE, S.S. Harvey H. Brown, C. H. Stevens, Operator*

*OA-2AW, C. C. Clarke, 91 Apu Cres., Lyall Bay, Wellington, N. Z.*

7,000-kc. band

wibhs wilmx wlasf wlaw wgh wlabz wlbvl wlnq w2cty w2alu w2az w2tpj w2vy w2ty w2kb w2me w2wi w2jp w3cin w3avk w3cfq w4we w4bl w4fu w4oc w4rn w4aj w5kq w5wi w5auz w5ac w5oa w5any w5atm w5vx w5bj w5atf w5bbe w5afb w5bbi w5bc w5dfv w5dkt w5czk w5ard w5dtg w5kg w5bz w5abk w5chf w5ue w5dve w5acz w5bit w5bbs w5bjia w5cej w5cjh w5dfm w5dep w5kb w5as w5bhl w5bcq w5bz w5bzf w5asi w5wn w5bpo w6aw w6bn w6ej w6ctz w6bvt w6bvk w6awp w6cfr w6dh w6dix w6am w6czu w6cul w6ahq w6cfh w6akh w6bzy w6pw w6tu w6pe w6aas w6akh w6cuk w6ax w6bgb w6bkg w6ed w6bfr w6chl w6ami w6aie w6dgt w6dok w6bch w6bsn w6abp w6dq w6cub w6cht w6ebn w6cis w6nx w6cyx w6aah w6cwa w6ctn w6dtt w6bvf w6akw w6cjh w6cwh w6haw w6czy w6bgb w6ej w6cul w6dgt w6akm w6bax w6ks w6eg w6akm w6bxk w6crq w6dwi w6wb w6dnn w6ags w7aax w7nh w7qe w7ai w7mx w7af w7abh w7lh w7lz w7ac w7agb w7rf w7pv w7ach w7ts w7aar w8cqv w8atn w8czz w8eno w8dod w8cnc w8dvt w8brf w8dcm w8dnn w8adm w8ees w8adt w8ccq w8ap w9ahw w9dws w9dng w9bqc w9cfn w9cgt w9ara w9rp w9cix w9mh w9ckf w9aok w9bvc w9cek w9bce w9cul w9bwj w9drj w9ama w9dxg w9eul w9add w9baf w9fq w9xi w9chs w9bqy w9bal w9fnz w9fl w9aid w9des w9dyz w9cia w9drj w9dkm w9eat w9fgo w9ead w9ej v4af v4fv v4gb v4ha v4ca v9bd v9aag ef-9ix ef-8xo ef-8fr ac-laf ac-lah ac-lid ac-law ac-3ac ek-4aap ac-2ff aj-4bk aj-7mf as-85ra oo-dgk su-2bt k7to k7hl k6ch k6dkt k6kz k6alm.

wlabd wlafu wlaej wlabl wlang wlbhm wblbo wblv wlbmg wblnl wlobb wlecl wlecf wifu wlgw wlkx wlmk wliu wlmx wloq wlrp wlrw wlsq wlvh w2aaj w2auo w2abn w2acg w2af w2afc w2aft w2ab w2alo w2axp w2bcb w2bhx w2bie w2boz w2bpu w2bse w2cdh w2cyx w2kq w2lx w2uc w2uk w2wq w3acz w3ahp w3amz w3ans w3kr w3fp w3tr w4ac w4cw w4ake w4eeo w4ahz w4aiy w4akg w4ama w4anu w4aq w4hr w4l w4oc w4pf w4zce w5adp w5afe w5aif w5ain w5bex w5bg w5bj w5fj w5gc w5kh w5la w5mx w5ql w5rg w5tx w5vh w5bx w5dca w5dya w5ech w5bad w5wi w5aac w5acz w5adh w5alw w5apc w5acz w5adh w5alh w5apc w5axf w5bhm w5bcs w5bgy w5byp w5cau w5eel w5edp w5chi w5civ w5cnt w5czg w5dcm w5ddg w5kcr w5xe w5ac w5ags w5agz w5hhw w5hca w5hcf w5heu w5bhz w5hi w5bir w5bkc w5bmr w5bpx w5hsh w5hdv w5bzo w5che w5cuv w5dvy w5dnc w5dop w5eaj w5edw w5eey w5ema w5eme w5eng w5eac w5eft w5euz w5eyl w5fam w5fgr w5fhy w5fnc w5fpx w5fcr w5ft w5gdh w5gdm w5gk v3bc z12me z13ah sb-1ca oc-2ab su-lcv k4aan nj-2pa nm-lax nn-hab nn-lnc oo-bam.

*14,000-kc band*  
w1alg wlasu wlaze w1ue w1z w2bou w3bqv w8db w5agc w6bto w6dzl w8adg w8dy w8ann w8apu w8aq w8bt w8cu w8cy w8x w8y w9fo velad ve2ax ve4cp ve4io.

(Continued on Page 88)

# Correspondence

The Publishers of QST assume no responsibility for statements made herein by correspondents.



## Clean Signals

802 No. Burris Ave.,  
Compton, Calif.

Editor, QST:

As comment on one of the points mentioned by Mr. H. M. Walleze in his article on page 27 of the November issue, I agree that it is entirely possible and practical to have a 100 per cent d.c. note with a filter obtained through the medium of "the kid brother's nickel bank".

I use a Kress 30-henry choke costing \$1.00 and 2 3-1/2  $\mu$ fd. Stromberg Carlson condensers listed in QST at \$1.75 each a few months ago. The conventional circuit is used to filter the output of two UX-216-B tubes fed by a 550-volt 250-watt transformer. There is practically no heating anywhere even if 100 mils input is pushed into a UV-210 in the "1929" type Hartley.

As for results!! I never get anything but a d.c. report and at 2000 miles they even give me crystal d.c. The locals at a mile or less say I sound like "B" batteries. Speaks well for QST's 1929 dope as well as for the filter.

Although it is not the best of practice, the entire power unit and filter is in a cabinet 10" x 10" x 10" and sits within 1/2" of a cabinet of the same size containing the transmitter.

In the light of my experience I can emphatically agree with Mr. Walleze that "1929 signals should be strictly pure d.c." and I go even further in saying that there is no excuse for the owner of a low power set such as mine not having such a signal. For the ham who can afford a fifty-watt bottle or more there is less excuse still! Here's to a 1929 signal or none at all.

—Fred A. Blethen—W6DXV—EX 1GAG

6144 Wayne Ave.,  
Philadelphia, Penn.

Editor, QST:

I thought probably the fellows would be interested in the performance of the "1929 type" transmitter.

I have been using a tuned-grid tuned-plate circuit, constructed according to QST's "1929" specifications. I used one UX-210 with four hundred volts of filtered r. a. c. on the plate. With six  $\mu$ fds. of condenser as a filter, I consistently get pure d. c. reports, and all state that the frequency is particularly steady. Very often they report the note as being crystal. I have made several tests with various sta-

tions. I would detune my antenna until about 85% of the maximum radiation was represented. I would then drop the radiation to about 50% of the total radiation. I found that they would invariably give me the same audibility report, in both cases, and they said that the latter would be steadier, although both seemed to be very steady. So fellows, don't worry about that last drop of radiation but tune her up until you get a good steady note, and go to it. You will be surprised at the way she steps out.

Well, gang, let's get together and clean up the air of those sloppy signals. We know it can be done.

—Jack Bane, W3RA.

Thetford Mines,  
Quebec, Canada.

The Editor, QST:

The 1929 equipment at VE2AC is almost complete at this time.

At present the transmitter under test is the Hartley circuit built as suggested in QST, August 1928. The arrangement was altered slightly to permit the insertion of a plate milliammeter, which I believe is necessary. I am working on 14,200 kc. filament and plate supply are from Thordarson T-2098 transformer and T-2099 double choke and 3 two- $\mu$ fd. condensers for filtering. 2UX-281's serve as rectifier. On my t.p.t.g. transmitter the same power supply and filter was used. Reports were r.a.c. but now with the new transmitter I am getting reports of pure d. c., very steady sigs. I could not believe it at first—so the monitor box came into being. I listened to the 1927 set; its note was raw a.c. to r.a.c. with considerable swing and creeping in the signals, and the note had to be followed up and down on the monitor dial. But the new baby 1929 model really gave me pure d.c. right here in the shack, and the monitor dial never budged more than 1/10 of a degree. Gosh! That knowledge gives a man some pleasant feelings. All QSO's said pure d.c. and steady signals so I guess it is true. The main troubles experienced in getting the set to work were:

1. Getting the exact spot for the filament clip on the tuning coil. 1/8" too far toward the grid side or to the plate side sets everything out of balance. There is where the plate milliammeter comes in handy.

(Continued on Page 66)

# An Unusual Rectifier Cure

By C. A. Briggs\*

**B**LINKING lights, welding of key contacts and bad sparking was eliminated by a simple change at station W3CAB. A 50-watt tube received its plate supply from a pole transformer through a chemical rectifier. The center tap was used for one of the high voltage supply leads according to the usual arrangement of Fig. 1. The keying was done in the 110-volt supply line. The transformer was designed so that when 220 volts was applied to the low voltage winding 2200 volts would be produced in the high voltage between the ends of the winding, or 1100 volts between either end of the winding and the center tap. The same high tension supply could also be secured by applying 110 volts to the center tap and one end of the low tension winding.

However, on attempting several times to use the 1100 volts on each side of the center tap for a plate supply, trouble resulted. The sparking, welding of the key, and blinking of the lights made the proposition impracticable. Consequently each attempt at high voltage supply resulted in dropping back from 1100 volts to 550 volts by applying the 110 volts supply to the outside ends of the low voltage winding.

The proposition was studied. It was concluded that the trouble possibly came from a magnetic saturation of the iron: Every so often the key would open at a part of the cycle which left the transformer core magnetized. Every so often

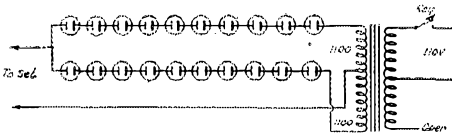

FIG. 1. WITH THIS ARRANGEMENT FOR 1100-VOLT PLATE SUPPLY, THE HOUSE LIGHTS BLINKED, THE CONTACTS OF THE KEY SPARKED BADLY AND OFTEN WELDED FAST

the following closing of the key was at an unfavorable point of the cycle. The already magnetized iron core tried to be magnetized further but could not. It was too nearly saturated. The result was practically a short circuit. This would last for a half cycle. A heavy current would flow for an instant, the contacts would weld, and the lights blink.

The circuit was then changed to that of Fig. 2. The 110-volt supply was left on the

outside terminal of its winding. This caused 1100 volts between the ends of the high tension winding. The center tap was not used. The rectifier was changed from the center tap arrangement to the bridge or diamond scheme of Fig. 2. This permitted the full high voltage, in this case

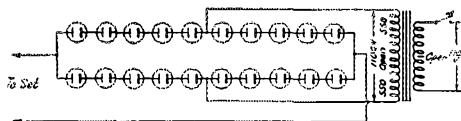

FIG. 2. WITH PLATE SUPPLY CHANGED TO GIVE 1100 VOLTS WITHOUT USING CENTER TAP, AND USING TRANSFORMER CORE AT HALF ITS ORDINARY FLUX DENSITY THE SPARKING AND WELDING OF THE KEY CONTACTS AND THE BLINKING OF THE LIGHTS DISAPPEARED ENTIRELY

1100 volts to be fed through to the tube, while keeping the magnetic density of the transformer low.

The effect was magical. The blinking of the lights and the welding of the key contacts disappeared completely. In spite of the fact that the power increased four hundred times the set operated as quietly as when the 550-volt supply was used.

## The Pacific Division Convention

**T**HE Key Route Inn, in Oakland, October 11th, 12th and 13th, was the Mecca for hamdom in this Division when a large attendance registered.

At the dawn of the first day delegates from every section of the Division began to arrive and by the time luncheon was served every one was in a mood to listen to the opening remarks by Director Babcock and members of the Convention Committee. The afternoon was devoted to code sending and receiving contests under the supervision of W. A. Hammond, W6ALX. Government license examinations were conducted by Mr. Linden, the Radio Supervisor. The Army and Navy was well represented and good talks made by some of their officials. Mr. K. B. Warner, Secretary-Editor, from A.R.R.L. Headquarters, gave us a good line on the Technical Program of the League.

The second day was certainly a busy one with technical talks by Frank C. Jones, W6AJF, and Dr. Herrold; lunch and races at Lakeside Park, also a special train to San Francisco for a tour, in fast automobiles with police escort, of the principal

\*Experimenter's Section, W3CAB, 1311 Spring Road, N. W., Washington, D. C.

stations in the city. W6DDN and the San Francisco fellows showed themselves good conductors. The day ended with a big smoker in the evening and entertainment presented at the Inn under the supervision of W6IP, consisting of motion pictures by the San Jose gang, a play by the San Francisco Radio Club, a good ventriloquist act by W6BAA, an hypnotic act and several stunts by the Oakland Radio Club. Good dances were given by young ladies from Miss Patricia Reynolds' Studio. We almost forgot to mention that W6CZR won the liar's contest.

Saturday was our big day starting with a big division meeting, W6CZR acting as chairman, and discussions of matters taken up by the SCM's and RM's previous meeting thoroughly gone over. Programs such as radio club management and the urging of public schools to establish classes in code and theory for beginners were discussed. Later in the day Lakeside Park was again a drawing card where photographs and motion pictures were taken of the delegates, after which big busses took us for a tour of KGO and the Oakland Airport, the point from which the Dole and Southern Cross flights across the Pacific were made. Several of the fellows were taken into the air by the pilots at the field and K. B. Warner, who is a Captain in the air squadron of the Connecticut National Guard, got his first glimpse of western aviation.

Like all well conducted conventions the big event was the Banquet, so well presided over by Radio Supervisor Linden. With plenty of singers and entertainment, talks by Director Babcock, Mr. Warner, Dr. Herrold and various others and not forgetting the awarding of the prizes, the convention came to a successful close with a decision that Los Angeles would hold the 1929 convention.

—J. W. F.

## The West Gulf Division Convention

**T**HE Second West Gulf Division Convention, held at Dallas on October 18th, 19th and 20th, was attended by a good enthusiastic and loyal crowd of A.R.R.L. members. The high light of the Convention was the presence of Secretary-Editor K. B. Warner and Communications Manager F. E. Handy from Headquarters. We were most fortunate in meeting for the first time Dr. Eugene Woodruff, Director of the Atlantic Division. Our own Director, Mr. Frank Corlett, was, of course, in attendance.

The first day of the convention was a day of fun for all visitors; all were admitted free to the Texas State Fair, the running races, the Southwestern Auto-

mobile Show and the various exhibits.

Friday forenoon was devoted to a short get-acquainted session followed by a Communications Meeting at which F. E. Handy, Communications Manager, held the floor. In the afternoon, under the able leadership of Director Corlett, who is officially connected with the Western Union, a very enjoyable trip was made through their plant. Later in the day the convention was turned over to "KB" for a general discussion of the affairs of the League and other topics of interest.

Another high spot of the Convention was the instructive and entertaining talk by Dr. Woodruff—his theme—one black board and some white chalk. The Doctor held us spellbound till 11 p. m., and talked his way right into the hearts of the West Gulf Amateurs.

Saturday morning opened with stunts and contests. W5ANC won the code contest for amateurs, and W5NW as usual walked off with the commercial honors. W5NW also volunteered to sit for the "Electric Chair" demonstration, a feature furnished by the Dallas Power & Light Co.

The last afternoon session was a most entertaining talk, by Dr. E. F. White, W5AFG, of Beaumont, on the subject of grinding crystals. Everybody sat up and took notice.

The final go-round of all conventions, the banquet, was held in the Hilton Hotel Ball Room and presided over by Director Corlett. Short talks were made by Lieutenant H. B. Thomas who spoke for the Navy, Mr. Warner, Mr. Handy and Doctor Woodruff. "Casey" Jones, W5QS, distributed the prizes to the winners and did a very satisfactory job of it too.

The climax of the Convention during the Banquet were personal greetings from President Maxim, and a short talk by Treasurer Hebert both delivered from Mr. Maxim's home in Hartford. This feature came as a surprise to the gang and was put on at exactly 9 p. m., CST. W5AKV had charge of amplifying arrangements and worked long and hard to perfect the job. Just how the voices of Mr. Maxim and Mr. Hebert were heard in Dallas seems a deep mystery. Adios, until we meet in San Antonio next year.

"Rip"

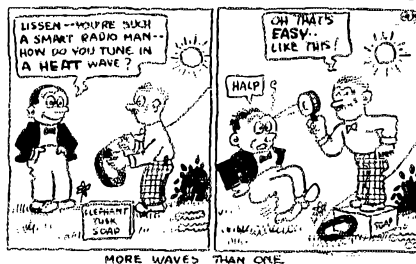



# The Communications Department

F. E Handy, Communications Manager  
 L. R. Huber, Asst. to Coms. Mgr.  
 1711 Park St., Hartford, Conn.

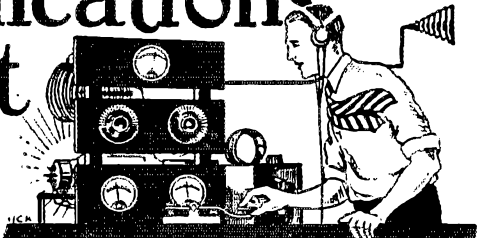

## Some Ideas to Consider in the New Year

**E**FFECTIVE January 1, 1929 your transmitter must be adjusted for operation *only* between the limits of the following bands:

- 1715-2000 kc. (150-175 meters)
- 3500-4000 kc. (75-85.7 meters)
- 7000-7300 kc. (41.1-42.9 meters)
- 14000-14400 kc. (20.83-21.43 meters)
- 28-30 mc. (9.99-10.71 meters)
- 56-60 mc. (5.00-5.35 meters)

### Good Advice

**W**ITH the increasing number of important commercial and government services working daily on either side of our bands there are a dozen self-evident reasons why wandering from our assigned frequency territory is no longer permissible and will no longer be tolerated. Off-frequency operation will seriously hurt amateur radio—and endanger our operating privileges. Of course the individual at fault will hurt himself first of all but incidentally his act will reflect unfavorably on all amateurs. In this connection, it must be noted that as an organization is an aggregate of many individuals—our reputation for law-abiding rests wholly and utterly on each and every member and amateur operator.

We understand that the Radio Division, Department of Commerce, shortly intend to establish several new frequency-checking stations in different parts of the country to assist in maintaining order in the different bands and to undertake the active enforcement of all the regulations as necessarily may require.

Such off-wave operation offenses as there have been in the past cannot help but have increasingly serious consequences if repeated in the future. As was mentioned last month, GBR sends official British press on \$103 kc. at 7 p. m. E.S.T. daily. This is widely copied by ship operators. The U. S. S. *Maryland*, bearing President-elect Hoover in his goodwill trip to South America carries high frequency equipment working near an amateur band, too. We could mention a half dozen other important services located near our bands—but these prominent examples will suffice. It is evident that off-frequency operation **MUST** come to a full stop—that if it does not stop because of individual initiative, the U. S. Government will have to step in and use the Big Stick. Just imagine the far-reaching consequences of a major delay in handling the tens of thousands of words to and from the U. S. S. *Maryland* which must be transmitted each day. Suppose for a moment that this should happen due to off-frequency amateur operation. If it should come to the attention of the President-elect, it might even change a previous good impression of amateurs and amateur achievements! Many comparatively small and seemingly unimportant occurrences in themselves have helped in winning or losing important decisions. Such off-frequency operation must be prevented. Complaints that might be made through official channels due to amateur QRM must be stopped by you and me at their source, in other words, before they ever occur. Amateur radio must not suffer any harm through lawless acts due to wilfulness or carelessness of individual members. If and when somebody gets the Big Stick and loses his operating privileges due to off-frequency trouble, he

is pretty sure to be extraordinarily out of luck. The A. R. R. L. stands for law-abiding operation—and will back no individual who gets into trouble through his own fault, injuring the chances of continued enjoyment for the whole amateur fraternity by his off-frequency operation.

The moral is this, *watch your frequency!* Avoid the danger of getting too close to the edge of the new amateur bands. Use a *monitor* and listen to your signal. Check against reliable marker stations of known frequency in adjusting the set. *Know* you are right before going ahead. Refuse to take chances. Get properly adjusted in the band promptly, today, *right now*—and avoid future difficulties for yourself and all of us by *checking frequency often*—whenever you open up.

### Did You Know

that there is no longer any acceptable excuse for off-frequency operation?

that good advice is only useful when heeded?

that long-winded CQs will continue to be in poor taste during 1929?

that QSR now means, "the distress call received from . . . has been attended to by . . ." Use QSP for queries and replies regarding the *relaying* of traffic.

that you can have key clicks, too—as well as the other fellow?

that toothpaste makes good filler for engraving on panels?

that the battle of "spark vs. cw." is over—and now d.c.c.w. will attempt to battle to the death with a.c.e.w.?

that "wobulation" and "broadness" are unavoidable with certain circuits using "raw" or self-rectified a.c. so that these types of power supply will be out? This is especially true *except* when high capacity tank circuits are used.

that a *monitor* will tell the story much more truthfully than even a brother ham?

that you may be interfering with your neighboring B. C. L.? Find out for *sure* and fix him up. It's another serious duty to amateur radio to keep your local public relations fixed up happily. Besides, you owe it to yourself.

that vacuum tubes have at last become about as cheap as electric light bulbs? At any rate this can be said of the common type of receiving tube!

that the antenna ammeter is a liar?

that one chap in Ohio regularly listens to WIMK'S broadcast to A. R. R. L. Members on 1790 kc. (168 meters) where there is less QRM? The sigs come in louder on 3575 and 7150 kc. though. How about it?

that one often needs the help of others? Join an affiliated radio club and attend the meetings where ideas may be exchanged with other 'hams'.

that it is not necessary to "go slow" when playing "QRS" piano rolls?

that an excellent theoretical article on "The Variation of Generated Frequency, with Changes in Filament Voltage, Grid Voltage, Plate Voltage and Resistance in the Tuned Circuit" appears in the December, 1928, number of the *Proceedings of the Institute of Radio Engineers*?

that this article shows the use of proper values of grid leak and grid condenser, also small L and correspondingly large C, to be necessary for constancy of frequency in a self-excited oscillator?

that a thing may be bad if put to a certain use, while it may be excellent in some other application? Take a 20 kw. or other big bottle for example—it all depends whose hand it's in—and what it's doing there. B/c stations have a field of usefulness, but we object to the harmonics.

that true friendship does not depend on darkness or ignorance? So be frank in giving the other fellow a report. Expect him to do the same by you. Be tactful and observe the golden rule—and make some real friends through your station.

that crystal control is relatively inexpensive (considering its many advantages)?

that crystal control properly applied will iron out the wrinkles in a power supply modulation?

that crystal control is a long step toward eliminating broadness caused by plate voltage changes and "wobulation" in amateur phones? If you have a phone that occupies a big slice of the 3500-3550 kc. territory or the 1715-2000 kc. territory, and which perhaps is heard even by your B. C. L. neighbors, please give this thought careful consideration. The A. R. R. L. will give this type of phone a nice boost. If you have one let's hear about it.

that crystal control is not a quack remedy—and must not be regarded as a cure-all in spite of its manifest advantages when properly applied? Examine your crystal to make sure it will not jump suddenly from one frequency to another (if the faces aren't absolutely plane this may happen), consider the possibility of the temperature coefficient changing frequency (especially if you work near the very edge of an amateur band), use good solid mechanical construction as in any other type of set up, arrange doubling stages (neutralized if necessary), so your crystal is a "frequency standard" working at reasonably low plate voltage—and is not the whole source of r.f. power.

that a monitor is necessary in order to properly adjust your transmitter for the most effective signal?

that consideration for others must be first in our thoughts to make our game enjoyable and keep it so?

that for this reason "testing" and "adjusting" should be done in daylight—not in congested evening operating hours?

that in consideration for other operators, power supplies must be cleaned up, and transmitters adjusted for sharp, steady, non-interfering signals for the good of all.

that 500-cycle 100% modulation on signals no longer insures popularity of an amateur station? In fact, it is guaranteed to produce unpleasant opposite effects!

that the cooperation of every amateur with these ends in mind would go a long way toward solving any remaining "1928" problem?

that QRV means, "send a series of V's"?

that 28 mc. has possibilities and is already being used in international two-day work?

that a water pipe is always a good ground? (It isn't.)

that QST is no longer in the international list of Q Code? It is replaced by CQ6.

that QST has been adopted by the A. R. R. L. as meaning, "general call preceding a message addressed to all amateurs and A. R. R. L. Members"?

that a quick change-over switching scheme (or a plug-in amplifying stage) is necessary to interpret "voices" and amateur phones (some can't be deciphered even then) at the same time a "peak" amplifier is to be had with its high amplification and added selectivity to use on the "steady" code signals?

that until you use a monitor you can never know just how your own signal sounds?

that until you use a monitor that you are not equipped to make the transmitter adjustments that will improve your signal so much?

that a monitor is the most inexpensive form of apparatus to effect a radical improvement in the performance of your station?

that a monitor can also be used as a laboratory oscillator or an emergency transmitter if properly planned in advance?

that a shielded portable receiver also constitutes a monitor?

that QST and the *Handbook* have recommended the use of monitors and high-capacity tank circuits since the summer of 1927? (and are still going strong—hi --F. E. H.)

that our A. R. R. L. system of numbering messages is to start the series of numbers over again annually, commencing January first? Better start a new "number sheet" (see *Handbook* for dope) today—and don't forget that originated messages start with "number one" on January first.

that accuracy is the first precept of the message handler? Yes, even before our much-prized "speed."

that speed in rattling a bug doesn't necessarily mean speed in passing traffic? It all depends on the two operators—and how they use their "beans."

that oscillation in monitors should be controllable? Too strong an oscillation may give deceptive comparisons.

that dots and dashes will be sent with the same relative lengths as formerly, during 1929? (It's so, according to W9CZC.)

that the stations that give the best account of themselves in emergencies are those that are prepared and properly equipped in advance? (Are you ready?)

that we still hear some wobbly—yes, and even broad amateur signals, too?

that it has been suggested that these stations be boycotted starting with January first? (At any rate, let's get critical and unhesitatingly and constructively call such things to the attention of the operators each time wobbly or broad signals are heard on worked.)

that resistance is fatal in a high-capacity tank circuit? Variable resistance (such as in clips or poor connections) introduces serious losses and spoils the best characteristics of the signals, also sometimes introducing an unforgivable instability.

that short leads (but not so short as to introduce extra losses due to "proximity" of coil and condenser) are essential?

that even if you use a Hartley circuit and insist on having plate and grid clips for flexibility in adjustment (control of grid excitation and plate impedance) that the tank circuit MUST be changed to have adequately heavy, short connections (not clips)?

that QRL now means, "I am busy"?

# Let's Get Serious About 1929 Amateur Band Receivers



**HAPPY NEW YEAR!**  
Start right by retiring that 1928 receiver. Get a line on this 1929

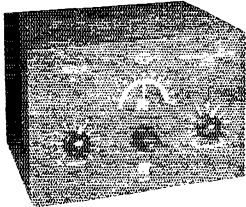

Cat. No. 192. A two tube Amateur Band S. W. Receiver kit complete as called for in circuit diagram. Metal case and aluminum front panel finished in black crystalline lacquer. Tuning condenser has noiseless friction vernier and dial scale is directly engraved on front panel. Completely tested and corrected. Instruction book in kit enables easy assembling and operation. A feature for traffic handlers is the tuning dial calibrated in kilocycles for telling frequency of an operating transmitter. Kit is for all three of the popular Amateur Bands—Price \$40. We completely assemble this kit at a moderate charge.

Send 25c for the second edition of the REL catalog and information on 1929 xmitters.

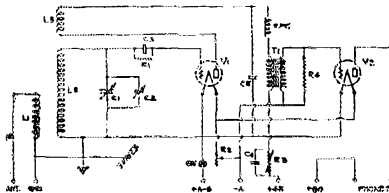

Amateur Receiver that spreads each band across the entire dial. The circuit shown is the old Stand-By Tuner but necessitates the new coil-condenser combination for full spread tuning.

C-1 and C-2 is the new REL tank and vernier unit with a capacity large enough to spread the band over the entire scale when the desired coil is plugged in. C-1, a semi-adjustable tank, need only be set when changing from one band to another, adjustment being made internally at the time the coil is interchanged. A notched disc automatically returns the tank capacity to the correct position.

The new coils are space wound on threaded ribbed one piece bakelite forms assuring rigidity and efficiency. Each coil plainly designates the range it covers. The one piece moulded coil base is fitted with 6 spring contacts which engage the coil jacks. You'll be giving the station a treat the day you build this receiver.

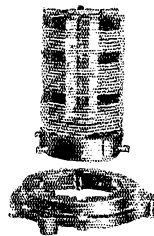

The Ultimate 1929 amateur receiver plug-in coil. Each coil form comprises three windings (primary, secondary, tickler). Three coils cover the three popular new amateur channels (8500, 7000, 14,000 k.c. bands). When tuned with the REL condenser specified here. The three coils and the coil base constitute the amateur band coil kit Cat. No. 192 Price 10.00.

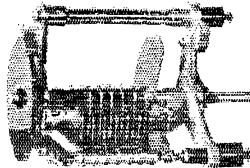

The REL specially designed variable condenser for use in conjunction with the above coils. This is the only variable condenser which automatically gives full spread tuning for each band. Vernier capacity 20 mmfd, tank capacity 210 mmfd. Any type of standard dial which fits on a 1/4" shaft may be used with this condenser. Cat. No. 187G condenser. Price \$6.50.

**RADIO ENGINEERING LABORATORIES**  
100 WILBUR AVENUE, LONG ISLAND CITY, N. Y.

## Fixed and Adjustable Resistors for all Radio Circuits



### Bradleyunit-B

**R**ADIO manufacturers, set builders and experimenters demand reliable resistors for grid leaks and plate coupling resistors. For such applications Bradleyunit-B has demonstrated its superiority under all tests, because:

- 1—Resistance values are constant irrespective of voltage drop across resistors. Distortion is thus avoided
- 2—Absolutely noiseless
- 3—No aging after long use
- 4—Adequate current capacity
- 5—Rugged, solid-molded construction
- 6—Easily soldered

Use the Bradleyunit-B in your Radio Circuits

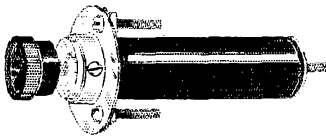

### Radiostat

This remarkable graphite compression rheostat, and other types of Allen-Bradley graphite disc rheostats provide stepless, velvet-smooth control for transmitters, scanning disc motors and other apparatus requiring a variable resistance.

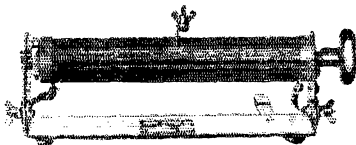

### Laboratory Rheostat

Type E-2910 — for general laboratory service. Capacity 200 watts. Maximum current 40 amperes. A handy rheostat for any laboratory.

Write for Bulletins!

ALLEN-BRADLEY CO., 277 Greenfield Ave., Milwaukee, Wis.

**Allen-Bradley Resistors**

## Volunteers Wanted!

**M**ORE volunteer transmitting stations are needed to broadcast code practice for the beginners' program that we are conducting. Approximately 500 beginners have responded to our recent notices in QST. Our supply of mimeographed material, exhausted by such a demand, will be revised and reprinted. Before this happens we shall need more reliable transmitters over the whole country.

The requisities are, briefly, that you have a good station and that you be willing to spend several hours each week transmitting code practice in the 160 meter band. Radiophone stations particularly are suitable for this work; we have several of them enlisted already.

If you feel that you would like to do some good work for the A.R.R.L., and if you are equipped to do it, kindly drop us a line giving the schedule that you propose to follow.

WVCCK is a new volunteer 160 meter transmitting station. His schedules are as follows:

MONDAY: 8:30 to 10:30 p.m., E. S. T.  
WEDNESDAY: 8:30 to 10:30 p.m., E. S. T.  
FRIDAY: 8:30 to 10:30 p.m., E. S. T.

### BEGINNERS ATTENTION!

Starting the first of January W5BDT (Gouldbusk, Texas) will be on the air on approximately 160 meters at 9 a. m., E. S. T. each Sunday and at 8 p. m. C. S. T. Tuesdays, Thursdays and Saturdays to send code practise for interested beginners. Mr. Slate of W5BDT will be pleased to receive letters from beginners letting him know how he is helping out and giving him suggestions on what sort of programs they would like. He will be glad to help anyone who writes in any way possible.

W9AWE (E. E. McKinney, Osceola, Mo.) on 1720 kc. (174.2 meters) seems to have had the most outstanding success with his code practise broadcasts which will be continued each Monday and Wednesday night, 10:30 to 11:00 pm C.S.T. throughout the winter. Both voice and code transmissions with a "telex" are used and the hundreds of letters from interested beginners are sufficient proof of the wide "coverage" of this station. On other nights of the week, look for "Mack" on 3790 kc (79 meters) at intervals between 7:00 and 9:30 pm C.S.T., using CW telegraph and glad to practise with any members of his "code class" gang who have received their licenses from the Supervisor.

A number of the stations in the "broadcast" band (545-1465 kc or 205-550 meters) are also broadcasting code practise lessons for interested listeners. We shall try to give a list of these stations with schedules in our next bulletin to those beginning amateurs who have placed their names on file at A.R.R.L. Headquarters. Voice and code is used by these stations in a special program arrangement worked out by the A.R.R.L. In a few cases the stations are using a code practise course of their own. The fourteen "prepared" broadcasts are so arranged that each "lesson" will be equally useful to new listeners or those who have followed the program starting with the first "lesson."

W9WK (Cogswell, N. D.) uses 'phone and buzzer-modulated CW on 1970 kc. (152.5 meters) Tuesday and Friday, 7:30 and 8 pm C.S.T.; Sunday, 11 to 11:30 am and 1:40 to 2 pm for code practise broadcasts. He gets excellent reports from Michigan, Oklahoma, Georgia and Kansas and is covering a lot of territory. He is on for two-way work between 6:30 and 8 pm and again after 10:30 pm, also.

W3ABQ (Lehigh University, Bethlehem, Pa.) sends code practise transmissions each Sunday at 1 pm EST on the 160-meter band, suggestions and announcements using "voice" making the meaning of what has been sent clear.

Here's the answer to every question about the principles, methods, or apparatus, of radio transmitting and receiving--

# THE RADIO MANUAL

By G. E. STERLING, Radio Inspector and Examining Officer, Radio Division, U. S. Dept. of Commerce.

Edited by ROBERT S. KRUSE, for five years Technical Editor of QST.

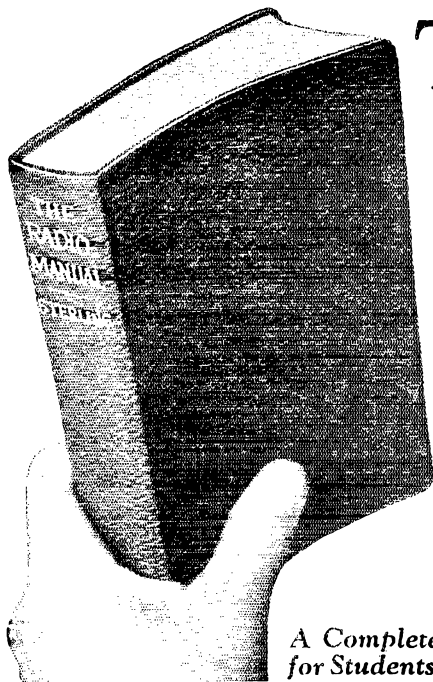

The new procedure adopted by the International Radio Telegraphic Convention is effective January 1st, 1929. THE RADIO MANUAL records it completely. Department of Commerce examinations for operator licenses are changed the first of the year. Only THE RADIO MANUAL presents all the material to meet the requirements of the questions. Progress has been steadily made in perfecting radio theory and practise. THE RADIO MANUAL, since it is the most up-to-date volume on radio, is the surest source of complete and accurate information on all points.

*A Complete Handbook of Principles, Methods, Apparatus for Students, Amateur and Commercial Operators, Inspectors*

## Complete Preparation for Government License. 16 Chapters Covering

1. Elementary Electricity and Magnetism
2. Motors and Generators
3. Storage Batteries and Charging Circuits
4. Theory and Application of the Vacuum Tube
5. Fundamental Circuits Employed in Vacuum Tube Transmitters
6. Modulating Systems Employed in Radio Broadcasting
7. Wavemeters, Piezo-Electric Oscillators, Wave Traps and Field Strength Measuring Apparatus
8. Marine Vacuum Tube Transmitters including detailed description of Model ET-3626
9. Radio Broadcasting Equipment including, for the first time in any text book, the complete equipment of Western Electric 5 Kilowatt broadcasting Transmitter used in over 75% of American broadcasting stations.
10. Arc Transmitters including description of Federal Marine 2 Kilowatt Arc Transmitter Type AM 4151; also models "K" and "Q"
11. Spark Transmitters including description of Navy Standard 2 Kilowatt Transmitter
12. Commercial Radio Receivers and Associated Apparatus
13. Marine and Aircraft Radio Beacons and Direction Finders.
14. The Development of Amateur Short Wave Apparatus. Complete details of construction, operation and licenses.
15. Radio Laws and Regulations of the U. S. and International Radio Telegraph Convention. Quotations of all important sections
16. Handling and Abstracting Traffic

## Examine It Free

Never before has so complete a treatment of radio theory and operation been compressed into a single volume. Here is information that otherwise you could secure only by consulting many different books. And every detail is vouched for by authorities of the first rank. The Manual is profusely illustrated with photographs and diagrams. There are 700 pages, bound in flexible fabrikoid that is extremely durable. The immediate demand for so valuable a handbook has already nearly exhausted the second large edition. To be sure of receiving your copy without delay, order at once. The volume will be sent for free examination. Pay or return in 10 days.

### Order On This Coupon

D. VAN NOSTRAND CO., INC., 8 Warren St., N. Y.  
Send me THE RADIO MANUAL for examination.  
Within ten days after receipt I will either return the volume or send you \$6.00.—The price in full.

Name ..... (QST 1-29)

St and Number .....

City and State .....

# Dubilier

## TRANSMITTING

# CONDENSERS

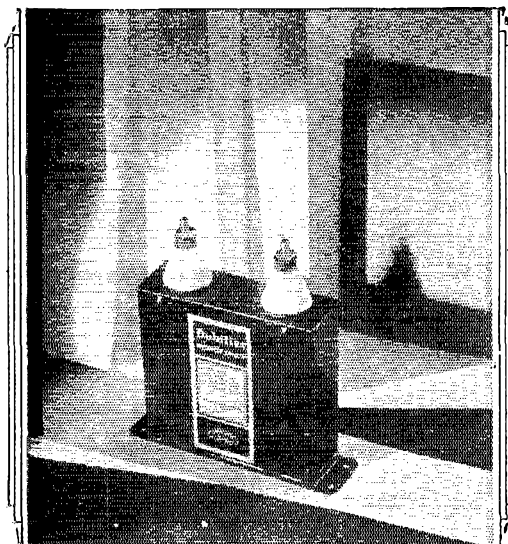

**D**UBILIER type 686 condensers have the usual Dubilier high safety factors for use in transmitter filter net works. 1000 volt DC rating.

May be connected in series where the working voltage exceeds 1000. Through series parallel connections practically any working voltage and capacity can be obtained.

DC voltage must not exceed 1000; or in A.C. supply filter circuits the transformer voltage must not exceed 750 volts per rectifier plate:

1 mfd. condenser \$5.00  
2 " " \$8.00

Write Dept. 42  
for free catalog

# Dubilier

## CONDENSER CORPORATION



10 E. 43rd St.  
New York City

W9DGN (Ellsworth, Minn.) transmits CW code practise and information for beginners on 1890 kc. (158.2 meters): Tuesday, 7.30 to 8 pm EST; Friday, 10.30 to 11.00 pm CST. These transmissions run from December 11 until April 1. Suggestions and communications from beginners are welcomed.

W8BMJ (Gloversville, N. Y.) on 8780 kc. will hook up the omnigraph each Sunday night and send other interesting material from 10.30 to 11.30 pm EST.

Each Monday, Wednesday, and Friday, 10.30 to 11.30 p.m. E.S.T. and Sunday 10.00 to 11.00 a.m. E.S.T. (effective January first), W2GL, Mr. William Klesse of Valley Stream, Long Island, will send code practise by omnigraph, the first half of the transmission for beginners, the last half for the speed hounds. An ICW note will be used for the code practise. Announcements will be by phone. W2GL will be found on 1910 kc. (157 meters). This station will be glad to QSO anyone who calls him after these transmissions.

W9ECF transmits code practise and information on 1765 kes. (170 meters) Monday, Tuesday and Thursday nights, 10.30 pm until 11.30 pm C.S.T. Announcements are made in both voice and code.

And say, you beginners, don't forget to drop a card or letter to every one of the volunteer stations that have arranged transmissions to help out. Let Headquarters know about the stations you receive, too, so everyone can be given credit for his fine work.

W1BOB and W2SJ are trying to compete with W2ZF and his Twentieth Century bunch. The new relay route is called "the Golden Gate Chain" and at present is made up of W1BOB, W2SJ, W8BEN, W9ACT, W9DZN, W9DQN, and W9GAG.

### Congratulations, New Zealand

**T**HE fellows at Gisbourne, N. Z. are doing their part to advance amateur radio in that country. Their excellent communication and experimental work is a credit both to themselves and to amateur radio. In addition to the 28 mc. pioneering of ZL2AC and others in this country, most excellent and valuable amateur communication work is being conducted.

It would be hard to find three amateur station owners in New Zealand more well known in international amateur circles than those we are presenting in the first photograph. From left to right, meet Robert J. Patty (ZL2AE), Ivan H. O'Meara (ZL2AC), and Syd Strong (ZL2AG).



In the return flight of the *Southern Cross* across the Tasman Sea, O'Meara was continuously alert at ZL2AC and it is reported on good authority that every message sent out by the plane (KHAB) was copied by him during the twenty-three hour flight. This is a feat which would be hard to equal anywhere. ZL2AC was copied on 23 mc. by W5ADO some time ago, has since been heard by several west coast stations—and now this station has the honor of being the *first* to work two-way with W6UF on that new frequency!

# RADIO AMATEURS..

*This short cut lifts you into  
the real* **MONEY CLASS**

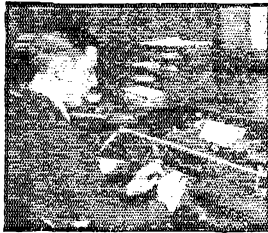

Radio Inspector  
\$2,000 to \$4,500 a year

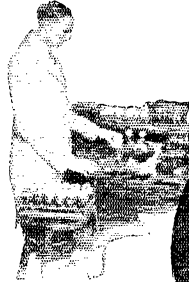

Radio Operator  
\$90 to \$200 per month  
with all expenses paid



Broadcast Operator  
\$1,800 to \$4,800 a year

**DON'T** look upon Radio as a mere plaything. Thousands of men are making big money at it—and so can you!

Just a little commercial training is all you need to give you that professional confidence and ability. You can secure this training in your spare time . . . through a marvelous home-laboratory course sponsored by RCA, General Electric and Westinghouse. Our big FREE Radio book tells all about it.

### Round out your knowledge with this home-laboratory training

Put the finishing touch to your Radio experience. Get the "How" as well as the "Why" of Radio with this commercial training. Only an hour or so a day—in spare time—is all you need. As part of your course, you receive absolutely free of extra charge—a magnificent outlay of fine apparatus. With this outfit you learn to build fine sets and solve the Radio problems that bring big pay. You acquire not only the ability but the confidence to succeed in a big commercial way.

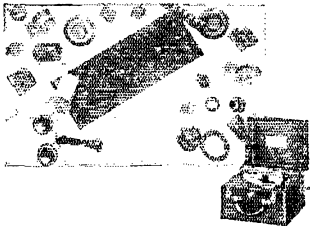

Training  
backed  
by RCA . . .  
General  
Electric . . .  
Westinghouse

Our graduates  
are in big demand every-

where. They enjoy greater success because they're posted right up-to-the-minute in everything in Radio. Radio's progress each year is measured by the accomplishment of the great engineers at work in the research laboratories of RCA, General Electric and Westinghouse. These three Radio organizations set the standards for the industry.

### Money back if not satisfied

The lessons prepare you for success in all phases of Radio—manufacturing, servicing, selling, ship and shore broadcasting, Television, Photoradiograms and Radio equipment. A signed agreement backed by RCA assures you of complete satisfaction upon completion of the training—or your money will be promptly refunded.

### Read this thrilling free book

It may mean the turning point in your life. It gives you the real "dope" about Radio and it describes in detail the famous training that has enabled us to place thousands of our students in fine positions, usually from 3 to 10 days after graduation! It tells in 50 fascinating pages and photos all about Radio's brilliant opportunities for adventure and success. Mail the coupon now—the book is absolutely free! Radio Institute of America, Dept. ST-1, 326 Broadway, New York, N. Y.



Radio Institute of America  
Dept. ST-1  
326 Broadway, New York, N. Y.

Gentlemen: Please send me your big FREE 50-page book which tells about the great opportunities in Radio and about your famous laboratory-method of radio instruction at home.

Name.....

Address.....

# JEWELL

## Transmitting Instruments

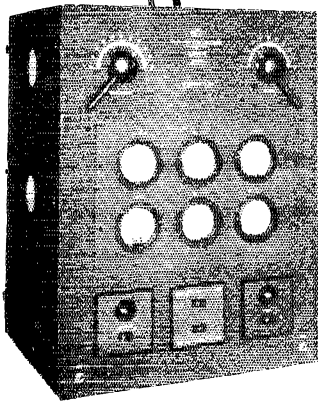

Transmitter made by Radio Engineering Laboratories equipped with Jewell Instruments

That Radio Engineering Laboratories should include Jewell transmitting instruments as a part of their popular transmitting equipment shown here is but another indication of the high esteem in which the Amateur Fraternity hold Jewell instruments. This Transmitter is one of several models using Jewell instruments which this company produces.

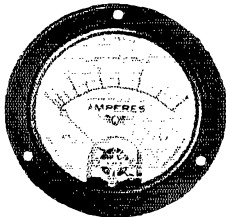

Pattern No. 64  
Radio Frequency Ammeter

This is the Jewell radio frequency ammeter which has enabled many Amateurs to make records never before dreamed of. Efficiency and high overload capacity are combined. The losses in the instruments are less than half the navy minimum requirement while it has a guaranteed overload capacity of 50%.

Our radio instrument catalog No. 15-C describes Jewell transmitting instruments in detail. Write for a copy.



**Jewell Electrical Instrument Co.**  
1650 Walnut Street, Chicago

"29 Years Making Good Instruments"

ZL2AE and its owner and operator, "Bob" Patty are shown in our other photograph. Patty is over six feet tall, weighs "fifteen stone" (to use real N.Z. terms) and we understand that he lifted ZL2AC's 80-foot mast bodily while Ivan slackened the guys on one occasion when this was moved sev-



eral feet while still standing. ZL2AE is the official amateur contact station for New Zealand for the Byrd Antarctic Expedition.

A UV-203-A in a split Hartley arrangement is responsible for plenty of DX as some 1500 cards—one from aqILM (Bagdad, Mesopotamia)—will testify. A half-wave 100-meter (300 kc.) antenna is used on third, fifth and ninth harmonics for operation on 9100, 15000 and 30000 kc. respectively.

Following one of the recent voice broadcasts of messages from friends and relatives of members of Byrd's exploration party from KDKA, ZL2AE checked with the SS. *City of New York*, WFBT, then 1400 miles south of the Marquesas QRD Dunedin, N.Z., which advised receipt of the broadcast without any omissions abroad all three of the vessels in Byrd's party. At the conclusion of the QSO, ZL2AE worked VE2BE in Montreal, Que., Canada, and S.C.M. Reid conveyed the report to Canadian Westinghouse, sponsor of the Byrd broadcast.

While short-wave voice broadcasting gets through successfully it seems to lack secrecy and give an undue publicity to personal messages. It also suffers some disadvantages and doubtfulness when carried on as a one way contact with uncertain transmitting conditions. We trust Continental code and hams specializing in bona-fide two-way work will always be ready to serve when needed, however. Here's wishing our friends in N.Z. further success with their communication work, 28 mc. experimenting, and DX achievements.

\* A "stone" = 14 pounds

## Expeditions

### WSBS

THE Yacht Carnegie of the Department of Terrestrial Magnetism (Carnegie Institute of Washington) was approaching Easter Island, approximately 5,000 miles from its home port and Washington, D. C., when we received our monthly radio report in early December. The screen grid receiver which "LJ" is using as WSBS still pulls in signals nicely from all parts of the world. The transmitter still does its stuff, too, although perhaps more difficulty was experienced in shoving quantities of traffic through in this direction due to local reception "conditions." The signals have been consistently worked on schedule from the eastern part of the U. S. A., the signal strength depending principally on conditions. Official traffic handled to and from WSBS is being relayed from Washington through W3BBW and W2SC to W1MK and thence to WSBS. But let's read the report from the *Carnegie*:

"The whole month of November was spent at sea. Although we had some trouble with weak signals, communication on the whole was good. Everything was fine until November 23 when our signals became practically unreadable in the Eastern U. S. during the late evening although they were fairly good earlier. On the 28th there was a marked improve-



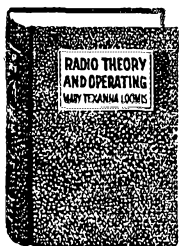

*Has stood the test for three years  
now in fortieth thousand*

**FOURTH EDITION**

## **“RADIO THEORY AND OPERATING”**

**992 Pages    800 Illustrations**

By Mary Texanna Loomis, President, and Lecturer on Radio, Loomis Radio College  
Member Institute of Radio Engineers.

The 4th edition came from press Sept. 1st, thoroughly revised, enlarged and right down to date, with the price remaining the same—\$3.50. This is the first text book or handbook to appear with the new 1929 laws and regulations, new “Q” signals, new 1929 frequency allotments as agreed upon by the International Radio Telegraph Conference of Washington, and with a complete chapter on aircraft radio operating and apparatus. It tells all about “MAYDAY”, the radio telephone distress call, latest types of marine arc and tube transmitters, latest types of American and European broadcast receiving apparatus, practical operation of broadcasting stations, with many photographs taken both in Europe and the United States, and the latest and most authoritative information on television and the transmission of still and moving pictures by radio. Also a chapter on radio compass and a sample abstract sheet and directions for handling traffic. For the broadcast service man there is a trouble chart, with many hints gleaned by experience. And there is considerable information on construction. Historical radio facts of world interest, which have not appeared in other text books, are told in a simple and straightforward manner with absolute proof of their authenticity. Where logic points to the more sensible viewpoint in theory, for instance as in the case of the direction of flow of electric current, the simpler point is chosen, with respect for the views of those who may still prefer to cling to the traditional statement which in the same breath they must admit is contrary to present light on the subject. The book is designed to meet all needs of radio students and instructors, on any phase of the subject. No such comprehensive work has been attempted before or since the compiling of this treatise. An instructor, living constantly in an atmosphere where keeping up to the times is requisite, has given this book to the world,—an instructor who has guided hundreds of young men into successful careers in various branches of the radio field, and with a touch of human sympathy which has made her name known around the world.

“Radio Theory and Operating” is now, and has been for some time the standard text book of nearly all the radio schools in this country and Canada; many universities and technical colleges, and all the U. S. Gov’t. army, navy and coast guard radio schools. It is in all the leading public libraries throughout the country and is handled by nearly all leading wholesale and retail bookdealers in the U. S. and many foreign countries. Beautifully bound in flexible red kraft leather stamped in gold.

**PRICE: \$3.50    POSTAGE PAID**

Buy of your bookdealer, or send check or money order to

**LOOMIS PUBLISHING COMPANY    DEPT. 5, WASHINGTON, D. C.**

# Cunningham RADIO TUBES

Standard Since 1915



**The unprecedented demand for Cunningham Radio Tubes is the best indication of their constant uniform quality.**

*Manufactured and sold under rights, patents and inventions owned and/or controlled by Radio Corporation of America.*

**E. T. CUNNINGHAM, Inc.**  
New York Chicago San Francisco

ment and signals were apparently good both early and late. Since then conditions have reversed. Signals are now poor in the early evening and better after dark reaching maximum around midnight or one a.m. EST. W1MK reports hearing us with fair audibility around 6 a.m. EST. with sunlight at both ends and in between. Which way did the signals go? Unfortunately the schedules with W2XAU and W3SZ have fallen through and W1MK is now our only eastern U. S. schedule. Hearty thanks to both RP and PH of W1MK for their hard work in taking our messages. A schedule was made with KDV5 (Canal Zone) but failed immediately. WSBS has only two schedules at present, namely W1MK and ZL4AO but we expect to make more this month. Calls worked: W3SZ, W8AVL, W2CCD, W2BAV, W1MK, W6BPC, W6CUT, W6AM, W2TY, W6RG, W8BOY, ZL2GO, ZL4AO, OA2ZN, KDV5. About 150 messages were handled. We expect to reach Easter Island this week from where we go to Peru. The weather is great and everyone is enjoying the trip. See you all next month. 73.

"L.A. Jones, Radio Operator, Yacht Carnegie.  
WSBS"

## WFAT and WFBT

Excellent amateur contact was maintained with the Byrd Antarctic Expedition throughout the month. The SS. *Eleanor Boling* (WFAT) docked at Dunedin, New Zealand, November 17. The high frequency equipment, WFAT, operated by Peterson and engineered by Hanson, kept the *Boling* in communication with all parts of the globe. In addition to keeping the hook clear of messages to and from friends and relatives of those on the expedition, WFAT was in touch with whaling vessels near the Antarctic region. It is understood that ice conditions are unusually bad there this year, heavy pack ice being reported from several locations. In early December, Clifford of W2AHC was QSO WFAT, then several hundred miles south of Dunedin, and it was reported that the *Boling* was proceeding to the Ice Barrier with the SS. *City of New York* (WFBT) in tow.

The same amateur stations we mentioned last month are continuing to handle quantities of traffic from WFAT and WFBT. W9REZ (Wichita, Kansas) worked WFBT from 6.30 to 8 am CST November 12.



## W2ALU PERSONNEL

W2ALU is owned and operated jointly by Fred Link "BV" (W4HVA) (left above) and J. B. Knight Jr. "DX" (W4DX) (right) at 583 Riverside Drive, New York City. W2ALU is one of the principal amateur contact stations handling traffic for the Byrd Antarctic Expedition. The station equipment pictured is that used in the International Relay Contest in which W2ALU placed second in the U. S. A.

handling twenty two messages at this time with only three minor repeats required. Operator Berkner reported nightly contacts with "hams" in Australia, Africa, and the South Seas with WFBT's 1 K.W. 8830 kc. (34 meter) set.

W8GT (Washington, D. C.) keeps a daily schedule with WFAT at 6.29 am EST. W9EGU (Hennepin, Minn.) handles regular traffic for the expedition with WFBT daily at 1200 GCT. W2RRB (Brooklyn, N. Y.) keeps daily schedules with WFBT except on Wednes-

# SM

## Huge Amplifying Power

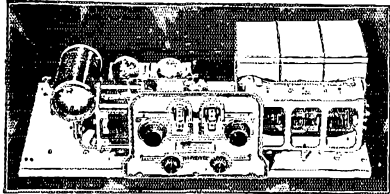

### S-M 720 Screen Grid Six

Read What They Say About It—

Gentlemen:

I have had this kit in actual operation for over a month and am astounded with the results. . . Stations which my friends and myself had given up as "lost at sea" have come thru like a ghost from the grave, and dance volume from a loudspeaker from the Pacific coast is a reality instead of a will-o-the-wisp. And—knife-edge selectivity. What a treat!

F. Lordan, Galveston, Texas.

Gentlemen:

On my set, which is a Silver Marshall Screen Grid Six, I am using a loop, it might be interesting to you to know that in testing with the loop for distance this last week I received (at Rochester, N. Y.) Los Angeles, Hot Springs, Arkansas; Davenport, Iowa; Jacksonville, Florida, and Omaha, Nebraska.

Clayton R. Bragg, Rochester, N. Y.

### New Push-Pull Apparatus

And now, S-M is glad to announce new super-quality push-pull audio transformers built on the Clough system, all offering curves flat from below 50 cycles to well above 5,000 cycles—transformers that give to "push-pull" a new and really startling significance. And their prices like their quality are unbeatable!

The new 257 is a push-pull input type, to operate from one amplifier tube into two 171A, 210, or 250 tubes, and lists at the low price of only \$7.00. Type 227 is a push-pull interstage transformer, to feed from two 112A, 226, or 227 tubes into two 112A, 226, 227 or 171A, 210 or 250 tubes, and lists at \$8.00.

Type 258 tapped output impedance is intended to feed from two 171A tubes into any standard speakers. Price \$5.00. Type 248 Universal output choke is designed to feed out of two 210 or 250 tubes into one to six or more standard speakers, and is provided with several impedance-matching taps. It will handle over 20 watts without core saturation. Price, 248 open mounted \$7.00; or 228 (in same case as 227) \$8.00.

Remember—S-M guarantees these push-pull transformers to have a finer frequency characteristic than any and all competitive types—bar none.

SILVER-MARSHALL, Inc., 858 W. JACKSON BLVD. CHICAGO, - - U. S. A.

- 250 type tubes, singly or in push-pull, with unbeatable S-M tone quality
- built into an existing receiver, or separately for radio and phonograph amplification
- at prices below all competition
- this is the S-M power amplifier story!

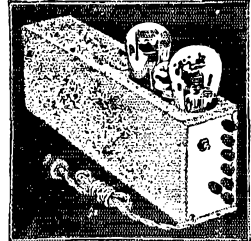

As a separate two-stage amplifier for homes and small theatres, working from radio or phonograph into a dynamic speaker, using one each '50, '26 and '81 tubes, the S-M 678PD far outclasses, in quality and price, any competitive amplifiers at prices up to double that of the 678PD: WIRED \$73; KIT complete \$65.

For portable use, to cover 2,000-seat or larger auditoriums, or outdoor crowds of up to 15,000, with optional voice, radio or record input—the S-M 685 three-stage Public-Address Amplifier is ideal. WIRED \$160, KIT \$125.

Conversion of any existing receiver to use '10 or '50 type power tubes is accomplished with no change of wiring, by using S-M 675ABC power supply which supplies all ABC power for the power tube, and receiver B as well. WIRED, \$58; KIT, \$54.

For large theatres, schools, hospitals, auditoriums or stadiums the S-M "PA" Rack-and-Panel Amplifiers, consisting of any required number of standard or special unit panels, will provide the finest possible amplification for any desired coverage. The performance of S-M "PA" type amplifiers is unconditionally guaranteed equal or superior to any and all competitive American equipment. Details will be found in the new S-M catalog; use the coupon.

### S-M 5-Prong Midget Plug-In Coils

The new S-M coils are ideal for all short wave set construction. A set of four (131T, 131U, 131V, and 131W, \$1.25) used with a .00014 condenser, covers the band from 17.4 to 200 meters. Two coils cover the broadcast band—131X (190-350 meters, \$1.25.) and 131Y (360-650, \$1.50). Unwound coil forms, 130P plain or 130T with 98 threads, 65c each.

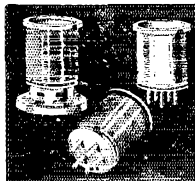

Are you receiving "The Radiobuilder" regularly? The coupon will bring a sample copy.

Silver-Marshall, Inc.  
858 W. Jackson, Blvd., Chicago, U. S. A.  
... Send your complete catalog, with sample copy of the Radiobuilder.  
... For enclosed 10c, send 5 selected Data Sheets, including those on 678PD, 685, and 720.

Name.....  
Address.....

# Are We Right?

You should have at least two of them---one for your complete 1928 file of copies, and one for each 1929 issue as published.

Keep them as a unit in a

## QST Binder

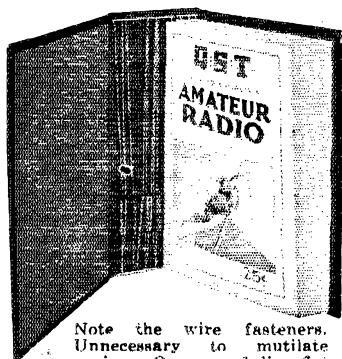

Note the wire fasteners. Unnecessary to mutilate copies. Opens and lies flat in any position.

One-fifty each  
postpaid

A binder will keep your QSTs always together and protect them for future use. And it's a good-looking binder, too.

## QST

1711 Park St., Hartford, Conn.

day and Saturday, handling almost a "boatload" of messages. 14.6 mc. (crystal controlled) is used at W2BRB for this work. W8AHC has received 210 messages from WFBT since he started his schedule. While only "42" were received and "14" sent to the expedition in the last month, WFBT is always putting a good signal through, and a bigger quantity of Byrd traffic is expected during the next "message month."

### CPA

F. A. Gunther of Radio Engineering Laboratories is on a trip down the west coast of South America—stopping at Arica, Chile and continuing to La Paz in Bolivia where he expects to remain approximately four weeks. He will operate a 75-watt high-frequency transmitter from that location using the call signal "CPA" and working in the 14,000- and 7,000-ke. bands. A 2000-volt generator will be used for plate supply. Schedules have been arranged tentatively with W2BW and W2XV. General amateur contact is much desired also. While the frequency of CPA cannot be specified exactly at this writing it will be in the bands mentioned above. Amateurs are requested to look for CPA between six p.m. and midnight E.S.T. each night during the last half of January and the first half of February.

### sbJTC

The American-Brazilian expedition arrived in Rio de Janeiro in late November. Palmer of W2ATZ is the radio operator. sbJTC uses a 500 cycle plate supply and two 210 tubes in a self-rectifying T.P.T.G. arrangement adjusted to points near the 14,000 and 7,000 ke. bands. This expedition will return to the U.S.A. next July. Due to the fact that this is a low power expedition station which will doubtless have many operating handicaps if the expedition is on the move, W8CFR and sb11B (our old-reliable GMD traffic circuit) are arranging to handle the bulk of the traffic to and from sbJTC on regular schedules. FB!

### WHDC

Stevens Miranda of Los Angeles and Daniel C. Blum of Chicago are setting out for a world cruise in their Yacht, the Nomad. Leaving Seattle, Washington, in mid-December they will sail to San Francisco, Los Angeles, and Panama, proceeding after a short stay at these ports of call to the South Sea Islands, Australia, New Zealand, New Guinea, New Hebrides, the Philippines, Japan, China, and Siam. It is hoped that the yacht may visit every world seaport and sail every navigable body of water.

It is planned to maintain communication with the U.S.A. on short waves throughout the entire trip. The high frequency equipment will operate on 11,100 ke. (27 meters), 9380 ke. (32 meters) and 5770 ke. (approx. 52 meters) for amateur contact work. A regular schedule has been arranged with W6DRO (Hill of Los Angeles) who hopes to maintain communication with WHDC during the entire trip around the world. Miranda is an old ham and Navy operator and will handle WHDC personally. Probably the 9380 ke. frequency will be most used for contact work the first month or two of the trip. Radio reports of WHDC's signals may be sent to W6DRO—or personal communications sent to Mr. Stevens Miranda, Care Tom Miranda, 343 North Marshfield St., Los Angeles, Calif.

### KDZ

The Wilkins Expedition is in the Antarctic. Several attempts have been made to fly over the pole but Wilkins has been hampered by bad weather. The expedition's station, KDZ, has maintained contact through the San Francisco Examiner station, KUP, schedules being kept nightly at 0200 Greenwich. KDZ works on 9700 ke. (31 meters) and is received best on the west coast near sundown (0100 to 0400 Greenwich). KUP works KDZ using 6336 ke. (47 meters) so it seems likely that good amateur signals will break through O.K. at these hours.

KUP (the San Francisco Examiner) is now licensed for work on 5585, 6336, 8350, 11170, and 16700 kcs. (53.7 47.4 35.9 26.9 and 18 meters). Ship

# This CROSLLEY

## AC Electric GEMBOX

# \$65.

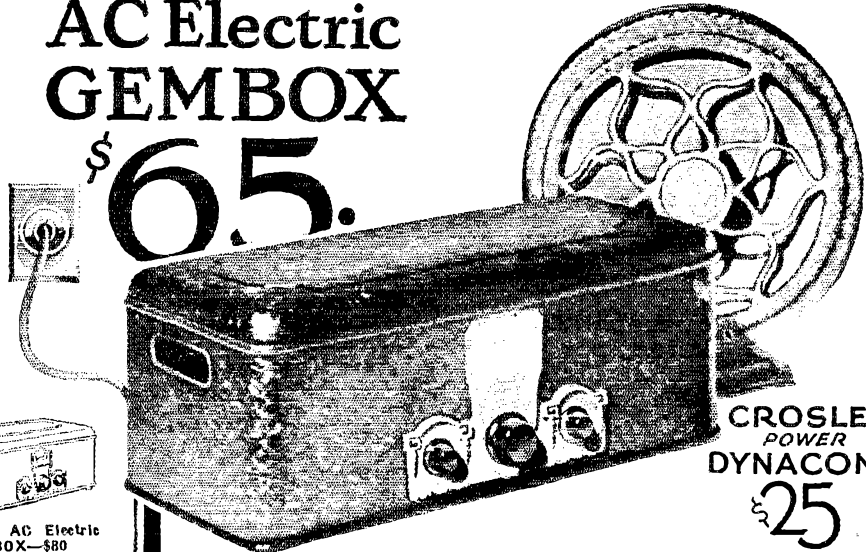

CROSLLEY  
POWER  
DYNACONE  
25

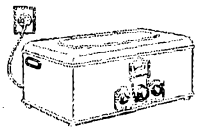

The 8 tube AC Electric SHOWBOX—\$80

Genuine Neutrodyne circuit—push-pull audio amplification with two 171 power tubes on last stage—trouble proof Mershon condenser supplying full 180 volts CONSTANTLY—modern illuminated dial—(7 tubes, radio, detector, audio stages and 1 rectifier, 8 in all)—operating dynamic type power speaker—unbeatable in performance and value offered—\$80.



Crosley Battery Type Sets embody superior advantages of new AC models. The 8 tube BANDOBOX operates the DYNACONE, new Crosley dynamic type speaker. Price \$85. The 5 tube BANDOBOX Jr. is a dry cell set very easy on batteries and operates loud speaker. Price \$35.

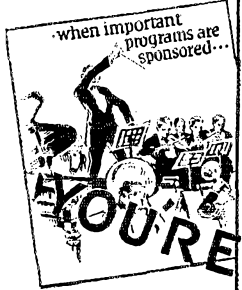

### ...gives no condenser trouble

The higher the voltage the better the reception. Crosley has designed this set to stand maximum power supplied CONTINUOUSLY. Celebrated Mershon Condensers used in the power supply section do NOT BREAK down. If they should be punctured they are self-healing. Paper condensers constantly break down and the only safeguard is to reduce power which reduces enjoyment of your radio.

### ...operates power speaker

The popular dynamic quality of radio reception is attained in the new power CROSLLEY DYNACONE. This speaker like its predecessor has created a tremendous demand because of its wonderful performance at so low a price. The range of true notes on this new speaker has been greatly increased over accepted standards.

### ...uses famous Neutrodyne circuit

This well known and preferred radio circuit is introduced into this inexpensive radio that you may possess the BEST possible apparatus for receiving radio programs. This with other Crosley features permits you a degree of selectivity and sensitivity that many a radio at twice and three times the \$65 price of this set will never have.

### ...embodies latest radio improvements

Modern illuminated dial for dark corners—is easy to read especially these days of hunting about for station reallocations. The rich gold highlighted brown case is both an attractive container and an efficient shield. Everything about this amazing set is NEW, UP-TO-DATE! Enormous demand—mass production—straight line assembly—enables Crosley to top the radio world with this unmatched value this season!

THE CROSLLEY RADIO CORPORATION

POWEL CROSLLEY, JR., Pres.

Department 18

Cincinnati, Ohio

Prices quoted are without tubes. Montana, Wyoming, Colorado, New Mexico and West, prices slightly higher.

# THERE WITH A CROSLLEY™



Perform that  
**"Adenoid Operation"**  
 on Your set!

TAKE out the "adenoids", those inferior transformers which make your set sound as if it were afflicted with a bad case of adenoids . . . then put in their place, the standard of excellence in Audio Transformers—AmerTran De Luxe.

Ever hear a child talk before and after an adenoid operation? Well, if you have, you will appreciate the difference AmerTran transformers will make in any set.

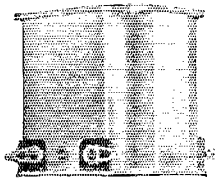

AmerTran De Luxe — 1st stage turn ratio, 3. 2nd stage turn ratio, 4.

Price each \$10.00.

AmerTran products are built exclusively for the purpose of achieving realism in tone. It cannot be done cheaply, or haphazardly. AmerTran's 30 odd radio products all play their definite part in producing the finest tone known to Radio.

Why not perform that "adenoid operation" today? See your dealer or write to us. Ask for Bulletin No. 1084.

# AMERTRAN

TRADE MARK REG. U.S. PAT. OFF.

AMERICAN TRANSFORMER COMPANY

Builders of Transformers for more than 29 years

40 EMMET ST.

NEWARK, N. J.

operators will be particularly interested to know that press is transmitted from this station daily at 0800 Greenwich on 6386 kc.

W6AYC is planning to work up some western traffic routes. Martin will be assisted in this by OM Dann of W6ZX who will pound brass at W6AYC regularly in the future, helping to put this station well up in the B.P.L.

Radio operators with the All-American Mohawk Malaysian Expedition to Borneo hope to engage in general two-way communication with amateur stations in the U. S. A. This expedition is expected to set sail from this country in late December—the call signal, frequency, and hours of operation to be made known at a later date (watch A.R.R.L. and WIMK official broadcasts). This expedition also hopes to establish radio contact with Byrd's base in the Antarctic according to an exchange of messages with Byrd through W9EDW and W9DDE.

W9EGU has handled a bunch of traffic on his regular schedules with WFBT (Byrd's City of New York). Operator Carl Peterson has taken over the night watch at WFBT. Several messages to "Pete's" family in Chicago have been handled and answers relayed back to WFBT with extra-quick amateur radio service. W9EGU gets the messages from the expedition, passes them to W9BZO on schedule. W9BZO delivers them by phone and takes the reply which is relayed back over the same route whenever conditions permit.

Traffic from the Byrd expedition bound for eastern points is passed along to W9AIN by W9BZO. It will be remembered that W9AIN is one of the mainstays of W3ZF's "20th Century Limited" traffic route so that the traffic for New York and way points is expeditiously handled and "beats the mail" by some days in every case.

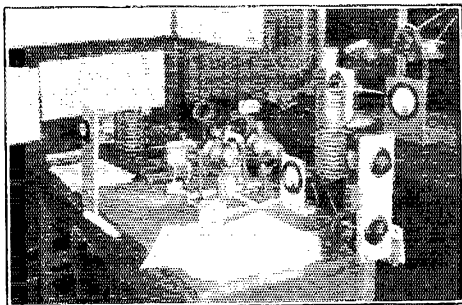

VE5GT

The main amateur contact station for the Stoll-McCracken Expedition (VOQ) of 1928. A full report of the excellent work of this station appeared in December QST (page V). Two 862's are used at VE5GT with a 1,000 volt motor generator for plate supply. Over 11,000 words of traffic were handled between VOQ and VE5GT!

### VOQ

Our article on VOQ Contact mentioned the work of W6JU, the station of the San Mateo Jr. College Radio Club, briefly. We are indebted to Mr. F. E. Emerson, now president of this organization of amateurs, for more complete details of the VOQ-W6JU work. For nearly two months W6JU handled VOQ's traffic on nightly schedules. Mr. W. H. McAulay of W6CLO operated W6JU and was principally responsible for the excellent contact that was maintained. Press handles with VOQ was sent to and from New York via Western Union. Dozens of personal messages were handled. McAulay did all this work while college was in session—even during "final exams"! When summer vacation came along and it became necessary to close the station, W6JU was instrumental in getting the traffic routed reliably over the VOQ-VE5GT route.

## Have You a Commercial License?

ARE you looking for a good Radio job in some commercial station, broadcast station or on board ship? I am getting more calls than I can fill for just such positions. The fact is I can't train men fast enough and am therefore forced to appeal everywhere for experienced men with commercial licenses who are willing to accept advancement in the Radio game.

### Urgently Needed

The steady growth of Radio means more jobs and bigger jobs all along the line for the man who really "knows his Radios." Radio employers are constantly after me to supply their needs. In order to avoid disappointing them, I will positively make **NO CHARGE** either to you or to your employer at any time if we place you. Nor will there be any obligation on you to take any position offered you, even if it means more money. It's entirely up to you to "take it or leave it" and I will repeat that this unusual offer is absolutely free and at

### No Cost to You

All applications will be considered on the basis of merit and in the order received here. Write today to Mr. Murray, Manager of the Employment Department of the National Radio Institute, stating your qualifications and grade of license you hold. Mr. Murray will hold your letter in strict confidence and will try to place you promptly. Get in touch with him today.

## Read This Letter

2320 Maple St.,  
Little Rock, Ark.

Dear Mr. Smith:

It will interest you to know that I have made between \$2,500 and \$3,000 in Radio since I enrolled with you. Now I am in Radio exclusively and with a

**Much Better Income** and a thousand times more pleasant and congenial work. I think I can honestly say that at least 85 to 90 per cent of this income is directly traceable to my

### N. R. I. Training

I have just successfully completed a transmitter of 250 watts (designed to operate to 1,000 watts) from the information and knowledge I got from my N. R. I. training. This is the transmitter for Station KQJF.

I feel as if I had gotten "Out of The Rut" and am beginning to live in the daylight of congenial and ever-developing outlook and future. I'm

Not A "Wise Egg" but just a plumber who got tired of cleaning out sewers and after mature life, with a wife and children to support, had enough disgust for the daily grind and

**Enough Ambition** to try to better myself, and enough self-control to pursue my purpose in spite of ridicule. I feel well repaid.

Your friend because you have helped me.

K. W. GRIFFITH.

## Many Fine Jobs for Amateurs

YOU "O M's" deserve first credit for what Radio is today—but why remain blind to the fact that Radio is now paying some of the biggest salaries in American industry for "work" that is play to you? Why be satisfied with dull, routine jobs when commercial Radio offers you **MORE MONEY** as well as work that is almost romance? Right now I am compelled to advertise for men to fill positions which are opening faster than I can train men to fill them.

### Your Opportunity Waiting

Every year hundreds of opportunities in the many branches of Radio are offered first to graduates of the National Radio Institute—to men I have trained. Calls for Radio service men, testers, inspectors, custom set builders, and operators for every kind of station come to me from all over this continent. Employers everywhere look to me for capable, trained men to fill their important posts, the jobs which pay the best money. Let me tell you what I can do for you.

### Get My FREE Book

Find out for yourself that there is big money in Radio—yes, a fine job, fame, travel if you like. No matter how much you know about Radio, no matter how good you already are at the game—I can give you valuable information that other hams have used to make good money **QUICK**. Write today for "Rich Rewards in Radio," my 64-page book about the practical way to better pay.

### Mail Coupon for Book or Write TODAY

Mr. P. J. Murray, Employment Manager,  
Dept. 9M51, National Radio Institute,  
Washington, D. C.

Dear Mr. Murray:

I want a good Radio job and I am well qualified to hold one. (Write kind of license held and kind of position wanted.) Rush me an Employment Application Blank, no obligation.

Mr. J. E. Smith, President,  
Dept. 9M51, National Radio Institute,  
Washington, D. C.

Dear Mr. Smith:

I want a good Radio job. Rush me your free book, "Rich Rewards in Radio," telling me how I can easily and quickly prepare for a commercial license and a big-pay Radio position.

Name \_\_\_\_\_ Address \_\_\_\_\_  
City \_\_\_\_\_ State \_\_\_\_\_

# The Undisputed Distance Champion

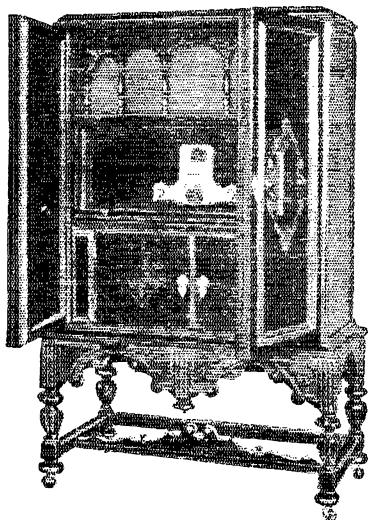

**T**HE Federal F47—and its companion table model, the F11—are undisputed distance champions.

Antenna and ground operation, with four stages of tuned radio frequency, detector and two stages of amplification together with precision standards of manufacture make possible a distance range, fine selectivity and remarkable performance found in no other radio.

These outstanding receivers are priced from \$145 to \$470 without tubes. Battery or light socket operated.

*(Prices slightly higher in west)*

Ask your neighborhood Federal Retailer for demonstration or write for complete specifications.

FEDERAL RADIO CORP., BUFFALO, N. Y.  
Operating Broadcast Station WGR at Buffalo  
Federal Ortho-sonic Radio, Ltd., Bridgeburg, Ont.

# Federal

ORTHO-SONIC

# Radio

BUILT TO EXCEED YOUR EXPECTATIONS

Say You Saw It in QST—It Identifies You and Helps QST

Correspondence Dept.

*(Continued from page 48)*

2. Antenna coupling: After 30 minutes testing a point was found, about 6" coupling was O.K. in my case.

3. Cushioned socket. The signals went swinging to and fro worse than a Charleston dance until the socket was jammed solid. I changed the socket for an ordinary one without the cushion immediately.

4. Shaky support, table or shelf on which transmitter is set. I put the set in a far corner of the shack and put it on 4 big rubber sponges. In this way serious vibration was avoided. For hours I listened in with the monitor box, asked my QSO companions to give me a report, and the pure d.c. steady signals came in R4, R5, R6, R7 depending on atmospherics, and time of the day. All this on 14,200 kc. On 28,000 kc. the set works fine though no outside testing was made, my receiver not being quite ready yet. But the frequency meter and monitor box gave me what information I wished.

I guess this might clear up some troubles of other "hams."

—Alphy L. Blais, VE2AC

## Tragedy

Minneapolis, Minn.

Editor, *QST*:

The clipping presented herewith from *The St. Paul Pioneer Press* should surely serve as a warning.

In this case there was no fuse in 110 volt lead. The main switch was connected in such a way that it cut everything off but the plate current. W9GEY attempted to make a change with one lead in his hand while working on the other.

—F. J. Gerdick, W9FR

### RADIO BUILDER KILLED SHOWING OWN WORK

RICE LAKE, WISC. NOV. 27—C. J. McDonald, 45-year-old Soo Line brakeman residing at Dresser Junction, was electrocuted while demonstrating a home-made broadcasting radio set.

McDonald, a radio enthusiast, had recently installed a 250-watt type transmitter, the largest built for amateurs, in addition to a large transformer. The number of his broadcasting station was W9GEY.

While showing some of his friends how the set worked, he received the full charge of electricity off the line and died almost instantly. He is survived by his widow and four children.

## About Television

Memphis, Tenn.

Editor, *QST*:

As a reader of *QST* I have been intensely interested in the articles pertaining to short-wave receivers and their application or use with resistance coupled amplifiers with and in conjunction with scanning devices.

There is a dearth of material on the subject of television except in certain publications. These articles are certainly whooping it up and seem willing to write up any



# THERMO-COUPLE-TYPE INSTRUMENTS-MODEL 425

**I**NSTRUMENTS of this type, originated and developed by the Weston Company, are universally employed for measuring both high and low frequency currents. Their use has extended with the wide application of radio frequency into a great number of fields of experimental engineering and commercial activity. Incomparable in their refinements of mechanical and electrical design and unusually accurate and dependable in performance for such small instruments, the Weston Miniature Meters—Thermo-Couple types as well as A. C. and D. C. models—are everywhere accepted as the highest standards for radio testing service.

## Thermo-Couple Types

Made as Thermo-Ammeters, Thermo-Milliammeters, and Thermo-Galvanometers or Current Squared Meters

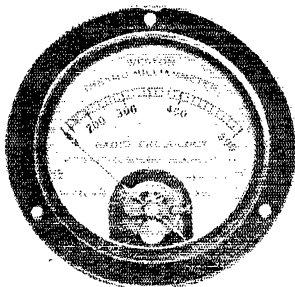

## For Panel Mounting

Flush Type—2" and 3¼" diameter. Furnished in metal or bakelite cases. Portable mounting bases also supplied.

The Weston Thermo-Couple Type Ammeter is furnished in ranges from one to 20 amperes having a safe overload capacity of 50%. It solves perfectly the problem of measuring high frequency currents such as are imparted to the antennae. Equally accurate for low frequency measurements and gives satisfactory service for D. C. measurements as well as A. C.

Milliammeters are furnished in three sizes—125, 250 and 500 ma. They give definite assurance of the output and accurate readings after hours of constant service. Extra large overloads will not burn out these meters. They are ideal for short wave transmission as they have a very low internal electrostatic capacity. For this reason they give the true value of the current in the circuit and do not disturb the constants in a transmitter.

*Write for Circular J.*

---

**WESTON ELECTRICAL INSTRUMENT CORPORATION**  
602 FRELINGHUYSEN AVENUE - NEWARK, N. J.

---

# **WESTON**

## **RADIO**

# **INSTRUMENTS**

## A detailed treatment of vacuum tube circuit theory

If you have not yet seen this book you will certainly want to examine it, as it furnishes you with a dependable, up-to-the-minute discussion of thermionic vacuum tube circuits; places in your hands thoroughly developed conventions which may be used in solving abstruse circuit problems with ease.

From elementary thermionic theory to the theory and design of amplifier circuits, the book covers each phase of the subject of vacuum tube circuits with detailed thoroughness.

### THEORY OF THERMIONIC VACUUM TUBE CIRCUITS

By LEO JAMES PETERS

Assistant Professor of Electrical Engineering, University of Wisconsin  
226 pages, 6x9, 110 illustrations, \$3.00

The consistent aim throughout this reliable manual has been to furnish the reader with a firm grasp of fundamental theory and a familiarity with methods of attacking problems so that he can investigate systems and circuit arrangements other than those discussed in the book.

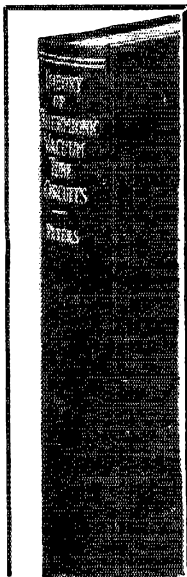

#### McGraw-Hill FREE EXAMINATION COUPON

McGraw-Hill Book Co., Inc.,  
370 Seventh Avenue,  
New York, N. Y.

You may send me Peter's Theory of Thermionic Vacuum Tube Circuits, \$3.00, postpaid. I will either return the book, postage prepaid, in 10 days, or remit for it at that time.

Name .....  
St. & No. ....  
City .....  
State .....  
Name of Employer .....  
Official Position .....  
(Books sent on approval in the U.S. and Canada only)  
Q.S.T. 12-1-28

## Mass. Radio School

Est. 1905

Earn \$35 to \$50 Per Week

The rapid expansion of RADIO has created many new positions on land and sea. Openings in Airways, Intercity Radio, Photophone and Television as well as Merchant Marine, Broadcasting, Radio Service and Repair Work. We specialize in training for service with the Radio Corporation of America.

Only school in N. E. conducting Radio, Morse Telegraph and Radio Service and Installation Classes.

We graduate and place in good positions more first class radio operators than any other New England Radio School.

Enroll Now. New term begins Jan. 7. Both Day and Night Classes. Send for Catalogue.

18 BOYLSTON ST. Tel. Han. 8784 BOSTON

old advertiser's product if the ads are forthcoming. Here's an illustration: Seeing the ad of one of these companies, I fell for it hook, line and sinker. Through a local jobber I placed an order for a receiver bearing a list of 100 iron dollars. This is what I received: Two scanning disks of cheap bakelite, both warped, the center holes unlike; a cheap resistance coupled amplifier. Now get this: Last but not least there was a flimsy stand on which was mounted a motor. The motor was a second-hand Dictaphone motor acquired in a job lot from somewhere. Not even new, mind you. Second hand, of say one thirtieth horsepower. The shaft was approximately  $\frac{1}{4}$ " in diameter and of such length that the weight of the disk caused uneven rotation.

There is one thing I do admire about you birds. You're always trying and the published articles are based on actual test and experiment. Let's have some real television articles. We know you are the only outfit that is on the square. Personally I'd like to get my hands on some of the manufacturers of the junk sent me. I'd also like to strangle some of the thirty cent experts.

—Hugh J. Mooncu.

(We refer Mr. Mooney to T. O. M.'s story on "Rotten Television" in this issue.—Ed.)

### Increasing Transmitting Antenna Efficiency

(Continued from Page 44)

ferent wavelengths and all the results were in accord with the above typical case.

In general, the addition of any concentrated structure to the ends of an antenna, of a value not exceeding 10 percent of the effective capacity or inductance of the

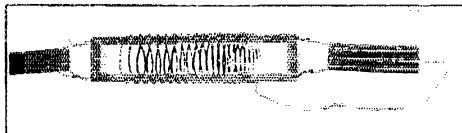

THE TYPE OF END LOADING COILS USED

Suspended between the Ohio Brass Company porcelain insulators in an insulating frame carrying the spaced winding of heavy copper. This is a 22-turn,  $2\frac{1}{2}$ " coil for use at 40 meters on a 60 foot antenna.

antenna itself, may be expected to increase the effectiveness about 14 percent, provided that the same potential amplitude is assumed in both cases.

### Strays

A reprint has been prepared of Dr. Chester W. Rice's article, "Short-Wave Radio Transmission and Its Practical Uses", which appeared in the July and August, 1927 issues of QST. Several errors appeared in the original publication, which have been corrected in the reprint. A copy of the reprint will be mailed to any QST reader upon request.

# Radio's most complete testing outfit

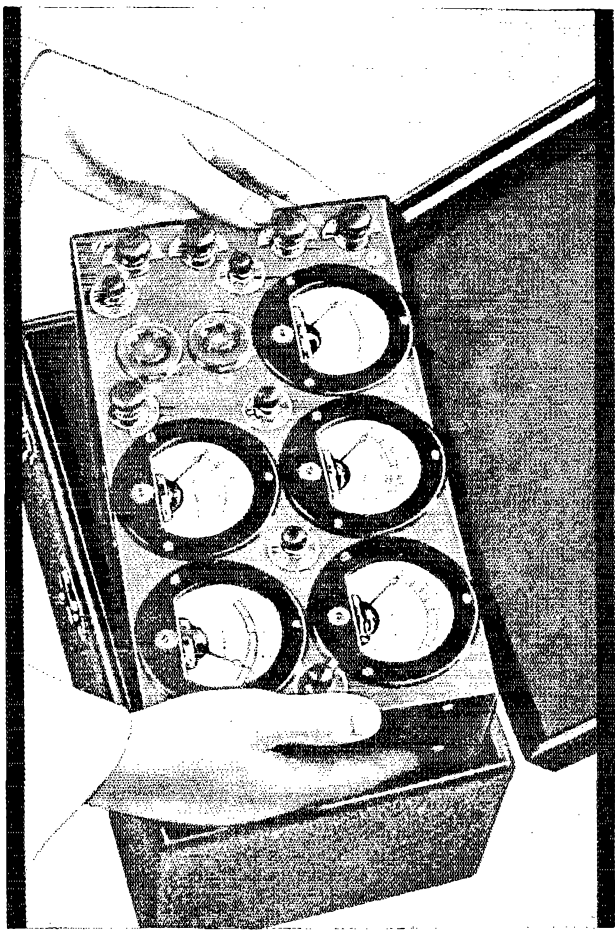

**Converts service calls into sure profits!**

**THIS** Hickok Set and Tube Tester meets every requirement of service dealers who demand accurate, complete testing equipment to safeguard their interests and increase their profits.

Within this single unit is incorporated the necessary apparatus for making any and every test on all types of AC and DC Sets and Tubes; it consists of five meters:

- Plate Voltmeter
- AC Filament Voltmeter
- DC Filament Voltmeter
- Grid Voltmeter
- Plate Milliammeter

Resistance per volt—1333- $\frac{1}{2}$  ohms

Two sets of cables are furnished for UV and UX or UY tubes; also attachments for all dome type tubes.

At a slightly extra cost, a serviceable black leather carrying case with a compartment for extra tubes, cables and tools is provided, making the Hickok Tester the logical complete equipment for service work.

A beautiful scientifically designed testing unit containing 5 meters at practically the same price you would pay for 2 meter testers.

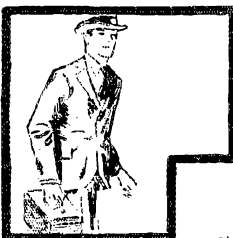

No buttons to push — no multi-scale meters to read.

The correct equipment for store and home service work everywhere.



Write for latest Service Manual No. 23 containing valuable Service Data on proper testing methods. Free upon request.

# HICKOK

“SEES ALL—TELLS ALL”

## RADIO SET TESTER

for every AC and DC Set and Tube

THE HICKOK ELECTRICAL INSTRUMENT COMPANY  
Cleveland, Ohio

## Complete Parts for SILVER-MARSHALL No. 730

### "Round-the-World" 4

A COMPLETE short wave receiver (17.4 to 204 meters) and two-stage audio amplifier. All wave lengths are covered with no dead spots. Amateur bands fall well to center of tuning dial. Net \$30.00. Completely constructed \$38.80. C.O.D. or cash with order. Postage or express extra.

### Also Complete Stock of

Leach Relays—R.E.L. Products—3000-Volt Rectobulbs—Omnigraphs—Vibroplexes—Silver-Marshall Shield Grids.

Send for New 1929 Ham Book—FREE

**C H I - R A D**  
**CHICAGO RADIO**  
**APPARATUS CO.**  
415 S. DEARBORN ST., CHICAGO



## You, Too, Can Have Full-Toned Reception

Two years ago few, except the experimental engineers, even dreamed of radio reception as it is today. No wonder Radio has come into its own—that politics and sports now reach millions of people here-to-for but little interested. The life-like reality of reproduction would indeed be startling had we not grown accustomed to it gradually.

You, too, can possess that kind of radio reception—at comparatively slight cost. Power amplification is the biggest reason for the marvelous quality of radio today. One of the greatest single successes of the 1928 season is the Dongan Power Amplifier Transformer, No. 7568, used with 2 UX 281 Tubes to supply B and C power to receiver and power for 2 UX 250 Tubes. With this Transformer use Dongan No. 6551 Double Choke.

You can secure information on Approved Parts—Transformers, Condenser Blocks and Units—for various books by writing the Dongan Laboratories.

Orders filled immediately on No. 7568 Transformer. Send check or money order. \$13.50

### Custom Set Builders

Can secure any of these items direct from factory at trade discounts.

### Set Manufacturers

Are offered the full cooperation of Dongan engineering department for their individual requirements.

**Dongan Electric Manufacturing Co.**

2999-3001 Franklin St., Detroit, Mich.

**TRANSFORMERS of MERIT for FIFTEEN YEARS**

## Before the Guy Wire Breaks

(Continued from page 40)

over the coming season and thought that if such a break occurred again, it would be a great nuisance to take down and raise the mast even once more. Why not extend the halyard raising by the endless pulley idea to the guys also? Accordingly, pulleys were fixed to all the junctions of the guy-wires. This may be a bit expensive but will save you much time and trouble if you do it in the direction of maximum pull, where there is a danger of a break which will bring the mast down. In this case, the pulleys for the guy-wires were only fixed to the higher junctions of the mast where hand cannot reach and not to each section of the guys where there is no necessity for such a thing.

Reel type insulators of the proper size or porcelain pulleys will serve our purpose excellently, and the 7-22 stranded wire or thick twine used in packing, slips over them easily. A thick wire was passed through each hole of the insulator, given a twist and tied firmly to the mast. Then a small spool of 7-22 wire was secured; an axle rod was passed through it and attached to angle brackets, so that the spool could revolve freely and supply the wire when it pulled. This whole arrangement was mounted strongly on a small wooden board and fixed near the anchors. One end of the 7-22 wire from the spool was taken over the groove of the guy-wire pulleys, brought down and tied with the anchors. The masts were then erected in the usual manner.

Now it is a very simple matter to put a new guy up if the old one breaks. You can break one and try the experiment. If only a section breaks you can bring down the whole guy and attach a new section. To raise a new guy you simply tie the guy-wire to the inside wire passing over the pulleys and pull it from the other side. The wire passes over the groove of the pulley and comes down into your hands and you have a double wire guy.

If you want a single wire guy pass the wire over the insulator just as described and when you have the return end, turn it into an eye joint or make a loop end and pass the other end through this loop. You may use a porcelain eye insulator if you think it is practicable in your case. If a piece of twine is tied to the loop, this will keep the looped end in position and the guy will go up quickly without getting entangled or stuck on the way. When the guy-wire breaks and you want to put a new one up you can pull this looped end and thereby clear the pulley of any piece of wire hanging over it. Now if you pull the unlooped end slowly and carefully the looped end will go up smoothly and when it terminates at the top pulley pull and tie the free end to the guy-wire strainers or anchors and you have a new guy without lowering the mast.

# What A Condenser Thinks About :

WELL, HERE I AM, JUST OUT OF THE BOX -- WONDER WHAT KIND OF A BIRD I'M WORKING FOR ?

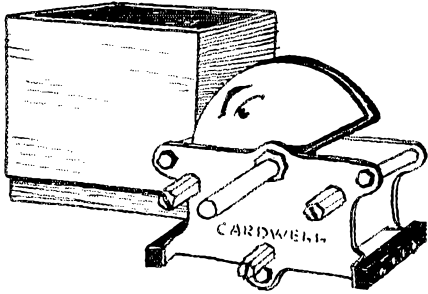

MUST BE ONE OF THOSE HAMS! - LOOKS LIKE A SHORT WAVE HEAP HE'S PUTTING ME INTO !

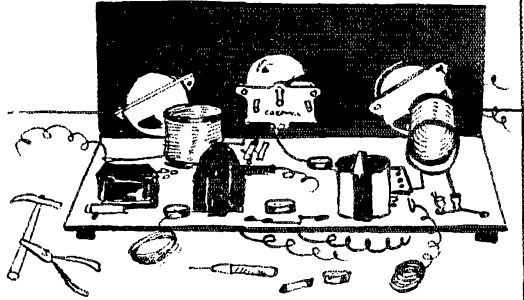

ALL READY TO PULL THEM IN NOW - HERE WE GO! - - - HOLD EVERYTHING !

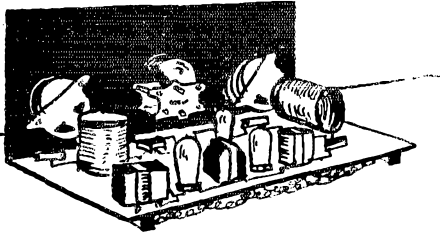

OUCH! YE GODS, ARE THEY CRAMPING EVERYTHING ON THE AIR INTO TEN POINTS ON MY DIAL ???



OH WELL! REAL CLASS WILL TELL! I'M PICKING THEM OUT EASY NOW! NOTHING TO IT - I'LL BET HE NEVER SAW SUCH TUNING AS THIS BEFORE!!

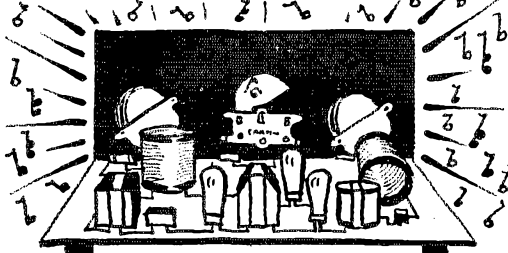

GUESS HE KNEW I WAS A THROUGHBRED WHEN HE BOUGHT ME! CARDWELL ALL THE WAY THRU! PARDON MY CONCEIT BUT I WAS BUILT TO STAND THE GAFF!!

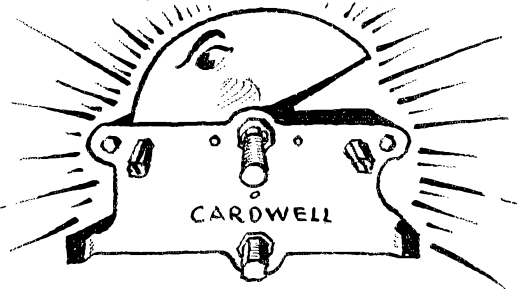

Yes, Class will tell. You're not gambling when you choose a CARDWELL taper plate condenser for your short wave receiver. Made in five capacities, .000075 to .0005—Transmitting condensers, too, for powers up to 50 KW. Send for descriptive literature.

## THE ALLEN D. CARDWELL MFG. CORP.

81 PROSPECT STREET

BROOKLYN, NEW YORK



# Reap Big Dividends from this Investment in Tone Quality

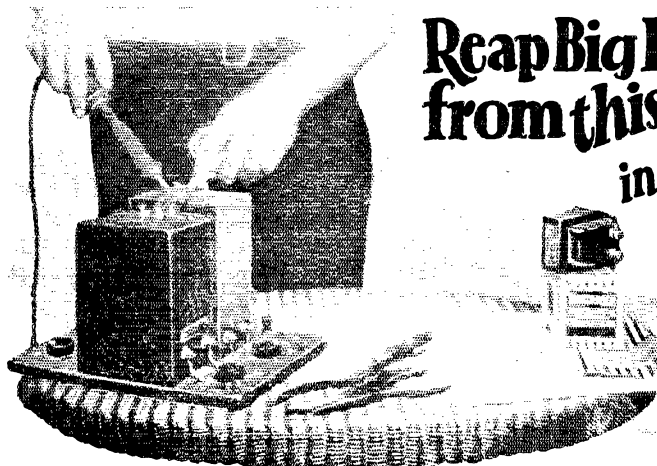

## A Thordarson Power Amplifier (Home Constructed) Will Transform Your Radio Into a Real Musical Instrument

WITH the insistent demand for quality reproduction, power amplification has become a vital radio necessity. Today, it is hard to find a radio set manufacturer who does not employ one or more power tubes in the output stage of his receiver.

There is no need, however, for you to discard your present radio instrument in spite of the fact that it is out-classed by newer models with power amplification. You can build a Thordarson Power Amplifier which, attached to your receiver, will provide a fullness and richness of reproduction that will equal or surpass the finest offerings of the present season.

Thordarson Power Amplifiers are exceedingly easy to assemble, even for the man with no previous radio experience. Only the simplest tools are used. Specific instructions with clear-cut photographs, layouts and diagrams insure success in home construction.

Whether your present receiver is factory made or custom built one of these amplifiers may be attached with equal ease. In fact, most Thordarson Amplifiers require absolutely no changes in

the wiring of the receiver itself, attachment being made by means of a special plug which fits the last audio socket of the receiver.

Thordarson Power Amplifiers for the home constructor and professional set builder range from the simple plate supply unit up to the heavy-duty three stage units employing the 250 type power tube in push-pull arrangement. These power amplifiers cover the requirements for every purpose and every pocket-book. They may be used with any type of horn, cone or dynamic speaker.

With a background of over thirty-three years manufacturing quality transformers, it is only natural that so many manufacturers of receiving sets of undisputed superiority have turned to Thordarson as the logical source of their audio and power supply transformers. The discriminating home constructor will do well to follow the lead of these manufacturers when buying his power amplifier.

Write to the factory today, enclosing 25c for the new "Power Amplifier Manual"—just off the press

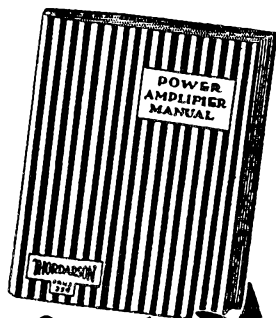

*New!*

No Amateur or Professional Set Builder Should Be Without This Book—

"POWER AMPLIFIER MANUAL"

A simple, yet complete, treatise on the subject of audio and power amplification, including full information on building, servicing, and testing power amplifiers in general. Also contains detailed specific construction data on twelve individual power units, with clear-cut layouts and diagrams of each.

25c

Send 25c in Cash or Stamps for This New Book—  
Just Off the Press!

# THORDARSON RADIO TRANSFORMERS

SUPREME IN MUSICAL PERFORMANCE

## MAIL THIS COUPON TO DAY!

THORDARSON ELECTRIC MANUFACTURING CO.  
500 West Huron Street, Chicago, Illinois

Gentlemen: Please send me your new "Power Amplifier Manual" for which I am enclosing 25c.

Please send me free of charge your instruction sheet on the amplifier I have checked below:

171 Single  171 Push-Pull  210 Single  210 Push-Pull (1 Stage)  210 Push-Pull (2 Stage)  250 Single (1 Stage)  250 Single (2 Stage)  250 Push-Pull (8 Stage)  210 Phonograph Amplifier

Name.....

Street and No.....

Town..... State.....

8086 F

All the latest data in advanced radio science

See it For 10 Days FREE

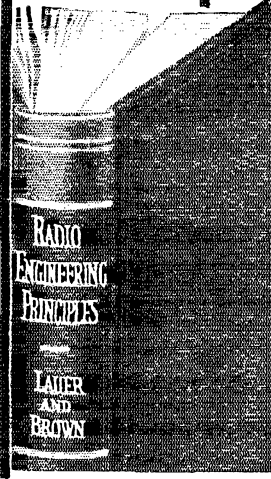

Four Good Reasons Why You Will Want to Examine This New Second Edition of

**Lauer & Brown's**

## RADIO ENGINEERING PRINCIPLES

301 pages, 6x9 227 illustrations  
**\$3.50 net, postpaid**

1. The book covers in detail the science and practice surrounding the 3-electrode vacuum tube;

2. It gives the principles involved in the functioning of all forms of radio apparatus;

3. In the development of principles, the electron theory is made use of;

4. Mechanical analyses are avoided—Mathematics is used only to indicate applications in problems of design.

This standard manual gives the latest and best basic data on all phases.

Some of the Topics

—radio-telegraphic transmitting circuits;

—ferro-magnetic or detuning modulation methods;

—mathematical theory of the balanced modulator;

—piezo-electric oscillators and resonators; —etc., etc., etc.

satisfactory answer to it, don't keep it to yourself but pass it along to us so that it may be given to all. It makes no difference whether you are definitely enrolled in the Experimenters' Section or not—you are an experimenter just the same and we will be glad to receive and pass along through *QST* such information that you may have acquired in the course of your experimentation.

—H. P. W.

## Rotten Television

(Continued from Page 24)

body. I have a husky hunch that a new system will have to be developed for all this, and that some smart aleck will develop it. I hope to be still in possession of my alleged faculties when that time comes. In the meantime, it's a wonderful field for serious experimental work for those who are willing to plug hard and expect very little in the way of immediate results.

But when all these ads and articles hold up the present developments as a finished product to the poor ignorant public, why then I have to say something. It's a garb bished crime, that's what it is!

Having got that off my chest let's get back to twenty meters and see what the little dots and dashes are saying.

—T. O. M.

### McGRAW-HILL FREE EXAMINATION COUPON

McGraw-Hill Book Co., Inc.,  
370 Seventh Avenue,  
New York, N. Y.

You may send me Lauer and Brown's RADIO ENGINEERING PRINCIPLES—New Second Edition \$3.50 net, postpaid. I will either return the book, postage prepaid, in 10 days, or remit for it at that time.

Name .....

St. & No. ....

City .....

State .....

Name of Employer .....

Official Position .....

(Books sent on approval in the U. S. and Canada only.) QST, 1-1-29

## Election Results

IN November, elections for A.R.R.L. Director were held in seven of our divisions. As we reported last month (page 90, December) Directors Corlett, Gravely, Segal and Weingarten have been re-elected without opposition; and in the Hudson Division there is a new director, Dr. A. LaFayette Walsh, W2BW, succeeding Dr. Dunn, who decided to retire from the Board and would not permit his name to stand for re-election.

In the Central Division election, Mr. Darr, the incumbent, has won over several other candidates and so succeeds himself, the figures being as follows:

Clyde E. Darr .....	533
Donald J. Angus .....	489
Loren G. Windom .....	205
Centennial S. Stark .....	55

Dr. White was not a candidate for re-election in the New England Division, with the result that that division has a new director in the person of Mr. Frederick Best of W1BIG of Augusta, Maine. Mr. Best, the S. C. M. of Maine, is a lively and well-known figure on the air, having won the "Goodfellow"—A.R.R.L. traffic trophy in 1926. The balloting in the New England Division resulted as follows:

Frederick Best .....	451
Homer E. Nichols .....	188

—A. B. W.

## RADIO OPERATORS WANTED

THE EASTERN RADIO INSTITUTE can train you quickly and thoroughly because:

MODERN AND EFFICIENT METHODS  
THOROUGH INSTRUCTION under staff of  
LICENSED COMMERCIAL OPERATORS  
MODERN APPARATUS including SHORT WAVE  
TRANSMITTER

FIFTEEN years a RADIO SCHOOL  
THE OLDEST, LARGEST and MOST SUCCESSFUL  
school in New England. RECOMMENDED BY THE  
A. R. R. L.

Day or Evening Classes Start Every Monday

SPECIAL CODE CLASSES

Write for Illustrated Prospectus

**EASTERN RADIO INSTITUTE**  
899 BOYLSTON STREET BOSTON, MASS.



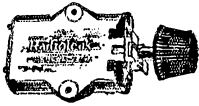

**Bradley Leak, 2.95**  
absolutely noiseless and  
Stepless .....

2500 to 30,000 ohm resistance. List  
\$.95, special \$2.95.

**\$4 Bradleystat No.  
E-210, Special \$1.60**



**\$3 Mesco Telegraph Key ..\$1.45**  
Signal Buzzer Set International  
Code on Baseboard .....\$2.45  
Helden braid 1/4 inch wide, ft .06

Television disks as specified  
in *QST* special **\$1.95.**

Acme 500 w. plate trans-  
former 1000-1500-2000 each  
side of centre tap, \$24.00.  
Acme B.H-1 transformer,  
255-510 each side of centre  
tap; also 2 fl. windings of  
4 v. each side of centre tap,  
\$10.25.

Acme C.W. 30 Henry choke,  
18 list - 150 M. A. single  
\$14.40; also other sizes at  
special prices.

# LEEDS

*The Home of RADIO*  
**45 VESEY STREET  
NEW YORK**

**New York's Headquarters for  
Transmitting Apparatus**

*When in Town Visit Our Store*

Full Line of Acme -- Thordarson -- Jewell -- Flech-  
theim -- General Radio -- Signal -- Bradley

### SPECIALS

- |  |      |
|--|------|
| Helden braid 1/4" wide; ideal for shielded grid tubes, ft  | .06  |
| Marked EBY binding posts; reg. 15c special each  | .05  |
| Patent Deluxe No. 124 Phonovox—The electrical pickup;<br>List \$13.50. Special                   | 8.25 |
| General Radio 247D .001 cond. plain or with vernier  | 1.75 |
| Dublier cond. .5 mfd. 1,000 v D.C. working voltage   | .85  |
| R.C.A.—U.V. 1718 Super Het. transformer  | 1.45 |
| Ward Leonard Resistances; its standard base receptacles;<br>sizes 300—600—900—1200 and 2000 ohms | .95  |
| \$15. Imported German head sets; very sensitive  | 3.45 |
| Honeycomb coils unmounted, all sizes in stock at 1/2 price.                                      |      |
| \$8 Signal Corps adjustable arm micro-transmitter for<br>panel mounting                          | 2.45 |
| \$9 Dublier condenser, 1mfd; 600 v. D. C. working type<br>903; limited quantity                  | 2.45 |
| R.E.L. Transmitting Inductances, per set   | 8.80 |
| Bristol 50 Henry choke   | 2.75 |

Pyrex Low-loss V.T.  
sockets, each 39c.

R. C. A. socket; note-  
tain base, metal top 50c

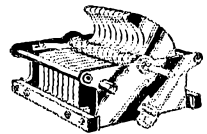

Cardwell con-  
densers, double  
spaced for trans-  
mitting, .00025 cap. **3.45**

Everything in  
**Cardwell**  
In Stock

- No. 12 Enameled copper  
wire, any length, ft. **\$0.1**  
No. 10 Enameled copper  
wire, any length, ft. **.013**  
Genuine Bakelite Panel  
10x14x1/4 ..... **1.50**  
Baldwin phones type C  
pair ..... **5.95**  
Myers \$5 4 1/2 volt Det.  
or Amp tube, complete  
with mounting clips **.95**



**Ward Leonard Resistance**  
\$4.75 list-6 1/2 inch long—300-  
1000 - 1200 - 3000 - 4000 -  
8000-11000 ohms; can be used  
for 2-50 watt tubes or less **\$1.45**

## ACME POTENTIOMETER RHEOSTAT

A combined Pot. and fila-  
ment Rho.

6 ohm rheo-100 ohm pot.  
30 ohm rheo-100 ohm pot.  
30 ohm rheo-300 ohm pot.  
TWIN RHEO for low  
voltage tubes. List \$3.00. Special each 65c



## ACME TRANSFORMER

Listed at \$5.00. The uni-  
versal transformer for  
Super Het. 30 K.C. Lim-  
ited quantity at \$1.10



## ACME CHOKE COIL

A high quality choke 1/10  
Henry at 100 mls.  
List \$5.00. Special \$1.25



## French Hand MICROPHONE

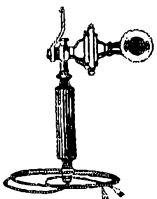

Listed at \$10  
Nickel Silver  
Finish  
Vulcanized  
rubber handle.

A wonderful  
buy **\$6.25**  
at . . .

## ACME VARIABLE RATIO A. F. TRANSFORMER



Recommended for short wave C.W. re-  
ception exclusively. Has sharp peak—  
gives excellent results. List  
price \$7.00 each. Special **\$2.75**

## General Radio—200 watt Full Wave TRANSFORMER

Type 565-B. Secondary voltages 1200  
volts (with centre tap) 7.5 v. 7.5 v.  
Maximum current 200 MA. 2.5 Amp  
2.5 Amp. Price

**\$13.50**



Two inch space wound  
Hamm. inductance No. 16 d.  
s. c. green. Special  
price per inch ..... **35c**

**MAIL ORDERS FILLED SAME DAY**  
10% Must Accompany All Orders

**PLEASE PRINT YOUR NAME AND  
ADDRESS PLAINLY to AVOID DELAY**



## NEON GLOW LAMPS

Made by General Electric  
Co., type G-10, standard  
base, 101 uses, as illustrated  
in *QST* May issue page 17  
Price only ..... 65c

## RADIO FOUNDATION TRANSFORMER



Offer for McCullough A. C. or equivalent  
tubes. Will carry 6 or 7 tubes—2 1/2-3-  
3 1/2 volts. List \$6.00. Special ... **\$2.25**

## VARIABLE FILAMENT TRANS- FORMER

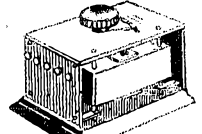

125 watt—110 volt—60c. Tapped at 4-7-  
10-13-17-20-24-30 volts. Limited quan-  
tity. List \$19.  
Special ..... **\$4.45**

Flechtheim Condensers  
all types 35% off list.

General Radio No. 358 Short  
Wave Meter, 14 to 25 me-  
ters, list \$22, special \$15.00



We carry the largest  
stock of  
**GENERAL  
RADIO PARTS**  
in the country

(Continued from page 24)

## A Simple Guide for Selecting Resistors

No matter how many claims are made for a resistor, you can always check up on its true worth by finding out who uses that particular make, and how it stands up under the rigid pressure of daily service.

We strongly recommend that you ask any one of the following companies about Harfield Resistors. They are but a few of a great number of concerns now purchasing Harfield Resistors in large quantities.

Western Union Telegraph Company  
Jensen Radio M'g Co.  
Spiltdorf Electric Co.  
Colonial Radio Corp.  
Samson Electric Company  
Philadelphia Storage Battery Company

Stromberg-Carlson Telephone Manufacturing Company  
Kolster Radio Corporation  
American Transformer Co.  
Dansteel Products Company  
Martin Copeland Company  
Zenith Radio Corporation

[Tell us about the resistor you want and let us make up a sample for you with prices.]  
Write to

**HARDWICK, FIELD, INC.**

FACTORY  
219 Grand St.  
Newark, N. J.



SALES OFFICE  
122 Greenwich St.  
New York

## Neutralization Means—More Power From Any Set

Science has proven that neutralization is the only satisfactory method of controlling oscillation in a Tuned Radio Frequency Circuit and that it increases the actual power per stage of amplification 25 to 300%.

The Neutrodyne principle can be applied to practically every set by the simple installation of X-L Vario-densers. The result is an amazing increase in the efficiency and power of the receiver. Send for interesting book of circuits and picture diagrams showing the use of the Vario-denser.

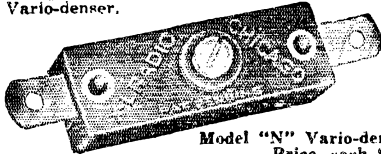

Model "N" Vario-denser.  
Price, each \$1.00

Has variable capacity, adjustable from 1.8 to 20 micro-microfarads, which is .0000018 to .00002 microfarads. Price each \$1.00.

**X-L RADIO LABORATORIES**  
Dept. D 1224 Belmont Avenue, Chicago, Ill

Send and Receive, nine Terminal Cam Switches in case (British) Type 238 42, price \$1.25; Type SE 2849 Receiver, Maker Ntl. Elec. Supply Co., wavelength range 1000-25,000 meters regenerates by means of ultraudion circuit, tuned Primary tuned secondary. Cabinet size 22 1/4" x 14 1/2" deep, condition used but O. K. price \$34.00; Weston Electric Inst. Co. Ammeter scale 0-150 amps. Internal shunt 8 inch face. Zero center, price \$15.00. Largest stock of Government Radio Transmitting and Receiving material in U. S. Send 2c stamp for our new and latest reduced price list, ship anywhere. **WELL'S CURIOSITY SHOP**, 20 South Second St., Philadelphia, Pa.

When both the coils are adjusted to give satisfactory operation, the excess leads may be clipped off and they may then be soldered into the tips of the tube base prongs. If the socket being used makes contact to the sides of the prongs, be sure not to wrap the lead wires around the prong as this will impair the contact.

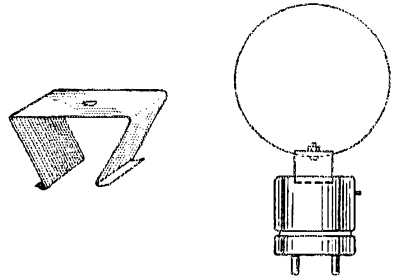

FIGURE 2. On the left is the metal piece which holds the coil form to the base tube. It may be made of any springy material. This view also shows more clearly the fact that the metal piece runs through the inside of the coil form and is fastened to it by means of a small machine screw and nut.

A coating of collodion, varnish, shellac or whatever may be your pet binding material may then be applied to the coil to keep the wires from shifting and changing the calibration of the set.



WHAT THE BROADCAST ENGINEER DOES ON HIS NIGHT OFF

## A Poor Man's M.O.P.A.

(Continued from Page 23)

current appears to be about normal for the tube in use. Previous experience with the same tube in a standard circuit is helpful here. The antenna may now be connected and, if tunable, tuned to resonance. This causes the strength of oscillations to increase (this is funny!) and the grid current will go up. Readjustment of C4 will bring the grid current back to normal if the antenna coupling is not too close or the capacity of C2 or C3 too small. Put the monitor to work.

The following remarks concerning Figure 6 may give some idea of what to expect from the circuit and, perhaps, save some postage for me. Some of the remarks may be con-

# Startling Price Reductions

**BUY NOW!**

Allied has cut prices to the bone — your big profits in radio can now be bigger — no need to wait any longer. Here's the season's outstanding values.

**On Everything  
In RADIO**

# RADIO

## 1929

**PRE-INVENTORY  
CLEARANCE  
EVERYTHING IN RADIO  
A.C. SETS-D.C. SETS  
DYNAMIC SPEAKERS  
PARTS-KITS  
ACCESSORIES**

**THE  
SLASHING  
EVENT  
OF THE  
YEAR**

**NET  
WHOLESALE  
PRICES**

**ALLIED RADIO  
CORPORATION  
711 W. LAKE ST. CHICAGO, ILL.**

### NEW 1929 CATALOG

A pre-inventory sale featuring some of the most drastic price reductions known to radio. Everything in our tremendous stock is offered in this sale. This large new catalog brings before you a tremendous array of radio values.

Every branch of the industry is represented—appealing to set builders interested in parts and kits—to dealers interested in the new sets and modern accessories—as well as agents for one of the season's most successful lines of A. C. and D. C. receivers.

### Wholesale Prices

Selling on an exclusively wholesale basis, the prices we now offer you are establishing new standards in radio values—new A. C. sets as low as \$32.95—attractively designed consoles for as low as \$16.25. Corresponding values are offered in kits, parts and accessories in nationally-advertised, quality merchandise from the country's foremost radio manufacturers.

**THE CATALOG IS FREE  
SEND FOR YOUR COPY NOW**

*Knigh Receivers  
for A. C. and D.  
Cooperation with  
an a visible r-c-  
ord for perform-  
ance. See new  
large catalog.*

# Allied Radio CORPORATION

711 W. LAKE ST.

Dept. P-2

CHICAGO

# Martin's Latest and Greatest Bu THE Great New **VIBROPLEX**

Reg. Trade Marks: Vibroplex, Bug, Lightning Bug

## No. 6



Japanned Base \$17  
Nickel-Plated \$19

The smoothest, easiest-working bug on the market. Not too fast, not too slow—but just right. Works where others can't.

## Famous Improved Vibroplex

Used by tens of thousands of operators because of its ease and perfection of sending.

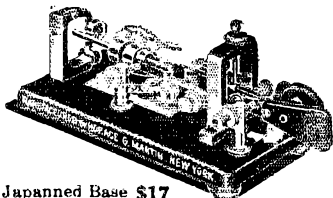

Japanned Base \$17  
Nickel-Plated \$19

## Special Radio Bug

Equipped with Extra Large, Heavy, Specially Constructed Contact Points for direct use without relay **\$25**

Be sure you get the Genuine Vibroplex. The Vibroplex Nameplate is your protection. Remit by Money Order or registered mail.

**THE VIBROPLEX CO., Inc.** 325 Broadway  
New York City  
Cable Address: "VIBROPLEX" New York

# Bargains Army and Navy Radio Surplus

Ammeter, Radiation, not wire 0-5 Amp. Gen Radio Co.	\$1.50
Wattmeter, A.C. and D.C. 0-750 watts, Roller-Smith	3.50
Ammeter, Thermo, 0-10 Amp, Weston, No. 425	7.50
Ammeter, A.F. 0-4 Amp. Koller-Smith	2.00
Transmitters, telephone type U.S.N. "Holtzer-Cabot" (used)	7.75
Motors, Edison (slightly used) 110 D. C. Fine for television	2.00
Motors, Hamilton-Beach, new 1/20 H.P. Universal 110 volt, complete with Ward Leonard variable vitrohm rheostat	5.00
Headphones, Navy type (used) Army, single (new)	1.50
Keys, airplane transmitting, Bane proof 1/2 inch silver contacts.	1.50
Cords, 7 ft., W.E. telephone, trimmed ends.	.20
Cords, 15 ft., 2 wire high tension, No. 18 armored	.30
Condensers, mica, Dubilier, .002 mfd. 7500 volt	7.50
Microphone, Airplane transmitter, West Elec, with breastplate	.85
Resistances, W.L. 600-900-2000 Ohm, its standard base	.60
Resistances, W.L. 500 Ohm, 2 Amp. var. field	5.00
Resistances, W.L. 5 Ohm, 12-4 Amp. Rat. charging, var.	3.00
Filters, W.E. radiophone, C.W. 968	3.50
Dynamotors, G.E. 12/750 volts	20.00
Dynamotors, W.E. 27 350 volts	15.00
Dynamotors, C.W. 25/275 volts, with ex. shaft	12.00
Dynamotors, Sperry, 6/400 watts, 40 amp input	15.00
Transformers, 110 Pri. 5-10-15 Sec 250 watt 60 cycle	7.50
Transformers, 110 Pri. 2300 Sec. with center tap, 200 watt, 80c	7.50
Magnets, army mine type.	1.00
Telephone & telegraph outfit, portable leather case (Strom-Carlson)	3.50
Telephone & telegraph & buzzer outfit, (parts value \$10)	3.00
Condensers, 1-1/10-1-20 25c 3mrd with taps	.50

Please include sufficient postage with remittances. Largest Government radio and electric surplus stock in U. S.

## Manhattan Electric Bargain House

Dept. Q 105-7 Fulton Street N. Y. C.

"All Experimenters! Here is Your Book at Last!"

### EXPERIMENTAL RADIO

THIRD EDITION

By Professor R. F. Ramsey, Indiana University  
xii+229 pages, 542 figs., cloth, 117 experiments, 152 figures.  
"In general, Ramsey manages to provide that missing fact which seems to be hidden in other books." Review, 3rd Ed. Q & T. "This book recommends itself to service men, custom-set builders, testers, and advanced experimenters."  
RADIO ENGINEERING. Price \$2.75, postpaid or C. O. D., Ramsey Publishing Co., 615 E. 3rd St., Bloomington, Ind.

siderably in error because they are mostly my own conclusions drawn from my own experience with the circuits mentioned. "It" refers to Figure 6.

It is not as stable as regards climbing, chirping, antenna changes and body-capacity effects as a properly designed, shielded and operated oscillator-amplifier set, but is equally stable as regards line voltage changes.

It is not as stable regarding climbing, chirping and antenna changes as a properly designed and operated, but unshielded,

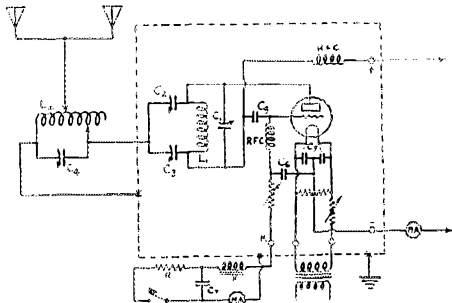

FIGURE 6. THE CONSTANTS HERE GIVEN APPLY TO 2,500 AND 7,000-KC. OPERATION

- C1—500 µfd.
- C2, C3—2A-plate Pilot midget condenser.
- C4—250 µfd. (Larger if 2,500-kc. phone transmission is desired.)
- C5—2,000 µfd.
- C6—1000 µfd.
- C7—0.5 to 1. µfd.
- C8—500 to 5,000 µfd.
- C9—500 to 5,000 µfd.
- L1—5 turns of 3/4" copper strip spaced 3/4" on a 3.5" form. (7,000 kc.) 12 turns of the same are used for 2,500-kc. operation.
- L2—Same as 3,500-kc. coil for L1.
- RFC—Your favorite choke. Make both chokes identical. Unwind same turns from each if oscillation is not good in both bands.
- R—200-ohm potentiometer.
- X—Primary of old audio transformer.

oscillator-amplifier set, but is more stable in the matter of body-capacity effect and just as stable as regards line voltage changes.

It is harder to adjust than any of the standard circuits, but adjustment is simpler and less critical than that of any oscillator-amplifier affair.

It is slightly less efficient in the narrow input-output sense than any of the standard circuits, but more efficient in the broader and more sensible sense of input compared with the effectiveness of the signal at the receiving station. It is far more efficient than an oscillator-amplifier in the narrow sense mentioned above.

Operators who are handicapped by an under-supply of patience with matters tedious will probably find it superior to the oscillator-amplifier arrangement.

It has as yet shown no particular advantages over other circuits at 14,000 kc. and higher frequencies; therefore, no constants are given for such frequencies.

If it is well adjusted, you will occasionally get crystal reports.

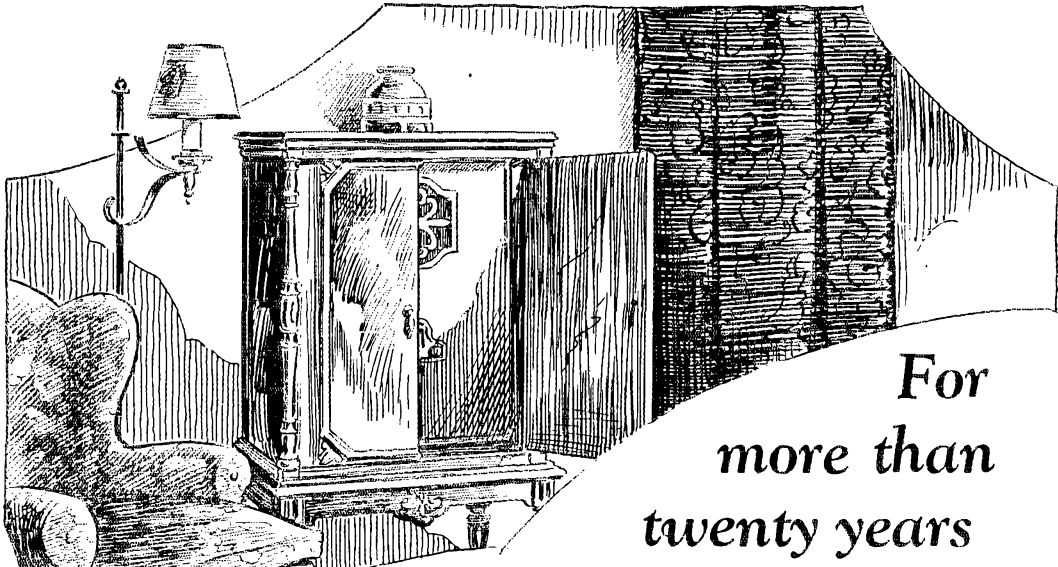

For  
more than  
twenty years

# —Faradon

Today, as two decades ago, experts consider Faradon Capacitors essential to reliable radio transmission and reception.

Then in the "wireless sets" and now in the most luxurious consoles, Faradon Capacitors are accepted as the standard of electrostatic condenser dependability.

We are always ready to assist in the solution of your capacitor problems.

WIRELESS SPECIALTY APPARATUS COMPANY  
Jamaica Plain, Boston, Mass., U. S. A.  
Established 1907

# Faradon

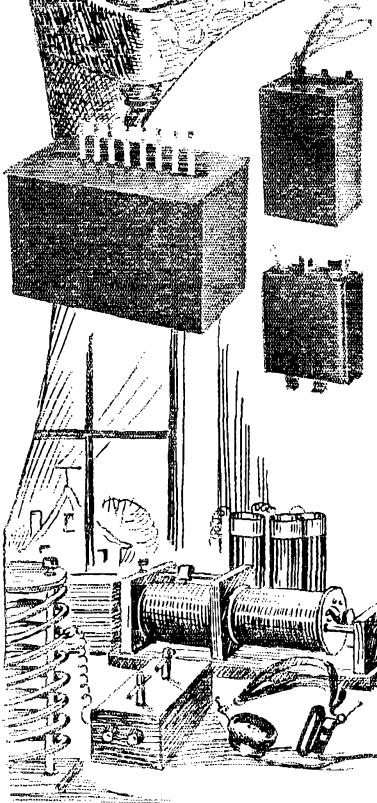

*Electrostatic Condensers for All Purposes*

# Potter Condensers

Quality  
Long Life  
Uniformity  
Economy



## Potter Interference Eliminator

Do not allow your radio broadcast programs to be spoiled by interference from oil burners, ice machine motors, violet rays, vacuum cleaners, fans, etc.

The remedy, connect a Potter Interference Eliminator to the line circuit at the point where the interfering device is connected, and enjoy good reception from your radio set.

Code 104-04 Interference Eliminator .....\$3.00



## The Potter Co.

North Chicago, Illinois

A National Organization at Your Service

## The Truth About Line Voltage Surges

It is of great importance that this menace to your receiver be eliminated. Whether the set is of the A.C. type or D.C. operated with power units, a Centralab Radio Control Box is an absolute necessity.

Radio Sets are designed to operate at approximately 100 volts A.C. Power stations fluctuate in their output so that the voltage delivered from the light socket often is as high as 125 or more.

This increases the output of the power supply in the set in proportion, causing a raise in the voltages supplied to the tubes in the set, which is injurious and results in a very distorted and "hard" tone of reproduction.

The prevention lies simply in the attachment of a Centralab Radio Control Box, which maintains an even, correct voltage on the receiver regardless of the line voltage. No complicated connections required. Plug the set in the Control Box and the Control Box in the wall. Your set and tubes are then permanently protected against injury from line voltage surges.

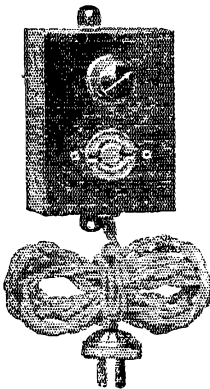

List Price \$3.00

# Centralab

CENTRAL RADIO LABORATORIES  
15 Keefe Avenue Milwaukee, Wis.

## The Total-Loss Receiver

(Continued from Page 30)

r.f. set should be taken with a grain of salt, for the bugs never were all taken out of my r.f. set. Probably never got all the coils and their respective ticklers or antenna coils just right. With some combinations it performed wonderfully. With it foA3V and I carried on successfully day after day (our mornings, the "long way around") for a whole month last spring after A3V's signals had become unreadable with my little TG&P receiver using two W.E. "N" tubes, than which I had never been able to find anything as good down to the time when the r.f. job came out. But on the lower part of the 7,000-ke. band it was

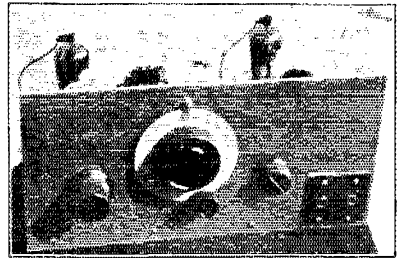

"—THIS FINE PIECE OF APPARATUS"

noisy and uncertain; my own fault, no doubt. On the other hand this "1929" receiver performs equally well over the whole range and as well as the r.f. set in A3V's neighborhood, 8,220 kc. And the "1929" has the further advantage that no amount of fooling with the feedback can move a station more than the thickness of a blonde hair.

Tks, gentlemen of the QST staff, for giving us this fine piece of apparatus.

## Strays

The new government list of "Amateur Radio Stations of the United States," listing 16,928 stations up to June 30th, is now ready for distribution. Although some 30-odd pages bigger than any previous edition, the price remains the same, 25c, for which amount it may be received from the Superintendent of Documents, Government Printing Office, Washington (stamps not accepted).

This book is accurate and well-printed; it is cheap; it deserves our support. It costs the Department of Commerce several thousand dollars out of their printing appropriation to make it available to us at two bits a throw. It is this book concerning which we recently warned the gang that more patronage was necessary if it is not to be discontinued. The supply is adequate, the value large. Get your copy from Washington—it belongs in every shack.

# Synchronous Motors for Television

In addition to building reliable and satisfactory motor generators, "Esco" has had many years of experience in building *electric motors* for a great variety of applications.

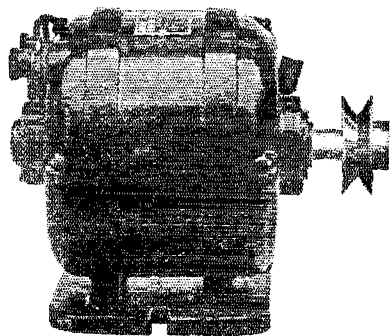

*Synchronous motors*, small, compact, reliable self starting are now offered for **Television** equipment. They require no direct current for excitation, are quiet running and fully guaranteed.

Other types of motors suitable for Television may also be supplied.

Write us about your requirements.

## ELECTRIC SPECIALTY CO.

25 South St.

Trade "ESCO" Mark

Stamford, Conn

### A REALLY FINE PRODUCT AT A POPULAR PRICE

New  
Advanced  
Design

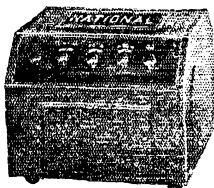

Price  
\$26.50  
(less tube)  
Send for  
Bulletin  
132-Q

## NATIONAL VELVET-B

NATIONAL CO. INC., MALDEN, MASS

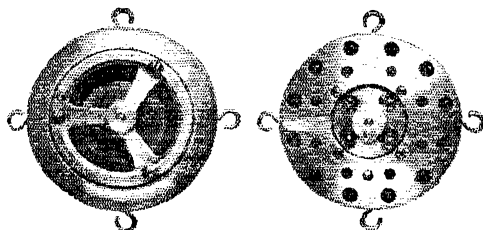

We invite inquiries from manufacturers, jobbers, dealers, etc., on our IMPROVED 2 button stretched diaphragm microphone. At \$67.50 we truly believe this to be the finest value in high-grade microphones for Broadcast, Public Address, Phonograph Recording, and other exacting uses.

Send us your microphone repairs. First quality work at low charges.  
E. F. JOHNSON COMPANY, Waseca, Minn.

Eighth Edition Just Off the Press

## Robison's Manual of Radio Telegraphy and Telephony

Completely Revised in June, 1928, and Up-to-Date.

Of the 6th edition of this book reviewed by QST it was said this is perhaps

"The Best Radio Book That Ever Came to This Desk"

The standard Navy book on radio originally prepared in 1907 by Lieutenant (later Admiral and C-in-C of U. S. Fleet) S. S. Robison. The present edition revised by Captain S. C. Hooper, U. S. Navy, now Director of Naval Communications.

780 pp. Price \$4.00 postpaid. 6th edition sold for \$8.00; 7th edition sold for \$5.50

Address: Secretary-Treasurer, U.S. Naval Institute, Annapolis, Md., U.S.A.

German Report

By F. Reiffen, Sec'y D. A. S. D.

Thirty meters has not been so good. Twenty comes through somewhat better, but fades worse. On 20 meters we hear mostly the U. S. W's, together with some SU, SB and SC. About the only stations heard on 30 are SB, OA and OZ.

Many contacts with OZ stations have been made on 31 meters, the best time being from 0600 to 1900GMT. 4YO has worked thirty OZ's with 70 watts input. 4CB rebuilt his antenna and with 35 watts input worked oz2AJ. 4KU with 45 watts worked oz2BP. The forty-meter band seems to be overloaded and distance work is routed mostly to either 20 or 30 meters, especially since many phones are QRMing

Report From Great Britain

By the Radio Society of Great Britain

At last some real ten-meter DX has been done by British amateurs; this is not because they could not do it before, but because they have only just received licenses. The honor of first contact with the United States goes to G6LL, who worked W2JN at 1430 GMT on the 21st of October for an hour and three-quarters, sending single. Signals were R6 at each end, and the input at G6LL was but 50 watts in a crystal circuit. Well done, OM! Immediately following this, GW17C hooked W2JN with only ten watts input. At 1800 the same day G2OD worked W2JN and W2AYR, with about 100 watts. On the next day a new British ham, G2FN, known to many as Rodman of ai2KT, raised W2JN with only eight watts input and on the following Sunday worked W6UF, getting R4 on the same power. G to W6th on ten meters with eight watts!

G2OD and G5LL have worked across several times. G5YK has erected a vertical antenna for both ten and twenty meters, from which much is expected. G5ML is now transmitting at 1400 GMT Sundays on ten meters. On 20, using a vertical ten-meter Zepp, he has raised OA, OZ and W, with QSA reports from VE, and several FO stations, including ISR, A5L, A7L. FO's are best around 1800 GMT most evenings. G6QB has completed his 1929 transmitter and with ten watts has had 86 from saDQ4, b2IG, foA4O (R4) and some W9's. He hopes to be crystal controlled on 20 and 10 next month.

G6XP has crystal on 21.7 and with ten watts raised W 1, 2 and 8, VE2 and reports from AG and PE.

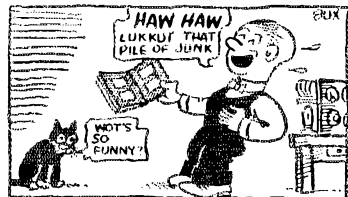

PROMINENT HAM WHO STARTED IN BACK IN HIS FINDS PHOTO OF HIS FIRST SET IN FAMILY ALBUM

CLAROSTAT  
BRACH  
Farrand  
SUNNILE  
ESCON  
BEDE  
YALE  
MULLER  
WINDAR  
Ad. Auriema, Inc.  
Manufacturers' Export Managers  
116 Broad Street, New York, N.Y.  
Scientifically equipped to economically export dependable receiving and transmitting radio apparatus

Build it  
Right

This New Catalog of

**YAXLEY**

parts and accessories will help you. Yaxley products are used in vital places in many of the most prominent and successful sets on the market today. Send for the new catalog.



YAXLEY MFG. CO.

Dept. S-9 So. Clinton St., Chicago, Ill.

**NEW RELAYS**

for amateurs and experimenters. We would be pleased to hear from you concerning your relay requirements.

If interested in television, write for our price list of television apparatus

Photo Electric Devices, Inc.  
594 Fifth Avenue Brooklyn, N. Y.



# A NEW RADIO RESISTOR CATALOG IS NOW READY

*write for your copy today*

We're beating the new Handbook out by an eyelash! Send for the newest revision of Circular 507, Vitrohm Resistors and Rheostats for Radio, and when you get your Handbook, you'll have two good books. Another important point—ours doesn't cost you a cent. Your call letters and address on a postcard gets it.

**WARD LEONARD ELECTRIC CO.**  
MOUNT VERNON, N. Y.

## JACOBS ANTENNA SPREADER



Made in both 5 in. and 7 in. diameter. Patented Sept. 8, 1928; Sept. 7, 1929. Effective Feb. 1st, 1928 price will be \$3.00 per dozen; \$4.50 for a half dozen.

Charles F. Jacobs (W 2EM)  
379 Park Place Brooklyn, N. Y.

## RADIO OPERATORS

Are You Handicapped by a Weak Arm or other weakness?

95 out of every 100 operators are handicapped by some weakness. Are you one of them? Would you place yourself in the hands of an expert who has developed many of the world's fastest and highest-paid operators, and follow his easy instructions if you thought his methods would help you to overcome your weakness? If you knew positively that his system would increase your sending and receiving speed 50 to 100% and make you a TOP-NOTCH operator? Don't delay. Write me in confidence. No obligation. Write NOW!

**WALTER H. CANDLER, Originator and Director**  
**THE CANDLER SYSTEM CO.**  
6343 S. Kedzie Avenue Chicago, Illinois

## EVERYTHING IN RADIO AT ATTRACTIVE PRICES. SETS or PARTS

Orders shipped exactly as ordered. Prompt Service. Write for Prices. Mail Order Only. We ship everything available in this city. Inquiries invited. Send Your Address

**ALL RADIO COMPANY**  
417 North Clark Street Chicago

## — LAST MINUTE SPECIALS —

E210 BRADLEYSTATS, list \$4.00, 6ne for A. C. Line Voltage Control .....	Our Price	\$1.60 ea.
Genuine Black Bakelite Panels 38" x 48", 3/16" thick. Reg. Price \$29. ....	"	8.75 "
U. S. ARMY Aeroplane Spark Transmitters, Gov. cost \$17 each .....	"	4.75 "
G. E. Kenotron Rectifying Tubes (Type T.B.1.) .....	"	1.25 "
Eby A.C. Adapter Harness with Volume Control. For 6 tube Sets, list \$10.00 ..	"	5.00 "
Gould Kathode Unipower, Automatic Radio "A" Power (6 volt), list \$39.50 ..	"	13.75 "
G.E. V.T.14—5 watt Transmitting Tubes. (A good power amplifying tube) ....	"	1.50 "

**AMERICAN SALES CO., 19-21 WARREN ST., NEW YORK CITY**

**1929?** Hull's Four Tube Ham Receiver Built of High Grade Parts, the Real Solution of Next Years Receiving Problem.

**ZURIAN RADIO SERVICE**

153 Dunning Street, Madison, Wis.

PZ of W9EK-XH

# ARCTURUS HAS IT!

## A 7-SECOND DETECTOR

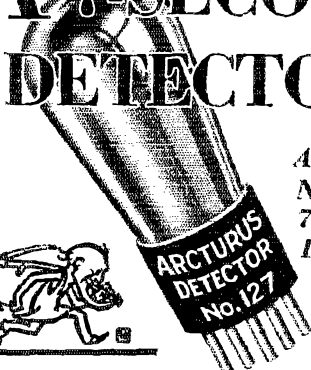

Arcturus  
No. 127  
7-Second  
Detector

## ARCTURUS A-C LONG LIFE TUBES

ARCTURUS RADIO COMPANY  
220 Elizabeth Ave., Newark, N. J.



## ALWAYS UP-TO-DATE

Issued quarterly, March, June,  
September and December.  
Single copies U.S. and Canada  
\$1.00 (Foreign \$1.10.) Yearly  
subscription \$3.25 (Foreign  
\$3.50.)

Amateur and Commercial Stations from 83  
different countries.

**Radio Amateur Call Book**  
508 So Dearborn St., Chicago, Ill., U.S.A.

## TRANSFORMERS

Guaranteed—Mounted—Complete

250 watt 550—700 each side .....	\$10.50
700 watt 1000—1500 each side .....	14.50
700 watt 2000—2500 each side .....	21.00

Chokes, Polyphase and 25-cycle Transformers  
Add \$2.00 for fil. winding

96ES F. GREBEN

1927 So. Peoria Street, Pilsen Sta., Chicago, Ill.

## More Profits To Set Builders

Elections, football game—big National event  
will boost radio business this year. Set build  
ers will reap a rich bon. Barawik service will  
make you money. Everything in A.C. sets short wave,  
television, auto supplies. World's latest radio  
stocks on hand. Orders shipped same day. Lowest  
rock bottom wholesale prices.

Write for Free Radio Catalog

**BARAWIK CO**

115 Canal St.,  
CHICAGO, U. S. A.



## Holland Section Notes

By W. Keeman, Traffic Manager, N. V. I. R.

The Holland amateur society, the N. V. I. R. is growing rapidly following a general meeting last spring at which a constitution was adopted, a new Board of Directors elected, etc. Several departments were established also, and new activity has begun to sparkle everywhere.

At last we received, together with the N.V.V.R., an invitation from the Postmaster General to formulate our wishes concerning amateur licenses and transmission restrictions. A special commission was created in order to study this subject, and a detailed report was sent to the Postal headquarters last summer. Afterwards, a combined meeting of the Boards of the N.V.V.R. and N.V.I.R. dealt with the same business, ending in almost complete agreement between the two Societies. We are quite sure now that in 1929 the world will be able to hear the first real licensed Dutch ham stations. (FB OMs!—Ed.)

In the meantime, the ordinary unlicensed work has been carried on as usual. Lots of phone stations are spoiling our good old 40 meter band, and now and then there comes out of one's headphones a mixture quite well illustrated by the cover of September QST. It is clear that this foolish noise will have to be transported elsewhere in 1929. For this reason it is a pity that the sort of people causing it can't be deported to 160 meters, this band being closed to us.

General reception conditions were good during the last part of 1928, apart from occasional QRN. This applies to 40 meters. On 20 only an occasional station was heard. Still, some hams have got splendid QSO's on twenty, although there is little reliability of contact here. It looks as though we would just have to dig out what we can from the 40-meter racket.

## Northern Ireland

By Frank R. Neill, Official Correspondent

The new conditions (i.e., wavebands) are now coming into use, and those who want them have generally been granted them as from October 15th. The new conditions seem to be quite liberal, and it does not seem that we will be badly hampered under the new licenses.

The intermediate for Northern Ireland is to be GI, that for Great Britain, as is already known, being G. Northern Ireland amateurs are subject to the same conditions as Great Britain, and licenses are issued by the General Post Office, London.

It is most pleasing to note the increase in the number of amateurs using crystal control on the new wavebands and it would seem that almost all stations in the British Isles will have a pure D.C. note from now on. It is to be hoped that the Continental fellows will follow suit.

# To Our Readers who are not A. R. R. L. members

Wouldn't you like to become a member of the American Radio Relay League? We need you in this big organization of radio amateurs, the only amateur association that does things. From your reading of *QST* you have gained a knowledge of the nature of the League and what it does, and you have read its purposes as set forth on page 6 of every issue. We should like to have you become a full-fledged member and add your strength to ours in the things we are undertaking for Amateur Radio. You will have the membership edition of *QST* delivered at your door each month. A convenient application form is printed below—clip it out and mail it today.

*A bona fide interest in radio is the only essential qualification for membership.*

American Radio Relay League,  
Hartford, Conn., U. S. A.

I hereby apply for membership in the American Radio Relay League, and enclose \$2.50 (\$3 in foreign countries) in payment of one year's dues. This entitles me to receive *QST* for the same period. Please begin my subscription with the .....issue. Mail my Certificate of Membership and send *QST* to the following name and address.

.....

.....

Do you know a friend who is also interested in Amateur Radio whose name you might give us so we may send him a sample copy of *QST*?

.....

Thanks

## QST OSCILLATING CRYSTALS

Amateur Band. (Attention 80 Meter band operators)

We have a limited quantity of crystals in the 3680 to 4000 band which we will dispose of at a special grinding charge of \$20.00 each. This special price to prevail during **JANUARY 1929 ONLY**. These crystals are our usual POWER crystals, absolutely guaranteed, and their frequency will be stated accurate to better than a tenth of 1%. Orders will be filled until stock is depleted at this price. Order yours now and save \$7.50. Prices for crystals in other Amateur bands unchanged. See December *QST* for prices.

Attention Owners of High Frequency Stations.

We are at your service to grind for you, power crystals for use with either UX210 or 50 Watt tube (the latter at reduced normal plate voltage) to within **FIVE HUNDREDTHS OF 1% (.05%)** of your assigned frequency in the 4000 to 6000 Band. Prices for grinding crystals to above specifications \$75.00 unmounted or \$85.00 mounted in power type of holder. These crystals absolutely guaranteed regards to frequency and output, and deliveries can be made within 5 days after receipt of order.

### SCIENTIFIC RADIO SERVICE

"The Crystal Specialists"

P. O. Box No. 86

Dept. A

Mount Rainier, Maryland

**LEARN**  
**Electricity**  
In 12 weeks by actual work, not correspondence —not books. Earn while you learn. Radio and Auto Courses included. You don't need advanced education or experience. *Send AT ONCE for 80p. New, FREE BOOK!*  
**COVNE ELECTRICAL SCHOOL, Dept. 19-38**  
500 South Paulina Street Chicago, Illinois

**AEROVOX** Makers of high quality resistors and condensers that are Built Better — to endure.  
**Write for The Research Worker.**  
A free monthly publication.  
**AEROVOX WIRELESS CORPORATION**  
68 Washington Street Brooklyn, N. Y.

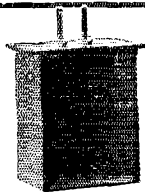

Designed to carry 250 mlls.

### 2 HENRY FILTER REACTORS

D. C. Resistance 20 ohms

Fine for use as Generator Filter, also as plate or Grid Reactor .....

**Special \$4.75 ea.**

*Manufactured by the world's largest electrical concern whose name we cannot mention*

at Price \$25.00 ea.

**AMERICAN SALES CO., 19-21 Warren St., N. Y. CITY**

# Send For WESTERN RADIO *New* 1929 Catalog

Dealers and Set Builders

THE NEW 1929 Catalog is crammed full of the FINEST, NEWEST, Nationally known A.C. sets, consoles, cabinets, dynamic speakers, kits, PARTS, eliminators and accessories at LOWEST PRICES. Largest stock of radio parts. Prompt delivery.

Write for our FREE catalog  
WESTERN RADIO MFG. CO.,  
128 W. Lake St., Dept. 01, Chicago

**"The Big  
Friendly  
Radio House"**

+++  
**FREE**  
+++



We here in "GI" have probably not had so much "cleaning up" to do as you fellows in the U.S. This is due, of course, to the fact that we were more restricted than you under the old conditions. Everyone by now is probably familiar with the news that every G and GI amateur in 1929 must possess a really accurate wavemeter. This should make for all-around improvement.

Any U.S. stations looking for GI hams will now find us on 42 and 21 meters.

## Spanish Section Notes

By Sr. Miguel Moya, President, EAR.

The second transmission contest organized by the Association EAR to develop communication with amateurs of Latin America has been concluded. The first prize, a gold medal, was awarded to EAR28, and two second prizes, silver medals, to EAR65 and EAR73. In recognition of the aid rendered by the amateurs of South America, the Association has elected the following as honorary members: saDE3 and DE8; sb2AH; su3AH and sc3AC.

There has been a great increase in receiving stations registering in the Spanish Section, and the number of legal transmitting stations authorized has now reached to EAR114. There are, besides, competent stations with provisional calls, amongst which EAR-B who established the first QSO between Nicaragua and the Canary Islands. A great many EAR stations are working the W's on QRP, and communication is especially easy on the 20-meter wave.

The Spanish Ambassador to Argentina made use of amateur radio in sending, via saDE3 a congratulatory message to EAR1.

As the letters assigned to Spain by the Washington conference consist of EAR, we are practically sure that this group will continue to be used by the amateurs as a part of their calls.

## Strays

A list of stations of the world on frequencies above 1500 kc. occupies about 30 pages of the Proceedings of the Institute of Radio Engineers for November 1928. The list should be of considerable value to the amateur. Individual copies of "The Proceedings" can be obtained at a cost of \$1.00 from the the Institute offices at 33 West 39th Street, New York, N. Y.

All League members should have received a copy of Vol. XII (1928 series) QST index with their December issue. If not received, kindly advise and we will promptly duplicate. Newsstand readers desiring a copy of this index may obtain same by sending us 4c in stamps.

**POLK  
BINDING  
POST**  
SENSATION OF THE NATION  
INSULATED

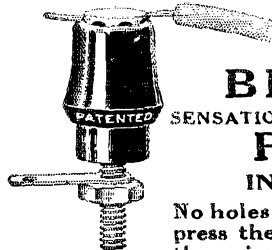

15 cts. Each

No holes to fish for—just press the sleeve and insert the wire in any position—quick action and holds tight—standard markings.

J. L. POLK, 41 Belle Ave., Troy, N. Y.

## 1929 RADIO BOOK

New Hook-ups. This book shows how to make Short Wave Receivers and Short Wave Adapters. How to use the new screen grid tube in D, C, and A. C. Circuits. How to build Power Amplifiers, and ABC Eliminators. Up to the minute information on all new radio developments. Set Builders, Fans, Dealers, send for it today.

KARAS ELECTRIC COMPANY  
4030A-N. Rockwell St., Chicago, Ill.  
Please send me your free book

Name.....  
Address.....  
City..... State.....

4030-A

**FREE  
to  
You**

Write  
for it!



# The A.R.R.L. Diamond Is the Emblem of a Real Amateur!



The League Emblem comes in four different forms. Its use by Members is endorsed and encouraged by the League. Every Member should be proud to display the insignia of his organization in every possible way.

**THE PERSONAL EMBLEM.** A handsome creation in extra-heavy rolled gold and black enamel, 1/2" high, supplied in lapel button or pin-back style. There are still a few fellows who are hiding their light under a bushel. Wear your emblem, OM, and take your proper place in the radio fraternity. Either style emblem, \$1.00, postpaid.

**THE AUTOMOBILE EMBLEM.** Introduced only this spring, already more than 800 cars are proudly displaying the mark of the "Radio Rolls-Royce." 5 x 2 1/2", heavily enameled in gold and black on sheet metal, holes top and bottom, 50c each, postpaid.

**THE EMBLEM CUT.** A mounted printing electrotype, the same size as the lapel button, for use by Members in any type of printed matter, letterheads, cards, etc. \$1.00 each, postpaid.

**THE "JUMBO" EMBLEM.** You've taken care of yourself, your car and your printing. How about the shack wall or that 100-footer? Think of the attention this big gold-and-black enamel metal emblem will get! 19 x 8 1/4", same style as Automobile Emblem. \$1.25 each, postpaid.

Mail your order and remittance NOW to

**The American Radio Relay League : : Hartford, Conn.**

## QUARTZ OSCILLATING CRYSTALS

Scientifically Prepared for Maximum Power and Unconditionally Guaranteed 1 in. sections, within 1% of your specified frequency, supplied at the following prices:

75-100 meters .....	\$15.00
100-200 meters .....	10.00
200-600 meters .....	15.00

1 in. tested blanks, 2 to 4 mm thick..... 5.00  
Sections of any practicable dimensions made to order  
Prompt Delivery

J. T. Rooney, B. Sc., 4 Calumet Bldg., Buffalo, New York  
"Ten years' crystallographic experience"

## BUGS

New, high-class instruments. Priced \$11 to \$17.  
Money back guarantee.

## D C RELAYS

Break-in and Single contact styles. High and Low voltages \$20.

**ELECTRO MANUFACTURING CO.**

443 Stevenson St., San Francisco, Cal.

## BECOME A RADIO OPERATOR

See the World. Earn a Good Income.  
Duties Light and Fascinating.

### LEARN IN THE SECOND PORT U.S.A.

Radio Inspector located here. New Orleans supplies operators for the various Gulf ports. Most logical location in the U.S.A. to come to for training.

Nearly 100% of radio operators graduating on the Gulf during the past six years trained by Mr. Clemmons, Supervisor of Instruction.

Member of the A.R.R.L.—Call "5 G R"

Day and Night Classes—Enroll anytime—Write for circular.

## GULF RADIO SCHOOL

844 Howard Ave. New Orleans, La.

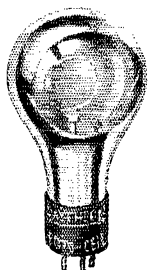

# Raytheon

This name represents leadership in tubes for television broadcasting and reception.

## Foto-Cell

A Television sending tube in hard vacuum or gas-filled types.

Correspondence is invited from amateurs in regard to Raytheon Television Products.

**RAYTHEON MFG. CO.**  
Kendall Square Building  
Cambridge, Mass.

## Kino-Lamp

The Television receiving tube adapted to all systems. Price \$7.50.



## DON'T GUESS!

Radio success or failure is largely a matter of knowing or guessing. And where all factors—voltage, tubes, circuits, etc.—are not precisely measured, you are *guessing* unless you supply hand-fitted resistance.



**CLAROSTATS** take the guess out of radio. The Grid Leak Clarostat is typical. It provides the precise grid leak value for best results, particularly in short-wave reception.

And in obtaining correct resistance values for grid-biasing and plate voltages, the Duplex Clarostat is a great favorite. It has two resistances, with center tap, each adjustable by means of ordinary screwdriver blade.

There are many other types of Clarostats for every conceivable radio purpose, in many designs, mountings and resistance ranges.

**WRITE** for literature describing the complete Clarostat line and how to better your radio set. Batter still, send 25c in stamps or coin for "The Gateway to Better Radio."

CLAROSTAT MFG. CO. INC.  
N. 6th St. Brooklyn, N. Y.

**CLAROSTAT**  
REG. U.S. PAT. OFF.

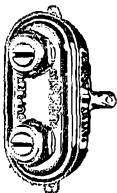

## PACENT DUO-LATERAL COILS

FOR laboratories, experimenters, engineers and for special circuits, Pacent Duo-Lateral Coils are the accepted standard.

A complete line of all standard turn ratios are always in stock.

Write for information and prices

Pacent Electric Co., Inc.  
91 Seventh Avenue, New York

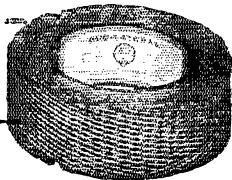

## Oscillating Crystals

Prices for grinding crystals to your approximate desired frequency in the various amateur bands are as follows:

160 METER BAND .....	\$13.00
80 METER BAND .....	\$12.00
42 METER BAND .....	\$4.00

We will state the frequency of each crystal to within a tenth of one per cent.

Crystals ground to your specified frequency between forty and six hundred meters, forty-five dollars.

Precision dust proof crystal mounting, five dollars.

Immediate Delivery.

All Work Guaranteed.

**PRECISION CRYSTAL SERVICE**  
P. O. BOX 1064 DETROIT, MICH

## Calls Heard

(Continued from Page 47)

T. H. Streeter, Jun., School House, Alford, N., Billingshurst, Sussex, England

20 meters

wlaze wlcje wicmf wlz w2ae w2ag w2bjv w2lwx w2rs w3iw w8ds fo-a3a ve2be fm-8rit em-smux ed-7ag et-1cf.

40 meters

wlbbm wlkw w2bhd w4ob w4rn w8edb w8cyp oa-2hc oa-3kr oa-3ks oa-3ls oa-3vp oa-5by oa-5hg oa-7cw z12ae es-2nag es-2nm fm-8jo ct-1bv em-smua el-1aiq as-lad ee-ear94.

## HAM-ADS

Effective with the October, 1928, issue of *QST* the following changes were made in the rules of this department. The Ham-Ad rate is now 15c per word. The restriction which has limited use of this column to members of the American Radio Relay League is removed and advertising may be signed either by company name or by an individual. A special rate of 7c per word applies to advertising which is obviously non-commercial in nature and which is placed and signed by an individual member of the American Radio League. Please read carefully the following conditions under which advertising in these columns will be accepted.

(1) Advertising shall pertain to radio and shall be of nature of interest to radio amateurs or experimenters in their pursuit of the art.

(2) No display of any character will be accepted, nor can any special typographical arrangement, such as all or part capital letters, be used which would tend to make one advertisement stand out from the others.

(3) The Ham-Ad rate is 15c per word, except as noted in paragraph (6) below.

(4) Remittance in full must accompany copy. No cash or contract discount or agency commission will be allowed.

(5) Closing date for Ham-Ads is the 25th of the second month preceding publication date.

(6) A special rate of 7c per word will apply to advertising which, in our judgment, is obviously non-commercial in nature and is placed and signed by a member of the American Radio Relay League. Thus, advertising of bona fide surplus equipment owned, used and for sale by an individual or apparatus offered for exchange or advertising inquiring for special equipment, if by a member of the American Radio Relay League, takes the 7c rate. An attempt to deal in apparatus in quantity for profit, even if by an individual, is commercial and takes the 15c rate. Provisions of paragraphs (1), (2), (4) and (5) apply to all advertising in this column regardless of which rate may apply.

IMAGINE an organization with over 4,000 clients scattered throughout the world, all radiowise dealers, builders, experimenters, hams. Over \$50,000.00 stock of highgrade receiving and transmitting parts only no sets. Spend \$5,000.00 yearly on our own experimenting. Carry nothing until it passes our tests. 50c brings prepaid over four pounds catalog, circuits, data, etc. Weekly data (more than all radio magazines together)—20 weeks—\$1.00, 52 weeks—\$2.50. Sample "Over The Soldering Iron," 32 page experimenter's magazine—25c. Full trade discounts to licensed hams and radiowise builders. We carry approved items advertised in radio. Kladag Radio Laboratories, Established 1920, Kent, Ohio. QUARTZ crystals, guaranteed oscillators 1928 frequencies, including foolproof holder, mountable brass discs with surfaces lapped true. 80 Meter band \$20.00 160. \$15.00 prepaid, cash with order. W2BDC, D.C. Akers, 181 Greenwood Ave., East Orange, N.J.

TRANSFORMERS 250 watt 2000V unmounted \$8.00. 650V 74-74 \$6.50. 550V-5 \$4.00. Chokes 250 M.A. 30H \$7.50. 160 M.A. 30H \$5.00. 100 M.A. 80H \$2.00. Write for specifications and material lists. Radio Parts Sales Co., Orange, N. J.

W&J selling out. Low and high power transmitters. Parts, meters, etc. 722 Burnside, Los Angeles, Calif.

(Continued on Page 52)



# UNI-RECTRON POWER AMPLIFIER



(IDEAL FOR USE WITH DYNAMIC SPEAKERS)

As the Uni-Rectron stands it is a super power amplifier, which can be used in connection with any radio set and loud speaker. Binding posts are provided for input to the Uni-Rectron and output to the speaker. Requires no batteries for its operation. It obtains its power from the 110 Volt, 60 Cycle alternating current lighting circuit of your house.

## MODEL AP-935

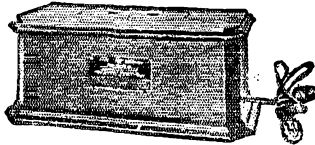

whisper to the loudest crash of sound—R.C.A. Uni-Rectron amplifies each note at its true value. High and low notes are all treated alike.

The volume and quality delivered will be a revelation.

Also by removing the input and output transformers it can be used as a source of power for an oscillating or transmitting tube, furnishing power for all circuits, grid, plate and filament and is the cheapest form of Power Supply for Amateur Transmitting purposes ever offered. New.

The UX-210 super power amplifying tube and the UX-216B or 231 rectifying tube are used with this amplifier, which cannot overload. From the faintest

LIST PRICE \$88.50  
(without tubes)

Special \$19.<sup>75</sup> EA.

## AMERICAN SALES CO.

19-21 Warren St.,

New York City

## CODE LESSONS FREE

With the **TELEPLEX** CODE INSTRUCTOR

Used  
By  
U. S.  
Navy



With each Teleplex Code Instructor we furnish without cost complete code instructions for beginners or advanced students. There's

to equal Teleplex for code practice. Sends you messages, radiograms, etc. — regular code traffic same as an operator would. No knowledge of code required. Code lessons recorded on strong, waxed-tape records make every thing simple and clear. Endorsed by U. S. Navy and leading schools.

Thoroughly tested and guaranteed to reproduce actual sending of expert operators. Write for descriptive literature, prices, etc.

Phonograph  
Motor

TELEPLEX CO., Dept. RL, 76 Cortlandt St., New York, N. Y.

## TRANSFORMERS, CHOKES COILS . . . . .

of all descriptions made  
to your specifications.

The crying need of the radio constructor and amateur for efficient coils, chokes, and transformers for either transmitter or receiver construction, is filled by the "Most Efficient" Power equipment manufactured by I. R. NELSON CO.

The new and radical core design developed by this company gives the small power transformers and coils all the efficiency inherent in large electrical construction work. Write in your wants. We will be glad to quote you. You will be surprised at the quality received for your investment. Prompt delivery on all orders.

I. R. NELSON COMPANY  
Bond Street Newark, N. J.

## SET Builders FREE

Barawik, the first and oldest radio specialty house, offers you unusual service this year. Bigger stocks, quicker shipments, lower prices. Deal with an old established, reliable house. Get honest goods honest service, honest prices. Barawik service makes you more money. Send now for big new catalog—showing lowest wholesale prices on sets, parts, short wave, etc.

**BARAWIK CO.** 111A CANAL STA., CHICAGO, U. S. A.



## NO TIME NOW

To try and keep in the swim with a 1923 model rectifier. Competition's too keen. Don't skimp. Back your transmitter with a power plant of unlimited capacity, almost perfect regulation—the mercury arc. Hear it respond with the clean, cutting, distinctive note that marks the accomplished operator. Be proud of your station. Performance unapproached by any other rectifier. Just read what the gang says, follow 'em,—and your rectifier problems are solved.

**RECTIFIER ENGINEERING SERVICE, CLEVELAND, OHIO**  
Radio W8ML 4837 Rockwood Road

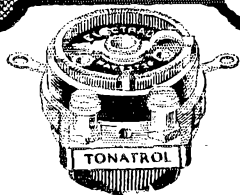

Exclusively Licensed by  
Technidyne Corporation  
under U.S. Patent Nos.  
1593638, 1034103, 1034104

## Designed for Every Circuit

A Complete  
Line of Volume  
Controls

# TONATROL

By incorporating Tonatrol in the receiver you build, you can control the volume from your loud speaker smoothly, from the faintest whisper to the resounding intensity of a brass band.

Tonatrol Volume Controls are designed in types to meet the specific requirements of all types of circuits. There are specialized volume controls for A.C. circuits as well as for the conventional battery type receivers. Can be had with filament switch, or power switch attached.

Electrad specializes in a full line of Controls for all Radio Purposes including Television.

Write for Free Circulars and Full Information

Dept. T-1 175 Varick St., New York

# ELECTRAD

## DODGE RADIO SHORTKUT

With Appendix and Hints for Better Key Work. Fixes Signals in Mind to Stay Put—Never forgotten. KILLS HESITATION and PRODUCES RESULTS—Ability to read and transmit legible Code—By attention few Short Days instead of Long Months.

### DODGE HIGH SPEED METHOD

(Intensive Speed Practice)

Most Efficient Speed Booster Known. Few hours attention raised reading speed from 25 to 40; increased confidence and accuracy.

### DODGE MORSE SHORTKUT

Master both codes our way and use either without tendency to mixup or confusion.

### REPORTS FROM 500 USERS

Tell the story—written on request. Radio Shortkut \$3.50 High Speed \$2.50 Morse \$2.50. MONEY ORDER. None C.O.D. Foreign, add Fifty Cents.

C. K. DODGE, BOX 100, MAMARONECK, NEW YORK

## RADIO IN BRASIL

When in Brasil, apply to M. BARROS & CIA for anything you need in connection with radio.

## M. BARROS & CIA

70 sob. Rua S. José 70 sob.  
Postal Box 39

### Rio de Janeiro

Telegraph address, Radioparte, Rio de Janeiro  
Branch: Avenida S. João 4, S. Paulo, Brasil

## The Heterodyne Low Freq. Generator

(Continued from Page 23)

As a design example, suppose we want to cover a beat frequency range of 20 kc. and that we have decided that the effects of beats between harmonics higher than the fifth will not be damaging. From the table we find that a suitable fixed frequency will be 120 kc. We must first find what the ratio of  $C_2/C_1$  will be (this is  $r$ ) and by rearranging equation (5) we get

$$r = \left( 1 + \frac{f_b}{f_1} \right)^2 \quad (8)$$

Solving for this we find that our value of  $r$  will be 1.44. Assuming we intend to use a 500  $\mu$ fd. variable condenser, it will be necessary to shunt it with a fixed capacity of 1,134  $\mu$ fd. This will result in a capacity range of from 1,134  $\mu$ fd. to 1,634  $\mu$ fd. which complies with our ratio of 1 to 1.44.

The inductance required can be determined either by the usual formula for resonance, knowing the capacity and frequency, or by means of equation (4). On substituting in equation (4), the values  $k = 159.2$ ,  $f_b = 20$ ,  $C_2 = .001634$ ,  $r = 1.44$ , we obtain for our value of  $L$ , 1,560  $\mu$ h.

We have, therefore, completely designed the oscillating receiver. On turning the variable condenser dial, the frequency will change from 100 to 120 kcs, or will vary 20 kc. which is the audible range. In order to obtain zero beat frequency at the highest frequency of the oscillating receiver, which will allow operation along the flattest portion of the curve, it will be necessary to make the fixed frequency,  $F$ , equal to 120 kc. Then, when the variable condenser in the receiver is at its minimum capacity, the beat frequency will be zero; when it is set at its maximum capacity, the beat frequency will be 20 kilocycles per second, and for various intermediate settings, various intermediate beat frequencies will result. A continuous variation in frequency from zero to 20,000 cycles will be obtained, spread out over a rotation of 180 degrees.

Various combinations of capacitance, inductance and capacitance ratio may be used. As the fixed frequency is made higher, the capacitance ratio,  $r$ , will be made lower and either the inductance, capacitance or both will be reduced in size. In all cases, however, in order to obtain zero beat at the highest frequency of the receiver, we must have the fixed frequency of the other oscillator equal to this. It is sometimes necessary to shunt a small micro-condenser across the fixed condenser in the fixed frequency oscillator circuit,  $F$ , in order to allow this oscillator to be adjusted to zero beat when the variable frequency circuit is set at zero. This is necessary because small variations in the voltages impressed upon the filament and plate circuits will cause slight changes in the frequencies at which these circuits are oscillating. It will also allow the effect of changing tubes to be compensated for and not require a major operation as might be necessary if such means were not provided.



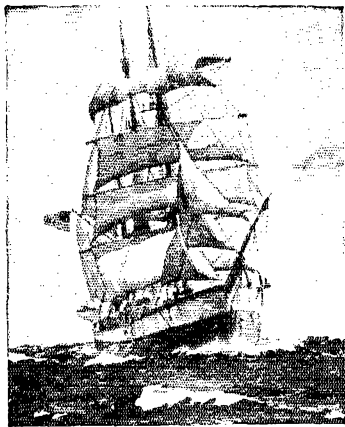

Wide World Photo of the "City of New York,"  
from a painting by Chas. Rosner, N. Y.

"We are Depending  
on your product,"

*writes the Radio Engineer of the*

**Byrd**

*Antarctic Expedition*

ON the Antarctic Expedition led by Commander Byrd,—as on his Arctic Expedition and Trans-Atlantic Flight—\*PYREX Insulators will again be depended on for unfailing radio insulation.

These seasoned explorers dare not entrust the success of their expedition—and possibly their lives—to any equipment which had not proven its complete ability to withstand the extreme conditions to be met. Their complete confidence in them is ringingly expressed by M. P. Hanson, Byrd's Radio Engineer.

"We have every confidence," writes Engineer Hanson, "that your products will render good service under the extreme conditions to be met, as they have done in the past."

PYREX Insulators are not affected by acid fumes, smoke or salt fogs. Their exceptionally low coefficient of expansion makes them indifferent to sudden temperature changes. Their dielectric strength is from 15 to 35% greater than porcelain. Their power loss is lower than any substance except pure fused quartz.

For complete technical information and catalogs on either PYREX Power Line or PYREX Radio Insulators write

**CORNING GLASS WORKS**

Dept. 0-4, Industrial and Laboratory Division  
New York Office: 501 Fifth Avenue



\*Trade-mark, Reg. U. S. Pat. Off.

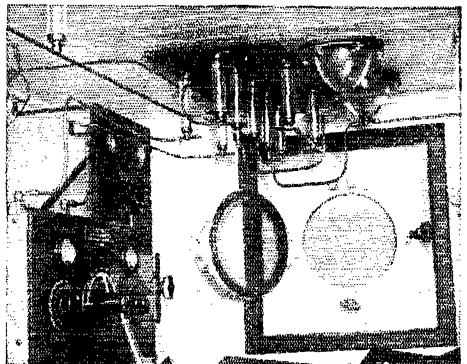

*PYREX Entering bowl and Stand-off Insulators on the ceiling of the radio room of the "City of New York." High power short wave transmitter shown on the left*

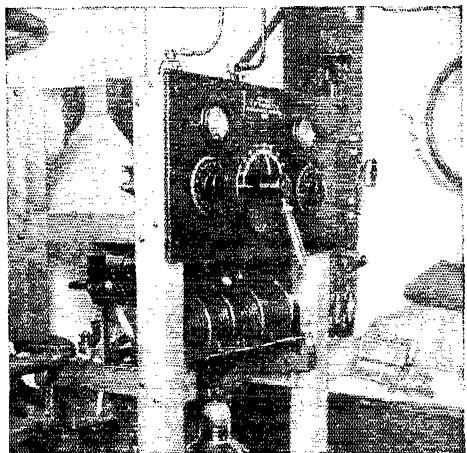

*Lower Section of high power short wave transmitter equipped with PYREX small Lead-in Insulators*

Say You Saw It in QST—It Identifies You and Helps QST

(Continued from Page 33)

MOTOR generator bargains. 750 Volt, 200 Watt, two commutator new General Electric motor generators direct connected to 110 Volt, 60 Cycle, 3500 R.P.M. single phase A.C. motors each \$45.00. 350 Volt, 150 Watt new General Electric motor generators direct connected to 110 Volt, 60 Cycle, 3500 R.P.M. single phase A.C. motors, with field resistance, each \$27.50. New  $\frac{1}{4}$  Hp. General Electric and Westinghouse 110 Volt, 1750 R.P.M., A.C. motors \$37.75 each. New television variable speed motors for 110 Volt Alternating Current \$7.00 each. A limited number of each of the above items. Also many others to 3000 volts all sizes. Write us your needs. Electrical Surplus Company, 1911 Chicago Ave., Chicago, Ill.

WANTED—60 watt transmitter parts, also storage "B" batteries. W2GL.

SPEAKERS, Rewound, Magnetized, Guaranteed, Fast Service, \$1.50 to \$2.50. Clark Brothers Radio Co., Albia, Iowa.

B ELIMINATORS, Repaired, New Condensers, Transformers, Chokes, Etc., Fast Service, \$2.00 to \$4.00. Clark Brothers Radio Co., Albia, Iowa.

TUBES receiving and transmitting. Write for list. Special X250, \$7.50 each, X210, \$5.00 each, X216B, \$2.00 each. REL type L inductance \$4.10 each. S. W. coils, set of four \$3.50. Write me your needs on power transformers. Mac, Seaford, N. Y.

2000 Volt 1000 Watt 1-phase drive motor generator \$225.00. 1500 Volt, 500 Watt 8-phase drive \$125.00. 1000 Volt, 200 Watt Esco 1-phase drive \$75.00. 1000 Volt 300 Watt, 1-phase drive \$75.00. 750 Volt, 300 Watt \$65.00. 200 Watt \$45.00. 350 Volt, 50 watt motor generators \$22.50. 400 Volt 100 Watt generators \$8.50. Couplings \$1.75.  $\frac{1}{4}$  Hp. 3450 speed motors \$3.50; 1750 speed \$7.50. Large stock of filament and plate supply generators. Queen City Electric Co., 1734 Grand Avenue, Chicago Illinois.

3000 Volt 4000 Watt double commutator motor generator. Generator direct connected to 110-220 Volt, 60 cycle, 1-phase motor. Fields separately excited by another motor generator 1-phase drive. Complete ready for installation, \$550.00. James Smat, 1734 Grand Avenue, Chicago, Illinois.

QSL cards, up to date. Samples free. The Mountain View Press, Mt. Montgomery, Nevada.

QSL cards. Cartoons. See ours before buying. H. M. Selden, Cranesville, Pa.

NUMBER two fifteen dial Omnigraph, brand new. First money order \$27.50 takes it. Grant H. Woldum, Decorah, Ia.

GENERATORS, used 200 watt 500 cycle, \$10.  $\frac{1}{2}$  kilowatt, \$15. Motor-generators 120 volt d.c. drive, \$45. D.c. dynamotors 6 to 400 volt 200 watt, \$15. 30 to 300, \$8. 120 to 12, 83 amps., \$45. 600 volt generators, 18, 275 volt, \$8. R. Wood, 46-29 102nd St., Corona, N. Y.

SURPLUS Apparatus, Victoreen 5 transformers, oscillator, antenna coil, cost \$44.00, sell for \$20.00. Madison Moore One Spot Super with Antenna Coil, 6 coils, cost \$63.00, sell for \$15.00. Two General Radio 285 Audio Transformers for \$6.00. 3 General Radio .0005 mfd condensers \$1.00 each. UP 1653 RCA 160 Mil Choke \$5.00. UP1368 RCA 325 Transformer \$15.00. All in good shape. Postpaid. Robert Daugherty, Box 367, Hamilton, Ohio.

MILLIAMMETERS, flush panel mounting, hand calibrated and accurate. Your choice 0-100, 0-300, or 0-400, \$1.25 Postpaid. Twenty-four hour service. New Price List mailed on request. G. F. Hall, 535 West Hortler St., Philadelphia, Pa.

QSLs 100 two color \$1.00. Government \$1.90. Radiograms, stationery. Samples. 9CKA Corwith, Iowa.

TRANSFORMERS—100 Watt, 60 Cycle, 750 Volts each side of center,  $\frac{1}{2}$  volt center tapped filament winding, will operate 1 or 2 210 tubes, \$7.25. 100 Milliampere filter choke 30 Henries \$5.00. Plate and Filament supply Transformers of any size, for 25, 40, 50, 60 or 500 Cycle supply to order Transformers exchanged. Scott Coil & Transformer Co., New Albany, Miss.

SELL or trade: New Leach relay, new REL wavemeter, nearly new Advance sync, new S-M wired "Round World" 4 tube receiver, 84 meter crystal, 25 cycle transformers, W. E. power speaker complete. Want 204A and portable typewriter. W9ARA, Butler, Mo.

SELLING out:—Westinghouse motorgenerator 250 watt 1000V \$50; Two kenotrons \$20; Two 203's \$20; Two UX-210's \$10; Special Acme power transformer 1500-1000V nl. Winding \$20; Thordarson fl. trans. 800 watt \$7; Two Cardwell transmitting .00045 \$16; Two Hammarlund transmitting .0001 \$10; Jewell Meters, D. C.-volt

meter 0 to 2000 V \$20; Antenna ammeter 0 to 5 \$6; Milliammeter 0 to 500 \$4; A. C. volt meter 0 to 15 \$4; Two 30 Henry chokes .003 \$30; For 2 mfd. filter condensers \$12; Four fifty watt sockets \$2; General Radio wave meter 70 to 1500 meters \$35; 15 dial omnigraph \$15; Three stage speech amplifier panel mounted in walnut cabinet with UX-112's \$25; Four Willard storage B's 45V \$20; WSRCA, 710 West Main St., Galion, Ohio.

BARGAINS on Acme Parvot and Sangamo new stock for transmitting B power pacs and B eliminators. U. S. prices. 2 mfd. 1000 volt \$3.85, 1 mfd. 1000 volt \$2.85, 1 mfd. 800 volt \$1.50,  $\frac{1}{2}$  mfd. 800 volt 90c. Self healing 14 mfd. B eliminator condenser block, U. S. Condenser Company \$6.50, 14 mfd. Parvot B eliminator block \$4.25. 30 Henry chokes in pairs only \$2.40. A. C. transformers for B eliminators Raytheon type 225, various Sangamo 14 mfd. blocks for pacs \$8.50, 210 Thordarson parvot blocks, \$8.50, A. B. C. 400 mil blocks 16 mfd. parvot \$10.50. Send 20% with order or full amount money order balance C.O.D. Kurtz-Kasch dials for shortwave sets for fine tuning, 99c. Ernie Johnson, E. G. J. Radio Corp., Bridgeport, Conn. Large stock but subject to prior sale. Established 15 years.

1929 M. O. P. A. 7 1/2 or 50 Watts, panel mounted, 5 meters, Power-Pack 750 volts D. C. Screen-grid Receiver and speaker. Whole or split. Cost \$150.00. Offer? —W4AGG, Oxford, N. C.

FOR sale—UP1016 power transformer and one DeForest H tube, both for \$20.00. Guaranteed. O. K. Edwin R. Carlson, Waterman, Ill.

CHOKES Dudio-wound 50H. 1000MA, unmounted—\$2.25. 30H. 100MA—\$1.35. 'B'Eliminator transformers 215V-112V—\$1.75. Aerovox 5000 ohm Wire-wound gridleaks—50c. Read-Rite milliammeters—\$1-. Pure rectifier elements and copper tubing inductance. Send for "Specials". Quick service, William Harrison, 35 Ft. Washington Ave. New York City.

EDISON storage B battery 100 volt kits, \$6.50. A eliminator cost \$35., \$9.00. B eliminators 150 volts \$12.50. Battery chargers \$3.50 cost \$13.50. Cone speakers units \$1.00. Motors  $\frac{1}{2}$  horsepower \$7.00, 904 North Fifth, Philadelphia, Pa.

WANTED—Navy standard receiver SE143, SE1220, SE1420 or IP500, also Audion box SE1071. State price, condition and manufacturer. Paul Trautwein, 15 Albany St., New York.

SPECIALS: 550 volt generator \$11; factory-built five tube broadcast receiver with tubes, \$14; Magnavox M1 speaker cost \$25, only \$8; Music Master speaker \$4; 12 volt, 500 watt filament transformer \$6; complete equipment for mercury arc rectifier and filter producing d. c. less mercury tube, \$19; custom-built two-tube shortwave receiver, best buy of all, includes Aero coils for short and broadcast waves, cost \$45, sacrificed at \$30 with tubes. Everything absolutely guaranteed. W9ESM

WANTED—condensers, mica transmitting, Dubilier .004 and .002. State amount and price. Manhattan Elec., 105 Fulton St., New York City.

TRANSFORMERS, 3 volt, 75 Watt, 5.75; 12 volt 150 watt, 6.50; mounted. Send for Ham List No. 2, Robert Annis 524 N. Oriental Indianapolis Ind, w9CUD

WHAT have you that you are not using and what do you want to trade for? Lowell Ecker, Sedan, Kansas

THORDARSON 650-volt power-filament transformer for 7 1/2-wattors \$6.90. Aluminum square-foot 85c; Lead square-foot 85c. UX-210 7 1/2-wattors \$6.25. UX-250's \$7.50. Potter 2000-volt test 1-MFD Condensers \$2.50; 2500-volt 1-MFD, \$3.25. Vibroplex \$10.50. "Ham-List" 4c. James Curtis, 1109 Eighth Avenue, Fort Worth, Texas.

TWENTY bucks takes new RCA 852 with REL mounting. Guaranteed. List for stamp. Walleze, 597 James Street, Hazleton, Penn.

NEON tubes General Electric type G10—can be used for television—dollar each. Westinghouse Rectox trickle chargers—\$23 but without cover, \$4.50. Add postage. W9AUB, 3823 Central Ave., Indianapolis, Ind.

SELL—24-1500 dynamotor with extension shaft and pulley \$25, or with belt and 1/3 h.p. motor \$35. F.O.B. Millington. Also Thordarson trans. R-198-\$5. QSL cards, stationery, blanks, etc. W8CUX, Millington, Mich.

QSL cards, two colors, \$1.00 per hundred. Free samples, 8DTY, 257 Parker Ave., Buffalo.

CRYSTALS: One each, 3513, 3538, 3548, 3550, 3575, 3600, 3513, Kc within 1/10%, extra large, ground to maximum output, \$15 each. Weston O-1.5A thermocouple \$10. O-2A, O-20V DC \$6. Jewell A-B relays \$2.75. REL type L inductances \$3.75. Marco illuminated controls \$1.50. Pyrex 8", ham size, 1", 12" \$2. Standoffs, 3"

\$1.75. 7" \$2. National Raytheon charger, with 2 1/4 cartridge, \$7. Southern Toy Cabinets, 10x24" 12" deep, \$10. 7x18" 10" deep, \$5. Solid oak, 10x21" 11" deep, \$10. Kennedy Phones, made by W. E., \$2.50. Multiplex 8 wire connector, \$2.50. Vibroplex carrying case, \$2. Paucake inductances, Signal Corps, 12 turns, 7" diameter, 1/4" phosphor-bronze, bakelite frame, 2 clips; fine for crystal oscillator, \$1. Telefunken 30 watt tube \$10. 8 watt \$4. UX216-Ba \$4. 500 cycle transformer, 110/1500-2000V, 250W \$5. Faradon UC1803 \$1. Sangamo 5000V .002, \$1.35. GR wall insulators, 15c. Weston plugs 15c. Yaxley & Federal jacks, SCC, SCFC, DFC, 15c. Tip jacks 6c. UX sockets, Benjamin, Gr, etc. 25c. All foregoing new, original packing. Following used, guaranteed perfect: Jewell O-1, 2, 2 1/2, 3A thermocouple \$6. O-150. O-300 O-1000 MA DC, \$4.50. O-15 ACV, \$4.50. Weston O-50V DC \$3.50. Clarostats, 50c. Bradley Radio-leaks, \$2. UPI719 5w leaks 75c. Bunnell Keys 1/4" \$1.50. Rheostats, RCA, GR, 50c. Condensers, GR, GI, 23pl. single or double spaced, \$1. Zenith cabinets, solid mahogany, 7x18 with panel, or 7x22, \$4 each. S/W receivers, details on request. E. G. Watts, Jr. 12954 Cedar Rd., Cleveland, Ohio.

"CRYSTALS: Carefully selected for maximum output. Your complete satisfaction guaranteed. 85 meter band \$17.50. Blanks \$4.00. W9DRD, Rollister, Edwardsville, Kansas."

SALE—Grebe CR-18 one year old perfect condition. Your certified check for \$60. takes it. H. B. Stover, 4535 Park Ave., Fond du Lac, Wisc.

SALE or trade: Paragon 10-R, RA-10, DA-2 perfect condition. Make offer. George Crooks, 223 Elm Street, Norristown, Penna.

HAMS: Zurian Radio Service will be glad to give quotations on any type of radio equipment you may want built. 153 Dunning St., Madison, Wisconsin.

LARGE stock BC and SW sets and equipment not need. Sell or trade for transmitting parts. C. C. Crayson, Box 925, Mexia, Texas.

SELL TPTG transmitter plug-in coils 20 and 40 meters receiver, one stage. Both in cabinets, \$40. Other equipment including wave meter. All A-1 condition. Write ETV, Des Moines, N. Mexico.

SHIP anywhere COD one slightly used UV203A seventeen dollars; five tested unused UV203 fifteen dollars each. Former 5FC, 417 East Locust St., San Antonio, Texas.

PLATE POWER for your set, the very heart of its performance. For quietness, DX ability, life-long permanence, absolute dependability, lowest ultimate cost, no other plate source even approaches the achievement of an Edison ste-l-alkaline storage B battery. Built painstakingly every joint pure nickel, upset-electrically welded. Genuine Edison Electrolyte. Our list describes complete batteries, construction parts, enameled aerial wire, silicon steel. Rectifier Engineering Service, radio 8ML, 4837 Rockwood Road, Cleveland, Ohio.

HAWLEY Edison element battery and parts standard for over five years. Look at our patent pending connector—no thin wire to drop off—contains 20 times more metal than regularly used. Heavy shock proof cells, fibre holders, etc. Everything for a rapid-fire "B" supply. Complete assembled 100 volt "B" \$10.00. Knock-down kits at still low r prices. Chargers that will charge in series up to 160 volts \$2.75 to \$4.00. Trickle B Charger for 90 to 150 volt "B" \$3.75. Special transmitter "B" batteries up to 6,000 milli-amp capacity, any voltage. Write for interesting literature, testimonials, etc. B. Hawley Smith, 860 Washington Ave., Danbury, Conn.

ENSALL Radio Laboratory receivers and Transmitters are of the most modern designs and are supplied to meet any particular requirements of the radio art. Transmitter designs for radiophone or C. W. Our long experience in the designing of special apparatus is your guarantee of quality and efficient apparatus. We also build to order any items desired. Literature on any apparatus forwarded on request. Ensall Radio Laboratory, 1208 Grandview Ave, Warren, Ohio.

FINAL Supply. Eight hundred brand new ball bearing generators just purchased from the Navy. General Electric 24/1500 volt 233 ampere triple commutator dynamotors \$37.50 with shaft adapted for external drive \$3. additional. General Electric 24/750 volt 2 ampere \$27.50 shaft \$3.00. Crocker-Wheeler 24/1500 volt 450 watts \$45. Hozer-Cabot 12/500 volt 35 watts \$20. 600 watt 500 cycle generators with exciters \$15. Transformers \$10. 900 cycle 200 watt with complete spark set \$30. Others in stock for your requirement. Literature and fotos. Henry Kienzle, 501 East 84th St., New York.

SPECIAL made rectifier aluminum with small percentage copper, stand more amperage, last longer, square foot \$1.25. Lead \$1.00. Elements, holes punched with bolts and nuts, new kind 1"x4" 15c, 1"x6" 17c, old kind 1"x4" 13c, 1"x6" 15c pair prepaid. Best Silicon steel .014" cut to order 25-35c lb. Postage extra. Geo. Senulz, Calumet, Mich.

OMNIGRAPHs, teleplexes, transmitters, receivers, Vibroplexes, meters, 50 watters, "S" tubes, motor generators, dynamotors. Bought, sold, traded. Ryan Radio Company, Hannibal, Mo.

SELL: 1KVA transformers 1100-2200-4400V each side CT, 110-220 primary. Used by Cornell Uni. at \$12.00. F.O.B. Det. F. G. Dawson, 5740 Woodrow Ave., Detroit, Mich.

DUBILIER .004 transmitting condensers wanted. Radio, 150 West 22nd St., New York.

Used 203 A and 211 \$18; new 217 A \$23; new 852 \$29; used \$20; used Western Electric 212A and 212D \$60 each; new Cunningham and RCA 210 \$6; new Cunningham and RCA 231 \$5; No 12 enameled aerial wire \$20 per 100; Aero or Call Boxes \$25; 10" insulators \$29; Freshman 375V, and two 1 1/2V, center tapped transformers \$2.75; Robbins & Myers motor generator \$65; all types used Jewell meters \$75 each; three tube wired Aer coil set, best equipment \$20; REL 50 tube sockets \$1.50; signal corps 3/16" contact key \$95; 210 Bradleystats \$1.75; new RCA 50 watters \$13.50, new 217A, 217B, \$25; new 90 volt Philco Storage Bdry \$8; free list, lots of used and new apparatus. What have you for sale or trade? David L. Marks, 125 Madison Ave., Albany, N. Y.

FOR Sale—UV203A used but in perfect guaranteed condition. \$15.00 cash. RCES, F. Greben, 1927 S. Peoria St., Chicago, Ill.

SELL—Aero SW Converter Receiver \$5; National SW Receiver \$12; Submariner \$4; J. I. Mulford, 535 S. Oxford, Los Angeles, Calif.

WANTED 204A or 204 tubes and mountings. State time used and condition. Sell or trade Grebe C.E. 18 receiver \$50.00. Robbins Meyers 1000 Volt 500 Watt 110 or 220 single phase A.C. motor generator \$85.00. Both perfect condition. Robt M. Smith, 9LD, 407 W. 8th, Kansas City, Mo.

SELL—Surplus transmitting and receiving parts. Write for list. 8DLG, Charles G. Carmalt, Brookville, Pa.

SWAP, sell or trade Mario sync. What have you. Need 1500V generator. How much? 2AYJ, Oyster Bay, N. Y.

GENUINE Edison Plates, large, A-1 condition, 2c pair. Drilled 2 1/4 pair. Postpaid. Limited number. Order now. C. R. Truitt, Novinger, Mo.

SELL or trade: New 60 cycle 300 watt transformer, 750-3000 volts. Rotary converter 110 d.c. to 75 volts 50 cycle a.c. 200 watts. Want 25 cycle power transformer, a.c. meters, 25 cycle filament transformer. M. J. Caveney, VEGGG, P. O. Angliers, Quebec.

SEND for list of used transmitting equipment. M. Zavis, Chio, Michigan.

SIX Faradon 1750V 1 mfd. filter condensers each \$1.75. A. c. filament voltmeter 0-10V, \$1.25. R.C.A. 300 ma. 50 Henry filter choke, \$13.00. Ed. Keers, 9CJR, 2300 E. Washington, Joliet, Ill.

TELEGRAPH sounders—ideal for break-in relays, 4-5-20 ohms. \$1.00 each. SQD, Room 701, 331 Fourth Ave., Pittsburgh, Penn.

HERE goes: 3AFA's dx 50 watt transmitter with S tube plate supply and 3 tube receiver. All new. Cost \$268.00. Sell for \$85.00. Vibroplex included. Getting married in June. 3AFA, Newton, Penn.

GREBE CR-18, \$32. M. C. White, 2014 Melrose Ave., Dayton, Ohio.

WRITE for price list of apparatus used at W8BFQ, 1218 Marlowe Ave., Lakewood, Ohio.

W2HN—Chas H. Burch, 150-66 116th Ave., Jamaica, Long Island, N. Y.

W4AJY—Arthur F. Hill, 1504 Wilmer Ave., Annlston, Ala.

W9DOE—Alfred Lee Bergtoid, 1318 Clara Ave., St. Louis, Mo.

W9GB1—Charles L. Hopper, 400 N. Walnut St., Litchfield, Ill.

Quality  
with Volume  
never possible  
before

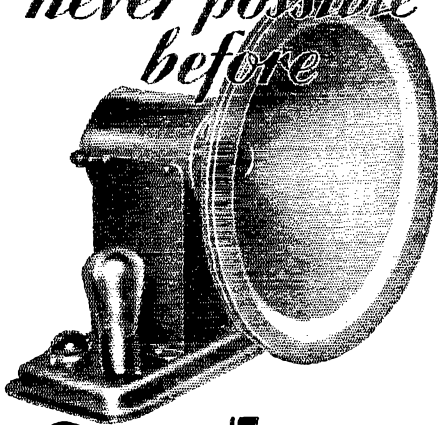

The Jensen  
**AUDITORIUM  
SPEAKER**  
*DYNAMIC, OF COURSE!*

Here is a new dynamic speaker by Peter L. Jensen which again sets the standard of reproduction, just as his first dynamic cone did in 1927.

It is called the Jensen Auditorium Speaker, and brings to you a quality, a brilliance and a volume of reproduction never attained before.

For use in auditorium or theatre this new all-purpose speaker should be operated from the largest amplifier. For home use it is just as efficient when operated from one type 171 amplifier tube.

Three models are available; one for field operation from 110 Volt DC; one for 220 Volt DC; one for 110 Volt AC. The latter type, illustrated above, requires a full wave rectifier tube, type 280 or 380. Approximately 18 watts are required to excite the field. The cone is 11 inches in diameter.

Write to us, or let your dealer demonstrate.

**JENSEN RADIO MFG. COMPANY**  
333 N. Kedzie Avenue, CHICAGO, ILL.  
212 Ninth Street, OAKLAND, CAL.

*Jensen Patents Allowed and Pending—Licensed under Lelephone and Magnavox Patents*



FOR YOUR CONVENIENCE  
**QST'S INDEX OF ADVERTISERS IN THIS ISSUE**

Aero Products, Inc.	3rd cover
Aercoax Wireless Corporation	82
Allen-Bradley Company	24
Allied Radio Corporation	17
All Radio Company	17
American Sales Company	23, 25, 26
American Transformer Co.	84
Arcturus Radio Company	32
Auriana, Inc., Ad.	32
A. R. R. L. Emblem	87
A. R. R. L. Handbook	2nd cover
A. R. R. L. Membership Blank	84
Barawik Company	81, 89
Barros and Cia., M.	90
Burgess Battery Company	1th cover
Candler System Company	88
Cardwell Mfg. Corp., Allen D.	71
Central Radio Labs.	80
Chicago Radio Apparatus Co.	70
Clarostat Mfg. Company	98
Corning Glass Works	91
Cosmo Electrical Supply	85
Crosier Radio Corporation	63
Cunningham, Inc., E. T.	61
Dodge, C. E.	90
Dowman Electric Mfg. Co.	70
Dubilier Condenser Corp.	56
Eastern Radio Institute	74
Electrad, Inc.	90
Electric Specialty Company	81
Electro Mfg. Company	87
Elkon, Inc.	95
Federal Radio Corporation	66
Farmica Insulation Company	96
Frost, Inc., Herbert H.	72
General Radio Company	1
Greiben, Frank	84
Gulf Radio School	87
Hadiwick, Field, Inc.	76
Hickok Electrical Instrument Co.	69
Jacobs, Chas. F.	89
Jewell Electrical Instrument Co.	58
Johnson Company, E. E.	81
Karas Electric Company	86
Leeds Radio Company	75
Loomis Publishing Company	59
Manhattan Electrical Bargain House	78
Mass. Radio School	68
McGraw-Hill Book Co.	68, 74
National Company, Inc.	81
National Radio Institute	65
Nelson Company, E. R.	39
Pacnet Electric Company	88
Photo Electric Devices, Inc.	82
Polk, John L.	86
Porter Company, The	80
Precision Crystal Service	88
QST Binder	62
QST Bound Volume	72
Radio Amateur Call Book, Inc.	84
Radio Engineering	1
Radio Engineering Labs.	55
Radio Institute of America	57
Ramsay Publishing Company	78
Raytheon Mfg. Company	87
Rectifier Engineering Service	89
Rooney, John T.	97
Saugamo Electric Company	9
Scientific Radio Service	93
Slicer-Marshall, Inc.	61
Telenex Company	89
Thordarson Electric Mfg. Co.	73
United States Naval Institute	81
Van Nostrand & Co., D.	55
Vibroplex Company	78
Ward, Leonard Electric Company	86
Well's Curiosity Shop	79
Western Radio Mfg. Company	86
Western Electrical Instrument Corp.	67
Wireless Specialty Apparatus Company	79
X-L Radio Labs	77
Yazley Mfg. Company	92
Zurian Radio Service	88

THE  
NEW  
5000 HOUR  
**ELKON**  
METALLIC RECTIFIER  
FOR  
"B" ELIMINATORS

At last a *dry* high-voltage rectifier! All of the advantages of a tube—none of its frailties—much longer life—more efficient—smoother power—no noise—now as perfect a rectifier for the "B" end as the Elkon "A" Rectifier—standard with "A" Eliminator manufacturers. And the Elkon Rectifiers are Self-Healing—line surges or accidental overloads are automatically taken care of—no permanent injury is done. The Elkon EBH replaces BH type tubes in "B" Eliminators. Simply take out the fragile 1000 hour tube and plug in the husky Elkon EBH 5000 hour Rectifier. Same characteristics, but what an improvement.

Use the Elkon EBH Rectifier! Eliminate all uncertainty of life, of successful operation. Build your own new "B" Eliminator or convert the one you have to up-to-the-minute radio efficiency.

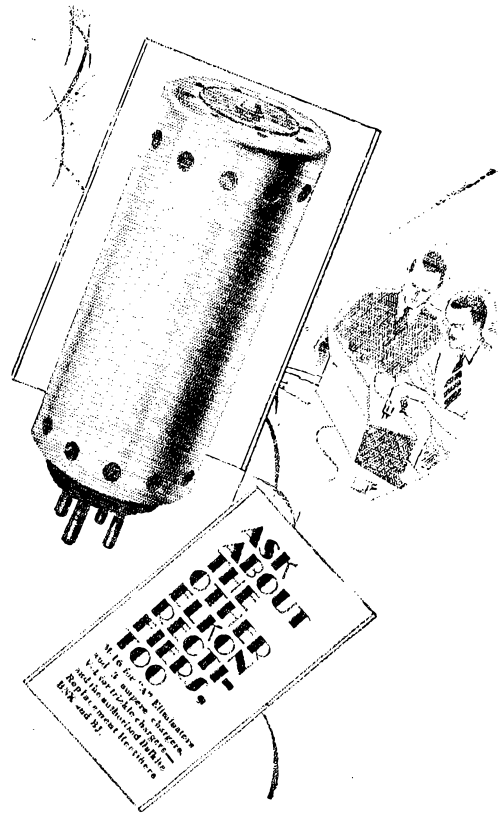

Radio Department

**ELKON, Inc.**

Division of P. R. Mallory & Co., Inc.

350 Madison Ave., N. Y. C.

Say You Saw It in *QST*—It Identifies You and Helps *QST*

ELKON, Inc., Dept. E-17, 350 Madison Ave., New York City  
Kindly send me complete information on Elkon Quality Radio Products

Name .....

Address .....

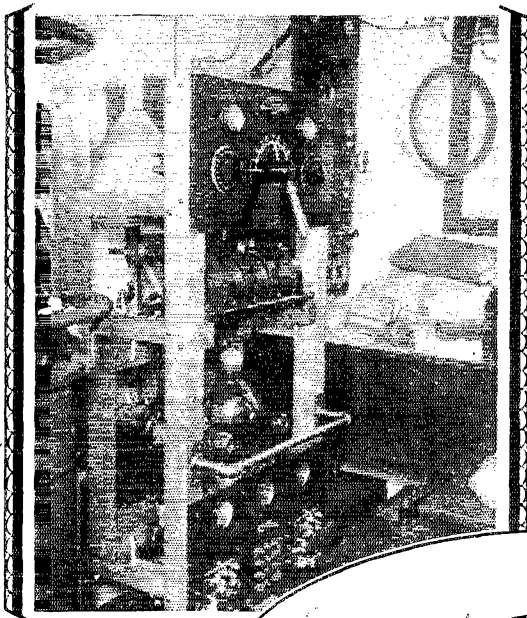

**BYRD'S  
RADIO**  
*is insulated  
with*  
**FORMICA**

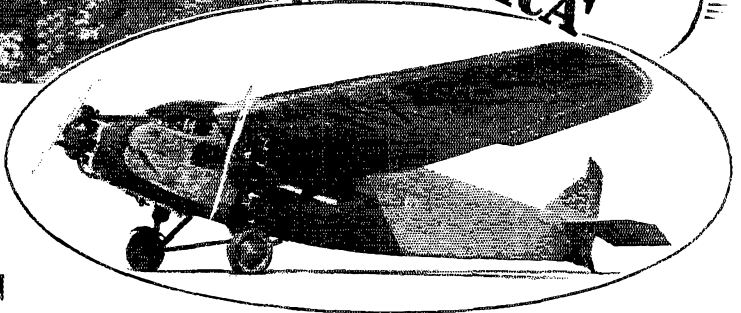

**F**ORMICA was used by the engineers, who designed the sending and receiving apparatus in use by the expedition, for panels, tubing and other insulating parts.

For fifteen years American radio men have known it as excellent insulation for high

or low frequency uses. It is high in quality and uniform—Phenol Fibre at its best.

Every year millions of automotive ignition systems, therapeutic apparatus, circuit breakers and electrical devices of all kinds are insulated with Formica. You can depend upon it.

THE FORMICA INSULATION COMPANY  
4620 Spring Grove Avenue                      Cincinnati, Ohio

**FORMICA**

# AERO COIL

## 1929

# SELECTIVITY

# LOW LOSSES

**T**HE new bands are narrower—  
To cut Q.R.M. now, only the  
*most selective receivers* can be used.

Selectivity and low losses in the  
tuning circuits are synonymous.  
Almost every condenser has neglig-  
ible losses, *but where can you find*  
*even an approach to the low losses of*  
*Aero coils?*

**I**N keeping with past performance, the  
adoption of the new bands finds Aero  
Products ready with new coil kits. The  
same low loss construction, with consequent selectivity even more important  
than ever before, is still adopted, but the new coils spread the new bands  
over the major portion of the dial, while still leaving sufficient space on each  
end to assure against lap-over. Designed especially for the new amateur  
bands, they are the most efficient coils which can be used. A new and better  
space-wound primary is also provided, and the same base, with the isolated  
grid terminal, is employed.

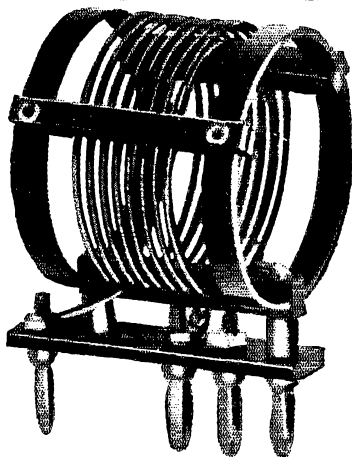

### AMATEUR SPECIAL KIT NO. LWT 13

covering new 20, 40 and 80 meter bands with .00003  
condenser, \*including plug-in base with new design of  
adjustable space-wound primary..... **\$12.50**

### ADDITIONAL COIL INT-A0

range 8.2 to 12.6 meters..... **\$4.00**

### BROKEN KIT PRICES

**AMATEUR SPECIAL COIL NO. INT-A1**  
range 19.1 to 27.6 meters..... **\$4.00**

**AMATEUR SPECIAL COIL NO. INT-A3**  
range 61.6 to 90.2 meters..... **\$4.00**

**AMATEUR SPECIAL COIL NO. INT-A2**  
range 34.4 to 48.6 meters..... **\$4.00**

**PLUG-IN BASE**  
with new space-wound primary, Type  
LWT 100-P..... **\$3.00**

\*Aero AE 942 Variable Condenser, .00003, each..... **\$1.50**

Ask for information on new Aero 1929 High-Power transmitter coils for UX852, 800, 250 and 500 watt

### Get the Big Green Book—Mail This Coupon Now

**AERO PRODUCTS**  
INCORPORATED

4611 East Ravenswood Avenue  
Dept. 311, Chicago, Ill.

Aero Products, Inc. 4611 E. Ravenswood Ave.  
 Dept. 311, Chicago, Ill.  
 Please send me a copy of your 25c Aero Green Book showing 61  
 pages of lowest modern circuits for short wave and broadcast receivers,  
 transmitters, coils and kits.  
 Name.....  
 St. & No. ....  
 City..... State.....(311)



*"Ask any Radio Engineer"*

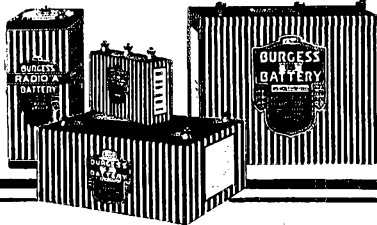

**BURGESS BATTERY COMPANY**

MADISON,

WISCONSIN



## Finding Stations to QSP Reliably

**O**FTEN it is necessary to find stations to relay traffic of importance to or toward its destination. Cy Barker of W9EGU suggests to the gang that the best record of the "standing" of various stations is reference to our official records of traffic activity in the Divisional and Sectional Reports in the Communications Department pages of the latest QST. Here at Headquarters also, we have reference to the activity reports a great many times each month in finding stations for particular work where a record or "recommendation of reliability" is essential. We can back W9EGU's suggestion and state that the idea of referring to these reports has proved both practical and convenient. Our monthly reports in QST constitute a regular twelve-times-a-year Official Relay Station list, up-to-date with changes and additions and showing the standing of different stations for a given month or over longer periods of time if more copies of QST are examined.

Quoting from Barker's letter containing this suggestion, "I find that the reports in QST are proving to be a most accurate one as to the stations that are most consistent and reliable. The traffic which I am getting from WFBT is what we may term 'important' traffic and therefore, the routing of such traffic must be given every consideration for accuracy, reliability in handling, and promptness in QSP and deliveries. While the texts of some of our WFBT messages are oftentimes of a casual, friendly, nature, they are as important as any messages can be, meaning all the world to the addressees, as I have found from letters received in acknowledgment of my handling of these messages. Just to give one example of finding a reliable QSP-point. I had regular traffic for Chicago and desired to find a reliable station working on the 7000 kc. band for a CERTAIN, SURE QSP. After listening and copying stations working on the 7000 kc. band, reference to the C.D. of QST proved that one of the stations heard (W9BZO) kept schedules and that he was handling a good number of messages right along. Consequently, I got in touch with him, and now have a good schedule with him, and all traffic is handled right."

### 28 mc.

**T**HERE is little that can be added to the excellent results that were reported last month. Plenty of "general" two-way communication on 28 mc. with perfectly ordinary equipment seems to indicate continued favorable conditions. Let us hope that these conditions may be maintained throughout several months of each year so that 28mc. operation with much enjoyment and some degree of reliability will help to relieve the threatened congestion on other amateur bands. Two-way communication is what really counts, and continued experimenting to this end should show profitable results.

In spite of the fact that solid two-way contacts have been established on several occasions between England and the U. S. A. and also between New Zealand and the United States, much yet remains to be established regarding the consistency of communication, and the seasonal and other variations which may be expected. It is hardly safe to make declarations and predictions as to the future until results of experimenting through a number of years are available. Most of our reports for this column were turned over to QST's editorial department this month for consideration in connection with the more detailed treatment of the subject of 28 mc. or ten-meter work which appears elsewhere in this issue. As this form of QST closes approximately one week nearer the date of publication than our other reading forms, recent and additional reports received too late for consideration by the editorial department will be included here as usual. In the future we shall probably have to shorten our 28mc. report, including only unusual results or those which point to some definite conclusions of value to all amateurs, as with the recent and continued favorable conditions many more reports are received of two-way communication than can possibly be used in our limited space here. Such things as the work between LZ2AC and W6UF—or that of G2OD and W1AQD (these reported last month) should be reported in detail to this department and especially such work as results in individual conclusions or respecting unusual results with "different" than ordinary equipment.

A report received from Mr. T. A. Iserbyt (Thornthorpe Heath, Surrey, Eng.), BR525 in early December regarding the reception of 28 mc. signals on November 18, listed W2BJV, W2ACN, W2BG, W1XAM, and W5WZ as "heard" at various times between 1853 and 1642 Greenwich.

Mr. T. P. Allen who conducts the R. S. G. E. Contact Bureau from Belfast, North Ireland, says, "Several of our stations are now getting across the pond every Sunday afternoon, G2OD, G6LL, G2KF, GW17C, G6YQ, G5VL, GW18B and G2FN have been QSO your stations, GW17C, G6YQ, GW18B and G2FN with less than ten watts input! G2FN has worked the sixth district twice on eight watts input and W2JN has heard G6DH with three watts input. I just received word today that G6WT heard o8AZ calling CQ on October 23th. I have received W1BLV, W1CH, W1BSU, W2BAC, W2BJV, W2CDR, W8CFR, W9BGQ and K1AGF all at very good strength on 28 mc. (Possibly one or two of these were harmonic instead of 28 mc. transmissions.—F. E. H.) Our stations are on the air every Sunday afternoon and looking for W men. We don't seem to hear any W stations during the week, but if you can get some to do transmitting on week days, our boys will look for them."

On December second W2BRB worked W6UF and W9EVC when the railroad induction let up. Kimmel of W2ACN writes as follows: "In the future I shall be on 30 mc. for further experimentation. I guess the job is nearly finished as far as opening up the 30 mc. band goes, so this will be my last report except in case of something unusual. I have cards or reports of my 30 mc. signals from England, Ireland, France, and two ships, one 4,000 miles east of New York, and the other 6,500 miles west of New York in the Pacific. November 11 I heard G6LL calling W2JN (9.30 am), also copied VE4CT at noon. At 2.15 pm EST W2TP called me and reported that EO18B was calling me. Shortly after this I was QSO W6DWP. On November 18 W6JU and W6TS were worked and they came in better than anything I have heard on 14 mc. for some time. EO17C called me but I didn't QSO at the time. On November 25 conditions were temporarily bad and only the locals came through. On December 2 at 9.20 am I copied e8CT working W2JN and at 9.45 am I worked e8CT for twenty minutes, this being my first foreign QSO in the 28 mc. band."

John Reinartz of W1XAM has been doing a lot of 28 mc. experimenting recently, sending us a number of good logs of the work carried out. Unfortunately we have only the most recent report at hand. On December second W1XAM worked G5VL and heard W6OM, W5WZ, e8CT, G6LL and PCRR.

Briggs of W1BVL says, "During October and November 28 mc. signals have been copied nearly every Sunday—those from W6UF being the most consistent. W6UF and W5WZ have been heard here an hour after sunset. Cloudy or rainy weather does not seem to affect signals from a distance. On October 28 both G2FN and W6UF were heard during their QSO. A detector and one-step a. f. with tube-base coils has been used and sometimes the signals are R7. W1BJD, W1CCZ, W6OM, W5WZ, W6AFB, W6UF, W6RAX, W9BHB, W9EHO, K1AGF, VE4CT, and G2FN have been copied at various times."

W6AM worked on 28 mc. most of the day on November 25. W6TS and W9FHS were R5 and R6 at intervals all day. W9CXX was R9, W6JU R3, and W5WZ was R8 around 9 am PST, having a splendid d.c. note. W9EF and W6AM were QSO from 1.15 until 1.45 pm PST when both faded below the noise level of power leaks and automobiles. o6CM reported that o63CW had copied W6TS on 28 mc. one Sunday at 1600 GCT. W6AM made some 28 mc. schedules with o6CM. o6BAM also reported that he would be joining the "gang" on 28 mc. in the near future.

W6EA passed three messages for the "east" along through W9DGZ on 28 mc. recently, the messages originating in the Philippines. W6EA has worked W9DGZ, W6DOW and W7ACY on this frequency also and been reported by W4ACT, W9EJQ, W9BGQ and W8DED.

W2AER reports Dec. 2nd hearing e8ct, R7, 20 cycles a.c.; G5ML, R6 d.c.; G5VL, R6 r.c.; G6LL, R6-7 d.c.; G5YK, R6 d.c.; G2OD, R7 d.c.; G6YQ, R4 d.c.; W5WZ, R6 d.c.

## Official Broadcasting Stations

### CHANGES AND ADDITIONS

#### (Local Standard Time)

W1ATJ 3950 kc. (75.90 m.) Mon. Wed. Fri. 6:30 pm; W1ANH Tues., Thurs., Sat. 7 pm; W1ALO 3500 kc. Mon., Wed., Fri. 7 pm; W6ABK 7890 kc. (38 m.) Mon. and Wed. 6 pm; W6ASM 7950 kc. (37.7 m.) Tues. and Fri. 7 pm; W6BZR 7058 kc. (42.4 m.) Mon. 6 pm and 14.235 kc. (19.9 m.) Wed. and Sat. 6 pm; W7AAT 7550 kc. (39.7 m.) 4 pm daily except Sun., 7140 kc. (42. m.) and 3650 kc. (82.14 m.) 11 pm daily except Sunday. W9EDD 7380 kc. (40.6 m.) Tues., Thurs., Fri. 5 pm.

## WIMK

A. R. R. L. Headquarters Station WIMK operates on frequencies of 3575 kc. and 7150 kc. Robert B. Parmenter, "RP" is the chief operator; his fist is familiar to most of the amateur fraternity. Occasionally other members of the Headquarters staff operate at WIMK. Their personal signs may be found in the QRA Section located immediately after the Ham-Ads of this issue.

Throughout this notice time will be given as Eastern Standard Time, which is also known as "75th meridian" or "Zone Plus 5" time.

**OFFICIAL AND SPECIAL BROADCASTS** are sent simultaneously on 3575 kc. and 7150 kc. at the following times:

8:00 p. m.: Sun., Mon., Tues., Thurs., and Fri.

10:00 p. m.: Mon. and Fri.

12:00 p. m. (midnight): Sun., Tues., and Thurs.

**GENERAL OPERATION periods** have been arranged to allow everyone who has the desire, to communicate with A. R. R. L. Headquarters. These general periods have been arranged so that they usually follow an *official broadcast*. They are listed under the two headings of 3500 kc. and 7000 kc., depending on whether the watch is devoted to listening on the 80- or the 40-meter band.

**3500 kc.—**

8:10 p. m. to 9:00 p. m. on Sun., Mon., Tues., Thurs., and Fri.

10:00 p. m. to 11:00 p. m. on Tues. and Thurs. (No OBC sent before these periods).

12:00 p. m. to 1:00 a. m. (or later) on Sunday night (Monday a. m.)

**7000 kc.—**

10:10 p. m. to 11:00 p. m. on Sun., Mon., and Fri.

12:00 p. m. to 1:00 a. m. on the following *nights* (actually on the morning of the day following): Mon., Tues., Thurs., and Fri. (Only on Tues. and Thurs. does the OBC precede these periods).

**SCHEDULES** are kept with the following listed stations, through any of which traffic will travel expeditiously. A. R. R. L. Headquarters. The frequency included within parenthesis indicates the band in which each individual station keeps the schedule with WIMK.

- W1ACH, Brookline, Mass. (3500)
- W1BIG, Augusta, Maine (3500)
- W1BQD, Newport, R. I. (3500)
- W1KY, Cambridge, Mass. (3500)
- W1VB, Newton, Conn. (3500)
- VE2BR, Pointe Claire, Quebec (7000)
- W2JF, Jersey City, N. J. (3500)
- W2PA, Port Antonio, Jamaica, B. W. I. (7000)
- W2SC, Governor's Island, New York Harbor (3500)
- W3BBW, Baltimore, Md. (3500)
- W3ZF, Philadelphia, Penna. (3500)
- W3ZS, St. David's, Penna. (3500)
- W4EL, Georgetown, S. C. (7000)
- W5JG, San Antonio, Texas (7000)
- W6ZD, Berkeley, Calif. (7000)
- W7TX, Seattle, Wash. (7000)
- W8AAQ, Oil City, Penna. (3500)
- W8AYB, Buffalo, N. Y. (8500)
- W8BYN, Columbus, Ohio (3500)
- W8WED, Holland, Mich. (3500)
- W8ZZ, Detroit, Mich. (3500)
- W9APY, Berwyn, Ill. (7000)
- W9BCA, Ft. Madison, Iowa (7000)
- W9BLI, Alton, Ill. (3500)
- W9DWS, Kansas City, Kans. (7000)
- W9OX, Louisville, Ky. (3500)
- VE9AL, Toronto, Ontario (5720 kc.)
- W9X1, Minneapolis, Minn. (7000)
- WSBS, Yacht Carnegie (9090 kc.)

## Traffic Briefs

Frequency meters? With our 1929 bands the ability to set our transmitters just where we want them within certain narrow limits will be important. We had thought that a setting to a few kc. per second might be possible with a carefully and sturdily designed frequency meter of the monitor box type, calibrated from standard frequency and "marker" stations.

In a recent number of the *Electrical World* we see it announced that, "a new line of resonant-circuit type instruments in which full scale range may be as small as a single cycle per second" has been developed by one of the larger manufacturers. A revolutionary development it would seem—and just the thing for 1929 perhaps. Alack! and alas. At the end of the article comes disillusionment. The range is here specifically given as from 59.5 to 60.5 cycles!

W9AGS, the amateur station of the Lane Technical High School of Chicago, Illinois, is offering as a trophy to the first station worked in each district and country after the first year, a large cast aluminum Indian head, which may be decorated in colors and which is a very attractive ornament for the wall. The heads are ten inches high and stand out several inches from the wall. W9AGS uses pure d.c. and works on 3500, 7000 and 14000 kc. bands. The only conditions are that two-way QSO be established, that the distant station get the personal sign of the operator at W9AGS and confirm it by a QSL-card with all details. This offer becomes effective Jan. 1, 1929. The Indian heads will be mailed postage prepaid to the lucky "first" stations, and all other stations will get one of the hand-painted QSL cards, drawn and decorated by the art department of the school. W9AGS is on the air Monday to Friday inclusive from 8 am to 4 pm CST as well as several nights a week.

At a recent meeting of the Hackensack Radio Association a cup was presented by that organization to Paul C. Oscanyan, Jr. While operating n1XL Oscanyan "met" Miss Astrid Funder, who at that time was operating the Danish Government Motorship *Disko*. The romance proceeded by radio; and now we must call Miss Funder, Mrs. Paul C. Oscanyan, Jr. Radio has played the role of Cupid more than once!

Ne8WG in Labrador will be operated all winter on approximately 14,300 kc. W8WA keeps a schedule at 6:15 p.m. E.S.T. with Ne8WG.

When two stowaways were discovered on Byrd's ship, the *C. A. Larsen*, a message was transmitted to the San Francisco *Examiner* station via ARDI and WFBT. The *Examiner* station, unable to QSO Los Angeles, the destination of the message, gave it to W7AAT, who got it through that night. Another case of somebody being on the job. Hurrah!!!

## ARMY-AMATEUR NOTES

**FIRST CORPS AREA:** We are pleased to announce that Davis S. Boyden, formerly 1st Lieut. Sig. Res., Radio Advisor on Amateur Matters to the First Corps Area Signal Officer, has been promoted to the rank of Lieutenant Colonel in the Signal Corps Branch, and appointed Division Signal Officer, 26th Division, Massachusetts National Guard. This appointment makes him a member of Major General Alfred P. Foote's Special Staff. W1SL and W1WF will continue to function with more pep than ever.

**SECOND CORPS AREA: Western N. Y. State Net:** W8AFG finally erected his antenna and is back on the Net schedules. W8AHC, W8BFG and W8AHK continue as the active stations in this Net. W8CVJ acted as N. C. S. for one schedule when W8DME was away. Army-amateur stations are needed in Buffalo, Rochester, and in northern part of N. Y. state. Interested amateurs should address their QSL cards to W2PF. **Eastern New York State Net:** W2KR reports all County Net Control stations functioning excellently. W2BGB and W2ANV handle the traffic for the northern part of this Net in good shape. W2BGO is a new station in the Manhattan Net. W2AGS is acting as N. C. S. for King's County Net as W2AND is busy with work temporarily. More activity is desired from the Long Island Net. **New Jersey State Net:** W2AOS is the acting N. C. S. and will continue if W2CP doesn't return. W3OH is a new station in Burlington County Net. W2ZL, W3ATJ, W2AT and W2AOP are keeping the weekly schedules for their respective Nets. Additional stations are needed for N. J. and Delaware Nets and those interested should communicate with W2PF. W2SC, the Corps Area N. C. S., located at Bedloe Island, N. Y. Harbor, handled over 1000 messages last month by having schedules with stations in every district. W2PF will alternate with W2SC in keeping the weekly Monday night schedules.

The monthly meeting of the Army-Amateur Nets and the Hudson Division A. R. R. L. at the Army Bldg. on Dec. 3rd was given over to the Navy. Ensign B. J. Fuld, W2BEG, of the Naval Reserve, arranged an interesting exhibition of motion pictures depicting the Navy in action on, under and over the sea. Talks on the Navy radio compass, radio procedure, etc. were given by men from the Third Naval District Communication Office.

**TRAFFIC BRIEFS**

In our October issue W6EC was credited as the station which cleared the frequency of KHAB, the Southern Cross, of QRM during the recent memorable flight to Australia. Recently we have learned that W7EK also did the same service, but at a different time during the flight. FB, OM's!!

W5AAE, W5AIR, W5LC, W5LP, W6EOM, W8VH, W9DI, W9CAA, W9DHH, W9DKM, W9EPX, W9FBF, W9FSI, W9FU, W9QY, W9SO and W9ZK are all equipped to work on 1750 kc. (160-meters). Some of these stations are doing excellent two-way work over surprising distances. Others are especially interested in working "new" hams who have just gotten on the air (especially W6EOM, 1715 kc, Ocean-side, Calif.) and still others send broadcasts of code practise material to beginners using code and phone in the 1750 kc. band. We should be interested in hearing from every station working on this band as so what results are being obtained—so we can pass the information along to others who may be interested.

Since the canning season in Alaska is over the Alaskan schedule proposition is not so prosperous. We are proud to announce, however, that W6DFW still keeps a good one, going with K7ABE. Whoops! I

A survey taken some time ago disclosed the fact that most broadcasting stations are manned by amateur radio men. Further disclosures reveal the National Biscuit Chewers (NBC) of the Blue and Red Networks. It is understood that "CQ NBC" is the general call of the order on the 7000 kc. band. The slogan is "We are the crack operators of the cracker gang"; the motto is "Unecuda".

Everybody is invited to QSO, whether belonging to the NBC gang or not. Familiar calls in the membership are: W2VI (Cliff Himoe, ex-WNP, now WEAJ); W2KP (Hagmann, WJZ); W2SJ (Strong, WGY); W8ABX (Long, WHAM), W8BRD; and W8BEN. Schedules and good operating practices with break-in are the general dictum of the organization. Members are eligible whether of the 204A or the 210 classification.

Oa5CM, QSO with W1MK the other morning, told us that the Australian "5's" were staging a three-month contest in which each participating station would attempt to work as many continents as he can. At the end the number of QSO's will be counted up (each continent counting so many points), and the station having the largest number of points will be declared the winner. The prize is an engraved shield.

The gang at HQ were recently visited by K7AD of Big Port Walter, Alaska, and W7PT of Torrington, Wyoming. Both K7AD and W7PT had come around from Seattle via the Panama Canal, on board ship as operators.

"I have become affiliated with the 'Anti-Bunk' party," says W9CZC, Route Manager for Iowa. "After thinking over its platform, it seems to me that it is a long step forward. In an endeavor to discard bunk, this noble group, under the able leadership of Will Rogers, believes in being perfectly natural and in telling the truth.

"Why can't we adopt this platform in radio? For instance, instead of asking for a QTA (1928 style) and blaming the weather or local interference, why not say: 'Your fist is bum at that speed; your spacing is rotten; your signals are wobbly; and I can't copy that fast anyway—please slow down.' It will be much easier to weed out troubles and faults if both parties concerned know what is wrong."

A football game between the high schools of Nashua and Concord, N. H., was reported by amateur radio through W1AFD, W1TA, and W1AUE. W1AFD was located at the field. W1TA, located a mile away, received the reports from the portable transmitter, and relayed them to W1AUE in Nashua, the game being played in Concord. Fine work, fellows!!

Some very praiseworthy work is being done by W6UO, W6LB, and W6CHG in the mountains of Nevada, in handling reports on road conditions over the difficult mountain-passes. The reports are given to the Nevada Automobile Association at Reno, for the benefit of tourists. Good Work, OM's!!

Canadian QSO's are not difficult at all if you will only listen for the Canucks on their own special frequency of 5720 kc. W5AMO, SCM of Oklahoma, says Q S T FOR JANUARY 1929

**BRASS POUNDERS' LEAGUE**

Call	Orig.	Del.	Rel.	Total
W2SC	225	76	706	1007
W1MK	154	154	428	736
W7AAT	235	56	438	729
op1HR	270	145	306	721
W3ZF	14	118	428	560
W6CHA	30	52	330	412
W9EDW	21	42	339	402
W9AIN*	28	37	336	401
W6AMM	107	233	34	374
W9AYK	29	3	320	352
W7MF	11	8	300	319
W7JC	160	137	18	315
W9DAE	15	36	261	312
K1PW	116	43	137	296
W8XE	72	20	192	284
W9DGW	4	9	268	281
W9RR	131	56	84	271
W9CET	93	46	129	268
W8DBM	52	18	176	246
W3AKB	22	48	175	245
W8CMB	40	30	170	240
W3QP	38	40	154	232
W1BLV	51	25	154	230
W1CQ	16	15	191	222
W8CNO	44	14	160	218
W8DII	98	39	72	209
W7ABB	58	27	124	209
W9DLD	19	19	168	206
W9RCA	38	54	112	204
W1ACH	70	63	69	202
W1AAW	16	29	167	202
W6EC	23	148	13	184
W2APV	38	116	-----	154
W9FAM	14	4	128	146
W9CRD	7	56	78	141
W1RNS	41	54	41	136
W1WV	59	64	8	131
W2AVP	15	97	16	128
W1KY	20	58	40	118
W1BIG	33	63	12	108
W4AI	19	55	6	80

\*W9AIN was omitted from last month's BPL by error. Figures were 31, 23, 386, 440.

Pending receipt of the official count of W8CHC's messages from his Section Manager, we tentatively list W2SC as holding first place in the B.P.L. W1MK, W7AAT, and op1HR also handled over seven hundred messages. W3ZF handled over five hundred in the "Twentieth Century" chain to Chicago.

All these stations appearing in the Brass Pounders' League are noted for their consistent schedule-keeping and reliable message-handling work in amateur radio. Special credit should be given the following stations responsible for over one hundred DELIVERIES in the message month: W6AMM, W1MK, W6EC, op1HR, W7JC, W3ZF, W2APV. Deliveries count!

A total of 200 or more bona fide messages handled and counted in accordance with A.R. R.L. practice, or just 50 or more deliveries will put you in line for a place in the B.P.L. Why not make more schedules with the reliable stations you hear and take steps to handle the traffic that will qualify you for B.P.L. membership also!

"I have been doing a little work with the Canadian amateurs lately on 5720 kc. There are some mighty good QSO's waiting for the U. S. hams. The Canadians' frequency is apparently better than our 7000 kc. band, as there is an absence of fading that 7000 is so famous for here lately." Do you want to know how to work the Canadians? Yes? Then read the Traffic Brief on page VIII of December QST. It tells all about it.

A mistake in the Navy Day ratings was disclosed recently after W3ZF and W8CFG had written in requesting a check on their standing as revealed in the list which appeared in December QST. Upon investigation it was discovered that several stations that are listed in the vicinity of W3ZF and W8CFG in the list were accidentally given that location and should be included near the top of the list. Our sincere apologies are offered for this most regrettable error. No mistakes were made in the selection of the highest ten competing stations, however.

## TRAFFIC BRIEFS

The Eastern Massachusetts Amateur Radio Association gets fed by WIKY at their meetings. And can she make waffles? Her OM won't have to starve!

Speaking of speedy QSR—W2SC recently passed W1MK a rush message for Galion, Ohio. As W1MK had to QSY to the 7000 kc. band for schedules very soon, this was passed to W8BRC who came in with a snappy come-back after a short directional CQ. W8BRC promptly passed the message to W8AKV who took it to the power company's telegraph station where he works. It was wired to Shelby, Ohio, and phoned to destination—all in two hours the same evening. Use the directional CQ in domestic and foreign work.

A large number of publications containing excellent information for the radio station and library may be

obtained for a nominal sum from the Superintendent of Documents, Government Printing Office, Washington, D. C.

Here is a list of four such publications, and the price of each:

The International Radiotelegraph Convention (Washington, 1927) (English translation) . . .	40c
The Radio Act of 1927 . . . . .	5c
Amateur Radio Stations of the United States (new list) . . . . .	25c
Commercial and Government Radio Stations of the U. S. (new list) . . . . .	15c

A complete list of the new Q signals and miscellaneous abbreviations appears in these two latter publications. The classification of amateur calls under the headings of cities and states in addition to the usual arrangement, makes the 25-cent publication particularly useful for reference in routing traffic or planning visits to amateur stations when traveling about the country.

## DIVISIONAL REPORTS

### ATLANTIC DIVISION.

**WESTERN PENNSYLVANIA**—SCM, A. W. McAuly, W8CEO—W8CHC, with eight schedules, again leads the procession with a total that approaches if it does not establish, the record with message handling from a single station. He posts notices in stores, soliciting traffic. The notices read "Radio message sent free to all parts of the globe." W8XE is on regularly again with several schedules. Dr. Woodruff is on the west coast receiving medical treatment. We all wish him a speedy recovery. W8KE will soon be crystal controlled. W8CFR is handling all traffic from the Brazilian-American expedition (JTC) through sb-1AW and sb-1IB. He is also on the USDA net. W8GI has but two schedules left. One of them is with the SCM. W8ABW is busy with BCL work. W8CEO has been sick most of the month. W8CYP is putting up a new antenna. W8DNO is doing some nice DX work. W8AKI keeps a schedule with W8SN. A late report from W8BNR last month advises that he has been bothered with an infected operating hand. He is remodeling his transmitter into a MO-PA and expects to be on the air with it soon. A card from W8GU, Biley, reports him at Pratt Institute. W8ARC is still somewhat under the weather. W8CES has moved to Pittsburg and will soon be on the air again with an improved transmitter. W8CZE had the misfortune to burn out his MG. Hard luck, OM. W8CJJ is brass pounding on the steamer *Morris* on the Great Lakes. W8AGQ burned out a 250 wattier. It is on the air with a fifty now. This station has been very active lately and is doing some good work, especially in important traffic over long distances. W8DGG and W8AJE are planning a trip to Denver, taking a portable transmitter along in a Ford. The Erie Radio Club had a booth at the local Radio Show and distributed literature advertising the amateurs' usefulness in emergencies. The Amateur Transmitters' Association is holding a banquet and old-fashioned hamfest at the Ft. Pitt Hotel instead of their regular monthly meeting this month. Ex-8BDI, H. D. Wood, former Secy. of the ATA, now pounds brass on the Atlantic and heard the SOS from the SS *Vestris*, but his ship was 600 miles away at the time. Visiting hams always welcome at the station of the SCM, W8CEO.

Traffic: W8CHC 2564, W8XE 234, W8RGW 71, W8CFR 38, W8GI 25, W8ABW 20, W8CEO 24, W8CYP 12, W8AGO 11, W8DNO 10, W8AKI 9, W8CNP 45.

**MD-DEL-D.** of C.—SCM, E. H. Layton, W3AIS—Maryland: W8BBW at Baltimore leads the entire section as high traffic man. W3TR maintains nightly sked with the Canal Zone. W8APX at the Academy is quite busy. Delaware: W3ALQ at Felton complains of little traffic on the 7000 kc. band. W3WJ is instructor for the local Naval Communication reserve unit. W3AJH is having trouble with key clicks. W8AIS is active on the 7000 kc. and 3500 kc. bands. Dist. of Columbia: W8GT reports the arrival of a Jr. op. Congratulations, OM. Also reports hearing WBFT daily. W3BWT reports no skeds as yet but worked a great number of stations. Darne has five ops on his staff. W3ASO maintains a sked with W4CS. W3AHP reports consistent communication with the west coast and Europe.

Traffic: Md: W8BBW 145, W3TR 19, W8APX 1. Del: W3ALQ 1, W3WJ 12, W3AJH 3, W3AIS 8. D. of C. W3GT 34, W3BWT 41, W3ASO 31, W3AHP 56.

**SOUTHERN NEW JERSEY**—SCM, M. J. Lotysh,

W8CFG—W8CFG again leads the section but evening work gouged his total badly. W8GFG's 3500 kc. signals were reported by ships in Europe, 2200 miles southeast of Brazil and 2100 miles south of Los Angeles. Who said 3500 kc. is no good for DX? W8HWJ is all rebuilt but has little time to operate yet. Tough luck, OM, as this section needs you badly. W3ARR and W8AWQ, both new-comers, turn in nice initial reports and show promise of future ORS material. The SCM fixed W3ATJ up with antenna dope and now he works all districts. W3ARC is still busy servicing but expects to be with us again after the holidays. FB, The Princeton Univ. club station, W8DH was lost when the School of Science Bldg. burned to the ground. W8BEI lights up his house every time he hits the key. W8KJ, W8SJ, and W8BSD's ORS appointments were suspended for not reporting since last spring. This was tolerated due to summer slump but another failure will mean cancellation. W3AQC expects to resume activity soon. You ORS are again warned of the 5 message minimum taking effect Jan. 1. The next report will find us in the throes of QRM and tid stations on all bands, and the only solution will be skeds. A prosperous holiday season to all.

Traffic: W8CFG 102, W8ARC 27, W8ARN 12, W8BWJ 16, W8ARR 6, W3ATJ 8, W8AWQ 8.

**WESTERN NEW YORK**—SCM, C. S. Tavior, W8PJ—W8ABX is back again with schedules and traffic. W8AKZ has been trying out current feed Hertz and has a couple skeds. W8ANX states his station will be on shortly. W8AVS of Homer, N. Y. is handling a few messages. W8BBP has a good traffic report this month. W8BFG wins the wooby prize this month with one message handled. W8BJO went hunting and from his report, says "Deers are better to him than Deer." W8BLP will open up again about Jan. 20 for traffic and schedules. W8BLV worked 7th district on a UX210 and handled fair traffic. W8BUP worked the 6th dist. W8CPC worked Texas and has a few schedules and fair traffic. W8CNT handled a few. W8CWS states that many of the gang are shirking on schedules. W8CVJ is working foreigners again. W8DII has a bunch of schedules and traffic. He worked the Panama Canal Zone and made the BPL twice over this month. W8DME has a bunch of skeds. He has been appointed a Naval Net station for Central New York. W8DSP is now in Syracuse and has many skeds. W8DUP has handled a few msgs. this month. W8FC has several skeds and has been handling good traffic. From the reports, it looks as if the gang are re-vamping everything in the ham field. January should bring out some mighty fine transmitters and receivers.

Traffic: W8ABX 11, W8AKZ 11, W8AVS 5, W8BBP 47, W8BFG 1, W8BGO 30, W8BLV 48, W8BUP 6, W8CPC 38, W8CNT 30, W8CSW 11, W8CVJ 31, W8DII 209, W8DME 21, W8DSP 10, W8DUP 8, W8PJ 9.

**EASTERN PENNSYLVANIA**—SCM, J. B. Morgan, 2nd, W3QP—W8ZF is shouting for more traffic and with a total like this month's! W8WJ is doing some very steady work even in the face of somewhat irregular schedules and illness at home. FB, George. W3QP is going off the air for several months on account of business pressure. W8AKB has a method for making the BPL in a week or less. Fran certainly has one fine bunch of schedules and keeps them with NAA precision. The crystal is finally working well at W8AVK after all these

years! School work still jamming up W3ADE. Two new MO-PA sets for 3500 and 700 are working at W3ANS. Joe says he is out for lots of schedules now. Wonder if he can work a sked on each set at the same time. Hi. W8SM, our old reliable, Bob Adams, is back with us again after eight month's silence. This time it's with an excellent phone rig on which he handles all his traffic. Welcome home again, OT. W3RA says he has a new MO-PA set going well and DX and traffic good. W8MQ reports a poor month but seems to have collected some traffic somehow. W3CDS has several schedules doing nicely and shows nice improvement in traffic. Everything rosy at W8AWO. W3AHZ trying to clear up his RAC note for 1929 use. Don't forget to do this fellows, it's important. W8DHT has been very busy with his job leaving little time to operate. W8AWO is installing an 852. Now watch Johnny step out.

Traffic: W8ZF 560, W3AKD 245, W3QP 232, W8MQ 170, W8WJ 109, W8AVK 88, W3ADE 73, W8AWO 56, W8SM 52, W8CDS 44, W8RA 28, W8DHT 12, W8BFL 9, W8CWO 5, W3ANS 4, W8AHZ 3.

#### CENTRAL DIVISION

**O**HIO—SCM, H. C. Storck, W8BYN—Well, gang, the good radio weather is here. Let's get on our toes and do things. W8CMB and W8DBM nearly tied this time. W8DBM leads as per usual. His call will be W8JA from now on. W8CNO made the BPL again and is happy. She was on only three weeks at that. Is now rebuilding for 1929. W8CAU turns in a nice total this time and says they are just hitting their stride now. W8CFL has a tube rectifier now. W8BBR is still bothered with power leaks and X-ray QRM. W8APB has a new mercury arc. W9CRI is operating from W8AVT and W8AEL for a while. W8DDK is still experimenting but turns in a good total. W8BAU has been spending his time grinding crystals. W8BOR seems to be rebuilding extensively. W8DVL has outgrown his transmitter and is rebuilding. W8AQU has been on 14,000 mostly. W8DDF is very QRW school. W8ADS is trying out 3500 kc. W8CSX is operating with a crystal on 7144 kc. W8CXD has been transferred to Akron and will start up there. W8AYO is keeping schedule with se-2EA and n-IUG. W8CFT's outstanding accomplishment this month has been to work several Australian YLs. Hi. W8BAC has his 852 on 8500 now. W8BYB is on 56 mc. with automatic transmitter and wants reports. W8CWC is back with us again. W8DMX is now on air with two 50 watters. W8CCS reports. W8DIH neglects his station to run W8DDQ. W8CNU has been rebuilding. W8ARW is moving his set. W8OQ and W8DTC report. W8DDQ has a new op. W8RN is coming back from "commercial land" and will be with us soon again. W8AQ is ex-W1AAC and has located in this section. Welcome, OM. W8EJ has been very QRW. There have been numerous complaints about stations handling dead traffic unashamedly and counting same. Let's not be guilty of such flagrant violations of the ORS code, OMs. A merry Xmas and prosperous New Year to you all.

Traffic: W8DBM 246, W8CMB 240, W8CNO 218, W8CAU 145, W8BYN 110, W8CFL 91, W8BBR 71, W8APB 65, W8CRI 61, W8DDK 59, W8BAU 58, W8BOR 47, W8DVL 40, W8AQU 40, W8DDF 21, W8ADS 19, W8CSS 19, W8CXD 17, W8AYO 16, W8CFT 16, W8BAC 14, W8BYB 14, W8CWC 13, W8DMX 11, W8CCS 9, W8DIH 7, W8CNU 5, W8ARW 3, W8OQ 3, W8DTC 3, W8DDQ 2, W8GL 2, W8PSY 2, W8DIA 1.

INDIANA—SCM, D. J. Angus, W9CYQ—W9AIN again leads the state. As soon as his crystal is going, he should raise that total. J. R. Frevermuth, W9BBJ, reports that the amateurs at Purdue Univ. have in operation a complete new amateur station in a club house building of their own and operating under the call W9CMV. They are operating on the 14,000 kc., 7000 and 8500 kc. bands. A 24-hour watch is kept. W8DPV is on again using 14,000 and 7000 kc. W9ASX is going to put in new 210's as soon as Santa brings them. W9EVA is having unusually good success with that new voltage feed antenna he recently put in. W9FZQ is a new station at LaPorte with a 210 and a new stick. The Television Club at South Bend are not yet seeing very much. W9GBF has a transmitter in his room at Purdue and handles traffic for the Indianapolis gang there (mainly requests for cash from home). W9BZZ is doing some good DX work on 7140 kc. W9EFZ just marked up his 42nd country. He is our pride and joy so far as DX is con-

cerned. Also he has been doing very good work on 28,000 kc. W9ETA is going big on 14,000 kc. W9EXW has regular skeds with nn-1NIC. W9FBY is putting in a new 50 watt, 1929 transmitter. The Indianapolis Radio Club are nicely located in their new quarters at 460 Century Bldg, and are now putting in a short wave receiver loaned by W9CYQ. They will start a code class December 7th, to last all winter. W9FCW is now plugging along in double harness. W9FCX rebuilt his transmitter and is now on the air again. W9FQ hit the ball with some traffic.

Traffic: W9AIN 401, W9GLO 19, W9EF 45, W9BZZ 22, W9GBF 20, W9ASX 47, W9EKW 55, W9EEY 32, W9EPH 4, W9CMQ 16, W9FCG 7, W9AEB 2, W9EVA 31, W9EXW 23, W9DSC 21, W9FQ 44.

KENTUCKY—SCM, J. B. Wathen, III, W9BAZ—Believe it or not, but a Ky. station has made the BPL. Old W9CRD is the prize baby. Give the lad credit—then "go thou and do likewise". W9ACS reports results FB with his transmitter. W9KZ is still having trouble getting his arc to perk. W9BAZ sports a new receiver. Look out, Asia. W9OX also has a new one. W9JL took a WFBT message. W9ENR still sticking on 14,000. W9CEE is getting high hat, moving his outfit to top of 11 floor bldg. W9AUH, W9AZY and W9FBV have picked new locations, hoping for the best. W9FQN says his location is terrible, but he was heard in France. W9MN is still busy with WLAS. W9BGA has his eye on 28 mc. School causes W9CRJ no little QRM. W9BAN reports new house almost completed. Will be on the air shortly. Best wishes, OM. Let it be said here and now that reports from non-ORS shall receive as much credit in this Section's space as they deserve. Get them in as soon after the 24th as possible. Take a tip and get those traffic totals up. A prize is coming, starting with the new year. Merry Xmas and good DX to all the gang.

Traffic: W9CRD 141, W9ACS 50, W9BAZ 19, W9OX 17, W9JL 14, W9ENR 12, W9CEE 11, W9CRJ 10, W9MN 3, W9BGA 2.

MICHIGAN—SCM, Dallas Wise, W8CEP—W8BCI is back on the air again with a UX-250 and handled a nice bunch of traffic. W8BV who is old 8CP of Holland is now working on 14 mc. and 7000 kc. and hopes to be on 3500 kc. soon. W8CAT has been trying out a 8500 kc. phone. W8BGY now has two UX-210's perking due to one of the contests at the Grand Rapids hamfest. W8CED says he had the poorest month ever on 14,000 kc. not hearing any OA or OZ stations. W9CE was QRW on a hunting trip. W9CSI intends going to Detroit to work. W8DVA handled fifteen messages with a 201A. W8DCW lost both the big masts but keeps on the air with a temporary antenna system. W8CWN has been doing broadcast service work. Look out we don't lose you, OM. W8DYH is going to install an outdoor antenna in hopes of improving his traffic total. W8DSF is experimenting with a Zepp antenna on 14,000 kc. W8ERS had a write-up in the paper and is getting quite notorious. W8CFM handled a msg from WFBT for Houghton, Mich. W8BAX is QRW helping care for a new Op. W8ACB has been helping get the Cass High transmitter in shape, their call being W8VH. W8AUB recovered enough from the Hamfest to send in a report and wants a QSO party every month. W8AYO of Eaton Rapids, ex-8BUD and ex-9CLP, is back with us again after three years' absence. W8DKX still has the xtal outfit perking and worked ten stations during the QSO party. He is quite active in the USDA Net, too. W8CYQ put up a new Zepp and now gets all R7 to R9 reports. W8AMS worked W8DKX on 8500 kc. and says 7000 kc. no good for Mich. QSO's. W8CKZ keeps his mercury arc in the garage, sort of an aircooled outfit now. W8BFH reports some new transmitters being built in Battle Creek. W8DED was QSA on the G.R. Hamfest and the SCM and he had quite some QSO. The Mich. QSO party on 3500 kc. was quite a success even tho it started off with a bad night. The weather cleared late in the evening and was FB for those who stuck. W8DED was QSO 12 and W8DSF and W8DKX had 10 each, also W8BGY. Most of the fellows who reported on the QSO party want one once a month. In talking the thing over at the Hamfest, decided that the third Friday of each month would suit most of the fellows. The next one on 8500 kc. will be held January 18, 1929. The 7000 kc. QSO party did not turn out so well owing to many forgetting the date. If there are enough who want a 7000 kc. party once a month will ar-

range that also. Write in your requests, fellows. The Western Mich. gang held their third Hamfest in Grand Rapids on Nov. 25th. About 25 were present. The SCM was surely glad to be there and meet all the fellows and for the pointers on xtal control he received from the skit put on by Mr. Ives of WASH and WSDQB. Wondered what caused those holes in the pavement around the station. Would like to find out which Axis that xtal was cut.

Traffic: W8BCI 59, W8BV 3, W8DVQ 8, W8CAT 8, W8BGY 24, W8CED 21, W9CE 16, W9CSI 23, W8DVA 15, W8DCW 12, W8GWN 6, W8DUH 18, W8DSF 7, W8BRS 24, W8CFM 15, W8BAX 24, W8ACB 7, W8AUB 27, W8AVO 8, W8BDK 39, W8CU 2, W8CKZ 9, W8DJR 19, W8BFH 21, W8CEP 18, W8DED 184.

ILLINOIS—SCM, F. J. Hinds, W9APY—Please gang, stay within our bands. Report the off-wave stations direct to ARRL and the Supervisor of Radio in your district. W8CNY has replaced the chemical with a pair of rectifier tubes. W9ANQ reports the new Waukegan club has 15 members and a new ham, FB. W9CNP says if the gang don't report next year, it will be because they have gone "West". W9AHK has a fifty now. Did you fellows know that W9FTU is 71 years old? Give him a buzz as he is there with the goods. We have a new traffic man in W9FMR. W9ERU says the Rockford Radio Club is popular because it has "No dues". Hi. How do you get away with it? W9FRU has an automatic mercury arc going nicely. W9FT was QSO ten countries in November. W9FOH is another new traffic man. Welcome, OM. W9GV knocks down the foreign QSO's yet. W9BXB had a fire which put him off the air 7 months. He is back with a bang a la 1929. W9CFD lives in Detroit. W9BNI loaned his receiver to the local power company to check time clock (Master Warren) with NAA time signals. FB, OM. Let's help W9CUH get Asia for his WAC. W9ACU is in constant contact with WFAT. W9DDE is going strong on traffic QRV. W9ITX has left us in favor of a "G" call. Good luck, OM.

Traffic: W9EJO 145, W9LL 106, W9DDE 102, W9ACU 76, W9DXZ 71, W9ERU 71, W9CNP 50, W9FCW 50, W9APY 48, W9GE 47, W9DCK 36, W9EAT 28, W9DOX 26, W9GV 26, W9FDJ 25, W9FDJ 21, W9ASE 20, W9FDY 19, W9AFB 16, W9BSH 16, W9RZO 16, W9CUH 16, W9FMR 15, W9DGK 14, W9AD 13, W9BVP 13, W9FT 11, W9FOH 11, W9ALK 10, W9AHK 9, W9CNY 9, W9ANQ 9, W9BKE 8, W9ETU 4, W9KR 3, W9ME 3, W9DWP 2, W9QD 2, W9CCZ 1, W9ECR 1.

WISCONSIN—SCM, C. N. Crapo, W9VD—W9DLD got into the RPL again after reassembling his transmitter. W9DEK has schedule with W9DLD and is going fine. W9BPW is on daily from 6 to 7 pm and has schedule with W9DGV. W9DTK is going along fine and keeping Naval traffic moving. W9FAW is increasing power and looking for more schedules. W9EWY reported via W9EYU. W9SO is putting in crystal control on 3530 kc. and 1790 kc. W9EWN is keeping the BCLs dodging in Dodgeville. W9CVI is putting in a screen grid receiver. W9EYH blew his filter and rebuilt his rectifier. W9EYU has daily schedule with W9RJY. He is putting in crystal control. W9BWZ says his wave hops, skips and jumps. W9OT also has trouble with his master oscillator. W9XH-EK has five schedules and wants more. W9DLQ says his 7000 kc. Zep works fine on 3500 kc. W9RJY is keeping three schedules on 3750 kc. W9LV is going good on 3500 and 7000 kc. W9RIB had his arm broken cranking his 1915 Lizzie. Tuff luck, OM. W9CYO says all he needs is traffic. W9RSS again reported. W9DND wants schedules on 7000 kc. W9DZZ has a small total owing to bum schedules. W9DJK would be on the air more except for the BCLs. W9EZZ sends first report, using 50 watter on 7690 kc. W9AZN is busy with BCL work. W9VD has MO PA outfit going in good shape now.

Traffic: W9DLD 206, W9DEK 124, W9BPW 97, W9EYU 50, W9FAW 37, W9EWY 33, W9SO 29, W9CVI 28, W9EYH 26, W9RWZ 23, W9DTK 22, W9OT 22, W9VD 7, W9EK 22, W9DLQ 20, W9RJY 17, W9LV 16, W9RIB 13, W9CYO 10, W9EWN 29, W9RSS 9, W9DND 8, W9DZZ 7, W9DJK 5, W9EZZ 2, W9AZN 1.

#### DAKOTA DIVISION

NORTHERN MINNESOTA—SCM, Carl L. Jabs, W9RVH—First honors go to the ex-SCM W9EGU. He keeps a daily sked with WFBT and handles some real traffic. Next in line is W9CTW

who helps to clear W9EGU's traffic. He is out for the crystal prize. More power to you. W9ERB reports having trouble getting a good note. Why. Why not read up in Handy's Handbook and QST. W9EHI says 7000 was no good most of the time. W9CKI reports little activity but says it won't be long. W9CF had a pleasant visitor in W9EFK. W9ADS gets 17 to 9 from both coasts using one 210. He is now rebuilding to use an 852 with 4 281 rectifiers. W9CTY is on for good and handling traffic for the city. W9FFU has a 7000 kc. Zeppelin antenna and is rebuilding to a 1929 Hartley. W9BCT has his station going at Fort Snelling. (He's in the Army now, Hi) He has accepted the Route Manager's job, so write to him for your schedules. He is a very fine fellow and I hope you will give him your support. His address is Neil B. Coil, Hdqrs. Co. 3rd Infantry, Fort Snelling, Minn. W9EHO reports QSO to the west coast easy on 28 mc. but only heard two 1's. W9BBT expects to visit the SCM. W9EGF is home after visiting hams and will be on soon. W9RMX is still off and says after losing his plate transformer, the wind changed his mast into a Horizontal one. Hi. W9VBH has completed rebuilding his entire station. He gets R8 to R9 from W9NIC, proving that the new current feed Hertz pushes some of the 210's juice out.

Traffic: W9EGU 182, W9CTW 63, W9ERB 44, W9EHI 17, W9CKI 16, W9CF 14, W9ADS 12, W9CTY 12, W9FFU 7, W9BCT 6, W9EHO 5, W9BBT 4, W9BVH 1.

NORTH DAKOTA—SCM, B. S. Warner, W9YV—W9CUT takes the lead in traffic handling this month. He handled traffic from four different countries, then had hard luck and blew his plate transformer and two rectifier tubes. W9CDO also had bad luck with his motor generator and burned it out. Now he uses B batteries for plate supply. W9RVF, the new RM, handled a nice bunch of traffic this month and says that he has another new ham started in his home town. W9FCA is a new ORS in this section working on 1715 kc. He says that No. Dak. stations are hard to QSO with but gets R5 from stations in the central states. W9IK has 15 watts and is looking for more bottles so he can increase to 20 watts. He keeps code practice (1750 kc.) skeds on Tues. and Fri. each week between 7:30 and 8 pm. FB, OM, keep the good work up. W9RRR is QRW with railroad work and BCL sets but says that he will be going strong in the very near future. W9DM is QRW with school work but promises that he will be on with a 1929 model as soon as he gets his plate supply rebuilt. W9DYV, the SCM, has been busy checking up on the Section and has not had much time to handle any traffic this month. There are a few ORS who do not report and if they care to keep their certificates, they will have to send in their report cards. This is the last notice.

Traffic: W9CUT 145, W9RVF 72, W9IK 3, W9CDO 2, W9FCA 2, W9DYV 2.

SOUTH DAKOTA—SCM, D. M. Paek, W9DGR—Real winter is here and several more stations are coming on the air now that the corn's picked and the football season's over. But what's the matter with the Sioux Falls gang this year? There's more life in that town, I know—show it. W9DWN has the usual high traffic total and may be heard daily on 7000 kc. and 3500 kc. W9DB is on more regularly now and is looking for skeds east and west. W9FKV is a new reporting station in Rapid City. W9EJY visited W9EJH and WNAX at Yankton and is on 7000 kc. and 3500 kc. daily. Other active stations are: W9AZR, Fort Pierre (7000 and 3500); W9EJH, Yankton (7000 and 3500 kc.); W9DGR, Huron (7000 and 3500). Other active stations are requested to report to the SCM.

Traffic: W9DWN 170, W9DGR 37, W9DB 26, W9FKV 5, W9EJY 4.

SOUTHERN MINNESOTA—SCM, D. F. Cottam, W9YA—W9COS has skeds with five stations. He keeps them several times per week and clears his hook every day in any direction. He is well pleased with a new antenna system. W9DOP is busy with school and rebuilding but manages to turn a good report because he has some skeds. W9EFK still works WFBT and continues with his regular DX work while building a new 222 receiver. W9BTW is very QRW school but with his new xmitter is doing nice work. W9ELA has been DXing this month. W9FOH has handled traffic on the DX order this month and has new call for Minneapolis which is W9GBD. W9DMA has simply been pounding brass this month. W9BKX is on regularly 7690 kc. W9DHP went to Madison, Wis., to see the football

game and saw W9EK. W9GH is on 7000 kc. W9AIR took a commercial exam and he says, "I flopped." Better luck next time, OM. He has heard some WFBT traffic and of course that is interesting to him because Op Berkner's home is at Sleepy Eye. W9DGE is counting the days when he will be thru with the boat job for the winter. As you know the election of a new SCM is under way and you will no doubt know who the candidates will be by the time this appears. It was necessary to extend the time of receiving petitions at Headquarters until Dec. 20. I have enjoyed the work for the section very much. In the future, my station will be heard on the air as it has been heard since 1913.

Traffic: W9COC 66, W9DOP 52, W9EFFK 12, W9RTW 17, W9EOH 9, W9ELA 7, W9DMA 9, W9BKX 6, W9DHP 2, W9GH 2, W9AIR 1.

#### DELTA DIVISION

**MISSISSIPPI**—SCM. J. W. Gullett, W5AKP—W5ANP says that he hasn't been able to get going much lately as he loaned part of his transmitter to a broadcast station WGCM but he says he will have his transmitting junk back soon. (I hope so, OM, as old Miss, needs all the traffic it can get). W6AED came back on the air November 25th with another Hartley rig on 7000 kc. and says it works much better than the old transmitter did. He says that he will change to 3500 kc. crystal controlled set on January 1, 1929. FB, OM. W5FQ says that he seems to be getting along much better with the BCLs lately as he isn't getting complaints about his transmitter interfering with their programs. W5AJJ has moved to New Orleans for the winter and says he had a real good reason for not operating his set during the latter part of Nov. as the stork visited his home Nov 12 and left a new brass pounder. (Congratulations on the new boy, OM). W5GG, ex5API, is off the air for a few weeks as he blew his motor-generator. He has been visiting W9EBC. W9FLS and W9BJE. (I hope to see you handling messages as you used to, OM). W5AKP has been handling a little traffic on 14 mc. but finds this band very unstable at night. He will come on with a new Pilot Wasp Receiver and a new 14 mc. transmitter within the next few days.

Traffic: W5AKP 58, W5FQ 24, W5GG 12.  
**ARKANSAS**—SCM. H. E. Vette, W5ABI—We have been having fine radio weather and you can see by the traffic totals that many of the gang are taking advantage of it. This month's traffic total is the largest that we have had in some time. Let's see if we can't double it next month. All ORS that have not been reporting are hereby warned that their ORS appointment will be cancelled if they are not heard from soon. W5HN is using a pair of 210's and gets good reports. W5BCZ handled the largest amount of traffic this month. He handled a 225 word message from the Byrd Expedition. FB, OM. W5BDD is getting out well. W5ARY is looking for a plate supply and will be on soon. W5ABI has taken on a better half and will have more time for radio now that he stays at home. Hi, W5AQX continues to handle his share of traffic and has several skeds. W5ARA hands in a nice traffic report and works several stations on schedule. He has worked six countries in the last month. W5ALY is a new station in El Dorado and is getting started with the aid of W5ARA. W5SS says that he sure is stepping out on fone. The Xmas rush is keeping him busy at the store so he does not have much time for traffic now. W5AUU has a MG now and hopes to be on the air regularly. W5IQ has rebuilt his complete station for 1929. W5ZAA continues to push his 210 xmitter. W5DD is putting up a new 65 foot pole and will be on 3500 kc. W5AAJ sends in a nice traffic total. Let's see just how many messages the Arkansas gang can handle next month. Will Arkansas lead the Delta Division? It all depends on you, kang.

Traffic: W5BCZ 32, W5ARA 24, W5AAJ 23, W5AQX 21, W5ABI 18, W5AUU 6, W5SS 1, W5HN 1.

#### HUDSON DIVISION

**EASTERN NEW YORK**—SCM. F. M. Holbrook, W2CNS—W2ABY discarded MG and installed a new transformer. W2AXX has junked old Hartley and trying 1929 Hartley with DC note. W2QU has raised 60 ft. mast. W2SJ keeps 7 schedules. W2BFF using 852 but bad tooth has held down traffic. W2AQL goes on to inactive list for few month. W2ANV working on 1945 kc. and has 4

good schedules. W2BGB is now NCS, Albany County, Army-Amateur. W2AGP back on 7000 kc. but had no luck on 14 mc. W2AYK has daily schedules. W2BKN handled traffic from Mayor of Yonkers in West Indies and messages from S. St. Mary via nj-2PA. W2BAQ sends first traffic report using 201A. W2BVF using 14 mc. and was QSO with SB. He is now forming a local Schenectady club with W2ACB, W2AAL, W2BLQ, W2AQS, W2BOY, W2BLE, W2BMS, W2ACY. W2ACY works on 14,000 kc. and 4895 kc. He had six visiting hams last month. W2AGR operates on 7000 and 3500 kc. but school cuts traffic low.

Traffic: W2BGB 82, W2QU 58, W2SJ 54, W2BFF 98, W2AQL 29, W2ANV 24, W2ABY 18, W2AKY 13, W2BKN 12, W2AXX 5, W2BAQ 7, W2BVP 5.

**NEW YORK CITY & LONG ISLAND**—SCM. M. B. Kahn, W2KR—W2AAG—Manhattan: W2SC comes through with a fine report and makes the BPL. Most of the traffic was handled through the Army-Amateur Net. W2KR is operating on both 3875 kc. and 7750 kc. but will change to top of 7000 kc. band with crystal control. W2BGO, RM of Manhattan, finds more traffic on the 3500 kc. band. He can usually be found there between the hours of 3 to 5 am daily. W2ECB is another station who has moved up to the 3500 kc. band. W2OV comes through with his first report. W2BNL is trying his 3500 kc. fone. Bronx: W2APV still gets lots of traffic from nj-2PA. W2BFPQ is a new ORS and alternate for W2KRN Army-Amateur Net. W2ALL, due to illness, is going to Texas, but will keep in contact with the east through ham radio. (Best of luck, OM—SCM). W2BBX is rebuilding and putting in a 203A as PA for his crystal set. W2AET is complaining that the gang is careless with messages QRA. Brooklyn: W2PF is very active on 3770 kc. as Army-Amateur Station and USDA station. W2CMU sends in his first report. W2BFG reports W2BRA of the Bushwick Radio Amateurs has a staff of 15 licensed ops. W2BRB is experimenting on 25,000 kc. with crystal control. W2BAZ is in line for an ORS appointment. W2BO is now regularly on the air after a long absence. W2AJL is on 28,000 kc. Long Island: W2AVP comes through with his usual fine report and is a new ORS (Welcome OM—SCM). W2AIZ was heard in Russia on 3500 kc. and almost dropped dead from the shock. W2AZV is a new candidate for an ORS.

Traffic: Manhattan: W2SC 1007, W2KR 106, W2BGO 64, W2ECB 31, W2OV 10, W2BNL 8, Bronx: W2APV 154, W2BFPQ 118, W2ALL 43, W2CYX 31, W2BRX 14, W2AET 11, Brooklyn: W2PF 67, W2CMU 36, W2BFG 23, W2BRA 16, W2BRB 16, W2BAZ 11, W2BO 8, W2AJL 5, Long Island: W2AVP 128, W2AIZ 66, W2AZV 21.

**NORTHERN NEW JERSEY**—SCM. A. G. Wester. W2WR—Traffic has been on the increase owing to more ORS coming back on the air. In another month traffic will be going thru Jersey in large bulk. RM W2CP had a meeting of traffic handlers at his home and renewed the traffic spirit in some of the hams. W2AOS and W2BIH have applied for ORS appointments. W2ASZ is too busy at college and has resigned as ORS. W2AVK will move to NYC shortly which means another good ORS will leave Jersey. W2MD had the highest traffic figure in our section. W2WR will be back on the air soon. W2AOP very busy with W2CP is getting traffic moving from all points into and out of Newark. W2ANG is building a new 1929 receiver. W2BAL has been very busy fixing BCL receivers. W2JG maintains 2 schedules a week with W9COC. W2CJX has been on 14,000 kc. which means little traffic handled. W2IS has been on very irregularly and has been working WKP in the Gulf of St. Lawrence. W2CW is building a new rectifier so is temporarily off the air. W2BY has been very QRW with school and receiving amateur OM visitors. W2AT can't keep schedules because of business pressure which keeps his traffic low. W2BFO is QRW at WAAM and with new xmitter, W2CO got married but hopes to get the set going soon. W2AOS is handling plenty of traffic in the Army Net. W2AEC got his Zepp perking FB but blew out plenty of parts of his xmitter.

Traffic: W2MD 155, W2AOP 50, W2ANG 11, W2BAI 11, W2JC 5, W2CJX 14, W2CW 6, W2BY 3, W2CP 50, W2AT 35, W2BDF 7, W2AOS 32, W2AEC 3.

#### MIDWEST DIVISION

**NEBRASKA**—SCM. C. B. Diehl, W9BYG—W9AN is starting up again. W9QY is on 1750 kc. W9DVR is rebuilding. W9FAM is on 3500 kc. and 7000 kc. for traffic. W9DNC handles important traffic and operates in the early morning.



W9DI is getting ready for winter's work. W9BQ is QRL chucking corn. W9BLW open for traffic. W9BBS all set. W9BQR is QRL in post office. W9CJT is going to school in Chicago. W9BYG had a cold. W9EUT works right along.

Traffic: W9ANZ 11, W9CQ 5, W8DVR 14, W9FAM 146, W9DNC 66, W9DI 3, W9BLW 6, W9CDB 14, W9EUT 19.

KANSAS—SCM, J. H. Amis, W9CET—Traffic has increased 100% over last month. F.B. gang, keep the good work up. W9CET leads the state in traffic and has the new 250 watt rig going with pure DC from a mercury arc. W9LN keeps a daily sked with Australia. W9BHR is instructing a class in radio at the local H. S. W9RUY loses his 50 but will be on again soon. W9FLG is the proud father of a new junior op. He wants to know what became of the Iowa hams who wanted Kansas skeds. W9DFY has hopes for an 852 soon. W9HL is keeping 4 skeds a week on 3500 and 7000 kc. W9CFN has near DC now and says traffic and DX are showing a big improvement. W9CKW is on 3500 kc. and wants regular skeds west. W9DIH has put in a mercury arc so his rectifier troubles are now over. W9CCS is very QRV school but is on some with a 1929 rig. W9FTY would like to have an ORS and is on 14,000 kc. regularly. W9BGX has come to life and will be on with two ops. The SCM has appointed two RMs, W9CFN and W9FLG. Give them your support, fellows, and watch traffic climb.

Traffic: W9BHR 17, W9FLG 70, W9DFY 21, W9HL 21, W9CET 268, W9CFN 146, W9CKV 24, W9DIH 15, W9LN 60, W9FTY 18.

IOWA—SCM, H. W. Kerr, W9DZW—Fifteen reporting stations with two ORS in the making set the pace, the non-ORS lead in number of reporting stations. How to originate refreshing traffic is the paramount question. Just a hint, gang. W9DEA and W9EIV got the front page of the Sioux City Tribune with a three column picture of their "den" and transmitters. In the article they extended an invitation to the public to send free Xmas greetings via their stations; the Tri-state Amateur Radio Club with 16 members has been organized. Code lessons will be given and broadcast over K3CJ. Get your just deserts in newspaper publicity. OMS. The press is always looking for hot news. W9EDW, a coming ORS, heads the list and issues a challenge to W9DEA to a traffic contest; to Puckett goes the honor of a sked with both WFBT and WFAT. W9DGW has a note that can be heard most any nite just a little below first magnitude on 3500 kc. His total proves it. W9BCA has a fine total with DX limited to Canal Zone; W9CZC wants immediate poetical report on any CC note heard from his station. W9DZP is QRV motion picture camera experimenting. W9DNZ, W9B1B and W9CWQ who were recent visitors at W9DZW, together with W9DZC entered the movies in Little Sioux. W9DZW has west sked with W9FAM. W9EJQ's totals begin to swell since finishing country work. He keeps skeds with W1CGR, W9AMO and W9DI and wants morning skeds on 3500 kc. W9E1W, new ORS, and consistent reporter, is elated over sked and fone contact with W7AAT. W9EHN's traffic slumped a bit but says more YLs are enlisting to raise the traffic totals of eastern Iowa. FB. They all get the fever when W9E1W's transmitter is displayed. W9DRA has moved out to operate WKBS at Galesburg, Ill. W9PB takes over W9DRA's cafe. W9FJA edits Cornell's "Royal Purple" but finds some traffic. W9BAT plays football and attends Coe College. W9DPL blew a 210. W9ASM has been trying 28 mc. Sunday afternoons—hears many, but no QSO yet. W9FFD sends first report, fine! W9CKQ says his sked with oa5HG is slipping. W9DEA is moving his set to his home and W9E1V will operate at former location with both ops. W9FZO another first reporter—come again! W9DNZ is making skeds with the west coast. W9EFH, after several months on the road, has settled down in Newton. Merry Xmas to the gang.

Traffic: W9EDW 402, W9DGW 281, W9BCA 204, W9CZC 114, W9DZW 102, W9EJQ 101, W9E1W 37, W9EHN 34, W9FJA 33, W9FZO 22, W9DEA 26, W9CKQ 12, W9FFD 7, W9ASM 4, W9DPL 1.

MISSOURI—SCM, L. B. Laizure, W9RR—W9ZK was high traffic man in St. Louis. Transmitters are ready for both upper bands. Others with good totals were W9BEU, W9DSU, W9DLB and W9BMU. W9DSU is a new ORS by transfer from Central Division. W9CBO is a new station. W9BEU keeps an oo-KAM sked daily except Sun. at ten pm. W9DZN advocates the gang getting to the top of the 7000 kc. band now. W9BMU is getting out well on fone and had a rag-chew with the SCM. W9DUD is getting good results after rebuilding. W9BHF

was also QSO the SCM. W9DOE enlisted five recruits for the USNR this month. W9DAE and W9AYK staged a traffic contest which was won by W9AYK. Both stations relied mainly on 3500 kc. for skeds. (Practically all the higher traffic scores were also on this band). W9FNJ, W9AYK and W9GBC reported by radio. W9GCT is a new station in Centerville. W9DHN added another sked and is also QRV on 1750 kc. band in addition to 7000 kc. W9CDF says key clicks are his worst QRM. W9ERM was busy. W9EUB was on week-ends. W9ECS handled plenty and says W9GCN is a new station in Sikeston and also that W9BVC visited the gang in that section in the interest of the USNR. W9EPX kept four skeds and found time to visit W9BFB and says he is getting on 3500 kc. W9BJA keeps three skeds on 7000 kc., one each on 14,000 and 3500. Broadcast harmonics and out of place fones are causing bad QRM on 3500 kc. at his station. (And everywhere else—SCM). W9BQS on 7000 kc. band says he would be on 3500 but the yard isn't big enough. HL. W9ASV got excellent total and a fine copy of the Navy Day broadcast as noted in last QST. W9DKG works three traffic skeds on 7800 kc. and another with vs-1FM in San Salvador, C. A. Kansas City is having excellent activity with much traffic moving. Over 500 messages were sent out from the radio show thru various local stations. W9EQC, W9BSB, W9FHV and W9DQN led the 7000 kc. gang. W9RR represented 3500 kc.; also handled the most messes per sked (only one sked. hi.) W9DQN is trying to assist W2SJ organize the western end of his "Golden Gate" traffic chain. W7AAT is working eastward with another chain leading from the north-west. W9BQC has a new commercial ticket. W9DOJ is keeping up the USDA test skeds. W9ZD is QRV television work. W9FIO is active. W9FHV is building SW receivers. W9FEH and W9FKH are on for traffic. W9EYP is temporarily QRT getting ready to move and operated some at W9ZD. W9BUR is also going to move. W9BUL applied for ORS. W9GCL is a new station at Calhoun, 75 miles south of K. C. W9BFB reports numerous visitors and rag chews by radio with W9EPX, W9FNU, W9FSI and others on 1750 kc. band. Look out for her on Sunday pm. W9FEH applied for ORS. W9CHE of St. Joseph was heard testing on 3500. Glad to hear you up there, OM. New radio inspector's office in P. O. Bldg., K. C. QRV for business, amateur exams on 1st and 3rd Fridays monthly. Commercial on same Thursdays. Now is the time to get that extra first ticket, OM.

Traffic: W9REU 47, W9BHF 3, W9DZN 17, W9DUD 11, W9ZK 118, W9BMU 20, W9DSU 34, W9DLB 21, W9DAE 312, W9DKG 54, W9ASV 80, W9BQS 4, W9BJA 89, W9EPX 18, W9ECS 66, W9FNJ 65, W9AYK 362, W9DHN 18, W9CDF 13, W9ERM 7, W9EUB 5, W9AHZ 25, W9FHV 53, W9ZD 38, W9EQC 68, W9EMH 4, W9FIO 31, W9DOJ 12, W9FTE 12, W9BSB 41, W9DQN 78, W9RR 271.

#### NEW ENGLAND DIVISION

MAINE—SCM, Fred Best, W1BIG—W1AUR, Route Manager for Central Maine, stepped on it this time and handed in a mean total. He is leading all the RM's for high total by a big margin, but is just a bit short of the BPL which is his goal. FB. Hall W1ANE, RM for Northern Maine, ran second to W1AUR and gives notice that he is going to give the whole works a real race next time. Nice work, Harry! W1CDX, RM for Western Maine, ran number three. His total just failed to reach W1ANH. My what a nice traffic race we are going to have between the four RMs and SCM before next report rolls in. W1AUS of Lewiston, ran number four on the list. Ken says he will be on soon with two 500 watters with a transformer built to make them talk—then watch his total! Nuff said. W1KQ and Mrs. W1AJC tied this month. FB, OM and OW. W1ARY has made application for an ORS and is in fair way to land it. He has a good weekly schedule with VE1AY so route your traffic for the Maritime Provinces thru him. W1BFX, one of our real old timers, is back on the 3500 kc. band with a good wallop. W1AQL, RM for Eastern Maine, complains of a power leak in Brewer that made life, as far as radio is concerned, very unpleasant for him. He has a fine schedule with W1ANE every day and is gradually lining up the Queen City gang into a real organization of traffic handlers. W1AJC has been moving to a new shack. He plans soon on having a real 3500 kc. outfit going for traffic and then he and the OW will have some large totals or we miss our guess. W1AGD, our OO, turned in a good report in spite of the fact that most of his time is spent on 28 mc. Lou has turned in some mighty



good work down there. WIART sent in his usual total. He is interested in and has done some notable work with low power on 7000 kc. and 14 mc. Practically all of the Maine gang received a letter of commendation from the Commandant, First Naval District, covering the Navy Day Broadcast. FB, gang! Everyone is on the job, and Maine is surely making a fine showing in all departments of our chosen hobby.

Traffic: WIAUR 161, WIBIG 108, WIANH 84, WICDX 69, WIAUS 26, WIAJC 23, WIKQ 12, WIAHQ 18, WIBFZ 15, WIAQL 13, WIAJC 23, WIAQD 9, WIART 5.

NEW HAMPSHIRE—SCM, V. W. Hodge, WIATJ—Traffic took quite a jump this month. Most of the stations have settled down for the season. WIIP threatens to make the BPL as soon as he gets his new transmitter going. WIAUE is now an ORS, and handles a lot of traffic with the help of five skeds. WIBTF is still busy with college work. WIJN is keeping regular schedules. WIAEF takes the prize for hard luck. He lost his big pole, power transformer and plate meter. Tough luck, OM. WIANS, WITA and WIAFD handled a lot of traffic for a radio show, WIAFD having set up his transmitter and receiver at the show. A Concord paper covered a football game by radio with the help of WIAUE, WITA, WIAFD and others. WIAVJ got a lot of publicity by getting news to Germany first of the landing of the "Bremen". He has just received the dope from Germany. WIBST is getting out well. WIATJ has got his crystal going and may be found on 3950 kc.

Traffic: WIIP 100, WIAUE 98, WIANS 135, WITA 125, WIBST 19, WIATJ 58, WIAEF 10, WIBFT 8, WIAFD 154, WIJN 9.

VERMONT—SCM, C. A. Paulette, WIIT—I have more report cards this month than usual—good work boys, and please keep it up. WICGX is again at the top of the list for traffic. Now, fellows if you will try and send a message to me once a week and let me know what's going on in your direction. We will try and have a condensed report of doings in this state broadcast once a week from WIAJG. WIAJG says he will begin the broadcasting on Wed. night at 10 pm, the first week in January. I had the pleasure of a QSO with VE2AS who was located in a mine 1700 feet underground with a portable transmitter. He reported my sigs R6 and he came thru about R8. He was in a drift of the mine in solid rock. A lot of good skeds are in operation throughout the state now, and it looks as if things would go big later on. WIYD reports that he has 15 operators in the making now. FB. WICGX has rebuilt his transmitter. WIFN reports a 1929 transmitter in operation at his station. WIBCK says he is going to be on very soon. WIAOO still very QRW with his work. WIEZ announces coming higher power and claims that 14,000 kc. is the best.

Traffic: WICGX 127, WIRJP 61, WIAOO 52, WIIT 47, WIBEB 84, WIYD 20, WIEZ 13, WIBCK 5, WIFN 8.

CONNECTICUT—SCM, C. A. Weidenhammer, WIZL—Four of the fellows managed to amass totals of over one hundred messages this month, two of the number, WIMK and WIBNS making the BPL. Let us try to double our hundred quotas and gain a monopoly of Conn. stations in the honorable mention column. WIVB reported by radio. WITD was obliged to discontinue all schedules during the month on account of a bad local power leak which made reception on all frequencies an impossibility. He hopes to get the power company to clear it up soon. WIBGC took two weeks off to revamp his transmitter so that it would measure up to 1929 standards. FB. The time is getting short for those who have not done that little thing. We commend WIBNS heartily on his 54 deliveries. Deliveries are what we are after in our traffic handling. The installation of a new MOPA set has kept WIAOX completely occupied during the month. He is praying that it will work as well as his old outfit. WICTI is out to make the BPL next month. We hope he's successful. Ells wants schedules with stations in every village, town and city in Conn. He is especially interested in the eastern part of the state and Bridgeport, Danbury, New Haven and other cities in the southwestern part. Tuesday, Thursday and Saturday nights after 8:15 are best for him. WIAFB is still unearthing new DX stations to work. His schedule with WITD was discontinued on account of WITD's power leak interference. Another rebuilding took place when WIAMG installed an MOPA with an 852 as its crowning glory. He

and WIAUK entertained WIAWQ and his father when they visited in New Haven. WIBI—IBQH is QRW with college work. His direct current house supply does not enable him to work much DX or handle much traffic. How about a rotary converter, OM? WIBWM is waiting for a new 210 tube. When it arrives, he expects to make up for lost time on 3500 kc. The situation at WIVE is altogether heart-rending. A decent outdoor antenna cannot be erected on account of the BCLs. Work on 14,000 kc. is about all that can be done—and then on an indoor antenna. Cheer up, ER. It could be worse. We are very pleased to hear from WINE, who is active on 7000 and 3500 kc. WIATG stated in his report that his 230 rectifier tube had been refusing to work properly with the filter he was using. He hopes to remedy the ailment and clear up his note soon. WIOS was QRW with other work during the month. Improvements on both transmitter and receiver have been made recently by WIBMG. With all these improvements in our stations, we should be able to do all sorts of splendid traffic work. WIAMC mentioned that DX had been rather poor during the month. Work at school kept him busy most of the time. WIBJK has been appointed Net Control Station for the Conn. area by Lt. Hertz of Boston. FB. All interested in Army-Amateur work are requested to write to him for complete information on the subject. WIZL has been working the Pacific Coast consistently on 25 mc. He should be on 3500 kc. for week-end schedules when this is read. WIBLF is active on 3500 and 7500 kc. with two transmitters, both using a 203A in the TP-TG circuit. He is looking for schedules. WIMK far surpassed previous totals. Parmenter reports that radio shows and WSBS are largely responsible for the increase. Several new schedules with the middle west and west coast are in operation and if things continue as they have, the thousand mark should be reached and passed. WIM recently did the Marine Corps a good turn when he relayed an urgent message to a Marine's wife in Bridgeport. He has been keeping a schedule with nm6NIC to keep the marine in constant touch with home. That is awfully good work. Congratulations! WIBIK—IZZA who was known to all amateurs recently as nmBX, underwent a very serious operation last month. From all reports, we delight to say, the operation was a complete success and Mr. Mapes is now convalescing at his home in Bridgeport. We all wish him a very speedy recovery. WIBM is very anxious to get going again, but he can't just seem to find the time to rebuild. WIRP made a new ham operator when he converted his uncle from BCLdom to Amateurism. The converted party uses the call W2ADK.

Traffic: WIAMC 5, WIBJK 16, WIBMG 4, WIOS 1, WIATG 12, WINE 12, WIVE 13, WIAMG 34, WIAFB 106, WICTI 110, WIAOX 8, WIBNS 136, WIBGC 4, WITD 34, WIZL 2, WIBLF 3, WIMK 736, WIVB 72.

RHODE ISLAND—SCM, C. N. Kraus, WIBCR—WIBLV is a new ORS and is making a very fine showing. WIBQD has been very busy rebuilding his set. WIAAL is doing fine work regularly. WIMO says traffic and DX are improving. WIBLS's only DX is se-2EA. WIBCRR has an 80 meter phone and wishes to QSO all stations in R. I. WIAWE is QRW new job and women.

Traffic: WIBLV 230, WIBQD 17, WIAAL 12, WIMO 10, WIBLS 7, WIBCRR 7, WIAWE 4.

WESTERN MASSACHUSETTS—SCM, Dr. J. A. Tessmer, WIUM—What do you think, fellows? WIDR made a 1929 QST model S. W. screen grid receiver and it worked at once. 6's and 7's pounded in R9. So, fellows—if you have any trouble—well, you know what I mean. WIAAC has moved to 121 West North St., Wardsworth, Ohio. His call is W8AQ. Alvin Rock, WIBKM, is a new ORS at Springfield and starts the ball rolling with 70 messages. Let's hope the ball keeps rolling. WIBVR is doing noble work trying to get traffic with 6's and 4's on his week end. HI. WIBIV is on the air again. WIANI has schedules with WIKY. Marvin says less YLs are more traffic and building screen grid. WIBNL is a new ORS from Saco, Maine. QRA is C. B. Kelley, 15 Harvard St. Good luck to you, OM Kelley, and the Worcester Radio Assn. at 274 Main St. anticipates a visit. WIAOF xtal xmmitter ready soon. Has schedules with fq-PM each week. For the benefit of those that don't know it, HI. traffic reports should be in before the 26th. (Attention R. A. N.)

Traffic: WIBIV 5, WIANI 39, WIADO 20, WIIL 16, WIAOF 6, WIBKM 70, WIEO 18.

EASTERN MASSACHUSETTS—SCM, E. L. Battery, WIUE—Looks as though this section was coming back to its old standard of traffic work again. Five

stations make the BPL this month—WIKY, WIACH, WICQ, WIWV and WIAAW. Fine work, OMs. We also have two new ORS in WICQ and WIAZE. Your SCM is having a number of inquiries regarding traffic work from non-ORS which looks very promising. WIKH has built a new Hull receiver and reports QRM nil—big volume. WIWV worked a little DX and maintained several schedules. WIKY says traffic better. She keeps five schedules, plus the rest of her RM work. WIFL is rebuilding. WIBVL was heard in England on 28 mc. FB. He says 28 mc. sigs have been coming thru very nicely. WIAGP, a new fellow in Saugus, sends in his first report. Let's give him and all other newcomers a helping hand. WIACH gets pure DC now with his new transmitter—he is next to report using an acoustic filter, WIKH being first. WIBLX has been investigating BCL QRM. WILM says he is getting warmed up again. WIRL is looking for good skeds. WIACA, all set for 1929, is going to stick to 3500 kc. this winter. WINK and WIUE were on Naval Drills every Tuesday as usual. Election over, WICRA reports result of his straw ballot—Hoover 206, Smith 39. Undecided 2, there being 48 stations represented. WIABA still finds some time to pound brass. The 150 watt outfit at WIASI is shaping up again. WIAZE handled some DX traffic. WIAKS, and WIBLD sent in their initial reports. Reports were received from WIBDV, WIBBT, WIAPK, WIPB, and WIRF. WIBZ is now working for Eastern Radio Institute—he has made several sea trips as radio operator. As the section is quite large, the SCM must have reports from you if you expect to see your station mentioned herein. At this time it is in order to wish you all a happy and successful New Year.

Traffic: WICQ 222, WIACH 202, WIAAW 202, WIKY 118, WICRA 120, WIWV 131, WILM 85, WIHK 47, WIBLD 48, WIACA 28, WIBLX 23, WIPB 23, WIUE 15, WIARS 13, WIAGP 12, WIAZE 11, WIASI 10, WINK 10, WIRY 9, WIAPK 8, WIBBT 3, WIRF 1.

#### NORTHWESTERN DIVISION

IDAHO—SCM, J. L. Young, W7ACN-7JL—W7ABB is our star traffic man this month and made the BPL, altho he was off the air and sick for about a week. Fire did a bad turn to two of our stations this month. W7ZN lost the top of his house and one story. He expects to be on right away, after being off the air about a year. W7BAD left his set on overnight and the transformer and transmitter went up in smoke together with the curtains. He had a close shave himself, as the fire had almost burned his bed while he was asleep. Nevertheless, he got another set on the air and turns in a nice total. He is a new man, ex-W9BAD. W7YA is on the air regularly with a crystal set with some new MG sets. W7QC is busy installing a new city water system, so designs his ORS and Q appointments. We have some new ORS with us. They are W7ALO, W7ACD and W7AJQ. They are looking for your traffic on all bands. W7ALC handled a stack of messages but lost his message file, so cannot give us his total. He has rebuilt but luck isn't so good as it used to be. W7ACD is building a new receiver and also a shack out under the old apple tree. He is also putting up some new antennas. The gang at W7HK are getting some new SW sets going and some new stations expect to be on soon. W7AGT forgot to renew his call but will be on as soon as he gets a new one. W7AJQ is on regularly on 700 kc. and is building a new MOPA crystal set to replace the old TPTG. W7ALW turns in his report and HE is TWINS. They are right there on all bands. W7QA-IY had a little slump in totals but promises to do better next time. W7GU has moved to Hoise and is on 3500 kc. quite a bit. He is busy with BCL work during the holidays. W7HE, Des Hart, of Caldwell, is a new ham on 7000 kc. and kicks out a wicked DC signal, using a 210 and a big R battery eliminator. W7VC of Caldwell is moving his station to Oregon for the winter but will be back next summer. W7ACN-W7JL has built a new shield-grid four-tube drum-dial set, and it is FB. Got it going the last day of the month. Antennas and power supply are next for improvement. Any new Idaho hams should slip your SCM a letter. Good work, gang. Show 'em Idaho is there with the goods.

Traffic: W7ABB 209, W7YA 100, W7BAD 45, W7ACD 12, W7IY 8, W7AJQ 7, W7ACN 2, W7ALW 2. W7ALC quite a few.

MONTANA—SCM, O. W. Viers, W7JC turned in a nice total and was only using one S watt. Daily schedules were kept with W6CRC, W9AVR, W7DD, W7HP and W7AAT. W7DD says local power leaks make it hard to copy anything. He would like reports on his new 3530 kc. phone transmitter.

W7FL says a radio club is being planned at the Montana State College. W7HP kept schedules and handed a nice list of traffic but forgot to report. Remember, gang, that he is the new KCM, so give him a lift. W7OW, who has been silent for several months, is starting up with a 112 on the 7000 kc. band. He is interested in television and wishes to QSL with others who are interested in the same. W7AAT worked on the 3500 and 7000 kc. bands with the 8S2 and kept several good schedules. Say gang! We have to snap out of our trance and get the reports into the SCM on the 26th. Several reports failed to come in this month and for some of them, about one more miss and the certificate is going to be cancelled.

Traffic: W7AAT 729, W7JC 315, W7DD 43, W7FL 10.

OREGON—SCM, R. H. Wright, W7PP—W7WR is open for schedules with the Northwesters, California, and Alaska. W7LT has been on 14,000 kc. but reports not much luck and will be on 3500 kc. soon. W7SI received a "heard" card from Copenhagen, Denmark. The box of snuff he expects hasn't arrived yet. Hi. W7FTL is putting in a 1K-860 power amplifier with a UX-210 oscillator. W7ABH is operating on the SS Caraco. W7UN has tried 25,000 kc. but says no luck. He now has a genuine 1929 DC signal. W7GQ is busy with BCL service work. W7QY is installing a 1929 transmitter to handle an 8S2. Upon popular demand, W7JN (Official Observer) has been given the authority to check unnecessarily long calls—lets keep to our standard League practice, fellows, and try and keep QRM to a minimum. W7PG, a fairly new call, with an old timer at the key, uses storage battery supply on a UX-210 for 7000 and 3500 kc. W7MF is high traffic man for this month, making the BPL. W7MV, W7AJW, and W7PP are all rebuilding and installing mercury arc rectifiers for 1929.

Traffic: W7MF 319, W7WR 68, W7UN 51, W7FU 51, W7PG 30, W7MV 23, W7ABH 20, W7SI 19, W7JN 19, W7GQ 7, W7AKM 6, W7LT 5.

#### PACIFIC DIVISION

SANTA CLARA VALLEY—SCM, F. J. Quemont, W6NX—W6JU, the station of the San Mateo Jr. College was appointed ORS this month and turned in a nice traffic total. The station is on 7812 kc. and is a part of a Junior College Radio Net. W6BVY is the control station of 3rd Communication Reserve Section of the 12th Naval District. The Commanding Officer, Lt. (jg.) E. J. Beall, besides drilling with other USNR stations, has again resumed his schedule with opLAU three times a week. W6AMM, the gateway to the Philippines was nearly put out by interference this month and between studies and the flu, it has been pretty hard for Bruce. All this did not, however, decrease traffic. W6BAX, the low power wonder, clicked with eleven 28 mc. stations with a 201A. Using a 210, he added 4 more, making 15 ten meter QSO's during the month. W6BMW put in a screen-grid amplifier and has reached the 1929 standard of reception. W6BYH is attempting to organize a radio club in Merced. Hams in his vicinity please note. W6NX took part in many USNR drills during the month.

Traffic: W6AMM 274, W6BVY 28, W6JU 26, W6BAX 18, W6BMW 16, W6BYH 5.

SAN DIEGO—SCM, G. A. Sears, W6BQ—Most of the gang either forgot their reports or did not mail them on time this month and as a result, our totals fall far short of the place they should be. Remember, gang, these card reports should be mailed not later than the 26th in order to be included and give your station the credit due. Let's have 100% next month. Ask your friend to report, too, even though he is not an ORS. We like to hear from all stations. W6EC leads the Section. He reports working AC-6AB, QRA Brown, 201 Kowloon Tong, Hongkong, China, QRH 7390 kc. Two complete transmitters on the air at W6EC now. W6BAM reports four skeds and traffic picking up fast. One sked is with KFR6 located at France Field, Canal Zone. W6BQ is now on 3798 kc. regularly and has a few skeds. QRV traffic east. W6DNS is back on the air after rebuilding and steps out in fine shape. W6BAS wants wave meters to calibrate from crystals (free adv.) W6BGL at Escondido is now a full fledged ORS and QRV traffic. W6AJM is back on the air again after rebuilding. We miss his big traffic totals. W6BFE has been heard on the 3500 kc. band. W6EOM at Oceanside wants to hear from beginners working on 1715 kc. His QRA is 201 South Hill St., Oceanside, Calif.

Traffic: W6EC 184, W6BAM 162, W6BQ 188, W6DNS 39, W6BAS 39, W6HGL 11.

ARIZONA—SCM, D. B. Lamb, W6ANO—W6BWS has been getting FB reports since he installed the 281's. He is going to rebuild soon on 7230 kc. and is also going to try 28 mc. W6CRA is on the air now on 7000 kc. W6DTU blew up a 210 grid leak plate blocking condenser and all the fuses in the house. He's getting to be a real ham now. HL W6EFC blew the 210. He is using a 201A which is getting out better. W6BJF worked Himoe of WNP from a six call in Glendale, Calif. He is doing some work on 28 mc. using remote control and one of the 1929 type Hartley xmitter. W6EEA heard W1CZ on 28 mc. and built an xmitter for that band but has never been able to work anybody out of town yet. W6DCO is grinding xtals for a new set to be built soon. W6CDU built a master oscillator using a 201A for oscillator, and a 210 for amplifier. W6ANO is using 100 watts now but he is planning on rebuilding to MO or TPTG. W6SW still keeps busy trying to get his mercury arc to working. Also YL QRW yet. W6BHC is trouble-shooting now and can't find much time on the air. W6AUI is now a motor cop on the Phoenix police force and is doing his stuff to keep the jail in business. HI, W6AMW is going to the U. of A. and spent Thanksgiving home. W6DIE is heard occasionally. W6DGY is also shooting trouble for BCLs. W6CCL is working radio with Sears, Roebuck Co.

Traffic: W6ANO 11, W6BWS 54, W6EEA 7, W6BJF 32, W6DFU 4, W6CRA 31.

SAN FRANCISCO—Acting SCM, C. F. Bane, W6WB—Due to the fact that most of the boys are still unaware of the appointment of a new official in lieu of Mr. Paterson resigning SCM, the reports are very scanty. Only three ORS reported and the non-ORS head the traffic totals. Look to your laurels, Ohs. W6AWA, W6DPF, W6DMT and W6DYB are certainly in line for ORS and all four are stepping out in great style. W6DPF's note is what we dream about and seldom hear. Hope to hear W6VR, former SCM on air soon with lots of traffic. W6DDN reports rebuilding over and now hungry for some good skeds. W6PW is back with us after a long stretch of night work. He is using fifty and seventy-five watt tubes in an ultraudion circuit and is the proud owner of a genuine 1929 receiver. May your traffic be in keeping with that receiver. Most of the boys have been bitten by the rebuilding bug and some fine layouts are in evidence. W6WN, the new OBS, falls in this class but promises great things for next month. W6DFS works Liberia with a 7½ watt. F.B. Let's have your report. W6JK was visited by the stork and reports new FB OM operator. W6WS says he is now going to sea. W6AAT is moving to San Rafael and is coming on with B battery supply. Drop me a line, OB. W6BGB in Santa Rosa is knocking holes in the air with a 250 watt and is thinking about putting in 500. Reports from any other Santa Rosa stations will be welcomed. W6WB falls out of the BPL this month on account of SCM job and rebuilding. With rebuilding about finished, things are looking rosy and the traffic totals should be considerably higher this coming month.

Traffic: W6DYB 50, W6DMT 38, W6DPF 19, W6WB 15, W6WN 30.

EAST BAY—SCM, J. Walter Frates, W6CZR—W6TP, chief RM, topped the traffic list again. W6ALX has been handling traffic as well as training new amateurs in code and theory out of a desire to see the old ARRL prosper and expand. W6DTM installed a high C transmitter and worked both the 7000 and 3500 kc. bands. W6BFO begins to loom up as a traffic man with the handling of a batch of messages and maintaining a schedule with OO-BAM in the South Seas. W6BSB still pounding away with the Ultraudion near 7410 kc. but says that the best DX he has worked has been Iowa. W6EDK, however, has managed to work the second district and Canada and is maintaining a sked with W6ATM. W6CZR has been off the air for several weeks due to illness and other reasons, but expects to have a second on shortly in the person of the honorable OW. W6BI continues to run traffic under difficulties and in the interims between Naval Reserve work. W6BPC at Vallejo is maintaining a schedule with K7ANS in what used to be known as NA and reports working WSBS under bad conditions at 6:30 pm PST November 21. W6ENV, a new man, announces that he has been on the air for about two weeks using flea power (201A) and will be out for traffic in the am. W6BZU at Concord continues to make his ORS reports by radio and is expecting to do some official observer

work shortly. W6BMS is rebuilding for 1929 by scrapping the Hartley and building a TPTG. W6BUX is back in Angwin from L.A. where he got a kick pounding brass at W6AM. His antenna came down in a storm but he has it up again and the 210 continues to pump a signal into Asia. W6EDR waits that he has blown his rectifier tubes. W6DDG is rebuilding and expects to burn the pants off the few kilocycles left to hams after the first of the year. W6BRJ has rebuilt for 3500 kc. band using two 210s for fone with Heising modulation. W6CGM had a little domestic dissention over the price of a new transformer but says he will suffer anything from the OW if he can just work the Philippines again. W6NO is pounding away at W6CCU's shack. W6CDA says he used to be convinced that the air would carry radio signals but now he's beginning to doubt it. W6COL reports being on 28,000 kc. He has a new fone set under construction. W6SR says other fellows have been carrying his messages. W6HJ says that Alaska has faded out entirely. W6CKS has started up at the Veteran's Hospital at Livermore. W6CKG is a new man who has opened up on the same lot with W6CZR. Hi. W6DKO is trying to make the 80 meter band work. Dr. Woodruff, W6CMP, director of the Atlantic division, has been a visitor here for several weeks and attended the Thanksgiving service of the Oakland Radio Club at which W6BSB acted as interlocutor. Eats and talks were enjoyed.

Traffic: W6IP 73, W6ALX 39, W6DTM 87, W6BFO 24, W6BSB 12, W6EDK 11, W6CZR 10, W6BI 8, W6DKO 8, W6BPC 8, W6ENV 7, W6BZU 6, W6DDQ 3, W6BMS 3, W6BUX 2, W6BRJ 1, W6EDR 1.

NEVADA—SCM, C. B. Newcombe, W6UO—W6UO, W6LB and W6CHG are keeping some regular schedules to report road conditions through the mountain passes. The reports are given to the Nevada Automobile Assn. at Reno, for the information of tourists. The SCM welcomes reports from active Nevada stations, whether they are ORS or not.

LOS ANGELES—SCM, D. C. Wallace, W6AM—W6CHA makes the BPL this month. He is keeping a number of good schedules. Forty stations report, with thirty handling traffic. W6OJ is down in Tahiti taking movies and every Friday night W6CHA goes over to W6OJ's shack and handles his set, enabling W6OJ and his wife to carry on a regular conversation. W6HT is rebuilding his transmitter to strict 1929 principles, using MO-PA and also working on the Long Beach A.R.R.L. banquet for Dec. 6ALR which is to be held at the Breakers Hotel. W6ALR wires in his report which is a good one. W6EGH handled 85% of his traffic through skeds and 90% through ORS and no message on the hook longer than 36 hours. W6DYJ worked four continents and Byrd's expedition. W6AM reports his 28,000 kc. transmitter and receiver working smoothly and easily. Deliveries to L.A. are the special biz of W6UJ. W6DKV wants to make the BPL. He worked two fives and one nine using neither antenna nor counterpoise. W6QL took msg. from WSG, USS 'Lydonia' off Norfolk, Va. to WRX off Panama and had answer in 20 min. W6BJX took K1HR sked one morning when W6AMM was sick and took 25 msgs. in 55 minutes. W6DSG is on 3 to 5 hours every day and reports DX very good. W6AKD hopes to get on 3500 kc. for good soon. W6DLI is going to be one of our good ORS. W6AWY is putting in an 852 with Rectobulb supply, 2200 volts on plate and says his will be 1929 model if there ever is one and that traffic will be his objective. W6FKC is keeping some good skeds and is arsaning for more. W6AGR reports VE4FB was R7 or 8, at 6 am PST using Ford coil and 201A Nov. 25. W6COT is down on 14,000 kc. after being on 7000 kc. for one year. W6DKX has just received appointments as official station USDA network and as official station for the Los Angeles County Sheriff's Major Disaster Squad. Through an oversight, his report was not included in last month's report. W6CUH reports that after four months, he will have to QSK sked with W1AH on account of bum conditions. On 28 mc. he has worked W2TP, W5WZ, W1BJD, W2AOL, W6AVS, W1ZL, W1AQD, W2WS and got R8 from W1ZL. W6DMG sends in a good report. W6AKW reports oa-3CP heard W6TS on 28 mc. on Nov. 3 at about 3 pm PST. About 20 oa's on 28 mc. W6ABK is having a lot of fun with 3500 kc. fone. W6DHR sends in a good report and also informs us that W6ABK is too lazy to get up so he works the gang from bed via remote control. W6CAG had the flu this month but handled some traffic just the same. W6AOS helped announce a high school football

game over public address system run by W600. W6BRO is preparing for the "zero hour" January 1, 1929. He has received his Amateur Extra First Class license. W6AEC sends in a good report, as does W6DHR. W6DLK, W6EEB, W6DEG, W6BVM, W6EAF, W6CZO, W6BHR and W6DNF report as usual.

The Associated Radio Amateurs of Long Beach have changed their meeting night from Mon. at 8 pm to Fri. night at 7:30 pm every week. Had election of officers at last meeting, elected W6ELZ, pres.; W6DYJ, Vice-Pres.; W6HT, Sec. and Treas. Talks on antennas were given by W6AM. A code class is being organized for the benefit of several new members who are interested in becoming amateurs. The A.R.A. is working hard and fast on the ARRL banquet and there is little doubt, if any, according to W6HT, that this will be the snappiest, hottest, hamfest ever put on in this section.

The Short Wave Club of Pasadena raffled off one Husky Plate Transformer at their meeting on Nov. 22nd. They are now having two meetings a month. Last meeting was at the home of W6BYA. In a former report, we stated that W6DYU did some good relay work, and it should have been W6DYJ. W6DJY sounds like CC and has very steady DC note. W6AVE moved to countryside near Fresno and has real wallop on 135 V. B. W6DJY has MO PA and says it is the nicest thing in the world. SCM, W6AM, has changed his office address from 109 West Third St. to 209 Pine Ave., Room 410-411, Long Beach.

Traffic: W6CHA 412, W6HT 84, W6ALR 77, W6EGH 71, W6DYJ 58, W6AM 51, W6UJ 50, W6DKV 48, W6QL 46, W6BJX 42, W6DSG 37, W6AKD 36, W6DLI 28, W6AWY 27, W6EKC 20, W6AGR 16, W6COT 16, W6DKX 12, W6BZR 10, W6EKC 10, W6CUH 8, W6DMG 8, W6AKW 8, W6ABK 7, W6DMG 5, W6DHM 4, W6CAG 3, W6AOS 3, W6RRO 3, W6AEC 2.

PHILIPPINES—This report came by radio through W6AMM—Lt. G. A. Bicher, K1PR keeps schedules with ac-WUY (Tientsin) at 5:30 pm daily; ac-SZW (Shanghai Observatory, China) 6 pm daily; K1RC (Radio School, Cavite, Navy) 8 pm; ac-2MO (China) 8:30 pm; W6AMM 9:30 pm daily; W6BJX 11:30 pm Thursday only. K1CY keeps sked with W6EC. K1AU has returned from a year's stay abroad and keeps sked with W6BVB again on Mon. Wed. and Fri.

Traffic: K1PR 721, K1CY 63, K1AU 23, K1PW 296.

HAWAII—SCM, F. L. Fullaway, K6CFQ—This section has been getting deader and deader as the months roll by. What say, gang? Let's snap out of it. K6EAT, the station of McKinley High School, reports for the first time. It is on 14 mc. and would like schedules with other high schools. K6CLJ, K6AKP and K6ENE are the operators. K6AVL turned in the high score. He reports working KDV5. On sked with W6AIN he handled 2352 words of messages. K6DQQ is doing a bit of reconstruction for 1929. K6CLJ reported the air dead on 7000 and 14,000 kc. Says he is learning French. K6DEY is returning to OH. He is going back on the air with crystal control, etc. He will make a good station for wavemeter checks. K6DCU's masts blew down in the storm so will be off till Xmas.

Traffic: K6AVL 118, K6DQQ 38, K6CLJ 10, K6EAT 9.

#### ROANOKE DIVISION

WEST VIRGINIA—SCM, C. S. Hoffman, W8HD—Reports have it that two old timers are back on the air—Jones of W8SP and old W8BDA. Welcome back, Oms! W8OK, too, is preparing for a big winter season of DX and traffic. W8DNN is suffering from YL QRM between skeds with W9AZY and W8APY. W8CLQ is doing some good work on 28 mc. QSOing W8TS and W8AOT; he also lead the traffic for the state this month. W8AUL worked n7NIC, the 5th Reg't. at Managua, Nic. W8DNL is doing some very good traffic work with W8BAU. W8DPO reports the OHs have faded with the winter season coming, his DX now being C. America. The SCM was glad to hear from ex-SCYR who reports he and W8DFC, a new station, a 50-watt set, very active as a relay station.

Traffic: W8CLQ 68, W8DPO 28, W8DFC 23, W8DNN 14, W8AUL 5, W8DNL 5.

VIRGINIA—SCM, J. F. Wohlford, W8CA—W8KU is making trip over to see GC-6NX and to get a QSO card for W8WM. W8TIN is back from sea on WJCX and threatens a new receiver. W8JT and W8II are busy. W8II is going good with his tele-

vision work. W3WD threatens to come on the air again soon. W8ALS has QRM from school and radio repair work and has had to cancel some of his skeds before 9 pm. W3FJ is on the air now with a 210 LCH circuit. He is ex-4AR. W8HO is doing a little work now. W8IB, a YL, seems to have good QSO and gets the QSLs in cards and fotos. W8AMB is repairing the transmitter. W8HY finds that school work interferes with his radio. W8BZ is still tinkering around with the old junk. W8ANV finds that his other business QRMS his radio activities. W8BDZ rebuilt his receiver and threatens to put out a wicked crystal signal. W8CKL has recently worked WFBT and will get sked with the Byrd Expedition soon.

Traffic: W8CKL 181, W8ALS 27, W3FJ 7, W8HY 5.

NORTH CAROLINA—SCM, Enno Schuelke, W4SJ—Traffic activities have picked up considerably with the advent of cooler weather. QRN has more or less "gone west" and things look better around this section. 1929 is about upon us and a lot of the fellows are getting the old set slicked up and changed according to 1929 ideas of what the well-equipped ham station will look like. Traffic is coming, as the more active stations will testify. W4AEW believes in piling them up as his total shows. His North and South skeds are going FB now. W4EL is back on the air again with a High-C Hartley and is spending most of his time DXing and chewing the rag. (Why not try some traffic, OM?) W4OC is the proud owner of an African drum which he received as a souvenir from f9PM with whom he still has a sked. Any of you fellows having traffic that way give the old boy a call and he will clear for you. W4HV reports not much doing because of repair work to BCL sets and trying to dope out new antenna systems. W4AB says he will be back home and on by Dec. 20th and will be ready for any and all calls he hears. W4SJ spent some time visiting W4AHH and reports a pleasant time rag chewing. W4AHH claims to have too much YL QRM (watch your step, OB). W4JR is still busy helping W4CQ rebuild WBT. Say, fellows, there is need of two Official Observer (OO) stations in this section. Who will volunteer for this work? Send in your application to your SCM. Here's wishing the whole gang a Merry Christmas and a Happy New Year.

Traffic: W4AEW 122, W4OC 41, W4TS 12, W4SJ 8, W4HV 3.

#### ROCKY MOUNTAIN DIVISION

COLORADO—SCM, C. R. Stedman, W9CAA—This report isn't going to give the Denver gang much of a boost and none too much can be said for the balance of the Section. It happens that the SCM has been unable to get to club meetings in Denver, and due to sickness has been unable to be on the air much the latter part of the month. For some other reason, no reports have been received from stations. Let's get going, gang. There is a provision in your appointment as ORS that requires your report regularly on penalty of losing the ORS. If you don't believe it, stop and think of it, then go look at your certificate and the pledge you signed at the bottom of the same before the SCM but his "John Henry" there. A pledge should mean something to you, fellows. I trust that I will not be put in the bad position again that I am in this time in trying to make up a report. W9CAA holds down a schedule with W9CZC and works west hit and miss in good shape. A number of requests for schedules have been received and are being given attention by the RM to whom the work was turned over. W9DGI has become one of the U. S. Department of Agriculture Net stations for Denver. W9DKM has been sick but pounds a little brass anyway. He and W9CAA have been playing around with 160 meters but W9CAA is the only one of the two who is getting out on that band. W9CDE says that 14 mc. is getting better but that 7000 is thick with QRM. He works W9FAE at Trinidad on schedule. W9EHP has been sick. W9DQV at Grand Junction seems to be doing good work. He has just been appointed ORS. W9ERN at Boulder lost his pole and antenna in an 85 mile wind. Hard luck, OM. W9CCM has a 75 watt but says she isn't getting out of the back yard with it. W9ERU has been quite busy with school work.

Traffic: W9CAA 82, W9CDE 4, W9DQV 47, W9EUR 3.

UTAH-WYOMING—SCM, F. N. James, W6BAJ—Activity in the Section has begun to take on a new aspect and we have more traffic stations than ever.

There are still several fellows in the section who are not reporting their traffic. Let's hear from you. It is not necessary to be an ORS in order to report. W6BTX and W6DPJ who are operating together, tried to make the BPL, but had too much QRM from school work. They have a remote controlled transmitter working on 14,000 and 7000 kc. W6DYE is starting to get some good schedules lined up, which his traffic total shows. W6RV has changed from 7000 to the 3500 kc. band. W6HXM sends in his initial report and he wants some good schedules. W6BAJ was QRW school so not much traffic. He is a USDA station. W6BVB is on 7000 kc. with an 882. W6DZX was only on about seven days, because of sickness and the set is being torn apart. Better luck next month, OB. What's the matter with you fellows in Wyoming? There must be some activity up there.

Traffic: W6BTX-W6DPJ 92, W6DYE 45, W6RV 21, W6DXM 18, W6BAJ 14, W6BVB 4, W6DZX 2.

### SOUTHEASTERN DIVISION

**A**LABAMA—Acting SCM, S. J. Bayne, W4AAQ—W4AAH maintains foreign schedules with his UX-852. W4VC has the prettiest DC note in North Alabama. W4JY more than held up his end of the monthly traffic total. W4AIY says his OW QRM's him with bridge parties. Hi, W4AJJ has a nifty fifty watt outfit and is doing fine work in Anniston. W4AHY spent the month experimenting with his transmitter. Shoot your traffic to W4AHP. He has his traffic routes mapped out with a bunch of schedules. W4AHR has been QRW school work but comes through with a pleasing report. W4AJR is on the job on the 7000 kc. band. W4AAQ is working DX on 7000 and experimenting with fone on 3500. W4TI and the Selma gang are heard often but reports from that section are lacking. Better get those reports in, fellows.

Traffic: W4AHR 59, W4JY 50, W4AHP 47, W4AJY 34, W4AJR 8, W4AIY 7, W4AAQ 7.

**FLORIDA**—SCM, C. E. Foulkes, W4LK—This will be the last report I will make as I am resigning this month. I am leaving Florida the first of the year and hope to work all the gang from my new location. I wish to thank all the gang for their co-operation and I wish you a happy New Year and good luck for the year 1929. Mr. E. M. Winters, W4HY, has consented to look after the affairs of the section until a new SCM is elected. His QRA is 2144 Roselle St., Jacksonville, Fla. Please mail all reports to him. Hope you will stand behind him and put Florida ahead. W4AI has handled the most traffic this month. W4BN has a regular sked with W4KY. W4TK wants some new DX. Tampa has a new ham in W4AJK. W4ARJ has returned home from the hospital. W4CK will be back in Miami soon after spending the summer in Washington, D. C. W4ACC is still building the new set. W4AGY says he can't get any traffic out of his QSO's. W4AEF has returned from a trip abroad. W4NE is working some DX. Will see the gang on the air as soon as I get settled in my new location.

Traffic: W4AI 80, W4BN 14, W4TK 10, W4AJK 8, W4ABJ 4.

### WEST GULF DIVISION

**S**OUTHERN TEXAS—SCM, R. E. Franklin, W6OX—Fine radio weather seems to be prevailing all over the section this month and I am expecting a larger report for next month. A large majority of the traffic handling stations are rebuilding their transmitters "1929 style". Here's hoping it increases the message totals. W6MS has applied for a renewal of his ORS and is on the air with the former 250 watt crystal controlled set of W5WE-W5ZAL. W5LP has just purchased a couple of 281's and is working on the 14,000 and 7000 kc. bands. He also has a fone going on 1700 kc. W5ABQ is the voice behind KGCI—now tell them about it, OM. W5HS has woken up after being dormant for quite awhile and we are hoping he will be with us for a long time this time. W5AHP has come to life with a 203A operating on the 7000 kc. band, using an attic antenna and has worked as far as Panama getting nice reports. FB, OM. W5AEA of Richmond, is having his transmitter revamped "1929 style" by W5OX and hopes to be on the air again soon with a real station.

Traffic: W5LP 15, W5ABQ 14, W5AHP 5, W5HS 5, W5MS 4.

**NORTHERN TEXAS**—SCM, J. H. Robinson, W5AKN—Evidently you fellows have grown tired of seeing your section written up in QST, from the way reports didn't show up. It seems the gang are all waiting until after the first of the year to hear what it sounds like, before making any changes. The Dallas hams are going to divide, some going to the 3500 kc. band while others to 28 mc., 14 mc., and 7000 kc. bands. A few of the old standbys reported as usual. W5BAD at Ennis heads the list for traffic this month. He says school takes up most of his time. W5HY was host to the Chief Operator from W5AIN, the Army-Amateur Net Control Station for a couple of days. They spent the time working DX and some traffic. W5ATZ reports working VE8CB, his first QSO out of the States, FB, OM. W5AAE is keeping a schedule with W5LC who is using a 201A. W5AAE also uses the same sort of transmitter both stations being in the 1850 kc. band (162.2 meters) and report R7 sigs. Reports from Illinois, Nebraska, Kansas and Missouri. Seems the high waves are OK. W5OE is rebuilding the station for 1929 operation. FB, OM. W5BBF has been hoboing over the state. (He must be a Dry Agent). Says he is now home getting the xmitter fixed for all frequencies (not at the same time?) W5AKN-W5BG moved the station into another part of the house so no traffic was handled. W5ACL has the heart's disease. Yes, YL's, understand his QRA is very portable.

Traffic: W5BAD 32, W5HY 15, W5ATZ 8, W5AAE 5, W5OE 4, W5BBF 1, W5ACL 1.

**OKLAHOMA**—SCM, J. G. Morgan, W5AMO—Activities in this neck of the woods seem to be running according to schedule. The SCM has been doing a little work with the Canadian amateurs on 5720 kc. There are some good QSOs waiting for the American-hams, gang. Listen in on them some evening. This frequency is apparently better than our 7000 kc. one as there is an absence of fading that 7000 kc. is famous for here lately. The SCM has been using a UX-210 lately and reports as good results from it as he used to get with the 852. However, a new 352 will be forthcoming shortly. W5APG is setting the pace for the Okla. City gang. More power to you, old timer. W5AFX is in the usual slump that follows a heavy DX conquest. W5AHD (Barlow Huff, Altus, Okla.) fell from an airplane and suffered a fractured skull in the accident. He is an old-timer and many of you will remember him from the 200 meter days. Better luck next time, old man, and hope your recovery will be speedy. W5AIR's sigs may be found on the 7000 and 1750 kc. bands. He also reports the usual QRM from studies at school. W5AYO reports that his results on 14 and 28 mc. have been very gratifying. His new xmitter works FB. W5VH has been handling a bunch of traffic lately and is desirous of suggesting that amateurs be a little more accurate in the copying of messages and the delivery of same. A good suggestion, OM. W5ANT has been doing a little work at KGCB and between that and the regular job he has had little time to pound brass. However, he brought down a nice total for messages in spite of the heavy schedule with the other things. W5ADV reports for the first time and promises to continue in the future. The SCM has heard a flock of DX answering him, but with a failure to connect. Better remodel the receiver, OM, or maybe I could sell you mine—how? Hi. Some of the Okla. hams are handling a lot of traffic and not reporting. C'mon fellows, some of you can just as well have your totals in QST. W5OM reports having been QSO both coasts in one day on the 28 mc. 14 mc., 7000 kc. and 3500 kc. bands.

Traffic: W5ANT 20, W5AMO 131, W5FJ 115, W5VH 42, W5AYO 9, W5AIR 4, W5ADV 11, W5APG 37, W5OM 117.

### CANADA ONTARIO DIVISION

**O**NTARIO—SCM, E. C. Thompson, VE4FC—Central Dist: VE3BL is our star traffic station this month. All his work was done on schedule on 5710 kc. using just the 210 supplied from batteries. A 500 watt set with arc rectified supply is expected to blast forth very soon from VE3BL. VE3BC runs a very close second with a fine traffic total and an enviable DX record. The lantern is doing its stuff.

VE9AL is making out his schedules OK despite the lack of his generator. VE9BJ is back on the air using 5710 kc. and is keeping schedules with eastern stations. VE8BO has been having the time of his life on 14,000 kc. making many contacts and handling some traffic. VE3EO has a new 1929 type transmitter using the usual 210 and is to be found nightly on 5710 kc. He is also interested in 23,000 kc. where he will be heard before long. VE3DV has a new motor-generator to help him live up to 1929 standards. VE3DC is still crystal-controlled on 5710 kc. VE3BT has taken to radiophone on the upper end of the 3500 kc. band. VE3CL now has a 210 with which he has been busy on 14,000 kc. When this is rad, he will be on 5710 kc. instead. VE3CQ sends in his first report and says that the 201A in the transmitter will soon give place to a 210. He favors 5710 kc. for traffic. VE3BP has some good schedules and handled some traffic on 7000 kc. He will be with us on 5710 very soon. VE3FC confines his work to keeping schedules on 5710 kc. which gives him plenty to do. VE3AZ has rediscovered the 5710 kc. band. Southern Dist.: VE3CS is the star in this district as usual but he is being given a good run for his money by all the rest. He is keeping several DX and local traffic schedules and his total shows that they are by no means in vain. His DX list now includes 41 countries. Five new ones have been added this month. He uses 5710 kc. VE3AQ is forming a traffic net of good stations with his own as the center and also finds time to handle traffic on schedule on 14,000, 7000 and 5710 kc. VE3IA is now back on the air and will be on 5710 kc. before this is in print. His slop-jars are now discarded in favor of a pair of 231's. VE3CB formed a code-class in his city and has 24 students, all of whom are prospective amateurs. Besides this, he is to be found regularly on all popular waves but mostly on 7000 kc. VE3AY says there is not much traffic on 7000 kc. but lots of good contacts. He will be on 5710 kc. before the end of Nov. VE3RG has worked across the Pond, making some friends among the "G's".

Northern Dist: VE3CJ up in the frozen north is again our King-Pin of the traffic net, which is working out in fine shape under his very enthusiastic leadership. His organization is not yet complete, but even so, a good deal more traffic than usual is flowing regularly in our Province and out of it. 90% of the work is done on 5710 kc. with the rest on 3500 kc. "Bud" the dynamic brass pounder and Route Manager, deserves huge credit for his fine work. VE3ET has been very active using 5710 kc. on sked, and he has worked up a fine traffic total. VE3EP is using 5710 kc. on schedules every evening from 7 to 8 EST.

Traffic: VE3BL 54, VE3BC 53, VE3CJ 52, VE3CS 43, VE3ET 30, VE3FC 25, VE9AL 17, VE3BP 10, VE3BO 8, VE3CL 1, VE3BT 1, VE3TM 1.

### QUEBEC DIVISION

QUEBEC—SCM, Alex Reid, VE2BE—The first hamfest held at station VE2AP was a great success and you can just imagine the rag-chewing that went on during the evening, it being the first gettogether of the clan since last winter. John deserves a great amount of praise for the fine station he has assembled in such a short time and all present wished him success in this greatest of all games. VE2BB with the help of VE2CA and VE2AP has rebuilt and installed an 852 and reports many foreign contacts. VE2BG reports three condensers gone west but still has a good note and keeps his nightly skeds. VE2CA is building a screen grid receiver. VE2BH is using the Franklin circuit and reports that it is the berries. VE2AD is working on a new fone set and will be on shortly. VE2HT, VE2BE and VE2AV are on 1750 kc. with fone on Sunday mornings. VE2BR turns in the best traffic report. He is the division's old reliable when it comes to traffic. VE2AC is a close second and says he is going to make his station a 100 message per month station during the winter. VE2BE has a morning sked with WFAT, S.S. *Eleanor Bolling* of the Byrd Expedition and handles considerable traffic. VE2BD has just received his license and can be heard most every evening. VE2AB of Quebec City is now on. This now gives us two reliable stations in the above city and fills a gap in our traffic route which we have been working on for years. VE2AL has more time now and is arranging winter skeds.

Traffic: VE2BR 69, VE2AC 37, VE2BE 29, VE2BB 25, VE2AL 8, VE2AM 14.

### VANALTA DIVISION

ALBERTA—SCM, E. J. Taylor, VE4HA—Sunday Nov. 4th we heard W8XK, W6AOT, and W5AWZ in 23 mc. band at about R5. VE4AH still working on his new installation and hopes to be on very soon. VE4CU likewise. Think VE4CL is out of town. VE4EP is on the road most of the time. Glad to welcome addition to our midst of VE4EY from Winnipeg. VE4FT is very active on 7000 kc. VE4HA is on 14,000 kc. most of the time. VE4HM rebuilt the 1929 transmitter—some note. Charlie, VE410 and VE4HC come in with a real kick here.

Traffic: VE4FT 2, VE4HM 2, VE4HA 1, VE4EP 1.

### CANADA PRAIRIE DIVISION

MANITOBA—SCM, D. B. Sinclair, VE4FV—VE4DK, a new ORC, leads the Section this month. FR, OM, keep it up. He is using a 210 in a 1929 type TP-TG circuit and gets a pure DC crystal note. Bad weather conditions and lack of power spoiled VE4FV's DX but he managed to QSO EG, NN, NJ, OZ and NR. He keeps a tri-weekly sked with ni-2PA when he can hear him. VE4AR sent in his initial report this month from Boisvevain. Always glad to hear from you, OM. VE4DB is working all around and is trying feverishly for an Aussie. VE4DI experiments with new circuits and is now testing out a 8500 kc. phone. We now have VE4GQ back with us again at a new QRA with a fundamental zeppelin antenna and a fifty on 14,000 kc. He worked several stations with his antenna system in the cellar. Hi, VE4FN now has a 1929 type Hartley and while he gets a beautiful crystal DC note, does not get out very well. He claims his Zeppelin antenna is at fault. The DC note of VE4EK is still heard. We have with us three new stations using temporary calls: VE4ZR, VE4WS and VE4MO. The most successful of the trio so far is VE4MO who is using a 201A in an 1876 (hi) Hartley on 14,000 kc. The experimental work of the section is being carried on nobly by VE4CT and VE4DU who are both working on the 23 mc. band with considerable success. The OBS activities of VE4DP seem to have inspired him with new life and despite the accident of blowing a 210 he is going strong with a fifty. VE4BP has been quite successful with his decrepit 210 and gets R7 from California. He was annoyed to find his chemical rectifier frozen solid the other day. Hi.

One of the best signals in the district is that emitted by VE4DJ. He is anxious to work DX but has had no luck as yet though R8's come thick. Two new stations have started up with their official calls recently, namely VE4JB and VE4HR. They are both using 1929 type Hartleys and Zeppelin antennas. VE4RU has been heard pounding away. VE4HF has finally decided that a rebuilt station is a necessity. VE4FO's antenna system runs from his shack down to the front and back fences. VE4GL, VE4DL and VE4DW are known to be active. How about some dope, OM's?

Traffic: VE4DK 17, VE4FV 13, VE4DB 4, VE4DI 6, VE4GQ 1, VE4FN 1, VE4AR 7, VE4EK 4, VE4DJ 8.

SASKATCHEWAN—SCM, W. J. Pickering, VE4FC—VE4GR is doing good work and is anxious for more traffic. VE4IH is QRV every day from 11 am to 3 pm on 7000 kc. VE4BM is still working on his Zepp. By the time the gang reads this, it will be 1929 and the SCM hopes all the stations will continue active and make the year a real one for traffic.

Traffic: VE4GR 13, VE4IH 9, VE4BM 8.

### LATE AND ADDITIONAL REPORTS

W8DJV is QRV school work. W4ABR is going good on 14 mc. He also heard W8BS long way around. R4, W9CJB, and W9FEH sent in their traffic by radio from their SCM, W9RR.

Traffic: W9DJV 4, W4ABR 8, W9CJB 11, W9FEH 13.

# A Message Handling System

By G. F. Lampkin\*

**F**OR several years there has been in use at W8CAU a message-handling system that has worthwhile advantages. When the standard A.R.R.L. notation is applied to the message blank it takes the form shown in Fig. 1.

The blank sheet, 8½" by 5½", is just half the standard typewriter size. On it are mimeographed the standard notation; city of origin, station of origin, message number, date, and check, in the arrangement shown. At the bottom of the sheet are noted the facts about the reception of the message, that is; the station from which the message was received, date, time and operator's sine. Similar data are recorded when the message is re-

The unique feature of the system lies in writing the destination of the message at the top of the sheet, and filing all messages in the rack shown in Fig. 2, and in the photograph. The six compartments of the rack are lettered NORTH, EAST, SOUTH, WEST, SENT and DELIVERY. Thus by placing a message in its proper place, a glance tells what traffic is on hand and where it is going. There is no littering of the station with traffic, no hurried searching through a hookful of papers for one message, and much less crazy routing of messages. The DELIVERY space gets messages intended for delivery, or which have been on hand the maximum of 48 hours and must be mailed. In the SENT compartment are placed the messages on which handling has been completed.

Once a month, the SENT messages are made up in a bunch and filed away. If occasion arises for locating a given message, this can be done by thumbing over the top of the file, for the identifying station call and number are conspicuous near the top of the sheet.

The example given is that for a message which was relayed through the station. Operator "OL" received the message Jan.

New York City			
CITY OF ORIGIN Denver Col		STATION WZK	
NUMBER 56	DATE Jan 25	CHECK	
<p>To Mr H W McCord 3456 Prospect St New York City -</p> <p>Howard left yesterday for Stockton, Cal. stop. He will write on arrival -</p> <p style="text-align: center;">Sey Dick</p>			
<p>Rec'd from: WZK 1/24/26 7:46 P "OL"</p> <p>Sent to: WZK 1/26 11:22 P "Fo"</p>			

**FIGURE 1. THE GENERAL ARRANGEMENT OF THE BLANK FOLLOWS CLOSELY THE RECOMMENDED MESSAGE FORM.** The city of destination is written at the top and is extremely helpful in the filing and locating of the messages.

layed. Or, if mailed or telephoned, notation to that effect is made after "sent to:". The text, of course, is written in the large central space.

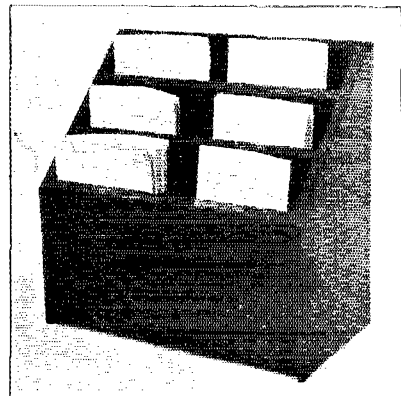

**THE FINISHED FILE.** It takes up a minimum of table space and allows the operator to see at a glance just what traffic is at hand. When contact with another station is obtained, it is but a simple matter to withdraw from the file all messages that should be sent.

26, 7:46 P.M., from W9EZM: "hr msg fm denver col W9ZX nr 56 jan 25 to mr h w mccord 3456 prospect st new york city—howard left yesterday for stockton cal stop

\*3612 Woodbridge Place, Cincinnati, Ohio



he will write on arrival—sig dick." The message was relayed the same night, and with the notations made after "Sent to," a complete story for the passage of the message through the station is had.

W5NW made the sunbeams shine for a resident of Laredo, Texas, when he delivered a filial message which came from a wandering son via Chilean IAL.

W2BAC tells us that he has been QSO IZZ, the S. S. Kueher, on approximately 14890 kc. (20.3 m.). W1BYV also has worked IZZ.

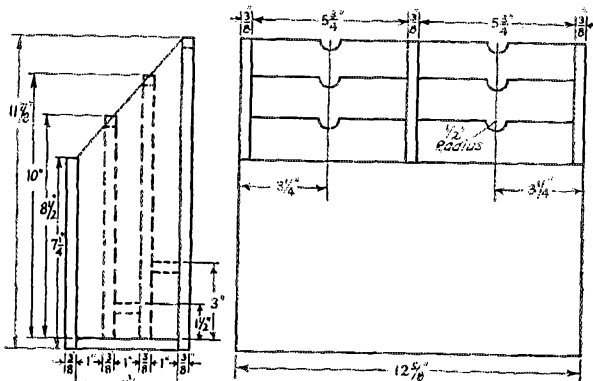

FIGURE 2. THE PLAN DIMENSIONS OF THE FILING CASE GIVEN ABOVE. The sections being arranged in steps allow each group of blanks to stand out in such a fashion as to allow any one message to be located almost instantly.

### TRAFFIC BRIEFS

Tracing messages is both interesting and profitable work as it shows up circuitous routings, unreliable stations and operators, or brings to light unusual conditions in connection with our local and long distance traffic work. Tracer forms are available at Headquarters and a few will be mailed on request to any traffic man who asks for them by postal or radiogram. All that is necessary in tracing a message is to attach a copy of the message to the tracer form (the first line of which has been filled out)—and to send this (preferably with several extra stamps for forwarding) to the station to whom your log indicates the message was given, with the request that the tracer form be filled in and passed along.

A recent tracer from W1MK on a relayed message for the Philippines shows what excellent time was made in handling one message. In spite of the fact that the message was handled by ten different stations, it was delivered in less than eight days, making substantial progress each day. Here is the routing, which shows that in spite of considerable relaying being necessary on the west coast to "land" the message at a station known as having reliable Philippine contacts every operator used his head so that the message got through: W1MK-W9ENM-W6OJ-W6BOY-W6ARD-W6UJ-W6SBJ-W6AJM-K1CM-K1HR (Hartford, Pueblo, Hollywood, Oakland, San Francisco, El Monte, Santa Barbara, San Diego, Ft. Mills P. I., Ft. McKinley P. I.).

If you keep a good log and a complete message file as required by our Rules and Regulations, and if each message is handled promptly and accurately (within 48 hours or one half the length of time required for foreign mail deliveries for continents outside North America), you don't need to worry about the damaging facts a tracer can show about your operation. Please be ready for tracers. Pass them on promptly as soon as the essential information has been filled in and any general comments on such matters as accuracy attached on separate sheets. We hope to run an article on general operating work when sufficient numbers of tracers have been examined so that general conclusions may be drawn.

W3AA will be on approximately 7.200 kc. (41.75 m.) and 14.870 kc. (20.88 m.) at Baguio, P. I., this winter.

W9ASX is responsible for the following story: "Miller, W9DUZ, was recently conversing with a philanthropic old gentleman, who asked him what good was derived from amateur radio. The man wanted to know, among other things, if all this long-distance communication was fact, whether W9DUZ had done any of it, and if there was anything beneficial to humanity in it at all. W9DUZ replied, 'Experimentation by the amateur is valuable experience itself to the individual participating as well as beneficial to humanity in general. All the long-distance communication of which you have heard has actually taken place, although I have been unable to take part in any of it, owing to low power caused by my unstable financial status. He was then queried as to the funds necessary for the establishment of a stable financial amateur status. Miller replied, 'Oh, about two or three hundred dollars.' (Such a liar—W9ASX). Thereupon, the old gentleman immediately sat down on a stump and penned out a check for 1/2 'grand'; and as our hero stepped forward to accept the gift—alas! he fell out of bed!"

When the DeMolay brothers met in conclave in Columbus, Ohio, many business and fraternal messages were handled for them by W8BBR, W8CNO, and W8BYN.

During the summer W2BME (one of W1MK's scheduled-station men) visited Hq. and the Brainard Field Station. He was rather taken aback on looking for the crystal in the transmitter to be told that there was none in the station—in spite of the crystal note. It reminded us of the garage mechanic who spent ten minutes hunting for the radiator to fill on a Franklin car.

W8BJQ has made several discs for his television receiver from old phonograph records and reports them as entirely satisfactory. Television now utilizes everything but the old razor blades. Any suggestions?



A LARGE NUMBER OF BRASS POUNDERS ARE TELEPHONE MEN. 4NT AT WILSON, N.C. IS A BUG SHOOTER