

QST

DEVOTED ENTIRELY TO

AMATEUR RADIO

PUBLISHED SINCE 1915 BY THE AMERICAN RADIO RELAY LEAGUE INC.

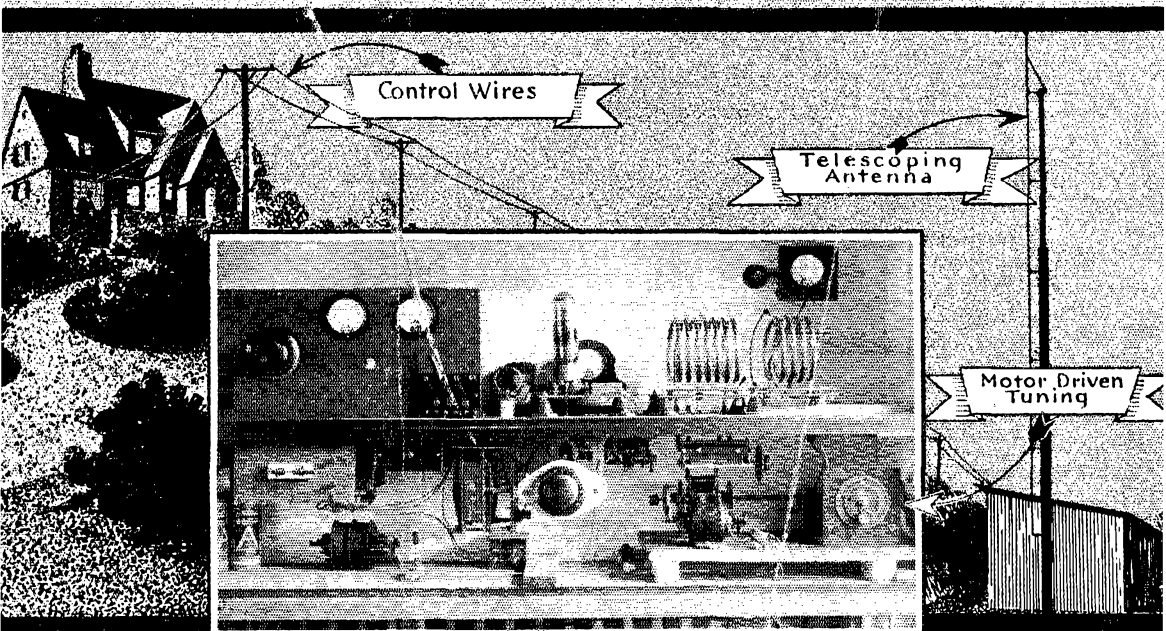

Teletuning See Page 32

JULY

1929

25^c

The New Fourth Edition of
**The Radio
Amateur's
Handbook**

By **HANDY** and **HULL**

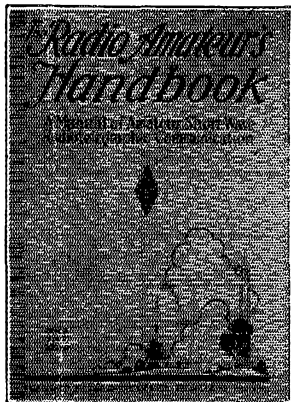

FOR THOSE WHO DON'T KNOW IT:

The Handbook is a practical manual of amateur radio in all its phases, published by the American Radio Relay League, the amateur's own organization. It starts at the beginning and tells the whole story: What amateur radio is, How to be a radio amateur, How to obtain your licenses, How to build the simple apparatus of a simple station, How to build the best known apparatus for the most modern station, How to operate the station. Enough information to keep you busy and interested for five years.

FOR THOSE WHO DO KNOW IT:

For years the Handbook has been the practical working guide of successful amateurs the world over. Now it has been completely revised in terms of 1929, by Mr. Handy, the League's Communication Manager, as to all the aspects of operating procedure, and by Mr. Hull, the director of the League's current Technical Development Program, as to all its features of apparatus and technical matters. Everything in it is on a 1929 basis, replacing the 1928 methods which used to be good enough but aren't any more.

MUCH THAT IS NEW — ALL THAT IS GOOD

Like QST, "Devoted Entirely to Amateur Radio"

Now in its 49th thousand

240 pages, 6½ x 9½, 188 illustrations

In wealth of treatment and profusely of illustration the Handbook is a big book. Printed in usual textbook style it would bulk 500 pages and cost at least \$4, but its publication in the familiar QST format makes for handiness and enables its distribution at very modest cost.

ALGERIAN PAPER COVER \$1

STIFF BUCKRAM BINDING \$2

Postpaid anywhere in the World

American Radio Relay League, Hartford, Conn., U. S. A.

RCA

RADIOTRON UX-842



A fine modulator or A. F. Power Amplifier

Filament Volts	7.5
Filament Amperes	1.25
Amplification Factor	3
Max. Plate Dissipation (watts)	12

Modulator

Normal Operating Plate Volts	350
Grid Bias Volts	-88
DC Plate Current (ma.)	14
Osc. Input Watts for each UX-842 (Mod. Factor 0.6)	8

A. F. Power Amplifier

Normal Operating Plate Volts	425
Grid Bias Volts	-100
DC Plate Current (ma.)	28
Plate Resistance (ohms)	2500
Undistorted Power Output (watts)	3

IN an amateur phone transmitter, Radiotron UX-842 will effectively modulate 8 watts of oscillator input power. It is, therefore, a most desirable modulator for the amateur who uses Radiotron UX-210 as an oscillator.

Having the same appearance, size, and construction as the UX-210, Radiotron UX-842 will give the amateur that stable and dependable performance so characteristic of the widely used UX-210.

Radiotron UX-842 may, for certain amateur use, be obtained through the RCA District Office nearest you.

Price \$12.50

RADIOTRON DIVISION

RADIO-VICTOR CORPORATION OF AMERICA

New York—261 Fifth Avenue

Atlanta—101 Marietta Street

Chicago—100 West Monroe Street

Dallas—Santa Fe Building, Unit No. 1

San Francisco—235 Montgomery Street



SPECIALS IN R.C.A. PRODUCTS



P. T. 537 FILAMENT RHEOSTATS

Rated to carry 15 amps.

An absolute necessity for the control of U.V. 203, 203A, 204, 204A and U.V. 851 Transmitting Tubes and 217, 217A, 217C and U.V. 1651 Rectifying Tubes.

LIST
\$10.00

Special **\$3.75 ea.**

ROTARY GRID CHOPPER WHEEL MODEL P.X. 1638

and Contact Brush Model P.T. 1642

For use with C.W. Vacuum Tube Transmitters. Gives 100 per cent modulation since oscillation can be completely started and stopped at audio frequencies. The note obtained can be varied to any desired pitch by changing the driving motor speed.

Complete with shaft bushing for 5-16" or 1/2" motor shaft. When ordering mention size wanted.



LIST
\$7.45

Special **\$1.25 ea.**

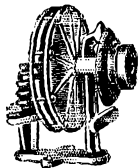

VARIABLE MICA CONDENSER

MODEL U.C. 1819
Capacity .0001 to .005 Mfd.

A Mica Condenser which may be varied continuously from a minimum to a maximum value. Its capacity curve is a straight line, it has a very low electric loss. Used as a grid, antenna, or secondary tuning condenser.

LIST
\$8.75

Special **\$1.75 ea.**

PORCELAIN LOW-LOSS SOCKETS

MODEL U.R. 542

For use with U.X. 866, 852, 865, 860, 245, 210 and 250 tubes

On account of its low specific inductive capacity and its high insulating qualities, these Sockets are excellent for Short Wave work and especially adapted to the above tubes.

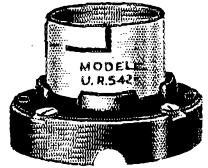

LIST
\$1.00

Special **50c ea.**

Dubilier High-Voltage Filter Condensers

(Newest Types, Nos. 902 and 903)

These Dubilier Filter Condensers are tested from 3 to 5 times their rated value, thus assuring a sturdy, scientifically designed product, far excelling the average Filter Condensers now being used. Widely separated soldering lugs are provided to insure long leakage path and to facilitate neat wiring. Each condenser brand new and packed in individual carton.

TYPE No. 902

Rated D.C. Working Voltage 400 V.

Capacity: 1 Mfd.

List Price \$2.50 ea. SPECIAL **75c ea.**

Capacity: 2 Mfd.

List Price \$3.50 **\$1.05**

Capacity: 4 Mfd.

List Price \$5.50 **\$1.65**



TYPE No. 903

Rated D.C. Working Voltage 600 V.

Capacity: 1 Mfd.

List Price \$3.00 ea. SPECIAL **90c ea.**

Capacity: 2 Mfd.

List Price \$5.50 **\$1.65**

Capacity: 4 Mfd.

List Price \$9.50 **\$2.85**

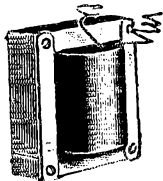

FILTER CHOKES

20 HENRIES

250 MILLS

Just what you want for obtaining a pure D. C. note for your Transmitter. Also can be used in "A" or "B" Eliminators.

Weight 5 pounds. Wiring heavily insulated. New and packed in individual cartons.

SPECIAL **\$2.50 ea.**

LAST MINUTE SPECIALS

R.C.A. Uni-Rectron Power Amplifiers — Model A, P. 935 List \$88.50 ea.	SPECIAL \$19.75 ea.
E210 BRADLEYSTATS, list \$4.00, fine for A.C. Line Voltage Control	1.60 "
Kolster K-8 Dynamic Reproducer, List \$175	49.50 "
U. S. ARMY Aeroplane Spark Transmitters, Gov. cost \$47 ea.	4.75 "
G. E. Kenotron Rectifying Tubes (Type T.B.1)	1.25 "
Gould Kathanode Unipower, Automatic Radio "A" Power (6 volt), list \$39.50	13.75 "
G. E. V.T. 14 — 5 watt Transmitting Tubes (A good power amplifying tube)	1.50 "
Eby A. C. Adapter Harness with volume control for 6 tube sets. List \$10.00	3.75 "

AMERICAN SALES CO., 19-21 Warren Street, New York City

*The most complete . . .
comprehensive . . . and
authoritative Radio Manual
ever published!*

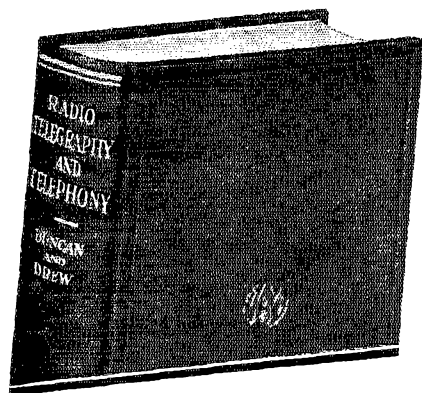

**26 Chapters—Containing
the Latest 1929 Practice**

Introduction to Radio
Magnetism
The Production of Electromotive Force
Electromagnetic Induction
Motor Generators
Curve Diagrams
Storage Batteries and Charging Circuits
Meters
Alternating Current
Condensers — Electrostatic Capacity — Capacity Measurements
Vacuum Tubes
Receiving Circuits
Alternating Current Operated Receiver and Tubes
Telephone Receivers, Loud Speaker Reproducing Units
Commercial Receivers
Rectifier Devices, Rectifier Circuits, Voltage Divider Resistors, Filter Circuits
High Voltage Condensers, How an Electric Circuit Oscillates
Antennae or Aerials
Resonance
Commercial Broadcast and Telegraph Transmitters
Commercial Tube Transmitters
Short Wave Transmitters and Receivers
Spark Transmitters
The Arc Transmitter
Direction Finders — Radio Compass
Appendix

Practical Radio Telegraphy and Telephony

By Rudolph L. Duncan
Director, Radio Institute of America

and Charles E. Drew
*Instructor in Radio, and in charge of Electrical Division,
Radio Institute of America*

Published May 1929

*A Practical Handbook for . . .
Radio Engineers, Operators, Amateurs,
Broadcasters, and Students*

More than 900 pages of practical information on Ship, Shore, and Broadcast Operating make this Radio Handbook indispensable for the practical radio man. Principles, methods and equipment are described clearly and interestingly and illustrated profusely with more than 460 supplementary and illuminating diagrams and photographs. This is all brand new 1929 data presented as a result of years of study and research on the part of two of America's foremost teachers of this subject. The book is a product of the School Division of the Radio Corporation of America, and therefore represents the last word on the subject.

Everyone at all interested in this most fascinating subject will find his most favorite phase of Radio clearly and fully discussed. Even the casual reader will enjoy this book and discover the answers to a great many radio mysteries about which he has vaguely wondered. This book will greatly increase the enjoyment of your radio and open your eyes to a great field of new and progressive discoveries.

Indispensable to the practical man and extremely interesting to the amateur, this book is also an ideal Wireless Operators' Handbook and a complete text for the student of Wireless Communication.

Never before has such a wealth of practical and usable data been collected in book form for the use of the many thousands for whom Radio is the most fascinating subject in the world.

Send in this coupon at once . . . and examine the book at our expense!

Price \$7.50

A Wiley Book

Free Examination Coupon

John Wiley and Sons, Inc.,
440 Fourth Ave., New York

GENTLEMEN: Kindly send me on ten days' free examination Duncan and Drew's "Radio Telegraphy and Telephony."

I agree to remit the price (\$7.50) of the book within ten days after its receipt or return it postpaid.

Name

Address

Position or Reference

Subscriber Yes QST 7-29
 No

Section Communications Managers of THE COMMUNICATIONS DEPARTMENT, A. R. R. L.

Eastern Pennsylvania*	W3ZF	ATLANTIC DIVISION		
Maryland-Delaware-District of Columbia*	W3BBW	Don Lusk	Box 188	Ardsley
Southern New Jersey	W3CFG	Errest Calhoun	1636 Thomas St.	Baltimore, Md.
Western New York	W8PI	M. J. Lotysh	Box 49, R. F. D. 1	Cranbury, N. J.
Western Pennsylvania	W8CEO	C. S. Taylor	598 Masten St.	Buffalo
		A. W. McAuly	309 Third St.	Oakmont
		CENTRAL DIVISION		
Illinois	W9APV	Fred J. Hinds	3337 Oak Park Blvd.	Berwyn
Indiana	W9CVQ	D. J. Angus	310 N. Illinois St.	Indianapolis
Kentucky	W9BAZ	J. B. Wathen, III	Mockingbird Valley	Louisville
Michigan	W8CEF	Dallas Wise	9187 Falcon Ave.	Detroit
Ohio	W8BYN	H. C. Storck	694 Carpenter St.	Columbus
Wisconsin	W9VD	C. N. Crapo	443 Newton Ave.	Milwaukee
		DAKOTA DIVISION		
North Dakota	W9DVV	B. S. Warner	309 4th Ave.	Enderlin
South Dakota	W9DGR	D. M. Pasek	780 Illinois St.	Huron
Northern Minnesota	W9BVR	Carl L. Jabs	1822 James St.	St. Paul
Southern Minnesota	W9EFFK	J. C. Pehoushek	130 Warwick St., S. E.	Minneapolis
		DELTA DIVISION		
Arkansas	W5ABI	H. E. Velte	315 No. Jackson St.	Little Rock
Louisiana	W5EB	M. M. Hill		Oakdale
Mississippi	W5AKP	J. W. Gillett	1708 23rd Ave.	Meridian
Tennessee	W4FI	Folk Perdue	c/o Radio Station WBAW	Nashville
		HUDSON DIVISION		
Eastern New York	W2CNS	F. M. Holbrook	2 Livingston Ave.	White Plains
N. Y. C. & Long Island*	W2BGO	V. T. Kenney	382 Wadsworth Ave.	N. Y. C.
Northern New Jersey	W2WR	A. G. Wester, Jr.	50 Princeton St.	Maplewood
		MIDWEST DIVISION		
Iowa	W9DZW	H. W. Kerr		Little Sioux
Kansas	W9CET	J. H. Amis	915 Lincoln Ave.	Topeka
Missouri	W9RR	L. B. Litzure	8010 Mercer St.	Kansas City
Nebraska	W9BYG	C. B. Deihl	3605 Cedar St.	Omaha
		NEW ENGLAND DIVISION		
Connecticut	W1ZL	C. A. Weidenhammer	33 Washington Place	Bridgeport
Maine	W1AQL	G. C. Brown	269 No. Main St.	Brewer
Eastern Massachusetts	W1UE	E. L. Battey	39 Royal St.	Wollaston
Western Massachusetts	W1UM	Dr. John A. Tessmer	8 Schaffner St.	Worcester
New Hampshire	W1AII	W. W. Hodge	227 Main St.	Claremont
Rhode Island	W1BCR	C. N. Kraus	92 Keene St.	Providence
Vermont	W1IT	Clayton Paulette		North Troy
		NORTHWESTERN DIVISION		
Alaska	WWDN	W. B. Wilson	U. S. LHT Fern	Ketchikan
Idaho**	W7ABB	H. R. McBirney	1720 Washington St.	Boise
Montana	W7AAT-7QT	G. W. Viers		Red Lodge
Oregon	W7UN	Wilbur S. Claypool	943 E. 30th St., S. E.	Portland
Washington	W7FD	Otto Johnson	4340 30th Ave. W.	Seattle
		PACIFIC DIVISION		
Hawaii	K6CFQ	F. L. Fullaway	2714 Manoa Rd.	Honolulu
Nevada	W6UO	C. B. Newcombe		Yerington
Los Angeles	W6AM	D. C. Wallace	209 Pine Ave., Room 410	Long Beach, Calif.
Santa Clara Valley	W6NLS	D. J. Quenent	1348 Hanchett Ave.	San Jose
East Bay	W6CZR	I. Walter Frates	368 62nd St.	Oakland
San Francisco	W6WB	C. F. Bane	262 Castro St.	San Francisco
Sacramento Valley	W6DON	Everett Davies	Rt. 5, Box 380	Sacramento
Arizona*	W6BWS	Russ Shortman	519 W. Madison St.	Phoenix
Philippines*	K1AII	M. E. Felizardo	252 Galicia St.	Manila
San Diego*	W6EOP	Harry A. Ambler	4101 Hamilton St.	San Diego
		ROANOKE DIVISION		
North Carolina	W3CA	J. F. Wohlford	118 Cambridge Ave.	Roanoke
Virginia	W8VZ	F. D. Reynolds	Box 1200	Fairmont
West Virginia				
		ROCKY MOUNTAIN DIVISION		
Colorado	W9CAA	C. R. Stedman	1641 Albion St.	Denver
Utah-Wyoming	W6BAJ	Parley N. James	430 "D" St.	Salt Lake City
		SOUTHEASTERN DIVISION		
Alabama	W4AAQ	S. J. Bayne	9 Park Ave.	Montgomery
Florida	W4AII	Harvey Chann	6002 Suwanee Ave.	Tampa
Georgia-S. Carolina-Cuba-Isle of Pine	W4RM	James G. Cobble	1124 Mayland Circle	Atlanta
Porto Rico-Virgin Islands*	K4KD	E. W. Mayer	Box 103	Ensenada, P. R.
		WEST GULF DIVISION		
Northern Texas	W5AKN	J. H. Robinson, Jr.	522 Cumberland St.	Dallas
Oklahoma	W5GFP	W. J. Gentry	610 Potenger St.	Shawnee
Southern Texas	W5OKX	R. E. Franklin	1806 Valentine St.	Houston
New Mexico	W5TT	L. E. Radka		Tucumcari
		MARITIME DIVISION		
Maritime*	VE3DQ	A. M. Crowell	69 Dublin St.	Halifax, N. S.
		ONTARIO DIVISION		
Ontario	VE3FC	E. C. Thompson	266 Queensdale Ave.	Toronto, O
		QUEBEC DIVISION		
Quebec	VE2RE	Alex Reid	169 Logan Ave.	St. Lambert
		VANALTA DIVISION		
Alberta	VE4HA	E. J. Taylor	10107-87th Ave.	Edmonton
British Columbia	VE5BJ	E. S. Brooks	2987 Camosun St.	Vancouver
		PRAIRIE DIVISION		
Manitoba*	VE4HR	A. V. Chase	109 Lanark St.	Winnipeg
Saskatchewan	VE4FC	W. J. Pickering	514 19th St. W.	Prince Albert

*Official appointed to act until the membership of the Section concerned choose permanent SCMs by nomination and election.

**Acting for the summer.

High Voltage Variable Air Condensers

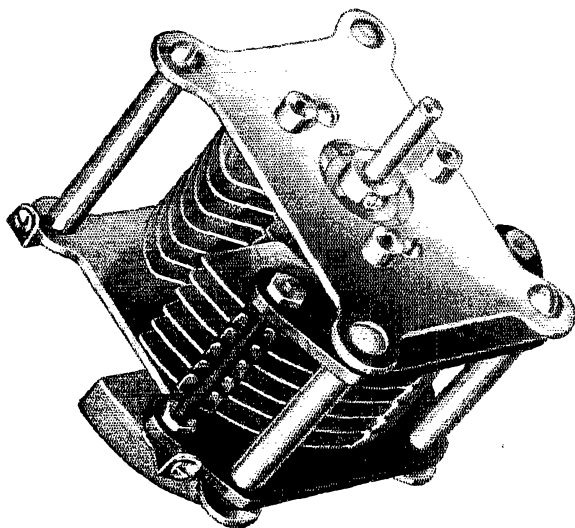

Continued tests under actual operating conditions have shown that the TYPE 334 Variable Air Condensers, formerly rated at 2000 volts, may safely be used on voltages up to 2500, root mean square, or 3500, peak.

This condenser is now available in a 250 mmf. size in addition to the regular 100 mmf. and 50 mmf. sizes.

PRICES

TYPE 334-R	250 mmf.	\$5.50
TYPE 334-T	100 mmf.	2.75
TYPE 334-V	50 mmf.	2.50

GENERAL RADIO COMPANY

30 STATE STREET
CAMBRIDGE, MASSACHUSETTS

274 BRANNAN STREET
SAN FRANCISCO, CALIFORNIA



QST



The Official Organ of the A.R.R.L.

VOLUME XIII

JULY, 1929

NUMBER 7

Editorials	9
Atlantic Division Convention	10
Official Frequency System	10
The Lunch-Kit Portable Receiver and Monitor	11
<i>Edward Braddock</i>	
The President's Corner	13
<i>Hiram Percy Maxim</i>	
Radio Frequency Couplings	14
<i>J. M. Grigg</i>	
Time Relay Control of Transmitters	17
<i>A. R. Richards</i>	
High-Frequency Reception on Trains	19
<i>Don C. Wallace</i>	
An Inexpensive Test Set for Broadcast Receiver Performance	21
<i>Wilfred Taylor</i>	
The A.R.R.L. Board Meets	24
Little-Known Tubes	25
<i>Harold P. Westman</i>	
QRH Rats, Mice and Bacteria	30
<i>William Justice Lee</i>	
W8CEO	32
T.O.M. Himself	37
Those Past Issues of QST	38
<i>Louis F. Leuck</i>	
The DX Meter	39
<i>D. F. Brocchi</i>	
Supervisor Cadmus Passes On	41
Midwest Division Convention	41
Junk	42
<i>Carl L. Rose</i>	
Experimenters' Section	43
The Communications Department	47
I.A.R.U. News	63
Calls Heard	66
Correspondence	68
Financial Statement	86
Hamads and QRAs	92
QST's Index of Advertisers	94

QST is published monthly by The American Radio Relay League, Inc., at Hartford, Conn., U. S. A. Official Organ of the A.R.R.L. and the International Amateur Radio Union

Kenneth B. Warner (Secretary, A.R.R.L.)
Editor-in-Chief and Business Manager

Clark C. Rodimon
Assistant Editor

G. Donald Meserve
Advertising Manager

Harold P. Westman
Technical Editor

James J. Lamb
Assistant Technical Editor

David H. Houghton
Circulation Manager

Subscription rate in United States and Possessions, Canada, and all countries in the American Postal Union, \$2.50 per year, postpaid. Single copies, 25 cents. Foreign countries not in American Postal Union, \$3.00 per year, postpaid. Remittances should be by international postal or express money order or bank draft negotiable in the U. S. and for an equivalent amount in U. S. funds.

Entered as second-class matter May 29, 1919, at the post office at Hartford, Connecticut, under the Act of March 3, 1879. Acceptance for mailing at special rate of postage provided for in section 1103, Act of October 3, 1917, authorized September 9, 1922. Additional entry at Concord, N. H., authorized February 21, 1929, under the Act of February 28, 1925.

Copyright 1929 by the American Radio Relay League, Inc. Title registered at United States Patent Office.
Member of the Radio Magazine Publishers' Association.

The American Radio Relay League

The American Radio Relay League, Inc., is a non-commercial association of radio amateurs, bonded for the promotion of interest in amateur radio communication and experimentation, for the relaying of messages by radio, for the advancement of the radio art and of the public welfare, for the representation of the radio amateur in legislative matters, and for the maintenance of fraternalism and a high standard of conduct.

It is an incorporated association without capital stock, chartered under the laws of Connecticut. Its affairs are governed by a Board of Directors, elected every two years by the general membership. The officers are elected or appointed by the Directors. The League is non-commercial and no one commercially engaged in the manufacture, sale or rental of radio apparatus is eligible to membership on its board.

"Of, by and for the amateur," it numbers within its ranks practically every worth-while amateur in the world and has a history of glorious achievement as the standard-bearer in amateur affairs.

Inquiries regarding membership are solicited. A bona fide interest in amateur radio is the only essential qualification; ownership of a transmitting station and knowledge of the code are not prerequisite. Correspondence should be addressed to the Secretary.

DIRECTORS

President
HIRAM PERCY MAXIM
Drawer 2102,
Hartford, Conn.

Vice-President
CHARLES H. STEWART
St. David's, Pa.

Canadian General Manager
A. H. K. RUSSELL
5 Mail Bldg.,
Toronto, Ont.

Atlantic Division
EUGENE C. WOODRUFF
234 W. Fairmount Ave.,
State College, Pa.

Central Division
CLYDE E. DARR
137 Hill Ave., Highland Park,
Detroit, Mich.

Dakota Division
C. M. JANSKY, JR.
Dept. of Elec. Eng., U. of M.
Minneapolis, Minn.

Delta Division
BENJ. F. PAINTER
424 Hamilton Nat'l Bank Bldg.,
Chattanooga, Tenn.

Hudson Division
A. LAFAYETTE WALSH
220 West 42d St.,
New York City

Midwest Division
PORTER H. GUINBY
817 Lauderdale Building,
St. Louis, Mo.

New England Division
FREDERICK BEST
13 East Crescent St.,
Augusta, Maine

Northwestern Division
K. W. WEINGARTEN
3219 No. 24th St.,
Tacoma, Wash.

Pacific Division
ALLEN H. BABCOCK
65 Market St.,
Southern Pacific Co.,
San Francisco

Roanoke Division
W. TREDWAY GRAVELY
Box 245,
Danville, Va.

Rocky Mountain Division
PAUL M. SEGAL
Box 1771,
Denver, Colo.

Southeastern Division
HARRY F. DOBBS
245 Spring St., N. W.,
Atlanta, Ga.

West Gulf Division
FRANK M. CORLETT
2515 Catherine St.,
Dallas, Tex.

OFFICERS

President HIRAM PERCY MAXIM, Hartford, Conn.
Vice-President CHARLES H. STEWART, St. David's, Pa.
Secretary KENNETH B. WARNER, Hartford, Conn.
Treasurer ARTHUR A. HEBERT, Hartford, Conn.
Communications Manager F. EDWARD HANDY, Hartford, Conn.

ADDRESS ALL GENERAL CORRESPONDENCE TO THE EXECUTIVE HEADQUARTERS AT HARTFORD, CONN.

EDITORIALS

12

HAVING just absorbed our usual noonday plate of beans at Mr. Eddie Kane's Palatial Pullman Diner which graces the avenue across from these headquarters, and all being quiet and peaceful through the establishment, it seems a fitting time for us to bat out our monthly words of wisdom, cheer, philosophy and what-have-you which for so many years have decorated this page.

We feel the urge to talk about international meetings that deal with radio. Not international meetings in general, for we can think of lots of other things we'd rather talk about and many that we could be more cheery about — but two particular international radio meetings which are a bit in our mind right now. One of these was at Prague, Czechoslovakia, in April, and the other is to be held at The Hague in September. After Washington we thought there would be a bit of a breathing spell until Madrid, but the international-conference idea seems to be nicely regenerated now and we mere users of radio needs must oscillate in phase with it.

After the fashion of the North American regional conference held at Ottawa recently, the European governments held a regional conference at Prague in April to deal with European regional problems. The United States sent over a delegation of observers, headed by Mr. W. D. Terrell, chief of the Radio Division of the Department of Commerce. The conference related only to European affairs and mostly to broadcasting, but the effect of some of its actions is reflected towards amateur radio and some of its doings have a direct bearing upon the radio amateurs of Europe — and therefore upon us. The Netherlands government had proposed and circulated a suggested uniform license for amateur stations, involving all the technical matters of amateur regulation: bands, power, measuring equipment, etc. Actually there was very little discussion of amateur matters. Mr. Terrell had opportunity to tell the conference of the encouragement given amateurs by the United States government. It was decided to leave these matters to an international technical conference to be held later in the year at The Hague.

It happens that the Washington Convention of 1927 provides for the existence of an International Technical Consulting Committee on Radio Communication, to meet every two years to ponder technical questions and give advice to the governments party to the convention. The Neth-

erlands government was assigned the duty of arranging for the first meeting. Now the call has come out for the first session, at The Hague in September, and the governments and radio organizations of the world are busy in preparation. It was to this meeting that the Prague conference referred numerous general technical questions about frequency separation, stability control, international standards, short waves for national services, and so on. The Netherlands government itself, in issuing the call for the meeting, includes the subject of amateur licenses, originally suggested at Prague, proposing "uniformity, as far as possible, in the technical conditions imposed on the holders of amateur licenses; international allocation of frequency bands for amateurs."

We have in the picture, then, another international confab on radio. This one has no administrative authority and its views are not binding upon any nation; it is advisory only and it is still the Washington Convention that governs. Some knotty problems are coming up, though. There is some disposition to upset the allocations of Washington, Germany in particular wanting the extension of broadcasting up to 2000 kc. or at least from 1715 to 2000 kc. and thus threatening the amateur shared band between those figures. All these technical stipulations governing stations may apply to amateurs unless exceptions are noted, and there are these direct proposals from the Netherlands of uniform international practice in amateur licenses, allocations and regulations. Life, it seems, is never to be dreary for radio folks.

The United States government already has organized committees paralleling the field of work of the coming Hague meeting, and the views of this country are being marshalled to take to the conference. The League has representation in these committees and the interests of the amateur are being looked after. We have nothing to watch our own government for — the United States view will be entirely sympathetic to its amateurs. We know that our government will not acquiesce to any international proposal for regulations that are more severe than it now has. Regulations for other classes of stations are not uniform internationally; why should they be for amateurs? Perhaps it is true that amateur radio in this country, because of its encouragement by the government, is more of a national asset than is the amateur radio of any other country — but all the more reason why our government should encour-

age this policy. We need, and we justify, more operating facilities than other nations possibly will be willing to give their amateurs. The Washington Convention marks the limit in international yielding for the sake of accord. Within the flexible regulations of that document there is room enough for any government to provide for or to curb its amateurs according to its own lights and their just deserts, and for this government there can be no more participation in those international schemes which receive acceptance only when the lowest common denominator is found for every nation's proposal. On the contrary we think that our government can testify, from its seventeen years of experience in amateur regulation, that other governments are unnecessarily alarmed about the great administrative difficulties attendant upon amateur control, and that it is in position to suggest that these other governments might much more freely encourage amateurs by more liberally providing for them in domestic regulations. But suffer American amateur radio to be cut to that measure of liberality to which such uninformed administrations might agree — never!

K. B. W.

Atlantic Division Convention

(Western and Central New York Section)

AUGUST 9-10 AT AUBURN, N. Y.

THE Finger Lakes Transmitting Society extend a cordial invitation to all "Hams" to attend this year's convention. The meeting place and lecture auditorium will be in the Chamber of Commerce Building, 160 Genesee St., Auburn, and the banquet will be served at Lake Side Inn, a well-known summer hotel on the shore of Owasco Lake, where ready access to Lakeside Park with its wonderful bathing beach and dance pavilion will add to the amusement side of the convention.

Several lectures will be given by prominent authorities. Plenty of prizes have been provided and there will be something doing every minute.

Don't forget the dates and bring along the Y.L., O.W. and friends; but be sure to write Albert Gifford, WSAHC, Union Springs, N. Y., and let him know you will be there.

Official Frequency System

THE Official Frequency Station Committee, a part of the Experimenters' Section of the A.R.R.L. has arranged the services described below for the benefit of the members of the League and others.

1. Standard Frequency Transmissions are sent by Standard Frequency Stations (known as O.F.S.-S.F.) on definite schedules with a high degree of accuracy. All the principal amateur bands are covered, several points being given in

each so that frequency meters may be accurately calibrated. These transmissions are based on piezo-electric frequency standards that are regularly checked by one or more of the leading scientific laboratories of the country.

2. Official Frequency Transmissions are sent by Official Frequency Stations (known as O.F.S.) at a somewhat lesser degree of accuracy. These stations do not transmit on regular schedules but announce their frequency at the end of at least every other transmission during their regular amateur operation. Such stations will measure the frequency of your emissions upon request.

Practical suggestions are always welcome and should be sent to the proper member of the Committee which is composed of the following: Don C. Wallace, W6AM, Chairman in charge of O.F.S., Room 410, 209 Pine Avenue, Long Beach, Calif.; Prof. C. M. Jansky, Jr., care of University of Minnesota, Minneapolis, Minn.; and Killian V. R. Lansingh, W6QX, in charge of O.F.S.-S.F., Box 751, Hollywood, Calif.

STANDARD FREQUENCY SCHEDULES

Friday Evening				Sunday Afternoon			
Time (p.m.)	Frequency			Time (p.m.)	Frequency		
	A	B	AB		C	D	CD
8:00	5700	7300	7300	3:00	14400	30000	30000
8:12	4000	7250	7200	3:12	14350	29750	29000
8:24	3900	7200	7100	3:24	14300	29500	28000
8:36	3800	7150	7000	3:36	14250	29250	14400
8:48	3700	7100	4000	3:48	14200	29000	14200
9:00	3600	7050	3850	4:00	14150	28750	14000
9:12	3550	7000	3650	4:12	14100	28500	
9:24	3500		3500	4:24	14050	28250	
				4:36	14000	28000	

Time is the local standard time at the transmitting station and the frequency is in kilocycles.

DIVISION OF TIME

- 4 minutes — QST QST QST de (call letters).
- 3 minutes — Characteristic letter sent very slowly and broken by call letters each half minute.
- 1 minute — Statement of frequency in kilocycles.
- 4 minutes — Time allowed to change to next frequency. Standard Frequency Stations.
- W1XV — Massachusetts Institute of Technology, Communications Experiment Station, Round Hill, Dartmouth, Mass., H. A. Chinn in charge. Uses Eastern Standard Time and characteristic letter "G."
- W9XL — Gold Medal Station, R. F. D. No. 3, Anoka, Minn., H. S. McCartney, in charge assisted by Lyall K. Smith, Ivan H. Anderson and George Collier. Uses Central Standard Time and characteristic letter "D."

ACCURACY

The transmissions of both of these stations will be within 1/10 of 1% of the frequencies herein announced, which is considerably better

(Continued on page 86)

The Lunch-Kit Portable Receiver and Monitor

By Edward Braddock*

SUMMERTIME will undoubtedly always be vacation time to most of us — that time when automobile trips, camping and week-end journeys are distinctly in order. However, when away from home and the station, need is often felt for a practical receiver fully portable with which close touch can be kept with amateur radio.

The portable receiver shown in the first photo was built to meet these demands — and then some. The metal lunch-kit provides a convenient means of transportation with the added advantage of suitably shielding the circuit within. Thus in the station it can be employed as a monitor to listen to the emissions of the transmitter. It is, therefore, unnecessary to put it on the shelf for the larger part of the year as is the case with many portable receivers. This is a distinct advantage when the funds out of which the station radio equipment is to be purchased are limited and small.

The circuit employed is shown in Fig. 1 and is unusual in no way. It has been used by amateurs for a long time and employs a throttle condenser to control regeneration. Plug-in coils of the very popular tube-base variety are provided so that the 3500-, 7000- and 14000-kc. bands may be covered.

The antenna and ground binding posts are mounted on the back of the case and are connected to the primary coil which is wound around the circular portion of the UX socket into which the plug-in coils fit. This prevents different an-

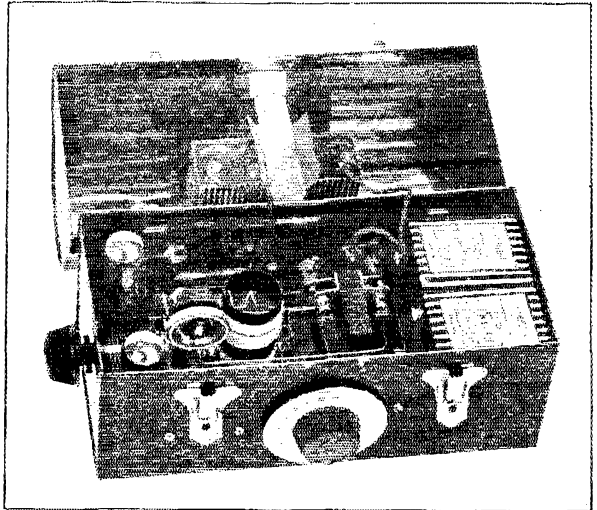

WHEN THE COVER IS LIFTED, WE FIND QUITE AN ASSORTMENT OF THINGS THAT THE MANUFACTURER NEVER INTENDED TO BE CARRIED WITHIN THE KIT

The strap to hold the thermos bottle in place does excellent duty in maintaining the "A" battery in position.

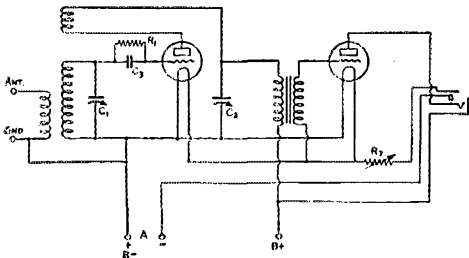

FIG. 1. — LITTLE NEED BE SAID CONCERNING THE CIRCUIT ARRANGEMENT; IT IS FAMILIAR TO ALL

- The parts used are as follows:
 C1 — 50 μ fd. Pilot midget.
 C2 — 100- μ fd. Pilot midjet.
 C3 — μ fd. Sangamo fixed condenser.
 R1 — 4-megohm grid leak.
 R2 — Carter 20-ohm rheostat.
 J — Yaxley single circuit filament-control jack.

* W3BAY, 8 Tanner St., Haddonfield, N. J.

tennas from shifting the position on the dial at which certain stations may be logged. The antenna post must be insulated from the metal box and this is accomplished by cutting or drilling a hole amply large enough to provide the necessary clearance and fastening a piece of bakelite by means of two screws so it will cover the hole on the inside of the box. The binding post is then mounted on the piece of insulating material.

The tuning and throttle condensers are mounted directly upon the side of the kit, there being no reason for insulating them from it. The tuning condenser which is rotated by means of a General Radio dial is mounted on the front of the box while the regeneration-control condenser is equipped with a small knob (there being no need for any scale) and is mounted at one end of the box. The only other piece of equipment that shows on the outside of the kit is the telephone jack which is next to the tuning dial. It, also, is

insulated from the box and is mounted in the same fashion as the antenna post.

The filament rheostat is not mounted on the

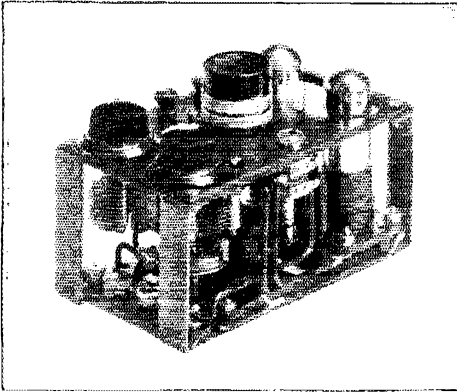

THE SET PROPER IS A COMPLETE UNIT THAT MAY BE EASILY SLIPPED OUT OF THE CARRYING CASE

Its open type of construction should help in its assembly and wiring, tasks that are usually difficult when a very compact set is desired.

front of the case at all. It is supported by means of the two heavy leads connecting it in the circuit and may be seen next to the tubebase coil in the next photo. This offers no hardship inasmuch as the telephone jack employed is of the filament control variety which will allow the rheostat to be set and readjusted only occasionally.

A pair of the smallest sized 22.5-volt "B" batteries supply voltage for the plates of the two

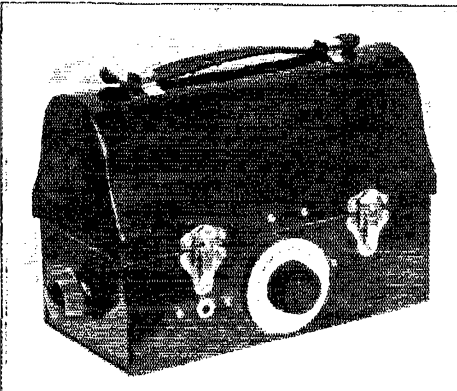

THE LUNCH-KIT PORTABLE

Unlike most portable sets this is a summer and winter affair inasmuch as it may be employed as a monitor during the greater part of the year. It may be picked up and carried off on the vacation trip at a moment's notice.

tubes and the filaments are lighted by means of a single 3-cell battery of the small-size heavy-duty variety. The "A" battery is mounted in the

top of the kit and is held in place by means of the metal strap which would normally be employed to hold a thermos bottle in place providing the receiver were supplanted by a suitable assortment of sandwiches etcetera. To prevent the metal strip from shorting one cell of the battery by making contact to two of the binding posts on it, a piece of heavy paper or light fibre is employed as an insulator. Sufficient space is available each side of the "A" battery to allow a pair of light-weight phones and a length of antenna wire to be stowed away. When being transported, the set is, therefore, entirely self contained.

The use of the single stage of audio amplification allows loud speaker signals to be obtained when the set is employed as a monitor. The advantages of this are many as will be quickly seen.

ANOTHER SET

Another portable set that was constructed about a year ago differs somewhat in its mechani-

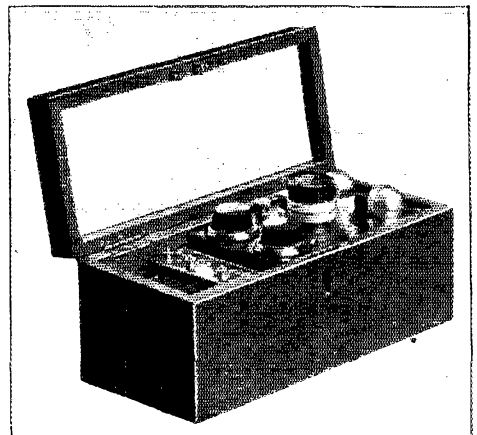

IN THIS VIEW THE SET HAS BEEN SLIPPED INTO THE CARRYING BOX

The "A" battery is located in the extra compartment with the "B" batteries which are not visible over the edge of the case. The cover may be locked in the closed position.

cal construction from the one just described. While it is not so ideally adapted for use as a monitor, it can be so employed providing it is placed at a suitable distance from the transmitter. On the other hand it will stand more knocking around because there are no dials or knobs protruding from the sides of the carrying case.

An excellent idea of the constructional details of the set may be obtained from another photo. The panel which is a piece of bakelite is supported upon two brass straps bent in the form of a "U." It carries in addition to the tuning and regeneration controls, the phone jack, filament switch, plug-in coil and antenna and ground binding

(Continued on page 82)



The President's Corner

A WORD FROM
HIRAM PERCY MAXIM

PRESIDENT OF THE AMERICAN RADIO RELAY LEAGUE AND
OF THE INTERNATIONAL AMATEUR RADIO UNION

DX Dreaming

It is great fun to dream, sometimes. I fell to dreaming in terms of DX the other night. I wondered how many of you fellows realized the real DX that is going on about us every day and every night. We think we are accomplishing something wonderful when, with a little bit of apparatus which we put together ourselves, we create an electromagnetic disturbance that sends out a wave that can be detected on the opposite side of the earth. The distance is one-half the earth's circumference or one-half of 25,000 miles, which is 12,500 miles. That is the maximum possible earthly separation that can be achieved. In other words, no two human beings can get farther away from each other than 12,500 miles.

Electromagnetic waves created by an electromagnetic disturbance travel at a velocity of approximately 186,000 miles per second. This is the velocity of light. Visible light is "radio" of enormous frequency.

If I am in Halifax, Nova Scotia, and you are in southwestern Australia, we are approximately at opposite points on the earth's surface, or 12,500 miles apart. It takes my wave $\frac{12,500}{186,000}$ of a second to reach your antenna, or .067 of a second.

Now consider the Sun. It is so hot that it radiates electromagnetic waves of a perfectly tremendous frequency. We call them sunlight. When we walk out into this sunlight we receive these radio waves from the sun. The sun is 93,000,000 miles away. Therefore it takes $\frac{93,000,000}{186,000} = 500$ seconds, which is just a little over eight minutes, for the wave to travel the

distance between the sun and the earth. This is pretty good DX, but not a circumstance to some of the other DX that is going on around us.

The light from the nearest of the fixed stars, which we see on any clear night, takes over a year to reach us — 186,000 miles every second of all that time! How far away must they be! The answer is: 365 days in a year means 365×24 hours, or 8760 hours. This multiplied by 60 equals 525,600 minutes. This multiplied by another 60 equals 31,566,000 seconds — 186,000 miles for every one of these seconds means 31,566,000 multiplied by 186,000, or 5,604,256,000,000 miles.

This means an unwieldy figure to handle, so we call that distance *one light year*. It's a long, long way for a little radio wave to travel, sure enough, but it makes the distance just the same, and every time we fix our gaze on one of those stars that is a light year away, our eyes are detecting the "signals" that left that star a year ago!

But that is not all. Our telescopes amplify these "signals" and enable our eyes to detect faint radiations of light from spiral nebulae as far away as 1,000,000 light years!

When we gaze at one of these spiral nebulae our eyes are detecting "signals" that left those remotely-distant bodies over a million years ago, when our little earth was very young. This is real DX and must inspire every radio man to serious thought.

With radio we have the means of communicating across the incomprehensibly great distances of celestial space. There is no other means that we know of that can do this. And we have been receiving all kinds of radio frequencies across these profound spaces for centuries. The latest are those described by Millikan and termed, by him, cosmic rays. At this time we have recorded almost the entire spectrum. And yet is it not odd that, notwithstanding all the multitude of different radio frequencies which we have detected, we have never had one single grain of evidence that any of them were originated by an intelligence? And hence the question, is ours the sole intelligence in all the cosmos? Will it be an amateur who first answers this great question? I can remember when I wondered if I was the only radio amateur in the world. There were lots of them, I later found. Are there lots of other intelligent beings in other worlds?

Radio Frequency Couplings

By J. M. Grigg*

THE radio frequency amplification obtainable with a vacuum tube is a subject which in lay circles has always been more or less clouded with a haze of uncertainty. This fact has resulted largely from individual treatment, leading to the conception that each coupling type is a thing for itself. Excepting the band-pass filters, all the useful coupling types are essentially equivalent, and a best perspective of the subject results from an examination of the type form. This requires, therefore, that all these types be reduced to a uniform symmetry that admits ready inspection. In so doing the writer attempts to supply simple equations in which substitution of the proper constants will give the needed information for all the common types of coupling. Thus the theoretical amplification and selectivity become known, and it is possible to conclude at once what probable values will best suit a given tube characteristic.

The equation for amplifications is

$$A = \left(\frac{\mu}{1 + \frac{a}{K^2}} \right) \frac{1}{K^2} \quad (1)$$

which applies to radio frequency couplings when tuned to resonance, and will apply also to resistance couplings.

The equation for selectivity is

$$S = \sqrt{\frac{Z_o r_p^2}{R(r_p + Z_o K^2)^2}} \quad (2)$$

In these expressions K is the coefficient of coupling and

$$a = \frac{r_p}{Z_o} \quad (3)$$

in which r_p is the internal impedance of the tube plate circuit and in all cases

$$Z_o = \frac{L}{C R} \quad (4)$$

L and C are those values by which frequency is determined, namely the effective inductance and capacitance values which satisfy the relation

* 5951 S. Tripp Ave., Chicago, Ill.

† For inductive coupling

$$M = K^2 L \left(\frac{L_2}{M} + 1 \right)$$

in which L_2 , the leakage flux, is equivalent to a separate inductance in the primary circuit. Since in best design the leakage should be negligible the above holds for inductive coupling, too.

$$\omega = \frac{1}{\sqrt{CL}}$$

while R is the high frequency resistance of the resonant circuit. In further explanation it might be pointed out that the product $Z_o k^2$ is the input impedance of the coupling.

Figs. 1 to 5 illustrate various coupling types to which this discussion applies, and accompanying these are expressions for the respective values of k , the coupling coefficient. All these types are examples of current or parallel resonance; in radio

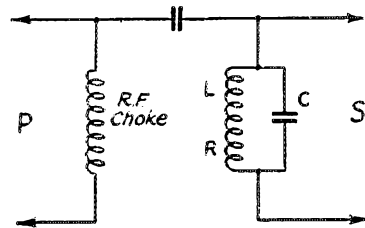

$K = 1$

FIG. 1

circuits parallel resonance is almost universal; exceptions being receiving loop antennas and tuned open antennas, both of which may be regarded as instances of series or potential resonance.

Returning to Equation (1) it is found that the maximum amplification occurs when

$$K^2 = a \quad (5)$$

in which case the highest theoretical amplification is

$$A = \frac{\mu}{2 K^2} \quad (6)$$

The circumstances surrounding this condition are important enough to dwell upon. First of all there is the condition that the tube delivers its maximum energy when the external (input) impedance is equal to the internal; that is, when the two loads are equal, or $Z_o k^2 = r_p$. If Z_o is smaller than r_p , any fractional coupling means a loss in amplification. Above the point of equality a step-up coupling of the proper fraction to maintain the balance of load insures the best voltage gain. In any case, whether the balance of load is maintained or not, it is evident from Equation (1) that the output voltage increases with Z_o , just as happens in the parallel case of resistance coupling

($k = 1$), when the coupling resistance is increased indefinitely. Equation (5) merely indicates the most efficient coupling for a given circumstance; whereas the limit of amplification is determined by μ and by the limit which may be assigned to Z_o , as fixed by the possibilities of the combination L, C , and R .

Within the proper limits a large value of Z_o is favorable also to selectivity. By definition selectivity is the ratio of the square-root per cent of the

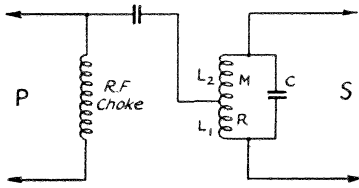

$$K = \frac{\sqrt{2L_1 \pm (L_1 + L_2 - L)}}{2L}$$

where $L = \text{the total inductance}$

FIG. 2

current-squared change to the per cent of capacitance (or inductance) change. Since detectors ordinarily register in squares, two circuits having the same selectivity will show the same separation of signals only when the amplifications are equal. Making the statement general, for the same separation of signals in two or more circuits, the respective sharpness of resonances must be proportional to the respective squares of μ , the amplification constants. An exception is made in the case of the straight-line, or heterodyne detector, but only when the beat signal is the audible signal, as for instance in code reception. The regenerative detector, in so far as it may be classed as straight-line, is also an exception. In these exceptions equal separation of signals requires sharpness of resonances proportional to the first power. In the latter statement is found a plausible explanation of the better selectivity of the regenerative detector; in the former an accounting for the difficulty in getting proper signal separation with the high- μ tube, such as the screen-grid tube.

Returning to Equation (2), if $k = 1$, S will have its highest value when $Z_o = r_p$, and will be equal to

$$\sqrt{\frac{L}{4CR^2}}$$

which is the utmost using the coupling of Fig. 1. If Z_o is greater than

$$r_p \text{ and } Z_o k^2 = r_p, S = \sqrt{\frac{L}{4CR^2}}$$

in which, with a different relationship of constants, a better selectivity may obtain. With the same constants, if

$$k^2 = 0, S = \sqrt{\frac{L}{CR^2}}$$

which is equivalent to the selectivity of a series resonance circuit of similar constants and which is the maximum it is possible to obtain. From this it may be observed that reducing the coupling from the optimum value to zero nets a gain in selectivity of only two times. Nevertheless, since the amplification will also reduce to zero it is evident that any desired ratio of S to A may be had by proper choice of the coupling coefficient. Considering, however, that amplification falls off badly in the process, the usefulness of this is of doubtful value. At best it amounts to little more than reducing volume to get wider dial separation of signals.

On the other hand, increasing the value of the square-root ratio L/CR^2 will result in a higher numerical value of S , but will not necessarily result in sharper tuning. This may be explained in the following manner. In the case of optimum coupling the two expressions may be written

$$A = \frac{\mu}{2} \sqrt{\frac{L}{r_p CR}} \text{ and } S = \frac{1}{2} \sqrt{\frac{L}{CR^2}}$$

in which the quantities L, C and R are common to both. From the first of these expressions it is evident that large voltage gains may be had merely by choosing a large L/C ratio. But in the actual coil L cannot be increased without a correspond-

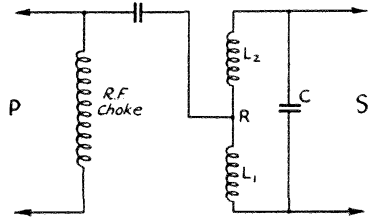

$$K = \sqrt{\frac{L_1}{L_1 + L_2}}$$

L_1 and L_2 in non-inductive relation

FIG. 3

ing increase in the value of R ; and if L varies as the square of the turns, R^2 will vary in approximately the same ratio. Moreover, because R in the first expression becomes R^2 in the second it will be found by trial that the gain in amplification due to increase in the value of L will not be accompanied by a proportionate increase in selectivity; that is, A will increase faster than S with resultant broader tuning. On the other hand, if R can be reduced the case will be reversed; that is to say, S will increase faster than A . Evidently, therefore, the true gain in coil design comes from a reduction in the value of R , which statement is axiomatic, and the widespread understanding of it is amply borne out in fact by the amount of effort spent trying to reduce the losses in coils.

The numerical value of R , the high frequency resistance, is related only remotely to the value of the direct current resistance. At lower frequencies, and in general as the wire becomes very small, it approaches the value of the d.c. resistance. For an example it might be stated that with such frequencies and inductances as are encountered in the broadcast band, the high frequency resistance is not likely to be less than 5 or 6 ohms, regardless of the coil design or gauge of the wire used. r_p , the impedance of the tube, varies with filament heat and the potential applied to the plate; also the value in the case of a detector tube is likely to be very much greater than in the case of an amplifier tube.

From a constructional standpoint the inductive coupling, Fig. 5, offers the best advantages, inasmuch as k may be readily adjusted for stability. From a standpoint of stability the circuit, Fig. 4, can hardly be surpassed. As has been previously pointed out by the writer, if the two condensers are chosen about equal in value, there is a balance of potentials such that the potential of the tap is zero with respect to the preceding grid. As k in this instance is .707, unusual amplification may be expected, and this may be increased by the use of tickler coils to secure the usual regeneration.

In showing applications of the foregoing theory, it will serve as well merely to show actual values as they have been chosen. In a typical case with the last mentioned coupling the frequency is 381 kc. The coupling coefficient is predetermined by the conditions of stable operation; or as has been stated by the requirement that the condensers be equal in value. Thus $k = \frac{1}{2}$. Now if L and C are .00029 henries, and .0006 10^{-6} farads respectively, and R is taken at approximately 7 ohms, the resulting value of Z_0 is 70,000 ohms. Multiplying this by $\frac{1}{2}$, the input impedance is 17,500 ohms. As the plate impedance of an ordinary tube will not differ greatly from the latter figure, the requirements for best amplification with a predetermined coupling are practically satisfied.

For experimental purposes a coil was made up as follows: There were 325 turns No. 31 s.s.c. on a 2" tube. The winding was 3.625" long, and had small loops brought out every $1\frac{1}{2}$ " for tapping. The calculated inductance and high frequency resistance at 381 kc. were 2.32 mh. and 27.1 ohms respectively. With a shunt capacity of .000075 μ fd., Z_0 was 1,138,000 ohms.

This coupling unit was tried with a 201-A tube. As Z_0 was excessive compared with the impedance of the tube, the value of a , Equation (1) was quite small, and the optimum coupling was $k = 0.35$. If the tap was taken $\frac{1}{4}$ the distance from the low potential end, then k was equal to this value, or 0.35 in this particular solenoid. It was surprising to find that it was impossible to couple at this point in an unshielded superheterodyne

and get stable operation with 90 volts on the plate and -3 on the grid. The amplification obtained was amazing, although for reasons that have been explained the tuning band at this volume of signal was a little too broad for practical service. The theoretical gain was 32 times; and taking into account the losses incidental to high step-up, it was actually perhaps better than 20.

Inquiry into the probable causes of the foregoing stable performance might prove to be profitable. The circuit used was that illustrated in Fig. 2. The plate supply was fed through a choke coil, and a blocking condenser, C_1 , was employed to insulate the succeeding grid and filament. This blocking condenser resulted in a slightly leading plate current, so that the potential fed back to the preceding grid, instead of being at right angles to the grid potential, had a small component in opposition to it. Now if the usual inductive coupling

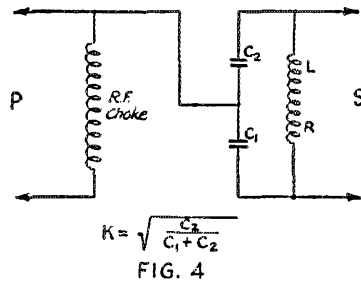

with leakage had been used, the leakage reactance, constituting in effect a free inductance in the primary circuit, would have caused the primary current to lag, and the feed-back would have had a component in the direction to sustain oscillation. This explanation was borne out in the fact that detuning to get a lagging current did cause oscillation.

Using the screen-grid tube with this coil the gain was of the first order. The point of maximum, as far as could be determined, did not fall at any intermediate point, indicating an impedance in the neighborhood of one million ohms at 90 volts. With the high amplification obtained, the tuning band, as in the previous case, was too broad to be of practical use, nor could a workable separation of signals be had until the amplification was cut down to a figure approaching that of ordinary tubes. Couplings of other constants also were tried, and the conclusion was, that where separation of signals is a requirement, the high amplification of this tube cannot be properly utilized with the ordinary methods of tuning. As suggested alternatives, regenerative detection would help, as would heterodyning to a low beat frequency; or since so much energy is available and some must be wasted, it might be wasted with profit in a band-pass filter.

(Continued on page 84)

Time Relay Control of Transmitters

By A. R. Richards*

THE ambition of most every radio operator, whether amateur or commercial, is to facilitate the handling of traffic at his station, and the greatest help toward accomplishing this end is the installation of automatic control. By means of properly placed time relays the operator can handle traffic with a minimum of delay and at the same time have the advantages of an efficient break-in system. This method of control completely eliminates possibility of error on the part of the operator as the

change the value of a current flowing in an electric circuit, a force is evidenced which opposes this change. In Fig. 1 it is assumed that a

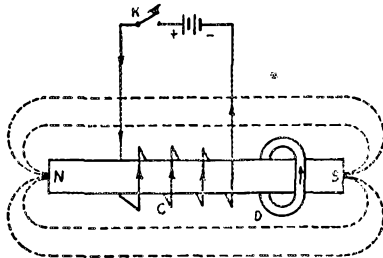

FIG. 1—THE CIRCUIT UPON WHICH THE LAW OF LENS IS TO BE DEMONSTRATED

The iron core running horizontally across the page carries two windings: One of these is actuated by the battery current and consists of a number of turns while the other is a single turn of large cross section. These are labeled C and D respectively. Any change in the current in C will cause a change in the magnetic field shown in dotted lines. This change in field will cause a current flow in D that produces an effect in C through its magnetic field which tends to keep the current amplitude in C constant.

mere depression of the transmission key is all that is necessary to start the set. The relays then close the power circuits in the proper sequence. When the key is left up for a period of time longer than necessary for spacing between words, the relays function in the reverse order, thus taking the set off the air.

The apparatus needed to install this system of control is inexpensive, and can usually be found in the experimenter's box of spare parts. One keying relay and two delayed-time relays are required. The keying relay, if not already used in the set, may be made from an automobile charging cut-out. The time relays are of special construction, but with a little attention to the following instructions a very reliable pair of instruments can be constructed.

As the average person is unfamiliar with this type of instrument, a brief explanation of the theory of operation will be given before launching into the actual details of construction.

Lens' Law states that if an attempt is made to

* Box 611, East Lansing, Mich.

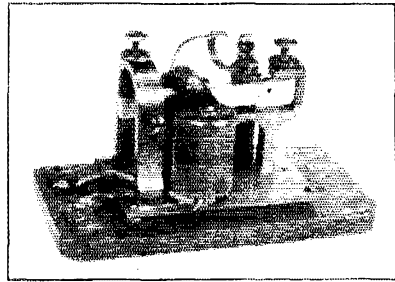

A COMPLETE RELAY

This particular one is the plate circuit time relay and carries but a single set of contacts. A bakelite or hard rubber post holds one of the contact springs while the movable one is mounted under the screw that holds the armature to the sounder bar. The usual adjusting screws for length of throw and spring tension are returned.

current of constant value is flowing through the turns of the coil "C" in the direction indicated. An unvarying magnetic field is thus created, and as a consequence no e.m.f. is induced in coil "D". Now if the circuit is broken by the key at K, the lines of force collapse and in doing this cut the turns of coil D. This produces an induced

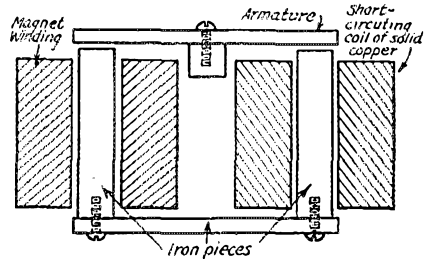
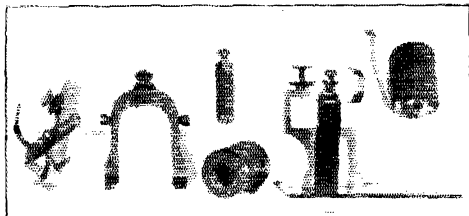

FIG. 2—A CROSS-SECTIONAL VIEW OF THE MAGNET ASSEMBLY

One of the magnet windings is replaced by a copper cylinder of similar dimensions which acts as the coil D in Fig. 1. The vertical iron pole pieces should be dressed off with a file so that the armature makes perfect contact with the entire face and no air-gap is obtained. Any air-gap in the magnetic circuit will materially affect the time lag of the relay.

e.m.f. in these turns, and as the coil is shorted on itself a current flows and produces a magnetic flux which opposes the decay of flux from coil "C". In this manner the magnetic field persists for an appreciable length of time after the initial current has ceased flowing. Use is made of this retarding action in the delayed-time relays.

As the strength of a magnetic field is proportional to the current flowing in the circuit and the current is inversely proportional to the resistance of the circuit, it is evident that coil "D" should be of as low resistance as possible and carry a high current. Since the resistance is so low, the voltage in the coil is not an important factor and hence only



A DISASSEMBLED RELAY

The sounder bar with the armature and contact spring and tension spring form the unit to the extreme left. To the other side of the yoke is the copper cylinder which replaces one of the magnet windings and above it may be seen the iron pole piece over which it fits. The base and arm of the relay with the hard rubber post holding the stationary spring contact are next in line and at the right appears the magnet winding which actuates the relay.

a single turn of heavy wire is necessary. This greatly facilitates construction, as a thick cylinder of copper may be used.

Two twenty-ohm sounders, a heavy bar of copper, two radio jacks, and a little patience are the chief requisites for the construction of these instruments. High resistance sounders are naturally more economical on the battery, but if only the low resistance type are available the magnets may be rewound. If the spool of one of the magnets is wound full of number 28 wire the resistance will be approximately fifteen ohms and will allow enough current to pass from a six-volt source to operate the relay nicely.

Both relays are built exactly alike as far as the magnetic system is concerned, and differ only in the number of contacts. The first step is the removal of one electro-magnet from each sounder. Only the iron cores of the removed magnets will be used in the relay assembly.

A bar of copper is now turned down in a lathe to approximately the diameter of one of the magnet windings, and drilled lengthwise so the iron core of the discarded magnet will fit snugly. The copper should not be long enough to extend above the iron core. These copper assemblies should be now mounted in place of the magnet just removed as is shown in Fig. 2. The iron cores must be carefully dressed with a file until the sounder armature rests on both at once when in the down position. No air-gap is permissible under operating conditions.

The contact assembly is comparatively simple. The springs are removed from the jacks and used for this purpose, as they are quite flexible in addition to having the silver contact as an integral part. One relay is equipped with one set of con-

tacts which is closed when the relay is not energized. The other relay is fitted with two sets of contacts so that one circuit is closed when the relay is energized, and a different circuit completed when the relay is not energized. A convenient method of mounting the contacts is to drill and tap a hard rubber rod so that it can be mounted directly on the sounder base. The movable contact is easily mounted by the same screw that fastens the armature to the hammer bar. These points are clearly illustrated in the photos.

After the relays have been connected as shown in Fig. 3, they must be timed. This adjustment is made by tightening or loosening the spring on the hammer bar. The double-contact relay should be adjusted to hold closed for about a second and one-half after the actuating circuit is opened, and the single-contact relay should remain closed for nearly three seconds after the energizing current has been removed.

When the transmitting key is open the battery sends a current through the plate circuit time relay which opens the plate circuit of the tube. When the key is closed, the battery energizes the keying relay and the time relay controlling the power to the plate and filament supply circuits. Even though the plate supply system may be operative, no plate voltage is applied to the tube because the plate circuit time relay which has the greatest lag has not as yet

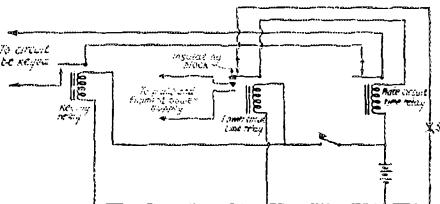

FIG. 3—THE CIRCUIT ARRANGEMENT EMPLOYED TO CONTROL THE TRANSMITTER BY SIMPLY PRESSING THE KEY ON THE OPERATING TABLE

The plate circuit time relay prevents the power being applied to the plate of the tube before the filament is fully lighted. Under keying at normal speeds the plate circuit and power circuit time relays are not operated but only the keying relay is in action. When the set is shut down for the night the switch S is opened to conserve the relay battery.

closed the plate circuit. However, after the filament of the tubes have reached their full brilliancy, the plate circuit time relay operates and the plate circuit is closed and voltage applied to the plates of the tubes.

When the key is opened for periods of less than a second and a half, only the keying relay is affected. If, though, it is opened for a longer time, the time relay controlling the power supply to the set will open and actuate the plate circuit time relay, thus shutting down the transmitter until the key is closed again. The switch S is provided

(Continued on page 20)

High-Frequency Reception on Trains

By Don C. Wallace*

RECEPTION of high-frequency radio signals with portable equipment on moving trains has apparently had but little attention from *QST* contributors and while a little broadcast reception on moving trains has been reported in *QST* I believe the date of this was sometime in 1920. Since then, no reports have been seen concerning high-frequency reception or transmission from moving trains, other than from semi-permanent installations.

On each of the various business trips taken from W6AM, a small portable (being less than one foot cube) is carried along or checked as regular baggage. This portable has the call W6ZZA, and in January, 1929, a trip was made to Washington, D. C. While there as well as along other points *en route* to and from Washington, D. C., schedules were maintained with Mrs. W6AM, who has her own license and call signing W6MA.

An interesting thing to note in this connection is that the first call from the Hotel Mayflower at Washington, D. C., was successful. In the last thirty-two 7000-kc. schedules with Mrs. Wallace, portable W6ZZA has not failed to establish communication from Washington State, Washington, D. C., Texas, or even San Diego.

While having a QSO with W6MA from W6ZZA, at that time located at the Hotel Mayflower, Washington, D. C., Mrs. Wallace was asked whether or not she would be willing to send each evening so that tests could be made from the train *en route* from Washington, D. C., to Long Beach, Calif. She replied that she would be glad to send each evening at 7 o'clock, and so the tests were begun that night.

Accordingly, from January 22nd until January 27th (the arrival at El Paso) W6ZZA listened in practically every night from one to four hours, collecting data on antennas for reception on moving trains. On only one of these nights could W6MA be heard, but on practically every night, plenty of amateur stations could be heard, which shows that reception of strong signals on the 7000-kc. band is entirely practical on a moving train.

The first antenna idea tried was to use the car frame as an antenna connected to the set as any other antenna system would. The results were negative whether the train was in motion or not. Next, the car frame was used as a ground and no regular antenna employed. This also gave no results either with the car in motion or still.

The third antenna tried consisted of a wire stretched across the smoking car, using the car frame as a ground, but during the evening this did not bring anything in loud enough to be decipherable.

The fourth antenna tried was a piece of No. 30 single cotton-covered wire stuck out under the window and allowed to trail behind the train. Tremendous racket occurred most of the time while the train was in motion, although when the

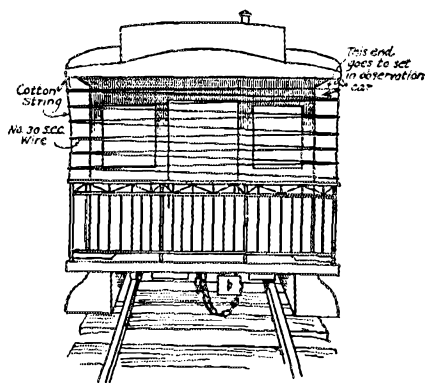

FIG. 1 — THE SUCCESSFUL ANTENNA SYSTEM FINALLY ADOPTED FOR TRAIN WORK

Two pieces of cotton string act as the vertical supports upon which the antenna wire is held. About sixty feet of No. 30 s.c.c. wire acts as the collector and the lead-in passes into the car where the set is located. Satisfactory reception may be had with the train either in motion or at a standstill.

train stood still, numerous stations could be heard. At that time, the conductor of the train thought he would help out the experiments, so he very carefully picked up the antenna wire and fastened it to the hand rail at the end of the car. I did not know that he was in on the experiment and was surprised to notice that no more signals could be heard. Finally, when the train started again, a survey outside of the car window showed that the antenna was no longer trailing, which accounted for the sudden disappearance of all signals.

The fifth antenna, which paralleled this same idea, consisted of a wire run the length of the car and spaced about four inches from the car side. No results were secured with this either, showing that the car side is pretty thorough shielding as far as ordinary evening reception on a portable is concerned.

The sixth antenna tried was a trailing wire on the back observation platform leaving the porta-

* W6AM, W6ZZA, 279 Molino Ave., Long Beach, Calif.

ble receiving set in the observation car where it was nice and warm. This trailing wire was capable of picking up signals, but they could not be read due to the fact that the wire bounced up and down as the train went along. With the car standing quietly in the station, however, normal reception was secured just about the same as any ordinary 15- or 20-foot piece of wire would give.

By this time, the train had arrived at Chicago, and after leaving Chicago for Denver, the tests were continued. It was found that two short

Somewhere between Chicago and Denver that night, W6MA was heard very nicely, and numerous other stations, such as WIZ, LPI, W6BAM, W3AHP, W9EGU, WSAJU, W4AEF and W8ML were all heard with varying degrees of readability, plenty good enough, however, to say that the experiment was an entire success and that the type of antenna suggested by Mr. Kob is perfectly satisfactory for favorable reception on trains.

The lead-in was run over the door leading into the observation car and insulated by a piece of paper placed under and above the wire. In this particular case the insulation of the paper sufficed.

The use of a ground was found undesirable as the unsteadiness of the signals increased and the signal volume was not apparently improved at all with its addition to the set.

The portable set used is the regular W6ZZA portable transmitter and receiver which is mounted in a leather case less than a foot cube. At the present time, the transmitter is using 2 UX-210 tubes, to operate on the a.c. line of the particular hotels in which it is temporarily located. The receiver uses two CX-399 tubes, hooked up in the familiar type of "Schnell" circuit. Plug-in coils are provided for transmission and reception on the 14,000-ke. band, the 7000-ke. band, and the 3500-ke. band. All of these bands have been used successfully in making QSOs with Mrs. Wallace, who operates the 500-watt transmitter at Long Beach, Calif. This transmitter uses a 6EX water-cooled tube and 6 of the 6EX Rectobulbs in a 6-phase plate supply.*

Upon arrival in El Paso, Texas, the set was hooked up in the Hotel Husmann, and communication soon established with the West Coast (W6ZBJ)

and a message given to tell Mrs. Wallace to get on the air. A QSO was then had with W6MA, and the train schedules discontinued as the balance of the trip was made in short jumps.

Time Relay Control of Transmitter

(Continued from page 18)

to open the battery circuit to the plate circuit time relay and conserve energy when the set is not being operated.

To prevent arcing, a 2- μ fd. condenser with a 110-volt lamp in series should be connected across these contacts, breaking high voltage circuits.

* See February, 1928, QST for further details.—EDITOR.

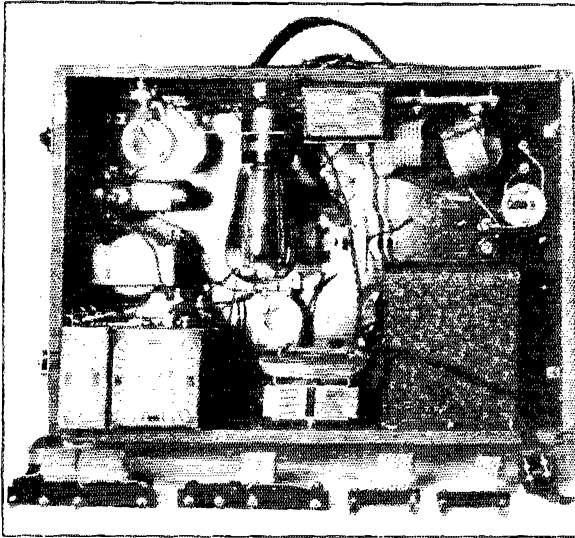

A REAR VIEW OF THE PORTABLE WHICH TRAVELS UNDER THE CALL OF W6ZZA

The receiver occupies the left-hand side of the case together with its plate and filament batteries. The rest of the case houses the transmitter which has since been increased in power to a pair of 210s. The power for the transmitter is obtained from a 110-volt a.c. line and is stepped up to 300 volts for the plate of the tubes by means of a National transformer. The receiving and transmitting coils are wound on celluloid and plug-in to suitable mounting bases. The license covering the transmitter is tacked to the inside of the cover of the case.

trailing antennas of about eight feet apiece did quite well as a certain span occurred between them and across the rear end of the car.

About this time, one of the other passengers on the train became thoroughly interested in the whole experiment. He was Mr. H. H. Kob, of 1459 Monroe St., Denver, Colo., who was just returning from two years engineering work in Liberia. While there, he had established an amateur station for the radio engineers, having put up their building, and was naturally interested in the tests. Mr. Kob suggested that we make a grid stretched over the entire rear back platform of the observation car. By using two pieces of string stretched from the corner of the roof down to the railing, a very satisfactory grid was stretched up, using about 60 feet of wire, and from then on reception was very nice.

An Inexpensive Test Set for Broadcast Receiver Performance

By Wilfred Taylor*

FOR many years it has been customary to speak of the performance of a receiver as being good, bad or indifferent. Such an opinion would depend upon many other things than the quality of the receiver. One must take into consideration the location of the set, the extent of the collector system, the season of the year, time of day, mood of the test operator and the character of the transmission equipment and type of program material used. Obviously, quantitative results were impossible and with the advance made in receiver design, it rapidly became imperative that some sound basis of comparison be devised which would allow suitable measurements to be obtained. To be of greatest worth it was essential that these measurements be based upon definite standards; it would then be possible to make comparisons between different receivers in various laboratories and obtain figures that would be comparable.

Working standards have been established and suitable measuring equipment has been developed in various laboratories which will allow the performance characteristics of a receiver to be obtained and compared with others. Specifications may be written covering all of the important characteristics of a receiver and perhaps some day such figures may play an important part in the selling of sets to the general public.

While it is very nice to build test equipment that will give results that may be duplicated at any future time and which will allow for comparison with measurements made in other laboratories, such equipment is very expensive and complex and not suited for the experimenter who is not producing a large number of receivers from the sales of which the cost of extensive test equipment may be obtained.

There is, therefore, a definite need for a simple inexpensive test set capable of giving comparative results over short periods of time. Such equipment would allow some definite information to be obtained to show what the resulting effects from changes were, and whether or not these changes being made were desirable. In many cases, the final decision will be a compromise between two or more factors that are incompatible and some convenient, inexpensive means of measuring the relative values involved will prove to be of inestimable worth.

The test equipment naturally divides into two

portions, that generating the signal to be supplied to the input circuit of the receiver and that with which the output power of the receiver is measured. Both should simulate normal conditions in order that incorrect readings do not result.

As it would be impracticable to make measurements on a receiver at all frequencies within the broadcast spectrum, three representative points have been chosen. These points are at 600 kc., 1000 kc. and 1400 kc. It is assumed that they will give sufficient information to allow the characteristics at other points in the spectrum to be predicted with sufficient accuracy.

OSCILLATOR

The driving circuit consists of a simple oscillatory circuit operated from the 110-volt a.c. line.

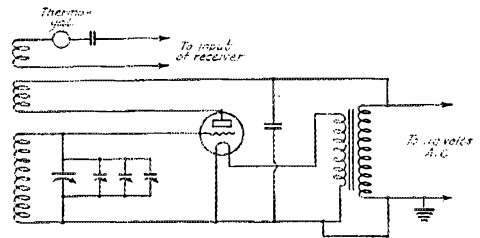

FIG. 1—THE OSCILLATOR OR DRIVER WHICH SUPPLIES THE INPUT SIGNAL FOR THE RECEIVER UNDER TEST

A simple oscillatory circuit is employed and three midsize condensers shunted across the main tuning condenser allow the generated frequency to be varied over a small range around each of the three test frequencies.

A step-down transformer supplies 5 volts for the filament of a 201-A and the plate voltage is obtained directly from the line itself. This is shown in Fig. 1.

This oscillator must cover the three test frequencies mentioned above and we may arbitrarily choose a 500- μ fd. variable condenser as the tuning element. The inductance across which the condenser is to be shunted may consist of 50 turns of No. 24 d.c.e. wire on a three-inch tube. A tickler of three turns is wound next to it and an additional winding of three turns is so mounted as to allow variable coupling to the first two windings. This last winding is a coupling coil to pick up a suitable signal to be impressed across the input terminals of the receiver under test.

In order that selectivity curves may be ob-

*Thompson, Conn.

tained, it is essential to employ some method whereby the frequency of the input signal may be adjusted with some degree of accuracy over a range of approximately 20 kc. each side of the three test frequencies. It would be possible to calibrate the main tuning control but this is not practical because of the large range of this control which would give a 20-kc. shift of frequency

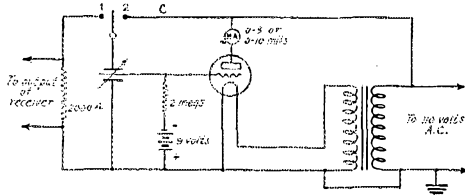

FIG. 2—THE MEASUREMENT CIRCUIT WHICH IS CONNECTED ACROSS THE OUTPUT OF THE RECEIVER UNDER TEST

The 2000-ohm resistor acts as a phantom load speaker and offers a constant impedance over the audible range. The output voltage of the receiver is compared with the line voltage by means of the capacitive potentiometer, the lower half of which is connected across the grid and filament of the tube voltmeter.

with but an insignificant motion of the dial. The better way is to employ a small vernier condenser in shunt of the main tuning condenser and calibrate the main condenser with the vernier at half scale. The vernier condenser will then allow the capacity across the coil to be varied over a small range with the possibility of reasonable accuracy in the setting and reading of the dial controlling it.

It is very desirable that the 40-kc. range (20 kc. above and 20 below the test frequency) of the vernier control be spread over practically the complete dial scale and because of the difference in the test frequencies and the total amount of capacity across the coil to set the frequency at these values it is impossible to use but one vernier condenser for all three ranges. Three vernier condensers of different capacity ranges are employed. They are of the straight-line capacity type and have capacity variations of approximately five, ten and fifty micromicrofarads respectively for the 1400-, 1000- and 600-kc.

These vernier condensers are all set at half scale (50°) when the main tuning control is calibrated for the test values and then they in turn are calibrated in kilocycles each side of the 50° point. The $5\text{-}\mu\text{fd.}$ vernier gives the desired range about the 1400-kc. test frequency, the $10\text{-}\mu\text{fd.}$ one about the 1000-kc. point and the $50\text{-}\mu\text{fd.}$ condenser is employed in conjunction with the 600-kc. value test frequency. These vernier condensers should *always* be set at half scale when not in use or else the calibration of the main tuning condenser will be incorrect.

This oscillator supplies a signal modulated 100% at 60 cycles. This frequency can be varied

over a 20-kc. range each side of the three test frequencies and the input to the receiver under test can be varied to suit conditions as they may be. The current in the coupling circuit is measured by a Weston thermo-galvanometer giving a full scale deflection on 115 milliamperes. A $2000\text{-}\mu\text{fd.}$ condenser is in series with the pick-up coil and meter so as to make this circuit more nearly approach the characteristics of an ordinary receiving antenna. The amount of current flowing in this circuit should be kept constant during all tests that are to be comparable.

VACUUM TUBE VOLTMETER

The second portion of the test set consists of a vacuum-tube voltmeter employed to measure the output of the receiver under test. A 2000-ohm resistor takes the place of the loud speaker because its value will be constant at all frequencies (assuming a non-inductive unit with but insignificant distributed capacity), whereas the impedance of the speaker will vary with the frequency.

As in the case of the oscillator, a 201-A is used and obtains its filament supply from the same transformer winding as the oscillator tube. The same arrangement for plate voltage also holds. A milliammeter having a range of either 5 or 10 mills is located in the plate circuit of the voltmeter tube and a biasing battery in series with a 2-megohm leak is connected between the grid and filament. A negative bias of about 9 volts will be about right. The circuit diagram is shown in Fig. 2.

A capacitive potentiometer illustrated in Fig. 3 is shunted across the resistor or phantom speaker. The stator assemblies of two $500\text{-}\mu\text{fd.}$

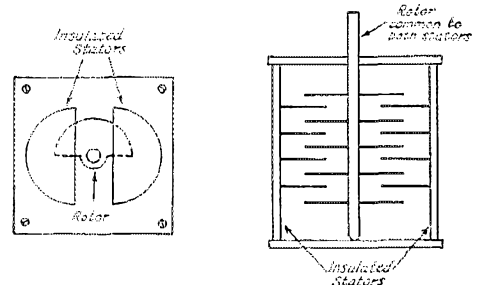

FIG. 3—THE GENERAL CONSTRUCTIONAL DETAILS OF CAPACITIVE POTENTIOMETER ARE SHOWN ABOVE

A single rotor assembly is mounted within two separate stator assemblies and as the capacity between the rotor and one of the stators is being increased, the capacity between the rotor and the other stator is decreased.

variable condensers are mounted upon a pair of end plates in such a manner as to allow the rotor assembly of one of them to rotate and interleave within both stators. It becomes the equivalent of two variable condensers in series mounted upon

the same shaft with their rotor assemblies 180° apart. Such a combination which is indicated in Fig. 4 could be used and might save some mechanical labor as it would only be necessary to drive two standard condensers from a unicontrol dial arranged to accommodate these units.

CALIBRATION

To calibrate the vacuum-tube voltmeter, the capacitive potentiometer is connected across the a.c. line by throwing the switch to position 2. The potentiometer is adjusted so that the capacity between grid and filament is a maximum while the capacity between grid and the high side of the line is a minimum. The setting of the potentiometer and the meter reading should be noted; these figures are for 110 volts or whatever the line voltage may be.

A variable resistance or capacitance is then inserted at "C" and serves to reduce the voltage applied across the potentiometer from the line. An a.c. voltmeter is connected across the outer terminals of the potentiometer to measure the voltage impressed across it. When a voltage lower than that of the line is applied to the potentiometer, the plate current as indicated by the milliammeter will be lower than the initial value obtained for the full line voltage. However, it will be possible to obtain the same plate current by adjusting the potentiometer so as to apply a larger proportion of the total voltage across the grid to filament end of it. We can, therefore, calibrate the potentiometer not so much in actual volts but in ratios to the line voltage. In practice the settings of the potentiometer are plotted against the voltmeter readings. At the start of a series of measurements, the switch is thrown to position 2 and the potentiometer set to measure the line voltage. This plate current reading is noted and becomes the standard reading for that period, marking the point from which all measurements are made. Thus, if either the tube or bias battery is changed, it is unnecessary to completely recalibrate the meter; one needs to but check against the line and obtain a new datum point.

SELECTIVITY MEASUREMENTS

In making selectivity measurements the vernier condensers of the oscillator are all set at 50° and the main tuning condenser adjusted to one of the test frequencies. The tube voltmeter switch is thrown to position 1 and the receiver under test is adjusted to give maximum reading on the milliammeter in the plate circuit of the voltmeter tube.

The switch is next thrown to position 2 and the line voltage reading taken with the potentiometer set for the lowest meter reading. After shifting the switch to position 1, the coupling coil to the oscillator is adjusted to give the same reading with the same potentiometer setting.

The appropriate vernier condenser of the oscillator may then be shifted an amount equivalent to 1 kc. and the potentiometer adjusted to give the standard reading. The voltage across the potentiometer can then be obtained from the calibration chart and represents the output voltage of the receiver.

By running over the complete range of the vernier and plotting the output voltage against the frequency it is possible to obtain a selectivity curve of the receiver under test. Curves obtained at the three test frequencies will show whether

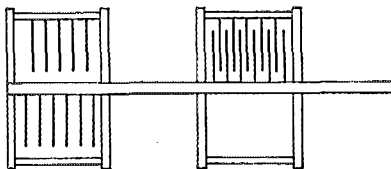

FIG. 4—INSTEAD OF MAKING SUCH A COMPLICATED ASSEMBLY FOR THE POTENTIOMETER AS SHOWN IN FIG. 3, TWO VARIABLE CONDENSERS MAY BE MOUNTED AS INDICATED ABOVE

The result will probably be a somewhat more bulky unit but the mechanical work will be reduced considerably.

the selectivity varies greatly over the range of the receiver and if the receiver tunes so sharply as to cut side bands or so broadly as to be unable to separate stations on adjacent channels. Theoretically, under present-day conditions, the curve should be flat topped and lie entirely within a 10-ke. band. However, in practice, this is only approximated by employing band-pass filters and an ordinary set, the voltage output of which fell off 20% of the resonance value at frequencies 5 kc. on either side of the resonance frequency, would be considered as very selective.

SENSITIVITY

The relative sensitivity of the set at the three test frequencies may be obtained by keeping the current in the input circuit constant and plotting the output voltage against the frequency. This will indicate whether the set is much more sensitive at one end of the spectrum as many sets are wont to be.

FIDELITY

It is not possible with this simple test set to check the fidelity of reproduction. It can be done by substituting a d.c. operated oscillator for the a.c. driven one and adding a modulator tube and source of audio frequency current that could be varied over the audible range.

While this test set is not the ultimate in such equipment, it is very much superior to the usual method of guessing as to whether a change in the receiver has improved its selectivity or sensitivity. Its cost is low and it should prove to be of great assistance to those experimenting with the design of broadcast receivers.

The A.R.R.L. Board Meets

THE American Radio Relay League is governed by a Board of Directors, one elected from each of the thirteen divisions in the United States, one from Canada, and the remaining two, the president and vice-president, elected by the other fourteen. On the 3d and 4th of May this Board of Directors had its regular annual meeting at Hartford. All sixteen directors, from every part of the country, and the officers of the League, were present. Two days were spent in an intensive examination into the affairs of the League, the deciding of numerous knotty problems, and the outlining of policies and the issuance of instructions to the officers for the coming year.

The official minutes of that meeting would fill nine pages of *QST*. Obviously our report of the proceedings must be very abbreviated. All the officers of the League reported at length to the Board on the branches of League activity coming under jurisdiction. Each director similarly reported, for the information of the remaining members, on conditions in his division. All of these reports laid suggestions and recommendations before the meeting, and by the time these were all examined and acted upon, the affairs of amateur radio in this country had had a very thorough going-over.

The finances of our organization were examined and its business affairs plumbed thoroughly; the headquarters establishment was inspected; the actions of the Executive Committee examined and ratified; communications from the International Amateur Radio Union, of which A.R.R.L. is a member, received and acted upon. Proposed new radio legislation was considered, likewise the plans for an international technical conference at The Hague in September, and the officers instructed thereon. Plans were made to bring amateur radio more prominently to the notice of the powers that be. The general status of our operating rights was studied closely, and instructions issued where necessary. Enforcement of regulations, suppression of broadcasting harmonics, amateur plate supplies, license regulations — all came in for their share of attention. The by-laws were amended to provide that a candidate for Section Communications Manager must be the holder of an O.R.S. appointment. The improvement of *QST*, anti-amateur ordinances, convention funds, various helps for members — these and many more topics engaged the attention of the Board. The welfare and the needs and desires of members in each division were gone into as each director reported on his territory.

The question of amateur message traffic came in for a big share of the Board's consideration. All of the nice *pro's* and *con's* of this complex

subject were gone into. The Board concluded that neither the text nor the importance of a message was a gauge to the right of an amateur to handle it; that the question of compensation was the only proper test; and that, in the related problem of identifying non-amateur stations, the purpose of the station was the only proper test.

Plans were made for a membership development program, the undertaking of educational work about amateur radio, increasing League membership, and bringing new people into the game.

Numerous requests came to the Board to consider anew the League recommendations to Washington concerning allocations for amateur phone. Telephony is growing; its followers want more space. Careful consideration was given all these requests. The Board did not feel that it would be proper to recommend any increase in the phone band at 3500 kc., and it could not persuade itself that any of the many proposals for time division were workable. It did view with favor, however, the desire of phone men for an opportunity to operate on a high-frequency international band. Manifestly it is suicide to attempt telephony in the vastly-congested 7000 band. The so-called 20-meter band offered an opportunity, however, but it was thought that some precaution ought to be taken to prevent the ruining of this vital long-distance band, something ought to be done to insure that the amateurs attempting telephony in it were reasonably proficient. Consideration was given the suggestion that telephony there be confined to crystal-control (as indeed it just about has to be to have hopes of success), but the Board thought it improper to suggest a regulation which departed from our present American practice of judging a station only by its output and not by its internal apparatus. Eventually it was determined to recommend to the authorities that the 14,000-ke. band be opened to radiotelephony on the part of those amateurs who possess the extra first class operator's license, and the headquarters officers were instructed to endeavor to secure such a modification of regulations. At the moment of writing the matter is still in process and no information can be given as to the outcome. An official broadcast will be made of any changes which result.

All in all, the Board meeting was typical of that careful examination of affairs and that wise planning for the future which is characteristic of A.R.R.L. government. The Headquarters office feels at the moment as if it had just had about five years' work cut out for it instead of one. Progress will show forth, we hope, as the months roll by.

— K. B. W.

Little-Known Tubes

The UX-841 and 842

By Harold P. Westman, Technical Editor

There have been developed a number of special-purpose tubes concerning which the amateur and engineer knows little. This is the first of a series of articles describing some of these tubes which are capable of performing duties for which the better-known tubes are not so well suited. — EDITOR.

THE last few years have certainly been prolific ones as far as the development and marketing of vacuum tubes is concerned. At the present time there are, perhaps, two dozen tubes from which one picks those desirable for use in a receiving set. While for obvious reasons the receiving tube has had the bulk of attention, one must not overlook the advances made along the line of rectifier and power transmitting tubes as well.

Assuredly, it would seem that there could be little reason for the existence of any other tubes than those readily available on the market. However, one may find a number of conditions into which these well-established tubes do not fit and it is to meet some of these that special tubes have been devised.

It would indeed be difficult to find someone who is not familiar with the UX-210. Its uses are manifold and varied and one finds it in the receiver

and the UX-842, high- μ and low- μ tubes respectively. They are designed for use in certain circuit arrangements for which the 210 is not so well adapted.

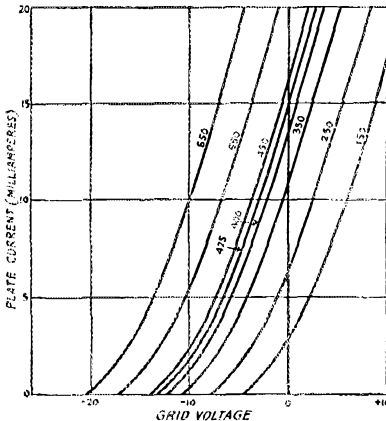

FIG. 1.— PLATE CURRENT VS. GRID VOLTAGE FOR THE 841

The numbers on the various curves indicate the plate voltage at which the curve was taken.

as well as the transmitter. We are also aware of the UX-865, the screen-grid 7.5-watt tube. Few, though, know of the existence of two other tubes in the 7.5-watt family. These are the UX-841

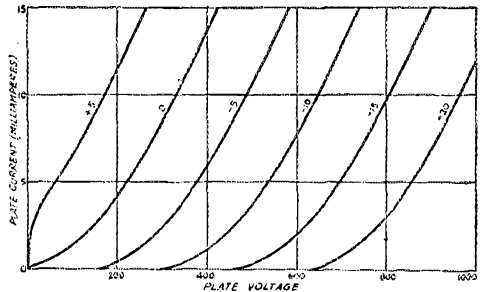

FIG. 2.— THE PLATE VOLTAGE-PLATE CURRENT FAMILY FOR THE 841

The grid voltages under which the curves were made are indicated on the curves.

The filaments of these two tubes are identical with that of the 210. There is little need be said about this element other than that a total emission of about 700 milliamperes is available when the voltage applied across its terminals is 7.5 and that this is reduced to approximately 175 milliamperes when the voltage is dropped to 6.

UX-841

We will first consider the UX-841 which has a high amplification factor or μ and is ideally suited for use in resistance or impedance coupled amplifiers when a tube of this power rating is essential. It may, perhaps, some day be the "for use in last audio stage only" tube in sets feeding electrostatic loud speakers concerning which we have been hearing a bit of late. Such speakers require high signal voltages for their satisfactory operation and it would seem that the 841 would be well-suited for the task. This is particularly true if one insists upon ample volume to indicate to the neighbors the possession of a "powerful" receiver as now seems to be the mode.

While it has no advantage over the use of a 210 as an ordinary oscillator, it does have a distinct advantage as far as its operation as a

voltage amplifier is concerned. It is excellently suited for use in the crystal-controlled transmitter and may be employed as the crystal oscillator tube or as an intermediate amplifier between the crystal tube and the power stage. Although in

and mutual conductance are not applicable when the tube is oscillating because they are based upon very small input voltages and if the input is of more than a few volts these values do not hold.

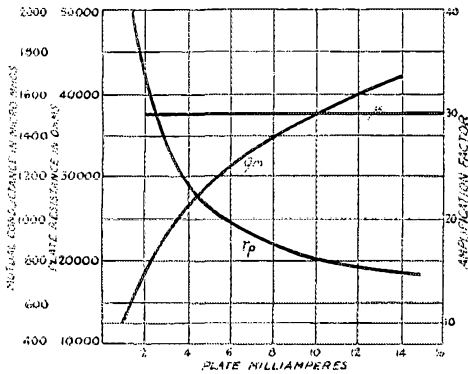

FIG. 3.— CURVES FOR THE PLATE RESISTANCE, MUTUAL CONDUCTANCE AND AMPLIFICATION FACTOR ARE PLOTTED AGAINST PLATE CURRENT ABOVE

These are for the 841.

this latter rôle it does not offer the advantages of the 865, both in gain and isolation between input and output circuits, it is much nearer within the reach of the amateur in price, a consideration of no small size.

Some idea of the ratings of the tube may be obtained from the following:

	Resistance coupled amplifier	Oscillator
Filament voltage	7.5	7.5
Filament current	1.25 amps (max.)	1.25 amps.
Plate voltage	425 (max.)	350 (max.)
Safe plate power dissipation	12 watts	15 watts (max.)
Output	Undistorted peak output voltage 250 volts	7.5 watts

With a filament voltage of 7.5, a plate voltage of 425 and a negative bias of 8 volts, the following characteristics are obtained:

Amplification factor	30
Plate resistance	21,500 ohms.
Mutual conductance	1.4 ma./v.

The direct inter-electrode capacities are:

Plate to grid	8 μ fd.
Grid to filament	5 μ fd.
Plate to filament	4 μ fd.

Figs. 1 and 2 show the effect upon the plate current of changes in either the plate voltage or the grid voltage. For a given value of plate and grid voltage, the plate current can be obtained from Figs. 1 and 2 and by applying this value to Fig. 3 one can ascertain the plate resistance, mutual conductance and amplification factor. This latter characteristic is constant at 30 over the range shown. The curves for plate resistance

Fig. 4 shows plate current vs. plate voltage curves. In addition, load lines for various values of plate load resistance are drawn in. These lines indicate the drop across the load resistor due to the plate current flowing through it and assume a supply voltage of 425. The voltage applied to the plate of the tube is that at which the plate current-plate voltage curve and the load line cross. Three values of grid bias are considered.

When the tube is used as a resistance-coupled amplifier, the maximum signal voltage that it can handle will depend upon the amount of distortion permitted. Under normal conditions the amount of distortion allowable is that which causes the generation of a second-harmonic of about 5 per cent. In practise in order to obtain as much output as possible, this value is usually held between 4.75 and 5.25 per cent, and it may be calculated by the following equation:

Per cent second harmonic =

$$\frac{1/2 (I_{max} + I_{min}) - I_0}{I_{max} - I_{min}} \quad (1)$$

where

I_{max} = Plate current at least negative grid voltage.

I_{min} = Plate current at most negative grid voltage.

I_0 = Steady plate current (no signal input).

As an aid in the design of resistance-coupled amplifiers, the curves of Figs. 5 and 6 are shown.

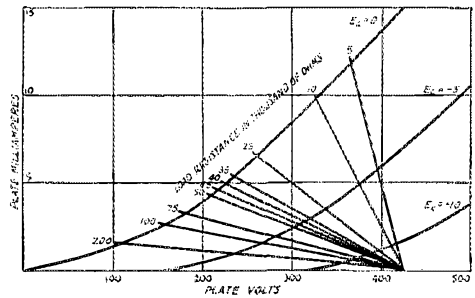

FIG. 4.— IN THE ABOVE, THE LOAD LINES HAVE BEEN DRAWN IN OVER THE PLATE VOLTAGE-PLATE CURRENT CURVES SO THAT DISTORTION MAY BE CALCULATED

The grid bias values are indicated on the curves

Fig. 5 considers the case of an amplifier operated from a supply voltage of 425 and shows the value of bias necessary for any value of plate load resistance between 10,000 and 100,000 ohms. The maximum grid swing permissible will be equal to the bias as the grid should draw current under no conditions. The voltage amplification and out-

put voltage for maximum grid input voltage are obtainable directly from the curves. The limiting factor for small values of load resistance is the curvature of the plate-voltage plate-current curves. When larger values of load resistance are employed, the plate current may go to zero which is the minimum current limit.

The use of a 425-volt supply does not allow the full gain to be had because the plate voltage will always be less than the rated value. When additional voltage is not available this cannot be avoided. However, the output of the tube may be fed to the grid of a 50-watt and if we employ the 1,000-volt plate supply for this tube on

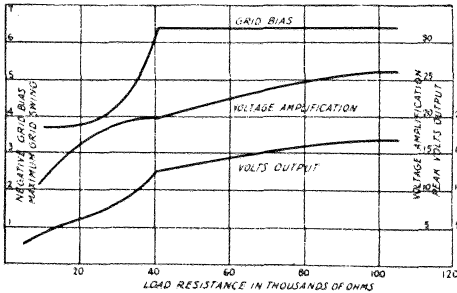

FIG. 5. — THESE CURVES WERE CALCULATED TO SIMPLIFY THE PROBLEM OF DETERMINING THE PROPER BIAS FOR THE 841 WHEN THE SUPPLY VOLTAGE IS 425 AND THE LOAD RESISTANCE IS KNOWN

The voltage amplification and maximum undistorted peak output voltage may also be directly obtained.

the 841, a material improvement in its operation will be obtained. It allows the use of much higher load resistors and Fig. 6 shows the bias necessary, output voltage and amplification possible for values of plate load resistance between 0.1 and 1. megohm.

In this case it is essential that the input signal be limited to a value that does not drive the mean plate voltage above 425 volts. It is this rather than distortion due to the generation of harmonics that limits the permissible output.

When the higher values of plate load resistance are used, it is possible for the grid leak through which bias for the succeeding tube is obtained to affect the operation of the tube by reducing the load resistance. The blocking condenser usually employed has a low impedance compared with the resistors involved and the grid leak can be considered as being in parallel with the load resistor. While this does not affect the operating point as far as the d.c. voltage applied to the plate is concerned, it does affect the generated a.c. voltage which is applied across the two resistors in parallel. So much for the 841!

UX-842

The UX-842 is a low-impedance type tube and is designed for operation as a speech-operated power amplifier and modulator. It has no ad-

vantage over the 210 when employed as an oscillator, while its low plate impedance may be considered as a disadvantage in that more careful

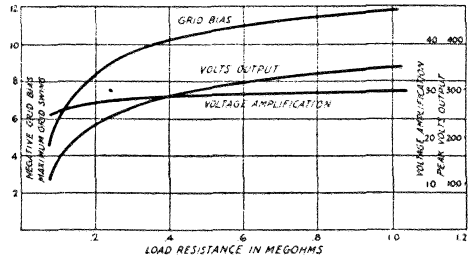

FIG. 6. — WHEN THE SUPPLY VOLTAGE IS 1000 VOLTS, A MUCH LARGER LOAD RESISTOR MAY BE USED AND THE AMPLIFICATION AND MAXIMUM OUTPUT VOLTAGE WILL BE MATERIALLY INCREASED

These curves show the proper bias and voltage output and amplification when this higher supply voltage is available.

circuit design and adjustment are necessary. It is accordingly, not recommended for oscillator use. Its rating is given below:

	Speech amplifier or modulator
Filament volts	7.5
Filament amperes	1.25 (max.)
Plate voltage	425. "
Safe plate power dissipation	12. watts
Output	3. "

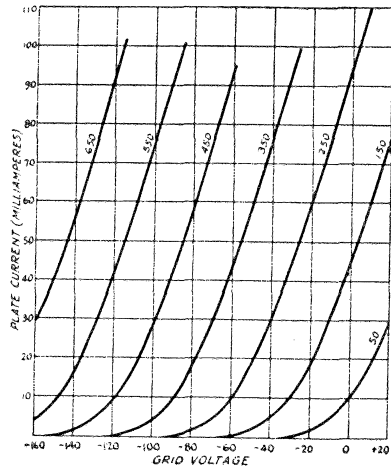

FIG. 7. — THE PLATE CURRENT IS PLOTTED AGAINST GRID VOLTAGE FOR THE UX-842 IN THIS FAMILY OF CURVES

The plate voltages at which the curves were made are indicated by the numbers near them.

Its constants under rated filament voltage, plate and grid voltage of 425 and minus 95 respectively are as follows:

Amplification factor	3.
Plate resistance	2500. ohms.
Mutual conductance	1.2 ma./v.

The direct inter-electrode capacities are:

Plate to grid	8. μ uid.
Grid to filament	5. μ uid.
Plate to filament	4. μ uid.

In Figs. 7, 8 and 9 we have similar curves for the 812 as are given in Figs. 1, 2 and 3 for the 841.

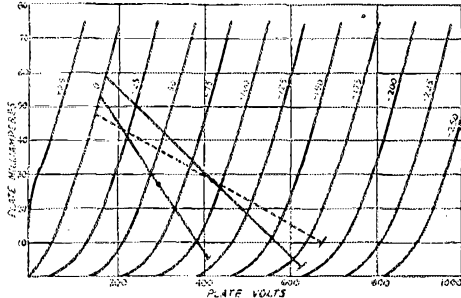

FIG. 8.—THE VERY IMPORTANT PLATE VOLTAGE-PLATE CURRENT FAMILY FOR THE 812

The grid voltage at which the curves were made are shown on them. The oblique dotted line is the preliminary load line drawn through the operating point and the 10-milliampere current point at twice the operating grid voltage. The distortion under these conditions was quite small and a lower limit of minimum plate current was chosen. The most suitable line for a plate voltage of 425 is the solid one passing through the same operating point as the dotted line. The other load line is for a plate voltage of 300.

As in the case of Fig. 3, Fig. 9 is based upon small input voltages and is not, therefore, applicable when the input is large.

When calculating the output power and proper load impedance, a resistance load is assumed as

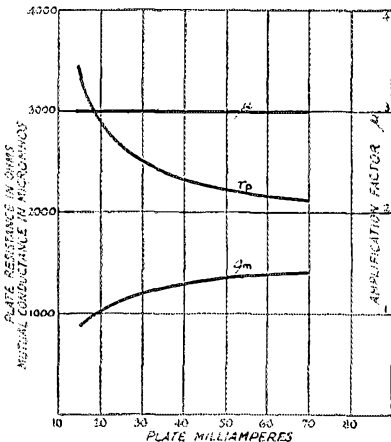

FIG. 9.—THE PLATE RESISTANCE, MUTUAL CONDUCTANCE AND AMPLIFICATION FACTOR ARE HERE PLOTTED AGAINST THE PLATE CURRENT FOR THE 812

this will result in a straight line for the load characteristic when this is laid out on the plate-voltage plate-current curves. If an impedance load were used, the characteristic would be an

ellipse, its exact shape depending upon several factors.

If the plate voltage is to be 425, it is essential to choose a value of plate current which will result in a plate loss of 12 watts, the maximum allowable. This then, calls for a plate current of 28 milliamperes which Fig. 7 indicates may be obtained with a bias of 93 volts.

There are two limits within which one must stay to prevent distortion: The grid must not draw current and it is necessary to operate on the straight portions of the curves. Fig. 8 indicates that it would be inadvisable to go much below 10 milliamperes plate current as the curves become too badly curved to allow distortionless amplification below this value. If the filament of the tube is lighted with direct current, the grid will start to draw current at zero grid voltage. If, though, the filament is lighted by alternating current, it will not be possible to go to zero voltage but this point at which grid current is obtained will be approximately 4 volts negative.

Assuming d.c. on the filament, we find that the operating grid bias of 93 volts will allow a swing

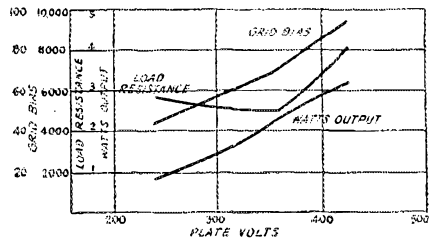

FIG. 10.—THESE CURVES GIVE THE PROPER GRID BIAS AND OPTIMUM LOAD RESISTANCE AS WELL AS THE OUTPUT FOR PLATE VOLTAGES BETWEEN 350 AND 425

At values above 360 volts, the plate dissipation is constant and the maximum allowable.

from 0 grid voltage to twice 93 or 186 volts. We judge the position of a curve for a grid voltage of 186 in Fig. 8 and set our lower plate current point on this curve at a value of 10 milliamperes which we had previously determined would be the probable lower limit for distortionless operation. A straight line is drawn from this point through the operating point and continued to the 0 grid-voltage curve. This line is shown dotted in Fig. 8. If now, we calculate the amount of second harmonic by means of Equation (1) we find that it is somewhat less than 1%. As our permissible value is 5%, we choose a lower minimum value of plate current and redraw our load characteristic line. If, in this particular case, we use a minimum plate current of 3 milliamperes, we will obtain the solid load line of Fig. 8 corresponding to our operating point of 28 mils and our calculations will show an harmonic content of approximately 5% which is the desirable operating condition.

The output power is then equivalent to:

$$\text{Power output} = \frac{1}{2} (E_{\max} - E_{\min}) (I_{\max} - I_{\min}) \quad (2)$$

and the proper value of load resistance

$$\text{Load resistance} = \frac{E_{\max} - E_{\min}}{I_{\max} - I_{\min}} \quad (3)$$

In the case being considered we have:

$$\text{Power output} = \frac{1}{2} (628 - 176) (0.059 - 0.003) = 3.16 \text{ watts.}$$

$$\text{Load resistance} = \frac{628 - 176}{0.059 - 0.003} = 8,060 \text{ ohms.}$$

Knowing that the power in watts is equal to the current squared times the resistance, we can obtain the value of a.c. current which is 19.8 mils.

When the plate voltage is low, the power output is not limited by the plate dissipation and the maximum power output is obtained when the load resistance is twice the plate resistance. A typical load line for a plate voltage of 300 is shown in Fig. 3.

In Fig. 10 we have curves showing the proper bias and load resistance for any plate voltage between 250 and 425. The maximum undistorted output power obtainable under these conditions

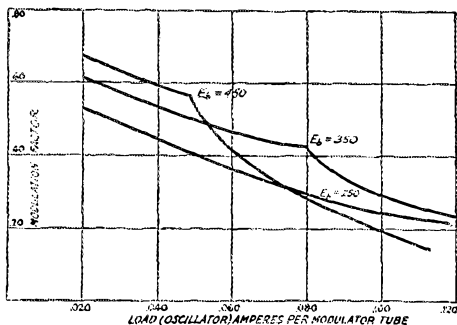

FIG. 11.—WHEN THE 842 IS EMPLOYED AS A PLATE MODULATOR, THE PERCENTAGE OF MODULATION CAN BE DIRECTLY OBTAINED IF THE MODULATED TUBE'S PLATE CURRENT IS KNOWN

This assumes a single plate supply for both tubes through a choke of infinite impedance and suitable bias and grid swing to the modulator tube.

may also be ascertained directly. For values of plate voltage below about 360, a plate load resistance of twice the plate resistance was chosen while for voltages above this value, use was made of the formulas (2) and (3).

MODULATOR

The 842 is well adapted for use as a plate modulator and Figs. 11 and 12 concern themselves with its use as such. These curves assume that the modulator and oscillator (or modulated amplifier tubes as the case may be) are operated

from a single source of voltage which is fed through a modulation choke of infinite impedance over the frequency range desired. The total current to the oscillator and modulator will, therefore remain constant.

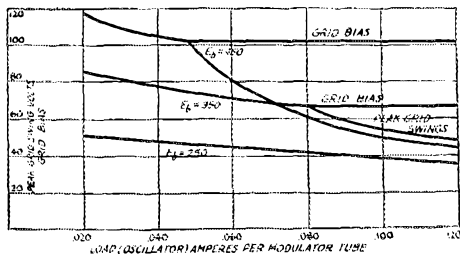

FIG. 12.—THE PROPER BIAS AND PEAK GRID SWING FOR THE MODULATOR WILL VARY WITH THE MODULATED TUBE'S PLATE CURRENT AND MAY BE OBTAINED FROM THE ABOVE CURVES WHICH ARE GIVEN FOR THREE VALUES OF PLATE VOLTAGE

Under these conditions, the oscillator plate resistance can be considered as being the load resistance for the modulator tube. Inasmuch as the load resistance has a considerable effect upon the output of the modulator, any change in the constants of the oscillator which reflects into the plate resistance of that tube will materially vary the percentage of modulation obtainable.

In this case when the load line is drawn in on the plate-voltage plate-current family, it is extended beyond the zero grid voltage curve to the zero plate voltage line. The value of current at which these intersect will be the total current supplied to the modulator and oscillator.

The percentage of modulation may be calculated:

$$M = \frac{E_{\max} - E_{\min}}{2E_o} \quad (4)$$

where

M = Per cent modulation.

E_{\max} = Plate voltage at highest grid voltage.

E_{\min} = Plate voltage at lowest grid voltage.

E_o = Plate voltage at operating grid voltage.

When high oscillator currents are employed, the modulator current must be kept at a value that limits the plate dissipation to a safe figure. In order to locate the position of the load line, this point for maximum modulator plate current is connected to the point on the zero plate voltage line corresponding to the sum of this modulator plate current and the chosen oscillator plate current. The line is extended in the other direction to twice the operating grid potential. In this case the swing will be limited by the minimum plate current value.

Fig. 11 shows what values of modulation may be obtained when the plate current to the oscillator tube is varied over a wide range. These

(Continued on page 86)

the tuning condenser also affects the wavelength.

It might be best to explain that consistent use of the term "meter" is used because all measurements were made on Lecher wires in centimeters and meters. When the frequency was desired in kilocycles, the wavelength figure was converted into terms of frequency.

A push-pull circuit arrangement which gave good results is shown in Fig. 4. In this case as in the others, the inductances were brass rods and L2 was so arranged as to be revolved, thereby allowing its distance and coupling to L1 to be varied. This is a free oscillator and is the circuit heretofore used by experimenters for the Rockefeller Institute.* We, however, prefer the Huxford circuit described in Fig. 2 and 3.

In order to transfer the energy developed by the oscillator into a useful "treatment circuit" it

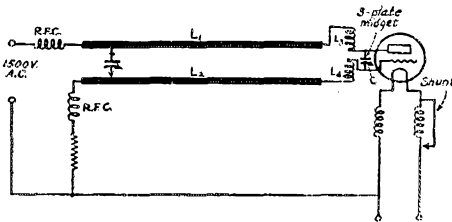

FIG. 3. — THE MODIFIED ARRANGEMENT WHICH EMPLOYS INDUCTIVE AND CAPACITIVE LOADING TO ALLOW THE RANGE TO BE EXTENDED TO 12 METERS

L3 and L4 are the loading inductances which are coupled together and C is the additional capacity used.

became necessary to build an ordinary "tuned secondary." This was done as shown in Fig. 5.

The r.f. ammeter was mounted on a sliding panel as was the condenser used for tuning. The sliding wires L1 and L2 furnished the means of tuning. The condenser consisted of two brass plates two and a half inches by four and a half inches and, later on, of two brass plates two inches and a half by eight inches long. All objects to be treated were placed between the plates — always protected by a glass box or glass test tubes.

The currents obtainable in the secondary circuit ranged as follows when a UX-S52 was employed with 1500 volts of a.c. applied to the plate:

Wavelength in meters	Current in amperes
1.7	1.5
2.0	1.8
2.5	2.2
3.0	2.7
4.0	3.3
5.0	3.5
8.0	3.8
10.0	4.0

* See *Journal Experimental Medicine* for February, 1929.

Below 1.7 meters oscillations could be obtained to about 1.4 meters but with such decreasing power as to make experiments valueless.

We started off with a mouse weighing 20 grams placed in a glass box. The circuit was tuned to 4.4 meters and the r.f. current in the secondary circuit adjusted to 1.3 amperes. The mouse died

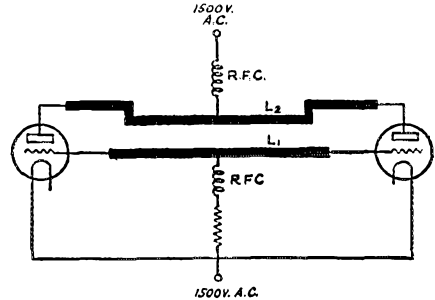

FIG. 4. — A PUSH-PULL ARRANGEMENT WHICH GAVE GOOD RESULTS

As in the other systems, L1 and L2 are brass rods. In this case L2 may be rotated to vary the coupling between the plate and grid circuits.

in three and a half minutes. This experiment was repeated a few times at other frequencies with similar results. Next some ordinary house flies were caught, placed in the same box and treated. At 0.5 amperes they flew about like mad — at 0.8 amperes they fell down and rapidly passed along into the fly "beyond."

After a few such experiments we figured it was time to sit down and dope out "whither next." We came to the conclusion it would be best to fall back on much simpler organisms than mice and flies. Since then we have run up and down the

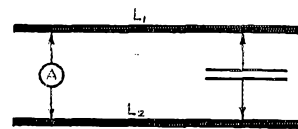

FIG. 5. — THE "TREATMENT CIRCUIT"

The condenser consisted of two brass plates between which the subject under test was placed. The circuit was tuned to resonance by sliding the ammeter or condenser along the two brass rods forming the inductance.

scale on distilled water, mineral oil, normal salt solution, staphylococcus, acidophilus, micrococcus catarrhalis, gram negative bacillus and some red and white blood cells. Strange things happen at different frequencies. Detailed charts showing the relative temperature rise of the different bacteria have been prepared but as yet sufficient work has not been done to warrant publication of any conclusions save one: Namely; so far, no germicidal effect on any bacteria due to the action of the high frequency energy proper has been

(Continued on page 88)

W8CEO

This is the third published entry in the Station Description Contest and has been submitted by the owner of the station, Mr. A. W. McAuley, 309 Third St., Okmont, Pa. It is notable that all of the first three descriptions, chosen because they were the best on hand, have come from the Eighth District. While we know that all of the good stations are not in the Eighth, from there have come the best descriptions. It is now up to the other W districts and foreign countries to prove their standing by getting their entries in. Let's go! — EDITOR.

FACING the coming of 1929 with a swinging antenna and some other undesirable transmitter features, W8CEO started plans for rearranging the station so as to meet, as far as practicable, the theoretical requirements of a 1929 amateur outfit. Consideration was given to the factors which it was thought would govern general operating conditions to the greatest extent. These were considered to be: A

THE ANTENNA SYSTEM

One of the first things required was a rigid antenna system, designed primarily for use on the 3500-ke. band, but adapted to the higher frequencies also. The tree which supported one end of the old antenna being seriously threatened by the hard-hearted woodman, it was necessary to locate the new antenna elsewhere. The only available space was about 200 feet from the house.

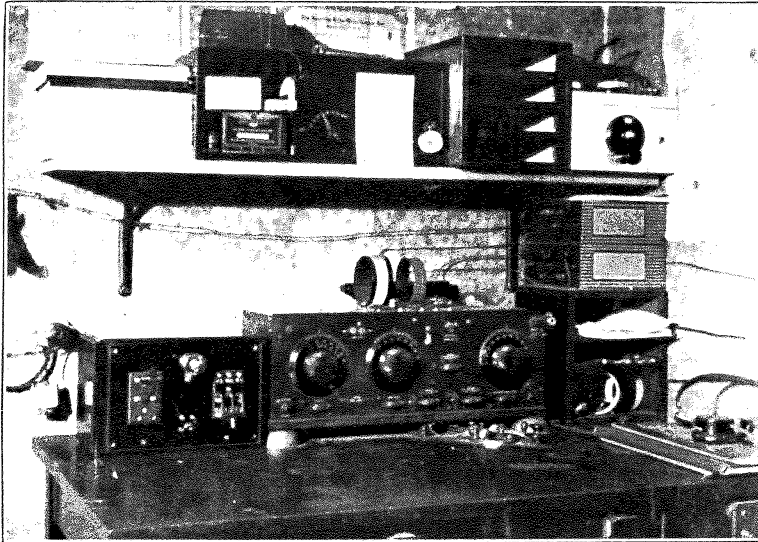

THE CONVENIENTLY-ARRANGED RECEIVING AND POWER CONTROL LAYOUT

The transmitter control is at the left and to its right is the remodeled Grebe receiver. The monitor is on the shelf at the upper right.

steady wave; a creditable note; a practical break-in; and last but not least, frequency adjustable over the band. Crystal control would insure the first two factors but it was believed that the disadvantages of difficulty in operating break-in and the impossibility of shifting the frequency would more than offset the advantages of crystal control. With an adjustable frequency, a quiet spot can almost always be found somewhere in the band. So the crystal was voted out by the one stockholder, and an attempt made to get a reasonably steady wave by other means.

This meant remote control, but upon listing the advantages and disadvantages of this, it was at once evident that it would be a good move, so plans were made along that line. The mast could be located near a garage, the transmitter installed in the garage, and control lines run to the house without trouble. The antenna system decided upon was a vertical radiator, approximately 60 feet long, but adjustable in length by means of a telescoping lower end. This part was for use on the 7000- and 14,000-ke. bands, voltage fed from a tuned tank circuit which is inductively coupled to the transmitter tank.

For 3500-kc. work a rigid counterpoise, also 60 feet long, was to be used and this system excited by the current feed method. A 65-foot mast was made in the following manner: A 30-foot chestnut pole, donated by the local power company, was

varnished with the exception of the chestnut pole. The strength of the mast was demonstrated when it was found that it would be supported in a horizontal position with a "horse" at each extreme end. Set six feet in the ground it is entirely self-supporting. It was set by means of a locomotive crane. Some time after its erection, a high wind blew 7 feet of the copper tubing from the top of the antenna. A lineman climbed the mast, using spurs, and after guying the side opposite him, the mast remained rigid and repairs were made without any trouble.

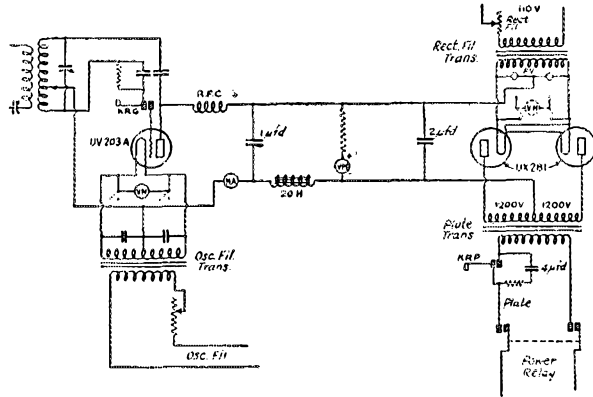

FIG. 1. — SCHEMATIC TRANSMITTER AND PLATE SUPPLY DIAGRAM

The transmitter circuit is the High-C Hartley. More complete details are contained in the text.

squared up at the top end for 3 feet and a box section 16 feet long, made of 1" boards, was nailed to the top of the pole. Another box section of 3/4" boards was inserted in the top of the first section for 18" and extended above for 24". A fir, 4" x 4" 24 feet long was inserted as far as the lower end of the second box section. The joints were metal stripped with box wrapping, the nail heads sunk into the wood with a nail set, and the cracks filled with "roof cement," a tarry, fibrous substance used for patching roofs. The 4" x 4" was lagged on all sides with "quarter round" for about half its length. Porcelain insulators were screwed to the pole at ten-foot intervals.

The radiator was made by soldering two sections of copper roof flashing together, thus forming a sort of oblong section tubing. This was mounted on the insulators by means of wooden saddles, both tubing and saddle being fastened by a small "U" bolt through the hole in the insulator. Two flexible joints were provided to prevent side strain on the insulators during erection. These joints were shunted by heavy copper braid. A copper ball was soldered to the top end of the copper tubing, and a brass sleeve with a set screw was provided at the lower end. Into this sleeve was telescoped a copper rod with a ball on its lower end. The whole radiator was cleaned and polished and everything well

THE TRANSMITTER AND POWER SUPPLY
 The transmitter was built on a white pine base, arranged to slide into a cabinet in the same manner, and for the same reason, as is done with receivers. All transformers, filter, keying relay, etc., are mounted on the lower side of the base, while the tubes, coils, meters, etc., are on the upper side. A panel, fitted with automobile celluloid window material, completely closes the cabinet while allowing a view of the apparatus. The box is large enough so that ventilation seems unnecessary. The vacuum tube used is a 203-A. Plate supply comes from a large home-made transformer giving 1200 volts, which is rectified by four UX-281 tubes, two of which are now over

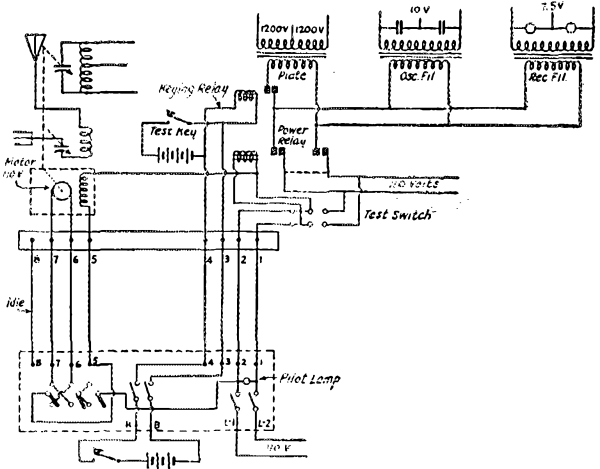

FIG. 2. — REMOTE CONTROL CONNECTIONS

The lower panel is that located at the remote control point. The motor is geared to the rotors of the tank and antenna tuning condensers.

a year old in this sort of service. This rectifier is inexpensive, simple, requires but small space and no attention. The current rating is well above that required for a single "50" so the tubes run cool. In fact, a single pair of these tubes seems to

work just as well as far as can be determined by observation and reports. The voltage drop across them would be less and better regulation is bound to result from using two pair, and their low cost and freedom from trouble over long periods would seem to make their use justified. It is planned to replace them with a pair of the mercury vapor tubes at the end of their active life. By keying in the primary of the plate transformer a high no-load voltage is prevented. Keying is done by a double-contact relay, one set of contacts keying the primary of the plate transformer, the other set opening the grid circuit of the oscillator tube when the key is up, so as to prevent noise in the receiver when working on the transmitting wave. The grid contacts close

UNIQUE TRANSMITTER TUNING SYSTEM

Now for the adjustable frequency. It may be reasoned that if several circuits can be ganged up in a receiver, where tuning must be close, it would be possible to gang the transmitter tuning controls. This scheme has been in use at WSCEO for some time so it was decided to do it by remote control. The main primary tank capacity is a large Cardwell of the transmitting type. This is set with the plates nearly all in and fixed. The tuning of this circuit is done by means of a General Radio type 334 T connected in parallel with the Cardwell. The General Radio condenser is fitted with one of their gears, and into this is meshed the hour hand gear of an old alarm clock. By filing the teeth of the escapement wheel it was

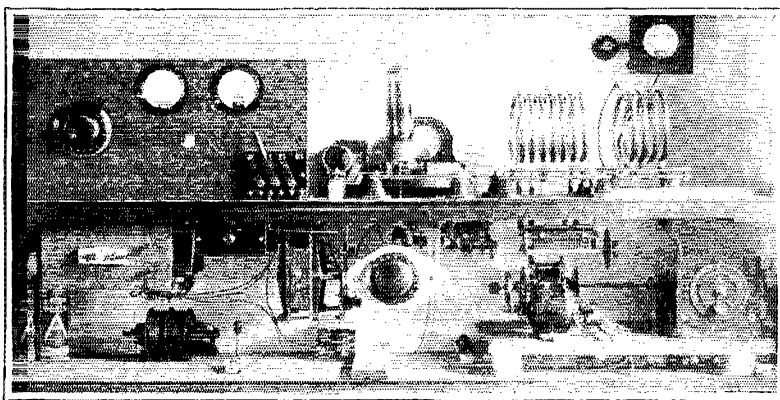

THE WELL-ENGINEERED REMOTE-CONTROLLED TRANSMITTER

The motor-driven tuning unit may be seen at the lower right.

before, and open after, the plate contacts. By keying the primary, first, key clicks are entirely eliminated and second, the maximum voltage is the load voltage and the voltage is zero when the key is up. A 4- μ fd. fixed condenser in series with an adjustable resistance is connected across the plate contacts. The resistance adjustment is critical, but when the correct value is reached the sparking at the points is eliminated. By loose coupling, carefully adjusting the transmitter, and using a filter system as large as can be keyed through without putting tails on the signals, a note can be had that practically eliminates undesirable modulation.

The keying relay was made from an old telegraph sounder. A heavy strip of bakelite was fastened to the arm, at right angles to it, and a Ford coil contact point bolted to each end of the bakelite strip. The sounder frame was screwed to a bakelite base and the lower contacts mounted on this base. The lower contacts are adjustable. The foregoing takes care of three factors: Steady wave; creditable note, and excellent break-in.

possible to make it mesh exactly with every other tooth of the General Radio fibre pinion supplies with their vernier tuning arrangement. On the shaft which carried this pinion is mounted a bakelite pulley about 2 $\frac{1}{2}$ inches in diameter. A small reversible series wound motor is belted to this pulley. It is not easy to find a small motor that will reverse readily on a.c. but this one does it nicely. The clock-work gear train is bolted to the frame of the General Radio condenser and the motor is fastened to the baseboard supporting the whole. A belt was made by winding linen thread over the pulleys until a belt of about $\frac{1}{8}$ inch diameter was made, the thread being spirally wound around the strands on the last few wraps. It was then tied and waxed. From the small motor pulley through the clockwork and condenser gear, a very large reducing gearing is provided so that the movement of the condenser plates is very slow. The armature is light, and the friction of the brushes is enough to bring it to a stop in a few revolutions after the switch is opened so that there is no drift of the condenser.

The antenna circuit is tuned with a large re-

ceiving type Cardwell, chosen on account of the ease with which it could be taken apart for trimming plates. Tuning adjustments were then made at places all along the band and curves plotted on the two condensers. These curves show where metal is to be removed from the plates of the antenna series condenser in order to make the curves coincide, so that the condensers may be connected together by a direct shaft. Matching the condensers is a tedious job and has to be done carefully, tuning each point as carefully as though it were planned to operate there regularly, but the result in case of operation compensates for all the work. This allows a change of frequency over the whole 3500-ke. band while at the same time maintaining correct transmitter adjustment. Since nearly all work at this station is done on this band, this feature is not used on the higher frequencies.

The motor is operated from the 110-volt circuit in the operating room. Of course, it is necessary to determine whether or not wires or other objects prevent operating on some frequencies within the band. It was necessary to break up a barbed wire along a picket fence at WSCEO before the whole of the 3500-ke. band could be used. The curves show the final tests on the condensers. Being able to shift the frequency readily to any point in the band, while at the same time maintaining good transmitter adjustment, is a great advantage. For instance: Station A is working Station B. Station C with such a frequency shift, wishes to QSO Station A. The receiver is set at zero beat on the frequency of Station B. The monitor is set at zero beat on the receiver. Then the transmitter frequency is adjusted to zero beat on the monitor. This last operation is done while station A is transmitting so as not to interfere with the signals of Station B. A is called just as B is signing off. It works surprisingly well. In case of QRM while transmitting, a "BK QSV" from the receiving station can instantly halt a procession of unnecessary signals. The transmitter frequency can be shifted up or down with the receiving operator following the wave, and a "BK OK" restores normal operation. This alone is worth all the work necessary to provide adjustable frequency. Then, too, a certain wave may kick into some locations better than others. A frequency that suits the receiving operator can be used. Practical elimination of interference with broadcasts gives 2½ hours more operating time each day.

It was necessary to run four pairs of telephone twist for the control lines, seven wires in use and one for a spare. A 110-volt magnetic switch throws the power on, and a triple-pole double-throw switch controls the condenser motor. The keying

relay is operated from the "A" battery while a pilot lamp helps the operator to remember to turn off the transmitter when closing down.

The inductances are made of copper tubing three-eighths inch in diameter, wound on a 4½-inch inside diameter and spaced ⅜ inch. 7 turns are used to 3500 kc. The center tap is fixed at the exact center of the coil and grid excitation is varied by changing the grid lead tap

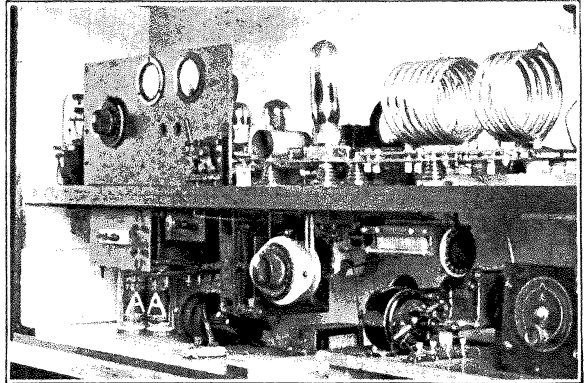

ANOTHER VIEW OF THE TRANSMITTER

The tuning unit and relays are at the lower right.

on the coil, moving it toward center to lower the feedback voltage. The coils are mounted on a sheet of bakelite which is fitted with General Radio plugs so that the different coils may be changed quickly. Two plugs in parallel are used on the condenser connections to provide the necessary current carrying capacity and metal caps are screwed to the socket ends so as to provide a sealed socket for mercury in case heating of the plugs should occur. No heating has been noticed and the mercury has not been added. It is possible that mercury will affect the metal plugs making it necessary to renew them frequently. The ends of the coils are flattened and bolted down through a heavy brass sleeve to a pair of "L"-shaped copper strips. The two General Radio plugs are fitted to the toe of each strip. One strip extends to the opposite end of the coil base and the plate connection plug is fitted to it. The center tap is fixed, and the grid tap is made by means of a clip.

The antenna coupling coil for 3500-ke. operation consists of 4 turns of the same size as the primary and plugs into a sliding base for varying coupling. It is fitted with grid, plate and center taps so that it may be plugged into the primary base for 7000-ke. work. When this is done, a tuned tank coil is plugged into the coupling coil base and the vertical part of the antenna excited by voltage taken from a tap on one end of the coupling coil. The same thing is done on 14 mc., using smaller coils. It has been found that the use

of a high value of primary capacity does all that is claimed for it when provision is made for the heavy tank current. It was feared that a pair of General Radio plugs would heat when forced to carry this current, but since the leads to the plugs and from the sockets are very heavy and care has been taken to see that a good fit is made by the plugs, no trouble from this source has occurred. Of course, with the keying system employed, it is not possible to use a large filter and while with certain transformers there might be some dis-

antenna coil while moving the frequency the width of the 3500-ke. band, as there is an apparent change of coupling as the frequency is shifted which affects things somewhat. The actual result of this coupling change is so slight that the receiving operator will not be able to detect any change in QRM if care is taken in matching the tuning condenser curves.

THE RECEIVER AND MONITOR

The receiver in use at present is a rebuilt Grebe "13." The cabinet and panel, with its original arrangement of sockets, rheostats, dials, etc., is used. The 50-ohm rheostats, with their "in" and "out" switches, come in handy for testing all types of receiving tubes without the necessity of changing "A"-battery voltage. The circuit has been changed to the conventional two-tube amateur affair using plug-in coils for different bands. The center dial controls a very small capacity in shunt to the grid circuit tuning condenser. The capacity of this condenser is such that a d.c. signal occupies 10 degrees on the dial; that is audible beat on one side, zero beat, and audible beat on the other side measures 10 degrees. Signal width may be readily measured in this way, and it is useful in following slow drifts in frequency and in changing from one side of zero beat to the other to avoid QRM on a received

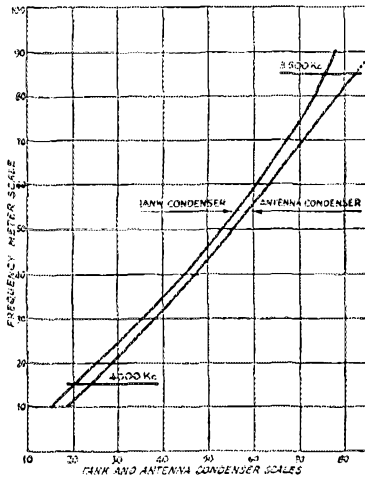
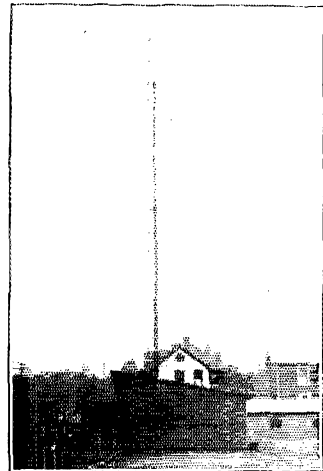

FIG. 2. CALIBRATION OF THE TANK AND ANTENNA TUNING CONDENSERS

The slight detuning noticeable on the upper part of the curve is helpful in offsetting an apparent tighter coupling at this end of the band.

advantage in keying the primary, if it can be done without too great a variation in the first rush of current in the windings, due to the residual magnetism of the core, the inherent advantages are many. A home-made choke estimated at 20 henrys, probably somewhat less, and a total of 3 μ d. capacity seems to be about the maximum that can be keyed through successfully. However, with these values of filter and with a High-C circuit it is not difficult to adjust the transmitter to obtain a note that very closely approaches d.c.: one that will readily pass muster for 1929. Experience with this outfit has shown that it is entirely practical to build a self-excited transmitter to meet the following requirements: (1) To produce a wave of such sharpness and steadiness as to be satisfactory for 1929; (2) to produce a note that will not be objectional to anyone; (3) to allow break-in operation, even on the transmitter frequency; (4) to allow a steady, continuous frequency adjustment from one end of the band to the other. It may not be possible to maintain exactly the same character of note and degree of energy transfer from primary to



THE VERTICAL ANTENNA

The transmitter is located in the "shack" immediately behind the mast. Control wires and the horizontal section of the antenna used on 3500 kc. are supported by the fence at the left.

signal. Use of this small shunt capacity also makes possible accurate tuning even though this main tuning condenser is somewhat larger than necessary to merely cover the band. It comes in handy sometimes to be able to watch the territory adjacent to our bands, and no doubt that this will become still more desirable as our affiliations with

Say Son, here's my picture..

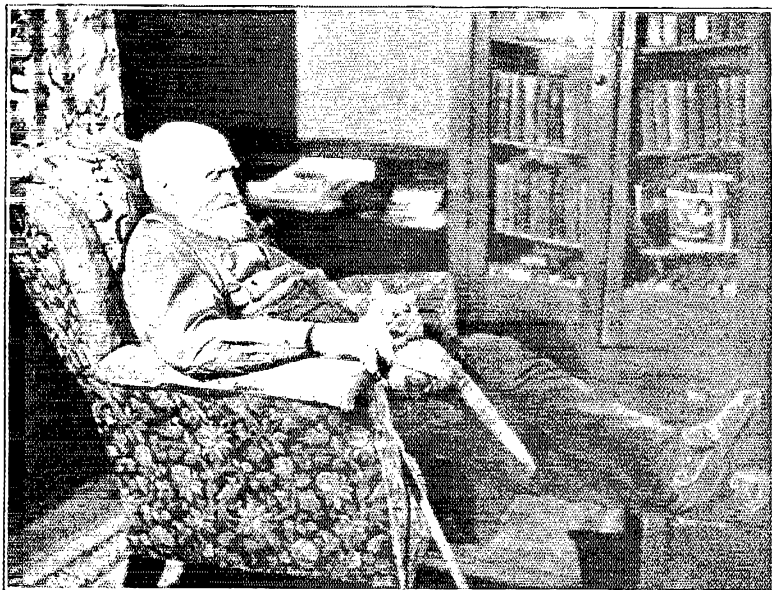

To the Gang at Headquarters
from The Old Man.

the Army and Navy are extended. A peaked audio amplifier is used, one stage having proved enough for all practical purposes. Practical accuracy in frequency measurement is had by making use of a monitor, made from a description of the "growler-oscillator" which appeared in *QST* for July, 1927. It was built shortly after that and has been a regular part of the station equipment since. Standard frequency signals from WWV and W9XL are used to check the calibration of the monitor dial scale. It has been observed that if the monitor is not fooled with, but it is placed in a convenient place and left alone, the calibration remains practically constant and only occasional corrections to the curve need be made and the deviation is of very small amount. The beauty of the monitor method of measurement is that indications are very sharply made, it being very easy to check the zero beats of both received signals and your own transmitter. The box is made large enough so that rugged batteries may be used, which makes for reliability of the instrument. A

vernier type dial, with a well marked scale, is an essential part of the monitor. A spare tube, selected on account of the fact that it works well and does not change the calibration, is kept on hand plainly marked "Spare Monitor Tube." Carefully selected spare receiver tubes are also kept on hand. A home-made frequency meter with a range somewhat larger than the monitor is kept in the station and its curves checked frequently. It is used mostly for transmitter experiments. It is so absurdly easy to make certain that the transmitter is in the band that there is not the slightest excuse for off-wave operation.

Stray-ed

It's apparently impossible to keep the "bachelor content" very high here at Hq. Don Meserve, W1FL, *QST*'s new Advertising Manager, stepped off on April 8th. Mrs. Meserve was formerly Miss Doris Lillian Foster of Northampton, Mass.

"There are only a few of us left."

Those Past Issues of QST

By Louis F. Leuck*

NO! Wrong again. Perhaps it was the September issue for 1927 or maybe the one that WIOFF borrowed the other day. It seems to me that there was a picture of an antenna on the cover — if we could only find that index, we'd be all right." — And thus do amateurs look up past articles in their back file of QSTs.

All of this might have been saved if they had taken proper care of these back issues. The simplest answer, of course, is to invest in a sufficient number of standard QST binders at \$1.50 each to take care of the stack. However, when the transmitter is in crying need of some new parts, it makes a fellow shudder to think of buying binders for a pile of magazines that has been accumulating for six or eight years. It's like killing off seven and a half watters before they are born!!

Permit your eye to wander to the photograph. In it you will see QSTs for four and a half years all dressed up in their "homespun" bindings. Six consecutive issues make up each section. The indices for all are combined in one folder as shown.

BINDING

The problem of binding these issues together is not as difficult as one might first suppose. A strip of brass or some other suitable metal is obtained and is bent and drilled as shown in Fig. 1. The template is laid along the bound edge of the magazine and the location of the four holes

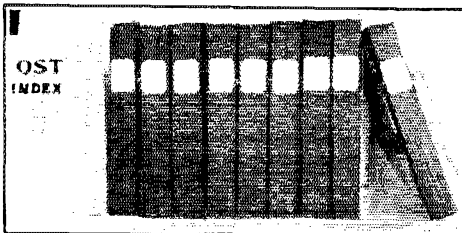

A STACK OF QSTs ALL DRESSED UP AND READY FOR A QUESTION TO COME ALONG

At the right is a section all ready for the application of the gummed cloth tape, a roll of which may be seen standing on top of the section with a box of white gummed stickers and the template. At the left, a fifth issue is being put in place on another section.

transferred to the magazine by a sharp pencil point. It should be noted that the template is held with its bent edges against the back and bottom edges of the magazine. The various issues

are not always cut to exact size and this method insures getting the bottoms even so that each bound section will be able to stand squarely on its own feet.

After the position of the holes has been laid out by means of the template, the holes must be punched. Each magazine should be punched separately to secure uniformity. Otherwise, the punch may go through a group of magazines at an angle and the error will become greater as the length of the hole is increased. The family ice pick

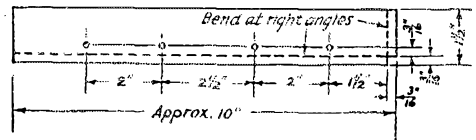

FIG. 1 — THE DIMENSIONS OF THE TEMPLATE FOR LAYING OUT THE POSITION OF THE HOLES ARE GIVEN ABOVE

makes an ideal punch for the job. One sharp tap of the hammer will drive the pick through just about right for each hole. To avoid complications it is well to do your bookbinding on a day when you are alone at home.

The next thing is to take two eight-inch lengths of No. 18 bare copper wire and bend them into the shape of the letter "U." The base of the "U" should be straight and two inches long and the corners sharply bent. Now, string six consecutive issues (the first or the last six of a year) on a pair of the "U"-shaped wires. Then press the copies firmly together and bend the protruding ends of the "U" toward each other. Flatten down and apply a drop of solder where they lap. Now, for appearance's sake, take a strip of black gummed cloth tape nine and a half inches long and apply it to the back edge of each section. This tape should be two and a half inches wide and it may be procured from any school supply house.

The year and the names of the six consecutive issues included in each section should be typed on a white gummed sticker. The sticker is then stuck in position on the back edge of the bound section and you are through.

THE INDEX

The yearly indices are all kept in a folder whose covers are made of a piece of flexible cardboard bent double. Take a strip of the same material and fold it lengthwise so as to form a "V"-shaped trough. Glue one face of the "V" along

(Continued on page 50)

* W9ANZ, 1718 South 14th Street, Lincoln Nebr.

The DX Meter

By D. F. Brocchi*

THIS is a home-made instrument for finding the distance between two points, given their latitude and longitude.

The calculation of the distance between two points on the earth's surface is to most amateurs a bothersome operation. This is particularly true when a large number of calculations are in order and with this in mind an instrument was devised to allow these distances to be scaled off without the use of any other information than the latitude and longitude of the two places involved. Although it will be impossible to directly measure long distances on a map based upon Mercator's projection, such a map will allow the latitude and longitude to be obtained.

A general idea of the device to be described may be obtained from the photo. The material used is sheet bakelite, fibre board, sheet metal, cardboard, or what you have, but it must be flat — and stay flat.

Two pieces of the material are hinged together along straight sides. The hinges are bent and set into the material so that their axes are at the intersection of the surfaces of the two pieces on the side where they fold together. This is shown in Fig. 1. A straight edge must touch the surfaces all over when they are opened flat and the two surfaces must touch each other all over when they are folded together.

If cardboard is used, the two pieces are laid edge to edge and a strip of thin cloth glued over the joint.

When the pieces are hinged, open them out flat and through the center draw the "equatorial line" at right angles to the joint, which is the "polar axis." Fig. 2 shows this clearly.

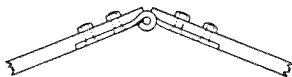
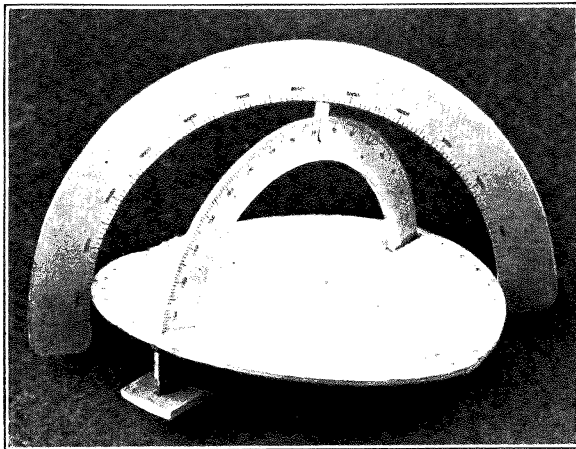

FIG. 1.—ONE METHOD OF HINGING SO THAT THE POLAR AXIS WILL BE AT THE SURFACE OF THE TWO PIECES BEING JOINED TOGETHER

From the same center draw the "latitude circle" just within the edges. Next, graduate each quadrant from 0 to 90° from the equatorial line to the polar axis and then cut neatly along the latitude circle and discard the outer portion.

If there is no protractor in the shack, the bristol board variety ranging in price from 10 to 40 cents, will do, or the plotting may be done by tangents, a more satisfactory method when the protractor is too small for the work in hand.

For the mathematically inclined, who might feel that the earth should be treated as an ellipsoid rather than a sphere, and that geographical latitude is different from geocentric latitude, it may



A VIEW OF THE INSTRUMENT ADJUSTED TO MEASURE THE DISTANCE BETWEEN TWO WIDELY-SEPARATED POINTS

In this case, the difference in longitude is very large and it is essential that the spacer be employed to prevent the distance scale from sliding along the edge of the latitude circle. In most cases, though, the difference in longitude will be somewhat less and the use of the spacer will not be required. The spacer is used only when the distance scale shows a tendency to slide along the latitude circle.

be pointed out that the errors involved are too small to be given consideration, a high degree of refinement not being required in the results for which the instrument is intended. Furthermore the distance scale, to be dealt with shortly, cannot be made to conform with an ellipsoid in more than one direction.

In Fig. 3 is shown the longitude scale. The outer radius is less than that of the "latitude circle" by an amount allowing the markings along the edge of the "latitude circle" not to be interfered with. Its inner radius depends on the width required for strength and stiffness. Before cutting, the scale is graduated from 0° at A to 180°, leaving some material beyond the ends of the graduation.

A slot through which this longitude scale may

* 4331 Thackeray Place, Seattle, Wash., U. S. A.

be passed is cut in the equatorial line (half each side of the line), its outer edge being at a distance

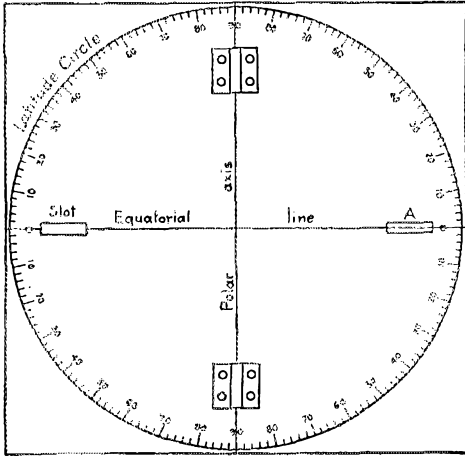

FIG. 2.—THE APPEARANCE OF THE LATITUDE PLANES JOINED TOGETHER AT THE POLAR AXIS IS SHOWN ABOVE

The excess material around the edge of the circle is carefully cut away leaving a perfect circle.

from the center equivalent to the outer radius of the longitude scale.

Now fold the instrument, and with a sharp pencil or scribe mark the outline of the slot as at A, Fig. 2. Then, fasten the end A of the longitude scale at this point in such a manner that the slot fits the scale in all positions as the two halves of

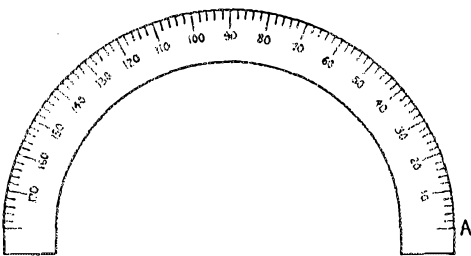

FIG. 3.—THE LONGITUDE SCALE WHICH FITS IN THE SLOTS IN THE LATITUDE PLANES

The end A is fitted into the slot A shown in Fig. 2 and is fastened so that the first line is flush with the surface of the latitude plane. The other half of the latitude plane can then be moved back and forth along the longitude scale and opened up to the difference in longitude between the two points to be measured.

the latitude circle are folded in and out. Some means must be provided to hold the instrument open at any angle, or a snug fit between slot and scale may serve the purpose.

The "distance scale," Fig. 4, is similar to the longitude scale and is separate from the rest of the "meter." The outer edge may be circular or not and at any convenient distance from the

inner edge, which must be circular and cut exactly to the same radius of the latitude circle. The graduation is plotted by protractor on the basis that 180° = 12,430 statute miles with the help of the following table. If the distance is

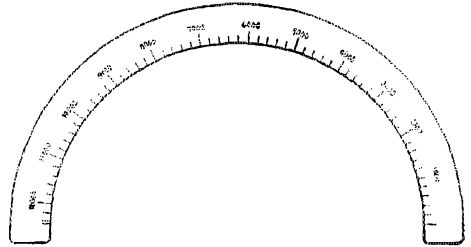

FIG. 4.—THE DX SCALE WHICH IS BRIDGED BETWEEN THE LATITUDE OF THE TWO PLACES IN QUESTION

The distance in statute miles may be read off directly.

required in nautical miles, multiply the statute miles by 0.839, or if in kilometers, by 1.609.

The "spacer," Fig. 5, is made of the same material as the longitude scale, and the height "h" is the same as the difference between the radius of the latitude circle and the outer radius of the longitude scale. Two flaps of thin card-

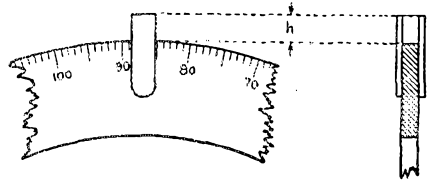

FIG. 5.—THE SPACER SHOWN ABOVE NEED BE USED ONLY WHEN THE DIFFERENCE IN LONGITUDE BETWEEN THE TWO PLACES INVOLVED APPROACHES CLOSELY TO 180 DEGREES

For most work this difference will be considerably less and it will be unnecessary as there will be no tendency for the distance scale to slide along the latitude circle.

board or other material are fastened to the sides to hold it in place when required.

The meter is mounted on a support consisting of two parts hinged or pivoted together with sufficient friction to hold in any position. The upper part has a projection to which is attached the free end of the longitude scale.

This construction gives the same result as measuring on the surface of a globe, inasmuch as it makes available those points in a globe that would be required in each case. The angle at the poles between the two meridians is given by the folding of the two planes of the instrument about the polar axis and is determined by the graduations on the longitude scale, while the distance scale gives the great circle distance as though it were applied on the surface of a globe.

To use the meter, open to the difference in longitude on the longitude scale, and measure the distance with the distance scale between the latitudes shown on the two halves of the latitude circle. If the distance is very nearly halfway around the earth, it will be found that the dis-

Daddy Cadmus was one of the original "wireless men" of the United States Government. When the Wireless Ship Act of 1911 was enacted, Mr. Cadmus and Mr. W. D. Terrell, the latter now chief of the Radio Division of the Department of Commerce, were appointed radio inspectors. Mr. Terrell was stationed at New York to look after the east coast and Mr. Cadmus was sent to San Francisco, with jurisdiction over all the ports of the Pacific Coast, to see that the radio communication laws were obeyed. These two men constituted at that time the complete radio force of our government. During 1913 Mr. Cadmus was transferred to Baltimore, from which place he presided over the Third District until the time of his death, except for a year during the World War when he was granted a furlough and entered the Navy with the rank of Lieutenant. During this period he was stationed at the League Island navy yard at Philadelphia, supervising the training of naval operators. At the conclusion of hostilities he returned to Baltimore and resumed charge of his old district.

CONVERSION TABLE OF STATUTE MILES AND DEGREES									
MILES	DEGREES	MILES	DEGREES	MILES	DEGREES	MILES	DEGREES	MILES	DEGREES
100	1.4	2,600	37.7	5,100	73.9	7,600	110.1	10,100	146.3
200	2.9	2,700	39.1	5,200	75.3	7,700	111.5	10,200	147.7
300	4.3	2,800	40.5	5,300	76.7	7,800	112.9	10,300	149.2
400	5.8	2,900	42.0	5,400	78.2	7,900	114.4	10,400	150.6
500	7.2	3,000	43.4	5,500	79.6	8,000	115.8	10,500	152.1
600	8.7	3,100	44.9	5,600	81.1	8,100	117.3	10,600	153.5
700	10.1	3,200	46.3	5,700	82.5	8,200	118.7	10,700	154.9
800	11.6	3,300	47.8	5,800	84.0	8,300	120.2	10,800	156.4
900	13.0	3,400	49.2	5,900	85.4	8,400	121.6	10,900	157.8
1,000	14.5	3,500	50.7	6,000	86.9	8,500	123.1	11,000	159.3
1,100	15.9	3,600	52.1	6,100	88.3	8,600	124.5	11,100	160.7
1,200	17.4	3,700	53.6	6,200	89.8	8,700	126.0	11,200	162.2
1,300	18.8	3,800	55.0	6,300	91.2	8,800	127.4	11,300	163.6
1,400	20.3	3,900	56.5	6,400	92.7	8,900	128.9	11,400	165.1
1,500	21.7	4,000	57.9	6,500	94.1	9,000	130.3	11,500	166.5
1,600	23.2	4,100	59.4	6,600	95.6	9,100	131.8	11,600	168.0
1,700	24.6	4,200	60.8	6,700	97.0	9,200	133.2	11,700	169.4
1,800	26.1	4,300	62.3	6,800	98.5	9,300	134.7	11,800	170.9
1,900	27.5	4,400	63.7	6,900	99.9	9,400	136.1	11,900	172.3
2,000	29.0	4,500	65.2	7,000	101.4	9,500	137.6	12,000	173.8
2,100	30.4	4,600	66.6	7,100	102.8	9,600	139.0	12,100	175.2
2,200	31.9	4,700	68.1	7,200	104.3	9,700	140.5	12,200	176.7
2,300	33.3	4,800	69.5	7,300	105.7	9,800	141.9	12,300	178.1
2,400	34.8	4,900	71.0	7,400	107.2	9,900	143.4	12,400	179.6
2,500	36.2	5,000	72.4	7,500	108.6	10,000	144.8	12,430	180.0

tance scale can be made to slide up and down against the latitude circle for a space amounting to several hundred miles so that the correct distance cannot be determined. When this happens, slip the spacer over the longitude scale at the graduation corresponding to one half the difference in longitude, and let the distance scale rest on the spacer.

It will be noted that the distance scale can be applied in four different positions in each case, excepting when the latitudes are equal, in which case only two positions are possible. If the meter is made accurately, all readings will be very nearly equal. For greater accuracy these four values may be averaged.

If the difference in longitude is too small to read the latitudes conveniently, it may be assumed as zero, the instrument opened out and the distance scaled along one half of the latitude circle without material error, or the latitude graduations may be extended across the edge of the circle, where they will always be in plain sight.

The author will be glad to answer all requests for additional information on the subject.

Supervisor Cadmus Passes On

MR. R. Y. CADMUS, the only Supervisor of Radio the Third District has ever had and the senior supervisor of the service, departed this life at Baltimore on May 7th after a prolonged illness. He was sixty-six years old. Burial took place in the Arlington National Cemetery, with full military honors. Floral tributes were many, amongst them one from President and Mrs. Hoover.

He was a friend of amateur radio. No amateur who knew him ever doubted that. Is there any more that we can say?

Mr. L. C. Herndon, senior inspector of the district, long-time amateur and League member, has been appointed Acting Supervisor at Baltimore.

Midwest Division Convention

WITH one of the finest settings and the largest attendance, the eighth annual radio convention at Iowa State College, Ames, May 10th and 11th, is now a memory.

Early Friday morning, delegates from all over the division, including visitors from South Dakota, Minnesota, and a large delegation from Chicago, registered and "hamfesting" began immediately.

Promptly at 1 o'clock, Professor D. C. Faber, in the name of the faculty and the Campus Radio Club, welcomed the delegates in well-chosen words and then turned over the meeting to Section Communications Manager H. W. Kerr, Chairman of the convention. Now we know why they call him "Kerr the Hustler." Without any frills speakers were introduced. Starting with a non-technical address, A. A. Hebert, Treasurer of the League, gave all the information at his command on "Our A.R.R.L.," which should make one proud to belong to the organization. There was disappointment because Bert Pucket, W9EDW, of Cedar Rapids, was unable to come to talk about his DX contacts with Byrd Antarctic Ex-

(Continued on page 88)

Junk

By Carl L. Rose*

Reading time, 35 CQ's

AS all radio widows know, you can't keep a good ham down. All of us may go hay-wire once or twice in our lives to the extent of letting such a simple matter as slipping a platinum band over a YL's finger temporarily sidetrack what had up to that time been a promising amateur career — but it doesn't last.

So our friend Bill, who had taken a fall from grace, as it were, found the joys of married life palling, and woke up one day to the fact that his old right mitt had developed a strong itch to pound a key.

There was only one thing to do about it. Bill told his better three-fifths that he had an important engagement at Fred's house, and went out. The business he wished to attend to was that of finding Fred home.

Fred was.

"'lo Freddie."

"We-I-I, Bill! C'mon in, old timer and stay a while. What's been the matter lately? I haven't heard your fist on the air for a long time."

"Guess you're right, Fred. To tell the truth, I stored all the old junk in the attic when I got married, and haven't touched anything but a door key since. I'm kinda thinking of getting back in the game, though, and thought I'd drop over and see what's new."

"Sure thing; let's go up to the room and see what's on the air."

A few minutes later, the two arrived in Freddie's operating room, where a nice 500-watt job took up most of the space along one wall.

"Gee, Fred, 's' nice outfit you got."

"Oh, she doesn't do so badly. I've worked about everything but Mars, and if she keeps on she's liable to do that."

"Say, you haven't got a spare 204 you want to sell, have you Fred? I have one stored up with the old outfit in the attic, but I'd like to add another to it and have a layout like this."

"Sorry, Bill, but I haven't. Tell you what, though — there's a kid down the street that pumps a tweet on the air with a 201-A. He's got a 204, but can't afford the juice to run it; you could probably buy it off him cheap."

"Sounds good to me, Fred. Let's go down to see him right now."

"Oke, Bill."

Thereupon Bill and Fred visited the kid who pushed the 201-A, and after telling him what a nice outfit he had, and looking over his QSL

cards and asking him how he got the good note, Bill worked around to the subject of the spare 204, and negotiations were finally completed to relieve the kid of it for twenty smackers.

Determined now to break out the old apparatus, Bill said good night to Fred and hurried home, highly elated over the good bargain he had just made. Arrived in the house, he slung his hat joyously at the rack, grinned to himself in the mirror, kissed his wife twice — most unusual — and questioned her as to the whereabouts of his old radio junk in the attic.

"Your radio apparatus? Oh, yes, dear; you'll find it in a pile down under the south window. I had a young man from down the street clean up, up there, and that's where he put it. There! I almost forgot. He was so interested in your old stuff that as payment for cleaning up I gave him an old electric bulb you had. Why, it was just like that one you have in your hand; you don't mind, do you, de —

"Bill!

"Bill! Mary! Mary! — oh, where is that maid? — Mary, run down to the doctor's as fast as you can! Something has happened to Mr. Smith! Oh, hurry, hurry!"

MORAL

When good tubes come cheap — there's a reason!

Strays

With Senate confirmation of two recent appointees on May 2d, the Federal Radio Commission again returned to its full strength of five members.

From the fourth zone, the middle-western states, President Hoover named Major General Charles McK. Saltzman, retired, Chief Signal Officer of the Army from 1924 to 1928. It was during General Saltzman's tenure as the chief of the Signal Corps that the Army-Amateur affiliation originated and took form. He was a member of the United States delegation at the international conference at Washington in 1927, and in the numerous preliminary sessions of our delegation held in the summer preceding the conference he was chairman of the technical committee. He knows amateur radio and he will continue to be a good friend at Washington.

From the first zone the President appointed William D. L. Starbuck, a New York City mechanical engineer and patent attorney residing in Connecticut.

* W9GGB, 2414 W. Taylor St., Chicago, Ill.

Experimenters' Section

SOME MORE CONCERNING THE SUPER-HETERODYNE

ONE of our experimenters writes as follows:

"I should like to call your attention to a few points about detection that may have been overlooked in the article describing the super-heterodyne receiver in the March issue of *QST*. The most important point of all is that it is a mistake to use grid detection in the first detector of a double demodulation receiver. I have just been building one for use as a field strength measuring set and, of course, could not resist hooking it up to an antenna and tuning through the amateur bands just to see how the '1929' notes were coming along. The first detector was an amateur receiver that happened to be handy and, of course, it sported the usual 250- μ fd. condenser and a 10-megohm leak. Signal strength was good but not by any means of the diaphragm buckling intensity. Further, the first detector tuned very broadly, a consideration where its selectivity is the only discrimination available for the elimination of a signal coming in on the second difference frequency. A little thought brought out the fact that the time constant of the leak-condenser combination was nowhere near suitable for detection of the 300-kc. intermediate frequency, whereupon a 20,000-ohm leak was substituted for the 10 megs. and the signal strength observed to take a very gratifying jump of about 10 db. But a little more calculation showed that even with this value of leak the proper impedance was not being offered to the 300-kc. current, so the condenser and leak were removed bodily and the job of rectification given over to the plate. The response from this shifting of responsibility was a further increase in sensitivity and an appreciable increase in the selectivity of the detector circuit, carrying with it some reduction in the noise level.

"It's just another item in the indictment of our old faithful grid detection circuit. We have known all along of the rather severe frequency discrimination that characterizes this type of detection but it takes an unmistakable example, such as this one of detecting at 300 kc., to bring the fact out with the force necessary to impress it upon us. One can go a step farther and say that grid detection should not be used in the second detector in a super-heterodyne either, which, of course, is only a soft way of saying that it has no place at all in this type of receiver. The difference between the intermediate frequency and the modulation frequencies is not sufficient to give the grid-series impedance a chance to do an efficient job of passing the one and building up a voltage drop from the other. Furthermore, with the high gain obtained in the two tetrode intermediate stages (3500 in my

particular model) tremendous voltages are built up on the grid of the second demodulator, voltages far beyond the ability of the grid rectification circuit to handle. Amateur signals were putting from 0.5 to 5 volts on the second detector grid in my receiver while broadcast carriers swung it anywhere from a volt to 15 volts. And from the fact that you employ but one audio stage in the receiver described in the March, *QST*, I judge that similar voltages are obtained there. Ninety to 135 volts on the plate, with suitable bias, are required to handle these inputs as otherwise the superhet 'hiss', due to overloading of the second

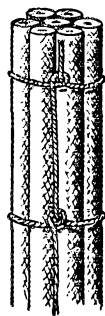

FIG. 1

detector by the impressed carrier with all of its complicated demodulation products, become unbearable if quality suitable for loud speaker operation is desired from the set.

"The point I have been trying to make is that whenever a detector is required to be something more than just an expedient for obtaining a maximum of noise from a minimum of tubes it pays to go to plate detection. The loss in sensitivity is far from being the out-of-sight proposition that most people imagine it. In fact, for the average circuit the difference is only about 3 to 1. For special cases such as for the first detector on a super-heterodyne, the plate detector actually comes out ahead by a factor that may be as great as 10 to 1, not to mention the increase in selectivity which becomes important in this instance when the detector under consideration is not oscillating. In this case, the improvement in the decrement of the circuit becomes noticeable.

"Another improvement which might be added to your circuit would be the use of a tetrode as first detector using plate rectification, of course, and some regeneration. A tetrode so used, when working into a suitably high impedance such as the first tuned circuit of the intermediate amplifier, either directly coupled through a choke and condenser or with a primary having the same

number of turns as the tuned secondary, will show a detection factor of 5 or 6. This should be compared with the unity factor of the triode plate detector or the doubtful grid detection factor which may run from 1/10 to 3, with luck. This figure does not consider regeneration and the addition of regeneration should actually increase the sensitivity faster than on a triode detector, which certainly seems to be another legitimate argument for the tetrode detector.

"It might also be mentioned that the a.c. screen-grid tube, the 224, has an appreciably higher conductance than the 222. This, together with the better screening of the a.c. tube gives a much higher detection factor and enables a practical and stable circuit for straight amplification to give about twice the gain as when using the dc. tetrodes. A gain readily obtainable at intermediate frequencies is about 100 per stage as against the theoretical and actual maximum of 50 for the dc. tube. I have actually obtained gains as high as 96 with the 222, but this gain would not permit of cascading stages successfully."

"DRESS"

"I have just finished reading the article on 'Dress' which appeared in the April issue of *QST* and would like to make a little suggestion about cabling. The whip stitch shown in Fig. 1 will work very well but there is one fault with that particu-

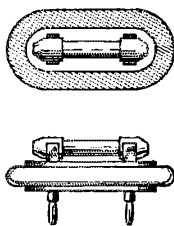

FIG. 2

lar stitch. It is that if the cord used in lacing the wires together should break through becoming worn or pulled too tightly the whole cable will come unlaced and thus make it necessary to do the job over.

"The stitch shown in Fig. 1 will hold 'till Doom's Day.' I learned this when some of the men from the local branch of the Telephone Company were putting in some remote control cable at the studio of WKBW."

— Francis M. King,
R. F. D. No. 1, Tonawanda, N. Y.

GRID CONDENSER AND LEAK MOUNTING

"A handy and flexible way to mount the grid condenser and leak is showed in Fig. 2. The condenser is fitted with G.R. plugs on one side and fuse clips, such as are used to hold fuses on automobiles, are screwed to the other side of the condenser. These small clips cost about ten cents per

dozen and are excellent for all types of resistor mounts.

"Two G.R. jacks are mounted on the sub-panel of the receiver along with two more fuse clips. A short strip of brass serves to connect one jack to one clip. The other clip goes to the filament. This arrangement allows the leak to be placed either across the condenser or from the condenser to filament. Thus, any desirable arrangement of the leak and condenser can be obtained in but a few seconds."

— Donald F. Holaday,
320 8th Ave., S. W., Aberdeen, S. Dak.

28,000 KILOCYCLES

We have received some data from D. C. Wallace of W6AM concerning the antenna system used by him in some of his 28,000-kc. work. The general arrangement is shown in Fig. 3 and consists primarily of three (or more) horizontal radiators fed by a two-wire feed line. The arrangement is such that it is possible to swing the lower end of the system and thus change the angle of radiation. The actual dimensions of the system are comparatively unimportant, inasmuch as the radiators may be any number of half waves long and the feed may be either of the voltage or current variety. The chief requirement is that the feed lines be plenty long enough, so as to allow the lower end of the structure to be swung over a considerable arc.

AN INSULATING COMPOUND

"An insulating compound that may be used anywhere in the receiver or transmitter without fear of introducing a loss is made by melting one part of good rosin with two parts of good beeswax. The ingredients are to be measured according to volume and not weight. When the mixture is molten, it may be painted on the piece of equipment or, such equipment as wooden panels, etc., may be soaked in it. Its advantages are that it hardens rapidly and is very tough and hard when cooled. It has no greasiness such as is found when paraffin is used."

— C. J. Paddon.

TRANSMITTING INDUCTANCES

"A means of greatly improving a transmitting inductance made of tubing is to slot it parallel to its axis and then round off the sharp edges. A machine shop will do the slotting quite cheaply and this is recommended, because it is a difficult job to do by hand.

"The reason for this slot is to prevent the flow of severe eddy currents which are set up circumferentially in the tube proper. These eddy currents cause a large heat loss and the slot, when applied to the inside of the coil, not only breaks the path of the eddy currents but also tends to concentrate the r.f. current on the outside of the tubing where it belongs."

— C. J. Paddon.

CAPACITY CONTROL OF REGENERATION

A method of improving the operation of a receiver employing a condenser to control regeneration is suggested by Martin Mytas of White Lake, Wis. It is shown in Fig. 4 and consists of a piece of wire or narrow strip of sheet metal placed about $\frac{1}{4}$ " away from the rotor of the regeneration control condenser and connected to the grid of the tube. It can be arranged to either increase or decrease the capacity across the input of the tube, depending upon its position in relation to the rotor plates and their direction of rotation. Its correct position must be found by experiment and it will vary with the particular set.

FREQUENCY VS. WAVELENGTH

Alpha Learned of 31 Burnette St., Providence, R. I., points out an interesting fact concerning the transmission of radio signals through water. The velocity of the wave through water is less than through air and this results in a change in the length of the wave which becomes about $\frac{3}{4}$ of its "air" value. However, the frequency is still the same and the setting of the receiver does not change. We thus have one more reason for considering the frequency of the emission as being the important factor.

CHEMICAL RECTIFIERS

J. F. Wohlford of W3CA suggests the use of the pint-size Mason fruit jar for containers for chemical rectifiers. He finds that the additional volume over that obtained with the more common

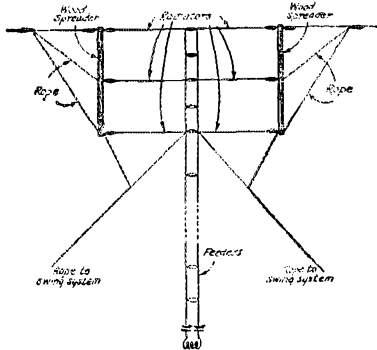

FIG. 5

jelly glasses is advantageous and allows larger elements to be employed. Because of these factors, the rectifier will usually run cooler.

DIRECTIONAL RECEIVING ANTENNAS

"The following, taken from the Communication Division Bulletin for March, issued by the Bureau of Engineering of the Navy, might be of interest to our members. It certainly should be tried out by some of your experimenters:

"*Directional Receiving Antennae.* A great deal

of the interference now being encountered on long distance, high frequency point-to-point Naval circuits can be eliminated by the simple expedient of erecting a directional receiving antenna.

"The antenna should consist of a single copper wire, about No. 14, strung on posts at a height of 4 to 6 feet from the ground for a distance of

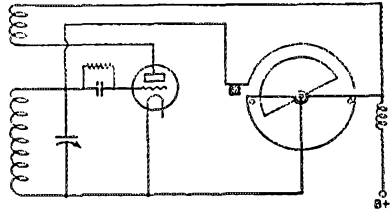

FIG. 4

approximately five half-wave-lengths in the direction of the transmitting station from which signals are to be received. The end of the receiving antenna which points toward the transmitting station should be grounded through a variable non-inductive resistance of 100 to 200 ohms connected to an iron pipe driven in the ground. At the receiver end, a variable 0.00015 mfd. air capacitor should be placed in series with the antenna for the small amount of tuning obtainable thereby, and to avoid grounding the receiver end of the antenna.

"The physical length in meters of the antenna should be close to $5/2$ times the shortest wavelength, in meters, of the transmitting station.

"As reception will be greatly improved on the three subharmonics of this frequency, only one antenna, based on the highest frequency employed, is necessary for reception within any one of the three subharmonic bands.

"The optimum height of the antenna throughout its length is 5 feet, but the height may be increased to 10 feet at points where the 5-foot wire may become an obstruction. The 100 to 200 ohm resistor is not critical in adjustment. Either insulated or bare antenna wire may be used, depending on the ease of insulating the antenna from its supports and other nearby objects."

— A. H. Babcock.

KEYING

Horatio Seymour of W6VZ brings to our attention a method of keying that has solved his difficulties. It is fundamentally the method described by Hoffman of W9EK in QST some years ago with the addition of some filter to take care of the clicks. The circuit arrangement is shown in Fig. 5.

PROBLEM T-28

The summer weather having arrived (at least we hope it will have by the time this is in print)

the amateurs' thoughts turn toward vacation time when hiking and camping will be the vogue. This in turn conjures up visions of that perfect portable set that we were going to build for this year. It would, therefore, seem quite reasonable to present this month the outline on problem T-28, covering portable transmitters and receivers.

There are really two distinct types of portable sets; one is the type that can be packed by a man, or two at the most, while the other is transported in a car or some such conveyance. The requirements are distinctly different and are chiefly noticeable when the power supply is examined.

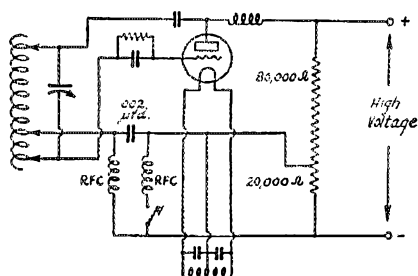

FIG. 3

One should first decide into which class the set to be constructed fits as this will determine the amount of weight and the type of accessories that must be carried.

The problem of devising a set to be carried in an automobile is, perhaps, the simplest. The set can usually be packed where it will receive but little jouncing and damaging blows. The filament supply for the tubes, both receiving and transmitting, may be taken from the car battery and if dry battery plate supply is desired, it will usually be possible to pack suitably sized batteries to last during the entire trip on which the set is to be used. If, on the other hand, the set is to be packed by one or two men, it will be impractical to cart along a heavy storage battery to supply filament power. Dry cells will usually have to be resorted to and one should avoid the fallacy of carrying along "B" batteries that will last for six months, although the "A" batteries will be good for but fifteen days. It is usually possible to calculate how long the set will be needed and how long one will be away from the source of supplies. With these points in mind, the battery supply should be so calculated as to allow satisfactory operation over the necessary period of time without the inconvenience of carrying any more weight and bulk in batteries than is actually needed.

One should also consider the advisability of employing as few tubes as possible and those of but a single type. This will reduce the chance of the set being put out of commission by tube

breakage and allow a minimum of replacement tubes to be carried.

Probably one of the most important considerations when the set includes a transmitter is that of obtaining a suitable radiating system. The conditions of operation will vary greatly and much thought and experimentation can be expended upon this portion of the problem.

In the attempt to provide loud speaker reception and extreme DX, one must not overlook the very important fact that the set should be portable and not just capable of being moved with the assistance of a couple of huskies.

The bibliography which follows is not limited to only those articles that concern portable sets but there are included many references to material that is applicable to the subject.

QST

Emergency Power Supply by Budlong, May, 1925 (47)

Loops and Fords by Oliver Wright, July, 1925 (33)

An Inexpensive Low-Power Transmitter from Receiving Parts by Turner, Dec., 1925 (35)

Speaking of Low-Power Work by Clayton, Dec., 1925 (44)

A Portable Transmitter by Waynick, Jan., 1926 (31)

A Power Amplifier for the Low-Powered Transmitter by Turner, March, 1926 (29)

Of, By, and For the Beginner by McCormick, June, 1926 (17)

Spark-Coil Portable Transmitters by Wilburn, Sept., 1926 (40)

A Portable Transceiver by Gunther, Oct., 1926 (36)

The Flying Loop by Wright, Nov., 1926 (36)

Low-Powered Crystal-Controlled Transmitters by Clayton, Jan., 1927 (14)

A Flexible Transmitter by Marco, March, 1927 (33)

A Complete Inexpensive Transmitter by Westman, May, 1927 (9)

A Flexible Crystal Transmitter by Glaser, June, 1927 (18)

A One Gnat-Power Portable by Westman, Aug., 1927 (25)

A Portable Power Supply by Sturm, Jan., 1928 (34)

A Low-Power Master-Oscillator Transmitter by Dudley, Feb., 1928 (10)

A Portable Transceiver by Radloff, March, 1928 (52)

Low-Power Flexible Crystal Control for Four Amateur Bands by McMinn, April, 1928 (15)

A Transmitter without Transformers by Hatry, April, 1928 (28)

A Portable Crystal-Controlled Transmitter by Angus, Oct., 1928 (33)

160-Meter Low-Power Transmitter by Hart, Nov., 1928 (37)

The Communications Department

F. E. Handy, Communications Manager
 L. R. Huber, Asst. to Coms. Mgr.
 1711 Park St., Hartford, Conn.

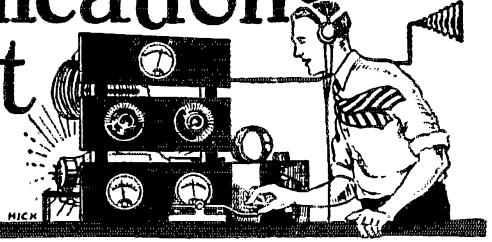

Portable Radio in Winter

By Ralph C. Folkman *

THE first and worst blizzard of the season: trains late, traffic slowed, thermometer flirting with zero — what setting more ideal for testing the ability of amateur radio to function in emergencies such as might be created by tornado, flood, or other disaster?

With lofty thoughts such as these, several shivering automobiles loaded with Cleveland amateurs tried to console themselves as they faced a gale-borne snow storm, determined to gauge the dependability of low-powered portable transmitters and receivers which they had devised and assembled.

Special licenses "to be used during the first week of January, 1929"; portable stations just about liftable; a conglomeration of food to be rendered appetizing (fond but vain hope!) by a bonfire in the woods; flannel shirts, knee-high shoes, stinging ears: all these were among the impedimenta loaded into our radio caravan in the early morning hours.

The first stop was Fairview Village, where W8BF consented to stand by for signals. Ten miles farther out a powwow was held beside the road. Here it was decided that the party should divide, each mobile station taking a different route.

W8GS was the call assigned to apparatus that shared the rear seat with me, and had it been a bit more human there probably would have been harsh words between us, for it spread over precious space and caused me to assume a painfully cramped position. Ellis A. Smith, WSQV, and Joe Stead, who filed application to go as "ballast," were the other passengers.

Like an air mail pilot making a "blind" landing in a blizzard, we sighted through the frosted windshield a camp site in a heavily wooded section. According to road signs noted prior to our halt, we must have been on the outskirts of Elyria.

The little receiver was resorted to first in order to determine that the locality was not infested with bothersome power leaks. Then pacing off sixty feet, we designed an aerial and counterpoise system for 3500 kc. operation, with the leads-in passing through convenient crevices near the car's windshield. To provide more room for apparatus and operator, food and tool kit were removed from the car.

While I attempted to string the aerial between wildly swaying trees, Smith and Stead undertook to build a fire. But their progress was stalled by the pounding blizzard, and they soon scrambled back into the car and resorted to more modern means — the heater from the engine's exhaust.

When the aerial had been erected, a general call was sent out, and the receiver dial hurriedly scanned for replies. W8AKX, another of the mobile transmitters, manned by Russell Karg and Ed Jenkins, was on the air and calling us.

A brief exchange of notes indicated that they were in Chippewa Lake Park, and had established contact with one station in Columbus and another in Marietta.

Then came wagers via radio as to which party was suffering the more from cold. Like the famished tramp who invested his last quarter in a thermometer in order to find out just how cold he was, we carried such a gauge, and thus had the advantage over W8AKX, who had to guess at the temperature. After this contact, W8BF in Fairview Village was given a "shout." He came right back, with a report that our signals were good.

We were troubled by interference from the ignition system of the engine, for although the car was not in motion, we ran the engine to get heat from the exhaust. The final approved procedure came to be intermittent speeding of the engine



THE AUTHOR AND W8GS

while we warmed up, and then cold silence while we cooled off. The slogan came to be "shut the door," for in addition to letting in the wintry blasts, the opening of the door detuned the receiver, due to shielding effect.

Then we decided to move to a more sheltered section. Once more established, with a higher antenna and less blizzard, another CQ was sent out. W8BF answered, giving us the cheering news that our code strength had doubled with the change, and that voice transmission was "as loud and clear as a broadcast station." As I described, through chattering teeth, our predicament to W8BF, other members of the party attempted to make a fire. Those weiners had to be roasted! But the blizzard again blew out the matches and numbed the fingers. Smith retreated to the door of the car, freely stating his opinion of the weather and telling me what he thought of trying to start that blanket-blank fire in the woods. W8GS's microphone picked up the exclamations and gave them to the world at large. Baumgardner at W8BF reported "perfect pickup of background talk!" The

Courtesy of the Cleveland Plain Dealer.
 * W8COX, Associate Radio Editor, the Cleveland Plain Dealer.

weiners never did find their way into a campfire, for the third attempt to generate some semblance of a blaze was halted by an old gentleman who emerged from the thicket and, having an atmosphere about him, suggested we cook at a nearby farmhouse instead of setting the woods on fire. The transmitter was on the air during his lecture; when it was terminated, several stations chirped in with a "hi!"

"One more call and we'll pull up stakes," I said, and proceeded to make W8GS do its stuff. And then our situation as others saw it was summed up graphically when a party of hikers passed.

"Kin you imagine that?" exclaimed a dameel who apparently was leader, "these Eskimos came out here in the sticks to listen to the Cleveland Orchestra."

That seemed reason enough for breaking camp. Other groups eventually wound up at the starting point, where a typical hamfest was held. And at last the unbroken package of weiners was sought out of our luggage and, through the

coöperation of Mrs. W8GS, a spread was set before the thawing group.

Each portable set used 201A tubes with 90 to 135 volts of B battery. W8AKX was designed "bread-board" style, while W8GS was built into a special cabinet, with batteries contained in the bottom. Filament current was supplied by dry cells. None of the transmitters rated an output greater than three watts.

Our makeshift antennas of course were not so good as they might have been. Swinging trees and other factors which we were unable to control did not have a helpful effect on the signals. But we found that an emergency network of lightweight stations could be established in case other means of communication "went out." There was no real emergency, of course but we worked under conditions that felt like an emergency. Notwithstanding the discomforts which we experienced, the adventure was really an adventure, and all of us that took part will remember it with joy.

A Club that Stays Organized

By E. O. Knoch*

The Communications Manager invites contributions on every phase of amateur communication activity, offering prizes for the best article selected each month from those submitted. The author whose article appears to have the greatest value each month has his choice of (1) a copy of the Radio Amateur's Handbook bound in Algerian, (2) six pads of A.R.R.L. message blanks, or (3) 500 A.R.R.L. log sheets. If a second prize article is printed, a reward similar to one of the above will be selected by Headquarters and forwarded to the winner. The right is reserved to use other articles at any time with the usual credit to the author. A wide variety of subjects on which articles would be welcomed appeared with our original announcement (March QST, page 62) and the offer stands good for all articles received in 1929 marked for attention in connection with the contest. If you could use one of our prizes, here is a way to get it free of charge by giving all amateurs the benefit of your practical experience. So far 80% of those entering our contest have received prizes, so you have better than a 2:1 chance of winning out and don't need to worry about the competition. Why not sit down and send us your ideas today?

The prize winning article by Mr. Knoch offers several interesting suggestions which we think are of practical value to our affiliation radio clubs, or to any and all "ham" clubs for that matter. By electing qualified officers to constitute an Executive Committee the business of the organization is efficiently conducted. This plan makes it possible to have more time available for interesting activities at the meetings. The club treasury is kept in a healthy condition . . . but we mustn't tell it all. The special duties of the various officers are outlined in Mr. Knoch's contribution. — Editor.

INTEREST continues to be great, and we think that some of the differences in our club organization may have something to do with it. Therefore, we are constrained to tell the rest of you about it, in the hope that some of the suggestions may be just the remedy needed to put life into flagging club organizations.

You'll all agree that too much routine business is boring in the extreme—for you've all been bored that way! We decided, therefore, to dispense as much as possible with this buzzaboo. So the club officers, comprising the Executive Committee, have regular meetings for this purpose, as well as to make detailed plans for any activities which the club may engage in, and to outline the next regular meeting, as well as to discuss the prospects of getting a speaker for the meeting. We try, whenever possible, to have a speaker who is an authority in his particular branch of radio, at every meeting.

Our officers are President, Secretary-Treasurer, Technical Chairman, Publicity Chairman, Communications Chairman, and Entertainment Chairman. There are no permanent committees, but each chairman may appoint helpers whenever necessary. The duties of the President and Secretary are as usual, but a word as to the duties of the other officers may not be amiss.

It is the duty of the Technical Chairman to have a prepared technical talk on some subject which has been suggested by the membership at the previous meeting. He uses a blackboard, and a general discussion usually follows the talk. His duties also include the supervision of any work done by the members, such as five and ten meter experi-

ments. He answers questions placed in the question box by members.

The Publicity Chairman, who, in our case, is a newspaper man, sees to it that notices of each meeting appear in the local paper, and that there is always a write-up of club activities and banquets, as well as of any outstanding achievements of individual members.

The Communications Chairman keeps tab on the members who are on the air, the traffic lanes, etc., as well as arranging for any special traffic activities, like the placing of message boxes at special functions which may occur (lodge conventions, etc.).

The Entertainment Chairman sees to it that the "cats" are always ready after the meeting adjourns, and arranges for any special entertainment, such as occasional movies, etc.

The Secretary has one duty which is not usual. This is the sending of cards announcing each meeting. These are sent to all interested persons as well as to members. In addition to the time and place of the meeting, any special features which would be instrumental in bringing a crowd are mentioned.

Meetings have been held in the homes of individual members, and the plan has worked well, since the club is not large. We hope, however, to have a permanent meeting place soon. A small club cannot afford to pay rent and live without imposing too great a strain on members' pocket-books. Our dues are only two dollars a year, and we have plenty in the treasury for any emergency which may arise, because expenses have been kept at a minimum. The refreshments, which are a regular feature of every meeting, are furnished by the member in whose home the meeting is held. To date only one member (and he willingly) has been twice called upon for this duty.

* Secretary, Short Wave Club of Pasadena, W6BJX, 2823 East Sixth St., Los Angeles, Calif.

The treasury is augmented considerably by frequent raffles or auctions, many of the articles disposed of being donated by members for the good of the club.

In short, we try to make every meeting so lively and interesting that no one will want to miss any of them, and we never spend time haggling over small unimportant points. Such things are disposed of in short order by the Executive Committee, and only matters of general interest are brought before the membership for consideration. This plan is used with success by other organizations, but we do not believe that it is general in amateur radio clubs. It is worth a trial.

WHY SLAM THE DOOR?

I am wondering how many amateurs feel as I do about the way some of the fellows answer a CQ and then, as soon as they find out the QRA or QRK, leave the other fellow holding the sack. Would those same amateurs slam their doors in the faces of strangers who might courteously answer their question as to whence he came? They do this sort of thing over the air.

It occurs to me that there are "manners" among radio amateurs as well as among all other classes of human society. It seems to me that this business of "slamming the door" is decidedly "bad manners." Let's stop it.

— H. L. Caveness, W4DW

Expeditions

MUCH of the pleasure and interest we amateurs find in our amateur radio work is in making the most of those opportunities we have of doing something for somebody else. There is a thrill that comes from contacting with individuals, expeditions, or ships in far off places, and a still warmer feeling if we are able to help these folks by handling messages to friends or associates as the occasion may demand.

While U. S. A. amateur stations are not permitted to communicate with commercial or government stations except in emergencies or for testing purposes (when the latter stations must make the first move looking toward QSO with amateurs), this restriction does not apply to communication with expeditions and small pleasure craft such as yachts and motor boats holding limited commercial licenses but which are unable to handle their communications with commercial or government stations.

To facilitate this work between amateur stations and small craft, expeditions, etc., we plan to print in this department a short directory of expeditions, listing the call signal and the frequency used for amateur contacts. Of course, we cannot and do not wish to give space to all of the small craft licensed at any one time — that would use up

more space than we could afford — and it would defeat the purpose of the column in showing amateurs just what calls are active, and where one may find them on the dial.

A cordial invitation is issued to all expeditions and small craft. We request that information on the call signal, frequency, route and duration of proposed trips, and operating hours be sent us so that each month we may print an up-to-date list in QST which will be mutually helpful to expeditioners and amateurs alike. Information should be sent us at least six weeks in advance of the start of a cruise when possible to allow for the necessary lag in publication schedules, although often it can be used to advantage in bulletins and telegraphic broadcasts to members if it is timely and of general interest. Amateurs working unlisted stations of the type in your list are requested to endeavor to secure full information on the identity and plans of the particular station, and to include the frequency and operating schedules in a prompt report to Headquarters on the matter. Any information which will help us to add to that in our tabulation will be greatly appreciated. A number of well-known expeditions on which we have some useful information are included in our first list which follows:

Frequency (kc.)	Call Signal	Station	Remarks
9045	WSBS	Yacht <i>Carnegie</i>	Carnegie Institute of Washington, Dept. of Research in Terrestrial Magnetism, on three-year world cruise, sailing from Yokohama, Japan, QRD San Francisco about June 20th. Opr., Lawrence Jones (LJ).
8370	WHDC	Yacht <i>Nomad</i>	On first lap of world cruise, San Francisco, Panama, Marquesas, New Hebrides, New Guinea, New Zealand, etc. Opr. Stephens Miranda.
468			On cruise to Tahiti. Opr. exW6CZX.
500			Sailed from Wiscasset for Northern Labrador and Baffin Land about June 15th. Opr., R. E. Brooks, of W9AFA. QSL cards requested and should be sent via QST.
8350	WIDJ	Yacht <i>Tempress</i>	Cruising through West Indies, may take world cruise.
Probably about 8300 and 11,200	WDDE	Schooner <i>Bowdoin</i>	Sailed from Bradenton, Fla., for Maine, June 1st, stopping at larger cities along coast. Opr., J. R. Foran.
8230	WIDC	Yacht <i>Abocena</i>	Antarctica.
8290, 5525	KFLF	Yacht <i>Ripple</i>	Byrd Antarctic Expedition.
7350, 8810	WFA	Base Station, Byrd Expedition	
13,180	WFD	Portable	
(Also 3290, 4405, 6580, 5650, 11,300, 16,717, 21,805)	WFB	Plane Floyd Bennett	
	WFC	Plane Stars and Stripes	
	WFF	Plane <i>Virginian</i>	
	WFAT	S.S. <i>Eleanor Holmg</i>	
	WFBT	S.S. <i>City of New York</i>	
3650	KVUA	S.S. <i>Lake Ormoe</i>	Ford Motor Company, bases at rubber plantation, Santa Ream, Brazil.
---	NITC (NIDK)	U.S.S. <i>Tampa</i> (<i>Tampa and Modoc</i>)	International Ice Patrol, Off Grand Banks, Newfoundland when on active duty.

28 Mc.

JAPANESE amateur station J2BY reports establishing the first two-way communication between Japan and Australian VK5HG on 28 mc. at 0150 Greenwich (10.50 a.m.) May 12, 1929. J2BY used a single 201A in an

ultra audion circuit. The plate input was five watts, voltage being supplied from a B eliminator. Contact was held for an hour following which VK3BQ worked J2BY for 25 minutes. After this VK3PM worked J2BY, the last contact terminating at 0345 Greenwich (12.45 p.m.) J2BY's antenna was Zeppelin fed, vertical, half-wave or 5 meters long. The Zepp was 2.5 meter long. Signals were about QSA4.

Mr. Walding (ZL1FT) of Auckland, N. Z., asks us to convey his thanks to U. S. A. "hams" for the numerous and pleasant chats he has had with them during the past season. He suggests a 28-mc. QSO party and we shall be glad to announce one if readers comment generally and favorably on his suggestion. ZL1FT has heard W6BCS, W9EF and W6-NQ on 28 mc., their signals being best about midday in N. Z. ZL1FT has been heard at J1TX and has been QSO with quite a number of the VK's who work on 28 mc. ZL1FT uses four 201A's in parallel and has no difficulty in getting down as low as eight meters. The set operates from 230-volts d.c., the natural period of the 28 mc. antenna being 65 meters. ZL1FT believes the 28-mc. band is a splendid band for daylight DX and suggests that all hands give it a real try out. He has operated here regularly for the last five months and can be depended on to be listening from 0000 to 0530 Greenwich Sunday (noon until 6 p.m. N. Z. time). ZL1FT lists the most active of the 28-mc. stations he hears: VK2TW VK3-PM VK3CP VK5HG VK4BB VK4AW VK3MY VK3BQ VK7DX VK2RX ZL1AX ZL1AO ZL1AN ZL1AC ZL1FT. A simple two tube receiver brings 'em all in.

Mr. Kimmel (W2ACN) of Palisades Park, N. J., reports little success since he worked E1SB and G2OD on March 10th. NKF and W2ALW are heard weekly through a high noise level (due to heavy motor traffic). W2JN and W2ACN have been calling and listening for PY1AA on schedule but thus far without much success. W2ACN had worked W6's, many European hams and locals and been reported 6500 miles from N. Y. C. out in the Pacific up to March 10th. He operates each Sunday 1330 to 1700 GMT and hopes for some favorable changes in the "ole Heaviside layer" soon. Give him a call.

When the Chamber of Commerce of Enid, Oklahoma, recently organized an 800 mile "Trade Trip" through the "pan handles" of Texas and Oklahoma, 120 Enid business men were kept in touch with home by the portable high frequency transmitter and receiver installed and operated by J. B. Lottridge, Assistant Director of Station KCRC and owner of W5AYG; Lyman Edwards, W5FJ; Thatcher Ploof, W5PA; Elmer Richey, W5ANT; and John Harding. Radio communication was established along the entire route, and at some points where telegraph and telephone communication would have been virtually impossible, the radio set did the trick in fine shape. Complete press stories were sent back to Enid newspapers by reporters who accompanied the train of thirty-five automobiles. Amateur radio is now thoroughly liked in Enid, and whenever a good word is needed by the local amateurs, there are 120 business men who will vouch for them. FB, boys! We hope to hear of more good work like this.

TRAFFIC BRIEFS

Remember the announcement of the 1928-1929 Roberts' Cup contest? This contest is a competition between individual Philippine and American operators of amateur radio stations conducted in accordance with the rules which appeared in June, 1928, QST. Logs and message files covering the period June 16, 1928, to June 15, 1929, inclusive will determine the winners. The closing date for receipt of logs and message files (entries) in the 1928-1929 contest is September 15, 1929. Any A.R.R.L. member in the Philippines or in the North American continent holding an operator's license and operating an amateur radio station is eligible to take part. Read page 45 of June, 1928, QST and get your entry in the mail today.

Organization of an intercollegiate amateur radio society has been progressing under the sponsorship of the George Washington University Radio Club. The name of the new organization is "College Amateur Union," with headquarters at the above university. Other college radio clubs interested in this most commendable organization should get in touch with Mr. Albert W. Small, George Washington University Radio Club, Washington, D. C.

SOUTHEASTERN DIVISION CONVENTION

The Gulf Radio Club at Tampa is planning a state convention July 19th and 20th and would like all of the gang to be there for a good time. For information and reservations

write the secretary, Harvey Chafin, 6002 Suwanee Ave., Tampa, Florida. We are looking for a good time so everyone come and bring someone else.

ELECTION RESULTS

Valid petitions nominating a single candidate as Section Manager were filed in a number of Sections on or before the closing dates that had been announced for receipt of such petitions. As provided by our Constitution and By-laws, when but one candidate is named in one or more valid nominating petitions, this candidate shall be declared elected. Accordingly, election certificates have been mailed to the following officials:

Section	Address	Two-year term begins
Ga.-S. C.-Cuba- Isle of Pines	J. G. Cobble, W4RM 1124 Mayland Circle, Atlanta, Ga.	May 15, 1929

In the Maine Section of the New England Division, Mr. Grover C. Brown, W1AQL, and Mr. John Singleton, W1CDX, ran together on the second ballot. Mr. Brown received 26 votes and Mr. Singleton received 17 votes. Mr. Brown, therefore, has been declared elected, his term of office beginning May 15, 1929.

NEW SECTIONS CREATED

As provided in the Constitution and By-Laws of the A.R.R.L., the operating territory of the League is apportioned into Sections for the purposes of administration of the League's field organization. Action may be taken by the Communications Manager acting with the advice and consent of the Division Director concerned in the United States, its territories, and Cuba, and with the advice and consent of the Canadian General Manager in Newfoundland, Labrador, and the Dominion of Canada.

Changes are announced in the Maritime and South-eastern Divisions and become effective at once on publication of this notice.

The territory including Georgia, South Carolina, Cuba, Porto Rico, and the Isle of Pines is apportioned into two Sections to be known henceforth as (1) the *Georgia-South Carolina-Cuba-Isle of Pines Section*, and (2) as the *Porto Rico-Virgin Islands Section*. As announced elsewhere, Mr. Cobble of W4RM has just been elected Manager of the first named Section. Nominating petitions are solicited naming a candidate for Manager of the Porto Rico-Virgin Islands Section, the closing date as stated elsewhere is our tabulation.

Newfoundland, New Brunswick, Nova Scotia and Prince Edward Island are consolidated into one Section to be known henceforth as the *Maritime Section*. Nominating petitions are solicited naming a candidate as Manager of the newly consolidated Section, the closing date as stated elsewhere in our tabulation. Mr. A. M. Crowell of W1DQ has been appointed acting Manager of the whole Section to function until such time as the membership of the Section acts in nominating and electing an official.

ELECTION NOTICES

To all A.R.R.L. Members residing in the Sections listed below:

(The list gives the Sections, closing date for receipt of nominating petitions for Section Manager, the name of the present incumbent and the date of expiration of his term of office.) This notice supersedes previous notices.

In cases where no valid nominating petitions have been received from A.R.R.L. members residing in the different Sections in response to our previous notices, the closing dates for receipt of nominating petitions are set ahead to the dates given herewith. In the absence of nominating petitions from Members of a Section, the present incumbent continues to hold his official position and carry on the work of the Section subject, of course, to the filing of proper nominating petitions and the holding of an election by ballot or as may be necessary. Petitions must be in Hartford on or before noon of the dates specified, all of which are 1929

Section	Closing date	Present SCM	Present term of office ends
Western N. Y.	July 15	C. S. Taylor	July 1, 1928
Nevada	July 15	C. B. Newrombe	Sept. 15, 1928
Virginia	July 15	J. F. Wohlford	Dec. 2, 1928
Arizona	July 15	D. B. Lamb	Jan. 3, 1929
San Diego	July 15	G. A. Sears	Feb. 2, 1929
Eastern Pa.	July 15	J. B. Morgan (resigned)	Mar. 7, 1930
Md.-Del.-D. of C.	July 15	H. H. Layton (resigned)	Jan. 7, 1930
North Carolina	July 15	Enno Schuelke (resigned)	Oct. 2, 1930
Porto Rico- Virgin Islands	July 15	-----	-----

Due to the resignation of Mr. Enno Schuelke, W4LK, in the North Carolina Section of the Roanoke Division, effective at once, nominating petitions are hereby solicited for the office of Section Communications Manager in this Section and the closing date for receipt of nominations at A.R.R.L. Headquarters in Hartford is herewith specified as noon, July 15, 1929.

CANADA

Nominating petitions for Section Managers in Canada should be addressed to Canadian General Manager A. H. K. Russell, VE9AL, 5 Mail Building, Toronto, Ontario. To be valid, petitions must be filed with him on or before the closing dates named.

British Columbia	July 15	F. S. Brooks	Dec. 2, 1928
Saskatchewan	July 15	W. J. Pickering	Dec. 2, 1928
Manitoba	July 15	D. B. Sinclair (resigned)	Jan. 7, 1930
Maritime	July 15	-----	-----

Due to the resignation of Mr. D. B. Sinclair, VE4FV, of the Manitoba Section of the Prairie Division, effective at once, nominating petitions are hereby solicited for the office of Section Communications Manager in this Section and the closing date for receipt of nominations by Canadian General Manager Russell is herewith specified as noon, July 15, 1929.

To all A.R.R.L. Members residing in the Sections listed:

1. You are hereby notified that an election for an A.R.R.L. Section Communications Manager, for the next two year term of office is about to be held in each of these Sections in accordance with the provisions of By-laws, 5, 6, 7 and 8.

2. The elections will take place in the different Sections immediately after the closing date for receipt of nominating petitions as given opposite the different Sections. The Ballots mailed from Headquarters will list the names of all eligible candidates nominated for the position by A.R.R.L. members residing in the Sections concerned.

3. Nominating petitions from the Sections named are hereby solicited. Five or more A.R.R.L. members residing in any Section have the privilege of nominating any member of the League who holds an O.R.S. appointment in their Section as candidate for Section Manager. The following form for nomination is suggested.

(Place and date)

Communications Manager, A.R.R.L.
1711 Park St., Hartford, Conn.

We, the undersigned members of the A.R.R.L. residing in the Section of the Division hereby nominate as candidate for Section Communications Manager for this Section for the next two-year term of office.

(Five or more signatures of A.R.R.L. members are required.)

The candidate and five or more signers must be League members in good standing and the candidate must be the qualified holder of a Communications Department, Official Relay Station appointment or the petition will be thrown out as invalid. The complete name, address, and station call of the candidate should be included. All such petitions must be filed at the headquarters office of the League in Hartford, Conn., by noon of the closing date given for receipt of nominating petitions. There is no limit on the number of petitions that may be filed, but no member shall sign more than one such petition.

4. Members are urged to take initiative immediately, filing petitions for the officials for each Section listed above. This is your opportunity to put the man of your choice in office to carry on the work of the organization in your Section.

— P. E. Handy, Communications Manager.

BRASS POUNDERS' LEAGUE

Call	Orig.	Del.	Rel.	Total
W2SZ	700	10	10	720
W4AEF	95	52	500	647
K1HR	224	109	298	631
W6DUR	---	175	400	575
W6CHA	27	50	490	567
W1MK	71	82	359	512
W1WV	370	52	22	444
W4ACC	8	5	420	433
W6SR	1	---	428	429
KDV5	350	50	25	425
W6EEO	48	232	136	416
W6ETA	58	21	332	411
W6AKW	9	9	390	408
W6AME	14	7	380	401
W8XE	43	80	240	369
W6ALX	8	10	346	364
W9FLG	60	65	205	330
W1BNS	12	21	283	316
W9COS	38	55	212	305
W7AAT	34	24	247	305
W1AOD	64	44	195	303
W6AVJ	222	13	50	285
W7BB	51	121	112	284
W4GV	207	6	68	281
W6BYY	88	112	86	276
W8CMB	14	20	220	254
W6AFU	7	14	232	253
W9FS	7	18	198	223
W5WF	48	40	126	214
W6ELC	17	31	166	214
W7ANQ	159	1	52	212
W9ESL	148	46	18	212
W5AOY	106	28	78	212
W4AQ	105	36	66	207
W6ZBJ	7	3	196	206
W6CGM	14	55	125	194
W7UN	42	67	78	187
W6DHM	10	102	65	177
W4ZD	96	59	16	171
W4AHP	54	53	58	165
W1BIG	12	98	55	165
W6IP	61	97	6	164
W1ATO	26	53	78	157
W4AP	40	60	54	154
W4EJ	50	64	38	152
W6UJ	10	84	50	144
W9BVF	42	64	32	138
W6EOA	5	53	78	136
W9DTK	48	72	8	128
W1KY	18	59	50	127
W6CBW	13	56	47	116
W4AHM	26	54	24	104
W6HM	36	66	---	102
W6HJ	17	78	2	97
W2QU	10	62	18	90
K6VCQ	25	50	2	77
W9CRB	3	57	14	74

The several amateur stations responsible for the best traffic work — the ones that are "setting the pace" in worthwhile traffic handling — are listed right up near the top of our B.P.L. the figures giving the exact standing of each station accurately.

All these stations appearing in the Brass Pounders' League are noted for their consistent schedule-keeping and dependable message-handling work in amateur radio. Special credit should be given to the following stations (in the order listed) responsible for over one hundred deliveries in the message month: W6EEO, W6DUR, W7BB, W6BYY, K1HR, W6DHM.

Deliveries count! A total of 200 or more bona fide messages handled and counted in accordance with A.R.R.L. practice, or just 50 or more deliveries will put you in line for a place in the B.P.L. Why not make more schedules with the reliable stations you hear and take steps to handle the traffic that will qualify you for B.P.L. membership also!

WIMK

A.R.R.L. Headquarters' Station WIMK operates on frequencies of 3575 kc. and 7150 kc. Robert B. Parmenter, "RP," is the chief operator; his list is familiar to most of the amateur fraternity. Occasionally other members of the Headquarters' staff operate at WIMK. Their personal signs may be found in the QRA Section of QST.

Throughout the following schedules Eastern Standard Time will be used.

OFFICIAL AND SPECIAL BROADCASTS are sent simultaneously on 3575 kc. and 7150 kc. at the following times:

8:00 p.m.: Sun., Mon., Tues., Thurs., and Fri.

10:00 p.m.: Mon. and Fri.

12:00 p.m. (midnight): Sun., Tues., and Thurs.

GENERAL OPERATION periods have been arranged to allow every one a chance to communicate with A.R.R.L. Headquarters. These general periods have been arranged so

that they usually follow an *official broadcast*. They are listed under the two headings of 3500 kc. and 7000 kc.; to indicate whether the watch is devoted to listening on the 80-meter band or to the 40-meter band.

3500 kc.:

8:10 p.m. to 9:00 p.m. on Sun., Mon., Tues., Thurs., and Fri.

10:00 p.m. to 11:00 p.m. on Tues. and Thurs. (No OBC sent before these periods).

12:00 p.m. to 1:00 a.m. (or later) on Sunday night (Monday morning).

7000 kc.:

10:10 p.m. to 11:00 p.m. on Sun., Mon., and Fri.

12:00 p.m. to 1:00 a.m. on the following *nights* (actually on the morning of the day following); Mon., Tues., Thurs., and Fri. (*Only* on Tues. and Thurs. does the OBC precede these periods).

Divisional Reports

ATLANTIC DIVISION

MD.-DEL.-D. OF C. — Acting SCM, F. Calhoun, W3BBW — W3BBW has cancelled all skeds for summer but will be on occasionally. W3MH is busy with Naval Reserve work. W3BCX is trying to get a phone going in Hagerstown. It is rumored that W3LB is going with the N.B.C. W3BWT seems to lead us in traffic this month, although other reports are missing. W3GT is "all up in the air" with planes and what not at the field, so he wants his ORS put in storage for awhile. Well, fellows, this is my first report as Acting SCM so please let me have lots more dope and more traffic next month.

Traffic: W3BBW 26, W3BWT 85.

SOUTHERN NEW JERSEY — SCM, M. J. Lotysh, W3CFG — First place goes to the SCM again but a few new stations have appeared and it looks as if we are due to have some better totals soon. W3CFG abandoned his famous old *sync* in favor of a pair of self-rectified 852's. W3BWJ is enlarging his shack and says he will be off for a while. W3ASG has been appointed an ORS and looks like a real find. W3UT has been working everything possible on 14,000 kc. W3BVG is very busy with WPG's new studio and mammoth public address system. W3AEP handled a message to Brig. Gen. Dawes in San Domingo in good time. W3ATP also turns in a few. Let's hear from more new stations. The SCM appreciates the many letters received from different members.

Traffic: W3CFG 70, W3ASG 26, W3BWJ 28, W3UT 17, W3BVG 11, W3AEP 10, W3ATP 8.

WESTERN NEW YORK — SCM, C. S. Taylor, W8PJ — Very few stations reported and things seem to be quite dead. W8ABQ is doing good work, teaching new hams the code. W8ADE has returned to the air again with a crystal. W8BGN has just put two UX866's in a new transmitter. W8BGV is remodeling his transmitter to crystal. W8BHA is back on again with some traffic. W8BHK makes the BPL this month. W8BJO managed to work Hawaii handling one message. W8BLP will be on 14,000 kc. for the summer with RAW AC. W8BLV handled one message. W8BWG worked Spain and Belgium. W8BWU keeps many schedules. W8CDC is back again with Army 50-watt power amplifier set. W8CNX will be off the air until next fall. W8CVJ says DX is good on 14,000 kc. W8CYG worked CZEKO. W8DSP has been called for active duty in the Naval Reserve June 1st to 15th at Sandy Hook, N. J. W8CMW, W8DIL, W8DQP, W8BMJ and W8AHC handled some traffic.

Traffic: W8ADE 2, W8AHC 20, W8BGN 4, W8BGV 13, W8BHA 5, W8BHK 11, W8BLV 1, W8BMJ 56, W8BWG 21, W8BWU 25, W8CMW 4, W8CNX 82, W8CVJ 7, W8CYG 23, W8DSP 140, W8DIL 31, W8DQP 12, W8PJ 35.

WESTERN PENNSYLVANIA — SCM, A. W. McAuly, W8CEO — Bad static on the 3500-kc. band has failed to stop traffic handling. Going over to daylight time has been the cause of some confusion but in general it looks as though traffic handling will continue through the summer with a less

serious drop than usual. W8XE, old reliable, leads this section this month. Their report came in just in time to make the report to HQ. W8CTG, a new ORS, takes second place with a nice total. He has a new push-pull transmitter on the 11,000-kc. band. W8CFR is the star DX traffic station in this section. W8DKQ is another new ORS doing good work. W8CEO invites the gang to look over his new "three band" receiver. W8DHW has arranged schedules with British amateurs to try for 50-mc. contact during June. W8BNR keeps a sked with the SCM. W8AGO is rebuilding. W8ARC has joined the Army Nat. W8DVZ is a new ORS. We could set the station clock by W8CNZ's report. The R.I. visited Erie and gave exams. When he left he had awarded a number of blue tickers and had left a blue feeding with a number of others. The Erie gang has a blue ticker operator aged 13 years. His name is Otto Herbst, Jr. Martin Long is another new operator with a blue ticket. Both of these boys were members of W8BHN's radio class at Y. M. C. A. and used the A.R.R.L. Handbook as one of their textbooks. W8VF is building a fifty watt station for operation on four bands using crystal control. W8CZE is located at Rocky Point, L. I., at station WNL, working on transatlantic phone. W8VF, W8BHN, and W8BVG received second grade tickets. W8BVG is overhauling his power boat. W8CRA reports working fourteen VK's and three ZL's in one week. W8AYH has a new transmitter. W8DLG says that you get about twice as far with DC instead of AC, and twice as many QSO's. W8CMP is taking a trip to northern New York. W8APQ says radio and farm work don't mix very well. A fine letter reports W8A(H active in Altoona. About fifty hams attended the auction of the A.T.A. It was a good night for buyers but a poor one for sellers. W8AGQ's 250 watt set is going off the air. W8DHU is leaving. W8BJC is a new call here and will soon be on the air.

Traffic: W8CUG 82, W8CFR 71, W8DKQ 37, W8CEO 33, W8DHW 31, W8BNR 19, W8AGO 14, W8ARC 8, W8DVZ 4, W8CNZ 2, W8XE 369, W8A(H 160, W8APQ 55, W8BK 26, W8CMP 24, W8DIG 23, W8AYH 17, W8AVY 7, W8CRA 3.

CENTRAL DIVISION

ILINOIS — SCM, F. J. Hinds, W9APY — Many of the busy traffic men gave up this month. Don't let the warm weather scare away the traffic. QMs W9GBI is operating on the S. S. *Ashabula*. W9CHY, an old sparker, is now on 7000 kc. with C. W. Hi. W9GJJ has a Zeppelin and a brand new 1929 Hartley. W9EZF has a mercury arc and an 852. W9CRR is doing some nice 2610 kc. work together with 14,000 and 3500 kc. W9EYA wants to know why it is the gang don't QSL more. W9DWA has an 852 and BCL troubles. Every time he QSYs, he has to go around and retune the traps he puts in BCL's antenna leads. W9DGK works fine DX with the old 210 and a Hertz. W9CNY is on 2610 kc. part of the time. FB, OM, W9ERU is studying up on crystals for his new sets this fall. W9DLI has an 852 and

a crystal on his end of 6 day Hawaiian schedules. W9AQJ works England on 14 mc. W9FRU has a new mast and is rebuilding the sets at W9BXB. W9BEF is out for an ORS. W9ALK is rebuilding his receiver *a la* May QST. W9FDJ obtained an 852 and rectabuls and worked all continents but Asia on 14,000 kc. W9CZL has increased power and is trying out a Hertz. W9KB has a new TGTP and says HCLs and all are now happy. Hi. W9AFF, W9FEX, W9FO, W9APY. Fred Schnell and "Matty" were delegates from Chicago to the Ames Convention. W9BNI is starting up on the Army Amateur Net. W9FI works Nicaragua consistently. W9BZO has cancelled all schedules for the summer. W9BNR is building a monitor. FB, OM. W9CNH reports Army schedules going along nicely now. W9FDY will be on 14,000 kc. W9NV has a new Zeppelin. W8CWO visited Chicago for awhile. W9FCW states it is hard to get and keep reliable schedules. W9AHC is making up a self-rectified transmitter to take to summer school and keep in touch with home via W9CKZ. W9RVP has changed his QRA. W9CUH states DX is good up near Waukegan. W9BSH is busy operating most of the time at WYJ where he is chief op.

Traffic: W9BZO 62, W9FI 46, W9DGG 36, W9FRU 35, W9FDY 23, W9KA 23, W9CZL 21, W9EZQ 21, W9CNY 20, W9APY 16, W9CRR 16, W9AFB 15, W9FDJ 15, W9CNI 14, W9DKK 14, W9EZE 14, W9CKZ 13, W9FMR 13, W9DOX 11, W9CUH 10, W9KB 9, W9FCW 8, W9DWA 7, W9ALK 5, W9BEF 4, W9FUA 4, W9EYA 3, W9NV 3, W9RNR 2, W9GJJ 2, W9ACU 1.

INDIANA — SCM, D. J. Angus, W9CYQ — The Indianapolis Radio Club staged a hamfest May 18th and 19th which was well attended by hams from all over the state. W9RW who has taken over the RM job for the north-western part of the state, wants all hams who are not ORS and located north of the Wabash and west of Mishawaka, to get their reports in to him by the 16th of the month. W9GGJ worked his first station and got the buck so bad he didn't do much good. W9ASX has sold out to the future traffic men of South Bend as he is preparing for the commercial operating game. W9RW will soon be on with MOPA. W9EVA has one of the best ships on the lakes. W9FQ is grabbing a wife. W9DUX is now at Nappanee on 14 and 7 mc. and getting good DX. W9DPV is on regularly with skeds on 7 mc. W9ESH has a YL which cramps his style. W9AIN blew his filter condensers so he is off. W9AHV is on 7 mc. with a 250. W9AEB is still rebuilding. W9GCO will soon be back at his home station. W9EGE, W9AHB rebuilt for 14 mc. but finds no traffic. W9VZZ reports that the Richmond Radio Club has their new call — W9FTW. W9DMU is a new ham at Richmond. W9PF reports so much YL QRM that he can't work. W9EXV still keeps foreign skeds. W9EKW still hits the ball on 3705 kc.

Traffic: W9EKW 47, W9DBJ 30, W9EXV 25, W9ASX 3, W9GBF 7, W9DSC 18, W9DZZ 15, W9DHI 12, W9AHB 1, W9GCO 3, W9AIN 6, W9CNC 14, W9CYQ 21.

KENTUCKY — SCM, J. B. Wathen, III, W9BAZ — Keep your eye on W9FS. He has two months to his credit. W9AZY gets crystal reports on his new xmitter. W9BWJ will be off the air for two months. W9CRJ is trying C.C. with varying success. W9JL reports "pre-war ham" in Lexington. W9GGB is building receiver to match his xmitter. W9ARIJ is busy replenishing his home-brew supply. W9CEE has been forced to resort to a 201A for kicker. W9FQN is QRW with Jr. op. Hi. W9EYV is off the air until he gets word from the R. I. W9BXK's total is small due to installing crystal. W9FZV has a five-tube receiver now. W9ENR is watching the mails for a WAC tag. W9GAL was heard in England QSA3. W9OX shifts wave for each sked. Hi. W9BAN ought to edit a newspaper — he writes such cute letters. W9JGJ is trying his hand at C.D. Several ORS are slipping. Be careful, OMs. Don't faw down go boom.

Traffic: W9FS 223, W9JL 109, W9BAZ 62, W9BXK 43, W9GAL 33, W9BAN 23, W9GJG 18, W9OX 17, W9ENR 15, W9GGB 10, W9CRJ 11, W9FQN 10, W9FZV 5, W9ARU 2, W9EYV 2.

OHIO — SCM, H. C. Storck, W8BYN — Well, gang, the summer is coming and the totals are dropping. The SCM is pleased with the way reporting is keeping up. There are several ORS certificates up for cancellation again, and some of you had better watch your steps. If you simply cannot

originate some good traffic to help your section, you can at least report for your own sakes, and save your certificates. W8CMB is the only one to make the BPL this time. W8BYN comes next on the list. W8GZ devotes most of his time to AA work. W8BKM's wife says he spends more time with the radio than with her. W8CRI reports things pretty quiet along the Potomac. W8ADS reports school almost out and rejoices. He reports that W8CK moved to the country with his set. W8BAU is all set for DX and AA work. W8BAC reports traffic slow and hard to get. W8DDK turns in 27 with no news. W8BBR says QRN and local QRM win over Kid Radio by a knock-out. W8DDF's antenna blew down and he has been busy with school. W8DTC is coming back with us. W8EZ is runner-up for ORS and comes thru with 14 for his first report. W8CFT says spring fever had them in its foul clutches. W8CSS has been rebuilding and is now on for good. W8CNO had tough luck, blowing thump filter condensers, etc. and is now rebuilding. W8CCS hasn't had much time to operate, but says the new 852 is going fine. W8PL has another station, W8DCX, going at his garage, and expects to have more time for the air. W8CMU has been rebuilding and has cancelled all his schedules but will be on again and working fine. W8CFL is busy with college baseball as usual this time of year. W8ARP says he gets tired of hearing "QRU hr nw, CUL, etc." W8AYO has been DXing on 14 and 28 mc. bands. W8LI has been off the air due to rebuilding and house-cleaning, but is on again and looking for schedules. W8DVL had to stay off the air for a while because of his license running out but all is OK now. W8DSY says he has a report that someone in Michigan is using his call on phone, and off frequency. W8CNU says time for radio getting more scarce each month. W8QU reports not much doing. W8DDQ is trying to keep, and get, all high school schedules. W8DIH wants to know why in heck everybody deserts 3500 kc. in mornings in summer and would like to hear from anybody that feels same way and is anxious to carry on in the early morning hours. W8BBH hasn't had much time for radio. W8APB has changed his address. W8AMI has been busy with school but will be on more when it is closed. W8RN is pounding brass at WTBL. W8EJ reports his new set FB. The SCM urges reports from all stations who hear ICW operating on the 7000 and 14,000 kc. bands and also about off-wave operating.

Traffic: W8CMB 254, W8BYN 162, W8GZ 146, W8BKM 68, W8CRI 62, W8ADS 37, W8BAU 34, W8BAC 30, W8DDK 27, W8BBR 25, W8DDF 24, W8DTC 17, W8EZ 14, W8CFT 14, W8CSS 12, W8CNO 11, W8CCS 10, W8PL 10, W8CMU 9, W8CFL 7, W8ARP 6, W8AYO 5, W8LI 3, W8DVL 2, W8DSY 2, W8DNU 2, W8OQ 2, W8U 2, W8DDQ 1.

WISCONSIN — SCM, C. N. Crapo, W9VD — The SCM has a new set, including a 167.7 meter crystal oscillator UX210, two UX210 frequency doublers and an 852 power amplifier. This layout permits operation on 1789.5, 3579, 7158, and 14,316 kc. W9DTK breaks into the BPL for the first time in several months. W9BWZ helps out the SCM by sending in three reports via amateur radio. W9BGT, an old timer (formerly 9CWZ) is back on the air again and now has three schedules. W9EYH was in town this month and paid a visit to the Milwaukee Radio Amateurs' Club. W9EMD is on the job as usual and always ready for QSP on 3500 kc. W9RPW has schedules with W9DTK and W9FBJ and building portable transmitters for use at Lacrosse Radio Club picnic which is to be held on May 25th. W9DID has temporarily cancelled all schedules except W9ERU and spends most of his time now entertaining visiting hams. W9FHU says there is nothing new around his station. W9CVI is keeping two schedules. W9DJK says the Lacrosse boys are all on the job.

Traffic: W9DTK 128, W9RWZ 116, W9BGT 102, W9EYH 54, W9EMD 42, W9BPW 32, W9DLD 30, W9FHU 16, W9CVI 13, W9DJK 5.

MICHIGAN — SCM, Dallas Wise, W8CEP — W8AUB now has a TPTG outfit using 281's for rectifiers but has trouble in getting out. W8AUT worked K6DWS with two 201A's using 250 volts of B batteries for plate supply. W8DSF has the outfit going again, using remote control. W8BRS is forming a club for "shut-in operators." If you know of any such fellows, have them get in touch with Walt.

W8ZF is closed on account of no operators to man the station. W8KD uses a 210 as his fifty went soft. W8JD blew his plate supply transformer but will be back on the air soon. W8BGY has moved to a new location and gets out well, doing some good DX on 7000-ke. band. W8ACB blew his 281's but keeps going with a chemical rectifier. W8CKZ complains of the QRN. Not much excitement up at W9CE's, although he handles a few. W8CU has a new power supply finished and hopes to get the transmitter ready some time, also. Hi. W8DYH is having a great experience getting his crystal outfit to go. He sends code practice for beginners Sunday noons using a Teleplex. Anyone interested, tune in on 3604 kc. W8CED is working on 14,000 kc. and was QSO 11 countries and 5 continents in one evening. W9BTQ has the 852 going great and is keeping several reliable skeds. W9EAY and W9EGF were QSO FL1AW, Liberia, West Africa. W9BTQ, W9AXE, W9EGF, W9EAY and W9EVG stages a "ham tour" May 5th and visited NUG at Eagle Harbor, a government compass station. The "Michigan Brass Pounders' Hamfest" held in Grand Rapids, April 20th, was well attended, there being about fifty present. The afternoon was spent in contests of all sorts. Mr. Marburger of W8CVQ gave an interesting talk on crystal control. A movie of transatlantic telephone and telefoto service was shown through the courtesy of the Bell Telephone Co. A banquet in the evening ended the day. The Grand Rapids gang intend holding a ham picnic during the summer, details later. W8PP, ex-8DEG, is on the air again and is doing some nice work on 7000-ke. band.

Traffic: W8AUB 21, W8AUT 6, W8BRS 12, W8BGY 44, W8ACB 8, W8CKZ 12, W8CED 18, W9CE 32, W9AXE 14, W9BTQ 28, W9EAY 4, W8CEP 20, W8PP 36.

DAKOTA DIVISION

NORTH DAKOTA — SCM, B. S. Barner, W9DYV — W9IK is now attending summer school at Valley City, N. Dak., and says that he will have a portable set at that point. He reports W9CIIM as a new lone station on the 1750-ke. band using two 201A tubes and B batteries for plate supply. W9DYA reports lots of QRM and busy with farm work. W9BVF turns in a very nice message total and has three regular skeds. W9FCA reports no traffic but says that he paid the RM of the Dakota section a visit and was successful in working VE4GR while at W9BVF's station.

Traffic: W9BVF 138, W9IK 3, W9DYA 2.

SOUTH DAKOTA — SCM, Dwight M. Pasek, W9DGR — W9DNS found some real operating rooms when he went to the hospital last month. He reports three of the Sioux Falls gang as investing in 866's which ought to make some real 1929 sigs. W9DWN mailed his report card from the Ames Convention. On his return he visited in Cedar Rapids, Chicago and Madison, Wis. W9AZR reports one schedule in the morning. W9ESD says that he has a new motor after a bad blowout. They (W9AZR-W9ESD) handled some PRR traffic for Wyoming. W9DIY is busy grinding crystals for KSOO. W9EUI reports a new set of B batteries, a Zepp antenna and a 210; so is all set for the summer. He would like to see some of the gang at noon on 7 mc. W9DLY is still pushing his sigs to all parts of the earth — added seven countries last month. W9DB is building a S. W. super. W9FOQ is QRL about work and track! W9DGR is operating very little at present. He is still shaking since the night the lightning struck his antenna and came into the room to dispute the right to the bed. Remember gang, it takes reports in the summer as well as winter to get the dope before everybody.

Traffic: W9DGR 25, W9DLY 11, W9EUI 6, W9DIY 6, W9DNS 1, W9DB 16.

SOUTHERN MINNESOTA — SCM, J. C. Pehoushek, W9EFK — We now have a scarcity of ORS in this section, so there is room for the reliable and active stations who are League members. The usual summer slump has hit this section early. W9COS is planning another canoe trip to "rest." They always struck me as lots of hard work. W9DBW finds it easy to get QSA5 from ZL and other DX. W9BKK still can't find any Minn. stations on 3500 and wants to know why. W9AIR went to the Ames Convention and had a peach of a time. He also visited the Rochester, St. James, Janesville, etc., gangs. W9DHP can't find time to pound brass. W9DBC says his liver takes all his time and

also hasn't been near the shack for a decade. W9EFK is entering the sixth stage of ham soon (?). W9DMA can't make the xmitter perk, so has been off air the whole month. W9BYA has a new Chevy six and likes it a lot. W9BLG-NC4BT has poor luck on 14 mc. lately.

Traffic: W9COS 305, W9DBW 16, W9BKK 11, W9AIR 7. **NORTHERN MINNESOTA** — SCM, Carl L. Jabs, W9BVH — If traffic has anything to do with the weather, spring is here. There seems to be a very decided slump in reports and many report inactivity. W9ERB takes the lead this month after W9EGU has held it ever since he retired from the SCM job. However, Cy has been off part of the month getting ready to take the two weeks' training in the Naval Reserve at Great Lakes, Ill., and it is hoped that he will continue the good work of the past when he returns. W9EHO reports no changes in his set this month. Hi. W9ADS is using an 852 and says he will have a M.O. soon. W9DOQ reports the Duluth and Superior hams have organized a radio club and meet at his house. W9CIV handled some NKF traffic to St. Paul in jig time and thinks all the hams have good receivers now, as he always gets QSA5 reports. W9CTW attended the Ames Convention and took the amateur extra first grade exam and passed. W9DPB just got back on the air at his new location and says it's a WOW. W9EHI is still inactive and will probably be off until next winter. W9BBT is busy seeding so is off, too. W9RVH is on very little as he is getting ready for the trip to the Pacific Coast. The Twin City hams are talking convention a lot and if words turn to deeds, we may have a Dakota Div. Convention next fall.

Traffic: W9ERB 14, W9EGU 54, W9EHO 29, W9ADS 15, W9DOQ 11, W9CIV 5, W9BVH 3, W9CTW 2, (Mar.-Apr.) — W9CIV 7, W9DOQ 6.

DELTA DIVISION

LOUISIANA — SCM, M. M. Hill, W5EB — W5WF pounds the brass regularly and ran up 214 messages with only four skeds. W5AQT and W5ANC are back on the air again. W5ANQ paid W5WF a visit recently. Incidentally, during this visit, W5WF was in communication with the second op during his visit to Arkansas. We are glad to welcome W5KH back again. He is working on 7000 and 14,000 kc. He and W5APA are moving to Shreveport. W5BDY says he is having lots of fun helping the new fellows along. It is reported that W5AHC is grinding crystals and will be on with a 1929 sig ere many days. W5BBO and W5VX have hung up their fones for the summer, claiming B bats cost too much. W5ANS is going after a commercial this summer. W5BDJ gets a vacation this month — watch out, fellows, he is coming to see you. W5LV has business relations which keeps his total down, also his DX to one VK and Alaska. W5AFE recently returned from a visit to Chicago on account of the death of his mother. W5PG delivered a message to a nice YL and as a result, she visited his shack. Since then he has contracted YLitis in the worst way. Hi. W5AD has purchased a screen grid 860, a 2900 v. mg and a crystal. A gale took away the antenna from W5EB. He now QSOs VK with an antenna 10 ft. high.

Traffic: W5WF 214, W5KH 30, W5RDY 25, W5PG 23, W5AXS 20, W5EB 15, W5AD 5, W5LV 4, W5BDJ 3.

ARKANSAS — SCM, Henry E. Vette, W5ABI — Due to the fact that the SCM has moved from the old address, it is feared that some of the reports will not be received in time to "make" QST. In the future, gang, please mail all reports to 315 No. Jackson St., Little Rock. W5HN and W5BCZ are working on the Army-Amateur Network and would like to hear from any of the gang that are interested. They are both in the 7000-ke. band. W5BDD is driving through to the east coast to take in the Radio Show and a factory course. W5ABI is just getting back on the air after having to tear down and move. W5EP is in Tyler, Texas, studying Western Union and sends the gang his 73. W5ARA has been appointed an Official Observer, so all off-wave stations had better watch out. W5JK says to tell the gang to listen for his portable station signals this summer — W5BHS. The portable station is to be taken on a camping trip and will be operated by W5JK, W5ACR, W5WF and W5ADJ. Well, fellows, let's see what next month will bring forth in the way of activities and better reports. If you are

rebuilding, let's hear about it, OM. And don't forget to change the SCM address in your QRA list.

Traffic: W5JK 16, W5ARA 4.

MISSISSIPPI — SCM, June W. Gullett, W5AKP — W5QQ, who is a radio engineer at WCOC, has been very busy with the BCL station. He is selling his transmitter to W5REV at Columbus and will be on the air with a UX-852 as soon as he gets settled down in Meridian. W5AQU heard frequently at the key of W4KY, will have a new transmitter on the air in Meridian within the next two or three weeks. W5REV wants an ORS certificate and says 14,000 kc. is FB. W5AGS had the misfortune of mixing up with three high-waymen in Atlanta where he is attending college and was pretty badly cut up by them. W5AED is the proud possessor of a Western Electric 212D and it is all rigged up in a high C Hartley circuit. W5LY is on 14,000 using UX210 and a UV202 in parallel and has worked both coasts. W5BFH is on 7000 kc. with a 50 watt and reports working England. W5AAP reports working all U. S. districts, Porto Rico and Jamaica on 7000 kc. recently. W5BEX is a new station in Booneville using two UV202 tubes. W5BBX has a new power transformer and he says it is too big for his UX-210 as it makes the plate of same get white hot and his transmitting condenser looks like it is afire when he steps on the key. Hi, W5AWP who is working a phone set in the 3500 kc. band reports that static has been so bad that he hasn't been doing much work. W5AYB has moved to New Orleans, La. W5AZV is using two UX-210 tubes in a self-rectifying circuit. W5BHL is a new station in Jackson. W5AJJ would like to get in touch with someone near using phone on 80 or 150 meter band. W5BDE hasn't been able to get his transmitter to oscillate lately. W5GQ has moved to a new location and has a transmitter going in the 7000-kc. band. W5FQ's 250 watt quit on account of the grid and plate touching when it got warm. W5AKP is rebuilding and will operate in the 7000-kc. band. W5AMR has moved to Lawrenceburg, Tenn., and we are sorry to see him go. Just watch the Mississippi gang for real results in the near future.

Traffic: W5AJJ 10, W5AZV 2.

TENNESSEE — SCM, Polk Purdue, W4FI — The SCM waited for reports too long for the past two months and failed to get his reports to QST on time. All of you have been notified that the 15th is the reporting date so get busy, gang. W4AJQ has been busy and reports no traffic. W4NP has sold his 203A and is using a 210 so he can get down to 14,000. W4FX has bought a car and forgotten about radio. W4DG has been on 3500 and made some fine contacts. W4HK is rebuilding. W4GL spent two days with the SCM last month. He is going north for the summer and has asked to be placed on the inactive list. W4NT has been appointed ORS and is one of the most active stations in Nashville. W4RP-W4ZZC has also been appointed ORS and is an active station. W4FI is on regularly with two UX210s using crystal control and is getting fine results.

HUDSON DIVISION

NEW YORK CITY AND LONG ISLAND — Acting SCM, V. T. Kenney, W2BGO — Of 26 ORS, we only received 17 reports this month — that will not do — and again we must get busy on cancellations of ORS. Seven or eight new ORS will be appointed within the next few weeks, and we hope to see more applications coming through. This is the slow season of the year for traffic, as the report shows, but is the best time to prepare for the busy season in September and October. Send in your applications for ORS and begin preparing your schedules for next fall, so that when the time comes around you will be able to take traffic for almost any place. Make schedules by mail now; do not wait for the frost or the first snowstorm, for that will be too late. Manhattan: W2BGO (Portable W2AXR) leads Manhattan with a very low score of 42 messages. W2BCB complains of local noises and cannot always be on the air, due to that disturbance. W2AFO has burned out his transformer, so has decided to go back to the old 210 again. W2BDJ is rebuilding, and W2OV hopes to get back on the air regularly, now that his business rush is over. W2AJP put a couple of 281's in his outfit and claims we will no longer hear his pure AC note. W2BNL has left our borough and can be found in the West Bronx — Bronx: This borough

has taken a turn for the better in traffic work and is led by W2ABS, who is now a new ORS. W2CYX keeps his skeds before breakfast every day, to work up an appetite. Our RM, W2BQP, keeps track of his district, but seems to have trouble QSOing the local gang. W2SF, a new ORS, gets his traffic through in a hurry and often gets answers within a short time. Although W2FF-W2RBX has worked the world, he hopes for better DX when he changes his QRA next month. W2AET cannot raise much traffic, but is always ready for it. W2AFT has rebuilt again and reports traffic moving fast. Brooklyn: W2BIV is going strong with his daily schedule with G5WK, and leads his borough in traffic. W2BO has left for Panama and Costa Rica; he will be back again in October. W2PF, Army Amateur Radio Aide, tells us that W2BRB is going West and bemoans the loss of a good second district ham. W2APB mixes his law studies with messages and is slated for an ORS appointment. Long Island: W2AVP, L. I. Route Manager, leads the Section with 114 messages, and is putting out a fine DC signal on 3500 kc. W2TV, of Babylon, will be an ORS soon. W2BKZ was omitted last month, but that new ORS holds his own in traffic, while W2AZU reports working five European stations on 14,000 kc. within an hour. W2als is kept busy at KCL labs and will get in the swim with traffic in the future.

Traffic: Manhattan: W2BGO 42, W2BCB 22, W2AFO 15, W2BDJ 9, W2AJP 6, W2OV 4. Bronx: W2ABS 56, W2CYX 55, W2BQP 52, W2SF 43, W2FF-2BBX 32, W2AGT 13, W2AET 6. Brooklyn: W2BIV 45, W2BO 41, W2PF 32. Long Island: W2AVP 114, W2TV 30, W2BKZ 28, W2AZU 5.

EASTERN NEW YORK — SCM, F. M. Holbrook, W2CNS — W2QU now has a fine receiver, after building three. W2EFF worked WFBT in the Antarctic. W2ANV rolls up traffic with two daily and two weekly schedules. W2BGB is off the air as now is boss printer. W2AYK reports W2QN as newcomer to Pelham Manor on 3500 kc. W2LU makes second report, and may be ORS some day. W2AGQ has three schedules on 3770 kc. W2ACY will be off the air until fall, to regain health. W2SZ is secretary of Radio Club of Rensselaer. W2AGR is temporarily working W1BZG. W2ALI has 1929 outfit all finished with 852.

Traffic: W2QU 90, W2BFF 81, W2ANV 40, W2AYK 21, W2ALI 5, W2LU 13, W2AGQ 10, W2ACY 2, W2SZ 158.

NORTHERN NEW JERSEY — SCM, A. G. Wester, W2WR — W2DX has gone to Detroit to live permanently. W2MD resigns on account of extra heavy business pressure, and the following ORS have been cancelled due to failure to report for a few months: W2CJD, W2AGN. This leaves a total of 16 active ORS in our section. W2WR is trying hard to find traffic on the 7000-kc. band. W2AOS, with the aid of a new receiver, is doing plenty of Army relaying. W2CP is back on the air again after a long period of silence. W2BDF maintains a fine schedule with W8IQ. W2ANG is bothered by YLs. W2CTQ is another who finds business too heavy to get on the air. W2CJX is stepping out to all corners of the world, with very little trouble. W2KP is fixing W2BY's receiver. W2CO is playing with 20 meters. W2AOP wrecked his Packard roadster. W2AUI is rebuilding from start to finish and expects to get 1929 reports.

Traffic: W2AOS 35, W2CP 8, W2CJ 13, W2BDF 4, W2MD 80, W2CTQ 6, W2CJX 38, W2AOP 8, W2AUI 3.

MIDWEST DIVISION

IOWA — SCM, H. W. Kerr, W9DZW — W9FZO puts Sioux City in the lead and aspires to the BPL — watch his town! W9BCA keeps his CAB, NIC and WSBS skeds. W9DXP works three bands and does nice work. W9EJQ is on occasionally. W9BTL is now operator on the lakes with call WJDD. W9CZC relinquishes the golf crown to 9CK by arbitration, since paving operations keep him from getting on the course. W9EIW missed the convention. Sorry, W9DVS, in the Des Moines Univ. "eggspence," nearly missed reporting at the C. D. H. W9FYC is off till cooler weather. W9DEA is on again. W9DGR is getting out good with a 201A. W9BWN is going to Rocky Point, L. I., in Comms. Eng. Dept. of R. C. A. W9EHN is leaving for Grand Rapids, Mich. W9BKV is W. U. operator at W9BCA's town, and is heard as "KS" from W9BCA. The Midwest Convention for Iowa was a great get-together, and the SCM appreciates the support he received. We look for-

ward to more ORS and greater activities during the coming summer, as a result. The Navy enlisted about 30 in the USNR, and Mr. Turner's exams will add to the "real tickets." The Army Net is struggling and hopeful within the state. The Tri-State Club at Sioux City is active for a ham-fest for four states this fall. The Campus Radio Club received their call — W9DTI. They're an active bunch in banqueting, at least. Mr. D. C. Faber, Director of the Eng. Extn. Svc. of the Iowa State College at Ames, and the boys at WOI have the thanks of the gang for the great interest taken in amateur affairs.

Traffic: W9FZO 136, W9BCA 121, W9DXP 68, W9EJQ 34, W9DZW 30, W9FFD 12, W9CZC 10, W9EIW 9, W9DVS 8, W9FYC 4, W9DEA 3, W9GDR 2.

KANSAS — SCM, J. H. Amis, W9CET — Due to QRN, which has been exceedingly bad on 3500 kc., during the past month, traffic has fallen off considerably. W9FLG, our congenial RM, leads the state in traffic, and is building a new S.G. receiver. W9ESL, on 3500-ke. fone and 7000-ke. c.w., takes second honors and is putting up two new 60-ft. lattice masts. Both W9FLG and W9ESL make the BPL. W9FUG passed his commercial exam and is now working at WREN. W9FTY will be off the air until he gets his plate transformers rebuilt. W9ECF is building a 1929 fone rig. W9GFO reports for the first time, and is putting in a 50-wattler. W9BPI, has been off the air for two months, but is back now with a new S.G. receiver. W9FRO still want a sked west on 3500 kc. for Calif. traffic. W9CFN reports heavy QRM from school. W9BTG is using a 202 with 800 v. CRAC. W9GHI is on 14,000 kc. a lot now, and finds it a good DX band. W9CET worked six countries, and is getting the old DX bug again. W9CKV has a new transmitter perking. W9BHR serviced 2 SM Round-The-World Fours and says the cure was a 1 meg. leak for one and no 1 ak for the other. W9SS lost a mast, and has been QRW with school. W9DEB reports for the first time, and wants an ORS. It is with deep regret that we must report the passing of Walter Heline, W9FERK, on May 2. He was a real ham, a true amateur, and a gentleman, and will be missed by all the gang in this section.

QRN is beginning to get bad on the low frequencies, so let's move up on the higher frequencies gang until fall and keep the ball rolling.

Traffic: W9FLG 330, W9FTY 100, W9GFO 22, W9BTG 9, W9CET 72, W9ERO 26, W9CFN 23, W9GHI 35, W9CKV 8, W9BHR 31, W9ESL 212, W9SS 13, W9DEB 25. MISSOURI — SCM, L. B. Laizure, W9RR — W9DZN led St. Louis traffic, and sends regrets on being unable to attend the Ames Convention. The Midwest Division Director was there and took first steps toward becoming Executive Officer for the Volunteer Communication Reserve, U. S. N. W9EDK, a new ORS, had his antenna chopped off the pole by the power company. Hi, W9GHG is keeping two skeds to stay in the ORS class. W9DUD will be on more, now that school is QRT. W9GEK got on the air, May 1, on the 14 mc. band and joined the USNR. W9BMU asks that his ORS be put in storage until fall, as he is rebuilding. Ex-W6LB of Mt. Montgomery, Nev., is now in St. Louis at W9GFS operator.

W9BJA was second high on traffic, using junkbox transmitter. W9GBT almost doubled his traffic, this month, and is planning improvements. W9DKG dropped skeds, but is rebuilding and getting ready for a summer undisturbed by school QRM. W9FBF visited at W9DKG for the nth time. Hi, W9FVM won second place in state debate contest and is working on xtal set. W9DHN got a visit from W5BEE, his sked. W9FBF has been traveling around again and reports a msg. from NN7NIC to the effect that operator Hymer there is QRD USA, leaving Managua May 1st. W9BUL reports ready for traffic on 7300 and skeds. W9EPX reports mostly quiet on 3500 with a new Hi-C stand-by transmitter in addition to xtal. W9DAE was kept out by QRN and QRN this month.

W9DQN threw out sloop jars and put in Rectobulbs. W9RR, W9BSB, and W9CFL, plus W9HS of K. C., Kansas, represented Kansas City at the Ames Convention. All hands report a great time in spite of bad weather and mechanical QRM. W9AIC is a new ORS moving here from the 6th district.

Traffic: W9DZN 50, W9EDK 12, W9GHG 6, W9DUD

5, W9GEK 2, W9BJA 56, W9GRT 25, W9DKG 7, W9FVM 3, W9DHN 3, W9FBF 2, W9BUL 2, W9EPX 1, W9DQN 84, W9ALC 2.

NEBRASKA — SCM, C. B. Diehl, W9BYG — W9QY has spring work caught up and is on the air more now. W9EEW is very busy this spring, but has time for QRR. W9DVR handles little traffic, but is very busy observing. W9DNC is very busy studying for commercial exam and with new Radio Club. W9DI is still in school but looking forward to summer vacation and radio. He reports W9BPA a new station at Gresham. W9BOQ reports, but has nothing to say. W9DLW got a kick out of observing BCLs. W9CHB is very busy getting the new Corn Husker Radio Club going. W9BQR is very busy in the post office. W9BYG is busy at this time. W9BBS has not said if he is a conductor yet or not.

Traffic: W9QY 12, W9EEW 4, W9DVR 4, W9DNC 10, W9DI 6, W9BOQ 6, W9BJW 4, W9CHB 6, W9GDB 4.

NEW ENGLAND DIVISION

RHODE ISLAND — SCM, C. N. Kraus, W1BCR — W1BQD reports traffic and DX better. W1BCR will be on regularly during the summer. W1AWE has come up to the 7000-ke. band because he doesn't get on much during the daytime and finds 14,000 kc. dead at night. W1BLV was heard in Europe with 135 volts on a 201-A. W1MO is still off due to rebuilding. Will the fellow using his call please apply to the inspector for one of his own? Hi.

The Radio Club of Rhode Island has purchased a new club house in East Providence. A real station will be kept on the air for traffic. Hams driving through R. I. this summer should drop around and see our layout. QRA is Pearl St. on the Ten-Mile River (Rumford), East Providence, R. I. The club plans a series of five-meter transmissions with various types of reflector antennas. Anyone interested should get in touch with C. N. Kraus, President of the Club.

Traffic: W1BQD 27, W1BCR 19, W1AWE 8, W1BLV 3. EASTERN MASSACHUSETTS — SCM, E. L. Batten, W1UE — W1AKS and W1APK have resigned their ORS on account of moving out of the Section. An ORS certificate has been issued to W1WU, who is doing some line relay work. A new station, W1LQ, has opened up in Wollaston. He uses a 210 and has already worked England. W1AZE worked his first Asian when he hooked Y12GQ. FB, W1WV is high traffic man this month. Most of the messages were to his old Harvard classmates announcing a reunion. W1WV was visited by VE5CC, W3KU and W1AD — that shows a fine sociable spirit. OM, W1ACA has a new 1929 receiver which gives full-diode coverage of all bands. W1RL will soon have his ORS. He, W1FI and W1UE took a cruise on the Eagle 46 with the Naval Reserves on May 12, and all enjoyed the experience. W1KH is using a couple of S66's with Kruse's tuned filter. W1KY has added several new skeds. She keeps pretty busy with her RM work. W1EK worked F, PA and K, and is always ready for traffic. W1BUB has applied for ORS. W1AAW says he is busy man these days. W1ASI has very good DC at last. W1ARS is having trouble with a local power leak, which hampers his traffic work. W1LM is back on summer sked, which means a let-up on message handling. W1AOT has put new blinds and awnings on his shack, and is all ready for visitors. W1CQ joined the R. C. C. Quite a few of the fellows attended the convention in Springfield, and our own E. Mass. gang won first prize for putting on the best stunt — prize was a complete receiver. Non-reporting stations are urged to report next month and all stations requested to report on time.

Traffic: W1WV 444, W1KY 127, W1ACA 53, W1LM 50, W1WU 48, W1ARS 35, W1KH 32, W1AOT 24, W1ASI 14, W1EK 14, W1AZE 10, W1AAW 3, W1RL 2.

MAINE — SCM, G. C. Brown, W1AQL — The new SCM wishes to extend to all those concerned his hearty thanks and appreciation for the loyal support in the recent election. He fully realizes that it will be quite some job to carry on the work in as efficient manner as did our friend and co-worker, Fred Best. However, with the usual cooperation and spirit of good fellowship which characterizes the Maine Section, there is no doubt but what his term will be

successful as well as pleasant. W1AQD is top liner this month. Fine work. We are glad to see you in the BPL. WIBIG has a lower total than usual this month due, we presume, to his being away at Hartford and to the USNR work. W1ATO is the next in line with a good total. W1AHY has skeds with W1AQD and W1AUR. W1ART comes across with a good showing this month. Mrs. W1AJC has a good lead on OM W1AJC this month. W1AJC and the SCM are running neck and neck this month. W1TR reports that W1ADV is on the air now. W1BFZ is working on a key thump filter. The SCM wishes to say that work on the convention is coming along fine and the real dope will soon be on its way to all the gang.

It is with deep regret that we have to report the passing of Leonard Randall, formerly of 1AXU, whose death occurred on March 30th. "Dutch" was a very nice chap, and we find it very hard to realize that he has departed forever from our midst. In his passing, the Queen City Club has lost one of its best workers, and amateur radio has lost a real friend. Our sympathy goes out to his people in their bereavement.

Many who remember Delmont Parsons, old 1KAY of Portland, Maine, and Castner's right-hand man in the Atlantic Radio Company in 1919 and 1920 will be sorry to learn of his recent death in a Ford airplane accident at Newark.

Traffic: W1AQD 303, W1BIG 165, W1ATO 157, W1AHY 71, W1ART 43, Mrs. W1AJC 27, W1TR 15, W1AJC 12, W1AQL 12, W1BFZ 6.

CONNECTICUT — SCM, C. A. Weidenhammer, W1ZL — Summer weather with its daylight saving time, its vacations and its static has started the let-down. There seems to be an unwritten law among amateurs that frequencies below 7000 kc. must be shunned at this time of year. Happen what may, we hope that a few of the gang will be faithful to 3500-kc. skeds. Some are getting out of warm beds at 7:00 a.m. to take advantage of the most favorable conditions on that band. More might try it with the exception, of course, of those of us who leave our homes before that hour. W1BGC is still on 7100 kc. W1MK reports that most of the schedules are working well. The QRN is making the copying of the DX schedules a bit difficult. W1CTI is one of the early risers, and he reports the air crystal clear and uncrowded at that time. W1AMC and W1AVT have formed a partnership. W1ADW worked thirty-four foreign stations and handled some DX traffic. W1AFB moved thirty messages in one evening recently. FB, W1BOD states that preparation for college exams will demand most of his time now. W1OS finds 14 mc. a bit tedious and must return to the gay whirl on 7000 kc. Hi, W1AOL hears few of the Connecticut gang. W1BHM will be on 14 mc. for the summer. W1RP expects to install a power house soon to supply voltage for his UX852. Hi. He keeps a schedule with 55X, our mysterious friend. W1BJK is still active. W1TD is building an MOPA outfit. W1BDP's schedule with W6AKW is still sure-fire. W1CKP handled a good traffic total. A Better Homes Exhibit in Vermont helped W1AOX amass a splendid total. W1AMG handled a lot of traffic for Europe and the Canal Zone. W1BNS crashed into the BPL with a whale of a total. He and W1WV handled the messages sent out by the Harvard Class of 1909 Reunion Committee. FB, W1BI-BQH promises much activity in his quarter now that school is out. W1ZL has finally erected an antenna that is wind-proof. Operation on 3500 kc. will be more regular during the summer. W1BZL in Stratford, W1CPO and W1ASC in Bridgeport, and W1AJB in Middletown, are new amateurs. W1BK is preparing for his annual transcontinental trek. He will be gone until fall and will use W1ZZA, his portable call. W1VE enjoys the food on his pocket. He sails between Norfolk and New York.

Traffic: W1AMG 137, W1BNS 316, W1AMC 5, W1AOX 90, W1CKP 51, W1BDI 24, W1TD 4, W1BJK 20, W1RP 62, W1BHM 36, W1AOL 55, W1AFB 73, W1ADW 6, W1AVT 3, W1CTI 2, W1MK 512, W1BGC 8, W1ZL 16, W1BOD 6.

WESTERN MASSACHUSETTS — SCM, Dr. J. A. Tessmer, W1UM — W1ADO is still operating at W1FG. W1NS has just finished rebuilding transmitter using xtal control. W1BZJ is rebuilding for 2 UX250s with d.c. supplies. W1CTF worked 27 stations out of 29 called with a

new set using 320 volts. W1ANI is going on Naval Reserve Radio compass station duty for 15 days. W1BVR is getting great DX and is on 41.6. W1AKZ is handling traffic to Europe. W1BSJ thanks everybody for the fine cooperation given by all who contributed to make the Springfield Convention a success. W1BWY says a monitor is now at the call of the members of the club. W1BNL continues scheduled with his new Zepp. W1UM is going to rebuild this month to 3500, 7000, and 14,000 kc.

Traffic: W1BGM 22, W1NS 7, W1ANI 20, W1AKZ 2, W1AWW 15, W1CTF 3, W1UM 9.

NEW HAMPSHIRE — SCM, V. W. Hodge, W1ATJ — Outside activities have claimed some of the gang's time lately. Radio conditions have been much better than during the winter, though. W1AUE is working nights, and has to operate daytime. W1AOQ will be going as soon as college lets out. W1IP sends in a good report, but says not much time for radio now. W1AUY will have a crystal soon for a 1929 rig. W1BFT was busy as usual. W1YB have a new transmitter on 3500 kc., and expect to work on 23 mc. soon. A new model A is taking up W1AUV's time now. W1BNK is on with a 1-kw. tube. He expects to be "in the air" with Bob Fogg at the Weirs this summer. A bunch of the fellows at Durham report a very fine trip to the G. E. plant and WGY at Schenectady and W2SZ in Troy. W1APK is a new ORS in Pembroke and is on 3500 kc. W1UN has an amateur extra first now. FB, OM.

Traffic: W1YB 111, W1IP 27, W1ATJ 25, W1AOQ 22, W1UN 22, W1AUY 2, W1AUE 23.

VERMONT — SCM, C. A. Paulette, W1IT — Traffic seems to be slowing up considerably, but it to be expected at this time of the year. The ORS in Vermont are swimming into line in fine shape, and it looks good for next fall. W1FN reports a club station now on the air on both 3500 and 7000 kc. at White River Junction. W1BDX has rolled up a fine total this month and takes the high honors for the state. W1BEB still perks FB and states that W1BBI has returned home after a long absence. W1JR sends in a report this month and promises to keep it up. W1AOQ has rebuilt his transmitter and is putting out a FB signal now. W1CGX is still doing his bit in both the traffic line and RM line. W1YD reports that W1BIQ is at the Randolph, Vt., hospital with pneumonia. We all extend our wishes for a speedy recovery, OM. W1BEC reports that he will be home from Ft. Benning, Ga., sometime in June. W1IT is having a hamfest at his camp on Lake Memphremagog the second week in June. Any ORS who wishes to be inactive, please notify the SCM so he can place you on the inactive list until you resume your active work.

Traffic: W1BDX 107, W1CGX 49, W1AOQ 26, W1IT 10, W1YD 6, W1BEB 3.

NORTHWESTERN DIVISION

MONTANA — SCM, O. W. Yiers, W7AAT — W7DD has a new screen audio receiver with built-in monitor. W7FL has a new monitor and is waiting for W9XL and W1XV to do their stuff. W7AEM, W7DJ and W7TB, all of Hardin, are too busy to be on much. W7AAT held schedules with K6DTG-K6A1Y-K7AMW and N1JL.

Traffic: W7AAT 305, W7DD 33, W7FL 25.

OREGON — SCM, R. H. Wright, W7PP — From this date forward, address all communications and traffic reports to the new SCM, W. S. Claypool, W7UN. W7UN has been playing Dan Cupid for a distant boy-friend. This accounts for his rating the BPL of message deliveries. W7YK as usual had an amateur Radio Booth at the school open house and accepted messages from the patrons. W7AMQ is now on 14,000, 7000, and 3500 kc. W7AAR now has a Hartley on 14,000, 7000, and 3500 kc. W7AHA will soon have a Meissner on the air. W7PV has a WAC certificate, having worked his last continent. W7AEU is buck on the air. W7WL has added four new countries and two continents to his list this month. W7IF has also had several European QSOs this month. W7UB is using 281s now. W7RR has six skeds which he keeps. FB, OM. W7PG has moved to Walla Walla; he will be on the air there soon. W7MV has started construction on a new transmitter. W7ABN is rebuilding the entire station. W7WB has sold out, another case of radio vs. yls. W7ED is on the air with a 50 watter. W7TU sold his outfit but is using a 5 watter on 14,000 and 7000 kc. W7KH

is very QRW with FFJI but he will be on soon with an excellent tone outfit. W7EC is one of the consistent stations in Oregon. W7PP is rebuilding entire transmitter and installing two 852's in push-pull instead of one as oscillator as heretofore.

Traffic: W7AMQ 212, W7PE 196, W7RR 192, W7UN 186, W7UB 60, W7IF 40, W7MV 35, W7WL 35, W7AAR 28, W7AMF 17, W7AEU 11, W7EC 6.

WASHINGTON—SCM, Otto Johnson, W7FD—W7BB takes the traffic honors for this month, handling 284 in a period of 17 days (and NIGHTS!!). He will soon take an operator job on the *President Grant* and will try to visit as many stations in Japan, China, and the Philippines as his job will permit. A new traffic station, W7JJ at Kent, takes second. W7TX, W7AG, W7VK, W7RR and W7LZ keep Seattle on the job. K7HL at Taku Harbor, Alaska, is going strong and will help run up our traffic totals. W7ACA at Prosser will be off the air for a while. Hurry back, OB. W7ACS, W7AFO and several other stations are on in Tacoma. W7GP at Olympia is getting a set going on a yacht and will make the trip to Juneau, Alaska, during the Annual Capital to Capital yacht race. He will work skeds with amateurs, using 13,330 kc. and 6592 kc.

W7AOB in Tekoa is improving his station and handling traffic in good shape. No reports were had from Spokane, but a visit of W7AJJ to the SCM reveals that an amateur BCL war is raging there. Amateurs have their antennas cut down and everything. Very poor power regulation is said to cause most of the trouble. A city ordinance affecting amateur radio stations is being investigated by our Director, Karl Weingarten. It is hoped the situation will improve soon.

In Everett we find one of our most enthusiastic groups of hams. W7PH sends in all the dope, for which the SCM is very thankful. The Zepp antenna has hit the Everett gang but they seem to get out in spite of it. W7LZ please note. Hi. W7EK is still going. W7JR blew his 171 but is now on with a 5 watt. W7NR has a bug now. W7ACY, W7MW, W7PH and W7AKP are the Zeppers. W7AAB is building a MOPA. W7JR handled a few. W7IT in Stanwood is on with a 201A. W7AGL expects to get on soon. The SCM will have W7FX on near LaConner during the summer. W7FD will be on at the old QRA soon, too.

Traffic: W7BB 284, W7JJ 100, W7VK 74, W7TX 70, K7HL 71, W7PH 31, W7EK 20, W7RR 16, W7AOB 16, W7AG 14, W7JR 13, W7AFC 8, W7AC 6, W7MW 6.

PACIFIC DIVISION

LOS ANGELES—SCM, Don C. Wallace, W6AM—Six stations make the BPL this month—W6CHA, W6AKW, W6AVJ, W6ZBJ, W6DHM and W6UJ. W6CHA has been taking over W6AD's sked with K1CM during the absence of W6AD at maneuvers at Fort Mather, Calif. W6AKW worked a British ship, amateur xg2XC near Vladivostok, he using 15 watts. W6AVJ has installed two of the new Rathcon R. S. Mercury Vapor rectifying tubes and says they are FB. W6ZBJ has been up in the mountains at Boys' Camp. W6DHM can't raise anything so is thinking of putting in a 2-kw. spark. W6UJ has been working on a portable with W6DYL. W6DYJ sent a radiogram and telegram to Seattle, and had an answer by radio before the telegram was delivered. W6DKV has a new call, portable W6ZZI. W6CUH worked all continents in one week with new xtal transmitter. Ground 3500 kc. xtal for W6AQJ. W6EQF sends in the news that he came on the air March 6th as an amateur for the first time since 1909 and has been QSO four continents, and eleven countries. W6BZR is still working around with airplanes and studying for commercial ticket. W6EFA has built a 14,000-ke. set and would like a couple of skeds in morning, afternoon or week ends. W6AEC is working now so won't have much traffic. W6ALR is teaching the YL the code. W6FT has good sked with K6AVL and would like some traffic for them. W6ESA heard RWX on 14,000 kc. W6AWP made his first European QSO the other night. W6AM is keeping weekly skeds with Byrd expedition. W6AKD changed over to 14,000 kc. for ten days and worked all continents with a QSA 5 from all. W6ETJ says his transmitter is not perking so hot now. W6EKX sends in a good total. W6APW's antenna pole blew down. W6DLI is building new shack and moving transmitter. W6TK has sked with China every Sat. W6ETC has

just started his first sked and is trying to get more traffic. W6ELZ is doing some good work for the Long Beach Associated Radio Amateurs in getting new members. W6QL graduated from the old reliable 210 to a 50 watt. He was recently appointed Asst. RM for the San Bernardino district. W6FVA sends in her first report—was down on 14,000 kc. for a while and worked her first Aussie. W6ZZA maintained schedules with W6DOJ while W6ZZA was near Canadian border. W6DOJ took daily bulletins from W6MA at hospital. W6EKC says DX has been good during past month. W6HT and W6DYJ are considering consolidating. W6LZI put up another Zepp to tune in new band. W6OF says to tell the gang that if any of them are going to spend their vacations in the High Sierras, to be sure to drop in and see him. He is located 63 miles north of Bishop, Calif. The fishing there is FB. W6AXE is going to make new schedules.

W6CHW, W6EPH and W6EPN send in good reports. W6DSG, W6COT and W6AGR are rebuilding. W6EKE and W6DYU are going to take a transmitter and receiver to military camp when they go in June. W6BRO has been spending lots of time every Saturday for the past month aboard the Yacht Nomad, WHDC, putting the set in shape. One of his messages was telegraphed to its destination at Ontario, Calif., and another sent by special delivery to the Marine Base Hq. in San Diego. W6DUJ and W6DZK have good totals. W6HS has his antenna up again so will be on week ends. W6EAF is keeping good skeds. W6DLK has not been on the air much. W6ASM is out for a commercial ticket. W6BJX, W6JF, W6EEB, W6CZU, W6MA, W6DPY report as usual.

Dates of the coming Pacific Division Convention at Los Angeles are November 29th and 30th.

Traffic: W6CHA 567, W6AKW 408, W6AVJ 285, W6ZBJ 206, W6DHM 177, W6UJ 144, W6DYJ 114, W6DKV 112, W6CUH 44, W6BZR 41, W6EFA 40, W6AEC 28, W6ALR 38, W6FT 32, W6ESA 31, W6AWP 30, W6AM 29, W6AKD 27, W6ETJ 27, W6EKS 25, W6APW 24, W6DLI 23, W6TK 22, W6ETC 21, W6ELZ 21, W6QL 20, W6EVA 17, W6ZZA 17, W6EKC 16, W6EPH 14, W6HT 13, W6DZI 11, W6OF 11, W6AXE 8, W6EPN 8, W6AGR 8, W6CHW 8, W6DSG 7, W6COT 7, W6EKE 6, W6DZK 6, W6BRO 5, W6DUJ 4, W6HS 3, W6EAF 2, W6DLK 2, W6ASM 1, W6FQF 62.

HAWAII—SCM, F. L. Fullaway, K6CFQ—Summer time is approaching and it is about time for a heavy run on traffic to start. The SCM hopes to be an operator on N1JN for the summer so the duties will be temporarily placed on someone else. Proper notification will be given to all active stations. K6AVL handled the most traffic by keeping skeds. K6DTG has a new MOPA that is a wonder. He keeps skeds with WSBS, the Carnegie, with about five others. K6CFQ made the BPL after a long absence. He keeps skeds with W6JU weekly. A sked was arranged by commercial cable on several hours notice and the required amount of heavy traffic necessary to get one's family to return on thirty hours notice was handled. K6DWS on Maui is a new ORS. Has a generator ripple that refuses to disappear. K6ENE is rather active but with AC. K6DJJ will soon be no more. K6ACW is on 7000 and 14,000 kc. with a 210. K6EST reports a new ham on Maui, K6AGQ. Kahlui. K6DPG says his skeds are all haywire. K6DQQ is on again with Hi C and a 222. K6CLJ was QSO two G stations on 14,000 kc. K6AFF will be on soon with an xtal. K6DEY is in Honolulu for good now, working for KNN.

Traffic: K6AVI 121, K6DTG 79, K6CFQ 77, K6DWS 70, K6ENE 57, K6DJJ 45, K6ACW 38, K6EST 24, K6DPG 15, K6DQQ 12, K6CLJ 7, K6AFF 1.

PHILIPPINES—SCM, M. I. Felizardo, K1AU—This report came by radio via K1CY, K1HR and W6EEO—K1AU is on most every night. K1HR uses two fifties in parallel on both sides of cycle. K1BD is a new station at Camp Nichols. K1AF the old reliable at Ft. Mills has a sked with W6AKW for east coast traffic. K1CM has a new op—Gisel went back to States taking the transmitter from K1BG with him. K1MC is still fiddling around, looking for something he can't find. Hi. K1AD is off the air entirely. K1RC is on intermittently. Everytime they graduate a class from the radio school, they put the station out of commission. K1LG is taking a vacation in Baguio. K9PL is still on. K1PW gets out with a bang. K3AA is closed for two years until M.I.T. turns him out with a R.E. degree. K1JR is more

active lately. K1CY has daily skeds with W6HM. K1EL is a new ham with a 210 and good prospects for improvement.

Traffic: K1HR 631.

EAST BAY — SCM, J. W. Frates, W6CZR — The summer doldrums are beginning to be felt. Hams of the section are beginning to desert their transmitters and receivers for the blandishments of the beaches, the forests, and those other focal points of vacation time. Through the work of W6CTX and associated operators at the Boy Scout Merit Badge Exposition at the Oakland Auditorium, a good traffic total was run up. In addition a number of the fellows made the BPL through deliveries. Station W6DUR, operated by Burke and MacClara, came out in the lead, probably due to the fact that two operators were on the job. MacClara will soon blossom out with his own station, call unassigned yet. W68K is having trouble making his fifty watter do its stuff. W6ALX has three hot skeds going and is rapping out the traffic in his usual style. W6CGM reports that a power leak blew him up around the fifth of the month and that P. I. contacts are very bad. W61P declares that Naval Reserve traffic is still holding up and that he will have his new 3500-ke. set going in fine shape soon. W6HJ reports that the talkies are replacing him at his Vallejo theater, and that he is moving to San Francisco after June 15. W6E1B has had his skeds temporarily discontinued because of his absence from home on active duty at NBP. W6BIW says that he has been QSO Australia on 14,000 kc. almost every night on his lone 210 tube. W6RJ is still rapping out on 3500 and reports that he has rebuilt his transmitter for High C to get that 1929 note. W6BZU is still functioning at Concord and reports a new man at Walnut Creek. W6EBA is working at Port Costa, Calif., and is planning on installing W6CDX there in his hotel room. W6EDR says that 3500 is the bunk as he works a graveyard shift which sets him in too late, and expects to move up to 1400 kc. W6BMS compiled a report for all his friends. W6EM1 is on 3500 kc. for USNR work. W6EBM has forsaken DX and gone into lone work. W6EDT has gone to 14,000 kc. and blew a grid condenser calling W6EMD three blocks away. W6BL, an ensign in the Naval Reserve, is on the U.S.S. *Colorado* this month. W6ANJ reports that he has been crippled by a power leak. W6EDT sends in his first report. W6AUT at Napa, manager of the Western Union, wants to talk Morse with any ham who can understand it. W6CUG finished his transmitter; it wouldn't oscillate, and now he's building a TPTG. W6CZN is getting on well with his 50 watter. W6BYS is having QRM from his motorcycle and his 250 watt bottle lies idle a little. W6OT is temporarily off the air due to BCL complaints. W6AAU has returned to his home after operating W6ZZE at Karluk, Alaska. W6DTM and W6DKO are making a tour of the country with a portable. W6CZR is still having trouble with his 50 watt High C Hartley.

Traffic: W6DUR 575, W6SR 429, W6ALX 364, W6CGM 194, W61P 164, W6HJ 97, W6E1B 71, W6BIW 60, W6RJ 38, W6BZU 35, W6EBA 25, W6EDR 19, W6BMS 17, W6BT 10, W6ASJ 4, W6EDT 2, W6EBM 1.

SACRAMENTO VALLEY — SCM, Everett Davies, W6DON — W6EEO comes to the top again with his K1HR schedule. He lost his schedule east and is mailing them. Our dear little YL, W6ETA, is sure giving W6EEO a run and she will catch up with him next month. All she has to do is sign her call once and the air is jammed with fellows calling her. W6AFU says his success was due to two good local schedules. W6ELC is on about fifteen hours a day. W6DON is on 3500 kc. every evening but YL QRM is getting bad. W6BDX did fine this month and is in the Army-Amateur Net. W6CGJ with his 1929 sizz and little 210 is putting another town on the map. W6DYE's set works but he studies Latin too much.

Traffic: W6EEO 416, W6ETA 411, W6AFU 253, W6ELC 214, W6DON 136, W6BDX 66, W6CGJ 48, W6DYF 7.

SAN FRANCISCO — SCM, C. F. Bane, W6WB — Very sorry to see that our star station W6AD was too busy with other activities to report this month. His place is taken this time by a new station in traffic handling, W6BL. W6BL and W6ERK make the BPL. W6ERK reported a week early on account of going on his vacation. W6DBD reports for the first time with a peach of a total and says DX also fair. We seem to have a new bunch of men reporting every month and

if we can depend on the old gang, also, to report, maybe we can give the East Bay Section a little competition. W6CIS reports as usual and says W1MK and WSBS skeds still going strong. W6DYB has dropped to 14,000 kc. DX fine but traffic not so good on account of heavy school work. W6AC has evidently given up in disgust and decided to wait until the power leak season is over. Hi. W6DPF has mastered crystal grinding at last and is now seriously engaged in building his set into a crystal layout. Now that W6PW is knocking receivers off the table on the east coast with his new crystal rig, why not a little traffic report, Jack? Owing to W6DZQ having moved, his totals run far below last month. W6DER reports. Keep it up, OM. W6EEH also joins us for the first time with a nice report. W6DSS says 14,000 kc. is the money for DX. All ORS except those whose numbers are 4020 or over are now being cancelled. If at any future time any of the former ORS want to resume activities, I shall be glad to issue them another certificate. W6DZZ is rebuilding into MOPA outfit and seems quite optimistic about the outcome. W6WN is now swinging into the RM job with full force, and is attempting to bring all the delinquents into the fold. W6WB was fairly successful on 14,000 kc. working four Frenchmen and two Englishmen. W6DSN is rebuilding and expects to be on the air soon with a good signal. W6KJ is too busy with domestic affairs to handle any traffic. W6CYP is now a traveling salesman so doesn't get on much but has a nice crystal job ready to use. W6FK still tries to QSO Europe. W6PR is still building them up and then tearing them down and is keenly interested in the higher frequencies. The third tri-Section hamfest is to be held in the latter part of June or the first part of July. It will be sponsored by the Associated Radio Amateurs of S.F., assisted by the S.F.R.C. in all probability.

Traffic: W6HL 511, W6ERK 102, W6DBD 72, W6CIS 51, W6WN 25, W6DYB 21, W6EEH 21, W6DER 17, W6DSS 16, W6DZQ 3, W6WB 6.

ARIZONA — Acting SCM, Russ Shortman, W6BWS — W6EH plans to resume traffic schedules soon with a UV204A. W6BJF reports a visit from W6DTM, W6DKO, and W6CLT. He is on 14,000 kc. now. W6BWS wishes that FO-ZS2B would QSL. He needs the card for his WAC. W6EAA says push-pull circuits are best. He makes the BPL on deliveries. W6DIB reports his new master oscillator with the two UX852s the berries for DX. W6OTU reports good DX on 14,000 kc. W6EFC sold his UX210 transmitter and is getting on again with a couple of UV201A tubes. W6CDU is still lamenting the fact that he has no power and he threatens to get on the air with a UX852 about July 15th. W6DCQ has finished his new shack and is going to have the new W6BWS TPTG working by June 1st. W6CRA is planning to move from the state soon. W6CWL is a new ham in Phoenix and is on the air using the transmitter he purchased from W6EFC. W6CWG is another new fellow in Phoenix who has been doing BCL service work. W6DIE has changed from TPTG to Hartley and sure has a nice signal with much better note. W6ANO is one of these sweet voiced broadcast announcers.

Traffic: W6EH 7, W6BJF 16, W6DTU 97, W6EAA 136, W6CDU 33, W6EFC 44, W6DIB 3, W6BWS 28.

SANTA CLARA VALLEY — SCM, F. J. Quenent, W6NX — W6AME came back strong this month to handle 401 messages which should place him near the top of the BPL. W6AME reports a crop of new ops materializing in Modesto — which is good news, this includes a YL. W6BY Y has demonstrated that 7000 is a good traffic band by clearing 278 messages. A daily sked with K1MC and AC3GO is taking care of all foreign traffic and all messages for the Philippines or China can be safely routed through W6BY Y. W6HM made the BPL again this month with 102 messages all of which were foreign, many of them long and important. W6JU handled important traffic from Hawaii. Making the WAC in 48 hours with 45 watts input is the latest from W6BAX. A long list of foreign contacts on 14,000 kc. bear out this claim. W6ESW reports that W1DJ on 30 meters is the yacht *Tempress* on a cruise to Tahiti. W6CZX is the operator. The Modesto gang visited W6BNH last month on a combination radio and fishing trip. W6AME came out with high honors followed by W6FY and W6CKH. W6BNH is located high in the Sierra Mountains and this visit was the first ham visit in three years.

Traffic: W6AME 401, W6BYY 278, W6HAI 102, W6JUI 84, W6BAX 6, W6ESW 5, W6BNH 1, W6NX 3.

SAN DIEGO — Acting SCM, H. A. Ambler, W6EOP — W6ACJ leads this month and is getting skeds lined up for through traffic east. FB, OM. W6DNS got several messages from the radio display. W6EPP is now an ORS. W6EOP has his new four tube screen grid la November QST, and had FB QSO with Malay States. W6EPZ blew up power transformer but expects to be on again soon. W6EC still holds sked with KIPW and NKF. W6EPK says he is going in for traffic handling. W6BVK built 7½ watt Ultraudion for 28 mc. W6RAM has an 852 and bought a new Ford. The acting SCM would like all in the San Diego Section to send in reports. Several of the gang here are in favor of starting a club. What do you say, gang? Let's get together and start the ball rolling.

Traffic: W6ACJ 164, W6DNS 84, W6EPP 60, W6EOP 55, W6EPZ 50, W6EC 30, W6DGW 21, W6EPK 18, W6BVX 12, W6BAM 6, W6BFE 2.

ROANOKE DIVISION

VIRGINIA — SCM, J. F. Wohlford, W3CA — The report this month is rather slim and the SCM wants to again warn the ORS that unless reports are received promptly and every month, the ORS will be cancelled. W3EC worked 143 stations during the month, has two regular schedules that work every day with good QSO and two others that work every day except Sunday. W3KR has two regular skeds and says W3AG and himself will QRM each other as soon as school QRM is over. W3BZ has three regular schedules working W1MK, W8CMP and W8ZZ. W3ZA is using MOPA circuit for his phone and likes it fine. W3CKL blew his two fifties that were used in self-rectified circuit and is back now with 210 tubes.

Traffic: W3EC 57, W3KR 20, W3BZ 6.

WEST VIRGINIA — SCM, F. D. Reynolds, W8VZ — What do you think about trying a little party some night on 3500 kc. and including all stations in West Virginia, just to see how many of our own gang we could work, just something to stir up a little good will among the fellows here in the state? Would you like to try it some night, say some Monday night after the Army-Amateurs have finished their work and could join us? I believe we could stir up about twelve or fifteen stations in various parts of the state which would represent the following cities: Huntington, Wheeling, Hinton, Mannington, Fairmont, Charleston, Parkersburg, Charles Town and Clarksburg. If you fellows really think you would like to try this, just drop me a card with your suggestions on it. Let's have a word from you. Ex-SLI boasts the call W8ATZ now and has applied for ORS appointment. There's a new man among us. W8ASH in Charles Town, W8ACZ hooked up with him the other night and says he is an old W.U. op and pre-war ham. W8CAY was responsible for West Virginia's message getting to Pree. Hoover, W8CLQ and W8ACZ worked him recently. W8CDV says he was on several nights during the past month and handled a few messages. W8HD reports being on 3500 most every night and every Mon. night at 6:30 when he has a schedule with W8OK. W8CLQ has been trying phone on his UX210 and says that most of the fellows give him good reports. W8BPU and W8VZ are spending their time doping out a crystal control rig for WMMN. W8DNN still sticks to married life which accounts for his not being on the air so much lately. We heard W8IT on 7000 kc. about a week ago. W8BCN is still playing with his UX210 and has managed to work some sixes and sevens on 7000 kc. W8DCM has a fifty watter now in place of his old 1 k.w. W8ALG continues to work good DX with his 250 watter. W8JK brought a class from the Physics Dept. at WVU down to see the KC plant the other day. He hasn't touched a key for about six years but is building up an 852 now. W8AEG is trying to get along with YLs and ham radio at the same time. W8BDP hooked up with England, France, Spain, Brazil, Tunis-Africa, and several ships. W8APN now sports the two letter call, W8JM and says it's great for DX. He lost his two UX281's and is now digging out Mason jars. W8AHF is being heard quite often on phone. W8DNN says it will be some time before he gets on the air again regularly. W8AUL has his mind on fishing these days? W8ATC is

attending Carnegie Tech, but will be in Huntington during vacation. Ex-W8CEK makes a trip through Fairmont about every two months and stops off for a visit. W8ACZ has his fifty watter in working order again with a chem. rectifier and has been working a number of stations on 3500. W8OK can be heard on 3500 every Monday night, working Army skeds. W8DPD can be heard most every night using phone on 3500 kc. W8BDX is intent upon getting through school so ham radio is taking a back seat. W8SP has his receiver ready to go but lacks a transmitter which complicates matters.

Traffic: W8ACZ 107, W8CLQ 32, W8JM 55, W8HD 10, W8CDV 3, W8VZ 5, W8OK 9.

NORTH CAROLINA — W4ZD had rather tough luck; a storm blew their 50 bottle transformer, relay and antenna but they're OK now. W4TS says that a Zeppelin antenna overcame bad location when all other types, powers, etc., failed. W4OC received a leopard skin from FQPM. He has worked all continents now. W4AEW says QRM is very bad and is going to work on 14 mc. this summer to keep away from it. He reports two new hams coming on soon. W4AGH received some silk handkerchiefs from one party for delivering a message for them. W4TN says college QRM will be over soon and he hopes to handle some more messages.

Traffic: W4ZD 187, W4TS 34, W4OC 16, W4AEW 15, W4AGH 7, W4TN 5.

ROCKY MOUNTAIN DIVISION

COLORADO — SCM, C. R. Stedman, W9CAA — The Radio Inspector paid another visit to Denver, with the result that there are a number of new first-class ham tickets in town as well as higher classes. W9CAA has gone back to a 210 tube, just to see what it's like. W9EAM is going to rebuilding and increase to a 50-watter. W9CSR got an amateur extra first ticket. W9CAA's father got him a ham first ticket, and will be on the air soon. W9CCM is off with a shot MG set. W9BQO, W9DGI, W9BJN and W9CNL are all too busy to do much. W9CJC, W9DQV and W9DRV are on 7000 kc. W9FXW reported by radio this month. He is out in the country and has to use a Ford coil to get high voltage, no power being available. W9CDE paid a visit to the Denver Club. W9DQD says he is still off until he can get some receiving tubes. W9CKN is busy now. W9BDY is moving from Brush to Greeley. Two other hams at Greeley will be on as soon as they can get their station licenses. W9EBF-W9FSC is going full blast on 3500 kc. W9DKM is leaving the state, heading for California. W9GGW has been trying a push-pull outfit, but says it's not much different than the other.

Traffic: W9CAA 12, W9FSC 16, W9CDE 5, W9FXW 2, W9CSR 6, W9EAM 48.

UTAH-WYOMING — SCM, P. N. James, W6BAJ — Now that the summer static is getting QSA, the fellows are beginning to QSY to 14 mc. The traffic totals should be good this summer, now that all the school QRM is over. W6BTX turned in another fine report this month. He was all set to make the BPL again, but he had to cancel all skeds on account of school work. W6BAJ finds that his new mercury arc is the only thing for a good power supply. W6DXM has moved down to 14 mc. and thinks that band is very FB. W6RV has had a hard time trying to scare up some traffic on 14 mc. W6CNX has a new transmitter, two UX852 in push-pull circuit with mercury arc and a zepp antenna. W6EKF was bothered with school QRM. So was W6DPO. W6DYE just returned from a vacation trip to Portland, Ore. He will be on regularly now. W6VFB has been sick.

Traffic: W6BTX 174, W6BAJ 43, W6DXM 12, W6RV 11, W6CNX 8, W6EKF 6.

SOUTHEASTERN DIVISION

GEORGIA-SOUTH CAROLINA-CUBA-ISLE OF PINES — SCM, J. G. Cobble, W4RM — They will appreciate reports from all divisions of this Section. W4KY heads the list of traffic. FB, OM, keep it up. W4SI is working at Asheville, N. C. W4RN entertains the Radio Club at his home this month. W4RM and W4VP consolidated at present but not much radio on account of YLs and BCLitis. K4AAN sends in a very good report on conditions in the West Indies. He is doing good work with one UV211 having received a card from ZL2GO giving him

R9. During last month he was QSO Ireland, France, England, Denmark, Spain, Germany and the Canary Islands. How's that?

Traffic: W4KY 118, W4RN 27, W4RM-W4VP 11.

ALABAMA — SCM, S. J. Bayne, W4AAQ — W4A1M has arranged several good schedules. W4AHZ has played bridge consistently this month. W4JY now operates from 10 p.m. until? W4AAH reports much business QRM. W4WS, ex5AC of Mobile, is now on and doing nice work in Birmingham. W4AX says a company of marines furnish him with plenty of traffic from Nicaragua. W4AJY's noisy receiver has been the source of much trouble to say nothing of loads of correspondence. W4A1Y is experimenting with tone. W4AHY is working a 210 while waiting for a 204A. W4RC has a YL operator, who is none other than Joe's sister. W4UV took a message for W6HM from XW7EFF in the Indian Ocean and delivered it in less than five hours. Nice work. W4AQ retains its place in the BPL. They lose five ops through graduation but we hope these will carry on among themselves. W4AHQ has an xmitter on 14 mc. for DX now. W4AKM is a new reporter. Welcome, OM. The shacks of W4TI, W4TH and W4FN were recently entered by some sneak-thief and their losses were heavy. The police have been working on the case and it is hoped that the culprit will soon be brought to justice. Please report any information you may secure. W4LT has moved to 7000 kc. for the summer. W4ZI is a new station at Troy. W4JA returns to Selma this month where he and W4TH will combine efforts. Four of the Montgomery gang recently visited the Auburnites. A fine time was had by all (combing the woods for W4ABQ). W4AHP pouended away overtime with many schedules to earn a berth in the BPL. W4AHR is suspicious of his soup rectifier. W4AJR says he's getting out better than ever. W4AKB has rebuilt his High C Hartley. W4MY is busy with W4PI but manages to be heard often. W4AAQ worked thirteen countries this month, having been on daily. W4AHO excavated his old 203A and has again put it into action.

Traffic: W4AQ 207, W4AHP 165, W4AHQ 112, W4AX 107, W4AJR 104, W4AAQ 65, W4AHR 55, W4TI 27, W4AKM 22, W4A1M 18, W4AAH 16, W4UV 16, W4MY 12, W4WS 9, W4AKB 9, W4AJY 6, W4AHZ 2.

FLORIDA — SCM, Harvey Chabin, W4AI — W4ABJ is back on the air again with a UX210 and "B" eliminator. W4AEE is a new ORS and OBS, and he sure is handling the traffic. He is installing a 250 watt set. W4IG is now about six miles from town. W4CH is on 14 mc. most of the time. W4AAO is now stationed in Porto Rico in the airplane service. W4IE kept a schedule with KFLF, Yacht Ripple twice a day on two trips to Cuba, handling all of her traffic both ways. W4OZ worked a VK and two KG's. He says that the early morning is better for DX and traffic than night. W4DU is using a 204A. W4OB expects to be on the air very shortly. W4TK has been building a MOPA. W4OO is leaving for the North. W4NE worked three continents in two nights. He has just been elected vice president of the Miami Radio Club. W4CC handled a rush message from the Virgin Islands to Birmingham, Ala. W4UY is a new fellow. W4ZP keeps skeds with W4AI, W4CT and W4UY. W4AJK has given up using a chemical rectifier. W4SE has moved from Leborne, Fla., to Indialantic. W4SD is working on 14 mc. W4IX is on the air at WRUF, with W4ABL at the key most of the time. W4AGN is training a YL baby at present. W4GD got married. W4ADB is keeping seven skeds, four are with foreigners. W4AFC built a MOPA. W4AFC is a married man now. W4AGR and W4AFC have combined now as one station. W4AGY is a station of the A.P. net. He QSO'd W4PI in St. Augustine, Fla., and exchanged messages and got W4PI a job with the Pan-American Air-Ways. W4PAO is a portable call of W4AGY. W4CT makes BPL this month and reports via radio. W4GV has a FB report this month. GK, is working in the grave yard at Lakeland and CZ of W4GV is working at the Western Union since school has closed. W4JV has a few 281's and two 210's now. W4CI was on during the spark days and has just started going again. W4SY says his sister and W4AI's sister are about to become operators at each other's station. W4PAW is a portable call of the SCM. W4AI has built some crystal sets. W4ACK is playing at

night in an orchestra. W4MS reports a new club. W4HY uses 14 mc. for the summer. W4MF has moved to the George Washington Hotel in Jacksonville. He plays his saxophone every night in the hotel's orchestra. W4AJD is an Official Observer. W4AKF is an ORS prospect.

Traffic: W4AEF 647, KDV5 450, W4ACC 433, W4AI 291, W4GV 281, W4CT 204, W4IE 152, W4AGY 94, W4AFC 65, W4AGR 65, W4ADB 58, W4SD 38, W4IX 38, W4SK 37, W4ACK 30, W4AJK 30, W4OZ 24, W4ZP 21, W4UY 15, W4CI 15, W4ABJ 14, W4NE 10, W4PAW 10, W4OO 10, W4TK 4, W4SY 4, W4HY 3.

WEST GULF DIVISION

OKLAHOMA — SCM, W. J. Gentry, W5GF — Well, gang, the traffic sure has taken a big slump this month. Please report on time. There will be some cancelled ORS next month if you don't start reporting, or give reason for not doing so. W5AIR has his arm out of the sling now and will be going soon. FB, OM, W5ARX is trying to make a broadcast station work. Hi, W5AAV says his crystal is working better now. He will be visiting in Illinois and Colorado after June 1st. W5AYF is building a new transmitter. W5KX is an OBS now with crystal on 3520 kc. W5ADK is loafing on the job. If W5APG is in the 20th century relay route, traffic must be slow from reports. Hi, The gang at O.U. are still experimenting. W5QI, the "Question Mark" isn't going yet. W5VH graduated this month. Congratulations, OM. We regret the loss of W5ASK, J. M. Boone, who was killed in an airplane accident in February. W5ASQ had hard luck and blew a couple of 281's. W5BEE is an early riser and reports it FB. W5IH is trying to get an old set with a crystal going.

Traffic: W5AAV 14, W5AYF 10, W5ASQ 5, W5BEE 9. NORTHERN TEXAS — SCM, J. H. Robinson, W5AKN — W5BAD is rebuilding his station for traffic work but has another on the air while the rebuilding is going on. W5WW is going to build a transmitter using a UX250. W5RAM reports DX good on 14,000 kc. W5BFF is keeping schedule with W5LP on Sundays. W5ATZ reports that he can change from the 14,000 to the 7000-ke. band in three minutes. W5AAE is still using the Ford Coil plate supply on the UX210. W5BG is on about twice a week.

Traffic: W5BAD 22, W5WW 21, W5RAM 19, W5BFF 18, W5ATZ 14, W5AAE 10, W5BG 2.

SOUTHERN TEXAS — SCM, Robert E. Franklin, W5OX — W5AQY makes the BPL again this month in spite of the fact that they had a fire in the station which caused some damage to the equipment. W5AHB handled quite a bit of traffic. W5AHP had the Radio Supervisor change his calls so that he is now using W5TD for his station and W5AHP for his portable. W5LP's 281's went west and after buying two rectobulbs, he is now having trouble with his power transformer. W5ASM is contemplating rebuilding. W5ABQ reports traffic and DX good. W5BFY formerly of the A-A station W5AIN, is now in charge of WVB's five transmitters. W5HS has been off the air for some time but is back with us again this month. W5OX accepted a Mother's Day message for the Philippines on Saturday for Sunday delivery. This message was turned over to W5TD who is in constant contact with the west coast and the message was delivered on time. I am gratified to see that most of the South Texas gang are improving their signals to comply with the 1929 requirements but on the other hand, it is deplorable to see how some of the fellows persist in cluttering up the air with signals that are only a step ahead of the old spark of yesteryear.

Traffic: W5AQY 212, W5AHB 61, W5TD 55, W5OX 30, W5LP 25, W5ASM 25, W5ABQ 23, W5BFY 10, W5HS 5.

CANADA

QUEBEC DIVISION

QUEBEC — SCM, Alex Reid, VE2BE — The Quebec gang are on nearly every evening and over the week ends pounding brass, getting wonderful DX and the best traffic report ever turned in by this division. Our RM, VE2AC, makes the BPL for the second time. Alphy also reports working England and France on 28 mc, 14,000 kc. came to life with a bang during May,

VE2AL, VE2BG, VE2BE and VE2CA working five or six foreign stations nearly every evening. VE2BB has rebuilt and reports many foreign contacts. VE2BT turns in his first report (Congrats, OM). VE2CA is moving and will be off for about a month. VE9CX reports many phone contacts on 1750 kc. VE2HT is making tests with our pilot VE2AL while flying over this district and reports are FB. VE2AA reports fine DX working G5RZ in his old home town. VE2HT is changing his shack around and will use remote control in the future.

Traffic: VE2AC 168, VE2BT 31, VE2BB 54, VE2AL 21, VE2BE 21, VE2BG 9.

ONTARIO DIVISION

ONTARIO — SCM, E. C. Thompson, VE3FC — Southern Dist.: All resources have been turned to discovering the why and where of Zepps. VE3HB and VE3CS are both doing good work with 7000-ke. fundamental. VE3AQ is back on 14,000 kc. again. VE3DG reports another Ontario club in action — the Southern Ontario Radio Association, with VE3BV President, VE3DG Vice-Pres., and VE3AQ Secretary-Treasurer, and the club boasts 12 members to date. FB, OMs, keep up the good work, Central Dist.: VE9AL heads the traffic list with a good total. A 3800 kc. schedule accounts for most of it, we believe. VE3BC will not be heard from again until Fall, as he is off to Northern Ontario on exploration. VE3RP has been working more regularly of late and has worked up some good DX as well as some traffic on 14,000 and 7000 kc. VE3CL has been playing with his receiver but still he's not entirely satisfied. VE3XJ has gone and got married, but still he swears that amateur radio is not doomed for him. VE3VS is on the air with a vengeance, using a UX250 as oscillator on 14,000 and 7000 kc. VE3AL was a portable station established for a week at the Toronto Home and Garden Exhibition. 3900 kc. was used exclusively and a good deal of traffic handled. VE3FC has been keeping a schedule nightly with VE2BT at Rouyn, Que., and some good traffic delivered has been the result. VE3GG is now located at Hydro, Northern Ontario, on the Nipigon River. VE3HP is on the air again. Northern Dist.: VE3ET is away from home a large part of the time but nevertheless heard a station in Turkey, He, and the owners of VE3AR and VE3BH all passed their radio operators' examinations OK and are all happy.

Traffic: VE3AQ 2, VE3CS 11, VE3CR 5, VE3HB 2, VE3AL 32, VE9AL 22, VE3FC 11, VE3RC 8, VE3CL 7, VE3BP 5, VE3VS 2, VE3ET 3.

MARITIME DIVISION

MARITIME — Acting SCM, A. M. Crowell, VE1DQ — The operators of VE1CA formerly of VE1AC wish to tender to amateurs a vote of thanks for their cooperation in handling messages from this station. VE1DQ expects to be on the air again by the time this is in print and some intensive reorganization work will be done.

VANALTA DIVISION

ALBERTA — SCM, E. J. Taylor, VE4HA — The good DX weather has had some effect on message totals, although VE4CC leads the gang this month with a good showing. VE4AF is still getting good DX. VE4GD is sure getting out FB. Mr. and Mrs. VE4EI sure do FB, both with message total and DX. VE4FB gets out fine with a 201A. VE4IT is on again. VE4GX and VE4JJ are on as usual and doing FB. VE4RA is after a DC note. The hams in Calgary have oil fever. VE4EY is on regularly but likes 14,000 band the best. VE4HM and VE4GT are out of town most of the time. VE4AH expects to be on again soon.

Traffic: VE4CC 23, VE4EI 14, VE4EY 8, VE4GD 5, VE4HA 2, VE4HM 4.

PRAIRIE DIVISION

SASKATCHEWAN — SCM, W. J. Pickering, VE4FC — The Regina District Radio Assn. is holding a convention during the Regina Exhibition week, August 2nd, and are having a booth equipped with a 250 watt

M.O.P.A. affair to handle traffic during fair week. As many of the gang as possible should try to be there, as there will be prizes for code work, good speakers and an opportunity to pound brass on the big set. VE4GO leads those reporting traffic this month and has been QSO VK2TW, VK5HG and G6YQ who gave him good reports. VE4IH reports very little activity down his way owing to this being his busy season. VE4GR says that traffic is scarce at his station. VE4FC has been on the sick list and therefore not on the air.

Traffic: VE4GO 38, VE4IH 8, VE4GR 7.

MANITOBA — SCM, D. B. Sinclair, VE4FV — Well, gang, the fatal moment has arrived. Your SCM is leaving for the States for three years in pursuit of knowledge and this report will be the last from his typewriter. VE4HR has been appointed as my successor, *pro tem*, and I am sure you will give him the loyal support you have shown me in the past. VE4FV had a last DX spurge, putting up a new antenna and working VK, ZL, G, CE, Hawaii, Alaska, Yukon and Canal Zone. VE4DJ is getting out fine and received a report from England. VE4HR also put a signal into the Old Country and is contemplating a new receiver so he can hear some DX. VE4JB is now using an Ultraudion and likes it fine. VE4DP is now using 750 volts on the plate of his 210 but with 10 mikes of filter, still has a good RAC note. Hi. VE4FN worked Alaska but claims he can't hear the DX. A newcomer has started up in Winnipeg using the temporary call VE4ZZ. VE4DK received a card from G5BY, who says he has called him several times but ND. VE4HX was only on the air once but worked a W8 on 14 mc. VE4EK has been very busy but is back on the air again with a M.O.P.A. set on 7 mc. VE4AR's report was late last month. Don't forget the new reporting date, OM. VE4GQ gave up his crystal in disgust and is now using a self-excited Ultraudion with two fifties in a push-pull circuit. VE4BP has been heard back on the air again and seems to put out a good sock on 14 mc. VE4DB, VE4IC and VE4CT are on now and again.

Traffic: VE4FN 10, VE4FV 2, VE4JB 5, VE4DJ 2, VE4DK 4, VE4DB 1.

LATE AND ADDITIONAL REPORTS

W2SZ handled quite a bunch of traffic during an exposition at R. P. I. W6CAG will be glad to arrange skeds with anyone. W6CBW makes the BPL with 56 deliveries, so that brings up the number of stations making the BPL for L. A. to seven. W6EAI has fast traffic skeds to north and east. W6BFI applies for an ORS. W6CTX handled quite a few exposition messages. W9CMQ misplaced W9EY's report so that is the reason for his being listed here.

Traffic: W2SZ 720, W6BFI 10, W6EAI 32, W6CBW 116, W6CAG 4, W6CTX 1184, W9EY 103.



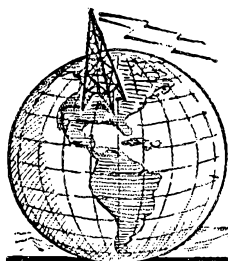

I.A.R.U. NEWS

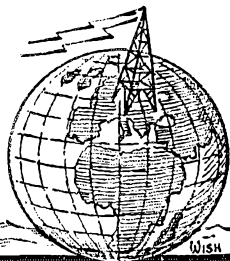

Conducted by A. L. Budlong

ALTHOUGH full details of the Prague Radio Conference are still to be obtained, it would appear now that the conference dealt principally with broadcast matters, and gave little or no attention to other services.

As far as the amateur was concerned, the conference seems to have adopted resolutions that each country should publish call lists of its amateurs, when and if they are officially licensed; and also that the regulations governing amateurs should be forwarded to a central bureau so that countries desiring to institute amateur licensing could have something to guide them.

Little if anything seems to have been done about the Dutch proposals for uniform amateur bands and regulations for Europe. We think this somewhat unfortunate, as the Dutch proposals, in the main, were very excellent indeed, and at least gave a good starting point.

It is probable, however, that the amateur question will be taken up again, and in detail this time, at the Hague Conference scheduled to take place this fall. The scope of the Hague Conference will be much greater, of course. Preliminary indications point to an active investigation into amateur matters, with some effort being made for a "standardized" type of amateur license. How far this can be carried throughout the world is problematical. It is quite possible that it will have considerable backing in Europe, however.

I.A.R.U. Headquarters urges amateurs everywhere to take steps now to find out what their individual government's intentions are with respect to the amateur question at the Hague meeting. In particular, the various national societies now constituting the Union membership are urged to get in touch with their officials. Preparedness is at least half of the battle, and it may save much trouble later.

HELP!

Have you noticed that foreign station photographs have been rather scarce in this column lately? The reason is that the compiler of this

column hasn't been receiving any. He wants to take this opportunity to solicit them from our foreign readers. This is no idle request. OMs. Photographs of many of the internationally known stations are always interesting. Send in yours. The photographs should be clear and sharp, but need not be unusually large. A few details of the outfit, antenna, etc., will make sufficient description to run underneath the photograph.

We also want photographs of foreign conventions, hamfests, etc. These make highly interesting material, and enable us to see what the other fellow looks like.

A NEW FEATURE

We want to make this department as interesting and useful as possible, and are always glad to receive suggestions along this line.

W8GZ has made an excellent suggestion. He hints that great numbers of amateurs would be interested in a table which showed the best times to work foreign DX. For instance, what is the best time for QSO between Europe and the Eastern part of the United States; the best time for United States-South African QSO, etc. W8GZ himself wants to know at what time he stands the best chance of hooking up with Chinese and Japanese stations. The compiler of this column thinks that from 1000 to 1200 GMT (5:00-7:00 a.m., E.S.T.) is the most favorable time, if some reports of Chinese and Japanese QSO's mean anything. This is for 7000-ke. work.

If you want such information, let us know, and then help supply it by writing us your own experiences with foreign DX, so that we can arrive at some conclusion as to the best average time.

CORRECTION

In the May I.A.R.U. column, we stated that Dutch amateurs could be proud of the work that their society had accomplished in getting such excellent proposals from the Dutch government on amateur matters, but very unfortu-

nately we gave the wrong initials in referring to the society. This error is regretted, and for the information of readers of this column we would state that the I.A.R.U. Section for Holland (and the only real amateur society in Holland) is the Nederlandsche Vereniging voor International Radioamateurisme, or the N.V.I.R.

AUSTRALIA

By the Wireless Institute of Australia

During the past twelve months two amateur bodies have been in existence in most of the States of the Commonwealth representing radio amateur interests, namely the W.I.A. and, later, the Australian Radio Transmitters' League, but such a state of affairs could not, of course, continue for very long. After a considerable amount of negotiation, during which the spirit which permeates the amateur movement everywhere prevailed, a successful agreement was reached between the Federal Executives of the two societies, and an amalgamation is now almost complete. Owing to the widely differing conditions which operate in each State, the various divisions had perforce to work out



MOST AMATEURS FAIL TO REALIZE THAT AUSTRALIA IS ALMOST AS LARGE AS THE UNITED STATES and that some districts therefore represent much more DX than others. The above map shows the States and numerals designating the corresponding radio districts. Note that one State has no district number. From this it will be seen that a U. S. ham working an Australian "6" may be accomplishing as much as 250 miles more DX than someone working a "2", "3", "4" or "7".

How many Australian districts have you worked?

their own difficulties, which have either been successfully overcome or, as in the case of West Australia, are still the subject of amicable negotiations. The net result is that the W.I.A. is now the sole representative of amateur interests in this country with a wide-awake division in each state. The amalgamation has greatly increased our prestige with the public and official

radio, with which Department we are in full cooperation in the administration of the radio telegraph regulations.

Tests: The 10-meter test with the R.S.G.B. is at present occupying the attention of the high-frequency men in an endeavor to establish contact, but up to the time of writing nothing has been heard of the G's in Australia on the 28-megacycle band.

The Second District (New South Wales Division) conducted a contact competition on the 3500- to 4000-ke. band between March 31st and April 14th, prizes being awarded for the greatest number of contacts made with stations outside the State.

A similar test has just been concluded in the Fifth District (South Australia) and a third is in progress in the Third District (Victoria), the arrangement of the contests being similar in each Division. Points are allotted for every contact made in any one day with stations outside of Victoria on the following basis: European contacts gain 10 points; U. S. A., North and South America, 8 points; New Zealand, 4 points; Western Australia, 3 points; and New South Wales, Queensland and South Australia and Tasmania, 2 points.

Second and Third Districts have been conducting Technical Instruction classes in the capital cities, for which a fee is charged to reimburse the lecturers, with the idea of training new operators. The scheme is meeting with very considerable success and has had the effect of encouraging a good number of B.C.L.'s to take an active interest in the amateur game.

The formation of a section of the Institute to investigate aeronautical radio communication is in progress in two States, Victoria and New South Wales, and a committee consisting of members of the Institute and the local aero clubs is now working on the details. Experiments will be undertaken in which members will install transmitting and receiving equipment in planes made available by the club.

The organization of the Air Force Communications Reserve in this country is being gradually completed and the first maneuver took place in April, when the local squadron, including the Federal President, H. K. Love, VK3BM, went into annual training.

The efficiency of the scheme was amply demonstrated recently through a serious accident in which the Chief of Signals to the Air Force was, strangely enough, concerned. VK3JK, J. K. Herd, whose station happens to be located at the scene of the crash, was instructed to report and was instrumental in establishing communication with the plane's headquarters.

A considerable amount of activity on phone is being experienced on the 80-meter band between 4000 and 3750 ke. between States and New Zealand and good results are being obtained

especially between the 3rd and 7th Districts (Victoria and Tasmania).

BRITISH NOTES

By J. Clarricoats, G6CL

On the 7-mc. band it was noted that fade-out occurred around 2100 G.M.T. on some evenings, but on most occasions all Europe could be heard from daybreak until midnight. American stations were again weak, whilst Asiatic Russia was not so easy to work as during March. The number of raw a.c. stations is decreasing, but the band is becoming badly jammed by commercials and high-power broadcasters. A large percentage of stations is still working off-wave and Russia continues to use illegal call signs.

The 14-mc. band has been excellent. Many more of our low-power men have W.A.C. certificates. Considering that the majority of our active transmitters use powers not exceeding 20 watts, their performances are remarkable, because most of the stations they work employ powers up to 100 watts.

On the 28-mc. band little new work has been accomplished. During the period of the R.S.G.B. tests, conditions were very bad, and only a few British stations made contacts. We hope to receive reports from our many friends overseas who listened during the test periods.

Commencing May 1st, R.S.G.B. will arrange to distribute all QSL cards sent to them whether for R.S.G.B. members or not. We would emphasize that R.S.G.B. is the only official amateur organization in Great Britain. The present membership exceeds 1400, representing almost all the active transmitters in the country. New members are always welcome and full particulars can be obtained from the Hon. Secretary, 53 Victoria St., London, S.W. 1. A free copy of the Society's monthly publication, the *T. & R. Bulletin*, will be sent to all interested amateurs who write to the above address.

DANISH REPORT

By Helmer Petersen, OZ7S

Conditions have been fairly good during the last few weeks.

On the 3500-kc. band we have heard no foreign amateurs, but connections with Danish amateurs could be established during the whole day and night.

On the 7000-kc. band conditions have been good, but QRN was horrible at times. For DX work this band won't do, as QRM makes every QSO impossible. Foreign stations heard on this band have been W, AG and FM.

The 14,000-kc. band has been excellent during the month, and best working hours seem to be from 0600 to 1800 G.M.T. During the day most

of Europe is heard with good strength, and during the afternoon, some U. S. A. districts. Later in the afternoon Australia, Dutch Indies, Asiatic countries, North and South Africa and Virgin Islands come in. After 1900 G.M.T. most strengths decreased, although VK and ZL were heard several times QSA2-3. QRM is increasing on the band, and worst about 0900 G.M.T. Very often the band seems to be quite dead, but a few CQ's will raise quite a few stations. Many Danish amateurs have got all continents on this band during the last few days.

On the 28-mc. band nothing has been heard, although many receiving stations are working in this territory. Only harmonics from commercial stations were heard, and it seems as if Denmark is very badly placed for the U. S. A. on this band.

FRENCH NOTES

From the R. E. F.

French amateurs are very much concerned over the QRM situation on the 7000-kc. band, finding it almost impossible to do any DX work there. It has decided to conduct an active campaign against poor notes, raw a.c., etc., and in addition has proposed that the various amateur bands be utilized as follows:

160 m. — Telegraphy and telephony. No restrictions.

80 m. — Principally for continental traffic. Telegraphy and telephony.

40 m. — Telegraphy only.

Continental work during the day, but not at night, night being reserved for DX alone.

20 m. — Telegraphy only. DX band.

10 m. — Telegraphy only. DX band.

5 m. — No restrictions.

The R.E.F. recommends that this proposal be given serious study, as without some such plan it will be almost impossible to conduct any DX QSO on 7000 kc. (The editor wishes to point out that this system is almost exactly that now in existence in the United States. — *A. L. B.*)

28-mc. work has been excellent in France recently. F8CT made the first France-Finland QSO in this band with OH2NM, and FI1B, a member of the R.E.F. in Indo-China, heard a Brazilian, PY1B.

HOLLAND

No Dutch report is available this month, but at the request of Mr. W. Keeman, the Traffic Manager of the N.V.I.R., we would advise all readers of this department that the address of the card-forwarding bureau for Holland has been changed, and is now as follows:

Bouwman,
Voorschoten,
Holland.

(Continued on page 73)

Calls Heard



SP3AR, Jan Ziembirski, Lwow, Bielowskiego 6, Poland

wiabd wiala wiasy wialw wiaawe wibft wiafl wiarq
wibls wibqs wicki wlex wlic wlpm wlii wiese wlef
wlys wlasd wlibub wlyx wloex wlmr wlatm widl wlif
wlyb wlyaj wleml wlyc wloox wlibal wlbou winq wlye
wlywl wlatm wlyw wliang wliai wleke wliadh w2ags
w2aao w2aql w2aj w2ak w2aub w2baz w2aur w2bi
w2ogd w2ouq w2ge w2xai w2yq w2ty w2tp w2og w2nf
w2ic w2gp w2com w2ahu w2ja w2bda w2zia w2aok w2bjm
w2erb w2om w2azk w2evj w2aod w2bhv w2apd w2atr
w2air w2kj w2ov w2bll w2arb w2jn w2anh w2sz w2aws
w2auj w2aql w2alq w2apn w2abm w2bf w2afj w2aad
w2bhx w2of w2bm w2ef w2ard w2ut w2tr w2bn w2awb
w2agd w2aba w2wm w2bl w2rb w2hz w2pk w2rn w2aef
w2ap w2tz w2to w2kg w2hz w2je w2ln w2lp w2ozr w2adq
w2vo w2aj w2eg w2anq w2onh w2xa w2dy w2did
w2dod w2hox w2awp w2aag w2hx w2uk w2epr w2axa
w2hen w2efm w2pk w2adm w2hal w2eiw w2odg w2xi
w2aok w2dkg w2oz w2dr w2ews w2epa w2bhh xau-ktf
xuu-6clv xw7eff xe-lad ne-lbr ve3ia ne-8rg ne-8ae xne-8jd
nj-2pa nu-9a nu-lmic k4aan nq-2ro nq-2ay nq-2sc om2jt
nu-5fl nq-5ex nq-7ex nr-2ags nx-lxl nz-tr5 ysiab yslfm
ze-2al ze-2ek ze-9aa ze-67ra ze-67ra ag-rb14 ag-7kad ag-7kah
ag-7ae ag-7as ag-7aa ag-7ab ag-7kag ag-7ao ag-7ar ag-7kwd
ai-2kw ai-2bj ai-2kt ai-2bv aj-4zz au-lab ag-9frg aq-1hf
yilfm yilmdz yi2gq ar-8mo ar-8uim as-lad as-las as-lak
as-lag as-lap as-lac as-ra03 as-35ra as-52ra as-72ra as-ber
as-rb9 au-lkah au-lkh au-lkab au-lam au-lai au-5ws
au-7kn au-7au au-8au au-8aa au-l2ra au-48ra au-trk
ib-hyo id-lpr ie-gm fe-egex sulna sutsw su8ar su8an
su8rs ik-5er im-ear50 im-ear88 im-ain im-ocup im-8gkc
im-8kik im-8vx im-8ev im-8rit im-8kua im-8jo im-tun2
en8mb eo-a3z eo-a2a zsfm zsfu z5fe v2bh fq-pm iq-ocd1
ir-aura ir-earb vk3vp vk3to vk4as vj1er k3aa z1lap z1lf
z1lv z1za z12ae z12be z12go z12bp z12bo z12bd z13aj
z13ar z13em z13ai z13ac z14aa z14ac z14av z14am z14ao
zu-lpl za-lpl za-d33 za-bal za-fs2 za-fes pylah pylar
pylbo pylcg pylca pylcj pylcm pylie pylid py2ad py2ab
py2ay py2ak py3ah py5aa py7ab se-2ab se-2as se-3ab
se-1ea su-2ak

Ben Stevenson, 21 Randolph Place, Newark, N. J.
14,000- and 7000-kilocycles band

w6awp w6aoc w6dzy w6dle w6dyn w6bpm w6gn w6ezz
w6vz w6cut w6ags w6dan w6cwl w6ei w6thi w6esw
w6eop w6drb w6bdx w6ary w6dyj w6eyx w6ehw w6ebp
w6dyo w6dog w6dij w6czm w6dms w6ehf w6eaa w7ed
w7af0 w7aj w7aa0 w7arb w7wg w7akj w7id w7akp w7aik
w7i w7na w7mw w7pl w7he f8id f8eo f8ep f8hr f8hz f8he
xpa pylid pylah g6hj g6hy g6bx g6ty g6fm g6xc g6yg
w6at on4tp on4ng on4it on4nu ct1bx ct1by ct1ae ear48
ear44 xpa0ja

Niels Jacobsen, 29 Bredgade, Copenhagen K, Denmark

14,000-kilocycle band

wiaed wialb wiaqt wibal wiaa slaw wleje wlegr wika
wlio w2aef w2md w2au w2rs w2adm w2axa w2hx w2iic
w2ib aulap xau2bj ar8ufm ce2ax fikol fk4ms im8kik
im8sc klem pk1jr pk4az su8an su8rs velbr velco ve2al
ve2ca voaaz vu2kt yilmdz yi2gq z1aa zsfm

A. G. Weynton, No. 1, Harcourt Plots, Brickley St., Cremorne, Sydney, Australia

14,000-kilocycle band

w1bux w1cjc w1arb w1fn w1aac w1aef w1aw w1rg w1aaj
w1bax w1ary w1cwl w1cza w1dyb w1eop w1kk w1kb
w1wn w1ahx w1mx w1vk w1ouz w1ax w1beu w1enc
w1dar w1dl w1bgq w1dgz w1of w1hm w1fl w1mt k1cj
k1em k6ha f8id f8hr f8mf f8mf g5hz g5ml g6hp oh2nm
pk4az sc3bf sc3bu uox y3ab

BRS188, Basil Hall, 25 Coombe Gardens, New Malden, Surrey, England

7000-kilocycle band

wlaed wlaek wlaf wlahx wlapk wlayj wiaxx wlbka
w1cib w1cmf w1enj w1cqs w1mk w1si w1wz w2ao w2aen
w2af0 w2afy w2agp w2aih w2aky w2anh w2anf w2any
w2ary w2auk w2bai w2bem w2bda w2bfo w2bhr w2bif
w2box w2bp w2bpd w2een w2erb w2evu w2eul w2f w2vj
w2kj w2nt w2ra w2rp w2ali w2alf w2auw w2avf w2aw
w2bk w2br w2ze w2ba w2ac w2aee w2aek w2aef w2ahm
w2aj w2bh w2cz w2li w2mi w2asin w2sa w2af w2hm
w2akp w2app w2baz w2bbj w2bck w2bcu w2bjo w2ek
w2kl w2eb w2dat w2hm w2lt w2wz w2lfo w2ama w2ab
w2bqe w2ene w2emv w2dyf w2eox w2fidj w2fqn w2fs
w2um w2wi w2zi zular au7ab au7as au7kad au7kwd
au7kzn au8un cm3af ct2aa freara freare helic j2vj kvd5
kfr5 ur2wd oa4q kdjf leuo xau2za xaurda x8p9y

14,000-kilocycle band

wiaao wlabg wlaei wladw wlapc wlahi wialb wiald
wile wlapq wlaqd wlaqt wlare wlare wiazd wiaze
wibal wibem wibfi wibil wibkf wibqs wibsk wibux
wleax wleek wlefi wleje wlemb wlemx wlenj wleox
wlooz wlepb wlegr wlda wldp wldq wlf wlr wli
wlio wljr wkh wly wlmr wimu wimv wimr wly wls
wisw wluw wlyw wli wli wza w2abu w2adp w2ady w2aef
w2afb w2ag w2age w2aje w2ain w2ake w2ak w2amm
w2anj w2any w2aof w2aog w2aah w2aq w2arb w2arx
w2atz w2auw w2ave w2bei w2bjf w2bjb w2bjg w2bjv
w2bke w2blg w2bhb w2bhp w2bvg w2et w2evj w2k
w2el w2k w2l w2p w2j w2k w2h w2jn w2mb w2md w2qu
w2sv w2sw w2adm w2adp w2ahh w2app w2aqi w2aaj
w2aqs w2bph w2cig w2cgs w2db w2eg w2jm w2ju w2of
w2ur w2uz w3oh w3ow w3ut w3bv w3vm w4by w4bw
w4cl w4db w4aef w4ha w4uq w4cq w4t w4zv w4ly
w4ne w4h w4si w4tn w4am w4ba0 w4bay w4ay w4cy w4ox
w4aac w4adg w4adm w4agy w4ake w4bz w4aop w4apd
w4atv w4avs w4axa w4azo w4aba w4bdt w4bvg w4bo
w4eew w4che w4chw w4csh w4sra w4dam w4ddk w4djm
w4doa w4dpo w4dre w4drp w4drs w4duq w4duw w4dy
w4kr w4ly w4oq w4uk w4ul w4za w4bmx w4bvh w4dar
w4dgz w4dgo w4of w4ol w4ox w4yep w4ygy w4hm
w4mt ar8ufm au7ab au7ab celah ce2ab ce3ae ce3bf ce5ab
ex1na ex1oa fa8bak file fk4ms fj5ek im8stg im8kik
im8rea im8rit im8sr imtun2 qpm k1em k4aky k4ni
lu4dq lu2fi u2pa oa4s pb7a pk1jr pk4az pylas pylas
py1em pyler py1ib py2ad py2ak py2ax py2be py2bf
py2ga su8an su8rs velap velar velay velbr velby velca
velco ve2aa ve2ae ve2al ve2bg ve2ca ve3bk ve3bm vk2ed
vk2ek vk2he vk2jj vk2kl vk3kn vk2lj vk2no vk2ns vk2rx
vk3bq vk3ca vk3ep vk3ex vk3de vk3zo vk3jr vk3jy
vk3lp vk3my vk3of vk3pa vk3pm vk3jr vk3ro vk3rx
vk4at vk4bh vk5hj vk5cm vk5hg vk5jh vk7k vk7ro
vo2bh vs1ab vs3ab vu2kt vu2kv yi2gq z2bc z4ao z4aw

z14x z14hg z21a za4m c12 c23 ddea pb7 rori dapa zsu2bj
x18wb xw7efi

ZLZGO, Harold G. Fowles, Box 512, Wellington,
N. Z.

velac velay velaw velap velar velay velbr velbi velbe
velbn velbh veloc veldq velico velda veldh veldp velac
velax velau velbe velbh velbg velbg velam vel3bp vel3bo
vel3hb vel3es vel3rf vel3bi vel3et vel3bu vel4f vel4ar vel4gd
vel4io vel4du vel4cc vel4gx vel4ek vel4hr vel4fn vel4g vel4hm
vel4jj vel4ih vel4db vel4hx vel4ti vel4aw vel5al vel5ad vel5co
vel5dp vel5ej vel5ep vel5dt

WSAPB, Chas. Kabelac, 13409 Southview Ave.,
Cleveland, Ohio

14,000-kilocycle band

g2lz g5cm f8axq f8pam ce2fb on4pf nj2pa pylap lu4dq
rwx g2zp g6yg f8dmf f8lx ce18b c11aa su8an rxr5 pylbi
lu8ad xpa0ja g6bj g6hf f8hr f8mist ce2ab c11ae oa4s fcpm
py1du lu4du vel4cc vel4gx vel4ek vel4hr vel4fn vel4g vel4hm
lulez ear65 g5bz f8ax f8lbp f8orm ce3ao c11by x9a pylaa
lu2bx ear74

WIBUX, Douglas H. Borden, Touisset, Mass.
14,000-kilocycle band

ar8ufm celah celai ce2ab ce3ac ce3bf cplaa c11aa c11au c11au
c11ae c11bx c11by c11ak c11cp d4aar d4al d4abg d4eb d4ed
d4dk d4jl d4kg d4uj d4xy ear1 ear6 ear10 ear37 ear65 ear74
ear91 ear96 ear98 ear116 e17c e18b eufak fa8bak f8aap
f8acj f8amj f8ar f8axq f8bf f8bl f8bw f8cj f8cp f8ct f8ddx
f8dmf f8dot f8ef f8er f8faf f8fk f8fr f8fat f8gdb f8glm f8gy
f8he f8hr f8hs f8il f8ix f8jeb f8jg f8jla f8jr f8jt f8kz f8lda
f8lbg f8lx f8mat f8odt f8oh f8olu f8oop f8orm f8pam f8pns
f8pro f8ra2 f8rbv f8rhj f8rko f8rmi f8sa f8saw f8toy f8uz
f8wz f8xd f8xy f8xx f8ypr f8yy f8za f1m fmyl g2ao g2ay
g2bm g2cb g2cf g2hd g2ii g2lf g2mm g2ow g2qy g2vq g2vw
g2xy g2yu g2zc g2zp g3aq g3az g5bd g5bj g5by g5bz g5cy
g5da g5ir g5lw g5ly g5ml g5mq g5ms g5oc g5pw g5qf g5qv
g5rm g5ub g5ux g5uy g5vl g5wk g5wp g5xd g5xg g5yg
g5yn g6bd g6bx g6ci g6cl g6co g6cr g6dr g6gc g6gs g6gz
g6hf g6hp g6ia g6ko g6lk g6ly g6mc g6nt g6nx g6oh g6pa
g6pp g6qb g6qt g6rb g6rw g6sm g6uh g6uj g6ut g6uz g6vp
g6wd g6wl g6wn g6wo g6wy g6xb g6xc g6xg g6xj g6xn
g6xq g6yq g6za fk4ms ftk6r fcpm g5bhn g5wd g6hi g6im
g6jwg g6yvw haf3an haf3r ilch ilto k4kd k4ni k6alm
k6clj k6eat lak lak lalw lj2pa lulez lu2bx lu2ka lu2li lu3dh
lu4dq lu6fc lu8de lu9dt on2nx oh3nx oh2nap ok1ab ok1au
ok1fm ok1rf ok1rv ok2et on4ar on4bd on4bu on4di on4fe
on4fu on4ij on4jd on4jm on4kg on4n on4o on4q on4r on4s
on4u on4v on4w on4z oz12u oz7b oz7t oz7z oz7af oz7ag
oz7ly oz7wh pa0bu pa0dm pa0dw pa0fb pa0fx pa0fp pa0fr
pa0gw pa0w pa0yf pa0ym pa0yq pa0wr pa0wx pa0xt pb7
py1aa py1ah py1at py1aw py1bl py1em py1er py1ca py1yb
py1yd py2ak py2ax py2bc py2ih py2ii py3ah sm5tm sm5tn
sm6ua sm7us ryle sp3ar sp3bp sp3sa su8an su8rs su8s
uoxl uolkr vk3pm vk3rj vk4bb vk5hg vk2na vk3go x9a
z1ap z1lf z1lw z1fz z1zbe z1zbg z1zbx z14ao yilmdz
yi2gq z24m jal rwx w2at waq wf8wb xpa0ja xpa0yz xpa0zz
xw7eff

OKRP19 — Alois Weirauck, Mestec Kralove,
Czechoslovakia

7000-kilocycle band

lajx laks lci0 lcpf zorb 3ec 5rb 8bcu 8dil aufkwd fm8gko
vo8g wx2px

14,000-kilocycle band

1aep 1act 1bal 1bjk 1bkl 1bux 1cjc 1cek 1emx 1dq 1zz 2ag
2aay 2ch 2dk 2gt 2hq 2mb 2md 2rs 2qa 2adf 3adm 3hf
3af 4nh 8adm 8avs 8axa 8dij 8hx 9auh 9df 9er 8arfjm
aulap celah ce3ac ce3cf cn8mc ex1cy file f9ur1 fm8ssr
fcpm k4ni lu2az lu6fc pk1jr pk4az py1at py1cc pylca
pylem pylid py2ce su8an su8rs uj1er velat velar vel2cg
vk5xg vu2kt yilem yilmdz yi2gq xw1em xau2cj ukf

WSQ, E. P. Kampf, USC & GSS Lydoniu
(Off Florida Coast)

otlaa ot1bf c11bx pa0gg pa0vn on4hp pa0fp on4pf on4ij
d8app f8acf f8ct f8fr f8pro f8ypr f8rko f8lbg f8jd f8cp f8hr

g6vp g5qu g5by g5ml g5bd g6xc g6xn g5vl g5bz g5yq
ear16 su8rs x18pp rxr5 rxr6 celah ce3bf g5wd py1be
py1d zia9tk x9a z14ae xk1m vk2tw vk2az vk2na vk2rx
vk2ho vk3jk vk3cx vk4bb vk5hg vk5ct k7gm k6cf2 k6avi
k6etf rky wid

Mark T. Churton, 13 Dester Ave., Mt. Eden,
Auckland, New Zealand

wiahx wiafp wlaqd wiaqt wiaxx wiaze wibal wlber
wlbea wlbfp wlbgs wlbus wlavl wicca wlcei wicck w1kd
wlmk wlmr wlmx wlpd wiry wisi wlisz wlzz w2aca
waf w2ag w2ags w2ajl w2aky w2alu w2ana w2anm w2aq
w2arb w2atz w2avb w2ayj w2baz w2bfq w2bid w2bir
w2bny w2bd w2by w2euz w2evj w2exl w2dn w2fp w2hg
w2lx w2m w2ml w2mq w2ms w2mn w2rr w2ac w2sv
w2ws w2xg w3afj w3ahp w3ans w3aqi w3bjm w3bnu
w3ea w3ec w3efg w3ehg w3ejn w3ekl w3de w3jy w3ky
w3lw w3muv w3ql w3qt w3sl w3vo w4ano w4abs w4abv
w4ac w4act w4aek w4atc w4agz w4ahh w4aq w4au w4cs
w4et w4fe w4fi w4gt w4ib w4ll w4nf w4pk w4rr w4sz w4tk
w4tu w4uy w4va w4vp w4wm w5aak w5al w5ak w5ak
w5ahm w5aim w5aom w5apq w5aqy w5at w5atf w5aut
w5ayo w5bam w5bat w5bbi w5beb w5bek w5bj w5co w5jc
w5ke w5om w5pa w5ql w5tq w5rd w5rg w5te w5ts w5tu
w5vx w5yg w6aaz w6acx w6ad w6ael w6ap w6ags w6aie
w6akm w6am w6aoe w6aou w6aov w6ar w6arp w6ard w6app
w6apz w6aq w6as w6av w6awa w6ax w6ayj w6ham w6baz
w6bf w6bfp w6bga w6bgz w6bhs w6biu w6bjy w6bx
w6bpo w6bpm w6bpo w6bqh w6boq w6bto w6btz w6buq
w6bvs w6byx w6byh w6bzf w6cdd w6ehk w6chl w6chq
w6chx w6cih w6cin w6cln w6cls w6cxn w6feru w6erx w6csb
w6cub w6cuh w6cuk w6vq w6vw w6wcv w6cyw w6czl w6czm
w6czx w6dea w6deq w6dev w6dey w6efv w6fdm w6der
w6dis w6dfw w6dhj w6dhs w6dje w6djj w6djj w6dkv
w6dkx w6dmg w6dms w6dou w6dow w6dpa w6da w6de
w6deg w6dtp w6dwi w6dyj w6dyn w6djz w6dc w6dc
w6ehf w6eil w6eij w6elp w6elr w6epz w6eqj w6es w6ly
w6tj w6tn w6ty w6vz w6zdz w7aat w7aay w7abg w7abq
w7aby w7acs w7adz w7aee w7aed w7afn w7afp w7agw
w7aik w7akp w7akz w7alk w7ek w7eg w7k w7lt w7l
w7lz w7mo w7nr w7si w7to w7tu w7deq w7cbd w7cas
w8ayo w8af w8ame w8at w8av w8avp w8ax w8ayo
w8az w8bk w8bl w8bq w8bq w8br w8cw w8chf w8co
w8eno w8era w8ex w8dat w8dem w8dnn w8dtn w8dum
w8gz w8ze w8aa w8adn w8af w8ahz w8aid w8aok w8aaa
w8atq w8auu w8aur w8bcu w8bue w8byf w8bqg w8bic
w8bob w8bqy w8bro w8bsh w8bwo w8ch w8che w8cib
w8ejh w8em w8epn w8er w8etq w8ecz w8dbm w8des
w8dzg w8dku w8dmt w8doo w8dr w8dws w8dyz w8ef
w8efe w8eij w8ejo w8eny w8epa w8eta w8flb w8ftz w8fr
w8gj w8gn w8gv w8hj w8hm w8ir w8ka w8kb w8ln w8m
w8so k7aun k7m k8akg k8alm kyalv k8bqg k8cb k8clj
k8dpg k8ddk k8ekr k8etf lodqe lohbi onefp on4ij ou4es
pylib pyqbc velco ve2bv ve2ca ve2ef ve4ey ve5co ve5go
rx5mx rx5ox rx1aa kd55 kfr5 selah selai sel2ab sel3ab
sel3ag sel3hf xg2aj xg3ck xg2ab xg1pp xu9aa xg8em xg2aa
xg2ws xexu7 xg2al xg2ck xg2mo f8aoj f8gdb f8bf f8cp f8ev
f8fc d4yt ng2je nh1ug lidy kjzb j2by j4kj j2b j4zz j2dk
j1xi j1sm j4dk j9fs j3bq j1ko k3bk pk1jr pk2aj x9a
oc8xz ouabi ou4s ou4ai ou5ji klw klad klrc k4aa klaf
klbg klbj klcm klgz klhr klip spear keni au7ao au12ra
oovdn om1tb oot1r eubkg eudka k4ab vzky knt are1 lgb
rwx joe agb ane lpi lad wik kel wfd wiat wbt

W. A. Bousfield, York St., Bellerive, Tasmania
14,000-kilocycle band

wladj wlako wlbus wiry w1zd w2ag w2aro w2blk w2fp
w2jn w2av w3ahh w3aef w5aoe w5aot w5ayy w5awd
w5bcq w3am w6app w6bam w6ohy w6cpm w6cub w6czm
w6dvc w6did w6den w6edw w6dhf w6eop w6gm w6lu w7abg
w7af w7aj w7ek w7ga w7nr w8adm w8axs w8bqw w8ccw
w8era w8w8ddf w8dqv w8aas w8dfy w8dgs w8ef d4jo
eu2ai fele g2xy g5bz g5by g5ml g5mq g5qv g5sw g5wk
g6bd g6oh g6cr g6mc g6at g6vp g6wi g6wo g6xb g6xn
g5xy f8aap f8acj f8br f8er f8fat f8gdb f8he f8ho f8hz f8j
f8jt f8orm fupr fjrko f8rr f8ss f8sf f8sh f8hf f8fn
jdl k1hd klhr ktavi k6eha k7mn oad1 oa4s ok1fm on4di
on4fe on4pf on4ij pk1hb pk4az sulaa jlav jlux jltz uoxz
vs3ab xlj.

Correspondence

The Publishers of QST assume no responsibility for statements made herein by correspondents



Justifiable Complaint

Indianapolis, Ind.

Editor, QST:

I have been holding my steam for a long time, and now it's time to let out a yelp.

When January 1st rolled around, things on 40 meters—I beg your pardon, 7000-ke.—seemed reasonably rosy, with most of the stations having notes which could be called "d.c." and the rest having smooth r.a.c., thanks to Ross Hull's articles in QST.

Now, however, things have changed. Apparently the fellows with self-excited sets have found that they can tune up the rig, using 1928 methods, and still raise fellows. Of course they can since their waves cover thirty or forty kilocycles, and are so easily tuned in. Ten of this kind of men with such stations will more than fill our 7000-ke. band, and needless to say, there are more than ten power-leak notes there, by a whale of a lot.

The result is that those having 1929 equipment are ORM'd on all sides unnecessarily, by selfish individuals whose enthusiasm varies directly as their antenna current. There is not the slightest excuse for an a.c. or poorly rectified note in any of our three popular bands, unless crystal control is used with d.c. on the oscillator. No stal note should be much broader than 10 ke. regardless of plate supply, and if well-rectified a.c. is used, with pure d.c. on the oscillator, the note almost invariably becomes pure d.c.

In my own case, if I substitute a self-excited 1928 type oscillator for the crystal oscillator, the note sounds terrible, but when the crystal is returned, the note becomes p.d.c. again.

Next! There are still far too many hams who let their frequency slip above WEM, which is 100 ke. outside our band. Hams have been heard lately who were on about 7800 ke. They can hardly expect to work unmolested in another's territory. Something will happen when the Navy and Commercials get mad enough, and the amateurs as a whole will get the blame for something that only a few are guilty of.

—Curtis C. Springer, W9EMR

A New Angle

Baldwin, Kans.

Editor, QST:

I am writing this letter in response to the numerous articles appearing in QST razzing the

phones. A majority of the authors of these letters are BCL's or c.w. men, who as a rule, don't know their "10 per" about fones.

A fone xmitter as a rule is affected by weather conditions, and is more difficult to adjust than a c.w. set, because the right amount of grid bias and having the xmitter adjusted too close to the "peak" are to be contended with.

Receiving sets are not all made to work on fone, so please don't accuse the fone of having rotten modulation when it is all in your receiver. Now c.w. men, why do you delight in bringing yourselves in the 3500 ke. fone band? Why can't you men let the fones have a hand or two? You have five of them, so why be such a hog and take all of them, including the one for fones?

The fone man's QSO is not any sillier than the c.w.'s QSO. You can't prove it, can you? If you think that you can, I wish that you would try it.

I own and operate W9GHI on 3500-ke. fone and 3500-, 7000- and 14,000-ke. c.w. and have worked all districts. The Ninth District has more fones than, and as good modulation as, any other district.

—Karlton Marquart

One for You and One for Me

Los Angeles, Calif.

Editor, QST:

In reading the last few issues of QST I have noted with interest the various articles as to splitting the 7000-ke. band into two sections. This, I believe when it comes to DX, would be the answer to our troubles. Handling traffic at night on 7000 ke. is almost nigh unto impossible; so as far as DX is concerned 7000 ke. is the thing.

There is, of course, the trouble of keeping everybody where he belongs. Our licenses state that we are licensed to operate on frequencies between 7000 ke. and 7300 ke. and with the band divided it would be a verbal agreement for the W stations to take one half or more of this territory and put the rest of the world on the other. That is where Old Man Trouble sticks his head in. How are we going to make the fellows keep out of that territory which is set aside for non-W and VE stations? All stations have a perfect right to operate on any frequency between 7000 ke. and 7300 ke. and it would be entirely wrong to ostracize anyone for such an offense, if I might call it that.

However, with a little coöperation from the gang and with the A.R.R.L. back of it, the seem-

"Here at last is The Book that we of the Radio profession have needed for a long time. It is the best and most complete handbook ever published" says J. H. Bloomenthal, Chief Radio Operator, U. S. S. B. Steamship "East Side".

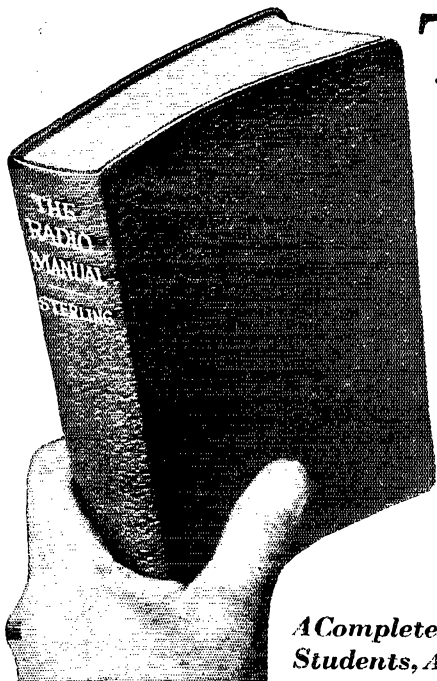

THE RADIO MANUAL

By G. E. STERLING, Radio Inspector and Examining Officer, Radio Division, U. S. Dept. of Commerce.

Edited by ROBERT S. KRUSE, for five years Technical Editor of QST.

Here's the answer to every question about the principles, methods, or apparatus of radio transmitting and receiving. A complete course in radio operation in a single volume. A handbook for students, amateurs, operators, inspectors. For the first time an entire course of training in one book -- the most complete and up-to-date work on radio. Developed simply and clearly from the elementary stage right through all phases of principles, practice, and apparatus so that a beginner with no knowledge of electricity may get all he needs either for amateur operation or to qualify for a government license as operator or inspector.

A Complete Handbook of Principles, Methods, Apparatus for Students, Amateur and Commercial Operators, Inspectors

Complete Preparation for Government License.

16 Chapters Covering

1. Elementary Electricity and Magnetism
2. Motors and Generators
3. Storage Batteries and Charging Circuits
4. Theory and Application of the Vacuum Tube
5. Fundamental Circuits Employed in Vacuum Tube Transmitters
6. Modulating Systems Employed in Radio Broadcasting
7. Wave-meters, Piezo-Electric Oscillators, Wave Traps and Field Strength Measuring Apparatus
8. Marine Vacuum Tube Transmitters including detailed description of Model ET-3626

9. Radio Broadcasting Equipment including, for the first time in any text book, the complete equipment of Western Electric 5 Kilowatt broadcasting Transmitter used in over 75% of American broadcasting stations
10. Arc Transmitters including description of Federal Marine 2 Kilowatt Arc Transmitter Type AM 4151; also models "K" and "Q"
11. Spark Transmitters including description of Navy Standard 2 Kilowatt Transmitter
12. Commercial Radio Receivers and Associated Apparatus including, for first time in

- any text book description and circuit diagram of Western Electric Super-heterodyne Receiver Type 6004C
13. Marine and Aircraft Radio Beacons and Direction Finders
14. The Development of Amateur Short Wave Apparatus. Complete details of construction, operation and licenses
15. Radio Laws and Regulations of the U. S. and International Radio Telegraph Convention. Quotations of all important sections
16. Handling and Abstracting Traffic

Examine It Free

Never before has so complete a treatment of radio theory and operation been compressed into a single volume. Here is information that otherwise you could secure only by consulting many different books. And every detail is vouchsafed for by authorities of the first rank. The Manual is profusely illustrated with photographs and diagrams. There are 700 pages, bound in flexible fabrikoid that is extremely durable. The immediate demand for so valuable a handbook has already nearly exhausted the fourth large edition. To be sure of receiving your copy without delay, order at once. The volume will be sent for free examination. Pay or return in 10 days.

Order On This Coupon

D. VAN NOSTRAND CO., INC.,
8 Warren St., New York City

Send me THE RADIO MANUAL for examination. Within ten days after receipt I will either return the volume or send you \$6.00 — The price in full.

Name..... QST 7-29

St. and Number.....

City and State.....

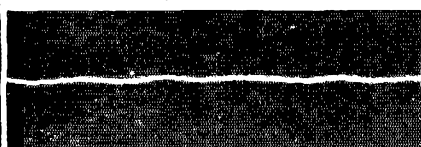

Oscilloscope showing noiseless performance of BRADLEYUNIT resistors



Oscilloscope showing noisy performance of other types of resistors.

A New Resistor That Assures Noiseless Reproduction

COMPARE the extraordinary quietness of the Bradleyunit Resistor with the noisy performance of other resistors. Many resistors cause disagreeable hissing noises in the loudspeaker. For pure, clear reproduction, use Bradleyunit Solid Molded Resistors. They are unaffected by temperature, moisture or age.

Follow the example of leading set manufacturers by standardizing on Bradleyunits for grid leaks in detector circuits and for resistors in resistance coupled amplifiers. The Bradleyunit is your assurance that noises in the loudspeaker cannot originate in your equipment.

Write today for data and prices

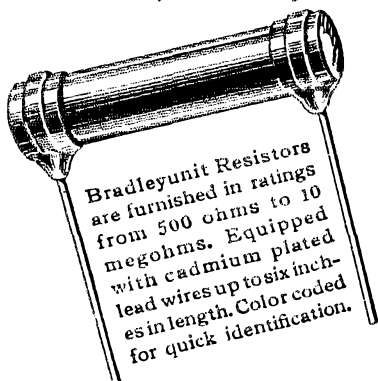

Bradleyunit Resistors are furnished in ratings from 500 ohms to 10 megohms. Equipped with cadmium plated lead wires up to six inches in length. Color coded for quick identification.

ALLEN-BRADLEY CO.
277 Greenfield Avenue, Milwaukee, Wis.

Allen-Bradley
PERFECT RADIO RESISTORS

ingly impossible always comes true, and this will be no exception.

I might also say that the "good evening 73 pse QSL" type of ham won't receive a hearty welcome on 3500 kc. because there lies the realm of traffic and rag-chewing.

I hope that this may be of some value to you in headquarters and with a real ham spirit I say, 73.

— Vincent W. Berry, W6DHM

The I.C.W. Racket

Syracuse, N. Y.

Editor, *QST*:

Having read the correspondence in the May issue of *QST* and as I'm no great lover of the i.c.w. sig., I think I'll speak my piece.

It may be all O.K. for a fellow to use i.c.w., spark, arc or any other piece of junk to cause QRM if he's in some unknown, or undiscovered continent or even another planet where radio is not, but when it comes to using it here I think he ought to be shot and buried before he gets out far with it. It's nice to turn on your receiver and listen to a guy near you using i.c.w., isn't it? The guy may like the sound of it but I think a lot of the fellows would rather have this guy hear the sound of the bells calling him into the world beyond. The hams who use a.c. are bad enough but it looks to me as if the guy with an i.c.w. note wants to give him a little competition. Well, I'll admit that he's got the fellow with a.c. beaten ten ways for raising a racket all over the band. This bird doesn't seem to care what he's doing to the ether as long as he can work someone. Doesn't he know the bands have been cut down, especially the 7-mc. band? Or does he know that and think that there's plenty of room and it won't matter if he monkeys with it? So fellows, let's get the idea of making QRM off our mind. What do you say?

Hoping to hear less i.c.w. notes,

— Chas. Noxon, W8QP

Variety

Route 2,
Hookstown, Penna.

Editor, *QST*:

Something has to be done about this animule Microfarad. What we need is two new names — one for Microfarad and another for Micro-Microfarad; so much different that they cannot be confused even by the girls which work in the "5 and 10." Picofarad is taboo — there might be ladies present which understand Spanish. Furthermore and likewise, it is only one letter different in writing and less than that phonetically.

We have got any number of pioneers in our gang from Hiram down to me whose names deserve to go down in history. QP, MIX, HAT, SK, DON and others galore. But we must call them something pretty soon as you will see later. When I get down to the Zero Ray Emitter I'll tell you all about it. Just at present my latest

KEEPING TABS ON THE FIRE DEMON

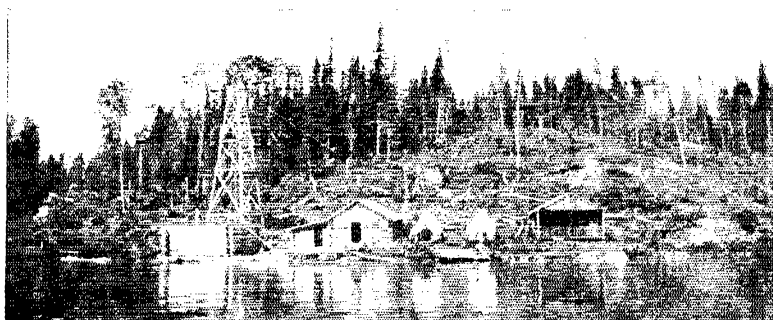

A RADIO STATION IN THE WILDERNESS

This picture shows the forest camp at Red Lake, Ontario, Canada, which is one of the nine places in that district where short-wave radio stations have been installed to keep airplanes and forest rangers in the vicinity in touch with headquarters. The radio shack is in the building next to the tower, the latter being used to dry hose after a forest fire. The call letters of the station are VE9BD.

Photo courtesy Radio Broadcast

BEFORE the wilderness Radio Station became a part of the Canadian forest service, millions of acres of forest land were sacrificed to the Fire Demon because of lack or failure of quick methods of communication.

CARDWELL CONDENSERS will be found in many such lonely stations as the one pictured above, depended upon the year through to secure help for the vigilant rangers and to warn against approaching fire.

From Pole to Pole dependence is placed in CARDWELL CONDENSERS where reliability is paramount and failure spells disaster.

CARDWELL CONDENSERS are made in sizes to suit every purpose, from balancing or neutralizing receiving circuits to equipping broadcasting Stations. Send for literature. * * * *

CARDWELL CONDENSERS

THE ALLEN D. CARDWELL MANUFACTURING CORP.
81 PROSPECT STREET * BROOKLYN, NEW YORK

THE STANDARD OF COMPARISON

Say You Saw It in QST -- It Identifies You and Helps QST

The value of your back copy file of *QST* is determined only by your ability to find a certain issue when you want it.

Can you always find the reference copy you seek?

Your answer will always be in the affirmative if you preserve each year's issues, and each copy as issued, in a

QST Binder

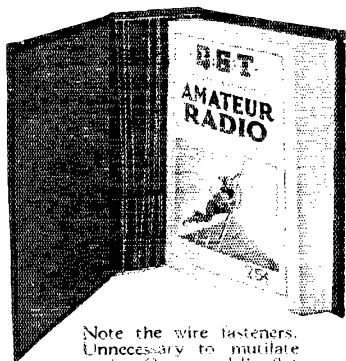

Note the wire fasteners. Unnecessary to mutilate copies. Opens and lies flat in any position.

One-fifty each
postpaid

A binder will keep your *QST*s always together and protect them for future use. And it's a good-looking binder, too.

QST

1711 Park St. Hartford, Conn.

set tunes by a capacity changing from .19 micro-microfarads to .18 micro-microfarads. Or maybe it's centimeters.

Well, while tinkering up my T-2 with a larger choke and smaller grid condenser so it would oscillate without dumping a whole flock of power lines into the filament, me and My Shadow (2nd Op) fell into an argyument on this devastating subject and I thought I would wind up by saying "Well, call it anything." "Alrite," sezee, "We'll call it Anything." About two minutes later I dropped a burr and crawled under the table after it and the derved fool repeated his statement. I crawled out with the missing article and sed very emphatically "Ain't that just what I sed?" He almost laughed his fool head off at something he hot that was funny. It was plain to be seen he was nutty.

"A-N-Y-T-H-I-N-G," sezee.

"Yep, you ain't forgot how," sezzi, and he fell a laughing agin. I retched the Woofhong down and soaked him just once. Half an hour later he begin breathing and I blew some "five brothers" in his face and he went to sleep again. Too many brothers.

A strange little creature appeared from nowhere, touching My Shadow on the brow — and I was alone in the shack; but before the state gets me I want to straighten this matter out to prevent other murders.

What thinkest thou? Shall we worry away with these clumsy terms forever when the day of Zero Rays and Negative Radiation is just around the corner and micro-microdons will be as common as High C Circuits are today?

Please name these monsters before my execution.

— Clarence Gerren

Service Its Own Reward

Pierre, S. D.

Editor, *QST*:

As the beneficiary of an inestimable service recently rendered by two amateur radio stations, one in California — W6AVJ, operated by Mr. Melvin S. Wood, at Gardena, and the other located in this city and operated by Mr. John Berg, Jr., W9DWN — I would like to publicly express my appreciation, through the columns of your magazine, *QST*, if that is permissible, of the efforts of these gentlemen in establishing communication between those caring for my younger daughter during a very serious illness and myself, to our mutual relief and satisfaction.

At the suggestion of a friend, with whom my daughter was staying, Mr. Wood endeavored for several days to get into touch with me through a South Dakota station, which was successfully accomplished on the evening of March 26th, when Mr. Berg, almost by accident, picked up the California station and enabled me to exchange several messages regarding my daughter's condition, much to our delight and satisfaction.

Since that date, through the courtesy and generosity of Mr. Wood and Mr. Berg, I have

THORDARSON TRANSFORMER

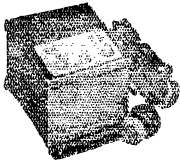

K. 195 Raytheon B-Eliminator transformer, designed as power supply for R-Battery eliminators using the Raytheon B-H tube. Has 2 secondary voltages — low 235 volts either side of centre tap — high 285 volts either side of centre. Transformer will carry the maximum current consumption of the Raytheon tube without overheating.

Listed at \$7.00
While they last, only..... **\$2.95**

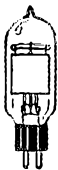

Television Lamp

The large K. H. lamp 4 1/2 inches high — contains 1 1/2-inch plate — carrying 8 to 50 M.A.
Special..... **\$5.50**

Make your own transmitting and receiving coils. Copper tubing transmitting inductance.

Size of tubing			
Inside Dia.	3/16"	1/4"	5/16"
2 1/8"	9c	10c	12c*
2 3/8"	9c	10c	15c*
3 1/8"	10c	12c	17c*

Prices per turn

Ham Green, double silk covered. No. 16 receiving inductance.

2 1/2" diameter..... 30c per inch
3" diameter..... 35c per inch

Aluminum Shield cans and panels of every description to order.

LEEDS

The Home of RADIO
45 VESEY STREET
NEW YORK

New York's Headquarters for
Transmitting Apparatus
When in Town Visit Our Store

Everything in

Cardwell

Acme
Thordarson
Jewell
Flechthelm
Signal
Bradley
Tobe
Pyrex
Fleron

IN STOCK



We carry the largest stock of General Radio Parts in the country.

*Prices subject to change without notice.

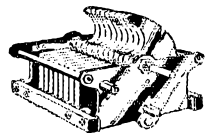

Cardwell con- \$4.45
densers, double spaced for transmitting, .00025 cap.



NEON GLOW LAMPS

Made by General Electric Co., type G. 10, standard base, 107 uses, as illustrated in QST, May issue page 17. Price only..... 65c



By Insistent Demand

LEEDS 50-watt socket, positive contact; heavy phosphor bronze springs, heavy brass shell; will hold your tube in one position. List \$2.50.

Special..... **\$1.75***

Photo Electric Cell



The well known K. H., the most sensitive tube for this purpose — 4 1/2 inches high. Lasts a lifetime with ordinary care.

Never sold for less than \$15. **\$12**
Now Special.....

FEATURING

3 new items — Leeds Radio Lab. — others to follow in future issues. This department under the supervision of the Short Wave Specialist Jerome Gross. We design, construct and advise on any material for the "Ham" Broadcasting station or laboratory. Write Jerry Gross for advice on any of your problems.

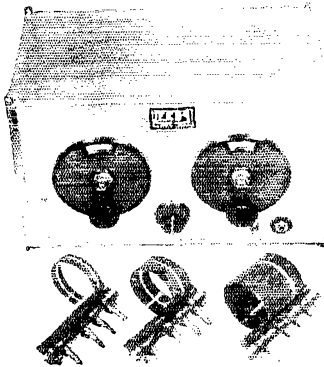

List price \$60.
Special Offer, net..... **\$37.50***

New LEEDS all aluminum plug in Short Wave Receiver. Coils not exposed, thereby insuring 100% shielded job. Short Wave — 3-tube Receiver — detector — 2 audio, using three 203-A tubes. Universal type, continuous range 15 to 100 meters; amateur type covers Ham bands 20-40-80 meters with generous spread on the dial.

New LEEDS 7 1/2-watt Hartley 1929 type Transmitter. Ideal for the beginner or anyone desiring a transmitter extremely simple to adjust and operate. Will operate with a 201-A tube, with 90 volts on the plate, up to a UX-210, with 30 watts input; has plug in transmitting coils. List price — kit \$55. Completely constructed \$70.
Special Offer, completely constructed..... **\$57.50***

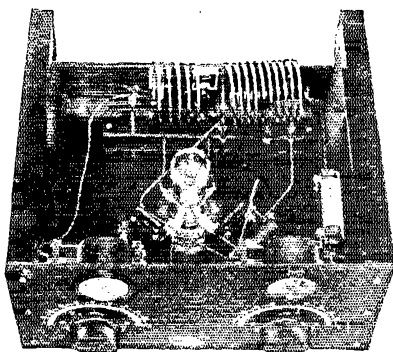

PLEASE PRINT YOUR NAME AND ADDRESS PLAINLY to AVOID DELAY

WRITE FOR SPECIAL PRICE LIST

MAIL ORDERS FILLED SAME DAY
10% Must Accompany All Orders

Cunningham RADIO TUBES

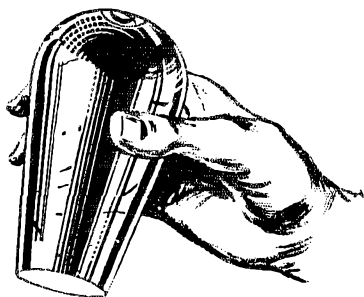

Where Tube Similarity Ends



Outside appearances may be similar or even identical between various makes of radio tubes.

It is the accuracy with which the parts are precisely manufactured and tested that gives Cunningham Radio Tubes their remarkable outstanding quality and long life.

Quality safeguarded from within

E. T. CUNNINGHAM, INC.
New York Chicago San Francisco
Dallas Atlanta

had almost daily reports as to the gradual improvement being made in the patient's condition, and for which words are not adequate to express my gratitude and keen appreciation.

I wish, however, to give my testimony to the value of such worth-while service as has been rendered by these radio amateur operators and so unselfishly performed, to whom I shall be under enduring obligations.

If this is a sample of what other amateurs are doing, they certainly are deserving of the highest commendation and worthy of the greatest consideration.

— E. F. Swartz

So We Be

Denver, Colo.

Editor, *QST*:

To the outsider getting into high-frequency code transmission, it seems to be a difficult proposition; he is confused by this kind of circuit and that kind of circuit, this kind of tube and that kind of tube, and when he talks to amateurs who are old in the game, he cannot find two who will agree on the kind of antenna to use or get any real definite dope. As a rule, he doesn't know that there is such a magazine as *QST* from which, with a very little study of its pages, he would be able to determine exactly what he wanted, how to go ahead, and (if he has any mechanical ingenuity) construct his station and get it on the air without burning up a lot of equipment.

For the life of me I cannot see how the amateur can operate his station without a good monitor; it not only gives an idea of what the note sounds like on the air but assists materially in proper sending.

Having had some years of experience as an operator for the Associated Press, I believe that the average amateur does not take sufficient pains with his sending; he is what you would call sloppy, chippy, and a sender of combination. I do not mean this criticism for all amateurs, by any means, but I have heard a lot of them doing as I just said. Particular pains should be given to sending call letters slowly and distinctly even though one's ability to receive them should be unlimited. A good steady call gets the contact.

— H. E. Madison

Why Is a Ham?

Sylvester Ave., Jamaica, N. Y.

Editor, *QST*:

We first became more or less of a devotee of our sleepless art — wireless telegraphy — through an accident.

One day in class we read the romantic and thrilling account of Jack Binn's heroic work and in the course of the story, our teacher (may she rest in peace) asked for the method used in sending or transmitting the then-used distress signal, "CQD." A boy with a voice like the boom of a dynamic speaker volunteered to do the enlightening. Cupping his hands over his mouth he shouted out the letters of the signal at the top

A NEW JEWELL 199 Set Analyzer

TESTS SCREEN GRID Sets



When used with Jewell Analysis Charts and Jewell "Instructions for Servicing Radio Receivers," the Jewell 199 Set Analyzer eliminates guesswork from radio servicing.

The rapid development of screen grid tubes and the marketing of screen grid receivers by large radio manufacturers demands a set analyzer for testing screen grid sets.

With the keen foresight which has characterized Jewell efforts in the radio service field, Jewell Engineers have already solved this problem. The New Jewell 199 Set Analyzer is equipped to test screen receivers.

Through a remarkable engineering achievement, this valuable feature has been added to the 199 without increasing the selling price. Today you can get a Jewell 199, equipped for testing screen grid receivers, *at no extra cost.*

THE New Jewell Pattern 199 Set Analyzer answers every requirement of accurate and rapid radio service. It is the same unit which has proved so popular with radio servicemen everywhere, plus the provision for testing screen grid sets.

Here is an instrument which will enable you to take the slack out of what are usually considered the dull summer months. By making service calls with the Jewell 199 you can build good will with your customers, pick up a nice bit of accessory business, and secure leads to a lot of new set sales. Sold by radio jobbers everywhere.

Mail the coupon for valuable data!

29 YEARS MAKING GOOD INSTRUMENTS
JEWELL
JEWELL

199 SET ANALYZER



Jewell Electrical Instrument Company
1650 Walnut Street, Chicago, Illinois

Of course we want to make our radio servicing more effective. Send your book, "Instructions for Servicing Radio Receivers," and information about the New 199 Set Analyzer for testing screen grid sets.

Name.....
Address.....

SPREAD THE BANDS

EVERY amateur receiver must spread each band over the entire tuning condenser scale. Modernize your present set by installing the REL amateur coil and condenser tuning combination. Maximum efficiency can only be obtained by using correct LC ratio. Each coil in the REL Cat. Number 182 coil kit is correctly designed to adapt itself to any type of short wave circuit which requires inductances having one, two or three independent windings. Slotted grooves hold coil to original calibration as each turn is held fast in place. Key slot assures proper plug in as coil will only fit base in correct position. The coil shown is one of a kit covering the 14,000, 7000 and 3500 KC bands. The one piece construction means rigidity, insures permanency unattained with any other type of coil. Ask for Cat. Number 182. Price: \$10.00 including three coils and base.

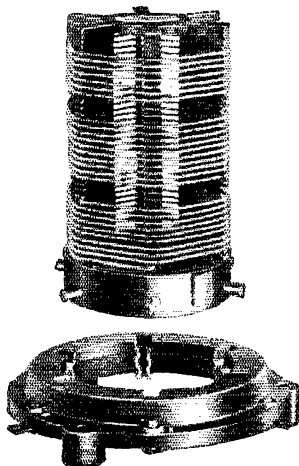

Here is the only variable condenser which will give full spread tuning over any narrow frequency range desired. Its design and construction is far above the usual types now available. It's a receiver condenser constructed more rigidly than most transmitter condensers. Tank capacity, 115 mmfd. Capacity of single plate vernier when spaced 1/16" — 30 mmfd. Ask for Cat. No. 187E. Price, \$6.25.

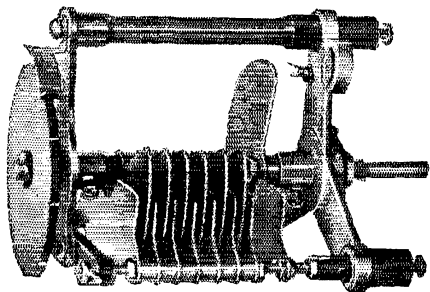

IF YOUR DEALER DOES NOT STOCK
THESE ITEMS, -- ORDER DIRECT

REL manufactures a complete line of amateur short wave transmitting and receiving equipment. Write today for your free copy of our new 16 page folder showing latest circuits.

Radio Engineering Labs.
100 Wilbur Ave., Long Island City

of his powerful lungs. Needless to say, there was much and prolonged laughter. In fact, some of the boys who knew how the signal was transmitted, literally and actually fell out of their seats. (For the benefit of the curious, that boy was neither part, parcel, warp nor woof of ourself.)

This episode was productive of two things. Firstly, that we were the unhappy hosts to a visitor in the person of our austere and forbidding principal and secondly, perhaps more importantly (?), it made us interested in that very fascinating, slumberless, eatless and YL-less art of keeping oneself young, fit and balmy. That, our indulgent and slumbering friends, was in the ancient and glorious days of 1914.

With due diligence, we learned the code, built a magnificent receiving set using a home-made crystal detector and a purloined 75-ohm 'fone receiver. Shades of our lamented and departed tubes! It worked. Then followed a period of patient listening. At last, success was ours. We had been able to make out the call of NAH. After a while our patience exhausted itself, our interest flagged and naturally radio just QSS-ed (QSC-ed) out of our life.

Many years later when we had grown worldly and wise and safely beyond the voting age, our interest in radio was suddenly rekindled by the blurbs of an amateur friend of ours. After much effort on our part together with aid and comfort from our friend we managed to secure the coveted ticket.

Then followed a period of much vexation, perturbation and all the rest of the -ations. We had to build a receiver and transmitter. This latter act was finally accomplished. Thus on the very memorable (?) day of August 28, 1928, another source of bedlam on the 7000-kc. band made its blushing modest appearance.

Since the arrival of the blue parchment, all has not been smooth sailing. We have built and rebuilt our set so many times that we do so now as a matter of habit! We have put most of our spare time and then some, into this hobby. The inroads made by the purchase of parts has put us on the verge of bankruptcy. We have lost out on sleep to an extent that makes the folks apprehensive over our physical condition. To cap it all, we have lost the girl friend. In return for this, we have derived much satisfaction in holding two-way communication with distant points. Amateur radio has been the means of making many a friendship and, we hope, enduring ones. Most important of all (call it selfish, if you will) we have a hobby which is so absorbingly interesting that when after a wearisome day of office work and school we seat ourself at the key, all our troubles, cares and worriments dissipate themselves into the thin air and we are living. Yes, we mean it, we are really and truly enjoying our mundane existence.

— Louis H. Roth

SM

Is There No Limit To What an S-M Receiver Will Do?

Australia to New York on Six Tubes

MORE and more astounding are the records of long-distance reception with Silver-Marshall screen-grid receivers. First the S-M 710 (Sargent-Rayment Seven) made itself famous as the one set which, in California, could be relied on to bring in Japanese broadcasting stations in any kind of favorable conditions—and often when conditions were otherwise. Later, reports began to be published of reception across the Pacific with the S-M 720 Screen-Grid Six—using only three screen-grid r.f. stages instead of four. Then, in March, came the publication of verified reception in New York City, from 2BL at Sydney, with the 710.

And now the Australia-to-New York record has been duplicated with the 720 Screen-Grid Six.

Not every one, perhaps, has the necessary skill to bring in stations from half way around the globe—but the hard-to-please listener, wherever he may be, soon finds that screen-grid tubes, combined with Silver-Marshall engineering, are the ultimate answer to every demand for superlative radio reception.

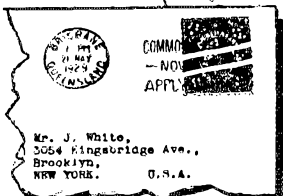
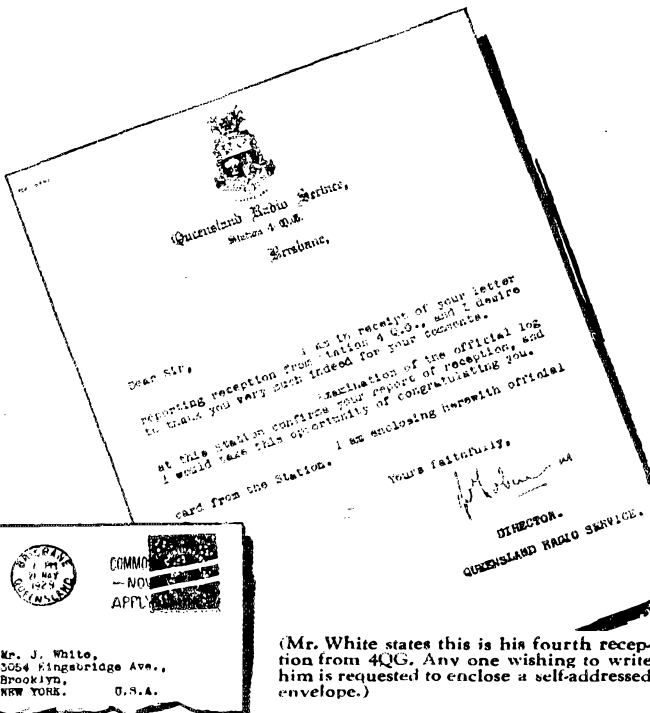

(Mr. White states this is his fourth reception from 4QZ. Any one wishing to write him is requested to enclose a self-addressed envelope.)

Never-Equaled Tone Fidelity With S-M Audio Transformers

Equally startling records for faithful musical reproduction have been made this season by S-M Clough System audio transformers. These remarkable instruments, practically eliminating hysteretic distortion in all types of radio receivers, are now available in a full line of models. The tremendously popular 255 and 256 straight audio types cost only \$3.60 NET, and correspondingly low net prices have been set on all other types, including push-pull and output transformers and chokes.



New List Prices (NET) on S-M Sets that Have Made History

S-M No.	Name	Scr.-Gr. Tubes	Wired Receiver	Component Parts, Total Cost
710	Sargent-Rayment Seven.....	4	\$113.40*	\$78.84*
720	Screen-Grid Six..	3	66.30*	44.79
720AC	Screen-Grid Six (All-Electric)...	3	70.20*	47.07
730	"Round-the-World" Four...	1	42.90*	31.71*
731	"Round-the-World" Adapter	1	30.00*	22.86*
740	"Coast-to-Coast" Four.....	1	48.60*	30.96
740AC	"Coast-to-Coast" Four (All-Elec.)	1	50.70*	32.97

*Price includes metal shielding cabinet.

Setbuilders who have taken advantage of the unique franchises granted by Silver-Marshall, Inc., to Authorized S-M Service Stations have found that the building of radio sets and amplifiers from S-M standard parts is a highly profitable as well as an interesting business. If you build professionally, and have not investigated the Service Station proposition, ask about it now. And in any case, do not miss the monthly S-M "RADIO-BUILDER"; every issue contains big news. Use the coupon.

SILVER-MARSHALL, Inc., 6409 WEST 65TH ST., CHICAGO, U. S. A.

Silver-Marshall, Inc.,
6409 West 65th St., Chicago, U. S. A.

... Send your new complete catalog, with NET prices, also sample copy of the Radiobuilder.

... For enclosed 10c, send five selected Data Sheets.

Name.....

Address.....

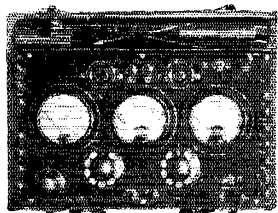

The New Radio Set Tester

THE radio industry is familiar with the Weston Model 537 Radio Set Tester — for A.C. and D.C. receivers. Service men hailed it with great acclaim a year ago, noting its many advantages over the Weston Model 519 — for D.C. only.

And NOW — here is another great advance — the Weston Model 547 — incorporating many additional features to meet the service testing requirements of radio's latest developments.

But with this NEW SET TESTER radio servicing is still further simplified, even taking into account the number of new tubes, sets and circuits.

Space won't permit description here — nor would words alone do this new set tester justice. You must see it for yourself — operate it — try to think up some service problem it can't solve. Try as you will the Model 547 will give you a quick and accurate answer every time. Convenient — complete — light and rugged. Handsome in appearance — and it will yield you handsome profits. It will increase your business and your prestige. **YOU CAN BANK ON IT!**

This instrument has many outstanding service features. But first of all it is a Weston — assuring you exquisite workmanship and complete service reliability. It is provided with three instruments — all $3\frac{1}{4}$ " diameter and furnished with bakelite cases. Carrying case, removable cover, panel and fittings are also made of sturdy bakelite.

**WESTON ELECTRICAL
INSTRUMENT CORPORATION**

602 Frelinghuysen Ave., Newark, N. J.

Weston
PIONEERS
SINCE 1888
INSTRUMENTS

I. A. R. U. News

(Continued from page 65)

INDIA

The Government's policy here is to cut down all amateurs to 10 watts or less, input. Exceptions are made in special cases. There are no special restrictions as to (a) type of wave (spark is barred, however), (b) quality of wavemeter, or (c) hours of operation. Operation is allowed on assigned wavelengths in the 7000-, 14,000- and 28,000-ke. bands. Phone or code may be used in all bands. Detailed diagrams and specifications of the set are required occasionally. The assigned prefix for India is VU.

VU2AY, input 30 watts d.c., will be on the air regularly from 1530 to 1730 G.M.T. after the end of July in the 14,000- and 7000-ke. bands only. Occasionally on 14,000 from 0130 to 0330 G.M.T. — H. F. Miller, VU2AY.

JAPAN

From Mr. K. Kasahara, J3DD, a member of the Executive Committee of the J.A.R.L. we learn that the frequency assignments of Japanese stations are being changed. Old assignments were for 7900 kc., but all new licenses are now being issued for 7100 kc., and most of the old stations are expected to change very soon. This means that amateurs looking for Japanese DX should expect to find them on 7100 kc. from now on.

DUTCH EAST INDIES

Last month we chronicled the formation of the N.I.V.I.R.A. as the amateur society for the Dutch East Indies. Almost 100 members are now enrolled, and officers have been elected as follows:

President	J. van Holst Pellekaan	PK3AN
Vice President	A. J. A. Schoevers	PK2AJ
Secretary	Egb. A. Krygsman	PK4AQ
Director	Hasselbach	PK2AL
Director	G. K. H. De Bont	PK6BA
Technical		
Director	F. H. E. Oldenboom	PK4AR
Technical		
Director	A. J. H. L. Rosenquist	PK1JR
Communications		
Manager	Egb. A. Krygsman	PK4AQ
Asst. to the		
C.M.	A. J. H. L. Rosenquist	PK1JR

As stated previously, all correspondence, and QSL cards for PK stations, should be addressed to Egb. A. Krygsman, Landas Estates, Palembang, Sumatra, D. E. I.

Our best wishes go to the new organization.

U. S. S. R.

By W. Vaneef, AU12RA

By the 1st of January, 1929, we had some 500 amateur transmitters, and 1500 registered short-wave receivers, compared to 63 transmitters and 400 receivers a year previous.

Last October the old call system (02RA, 10RA, etc.) was dropped, and the American system adopted, so that the calls now consist of

Special Offer—

During July and August only

A year's subscription to QST

(either new or renewed)
and a copy of the ninth edition of the

Radio Amateur's Handbook

By Handy and Hull

(in its 51st thousand)

\$3.00

(foreign countries \$3.50)

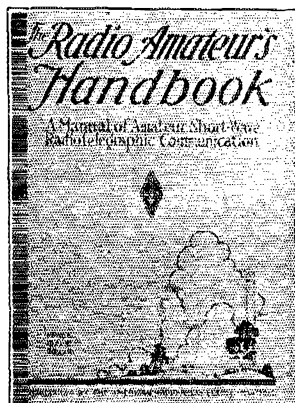

FOR THOSE WHO DON'T KNOW IT:

The Handbook is a practical manual of amateur radio in all its phases, published by the American Radio Relay League, the amateur's own organization. It starts at the beginning and tells the whole story: What amateur radio is, How to be a radio amateur, How to obtain your licenses, How to build the simple apparatus of a simple station, How to build the best known apparatus for the most modern station, How to operate the station. Enough information to keep you busy and interested for five years.

FOR THOSE WHO DO KNOW IT:

For years the Handbook has been the practical working guide of successful amateurs the world over. Now it has been completely revised in terms of 1929, by Mr. Handy, the League's Communication Manager, as to all the aspects of operating procedure, and by Mr. Hull, the director of the League's current Technical Development Program, as to all its features of apparatus and technical matters. Everything in it is on a 1929 basis, replacing the 1928 methods which used to be good enough but aren't any more.

MUCH THAT IS NEW — ALL THAT IS GOOD

SPECIAL OFFER A copy of the \$1.00 edition of the HANDBOOK;
a year's subscription to QST and a year's membership in the American Radio Relay League.

ALL FOR THREE DOLLARS!

(Foreign countries \$3.50)

Note: If you want your copy of the Handbook in stiff buckram binding add \$1.00 to your remittance.

Even if you are already a member of the League and a subscriber to QST, you may avail yourself of this offer. Simply mention that fact and instead of entering it as a new subscription we will extend your present subscription for another year, and send a copy of the Handbook at once.

AMERICAN RADIO RELAY LEAGUE

1711 Park Street

Hartford, Connecticut

U. S. A.

AMERICAN RADIO RELAY LEAGUE
Hartford, Conn., U. S. A.

Dear Sirs:

I want to take advantage of your Special Offer and enclose remittance.

I am
I am not a member of the League.

How to select, operate
and care for radio
receiving sets—

Practical Radio

Including the Testing of Radio Receiving Sets

New Third Edition

By JAMES A. MOYER, Director of University Extension, Mass. Dept. of Education, and JOHN F. WOSTREL, Instructor in Radio Division of University Extension, Mass. Dept. of Education

378 pages, 8½ x 8, 223 illustrations
\$2.50

THE book presents the fundamental principles of radio so simply and clearly that any person of average training will be able to read, understand and apply them. Both the inexperienced amateur and the technically trained specialist will find the book valuable. In Chapter XI there are accurate working drawings as actually used in radio shops together with complete lists of materials required for constructing eight typical receiving sets.

The book tells you:

— what radio is — how a radio set works — how to select, operate and care for radio receiving sets — how to construct your own receiving set — how to test your set — how to select a loud speaker — how to select, test and use vacuum tubes properly — how to locate common troubles — how to remedy them.

See
this
book
FREE



McGRAW-HILL FREE EXAMINATION COUPON

McGraw-Hill Book Co., Inc.
370 Seventh Avenue,
New York, N. Y.

You may send me Moyer and Wostrel's PRACTICAL RADIO, third edition, \$2.50 net, postpaid. I will either return the book, postage prepaid, in 10 days, or remit for it at that time.

Name

St. and No.

City

State

Name of Employer

Official Position

(Books on approval in U. S. and Canada only) QST 7-20

3000 V. Recto Bulbs

In stock — 3000 Volt New Type R3 Rectobulbs.
Net price each \$10.00. Also Leach Relays — R.E.L.
Products, Omnigraphs — Vibroplexes.

Complete Parts for Silver-Marshall

No. 730 "ROUND-THE-WORLD" 4

A COMPLETE short wave receiver (17.4 to 204 meters) and two-stage audio amplifier. All wave lengths are covered with no dead spots. Amateur bands fall well to center of tuning dial. Net \$30.00. Completely constructed \$42.00. C.O.D. or cash with order. Postage or express extra.

Send for New 1929 Ham Book — FREE

WE HAVE AERO MONITORS IN STOCK

CHI-RAD

CHICAGO RADIO APPARATUS CO.

415 S. DEARBORN STREET

CHICAGO

a number, denoting the district, followed by two letters. The transmitters of clubs and scientific institutions have a number, followed by three letters, the first of which is K.

Most of the Soviet stations are working on r.a.c., or d.c., and there are very few using raw a.c. The average power is between 10 watts and 20 watts, although a few are allowed to use up to one-half kilowatt. Crystal control is rarely employed.

As a result of a conference of the amateur clubs held in Moscow, it has been decided to employ the prefix EU for amateur stations in European Russia, and AU for Asiatic Russia. Our Government did not take part in the Washington Conference, and has left it to the amateurs themselves to decide the questions about calls and waves.

Many expeditions were made during the last year or so, and amateurs have taken part in most of them. The most successful was the Russian-German expedition to the Pamir tableland. At the present time there is an expedition in the Bering Strait region which is using four short-wave transmitters. The calls are RB71, RB72, RB73 and RB74, and schedules are kept with Russian amateurs.

The Government here is very favorably disposed toward amateurs; licenses are issued freely, and without charge, and the postal department forwards QSL cards among Russian amateurs free of charge. Prizes are donated for tests, too.

With such cooperation, and with an active interest in shortwave work being taken by many amateurs, it is hoped that the good results so far secured will be continued in the future.

Official Frequency System

(Continued from page 10)

than the accuracy to which the average good amateur frequency meter can be calibrated and kept constant. During each transmission by W1XV its exact frequency will be announced to within 1/100 of 1% for the benefit of those able to use such accuracy, but for all regular amateur purposes the transmissions of both stations may be assumed to be equal to the figures herein given. While no responsibility, financial or otherwise, is assumed for the accuracy of these transmissions, every effort will be made to have it exceed the figure given.

STANDARD FREQUENCY SCHEDULES

For July and August

Date	Schedule	Station
July 5, Friday	A	W1XV
7, Sunday	CD	W9XL
12, Friday	AB	W9XL
19, Friday	B	W1XV
21, Sunday	C	W1XV
26, Friday	AB	W9XL
Aug. 2, Friday	A	W1XV
4, Sunday	CD	W9XL
9, Friday	AB	W9XL
16, Friday	B	W1XV
18, Sunday	C	W1XV
23, Friday	AB	W9XL

The Two-Range Receiver (15-300, and 290-570 meters) with Its Own Coil Storage

Gets short-waves
AND Broadcasts
All in One
Operates from
NATIONAL
Voltage-15
Write us today
for full details

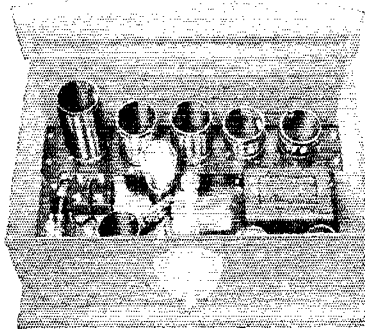

The 6 coils of the SW-4 THRILL BOX are kept in the cabinet, all in a row, each in its special storage socket. Thus they are protected from damage and dust, and are always on hand and ready to use. Every other detail is just as carefully thought out. The SW-4 is not a copy — it bristles with new and ingenious details for your convenience and pleasure.

NATIONAL

4-Tube THRILL BOX SW-4
NATIONAL CO. INC., Malden, Mass.

Est.  1914

BECOME A RADIO OPERATOR

See the World, Earn a Good Income,
Duties Light and Fascinating

LEARN IN THE SECOND PORT U.S.A.

Radio Inspector located here. New Orleans supplies operators for the various Gulf ports. Most logical location in the U. S. A. to come to for training.

Nearly 100% of radio operators graduating on the Gulf during the past seven years trained by Mr. Clemmons, Supervisor of Instruction.

All graduates placed. Runs to all parts of the world.
Member of the A.R.R.L. — Call "W5GR."
Day and Night Classes — Enroll any time.

Write for circular

GULF RADIO SCHOOL

844 Howard Ave. New Orleans, La.

TRANSFORMERS

Guaranteed — Mounted — Complete

2 K. W. 2000 — 2500 each side..... \$40.00

700 watt 1000 — 1500 each side..... 14.50

700 watt 2000 — 2500 each side..... 21.00

Auto-Transformers, Chokes, Polyphase and 25-cycle

Transformers. Add \$2.00 for hl. winding

JCES FRANK GREBEN

1927 So. Peoria Street, Pilsen Sta. Chicago, Ill.

"WHAT B-ELIMINATOR SHALL I BUILD?"

Send 10c to Dept. Q7 for this
helpful construction book

175 Varick St., New York, N.Y.

ELECTRAD

INC.

Wholesale Prices

for Dealers, Agents and Set Builders — prompt deliveries



OUR huge Wholesale Radio Catalog No. 19 (2ND EDITION) is a valuable encyclopedia — a liberal Radio education. Mailed immediately on request — absolutely

FREE

1500 illustrations and
6000 articles

FROM many years in the Radio Mail Order Business, we have learned how an organization must be efficiently run to gain and retain the good will of our customers.

Radio Specialty Co. ships orders promptly — offers you 100% thorough satisfaction — and sells at rock-bottom net prices.

Our catalog contains the largest assortment of completely assembled all-electric AC Receivers at amazingly low prices, and other Radio Merchandise including such lines as Pilot-Silver-Marshall — Carter-Astra — Yaxley — Tole — Hammarlund — Amer Iran — Cunningham — Longan — Thordarson — Muter, etc., etc. The latest improvements in Radio are listed and thoroughly described in this great catalog: AC All Electric Sets with self-contained ABC power supply — Public Address Amplifier systems — A.C. Set Converters — A and B Climbers — Dynamic Speakers and Units — Magnetic Speaker Chassis — 245 and 250 Tube Amplifiers — Airplane Cloth Speakers — Push-Pull Power Amplifiers — Electric Phonograph Turn-Tables — Combination Radio and Electric Phonograph Consoles — Speaker Tables — Short Wave Sets and Adapters — Shield Grid Tube Kits — Television Parts — Electric Household Appliances, Tools, Workshops — CAMERAS, — etc.

Send for Catalog No. 19 (2ND EDITION) today

Radio Specialty Co. 100S Park Place

New York

Radio's Oldest Mail Order House

ACME WIRE PRODUCTS

Coils — Magnet Wire Wound
 Magnet Wire All Insulations
 Varnished Insulations
 Parvoit Filter and By Pass Condensers

All products made to Recognized Commercial Standards including those of:

National Electric Mfrs. Assn.

Radio Manufacturers Assn.

American Society for Testing Materials

For 25 years manufacturers and suppliers to the largest and most discriminating users.

THE ACME WIRE CO.

NEW HAVEN, CONN.

Branch Offices:

New York

Cleveland

52 Vanderbilt Ave.

Guardian Bldg.

Chicago

842 N. Michigan Ave.

OFFICIAL FREQUENCY STATIONS

(Required accuracy 3/10 of 1%)

W1AAC, W1AVW-W1ZL, W1AWW, W1AXA, W1BD, W1BZQ, W1CCW, W1CK, W2CDC, W2CLA, W2DS, W2EF, W2MU, W2UV, W4BY, W4LK, W5EW, W5MN, W5OX, W5SP, W5ZAV, W6AKW, W6AM, W6AYC, W6AVJ, W6BB, W6BGM-W6CVO, W6BMW, W6BRO, W6BZU, W6CAE, W6CDY-W6CPX, W6CMQ, W6EC-W6XE, W6QL, W6QX, W6WN, W6ZV, W7AAT, W7GQ, W8APZ, W8BAV, W8BZT, W8EQ, W8GZ-W8ZG, W9AHQ, W9AVG, W9AXQ, W9BGH, W9BGK, W9BVC, W9CPM, W9EFO, W9EGU, W9IG, G2OD, G2NM, G5BY, G5YK, G6CL, G15NJ, VE2BE, VE3CO, VE3FC, VE4BT, VE9AL, VK5BG, VK5LF, VK7CW and ZL2AC.

Reports on Standard Frequency Transmissions are solicited from all who take advantage of this service. Regardless of how far from or near to the transmitting stations you may be, your report is of interest to us. Standard blanks which will facilitate your compilation and our handling of the reports are available on request. All reports should be directed to: Experimenters' Section, American Radio Relay League, 1711 Park Street, Hartford, Conn.

After your report has been checked and acknowledged, it will be forwarded to the Standard Frequency Station upon whose signals it comments.

— H. P. W.

DODGE RADIO SHORTKUT

Kills Hesitation — Produces Results
 Quickly Qualifies for Code Exam.
 Puts Opportunity within Easy Reach

REPORTS FROM 500 USERS PROVE THIS

Tells whole story and who's who—with each order.

CONSIDER these extracts from reports on file:

W9CGL—Studied one evening—copied 15 per.
 W9CHZ—Mastered code easily; now do 15 per.
 W9CIT—From scratch qualified in 2 weeks.
 W9CJY—Speeded up from 8 to 17 very soon.
 W9CKS—Great help in mastering the code.
 W9CKV—Quickly increased code reading speed.
 W9CMW—Up from 15 to 25 per in 4 hours.
 W9CNC—Speed was 5. Now 25 and Commercial.
 W9CNT—3 hours with DRS—no more trouble.
 W9CPO—Easy to learn. Now copy 15 per.
 W9CSK—Up from 13 to 22 in few weeks.
 W9CSU—Thought never would be able read code.
 W9CZG—DRS all OK and well worth the price.
 W9DAP—Licensed after little effort.
 W9DMK—Raised speed 8 to 15 in 2 weeks.
 W9DRZ—Speed was 10 QSZ—now 25 sent once.

DODGE HIGH SPEED METHOD
 (Intensive Speed Practice)

Most Efficient Booster Known for 25 per ops.
 W2BXY—W5AHM—W8CJK—W8CPQ—W9DCD
 Up from 25-27 to 35-39 easily few weeks.

FREE—Hams who order Radio Shortkut in July, promise Test and quick Report on our High Speed will get copy that method FREE.

DODGE MORSE SHORTKUT

Master both codes our way and use without mixup.
 W2BXY—W5ANW—W8CJK now use both codes.

Radio Shortkut \$3.50. High Speed or Morse \$2.50. Money Order. None C.O.D. Foreign add Fifty Cents.

C. K. DODGE

Box 100

Mamaroneck, New York

The Lunch Kit Portable Receiver and Monitor

(Continued from page 12)

posts. A portion is cut out at one end to pass the two '199 tubes, the sockets for which are mounted directly beneath on a strip of bakelite fastened to the two pieces of brass which support the panel.

Two other pieces of bakelite are bridged across these brass straps. One of these pieces carries the audio transformer and the other mounts the "A" and "B" battery binding posts.

There is an additional compartment in which the "A" and "B" batteries fit in the case provided for the set and the hinged cover can be locked closed to prevent the equipment from being spilled accidentally.

There is no particular reason why anyone cannot duplicate either of these sets or build similar units for but a few dollars. There are many pieces of equipment on the market that are small and light enough to fit readily into such a design. It will be found that this sort of a portable will prove of considerable worth not only on the road but at the home station as well.



The niftiest jigger for making the connection to the control grid (the one on top of the tube) of the 222 and 224 yet seen is the National Company's "Grid-Grip." It is nicely tinned, equipped with a soldering lug and certainly does grip.

QSL CARDS FREE to Stations using Vitrohm Radio Resistors

Ward Leonard wants all amateur stations using Vitrohm Radio Resistors to have a supply of printed QSL cards — with our compliments.

Twenty-five of the new QSL cards, printed on both sides, ready to use, will be sent free upon request to any station using Vitrohm Resistors. More of the cards if you want them. Send in your request now. There is no charge or obligation of any kind.

New Bulletin 507 Covering Vitrohm Resistors for Radio

A complete line of Vitrohm Resistors for radio receivers and transmitters is included in this new bulletin. Every up-to-date station will want a copy. It will be sent anywhere upon request free of charge.

Ward Leonard Electric Company

31 South Street Mount Vernon, N. Y.

X-L VARIO-DENSER

Increases Efficiency and Power of Receiver

X-L Products give accurate values and dependable service. Endorsed by radio engineers, designers and set builders and standard in all best known circuits.

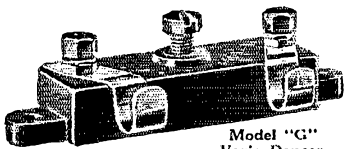

Model "G"
Vario-Denser

Model "G" with grid clips made in three variable capacity ranges. Price each \$1.50.

Model "N" has variable capacity, adjustable from 1.8 to 20 micro-micro farads. Price each \$1.00.

Bakelite insulated X-L Push Post, the most perfect binding post made. Plain or all standard markings. Price each 15 cents.

Manufacturers of the X-L Link, the 100% Voltage Control and many-purpose Light Socket Adapter.



X-L Push
Post

Write for descriptive literature and free book of circuit diagrams

X-L RADIO LABORATORIES

Dept. D 1224 Belmont Ave. Chicago, Ill.

RADIO IN BRASIL

When in Brasil, apply to M. BARROS & CIA for anything you need in connection with radio.

M. BARROS & CIA

70 sob. Rua S. José 70 sob.
Postal Box 89

Rio de Janeiro

Telegraph address, Radioparte, Rio de Janeiro
Branch: Avenida S. João 4, S. Paulo, Brasil

DAY AND EVENING CLASSES IN RADIO OPERATING

Next terms start July 15th and Sept. 1st

For further information and circular, address

The Registrar
FEDERAL RADIO AND RAILWAY INSTITUTE
517 Wells Street Milwaukee, Wisconsin

Do you know that the 1929 Handy and Hull Handbook is available in bound form — \$2.00 per copy, postpaid?

When ordering a copy of this new edition, look at your present copy and determine if you want the 1929 copy in more permanent form.

SET Builders FREE

Barawik, the first and oldest radio specialty house, offers you unusual service this year. Bigger stocks, quicker shipments, lower prices. Deal with an old established, reliable house. Get honest goods, honest service, honest prices. Barawik sets you more money. Send now for big new catalog showing lowest wholesale prices on sets, parts, short wave, etc.

117-A CANAL ST.,
BARAWIK CO. CHICAGO, U. S. A.

LATEST
RADIO
GUIDE

Synchronous Motors for Television

In addition to building reliable and satisfactory motor generators, "Esco" has had many years of experience in building electric motors for a great variety of applications.

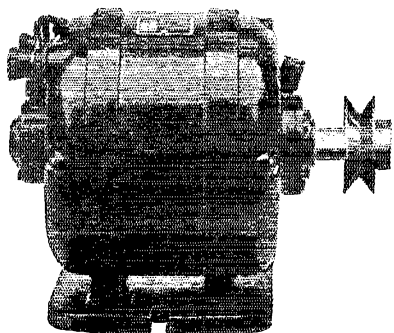

Synchronous motors, small, compact, reliable self starting are now offered for *Television* equipment. They require no direct current for excitation, are quiet running and fully guaranteed.

Other types of motors suitable for Television may also be supplied.

Write us about your requirements.

ELECTRIC SPECIALTY CO.

25 South St.

Trade "ESCO" Mark

Stamford, Conn.

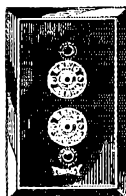

Wire Your Home for Radio

For every radio need, in brushed brass or Bakelite. Fit standard electrical switch or outlet box. Single plates and in gang in many combinations.

No. 135 — For Loud Speaker.....	\$1.00
No. 136 — For Aerial and Ground.....	1.00
No. 137 — For Battery Connections.....	2.50
No. 138 — For A. C. Connections.....	1.00

(Bakelite, 25c additional per plate)

YAXLEY MFG. CO.

Dept. 5 — 9 So. Clinton St., Chicago, Ill.

WIRELESS EGERT ENGINEERING INC.

179 GREENWICH ST., N. Y. City

WE

eliminate any type of man-made static.

design and construct special Radio and Electrical relaying systems.

build Special Transmitters, and long or Short wave receivers to order. Amplifiers constructed and designed to order.

See the new **SHORT WAVE 4** Just Announced by our Company. The Best Short Wave Set you can buy to-day.

NO NEED TO WORRY

Over current or voltage peaks. Unlimited power for your transmitter. Power to spare for Hi-C tanks, loose coupling, perfect signals. Who'll ever need 5000 mls. 8000 volts peak?? But it's there, ready for you, if your transmitter is powered with a Mercury Arc. Filamentless, long life, full wave in a single tube. Filters to XTAL. DC. Completely automatic, no waiting to start. Ask the gang. Special in Edison Bs, won't last long.

RECTIFIER ENGINEERING SERVICE

4837 Rockwood Rd. Radio W&ML Cleveland, Ohio

Radio Operators

Raise Your Speed 50 to 100% in Short Time

Write at once for information about **The Candler System Course in High-Speed Telegraphing and Self-Mastery** — the only "short-cut" to greater speed, accuracy and endurance that mean **BIGGER PAY, DOUBLES** speed of slow operators. Makes fast operators **FASTER**. Takes the kinks out of sore arms. Relieves "glass" arm. Restores the grip. Prevents fatigue, cramps, paralysis and kindred ills. Over 40,000 operators have been developed by this system. McElroy, world's champion radio operator endorses no other system. Begin now! In a few weeks you'll have more speed than you ever thought possible. Our money-back guarantee protects you. Write now!

THE CANDLER SYSTEM CO., Dept. RL.

6348 S. Kedzie Ave.,

CHICAGO, ILL.

SPECIAL TO AMATEURS

Barawik's new shortwavedept. has everything that amateurs desire. The Barawik Radio Guide gives full details. Send for it.

FREE RADIO GUIDE

SEND FOR IT!

Shows the latest wrinkles, newest developments in radio at startlingly low prices. Get the set you want here and save up to 50%. The best in parts, kits, complete factory-built sets and supplies. Orders filled same day received. Write for free 264-page copy NOW. Wholesale prices to set builders, dealers, agents.

BARAWIK CO. 117 Canal Sta., CHICAGO, U. S. A.



A SPECIAL DEPT. FOR RUSH JOBS

WHEN a manufacturer wants a resistor built to specifications—he usually wants it in a hurry.

That's why we've installed a special department for just such rush jobs. 72 hours after we get your specifications, samples are on their way to you. We even ship by air mail if you desire.

And we don't stop the rush with delivery of samples. If samples are satisfactory (and practically all of them are) we can ship quantities in the same quick time. Write to

HARDWICK, HINDLE, Inc.

Sales Dept.
122 Greenwich Street
New York City



Factory
215 Emmet Street
Newark, New Jersey

RESISTORS



Build Your 1929 Receiver with Approved Parts

A Complete Selection of Audio and
Power Parts and Units

- No. 994 — Power Amplifier Transformer..... \$12.00
- No. 2189 — Push Pull Output Transformer..... \$12.00
- No. 2142 — Push Pull Input Transformer..... \$4.50
- No. 3107 — Straight Output Transformer..... \$12.00
- No. 2158 — Audio Transformer..... \$4.50
- Two Secondary Windings (for either No. 2189 or 3107):
one for Magnetic type and the other for Dynamic
type Speaker.
- D-946 — Standard Condenser Unit..... \$22.50
- This Condenser Unit is also designed especially for use
with No. 994 Transformer for Power Amplification.
- No. 5554 — Double Choke, use in Filter Circuit, \$11.00
- These Dongan Parts are available now. Equip your
receiver with this new amplifier — and enjoy still
another of Radio's greatest advancements.
- For Push Pull Radio and Phonograph Amplifier:
- No. 2124 — Transformer..... \$6.00

Dongan Electric Manufacturing Co.

2999-3001 Franklin St., Detroit, Mich.
"TRANSFORMERS of MERIT for FIFTEEN YEARS"

Little-Known Tubes

(Continued from page 29)

values are contingent upon the operation of the modulator as indicated in Fig. 12 which gives the proper grid bias and maximum peak grid voltage usable.

When either 841 or 842 tubes are operated in parallel, a resistance of approximately 100 ohms should be placed as near to the grid of each tube as is practical. This will prevent the generation of parasitic high frequency oscillations between the tubes. If 841's are used as oscillators (842's should not be so employed) the resistors may be supplanted by suitable chokes which will have less effect upon the efficiency of the circuit. In all cases, the plate voltage should be reduced when a new circuit is being set in operation.

Financial Statement

BY order of the Board of Directors the following statement of the income and disbursements of the American Radio Relay League for the first quarter of 1929 is published for the information of the membership.

K. B. WARNER, *Secretary.*

STATEMENT OF REVENUE AND EXPENSES FOR THE THREE MONTHS ENDED MARCH 31, 1929

REVENUE		
Advertising sales, QST.....	\$16,938.05	
Newsdealer sales.....	12,831.88	
Advertising sales, handbook.....	2,382.23	
Handbook sales.....	5,799.89	
Dues and subscriptions.....	11,637.71	
Back numbers, etc.....	848.46	
Emblems.....	95.65	
Interest earned.....	662.51	
Cash discounts earned.....	354.92	
Bad debts recovered.....	125.22	\$52,076.52
<hr/>		
Deduct:		
Returns and allowances.....	\$5,627.95	
Less portion charged to re- serve for newsstand returns..	191.75	5,436.20
<hr/>		
Discount 2% for cash.....	347.63	
Exchange and collection charges..	10.86	5,794.69
<hr/>		
Net revenue.....		\$46,881.83
<hr/>		
EXPENSES		
Publication expenses, QST.....	\$14,203.53	
Publication expenses, Handbook..	3,679.11	
Salaries and commissions.....	14,469.85	
Forwarding expenses.....	773.07	
Telephone, telegraph and postage	1,097.78	
Office supplies and general ex- penses.....	2,093.35	
Rent, light and heat.....	833.05	
Traveling expenses.....	1,004.23	
Depreciation of furniture and equipment.....	538.33	
Communications Department field expenses.....	63.57	
Headquarters Station expenses...	43.15	
Bad debts written off.....	300.00	
<hr/>		
Total expenses.....		\$9,099.07
<hr/>		
Net gain from operations.....		\$7,782.76

The Ultimate Transmitter

It will get you through like hand sending. Under cover that locks in place only need be removed to adjust speed or clean points. Beautiful black frosted enamel finish 2 1/4 x 3 3/4 x 2 1/2" high, weighs three pounds.

View with cover in place

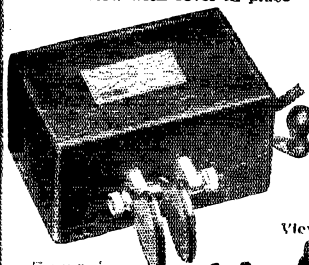

All parts die cast and interchangeable. Finger paddles are adjustable and have milled surface. Prevents sticking to fingers.

Relay and remote control model 1371 contacts welded in place.

\$12.50

View with cover removed

Four instruments in one, double or single lever. Right or left hand. Four vacuum feet. When you order state if for left hand use.

Send for our descriptive circular.

Remit by money order or registered mail.

Do not strain your nerves with an old worn out bug.

L. C. McIntosh, Special Sales Agent
4163 Budlong Ave., Los Angeles, Cal.

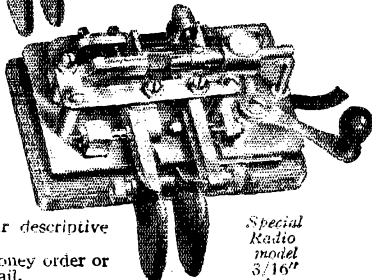

Special
Radio
model
3/16" dot
contacts
\$15.00

QRH Rats, Mice and Bacteria?

(Continued from page 51)

found. However, a consistent heating effect increasing at a fairly regular rate from 1.5 meters to 15 meters with a peak around 5 meters for a normal salt solution has been noted. It is also interesting to note that a suspension of gram negative bacillus shows little heating effect around five meters but a great heating effect at 50 meters. The reverse appears to be true with the salt solution: Namely, a maximum heating effect around 5 meters and a very slight heating effect around 50 meters.

Perhaps a word of warning might be in order inasmuch as the electrical part of this experiment can be duplicated by almost anyone who has the equipment. The bacteriological work should be attempted only in a laboratory experienced in such work. Be careful in handling ultra-high frequencies for the resulting effects are not yet fully understood — there is some heating effect noticeable in human beings in the neighborhood of 5 meters which may have delayed action but it is thought not. There is, as yet, no conclusive evidence either way.

Midwest Division Convention

(Continued from page 41)

pedition, but D. C. Rawls, an old time Des Moines amateur just returned from China where he has been for a number of years, filled in the gap most interestingly on radio in that country.

While lectures were taking place, George S. Turner, an old-time amateur but now Radio Inspector for the Ninth District, conducted examinations and from his report quite a number of amateurs were made happy by passing the test. Louis Huber, formerly of this Section and now assistant to Communications Manager at Headquarters, was perfectly at home and gave the gang a good talk on the activities of the Communications Department. Prof. C. M. Jansky, Jr., of the University of Minnesota, as well as Consulting Radio Engineer, spoke on "Opportunities in the Field of Radio Communications and its Various Ramifications," which proved one of the good addresses given. A new Y. L. in the Division is Miss Lois Crawford, W9DLW of Boone, who attended her first convention. If you hear her, fellows, give a helping hand — she is a little diffident.

Lt.-Commander R. H. G. Mathews, U.S.N.R., our old Matty of 9ZN fame, showed up with a medical examiner and before the convention was over he had enrolled 26 in the Naval Reserve, with the assistance of Boyd Laisure. Fred Schnell, now with Aero Products, presented one of the best addresses and with his lantern slides left nothing to imagination on the new wavemeter which is being brought out by his firm. Carl Menzer, Director WSUI, Iowa City, talked on Fundamentals and present uses of Television and Phil Konkle, W9YT, explained crystal control

THE RADIO BOOK

that has been endorsed and is in constant use by United States Gov't and over 300 Universities, Schools and Technical Colleges in this and foreign countries.

"Radio Theory and Operating"

By Mary Texanna Loomis

President, Loomis Radio College
Member Institute of Radio Engineers

Fourth Edition revised and enlarged to 992 pages, 800 illustrations and right up to date. Flexible Kraft Leather binding.

Price \$3.50 — Postage Paid

For sale by bookdealers throughout U. S. and many foreign countries, or may be purchased direct from the publishers. Send check or money order to

LOOMIS PUBLISHING COMPANY
Dept. 5 Washington, D. C.

**New Design
New Performance**

**EDELMAN
CONDENSERS**

**FOR
FILTER BLOCKS**

350 and 700 Volt Operation

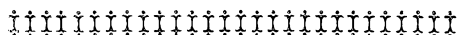

POTTER

True-Tone Electrostatic

REPRODUCER

Condenser Type

THE POTTER CO.
North Chicago Illinois

**A RECEIVER
IS LIKE A CHAIN**

A chain of parts, if you please . . . transformers, tubes, condensers, resistances and the like as links of the chain. Unless each link performs to perfection the whole receiver is condemned and your name with it.

A lot of grief can be traced to one little part . . . the volume control. Noises are set up . . . unevenness of control develops . . . locals are hard to handle.

You can save yourself plenty of trouble by seeing that the name "Centralab" is stamped on the volume control.

Central Radio Laboratories
20 Keefe Ave. Milwaukee, Wis.

oscillators; and Bill Heinz, had WHO'S control car which proved interesting to those connected with broadcasting stations. I am a little ahead of the story, because the banquet was held on Friday evening instead of being the usual closing affair on Saturday. It was a great event and was held in Memorial Union Hall. Dinner was prepared and served by the co-eds of the Domestic Science Class and would put to shame some of the chefs in leading hotels. The most disappointed "ham" was "Swyx" Solotar, W2CYX, who came all the way from the wilds of New York City and missed, as he said, the best part of the convention, the dinner. He arrived on Saturday! Well, to get back to the banquet, Director Quinby, who was very much in evidence during the convention, was the shining star of the dinner. He acted as toastmaster and took delight in "roasting" Schnell, Mathews, Huber, Jansky, Hebert and several other speakers; but it all made for a pleasant evening ending with the distribution of prizes, for which our thanks go to all those manufacturers who contributed so generously.

The closing of all events by Saturday afternoon gave the fellows a chance to gather around the hotel lobby in the evening while awaiting their trains and cemented friendships which we hope will last until they can be renewed at next year's convention.

—A. A. H.

Those Past Issues of QST

(Continued from page 38)

the back edge within the covers just made. The index sheets can be fastened to the free face of the "V" by means of three double pointed brass paper fasteners.

With the stack of QSTs bound and labelled in the above manner, it will no longer be necessary to set aside a half day to look up what so and so



IN THE PROCESS

said about this or that. These bindings are guaranteed to withstand the attacks of storms, quakes, winds, junior ops or what have you. There is one important warning: Don't try to lick the gummed tape unless you have an exceptionally strong stomach!



For CONTROLLING THOSE "BOTTLES"

Here's what you have been waiting for—a precisely adjustable resistor of wide range, that can stand the puff!

The SUPER-POWER CLAROSTAT is a giant variable resistor of 250-watt rating. In 3 resistance ranges — 1/4-10 ohms, 25-500 ohms, and 200-100,000 ohms. Dissipates heat rapidly and safely. Mica insulation and asbestos packing, special resistive material, and heavy brass case. Large bakelite knob. Long shaft which may be cut to any length. Special mounting bracket to hold hot casing away from panel.

Ideal as filament and plate control for transmitters; speed control for motors up to 1/4 h.p.; field rheostat for generators; heat control for soldering irons, etc.; and indispensable in laboratory work. Only \$6.00 list!

WRITE for data sheet on the *SUPER-POWER CLAROSTAT* and other radio aids. Ask your dealer to show you the complete line of Clarostats, because "There's a Clarostat for Every Radio Purpose."

CLAROSTAT MFG. CO., INC.
Specialists in Radio Aids
283 N. 6th St., Brooklyn, N. Y.

It Will Interest You!

See Page 79

*This Issue
of QST*

Offering a copy of the latest edition of the "Handbook" and a year's subscription to *QST* at a **SPECIAL PRICE**

**FREE INFORMATION NOW READY
WRITE FOR YOURS NOW!**

Transcontinental Coils

Gotham Engineering & Sales Co., Nat'l Agts.
50 CHURCH ST., Room 370, NEW YORK CITY

Jensen Patents
allowed and pending.
Licensed under
Lektrophone
Patents

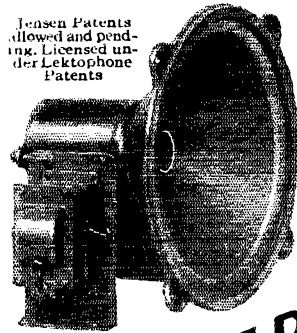

ANSWERING

the demand
of an **INDUSTRY**
the new
Jensen
CONCERT DYNAMIC

Peter L. Jensen has applied entirely new and original principles in the design of this new dynamic. The cone is 10 inches in diameter. The moving coil represents an innovation in design. The sensitivity is greater than that ever attained in any previous dynamic speaker, and the ability to reproduce enormous volume is exceeded only by the Jensen Auditorium Dynamic.

The Concert Dynamic definitely sets a new standard of excellence. For along with the musical reproduction of bass notes as low as 30 cycles, the higher frequencies are reproduced with extraordinary brilliance. In fact the entire musical scale is reproduced with a brilliance and firmness of quality never acquired before.

There is no need of a "side by side" comparison to appreciate the superiority of this new speaker. Wherever it is heard its performance is both startling and impressive.

Write for complete information and ask for a frequency response curve of this new speaker if you are interested. Ask also about the new Jensen Imperial, a beautiful cabinet equipped with either the Concert or Auditorium Unit.

NEW LOW PRICES

JENSEN CONCERT DYNAMIC
with 10 inch cone

D7AC, \$35.00 D7DC, \$27.50

JENSEN AUDITORIUM DYNAMIC
with 12 inch cone

DA5AC, \$70.00 DA5, \$55.00 DA4, \$55.00

JENSEN RADIO MFG. COMPANY
6601 S. Laramie Ave., Chicago, Ill. 212 Ninth St., Oakland, Calif.

HAM-ADS

(1) Advertising shall pertain to radio and shall be of nature of interest to radio amateurs or experimenters in their pursuit of the art.

(2) No display of any character will be accepted, nor can any special typographical arrangement, such as all or part capital letters be used which would tend to make one advertisement stand out from the others.

(3) The Ham-Ad rate is 15c per word, except as noted in paragraph (6) below.

(4) Remittance in full must accompany copy. No cash or contract discount or agency commission will be allowed.

(5) Closing date for Ham-Ads is the 25th of the second month preceding publication date.

(6) A special rate of 7c per word will apply to advertising which, in our judgment, is obviously non-commercial in nature and is placed and signed by a member of the American Radio Relay League. Thus, advertising of bona fide surplus equipment owned, used and for sale by an individual or apparatus offered for exchange or advertising inquiring for special equipment, if by a member of the American Radio Relay League takes the 7c rate. An attempt to deal in apparatus in quantity for profit, even if by an individual, is commercial and takes the 15c rate. Provisions of paragraphs (1), (2), (3) and (5) apply to all advertising in this column regardless of which rate may apply.

PLATE POWER for your set, the very heart of its performance. For quietness, DX ability, life-long permanence, absolute dependability, lowest ultimate cost, no other plate source even approaches the achievement of an Edison steel-alkaline storage B battery. Built painstakingly, every joint pure nickel, upset electrically welded, genuine Edison Electrolyte. Our list describes complete batteries, construction parts, insulated aerial wire, silicon steel. Available immediately, filament and plate transformers for the new 866 rectifier, complete plate power units. Rectifier Engineering Service, radio WSM, 4837 Rockwood Road, Cleveland, Ohio.

THE most complete line of modern short wave receivers for every particular service. Four to nine tube designs. Radiophone-CW transmitters, of any power or type. We take a complete line of apparatus including speech amplifiers, filter coils, transformers, rectifiers, variable condensers, inductances, etc. Any special apparatus, designs, made to order using your parts if desired. Prices on request. New bulletin lists complete line of apparatus. Write for copy, Ensell Radio Laboratory, 1208 Grandview Ave., Warren, Ohio.

SPECIALLY made rectifier aluminum with small percentage copper, stand more amperage, last longer, square foot \$1.25. Lead \$1.00. Elements, holes punched with bolts and nuts, new kind 17" x 47" 15c, 17" x 67" 17c, pair prepaid. Best Silicon steel 114" cut, to order 25-35c lb. Postage extra. Geo. Schulz, Calumet, Mich.

NEW HV217A, \$17. New 217C, \$25. Unmounted, 1000-volt condenser, 2 mid., \$1.50; 3 1/2 mid., \$1.85. Freshman 375-volt two 7.5 volt center tapped windings, \$2.75. Thoradson 220 and 255 center tapped transformer, \$1.95. Microphone cases, \$2.25. C.P. aluminum, \$70 sq. ft. Signal Corps 3 1/2" silver contact keys, \$9.95. Grebe CR18, \$35. RCA 210 tubes, new, \$6. UV866, \$12. New rectobulbs, \$10 prepaid. 234W microphones, \$4. Samzamo 00025, 001, 002, 5000-Volt mica condensers, \$1.60 each. 30 Henry 150-mill chokes, \$1.90; Signal high frequency buzzers \$95. Aerovox 5000 ohms grid leaks, \$40. Used Mercury arcs cheap. New Flechtheim 300-volt pigtail leads: 1 mid., \$3.50, 2 mid., \$4.50, 1 mid., \$6.50. Westinghouse aeroplane 275-volt transformers, \$6.50. Guaranteed UX210, same size plate as UX250, \$4.50. One REL Wavemeter, list \$22 — special \$12.50. New Bacon phonovoxes, \$7.50. Amateur call books, \$3.55. New UX552, \$25. *Send \$20 thousand of other buys.* Send for monthly ham sheet. We want transmitting tubes. What have you for sale or trade? David L. Marks, 125 Madison Ave., Albany, N. Y.

TRANSFORMERS made by G. E. guaranteed to deliver 1 kw. at 1100, 2200, 4400 volts each side e.t. for \$12.00 F.O.B. Detroit. Used by Naval Reserve and Colleges. F. G. Dawson, 5740 Woodrow Ave., Detroit, Mich.

PANEL engraving — finest workmanship on radio laboratory apparatus. Request price list. A. L. Woody, 19 S. Wells St., Chicago, Ill.

TRANSFORMERS — 100 watt, 110 volt, 60 cycle, 750 volts each side center tap, one 7 1/2 volt center tapped filament winding — \$7.25. Same as above but with two filament windings \$8.00. The above will operate two 210 tubes. Same as above but 150 watt for operating two 250 tubes — \$9.25. All mounted. We supply to specifications any size transformer or choke for amateur or broadcast stations. Scott Coil & Transformer Co., New Albany, Mississippi.

WESTERN electric tubes, transformers, microphones, condensers, General Radio condensers, Weston meters, and other nice electronic equipment. Am moving to an apartment, where there's no room for radio, so everything must go. Send for list. A. M. Elliott, 7th and Montauk, Bayside, L. I., N. Y. C.

ENGRAVED bakelite escutcheons, per ad, April QST, add finishing professional touch to your apparatus. Stamp for list, dime for sample. Clark Laboratories, Danville, Va.

WESTERN Electric 7A amplifier with three W. E. 216A tubes and W. E. 518W speaker. Excellent for code amplification. Good condition. \$25. Edw. Scribner, Schoharie, N. Y.

FOR SALE — 15 dial Omnigraph like new. No reasonable offer refused. W9DHJ.

WANTED — long wave commercial or navy receiver tuning from 600 meters up. W9DHJ.

SACRIFICE — 875 volt, 200 amp. tap at 375 volts, 280 amp. motor 110 a.c. 3500 R.P.M. Three unit, \$25. Guaranteed. P. J. Dombek, Houlton, Maine.

WANTED — three UP1368 transformers. WMBH, Joplin, Mo.

FOR SALE — Four 48-volt units Willard storage B batteries. One 6-volt Willard storage battery. One Grebe cone speaker. Best offer takes them. Kenneth Alley, West Frankfort, Ill.

QST's all-purpose super-hot kits. Get our price. We build them in two styles at two prices. Hatry & Young, 126 Ann St., Hartford, Conn.

KNAPPA eliminator. New, \$16. D. L. Currens, Owensboro, Ky.

FOR SALE — two new 50-watt tubes, transformers, etc. Very reasonable. Martha Franstein, 2109 Green St., Philadelphia, Pa.

WESTON special No. 301, 1000 ohms per volt, 0-1000 volts, with external resistor, \$12; same 0-2000 volts, \$14. Jewell spec. No. 64, 1000 ohms per volt, 0-1000V, with external resistor, \$11; same but 0-2000V, \$13; 250-watt unmounted transformer, 500-750 and 1000 volts each side, \$8.75; 250 MA choke, \$6.75; 160 MA choke, \$5; 100 MA choke, \$2; 100-watt filament transformer, \$1.50; 50-watt filament transformers, \$3.50; 650-volt transformer, \$5.50; 100-cell Edison navy "B" battery 3 1/2 AH, \$30; 5-cell 6-volt Edison 150 AH battery, \$15; 100-watt filament transformer, \$4.50; 50-watt, \$3.50. Westinghouse flush 250 MA meter, \$3.50; Westinghouse 0-150 voltmeter with transformer, \$8. Write for list. M. Leitch, Park Drive, West Orange, N. J.

HAMS — We manufacture high voltage fixed condensers, transformers, chokes, wire wound resistances, metal cans and chassis and are equipped to build these units to your specifications. We can quote prices which are lower than you have been paying. Also we can furnish you with standard apparatus at 30% discount. Write us and let us know your wants. Electro Laboratories, 281 East 137th St., New York City.

D. C. Motor Generator for sale cheap. Station dismantled. Input 110 volts d.c. Output 800 volts d.c. 200 watts. 355 Central Park West, New York City. N. Y. phone. Riverside 2970 — Finlay.

FOR SALE — 10 mid. 1000-volt filter condensers, \$2 each. Grebe CR18, \$40. W8KH, 216 Hartford St., Dayton, Ohio.

HAMS — Get our samples and prices on printed call cards made to order as you want them. W9APY Hinds, 19 S. Wells St., Chicago, Ill.

SELL S-tube a.c. Crosley Showbox with Dynacone and tubes. First class condition, used about a month. Real bargain at \$60. W3ANV, Box 108, Waynesboro, Va.

WANTED — 6V or 12V to approximately 450V dynamotor. Must be in good condition. State full particulars. W9WB.

RELAYS, with strong tungsten steel contacts that will break lots of volts. A bargain \$2 each. Slightly used ones, \$1.50. Also R.C.A. UX 213 rectifier tubes for providing d.c. on the plate of your 7 1/2 wattler \$1.95 each. Postpaid. Mitchell Radio Company, 635 Waveland Ave., Chicago, Ill.

WANTED — Navy standard receivers, SE143, SE1220, SE1420, IP500, IP501 — also spark gap units. State price and condition. Paul Trautwein, 38 Park Place, New York City.

FOR SALE — New set of Victor Marconi code records, and a 15-dial Omnigraph with set of 15 dials. Will sell both for \$15 or trade for h.c. radio set of equal value. O. L. Ertel, R. F. D. No. 1, Box 90, Harrison, Ohio.

THORADSON 650-volt power-filament transformers for 7 1/2-wattlers, \$6.90. Potter Condensers: 1-mfd. 2000-test voltage, \$2.50; 1-mfd. 2500-test, \$3.25. Aluminum, square foot, \$5c. Lead, square foot, \$5c. Send 4c. for Curtis's Greatest Bargain-List. Curtis Sales Company, 1109 Eighth Avenue, Fort Worth, Texas.

USED parts bought, sold, exchanged. W9CKA, Corwith, Iowa.

3000-volt 6000-watt double commutator motor-generator, 10-h.p. 3-phase drive, \$685 complete; 3000-volt 4000-watt 7 1/2 h.p. 3-phase drive complete, \$550, 500-cycle 1-k.w. ballbearing motor-generator, 110V, d.c. drive, \$225; 350-cycle 1 1/4 k.w. ballbearing motor-generator 110V, d.c. drive, \$225; 2-5-k.w. Rotary Spark Gap 110V, d.c. drive, \$145; 1000-volt 200-watt Esco 1-phase drive, \$73; 750-volt 250-watt new General Electric motor-generators, \$32.50; 200 watt, \$42.50; 32-volt drive motor-generators: 750-volt 150 watt, \$37.50; 200 watt, \$45; 300 watt, \$65. 400-volt 100-watt generators, \$8.50; 3 1/2-h.p. 3150 speed motors, \$8.50; repulsion induction motors, \$10.50. Converters, 32 volt d.c. to 110 volt a.c. 300-watt, \$35; 110-volt drive 500 watt, \$65. Large stock plate and filament generators. Queen City Electric, 1734 Grand Avenue, Chicago, Ill.

712-watt transmitter complete, want UV203A or what have you? W8DYY.

SEND 4c. for Curtis's Greatest Bargain-List. Curtis, 1109 Eighth Avenue, Fort Worth, Texas.

QSL cards, cartoons, stationery, blanks, wall cards, etc. H. M. Seldon, Cranesville, Pa.

SELL four tube BCL receiver. Browning-Drake type with 199s, \$30. Write for list. Gussie Groth, Hartley, Iowa.

HAVE quit building sets. Decided bargains in condensers, tubes, transformers, etc. List for stamp. Box 325, Freewater, Ore.

WHAT do you want? Yaxley, Tobe, Elkon, Pilot, Hammarlund, Cornish Wire, Electrad, National, at attractive discounts. We ship postpaid, C.O.D. if you wish. Hatry & Young, Hartford, Conn.

SELL or trade—WE212D 250 with mounting, no choke in grid, \$25; 1/2 h.p. 110v a.c. or d.c. motor, series field, ball-bearing, 1/2 in. shaft, reversible, 5,000 r.p.m. light load if desired, \$18 f.o.b. Wanted: 1 or 1.5 m.a. Weston 301, multimeter, oscillograph, single phase 1/2 h.p. 110 v. 1800 r.p.m. 60 cy. induction motor, PR9 or PR5 relay. State condition, best price or swap. F. E. Handy, 1711 Park St., Hartford, Conn.

SELL one Aero radiophone and C. W. transmitter, 15 watt, three meters, one stage speech amplification, two sets of plug-in inductances, 40 to 190 meters, complete with four 210 tubes less power supply and microphone. Price, \$65. Also one Silver-Marshall screen grid round the world four \$20, and one R.E.L. type A wavemeter \$10. No trade. L. S. Pettygrove, W9EOA, Oxford, Neb.

FOR SALE—600-watt, 1500-volt Esco generator plus coupling. This husky machine will be sold for \$45 f.o.b. Hartford, C. C. Rodimon, 1711 Park St., Hartford, Conn.

SPECIALS—accurate panel meters, 0-100, 0-400 milliamperes, \$1.15, 0-15 volt a.c. \$2.35. Wall insulators G.R. 19c. Roller-Smith 0-6 amps, \$3.75 used. Write your needs. Anything built to order. Lower prices. Finch Radio Laboratories, W8GE, 100 Grove St., Syracuse, N. Y.

QSL cards, two colors, \$1 per hundred. Free samples. W8DTY, 257 Parker Ave., Buffalo, N. Y.

TRANSMITTING tubes bought, sold and exchanged. Nassau Radio, Seaford, N. Y.

TRADE—high power rifle, Navy Sextant or many others, for large transmitting tube. Box 21, Seaford, N. Y.

POWER transformers and adjustable chokes for transmitters in stock or built to your specifications. Transformers for power amplifiers, eliminators and electric set power packs for a.c. tubes. Repair and replacement service. Silicon transformer steel 014" cut to size, 22c. per pound. Stock sizes shell type core laminations. Send 25c. for samples. Catalog on request. Specializing in power equipment. Electrone Laboratories, 834 N. Randolph St., Philadelphia, Pa.

NAVY Dynamotors General Electric 24/1500 volt \$37.50; 24/750 volts, \$27.50; 12/350 volts, \$18; Crocker-Wheeler 24/1500 volt 450 watt, \$45; Holtzer-Cabot 12/500 volt, \$30; Westinghouse 6/15 volt 500 watt, \$15; 10/350 volt, \$18; 27.5/350 \$15; Twins for 700 volts, \$28; 900 cycle \$22.50; 1/2k.w. 500 cycle, \$15. Complete list. Henry Kienzie, 501 East 84th St., New York City.

SELL transmitter complete with power supply and tubes ready to plug in line. Perfect d.c. note. Photo on request. Fifty dollars cash. L. L. Walker, 53 Wayland St., Wollaston, Mass.

SELL or trade—21-1500 volt dynamotor; new 203-A; new 852; new 204-A; WE212D; 85 meter crystal; advance sync.; mercury are outfit; other apparatus. W4AKA, Butler, Mo.

IN stock—imported English crystals; freq. to .1%. Ordinary type, \$15. power type, \$19 in 160 or 85 meter bands. Dust proof holder, \$2; mercury vapor Rectobulbs, \$10. Prepaid with safe delivery guaranteed. New 10 mid. 1000-volt filter condensers, \$1.90. Anything else you need at dealers discounts. Write Henry's Radio Shop, Butler, Mo.

OMNIGRAPHS, teleplexes, transmitters, receivers, Vibroplexes, meters, 50 watters, "S" tubes, motor generators, dynamotors, converters, supersynces, bought, sold, traded. Ryan Radio Co., Hannibal, Mo.

AMATEURS—experimenters, builders. We serve over 4000 IRE, ARRL, etc., experimenters and "nuts." Full discounts. \$50,000 stock approved parts—no sets. Over four pounds catalog, circuits, data, prepaid, 50c. Weekly bulletins (new items, results of experiments, etc.) 20 weeks, \$1. Sample experimenters "Over the Soldering Iron" magazine, 25c. Transmitting data, price list, etc., 25c. Kladag Radio Laboratories, established 1920, Kent, Ohio.

SURPLUS apparatus—amrad antenna switch, \$1; Boston marble base key, \$1.25; GE5000 ohm, 50-watt gridleak, \$1.25; 50 Henry 100 mil choke coil, \$3.50; WE284W desk microphone, \$5; Thordarson 650-volt plate transformer, \$3.50. W2AHO, Derrick, 24 Carleton St., East Orange, N. J.

SPECIAL summer prices on crystals. 2500 Kc band \$14.00. 1700 Kc band \$9.00. Blanks \$ 4.00. W9DRD, Herbert Hollister, Edwardsville, Kansas.

SCREW-HOLDING screwdriver! Sells \$1 50. Factories, garages, men, mechanics, electricians, radio men buy on sight! Exclusive territory; free trial offer! Jiffy, 1126 Winthrop Bldg., Boston.

Q R A SECTION

50c straight with copy in following address form only:

K7ALQ—E. B. Elliott, Light-House Depot, Ketchikan, Alaska.
W6EH—Charles C. Messman, 17 E. Jefferson St., Phoenix, Ariz.

WIMK

A.R.R.L. Headquarters

R. B. Parmenter, Chief Op. "rp."

The following calls and personal sines belong to members of the A.R.R.L. Headquarters gang:

W1AL H.P. Westman "ws."
W1BDI-W1XL F. E. Handy "fh."
W1EH K. B. Warner "kb."
W1BUD A. L. Budlong "bud."
W1CE1 J. J. Lamb "jm."
W1ES A. A. Hebert "ah."
W1KP F. C. Beekley "beek."
W1PX C. G. Kenetic "ek."
W1SZ-W1BIZ C. C. Rodimon "rod."
W2JR G. D. Mesere "dm."
W9BR B. Dudley "bd."
W9DOA L. R. Huber "ou."

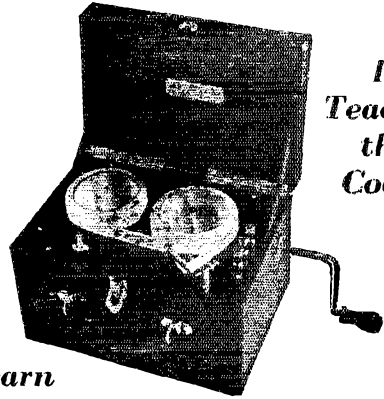

It Teaches the Code!

Learn Telegraphy with TELEPLEX

TELEPLEX is the practical code instructor. Works like a phonograph. Waxed tape records send signals like a real operator. Complete code instructions furnished with every Teleplex. Sends messages, radiograms, etc.—regular code traffic like an expert operator. Used by all leading schools. Endorsed by U. S. Navy. **Guaranteed to teach you the code or it costs nothing.** Speedy, simple, clear. Ideal for advanced students or beginners.

FREE 10 DAYS TRIAL!

So sure are we that you will be absolutely satisfied with your purchase, that we will let you try it in your own home **ON 10 DAYS FREE TRIAL!** You are the sole judge. Where can you match that astounding offer? **ACT TO-DAY!** Write for full facts about Teleplex. No obligation.

TELEPLEX CO., Dept. G12, 76 Cortlandt St., New York, N. Y.

To Our Readers who are not A.R.R.L. members

WOULDN'T you like to become a member of the American Radio Relay League? We need you in this big organization of radio amateurs, the only amateur association that does things. From your reading of *QST* you have gained a knowledge of the nature of the League and what it does, and you have read its purposes as set forth on page 10 of this issue. We should like to have you become a full-fledged member and add your strength to ours in the things we are undertaking for Amateur Radio. You will have the membership edition of *QST* delivered at your door each month. A convenient application form is printed below — clip it out and mail it today.

A bona fide interest in amateur radio is the only essential qualification for membership

AMERICAN RADIO RELAY LEAGUE
Hartford, Conn., U. S. A.

I hereby apply for membership in the American Radio Relay League, and enclose \$2.50 (\$3 in foreign countries) in payment of one year's dues. This entitles me to receive *QST* for the same period. Please begin my subscription with the issue. Mail my Certificate of Membership and send *QST* to the following name and address.

.....

.....

Do you know a friend who is also interested in Amateur Radio, whose name you might give us so we may send him a sample copy of *QST*?

.....

Thanks

For Your Convenience

QST'S INDEX OF ADVERTISERS IN THIS ISSUE

Acme Wire Company	82
Aero Products, Inc. <i>3rd cover</i>	
Allen-Bradley Co.	70
American Sales Company	2, 3, 87, 89
Arcturus Radio Tube Co.	84
Aurisma, Inc., Ad.	84
A.R.R.L. Application Blank	94
A.R.R.L. Handbook	88, <i>2nd cover</i>
A.R.R.L. Special Offer	79
A.R.R.L. Special Offer	94
Barawik Company	\$3, 85
Barros & Ch., M.	83
Burgess Battery Co. <i>1st Cover</i>	
Candler System Co.	85
Cardwell Mfg. Corp., Allen D.	71
Central Radio Labs.	90
Chicago Radio Apparatus Co.	80
Charstat Mfg. Co.	91
Corning Glass Works	87
Cunningham, Inc., E. T.	74
Dodge, C. K.	82
Dongan Elec. Mfg. Co.	86
Eastern Radio Institute	87
Electrad, Inc.	81
Electric Specialty Co.	85
Ewing, Edwin C.	87
Federal Radio & Railway Institute	83
Frost, Inc., Herbert H.	89
General Radio Co.	6
Grohen, E.	81
Gulf Radio School	81
Hardwick, Hindle, Inc.	86
Jensen Radio Mfg. Co.	91
Jewell Elec. Inst. Corp.	75
Leeds Radio Co.	73
Loomis Publishing Co.	88
Manhattan Electric Bargain House	96
McGraw-Hill Book Co.	80
McIntosh, L. C.	88
National Company	81
National Radio Tube Co.	89
Parvut Electric Co.	89
Patten, E. E.	89
Potter Company	90
QST Binder	27
Radio Engineering Labs.	76
Radio Specialty Co.	81
Radio-victor Corporation of America	1
Rectifier Engineering Service	85
Rooney, John T.	87
Scientific Radio Service	89
Silver-Marshall, Inc.	77
Teleplex Company	93
Thordarson Elec. Mfg. Co.	95
Transcontinental Coils	91
Van Nostrand Co., D.	69
Vibroplex Company	87
Ward-Leonard Elec. Co.	88
Weston Elec. Inst. Corp.	78
Wiley & Sons, John	4
Wireless Expert Engineering, Inc.	55
X-L Radio Labs.	83
Yasley Mfg. Company	85



BARGAINS ARMY AND NAVY RADIO SURPLUS

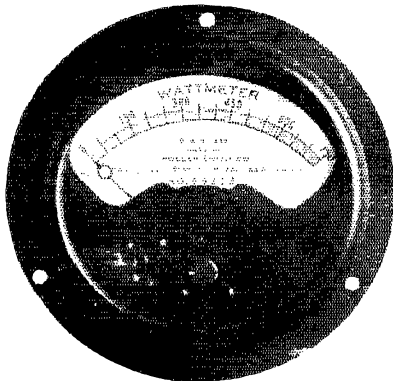

Wattmeter, Roller-Smith, Operates on either A. C. or D. C. Max. Volts 150, Max. Amps 7.5, Zero Adjuster, Actual size 4 1/2" diam., 3" deep, black frame, flush mounting. Original price, \$28. Our price, \$3.50.

Volumeter, Westinghouse, No. 49249 cabinet portable, 2 scale 0-8-150, List \$6.50	\$ 2.50
Voltmeter, Weston, No. 267 D.C., 0-70	2.50
Ammeter, Weston, No. 267 D.C., 0-40	7.50
Ammeter, Weston, No. 267 D.C., 0-1.0	7.50
Ammeter, Weston, No. 301 D.C., 50-40-50	5.00
Voltmeter, Weston, No. 269 D.C., 0-50	7.50
Ammeter, Weston, No. 269 A.C., 0-10	7.50
Amp. hour meter, Sangamo, bat. charge and discharge, type MS 2 sizes, 0-300 and 0-500, List \$50.00	10.00
Ammeter, Westinghouse, A.C., 3" dia. less external shunt 0-400	10.00
Voltmeter, Westinghouse, A.C. 3" dia. with external res. 0-175	12.50
Generator, self ex., 1/2 K.W., 500 cycle, 250 volt	15.00
Dynamometers, twin, Westinghouse, C.W. 927, 30/750 volt, .08 amp.	25.00
Dynamometer, single, Westinghouse, C.W. 927, 30/375 volt, .08 amp.	15.00
Dynamometer, Gen. Elec. 12/350 volt, .143 amp.	20.00
Dynamometer, Crocker Wheeler, 25/275 volt, external shaft	12.00
Dynamometer, Sperry Gyro Co., 6/400 volt, 200 watt, ext. shaft	15.00
Motor Generator, Crocker Wheeler, 110 D.C., 200 A.C., 500 watt, 500 cycle, Ball bearing	50.00
Motors, Hamilton Beach, 1/20 H.P. universal, var. speed, 110 volt	5.00
Motors, Edison, universal, 50 watt, double shaft, 110 volt	3.50
Motors, Edison, D.C., 10 watt, double shaft (List \$10.50)	2.00
Motors, Underwood, D.C., 75 watt, double shaft, 1200 R.P.M., 110 volt	3.00
Dynamometer armatures, Gen. Elec. triple commutators, two sizes, D.C. 12/750 volt and 24/1500 volt, complete with ball bearings (build field and save \$30.00)	\$12.50
Transformers, West. Elec. radio, 50,000 ohm impedance, input type D-14794, (Ratio 3.4-1 (500 volt)	1.50
Transformers, Peiriss, 120 input, 5-10-15 volt output, 1/2 K.W., 60 cycle	7.50
Transformers, G. E. current type, 125 to 2500, with center tap, 60 cycle, 200 watt.	7.50
Transformers, Amer. Tran., 220 to 30,000, open core, 2 K.W., 60 cycle	75.00
Transformers, Amer. Tran., 220 to 8000, closed core, 2 K.W., 500 cycle	15.00
Transformers, Simon, 220 to 11500 closed core, 1/2 K.W., 500 cycle	5.00
Transformers, Amer. Tran., 220 to 12500 closed core, 2 K.W., 500 cycle	25.00
Transformers, Special 250 Primary, 30 taps stepdown, 4 KVA, 60 cycle	50.00
Rheostats, variable, 300 ohm, 3 ampere	.75
Potentiometers, var., 200 ohm, 1.5 amp. airplane type	1.00
Potentiometers, var., 1100 ohm, 1 amp. airplane type	1.00
Potentiometers filament, 1 ohm, 8 amp. airplane type	.75
Gasoline Engine, 1 cylinder 2 cycle Smith 2 horsepower, complete	25.00
Gasoline Engine, 2 cylinder 2 cycle Sterling 3 horsepower, complete	50.00

Gasoline Engine, 4 cylinder 4 cycle Henderson 20 horsepower, air cooled with Sturtevant blower all aluminum body, complete with hand starter and separate transmission	\$75.00
Condensers, West. Elec. 21AA 1000 volt 1 mfd. A.C. test, very good valve	1.00
Condensers, Century, 500 volt, 4 mfd.	1.25
Condensers, Kellogg, 500 volt 2 mfd.	.50
Condensers, Dubilier, mica, working volts 40,000, cap. (3) .002-.001-.0008	40.00
Condensers, Dubilier, mica, working volts 12,000, cap. .0004	10.00
Condensers, Dubilier, mica, working volts 3,600, cap. .32	10.00
Condensers, Century, volts 500 A.C., cap. 4 mfd.	1.25
Condensers, Wireless Specialty, copper leyden glass var. 10000 working voltage .002 mfd.	2.00
Condensers, Dubilier, mica, transmitting, 8500 working voltage .004 mfd.	10.00
Condensers, Dubilier, mica, transmitting, 12500 working voltage .004 mfd. Prices on request	
Condensers, Wireless Specialty, transmitting, 12500 volt .004 mfd. Prices on request	
Keys, transmitting, Army practice	1.00
Keys, transmitting, Airplane flameproof, silver 1/2" contacts	1.50
Keys, transmitting, Airplane flameproof, silver, 1/2" contacts, with blinker light mounted on bakelite base, List \$7.50 - Special	2.00
Keys, transmitting, Navy, 2 K.W., silver, 1/2" contacts	5.00
Keys, transmitting, Navy 1/2 K.W., "Mesco" silver	2.00
Headphone, Army, with strap, 120 ohm	.75
Headphone, Navy Radio School type, leather headband, 75 ohm	1.50
Transmitter, telephone, U. S. N., 30 ohm (used)	.75
Radiophone transmitter unit, Western Electric CW326	1.50
Magnets, Army mine and ringer type, has 4 large fixed magnets, good value	1.00
Magneto-generator, Marconi, hand driven, 1500 volts, D.C., 12 milliamps	12.50
Magnets, permanent, U shaped Western Electric, large size	.50
Variometers, Gen. Radio No. 107D and 107E, with series and parallel connections	5.00
Telephone and telegraph portable sets, aluminum case, leather covered and carrying strap, including condensers, induction coil, key, micro-transmitter and receiver	3.50
Telegraph and buzzer portable sets, mahogany case, 2 tone platinum contact high freq. buzzer, 2 telephone toggle switches, potentiometer, sending key, 3 mfd condensers, transformer and 2 choke coils, receiver, \$30 value	5.00
Receivers, Signal Corp type, B.C. 11A, 200-600 meters, with cry. det. and Century buzzer in portable case	7.50
Receivers, Navy, C.N. 113, 300-2500 meters	15.00
Receivers, Signal Corps, 300-3000 meters, with built-in tube detector, portable	20.00
Receivers, Marconi, 500-2500 meters, type 106, commercial ship type	35.00
Receivers, Navy, C.N. 240, 1000-10000 meters	50.00
Receivers, S.E. 143 and I.P. 500. Prices on request	
Insulators, Electro-se, strain 7 1/2-15, 12"-35, 18"	.35
Switch, Telephone, toggle, 2-4-6-8 points	.50
Coils, magnet, small, 70 large	.50
Coils, induction, small size	.25
Coils, Retardation, West. Elec. Co. 57C, 83 ohm, 2 windings	7.00
Buzzers, Century high freq., 2 coils	1.50
Buzzers, West. Elec. extra quality high freq.	1.50
Code practice set, Navy type, 1/2 K.W., Bunnell brass key, Mesco high pitch buzzer, 75-ohm headphone, mounted on Bakelite base with 5 large binding posts, some with extra D.P.D.T. switches	4.50
Air compressors, Kellogg, Model T, 1 1/2 cu. ft. per min., weight 6 lbs., 600 R.P.M., 125-lb. pressure	3.00
Milliammeter, Westinghouse, type C.A. 0-250, zero adjustment, flush mounting	5.00
Ammeter, Westinghouse, type C.A. 0-1, zero adjustment, flush mounting	5.00
Voltmeter, Westinghouse, type C.A. 0-35, zero adjustment, flush mounting	5.00
All above type C.A. meters operate on either A.C. or D.C. Regular price	10.00
D.C. Ammeter, Westinghouse type PX2, 0-5, regular price \$10.00	5.00

WANTED

CONDENSERS — 2000 to 15000 volt, all capacities
 RECEIVERS — 1P-501, SE-1420, SE-143, CGR-1, SE-120
 QUENCHED GAPS — From spark transmitters, Navy S.E. 908-1001-1002-1005. Give complete particulars and prices.
 DETECTORS, TUBE — SE-1071, SE-1071A.

Largest Radio and Electric Supply House in U. S. devoting eight floors to and specializing on Army and Navy Surplus. Due to rapidly moving stock and as new items are continually arriving we are unable to publish a catalog. Write us your particular requirements. Sufficient postage and deposit of 20% required on C.O.D. orders. No C.O.D. ON CANADIAN Orders.

MANHATTAN ELECTRIC BARGAIN HOUSE, Dept. Q, 105-7 Fulton St., New York City

AERO COIL

Wave-Meter

New!

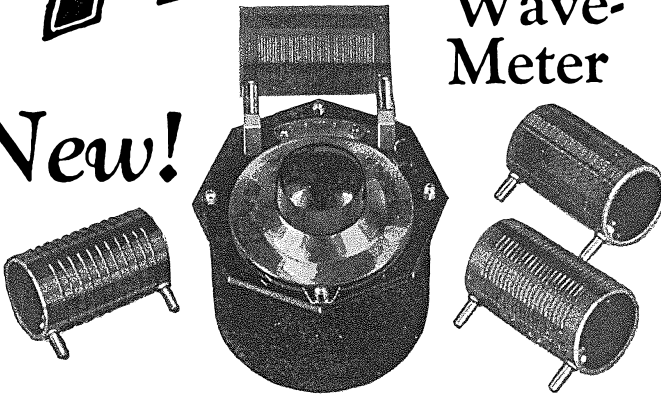

100 Divisions — Readable to 1-10th of a Division

The Aero Wavemeter was designed for the radio amateur and the experimenter. It is of rugged mechanical and good electrical construction and meets the exacting requirements of the properly conducted amateur station.

Using the principle of the "series gap" condensers, and having a definite fixed minimum capacity, the amateur wavelength bands are spread over a great many dial divisions. The velvet vernier dial has 100 divisions, each of which may be read to one-tenth of a division. The 5-meter band covers 40 dial divisions; the 10-meter, 40 divisions; 20-meter, 17 divisions and the 40-meter band, 25 divisions.

Price.....\$24.00

For the 80-meter band, two coils are used. One (72 to 82 meters) covers 45 divisions, and the other (80 to 90 meters) covers 65 divisions.

Each coil excepting the 5-meter, uses No. 18 enameled wire tightly wound into grooves of the bakelite tubing. The tubing has a 3/8 in. wall and is 2 in. in diameter. The Aero heavy duty plugs and jacks make positive contact. The heavy brass case has a black crackle finish. The 3/16" black bakelite top is hexagonal shape to prevent rolling. Each wavemeter is individually hand calibrated. Standard coils shown are 20, 40 and 80 meters, included in price. 5- and 10-meter coils extra.

Aero High-Power Xmitter and 150-Watt Amplifier

For operation on 10-20-40-80-100M. Bands

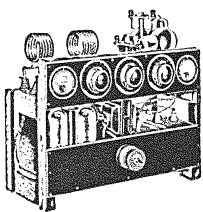

The first high-power amplifier to use the UX-860 screen grid tubes. 1929 in Every Detail. 150 Watts of Pure D.C. Signals with a Stability Which Has Caused Favorable Remarkable Everywhere. Flexibility that Fills Every Ham Need.

You can use either two UX-852 tubes when using this new Aero Kit No. 52 as a single unit for a transmitter; or two UX-860 (screen

grid) tubes, employed when using with Aero Kit No. 55; or as a 150-watt amplifier in any master oscillator combination. For those desiring a master oscillator system, this unit works with a high degree of efficiency as an amplifier. With two screen grid UX-860 power tubes in this arrangement, it requires no neutralizing. Hook this unit on your present oscillator, converting it into a 1929 job, with ample power for ham use.

Power supply delivers 2000 volts at 250 M.A. Employs two of the R.C.A.'s newest rectifiers, UX-866. Due to the construction of the UX-866, unusually high voltage may be applied safely to them.

Kit No. 52 — Including the power supply, but not including tubes. List Price.....\$259.00
 Kit No. 55 — Less power supply and tubes. List Price.....\$114.00

Aero Listening Monitor

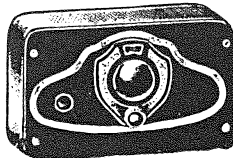

The Aero Listening Monitor enables any amateur transmitter to check his own note to know whether it is

pure D.C. or not. It is a safe, sure and accurate way of knowing your station without depending upon the reports of others. Watching the ammeter won't help you — you need the Aero Monitor to be absolutely positive.

The Aero Monitor is a completely shielded unit encased in a black metal cabinet, size 9 x 5 1/4 x 2 3/4 in. Filament and B supply is included. It operates with a UX-199 type of tube and employs a stable circuit, delivering a signal intensity of about R-4 or 5. Equipped with automatic filament control. The battery supply is thoroughly shielded from the R.F. A reliable, scientific instrument. Ship. wt., about 2 1/4 lbs.

Model M-29 Aero Monitor, including Dry Batteries, but no tube. List Price, \$15.00

Send for Aero Green Book and 1929 Supplement showing newest Short Wave Products. Price.....25c

Send for advance information on new Short-wave developments for 1929-1930. Sent free to QST readers

4611 E. Ravenswood Ave., Dept. 389

AERO PRODUCTS
INCORPORATED

Chicago, Illinois, U. S. A.

New 1929 Receiving Coils

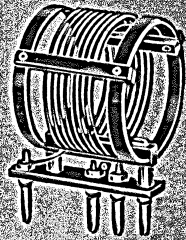

Designed for the new practice kit 20, 40 and 80 meter bands. For use with 00003 condenser. Includes plug-in base with new design adjustable base. Wound primary. Complete Kit. L. W. T. 15, 3 coils, \$12.50. Single coils — 8.2 to 12.0 meters, \$1.94; 12.5 meters, 40.0 to 45.0 meters, \$75.0; 80.0 meters, \$4.00 each. L. W. T. 100-P. Plug-in base, \$3.00; 00003 Condenser, \$1.50. This condenser to be shunted with a 00008 Fixed Condenser.

New 1929 Transmitting Coils

In accord with 1929 practice. First use of plug-in coils for high power up to 75 amperes. Heavy aluminum carries 500 watts safely. Large space bar superior to glass. Many new features.

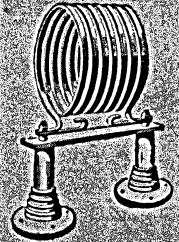

For use with 450 m.mfd. condenser. Kit of 2 coils with plug-in mounts, 9.6 to 27.0 meters \$15.00; 14.2 to 43; also 31.8 to 90.3 meters, \$15.00. Single coils, \$5.50, without base. Plug-in mounts, rings only, pair \$3.50; Plugs only, with nuts, pair \$2.00.

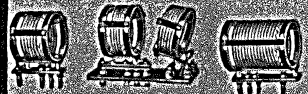

Aero Short-Wave Receiving Coils. Small in diameter, providing a much smaller external field, a better shape factor and improved efficiency. The Kit consists of three coils (16.5 to 89.5 meters). Price, \$12.50. L.W.T. 12 (15 to 135 meters) 2" diam. \$12.50

Aero Shield-Grid Coils
 LWT-11 Kit of 3 coils (16 to 90 meters) \$11.50
 LWT-10 Kit of 3 coils List \$10.50

SINGLE COILS — Secondary and Ticker

- Inc-101 — 16.5 to 32 me \$4.00 net
- Inc-102 — 26.2 to 48.7 me \$4.00 net
- Inc-103 — 46.7 to 89.5 me \$4.00 net
- Inc-104 — 87 to 155 me \$4.00 net
- 100-P — Base with space-wound primary \$3.00
- 100-W — Base without primary coil \$1.50

Aero Transmitting Coil Kits
 2048-K — 16 to 52 meter kit \$12.00
 4080-K — 30 to 90 meter kit \$12.00
 9018-K — 72 to 190 meter kit \$12.00

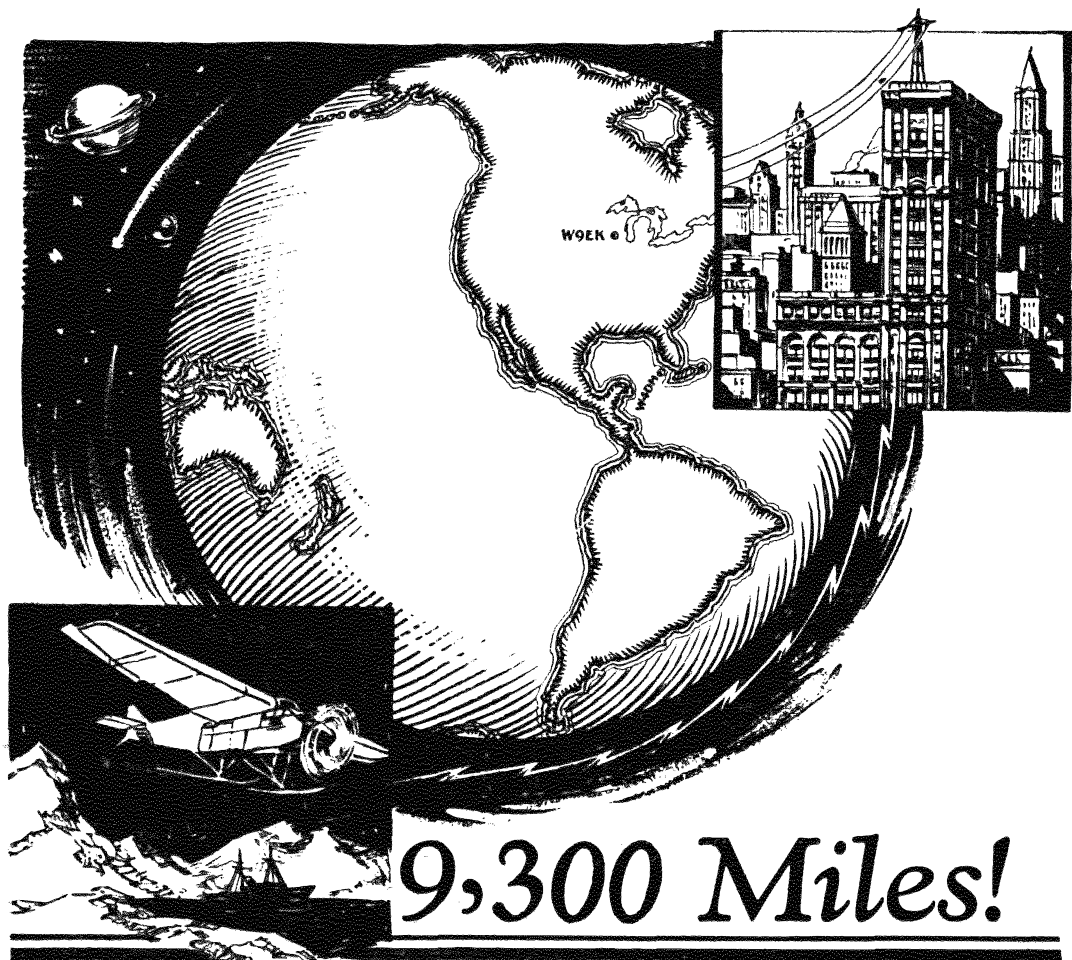

The World's Record! Direct two way radio communication between the New York Times Radio Station and Commander Byrd's Airplane flying over the Antarctic.

Every Radio Amateur should know that Burgess Radio Batteries are used in the Antarctic Expedition radio stations.

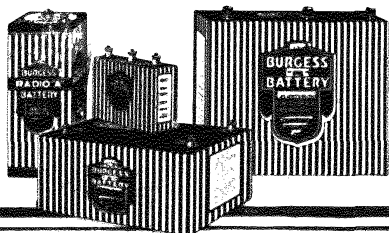

Ask Any Radio Engineer

BURGESS BATTERY COMPANY

MADISON,

WISCONSIN