

# QST

DEVOTED ENTIRELY TO

# AMATEUR RADIO

PUBLISHED SINCE 1915 BY THE AMERICAN RADIO RELAY LEAGUE INC.

*Jim Lamb  
W1CEI*

*Lele R.  
W1SZ*

*Hiram Percy Maxim W1AW*

*Geo Grammer W1DF*

*A.R. Budd  
W1EUB*

*B. Dudley  
W1ALY*

## HAPPY NEW YEAR

to

## AMATEURS EVERYWHERE

from

## The A.R.R.L. H.Q. Staff

*R.P.  
W1MK*

*J. W1E*

*J. Swamer  
W1EH*

*David Houghton  
W1WJ*

*W.E. Handy  
W1DZ-W1WJ  
W1PX*

*J. Donald  
W2IR-W1FL*

*W1E*

# JANUARY, 1930

# 25¢

# GREAT NEWS IN RADIO!



## A.C. SHORT-WAVE RADIO PILOT SUPER-WASP

David Grimes, John Geloso and Robt. S. Kruse have successfully solved the engineering problems inherent in A.C. Short-Wave reception. By developing the Pilotron 227 tube for use as detector, great clarity and signal strength is obtained. Both A.C. and Battery-operated models employ the screen grid tube. Range 14 to 500 meters.



KIT K-115 (A.C. Operated)

**\$34.50**

POWER PACK EXTRA  
(Pilot K-111 recommended)

KIT K-110 **\$29.50**  
(Battery operated)

### DO YOU BELONG?

The Radio International Guild and its official organ, "Radio Design" are of particular interest to progressive experimenters and constructors. Membership 50c per year, which includes four quarterly issues "Radio Design," jammed with latest data (written by practical radio engineers), and advisory engineering consulting service. Return Coupon Now.

RADIO INTERNATIONAL GUILD, 103 Broadway, Brooklyn, N. Y.

Enclosed please find 50c for which kindly enroll me as a regular member Radio International Guild, which includes four quarterly issues of Radio Design, membership pin, certificate and identification card.

Name \_\_\_\_\_  
(Please write or print plainly)

Address \_\_\_\_\_

City \_\_\_\_\_ State \_\_\_\_\_

# PILOT RADIO & TUBE CORP.

WORLD'S LARGEST  
RADIO PARTS PLANT  
(Established 1908)

Prices quoted are  
for Custom Set-Builders  
in U. S. A.



TRADE MARK

323 BERRY STREET  
BROOKLYN, N. Y.  
U. S. A.

Get Latest Catalog from  
nearest Authorized Dealer  
or Direct from Factory.

# RCA RADIOTRON

## UV-861

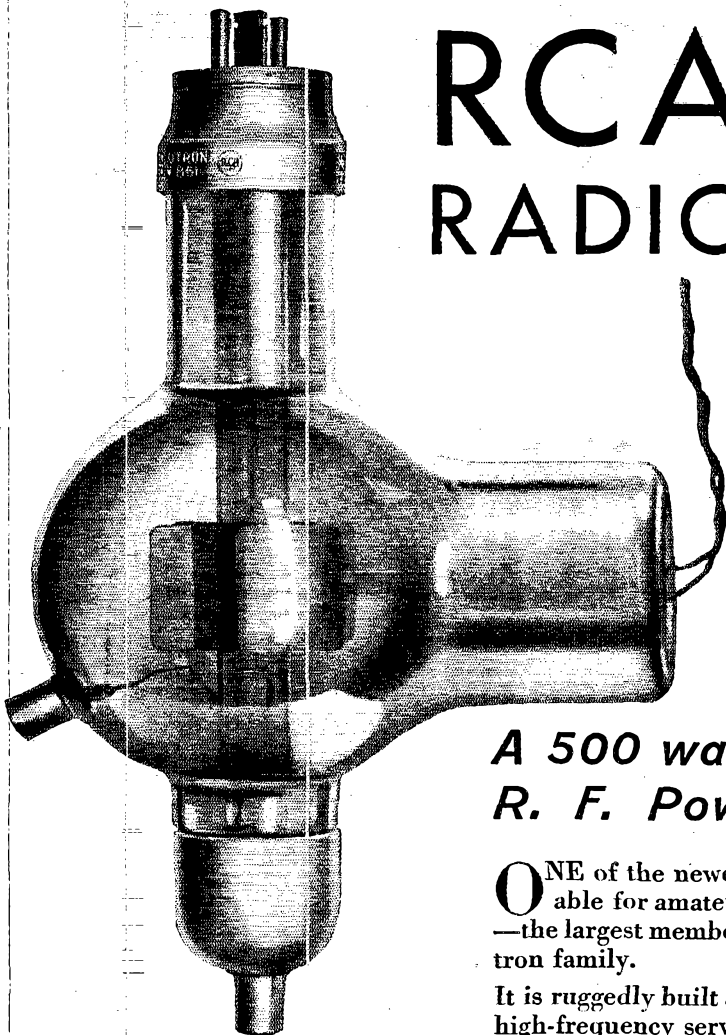

### *A 500 watt screen-grid R. F. Power Amplifier*

**O**NE of the newest transmitting tubes suitable for amateur use is Radiotron UV-861—the largest member of the screen-grid Radiotron family.

It is ruggedly built and especially designed for high-frequency service. Its fourth electrode—the *screen*—shields the grid from the plate and thereby effectively reduces feed-back and self-oscillation within the tube itself.

As a result, remarkable operational stability and large R.F. power output may be obtained from Radiotron UV-861 even at the higher frequencies.

The excellence of its characteristics and the gratifying smoothness of its performance will enable amateurs to accomplish amazing results in the field of high-frequency transmission.

Filament Volts . . . . .	11
Filament Amperes . . . . .	10
Amplification Factor . . . . .	300
Normal Operating Plate Volts . . . . .	3000
Nominal Screen Volts . . . . .	500
Max. Plate Dissipation (watts) . . . . .	400
Max. Screen Dissipation (watts) . . . . .	35
Power Output (watts) . . . . .	500
Max. Over-all Length . . . . .	17 7-32"
Max. Over-all Width . . . . .	13 1-4"

Price \$295

*Write nearest RCA District Office  
for further information*

## RADIO-VICTOR CORPORATION OF AMERICA

New York—261 Fifth Avenue  
 Atlanta—101 Marietta Street Chicago—100 West Monroe Street  
 Dallas—Santa Fe Building  
 San Francisco—235 Montgomery Street

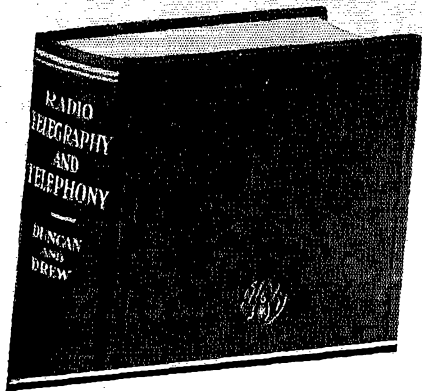

The most complete . . .  
comprehensive . . . and  
authoritative Radio Manual  
ever published!

# Radio Telegraphy and Telephony

26 Chapters—Containing  
the Latest 1929 Practice

Introduction to Radio  
Magnetism  
The Production of Electromotive  
Force  
Electromagnetic Induction  
Motor Generators  
Curve Diagrams  
Storage Batteries and Charging  
Circuits  
Meters  
Alternating Current  
Condensers—Electrostatic Capa-  
city—Capacity Measurements  
Vacuum Tubes  
Receiving Circuits  
Alternating Current Operated Re-  
ceiver and Tubes  
Telephone Receivers, Loud Speaker  
Producing Units  
Commercial Receivers  
Rectifier Devices, Rectifier Circuits,  
Voltage Divider Resistors, Filter  
Circuits  
High Voltage Condensers. How an  
Electric Circuit Oscillates  
Antennae or Aerials  
Resonance  
Commercial Broadcast and Tele-  
graph Transmitters  
Commercial Tube Transmitters  
Short Wave Transmitters and Re-  
ceivers  
Spark Transmitters  
The Arc Transmitter  
Direction Finders—Radio Com-  
pass  
Appendix

By Rudolph L. Duncan

President R. C. A. Institutes, Inc.

and Charles E. Drew

Instructor in Radio, and in charge of Electrical Division  
R. C. A. Institutes, Inc.

Published May 1929

A Practical Handbook for . . .  
Radio Engineers, Operators, Amateurs,  
Broadcasters, and Students

More than 900 pages of practical information on Ship, Shore, and Broadcast Operating make this Radio Handbook indispensable for the practical radio man. Principles, methods and equipment are described clearly and interestingly and illustrated profusely with more than 460 supplementary and illuminating diagrams and photographs. This is all brand new 1929 data presented as a result of years of study and research on the part of two of America's foremost teachers of this subject. The book is a product of the School Division of the Radio Corporation of America and therefore represents the last word on the subject.

Everyone at all interested in this most fascinating subject will find his most favorite phase of Radio clearly and fully discussed. Even the casual reader will enjoy this book and discover the answers to a great many radio mysteries about which he has vaguely wondered. This book will greatly increase the enjoyment of your radio and open your eyes to a great field of new and progressive discoveries.

Indispensable to the practical man and extremely interesting to the amateur, this book is also an ideal Wireless Operators' Handbook and a complete text for the student of Wireless Communication.

Never before has such a wealth of practical and usable data been collected in book form for the use of the many thousands for whom Radio is the most fascinating subject in the world.

Send in this coupon at once . . . and examine the book at our expense!

Price \$7.50

## A Wiley Book

### Free Examination Coupon

John Wiley and Sons, Inc.  
440 Fourth Avenue, New York

Gentlemen: Kindly send me on ten days' free examination Duncan and Drew's "Radio Telegraphy and Telephony."

I agree to remit the price (\$7.50) of the book within ten days after its receipt or return it postpaid.

Name.....

Address.....

Position or Reference.....

Subscriber  YES  
 NO

QST-1-30

# Section Communications Managers of THE COMMUNICATIONS DEPARTMENT, A. R. R. L.

Eastern Pennsylvania Maryland-Delaware-District of Columbia Southern New Jersey Western New York Western Pennsylvania	W3ZF W3BBW W3BWJ W8PJ W8CEO	<b>ATLANTIC DIVISION</b> Don Lusk Forrest Calhoun Norman R. Weible C. S. Taylor A. W. McAuly	116 West Wyoming Ave. 1636 Thomas Ave. 120 Frazar Ave. 598 Masten St. 309 Third St.	Germantown, Phila. Baltimore, Md. Collingswood Buffalo Oakmont
Illinois Indiana Kentucky Michigan Ohio Wisconsin	W9APY W9CVO W9BAZ W8CEP W8BYN W9VD	<b>CENTRAL DIVISION</b> Fred J. Hinds D. J. Angus J. B. Wathen, III Dallas Wise H. C. Storck C. N. Crapo	3337 Oak Park Blvd. 310 N. Illinois St. Mockingbird Valley 9187 Falcon Ave. 694 Carpenter St. 443 Newton Ave.	Berwyn Indianapolis Louisville Detroit Columbus Milwaukee
North Dakota South Dakota Northern Minnesota Southern Minnesota	W9DVV W9DGR W9BVH W9EFK	<b>DAKOTA DIVISION</b> B. S. Warner D. M. Pasek Carl L. Jabs J. C. Pehoushek	309 4th Ave. 780 Illinois St. 1822 James St. 60 Melbourne Ave., S. E.	Enderlin Huron St. Paul Minneapolis
Arkansas Louisiana Mississippi Tennessee*	W5ABI W5EB W5AKP W4SP	<b>DELTA DIVISION</b> H. E. Velte M. M. Hill J. W. Gullett James B. Witt	315 No. Jackson St. 1708 23rd Ave. 832 N. Fifth Ave.	Little Rock Oakdale Meridian Knoxville
Eastern New York N. Y. C. & Long Island* Northern New Jersey	W2OU W2BGO W2WR	<b>HUDSON DIVISION</b> H. H. Rosenthal V. T. Kenney A. G. Wester, Jr.	Box 740 1836 Hone Ave. 50 Princeton St.	New Rochelle Bronx Maplewood
Iowa Kansas Missouri Nebraska	W9DZW W9CET W9RR W9BYG	<b>MIDWEST DIVISION</b> H. W. Kerr J. H. Amis L. B. Laizure C. B. Deihl	915 Lincoln Ave. 8010 Mercier St. 5605 Cedar St.	Little Sioux Topeka Kansas City Omaha
Connecticut Maine Eastern Massachusetts Western Massachusetts New Hampshire Rhode Island Vermont	W1CTI W1AQL W1WV W1UM W1ATJ W1BCR W1IT	<b>NEW ENGLAND DIVISION</b> Frederick Ells, Jr. G. C. Brown M. W. Weeks Dr. John A. Tessmer V. W. Hodge C. N. Kraus Clayton Faulette	7 Union Ave. 269 No. Main St. 40 Norfolk Rd. 8 Schafner St. 327 Main St. 92 Keene St.	Norwalk Brewer Chestnut Hill Worcester Claremont Providence North Troy
Alaska Idaho Montana Oregon Washington	WWDN W7ACN-JL W7AAT-7QT W7UN W7ACS	<b>NORTHWESTERN DIVISION</b> W. B. Wilson James L. Young O. W. Viers Wilbur S. Claypool Eugene A. Piety	U. S. LHT Fern 303 13th Ave., So. 1059 Greenwood Ave. 912 No. Ainsworth St	Ketchikan Nampa Red Lodge Portland Tacoma
Hawaii* Nevada* Los Angeles Santa Clara Valley East Bay San Francisco Sacramento Valley Arizona Philippines San Diego	K6NL W6UO W6EQF W6NQ W6CZR W6WB W6DON W6BWS K6ACY W6EOP	<b>PACIFIC DIVISION</b> R. B. Rietow C. B. Newcomb E. E. Sandham F. J. Quement J. Walter Frates C. F. Bane Everett Davies Russ Shortman S. M. Mathis Harry A. Ambler	c/o Mutual Telephone Co. 4508 8th Ave. 1348 Hanchett Ave. 368 62nd St. 262 Castro St. Rt. 5, Box 380 519 W. Madison St. Army-Navy Club 4101 Hamilton St.	Honolulu Yerington Los Angeles San Jose Oakland San Francisco Sacramento Phoenix Manila San Diego
North Carolina Virginia* West Virginia	W4TS W3CA W8ZV	<b>ROANOKE DIVISION</b> Hal S. Justice J. F. Wohlford F. D. Reynolds	Box 552 118 Cambridge Ave. Box 1200	Canton Roanoke Fairmont
Colorado Utah-Wyoming	W9CAA W6BAJ	<b>ROCKY MOUNTAIN DIVISION</b> C. R. Stedman Parley N. James	1641 Albion St. 430 "D" St.	Denver Salt Lake City
Alabama Florida Georgia-So. Carolina-Cuba- Isle-of-Pines Porto Rico-Virgin Islands	W4AAQ W4AII W4RZ K4KD	<b>SOUTHEASTERN DIVISION</b> S. J. Bayne Harvey Chafin M. S. Alexander E. W. Mayer	7 Cramer Ave. 6002 Suncane Ave. 79 Rogers St., S. E. Box 103	Montgomery Tampa Atlanta Ensenada, P. R.
Northern Texas Oklahoma Southern Texas New Mexico	W5BG W5GF W5OX W5AHI	<b>WEST GULF DIVISION</b> J. H. Robinson, Jr. W. J. Gentry R. E. Franklin Leavenworth Wheeler, Jr., Box 33	522 Cumberland St. 616 Pottenger St. 1806 Valentine St. Box 33	Dallas Shawnee Houston Valmore
Maritime*	VE1DQ	<b>MARITIME DIVISION</b> A. M. Crowell	69 Dublin St.	Halifax, N. S.
Ontario	VE3FC	<b>ONTARIO DIVISION</b> E. C. Thompson	266 Queensdale Ave.	Toronto, 6
Quebec	VE2BE	<b>QUEBEC DIVISION</b> Alex Reid	169 Logan Ave.	St. Lambert
Alberta British Columbia	VE5AL	<b>VANALTA DIVISION</b> J. K. Cavaleky	4868 Blenheim St.	Vancouver
Manitoba Saskatchewan*	VE4HR VE4FC	<b>PRAIRIE DIVISION</b> A. V. Chase W. J. Pickering	109 Lanark St. 514 19th St. W.	Winnipeg Prince Albert

\*Officials appointed to act until the membership of the Section concerned choose permanent SCMs by nomination and election.

## FOR FIFTEEN YEARS

the General Radio Company has been manufacturing instruments for the amateur which have made a reputation for sound design, quality, and reliability. Among these are

Frequency Meters

Quartz Plates for

Piezo-Electric Oscillators

Audio-Amplifier Transformers

Power-Supply Transformers

Variable Air Condensers (for  
work on short waves)

New items are under development. Send for Bulletin 931-X and ask to receive future announcements as they appear in the *General Radio Experimenter*

## GENERAL RADIO COMPANY

30 STATE STREET  
CAMBRIDGE, MASSACHUSETTS

274 BRANNAN STREET  
SAN FRANCISCO, CALIFORNIA



# QST



## The Official Organ of the A.R.R.L.

VOLUME XIV

JANUARY, 1930

NUMBER 1

Editorials	7
WWV Standard Frequency Transmissions	8
The A.C. High-Frequency Receiver	<i>Beverly Dudley</i> 9
Trophies and Certificates for the January and February Tests	<i>F. E. Handy</i> 15
G5BY Wins 1929 Station Description Contest Cup	17
Navy Day — 1929	<i>E. L. Batley</i> 18
Hunting Trouble on 28 Megacycles	<i>Alphy L. Blais</i> 21
A Micro-Condenser for Amateur Band Tuners	<i>A. L. M. Dingee</i> 24
A Power Transformer for the Lean Purse	<i>E. H. Harrington, Jr.</i> 25
"20-Meter" 'Phone Authorized	26
Hams Are Born — Not Made	" <i>Felix</i> " 27
Quartz Crystal Facts	<i>J. Herbert Hollister</i> 29
Matching the Speaker to the Output Tube	<i>J. M. Thomson</i> 31
Accurate Wire-Wound Resistors	34
Passing the Government Examinations for Operator's License — Part I	<i>Beverly Dudley</i> 35
Technical Information Service Rules	37
A.R.R.L. Election Results	38
Plate Supply Filters and Keying	<i>J. C. Coe</i> 39
Official Frequency System	41
W9BAG	42
Experimenters' Section	47
I.A.R.U. News	49
Calls Heard	51
Correspondence Department	52
Book Reviews	86
Silent Keys	88
Hamads and QRA's	92
Index of Advertisers	94

QST is published monthly by The American Radio Relay League, Inc., at Hartford, Conn., U. S. A.  
Official Organ of the A.R.R.L. and the International Amateur Radio Union

Kenneth B. Warner (Secretary, A.R.R.L.), Editor-in-Chief and Business Manager

James J. Lamb  
Technical Editor

Beverly Dudley  
Assistant Technical Editor

Clark C. Rodimon  
Assistant Editor

David H. Houghton  
Circulation Manager

G. Donald Meserve  
Advertising Manager

Advertising Offices..... 55 West 42d Street, New York City  
Editorial Offices..... 1711 Park Street, Hartford

Subscription rate in United States and Possessions, Canada, and all countries in the American Postal Union, \$2.50 per year, postpaid. Single copies, 25 cents. Foreign countries not in American Postal Union, \$3.00 per year, postpaid. Remittances should be by international postal or express money order or bank draft negotiable in the U. S. and for an equivalent amount in U. S. funds.

Entered as second-class matter May 29, 1919, at the post office at Hartford, Connecticut, under the Act of March 3, 1879. Acceptance for mailing at special rate of postage provided for in section 1103, Act of October 3, 1917, authorized September 9, 1922. Additional entry at Concord, N. H., authorized February 21, 1929, under the Act of February 28, 1925.

Copyright 1929 by the American Radio Relay League, Inc. Title registered at United States Patent Office.  
Member of the Radio Magazine Publishers' Association.

# The American Radio Relay League

The American Radio Relay League, Inc., is a non-commercial association of radio amateurs, bonded for the promotion of interest in amateur radio communication and experimentation, for the relaying of messages by radio, for the advancement of the radio art and of the public welfare, for the representation of the radio amateur in legislative matters, and for the maintenance of fraternalism and a high standard of conduct.

It is an incorporated association without capital stock, chartered under the laws of Connecticut. Its affairs are governed by a Board of Directors, elected every two years by the general membership. The officers are elected or appointed by the Directors. The League is non-commercial and no one commercially engaged in the manufacture, sale or rental of radio apparatus is eligible to membership on its board.

"Of, by and for the amateur," it numbers within its ranks practically every worth-while amateur in the world and has a history of glorious achievement as the standard-bearer in amateur affairs.

Inquiries regarding membership are solicited. A bona fide interest in amateur radio is the only essential qualification; ownership of a transmitting station and knowledge of the code are not prerequisite. Correspondence should be addressed to the Secretary.

## DIRECTORS

*President*  
HIRAM PERCY MAXIM  
Drawer 2102,  
Hartford, Conn.

*Vice-President*  
CHARLES H. STEWART  
St. David's, Pa.

*Canadian General Manager*  
ALEX. REID  
169 Logan Ave.,  
St. Lambert, P. Q.

*Atlantic Division*  
EUGENE C. WOODRUFF  
234 W. Fairmount Ave.,  
State College, Pa.

*Central Division*  
CLYDE E. DARR  
137 Hill Ave., Highland Park,  
Detroit, Mich.

*Dakota Division*  
CY. L. BARKER  
Henning, Minn.

*Della Division*  
M. M. HILL  
P. O. Box 274  
Natchitoches, La.

*Hudson Division*  
A. LAFAYETTE WALSH  
220 West 42d St.,  
New York City

*Midwest Division*  
I. R. HUBER  
718 N. Gilbert St.,  
Iowa City, Iowa

*New England Division*  
FREDERICK BEST  
13 East Crescent St.,  
Augusta, Maine

*Northwestern Division*  
K. W. WEINGARTEN  
3219 No. 24th St.,  
Tacoma, Wash.

*Pacific Division*  
ALLEN H. BABCOCK  
65 Market St.,  
Southern Pacific Co.,  
San Francisco

*Roanoke Division*  
W. TREDWAY GRAVELY  
Box 245,  
Danville, Va.

*Rocky Mountain Division*  
PAUL M. SEGAL  
Box 1771,  
Denver, Colo.

*Southeastern Division*  
HARRY F. DOBBS  
245 Spring St., N. W.  
Atlanta, Ga.

*West Gulf Division*  
FRANK M. CORLETT  
2515 Catherine St.,  
Dallas, Tex.

## OFFICERS

*President* . . . . . HIRAM PERCY MAXIM, Hartford, Conn.  
*Vice-President* . . . . . CHARLES H. STEWART, St. David's, Pa.  
*Secretary* . . . . . KENNETH B. WARNER, Hartford, Conn.  
*Treasurer* . . . . . ARTHUR A. HEBERT, Hartford, Conn.  
*Communications Manager* . . . . . F. EDWARD HANDY, Hartford, Conn.

ADDRESS ALL GENERAL CORRESPONDENCE TO THE EXECUTIVE HEADQUARTERS AT HARTFORD, CONN.



# EDITORIALS

**A** GLORIOUS international opportunity comes with the opening of a portion of our 14,000-kilocycle band to telephony, as is reported in detail elsewhere in our pages. We have here the opportunity to attempt by voice the numerous communication feats which we have done by the key. Who will be the first to talk by voice with these far-off places? Communication with them by telegraphy has become a commonplace, perhaps on occasion too much of a commonplace, but here is a chance that fires the imagination and challenges the best technical practice of which we are capable. We do these things with utter ease by code but it will be quite a different sort of job to duplicate them by 'phone. When we succeed we shall have done a real piece of radio engineering.

These difficulties but what the amateur appetite, however, and instill the desire to be up and doing. So we're off, fellows, on a new branch of the international amateur game, and not one of us can foresee the results. New technical achievements seem a reasonable supposition, but it is also possible that this new use of voice will make a profound addition to the "intangibles" which are so prominent in any summation of the contributions amateur radio has made to the history of mankind. If world-wide, amateur telephony becomes a commonplace, how much may we not quicken those ties of international friendship which come from amateur contacts! How much more vivid and real they may be!

The way to these glories is beset with difficulties. Technically this is particularly true. It is doubtful that anything other than crystal-control on the transmitter will give sufficient stability and freedom from "wobblating" to put understandable speech across the oceans on these frequencies. Or that anything less sensitive than a superheterodyne will suffice to receive these voice signals satisfactorily. Unfortunately telephony always has been expensive. A good 'phone station has cost about three times as much as the comparable telegraph station. This difference will be emphasized, we believe, with the high-frequency 'phone work. So we must realize from the start that transocean telephony will be neither easy nor cheap. There may be other difficulties, too. Whereas every foreign amateur can read "QST English" and in the gradual building up of international contact has absorbed the abbreviated American words that make up the usual DX contact, it is likely to be quite a different story when we rely upon the spoken word to convey our

intelligence. Even with good strong signals and no static and no distortion, many a contact may fail before the language barrier which our abbreviations so nimbly leap in the use of code. Even when we talk to our cousins in the far-flung lands of the British Empire we cannot be too sure that our harsh American accent will convey much intelligence to the carefully attuned British tympanum. We may need a new international abbreviation to mean, "I hear you perfectly, but I haven't the slightest idea what you are talking about."

But the more credit to us if we succeed in the face of these difficulties. This is chiefly an opportunity for the already-skilled 'phone men. They have said for long that voice made for more humanness in QSO's, for the building of more tangible friendships. Twenty-meter 'phone offers its challenge chiefly to them. Let them now show the rest of the amateur world what they can do.

And let QST make a plea for caution and mutual consideration as we enter this new work. This 14,000-kilocycle band is our narrowest and, in terms of commercial jealousy, our most valuable one. There will be trouble if we get outside our band and smear up the high-priced DX traffic of some hot-dog commercial circuit to far places. Transmitters must be accurately located within the band. The monitor is vitally important in this work. In terms of the channel separation used by the Federal Radio Commission, the 'phone space opened to us is capable of accommodating only six amateur 'phone stations operating simultaneously, wherever they be located in the world. We know that the standards of amateur contact will let many more stations than that work satisfactorily, but the band is indisputably very narrow and there will be interference. Mutual forbearance will be necessary. Let each man remember not to hog it all, to give the other fellow a chance. We wish particularly to voice the prayerful hope that each operator will take it upon himself to monitor his transmissions constantly, keep his audio quality good, and, most important of all, know that he is modulating a steady carrier and not "wobblating" it all over the place. Let just two or three evil stations do that and the band will not be fit for human habitation, either for telephony or telegraphy, either for these operators themselves or anyone else. Really a risky business, this fourteen-megacycle 'phone, because the unaccomplished or inconsiderate operator has so great a chance of spoiling things for everybody else. Cooperation will be necessary.

here as in no other amateur band. QST strongly feels that at least at this opening stage of the game no station should engage in the new work without employing crystal control, partly to insure accuracy of frequency but more particularly to offer guaranty that the operator's voice is

modulating the output instead of wobblulating it to the generation of unintelligible phuts and fizzes on every twenty-meter receiver in the world!

GA and GL!

K. B. W.

## WWV Standard Frequency Transmissions

THE Bureau of Standards announces a new schedule of radio signals of standard frequencies, for use by the public in calibrating frequency standards and transmitting and receiving apparatus. The signals are transmitted from the Bureau's station WWV, Washington, D. C. They can be heard and utilized by stations equipped for continuous-wave reception at distances up to about 1000 miles from Washington.

The transmissions are by continuous-wave radio telegraphy. A complete frequency transmission includes a "general call," "standard frequency signal," and "announcements." The general call is given at the beginning of each 12-minute period and continues for about 2 minutes. This includes a statement of the frequency. The standard frequency signal is a series of very long dashes with the call letter (WWV) intervening; this signal continues for about 4 minutes. The announcements follow on the same frequency at the "standard frequency signal" just transmitted, and contain a statement of the frequency. An announcement of the next frequency to be transmitted is then given. There is then a 4-minute interval while the transmitting set is adjusted for the next frequency.

Information on how to receive and utilize the signals is given in Bureau of Standards Letter Circular No. 171, which may be obtained by applying to the Bureau of Standards, Washington, D. C. Even though only a few frequencies are received (or even only a single one), persons can obtain as complete a frequency meter calibration as desired by the method of generator harmonics, information on which is given in the Letter Circular. The schedule of standard frequency signals is as follows:

Eastern Standard Time (P.M.)	Jan. 20	Feb. 20	Mar. 20	Apr. 21	May 20	June 20
10:00	1600	4000	550	1600	4000	550
10:12	1800	4400	600	1800	4400	600
10:24	2000	4800	700	2000	4800	700
10:36	2400	5200	800	2400	5200	800
10:48	2800	5800	1000	2800	5800	1000
11:00	3200	6400	1200	3200	6400	1200
11:12	3600	7000	1400	3600	7000	1400
11:24	4000	7600	1500	4000	7600	1500

## Strays

The following is the list of calls used at Mass. Inst. of Technology as it now stands:

Call	Address
W1XV	Round Hill — Experimental Round Hill, Mass.
W1AXV	Round Hill — Amateur " " "
W1XAN	Round Hill — Portable " " "
W1XMX	Mass. Inst. of Tech. — Experimental M. I. T., Cambridge, Mass.
W1BXM	Mass. Inst. of Tech. — Amateur M. I. T., Cambridge, Mass.
W1MX	M. I. T. Radio Society — Amateur M. I. T., Cambridge, Mass.
W1BMX	First Corps Area Net — (Amateur) operated by M. I. T. Radio Society. M. I. T., Cambridge, Mass.

The experimental stations are required to use specific frequencies. They are as follows:

KC.	W1XAN	W1XV	W1XMX
1604		X	X
1608	X		
2302	X		
2398		X	X
3076	X		
3256		X	X
4108	X		
4795		X	X
5510	X		
6155	X		
6425			X
8650			X
12,850			X
17,300			X

### DISTORTION RULE OBTAINABLE

A power tube distortion rule with 5 per cent distortion scale has been made up for the Westinghouse Lamp Co., Bloomfield, N. J., by Keuffel and Esser. The design and uses of this rule were given in the article "The Use of the Distortion Rule in Power Output Calculation," QST, Nov., 1929. The rules available are limited in quantity at present and are obtainable from the Westinghouse Lamp Co., at cost, which we understand is about \$1.50. One of these rules can save a lot of time and tedious work for anyone frequently called upon to make computations on the output characteristics of power tubes and modulators.

# The A.C. High-Frequency Receiver

By Beverly Dudley, Assistant Technical Editor

*The results of experiments with a high frequency receiver operated entirely from the 110-volt, 60-cycle power mains indicate that an a.c. receiver is entirely satisfactory for high frequency 'phone or c.w. reception. The hum resulting is negligible and does not modulate signals or otherwise interfere with reception. The constructional details for a receiver using a screen-grid radio frequency amplifier, a screen-grid regenerative detector, and an indirectly heated triode audio amplifier are given. — EDITOR.*

IT has not been possible, until recently, to operate high frequency regenerative receivers satisfactorily from the 110-volt, 60-cycle power line. There are several good reasons for this. Autodyne receivers are used principally for high frequency reception of telegraph and 'phone signals and a vacuum tube which is oscillating, or is adjusted for conditions of critical regeneration, is extremely sensitive to slight voltage variations regardless of whether these variations originate in the antenna or in the power supply.

The principle source of trouble has been, of course, the signal modulation and hum resulting from the use of alternating current on the filaments. The advent of the indirectly heated cathode type tubes, particularly the heater type screen-grid tube, has largely contributed toward the elimination of undesirable hum and signal modulation and has made the a.c. high-frequency receiver an actuality.

A.c. operated receivers could have been built as soon as the 227 type of tube was commercially available, and while the filament storage battery could have been eliminated in such receivers, they would have had little or no advantage over similar sets using 201-A tubes. There was little advantage in attempting to operate high frequency autodyne receivers from alternating current until indirectly heated screen-grid tubes came along.

While the entire elimination of hum is not a requisite for the successful operation of a.c. receivers, it is essential that the residual hum be reduced to a point where it is greatly below the level of the signal and that it cause no modulation or distortion of the received signal.

## EXPERIMENTS WITH A.C. HIGH-FREQUENCY RECEIVERS

In an effort to determine just how satisfactorily a.c. operated receivers would prove to be at frequencies above 3000 kc., an experimental set-up was constructed. The bread-board type of lay-out was used to facilitate quick changes.

In building the a.c. receiver, the tube line-up was considered first. The 224 tube gives good gain at high frequencies because of its low grid-plate capacity, high amplification factor, and high mutual conductance. Its plate resistance is such that a tuned radio frequency circuit may be inserted in its output with the assurance that a reasonably good match can be obtained between the plate resistance and the external

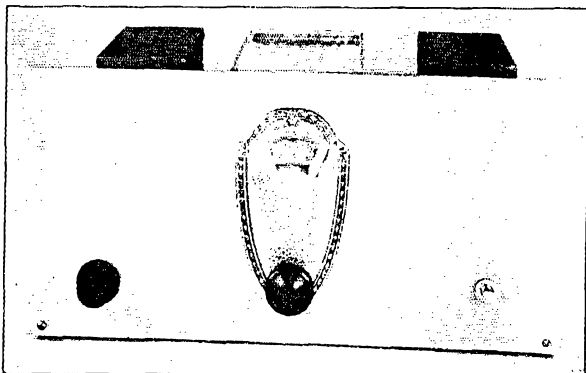

THE FRONT OF THE RECEIVER PRESENTS A PLEASING APPEARANCE

impedance of the tuned circuit. This makes the tube well adapted to impedance-coupled radio frequency amplifiers. The use of the 224 tube as a regenerative detector provides a high gain detector circuit, as has already been mentioned in the Experimenters Section,<sup>1</sup> and permits the effective use of a tuned coil in its plate circuit for obtaining the selectivity resulting from peaked audio amplification. This arrangement provides peaked audio amplification with one less stage than is required when using a low  $\mu$ , low impedance detector tube. If peaked audio amplification is not required, a resistance may be inserted in the plate circuit of the screen grid detector in place of the tuned circuit. Regeneration control by resistance variation of the screen grid voltage provides a method of unusually

<sup>1</sup> Experimenters' Section, page 30, QST, October, 1929.

smooth control of oscillation and regeneration. The 227 tube was chosen for use in the audio amplifier because it is the best tube available for low level audio amplification using a.c. filament supply. Its characteristics are such that

signals, and one could operate the set for hours without being annoyed by the slight residual hum which was present.

The results obtained with an exceedingly "hay wire" accumulation of apparatus were so encouraging that a second stage of audio frequency amplification was added to the receiver. The wiring diagram of the receiver with the additional stage of audio amplification and with cathodes in parallel is shown in Fig. 2. Both the signal strength and the hum audibility were increased by the second stage of amplification, but the hum to signal intensity ratio was not increased; if anything, the ratio was slightly less when the second audio amplifier was added.

Several weeks were spent in playing around with the bread-board receiver and in learning its idiosyncrasies. There was certainly nothing pretentious about its appearance. The bread-board receiver was not a piece of equipment which we could view with pride but it was important because of the facts it brought out.

#### WHAT WE LEARNED FROM THE EXPERIMENTAL MODEL

The satisfactory operation of the experimental receiver showed that not only is the operation of high frequency regenerative receivers from a.c. practicable, but also is successful and desirable as well. While the hum may not be entirely eliminated, it can be reduced to such an extent that it does not interfere

with even the weakest signal that can be copied. Moreover, the operator can only detect the presence of hum by turning off the a.c. heater power supply and by listening for it with a headset while the cathodes cool. To one not familiar with the receiver no more hum is noticeable than that heard on any d.c. receiver operated in the vicinity of an electric light circuit.

The hum due to the use of alternating current for the heaters is insignificant compared to that resulting from the use of a mediocre or even a fairly good "B" battery substitute provided, of course, that the receiver is properly constructed. For this reason an unusually good "B" battery substitute with an adequate filter is advised if best results are to be obtained from a set completely operated from the 60-cycle line.

Another thing learned from working with the experimental model was that the heaters could be operated either in series or in parallel as long as the tubes have the same heater voltage and current rating. The indirectly heated cathode type of tube is not critical with respect to the heater voltage or current ratings. This is a decided convenience, for a three-tube receiver can be operated from a 7.5-volt filament transformer,

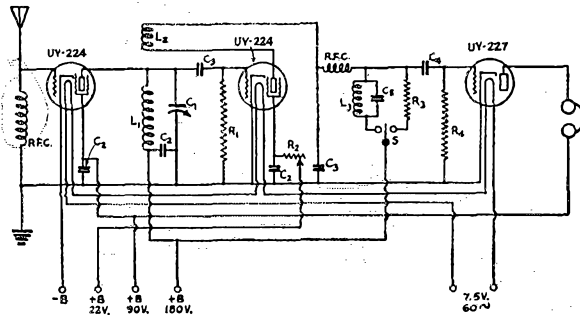

FIG. 1. — THE CIRCUIT OF THE FIRST EXPERIMENTAL BREAD-BOARD RECEIVER

- $L_1$  — Grid tuning inductance; varied with experiments conducted and frequency at which receiver was operated.
- $L_2$  — No data can be given as this coil depended upon the size of  $L_1$ .
- $L_3$  — Ford spark coil secondary.
- $C_1$  — 50  $\mu$ fd. midjet tuning condenser.
- $C_2$  — 0.01  $\mu$ fd. fixed condenser.
- $C_3$  — 100  $\mu$ fd. fixed condenser.
- $C_4$  — 0.005  $\mu$ fd. to 0.01  $\mu$ fd. audio tuning condenser.
- $R_1$  — 2 megohm grid leak.
- $R_2$  — 100,000 ohm regeneration control resistor.
- $R_3$  — 200,000 ohm plate circuit resistor.
- $R_4$  — 2 to 5 megohm grid leak.
- RFC — Radio frequency choke coil.
- S — Switch to change from peaked to "quality" audio amplifier.

The filaments were wired in series and were either left "floating" or were connected in various manners (as described in the text) to the cathodes and ground.

it may be used with a headset without the use of additional output or coupling devices.

Fig. 1 shows the circuit which was used in the first experimental receiver. The heaters of the three tubes are connected in series and are left "floating." Preliminary work on this receiver was done with a d.c. filament supply and it was found that although the rated heater voltage for the three tubes when operated in series was 7.5 volts, the receiver operated exceedingly well from a 6-volt storage battery. The d.c. operated receiver made an excellent high frequency receiver since it was free from the microphonic noises which are so troublesome in receivers using the 222 tube. When the receiver was operating satisfactorily, the d.c. heater supply was replaced by an a.c. supply.

Various methods of connecting the heaters to ground were tried but it was found that even with the heaters floating the set was surprisingly quiet and free from hum. The wiring was changed to operate the heaters in parallel and the same quiet operation was observed. A slight hum was noticeable when the cathodes were operated from a.c., it is true, but the hum was not at all objectionable. It did not modulate

or a 6- or 8-volt storage battery if the heaters are connected in series. If they are connected in parallel the tubes may be operated from a 2.5-volt transformer secondary, a 2-volt storage battery, or a 4-volt storage battery, provided a resistor is connected in the cathode circuit to

was further reduced by grounding one side of the heater wiring. Grounding one side of the heater wiring through a resistor of between 0.1 megohm and 0.5 megohm was found to be more effective in hum elimination than grounding the heater circuit through a low resistance path,

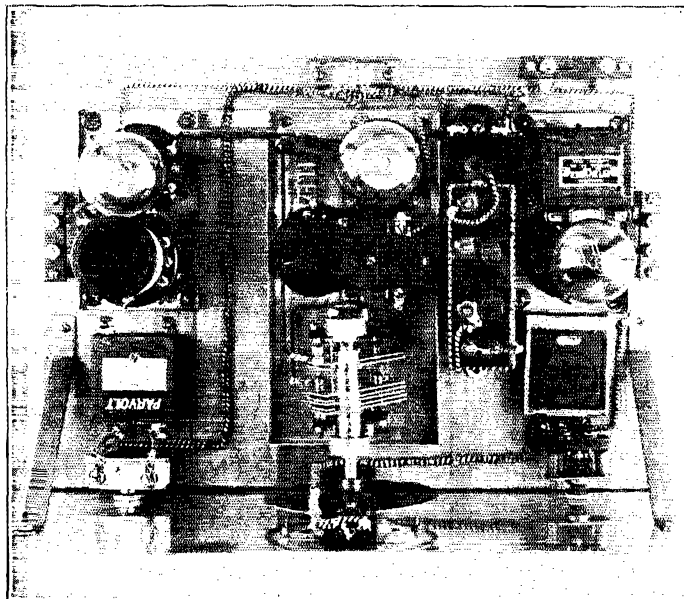

A TOP VIEW OF THE RECEIVER WITH THE SHIELDS REMOVED

drop the terminal voltage to not more than 2.5 volts.

In the experimental receiver we have been talking about (and later in the final receiver) the slight residual hum was found to be constant for any or all of the various amateur bands covered by the receiver. Apprehension that the hum audibility might increase directly as the signal frequency was found to be unwarranted. No residual hum peaks were discovered at any frequency, and the operation in the 14,000-kc. amateur band was as successful as operation in the 1750-kc. band. It was impossible to make the detector oscillate at frequencies greater than about 20,000 kc. and it is for this reason that no coil winding data are given for amateur bands of frequencies higher than 14 mc.

#### FURTHER ELIMINATION OF HUM

Experience with the experimental receiver clearly indicated that little trouble should be encountered in the elimination of hum from the cathode circuits. Connecting the detector grid return and the cathodes of the tubes to ground did more than anything else to reduce heater circuit hum.

With series connections of the heaters the hum

but best operation was obtained when the heater wiring was connected to ground through a 1- $\mu$ fd. condenser. When operating the heaters in parallel, the cathodes should be connected to a mid-point of the transformer secondary winding, or to the variable arm of a voltage divider of approximately 50 ohms resistance connected across the heater. Operating without d.c. bias between the heater and the cathode is the normal one for minimum hum and is to be preferred. In some broadcast receivers it has been found that biasing the heater approximately nine volts negative with respect to the cathode may be helpful in reducing the hum but this practice has not been found beneficial in the receiver described in this article although bias between the heater and cathode may be useful in some high frequency receivers. The use of shielded or twisted heater wiring for the purpose of hum reduction was found unnecessary, although these precautions might be of use in some individual receivers.

#### TESTS WITH A.C. TUBES

Up to the time of writing all tests have been made with Radiotron, Cunningham and DeForest type -24 and -27 tubes because these were

readily available. A sufficient number of these tubes was used so that results given in the following paragraphs may be taken as representative.

None of the tubes used was found to be critical as regards heater voltage or current. In general, it was found that successful operation could be obtained with as little as 1.7 volts across the heater terminals, and satisfactory results have been obtained by operating the heaters at 1.5 volts. Nevertheless, it is recommended that the heaters be operated between 2.0 volts and 2.5

to select the tubes most free from hum where tube selection is possible), all of the tubes which have been used so far have been found sufficiently free from hum to be satisfactory in operation. The fact that indirectly heated tubes require a long time to become thoroughly heated, makes it difficult to compare them in a receiver by aural methods.

CONSTRUCTION OF THE FINAL RECEIVER

The circuit of the final model shown in the photographs is given in Fig. 3. This receiver has

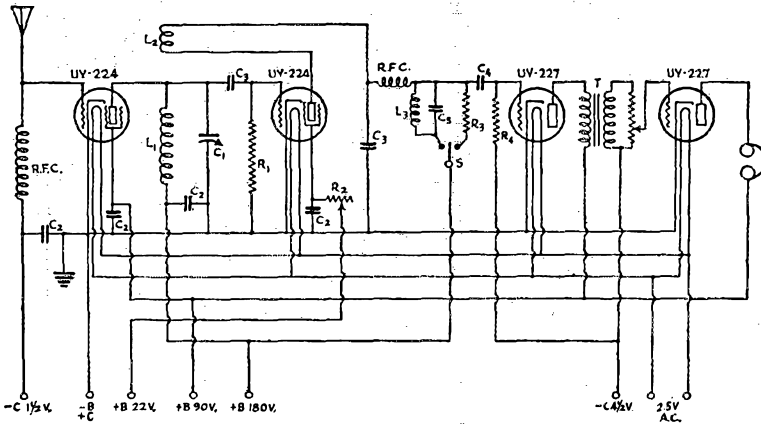

FIG. 2.—ANOTHER ARRANGEMENT USING TWO AUDIO STAGES WITH THE FILAMENTS OF ALL TUBES IN PARALLEL

"T" is an audio frequency amplifying transformer. All the other pieces of apparatus use the same designating letters as in Fig. 1.

volts as specified by the manufacturer. The tubes will heat more quickly and operate sooner after the heater current is turned on when the heater is operated at rated voltage than when operated at reduced voltage. All of the tubes used so far required approximately half a minute of heating before signals could be heard, but as a general rule the tubes did not reach normal emission until about two minutes after the heater current was turned on. Signal audibility increased from the time the detector tube oscillated and brought in the first signal until the tubes were heated for approximately two minutes, after which no further signal increase was observed.

While some individual tubes were freer from a.c. hum than others (which makes it desirable

several advantages beside that it may be entirely operated by batteries, a transformer and "B" battery substitute, or a combination of these. The semi-tuned input circuit of the radio frequency amplifier allows adjustment of the antenna coupling coil for maximum signal strength and minimum interference from broadcast signals without the necessity of tuning the input circuit. Shielding is used, both as an aid to selectivity and for the realization of maximum gain from the radio frequency amplifier and detector circuits. The set is quiet in operation, for the tubes are free from microphonic effects. The detector tuning is independent of the antenna circuit constants because of the use of the shielded coupling radio frequency ampli-

Coil No.	Approximate Frequency Coverage in Kilocycles	No. of Turns		Form Diameter	Remarks
		$L_x$	$L_z$		
1	.....	..	..	...	r.f. choke coil for antenna circuit for reception in 1750-ke. band.
2	1700-2050	60	18	1.5"	Both tuning condensers used.
3	3400-4100	31	10	1.5"	Both tuning condensers used. Turns are space wound.
4	6950-7450	14	7	1.375"	Small tuning condenser used.
5	13,800-14,500	6	5	1.375"	Small tuning condenser used.

Unless otherwise indicated, all coils are "close wound."

fier. Operating controls have been reduced to a minimum, and the receiver is entirely free from body capacitance effects. The symmetrical arrangement of apparatus used is a logical one, for the mechanical layout follows closely the arrangement of equipment in the schematic wiring diagram. These points are always advantageous, not only from the standpoint of appearance but also from those of common sense and simplicity of assembly.

There is little of the strange or unusual about the receiver. In wiring the set, No. 14 solid insulated wire is used in the radio frequency and audio frequency portions of the circuit because of its strength and rigidity. The d.c. battery leads are made of bell wire and are cabled and laced following the standard telephone practice. A battery cable with plug and jack is used for making the connections between the receiver and the plate battery or "B" substitute; other connections to the receiver are made to binding posts. All of the wiring, with the exception of the filament or heater wiring and the grid bias connection to the radio frequency amplifier, is above the baseboard and all of the component parts used in the construction of the receiver are "above board." Care must be exercised in insulating the wiring at points where it goes through the shields since the shields may cut through the insulation unless it is quite heavy.

The 14,000- and 7000-kc. coils are wound on UY tube bases which are  $1\frac{3}{8}$  inches in diameter, and the 3500-kc. and 1750-kc. coils are wound on commercial tube base forms,  $1\frac{1}{2}$  inches in diameter. A radio frequency choke coil, used principally as an antenna choke coil for reception in the 1750-kc. band, is mounted inside a tube base. The details of the coils for the various frequency bands are given in the accompanying table which will serve as an approximate guide to the construction of suitable coils for similar receivers. Because the stray and distributed capacitance and inductance of the coils and wiring, the inter-electrode capacitance of the tube, and even the voltages at which the tubes are operating effect the frequency of the circuit, it is impossible to give coil specifications which will hold true in all cases.

Unlike the usual practice in most untuned input circuits, an interchangeable plug-in antenna coupling coil is used. This permits the operator to choose the best antenna coupling coil for any frequency band, and reduces the interference from local broadcast stations. Except for 1750-kc. reception, where the radio frequency choke coil is used in the antenna circuit, one of the spare plug-in coils for the de-

tor circuit is used in the input. This arrangement is flexible and requires only one more coil than is actually needed for tuning the detector circuit to the several frequency bands. In general, the coil most suitable for the antenna or input

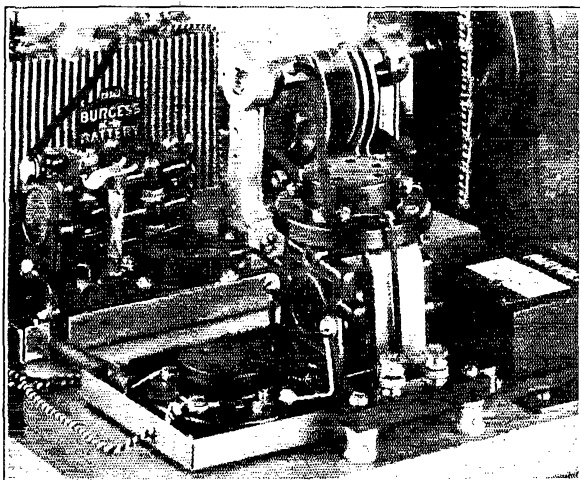

THE CONSTRUCTION OF THE RADIO FREQUENCY AMPLIFIER AND DETECTOR UNITS IS SHOWN MORE CLEARLY IN THIS PHOTO

circuit is the size larger than that used in the detector circuit. Thus, for reception in the 7000-kc. band, the 3500-kc. coil is used in the antenna or input circuit.

The tuning condenser is made in two separate sections. One section consists of two plates, double spaced, having approximately 10  $\mu\text{fd}$ . capacitance, and is always connected in the circuit. The other section consists of five plates, double spaced, having approximately 40  $\mu\text{fd}$ . capacitance. The second section may be put in the circuit by connecting the coil form prongs marked C and G together. The connection of the prongs in the coil forms for using the smaller condenser is shown in Fig. 4A while the connection for using both sections in parallel is indicated in Fig. 4B.

It will be noticed that a grid bias battery is incorporated in the receiver. This is done to minimize the possibility of hum pick-up in the grid bias connections and because commercial "B" battery substitutes are seldom provided with binding posts giving the desired grid bias voltage. Moreover, the battery is small and, since there is no current drain upon it, there is no reason why the battery cannot be incorporated within the receiver. The radio frequency amplifier is given a bias of 1.5 volts, while the audio amplifier has a 4.5-volt bias. No bias, other than that obtained from the grid leak, is applied to the detector tube. Grid leak bias is used on the detector tube because grid leak detection is more suitable than

plate detection for signals of low level. Only one stage of radio frequency amplification is used ahead of the detector tube so there is no reason for resorting to anode-bend rectification.

heater and plate voltage, and (when the tubes are thoroughly heated) making the necessary tuning and regeneration adjustments. Operation is extremely simple.

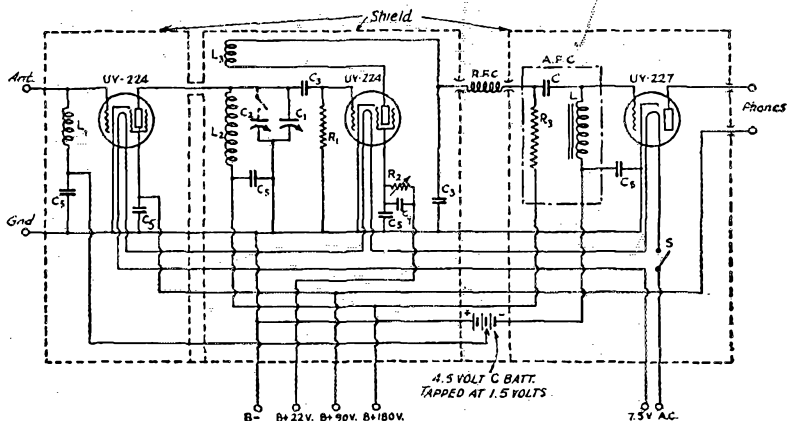

FIG. 3. — THE CIRCUIT OF THE FINAL RECEIVER

Refinements not shown in Fig. 1 or Fig. 2 were incorporated in the final model. A comparison between this diagram and the photographs will show the similarity between the schematic wiring diagram and the mechanical layout of the apparatus.

L<sub>1</sub> — Antenna coupling inductance. See text and table for details.

L<sub>2</sub> — Tuning inductance. See the table for details.

L<sub>3</sub> — Regeneration coil. See the table for details.

C<sub>1</sub> — 10- $\mu$ fd. tuning condenser.

C<sub>2</sub> — 100- $\mu$ fd. tuning condenser.

C<sub>3</sub> — 100- $\mu$ fd. condenser.

C<sub>4</sub> — 1- $\mu$ fd. condenser.

C<sub>5</sub> — 0.01- $\mu$ fd. fixed condenser.

R<sub>1</sub> — 2-megohm grid leak.

R<sub>2</sub> — 100,000-ohm regeneration control resistor.

R<sub>3</sub> — 250,000-ohm plate coupling resistor.

S — Filament switch.

RFC — Radio frequency choke coil.

AFC — Audio frequency coupler. Satisfactory constants for the resistance, inductance and capacitance of a satisfactory unit are, respectively:

R<sub>a</sub> — 250,000 ohms.

L — 30 henrys.

C — 0.01  $\mu$ fd.

OPERATION OF THE RECEIVER

As may be seen from the front view of the receiver, the operating controls have been reduced to a minimum. The knob at the left con-

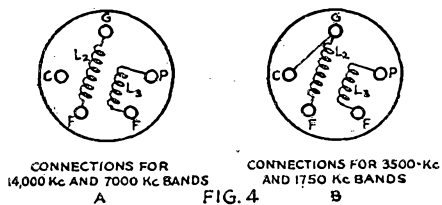

controls regeneration, the control at the right is the filament switch, and the center knob and dial controls the tuning of the detector circuit. Operation of the receiver consists of inserting the correct detector circuit and input coils, applying

The oscillation control is unusually smooth, provided a satisfactory resistance unit is employed to vary the screen grid voltage,<sup>2</sup> and has little effect on tuning. The 1- $\mu$ fd. condenser shunted across the regeneration control reduces any noise which might be caused by variation of the resistor. The regeneration control may be still further improved by shunting it with a resistor of several megohms so that the total resistance variation is smaller than if the fixed shunt resistor were not employed. Of course the total resistance of the two parallel resistors is less than the resistance of either one of them, so that the screen grid voltage is greater, and this may influence the number of turns used on the tickler coils. The fixed shunt resistor must be of high

<sup>2</sup> See "Resistance Control of Regeneration," QST, Aug. 1929.

(Continued on page 78)



# Trophies and Certificates for the January and February Contests

By F. E. Handy, A.R.R.L. Communications Manager

**A**LL information necessary for participation in our All-Section Sweepstakes Contest (January 18th to 31st inclusive) or in the Third International Relay Competition (February 15th to 28th inclusive) was given in December *QST* under the subject of *Coming — Operating Activities*.

The prompt and enthusiastic response which followed announcement of our 1930 competitions bodes well for the success of both events. Just a few weeks more and contest number one will be in

realize it, the February *world wide* tests will be here.

We strongly wish that this magazine for once might be printed in colors to do justice to the blue and brown handsomely lithographed certificates which will be presented to the winners in each country and section in our International and All-Section tests! The black-and-white reproductions which appear herewith will give you a little idea of how these attractive 8½" by 11" testimonials of success will look. They really can't do the subject justice, though perhaps participants can use imagination.

While we were enthusiastic about the spontaneous interest in both contests, the unusual DX possibilities of the February competition, and the big records, new contacts and friendly spirit sure

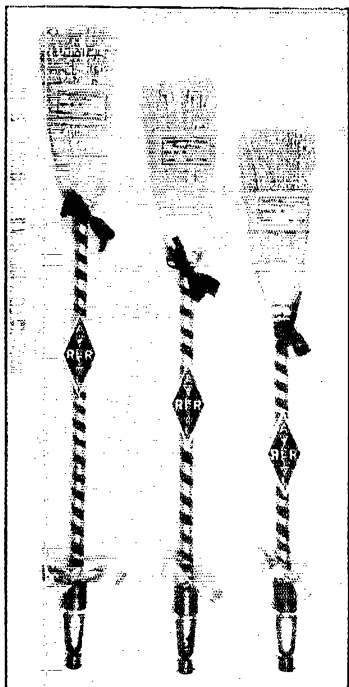

THE SWEEPSTAKES TROPHIES

These novel prizes will be presented to the three highest scoring stations in the January Sweepstakes Contest in whatever Sections they may be found.

full swing. There will be two weeks to cram full of operating enjoyment, two weeks of unparalleled opportunities. How many stations can be worked and messages exchanged in the given time? How many Sections of our A.R.R.L. field organization is it possible to contact in this fashion in fourteen days? And what scores!! Then almost before we

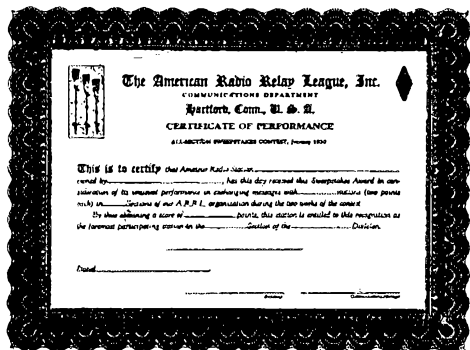

ONE OF THESE BROWN HANDSOMELY LITHOGRAPHED CERTIFICATES WILL BE AWARDED TO THE VICTORIOUS STATION IN EACH A.R.R.L. SECTION IN OUR ALL-SECTION SWEEPSTAKES CONTEST

to be developed in the January tests, the idea struck us that to do the January tests justice we ought to present the three highest scoring stations in the whole field organization some special trophies or prizes as symbols of victory in addition to the certificates they might win.

History gives us some interesting information concerning various symbols of victory. A Dutch commander, Admiral Tromp, defeated the British fleet under Admiral Blake at Dover, England, in 1652. Complying with the custom of the times, the Dutch commander sailed up the English Channel with a broom hoisted at the masthead of his flagship, denoting that he had successfully "swept the seas." Prizes in any contest may be

referred to as "stakes." Webster informs us that among other things "sweepstakes" signifies "a clean sweep." The highest scoring stations in our January contest by virtue of skillful operating will be winners by virtue of having literally "swept the air," piling up points by a large number of successful QSOs with individual stations together with a surprisingly large number of sections contacted!

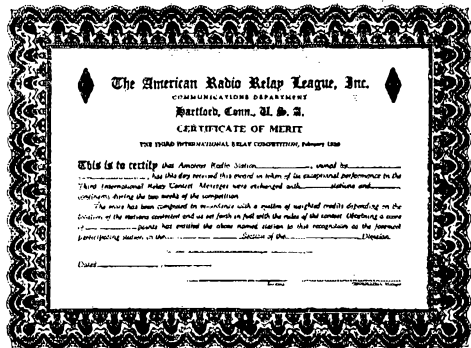

HERE IS THE CERTIFICATE OF MERIT TO BE AWARDED TO THE LEADING STATION SCORING THE HIGHEST NUMBER OF POINTS IN EACH AND EVERY U. S. OR CANADIAN SECTION IN THE THIRD INTERNATIONAL RELAY COMPETITION

How would you like to win one of these blue lithographed certificates? If you wish to enter and get in on the fun of participating in this DX party, and perhaps taking a crack at a certificate, send your QSL-entry card now before it is too late. For dates and all details see December QST.

Fine! So our first contest has been officially named the All-Section Sweepstakes Contest, the sweepstakes emblems, symbolic of victory, appearing in miniature on each of the award certificates. Now for the trophies themselves. A sweepbroom for the masthead of our radio stations might be appropriate even if a bit clumsy, but unfortunately, since the advent of high frequency communication and the obsolescence of rotary spark gaps and high multi-wire antennas, we don't all have conspicuous masts. For this reason we have deemed it appropriate to design some real radio man's trophies suitable for display in the winning station.

A sweep-broom, significant of victory, emblazoned with our A.R.R.L. emblem, and approximately three feet long has been selected as a basis for our trophies. The League colors, black and gold, are used throughout in the design. Like the Wouff-Hong and Rettsynitch (the traditional emblems of the amateur fraternity) these sweepstakes' insignia are also fashioned of radio materials. A symbolic vacuum tube is firmly affixed to the handles of our three prizes. The call signals of the stations winning our three sweepstakes trophies or grand prizes will be inscribed in black on a background of varnished cambric, better known to amateur constructors as empire cloth.

The photograph of our three special prizes, lacking only the call signals and scores of the winners, is shown herewith. How would you like to have one of these sweepstakes trophies for *your* station? By proper application you may win one of the sixty-eight sweepstakes certificates and also one of the three sweepstakes trophies!

Then in mid-February the Third International Relay Competition opens. Sixty-four "certificates of merit" will be available to issue to participating amateurs in the A.R.R.L. Sections in the United States and Canada. All amateurs operating stations anywhere in the whole wide world are invited to take part. Just as many "certificates of merit" will be issued as there are participating and reporting foreign localities as was explained in our announcement last month. In both contests the main competition you receive will be that of the operators in your immediate Section of our A.R.R.L. organization. Provision has been made to tabulate the Section scores too, to determine for both contests which Sections have the most active organization in proportion to the distribution of licensed amateurs in the different sections. This contest will be a big opportunity to roll up new international DX records and make the WAC Club. But amateurs in the U. S. A. and Canada must remember that it is necessary to submit entries in advance of the February competition to obtain the special logs, serial numbers, and test messages for use in the international contest. Better read the rules of the February contest that were printed in December QST, and send your entry right now before it is too late to enter.

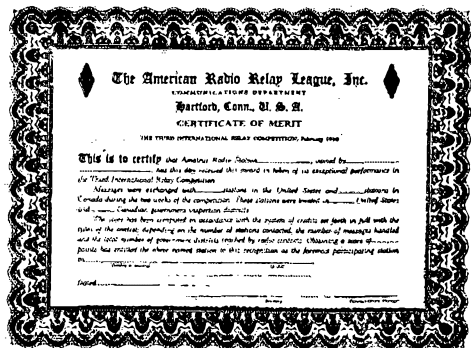

IN WHATEVER COUNTRY YOU LIVE, YOU WILL COMPETE DIRECTLY ONLY WITH OTHER AMATEUR STATIONS USING THE SAME INTERNATIONAL PREFIX TO THEIR CALL SIGNAL THAT YOU USE, IN OUR FEBRUARY TESTS

The attractive blue certificates that will be given to the leading station in each locality outside the U. S. A. and Canada in the Third International Relay Competition is shown above.

#### QUESTIONS AND ANSWERS

There seems to be a universal understanding of our February tests, the Third International Relay Competition, possibly because this will be similar

(Continued on page 80)

# G5BY Wins 1929 Station Description Contest Cup

Other Prizes Won by W8CEO, W1WV and W8BQ

**T**HE Station Description Contest announced in the March, 1929, issue of *QST* ended with the publication of the last station description which was in the December number. The closing date for entries was October 10th—and what a grand rush there was at the last minute! As only one description could be published in a single issue, competition between the late-comers was decidedly keen.

As stipulated in the rules for the contest, the best description on hand was published in each issue of *QST*; W8ARO started the contest in May and W2FL completed it in December. In the final judging of the eight descriptions published, the winners were as follows:

First place, with the handsome sterling silver cup as the prize, went to G5BY, Mr. H. L. O'Heffernan, of Croydon, Surrey, England.

Second place, and the \$25 cash prize. . . . W8CEO

Third place, with the \$15 cash prize. . . . W1WV

Fourth place, and the \$10 cash prize. . . . W8BQ

The Editors of *QST* acted as judges, and the decisions were based on the points listed on page 38 of the March, 1929, issue of *QST*. These, together with the rules for the contest given in the announcement, also determined the choice of the station description for each of the months of the contest. Just to refresh the memories of those who may have forgotten them, the fourteen points are again given:

Ingenuity employed in design, construction and arrangement.

The transmitter.

The receiver.

Power supply for transmitter.

The antenna system.

Change-over arrangement.

Provisions for monitoring transmitter output for quality.

Provision for knowing accurately the emitted frequency of transmitter.

Provisions for working on different bands.

Provisions for rapid and accurate shift of frequency within each band.

The goodness of the keying system.

Workmanship.

Extent to which the apparatus is "home made."

Interest and intelligibility of the descriptive manuscript and illustrations.

Each of these points was given commensurate weight and the system of judging was such that

there was no possibility of foretelling who was ahead prior to the final tabulation of the points; moreover, the tabulation revealed that there is still room for a great deal of modernization in

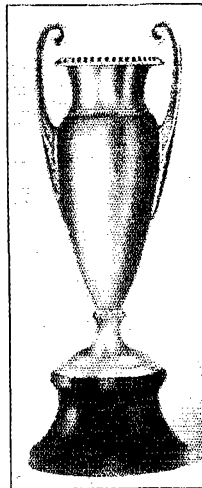

THE STERLING SILVER CUP WON BY G5BY

The cup is engraved, "First Prize, QST Contest for Best Amateur Station, 1929. Won By H. L. O'Heffernan, G5BY."

even our best amateur stations, if those entered in the contest are the criterions by which amateur stations the world over are to be judged.

The purposes of the contest were to place before the amateur fraternity practical examples of the background principles brought forth by the A.R.R.L. Technical Development Program; and to revive the "Amateur Radio Stations" feature of *QST* with descriptions of merit. There is no doubt that these two primary aims have been accomplished. Actual applications of the Technical Development Program principles are exemplified in the station descriptions published during the last eight months of 1929. Every amateur having a station of which he is justifiably proud cannot help but appreciate the advantages accruing to himself and other fellows in the game with the publication of a description of his station in *QST*. The present season is unquestionably bringing forth better amateur stations and practices. Descriptions of such stations and details of these practices should and will be chronicled in these pages.

(Continued on page 80)

## Navy Day—1929

By E. L. Battey, Asst. to the Communications Manager

FOR a number of years a program of Navy Day telegraphic broadcasts to amateurs has been carried out under the auspices of the Navy League of the United States. These broadcasts are in the nature of commendatory and inspirational messages from the Secretary of the Navy and the President of the American Radio Relay League. The broadcasts are conducted in the form of a "receiving competition" open to all amateurs.

Each amateur turning in a copy of the Navy Day messages is listed on an Honor Roll which is made up of those who have copied the messages. Participants are listed in the order of the number of errors made in their copies. In past years the ten amateurs having the most perfect copies received a letter of appreciation from the Secretary of the Navy or the Chief of Naval Operations. So great a number of perfect and near-perfect copies were received in the 1929 competition that ten letters were found to be insufficient, if deserving stations were to be given full credit. Therefore, the Secretary of the Navy agreed to furnish an additional ten letters, making a total of twenty. This made it possible for the grading committee to much more readily differentiate between the best copies, and place every participant a bit higher on the Roll.

By looking back over the past few years, we realize the increasing interest being shown in Navy Day competition. In 1925, with twelve stations sending the broadcasts, only 40 participants sent in reports. In 1926 eight stations sent the message and 41 amateurs reported reception. 129 amateurs copied the broadcasts in 1927 from seven stations. In 1928, to prevent the possibility of overlapping transmissions from different stations and to insure that everybody had a chance to get the messages, but two stations were chosen to send the broadcasts; NAA and W1MK. The result was that 240 copies were turned in for checking.

1929 activity surpassed all other years! 254 amateurs copied the messages. This is the greatest number yet to copy the Navy Day broadcasts and it emphasizes the friendly relations that exist between our United States Navy and the radio amateurs.

1929 Navy Day came on October 28th and in accordance with the announcement in October QST, the messages were sent from NAA and W1MK. NAA transmitted on 4015, 8030 and 12045 kc. at 7:30 p.m., E.S.T., and W1MK on 3575 and 7150 kc. at 8:30 p.m., E.S.T. The fact that both stations are located in the eastern part

of the country gave the amateurs in that section an obvious advantage. This has been called to the attention of the office of the Director of Naval Communications and we understand that NPG, San Francisco, California, will take part in future competitions at a suitable time for all the participants concerned. At the time of the NAA broadcast it was only 4:30 p.m. on the West Coast and the majority of the participants were not home from their daily occupations, thereby missing the first part of the broadcast by arriving home late. The W1MK broadcast also came at a rather early hour. Ordinarily signals from the East Coast do not come through well on the West Coast at such early hours. These circumstances had to be given consideration when the copies were being checked. Western participants were given additional credits and preference over eastern participants in proportion to the apparent handicap involved.

A word as to the method of grading the copies received might be in order at this time and save the grading committee from the wrath of those amateurs who do not take a very high place on the Honor Roll. Copies were received from 251 amateurs. All except 62 of these submitted copies of both NAA and W1MK, which made a total of 446 copies to be checked. The first step was to go through these copies to check up on the number of errors made. After this, those submitting both copies were separated from those submitting but one. The first group, those having both copies, were sorted out as follows: Perfect copies came first; those with one copy perfect came next, arranged according to the number of mistakes on the imperfect copy and the distance of the participant from NAA and W1MK; those having but one error on each copy were given next place, arranged according to distance, conditions, etc.; the remaining were arranged according to the total number of errors made on both copies, participants at the greater distances and working under greater difficulties being given the higher places. The second group, those submitting but one copy, were sorted in a like manner — perfect copies first, the men at the greater distances given the preference, etc. Those in the second group follow the first group on the Honor Roll. In view of the disadvantages that western participants had, they were given additional credits as mentioned in the preceding paragraph, and because of this fact, stations W6AW, W7EO, W6DLI, W6BVY and W6EFA were given a place among the first twenty, even though their copies were not perfect. Taking into consideration

the difficulties under which they worked, the committee decided that they had displayed a copying ability equal to some of the eastern participants turning in perfect copies. It was an extremely difficult task to decide what place on the Honor Roll the many perfect and near-perfect copies should take, and it was only after very careful thought and consideration that each station was given its place thereon. The first 100 stations listed all submitted very fine copies and should feel justly proud of their work.

Receiving conditions during the broadcasts, while somewhat varied, were quite favorable the country over, QRM being the principal difficulty encountered by all participants. W1MK, working in the amateur bands, was much more badly hit by QRM than was NAA. QRM from other amateur stations was so bad on 7150 kc. that W1MK could not in some cases be located, and when located considerable trouble was had in pruning the QRM from the edges. Discovering this fact, a number of participants changed to 3575 kc. and consequently lost part of the message in so doing. NAA suffered from QRM from a couple of commercial stations working on their 8030-kc. frequency. A number of careless individuals projected themselves before the scornful eyes of many participants by thinking they could work more stations by tuning their transmitters to NAA's frequency — outside the amateur bands. But they gained nothing except the curses of their fellow amateurs. 3500 kc. averaged the best frequency for copying both stations. Practically the only radio-QRM experienced on that band was from amateur 'phones overlapping their band. 'Phone interference was reported from every section of the country. W7ABH, Portland, Oregon, finding W1MK hard to copy on 7150 kc. moved to 3575 kc., where he made a reasonably good copy of President Maxim's message. A number of West Coast participants made perfect and near-perfect copies of NAA on 12,045 kc. Conditions were reported fine on that frequency except for occasional fading. Local weather conditions in some sections hindered reception. QRN accompanied a snow storm in Denver, Colorado. It was raining hard at North Platte, Nebraska. QRN was bad at Baytown, Texas, and a bit troublesome in some parts of Pennsylvania. Receiving conditions were fair in California. Our old friend, power leak, was present at some stations during the broadcasts. Others reported that their neighborhood QRM plants promptly commenced their deviltry at the start of the messages. These included street arc-lights, commutator ripples from motors in cotton and flour mills, power houses, electric refrigerators and oil burners. QRM didn't bother W8GZ, but his Ford was stolen while he was copying W1MK!

Reports on signals from NAA and W1MK were very well balanced. 192 participants copied both stations! Throughout the entire eastern section

of the country practically no difference was noted in the signals from these stations, the average report being QSA5. W7BB at Seattle, Washington, reported both stations R5-7, W1MK covered with QRM. At Jamestown, North Dakota, W9BVF reported NAA QSA5 R9 and W1MK QSA5 R7-8 on 3500 kc.!! W9BDP copied both stations in the railroad station at Falmouth, Indiana. W1MK was copied at Balboa, Canal Zone, on 7150 kc. Reception in the southwest was a bit better on NAA because of the heavy QRM on W1MK, although W1MK was copied with difficulty. In the midwest one station was as easily copied as the other, with occasional cases where W1MK suffered because of QRM.

Many stations waited until the last minute to locate NAA and W1MK on their receivers and thereby missed large portions of the first part of the messages. E. W. Mayer, K4KD, however, took a very far-sighted attitude and his unusual work is well worth recounting. Mayer started making observations on both stations a week previous to the broadcasts, logging them both on their 3500- and 7000-kc. frequencies at the same time using separate receivers and split headphones, one 'phone on each receiver. He checked his receiver calibrations each day to make sure they were correct and that he would have no trouble in logging the stations on Navy Day. The NAA message was copied 100% on 8030-kc., and W1MK was copied 90% on 3575 kc. and 10% on 7150 kc. by means of the split headphones. Had it not been for the fact that K4KD had previously arranged this unique method, and had he chosen to listen on 7150 kc., he would have been able to copy only 10% of the W1MK message!

The 1929 Navy Day broadcasts are printed following the Honor Roll. These are not guaranteed to be free from errors and are not meant to be used for checking purposes. They are printed only for the information of those interested. The first twenty men, whose names are set aside from the rest on the Honor Roll, will receive a letter of commendation from the Secretary of the Navy, as already explained.

It is hoped that there will be even more interest in the 1930 broadcasts, and that *twenty* letters will be insufficient when copies are graded!

#### THE 1929 NAVY DAY HONOR ROLL

W4BG — F. E. Lane, Jacksonville, Fla.  
 W9DXY — P. H. Quinby, St. Louis, Mo.  
 W2CEV — J. Pascal, Columbia, Mo.  
 W9CZC — B. E. McElwain, Blencoe, Iowa  
 W6AW — Roland D. Richardson, Oakland, Calif.  
 W7EO — Herman T. Louis, Dayton, Ore.  
 W6DLI — R. J. Ogborn, San Pedro, Calif.  
 W6BVY — E. J. Beall, Newman, Calif.  
 W6EFA — Joseph P. Walter, Los Angeles, Calif.  
 W9AT — Don H. Mix, Madison, Wis.  
 W9EFX — Frederick Seifert, Milwaukee, Wis.

W9BFI — Leon Mears, LaCrosse, Wis.  
 W9BNI — R. L. Whannel, Springfield, Ill.  
 W8SS — Kenneth Stocker, Detroit, Mich.  
 W1BIG — Frederick Best, Augusta, Maine  
 W1HI — Charles F. Silver, Lynn, Mass.  
 W1BXX — N. E. Blackie, Roxbury, Mass.  
 W8APQ — Martin L. Croft, Martinsburg, Pa.  
 W2NL — H. Wilm, Jersey City, N. J.  
 W8DME — Chas. J. Heiser, Auburn, N. Y.

The remaining 234 stations on the Honor Roll are here also listed in the order of high scores:

W1PE, W1BML, W8DPI, W7ABH, K4KD, W7AJ, W6UJ, W9CSR, W9BAO, W9AQG, W4EZ, W9ERU, Wesley S. Blanchard (Opr. NMNY), W3ADE, W3BD, W2LU, W8AFG, R. T. Wachob (Opr. NMNY), W2CDM, W2BEG, W1AIT, W1ART, W1QH, W9CE, W8DMS, W1BXXH, W1BOP, W1CRA, W9COS, W9UZ, W4JR, W1ATO, W1IR, W1BFT, W2AOS, W2BPQ, W1ZL, W8CFL, W8VD, W1BOD, W9CCE, W8PP, W1AJC, W2PF, W8BKM, W9AIR, W5NW, W7BB, W6EPZ, W6ETJ, W7AIG, W6UO, W7OV, W6EEB, W6ETC, W9EAZ, W9DH, W8HD, W8RQ, W8CEO, W2OP, W2ATA, W1CDX, W1IP, W9PW, W8OA, W1ATJ, W9GAD, W1APK, W1MO, W1ACH, W4KK, W9FWG, W8AMB, W9ANT, W3AR, W8GZ, W8AHP, W9DSC, W1AOT, W2CL, W9BWZ, W8DLD, W8DSP, W8CZM, W8AWO, W8CUG, W3MC, W1BCR, W9BVF, W9EFH, W4GY, W9DTK, W9EGE, Alva Parham, W8CNO, W3UN, W1QR, W9CFL, W9EVB, W4AJH, W8DYH, W1AVJ, W1ASU, W9BXX, W9CUH, W8BWE, W1AMU, W4AHP, W8ACZ, W5QN, W9FBX, W8CMB, W9CNY, W1ZA, W8JH, W1BST, W1COV, W9BLL, W9FBJ, W9FO, W8BRO, W8BDV, W3ATP, W4AGN, W2ACD, W1PY, W1BEH, W9BBS, W2AUP, W8ABX, W1BBT, W9DHN, W3IE, W5BBF, W9SS, Donald E. Maxham, W4SI, W8DCE, W1CRC, W1AP, W8DUT, W4SK, W8CDT, W1AUC, W9AUH, W1MT, W4AAH, W9CAF, W4PD, W9EHF, W8UC, W9GKI, W9ELL, W1BFZ, W1ADO, W2BVF, W9CKM, W2AZA, W1BNM, W5ARE, Paul Tullis, W4UE, W9AAR, W9DEB, W9CEX, W9BDP, W8KD, Fred F. Russell, W1ABM, W4TI, W2AOJ, J. C. Van Horn, Wm. B. Schaum, W2ATT, W1BKS, W8ATM, W8MV, W3APT, W2CC, W9EBB, W4AFQ, W8AIH, E. W. Lockwood, W5TV, W9CTW, W9FBE, W9EAM, W4WS, W1UE, K4KV, W9DGS, W5ASQ, W9CXY, W3BVG, W1KY, W9OT, W1ANH, W1KQ, W2AVR, W9BAZ, W1AFD, W9FDJ, W2BTC, V. C. Lawrence, F. E. Fairchild, W4VR, W4ABJ, V. C. Colley, Phil Skinner, C. Rein-schmidt, W4HQ, Robert M. Watson, Newell D. Voss, Thos. Bledsoe, H. B. Waddell, Alvin Quina, Wallace Mayo, S. D. Jernigan, W2AZV,

W9GGB, W2ANV, W1AVI, W9BSM, W1ES, W9ABG, W1WQ, W2BJO, W1AQL, G. Mathe-son, W3CY, W8PR, W9FFD, W2BBP.

#### THE 1929 NAVY DAY BROADCASTS

From NAA:

NR1 Govt. Washington, D. C., fd. 7:30 p.m. 28 October, 1929, CK 298.

To the Radio Amateurs of the United States.

Yesterday was the eighth anniversary of the institution of Navy Day and the seventy-first of the birth of that great American, former President Theodore Roosevelt, to whom the Navy owes so much. Upon the observance of Navy Day today I take the greatest pleasure in sending greetings to the radio amateurs of America. This country and the United States Navy has every confidence in your continued progress and places well justified reliance upon your assistance in time of war or any other emergency.

The amateur has reached his highest development in the United States and probably in no other country has he contributed so much to the progress of the radio art. You were the first to discover and demonstrate the world encircling practicability of high frequency.

In the last war the Navy built up its operating personnel largely by recruits from the amateurs of the country and should a national emergency again arise I feel certain that we will again find you ready.

Many of you are in our Volunteer Naval Communication Reserve, a branch of the service of which I am justly proud. To those who have not yet become affiliated, I would extend a cordial invitation to join. You will find the association helpful and the Navy will gain much. By furnishing communication during devastating storms and floods, the Volunteer Reserve, by means of its communication network, has already made a most enviable record.

In conclusion I wish to congratulate you upon your very great accomplishments in the past and assure you of my interest and confidence in your future progress.

C. F. ADAMS, Secretary of the Navy.

From W1MK:

QST QST QST de W1MK W1MK W1MK.

To the Radio Amateurs of America.

Once a year the President of the United States sets aside a day which is known as Navy Day. For years past it has been the practice of the A.R.R.L. to cooperate in a program which shall pay a fitting tribute to our United States Navy. The President of the A.R.R.L. tonight takes the key of our headquarters station in an effort to help make this program a success. He asks every radio amateur to enter into the spirit of the affair and to do his part. The Secretary of the Navy will send to the ten amateurs who copy this message most perfectly a personally signed letter of appreciation and all participants sending headquarters copies of the two Navy Day broadcasts to amateurs will be included in the Navy Day Honor Roll which will appear in December QST.

Let me take this occasion to remind every one of you that the radio amateur occupies a very important and responsible position in his country. If he owns and operates an efficient radio station he is doubly important. In times of public emergency he may be the one to save life and property and alleviate suffering as no one else can. This has happened many times in the past and will happen again in the future. The Navy appreciates this and it is a mark of this appreciation that your President is invited to take an important part every year in Navy Day celebration.

Let me also remind you that the Navy offers us radio amateurs a particularly attractive Volunteer Reserve enrollment. If you are physically fit you can be a member of the U. S. Naval Reserve and sign U.S.N.R. after your name. Write in to headquarters for full information.

(Sig.) HIRAM PERCY MAXIM, Lieut. Comdr. U.S.N.R.,  
 President, American Radio Relay League.

# Hunting Trouble on 28 Megacycles

By Alphy L. Blais\*

**T**HE 28-mc. band, over a year old now, has spelled trouble for more amateurs in twelve months than any other band. Poor conditions, lack of coöperation between experimenters and too little boosting and a scarcity of information, are some reasons why 28 mc. has not been used extensively.

Happily, there seems to be a renewal of interest and activity at this time. Let's hope that the amateur will awaken "en masse" to the usefulness of this 28-mc. youngster and cultivate it more heartily. There are thrills and surprises hidden right in this band; a few drawbacks and troubles one can easily master and cure.

The major trouble originates in the receiver. The amateur complains that he cannot get up to 28 mc. and, if he does, the performance of his receiver is so erratic as to discourage him in plugging ahead at remodeling after the tenth trial. Others cannot locate the band on the receiver. A calibrated monitor will help in this case, as will be shown later.

I venture to say that 90% of the trouble originates in the reception end of the 28-mc. problem, and if one may judge by the many requests for information received, the case is true for 95% of the amateurs trying out this band. Dead spots, absence of regeneration, noises and what not, are some of the troubles encountered while trying out the receiver.

During the last year of experimenting on 28 mc. all results, whether negative or positive, were carefully noted and analyzed afterward. The conclusions drawn helped in building a receiver which would please even the most exact listener.

As far as the transmitter was concerned, the main item was to get it perking on 28 mc. The t.p.t.g.; Colpitts, Ultraudion, m.o.p.a. — all of them oscillated without trouble. (I'm not talking about the quality of the note, stability of frequency and key thumps. These were taken up later and cured one at a time after the receiver had been put to work and the transmission question had come up.)

### AUDIO AMPLIFIER

To simplify matters and to reduce the causes of trouble, it is preferable to have an audio amplifier run independently from the detector and radio frequency stage, when the latter is used. By building a good amplifier, and operating it with batteries separate from those used on the de-

detector, better results are obtained. Moreover, this centers most of the trouble hunting in the first part of the receiver. Both transformer

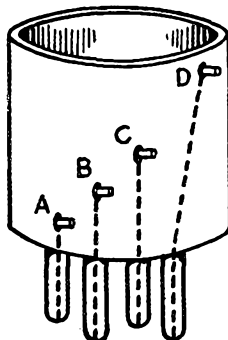

FIG. 1. — WINDING TERMINAL ARRANGEMENT ON THE TUBE-BASE

*Tickler terminals connect to "A" and "B," grid coil terminals to "C" and "D." The arrangement was suggested to the author by Mr. C. V. Smith, Jr., of Thetford Mines, Que.*

coupled amplification and peaked amplification are used. This amplifier is mounted in a metal box grounded to reduce the hum generally present in audio amplifiers.

### DETECTOR

As will be seen by the diagram, a regenerative detector is used. Capacitative antenna coupling and resistance control of regeneration are preferred to inductive antenna coupling and throttle condenser because:

- Dead spots are reduced to a minimum.
- Receiver remains calibrated.
- Regeneration is controlled easily.
- Signals are steadier under large variations of regeneration control.

Operation is smoother all over the scale.

The detector is mounted on a metal panel to reduce body capacity and to simplify wiring. No ground is used though all connections common to the positive filament are soldered to a metal sheet screwed under the baseboard.

### 28-MC. COIL

The 201-A type tube base seems to be the ideal form on which to wind the coil. Moreover, it is inexpensive and the amateur may wind dozens of coils at low cost and a saving of time in designing the proper one for his receiver.

Four holes are drilled through the bakelite sides at an angle of 45 degrees. Next, four leads of

\* VE2AC-VE2AS. P. O. Box 221, Thetford Mines, Quebec, Canada.

number 14 tinned wire are soldered to the base prongs and brought out through the holes, and allowed to extend outside about  $\frac{1}{4}$  inch. (Fig. 1.) This will simplify the winding and save time in cutting the wire to correct length, or in taking all wire away and rewinding completely.

Once the coil form is ready, wind about 4 or 5 turns of No. 22 or 20 d.c.c. or d.s.c. wire, spacing the turns and covering about 1 inch on the base. Next, jumble wind about 4 or 5 turns No. 28 or 30 d.c.c. in the same direction as the first winding. The latter fine wire coil is the plate coil. To wind these coils, simply twist a few turns around the heavy wires extending from the coil form and then wind the required number of turns as mentioned above.

Next insert this coil in your receiver, and try getting something on the set. Look for oscillation by turning the tuning dial from 0 to 100 and adjust regeneration control to get steady oscillation all over. It might be necessary to vary the small antenna condenser to avoid dead spots. If the set oscillates too freely and you cannot stop this, take off one turn of the plate winding.

With the help of a monitor or any oscillator at hand, determine the frequency of the signals heard, if any, or get the beat note from the monitor on the receiver and compute frequency. Be careful not to mistake a harmonic for a fundamental signal. It is advisable to try and get a known harmonic of 14 mc. or its fundamental. Once you have picked up this signal from the monitor and know which it is (let's say it is 14 mc.), cut  $\frac{1}{4}$  turn from the coil you are testing. Repeat the above tests to determine the frequency of signal received, at the same time cutting off some of the tickler turns if regeneration cannot be controlled with the resistance. Try and get the set to oscillate when about half of the resistance is being used. Just keep cutting the grid-filament coil until you have two turns of wire left on the form, and see that regeneration still occurs. If at that point regeneration ceases, it might be necessary to discard the old tickler winding and rewind with one turn more than there was before.

With two turns of grid-filament coil, listen in for a harmonic of 14 mc. and, if you cannot get it, determine what frequency you can receive on by using the monitor. Next space these two turns more. This will raise the frequency up to a point where you will be receiving on 20 to 24 mc. Now you will probably be running into trouble with the regeneration. Instead of cutting off some of the tickler, try bunching the 3 or 4 turns more closely and try again for oscillation; failing which, push this tickler farther away from the other winding and retest for oscillation. If ND, simply push the tickler closer to the grid-filament coil. Be sure that this tickler is wound in the same direction as the other.

You've got to keep at this cutting game for

quite a while if you want to get the set working. It might happen that you will fall on the right arrangement at the start, yet you may have to wind and rewind for hours before striking it right. That's one of the discouraging things about 28-mc. testing. It demands more patience than skill at times.

As has been said, you are probably around 22 or 24 mc. All cuttings now should be on the order of  $\frac{1}{4}$  inch at a time and greater spacing should be tried. You'll finally get within the 28-30-mc. band, and now all that remains is to cover all of it. Once more determine what portion of the band you are receiving on, always with the aid of the monitor. Let's say you pick up between 26 to 29 mc. Space the winding of the grid coil very slightly, and test with the monitor again. This ought to bring you up to 27-30 mc. or slightly less. Continue spacing the  $1\frac{1}{2}$  to 2 turn coil, and you will end by getting right in the band.

If at this time you have failed getting right in 28-30 mc., rewind your coil completely with a smaller size of wire, and repeat all of these tests. Try larger wire if the latter does not suit.

Here are the dimensions of coils that cover the band at VE2AC-VE2AS:

Seven and one half inches No. 22 d.c.c. on tube base with Cardwell 191-E variable condenser. Frequency covered, 30.17-27.80 mc.

Three turns No. 30 d.s.c. wound directly in center of coil form and over portion of grid-filament coil.

Regeneration is obtained without varying resistance, when about half the 50,000 ohms is used. Antenna condenser is at minimum capacity.

#### ACCESSORIES

Use first quality equipment throughout if you want near to perfect results. Beware of dust and grit in any of the variable parts of the tuning accessories. If you are dreaming of those nice cushioned sockets which dance to and fro, just change your mind and use the good old sturdy and steady type. You'll have enough signal swinging without making things worse with the cushioned sockets.

If your front panel is metal, don't use a metal dial for tuning, especially on 28 mc. Metal rubbing against metal causes noise which spoils all reception. Use a bakelite dial, or if you have to use the metal one, place a felt pad between dial and panel to prevent the trouble mentioned.

The 50,000-ohm resistor might be of any good make, though Frost and Bradley units work very fine here. They are noiseless when varying the resistance.

Cardwell condenser 191-E is the favorite for 28 mc. here. Another condenser, the General Radio Type 558, gives full coverage when one of the rotor plates is removed. This condenser has, besides the rotor and stator commonly found in



condensers, two circular rotors which act as a fixed condenser shunted across the tuning one.

With the General Radio condenser the coil for 28 mc. varies but slightly from that described for 191-E Cardwell.

REGENERATION TROUBLES

Sometimes the receiver will stop oscillating. While the tubes are lighted, take out the coil from its socket and re-insert it. This generally stops the trouble. Slightly tapping the detector tube or taking it out of the socket and re-inserting it will bring the set into oscillation once more. If these methods fail, place your fingers on the coil and shake the tickler winding a little, pressing on it or trying to move it up or down just a frac-

An indoor antenna of fine wire (No. 26 d.s.c.) proves very satisfactory.

SCREEN-GRID TUBES ON 28 MC.

The 4-tube screen grid receiver described in QST and in the Amateur's Radio Handbook, is a very efficient set for 28-mc. work.<sup>1</sup> As the subject has been covered thoroughly in the above mentioned references, repetition here will be unnecessary. The detector part of the above receiver differs very little from that of the detector described in this article, and the procedure of coil making is the same. The troubles encountered can be cured in the same manner.

DETECTOR TUBES

The UX-201-B is one of the best detectors. It is non-microphonic, and the background noises are less pronounced than in the other types; in fact they are almost unnoticeable. Out of three dozen tubes tried out, every UX-201-B (six of them) surpassed the others. Better still, if you can get it, is the Northern Electric Nor-Phonic tube DX-235 — the best tube for ten meter work. Occasionally one will be found that is microphonic, but that is one in a hundred. Next comes the famous "peanut tube," using dry cells for filament lighting (1.5 volts). It is almost a perfect tube as detector, amplifier or oscillator.

This does not infer that other types of tubes are not good performers; they are, but the best performers are particularly mentioned.<sup>2</sup>

READING MATTER

In a succeeding article the transmitter will be treated; also a study on the autodyne receiver will be given. To assist in the construction of your 28-mc. equipment, the following references are suggested:

QST, May, 1928, page 9 (How to get started on 30 mc.).

QST, May, 1928, page 11 (On the Ultraudion: a fine study on this circuit, with an abundance of dope and sketches).

QST, August, 1928, page 37 (A real encyclopedia on 28-mc. transmitters actually in use by many amateurs).

QST, October, 1928, page 31 (All about the 28 mc. beam antenna at W1CCZ, with dimensions for duplication).

QST, November, 1928, page 29 (A crystal-controlled transmitter).

(Continued on page 30)

<sup>1</sup>QST, November, 1928, Radio Amateur's Handbook, fourth and fifth editions, page 68.

<sup>2</sup>Unfortunately for the American amateur, these tubes are not on the market in the U. S. A. The UX-201-B is similar in characteristics to the UX-201-A with the exception of the filament. The DX-235 resembles the UX-201-B. The "peanut tube," also known as the "N" tube, is made in the U. S. A. by the Western Electric Co., but is not available to the amateur through the usual channels. Most of us must be content with the "good performers."

— Editor.

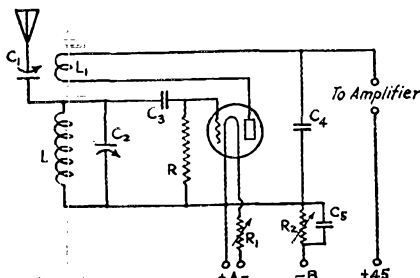

FIG. 2 — THE DETECTOR CIRCUIT

- C<sub>1</sub> — 2-plate midjet condenser.
- C<sub>2</sub> — Cardwell 191-E, 75-µfd. variable.
- C<sub>3</sub> — 100-µfd. Sangamo fixed condenser.
- C<sub>4</sub> — 6000-µfd. Sangamo fixed condenser.
- C<sub>5</sub> — 0.1-µfd. Sangamo fixed condenser.
- R — 6-megohm grid leak.
- R<sub>1</sub> — 30-ohm rheostat.
- R<sub>2</sub> — 50,000-ohm variable resistor (See text).
- L and L<sub>1</sub> — Grid and tickler windings. See text for details.

tion of an inch. Any of the above, or all of them, cured the regeneration trouble here whenever the set stopped oscillating. In some cases, to obtain steady regeneration it was necessary to wind a coil with as many as 8 turns on the tickler.

NOISES

Very poor reception may result if the "B" batteries are defective, even though they register full voltage.

A hissing sound in the 'phones and too much background noise are often stopped by taking out the coil from its socket and re-inserting it while the filaments are burning. These same noises are often caused by a chemical action at the storage battery terminal posts, action taking place when too much dirt and sulphate accumulate on the battery clips. Clean them and see that a very good contact is made right there.

ANTENNA

Any kind of antenna seems suitable for reception work. It must be well insulated and rigid.

# A Micro-Condenser for Amateur Band Tuners

By A. L. M. Dingee\*

IN connection with recent research work it was found necessary to build a very small vernier condenser having a straight-line capacity characteristic. The general smoothness of operation and reproducibility of scale readings of the instrument here described should make it useful as a tuning device for high frequency receivers.

The photograph shows the construction of the instrument and is self-explanatory. The fixed

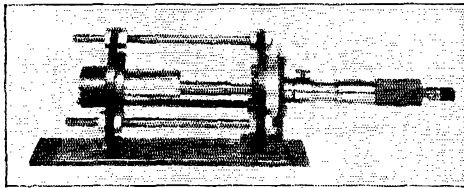

THE MICRO-CONDENSER

brass cylinder has an inside diameter of eleven-sixteenths of an inch. The movable cylinder has an outside diameter of five-sixteenths and is drilled at one end to make a force fit over the quar-

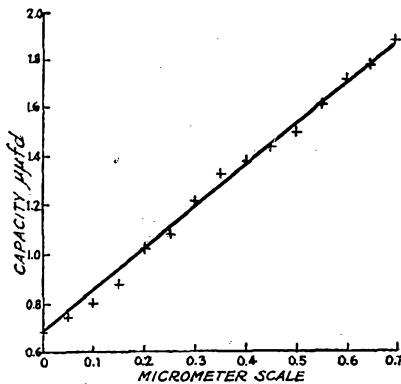

FIG. 1

ter-inch end of the micrometer head. This latter is similar to those used on micrometer calipers and may be obtained through a hardware store for about eight dollars; either the metric (centimeter) or English (inch) type can be had, the latter with or without vernier; both have a motion of one inch. If this is fully utilized, the metric type affords a scale having twenty-five hundred

divisions, the English type with vernier ten thousand divisions. It is suggested that for radio work the former probably would be sufficiently finely divided and is very much easier to read than either English scale.

Although the total movement of the smaller cylinder is one inch, both cylinders were made two inches in length to obtain the constant condition of the surroundings of the ends of the cylinders necessary for the desired straight-line relation between scale setting and capacity, one cylinder never being completely within the other. Fig. 1 shows the variation of capacity of the condenser and leads in micro-microfarads against scale reading. It will be observed that the total variation in capacity is less than two micro-microfarads. When employed in parallel with a fixed capacity of about 90 micro-microfarads to control a one megacycle oscillator this condenser permitted adjustment of the beat note to easily within a fraction of a cycle per second. When used in parallel with a 100 micro-microfarad capacity on thirty meters, it should cover a band about 100 kilocycles wide.

If it is desirable to have the condenser cover a wider band, the fixed capacity in parallel may be reduced, at the same time increasing the tuning inductance. Thus if the previous value of 100 micro-microfarads be halved the band width will be doubled. Of course the same effect can be obtained by increasing the diameter of the movable cylinder. A convenient expression for calculating band width is as follows:

$$\frac{df}{dc} = \frac{-f}{2c}$$

where  $df$  is the band width in kilocycles,  $dc$  the range of the condenser in micro-microfarads from "all in" to "all out,"  $f$  the frequency in kilocycles per second and  $c$  the total capacity across the tuning coil (including tube and distributed capacity) in micro-microfarads.

## Strays

If we continue to get any more free QSL cards, the regular printers will have to go out of business.

C.C.R. of Hdq. recently built a novel filament lighting transformer. The transformer had negative regulation, so that the voltage went up as the load was applied!

\* Rogers Laboratory of Physics, Massachusetts Institute of Technology, Cambridge, Mass.

# A Power Transformer for the Lean Purse

By E. H. Harrington, Jr.\*

ONE of the most discouraging things about making up your own power and filament supply transformer is the difficulty of winding the 5000 or 6000 turns required for the center-tapped secondary, especially when no winding machine or lathe is available. Another discouraging thing is the cost of the material required. In this transformer both of these difficulties have been avoided; the first by using honeycomb coils for the high-voltage secondary and the second by digging up the necessary material, at the least cost.

The core is from an old power transformer and was secured from the local electric equipment dealer. It should have a cross-section of not more than  $1\frac{3}{8}$  inches so that it will fit inside the hole in the center of the honeycomb coils. The inside diameter of the usual honeycomb coil is 2 inches. Therefore the maximum allowable cross-section of the core is  $1\frac{3}{8}$  by  $1\frac{3}{8}$  inches. It would be better to use a core of slightly less cross-section to permit the winding of several layers of insulating tape over the core.

In addition to the core, the following material (at approximately the prices noted) will be necessary:

2 second hand 1500-turn unmounted honeycomb coils	\$1.00
2 second hand 1250-turn unmounted honeycomb coils	1.00
About $\frac{5}{8}$ lb. of No. 18 or 20 d.c.c. enameled wire	1.35
Iron angles for mounting, bolts, binding posts, tape, etc. (mostly out of the junk box) about	.63
Total cost, about	\$3.98

The first step is to disassemble the core by removing one "leg" so that the windings may be

The primary winding consists of 450 turns of No. 18 (or No. 20) d.c.c. enameled wire, the leads being brought out at the ends of the winding. After the primary has been completed, the filament winding is put on over it, several more layers of heavy wrapping paper being wound on

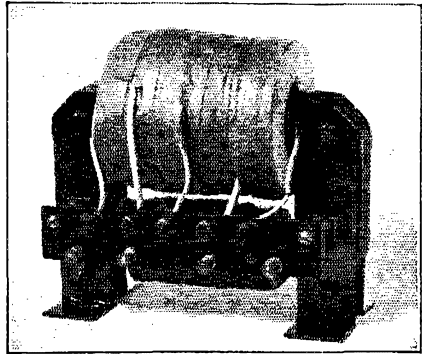

THE COMPLETED TRANSFORMER

It supplies plate and filament power to one or two UX-210 tubes.

over the primary before the filament winding is made. The filament winding is 40 turns for a starter, turns being removed later if the filament voltage is too high.

After the primary and filament windings have been made up, they should be slipped off the form and pushed on one leg of the core. If the primary does not fit the core snugly, flat strips of wood may be used as wedges to hold it tightly in place.

The high-voltage secondary should be assembled next. Place one of the honeycomb coils on a piece of good heavy cardboard and mark out the outer and inner circumferences with a lead pencil. Eight such pieces of cardboard should be laid out, two to go between each honeycomb coil and its neighbor and two for the ends to insulate the windings from the shorter legs of the core. After cutting out the insulating discs, they should be boiled in paraffin to make them moisture-proof and the high-voltage winding is ready for assembly. If there is room for a little additional insulation between the core and the insides of the honeycomb coils, several layers of insulating tape may be wound on the core before the coils are slipped in place.

After the coils have been placed on the core, rounded wooden wedges should be pushed in to hold them firmly in place. The leg of the core

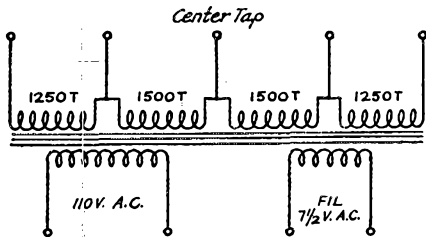

FIG. 1

slipped on easily. Then make up a form of wood, slightly larger than the core cross-section, on which the primary is wound. Several layers of heavy wrapping paper are wound on first to serve as insulation between the primary and core.

\* W9CRR, 323 West Exchange St., Geneseo, Ill.

(Continued on page 72)

## "Twenty-Meter" 'Phone Authorized

### New Vistas Unfold as Commission Opens Part of 14,000 Band to Specially Qualified Amateurs

**A**T the petition of the A.R.R.L. the Federal Radio Commission has opened the amateur frequencies from 14,100 kc. to 14,300 kc. to amateur radiotelephony by the holders of extra class amateur operator's licenses and other amateurs of undoubted technical qualifications. Now "20-meter 'phone" is possible.

On November 6th the Commission issued General Order No. 76 in which it modified its last general order on amateur telephony in such a way as to include the band 14,100 to 14,300 kc. (21.28 to 20.98 meters), "provided, however, that operation in the band of 14,300 to 14,100 kilocycles will be permitted only by operators holding extra first class operator's licenses or, lacking such licenses, by operators who in their applications for station licenses show special technical qualifications and ability to operate within the limits prescribed herein."

On November 12th the Radio Division Department of Commerce, transmitted the general order to all Supervisors of Radio, with instructions that "Amateur station licenses permitting such operation issued to those properly qualified should have inserted on the face thereof, in the proper place, the additional telephone band."

Possession of the extra class amateur licenses will be deemed *prima-facie* evidence of qualification for the privilege. Holders of this grade of operator license who wish to work 'phone in this band should write a letter of application to their Supervisor, returning their *station* license for endorsement.

While it is intended to confine the right to work 'phone in this band to the better-qualified amateurs, the extra-class operator license requires a code speed of 20 words per minute and there is no justification for requiring more than the normal amateur code speed of 10 words per minute from the operators of 'phone stations. Therefore the right to work 'phone in this band will also be given to other amateurs who apply and "show special technical qualifications and ability to operate within the limits prescribed." Amateurs experienced and proficient in the use of 'phone should have no difficulty in securing the authority.

*It is to be carefully noted that, unlike most amateur privileges, this one is not made immediately available, even to the holders of the extra class operator license. Special individual application must be made to the Supervisor, and endorsement of the new*

*band secured on the station license, before operation may begin.*

Action to secure the high-frequency 'phone privilege dates back to May of 1929 when the A.R.R.L. Board of Directors, at its annual meeting, voted to ask the authorities to open the whole 14,000 band to amateur telephony by specially-qualified amateurs. Application was immediately filed at Washington. The Supervisors of Radio were canvassed, and reacted favorably. The Commission then delayed action until after the C.C.I.R. meeting at the Hague, to see if any decisions affecting the amateur were adopted. That over, study was resumed. The engineering division of the Commission considered the possibility of long-distance interference with very important commercial services bordering upon the amateur band so serious that they were willing to recommend the use of 'phone only in the central 200 kc. of the band. These are the figures approved by the Commission in November. The effect is to provide a 100-kc. guard band on each side of the telephone band, also retaining part of the band exclusively for amateur telegraphy.

The 14,000 band is the narrowest amateur band. It contains but 13 two-tenths per cent telegraph channels. Unskilled operation of a very few amateur 'phones which "wobulated" badly would render the band useless to everybody. That is why our Board requested that the right to operate 'phone there be limited to amateurs of demonstrated technical ability. It will be a hard job to make a good 'phone on 14,200 kc., one that gets speech through to distant lands, and it is certainly not beginner's work. However, amateurs of experience and of technical qualifications at least as great as that required to pass the extra class operator's examination, particularly if they are familiar with modern 'phone operation as has been treated at great length in *QST* during 1929, may expect to be authorized to tackle the job.

A new world now opens its doors. *QST* will help with authoritative information as fast as it can be garnered. Reports of your experiences will help.

— K. B. W.

### Strays

Huddy, W111, reading the article by Windom on antennas and noting that the antenna specified worked OK with feeders up to 1200 feet thought he would carry this experiment a little further — he made a feeder 2000 feet long. It worked!

# Hams are Born—Not Made

By "Felix"\*

**W**AYLAND MARTEL ("SOUP-BONE") GROVES, otherwise 5NW (now doncha go to critincizin' — this was in the days before the funny little "W" was stuck on for dead-end effect), and I sat in my shack after a hard night DXing. When I say "hard night," I mean four hours spent dodging broad sigs, QRM, QRN, receiver heterodynes and neighborly buckshot; all the while fanning the fil. transf. and cajoling the antenna ammeter with one hand and pouring water in the rectifier jars with the other.

"Hams," says Soupbone, stretching out his scrawny legs on my desk and putting his feet in the middle of my single circuit static inhaler, "are born and not made."

"In the same manner as porcelain antenna wire!" I snorts, not only bein' disagreeable on general principles, but also because he's clicked wid three Aussies and a Zedder that mng, leaving me holding the sack wid a single Hawaiian.

"Just like five watters," he returns, ignoring me, "mebby they all look alike and all cost eight plunks per each, but there's one in a dozen that'll stand the gaff!" For verification he points at the row of dead soldiers I got strung along the wall.

"Just who," I asks, "do you refer to as bein' a born ham?"

"My own beloved brother-in-law, 5XXX!"

"That megowit? T'lissen to his fist you'd think he was a Alabam' darky ahold of the business end of a pumhandle in the middle of a dark graveyard! Be your wavelength!"

"Nev' mind," says he, "he's a born ham."

"Born-and-made, but when they assembled him they musta left some gears out. The only use that egg has for his head is for insulation between his ears."

"Lemme tell you somethin'," he begins, helpin' himself to my cigs and strikin' a match on mi tank tuning dial (?\*!!) . . .

"You think," I breaks him, "that your bein' his brother-in-law makes him a ham by proxy. Wy if that goof would call me I'd sue him for slander, libel. . . ."

"Lower your input. You're overloadin' your brain — if any. Just because mi sis wouldn't so much as go to a hop wid as big a bum as you are, you get off-wave 'cause I say the guy she married is a real ham."

"A whole roomful of factory-boughten apparatus that a sap can't make oscillate except on Monday, Wednesday and Friday makes a

BCL a ham, does it?" I asks.

"I'll admit that 5XXX don't punch out so well wid his two fifties as we do wid our fivers, but just the same . . ."

"If that milliwit would stay on wave he might raise a '9' early some mng when the QRM wasn't bad. The only time he's on wave is when he's passin' thru the band!"

"I suppose," scoffs Soupy, "if he'd throw all his equipment in the junk heap, rif up a sway-back antenna like yours, tie a coupla bricks to his ctpe to reduce QSS, an' hang his fil. transf. under the table in a bucket of ex-automobile oil, you'd call him a ham!"

"That guy thinks a kilocycle's got valves!"

"This mng while I was layin' in my bunk tryin' to figger out hw I could stack a few more watts on the plate of mi 202 and still keep it fm pourin' down in the base, I overhears sum first rate gossip the Ma is QSTing to the OM."

"Abt the size of th' light bill?" I ventures.

"Naw, I got that cured by blowin' some emery-dust in the meter bearings. This is abt sis an' her yes-man."

The gossip. 5NW relays to me sounds somethin' like this:

"George," says Soupy's Ma, "our son-in-law is a brute!"

"Uh huh," fm 5NW's OM, "all men are. What's the matter now?"

"He flatly refused to buy Milly a dress when the poor child's almost naked now!"

"That's right," says the OM, "even tho she's got more clothes than the Salvation Army!"

"Oh, why did I let her marry that crazy radio nut anyway?"

"Let her!" snorts Pop. "You didn't have much to say about it. They was married two weeks before we knew it. Besides, it better be radio gadgets than likker and wild parties wid other wimmen!"

"Milly sez," comes back Ma, "that he went and bought a fifty-volt tube or some sort of doo-dad with the money she coulda bought a new sport dress with."

"On topa that," retorts the Big Gun, "you're gettin' close to home when you run down radio. Your own darlin' little Martel spends half the night DXing — whatever that is — an' he don't even eat without the edge of some radio magazine in the soup plate!"

At this point in the gossip, I breaks him and advises him that if he don't quit messin' wid the adjustments on my bug, I'd install him wid complete mayhem equipment.

\*W5LS, 1321 W. Chestnut St., Denton, Tex.

"That's beside the point," says Soupy. "I'm tryin' to prove to you that 5XXX has got the makin's of a ham."

"Use ur own bug to prove it!" I snorts. "And besides, if a yokel mistreats his wife, does it make him a good ham? I once knew a bum who beat his wife twice a day durin' the week an' three times on Sunday, and yet he didn't know a transformer fm a triple-pole switch!"

"Take your brains for a walk, they need the exercise."

We then calls the little argument a tie, on acct of Soupy's havin' a 9 a.m. class at college and my having to QSY down to the telephone office where I wired jacks an' stole solder eight hours a day with my eyes on the clock and my brain on tfc skeds.

I don't see Soupbone for several days, but every mng I gets an earful of 5NW receiver hetrodynes, not to mention the third-rate, fourth-class buzz-saw noise he's got the nerve to call a signal. I also hears 5XXX's anemic sig once when I'm up lissenin' to one of my clothes-line harmonics. Mebby "cave-manning" his wife makes a better ham outta him, but you couldn't tell it by his fist. It still sounds like the backwave of a Navy arc. I hear him askin' 5DM what he could do to raise his radiation. 5DM advised him to take the shunt off his ammeter! I can see that "Springy" Vannoy likes him about the same as I do.

A coupla weeks later I actually hears 5XXX on the proper wave fr three mngs in succession. I dismisses the idea as bein' one of those guys has who see pink elephants with straw hats and blue neckties on, an' settles down to rebuilding mi receiver, usin' three circuits to scare off QRM. I'd just finished an' was in the back yard chasin' the neighbor kids off for usin' mi counterplunk as a trapeze when 5NW blows in with a big grin on his pan.

"I toldja!" he almost shouts.

". . . that the Hartley ckt is better than the 4 Coil Mesny but you'r' all cock-eyed!" I supplements.

"Pull your switch an lissen a while! You know I was tellin' you abt 5XXX an' Milly — well, there's some new developments. Nevermind how I got the dope, but. . ."

"Mebby he turns out to be Dr. Stiminetz wid blue whiskers an' a pyrex arm?" I asks hopefully, but 5NW didn't even QRK.

"The other nite (began 5NW) 5XXX was tryin' to get his fifties to smile instead of blush when Milly hollered fr him to please come to bed. He didn't hear her fr the first 45 minutes 'cause he's got his WE's clamped close to his head. Finally she gets tired CQin' fr him an' QRTs.

"Abt a coupla hours later she wakes up an' he's still not in the bunk. She gets up an' stumbles over wire, tools, inductances, an' whatnot into the shack. 5XXX had raised his first '6,' an' by

shutting his eyes an clampin' the cans tighter, he could almost hr the '6.'

"Are you ever comin' to bed?" she asks.

"Pipe down!" he yells in a voice that could be heard to Hickory street. 'I got 6CCI!'

"Right then Milly starts up the tear-generator an' throws a cryin' jag. She first bawls QRZ, then QRK, an' finally abt R14, but still he didn't even turn around. She stands on her tiptoes an' accuses him of almost ev'ry thing from havin' halitosis to soakin' his invilid Granmommer in the eye wid a sock full of stove-bolts. Still, he don't even hear her.

"As a last resort, she jumps over an knocks his receiver off the table onto the MG. It lands bottom-up on the shaft, an' what the couplin' didn't do toward scramblin' it, the 1500-volt leads did!

"When the burnt-rubber smoke screen blows away, he looks at her once, grabs a stray piece of bakelite panel, turns her over his knee an' gives her the goshawfulest lambastin' she ever got. He did a job the OM would be proud to claim!

"She naturally runs home to Ma, while he sits around, dumblike, lookin' first at the remains of his three toob hetrodyne-brewery, an' then at the kitchen sink full of last nite's dishes. Finally he wraps some junk up in a bundle an' trecks off to work.

"By the aid of much blah-blah, Ma gets Milly calmed down a bit, an Pop hasta make a quick QSY to the radio shack to keep them fm seein' him grin. Ma can't get Milly in the idea of gettin' back in synchronism wid her 'tyrannical, brutish, maniac, whatnot husband,' but finally she is begged into the notion of goin' back fr her clothes. At this stage of the game T.O.M. grabbs mi fone an' does sum QRQ telephonin' in a tone so QRZ that I couldn't hear wot he says or who he was QSO.

"Milly musta been gettin' ready to leave 5XXX's QRA abt the time 5XXX blows in. This time he's got two bundles. Guess what's in 'em? One of them is the new sport dress Milly's been CQing so long fr. I dunno what he says to her, but he musta done an artistic job of it, 'cause it didn't take him but half an hour an' three good crys to get her to begin QSOing the dishes an' stirrin' up some chow.

"While she's removin' the a.c. ripples fm the chinaware, he unwraps some receiver parts to take the place of those that's been fried that mng. Besides that, he's got one of these new seven-an-a-half watters. Ever' once in a while, he'd come in the kitchen wid a condenser in one hand an' a screwdriver in the other an' ask 'How is 'ittle tootsie wootsie?' an' then make a dive fr the shack agn.

"I don't know anything more except that this a.m. I heard an Aussic CQing, an' called him 'til

(Continued on page 30)

# Quartz Crystal Facts

By J. Herbert Hollister\*

**W**ITH just a year of the narrow-band era behind us, we find the ranks of the quartz crystal exponents growing daily. At this time last year most of us thought crystal control was only some trick arrangement for the other fellow to play with and squander his money on. There were few, however, who did not envy the crystal controlled station with the beautiful bell-like note which was always to be found at exactly the same spot on the dial.

From sheer necessity, brought on by the crowded condition of the bands, increasing numbers of us have turned to crystal control for the solution of our problem. Naturally, with this growing demand, prices for quartz plates and blanks have been forced down until they have reached a level where they represent the best value on the amateur's shopping list.

Educational articles in *QST* and other publications have done much to call our attention to the fact that the grinding of crystals is not necessarily a laboratory job.<sup>1</sup> The following facts are intended to supplement previous articles, and are prompted by many inquiries which have been received by the writer.

The two common axes on which plates are cut are shown in Fig. 1. The sketch represents a cross section of crystal, and Fig. 1A shows the "thin" cut. That is, plates cut on this axis will be thinner for a given frequency than those cut on the axis shown in 1B, which we will call the "thick" cut.<sup>2</sup>

\* W9DRD, Edwardsville, Kansas.

<sup>1</sup> Details of crystal structure, cutting slabs and grinding plates are contained in the following *QST* references: Crystal Control for Amateur Transmitters, Nov., 1925; Examining Quartz for Oscillator Use, Sept., 1926; Crystal Cutting (Correspondence) Feb., 1926; Looking at Quartz (Correspondence) Nov., 1926; A Method of Grinding Quartz Plates, May, 1927; The Grinding of Quartz Plates, Jan., 1928; A Crystal Grinder, May, 1928; Debunking Crystal Control, Dec., 1928; New Crystal Fragments (Experimenters' Section) Nov., 1929. — EDITOR.

<sup>2</sup> Observations on Modes of Vibration and Temperature Coefficients of Quartz Crystal Plates, *Proc. of I. R. E.*, July, 1929, and *Bell System Tech. Journ.*, July, 1929.

When the plate is cut so that its major surfaces are parallel to the optic (Z) axis and perpendicular to an electric (X) axis,

$$t = \frac{112.6}{f}$$

(This is the "thick" cut.)

When the major surfaces are parallel to both the optic (Z) and electric (X) axes,

$$t = \frac{77}{f}$$

(This is the "thin" cut.)

Where  $t$  = thickness of plate in inches.

$f$  = frequency of oscillation in kilocycles per second.

— EDITOR.

Both cuts are desirable for use in the amateur bands, and each has its own peculiarities which must be understood before attempting to produce a finished plate from the blank.

## THE THIN CUT

Plates cut on the axis parallel with any true face of the crystal, as shown in Fig. 1A, will average approximately 3.9 meters per .001 inch of thickness. This means that a plate ground for the top of the 1750-kc. band will be about .044 inch thick. Since the frequency increases in

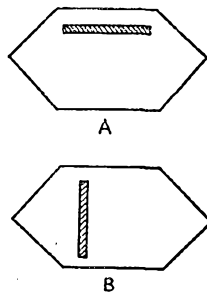

FIG. 1

inverse proportion with the thickness of the plate, as long as the axis remains unchanged, we know that a 3500-kc. plate cut on this axis will be about .022 inch thick, and a 7000-kc. plate will be about .011 inch thick.

This cut is quite desirable for the two lower frequency bands but not so good for 7000 kc., as .011 inch is not much of a thickness for anything to have, let alone a substance as brittle as quartz. Then again it is very hard to keep low spots out of such a thin crystal due to pressure from the finger while grinding. An interesting thing about plates cut on this axis is that they apparently refuse to oscillate if the center is ground even slightly thinner than the edges. These plates are very easy to make oscillate and will usually kick off very nicely if the two faces are brought to within .002 or .003 inch of parallel, even though the faces are quite rough from grinding with a coarse abrasive. It is of course desirable to grind all the chips and nicks out of the edges but this is not really necessary with plates cut on this axis. This edge beveling is best done on a small carborundum stone using light oil just as in whetting a knife.

The best routine to follow in grinding the plate from a blank cut on the thin axis is to first finish one face with FFF carborundum or alundum

grain, until the rays of an electric light are seen to be evenly reflected from its surface. This face will then be used as a reference face and all grinding done on the other side. When grinding a 3500-kc. plate, the rough grinding (done with No. 100 grain on a plate glass lap with a little water to prevent chipping) should cease when the thickness reaches about .025 inch. We will assume that this thickness is fairly uniform over the whole plate and that there are no low corners. The finishing job is best done on a new piece of glass with FFF grain and a piece of light glass such as half of a microscope slide placed on top of the crystal to stiffen it and prevent the center from grinding thinner than the edges. Just a little moisture between the crystal and the top glass will cause the crystal to adhere to it. When the plate reaches a thickness of about .023 inch it may be given a frequency test in an oscillator and so brought on down to the desired point.

#### THE THICK CUT

Plates cut on the axis at right angles to any true face of the crystal, as shown in Fig. 1B, will average approximately 2.6 meters per .001 inch of thickness. This will make the 1750-kc. plate about .064 inch thick, the 3500-kc. plate about .032 inch thick and the 7000-kc. plate about .016 inch thick. It seems to be essential that there be no greater thickness in the center of the plate than at the edge and, in fact, much greater output is obtainable with this cut if both faces are ground slightly concave by applying pressure at the center while grinding. For this reason this cut is not so good for plates of lower frequency than 3500 kc., as there is not much bend to a plate thicker than .032 inch, and it is hard to grind the center thinner than the edges.

It is very important that the edges of plates cut on this axis be ground entirely free from nicks. In fact, it has been found that many of these plates refuse to oscillate until the edges are carefully beveled, even though the grinding job is nearly perfect.

If too much is taken out of the center, the plate may oscillate at two frequencies quite close together, and jump back and forth in a most aggravating manner.

It is quite common to find a spot in the center of plates ground as described above, and corresponding dark spots on the upper and nether electrodes of the holder. These spots are probably caused by a brush discharge between the two holder plates and the heat so generated might possibly amount to enough to rupture the plate. However, there is very little danger of this if the center is only .0002 inch thinner than the edges.

More care is required in producing plates from blanks cut on the thick axis, but the added bulk of crystal is desirable at the higher frequencies. Results indicate that there is little or no difference

in the output of the plates cut on the two different axes.

#### 7000-KC. PLATES

Generally speaking, too little attention has been given to plates ground to a fundamental frequency of 7000 kc. One of these thin plates has been used by the writer in a transmitter for the past two years with a 210 oscillator using from 450 to 600 volts on its plate. The crystal is still perfectly good and its use makes it possible to work in the 14,000-kc. band with only one doubler-amplifier.

In grinding a plate to a fundamental frequency in the 7000-kc. band, only slightly greater care is needed than in grinding one for 3500 kc. Using the thick cut, the variation in thickness should not exceed .0001 inch, and the center of the plate may be left .0001 inch thinner than the edges.

If the above memoranda serve directly or indirectly to help more little crystals into this tempestuous world of amateur radio, well and good for all concerned. Those of us who are now using crystal control know that we would not care to be on the air at all without that ever active bit of vibrating rock which keeps our note always the same, and on the same frequency.

### Hunting Trouble on 28 Megacycles

(Continued from page 23)

QST, January, 1929, page 9 (a review of the whole subject including data for the antenna).

If you are not discouraged by this time, go over the issues of QST for 1926 and 1927 and read all about 5-meter work. This will prove very beneficial to the 28-mc. experimenter.

### Hams are Born—Not Made

(Continued from page 28)

I thot the cement was gonna melt in the tube base. When I switches back, I hears the Aussie's squeaky sig say: 'RR 5XXX DE VK2XXX GE UR PDC QSA5 HR ES STDI FB FB . . .'

"Yeah, hams are born, an' not made!"

### Strays

We wonder where the I.R.E. would obtain its secretaries if it were not for the A.R.R.L.!

The a.c. high frequency receivers are with us Now the modern ham will have to purchase one of those automatic tuning devices (the kind that looks like a cash register) before he can boast of a 1930 receiver.

Figure this one out! The frequency of a coil for an oscillating receiver was higher after being given a coat of "air-plane dope" than before.



# Matching the Speaker to the Output Tube

## The Design and Operation of the Output Transformer

By J. M. Thomson\*

*In usual audio-frequency power amplifier practice, too little attention is paid to the output coupling device between the output tube or tubes and the speaker. It often occurs that the otherwise good design of an amplifier is nullified by improper coupling between the output and the reproducer. Mr. Thomson points out the considerations involved and supplies practical data for the design of satisfactory coupling transformers for both magnetic and dynamic types of speakers. — EDITOR.*

**D**UE to the extended use of power tubes with magnetic and dynamic types of speakers, the use of output transformers to match the speaker to the tube has become of vital importance. "Magnetic" is here used, in referring to permanent magnet moving armature types of speakers, while "dynamic" is used in referring to moving coil inertia controlled types. The following paper gives a general idea of the operation of output transformers.

The standard connection for an output transformer with a power tube and speaker is given in

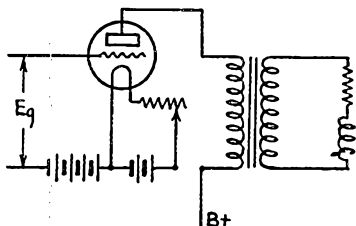

FIG. 1. — TYPICAL CIRCUIT FOR POWER TUBE WITH TRANSFORMER COUPLING TO THE SPEAKER

Fig. 1. Fig. 2 gives the equivalent connection as far as a.c. voltages and currents are concerned. Using Kirchoff's Laws and the symbolic method, the current in the speaker can be developed in terms of the tube, speaker and transformer constants. The formula for the speaker current,  $I_2$ , is

$$I_2 = \frac{\omega M E}{\sqrt{(R_1 R_2 - X_1 X_2 + \omega^2 M^2)^2 + (R_2 X_1 + R_1 X_2 + R_1 X)^2}} \quad (1)$$

Where

$\omega = 2 \times 3.14 \times$  frequency in cycles per second.

$M =$  mutual inductance in henries.

$E =$  a.c. voltage applied to the grid of the power tube, multiplied by the amplification factor of the tube.

$R_1 =$  total resistance in the primary circuit in ohms.

$=$  plate resistance of the tube plus the primary resistance of the transformer.

$R_2 =$  total resistance of the secondary circuit of the transformer.

$=$  resistance of the speaker plus the resistance of the secondary coil of the transformer.

$X_1 =$  reactance of the primary coil of the transformer.

$X_2 =$  reactance of the secondary coil of the transformer.

$X =$  reactance of the speaker.

In a good transformer with the usual values of leakage inductance,

$$\omega^2 M^2 = X_1 X_2$$

$$\omega M = n X_1$$

$$X_2 = n^2 X_1$$

Therefore:

$$I_2 = \frac{n X_1 E}{\sqrt{(R_1 R_2 - X_1 X)^2 + (R_2 X_1 + R_1 n^2 X_1 + R_1 X)^2}} \quad (2)$$

The power input to the speaker is  $I_2^2 r$  and for "r" a constant will be a maximum when  $I_2$  is a maximum. A little experimenting with Formula 2 will show that the values which affect  $I_2$  the most are the primary reactance,  $X_1$ , and the turn

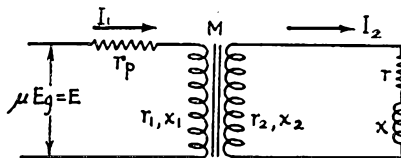

FIG. 2. — EQUIVALENT CIRCUIT OF THAT SHOWN IN FIG. 1

ratio, "n." The primary and secondary resistance affect the current,  $I_2$ , but not very markedly.

The following tabulation shows the effect of changing the primary impedance of an output transformer:

\* Ferranti Electric, Ltd., Montreal, P. Q., Canada.

MAGNETIC SPEAKER AT 50 CYCLES

Tube impedance.....	2000 ohms
Speaker resistance.....	1500 ohms
Primary resistance.....	1000 ohms
Secondary resistance.....	1000 ohms
Speaker impedance at 50 cycles.....	1950 ohms
Turn ratio.....	1/1
Amplification factor of tube.....	3.5
R.M.S. a.c. voltage on grid of tube.....	20 volts

Primary Impedance in Ohms	Secondary Impedance in Ohms	Speaker Current in Mills	Power Input to Speaker in Milliwatts
2000	2000	8.46	104
4000	4000	10.8	175
15,000	15,000	12.1	220
Infinite	Infinite	12.4	232

DYNAMIC SPEAKER AT 50 CYCLES

Tube impedance.....	2000 ohms
Speaker resistance.....	5 ohms
Primary resistance.....	1000 ohms
Secondary resistance.....	1 ohm
Speaker impedance at 50 cycles.....	5 ohms
Turn ratio.....	20/1
Amplification factor of tube.....	3.5
R.M.S. a.c. voltage on grid of tube.....	20 volts

Primary Impedance in Ohms	Secondary Impedance in Ohms	Speaker Current in Mills	Power Input to Speaker in Milliwatts
2000	4.5	205	210
4000	9.75	244	296
15,000	37.5	260	340
Infinite	Infinite	260	340

With both types of speaker the current increases as the primary impedance is increased. In the magnetic type, when the primary impedance is changed from 2000 to 15,000 ohms, the speaker current increases 46%, giving 112% increased power. With the dynamic speaker the current input increases 27% with a gain in speaker power of 62%. The power input for the condition of infinite primary impedance is the theoretical maximum power input to the speaker.

Figs. 3 and 4 show the power input to magnetic and dynamic speakers when the turn ratio (*n*) is varied. In the magnetic type the power input decreases with increasing frequency. This corrects for the characteristics of the speaker and helps to give a more uniform response. These curves also show that with this type of speaker it is possible to change radically the balance between high and low notes by changing the turn ratio.

The results for a dynamic speaker are similar, but the power input for a perfect speaker is almost independent of frequency. The loss in power at the lower frequencies is due to reduction of the primary reactance with frequency, and consequently the frequency should be carefully chosen so as to give the best possible balance between low and high frequency notes. A transformer with a primary inductance of 40 to 50 henries would give practically a flat curve. The

primary inductance should be measured with direct current (equal to the normal plate current) flowing in the coil. The voltage to be used in making the inductance measurement should be

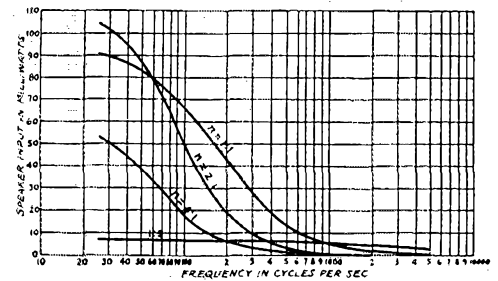

FIG. 3. — POWER INPUT PLOTTED AGAINST FREQUENCY AT VARIOUS VALUES OF TURN RATIO, MAGNETIC TYPE SPEAKER

- Plate impedance 5000 ohms
- Primary Resistance 500 ohms
- Secondary Resistance 500 ohms
- Speaker Resistance 1000 ohms
- Primary Inductance 60 henries
- Secondary Inductance 60/n<sup>2</sup> henries
- Speaker Inductance 6 henries
- Amplification factor 7
- 10 volts (r.m.s.) impressed on grid of tube "n" is the ratio of primary turns to secondary turns

equal to the a.c. voltage that will be impressed on the coil when operating under normal conditions. The inductance should also be measured at a number of frequencies in the audible range to get the effect of the self-capacities of the primary and secondary coils. For example, a UX-171-A tube has an amplification factor of 2.5 and a plate current of 20 mills at 180 volts "B" and -40 volts grid bias. It is assumed that experiments will be made using a 15-volt (r.m.s.) grid swing on the 171-A; then the inductance measurements should be made with 20 mills d.c. in the primary coil and an a.c. voltage of 2.5×15=37.5 volts. When used in a receiver the grid swing on the output tube will vary over a wide range. In this case the worst condition is assumed and an a.c. voltage of 1 to 2 volts would be used.

The correct value of "n" for a given set of conditions can be obtained mathematically by differentiating Equation 2, using "n" as the variable and then solving for "n." If this is done it will be found that

$$n^2 = \sqrt{1 + \frac{R_1^2}{X_1^2}} \times \sqrt{\frac{R_2^2 + X^2}{R_1^2}}$$

for maximum power input. If the primary reactance is very large as compared with the total resistance in the primary circuit,

$$\frac{R_1^2}{X_1^2} = 0 \text{ and } n^2 = \sqrt{\frac{R_2^2 + X^2}{R_1^2}}$$

This is the commonly used impedance ratio formula. Two things must be noted about this

formula. First,  $R_1$  is equal to the plate resistance of the tube plus the resistance of the primary coil and  $R_2$  is equal to the resistance of the speaker plus the resistance of the secondary coil. Second, the turn ratio is not independent of frequency unless speaker reactance is zero. This means that generally it is only possible to set the conditions to give the maximum power input at one frequency.

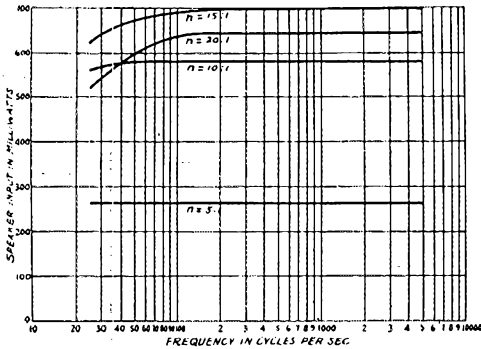

FIG. 4. — POWER INPUT PLOTTED AGAINST FREQUENCY AT VARIOUS VALUES OF TURN RATIO, DYNAMIC TYPE SPEAKER

Plate impedance	3000 ohms
Primary resistance	500 ohms
Secondary resistance	1 ohm
Speaker resistance	10 ohms
Primary Inductance	20 henries
Secondary inductance	20/n <sup>2</sup> henries
Speaker inductance	0 henries
Amplification factor	3.5
25 volts (r.m.s.) impressed on grid of tube	
"n" is the ratio of primary to secondary turns	

It is apparent from these considerations that the power input to the speaker, and consequently the tone quality, can be changed by varying the value of the primary impedance to the turn ratio of the output transformer. To obtain the best results the primary inductance should be made as high as possible and the turn ratio chosen to give the maximum power input with the proper balance between the high and low tones. The resistance of the primary and secondary coils of the transformers should be kept as low as possible to keep the copper losses in the transformer small and the efficiency high. In magnetic speakers it will be found generally that if the ratio is chosen to give the maximum input between 40 and 60 cycles, good tone balance will be obtained. In dynamic speakers the turn ratio should be chosen to give the maximum input at the lowest frequency to be amplified.

The power input to a speaker is also affected to some extent by the leakage inductance and the self-capacitance of the primary and secondary coils. The leakage inductance is due to the fact that it is not physically possible to put two coils in the same place. This causes each coil to have some magnetic lines of flux which do not link with

the turns in the other coil. As a result of this, each coil acts as though it had a small choke in series with it.

The net result is a reduction in power input to the speaker. The reduction in power varies with the frequency and the reduction is, in general, greatest at the higher frequencies. The overall tone quality of a set can be changed by the use of a high leakage transformer. For example, if the speaker has a response curve that rises at the higher frequencies, the use of a high leakage transformer will reduce the high frequency power input more than the low frequency input and the overall response will be more uniform. The leakage reactance will vary directly as the square of the number of turns in the coil, inversely as the length of the leakage path and directly as the width of the leakage path. The width of the leakage path depends on the width of the coils and the gap between the primary and secondary coils. The leakage inductance can be reduced by dividing the primary and secondary coils into a number of sections and interleaving the primary and secondary sections. Fig. 6 shows a primary coil interleaved between two sections of secondary winding.

A capacity effect is obtained whenever two conductors separated by a dielectric have a voltage impressed on them. If the surface area of the conductors is small and the distance between them large, the capacity will be small, although this small capacity may be large enough to become an important factor at high frequencies. In transformer coils a voltage is induced between turns and between layers. The surface of the conductors is small, but the spacing is also small and the self-capacity may be appreciable. The result is equivalent to an infinite number of condensers in series and in parallel. As a first approximation this capacity is usually represented as a small condenser shunted across the coils. In the output transformer the capacity is

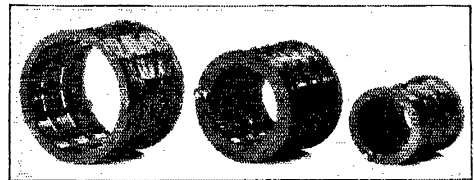

FIG. 5. — TRANSFORMER COIL WINDING DESIGNED FOR MINIMUM DISTRIBUTED OR SELF-CAPACITANCE

Since the dielectric is mostly air, its losses are low.

generally small and increases the power input to the speaker. If the self-capacity is increased to a large value it will eventually act as a short circuit and reduce the power input to the circuit.

Fig. 5 shows the construction of a coil which has been designed to keep the self-capacity low.

The coil is divided into sections and air is used as the principal insulation.

The question is: What limits must be set to the various quantities to arrive at a good commercial transformer? For example, the greater the impedance of the transformer, the greater the resistance and therefore the greater the losses in the transformer. However, the following values have been found to give very satisfactory results:

The primary reactance at the lowest frequency to be transmitted, usually 50 cycles, should be at least twice as large as the plate impedance of the tube. Ideal results will be obtained if the primary impedance is five times as large. The

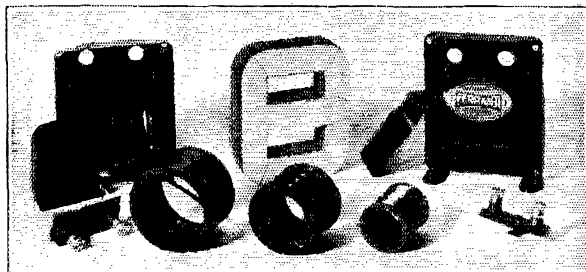

FIG. 6. — TRANSFORMER COILS WITH PRIMARY WINDING INTERLEAVED BETWEEN TWO SECTIONS OF SECONDARY WINDING

*This method of assembly reduces leakage inductance.*

primary resistance of the secondary coil should be not greater than one-fifth of the speaker resistance in a magnetic speaker. For best results with a dynamic speaker the secondary resistance should be less than one-eighth to one-tenth of the speaker resistance. The speaker will, however, operate quite satisfactorily with a secondary resistance one-fifth of the speaker resistance. The leakage reactance of the transformer should be less than one-half of 1% unless the speaker response is to be corrected by the output transformer. The self-capacity of the primary coils should be made as small as possible.

The turn ratio of the transformer should then be calculated by the formulas given in the first part of the paper. Occasionally, because of the response curve of the speaker, the value of "n" for maximum power input is not the value which will give the best overall response curve. This can only be checked experimentally and a transformer with two or three taps in the secondary will be very useful in carrying out the test. In any case, the value of the turn ratio, "n," is not very critical, and it will generally be found that a variation of  $\pm 25\%$  from the correct ratio will not affect the results very materially.

## Accurate Wire Wound Resistors

THE use of B-battery substitutes has been responsible for many very good resistors being made available to the amateur within the past few years, and the description of another wire wound resistor might not seem worthwhile. But when one considers that the recently announced "Super Akra-Ohm" units are wire wound, non-inductive units, may be obtained in stock sizes of from 5000 ohms to 5,000,000 ohms, that the units are constructed to insure insulation to withstand undesirable atmospheric conditions, that they will dissipate 1 watt safely, and finally that they are available to within 1% plus or minus of their specified resistance, it seems that these units would be of interest to the amateur.

The units are constructed in "pics," the wire being wound in opposite directions in alternate pics so the resistor is practically non-inductive. They are provided with 8-32 terminal clips which permit quick experimental set-ups. The units are sufficiently small to be mounted in the usual grid leak mounting. The 6-M resistors are supplied to 1% plus or minus of their specified resistance but more accurate units may be obtained upon special order from the Shallexross Mfg. Co., Collingdale, Pa.

## Strays

While visiting the General Electric Co. plant at Pittsfield, Mass., recently, we got to speculating about radio reception in and near Pittsfield. The high voltage laboratory has a five-million volt transformer together with its proper condensers and spark gaps, and when this equipment gets going —!

The cut label on page 18 of the October issue of *QST* had the designations of the coils  $L_2$  and  $L_3$  transposed. The coils with the greater number of turns should have been marked  $L_3$ .

Lightning struck W9BAN some time ago and rather thoroughly demolished the tubes, transformers, meters, relay, condensers, and welded the key contacts together.

Taylor's saying, "Lightning can't strike my antenna" should be made one of the famous last words.

A copy of 1929 (Volume XIII) *QST* index was sent loosely with a copy of December going to each subscriber. If you didn't get yours, please let us know and we will promptly forward one. Newsstand readers may obtain a copy of this index by sending us 4¢ in stamps.

# Passing the Government Examination for Amateur Operator's License

By Beverly Dudley, Assistant Technical Editor

PART I\*

**S**IMPLE as it is, the examinations given by the Department of Commerce to prospective amateurs are too frequently the downfall of the radio neophyte. It is with the idea of indicating the type of questions asked during the government examination as well as aiding the prospective amateur over his first real difficulty that this article is written.

The examination for an amateur operator's license does not include all of the questions given in this article. Generally the examination consists of but ten simple questions. This discussion of the subject is necessarily more extensive and complete, with enough additional material added to the essential questions to give some background to the minimum required amateur knowledge. The person who can send and receive the signals in the International Morse Code at a speed of ten words per minute (five letters to the word) and can answer the questions in this article should have no fear whatever of the government examination. The answers to the questions asked in the examination may be found in "The Radio Amateur's Handbook" as well as here.

The examination contains questions of two types: questions relative to the radio laws and regulations and those intended to disclose the candidate's technical proficiency. In this installment the first mentioned class of question is discussed by the means of typical questions and answers.

Q. 1. What is an amateur?

A. 1. A radio amateur is an individual interested in the art of radio communication from a strictly personal point of view and without pecuniary interest. In radio regulation the term is applied to those who have licenses and operate their own private transmitting and receiving stations.

Q. 2. Why are amateurs subject to federal regulations?

A. 2. Some regulation of all radio communication is required to prevent chaos. Signals emitted even by very low-power transmitters, are not confined to the State in which the signal is originated, and since interstate communication is outside the jurisdiction of the various States, it naturally comes under federal jurisdiction.

\* In two parts. The second section of this article dealing with technical matters in the amateur examinations will appear in the next issue of QST.

Q. 3. Are amateur stations subject to state or municipal regulations?

A. 3. No, except as the latter may exercise a legitimate police power in safeguarding health, enforcing electrical codes, and abating nuisances.

Q. 4. What are "quiet hours"? Under what conditions are they imposed?

A. 4. Quiet hours, from 8:00 p.m. to 10:30 p.m. local time and on Sundays during the broadcast of local church services, are imposed upon amateur stations which interfere with other radio services. No quiet hours need be observed at amateur stations operating without interference to other radio services.

Q. 5. What is the Washington Convention of 1927?

A. 5. The Washington Convention is an international treaty on radio communication drafted at Washington, D. C., in 1927, which sets forth rules and regulations relative to modern radio communication. It was signed by almost every nation.

Q. 6. Is the Washington Convention binding upon the United States?

A. 6. Yes, the United States ratified the Convention, and in this country it has the power of law.

Q. 7. What is the Federal Radio Commission?

A. 7. The Federal Radio Commission is the regulating and licensing authority on matters dealing with radio communication in the United States. It is composed of five commissioners appointed by the President. Among its duties they: (a) classify radio stations; (b) prescribe the nature and service to be rendered; (c) assign bands of frequencies or wavelengths; (d) determine the power, operating hours and location, of each class of station. It is the Federal Radio Commission which issues station licenses. Operator's licenses, however, are issued by the Department of Commerce.

Q. 8. What are the rules and regulations regarding the secrecy of radiograms?

A. 8. See Section 27 of the Radio Act of 1927. Briefly, the contents or meaning of an addressed message must not be divulged to other than the addressee or his agent, except to an authorized communication channel or upon the demand of a competent court; nor may a message be intercepted and divulged even to the addressee without the authority of the sender; nor may any

person use the information in an addressed message for his own benefit. The law does not apply to information which has been broadcast for public use.

Q. 9. What penalties may be imposed for violation of radio laws and regulations?

A. 9. For violating any provision of the Radio Act of 1927, punishment may be by fine not exceeding \$5000 or imprisonment not exceeding five years, or both. For violating or failing to observe any rule contained in any international treaty ratified by the United States, or made by the licensing authority, the punishment is made by imposing a fine of not more than \$500 for each offense. In addition, an operator who violates any law or regulation, wilfully damages apparatus, transmits superfluous signals or profane or obscene language, or wilfully or maliciously interferes, may have his license suspended for a period not to exceed two years.

Q. 10. What class of radiograms holds precedence over all others?

A. 10. Radiograms relative to distress calls hold precedence over all other classes of radiograms.

Q. 11. What is the law regarding the transmission of fraudulent communications?

A. 11. No one shall knowingly transmit any false or fraudulent signal of distress, or communication relating thereto.

Q. 12. What are the international regulations relative to the maintenance of constant frequency and purity of signals?

A. 12. The waves emitted must be as constant in frequency and as free from harmonics as the state of the art will permit.

Q. 13. Give the meaning of the following signals; SOS, CQ, QRT.

A. 13. SOS is the international distress signal.

CQ is the general call to all stations and has two uses. It may be used as a signal of inquiry when desiring to communicate with any station within range, in which case the signal is terminated with the letter K, or as a preface to broadcasts to which no reply is expected. In the latter case the terminating letter K is omitted. QRT means "stop sending."

Q. 14. What is the law regarding the amount of power to be used to communicate over a given distance?

A. 14. The minimum power required to insure satisfactory communication should be used at all times.

Q. 15. What is the distress signal for radiotelephony?

A. 15. "Mayday," from the French pronunciation of "M'aider" meaning "help me."

Q. 16. What signal denotes the end of a message?

A. 16. - - - - -

Q. 17. What signal denotes the conclusion of communication between two stations?

A. 17. - - - - -

Q. 18. What does the letter K mean at the end of a transmission?

A. 18. It is the invitation to transmit meaning in effect, "go ahead."

Q. 19. What persons may operate amateur stations?

A. 19. Only holders of radio operator's licenses issued by the Department of Commerce are permitted to operate amateur stations.

Q. 20. What are the restrictions placed upon amateur stations regarding the transmission of news, music, lectures, or any form of entertainment?

A. 20. Amateur stations are not authorized to broadcast news, music, lectures, or any form of entertainment.

Q. 21. What are the regulations concerning communication between amateur stations and government or commercial stations?

A. 21. Amateur stations are not permitted to communicate with commercial or government stations unless authorized by the licensing authorities except in emergency or for testing purposes. This restriction does not apply to communication with pleasure craft such as yachts or motor boats which may have difficulty in establishing communication with commercial or government stations.

Q. 22. What frequencies are assigned to amateurs by the International Radiotelegraph Convention which met at Washington, D. C. in 1927?

A. 22. The following frequency bands are made available to amateur stations:

1715 kc. to	2000 kc.
3500 kc. to	4000 kc.
7000 kc. to	7300 kc.
14,000 kc. to	14,400 kc.
28,000 kc. to	30,000 kc.
56,000 kc. to	60,000 kc.
400,000 kc. to	401,000 kc.

Q. 23. What frequencies may the amateur use for radiotelephony?

A. 23. The following frequency bands may be used for amateur radiotelephony:

1715 kc. to	2000 kc.
3500 kc. to	3550 kc.
56,000 kc. to	60,000 kc.

In addition, specially qualified amateurs may obtain permission to operate 'phone transmitters in the band between 14,100 kc. and 14,300 kc.

Q. 24. What frequency bands are assigned exclusively to amateurs?

A. 24. The following frequency bands are assigned exclusively to amateurs by international agreement:

7000 kc. to	7300 kc.
14,000 kc. to	14,400 kc.

Q. 25. What amateur bands are shared, and with whom?

A. 25. The 1715-kc. to 2000-kc. and the 3500-kc. to 4000-kc. bands are internationally assigned as shared between fixed service, mobile service, and amateurs. In the United States these bands are assigned only to amateurs except for limited use of the 3500-kc. band by off-shore Naval aircraft. The 28,000-kc. and the 56,000-kc. bands are available for experimental as well as amateur uses.

Q. 26. What vessels of the United States are obliged by law to carry radio equipment?

A. 26. The following is quoted from the Wireless Ship Act of July 23, 1912: ". . . from and after October 1, 1912, it shall be unlawful for any steamer of the United States or of any foreign country navigating the oceans or the Great Lakes and licensed to carry, or carrying, 50 or more persons, including passengers or crew or both, to leave or attempt to leave any port of the United States unless such steamer shall be equipped with efficient apparatus for radio communication, in good working order, capable of transmitting and receiving messages over a distance of at least 100 miles day or night."

Q. 27. What is the SOS frequency?

A. 27. 500 kc. (600 meters).

Q. 28. What is the priority of various classes of radio communication?

A. 28. (1) Distress calls and communications relating thereto.

(2) Communications preceded by the urgent signal (XXX).

(3) Communications preceded by the safety signal (TTT).

(4) Communications relative to radio-compass bearings.

(5) Government radio telegrams.

(6) Radiotelegrams relating to the navigation, movement, and requirements of ships, the safety and regularity of air-services, and radiotelegrams containing weather observations destined to an official meteorological service.

(7) Service radiotelegrams relative to the operation of the radio service or to the radio telegrams previously exchanged.

(8) Public correspondence radiograms.

Q. 29. What is meant by "superfluous signals?"

A. 29. Superfluous signals are those which are not necessary in carrying out radio correspondence; their use is forbidden.

Q. 30. What are the international regulations relative to the exchange of communications between amateur stations of different countries?

A. 30. Such exchange is forbidden in cases where either country gives notice of its opposition to such communications between amateurs; otherwise it is permitted. Except where interested

governments have made special agreements between themselves however, "the communications must be carried on in plain language and must be limited to messages bearing upon the experiments and to remarks of a private nature."

It is highly desirable that every prospective amateur become familiar with the provisions of the Washington Convention, the Act of 1927 regulating communication in the United States, and the regulations of the Federal Radio Commission and the Radio Division of the Department of Commerce. Much of this information has appeared in *QST* and the "Radio Amateur's Handbook."

## Technical Information Service Rules

Please observe the following rules when writing the Technical Information Service:

1. Before writing, consult the *Radio Amateur's Handbook* and your files of *QST*. Nine times out of ten you will be able to find the answer in *QST* or the Handbook.

2. If reference is made to the *Handbook*, mention the page and the edition to which you refer. If reference is made to *QST*, mention the page and issue you have in mind.

3. Number the questions and make a separate paragraph for each question. Make the questions as brief and as direct as possible.

4. Give as much information concerning the operation of your set as possible so we can at least guess where the trouble might be. Don't simply tell us: "My set won't work — what's the matter with it?"

5. Write on one side of the paper only, and use a typewriter if possible.

6. Make diagrams on separate sheets of paper and fasten them to your letter with a pin or paper clip. All diagrams should be schematic — do not send pictorial diagrams.

7. Print your name and address in full on each sheet of paper. A return address on the envelope is not sufficient, as the envelope is destroyed by the office manager as soon as the letter is opened.

8. Keep an exact copy of your questions and diagrams, and mention that you have done so.

9. Do not ask for opinions on, or comparisons of, business concerns or their products.

10. Enclose postage for the reply but do not send an envelope. It is much more convenient for us to use our own envelopes with our stationery.

11. Address all questions to the Technical Information Service, American Radio Relay League, 1711 Park St., Hartford, Conn.

(Any back copies of *QST* to which we refer you may be obtained from our Circulation Department for twenty-five cents each.)

# A.R.R.L. Election Results

## Some Changes on Our Board of Directors

**A**R.R.L. Directors serve for two-year terms. The terms of half of them expire in odd-numbered years, of the other half in even-numbered years. This fall elections were held in six of our divisions in the United States, and in the Canadian Section, to choose directors for the 1930-1931 term. Some changes now occur in our Board. The results were as follows:

### ELECTED WITHOUT BALLOTING

Our by-laws provide that if there is but one eligible nominee in an election area, he shall be declared elected without balloting by the membership. This was the case in several of the elections.

*Canadian Section.* Mr. A. H. Keith Russell, for many years the Canadian General Manager, reluctantly and to our great regret decided not to stand for reelection to the Board. Two other names were put in nomination, Mr. Alex. Reid, VE2BE, St. Lambert, P. Q., and Mr. Alphy Blais, of Thetford Mines, P. Q. Mr. Blais withdrew his name and Mr. Reid, as the only other nominee, was declared the new Canadian General Manager, taking office January 1st.

Mr. Reid has been a licensed amateur since 1919, the S.C.M. for the Province of Quebec since 1927, and is a past president of the Montreal and District Radio Club. As he was Mr. Russell's own choice as his successor, Canadian amateurs may be sure of his qualifications.

*Atlantic Division.* The incumbent, Prof. E. C. Woodruff, W8CMP, received four nominating petitions, with none filed for anyone else. This certainly makes the Atlantic Division unanimous in its choice, and "Doc" has been declared reelected.

*Dakota Division.* Prof. C. M. Jansky, Jr., for many years the Dakota director, has recently removed from that division and made himself ineligible for reelection. But one name was placed in nomination, that of Mr. Cy. L. Barker, W9EGU, of Henning, Minn., who therefore now succeeds Prof. Jansky. Mr. Barker is an old-time amateur who is well-known on the air, an O.R.S., and the former S.C.M. for Northern Minnesota.

*Delta Division.* In this election the only nominating petition received before the legal closing hour established by our by-laws was for Mr. M. M. Hill, W5EB, of Oakdale, La. Petitions were also received for the incumbent, Mr. Benjamin F. Painter of Chattanooga, for Mr. Bradford Hearn of Shreveport, and for Mr. R. B. Somerville, of Selma, Ala., but they all arrived after the closing hour and could not be considered. Mr.

Hill therefore succeeds Mr. Painter, effective the first of the year. He is the head of the science department in the Oakdale High School and for some time past has been the A.R.R.L. S.C.M. for Louisiana.

### RESULTS OF BALLOTING

In the other three divisions in which elections occurred there was more than one candidate, so that the choice was made by balloting by the membership of the division. The results:

*Midwest Division.* In this division Mr. Louis R. Huber, W9DOA of Iowa City, Iowa, won over Mr. John H. Amis, W9CET of Topeka, Kans., by 340 votes to 113. Thus Mr. Huber succeeds Mr. Porter H. Quinby, long-time Midwest director, who felt obliged by business pressure to retire from our Board.

Mr. Huber, a student at the University of Iowa, has been very active in A.R.R.L. affairs in recent years. An O.R.S., he was S.C.M. for Iowa in 1926 and did valiant A.R.R.L. work in the days of the "Inkslingers" but is probably best known for the year which he recently spent at the Hartford headquarters as Assistant to the Communications Manager.

*Pacific Division.* In this division it would appear that Mr. Allen H. Babcock, W6ZD, of Berkeley will be returned over his two opponents, Dr. J. E. Waters, W6EC, of Anaheim, Calif., and Mr. M. E. McCreery, W6LJ, Los Angeles. The count at the end of the official voting period being 470 for Mr. Babcock, 188 for Dr. Waters, and 58 for Mr. McCreery. The Executive Committee of the League, however, in view of a protest from Philippine members that they have not had time to cast their votes due to the distances involved, has declared that the Pacific elections will be regarded as incomplete pending receipt of Hawaiian votes up to noon of December 15, 1929, and of Philippine votes up to noon of February 15, 1930, at which time the final count will be made.

*Southeastern Division.* In this division also there were three candidates: the incumbent, Mr. Harry F. Dobbs, W4ZA of Atlanta; Mr. Forrest W. Dana, W4AGR of West Palm Beach, Florida, and Mr. Charles W. Davis, W4PM, Atlanta. The count: Mr. Dobbs, 73; Mr. Dana, 49; Mr. Davis, 41. Thus Mr. Dobbs, who has represented the Southeastern Division on the A.R.R.L. Board for the past six years, is now returned for an additional two years.

QST welcomes the new directors and hopes soon to be able to present more interesting sketches

(Continued on page 90)



# Plate Supply Filters and Keying

By J. C. Coe\*

**T**HERE are a number of factors effecting the stability of the signal emitted from a single tube short-wave transmitter operating from the standard 110-volt, 60-cycle power supply. A filter system may look fine on paper, and surely capable of delivering practically pure d.c., but just try keying it once. No matter how carefully the oscillator may be constructed and adjusted the signal may sound "chirpy," or the dashes may have long "tails" if the filter is not right. High voltage surges may cause the tank condenser shunting the plate coil to break down when the key is closed or opened — or both. At least they may cause bad key clicks. The method of keying and the filter used are of great importance, and are interlocked. The manner in which a given set of chokes and condensers is arranged effects not only the note as far as smoothing action is concerned, but also its steadiness, and to a large extent the value of the rectified voltage available to the plate. It is the writer's conviction that in the filter lies the root of much evil.

Different types of oscillator circuits were used so the following remarks are intended to be general, applying to any oscillator circuit, and the conclusions reached are the result of considerable experimenting, the results of which were incorporated in two types of transmitters built by the Signal Corps, the 8-TR-3, using one or two 50-watt tubes in parallel, and the 8-TR-4 using a single 250-watt tube. The wavelengths covered are from 32 to 75 meters, depending upon the coils used. No attempt was made to obtain a "pure" d.c. note, but one steady and sufficiently smooth for the purpose was the result. Government business has been handled over a number of each type of set for a considerable period of time, and each has required but very little attention.

In each case two UX-866 rectifier tubes were used. Although the inverse peak plate voltage in the 8-TR-4 is a little more than the 5000 volts specified, tube life has been excellent. Fig. 1 shows the filter adopted, and this, in the opinion of the writer, is the minimum upon which the amateur should build. Another section might well be added. For the 50-watt tubes,  $C_1$  was 2  $\mu$ fd. and  $C_2$  .6  $\mu$ fd. For the 250-watt tube,  $C_1$  was .5  $\mu$ fd. and  $C_2$  .5  $\mu$ fd. with a 30-henry choke between in each case. The reason for the different values of capacity will be covered in the latter paragraphs of this article. Both types of sets were

wired to be keyed in the primary of the power transformer.

## KEYING

Keying in the grid was found to be least desirable especially with the 250-watt tubes, because of the high surge potentials appearing across the tank condenser. If the plate supply is 2000 volts pure d.c. and the grid potential is 350 volts below the filament during oscillation, with the key up this value of grid bias will be

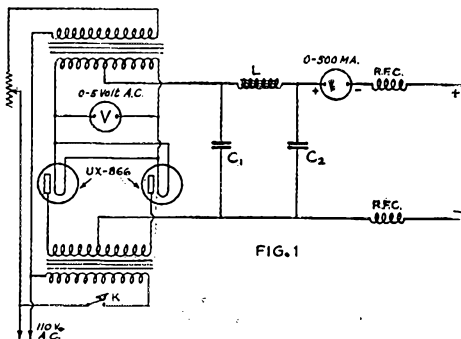

FIG. 1

come much greater, thereby blocking oscillations. In other words, the grid potential is 2350 volts below that of the plate while oscillations are taking place, but when the tube is inoperative this necessarily becomes a much higher value. In fact, the grid may assume such a high negative potential that some conduction manages to take place by leakage, thereby momentarily reducing the grid potential. This is accompanied by a slight rise in plate current. This process repeats itself. In some instances the plate current rises and falls so slowly that the pulsations may be counted, and again they may occur as frequently as 100 times per second. In any event this is the cause of considerable noise, because the plate current each time reaches a sufficiently high value for oscillations of a sort to take place. A resistance placed across the key is the only means of preventing this, but then a weak signal is sent out continuously, which is not desirable. The above mentioned fluctuations in plate current with the key up cannot occur with the key in the center tap, as in Fig. 2, because both plate and grid circuits are broken.

## SURGES

With grid or center tap keying, the full plate voltage is always upon the plate of the tube. In

\* Assistant Radio Engineer, Signal Corps, Box 151, Fort Sam Houston, Texas.

fact when the key is opened this voltage may increase considerably. With keying, the plate voltage is shifted from one high value to a higher value. Each filter condenser must discharge to just the extent by which its voltage is lowered when the key is depressed, and must assume an additional charge as the voltage builds up when the key is opened. If the voltage across a 1- $\mu$ fd. condenser varies between 2000 and 1800, then .02 joules must be released or taken on when the voltage drops or rises again. The figure, .02, is obtained by the formula:

$$W = \frac{C(E_1 - E_2)^2}{2}$$

$$\text{or } W = \frac{(.000001)(2000 - 1800)^2}{2} = .02$$

Where  $W$  = energy in joules.  
 $C$  = capacity in farads.  
 $E_1$  = higher voltage.  
 $E_2$  = lower voltage.

This may not appear to be much energy, but it is equal to the total energy stored in an inductance of 10 henries carrying 63 milliamperes as may be seen from the formula:

$$W = \frac{L(I)^2}{2} \text{ or } W = \frac{10(.063)^2}{2} = .02$$

Where  $W$  = energy in joules.  
 $L$  = inductance in henries.  
 $I$  = current in amperes.

In like manner the current in the inductance must change, and energy transfers take place on each make and break, each causing a considerable

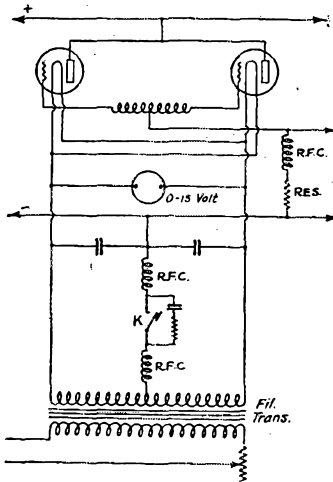

FIG. 2

shock to the system. Thump filters are of considerable use in reducing these effects.

Keying in the primary of the transformer supplying the plate power subjects the system less to surges because the voltage on the output side of

the filter rises gradually, comparatively speaking, since the current must build up in the transformer windings, and the inductance of the windings retards the rate of increase. Much of this initial inflow of energy is used to charge the various condensers of the system, and as they become charged there is a greater proportion available to the tube, all of which tends to give a more gradual rise in oscillations than in the methods previously discussed.

On the instant of breaking the primary circuit all the energy stored in the filter units must be dissipated. Since the rectifier tubes will not pass inverse currents unless subjected to enormous potentials, the stored energy must spend itself otherwise, as in driving plate current through the tube. If  $C_1$  and  $C_2$ , Fig. 1, are each 2  $\mu$ fd. and a 12-henry choke is used, there will be a total of 8 joules stored in the condensers at 2000 volts, and only .24 joules will be stored in the choke coil at 200 mils. The result is that current will flow in the plate circuit for a considerable period of time after the contacts have opened, and current has ceased to flow in the transformer windings. The signal will be decidedly chirpy, and the dashes will have long tails. Even with  $C_2$  reduced to .5  $\mu$ fd. there is some fluctuation noticeable at 2000 volts, but at 1000 volts the note is steady. The reason is that at 1000 volts a given condenser can store only one-fourth as much energy as at 2000 volts. A .5- $\mu$ fd. condenser will store just as much energy at 2000 volts as a 2- $\mu$ fd. condenser at 1000 volts. The use of a resistance across the high voltage in order to absorb surplus energy was not found practicable as it must consume altogether too much current to be of any help, and it is objectionable because of the drop this additional current causes in the series choke coil. A larger choke coil was found desirable since its energy storage is more nearly comparable to that stored in the condensers. Furthermore, if  $C_1$  is too large the rectifier tubes may be overloaded.<sup>1</sup> A d.c. milliammeter placed in the plate circuit of a rectifier tube will indicate the average current over the entire cycle, so this must be considered in determining the peak value during the conducting period.

#### FILTER REGULATION

In many filters the variation in voltage across the plate from no load to full load (when keying in the grid or in the center tap) is very large. Regardless of the method of keying used, an improper arrangement of filter units results in a rather low d.c. voltage available to the tube. Many times this is blamed on the ohmic resistance of the choke coils; it is often only a minor cause.

(Continued on page 74)

<sup>1</sup> This is particularly important in connection with the use of mercury-vapor type rectifier tubes since the initial surge into a large filter condenser connected across the rectifier output may cause the peak current rating of the tubes to be exceeded.

# Official Frequency System

**T**HE Official Frequency Station Committee, a part of the Experimenters' Section of the A.R.R.L., has arranged the services described below for the benefit of the members of the League and others who may wish to use them.

1. Standard Frequency Transmissions are sent by the Standard Frequency Stations (known as O.F.S.-S.F.) on definite schedules with a high degree of accuracy. All the principal amateur bands are covered, several points being given in each so that frequency meters may be accurately calibrated. These transmissions are based on piezo-electric frequency standards that are regularly checked by one or more of the leading scientific laboratories of the country.

2. Official Frequency Transmissions are sent by Official Frequency Stations (known as O.F.S.) at a somewhat lesser degree of accuracy. These stations do not transmit on regular schedules but announce their frequency at the end of at least every other transmission during their regular amateur operation. Such stations will measure the frequency of your transmission upon request.

Practical suggestions are always welcome and should be sent to the proper member of the Committee which is composed of the following: Don C. Wallace, W6AM, Chairman in charge of O.F.S., Room 410, 209 Pine Ave., Long Beach, Calif.; Prof. C. M. Jansky, Jr., care of University of Minnesota, Minneapolis, Minn.; and Killian V. R. Lansingh, W6QX, in charge of O.F.S.-S.F., Box 666, Hollywood, Calif.

## STANDARD FREQUENCY SCHEDULES

Time (p.m.)	Friday Evening Schedules			Friday and Sunday Afternoon Schedules			
	Frequency, kc. A	B	AB	Time (p.m.)	Frequency, kc. BB	C	CD
8:00	3500	7000	7000	4:00	7000	14,000	28,000
8:12	3550	7100	7100	4:12	7100	14,100	28,000
8:24	3600	7200	7200	4:24	7200	14,200	30,000
8:36	3700	7300	7300	4:36	7300	14,300	14,000
8:48	3800	.....	3500	4:48	.....	14,400	14,200
9:00	3900	.....	3650	5:00	.....	.....	14,400
9:12	4000	.....	3850				
9:24	.....	.....	4000				

The time is the local standard time at the transmitting station. 8:00 P.M. at W1XV-W1AXV is 0100 G.C.T. and 8:00 P.M. at W9XL-W9WI is 0200 G.C.T. Similarly, 4:00 P.M. at W1XV-W1AXV is 2100 G.C.T. and 4:00 P.M. at W9XL-W9WI is 2200 G.C.T. Due to the new regulations of the Federal Radio Commission concerning experimental licensed stations, the Standard Frequency Stations will in all probability use the amateur calls W1AXV and W9WI for these schedules.

## DATES OF TRANSMISSION

Date	Schedule	Station
Dec. 6, Friday	A	W1AXV
" 8, Sunday	CD	W9WI
" 13, Friday	BB	W1AXV
" 13, Friday	AB	W9WI
" 20, Friday	B	W1AXV
" 27, Friday	AB	W9WI
" 29, Sunday	C	W1AXV
Jan. 3, Friday	A	W1AXV (W1XV)
" 5, Sunday	CD	W9WI (W9XL)
" 10, Friday	BB	W1AXV
" 10, Friday	AB	W9WI
" 17, Friday	B	W1AXV
" 24, Friday	AB	W9WI
" 26, Sunday	C	W1AXV
" 31, Friday	A	W1AXV
Feb. 2, Sunday	CD	W9WI
" 7, Friday	BB	W1AXV
" 7, Friday	AB	W9WI
" 14, Friday	B	W1AXV
" 21, Friday	AB	W9WI
" 23, Sunday	C	W1AXV

Schedule "BB" sent at 2100 G.C.T. on one Friday of each month is transmitted at that hour for the particular benefit of European stations. If sufficient reports on its reception are not received, it will be discontinued.

## THE STATIONS

W1XV-W1AXV: Massachusetts Institute of Technology, Communications Department Experiment Station, Round Hill, Dartmouth, Mass., H. A. Chinn in charge. Uses Eastern Standard Time and characteristic letter "G."

W9XL-W9WI: Gold Medal Station, R. F. D. No. 3, Anoka, Minn., H. S. McCartney in charge, assisted by Lyall K. Smith, Ivan H. Anderson and George Collier. Uses Central Standard Time and characteristic letter "D."

## DIVISION OF TIME

A total of 12 minutes is allotted to each transmission divided as follows:

- 4 minutes — QST QST QST de (call letters).
- 3 minutes — Characteristic letter ("G" or "D") sent very slowly and broken by call letters each half minute.

1 minute — Statement of frequency in kilocycles to nearest integral figure.

4 minutes — Time allowed to change to next frequency.

## ACCURACY

The transmissions of both stations will be within 1/10 of 1% of the frequencies herein announced, which is considerably better than the accuracy to which the average good amateur frequency meter can be calibrated and main-

(Continued on page 76)

## W9BAG

*Although the Station Description Contest is over, and the results of the contest are reported elsewhere in this issue, QST will continue to publish descriptions of modern amateur stations as the proper material and space permit. A great number of station descriptions was received the last few days of the contest and some of these will appear in early issues of QST. — EDITOR.*

**T**HE station of Frank Smolek, W9BAG, of 4452 S. Troy St., Chicago, like many other stations, started back in the dark ages when synchronous spark gaps and "audions" were the latest word in station equipment. But we aren't so much interested in the past as we are in the present and future, and while

### THE TRANSMITTER

Before attempting the construction of the completed panel assembly shown in the general view of the station, the equipment was gradually built up from a low power outfit to its present size in "bread board" fashion. This was done to make absolutely certain that results would be

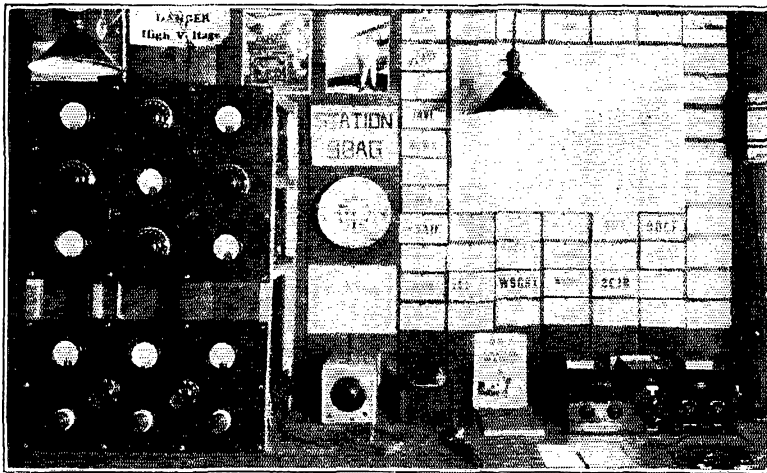

GENERAL VIEW OF W9BAG

*The transmitter may be seen at the left, the monitor under the clock, the absorption type frequency meter behind the microphone and the superheterodyne receiver at the right.*

practically every type of equipment has been used in the changes which developed from year to year we shall eliminate the intermediate steps and plunge into the description of the present W9BAG.

The photographs indicate at once that the station is neatly arranged and suitable for either traffic handling or experimental work. The general view of the station does not indicate the technical advances that are made in the station, but these may be observed from the schematic wiring diagrams. The station is a modern one in all respects. It is crystal controlled, uses the improved or "100 per cent" Heising system of modulation for radio telephony, has both an absorption type frequency meter and a heterodyne monitor available for checking the quality of emitted signals and, finally, has a mighty effective receiver to complete the station equipment.

gratifying when the final transmitter was assembled.

Every item within the transmitter has been arranged to give not only the essential technical details for 1929 operation, but to provide neatness of apparatus as well. W9BAG is entirely crystal controlled, not only to have an absolutely steady signal but also to construct a transmitter which would operate satisfactorily in the 'phone band. It was believed that a transmitter constructed to give the essentials for a real 'phone signal such as a d.c. plate supply, good frequency control and high percentage of modulation, would work very well when used for telegraphy in the respective c.w. bands.

The transmitter uses a completely shielded 210 crystal oscillator. The tuning of the oscillator is controlled by the lowest center dial on the upper panel as may be seen in the photograph. Plate current is indicated by the millimeter

directly to the left of this control. A neutralized 210 buffer stage operated as a Class B<sup>1</sup> amplifier acts not only as a radio frequency amplifier, but also affords exceptionally good frequency control

the 'phone band a crystal with the frequency of 3521 kc. is used. Operation throughout is on the fundamental. For 7000-kc. operation a 3560-kc. crystal is used in the oscillator and the buffer

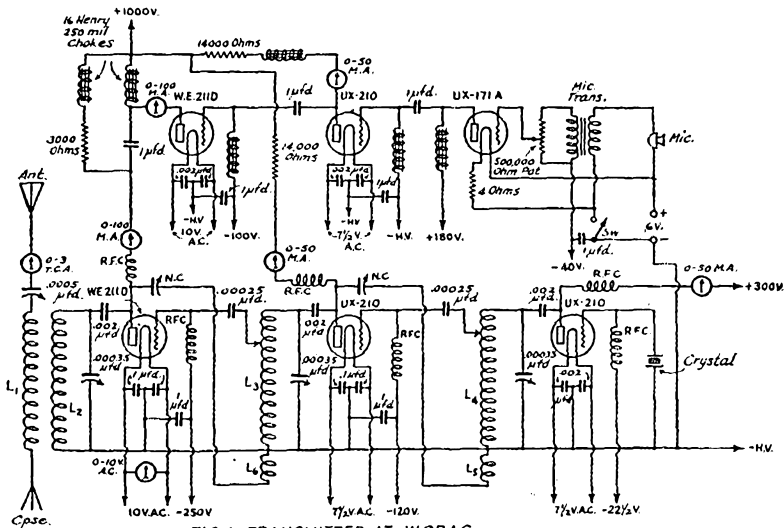

FIG. 1. TRANSMITTER AT W9BAG.

when the 50-watt final amplifier is being modulated for radio telephony. The 210 buffer stage feeds the 50-watt Western Electric final amplifier.

acts as a frequency doubler. For 14,000-kc. operation the final amplifier is again doubled. For 'phone work a Federal hand microphone

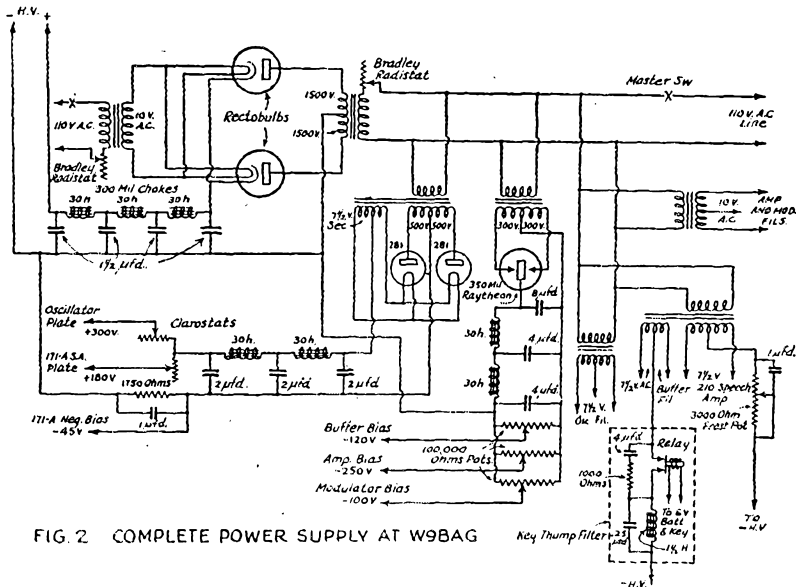

FIG. 2. COMPLETE POWER SUPPLY AT W9BAG

This stage is neutralized and operates as a Class C amplifier. The 50-watt amplifier in turn feeds the antenna and counterpoise. For operation in

is used in conjunction with a Silver-Marshall microphone transformer. This actuates a 171-A first stage amplifier. The 171-A feeds the 210 intermediate speech amplifier which in turn feeds the 50-watt modulator. The Western Electric

<sup>1</sup> See "Vacuum tube Amplifier Definitions" by Dart and Atwater, page 29, September, 1929, QST.

50-watt tube modulates the final amplifier. A high percentage of modulation is obtained by using both the double choke and a voltage dropping resistor which allows the power ampli-

microphone transformer input and grid bias on the second speech amplifier stage.

The lower panel contains the line voltage meter, a 2000-volt d.c. voltmeter and a 0-15-volt

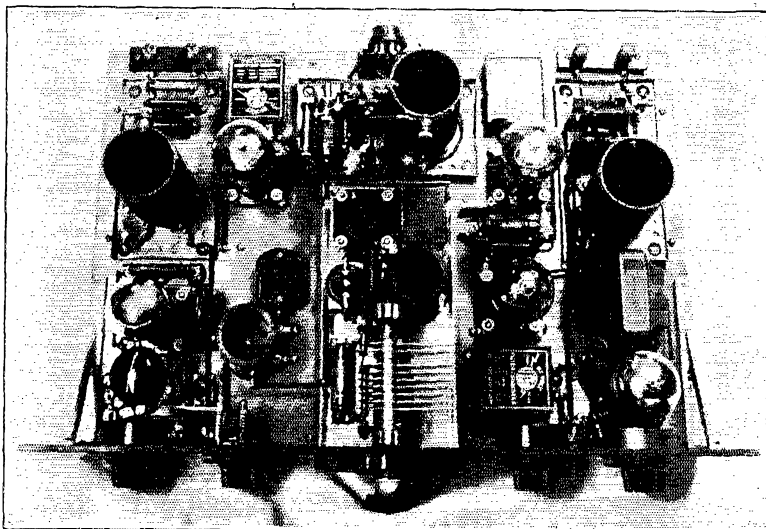

REAR VIEW OF RECEIVER

*The receiver used at W9BAG is a copy of the superheterodyne receiver described in the March, 1929, issue of QST. Need more be said?*

fier to operate at a lower voltage than the modulator.

A novel feature is incorporated in the audio system of the speech amplifier in that the cores of the impedance transformers were especially constructed. A high impedance choke coil with an ordinary iron core was rebuilt by removing the original laminations and substituting "Armco" iron. To match the impedance of the various circuits, it was necessary to interlace the laminations of the plate chokes and to butt the cores of the grid chokes. This system of amplification was found to give excellent reproduction. Voice signals were reported as being undistorted and perfectly modulated a report which was substantiated by a check with the monitor.

The meter located in the center of the upper panel indicates buffer plate current. The dial directly to its left controls the frequency of the buffer stage. The meter at the upper left indicates plate current of the final amplifier. The center top tuning controls adjusts a double-spaced National condenser which controls the frequency of the final amplifier stage. The meter at the upper right hand corner shows antenna current which is adjusted by the condenser control directly below it. The two small knobs off the center and to the right are neutralizing condensers between the oscillator and buffer and between the buffer and final amplifier. The two small controls at the right of the center regulate

a.c. meter which measures filament voltage on the 50-watt tubes. Two Bradley Radiostats located in the center, regulate filament voltage on the 50 watters and control the primary of the plate voltage transformer. The switches at the bottom control the line input, the modulator and speech amplifier (which are turned off for c.w. operation) and the filament supply of the Rectobulbs which naturally are heated before plate voltage is applied. The upper shelf contains all the audio and high frequency parts of the transmitter, such as shielded crystal oscillator, modulator chokes, buffer stage, neutralizing condensers, final amplifier inductance, final amplifier tuning condenser, antenna tuning condenser, impedance chokes, crystal oscillator bias battery and the various plate resistors.

A careful study was given to the matter of frequency change when the station was being designed. As a result, a system was incorporated which allows operation in practically every band. The oscillator coil is interchangeable. The 3500-kc. coil is made of 12 turns, while the 7000-kc. coil consists of 7 turns. The buffer and final amplifier inductance are the REL type for 3500-kc. and 7000-kc. work. For 14,000-kc. operation the 3500-kc. coil is used in the oscillator, a 7000-kc. REL inductance in the buffer and a 4-turn home made coil in the final amplifier. For 7000-kc. operation it was found necessary to neutralize the final amplifier and buffer stage.

However, for 14,000-kc. operation, neutralizing was not required. The fact that grid leads of the r.f. stage were made extremely short, enabled the circuit to be neutralized very easily and no trouble was experienced in this respect.

#### CHECKING THE SIGNAL

Inasmuch as crystal control is used at W9BAG at all times, variation of frequency was practically eliminated. Nevertheless a home made monitor

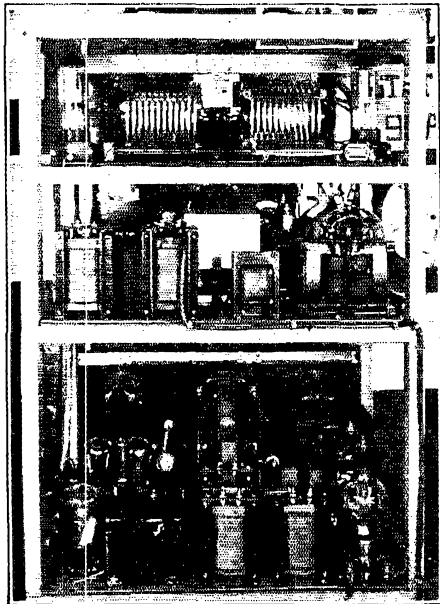

REAR VIEW OF THE TRANSMITTER

The several rectifier and filter systems may be seen in the bottom section. The middle shelf contains the crystal oscillator, intermediate amplifier, speech amplifier, filament transformers and voice chokes. The top shelf contains the final 50 watt amplifier, 50 watt modulator and amplifier and antenna tuning equipment.

is used to check the note of the transmitter and also to check the quality of modulation when 'phone is used. The monitor is identically the same as described in a recent issue of *QST*, with the exception of the tickler coil which is adjustable, thereby controlling regeneration so that oscillation may be stopped when checking the 'phone. The use of a regeneration control on monitors is well worth while but does not seem to be appreciated by the average amateur. A true idea of what the emitted signal sounds like can only be obtained when the monitor is barely oscillating; a persistent oscillator is of little use.

An absorption type frequency meter is used to check the frequency when the transmitter is changed to operate in the various bands. The monitor and frequency meter may be seen on the table in the center of the photograph of the station.

#### THE POWER SUPPLY

The bottom shelf of the transmitter contains the 2000-volt power supply, a separate 500-volt power supply and a 400-volt "C" bias power pack. The main power supply consists of a ten-volt filament transformer, two Rectobulbs in a full wave rectifier and a Thordarson center tapped plate transformer having 1500 volts on each side. The filter consists of three 2000-volt, 2- $\mu$ f. fixed condensers and three 30-henry filter chokes. The 500-volt supply is composed of two 281's in a full wave rectifier with the usual 500-volt power transformer and filter. The "C" bias supply is composed of a high voltage transformer, a condenser bank of 20  $\mu$ fds. and a Raytheon tube for rectification. "C" bias variation is secured by the movable arm of a 100,000-ohm potentiometer directly across the output. Three potentiometers are used. They supply "C" bias for the buffer stage, the final amplifier, and the modulator tubes. "C" bias on the intermediate speech amplifier is obtained by the use of a dropping resistor through the negative filament return. Bias on the 171 is obtained through a section of the voltage divider on the 500-volt supply. The 500-volt unit delivers plate voltage to the 171 speech amplifier and the oscillator tubes. Voltage for the intermediate amplifier and buffer is obtained through dropping resistors from the main power supply. All checks made over the air and on the receiving end, indicate each power supply to give perfectly smooth d.c. with exceptionally good regulation.

Many systems of keying were tried at W9BAG without a great deal of success. When using c.w., key-thumps appeared which bothered the neighbors badly no matter what frequency was used, or else the household broadcast receiver was completely blocked. All methods were discarded as being unsatisfactory until the one illustrated in Fig. 2 was constructed. This proved to be very excellent inasmuch as a broadcast receiver was not affected in the least when operated ten feet away from the transmitter. Naturally the neighbors ceased to complain. The key thump filter consists of a 1000-ohm resistor in series with a 4- $\mu$ f. condenser directly across the contact of the keying relay, and a series inductance of 1  $\frac{1}{2}$  henrys shunted by a  $\frac{1}{4}$ - $\mu$ f. condenser between the relay and the return to ground.

#### THE ANTENNA

After several years of experimenting with every known type of antenna, including the current- and voltage-feed systems, it was finally decided to use an antenna and counterpoise for 3500-kc. operation. A 2-inch cage is suspended 45 feet above the ground between two steel masts. The antenna is one continuous cage direct to the lead-in insulator. Aerial and counterpoise are each 70 feet in length which allows operation on the fundamental frequency.

For 7000-ke. operation a single wire voltage fed system is used, the feeder being connected directly to the amplifier plate inductance. Operating the antenna at double frequency enables the 14,000-ke. band to be used for communication.

#### THE RECEIVER

Many short-wave receivers have been built and rebuilt since the introduction of high frequency

any greater than that found in the usual receiver. With only a 112-A detector and 171-A first audio amplifier, volume is unusually good. The results produced by this receiver more than warranted the original cost.

Batteries for the operation of the set are located under the operating table. A Tungar bulb charges the "A" battery as well as the Edison "B" batteries.

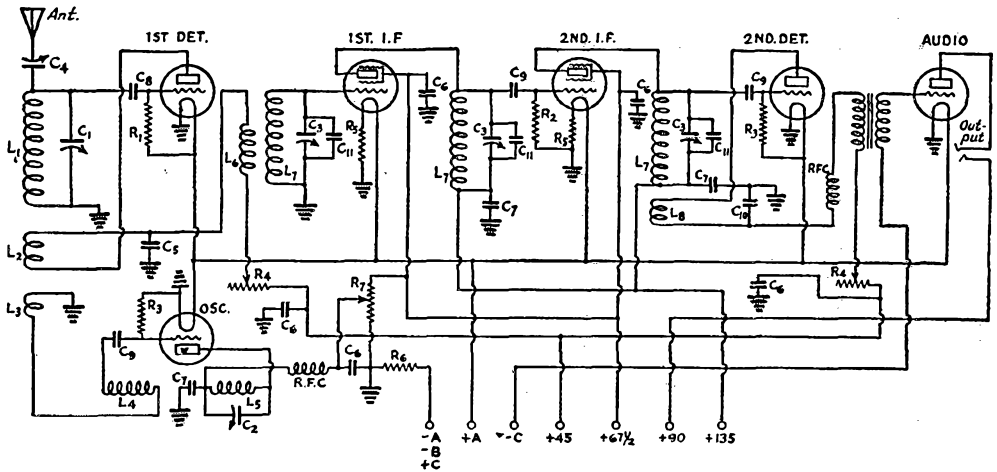

FIG. 3. — THE RECEIVER USED AT W9BAG

- C<sub>1</sub> — 13-plate midget condenser.
- C<sub>2</sub> — 27-plate National divided stator.
- C<sub>3</sub> — 23-plate midget condenser.
- C<sub>4</sub> — 5-plate midget condenser.
- C<sub>5</sub> — 250- $\mu$ fd. fixed condenser.
- C<sub>6</sub> — 1- $\mu$ d. by-pass condenser.
- C<sub>7</sub> — 25- $\mu$ fd. by-pass condenser.
- C<sub>8</sub> — 250- $\mu$ fd. grid condenser.
- C<sub>9</sub> — 500- $\mu$ fd. fixed condenser.

First detector, oscillator and intermediate coils are constructed identically the same as listed in the March issue of QST.

- C<sub>10</sub> — 4,000- $\mu$ fd. fixed condenser.
- C<sub>11</sub> — 100- $\mu$ fd. fixed tuning condenser.
- R<sub>1</sub> — 4-megohm gridleak.
- R<sub>2</sub> — 6-megohm gridleak.
- R<sub>3</sub> — 2-megohm gridleak.
- R<sub>4</sub> — 50,000 ohm variable resistor.
- R<sub>5</sub> — 15-ohm fixed resistor.
- R<sub>6</sub> — 2-ohm rheostat.
- R<sub>7</sub> — 100,000-ohm volume control.

reception, but all of them were more or less unsatisfactory. When the March issue of QST appeared, it was decided to build the superheterodyne receiver described in that issue. The photograph indicates a receiver almost identical with the one shown in that issue. Fig. 3 shows the circuit.

The results obtained with this receiver have been so exceptional that it was not deemed necessary to make the additions or improvements suggested in later issues of QST. The oscillator and first detector coils are constructed from the data given on page 18 of the March issue; therefore they need not be described here.

On a 10-foot aerial, DX 'phone and c.w. signals can be copied anywhere in the room on the loud speaker. The volume is at least five to ten times that obtained with the ordinary short-wave screen-grid receiver, but the amazing factor is that the noise level at that signal volume is not

A modulometer is in the process of construction so that the percentage of modulation can be accurately determined. This equipment is being built so that the operation of the 'phone transmitter may be as accurately determined as the operation of the c.w. portion of the set, and to be in keeping with the recent changes and advances which have been made in the station. At the present time experimental work is nearly completed and the station is ready for traffic and rag chewing. These activities have not been greatly indulged in during the summer as most of the time was spent in getting the station into shape for the winter evenings. Every item within the transmitter and power supply has been constructed so that each part operates at about 50 per cent of its maximum rating, thus allowing a safety factor which gives consistent performance at a minimum upkeep.



# Experimenters' Section

## AN A.C. RECEIVER

**T**HE prime reason for recommending the use of the UY-224 and UY-227 tubes in high frequency receivers as was done in the Experimenters' Section of the October and December issues of *QST* was because of their high gain and freedom from microphonic noises. Moreover, it was suspected that the indirectly heated tubes could be operated with an alternating current heater supply with more or less success as was hinted in this department last month.

The fact that high-frequency receivers operated entirely from the 110-volt, 60-cycle light socket are practicable and practical is substantiated in "A.C. High-Frequency Receivers" in this issue. But we

with its operation that I would like to pass the idea on to the rest of the fellows.

"The set is the most gratifying I have ever operated and has plenty of volume. High-frequency 'phones are received on a loud speaker with only two tubes. Moreover, the set is cheap to construct and not difficult to get operating properly. The circuit is shown in Fig. 1.

"I have been using this receiver for more than a month now and can hear VE stations (telegraph) about 9 p.m., QSA4 while the sixth district stations come in with good volume at 7:30 p.m. Ordinarily it is 10 p.m. before the G's come in on the 7000-kc. band.

"The circuit can be made still better by adding a stage of tuned radio frequency amplification using a UY-224 and another screen grid tube in the audio amplifier. The regeneration is very easy to control and no hum can be observed when using the headset."

The circuit of Fig. 1 shows a variable resistor in the screen grid circuit for controlling regeneration as well as a throttle condenser regeneration control. It is doubtful if both of these controls are required although in a particular receiver both may be useful. The negative side of the "B" battery is not shown grounded in Mr. Grogan's receiver but it might be advantageous to connect the rotor of the tuning condenser, the cathodes, and the negative side of the plate battery to ground to reduce body capacity effects and to reduce the possibility of hum which might be present with some tubes.

The use of a UY-224 detector tube provides an excellent means of obtaining "peaked" audio amplification by substituting a tuned circuit in place of the resistor in the plate circuit of the detector tube.

### A NOVEL CRYSTAL MOUNTING

The method of mounting a quartz plate for crystal controlled transmitters is sometimes a source of difficulty to the amateur. Good crystal mountings are expensive and the average amateur does not always have the mechanical facilities with which to construct a crystal holder of the design he would like. An unusually interesting crystal holder, which should not cost the average amateur anything to speak of is suggested by F. W. Phillips, W1CRH. It is made of parts which are, no doubt, available from the junk boxes of most amateurs.

Fig. 2 shows the W1CRH crystal holder. It is constructed from a watch case headset, and the method of construction is obvious from a glance at the figure. The metal watch case shells are easier to use if electrical connection is made from the lower brass plate to the binding post at the

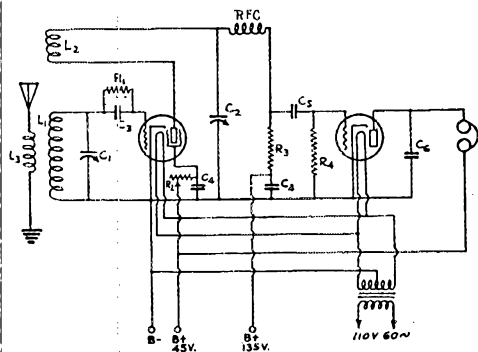

FIG. 1. A HIGH-FREQUENCY RECEIVER WITH A.C. FILAMENT SUPPLY

- L<sub>1</sub> — 33 turns on 1 1/2-inch tube for 3500-kc.  
15 turns on 1 1/2-inch tube for 7000-kc.  
5 turns on 1 1/2-inch tube for 14,000-kc.
- L<sub>2</sub> — 10 turns on 1 1/2-inch tube for 3500-kc.  
6 turns on 1 1/2-inch tube for 7000-kc.  
5 turns on 1 1/2-inch tube for 14,000-kc.
- L<sub>3</sub> — Antenna coupling coil.
- C<sub>1</sub> — 50-μfd. Midget tuning condenser.
- C<sub>2</sub> — 100-μfd. midget regeneration condenser.
- C<sub>3</sub> — 100-μfd. grid condenser.
- C<sub>4</sub> — 0.5-μfd. by-pass condenser.
- C<sub>5</sub> — 6,000-μfd. 250-volt fixed condenser.
- C<sub>6</sub> — 2,000 μfd.
- R<sub>1</sub> — 2-megohm grid leak.
- R<sub>2</sub> — 100,000-ohm regeneration control.
- R<sub>3</sub> — 30,000 ohms. (A resistor of 100,000 ohms to 200,000 ohms, with plate voltage of 180 will probably work out much better. — Editor.)
- R<sub>4</sub> — 1- to 5-megohm grid leak.
- T — 2.5-volt center tapped filament transformer.

have further evidence of the success of high-frequency receivers which have their heaters operated from alternating current from W. F. Grogan, of Fort Myers, Fla., who writes:

"I am enclosing a diagram of a new high-frequency set which I have built. I am so pleased

side of the shell. The crystal holder is dustproof and by properly fitting the spring connection to the top brass plate the pressure may be varied, if

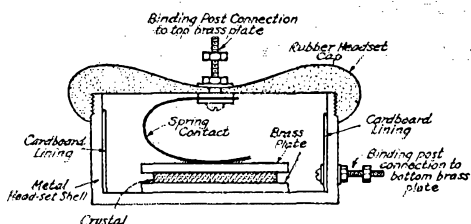

FIG 2

so desired, by tightening the cap on the headset shell. The only care that need be exercised with this type of crystal holder is to make sure that the surfaces of the brass plates which come in contact with the crystal are perfectly flat.

While speaking of crystal holders we might mention that John Reinartz has about the "Scotchest" crystal holder we've ever laid our eyes on. Readers of *QST* are aware of the fact that John never does things the way another amateur would tackle a job.

The Reinartz crystal mounting consists of two brass plates with their faces ground flat. The crystal is inserted between the two ground faces and the entire assembly is held together with a rubber band. A flexible wire soldered to each brass piece which is used to make contact with the remainder of the circuit completes the crystal mounting. This is certainly the simplest crystal mounting we have run across in a long time and as far as economy of apparatus is concerned can't be improved much.

#### A NOTE ON HIGH FREQUENCY ANTENNAS

Information on antennas for high frequency operation has appeared so frequently in *QST* that it always seems that there is little left to say on the subject. Antenna-counterpoise systems, single- and two-wire fed antennas and various hybrid types of radiating systems have been sufficiently described in this and other journals for any amateur to construct a satisfactory antenna in almost any type of location no matter how poor it may be.

C. H. Lorenz, of W2FE sends in an idea which is worth passing on. Experiments at W2FE have been with single- and two-wire feeders on Hertz antennas and the results obtained indicate that one feeder system is as good as another when they are properly constructed.

Attention is brought to the fact that many amateurs overlook the important point of accurately measuring the length of the antenna. In many instances the length is guessed at. As a general rule this makes little difference where self-excited or self-controlled oscillator amplifier

transmitters are used, since the transmitter can be tuned to the exact frequency of the antenna for best results. However, where crystal controlled transmitters are used it is not possible to alter the frequency of the transmitter unless several crystals are available, and to obtain maximum radiation from the antenna the antenna must be of the proper length to resonate at the operating frequency.

The proper method of determining the length of the antenna is given in the Handbook and has appeared in "The Zepp" (*QST* for September, 1928). In cutting the antenna to the proper length W2FE points out that the maximum length of the antenna is to be considered. Many amateurs measure the length of the antenna from the end of one insulator to the end of the next, but as the length of the wire used at the insulators is not figured into the antenna length, an error of a foot or more may creep into the antenna design. Failure to observe this rule may make the antenna as much as 50 or 60 kilocycles off resonance.

#### A DELAYED TIME RELAY FOR THE TRANSMITTER

The problem of properly putting the station in operation at the throw of a single switch with the knowledge that the filament of the transmitting tubes will be thoroughly heated before plate voltage is applied is sometimes of interest to amateurs who construct their stations for maximum convenience and comfort.

A method of automatically applying the plate voltage to a transmitter several seconds after the

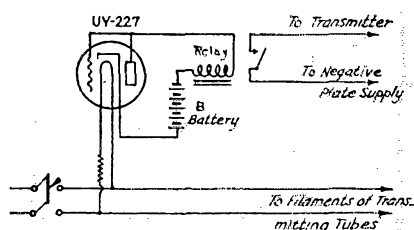

FIG 3

filaments have been lighted is shown in Fig. 3. A UY-227 tube is connected in the manner shown. Its heater is supplied from the power source operating the oscillator or amplifier tube filaments. Resistors are used to limit the current to 1.25 amperes for proper operation of the heater of the UY-227 tube.

Because a ceramic insulating sleeve and the cathode must be heated before plate current begins to flow, the filaments of the transmitter are lighted about half a minute before the relay is closed and plate power is applied to the transmitter. Plate voltage is applied to the tubes as long as the filaments are kept lighted after the relay is once closed. The grid and plate of the UY-227 tube are connected together because the

(Continued on page 82)

# I.A.R.U. NEWS

Devoted to the interests and activities of the

## INTERNATIONAL AMATEUR RADIO UNION

President: H. P. MAXIM

Vice-Pres.: C. H. STEWART

Secretary: K. B. WARNER

Headquarters Society:

THE AMERICAN RADIO RELAY LEAGUE, Hartford, Conn.

### MEMBER SOCIETIES

American Radio Relay League  
 Asocacion E. A. R.  
 Associazione Radiotecnica Italiana  
 Canadian Section, A. R. R. L.  
 Deutschen Amateur Sende und Empfangs Dienstes  
 Experimenterende Danske Radioamatører  
 Nederlandsche Vereniging voor Internationaal Radio-  
 amateurisme

New Zealand Association of Radio Transmitters  
 Norwegian Radio Relay League  
 Radio Society of Great Britain  
 Reseau Belge  
 Reseau Emetteurs Francais  
 South African Radio Relay League  
 Wireless Institute of Australia

Conducted by A. L. Budlong

**T**HERE is one "rotten" subject we hope The Old Man will write about some day. It might be called "Rotten Reading of QST." To illustrate what we mean we will mention that about ten days after the October issue of QST came out (that was the issue that had the first set of DX time-tables) we got letters from two League members. One of them wanted to know why it was that QST never printed any information on when to look for foreign DX, and the other asked for some DX time schedules.

Well we replied by suggesting that they read the QST they had just received. One of them replied to the effect he was glad to have it called to his attention, because he never read the I.A.R.U. Department, and the other had seen the tables, but didn't believe they would work for him. He hadn't even given them a try!

Now we wouldn't get all steamed up about these two cases if it weren't for the fact that they reflect a wide-spread condition. QST prints a description of a screen-grid receiver, and yet the Information Service continues to receive its usual requests for information on how to build one. In most of the cases it turns out that the seekers for information saw the receiver article but wanted assurance that it would work all right for them. Your compiler recently attended a radio club meeting and during his talk commented on the beautiful simplicity of the single-wire-fed Hertz antenna. At least a dozen of those present inquired as to where they could get dope on this

system, in spite of the fact that the excellent article by Windom in the September issue had been out for a month. It was there for all to see. Most of the inquirers admitted they had noticed the article but "hadn't read it." We print a list of QSL bureaus in our own department of the ol' magazine, and in spite of it continue to get the usual stream of requests for QSL bureau addresses from League members.

Practically all the applicants in each of the cases cited above state they read QST regularly. Yes they do — not! Tell it to the Marines! They glance at the cover, look in the C.D. to see if their traffic report got in, run down through "Calls Heard," glance idly at the illustrations in the rest of the magazine, and call it a day.

We hope T.O.M. reads this and acts accordingly. In the meantime if somebody writes us asking if we would please tell them what societies are members of the I.A.R.U., we are going to rush madly down Main Street and murder ourselves a couple of nice old ladies, or shoot a policeman, or something.

Just about this time we hear someone murmuring that when they turn to the I.A.R.U. department they want international news, and not bum sermons. Well, we suppose they're right.

The prefix for Philippine amateur calls has been changed from K to KA. This should help a lot in picking them out. Better make a note of it.

We take great pleasure in presenting herewith the first of what we hope will be a steady series of biographies of the presidents of I.A.R.U. member societies.

*Mr. Paul de Neck, President of the Réseau Belge:* Mr. de Neck started his ham career in 1908, with the usual array of coherers and ignition coils. There followed a period of experimentation with arcs, huge spark coils, crystal detectors,



MR. PAUL DE NECK, PRESIDENT, RESEAU BELGE

etc. About 1913, together with about thirty other experimenters, he was instrumental in forming the first Belgian amateur society. During the war he got a lot of experience in the "signal corps" of the Belgian army, and also collected a considerable amount of German radio apparatus! This latter acted as a beginning for Mr. de Neck's amateur station after the war.

In 1923 a small group, of which Mr. de Neck was one, founded the Réseau Belge, which has now grown to have four hundred members. Mr. de Neck was elected the president a few years ago.

He holds degrees in electrical and metallurgical engineering, but is now associated with his father's stock brokerage business. There is a Mrs. de Neck, too, and three junior operators.

ON4UU, the station of the R.B.'s president, is well known. At present it consists of a 1929 push-pull Hartley working into a Zepp on 14,000 and 28,000 kcs., with the usual receivers. It is difficult to say how long this rig will be in operation, however, since, in the words of its owner, "the station sets change every month."

In other words, Mr. de Neck is a real amateur.

We would like very much to receive photographs and short biographical notes from the presidents of all the other sections of the Union.

And now to some more DX time-tables. Just at present we have more information than we can

use in one issue, so some of it will be held over until February. This means that a few people who were told their material would appear in January are due some apologies. All contributions are very gratefully acknowledged, however, and wherever usable, will be printed.

We are going to use all our space for this feature this month in printing a list submitted by Bruce Hoag, W8AXA, for the 14,000-kc. band (Eastern U. S.). We believe this list will be particularly appropriate in view of the Communication Department international tests, because it gives definite call letters for stations in many of the fewer worked countries. The times, as usual, are GCT, with 0000 representing midnight. For E.S.T. subtract 5 hours, for C.S.T. subtract 6 hours, subtract 7 hours for M.S.T. and 8 hours for P.S.T. Some deviation from the exact times given must be expected for seasonal differences, of course.

14,000 kc.

#### Asia

Iraq. 0100. yilmz  
Syria. 0100. arSufm

#### Europe

Austria. 0200-0400. uosx, uoxl  
Belgium. 2000-2200. on4uu, etc.  
Czechoslovakia. 2300. ok1rv, ok1fm  
Denmark. 2300-0000. oz7jo, oz7zg  
Spain. 2300-0000. ear96, ear98, etc.  
France. 2000-0000. f8aja, etc.  
Great Britain. 2000-0000. g7ml, etc.  
Italy. 2300-0000. 11fp  
Jugoslavia. 0000 (but rarely heard). un7dd  
Germany. 2300. d4xn, d4vp, etc.  
Sweden. 2300. sm6ua  
Netherlands. 2200-0000. pb7, pa0vn  
Portugal. 2100-0000. ct1bx, ct1by, ct1aa  
Finland. 1200-1400. oh7nb, oh2nm  
Poland. 2300. sp3pb  
Hungary. 2300. haf8b

#### Africa

Egypt. 0100. su8rs  
Algeria. 2300. fm-ocup, fm8fva  
Tunisia. 2300. tun2  
French Equatorial. 2300. fqSwb  
South Africa. 2000. zs4m, zu6a. seasonal  
Cameroon. 2300. fqpm

#### North America

Alaska. 0400. k7mn, k7ady. seasonal  
Newfoundland. 2300. vo8ae  
Honduras. 2300  
Jamaica. 1400-0000. nj2pa  
Mexico. 2300-0300. x9a  
Porto Rico. 2300. k4akv, k4kd  
Virgin Islands. 2300. k4aan  
Cuba. 2300.  
Costa Rica. 2300. ti2ea, ti2ags  
Panama. 0100-0300. rx1aa  
Canal Zone. 1200-0400

(Continued on page 60)

# Calls Heard



Fred Karklin, Apartado 101, Monterrey, N. L., Mexico

wlapj wlasu wlaue wlejd wlpr wldl wlfce wlii wlip  
wljr w2as w2ahd w2aja w2akm w2alu w2amh w2aot  
w2ase w2aun w2axl w2bfi w2bzo w2buy w2cvf w2cxl  
w2czz w2jn w2jo w2jv w3ain w3ahw w3aru w3avo w3awl  
w3ekl w3fq w3gz w3mw w3sz w3tb w3zcc w4aaq w4aaw  
w4abv w4aci w4adb w4aej w4aeq w4aha w4ahz w4ajb  
w4ajh w4amx w4anh w4ao w4bk w4ca w4cw w4du w4jx  
w4ka w4kh w4kv w4nb w4nn w4nz w4oi w4qq w4rz w4ti  
w4to w4ty w4vc w4vw w5aar w5aav w5afx w5alh w5ain  
w5ajl w5aoz w5awd w5azs w5hat w5bbx w5bcz w5bdj  
w5bfw w5bfx w5bhq w5bhv w5es w5hj w5jv w5mi w5pa  
w5qj w5rj w5sw w5vl w5wf w5ww w5yw w5zk w6am  
w6adw w6ajp w6ajr w6ajv w6ann w6aov w6ara w6awa  
w6bam w6bdd w6bet w6bfe w6bfg w6bgo w6big w6bju  
w6blx w6bpm w6bpu w6bqq w6bsp w6bts w6bxy w6bzb  
w6cei w6chl w6cjr w6clz w6cne w6cnk w6cnn w6cns  
w6crb w6cre w6cto w6ctp w6cui w6cuh w6cvd w6cwi  
w6dak w6dcq w6dqq w6dln w6dlu w6dmk w6djo w6dsh  
w6dtg w6dtu w6dwa w6dwi w6dwy w6dyy w6eb w6eaa  
w6ebg w6ebm w6edo w6egh w6egk w6egv w6ehi w6ejz  
w6eos w6epf w6epi w6ept w6esa w6esz w6etp w6fk w6ha  
w6ht w6js w6oq w6sw w6vk w6wb w6wn w6zs w7aah  
w7aax w7abh w7acy w7adb w7afj w7aiz w7akz w7amm  
w7amo w7hr w7oj w7om w7or w7agj w7aje w7apm w7avo  
w7avp w7ayo w7ayv w7azo w7bzy w7bae w7bbx w7bbg  
w7bcf w7bcq w7bgw w7bjg w7bkk w7bhh w7bqi w7bqu  
w7brv w7bvt w7cj w7cen w7cco w7cft w7chg w7cko w7crl  
w7coq w7cpe w7csw w7ctj w7cxv w7dcx w7dno w7dqk  
w7em w7hl w7jl w7kc w7kx w7mb w7pe w7pl w7pp w7sg  
w7uf w7sz w7acl w7ads w7afn w7agu w7apm a9aah a9aaz  
w9arf w9ark w9atq w9aui w9avc w9azv w9baz w9bba  
w9bbo w9bca w9beq w9beu w9bgr w9bjc w9bjv w9bna  
w9bnx w9bnf w9boa w9bpn w9bvq w9bvt w9bwx w9bxk  
w9cf w9cdu w9cfn w9chx w9cmf w9cou w9cpv w9cud w9csg  
w9cti w9cvt w9cwx w9dbj w9dbx w9ddy w9dly w9djk  
w9dlg w9dla w9dma w9dna w9dpb w9dsk w9dxe w9dxp  
w9dzm w9eah w9ege w9eij w9ejj w9ekl w9ekq w9eno  
w9enr w9eos w9eqc w9euy w9etq w9evt w9fi w9fz w9fae  
w9fcx w9fdj w9fld w9fdw w9fem w9fgj w9fil w9fiw w9fmr  
w9fmu w9fsv w9fvy w9fur w9fyv w9gq w9gac w9gav w9gbx  
w9gcz w9gdm w9gfh w9gft w9ggv w9ghz w9ghv w9gii  
w9hd w9hw w9lk w9na w9nb w9ss w9ui w9uz k6alm k6cib  
k6dju k6dgt ve2bd ve2be ve3sb ve4as ve4br ve4ho cm1az  
cm2jm cm2yb cm5fl cm8by trc2 lu3pa nnFX nnlic  
ti2hv ti8tsa pylah vcifg x9a zt6z.

W9UM-W9BOH, M. W. Macy, Lake Wawasee, Syracuse, Ind.

7000-cc. band

w7aax w7adm w7aff w7agc w7alj w7alk w7amr w7ao w7bb  
w7cx w7dw w7gc w7hn w7ho w7hv w7kj w7li w7lt w7lz  
w7na w7nr w7pa w7zz w6acj w6aek w6ajq w6all w6ap  
w6aro w6asn w6bbh w6bpe w6bq w6bjn w6bhb w6bz  
w6bzv w6eda w6emo w6epu w6cqu w6cry w6exp w6dav  
w6deg w6den w6dfs w6dio w6dlx w6dzn w6djl w6dto  
w6dui w6dur w6ea w6ebg w6efa w6elr w6ely w6elz w6eme  
w6eos w6ecu w6erk w6eru w6ery w6ha w6mc w6nf w6nh  
w6re w6sf w6sw w6a w6as w6at w6bn k7aop vk2hc vk2hl  
vk3pp vk3pa vk3yv vk4at vk4do vk5jh velax ve4hp  
ve5he kfr5 kfr6 kfu5 kdv5 ti2hv ti2wd ti2ea ti2fg cm2ac  
cm2az cm2yb cm5fc cm5fl cm5az helcg heldr hc2jm hc2hp  
k6avl k6bhl k6bqh k6def k6dgt k6edj k6etf nj2pa x9a x9b

x29a zlian z1fw z1bu z13as z14ae nnfx nnxc nnlnic nn3nic nn7nic nncab 55x k1kd zsz2b bam geo oolrj

W9BWC, M. Von Ploennies, 3851 Lincoln Ave., Chicago, Ill.

w6aaq w6by w6btv w6dt w6dqq w6eog w6hj w7aav  
w7afz w7alj w7ek w7mm velar ve1cr ve1da ve2al ve2bg  
ve3bo ve3bq ve3cx ve3dd ve3eo ve3va ve4bq nnfs nnlic  
nnex x9a x9b e2jm lu3dh 55x k6avl k6dju kdv5 cm2yb  
cm3af g5by g5ml g6xb g6xj z5c z5d z2ac z2aw z3be  
z4ae vk3ac vk3ga vk3kh vk4cg vk5hg vk5ja vk7ch ear62 ear92

VE4BQ, J. L. Green, 115 Furby St., Winnipeg, Manitoba, Canada

7000-cc. band

k6axw k6bra k6cjs k6eyc k6ddq k6dv k7ak k7aop lg  
vk2aw vk2zv vk2jc vk2zo vk2ow vk2sm vk2tm vk3jk  
vk3pp vk3pa vk3gr vk3vr vk4bh vk4bu vk4do vk4th  
vk4wh vk5aw vk5gr vk5hg vk5mj vk5wr ve5aw x9a  
x29a z1aj z1be z1bp z13as z13cm z14am

14,000-cc. band

celah ce2ab ce3bf cm2jt d4jl f8ex f8da f8dot f8fr, f8ff  
f8hcl f8afr f8wb f8whg g2ao g2cx g5bj g5by g5qa g5yx  
g6hp g6ll g6nt g6qg g6rb g6vp g6uh g6wb g6wt g6wy  
hb9d lu3dh lu3fa kfu5 on1fp on1hc on1ij on1ro on1rs nj2pa  
py1aa pylah pylav pylax pylbr py2aj sslap ti2hv vo8ae  
vo8cm x9a x1am

W4VK, Taylor B. Rice, Ripley, Tenn.

bal ce3bf cm2jm cm2sf cm2sh cm2yb cm5fl cmz7 gh4  
kl dj klmc k6cib k6dvd ti2hv ti2wd ve2bh ve3cm ve3aa  
ve4bg ve4bq ve4br ve4ce ve4ef ve4gd ve4hb ve4jb vk2hg  
vk2hl vk2ku vk2sg vk3pa vk3pp vk3rg vk4bh vk5bj  
vk5kj vk5mj vk5sw vk5vr kfu5 nnlic nj1 vlwn vlvc  
w7aax w7abh w7aiz w7lx w7dc w7dd w7fh w7hp w7iy  
w7ke w7lp w7mb w7mh w7ny w7om w7pc w7qd w7tj  
w7uv w7uz w7wy w7wd

VK2RX, Rockdale, N. S. W., Australia

14,000-cc. band

w1bur w1ry w1cj w1alm w2abu w2amr w2bn w2bjg  
w2dp w2jn w2rs w2wi w4ae w4aj w5bek w5jv w5ql  
w6aw w6aez w6bjd w6brv w6bx w6cu w6car w6cub  
w6cqu w6dow w6dbo w6fh w6fk w6epv w6eva w6epz  
w7hn w7ga w7vp w8ap w8bud w8ca w8ld w8djj w8dsi  
w8dyk w8gz w9av w9afn w9cex w9crd w9dly w9dkg w9ef  
w9env w9emr w9fbv w9fj w9gbg ac1bd ac3fr ac6ay celak  
celah celai ce3bm ct1aa cx2ak d4uj d4yt ear2l ear116  
f8axq f8ca f8da f8fk f8gy f8ho f8jj f8wb f8whg f8xh f8zx  
g2op g2yu g5bz g5uq g6nf g6nt g6uh g6wi g6wt ilau j1tx  
j2by j3dd laig oa1l oa4o oa4q oa4t on4bx on4fm on4fp  
on4hc on4hp on4ja on4us on4vw oz7y pk3bm pk4az sm5uk  
sp3kx su8rs ti2hv x9a

VS7AP, A. M. Rahim, Wellawatte, Colombo, Ceylon

14,000-cc. band

au7ab au7kad ac1bd ac3fr ar8ufm ct1bx ct1aa ct3aa d4fw  
d4uak d4aar d4by d4agn d4vp d4an d4jb d4aci d4ua ear2l  
(Continued on page 56)

# Correspondence

The Publishers of QST assume no responsibility for statements made herein by correspondents



## Standard Frequencies for the Commercials

Western State Teachers College,  
Kalamazoo, Mich.

Editor, QST:

I want to say a word in appreciation of the service of standard frequency transmissions from W1XV and W9XL. There is certainly great need for this service if one can judge from the number of amateur stations that are outside the legal frequency limits. Continued publicity through QST will certainly encourage a more extensive use of this standard frequency service.

I have been attempting to calibrate a new heterodyne frequency meter from these standard transmissions. Listened for W1XV-W1AXV on the afternoon schedule of October 11, but was unable to hear him. Tried W9XL on the evening schedule of the same date. In the 7000-kc. band I was able to hear his 7000-kc. transmissions but nothing after that. I might say that they were pretty well covered up by automatic signals from commercial stations with very strong off-wave key clicks. WIK, just below 7000 kc. and WEE on about 7050 kc. were the worst offenders. W9XL's signals in the 3500-kc. band are very strong and easily received.

Perhaps some of these standard frequency transmissions would prove of some service to commercial stations who seem to have trouble in keeping their signals out of the amateur bands. I wonder if the fact that key clicks from these commercial stations, which block off sections of the present narrow bands, does not encourage some amateurs to be careless about keeping their own signals within the amateur channels?

— H. C. Marburger, W8CVQ

## Some Comparisons

Editor, QST:

Tonight, having no power supply for my portable transmitter, I listened in on the various bands. I made a comparison of the two general classes of notes in the 3500-kc. band and in the 7000-kc. band. Here is what I found, which I believe to be somewhat interesting:

2 r.a.c. signals, or 13%	3500-kc. band	14 d.c. signals or 87%
36 r.a.c. signals, or 70%	7000-kc. band	15 d.c. signals or 30%

These figures were made by tuning over the band only once at about 7 p.m. Eastern Standard Time. One notices, immediately, the difference in the number of stations on each band as well as the relative quality of the notes on the two bands. When the relative widths of the two bands are compared, one can hardly be surprised at the difference in the number of stations on each band. I hope some of the fellows will be induced to put in some filter so that the percentage of r.a.c. signals will soon be smaller than given above.

I was recently in Europe and noticed that the general run of European stations are entirely modern, where the owner can afford it. Most of the European stations have much better receivers than the usual American amateur station has.

— John N. Boland, W3ASC

## More Statistics on QSL Cards

Concord, N. H.

Editor, QST:

In reading W9AAB-W9DNY's figures about QSL cards, I was interested to find out just how the percentage of QST receipts was at my station. I have kept an accurate record of every station worked, and whether they have sent me a card or not. After every new QSO, I fill out a card for the station. If the call-book address is not correct, I set aside the card until the new book comes out or until I receive a card from him. The following percentages are taken ever since the station has been on the air up to the first of this month (five years).

Distric	Cards Received
1st	68%
6th	63%
5th	57%
8th	55%
9th	52%
7th	50%
3rd	49%
2nd	45%
4th	40%
Canada	53%
Foreign countries, outside U. S. A. and Canada	64%

Total number of different station contacts is 1161 with a percentage of 56. This is somewhat better than W9AAB-W9DNY's record but certainly is far from where it should be. I was surprised myself because I didn't think that my percentage would be much different than his. I do think that the cards are coming in just as well

# SM

## One Mile from WSM— 400 from WMAQ—and the 712 Cuts 20 kc.!

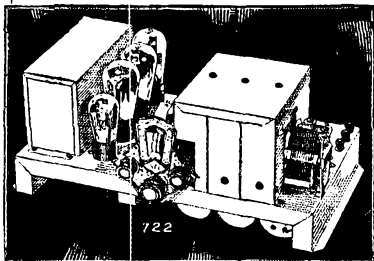

**722 Band Selector  
Seven**

Providing practically all 1930 features found in most new \$200 receivers, the S-M 722 is priced absurdly low in comparison. 3 screen-grid tubes (including detector), band filter, 245 push-pull stage—these help make the 722 the outstanding buy of the year at \$74.75 net, completely wired, less tubes and cabinet. Component parts total \$52.90. Tubes required: 3—'24, 1—'27, 2—'45, 1—'80.

### Beautiful Cabinets

The handsome new 707 table model shielding cabinet, finished in rich crystalline brown and gold, suitable for 722, 735, or 735DC, is only \$7.75. Special arrangements have been made whereby these receivers may be housed in magnificent consoles especially adapted to them. Be sure to send for the new Fall S-M General Parts Catalog, for details of these cabinets.

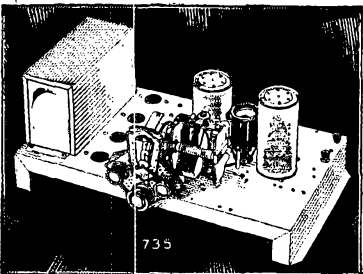

735

The Radiobuilder, a monthly publication telling the very latest developments of the S-M laboratories, is too valuable for any setbuilder to be without. Send the coupon for free sample copy, or to enter your subscription if you want it regularly.

**SILVER-MARSHALL, Inc.,** 6409 WEST 65TH ST. CHICAGO, -- U. S. A.

**W. W. Dillon & Co.**  
Realtors  
Nashville, Tennessee

"Silver-Marshall, Inc.,  
Chicago:

"I have had your 712 tuner for about ten days now . . . over a hundred stations have been received . . . I live within a mile of the towers of WSM (650 kc.) but am able to bring in WMAQ (Chicago, 670 kc.) and KPO

(Oakland, Calif., 680 kc.) . . . I find I get results on a short indoor aerial which you claim only when using a longer outdoor antenna . . . I am using 30 feet of rubber-covered wire tacked up in the attic . . . Some night I may put up a decent aerial, connect it as you direct and bring in China."

—M. G. Horkins

The custom-built S-M 712 used by Mr. Horkins is a straight one-dial all-electric tuner, as easy to operate as the cheapest radio. Whether it's a world-beating set for your own home, or a custom design to build for "fastidious listeners"—the S-M 712 so far overshadows competition that comparison becomes ludicrous.

### And if You Prefer a Still Lower Cost—

"Silver-Marshall, Inc., Chicago:

"I received my 722 . . . That receiver is certainly the best for the money—KDKA or WBZ without any heterodyning at blasting volume, or WRVA and WPG, or WJZ and WBBM, or WEAJ and WMAQ. (All four are 10 kc. separations.) WJZ, WGY, KDKA and CKAC, 400 to 600 miles away, are regular daylight features . . . I will keep on boosting Silver-Marshall sets like I have been doing since four years ago."—Gleason Belzile, Rimouski, Quebec, Canada.

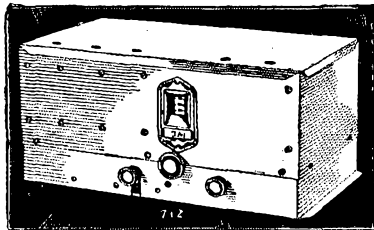

**The New "Boss of  
the Air" — S-M712**

Far more selective and sensitive even than the Sargent Rayment 710, the new all electric single control 712, with band filter and power detector, stands far beyond competition regardless of price. Feeds perfectly into any audio amplifier, the S-M 677 being especially suitable and convenient. The 712 can be easily mounted for use as radio tuner in a rack-and-panel amplifier installation; the superlative quality of its reception makes it ideal for this purpose, while the low-impedance power detector works perfectly into any type of power amplifier. Tubes required: 3—'24, 1—'27. Price, only \$64.90, less tubes, in shielding cabinet. Component parts total \$40.90.

### 677 Amplifier

Superb push-pull amplification is here available for only \$58.50, less tubes. Ideal for the 712, since it furnishes all required power (180 volts B, 2½ volts A.C.). Tubes required: 2—'45, 1—'27, 1—'80. Component parts total \$43.40.

## Short Wave Reception Without Batteries

A screen-grid r.f. stage, new plug-in coils covering the bands from 17 to 204 meters, regenerative detector, a typical S-M audio amplifier, all help to make this first a. c. short-wave set first also in performance. Price, wired complete with built-in power unit, less cabinet and tubes, only \$64.90. Component parts total \$44.90. Tubes required: 1—'24, 2—'27, 2—'45, 1—'80. Two extra coils, 131P and 131Q, cover the broadcast band at an extra cost of \$1.65.

Adapted for battery use (735DC) price, \$44.80, less cabinet and tubes. Component parts total \$26.80. Tubes required: 1—'22, 4—'12A. All prices net.

Ask about our  
Authorized  
Service Station  
Appointment!

Silver-Marshall Inc.  
6409 West 65th St., Chicago, U. S. A.

.....Send your new fall catalog, with sample copy of the Radiobuilder.

.....For enclosed 10c, send five new S-M Data Sheets, including those on 722, 712, 735, and 677.

Name.....

Address.....



**Facts you must know to pass the radio operators' examination—**

**H**UNDREDS of practical radio questions and answers are contained in this book. It gives you an authentic source of "inside information" on what you will be asked in qualifying for the amateur or for every grade of commercial operators' license.

**Radio Operating Questions and Answers**

**By Arthur R. Nilson and J. L. Hornung**  
*Second Edition*

267 pages, 5 1/2 x 8, 91 illustrations. \$2.00 postpaid.

This is the enlarged second edition of a book formerly published as *Radio Questions and Answers*. It covers the great advances which have been made since 1921 in the art of radio communication; it takes into account the new technique of broadcast-station operation which has been evolved through electrical, mechanical and physical improvements.

**Chapters**

- I. — Diagrams and Explanation of Complete Commercial Transmitter, Receiver, and Auxiliary Equipment.
- II. — Tube Transmitters.
- III. — Arc Transmitters.
- IV. — Spark Transmitters and Transmitters in General.
- V. — Receiving Apparatus and Radiocompass.
- VI. — Storage Batteries.
- VII. — Motors and Generators.
- VIII. — Radio Laws and Traffic Regulations.
- IX. — General and Theoretical Questions.
- X. — Broadcasting Transmitters.
- XI. — Amateur-Station Operation.

**Fill out this coupon—**

You will receive the new second edition for 10 days' FREE examination. It covers the latest laws and regulations governing radio operators and the operation of radio stations. ORDER NOW.

**McGraw-Hill FREE EXAMINATION COUPON**

McGraw-Hill Book Co., Inc.  
370 Seventh Avenue  
New York, N. Y.

You may send me Nilson and Hornung's *Radio Operating Questions and Answers* \$2.00 postpaid. I will either return the book, postage prepaid, in 10 days, or remit for it at that time.

Name.....  
Street and No.....  
City.....  
State.....  
Name of Company.....  
Official Position.....  
(Books sent on approval in the U. S. and Canada only)  
Q.S.T. 1-30

now as they did three and four years ago so I do not believe that the QSL situation is any worse than it has been.

— C. B. Evans, W1BFT

**Old Timer Has His Say**

40 Underwood St.,  
Newark, N. J.

Editor, *QST*:

I have been getting *QST* from the newsstands since June 1921 and think it is about time I became a member, so if there is any more room in your League, please make me a member.

I started in 1908 to try to copy code with a coherer and relay which never worked and finished with a silicon detector, an electrolytic detector, loose coupler and Brandes 'phones. Also had a 1-inch spark coil with the vibrator screwed down in order to get that "skeeter" note, a sync spark gap and a 6-volt 60-ampere hour battery that I carried two miles to be charged. The spark coil was purchased from a fellow by the name of Chambers in Philadelphia who was making a lot of noise in the newspapers about copying "wireless" with dish-pan and bed-spring antennas.

At that time Collins was trying to bust the ether with a radio 'phone using revolving carbon discs for a microphone. I tried but never heard him. I copied press from WCC at Wellsfleet, Cape Cod, nearly every night, and used to hear SC, PT, NAH, NAS, NAL and others I don't recall at the present time, as well as numerous ships.

I quit the game about 1912 when I came home one night to find my mother had called in the junk man and cleaned me out. I rushed over to the junkie, but was too late, for he was breaking up the last piece of equipment — a 6-volt ring armature motor from an Edison cylinder phonograph. This I had rigged up with a bicycle frame as a generator to charge the battery. It seemed simpler to sit down and walk those four miles to charge the battery than to carry the battery that distance.

My mother was not to blame for calling in the junk man as I was making a "coffin" and had wound pies and pies of wire and had upset a pan of wax on the stove and smoked everybody out of the house.

I wonder if there is anybody who remembers hearing my station in Frankford, Philadelphia, twenty years ago? I used the home made call letters WBS.

I'm going to try and slip through for a license. They say "one once a man and twice a boy." I'm thirty-five years old this month, so I guess I'm starting back again.

— Wm. B. Schaum

**W2KU Helps Out**

Paudash, Ontario.

Editor, *QST*:

I'd like to tell you about a little incident concerning myself and to express my great appreciation and belief in amateur radio.





“Madam—let me  
introduce the  
**FACTORY  
ENGINEER”**

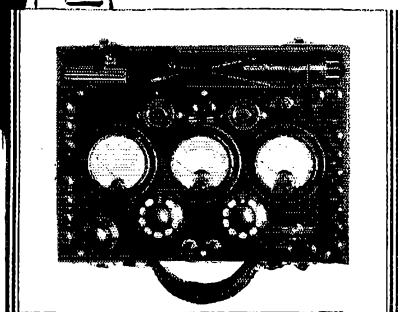

*Take this  
consulting specialist  
with you on your  
radio servicing calls*

**T**HINK what it would mean to your business if you were known to employ factory engineers for servicing radio sets — engineers familiar with every constructional feature! You would get every servicing call in your territory, because customers would have confidence that these men would know just what to do in every instance, and could promptly restore the set to perfect order.

That's exactly what the Weston Model 547 Radio Set Tester is in effect. It enables your servicing men to become as experienced and efficient as factory engineers. It helps the manufacturer make good his guarantee of performance; it helps you increase your servicing business with steadily increasing profits, and makes friends for your business and customers for your merchandise.

All told, the Model 547 is an outstanding achievement of the year and no dealer or service organization can afford to be without one. Write for detailed instructions on the scope of this instrument.

**Weston**  
PIONEERS  
SINCE 1888  
**INSTRUMENTS**

**WESTON ELECTRICAL INSTRUMENT CORPORATION**  
602 Frelinghuysen Avenue                    ::                    Newark, New Jersey

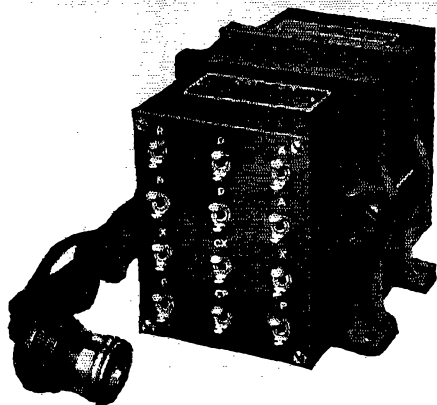

## New! the PF245A AmerTran Power Transformer

Continuing its progress in the development of power transformers for all radio receiving sets the American Transformer Company announces the perfection of the new type PF245A. This new power transformer operates a radio receiver equipped with 2½ volt heater for heater type A.C. tubes and 2½ volt filament for a power tube (UX245 or CX345) which closely approaches the 210 in undistorted watts output.

The AmerTran Power Transformer Type PF245A is designed for a 60 cycle 115 volt line source, and has a continuous rating of 100 VA. with primary taps for 100—108—115—120 volts. A four point radial switch regulates the operation for different primary voltages. There are five secondary windings. Because of its lower maximum voltages, all secondary connections terminate in solder lugs attached to a bakelite terminal board.

This new, heavy duty power transformer is compact, sturdy, beautifully machined and mounted in castiron end clamps provided with mounting feet. Like all AmerTran Transformers the PF245A is built to deliver sufficient excess voltage for maximum requirements.

Fill out and mail the coupon for AmerTran Bulletin No. 1088 giving complete description of the PF245A Power Transformer.

List Price \$22. East of the Rocky Mountains.

**AMERTRAN**  
AMERICAN TRANSFORMER CO.

AMERICAN TRANSFORMER CO.  
178 Emmet St., Newark, N. J.

AMERICAN TRANSFORMER CO.  
178 Emmet St., Newark, N. J.

Please send me complete information on the new PF 245A Power Transformer.

Name.....

Address.....

An operation for appendicitis kept me in the hospital in New York for six weeks last summer. When I recovered sufficiently I came up here to our Canadian camp. It is 17 miles from the nearest railroad and there are no telephones. Because I am not a British subject, I am unable to operate a transmitter here, but of course have a short wave receiver.

I heard W2KU, operated by Mr. Oscar Ochmen, one day and wrote him asking him if he would take a few messages and send them to me. He came back on the air upon receipt of my letter on schedule time and hasn't missed a day, nor I a word for over a month. He has sent me news bulletins (for my own personal information) and many personal messages. A short time ago I was taken with a relapse. Got word to him to see my doctor. He did so and sent me medical advice and I am now almost entirely recovered.

This is just another proof of the worth of amateur radio and its dependability in cases of emergency.

I couldn't go on enjoying the benefits of such an organization as the A.R.R.I. without being a member. Send QST to my Brooklyn address please.

— Alfred D. Greene

### Calls Heard

(Continued from page 51)

ear113 es2ex fk2ms fk4ms fk5er fk6er fa8bak fa8bm f8hm f8hr f8ep f8eo f8ej f8do f8kz f8zb f8da f8rko f8jf f8xz f8wb f8pb f8fg f8wg f8tan f8dae f8axq f8wlp f8ar g6xc g6ll g6wl g6bz g6wp g6wt g6uq g6tz g6ms g6ux g6bd g2bm g2ax g6nt g6hp g6rr g6rn g6ml g6vp g6pp g6jn haf3e llgl llcoo k6muy kfr5 oh2nad oh2nap oh2nag ok2lo ok2cm ok1ab ok1m on4tu on4j on1m on1p on4us on4ft on4ar ok3sk ok1mx ok1bk ok1rv oz7t oz5a oz5t oz5w oz7y pa0qf pa0vn pa0wr pb7w pk3bm pk4az pk4bo pk4bf su8rs su8kw su8wy sm6ua sp3ar un7ww uowg velbr vk4rb vk4bh vk5gr vk6mu vk2no vq2bh vq2nc vs3ab vu2dr vu2bg vu2ve yu2ek w1ajt w2hj w8alt w2el w2aan w2bjg w2nf yilac yilim yilmdz yizgq zllfw zllas zl2cu zu6n zs4m zt6x zt1r zs2u

7000-kc. band

k1af k1dj k1zc k1pw k1cc k1jr k1ac k1hr k1xa k1ee k1el k1rc k1mc vs1ab vs3ab vs6ah zs4m vk5hg vk5mk pms

W5LS, "Felix" Johnson, 1821 W. Chestnut St.,  
Denton, Texas

(Heard off Chile Coast)

w1amd w1awk w1dl w1mk w1rp w2anr w2apk w2aun w2bae w2bay w2bda w2cqd w2xel w2fa w2mk w2nl w2sm w2wr w2wy w3aiz w3anh w3apo w3avf w3axz w3cnj w3pt w3zg w4aa w4aef w4uld w4ao w4ax w4fx w4il w4ia w4jr w4qb w4ql w4sh w5afg w5ahq w5azs w5bbe w5bbx w5bhv w5be w5gr w5je w5jw w5oh w5ql w5uf w5ww w6aaah w6aak w6ac w6ad w6ahp w6aob w6aqp q6aso w6avj w6axe w6bam w6bpc w6efk w6efx w6efz w6cui w6cnw w6cpu w6cqq w6cui w6cuy w6czx w6dal w6dli w6dwi w6dwm w6dzz w6ebg w6ebz w6edf w6egk w6ehi w6eii w6ecu w6kj w6ns w6sf w6tf w7aah w7abh w7bb w7l w7na w7wl w8amb w8axz w8ayh w8azq w8bae w8bay w8ben w8bdf w8byt w8cfw w8chg w8cib w8cnr w8esm w8evi w8ci w8cu w8dc w8dyr w8eb w8kc w8pl w8sg w8sy w8us w9azc w9ahc w9ahq w9af w9atu w9avh w9bdt w9boa w9bpq w9bpq w9bw w9bre w9bxk w9erd w9etw w9dfy w9dpp w9dr w9ebb w9ebo w9emr w9ez w9faq w9fkl w9fqz w9fqs

# Fans!

Consider these

## 12 Points of Excellence

combined with many others in the

### NEW 1930 **BROWNING-DRAKE** screen-grid **RADIO**

1. Screen-Grid Tubes.

2. Semi-automatic tuning — both kilocycles and call letters on dial.

3. Five tuned circuits — nine tubes.

4. Tuned antenna.

5. Push-pull audio (245 power tubes).

6. Power detection (plate rectification) optional.

7. Band-pass filter

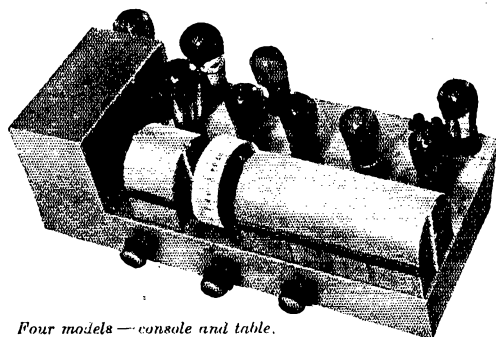

Four models — console and table.  
Table model, \$102.50. Consoles  
from \$142.50 to \$188.50.

effect 10 KC selectivity.

8. Mershon trouble-proof condenser.

9. Voltage, regulation adjustment (manual).

10. Power unit integral part of chassis.

11. Special electrodynamic speaker.

12. Selected walnut and American gumwood cabinet, hand-rubbed satin Duco finish.

See — hear — test this set for tone — for distance, for selectivity, for everything you want in a radio set. We welcome inquiries and can present an unusually attractive franchise proposition to any of you who are dealers.

**Browning-Drake Corporation**

228 Calvary Street, Waltham, Mass.

*Over 1,500,000 people listen-in on Browning-Drake Sets*

# Solid Molded

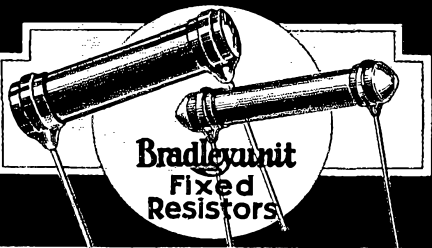

**Bradleyunit  
Fixed  
Resistors**

**Rugged—Accurate—Permanent**

**SOLID MOLDED**—that is the secret of the superior performance of the Bradleyunit. Made in ratings from 500 ohms to 10 megohms, these accurate, noiseless fixed resistors are the choice of the leading set manufacturers for grid leaks and plate coupling resistors.

All Bradleyunits are color-coded for quick and easy identification. They are not fragile. There are no production losses due to breakage. Temperature,

## Compare These Oscillograms



Oscillogram showing noiseless performance of Bradleyunit Resistors.



Oscillogram showing noisy performance of other types of resistors

moisture, and age do not affect Bradleyunit accuracy.

Follow the example of leading radio manufacturers, and standardize on the Bradleyunit. Write for further information and prices.

ALLEN-BRADLEY CO.  
277 Greenfield Ave. Milwaukee, Wis.

**Allen-Bradley**  
PERFECT RADIO RESISTORS.

w9fw w9ftz w9fuq w9fi w9gdh w9gfo w9gm w9nk w9ui  
w9un w9us hc2gr hc2jc hc2jm k1mo k4aan k4kd k6avl  
k6boe k6ega k6cwb nn1nic vk2dc vk2jo vk2sa vk3ml  
y1lac z1zaj z1zas z1zda z1zgr z1zab x9a

SP3KX, Zygmunt C. Bresinski, Grottgera 2,  
Poznan, Poland

14,000-ko. band

w1abr w1afb w1anz w1avj w1bfz w1bkd w1bke w1bkf  
w1bkr w1bux w1bvl w1bwa w1cex w1ceh w1cib w1cmb  
w1cmx w1kx w1kn w1ko w1mo w1np w1om w1ry w1we  
w1ws w2aaw w2adr w2aet w2ahy w2ai w2amr w2aog  
w2ary w2atf w2atz w2avb w2bai w2bda w2bhg w2jg w2boz  
w2bux w2ch w2cin w2cix w2cwr w2dab w2el w2fb w2gpr  
w2hj w2hr w2mb w2md w2or w2rs w2rv w2vd w3ao w3adr  
w3ajd w3apn w3arp w3atj w3avo w3bmc w3bnu w3bph  
w3bqv w3jn w3kj w3pf w3ut w3wm w3aef w3acc w3alh  
w3be w3ft w3js w3zp w3gq w3alm w3tk w3adm w3alh  
w3apb w3ase w3axa w3axo w3bee w3bud w3caq w3ctj  
w3eqs w3djv w3dub w3hx w3mc w3uk w3tkd kfr5 ac3ir  
aulai aulak aulal aulcg au7kad fm8gkc fm8cfr fm8jo  
fm8sm fm8smu fm8xx fm8tun2 fk5er fqpmm nj2pa celuh  
ce2ab ce3ac ce3ah ce3bi ce3bm cm2jt lu2ca lu3dh oa1s  
ocna pk1jr pk3bm pk4az pylah pylaw pylax pylbr pylca  
py1cl pylcr pylcm py1id py1xl py2ag py2ak py2ay py2bc  
py2bg rx1rf rx2ax su8gm su8kx su8wy ve1br ve2aa ve2bg  
ve2br ve3da ve4cu vk2rx vk3bd vk3pp vk4rb vo8ae vs3ab  
vs7ap xpa0ja yilac yillm yilmdz z1lax ze4m

W3HO, R. D. Crawford, 106 N. Dooley Ave.,  
Richmond, Va.

w5aap w5aar w5abi w5acc w5afi w5ain w5ait w5aha w5adp  
w5ado w5ahe w5aju w5alz w5aoz w5aqe w5aqx w5ark  
w5aro w5aue w5axs w5aye w5ayo w5azv w5bbe w5bbx  
w5bdh w5bdj w5bfp w5bhm w5bhv w5bij w5bil w5ebu  
w5ec w5df w5ef w5fg w5gq w5gr w5jc w5jd w5la w5mk  
w5nd w5ql w5qq w5rj w5si w5tj w5uo w5ux w5vl w5ww  
w5yl w6ac w6adp w6aga w6alw w6ann w6arv w6axm  
w6bgv w6bly w6boa w6bpc w6bpm w6bpo w6bqk w6bvx  
w6bzy w6cuv w6cha w6cht w6chu w6cib w6cjj w6cto  
w6cul w6cui w6czx w6dbo w6dcg w6de w6djw w6dmk  
w6dog w6drb w6dzq w6dzj w6eaa w6eb w6ebg w6ec w6ecg  
w6ehi w6ej w6eii w6ejc w6el w6elq w6esb w6fz w6hs w6io  
w6pw w6eqb w6sj w6te w7aav w7abh w7abk w7afr w7aki  
w7ap w7aq w7bb w7dc w7fa w7hv w7im w7jv w7nv w7oa  
w7or w7qo w7tj w7wl w7zz ve1br velcw ve2ac ve2ca ve2od  
ve3aq ve3bm ve3bo ve3cu ve3dd ve3de ve3eo ve3hb ve3kr  
ve3rf ve4bq ve4cu ve4ic ve5cp k4aan k4akv k4kd k7kf  
x9a x29a ce3ac cm2jm cm2jt cm2sh cm5fl ct1aa ct1bx ef8ct  
ef8er lu9dt nj2pa nj3pa nn1nic oz2mb pylaa pylca pylah  
pylid pylla py2ak py2al py2bf py5af py7ab ti2hv ys1nm  
zu6w cda cx7 cmyl eq7 fqpmm kiu5 kvua ng1vo nx0nic  
wsdn xen0ja

W3AIZ, J. Frank Wise, Jr., 18 North Oak Ave.,  
Clifton Heights, Pa.

7000- and 14,000-ke. bands

w6ad w6aef w6afa w6am w6amo w6amw w6aie w6aov  
w6aqj w6avq w6awd w6bck w6bet w6bgi w6bi w6bmu  
w6btm w6bdz w6bau w6chk w6chp w6cui w6cul w6cww  
w6cxw w6dre w6dxn w6ejc w6ekc w6elm w6eif w6enx  
w6eqc w6eva w6eti w6eov w6ft w6kn w6nz w6oi w6tg  
w6xbb w7aah w7aao w7aat w7aax w7ait w7alm w7amo  
w7ba w7bb w7bu w7ex w7fe w7hv w7jv w7li w7lz  
w7ry w7ts w7tx w7ua w7uz w7vk w7wb w7wl w7zb w7zz  
ba1 cm2jm cm5cx cm8uf cmz53 d4abr d4ya ear21 ear69  
ear98 ear113 f8rkl hc2jj i1ll k4acf k4akv k4kd k4aan k6bex  
k6dvk 6dqg k6ewe kalhr nj2pa nn1nic nn1cab nfx pylaa  
pylaw pylca rpx velca velcc ve4aj ve4gf ve4hp ve4tr  
ve4ic ve5aw ve5gt vk2tw vk3kj vk3pa ykctck ck7ch vk7cw  
vk7wi wsbs x9a x29a x2x x2por wyf

W9GHI, Karlton Marquardt, Baldwin, Kans.

3500-kc. 'phone band

w1aby w1ajr w1ajt w1aoz w2aca w2bee w2gj w2nj w2vn  
w3abn w3aex w3cv w3ns w3pr w3qo w3oo w4aq w4lt  
w4oa w5aox w5aq w5awg w5awp w5kx w5pp w6abf w6biu  
w6bjq w6ekc w6ean w6ep w6awm w6kt w6rd w7acj w7aen  
w7ant w7wp w8adf w8aao w8ahz w8ajh w8akw w8ant

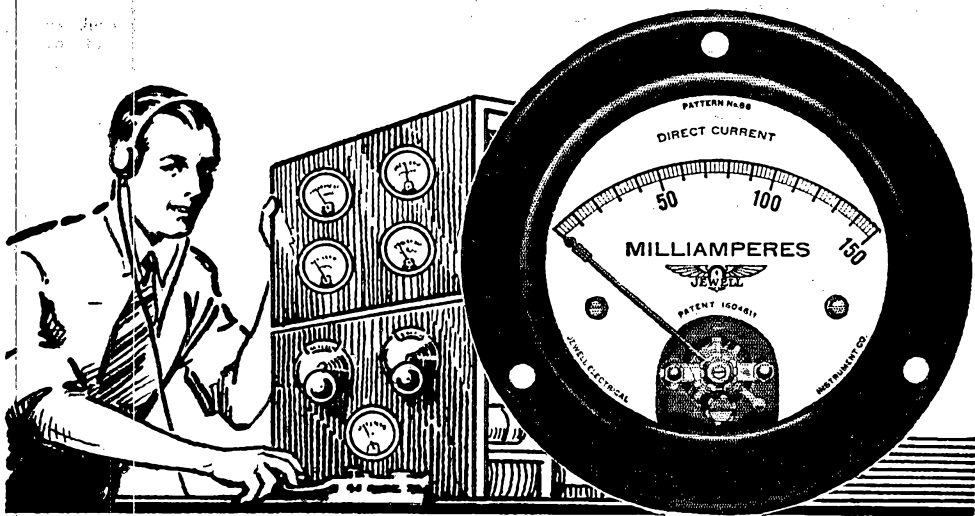

# For DX Records use Jewell Meters

Since the very inception of amateur broadcasting, Jewell Instruments have been favorites of radio hams.

Now the Jewell Trio, consisting of Direct Current, Alternating Current, and Radio Frequency Instruments, which are so popular with amateurs, is available in moulded bakelite cases.

Produced in the precision moulding plant of the Jewell Electrical Instrument Company, these bakelite cases are extremely good looking and will remain so because there is no enamel to chip off. The bakelite is thoroughly cured before the instrument is assembled. The result is a completely insulated case, neat in appearance, and one that will not show age.

Jewell Miniature Instruments in bakelite, as well as metal cases, are provided in a great variety of ranges and sizes that meet every need of amateur broadcasting.

## *New Ultra Sensitive D. C. Meters*

In these same excellent bakelite cases, Jewell now provides instruments with full scale readings of 200, 300, and 500 microamperes. These instruments in microampere ranges list at \$24.00 each.

## *Low Range High Frequency Meters*

Also in bakelite case, Pattern 68, high frequency instruments are furnished with full scale readings of 10, 25, 50, and 100 milliamperes. The 10 milliampere range lists at \$40.00; the 25 milliampere range, at \$37.50; the 50 milliampere range, at \$35.00; and the 100 milliampere range, at \$32.50.

30 YEARS MAKING GOOD INSTRUMENTS

# JEWELL

JEWELL

## Radio Instruments

**Jewell Electrical Instrument Company**  
1650 Walnut Street, Chicago, Illinois

Please mail literature covering the complete line of Jewell Radio Instruments.

Name.....

Address.....

# Are We Right?

You should have at least two of them — one for your complete 1929 file of copies, and one for each 1930 issue as published.

Keep them as a unit in a

## QST Binder

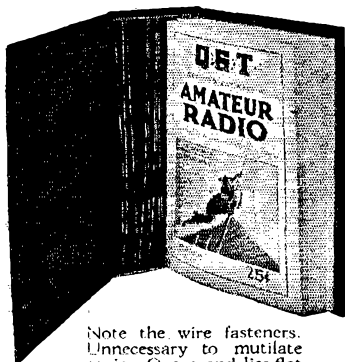

Note the wire fasteners. Unnecessary to mutilate copies. Opens and lies flat in any position.

One-fifty each  
postpaid

A binder will keep your QSTs always together and protect them for future use. And it's a good-looking binder, too.

QST  
1711 Park St., Hartford, Conn.

w8aol w8aos w8aay w8bae w8bro w8buw w8bwx w8bxq  
w8cec w8dbq w8dce w8ded w8dan w8dpd w8esl w8ne w8rw  
vethw

*W9BFW, Chester Rector, R.F.D. No. 1, Tipton,  
Ind.*

3500-ke. 'phone band

w1bjz w1cdx w1cgr w1cki w1zcg w1alk w1zap w1zaj w1zbo  
w1zgj w1zhy w1zpee w1zpyu w1zax w1zaf w1zav w1zbf w1zcg  
w1zrb w1zwm w1zraq w1zce w1zdo w1zawp w1zawg w1zbie w1zgia  
w1zgj w1zgp w1zaai w1zaf w1zafy w1zahw w1zahz w1zajw w1zakw  
w1zal w1zaou w1zasb w1zasy w1zatj w1zawu w1zbdm w1zbw  
w1zbf w1zbiw w1zboe w1zbxz w1zboz w1zbza w1zaoz w1zawt  
w1zakf w1zecz w1zefa w1zefl w1zcid w1zcmj w1zcmr w1zbsi w1zdoc  
w1zdl w1zgy w1zign w1zgki w1zlk w1zop w1zpia w1zpkp w1zrd  
w1zrw w1zsi w1zwm w1zewu w1zab w1zagr w1zagz w1zahi w1zbnv  
w1zbt w1zbx w1zcu w1zbi w1zdp w1zdpw w1zesl w1zeso w1zbiw  
w1zfbx w1zflz w1zfl w1zflz w1zghi w1zsl w1zmm w1zcyq w1zdi  
ve3ac ve3hb ve3cm

*W6BUZ, Howard Fast, 1529 South Ave., Rcedley,  
Calif.*

3500-ke. 'phone band

w5gu w5kx w6aan w6ani w6abf w6alg w6bca w6beh w6bif  
w6bjq w6bla w6bru w6bst w6bto w6bwt w6cca w6ceg  
w6cqm w6erc w6dix w6dva w6fef w6ehw w6erc w6esv  
w6kd w6kt w7aek w7aew w7if w7pw w9hcg w9cju w9dxn  
w9esl w9eyv

1750-ke. 'phone band

w9aek w9ewe w9exp

14,000-ke. band

ac1bd celah ce2ci ce3bf ce2bm k4azp k4bo lu3pa lu8dy  
oa40 on4fp pk3bm pylah py2aj ve2aa ve2be ve4bx ve5cp  
vk2jc vs6ah 6ly per wbs

*D4AAR, Christoph Schmelzer, Lichtentanne, Sach-  
sen, Germany*

14,000-ke. band

ac1bd ac3fr ar2gb ar8ufm aulai aulao aulap au7ab au7kad  
ce2ab ce3ac em2ft ct2aa filol fk2ms fk5er fk6er fm8ev  
fm8gke fm8kik fm8rit fm8sr fo2sr lu9dt pk1fr pk3bm  
pk4az pk4bg pylah pylaw py1be klcm k4azp su8an su8kw  
su8rs su8wy ti2ku velar ve1br ve2bb ve3rf vk2rx vk3wx  
vk4fe vk4fa vk4rb vk5gh vq2bh vq2hc vq4msb vs3ab  
vs7ap vs7rl vu2dr vu3kt wlabv wladw wlae wlahi w1alz  
w1apf w1aze w1bil w1bfd w1bfx w1bra w1bux w1bv w1caw  
w1cfe w1cmx w1ry w1vz w1xu w1yb w2abu w2aef w2ake  
w2amr w2amt w2anx w2aof w2aog w2arb w2avr w2auz  
w2ayr w2bka w2bki w2bh w2bla w2boa w2boz w2fl w2mb  
w2nf w2rs w2sv w3afd w3afh w3bmc w3cgs w3kf w3ln  
w4acc w4aef w4ale w4vy w4zf w7eff w8z w9erd y1ao  
yilmzd y1zq y1lf y1zb y1zbx y1zba y1z3as y1z3bx y1z4ao y1z2n  
z54e z54m z55d z55w z56z z56n rwx

*W1AZE, E. L. Hagar, 30 Adams Ave., West  
Newton, Mass.*

14,000-ke. band

ce2ab ce3ab ce3ag cm8l ct1aa ear65 ear98 f8daf f8dh f8gdb  
g2ao g5by g5ml g6mc g6wt g6vp he2jm k4kd kfr5 kfu5  
on4fe on4ro on4rs on4ls pylaw py2al py2ay an14a vefio  
vo8ae vo8aw vo8mc w6dcv w6dre w6dzi w6eic w7be w7qd  
w7jt x9a xy z51p z52n z54m z55l pu6n

*VE3ET, G. V. Lawrence, Box 186, Parry Sound,  
Ontario, Canada*

ce2ab ce3ab ce3ag ce3bf em2emg em2jt em2sh em2yb  
em3fc em5fl em8by d4an f8btr f8ex f8wb g6qb g6wy hc1dr  
hc1fg hc2bp k4akv k4kd k6bra kd5v kf2f kfu5 lu3dh lu3fa  
lu3pa lu3pu lu4da lu9dt nj2pa nlnic n7nic nncab nfx  
on4hc on4us on4ww oxa pylaa pylah pylaw pylbr pylca  
py1cl py1em pylia py2ad py2aj py2ak py2bf py2bz pylaa  
t12ea ti2hw vo8aw wfa wite wye xf8hp xw6chk xy x9a

# SCREEN GRID . . . TONE TESTED LOWEST PRICES

—No wonder they're all buying

## CROSLEY

**T**HOUGH still demanding quality, the public has an eye to economy these days! That's why Crosley Radio is now more popular than ever! Everybody is asking for Crosley—thousands of brand-new sets are rolling out of the big Crosley plant each day.

National advertising in the leading magazines and farm papers is playing its part, too. The story of how the most noted musical artists in America were engaged to tone-test Crosley Radio and give Crosley engineers the benefit of their suggestions is spreading like wildfire.

But check the sets, themselves . . . you'll see plenty more reasons why the Crosley line is so Red Hot! These sets embody every modern feature—and practically the entire line can be sold complete with tubes below the \$150 price level!

Your Crosley distributor has other facts to tell you, equally interesting and full of profit possibilities. Get in touch with him!

THE CROSLEY RADIO CORPORATION  
Powell Crosley, Jr., Pres.  
CINCINNATI, OHIO

Home of WLW—"the  
Nation's Station"

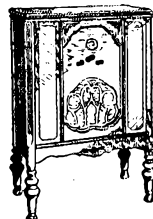

*CROSLEY 33-S. This graceful Crosley 7-tube Screen Grid cabinet model, with Dynacoil Speaker, is beautifully finished in two tones of satiny walnut veneer.*

**\$112**  
(without tubes)

*Other handsome 7 and 8 tube Screen Grid table and Cabinet models.*

**\$56.50 up!**

Western prices slightly higher

*You're there with a*

# CROSLEY

Say You Saw It in QST — It Identifies You and Helps QST

# Cunningham RADIO TUBES

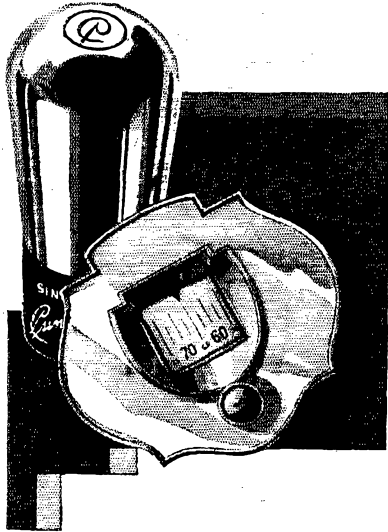

## Good Results are certain with Cunninghams behind the dial

Because of their uniform quality and carefully tested construction, Cunningham Radio Tubes can be depended upon for maximum service and absolute accuracy.

Performance claims are backed consistently year after year, by the steady, efficient service these tubes render in millions of American radio receivers.

Standard Since 1915

**E. T. CUNNINGHAM, INC.**

New York Chicago San Francisco  
Atlanta Dallas

Manufactured and sold under rights, patents,  
and inventions owned and / or controlled by  
Radio Corporation of America

George Petersen, 820 40th St., Brooklyn, New York  
City, N. Y.

3500-kc. phone band

w1abt w1bga w1cki w1qo w2abi w2acg w2acx w2alk w2aoo  
w2aow w2azy w2baj w2bcz w2bee w2bgz w2bpl w2bps  
w2bql w2bsw w2fr w2gj w2hy w2iu w2jk w2ma w2nj  
w2qn w2ry w2st w3abn w3ac w3acz w3adq w3aex w3ag  
w3ain w3ais w3anw w3aoq w3ati w3bfz w3car w3cgb  
w3cv w3jf w3aah w3adf w3adi w3aih w3agw w3akf w3art  
w3awu w3bbq w3bf w3biw w3bk w3bl w3bd w3pnd w3bl  
w3hyc w3cut w3ix w3rd w3xk w3bjw w3eto

R076 A. Comender, Burg. Meineszlaan 91b,  
Rotterdam, Holland

w1aep w1afd w1alb w1app w1bec w1bkr w1blo w1bnp  
w1bux w1bqs w1cib w1cte w1cmx w1cut w1da w1gf w1kn  
w1om w1rp w1xv w1zl w2aba w2abu w2ago w2aih w2amr  
w2ary w2ate w2atz w2bif w2bih w2bmc w2bmm w2bnx  
w2box w2bqw w2cin w2ctx w3dp w2fl w2mb w2ra w3ais  
w3asg w3bph w3tm w3pf w4ft w3adm w3atz w8cpc w8gz  
w8uk w8za w8zcc w9dar k-lkd ac1bd aulap aulaw celak  
ce2ab cm8rx fk4mi fm8cfr fm8rit f28gom lu2ca lu3dn pk4as  
py1ah pylaw pylca pylcp py3ah su5an su8kw su8rs su8wy  
velbr velbv vo8ae vq2bh yilmzd zs4q z5w z6z zu6n

AU1AI, Hitroff, Nahanowitcha St. 18, Tomsk,  
Siberia

14,000-kc. band

w1ekw w1esm w1we w1ss w2aaf w2aeb w2bai w2ch w2el  
w2dg w2hj w3ja w3nf w8ax w8au w8buo w8cu w8rd  
ac1bd ac3fr ar8umf celak celah ce2ab ce3ac ce3ag ce3bf  
ct1aa ct1br ct1bx d4uj d4al d4kg d4ug d4ul d4fv d4fw  
d4ka d4un d4jl d4yt d4hi d4aaz d4iak d4uab ei2c ce7c  
es3ex f8gdb f8fd f8pam f8fem f8ctz f8orm f8zko f8jt f8zcm  
f8eo f8ho f8bgb f8hr f8xh f8azz f8mrg f8faf f8ha f8mst  
f8hx f8he fjaap f8rab f8da f8swa f8lda f8tan f8awk f8wb  
f8zx f8aja f8jf f8whg f8xw f8vp f8rk f8ex g2ao g2bm g2zp  
g2ax g2gf g2dz g2op g5ml g5nf g5wk g5vl g5wp g5yg  
g6by g5uw g5mg g5yx g5ux g5vm g5zu g6dh g6dr g6zb  
g6xx g6vp g6wo g6za g6jg g6hn g6vj g6xn g6nf g6wl g6xq  
g6uh g6rr g6lk g6fy g6bd haf3xx haf3fx haf6b ilg1 la2c  
lu2ca lu2fi lu3dh lu3fa lu3pa luidd lu8dy lu9dt oh2nab  
oh2nad oh3nx oh3np oh5ul oh7nb okaas2 oklab oktau  
oklmx oklm on4fn on4us on4ar on4fm on4ft on4ro on4tu  
on4fc on4ij on4gm on4gr on4ja on4jx on4iw on4te on4bn  
on4ke on4my onr33 oz4v oz5a oz7y oz7ay oz7cl oz7t  
pa0fn pa0gw pa0qf pa0cx pa0dw pa0zf pa0fr pa0vn pa0aq  
pa0wim pa0wz pa0hb pa0ck pa0zj pa0wj pb7c nk1jr pk3cm  
pk1az pk4bo pylca pylcm pylaw pylcl pylas pylbr  
py1be py1ax py2ik py2ad py2bg py2ak py2bc py2ay py3rx  
zyle tdpd tm5tm tm5uv tm5yf tm5tn tmtuk tm6zb tp3ax  
tp3nb tp3kv tpps tu8an tu8rs tu8kw tu8wy un7ww aox1  
ve3ln ve3ag vk4ab vs3ab vs6ah vs7an vu2dr vu2by vu2kt  
yilmzd yilac yi2gg zl3as zs4m zu6n

W9AEW, W9BRH, Vernon Holmes, Alpha  
Sigma House, 109 River St., Iowa City, Iowa

7000-kc. band

vk3ei vk5aw kdv5 kfr5 kfr6 kfu5 ti2hv ti2wd em1az  
cm2yb cm5by cm5fl cm5ry cmz5 hcldr hclfg kc2jm x9a  
x29a zllfc zl2gk zl2go nulinic nn7nic nafx yal9j zslb hl  
tela xy k6cjs k7ak k7mk wfat

14,000-kc. band

lu3fa lu9ce pylah pylaw pylax pylcr pylcs py2ay py2bw  
py2ii velbr velcw ve5ep vo8aw kfu5 celak ce2ab ce3ab  
ce3ac ce3ag ce3bf ce3bm ti2ea ti2hv em2jt cm5fl x9a zllao  
oa4o ear96 cx2ak zs2c zs2n zu6n p88 xy

W1MS, Charles H. Horton, 173 North Adams St.,  
Manchester, N. H.

14,000-kc. band

ce2ab ce2ad ce3bf ce3bm em2jt em5cx ct1aa cx2ak f8bq  
f8da f8ex f8hpx f8jf f8oc g2ao g6dh g6gs g6wt g6wy k4aan  
k6akv on4us lu3dh lu3pa lu8en nj2pa pylah pylaw pylca  
py1cl py2ak py2ay py2ih py2ik velbr ve3bm ve3hb ve3dd  
ve4fc ve3hr ve5ep vk2aw vk5hg vk5wr vo8aw vo8mc wfa  
zs4ms



Airplane Floyd Bennett, which carried the Byrd party safely to and from the South pole

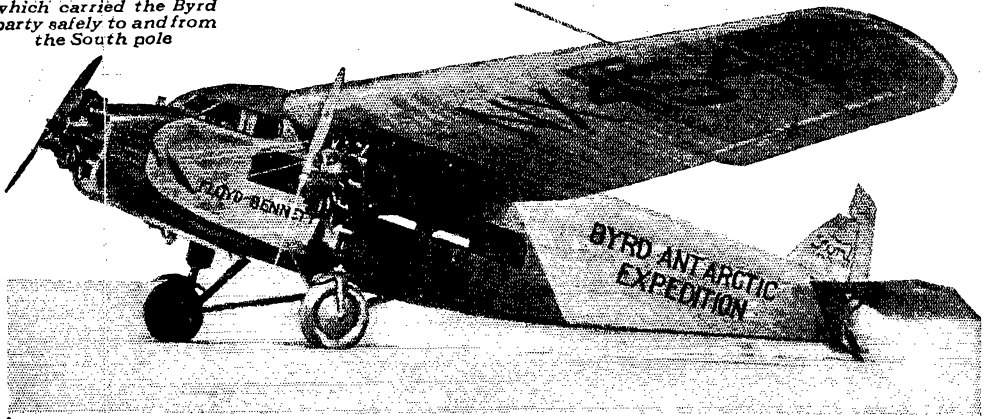

## The First Radio Message from the South Pole — flashed over antennae equipped with PYREX Insulators

*"Radio made this expedition possible" says  
Commander Byrd*

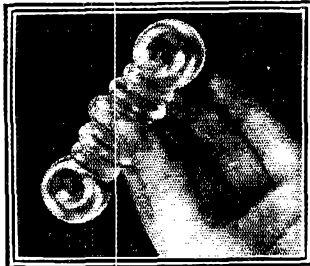

Four PYREX Insulators like this are used on the antennae of the Floyd Bennett

**T**RIUMPHANT at last, after months of preparation, Commander Byrd has flown over the South Pole. From his airplane, the Floyd Bennett, he flashed the news by radio while flying directly over the Pole.

On all his base ship, airplane, and portable stations Commander Byrd uses PYREX radio insulators, exclusively. They have well earned his confidence. The Commander's radio message that he was flying over the North Pole, his distance record for low-wave length signals, his reports from the transatlantic airplane, America — all were sent over PYREX insulator equipped antennae.

Broadcasting stations, marine and stationary radio communication systems and critical amateurs all over the world find that PYREX insulation preserves maximum strength and clarity of radio impulses.

PYREX Radio Insulators are but one of the many Corning Glass Works achievements that contribute to human safety, comfort and industrial progress.

**CORNING GLASS WORKS, Dept. 64**  
*Industrial and Laboratory Division*  
**CORNING, N. Y.**

T. M. REG. U. S. PAT. OFF.

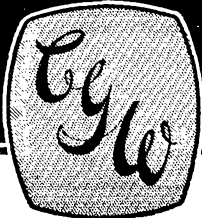

# PYREX

A MARK OF CORNING GLASS WORKS

## RADIO INSULATORS

Say You Saw It in QST — It Identifies You and Helps QST

# ACME WIRE PRODUCTS

Coils — Magnet Wire Wound  
Magnet Wire All Insulations  
Varnished Insulations  
Parvot Filter and By Pass Condensers

All products made to Recognized Commercial Standards including those of:

National Electric Mfrs. Assn.  
Radio Manufacturers Assn.  
American Society for Testing Materials

For 25 years manufacturers and suppliers to the largest and most discriminating users.

## THE ACME WIRE CO. NEW HAVEN, CONN.

Branch Offices:

New York Cleveland  
52 Vanderbilt Ave. Guardian Bldg.  
Chicago  
842 N. Michigan Ave.

## BOUND VOLUME XIII of QST

WE have now a limited number of copies of Bound Volume XIII of QST. Vol. XIII comprises the entire 1929 series of QST. This volume is made up of two books or sections, each containing six issues of QST. This volume is handsomely bound in red cloth and with gold imprint.

The complete volume is priced at \$5.00, postpaid.

Better act quickly — only a few copies available.

### QST

1711 Park St. Hartford, Ct.

W1ABG, Al Giddis, 53 Lamb St., Lowell, Mass.

7000-ke. band  
cm2yb cm5fc er3 hc2bp hc2grc hrc2 kfry nnfx nn1nic tj2wb vk3pp x9a wgrd wuaa

14,000-ke. band  
ce2ab ce3bf ce3bm cm2jt cm5ex cm5fl cr2ak d4aar d4jl d4yt f8aap f8axq f8jc ce2j g5ml g5ms g5qa g5ci g5gh g5ll g6vp g6wt c6xb g6xj haf8b lu3dh lu9dt ou1au on4fp on4hc pa0qf pylaa pylah pylaw pylax sn1aa vo8mc vp2oux wfa zu6n

W2AFJ-W2SN, H. W. Yahnel, Lake St.,  
Helmetta, N. J.

vk3pp vk3rg vk2ch vk3ls vk2aw vk3cu vk3ru vk2ns vk2hm vk3pa vk3ja vk2ao nj2pa nn0nic x29a cm2yb cm2jm cm5fm cm5fl z12bz z12gn z13cr z11fr z12bz z14bg z13cm z12al z12bz z12bi z13bb z13cm vo8z k4kd k4atr k6brt k6bra g5by tj2wd kfu5 kdvs wgrd

W5AVD, John T. Furlow, Mount Enterprise,  
Texas

7000-ke. band  
vk2aw vk2jk vk2ku vk2ow vk2yd vk3jk vk3rg vk3ru vk3vp vk3wo vk4bh vk4cg vk5gr vk5hg vk5it vk5mj vk5wr vk6he vk7lj z12gn z14ao z14ac ve4gd vetho

OKRP 19, Alois Wcirauach, Mestec Kralove,  
Czechoslovakia

w1ads w1ae w1aeh w1aep w1agx w1ajc w1ajt w1ans w1asu w1avg w1azk w1ber w1bft w1bil w1bux w1caw w1ccs w1cmx w1erd w1da w1ek w1fb w1fc w1ih w1mo w1rw w1vz w1zs w2acd w2afz w2agx w2ai w2amr w2any w2ate w2avg w2bda w2dfl w2bh2 w2bjg w2bjv w2bn w2bvx w2boa w2boz w2bss w2eh w2eug 32el w2jn w2mb w2rs w3ahw w3ajd w3ard w3atj w3cd2 w3cz w3ke w3pf w4aef w4af w4bn w4ec w4pb w4va w4zp w8adm w8bbp w8box w8fs ac1bd ar8ufm au7ab au7as au7kad celav ce2ab ce3ac ce3ag ce3bf cm2jt ct2as ct3aa fk2ms fm8gk fm8jo fm8kik fm8mat fm8rt fm8smu k4aan k4akv k4kd lu2ca lu3dh lu3dt lu3fa lu3pa nj2pa pk4bf pylaa pylad pylah pylaw pylax pylbe pylcl py2ag py2ay su8kw su8rs velav ve1cw ve2al ve2bd ve2bg ve2ca vk2no vk3xo vk5dx vk5hg vo8ae kfh5 kfu5

W6ERK, George W. Mesher, 2949 Sacramento  
St., San Francisco, Calif.

7000-ke. band  
w1abt w1rp w1agj w1cak w1cek w1adw w1mk w1sz w1asu w1anz w1xc w1xm w1xy w2fp w2gd w2bda w2fc w2fy w2blx w2cxl w2jc w2bif w2acg w2cvj w2bda w3aws w3awb w3bwt w3sn w3vb w3adf w3ckl w3ga w3db w3nz w3apn w4ahz w4gn w4ahx w4agr w4ahc w4sh w4sp w4we w4ct w4ar w4akv w4kh w5jc w5rg w5ql w5ahi w5ahb w5pg w5ix w5bfp w5bqs w5bn w5z w5aep w7aic w7lp w7abh w7abg w7bb w7aer w7aut w7lz w7acd w7aby w7agn w7ajn w7fh w7gh w7ao w7aot w7om w7pp w7ac w7df w7dd w7ar w7tx w7wh w7un w8ake w8axz w8bts w8cau w8uk w8bbp w8ads w8bek w8wo w8wz w8mb w8ekl w8bau w8bsr w8bth w8cfv w8fz w8iq w8np w8qm w8apm w8atz w8duw w8dvt w9ara w9ot w9cwx w9dwx w9eta w9eru w9ldd w9dfq w9dlq w9awn w9cka w9sk w9ai w9ar w9evn w9bkr w9ebo w9enw w9xl w9azq w9fg w9bv w9dli w9gt z12ab z12dl z11ft vk2kj ac8ag et4ab nn1nic k6cjs k6avl k6dtg k1pr k1pw k1hr k1ce k1dj k9pl et1cc cm2jt on4pj pylie z11fr oobam ac8rv

14,000-ke. band  
celah ce2ab ce3ab ce3bf cm2co cm2ay cm2jt f8ct f8fc f8fk f8hm f8jr g2ax g2zp g5by g5bq g5rb g5jo lu2ca lu8en lu3fk oa4s pylaw vk2rx vk3bq vk3cx vk3ks xw7eff vk2yj vk4bd vk3wx vk2ac vk3cp

### I.A.R.U. News

(Continued from page 50)

Oceania

Australia. 1100-1330. vk3cp, vk2lj. seasonal  
New Zealand. 0400-0600. 1200. z12bx,  
z11ao. seasonal

# "THE GOOD WILL OF THE MAN BEHIND THE GUN"!

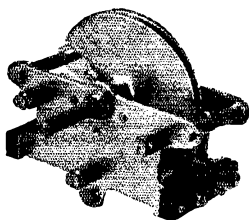
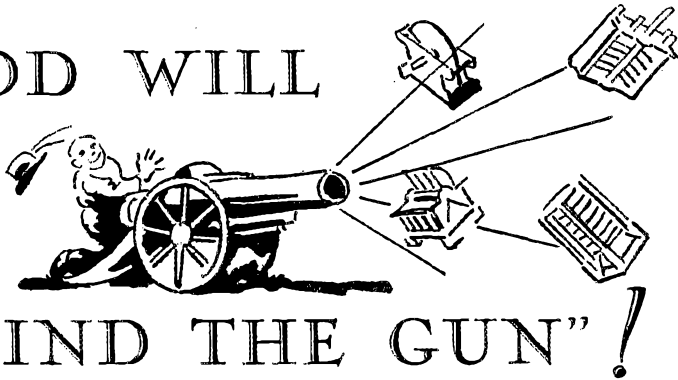

*Taper plate 191-E  
Ideal for short wave receivers*

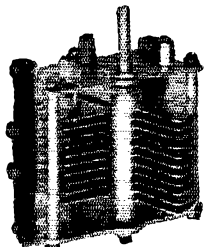

*Transmitting type 164-B  
Capacity—.00022 mmfd.*

INGENIERO Y DIRECTOR  
**AVANADO CESPEDES MARIN**  
APARTADO 25  
HEREDIA, COSTA RICA

HEREDIA  
Distancia: 150 millas  
Elevacion: 250 metros

EL CENTRO DE AMERICA  
September 18th 1929

RADIO  
**NRH  
HEREDIA  
COSTA RICA**

The Allen D. Cardwell  
Manufacturing Corp.  
Brooklyn, N. Y.

Para los que les repiteler:  
and

COLOMBIA  
CUBA  
GUAYAMA  
MEXICO  
COSTA RICA  
HONDURAS  
SALVADOR  
NICARAGUA  
COSTA RICA  
CHILE  
MEXICO  
JAMAICA  
SAN DOMINGO  
HAITI  
PUERTO RICO  
PARAGUAY  
AZORES, PEARL  
CHICAGO  
MONTREAL  
PARIS  
LONDRES  
LONDRES  
LONDRES  
LONDRES  
LONDRES

Este certificado me lo repiteler:  
Londres  
Londres  
Londres  
Londres  
Londres

Yours very respectfully,  
Avanado Céspedes Marin

La estacion de Radio más pedida del mundo transmisionde con las grandis  
Premiada por el Gobierno de Costa Rica con Franc: La mejor "Radio"

## CARDWELL RECEIVING Condensers in all standard capacities. Transmitting Condensers for powers up to 50 K. W.—Fixed (Air dielectric) transmitting condensers. One for every tube and purpose, and each one an engineering masterpiece.

Allen D. Cardwell Mfg. Corp.

81 PROSPECT STREET  
Brooklyn, N. Y.

IF YOUR DEALER DOES NOT STOCK + + ORDER DIRECT

We have prepared literature which we would like you to have. Requests will be promptly filled. Now, more than ever—Cardwell Condensers are "The Standard of Comparison."

## THE RADIO BOOK

that has been endorsed and is in constant use by United States Gov't and over 300 Universities, Schools and Technical Colleges in this and foreign countries.

# "Radio Theory and Operating"

By *Mary Texanna Loomis*

*President, Loomis Radio College  
Member Institute of Radio Engineers*

Fourth Edition revised and enlarged to 992 pages, 800 illustrations and right up to date. Flexible Kraft Leather binding.

Price \$3.50 — Postage Paid

*For sale by bookdealers throughout U. S. and many foreign countries, or may be purchased direct from the publishers. Send check or money order to*

**LOOMIS PUBLISHING COMPANY**  
Dept. 5 Washington, D. C.

## RADIO BARGAINS

### Fully Guaranteed

#### At Less Than Manufacturer's Cost

Short Wave Sets, one tube, complete with 5 coils. 30 to 550 meters. . . . . \$6.45

250 Power Amplifiers. . . . . \$19.75

7 tube A.C. Chassis completely assembled with pack. . . . . \$24.50

16 Mfd. Condenser Blocks 500 to 1000 working voltage. . . . . \$3.90

No. 1003 Power Transformers, shielded. Sec. 600 V., 7½ V. C. T. to case, 1½ V., 2 chokes. For one 281, one 250, one 227, and four 226 tubes. . . . . \$5.00

No. 875 Transformer. Sec. 375 V.—375 V. 5, 5, 2½, 1½, and 1½ V. High and low pri. and 2 chokes. Will take care of 10 A. C. tubes or less. . . . . \$4.25

Vitrified Power Pack Resistances. 180 volt 16,600 ohms, tapped at 1500, 7800, 15,100 and 16,600 ohms. . . . . 90

Microphone Transformers 95c. UX 281 type tubes \$2.25. 245 tubes \$1.75. 250 tubes \$3.50. 280 tubes \$1.35. 224 tubes \$1.95. 210 tubes \$2.75. 227 tubes 95c. 171 tubes 95c.

Send for Free List

## CHAS. HOODWIN CO.

4240 Lincoln Ave. Dept. A-8 Chicago  
Dealers in Bankrupt Radio Stocks

Hawaii. 0300-0400. seasonal  
Dutch East Indies. 1200. pk1jr. seasonal

### South America

Argentina. 2300-0200. lu9dt, lu3dh, lu2ca

Brazil. 2200-0100. pylaw, pylca

Chile. 0000. ce1ai, ce1ah, ce2ab

Paraguay. 2300-0000. zp7ab

Peru. 0300-0400. oa4q, oa4s

Uruguay. 2300. ex2ak, ex3ah

Remember that the above is for 14,000 kc., and will vary somewhat from the times stated. Some of the stations listed may be off the air, too. But it is intended only as a guide, and as such seems to be pretty darned keen. Use it.

More tables next month, including one from W6QL for both 7000- and 14,000-kc. bands.

And now for some reports of foreign activity. All of the reports herewith came by the time-honored mail route, but we have high hopes for some radio'd reports in the near future. Step on it, gang.

### DANISH SECTION

By Helmer Peterson, oz7s

Conditions have not been good lately, due mostly to the great amount of QRM and QRN.

On the 7000-kc. band many signals have been heard in the early mornings. ZL came in especially well. W1, 2, 3 and 8 were heard, but generally weaker than a month ago. During the day all Europe was heard up to about 1700 GCT, after which European signals faded out.

Conditions on 14,000 kc. are rather bad, and not at all constant. ZL and VK, and sometimes CE, LU and PY are heard, from about 0630 to 0900 GCT, but their strength is inferior to that of a month ago, and some mornings the band was quite dead. During the day most of Europe and North Africa could be heard with moderate strength.

On the 28,000-kc. band conditions have been bad. Harmonics from commercial stations were the only signals heard, although it is worth noting that these were received with excellent signal strength.

### BRITISH SECTION

By J. Clarricoats, G6CL

One of the chief events during the fall was the Fourth Annual Convention of the Radio Society of Great Britain in London. Well over 100 amateurs attended the various meetings, and real "ham spirit" prevailed throughout the proceedings. The convention opened with a lecture delivered by Mr. H. M. Dowsett on beam radio stations. A meeting of the District Delegates, at which all British areas were represented, proved most interesting, and many helpful suggestions were passed to the Headquarters staff. During the main business meeting, the election of new representative and district managers was made. The following are the names of Representative Members for 1929-30:



# Every Transmitting Amateur Uses These Forms



*—a reminder that  
your supply may be low—*

### Members' Correspondence Stationery

One color (black) heading now being used at greatly reduced cost to members. Write your radio letters on League stationery—it identifies you. Lithographed on 8½ x 11 heavy bond paper.

- 100 sheets . . . . .50c
- 250 " . . . . . \$1.00
- 500 " . . . . . \$1.75

(Postage Included)

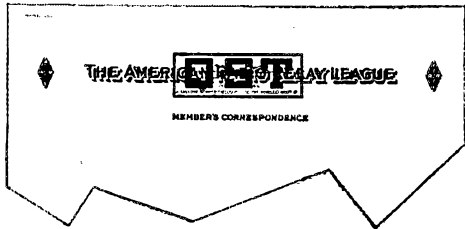

### A. R. R. L. Log Sheets

Designed by hams for hams. 8½ x 11 bond paper, punched for standard three-ring loose-leaf binder. 125 sheets postpaid for \$1.00 or 500 for \$3.50.

### Official A. R. R. L. Message Blanks

Most convenient form. Designed by the Communications Department of the A.R.R.L. Well printed on good bond paper. Size 8½ x 7¼. Put up in pads of 100 sheets. One pad postpaid for 35c or three pads for \$1.00.

### Message Delivery Cards

Neatest, simplest way to deliver a message to a near-by town. On U. S. stamped postals 2c each. On plain cards (for Canada, etc.) 1c each, postpaid.

## American Radio Relay League

1711 Park Street



Hartford, Conn., U. S. A.

# Which ?..

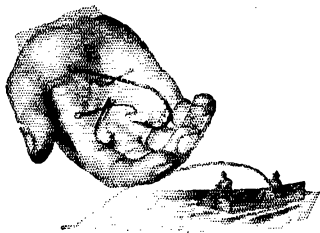

## would you buy to hook a tarpon?

"The big one," you reply — "naturally!"  
... You can see at a glance what a fishhook is capable of doing. So many of the smaller items we use are like that. They hardly require a second thought. But **RESISTORS** are not as readily distinguished — nor as readily specified — as fishhooks. You can't take three or four in your hand — pick out one — and say: "We want five thousand like this." They do require a second thought. And we specialize in giving it to them!  
We offer you specialized Resistor knowledge, an efficient production system, absolute accuracy and **RAPID DELIVERY**. We build samples to your specifications and have them on their way to you within 72 hours. . . . Your request will give us an opportunity to deliver what we promise.

### Write for our New Catalog

Catalog No. 429 shows the standard types we stock, offers specially built models and brings you simplified Resistance Tables that should prove decidedly helpful. Write for your copy.



## RESISTORS

**HARDWICK, HINDLE, INC.**

Sales: 122 Greenwich St. New York City  
Factory: 215 Emmet St. Newark, N. J.

## It's EASY to Get a HANDBOOK

(Sixth Edition)

### DIRECTIONS:

Realizing that Handbook must be had, proceed as follows:

- (1) Fill out below, tear off.
- (2) Reach in pocket, produce U. S. A. \$1 bill, old or new size (we don't care).
- (3) Clip together, mail us.

Handbook Factory,  
1711 Park, Hartford.

**SEND IT AT ONCE.**

\_\_\_\_\_  
(Name)

\_\_\_\_\_  
(Street or P. O. Box)

\_\_\_\_\_  
(City and State)

Licence Manager	G. Marcuse, G2NM
Social Manager	J. Clarricoats, G6CL
Publicity Manager	A. Watts, G6UN
QRA Manager	M. Pilpel, G6PP
QSL Manager	D. Chisholm, G2CX
Honorary Editor	G. Thomas, G5YK
Contact Bureau	G. Powditch, G6VL

The appointment of Mr. Watts as Publicity Manager has created much interest in our society, and it is hoped that in future the society will extend its sphere of activity into many new lands.

Members of foreign and colonial societies are invited to apply for membership in the R.S.G.B. The subscription per annum being 15/-. All inquiries should be sent to the Hon. Sec., 53 Victoria Street, London, S.W. 1.

Colonial receiving amateurs joining R.S.G.B. will, in future, be entitled to use a special identification number. These will take the form of B.E.R.S. (British Empire Receiving Station), 1, 2, 3, etc.

Receiving stations within the British Isles will continue to use B.R.S. numbers.

The convention concluded with a dinner attended by over 100 transmitting and receiving amateurs. Mr. Gerald Marcuse, President of the Society, took the chair at all meetings.

### GERMAN SECTION

By W. Rach, D4AL, Sec'y, D.A.S.D.

DX conditions on 14,000 kc. have improved somewhat. Among other amateurs, D4YT was able to work all continents during September and October and to get R9 reports from most parts of the world. His input was 400 watts.

D4BY continued his work from a small boat on a lake near Berlin, and with 4 watts managed to QSO ZL, VK, LU and PY.

D4AN reports fine results with a new 300-watt crystal-control rig.

D4AAR in Saxony is a newly appointed WAC member, and is very proud of it.

**IMPORTANT.**—Owing to some trouble we are compelled to ask our foreign friends not to give any messages to D stations for delivery to a third party.

Note that last paragraph, fellows. It means that for the present you shouldn't try to shoot any message traffic into Germany unless it is a message intended for the station you are working. No "third party" traffic, in other words.

### POLISH NOTES

By the Lwowski Klub Krotkofalowcow

Activity in amateur work in Poland has been stimulated greatly during the last year. The L.K.K. has added considerably to its membership, and has divided Poland into five districts, for amateur purposes. These districts center around Lwow, Warsaw, Krakow, Wilno and Poznan. District managers are appointed to head each district.

# THORDARSON DOUBLE FILTER CHOKES

**CONTAINS TWO 18 HENRY 250 MILL CHOKES**

This Thordarson heavy duty, rugged double Filter Reactor is excellent for Filter Circuits in Transmitters, Power Amplifiers, "B" Eliminators and various other purposes.

Each Choke has a 2000 Volt insulation and the D.C. resistance of each Choke is 108.5 ohms.

When connected in series this Filter Reactor has a capacity of 36 henries at 250 mills, and when connected in parallel 18 henries with 500 mills carrying capacity.

Weight for shipment 14 pounds. Dimensions 3 x 7 x 5 1/2 in. Equipped with mounting brackets.

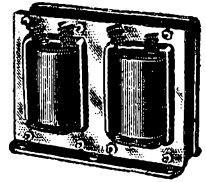

MODEL T-2458  
List Price \$19.50

**SPECIAL \$6.25**



TYPE PL 571  
List Price \$7.25

## Dubilier High Voltage Filter Condenser

**4 MFD. D.C. WORKING VOLTAGE 600 V**

These Filter Condensers are designed for use in filter circuits in Transmitters, and all high Voltage Socket power devices and Power Packs.

**SPECIAL \$2.25**

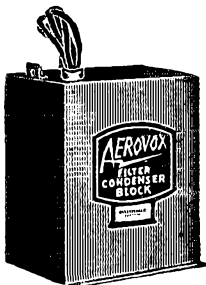

SIZE 6" x 5" x 3 1/2"

## AEROVOX OR Dubilier

**7 MFD. HIGH VOLTAGE FILTER CONDENSER BLOCKS**

Finest non-inductive High Voltage Filter Block ever made. Designed for use with UX-250 Power Tubes but can be used safely in filter circuits of transmitters or high power Amplifiers in any combination of capacities desired.

Each Unit is equipped with long, heavy, flexible leads, convenient for easy wiring, and also has mounting brackets. Latest design.

The insulation resistance of these Condenser Blocks is in excess of R.M.A. and N.E.M.A. standard requirements.

Due to the request of manufacturers of these Condenser Blocks we cannot divulge the high list price of same.

**SPECIAL \$3.25 PER BLOCK**

CAPACITY	RATED D. C. WORKING VOLTAGE
2.0 MFD. . . . .	1000 V
1.0 " " " " . . . . .	800 V
1. . . . .	800 V
3. . . . .	400 V

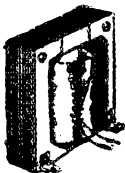

## 50 HENRIES FILTER CHOKES

These are very efficient Chokes for use in Filter Circuits for your Transmitter, A and B Eliminators or Power Packs.

The Choke Coils are very well constructed and are made with air gaps to prevent magnetic saturation from direct current.

85 MILLS  
**SPECIAL \$1.50**

## Faradon OR POLYMET

**5 MFD. HIGH VOLTAGE FILTER CONDENSER BLOCKS**

This condenser block is ideal for use in "B" eliminators, Power amplifiers and experimental work.

4 mfd. D. C. working voltage 400 v.  
1 mfd. D. C. working voltage 600 v. **SPECIAL \$1.50 PER BLOCK**



AMERICAN SALES CO., 19-21 Warren Street, New York City

ELECTRAD  
Super-TONATROL



## Built to SATISFY

YOU "DXers" who are always trying to tease your receivers into doing an extra 100 miles or so are hard on volume controls — Here's one that will satisfy you. Tests approximating 10 years' average use fail to develop signs of wear or resistance variation. Resistance element permanently fused to enameled metal plate dissipates 5-watts. Pure silver floating contact provides smooth step-less operation which improves with use. Metal cover, firmly riveted — Bakelite insulation. 7 types for every volume control purpose. \$2.40 to \$3.50.

175 Varick Street, New York, N. Y.

# ELECTRAD

INC.

Write Dept. Q1  
for Super-TONATROL circular.

## DODGE RADIO SHORTKUT QUICKLY MEMORIZED EASILY VISUALIZED PRODUCES RESULTS

From W5QN

"MOST benefit to me from DRS was the suggested and expected visualization of the symbols as you have them grouped on your chart which makes the task very simple and easy. You cannot put too much stress on this point as visualization is a product of the imagination which is a product of the subconscious mind.

"For success the code symbols must be FIRMLY FIXED IN THE SUBCONSCIOUS MIND. THE VERY BEST WAY TO DO THIS IS BY THE SIMPLE PROCESS OF VISUALIZING THE SYMBOLS AS GROUPED ON YOUR CHART.

"I never let a day go by without going over that chart and again visualizing the symbols. Speed is constantly increasing and can now read code freely at 35 per."

REPORTS from 500 Users go with DRS.

Above is the second report to mention increasing speed beyond 30 per by use of DRS.

Much "PEP" in visualization when given attention.

Radio Shortcut \$3.50. High Speed \$2.50. Money order. Foreign Add 50 Cents. C.O.D. in U. S. if send One Dollar.

**C. K. DODGE**

Box 100

Mamaroneck, New York

We have also started an official publication, called *Krotkofalowiec Polski*, whose editor is Stanislaw Kozlowski, SP3BB. In addition, short-wave publicity has been disseminated as far as possible.

In the recent elections in the L.K.K., the following officers assumed office:

President	Lt. Stanislaw Komarnicki, SP3CG
1st V.P.	Ing. Adam Ebenberger, SP3DX
2d V.P.	Dr. Tytut Vrabetz, SP3DR
Secretary	Jan Ziembicki, SP3AR
Treasurer	Karol Kulawik, SP3LV
Directors	Stanislaw Kozlowski, SP3BB, and Zbigniew Bartz, SP3FS

It will be noted that the prefix SP has been adopted to supersede the old ET, and the figure 3 used to designate all calls.

Down to the bottom again. Incidentally, we had a brilliant idea for getting in reports from our various member societies. That is, we think it is brilliant. The scheme would be to run a heading for each country where there is an I.A.R.U. member society. We'd do this each month. If we didn't get a report from that society, and couldn't generate any items about it, we'd say so, but we'd leave the heading.

On second thought we see disadvantages to this. And yet, it might work out all right. Well, we'll think about it. . . .

### REGARDING THE FEBRUARY INTERNATIONAL TESTS

We thought the paragraph above ended the department for this month, but since writing it Communications Manager Handy has asked that we insert the following item especially for the attention of foreign amateurs in connection with the forthcoming international tests:

*Attention:* All hams in localities *outside* the mainland United States and Canada.

A number of letters and radiograms have been received asking about the Relay Contest which will be held February 15th to 28th inclusive. Here's the dope in brief for all of you.

1. Read pages 39, 40, 70, 72 and 74 of December, 1929, *QST* — also the dope this issue.
2. During the tests work as many United States and Canadian stations as possible.
3. Each station worked will give you a short test message with a special number. This counts *one* in your score.
4. Write a reply of ten or more words, give it the same serial number, and send it to a different United States or Canadian station than the one from which you got that serial number. This counts *two* in your score.
5. Work as many stations as you like to run up the score. Though it's not possible to get more than three points for each station worked, you can doubtless work many stations during the contest. Turn in your confirmations promptly at close of the contest (see Rule 6).
6. The summation of all the points made with individual stations is to be multiplied by the number of United States and Canadian districts



# Here's the Answer

to every question about the principles, methods, or apparatus of radio transmitting and receiving. A complete course in radio operation in a single volume.

## THE RADIO MANUAL

A New Edition

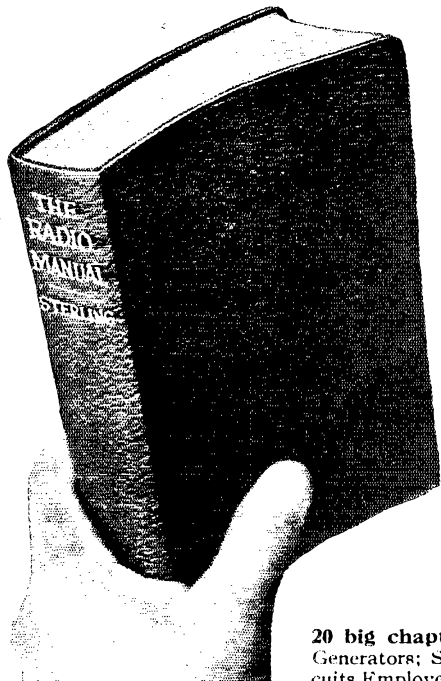

Complete  
Preparation  
for  
Government  
License

Complete new chapters on aircraft radio equipment; Practical Television and Radiomovies with instructions for building a complete outfit; radio interference; 100% modulation; latest equipment of the Western Electric Co.; the Marconi Auto-Alarm System; and many other developments of the past year. All this information is added in the new edition and, besides, the entire book has been brought right up to date with much new material. **The Radio Manual** continues to be the one complete and up-to-the-minute handbook covering the entire radio field.

*A Complete Handbook of Principles, Methods, Apparatus for Students, Amateur and Commercial Operators, Inspectors*

By G. E. STERLING, Radio Inspector and Examining Officer, Radio Division, U. S. Dept. of Commerce.

Edited by ROBERT S. KRUSE, for five years Technical Editor of QST.

**20 big chapters cover:** Elementary Electricity and Magnetism; Motors and Generators; Storage Batteries and Charging Circuits; The Vacuum Tube; Circuits Employed in Vacuum Tube Transmitters; Modulating Systems and 100% Modulation; Wavemeters; Piezo-Electric Oscillators; Wave Traps; Marine Vacuum Tube Transmitters; Radio Broadcasting Equipment; Arc Transmitters; Spark Transmitters; Commercial Radio Receivers; Marconi Auto-Alarm; Radio Beacons and Direction Finders; Aircraft Radio Equipment; Practical Television and Radiomovies; Eliminating Radio Interference; Radio Laws and Regulations; Handling and Abstracting Traffic.

An immense amount of information never before available including detailed descriptions of standard equipment is presented.

### Examine It Free

Never before has so complete a treatment of radio theory and operation been compressed into a single volume as in this Revised Edition of **THE RADIO MANUAL**. Here is information that otherwise you could secure only by consulting many different books. And every detail is vouched for by authorities of the first rank. The Manual is profusely illustrated with hundreds of photographs and diagrams. There are 900 pages, bound in flexible fabrikoid that is extremely durable. The immediate demand for so valuable a handbook will quickly exhaust the first edition. To be sure of receiving your copy without delay, order at once. The volume will be sent for free examination. Pay or return in 10 days.

### Order On This Coupon

.....

D. VAN NOSTRAND CO., INC., 250 Fourth Ave., N. Y.

Send me the Revised Edition of **THE RADIO MANUAL** for examination. Within ten days after receipt I will either return the volume or send you \$6.00. — The price in full.

Name..... (QST 1-30)

St. and Number.....

City and State.....

# HARNESSING A MIGHTY POWER your Radio!

a delicate, intricate network of coils and transformers — cascading amplifications tube by tube. Such power must be harnessed — if the result is to be a smoothly flowing, clear reception.

A CENTRALAB volume control in your radio does just that . . . and it does it smoothly . . . silently . . . surely. It means much if your radio is CENTRALAB equipped.

## Centralab

Central Radio Laboratories  
20 Keefe Ave. Milwaukee, Wis.

## 2 Testers you need at a price you can afford



Ratest Pocket \$7.50  
Oscillator

Simple and handy as a flashlight. A combined high and low frequency generator and continuity tester; furnishes signal for synchronizing and neutralizing and for final checking; tests audio frequency amplifier; checks small and large condensers; can be used as code test. A marvelously efficient, compact radio trouble shooter that speeds up your work.

## Ratest Handy \$19.50 Tube Checker

Tests Screen Grid and all other tubes in general use, both A. C. and D. C. Incredibly simple and compact, yet the most efficient tester ever designed. No complicated switches. Separate socket for each voltage, with voltage and normal readings plainly shown. Operates from A. C. line. Anybody can use — practically foolproof. Comes in handsome hardwood case — an ornament to your counter or shop and the best \$19.50 you ever spent for tube service and sales.

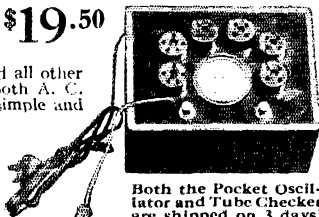

Both the Pocket Oscillator and Tube Checker are shipped on 3 days trial. Purchase price refunded by express agent, if you are not entirely satisfied. You can't lose

RATEST INSTRUMENTS COMPANY  
Greenwood, Miss.

with which you have succeeded in communicating during the contest in determining the total score.

7. Certificates of Merit in our Third International Relay Competition will be awarded the winning amateur stations in each foreign locality or country as determined by the list of international prefixes. (See a photograph of one of these handsome certificates elsewhere in this issue of *QST*.)

The frequency bands that will be used by United States and Canadian amateurs lie between the following limits: 14,000-14,400; 7000-7300; 3500-4000; and 1715-2000 kc. Those who can use 14,000 kc. will find it to their profit to do so in these tests to make 100% use of the 24 hours in every day.

A word of caution: North American amateurs working *outside* their assigned frequency bands will disqualify both themselves and stations they handle test messages with and make it impossible for either to receive a certificate in case they should qualify for it. So see that stations you work are *INSIDE* whatever band they are near before you call them. *You* may use any frequency permitted by your government's regulations.

Better get your station ready for the tests NOW. If you can't receive on 3500, 7000, and 14,000 kc., you are going to be handicapped in the tests. The transmitter should be able to go quickly from one band to another too to make best use of all the operating time.

Do the best you can in the February Contest and let us have a report of each and every score for *QST*. Even if it proves to be only "1," due to hard luck in burning out a tube, we want it just the same.

Here's luck to all. Looking forward to February 15th and to your reports. — F. E. H.

## A Power Transformer for the Lean Purse

(Continued from page 25)

which had been removed is next replaced and a 1/4-inch hole is drilled in each corner of the core for the mounting bolts which also hold the core together.

Before making the final connections and mounting the terminal strip, the voltage delivered by the filament winding should be checked. Connect the filament of a UX-210 (or of two UX-210's in parallel) to the filament winding terminals and excite the primary from the 110-volt a.c. line. The voltage across the filament winding should be 7 1/2. If it is too high, remove turns from the winding until it is correct. The filament winding may now be taped.

The honeycomb coils should be connected as shown in Fig. 1, the two 1500-turn coils being in the center and the 1250-turn coils at the ends. The inside connection of one coil should be connected to the outside lead of the next, care being taken to keep the leads insulated from the windings and other leads. The leads from the primary, filament and high-voltage secondary are brought out to

# YOU'RE WANTED *for a*

## Big Pay Radio Job

**Amateurs— you are just the men Radio wants for the many \$50, \$60, \$75 and \$100 a week jobs opening every year.**



Broadcasting stations need trained men continually for jobs paying \$1,800 to \$5,000 a year.



Operators on board ships see the world with practically no expense and make \$85 to \$200 a month besides.



Servicing sets is paying N.R.I. men \$200 to \$1,000 a year in spare time.



Hundreds of operators will be needed soon for commercial land stations being opened in our leading cities.



Radio Factories employ thousands. Salaries for well-trained men range from \$1,800 to \$5,000 a year and over.



Why not capitalize on work that is fun to you—get in the field—get some of the good jobs that are opening regularly. My Employment Department is getting three times as many calls for graduates this year as it did last year.

**Pick the job you want  
I'll train you quickly to fill it**

You've got a good start towards success in Radio. You are the logical man for this work—you are deeply interested in Radio—and with a little more preparation I am sure we can fit you for one of Radio's good jobs. Many amateurs have stepped into fine jobs after completing my course. Read their letters in my book "Rich Rewards in Radio."

**Television and Talking  
Movies are included**

Principles underlying Television, constructing Television experimental apparatus, Radio's use in connection with Talking Movies, by Railroads, in Aviation, Broadcasting Stations, Shipping Companies—not one branch, but all of them are covered. You're not a "one

job" man when you finish my course. You're ready for a large number of them.

**Lifetime Employment  
Service**

I not only train you quickly and inexpensively at home during your spare time, but when you graduate I help you find a job. The services of my Employment Department will be open to you as long and as often as you need its help.

**Your money back if not  
satisfied**

The day you enroll I will send you an agreement legal and binding upon the Institute to refund every penny of your money when you complete my course if you are not satisfied with my lessons and instruction service. You are the only judge.

**Get my book at once**

I couldn't begin to tell you all about the many features of my training in this small space. So send for my book. It won't cost you a cent and you won't be under the slightest obligation. Clip and mail the coupon at once.

J. E. SMITH, President,  
National Radio Institute,  
Dept. OA 46, Washington, D. C.

### I give You 8 Outfits of Radio Parts for a Home Experimental Laboratory

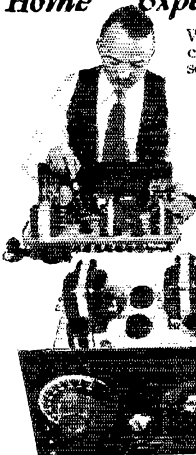

With them you can build over 100 circuits. A. C. set circuits, those using screen grid tubes, push pull amplification, circuits designed for all types of vacuum tubes in all types and stages and others are included. You experiment with and build the fundamental circuits used in

front view of five tube screen grid tuned Radio frequency set that you can build with my parts.

Majestic, Radiola, Stewart-Warner, Zenith, Philco, Edison, Stromberg-Carlson, and other sets.

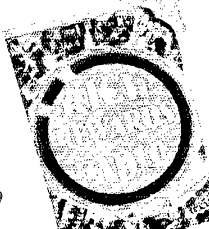

**THIS COUPON IS GOOD for  
One FREE COPY OF  
MY BOOK**

*mail it  
now*

J. E. SMITH, President,  
National Radio Institute, Dept. OA 46,  
Washington, D. C.

Dear Mr. Smith: — Send me your new 64-page book "Rich Rewards in Radio."

Name .....

Address .....

City.....State.....

90J

of La Grange, Ill., says:

## New Super Wasp AC Short Wave Receiver

Is a Wow!

Got 5SW Phone Broadcast first night in operation. Comes in kit form or completely constructed.

1930 Ham-Book FREE

Everything for Hams. Crystals and Crystal Holders. 3000 volt new type R3 Recto bulbs (\$10.00). If it's good, we've got it!

Send today for your free copy

**Chicago Radio Apparatus Co.**

Dept. Q

415 S. Dearborn Street Chicago, Ill.

The NEW Martin

## VIBROPLEX No. 6

Reg. Trade Marks: Vibroplex; Bug; Lightning Bug

In Attractive Colors Blue Green Red

The smoothest, easiest-working bug on the market. 10 New Features. Fast or slow speed. A great bug for amateurs.

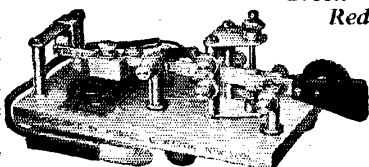

Black or Colored.....\$17 Nickel-Plated.....\$19

**Famous Improved VIBROPLEX**

Used by tens of thousands of operators because of its ease and perfection of sending.  
Black or Colored.....\$17  
Nickel-Plated.....\$19

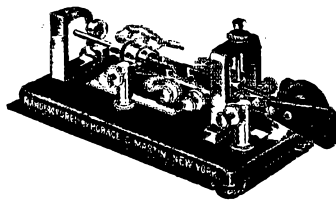

**Special Radio Model** Extra Large, Specially Constructed Contact Points for direct use without relay. Black or Colored.....\$25

Your old Vibroplex accepted as part payment Remit by Money Order or registered mail

**THE VIBROPLEX COMPANY, Inc.**

825 Broadway, New York City

Cable Address: "VIBROPLEX" New York

the binding posts on the terminal strip which is mounted on two U-shaped pieces bolted to the core. The secondary should also be taped and the whole transformer given a good coating of insulating paint. This improves the appearance and gives better insulation.

Using the two 1500-turn coils only, the plate winding delivers about 375 volts each side of the center-tap to a full-wave rectifier. The entire secondary winding delivers about 685 volts each side. The lower voltage is the only one which has been used so far, the rectifier being either a UX-280 or a pair of UX-201-A's in a full wave circuit. The transmitter is operated on 14,000 kc. (20 meters) and uses two UX-210's. Two out of three reports are "pure d.c." or "xtal", and the UX-201-A's deliver just as much plate current (70 milliamperes) to the transmitting tubes as the UX-280 does.

For a filament center-tap, two 10-watt, 110-volt lamps are connected in series across the filament winding with the center tap connection to their mid-point. This arrangement has been giving f.b. service.

A high-resistance "bleeder" across the output of the filter is used and recommended. It saves filter condensers and discharges the filter when the set is shut down.

The honeycomb coil type of secondary might be used for higher voltage secondaries (if the current required by the transmitter is not too great). The dope for transformer design will be found in the Handbook.

## Plate Supply Filters and Keying

(Continued from page 40)

More voltage (average value as read by a d.c. voltmeter) can be supplied to an oscillator tube than the transformer secondary is capable of supplying at practically no load to a high resistance a.c. voltmeter. A filter may be laid out in such a manner that a transformer giving 750 volts a.c. on each side of the center tap may actually deliver 900 volts at 125 milliamperes. Peak values of voltage across the rectifier output may reach much higher values than 750 times 1.41, which helps explain why so many condensers so placed are mysteriously blown. Those same condensers and choke coils can be rearranged so that this same transformer will not be capable of supplying more than 650 volts at 125 mil amps. To explain this consider a simple case.

Take a transformer giving 750 volts effective on each side of center tap at no load and place a good condenser across each half (no rectifier tubes) and measure the voltage. It may be well over 1000 volts effective if the condenser is large enough and good enough. Take a pair of resistances each of which is adjusted to draw the same current as the condensers did, and substitute them in place of the condensers. The voltage now may be 700 volts. A pair of choke coils, each drawing the same current as the condensers or resistors, will show a still lower voltage. The better the time constant, (the  $L/R$  ratio) the greater will be the drop. Much the same results are ob-

# CRYSTAL CONTROL TONE for C. W. Transmission

REL Cat. No. 215 Basic CW Telegraph Unit is the typical modern multi stage transmitter for the amateur who desires to use the best. Frequency flexibility throughout each amateur band with crystal controlled note at all times. Shift quickly and easily anywhere in the bands.

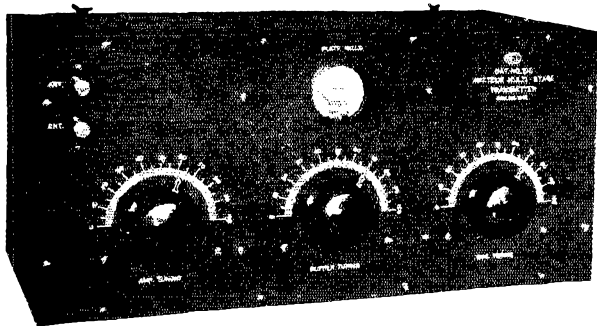

**CAT. 215 TELEGRAPH UNIT**

The REL Cat. No. 215 transmitter kit is furnished with all necessary parts including metal case, drilled and engraved aluminum front panel and a very concise instruction booklet giving information on the assembly and operation. Extremely simple to operate. Consumes minimum amount of power. Employs standard broadcast receiver tubes. May be operated from B batteries, ordinary B eliminators or other similar sources delivering 300 volts D.C. A complete low power transmitter ready for immediate operation. Employs UY-227 master oscillator tube, UY-224 screen grid buffer tube and UX-245 power amplifier tube. Will deliver 10 watts to the antenna as a CW telegraph transmitter.

The Cat. No. 215 CW transmitter kit has been specially priced to meet the demands of every amateur. The price including one set of plug-in coils for any of the three popular bands is **\$56.00**. (When ordering specify for which band you desire the coils.) Additional coils to cover other bands may be purchased at \$7.00 per set of three.

## 100% MODULATION for Phone Work

REL No. 225 modulator and speech amplifier unit designed to operate in conjunction with Cat. No. 215 CW telegraph transmitter functions as 100% system modulator. When used with Cat. No. 215 unit will deliver 30 watts on modulation peaks into the antenna.

The REL Cat. No. 225 modulator and speech amplifier kit comprises all apparatus necessary and also includes metal cabinet and drilled and engraved aluminum front panel. The cabinet has the same height and depth dimensions as the transmitter. The modulator may be placed directly alongside of the Cat. No. 215 thereby giving a very neat appearance.

The same type of power supply may be used except that the plate voltage necessary will be 550 to 600 volts. The UX-250 tube is employed as modulator and the UY-227 tube is employed as speech amplifier. The No. 225 modulator kit sells for **\$42.00**.

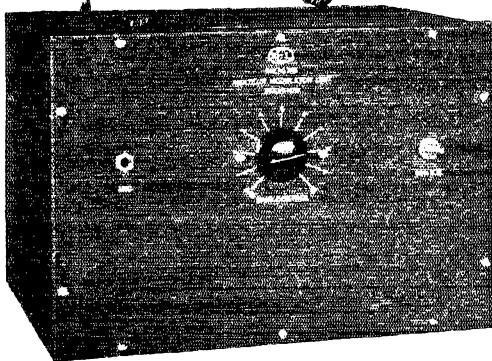

**CAT. 225 MODULATOR UNIT**

The amateur who desires a modern station should install both of these units. He will then have a perfect CW transmitter and a clear 100% modulated phone set. REL will be glad to forward you literature describing these two units

**RADIO ENGINEERING LABORATORIES, INC.**  
100 WILBUR AVENUE, LONG ISLAND CITY, N. Y.

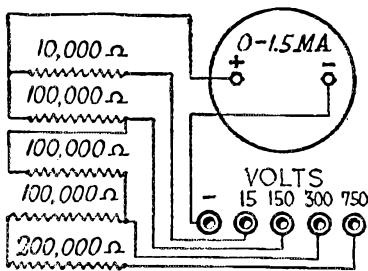

## A Voltage Multiplier

The Super Akra-Ohm wire-wound Resistor is especially adapted for use as a Voltage Multiplier as shown in the above diagram. It is carefully designed to insure an accuracy of 1% and a constant permanency of calibration. Its use is also highly recommended for Laboratory Standards, High Voltage Regulators, Telephone Equipment and Television Amplifiers and Grid and Plate Resistors, etc.

**BULLETIN 62** contains the first complete chart for the use of accurate resistors with microammeters and milliammeters. Send for your copy today. There is no obligation.



**Shallcross Mfg. Company**

**ELECTRICAL SPECIALTIES**  
700 PARKER AVENUE  
Collingdale, Pa.

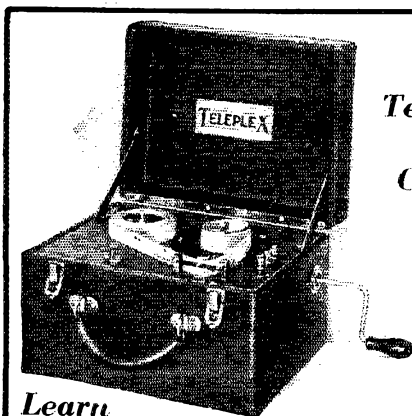

*It  
Teaches  
the  
Code!*

## Learn Telegraphy with TELEPLEX

**TELEPLEX** is the practical code instructor. Works like a phonograph. Waxed tape records send signals like a real operator. Complete code instructions furnished with every Teleplex. Sends messages, radiograms, etc.—regular code traffic like an expert operator. Used by all leading schools. Endorsed by U. S. Navy. **Guaranteed to teach you the code or it costs nothing.** Speedy, simple, clear. Ideal for advanced students or beginners.

### FREE 10 DAYS TRIAL!

So sure are we that you will be absolutely satisfied with your purchase, that we will let you try it in your own home ON 10 DAYS FREE TRIAL! You are the sole judge. Where can you match that astounding offer? **ACT TO-DAY!** Write for full facts about Teleplex. No obligation.

**TELEPLEX CO., Dept. N-12, 76 Cortlandt St., New York, N. Y.**

tained by using different loads across the output side of a full wave rectifier, as in the latter case the load simply has a tube in series with the active half of the transformer winding. It comes down to this: A capacity of sufficiently high value whose losses are low will actually boost the voltage, but a condenser with considerable leakage and dielectric losses will not be as effective as one of the same capacity of better construction. It is just as important that a good condenser be used as it is that a choke coil of low d.c. resistance be used.

Since  $C_2$  has a choke coil placed between it and the rectifier and therefore has a smoother voltage across its terminals, it is not possible for it to accomplish the same effect upon the final voltage that  $C_1$  is capable of. In fact, it will usually have the opposite effect that  $C_1$  has. A specific case is one in which  $L$ , Fig. 1, was 30 henries,  $C_2$  was .5  $\mu$ f. and  $C_1$  was removed. The voltage available to a 250-watt tube from a 2000-volt, 1-k.v.a. transformer was only 1650 volts at 190 milliamperes. With  $C_1$  replaced in the circuit and equal to .5  $\mu$ f., the plate voltage became 2250 with a plate current of 230 milliamperes to the tube. In the latter case the load presented to the transformer was capacitative and not inductive, and the output into the antenna was 40% greater.

In conclusion, the amount of capacity which can be placed directly across the rectifier output is limited by the current carrying capacity of the rectifier tubes and transformer and by the difficulty they add to keying, and by the fact that a capacity so placed may deliver too much voltage to the oscillator. If  $C_2$  is too large, keying is impaired and the voltage suffers. Large capacitances are worse trouble makers than inductances capable of storing the same amount of energy, due to the high rate of change of current possible in condensers when they first begin to charge or discharge. Because of these facts, the use of more inductance and very little additional capacitance is recommended in amateur filters, regardless of the number of sections.

## Official Frequency System

*(Continued from page 41)*

tained constant. During each transmission by W1XV-W1AXV the integral frequency nearest its exact frequency within 1/100 of 1% will be announced for the benefit of those able to use such accuracy, but for all general amateur purposes the frequency of transmission of both stations may be assumed equal to the figures as herein given. While no responsibility, financial or otherwise, is assumed for the accuracy of these transmissions, every effort will be made to have it exceed the figure given.

Reports on Standard Frequency Transmissions are solicited from all who take advantage of this service. No matter how far from or how near to the transmitting station you may be, your report will be of value to us. Standard blanks which will facilitate your filling out and our handling of the reports are available on request. All such requests and reports should be addressed to: Experiment-



# Speed . . . Accuracy . . . Skill . . . in trouble shooting

**A**“MAZING!” That’s the way radio technical men speak of the SUPREME DIAGNOMETER. Its numerous remarkable qualities have brought the complete facilities of the laboratory to the home of the set-owner — adding speed and accuracy to the skill of the service-man. No other device approaches it in flexibility, completeness and range. Set testers check only 29%–40% efficient in comparison with its capacity. Comes in handy carrying case providing compartments for all tools and spare tubes, or at the option of the purchaser, in an even smaller case, for the service-man who does not wish to carry tools and tubes in same unit.



## and, now, the most practical laboratory test panel

In keeping with SUPREME standards, unquestionably the most advanced test panel ever produced. Of heavy reinforced bakelite, it adds to the trim workmanlike appearance of laboratory or shop. Makes the DIAGNOMETER a dual purpose instrument — shop or portable service — instantly disconnectable.

*Most good distributors stock the Supreme. If yours cannot supply you, address, for full information, without obligation,*

**SUPREME INSTRUMENTS CORPORATION**  
351 Supreme Bldg. Greenwood, Miss.

# SUPREME

## Radio Diagnometer

*conceivable*  
Makes every test on any Radio Set-

### “Supreme” Features

The Supreme oscillation test gives the only dependable test on tubes; tubes tested under actual operating conditions.

The Diagnometer tests all tubes, including screen grid.

Tests both plates of 80 type rectifier tubes; provides bias emission tests on tubes.

All tubes tested independent of radio.

Locates unbalanced secondaries.

Reads both positive or negative cathode bias.

Provides D. C. continuity test without batteries.

Furnishes modulated signal for testing synchronizing, neutralizing, etc.

Aligning of condensers by Thermo-couple meter or A.C. meter.

Neutralizing with tubes used in the set.

Tests gain of audio amplifiers.

3 precision meters; one 4 scale D.C. Voltmeter 0/750/250/100/10 volts, resistance 1000 ohms per volt. One 4 scale A.C. Voltmeter 0/750/150/16/4 volts. One 3 scale Mil-ammeter 0/125/25 mills. 0/2—1/2 amps.

External connection to all apparatus.

Universal analyzer plug.

Thermo-couple meter for varied uses.

Measures resistances in three ranges, 150 to 30,000 ohms (calibration curve furnished) 10—200 ohms .1 to 25 ohms.

Makes all analysis readings.

Screen grid socket analysis without producing oscillation.

Measures capacity of condensers .1 mfd to 9 mfd.

Tests charger output by meter.

Bridges open stages of audio for tests.

Rejuvenates thoriated filament tubes.

Contains 500,000 ohm variable resistor, 30 ohms rheostat and .001 mfd, .002 mfd and 1 mfd condensers for testing.

Detects shorted variable condensers without disconnecting r.f. coil.

Provides low resistance measurement for rosin joints.

Provides simultaneous plate current and plate voltage readings and the customary readings of A.C. and D.C. filament voltage, grid voltage, cathode bias, screen grid voltage, line voltage, etc.

The laboratory test panel is equipped with a variable condenser for varying the frequency of the oscillator.

Provides many other tests, readings and functions.



# LISTEN

--there's  
**NO HUM**

With

# ARCTURUS

BLUE A-C LONG LIFE  
**RADIO TUBES**

**ARCTURUS RADIO TUBE COMPANY**

Newark, New Jersey

## WANTED

Burnt out transmitting tubes. Types 204, 204A, 851, 852, 856, 860, 861 and W. E. 228

**VACUUM TUBE EXCHANGE**

954 Slocum Ave.

Ridgefield, N. J.

## HILET POWER TRANSFORMERS AND CHOKES

2 KW 2000-2500 volts each side, \$40.00, 700 watts, 1000-1500 volts each side, \$14.50, 250 watts, 500-750-1000 each side, \$10.50, unmounted \$9.75. 100 watt 325 volts each side, two 7 1/2 V windings, \$6.50. 100 watt filament any voltage \$4.50. Chokes with adjustable core 250 MA \$7.50, 160 MA \$6.00, 500 MA 30 H \$25.00. Specials to order. Write for specifications.

HILET ENG. CO. (One Day Delivery) ORANGE, N. J.

## MEN ARE IN DEMAND

IN ALL BRANCHES OF RADIO

Prepare thru a school with a reputation for efficiency. Our courses are easy, interesting and effective. We have large classrooms, laboratory, workshop, dormitory, and many other new features.

Subjects Taught  
Commercial Radio      Radio Service  
Radio Broadcast      Laboratory  
Vitaphone-Musician      Navigation  
Radio Mathematics

Mid-year Semester Begins Jan. 20, 1930  
Literature upon Request



# COMMERCIAL RADIO INSTITUTE

38 W. BIDDLE ST. **FOUNDED 1920** BALTIMORE, MD.

ers' Section, American Radio Relay League, 1711 Park St., Hartford, Conn.

After your report has been checked and acknowledged, it will be forwarded to the Standard Frequency Station upon whose signals it comments.

OFFICIAL FREQUENCY STATIONS  
(Required accuracy 3-10 of 1%)

W1AVW-W1ZL, W1AWW, W1AXA, W1BD, W1BZQ, W1CCW, W1CK, W2BO, W2CDC, W2CLA, W2DS, W2EF, W2MU, W2UV, W4BY, W4LK, W5EW, W5OX, W5SP, W4ZAV, W6AKW, W6AM, W6AYC, W6ACE, W6AVJ, W6BB, W6BGM-W6CVO, W6BMW, W6BRO, W5BZU, W6CAE, W6CDY-W6CPX, W6CMP, W6EC-W6XE, W6QL, W6QX, W6WN, W6ZV, W7AAT, W7GQ, W8AQ, W8APZ, W8BAV, W8BZT, W8EQ, W8GZ-W8ZG, W9AHQ, W9ACG, W9BGH, W8BGK, W9BVC, W9CPM, W9EFO, W9EGU, W9IG, G2PD, G2NM, G5BY, G5YK, G15NJ, VE2BE, VE3CO, VE3FC, VE4BT, VK5BG, VK5LF, VK7CW and ZL2AC.

STANDARD FREQUENCY TRANSMISSIONS OF WWV

Schedules of standard frequency transmissions from WWV, The Bureau of Standards, Washington, D. C., will be found on page 19 of the August issue of *QST*.

—J. J. L.

## The A.C. High-Frequency Receiver

(Continued from page 14)

grade to keep noise down to a minimum level, as otherwise the noise resulting from an inferior shunt resistor will outweigh the advantages gained.

There is little that could happen to a correctly built receiver of the type shown to prevent its successful operation. The amateur is usually able to remedy difficulties encountered in d.c. operated receivers, so the only stumbling blocks he is likely to encounter are those due to the feature of a.c. operation.

If it is found that the receiver has a decided hum when it is operated entirely from the 110-volt 60-cycle line, it is quite likely that the "B" battery substitute is the cause of the major portion of this hum. The use of an adequate filter on "B" substitutes cannot be too urgently recommended: Doubt regarding the effectiveness of the substitute can be dispelled, however, by operating with "B" batteries. The total plate current of the receiver is only 4 milliamperes, and this is a sufficiently small drain to make the use of even the smallest size "B" battery economical. With a "B" battery plate supply the only possible source of hum is that due to the heater circuits, and hum from this source will not ordinarily be found objectionable. If hum is serious with the battery plate supply, it is quite possible that the heater circuit has not been grounded, that the heater voltage is not high enough, or that an unusually bad tube has been encountered.



## THORDARSON TRANSFORMER

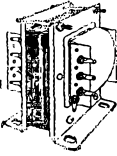

150 watts, 400 volts each side of centre tap at 375 M. A. 5 volt filament, centre tap. Fine for power supply for 7 1/2 watt or for crystal control power supply. Specially priced for a short time only. Each \$3.95

Make your own transmitting and receiving coils. Copper tubing transmitting inductance.

	Size of tubing		
Inside Dia.	3/16"	1/4"	5/16"
2 1/8"	9c	10c	12c*
2 3/8"	9c	10c	15c*
3 1/8"	10c	12c	17c*

Prices per turn

Ham Green, double silk covered, No. 16 receiving inductance.  
2" diameter.....30c per inch  
3" diameter.....35c per inch

# LEEDS

*The Home of RADIO*  
**45 VESEY STREET**  
NEW YORK  
New York's Headquarters for  
**Transmitting Apparatus**  
*When in Town Visit Our Store*

EVERYTHING IN  
ACME JEWELL PYREX  
BRADLEY FLERON  
THORDARSON  
ELECTRAD NATIONAL  
LYNCH SIGNAL  
FLECHTHEIM  
NATIONAL RECTOBULB  
GENERAL RADIO  
CARDWELL  
IN STOCK

## THORDARSON B-Eliminator TRANSFORMER

using the Raytheon B-H tube. Will carry the maximum current consumption without overheating. 285 volts on each side of centre. Lower voltage may be obtained if desired. Listed at \$5. Special NOW only...\$1.65

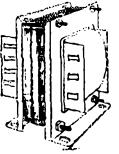

## NEON GLOW LAMPS

Made by General Electric Co., type G. 10, standard base, 101 uses, as illustrated in QST May, 1928, issue page 17. Price only.....65c

Aluminum Shield cans and panels of every description to order.

## SHORT WAVE RECEIVER

### The LEEDS 1930 SPECIAL

A short wave receiver that's got them all beat. Best circuit design and finest mechanical construction. Praised by "Hams" everywhere as the greatest short wave receiver ever made.

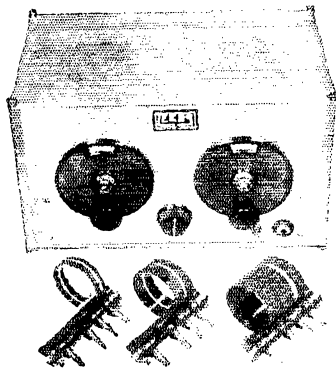

— detector — 2 audio, using three 201-A tubes. Universal type, continuous range 15 to 100 meters; amateur type covers Ham bands 20-40-80 meters with generous spread on the dial.

List price \$60.  
Special Offer, net.....\$37.50\*

What some prominent users say — "More than delighted with its performance." "4PD." "Far exceeded expectations." "2AFS." "Oscillation and tuning control far best I have ever seen." "Signal strength amazingly loud and response very clear."

In use by a constant host of Hams from coast to coast. 3-tube Receiver

## NEW 1930

## SHORT WAVE X-MITTER

### The LEEDS High-C 75 Watter

A real X-mitter for those who are satisfied only with the best. Incorporates all the latest developments of the past year, insuring highest efficiency. Size 10" x 14" x 17" overall; adjustments and operation very simple. Finest results are possible even in the

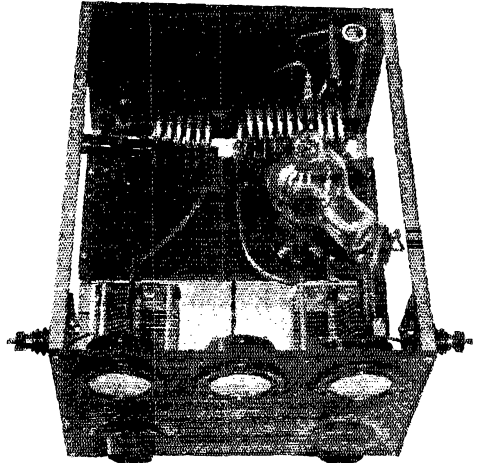

hands of a comparatively inexperienced operator. Hartley High-C circuit employed. Insuring constant frequency stability. Employs one UX852 tube as an oscillator; wired almost entirely with copper tubing, still further adding to its electrical efficiency.

## LEEDS RADIO LABORATORIES

Precision Custom Built Short Wave Receivers and Transmitters

This department under the supervision of the Short Wave Specialist Jerome Gross. We design, construct and advise on any material for the "Ham" Broadcasting station or laboratory. Write Jerry Gross for advice on any of your problems.

PLEASE PRINT YOUR NAME AND ADDRESS PLAINLY to AVOID DELAY

WRITE FOR SPECIAL PRICE LIST

MAIL ORDERS FILLED SAME DAY  
10% Must Accompany All Orders

**PIERCE AIRO** Cardwell **Connecticut**  
 THE ACME WIRE CO.  
 Dubilier **Weston** **PYREX** **Raytheon** **Weston**  
 RADIO ENGINEERING LABORATORIES  
 Gordon **Ward Leonard** **ELKON**  
 Kurz-Kasch **CLAROSTAT**  
 Ward Leonard **ELKON**  
 Virohm **Farrand**  
**Rajah** **PARVOLTS**  
**Knapp** **ELKON** **HOWARD** **RADIO**  
 AD. AURIEMA, INC.  
 Manufacturer's Export Manager  
 116 Broad Street, New York, N. Y.  
 Scientifically equipped  
 to economically export  
 dependable receiving  
 and transmitting radio  
 apparatus

The filament transformer might be the cause of some hum if it is unshielded or poorly constructed. A transformer with loose laminations is almost certain to give trouble due to mechanical vibration of the core. An unshielded transformer is not so desirable as a transformer which is shielded with an iron case, for it is often desirable to ground the iron case. To further reduce any trace of residual hum which might be present, the filament transformer should be several feet from the receiver; it should not be mounted on the operating table. The same precautions are of course applicable to the "B" battery substitute, if one is used.

The experimenter should realize that this receiver is but a forerunner of the more improved models which amateur ingenuity will bring into being. Countless improvements and modifications in design can and will be made by those who put themselves to it. Improvement in regeneration control, modifications in tuning arrangements, increased audio frequency selectivity and desirable features as yet unforeseen can be forthcoming. Many hands and minds applied to the problem will do the trick and the results will be chronicled in *QST* as the contributions are sent in.

The a.c. receiver has come to amateur radio to stay.

### G5BY Wins 1929 Station Description Contest Cup

(Continued from page 17)

Read over the suggestions given in the March, 1929, issue of *QST* and the winning station descriptions. Compare your own station with those which were judged the best. Take advantage of the good features they contain in improving your equipment. Add to these the more recent developments together with those your own ingenuity can devise. The resulting station description, incorporating the necessary photographic illustrations, will surely mean a better "Amateur Radio Stations" section for the 1930 issues of *QST*.

— J. J. L.

### Massachusetts Radio and Telegraph School

18 Boylston Street, Boston  
 Send for Catalogue

Tel. Hancock 8184 *Established 1905*

### TRANSFORMERS

Guaranteed — Mounted — Complete  
 600 watt 800—1200—1800 each side ..... \$17.00  
 700 watt 1000—1500 each side ..... 14.50  
 250 watt 500—750—1000 each side  
 unmounted \$9.75; mounted \$11.50  
 Auto-Transformers, Chokes, Polyphase and 25-cycle  
 Transformers, Add \$2.00 for fil. winding  
**SCES FRANK GREBEN**  
 1927 So. Peoria Street, Pilsen Sta. Chicago, Ill.

### Oscillating Quartz Crystals



Guaranteed — easy oscillators, carefully selected for maximum output, and ground to your approximate frequency which is stated accurately to within one-tenth of one percent.  
 1715—2000 Kilocycle band ..... \$12.50  
 3500—4000 Kilocycle band ..... 17.50  
 One-inch oscillating blanks ..... 5.00  
 We also supply "POWERTYPE" crystals to broadcast and commercial stations.  
 Write for literature  
**American Piezo Supply Company**  
 1101 Huron Building Kansas City, Kansas  
*Specialists in frequency precision*

### Trophies and Certificates for the January and February Contests

(Continued from page 16)

in many respects to our previous international tests in which many readers have taken part. We believe that a thorough study of the announcement in last *QST* and the rules of either or both contests will enable anyone to take part intelligently in January and February. If there is the slightest doubt in anyone's mind on any points in connection with these activities, we shall be pleased to straighten the matter out if that amateur will write us. A few questions have come up on the subject of the January All-Section Sweep-

# Have You Seen the NEW RADIO NEWS

*If it's  
radio news..  
it's in  
RADIO NEWS*

The NEW RADIO NEWS  
Dept. 3801,  
381 Fourth Avenue  
New York, N. Y.

*Gentlemen:* Please send me the next 9 issues of the NEW RADIO NEWS at your special introductory offer of only \$1, which I enclose. (Regular newsstand price is \$2.25 for 9 issues, or \$2.50 a year by subscription.) I understand that you will cheerfully return my dollar if I am not perfectly satisfied after reading the first issue.



Name.....

Street Address.....

City..... State.....

**O**CCASIONALLY a man gets so close to radio that he doesn't see the broader aspects of the industry. *Certainly* it is all right to know about the newest receivers, and how to build them. *Certainly* the newest discoveries in servicing and handling radio parts and sets should be told clearly and at length in the magazine he reads. The NEW RADIO NEWS brings you all this every month.

*But it brings you much more than this.* It provides you with the vital radio news of the whole world in a terse, business-like way that demands reading by every man whose interest lies in radio.

Beyond the fact that the NEW RADIO NEWS is actually new from cover to cover, you begin to realize that RADIO NEWS has grown up.

It sees with modern vision the trends and developments in the radio industry. If a new discovery in television occurs in Greece or even Patagonia, you'll find all you want to know about it in the NEW RADIO NEWS. If the Federal Radio Commission makes some new ruling, you can count on RADIO NEWS for the complete story of it. If an Austrian inventor designs a new improved radio tube, you'll be sure to find it all explained in RADIO NEWS.

That is why we say *with emphasis* — if it's radio news, it is *in* RADIO NEWS. And if you are the sort of man whose mind seeks an *executive's viewpoint* of radio's rapid progress, you'll want the NEW RADIO NEWS delivered to you every month.

## *A Special Offer to Radio Men*

To introduce the NEW RADIO NEWS to those in the industry, we offer to send you *the next 9 Big Numbers for a single \$1!* On the newsstands you would have to pay \$2.25 for these same 9 issues, or \$2.50 a year by subscription. We make this exceedingly low offer, because we know that once you see the NEW RADIO NEWS, you will continue to read it in the years to come.

Simply fill out and mail the coupon at the left. It brings you the Big New RADIO NEWS at a jobber's discount.

# AEROVOX

BUILT BETTER  
CONDENSERS AND RESISTORS

## Takes Out the Hum In Any Dynamic

**I**N spite of the many methods utilized to eliminate the hum in A. C. dynamic speakers, many of the best dynamics still have a hum which is sufficiently pronounced to be objectionable.

You will be surprised at the completeness with which an Aerovox 1500 mfd. "A" condenser, connected across the field coil or across the rectifier output will eliminate the hum and increase the sensitivity of the speaker.

Complete details and comparative data showing the results of using an "A" condenser to eliminate hum will be furnished on request.

A complete catalog of all Aerovox condensers and resistors will be sent free on request.

**AEROVOX WIRELESS CORP.**  
 78 1/2 Washington St., Bklyn., N. Y.   
**PRODUCTS THAT ENDURE**

**HALLMARK OF EXCELLENCE**  
 for  
 FILTER CONDENSERS, BY-PASS  
 CONDENSERS, RADIO INTER-  
 FERENCE FILTERS AND POWER  
 FACTOR CORRECTION BANKS  
  
 Write for complete catalog of Cornell Products,  
 including our new "Cub" Condenser.  
**CORNELL ELECTRIC MFG. CO.**  
 Long Island City New York

**QUARTZ OSCILLATING CRYSTALS**  
 Scientifically Prepared for Maximum Power and Unconditionally Guaranteed  
 1 in. square sections, of your approximate specified frequency, supplied  
 at the following prices:  
 75-100 meters.....\$12.50  
 100-200 meters..... 10.00  
 200-500 meters..... 15.00  
 1 in. Teated blanks, 200-400, 400-600 meters..... 5.00  
 Dustproof Bakelite mounts..... 3.00  
 For 1 1/2 in. sections, above prices are doubled.  
 Sections of any practicable dimensions made to order. Prompt Delivery  
**J. T. Rooney, B. Sc., 4 Calumet Bldg., Buffalo, New York**  
 "Twelve years' crystallographic experience"

**BECOME A RADIO OPERATOR**  
 See the World, Earn a Good Income,  
 Duties Light and Fascinating  
**LEARN IN THE SECOND PORT U.S.A.**  
 Radio Inspector located here. New Orleans supplies  
 operators for the various Gulf ports. Most logical location  
 in the U. S. A. to come to for training.  
 Our students qualify for the various branches of radio  
 Ashore and Afloat. Every graduate placed. Runs to all parts  
 of the world.  
 Special courses. Day and Night classes. Enroll any time.  
 Oldest and Largest. Radio School South.  
 Literature on request.  
**GULF RADIO SCHOOL**  
 844 Howard Ave. New Orleans, La.

stakes Contest. To insure a general understanding of the points involved, some questions and answers follow:

Suppose W8DSP QSO's with W8ARX and takes from W8ARX a message originated at W2MA and addressed to an individual in Chicago. "Can this count as a contest message?" asks W8DSP.

Yes, providing the message is handled during the period of the January contest, provided that W8DSP turns in a copy of the message to the contest committee with information on station, date, time, etc., according to Rule 3 and provided that W8DSP also gives W8ARX a bona fide message sometime during the two weeks of the competition similarly making a record of this occurrence for the contest judges. This may be either a special message which he originates for W8ARX (or to be further relayed by W8ARX) or a message W8DSP has received in the course of regular relaying for W8ARX or some point beyond.

VE3ZZ asks what type of message texts should be exchanged in verification of a QSO, if the following examples would do, or if these would be considered "rubber stamp" texts: *Do you think we could keep a regular schedule question. How many points has your station acquired in these national tests query.*

The texts are O.K. as they differ materially from each other. Many other questions or facts pertinent to the apparatus in stations, localities, opinions regarding conditions, DX, traffic or radiophone operation, comments on the characteristics of different amateur frequencies, off-frequency operation, regulations, the interference question, high quality signals, beginners, broadcast or ship operating, organization work, Army or Navy Net operation, station descriptions, QST articles, message procedure, laws, etc., would make excellent texts for messages to be originated in the contest, not to mention the variety of non-radio subjects that could be called upon when operators in remote districts may find themselves short of regular traffic.

Is it necessary when sending a message which you originate for delivery at a station which you contact, to put in the name, street address, etc., or will the call signal, city and state suffice?

As a general rule, the more complete the address the better. Far too many messages on A.R.R.L. message blanks are returned here by the post office department daily because they lacked a sufficient address to insure delivery. In the course of a year we wear out several call books trying to complete the addresses on such communications. Every message to be relayed through even one station should have the name as well as street and number and all other possible information. However, in the case of messages going direct from originator to addressee the call signal, city and state will be deemed adequate. Participants may guide themselves accordingly.

Is the following form and order the correct A.R.R.L. form to be used in contest messages, or if not, what is the right form?

See the example of proper message form and order in the Fourteenth edition of the Rules and Regulations of the Communications Department (November 1929) sent free on request. If you haven't this useful pamphlet drop us a postal today. Only messages complete and correct in every respect will count in our January competition. The proper order follows: City and state of origin, station of origin, number, date, check (unless omitted), complete address, text and signature.

How should messages complete in other respects but bearing no signature be sent?

With the words "no sig" after a double dash at the end of the text.

## Experimenters' Section

(Continued from page 48)

emission current is greater than the plate current with normal grid bias and as a result, a less sensitive relay is required than would be the case if the grid were brought back to the cathode.

# BARGAINS

# ARMY AND NAVY RADIO SURPLUS

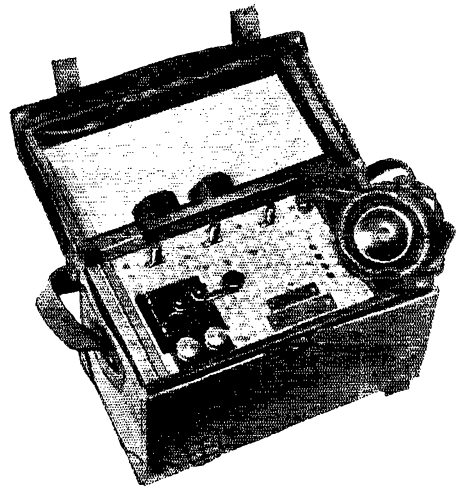
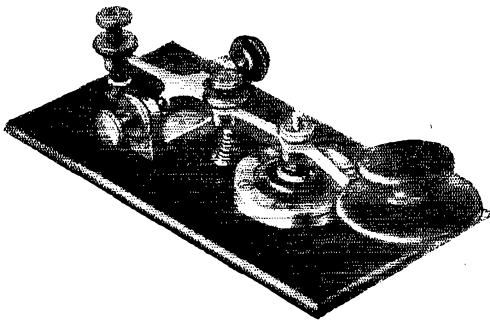

- Keys, transmitting, Airplane flameproof, silver  $\frac{1}{2}$ " contacts, double skirt knob..... \$1.50
- Western Electric Dynamotor C.W. 927. Two 32/250 volt dynamotors in shock-proof hanger. Used in parallel give 160 mls. at 350 volts, in series, give 80 mls. at 700 volts. Can be used to operate transmitters to 50 watts from 32 volt D.C. 1.5 amp. input. Two dynamotors in hanger..... 25.00
- Single dynamotor without hanger..... 15.00
- West. Elec. Switchbd. C.W. 928. Control for Dynamotor C.W. 927. Has starting switches, fuses, 0-50-500 voltmeter, switches for testing main lines and output. Also complete filter system. Special..... 8.00
- Dynamotor, West. Elec. 12/350 volts, C.W. 1056 on heavy Bakelite base, with filter. 80 mil. output..... 18.00
- Dynamotor, G.E. Navy, Airplane, 24/1500 volts, 350 watt. Specially priced..... 32.50
- Dynamotor armatures, General Electric triple commutators, two sizes, D.C. 24/750 volt and 24/1500 volt, complete with ball bearings (build field and save \$30)..... \$10.00 and 12.50
- Ammeter, Westinghouse, type C.A., either 0-1, 2 or 3 amps., zero adjustment, flush mounting. Slate size Ampere hour meter, Sangamo, battery charge and discharge, type MS, 2 sizes, 0-300 and 0-500. List \$50.00..... 5.00
- Milliammeter, Westinghouse, type C.A. 0-500, zero adjustment, flush mounting..... 5.00
- Voltmeter, Westinghouse, type C.A. 0-25, zero adjustment, flush mounting..... 5.00
- Voltmeter, Westinghouse, A.C.  $\frac{3}{8}$ " diameter with external resistance 0-175 volts, 60 cycle power house type..... 12.50
- Voltmeter, Westinghouse model PT, 3 scale, 0-5, 0-7.5, 0-150 for measuring A, B and C voltages, portable Bakelite case, Special..... 3.00
- Motor generator, Crocker Wheeler, 110 D.C. 220 A.C., 500 watt, 500 cycle. Ball bearing..... 50.00
- Complete line 500 cycle motor generators  $\frac{1}{2}$  to 5 K.W. Prices on request.
- Transformers, Peerless, 120 input, 5-10-15 volt output,  $\frac{1}{2}$  K.W., 60 cycle..... 7.50
- Transformers General Electric, 125 to 2500, with center tap, 60 cycle, 200 watt..... 7.50
- Transformers, Simon, 220 to 11500 closed core,  $\frac{1}{2}$  K.W., 500 cycle, "pancake" secondary..... 5.00
- Air compressors, Kellogg Model T,  $\frac{1}{4}$  cu. ft. per min. weight 6 lbs., 600 R.P.M., 125-lb. pressure. Requires  $\frac{1}{2}$  h.p..... 3.00
- Condensers, West. Elec. 21AA, 1000 volt A.C. test, 1 mid..... 1.00
- Condensers, Dubilier, mica, working volts 12,000, capacity .0004..... 10.00
- Condensers, Dubilier, mica, 40,000volt, .0012-.0015-.0008 or .003 mid..... 30.00
- Condensers, Dubilier, mica, working volts 3,600, capacity .32..... 10.00
- Condensers, Wireless Specialty, copper glass leyden jar, 10,000 working voltage .002 mid..... 2.00
- Condensers, Dubilier, mica, transmitting, 8500 working voltage .004 mid..... 10.00
- Condensers, Dubilier, mica, transmitting, 12,500 working voltage .003 mid. Prices on request..... .95
- Transmitter, telephone, Holtz Cabot, carbon granular, Western Electric Radiophone transmitter unit 326 W. Regular price \$12.00. Special..... 1.50
- Headphone, double Holtz Cabot, U. S. Navy..... .75
- Headphone, Army, with strap, 120 ohm..... .75
- Headphone, Radio School, leather headband, 75 ohm..... 1.50
- Keys, transmitting, Army practice, silver contacts..... 1.00
- Keys, transmitting, Airplane flameproof, silver  $\frac{3}{4}$ " contacts, with blinker light mounted on Bakelite base. List \$7.50. Special..... 2.00

- Telegraph and buzzer portable sets, mahogany case, 2 tone 4 contact platinum contact high frequency buzzer, 2 telephone toggle switches, balenometer, sending key, 3 mid. condensers, transformer and 2 choke coils, receiver, \$30. value..... \$ 5.00
- Keys, transmitting, Navy  $\frac{1}{2}$  K.W., "Mesco" silver contacts..... 2.00
- Buzzers, Century & Mesco high freq., 2 coils..... 1.50
- Buzzers, Western Electric, Extra quality, high frequency, Receivers, Signal Corps type, B.C. 14A, 200-600 meters, with crv. det. and Century buzzer in portable case..... 7.50
- Receivers, Navy, C.N. 113, 300-2500 meters, crystals..... 7.50
- Receivers, Navy, C.N. 240, 1000-10,000 meters, original cost \$500..... 50.00
- Receivers, S.E. 143 and I.P. 500. Prices on request.
- Insulators, Electrosec, Navy receiving strain, 75 per doz. Heterodyne, Signal Corps, type B.C. 104. 1000 to 3000 meters, with detector..... 1.25
- Coils, Choke, Western Electric Co. 57C, 83 ohm, 2 windings, Rinc for filter..... 1.00
- Loudspeaker Unit, Western Electric, 193 W. Ideal for monitoring your transmitter. Without cord..... 3.00
- Magnets, Army mine and ringer type, has 4 large fixed magnets. Good value..... 1.00
- Battery, U. S. Army, lead-acid type, 10 volt, 20 ampere hour. Consisting of 5 individual 2 volt cells in carrying case..... 5.00
- Individual 2 volt cells, minus electrolyte..... 1.00
- Generator, airplane, Signal Corps, with shaft, can be used as motor or bat. charger, 12 volts, 33.6 amp..... 10.00
- Sounders, Signal Corps, 120 ohms, with adjustable magnets..... 2.50
- Generators, Westinghouse 110 volt, A.C. 900 cycles, 200 watts, self excited..... 15.00
- General Radio Variable Inductor, type 190, 150 M.H. or 650 M.H..... 6.50
- Relays, Western Electric 122 AB, double pole, double throw, 350 ohms, operates on 20 mls, 6 volts, handle 2 amps. per contact. Reg. price \$17.00..... 2.50
- Storage batteries, Edison Nickel Alkali 225 amp. hr. type A-6 1.2 volts per cell, weight each 20 lbs..... 4.00
- Voltmeters, D.C. portable, new Weston model 45, 3 scale 0-3-15-150 guaranteed  $\frac{1}{2}$  of 1% accurate..... 40.00
- Ammeters, D.C. portable, new Weston model 45, 3 scale 0-1.5-15-150 with 3 scale external shunt and leads  $\frac{1}{2}$  of 1% accurate..... 40.00
- Generators, 12 volt, 60 amp. has automatic controls..... 20.00
- Filters, heavy duty, West. Elec. 936 in steel cabinet, made for gasoline engines, fine for motors, high frequency apparatus, etc. Has large inductance, high imp. chokes, low imp. hi cap. condensers..... 7.50
- Motor generator, R & M, 110 D.C. 3  $\frac{1}{2}$  h.p. to kw. 20 volt 80 amp. Great for large station filament supply. Price on request.
- SPECIAL — U. S. Army instruction books on elementary and advanced telephony and telegraphy. Hundreds of pictures and diagrams..... 1.00

Largest Radio and Electric Supply House in U. S. specializing on Army and Navy Surplus. Write us your particular requirements. Sufficient postage and deposit of 20% required on C.O.D. orders. NO C.O.D. ON CANADIAN ORDERS.

**MANHATTAN ELECTRIC BARGAIN HOUSE, Dept. Q, 105-7 Fulton St., New York City**

# FROST-RADIO

As the world's largest manufacturers of high grade variable resistors, we are singularly well equipped to supply your requirements, no matter what they may be.

Write us in detail regarding your variable resistor problems, and have us submit samples to meet your specifications.

**HERBERT H. FROST, Inc.**

*Main Office and Factory: ELKHART, IND.*

HERBERT H. FROST, Inc.  
160 North LaSalle Street, Chicago

Send me your Parts Catalog by return mail. I understand that it will be sent to me FREE and postpaid.

Name.....

Address.....

City..... State.....

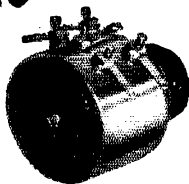

No. 899. Double depth metal shell unit in rheostat or potentiometer type. Rotors in same electrical connection. Composition elements, 5,000 ohms to 1 megohm in each unit. Diameter, 1 7/8 in. Depth of shell, 1 3/16 in.

# P A C E N T

## Duo Lateral COILS

The complete line of all standard turn ratios preferred by leading laboratories and engineers.

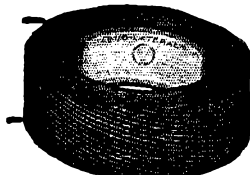

Write for information and prices

**PACENT ELECTRIC CO., Inc.**  
91-7th Avenue New York City

TRI-STATE HEADQUARTERS

PENNSYLVANIA — OHIO — WEST VA.

WHOLESALE RADIO

To DEALERS and SET BUILDERS we offer the most prompt and efficient service. We handle only the best merchandise and give MAXIMUM DISCOUNTS.

GET OUR CATALOG

**CAMERADIO**  
430 WOOD ST.  
at Diamond St.  
PITTSBURGH PA.

## AUDIO FREQUENCY SELECTIVITY

The number of amateurs on the air together with the narrow widths of the frequency bands assigned to amateur services results in our present bands being highly congested. There are several methods of obtaining the proper selectivity to separate the desired transmitting station from the myriads of undesired signals. The coils and tuning condensers may be constructed so the amateur band is effectively spread over 90 divisions or more of the tuning dial. Tuned radio frequency amplification may be used as an aid to selectivity, but this is not desirable since it complicates the operation of a receiver and may be more trouble than good. A good method of obtaining selectivity for telegraph communication is to employ an audio amplifier which has its response curve peaked at approximately 1 kilocycle. Regardless of the manner in which such an amplifier distorts the received signal this appears to be the only practical solution to successful amateur telegraph communication free from QRM. The use of peaked audio amplifiers implies the use of sharp signals and transmitter employing a good d.c. plate supply and we heartily endorse both of these practices.

For those who may be interested in experimental work on methods of obtaining audio frequency selectivity or related problems the following bibliography is appended.

### METHODS OF OBTAINING AUDIO FREQUENCY SELECTIVITY

#### QST References

- A Tuned Audio Transformer, Braden, page 43, March, 1925.
- The McCaa Anti-Static Devices, Kruse, page 29, April, 1926.
- High Ratio and High Amplification, Kruse, page 27, September, 1925.
- A Simple Audio Oscillator, Halstead, page 25, September, 1925.
- Measurements of the Voltage Ratio of Audio and Radio Transformers, Ramsey, page 24, August, 1925.
- Peaked Audio Amplifiers, Kruse, page 29, April, 1926.
- Short Wave Receiving Sets, Hatry, page 21, July, 1926.
- A Device for Limiting Signal and Static Intensity, White, page 36, June, 1927.
- Better Audio Amplification for Short Waves, Hatry, page 15, August, 1927.
- The Helpful Audio Filter, page 37, Jan. 1928.
- Practical Audio Filters, Hatry, page 19, May, 1928.
- Acoustic Wave Filters and Audio Frequency Selectivity, Bourne, page 23, August, 1928.

#### Proc. I.R.E.

- The Determination of the Audibility Current of a Telephone Receiver with the Aid of a Wheatstone Bridge, Washburn, page 99, April, 1928.
- Distortion Free Telephone Receiver, Bethenod, page 163, April, 1923.

# QST Oscillating Crystals

## AMATEUR BANDS:

(New prices effective October 1st 1929)

Winter is coming and no doubt you are going over your transmitter removing those weak links so as to get the most possible efficiency from your set.

One item of great importance is the *frequency stability* of your set. Does it *stay on one frequency*? If not, our *power crystals* will solve that problem. SCIENTIFIC RADIO SERVICE crystals are *known* to be the best obtainable, having ONE single frequency and highest output. With each crystal is furnished an accurate calibration guaranteed to *better than a tenth of 1%*. New prices for grinding *power crystals* in the *amateur bands* are as follows:

1715 to 2000 Kc band . . . . . \$18.00 (unmounted)  
 3500 to 4000 Kc band . . . . . \$25.00 (unmounted)  
 7000 to 7300 Kc band . . . . . \$45.00 (unmounted)

## BROADCAST BAND:

*Power crystals* ground in the 550-1500 Kc band accurate to plus or minus 500 cycles of your specified frequency fully mounted for \$55.00. In ordering please specify type tube, plate voltage and operating

temperature. All crystals absolutely guaranteed regards to output and frequency and delivery can be made within two days after receipt of your order.

## CONSTANT TEMPERATURE HEATER UNITS:

We can supply heater units guaranteed to keep the temperature of the crystals constant to *better* than a tenth of 1 degree centigrade for \$250.00. Two matched crystals, ground to your assigned frequency in the 550-1500 Kc band with the heater unit complete \$360.00. More detailed description of this unit sent upon request.

## ATTENTION AIRCRAFT AND COMMERCIAL RADIO CORPORATIONS:

We invite your inquiries regards your crystal needs for Radio use. We will be glad to quote special prices for POWER crystals in quantity lots. We have been grinding *power crystals* for over *nine years*, being *pioneers* in this specialized field, we feel we can be of real service to you. We can grind *power crystals* to your specified frequency accurate to plus or minus .03%. All crystals guaranteed and prompt deliveries can be made. A *trial will convince you*.

## SCIENTIFIC RADIO SERVICE

"THE CRYSTAL SPECIALISTS"

P. O. Box 86

Dept. P3

Mount Rainier, Maryland

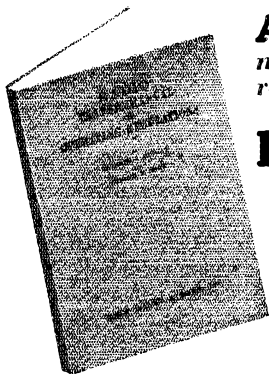

**At Last!**—a book containing all the rules of commercial and government radio traffic—and operating regulations.

## Radio Traffic Manual and Operating Regulations

By R. L. DUNCAN and C. E. DREW

R. C. A. Institutes, Inc.

THE ONLY BOOK OF ITS KIND!

At last here is a book for students, amateurs, or radio operators who contemplate entering the commercial field. With the help of this little book — the only complete one of its kind — you may learn quickly and easily all the government and commercial traffic rules and operating regulations. Duncan and Drew, the two well-known authors of "Radio Telegraphy and Telephony," have set forth clearly and accurately in 181 pages all the information on the subject that you will want. Everything from Morse Code and Conventional Signals to the issuance of Radio Operators' Licenses is included in detail. An excellent index in the back of the book makes every topic easy to locate. \$2.00

### CHAPTER HEADINGS

- Acquiring the Code
- Operating Rules and Regulations of the Radio Marine Corporation
- International Radio Telegraph Convention
- U. S. Radio Act of 1927
- Ship Act of July 23rd, 1912
- Regulations Governing the Issuance of Radio Operators' Licenses

### ON APPROVAL COUPON

John Wiley and Sons, Inc.

440 Fourth Avenue, New York

Gentlemen: Kindly send me, on approval, Duncan and Drew's "Radio Traffic Manual." At the expiration of ten days I agree to remit \$2.00 or return the book postpaid.

Name .....

Address .....

Reference .....

QST-1-30



RECOMMENDED FOR AMPLIFIER  
AND SERVICE ENGINEERS

*Amplifier Parts  
for use with 245 Tubes*

- No. 994 — Power Amplifier Transformer **\$12.00**  
Either No. 2189 — Push Pull Output Trans-  
former..... **\$12.00**  
*with*  
No. 2142 — Push Pull Input Transformer **\$4.50**  
*or*  
No. 3107 — Straight Output Transformer **\$12.00**  
*with*  
No. 2158 — Audio Transformer..... **\$4.50**  
D-946 — Standard Condenser Unit... **\$22.50**  
No. 5554 — Double Choke (use in Filter Cir-  
cuit)..... **\$11.00**  
No. 2124 — Transformer (Radio and Phono-  
graph Amplification)..... **\$6.00**

*Send check or money order for prompt delivery*

**Dongan Electric Manufacturing Co.**

**2999-3001 Franklin St., Detroit, Mich.**

“TRANSFORMERS OF MERIT for FIFTEEN YEARS”

**EASTERN AMATEUR  
HEADQUARTERS**

**NEW NATIONAL**  
[Short-Wave Thrill Box in Stock]

**High Voltage Condensers  
Jewell TRIO in Stock**

**Lowest Prices on Aero  
and Thordarson Parts**

*Hams, send for our Special  
Amateur Catalog*

**M. & H. SPORTING GOODS CO.**

512 Market St., Phila., Pa.

**RADIO TONIC!**

No matter what set; no matter what skill; no matter what  
experience; no matter what trouble—there is just one way  
to make your set right—

**CLAROSTAT**

WRITE for data on Clarostat line or ask your dealer  
about it. Better still, send 25c in stamps or  
coin for “The Gateway to Better Radio.”

**CLAROSTAT MFG. CO., INC.**

*Specialists in Radio Aids*

283 N. 6th Street :: Brooklyn, New York

Radio Transmission Measurements, by Bown,  
Englund, and Friis, page 115, April, 1923.

The Testing of Audio Frequency Transformer  
Coupled Amplifiers, Diamond and Webb, page  
767, September, 1927.

Notes on the Testing of Audio Frequency Ampli-  
fiers, Dickey, page 687, August, 1928.

*Books*

Principles of Radio Communication, Morecroft.  
(Second Edition, page 971-981, also pages 905-  
921.)

Peaked Audio Amplifier, page 66, fifth edition,  
*Radio Amateur's Handbook*.

The I.R.E. references deal principally with meth-  
ods of audio frequency measurements.

**Book Reviews**

By James J. Lamb, Tech. Ed.

*Elements of Radio Communication*, by John H. Morecroft. Published by John Wiley & Sons, Inc., New York (Chapman & Hall, Ltd., London). 269 pages and 170 figures, including circuit diagrams and photographic illustrations. Price, \$3.00.

This book is not an abridgement of the same author's comprehensive *Principles of Radio Communication*, but is intended as an introduction to the latter. While it is an admirable “first-year” textbook for the student of radio engineering, it is just as well suited to the requirements of the out-of-school student. The theory is aptly tied to the practical. Mathematical knowledge beyond simple algebra is unnecessary for its complete understanding and the simple, concise style of the author permits a pleasingly graphic mental picture of the material presented. To the transmitting amateur, the chapters, The Vacuum Tube and Its Uses, Radio Telegraphy, Radio Telephony, and Receiving Sets have the greatest appeal. The volume concludes with 117 practical problems whose solution will assist the student in crystallizing the knowledge gained from his reading, and these are followed by a well-chosen alphabetical index. Morecroft's *Elements* should be on the book-shelf of every student of the art.

*Radio Telegraphy and Telephony*, by Rudolph L. Duncan and Charles E. Drew. Published by John Wiley & Sons, Inc., New York (Chapman & Hall, Ltd., London). 950 pages, 468 illustrations. Price, \$7.50.

This is perhaps the most ambitious practical textbook on radio to come to our attention. The fundamental theory is explained in a fashion obviously intended for the tyro, although in the effort to attain simplicity slight inaccuracies are occasionally introduced. The material on commercial telegraph and broadcasting equipment is useful to operators handling RCA transmitters as well as to those preparing for commercial operators' license examinations. The chapter on short-wave transmitters and receivers contains examples of amateur equipment. Unfortunately, a decidedly 1928-type transmitter is erroneously captioned “1929 QST type.” An appendix of handy tables and the schematic circuit of a complete ship-board installation with instructions for operating the transmitter is followed by a voluminous alphabetically arranged index.

*How To Pass U. S. Government Radio License Examinations*, by Rudolph L. Duncan and Charles E. Drew. Published by John Wiley & Sons, New York (Chapman & Hall, Ltd., London). 169 pages, 92 illustrations. Price, \$2.00.



# NATIONAL

New Series TMU  
Transmitting Condensers

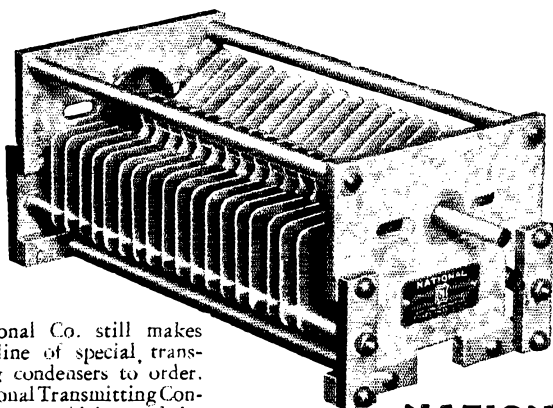

National Co. still makes a full line of special, transmitting condensers to order.

National Transmitting Condensers are widely used by the U. S. Government, broadcasting stations and members of the ARRL, everywhere.

Made by the makers of the famous NATIONAL Velvet Vernier Dials.

Write for full information, mentioning QST.

We announce two new series of 5000 Volt and 7500 Volt Transmitting Condensers, the NATIONAL Model TMU.

These embody all the very latest features for efficiency, steadiness of signal and rigidity of construction.

Capacities: 5000 V. Series, up to .0005 Mfd.; 7500 V. Series, up to .00025 Mfd.

All plates have rounded edges.

**NATIONAL COMPANY INC.**  
ENGINEERS AND MANUFACTURERS  
61 SHERMAN ST., MALDEN, MASS.

Est. 1914  W. A. Ready, Pres.

## Just Published!

A Sure Way of Passing Your Government Examinations!  
Here Are All the Questions—Completely Answered

IN

# How to Pass U. S. Government Radio License Examinations

By R. L. Duncan and C. E. Drew

R. C. A. Institutes, Inc.

Don't take any chances with your examinations. Careful study of this book will insure success in obtaining your Government Radio License, because it contains full particulars, questions and answers, on the latest radio examinations by the government.

It will not only give you all the data, but through the

question and answer method used in the text, will teach you how best to express yourself and put that knowledge into words.

259 questions with complete answers show you just what will be expected of you. Order a copy now—and start studying! **\$2.00**

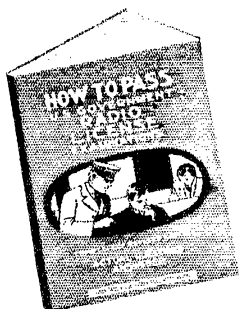

### CONTENTS

Foreword  
Regulations Governing the Issuance of Radio Operators' Licenses  
Commercial and Broadcast Transmitters  
Radio Receiving Apparatus  
Motors and Generators  
Storage Batteries and Auxiliary Apparatus  
Radio Laws and Regulations  
Appendix

### ON APPROVAL COUPON

John Wiley and Sons, Inc.  
440 Fourth Avenue, New York

Gentlemen: Kindly send me on approval Duncan and Drew's "How to Pass." At the expiration of ten days, I agree to remit \$2.00 or return the book, postpaid.

Name .....

Address .....

Reference .....

QST-1-30

# DOUBLE YOUR SPEED

Make MORE MONEY

Through The **CANDLER SYSTEM Courses in Speedhand—High-Speed Telegraphing and Telegraph Touch-Typewriting.**

**Speedhand** — A complete system of telegraphic-code shorthand. Increases transmitting speed 50% in one day. Send whole words instead of single letters. Big demand for Speedhand-code operators.

**High-Speed Telegraphing** — the only recognized "short-cut" to speed and accuracy in telegraphing. Gives you alert, well-trained and perfectly Co-ordinated facilities necessary to the highest degree of Skill. Developed world's fastest operators. Doubles speed of beginners in few weeks. Makes fast operators **Faster**. Strengthens Weak ARMS.

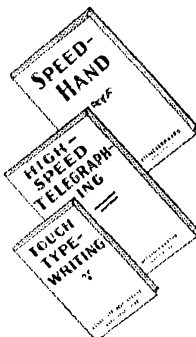

**Telegraph Touch-Typewriting** — the only typing course teaching the correct use of the "mill" in telegraphy. Doubles typing speed in few days. Makes receiving easy.

Write for full particulars of these Courses. Learn what they are — what they are doing for radio operators, and what they will do for You. Write now! A postcard will do. Say if interested in combined or separate courses.

**THE CANDLER SYSTEM CO.**  
6343 S. Kedzie Ave., Dept. RL  
Chicago, Ill.



Walter H. Candler  
Former World's Champion Operator and Author of The Candler System Courses

Specialists for

## AMATEUR RADIO EQUIPMENT

Shortwave frequency meters.....\$12.50  
The Audio Oscillator for laboratory testing..... 17.50  
Special apparatus built to order. Either to our design or following your specifications.



**WIRELESS EGERT  
ENGINEERING, Inc.**  
179 Greenwich Street  
New York

## New Book on POWER AMPLIFIERS

Every man interested in Power Amplifiers needs this new, revised and up-to-date treatise on how to build them... how to secure true reproduction over a range from 25 to 8000 cycles... how to match impedances... how to develop tremendous power. 10 different 2 and 3 stage amplifiers with diagrams and components. Sent postpaid for 15c. coin.

**FERRANTI, INC.**

130 W. 42nd St. Desk 81 New York, N. Y.

This catechism of radio questions and answers, reminiscent of Bucher's book of the same title of which this is apparently a revision, will be welcomed by those preparing for any grade and class of U. S. Government radio operator's license. The chapter arrangement follows that of the sections of the commercial theoretical examination, each being made up of typical examination questions and concise answers. The book should be studied in conjunction with a good text and is not, in itself, intended as a complete preparatory text. The questions and answers are prefaced by a chapter on the requirements for and authority of the various licenses, and are followed by a handy appendix of formulas, symbols, international abbreviations and code chart.

*English and Science*, by Philip B. McDonald. Published by D. Van Nostrand Company, Inc., New York. 186 pages. Price, \$2.00.

It is difficult to conceive that two such prosaic subjects as English and Science could be interestingly and entertainingly treated in a practical text intended to assist the technical writer in doing his job more accurately and concisely — until such time as an opportunity of browsing through this book is offered the fortunate reader. Its attractiveness is such that the first reading is from cover to cover; its practicality requires that it be kept on the bookshelf of the technical writer for ready reference. Would that every *QST* contributor had a copy — and used it.

*A B C of Television*, by Raymond Francis Yates. Published by The Norman W. Henley Publishing Co., New York. 205 pages, 78 illustrations. Price, \$3.00.

A practical treatment of the elements of television with particularly complete chapters on photo-electric cells, amplifiers and scanning methods. Still picture transmission is not neglected, and descriptions of the Siemens-Karolus, Bell Telephone, Cooley and Ranger systems are given. Television systems covered are the Baird, Jenkins, Alexander and Bell Telephone Laboratories. Through cooperation of the latter, the author has been enabled to give considerable data on the experimental equipment developed by that organization. The volume concludes with a chapter in which detailed instructions for the construction of an experimental television receiver are given.

*Radio Traffic Manual and Operating Regulations*, by Rudolph L. Duncan and Charles E. Drew. Published by John Wiley & Sons, Inc., New York (Chapman & Hall, Ltd., London). 187 pages. Price, \$2.00.

An operating manual for the commercial man giving the regulations of the U. S. Department of Commerce and the Radiomarine Corporation.

## Silent Keys

It is with deep regret that we record the passing of these amateurs:  
Gordon Jeffries, W8CZJ, Cleveland, Ohio.  
Hugo Anderson, W9BKN, Ironwood, Michigan.  
Clyde C. Cunningham, W1AEW, Westfield, Mass.  
Edwin H. Poad, W8UK, Cleveland, Ohio.



An excellent article on "Single Wire Transmission Lines for Short-Wave Antennas" by Everitt and Bryne was published in the October, 1929 Proceedings of the I.R.E. This is essentially

# Condensers you'll be proud to own

These condensers are planned to meet the demand of discriminating purchasers who wish precision built instruments of fine appearance and highest efficiency. They should not be confused, because of their low price, with made-over receiving condensers or other makeshifts. They are super-station type instruments and adequate to take their place in the amateur station of today and tomorrow. Buy these condensers for the future.

## VARIABLE TYPE MODEL 2

Electrical features of this condenser are its high conductivity, its hard rubber insulation in a very weak field, and its  $\frac{1}{4}$ " spacing of heavy, rounded corner, aluminum plates. Its sturdiness is shown in its heavy truss type cast aluminum ends, its over-size bearings and large tie rods. Overall length 11 in.  
Capacity .000175 mfd. Price \$13.50

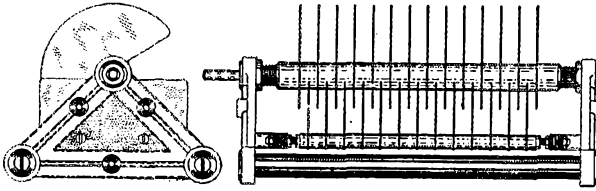

## TANK CONDENSER MODEL 3

Follow best practice and give your transmitter that super station effect in appearance and performance with this unit. Same efficiency and construction as Model 2 but adjustable by removal of plates. Size  $4\frac{3}{4}$ " x  $5\frac{3}{4}$ " x  $11\frac{1}{4}$ ".

Capacity .0002 mfd. Price \$12.00

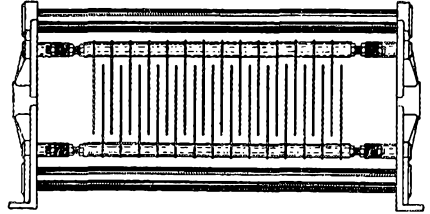
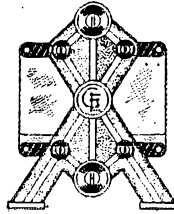

We also manufacture power supplies and other amateur and laboratory apparatus. Send dime for bulletins

THE GENERAL ENGINEERING CORPORATION

Charlotte, Mich.

### TALKS TO LONDON FROM PLANE IN AIR

Reporter in Craft Speeding Over City Has Conversation Across the Ocean.

#### THREE CALLS ARE MADE

Words Understood Clearly in Spite of Static—Electric Experts Pleased With Results.

Special to The New York Times. HADLEY FIELD, N. J., June 23.—Flying at ninety miles an hour today with a thick fog blanket blotting out the earth below him, W. W. Chaplin, Associated Press reporter, casually turned to a microphone and asked for the London office of the news association. The request, relayed through the laboratories of the Bell Telephone Company, passed on to the radio ocean radio telephone station at Belfast, Me., and then carried again on the air across 3,000 miles of ocean to London. The connection was made quickly and Chaplin asked that Miss Martha Dalrymple of the London office be called to the phone. The conversation, once greetings were over, Chaplin said later, had to do mostly with the weather. It was broken somewhat by static but the two persons talking, one in a fog-bound plane a half-mile in the air and the other in a fog-bound London office, understood each other and exchanged greetings.

## "ESCO" Airplane Generators provided the power for this remarkable achievement

Two "ESCO" Airplane Generators (wind driven) were mounted on the Bell Telephone Airplane. One supplied power to the transmitter and the other to the receiver. Both were of standard "ESCO" design which insures reliable service under the severe operating conditions common to aviation.

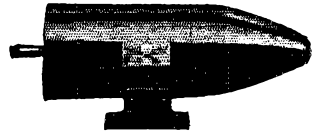

Low wind resistance, light weight, non-corroding parts, ball bearings, tool steel shafts, steel shells, cast steel pole pieces, weather proof construction, many sizes to choose from, high voltage and low voltage windings to suit individual requirements, are a few of the many reasons for "ESCO" generators being the first choice.

**ELECTRIC**  **SPECIALTY**  
**COMPANY**

225 SOUTH ST.

STAMFORD, CONN.

Manufacturers of motors, generators, dynamotors and rotary converters

# A New RECTOBULB

## Type R81

Mercury Vapor Efficiency in —

**RECTIFICATION**                      **LOAD CAPACITY**  
**REGULATION**                      **FILTERING**

To be installed in place of any Type 281 Rectifier Tube — simply plug in — that's all.

Fil. Volts . . . . . 7.5                      Fil. Cur. . . . . 1.25  
Plate Volts . . . . . 750                      Plate Mils . . . . . 150

**ONLY 10 VOLTS DROP IN TUBE**

**Price \$7.00 each**

Sent Postpaid if cash with order — Immediate delivery

### Type R3 RECTOBULBS

Still "SUPREME" as 3000-volt — 250 Mil. Transmuting Rectifier — ask the "HAM"

**Price \$10 each**

Rectobulb Distributors — **CHIRAD** — Chicago —  
Fort Orange Dist. Co., Albany, N. Y.

### Guaranteed Repairs

UX852 . . . . . \$16.50                      WE211 . . . . . \$16.50  
UV203A . . . . . 211 — 845                      \$19.00  
UV204A . . . . . \$60.00                      WE212 . . . . . \$40.00

## NATIONAL RADIO TUBE CO.

3420 18th Street                      San Francisco, Calif.  
"A HAM INSTITUTION"

**WE** believe our latest model microphone is the best value obtainable. It is unexcelled in workmanship, attractive in appearance and superb in performance, yet it is lower in price than any other.

List price \$67.50                      Usual discounts

## E. F. JOHNSON CO.

WASECA

MINNESOTA

### HEY HAMS!

#### YOU CAN GET MUCH BETTER RESULTS!

By using "SILVER-CLAD" — the new aerial wire with its low-resistance, pure silver surface. A real help to transmission and reception and especially so on shortwaves. Many fail to realize that a set can perform no better than the condition of its aerial permits. Maybe that's why you aren't getting DX! Give your set new life by replacing your old, corroded aerial with "SILVER-CLAD" today. It is best for picking up the delicate wave impulses. 100-foot length only \$2.00 postpaid.

#### RADIO LABORATORIES

P. O. Box 88, Oakley

Cincinnati, Ohio

# BRUTE FORCE

For that steam roller signal that crashes thru, gets there by flattening every obstacle. A signal backed by that most powerful of rectifiers — the mercury arc. Long, trouble-free life, full wave, instantaneous automatic starting, current and voltage ratings far above any transmitter demand. Put in an arc and operate.

## RECTIFIER ENGINEERING SERVICE

W8ML 4837 Rockwood Road  
CLEVELAND, OHIO

a more detailed description of the tests described by Windom under "Notes on Ethereal Adornments" and while of little interest to the traffic man, is a worthwhile paper for the engineer or experimenter.

A device which enables a pilot to switch on airport lights from the air by pressing a button has been perfected recently. It consists of a miniature radio transmitting set, effective over a twenty-mile radius, which controls the airport lights through a radio control system. The transmitter uses modulated waves.

H. Barkhausen, of Dresden, Germany, and J. C. Bird, G2JB, of Wembly, Middlesex, England, were among those who attended the meeting of the Institute of Radio Engineers at New York City on October 2. The meetings are getting international.

The following quotations are taken from an advertising pamphlet of radio tubes, picked up at the New York Radio Show:

"Radio Tubes make any set better."

"The less the air, the higher the vacuum, the clearer will be the resulting tones."

The last night of the New York radio show, six amateurs had dinner together in one of New York's restaurants. As one of them remarked, "Of the six amateurs, none are from the state of New York, and each one is a native of a different state." The gang was composed of: WIAOZ, Waterford, Conn., W1FL, Hudson, Mass., W3BVA, York, Penn., W9BR, Chicago, Ill., W9CEI, Michigan, N. Dak., and W9IG, Minneapolis, Minn.

Then, too, another reason the average ham is "broke" is because he has so many convention and hamfest pictures to buy.

The New York radio show was an excellent furniture exhibit!

## A.R.R.L. Election Results

(Continued from page 38)

of them for the information of the membership. In bidding *au revoir* to the retiring directors let us remember that each of them for long years served his division faithfully and to the very best of his ability. They did their part in making A.R.R.L. what it is today.



## Here She Is, Gang!

A Real oil condenser that won't blow up every week!

Working voltage  
2000 volts; 2 mfd.

Price \$16.00  
*F.O.B. Factory*

*Cash or money order  
with order*

**BROWN & CAINE**  
INC.

Chicago Division  
of Tung-Sol Lamp Works, Inc.

2317 Calumet Ave.  
CHICAGO, ILLINOIS

## LIFE-TIME DX AERIAL

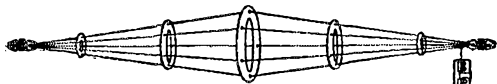

**Guaranteed Double Volume and Sharper Tuning**

receiving set because of short length but has enormous pick-up because 150 feet of No. 12 enameled wire is used. Made for owners of fine radio sets who want great volume on distance without destroying sharp tuning. (Also used by many owners of short-wave outfits.) "Makes a good radio set better." Insurance approved Lightning Arrestor furnished. Price \$10.00

**No. 60—Length 60 feet. Price \$12.50**

Assembled — ready to string up. "BIG BOY" Size. (Same description as above, except that 300 feet of wire is used making this the most efficient and powerful aerial possible to manufacture.)

Manufactured  
by

**THOROLA RADIO PRODUCTS**

1014 So. MICHIGAN BLVD.  
CHICAGO, ILLINOIS

## No. 30 Length 30 feet

Assembled ready to string up. Brings in great volume, but retains the selectivity of a 30-ft. aerial. Rings are heavy gauge solid zinc. Duplicates in design and non-corrosive materials the aerials used by most of largest Broadcasting Stations. Design permits using this powerful aerial in 30-ft. space (preferably outside). Sharpens tuning of any

## Eighth Edition Robison's Manual of Radio Telegraphy and Telephony

Completely Revised in June, 1928, and Up-to-Date.

Of the 6th edition of this book reviewed by QST it was said this is perhaps

**"The Best Radio Book That Ever Came to This Desk"**

The standard Navy book on radio originally prepared in 1906 by Lieutenant Commander (later Admiral and C-in-C of U. S. Fleet) S. S. Robison. The present edition revised by Captain S. C. Hooper, U. S. Navy, now Director of Naval Communications.

780 pp. Price \$4.00 postpaid. 6th edition sold for \$8.00; 7th edition sold for \$5.50

Address: Secretary-Treasurer, U.S. Naval Institute, Annapolis, Md., U.S.A.

# HAM-ADS

(1) Advertising shall pertain to radio and shall be of nature of interest to radio amateurs or experimenters in their pursuit of the art.

(2) No display of any character will be accepted, nor can any special typographical arrangement, such as all or part capital letters be used which would tend to make one advertisement stand out from the others.

(3) The Ham-Ad rate is 15c per word, except as noted in paragraph (6) below.

(4) Remittance in full must accompany copy. No cash or contract discount or agency commission will be allowed.

(5) Closing date for Ham-Ads is the 25th of the second month preceding publication date.

(6) A special rate of 7c per word will apply to advertising which, in our judgment, is obviously non-commercial in nature and is placed and signed by a member of the American Radio Relay League. Thus, advertising of bona fide surplus equipment owned, used and for sale by an individual or apparatus offered for exchange or advertising inquiring for special equipment, if by a member of the American Radio Relay League takes the 7c rate. An attempt to deal in apparatus in quantity for profit, even if by an individual, is commercial and takes the 15c rate. Provisions of paragraphs (1), (2), (4) and (5) apply to all advertising in this column regardless of which rate may apply.

PLATE power for your set, the very heart of its performance. For quietness DX ability, life-long permanence, absolute dependability, lowest ultimate cost, no other plate source even approaches the achievement of an Edison steel-alkaline storage B battery. Built painstakingly; every joint pure nickel, upset electrically welded. Genuine Edison Electrolyte. Our list describes complete batteries, construction parts, enameled aerial wire, silicon steel. Available immediately, filament and plate transformers for the new 872 rectifier, complete plate power units. Rectifier Engineering Service, radio W8ML, 4837 Rockwood Road, Cleveland, Ohio.

AMATEURS — experimenters, builders. We serve over 4000 I.R.E., A.R.R.L., etc. experimenters and "nuts." Full discounts. \$50,000 stock approved parts — no sets. Over four pounds catalog, circuits, data, prepaid, 50c. Weekly bulletins (new items, results of experiments, etc.), 20 weeks, \$1. Sample experimenters "Over the Soldering Iron" magazine, 25c. Transmitting data, price list, etc., 25c. Kladag Radio Laboratories, established 1920, Kent, Ohio.

SPECIAL rectifier aluminum, \$1.25. Lead, \$1.00 square foot. Elements 1 x 4 15 cents, 1 x 6 17 cents pair. All prepaid. Best silicon transformer steel cut to order, 25-35 cents pound. Postage extra. George Schulz, Calumet, Mich.

THE most complete line of modern short wave receivers for every particular service. Four to nine tube designs. Radiophone-CW transmitters, of any power or type. We make a complete line of apparatus including speech amplifiers, filter coils, transformers, rectifiers, variable condensers, inductances, etc. Any special apparatus, designs, made to order using your parts if desired. Prices on request. New bulletin lists complete line of apparatus. Write for copy. Enssall Radio Laboratory, 1527 Grandview St., S.E., Warren, Ohio.

TELEGRAPHY — Learn Morse and wireless telegraphy. Big salaries. Tremendous demand. Expenses low. can earn part. Catalog free. Dodge's Institute, Wood St., Valparaiso, Ind.

POWER crystals for broadcast and amateurs, ground to your frequency. Write and get our prices. Filter condensers, 1000 volts, d.c., \$2.50. All absolutely guaranteed. Fitz-gerald Harrison Laboratories, 43 Summit Ave., New London, Conn.

EX-NAVY dynamometers and generators of unusual construction, ball-bearing and new. Shaft extension for external motor or gasoline engine, \$3 additional. General Electric 24/1500 volt, 350 watt, \$37.50; 24/750 volt, 150 watt with filter, \$27.50; 12/350 volt, 50 watt used, \$15; Holtzer-Cabot 12/500 volt, 35 watt, \$20; Westinghouse 6/15 volt, 500 watt, with propeller, \$15; 27.5/350 volt, .08 ampere special \$12.50; twins for 700 volts, \$20; 10/350, \$28; 14-kw. 500 cycle with d.c. exciters, \$15; 900 cycle 200 watts, \$15. With complete aircraft spark transmitter, \$30. 1-kw. 500 cycle slip motor generators. Complete list, Henry Kienzle, 101 East 84th St., New York City.

ARRL sweater emblems should be worn by all League members. They are yellow and black 5" x 8" diamond, felt letters and embroidered symbol. Only \$1.00. Money order or currency only accepted. Eric Robinson, 135 Jefferson Road, Webster Groves, Mo.

FOR Sale — Acme 1/4 kw plate transformer, 550 1100 either side center. REL type L inductance. Vitrohm 15,000 power leak. Cardwell taper-plate .0005 inid. Five-watt leaks. Miscellaneous parts. — WBCOS, Rochester, Minnesota.

CHOKES — Heavy construction, large condensers unnecessary with these chokes. All sizes. Write for list. Scott Coil & Transformer Co., New Albany, Miss.

SALE or Trade Omnigraph No. 2. Complete with 30 dials. Highest offer takes it. Pilot wasp kit for sale or trade. Raymond Berkey, Humeston, Iowa.

WESTON 1.5 amp. thermoammeters, \$7.00; hot wire ammeters, \$2.00; miscellaneous d.c. meters, General Radio wavemeters, 150-710 meters, including galvanometer, at \$4. Complete in case, easily changed to short wavelengths. Jas. Coe, Ft. Sam Houston, Texas.

OLD numbers QST for sale, 95 copies from June, 1921, to date. Henry Kienzle, 501 East 84th St., New York.

FOR sale. Tubes, 210's, \$4.75; 250's, \$5.50; 281's, \$4.00. Grid-leaks 100 watt, any size, \$1.50. Also filter condensers all sizes. No c.o.d.'s. Amateur Supply Co., Meredith, N. H.

SELL — Screen grid BCL set. Short and long wave receivers. Cheap. W8CEK 221 Barron Ave., Johnstown, Pa.

2 Slightly used 203As, \$12.50 each. Also a few matched type 866s, \$4.00 each. The 866s are new but seconds, good life. sale del. guaranteed. E. Ewing, 29 S. LaSalle St., Chicago, Ill.

FOR sale. Two brand new Western Electric 211-D, 50-watt tubes, guaranteed \$15 each, or what you have. Send stamp for list other xtals. "Pep," P. O. Box 205, Montgomery, Ala.

DAY FAN motor generators: 180 v., 26 amp., new, \$30, used, \$20; 450 v., 06 amp., 7 1/2 v. 1.75 amp., used, \$25; 180 v., .25 amp. filters, new, \$10; rebuilt Westinghouse generator 400 v., .25 amp., \$10. Walter E. Short, Antioch College, Yellow Springs, Ohio.

HAMS — Get our samples and prices on printed call cards made to order as you want them. W9APY, Hinds, 19 S. Wells St., Chicago, Ill.

3-tube SW set, plate transformer, and inductances. Sell cheap; trade. Gerhard Ebenhahn, Omeme, N. D.

50-watt transmitter, \$30. Short wave screen grid receiver, 15/490 QST's, \$2. E. Carter, 922 Crane St., Schenectady, N. Y.

WESTERN Electric 7A amplifier, tubes and horn, \$25. L. M. Whitehurst, 3226 Cliff Ave., Richmond, Va.

TRANSFORMERS — 100 watt, 110 volt, 60 cycle, 750 volts each side of center tap, one 7 1/2 volt, center tapped filament winding, \$7.25. Same as above but 2 filament windings, \$8. Same as above but 150 watt, \$9.25. Same as above but 250 watt, \$11.50. Heavy construction, no heating, good regulation. Remit 25% with c.o.d. orders. The above will operate two to four 210 tubes. Scott Coil & Transformer Co., New Albany, Miss.

ULTRATONE air column speakers 10 1/2" High 1 1/4" Wide 11 1/4" Deep. Direct from factory. Each \$1.25. Ultratone Manufacturing Co., 1046 W. Van Buren St., Chicago, Ill.

SELL — Ham xmtr parts and receivers. Guaranteed. Send for list. W9AJH.

1929 receiver — surplus equipment. One stage radio frequency detector and two audio. A good buy, \$22, or \$25.50 with tubes. Practically new. W3ALD, Pottstown, Pa.

DURALUMIN — Microphone diaphragm, special treated .002" x 4" x 4", \$2. W9BWI, Fort Wayne, Ind.

FOR sale — Complete 50-watt master oscillator power amplifier radiophone. Plate supply, 1500 watts, 1100 volts. Mercury arc rectifier. A real phone priced to sell. Also extra arc tubes, many other parts. Write for description, prices and pictures. W9EJZ.

ONE thousand watt G.E. transformers, eleven hundred, twenty-two hundred, forty-four hundred, each side c.t., as advertised QST twenty months, \$12 f.o.b. Detroit. Also 500 watters at \$6. Guaranteed unconditionally. F. G. Dawson, 5740 Woodward Ave., Detroit, Mich.

3000 v. 4000 w. 7 1/2 hp. 3-phase drive double commutator motor generator, complete, \$350; 2500 v. 500 w. double commutator, single phase drive complete, \$225; 2-5 kw. rotary spark gap 110 v. dc. drive, \$35.00; 1000 v. 200 w. 1-phase drive Esco motor generator, \$75; 300 w. G.E., \$95; 750 w. 250 w. motor generators, \$50; 150 w. \$40; 1/2 hp. 3450 speed motor, \$10.50; 1/2 hp. 110 v. a.c. synchronous 1800 speed motor, \$20; 8 v. 5 ampere generators, \$6.50. Queen City Electric, 1734 Grand Ave., Chicago, Ill.

SALE or trade: Complete 75-watt Xtal Xmitter with plate supply; short wave receiver; 600 volts Willard "B's"; motor generator, dynamotor. Want, typewriter, television apparatus or amateur movie camera and projector. W9ENG, Mound Valley, Kans.

WANT couple 204A tubes. Sell Esco 2000-volt 600-watt Mg, Kellogg broadcast type 2 button microphone new, truck load surplus equipment. Macy, W9UM.

HETERODYNE frequency meters, enclosed, accuracy 99.8%, \$10. Shipping weight fifteen pounds. E. Bromley, 7023-37th Ave., Kenosha, Wis.

PLATE supply transformers, 1000 and 1500 volts each side center, 300 watt, \$11.50; 500 watt, \$14.50; 2500 and 3000 or less each side center, 300 watt, \$15.00; 500 watt, \$18.50. Any size or voltage to specifications. Add \$1.00 each for filament windings. Write for our new price list of other sizes. Scott Coil & Transformer Co., New Albany, Miss.

NEW full-wave rectifier tubes. Tungar type, made by Westinghouse. Rated 2 amperes d.c. Mogul base. Will replace two half-wave tubes in mercury arc "keep-alive" circuit, charger, A-limiter, etc., \$2 prepaid. W9DWA R. V. Howard, 5508 Fulton St., Chicago, Ill.

SELL  $\frac{1}{2}$  horse single phase induction motor, \$8.00. Mounted honeycombs, 75, 100, 250, 300, 400 turns, all for \$4 c.o.d. only. T. C. Lightfoot, 25 So. Harwood Ave., Upper Darby, Pa.

NEW Morton Elec. Co. MG. sets up to 2000 v. 500 w. sold at wholesale. Hanson, 4832 Rice St., Chicago, Ill.

CONDENSERS! We were fortunate in purchasing a quantity of Parcon condensers at extremely low prices and pass them along to you at practically the manufacturer's cost. Every one brand new. Transmitting filter condensers, 1000 volts d.c. working (Remember that the "working voltage" of a condenser is usually one-half the "test voltage," so don't be misled by "test voltage" ratings), 2 mfd., \$2.40; 4 mfd., \$3.95; 6 mfd., \$5.15; 8 mfd., \$6.90. Buffer, 1-0-1 mfd., 97 c. 1750 volt d.c. working: 1 mfd., \$3.70; 2 mfd., \$5.30. Mica grid and plate condensers: .002, .001, or .0005 mfd.; 750 volt working, 96 c.; 1500 volt, \$1.18; .002 mfd., 2250 volt, \$1.73. Freshman 10.1 mfd., 850 volt block, tapped at 1-1-1-2-2-1 mfd., \$3.65. Unmounted 1 mfd., 1000 volt, 40 c., 4 for \$1.45, 8 for \$2.80;  $\frac{1}{2}$  mfd., add 15 c. Well-made, mounted power chokes, 30 Henry, 175 milliamperes, \$2.40. 30 H, 120 MA, \$1.90. Brach 125 watt power transformers, 600, 7 $\frac{1}{2}$  and 7 $\frac{1}{2}$  center-tapped, secondaries, ideal for UX-210 transmitter or amplifier, \$3.75. Ward-Leonard 5000 ohm, 60 watt mounted grid-leaks, 85 c. Everything new and tested. "Quick service." Send for "Specials." William Harrison, 35 Ft. Washington Ave., New York City.

QSL's 100 two-color, \$1.00. Samples. W9CKA, Corwith, Iowa.

SELL new Silver Marshall Round World Four with tubes. Write for dope on set and extra parts. Howard Wacker, 2530 Spring Garden Ave., Pittsburgh, Pa.

500-cycle generators 200 watt, \$10;  $\frac{1}{2}$  kw, \$15; motor generators d.c. drive,  $\frac{1}{2}$  kw, \$20;  $\frac{1}{2}$  kw, \$35; New, \$50; 1 kw, \$100;  $\frac{1}{4}$  kw ac drive, \$35; 275 volt d.c. generators \$5 used. R. Wood, 16-20 102d St., Corona, N. Y.

QSL cards, two colors, \$1.00 per hundred. Free samples. W8DTY, 257 Parker Ave., Buffalo, N. Y.

SELL nearly new Marlo Sync., \$35. Complete mercury arc solinoid operated, new, \$35 f.o.b. W9PT, Chicago, Ill.

CRYSTALS, any frequency, 50-meter band, \$10. W8DMI.

MERCURY vapor rectobulbs, hi-power, \$10; low-power \$7; Pilot Super-Wasp, \$29.40; W.E. and R.C.A. trans. tubes; crystals: 25% off on REL, Ward Leonard, Jewell, Signal, Leach; 30% on Thordarson, Sangamo, Cardwell, 35% on Tohe and Flechtheim. Any other apparatus. Write Henry's Radio Shop, W9ARA, Butler, Mo.

CRYSTALS of highest quality, 7000 k.c., \$19.00; 3500 k.c., \$14; 1750 k.c., \$9; Guaranteed blanks, \$4. W9DRD, Herbert Hollister, Edwardsville, Kans.

OMNIGRAPHS, teleplexes, transmitters, receivers, super vamps, portables, monitors, Vibroplexes, meters, 50 watters, dynamotors — bought, sold, traded. Ryan Radio Co., Hannibal, Mo.

W9COS — This station devoted to traffic. Open for traffic to Philippines and China by daily schedule, via west coast. Traffic mailed in receives prompt attention. QRU?

SALE — Western Electric tubes, No. 101F, fine amplifiers, may be used in transmitters, 69 c. each (tested). Radio Salvage, 1063 W. Van Buren St., Chicago, Ill.

SEND for list practically new parts, Amertrau push-pull 250 power supply unit, Remler audio transformers, and other parts wanted for best tone audio stages. State what you want. Will sell at half wholesale cost. Address M. M. Osborn, Suffolk, Va. BALDAR variable speed condenser motor for television. H. M. Licht, Streator, Ill.

TRADE — one 0-5 amp. Jewell radio frequency ammeter for one of about 0-1 amp. or 0- $\frac{1}{2}$ . Frank H. Jennings, Box 133, Mt. Carmel, Ill.

SELLING out. W8AVO, Eaton Rapids, Mich.

HILET transformers and chokes, one day delivery. See Hilet advertisement. Jewell 54 d.c. volt-meter 1000 ohms per volt, 0-2000 ohms with external resistor, \$14; 0-1000 volts, \$13; No. 74 a.c. 0-1000 volts, \$9. Edison 6 v. 150 AH battery, \$15; Edison "A." battery outfit with charger, \$30; audio coils 30 c. Write for specifications. Leitch, Park Drive, West Orange, N. J.

SELL one 550 and one 1000-volt motor generators. What do you have that you are not using? What do you want to trade for? Lowell Ecker, Sedan, Kans.

BARGAIN — UV204A slightly used. Guaranteed perfect, \$60. W2AVF.

SELL — New RCA super-heterodyne catacombs, RCA No. 8150. Fine for short wave experiments and portable receivers. Formerly \$73.50, now \$13.95. Still a few left. Ludwig Hommel & Co., 929 Penn Ave., Pittsburgh, Pa.

FOR sale — 1 transformer 12 v. filament, 1380 center tapped, \$10. 1 screen grid Silver Marshall receiver. Wired, \$40. W. O. Williams, W9FQC, Eldora, Iowa.

UX860, \$25; UX852, \$20; .00045 National 3000 volt, \$10; 2500-3000 volt 700 watt xmr, \$17; two Rectobulbs, \$14; GR558 frequency meter, \$15; 40 mtr. power crystal, \$20; 80 mtr. \$15; complete TCTP xmr, complete crystal transmitter, receiver, monitor, 210s, 281s; lots other parts, chokes, xmrs. Weston meters, etc. W8F7 Bennett Hill, 4214 Three Mile Drive, Detroit, Mich.

QSL's — Your copy, two colors, \$1.25 hundred. Samples. W2AKE, 1317 Rosedale Ave., New York City.

QSL cards, stationery, cartoons, wall cards, etc. Seldens, Cranesville, Pa.

POTTER condensers, test voltage 1 mfd. 2000, \$2.50; 2500, \$3.25; 2 mfd. 1000, \$2.50; 2000, \$4; 650 volt power filament transformers, \$6.90. Plate supply 550 and 750, \$12. Aluminum square foot, 85c; lead, 85c; Ham List, 4c. Curtis Sales Company, 1109 Eighth Ave., Ft. Worth, Texas.

WANTED — Navy standard receivers, SE143, SE1220, SE1420, IP500, IP501, also 203A and 204A tubes and spark gap units. State condition and price. Paul Trautwein, 38 Park Place, New York City.

FOR sale — complete amateur station WICE. Cheap, for cash. F. G. Carr, Lancaster, N. H.

HAVE you our new price list? Write for it. QST superhet parts, wound intermediates, advice and assistance. Let us help you with that special problem. Hatry & Young, Hartford, Conn.

QSL's — plain at \$1 per hundred. W9BEU, 9032 Windom St., St. Louis, Mo.

WANTED — your radio wants. Parts for that receiver, transmitter or power supply. Special apparatus. Pontiac Engineering Co., 1100 Ave. I, Brooklyn, N. Y.

PANEL engraving — finest workmanship on radio laboratory apparatus. Request price list. A. L. Woody, 19 S. Wells St., Chicago, Ill.

PRINT your own radio call cards, stationery, circulars, advertising, etc. Junior presses, \$5.90; job presses, \$11; rotary, \$149. Print for others; big profit. Easy rules furnished. Write for catalog presses, type, paper, etc. Kelsey Company, Q-18, Meriden, Conn.

FOR sale, complete parts for 3 phase rectifying system and good assortment of meters and other parts all new and unused at big bargains. Write for list and prices to Station W1BF, Huron Bldg., Kansas City, Kans.

## Q R A SECTION

50 c. straight with copy in following address form only:

W2AUR — E. Stolzenberger, 720 Forest Ave., Ridgewood, Brooklyn, N. Y.

W2BJJ — Hackensack Radio Association, Y.M.C.A. Bldg., Hackensack, N. J.

W2BSR — Arthur M. Braaten, Box 979, Riverhead, Long Island, N. Y.

W2BWG — R. J. Mahler, 152 South Grand Ave., Poughkeepsie, N. Y.

W3AJ0 — E. Stolzenberger, 164 Nassau St., Princeton, N. J.

W6IQ — Ben A. Ott, 8148 Virginia Ave., South Gate, Calif.

### WIMK

#### A.R.R.L. Headquarters

R. B. Parmenter, Chief Op. "rp."

The following calls and personal sines belong to members of the A.R.R.L. Headquarters gang:  
W1BDI-W1XL F. E. Handy "fh."  
W1AL B. Dudley "bd."  
W1EH K. B. Warner "kb."  
W1BUD A. L. Budong "bud."  
W1CEI J. J. Lamb "jm."  
W1ES A. A. Hebert "ah."  
W1FL-W2JR G. Donald Meserve, "dm."  
W1PX C. G. Kenefick "ck."  
W1SZ-W1BIZ C. C. Rodimon "rod."  
W1UE E. L. Battey "ev."

# To Our Readers who are not A.R.R.L. members

WOULDN'T you like to become a member of the American Radio Relay League? We need you in this big organization of radio amateurs, the only amateur association that does things. From your reading of *QST* you have gained a knowledge of the nature of the League and what it does, and you have read its purposes as set forth on page 6 of this issue. We should like to have you become a full-fledged member and add your strength to ours in the things we are undertaking for Amateur Radio. You will have the membership edition of *QST* delivered at your door each month. A convenient application form is printed below — clip it out and mail it today.

*A bona fide interest in amateur radio is the only essential qualification for membership*

AMERICAN RADIO RELAY LEAGUE  
Hartford, Conn., U. S. A.

I hereby apply for membership in the American Radio Relay League, and enclose \$2.50 (\$3 in foreign countries) in payment of one year's dues, \$1.25 of which is for a subscription to *QST* for the same period. Please begin my subscription with the ..... issue. Mail my Certificate of Membership and send *QST* to the following name and address.

.....  
.....  
.....  
.....  
.....  
Do you know a friend who is also interested in Amateur Radio, whose name you might give us so we may send him a sample copy of *QST*?

*Thanks*

## For Your Convenience QST'S INDEX OF ADVERTISERS IN THIS ISSUE

Acme Wire Company .....	64
Aerovox Wireless Corp. ....	82
Allen-Bradley Company .....	58
American Piezo Supply Co. ....	80
American Sales Co. ....	69
American Transformer Co. ....	56
Arcturus Radio Tube Co. ....	78
Aurisma, Inc., Ad. ....	80
A.R.R.L. Apparatus .....	67
A.R.R.L. Application Blank .....	94
A.R.R.L. Handbook .....	68, Cover III
Brown & Caine .....	91
Browning-Drake Corp. ....	57
Burgess Battery Co. ....	Cover IV
Cameradio Co. ....	84
Candler System Co. ....	85
Cardwell Mfg. Corp., Allen D. ....	65
Central Radio Labs. ....	72
Chicago Radio Apparatus Co. ....	74
Clarostat Mfg. Co. ....	86
Commercial Radio Institute .....	78
Coriell Electric Mfg. Co. ....	82
Corning Glass Works .....	63
Crosley Radio Corp. ....	61
Cunningham, Inc., E. T. ....	62
Dodge, C. K. ....	70
Dongan Elec. Mfg. Co. ....	86
Electrad, Inc. ....	70
Electric Specialty Co. ....	89
Ferranti, Inc. ....	88
Frost, Inc., Herbert H. ....	84
General Engineering Corp. ....	89
General Radio Co. ....	84
Gretzen, F. ....	80
Gulf Radio School .....	82
Hardwick, Hindle, Inc. ....	68
Huet Engineering Co. ....	78
Hoodwin Co., Chas. ....	66
Jewell Electrical Instrument Co. ....	59
Johnson Company, E. F. ....	90
Leeds Radio Company .....	79
Loomis Publishing Co. ....	66
McGraw-Hill Book Co. ....	54
Manhattan Electric Bargain House .....	83
Massachusetts Radio & Telegraph School .....	80
M. & H. Sporting Goods Co. ....	86
National Company .....	87
National Radio Institute .....	73
National Radio Tube Co. ....	90
Pacent Electric Co. ....	84
Plot Radio & Tube Corp. ....	Cover II
QST Binder .....	60
QST Bound Volume .....	64
Radio Engineering Labs. ....	75
Radio Institute of America .....	96
Radio Laboratories .....	90
Radio News .....	81
Radio-Victor Corporation of America .....	1
Rates Instrument Co. ....	72
Rectifier Engineering Service .....	99
Rooney, John T. ....	82
Scientific Radio Service .....	85
Shallcross Company .....	76
Silver-Marshall, Inc. ....	53
Supreme Instruments Corp. ....	77
Teleplex Company .....	76
Thordarson Electric Mfg. Co. ....	85
Thorola Radio Products Co. ....	91
U. S. Naval Institute .....	91
Vacuum Tube Exchange .....	76
Van Nostrand Company, D. ....	71
Vibroplex Company .....	74
Weston Electrical Instrument Corp. ....	55
Wiley & Sons, John .....	2, 85, 87
Wireless Egert Engineering, Inc. ....	88





GREET THE NEW YEAR WITH A 1930 SIGNAL BY USING THE FAMOUS  
**THORDARSON POWER SUPPLIES.**  
 WRITE & SEND US UR QSL CRDS FOR OUR NW HAM LOG BK.

**THORDARSON**

ELECTRIC MFG. COMPANY 500 WEST HURON STREET CHICAGO, ILL.

# Glorious Adventure awaits you in **RADIO**

**R**ADIO needs men just like you. Thousands of opportunities are now open for fellows who already know something about radio . . . who "think" radio, who "play" with radio, men who are "radio-minded" . . . radio amateurs! You, too, can use the knowledge you already have as a stepping-stone to success in radio. All you need is a little commercial training in order to make good in this fascinating profession. Others have done it and so can you. RCA Institutes actually trains you for success. It gives you the practical as well as the theoretical knowledge . . . the "how" as well as the "why" of radio. You study under the direction of nationally known experts . . . men who have made good in radio and can show you how you, too, can make your mark in this, the fastest-growing industry in the world today.

### Get a Commercial Radio License

Radio needs you. Never before has there been such an opportunity for rapid advancement. On ship or shore, the constant demand is for men . . . more men . . . trained men! Large broadcasting stations, manufacturers, dealers, as well as steamship companies are continually asking for men who have the knowledge and the confidence to hold a well-paid position in Radio. You, too, can now get that knowledge . . . You can be trained for a good paying radio job.

*This is the Only Course Sponsored by the  
Radio Corporation of America*

RCA is the world's largest radio organization. It sets the standards for the entire radio industry.

**This book is yours free . . . SEND FOR IT TODAY!  
Clip this Coupon NOW!**

## **RCA INSTITUTES, INC.**

Formerly  
Radio Institute of America



And the RCA Institutes' home laboratory training course enables you to quickly learn the secrets of radio. It enables you to obtain a thorough, practical education in radio in your spare time . . . You get the inside information, too, because you study right at the source of radio achievement. You learn radio by actual experience with the remarkable outlay of apparatus given to every student.

*See for Yourself why RCA Graduates  
Earn Big Money in Radio*

Clip this coupon now . . . send for this free book. Or, if you wish, step in at one of our resident schools and see for yourself how RCA Institutes actually prepares men for success in radio. Come in and get this free book or send for it by mail. Everything you want to know about radio. Each page packed with pictures and descriptions about the amazing opportunities in this vast, world-wide, money-making profession.

For the added convenience of students who prefer a Resident Study Course, RCA Institutes, Inc., has established Resident Schools in the following cities:

New York . . . 326 Broadway  
Boston, Mass. . . 899 Boylston St.  
Philadelphia, Pa. 1211 Chestnut St.  
Baltimore, Md. 1215 N. Charles St.  
Newark, N. J. . . 560 Broad St.

Home study graduates may also attend any one of our resident schools for post-graduate instruction at no extra charge.

RCA INSTITUTES, Inc.  
Dept. AH-1, 326 Broadway  
New York, N. Y.

Gentlemen: Please send me your FREE 40-page book which illustrates the brilliant opportunities in Radio and describes your laboratory-method of instruction at home!

Name   
Address

# 60,000 AMATEURS CAN'T BE WRONG!

That's the number who have put their  
reliance in the A.R.R.L. Handbook

All over the world the Handbook has been sent, in five successive editions, to tell its story of practical amateur radio to beginner and old-timer alike. It has quickly established itself as the standard manual of the practicing amateur. Everywhere it is hailed as the greatest fund of helpful information that an amateur ever saw.

And now, with the necessity of printing additional copies for the orders that roll in every day, additional material has been added in the same helpful fashion. We have pleasure in announcing the appearance of

## THE *The Sixth Edition of* RADIO AMATEUR'S HANDBOOK

*By Handy & Hull*

Revamped and overhauled as the Handbook always is before each successive edition, this new printing contains new and modernized material on two subjects of current importance: Crystal Controlled Transmitters and Radiotelephony. Thus, more than ever, it contains the answers to your questions. Between these covers is everything the A. R. R. L. can think of that is worth the telling for the guidance of a practical radio amateur.

It tells the story of amateur radio; what it is all about; how to become an amateur; how to build and adjust your apparatus; how to operate your station.

For the more advanced amateur there are working descriptions and building instructions for all kinds of receivers, transmitters, antenna systems, frequency-meters, power supplies, modulation systems, monitors, and keying methods; and detailed explanation of the complexities of modern operating procedure.

A world of valuable information, printed in "QST" format and bound in durable paper covers so that the price may be modest.

---

*Blue-and-Gold Paper Cover, \$1.00*

*Stiff Buckram Binding, \$2.00*

---

◀ *We honestly don't see how you can get along  
without the Handbook. Order yours to-day!* ▶

American Radio Relay League, Hartford, Conn., U. S. A.

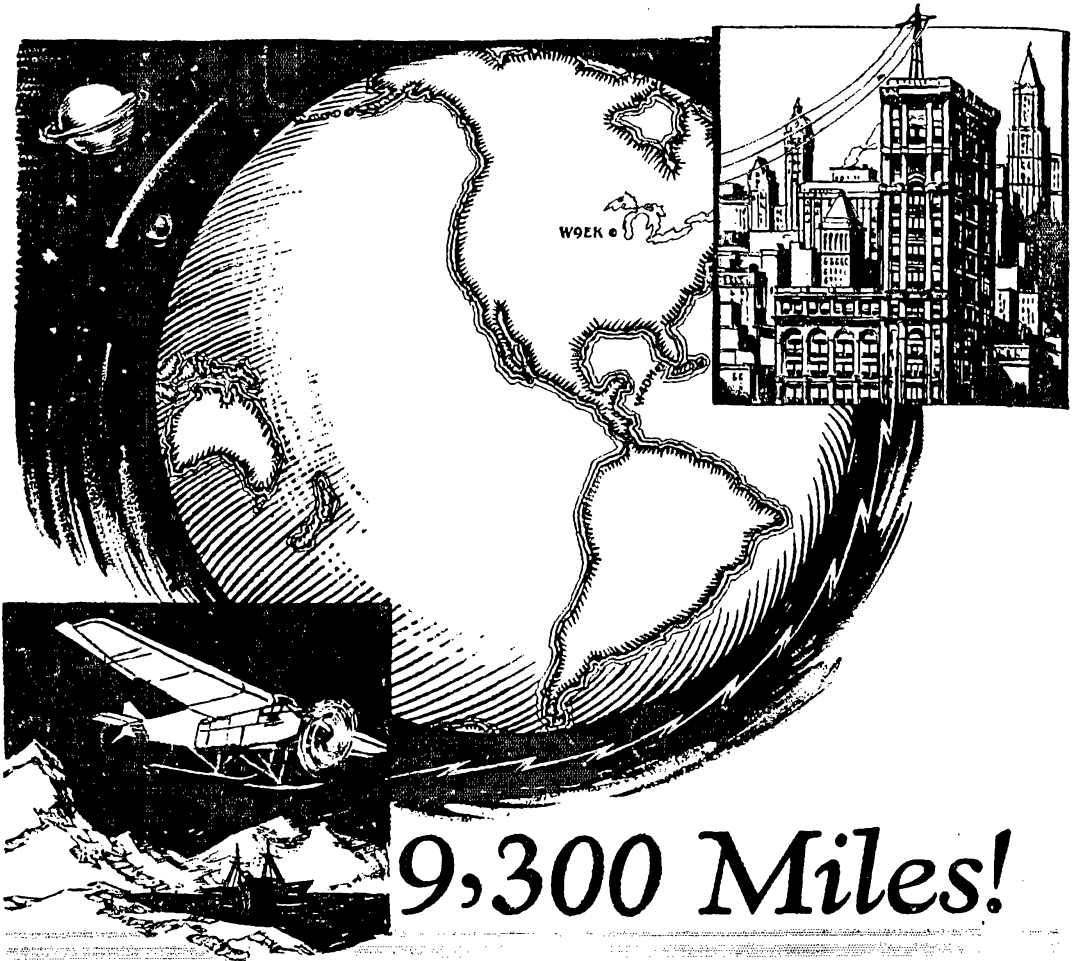

# 9,300 Miles!

Continuous direct two-way radio communication is being maintained between the New York Times Radio Station and Commander Byrd's Antarctic Expedition—a radio record.

Every Radio Amateur should know that Burgess Radio Batteries are used in the Antarctic Expedition radio stations.

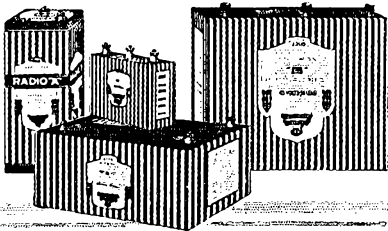

*Ask Any Radio Engineer*

**BURGESS BATTERY COMPANY**  
MADISON, WISCONSIN

# The Communications Department

F. E. Handy, Communications Manager  
E. L. Battey, Asst. to Coms. Mgr.  
1711 Park St., Hartford, Conn.

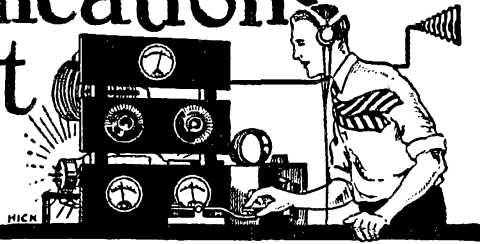

## Why Handle Traffic?

By R. P. Griffith \*

*In March, 1929, QST we invited contributions on all phases of amateur communication activity, offering prizes for the best article submitted each month during 1929 and selected for publication. By the time this magazine reaches you this contest offer will be drawing to a close. We shall continue to publish the best articles received on any phase of amateur organization or communication work in these columns. Your contributions are solicited and will receive careful consideration. — COMMUNICATIONS MANAGER.*

WE have had two very good articles lately dealing with "how to handle traffic." Speaking from recent experiences and a general view of conditions for the past two years, it seems to me that something should be said on *why* handle traffic! In the past few days five stations have quit me without a word when I mentioned "QSP?"; two more politely declined and signed off; two others calmly ignored the reference to traffic and went on with the conversation. Let's give these last all due credit. At least they knew how to rag-chew pleasantly and interestingly.

What reasons do so many amateurs give for not taking and reporting traffic? I have heard three. (1) "I do not have time." (2) "I sent a message once and never heard from it. Messages never get anywhere, so what's the use?" (3) "Most messages are trivial and unimportant, not worth sending. No one would care whether they got through or not."

Now what about this? If an operator actually doesn't have time to relay and deliver messages he is absolutely right in refusing to accept them, no question about that. No one should begrudge him an occasional half hour of enjoyment of his station on that account. But if we then hear him rag-chewing and report-hunting two or three hours a day for a week, we are obliged to conclude that he is a cheerful prevaricator!

The answer to the second excuse may be found very quickly in the traffic summaries distributed monthly by Headquarters to all Communications Department officials. These show the total number of messages originated and delivered, and an average over any considerable period of time shows that a little better than 85% of the messages originated are actually delivered. That is not a good answer, but at least it proves that from that standpoint the game is well worth while.

The third objection will bear study from several different angles. Anyone who has run through a file of two or three hundred amateur messages will admit that, at first glance, there is some truth in the charge. Again, looking over a box of letters I have from men and women all over this part of Iowa gratefully acknowledging receipt of messages I have mailed to them, would lead to a different conclusion. The most trivial birthday greeting or other remark of apparent unimportance may be linked with some incident or association known only to the sender and the recipient which gives the communication a different meaning and importance to these persons.

\* A. E. R. L. Route Manager, W9EJQ, Goldfield, Iowa.

1 Six traffic summaries taken at random in the past year show the average number of stations handling and reporting traffic, out of nearly 19,000 licensed (approximately), as but 548, or less than 3%.

Finally, and here is the main point, traffic handling is more nearly like commercial or military operating than any other activity we engage in. It is the best preparation for being useful to the community or the nation in an emergency. The rag-chewer does not attempt to copy one word in twenty that he hears. Many do not copy at all. Such an operator does not need or develop strict accuracy. He has a fair idea of what the other man will be talking about and if he misses a word or two he fills it in mentally from the general trend of the sentence, just as we do in ordinary conversation on the street. Put him to making actual copy and the chances are a dozen to one the act of writing would distract his attention from the code, the copy would be poor, and he would be a total loss. "Guessing" habits on the part of an operator lead to serious garbling and errors in messages which cannot be tolerated. When messages are relayed through several stations with such operators the errors are cumulative. Accuracy is a prime requisite of the real operator!

The rag-chewer would be a total loss without considerable training to correct his faults. Not so the traffic man. If an operator can receive, copy, and relay a message with preamble, address, and signature *correctly*, he can just as easily do the same with a message that will set an army in motion, recall a fleet or reassure some family of individual or group safety after an earthquake or other community disaster. If the process of handling a message one hundred to three hundred times a month for a year or two, and carried on the work carefully, accurately and honestly, he will have acquired a degree of confidence in operating which alone will make him a valuable help when help is needed in emergency. He will also have given the same training in carefulness and proficiency to a number of other operators. For this purpose the worthwhileness of the messages does not matter in the least but only the spirit in which the operators play the game.

Who owns the air anyway? Risking disagreement with a few amateurs, I must say emphatically that *we don't!* Neither do the broadcasters, or the ship stations, or any commercial communications organizations. Who, then? *The whole people*, of course! And our government, acting as guardian of the property of the people, and as the agent of the people in portioning out radio communication channels to those who desire to use them, logically enough, can be guided by one consideration only. Service. Public interest, convenience or necessity. This is right, just, and I believe exactly as it should be.

A number of the gang have found fault with our representation in the Washington Convention, claiming that our representatives were not insistent or energetic enough in defending our alleged "rights." Good Lord! What did you

give them to work on? A three per cent record<sup>2</sup> of service! Ninety-seven per cent of our stations operating solely for selfish enjoyment, and practically refusing to engage in the principal activity which gives contact with, and gets the favorable attention of the owners of this air we use. The only activity that gives a useful service to others in normal times, and the one which best prepares us to give service in an emergency,<sup>3</sup> local or national, is message handling. What more could our men do? If they had been backed by a real record of service, and by a host of loyal friends and boosters scattered in every community in our country, perhaps there would have been a different story to tell. It is worthy to note that at the time of the Washington Convention nearly 90% of our traffic was being handled on the 3500-ke. band, and of the four bands in common use, that one alone was not cut down.

The purpose of a radio station is to communicate. That implies messages of some kind. A radio station that never handles traffic is comparable to a basket-ball team that never handles a basket-ball.

<sup>2</sup> The author explains where the figure of three per cent is derived in footnote 1. However, it might be observed that not all licensees are active at any one time. It is estimated that not more than about 40% of the licensed stations get on the air at the same time even during the season of greatest activity. It may be of interest to readers if we state that at the peak of the season (February and March) a maximum of 1000 stations report message handling work each month, which falls to slightly less than 500 reports in the months of June and July, after which activity can be counted on to increase steadily and substantially each month until February. The number of stations reporting "zero traffic" are not included of course, using the 40% factor, and our annual average of 750 reports listing traffic, the "three per cent" mentioned in the text becomes approximately ten per cent. — F. E. H.

<sup>3</sup> The U.S.N.R. (C) VS and the Army Amateur Net organizations invite your attention and offer amateurs an opportunity to become familiar with tactical procedure, to exercise the skill and initiative developed in handling messages, to participate in organization work, and thus assist us to be fully organized and prepared for any and all emergencies of any kind, if we accept the challenge. — F. E. H.

## New Year's Resolutions in Order

NINETEEN TWENTY-NINE has passed in review. It seems time to check up and take account of stock.

If we pause a moment to examine present operating conditions, we may be able to see more clearly just where we are bound so that we may correct our course and steer our craft in the proper direction for the good of all concerned. The narrow frequency bands in which we operate to-day offer room enough for fairly satisfactory operation of many well-monitored stations of modern amateur construction. These bands are not wide enough to make it possible for us to endure the operation of selfish or careless individuals who occupy more than their fair share of the ether, and especially will this prove true during the January and February tests when many more hams will be on the air than at any other time of year.

Congestion in our bands due to carelessness and lack of consideration for others can be controlled by public opinion expressed through individual criticism. If not so controlled, group or collective action to bring about corrective regulations and restrictions may be necessary. A spirit of willingness to receive criticism and an active desire to help others with frank reports and suggestions tactfully made should go far to enable us to meet any situations that arise. What amateur does not want to so adjust and operate his station that he may be justly proud of his signals?

It is a nerve-racking experience to try to copy a DX signal and have the chap in the next district open up with his 1927-type set, blotting out half the band. Lengthy test and CQ calls are too often the rule. A.C. and r.a.c. notes are too frequently unnecessarily broad. The Q Code is still misused or ignored by amateurs although we see some steady improvement here. Superfluous transmissions and inexcusably wabbly and interfering 500- and 60-cycle signals do clutter up the air. Directional calls still bring answers from other countries than the one called, not to mention the time wasted by too-lengthy replies. These criticisms and claims that the rough broad signals are more in vogue than they have been since the days of the spark coil appear in QTC, the official organ of the Wireless Institute of Australia and in the T. & R. Bulletin of the R.S.G.B. as well, and that they are justly applicable to U. S. and Canadian amateur stations as well as those abroad goes without saying. Sit down

and attempt to log a good number of "high quality signals" for the column of QST and let us know what you hear. The off-frequency situation is one that needs individual attention, too. There is no excuse for any off-frequency work and unless watched by all, amateur radio will pay the penalty.

It is hoped that all who read this article may be both frank and tactful in suggesting improvement where they see this possible in the signals worked. Operating practices need as direct attention as station adjustment. C. D. officials, affiliated club organizations and holders of ORS appointments are intrusted with the responsibility of setting the pace. You who read these columns can exert a tremendous influence by lending your weight to a movement for better conditions, uniform operating practices and the like. You and I should look ourselves over carefully, revamping stations not in line with the best modern practice, learning and using the new Q Code and miscellaneous abbreviations where these have not already been put into effect at our stations. We must make a special effort to keep our stations in the lead and to set the right kind of examples in all we may do. This cannot but have a powerful effect in improving operating conditions. It will not only keep us in the lead but also will raise the standing of the whole amateur fraternity.

— F. E. H.

## Traffic Briefs

W1ANH at Washburn, Maine, is the most northern radio station in the United States!

Cupid shoots his arrows very straight and with wisdom these days. He has recently united W1AEQ and YL W1OS; and W6DOB and YL W6AET. There should be perfect harmony (at least in radio matters) in these families. Hi, WIBW is also one of our "newly-weds."

Hong Kong amateurs are now licensed with prefix VS. They cannot handle messages.

The Miami Amateur Radio Club extends a cordial invitation to all hams who visit Miami or vicinity this winter to get in touch with the secretary, E. D. Miller, 759 N. E. 68th Street, Miami, and take in one of their meetings.

Stations operating in the 7-mc. band having traffic for W1MK to QSP to Europe or the Philippines should, rather than hold it until they are able to QSO W1MK, try to pass it to some station that W1MK schedules or to some station in the direction of Hartford. Because of the heavy QRM on 7 mc. W1MK's schedules many times run over the allotted time, and, therefore, a comparatively small period is left for "general operation." 3.5-mc. traffic comes through okay.

W1XXX has at last found an "ideal" BCL environment! His mother recently made a social call on Mrs. BCL, living in the apartment on the floor below the ham station. The conversation jumped from one thing to another (as it sometimes does) and finally a discussion of radio came up. The BCL asked W1XXX's mother if she had a radio. The answer was, "No. But my son has a sending set." "Oh!" came a startled reply, "Has he got one of those? I'm so sorry. I'll bet we interfere terribly with his work. We must be careful not to use our radio so much." Hi Hi. (This is a true story — ham's name on request. — E.L.B.)

W8CEO says: Prospective hams or new hams whose calls are not listed in call books and who desire to join in radio gatherings should send their names, addresses and calls to the secretary of their local club. There is little way to locate new fellows except when they come forward.

The U. S. Prohibition Service is installing two short wave shore stations and three patrol boat stations in Porto Rico. These are expected to be in operation about January 15th and will use both telephone and telegraph on frequencies of 4205 and 3385 kc. The call letters will be as follows: NUXB, NUSJ, NUXP, NUXS and NUXZ. Amateurs are requested to listen for these stations and, if possible, communicate with them and give reports.

## EXPEDITIONS

The Oxford University Expedition (VP50UX) has been located at Moraballi Camp, Essequibo, British Guiana, S. A. The operator, Mr. M. G. Creswell, has been working on 14,000 kc. for DX contact and 7000 kc. for contact with the survey party which has a 10-watt portable set. Reports on VP50UX should be sent to Mr. Edwards, G6XJ, Wellhead Lane, Perry Barr, Birmingham, England.

On one occasion Potter of W6AKW heard PMZ, the station of the All-American Lyric Malaysian Expedition, when the field set was being used to contact VS3AB at Singapore. Operator Wells of PMZ experienced trouble with all but the louder stations during the QRN season, but he was successful in contacting W7ABH, November 18th, and the schedules with Foster of W6HM have been maintained successfully, Mondays, throughout the trip. Stevens, W7BB, contacted PMZ several times. The base station (PMZ), Peorock Tjahoe on the Barito River of Bandjermasin, 20 miles south of the equator) worked on 7340 kc., the complete set up including telescoping mast, gas engine and generator, weighing less than 200 pounds. A report from operator Wells, ex-W3ZD, relayed by W6AKW and W8CNR, follows: "When Potter copied our portable set the input was less than 7½ watts, and the antenna was a poor affair draped about on cocoon palm. Needless to say, the cooperation of fellow hams has been great, and it's

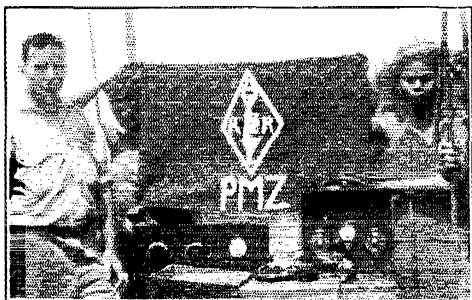

**HARRY W. WELLS, CHEVY CHASE, MD., AND RADIO RESEARCH ENGINEER** with the party, with some natives, portable radio equipment and a silk flag of the American Radio Relay League with PMZ the call letters of the expedition's short wave 50-watt station.

The emblem has been carried into new territory insofar as radio is concerned. Amateurs in all parts of the United States and other lands have cooperated with the party by relaying messages, and the work of our operators is deeply appreciated. L. R. Potter of W6AKW, Lancaster, Calif., has been the principal contact between the party and the Chicago headquarters.

certainly appreciated. The bulk of the traffic has been relayed to K1AF, and by that station to W6AKW, but the rest is sent directly to the states through schedules with W6AKW, W6AM and W6HM. Conditions here are far from ideal as the moisture ruins equipment and the static is never ending."

## WFA

Malcolm P. Hanson sends greetings from Antarctica, and asks us to explain to all who have been looking for a message that operation has been somewhat limited, due to the fact that the gasoline required for airplane exploration flights comes before that allotted to the radio station.

LA1G contacted WFA some time ago, and was copied OK in spite of some QRM from the gas engine. Operator Peterson was at the key of WFA, and a jolly chat in Norwegian was carried on for a half hour in addition to the traffic handled. LA1G worked WFA on the 14,000-kc. band and in October, quite exceptional work with the antipodes for the season. W7BB, W2QU and W1C10 reported interesting contacts and traffic handling with WFA.

Wallace of W6AM took a message from the "Junior Sun" of Long Beach, to Scout Paul A. Siple, special assistant and

orderly to Commander Byrd on the South Pole expedition, transmitting the radiogram, and receiving the reply, also of about fifty words, in just eleven minutes! What wouldn't we have thought about a record like that a few years ago? FB!

## 28 Mc.

Atwater of W2JN reports that signals have been slow in coming through this year. Last year they were coming in around the first part of October. The supposition voiced by Dr. Taylor of the Naval Research Lab to the effect that we are on the downhill side of the cycle of good high frequency transmission seems to be a correct one if we can judge by the length of time it has taken 23 mc. to come to life this fall!

Schedules which W2ACN and W2JN have had with PY1AA of Rio have not yet resulted in two-way contact. PY1AA has not been heard, although he reports hearing W9EF, NK F and W2JN this summer, as well as the harmonics of W1K and WKU. PY1AA has been heard r8 by D4YT of Germany. An interesting report of 28-mc. reception comes from ZT6C of Johannesburg, South Africa, who heard W2JN working W2ACN at 1545 GCT, October 13, 1929. ZT6C was heard calling W2JN at this time by G6LL of London. This reception of a W station by a South African marks just a year from the time A8V (now ZS4N) of Durban heard W2JN at 1540, October 14, 1928. A later report from ZT6C states that he also heard W2AQB.

Signals heard or worked are as follows: November 10, 1929, W2JN worked G2OD 1624 to 1655 GCT, Maximum strength r7 both ends. G2OD heard W2NM at 1705. W9CVN heard r7 by W2JN from 1730 until 2200. W5BIL heard at W2JN r7 at 1735. VE4GQ heard at W2JN r9 at 1800. VE4BQ heard by W2JN r6 at 2053. Reception of the above W and VE stations is probably their second harmonic. ZT6C heard W2JN from 1600 to 1700. November 17th: G5WK heard r5 calling W2NM at 1515. W2JN worked G6LL at 1550, but it was an unsatisfactory QSO as G6LL soon faded out. G6LL was heard at W2NM. W2JN worked G2OD at 1600 and was also heard by G5BY. G2OD heard at W2ACN. VE4GO heard working W8CPC at 1740 on second harmonic. Approximate frequencies of the above stations are as follows: G2OD c.e. d.c. 28390 kc.; W2ACN c.e. d.c. 28410 kc.; W2NM c.e. d.c. 28300 kc.; W2JN c.e. d.c. 28400 kc.

A list of 28 mc. stations heard or worked by W2JN between September 30, 1928 and March 31, 1929 follows: W5AEC, W5AOT, W5OH, W5TP, (W5WZ), (W5YG), (W6AM), W6BAX, W6CZA, W6UF, W9AKM, W9DKM, W9EVC, PCRR, WGT, (K4AGF), VE4GO, (G6LL), (E017C), (G2FN), G6DH, G2KF, K4SA, (EF8CT), (G6YQ), (G5ML), (G5VL), VE4GQ, G5YK, (G6HP), (G2OD), (E18B), (G6C1).

The antenna for 28-mc. operation is a 7/2 wave horizontal wire, 10 meters in height, and runs between garage and house in an east by west direction. It is excited at the westerly end by a ¼ wave zeppelin feed line. The receiving aerial is a wire about 70 feet long located on top of house and running in a north by south direction.

G5BY contacted W2JN on 28 mc., Sunday, December 1st, at 1400 Greenwich, reporting signals QSA5 R8 and receiving an excellent report himself. W2NM was also heard by G5BY. G5BY may be found on 28,334 kc. each Saturday and Sunday, 1400 until 1700 Greenwich, and glad to QSO anyone. Several U. S. A. stations were also heard on December 1st by G5ML, who reported to W2RR, word being received via W8KR and W1UE. The best heard were between 1200 and 1700 Greenwich, W2JN R 8, W2AQB R 8 and W2NM R 7.

## Traffic Briefs

W8FD and W9ERU are now holders of Extra First Class Amateur Operators tickets! These licenses permit their owners to use the new 14,100 to 14,300-kc. amateur 'phone band after special application has been made to the Radio Supervisor. Non-holders of these licenses wishing to use this new band must present an application showing special technical qualifications and ability to operate within the prescribed limits. Those interested in 14-mc. 'phone are urged to get their Extra Firsts before making application for the 'phone privilege to their Radio Supervisor.

## Traffic Briefs

"When I received my QST for December I received the biggest kick of my life. The International Tests is what I have been looking forward to for a long time. During the last contest I was just getting going in first-class shape in ham radio, so I did not participate. This year I am going to try my luck, and planning to use the 14,000-kc. band exclusively." — *W9EAP*. This is but one example of the enthusiasm accompanying almost all the early entries. *Don't forget* to get your own QSL-entry card in early for the February Contest, our Third International Relay Competition. Only those amateurs in the U. S. and Canada whose entries are received during *this month*, January, will be able to take part.

The All-Section Sweepstakes Contest will be held January 18 to January 31 inclusive. The Third International Relay Competition is scheduled to take place February 15 to February 28 inclusive. Remember those dates. Read details elsewhere in this issue, and follow the rules set forth in December QST closely. These contests have a number of important objectives. They promote national and international fellowship and good will in addition to making possible some rare sport and a pile of new records for every station that takes part. Get on the air and plan to participate as fully as possible. Whether your score be large or small, be sure to report it so that full credit to everyone may appear in QST, and more important to boost the standing of *your* section or *your* country!

In connection with the February tests, make *sure* of getting your message assignment sheet in time, by sending your entry card in NOW.

It will be interesting to see which foreign localities can QSO most (a) United States and (b) Canadian amateurs during the two weeks of the February Contact Contest.

Amateurs everywhere are requested to *pay no attention* to calls from stations working *outside* amateur frequency bands specified in the Washington Convention, *except to log these transmissions and turn them in* for checking in confirmation with Official Observers logs. This request goes for *both* the January and February competitions.

The latest idea in QSL cards comes from W4AIQ. He uses a card with a stamped reply card attached. That's about the best for the recipient we have heard of. All he has to do is fill in the report and drop the card in the mail. FB!

Foreigners, attention! Among the amateurs in the U. S. desiring schedules with foreign countries is W4AIQ at Memphis, Tenn. Drop him a card, if interested.

The Communications Department was indirectly impressed by one on November 19 when CM Handy was presented with a junior op (his second, by the way). Congrats, FH!! Before long those ops will be able to keep WIBDI on the air for you. Hi.

Say, fellows, do you realize that the Pacific Division has led the country in traffic for four consecutive months? Wake up!! Isn't there some Division that can show them up? Competition is the spice of this traffic handling game.

Two objections to our lists of "Prehistoric Signals" have been received, which make us wonder if the gang is aware of the fact that even the *most* expensive of apparatus is NG and will not give a decent note unless it is intelligently used!!

W4HY tells us of a very realistic happening during one of his QSOs with W8BDT. In the middle of the QSO, W8BDT said, "QRX, OM, while I kill a spider. He's a big whoppa and hopping all over the railing." W4HY says he imagined that he could actually hear W8BDT hit that spider! This just shows how close to the other fellow we sometimes feel during our QSOs.

Did you ever wonder why your station is never mentioned in the Divisional Reports? It would be, if you sent your Section Communications Manager an account of your activities each month. Reports should be mailed to the SCM

on the 15th of each month, covering activity for the preceding month, 15th through the 15th.

A tip for the DX man — HC1FG says that foreign stations have an understanding with one another never to answer a U. S. station's CQ, as it is useless due to the heavy QRM in the United States. This is particularly true on 7000-kc. Let's not waste too much time with our lengthy DX CQs.

W5CFR has a daily schedule with WFA.

A route is being worked out to speed up west-to-east traffic. It is hoped that when plans are completed and schedules are functioning properly traffic leaving the west coast at 6 a. m. will reach the east by afternoon. The stations on the route at present are W6ACJ, W5AHI, W9FKD, W9AP, W8BAU and W1ZA. A couple more stations are needed east of Kansas, and W5AHI or W6ACJ would be glad to hear from anyone interested.

## Genus BCLus

The following is taken from a 'phone man's host of experiences with BCLs. W2ACG had a good 'phone outfit, so good in fact that it covered a multitude of bands — the 'phone band, the broadcast band, and the ship band. Hi. One night while he was adjusting a wave trap in a neighboring apartment house (one of those dwellings that hams swear at, not by), W2BN was modulating W2ACG's carrier by shouting into the mike. Everything was going fine when W2BN did a most undiplomatic stunt — in his Sunday-best style he requested all BCLs hearing the transmission in their receivers to cooperate by calling W2ACG on Bell telephone!! Several *bona fide* complaints came in that required all the "salve" W2ACG could disseminate. Hi. Later the 'phone rang again, and after much trouble it was finally gleaned that a town in New Hampshire (near the Canadian border) was calling. After the telephone operator had been convinced that W2ACG wouldn't pay the charges, she informed him that by not connecting him with the fellow at the other end, the charge would be only 35 cents, a mere report charge. By this time the operator was getting quite sociable and was willing to QSP the dope the fellow had for W2ACG. He wanted to report that W2ACG was coming through up there! According to the operator, he was the favorite son and radio expert of the town. Hearing W2ACG must be the same to him as hearing WEAT R9 would be to most amateurs. Hi.

Albert Reiss, W2BN.

Official Broadcasting Station W8CEO has adopted a new method of sending the broadcasts, which other OBS could very effectively follow. The message is sent twice, first at 20 words per minute for the advanced amateur, and then at 10 w.p.m. for those who cannot copy at the higher speed and beginners who wish to use the broadcast for code practice. This procedure is carried out at promptly 7 p.m. E.S.T. on Monday, Wednesday and Friday nights on 3705 kc. Beginners especially are urged to watch for W8CEO!

No one will dispute the statement that QRM is fierce on 7000 kc. Many fellows are moving to 3500 kc. in an effort to find a clear spot, and that band is gradually becoming more crowded. But what of 14,000 kc.? That band isn't used anywhere near as much as it should be! We have 400 kc. in the 14,000-kc. band — 400 good kilocycles just waiting around for us to use them!! If you don't believe this, listen on that band some time. It is an excellent band for DX and long-hop traffic handling. Get down in the wide open spaces of 14,000 kc. and give it a try!

The revised edition of the "Rules and Regulations" of the Communications Department is now ready. If you can use a copy, drop us a line. All O.R.S. will receive a copy with the next bulletin.

We recently caught a well-known brass pounder keeping his Tuesday schedules on Wednesday! And he kicked because the "fellows don't keep their schedules." We hope this isn't a habit with brass pounders!! Hi.



# Traffic Summaries

OCTOBER-NOVEMBER

Pacific led by East Bay	11,269
Central led by Ohio	5934
New England led by Eastern Massachusetts	5568
Atlantic led by Eastern Pennsylvania	4344
Hudson led by New York City and Long Island	3888
Midwest led by Missouri	3174
West Gulf led by Northern Texas	1954
Northwestern led by Oregon	1508
Roanoke led by Virginia	1099
Southeastern led by Florida	1063
Dakota led by Southern Minnesota	1022
Delta led by Louisiana	838
Quebec	293
Rocky Mountain led by Colorado	255
Ontario	148
Prairie led by Saskatchewan	101
Vanala led by British Columbia	37
685 stations originated 10,317; delivered 8138; relayed 23,141; total 42,495 (80.5% del.).	

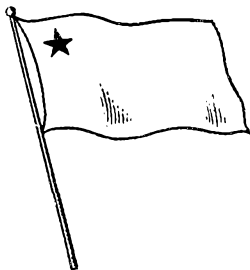

The East Bay Section in the Pacific Division leads the country this month and takes the *Traffic Banner* away from the Los Angeles Section, after the latter had carried it for three consecutive months. Good work, East Bay! This Banner will go each month to the Section with the largest total of *real* messages. A traffic summary showing the standing of the various Divisions for the past month is printed above. What place does yours take? What Section will carry the banner next month and help their Division head the list?

## YACHT "CARNEGIE" BURNED

The non-magnetic ship *Carnegie*, better known to amateurs as WSBS, is no more, and her three-year cruise of investigation has been brought to an unexpected termination. We understand that while the *Carnegie* was at anchor in the harbor at Apia on November 30th, loading gasoline, an unfortunate explosion occurred, the fire resulting sweeping quickly through the wooden vessel and spreading to five other craft, which were also destroyed. The explosion, according to early reports, blew Captain Ault from the quarter deck into the water and resulted in his death. Several other members of the crew were injured and one was reported missing. Since the radio operator, Stuart Seaton of W3BWL, is not listed among those injured we may assume his safety. The fire spread so rapidly that only the cash and ship's books were saved. The *Carnegie* carried twenty-five persons. The U.S.S. *Ontario*, sixty miles from the scene of the disaster, was instructed to proceed to the rescue of the scientific party. Our sympathies are deeply stirred by this disaster, which removes one of the expeditions from our list, and which concerns a group of individuals we had come to know through our opportunities to be of service in keeping them in contact with friends, and with the expedition's Headquarters, the Department of Terrestrial Magnetism, Carnegie Institute of Washington.

During October and November, VE4IH, W6AYC, and W7LZ reported their contacts with WSBS, giving us the position of the *Carnegie* on each occasion.

W6DE at Culver City, California, requests traffic for his schedule with LU8EN at Buenos Aires, South America. This is a reliable daily schedule and should be an excellent route for South American traffic.

QST FOR JANUARY, 1930

# BRASS POUNDERS' LEAGUE

Call	Orig.	Del.	Rel.	Total
W3ZP	1675	4	2	1681
W6AD	113	304	795	1213
W2CXL	71	491	461	1023
W6TM	139	288	398	825
W2AVR-2ARM	14	8	764	786
K4IHR	235	174	240	769
W1MK	97	110	538	725
W1B1L	26	42	574	642
W6IP	116	112	492	629
W6ALX	26	45	548	619
W3BWT	182	75	294	551
W6AKW	35	37	452	524
W1AMU	23	17	462	502
K4IDJ	379	72	18	469
W9COS	63	217	166	446
W6OT	—	—	414	414
W8DYH	31	52	319	402
W5HY	200	183	18	401
W8CNO	38	21	316	375
W3ARU	67	257	1	325
K4IAF	180	40	114	334
W6EIB	10	14	300	324
W6CGM	46	141	132	319
W6SS	311	—	—	311
W9DLL	40	39	238	307
W1IP	18	29	254	291
W6AMW	14	27	254	295
W1CMZ	31	40	220	291
W8CUG	8	26	253	287
W8CRI	74	16	185	375
W6HTZ	37	43	184	264
W1BET	127	30	96	253
W1ACH	68	80	102	250
W9DXY	15	3	230	250
W1TF	39	45	157	241
W5PFC	19	39	182	240
W2CUF	30	24	186	240
W2AFV	7	70	157	234
W9EJQ	19	25	190	234
W5AQY	116	71	46	233
W6ATT	35	10	186	231
W9CET	21	17	188	226
W9PKD	12	21	191	224
W6CBW	12	69	138	219
W8LT	75	36	107	218
W8AEQ	30	24	164	218
W1QH	—	1	190	215
W1BZ	214	—	—	214
W1LQ	49	71	90	210
W2AC	42	88	78	206
W7HP	26	20	158	204
W2APV	63	139	—	202
W9ZZ	5	192	4	201
W1ZA	87	9	105	201
W6FRK	21	57	120	198
W1AFB	36	56	92	194
W6RIP	38	52	85	175
W6ASH	17	51	102	170
W8CFR	31	101	19	151
W6ETA	21	52	76	149
W2AVP	—	73	68	141
W9RKL	33	66	40	139
W6EPZ	13	50	72	135
W3TF	20	26	24	120
W9BCA	27	75	—	102
W7BB	7	79	8	94
W5RJ	27	53	12	92
W9FFX	14	59	13	86

The several amateur stations responsible for the best traffic work — the ones that are "setting the pace" in worthwhile traffic handling — are listed right up near the top of our B.P.L., the figures giving the exact standing of each station accurately.

All these stations appearing in the Brass Pounders' League are noted for their consistent schedule-keeping and dependable message-handling work in amateur radio. Special credit should be given to the following stations (in the order listed) responsible for *over one hundred deliveries* in the message month: W2CXL, W6AD, W6TM, W3ARU, W9COS, W9ZZ, W5HY, K4IHR, W6CGM, W2APV, W6IP, W1MK, W8CFR.

Deliveries count! A total of 200 or more bona fide messages handled and counted in accordance with A.R.R.L. practice, or just 50 or more *deliveries* will put you in line for a place in the B.P.L. Why not make more schedules with the reliable stations you hear and take steps to handle the traffic that will qualify you for B.P.L. membership also!

## Army-Amateur Notes

THE Armistice Day Test Message from Major-General George S. Gibbs, Chief Signal Officer of the Army, was transmitted from W2CXL at various times during the evening of November 11 on both the 3500- and 7000-ke. bands. The text of the message is given herewith for the information of those interested:

"The past year has seen the Army-Amateur system making giant strides towards the perfection of a nationwide ama-

teur system. Through, and by means of this system, the effects of storms and other disaster producing causes may be reduced to a minimum by providing emergency means of communication.

"This system enables aid and relief to be promptly furnished, and neither the citizens of your community nor myself can fail to appreciate that your personal efforts and cooperation are bringing nearer the day when an Armistice will be effected with the powerful natural elements that endanger the peace, happiness and prosperity of our country."

**FIRST CORPS AREA:** Captain J. C. Platt, Jr., S. C., Liaison Officer Army-Amateur Radio System, First Corps Area, has been promoted to the rank of Major. Major Platt continues as Liaison Officer for the First Corps Area.

**SECOND CORPS AREA:** Stations are now fully organized and the various Nets are functioning very well. Procedure lessons are sent from W2PF each Monday at 8:30 p.m. for the instruction of all Second Corps Area A-A stations. Twenty-four of the 31 Army-Amateur stations in this Area copied the Armistice Day message.

**FIFTH CORPS AREA:** The West Virginia net is the outstanding net in this Area, having practically 100% representation at each schedule. W8OK is the NCS. The Ohio State net has a good showing each Monday. The Kentucky and Indiana nets are being reorganized. Ohio, West Virginia and Kentucky reported excellent results on the Armistice Day message. W8GZ-W8ZG has been assigned the call WIH for use on the Army frequency of 6990 kc.

**NINTH CORPS AREA:** Many stations copied the Armistice Day message. W6DLI copied it on a portable. W6UO is running a schedule with W6EDK, W6EAF, W6BAJ, W6DQV and W6DQO are working regularly. W6DFR handled 37 messages and W6EDK 25. Stations desiring to join the net, please write to W6DFR for application blanks.

#### BEGINNERS, ATTENTION!

A description of a transmitter for the 3500-, 7000- and 14,000-ke. amateur bands was published in December *QST*. This transmitter has been designed especially for men who have had no experience with amateur radio, and is an excellent outfit. Instructions on how to build a simple receiver for the 1750- and 3500-ke. bands appeared in November *QST*. This is an ideal set for receiving code transmissions on 1750-ke. which have been arranged for your benefit. A list of the "volunteer stations" that are sending code practice and other information for your special benefit was printed in December *QST*. There are no changes in the list this month except that W4LT has changed his hours to 9-10 p.m., and W6EAF has found it necessary to discontinue the broadcasts. A list of the stations sending code practice will be gladly sent you, if you will drop us a line. The Radio Amateur's Handbook contains useful suggestions for learning the code and much other information that you would find helpful. We invite requests for any information you may need. Just drop a line to the Communications Department and we shall do our best to help you.

## W1MK

A.R.R.L. Headquarters' Station W1MK operates on frequencies of 3575 kc. and 7150 kc. Robert B. Parmenter, "RP," is the chief operator; his list is familiar to most of the amateur fraternity. Occasionally other members of the Headquarters' staff operate at W1MK. Their personal signs may be found in the QRA Section of *QST*.

Throughout the following schedules Eastern Standard Time will be used.

**OFFICIAL AND SPECIAL BROADCASTS** are sent simultaneously on 3575 kc. and 7150 kc. at the following times:

8:00 p.m.: Sun., Mon., Tues., Thurs., and Fri.

10:00 p.m.: Mon. and Fri.

12:00 p.m. (midnight): Sun., Tues., and Thurs.

**GENERAL OPERATION** periods have been arranged to allow every one a chance to communicate with A.R.R.L. Headquarters. These general periods have been arranged so that they usually follow an official broadcast. They are listed under the two headings of 3500 kc. and 7000 kc.; to indicate whether the watch is devoted to listening on the 80-meter band or to the 40-meter band.

3500 kc.

8:10 p.m. to 9:00 p.m. on Sun., Mon., Tues., Thurs., and Fri.

10:00 p.m. to 11:00 p.m. on Tues. and Thurs. (No OBC sent before these periods.)

12:00 p.m. to 1:00 a.m. (or later) on Sunday night (Monday morning).

7000 kc.

10:10 p.m. to 11:00 p.m. on Sun., Mon., and Fri.

12:00 p.m. to 1:00 a.m. on the following nights (actually on the morning of the day following): Mon., Tues., Thurs., and Fri. (Only on Tues. and Thurs. does the OBC precede these periods.)

**SCHEDULES** are kept with the following stations, through any of which traffic will travel expeditiously to A.R.R.L. Headquarters, on 3500 kc.: W1ACH, W1KY, W1VB, W1WV, W1ZA, W2JF, W3BWT, W3SN, VE3BC, VE3DA, VE3ET, W5AAG, W5CUG, W5HL, W5JD, VE9AL, W9APY, W9BLI, W9OX; on 7000 kc.: W6AKW, W6CIS, W6TM and W9QF.

## Official Broadcasting Stations

### CHANGES AND ADDITIONS

(Local Standard Time)

W2PF (3876), Wed., 10:30 p.m.; K1KD (approx. 7050), Tues., Thurs., 10:30 p.m.; W5AED (7100), Mon., Thurs., 10:15 p.m.; Tues., Fri., 1:15 p.m.; W5AHB, Mon., Tues., Wed., 12:30 p.m.; W7AAT-QT (7040), daily except Sun., 3:30 p.m.; W7FL (3571.1), Tues., Thurs., midnight (7142.8), Mon., Wed., Fri., 6:15 p.m. (14,285.7), Sun., 3:00 p.m. (3510 phone), Sun., 6:15 p.m.; W8CEO (3725), Mon., Wed., Fri., 7:00 p.m.; W8CRA (14,050), Sun., 6:00 a.m., Sun., Mon., Tues., Sat., 5:30 p.m. (28,000), Sun., 2:30 p.m.; W9CJQ (3660), Mon., Fri., 7:00 p.m.; W9CTW (7175), Mon., Wed., Fri., 1:00 p.m.; W9DXZ (3710 ec.), Mon., Wed., 7:30 p.m.

## High Quality Signals

3500-ke. band: W1A0I\*\*, W1CCZ, W1CGR, W1CQR, W1MK\*\*\*, W1NV, W1VB, W1WZ, W2ACB, W2AEF, W2AG\*\*\*, W2AIZ, W2AOS, W2ATP, W2BLF, W2BRH, W2BYO, W2CLA, W2CXL\*, W2DV\*\*, W2DW, W2EC, W2GV, W2LU\*, W2OP\*, W2PF\*, W2SC, W3ARU, W3AWQ, W3BWT\*, W3DH, W3MA, W3MI, W3LV, W3RO, W3VM, W3ZV, W3AHP, W4AIW, W4ALD\*, W4JR, W4KV, W4LM, W4OC\*, W5APG\*, W5AAQ, W5AII, W5AQ, W5ARC, W5ARX\*, W5ASZ, W5ATD, W5AX, W5AY, W5BFG, W5BRO, W5BSY, W5CEO, W5CEP\*, W5CMP (c.c.)\*, W5CNO, W5CR\*\*, W5CUG\*, W5DAQ\*\*, W5DED, W5DF, W5DSS (c.c.), W5DXP, W5DYH, W5GL, W5HD, W5HL\* (c.c.), W5KR, W5QN, W5WJ, W5WO, W5ZZ, W5AKH, W5ANR, W5AZN, W5BKJ\*\*, W5CAA, W5CYQ\*\*, W5DLD\*\*, W5DLQ, W5DSC, W5DXZ, W5EBO\*, W5FHD, W5FRU\*, W5FUD, W5GBF, W5GCL, W5OX\*, W5VD, W5YI, VE3DC.

7000-ke. band: W1AQ, W1AWL, W1BWA, W1ID\*, W1MK\*, W2A0J, W2APQ, W2BFF, W2BFI, W2FF, W2HP, W2JN, W2MK, W2PX, W2UP, W3ADO\*\*, W3AFR, W3AFT, W3ANF, W3ANH, W3ASG, W3LA, W3WZ, W4AGR, W4AHL, W4AKT, W4EI\*, W4HE, W4WS W5AFI, W5AFX, W5BAT\*, W5EB, W5HY, W5SV, W6AJP, W6AKW, W6AM, W6BAU, W6BQP, W6CAR, W6CAT, W6CDU, W6DI, W6DLI, W6DZJ, W6EGX, W6EOP, W7UJ, W8ADE, W8ADU, W8AFM, W8ALH, W8ALU, W8ANL, W8AU, W8BAU, W8BBR, W8BCQ, W8BNE\*, W8BR5\*, W8BTI, W8CHI, W8CHO, W8CNO\*, W8CTJ, W8CUT, W8DLD, W8EM, W8EQ, W8GZ (7200) W8LT\*\*\*, W8NP, W8PL, W9AHZ, W9AQS, W9ARA\*\*, W9BEZ\*\*, W9BNZ, W9BPB, W9BVB\*, W9CIW\*, W9CTW\*\*, W9CVI, W9CVN\*, W9CVH\*, W9DGH, W9DIH\*, W9DLI, W9DQP, W9DWU, W9DXP\*\* (7090), W9DZM, W9EAG, W9EAS, W9EBO, W9EGF\*, W9EGU\*, W9EHO\*, W9EXW, W9FIL, W9FSE, W9FV1\*, W9GAR, W9GCP, W9GUG, W9LT\*, W9MQ, W9MR, W9GF, W9YC, VE2CA\*, WYF.

14,000-ke. band: W1AYG, W1BLI, W1BMC, W1BR, W1CJC, W1DP, W1FC, W1MK, W1MS, W2ABV, W2BJ, W2BQU, W2FP, W2FL, W2MR, W3AAZ\*, W3ACH, W3IC, W3JM, W3AKH\*\*, W4NN, W5AAK, W5QU, W7ED, W7EK, W8DRJ, W8FZ, W8RH, W8UL, W9AWI, W9BWW, W9CPS, W9DDY, W9EF, VE1BR, VE2AC, VE2AS, VE2BD, VE2BE, VE3ET, PY1AH, X9A.

Well-operated stations: W1MK, W2AG, W2AOS, W2CLA, W2CXL, W3MI, W3UO, W7EK, W8AX, W8DYH, W8VZ, W9CYQ.

Good 3500-kc. phone: W2FR, W2GJ, W3AEX, W3A1N, W4QZ, W8AJH, W8RD, W8WF, W9BJW, W9MM.

Prehistoric signals: W2AGX, W2BOX, W2HVJ, W3II, W3RJ, W3TQ, W4AHN, W4AIW, W4FT, W6CXY, W8CJL, W8DPD, W8RS, W8SB, W9DRE, W9US, VE3BJ.

NOTE.—The stars indicate the number of extra times stations were reported.

### ELECTION NOTICES

To all A.R.R.L. Members residing in the Sections listed below:

(The list gives the Sections, closing date for receipt of nominating petitions for Section Manager, the name of the present incumbent and the date of expiration of his term of office.) This notice supersedes previous notices.

In cases where no valid nominating petitions have been received from A.R.R.L. members residing in the different Sections in response to our previous notices, the closing dates for receipt of nominating petitions are set ahead to the dates given herewith. In the absence of nominating petitions from Members of a Section, the present incumbent continues to hold his official position and carry on the work of the Section subject, of course, to the filing of proper nominating petitions and the holding of an election by ballot or as may be necessary. Petitions must be in Hartford on or before noon of the dates specified, all of which are 1930.

Section	Closing Date	Present SCM	Present Term of Office Ends
W. Va.	Jan. 21, 1930	Reynolds (resigned)	Dec. 20, 1930
Nevada	Jan. 21, 1930	C. B. Newcombe	Sept. 15, 1928
Virginia	Jan. 21, 1930	J. F. Wohlford	Dec. 2, 1928
Tennessee	Jan. 21, 1930	Polk Perdue (resigned)	Oct. 2, 1930
Montana	Jan. 21, 1930	O. W. Viers	Nov. 5, 1929
East Bay	Jan. 21, 1930	J. W. Frates	Feb. 18, 1930
Northern			
Texas	Jan. 21, 1930	J. H. Robinson	Mar. 7, 1930
Alaska	Jan. 21, 1930	W. B. Wilson	Mar. 28, 1930
Hawaii	Jan. 21, 1930	F. L. Fullaway	Jan. 7, 1930
Louisiana	Jan. 21, 1930	M. M. Hill (resigned)	Dec. 30, 1930

Due to the resignation of Mr. Polk Perdue, W4FI, in the Tennessee Section, Mr. F. D. Reynolds, W8VZ in the W. Va. Section, and of Mr. M. M. Hill, W5EB, in the Louisiana Section, effective at once, nominating petitions are hereby solicited for the office of Section Communications Manager in these Sections, and the closing date for receipt of nominations at A.R.R.L. Headquarters is herewith specified as noon, January 21, 1930. Reports from ORS in Tennessee, should be sent to the Acting SCM listed on page 3 of QST. Mr. Hill will handle the work in his Section until a successor is elected.

### CANADA

Nominating petitions for Section Managers in Canada should be addressed to Canadian General Manager Alex Reid, 169 Logan Ave., St. Lambert, Quebec. To be valid, petitions must be filed with him on or before the closing dates named.

Saskatchewan	Jan. 21, 1930	W. J. Pickering	Dec. 2, 1928
Maritime	Jan. 21, 1930		
Alberta	Jan. 21, 1930	E. J. Taylor (resigned)	Mar. 28, 1930
Quebec	Jan. 21, 1930	Alex Reid (resigned)	Sept. 15, 1930

Due to the resignation of Mr. E. J. Taylor, VE4HA, in the Alberta Section, effective at once, and Mr. Alex Reid, VE2BE, in the Quebec Section, effective with the election of his successor, nominating petitions are hereby solicited for the office of Section Communications Manager in these Sections, and the closing date for receipt of nominations at A.R.R.L. Headquarters is herewith specified as noon, January 21, 1930. Reports from ORS in Alberta should be sent direct to the Canadian General Manager until a new SCM is elected.

To all A.R.R.L. Members residing in the Sections listed:

1. You are hereby notified that an election for an A.R.R.L. Section Communications Manager, for the next two-year term of office is about to be held in each of these

Sections in accordance with the provisions of By-laws, 5, 6, 7 and 8.

2. The elections will take place in the different Sections immediately after the closing date for receipt of nominating petitions as given opposite the different Sections. The Ballots mailed from Headquarters will list the names of all eligible candidates nominated for the position by A.R.R.L. members residing in the Sections concerned.

3. Nominating petitions from the Sections named are hereby solicited. Five or more A.R.R.L. members residing in any Section have the privilege of nominating any member of the League who holds an O.R.S. appointment in their Section as candidate for Section Manager. The following form for nomination is suggested:

(Place and date)

Communications Manager, A.R.R.L.

1711 Park St., Hartford, Conn.

We, the undersigned members of the A.R.R.L. residing in the ..... Section of the ..... Division hereby nominate ..... as candidate for Section Communications Manager for this Section for the next two-year term of office.

(Five or more signatures of A.R.R.L. members are required.)

The candidate and five or more signers must be League members in good standing and the candidate must be the qualified holder of a Communications Department, Official Relay Station appointment or the petition will be thrown out as invalid. The complete name, address, and station call of the candidate should be included. All such petitions must be filed at the headquarters office of the League in Hartford, Conn., by noon of the closing date given for receipt of nominating petitions. There is no limit on the number of petitions that may be filed, but no member shall sign more than one such petition.

4. Members are urged to take initiative immediately, filing petitions for the officials for each Section listed above. This is your opportunity to put the man of your choice in office to carry on the work of the organization in your Section.

— F. E. Haney, Communications Manager.

### ELECTION RESULTS

Valid petitions nominating a single candidate as Section Manager were filed in a number of Sections on or before the closing dates that had been announced for receipt of such petitions. As provided by our Constitution and By-laws, when but one candidate is named in one or more valid nominating petitions, this candidate shall be declared elected. Accordingly, election certificates have been mailed to the following officials:

Georgia-South	M. S. Alexander, W4RZ	Nov. 15, 1929
Carolina-Cuba	79 Rogers St., S. E.	
Isle of Pines	Atlanta, Ga.	
New Mexico	Leavenworth Wheeler, Jr., W5AHI Box 33, Valmora, N. M.	Nov. 15, 1929

In the Los Angeles Section of the Pacific Division, Mr. Bertram E. Sandham, W6EQF, Mr. Foster Strong, W6ELZ, Mr. Hal E. Nahmen, W6HT, Mr. E. O. Knoch, W6RJK, and Mr. Edrie P. Jobe, W6AKD, were nominated. Mr. Sandham received 45 votes, Mr. Knoch 39, Mr. Nahmen 17, Mr. Strong 13, and Mr. Jobe 11. Mr. Sandham has, therefore, been declared elected, his term of office beginning December 1, 1929.

In the Connecticut Section of the New England Division Mr. Frederick Ells, Jr., W1CTI, Mr. John E. Dwyer, W1AOX, Mr. H. B. Gompert, W1AMG, and Mr. V. W. Loper, W1RP, were nominated. Mr. Ells received 28 votes, Mr. Dwyer 22, Mr. Gompert 20, and Mr. Loper 10. Mr. Ells has, therefore, been declared elected, his term of office beginning November 30, 1929.

In the Southern New Jersey Section of the Atlantic Division, Mr. Norman R. Weible, W3BWJ, and Mr. Bayard Allen, W3ATJ, were nominated. Mr. Weible received 31 votes and Mr. Allen received 16 votes. Mr. Weible has, therefore, been declared elected, his term of office beginning November 30, 1929.

In the Washington Section of the Northwestern Division, Mr. Eugene A. Piety, W7ACS, and Mr. E. V. Casey, W7TZ, were nominated. Mr. Piety received 33 votes, and Mr. Casey received 30 votes. Mr. Piety has, therefore, been declared elected, his term of office beginning November 30, 1929.

# DIVISIONAL REPORTS

## ATLANTIC DIVISION

**M**ARYLAND-DELAWARE-DISTRICT OF COLUMBIA — SCM, Forrest Calhoun. W3BBW — Well, fellows, this is one of the finest reporting months so far, and the SCM wants to thank you for your splendid cooperation. We have several openings in this section for reliable (O. O.) Official Observers, stations which have an accurate means of checking frequency, and for some Official Broadcast Stations. Let me hear from any one who feels he can qualify for either or both. Maryland: W3AHL turns in a nice report and may soon be an ORS. W3AJR worked Colorado on 3.5 mc. W3CGC has a sked with W3BWT, our RM. W3GF, a prospective ORS, was QSO CZY-127 on five consecutive nights on 14 mc. FB, OB. W3BBW has put a sign at the Y.M.C.A. soliciting traffic. W3NY says he can't find traffic anywhere. W3DG is having a mighty hard time getting started. Delaware: W3AJH is QRL operating at WDEL. W3ALQ is doing carpentering around his house and is going to rebuild. Dist. of Columbia: W3BWT is leading us by a big margin. He keeps four skeds and handles lots of traffic. W3NR, an old-timer, who has been away at sea, will be reinstated soon as ORS. W3LX has received his ORS and wants skeds. W3GT is doing some nice 14-mc. work. W3ASO is working on 7 mc. W3ALF is having trouble with BCLs. W3PM is operating at W3BWT while rebuilding. W3CDQ, our YL, is now an ORS and is out for traffic. W3AKR got back on after being off the air since May. Both W3AKR and W3PM are prospective ORS. Don't forget to send in any news you may have, also those lists of high quality signals or off-wave stations. W3ALF sent in a nice list of high quality signals.

Traffic: W3BWT 55L, W3AJR 153, W3ASO 112, W3CGG 65, W3BBW 55, W3GF 36, W3ALF 23, W3GT 9, W3AJH 9, W3AHL 6, W3NR 5, W3LX 3, W3NY 1, W3AJR 45, W3ASO 27.

**SOUTHERN NEW JERSEY** — Acting SCM, N. R. Weible. W3BWJ — All indications point towards a very active season for this section. W3ASG has a new push-pull transmitter on 14 and 7 mc. W3ARR continues to handle traffic on 3.5 mc. There is considerable activity at the Princeton University Radio Club with their station handling the greatest amount of traffic in this section. W3BWJ has separate transmitters for each band used. W3ATJ is busy once more with Army-Amateur schedules. W3AWL manages to handle traffic in spite of the fact that he has a new car.

Traffic: W3ASG 42, W3ATJ 30, W3ARR 21, W3BWJ 12, W3DH 75, W3AWL 18.

**WESTERN NEW YORK** — SCM, C. S. Taylor. W8CPJ — WSAGI is busy with schedules with W6DNS. W8APD is on 14 mc. now. W8AVM has joined the U.S.N.R. W8BAV states that the gang in Jamestown, N. Y., are cooperating with one another in the suppression of key thumps in and about the town. The Jamestown Radio Club is growing fast. W8BDV is operating schedules with W2CYL, W1KH and NDB. W8BXB is another lone operator on 3.5 mc. W8CDB keeps schedules with VE3BC. W8CEZ has a new 210 transmitter which fails to work. W8CHL is back on the air on 3.5 mc. W8CWN is after traffic and schedules. W8CMU is operating lone on 3.5 mc. at Jamestown. W8CMW has acquired an OW. W8CWX is experimenting with a new receiver. W8CPC is now known by all countries on the globe. In fact, his DX has made W8UL jealous of him. HI. W8CSW is back at school again. W8CVJ has a new TPTG transmitter. W8CYG, a new ham in Penn Yan, desires traffic and schedules. W8DII is handling traffic. W8DME is keeping schedules with W8AHK and NDB. W8DSA has purchased an 852 and two 866's and is engaged in the construction of a new super-power transmitter. W8DTH attended the Air Races and looked over some aeroplane transmitters. W8DTH, W8BXB, W8CMU and W8BF have built transmitters such as used in the airplanes at the races. W8DYI visited many hams in Jamestown. W8QA has schedules with W8DSP. W8DAJ has a new aeroplane, so he still is in the air. HI. W8QB has been busy rebuilding his receiver. W8QL has schedules with W8CKI, W2OP, W8JQ and W9EJQ. W8PJ has been handling traffic to quite an extent. Many new requests are on hand for ORS. New Official Broadcast Station appointments must be made, and good reliable amateurs are solicited for this work. The SCM had a visit from VE5BA, who visited many amateurs during his stay at Buffalo. W8TH has rebuilt his

transmitter. W8UL has been busy working foreigners. Well, gang, next month with new ORS and dead wood weeded out, Western New York will be going 100% strong in A.R.R.L. spirit.

Traffic: WSAGI 15, W8BDV 49, W8BEN 9, W8BFG 16, W8BGV 25, W8BJ 22, W8BMJ 19, W8CDB 31, W8CHL 3, W8CVJ 3, W8DII 8, W8DME 23, W8QA 28, W8QL 66, W8PJ 23, W8TH 6.

**EASTERN PENNSYLVANIA** — SCM, Don L. Lusk. W3ZF — Several stations are in line for ORS certificates. In general, everything is on the upward trend. W3PB, W3SM and W3ZF installed an amateur xmitter at the Philadelphia Electric and Radio Show, and pushed over 1675 messages for what we believe is a record for a single week's operation. W3SM has applied for reinstatement of his ORS and had a nice total this month. W3PB spent all of his time at the Radio show. W3LC is third in traffic handling this month. W3AKB has been off the air rebuilding, but promises to chase traffic this month. W3UX is fast becoming a traffic man of note. W3AFE is due for an ORS soon. W3TB will use 852's soon. W3MC has been appointed an ORS. Congrats, OM. W8AWO has had school QRM. W8DHT is bothered with YL QRM. HI. W8VD came back to the 3.5-mc. band for traffic. W8DRG has a new QRA and will start the code broadcasts very shortly. W3GS has had trouble trying to work at school and operate his xmitter, too. Joe Smith, an operator at W3KLC, helped out considerably during the Radio Show. W3ARC also gave a hand. Come on, fellows, let's win that traffic banner and keep it! More reports and larger totals will have to be made to make this possible. W6AM has requested the name of a prospective Official Frequency Station who is preferably CC. Anyone interested please communicate with W3ZF.

Traffic: W3ZF 1681, W3SM 148, W3LC 75, W3AKB 67, W3UX 57, W3AFE 50, W3TB 40, W8AWO 39, W8DHT 38, W3MC 36, W8VD 28, W8AUR 10, W3GS 13.

**WESTERN PENNSYLVANIA** — SCM, A. W. McAuly. W8CEO — There are several fellows on the ORS list who have been very lax in reporting. This is a warning that the slate is going to be wiped clean the first of the year, and that hereafter only those who are reasonably consistent in reporting will be kept on the list. W8CUG, with eight schedules, is still leading the section. Route your traffic for headquarters through him, as he has a daily schedule with W1MK. W8CFER is the runner-up. W8DLG, a new ORS, is doing fine work. W8YA is on the air on the 3500-ke. and 7000-ke. bands. W8DUT is putting in crystal control. W8DVZ says football is cutting into his traffic work. W8VI, the station of the Juniata Radio Club of Huntingdon, is all ready with the exception of a good filter. W8CEO has the mast up again and everything working smoothly. W8DHW is still experimenting with 56-mc. transmitters. W8AJE is trying to drag an ex-commercial operator into the ham game. W8CMP is still battling out the traffic. W8KD is going after an ORS. W8GI had his ORS appointment cancelled. W8AGO worked all U. S. districts on 3500-ke. band while using an input of six watts. The officers of the Erie Amateur Club are working on plans for the Atlantic Division Convention. W8AVY sends in a nice total for a non-ORS. W8DNO is in the Navy Net. W8AGQ, the station of the Oakmont High School, on the air since the old spark days, is being dismantled and the material disposed of. W8ARC is Secretary for the Pittsburgh Club and W8AMA for the Erie Club. Get in touch with them if you want to get in on some good times.

Traffic: W8CUG 287, W8CFER 151, W8DLG 88, W8YA 51, W8DUT 51, W8BGW 22, W8DVZ 14, W8VI 12, W8CEO 10, W8DHW 9, W8AJE 6, W8CMP 37, W8AVY 25, W8DNO 8.

## CENTRAL DIVISION

**KENTUCKY** — SCM, J. B. Wathen, III. W9BAZ — The QSO Contest sponsored by the N. K. R. A. of Covington closed November 1. W9BKK topped the list and pocketed first prize of \$7.50 — nice going! W9CEE says DX is wonderful, but traffic scarce. We will shortly have W9BWJ back with us. Things are going light at W9JL. A new 852 is perking at W9AZY. W9ETD is in a new home and promises a big noise. W9GBX is getting R7, QSA5 in Africa with his 210. W9EYW nearly kicked the bucket, but is getting in fine shape again. W9GJG is now W9ZZE in the Southwest. W9ELL is a brand-new ORS. W9GGB is again

rebuilding. W9FZV is still busy with asphalt business. W9ENR's report sure was a welcome one. W9OX has a new push-pull which is the envy of the town. W9BAN has a 10-kw. tube — for display purposes only. "How dry I am" will be sung by W9ARU in Cuba. W9EDQ has applied for ORS. Incidentally a couple of ORS lost their tags for not reporting this month.

Traffic: W9OX 81, W9BXX 67, W9JL 64, W9ENR 57, W9HAZ 56, W9GBX 12, W9BAN 11, W9EYV 11, W9AZY 9, W9GGB 9, W9CEE 6, W9ELL 5, W9ETD 4, W9FVZ 3. INDIANA — SCM, D. J. Angus, W9CYQ — W9ASK, operator on the S.S. *Seator*, sent out an S.O.S. and jumped overboard as his ship sank after being rammed by the S.S. *Marquette*. His S.O.S. was the means of saving part of the crew. FB! He was also saved. W9AKD lost a plate transformer, so cannot menace the BCL's until he gets another. W9FCX claims he is the best ham in Crumstown, as he is "it." W9GGS has changed to screen-grid receivers. W9EDC will be on as soon as his power supply arrives. W9GJS is beginning to handle considerable traffic at Seymour. W9CIC is the star station of the state with a total of 60 messages. W9BEJ complains that his set has an arc in it. W9MQ has a new remote-controlled transmitter. W9BQE has a new shield grid receiver. W9COL was presented with a new junior op, weight 10 lbs. W9GHP has changed from 7000 to 3500 kc. for the winter. W9PC bought W9AFI complete, and was issued the same call under which this set was operated for a number of years. W9ABV, W9AET, W9CLF and W9EPU are new stations at Fort Wayne. The Radio Traffic Association of Fort Wayne is meeting regularly with a definite program for every week. W9CIC, C. M. Fishback, is Route Manager of Indiana District No. 6 which comprises the countries in the southeastern corner of the state. Amateurs in this district please get in touch with W9CIC. W9GJS is going strong on 3500 kc. W9AJJ is a new ham in Seymour. W9A00 is blossoming out with a new 50-watter on 3500 kc. W9CIC is very busy heading up the new Naval Reserve unit at Seymour.

Traffic: W9CIC 60, W9AEB 4, W9GKI 8, W9GGJ 1, W9AXI 3, W9COI 4, W9GGP 2, W9BKJ 18, W9EMR 36, W9DSC 7, W9AXH 6, W9AHB 2, W9DJB 6, W9GJS 11, W9CYQ 13.

ILLINOIS — SCM, F. J. Hinds, W9APY — W9DXZ is again with us. W9AFF is doing nicely with a MOPA on 3.5 and a TPTG on 7 mc. using a new 65½-foot Hertz V.F. W9FO keeps a nice bunch of schedules. W9BHW says when he gets enough courage he will put a new Zepp up on the roof. According to W9AKA, 3.5 mc. is the best for traffic work. W9BLL has a number of nice schedules and a fine traffic report. As soon as the new power supply arrives, W9CKM will be on with a bang for traffic. W9REF states he is a television ham and is out for a 14,000-kc. phone set. W9FUR reports 14 mc. poor and expects to be on 28 mc. soon. W9EGY is a new ham at Zion City, Ill. W9ANQ and W9CUH are the only active stations in Waukegan. W9GJ says a new phone band will certainly be welcomed to relieve our present bands. The Radio Club of the Austin Y. M. C. A. has its station W9BZD on 7000 and 14,000 kc. W9GIV is going fine again. The QRM at W9BMQ is bad due to local high school QRM, consisting of elevator motors, spark coils in laboratories, etc. W9CCR is using a home brew transformer with 4 201A's for rectifier. W9ERU has just become owner of a brand-new extra first-class amateur license. W9BRY has a MG on a 210 High C Hartley. W9ETP moved into the basement and works on 7 mc. The Chicago Radiofone Club wishes to announce it would like to have more members. (See W9EZN.) W9KB is trying out some new filter condensers. A new power supply is being built with W9CKZ. Will someone tell W9FDY how to get PDC with his 8 mikes, 30 henries and recto-bulbs on a 203-A? W9DGG is on the Wisconsin Army Net in the Illinois Section. W9ACU is an OBS now. W9DJ has 150 watts on a 3530-kc. fone. W9CCZ reports bad QRN and QRM. Many schedules are being kept as usual at W9BKI. W9BVP is pounding away as usual. Push-pull experimentation has been going on at W9BZO. W9FCW reports traffic picking up. The new voltage-fed Hertz at W9BRX is going fine. W9CUH has just pitched camp on 3.5 mc. for the winter. The MG blew out at W9AMO, so AC is being used until further notice. W9BNI copied the AA message complete from W2CXL. NN-CAB is in Chicago, according to W9BCA. W9CZL has a new key filter which gives him better QRL. W9FDJ reports African DX. W9ALK and W9GIV are very QRL. W9BRR has applied for a 14,000-kc. fone permit.

Traffic: W9BKL 139, W9FO 114, W9ERU 86, W9BLL 76, W9APY 58, W9BNI 45, W9AKA 43, W9GJ 42, W9CZL 38, W9FDY 34, W9DGG 25, W9BMQ 23, W9CUH 22, W9BNR 18, W9BEF 17, W9DOX 16, W9AFF 13, W9AFN 12, W9BHW 11, W9BVP 11, W9BZO 11, W9FCW 11, W9GIV 11, W9AD 10, W9ANQ 9, W9AMO 7, W9KB 7, W9FDJ 6, W9ACU 5, W9CRR 4, W9DYZ 3, W9ALK 2, W9CKZ 2, W9CCZ 1.

MICHIGAN — SCM, Dallas Wise, W8CEP — W8ACB is getting ready to work again with a chemical rectifier and a 410. W8KN is looking for schedules with other schools. W8BRS has been going great guns. W8DED is now using a pair of UX869's and a new Zepp antenna. W8RV has a new Hertz with a one-wire feeder system. W8ZF is now ready to go on the air. W8AUB works the station when home on week-ends. W8CAT built seven new transmitters in one week and then went back to the old reliable Hartley. W8JD now has the xtal on the air. W8DYH leads the traffic handlers again. W9EGF, way up in Laurium, did some storm service work this month. W8AZO is QRL work. W8DSF has the old set going on 3500. W8BRO has a MG now and wants another QSO party soon. W8CJZ reports for the first time. W8DHC has moved up to 3500 for the winter. W9AXE now has his ORS. W8DFS says he is always getting mixed up with W8DSF. W8CU has been working with a screen-grid detector. W9CE has gone hunting, and here's hoping he is one that comes back. W8CKZ is still QRL work. W8AX has been on with both fone and CW. W8MV has QRM from Fords on 14,000. W8AEQ has several reliable schedules on 7000. W8AAF was heard during the QSO party. W8ZZ has been ill, and we hope that he is feeling great again now. W9EQV, W8QN, W8HL and W8DYQ reported via radio through W8DYG. WYE, located at Selfredge Field, has a couple VT's working back to back into a 3500 Hertz. The November QSO party went over fine, and it was sure great to hear the gang at it that night. W8DYH took the honors on 3500, working 20 stations before midnight. W8BWR was second with 15 and Captain Baldwin of W2CXL was third with 12. W2WC, W8SH, W8CJ, W9DFZ were recent visitors at the SCM's shack. W8WO has been trying an 852 on 11,000 kc.

Traffic: W8ACB 1, W8DMS 32, W8KN 4, W8BRS 104, W9DUE 8, W8DED 14, W8DVQ 4, W8BV 2, W8ZF 1, W8AUB 2, W8SH 12, W8CAT 89, W8JD 38, W8DYH 402, W9EGF 31, W8AZO 6, W8DSF 6, W8BRO 77, W8CJZ 6, W8DHC 26, W8PP 5, W9AXE 21, W8DFS 3, W8CU 10, W9CE 13, W8CKZ 12, W8AX 35, W8MV 7, W8AEQ 218, W8AAF 4, W8DXM 4, W8DYQ 9, WYE 162, W8HL 11, W8QN 167, W9EQV 31, W8CEP 76, W8WO 6.

OHIO — SCM, H. C. Storck, W8BYN — Well, gang, here's another report, and you have done your share to make it a fine one, too. The OW, W8CNO, leads the state again, with 375. W8CR comes next on the list, turning in 275, which is very FB also. W8LT, the station at Ohio State University, also makes the BPL with 218. Three make the BPL this month! Hurrah for Ohio. W8AQ says that if the reporting date had been the 16th, he would have made the BPL too, as he handled 35 messages on the 16th. W8BBR turns in a FB total. W8GZ turns in a nice total, and a report on AA activities. W8CWC is putting up two 80-foot steel towers. W8BKP is on with an 852 and working a lot of DX. W8BAC is GONE. Hi. Another case of jumping into double harness. Congrats, OM, and hurry back. W8ADU, another YL op of Delaware, Ohio, sends in her first report, and puts lots of the regular ORS to shame. W8BKM turns in a good total and reports on several local hams. W8ADS has a phone in action on 3500. W8SG blew up his filter condensers and rectifier, and is now using a MG. W8LI is getting interested in traffic. W8OH is runner-up for ORS. W8DBK has been trying 14 and 7 mc. for traffic. W8CFT has been busy with school. W8NP got his total between the 1st and 15th. FB. W8ARW and another fellow are building a shack for radio exclusively. W8CIY reports QRL a nice YL at college and also with a new Nash sport roadster. W8AZO turns in his first total since last winter. W8BEA is about disgusted with schedules and his note. W8PL is still busy with the "talkies." W8ATL has been in the hospital for three months, having been in an auto accident, but is recovering rapidly. He says that his sister is second op at W8ATL. W8DVI, says he is ready to take Cleveland traffic any time. FB. W8TF says QRM is holding a convention on 3500 kc. around his place. W8EJ is back again. W8CCS wrote the SCM about his trip to the west coast, and made me wish I'd been along. W8BZL

sends in a FB report on the doings of several hams and the Buckeye Shortwave Radio Association. W8RN says he may not be with us this winter because he may accept an operating job on the salt water. Let's have your reports on time, OMs, and please, when you are going to be inactive for a long time, request honorable cancellation of your ORS so that you will not be just written off of the list as dead wood.

Traffic: W8CNO 375, W8CRI 275, W8LIT 218, W8AQ 168, W8BBR 161, W8GZ 125, W8CWC 89, W8AKP 42, W8BAC 38, W8ADU 36, W8BKM 35, W8ADS 27, W8SG 26, W8LI 23, W8OZ 23, W8DBK 22, W8CET 22, W8NP 21, W8ARW 11, W8CIY 11, W8AZO 10, W8BYN 10, W8REA 10, W8PL 9, W8DDK 8, W8ATL 8, W8DVL 5, W8IF 5, W8EJ 2.

WISCONSIN — SCM, C. N. Crapo, W9VD — W9DLD finds it necessary to resign as Route Manager to devote more time to his father's business. Good luck to you, Joe! W9EBO is trying 14 mc. W9EFX is going good on 7 and 3.5 mc. W9DTK is on the air every Friday from 7 to 10 p.m. as section control station for the Naval Reserve. W9FBJ is very active in the U.S.N.R. W9SO is working six schedules and is western key station for the College Radio Union. W9FAW wants Army Net contacts. W9DJK has schedules with W9BN and W9CNH. W9FSS is very active in the A.A. Net. W9DLQ has a new 4-tube screen-grid receiver. W9AZN has his crystal going now. W9OT has consolidated with W9AMP at new location and has a 55-foot pole to hook on to. W9BIT, formerly W9BYE at Milwaukee, is now operating WHBY at St. Norbert College, West DePere. W9VD is quite busy organizing the 65th Cavalry Net in Wisconsin and is on 3740 kc. every Monday from 7 to 10 p.m.

Traffic: W9DLD 307, W9EBO 128, W9EFX 58, W9DTK 71, W9FBJ 60, W9SO 50, W9FAW 47, W9DJK 14, W9FSS 40, W9DLQ 29, W9AZN 23, W9OT 21, W9BIT 21, W9VD 11.

#### DAKOTA DIVISION

**N**ORTH DAKOTA — SCM, B. S. Warner, W9DYV — W9FCA says his new UX-250 sure does its stuff with 225 volts of storage B batteries on the plate. W9BVF takes the lead in traffic this month with a very nice total. W9DM has returned to the air with one 201A tube. He has started a radio class at school. W9DYA is still QRT on the faru.

Traffic: W9BVF 122, W9DM 12, W9FCA 2.

SOUTHERN MINNESOTA — SCM, J. C. Pehonslek, W9EKK — W9COS, with three daily skeds, handled nearly 500, and makes his usual place in the BPL. W9BN has five skeds and seven ops, all going strong. W9YC, formerly W9XI, is going with a self-excited set temporarily. W9DRG is making a couple of ops out of some Army men. W9BHZ is on 7200 daily and pushing traffic in great style. W9CIX is using a new SM short-wave AC receiver and says it's OK. W9DMA's new layout is working FB: W9AIR has a five-point sked system going now. W9ELE had a ham fone fest there, and got some things adjusted. W9EYL has his xmtr all torn down. W9DBC's overtime helped the pay check, but not the traffic total. W9DGE has W9DKX and W9BHR for company on the Thorpe until the winter tie-up. W9ETS is working at the Minnesota Theatre evenings. W9EKK has his outfit all wired. W9DGH is having lots of fun with xtal control. W9AQH is back in town. W9ELJ is on the west coast with Vitaphone. W9DAW is also going with the Vitaphone gang. W9DSH is planning on going west with Tommy Edmunds. W9CRW, W9AMK and W9DOP push the key at W9YC as do W9EJJ, W9DPX, W9DHP etc.

Traffic: W9COS 448, W9BN 162, W9YC 29, W9DRG 22, W9BHZ 16, W9CIX 4, W9DMA 4, W9AIR 3.

NORTHERN MINNESOTA — SCM, C. L. Jabs, W9BVH — W9CTW leads in traffic and has just been appointed Route Manager for Northern Minnesota. He is a booster for traffic handling and is trying to put the section nearer the top. Give him your support, fellows, so his efforts will not be in vain. W9DOQ is now working in the 7000-ke. band. W9GGQ reports little activity around Park Rapids. W9BIW sends in a bunch of reports on 1929 sigs. Thanks, OB. W9CIY and W9ADS are installing a fone station in the new City Hall at Hibbing. W9AV has had trouble with his receiver. W9BCT is rebuilding to an ultraudion. W9BBT is off at present. W9CF thinks the local Home Guard is going to install an amateur xmtr with a couple of 50-watters. This is a very short report for this time of the year, but it is hard for the SCM to write an interesting report unless you fellows send in more news.

Traffic: W9CTW 44, W9DOQ 38, W9GGQ 21, W9BVH 20, W9BIW 10, W9CIY 3, W9AV 2, W9CF 57.

SOUTH DAKOTA — SCM, Dwight M. Pasek, W9DGR — Over a dozen cancellations were made this month. This might be a hint to those who still hold an appointment. The SCM will be glad to receive applications for a few ORS, as we need to boost our traffic reports. W9DB is the only station to report traffic, and is active on 3525 kc. W9YAM is a new station at the University at Vermillion. It is operated by Scholes W9BOW, Vert W9EUJ, and Sirois W9AAR. W9CKT is on regularly, and reports that W9DYX at Rapid City is the only South Dakota station he can hear.

W9DB 3.

#### DELTA DIVISION

**A**RKANSAS — SCM, Henry E. Velte, W5ABI — The R. I. paid us another welcome visit. W5AQX is our star traffic handler this month. He has been appointed an Official Broadcasting Station, and the gang should look for him on 7160 kc. W51Q and W5HN are both on pretty regularly. W5BCZ is selling out. W5ACA, our former SCM, was married on Oct. 25th. We wish to extend congratulations to both he and his wife, and wish them lots of happiness. W5ABI is installing a mercury arc rectifier. Here is looking forward to more reports next month.

Traffic: W5AQX 36, W5ABI 12, W51Q 6.

TENNESSEE — Acting SCM, J. B. Witt, W4SP — Well, fellows, do you care to have a report in these columns each month for Tennessee or not? It is up to you, for I cannot make out a report without any dope. The only station to report this month is W4VK. He is keeping skeds with W5BEV, W9GBI and W9GCP. FB, OM, W4HD is working everything. W4DG is building a new transmitter. W4FX and W4HK are on occasionally.

Traffic: W4VK 4, W4SP 2, W4HD 3.

MISSISSIPPI — SCM, J. W. Gullett, W5AKP — The amateurs in Mississippi are gradually waking up. W5AZV of Jackson leads the section in messages handled. W5BHL is working real DX with a UX-201A. W5AWP is getting real good reports on his 50-watt lone in the 3500-ke. band. W5AED complains that the QRM in the 7000-ke. band is terrible. W5AJJ is still threatening to come back on the air. W5AAP has his transmitter parked at 7150 kc. and says that his "S" tubes have decided to go to work again. W5AOM of Meadville is in the hospital at Natchez with an attack of pleurisy. Sorry to hear of your illness, OM.

W5MI is the only active amateur in Natchez but, being a doctor, he has very little time to operate his transmitter. W5AGV is going to school at Georgia Tech., and his new call in the fourth district is W4CX. W5AQU is attending dental school in Atlanta, and his new call for the winter is W4MP. W5AMR is the new engineer of WCOG in Meridian. W5QQ is going to move his transmitter and will work in the 14,000-ke. band. W5FQ has added Cuba to his list of foreigners worked. W5GQ is working real DX with his UX-210. W5AKP has been held up waiting for a transformer.

Traffic: W5AZV 41, W5AWP 24, W5AED 18, W5AAP 5.

LOUISIANA — SCM, M. M. Hill, W5EB — Fellows, I certainly appreciate your many expressions of congratulations upon my being elected Director of our Division. I assure you I will do my best to serve the League to my best ability. Since I am Director, I am resigning as SCM with this report. That leaves a vacancy for a new SCM — let's get a live wire. What say? General activity for the state is on an increase. W5ANC of Shreveport is going to be on the 7000-ke. band soon. W5WF, old faithful, makes the BPL again. W5ANQ runs up a nice score again. W5BDJ has a crystal. W5BHV is keeping the tubes warm on regular skeds. W5RR is at LSU, and says W5YW is going to have six ops, W5BAY, W5UI, W5AQP, W5BHH, W5AKW and W5RR. W5AXS at last has his xtal where it will pay off. W5NS has a bad case of YLitis. W5ANA has a nice bunch of skeds. W5WG has ideas of xtal on 14,000 kc. W5EB has moved to Natchitoches, La.

Traffic: W5WF 214, W5EB 124, W5BHV 106, W5ANQ 102, W5YW 90, W5BDJ 49, W5WG 2.

#### HUDSON DIVISION

**E**ASTERN NEW YORK — SCM, H. J. Rosenthal, W2QU — The Larchmont Radio Club announces that they are buying a clubhouse, installing a quarter KW transmitter, and will have an operator on watch every night to take care of all the traffic for this district. Calls and schedules will be announced next month. W2CUF, who has

just received his ORS appointment, heads the traffic list this month. W2LU is still keeping traffic moving with four schedules. W2ALI manages to listen in between service calls in his radio business. W2ACB reports growing amateur activity in Schenectady. W2ACY is unable to spend much time on the air, but picks up a few odd messages. W2AGR has moved to the first district and will soon have an ORS there. W2BUW and W2RD get their messages from a girls' college and are guarding their source of supply. Hi. W2BMC will be an ORS soon. W2ANV is now an Army-Amateur Net control station and W2OP is the alternate. W2OP has moved his transmitter into the garage so he can use break-in. W2SZ handled a play by play report of the CCNY-RPI football game with W2HJ at the other end. W2BKN is starting schedules and will have a big traffic report next month. W2BAE is keeping a daily schedule with W1WV in Boston.

Traffic: W2CUP 240, W2LU 140, W2QU 65, W2BAE 56, W2RD 48, W2ACB 46, W2OP 41, W2ANV 40, W2BMC 38, W2BUW 31, W2ALI 13, W2SZ 8, W2ACY 8.

NEW YORK CITY AND LONG ISLAND — Acting SCM, V. T. Kenney, W2BGO — Manhattan: W2AFV, an ex-ORS, using an 852 with 250 watts input, sends in a nice traffic total. W2BDJ is to be the operator at the 22nd Engineers Armory in N. Y. C. as soon as a call is issued for the station. W2AFO is back with us again on 7030 kc. W2HJ, the Radio Club of the City College of New York, is trying hard to arrange skeds with other colleges throughout the country. W2AOY has tried the "W9EK system of keying," and is telling the world of the wonderful results obtained. W2BCB keeps Army skeds on Monday nights. W2KR promises action with a portable at Blue Point, L. I., and can be recognized by the call of W2AXR. W2BNL is getting out with a 3.5-mc. fone using a 210 oscillator. Bronx: W2APV has increased his skeds to 16 a week and makes the B. P. L. again. W2BBX-2FF is working on 14 mc. W2ALI complains of difficulty in getting rid of traffic on 7 mc. W2AFT is a new Army station in the Bronx. W2AET is dividing his time between camping and radio. Brooklyn: By keeping 16 skeds weekly, W2AVR-W2ARM has piled up a very nice total. W2PE, Second Corps Area NCS alternate, is stepping out with his new outfit of intermediate amplifier on crystal oscillator. W2BYF, an ORS of the WNY Section, refuses to be inactive while attending school in our section, and keeps traffic moving just as if he were home. W2BIV complains of the out-of-band stations and would like to get after them. W2BO, the Brooklyn 00, can be heard as an OBS on the 7000-ke. band using crystal control on 7130 kc. W2CCD-W2APB can now be heard on the 3.5-mc. band with a good fone. W2ATZ, the newest ORS among us, reports that his protégé can be heard as W2HVY. Long Island: W2AVP is doing his job as RM for L. I. and is continually adding stations to his long list of skeds. W2ASS is busy with the transmitter of the Nassau Radio Club, a new club in our section, which promises to be one of the few real radio clubs we now have. It meets in an ex-Real Estate office at Oceanside, L. I., one and a half blocks off Long Beach Rd. on Atlantic Ave. W2ATT is on the air regularly. W2Akw, who recently came from W9BWN in Des Moines, Iowa, has his transmitter going and will take your traffic for the vicinity of Rocky Point, L. I., where he is helping keep the RCA station going. W2AA of Merrick is looking for more traffic. W2OJ, an old-timer, pre-war XVV and post-war W8BLX-W8VS, is the secretary of the Nassau Radio Club.

Traffic: Manhattan: W2AFV 234, W2BDJ 25, W2AFO 18, W2HJ 15, W2AOY 13, W2BCB 13, W2KR 5, W2BNL 2. Bronx: W2APV 202, W2BBX 29, W2AII 27, W2BGO 16, W2AFT 13, W2AET 6. Brooklyn: W2AVR-W2ARM 786, W2PF 74, W2HVF 60, W2BLV 35, W2RO 30, W2CCD 20, W2ATZ 18. Long Island: W2AVP 141, W2ASS 17, W2ATT 9, W2AKW 5, W2OT 24, W2AA 1.

NORTHERN NEW JERSEY — SCM, A. G. Wester, W2WR — The coming A.R.R.L. Sectional traffic contest should bring every ORS on the air and the SCM wants to see this section show some action. Warnings have been sent to delinquent reporters and they are now stricken from the ORS membership. W2WR is putting consistent signals in all parts of the U. S. and possessions. W2IS is busy with WRMS. W2ANG has taught his YL in N. Y. the code and she is soon to apply for a license. W2BAL is due to return to the air. W2JC has an excellent xtal station. W2AOS, our famous A-A station, had fine reception on the Navy Day program. W2JF again makes the B.P.L. and his traffic this year takes the place of W2CP, who kept our station in the fore last year. W2CJX had some fine QSOs with S. A. this

month. W2BR has been helping VE3CR get started by correspondence. W2AI leads the non-ORS and has been keeping skeds with FK5CR and FK6CR on 14 mc. W2APU is being appointed an ORS this month. W2DV has been busy with A-A skeds. W2AUP has been busy putting up new antenna systems.

Traffic: W2WR 1, W2JF 120, W2AOS 13, W2JC 16, W2CJX 14, W2AI 52, W2APU 10, W2DV 11, W2AUP 6, W2CNL 1023.

#### MIDWEST DIVISION

IOWA — SCM, H. W. Kerr, W9DZW-9GP — Our RM, W9EJQ, makes the BPL and leads the host. W9ESP follows with W9BCA nosing out W9FFD from third place. Grandpa now has a distinctive call for the "fireside" xmtr through the kindness of the Department, i.e., W9GP. W9CNZ comes again with a nice report. W9EIV has a t.p.t.g. on the air. W9FWG has RCL troubles to eliminate. W9EJA reports a nice bunch from the college town. W9FLK picks a few, as does W9ELV. W9FQG sent his report by radio. Mrs. Glenn Joslin now has the W9EIV license, since Pauline was married and finds time to keep skeds, among other duties. W9GCP radioed his report. W9DXP is back from two weeks vacation in Chicago. W9GKL continues to keep Ames on the list. W9EJQ visited the W9GCP station on the farm. W9BTL and W9CUX are expected home from commercial work on lake steamers for winter vacation. W9LA, W9DVS and W9BQT are schooling at Ames. W9CFN is on 7 mc. with 210's in push-pull. W9BWN may be heard from Rocky Point with his W2AKW call. KOLL is honored by two Iowa and two Nebraska hams on the operating staff. We hear some phone folks with improved modulation. PB, 73 and Happy New Year.

Traffic: W9EJQ 234, W9ESP 108, W9BCA 102, W9FFD 101, W9DZW 100, W9DNZ 83, W9EIV 39, W9FWG 39, W9EJA 39, W9FLK 30, W9ELV 27, W9FQG 22, W9EIV 20, W9GCP 19, W9DXP 8, W9GKL 2.

KANSAS — SCM, J. H. Amis, W9CET — W9FKD and W9CET make the BPL. W9FKD is on a cross-country hook-up. W9CET is keeping five schedules. W9DEB says thanks to W9FLG and W9CET, the 210's are on the air. W9SS reports W9DFY has been afflicted with a new saxophone and YL. W9BTG hopes to make the BPL soon. W9GFO has just discovered that 14,000 kc. is good for DX. W9BEZ is a post-office clerk. W9FLG, the RM, is all set for the winter. The SCM again trims the RM in traffic. W9ESL built a new plate transformer for his 3500-ke. fone rig. W9CFN has put his rig on a panel. W9HL is lining up a nice bunch of skeds. W9GHI is installing a MOPA. W9BPL claims 14,000 kc. is getting better day by day. W9BKR has written a bed-time story involving the SCM. Hi. The following ORS appointments have been made: W9SS, W9BTG and W9GFO. The K.V.R.C. meets the second and fourth Friday of each month, at 8:00 p.m., at Topeka Chamber of Commerce. All amateurs are invited to attend.

Traffic: W9CET 226, W9FKD 224, W9DEB 65, W9SS 49, W9FLG 46, W9BTG 35, W9GFO 31, W9BEZ 31, W9FLG 30, W9ESL 28, W9CFN 10, W9HL 7, W9GHI 7.

NEBRASKA — SCM, C. B. Dieh, W9BYG — W9ANZ has to see the R. 1. soon. W9FEW reports from Chicago. W9DTH is working on a new filter. W9DRF changed his address to 5321 No. 27th St. W9DVR is still fighting his freq-meter. W9FAM rings the bell this time, and wants another southern schedule. W9DI is home week-ends. W9BOQ craves traffic. W9CHB has schedules, and handles neat traffic. W9BBS is pretty busy (conducting), but finds some time for radio. W9CDB is too busy in the shop to finish the old set. W9BRQ expects more traffic soon.

Traffic: W9DTH 3, W9DVR 7, W9FAM 131, W9DI 7, W9BOQ 21, W9CHB 21, W9BBS 6.

MISSOURI — SCM, L. B. Laizure, W9RR — W9DXY leads the state in traffic. W9FTA was second high in St. Louis. New ORS were issued to W9DXY, W9PW, W9FTA. W9DOE is located in Minnesota. General activity is excellent this season among St. Louis stations. The U.S.N.R. is making good headway with three officers commissioned and about thirty men enlisted. W9PW is personnel and publicity officer for Missouri, Kansas and Nebraska. W9DXY is Executive Officer for the same territory. W9EAZ is St. Louis Unit Commander. W9BAO is organizing an enlistment campaign to boost the enlistment in the St. Louis vicinity. W9DZN is back home temporarily between jobs. W9EDK is moving. W9BEU is putting in a 20A. W9BMU combined traffic and DX this month. W9DUD applied for U.S.N.R. enlistment. W9FUN reports school QRM.

W9AMR says he has a 100% hay wire set that works better that way. W9GHG complains about lack of traffic on 7-mc. band. W9DNO sends a long report and news letter from Columbia. W9DKG is working on a newspaper in Rolla, Mo. W9CDU had bad luck with blowing up stuff. The R. I. put on exams in Nevada. W9EPX is still in Chicago. W9BJA continued his skeds for Weather Bureau reports. W9GBT did some rebuilding. W9DHN is the probable new RM. W9EFR wants a 7-mc. sked in most any direction. W9FYM reported again. W9CJB is a new ORS. W9GJF and W9CYB are on considerably in Festus. W9FAL was made NCS for A-A net in fourth Missouri district. A ham column is running each Sunday in both K.C. papers. W9EQC leads Kansas City in traffic. Old W9FM is back after several years absence as W9CVT. W9DQN, QST's U.S.N.R. information, broadcasts Monday, Wednesday, and Friday, at 8:00 a.m., on 7-mc. band. W9CFL has almost completed a 250-watt layout. W9LR is trying to get going. W9ZZ is beginning to drag in the reports.

Traffic: W9DXY 250, W9DZN 6, W9GHG 3, W9BEU 21, W9AMR 3, W9FUN 10, W9DUD 25, W9BMU 31, W9FTA 68, W9PW 14, W9CJB 42, W9FYM 1, W9EFR 4, W9DHN 126, W9GBT 6, W9BJA 162, W9CDU 13, W9CVT 27, W9EQC 152, W9DQN 53, W9ZZ 201.

#### NEW ENGLAND DIVISION

**E**ASTERN MASSACHUSETTS—SCM, M. W. Weeks, WIWV—WICMZ leads the section this month and makes the BPL along with WIACH and WILQ. FB, George! Navy drills help WIACH's traffic. WILQ is now ORS and has certainly earned his appointment. WIASI is planning some 1715-ke. work. W1BBT is still buying junk, and we hope it will be working soon. WIWU visited WIASU and others in Worcester and had a fine reception. W1BLD is at Danvers, for part of his school course, at the Champion Tube Works. W1BVL has resigned his ORS to teach W1BLD all he knows. We shall miss Dick and hope the time will come when we can see him in the BPL again. W1BOB is being bothered by school QRM. W1AZE is beginning to believe 3500 kc. is the place for traffic. W1KY is flivvering to Concord, Mass., each day, but turns in a reasonable total in spite of less time on the air. WIWV won third prize in the QST Station Description Contest. W1LM had a fine total, but says his nerves are shattered from 3500-ke. QRM. Our new RM, W1KH, is lining up some fine traffic routes. He reports a 14,000-ke. QSO with SN1AA in Ascension Island. Speaking of DX, your SCM used to work plenty on 7000 kc., but now on that band there are so many broad AC notes that DX has no chance to be heard. As soon as the gang rebuilds for sharp DC notes, we may expect better luck.

Traffic: WICMZ 291, WIACH 250, WILQ 210, W1LM 180, WIWV 160, W1CRA 107, W1KH 83, WIARS 68, W1KY 49, W1BKR 48, WIACA 32, W1BU 30, W1ASI 28, W1BZQ 28, W1AZE 26, W1AGS 8, W1BTT 5, W1BLD 4.

**WESTERN MASSACHUSETTS**—SCM, Dr. J. A. Tessmer, WIUM—W1AMZ gets a great kick out of his brass pounding. W1NS is at the Edison laboratories at West Orange. WIAPL has a small shack at his new location, 221 Plainfield St., Springfield, Mass. W1BKS says that W1BSN still works K6 every morning, and that W1AWW is busy with BCL work. W1BFA seems to be silent lately. W1AKA is ex9EDM and ex9DQB. W1BKS has a new electro bug that works FB. W1ATK is on 7000 kc. W1BCH had to have a police permit to move that mast of his. Hi. W1AKW has started up on 7 mc. W1AKW is located at Springfield Air Port. W1PH pounds brass now and then. W1CQR is our DX man. He and W1AEP chat with Byrd occasionally. W1PY is on phone as is W1CGR. W1BAA is coming on with xtal. W1ZA, exWSBM, star traffic man of Ohio makes the BPL. WIUM almost got his xtal set working with the aid of W1CNL and W1ACY. W1ASU is getting 9 plus reports on his xtal. WIADO is getting fine reports on 500 cycle. WIACV is in Worcester installing the new dial fone system. WIACV and W1BNL attended a meeting at the Providence Club. W1AOF is in West Africa for about six months or a year. The Worcester Radio Club is having its annual Thursday evening meetings at 274 Main St., Room 391. Anyone interested in amateur radio is welcome.

The Berkshire Brass Pounders had their set, W1BWB, at the Pittsfield Radio Show, where they originated 214 messages. W1AZD has been busy on the air with his 204A. Our YL, W1AJJ, is getting into the traffic game and likes it. W1BKG has trouble with BCLs and consequently only operates in the morning. W1AZW has three skeds and is

handling lots of traffic. He wants a sked with Worcester. W1VC has the bug again after nearly two years' silence and will soon beat the air with a 50.

Traffic: W1BNL 51, W1ASU 2, W1AMZ 3, W1ADO 13, W1BKF 20, W1BWY 22, W1EO 12, W1AJJ 19, W1BBZ 24, W1AZW 121.

**MAINE**—SCM, G. C. Brown, W1AQL—The A.R.R.L. was represented at the recent Bangor Radio Show in the form of a short-wave station installed and operated under the auspices of the Queen City Radio Club. The booth was the center of a large amount of attraction, and the public came across with a goodly number of messages. Permission was obtained from Mr. Kolster's office to use W1BFZ's call. Work on the new club headquarters at Bangor is progressing in a very creditable manner, and it is expected the call letters W1ACR will be assigned to the new station. The SCM was very pleasantly surprised with a recent visit from W1BKN of Houlton. W1CWX says he has his phone set going fine now. W1AFA has a good list of schedules. W1ACW says that he is going FB in Mars Hill now. W1ACV is using xtal with a push-pull output 100 watts. W1QH has been a busy man with the key this month and is top liner. W1ASJ of Bar Harbor tells us that the Bar Harbor Club is on the air with a 100-watt station. The call is W1BGS. FB. W1BFZ has a fine total this month. W1ANH is the most northern radio station in the U. S. W1ACR sends in a good total. WIATO reports a good list of schedules.

Traffic: W1QH 215, W1BFZ 189, WIATO 127, W1AUR 135, W1ANH 111, W1KQ 91, W1AQD 88, W1CDX 77, W1AFA 65, W1TB 43, W1AQL 30, W1ACW 36, W1AHY 8, W1ACV 3.

**VERMONT**—SCM, C. A. Paulette, WIIT—The report cards are still coming in a very slowly, gang! We are making an awful showing—only three reporting stations this month. I hate to make any drastic cuts in ORS, but it's got to come unless you do report, as that is the A.R.R.L. law. Send in a few reports and everything will be FB. Our CRM, W1CGX, is very active again now and can be found on 3650 kc. with a PDC note every night. W1BJP is working night and day, so not much time left to come on the air, 73 gang, and try to get your reports in next month.

Traffic: W1CGX 18, WIIT 14, W1BJP 12.

**RHODE ISLAND**—SCM, C. N. Kraus, W1BCR—W1BII, a d W1AMU make the BPL. W1MO handled some traffic on 14,300 kc. W1BQD is on 14 and 7 mc. W1BCR will soon be on the 14,000-ke. band with a crystal-controlled fone. W1AWE is working good DX with his new UX852. The Radio Club of Rhode Island invites hams to drop in and visit them. Robert Meader, a graduate of Brown University, is devoting his time to five-meter work with reflector antennae. Experimenters interested in arranging schedules or wishing information on this work should write Mr. Meader in care of the club, 92 Keene St., Providence, R. I. President Kraus is in charge of construction work on a television transmitter. The club would like to exchange speakers with any other clubs in New England or Eastern New York. Regular weekly meetings are held every Monday evening at the club house, Pearl St., Rumford, R. I.

Traffic: W1BII 642, W1AMU 502, W1BCR 45, W1MO 24, W1BQD 8, W1AWE 4.

**NEW HAMPSHIRE**—SCM, V. W. Hodge, W1ATJ—W1IP and W1BT both make the BPL this month. W1APK is doing BCL service work. W1AUE handles a few. W1AUY is experimenting with crystal control. W1AEF reports visiting W1ANS with W1P. W1COW is back at Phillips Exeter with an 852 outfit, and wants skeds for Wednesday and Saturday afternoons. W2EI is second op. W1CEQ is on at Durham with a 50 and 3 ops. W1MS is DXing in the 14-mc. bands, with fine results. W1AGO has started in Nashua. W1TA is rebuilding. W1AFD reports 14-mc. band dead. Simpson, W1HO, is in high power transmitter section with G. E. W1AFD, W1AOF, W1AUE, W1AUY, W1AVJ, W1BLP, W1CMB, W1COT, W1IP and W1MS recently passed examinations for amateur first tickets.

Traffic: W1IP 301, W1BFT 253, W1AEF 40, W1CEQ 27, W1ATJ 24, W1AUE 9, W1APK 7.

#### NORTHWESTERN DIVISION

**M**ONTANA—SCM, O. W. Viers, W7AAT—W7HP takes traffic honors this month and makes the BPL. FB Lindy! W7FL handled a few. W7DD reported by radio. W7AAW is still going strong. W7AEM is building a new phone transmitter for the 3500-ke. band.



W7ANT will soon be on again with a new 75-watt high-capacity TPTG. W7AHN has been laid up most of the summer, but is gradually getting back on his feet. W7AY of Eugene, Ore., visited the SCM on Labor Day and had a FB chat. W7AAT is going strong.

Traffic: W7HP 204, W7AAT 67, W7FL 35, W7AAW 28, W7DD 14.

IDAHO — SCM, J. L. Young, W7ACN-W7JL-W7ST-ALD, W7JW and W7ACN-JL are attending the College of Idaho, while W7ABB is one of the ham population at the University. W7AHC and W7PJ are keeping KIDO on the air. W7ST is teaching radio at the Boise High School in the afternoon and attending the C. of I. in the mornings. W7ALC now lives in Boise and does the radio work for Montgomery Ward & Co. there. Ex-7GX does the same for the Nampa store. W7GU is on the air in Boise. W7KA, ex-W7AFK, lives in Caldwell now. W7ALW is holding the ship for northern Idaho. W7ACD says he is putting up a new sky-piece. W7IY paid him a visit early in November. W7HE has given up radio for talkie experimentation. W7II is also a talkie operator. W7ACK has a big radio class at the Nampa High School this year and says a number of his pupils are applying for licenses. W7ACN-JL will soon have a second op as his kid brother is studying ham radio in school. The SCM would appreciate a long letter from every ham in Idaho, to enable him to get the radio activities in the state reorganized. Please give details about your station, traffic and yourself.

Traffic: W7ACD 6, W7ACN 4.

WASHINGTON — SCM, Otto M. Johnson, W7FD — W7BB is high this month with 94. He has worked WFA several times. W7LZ also has QSO'd WFA. W7ACS and W7IZ are electioneering for the office of SCM. W7FD wishes to thank all the gang for their cooperation during the past several years with him as ADM. Acting SCM, and SCM. The friends made will be long remembered. So much for our "Swan Song." In Seattle W7TX, W7AG-W7SL, W7LZ and several others are still doing their stuff. W7TX reports most Alaskan stations closed down for the season. Up in Everett W7RW, W7MW, W7ACY and several others are on. W7PH is devoting all his time to "talkie" movie equipment. W7ABN is on the ship *Vigilant*, with Capt. Matt Peasley, as radio op. They are Honolulu bound. W7ACA is back and wants skeds. W7MP is in the Forestry Service at Cle Elum. W7AIX is going to Ft. Monmouth to the Signal Corps Laboratory, and will soon be signing W2PDQ or something. W7ABU is a newcomer in Kennewick. W7GP and W7AMO keep Olympia on the map. W7AOB at Tekoa is off the air for a while, due to his going to WSC. W7AFO is the main DX'er of Tacoma. How about that annual Seattle-Tacoma and way points bathtub party? W7BR and W7AG please note! W7FD now signs off as SCM. 73, 88 (to the YLs) and 99 are in order. Don't forget to report to your new SCM regularly!

Traffic: W7BB 94, W7AMO 35, W7ACA 27, W7AG-SL 27, W7TX 22, W7LZ 16, W7ABN 15, W7IZ 14, W7AOB 11, W7AFO 8, W7RW 8, W7MW 6, W7MP 1, W7PH 1.

OREGON — SCM, Wilbur S. Claypool, W7UN — W7MY takes the cake with the highest total. Baker is kept alive by W7CX. W7ABH makes BPL with deliveries and got R8 GA QRQ from HC1FG. W7WL keeps three nice skeds. W7AHA had the tough luck of having his set torn down by the OM. W7PV is known as the Eugene Super-DX station. W7PE handles some. W7ALM, W7ED and W7WB from Astoria and W6AM paid the Rose City Amateur Radio Club a visit on Armistice Day. W7IF reports traffic. W7MY is on in the mornings. W7PP is giving up radio. W7WP held a sked on 14 mc. with ON4FP. W4WB worked WFA. W7AC is going in for traffic. Mrs. W7AJX is now W7AHJ. W7UV, W7ALK and W7WY all report. The SCM entertained the RCARC, November 25, with a Hamfest. About 26 were present.

Traffic: W7MY 166, W7CX 104, W7ABH 64, W7UN 50, W7WL 53, W7WP 102, W7AC 69, W7WB 46, W7AHA 38, W7PE 35, W7ALM 49, W7PY 26, W7IF 24, W7MV 16, W7UV 11, W7WY 8, W7ALK 3, W7AJX 1.

#### PACIFIC DIVISION

LOS ANGELES — SCM, D. C. Wallace, W6AM — This is my last report, gang, and all your cooperation over the last three years is greatly appreciated. The Pasadena Short Wave Club will have their regular meeting in the Clubroom at 230 S. Hudson Ave. At the last meeting of the Associated Radio Amateurs of Long Beach, Dr. Swinerton gave a very interesting talk. W6CTC is on the

air again. W6EHX reports that they took a 132-word message from KA1PW and delivered it to Coolidge, Ariz., within 24 hours. The Associated Radio Amateurs of Long Beach had election of officers Nov. 1st — W6EJF, President; W6DYV, Vice President; W6CHW, Secretary, and W6EQW, Treasurer. W6DZK sent a message to ARC wishing the new officers success. WFA was QSO'd by W6CUI. W6FJ worked hard on the convention. W6BOU has two UX-210's going in T.G.T.P. push-pull. W6MA reports five skeds kept with W6ZZA at Portland during five days. W6BJX is on 7143 kc. W6AGR is on 7080 kc. W6ZZA is making a crystal-controlled portable. W6DZI is using one 280 rect. with 600 volts on each plate. Hi. W6ACT worked the Danish Motorship, *Tongling*, when they were 600 miles south of S. A. Their call is XOZ7AW on 14,000 kc. W6EKE reports that a station has moved away from next door so that he can operate with less QRM. W6EQD has been on 3.5 mc. for past month and has worked all U. S. and Canada. W6HFI is studying for a commercial license. W6ESA rebuilt his station. W6ASM wants more stations on the 14-mc. band. W6BNY is operated by two brothers. W6CBS worked PY1ED. W6AXE was QSO WSBS while they were near Samoa. W6EAF is on 3725 kc. W6AM is crystal-controlled, 1 KW. 6 phase, 7200, 14,400 and 28,800 kc., using W6BAS power crystal ground to exact frequency. W6DHM reports that they have two buzz-saws on an 852 and a 210. W6ZBJ is on 7068 kc. W6BZR worked eleven Argentine stations. W6ETJ is using a 201. W6CBW is deserting the poor old 210 in favor of a 204. W6AKW has a fine sked with W2CXL now. W6ABK is putting up a new antenna pole preparing for winter DX. W6AKD handled a few. W6EAU, W6EUH, W6CZT, W6CUI, W6DKV, W6UJ, W6DLI, W6BCK, W6EPH, W6EQF, W6COT and W6HT all send in reports. Your retiring SCM wishes the new SCM a successful two years. It certainly has been great to work with a section like this, where activity is at a fever pitch all of the time. This is also borne out in noting the last three QST Traffic Banners — the only three given thus far. They all went to the L. A. section. Keep up the good work, men!

Traffic: W6AKW 524, W6CBW 219, W6ETJ 81, W6BCK 80, W6BZR 58, W6CBJ 52, W6DLI 45, W6DHM 41, W6AM 38, W6UJ 33, W6DKV 29, W6EAF 28, W6AXE 25, W6CBS 25, W6BNY 24, W6CUI 23, W6ASM 20, W6ESA 14, W6HT 12, W6BFI 11, W6EDQ 10, W6EKE 9, W6COT 8, W6ACL 8, W6DZI 7, W6ZZA 7, W6CZT 6, W6AGR 4, W6BJX 2, W6MA 1, W6EQF 37, W6EPH 12, W6AKD 16.

EAST BAY — SCM, J. Walter Frates, W6CZR — As this is the last month in the inter-sectional traffic competition between the East Bay and Los Angeles Sections, there was a great deal of last-minute work among the traffic stations. W6IP and W6ALX staged a spirited contest for second place among the individual stations and, after several weeks of continuous brass pounding, W6ALX managed to top the CRM of the section by one message. W6ALX worked in conjunction with W6SS, the station maintained by the Oakland Radio Club in a booth at the Pacific Slope Dairy Show in the Oakland Auditorium Arena. W6IT, President of the Oakland Radio Club, was responsible for most of the operating work at W6SS and W6OT. The booth contained a display of amateur equipment, literature on the League, and the FB xmitter donated by W6BJW. One of the features was a big map showing the location of practically all the ham stations in the section. W6AQ was instrumental in securing the booth and embellishing it. W6IP ran up his big total with some of his extensive Naval Reserve messages. W6EIB was third in the section in spite of the fact that he was left with only one sked when K6DTG was temporarily out of commission. W6CGM was the high man for deliveries; practically all of them secured from P. I. and the Orient. Station W6AMW, maintained by Loney and Babcock of the Marine Corps at Mare Island, made its bow as a traffic station and an ORS this month with a big total. W6BTZ also was among the leaders in the traffic work. W6ATT ran up an individual total besides acting as a receiving point for W6SS at W6OT, the club station. W6ASH in Berkeley still reports much traffic. W6ETA is proving a valuable ORS by her traffic work. W6BI reports that his two UX-210's went west. W6BYS is working both on 7 and 3.5 mc. W6BIW of Piedmont is pushing his usual punch out on the air. W6EDK is still pounding away on 3.5 mc. with traffic, official League broadcasts, and Army Net work. W6EDO says he hopes to have his four-tube screen grid receiver operating soon. W6RJ says there is no news at his shack. W6BMS wants to know what he is to do when he QRMS a BCL with an xtal

receiver. W6CIM of Berkeley, a new man, is getting good results with a 201A with 350 volts on the plate. W6EJA reports his station getting out to distant points, such as El Cerrito, Berkeley and Oakland. Hi. W6CCG is building one of the low power fones in September QST. W6EW received a card that he was heard in Germany in June. At that time he was using two 171's in push-pull TPTG with 300 volts on the plate. W6BHF is still pushing traffic when he gets a chance. W6ASJ has a FB MOPA wrecking the air again. W6BZU is still battling away on 3.5 mc. W6EDR says since he gave up YLs for golf, he is spending much time pounding the "brassie." The section, under its new call of W6GB, maintained a booth and station at the East Bay Merchants' and Manufacturers' Exposition. The section call can only be signed on authority of the SCM for purely sectional communication stunts. East Bay section stations will answer with their own calls on a general call for W6GB. The Oakland Radio Club held a smoker during the past month with the initiation of new candidates, eats, smokes and other features.

Traffic: W6IP 620, W6ALX 619, W6EIB 324, W6CGM 319, W6AMW 295, W6BHT 254, W6ATT 231, W6ASH 170, W6ETA 149, W6BI 126, W6BYS 121, W6BIW 108, W6EDK 77, W6EDO 53, W6WRJ 40, W6BMS 22, W6CIM 17, W6EJA 16, W6BHF 14, W6ASJ 11, W6BZU 8, W6EDR 4, W6OT 414, W6SS 311, W6DWI 97.

SANTA CLARA VALLEY — SCM, F. J. Queument, W6NX — W6DCP a newly appointed ORS, topped the list of traffic handlers, closely followed by W6DCG, who will soon be ORS. W6JU lost their MG and are now using tube rectifiers. W6ALW is back on 7000 kc. with an 852. W6ESW is on 7300 kc. W6BAX, W6BY and NX, all members of U.S.N.R., participated in radio drills Navy Day. W6BAX celebrated by QSOing two Frenchmen, five Australians and one Argentine after the drill. W6AME moved to a better location and remote controlled the set. W6BNH is getting ready for winter DX from his High Sierra location. W6YG handled a nice bunch of traffic. This station is at the Santa Cruz High School under the supervision of F. A. Kazamarek. W6BHY is still endeavoring to locate skeds with the East and Hawaii. The Modesto Radio Club has applied for portable license; W6DQH visited the SCM this month, and reported things picking up in Modesto, FB.

Traffic: W6DCP 59, W6DCG 46, W6YG 40, W6JU 25, W6ALW 20, W6ESW 9, W6BAX 13, W6AME 2, W6BNH 2, W6NX 4.

SAN FRANCISCO — SCM, C. F. Bane, W6WB — W6AD leads everyone in the section this trip, having over 1000 messages. That certainly is great work, Schmidt, and we hope that you will keep it up. W6ERK makes the BPL as usual. W6BIP makes the BPL also, which is FB considering that he had only his monitor for a receiver. W6CIS says his W1MK sked is holding good, but his Philippine one is not going so good. W6WN says he will be off until he grinds a new rock. W6DFR says things are going along FB. W6DBD reports as usual. W6AYT is out after bigger and better traffic and hopes to connect. W6ERS is having lots of trouble with his xmitter. W6PW is doing all sorts of weird things with his crystal. W6AST has designed a new receiver using AC tubes and screen-grid detector that surely is a wow. Let's get together and do some reporting, if we want to give the other sections some competition. Only eight men reported this month which is about 40% of the usual number. Although this report reaches us rather late, the entire section wishes to express to Director Babcock their happiness over his splendid recovery from his illness.

Traffic: W6AD 1213, W6ERK 198, W6BIP 175, W6CIS 41, W6WN 39, W6DFR 37, W6DBD 25, W6AYT 8, W6ERS 8.

SAN DIEGO — SCM, H. A. Ambler, W6EOP — W6EPZ again makes the BPL with 50 deliveries. W6ACJ leads the section in total messages handled. W6EOP found time to handle a few. W6EPP, our new RM, is getting skeds lined up. W6BGL will be on soon with a couple of 852's in push-pull. W6BAM is on 7- and 3.5-mc. bands. W6BFE will soon be ready for skeds. W6CNK has his new generator going. W6CTR is still working on the new set. W6HY is visiting the hams at Frisco and Los Angeles. W6DNW has his new 50-watt set on now. W6CTP worked LU with 270 volts of B batts and a 112A and got QSA5. W6DNS has a new Ford and a new YL. W6CZK will be on with a 250-watt TPTG. W6QY is still QRL with the screen-grid detector.

Traffic: W6ACJ 157, W6EPZ 135, W6EOP 42, W6EPP 33, W6BGL 22, W6BAM 22, W6CTR 12, W6EOS 9, W6CTP 8.

HAWAII — SCM, F. L. Fullaway, K6CFQ — The SCM leaves this month for the States and will be back in several months. Reports for the next few months should be sent to Ray Rietow, care Mutual Telephone Co. Biz of K6AVL sends in his last report. He is leaving for good and will be back on the air with a W8 call. Menge, also of K6AVL, will carry on. K6CIB kept skeds with WSBS, K6CJS and NIJN. K6ALM is still pounding them out. K6AXW is going to rebuild to one quarter kw. FB. K6ERH has been testing with fone on 3.5 mc.

Traffic: K6AVL 84, K6CIB 43, K6ALM 12, K6BXW 11, K6ERH 11.

PHILIPPINES — SCM, S. M. Mathes, KAICY — KA1AC keeps regular schedules with KA1JR. Traffic for Laguna Province should be routed through latter station. KA1AF, KA1CM and KA1MC have made arrangements for cooperative handling of Corregidor traffic. KA1AF will operate two transmitters, one on 7300 kc. and one on 14,500 kc. KA1CE, KA1HC and KAICY are handling the bulk of Manila traffic. KA1DJ hands in a splendid traffic report this month. FB, OM. KA1EL is doing fine with a 210. KA1HR is our banner station. KA1PW is handling traffic for northern Luzon. KA1RC is still clearing our Cavite traffic. KA1SC, the Army Net control, may be heard at regular intervals. KA1ZC, operates on Tuesdays and Fridays. Hong Kong amateurs are now licensed with prefix VS. No messages can be handled. Shanghai and northern China amateurs still use AC prefix. AC8RV, AC8JK and AC2AL are most active stations. AC9GH in Hupeh may close on account of civil war. All ORS in Philippine Section are revoked as of December 1 to facilitate reorganization. Complete new assignments will be announced in next report.

Traffic: KA1AF 334, KAICY 62, KA1DJ 469, KA1HR 769.

ARIZONA — SCM, H. R. Shortman, W6BWS — W6DRE will be an ORS soon. W6AWD, our new ORS, is looking for skeds in all directions. W6BJF is keeping several fine schedules. W6CWI has rebuilt into push-pull Hartley. W6EAA likes his push-pull Hartley better every day. W6BWS reports that Bob Reed of W9LK has moved to Phoenix. W6CDU is trying to QSO the Philippines. W6DIR has gotten back to Phoenix. W6EH has been transferred from KGTL in Kingman to the construction department of Western Air Express in Los Angeles. W6ASA spent a few days in Phoenix at the University of Arizona-Pomona College football game. W6EFC reports being canned at the "Brewery." W6HS-DKX has moved to Phoenix and gone into business for himself. W6DGY is still at KFAD. W6DIE is still jerking soda in his OM's drug store.

Traffic: W6DRE 22, W6BWS 6, W6CDU 27, W6AWD 28, W6EAA 14, W6BJF 39.

SACRAMENTO VALLEY — SCM, Everett Davies, W6DON — W6EEO is now W6TM and is still keeping up his old record. Miss Sutherland, her brother, and W6DON wish to thank W6TM and KA1HR for their wonderful cooperation in handling traffic to and from the Philippines at the time the brother was sick there. W6BSQ expects to try out W6TM's method of handling traffic. W6BYB is on 14 mc. W6AFU and W6DYF both report.

Traffic: W6TM 825, W6BSQ 70, W6AFU 19, W6DYF 16, W6AIM 15.

#### ROANOKE DIVISION

NORTH CAROLINA — SCM, Hal S. Justice, W4TS — The Route Manager, W4AEW, has dope on most of the traffic handling stations in the Section, and can arrange skeds for anyone. W4OC expects a sked with W1AOF, now enroute to Africa. W4WI finds that college work and radio don't mix very well. W4JR keeps three 3500-ke. skeds. W4AHH finds QSO North and South difficult. W4TS is getting good results with a 224 screen-grid detector and R.F. amplifier. W4AA-4ACA complains of QRM from elevators and transformers. His station is located at WNRC, where he is an operator. W4DW is attending N. C. State College of Agriculture and Engineering. W4WE is lining up some skeds. W4ABV is servicing BC sets now.

Traffic: W4ABV 53, W4AEW 47, W4ACI 32, W4WE 25, W4TS 18, W4DW 13, W4AA-4ACA 12, W4WI 10, W4AHH 9, W4JR 8, W4AFW 4, W4OC 2.

VIRGINIA — SCM, J. F. Wohlford, W3CA — W3ARU has been appointed Route Manager and also issued ORS certificate. W3APT, W3MO, W3AHW visited the station recently. W3MO had his license cancelled by some misunderstanding, but is all "jake" again now. W3MT loaned his transmitter to W3MO. W3APT is building a new shack.

W3AHW has a sked with W2VO. W3AGF is a new station at Norfolk. W3PK is putting an 852 on the air. W3NT is getting out FB. W3ARD is still getting out with his 50-watter. W3WS-W3AAJ is using a MOPA circuit. W3ALS is on with a new receiver. W3TJ, an old-timer, is back on the air. W3FJ has skeds with W3ARU and W3BBW. W3AGH is a new ham at Ashland, Va. W3BGS is back on the air again with TGTP circuit. W3HY is back after spending some time in Europe. W3AHQ is trying to work the phone band. W3ZA talks to them all on his 3500-ke. phone outfit. W3WO is working the 3.5 and 7-mc. bands. W3BZ is getting rigged up on 3.5-mc. again. W3BDZ is still working on that transmitter. W3CKL is working them all around the map now. W3CA worked a few skeds. Please write to W3ARU, the Route Manager, if you want schedules.

Traffic: W3ARU 365, W3APT 64, W3ALS 37, W3TJ 9, W3FJ 43, W3HY 1, W3WO 8, W3CA 28, W3MO 22.

WEST VIRGINIA — Acting SCM, C. S. Hoffman, Jr., W8HD — W8VZ has secured a position in Chicago, so W8HD is taking care of this report. The reports given were all received via radio. Monday nights finds the state alive with A-A Net schedules. W8OK, using a quarter kilowatt 500-cycle crystal-controlled set, is State Control station. The new ruling that station licenses be only issued to individuals, caused W8WK, the Telegraphic Radio Club of Huntington to be cancelled. W8DCM has been issued the call. W8RI, W8VZ, W8DCM, W8IT and W8DKB are working in other cities. W8BTV is Alternate A-A for Wheeling. W8AUZ visited W8DPO, and was thrilled by working England in the afternoon. The Fairmont gang, led by W8ACZ, is heard on consistently. W8ADI has a nice visit with W8CAY. W8HD suggests the gang get together and appoint another SCM in view of W8VZ' working out of town. W8HD does not wish the office, as business obligations make it impossible to properly fulfill the position.

Traffic: W8OK 148, W8AUZ 46, W8BTV 45, W8HD 31, W8DPO 16.

#### ROCKY MOUNTAIN DIVISION

UTAH-WYOMING — SCM, Parley N. James, W6BAJ — W7AAH turns in a nice report. W6RV is on 3500 kc. with low power phone and c.w. The wind blew W6EKF's antenna down. W6BAJ also had his antenna blown down. Hi. W6DXM is now located at the University of Colorado in Boulder. W6CNX is QRL with BCL radio business. W7AGV is a new station at Cody, Wyo.

Traffic: W7AAH 24, W6CNX 19, W6RV 5, W6EKF 2, W6BAJ 1.

COLORADO — SCM, C. R. Stedman, W9CAA — W9CAA leads in traffic this month. W9EAM is doing quite consistent work. W9EBF has moved to Nebraska. Sorry to lose you, OM, W9BQO is selling all of his stuff. W9EDM at Greeley has applied for ORS. W9ECP at Limon is working out with a 210. W9DTY can't get out of the backyard. W9ABY is a new ham at Greeley. W9DOC is getting out nicely. W9CSR has an amateur extra first ticket and is going to try phone on 14,000 kc. W9FXV, at Boone, is still working out in line shape. W9APR is a new Denver ham working on 3500 kc. W9AAC uses two 210's to good advantage. Ex9CDQ is now W9RJ. W9CHV, the RI, will soon be on and will be glad to give hams a check on their frequency. W9CJC and W9AAB are both operating on 7000 kc. W9CCM has a dud 50-watter that is keeping her off the air. W9CDW is thinking of selling out. W9FBE, at Pueblo, seems to be about the only sign of activity in that town. All stations in the state of Colorado who are on the air are urged to send in reports of activity. Reports must be in the SCM's hands not later than the 17th of each month in order to make QST.

Traffic: W9CAA 134, W9EDM 35, W9EAM 25, W9CSR 10.

#### SOUTHEASTERN DIVISION

GEORGIA-SOUTH CAROLINA-CUBA-ISLE OF PINES — SCM, M. S. Alexander, W4RZ — Well, fellows, this section has a new SCM now, and with your help he will put a snappy report in every month, so don't fail to send in your traffic report and dope on your stations. Atlanta hams are preparing to entertain the fellows who attend the big Southeastern Division A.R.R.L. Convention to be held at Atlanta in December. W4KA finds it rather cold in his basement shack, so guess he will have remote control before long. W4PM will be an ORS soon. W4KV has just received his ORS appointment. W4AHA is South Carolina State control station of the A-A net. W4SI

can't decide whether to use AC or DC plate supply. (We hope he uses the latter.) W4RZ will be on the air soon with a MOPA with fifty-watts power.

Traffic: W4KV 69, W4YA 65, W4RZ 49, W4AHA 30, W4PM 27, W4BO 12, W4PD 2.

ALABAMA — SCM, S. J. Bayne, W4AAQ — W4IAM let the license expire and has obtained the call W4PAI. W4WS has a new screen-grid receiver and reports W4MT and W4KP as new stations in Birmingham. W4IM is preparing for a commercial ticket. W4JY reports after a long absence. W4AAH is back among the traffic handlers again. W4VC is having as good success with his 210 as he did with the fifty. W4HZ is now using a fifty-watter. W4WR, an ex-first district ham, is getting out nicely with a 210 on 3500 kc. and 7000 kc. W4AKM says the roof to his shack leaks. Hi. W4JX and W4AKP have contrived a unique way of sending pictures by radio. We regret to learn of serious illness and death in W4AJB's family. W4TT and W4IA are keeping a schedule. W4IT has removed to 1750-ke. fone band and broadcast code practice twice weekly. W4WF has moved to Dothan and is active with fone as usual. W4ZI, W4VY, W4FY, W4QM, the gang at Troy, are having a time avoiding local fone QRM among themselves. The SCM had the pleasure of meeting W4JQ in Montgomery recently. W4AJY and W4IY have formed a partnership and will be active again. W4IIR is kept busy with Army-Amateur work. W4AHP has worked 14 mc., 7 mc., 3.5 mc. consistently, with a little fone work thrown in. W4JR blew his grid leak. W4AKB has installed a pair of UX281's. W4HB sold out to W4FY and is building a new outfit. W4AAQ handled considerable traffic on fone. W4OA still has trouble with his modulation. W4KA, formerly a partner at W4GN is now located at Birmingham.

Traffic: W4AAQ 34, W4AHP 30, W4TI 20, W4IM 18, W4AHR 16, W4LT 16, W4PAI 14, W4AKM 13, W4JX 12, W4JY 8, W4AAH 7, W4EW 6, W4VC 6, W4ZI 6.

PORTO RICO-VIRGIN ISLANDS — SCM, E. W. Mayer, K4KD — K4KD and K4AKV copied Navy Day broadcasts. K4AKV reports 14 mc. gone haywire lately. K4AGF reports the delivery of a message to New York via W2APV, who phoned same and gave reply to K4ACF inside of four minutes. K4KD keeps six schedules weekly. It is the sad duty of the SCM to report the passing of Ernesto Aleumar, K4AAG, who died after an illness of four months. At the time he was taken ill he was all ready to go on the air with a new station. His passing will be deeply regretted by the gang. K4AAN, tennis champ of Virgin Islands, has applied for ORS.

Traffic: K4KD 70, K4AAN 62, K4AKV 12, K4ACF 3. FLORIDA — SCM, Harvey Chafin, W4I1-W4P4W — W4AGR leads us this month with 106 messages. W4AGR was QSL WFA on Nov. 11. We are very proud to have KDV5 with us again. He would like a few skeds. His QRA is Tenth Sig. Co., Corozal, Canal Zone. W4SK would like a sked with Jax. How about it. W4MF, W4AKH, or some of you fellows? W3NB's new QRA is 773 N. W. 35th St., Miami. W4QL blew out his transformer. W4AKH reports for the second time. FB. W4AGY says more traffic next month. W4KA has now worked 25 states and VE 1 and 2. W4AFZ, X9HP is now at Avon Park, Fla. W400 reports that there are five stations in St. Pete. They hope to start a radio club soon. W4SY, better known as "Sugar" has sure been putting in this month rebuilding. W4TK reports that he is expecting a lot of DX. W4TK reports a new ham in Jacksonville, an old Morse operator, using the call W4KW. Please send me your full QRA, OM, so I can forward you some report cards — SCM.

The SCM would like to hear from all the new stations. Without reports on the 16th of each month, your SCM cannot tell the gang what is going on.

Traffic: W4AGR 56, W4AFZ 60, KDV5 105, W4SK 52, W4MF 45, W4I1 40, W4QL 25, W4AKH 21, W4AGY 15, W4HY 14, W4KA 8, W4SY 6, W400 6, W4TK 3.

#### WEST GULF DIVISION

OKLAHOMA — SCM, W. J. Gentry, W5GF — Hats off to Hardin of W5CB and Ehret, W5APG, for their fine totals! FB, OMs. W5AYF reports. Shawnee has two new hams, W5AFH and W5BJJ. W5GF blew his 852 and high-voltage condensers. W5SW has been sick. W5MM is rebuilding. W5AGN has a new receiver. W5AUV is going good now. W5AAV has a couple 210's with a 140 watts input. W5QL works 'em all. W5VH is going to business college. Please don't forget that reports should be mailed on the 16th of each month.

Traffic: W5CB 96, W5APG 59, W5AUV 27, W5AAV 15, W5GF 5, W5AYF 3.

**NORTHERN TEXAS** — SCM, J. H. Robinson, W5BG — W5HY makes the BPL again. He has been keeping skeds with W5AQY at College Station. W5FC has been keeping a party in Oklahoma City informed as to the condition of his sick wife in Dallas, Texas. Good work, OM. W5RJ says he and his new OW are OK. W5AAE has been using fone. W5BBF is keeping skeds with W5WW and W5BAM. W5BAM doesn't have much to report. W5BAD reports that he and W5GZ handled lots of traffic during the Ellis County Fair. W5GZ is having lots of trouble with his 150-watt tube. W5JF says the Boy Scouts are giving him lots of traffic. W5JD has dusted the cobwebs off the 250-watt crystal-controlled set and is on again.

Traffic: W5HY 401, W5FC 240, W5AAE 88, W5BAD 88, W5BBF 47, W5BAM 34, W5GZ 18, W5DF 14, W5JD 5, W5BG 1, W5ACL 1, W5RJ 92.

**SOUTHERN TEXAS** — SCM, Robert E. Franklin, W5OX — W5AQY makes the BPL both ways this month. FB! W5AHB reports DX very good. W5BBY says he is going to make some of the other fellows step to keep up with him. W5AJD is still keeping some good skeds. W5AEA also handles quite a bit of traffic. W5TD is one of the consistent stations reporting. The SCM is on most any evening about 5:30 to 6:30 p.m.

Traffic: W5AQY 233, W5AHB 83, W5BBY 63, W5AJD 61, W5AEA 55, W5TD 15.

**NEW MEXICO** — SCM, Leavenworth Wheeler, W5AHI — Just a word of appreciation to you fellows who, have put me in office. I shall do my best to serve you and with all active stations reporting. I know we can put this Section back on its feet again. W5TV leads the Section with a mighty good total made possible by three daylight skeds. He and W5EF are interested in the U.S.N.R. W5AOD has been rearranging his shack. W5AJL has rebuilt his entire station. W5ND, our AA State Net control, is active. W5AHI is again in operation holding down its link in a west to east traffic route. Any further active stations in the Section are urged to communicate with the SCM. Remember the 16th, men, and we'll show the country that there is a New Mexico Section.

Traffic: W5TV 88, W5AHI 75, W5AJL 26, W5AOD 15, W5EF 8.

## CANADA

### QUEBEC DIVISION

**QUEBEC** — SCM, Alex Reid, VE2BE — Your SCM has been elected Canadian General Manager. In resigning as SCM, I wish to thank all members in this division for the assistance they have rendered me for the past four years. When I take over my duties as C.G.M. on January 1st, I trust I will receive the same whole-hearted coöperation from all members in Canada, and can assure you that I will be glad to receive advice and criticism from the whole Dominion. Our dream of an all-Canadian Traffic Route is almost a reality, and before this goes to press it is our hope that traffic will be moving over this new Canadian route. VE2CA is now the holder of a WAC certificate. Mrs. VE2CA is now on the air regularly. VE2AC is going to Washington and will have the pleasure of an interview with Dr. Taylor of NKF. VE2BD has a new transmitter. VE2BH will be on the air shortly with crystal control. VE2AX is using a new push-pull with two fifties. VE2AP is using an 852 in TPTG. VE2AY sends in his second traffic report and will soon be an ORS. VE2AC again enters the BPL. VE2BB received many comments on his recent letter in QST.

Traffic: VE2AC 206, VE2AY 10, VE2BB 11, VE2BE 55, VE2CA 14, VE2BG 9, VE2AL 8.

### ONTARIO DIVISION

**ONTARIO** — SCM, E. C. Thompson, VE3FC — Central District: VE3BC leads the Section in traffic once more and sets a wonderful example of what can be done with a little perseverance and a few schedules. VE9AL also has a very nice traffic total due to his schedules with W1MK and W8DAW. VE3DA has been doing some fine work on 3.65 mc. VE3CB keeps a schedule daily with VE3BC and makes one link of a proposed Trans-Canada chain. VE3BO had 184 contacts with other stations in one month on 7 mc. We are sorry to record that VE3CJ has resigned as RM, but there is always a silver lining to any cloud, and in this case it is VE3BO, who will carry on. VE3CL says that his tribulations are now over and that everything with

him is FB. VE3BP has a MOPA transmitter working on 7 mc. Eastern District: J. H. Hewson, VE3NM — VE3JW works all districts on a telephone wire aerial and an 852. VE3XO hopes to soon acquire a pair of 852's. VE3XQ has moved to Kingston. VE3XM is still doctoring Movietones. Northern District: VE3ET wants a "checker playing sked" with some fiend of that ilk. He reports that VE3DM at Coldwater will be on the air on 7 and 3.5 mc. by the time this is read. VE3GG is now at Hydro after five years at Sandy Falls, and is using an old 202 with about 25 watts input on 7 and 14 mc. VE3DP at South Porcupine is knocking 'em all dead with a battery-operated pair of 210's. VE3EN now of Schumacher, is preparing to ditch the YLs and get back to his first love, a nice 11" low-power transmitter.

Traffic: VE3BC 70, VE9AL 20, VE3DA 16, VE3CB 11, VE3ET 10, VE3BO 9, VE3CL 6, VE3BP 3, VE3FC 3.

### VANALTA DIVISION

**BRITISH COLUMBIA** — SCM, J. K. Cavalsky, VE5AL — A 3500-ke. traffic net is under construction and it is hoped that we can cover the whole province and the state to the South. How about some of you boys in the interior joining up with the gang? VE5AK is hitting out on 14 mc. VE5AN has a MOPA set using a couple of 201A's. VE5CF is busy at night school. VE5BM is still holding down his sked with VE5GT. VE5CN is working nights. VE5DD is rebuilding his set. It is rumored that VE5HB is coming back on the air. Glad to hear it, Fred. VE5AL boasts a nice new mast. VE5AC has a new op now. Congrats, OM. VE5CW is building a MOPA set. The Vancouver Island stations are coming to life. VE5CT is hitting his old stride with the Belgium tube. VE5CO has a class of boys under tow and is trying to teach them the code. VE5CE is on the 7000-ke. band. VE5BR at Savary is leading the gang with skeds. The second op at VE5BL is holding down the key while the first op is at sea.

Traffic: VE5AC 13, VE5BR 3, VE5AK 3, VE5AL 18.

### PRAIRIE DIVISION

**MANITOBA** — SCM, A. V. Chase, VE4HR — VE4DJ leads the gang in traffic. VE4BQ, VE4DK and VE4GQ are carrying out experimental work on 28 mc. VE4JB is experimenting with a screen-grid receiver. VE4IC has discarded the 201A in favor of a UX-210. VE4DK has been heard in Brazil and New Zealand. VE4BQ and VE4GQ have been appointed ORS.

Traffic: VE4DJ 14, VE4BQ 12, VE4HR 11, VE4IC 10.  
**SASKATCHEWAN** — SCM, W. J. Pickering, VE1FC — VE4IH certainly turned in a nice traffic total this month. A crowd from Moose Jaw dropped in on the Regina bunch on Armistice Day and spent the day visiting ham shacks. VE4AO sold his M.G. and is wondering what to use for power supply. VE4HO has changed his location. VE4AS and VE4HL managed to bridge the gap between Moose Jaw and Regina. VE4EL buried his 210 recently.

Traffic: VE4IH 51.

### LATE AND ADDITIONAL REPORTS

W6BTX has been sick for a while so not much traffic to show. W3GS sends in a good report this month.

Traffic: W6BTX 21, W3GS 66.

**QSP** — or deliver

