

QST

devoted entirely to

amateur radio

June
1938
25 cents



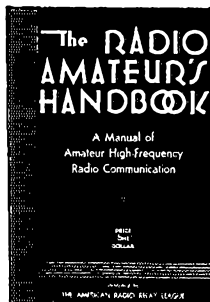

The New Tenth Edition

RADIO AMATEUR'S HANDBOOK

The Radio Amateur's Handbook is the indispensable guidebook to Amateur Radio.

Published by the national association of radio amateurs, at the demand of the membership, it is complete, well-written and authoritative. Each year since 1926 it has been revised to keep in step with the constantly changing technique of short-wave radio communication. Now in its tenth edition, it has been brought right up to date. It treats adequately of all the aspects of amateur radio. It explains in understandable fashion all those little points which are frequently puzzling to the beginner — and for those well advanced in amateur radio it describes and suggests and advises and instructs on the newest and best in equipment and practices.

There is only one Radio Amateur's Handbook. There is no other book which even approaches it. It is the first and most vital piece of equipment for any amateur radio station.

ABSOLUTELY ESSENTIAL

One Dollar — Postpaid Anywhere

(Bound in cloth, \$2.00)

The American Radio Relay League, Inc.
WEST HARTFORD, CONNECTICUT

"THESE MODERN RHEOSTATS GIVE PERFECT FILAMENT CONTROL"

says

JOHN WALLACE—Designer of W9USA

Ohmite all-porcelain, vitreous-enameled rheostats are ideal for use in transmitting work. They are inherently noiseless in operation and give very close control of current and voltage. These rheostats are made in proper sizes and resistance values for controlling the filaments of all transmitting tubes.

Ohmite rheostats are used in the transmitters of W9USA and W9USB now in operation at the CENTURY OF PROGRESS EXPOSITION in Chicago. Be sure to see them when you visit the "ham" exhibit in the Transportation Building. In the meantime, send for the new eight-page **Ohmite Rheostat and Resistor Bulletin No. 9** and the data sheet which shows the proper resistance and wattage rating of rheostats for controlling present-day transmitting tubes. The coupon below will bring your copy at once.

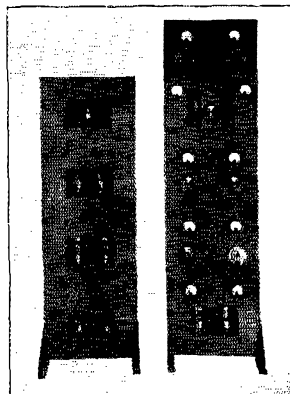

Original Transmitter—W9USA

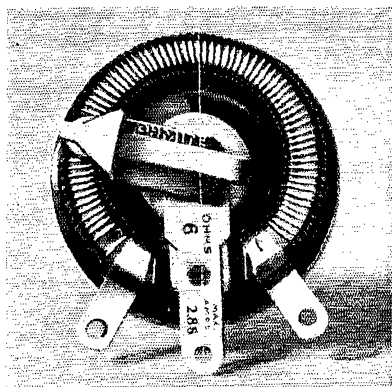

Ohmite rheostats were not selected by chance for use in W9USA but because they mark a real step forward in rheostat design. As the resistance wire is wound over a porcelain core and is covered with vitreous enamel, each turn is fused rigidly in place and is protected against both mechanical and electrical injury. The use of a metal-impregnated graphite contact insures low contact resistance and absolute freedom from arcing and sticking.

Ohmite rheostats are made in resistance values to satisfy all amateur needs. A **data sheet, Number 103**, gives the proper resistance value and wattage rating of rheostats to control the filaments of 203A, 204A, 211, 211D, 211E, 212D, 845, 849, 852, 860, 866, and 872 tubes. A copy of the data sheet will be sent along with the bulletin. Get your copy now.

OHMITE

MANUFACTURING COMPANY

OTHER OHMITE PRODUCTS FOR AMATEUR AND SERVICE MAN

- "Red Devil" Cement Coated Resistors
- Vitreous Enameled Fixed Resistors
- "Dividohm" Semi-Variable Resistors
- "Determohm" Resistance Boxes
- "Handy-Ohm" Resistance Indicators
- Resistors Accurate within 1%
- Transmitting Grid Leaks

All of These Units Are Shown in Ohmite Bulletin No. 9

Ohmite Manufacturing Company
631 N. Albany Ave., Chicago, Ill.
Please send my copy of the new eight-page Ohmite Bulletin No. 9, and the new tube control data sheet.

Name.....
Address..... Call.....
City..... State.....

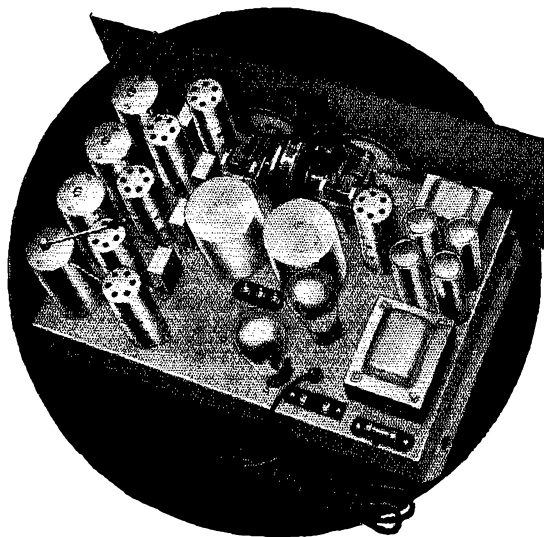

A FEW COMET "PRO" USERS

Several of the users, listed below, operate more than fifty COMET "PRO" Short-Wave Superheterodynes — some operate more than one hundred.

Picture in your mind the exacting performance which such organizations require. You will then realize what a delight it would be to you to own this superb receiver, built to professional standards.

MAIL COUPON FOR DETAILS

AIRWAYS

American Airways
Eastern Air Transport
Northwest Airways
Transcontinental & Western Air, Inc.
Inter-American Aero Travel and Supplies
44th Division Aviation, N. J.
War Department, Air Corp., Wright Field

BROADCAST SYSTEMS

Columbia Broadcasting System
Station WOR
Station WOWO
Station WAJU
Station WINS
Station WCAO
Icelandic State Broadcasting Service, Reykjarik, Iceland
Short Wave Station VE9GW, Canada
Station CMKA, Cuba

NEWS SERVICE

American Radio News Service
U. S. Embassy, Santiago, Chile
Argentine Embassy, Paris, France

DOMESTIC COMMERCIAL SERVICE

Georgia Agricultural Dept.
Police Dept., Youngstown, O.
Police Dept., Klamath Falls, Ore.
Albany Junior Chamber of Commerce
Mississippi State Penitentiary
Hotel New Yorker

FOREIGN COMMERCIAL SERVICE

Radio Electric, Switzerland
Technish Bureau, Kolomen, Holland
Prometheus, Greece
Rothermel Corp., Belgium
Eltone Ceritte, Italy
Muvaffak Bey, Ankarg, Turkey
Standard Oil Co. of Venezuela
Harry Pegram, South Africa
W. F. Greene, Dutch West Indies
Pedro Perez, Saintz, Spain
Post Exchange, Canal Zone

WAR DEPARTMENT

Message Center, Washington
Headquarters, 8th Corp Area,
Fort Sam Houston

Signal Section, San Francisco
Signal Section, Honolulu, T. H.
Signal Section, Manila, P. I.
Signal Section, Corozal, C. Z.
Headquarters, 4th Corp Area,
Fort McPherson
Headquarters, 9th Corp Area

NAVY DEPARTMENT

Naval Research Labs., Washington
U. S. S. Woodcock
Radio Material School, Washington
9th Naval District
U. S. Navy Yard, Charleston, S. C.
Marine Corp., Signal Section

FOREIGN GOVERNMENT SERVICE

Department of National Defense, Canada
Director of Signals, Canada
Director of Naval Stores
Royal Administration of Telegraph, Stockholm
Radio Nautica, Italy
First Brigade Exchange, Haiti

PROMINENT AMATEURS IN ALL DISTRICTS

HAMMARLUND MANUFACTURING CO.
424 W. 33rd St., New York

Check here for General Catalog. Check here for folder on new Air-Tuned I.F. Transformers. Check here for new booklet describing the COMET "PRO" in detail.

Name

Address

Q-6

For Better Radio
Hammarlund
PRECISION
PRODUCTS

QST

Published monthly, as its official organ, by the American Radio Relay League, Inc., at West Hartford, Conn., U. S. A.; Official Organ of the International Amateur Radio Union

devoted entirely to

AMATEUR RADIO

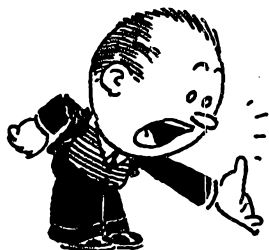

| | |
|--|----|
| Editorials | 7 |
| Duplex Portables <i>F. P. Keefer and L. E. Grant</i> | 8 |
| Circuits Within Circuits <i>George Grammer</i> | 11 |
| International Field Day — June 10-11 | 15 |
| Transmitter Power Supply from Low-Voltage D. C. <i>Lyle L. Farver, W8EZQ</i> | 16 |
| The Development of the Transmitting Antenna <i>Edwin R. Sanders, W1EDY</i> | 17 |
| Central Division World's Fair Convention (Announcement) | 20 |
| Wisconsin — Central Division Convention (Announcement) | 20 |
| Silent Keys | 20 |
| A Dial-Coded Universal Tube Checker and Circuit Analyzer <i>Clinton B. DeSoto</i> | 21 |
| Atlantic Division Convention (Announcement) | 23 |
| Transformerless Plate Supplies | 24 |
| Converting Standard Superhets to S. S. Receivers <i>James J. Lamb</i> | 25 |
| Sweepstakes Contest Results — 1932 <i>E. L. Battey</i> | 27 |
| A More Stable Oscillator of High Harmonic Output <i>James J. Lamb</i> | 30 |
| Air-Type Alignment Condensers for Plug-In Coils | 32 |
| For the Experimenter | |
| INEXPENSIVE CRYSTAL OVEN — ELECTRON-COUPLED 100-KC. OSCILLATOR — MORE ON TRANSMISSION LINE INTERSTAGE COUPLING — R. F. VOLUME CONTROL CONNECTIONS — KEY FILTER CONSTANTS — HARD-DRAWN VS. SOFT COPPER WIRE | 33 |
| Amateur Radio Stations <i>WBHD-WLHB, Wheeling, Va. W9JNV, Woodmen, Colorado</i> | 36 |
| For Code Learning | 37 |
| Communications Department | 38 |
| I. A. R. U. News | 53 |
| Calls Heard | 55 |
| Correspondence Department | 56 |
| Standard Frequency Transmissions | 68 |
| Hamads | 75 |
| QST Index of Advertisers | 78 |

JUNE
1933

VOLUME XVII
NUMBER 6

Kenneth B. Warner (Secretary, A.R.R.L.), *Editor-in-Chief and Business Manager*; Ross A. Hull, *Associate Editor*; James J. Lamb, *Technical Editor*; George Grammer, *Assistant Technical Editor*; Clark C. Rodimon, *Managing Editor*; David H. Houghton, *Circulation Manager*; F. Cheyney Beekley, *Advertising Manager*; Ursula M. Chamberlain, *Assistant Advertising Manager*.

Editorial and Advertising Offices
38 La Salle Road, West Hartford, Conn.

Subscription rate in United States and Possessions and Canada, \$2.50 per year, postpaid; all other countries, \$3.00 per year, postpaid. Single copies, 25 cents. Foreign remittances should be by international postal or express money order or bank draft negotiable in the U. S. and for an equivalent amount in U. S. funds.

Entered as second-class matter May 29, 1919, at the post office at Hartford, Connecticut, under the Act of March 3, 1879. Acceptance for mailing at special rate of postage provided for in section 1103, Act of October 3, 1917, authorized September 9, 1922. Additional entry at Concord, N. H., authorized February 21, 1929, under the Act of February 28, 1925.

Copyright 1933 by the American Radio Relay League, Inc.
Title registered at United States Patent Office.

Don't Let Your Station Get Into Bad Habits

Keep its standards high

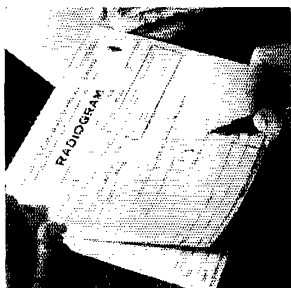

Message Blanks. Most convenient form. Designed by the Communications Department of the A.R.R.L. Well printed on good bond paper. Size $8\frac{1}{2} \times 7\frac{1}{4}$. Put up in pads of 100 sheets. One pad postpaid for 35c or 3 pads for \$1.00.



Log Books. Bound with heavy paper covers. $8\frac{1}{2} \times 10\frac{3}{4}$. Contains 39 log pages, like above, and 39 blank pages for miscellaneous notes. Also list of Q sigs, message number sheet and sheet of cross-section paper. 40c each or 3 for \$1.00. Postpaid.

THESE
AMATEUR
OPERATING

FORMS
ARE
A TREMENDOUS
HELP IN
KEEPING YOUR
STATION
NEAT
AND YOUR
OPERATING
PRACTICES
ORDERLY



A.R.R.L. Letterheads. Write your radio letters on League stationery — it identifies you. Lithographed on $8\frac{1}{2} \times 11$ heavy bond paper. Postpaid. 100 sheets, 50c; 250 sheets, \$1.00; 500 sheets, \$1.75.

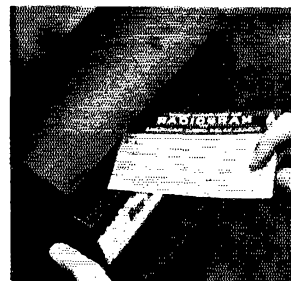

Message Delivery Cards. Neatest, simplest way to deliver a message to a nearby town. On U. S. stamped postals 2c each. On plain cards (for Canada, etc.) 1c each, postpaid.

The American Radio Relay League, Inc.

West Hartford, Connecticut

Section Communications Managers of THE COMMUNICATIONS DEPARTMENT, A. R. R. L.

| | | | | |
|--|---|--|--|--|
| Eastern Pennsylvania Maryland-Delaware-District of Columbia Southern New Jersey Western New York Western Pennsylvania | W3GS W3NY W3QL W8DSP W8CUG | ATLANTIC DIVISION Jack Wagenseller Harry Ginsberg Gedney Rigor Don Farrell C. H. Grossarth | 210 Main St. 2305 N. Pulaski St. 412 2nd Ave. 213 Hickok Ave. R. F. D. 3, Elcher Rd. | Pennsburg Baltimore, Md. Haddon Heights Syracuse Emsworth, Bellevue, Pa. |
| Illinois Indiana Kentucky Michigan Ohio Wisconsin | W9WR W9TE W9OX W8DVH W8BAH W9FSS | CENTRAL DIVISION Fred J. Hinds Arthur L. Braun Carl L. Pfumm Kenneth F. Conroy Harry A. Tummonds Harold H. Kurth | 6618 West 34th St. 1321 Spruce St. P. O. Box 359 7553 E. Robinwood Ave. 2073 West 85th St. 2550 N. 8th St. | Berwyn Indianapolis Louisville Detroit Cleveland Milwaukee |
| North Dakota South Dakota Northern Minnesota Southern Minnesota | W9DGS-IFW W9DKL W9DOQ W9EPJ | DAKOTA DIVISION Wm. Langer C. B. Miller Palmer Andersen Norman Beck | 313 First Ave., S. 449 N. 5th St. Route 1, Box 270 415 Grand St. | Jamestown Redfield Duluth Winona |
| Arkansas Louisiana Mississippi Tennessee | W5ABI W5WF W5AZV W4AFM | DELTA DIVISION H. E. Vette W. J. Wilkinson, Jr. William G. Bodker F. F. Purdy | 2918 West 15th St. 1624 Allen Ave. 1013 Bratton St. P. O. Box 173 | Little Rock Shreveport Jackson Kingsport |
| Eastern New York N. Y. C. & Long Island* Northern New Jersey | W2LU W2AZV W2CO | HUDSON DIVISION Robert E. Haight E. L. Baunach Walter A. Cobb | 1080 Helderberg Ave. 7823 10th Ave. 28 Ampere Parkway | Schenectady Brooklyn East Orange |
| Iowa Kansas Missouri Nebraska | W9FFD W9FLG W9EVG-HCP W9FAM | MIDWEST DIVISION George D. Hansen O. J. Spetter C. R. Cannady Samuel C. Wallace | Box 27 305 Western Ave. 210 W. McCarty Green St. | Salix Topeka Jefferson City Clarks |
| Connecticut Maine Eastern Massachusetts Western Massachusetts New Hampshire Rhode Island Vermont | W1CTI W1CDX W1ASI W1ASY-W1RB W1ATT W1AFO W1BD | NEW ENGLAND DIVISION Frederick Ella, Jr. John W. Singleton Joseph A. Mullen Earl G. Hewinson V. W. Hodge Stanley Atkinson Roy Gale | 19 Merrill Rd. 16 Mercer St. 33 Cortland St. 8 Sullivan St. 186 Magnolia St. 41 Beacon St. | Norwalk Wilton Ashmont Springfield Claremont Auburn Barre |
| Alaska Idaho Montana Oregon Washington | K7PO W7AXH W7AAT-7QT W7ABZ W7RT | NORTHWESTERN DIVISION Richard J. Fox Charles K. Thrapp O. W. Viers Raymond L. Cummins John P. Gruble | Box 301 1011 East Jefferson St. 4835 N. Amherst St. 1921 Atlantic St. | Ketchikan Boise Red Lodge Portland Seattle |
| Hawaii Nevada Los Angeles Santa Clara Valley East Bay San Francisco Sacramento Valley Arizona Phillippines* San Diego San Joaquin Valley | K6COG W6EAD W6AAN W6AMM W6ZM W6CAL W6DVE W6BJF-W6QC KA1XA W6EOP W6DZN | PACIFIC DIVISION C. D. Staten Keaton L. Ramsay Francis C. Martin Bruce Stone S. C. Houston Byron Goodman Geo. L. Woodington Ernest Mendoza Newton E. Thompson Harry A. Ambler G. H. Lavender | Pearl City 1151 Buena Vista Ave. 738 W. Huntington Drive R. 1, Box 311 2523 23rd Ave. 141 Alton Ave. 716 Redwood Ave. 1434 East Madison St. 714 Tennessee 4101 Hamilton St. 8, Box 425 | Oahu Reno Arcadia San Jose Oakland San Francisco North Sacramento Phoenix Manila, P. I. San Diego Stockton |
| North Carolina Virginia West Virginia | W4AVT W3AAJ W8HD | ROANOKE DIVISION G. H. Wright, Jr. R. N. Eubank C. S. Hoffmann, Jr. | 2817 Montrose Ave. 126 Washington Ave. | Wendell Richmond Wheeling |
| Colorado Utah-Wyoming | W9BTO W6DPJ | ROCKY MOUNTAIN DIVISION T. R. Becker C. R. Miller | 1176 Gaylord St. 134 E. 2nd North St. | Denver Provo, Utah |
| Alabama Eastern Florida Western Florida Georgia-So. Carolina-Cuba- Isle-of-Pines-Porto Rico- Virgin Islands | W4KP W4NN W4MS W4PM | SOUTHEASTERN DIVISION L. B. Elwell Ray Atkinson Edward J. Collins Chas. W. Davis | 1066 Waverly St. 329 East First St. 1517 East Brainard St. 668 Cooleedge Ave., N.E. | Tarrant Jacksonville Pensacola Atlanta |
| Northern Texas Oklahoma Southern Texas New Mexico | W5AUL W5VQ W5BHO W5AUW | WEST GULF DIVISION Glen E. Taibutt Emil Gisel David H. Calk Jerry Quinn | 1902 South 11th St. 1st Balloon Co. 6726 Ave. Q 518 W. Marquette Ave. | Abilene Fort Sill Houston Albuquerque |
| Maritime | VE1DQ | MARITIME DIVISION A. M. Crowell | 69 Dublin St. | Halifax, N. S. |
| Ontario | VE3HB | ONTARIO DIVISION H. W. Bishop | 258 Egerton St. | London |
| Quebec* | VE2AP | QUEBEC DIVISION J. C. Stadler | 4334 Westmount Ave. | Westmount, P. Q. |
| Alberta British Columbia | VE4HM VESAL | VANALTA DIVISION C. H. Harris J. K. Cavalaky | 10806 125th St. 4868 Blenheim St. | Edmonton Vancouver |
| Manitoba Saskatchewan | VE4GC VE4EL | PRAIRIE DIVISION Reg. Strong Wilfred Skaffe | 284 Marion St. 2040 McTavish St. | Winnipeg Regina |

* Officials appointed to act until the membership of the Section choose permanent SCM's by nomination and election.

The American Radio Relay League



• **T**HE AMERICAN RADIO

RELAY LEAGUE, Inc., is a non-commercial association of radio amateurs, bonded for the promotion of interest in amateur radio communication and experimentation, for the relaying of messages by radio, for the advancement of the radio art and of the public welfare, for the representation of the radio amateur in legislative matters, and for the maintenance of fraternalism and a high standard of conduct.

It is an incorporated association without capital stock, chartered under the laws of Connecticut. Its affairs are governed by a Board of Directors, elected every two years by the general membership. The officers are elected or appointed by the Directors. The League is non-commercial and no one commercially engaged in the manufacture, sale or rental of radio apparatus is eligible to membership on its board.

"Of, by and for the amateur," it numbers within its ranks practically every worth-while amateur in the world and has a history of glorious achievement as the standard-bearer in amateur affairs.

Inquiries regarding membership are solicited. A bona fide interest in amateur radio is the only essential qualification; ownership of a transmitting station and knowledge of the code are not prerequisite. Correspondence should be addressed to the Secretary.

A directory of the amateur societies affiliated with the League, showing their times and places of meetings, is available upon request.

DIRECTORS

- President*
HIRAM PERCY MAXIM.....W1AW
Box 216, Hartford, Conn.
- Vice-President*
CHARLES H. STEWART.....W3ZS
St. David's, Pa.
- Canadian General Manager*
ALEX. REID.....VE2BE
169 Logan Ave., St. Lambert, P. Q.
- Atlantic Division*
EUGENE C. WOODRUFF.....W8CMP
234 W. Fairmount Ave., State College, Pa.
- Central Division*
LOREN G. WINDOM.....W8GZ-W8ZG
1375 Franklin Ave., Columbus, Ohio
- Dakota Division*
LAWRENCE E. LINDESMITH.....W9GKO
1055-85th Ave. W., Duluth, Minn.
- Delta Division*
M. M. HILL.....W5EB
P.O. Box 274, Natchitoches, La.
- Hudson Division*
BERNARD J. FULD.....W2BEG
280 Broadway, New York City
- Midwest Division*
H. W. KERR.....W9DZW-W9GP
Little Sioux, Iowa
- New England Division*
G. W. BAILEY.....W1KH
74 Webster Road, Weston, Mass.
- Northwestern Division*
RALPH J. GIBBONS.....W7KV-W7BIX
35 Park St., Walla Walla, Wash.
- Pacific Division*
S. G. CULVER.....W6AN
2303 Seventh Ave., Oakland, Calif.
- Roanoke Division*
H. L. CAVENESS.....W4DW
State College Station, Raleigh, N. C.
- Rocky Mountain Division*
RUSSELL J. ANDREWS.....W9AAB
169 So. Ogden St., Denver, Colo.
- Southeastern Division*
J. C. HAGLER, JR.....W4SS
2424 McDowell St., Augusta, Ga.
- West Gulf Division*
FRANK M. CORLETT.....W5ZC
2515 Catherine St., Dallas, Tex.

OFFICERS

- President*HIRAM PERCY MAXIM, W1AW
Hartford, Connecticut
- Vice-President*CHARLES H. STEWART, W3ZS
St. David's, Pennsylvania
- Secretary*KENNETH B. WARNER, W1EH
West Hartford, Connecticut
- Treasurer*ARTHUR A. HEBERT, W1ES
West Hartford, Connecticut
- Communications Mgr.*, F. EDWARD HANDY, W1BDI
West Hartford, Connecticut
- General Counsel*PAUL M. SEGAL, W3EEA
1010 Shoreham Building, Washington, D. C.

Address all general correspondence to the executive headquarters at West Hartford, Connecticut



THE EDITOR'S MILL

HERE we sit, with the end of April yet a week away, tapping out an editorial for June *QST*, trying to think of things from a mid-summer point of view. The lawns and shrubbery of Connecticut have been stirringly green for several weeks but every tree is still a barren frame. Not ten days ago we had an R5 snowstorm, and the snow still lies feet deep not many miles to the north of us. Although we realize perfectly well how foolish it will look in print as July dawns, we want to observe that it has seemed an endless winter and that, excellent as operating conditions have been, we are looking forward with unusual zest to the special kind of operating and experimenting that summer makes possible.

We are impressed with the profound difference between summer brasspounding now-days and that of our kid years. The old-timer thinks with a sigh of the days of yore, of that romantic period when a singing rotary gap crashed blue-white fire from the charge of a hundred pounds of glass and foil and from its four-wire flat-top sent musical signals to an anxious receiving operator sliding his loose-coupler and jiggling a suspended magnet before his single glowing audion. Fond two-hundred-meter days, when a transmitting inductance was a hundred feet of inch-wide copper ribbon in a pancake! Softened by time, our memories are less vivid of the summer static that, even in mid-day, made a noisy crackle a hundred feet from the unwearable 'phones. We remember that old "tuning indicator" we made a great deal more clearly than we do the weeks when we couldn't hear a single signal through an unending Niagara of atmospherics.

What a different story it is to-day! C.W. may not possess the romance of spark but it is an unbelievably effective method of modern communication — it solved the interference question. Pure d.c. notes may lack the individuality of the old rotary's tones but they give clean signals at the maximum terrestrial distance. High-frequency operation may give no play to the latent civil-engineering ability in the amateur builder but it has licked the static problem.

Ten years ago amateur radio used to shut down almost completely during the summer, simply because it wouldn't work then. To-day there is scarcely a difference between winter and summer. Our modern methods are so effective that we can carry about with us transmitters and receivers capable of the most respectable DX, despite the dragons of QRN and QRM that used to feature *QST*'s summer covers. No ham's vacation is now complete without a portable rig. And with the blooming of summer WX, clubs have an excellent opportunity to have a lot of sport and competition by staging radio field days, as the British amateurs do so successfully.

Then, in particular, there's the business of 10 meters and 5 meters. That is essentially a job for the summer, when outdoors is more pleasant than the shack, when it is sport to put a portable in the car and try the high places, whether they be hilltops or grain elevators. We amateurs, we suggest, have an absorbing piece of work ahead of us in this "5&10" development, comparing the two, devising better gear, and eventually bending these ultra-high bands to our needs. *QST* earnestly hopes that there will be a relatively tremendous interest in this work this summer. We know from our experience that those who participate will have a most enjoyable time of it.

Ho, then, for summer!

K. B. W.

Duplex Portables

Suggestions for Week-Ending Stations

By F. P. Keefer* and L. E. Grant†

IN the past two years a number of portable transmitters and receivers has been described in the pages of *QST*. In most cases the transmitters described were portable only when used in conjunction with a car. Some were completely self-contained, but depended on an a.c. source for their power supply, and usually weighed 65 pounds or more. Some of the receivers, while being self-contained in that they carried batteries, did not contain the antenna, 'phones

transmitting. The second tube, the audio amplifier, is idle when transmitting.

DETAILS OF CONSTRUCTION

As shown in Fig. 1, the Hartley circuit is used with suitable modifications to fit the peculiarities of this type of service. There are two grid leaks in the circuit — both in series when receiving and one, the receiving leak, shorted out when transmitting; the regeneration control, a 10-megohm variable resistor, is cut out of the circuit when transmitting so the full battery voltage is on the oscillator tube; and a midget 15- μ fd. condenser is in the circuit when receiving and out when transmitting since if one transceiver is to work the other it is necessary to have them send and receive on the same frequency. Without this balancing condenser in the circuit the transmitter frequency is about 15 kc. lower than when the send-receive switch is in the receiving position. All the changes just mentioned are accomplished by a double-pole double-throw two-position midget switch, — the one to the right and below the meter in the front view of the panel. We planned to use Type 30 tubes, and a meter on the panel shows the correct filament voltage, and also the plate current in the detector-oscillator circuit. The switch on the left-hand side of the panel, a double-pole double-throw midget switch with a neutral position, makes the meter read up to three volts when thrown to the right, and up to 30 milliamperes when in the left-hand position. The two binding posts at the left-hand top are the antenna connections. They are both insulated from the panel so that a feeder system or an antenna-counterpoise may be used. The knob directly below is the rheostat, with the regeneration control at the bottom left corner. In the lower center is the balancing condenser knob, and the tuning condenser control is to the right at the bottom. The antenna tuning condenser is the one directly above. Two jacks at the bottom of the panel take care of the 'phones and key.

The set itself measures $9\frac{1}{4}$ inches long, 6 inches high and $4\frac{7}{16}$ inches deep. The sub-panel is a piece of $\frac{3}{16}$ -inch bakelite $8\frac{5}{16}$ inches long and 3 inches wide, mounted on sub-panel brackets so there is a space of about $1\frac{1}{2}$ inches between it and the front panel to allow space for the variable condensers, etc., on the lower part of the panel. The audio transformer, the two tubes and the plug-in coil are mounted on the sub-panel, the coil being placed between the two tubes. The

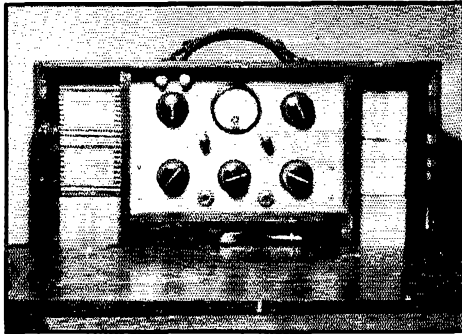

READY FOR ACTION

The portable transceiver in its carrying case, complete with batteries, 'phones and antenna equipment. The outside dimensions are approximately 17 by 8 by 5 inches and the outfit weighs but 23 pounds including all accessories.

and so forth. The receiver which did contain everything had the disadvantage that the knobs and controls were exposed while the set was being carried. They all had their merits, however.

The set to be described in this article does not fall into any of these classes of portable. Two of the sets were made, each duplicating the other. Using only one set you have a *completely* self-contained portable transceiver. It weighs 23 pounds; therefore you don't need a car to carry it around. Even as a portable receiver alone it is small; in that case you'll have room for your lunch.

Since both sets are the same we'll describe just one and later explain some combinations that can be used with both rigs. The set was made first and when completed in its smallest form a carrying case was made to fit around it. After trying a number of different schemes for combining a receiver and a transmitter, a circuit was chosen which used two tubes. The first tube acts as a detector when receiving and as an oscillator when

* WDRC, 8 Simpson St., Hartford, Conn.

† WDRC, 566 Blue Hills Ave., Hartford, Conn.

gridleaks are mounted in holders at the left end of the sub-panel, looking at the back. Fixed condensers and the r.f. choke are mounted on the under side of the sub-panel.

One of the moving contacts of the send-receive switch goes to the plus "B" while the other moving contact goes to the grid side of the coil and at the same time to the outside connection of the grid leak. In the receiving position the plate current flows through the battery to the switch and through the regeneration control. The stator plates of the balancing condenser, C_1 , are now connected to the grid side of the coil. Flip the switch to the send position and the current flows through the switch to the key. The 'phone jack is also shorted, to eliminate the impact of the key across the primary of the audio transformer.

The resistor R_4 , shunting the milliammeter when S_2 is thrown to the right, consists of about 8 inches of wire salvaged from a defunct 6-ohm rheostat. To make the reading accurate we took the 8 inches of wire and with a 30-milliamperemeter as a check kept trying different lengths until the correct length was found. The advantage of using a meter switch with a neutral position is that it then becomes possible to use the meter in another circuit without removing any of the connections in the set. The voltmeter multiplier resistance, R_3 , is a semi-fixed resistor with a sliding clip, and having a total resistance

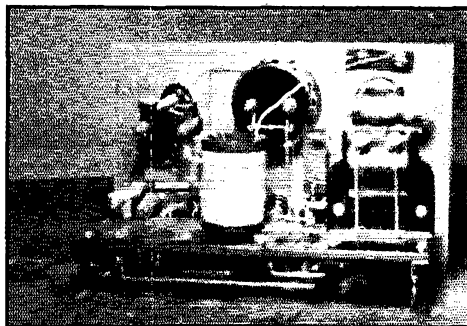

A GLIMPSE BEHIND THE PANEL

Showing the sub-panel with the audio transformer and r.f. coil in place. The tubes fit into sub-panel sockets on either side of the coil.

of 1500 ohms. The actual resistance in use is approximately 1000 ohms.

The carrying case, built especially for this set, is made of white pine stained walnut and then varnished. The upper middle compartment holds the set, the compartment just below holds the 'phones, key, antenna wire, etc., while the compartments at the left and right will each hold three small 22½-volt batteries and two 4½-volt "C" batteries. When the front cover is closed, everything necessary for operation is in and nothing is exposed. A leather carrying handle is fastened to the top. Dimensions are given in Fig. 2.

OPERATING THE TRANSCEIVERS

Most of the work done with the portable has been on 80 meters, using an antenna system consisting of two wires 33 feet long, with a loading coil of approximately 30 turns of No. 22 wire on a 1½-inch diameter form in each leg. A regular full-size antenna would be advantageous, of course, if conditions will permit its use. No. 24 wire was used a few times with fair success. For insulators we used four pieces of bakelite about three inches long; the antenna wire was wound directly on these when not in use. The two insulators at the set end are fastened to the leather handle of the case, while the other two are usually attached to a tree on each side of the transmitter, the antenna taking the shape of a V.

Well, let's see how she works. You take one set and I'll take the other. You go in a northerly direction and I'll go down the other way. It's 1 p.m. now. At

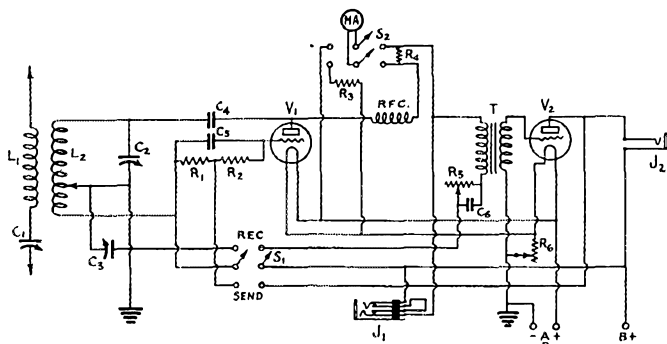

FIG. 1 — THE TRANSCEIVER CIRCUIT

- C_1 — 100- μ fd. midget condenser.
- C_2 — 50- μ fd. " "
- C_3 — 15- μ fd. " "
- C_4 — .001- μ fd. fixed condenser
- C_5 — 250- μ fd. " "
- C_6 — 25- μ fd. " "
- R_1 — 10,000 ohms.
- R_2 — 2 megohms.
- R_3 — See text.
- R_4 — See text.
- R_5 — 10-megohm variable resistor.
- R_6 — 25-ohm rheostat.
- SW_1 — D.P.D.T. midget switch, 2-position.
- SW_2 — D.P.D.T. 3-position.
- RFC — High-frequency choke.
- MA — 0.3 ma. d.c. milliammeter.
- J_1 — Double-circuit jack.
- J_2 — Single-circuit jack.
- T — Audio transformer.

COIL DATA

| Band | L_1 | L_2 |
|-----------------------|---------|--|
| 3500-400 kc..... | 8 turns | 38 turns, tapped 8, 11, 13 and 16 turns from grid end. |
| 7000-7300 kc..... | 6 turns | 25 turns, tapped 7 and 9 turns from grid end. |
| 14,000-14,400 kc..... | 5 turns | 9 turns, tapped 3 turns from grid end. |

All coils wound with No. 24 d.c.c. wire on National plug-in forms, diameter 1½ inches. L_1 and L_2 spaced approximately ¼ inch apart on forms.

the end of two hours we'll try to work each other. OK? Let's go. (Elapse of an hour and forty-five minutes.) Well, I've got 15 minutes more; guess I'll look around for a good location. Yep, there is a good place between those two pines that should do the trick. Antenna's up. 'Phone plug in. Key plug in. Turn the meter switch to the right. Two volts, OK. Turn the meter switch to the left and the send-receive switch in the receive position. There are three pencil marks over the tuning condenser knob. The two outside ones indicate the limits of the band and the center

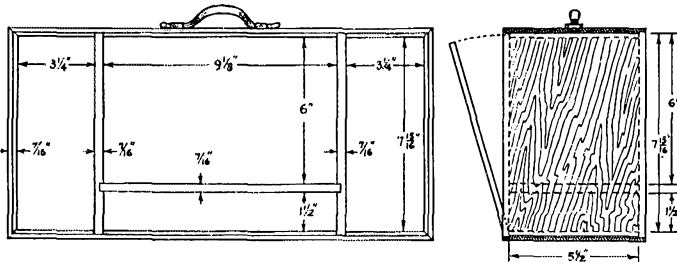

FIG. 2—CARRYING CASE SPECIFICATIONS

one indicates the middle of the 80-meter band — also the frequency we have previously agreed upon to work each other. Let's tune around first to see if we hear anyone just to be sure we're in the band. Yep, she's OK. Hm, 2 p.m. I ought to be hearing W1AHC calling me now. The arrow on the tuning condenser points to the mark on the dial—the middle of the band. There he is now — hurrah, the ole peanut whistle works!! I'll tune him in as loud as possible. Tune the antenna to resonance; that brings him in louder. He says go ahead, OK. Flip the send-receive switch to send position, press the key — 8 mils, the milliammeter says, only a little more than one watt input but maybe she'll get him. That call ought to be long enough. Back goes the switch to receive position. Nope, I don't hear him, but maybe he had to tune me in on a slightly different frequency, so I'll just tune around with the balancing condenser. Hurrah, got him all right! The balancing condenser doesn't change the frequency of the oscillator any, so when I shift to the send position everything will be OK. "Where are you, Larry? Your sigs are QSA 4 but swing somewhat? GA." Larry says he's up in the old fire tower and the wind is blowing like heck. We chew the fat for a while, try some experiments with the antenna and call it a day. We weren't more than 10 miles apart, but the input was only a little over a watt. We certainly did get a great kick out of it, though. Let's try it again sometime for 30-mile DX. Say — I wonder how she'd work with a full size antenna?

Although you can have a whale of a lot of fun taking a hike like the one above a more practical way of using the transceiver is suggested and was

one of the main reasons why the portable was built. Reading Seaton's article, "Investigating the Directive Properties of an Amateur Antenna," in May, 1932, *QST*, gave us the idea of erecting several antennas at the home station so arranged that a choice of any one could be made to be used with a single transmitter. One of us will go out with one of the portables and equipment for measuring the relative field strength. We'll probably use another receiver with the output feeding into a vacuum-tube voltmeter. Some arrangement will have to be made to check the sensitivity

of the set at different locations in order to give accurate readings — some sort of standard signal generator. Then when one of us is about a mile away from the home station, we'll call him on the portable and tell him to "GA on antenna No. 1." When the readings are taken, we'll say "GA on antenna No. 2," and so on. The input to the home transmitter will, of course, have to be the same for each

antenna. When the readings on each antenna are completed we'll move on to another location at approximately the same distance away from the home transmitter. We'll do this until we've made a circle just as Seaton described in his article, then we'll make a map and see just what antenna will be best to work that Asian station next time.

At the home station the set has been used as an auxiliary receiver and also as an auxiliary transmitter. When used as a transmitter at home the tube is a 71-A. With 200 volts on the plate the best DX so far was with a station over 200 miles away, this at 11 a.m. on 80 meters. With about 300 volts on the plate it works well over a radius of 100 miles on 80 meters. It is suggested that if both portables are taken out together the circuit of one be slightly modified so that it will work best as a receiver. This can be done by moving the tap on the plug-in coil so that there is a greater ratio of grid turns to plate turns and by moving the stator connection on the tuning condenser, C_v from the plate end of the coil to the grid end. It is also desirable to reduce the plate voltage to about 67½ volts. To make the other set into a portable transmitter of maximum efficiency move the connection on the rotor plates of the tuning condenser from the grid return to the grid end of the coil. Remove the audio tube and use all the plate voltage available — up to 300 volts with a 71-A or 200 volts with a 30. The filaments of the 30 tubes do not seem to be able to "take it" as a 71-A will. If the plate current on a 30 is more than 8 or 10 mils the signal will chirp. We've been using the peanut whistlers as monitors at the home station, too, and as intercommunicating sets be-

(Continued on page 35)

Circuits Within Circuits

A Discussion of Parasitic Oscillations in Neutralized Amplifiers

By George Grammer, Assistant Technical Editor

PARASITIC oscillations are treacherous things because, while their effects may be quite evident, it is in the ordinary course of events hard to put one's finger on them or even to do more than suspect that they exist. This story concerns the causes and cure of parasites peculiar to the neutralized amplifier — probably a more fertile field for parasitic oscillations than either the screen-grid amplifier or the ordinary oscillator, although they are likely enough to be present in the latter.

The important visible effects of parasitic oscillations in an r.f. power amplifier are deficient output and low efficiency in spite of adequate excitation and what appears to be perfect neutralization. Faced with this state of affairs, a little investigation of parasitic possibilities is called for — assuming that the sometimes-not-so-obvious things, like tuning a doubler to the wrong harmonic or having an L - C combination that won't hit the right frequency, have been eliminated from the picture. When a tube tries to deliver power simultaneously on two unrelated frequencies the result is that it does a poor job on both.

Parasitic oscillations as we have met them may be divided roughly into three groups: Those on comparatively low frequencies, that is, lower than the desired frequency; those on very high frequencies but not in the ultra-high region; and finally, ultra-high frequencies. Usually it is the last group that comes to mind whenever the word "parasitic" is mentioned, but the others are just as likely to occur and can do just as much damage to the output and efficiency of an amplifier.

One factor which usually operates to conceal the existence of parasitic oscillations — except for their effects — is the fact that most amplifier tubes are operated with a certain amount of fixed bias, usually enough to cut off plate current, and therefore oscillations cannot start when the excitation is removed. In those cases where the amplifier bias is provided by a grid leak it is not so good for the health of the tube to stop the excitation and leave the high voltage on the plate unless higher-than-usual μ tubes are being used. On the other hand, about the only way to find out if parasites exist is to hunt for them with the normal excitation cut off. Most of our information has been acquired on amplifiers using Type 46 tubes, since these tubes require no fixed bias and their plate current is low without

excitation — but still not too low to prevent parasites from getting a start.

LOW-FREQUENCY OSCILLATIONS

The circuit constants and arrangement of the ordinary amplifier are such that low-frequency parasitic oscillations are encountered less frequently than the other two classes. Nevertheless, they do occur now and then by some such combination of values as shown in Fig. 1. The upper drawing, Fig. 1A, is a conventional neutralized amplifier circuit, and as such would seem to be

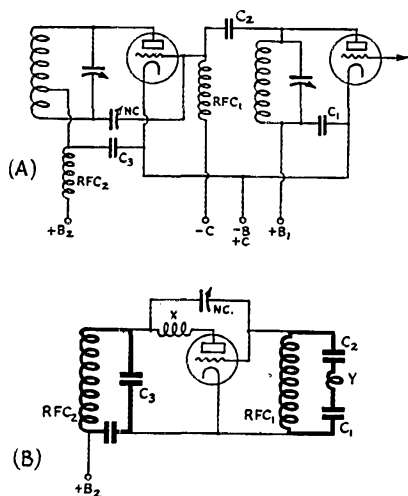

FIG. 1 — HOW LOW-FREQUENCY PARASITIC OSCILLATIONS CAN BE GENERATED IN A NEUTRALIZED AMPLIFIER

quite normal in all respects. But a little closer inspection shows that the thing can be turned into quite a different breed of circuit if conditions are right — or wrong, from the other viewpoint. Looking at the lower drawing, Fig. 1B, we find in the heavy lines all the elements of a tuned-plate tuned-grid oscillator formed by innocent-looking r.f. chokes and by-pass condensers. Suppose that RFC_1 and RFC_2 are identical in characteristics. Suppose again that by-pass condenser C_3 has about the same capacity as coupling condenser C_2 — something that happens quite frequently in ham transmitters when the desirable values are not always to hand — and further suppose that C_1 is large compared to C_2 . The capacity C_1 is the last filter condenser in the power supply.

Then the two circuits in heavy lines will both be tuned to the same frequency and the conditions for self-oscillation are fulfilled. For the parasitic frequency the regular tank coils are nothing but rather small inductances, and have practically no effect on the oscillation. Further, the neutralizing condenser, NC , helps the parasite along because at the low frequency it increases the grid-plate capacity of the tube; the neutralizing portion of the regular tank coil, represented at X in Fig. 1B, is nothing more than a long lead for the low frequency. And yet the amplifier may be perfectly neutralized at the operating frequency!

Furthermore, the choke and condenser specifications do not have to be fulfilled so rigorously as suggested above. The same type of oscillation could exist if C_3 were larger than C_2 and RFC_2 were smaller than RFC_1 — also quite possible, since we usually put the biggest chokes in the grid circuit and smaller ones in the plate where, with series feed, the choke can be skimped somewhat. Or a combination of chokes in both the

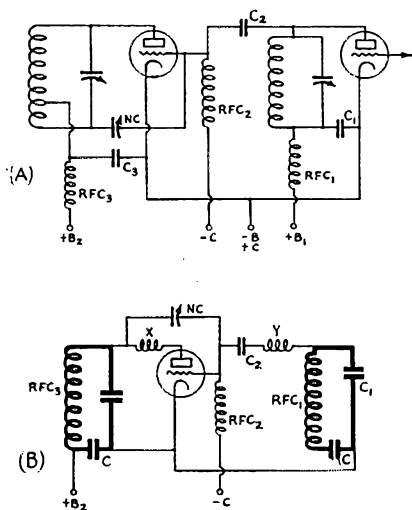

FIG. 2 — ANOTHER POSSIBLE LOW-FREQUENCY PARASITIC CIRCUIT

stage affected and the preceding and following stages can cause oscillations to be set up. Still another way is that shown in Fig. 2, in which there are three chokes. If the plate chokes are small compared to the grid choke, the latter will continue to work as a choke even when the others start to act like tank coils.

Once this type of parasite is identified — not hard to do because a neon bulb will show r.f. at the set side of the plate choke — it can be cured quite easily. Simply remove one of the offending chokes entirely — if the by-pass condensers are big enough a choke isn't needed anyhow in a series-feed circuit — or put in one with a different

value of inductance. The same thing can be accomplished by changing the size of one of the fixed condensers. We wouldn't be surprised to find that a lot of trouble that amateurs blame on "poor chokes" could be traced to something of this kind.

HIGH-FREQUENCY OSCILLATIONS

The second type of parasitic oscillation is a particularly mean one because it spoils a nice system of coupling into an amplifier tube having a low-impedance grid circuit. Although a persistent oscillator once it gets a chance to work, it can be killed off quite easily — even though a couple of cases of this kind did make us do quite a bit of head-scratching before the cause was discovered.

Fig. 3 shows how it comes about. At A we have the type of circuit in which the excitation is tapped down on the tank coil of the preceding stage to avoid overloading the exciter or to obtain maximum power transfer from a high-impedance output circuit to a low-impedance input circuit. This method of coupling is quite common when the amplifier tube has a high amplification factor, and especially when the exciter also is a high- μ tube. The heavy lines in Fig. 3B show the parasitic circuit. The turns on the exciting amplifier tank coil between the excitation tap and the cold end of the tank become the grid coil of a t.p.t.g. oscillator, while the neutralizing turns in the amplifier plate tank act like a plate coil. The amplifier tuning condenser becomes simply a bypass, while the whole circuit is tuned by the tube capacities and the neutralizing condenser. These circuits are rather low- C , and the parasite will persist over quite a range of taps on both coils. Once again the neutralizing condenser helps along the oscillation instead of suppressing it.

The easiest way to fix this one is to discard the tap on the exciter tank coil and connect the coupling condenser right on the plate end. Then the circuit will tune to only one frequency — the right one. To avoid overloading the exciter stage it is necessary to reduce the size of the coupling condenser, however. About the best that can be done is to make the coupling capacity such that the exciter tube draws normal plate current. This is not the most efficient method of coupling, but then neither do parasitic oscillations promote efficient operation. Another scheme might be to put the neutralizing winding on the exciter tank, retaining the variable excitation tap. This should work out satisfactorily if the actual neutralizing capacity in use is not too large; in the latter case the circuit is simply changed from the t.p.t.g. to the Hartley so far as the parasite is concerned.

It is interesting to note that oscillations of this kind will not exist if the stages are coupled through a transmission line such as those described in the Experimenters' Section in May *QST* and also in

this issue — unless one persists in tapping the coils for some reason or another.

THE ULTRA-HIGHS

Ultra-high-frequency oscillations usually are confined to the apparatus associated with a single tube or stage and result principally from faulty circuit layout — in most cases, leads too long. Take Fig. 4, for instance; the simple neutralized-amplifier circuit at A can be transformed quite readily into the ultraaudion if the leads from the tuning condenser, *C*, to the plate and grid of the tube (the grid lead going through the neutralizing condenser, of course) are several inches long. The tank tuning condenser is a bypass for the ultra-high frequency. Identification of this type of oscillation is not difficult. Simply take the tank coil out of the circuit and touch the plus B lead to the stator plates of the tuning condenser. The tube will keep right on oscillating if the diagnosis is correct — and will take plenty of plate current in doing it.

We must plead guilty to having little faith in the antidotes for this type of oscillation that for years have been accepted as cure-alls — meaning chokes of a few turns in the grid circuit or grid resistors of a few hundred ohms or so. Small chokes or grid resistors are useful for certain types of oscillation, but recently we had some experience with an amplifier afflicted with this sort of parasite in which they proved to be wholly useless. Chokes placed in either the plate or grid leads and consisting of everything from a few turns up to relatively large coils that were fair chokes at 14 megacycles did just one thing — they changed the frequency of the parasitic oscillation, but had practically no effect on its strength. Resistors of various sizes in the plate and grid leads simply got hot — one small resistor rated at a few watts burned out in a few minutes, and this with a single 46 tube with about 300 volts on the plate. The resistors, on the other hand, were very effective in reducing the output on the operating frequency, and one having enough resistance to eliminate the parasite also eliminated most of the output.

Without doubt the best thing to do when an ultra-high frequency oscillation of this type shows up is to use an entirely different physical layout, and particularly one in which the leads from the tube to the tank condenser are short. A grid choke that is good at the operating frequency and inefficient at ultra-high frequencies is a big help, because then the grid is grounded effectively at the parasitic frequency and oscillations don't get a chance to start. The small sectional honey-comb-type chokes seem to be too good all along the line to be depended upon for incidental — or accidental — parasitic suppression, however.

The amplifier for the low-power crystal transmitter recently described in *QST*¹ had a bad

¹"An Amplifier for the Beginners' Crystal Transmitters." *QST*, February, 1932.

case of ultra-high frequency parasitic oscillations of this type, the vertical arrangement of the amplifier being responsible. It was necessary to mount the tank condenser above the tops of the tubes to follow the original layout scheme, and this in turn meant that the critical leads each had to be about eight inches long, forming a fairly

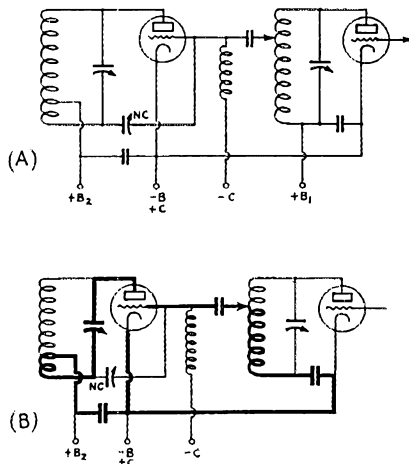

FIG. 3 — A HIGH-FREQUENCY PARASITIC CIRCUIT RESULTING FROM THE USE OF A TAPPED EXCITATION COIL

large loop with the tuning condenser in the middle. The amplifier, which uses two tubes connected in parallel, went into oscillation with a will, even though neutralized, and investigation showed that the wavelength was approximately five meters. Removing one tube made no difference at all, while so-called parasitic chokes and resistors gave the results detailed above. The thing that finally stopped it was somewhat unorthodox but effective. Referring to Fig. 5A, it will be noted that a small coil, marked *X*, is connected between the grids of the two tubes, with the neutralizing condenser connection being taken off only one of the grids directly. The coil *X* is not a choke, although physically it looks like a parasitic choke; actually it loads the parasitic circuit of one tube so that tube tends to oscillate on a slightly different frequency from the other. As a result neither of them can do anything and the parasite disappears. The coil should be just big enough to prevent parasitic oscillation; if it gets too big it will act as a choke and the other tube will oscillate by itself — and there is also the danger, if the coil is too large, that it will upset the neutralization of one tube and cause the excitation to be unevenly divided. Practically, a coil which is effective in preventing parasitic oscillations from starting has no noticeable effect on either neutralization or excitation at the frequencies on which the amplifier is to work. The interesting point about the whole

thing, however, is that if a single tube had been used in the amplifier it is doubtful if the parasitic oscillation could have been eliminated without a change in layout. The use of two tubes in parallel made a practical, if somewhat primitive, solution possible.

Speaking of operating tubes in parallel reminds

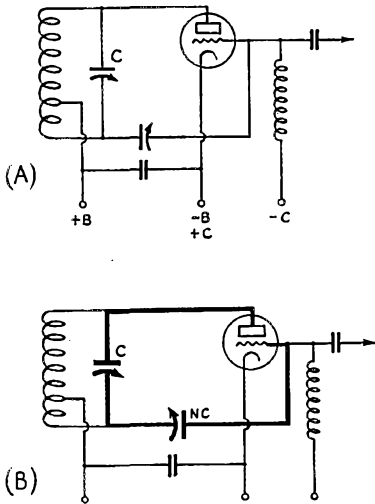

FIG. 4 — ULTRA-HIGH-FREQUENCY OSCILLATIONS CAN BE GENERATED IF THE LEADS FROM THE AMPLIFIER TUBE TO THE TANK CONDENSER ARE TOO LONG

us that so far we have neglected the one classic case of parasitic oscillation that springs to the mind of the ham of some years experience (before the push-pull vogue pushed parallel operation into the background) whenever the subject is brought up — oscillations “between the tubes.” When the plates and grids are connected together and common leads are brought out from the centers of the connecting wires, as in Fig. 5B, the result is supposed to be a push-pull circuit which invariably oscillates vigorously at about a meter or so. The possibility of oscillations of this sort occurring with two small tubes of the based variety set one alongside the other is very remote indeed. The only tubes we’ve ever seen that would oscillate in this fashion were a pair of CG1162’s — and at that the leads had to be appreciably longer than necessary for ordinary paralleling. Even if this sort of oscillation does exist, it can be stopped very easily by unbalancing the circuit; in other words, taking either the plate or grid lead directly from one tube socket instead of at the center of the connecting wire. With larger tubes not having all the connections brought out to one base, such as 852’s and 204-A’s, the longer length of lead required may be sufficient to permit the two tubes to oscillate. In such a case a small center-tapped choke in

either the plate or grid connection or even a simple unbalanced connection should cure it.

PUSH-PULL AMPLIFIERS

In looking over the circuits presented here it should of course be obvious that they apply equally well to tubes in parallel as to a single tube. It is perhaps not so obvious that they also be re-drawn for push-pull amplifiers, but it is nevertheless true. Push-pull circuits equivalent to those of Figs. 1 and 2 would show just the same sort of operation, since the tubes are in parallel for the parasitic frequency. A push-pull amplifier is, in fact, even more likely to oscillate in this fashion when the chokes and by-pass condensers form two resonant circuits than is a single tube, because the feed-back capacity is greater. Oscillations of the type shown in Fig. 3 are not likely to occur in push-pull amplifiers, however, if the input and output circuits are symmetrical, nor are oscillations like those of Fig. 4 provided the connecting leads in the grid and plate circuits, as well as the neutralizing condenser connections, also are symmetrical. But symmetry is important; an unbalance which might have no measurable effect at the operating frequency may be sufficient to let an ultra-high-frequency oscillation start. In other words, the cross-neutralization of the tubes must be equally effective at the ultra-high frequencies as at the operating frequency.

SOME HINTS AND DON'TS

We remarked at the outset that if an amplifier which seems to be neutralized properly and

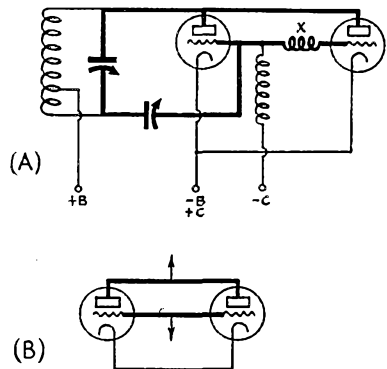

FIG. 5 — ONE WAY OF ELIMINATING ULTRA-HIGH-FREQUENCY PARASITIC OSCILLATIONS WHEN TWO TUBES ARE USED IN PARALLEL IS SHOWN AT A

B shows how the connecting wires between two tubes in parallel can form a push-pull parasitic circuit. Oscillations of this type are uncommon with small tubes.

excited adequately fails to live up to expectations, something should be done to find out whether or not parasites are getting in their fine work. To hunt for them, put plate voltage — not neces-

sarily full voltage — on the amplifier and use a bias value which should give a reasonable amount of plate current. If the plate current seems higher than it should be, or if it changes when different parts of the circuit are touched with a finger, oscillations of some sort are being generated. A neon lamp will be useful. If no indications of oscillation are present, look somewhere else for the cause of the inefficiency, but if oscillations *do* exist the next step is to measure the frequency. An absorption wavemeter which will cover the range between 5 and 500 meters is exceedingly valuable and not at all difficult to make from a few odd coils and an old variable condenser. The exact frequency is unimportant; what we want to find out is whether it is ultra-high, high, or low. Once that is determined the circuit should be gone over with an eye to digging out possible combinations that could result in an oscillation of that frequency. Of course other varieties of parasitic circuits than the ones just discussed can exist, and probably do; the possibilities are not by any means exhausted. But half the battle is in locating the bug; afterwards some sort of corrective scheme always can be worked out.

Having encountered all the things outlined above in building neutralized amplifiers, we've prepared a list of don'ts which we are going to follow the next time we put one together. Here they are:

Don't use r.f. chokes in places where they are not needed. If it's a series-feed circuit there should be no r.f. at the "ground" end of the tank and a good-sized non-inductive by-pass condenser will tie it down to the filament very solidly. So why have a choke?

Don't use the same size of by-pass condenser in conjunction with chokes of identical characteristics associated with the plate and grid circuits of a single stage. Possibly other apparatus will detune one circuit sufficiently to prevent oscillation, but there is no need to borrow trouble. This applies particularly to those circuits which have series feed on both grid and plate sides.

Don't tap down on the exciter tank coil to feed the amplifier grid. Use a small coupling condenser and put it right on the plate end of the coil.

Don't have long leads from the amplifier tube to the tank condenser.

When we get this "don'ted" amplifier finished we'll be disappointed if some new variety of bug doesn't show us its teeth. That's what makes neutralized amplifiers interesting.

Strays

W8BMF finds that antenna insulators make good winding forms for r.f. chokes. A choke suitable for the 3500- and 7000-kc. bands can be made by winding 45 turns of No. 24 in each groove of an insulator having four grooves.

International Field Day— June 10th—11th

CLUBS, 56-mc. operators, *all hams* with licenses for portable stations, attention!! Starting Saturday at 4 p.m. local time (June 10th) and ending Sunday at 7 p.m. local time (June 11th), all U. S. A. and Canadian station owners are invited to schedule "field activities," excursions with concentrated operation of *portable* transmitters and receivers. Only portable stations, actually in the field, away from the "home" address are eligible to submit field day scores.

The object will be for each "portable" station to work as many other amateur stations as possible — each to count one point toward a score. *Any or all amateur frequency bands may be used*, voice or c.w. telegraph likewise. The "total" of such points may be multiplied by the number of A.R.R.L. Sections worked. Contact with another *portable* station at any point except its base, or home address, will "rate" double credit, or two (instead of one) points. Two-way work with a foreign station shall entitle the operator of the "portable" to triple credit, or three (instead of one) points, in addition to which each foreign country (prefix) may be added to the number of Sections to increase the "multiplier." The R.S.G.B., N.V.I.R. and R.B. are sponsors of similar national field days in Europe, and we hope this may assume an international complexion. All amateurs with licensed *portable* stations are invited to take part . . . each such station will please report its *power* and *frequency* band used, and its *log* of operation and *score* for the period given, within the week following the Field Day. Also, gang, don't forget to comply with F.R.C. regulations for portable station operation. Notify your Radio Supervisor of the approximate location and time of intended operation of the "portable" by postal or letter, just in advance of the "field" radio work. We shall be interested to know how many clubs plan outings, and also suggestions for a similar activity for 1934 (if you want one) will be welcomed.

Besides offering an opportunity to get out in the open in this fine spring weather, the real object of this contest is to test "portables" wherever they may be available. If successful we want to make it an annual affair.

— F. E. H.

Transmitter Power Supply from Low-Voltage D.C.

By Lyle L. Farver, W8EZQ*

THE power supply being used at W8EZQ probably will be of interest to those amateurs who are handicapped by having nothing but low-voltage d.c. for power supply. It operates directly from the 32-volt Delco lighting circuit here but the same idea may be used on any d.c. supply from a single 6-volt storage battery to the 220-d.c. used in some village lighting circuits.

The rig here consists of a special home-made spark coil having two filament windings, one for the Type 80 rectifier and one for the 10 oscillator, in addition to the high-voltage winding and primary. The circuit, with the exception of the primary, is identical with the well-known a.c. rig using a half-wave rectifier and brute-force filtered system. Fullwave rectification is of course more desirable, but unfortunately the wire on hand for the h.v. secondary was not sufficient to give enough voltage each side of the center-tap. The result was the half-wave system using the two sections of secondary in series. The complete circuit of the power supply is shown in Fig. 1.

The core of the spark coil used now is made up of laminated iron and measures $1\frac{1}{2}$ by $1\frac{1}{4}$ inches in cross section. The first coil tried used a soft iron wire bundle one inch in diameter. The length in both cases was 7 inches. There seems to be no advantage to the larger core; it was tried in an effort to reduce the number of turns per volt, but it was found that 10 turns per volt was the best that could be done. This gave 320 turns of No. 20 enameled wire on the primary for 32-volt operation. A smaller number of turns caused prohibitive sparking at the buzzer points. The 5-volt winding for the 80 rectifier contains 60 turns of No. 20 enameled wire; a few extra turns were added here for good measure but the voltage was not excessive. The winding for the filament of the 10 oscillator contained 90 turns of the same wire; the extra turns here made the use of a filament rheostat necessary.

The high-voltage secondary contains 2.8 lbs. of No. 28 s.c.c. wire, wound in two sections of 3450 turns each. These sections are wound in even layers with a piece of typewriter paper between each layer. Thinner paper was not used because of the trouble with the end turns of each layer.

The interrupter is the regular Ford buzzer

*Unionville, Mich.

assembly, with a toothpick under the brass reed on the stationary contact and an extra spring-steel vibrator under the regular Ford vibrator to add stiffness and increase the frequency.

The whole power supply is assembled in a wood box 10 by 10 by 6 inches. A four-wire cable about 9 feet long, carrying the 10 filament supply and the high-voltage leads, runs from the power supply to the oscillator. This power unit is then placed in the next room as far away from the operating position as possible. In this way the noise of the buzzer is scarcely audible, which is greatly appreciated by the rest of the family.

The oscillator unit is a vertical breadboard layout using the single-control transmitter circuit. The rig has been on the air every day since early February, and the log shows 40 contacts during 15 days, all on the 80-meter c.w. band. The QRI reports are two near d.c., 6 crystal p.d.c. and all the rest p.d.c. Signal strength

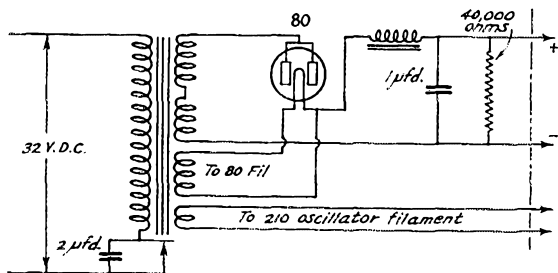

FIG. 1

varied from R6 to R8 with the average about R7. These contacts were all with 8th and 9th district stations within a radius of about 300 miles. The plate current with antenna on is 55 mls, and with antenna off about 38 mls. The actual voltage is not known but it put the pointer off the scale on a 300-v. meter early in the experiment.

In a problem of this kind there are always detail difficulties, and I would be glad to hear about them from anyone building a similar rig. The most unsatisfactory part of the thing is the buzzer. Possibly a circuit breaker such as is used on automobiles, operated by a small motor, would do the trick. A closed-core transformer could then be used with a possible improvement in the voltage regulation and the number of turns required per volt.

(Continued on page 72)

The Development of a Transmitting Antenna

Introducing a Loaded System for Small Space

By Edwin R. Sanders, W1EDY*

IN SPITE of the numerous articles on transmitting antenna systems which have appeared in *QST*, there still seems to be considerable misunderstanding of amateur antenna operation. I propose, therefore, to cover a

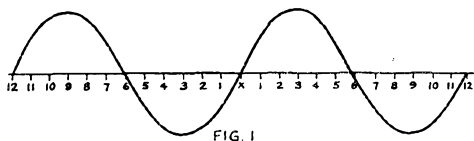

FIG. 1

bit of underlying theory, as painlessly as possible, then consider methods of adjustment and finish with a description of the novel arrangement at W1NI.

Let us first review antenna behavior and the formation of standing waves on wires. Suppose we have a long wire, one end of which is open and the other is tied to some point of relatively high potential in an oscillator. The variation of voltage at the oscillator end will start a wave, consisting of both voltage and current, in phase, moving down the wire. This is a traveling wave and, were the wire infinitely long, it would keep going indefinitely. Since the wire has an open end, the current must become zero at the end. The energy of the wave being evenly divided between the current and the voltage, the voltage must rise at

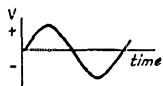

FIG. 2

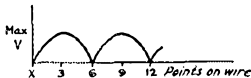

FIG. 3

the end to double its value in the wave. This high voltage starts an identical reflected wave back over the wire, except that its current is reversed in phase. A reflection is also produced when a wave reaches a grounded end of the wire, the voltage going to zero and the current to double its former value. Here there is a voltage phase reversal.

A model may be simply made to represent the formation of standing waves from these two traveling waves moving in opposite directions with the same velocity. Trace two copies of Fig. 1 on cellophane (it will take ink all right). Now make a copy of the scale of this drawing on a single line to represent the wire. These cellophane waves represent the two waves moving in opposite directions and each should be marked with an arrow indicating its direction. Start with the

points "X" on top of each other and slide the cellophane waves in their respective directions, keeping each cellophane "X" the same distance from the "X" on your wire. The voltage, if the wave represents voltage, at the "X" on the wire will be the sum of voltages in the two waves at each instant as they move by. At "X" the voltage will always be equal to zero as the two waves always cancel out. If we plot the curve of the instantaneous voltage at point 1 on the wire against time we find it to be of the form of Fig. 2. The points for this curve are obtained by sliding the waves along the wire, keeping the "X" points equidistant from "X" on the wire, and watching the sum of the voltages at point 1. Likewise we can treat points 2, 3, etc. If we plot the maximum amplitudes of voltage at each of these points we get the curve of Fig. 3. So we have the standing waves of voltage on our line.

Since the current in the *reflected* wave is reversed in phase, its cellophane curve is below the line whereas the voltage curve was above. The forward wave, of course, is the same as the voltage. It will be found to give standing waves similar to the voltage except that its maxima coincide with voltage minima, and vice-versa.

Thus we have a possible resonator whenever we have a piece of wire a half-wavelength long with both ends similarly terminated (that is, both grounded or both open), or a quarter wave long

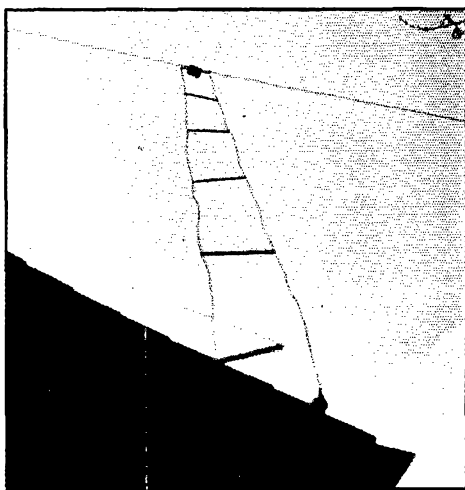

A WORM'S-EYE VIEW OF W1NI'S FEEDERS

* Engineer, WTIC, 29 Curtiss St., Hartford, Conn.

with ends differently terminated. Any combination of these in series also will resonate. A few of these resonators are indicated in Fig. 4. It makes no difference whether a half-wave of wire is

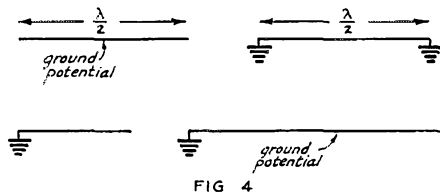

stretched out straight as an antenna or doubled to make a pair of feeders; its standing waves will be just the same. But when doubled to make a pair of feeders there is very little radiation. Hence there is very little radiation resistance, the total resistance of the system is low and the current induced into it by a given oscillator will be high. This high current is merely a circulating current, however, and does not represent high power radiated.

In considering a transmission line, let us start with a very short line with its receiving end open and wire of zero resistance, and slowly increase the length. Looking into the sending end, it will look first like a small capacity which increases to infinite capacity when the line becomes a quarter-wave long. To make the line resonant when between zero and a quarter wave long it is necessary to introduce an inductance such that, with the capacity, it will resonate at the desired frequency. (Methods of coupling lines to transmitters will be discussed later on.) This will give a voltage loop at the receiving end of the line as in Fig. 5. It will be observed that when the capacity which represents the line is very small or very large it may be hard to make an inductance to resonate with it. This accounts for a good many amateur lines which apparently will not resonate.

The capacity which represents the line must not be confused with the actual physical capacity between the two wires. There is no relation between the two, as is obvious from the fact that the capacity of these two wires could never reach infinity or zero, as we shall see before we are through.

When the length of our line passes the quarter-wave point it goes through an immediate and sudden change, becoming like an inductance of zero size instead of infinite capacity. These are really alike, because both infinite capacity and zero inductance represent a short circuit. As the line increases in length the inductance which represents the line increases, reaching infinity when the line becomes one-half wave long. When

between a quarter- and one-half wave in length the line may be resonated by using a capacity of the proper value to fit the inductance which represents the line at a given frequency. (Fig. 6.)

When the line passes the half-wave point it suddenly changes from appearing like an infinite inductance to a zero capacity. Again infinite inductance and zero capacity are the same (both equal to an open circuit). Looking into the line as it increases up to three-quarter wave long we see a variation identical with that between zero length and a quarter wave. So the line continues repeating itself after each half wavelength.

This line is unloaded, of course, so properly we should consider some load resistance connected across the receiving end of the line. Suppose this resistance to be larger than the characteristic impedance. Now, upon looking into the line, where we saw pure inductance or capacity we now see both inductance and resistance, or both capacity and resistance. Also, the standing waves

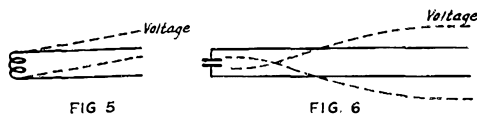

on the line are not as bad as before. That is, the voltage at the voltage loop will not be as high nor the voltage at the voltage node as low as formerly. If the line is loaded with resistance equal to its characteristic impedance the voltage and current variations along the line are ironed out so the voltage and current are both constant throughout the line, regardless of where we measure them. When looking into the line we see only pure resistance, the capacity and inductance having disappeared. If the line is loaded with a resistance less than the characteristic impedance the standing waves reappear and where we saw resistance

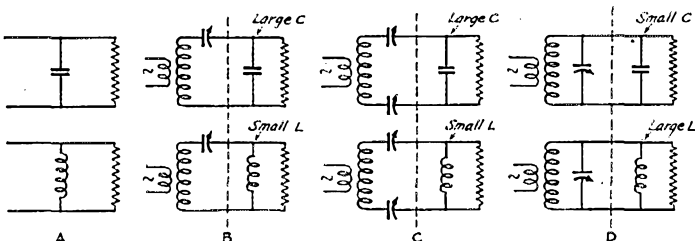

and capacity before we now see resistance and negative capacity, or inductance. Likewise where we saw resistance and inductance we now see resistance and capacity.

Suppose we have a long line and we come back from the receiving end some short distance and look into the line toward the receiving end. We see some impedance made up of resistance and either inductive or capacitive reactance. We can now cut off this short section, terminate the line

with the impedance which represents the line which we cut off, and the rest of the line, from the sending end to this point of bisection, will operate just as it did to start with. This impedance which we used to terminate the line represents the impedance of our antenna and this is the condition under which most lines are operated. We would like this impedance to be pure resistance and equal to the characteristic impedance of the line. If it was we would get no standing waves on the line, therefore no radiation from the line (which radiation ordinarily represents largely loss) and a minimum of loss in the resistance of the wire of the line itself.

Usually we do not know with what impedance our line is terminated so we cannot predict the positions of our standing waves; but we can always get a maximum of output from our line by making it resonant. That is, we must compensate for the reactive component of the impedance which we see when looking into the sending end of our feeder system with the antenna in place at the receiving end.

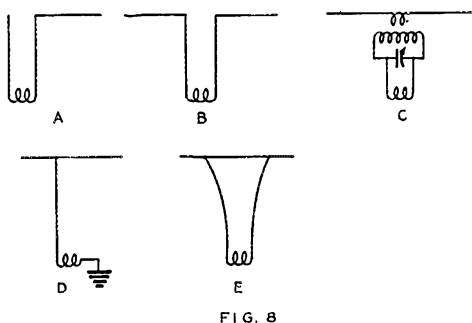

FIG. 8

When we come to tuning, we find upon looking into the line that it may be represented by either an inductance or capacity with a parallel resistance which represents the load on the transmitter. (Fig. 7A.) When the reactance component which represents the line is small (small inductance or large capacity), the line is best tuned with a series condenser as in Fig. 7B or 7C. If the line reactance is large (large inductance or small capacity) it is best tuned with a parallel condenser, Fig. 7D. If it is inconvenient to shift the feeder tuning device to tune feeders whose length requires the opposite arrangement, each feeder may be loaded with a coil which amounts to a quarter wave of feeder. Probably to wind one-eighth wavelength of wire in each coil will be satisfactory. If a set of feeders will not tune without the coils it will with them, and vice-versa.

There are a number of methods of feeding antenna through transmission lines, a few of which are shown in Fig. 8. The voltage and current feed systems of 8A and 8B both have stand-

ing waves of large amplitude. The circuit of 8C will give very good results but is complicated to adjust and requires a good deal of suspended equipment. Circuit 8D is very good, but if it is out of adjustment much greater radiation occurs from the feeder than with a two-wire feeder. The arrangement of figure 8E is simple and works well. Like 8C and 8D it must be designed for and operated at a single frequency. With these, considerable advantage may be obtained by tuning the feeders when the frequency differs or the

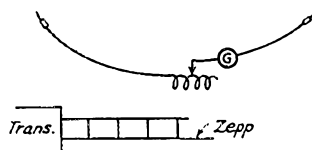

FIG 9

design is in error. The design, of course, should consider the effects of conductors and dielectrics in the antenna field but seldom does.

LOADING THE ANTENNA

In case the space available is insufficient for the type of antenna we desire to erect, we can always introduce loading coils to any of the types shown. The antenna system of 8E is simple, lends itself to easy adjustment, can be readily loaded with inductance and for most adjustments will have standing waves of small amplitude on its feeders. When the frequency of such an antenna does not coincide with the transmitter it will load the line with an impedance which has considerable reactance as well as resistance. As ordinarily installed without tuned feeders, therefore, little energy reaches the antenna compared to the tuned feeder condition.

Mr. Jackson of W1NI was confronted with the problem of putting up a half-wave 80-meter antenna (ordinarily 132 feet long) in a 92-foot space. We decided to put a horizontal wire loaded with an inductance at the center to bring its natural resonant frequency down to that of the crystal-controlled transmitter. This worked out to give 45 feet of wire each side of the coil, which was 18 turns, 3 inches in diameter, of No. 12 wire spaced $\frac{1}{8}$ " between turns, heavily doped with paraffin. The coil size was determined by lowering the antenna and inserting a coil and current indicating device—an r.f. thermogalvanometer was used—as shown in Fig. 9. The feeders were stretched out near the ground and about 6 feet of wire tied to one side to behave something like a very short Zepp and give us enough field in the yard to read on the current indicator. It is advisable to reduce the transmitter power when operating the feeders thus—we burned up an r.f. choke by neglecting to do so. Also, the transmitter frequency should be that

which it is desired to use on the finished antenna. The driving antenna connected to the feeders must be kept small compared to the antenna being adjusted or the antenna's resonant frequency will be changed by the mutual inductance.

The coil turns were adjusted for maximum current in the antenna. Then the dead end turns were removed and the coil doped heavily with

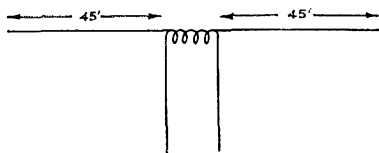

FIG. 10

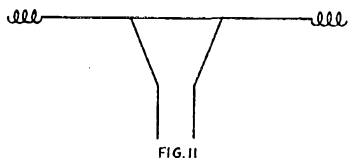

FIG. 11

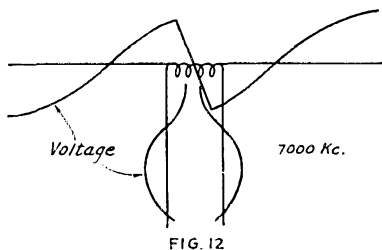

FIG. 12

paraffin. A good rule of thumb seems to be to wind into the coil half the length of wire that was removed from the middle of the antenna. This antenna has the advantage that the feed lines do not have to spread into a "Y" to meet the antenna, thus eliminating some reflection at this point. This method of tuning the antenna to the transmitter frequency is good practice. After removing the current indicator, the feeders were fastened to each side of the coil, the antenna pulled up and the feeders tuned for maximum feeder current at the sending end. (Fig. 10.)

The antenna has given exceptional results. Using a pair of 210's with an input of 140 watts, the West Coast is frequently worked on 3500 kc. and the signal is frequently reported as the loudest from the East.

Another suggestion to put an 80-meter antenna into this space was that a coil be put at each end of the antenna to load it as in Fig. 11, which would probably work about the same as the center loading method. This provides a radiating section of wire with high current, while the center loading method provides a radiating section with high voltage. Since the radiated wave is both electric and magnetic it probably makes little difference

which is used except that the center loading method is easier to couple.

The antenna was fed on 7000 kc. with results which were better than most 40-meter antennas used previously. The standing waves on the antenna and feeders then appear something like Fig. 12. It should operate in a similar manner on 14-mc. At 40 and 20 meters the standing waves on the feeders are worse than at 80 meters, though they are not as bad as the antennas of 8A and 8B. This makes the antenna very flexible as to frequency adjustment. Of course, when the frequency band is changed the feeder tuning will require readjustment, possibly with the aid of loading coils in each feeder wire.

Central Division World's Fair Convention

Chicago, Ill., August 3rd, 4th and 5th

Under the auspices of the World's Fair Radio Amateur Council, and sponsored by the affiliated Radio Clubs of Chicago. All the wide world invited. Full details in the July issue.

Central Division (Wisconsin) Convention

Wausau, Wis., Hotel Wausau, June 10th and 11th

A good time for all — COME ALL. Write Bob Johnson, Secretary, Northern Wisconsin Radio Club, 1239 South River St., Eau Claire, Wis.

Silent Keys

It is with deep regret that we record the passing of these amateurs:

Milton E. Adams, W9AQT-KBN, Minneapolis, Minn.

George Bolin, W9GPX, Omaha, Neb.

Harold P. Covington, W3BTE-CV, Baltimore, Md.

Harold L. Ellsworth, W8ECA, Fulton, N. Y.

DeWitt C. Palmer, W3AEN, Philadelphia, Pa.

Richard A. Spanagel, W6EUT, Tucson, Ariz.

The Dial-Coded Universal Tube Checker and Circuit Analyzer

By Clinton B. De Soto*

THERE are nearly one hundred standard types of receiving and low-power transmitting tubes now being manufactured, exclusive of the numerous special types of single manufacturers. Each has some essential structural or electrical difference from all the others. There are no groups larger than six having the same element arrangement, and these operate at different potentials and have different characteristics. The advent of new bases and terminal arrangements in recent months has rendered obsolete almost all of the standard tube testers of past days. It seems likely that any device designed to accommodate existing types of tubes will be equally obsolete a year from now, for the new types are still coming in an unmitigated stream. The need for a universal device which will enable the testing of any combination of elements, pins and associated voltages and currents — limited only, of course, by the total available number of pins and caps — is apparent.

The layout to be described approximates this ideal, in that it will accommodate any combination of elements in tubes having up to eight terminals in seven pins and a cap. It is unlikely that the tube manufacturers, prolific as they may be, will exceed this combination for some time to come. If they do, adapters will undoubtedly be available to extend the range of the checker.

In addition to this universal tube checker, there is incorporated in the device a circuit analyzer which provides a flexible medium for measuring voltages and currents, as well as static characteristics, in any vacuum-tube circuit. The analyzer is, in its own way, fully as flexible as the tube checker, for with the use of suitable meters there are few conditions to which it is not applicable.

THE BASIC IDEA

At present, there are a maximum of eight available terminals on a vacuum tube — seven pins and a cap. Of these, four terminals are always connected to the same elements.¹ Pins No. 3 and 4 are always filament or heater terminals, the cap always goes to a control grid (with one unimportant exception), and pin 2 is always a plate.

* WICBD, Assistant to the Secretary, A.R.R.L.

¹ Special sockets which will take both the standard 7-pin and the new small 7-pin tubes are available; if one of these is not used, an adapter will have to be secured when provision is made for checking the most recent tube types.

This leaves four pins which may be, and are, connected to any one of the following kinds of elements: cathodes, Nos. 1, 2 or 3 grids, diode "patches," or plates.

To simulate the actual operation of a vacuum tube a universal tube checker, therefore, must be fitted to handle any one of these elements on any of the four terminals. Each element requires

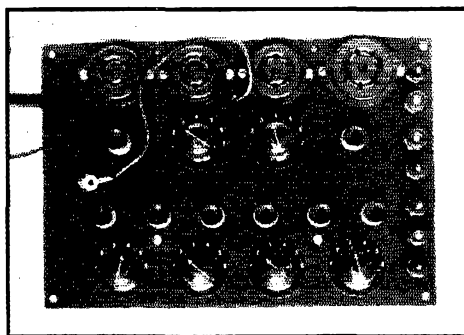

FRONT VIEW MINUS BOX HOUSING

a definite and usually a different potential to be applied to it. The problem, then, is to provide such potentials and to be able to connect any one potential to any one pin. This has been accomplished by means of four rotary switches, one in each pin circuit.

As a result, the actual operation is a simple procedure, if use is made of the table accompanying this article. The telephone-number effect which represents each different tube refers to the mechanical arrangement as well as electrical potentials. A representative tube, the 59, has the following number: 3-6332. The first numeral, 3, indicates the setting for the upper left hand rotary switch dial (see illustration and circuit diagram), which regulates filament potential. The numbers on the dial plate indicate filament voltages, as follows: 1, off; 2, 2 volts; 3, 2.5 volts; 4, 5 volts; 5, 6.3 volts; 6, 7.5 volts; 7, 30 volts.

The next four numbers apply to the row of rotary switches which control the connections of the four tube pins which have no fixed connections, Nos. 1, 5, 6 and 7. Each rotary switch has six positions, each supplying a different voltage, as follows: 1, off; 2, negative grid, normally -10 volts (control, or No. 1 grids); 3, zero (cathodes, suppressor or No. 3 grids); 4, +10 volts (diode patches, rectifier plates); 5, +65 volts (screen or

No. 2 grids); 6, +100 volts (accelerator or No. 2 grids, plates). In the 59, pin 1 is connected to the No. 2 grid or accelerator, and the switch is therefore set at position 6. Pin 5 goes to the cathode (normal in all cathode tubes), which means position 3 on the second switch. Pin 6 is the suppressor, or No. 3, grid, also position 3 on the third switch; while pin 7 is the control or No.

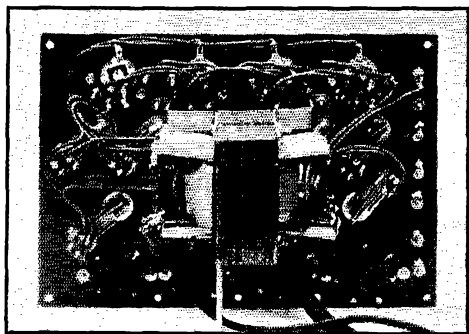

BEHIND THE PANEL IS SEEN AN ARRAY OF WIRING AND JACKS

1 grid, biased negative on position 2 in the fourth switch.

The actual tube check is based on the familiar grid shift. This test is most useful in that to a certain extent it combines all others—"gm," emission, gas, etc. If the plate current is low and the grid shift not normal the tube can be assumed to be low on emission; if the plate current is high it is either gassy or has some structural defect. In any event, a tube showing readings appreciably different from the standard is defective; we are not diagnosticians interested in determining just exactly what is wrong.

The test is made by simply noting the plate current on a milliammeter connected to the binding posts on the checker, after the tube under test has been inserted and allowed to warm up, and comparing with the value indicated on the left of the diagonal, in the table. The grid shift push button is then depressed, and the resulting change also compared with the standard. The result will indicate the worth of the tube in percentage. Variations of 10% are allowable in tubes having very nearly the same performance; more than 25% indicates a faulty tube.²

A feature which has been added since the photographs were made is the rectifier plate switch, which changes the plate potential from 100 to 10 volts so that excessive current will not

be drawn. An "off" position is also provided, for use with the new dual Class B tubes, or when diodes having plates on other pins are being checked.

AS A CIRCUIT ANALYZER

When used as a circuit analyzer, all dials are first set at zero and the locking push button depressed, the proper meters being connected to the binding posts. No meters were included in the unit because most of us have too few meters to devote any number of them to one special purpose, and in this case it is relatively easy to connect to any kind of transmitting or portable meters that may be available. A 0-10 milliammeter will be satisfactory for analyzing r.f. and detector circuits, although an 0-50 or 0-100 ma. range will be necessary for power stages, and even higher for rectifier circuits. The filament voltmeter should have a range covering the filament voltage in the circuit under test, a 7.5-volt meter usually being satisfactory. The a.c.-d.c. voltmeter can have a full scale reading of 300 volts (1000 ohms per volt) for most work; but here, as well, almost any available meter can be used. It can be connected in either of two ways. If the outside binding posts are used, a connecting wire should be run from the lower post to the set chassis, or ground. This connection gives a direct voltage reading to ground. The alternate connection, using the upper and inside posts, provides a cathode return connection and is useful for many

| Tube Type | Dial Setting | Shift |
|-----------|--------------|---------|
| '01A | 4-2000 | .5/2.5 |
| '10 | 6-2000 | .5/1.5 |
| '12A | 4-2000 | 1/3.5 |
| 24A | 3-5300 | 1/3 |
| '27 | 3-2300 | 1.5/5 |
| '30 | 2-2000 | .5/2.5 |
| '31 | 2-2000 | .5/2.5 |
| '32 | 2-4000 | 3/1.5 |
| '33 | 2-2300 | 1/4 |
| '34 | 2-4000 | 3/1.5 |
| '35 | 3-5300 | .5/4 |
| '36 | 3-5300 | 1/4.5 |
| '37 | 5-2300 | 1.5/3.5 |
| '38 | 5-5300 | 1.5/2 |
| '39 | 5-6300 | 2/4 |
| 41 | 5-5320 | 2/5 |
| 42 | 5-3320 | 2.5/6 |
| 44 | 5-6300 | 2/3.5 |
| 45 | 3-2000 | 1/2.5 |
| 46 | 3-2300 | 1/4 |
| 47 | 3-2300 | 1.5/5 |
| 49 | 2-2300 | 1/3 |
| 50 | 6-2000 | .5/1.5 |
| 55 | 3-0300 | 2/5 |
| 56 | 3-2300 | 4/10 |
| 57 | 3-6330 | 1.5/7 |
| 58 | 3-6330 | 2.5/6 |
| 59 | 3-3332 | 2.5/5.5 |
| 71A | 4-2000 | .5/2 |
| 75 | 5-0300 | 3/8 |
| 77 | 5-6330 | .7/4.5 |
| 78 | 5-6330 | 2/5 |
| 79 | 5-0330 | 3.5/8.5 |
| 85 | 5-0300 | / |
| 89 | 5-3330 | 2.5/6 |

² Production tolerances in tube manufacture and variations in individual transformers may result in appreciable variations in actual plate current from the values shown, with different tubes. This is not important; the degree of actual shift is the qualifying factor which determines the worth of a tube.

forms of analysis. If the tube has a cathode, it will be necessary to set the pin 5 rotary switch (second from the left in the row of four) to position 3 to obtain this reading.

Proceeding with the actual analysis, the tube is removed from the socket in the circuit to be analyzed, and the analyzer plug, with the proper adapter attached, inserted. The tube is placed in the proper socket on the analyzer. Grid caps, if any, are attached.

Filament or heater voltage of the circuit under test will be read automatically when the plug is inserted. Rotating the upper right hand rotary switch will give voltage readings on all tube elements except heater; these should be checked with requirements. The voltage readings as indicated by numbers on the dial plate are, in order: 1, off; 2, grid cap; 3, pin 1 (No. 1, 2 or 3 grid, diode, plate); 4, pin 5 (cathode, No. 2 grid); 5, pin 6 (No. 2 grid, diode, plate); 6, pin 7 (No. 1 grid, etc.); 7, pin 2 (plate).

Current readings in any of the circuits are taken by depressing the proper push button of the row of six, which correspond in order to the six used positions on the voltage selector switch. To read current and voltage simultaneously, it is necessary merely to set the selector switch and press the corresponding push button (the order being from left to right, of course).

"COLD" CIRCUIT ANALYSIS

Such is the procedure for operating circuit analysis. Frequently, however, a static analysis is also desirable, with no power applied to the receiver. The use of this analyzer facilitates the making of such a test. It is merely necessary to use an ohmmeter in place of the voltmeter to determine the sum total of the resistances in a circuit, or a capacity meter to check the capacitance values. By substituting either for the milliammeter, and depressing pairs of push buttons, inter-circuit resistances and capacities can be checked readily.

Atlantic Division Convention

Hotel Lafayette, Buffalo, N. Y., June 23rd and 24th

The Radio Association of Western New York cordially invites all amateurs to attend this affair—the biggest of all. R.O.W.H. initiation — wonderful program and all for \$3.00. Ladies' ticket for Banquet, \$1.50.

Further information from T. W. Connette, Chairman, 115 Main St., Lockport, N. Y.

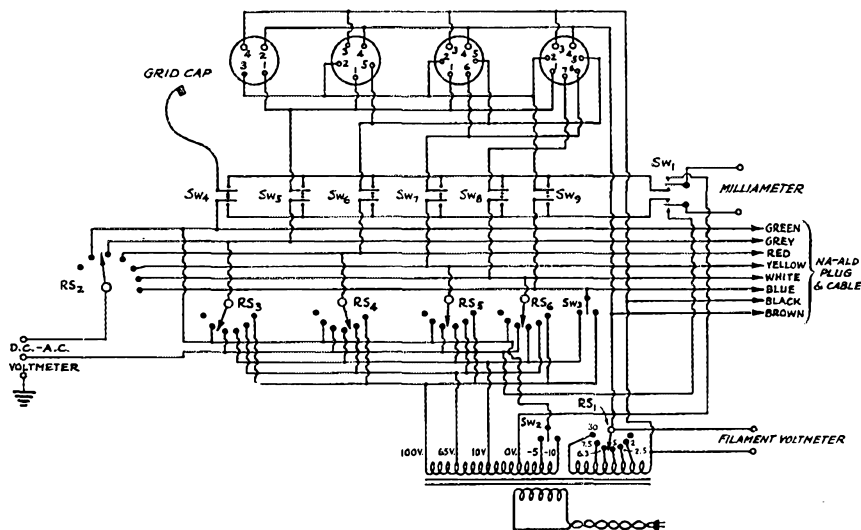

FIG. 1 — THE CIRCUIT DIAGRAM IS EASY TO FOLLOW

RS1 and RS2, filament selector and voltmeter selector respectively, are Yaxley type 1617 rotary switches. RS3 through RS6 are type 1616.

SW1 is a Yaxley 2006L push-button switch, while SW2 and SW3 are type 2003, the latter with "off" position. SW4 through SW9 are type 2006.

The analyzer cable plug is the Na-Ald type 907WLC, with adapters as follows: 976DS, 975DS, 974DS.

The four sockets are Eby, type 12.

All parts are mounted on the 7 x 10 inch bakelite panel, the transformer being supported by suitable brackets. The transformer core and 115-volt primary winding are from a Thordarson T-5002 replacement transformer, the secondaries being removed. Two new secondaries are wound on the primary. The first is 525 turns of No. 34 single-silk enamel-covered wire, tapped at 24, 48, 96 and 360 turns; the second is in two sections, one section consisting of 36 turns of No. 18 enamel wire, tapped at 9.5, 12, 24, and 30 turns, connected to a second section of 100 turns of No. 24 enamel wire. Connections to the various taps are shown in the circuit diagram.

Transformerless Plate Supplies

THE idea of taking the power for receiving tube plates direct from the power line without the intermediary services of a transformer is by no means new, but it is only recently that the practice has been at all widespread. "Transformerless" or "universal" receivers are popular in the extremely low-price class in the broadcast field, and it is for these sets that the new 25Z5 rectifier has been developed. The 25Z5 has two separate cathodes and plates — and is equipped with a relatively high-voltage heater. Consequently it is possible to do things with this tube that could not be done with previous types without an unjustifiable amount of auxiliary apparatus.

To the ordinary amateur the saving represented by the elimination of the transformer from a receiver plate supply is not great because the smoothing filter, which represents a large part of the cost, is just as necessary and must be just as elaborate, if not more so. Besides, the receiving tube filaments have to get power from somewhere, and this usually means that a transformer is needed anyhow, since serious operation of filaments from the 110-volt line is not so satisfactory with regenerative receivers. Nevertheless it is possible to make a very compact plate supply without a transformer — probably useful for a portable set, for instance. Again, a plate supply of this type can be used to replace the B batteries often used with receivers employing a.c. tubes.

Three circuits using the 25Z5 rectifier are shown in Fig. 1. The first — and in many respects the most satisfactory of the lot — is the ordinary half-wave circuit, the plates and cathodes of the two diodes within the tube being connected together. The filter is a two-section affair, using three 8- μ fd. electrolytic condensers and a pair of miniature chokes (about 50-mil. capacity). A 300-ohm resistor is connected in series with the heater of the 25Z5 to drop the voltage to 25 volts. This resistor should be capable of dissipating about 30 watts continuously. A plate supply of this type has shown itself to be capable of operating a standard three-tube regenerative receiver very satisfactorily. With the receiving-tube heaters grounded in the usual way through a center-tapped resistor, there was no noticeable hum attributable to insufficient filtering. There may be some trouble with tunable hums — a different breed of noise altogether — but these usually can be eliminated by shunting a fixed condenser of about .002- μ fd. capacity across the plate and cathode of the rectifier tube, and sometimes by connecting a non-inductive .1- μ fd. condenser across the 300-ohm resistor. The output voltage is about 140 with the receiver and voltage divider connected. The 25-watt lamp is in the circuit to

prevent blowing of fuses should the negative side of the power supply be connected to the ungrounded side of the 110-volt line. One of the chief advantages of this half-wave circuit is that a direct ground may be used on the receiver. If the power supply is plugged in "wrong way to," the lamp will light but no damage will be done.

The full-wave circuit is shown chiefly as a matter of interest, in that it is possible to make a

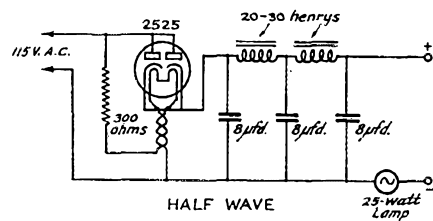

HALF WAVE

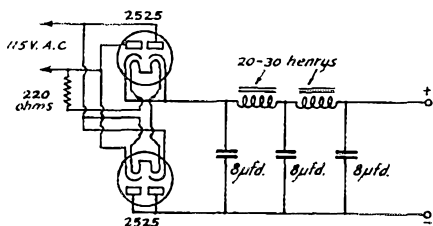

FULL WAVE

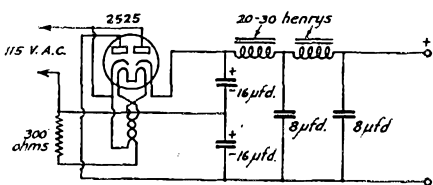

VOLTAGE DOUBLING

bridge rectifier with but two tubes. Using exactly the same filter as with the half-wave circuit, the bridge rectifier had much more hum, possibly because the predominating ripple is 120 cycles instead of 60 and a little bit of it is much more apparent to the ear. The output voltage was exactly the same as with the half-wave circuit. A direct ground cannot be used on a receiver supplied plate power from this type of circuit. The best that can be done is to ground through a mica condenser of about .002 μ fd.

The voltage-doubling circuit offers about the same hum difficulties as the full-wave circuit and has the same limitation on grounding the receiver. Its principal claim to consideration is the fact that fairly high output voltage is obtainable.

(Continued on page 72)

Converting Standard Superhets to S. S. Receivers

By James J. Lamb, Technical Editor

CAN I add a quartz filter unit to my So-And-So Superhet to make it a Single-Signal job — and how is it done?" This query from a large number of *QST* readers has prompted a survey of the possibilities, with the concrete information presented herewith as the result. The filter unit can be incorporated, provided the superhet has the absolutely necessary stability and band-spread tuning facilities. The stability must be commensurate with the high selectivity, as we have emphasized repeatedly, and geared-down tuning is demanded in direct proportion to the selectivity. All superhet receivers may not have the order of stability that is prerequisite, nor may they be fitted with suitable tuning control. But several modern high-frequency superhets of standard type are suitable for the conversion, especially those that incorporate the stabilized oscillators adopted from *QST*'s original S.S. receiver and have provision for band-spread tuning. Other types would require overhauling according to their individual needs, mostly in their high-frequency oscillators and in fitting them for band-spread tuning. Our advice is, therefore, to restrict the conversion to receivers that already have the necessary stability and are fitted for band-spread tuning. We cannot give detailed instructions for other types nor can we vouch for their performance as S.S. superhets.

The major change, of course, is insertion of the filter unit between the first detector and first i.f. tube, as shown schematically in Fig. 1. The basic elements of the filter unit are the same as in the original S.S. superhet (Aug., 1932, *QST*); namely the input transformer, the input tuning condenser (selectivity control), the air-gap mounted quartz crystal, the filter switch, the phasing condenser, and the output coupling resistor and choke. The input coupling transformer, L_1L_2 , in this case can be the regular first i.f. transformer of the receiver. The primary may be tuned as usual but the secondary tuning job will be taken over by the split tuning condenser, C_3 (selectivity control) incorporated in the filter unit proper.

There are two possible physical arrangements for the filter unit. The filter equipment can be assembled in a separate shielded compartment external to the receiver or, still better, built into the receiver as an integral part. Typical examples of the two methods are shown in the photographs, one a separate filter unit adapted to the latest model Hammarlund "Comet Pro" and the other a filter built into the new National "Communica-

tion Type AGS." The external unit is convenient in that its adaptation requires minimum alteration of the receiver's wiring, etc., but is penalized by the long shielded r.f. leads necessary to make the trip out to the filter unit and back. In the case illustrated, the shielded leads (two to the input tuning condenser, one from the filter back to the first i.f. grid) are run through the ventilating louvers in the side of the "Pro's" metal case. Theorists may shudder at the large dielectric

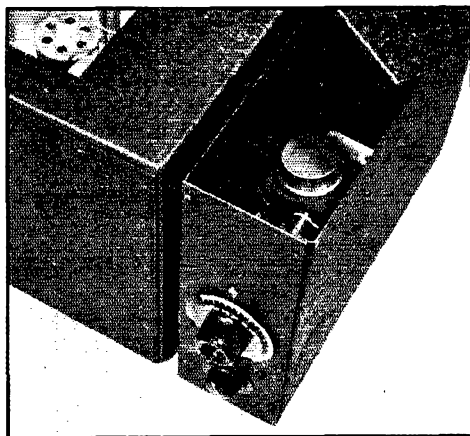

AN EXTERNAL TYPE FILTER FOR USE WITH THE HAMMARLUND "COMET PRO," DESIGNED BY W2AOE

The shielded r.f. connections are run in through the ventilating louvers in the right side of the receiver cabinet.

losses promised by such treatment of the tuned circuit — but the performance, even with this handicap, is surprisingly good. The built-in filter arrangement is preferable, of course.

THE FILTER UNIT

In planning the filter unit, the following features must be considered:

1. The portions of the circuit at r.f. potential above ground should be completely shielded. The external type unit should be in a metal case and the three "hot" r.f. leads connecting it to the receiver circuits should be shielded.
2. The mechanical arrangement must be such as to give panel controls for the condenser C_3 and the three-way switch.
3. The precautions regarding unbalance to ground, etc., pointed out in March, 1933, *QST*, should be observed as far as possible.

4. The filter circuit must be tunable to the intermediate frequency of the receiver. This means that the crystal must be ground to the intermediate frequency and the condenser C_2 must be of the right size to tune the secondary L_2 of the i.f. transformer to that frequency. A split-stator condenser of 140 $\mu\text{fd.}$ per section (70 $\mu\text{fd.}$ maximum for the two sections in series)

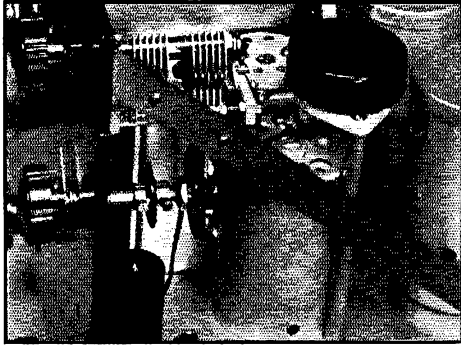

A FILTER INSTALLED AS AN INTEGRAL UNIT IN THE NATIONAL "AGS" SUPERHETERODYNE, WITH THE COMPONENTS GROUPED ABOUT THE FIRST I.F. TRANSFORMER

The crystal, in the black bakelite case, is mounted above the transformer shield, with the adjustable Isolantite-base phasing condenser in the background. The selectivity control condenser is mounted on the front panel, with the switch below it.

will be generally satisfactory for receivers having 465- to 525-kc. intermediates. Remember that the capacity of the shielded input leads is in parallel with the two sections of the tuning condenser — and will amount to something like 25 $\mu\text{fd.}$ for each lead.

5. The shielded leads should be as short as possible, especially the two connecting the secondary of the i.f. transformer and the split tuning condenser. These two leads also should be of identically the same length. The shielding of the leads should be positively grounded — which means soldered, not just rubbing against the chassis.

In addition to these salient features, the general considerations covered in the March QST article on filters should be observed.

In the external unit shown, the split tuning condenser is single-hole mounted on the front panel of the metal case — which case, by the way, can be of any convenient size. The one shown happens to be considerably larger than necessary because it was made to match the height and depth of the Comet Pro with which it is used. The remaining components are supported on a bakelite base that is supported from the front panel and the sides of the case. The switch is underneath this bakelite shelf, immediately under the crystal, on a small bakelite panel

"angled" to the shelf. A fiber shaft couples the switch to the front panel control knob.

Preliminary to making connections to the receiver, the first i.f. transformer must be removed and its secondary tuning condenser (the one on top) disconnected from the secondary coil. Short insulated leads from this coil are then brought out through holes in the transformer shield can. When the leads from the filter unit have been pulled in, they are simply soldered to these secondary connections. The output lead from the filter is equipped with the grid clip removed from the former grid lead.

In the built-in type filter, the components are placed as convenience and room available may dictate, and need not be enclosed in a separate shield — provided the other circuits of the receiver have their own shields and provided the whole receiver is enclosed in a metal box. If the first i.f. transformer is adjacent to the front panel (as it is in the National "AGS" and in the "Comet Pro") the job is relatively simple, because no long extension shafts to panel controls are required. The split tuning condenser (selectivity control) may be mounted right on the front panel, since its rotor is grounded anyway. The switch, however, should be supported on insulation spaced away from the panel, in the manner shown for the "AGS." The phasing condenser and crystal also should be in the clear, as far as metal shielding is concerned.

(Continued on page 72)

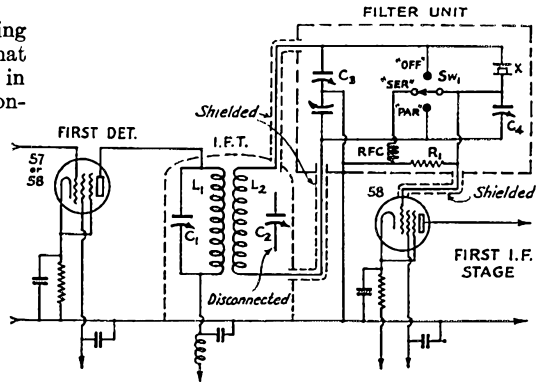

FIG. 1 — THE FILTER UNIT IS CUT IN BETWEEN THE FIRST DETECTOR AND FIRST I.F. STAGE

- L_1L_2 — Primary and secondary of the receiver's first i.f. transformer.
- C_1C_2 — Primary and secondary tuning condensers of first i.f. transformer. C_2 is disconnected and not used.
- C_3 — Input tuning condenser (selectivity control) split stator type, 140- $\mu\text{fd.}$ per section (or two smaller condensers in parallel).
- C_4 — Phasing condenser, 25- or 50- $\mu\text{fd.}$ midget variable, or equivalent adjustable compression type.
- R_1 — 1-megohm grid coupling resistor.
- RFC — Grid coupling r.f. choke, 10-millihenry or larger (broadcast-band type).
- SW — Single-gang three-way switch (coil-switching type).

If filter unit is outside receiver's metal cabinet, the r.f. leads should be shielded as indicated. Filter connections are the same with screen-grid tubes of types other than those indicated.

Sweepstakes Contest Results—1932

By E. L. Battey, Assistant Communications Manager

DAH-dit-dah-dit dah-dah-dit-dah dit-dit-dit dit-dit-dit" will be remembered as the "battle cry" of the big "A.R.R.L. Third All-Section Sweepstakes Contest," November 12-21, 1932. More fun, more participants, larger scores, all helped to make this Sweepstakes "the greatest national QSO contest" in the history of the A.R.R.L.

There were 532 reporting participants. Total participation is conservatively estimated as well over 1000. Reported scores total 1,885,718 points. The highest "one man score" — 56,420 (!) was made by W8ER. 57 scores over 10,000, 25 over 15,000, 12 over 20,000! Stations active in all 69 A.R.R.L. Sections . . . what a contest! W9GCX worked 63 of the possible 69 Sections. W8ER and W6CXW each contacted 62 Sections. 24 operators worked 50 or more Sections. These facts will speak for themselves as to the degree of activity in this Sweepstakes!!

For the benefit of the uninitiated, the Sweepstakes is an annual QSO Contest, open to all amateurs in the 69 Sections of the A.R.R.L. field organization. The idea is to work as many different stations in as many different Sections as possible, exchanging at least one message with each station as proof of "solid" QSO. If a message is sent and acknowledged, "one point" is scored; if a message is exchanged both ways, "two points" are scored. The summation of all points is multiplied by the number of Sections contacted for final score. With the possible multiplier of 69 the scores literally "shot up like rockets" — and it was half the fun of the contest to watch the scores build up as new Sections were contacted.

Aside from its intrinsic worth as an enjoyable operating activity, the Sweepstakes proved meritorious in other ways; it was of great value in that it helped amateurs to learn *correct operating* and message handling procedure. Many a newcomer to amateur radio handled his "first message" in the Sweepstakes. Many an amateur reported his operating ability improved after SS participation. Even though the texts of some of the messages handled were of small value, it did take operating ability to handle them! Thus did the Sweepstakes help to "make operators."

Bronze watch charm awards to the highest scoring participant in each A.R.R.L. Section were made in 67 Sections, all except East Bay and Alaska, from where no reports were received. The winner in each Section is listed first in the scores for his Section. Congratulations, winners!

Special charm awards, in Gold instead of Bronze, were made to the highest scorer in all U. S. A. Sections, and the highest scorer in all

Canadian Sections — W8ER, 56,420 points, and VE3GT, 25,636 points. Bravo, OMs!!

Some of the particularly high scores are worthy of special mention: W9AUH 35,262, W6CXW 24,428, W9FUT 23,850, W9BMA 23,409, W2TP 23,016, W9GCX 21,987, W4TO 21,896, W9YB 20,577, W8CPE 20,460, W1BVP 20,200. A study of the score list will disclose many other noteworthy results. Contestants working 50 or more Sections deserve particular commendation: W9GCX 63, W6CXW W8ER 62, W8DED 59, W9BLZ 58, W9YB 57, W2TP W4TO W5WF W9UM 56, W2DJO W9ABB W9AUH 54, VE3GT W6AOA W9GBJ 52, W2AFV W8AWK W9BMA 51, W1BVP W7NR W8APQ W8EIS W9BAN 50.

Among the 'phone stations active were W8ALC, W9CUK and W1APK. Special credit goes to W8ALC, whose score, 9374, made entirely on



3.9-mc. 'phone, is the highest ever achieved by a 'phone station in a contest of this kind! FB!

Activity on 1.7 mc. was greater than in the 1931 Sweepstakes. 56 mc. was used for the first time. Whereas in 1931 we found 7 mc. leading 3.5 mc. from the standpoint of "occupancy" during the SS, in 1932 we found the "occupancy" about equal in those two bands, with 3.5 mc. having a slight edge on 7 mc. The 3.5- and 7-mc. bands carried the peak of Sweepstakes activity. Approximately 64% of all participants did some or all operating on 3.5 mc.; a like percentage used 7 mc. 32% used 14 mc., 4% 1.7 mc., and 6% 56 mc.

A few memories of SS participation: A frequent question, "What does SS mean?" — and the guesses: Steam Ship, Single Signal, Stanley Steamer, Sunday School, Simple Simon, Sweep Steaks. (W1BVP says, "They did make good food for entertainment.") W5NT promised his

YF new furniture, if he should win, provided that she not molest him during the time he spent on the air . . . so when W5NT won the YF won, too! In each of the three Sections, Ohio, Missouri and Western Massachusetts, "Springfield" was the only city contacted by W4BGA. And another Springfield, "Springfield, Tenn.," was represented by W4HA. W1EF's first two points were with W6CAL, a DX start. W9BMA had but 8 hours sleep during the SS, and, as he puts it, "wore callouses on his hands that a lawnmower would be proud of." W8APQ showed what "low power" would do in an SS, using a '45 with 400 volts—his score, 15,300! W2DOG called it "The Victory of the Unemployed," due to the number of hours they could spend on the air. W8DDS derived numerous things from the contest, including a scrap with the YL, a better fist, loss of 100 hours sleep, a two-day headache, a stiff neck, and one heck of a good time! W9ZZBZ/BWJ used an outline map of A.R.R.L. Sections, pencil-shading each Section as contacted. W3CL discovered that during the SS more sleep was lost, less food eaten, and more cigarettes smoked than at any other time of the year! W9DGS swore off the use of "CQ" or "CQ SS" right at the start of the contest, and his score didn't suffer as a result. . . . Moral: More listening and calling plus less CQing equal more QSOs.

Representative comments on the Sweepstakes:

"I don't think I will win a prize, but I believe that I obtained the weight of many gold medals in operating experience. Therefore I win anyway!" — W8HGG. "I think most of the fellows will agree that it is the best organized fun in amateur radio." — W8DVZ. "It was a grand success. One met many good operators, it helped the beginners, brought our organization more closely together, and paved the way for many future individual schedules. I am certainly going to watch for announcements of similar contests." — W9UM.

Another Sweepstakes is scheduled for the fall of 1933! Watch for the announcement and get in on the fun.

Sweepstakes Standing by Divisions

| | |
|--|-----------|
| Central led by Ohio (96082) | 374,159 |
| Atlantic led by W. Penna. (145146) | 345,978 |
| Hudson led by N. Y. C.-L. I. (76243) | 201,056 |
| New England led by W. Mass. (51265) | 157,206 |
| Pacific led by Los Angeles (47098) | 148,959 |
| Midwest led by Missouri (52774) | 124,073 |
| Dakota led by No. Dakota (35301) | 111,534 |
| Canada led by Ontario (52904) | 99,259 |
| Roanoke led by No. Carolina (49319) | 81,257 |
| Northwestern led by Waah. (31679) | 80,501 |
| Delta led by Arkansas (27193) | 64,571 |
| Southeastern led by Ga.-S. C. (23323) | 42,855 |
| West Gulf led by Oklahoma (27065) | 41,054 |
| Rocky Mountain led by Colorado (12535) | 13,256 |
| Total Scores | 1,885,718 |

Scores

Third All-Section Sweepstakes Contest

(Total scores for each Section shown after name of Section. . . . Asterisks denote stations not entered in contest, reporting to assure that stations they worked get credit. . . . Number Sections contacted shown in parentheses after call. . . .)

| | | | | |
|-----------------------------|-----------------------------|------------------------------|--------------------------------|------------------------------|
| <i>W. Penna. 145,146</i> | W3AKU (21) 2247 | W8FAZ (19) 817 | W2DBQ (36) 8640 | W2DEN (19) 1558 |
| W8EH (62) 56420 | W3AKB (18) 1656 | W8EXI (14) 770 | W2DCK (30) 7800 | W2DFB (20) 1460 |
| W8CFE (44) 20460 | W3BUI (21) 1428 | W8WE (17) 680 | W2CQU (39) 7059 | W2BEP (16) 1440 |
| W8EIS (50) 15750 | W3CAA (22) 1320 | W8BMK (16) 672 | W2BGO (26) 3640 | W2DY (16) 1104 |
| W8APQ (50) 15300 | W3AOR (20) 1080 | W8PO (14) 658* | W2DOG (24) 2160 | W2ELC (17) 986 |
| W8CFG (28) 7168 | W3AZF (14) 532 | W8EBY (13) 533 | W2QP (17) 1734 | W2PY (15) 645 |
| W8EDD (39) 5187 | W3CEM (13) 468 | W8GVX (14) 490 | W2AZV (19) 1615 | W2CJX* (6) 72 |
| W8HGG (26) 4654 | W3QV (12) 384 | W8GHD (6) 54 | W2BWW (21) 1470 | W2CBA* (1) 2 |
| W8DVZ (31) 4433 | W3BRZ (11) 264 | W8BMX (5) 45 | W2DUP (14) 1232 | |
| W8VI (33) 4393 | W3AZJ (9) 234 | W8BAH (2) 20 | W2CUH (12) 672 | |
| W8ECH (27) 3213 | W3ZG (4) 40 | | W2BMH (12) 476 | <i>N. Y. C.-L. I. 76,243</i> |
| W8DQN (29) 2928 | W3CHH (2) 8 | <i>Indiana 91,209</i> | W2AQN (10) 250 | W8WY (37) 4065 |
| W8DML (28) 2520 | W3FX* (2) 10 | W9MUT (45) 23850 | W2BWD (11) 242 | W8BEN (39) 6942 |
| W8GN (22) 1518 | W3BVX* (1) 2 | W9YB (57) 20577 | W2BOT (8) 136 | W8CDB (38) 6612 |
| W8CKE (14) 546 | | W9UM (56) 18538 | W2GP (7) 128 | W8FDY (27) 4779 |
| W8CMK (10) 450 | <i>Ohio 96,082</i> | W9ABB (54) 13716 | W2DXL (6) 90 | W8DHU (25) 4250 |
| W8FCV (9) 207 | W9ZZBZ (49) 18130 | W9AET (28) 6188 | W2IO (6) 84 | W8DBJ (26) 2964 |
| W8CTE* (1) 2 | W8FFQ (39) 14274 | W9DHI (34) 3468 | W2CJL (3) 84 | W8AGS (22) 2376 |
| | W8DDS (37) 10767 | W9HUO (19) 950 | W2EBT (6) 66 | W8EUY (25) 2175 |
| <i>E. Penna. 109,432</i> | W8ALC (43) 9374 | W9JRK (16) 914 | W2CKQ (4) 32 | W8KZ (24) 1992 |
| W3ARK (43) 13932 | W8FDV (30) 7830 | W9CKY (18) 918 | W2APZ* (4) 28 | W8CJJ (20) 1540 |
| W3BKQ (40) 13920* | W8BYD (32) 7200 | W9AHA (14) 672 | | W8AAC (17) 1054 |
| W8FCB (43) 11997 | W8DKK (36) 5328 | W9FIY (13) 624 | <i>No. New Jersey 70,576</i> | W8EDB (14) 882 |
| W3BRH (35) 11025 | W8DMK (29) 3741 | W9EZR (10) 360 | W2WTP (56) 23016 | W8CGW (13) 650 |
| W8FLA (28) 9576 | W8AEL (23) 2622 | W9TE (11) 264 | W2DIU (48) 16176 | W8FFY (14) 518 |
| W8CVS (33) 8217* | W8GGO (30) 2340 | W9GFS (6) 132 | W2BLV (42) 6594 | W8CLP (14) 490 |
| W3ADE (34) 7378 | W8CGS (20) 1760 | W9BQH* (2) 8 | W2DMY (31) 4495 | W8AQE (14) 448 |
| W3CHU (30) 6390 | W8UC (26) 1664 | W9JFB* (1) 2 | W2ASY (31) 3007 | W8AYU (13) 364 |
| W8EUX (34) 5644 | W8DTW (20) 1580 | <i>N. Y. C.-L. I. 76,243</i> | W2CIM/ZZEN (27) 2835 | W8BFG (12) 348 |
| W8UV (26) 4056 | W8DEM (22) 1430 | W2AFV (51) 15096 | W2CKJ (25) 2725 | W8CGW (8) 112 |
| W3CL (27) 3564 | W8ID (19) 1406 | W2DJO (54) 11772 | W2EKM (24) 2424 | W8BLP (7) 112 |
| W3ATR (29) 3509 | W8FGV (15) 1065 | W2AUS (39) 11739 | W2DRN (21) 2037 | W8AGW (1) 2 |
| W3CDN (29) 2639 | W8BRQ (16) 832 | | | |

* Station Score. Opr. Benner 13,338, Wardell 8, Taylor 2. † Station Score. Two oprs.
 ‡ Station Score. Opr. "Les" 6090, "Gus" 611.

A More Stable Crystal Oscillator of High Harmonic Output

By James J. Lamb, Technical Editor

SOMETHING over two years ago we started out on what promised to be no more than a squirrel hunt — and came in with a bear. The oscillator circuit that is to be described (the bear) came about as the consequence of prying into the possibilities of applying crystal stabilization to the dynatron oscillator (the squirrel hunt). Starting with the usual dynatron arrangement of the screen-grid tube, the crystal was connected

tion with the crystal in the control-grid circuit. At this stage our enthusiasm cooled for the stabilized dynatron as something of practical importance in point of harmonic generation with anything like decent power output. The dynatron could be stabilized, all right, and was interesting to play with — but totally impracticable for standard type tubes when viewed as a hot possibility for either transmitter control or frequency calibration work. It wasn't exciting as an exciter, because the screen grid of even an 865 had to be run white hot (screen at 350 volts, plate at 200) to get enough power output to drive an amplifier stage worth driving. And the harmonics available for calibration work weren't encouraging, either.

Then the screen and plate voltages were interchanged to convert the thing to a regenerative rather than a negative resistance (dynatron) oscillator. Results were immediate. The efficiency was greatly improved, the power output went up and the harmonic family grew to a whole tribe. The performance became all that might be expected of a vigorously oscillating triode direct-coupled to an enthusiastic distorting screen-grid amplifier. Going further, the ground point was moved from the cathode to the screen circuit, making the screening action completely effective, and unexpected operating features unprecedented in crystal-controlled oscillators as we had known them were uncovered.

The basic circuit finally developed is shown in A of Fig. 1. The tuned circuit is connected between cathode and ground, certainly a peculiar seeming position, and the crystal between the grid and cathode. The resistor across the crystal is the grid leak, furnishing negative bias by virtue of the rectified grid current flowing through it from grid to cathode. The rotor of the tank condenser is at ground potential for both r.f. and d.c., and need not be insulated from a shield. The screen grid is brought to ground potential, as far as r.f. is concerned, by the by-pass condenser connecting it to the negative "B"; and the heater is similarly by-passed to keep it from "floating" and causing erratic performance.

For calibration work we want the output circuit non-selective so as to distribute power over the widest possible range of harmonic frequencies; hence the load resistor R_2 , offering a fairly constant load impedance from the fundamental frequency up to the several-hundredth harmonic. To further the uniformity in harmonic power distribution, the series coupling condenser C_3 is

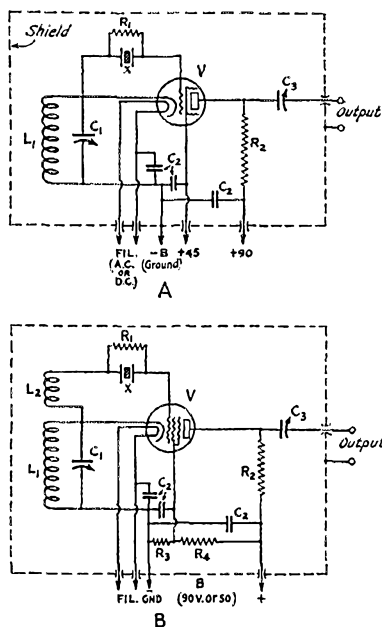

FIG. 1 — THE ESSENTIALS OF THE NEW CRYSTAL OSCILLATOR CIRCUIT

It is characterized by exceptional stability and harmonic output. The arrangement of A is generally satisfactory for all but low radio frequencies, for which B can be used. Tuned circuit constants are usual for the frequency of the crystal. A typical 100-*kc.* combination would be a 300-turn honey-comb coil for L_1 , a 25-turn coil for L_2 and a 500- $\mu\text{fd.}$ variable for C_1 . The leak R_1 can be 100,000 to 250,000 ohms, the load resistor R_2 50,000 to 100,000 ohms and the divider resistors of B each 10,000 ohms. The by-pass condensers C_2 should be .005- $\mu\text{fd.}$ and up, preferably around .05- $\mu\text{fd.}$ at 100 *kc.* The output coupling condenser C_3 can be a 100- $\mu\text{fd.}$ midget. Any screen-grid tube of the heater type can be used — 24-A, 36, etc. as in A; or pentode type *s.g.* tubes such as 57 and 58 as in B.

first in the screen-grid circuit, then in the plate circuit and finally in the control-grid circuit. The tuned circuit also was switched about, finally landing in the screen circuit in combina-

quite small so that its reactance will be large at the fundamental and lower harmonics, but decreasing to give proportionately greater coupling as the harmonics progress upward in frequency and downward in kick.

The circuit of "B" in Fig. 1 shows a variation in the grid circuit that effectively encourages a lazy crystal to get going. A small inductance,

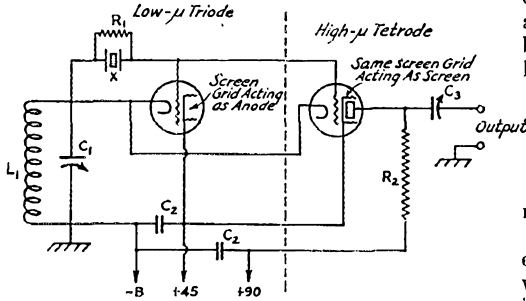

FIG. 2—THE CIRCUIT IS APPROXIMATELY EQUIVALENT TO A LOW- μ TRIODE OSCILLATOR WITH ITS GRID DIRECT-COUPLED TO THAT OF A HIGH- μ SCREEN-GRID AMPLIFIER

L_2 , is connected in series with the crystal, between it and the cathode, and coupled to the cathode-ground coil. This spur is unlikely to be necessary except in the case of a lethargic low-frequency crystal (100-kc. and lower). The tube connections shown in "B" are recommended for pentode type r.f. tubes, such as the 57 and 58, in this oscillator circuit. As indicated, the suppressor grid is tied to the screen instead of to the

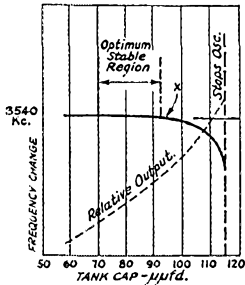

FIG. 3—OSCILLATION PERSISTS INTO THE STABLE TUNING REGION INDICATED

The usual oscillator with the crystal connected between grid and cathode stops in the vicinity of "X."

cathode, thus thwarting it in performing its intended function of preventing secondary emission from the plate. Secondary emission is not undesirable in the present instance. Alternative connections for battery and rectified a.c. "B" supply are also illustrated in the two diagrams of Fig. 1.

HOW THE CIRCUIT WORKS

Before going further, let's rationalize the circuit so that we can become better acquainted

with it. Broken down into its approximate equivalent, it takes the form shown in Fig. 2. Essentially it is a low- μ triode crystal-controlled oscillator with its grid coupled directly to that of a high- μ screen-grid amplifier. Both tubes get the same excitation and the same negative grid bias, because they have the common grid-cathode circuit. Now we know that an oscillating low- μ tube automatically gives itself a large grid swing and a correspondingly high bias. Otherwise it just doesn't oscillate. We also know that when a high- μ amplifier is distressed by a large grid swing and high bias there is great distortion and output rich in harmonics results. That's the way we try to work the frequency doublers and triplers in our transmitters. It is in this equivalence that this oscillator's harmonic generating properties lie.

Actually separating the two sets of functioning elements by putting them in individual envelopes would change the picture, however, because then it would be necessary to supply the losses of two grids instead of one, grid-cathode and cathode-screen capacitances would be doubled and inherent compensation properties of the circuit

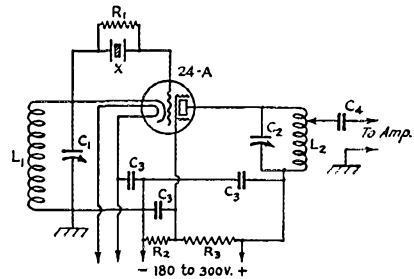

FIG. 4—FOR TRANSMITTER CONTROL THE OUTPUT CIRCUIT SHOULD BE TUNED TO SELECT THE DESIRED HARMONIC

A low-power arrangement for heater-type tubes is shown. Circuit constants are usual and correspond to those of Fig. 1.

would be less effective. The inherent stability of this circuit is a property no less marked and valuable than its harmonic generating ability and is unlike that of any other crystal oscillator in our experience. Particularly prominent is its insistence on constancy of frequency with changes in circuit constants when the tank circuit is tuned far into the inductive reactance region (to the low capacitance side of resonance). Through this region of tuning it persists in oscillating long past the point where the conventional crystal-controlled oscillator gives up and quits. The tuning curve of Fig. 3 is typical in illustrating this feature of the oscillator's operation.

As with the ordinary crystal oscillator circuit, the change in frequency with tuning of the tank circuit is greatest near resonance; that is, near the crystal's natural frequency, where it quits sud-

denly. However, in contrast to the usual circuit that stops oscillating when the tank is but slightly detuned towards the low-capacitance side of this resonance point, this one continues to oscillate past that point. Furthermore, when the tuning has progressed into the optimum region, marked off in Fig. 3, the frequency curve becomes flat. *This means that relatively large changes in circuit constants are no longer importantly effective in causing frequency variations.* Since the power output drops off as the tank reactance becomes increasingly inductive, the optimum operating setting should be in the region indicated. It is needless to say that this property, combined with that of harmonic generation, is decidedly valuable. A particularly useful application is in the frequency standard. For instance, a 100-ke. crystal oscillator using this circuit is not only especially stable but also delivers harmonics through the 140th (in the 14-mc. band and higher) that are sufficiently strong to block the detector of an oscillating regenerative receiver. The electrostatic screening between the output and the rest of the circuit of course gives isolation from load conditions and adds further to the stability.

POWER CIRCUITS

Of course no amateur can consider an oscillator circuit without speculating on what it might do in a transmitter. This is especially likely when a crystal-controlled oscillator holds promise of delivering some power at harmonic frequencies. In this case the oscillator is particularly suited to transmitter use, not only because it is stable and is a good harmonic generator, but also because it can do its stuff while treating the crystal kindly. A low-power version using a Type 24-A tube is diagrammed in Fig. 4. The circuit is essentially the same as the basic arrangement of Fig. 1, the modification being the use of a tuned circuit in the plate to select the desired fundamental or harmonic output. For somewhat greater output but with some sacrifice in screening action, a pentode type audio tube such as the 59 can be fitted into the same circuit. With the 59, the inner grid serves as the control while the two outer grids tied together serve as the screen. Plate voltage of 400 or so and screen voltage of 200 give real output with this type tube. Since the screening is imperfect, however, it is inadvisable to tune the plate circuit to crystal frequency — unless the cathode coil is shorted and the circuit converted to the conventional pentode crystal circuit.

Measurements on a "tritet" oscillator of the type shown in Fig. 4 indicate that the harmonic power obtainable, relative to fundamental output, approximates 80% for the second harmonic, 65% for the third harmonic and 35% for the fourth harmonic. Use of the circuit therefore reduces considerably the number of frequency multiplying stages necessary in crystal-controlled transmitters.

Air-Type Alignment Condensers for Plug-In Coils

IN the early development of the Single-Signal receiver it was immediately realized that circuit stability good enough for receivers of ordinary selectivity was utterly inadequate for the rigorous requirements imposed by really high selectivity. In the first articles describing the S.S. receiver (*QST*, Aug. and Sept., 1932) it was emphasized that the mica-type adjustable condensers were totally inadequate in stability, both for alignment and padding in h.f. circuits and for tuning in i.f. transformers. Manufacturers were quick to adopt *QST*'s lead in adopting air-condenser tuning for their i.f. transformers; and

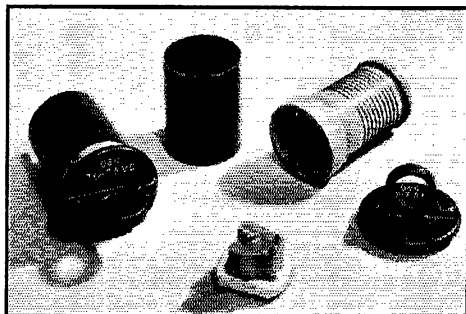

now special air condensers have been developed for the individual alignment of the high-frequency circuits, a circuit feature necessary for close tracking in the single-control tuning of a superhet.

This type condenser displaces the usual adjustable mica-type "trimmer" and fits inside the coil form. As shown in the photograph, the condenser is of the single-bearing type, mounted on an Isolantite plate formed to nest in the recess moulded in the top of the coil form. A slot is cut in the end of the shaft so that the condenser can be adjusted with an insulated screw driver through a hole in the handle assembly, with the coil assembled and plugged into the receiver. The alignment condenser has a maximum capacitance of 140 $\mu\text{mf.}$, making it suitable for use with coils covering a wide variety of frequency ranges. With coils that are tapped to give band-spread tuning, the condenser is connected in parallel with the winding. It also can be connected as the series "tracking" condenser (in series with the main tuning condenser) for band-spread tuning with untapped coils.

The new condenser and panel-type plug-in coils illustrated are products of the National Company, Malden, Mass.

Strays

Albert Chaney, not Alfred, was author of the "First Detector" article in May *QST*.



Inexpensive Crystal Oven

By H. B. Stover, W9GEX *

THE following information on the crystal temperature control box used at W9GEX may contain some suggestions of value to the rest of the gang. The box itself, a cross-section of which is shown in Fig. 1, has no particularly unusual features. The outside box is made of wood and measures approximately 15 by 15 by 5 inches. The heat-insulating layers are celotex and sheet asbestos, as shown in the drawing. The heating elements are asbestos cards wound with Nichrome wire of the type used in heating pads,

move the resistance unit. Then unsolder the adjusting screw so that it can be set for your particular use. To adjust mine, a board was put on a steam radiator and a thermometer placed on the board to measure the temperature, which was approximately 100 degrees *F*. Then I backed off on the adjusting screw and hooked a 110-volt lamp in series with the unit, placing the latter alongside the bulb of the thermometer. After a moment it opened, showing it was operating at about 100 degrees. Once an approximate adjustment has been obtained the operation of the unit should be checked by removing it from the source of heat until it recloses and then replacing it by the thermometer to see if it operates again at the same temperature. When the adjustment is satisfactory the unit should be mounted on the side of the aluminum box and enclosed with pieces of asbestos so it will not be affected by direct radiation from the heaters.

On testing the completed oven it was found that the heaters were taking too much current, causing the thermometer to shoot way up before it took its final position. This was overcome by placing a lamp in the circuit externally, to govern the amount of current entering the box. With a 75-watt lamp in series and the oven running constantly for 10 hours, the maximum change was .5 degree *F*. The thermostat operates every 15 to 20 seconds, on and off.

The thermometer, a fairly accurate one, can be purchased at a dairy supply company or drug supply house for \$1.00. More accurate ones are available, of course, but the cost is greater.

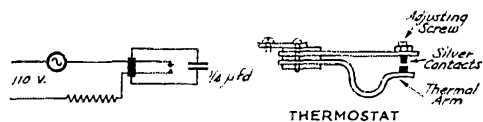
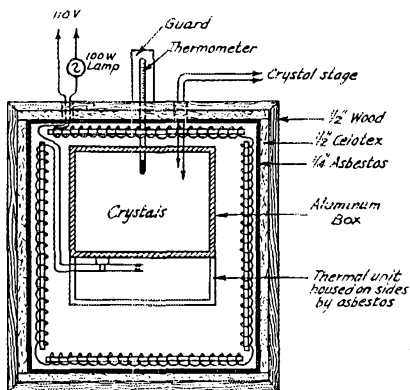

FIG. 1 — CRYSTAL OVEN USING AUTOMOBILE GENERATOR THERMOSTAT

electric irons, etc., and which can be obtained at almost any electrical supply house. The heaters completely encircle the inner aluminum box in which the crystals are housed.

Not wishing to make much of a cash layout for a thermostat, the writer hit upon the idea of using a thermal unit of the type used in automobile generators to limit the charging rate. These units which are designed to open at 160 degrees *F*., have silver contacts, and are well made. One can be taken from an old Delco-Remy generator in the junk yards. Clean it up and re-

Electron-Coupled 100-kc. Oscillator

The circuit of Fig. 2 is used by Theodore H. Stahl, Birmingham, Mich., to give 100-kc. points in the 3500-kc. band. The circuit is that of the ordinary electron-coupled oscillator as used in frequency meters except that the output circuit is tuned to increase the harmonic response. A 750-turn honeycomb coil, tapped about $\frac{1}{3}$ of the distance from the inner end, is tuned by a .001 variable condenser to reach 100 kc. With the output circuit tuned to 5000 kc., the oscillator may be set to zero beat with WWV's transmissions and if checked regularly will make a good frequency substandard.

Mr. Stahl also suggests adding an amplifier to the oscillator to increase the strength of the harmonics.

* Court and Macy Sts., Fond du Lac, Wis.

More on Transmission-Line Interstage Coupling

In last month's Experimenters' Section a method of coupling a single-ended stage to a push-pull amplifier by means of an untuned line was described. A similar type of coupling has been used independently by a group of West

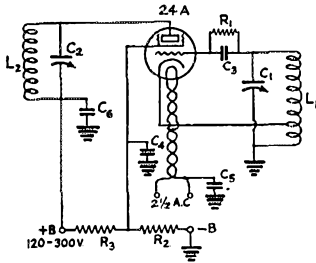

FIG. 2 — ELECTRON-COUPLED 100-KC. OSCILLATOR

- L_1 — 750-turn honeycomb coil tapped approximately 250 turns from inner end.
- L_2 — 17 turns No. 18 d.c.c. spaced to occupy $1\frac{1}{2}$ inches on $2\frac{1}{2}$ -inch form.
- C_1 — .001- μ fd. variable condenser.
- C_2 — 250- μ fd. variable condenser.
- C_3 — 100- μ fd. fixed condenser.
- C_4 — .001 μ fd. or larger.
- C_5 — .25 μ fd. or larger.
- C_6 — .005 μ fd. or larger.
- R_1 — 50,000 ohms.
- R_2 — 10,000 ohms.
- R_3 — 3000 ohms.

Coast amateurs, and a letter from Byron Goodman, W6CAL-QV, quoted in part below, points out the advantages of this system over capacity coupling, and tells how to make the adjustments:

"A method, due to Charles Lytton of Redwood City, that has been used to good advantage by

grid coil of the next amplifier. One side of the line is connected to the cold end of the grid coil, and the other side is tapped two or three turns up the coil. The rest of the circuit is conventional, as shown. To get the line matched to the coil, the tap is moved up and down the coil until, with constant grid bias, a maximum reading of the grid milliammeter is obtained (with no plate voltage).* At this point the excitation will be maximum, since the meter reads rectified grid current. Adjustment of the coupling of the pick-up coil can also be tried, and the loosest coupling consistent with high grid mils should be used. The amplifier is then neutralized in the conventional way, and slight retuning done all around. Neither the adjustment of the impedance match or the pick-up coil coupling will be found to be critical. Once the line is matched, a permanent plug-in grid coil can be made to facilitate band changing.

"The tuned grid coil acts as an autotransformer, and grid swings equal to several times the plate voltage of the exciting amplifier have been obtained, which is of course impossible with capacity coupling. The system is useful where several doubler stages are used since large grid swings, making for successful doubling, can be obtained. For doubling, the grid coil is tuned to the frequency of the exciting stage, and the doubling is done in the plate circuit. Lytton uses three regenerative pentode quadruplers, coupled by this system, and with a 3.5-mc. crystal has a crystal-controlled 56-mc. 'phone that is hard to beat for simplicity. W6MV has a 211 with 1400 volts on the plate, and the 852 it excites, coupled by this system, has 30 mils grid current with 1600 volts bias. The 852 runs cold with 980 watts input. At W6CAL, the 28-mc. output was quadrupled, using this type of coupling to the final stage. Several local stations use it, and excite 852's quite well with 10's, permitting more than twice as much input to be used as with capacity coupling."

R. F. Volume Control Connections

Referring to article on page 22, April *QST*, concerning change of volume control on National SW-3 from the audio to the radio frequency end of the receiver, a better method of making the connections is shown in Fig. 4.

The Yaxley 30,000-ohm tapered potentiom-

* Strictly speaking, this adjustment should be made with the amplifier plate voltage applied and the tube delivering power, because the input impedance of the tube changes both with plate voltage and load. The practical difference is likely to be small, however. — EDITOR.

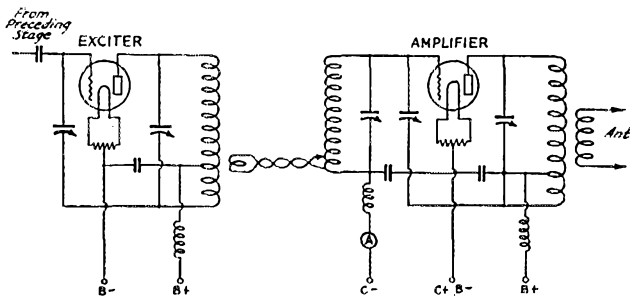

FIG. 3

many of the local stations, is the so-called 'impedance line' coupling. It is a modification of inductive coupling that has several distinct advantages: the amplifier can be removed from the preceding stage by several feet with no loss of excitation, there is no strain on the grid choke, and a decided voltage step-up is obtained.

"As shown in Fig. 3, a two-turn pick-up coil is loosely coupled to the exciting amplifier, and from this pick-up coil a twisted line is run to the

eter which is usually used in this case is inductive and difficulties are encountered unless

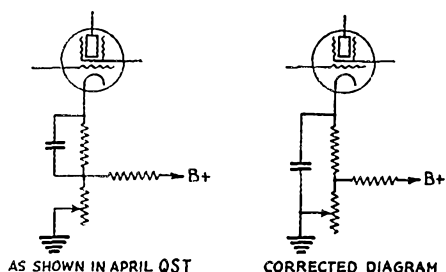

FIG. 4 — CORRECTED DIAGRAM FOR R.F. VOLUME CONTROL ON SW-3

the bypass condenser includes the potentiometer in addition to the actual fixed cathode resistor.

— Jack Wagenseller, W3GS-BF

Key Filter Constants

Using an inductance-capacity-resistance key thump filter of the type shown in Fig. 5, H. E. Vernon, W2EET-BTJ, has worked out the following formulas for determining the right size

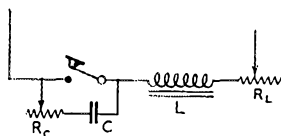

FIG. 5

of resistor to use once the inductance and capacity values have been decided upon. The formulas are:

$$R_L = 20 \times L \text{ in henrys}$$

$$R_c = \frac{50,000}{C \text{ in } \mu\text{fd.}}$$

These formulas are based on time constants of $\frac{1}{16}$ th second, which should be ample delay for eliminating transients caused by shock excitation when the voltage is applied to the keyed tube.

Hard-Drawn vs. Soft Copper Wire

When we recently considered putting up a 160-meter fundamental antenna, we ordered some antenna wire and were shipped, by mistake, some No. 12 enameled magnet wire. The question arose as to the stretch and final strength of this No. 14 magnet wire. A very simple tensile testing apparatus was rigged up and several samples tested, with data being recorded as to the increase in length up to the breaking point. The results of tests on a number of samples showed the wire to have an ultimate strength of approximately 150 lbs., and the amazing property of stretching,

before breaking, to the extent of $1\frac{1}{8}$ inches in an original measured length of $6\frac{1}{2}$ inches, the distance between markers on the sample being $7\frac{3}{8}$ inches at the time the wire broke. In the case of an 80-meter fundamental antenna, this would give a total stretch of 280 inches. Why then measure to the fraction of an inch or test for the proper length? The first heavy wind or load of ice will give the antenna considerable additional length.

With these thoughts in mind an investigation was made of the genuine "hard drawn" No. 12 copper wire. In the same test setup, the hard drawn wire showed a breaking strength of approximately 300 lbs. This wire showed a stretch of approximately $\frac{1}{64}$ of an inch in the 6.5 inches between markers, when stretched to the breaking point of 300 lbs. If the hard-drawn wire is stretched up to a 150-lb. load, sufficient to break the magnet wire, the total stretch would be only approximately one inch, compared with 280 inches for the softer wire.

— John H. McAulay, W7BUX

Duplex Portables

(Continued from page 10)

tween local stations. Another suggestion might be to use it at local bazaars, fairs, clubs and gatherings where it would be inconvenient or impossible to use a larger portable — for instance if space is limited or no a.c. power is available for the larger types of portable transmitters. Of course the transceiver would simply be used as pickup or relay station, passing on messages to the base station.

These portables have been in use for over six months and are still going strong.



From the RCA Victor Company of Camden, N. J., we learn that they are now supplying type UV-203-A with graphite anode at no increase in price. These tubes can be obtained in matched pairs for Class B audio use, if desired.

The approved ratings, which are conservative enough to insure long life and satisfactory operation, are as follows:

| Audio Frequency Power Amplifier—Class B | |
|---|---|
| Maximum operating d.c. plate voltage.. | 1250 volts |
| Maximum d-c plate current | Averaged over any audio frequency cycle... 0.175 amp. |
| Maximum plate dissipation | |
| Typical operation: $E_b = 1000$, $E_c = -35$, $E_f = 10$ V. d-c | |
| Zero signal plate current..... | 0.005 amps. |
| Maximum signal plate current.... | 160 milliamps. |
| Peak output..... | 100 watts |

The above ratings relate to one tube only.

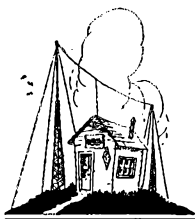

Amateur Radio STATIONS

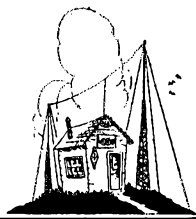

W8HD—WLHB, Wheeling, W. Va.

C. S. HOFFMAN, JR., became interested in radio during the World War and soon after the Armistice was signed and the ban on amateur activities lifted, installed a $\frac{1}{4}$ -kw. spark outfit with the usual trimmings and a loose coupler and crystal detector as the receiver. The first call held was 8BSU. A few years later, using two 202's on 200 meters, 8BSU worked the entire U. S.

bands, although 1.75- and 14.0-mc. also can be worked. Since completion of this transmitter in early summer, 1932, its signals have been heard in every state in the U. S., QSA5 R9 reports being received from all U. S. and Canadian Districts on 3.5 mc. Other 3.5-mc. DX includes reports from Europe, South Africa, Australia and New Zealand during the summer.

On the operating table is an SW-3 receiver and an external power amplifier for speaker use. There is also an electron-coupled oscillator and a G. R. wavemeter.

Many kinds of antennas have been tried at W8HD, and for simplicity of operation and minimum directional characteristics, a Marconi-type with counterpoise has been found most satisfactory. This antenna gives a strong enough ground wave to overcome skip to a great degree on schedules held with Army Amateur stations in West Virginia.

Hoffman is now serving his third term as S.C.M. of West Virginia, and was one of the nominees for Director of the Roanoke Division last fall. He also is one of the oldest O.B.S. and O.R.S. An Amateur Extra First Operator's license has been held for six years.

W8HD (and ex-8BSU) is also one of the oldest members of the Army Amateur Radio System. For the past two years W8HD has been Alternate Net Control A.A.R.S. for West Virginia. The War Department has recently assigned the special call WLHB for Army Amateur use on 3497.5 and 6990 kc.

In spite of a program of almost constant experimentation and S.C.M. correspondence, W8HD handles a fair amount of traffic each month, and is always pleased to rag-chew or QSP traffic.

A half-dozen portable calls have been issued to Hoffman from time to time, each having been used in connection with some particular experiment. Chief among these calls were 8QY and 8AKZ.

W9JNV, Woodmen, Colorado

W9JNV, owned by B. P. Hansen and located at the Modern Woodmen American Sanitarium, went on the air May 27, 1932. This was the first time on the air as an amateur for the



and was among the first hams to be heard by NZ4AA in New Zealand. Trolley line juice supplied the plate voltage, giving 8BSU a characteristic signal which became quite famous.

The call was changed to W8HD during 1927. Transmitters at W8HD have been many and various in design, with power outputs ranging from $7\frac{1}{2}$ to 500 watts. The transmitter shown in the photograph is crystal controlled, using a 47 crystal oscillator, a 210 buffer-doubler and an 852 power amplifier. Input to the final amplifier runs from 150 to 350 watts. Plate voltages are obtained from rectified alternating current, with 550 volts from the local trolley line as an auxiliary supply. Grid bias for the buffer and amplifier is obtained from storage batteries; a leak is used in the crystal circuit. The low-voltage rectifier, oscillator and buffer-doubler are built in aluminum shield boxes. Each of these is an individual unit and may be taken from the main transmitter assembly in a minute or less.

Operation is chiefly on the 3.5- and 7.0-mc.

owner since 1924, when he closed his old station, 9BQ. The station was planned to fit the conditions under which it was to be used, and has been highly successful in keeping the operator resting quietly in bed while working the set.

A portion of this transmitter can be seen in the photograph behind the operator's bunk. Power supplies are contained in a large lower rack. All other units are identical in size so they will match up whether piled up one on the other or lined up



W9JNV IN ACTION

in a row on a shelf or table. Copper shielding surrounds each unit and shields the parts of each transmitter from each other. Part of the shielding has been removed to show the interior of the transmitters.

The power unit supplies $2\frac{1}{2}$, 5, $7\frac{1}{2}$ and 10 volts from three filament transformers. There are several spare supplies of each voltage. The high voltage is 1500 volts from a pair of 866's through a two-section filter. There is also a separate 350-volt supply and a 550-volt supply. Several B eliminators supply bias voltages. Regulation of any keyed power supply is maintained constant by the stunt described in October, *QST*, page 80.

The 80- and 40-meter bands are handled by an m.o.p.a. transmitter using a high-*C* Hartley as oscillator and a low-*C* 210 amplifier. The 210 takes 1500 volts at about 120 mils on either 80 or 40. The oscillator coils are plug-in to change bands. It is not necessary to tune the amplifier coil as the tuning condenser for this stage covers a sufficiently wide range to permit operation at any part of either band.

A second transmitter for 40 and 20 meters employs a 47 crystal oscillator, a 46 doubler and a pair of 46's with grids in push-pull and plates in parallel as a second doubler. On 40 meters the first 46 is used as a straight neutralized buffer which works better than the more conventional method of doubling and then amplifying. The output stage, except for tank constants, is identical with that of the 80-40-meter m.o.p.a. — a straight, neutralized 210 stage that can be operated Class C and modulated with the Class B modulator unit if 'phone operation is desired.

This unit also carries about 1500 volts at 120 mils. Neither of these final stages shows the slightest sign of heating when everything is in exact resonance, but things happen fast if a tuning condenser is off as little as a half degree.

The transmitting aerial is a 133-foot single-wire fed Hertz stretched from the hospital roof to one of the smaller buildings. The feeder is about 350 feet long. The station is located on the eastern slope of Mt. Cedar at an elevation of 7000 feet; all is clear to the East but the Pike's Peak range rises straight up to another 7000 feet or so a few miles to the West. However, operation West has been decidedly favorable. The location is a ham's dream come true — no power QRNN — no other hams within 10 miles — high location and perfect quiet.

The receiver circuit is similar to the one described by Cassler in December, 1931, *QST* and uses a 58 untuned r.f. followed by a 35 detector and a 47 audio. Batteries are used on the r.f. stages and a good eliminator supplies the pentode plate power. A calibrated monitor is built in a copper can. A switching arrangement feeds the output of the monitor to the audio stage of the receiver when the station is in the transmitting position. The monitor is on all the time that the station is in operation, providing a continuous check on note and frequency.

The key, bug and power and monitor switches are all mounted on a 10- by 19-inch board which lies on the bed at the operator's right hand, the left hand takes care of the receiver. Master switches located just under the receiver shelf make it easy to switch on filaments, the receiver, and to throw the lightning switches without getting out of bed.

Traffic has been the main activity of the station although work has been on 160-meter 'phone and c.w.; 20- and 80-meter 'phone, experimental work on voltage regulation and on receivers and on carrier suppression for 'phone. The first serious traffic work was the handling of the large quantity of W6USA traffic just before and during last year's games. In March of this year the station closed down after handling, in three days, 471 messages into and out of the recent California earthquake area.

For Code Learning

THE beginning amateur usually finds that the greatest stumbling block on the path leading to a license is learning the code. The help of an experienced amateur is not always available, and in cases like these automatic transmitting machines are valuable. Automatic code-transmitting machines have been obtainable for a long time, but it is only recently that one has been developed which will not only transmit but

(Continued on page 70)

THE COMMUNICATIONS DEPARTMENT



F. E. Handy, Communications Manager
E. L. Battey, Assistant Communications Manager



ELSEWHERE in this issue is announced the plan for a Field Day test of portable equipment for the above dates. The idea of a local, national, and international outing ought to be popular. If a sufficient volume of results of portable station work is reported, perhaps we can make it an annual affair. At any rate, we hope this announcement will serve as a test of the emergency availability of portable stations and equipment, and be just as valuable as local Fire Prevention Week or like endeavors, in its own special field of focussing attention on the subject of "preparedness" for communications emergencies of course.

Any difficulties encountered with equipment in such a test should serve to inform the operators and owner of a portable station as to what might be expected under the more strenuous conditions of a true emergency call. If so, the modifications in design adopted in these sets in the immediate future should place all our stations in a position to do even better work in the future should occasion arise.

So don't pass up this opportunity to get out in the open and try some communication with a portable set. If you haven't a license for a portable station yourself, get in touch with your nearest radio club (see page 41, March 1933 *QST*) and help promote some activity of this nature through the club — or work with some other amateur who does have a license for portable equipment. It is not the purpose of the contest to use regular amateur stations from any regular location. The Field Day in effect invites *portable* stations to take part in a special *QSO Party*. This activity is designed for *portable stations only*, with the exception that these field stations may communicate with *all* amateur stations, in whatever band they work, in demonstrating their communicating ability. See the announcement on page 15 and don't pass up the June 10th-11th tests.

Effective with this issue of *QST*, we are adopting a new plan of classifying stations in the B.P.L. This change is made at the suggestion of the Delmarva Amateur Radio Club (Salisbury, Md.) and at the instance of A.R.R.L. Route Managers and S.C.M.s with whom proposed policies have been discussed. The D.A.R.C., in commenting, "feels that it has at times been impossible for a single operator to compete equally with clubs and stations having more than one operator."

All stations that "make the B.P.L." will continue to appear in the B.P.L. The requirements are the same as ever. However, stations having more than one regular operator (or where as much as 5% of the traffic is handled by other than the regular operator) will be grouped together in the Brass Pounders' League, apart from one-operator stations. All stations having more than one operator are requested to report to their S.C.M., without fail, their entire station total, and the number

of operators contributing in this work, whenever the total or number of deliveries is sufficiently high to "rate" B.P.L. consideration. It is hoped that this change will be more fair to every operator concerned, and your cooperation in making all our listings correct and accurate will be greatly appreciated. — F. E. H.

W9USA

For six months (June 1st to September 1st) the Chicago 1933 World's Fair, "A Century of Progress," will be in full swing. As reported, page 18, April *QST*, W9USA and W9USB are expected to be in continuous operation throughout the period of the Fair.

The World's Fair Radio Amateur Council, in charge of the 2000 square feet of amateur exhibit space, has arranged instructional displays (showing the wherefore of "resonance," "oscillation," etc., by analogy), and historical apparatus collections, and provided an information desk and general meeting place for all ham visitors, as well as arranged a striking display of new apparatus through the commercial or manufacturers' exhibits.

W9USA is endeavoring to keep lined up one ultra-reliable schedule in each of the 48 states, giving preference to stations operating in a state distributing network, or provided with a good system of five-point schedules for reliable traffic distribution. W9USA uses 3630 kc. for traffic work, and operates on 3907 kc. for voice communication. More transmitters on additional frequencies will probably be in operation by the time this is in print. All hams are asked to cooperate in giving W9USA assistance in handling and delivering traffic promptly.

QSP Chicago

A new Chicago amateur organization under this name has just been formed to facilitate message *deliveries* in that city all this summer. Each of the member-stations are crystal-controlled. Secretary Read, W9AA, writes of the plan as follows: "Our schedule will be changed each week, our stations keeping watch in rotation to make the hours equally fair to all. We shall be on watch from 9 p.m. to 1 a.m. nightly (Central time) and answer all calls (CQ CHGO) through the station on watch. All members of QSP CHICAGO will use frequencies between 7050 and 7100 kes. Our standards of station performance and operating ability will be the highest. W9LIB, W9CY, W9EQG, W9EJC, W9FCB, W9KB and W9AA are permanent members. W9LW, W9SJ and W9AFN will act as alternates, ready for work in any emergency. In the absence of traffic, stations will identify themselves at 10-minute intervals calling VVV QSP CHGO VVV W9 — AR QRZ? We plan to specialize on 'deliveries' to assist the many amateurs who will be in Chicago during the Exposition. We are cooperating with rather than competing with W9USA and endeavoring to offer an additional special service."

CQ CHGO (when you have traffic) between 9 p.m. and

1 a.m. C.S.T. and listen for replies between 7050 and 7100 kcs. "QSP CHICAGO" is ready for your call.

On 28 Mc.

W5ATY (Fort Worth, Texas) transmits on 28.8 mc. each Sunday between 9 a.m. and 7 p.m. C.S.T. Using a single '10 with 27 watts input he reports a QSO with HB9B Basel, Switzerland, starting at 10.35 a.m., April 23rd. As a result of the February-March 28-mc. tests, W9ARW reports hearing K4AAN and W5BD on February 25th, and W5OW on March 4th. These stations were heard between 9:00 and 10:30 p.m. C.S.T.

W6XBC

Reports are requested by station KUMA, Yuma, Ariz., on reception of their experimental transmitter, W6XBC, which is to be used for broadcast pickups. Frequencies authorized are 27,100, 34,600, 41,000, 51,400 and 60,000-100,000 kc. W6XBC will operate regularly from 8:30 to 9:30 p.m. M.S.T., each Thursday, as well as at other indeterminate times. Reports appreciated.

Through W2BSR we learn that the Riiser Larsen Expedition (LMZ) was recently lost at sea en route to the Antarctic. The party is returning to Norway on a whaler.

The following contribution by Mr. J. H. MacLafferty, Jr., W6RJ, wins the C. D. article contest prize for this month. Your articles on any phase of amateur communication activity are likewise solicited. See the announcement page 56, March 1933 QST. Send yours today.

— F. E. H.

Traffic Don'ts

By J. H. MacLafferty, Jr., W6RJ*

ONE of the important phases of the Radio Amateur's work in justifying his existence is the relaying of radiograms without charge to the public. It is one of the means by which he supports his claim that his station is operated in the "interest, convenience and necessity" of the people. The reliability and accuracy with which he handles worth-while message traffic have much to do with his status.

Somebody or other has said, "Anything that is worth doing at all, is worth doing well." Oftentimes we note the date and text of messages received at our stations and scratch our heads and wonder. "Deepest sympathy in your bereavement—" originated three weeks ago. One the other night for Manitoba in which the hopeful sender ventured, "— you will probably get this on Mom's birthday." "Yeah, so's your Aunt Emma," said I as I looked at the date.

During the traffic reporting month, February 16th to March 15th last, 2030 stations originated 39,548 messages and 30,136 were delivered, which means that 23.6% of the originators will give us the "raspberry." While perhaps we are not all at fault, such individual shortcomings reflect on the whole fraternity. Another case of the diligent suffering for the acts of the careless.

True, our shortcomings do not look so good in print. Let us be honest with ourselves. Let us brass-pounders give thought to the end that our service and our status may be improved. Isn't that what we all want?

Modern technical information and equipment, together with the facilities of our traffic organization, make it easily possible for us to render a valuable service. If something is wrong with our individual procedure, let's fix it. My own is far from perfect. Here are some DON'TS that will help, listed in what is believed to be the order of their importance:

DON'T operate illegally. DON'T be afraid to REFUSE

*ORS, T.L.S., 2901 Rawson St., Oakland, Calif.

traffic for relay. If you are not reasonably certain you can forward the message, DON'T TAKE IT. DON'T forget that the speed with which messages pass through your station and the reliability and accuracy with which they are handled are of more help to Amateur status and everybody concerned than the number of messages handled. DON'T EVER allow a message to die on the hook. Only "rotten squirts" do that. DON'T keep a message more than 48 hours. If you can't QSP by radio, mail it. DON'T give traffic to a station whose ability to QSP is doubtful. DON'T encourage the origin of any but worthwhile radiograms and DON'T suggest lengthy messages (for speed, accuracy, and efficiency in amateur work are thus improved). Ask the sender to make it "short 'n' sweet" as possible. (I can hear a lot of the gang saying "Amen" to that one—hi.) DON'T hesitate to ask for QRS if you need it, and DON'T forget to report to your SCM on the 16th of each month.

Earthquake Lessons—Re QRR Work

IF DISASTER visited your district would you have been prepared to accept the responsibility of establishing radio communications? Do you have equipment at hand to function unflinchingly in emergency should occasion arise? . . . if commercial power supplies failed? Lesson 1—be prepared.

Emergencies are always unexpected. This is no excuse for being caught unprepared. In your station keep on file addresses of state, county and local Red Cross officials, local military units, the police department, the nearest dispatcher's office of the railroad, etc., as well as those of the mayor, governor, and press associations. Page 184, 10th Edition Handbook, summarizes what to do, and what messages should receive priority in emergencies.

Give some thought now to the possibility of actual emergency. Outline the plans that you will follow in such a way that your work in a time of stress will be as effective as possible, and reflect fullest credit on amateur radio and yourself.

"It was pathetic to hear a few 6's (and stations in other districts working 6) unable to get off their stuff in a hurry, simply because they had never done anything but chat or exchange reports. Some operators when obliged to make fills were helpless. — W9ADG." Lesson 2. If you haven't made yourself a proficient operator, start to do so right now. If you are reasonably proficient, add to your proficiency. Know message form? See the Handbook chapter on "Message Handling." Know procedure? Study the following for a starter! Any that you don't use now, put into use in your next QSO . . . get operators in your circle of amateur acquaintances to use 'em. Actually use 'em every day, on the air, until familiar with all.

AA All after (used after to request a repetition)

AB All before (used after to request a repetition)

WA Word after (used after to request a repetition)

WB Word before (used after to request a repetition)

BN All "between" . . . and . . . (used after)

‡ (.) Start me where? (When request for a fill is not received OK)

HR or P Here message. (After a call or message, indicates more traffic)

C Correct or yes.

N No.

O.B.S.

The following is a supplement to the list of A.R.R.L. Official Broadcasting Stations in November QST (page 51):

WIACK, WIAWO, WICCX, WILH, W2AMM, W2CZP, W2SN, W3BIG, W3CVN, W5AFW, W8DPR, W8EEQ, W8EEW, W9BTG, W9CHA, W9GDU, W9HPQ, VE2CO.

BRASS POUNDERS' LEAGUE

(MARCH 16TH-APRIL 15TH)

| Call | Orig. | Del. | Ret. | Total |
|-------|-------|------|------|-------|
| W3CXL | 328 | 518 | 1456 | 2302 |
| W9V8 | 78 | 512 | 1522 | 2112 |
| W6EWQ | 475 | 335 | 1162 | 1972 |
| W5OW | 17 | 172 | 1619 | 1808 |
| W9ESA | 11 | 66 | 1430 | 1507 |
| W9KG | 6 | 115 | 979 | 1100 |
| W8DDS | 67 | 182 | 837 | 1086 |
| W9AUX | 75 | 42 | 938 | 1055 |
| W6CDA | 15 | 49 | 980 | 1044 |
| W9AMB | 23 | 175 | 818 | 1034 |
| W8AIB | 38 | 27 | 928 | 993 |
| W5BBI | 16 | 61 | 903 | 980 |
| W9JID | 99 | 67 | 810 | 976 |
| W1UN | 296 | 187 | 464 | 947 |
| W6EQ | 280 | 171 | 472 | 923 |
| W8CPE | 352 | 376 | 162 | 920 |
| W6UO | 15 | 18 | 886 | 914 |
| W3OK | 168 | 121 | 611 | 900 |
| W8DZ | 80 | 52 | 760 | 892 |
| W9GEP | 466 | 217 | 185 | 868 |
| W6EMC | 9 | 14 | 738 | 811 |
| W8PP | 34 | 48 | 683 | 765 |
| W8AWX | 106 | 183 | 471 | 760 |
| W8BBH | 94 | 123 | 536 | 753 |
| W3CJS | 58 | 225 | 458 | 741 |
| W8QV | 95 | 125 | 528 | 738 |
| W8ETL | 119 | 52 | 532 | 733 |
| W8EIS | 206 | 210 | 312 | 728 |
| W9CSY | 37 | 64 | 622 | 723 |
| W9DGS | 25 | 57 | 626 | 708 |
| W9GCG | 42 | 33 | 625 | 700 |
| W6HEM | 14 | 32 | 686 | 694 |
| W6BFO | 58 | 187 | 449 | 694 |
| W8FDY | 42 | 20 | 631 | 693 |
| W6EDW | 70 | 149 | 470 | 689 |
| W3AGN | 305 | 85 | 288 | 678 |
| W7KL | 222 | 444 | 49 | 676 |
| W2BZZ | 15 | 31 | 618 | 664 |
| W8JE | 49 | 57 | 545 | 651 |
| W9AET | 54 | 62 | 528 | 644 |
| W8BAH | 158 | 139 | 328 | 625 |
| W3CL | 92 | 165 | 360 | 617 |
| W9EAD | 29 | 32 | 536 | 597 |
| W3ALX | 24 | 67 | 487 | 578 |
| W8GQJ | — | 66 | 503 | 569 |
| W6ALU | 105 | 165 | 298 | 568 |
| W9E3W | 112 | 316 | 127 | 555 |
| W9AZR | 33 | 66 | 467 | 555 |
| W3CXM | 37 | 163 | 294 | 554 |
| W8PO | 59 | 41 | 449 | 549 |
| W6EDO | 21 | 39 | 486 | 546 |
| W9DKL | 19 | 21 | 504 | 544 |
| W9BN | 39 | 43 | 410 | 542 |
| W6MK | 351 | 187 | — | 538 |
| W8FTW | 28 | 9 | 501 | 538 |
| W4HA | 4 | 26 | 502 | 532 |
| W8EEQ | 285 | 56 | 189 | 530 |
| W9DRO | 106 | 74 | 344 | 524 |
| W6FCT | 27 | 33 | 444 | 523 |
| VE3QE | 97 | 298 | 118 | 513 |
| W9BKX | 41 | 53 | 418 | 512 |
| W1FEX | 373 | — | 133 | 506 |
| W9ENE | 50 | 34 | 420 | 504 |
| W9HJC | 17 | 34 | 450 | 501 |
| W1CJD | 15 | 26 | 480 | 501 |

MORE-THAN-ONE-OPERATOR STATIONS

| | | | | |
|-------|-----|-----|------|------|
| W2DIU | 412 | 278 | 1176 | 1866 |
| W3BN | 373 | 189 | 1090 | 1652 |
| W9BNT | 175 | 541 | 588 | 1304 |
| W9BN | 23 | 45 | 1110 | 1178 |
| W3BKQ | 86 | 77 | 967 | 1130 |
| W6YJ | 781 | 24 | 218 | 1023 |
| KAIHR | 226 | 206 | 478 | 910 |
| W9NF | 43 | 216 | 484 | 743 |
| W9USA | 29 | 113 | 380 | 722 |
| W3BWT | 105 | 134 | 589 | 628 |
| W8YA | 91 | 78 | 434 | 603 |
| WSNT | 67 | 98 | 396 | 561 |
| W8WF | 27 | 42 | 457 | 527 |
| W1ME | 49 | 196 | 281 | 526 |

These stations "make" the BPL with totals of 500 or over. Many "rate" extra credit for one hundred or more deliveries. The following one-operator stations make the BPL for delivering 100 or more messages; the number of deliveries are as follows: Deliveries count!

| | | |
|------------|------------|------------|
| W6HM, 234 | W9FSS, 163 | W8HGG, 105 |
| W2ANV, 187 | W1BZO, 121 | W5MN, 104 |
| W8FX, 185 | W6HW, 118 | W8EFC, 104 |
| W8CUG, 177 | W6EKL, 108 | KAILG, 103 |
| W7BSX, 173 | W6HML, 108 | |

A total of 500 or more, or just 100 or more deliveries will put you in line for a place in the B.P.L. Make more schedules with reliable stations. Take steps to handle the traffic that will qualify you for B.P.L. membership also.

XXON4AU

In late May and early June, W/VE hams may hear or take part in preliminary tests with a Belgian station (member-station of the Reseau Belge — I.A.R.U.) working in the high frequency end of the 7- and 14-mc. bands. This station will use a Hertz antenna (current feed) on the wings of a Bush-moth gypsy 115 H.P. 'plane. The station will use 25 watts for code, and 40 watts for 'phone transmissions.

Listen especially on Thursdays and Sundays, near 7300 or 14,400 kcs., between 1500 and 1800 (Summer Greenwich Time), or 10 a.m. and 1 p.m. E.D.S.T., for a dc or xdc signal signing XXON4AU (or W5 when in communication with H5). Mr. Mahieu of Peruwelz, Belgium, is looking forward to DX QSOs with W/VE stations, and a special airplane QSL will be forwarded confirming reports and QSOs. This May and June work from a 'plane is preparatory to holding communication with Max Cosyns' (Prof. Piccard's assistant) expedition to the stratosphere. This scientific work is now scheduled definitely for July.

Route Manager Brown, W6BPU (Pasadena), reports that at the time the 'quake came along W6DKM had saved up \$8.00 for a new tube. He actually spent \$8.40 in delivering messages, telling the gang he would rather help the people get word to their relatives than get a flock of new tubes. That's a real example of true ham spirit!!

'Phone Tests with Belgium

ON4ZA, Headquarters station of the Vlaamsche Radio Bond, a Belgian organization of amateurs, will start experimental 'phone transmissions each Sunday morning throughout June, on a frequency near 3500 kc., between 0030 and 0130 G.C.T., at which time ON4ZA will listen for any DX station calling him. Announcements will be made in English, Flemish, French, and German, between test gramophone record transmissions. A 40-watt transmitter, dynatron-controlled, Class B with 46 tubes will be used, and reception accomplished with an S.S. receiver. The object is to see what 3.5-mc. DX can be accomplished, and all reports will be welcomed and answered by a special card. Address reports to ON4ZA, V.R.B., P. O. Box 65, Ghent, Belgium.

Listen for ON4ZA, June 3rd, 10th, 17th, and 24th, between 7.30 and 8.30 p.m. E.S.T., which is the same as 8.30 to 9.30 p.m. E.D.S.T. We are asking ON4ZA to try to work the W-hams who call on voice (between 3900 and 4000 kc.) at the end of his test period.

Traffic Briefs

The Adirondack Amateur Radio Club will sponsor the 1933 Northern New York Annual Hamfest. It will be held in Malone, N. Y., May 30th, 7 p.m., at the Hotel Flanagan. All U. S. A. and nearby Canadian amateurs are invited. There will be plenty of stunts, prizes, and a large display of amateur equipment, as well as an illustrated lecture on tubes and superhets. One dollar for the dinner and only 25 cents for registration.

Michigan, attention! Jay A. Dyer, Secretary-Treasurer, Marquette County Radio Amateurs, announces Upper Peninsula Michigan Hamfest to be held at Marquette, June 23rd-24th. All welcome. Good time assured.

Phil Gildersleeve, W1CJD, better known as "Gil," QST's cartoonist, entered the "fifth stage" of amateur radio on May 1st. Mrs. Gildersleeve was formerly Miss Helen Fagan of East Hampton, Conn. Congrats, Gil.

W5BYX, W. H. Edens, Jr., Arcadia, La., is interested in organizing a coast to coast traffic lane. Those interested in such a project should communicate with him, giving data on present schedules, hours of operation and frequencies used.

ELECTION NOTICES

To all A.R.R.L. Members residing in the Sections listed below; (The list gives the Sections, closing date for receipt of nominating petitions for Section Manager, the name of the present incumbent and the date of expiration of his term of office.) This notice supersedes previous notices.

In cases where no valid nominating petitions have been received from A.R.R.L. members residing in the different Sections in response to our previous notices, the closing dates for receipt of nominating petitions are set ahead to the dates given here-with. In the absence of nominating petitions from Members of a Section, the present incumbent continues to hold his official position and carry on the work of the Section subject, of course, to the filing of proper nominating petitions and the holding of an election by ballot or as may be necessary. Petitions must be in Hartford on or before noon of the dates specified.

Due to resignations in the Quebec and Northern Minnesota Sections nominating petitions are hereby solicited for the office of Section Communications Manager in these sections and the closing date for receipt of nominations at A.R.R.L. Headquarters is herewith specified as noon, June 15, 1933.

| Section | Closing Date | Present SCM | Present Term of Office Ends |
|--------------------|----------------|----------------------------|-----------------------------|
| Mississippi | June 15, 1933 | Wm. G. Bodker | Jan. 15, 1933 |
| Quebec* | June 15, 1933 | Alphy Blais (resigned) | |
| Northern Minnesota | June 15, 1933 | Palmer Andersen (resigned) | |
| Arizona | July 10, 1933 | Ernest Mendoza | July 15, 1933 |
| Eastern Pa. | July 10, 1933 | J. Wagenseller | July 15, 1933 |
| Eastern N. Y. | Sept. 15, 1933 | R. E. Haight | Sept. 18, 1933 |
| Eastern Mass. | Sept. 15, 1933 | J. A. Munn | Sept. 18, 1933 |
| Ontario* | Sept. 15, 1933 | H. W. Bishop | Sept. 15, 1933 |

1. You are hereby notified that an election for an A.R.R.L. Section Communications Manager, for the next two-year term of office is about to be held in each of these Sections in accordance with the provisions of By-laws 5, 6, 7, and 8.

2. The elections will take place in the different Sections immediately after the closing date for receipt of nominating petitions as given opposite the different Sections. The Ballots mailed from Headquarters will list the names of all eligible candidates nominated for the position by A.R.R.L. members residing in the Sections concerned. Ballots will be mailed to members as of the closing date specified above, for receipt of nominating petitions.

3. Nominating petitions from the Sections named are hereby solicited. Five or more A.R.R.L. members residing in any Section have the privilege of nominating any member of the League as candidate for Section Manager. The following form for nomination is suggested:

(Place and date)

Communications Manager, A.R.R.L.
38 La Salle Road, West Hartford, Conn.

We, the undersigned members of the A.R.R.L. residing in the Section of the Division hereby nominate as candidate for Section Communications Manager for this Section for the next two-year term of office.

(Five or more signatures of A.R.R.L. members are required.) The candidates and five or more signers must be League members in good standing or the petition will be thrown out as invalid. The complete name, address, and station call of the candidate should be included. All such petitions must be filed at the headquarters office of the League in West Hartford, Conn., by noon of the closing date given for receipt of nominating petitions. There is no limit of the number of petitions that may be filed, but no member shall sign more than one such petition.

4. Members are urged to take initiative immediately, filing petitions for the officials for each Section listed above. It is your opportunity to put the man of your choice in office to carry on the work of the organization in your Section.

— E. E. Handy, Communications Manager

* In Canadian Sections nominating petitions for Section Managers must be addressed to Canadian General Manager, Alex Reid, 169 Logan Ave., St. Lambert, Quebec. To be valid

such petitions must be filed with him on or before the closing dates named.

ELECTION RESULTS

Valid petitions nominating a single candidate as Section Manager were filed in a number of Sections on or before the closing dates that had been announced for receipt of such petitions. As provided by our Constitution and By-laws, when but one candidate is named in one or more valid nominating petitions this candidate shall be declared elected. Accordingly election certificates have been mailed to the following officials, the term of office starting on the date given.

| | | |
|--------------------|--------------------------|----------------|
| Iowa | George D. Hansen, W9FFD | March 20, 1933 |
| Western Fla. | Edward J. Collins, W4M8 | March 20, 1933 |
| Northern Texas | Glen E. Talbut, W5AUL | April 15, 1933 |
| North Carolina | G. H. Wright, Jr., W4AVT | April 15, 1933 |
| N. Y. C. and L. I. | Edward L. Baunach, W2AZV | April 15, 1933 |

In the Rhode Island Section of the New England Division, Mr. Stanley Atkinson, W1AFO and Mr. Charles Newton Kraus, W1BCR, were nominated. Mr. Atkinson received 32 votes and Mr. Kraus received 23 votes. Mr. Atkinson's term of office began May 4, 1933.

First Annual American Inferno

On April 16th the First Annual American Inferno — ski race from the summit of Mt. Washington, N. H. — was run under the auspices of the Ski Club Hochgebirge of Boston. 56-mc. communication was maintained between the starting and finishing points of the race by Alexander McKenzie, W1BPI, operating W1FEX, the Mt. Washington Observatory at the Summit, and Joe Dodge, W1UN, operating W1OB at the Cascades, with the assistance of Harris Fahnestock, Jr., W1ZL. This was the first time in the United States that a ski race was timed on one watch, thus eliminating the lengthy computations involved in correcting the times for deviations between the previously synchronized watches at the start and finish.

LeRoy Haley, W9GNK, postmaster at Tacoma, Colo., claims the poorest radio location in the U. S. . . . in bottom of a canyon, 900 feet wide and 1000 feet deep, 300 feet from a 10,000-hp. hydro-electric generating station (QRM!!) and surrounded by tall pine trees (antenna strung between two of them). On the east the canyon wall goes on up for 6000 feet more! Wow!

W6FFP has a separate transmitter on each of the bands 14, 7, 3.5 and 1.7 mc. To change bands he merely switches the keying leads. He reports good results on the 1.7-mc. band, having worked W9EFC and W9EKK using a 7-mc. half-wave Zepp.

From W3ATJ, Mt. Holly, N. J.: "I worked ZLIAS on April 10, 1930, at 11:00 p.m. E.S.T. on the 14-mc. baud. I was using a high-C Hartley with 270 volts on the plate. The rig drew 45 mills, and with the antenna coupled, 60 mills. I worked him with 'phone for over an hour."

Relative Standings of the Ten Highest Sections—Mar.-Apr.

| Messages Per Station (25%) | Stations Reporting Traffic (25%) | Gain or Loss (Traffic Reports) (25%) | Traffic Total (25%) | Standing Based on Average of All Four Ratings % | Section Communications Manager |
|----------------------------|----------------------------------|--------------------------------------|---------------------|---|--------------------------------|
| Nev. 484.5 | Los Ang. (680)* 144 | Mo. +17 | Ohio 9059 | Ohio 67.5 | Tummonds, W8BAH |
| M.-D.-D. C. 333.1 | Mich. (624)* 120 | Ohio +11 | Los Ang. 8610 | Los Angeles 47.5 | Martin, W6AAN |
| E. Bay 278. | Ohio (864)* 78 | Conn. +4 | Mich. 7336 | Wisconsin 42.5 | Karich, W9FSS |
| Ark. 241.5 | Wis. (158)* 74 | Wis. +4 | Wis. 7247 | Michigan 42.5 | Conroy, W8DYH |
| Hawaii 241.1 | Mo. (324)* 74 | N. H. +4 | E. Pa. 6240 | Missouri 40. | Cannady, W9EYG |
| W. Pa. 211.3 | Ill. (890)* 70 | No. Dak. +4 | M.-D.-D. C. 6330 | M.-D.-D. C. 35. | Ginsberg, W3NY |
| Colo. 197.5 | Wash. (374)* 58 | La. +4 | Ill. 6288 | East Bay 25. | Houston, W6ZM |
| P. I. 191.3 | Wis. (353)* 49 | Ind. +3 | S. Minn. 5344 | Connecticut 25. | Elli, W1CTI |
| E. Pa. 182.8 | Conn. (37)* 49 | Ky. +3 | E. Bay 5008 | Nevada 25. | Kanary, W6EAD |
| S. Tex. 177.8 | Oregon (260)* 43 | Alaska +3 | W. Pa. 4861 | Illinois 22.5 | Hinds, W9APY-WR |



OHIO gets the Banner for the first time in over a year. Los Angeles is in second place, followed by Wisconsin and Michigan. L. A. and Michigan each have over 100 traffic reporting stations. FBI! The following Sections lead all other Sections in their Divisions, order of listing showing relative standing of their different Divisions: Ohio, Eastern Pennsylvania, Kansas, East Bay, Southern Minnesota, Connecticut, Tennessee, Northern New Jersey, Southern Texas, Virginia, Oregon, Ontario, Colorado, Alabama. During the March 16th-April 15th month, 1818 stations originated 26,960; delivered 25,591; relayed 103,878; total 156,429. (94.8% del.) (86.3 m.p.a.)

* Section A.R.R.L. membership shown by () % reporting traffic: Va. 46.8%, Mo. 22.8%, Los Ang. 21.2%, Mich. 19.3%, Wash. & Ore. 16.5%, Wis. 13.9%, Conn. 13.3%, Ohio 9%, Ill. 7.9%.

56-Mc. Tests

Some 56-mc. work is now being planned for the latter part of June between three Maine points, roughly 100 miles apart, Mt. Katahdin, Mt. Cadillac, and Mt. Bigelow. W1BFZ and Pierce (ex-1EB) plan to spend a week, the latter part of June, on Mount Katahdin, working as many stations as possible via 56 mc. W1AUC and W1ARV will probably have a gang of hams on Mt. Cadillac and Mt. Bigelow respectively. All Maine hams who are licensed for portable station operation, and also any out-of-state visitors who can arrange to do so, are invited to communicate with J. A. Pierce, 100 Maine St., Orono, Maine, and take part in these 56-mc. activities.

ATLANTIC DIVISION

SOUTHERN NEW JERSEY—SCM, Gedney M. Rigor, W3QL—Outstanding work in handling 'quake messages was accomplished. Many of our gang were in the thick of this work.

Traffic: W3BYM 22 AZZ 8 BDB 15 CWL 10 BUU 2 QL 9 PC 38 BLV 6 AYA 5 BEI 23 AOV 15 AEL 12 BDO 2 ADL 27 CLQ 29 ZI 6 BYR 11 CNI-BQC 1 AKI 11 IS 2 APN 115.

MARYLAND-DELAWARE-DISTRICT OF COLUMBIA—SCM, Harry Ginsberg, W3NY—W3BAK, W3SN, RMs. W3BWT, Chief RM. W3SN has a daily A.A.R.S. affiliate net connecting all Maryland. The Washington Radio Club held hamfest Apr. 15th with FB crowd. The Frederick Amateur Radio Association elected W3ABA, pres.; W3WN, vice-pres.; Anderson, secy., W3BJV, treas. The last technical meeting until fall of the Institute of Radio Conferes was held at a dinner Apr. 21st. W3AHA spoke on mixing panels and matching impedances. W3CV is a silent key. W3NY does not intend to run for re-election as SCM. District of Columbia: W3CXL found re-traffic good. W3BWT is going strong. W3WU reports for first time. W3LL has to erect new antenna. W3NR is rebuilding BCL receiver. W3CDQ participated in DX tests. W3AJL promises traffic. Maryland: W3CJS holds up Baltimore on traffic map. W3BXX is doing FB traffic work. W3CQS was present at D.C. hamfest. W3CMS is building MOPA. W3CTD guarantees Hagerstown delivery. W3CDG is QRL farming. W3LA rebuilt receiver. W3BRS reports 14-yr.-old graduate of the WARC code class. W3BGI is rebuilding antennas. W3CZH, ex-8VZ, keeps 8DSS in contact with his brother. W3CIZ helps out. W3ZD is building a 'phone rig. W3BHE is awaiting ORS. W3DG is going in for 1.7-mc. 'phone. W3AVD is building panel job. Delaware: W3BAK has great support in his run for SCM job. W3CPG is experimenting on 56 mc.

Traffic: W3CXL 2302 SN 1652 CJS 741 BWT 628 BAK 245 BXX 211 CQS 181 CMS 100 CTD 64 CDG 45 LA 41 BRS 24 WU 23 BGI 21 CZH 20 CIZ-IL 11 ZD 7 NR 3.

WESTERN NEW YORK—SCM, Don Farrell, W8DSP-GYV—W8GWZ spent winter in Florida. W8AFM is QRL Atlantic Division Convention. There will be special prizes for those who purchase the first two hundred tickets. W8BGN says forty-one hams took exam at Rochester. W8ABX is on 56 mc. W8BHK is using a type '60 in final. W8AJS is interested in ORS. W8ERU reports that W8CN worked a ZL on 3.5 mc. W8AKX had a 100% QSO with PY2BN. W8AYI has a complete new outfit. W8FEG has a new junior op. W8BJO is off on account of depression. W8ARX is rebuilding. W8GUJ had several of the gang help him erect new antenna. W8DWJ will be on the air from his summer home in the Adirondacks. W8AVS is awaiting transmitter he won from the Empire State Labs. W8DT has an FB-7. W8BAI maintains a Hertz antenna is better than a Zepp. W8HNZ will handle traffic. The Mohawk Valley Brass Pounders recently installed new officers. W8FSG is going on 1.7-mc. 'phone. W8HZH was recently wedded. W8DGR will have W8DEB perform the ceremonies for him and the YL. The Adirondack Amateur Radio Club has a type

'61 for prize to be given at hamfest on May 30th. The Mohawk Valley Amateur Radio Club has become affiliated with the League.

Traffic: W8AWX 760 FDY 693 DII 301 DSS 229 BWY 213 BFF 172 DHU 90 BDK 62 BR 39 CPC 34 BQJ-EUY 26 GWT 19 DES 18 DME 16 DHQ-DSP 13 HKF 11 DMJ-CDB 7 AGS 6 FMX 5 BLH 3 JE 651 IY 218 CPJ 177 GPT 28 GWY 25 CQW 22 AYM 20 CBK 18 BGL 15 FYF 9 FFU 6 GZM 4 ERU 3.

WESTERN PENNSYLVANIA—SCM, C. H. Grossarth, W8CUG—W8CPE leads the Section. W8EIS came out second in PSP contest. W8YA handled a lot of PSP traffic. W8HGG is after OBS appointment. "More schedules," says W8CCD. W8EDG will be QRL other activities. W8DKL has a new layout. W8WQ turns in nice total. "Still rebuilding," says W8FKU. W8DYF thinks e.c. oscillator beats crystal. W8GBC received unlimited 'phone license. W8DZY was active in PSP contest. W8DYL, KD and AEG report. W8CLG says W8NE is going in for c.w. W8GAP has a new car. W8CMP didn't miss a PSP! W8FRA reports by radio. W8IAT is working a lot of DX. W8CFR is looking for a job. W8HUL reports W8BVE back on the air. W8GYH is rebuilding for c.c. W8AVY is heard on 7 mc. occasionally. W8HWU is building c.c. rig. W8IFB and ITF are new hams. W8BWL is new ORS. W8CUG won third prize in PSP contest. Who wants an RM job? W8AJE has asked to have his appointment cancelled.

Traffic: W8CPE 920 EIS 728 YA 603 CUG 483 HGG 396 CCD 313 EDG 285 DKL 216 AJE 205 WQ 181 DYV 149 FKU 92 FRA 73 DYF 53 GBC 36 CLG 30 CMP 23 DYL 27 AEG 19 CFR 11 IAT 6 HUL 5 HWU 2.

EASTERN PENNSYLVANIA—SCM, Jack Wagenseller, W3GS-BF—W3AQN, W3ALX, W3OK, W3CL and W3BKQ all make the BPL. The Quaker Radio Club has 85 members now. W3ASF is on 56 mc. W3CLG is rebuilding. W3BKQ is joining the A.A.R.S. W3CL operated in an airplane during the Akron disaster. W3ADE was presented with a YL operator. W3AQN is trying to make the 1000 mark. W3AHD was off due to changing QRA. W3AZT applied for an airplane license for ultra-high frequency work.

Traffic: W3VR 49 MR 4 AQN 678 CEM 12 BIS 43 ANZ 8 ADE 19 MC 247 ALX 578 CUI 24 CHU 7 AZF 2 NF 86 AAV 90 BEY 342 BLS 23 BPX 20 CJA 30 APX 1 OK 900 CL 617 AKB 275 BRH 72 BKQ 1130 ABZ 165 DZ 15 BIJ 8 ABT 301 COV 5 BF 29. W8CFE 112 EOH 12 FLA 79 AFV 352 CFF 65.

CENTRAL DIVISION

KENTUCKY—SCM, Carl L. Pfumm, W9OX—W9CIM noses W9OX out of first place. MD makes W9JYO suspend schedules. W9BAN and IFM are getting near the top. W9BWJ's 73-foot stick stops all ham traffic on Highway No. 60. W9CNE has an FB-7. W9ETT is back to his old love, c.w. W9FHZ is welcome newcomer to state network. W9ELL-W9AUH take beer-drinking contest at radio club. W9MGT applies for ORS. W9EYW has new ACSW-45. W9GNV gets out well on 1.7-mc. 'phone.

Traffic: W9CIM 358 OX 351 BJA 197 JYO 157 BAN 124 BWJ 115 IFM 103 AUH 87 KKG 83 HAX 64 ARU 60 EQO 56 CNE 51 ETT 39 FEZ 36 ELL 34 FQQ 21 MGT 20 EYW 18 CIS-AQV 17 ERH 16 GOB 13 BAZ 11 CDA 9 EGO 8 FBJ 4.

MICHIGAN—SCM, Kenneth F. Conroy, W8DYH—To the 354 amateurs attending the recent D.A.R.A. Hamfest, we wish to express heartfelt thanks. W8DZ dethrones W8PP! W8PP is taking a well-earned vacation. W8FTW is after schedules. W8ARR (W8DUR) boasts, "Didn't un-soldier a thing this time!" W8BMG reports the death of his brother-in-law, W9FJT, a real amateur. W8AMS reports again after six years. W8QT claims rebuilding—we spell it T-h-e-r-e-s-a. W8DFE, HBZ, WR and HZO can't take it, spills W8GBB; they've gone H.F.—QRN. W8GQB has a 7-mc. trans-con going. W9HSQ wants all hams at the Marquette Hamfest, June 24th and 25th. W8BGY wants the ORS shelved for summer. W9HXB's transmitter feels "depressh." W8AYO

knocks 'em cold in IRC. W8IFO has troubles because the fact that his head-band is swell for marcel-waves! W8DVC is added to our list of "Rushin' Reds." W8FX will take a sax-o-phone/me for trap drum rigging. W8SH is not going to be shh-ed anymore. W8EVC plans on coasting for summer. Lookie how W8EHD is putting Millington on map! W8IDB pushes 'em out FB. W8GUC is after traffic. W8DWB is back to work. Mrs. W8DYH's code practice group on 3838 kc. increases. QSL. W8DLX wants to know if W8QT is through with the Grand Rapids Kresge piano playing gal! Yes, W9BBP, Michigang has gone YL. W9HK is rebuilding. W8WO reports treating 54 cases of measles. W9YX is on all bands. W9EQV's "B" batts are down with his spirits! The Ivory Brothers, W8FVP and HSH, are trying to be 99 44/100% pure d.c.! See you with D.A.R.A. TFC Bulletin; copy free to any station reporting to SCM, W8DYH, on 16th of each month. Another one to the barn-yard club — W8HOG, Detroit.

Traffic: W8DZ 892 PP 765 FTW 538 FX 407 EHD 404 EVC 330 DWB 233 BGY 205 DLX 181 AYO 159 IDB 154 DUR 142 GBB 141 QGB 139 FAV 126 IGA 125 ARR 116 QT 110 CST 83 CPY 82 DVC 76 CFM 56 HUD 50 EDO 47 AW-FWT 46 GDR 45 BHH-DYH 37 GMB 34 BBX 33 BJ-DED 30 GUC 29 BMG-ETP 27 BIK-CUX 24 EGI 23 CEU-GRN 22 CTH-DMR 21 FRW-JO 19 COW-HBZ 17 FVP 16 HOT-HZO-IFO 15 BWB 14 CPH 12 BTK-HHQ-IFE 9 DSQ-ERQ-NR 8 AJL-DCQ 7 AMS-BIU 6 IHN 5 HKT-UC-WR 4 CTD-EVJ-GG-KJ-MV-3 AAF-AUB-EBQ-ECB-EGX-GSZ-HNQ-HPH-IKO-SH 2 AKN-CU-FXB-HA-HAN 1 JX 28 BCC 33 IFQ 12 BXJ 8 FPK 3. W9BBP 255 CE 84 HXB 49 DQT 45 IJH 41 DCN-DSJ-GQF 32 ADY-CWR-FSK 28 CSI 20 HSQ 16 YX 15 IOV 13 EXT 8 EQV 7 CEX 6 CGP-EGF-ISC 3 EEM 2 EVI 31 IHM 14 DAB 13 EQQ-LGU 5 AAM 2.

WISCONSIN — SCM, Harold H. Kurth, W9FSS — W9FSS made the BPL. W9LJU is moving. W9ARE gets good results. W9HGG was appointed RM and ORS. W9AMB made a new high total of 1034! W9EBO has a junior op. W9AHJ-IUW is a P.A. man. W9BXZ is building a 1750-ke. 'phone. W9HFL plays his banjo at WRJN. W9AUX again hits the top for traffic. W9KYY will be on soon. W9IQW is awaiting opr. ticket. W9IHG received a notice from the F.R.C. for off-freq! W9BCF has YLitis. W9GRM is on daily. W9M1H is a new Appleton ham. W9HVB has a ship job. W9IUZ has two oprs. W9GEX rebuilt his s.s. receiver. W9GVF is having receiver trouble. W9KXA displayed his new FB7 at the Fondy Club. W9ERZ rebuilds. W9CCI likes his single wire antennas. Someone is using W9HKL's call. W9EED is doing research work on RF chokes. W9IPF is getting interested in traffic. W9GQU took the exam at Wausau. W9DRO made the BPL. FB. W9ASQ and HDP are on 'phone. W9DXI is putting up an 88-ft. mast. The Sheboygan Radio Club plans two contests with prizes. The Fond Du Lac Club is planning a picnic and field day. The Milwaukee Radio Club is busy on its 10th annual QSO Party. The Four Lakes Radio Club gave W9AMB a tube for his good traffic work. Wisconsin defeated Southern Minnesota by two thousand messages in its traffic contest. Northern Wisconsin Radio Club is holding a state A.R.R.L. Convention on June 10th-11th at Wausau. W9DIT is in charge of reservations. The QSO Party at W9DRO's studio was a huge success.

Traffic: W9AUX 1055 AMB 1034 HGG 700 DRO 524 FSS 444 ERS 381 HSK 301 JCW 283 HMS 280 JDP 250 DXV 275 IYL 202 GPQ 155 BXM 103 GFC 100 AON 153 IUC 90 HTZ-HRM 85 KJR 84 GVL 82 JCH 65 FAA 60 ESZ 44 GWK 42 BKR 41 IHG 34 ZY 32 GQU 28 IPF 27 AVM 24 AVG 21 LEC 20 EEQ 14 HTY-DXI 13 BQM 12 KLL 4 MIK 3 RH 9 LAS 10 AZN 8 DNU 4 FBU 10 GYQ 7 BQM 12 AJH 5 VD 10 BWV 9.

INDIANA — SCM, Arthur L. Braun, W9TE — A free copy of the *Hoosier Bull* goes out to all those who report. W9AKJ does his stuff as OO. W9AET is new RM. W9AEB has a new bug. W9AXH worked a K6 and X for DX. W9AXK has crystal rig perking FB. W9AUT has

improved his note. W9BKJ will be glad to check the freq. of stations worked. W9CTT worked G-PY-F-K5 with a pair of '46s working as doublers on 14 mc. W9CKB manages to snag some traffic. W9CRZ is having fun trying to find a bootleg station in his town. W9DJU will be active as soon as he gets his '68 for power supply. W9DPL uses W9FQ's transmitter. W9EPT has recovered from his operation. W9HKZ and DET passed the amateur exam. W9HZH is coming on with a new 100-watt rig. W9GYB has a portable signing W9FDY at Purdue. W9EXL keeps a few schedules. W9FYB attended the hamfest. W9FZQ manages to break out with a few QSOs with his '45s. W9DHI has a half-kw. rig. W9APV is moving his rig to the basement. W9JLH is a YL op at LaPorte. W9FQ got the Royal Derby Club of Hobart; they all attended the hamfest except their grandpad. W9HUV is getting lined up for ORS. W9GNY is doing FB with traffic. W9JRR is giving code practice on 1.7 mc. W9TE resigned as A.A.R.S. W9MFFZ is a new ham at Ft. Wayne. W9LWK is the call of the Ft. Wayne Radio Club. W9ETH is doing 'phone work with an ant. 3 ft. above ground. W9HKH is building new receiver. W9HUO is building a new crystal rig. W9HBK is rebuilding. W9HIU is trying to get rich selling oil filled condensers. W9FMM worked VK-ZL-K5-K6-CM-X. W91QU is planning on a couple '52s. W91MT moved. W9RS keeps Connersville on the map. W9LLV is new ORS. W9MM is planning on 14-mc. 'phone. W9LYY is hoping to have some nice traffic totals. W9MQQ is a new ham in Indianapolis. W9MQV is a new ham at Greencastle. W9JRK and HML are looking for a few schedules. W9HSF is awaiting license change. W9DYQ is at his favorite pastime, rebuilding. W9GGP has acquired a crystal. W9LCL reports for the first time. W9ESU handles traffic. W9AEA is improving his rig. W9HKY flunked the 'phone exam. W9AHL is planning a 3.9-mc. 'phone. W9JHY blossomed out with a 'phone rig. The Indianapolis Radio Club will soon start on plans for their summer outings.

Traffic: W9AET 644 ESU 311 DHJ 7 HML 134 AXH 12 AXK 17 AUT 42 BKJ 10 CTT 86 CKB 56 CRZ 22 DJJ 2 EPT 64 ERZ 4 EXL 20 FRY 8 Fyb 12 FQ 33 GGJ 3 GFS 12 HUV 23 GNY 39 JRR 14 HKH 16 JOQ 27 HBK 64 HPQ-KDD 3 TMT 65 JRK 43 RS 12 LLV 22 MM 24 LYY 13 FUT 306 TE 29 YB 267 FDY 2.

ILLINOIS — SCM, F. J. Hinds, W9APY-WR — RMs, W9DDE, CRT, ERU. W9IU has a new call, W9KAK. W9ALE is toastmaster of the "3" No Club. Ogle County Radio Traffic Ass'n plans a "Hidden Transmitter" Contest for June 11th. W9AND, GFY, JTC and BTT are taking Commercial and Unlimited 'Phone exams. W9BIN says his YF "approves" of ham radio. W9DBO is our newest OBS. W9EEZQ's c.c. set is built into a bookcase. W9IVF and IYA are moving. W9HQH did fine earthquake traffic work. Fine new FB7 at W9LNV. W9KEH is rebuilding for 3500-ke. operations. New QRA for W9DYG. W9BRX reports 14 mc. conditions poor. W9ACU is working 14-mc. 'phone. W9ACE gave a "Ham" talk to the local women's club. 1.7-mc. 'phone at W9ATS. W9AFN has worked 50 different ZL chaps. W9AYO is organizing his club for traffic activities. W9AVB was the first unlimited 'phone man to start up W9USA on 3.9-mc. operations. W9BTT spends all of his time on c.w. for traffic. W9CNO worked VK and K6 with a '46 in final. W9CEO won prize in 3.5-mc. contest. W9CUH operated at W9USA two days. W9DOU is in chain of traffic stations for W9USA nets. New receiver soon at W9DZU. New Jan. QST receiver at W9FXE. W9FO is going to erect a new pole. W9EMN says the new "ORS" period FB. W9LZM is ex-W9ACW. W9EZY has a '47 on 3.5 mc. W9FGV uses crystal on 3557 kc. W9FRA figured up the W9USA report. W9KHD dopped a '10. W9KA has the crystal working. W9LW says DX as usual every night. Crystal at W9LIV. W9HKC says, "New bug here, thanks to W9HMB." W9HUC is one of the lucky boys to QSO W9USA. W9FGD is on 3.9-mc. 'phone. W91LY passed the 2nd class commercial exam. W9IU' changed QRAs. W9IEP is trying to get a 120-watt amplifier working. W9IYP is now crystal-controlled.

W9JZY is rebuilding. W9SG reports fine DX. W9GJJ will be on the lake boats this summer. W9LOJ worked his DX after the club DX contest was over. HI.

Traffic: W9VS 2112 USA 722 ENH 504 DOU 356 CGV 242 HKC 174 AND 151 BTT 145 CRT 128 HMB 125 IVF 112 FCW 101 HQH-LEP 98 ERU 87 OQ 83 JZY 74 KEH 68 ILY 61 EZQ 58 ALE 56 DYG-IYA 47 KA 41 CNO-FXE 36 ILH 35 INZ 32 EMN 30 ACE-DBO 28 CZL 27 CUH 25 APY-DSS-FGV-ICN 22 ILG 20 AFN 18 IYP-PA 14 ATS 13 DGK-LNV-LW 12 ACU 10 AVB 9 DZU-PO 7 FGD-HUU-IZP-KAK-ZZBS 6 AMO-BIN-HUX-LIV 5 EZV-IUF-JO-SG 4 AYO-GJJ-LZM 3 CEO-LOJ 2 KHD-WR 1 AAW 4.

OHIO—SCM, Harry A. Tummonds, W8BAH—W8DDS Chief RM Ohio. Write for your copy of Ohio district map. District No. 1: W8DVL RM. W8FFK stayed up all night to handle traffic. W8DTF and FNX report that W8ITI is new Elyria ham. Tubes gone west at W8FF. W8DVL leads his district. W8RN is on lakes on KKUI. W8BAH handled U.S.N.R. traffic. W8DDS leads the state. W8ZZB says not much portable work this month. W8DVI is 100% c.w. W8EFW reports new hams in Cleveland Heights, W8IRM, W8IVF. W8HVX is on 7 mc. W8BMX is rebuilding. W8GLT handled earthquake traffic. W8GDQ reports new station in Wellington, W8GNN. W8DAT has '03A going. W8FPL got 564 points in DX tests. W8EHO has no schedules. W8AOJ reports for W8AUN. W8BYD is on 1.7-mc. phone. W8EPP is on 3625 kc. W8ACJ is Official Observer. W8TH handled rush message to Detroit and got answer. W8FXH schedules W8DVL. A.C. receiver at W8GVL. W8ELC reports by QSL card. W8AUM will be ORS. W8EBY reports high school disbanding all clubs. W8FGP, HRI, FFM, IRM, BRB, HPW and BAC report. We welcome W1BZD, former RM Vermont, who is now living in Cleveland. District No. 2: W8BKM RM. W8AQX wants job on lakes. W8EEZ joins A.R.R.L. W8BKM has trunk line schedules. W8UX was issued National portable, W8ISG. W8EJ is Unit Commander, U.S.N.R., Youngstown. District No. 3: W8APC RM. W8GOD was acting RM when W8APC was off air. W8CMY is on phone 100%. W8DTW reports via radio. W8ESN sends first traffic report. W8DIH is cooperating with Ohio Listeners League on Interference. W8APC, RM, forwards report from Maumee Valley Radio Club and lists following as handling traffic: W8APC, ATN, EVS, BZD, GJS, EME, ELP, IHQ, CIV. Lots of 56-mc. activity in Toledo with W8FO, ARF, ANW, CKD, COC, ESV, BZD, HKM, FFY, HOY, DPN, W9IBZ, W8FEM. We have received a copy of the new M.V.R.A. bulletin, and suggest that you write to W8APC for your copy at once. District No. 4: W8EEQ RM. W8ICC applied for ORS. "Hope you can use this total," says W8DEM. W8WE is now ORS. W8UW is one of the leaders in A.A.R.S. net. RM W8EEQ leads his district to better showing this month. W8PO again sets pace for District No. 4. W8ANZ will be ORS next report. W8EMK schedules W8WE. District No. 5: W8FGV RM. W8BKR reports by radio. RM W8FGV makes the BPL. W8BMK took part in a school play. W8FDV has dynatron all set to work. W8EXI is trying to raise dough to join A.R.R.L. District No. 6: W8BBH RM. W8EQC reports activity of Springfield Traffic Fest. W8ECR reports traffic for W8GCI. FB. W8GJ is using temporary antenna. W8DPR is ORS. W8HEY almost made the BPL. RM W8BBH leads his district. W8CXF worked PY and FAR. W8IEJ passed Radio Telegraph Second exam. W8GDC says W8BZK is new Columbus ham. W8GSO says all hams in Lancaster have Am. Firsts. W8HTI has two 7-mc. sky hooks per QST. District No. 7: W8VP RM. W8EUR is new reporter. W8EQB handled sickness traffic. W8VR is rebuilding into cabinet job. RM W8VP will be all set in few weeks. District No. 8: W8CGS RM. W8BKE reports from Circleville. W8GES is having trouble with c.c. W8DUV says no important traffic handled. RM W8CGS is after DX. W8NC, Lieut. Breckel, reports for U.S.N.R. Section Control station. W8BRQ reports. W8IDY reports new club at Cincinnati, Ohio, with W8IRI, Ex-W4JI, now WSDI, W8EFV, BTZ,

EDX, FIV, DAF, GBI, EAQ, BCT, AEH, IDF, IDX, BRQ, GCR, GD attending first meeting. W8BTI is pres., W8BRQ vice-pres., W8IDY secy.-treas., W8GCR activities manager.

Traffic: W8DDS 1086 BBH 753 FGV 738 BAH 625 PO 549 RN 542 EEQ 530 GCJ 569 DVL 423 FF 399 GOD 385 HEY 303 DPR 200 BKM 169 DTF 168 EEZ 154 UW 150 WE 130 EQC 102 DEM 89 FFK 75 BKR 70 AQX 62 ICC 56 EQB 54 EUR 55 EBY 43 NC 40 GZ 36 DIH 32 CGS 25 AUM 24 ELC 22 DUV 21 EMK-ESN 20 APC 26 IHQ 25 HTI 20 GVL 16 EJ-FXH-TH-ACZ 14 VP 13 EPP 12 BYD-FNX-ANZ-AOJ 11 GSO 10 EHO 9 DTW-FPL 7 GES-BMK-DAT 6 VR-GDQ-GLT 5 BMX-GDC-HVX 4 IEJ CXF-EFW-BKE-DVI-UX 2 CMY-ZZB 1 ATN-GJS 4 EVS 7 BZD-EME 6 ELP 5 CIV 3.

DAKOTA DIVISION

SOUTHERN MINNESOTA—SCM, Norman Beck, W9EPJ-CGR—W9BN wins traffic banner. W9JID, CSY, CPP, EPJ, IXQ handled earthquake traffic. W9DCM is eligible for ORS. W9DEI worked ship in Arctic Circle. W9BLG goes back to Canada. W9IAE is on a Hawaiian traffic route. W9FHF has been appointed Alternate D.N.C. in A.A.R.S. W9EGG plans to go to radio school. W9FCS is all rebuilt. The whole Section mourns the passing of W9AQG, Milt Adams of Minneapolis, who was killed in an auto accident April 17th. Be ready to do your share in the relaying of traffic from W9USA.

Traffic: W9BN 1178 JID 976 CSY 723 BKX 512 CPP 223 BNN 198 EPJ 193 AIR 170 KHY 150 DH 135 DRG 98 BEZ 91 GCN 86 IXQ 80 BPK 65 GLE 43 JBA 41 ERT-EYS 37 IAE-FCS 36 BKK 30 BLG 29 JMV-DGE 28 DEI 25 DCM 16 YC 10 KKM 8 FMA 5 KDI 4 FNK 3 DMA 2 JFH 48. (W9JFH 50 Feb.-Mar.)

NORTH DAKOTA—SCM, Wm. A. Langer, W9DGS-IFW—W9IGR, AFM, and EVQ received license renewals. W9DFG and FIV are ORS applicants. W9IGR is building class "B" modulator. W9KBE is experimenting with flea power. W9AZV put his 7-mc. zepp to work on 3.5 mc. W9GER, new ORS, received portable call, W9MJG. W9BTJ reports c.c. rig working FB. W9MGR is a newcomer at Carrington.

Traffic: W9DGS 708 HJC 501 EGI 250 IK 106 FIV 90 IGR 73 DM 50 KBE 40 AZV 26 DYA 20 EVQ 13 JZJ-JAR 11 GER 7 DPT 6 BTJ 5.

SOUTH DAKOTA—SCM, Carrol B. Miller, W9DKL-GIO—Two stations making the BPL are W9AZR and W9DKL. W9ALO says the Autodyne receiver à la Jan. '33 QST is sure FB. W9BJV has gone 100% phone. W9DGR has been visiting W9TY, GPB, KPQ and LDU. W9DKL visited W9BAE, CFU and FDD. W9FKL moved to 7 mc. W9FDD finds the SCM's sister a great attraction. W9FOQ has his trouble fracturing crystals. W9GTG's Ford spark coil power supply works FB on 1.7-mc. phone. 29 foreign districts worked in five weeks by W9IDW. W9IEK is having trouble lining up A.A.R.S. phones on 1.7 mc. W9BAE is using a ribbon Mike. W9JKY and JBT are working 1.7-mc. phone. W9CFU moved to 232 Iowa St. SE. W9IQD is preparing for exams. W9KPQ is building c.c. rig. W9LDU works both coasts on 1.7 mc. W9NM will be on 7 and 3.5 mc. this summer. W9CDW, GQH, DJN and DKL are leaving for the Dakota Division Convention.

Traffic: W9AZR 555 DKL 534 FDD 361 GTG 135 HAT 112 DGR 82 FOQ 71 FKL 69 IEK 49 ALO 34 IDW 9 JLA 7.

NORTHERN MINNESOTA—SCM, Palmer Anderson, W9DOQ—W9HZ took a bus load of hams to and from Convention. W9FNJ expects to operate W9YC next fall. W9CDV is building a portable 56-mc. outfit. W9EGU is putting on his 14-mc. phone. W9FNQ is QRL U.S.N.R. W9FTJ will be on the air regularly. W9HEO says the transmitter is ready to go. W9HNS is on the air from St. Mary's Hospital at Duluth. W9AEL has 3 schedules. W9JDW handled Greenland Expedition traffic. W9JIE is new ORS. W9BVI had a great time in DX

contest. W9HDN blows plate blocking condensers. W9ISA got 88 as mark in amateur exam. W9IPN is working DX. W9GRH reports from Morgan Park. W9KRG sends his first report.

Traffic: W9HZ 56 EGU 2 FNQ 41 HNS 26 HDN 51 AEL 34 DJW 16 JIE 117 BVI 8 IPA 10 IPN 65 GRH 6 HEO 2 KRG 10.

DELTA DIVISION

ARKANSAS—SCM, Henry E. Velte, W5ABI—W5CCW wants QRS. W5BED is going to get a room in town so he will have use of a.c. W5IQ has been QRL A.A.R.S. W5PX has six daily schedules. A newly organized radio club is the Pine Bluff Radio Club with W5BUX, pres.; W5SI, vice-pres., and T. W. Mozart, secy. and treas. W5JK has an Extra First ticket. W5BDB has hopes of getting on the air. W5CR has been helping W5YM with 56-mc. experiments. W5SQ sends in a nice report for Texarkana gang. W5ANZ and CEO are building c.c. rigs. W5AXP worked VK. W5ABI installed new antenna. W5AAJ reported by radio. The mighty W5BMI has his usual FB traffic total.

Traffic: W5IQ 182 PX 364 BUX 30 JK 22 AAJ 113 BMI 980 ABI 91.

TENNESSEE—SCM, F. F. Purdy, W4AFM—The first issue of a *Tennessee State Ham Bull* was favorably received. Hereafter only those hams who report regularly will get a copy gratis each month. W4HA makes the BPL. W4PL reports his recent trip to Florida. W4RO is QRL. W4ALM, AXN and BRP report. The East Tennessee Amateur Radio Association has new QRA, Club Room of the East Tenn. Power Company Office Bldg., East Main Street, Johnson City. W4AD entertained the members with a two-reel movie, "Wizardry of Wireless." W4BOZ and AFM sojourned through Virginia and Kentucky to Huntington, W. Va. W4AYV wants to make the BPL. We all join in expressing our sympathies to W4ABM in the loss of his child. W4ZP reports for first time in three years. New stations: W4BXG, BXQ, BGC, AQD. W4ZZ and BUH are afflicted with YLitis. W4LU and OV split their time between 'phone and c.w. W4BVP is experimenting on 7 mc. W4LC took on an OW. W4HL and AJJ have unlimited 'phone tickets. W4JG has Radiotelephone First Class ticket. W4LO has new '04A.

Traffic: W4HA 532 AFM 437 PL 145 EX-RO 132 BOZ 115 AAD 112 BBT 100 AYW 93 BQK 22 ZP 16 AAO 15 LU 8 AXU 5 BUC-BXG-ALM 4 ZZ-BDZ 2.

LOUISIANA—SCM, W. J. Wilkinson, Jr., W5WF—W5DAQ, former 5PM, is back with us. W5AUO expects to be on regularly. W5AXU has been on 14 mc. W5ANQ is on 7 mc. W5BFP is on again. W5ACV QSPed message for the President. W5BI was heard in South Africa. W5BYX is going to join A.R.R.L. W5BZR keeps schedules. W5CYW is new ham at Dubberly. W5APA is working in Shreveport. W5BPV reports. W5AXD is in sound truck business. W5AYZ works her brother at W5YW. W5ACA has been rebuilding. W5ST was heard in Czecho-Slovakia. W5CKI burned out power transformer. W5ABS is grinding crystals. W5EC handles traffic. W5EB is getting Coast Guard net organized. W5AFW visited the SCM. W5BMM is building 'phone rig. W5CEW and MO got new tickets. W6ZZAM is with us this month. W5BPL says, "No job, no jack, no juice." W5BYY has nice signal. W5WF is keeping traffic schedule. W5BS hasn't much time.

Traffic: W5WF 527 BYX 167 EB 106 AFW 241 BZR 31 ACV 20 ACA 18 BI-DAQ-KC 12 AVO 13 YW 9 BMM 2 AYZ 11 BS 2 W6ZZAM 8.

HUDSON DIVISION

EASTERN NEW YORK—SCM, Robert E. Haight, W2LU—W2BZZ is traffic leader. "Spring is here," says W2BJA. New club: Albany Amateur Radio Assn.: pres., W2ENC; vice-pres., W2EGF; secy., W2ANV; treas., W2CJS. W7IN visited W2UI. W2BVR reports FB DX. "W2FKL is new ham in New Rochelle," reports W2ATM. W2DDW reports activities of Mid Hudson

Club. W2DQD is pounding out traffic. W2DEL is building QST's latest Monitor. W2CBN is heard on 3.5 mc. W2AN works all bands. W2KWK is going strong. W2DWO is secy. MHARC. W2CFU reports via radio. Welcome, W2BOG. W2DNN reports W2BWB on 1.7-mc. 'phone. W2QY is on 1757 kc. W2ENY missed his line in last report. W2AMM is 'phone OBS on 3.9 mc.

Traffic: W2BZZ 664 BJA 416 ANV 378 ENC 208 LU 203 UL 65 BVR 56 ATM 43 DDW 26 DEL 25 DQD 26 EGF 20 CBN 18 AN 16 KW 15 DWO 12 CFU 11 BOG 8 DNN 6 QY-ENY 4 BLL 1.

NORTHERN NEW JERSEY—SCM, Walter A. Cobb, W2CO—North Jersey gang are looking forward to Hudson Division Convention, Brooklyn, May 25-6-7. 16 mm. film of Bloomfield's 56-mc. outing still in demand; any club wishing to exhibit same, communicate with the SCM. W2CZP and SN are new OBS. Naval Reserve Transcon Net functioning with W2ALD eastern terminus. W2BTT assumed charge of Ecuadorean BC station. W2DRN was winner of Paterson DX contest. YL is said to be wasting time on W2DOU. String is favored by W2DNX for BCL antenna. W2EOH had bad heart attack, when QSO his first YL station, W2EOA. W2DTR raises every "6" he calls on 7 mc. W2EAG is a regular contributor to the Saturday night QRM on 3.5 mc. W2CO gave talks before the South Jersey and the Greater Camden Clubs. W2AJC, CDD, CIZ and DEA are partners in a 100-watt rig. W2BXM had W2FIF assigned to him for portable use. Ocean County Club provided 11 new League members at April meeting. W2CPZ is able to QSO on any frequency. W2BQV found new 45-footer. W2AQP dropped coil on his watch. W2DYR has extremely commercial-looking 1.7-mc. outfit. W2ELJ reports neighbor's kids let his skywire slip through top pulley. W2CGG bought OW canary for Easter so she says QRL shack to teach him to sing. W2ESX moved transmitter from his store. Whitnah of W2DIU gets traffic practice from Army long wave WTW. "World's champion rebroadcaster" is rating of W2TP. Fine report from W2BPY. W2DPA requests morning schedules. W2EYM takes time off from college for hamming. W2EKM offers to help out with W9USA traffic. W2EWW is only offer of help as OO.

Traffic: W2DIU 1866 BPY 268 CIM 53 CGG 44 EIC-DPB 38 EJK 33 CJX 20 TP-JC-CIZ 12 ABT 8 EKM 347 DRV 137 EIP 96 AUP 85 DYR 47 BXM 32 DVN 27 CZP 23 BWZ-BQP 21 ETQ 1.6 CBY 15 ALD 13 ESX 12 ELJ 11 CEQ 10 CHH 9 BYM-EOH 7 CO 4 EYN 2 CTV-SN 1.

NEW YORK CITY AND LONG ISLAND—SCM, E. L. Baunach, W2AZV—W2BMH has 4-stage rig perking. W2PF is heading for World's Fair. W2CGD handles traffic on all bands. W2LB has been promoted to Lieut. W2OQ reports a new Jr. op. W2DJP is active in A.A.R.S. W2CYX, AWT and AOP are out for OBS. W2EW is looking for 7-mc. men who QSP. W2WP is teaching a local YL the code. W2CBB will be ready for ORS party. W2DBQ wants good ops for the A.A.R.S. W2CHK says W2BGF and Ex-2BIY operate W2BXX of the Brooklyn Polytech. W2DQK is installing c.c. W2DUP is operating on a schedule-less basis. W2AHO and DPU are QRL school. W2EYS and EYQ send first reports. W2CYA built the July-Aug. 1932 QST 1.7-mc. 'phone-c.w. transmitter. W2LG is heard on 1.7 and 3.5 mc. W2BAS will handle only important traffic. W2BNJ will soon be ORS. W2DTT is working '80 with 400 watts input à la QST. Our Director, W2BEG, is having much success with his Hudson Division Conference. W2DOG can shift to 3530, 3641, 3871 kc. W2BGO schedules west coast daily. W2VL is on 7 mc. W2AIZ sends a nice total. W2AZV keeps a continuous watch on 3.5 mc. every morning between 7 and 9 a.m. W2CPY, DQW, BVT, BKY and CUD are on 56 mc. W2EGA finds 1.7 mc. FB. W2DBE is working DX. W2ASG has four receiving antennas. W2KJ has decided to try 3.5 mc. W2DXL is installing Grammer's new rig.

Traffic: W2ADQ 366 DBQ 335 DJP 184 DUP 155 AZV 150 BGO 127 CHK 112 AIZ 96 DQW 78 ARO 70 BNJ 54

AIQ 38 AWT 39 AGL 33 BAS-EYQ 32 DQK-DOG 28
CVX 27 AAK 14 CCD-EYS 11 VL-DXL 7 BMH 1.

MIDWEST DIVISION

NEBRASKA—SCM, S. C. Wallace, W9FAM—
W9BNT is organizing new A.A.R.S. operative di-
rective net. W9DEA is thinking of signing up with
Forest Reserves. W9DMY is working AA net. W9DXY
rebuild transmitter and receiver. W9FUW is busy with
convention plans. Heartfelt sympathies to W9EHW from
all of us on the death of his father. W9AFD expects to
have station at Nat'l Guard Camp this summer. W9IFZ
handled a lot of Calif. quake traffic. W9ISJ has new
MOPA. W9DI says there will be a convention in Lincoln
in May. W9BQR is holding fort. W9DGL says DX not
so hot. W9HYR built portable receiver. W9DFF thumbed
his way over to see W9EWO, Easter. W9EWO is in the
hog-raising business, Box 53, Kearney. W9FAM is QRL
garden work. W9JQD says W9FCT is busy as Judge.
W9HNG sends in nice letter. W9HTU sends usual FB
report. W9KJP is getting Omaha lined up. W9BUC
is helping in U.S.N.R. drills. W9LVB reports. W9MKG
is going to take transmitter to Nat'l Guard Camp in
August. W9DEP visited Lincoln and W9CWM took him
to Crete meeting CARA.

Traffic: W9BNT 1304 DMA 431 DMY 227 FAM 222
DXY 81 FUW 66 EHW 41 AFD 113 IFZ 75 ISJ 10 DI 4
BQR 3 DGL 2 HYR 25 DFF 12 EWO 10 JQD 2 HTU 125
KJP 5 BUC 36 DEP 5.

MISSOURI—SCM, C. R. Cannady, W9EYG—RMs,
W9BMA and W9FTA. W9NP leads the state in traffic,
being in general U.S.N.R. hook-up with BCA, PB, RR,
and GSF in clearing earthquake traffic. W9CJR fell
slightly behind in ACTIVITY CUP race but, in year's
standing, still holds slight lead. W9BMA is getting lined
up with W9USA. W9FTA is trying to get St. Louis lined
up with W9USA. The following stations continued help-
ing clear the earthquake traffic for Missouri: W9DCB,
HUG, ECE, JJB, GBJ, JBV, ENF, EFC, and EYG.
W9HUZ is ready to come back. W9DUD is working on
SS receiver. W9BGS renews ORS. W9BAU sends FB
report. W9AWC donates HCL set to the YL. W9BTD
has c.c. '52. W9CWH is now LVA. W9HWE took to
grinding crystals. W9IJO worked first VK. W9IHW
completed his first year on air. W8CLT is visiting W9HHK.
W9KYF is QRL YLs. W9KWC-GIH sold out. W9KXS's
antenna blew down. W9APW is c.c. W9HVJ joins in with
"conditions rotten." W9DUM is building new receiver.
W9AOG reports big score in DX contest. W9FYM
was unable to be with us much. W9HNM got by teachers'
exam. W9LBA is new ham in Brookfield. W9ASV made
WAC which was celebrated by party given by Ozark
Amateur Radio Association. W9AAN sends FB report
from Richland.—DCD duplicates it from Clinton.
W9JYG has crystal fever. W9AWE is QRL. W9IXO is
doing DX work. W9AIJ is QRL account of death of
mother-in-law. W9DLC is QRL garage work. W9GDU
is now c.c. 852. W9LTH moved to 2311 Minnesota, St.
Louis. W9ILI is back to 1.69 'phone. W9HVC ditto.
W9CCW put on new '03A. W9GUQ was sent to Keokuk
on subchaser. W9FAB is back on 14 mc. W9FWQ is
QRL school. W9GSO is back on 3.5 mc. W9HVP and
HVF are trying 7 me. W9HVN dismantled 14-mc. rig.
W9KIK is building new rig. W9KIR is trying for hi-pwr.
W9HJL and HVC consolidated. W9GTK is QRL again.
W9CCZ is working 1.75-mc. 'phone. W9CGB and HWD
are rebuilding. W9FQY is working DX. W9BSH has FB
sig. W9FIZ registers protest against C.D. space in QST
being cut! The Mount City Radio Amateurs have ap-
plied for affiliation and are working in conjunction with
other affiliated clubs in connection with the 1933 MID-
WEST CONVENTION. The St. Louis Amateur Radio
Club reports convention plans coming FB. The Hannibal
Amateur Radio Club is cooperating with the Boy Scouts
of America in putting on a radio class. The Heart of
America Radio Club and the South Missouri Association
of Radio Amateurs are planning a series of contests
within the clubs.

Traffic: W9AIJ 57 BLR 4 EFC 19 FKF 5 CJR 201
FSL 7 GTK 2 ENK 1 FEH-LLJ 15 IXO 28 HUG 20
LTN 6 JVL-HUI 4 ECE 46 EME 4 ENF 33 JUB 6 FYU
13 FJV 118 FYM-EHS 7 MAK-GLY 1 EYG 15 HCP 4
JPT 6 IOS 4 GBC 14 CJH 4 KEX-HLK 1 ASV 44 RR 96
ZZ 5 CFL 15 NP 748 HNM 14 GDU 3 DLC 3 FTA 51
TA 35 KFL 16 DCD-AAN 3 KYG 2 FTD-BSS 1 CCZ 6
JBV 67 GBJ 104 JBD 11 DUM-AOG 1 HON 55 JOS 13
BMA 406 ZZI 3 EQC 4 FHV 106 JFA 18 JWI 2 AUC 1
DUD 7 EWT 5 BGS 3 BAU 77 AWC 23 HWE 10 DCB 14
IJW 2 HVJ 12 FIZ 27.

IOWA—SCM, George D. Hansen, W9FFD—W9BPG,
RM. W9ABE, RM. W9ACL leads the Section. W9LZI
is the latest in his midst. W9ABE is our newly appointed
RM. W9GXU turns in a good report. W9FFD is QRL
Army and Navy schedules and traffic. W9IO lists nice
bunch of schedules. W9HPA is new ORS. W9BWF
is broadcasting w.m. W9LCX has schedules working first
rate. W9BPG, RM, desires word from you fellows about
your schedules. W9CWX is at the new 3.2. W9FYC has
good report. W9DUN blew receiver tubes. W9DFZ
handled an origination from OMITB and delivered it in
Chicago in less than 24 hrs.! W9FYX is working
portable W9LZN. W9CYL and CFZ are busy with work.
W9ERY needs a schedule West. W9DEA is working
nights. W9JDV and LBS are first reporters. W9EMS
is rebuilding. W9DMX and GWT report. W9AHX reports
for his portable W6ZZBL. W9FXX is building portable
under call W9ECD. W9DTI reports DX as K6, K5.
W9EIV roams around this month and helps the totals
of W9JXA, the SCM portable, and at W9IFI. W9FEB
opr's license expired. W9FZO is new Editor of *Static*, Tri-
State Club paper. W9LEZ reports FB total. W9HOH is
working 7 me.

Traffic: W9ACL 293 ABE 259 GXU 245 FFD 223 IO
175 HPA 96 BWF 95 LCX 87 BPG-CWG 73 FYC 69
DUN 34 DFZ 33 FYX 30 CYL-ERY 21 DEA 12 JDV
11 EMS-DMX 9 LBS 7 AHX 6 GWT 5 CFZ-FXX 3
DTI 2 LZN 4 HOH 2 JSO 11 JXA 74 FZO 6 LEZ 67.
W6ZZBL 5.

KANSAS—SCM, O. J. Spetter, W9FLG—RMs:
W9KG, W9CFN. W9KG leads the Section with over a
thousand. W9GBP takes second place. W9ERR set up
portable W9LQL at K.S.A.C. Engineers Open House
and handled a nice bunch of messages. The College Radio
Club had an excellent display at the Open House.
W9BYM is awaiting license. W9DVQ is trying 56 mc.
W9KFC rebuilds to MOPA. W9APF has a 50-watter.
W9BTG has been appointed OBS. W9EYI is moving.
W9BUY blew '65 and two '66s. W9BYV expects to have
portable at Scott County State Park. W9AWR reports
Garden City Radio Club planning on booth at County
Fair. W9LNW is new call in Garden City. W9IQI is
QRL gas station. W9LM is new reporter from Kansas
City. W9PB reports president of Hiawatha Amateur
Radio Club uses a W.E. 5-KW water-cooled tube as a
gavel when conducting meetings. W9GCL reports JVC
rebuilding for crystal. W9BGL spends week-ends build-
ing up his c.c. transmitter. W9KRL is new reporter.
W9DEB raises anchor and moves again. W9LFN adds
another stage to his c.c. rig. W9KDO goes MOPA.
W9CUF buys out ex-9BHR. W9FRC gets another
crystal. Something is being heard in Topeka which sounds
like W9AMD? W9FLG is having transformer troubles.
Manhattan College Radio Club elects following new
officers: W9ERR, pres.; W9ZZZ, vice-pres. and W9DDJ,
sec. Jayhawk Radio Club organized at Seneca with fol-
lowing officers: W9FXY, pres.; W9IFF, vice-pres.,
W9NL, secy.-treas., and W9BTG, technical adviser.
W9ESL has new c.c. osc. and monitor. W9BDB has new
50-watter. W9MKW is new call in Hiawatha. W9CVN
continues to QSO plenty DX. W9ABG has 200-volt plate
supply. W9EGL will be on soon. Bob Whitmer, ex-9BFP-
BQV, was recent visitor in Wichita. W9BNS is new
WARC member. W9LKD reports new junior op. W9HTF
enjoyed week end visit of W9APF family. W9BEZ is
still the old trusty in U.S.N.R. work. W9JMS, JDW, and
BKW are heard on in Wichita. W9BSX gives FB talk

on s.s. super at recent WARC meeting. Code practice is held an hour before each WARC meeting, with good attendance. W9DSD is on from new QRA. W9EAG is back in Wichita. W9FVZ and CCM are seen in Wichita now and then. W9BJ, DAL and BCY furnished 56-mc. equipment at WARC meeting April 13th. W9DWO is kicking 50-watters with '45 in parallel. Wichita Amateur Radio Club is planning big feed first meeting in May. W9BLA is back in Wichita after operating in Chicago. W9LMB has been transferred to Texas. W9HWV schedules W9AWQ in Colonel's home town on Federal Inspection nights.

Traffic: W9KG 1100 GBP 868 ERR 369 FLG 343 CUF 199 KRL 181 FRC 149 KCR 111 AWP 140 BTG 121 KDO 84 KFQ 83 GUZ 82 CKV 77 CNW 70 BYM 58 BFZ 54 DVQ 49 COA 45 DEB 44 CVN 39 CFN 38 LM 30 ESL 25 NI 23 PB 21 ESW 19 HLE 13 IEL-GCJ 12 APF 11 BGL-PKD 10 BYV 9 KXB 7 LFB 5 FMX 4 HWW 3 ABG-IQI-ELU 2 BUY 1.

NEW ENGLAND DIVISION

MAINE—SCM, J. W. Singleton, W1CDX--W1BOF leads. W1CFG is working hard. W1CPT won Maine award in Sweepstakes. W1GBD, GDX, GEU, FTQ, GBM, and FWZ are new hams. Ex-W2AOR has moved to New Castle. New club in Rockland, The Knox County Wireless Club.

Traffic: W1BOF 244 CHF 219 CRP 216 CDX 169 DKO 138 APX 135 EF 114 DEQ 80 BNC 75 BUO 69 BTG 67 EFA 63 OR 55 EOX-AQW-DHH 35 BJA 34 BEU 12 DIW 13 AFT 20 AFA 11 FNG 9 VF 8 BTA 2 EUA 28.

VERMONT—SCM, Roy L. Gale, W1BD--W1ATF and DXH handled emergency traffic. W1BJP uses 'phone and c.w. W1AXN is thinking of adding 'phone. W1EJF, GAE, and FPS send first reports. W1DUL wishes to join A.A.R.S. W1EHB has portable GFE. Storm took W1DAJ's skywire. Ex-W1BZD reports from Cleveland, Ohio. W1BNS, CBW, and EGU QRL school.

Traffic: W1ATF 97 BJP 57 DEX 48 BD 40 BNS 38 AXN 37 CGV 28 EAF 13 ERJ 12 CBW 4.

EASTERN MASSACHUSETTS—SCM, Joseph A. Mullen, W1ASI--Our Director, W1KH, was QRM'ed by a bad tooth. The SCM thanks the gang for hearty co-operation in putting the ham-broadcasts over. W1AGA is QRL as R.M. W1ABG reports conditions irregular. W1VS was laid up with the mumps. W1WV is working DX. W1ABF is in quest of a ship. W1LM is hibernating for the summer. W1ACH has a '10 working on 56 mc. W1BBY schedules VE. W1CHR has rack and panel job. W1CUO is rag chewing. W1BFR reports the depression over. W1BMW is an OO. W1JJ attended the funeral of his 50-watters. W1BZO hit the BPL. W1BEF is active in traffic. W1EVJ tied in the island of Nantucket for the telephone company during recent storm. W1ALP schedules W1FNG. W1WU has new 212D. The North Shore Club has the best OB system in the Section. The Fall River Club had a hamfest on April 19th, as did the South Shore Club on April 6th. W1EVC and BPK have applied for ORS. W1BTL's transmitter may be heard during the talkie show in the local theatre! W1BO bought a 212D. Ex-W1BCF is on with call W1AMV. W1EIF is on with pair of 50-watters.

Traffic: W1BZO 326 LM 225 BFR 132 BBY 91 ASI 88 WV 85 BEF 84 AGA 70 ACH 59 ABG 58 KH 57 VS 54 BMW-CHR 25 DFS 39.

CONNECTICUT--SCM, Fred A. Ells, Jr., W1CTI--W1MK climbs back with the BPL. W1CJD had to cut a few schedules and jump on the fire wagon. W1CTB is buck on 3500 kc. W1CKE and AUT are contacting successfully on 56 mc. W1CKQ is getting 1.7-mc. 'phone into operation. W1PLQ and FOG manufactured their own bugs. W1CTI is taking over the 9:30 a.m. Sunday broadcasts. W1ES is back from Florida. W1AMG expects to schedule W2BC when he goes aboard WQBG. W1DOW says the Bristol Radio Club had no trouble hooking W6's with feeders wrapped around a tree and the antenna about 10 feet from the ground!! W1BDI, APW and AKI

handled earthquake traffic. W1WU handled "hot" traffic from China and the Philippines via W6AOR; also results of intercollegiate boxing meet were gotten from the ring-side for *The Yale News* via W8YA. The Yale Radio Club originated a bunch of traffic during the Engineering exhibition. W1DGG says DX contest put crimp in traffic. W1BMP says traffic gets to be a bore. W1FGV joined A.A.R.S. and installed his 849. W1ERU got his MOPA perking OK. Most of W1AJB traffic was handled during Army drills. W1EFW says 56 mc. perking well. W1BHM put two messages from China into Europe, took a message from a "G" for W6CXW and gave it to a station in the same city (L.A.) the same day. W1AFB QTA'ed schedules. W1DMK says BYW is a good doctor for key clicks. W1FDM scored 728 in DX contest. W1BFS is in his new place in Shelton. W1UZ has been curing a case of spring fever! W1EAO says the Hartford County Amateur Radio Assn. has an interesting QSO party Sunday mornings with W1AVK, 3904-kc. 'phone, as control station. W1DCM is Traffic Manager of A.R.R.C. of New London. W1AZG is back on 3.5 mc. The Conn. Brass Pounders Association is issuing a monthly bulletin, *Hamonics*, covering all New England with up-to-the-minute news and gossip of interest to all active operators. *Hamonics* prints news items which the SCM's of New England are unable to include in their QST write-ups, due to lack of space. A charge of five cents a copy is being made to partly cover publication and mailing costs. Drop a line to W1CBA, Box 252, Noroton Heights, Conn., and get your name on the mailing list.

Traffic: W1MK 526 CJD 501 AMG 363 DOW 300 BDI 299 YU 250 DGG 199 BMP 157 FGV 134 ERU 130 AKI 101 AJB 89 BYW 78 APW 71 ESD 64 EFW 50 BHM-AFB 47 NE 35 DMK 33 DBU 31 AUK-FDM-DEP 26 DCI 25 BIQ 22 CTI 21 CTO 15 GC 13 BNB-CUH 12 BFS 11 CIG 9 UZ 8 QV 7 BDS 6 EWD 5 ANG-ALE 4 EAO-FOZ-CNU-CUX 3 DCM-ABN 2 CVD 33 FIO 34 BWM 14 APZ 11.

WESTERN MASSACHUSETTS--SCM, Earle G. Hewinson, W1ASY-W1RB--Traffic leader this month is W1EFM. W1BCX is believed to have won the sectional traffic prize for 1932-33 season. RM W1BVR has a complete file of ORS schedules. W1DVV is still not satisfied with his c.c. rig. W1AJD complains about "young squirt" QRM. W1APL tried hard to QSO J1GA. W1CJG complains of the W1AJD jinx on his transmitter. W1ADF says FNY is going to RCA school in NYC. W1CWP is going on 1.7-mc. 'phone. The flea power DX contest howl is heard from W1BPT. W1FJF reports traffic for three hams. W1COI has joined W1APL in DXing. W1ZB has bunions on his ears from DX contest. W1ECE is QRL school. W1BNL has switch system for changing 14-7-3.5 mc. W1RZA received a rag chew on QST from W1ASY. W1BWY has an FB-7. W1CIZ gets himself a ROYAL. New hams: W1FWJ, FGN, and FZI. The A.R.R.L. program over WBZA will be continued in the fall. W1ASY, BSJ and EBI did FB work for Western Union when the wires came down during recent ice storm in New England. QSPs through to Brattleboro were difficult, but ham radio finally made it.

Traffic: W1EFM 126 BCX 114 BVR 104 CJR 76 DVV 66 AJD 64 ARH 45 ASY 42 BWY 20 APL 30 DCH 26 FOF 25 ETC 23 FNW-CJK 22 ADF 21 CWP-BPT-BZA 13 BNL-BFN 11 DJQ 10 AFI-FFJ 9 CIZ 8 COI 4 OF-ECE 3 ZB-BSJ 2 FAJ 8 FCL 7 ASU 4 DLD 5.

NEW HAMPSHIRE--SCM, V. W. Hodge, W1ATJ--W1AVG is getting fine reports on 3.9-mc. 'phone. W1AVJ has c.c. 250-watter. W1FQM is new man in Concord. W1EAW is recovering from operation. W1CCM has been forced to discontinue ham work. Please drop him a line, gang, at Glenciff Sanatorium, Glenciff, N. H. W1EWF is on 14 mc. W1UN is still handling press and weather with Mt. Washington. W1AUY says spring fever has got him. W1APK was heard by G5UM on 1.7-mc. c.w. W1FCI and BGL are keeping regular schedules. W1FEX handled 90% of his traffic with W1UN on 56-mc. 'phone. W1DNC is still going with a 1925 '02 tube. W1BEO reports bad conditions. W1EZT and AXL had antenna

trouble. W1ADR is getting out well. W1CBJ worked hard in recent DX contest. W1CPM was heard in Germany on 3.5 mc. W1CWT QSO'd Trinidad on 3.5 mc. W1EAK has a new Jr. op. W1EAY is QRL A.A.R.S. W1ENX is trying 14 mc. W1EAL has new c.c. MOPA. W1DSX joined A.A.R.S. W1BMM and AVL are DX'ing. W1DMI has new c.c. rig. W1EES handled QRR traffic during storm. W1SK reports good traffic. Miss Dorothy Wilkins is now portable W1FTJ. W1ATJ handled press and Telephone Company traffic during storm with W1CME, Manchester. W1BII and IP also taking tricks at the key. W1AXL has cancelled schedules. W1AFD and BEJ keep daily schedules on 56 mc., as do W1FGC and CVK. W1AGO, BXU and AEF are on 1.7-mc. 'phone. W1ANS boasts new 250-foot Zepp. W1TA has a new job.

Traffic: W1UN 947 FEX 506 DMI 88 DNC 82 EAK 51 SK 32 FCI 28 IP-BEO 20 EES 17 AXL 11 EAL 10 BGL 8 DSX 4 EZT 3 EWF 2 AUY-BMM-AEF 1.

Late Reports: RHODE ISLAND. Ex-SCM W1AWE. Our new SCM is W1AFO. W1EOF leads the Section and was heard in Germany on 3.5 mc. W1ASZ schedules W1CAW and W1CGO. Traffic: W1EOF 63 ASZ 22 CGO 2.

NORTHWESTERN DIVISION

OREGON — SCM, Ray Cummins, W7ABZ-CBB — W7KL bangs out the biggest total. Big doings at Coos Bay, April 8th and 9th, when the Oregon Amateur Association was in convention. Among those attending were W6RJ, PQ, CKO, W7PL, AIP, KV, PL, BEK, BGF, BRH, and ABZ and XYL. W7BO has unlimited ticket. W7BZS is QRL school and farm. W7AQX has another 1000-watter. W7BEE and BUF have new FB 7's. W7QW is QRL KORE. W7ZZAR is QRL business. W7KH is heard on 'phone. W7ANB is servicing BCL sets. New officers of Coos Bay Club: pres., W7ZZZ; vice-pres., W7BUF; secy., W7BLN. W7CMK and CSQ are in same ward in the hospital. W7DBR and DCR are new hams. W7AES and BDR are an inseparable pair. W7ANW is now 1.7-mc. 'phone. W7AJW is the station of the RCARC. W7AHJ, CEJ, AYV, and AOI are new ORS. W7SO left for Alaska. W7ZZAL reports for Klamath Falls: W7BT moved to Salem. W7QP is back in Klamath Falls.

Traffic: W7KL 676 ABZ 283 LT 273 WR 205 AXJ 146 CTC 118 CEJ 109 AYV-CUV 82 DP 67 HD 64 AIG 29 AEM 53 CXK 63 AMF 46 CBA 41 AOI 40 APE 30 CFM 17 AEZ 16 COU 13 BHT 12 ALM-AID 10 BBO 9 SY-CRK-BTH 8 UJ 7 BWD 6 AJW 5 QY-BOO-AHJ-BLN 4 BOH-BKL-BMA-AXO-ANY-WL 2 BDU 1 ZZAL 52.

IDAHO — SCM, C. R. Thrapp, W7AYH-CKO — W7BAA leads the Section. W7AVP has nice bunch of deliveries. W7BCU reports by radio. W7AVZ got station license transferred. W7NH is going to 7 mc. W7ATN had a fire in his shack.

Traffic: W7BAA 58 AVP 42 BCU 18 BAU-AYH 17 NH 16 CSW 11 JY 9 AVZ 1.

MONTANA — SCM, O. W. Viers, W7AAT-QT — W7FL has portable W7CWF. W7BNL and BVE are on 1.7-mc. 'phone. W7BAY and BDJ have c.c. W7CBY has portable W7CXV. W7AQN has nice total. W7CCR has 3.9-mc. 'phone. W7BGC and AHU are QRL school. W7BHB had license trouble. W7AOD worked ON4AU. W7CHW has portable W7CYE. W7BMX will soon rebuild. W7DBU is the Great Falls High School station. W7DAJ is new station. W7BQG has MOPA. W7ASR-BIN is now at Great Falls. W7BOZ is rebuilding. W7AYR works K6. W7AOH is constructing c.c. rig. W7CTP blew his "appendix." W7COX is perking. The SCM visited W7AXG. W7CVE is W7BKM's YL.

Traffic: W7FL 60 AQN 178 CCR 22 AOD 29 BDJ 2 BMX 104 BQG 25 BOZ 15 BVE 6 AFU 53 BCA 6 BTL 7 BUG 4 CME 16 CUK 2 ASQ 83 HP 43.

ALASKA — SCM, Richard J. Fox, K7PQ — K7ARL will be back on air when his wood chopping is caught up. K7ATA handled quite a bit of earthquake traffic. K7BGX took commercial exam. K7UT visited K7PQ en route home. K7OCK is assembling K7AHK. K7AVU burned up his transformer. K7BND and K7BOE lost their shack

and all belongings in a fire. K7CPX visited K7BFO. K7AZS is new Anchorage ham on 1.7-mc. 'phone. K7ASH is installing Naval Reserve station.

Traffic: K7AAC 2 AFT 14 RWQ 41 CJF 53 ATD 45 ANQ 92 BNW 134 PQ 140 FF 329 BFO 189 AZ 74 BVH 72 CDV 53 BOE 26 ASM 23 BMC 10 CPX 9 BPD 5.

WASHINGTON — SCM, John P. Gruble, W7RT — W7BSX makes the BPL on deliveries. Yakima's YL, Miss Black, has call W7DCN. W7CXL is new station at Aberdeen. K7UT is visiting Seattle during filming of a new picture. W7JF clicked F8PZ on 14 mc. Kelso High School is to use W7DCQ. More new stations reported: W7CZB, DBI, DBF, DAI, CYW, CYG. W7CQJ worked a W8 with a pair of '01As. W7BWS sells crystals. W7ALE reports for Centralia bunch. Our ex-Director, W7BG, reports rebuilding. W7PH is in Seattle after several years operating aboard S.S. *Olympic*. W7AF has left for Alaska. W7CJR returned from California. W7ADU is one of the few seventh district 14-mc. 'phones. W7AAN, AHT, CLR, and BZC are busy with 56-mc. equipment. W7AGO left for southern California. W7CIV is editor of the Spokane amateur paper, *Ham-Boners*. W7BBY clicked G5OG on 14 mc. The Spokane Radio Operators' Club is sponsoring a big get-together for that vicinity for June 10th-11th. It will be an informal hamfest with no fees of any kind. 56-mc. tests are to be conducted. For full information write the secretary, W7AHT. Other sections of the state are invited to join in on the fun during the International Field Day tests, June 10th-11th. Get those portables going on all bands, and enjoy the thrills of field experimentation. Canadian VE5AA will have a portable in the Canadian Rockies. W7ZZH-W7CEN-W7CCZ will be used on the expedition to Mt. Whitehorse. Remember the date of the biggest field day ever attempted: JUNE 10th-11th . . . BE THERE!

Traffic: W7CND 19 AHQ 149 CNW 34 BBK 3 APR 12 IG 361 BNI 19 BRE 56 KO 4 AYO 53 CMF 1 BLX 16 WY 302 BZC 15 BWS 72 CGI 3 AIT 35 SL 4 CSA 16 LD 27 GN 14 CPD-AZI 2 AAF 10 CHH 70 BVM 2 CZY 7 JF 9 HS 104 BB 50 BDW 5 APS 16 BSX 396 ABU 3 BKE 87 ADS 8 AQ 89 AFC 59 CPF 41 CLJ-AYC 17 QI 11 AJI 8 CKR-CUF-BBY 5 AHT 1 COZ 4 AUI 3 AAN 1 BHH 237 AYP 45 BYB 48 CPK 2 BUK 17 BFL 43 CNR 11 BCC 78.

PACIFIC DIVISION

ARIZONA — SCM, Ernest Mendoza, W6BJF-W6QC — This report written by W6BRI for W6BJF. W6ALU is hot at it. W6BJF-QC took portable on National Guard trip to search for lost flyers. W6FJL and DRX junked together. W6EGI has new FB-7. W6GFK sports new receiver. W6DPS has portable W5CUS. W6CVW goes in for DX. W6GZU sends traffic report. W6DJH schedules W6EL. W6CGL goes c.c. W6GJC enjoys the scenery. W6HAX, hang onto that '01-A, or someone else will. Wonder how W6BLP manages so many vacations. W6CEC feels the effects of moving. W6EQU and BVN are QRL. W6EFC schedules K6GUA and W6AFU. W6GYM is new ham.

Traffic: W6ALU 568 EFC 122 BLP-BRI 82 CGL 39 DJH 29 CQF 20 GZU 19 CVW 13 CEC 6 GFK 3.

SAN JOAQUIN VALLEY — SCM, G. H. Lavender, W6DZN — W6EXH leads in traffic. W6AOA won the Sweepstakes award for the Section. W6CVT is installing c.c. W6HIA and DXB report good results on 1.7 mc. W6CLP handled several death messages. W6AME has turned miner. All of W6BHQ's traffic is trans-Pacific. W6FBQ is on 1.7-mc. 'phone. W6FYM says FBQ has all of his equipment tied up in that 'phone rig. W6FFU uses a regular frequency meter and a polyphase slide rule for finding the higher frequency bands. W6GXL was issued the call of W6HUF for his portable. The Reedley Junior College Radio Club is giving weekly lessons on code and theory. W6EPQ reports more grief with his transmitter. W6BFH is QRL YL that arrived awhile back. W6GQZ handles traffic when her OM gives her a break. The SCM is organizing OO's to help clear the air of all broad rough signals. W6GEG moved out in the country on ac-

count BCL QRM. The Stockton Radio Club celebrated the return of beer with a big party. W6FW, AK and AV had a hi-speed code test—results, AV won.

Traffic: W6EXH 440 DZN 102 BHQ 85 AME 67 FFU 68 ZZCO 55 CLP 23 FZA 21 DQV 18 FBQ 15 CVT 18 AGV 12 GQZ 5 BFH-EPQ 8 HIA 3 FCM 1.

SANTA CLARA VALLEY—SCM, Bruce Stone, W6AMM—Help is requested in locating following equipment stolen from W6YU: Standard nickel-plated Vibroplex, Western Wireless Dynamic Mike, Weston Type 301 8-Volt D.C. meter with a red line at 5 volts. W6YG can clear traffic almost anywhere. RM W6FBW is in the hospital for appendicitis operation. W6AZC's activity is increasing rapidly. W6DBB is 'phone editor of the Section bulletin. W6DHV and FMT (YF and YL) are raising their traffic totals each month. W6CEO has resumed daily work with P.J. W6QR spends most of his time on 'phone. W6YL is becoming very active. W6CDX (QSOed three VKs with a pair of '45s. W6DSZ QSOed 26 countries in all continents during DX contest. W6ENF is on all bands.

Traffic: W6FQY 457 HM 367 YG 293 FBW 271 AZC 153 DBB 70 YU 47 DHV 40 CEO 36 FMT 34 QR 33 NJ 25 YL 27 DSZ 18 CW-ACV 16 BDR 11 CNN 10 DNY 7 AOD-CDX-EEH 6 DSE-BSO-GOZ 5 DDS 3 FNF 1.

PHILIPPINES—Acting SCM, Newton E. Thompson, KA1XA—Mahoney of OMITB is in Manila on way to Peking. E. J. Esbrook is now operating OMITB. SCM party and meeting of PARA at KA1XA April 23rd; eats and everything.

Traffic: KA1HR 910 LG 404 CO 196 NF 112 NA 105 XA 79 JR 53 TS 22 KA9WX 130 EP 44 KA4GR 53 OM1TR 188.

SACRAMENTO VALLEY—SCM, George L. Woodington, W6DVE—W6FEJ, BHM and GVM are associate editors of QRU? dope sheet. W6GSP is using a 216A. W6GCM is still perking. W6FPH worked a ZU. W6AIM is back from Navy cruise. W6GTZ blew a transformer. W6SK is new traffic man. W6CKO and BPE attended Oregon State Convention. W6UM has new e.c. rig on the air. W6HKM and HMB are new hams in Woodland, reported by BHE. W6FKM has completed a big c.e. job. W6UCUM and GBB are experimenting with 56 mc. W6ELC is back from Los Angeles. W6BYB blew a 1-KW Bottle. W6AID, FLR, GHN, and GVM are playing with 1.7-mc. 'phones. W6CKH has c.e. rig on 7 mc. W6HHB is new station at the Sierra school.

Traffic: W6CKO 309 DVD. 159 AK 139 CGJ 35 AHN-GAC 21 BYB 15 DVE 12 FW-CIR 10 EWB-FEJ 9 SK 2 GKK-WJ 1.

EAST BAY—SCM, S. C. Houston, W6ZM—CRM, J. H. MacLafferty, Jr., W6RJ. W6CDA reports largest one-man-station total ever turned in in this Section! W6YJ had open house at the school for a week. W6AIS and BPC handled a large amount of earthquake traffic. W6HHM says Trunk "F" is working fine. W6RJ attended the Greater Oregon Amateur Radio Convention. A new transmitter has been installed at the NR station at El Cerrito, W6RF, W6FIL and BUX have consolidated. The Radio Club of Central Trades School is planning another visit to some commercial station. W6ZM has been busy operating his set at the Unemployed Exchange Association under his portable call AQ, with the capable assistance of EGM and FXV. "Doc" Messing is on the air again after a long absence with the call of W6HOW! Regular Section meetings are held at the Central Trades School on the second and fourth Fridays each month. Come down and get acquainted; all are welcome.

Traffic: W6CDA 1044 YJ 1023 AIS 993 HHM 696 EDO 546 RJ 254 FAC 151 RF 134 RLP 33 BUX 23 CTE 19 CX 17 YM 16 CYE 15 AQ 14 CZ 13 HOW 12 HH 5.

HAWAII—SCM, C. D. Slaten, K6COG—K6EWQ is up in the BPL. K6CRT is on with c.e. K6AIU is building pair of '04A's into final stage. K6FAB is back with new outfit. K6DSF has been working 3.5 mc. K6GQF has been giving 14 mc. a tryout. K6GUA has taken over the ham column in the local paper. K6AJA is hoping to put a BC

station on the air. K6COG and GUA are planning c.c. outfits. The O.A.R.C. is going strong.

Traffic: K6EWQ 1972 GUA 349 GBY 78 COG 74 CIB 54 GQF 47 CRT 40 FAB 16 DSF 15 CRU-EDH 4.

NEVADA—SCM, Keston L. Ramsey, W6EAD—W6UO established a record high for Nevada in traffic. W6HOB has 250-watter. W6AJP is organizing U.S.N.R. unit in Reno. W6FUO is on 1.7-mc. 'phone. W6ATN has high-power 'phone. W6ACU is on with a '52. W6GPT has a pair of '45s. W6EAD is building portable transmitter.

Traffic: W6UO 914 AJP 55.

LOS ANGELES—SCM, Francis C. Martin, W6AAN—The new set-up with W6BPU as Chief RM, W6ETJ, W6FGT, and W6EDZ as RMs is putting through the deliveries in good shape. The Southeast Radio Experimental Association of Bell under the guidance of W6EJZ, C. M. Feay, put over the quarterly banquet in fine shape with 265 in attendance, including W6AN, our Director. W6ERM passed Amateur Extra First. W6FEW reports for the San Gabriel Valley Short Wave Club. Gordon Larson, ex-9DSW and 9XI, is now W6LLB. W6GNM is working 56-, 28- and 1.7-mc. 'phone. Another old-timer, Frank Allen of the technical staff of Transcontinental Western Air, is back on as W6HBS. "Bill" Lippman, chief op at W6USA last summer, married in January. Portable W6HGU with W6FXS and W6HAC did good emergency work during the quake with set-up at Midwick Emergency Hospital. W6VR is back on after trip East. The following handled no traffic, but reported: W6ADJ, BDH, CDM, CES, CJS, GOX, ESA, SN. Look for Don Wallace in San Francisco during May with that famous portable W6ZZA. W6BJX got in on some earthquake traffic.

Traffic: W6ETL 733 BPU 694 EDW 689 MK 538 FGT 523 EK 344 AUB 335 ETJ 303 EBK 288 CVF 243 BZF 206 HGQ 185 ETM 166 AOR 162 HT 159 NF 154 AKW 152 EKZ 137 GXM 136 HEW 131 DYJ 118 ADH 108 YBB 103 AM 87 ACL 75 AAN 73 EZG 99 DVT 92 GEX 75 EGQ 60 DJS 59 EQW 58 CUZ 56 FKF 52 BGN 51 EDZ 50 EGJ 47 DVV 46 DQZ-EUV 40 CQM 37 ANN-FVD-GKZ 34 B8Z-YAK 33 CIX 30 FJT 27 FWN 26 EAN-ERM 24 CXW 20 MTV 19 CUY-ESK-FNG 18 FFN 17 CAH 16 HBS 15 CVV-FIW 14 DWP 13 FMP 12 GQL 11 BVZ-CQG-DQI-KHZ-HYJ-GMA-GSE-ZZA 10 DEH-FEW-FXR 9 FJS-FOZ 8 CLY-FDM-GEV-HXP 7 BPD-CCF-DOP-FLY-GJA-HLB 6 BCE-CYS-DOK-EMY-EWY-FET-FRT-GEZ-HLY 5 BOB-CGP-CTX-DRQ-DYQ-ERL-FXZ-GLZ-GNM-GPX-GSL-GTE 4 BER-BXG-DLN-FMO-GTG-HAZ-LC-ON-TVN 3 AZU-BGF-BBP-BRO-CTS-CUH-DZR-ECC-EPE-ETX-FSE-GMC-GNZ-HDV-PD 2 AGF-BQF-DFG-DTX-DZI-EQJ-FSJ-ELU-FYW-LY-MA 1 BJX 54.

SAN DIEGO—SCM, H. A. Ambler, W6EOP—W6BMC makes the BPL. W6DQN turned in a nice total. W6FWJ is back. W6BAM is going strong. W6EFK has four schedules. W6CNB worked a W1. W6EEK says 14 mc. FB. W6BHV was in DX contest. W6BLZ has gone on trip to the Grand Canyon. W6EOP has new all a.c. e.c. frequency meter-monitor. W6AKY says DX FB. W6ACJ is rebuilding to c.c. W6EPW is east on a visit. W6AXN and CNQ are A.A.R.S. W6DWA is attending school in Los Angeles. W6BBR and AMO took portable to the beach. W6HQM is a new ham. W6BAS calibrated frequency meter for the SCM. W6BCF has receiver trouble. W6CTP and AMO were in DX contest. The San Diego Amateur Radio Club has been organized with following officers: W6APC, pres.; W6EDJ, vice-pres.; W6GNP, secy.; W6FMJ, treas.; W6BZE, Bus. Mgr.

Traffic: W6BMC 811 DQN 354 FWJ 312 BAM 133 EFK 95 CNB 61 FQU 30 EEK 28 BHV 10 BLZ-EOP 9 AKY 5 ACJ 3 AXN 4 AMO-CNQ 2 BBR 20.

SAN FRANCISCO—SCM, Byron Goodman, W6CAL—A 7-day absence to the Oregon Convention keeps W6PQ just under a thousand! RM W6BVL suffers from YLitis, but his traffic doesn't. Away from home, RM W6BTZ plans rebuilding. W6ABB awaits ticket at new

QRA before resuming schedules. NR station W6NK turns over a few! K6VG visited W6GIS, who says K6 traffic FB on 3.5 mc. TL "B" is working smoothly, says W6CIS. W6EQA reports that a 10-tube super can bring in a little DX. W6MV is putting up a new Zepp. W6BIY was heard in England on 7 mc. HC on 7 mc. is DX at W6AZK. PP '10s worked ten countries in two weeks at W6GKO. W6FVJ had three different antennas up within five days. W6BMK likes an '01A with 180 volts for 7-mc. work. W6EKQ schedules Oregon. W6EYY likes duplex work on 1.9-mc. 'phone. W6IU casts longing glances at 14 mc. W6AZX is getting receiver down to 28 mc. Three new countries for W6DZZ on 7 mc. W6GOV reports swell DX on 3.5 mc. W6HIR is building 50-watt rig at new QRA. New '03A in MOPA works fine at W6BIM. W6GWW works only the J's that don't QSL. New 3.5-mc. Zepp at W6COP. China schedule at W6DXW. W6BFZ is on again with '10s in final. The taciturn W6ZS works ZS2A. S-tube super at W6BWZ. W6FZP is QRL moving to new QRA. W6BIP is mistreating his '10 with 1300 volts. W6AAR merges with W6BGW in new 1-KW job. Final amplifier trouble at W6DTR. VP4AA makes 33rd country for W6CAL's '10. W6EVI plans new Lamb 5-tube super. W6CBN swears by doublet receiving antenna. 56 mc. gets a play at W6WC. W6FPU plans new 'phone rig. W6HSQ tests with W6CSX on 56 mc. War will soon be declared in this Section on hum signals when the Vigilance Committee reads again. How's your note?

Traffic: W8PQ 923 BVL 240 BTZ 218 ABB 214 NK 165 GIS 164 CIS 155 EQA 43 MV 39 BIY 29 AZK 28 GKO-FVJ 26 BMK 25 EKQ 23 IU-EYY 22 AZX 21 DZZ 17 GOV-HIR-BIM 14 COP-GWW 12 DXW 9 BFZ 8 ZS-BWZ 7 FZP 6 BIP 4 AAR 3 DTR-CAL 1.

ROANOKE DIVISION

WEST VIRGINIA—SCM, C. S. Hoffmann, Jr., W8HD—W8CSF won Cardwell Transmitting Condenser for best code speed at East Liverpool Hamfest. W8HD was heard in Europe on 3.5 mc. W8HBB, HCL and DOB are working at new locations. W8BKG's ORS was endorsed for another year. W8CHM and DSO are first to endorse the proposed OPS idea. W8TI notes a decided decrease in off-frequency transmissions. W8FFO used spark coil plate supply! W8DSJ is building an e.c. oscillator. W8CMJ and EIK desire traffic. W8HD schedules W9USA-USB. W8GRJ and DPO continue working VK's. W8CHM worked OA4Z. W8CZ is working in Bluefield. W8HIU is operating CZ. New stations: McMechen, W8IQY; Bluefield, W8ILF, IPH, ING. The W. Va. Bulletin has made its first appearance; a copy was sent by the SCM to all reporting stations. See you all at the Bluefield Ham Convention! Beginning May 15th, W8GB will donate an "X" cut crystal to the station leading the state each month in traffic. This offer will continue for three months. The crystal will be furnished in either the 1.7-, 3.5- or 7-mc. bands.

Traffic: W8CMI 277 EIK 148 BWK 146 BOW 100 BJB 58 HD 34 CSF 22 HCL-ELO 16 TI 10 BKG 12 DSJ 8 EL-EWM 5 GRJ 3 FFO 2 FQB 1 DPO 14.

NORTH CAROLINA—SCM, G. H. Wright, Jr., W4AVT—Every member of the Section deeply appreciates the fine work done during the past three years by H. L. Caveness, W4DW, as SCM, and feel proud that he has been elected to represent the Roanoke Division on the Board of Directors. Hege at W4NC has been appointed Chief Route Manager. W4EG is president of a new Raleigh Amateur Radio Club. W4BCG is having trouble getting c.c. rig going. W4VN reports via radio. W4JR is off on account of depression. W4ANU is after ORS. W4AMC is working DX on 7 mc. W4AIS is working all hands. W4DQ is adding a pair of 50-watters. W4ABN, NC and AMC have new FB7's. W4AL is in search of DX. W4GW is boosting Naval Reserve. Ex-CM8AZ is now located in Concord with call W4BYN. New hams this month: W4BST, BWO, BWE, BYE, BWT, and BVU. W4BHR is adding a 50-watt. W4QI is keeping lots of schedules. Spring fever has W4HX. W4EJ is back on the air. W4MI is competing with Hi-Speed automatic send-

ers. Too much QRN for W4AXZ. W4BJZ has '03-A on 3.5 mc. W4BPU has moved to 3.5 mc. W4PFA rebuilt. W4BIU, ABT, and OG are handling some traffic.

Traffic: W4ATC 354 AOA 316 AIS 100 BRK 76 NC 74 VN 69 AAE 59 TP 40 BHR 27 GW-EG 24 DW-AVT 23 QI-RE 20 TJ 17 ABT 13 AMC-BUE 12 ZH-TO 10 BKS-ALT-JB-IF 8 ATS-BVY 7 BPU-TR 6 ANU 5 BJZ-OG 4 MR 1.

VIRGINIA—SCM, R. N. Eubank, W3AAJ-WS—New calls in state: W3BXH, DFU, CZJ, DFW, CUV, DAM, BZN, CYU, DEH, DDY, DBB, DDE, BXL, CVF, CLZ, CXT, CTP, CWJ, BQZ, DCK, DCN, DDG, DGH. Virginia BPLs: W3NT, CXM. Moved: W3BTR, BAD, CSY Phila., BPA, KA Trenton, CUR Roanoke, ARD Sea. Lots of Virginia schedules: W3AGW, BRY, AAJ, BPI, GE, CFL, CMJ, FJ, WO, CVN, BXP, BJX, ZA. On 'phone: W3GY, ZA, CNY, R.L. Sick: W3APT, JI. New equipment added: W3BFW, BYA, AAJ, CSI, BDZ, BXP, GE, DAM, FE, BSM, QN, DEH, NB, WW, AIJ, CZJ, BUY, CVU, LY. Rebuilding, etc.: W3BXN, BZ, AJA, NB, BPA, AMB, CBZ, UVA, BLE. Want schedules: W3APU, BGS, CFV, BRE, COO, TN, CUV, AOT, W3OM is very active. Working DX: W3BSB, NE, BAN, WM, BWA, BFQ, CLD, BZE, AAJ, BDZ, CZX, ASK, ADD, AG, LY, AEL. 'Phone and c.w.: W3GY, ACN, AJA, BSM, FJ, BEP, AG, AHQ. W3BJX sends lots dope. QRL: W3AU, AAF, BAI, MQ, VZ, AUG, CVU, WO, AVR, AEW, AII, AZU, CKM, ATY. See you West Virginian Hotel, Bluefield, W. Va., Sat.-Sun., May 27th and 28th. Grand convention! Only \$2.50. Come! New traffic reporters: W3BYQ, CYU, BFQ, AOT, APT, ASK, AZU, BDZ, BFW, BIG, BJX, BPB, BTR, BUY, BWA, FE, CZX, CZJ, LY, CVF. W3CAH spent month in Akron, O. W3CVN is most outstanding Virginia station this month. W3QN is Richmond's YL op. W3CNY, CVN, BIG are now O.B.S. W3HV, CDW, BEP, AEL send dope on others. W3AKN renews ORS. W3BIW is c.c. on all bands. W3BHN is real traffic man.

Traffic: W3NT 561 CXM 554 BNE-BJX-FJ 176 AAJ-CVN 119 GE 95 QN 78 CMJ 77 WO 73 CVU 70 BXP 49 BRY 47 CFL 37 CLH 33 OM 75 AGW 19 AHQ 18 COO-CSI 17 AG-BUY 16 BAI-BYA-HV 14 BPI-CFV 13 AKN-BZE-CZX 11 AAF-AII-BRE 10 GY-AUG 9 BYQ-CNY-WM 7 BGS-BPB-CHE 6 TN 12 APU-BSM-UVA 5 BFQ-CDW 4 BFW-CPN/WN-CLD-FE-NE 3 BIW 5 APT-ASK-BSB-BTR-CYU-CZJ-MQ-LY-BDZ 2 AOT-AZU-AVR-BIG-BWA-CKM 1 ATY 200 AEL 13 ZA 9 BLE 16 CVF 1.

ROCKY MOUNTAIN DIVISION

UTAH—WYOMING—SCM, C. R. Miller, W6DPJ —W7COH schedules about ten stations. W7AWG heads traffic list. W7DBK is on in Pinedale. W7BFS gets out well. W7AXG is looking for stray RF. Crystal rig at W7AEC. W6DAM has gone c.c. W6FYP is working on portable. An interesting talk on high frequency work was given before the UARC by W6EXL and W6FEF. W6EYS will probably move to Salt Lake City. W6CRX is on 3.9-mc. 'phone. School hinders work at W6EZZD. Officers of UARC are: W6GQC, pres.; W6GIO, vice-pres.; W6AFN, sec.-treas. Everybody come and bring your ham friends to the big convention near Moose, Wyoming, August 5th and 6th. A very unusual and interesting kind of hamfest—ask W7AWG, W7HX, W7BAA or W6DPJ for particulars.

Traffic: W6DPJ 149 BTX 59 AHD 15 DGR 5 GQC 2. W7AWG 172 COH 69.

COLORADO—SCM, T. R. Becker, W9BTO—The Denver Radio Amateurs went down to the Springs to an FB hamfest given by the P.P.A.R.A. The convention this year will probably be held at the Springs under the auspices of the P.P.A.R.A. W9ESA again makes the BPL. W9FA is out of the city. W9CJZ is QRL KFEL. W9LYE took a Broadcast Ticket. W9BYY is using a lone '10. W9CUB is out of the hospital. W9BTO passed the unlimited 'phone exam. W9AUJ threatens to put in low-power 'phone. W9FFY was on RMNite and made 17 contacts. W9HIR is the champion DX station of Col-

orado. W9GVN finally made the Naval Reserve. W9JGA will be on 14-mc. 'phone. W9IPIH has his SS receiver perking FB. W9AAB, our Director, leaves for the conflag at Headquarters. W9CWX is hunting DX. W9IJU is hunting for that d.c. note on 7 mc. W9KIN is looking for another Super. W9BJN is on with new c.c. rig. W9FRP will have P'B rig. W9AQN is selling out. W9CND is QRL work. W9DDF is using a sick 50-watter. W9APR gets on once in a while. W9LNB is on 1.7-mc. 'phone. W9JB is busy with the Naval Reserve. W9MAQ is a new station in Denver. W9MFX is on with low power. W9BQO went East recently. W9EMU has '52s linear in his 'phone. W9ACV schedules W7AAT. W9EAM is not feeling well. W9GHL is busy at North High. W9RJ is in the Ham Parts trading business. W9IAV is coming on 'phone. W9BYK changed back to '10s PP. W9HFW is having troubles. W9BCW is QRL trying to blow up KOA. W9GBQ blew his plate transformer. W9EKQ is still with the A.A.R.S. W9HJS is on now and then. W9BYC has a 50-watter for 7 mc., and '10s for 14 mc. W9YL has been working DX. W9FYK is trying to sell and borrow. W9FFU is on with a '10. W9HIR blew plate transformer. W9KKJ has a new call. W9JRV is QRL YF. W9FYL is QRL school. W9KKR is on once in a while. W9LLP borrowed enough stuff to get on. W9KRV is using a 50-watter in final. W9GGP let his license expire. W9GCM has been on 1.7-mc. 'phone. W9BRZ and KKY are re-building. W9JFD felt the earthquake. W9TX was a Loveland visitor. W9IFD worked his first VK and ZL. W9GNK sends his usual FB report. W9LZA is a new station. W9IDC and IQF lost their temporary tickets. W9GNK was heard in N.Z. on 3850 kc. W9DQD has been working. W9GLG has been working. W9CDE handled some earthquake traffic. W9GYV is planning to investigate 28 mc. W9EHC and FXQ passed unlimited 'phone exam. W9MKG, of Holdrege, Nebr., visited W9EHC-FXQ. W9EYN is keeping W9JNV's schedules. W9MEN is W9LFE's new portable. W9JQC is building c.c. rig. W9JAV, LIU, EPN, EXV, HDI, AMS, IQS, and DYP are QRL — probably 3.2 beer. HI. W9JNV is on 14 mc. at his new QRA and uses W9KNZ, his portable call. W9DNP and JCQ worked WIMK.

Traffic: W9ESA 1507 IFD 10 JNV 23 CDE 24 BTO 12 EYN 148 EHC/FXQ 5 LFE 21 JCQ 23.

SOUTHEASTERN DIVISION

EASTERN FLORIDA — SCM, Ray Atkinson, W4NN — W4BGG is doing nice traffic work. W4BGR is c.c. W4UX sold out. W4AZB has new 250-watt c.c. job. W4PK has new transmitter. W4BIN graduated from high school. W4DT is back. W4AGP and AJX did well in DX contest. W4AVD, ZU and BGL are handling traffic. W4ALP has 250-watt rig. W4TZ moved near WDAE. W4CI has a 50-watter. W4AKJ built a 3.5-mc. portable. W4PQ uses vertical ant. W4BKN and BRL are new hams. W4AI missed a trip to Europe. W4OT reports. W4DZ has new a.c. receiver. W4WS reports good DX. W4BNR is building 1.7-mc. 'phone. W4ANY and AWE have 56-mc. 'phones. W4AGB has unlimited 'phone ticket. W4NN is on 14 mc. W4MF is on 'phone.

Traffic: W4BGG 76 AVD 58 NN 45 AKJ 40 BGR 32 WS 26 AII 12 AKH 11 AGB 9 TZ-BGL 8 BIN-ZU 7 AJX 5 BNR 2.

GEORGIA-SOUTH CAROLINA-CUBA-ISLE OF PINES-PORTO RICO-VIRGIN ISLANDS — SCM, Chas. W. Davis, W4PM — W4WZ is resting up. W4IR is holding up his end. Nice letter from K4BU. K4RJ finished his c.c. rig. K4UG is changing to c.c. ExK4KD lives in Santurce. K4AOP is coming on again. K4BRN is active. K4LW and K4BU are QRL NEJ. K4BRN busts sister's ornamental lamp for the quartz crystals! K4BSE is on with PP '45s. W4ATZ is on with 150-watt c.c. job. W4AKU is back in Spartanburg. W4AHT is on 3.5 mc. W4AOX is on with TNT '45. W4BAC stood 'phone exam in Albany, also W4ATO, W4AUO. W4PFG has PP 50-watters. W4BDV is active.

Traffic: W4IR 162 BAG 36 ATZ 23 BQX 12 BWN 35. ALABAMA — SCM, L. D. Elwell, W4KP — W4AAQ

was QSO VK and K6 on 3.5 mc. A club is being started in Mobile. An old-timer is on with the call W4BXV. W4OA has new speech amplifier. W4BSL reports for first time. W4GN has gone West to pound Morse again. W4PFR has taken up 14-mc. 'phone. W4DS, our RM, has some fine traffic lines. W4BAI reports via radio. W4BCV is on 7 mc. W4APU is high traffic station. W4DD was second high. W4ALG and AAQ are new ORS. W4BJA is ORS to be. W4JX is coaching hams to be. W4FL says west coast DX fine. W4BMM is on 1.7-mc. 'phone. W4BDH is going to 14 mc. W4AYK is using W4PDH. W4HO is busy at WSFA. We regret to hear of the loss of W4ASM's father.

Traffic: W4APU 128 DD 100 DS 76 BAI 59 AAQ 55 ALG 34 BJA 36 AG 18 ALA 11 BIT 9 FL 8 AP-ZS 4 BSL 3.

WESTERN FLORIDA — SCM, Eddie Collins, W4MS-W4ZZP. R.M., W4ACB-PCN. The SCM thanks all for the kind thoughts of sympathy in the loss of his mother. W4AXP and AGS renew ORS. W4AQY-PDS gets out FB. W4BGA received his "EAR" card. W4BSJ QSO'd ZL, EAR and VK. W4AUW is experimenting on 28 mc. W4AUV is deserting 1.7-mc. 'phone. W4BKD and BMJ are awaiting the R.I. W4BOW has an all a.c. receiver running off of spark coils! W4AUA is proud owner of an A.R.R.L. Public Service Certificate. W4BKV knocks 'em out in great style. W4BPI is QRL school. W4KB's crystal oven perks FB. W4AQ is trying new circuits. W4QR is on all frequencies. W4ACB-PCN is thinking of c.c. W4BFD has antenna up again. W4ASV lost A.B. power unit. W4QU reports receiver trouble. W5ZZR is all wed! W6HET has increased power. W4VR promises an FB7. W4QU is on with 250 watts. W4BGB is active on 3.5 mc. W4ZZAO has a new Ford V8. W4BCB can't find any hams in Jax. W4MS-ZZZ is working on c.c. rig. Hope to CU all at hamfest at W4KB's last of May.

Traffic: W4AGS 11 KB 19 BFD 5 BSJ 10 BGA 8 MS 6.

WEST GULF DIVISION

NEW MEXICO — SCM, Jerry Quinn, W5AUW — W5CWM is new ORS. W5BVC is on again. W5CJP is looking for R.I. W5JZ is heard from. W5AOP has new receiver. W5CVB has W.E. 5-watters. W5BNT has '45s in PP. W5ZM schedules W5CWM. W5CJG blew buffer tubes. W5AUW has kw. input. W5CVG (YF of AUW) will be on soon.

Traffic: W5AUW 183 CWM 111 BNT 46 ZM 41 AOP 30 BVC 14 CGJ 8 CJP 7 JZ 6 CVB 5 CVG 4 ZZQ 13.

OKLAHOMA — SCM, Emil Gisel, W5VQ — W5BMU is high man. W5ASF comes in second. W5CEZ has a.c. QRM in new location. W5ALD is going to put on high power. W5BPM reports traffic falling off. W5BDX worked a K6. W5AKX has c.c. rig going. W5CPI is active. W5AND worked a ZL. W5GW is new ORS. W5BQA worked a VK6. W5CVA is ex 5ADQ of '23. W5PP-W5AJO has a pair of 575 rectifiers. W5DDM, DCU and CRW are new hams. W5ATO has BCL trouble.

Traffic: W5BMU 338 ASF 287 CEZ 143 ALD 136 BPM 116 BDX 113 CVA 62 AKX 41 CPI 33 BOE 25 AND 11 BQA 6 GW 5.

NORTHERN TEXAS — SCM, Roy Lee Taylor, W5RJ — W5AUL is high traffic man again and is now SCM of Northern Texas, succeeding W5RJ, resigned. W5BII reports traffic picking up. W5IT is pounding out a good total. W5ANU wants a National PBX. W5BVF has had the measles. W5AJG has static trouble. W5AHC, CPX and EL have 3-year tickets. W5ASA got another report in OK. W5CPU says BXT, CPU and BKJ are having Saturday hamfests and church on Sundays. W5CLU is on now and then. W5RJ is quitting all League activities due to pressure of business. W5ARS and AFQ are new ORS. W5BZ1' is a new OBS. W5AMK reports for Cen-Tex Amateur Radio Club. W5AHZ, BEO and BEQ are active in Belton. Ex W5AMW has a "D" call. W5CKP is pushing 14 mc. W5LMM will be back soon. W5AMK's YF passed exam.

Traffic: W5AUL 282 BII 233 IT 173 ANU 58 BVF 93 AJG 50 AHC 73 ASA 18 AFQ 17 BKJ 3.

SOUTHERN TEXAS—SCM, David H. Calk, W5BHO—W5OW again leads the Section with the highest traffic total. W5BKE reports traffic falling off. W5MN has seven daily schedules. W5YL works Duplex-Triple with the 3.9- and 1.7-mc. bands on 'phone. W5YH works lots of DX. W5PY needs Europe and Africa for his WAC. W5BKY wants 7-mc. daylight schedules. W5ADZ is new RM. W5TD reports no luck on RMNITE. ORS W5BNJ was placed back on active list. W5ES will be 14-mc. 'phone soon. W5GJ sends nice report. W5AXO is attending Texas Military Institute. W5AAI has YLitis. W5AUC is now SWL listening to Trans-atlantic and Trans-pacific BC. W5BNK will soon move to Chanute Field, Ill. W5ABQ is QRL repairing BC sets. W9AJC has reinstated for another three years. W5HX has worked all "W" districts, 45 states and 4 continents with a '12A and 300 volts "B" batteries. W5CVW is now stationed in Ft. Crockett, Texas, with the Air Corps. (He is Ex-8BWK-2BMS-1CMEI.) W5BZW needs Africa to make "her" WAC. W5MS reports much activity in DX contest. W5AQK has completed c.e. rig. W5RXX, Corpus Christi Radio Club station, is being rebuilt. W5CHI is rebuilding. W5CHN has been putting his time on 1.7-mc. 'phone. W5HP works W5CHN's 'phone. W5ALV is putting his job in rack and panel. W5BDQ pilots hams around in his plane. W5TO is on with c.e. W5CMO had filter trouble. W5CHI with '45 in final stage was heard in Japan. W5BOY is building a '10 final amp. crystal. W5ZX is building 1.7-mc. 'phone. W5FH and HZP are going 'phone. W5WE log shows nine out of every ten stations called are worked. W5ZN works his rig now and then. W5ZL, operator on the Tanker Federal, visited the hamfest held by the Valley Radio Club at Brownsville and Matamoros, Mexico. W5CDS was a visitor in Corpus Christi. The Corpus Christi Radio Club meets every Friday night at 8 p.m. Visiting hams are invited to attend. On April 9th the Houston Amateur Radio Club gave a barbecue at the San Jacinto Battle Ground; about 40 hams were in attendance.

Traffic: W5OW 1808 BKE 315 MN 204 ES 99 YL 56 YH 51 CVW 33 PF 19 MS 17 BZW 13 BNJ 14 TD 20 BKY 8 ADZ 4 BHO 6.

CANADA

MARITIME DIVISION

NOVA SCOTIA—SCM, A. M. Crowell, VE1DQ—VE1ER shows nice total. VE1CY is trying 1.7 mc. VE1CW is using remote control. VE1EX is a former Morse man. VE1FC is on 3.5 mc. VE1EB, EY and CV are T.L.S. VE1AW has 'phone on 3.9 mc. VE1EP, AS and FB are using 1.7 mc. New class "B" rig at VE1AX. VE1ET gets out well. VE1DQ has "new auto QRM." VE1BY is on 3.5 mc.

Traffic: VE1ER 123 EP 25 EX 12 FC 10 CW 1.

ONTARIO DIVISION

ONTARIO—SCM, H. W. Bishop, VE3HB—VE3IB was four weeks in a dark room with eye trouble. VE3OO contacted an SM ship off coast of Africa. VE3LN gets heard cards from Poland. VE3NU and PAI have new receivers. VE3HA is experimenting. VE3CZ pounds a little. VE3LY complains of dead schedules. VE3HU is QRL broadcasting hockey games. VE3FW is rebuilding. VE3GS is "nuts" over high power 'phone. VE3GB has c.e. VE3PY disconnected his ant. and forgot it. VE3OZ has "Hartley failure." VE3NX gets good reports. VE3AU claims to have lowest powered 'phone in existence: 1 watt. VE3JU is building 5-tube s.s. receiver. VE3QI made 113 contacts in 7 weeks. VE3QE is on 7 mc. VE3QI uses MOPA. VE3BU charges his batts with a windmill driven gen. VE3DC is QRL garden. VE3QE is one of RM VE3HP's flock. VE3QI is a newcomer. VE3RR an old-timer back on the air. VE3WV sends the SCM his 10-year-old card. VE3JI is new RM at Ottawa. VE3TM is an ORS. VE3XJ wants to get in touch with any of the gang interested in 56 mc. VE3JG has his antenna in a cemetery. VE3KY is just married. VE3GL is on 14 mc.

Traffic: VE3AD 597 TM 384 DW 327 JI 133 WX 555 QK 513 OH 115 HB 70 RO 82 HP 46 LY 45 OF 44 WF 33 LI 3I 1H 27 GT 22 SA 17 OF 13 WK 12 WV 11 AU-QB 8 WJ-EC 6 IB 7 RK-LM 4 CI 5 HT 3 JP-DU 2 VE9AL 13.

QUEBEC DIVISION

QUEBEC—Acting SCM, John C. Stadler, VE2AP—VE2FE says schedules difficult to keep. VE2CA is building s.s. receiver. VE2AC is rebuilding throughout. VE2BG and BE are out for 14-mc. 'phone DX. VE2AP is back on 'phone. 56 mc. is interesting VE2EM, AX, CD, and FW. VE2DR is going to Sweden. VE2CO is the district OBS. Who is the winner of the Payette Contest? Choice between VE2CA, CQ and CX. VE2DX is moving to St. Lambert. VE2AB worked his first "G" on 14 mc. The Westmount Radio Club had a hamfest with record attendance of 71. If you can go to hamfest at Malone, N. Y., on May 30th, 'phone VE2AP for arrangements. If you did not get your copy of the WRC Bulletin, write and ask for it.

Traffic: VE2FE 63 BB 55 CO 5 DR 40 CA-CX 6 BG 24 AP 94.

VANALTA DIVISION

ALBERTA—SCM, C. H. Harris, VE4HM—VE4BV has c.e. transmitter. VE4BZ is active. VE4DQ is on 14 mc. VE4EA is low powered on 7 mc. VE4EO is re-arranging station. VE4FJ keeps Jasper on the map. VE4BA is rebuilding. VE4IZ is QRL University exams. VE4MG sends his first FB report. The YF at VE4HM keeps schedules while the OM is away. VE4CX has new c.w. and 'phone rig. VE4HC and EZ visited the Edmonton gang. VE4DT is quiet this month. VE4GY is on stealthily.

Traffic: VE4BZ 107 IZ 34 DQ 12 MG 9 EO-HM 5.

BRITISH COLUMBIA—SCM, J. K. Cavalsky, VE5AL—VE5HA gets QRM from a substitution. VE5FY is on night shift. VE5IH is using MOPA. VE5GJ is getting out better. VE5AG has c.e. rig. VE5EV is rebuilding. VE5FE worked Newfoundland.

Traffic: VE5HJ 5 DO 17 AC 57 HQ 114 FG 12 GS 5 AL 29 DH 12 GJ 5.

PRAIRIE DIVISION

MANITOBA—SCM, Reg Strong, VE4GC—Keep in touch with local activities through the M.W.E.A. Bull. VE4BT is back in Winnipeg. VE4FT works lots DX. VE4MW says schedules getting back to normal. VE4BQ has a new call in the N.W.T., VE5JQ. VE4AK is located at Strathclair. VE4FU has completed the 'phone. VE4CP has high-power c.e. job. VE4CS pounds brass between studies. VE4LL is still testing. Mrs. VE4LL is often at the key. VE4AC says skip is not high enough for his 'phone to cross the International boundary. VE4IF's hobby is building transformers. VE4LN has a fine DX record. VE4MK has crystal note. Ex VE4IS is coming on again. Heard on 7 mc.: VE4RC, RH, MY, YK, and RX. VE4CI worked a VK and HC. Technical talks are given at the M.W.E.A. every second Thursday of the month. VE4LT is editor of the "Bull." VE4MV prefers 14 mc.

Traffic: VE4MW 47 GC 21 KX 16 CI 12 IP 10 DK 8 FT 7 AG 6 FP 5 KU 3 ZR 2.

SASKATCHEWAN—SCM, Wilfred Skaife, VE4EL—The Regina gang is staging a big convention and will have a stand in the Grain Building at the World's Grain Show, July 24th-Aug. 5th. Schedules are wanted. The call will probably be VE4WGS. Frequencies will be 3525, 7050 and 14100 kc. VE4MH and ND would like schedules. VE4MT has had some success on 1.7-mc. 'phone. VE4GN made another "G" contact. VE4KV reports 14 mc. very good. VE4BB reports 7 mc. good for schedules. VE4EH is getting out well on 'phone. VE4CM is tuning up his 150-watt c.e. VE4EL thinks we should have another Sunday party on June 4th.

Traffic: VE4BB 204 AT 171 CM 122 AU 106 EH 62 HG 52 LP 19 EL 17 AZ-IY 16 MH 9 GN 8 KB 8 JG 6 BR 4 AV 3 CV 2 GF-MT 1.

• I . A . R . U . N E W S •

Devoted to the interests and activities of the
INTERNATIONAL AMATEUR RADIO UNION

President: H. P. MAXIM

Vice-President: C. H. STEWART

Secretary: K. B. WARNER

Headquarters Society: THE AMERICAN RADIO RELAY LEAGUE, West Hartford, Conn.

MEMBER SOCIETIES

American Radio Relay League
Associazione Radiotecnica Italiana
Canadian Section, A. R. R. L.
Deutscher Amateur Sende-und-Empfangs
Dienst
Experimenterende Danske Radioamatører
Liga Mexicana de Radio Experimentadores
Nederlandse Vereniging voor Internationaal Radioamateurisme

Nederlandsch-Indische Vereniging Voor
International Radioamateurisme
New Zealand Association of Radio Trans-
mitters
Norsk Radio Relæ Liga
Polski Zwiasek Krotkofalowcow
Radio Society of Great Britain
Rede dos Emissores Portugueses

Reseau Belge
Reseau Emetteurs Français
South African Radio Relay League
Suomen Radioamatööriliitto r.y.
Sveriges Sändareamatörer
Unión de Radioemisores Españoles
Union Schweiz Kurzwellen Amateur
Wireless Institute of Australia
Wireless Society of Ireland

Conducted by Clinton B. DeSoto

National:

The proposal to the Spanish government of a new system of call signal assignment and distribution in Spain is being contemplated by the *Unión de Radioemisores Españoles*. This proposal, if plans now being worked out reach fruition, will provide for a system of numbered districts such as is to be found in many other countries, with the single numeral following a two letter prefix which will be in accordance with standard international practice. This numeral will indicate geographical location, while the actual identifying call signal will be an additional two or more letters as is the custom throughout the rest of the world. The now well known but unconventional practice of the Spanish in assigning a three letter prefix with an identifying numeral seems to be on its way to the discard, although it is likely that the actual change will not occur until next year.

The recent combination of the forces of the *Asociacion EAR* and the *Red Espanola* in that country under the banner of U.R.E. has met with enormous popular approval. Almost without exception, every amateur in Spain is working enthusiastically for the good of the common society. The regional organization has been overhauled in the light of the recent fusion, with existing R.E. and EAR provincial branches welded into a unified body.

In line with the amateur emergency corps being organized in many countries, South Africa now has an emergency communications system actively functioning. According to Oscar Egenes, ZT5R, S.A.R.R.L. correspondent, stations throughout the country have been appointed to act on the instructions and under the supervision of the National Defense and Postal authorities, in times of major or other emergencies. With

special permission to handle interdivisional traffic the stations operating in this net have been brought up to a very creditable pitch of efficiency, and the scheme is gradually being enlarged.

On Sunday, March 5th, the first Cuban Amateur Radio Day was observed throughout the Republic of Cuba, with festivities centering in Havana. At 11 a.m. a message was transmitted from CM2NA, CM2SV and CM2JM to be copied by amateurs throughout the country in competition for a prize offered by the *Radio Club de Cuba*. At 12 noon the members of the short wave section gathered at a dinner, which was followed by a trip to broadcast station CMAF. A special program was broadcast in honor of amateur radio, featuring an address by A. Saenz de Calahorra, CM2WW, president of the short wave section. It is the intention of the *Radio Club de Cuba* to make this Radio Amateur Day an annual affair, observing it on the first Sunday in March of each year, much the same as is done in Argentina.

The membership of the R.S.G.B. has been increasing at a rate of more than 50 per month during the past few months, it is reported by J. Claricoats, secretary. While many other national societies do not show any such definite growth, we have not heard of any country in which amateur radio is actually declining. Both in power and prowess the radio amateur is steadily gaining strength.

Field Day:

The international field day scheduled for the weekend of June 10th and 11th as an outgrowth of the national field day instituted by the R.S.G.B. for British Empire stations on those dates, is now the subject of active encouragement and planning by the *Reseau Belge*, N.V.I.R.,

and A.R.R.L., with a special announcement concerning it to be found in the Communications Department of this issue of *QST*.

R.S.G.B.'s revised rules provide for commencement of the event at 1600 G.C.T. June 10th, ending at 1900 G.C.T. June 11th. Each of the 17 English and Welsh districts, together with the four Scottish districts, will put into operation one or two portable transmitters. When more than one transmitter is in operation, they will



THE RADIO CLUB DE CUBA HOLDS ITS FIRST ANNUAL RADIO AMATEUR DAY

At dinner, seated left to right: CM2WA, CM2ZB, CM2GR, CM2NA, CM2SV, Enrique Anca, president of the Radio Club de Cuba, CM2WW, CM2QY, J. M. Duquesne, secretary, CM2JM, CM2WD, CM2RS, CM2AX.

occupy different bands, the one designated "A" working on 1.7 and 3.5 mc. while "B" will use 7 and 14 mc. The prefix XG will be used to distinguish these stations as portables.

Points will be scored for contacts with all stations outside the district, and these points will be multiplied by four if the station worked is also a portable. Four points will be scored for contacts with other British portable stations, eight points for contacts with European portables, and sixteen points for portable station contacts outside Europe. Contacts with B.E.R.U. stations outside Europe will count 32 points.

The field day will be truly international in character, and any amateur entering the activity will find a hearty reception. Reports should be made direct to national society headquarters, unless otherwise advised.

General:

Recent exceptional DX work includes the QSO on 3.5 mc. between Edward Falls, Jr., W6FTV and M. Dubois, F8BD, at 1200 G.C.T. on April 1st W6FTV was using four '01A's in his transmitter at the time A number of Australian stations have worked all continents on 'phone, but lack the QSL cards necessary to acquire that exceptional rarity, the WAC-on-'phone Among them are Con Bischoff, VK2LZ, and Don Taylor, VK5DX The Overtone King (Eric W. Trebbilcock, 784 Hare Terrace, Moonta, S. Aust.) nomi-

nates H. A. McLeod, VK3YR, as a member of the "H.A.M. Club" South African amateurs stood by during the entire time of the non-stop flight from England to Capetown, from 1230 G.C.T. on February 6th to 1630 G.C.T. on the 8th With the emergency net functioning, messages were picked up every hour from GEZAA, although the transmitter had only 7.2 watts input from dry batteries ZC6CN, ZC6FO, and ZC6KR are all actively on 7 and 14 mc. from Palestine, with the best times for each band respectively being 2000 to 0400 G.C.T. and after 1600 G.C.T. on 14 mc. ZC6KR is the new station of K. S. J. Racombe, well known in YI and SU, the new address being Rafi Rambleh, Palestine Send all QSL cards for the region to him, in a plain envelope Guy Grossin, F8RJ, did some splendid work on 1.75 mc. before going off the air recently, his station having been heard in Asia, Africa, and mid-Atlantic He has heard some eighteen W stations in that band, as well as some R3-4 'phone A new record for WAC: G. A. Shoyer, ZSIH, on February 11th worked the six continents in 2 hours and 2 minutes The stations worked were VU1AA, VK2JZ, W8CCW, SU1EC, PY2BN, and G6YL

Special:

This month we make mention of "Break-In," official organ of the N.Z.A.R.T., which recently changed its size, format and style. Its 32 pages contain a wealth of general and personal New Zealand amateur material, with a well-chosen sprinkling of technical matter. To quote a recent editorial, "in size, at least, it ranks among the foremost of amateur publications," and there is no need to restrict that remark to quantity of content alone. The editor is A. R. Harris, ZL4CA, while the technical editor is W. G. Collett, ZL4BP. The annual subscription rate 7/6, posted, and the address is P. O. Box 517, Dunedin.

Invitation:

The World's Fair Radio Amateur Council, affiliated with the American Radio Relay League, extends a most cordial invitation to the amateurs of the world, and particularly to those within member-societies of the I.A.R.U., to attend the World-Wide convention it is sponsoring in Chicago on August 3rd, 4th and 5th, in conjunction with the Century of Progress Exposition.

A splendid program has been arranged, both at convention headquarters, the Medinah Athletic Club (where personal accommodations are available at nominal rates), and in connection

(Continued on page 56)



CALLS HEARD



W6BYB, John Mayes, 2908-25 St., Sacramento, Calif.

(7- and 14-mc. bands)

ct1aa ct1az ct2ae ct2aw cr6ad cr7ac cr7ad d4bit d4fo ear96 ear185 ei2d ei5f ei8b f8dt f8ex f8fe f8gg f8pz f8tq f8wb f8ww fm8ih g2ak g2bh g2bm g2hp g2ii g2io g2zl g2zl g2nh g2za g5bj g5by g5la g5vb g5vr g5ml g5yh g5vl g5is g5yz g5hd g5cv g5sy g5ra g5py g6wq g6wy g6cw g6qb g5hv g5qx haf6a la1g oh3na oh5ng on4au on4dj on4en on4fe on4za on4rup oz1k pa8az pa8im pa8kw pa8qq pa8vb pa8xf sm5ur su1ec vu2ah vu2jb vu2lz

W1FJE, Bill Hertz, 22 Center St., New Haven, Conn.

(7-mc. band during April)

au1ka j2cb kalhr kalnf pk3gw xulff

W6CTM, B. D. Casentini, Box 53, Salinas, Calif.

(14,000-kc. band)

oh4au ear185

WSIVO, Walter Turner, 161 Harding Place, Syracuse, N. Y.

(14-mc. band)

yi2ds ok2va ('phone)

OK1AW, Al. Weirauch, Mestec Kralové, No. 9, Czechoslovakia

(7-mc. band between Jan. 1st and Apr. 15th)

ac2rt kally kalts om1tb talc xx5et vk2oc vk3kr vk3wl vk4kg vk5hg vk5mu vk6hf z13az

(14-mc. band between Jan. 1st and Apr. 15th)

hc1fg hsb1k pk1ci vk2ba vk2hw vk2oc vk2sw vk2xu vk2xy vk3bw vk3cw vk3go vk3jj vk3kx vk4gk vk5gr vk5wr vs1bb vs8ae xulu xx1ae z14ai z14ck w2oda ('phone)

W6DSZ, F. Clapp, 141 Walnut Ave., Santa Cruz, Calif.

(7-mc. band)

on4av ear96

(14-mc. band)

ear96 ear185 g5yh g2ak ei8b g2ii g5is g6qb f8pz on4au g5by f8gg g5vl g6pz g5ml g2lz on4zz on4rup g5la

G2HJ, K. E. Brian Jay, The Quinta, Elm Close, Amersham, Bucks, England

(7000-kc. band)

w6bc w6bgs w6bqp w6cd

W2BYD, C. A. Froebel, 1006 E. Grand St., Elizabeth, N. J.

(7-mc. band)

ka1hr uh2d j1dm j2ce

(3.5-mc. band)

fm8ih k6baz (fone) k7ff k5aa

W7JZ, W. E. Cruse, Seattle, Wash.

(14-mc. band)

ear96 ear185 oh5ng f8pz on4au g5la g5ml g2nh

H. S. Bradley, 66 Main St., Hamilton, N. Y.

(7-mc. phone)

hj3abd hj4abb yv2am hc1fg ce3ag x1q ear262

(14-mc. 'phone band)

oa1b ti3la k6baz yv2am re4gu

(3.9-mc. 'phone band)

w6aek w6atn w6axq w6bkz w6btk w6cgk w6cjq w6cla w6cne w6cz w6dcq w6dgi w6diz w6dhi w6dte w6dxt w6ean w6efd w6ehm w6ep w6eya w6fai w6fdo w7agp w7agq w7aqx w7bcu w7fp w7ia w7ii

W7CHT, Howard G. Earp, 1205 1st Ave. South, Payette, Idaho

(14-mc. band)

on4au on4rup on4za f8gg f8pz g6qb g6yh g5vl ear96 oh5ng d8bd lu3fa lu3oa

Frank R. Grey, 2434 South 56th Ave., Cicero, Ill.

(14-mc. 'phone band)

oa1b yv2am g5by g5fv x1b x1t k5ae k6baz

(7-mc. 'phone)

hj4abb hc1fg hc2rl x1q yv2am ear262 ce3ac

(3.9-mc. 'phone band)

x3b x1g g6rx

~~Strays~~

The foil from an old filter condenser makes excellent fuse material for protecting high-voltage rectifiers. To make a fuse for a Rectobulb the foil should be cut in a strip about an eighth of an inch wide and about an inch long. Narrower strips will do for smaller rectifiers. These fuses can be mounted in any convenient way.

— W6DER

I. A. R. U. News

(Continued from page 54)

with the Exposition itself. The international visitor is being kept most carefully in mind in making preparations for the convention, and according to William E. Schweitzer, W9AAW, chairman of the entertainment committee, it is desired to especially honor and cater to amateurs from other lands.

Every amateur who can find it convenient to be in Chicago, U. S. A., in early August, should make an effort to attend this convention. It will be well worth while. If you intend to visit the Century of Progress Exposition this summer, center your plans around the convention. Above all, inform the convention committee of your intended presence and make reservations well in advance.

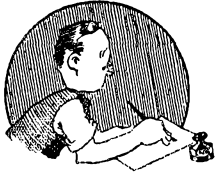

CORRESPONDENCE

The Publishers of *QST* assume no responsibility for statements made herein by correspondents

Visiting Lists

Minneapolis, Minn.

Editor, *QST*:

With the summer sun beginning to shine and the magazines filled with travel ads, many a ham will become a victim of the wanderlust bug. . . .

The fact that several American amateurs visit European countries each summer is not well recognized by the I.A.R.U. units. When my lucky chance to go last summer appeared, I attempted to get information in various large centers about how to reach foreign amateurs. Had G5BY's telephone number not been printed in *QST*, I should probably have missed one of the most enjoyable excursions of my entire trip.

I feel sure that any American amateur would gladly entertain amateurs in Berlin, Amsterdam, Paris or London, if the foreign amateur would help the American see more real native life. Let's try to see what foreign amateurs can be placed on a visiting list for touring American or Canadian amateurs!

— Payson R. Gould, W9DHP

On Interference Elimination

Syracuse, N. Y.

Editor, *QST*:

Unfortunately, as has been pointed out frequently in the columns of *QST*, and as many hams have found out for themselves, BCL QRM is not only vicious, but it has the rotten trick of not disappearing when orthodox methods are used. What does the average ham do when the BCL from next door or the next block comes in and says that he can't use his set when the transmitter is in use? Usually he grabs the *Handbook* and starts to read. In many instances he does not adhere strictly to the advice given therein and the results are nil. My formula for interference elimination has worked on every ham rig where it has been in use, and on only one occasion has it been necessary also to use a trap on the BCL set. In all other cases the cure has been effected at the transmitter.

The greatest benefit was obtained by making the plate leads to the rectifier tubes short. By short I mean just that — those on my present rig are two inches long. These leads are run with shielded cable and the shield is then grounded. Here is what happened. The people who live next

door were bothered with a bad hum in the BCL set whenever my rig was keyed. When the leads were changed as noted above, this hum disappeared. A bad key click was left, however. Being inquisitive, I tried all the key-click filters shown in the *Handbook* and every single one of them worked to perfection. To make certain that there would be no more difficulty of any kind I grounded the negative high voltage and the frames of all transformers, and my 20-meter signal, which had always been r.a.c., changed to d. c.

I am indebted to W8FXX-CYT, who has a big 'phone rig on the 3900-4000 band, for this dope. He cured QRM from his 'phone outfit by these methods, and that to me is a miracle, for the few times I used 'phone (even on 5 meters) the BCLs howled.

— Arnold M. Weichert, WSAOW

Unlimited C. W. Licenses?

527 Paloma Drive, South Pasadena, Calif.

Editor, *QST*:

A short time ago I had a chance to ask the R.I. what he thought of the idea of having an unlimited c.w. license and assigning the whole 40-meter band to all persons holding this type of license. He thought the idea was good, but said that anything like that would be entirely up to the hams themselves.

The qualifications could be about the same as those for the unlimited 'phone license. The person should hold a regular amateur license for at least one year and by a log be able to show he has been active for that period of time. Then the person should be able to pass a theory and code test. This license should require all persons holding it to put out a high quality signal, preferably controlled by a crystal or equal. It seems to me if a person is willing to go to all this extra work he is entitled to the extra privileges.

I don't think I am alone with the idea that something must be done about the 40-meter band.

I think this type of license would do the following things for Ham Radio:

1. Spread the hams out over the various bands more evenly.
2. Reduce QRM on the 40-meter band.
3. Give a higher average of good signals on 40 meters due to the requirements of the extra license.

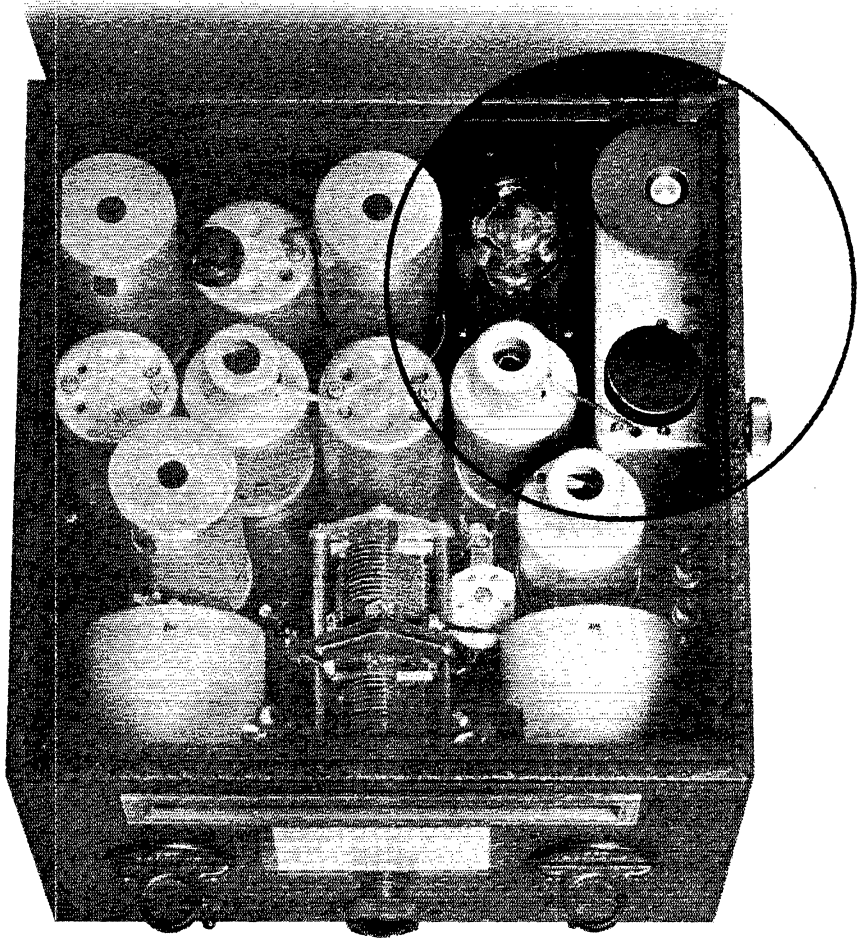

THE SINGLE-SIGNAL FBX

● Controllable selectivity instantly adaptable to every communication requirement, C.W. or Phone, is hanging up records for the Single-Signal FBX. Only in a receiver specifically designed for true Single-Signal operation is such performance to be found. From their very inception, the FB7 and FBX receivers have been designed with this end in view, and no compromise has been permitted. Using the basic variable selectivity quartz filter circuit developed by James J. Lamb, National engineers have been unhampered in the coordinated design of receiver and crystal filter X-unit, thus insuring that the FBX would be free of the usual handicaps of adaptation. Completely controllable selectivity from 10 kc. to the highest that can be used for c.w. reception is accompanied by the requisite high stability and smooth vernier tuning. The FBX is exceptionally suited to summer operation — background and static are reduced as much as 75% with the S.S. filter.

NATIONAL COMPANY, INC., MALDEN, MASS.



ACME-DELTA

CHASSIS PARTS FOR POWER SUPPLIES

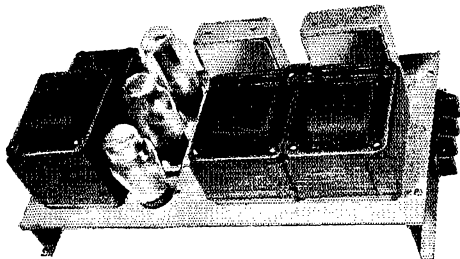

**AMATEURS
FOR COLLEGE LABORATORIES
GENERAL EXPERIMENTAL USE**

Specifications

INPUT — 115 v. — 60 cycles
 OUTPUT — 1000 v. at 250 m.a.
 *500 v. tap unfiltered.
 RIPPLE — 0.28%
 REGULATION — 11%
 TUBES — 3 Type 83 in bridge
 SIZE — 17" x 8½" x 6½". Weight 41½ lbs.
 See March Issue QST

PARTS FOR ABOVE

AD 25 — Plate Transformer 1200 v. —
 300 m.a. **\$8.75**
 AD 1010 — Filament Transformer. **4.25**
 AD 34 — Swinging Choke 8/40 Hy. 275
 m.a. **5.50**
 AD 45 — Smoothing Choke 12 Hy. 275
 m.a. **5.50**
 AD 53 — 2 mfd — 1300 v. Pyranol Cond.
 @ \$4.72 including mountings **9.44**
 AD 101 — Terminal Panel — Drilled
 and Engraved. **1.25**
 AD 100 — Chassis Plate — Drilled and
 Tapped. **5.00**

Total Parts Cost. \$39.69

Price complete assembled, wired and tested \$49

With the purchase of any or all of the above we will include a circuit schematic and photos showing assembly and wiring in place.

*BULLETIN AD2 describes in detail the above with external 500 v. filter.

AD61 — 400 v. at 175 m.a.

AD62 — 750 and 375 volts or 500 and 250 volts at 250 m.a. maximum.

Keep a complete file of Delta Bulletins — AD — AD1 and AD2 sent on request

F. S. Dellenbaugh, Jr.
 Pres. &
 Chief Engr.



G. E. M. Bertram
 Treas. &
 Gen. Mgr.

SUCCESSORS TO ACME APPARATUS CO.

4. Allow more traffic to be handled with less error.

(a) Reducing the QRM on 40 meters.

(b) It will put more stations on 160 meters making traffic handling on this band better.

(c) Making 160 meters better for short haul traffic, relieving it from 40 meters.

5. Invite more hams to use the seldom-used 160-meter band.

Let's hear from the unlimited 'phone hams in regards to their ideas as to how the unlimited license has helped them. If it was put to vote do you think they would go back to the old method of free-for-all 'phone?

— D. Galbraith, W6DXM

The QSL Fanatic

Beach Arlington, N. J.

Editor, QST:

I have here a QSL card from a W9, to which I would like to call your attention in the interests of ham radio. Over the call, in bold capitals, is the title "President of the Anti-Slacker QSL CLUB" and just above his signature one finds this:

"Join the ANTI-SLACKER QSL CLUB free. Membership and card free. Don't waste your time, juice and cards! QSO with real live hams not slackers who don't QSL! We keep a perpetual list of slackers. Combined up-to-date lists 25 cents each."

Isn't that "sumpin'"? I don't think much of that scheme, do you? When I was QSO this W9 I did *not* ask for his QSL, and now I get his card and am compelled to QSL or be placed on this "blacklist" so that other hams who are QSL hounds will be able to save their "time, juice and cards" and not call me. I sent him one of my cards and returned his with thanks. There is no room on my wall for it.

All right. A QSL is a voluntary procedure. What about the poor fellow who is unemployed and can't afford the luxury of cards? Isn't this list going to hamper his style seriously and prevent him from getting the maximum of enjoyment out of ham radio? What good is a QSL card if it is extorted from a guy? What kind of ham would capitalize on this kind of a list? I'll wager that 80% of the calls on the list are there because of financial inability to have cards printed, and I'll bet the other 20% are hams who never *requested* a QSL. Now, a fellow who promises a fair exchange of cards and falls down on his end of the bargain is, I'll admit, a creature we would be well rid of, and no method would be too harsh for him. But this business of blackballing a fellow who never promised a QSL nor even *asked* for one, and who is *unable* to ask for one because he hasn't any cards, is, in my humble opinion, contrary to the spirit and the ideals of ham radio; to charge money for the lists and capitalize a ham's misfortune is the height of lowness (begging your forgiveness for the crude

The Winnah-a

and
FEATHERWEIGHT
CHAMPION

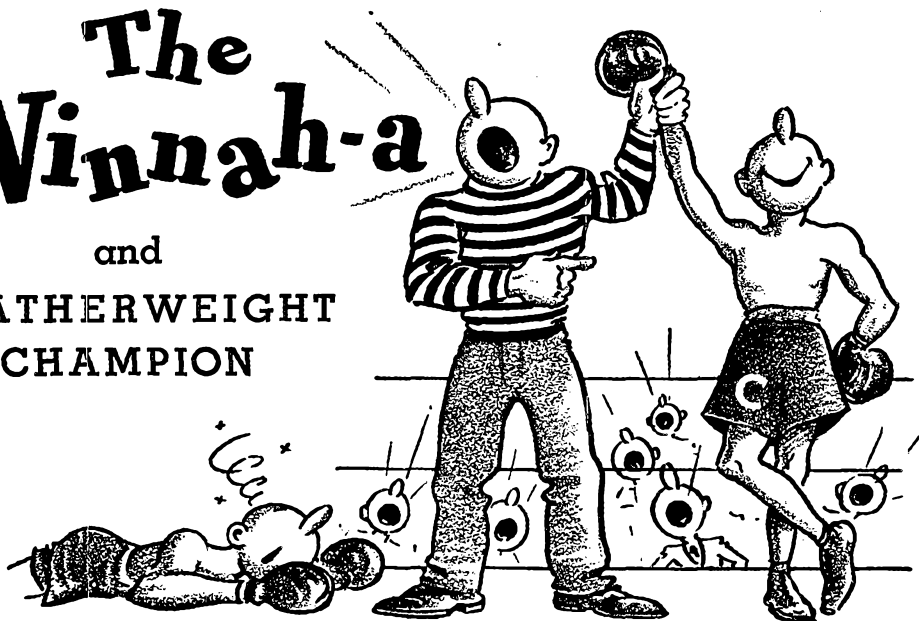

The CARDWELL Midway "Featherweight", efficient, compact and most rugged of small condensers, pioneer in its class, utilizes the same outstanding and time-proven principles of construction so long identified with other CARDWELL condensers.

CARDWELLS were recognized as the "Standard of Comparison" perhaps before many present-day juvenile "Hams" were born, and you'll find that to many thousands of Amateurs and Engineers who have grown up with Radio and who today are the leaders in that field, the condenser most worth having still is a CARDWELL.

Win with winners—say CARDWELL when you buy condensers.

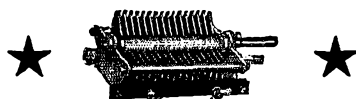

CARDWELL Midway "Featherweight" condensers are made for transmitting and receiving, in a variety of combinations and sizes—single, split stator, band-spread and for neutralizing, as are also the long famous CARDWELL "standard" size condensers, fixed and variable.

CARDWELL High Voltage condensers are used in hundreds of commercial radio-telegraph and broadcasting stations and in high powered transmitters of the U. S. Army and Navy.

The CARDWELL Type S-2244, oil-dielectric, self-healing fixed condenser is ideal for use with induction furnaces and tube bombardiers, eliminating replacement expense and production delays.

Send for literature.

The Allen D. Cardwell Mfg. Corp'n.

83 Prospect Street, Brooklyn, N. Y.

Any reliable supplier should cooperate with you to enable you to get what you want. He can get CARDWELLS for you if he does not keep them in stock. Get what you want—insist on CARDWELLS. Order direct from us if your dealer will not supply or let us tell you where you may buy.

" T H E S T A N D A R D O F C O M P A R I S O N "

NO MORE WORRYING ABOUT YOUR LICENSE EXAMS

if you have a copy of this brand-new
League publication

THE RADIO AMATEUR'S LICENSE MANUAL

Authoritative, covering every phase of amateur licensing, and written in clear, concise *QST*-manner to cover every aspect of present-day license procedure, it has been prepared in response to an uninterrupted demand for information on how to pass your examinations and apply for licenses.

It tells you where to write for forms, how to fill them out, who to send them to; it contains pertinent radio law, the F. R. C. amateur regulations, the operator regulations.

A complete question-and-answer section covers every type of question you will be asked, either for temporary, first-class or extra-first amateur ticket.

For the 'phone amateur who wants the unlimited 'phone endorsement, it definitely and especially includes all particulars of the special examination for Unlimited 'Phone. The questions, the answers, the diagrams — all are there.

Twenty pages of *QST* size, with attractive two-color cover, it is the biggest two-bits worth you ever saw, and is cheap insurance against the possibility of flunking out on your examination.

*Enables any amateur to qualify
for any amateur license*

PRICE 25 CENTS POSTPAID
(no stamps, please)

THE AMERICAN RADIO RELAY LEAGUE, INC.

WEST HARTFORD, CONN., U. S. A.

but unpremeditated humor). Honestly, it just burned me up.

I'm not an A.R.R.L. member, but I buy *QST* at the stands because I've been unemployed for two years and I just can't scrape up the \$2.50 in one lump. However, I used to belong, and have been in the ham game for seven years. In all that time I've never run across a scheme as despicable as this.

— A. Gurtcheff, W2AFC

BCL Experiences

211 S. Tracy St., Bozeman, Mont.

Editor, *QST*:

We have been noticing of late that there has been a great deal of attention in the amateur circle to the problem of interference to BC listeners. We have one or two cases in mind that are authentic and happened here in Montana.

One amateur in Butte who before becoming an amateur was a BCL turned the writer in to the R.I. as causing serious interference to him. Upon investigation the set was found to be unbalanced and even brought in several amateur 'phones in Idaho on 2600 kc. Both of these stations were known to be operating in the then amateur 3500-3550 'phone band. This same fellow at a later date asked another ham down to advise him in regard to his transmitter. The visitor noticed that while calling CQ he slowly rotated his plate tank condenser. When asked why this was done he said, "Why if I cover the whole band with a CQ someone is bound to pick me up." !!!

In Helena an amateur of long standing installed a wave trap in a nearby BCL's antenna to eliminate the QRM. Several days later the set went haywire and the serviceman called in said that several tubes were dead and that it was entirely due to the wave trap in the antenna!

— G. A. Woodhouse, W7FL

— W. Sullivan, W7BNL

Something to Think About

Editor, *QST*:

Present-day off-frequency operation is something pretty serious and is getting more so every day. Without a doubt the forty-meter ops are the worst offenders. Naturally the first thing anyone would say is that there should be more off-frequency work near the forty-meter band than on the others, since there are more working on forty meters. Well, that's all true. Not counting Sunday, the off-wave offenders are pretty well divided among the bands. But on Sunday 95% of the offenses are committed on forty meters, with twenty meters falling next in line.

Let's get to the point. Why in the name of little green crab apples should there be exactly 52 stations operating below the forty-meter band on one afternoon and every one of them between 7300 kc. and 7375 kc.? Yeah, it was on Sunday afternoon and no, OM, the dials hadn't slipped.

Well, here is the reason: A certain very well-

GRAND OPENING INTRODUCTION

The New HAMMARLUND SINGLE SIGNAL RECEIVER

representing, we believe, the finest short wave receiver available and we can highly recommend it to those who are satisfied only with the best. This job incorporates all the features you have wished for. Write for full data or come in and look it over.

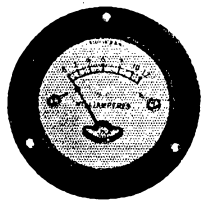

HOYT ANTENNA METERS

Hot wire antenna meters, 1 1/2, 3 and 5 ampere ranges. Why do without antenna meters when you can buy them at this Special price?... \$2.95 Hoyt perfectly damped meters at a price. These are not to be confused with the usual meter "bargains," 2" mounting hole, flange 2 1/4" diameter, supplied in the following sizes: 10 m.a., 50 m.a., 100 m.a., 150 m.a., 250 m.a., 300 m.a., 4 volt A.C., 10 volt A.C., 15 volt A.C., 10 v. D.C. Price each, \$1.60, 3 for \$4.50

EXTRA!!!

DeForest '46's 69c
Stock up on this useful type of tube for the future — while they last

| | |
|----------------------------------|--------|
| Midget 2.5 v. 6 amps C.T. | \$.85 |
| Midget 5 v. 3 amps for '83 C.T. | \$.85 |
| Midget 2 1/2-7 1/2 and 5 v. C.T. | \$1.25 |
| Midget 5-7 1/2 and 7 1/2 v. C.T. | \$1.50 |
| Midget 5-7 1/2 and 7 1/2 v. C.T. | \$1.50 |
| Cased 6.3 v. 1 amp. | \$1.75 |
| Thord. 30 H 75 MA. | \$.59 |

KENYON TRANSFORMERS

| | |
|--|--------|
| K-40. 325 v. each side C.T. 40 MA 5 v. 2 amps. 2 1/2 v. 5 1/2 amps. | \$.95 |
| K-90. 375 v. each side C.T. 100 MA 5 v. 2 amps. 2 1/2 v. 7 amps. 2 1/2 v. 12 amps. | \$2.25 |
| KR-5. 550 v. each side C.T. 150 MA 2-7 1/2 v. 2 1/2 amps. ea. 1 1/2 v. 6.3 amps. — 2 1/2 v. 10 amps. | \$3.95 |

| | |
|--|--------|
| MORRILL 2 mfd 2000 v. working | \$5.50 |
| MORRILL 2 mfd 3000 v. working | \$7.25 |
| Oil Immersed 2-2 mfd sections in one metal case 1400 volts working | \$1.75 |

GROSS Special Power Transformer
for use with '83 tube will give an output of 500 volts D.C. at 350 MA with choke input. Run your entire R.F. and Class B off this transformer. The regulation for the class B is about 5%, filaments are two 7 1/2 v. and one 5 v. Special. \$5.90
A transformer having the same filament windings as above — at 300 MA having 750 volts each side of C.T. Special. \$5.90

HOYT MOVING COIL METERS

Special lot 2" meters with wide flange cases. While they last only \$2.95
100, 200, 300 MA

GUARANTEED TUBES

| | |
|---|--------|
| Heavy duty Isolantite top 866's | \$2.25 |
| 888-871's | \$1.25 |
| 83's | \$.90 |
| 210's | \$1.40 |
| DeForest 410's | \$1.25 |
| DeForest 510's | \$3.90 |
| Isolantite top 210's plate lead on top, | \$2.65 |
| Sylvania 46's and 47's | \$.85 |

HAMMARLUND air-tuned intermediate I.F. transformers 175, 465 and 525 K.C. plain or center tapped types. \$2.55
Complete I.F. and osc. kit for the Comet Pro. \$10.30
If it's in the Hammarlund catalogue we have it in stock

All other types at low prices

PRICES CUT

Plated copper tubing inductances wound and ends drilled free

| Inside dia. | 3/16" | 1/4" | 5/16" |
|-------------|----------|----------|----------|
| 1 1/4" | 5c turn | 5c turn | 10c turn |
| 2 3/8" | 6c turn | 6c turn | 10c turn |
| 3 1/2" | 10c turn | 10c turn | 12c turn |

ALUMINUM

Cut to size specified

| | |
|--------------------------|-------|
| 1/16" thick per sq. inch | 7/10c |
| 3/32" thick per sq. inch | 3/4c |
| 1/4" thick per sq. inch | 1c |

NEW!!! STAND-OFF JACKS

1 1/2 inches high — make better contact — can be screwed on top of any stand-off insulator — fit any G.R. type plugs sold thousands — only \$1.05

High grade filament transformers shielded in metal cases, center tapped secondaries 2.5 volt 10 amperes for 866's
10 to 12 volts at 8 amperes — either type \$2.50
Special — 10 to 12 volt 7.5 amp. filament transformer, extra special. \$3.95

| | |
|--|--------|
| Beehive stand-off ins. | \$.05 |
| Isolantite 3" spreaders. Special 10 for | \$4.40 |
| Natural bakelite 7" spreaders — improved type with set screws only | \$.15 |

ACME SOLID ENAMELED COPPER ANTENNA WIRE

| | |
|---------------------------------|--------|
| No. 14 (any length) per 100 ft. | \$.30 |
| No. 12 (any length) per 100 ft. | \$.45 |
| No. 10 (any length) per 100 ft. | \$.80 |
| No. 8 (any length) per 100 ft. | \$1.20 |

"GC 30" SERIES XTAL TRANSMITTERS

SEE MAY QST.
Write for data

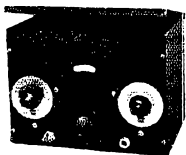

The "EAGLE" Three Tube Short Wave Receiver

Only finest material used thruout — employs one '32 R.F., one '32 Detector and one '33 Pentode Audio — 15 to 200 meters — four coils supplied. The "Eagle" is economical — two dry cells will operate the filaments. See March or April QST for full description on this most excellent value in short wave receivers.

'Eagle' Completely Wired and Tested. \$10.95
Three Tubes Tested in Your Receiver. \$3.50

20% deposit with all C. O. D. orders. Remit by M. O. Include Postage.

GROSS RADIO INC.

51 VESEY ST., N. Y. C.
TEL. BARCLAY 7-0161

Just published— Chaffee's long- awaited book on vacuum tubes

Here is a thorough and authoritative treatment of vacuum tube fundamentals containing considerable new and hitherto unpublished material. Covers the foundation of the subject fully and will be of high reference value to all concerned with any branch of vacuum tube technique.

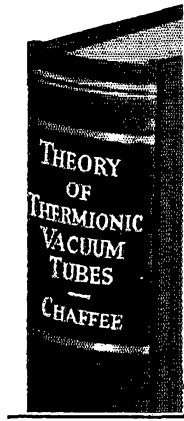

Theory of Thermionic Vacuum Tubes

by E. LEON CHAFFEE
Professor of Physics, Harvard University
(Electrical Engineering Texts)
666 pages, 6 x 9, 357 illustrations, \$6.00

HERE at last is the first of two volumes by Dr. Chaffee, embracing the results of his researches in thermionic tubes. His work is widely known and this book now makes available his important contributions in this field, much of it original material published here for the first time.

This volume covers low power tubes and is complete in itself. It gives a comprehensive theoretical treatment of thermionic emission and of the vacuum tube, covering its use as an amplifier and detector as well as its general properties.

The treatment is fundamental, avoiding discussion of multifarious circuits, but covering those principles, an understanding of which makes possible the analysis of any circuit and any application. Among the new material developed by the author, some of it presented here for the first time, is that on such subjects as the path of operation, large-signal regeneration, regeneration in coupled circuits, non-linear elements, detection, etc.

Keith Henney, Associate Editor of *Electronics*, says, "A monumental work. I predict it will soon become the final authority on tubes."

See this new book on approval. Send this coupon

McGRAW HILL BOOK COMPANY, Inc.
330 West 42nd Street, New York City

Send me Chaffee — Theory of Thermionic Vacuum Tubes for 10 days' examination subject to approval or return. Within 10 days of receipt I will send \$6.00 plus a few cents for postage and delivery, or return the book postpaid. (We pay postage on orders accompanied by remittance.)

Name.....

Address.....

City and State.....

Position.....

Name of Company..... QST-6-33
(Books sent on approval in U. S. and Canada only)

known third district station with considerable power had oozed down to 7350 through carelessness and worked there for two hours before somebody woke him up and told him the war was over.

Well, what was the result of all that? Just this, that little Johnny Offwave and fifteen of his brothers noticed him down there and decided that he must be close to the bottom of the band; and their monitors not being calibrated they got on the low frequency side of him. I thought at first that they wuz moving the band, and called Pop in and he put me straight.

Well, what's to be done about it? The only thing you can do is to urge these fellows who have more than the average amount of power and self-excited circuits to check their frequencies more than ever. Pop says he has heard this same thing happen time and time again, and that nothing can be done about it. But you fellows who are guilty of pulling such pranks, wake up and look at yourselves in the mirror. Are you a good operator? Yes. But you are still not good enough to guess within fifteen or twenty kilocycles of your frequency.

It's easy to see why those of you who only check by marker stations can go astray on Sunday, when half of the commercials are in the hay, so build you something that will stay calibrated over Sunday anyway. There are too many uncalibrated monitors in the country now and — but oh, well, everyone knows that — nuff said.

— *The Old Man's Son*

Too Much Modesty

1308 Orange St., Fort Worth, Texas

Editor, QST:

In my thirteen years of active amateur activity I have often heard it said that we are hiding our light under a bushel. This is a well-founded statement. There seems to be a feeling among the amateur fraternity that as long as we know all about ourselves there is no need of our boasting to outsiders regarding our prowess.

Being engaged in writing for magazines and newspapers I know that such mediums are interested in our undertakings. A.R.R.L. furnishes publicity to newspapers and agencies throughout the country. This is actually effectual in only a limited number of cases. Why is this so? I am constantly asked by fellow operators. The reason is this: Hundreds of organizations, corporations, clubs, etc., maintain publicity departments. The editor of the average daily finds his desk every morning only after clearing away a landslide of such publicity. Many of these publicity writers are employed by companies that spend several thousand dollars yearly for newspaper advertising. It even becomes necessary for an editor to waste-basket much of this "paid" material. What chance then has news of amateur radio as furnished by a standard publicity service?

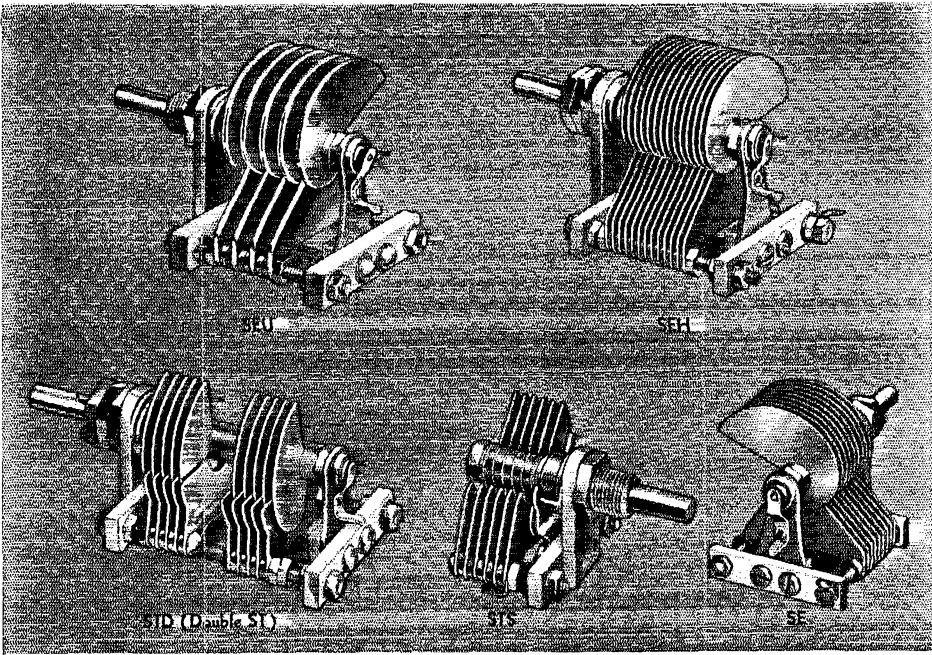

HIGH-FREQUENCY TUNING CONDENSERS

The success of National H. F. Receivers is due in no small measure to painstaking attention to every detail. Nowhere is this more apparent than in the design and construction of their tuning condensers.

Compact, highly efficient, and utterly reliable, these little condensers embody every refinement that years of specialization in short wave design have shown to be desirable. Isolantite stator insulation, thick non-resonant aluminum plates, constant impedance, noise free rotor connections, and insulated main bearings are all small details to be sure, but combined with the best materials and fine craftsmanship, they provide the ultimate in performance.

If you do not already use National Condensers, see them at your dealers, for we are sure you will be as proud to own them as we are to build them.

| Catalog Type No. | Capacity in Mmf. | Air Gap | Plate Shape | Rotor Plates | Stator Plates | Depth behind Panel | List Price |
|------------------|------------------|---------|-------------|--------------|---------------|--------------------|------------|
| SE- 50 | 50 | .026 | 270° SFL | 6 | 5 | 2 3/8" | \$3.00 |
| 75 | 75 | .026 | | 8 | 7 | " | 3.25 |
| 100 | 100 | .026 | | 10 | 10 | " | 3.50 |
| 150 | 150 | .026 | | 15 | 14 | 2 3/4" | 3.75 |
| SEH- 200 | 200 | .0175 | | 14 | 13 | 2 1/2" | 3.75 |
| 250 | 250 | .0175 | | 16 | 16 | 2 3/4" | 4.00 |
| 300 | 300 | .0175 | | 20 | 19 | 2 3/4" | 4.00 |
| 335 | 335 | .0175 | | 22 | 21 | 2 3/4" | 4.25 |
| SEU- 15 | 15 | .055 | | 3 | 3 | " | 2.50 |
| 20 | 20 | .055 | | 4 | 4 | " | 2.75 |
| 25 | 25 | .055 | 5 | 4 | " | 2.75 | |
| ST- 50 | 50 | .026 | 180° SLW | 6 | 5 | 2 3/8" | \$1.80 |
| 75 | 75 | .026 | | 8 | 7 | " | 2.00 |
| 100 | 100 | .026 | | 10 | 10 | " | 2.25 |
| 150 | 150 | .026 | | 15 | 14 | 2 3/4" | 2.50 |
| STH- 200 | 200 | .0175 | | 14 | 13 | 2 1/2" | 2.75 |
| 250 | 250 | .0175 | | 16 | 16 | 2 3/4" | 3.00 |
| 300 | 300 | .0175 | | 20 | 19 | 2 3/4" | 3.25 |
| 335 | 335 | .0175 | | 22 | 21 | 2 3/4" | 3.50 |
| STN- 18 | 18† | .065 | | 4 | 3 | 1 3/8" | 2.00 |
| STHS- 15 | 15 | .0175 | | 2 | 1 | 1 3/16" | 1.40 |
| 25 | 25 | .0175 | 2 | 2 | " | 1.50 | |
| 50 | 50 | .0175 | 4 | 3 | " | 1.60 | |
| STD- 50 | 50* | .026 | 6* | 5* | 2 3/8" | 3.50 | |
| STHD-100 | 100* | .0175 | 7* | 7* | " | 4.50 | |
| SS- 50 | 50 | .026 | 180° SLC | 5 | 4 | 2 1/8" | \$1.80 |
| 75 | 75 | .026 | | 7 | 6 | " | 2.00 |
| 100 | 100 | .026 | | 9 | 8 | " | 2.25 |
| 150 | 150 | .026 | | 12 | 12 | 2 3/8" | 2.50 |
| SSH- 200 | 200 | .0175 | | 11 | 10 | 2 3/8" | 2.75 |
| 250 | 250 | .0175 | | 13 | 13 | " | 3.00 |
| 300 | 300 | .0175 | | 16 | 15 | 2 3/4" | 3.25 |
| 350 | 350 | .0175 | | 18 | 18 | 2 3/4" | 3.50 |
| SSN- 18 | 18† | .065 | | 3 | 3 | 1 3/16" | 2.00 |
| SSS- 20 | 20 | .0175 | | 1 | 2 | " | 1.40 |
| 30 | 30 | .0175 | 2 | 2 | " | 1.50 | |
| 50 | 50 | .0175 | 3 | 3 | " | 1.60 | |
| SSD- 50 | 50* | .026 | 5* | 4* | 2 3/8" | 3.50 | |
| SSHD-100 | 100* | .0175 | 5* | 5* | 2 3/8" | 4.50 | |
| 150 | 150* | .0175 | 8* | 8* | " | 5.00 | |
| 2SE- 100 | 100* | .026 | 270° | 10 | 10 | 5" | \$5.50 |
| 2SEH- 200 | 200* | .0175 | SFL | 14 | 13 | " | 6.50 |
| 2SEH- 335 | 335* | .0175 | SFL | 22 | 21 | " | 6.75 |

*Per Section

†3000 Volt Rating

‡Usual Trade Discounts Apply



NATIONAL COMPANY, INC., MALDEN, MASS.



...built into every 276A tube!

Unusually rugged in structure, the 276A—for radio telephone transmitting—maintains uniform characteristics over a long life, as proved in many broadcasting stations.

The 276A is a three-element tube used as an oscillator, radio-frequency amplifier, modulator or audio-frequency amplifier. Low internal capacities permit operation over a wide frequency range. Characteristics are as follows:

| | |
|---|------------------|
| Filament Voltage..... | 10 volts |
| Filament Current..... | 3 amperes |
| Average Characteristics with Plate Voltage of 1000 volts and a grid bias of -45 volts. | |
| Average Plate Current..... | 100 milliamperes |
| Average Plate Resistance..... | 3500 ohms |
| Average Amplification Factor..... | 12 |
| Average Mutual Conductance..... | 3400 micromhos |
| Approximate Direct Interelectrode Capacities | |
| Plate to Grid..... | 9.0 Mmf. |
| Plate to Filament..... | 4.0 Mmf. |
| Grid to Filament..... | 6.0 Mmf. |
| Maximum Operating Plate Voltage..... | 1250 volts |
| Maximum Continuous Plate Dissipation..... | 100 watts |
| Maximum Overall Length..... | 7 15/16" |
| Diameter of Bulb..... | 2 5/16" |

For booklet describing this and 25 other Western Electric tubes, write Graybar Electric Co., Graybar Building, New York.

Western Electric

RADIO TELEPHONE
BROADCASTING EQUIPMENT

Distributed by **GRAYBAR Electric Co.**

It has been my personal experience that amateurs fear giving their local newspaper items on their doings. Not because they are afraid of not getting it printed, but because they fear the personal jealousy and censorship of *fellow amateurs*. Editors are chiefly concerned with names in presenting a story. They don't care what A.R.R.L. is doing in Hartford. They are interested in what Johnny Smith, amateur operator living at 611 Blank St., has accomplished by way of DX or traffic handling. Brother hams will immediately criticize Johnny as "boasting" about his station when they have been doing the same DX or traffic work for years. However, the little news items like the Smith one have done more to popularize amateur radio than any other single publicity medium. Townsfolk know the Smiths and are interested in their doings. Hundreds of readers who would never have heard of amateur radio are interested by Smith items.

I have written thousands of words in articles concerning amateur radio for such publications as *The Dallas News*, *Fort Worth Star-Telegram*, *Southern Aviation*, *Electrical South*, *American Boy*, etc., and nearly always find a hearty welcome. In so doing I have used photos of representative amateur stations and have had a hard fight securing such material from misunderstanding amateurs. Am now working on the story of amateur radio for one of the big mags and find it almost impossible to secure the loan of station photos and information regarding same. If every amateur would furnish his paper with choice items there would be no need to worry about the encroachment of commercial interests into our bands. We would have public sympathy!

Double space all newspaper copy and type it. Include names of local hams and their QRA's. Send along a picture, if possible. Don't hesitate to call the City Desk and ask the City Editor if he could use your dope. Let's quit being childish and advertise ourselves.

— *Elbert Haling, W5HY*

Strays

The *Philadelphia Evening Bulletin* recently published a list of the first 100 in automobile registrations and their owners. It is interesting to note that No. 88 is assigned to Cardinal Daugherty of Philadelphia.

We hear of the ham who does things in a small way. Producing one thin dime at a radio shop, some ten feet of hook-up wire changed ownership. With this he assembled a power supply, two-tube transmitter and a three tube a.c. receiver, had 3 feet left over with which he got a rebate of one antenna insulator!

A hint for putting a finish on aluminum panels: If a small hunk of cloth is wadded up in the jaw chuck of a lathe or electric drill, wet, sprinkled with carborundum powder, and applied to the panel with pressure determined by experiment, a pleasing whorled finish will result. Care must

YOU ASKED FOR IT

S-O-O-O-O-O-O-O Here It Is!

Information — ideas — suggestions. Practical tips, brainstorming that worked, money-saving dodges, time-saving thoughts. . . . A whole book full of them!

HINTS AND KINKS FOR THE RADIO AMATEUR

(No. 10 in the A.R.R.L. series entitled *The Radio Amateur's Library*)

FOR years hams have told us that one of the most practical and valuable features of *QST* is the Experimenter's Section. But — try to recall when it was you saw that swell (but, alas, only dimly remembered) suggestion for band-spreading, or a click filter, or break-in. What was needed, we were told, was a compilation of all the best ideas, brought under one cover, segregated by subjects, and indexed. And here it is — an intensely practical book, filled out with selected additional ma-

terial, with dozens of valuable and workable ideas gleaned from the practical station experience of successful amateurs. Chapters on workshop ideas, receivers, transmitters, amateur, phone QRM elimination, keying, power supply, and so on.

An ever-present help in time of trouble, and worth its weight in inflated currency when you are desperate for an idea; it is another of those League publications you simply can't do without.

80 pages in attractive paper covers

Price: 50 cents, postpaid anywhere

THE AMERICAN RADIO RELAY LEAGUE, INC., West Hartford, Conn. U.S.A.

AMATEURS West of Rocky Mountains

We can supply all parts for the new circuits

Send for your Catalog of Nationally Advertised

Transmitting and Receiving Parts at LOWEST PRICES

Amateurs' Headquarters of the West

RADIO SUPPLY CO.

H. A. Demarest, President

912-914 So. Broadway Los Angeles, California
(W6FBI located in Building)

MID-WEST SPECIAL BARGAINS

Thordarson 2½-volt Filament Transformer — T3314 — 2½ volts, 10 amps., 7½ volts at 1¼ amps. \$0.95
Mershon Electrolytic Filter Condensers — 8 mfd. Inverted Type — 400 volts DC29
Thordarson 210 Power Transformer — T3773 — Two 7½-volt, 2½ amp. windings 3 volts at 7 amps., 1200 volts C.T. at 125 a. 1.95
Mid-West Quartz Crystals — We will furnish within 5 KC of your specified frequency. Satisfaction guaranteed. 2.50

Write for our new complete list Address Dept. Q

MID-WEST RADIO MART

Builders of W9USA

520 S. State Street Chicago, Illinois

FREE Candler System Code Guild Sked

DAILY C. S. PRACTICE PROGRAMS ON AMATEUR BANDS

Send for your FREE copy of the Candler Short Wave Press Schedules now. Learn to copy px from Candler trained ops, sending out of many of the principal px stations. Amazing results in short time. FREE ADVICE IF "STUCK." Write Candler. No obligation. Junior Course for beginners. Advanced Course for ops with speed of 10 wpm or over who want to get in 30 to 45 wpm class and copy behind. Also Radio Typing Course. Save time and money by sending for FREE BOOK today.

If you want to be a FAST and ACCURATE OPERATOR get your training where the CHAMPIONS GOT THEIRS

"Candler training enabled me to copy 56½ wpm for the all-time record." — T. R. McELROY, Official Champion Radio Operator of the World, 46 Everdean St., Boston, Mass.

Get the benefit of Candler's twenty years' experience in developing experts. Let him show you how he can do for you what he has done for so many others. Your questions will be answered personally and promptly. No obligation. Write now!

WALTER H. CANDLER
World's Only Code Specialist, Instructs You Personally



Candler System Co., Dept. 56
6343 South Kedzie Ave. Chicago, Illinois



The **NATIONAL**
SHORT-WAVE
LIBRARY

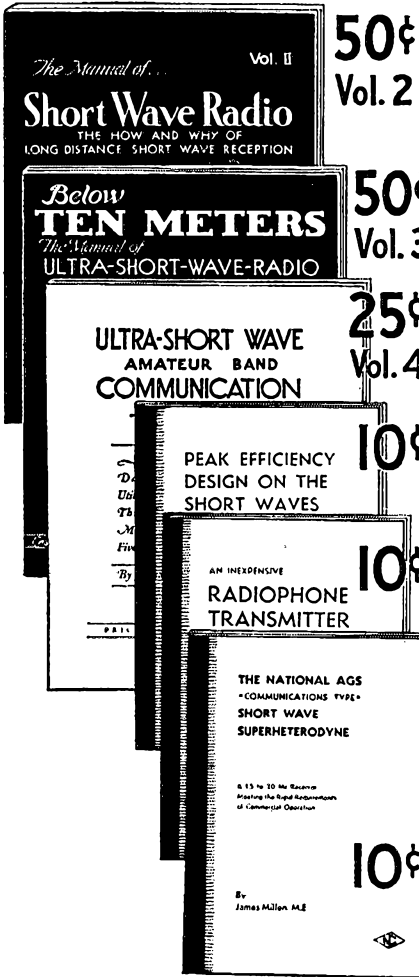

● Just a few of the Manuals and Bulletins issued by the Engineering Department of National Company. Sent postpaid on receipt of the indicated prices.

NATIONAL COMPANY, INC.
MALDEN, MASS.

be taken, however, that the chuck does not touch the panel in its mad flight or the panel will be ruined.

— W2DWO

W3AHQ has an auxiliary key connected in the 110-volt line to his transmitter and placed on the floor under the operating table within easy reach of his foot. Besides making a convenient power switch for ordinary operating, the key is handy when making adjustments to the transmitter because the power can be put on and off quickly. If things start to happen in the set the juice can be turned off in jig time.

Iowa State College publishes an interesting and comprehensive booklet entitled, "The Location and Elimination of Radio Interference," dealing with interference caused by defective power-line apparatus and electrical machinery. Copies may be obtained from The Director, Iowa Engineering Experiment Station, Ames, Iowa.

W2ADL's police pup knows "HI" when sounded on an auto horn and is quick to come back with a bark.

Help Us—and Help Yourself!

THE Post Office Department recently announced that a fee of 2 cents, payable by the publisher, shall apply to each change of address notice we receive from any post office. During the course of a year we receive hundreds of such notices. It is our desire to minimize the expense of this service, which heretofore has been free. You can help by *promptly* advising us *direct* of your new address, giving your old address at the same time.

Many publishers, as you probably know, have a very strict change-of-address policy, requiring as much as five or six weeks' advance notice if they are to be held responsible for delivery of the current issue of their publications. Recognizing *QST's* intense reader interest, we have never established such a policy, believing each reader should receive every copy of *QST* even though in many cases the fault of non-delivery is not ours. We plan to hold to this policy, but your co-operation, particularly in view of the direct expense now involved, will be appreciated.

Won't you help, both in the matter of lessening the number of 2-cent fees and in our desire to promptly supply each issue of *QST* as it appears?



LOST and seldom found:

REPUTATIONS, COLLAR BUTTONS, SCISSORS, ETC., ETC.

and to this abbreviated list may we add almost any back issue of QST? Nearly every day we have to offer regrets for our inability to furnish certain back issues of QST. Now for many years QST has carried an illustration similar to this one shown here.



In order that devotees to the art may keep their QSTs — protect them against loss or damage. They are offered to readers of QST at a modest cost. Each binder accommodates twelve issues of QST and the index. The binders are sturdy, cloth covered, deep maroon in color, excellent in appearance and cleverly designed to take each issue as it is received and hold it firmly without mutilation. Don't delay. Order today a binder for your 1933 copies — and enough binders to accommodate the file of QSTs which you have already accumulated.

WHY?

\$1.50 EACH POSTPAID ANYWHERE

THE AMERICAN RADIO RELAY LEAGUE, INC. WEST HARTFORD, CONNECTICUT



UNIVERSAL

Protected Diaphragm Type
1933 MODEL "X"

Here is microphone value without precedent! A brand new, 1933 model, protected diaphragm type 2-button microphone listing at only \$10.00!

Exceeds every reasonable requirement for quality performance. And in addition, this sensationally successful Model "X" is now made damage proof by the new, scientifically designed diaphragm protection. Yet the list price remains at \$10.00.

UNIVERSAL MICROPHONE CO., LTD.
424 Warren Lane, Inglewood, Calif., U. S. A.

MODESTY IS APPRECIATED

We don't over-rate our grid leaks. We tell you, accurately, the watt dissipation rating of each as well as the tubes with which each may be safely used. It's all in the new free booklet 507. Complete information is also given of the various gadgets you need and about which you want to know more.

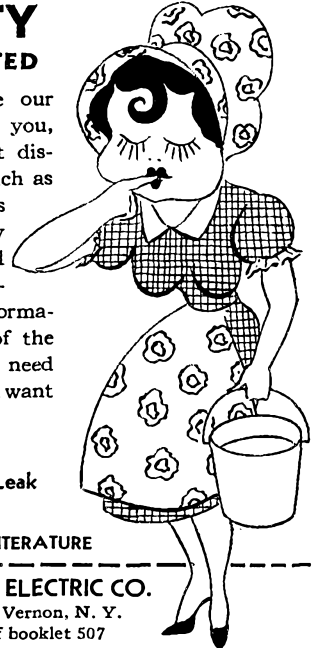

VITROHM

Transmitting Grid Leak
RESISTORS

SEND FOR NEW 507 LITERATURE

WARD LEONARD ELECTRIC CO.

41 South Street, Mount Vernon, N. Y.

Send me a free copy of booklet 507

Name.....
Street.....
City and State.....
Call Signal.....

RCA INSTITUTES

Recognized Standard in Radio Instruction Since 1909

Technical Training Courses in Radio and Associated Electronic Arts

Practical Radio Engineering — Sound Engineering —
Broadcast Transmission — Servicing — Operating

Resident Schools at New York and Chicago
Extension Courses for Home Study

Illustrated Catalog on Request

RCA INSTITUTES, INC.
Dept. ST-6

75 Varick Street, New York
1154 Merchandise Mart, Chicago



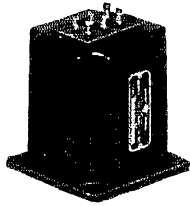

KENYON LABORATORY STANDARD TRANSFORMERS

have been developed to meet the most exacting requirements of broadcast and transmission engineers. The standard established for these units is shown in a typical frequency response curve of the KPP-2A3. All Laboratory Standard transformers are shielded in high permeability cast iron housings to minimize pickup from stray electrostatic and electro-magnetic fields.

FREQUENCY CHARACTERISTIC KPP2A3

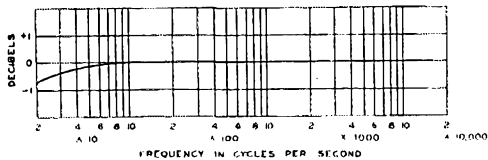

Net Wholesale Price

- KLL — To mix a double button mike, a moving coil mike or a low impedance pickup to a line. Input and output have multiple line connections.* 0 level. . . . \$9.00
- KLG — Input to grid. Multiple line * to split secondary of 120,000 ohms. 0 level. 9.00
- KDL — Single triode plate to a multiple line.* 0 level. . . 9.00
- KA31 — Cascade triode plate to single grid. 0 level. . . . 4.80
- KPP2A3 — P.P. 2A3 plates for fixed or self bias to a multiple * and tapped voice coil line.** 12.00
- KB59-10 — P.P. 59 plates to class B 210 grids. 12.00
- KB-210 — P.P. 210 plates to multiple * and tapped voice coil line.** Will handle 60 watts. 18.00
- KB210RF — Class B P.P. 210 plates to R.F. stage. Will handle 60 watts. 18.00
- KB-10 PT — Power transformer for class B 210's with provision for A.C. bias supply. 18.00

* The terminations on the Kenyon multiple line are 500, 333, 250, 200, 125 and 50 ohms.

** The terminations on the Kenyon tapped voice coil line are 15, 7 1/2, 4.5, 3, and 1.5 ohms.

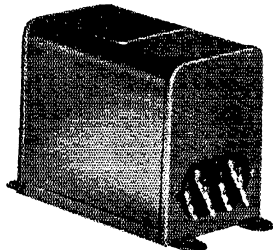

KENYON

All Purpose Class B Amplifier Components represent the finest material obtainable in medium priced amplification equipment. Refinements in design and highly supervised production has made possible units which are unapproachable for overall quality in material of this price range.

NEW CLASS B UNITS

Net Wholesale Price

- B-531 — Driver 53 plate to 53 grids 3.60
- B-530 — P.P. 53 plates to 500, 15, 8 and 4 ohms. . . . 3.60
- B-53 RF — P.P. 53 plates to R.F. stage. Secondary tapped. 3.90
- B-53 PT — For use with 53 or 2A3 tubes. 420-0-420 — 125 MA, 2 1/2 V. C. T. 5 A., 2 1/2 V. C. T. 10 A., 5 V. 3 A. . 4.80

ASK YOUR KENYON distributor for Bulletin ABTRM which lists more than 250 standard units for radio, broadcast and amateur transmission applications. 16 schematic layouts for Class A and Class B amplifier systems also shown.

KENYON TRANSFORMER CO., INC.

122 Cypress Avenue

New York, N. Y.

Strays

When a 'phone jack is mounted on the metal panel of an a.c. receiver the bother of insulation and danger of high voltage on the 'phones can be overcome by grounding one side of the jack and connecting the other side to the cathode of the Type '27 amplifier, thereby using the resistance of the 'phones to replace the bias resistor. Plate voltage is connected directly to the plate. Results are exactly the same as if the 'phones were in their regular location, and the highest voltage across them is that of the bias, usually between six and nine volts.

— W2BYW

Standard Frequency Transmissions

| Date | Schedule | Station | Date | Schedule | Station |
|----------|----------|---------|----------|----------|---------|
| June 2, | B | W9XAN | July 5, | BB | W1XP |
| | B | W6XK | | C | W9XAN |
| June 7, | BB | W1XP | July 7, | B | W9XAN |
| | C | W9XAN | | A | W6XK |
| June 9, | B | W9XAN | July 12, | B | W1XP |
| | A | W6XK | | BB | W9XAN |
| June 14, | B | W1XP | July 14, | BB | W6XK |
| | BB | W9XAN | | A | W9XAN |
| June 16, | BB | W6XK | July 15, | BX | W6XK |
| | A | W9XAN | July 16, | C | W6XK |
| June 17, | BX | W6XK | July 21, | A | W6XK |
| June 18, | C | W6XK | July 23, | C | W1XP |
| June 23, | A | W6XK | July 26, | A | W1XP |
| June 25, | C | W1XP | July 28, | B | W9XAN |
| June 28, | A | W1XP | | B | W6XK |
| June 30, | B | W9XAN | | B | W6XK |

STANDARD FREQUENCY SCHEDULES

| Time (p.m.) | Evening Sched. and Freq. (kc.) | | Time (p.m.) | Afternoon Sched. and Freq. (kc.) | |
|-------------|--------------------------------|------|-------------|----------------------------------|--------|
| | A | B | | BB | C |
| 8:00 | 3500 | 7000 | 4:00 | 7000 | 14,000 |
| 8:08 | 3600 | 7100 | 4:08 | 7100 | 14,100 |
| 8:16 | 3700 | 7200 | 4:16 | 7200 | 14,200 |
| 8:24 | 3800 | 7300 | 4:24 | 7300 | 14,300 |
| 8:32 | 3900 | | 4:32 | | 14,400 |
| 8:40 | 4000 | | | | |

| Time (a.m.) | Sched. & Freq. (kc.) |
|-------------|----------------------|
| 6:00 | 7000 |
| 6:08 | 7100 |
| 6:16 | 7200 |
| 6:24 | 7300 |

The time specified in the schedules is local standard time at the transmitting station. W1XP uses Eastern Standard Time, W9XAN, Central Standard Time, and W6XK, Pacific Standard Time.

TRANSMITTING PROCEDURE

The time allotted to each transmission is 8 minutes, divided as follows:

- 2 minutes — QST QST QST de (station call letters).
- 3 minutes — Characteristic letter of station followed by call letters and statement of frequency. The characteristic letter of W1XP is "G"; that of W9XAN is "O"; and that of W6XK is "M."
- 1 minute — Statement of frequency in kilocycles and announcement of next frequency.
- 2 minutes — Time allowed to change to next frequency.

THE TRANSMITTING STATIONS

W1XP: Massachusetts Institute of Technology, Round Hill Research, South Dartmouth, Mass., Henry G. Houghton in charge.

W9XAN: Elgin Observatory, Elgin National Watch Company, Elgin, Ill., Frank D. Urie in charge.

THREE THRILLING DAYS FULL OF TRIPLE-ACTION FUN . . . ALL FOR \$10.00

CHOOSE ANY 3 DAYS YOU DESIRE

Do you long to visit the great city? See its sights—enjoy its fun? Here's your chance. Stay at a metropolitan hotel, enjoy three days of dining, dancing, shows and sights.

- | | |
|---|---|
| 1 Room, two nights, three days—private bath and radio. | 5 Theatre, orchestra seat—matinee or evening performance. |
| 2 Six meals: Two breakfasts, one luncheon, one dinner at hotel. | 6 Bus sightseeing trip with guide. |
| 3 Hollywood Night Club—dinner, dancing and floor show. | 7 Trip to top of Chrysler Building. Seventy-four stories in the clouds. |
| 4 Bohemia Restaurant—luncheon, and dancing. | Only \$10.00 per person, all-inclusive price. No extras. Send reservations today. |

A WEEK-END OF FUN IN NEW YORK ALL FOR \$5.50

See New York at its gayest. Now's the time. Dine, dance, and see the sights of the city. Stop at a metropolitan hotel—at the unprecedented all-inclusive price, \$5.50. No extras.

- | | |
|--|--|
| 1 Bright, comfortable room—private bath and radio. | 4 Excellent orchestra seat, Radio City Music Hall. |
| 2 Luncheon and breakfast at hotel, or Saturday lunch at Bohemia. | 5 Sightseeing bus trip with guide. |
| 3 Hollywood Night Club—dinner, dancing and show. | Remember \$5.50 per person pays everything. |

REGULAR RATES, \$2.00 to \$3.00 SINGLE, \$3.00 to \$4.00 DOUBLE

FREE—Write Dept. Q for copy of "New York in Your Pocket"

HOTEL TIMES SQUARE

Under direction of Wm. S. Brown
TIMES SQUARE, NEW YORK

Introductory Special 2-BUTTON MICROPHONE

A good, 200 ohms per button microphone at a low price. Pure gold contacts. Low hiss level. Duralumin diaphragm. Scientifically damped. Frequency, 40 to 3500 cycles. Dia. $2\frac{1}{4}$ " over all thickness $1\frac{1}{2}$ ". Chromium finish, weighs 1 lb. packed. For any type mounting—desk, suspension ring, banquet SPECIAL stand, sound truck, etc. A \$10.00 value for \$3.95. Send for catalog on other microphones and amplifiers. EACH

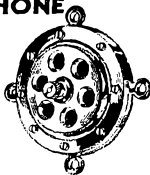

412 N. Leavitt St. Chicago

LOW RANGE FUSES

- Littelfuses for Instruments: Amps.: 1/100, 1/32, 1/16—20c ea. 1/8, 1/4, 3/8, 1/2—15c ea. 1, 2—10c ea. For milliamperes, ham rectifiers, etc. Use for radio B circuits. High Voltage
- Littelfuses: 1000, 5000, 10,000 volt ranges in 1/16, 1/8, 1/4, 3/8, 1/2, 3/4, 1, 1 1/2, 2 amps. Renewable. Price 35c to \$1.25 ea. NOW—\$100 PROTECTION GUARANTY. Get New Cat. *5.
- LITTELFUSE LABS. 1784 Wilson Ave., Chicago

Quicker than a Short circuit! LITTELFUSES

PRECISION CRYSTALS

High Output Accurately Calibrated FREE Plug-in, dustproof holder, with G. R. plugs, given with each crystal purchased this month. This is the last month that this holder will be offered free.

PRECISION crystals are X cut, one inch square from the best grade of Brazilian quartz. They are accurately ground for maximum output, thoroughly tested and fully guaranteed. A calibration is furnished accurate to within 0.05%. These crystals are well known for their high quality.

- 1750 kc. band within 2 kc. of your specified frequency... \$4.50
 - 3500 kc. band within 4 kc. of your specified frequency... 4.50
 - 7000 kc. band within 20 kc. of your specified frequency... 5.50
 - 7000 kc. band within 7 kc. of your specified frequency... 6.50
 - Plug-in, dustproof holder with G. R. plugs... 1.50
- (This holder is given free with each crystal purchased this month.)
Temperature controlled oven, accuracy plus or minus 1/2 degree centigrade... \$25.00

This oven accommodates two crystals and is intended for amateur stations or commercial stations where an accuracy of .03% is required, such as police stations. Thermometers, thermostats, temperature controlled ovens, oscillators and crystals for commercial use gladly quoted on. Write for description and prices.

PRECISION PIEZO SERVICE
427 Asia Street Baton Rouge, La.

PANELS—BAKELITE—RUBBER—ALUMINUM
All Sizes Cut to Order
Drilling, Engraving & Special Work
BAKELITE TURING & RODS
ALUMINUM CANS—6 x 5 x 9, \$1.70—6 x 10 x 7, \$2.75—7 x 9 x 14, \$4.45, and many other sizes. Special sizes to order.
ALUMINUM CHASSIS—1 threaded brass studs for 6/32 screws. Length from 1/2" to 6"—price 5c to 30c.
Insulating bushings for all size shafts from 75c to \$1.90 per dozen
Couplings in brass or bakelite—15c
Transmitting frames and racks
Mail orders filled same day.
UNITED RADIO MFG. CO., Est. 1923, 191 Greenwich St., New York

have you heard...

- ABOUT the FIRST Residence School for Practical Radio Engineering offering thorough Practice and Theory, without requiring 4 years of college engineering!
- ABOUT the new complete residence course PLUS the famous home study plan, which enables the student to study intensively at home with follow-up laboratory work on actual equipment!
- ABOUT the fine working equipment and capable staff of trained instructors!

Send for new
FREE CATALOG
Just off the Press

CAPITOL RADIO ENGINEERING INST.
14th and Park Road Washington, D. C.
Dept. QS-6

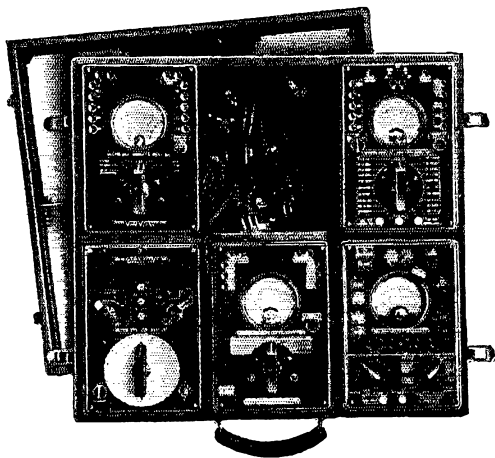

Now—
all 5 in one set
... to satisfy every service requirement

COMPACTLY housed in a single carrying kit, Weston now offers the complete set of 5 Standardized Service Units: Analyzer, Volt-Ohmmeter, Test Oscillator, Tube Checker and Capacity Meter. The combination is a portable laboratory that makes intelligent servicing of any set easy and certain. It contains every instrument for making both Point-To-Point and Tube Checker-Analyzer tests as desired.

With the addition of this 5 unit set Weston has rounded out its line of Standardized Service Unit combinations. Those who prefer the Tube Checker-Analyzer method will want the set containing the Test Oscillator, Tube Checker and Analyzer. For those who prefer the Point-To-Point method Weston offers the kit containing a Test Oscillator, Capacity Meter and Volt-Ohmmeter.

Bear in mind that each unit is entirely independent and can be bought and used separately. It can then be combined in the multiple unit case at some later date. We will be glad to furnish detailed description. Write to.....Weston Electrical Instrument Corporation, 602 Frelinghuysen Ave., Newark, N. J.

WESTON·JEWELL
Radio Instruments

WESTON ELECTRICAL INSTRUMENT CORPORATION
 602 Frelinghuysen Ave., Newark, N. J.
 Please send me further information
 on Weston-Jewell Service Equipment.

Name _____

Address _____

W6XK: Don Lee Broadcasting System, Los Angeles, Calif., Harold Peery in charge.

WVW 5000-KC. TRANSMISSION

The 5000-kc. transmissions of the Bureau of Standards station, WVW, are given every Tuesday continuously from 12:00 noon to 2:00 p.m., and from 10:00 p.m. to midnight, E.S.T. The accuracy of these transmissions is to better than 1 cycle (one in five million).

— J. J. L.

For Code Learning

(Continued from page 37)

will also record hand sending and thus permit the user of the machine to make new practice material and, possibly more important, check up on his sending style. The "Master Teleplex" has this additional feature.

The "records" in the Master Teleplex consist of paper tape on which the dots and dashes have been printed with a special conducting ink. The tape is fed through a contact mechanism by means of a clock-work drive. As the contacts pass over the inked characters a current, furnished by an external battery, flows and actuates a vacuum-tube which operates as an audio oscillator. The output of the oscillator is fed to a pair of headphones. The rate at which the tape travels can be regulated so that code speeds from a few words to about thirty words per minute can be obtained. Several practice tapes are furnished with each machine.

Blank rolls of tape are available for home recording. The Master Teleplex is furnished with a key and inking pen as well as a supply of the conducting ink. The ink is fed to the pen from a small pot arranged so the rate of flow can be regulated satisfactorily. The recording feature is exceedingly valuable because this hand-made record can be compared either visually or aurally with the regular practice tapes and such common faults as poor spacing of characters, irregular sending, disproportionate time-values for dots and dashes, etc., can be readily observed and corrected.

A second model of the Master Teleplex fitted out for Morse operation, in which the audio oscillator is replaced by a vacuum tube-operated relay which opens and closes a local circuit, also is available. The Master Teleplexes can be rented or purchased from the Teleplex Company, 76 Cortlandt St., New York.

Sweepstakes Contest Results—1932

(Continued from page 29)

| | |
|----------------------------------|---------------------|
| WIBOS (6).... 162 | W. Florida \$,616 |
| WIBDQ* (1).... 2 | W4AGS (21).... 1365 |
| | W4BGA (17).... 782 |
| Maritime \$,310 | W4ACB (11).... 385 |
| VOSAW (18).... 1494 | W4AQY (7).... 84 |
| VEICY (12).... 948 | |
| VELEP (14).... 868 | Saskatchewan \$,205 |
| | VE4BS (21).... 1890 |
| Idaho \$,916 ¹¹ | VE4EH (9).... 315 |
| W7UQ (32).... 3072 ¹² | |

¹¹ Total of individual scores of operators at W7UQ for Section Total.

¹² Station Score. Opr. "W7ABB" 2914, "W7CMY" 2.



McMURDO-SILVER

THE HAM SUPER IS HOT . . . AND HOW!

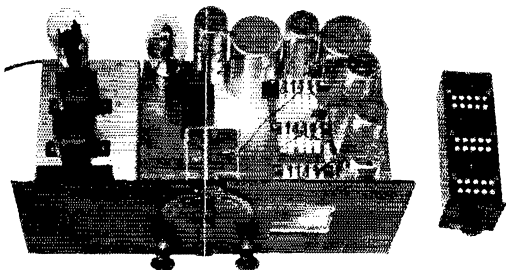

IF YOU WANT TO KNOW about the hottest receiver on the market today, better find out about the set about which W9DFT, 9AIO, 9PK, 9AFN, 9LW, 9CYE and more hams you know say "amazing . . . ten times as much DX . . . heard KA's, J's, AU's, VU's, YM's . . . worked VK2HQ and VK5HP between two locals . . . worked EAR46 just 500 cycles away from RXC without the least bit of interference."

And—designed by Fred Schnell, Bob Kruse and McMurdo-Silver, the Ham Super has been chosen for W9USA at the World's Fair.

Send a 3c stamp if you want to know about the cheapest and hottest ham receiver today, and other ham specials, such as a depression priced all A. C. frequency meter monitor.

McMURDO-SILVER, INC.

1136 W. AUSTIN AVENUE

CHICAGO, ILLINOIS

PACENT Carries On!



Louis Gerard Pacent has personally purchased the principal assets of former Pacent companies. Pacent Essentials as well as new products will be manufactured and marketed by this organization. A new merchandising policy means more profit and better value for you.

Write for details of the new and enlarged line of Pacent Essentials, as well as "New Deal" Merchandising Plan.

PACENT ENGINEERING CORP.

Louis Gerard Pacent, Pres.

79 Madison Ave. New York

Radioformers
Line Filters
Phonovoxes
Recordovox
Compensating
Phonovox
Etc., etc.

PACENT



EXTRA!!!

Premier Prices Now within the Reach of All

80 and 160 meter, X or Y cut crystal within 20 kc. of specified frequency. Calibrated in plug-in type holder — COMPLETE WITH HOLDER \$5.00

Crystal — Mounted in plug-in type, air-gap holder for Single-Signal receiver — 465 kc. to 525 kc. — COMPLETE WITH HOLDER. . . . \$7.50

All calibrations made with a General Radio Frequency Standard — Checked with Bureau of Standards Transmissions and Naval Observatory time signals. All calibrations guaranteed accurate to within .001%

Crystals of all descriptions made to order—Prices upon request

PREMIER CRYSTAL LABORATORIES, INC.

53 PARK ROW

NEW YORK CITY

PRESENTING

A SUPERHETERODYNE RECEIVER

FOR 5 AND 10 METER WORK

SIMPLE COMPACT EFFECTIVE

\$35.00 LIST, LESS USUAL TRADE DISCOUNT

WRITE FOR PARTICULARS

THIS MONTH'S SPECIALS TRANSFORMERS

| | |
|---|--------|
| No. 866— 2½v—10A—10,000v insulation | \$2.75 |
| No. 210— 7½v—5A | 2.75 |
| No. 211—10v—7½A | 3.75 |
| Fil. trans. for 83 bridge, three 5v @ 3½A | 3.85 |
| Swinging choke, 30H @ 40ma to 6H @ 200ma | 5.50 |
| Filter choke, 12H @ 200ma, 80 ohms | 5.50 |

These transformers are steel-cased with bakelite terminal plates. Suitable for commercial and amateur service.

Made by

KALTMAN & ROMANDER

62 Court St.

Newark, N. J.

Telephone MA 3-2020

HAVE YOU HEARD ABOUT THE NEW LICENSE BOOK? See page 60

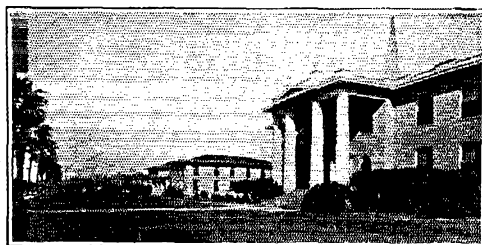

In 3 to 7 months we train you to secure government license. Course consists of Wireless Code, Radiophone, Microphone-Studio Technique, Television, Service, Police, and Aeronautical Radio. We are authorized to teach RCA Institutes, Inc., texts. Return coupon for details.

Name
Street or Box
City and State

PORT ARTHUR COLLEGE

PORT ARTHUR, TEXAS

To Our Readers who are not A.R.R.L. members

YOU should become a member of the League! That you are interested in amateur radio is shown by your reading of *QST*. From it you have gained a knowledge of the nature of the League and what it does, and you have read its purposes as set forth on the page opposite the editorial page of this issue. We should like to have you become a full-fledged member and add your strength to ours in the things we are undertaking for Amateur Radio. You will have *QST* delivered at your door each month. A convenient application form is printed below — clip it out and mail it today.

A bona fide interest in amateur radio is the only essential qualification for membership

AMERICAN RADIO RELAY LEAGUE
West Hartford, Conn., U. S. A.

I hereby apply for membership in the American Radio Relay League, and enclose \$2.50 (\$3.00 outside of the United States and its Possessions, and Canada) in payment of one year's dues, \$1.25 of which is for a subscription to *QST* for the same period. Please begin my subscription with the issue. Mail my Certificate of Membership and send *QST* to the following name and address.

.....
.....
.....

Do you know a friend who is also interested in Amateur Radio, whose name you might give us so we may send him a sample copy of *QST*?

.....

Thanks

| | |
|--|---|
| Mississippi 2,158 W5BUI (26).... 2158 | Utah-Wyoming 721 W6BTX (15).... 630 W7COH (7).... 91 |
| New Mexico 1,176 W5ATW (21).... 1176 | Hawaii 125 K6ACW (5).... 65 K6EDH (4).... 60 |
| Sacramento V. 1,068 W6CGJ (12).... 618 W6GAC (10).... 260 W6BYB (8).... 160 ¹³ | Vermont 2 W1ATF (1).... 2 Philippine Islands 2 KA1JR (1).... 2 |

¹³ Station Score. Two ops.

Transformerless Power Supplies

(Continued from page 24)

Actual measurement, using the same three-tube receiver as a load, showed that the output voltage was about 240 volts. The regulation will depend principally on the size of the two input condensers. Anything from 8 μ f. up seems to work well at the small load taken by the usual ham receiver.

Let us repeat once more — do not use a direct ground on the receiver with either the second or third circuits. One of two things is sure to result — either one rectifier will be inoperative; or, if the ungrounded side of the power line is connected to ground through the rectifier tube, the tube will be ruined. In the voltage doubling circuit there is also the possibility of blowing out one of the input condensers, to say nothing of line fuses.

— G. G.

Transmitter Power Supply from Low-Voltage D.C.

(Continued from page 16)

This power supply seems to require less filter than the usual a.c. rig. The choke is an old make-and-break coil from a gasoline engine. Only one filter condenser is used. An 8 μ f. condenser was first tried in place of the 1 μ f. but did not improve the signal to any extent.

A word of warning may be in order against the use of a 60-cycle a.c. volt meter in checking the filament voltage. The meter I have seems to read one-half the actual voltage although it checks o.k. on a.c. broadcast sets.

Converting Standard Superhets to S. S. Receivers

(Continued from page 26)

As an alternative to placing the filter circuits "above deck," if there is space the whole works may be assembled in the sub-base region, underneath the first i.f. transformer. This method has been applied successfully to a "Comet Pro" by Hendricks and Harvey. The selectivity control condenser is put in place of the volume control, the volume control moved over to the left side to replace the tone control and the tone control put in the spare-parts box. Tone control is non-essential when the filter is used, because the selectivity control takes over its duties. The small filter-switch knob is placed at the right in a position to balance the 'phone jack at the left, for appearance's sake.

Where space is at a premium, it may be necessary to use a split condenser with a shorter frame

Amateur Headquarters

\$85 National SW-45 Receivers, Special **\$16.50**

5-tube tuned R. F. Uses two 35's, one 27 and two 45's. Coils available from 9 to 2000 meters.

Brand New Jewell No. 589 D.C. Voltmeters **\$1.50** each
While they last. Range 0-7 volts

The New National SRR 5-Meter Receiver **\$14.70**
Compact, High Sensitivity. Low Hiss Level. A Special.

At Last! Navy Knobs 25c each
For Hand Telegraph Keys

Complete Kit of Parts for building 5-Meter Receiver **\$11.75**
See constructional details in May QST.

Build Your Own Monitor Complete Kit of Parts, Less Tube and Batteries **\$5.00**

M. & H. SPORTING GOODS CO.

512 MARKET ST., PHILADELPHIA

New I. F. Coil Kit for Single-Signal Receivers

Send stamp for details and circuit diagram

T. F. CUSHING

349 Worthington St.

Springfield, Mass.

"HAM" PARTS

866 transformers, coil-forms, condensers, resistors, midjet condensers, chokes, power transformers, sockets, lugs, spaghetti, aerial insulators, feeder spreaders, mikes, tubes, meters, potentiometers. Stop by and see the largest parts stock in New England.

HATRY & YOUNG, HARTFORD, CONNECTICUT

Radio Operating Radio Servicing—

Prepare for the new Government Radio Operating license examinations; Radio Operator, Marine and Broadcasting. Also Radio Amateur Telegraph and Telephone. Resident courses. Write for booklet "Opportunities in Radio."



West Side YMCA Trade & Technical Schools
4 West 63rd Street, New York City

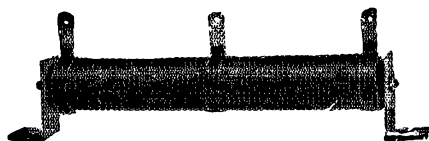

Noiseless

TRANSMITTER GRID LEAK

MONEL METAL contact bands and lugs, and a positive clamp for the resistance wire, mean accurate values, uniform expansion and certain contact.

The Electrad Vitreous-Enameled, Wire-Wound Transmitter Grid Leak is guaranteed not to develop noise or open circuits.

Type TG — 190 watts — 1 1/4" x 10"
Type TL — 90 watts — 1" x 6"
Type CF — 40 watts — 1/2" x 4"

Your dealer can supply you

Write Dept. Q-6
for Complete Catalog

175 Varick St., New York, N.Y.
ELECTRAD

EASTERN RADIO INSTITUTE, INC.

Founded 1913

Offers courses in Marine Operating, Broadcasting, Aviation Radio, Servicing, Advance Service, Television and Sound.

899 BOYLSTON STREET

BOSTON, MASS.

ALUMINUM BOX SHIELDS Genuine "ALCOA" stock, silver dip finish, 5 x 9 x 6, \$1.65, 10 x 6 x 7, \$2.65. Any Size to Order. SOMETHING NEW! Your call letters, or any marking for your panel, on BLACK aluminum ribbon. Looks like engraving on bakelite. 5c. each, sample, 8c.

Foil for condenser or velocity mike 1/4 mil., 25c. ft. 2 1/2 MH 4 section r.f. choke, 55c. 1/2 watt Neon lamp, 35c. New Master Teleplex on demonstration.

W 2GT.

BLAN, the Radio Man, Inc.

177 Greenwich St.
New York City

WESTON METER BARGAINS



Model 301

GENUINE



Model 267

Universal A.C. — D.C. With 5-Position Scale... \$8.40
Complete Set Resistors and Shunts... 7.95
0-1 Milliammeters (1000 Ohms per Volt)... 5.25
0-10 Milliammeters... 5.25
0-100 Milliammeters... 5.25
0-10, 25, 50 or 100 D.C. Voltmeters... 4.45
0-150 Voltmeters D.C.... 5.88
0-15 A.C. Rect. Type... 6.00
0-150 A.C. Rect. Type... 6.50

Milliammeters, 0-10, 0-25, 0-50, 0-100, 0-300, 0-500 \$5.00
Ammeters 0-2, 0-3, 0-7 1/2, 0-10, 0-15... 5.00
Voltmeters D.C. 0-15, 0-20, 0-25, 0-50, 0-100, 0-200, \$6.50; 0-500, \$7.40; 0-1000... 8.50
A.C. Voltmeters, Rect. Type 0-15 or 0-150... 6.00
Milliammeters 0-1 (1000 Ohms per Volt)... 6.00

Postage included in above prices

25% deposit with C.O.D. orders

Send for Bulletin No. 4

416 N. Leavitt St.

CHICAGO, ILLINOIS

if the
trouble
is here
or here



**Replace with
Centralab Volume Controls
& Fixed Resistors**

The Centralab Volume Control Guide gives you all the latest dope on replacements. Jobbers everywhere carry complete stocks. . . . Centralab Units have set the standard by which all others are judged. Send for the new 50c Volume Control Guide . . . it is yours for two 3c stamps.

CENTRAL RADIO LABORATORIES

Centralab

Dept. D MILWAUKEE

NEW 1933 CORNELL CATALOG



A complete line of oil and electrolytic transmitting condensers described in our new 1933 Catalog. Sent free on request. Write for your copy now.

CORNELL ELECTRIC MFG. CO., Inc.
Long Island City New York

GULF RADIO SCHOOL

Radiotelegraphy Radiotelephony
Radio Servicing

SECOND PORT } 1007 Carondelet Street
U. S. A. } NEW ORLEANS, LA.

BLILEY CRYSTALS

POWERFUL ACCURATE UNIFORM

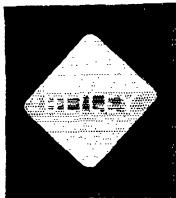

A scientifically manufactured crystal, powerful in output, accurate in frequency, and uniform in quality. 40, 80, 160M quartz x-cut crystals, supplied within 25Kc, \$4.50; 5Kc, \$5.50; 0.5Kc, \$6.50. 20M, within 50Kc, \$12.75. Frequency tolerance -- 0.05%. Calibration error considered zero.

BLILEY molded bakelite holders. For 20-40M, \$1.50; 80-160M, \$1.50. SS Filter, 465-525Kc, mounted, \$6.50. 100Kc, mounted bar, \$8.50.

Quartz crystals manufactured to your requirements from 20Kc to 15Mc, Precision constant-temperature equipment. Write for folder Q250.

BLILEY PIEZO-ELECTRIC CO., ERIE, PA.

than that of the usual 140- μ fd. per section type. If so, the necessary capacitance can be given by two smaller condensers in parallel instead of the one of larger size. The capacitance range required in operation is only a part of the total in circuit, so the use of a fixed section in parallel with the variable section is an advantage rather than a disadvantage.

Detailed instructions for preliminary tuning up and operation are identically the same as given for S.S. receivers in previous articles and need not be repeated here. Refer especially to March, 1933, *QST*, for the routine.

WHAT TO EXPECT

The addition of the filter unit to a receiver that has the prerequisite stability and band-spread tuning actually makes it another receiver altogether. For both c.w. and 'phone, the effective selectivity is improved several hundred percent. A likely first impression is a seeming reduction in sensitivity, because the gross volume drops when the filter is switched to "series." There should be a slight loss in the filter even at its resonance frequency, of course, but this is relatively slight; that is, the loss at resonance for a pure c.w. carrier is small. However, the reduction in audio frequency components with a speech-modulated signal and in general hash from background and neighboring signals is large. With high selectivity "losses" of this sort are not only inevitable but are also just what we are after. When making comparisons of the c.w. sensitivity with and without the filter, therefore, pick out a steady d.c. signal and concentrate listening attention on it. The gross noise should go down when the filter is switched in — but the effective output for the desired good signal actually should increase. For the 'phone test, concentrate attention on the lower tones of a high quality signal. When the filter is switched in and the receiver tuned "on the nose," the highs will drop out (along with the general interference) but the lows actually will appear to come up. Admittedly this does not give true reproduction of the signal. But then the high selectivity need be used only when interference requires it; and loss of "quality" is small payment for intelligible reception of signals that otherwise would be unintelligible "hash."

CLIFFORD A. HARVEY

formerly of
Hendricks & Harvey

announces the opening of the
HARVEY RADIO LABORATORIES

12 Boylston Street
BROOKLINE, MASS.

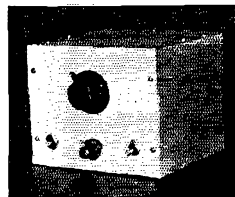

Have a really portable 5 meter station for that portable call! The Harvey 5 meter combination transmitter-receiver uses only two tubes, one type '30 and one type '33 and requires but 90 volts of light duty battery for plate power. Light in weight, smaller in size than the batteries that run it. Ruggedly built, completely enclosed in aluminum case. Less tubes and batteries \$16.50. Radio equipment for all frequencies custom built to *QST* or your own specifications.

HARVEY RADIO LABORATORIES

12 BOYLSTON STREET BROOKLINE, MASSACHUSETTS

HAM-ADS

(1) Advertising shall pertain to radio and shall be of nature of interest to radio amateurs or experimenters in their pursuit of the art.

(2) No display of any character will be accepted, nor can any special typographical arrangement, such as all or part capital letters be used which would tend to make one advertisement stand out from the others.

(3) The Ham-Ad rate is 15c per word, except as noted in paragraph (8) below.

(4) Remittance in full must accompany copy. No cash or contract discount or agency commission will be allowed.

(5) Closing date for Ham-Ads is the 25th of the second month preceding publication date.

(6) A special rate of 7c per word will apply to advertising which, in our judgment, is obviously non-commercial in nature and is placed and signed by a member of the American Radio Relay League. Thus, advertising of bona fide surplus equipment owned, used and for sale by an individual or apparatus offered for exchange or advertising inquiring for special equipment, if by a member of the American Radio Relay League takes the 7c rate. An attempt to deal in apparatus in quantity for profit, even if by an individual, is commercial and takes the 15c rate. Provisions of paragraph (1), (2), (4) and (5) apply to all advertising in this column regardless of which rate may apply.

Having made no investigation of the advertisers in the classified columns, the publishers of *QST* are unable to vouch for their integrity or for the grade or character of the products advertised.

OVER six pounds radio data, circuits, bulletins, 50¢ postpaid. Beyond Rockies, 75¢. Kladag Kent, Ohio.

MICROPHONE and meter repairs. Low prices, Quick Service. Sound Engineering Corp., 416 N. Leavitt St., Chicago.

QUARTZ—Direct importers from Brazil of best quality pure quartz suitable for making piezoelectric crystals. Diamond Drill Carbon Co., 719 World Building, New York.

TRANSFORMERS, reactors made to order. Accurate, dependable. Prompt shipments. Write for quotations. Baker Engineering Laboratories, Fort Wayne, Indiana.

VOLOVOX Dynamic Microphone. A new standard of microphone value. \$7.75 postpaid in U. S. Baker Engineering Laboratories, Fort Wayne, Indiana.

QSLs—SWLs, W6DOU, Hayward, Calif.

.001 Dural for condenser mikes, 36 sq. in., 25¢. .0005 Dural for ribbon mikes, 36 sq. in., 50¢. Good tubes all kinds and sizes. Buy, sell, trade. W9ER, Timken, Kans.

WILL trade new Vibroplex for good 852. R. W. Johnston, 2925 Washington Ave., Sioux City, Iowa.

RCA Condenser Microphone, three stage amplifier, 25 ft. shielded cable tubes, suitable for commercial broadcast work \$125. Pilot d.c. super wasp, tubes, \$15. Trade, half cash half new xmitter tubes. F. Bornemann, 175 Eighth Street, Troy, New York.

CRYSTALS—80 or 160-inch square, \$2. Less than inch \$1.50. Oscillating blanks, \$1.25. W2BVF, Hollis, L. I.

TRADE 40 meter xtals for meters, etc. W4KP.

CRYSTALS unconditionally guaranteed. 160-80 meter bands, \$3.50. 40 meters \$4. Finished blanks, \$1.50. Write for price list. Bellefonte Radio Engineering Lab., Bellefonte, Penna.

MODERN test equipment built from your spare meters, lowest prices. W9DWQ, Valley Center, Kans.

JEWELL-Weston all meters repaired. 50¢ up. W9DWQ, Valley Center, Kans.

NATIONAL SW3 with coils and tubes, \$20. W5WR, 2628 E. 6th St., Tulsa, Okla.

QSL cards, two color, cartoons, message blanks, stationery, snappy service. Write for free samples to-day. W1BEF, 16 Stockbridge Ave., Lowell, Mass.

TRADE three 80 or one 40 meter crystals for Thordarson double 18 henry 250 mil choke. W9HZG.

NEARLY new 32 d.c. to 110 a.c. 60 cycle 500 watt rotary converter. Run transmitter from delco. Fine for high power portable. Cheap for cash. Moody McDonald, W5AQX, Hot Springs, Ark.

QSLs! W8DED QSLs! Printed for particular hams! Free Samples! W8DED, Holland, Mich.

SELL Supreme model AAA-1 diagonmeter. First \$50. K6AJA. Guaranteed A-1 condition.

SELL or trade—Gross 56 mc receiver. Want low-powered transmitter. Cline, 5230 Locust St., Philadelphia, Pa.

WANTED: Used factory-wired National SW3 a.c. or combination. Give particulars. P. O. Box 374, Brownsville, Texas.

WILL trade Esco motorgenerator, runs on 110 v. a.c. 60 cycle output 500 v. 200 mil d.c., for Weston set analyzer. Prefer model 565. What have you? W6DLJ, 1103-12th St., Modesto, Calif.

WANTED—phone transmitter. Trade Frigidaire unit, saxophone. Morgan, 1210½ E. 33, Savannah, Ga.

QSLs, by Maleco. Finest in country. Free samples. Maleco, 1512 Eastern Parkway, Brooklyn, N. Y.

WANTED—Good UV861. W5AUB.

SURPLUS apparatus bought, sold, traded. W5AUB.

CRYSTALS: See last month's ham-ad for dollar special. Wm. Threm, W8FN, 4021 Davis Ave., Cheviot, Ohio. Phone Montana 0665.

FINANCIAL reasons sacrifice immediately my Scott all-wave custom built twelve tube superheterodyne. Massive walnut cabinet tubes complete. Receive all over the world. First money order seventy-five dollars receives same, others returned promptly. Glenn Watt, Chanute, Kansas.

SELL—trade—terms: Dynatron, superhet converter, Teleplex, Pilot Wasp, Silver Marshall 728SW 12 tube, all wave receiver, King trumpet, typewriter. Want 212Ds, etc. Harper Richards, Argyle, N. Y. W8IV.

FINEST QSLs. T. Vachovetz, Elmsford, N. Y.

FOR sale—SW3 tubes, coils for 4 bands, \$15. W1FRQ, Longmeadow, Mass.

COMPLETE xtal controlled portable, \$35. Stamp brings info. W9DKF, Peoria, Ill.

EXTRA rigid 1/16" aluminum cans 6x5x9 inches, \$2.25. Postpaid, cash, guaranteed. 1/4" brass corner post sets for cans, QST receivers. Write R. H. Lynch, W6DZI.

OMNIGRAPHS, Teleplexes, Vibroplexes, meters, receivers, transmitters, mikes. Bought, sold, traded. Ryan Radio Co., Hannibal, Mo.

MERCURY arc tube, brand new, will give 4000V 2 amps. \$14. Chas. H. Warriner, 1322 Diversey, Chicago.

TRADE—LeRhone airplane motor for radio apparatus. Box G, Richland Center, Wis.

WIRELESS code classes in New York. All speeds. Complete training for amateur license. \$1. --- weekly. Hart, 3407 Washington Ave., Astoria, L. I.

A perfect and instantaneous indicator, for RF flow in tank and percentage of modulation. Beats any and all meters for tuning and neutralization. Specially constructed fourteen inch "Neon" tube with special electrode. Built to absorb negligible current. Comes complete with instructions for all types of work \$3.00. Write for quotations on all types of neon and thyatron tubes. W8CCS. 1719 Waller St., Portsmouth, Ohio.

CRYSTALS: Guaranteed excellent oscillators, 160 or 80 meters, \$1.35 postpaid. 1" Blanks 65¢. Irregular shapes 25¢. Standard dust-proof plug in Holders 75¢. Pure Brazilian Quartz \$1.50 lb. and up. Fisher Laboratory, 1200 E. Nevada, El Paso, Texas.

QSLs 100 one color, 50¢, two colors, 80¢. Samples. 2143 Indiana Ave., Columbus, Ohio.

\$1,000,000 station. See March ham-ad, April display advertisement. Relay racks, panels, transmitters. Rectifier Engineering Service.

XTALS. 1", 80, 160. Prompt service, guaranteed, \$1.35. W9HWE.

CRYSTALS cheap. Unconditionally guaranteed. See former ham-ads. W6BCX.

VIBROPLEXES, brand new, \$12. Rebuilds, \$6 to \$9. Guaranteed. Lydeard, 23 Circuit, Roxbury, Mass.

QSLs, 75¢ a 100, two colors. W9DGH, 1816 5th Ave. N., Minneapolis, Minn.

SELL complete dx station. J. L. Traub, Henning, Minn. Ex-W9FNJ.

FIRST \$50. takes new National SW-58 receiver, National AB-S power supply, RCA tubes, speaker and fones, coils from 10 to 200. Also band-spread 40. W. Ryder, Jr., W9CIY, Hibbing, Minn.

FB-7s, \$26.46; coils, \$5.88. SW3s, \$14.40; coils, \$2.70. Guaranteed 866; \$1.95; Comet Pros. Any apparatus. Sell, trade used apparatus too. Write Henry's Radio Shop, Butler, Mo.

TRADE Gronert cornet, perfect condition, for complete phone or cw xmitter or what have you. C. J. Nelson, Cheyenne Wells, Colo.

TRANSMITTING and receiving equipment manufactured to order. Holmes C. Miller, Radio Engineer, Box 105, Palo Alto, California.

NEW log books, for the new regulations. 35¢ ea. 3, \$1. Hillcrest, Cranestville, Penna.

CODE machines, tapes and complete instruction for beginners or advanced students. Both codes. For rent, \$2. per month. Rental to apply on purchase price. Extra tapes for all machines. Instructograph, 912 Lakeside Place, Chicago.

NATIONAL shortwave tuner, \$4. 5 tube receiver REL parts. \$10. 3 auto radio kits, complete with speakers and suppressors, \$9.75 each. D. Salvini, 48 Maple St., Newton, Mass.

QSLs. Samples for stamp. "Gil" Cartoon Service, West Hartford.

TRADE—\$100 self-winding wrist watch for meters. W9EXJ, Atkinson, Nebr.

WANT—852s, 03A, sockets, meters, mike, etc. Trade 04A, \$18. tennis racket. W9EXJ, Atkinson, Nebr.

QSLs, 85c. Samples. W8AKY.

203As brand new, Westinghouse or GE, \$10. 203A class B transformers \$8.50 pr. Counterbalanced Cardwell 166Bs—\$20. Heavy duty 866s—\$2.50. 872s—\$7.50. New RCA UX-250s—\$1.75. Weston type 301 milliammeters (some new, all new condition, most all ranges) \$3.75. 204As—\$20. 212Ds—\$16. Diaphragms installed in WE mikes \$5. Instructographs, etc. List. Ewing, 1057 Pratt Blvd., Chicago.

CRYSTALS: See our advertisement page 71. Precision Piezo Service.

CRYSTALS ground to your approximate frequency, \$1.35. W4VK, Ripley, Tenn.

ELECTRON Coupled—a.c.-d.c. Monitor Frequency meter, with tube, \$13.50. Complete with a.c. power supply, \$18.95.

TRF Autodyne Receiver, \$19.95. Beginners Crystal Transmitter, \$20. Five meter receiver, \$12. Transmitter, \$7. Write for catalogue. We build to order. Precision Radio Laboratories. Dept. 7C: 307 West 79 Street, NYC.

TWO color QSLs, 50 to 75 cents per hundred. W9GOF, Mishawaka, Ind.

ATTRACTIVE new QSLs. Free samples. Huntington Press, 190 Huntington Ave., Buffalo, N. Y.

QSL cards, samples free. Crystals. W8CPE, Springdale, Pa.

CINO 50 watt sockets, \$1. postpaid. Panels engraved. United Radio, Inc., 1103 Vine St., Cincinnati, O.

TRANSFORMERS—46s, class B, \$4.95 pair. 203As class B \$9.95 pair. 70 watts of audio from 46s. Write for dope. W8UD, Douglas, Mich.

250, two stage, Dayfan amplifier with power pack, less transformer. Only \$1.95. John Kavalasuskas, 1426 Muskegon Ave., Grand Rapids, Mich.

GOOD QSL cards. Samples. Radio W9EHI, 513 Sparkman Ave., Duluth, Minn.

CRYSTALS: X cut, 1" or 1 1/16" sq. accurately finished, 160 or 80 meters, \$2. Oscillating blanks with compound, \$1. Holders, \$1.25. W8DLM, Rochester, Mich.

SWAP Underwood typewriter for transmitting parts. Need 203A. W2DNN, Ossining, N. Y.

QSLs, 200 2 colors. \$1. W6FZQ, R5, Box 278, Phoenix, Ariz.

SELL: 5 meter xmitter and receiver. Sets used in tests described page 25 December QST. Will sell at loss. W1WR.

Learn at Home to be a

Good
Radio
Operator

It's Easy

with
The NEW MASTER

Code Teaching Machine

Pleasant, interesting work. An officer aboard ship. Opportunity to see the world and get paid for it. No experience necessary. We furnish a Complete Code Course and lend you The NEW MASTER TELEPLEX. Course prepared by leading authorities on the subject, makes learning easy as A B C. . . . TELEPLEX has instructed more students in code in the past ten years, than all other systems combined. . . . It is the only instrument ever produced that will record your own sending in visible dots and dashes, and then repeat it to you audibly on headphones. . . . Enables you to make your own records, as many as you want without extra cost. . . . Provides unlimited practice material. Used by U. S. Army and Navy, R. C. A., A. T. & T. Co. and principal schools. Get started on the code NOW! If you can already read the code we pick you up at your present speed. Easy terms. Write for folder Q-17 giving full details.

TELEPLEX COMPANY

76 Cortlandt Street

New York, N. Y.

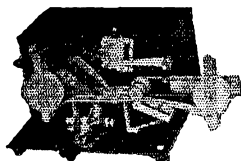

Teleplex

QST OSCILLATING CRYSTALS

"Superior by Comparison"

WHY YOU SHOULD USE SCIENTIFIC
RADIO SERVICE CRYSTALS

- 1 Since 1925, we have been specializing in producing Piezo Electric Crystals exclusively.
- 2 Since 1925, Scientific Radio Service Crystals have stood the test and are recognized the world over for their Dependability, Output and Accuracy of Frequency.
- 3 Since 1925, owners of Broadcast and Commercial Short Wave stations have found that no chances can be taken in getting the cheaper grade of crystals and that invariably they call on Scientific Radio Service for the Best.
- 4 Since 1925, we could be depended upon to make Prompt Shipments. This coupled with a crystal Second to None considering Output and Accuracy of Frequency has earned during these years a reputation which we jealously guard. Therefore, Get the Best.

Price list sent upon request

SCIENTIFIC RADIO SERVICE

"The Crystal Specialists"

124 JACKSON AVENUE, UNIVERSITY PARK
HYATTSVILLE, MARYLAND

CHI-RAD

for EVERYTHING in Short Wave Equipment

The smartest "hams" know about this place to buy better equipment cheaper . . . why don't you get wise, too? Frin-stance:

HAMMARLUND COMET "PRO"

A receiver too nationally well-known to require description or "sales talk" here . . . it's just that CHI-RAD can give you the best price!

NATIONAL "FB-7" AND "FB-X"

A pair of receivers that are making short wavers talk! Get complete data from CHI-RAD, together with "low-down" prices that will please you.

KITS

Nessir! We have that famous Wallace Hoover Prize-Cup Kit . . . an' ain't it something? Get all details from us. All the other new, good kits, too!

NEW '33 SHORT WAVE MANUAL

You're not a real "ham" without one . . . it's by Wallace, and represents a big-money value at \$1.00 . . . better send for yours right now!

ALUMINUM OR ELECTRALLOY PANELS

Cut to the size you want . . . and at mighty reasonable prices. . . . Ask us!

Honestly, you ought to have the complete CHI-RAD loose-leaf catalog. Send 10c for it NOW!

CHICAGO RADIO APPARATUS CO., INC.
412 S. Dearborn Street, Dept. Q-3, Chicago, Illinois

Your Nearest Dealer Is Your Best Friend

Your nearest dealer is entitled to your patronage. You can trust him. He is equipped with a knowledge and understanding of amateur radio. He is your logical and safe source of advice and counsel on what equipment you should buy. His stock is complete. He can supply your needs without delay. His prices are fair and consistent with the high quality of the goods he carries. He is responsible to you and interested in you.

Patronize the dealer nearest you—You can have confidence in him

| | |
|--|---|
| CHICAGO, ILLINOIS Chicago Radio Apparatus Company 415 South Dearborn Street Dependable Radio Equipment Established 1921 | NEWARK, NEW JERSEY Kaltman & Romander 62 Court Street Drop In for an over-counter QSO |
| CHICAGO, ILLINOIS Mid-West Radio Mart 520 S. State Street All standard lines carried in stock | NEW ORLEANS, LOUISIANA Rose for Radio 129 Camp Street Complete stock quality radio parts |
| CLEVELAND, OHIO Northern Ohio Laboratories 2073 West 85 Street W8BAH serving Cleveland and greater Cleveland Hams. | PHILADELPHIA, PENNSYLVANIA Eugene G. Wile 10 S. Tenth Street Complete Stock of Quality Merchandise |
| CLEVELAND, OHIO Radio Servicemen's Supply Co. 206 Prospect Street Wholesale Distributors catering to Amateurs, Dealers, Servicemen | PORTLAND, OREGON Guy B. Paine Company 391 Stark Street Transmitting and Receiving Parts |
| DENVER, COLORADO Vreeland Radio Corporation 1639 Tremont Street Amateur Radio Headquarters in the Rocky Mountain Region | PROVIDENCE, RHODE ISLAND W. H. Edwards & Company 32 Broadway, Room 23 A full line of reliable Amateur Equipment & Supplies |
| DETROIT, MICHIGAN Radio Specialties Company 171 E. Jefferson Avenue Ham Supplies — National & Hammarlund Sets and Parts | ST. LOUIS, MISSOURI Walter Ashe Radio Company 1100 Pine Street W9FIS in charge of the oldest and largest parts store in St. Louis |
| HARTFORD, CONNECTICUT Radio Inspection Service Company 227 Asylum Street Complete line of guaranteed parts | ST. PAUL, MINNESOTA Lew Bonn Company 2484 University Avenue Rex L. Munger, W9LIP, Sales Engineer Complete Radio Stock |
| INDIANAPOLIS, INDIANA Kruse Radio, Inc. 33 West Ohio Street Everything for the radio amateur and serviceman | SAN FRANCISCO, CALIFORNIA Offenbach Electric Company, Ltd. 1452 Market Street "The House of a Million Radio Parts" |
| KANSAS CITY, MISSOURI Burstein-Applebee Company 1012-14 McGee Street "Specialists" in supplies for the Amateur and Serviceman | SCRANTON, PENNSYLVANIA Radio Service & Supply Company 608 Linden Street The only "Ham" Supply Store in N. E. Pennsylvania |
| KANSAS CITY, MISSOURI Radio Laboratories 1511 Walnut Amateur Headquarters — Complete Stock — Quality Parts | SPRINGFIELD, MASSACHUSETTS T. F. Cushing 345 Worthington Street An amateur, endeavoring to sell good parts |
| MIAMI, FLORIDA Pan American Radio, Inc. formerly Fessenden-White 1809 NE Second Avenue Everything in Radio | SYRACUSE, NEW YORK Roy C. Stage, W8IGF Complete stock of standard Ham & BCL parts Standard Discounts. Free technical service by W8AOW |
| MILWAUKEE, WISCONSIN Radio Parts Company, Inc. 332 West State Street Complete stock Nationally Known products | UTICA, NEW YORK Vaeth Electric Company 701 Varick Street Wholesale Distributors of Radio Parts and Supplies |

This advertisement is paid for by the firms listed above. Qualified dealers are invited to apply for rates, etc., to Advertising Department, QST

Say You Saw It in QST — It Identifies You and Helps QST

You Are Protected When You Buy From QST Advertisers

¶ "Advertising for QST is accepted only from firms who, in the publisher's opinion, are of established integrity and whose products secure the approval of the technical staff of the American Radio Relay League."

Quoted from QST's advertising rate card.

Every conceivable need of a radio amateur can be supplied by the advertisers in QST. And you will know the product has the approval of the League's technical staff.

● See Editorial April issue of QST

For Your Convenience QST'S INDEX OF ADVERTISERS IN THIS ISSUE

| | |
|---|----------------------|
| A.R.R.L. Application Blank | 72 |
| A.R.R.L. Booklet | 60, 65 |
| A.R.R.L. Handbook | Cov. II |
| A.R.R.L. Supplies | 4 |
| Blan, The Radio Man | 73 |
| Biley Piezo-Electric Co. | 74 |
| Burgess Battery Company | Cov. IV |
| Candler System Company | 65 |
| Capitol Radio Engineering Institute | 69 |
| Cardwell Mfg. Corporation, Allen D. | 59 |
| Central Radio Laboratories | 74 |
| Chicago Radio Apparatus Co. | 76 |
| Collins Radio Company | 80 |
| Cornell Electric Mfg. Company | 74 |
| Cushing, T. F. | 73 |
| Delta Mfg. Company | 58 |
| Eastern Radio Institute, Inc. | 74 |
| Electrad, Inc. | 73 |
| Gross Radio Company | 61 |
| Gulf Radio School | 74 |
| Hammarlund Mfg. Company | 2 |
| Harvey Radio Laboratories | 74 |
| Hatry & Young | 73 |
| Kaltman & Romander | 71 |
| Kenyon Transformer Company | 68 |
| Leeds | 79 |
| Littelfuse Laboratories | 69 |
| McGraw-Hill Book Co. | 62 |
| M & H Sporting Goods Co. | 73 |
| Midwest Radio Mart | 65 |
| National Company | 57, 63, 66, Cov. III |
| Ohmite Mfg. Company | 1 |
| Pacent Engineering Corp. | 71 |
| Port Arthur College | 71 |
| Precision Piezo Service | 69 |
| Premier Crystal Labs. | 71 |
| QST Binder | 67 |
| Radio Supply Company | 65 |
| RCA Institutes, Inc. | 67 |
| Scientific Radio Service | 76 |
| Silver, Inc., McMurdo | 71 |
| Sound Engineering Corp. | 69 |
| Teleplex Company | 76 |
| Times Square Hotel | 69 |
| United Radio Mfg. Co. | 69 |
| Universal Microphone Co. | 67 |
| Universal Wireless Sales Co. | 73 |
| Ward Leonard Electric Co. | 67 |
| Western Electric Co. | 64 |
| Weston Electrical Instrument Corp. | 70 |
| West Side Y.M.C.A. | 73 |

The— 32A and 32B COLLINS TRANSMITTERS . . .

. . . announced in the April issue of *QST* have been writing a brilliant page in Amateur Radio history. Never before has a complete, self-contained, 20-watt CW or radiophone transmitter been built in such compact and efficient form, and *never before* has anything approaching these transmitters in performance been offered at anywhere near their price.



These instruments have met with a most enthusiastic reception and the volume of sales has again amply proven the soundness of the Collins principle of building transmitters of outstanding performance at a price so reasonable that amateurs cannot afford to build their own from composite parts. A new feature of the 32B's now in production is a self-contained, high gain, speech

amplifier operating direct from a double-button carbon, or condenser microphone. The 32B has an overall frequency response flat within three decibels from 70 to 10,000 cycles, measured from microphone to antenna. Both the 32A and the 32B are of the distinctive high-class workmanship and appearance always distinguishing Collins products.

Write for **FREE** Bulletin
giving detailed specifications and prices

COLLINS RADIO COMPANY
CEDAR RAPIDS, IOWA

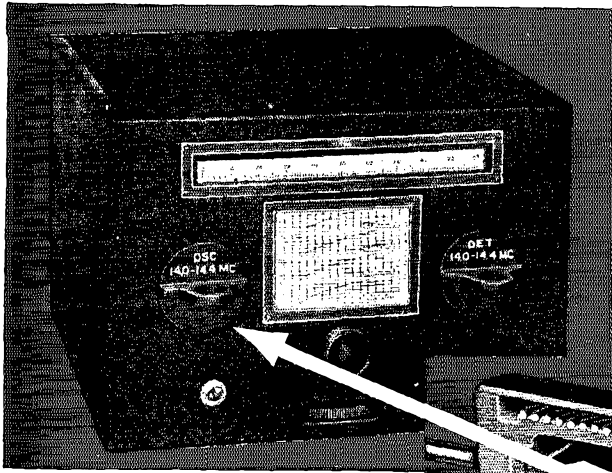

FB-7 -X

TRUE TRACKING!

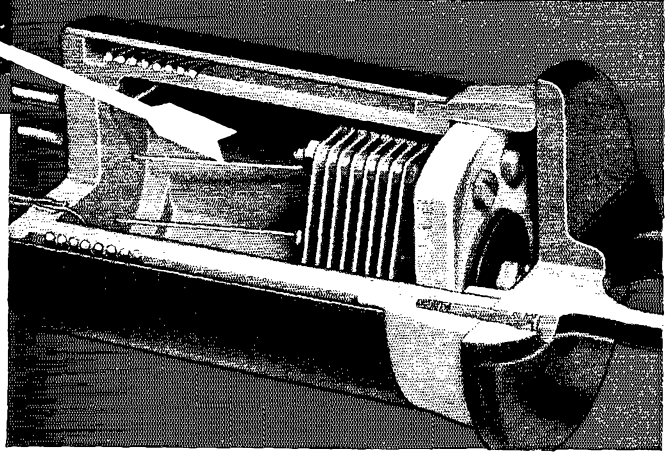

True Tracking is essential for maximum image suppression and sensitivity in precise single-control tuning of high-frequency superheterodyne receivers. • Only by advanced circuit engineering and the proper coordination of such specially developed components as shielded R39 inductances with individual air-dielectric adjustable padding capacitances, can permanent "drift-free" True Tracking be obtained. • Permanent True Tracking is just one of the exclusive features of National FB-7, FB-X and AGS receivers.

 **NATIONAL COMPANY, INC., MALDEN, MASS.**

Burgess Batteries on display at the radio amateur exhibit at the Century of Progress exposition.

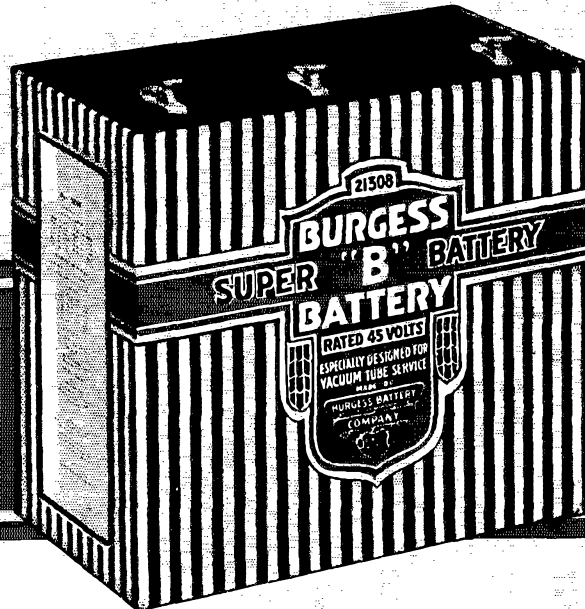

HAMS!

COMPETITORS CAN'T DODGE THESE FACTS

You'll dodge a lot of grief if you side-step the fancy, 100% plus claims being made about "performance . . . power . . . capacity" for less money than a Burgess SuperB Battery costs.

Burgess is a pioneer in making "B" batteries. They have made them for years and their batteries have been used by every important scientific expedition, because experience proved that no other battery was as dependable under the most severe extremes in temperature. Wherever human life has been at stake, Burgess Batteries have been used. Ask any radio engineer.

Tests today show that Burgess Batteries are even better than they were a year ago. A simple method for you to find out what people think of Burgess Batteries is for you to check through the back numbers of your own magazine: Q. S. T. Look at the illustrations . . . and you'll see Burgess Batteries in them. You can recognize them by their famous black and white stripes.

You can depend upon Burgess Batteries. They are worth every cent that they cost.

BURGESS BATTERY COMPANY

Engineers and Manufacturers of Acoustic and Electric Products

Sales Offices: NEW YORK, 202 East 44th Street

CHICAGO, ILL., 111 West Monroe Street

NEW YORK

CHICAGO

KANSAS CITY, MO.

SAN FRANCISCO

ATLANTA

BOSTON

MINNEAPOLIS

LOS ANGELES

In Canada—Niagara Falls and Winnipeg

BURGESS BATTERIES