

# QST

February, 1935  
15 cents

devoted entirely to

# amateur radio

In this issue—  
Full Details  
of Improved  
Antenna  
Systems

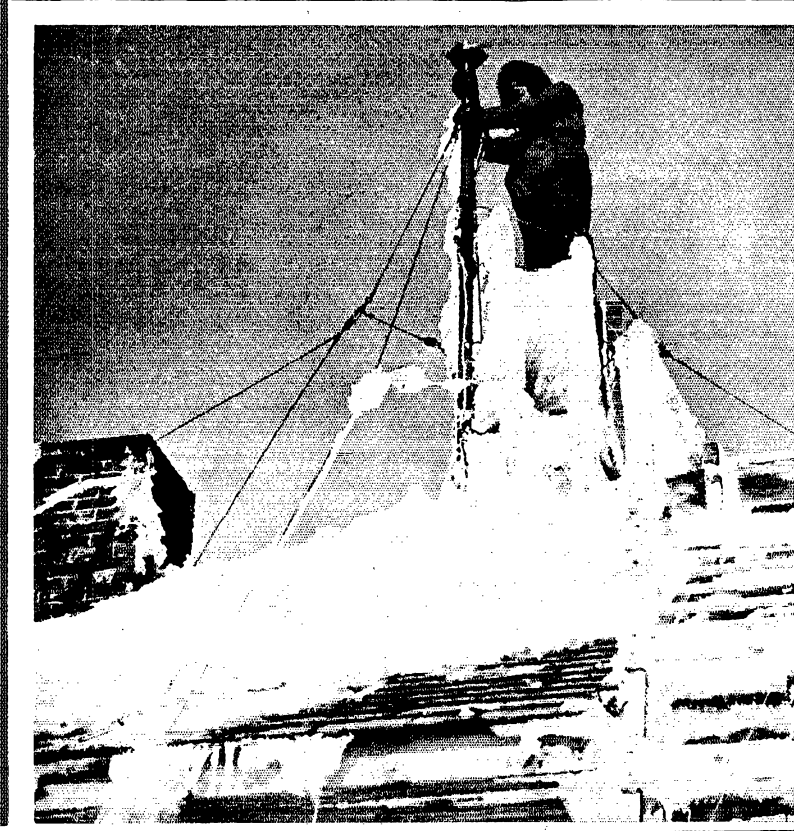

**COLLINS  
30FX**

**MORE WATTS  
PER  
DOLLAR!**

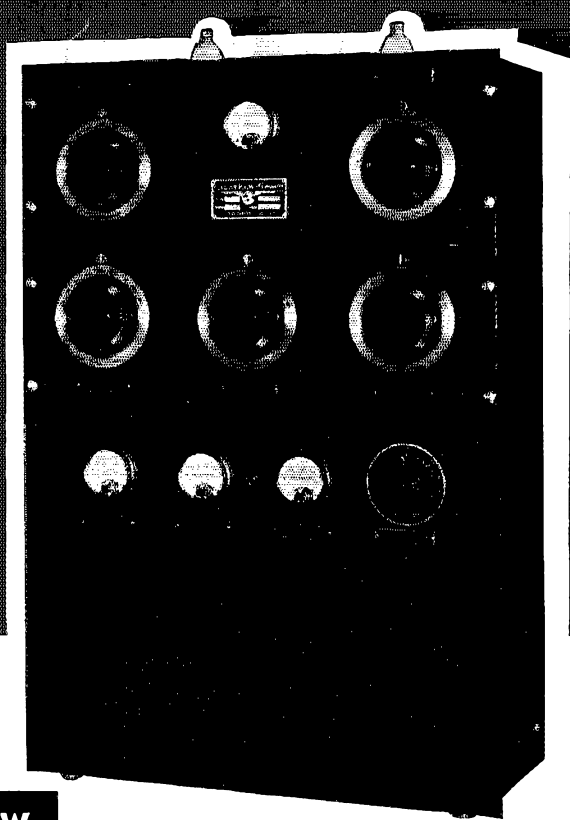

**100 WATTS CW**

**CONTROL-GRID MODULATION**

**40 WATTS PHONE**

**FIXED NEUTRALIZATION**

**1500 TO 15,000 KC.**

**NEAT APPEARANCE**

**FINE WORKMANSHIP**

**MODERATELY PRICED**

The 30FX is the ideal 1935 amateur transmitter — it is simple to adjust — its cost is low and its performance is guaranteed. Here is a Transmitter (final amplifier 211 triode) capable of putting into your antenna a full 100 watts of CW power, or a phone carrier of 40 watts — one-fourth the peak power at 100% modulation.\* The highly efficient COLLINS control-grid system of modulation assures perfect speech transmission without fuss or waste of power.

★ When used as a phone a COLLINS 7X high-fidelity speech amplifier is recommended.

For complete technical information write to —

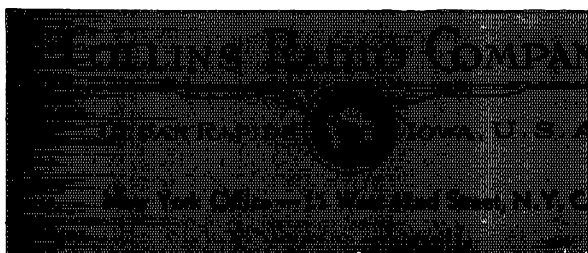

# STILL AHEAD in Performance!

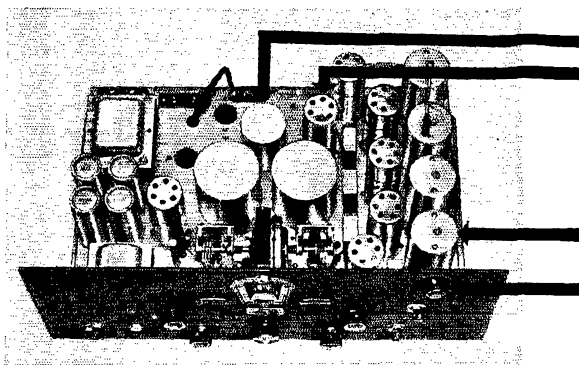

**AUTOMATIC  
VOLUME CONTROL**

*and*

**CRYSTAL  
FILTER**

## COMET "PRO"

*The Most Modern*

## RECEIVER

**4 models**  
 STANDARD  
 STANDARD + A.V.C.  
 CRYSTAL  
 CRYSTAL + A.V.C.  
 Operating on  
 Battery, D.C.,  
 or A.C. in all  
 Voltages and Cycles

**T**WO years ago, the Hammarlund COMET "PRO" Superheterodyne assumed instant leadership because it met the exacting demands of professional operators and advanced amateurs, interested in both phone and code reception between 15 and 250 meters. It still holds its eminence by virtue of conspicuous performance.

The Hammarlund files bulge with praise from "PRO" users — amateurs, professionals, air and steamship lines, broadcasting networks, police and armies and navies — in every corner of the world, who chose this amazing receiver after exhaustive competitive tests.

All models include the distinctive features of single-control band-spread tuning at all frequencies, *without extra coils* — plus all other refinements one would expect in so advanced a receiver.

The Crystal model, for CW and amateur 'phone work, employs an improved crystal circuit (*patent applied for*). This permits simultaneous parallel elimination of a strong heterodyne, while retaining the sharp, peaked characteristic of the series connection — all with substantially no loss of signal strength on pure CW. A flip of a front-panel switch instantly converts the Crystal "PRO" into the Standard "PRO", with all of its original high selectivity and sensitivity unimpaired.



### Mail Coupon for Details

HAMMARLUND MANUFACTURING CO.  
 424-438 W. 33rd St., New York

Check here for FREE information on the Comet "Pro" Receiver.  Check here for FREE new 1935 General Catalog.  Check here and attach 10c for 16-page Hammarlund 1935 Short-Wave Manual, illustrating and describing most popular S-W circuits of past year, with schematic and picture diagrams and parts lists.

Name .....

Address .....

.....Q-2





## PARALLEL ASSEMBLY

—NEW, MORE EFFICIENT BATTERY DESIGN

BURGESS Engineers have developed a new principle of dry battery construction, one which makes possible the use of smaller, more efficient cells in batteries built for heavy duty service. The new principle is the parallel assembly of selected cells, without the usual marked drainage to the voltage of the weakest cell. A revolutionary conception in battery design, it has been proved decidedly more efficient.

In the new line of BURGESS Batteries for 1935 are three built by parallel (or series-parallel) assembly of size F (No. 10) cells. Each one has been proved more efficient in laboratory tests and in actual use. They are—

The BURGESS Power House—a 200 ampere-hour, 3 volt battery

The BURGESS Little Uniplex—a 40 ampere-hour, 6 volt battery

The BURGESS Little Six—a 40 ampere-hour, 1.5 volt battery

The new BURGESS Parallel Assembly may solve your special battery problems. BURGESS Engineers will be glad to help you. The photograph above shows H. E. Lawson, Research Engineer, with the BURGESS Power House, Little Uniplex, and Little Six. BURGESS BATTERY CO., Freeport, Ill.

# ≡ BURGESS ≡

# QST

Published monthly, as its official organ, by the American Radio Relay League, Inc., at West Hartford, Conn., U. S. A.; Official Organ of the International Amateur Radio Union

devoted entirely to

# AMATEUR RADIO

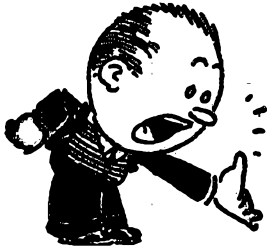

Editorials . . . . .	7
Stray-nge Strays . . . . .	8
A New Antenna System for Operating Control of Radiation <i>John L. Reinartz, W1QP</i>	9
Amateurs Aid in Lost-Plane Search . . . . .	12
Stabilizing the Ultra-High Frequency Transmitter <i>Ross A. Hull</i>	13
Getting Cooperation in the Antenna System <i>William J. Goodell, Jr., W1BDH, W2DJT</i>	16
'Phone-C.W. QSO Contest . . . . .	20
Armistice Day Message, 1934 . . . . .	21
Matched-Impedance Coupling to the Zepp Antenna <i>L. L. Hardin, Jr., W3AQC</i>	23
Hamdom . . . . .	25
What the League Is Doing . . . . .	26
Grinding and Finishing Quartz Crystal Plates <i>Ivan H. Loucks, W9ON</i>	28
With the Affiliated Clubs . . . . .	32
The Seventh International Relay Competition . . <i>F. E. Handy</i>	34
Band Switching in the Universal Exciter Unit <i>F. G. Southworth, W5EOW</i>	38
Experimenters' Section	
AUTOMATIC CARRIER SWITCHING, SUPPRESSOR-GRID KEYING, AUTOMATIC MICROPHONE BATTERY SWITCH — WASHING OUT B.C. INTERFERENCE, SINGLE-TUBE E.C. FREQUOMETER-MONITOR	39
Amateur Radio Stations . . . . . <i>W9KJF, W8HWR</i>	42
I. A. R. U. News . . . . .	43
Operating Notes . . . . .	45
Correspondence Department . . . . .	61
Standard Frequency Transmissions . . . . .	68
New Schedules for WWV . . . . .	68
Hamads . . . . .	90
QST's Index of Advertisers . . . . .	94

## FEBRUARY 1935

VOLUME XIX  
NUMBER 2

Kenneth B. Warner (Secretary, A.R.R.L.), *Editor-in-Chief and Business Manager*; Ross A. Hull, *Associate Editor*; James J. Lamb, *Technical Editor*; George Grammer, *Assistant Technical Editor*; Clark C. Rodimon, *Managing Editor*; David H. Houghton, *Circulation Manager*; F. Cheyney Beekley, *Advertising Manager*; Ursula M. Chamberlain, *Assistant Advertising Manager*.

*Editorial and Advertising Offices*  
38 La Salle Road, West Hartford, Conn.

Subscription rate in United States and Possessions and Canada, \$2.50 per year, postpaid; all other countries, \$3.00 per year, postpaid. Single copies, 25 cents. Foreign remittances should be by international postal or express money order or bank draft negotiable in the U. S. and for an equivalent amount in U. S. funds.

Entered as second-class matter May 29, 1919, at the post office at Hartford, Connecticut, under the Act of March 3, 1879. Acceptance for mailing at special rate of postage provided for in section 1103, Act of October 3, 1917, authorized September 9, 1922. Additional entry at Concord, N. H., authorized February 21, 1929, under the Act of February 28, 1925.

Copyright 1935 by the American Radio Relay League, Inc.  
Title registered at United States Patent Office.

# 1935 + TWELFTH EDITION OF THE RADIO AMATEUR'S HANDBOOK

**S**WEEPING changes in short-wave radio technique have been made since publication of the last edition. These changes have called for a drastic revision of the book. The chapters devoted to apparatus design and construction have been rewritten all through, with new illustrations and new circuit diagrams. Needless to say, the new methods and technique which have so recently almost revolutionized ultra-high frequency working have been treated in full detail.

The twelfth edition is more than half as large again as the first edition. The chapter on receivers, for instance, has been enlarged and rewritten to cover all the recent developments; while the chapter on transmitters has been expanded to permit discussion of all the new methods devised during the last year. New circuits and layouts are given and a special attempt made to treat all possible problems which could be faced in designing or adjusting transmitting equipment. Drastic changes in circuit arrangements for the ultra-high

frequencies have meant a complete rewriting of the chapter devoted to that subject. New transmitters and receivers employing new circuits are described for all three of the ultra-high frequency bands. Full details are also given of directive antenna systems for these bands. All of the chapters have had their share of attention to bring the book up to the minute. The chapters on antennas, keying, power supplies, have all been revamped so that all equipment and circuits can truly be said to represent the best in current practice.

*In other words, our policy of leaving nothing in the book that does not represent the very latest practice has been maintained to the letter.*

**268 PAGES — 237 ILLUSTRATIONS**

**\$1**

**AT ANY PRICE, AN AMATEUR COULD  
ILL AFFORD TO BE WITHOUT IT**

• **Postpaid**

(BUCKRAM BOUND, \$2.00)

**THE AMERICAN RADIO RELAY LEAGUE, INC.**

WEST HARTFORD, CONNECTICUT

## Section Communications Managers of the A.R.R.L. Communications Department

All appointments in the League's field organization are made by the proper S.C.M., elected by members in each Section listed. Mail your S.C.M. (on the 10th of each month) a postal covering your radio activities for the previous 30 days. Tell him your DX, plans for experimenting, results in 'phone and traffic. He is interested, whether you are an A.R.R.L. member or get your QST at the newsstands; he wants a report from every active ham. If interested and qualified for O.R.S., O.P.S. or other appointments he can tell you about them, too.

<p>Eastern Pennsylvania Maryland-Delaware-District of Columbia Southern New Jersey Western New York Western Pennsylvania</p>	<p>W3GS  W3BAK W3QL W3DSP W8CUG</p>	<p><b>ATLANTIC DIVISION</b> Jack Wagenseller  Edgar L. Hudson Gedney Rigor Don Farrell C. H. Grossarth</p>	<p>26 Meadowbrook Ave.  412 2nd Ave. 213 Hickok Ave. R. F. D. 3, Eicher Rd.</p>	<p>Llanerch, Upper Darby Laurel, Delaware Haddon Heights Syracuse Emsworth, Bellevue, Pa.</p>
<p>Illinois Indiana Kentucky Michigan Ohio Wisconsin</p>	<p>W9WR W9TE W9AUH W8DYH W8CIO W9FSS</p>	<p><b>CENTRAL DIVISION</b> Fred J. Hinds Arthur L. Braun G. W. Mossbarger Kenneth F. Conroy Robert P. Irvine Harold H. Kurth</p>	<p>6618 West 34th St. 5211 Brookville Rd. Box 177 7538 E. Robinwood Ave. 5508 Northcliffe Ave. 9 South Randall Ave.</p>	<p>Berwyn Indianapolis Camp Taylor Detroit Cleveland Madison</p>
<p>North Dakota South Dakota Northern Minnesota Southern Minnesota</p>	<p>W9JVP W9PFI W9TIE W9DEI</p>	<p><b>DAKOTA DIVISION</b> Fred J. Wells Mike G. Strahon Robert C. Harshberger Francis C. Kramer</p>	<p>1022 11th St., S. 601 S. Grange Ave. 1200 Fauquier St. W. Bluff St.</p>	<p>Fargo Sioux Falls St. Paul St. Charles</p>
<p>Arkansas Louisiana Mississippi Tennessee</p>	<p>W5ABI W5DWW W5CWO W4BBT</p>	<p><b>DELTA DIVISION</b> H. E. Veite W. J. Wilkinson, Jr. J. H. Weems, Jr. Merrill B. Parker, Jr.</p>	<p>2918 West 15th St. 1624 Allen Ave. P. O. Box 244 1912 Oak St.</p>	<p>Little Rock Shreveport State College Chattanooga</p>
<p>Eastern New York N. Y. C. &amp; Long Island Northern New Jersey*</p>	<p>W2LU W2AZV W2FOP</p>	<p><b>HUDSON DIVISION</b> Robert E. Haight E. L. Baunach Charles J. Hammersen</p>	<p>1080 Helderberg Ave. 7823 10th Ave. 92 Claremont Ave.</p>	<p>Schenectady Brooklyn Verona</p>
<p>Iowa Kansas Missouri Nebraska</p>	<p>W9LEZ W9FLG W9EYG-JPT W9FAM</p>	<p><b>MIDWEST DIVISION</b> Phil D. Boardman O. J. Spetter C. R. Cannady Samuel C. Wallace</p>	<p>325 Kirkwood Blvd. 305 Western Ave. Broadway at Ninth Green St.</p>	<p>Davenport Topeka Monett Clarke</p>
<p>Connecticut Maine Eastern Massachusetts Western Massachusetts New Hampshire Rhode Island Vermont</p>	<p>W1CTI W1CDX W1ASI W1BVR W1APK W1QR W1ATF</p>	<p><b>NEW ENGLAND DIVISION</b> Frederick Ellis, Jr. John W. Singleton Joseph A. Mullen Percy C. Noble Basil Cutting Albert J. King Harry Page</p>	<p>19 Merrill Rd. 10 High Street 218 Jamaica-way 37 Broad St. 70 Metropolitan Park Dr. R. 1</p>	<p>Norwalk Wilton Jamaica Plain Westfield Pembroke East Providence Hinesburg</p>
<p>Alaska Idaho* Montana Oregon Washington</p>	<p>K7PQ W7NH W7AAT W7AMF W7AYO</p>	<p><b>NORTHWESTERN DIVISION</b> Richard J. Fox Nellie H. Hart O. W. Viers Frank L. Black Stanley J. Belliveau</p>	<p>Box 301 Box 6 Box 265 1502 McPherson St. Route 7, Box 387</p>	<p>Ketchikan Twin Falls Red Lodge North Bend Yakima</p>
<p>Hawaii Nevada Los Angeles Santa Clara Valley East Bay San Francisco Sacramento Valley Arizona Philippines San Diego San Joaquin Valley</p>	<p>K6EWO W6EAD W6BPU W6BMW W6ZC W6CAL W6DVE W6BJF-W6QC K41XA W6EOP W6FFP</p>	<p><b>PACIFIC DIVISION</b> Atlas O. Adams Keston L. Ramsay Howell C. Brown Charles J. Camp P. W. Dann Byron Goodman Geo. L. Woodington Ernest Mendoza Newton E. Thompson Harry A. Ambler Clyde C. Anderson</p>	<p>21st Infantry Brigade 1151 Buena Vista Ave. 120 N. El Molino Ave. 318 Hawthorne Ave. 1821 Chestnut St. 141 Alton Ave. 716 Redwood Ave. 1434 East Madison St. P. O. Box 849 4101 Hamilton St. 931 Orange Ave.</p>	<p>Schofield Barracks Reno Pasadena Palo Alto Berkeley San Francisco North Sacramento Phoenix Manila, P. I. San Diego Fresno</p>
<p>North Carolina* Virginia West Virginia</p>	<p>W4EG W3BRV W8HD</p>	<p><b>ROANOKE DIVISION</b> N. M. Patterson Neil E. Henry C. S. Hoffmann, Jr.</p>	<p>2804 Hillsboro St. 1017 Knight St. 100 20th St.</p>	<p>Raleigh Lynchburg Warwood, Wheeling</p>
<p>Colorado Utah-Wyoming</p>	<p>W9FA W6GQC</p>	<p><b>ROCKY MOUNTAIN DIVISION</b> Glen Glasscock Arty W. Clark</p>	<p>1171 Detroit St. 260 So. 9th West</p>	<p>Dënver Salt Lake City, Utah</p>
<p>Alabama Eastern Florida Western Florida Georgia-So. Carolina-Cuba* Isle-of-Pines-Porto Rico- Virgin Islands</p>	<p>W4KP W4BCZ W4MS  W4CE</p>	<p><b>SOUTHEASTERN DIVISION</b> I. D. Elwell Philip A. McMasters Edward J. Collins  Bannie L. Stewart</p>	<p>1066 Waverly St. 212 9th St., North 1517 East Brainard St.  310 Orange St.</p>	<p>Tarrant St. Petersburg Pensacola  Georgetown, S. C.</p>
<p>Northern Texas Oklahoma Southern Texas New Mexico</p>	<p>W5AUP W5CEZ W5ADZ W5DUI</p>	<p><b>WEST GULF DIVISION</b> Glen E. Talbutt Carter L. Simpson Bradfield A. Beard Dan W. De Lay</p>	<p>1133 Amarillo St. 2010 So. 4th St. 2030 Quenby Road 407 South Girard St.</p>	<p>Abilene Ponca City Houston Albuquerque</p>
<p>Maritime</p>	<p>VE1DQ</p>	<p><b>MARITIME DIVISION</b> A. M. Crowell</p>	<p>69 Dublin St.</p>	<p>Halifax, N. S.</p>
<p>Ontario</p>	<p>VE3GT</p>	<p><b>ONTARIO DIVISION</b> S. B. Trainer, Jr.</p>	<p>4 Shorncliffe Ave.</p>	<p>Toronto</p>
<p>Quebec</p>	<p>VE2EE</p>	<p><b>QUEBEC DIVISION</b> Stan Comach</p>	<p>780 Brault Ave.</p>	<p>Verdun, P. Q.</p>
<p>Alberta British Columbia</p>	<p>VE4GD VE3AC</p>	<p><b>VANALTA DIVISION</b> J. Smalley, Jr. R. K. Town</p>	<p>611 1st Ave., N. W. 1754 Graveley St.</p>	<p>Calgary Vancouver</p>
<p>Manitoba Saskatchewan</p>	<p>VE4GC VE4EL</p>	<p><b>PRAIRIE DIVISION</b> Reg. Strong Wilfred Skaife</p>	<p>711 Ashburn St. 2040 McTavish St.</p>	<p>Winnipeg Regina</p>

\* Officials appointed to act until the membership of the Section choose permanent S.C.M.'s by nomination and election.

# The American Radio Relay League



THE AMERICAN RADIO RELAY LEAGUE, INC., is a non-commercial association of radio amateurs, bonded for the promotion of interest in amateur radio communication and experimentation, for the relaying of messages by radio, for the advancement of the radio art and of the public welfare, for the representation of the radio amateur in legislative matters, and for the maintenance of fraternalism and a high standard of conduct.

It is an incorporated association without capital stock, chartered under the laws of Connecticut. Its affairs are governed by a Board of Directors, elected every two years by the general membership. The officers are elected or appointed by the Directors. The League is non-commercial and no one commercially engaged in the manufacture, sale or rental of radio apparatus is eligible to membership on its board.

"Of, by and for the amateur," it numbers within its ranks practically every worth-while amateur in the world and has a history of glorious achievement as the standard-bearer in amateur affairs.

Inquiries regarding membership are solicited. A bona fide interest in amateur radio is the only essential qualification; ownership of a transmitting station and knowledge of the code are not prerequisite. Correspondence should be addressed to the Secretary.

## DIRECTORS

HIRAM PERCY MAXIM	<i>President</i>	W1AW
Box 216, Hartford, Conn.		
CHARLES H. STEWART	<i>Vice-President</i>	W3ZS
St. David's, Pa.		
ALEX REID	<i>Canadian General Manager</i>	VE2BE
169 Logan Ave., St. Lambert, P. Q.		
EUGENE C. WOODRUFF	<i>Atlantic Division</i>	W8CMP
234 W. Fairmount Ave., State College, Pa.		
EDWARD A. ROBERTS	<i>Central Division</i>	W8HC
2699 Endicott Rd., Shaker Heights, Cleveland		
CARL L. JABS	<i>Dakota Division</i>	W9BVH
1822 James St., St. Paul, Minn.		
M. M. HILL	<i>Delta Division</i>	W5EB
P. O. Box 274, Natchitoches, La.		
KENNETH T. HILL	<i>Hudson Division</i>	W2AHC
115 Willow St., Douglaston, L. I., N. Y.		
H. W. KERR	<i>Midwest Division</i>	W9DZW-W9GP
Little Sioux, Iowa		
G. W. BAILEY	<i>New England Division</i>	W1KH
74 Webster Road, Weston, Mass.		
RALPH J. GIBBONS	<i>Northwestern Division</i>	W7KV-W7BIX
3933 N. E. 76th Ave., Portland, Ore.		
S. G. CULVER	<i>Pacific Division</i>	W6AN
2962 Russell St., Berkeley, Calif.		
H. L. CAVENESS	<i>Roanoke Division</i>	W4DW
State College Station, Raleigh, N. C.		
RUSSELL J. ANDREWS	<i>Rocky Mountain Division</i>	W9AAB
1867 So. Lafayette St., Denver, Colo.		
J. C. HAGLER, JR.	<i>Southeastern Division</i>	W4SS
2424 McDowell St., Augusta, Ga.		
WAYLAND M. GROVES	<i>West Gulf Division</i>	W5NW
Neches, Texas		

## OFFICERS

<i>President</i>	HIRAM PERCY MAXIM, W1AW
	Hartford, Connecticut
<i>Vice-President</i>	CHARLES H. STEWART, W3ZS
	St. David's, Pennsylvania
<i>Secretary</i>	KENNETH B. WARNER, W1EH
	West Hartford, Connecticut
<i>Treasurer</i>	ARTHUR A. HEBERT, W1ES
	West Hartford, Connecticut
<i>Communications Mgr.</i>	F. EDWARD HANDY, W1BDI
	West Hartford, Connecticut
<i>General Counsel</i>	PAUL M. SEGAL, W3EEA
	1010 Shoreham Building, Washington, D. C.

Address all general correspondence to the executive headquarters at West Hartford, Connecticut





# THE EDITOR'S MILL

A NEW variety of "license renewal trouble" is being experienced. It is the purpose of these lines to offer a few words of help to those who are exposed.

In the dim dead days now gone beyond recall, amateur station licenses and amateur operator licenses were issued separately by independent agencies. Some of them were extended varying lengths of time by proclamation. Of course every amateur who has gone up for a new ticket in the past year and a half has received the combination station-operator card license but there are still many of the separate licenses in existence. Because the old style of station license had been extended longer than the old style of operator license, it happened that during 1934 the only expirations were of operator licenses and we amateurs developed a pretty good understanding of how to take care of applications for renewal. We learned that it was only necessary to fill out Part I of the application blank, asking for a renewal of the operator license, and send in both the expiring operator license and the existent station license to the F. C. C., which would then issue a combination renewal, at the same time extending the station license to expire simultaneously with the operator license.

That same accident of extended dates is operating this year to change the circumstances completely. It happens that from January until some time in the summer of this year the only expirations are going to be of station licenses. That is why we called attention in a recent issue to the desirability of looking up the expiration date on your old station license and filing renewal application in plenty of time. Many of the fellows seem to be experiencing difficulty in filling out the forms correctly, and we learn that many applications have to be returned for correction. The matter is important because if the applications are not submitted in strict compliance with the rules and regulations, the licensee suffers delay and may have to go off the air while the papers are being corrected.

Let us suppose that you have an existing operator license that has some time to run and a separate station license that is to expire within sixty days. You write to your district inspector for an amateur application blank. The proper procedure then is to leave Part I blank, about the operator license, but carefully fill in Part II about the sta-

tion license, go before a notary public and execute the "applicant's jurat," attach *both* of your licenses, and mail the whole business direct to the F. C. C. at Washington. If everything is in good order the result will be one of the new combination card licenses running for three years and resulting incidentally in the automatic extension of your operator license.

So far so good, but there have been some changes in regulations since those original station licenses were issued and some of them are not eligible to renewal. In the first place, a station license is now issued only to an individual who is himself a licensed amateur operator. If in the past you held a station license but no operator license, and had somebody else do your operating, you are absolutely out of luck unless and until you also qualify as an amateur operator. Moreover, with the exception of bona-fide clubs and a few military reserve outfits, a station license is issued only to an individual who is personally possessed of the desire to pursue the technique of amateur communication; and numerous telegraph schools and business colleges that once had amateur station licenses will find that they cannot be renewed, simply because such organizations cannot qualify as individuals personally interested in amateur technique.

But we'll suppose that you're an ordinary American ham unencumbered by such considerations. With one exception you won't have much trouble, but it is an excellent idea to read over the amateur regulations thoroughly before filling out the form because you must not propose in your application to operate under any conditions that are prohibited by regulation. The one point referred to in the foregoing sentence is Item 30 of the application where space is provided for you to state that "during the past three months I have operated *my* amateur station in communication with three amateur stations as follows," followed by spaces to show the date, time, calls and licenses of three stations worked. The governing regulation is Rule 402 which states that "amateur station licenses . . . may, upon proper application, be renewed provided . . . the applicant has used his station to communicate by radio with at least three other amateur stations during the three-month period prior to the date of submitting the application. . . . Proof of such communication must be included in the application by stating the

call letters of stations with which communication was carried on and the time and date of each communication. Lacking such proof, the applicant will be ineligible for a license for a period of ninety days."

For the first time we are experiencing the operation of a rule intended to remove deadwood from the amateur list by denying renewals to inactive stations. The Commission is going on the thesis that they should devote more of their time and money to active stations and less of it to those whose activity does not warrant it. *A station that has not been active within the last three months of its license period is ineligible for renewal and its station license will not be renewed.* Moreover, a penalty for inactivity is applied to the applicant, in that he must wait ninety days before he becomes eligible to apply for a new station license. It is, in fact, just a little bit tougher than that: the station license is renewable only if *the applicant has used his own station during the three-month period prior to the date of submitting the application.* The applicant wants a new combination operator-station license but it will not be issued unless he himself has pounded brass in his own station within three months of the time that he files the renewal application.

Active amateurs will have no difficulty with this. It is simply necessary to consult the log and cite three cases of communication within the past three months where *you* operated, carefully filling

in the required data so that the Commission may, by correspondence with the parties cited, verify the fact of your activity. If you have been inactive, there's nothing to it but to get active again and be able to prove it. Moreover, it won't do to have someone else operate your station, for it is necessary to supply an indication of your own operator activity before extending your operator license. Nor may you get your operator activity over someone else's station, rather than your own, since you are not entitled to a station renewal if you do not possess an active station capable of engaging in communication. The rule is not new, having been in force a year and a half, but many an inactive amateur will run afoul of it for the first time in the coming months. It is only fair, we'll all have to admit, that there be some restriction against renewing the licenses of non-existent stations. Although renewal as such is denied them, such fellows are not by any means barred from amateur radio; ninety days after their expiration date they are eligible to ask for a new station license and in all probability will get their old call again.

Starting next autumn there will be both operator and station licenses expiring, and both will have to be watched—but that is too far away to worry about now. By sometime next year everybody will be operating under the new form of combined concurrent licenses, and thereafter everything should be smooth sailing.

K. B. W.

## Stray-nge Strays

### Mirabile Dictu

Marconi did not invent radio. . . . The mighty R.C.A. once turned to hams to deliver a message to the Arctic for President Coolidge. The message was routed and a reply obtained. . . . An apprehensive father appealed to the Federal Radio Commission to revoke his son's license in order that the youngster might find time to eat his meals and sleep nights. . . . B-r-r-r, *Jack Frost* has written a radio book! . . . An amateur station pinch hit for one of Uncle Sam's big Naval stations, signing the call, NBB. . . . Tom Banzhaf, 6CTE is the only ham on record to die while listening in.

### One and Same

What used to be omnibus bar is now just plain, old bus bar. . . . *Cymoscope* is another name for radio detector. . . . Muscovy glass is *mica*.

### Personalities

Hiram Percy Maxim, founder and President of the A.R.R.L., was the first paid member of the International Amateur Radio Union. . . . The

Old Man was first to mention the Wouff-Hong and Rettysnitch, but in the beginning he didn't know what they were himself.

The Old Man's warmest felicitations to the Czechoslovakian government which requires that prospective radio operators be "self-righteous, reliable, and irreproachable." . . . The first American ops' tickets were labelled *Certificate of Skill*. . . . It was once necessary to secure an experimental ("X") license in order to use any wavelength below 200 meters. . . . Failure to display radio licenses is an offense punishable by fine.

A popular book was dedicated to A.R.R.L.

### Rambling Around

Hark ye, phone hounds—*Oh Lowe Gain* operates a restaurant in Boston. . . . The Old Man, ham radio's sage at large, has had QST smoking with his wrathful articles ever since January, 1917, yet his identity and location remain unknown. . . . Mussolini and King George are among the dignitaries who have received messages handled by W2ZC.

(Rufus P. Turner, W1AY, who contributes these facts, is willing to send proof of any of them on receipt of a stamped envelope.—EDITOR.)

# A New Antenna System for Operating Control of Radiation

Fitting Antenna Characteristics to Varying Communication Conditions

By John L. Reinartz,\* WIQP

In the list of amateurs who as amateurs have made original contributions to the world's understanding of short-wave radio communication, and hence to its practical development, the name of John Reinartz stands high. His work during 1924 and 1925 on the behavior of short waves and his resulting theory of short-wave radio propagation (published in *QST*) in our opinion rank as the pioneer piece in this field, even though it has not been so credited in the bibliographies of many later non-amateur workers and writers. The antenna system he describes in the present article is in logical sequence to his earlier work in the short-wave realm, since it promises to make amateur communication (and other communication, too) even more effective. From an amateur and to amateurs, we as amateurs present it.—EDITOR

EARLY in 1924, the author, with the cooperation of a notable group of other early experimenters, began the series of experiments in radio transmission on wavelengths below 60 meters which resulted in conception of the reflection theory presented in the April, 1925, issue of *QST*.<sup>1</sup> This theory explained the phenomenon of the "dead belt," which we now call "skip distance," and included the hypothesis that there was more than one reflecting layer. In the light of confirmation of this theory by subsequent developments, the following prediction, quoted from that first article, is of particular significance:

"If we are willing to choose the wavelength for each particular distance and each particular time of day it is possible to put the region of strongest signal right on the receiving station and to obtain communication with strong signals but small input power."

Another significant point made in this article was to the effect that only waves which started upward at low angles were effective for long-distance communication on wavelengths below 60 meters, the then-considered low angle of 45 degrees from the horizontal being specifically mentioned. Further investigation of the most favorable angle followed in the summer of 1925, when the author was a member of the MacMillan expedition to North Greenland. As illustrated in Fig. 1, measurements on the apparent angle at which 20- and 40-meter signals from amateur and commercial stations arrived over the tops of the mountains surrounding Etah Harbor were consistently 18.5° above the horizontal.<sup>2</sup> From this it was logically concluded that, at frequencies of the order of 7000 kc. and higher, only the energy radiated from the transmitting antenna at low

angles above the earth's surface would be useful for communication over great distances where the reflected (sky) wave serves rather than the direct (ground) wave.

Still further investigation has shown that, while low-angle radiation in general is better for reflected-wave communication on the higher frequencies, one particular angle may be best for communication on the chosen frequency over a given path under conditions determined by the time of day, season of the year, receiving location, etc. In other words, *the advantage of choice of the right frequency can be augmented by choice of transmitting antenna characteristics to fit the particular conditions existing for that frequency at the time of the QSO.* In addition to choice of frequency,

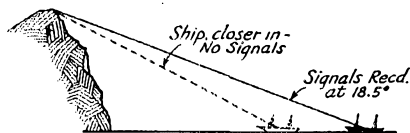

FIG. 1

therefore, choice of angle above the horizon on which the radiated energy can be concentrated, and perhaps of polarization of the emitted wave as well, unquestionably should increase the effectiveness with which the amateur is able "to put the region of strongest signal right on the receiving station and to obtain communication with strong signals but small input power."

Of course it is now well known that certain types of fixed antennas, such as the half-wave vertical and the harmonically operated horizontal, radiate principally at more or less low angles; and that certain other types, such as half-wave horizontal, radiate principally at high angles.<sup>3</sup>

<sup>3</sup> *The Radio Amateur's Handbook*, A.R.R.L., Chapter Twelve. For more complete discussions refer to such texts

\* 178 Wadsworth St., Manchester, Conn.

<sup>1</sup> J. L. Reinartz, "The Reflection of Short Waves," *QST*, April, 1925.

<sup>2</sup> This observation was reported before a meeting of the New York Section of the Institute of Radio Engineers in the Fall of 1925.

It is also well known that vertical types start the waves off with vertical polarization, while horizontal types start them off horizontally polarized. And there is no denying that different types do give widely different results, even when tried

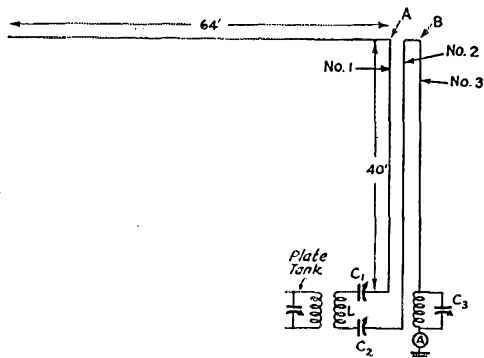

FIG. 2—THE NEW ANTENNA SYSTEM IS BASICALLY A CURRENT-FED HERTZ WITH ONE QUARTER-WAVE END SECTION HORIZONTAL AND WITH THE OTHER QUARTER-WAVE END SECTION (WIRE NO. 3) BENT DOWN VERTICAL AND CARRIED INTO THE OPERATING ROOM

Radiation characteristics of the vertical portion are varied by adjustment of the tuning, as described in the text.

separately at the one transmitting location. But it is hardly practicable for each amateur station to be equipped with an assortment of antennas from which the operator may choose the particular type that will give him the best radiation characteristic for the conditions required by the QSO of the moment. He ought to have a single antenna which could be adjusted to suit these conditions. And it should be adjustable from within the shack, right at the operating position.

#### THE NEW SYSTEM

It was the desire to be able to do this and to make use of the type of radiation given by a horizontal system as well as the type of radiation given by a vertical system that led the author to evolve the antenna system shown in Fig. 2 and diagrammed "stretched out" in Fig. 3. Basically it is a current-fed Hertz antenna with one quarter-wave end section horizontal and with the other quarter-wave end section (wire No. 3) bent down vertical with the two feeders and carried into the operating room. All three of the vertical wires are conventionally spaced as feeders. In order to give control of the third wire, in so far as its contribution to the radiation pattern is concerned, this wire is connected through a tuning system to ground. The other two feeder wires are treated in the usual manner, connecting to

as *Radio Engineering*, by F. E. Terman, Chap. XIV; and *Short-Wave Wireless Communication*, by Ladner and Stoner, Chap. XII. The latter treatment pertains particularly to short-wave systems.—EDITOR.

the antenna coupling circuit of the transmitter.

At the top, where the three vertical wires end, No. 1 wire connects to the quarter-wave horizontal section and No. 2 connects with the No. 3 wire which returns to the operating room. When the system is operated as a current-fed Hertz antenna would be operated, two voltage nodes exist at the top of the mast, one (A) at the point of contact between No. 1 vertical wire and the quarter-wave horizontal section, and another node (B) at the point of contact between No. 2 wire and No. 3 wire. The third wire then functions to give considerable high-angle radiation vertically polarized along with the horizontally polarized high-angle radiation that normally takes place from a horizontal antenna placed a quarter-wave above ground. When, by manipulation of the tuning adjustments within the operating room, node B is

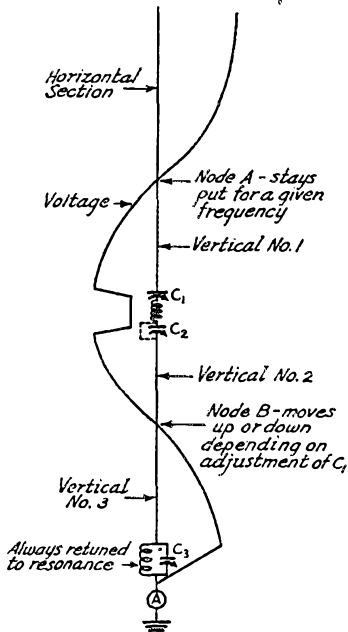

FIG. 3—THE WHOLE SYSTEM STRETCHED OUT TO DEMONSTRATE THE STANDING-WAVE VOLTAGE DISTRIBUTION

moved downward along either No. 2 or No. 3 wire, then the radiation pattern takes on more low-angle radiation than high-angle. When the node is down from the top of the mast an eighth of a wave the greatest low-angle effect is noted. The field strength patterns illustrating this, shown in Fig. 4, were obtained from a scaled-down model built for 23-mc. (10-meter) fundamental operation. The movement of the voltage node B was indicated by the change in brightness of small Mazda lamps placed in the vertical wires every thirty-second wavelength from the top downward.

To facilitate duplicating known settings, all

changes are described in terms of the capacitance scale of  $C_1$ . It is clear that when this condenser setting is varied from maximum to minimum, voltage node B shifts location along the No. 3 vertical wire (with resonance maintained by adjustment of condenser  $C_3$ ). In the graphs all settings refer to condenser  $C_1$ , condenser  $C_2$  being either shorted out or set to a maximum value, as operating results indicate the need, and left untouched for the range of any one amateur band. The coupling coil  $L$  determines to a great extent the initial setting for  $C_1$ . In general it is such as to place the voltage node an eighth-wave down from the top when the setting of  $C_1$  is near the maximum capacitance value, thus providing more than enough capacity range to move the node to the top.

The parallel tuning system of condenser  $C_3$  is such that it normally tunes to the frequency range of the amateur band which is being used. This tuning combination is used to restore resonance when an adjustment of  $C_1$  has been made. Resonance is indicated by the highest reading of the r.f. ammeter for that adjustment of the node

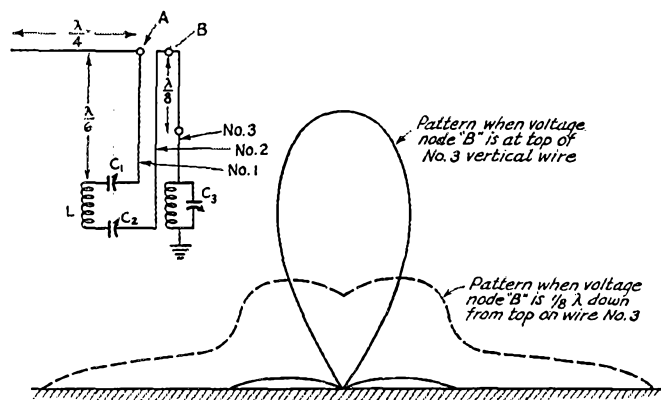

FIG. 4—ILLUSTRATING CHANGE IN THE VERTICAL-PLANE FIELD-STRENGTH PATTERN WITH SHIFTING OF THE CURRENT NODE ON WIRE NO. 3

The horizontal section is perpendicular to the plane of the paper. These data were obtained on a 28-mc. (10-meter) model.

position, this r.f. meter indication being different for different adjustments.

#### TEST RESULTS

Actual operation of the system calls for node B to be an eighth of a wave down from the top of

wire No. 3 (low-angle radiation) during the daytime when operation is in the 3500- to 3900-ke. band, and up within a thirty-second of a wave from the top (higher-angle radiation) during the

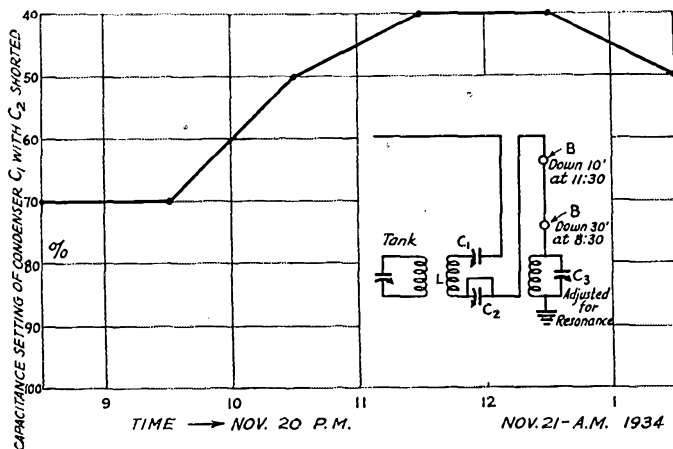

FIG. 5—RESULTS OF TEST BETWEEN TRANSMITTING STATION AT MANCHESTER, CONN. (W1QP) AND RECEIVING STATIONS AT MARION, OHIO (W8BAS AND W8CMI), ON 3500-KC. BAND

Decreasing capacitance scale reading of condenser  $C_1$  corresponds to rising position of the node on wire No. 3. As shown in Fig. 4, raising the node gives higher-angle radiation—which is apparently more suitable for night-time communication over this particular test distance on the 3.5-mc. band frequency used.

late evening hours. Repeated tests have shown that compensation for the advance of time from early evening to past midnight must be made by a change in the location of node B in order that maximum signal strength may be maintained at the receiving station. The results of a typical test demonstrating this are shown in Fig. 5.

During daytime operation, it is noticed that although there is one generally satisfactory setting, slight changes can be made in the position of the node to give "best" signal at some particular receiving location. Even when two stations are in the same general direction and at the same moderate distance from the transmitter but are separated from each other by a few miles, there is quite likely a different "best" setting for each station. This has occurred regularly when working with stations in and near New York City. With two stations contacted at the same time, and adjustments made by shifting the node, the reports from each of the two stations always indicated that they did not agree with each other as to which was the best-signal setting. One would specify a setting that the other had said

was several points lower in signal strength, and *vice versa*. The indication here is that some control of polarization is effected, since the chance of two stations having identical receiving antenna conditions is very remote.

When stations in a line are contacted, such as from Manchester, N. H., through Thompsonville, Conn., New Haven, Conn., and to New York City, there is no agreement between any of the stations as to the best signal setting. Each names

amateur antenna system. The control of the radiation pattern and the possible control of the polarization of the emitted wave still is evidenced at double and four times the fundamental frequency for which the system is designed, better signal response being reported over the conventional half-wave or full-wave voltage-fed system when used in the 40- and 20-meter bands.

The author wishes to acknowledge the help received from many amateur stations, notably W1CMB, W1MY, W1FND, W1YU, W2BGO, W2HOY, W8AKV, W8BAS, W8LUS and W8CMI.

More work needs to be done on the system to obtain all the information possible, since that given in this paper is but preliminary. Results so far obtained justify the system and point to eventual control of the factors that determine radiation of energy from a transmitter. It is also possible that directivity control can be obtained. Furthermore, this system at the same time saves half of the space that would be needed for a half-wave voltage- or current-fed horizontal antenna system such as is now common.

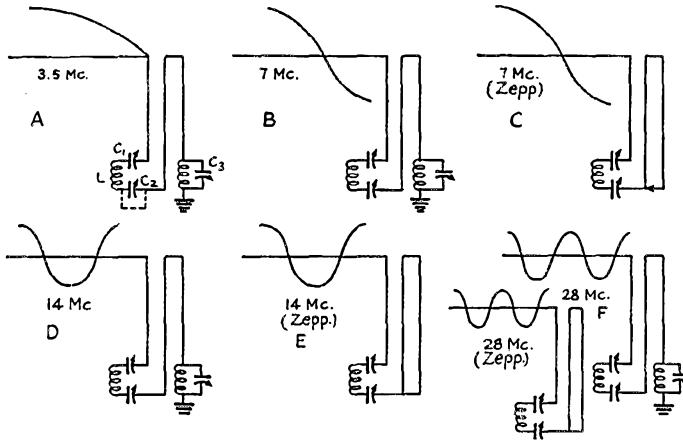

FIG. 6—CONTROLLED-RADIATION OR CONVENTIONAL ZEPP CONNECTIONS FOR OPERATION ON VARIOUS AMATEUR BANDS, WITH VOLTAGE CURVES SHOWN FOR THE HORIZONTAL SECTION

a setting for a best signal that the others say is not nearly the best. This further indicates control of polarization. While the adjustment changes are then slight, they still are effective to a given receiving location. The total movement of the node location may be less than a sixteenth of a wave.

Night-time operation, on the other hand, has been over greater distances and has precluded direct ray (ground-wave) reception. In this instance the effect produced could be both change in polarization and in the effective angle of radiation. A day-time test to the same receiving location, carried on at two o'clock in the afternoon and on the same frequency, also indicated that a particular best setting was run through, on either side of which adjustment the signal strength was down a noticeable degree.

As shown in Fig. 6, the antenna system can be used for controlled radiation operation at twice the frequency that it was built for (Fig. 5B), or at four or eight times its fundamental frequency (Figs. 5D and 5F). Further, in all cases it can be used as a conventional voltage-fed antenna with simple two-wire feeders, wires No. 2 and 3 being connected in parallel (Figs. 5C, 5E and 5G). Hence we have then a truly all-around all-wave

## Amateurs Aid in Lost-Plane Search

ONCE more amateurs forsook family and fireside to help establish radio communication in an emergency. During a severe storm an American Airlines plane had crashed in a forced landing on Friday, December 23th, somewhere in the Adirondacks. The exact location was not known

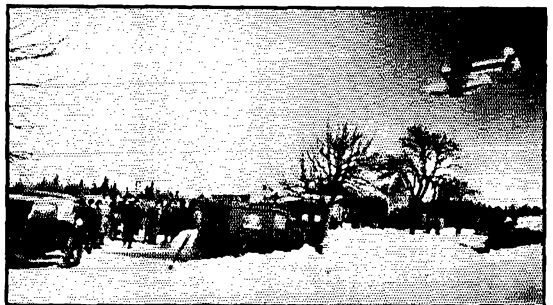

SCENE OF OPERATIONS AT GE1000 WITH PHOTOGRAPHERS AND NEWSMEN MUCH IN EVIDENCE

and weakened batteries on the plane's radio made it impossible to take an accurate radio bearing. With the weather 25 below zero the men had to be

(Continued on page 78)

# Stabilizing the Ultra-High-Frequency Transmitter

## Resonant Short-Line Frequency Control for 2½- and 5-Meter Oscillators

By Ross A. Hull\*

ON THE list of Things That Something Ought to Be Done About in ham radio, one very important item has long been the stabilization of ultra-high-frequency transmitters. The problem has existed since our ultra-high-frequency communication first became practical and has been increasing in importance from year to year as the u.h.f. bands have become more and more occupied.

Of course, a great deal of work has been done on the problem. Ways and means have been found, for instance, to provide oscillator-amplifier transmitters on 56 mc. Then, 56-mc. crystal-controlled transmitters have been improved to the point of practicality. These schemes, though, have never found much favor simply because of the great complexity of the necessary gear. Further, they have been really practical only for the 56-mc. band. The thought of a medium-powered crystal-controlled transmitter operating at, say, 1¼ or even 2½ meters is by way of being absurd. We have always thought that this "string of amplifiers" method of getting a stable signal on the ultra-high frequencies represented the wrong approach—a method fundamentally unsuited for the job.

Probably the first really effective simple method of stabilizing

u.h.f. oscillators was the "long lines" control,<sup>1</sup> in which system the normal grid circuit was replaced by a long pair of wires or concentric tubes comprising either a resonant or an aperiodic line. For some obscure reason, this method has never been widely adopted in amateur work.

The next simple stabilizing method of importance was that described by Dr. F. A. Kolster<sup>2</sup>—the "derby hat" scheme. This arrangement, too, has failed to find much favor in amateur circles, probably because of the constructional difficulties involved in building the "hats" and because of their large dimensions.

Now comes what we believe to be an intensely practical and effective scheme based on suggestions made by Dr. F. E. Terman.<sup>3</sup> We cannot help thinking that this new method represents a definite stride towards the ideal and that it will find wide use in ham work.

The basis of the scheme can best be explained by comparing it with crystal control. In the normal crystal oscillator, the grid circuit consists of the crystal itself—an electro-mechanical resonant circuit having a very high  $Q$ , a high ratio of reactance to resistance or a low power factor (they all mean the same thing). In the new arrangement, the crystal is displaced by an electrical resonant cir-

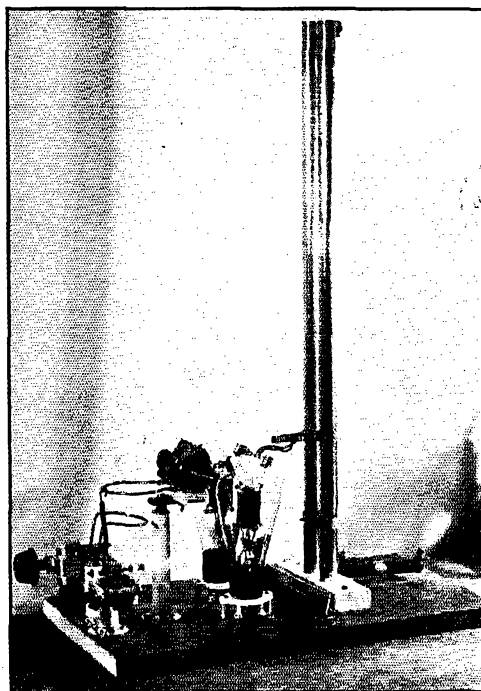

FIG. 1—A TYPICAL 2½-METER TRANSMITTER WITH HIGH-Q SHORT-LINE FREQUENCY CONTROL

The transmitter is very similar to the usual TNT affair except that the grid coil is replaced by a quarter-wave long resonant line made of large copper tubing. An extremely high order of frequency stability may be obtained with this arrangement.

\* Associate Editor, QST.

<sup>1</sup> "New Methods of Frequency Control Employing Long Lines," by J. W. Conklin, J. L. Finch and C. W. Hansell, *Proceedings of the Institute of Radio Engineers*, November, 1931.

<sup>2</sup> "High-Q Tank Circuits for Ultra-High Frequencies," by Frederick A. Kolster, QST, May, 1934.

<sup>3</sup> "Resonant Lines in Radio Circuits," by F. E. Terman, *Electrical Engineering*, July, 1934.

circuit having a similarly high  $Q$  and providing a similar electrical "fly-wheel" action. This resonant circuit is, of course, the crux of the whole matter.

In his paper, Dr. Terman points out that if we have a pair of parallel or concentric metal tubes, each a quarter-wave long, we can obtain a

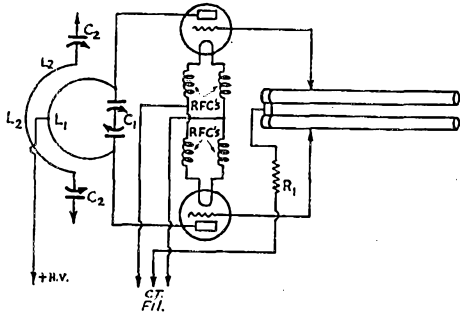

FIG. 2—THE CIRCUIT OF THE TRANSMITTERS ILLUSTRATED IN FIGS. 1 AND 3

$C_1$ —For 112 mc., 35  $\mu\text{fd.}$  per section—Hammarlund MCD-35-X used.

For 56 mc., 100  $\mu\text{fd.}$  per section—National Type TMP 100 suitable.

$C_2$ —50 or 75  $\mu\text{fd.}$  midgeet condensers.

$L_1$ —Single turn  $2\frac{1}{2}$  inches diameter for 112 mc. Single turn 4 inches diameter for 56 mc. The length of connections from the turn to the tuning condenser will have an obvious influence on the diameter of the turn used. Tubing of  $\frac{1}{8}$ - or  $\frac{1}{4}$ -inch diameter is suitable.

$L_2$ —Single turn same diameter as  $L_1$ .

$R_1$ —10,000 or 15,000 ohm 10-watt resistor.

R.F.C.—15 turns of No. 14 wire  $\frac{1}{2}$ -inch inside diameter for 112 mc. 18 turns of same wire  $\frac{3}{4}$ -inch diameter for 56 mc. Turns are spaced slightly.

Copper tubes  $\frac{3}{4}$ -inch outside diameter and spaced  $\frac{3}{4}$ -inch are used in the 112 mc. transmitter. The 56 mc. tubes are  $\frac{1}{2}$ -inch spaced  $\frac{1}{2}$ -inch.

resonant circuit by bridging the tubes at one end. This, of course, is nothing new. He then goes on to show that the  $Q$  of this resonant circuit goes up in direct proportion to the diameter of the tubes provided the correct order of spacing is maintained between the tubes. He establishes, for example, that a pair of tubes 10 cm. in diameter could provide a circuit with a  $Q$  of 6500 which, he explains, is equal to or greater than that of a quartz crystal (at the higher frequencies). Here, then, is a stabilizing device which is at once simple and applicable to transmitters on any of the ultra-high-frequency bands on which we are now working.

For the last couple of months we have been experimenting with this stabilizing arrangement on the transmitters at WIAL. A description of these transmitters will probably serve to show the practical application of the high- $Q$  resonant line idea.

Fig. 1 illustrates the mechanical arrangement of the 112-mc. ( $2\frac{1}{2}$ -meter) transmitter—a typical example of a push-push oscillator with short resonant-line control. The line is, of course, the two vertical copper tubes connected together at

the lower end with a movable jumper. Studied in conjunction with Fig. 2, this illustration is completely self-explanatory. It will be noted that the circuit departs somewhat from normal practice by having r.f. chokes in the four filament leads and in having no by-pass condensers from the plate or grid-feed leads. The r.f. chokes, particularly at the frequencies higher than 56 mc., were found to be essential. Even at 56 mc. they are of great advantage. The lack of by-pass condensers is no disadvantage. Rather, their elimination greatly simplifies the business of getting voltage nodes at the centers of the grid and plate circuits.

The 56-mc. transmitter at WIAL is illustrated in Fig. 3. Its circuit is exactly similar to that of Fig. 2, the only differences being in the length of the resonant line, the plate tank circuit and the size of the filament chokes.

In tuning this type of transmitter it is as well to start out with a resonant line a full quarter-wave long. Then, with the grids connected about one-third the line length from the shorted end, the plate tank is tuned until the plate current takes a sharp drop—indicating oscillation. The jumper on the line and the grid taps are then varied until oscillation is obtained at the desired frequency and with the lowest possible value of plate current. The oscillator is then coupled to the antenna circuit in the usual manner.

There are many things about this type of

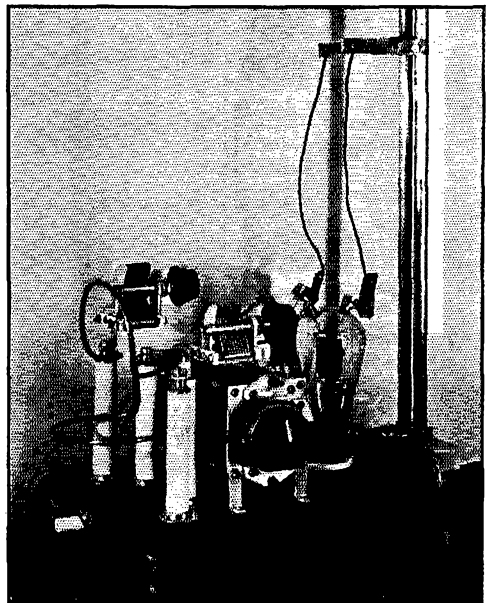

FIG. 3—THE TRANSMITTER RESPONSIBLE FOR ALL THE HARD SLEDDING AT WIAL

This 56-mc. oscillator was first operated with a normal type of tuned grid circuit. Substitution of the resonant short line grid circuit resulted in a marked improvement in stability.



arrangement still to be studied. There is needed, for instance, a decision on the practical merit of line tubes of very large diameter. The largest tubes tried so far at W1AL were 2½-inches in

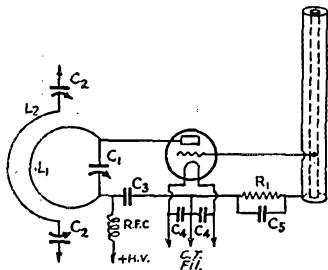

FIG. 4—SHORT-LINE CONTROL AS APPLIED TO A SINGLE-TUBE OSCILLATOR—A SUGGESTED CIRCUIT

- C<sub>1</sub>—Any 35 to 75 μfd. condenser with plate spacing appropriate for tube used.
  - C<sub>2</sub>—50 or 75 μfd. midjet condensers.
  - C<sub>3</sub>—250 μfd. condenser of suitable voltage rating.
  - C<sub>4</sub>—250 μfd. or larger receiving type condensers.
  - C<sub>5</sub>—100 μfd. or smaller.
  - R<sub>1</sub>—10,000 to 20,000 ohms of rating to suit tube used.
- One satisfactory short line would have an outer tube 2½ inches inside diameter and an inner tube ¾-inch diameter. Other combinations of tube sizes may be determined from data given in the text. The tubes are soldered to a shorting disk at the lower end.

diameter; the smallest, ½-inch in diameter. No very marked difference in performance was noted in the very rough survey made. Both of them, however, gave a signal steady enough to be receivable on a selective superheterodyne and with very careful adjustment of the transmitter, 'phone signals could be read on an oscillating autodyne receiver tuned to zero beat. Further experiment

will doubtless reveal some optimum tube diameter taking both performance and cost into consideration.

A typical single tube circuit is that shown in Fig. 4. In this case a concentric line is shown. An open line probably would be of similar effectiveness. The chief problem in this case is adjustment of the grid tap. In practice, it would probably be necessary to drill several large holes in the outer conductor to allow appropriate manipulation of the grid-lead clip.

In determining the spacing of the conductors in these resonant lines, the following ratios are observed:

$$\frac{b}{a} = \text{something between 9 and 10 for concentric lines and between 3 and 4 for the open type line}$$

When  $b$  = inner radius of outer conductor in concentric line, or the spacing between tube centers in open line.

$a$  = outer radius of inner conductor in a concentric line, or the tube radius in an open line.

In the case of the open line this is the equivalent of saying that the tubes should be spaced slightly less than their diameter.

While 800 tubes have been used in the transmitters illustrated, this does not mean that the new stabilizing scheme is not applicable to circuit employing other tubes. The resonant line may obviously replace the grid circuit in any normal ultra-high frequency oscillators using any of the conventional vacuum tubes. Appropriate adjustment of the line length and of the grid tappings will, of course, be essential.

## Another Successful 56-mc. Directive Antenna

**E**AGER to break a 56-mc. path from Long Island through to Connecticut and down through New Jersey, Charles Nuebling, W2EKC, erected this stunning rotatable directive array. Using only a single 45 tube, the station has pumped a walloping signal into W1AL (90 miles or so) and appears to be getting through to the third district consistently.

Though the whole structure appears to be frail, such is far from being the case. It has already withstood a 50-mile wind and, according to W2EKC, looks good for many more. The entire upper structure is of wood, supported on a heavy ball bearing and capable of being rotated with a "brass wheel" coupled with ropes. The supporting tower is 42 feet high.

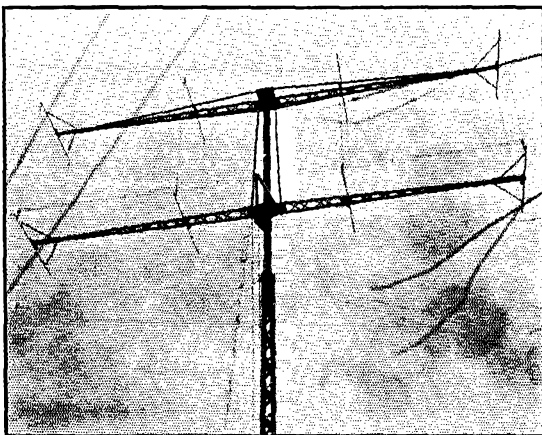

# Getting Coöperation in the Antenna System

A Practical Survey of the Important Features of Different Types

By William J. Goodell, Jr.,\* WIBDH & W2DJT

WITH radio activity increasing, many of us are considering making changes in our rigs and many an eye is cast aloft with no doubt some thought as to how we can improve that long neglected radiation system. After all, the sky wire is really the most important DX-getting element of the station—and probably the most neglected.

In any radiation system there are three major considerations; namely, the radiator, the feeder system, and the impedance matching devices used between feeder line and antenna and between the feeder line and transmitter tank circuit. Proper consideration of any one of these factors alone will not give an efficient system; yet when each is considered with respect to the others, a truly efficient system results—to put it mildly, much more efficient than a good many of our present antennas! Therefore, it will be our object to point out how these factors affect our system and how we can coördinate them to our ultimate advantage. For no good reason at all, let us start with the radiator itself—the antenna—and see how, perhaps by a mere change in position, we can improve its qualities; boost its effective radiating efficiency.

## VERTICAL AND HORIZONTAL DIRECTIVITY

Each radiator, whether of horizontal or vertical

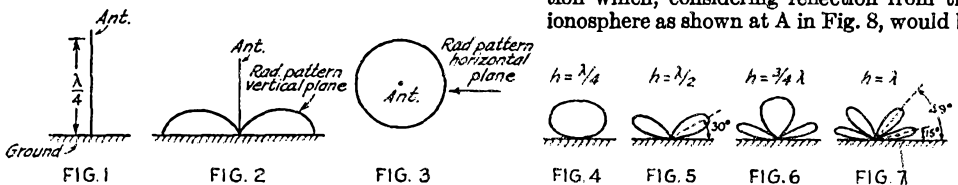

type, has characteristics in one plane or another as a result of which it sends out stronger waves in certain directions than in others. These directional characteristics depend principally upon two factors—the height above ground and the length of the radiator, both described in terms of wavelength ( $\lambda$ ).

An antenna located near earth or ground (as amateur station antennas invariably are) has its directional characteristics affected by the presence of the earth because the radiation downward is reflected with a change in phase of the electrostatic field so that it will either add to or sub-

tract from the direct radiated field according to the relative phases.

In general, radiation patterns showing the radiated field in both the vertical and the horizontal planes for any single radiator give us a picture of the performance to be expected. Consider the quarter-wave vertical radiator in Fig. 1, its relative directional radiated field being represented approximately by Figs. 2 and 3 in the vertical and horizontal planes respectively.<sup>1</sup> We see from these two figures that while a vertical single wire radiates equal amounts of energy in horizontal directions that are perpendicular to the wire, the radiation in the vertical plane varies from maximum at or near the horizontal (low angles) to zero in the vertical direction (high angles).

Going to a more commonly used type, let us take a horizontal antenna and study its radiation patterns in the vertical plane for various heights above the ground. Assuming a perfect ground and a half-wave (fundamental) antenna or radiator in a horizontal position equidistant from the ground throughout its entire length, we find that the earth causes a distinctly different pattern for each quarter-wavelength we raise it above the ground. Relative patterns are shown in Figs. 4, 5, 6 and 7.

From Figs. 4 and 6 we quickly realize that a lot of energy is being wasted in high-angle radiation which, considering reflection from the ionosphere as shown at A in Fig. 8, would be

<sup>1</sup> It must be remembered that the particular earth condition (conductivity) prevailing has a profound effect on the vertical-plane radiation pattern; and that the effective earth conductivity can and does vary with frequency. Hence, illustrative radiation patterns must not be taken as literally applicable to every antenna installation of the given length and height above ground. For instance, while the antenna of Fig. 1 would give a vertical plane pattern resembling the one shown in Fig. 2 at a frequency below 10,000 kc., where the ground could be considered finitely conductive, at a higher frequency the earth would become negligibly conductive and there would be no perfectly horizontal radiation. (See *Short Wave Wireless Communication*, by Ladner and Stoner, Chap. XII.) Hence the low-angle radiating properties ascribed to such vertical antennas must be taken with exceptions for the amateur 14-mc. band and higher frequencies.—EDITH.

\*308 East Second Avenue, Roselle, N. J.

of no value at a distant receiving station, D. Lower angle radiation, as shown in Figs. 5 and 7, represents the more suitable condition which will

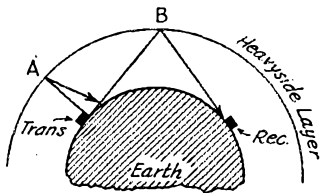

FIG. 8

give us a maximum reflected wave from the ionosphere to the distant receiver, as shown by B of Fig. 8.

From Figs. 4, 5, 6 and 7, it would appear that a half-wavelength represents a desirable height for a horizontal radiator operating at its fundamental frequency, giving us effectively useful radiation in a lobe from 25° to 45° above the horizontal. At a wavelength above ground we find the earth effect causing cancellation of radiation in the directions which make angles of 0°, 30° and 90° with respect to the horizontal, while the effect is a reinforcement of the radiation at 15° and 49° with respect to the horizontal. While this gives low-angle lobes, under some conditions these might cause selective fading at the receiving station because of the difference in the lengths of the paths traveled by the energy radiated at the two angles 15° and 49°.

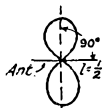

FIG. 9



FIG. 10

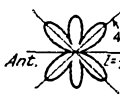

FIG. 11

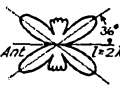

FIG. 12



FIG. 13

It is already apparent that the height of our antenna above ground has a very direct and important bearing on its radiation characteristics and the resulting field strength of our signal at the distant receiving station. Now let us have a look at our other characteristic of antenna radiation, namely, that of varying its direction of maximum radiation in the horizontal plane.

Referring to Figs. 9, 10, 11, 12 and 13, we find that by changing our radiator's length from  $\lambda/2$  to a length of  $5\lambda$  we have moved our direction of maximum radiation from an angle of 90° with the antenna to a 22.5° angle, and at the same time have created four paths of maximum radiation instead of the original two. Corresponding changes are shown in the other figures in which we see the effect of lengths equal to  $\lambda$ ,  $3/2\lambda$ , and  $2\lambda$ , various definite changes in the angles of maximum radiation taking place as the length of the antenna is varied with respect to the wavelength.

Thus we find that without moving the direction in which our antenna points (compass bearing) we may change its radiation distribution (angles

of maximum radiation) by merely increasing or decreasing its length; or keeping the length constant, by changing the frequency in harmonic steps. While the figures shown are intended principally to illustrate radiation patterns in the horizontal plane, it also should be pointed out that the radiation pattern in the vertical plane is similarly affected by increasing antenna length in terms of wavelength, the lobes pictured as giving smaller angles with the line of the antenna, also giving concentration of radiation at low angles in the vertical plane. Hence the horizontal type antenna operated at increasingly higher harmonics gives lower-angle radiation. This accounts for the excellent results obtained on 7 and 14mc. by the many amateurs who use their 3.5-mc. fundamental antennas as  $\lambda$  and  $2\lambda$  radiators on the higher frequencies.

The above figures are further interesting in that they furnish the basis for some of the more recent types of directive antennas suggested for amateur use. Consider for instance the so-called "V" or folded long-wire antenna pictured in Fig. 14. Here we have two single wire radiators fed at the apex of the V and separated by an angle  $\phi$ . This angle is directly dependent upon the length

of each radiator and is equal to twice the angle of maximum radiation from any single wire radiator pictured in Figs. 9 to 13 inclusive. Fig. 15 shows how their fields combine to create a beam in which the energy is concentrated, with very little radiation along the line XY.

To clarify the above, let us consider two examples: First we will take an antenna one wavelength on a side (this will hold for any of the ham bands). Referring to a single wire  $\lambda$  in length (Fig. 10), we find its angle of maximum radiation is 54°; therefore  $\phi$ , which is twice 54°, or 108°, represents the angle of separation. Our antenna will be that represented by Fig. 16. Now let us take an antenna of a length per side of  $2\lambda$ , an entirely reasonable length for an amateur antenna for the 10-, 20-, or 40-meter band. By referring to Fig. 12,  $\phi$  becomes 72° and our antenna looks like Fig. 17. Other combinations may be easily developed knowing the proper angle for the desired wavelength, or *vice-versa*.

#### IMPEDANCE MATCHING

Going on to our second consideration in the radiation system, let us consider the impedance matching question. Referring to the chart of Fig. 18, we have the cold facts layed out before us as to just what loss we can expect for any mismatch

at any point in our system. Since examples are the best illustrations, let us consider two. First, suppose that we have a half-wave horizontal antenna which we wish to feed directly at the center with a 600-ohm line and that our antenna impedance at the point of feed is roughly 75 ohms. Under these conditions we have an impedance ratio of 75 to 600 or 0.12. Referring to our chart we find a loss of approximately 4.2 db. This, in

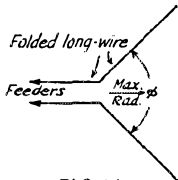

FIG. 14

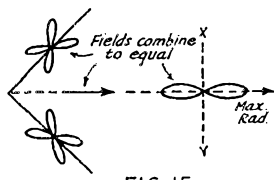

FIG. 15

trates a typical set-up for this type of feeder and while it has the advantage of helping us get our antenna away from the transmitter and out into the clear, and is tunable over a wide frequency range, as a feeder system with a high degree of efficiency it has little to recommend itself. Among its faults are: High transmission line loss

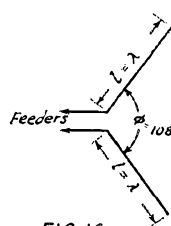

FIG. 16

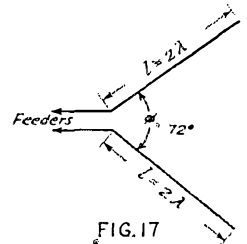

FIG. 17

terms of power supplied to our antenna, represents a loss of nearly 60%; in other words, only 40% of our power is getting into the antenna.

Another illustration of note is that of loss because of poor impedance matching between our transmitter tank circuit and the feeders. Here again we are attempting to couple two unequal impedances, a 600-ohm feeder line to, say, a 3000-ohm tank circuit. The loss under the extreme condition of a ratio of 600 to 3000 or 0.2 would be (from our chart) 2.8 db. With proper coupling, as by use of the pi-section network,<sup>2</sup> this last loss can be made negligible with a resultant 25 to 30% increase in output and a consequent increase in efficiency. (See A. A. Collins' article in Feb. 1934 QST.) Other schemes, such as attempting to tap onto a tank coil at 600 ohms, etc., while partly reducing the loss, do not come up to the ease of operation and adjustment of this more adaptable system, and it is this form of coupling which is heartily recommended in every case for better efficiency.

It is interesting to note at this point that when using an impedance matching system at the junction of feeder and transmitter tank, quite often the impedance matching network has at its output not the supposed feeder line 600-ohm impedance, but an impedance of a different value which is a reflected impedance caused by an impedance mismatch at the antenna end. Hence standing waves will not be prevented from appearing on the feed line and, while it represents a tuned condition creating a better load on the transmitter, it is not the proper load as far as the antenna itself is concerned.

From the above it would appear that our greatest loss comes at the junction between the antenna and the feed line. One of the most commonly used systems around amateur stations today is a feed line comprising an integral number of  $\lambda/4$  sections—a resonant feeder. Fig. 19 illus-

which increases rapidly with any change in its electrical length (due to tuning, weather, etc.); the creation of standing waves which, if the power is large, may cause insulation and constructional troubles; and promotion of a generally poor power factor. It is further recognized that, even should this type of transmission line be perfectly tuned throughout, its losses, because of the standing waves on it, can never be as small as those of the non-standing wave type or non-resonant transmission line. Hence, if we are to feed our antenna from a distance of more than a half-wavelength or so, it will pay us to follow the lead of the commercial companies and improve our antenna system by the use of the non-resonant type of line.

Two main drawbacks to the use of non-resonant transmission lines, as viewed by the amateur, are the trouble of making an impedance match between line and antenna and the fact that the antenna can only be used on one band. The latter is purely a question of how many bands the amateur wants to work on, what antenna system efficiency he is interested in having, and what he will tolerate in physical and mechanical difficulties arising in

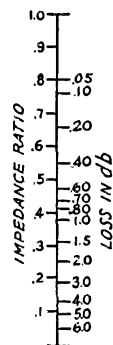

FIG. 18

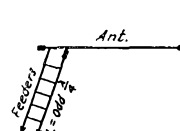

FIG. 19

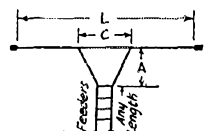

FIG. 20

the construction of several antennas (bearing in mind that, by switching, the same transmission line may be used to feed any one of several antennas).

<sup>2</sup> W. L. Everitt, "Output Networks for R. F. Power Amplifiers," Proc. I.R.E., May, 1931.

COUPLING SYSTEMS

Various schemes have been devised for matching the non-resonant feed line to the antenna. A

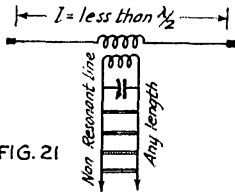

FIG. 21

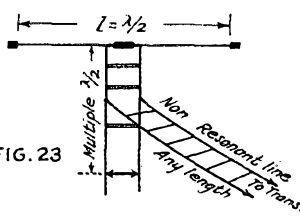

FIG. 23

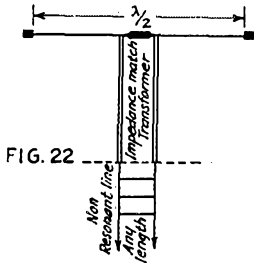

FIG. 22

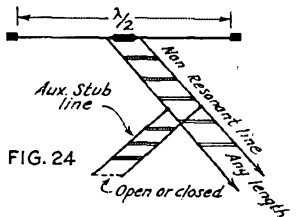

FIG. 24

few of the more practical are shown in Figs. 20, 21, 22 and 23. Fig. 20 represents perhaps the most simple type of all to construct and adjust. (Reference should be made to *The Radio Amateur's Handbook* for the various dimensions of  $L$ ,  $C$ , and  $A$ .) Some mention has been made of the fact that the impedance-matching "Y" is part of the antenna and therefore a rupture of the radiated field results which cuts down the efficiency of radiation from the flat-top. This is true; but even considering this fact, the gain of energy in the antenna itself through the use of an impedance match between feeder and antenna would tend to make this fault one of minor consideration.

In Fig. 21 we employ a transformer (coils) to match impedances. This gives one the idea of link coupling and, while perfectly possible for amateur use, has its largest drawback in the use of coils which have to be placed directly in the radiator.

In Fig. 21 we find the so-called quarter-wave matching link type antenna system. This system employs a quarter-wave section which functions as an impedance matching transformer, the theory of operation being that the antenna impedance  $Z_a$  and the transmitter end impedance  $Z_t$  are related to the line impedance  $Z_l$  by the expression  $Z_t \times Z_a = (Z_l)^2$ . By choosing the proper spacing and size of the conductors in the linear transformer, any two real impedances may be matched providing they do not differ too much in value. This is the system developed by the Bell Telephone Laboratories for their high frequency antenna arrays at Lawrenceville, N. J. Reference should be made to the article by Johnson and Glover in the January 1934 issue of *QST* for the detailed specifications of this system.

Fig. 23 represents a system of match used to a large extent by the Radio Corporation of America on their commercial antennas, while Fig. 24 shows a similar type as applied by A. T. & T. The antenna is connected to a short-resonant line in Fig. 23, and the non-resonant line is then connected to the proper point on the resonant line to give the required terminating impedance. The short resonant line acts as an impedance-matching transformer in which the ratio of impedance transformation depends upon the point of connection. This matching method was used in the rotary beam described by W3CJ in July 1934 *QST*, to which the reader should refer.

The latest and perhaps the most adaptable system of effecting an impedance match between line and antenna is shown in Fig. 24. Use of this system at KA1NA was described by Lieut. Redgrave in November 1934 *QST*. The Bell Laboratories receive the credit for its development and an

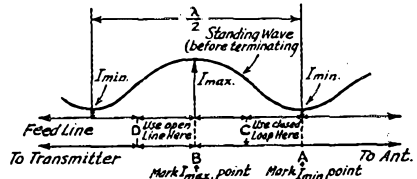

FIG. 25—SHOWING THE TWO POINTS D OR C AT WHICH THE AUXILIARY OPEN LINE OR CLOSED LOOP MAY BE PLACED (POINT D TAKING THE LINE AND POINT C THE LOOP), AND CALCULATIONS SHOWING THE RESPECTIVE DISTANCES FROM POINTS OF MINIMUM AND MAXIMUM CURRENT ALONG THE LINE AS DETERMINED BY THE MEASURING DEVICE (SEE TEXT) IN TERMS OF  $\lambda$  AND LENGTH OF AUXILIARY LINE OR LOOP TO BE USED

(Remember only one or the other is used, depending upon the position selected on the feeder line).

Ratio $I_{max}/I_{min}$	Distances		Length of Line (For D)	Length of Loop (For C)
	B to D	A to C		
0.9	0.123 $\lambda$	0.128 $\lambda$	0.08 $\lambda$	0.232 $\lambda$
0.8	0.119 $\lambda$	0.134 $\lambda$	0.07 $\lambda$	0.210 $\lambda$
0.7	0.114 $\lambda$	0.139 $\lambda$	0.06 $\lambda$	0.191 $\lambda$
0.6	0.108 $\lambda$	0.143 $\lambda$	0.05 $\lambda$	0.170 $\lambda$
0.5	0.100 $\lambda$	0.153 $\lambda$	0.10 $\lambda$	0.150 $\lambda$
0.4	0.090 $\lambda$	0.162 $\lambda$	0.122 $\lambda$	0.130 $\lambda$
0.3	0.080 $\lambda$	0.175 $\lambda$	0.145 $\lambda$	0.108 $\lambda$
0.2	0.068 $\lambda$	0.187 $\lambda$	0.170 $\lambda$	0.080 $\lambda$

Distances and lengths of the line or loop are given in terms of  $\lambda$  or one wavelength. Wavelength,  $\lambda$ , in meters, equals 300,000 divided by frequency in kilocycles. One meter equals 3.28 feet.

excellent explanation of this system will be found in the *Proceedings of the Institute of Radio Engineers* for July, 1932, in the technical paper, "Transmission Lines for Short-Wave Radio Systems," by Sterba and Feldman. This system operates on the theory that a complex impedance, such as one finds on a resonant feed line, may be changed to the surge impedance of the line by attaching a shunt reactance of the proper value. A short section of line is used for this reactance and a position along the line for shunt reactance of either a leading or a lagging power factor may be chosen. This may be at a place on the line most convenient from an actual construction standpoint since one has a choice of two positions for every  $\lambda/2$  length of line. Actual adjustment of the system is as follows:

The transmission line is first built to the desired length and attached to the antenna. With power applied, the standing waves on the line, resulting from the poor termination at the antenna, are measured for their maximum and minimum values by some form of a measuring device. (The one used at KA1NA will do nicely; also see the above I.R.E. paper.) Points of minimum and maximum values should be marked on the line and the ratio of minimum to maximum determined. Once this ratio is known, a glance at Fig. 25 will indicate the approximate position and length of the shunt reactance or auxiliary line. It will be noted that in one case we have a short section of open line and in the other a closed loop, there being a short across the end of the latter.

(Continued on page 22)

## 'Phone-C.W. QSO Contest

February 9th-10th; February 16th-17th

**H**OW many 'phone stations can any key-pounding amateur radio operator QSO in two week-ends? How many c.w. telegraph stations can any ham operator behind a mike contact in the same time? All 'phone hams are invited to try it! All brasspounders likewise!

the final score. 'Phone-'phone and c.w.-c.w. QSO's do not count, but all 'phone-c.w. QSO's should be recorded by a simple tabulation in the form suggested herewith.

This contest is designed to produce *new* QSO's for you; this should result in new friendships,

Contest starts: Feb. 9th, and Feb. 16th (Sat.).....	E.S.T. 4 p.m.	C.S.T. 3 p.m.	M.S.T. 2 p.m.	P.S.T. 1 p.m.
End of first period: Feb. 10th (Sunday).....	11.59 p.m.	10.59 p.m.	9.59 p.m.	8.59 p.m.
End of second period: Feb. 17th (Sunday).....	11.59 p.m.	10.59 p.m.	9.59 p.m.	8.59 p.m.

Scoring: Each two-way contact, 'phone-c.w. or c.w.-'phone, counts *one*. The sum of all points made in the contest period will be multiplied by the *number* of A.R.R.L. Sections\* worked to give

new acquaintances among neighboring hams. It is a heap of fun to roll up scores and test the range and reliability of our stations. A chance at new records, an opportunity to brush up code skill to rank with the best of them, a chance to

\*See page 5, this issue, for a complete list of the 69 A.R.R.L. Sections.

(Continued on page 22)

Report of 'Phone Station W5XYZ			
A.R.R.L. Section * .....			
Power Input to last stage .....			
Name and address .....			
Date and Time (Local)	Frequency Band	Station Worked	Section (New sections indicated by check)
Feb. 9th			
3.01 p.m. C.S.T.....	3900 kcs.	W2DBQ	√N.Y.C.-L.I.
3.12 p.m.....	"	W9BAZ	√Ky.
3.50 p.m.....	14,150 kcs.	W1EWD	√Conn.
4.20 p.m.....	3900 kcs.	W9PPM	√Ky.
4.30 p.m.....	"	W6LIE	√San Francisco
Claimed Score: 5 stations worked in 4 different Sections 5 × 4 = 20 (total score)			

Form for Reports to A.R.R.L. on 'Phone-C.W. QSO Party Showing How Work Should Be Tabulated

# Armistice Day Message, 1934

**T**HE sixth annual Armistice Day Message from the chief signal officer of the Army to all members of the Army Amateur Radio System was transmitted on the night of November 12, 1934 from WLM-W3CXL, the Army Net Control Station of the A.A.R.S., located in the War Department in Washington, D. C.

In accordance with established practice the reception of this message was made a competition for the nine corps area organizations of the A.A.R.S. This year, in addition, competition was held between the states composing each corps area. Each amateur was requested to copy the message and mail the copy to his Corps Area Signal Officer to be checked. Each state and corps area was scored on the percentage of properly copied and serviced mailed-in copies received from all members of the state and corps area.

The message was transmitted at the regular broadcast periods of 7:00 p.m. and 10:00 p.m., E.S.T., on the special A.A.R.S. frequencies of 3497.5 and 6990 kcs. simultaneously. Most of the corps area net control stations rebroadcast this message once or twice to assist members who were unable to hear WLM-W3CXL.

The Chief Signal Officer's message was as follows:

**"TO ALL ARMY AMATEURS—**

**ON THIS SIXTEENTH ANNIVERSARY OF THE SIGNING OF THE ARMISTICE IT IS BEFITTING THAT WE PAUSE TO HONOR THOSE WHO DIED TO MAINTAIN OUR NATIONAL HONOR AND INTEGRITY STOP THE SUPREME SACRIFICE THEY MADE FOR US SHOULD SPUR US ON TO A UNITED EFFORT TO BE READY TO HELP OUR COUNTRY IN ANY LOCAL OR NATIONAL EMERGENCY OR DISASTER SO THAT FUTURE LOSS OF LIVES WILL BE MITIGATED TO THE GREATEST EXTENT POSSIBLE STOP TO YOU WHO HAVE SO WILLINGLY GIVEN YOUR TIME AND ENERGY TO PERFECT AN EMERGENCY RADIO COMMUNICATION SERVICE THAT WILL BE AVAILABLE WHENEVER NEEDED BY OUR GOVERNMENT AND THE RED CROSS I GIVE MY MOST WHOLEHEARTED THANKS AND COMMENDATION—**

**IRVING J CARR  
MAJOR GENERAL  
CHIEF SIGNAL OFFICER OF THE ARMY"**

In response to this message 948 properly prepared and serviced copies were received by the nine corps area signal officers from the 1,511 members of the system, or a percentage of approximately 63. No record was kept of the number of messages not properly copied and serviced.

To the Fourth Corps Area went the honors for having the highest percentage of members mail in copies of the message.

The records of each corps area in order of their standing are as follows:

**FOURTH CORPS AREA**, comprised of the states of Alabama, Florida, Georgia, Louisiana, Mississippi, North Carolina, South Carolina and Tennessee (Captain Harry L. Vitzthum, Sig. C., W4SM-WLR, Liaison Agent and Captain Myrl F. Jones, U. S. Army, Retired, W4IR-WLRY,



**JAMES W. SPRATLIN,  
W4KV-WLR, OPERATOR,  
FOURTH CORPS AREA  
NET CONTROL STA-  
TION**

**The Fourth was the winning CA. in the Armistice Day Message Contest.**

Radio Aide), with 125 members, received copies from 101 members or a percentage of 81. The states of South Carolina (W4MN, Net Control Station), and Florida (W4AKJ, C. W., Net Control Station and W4LS, Phone Net Control Station), tied for first place within the corps area with 100% returns from their members.

The Fourth Corps Area honor roll includes: South Carolina: W4MN (N.C.S.), AFQ, CIR, BZX, DX, BEN. Florida: W4AKJ (C.W. N.C.S.), W4LS (Phone N.C.S.), NF, GQ, ACB, AGR, AGS, AWO, BGL, AKV, CAM, QG, DCN, WS, DU, COS, BAM, AQU, AWE, BNI, ACZ, ADB. Alabama: W4RS-TI (N.C.S.), RS-OH, DS, BCU, CYW, AUP, KB, BMM, BDH, APU, KP. Georgia: W4AAY (N.C.S.), BQX, ATZ, ABS, BAG, BZW, AJH, KV, IR, AGI, WC, PM, ADN, BGE, OX, BW, CAO, CM, OL, CDH, JL. Louisiana: W5ZK (N.C.S.), DEJ, FQ, CWQ, ID. North Carolina: W4ABT (N.C.S.) DW, EG, BHR, AEH, CXC, AGF, BST, Tennessee: W4RO (N.C.S.), ATW, AFI, BOZ, BBT, OV, BDF, BQK, AYW, AEP, AFM, ACU, AZM, PPL, BPE, LU, AAO.

**SEVENTH CORPS AREA**, comprised of the states of Arkansas, Iowa, Kansas, Minnesota, Missouri, Nebraska, North Dakota and South Dakota (Captain John J. Downing, Sig. C., W9BNT-WLU, Liaison Agent, and Mr. H. W. Kerr, W9DZW-WLUY, Radio Aide), with 173 members, received copies from 132 of them, a percentage of 76. Missouri won first place with 96% of its members sending in satisfactory copies of the message. Their call letters include W9EFC (N.C.S.), W9ENF (Alternate N.C.S.), W9ISB (Phone N.C.S.), W9AIJ, NNZ, BMA, FHV, ECE, CJR, MZD, GSO, IXK, KCG, RTG, GTK, PYF, ARH, OQI, DHN, EPV,

FJV, DIC, HUG, SGP, JAP, CJL, RYD, LBM.

EIGHTH CORPS AREA, comprised of the states of Arizona, Colorado, New Mexico, Oklahoma, and Texas (1st Lieut. Louis J. Tatom, Sig. C., W5OW-WLJ, Liaison Agent), has a membership of 98, of whom 67 or a percentage of 68 mailed in acceptable copies. New Mexico led all others with a maximum score of 100%. This state's honor roll includes W5CGJ (N.C.S.), W5ZM (Alternate N.C.S.), W5CJP, DLG, DUI, ND.

FIFTH CORPS AREA (Staff Sgt. Richard W. Martin, 18th Signal Service Co., Liaison Agent and Lieut. Loren G. Windom, Inf.-Res., W8ZG-WLH, Radio Aide), comprised of the states of Indiana, Kentucky, Ohio and West Virginia, has 165 members of whom 102 submitted copies, a percentage of 61.8. Kentucky and West Virginia tied for first place with a score of 100%. Their honor roll includes: Kentucky: W9HAX (N.C.S.) W9BWJ and W9CDA (Alternate N.C.S.'s), W9CNE, EDQ, CIM, PAZ. West Virginia: W8OK (N.C.S.), W8HD and W8EIK (Alternate N.C.S.'s), W8AFB, BDD, CMJ, DMF, ELJ, EZR, HWT, IKN, KKG, LJX, FVU, MCR.

NINTH CORPS AREA (Captain R. B. Woolverton, Sig. C., W6ZG-WLV, Liaison Agent and Mr. J. H. MacLafferty, Jr., W6RJ-WLVB, Radio Aide), comprised of the states of California, Idaho, Montana, Nevada, Oregon, Utah, Washington, Wyoming and the Territory of Alaska, has the greatest number of members among the corps areas. With a membership of 303, they attained a percentage of 61.4 with 186 members submitting satisfactory copies. Nevada won the contest among these states with 100% score. Its honor roll includes W6UO (N.C.S.), W6AJP (Alternate N.C.S.), W6AAX, GYX, HGL, IKJ, EGA.

FIRST CORPS AREA (Captain George W. Morris, Sig. C., Liaison Agent and Mr. Fred C. Bigelow, WLGL-W1PI, Radio Aide), comprised of the states of Connecticut, Maine, Massachusetts, New Hampshire, Rhode Island, and Vermont, has a membership of 116 members, 71 of whom sent in satisfactory copies, giving a percentage of 61.2. State honors went to Connecticut which went over the top with 100%. Their honor roll includes W1BMP (N.C.S.), W1APZ, BIQ, CVL, DBU, DMP, DFT, EIU, ESD, FOU, HAX.

SECOND CORPS AREA (Captain James A. Eyster, Jr., Sig.-Res., WLN-W2SC, Liaison Agent and Captain David Talley, Sig.-Res. WLN-W2PF, Radio Aide), which includes the states of Delaware, New Jersey and New York with a membership of 85, received satisfactory copies from 51 members giving them 60% for score. The leading state was New York with 56% score won by the following honor members: W8CN, CSE, BME, DZU, ESY, JMC, JE, AQE, CDK, ELU, FYF, GZM, LJD, JAK,

EEN, W2BJA, FDQ, EYQ, OQ, LG, DBQ, PF, SC, ELK, DFU, BGS, HF, CA, GRB, SX, DQW, EYS, BGO, GGP, BWS and EZJ.

THIRD CORPS AREA (1st Lieut. H. O. Bixby, Sig. C., WLQ-W3SN, Liaison Agent, and Mr. E. D. Hartman, Radio Aide, WLQA-W3OK), comprised of the states of Maryland, Pennsylvania, Virginia and the District of Columbia, had 165 of their 300 members submit properly prepared copies giving them 55%. The winning state was Virginia with 79% and with the following stations on their honor roll: W3FJ (N.C.S.), W3BYA (Alternate N.C.S.), W3BJX, EQU, CHE, BRY, CFL, ENJ, ECQ, CYK, BFW, AZU, APU, AOT, EBD, EGD, GE, EMA, DQB, COO, ELA, EUL, EHL, DWE, ALF, EHx, DZW, EQC, EPX, BXP, DCU, BTM, CJV, DVO.

SIXTH CORPS AREA (Pvt. R. J. Dutch, Sig. C., WLTA-W9ANR, Liaison Agent, and Lt. C. W. Roth, Sig.-Res., WLT-W9DOU, Radio Aide), comprised of the states of Illinois, Michigan and Wisconsin, has 141 members, 72 of whom submitted satisfactory copies giving them a percentage of 50. The leading state was Illinois with a 73% score. The members on the Illinois honor roll include W9IVF (N.C.S.), W9CGV (Alternate N.C.S.), W9ANR, DOU, KJY, FP, KZV, ILH, IEP, BIN, HUM, DPD, HQH, HKC, MLH, KXE, OXA, ORT, KOQ, MKK, JO, NGG, NDB, HUX, ICN, MIN, IYA, INZ, OMA, DBO, AMO, PGB, DAY, NXG, KRZ, NXZ, NQC, STG, LNI, HB, HPG.

The chief signal officer is very gratified that so many amateurs participated in the competition this year. It is an increase of about 25% over that of last year's Armistice Day Message Contest.

## Getting Coöperation in the Antenna System

(Continued from page 80)

The auxiliary line or loop is cut to length and hung on the feeders loosely at the approximate position, good contact between feeders and auxiliary line being necessary. A check is then made on the standing waves with the measuring device and slight final adjustments are made by sliding the auxiliary line along the feeders until the standing waves are reduced to a minimum. Two r.f. meters a quarter-wave apart in one of the feeders will also assist in this adjustment, their readings being approximately equal when a perfect termination has been made. The feed line then loses its standing waves and becomes a simple low-potential line with a correspondingly low power-transfer loss between the transmitter and antenna.

It is evident from the figures that the non-resonant transmission line should be at least

(Continued on page 70)



# Matched-Impedance Coupling to the Zepp Antenna

## A Convenient End-Feed System of High Efficiency

By L. L. Hardin, Jr., \*W3AQC

IT HAS long been the opinion of the writer that the antennas used at the great majority of amateur stations, in this country at least, leave much to be desired as far as efficiency is concerned. When it is considered that some operators obtain almost unbelievable miles per watt with some tricky form of antenna, and not the directional kind at that, it can be seen that any improvement that can be made in this part of the transmitting equipment is of great value.

After working with all forms of conventional antennas on several bands, the author finally decided to start working on this situation earnestly and try some of the schemes that most of us somehow never get around to trying out. In this search for a better antenna the first thing decided upon was that so far as possible there should be no standing waves in the system except on the radiator itself, where they belong; hence, all impedances in the system should be matched as nearly as possible to perfection.

With the above ideas in mind, the advantages and disadvantages of the various matched impedance systems were studied in order to determine which might prove to be the most useful to the greatest number of amateurs. On first sight it was found that all of these better known systems have certain features which make them more or less uninteresting to a large number of prospective users.<sup>1</sup>

The antenna matching arrangement finally decided upon as having the best possibilities, as far as the above conditions are concerned, is that described briefly in F. E. Terman's *Radio Engineering*, pages 538-542, and is similar to that used by W3CJ in the rotary beam described in July 1934 *QST*. It is for the purpose of bringing this arrangement to the attention of the amateur fraternity and of giving simple means for adjusting it for proper operation that this article has been written.

This antenna employs a resonant quarter-wave transformer section. This quarter-wave section

actually consists of an end portion of the antenna folded back on itself, as in the Zeppelin feed arrangement, and may be made of the same conductor as that of the antenna. In fact, this is to be preferred. The conductors of the quarter-wave section should not have an insulating covering of any kind, as will become evident later on in this discussion.

As pointed out in numerous places in the literature on the subject, the impedance of a quarter-wave section with a closed end varies along its length from a low value at the closed end to a value of several thousand ohms (ideally, infinite impedance) at its open end. Since the impedance at the end of the antenna is also high, what better

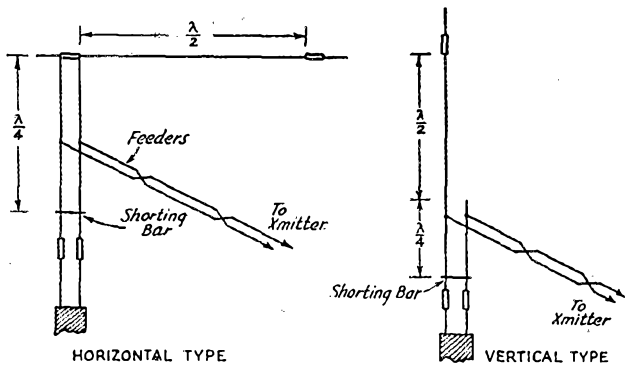

FIG. 1—THE END-FEED QUARTER-WAVE SECTION COUPLING SYSTEM IS ADAPTABLE TO EITHER HORIZONTAL OR VERTICAL HERTZ ANTENNAS

device could be asked to match the impedance of a feed line of any ordinary value of impedance to the high end-impedance of the antenna proper?

The basic idea is shown diagrammatically in Fig. 1. A method of use for both horizontal and vertical radiators is shown, although other arrangements will no doubt occur to the prospective user which will enable him to fit the system to his particular requirements. The shorting bar is used, as described later, to adjust the quarter-wave section (any odd quarter-wave length may be used but a single quarter-wave section is best for obvious reasons) to the proper length under operating conditions. The position of the feeders is determined experimentally for a line having any customary value of impedance, under actual

\* Formerly Haddon Heights, N. J. Now Clover, S. C.

<sup>1</sup> For discussion of the various systems, see W2DJT's article in this same issue.—EDITOR.

working conditions, without the use of mathematics.

The length of the radiator proper is figured from the usual formulas found in the *Handbook* and the quarter-wave section is made a foot or so longer than the computed value in order to allow for adjustment. The spacing of the wires in the quarter-wave section preferably should be the same as the spacing of the feeder system, although a slight deviation from this value will not introduce any serious losses.

The feeder system may be of the conventional parallel-wire type or may consist of a transposed line in order to maintain a more perfect balance to ground. If the transposed line is decided upon the transposition insulators should be placed at equal distances along the line. As there are no standing waves on the feeders when the tuning process has been completed, the value of spacing between the transposition blocks is not extremely critical; but it will pay the user to make the line as symmetrical as possible. The length of the line may be anything up to a thousand feet or so, if necessary, without introducing any serious losses. The surge impedance of the line need not be known because, regardless of its value, the line can be matched to the quarter-wave section. The feed line can be matched to the output tank of the transmitter by any of the usual systems shown in the *Handbook*.

#### GETTING THE RIGHT ADJUSTMENT

After the foregoing parts of the antenna have been erected the tuning process can be started. In order to facilitate this work it is advisable to construct some sort of a field strength indicator. The one described by Nordor on page 22 of *Hints and Kinks* and shown schematically in Fig. 2 will be quite satisfactory. The parts for this little instrument should be available around almost any up-to-date ham shack. Naturally, the operating frequency of the transmitter should fall within the tuning range of this indicator. This meter is placed well away from the antenna but near enough to the shack so that the operator can conveniently observe the approximate position of the meter pointer while making adjustments.

The shorting bar is placed at the measured quarter-wave point on the "transformer" to start with, and the feeders are temporarily connected a point approximately one-third of the distance from the shorting bar to the antenna proper, for a transmission line of between 400 and 600 ohms impedance. The transmitter is then started up (when there is practically no use being made of the band, incidentally!), and the feeder system loosely coupled to the output tank. The field strength indicator is tuned to resonance and the reading noted. It may be necessary to connect a short piece of wire to the indicator as shown in Fig. 2 to increase the pick-up if the transmitter power is low. If this is done, care should be taken

that the position of the pick-up wire is not allowed to change during the tuning up process.

The position of the shorting bar and the position of the feeders are then varied alternately, by small amounts in both directions along the quarter-wave section, until the field-strength meter indicator shows the highest reading.

As a final check on the adjustments arrived at in this manner it is necessary to couple the feeders to the final tank of the transmitter in such a manner that the proper value of load is obtained on the final stage, after which the above adjustments should be rechecked in order to correct for any unbalances brought about by changing the loading at the transmitter end of the line. At this point in the procedure it is also necessary to check

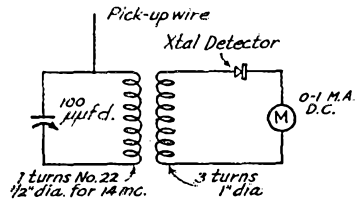

FIG. 2—DIAGRAM OF THE FIELD-STRENGTH METER USED IN ADJUSTMENT OF THE ANTENNA SYSTEM

the feeders for standing waves. This can be done by means of a thermocouple galvanometer, if one happens to be available; or with the field-strength indicator previously described, provided that its sensitivity is reduced by detuning the tuned circuit—or better, in some cases, by removing it altogether. By touching either instrument to the feeders, an equal reading should be obtained on each feeder separately or at different points along one feeder. If this is not the case, the position of the feeder tapings on the quarter-wave section should be changed slightly until this condition is obtained. For the hypercritical, it would pay to readjust the shorting bar again for maximum current, although once the maximum indication point is found, as shown by the field meter, the feeders are in general pretty close to the proper point.

With regard to this last operation, the writer noticed that in approaching the proper point for the feeders from one direction, one feeder was "hotter" than the other; whereas when approaching this point from the other side the previously "hot" feeder became the "cold" one. By this means it was possible to determine on which side of the proper point the feeders happened to be located. In order to make the adjustments described above with the power on, it is advisable to make sliding joints for adjustment purposes. And if severe radio frequency burns are to be avoided, all adjustments should be made by means of a heavy pair of pliers grasped firmly in

(Continued on page 41)

# H A M D O M



**I**N 1897 in Crefeld, Germany, a three-year-old tot sat entirely nude on the sidewalk outside his home and read newspapers upside down.



Passers-by smiled; a harassed mother coaxed and pled. Such is the earliest recorded incident in the literary career of Lieut. John Leonard Reinartz, perhaps the most widely known figure in Hamdom. His radio career began in 1909 with a coherer and single-slide tuner; in 1910 there was a spark coil transmitter signing JL. With the

World War John went to Camp Upton, Long Island, became disabled, and then taught prospective radio men. He developed the famous Reinartz tuner in 1921, and the transmitting circuits with which Leon Deloy and Fred Schnell and he worked across the Atlantic in 1923. In 1925 he first proposed the reflection theory explaining the peculiar behavior of the then-new short waves. In the same year he went North with MacMillan and Byrd, demonstrating the efficacy of the short waves. At present, he divides his time between the "best girl," amateur and Naval Reserve activities, and research work for RCA.

**"T**HE Dixie Squinch Owl," that harbinger of good cheer from the 4th C.A., A.A.R.S., is edited, published, addressed, licked and toted

to the post office by Radio Aide Myrl F. Jones, W4IR. The king of the Squinch Owl's domain was born in the 5th C.A. (Kaintuck') but moved to the 4th C.A. (Jawjuh, no less) as soon as he was old enough to do something about it. His radio experience dates from 1908, when he began to monkey with field radio sets of the Signal Corps, mostly on the



heavy end of a hand generator. From then on the tale goes: Radio operator at Nome and St. Michael, Alaska, 1909 to 1912; radio operator, U. S. transport service at sea, 1913; submarine cable operator at Valdez, Alaska, 1914; captain

commanding Company "A", 6th Field Signal Battalion, 6th Division, overseas. The rest of it is contained in the inimitable autobiography which is the proud possession of each member of the 4th C.A. It... but you'd better try to get a copy from W4IR. Latest achievement is Armistice Day win!

**REV. ROMUALD FOX, O.S.B.**, finished building a new \$70,000 church in Valley Falls, Kansas, in 1926.



At the same time he gave way to the radio broadcast bug that had bitten him in 1921, and installed an RCA Model ET-3619-3620 broadcast station. In 1927 he got the amateur call W9ESL, and he's been active in the game ever since. He has been A.A.R.S. Corps Area net control on 'phone, and organized the original 'phone net in the 8th C.A. O.O., O.R.S., O.P.S., O.B.S., P.A.M., Wouff Hong degree team—he has played the game of amateur radio to the full. Just at the moment, he's working hard on a large sound trailer (Black Maria style) used for public address work at church, civic and school affairs.

**LAWRENCE J. RYAN**, of Hannibal, Mo., is 73 years old and on the 75 meter 'phone band.

If that isn't sufficient identification, we might tell you that he's also known as the Wooden Indian. Oh, yes, he's very well known indeed—oldest operator on the 4 mc. band, he claims; oldest active amateur in the world today, perhaps. Active? Why, he's super-active. Tune around on that 'phone band at any time—3 o'clock in the morning or 3 o'clock in the afternoon—and you'll probably hear him



singing away, cheerful as ever. He's the best baritone on 75 meters, to hear him tell it; he'll sing your call for \$2.00, and can that tremolo fill the old breast with pride! One thing more—Larry is the millionaire 'phone operator, ask him.

# What the League Is Doing

League Activities, Washington Notes, Board Actions—For Your Information

## Election Results

Seven A.R.R.L. divisions have just held elections to choose their directors for the 1935-1936 term.

Four old directors were returned to office, three new ones elected, and a new alternate director chosen in each division.

In December *QST* we reported that the Roanoke and Rocky Mountain divisions returned Professor Caveness, W4DW, and Mr. Andrews, W9AAB, respectively, and that their respective alternates are Mr. J. Frank Key, W3ZA, and Mr. Lewis D. Stearns, W6BTX. No competing names were suggested for any of these offices, so that they were declared elected without balloting by the membership. There was competition in the other five divisions, however, and this is the story of the result.

### CENTRAL DIVISION

The Central Division chose for its new director Mr. Edward A. Roberts, W8HC, of Cleveland, who won handily over Mr. G. L. Eldred, 1011 to 559. The former director, Mr. Windom, was not a candidate for reelection. Mr. J. B. Wathen III, W9BAZ, Louisville, Ky., was elected alternate director. The figures:

For director:	
Edward A. Roberts .....	1011
George Lane Eldred .....	559
For alternate director:	
J. B. Wathen III .....	711
Carl L. Hansen .....	603
Wesley E. Marriner .....	249

Mr. Roberts, a retired executive of mature years, is active on both 'phone and c.w., holding A.R.R.L. certificates as Route Manager and O.P.S. He has an elaborate station incorporating three 'phone transmitters and two complete c.w. outfits for various purposes in the different bands.

### HUDSON DIVISION

The Hudson Division elected a new director in the person of Mr. Kenneth T. Hill, W2AHC, of Great Neck, Long Island, while Mr. Robert M. Morris, W2LV, of Millburn, N. J., was elected as his alternate. Ballotting figures:

For director:	
Kenneth T. Hill .....	590
Bernard J. Fuld .....	441
For alternate:	
Robert M. Morris .....	731
S. M. Riccobono .....	297

Mr. Hill, a telephone engineer, comes to the Board with twenty years of ham experience. We shall present a longer sketch of him, and of the other new directors too, in our "Hamdom" column soon.

### NEW ENGLAND DIVISION

Director Bailey, old "KH," was returned to office by a whopping majority. Mr. Joseph A. Mullen, W1ASI, Ashmont, Mass., was elected the alternate. The count:

For director:	
George W. Bailey .....	594
Horace Young .....	190
Walter E. Lessard .....	82
For alternate:	
Joseph A. Mullen .....	512
Isaiah Creaser .....	350

### NORTHWESTERN DIVISION

Director Gibbons was likewise returned to the Board by a husky majority, while Mr. A. L. Smith, W7CCR of Missoula, Mont., is the newly-elected alternate. The tally:

For director:	
Ralph J. Gibbons .....	310
Robert H. Votaw .....	101
For alternate:	
A. L. Smith .....	201
M. R. Cooper .....	113
Nillo E. Koski .....	97

### WEST GULF DIVISION

The West Gulf staged the real upset of the 1934 elections in a spirited campaign that brought in 61.8% of the ballots sent out, an unusually high percentage. Mr. Wayland M. Groves, W5NW, of Neches, Texas, was elected director over the veteran incumbent, Mr. Frank M. Corlett, and Mr. C. L. Nelson. The count:

Mr. Groves .....	234
Mr. Corlett .....	147
Mr. Nelson .....	75

Mr. David H. Calk, W5BHO, of Houston, Texas, was the only candidate for alternate and so was declared elected.

Mr. Groves, the new director, is an active high-power 40-meter man whose experience dates back to the spark days. His YF is a hamess, call W5DUR. He is chief clerk and telegraph operator for the Humble Pipe Line Company at Neches.

The directors have the right to appoint assistants to help them in their duties. Such assistant directors have no legal status in the A.R.R.L. machinery; that is, they are the administrative assistants of the directors but cannot vote or otherwise replace the director. The alternate director, however, is an official elected for the purpose of representing the division at Board meetings and casting its vote when the director cannot attend. On the other hand, an alternate

director is not an assistant director unless he is also so named by the director. His duty normally is simply to represent the division at Board meetings when called upon to that end by the director.

*QST* is certain that it speaks for the membership in welcoming the new members of the Board to the A.R.R.L. official family, and in expressing the gratitude of all of us to the outgoing directors



**EIGHTEEN YEARS AN  
A.R.R.L. DIRECTOR**

for their splendid service to A.R.R.L. All of these men have worked sincerely, during the years of their office, to advance amateur radio and our League. This is particularly true of Frank Corlett of the West Gulf Division, who had been for nearly eighteen years a member of the A.R.R.L. Board. First elected a director in February of

1917, he was one of the war-time directors who participated in the post-war reorganization and was eight consecutive times reelected to the Board. He was the dean of the division directors and in length of service to A.R.R.L. as a director is exceeded only by Mr. Maxim. Ye Ed was a fairly-Young Squirt playing with a spark gap in Illinois when Corlett was first elected to the Board. Eighteen years! That deserves some rousing cheers.

The 1934 elections marked the first occasion where members were required to state whether they were licensed amateurs. The statistics are worth reviewing. Let us first get the facts straight: By a recent amendment to by-laws, the right to vote in A.R.R.L. elections is confined to members who are either amateur station licensees or licensed amateur operators, or who have maintained uninterrupted membership in the League since before the enactment of that change. That is to say, any member accepted by the League since the middle of last May comes into it under a by-law which plainly states that unless he is a licensed amateur he will not have the right to vote. On the other hand, members may not be deprived, without their consent, of rights that

they had at the time they joined, so that even unlicensed members who maintain their membership without lapse are constitutionally entitled to vote—if they want to.

It has been suggested that membership itself ought to be confined to those who are licensed amateurs. The trouble with this proposal is that it would make the membership contingent upon a factor which is not within the control or knowledge of the League. A chap would get a license and want to join the League. First he would have to prove that he had a license. Then, during the life of his League membership, his station license might expire and he might forget to renew it, or perhaps it would be his operator license—and he would lose the right to be a member of the League. The F.C.C. might even get busy and suspend his operator license for over-modulation or working outside the bands, and that might be for two months or two years. Thus his A.R.R.L. membership would terminate or be broken into for variable and unpredictable periods of time, with no conceivable method for the headquarters to keep adequate check on it. No, the idea isn't practicable. Much thought has been expended upon this general subject for many years by A.R.R.L. directors and officers, all wishing for some method whereby A.R.R.L. determinations might be made by licensed amateurs only. Not for some years was the present idea uncovered, and it is the only workable one that has been. It provides, in short, for letting any interested person become a member of the League but for confining the vote (partially at present and rigidly as quickly as possible) to licensed hams.

Now for those figures we were talking about. They are shown in the table herewith. 81.6% of those who cast ballots in the 1934 elections are the possessors of station licenses, the figure varying from 77.1% in the Hudson Division to 86.9% in the Northwestern. There are some amateurs who have an operator license but no station license, and these accounted for 0.3% of the vote. A total of about 82% of the ballots thus were cast by members who are licensed amateurs, the residual 18% by those who are not at present the holders of either station or operator license and who rely upon membership prior to the last Board meeting for their right to vote. These

*(Continued on page 80)*

#### ANALYSIS OF 1934 BALLOTING

SHOWING ON WHAT FACTOR THE RIGHT TO VOTE WAS BASED

	Central	Hudson	New England	North- Western	West Gulf	National Average
Station License .....	82.3%	77.1%	83.4%	86.9%	81.3%	81.6%
Operator License .....	0.3	0.3	0.1	0.2	0.6	0.3
Total Licensed .....	82.6	77.4	83.5	87.1	81.9	81.9
Prior Membership .....	17.4	22.6	16.5	12.9	18.1	18.1
	100.0	100.0	100.0	100.0	100.0	100.0

# Grinding and Finishing Quartz Crystal Plates

By Ivan H. Loucks,\* W9ON

In this article the author concludes his description of the detailed procedure of making oscillating quartz crystal plates which began in January QST with the article on cutting blanks from the natural crystal. In coming issues there will be further articles on crystal oscillator and filter circuits, as well as on practical features of the newer crystal cuts.—EDITOR

**Q**UARTZ crystal grinding consists essentially of shaping up the faces and edges of a properly cut quartz crystal blank so that it will oscillate freely in a transmitter and control that transmitter on some desired frequency. The conditions which must be met before the blank will do so may be briefly listed as follows:

1. The blank itself must have been cut from a good natural crystal and must be free from impurities or flaws in crystalline structure. If an X-cut or Y-cut, it must also have been cut so that its faces are exactly at right angles with either an "X" or a "Y" axis of that crystal.

2. The faces of the blank must be perfectly flat and parallel with each other.

3. The edges of the blank must be free from nicks, cracks, chips, sharp corners or other irregularities.

4. The thickness of the blank must be such that it will oscillate on the desired frequency. This critical thickness is different for the X, Y and zero coefficient-cut plates. While rarely identically the same for two plates of the same cut, it may be determined approximately from the curves or the formulas of Fig. 1.

If it can be assumed that the blank was properly cut from the original crystal, the first condition above may be disregarded. The grinding job, then, must include satisfying the other three. The equipment needed for this job consists mainly of a small glass plate, a supply of powdered carborundum, and a pair of micrometer calipers. The micrometers are the most important part of the grinding equipment, and should have a readable accuracy of approximately one ten-thousandth of an inch. Only a small amount of carborundum is needed, but several different grades should be available, ranging from No. 200 or No. 400 to the finest obtainable, which is about No. 900. This carborundum may be secured from any manufacturing optician. The glass should be as hard a grade as it is possible to obtain, and should be perfectly smooth and flat. "Flint" plate glass is preferred, but pieces of old automo-

bile plate glass ten or twelve inches square are suitable and are easy to obtain.

Much has been said about cleaning a quartz plate in Carbona (carbon-tetrachloride), or alcohol. These may be necessary if there is grease on the blank; otherwise it is sufficient to wash it carefully in water and dry it on a clean cloth. This should be done every time the blank is to be

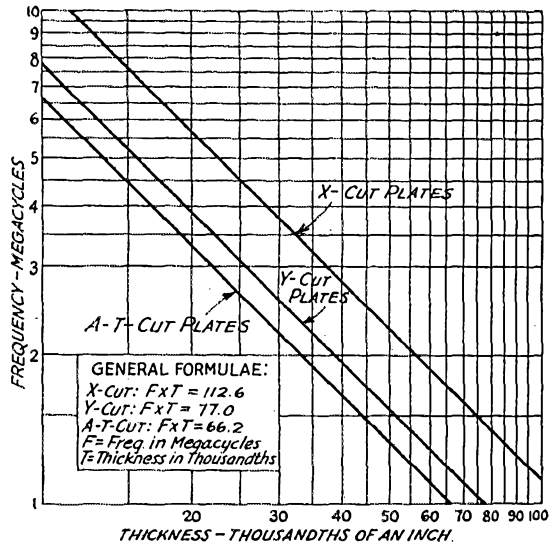

FIG. 1

inspected or "miked," to keep the carborundum out of the micrometers, and every time it is put in the holder of the test oscillator. The holder and the crystal must each be perfectly clean and dry whenever tests are made for oscillating properties.

In grinding the blank, a small amount of the appropriate grade of powdered carborundum is placed on the glass and enough water is added to make a fairly thick mud. The quartz blank is then scrubbed back and forth in this grinding mixture, with one finger, in long smooth strokes covering almost the entire face of the glass. The use of one finger, if held on the top center of the blank, reduces the tendency to tip the blank

(Continued on page 74)

\*U. S. Radio Inspector, 222 West Ninth St., Grand Island, Neb.

# Operating Notes on the New Pentodes

SINCE the brief announcement of the new Raytheon RK-23 and RK-25 and R.C.A. 802 tubes in December *QST*, more detailed information on the tubes has been released by the manufacturers, and some of the tubes themselves are beginning to get around in amateur circles. Tests have shown that they do just about what would be expected of them, considering their power ratings. Besides the suppressor-grid modulation feature for low-power phone work, the typical pentode characteristic of high output with low excitation power makes them ideally suited to use as buffer amplifiers—and, for that matter, as final amplifiers in transmitters in which the number of stages must be kept to a minimum. An r.f. output of 25 watts is not difficult to obtain from one tube by going slightly over the normal plate-current rating, and this with excitation quite small in comparison to that usually handed to a 10 or other three-element tube of comparable power rating.

Both the 802 and RK-23 (to save space we'll consider the RK-23 and RK-25 synonymous, since the tubes are identical except for their heater ratings) can be used in the same sockets in which the multitudinous 59's are now installed. All the 59 connections still apply except for the plate pin, which is left blank in the case of the RK-23 and is used with the 802 to make connection to extra shielding inside the tube. This shielding is not a tube element, however, so the plate pin on the socket should simply be connected to ground. Fig. 1 shows the top-of-socket connections for both tubes.

By way of review, the general characteristics of the tubes are given below:

	802	RK-23	RK-25
Heater voltage.....	6.3	2.5	6.3 volts
Heater current.....	0.95	2.0	0.8 amp.
Grid-plate capacitance...	0.15	0.04	$\mu$ fd.
Input capacitance.....	12.0	10.0	$\mu$ fd.
Output capacitance.....	8.5	10.0	$\mu$ fd.
Max. plate dissipation...	10	12	watts
Max. screen dissipation...	6	6	watts
Max. plate voltage.....	500	500	volts
Max. screen voltage.....	250	200	volts

The safe plate current will vary with the type of service, depending upon the plate efficiency to be expected. In Class-C service where the tube is used as an unmodulated power amplifier—with efficiency high enough to keep the plate dissipation within the maximum rating, the maximum plate current rating is 60 milliamperes. For other

types of service the plate current will be limited by the safe plate dissipation.

The screen current will likewise vary in different types of service. It is important that the screen dissipation be kept at or below the rated value; i.e., the screen should not be allowed to show more than a dull red heat.

## SUPPRESSOR-GRID MODULATION

The suppressor modulation characteristics of the two tubes appear to be quite similar. Power outputs of the order of 3 to 3.5 watts, capable of being modulated 100 percent, are obtainable from both types of tubes under maximum operating conditions. The required peak audio grid swing on the suppressor is 65 volts with the 802 and 75 volts with the RK-23, negative bias on the suppressor being 45 volts on the former, 30 volts on the latter. The audio power requirements imposed by the small current taken by the suppressor-grid are slight, and are well within the capabilities of a Type 56 tube. Control-grid bias for suppressor-grid modulation is not critical, running

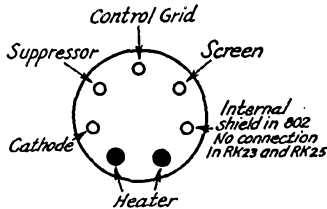

FIG. 1—SOCKET CONNECTIONS OF THE NEW R.F. PENTODES  
The connections are viewed from the top of the socket.

between 75 and 90 volts.

The following table, taken from the published data on the 802, shows what may be expected from this tube as a suppressor-grid modulated amplifier under different operating conditions:

Plate voltage.....	400	500	500 volts
Screen voltage.....	150	200	200 volts
Control grid bias (approx.)....	-85	-90	-90 volts
Suppressor bias.....	-40	-53	-45 volts
Peak audio suppressor voltage....	40	53	65 volts
Peak r.f. excitation voltage.....	125	125	125 volts
Plate current.....	18	20	22 ma.
Screen current.....	28	28	28 ma.
Control grid current.....	7.5	5.0	4.5 ma.
Driving power (approx.).....	0.9	0.6	0.5 watts
Peak power output (approx.)....	8	12	14 watts
Carrier power output (approx.)...	2	3	3.5 watts

The first two operating conditions are of interest because the audio-frequency suppressor voltage swings only to the zero-voltage point and not into the positive region, as is the case in the last column. The increase in carrier output resulting from driving the suppressor-grid into the positive region is quite small. In all cases the r.f. power required for excitation is less than one watt.

Suppressor modulation characteristics of the 802 are shown graphically in Fig. 2. The r.f. output current curve bends off quite sharply above 25 volts positive on the suppressor, indicating that this is about the limiting voltage for distortionless modulation.

### GRID-BIAS MODULATION

The curves of Fig. 3, showing the performance of the 802 as a grid-bias modulated amplifier, also will be of interest. Two sets of operating conditions for this type of service are given below:

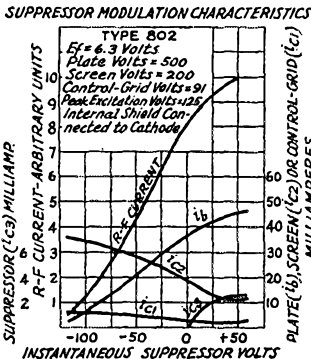

FIG. 2.—SUPPRESSOR-GRID MODULATION CHARACTERISTICS OF THE 802

Plate voltage	400	500 volts
Screen voltage	150	200 volts
Control-grid bias (approx.)	-105	-130 volts
Suppressor voltage	0	0 volts
Plate current	25	25 ma.
Screen current	7.5	8 ma.
Grid current	2	1 ma.
Peak r.f. excitation voltage	125	145 volts
Peak audio grid voltage	40	50 volts
Driving power (approx.)	1	0.8 watts
Peak Power output (approx.)	12	16 watts
Carrier power output (approx.)	3	4 watts

Comparison of grid-bias modulation with suppressor modulation shows that the plate efficiency and output to be expected are approximately the same, and also that the same modulator tube that satisfies the requirements of suppressor modulation also will be adequate for grid-bias modulation. Slightly more excitation power is needed for grid-bias modulation, although the difference is not great. The chief differences between the two systems lie in practical operating considerations; the grid-bias system requires more careful adjustment than the suppressor system for linear modulation, and it is necessary to use a bias source having exceptionally good voltage regulation, such as a bank of batteries. Suppressor modulation, on the other hand, is quite tolerant so far as adjustment is concerned, and the bias for both control grid and suppressor can be obtained in the same way as they would in ordinary telegraph service.

The tubes also can be used as Class-B linear amplifiers, giving outputs and plate efficiencies comparable to those obtained with grid-bias and suppressor modulation. Because of the small power output, however, it is probable that a setup with a preceding modulated amplifier requiring, as it might, additional driving stages, would be an uneconomical way of obtaining three or

four watts of modulated output. The tubes are not recommended for use as Class-C plate-modulated amplifiers.

### USING THE TUBES AS AMPLIFIERS

If the tubes are used to replace 59 doublers in an existing layout with the hope that they also can be used as straight un-neutralized amplifiers, it is quite possible that some physical changes in the circuit will have to be made. As is the case with any screen-grid amplifier, care must be taken that there is no chance for feedback between plate and grid circuits by a path external to the tube itself. This may or may not mean that the input and output circuits will have to be shielded. From our experiments with the tubes it seems quite certain, however, that the tubes themselves have to be shielded, although complete shielding is not necessary. A short shield which encloses the base and lower part of the tube and extends up around the lower part of the plate is sufficient, its purpose presumably being to shield the plate lead from the rest of the tube and thus eliminate any extra and unwanted grid-plate capacity. Both types of tubes have been operated successfully with no tendency toward self-oscillation with no other shielding in the circuit than this. It was necessary, however, to arrange the input and output tuned circuits so that coupling between them was minimized (coil

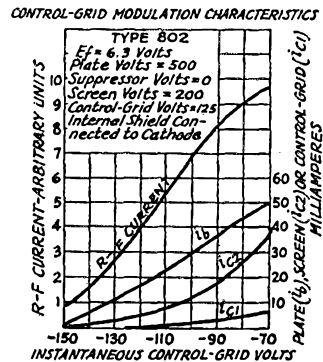

FIG. 3.—GRID-BIAS MODULATION CHARACTERISTICS OF THE 802

axes at right angles) and to have them fairly well separated physically. In compact sets the input and output circuits probably would have to be rather completely shielded from each other.

A typical amplifier circuit is shown in Fig. 4. The plate tuned circuit  $LC$  should be low- $C$  at the operating frequency. The grid leak  $R$ , when used, may have a value between 20,000 and 50,000 ohms, the former giving somewhat more output when amplifying straight through and the latter better output when doubling. The difference is small, however. The by-pass condensers,  $C_2$ , are not critical as to value and should be fairly large



—0.002 or more. The exception to this would be the suppressor-grid by-pass when the suppressor is to be modulated, in which case the condenser should not be so large as to cut off the higher audio frequencies. A 0.001 condenser should be satisfactory for this work.

When the tube is capacity-coupled to the preceding stage the capacity of the excitation condenser,  $C_1$ , should be adjustable for best results. Too much capacity at  $C_1$  will overload the previous stage and reduce the output. A value around 30  $\mu\text{fd.}$  is about right; satisfactory adjustment can be obtained by using an air midget having a maximum capacity of 50 or 100  $\mu\text{fd.}$  and adjusting it for best output under actual operating conditions.

Cathode bias may be used according to the alternative system shown in Fig. 4, in which case the grid leak  $R$  may be omitted. The cathode resistor  $R_1$  should be variable and have a maximum resistance of about 2000 ohms, and should be capable of dissipating about 10 watts. The adjustable feature makes it possible to find the optimum operating bias. Cathode bias offers protection to the tube, in case of excitation failure, which is lacking when the grid leak alone is used.

As power amplifiers, the tubes give greatest output when the screen-grid voltage is maintained at the recommended values. Increasing the screen voltage beyond this only causes the tube to become unstable and exhibit the usual sign of grid emission—climbing plate current. Very nearly maximum output can be obtained with the suppressor grid tied directly to the cathode. A slight increase in output results when the suppressor is operated at a positive potential of 40 or 50 volts, but the increase does not seem to warrant the extra power supply complication unless a suitable tap already is available on the voltage divider. Screen voltage is preferably obtained from a voltage-divider tap, although a dropping resistor from the plate supply may be used. A 10-watt resistor of about 20,000 ohms is recommended as a series dropping resistor.

When using the tubes as doublers the screen voltage sometimes can be reduced with benefit. In one case cutting the screen voltage to half the rated maximum value left the power output unchanged but improved the plate efficiency, as evidenced by lower plate current. An output of 5 to 10 watts is to be expected from one of the tubes as a doubler.

Excitation requirements appear to be quite small and the plate efficiency high when the tubes are used as straight power amplifiers for c.w. work. In a test set-up one of them gave an output of 25 watts on 7 mc. with a d.c. plate input of slightly over 30 watts, the excitation being taken from a Tri-tet oscillator doubling from a 3.5-mc. crystal with only 250 volts and 15 ma. on the plate. Higher oscillator voltage gave no increase in output.

The tubes also can be worked successfully as controlled oscillators or oscillating amplifiers, locking in very readily when coupled to a weak crystal-controlled source. Ordinarily there will be a tendency toward self-oscillation in non-shielded circuits if particular care is not taken to prevent

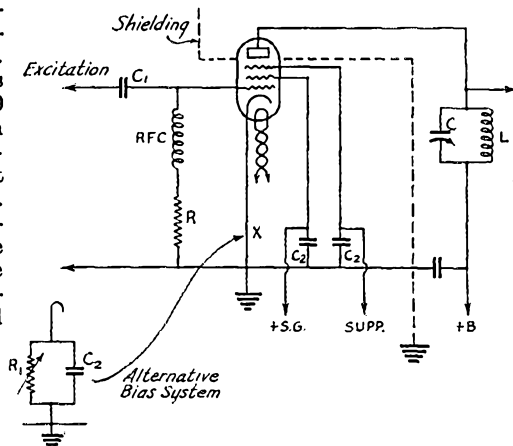

FIG. 4—A TYPICAL AMPLIFIER CIRCUIT FOR THE R.F. PENTODES

Tuned-circuit and by-pass values do not differ from those used with other tubes. The only circuit element likely to be critical in adjustment is the coupling condenser,  $C_1$ , which preferably should be a midget variable of about 100  $\mu\text{fd.}$  maximum capacity.

feedback external to the tube itself; this tendency can be used to advantage if the tube is to be used as a locked oscillator, since no particular provision need be made for intentional feedback.

One of the tubes used as a regenerative amplifier can easily be controlled on 14 mc. by a Tri-tet oscillator having its plate circuit tuned to the fourth harmonic of a 3.5-mc. crystal.

#### AS OSCILLATORS

The tubes may be used as electron-coupled oscillators, in which case they have the advantage over the 59 that the plate circuit may be tuned to the fundamental as well as a harmonic frequency. Experience with them indicates that tuning through resonance on the fundamental produces a considerable frequency change, at least in an unshielded circuit. Possibly thorough shielding would help to reduce such a frequency change. Frequency stability with respect to changes in plate-supply potentials (with the screen supply coming from a voltage divider across the plate supply) is excellent, however; changes in supply voltage of the order of 25% produce only a barely perceptible change in frequency. For maximum stability of this type it is necessary to find the optimum screen-to-plate voltage ratio, just as in the case of other electron-coupled oscillator tubes. A screen voltage of one-third the plate voltage is about optimum.

(Continued on page 66)

# With the Affiliated Clubs

**G**REETINGS to the following clubs, affiliated with the A.R.R.L. on December 14, 1934:

Elkhart Amateur Radio Club, Elkhart, Indiana.

Halifax Amateur Radio Club, Halifax, Nova Scotia, Canada.

## Hamfests Scheduled

... at Boston, Mass., February 2d

The annual hamfest under the auspices of the South Shore Amateur Radio Club and the Eastern Massachusetts Amateur Radio Association will be held at the Hotel Bradford, Boston, on Saturday, February 2d. Tickets, including admission and banquet, \$2.00. Admission only, with chance at prizes, \$.50. The general program will include speakers, stunts, contests, organization meetings, plenty of prizes and a real banquet. The following comprise the "committee in charge": W1ZK, W1AKY, W1ASI, W1KH, W1HRF, W1SB. This team has turned out some gala affairs in the past . . . don't fail to be at the Bradford on February 2d!!

... at Cleveland, Ohio, February 2d

The Lakewood Radio Club will hold its third annual hamfest February 2d at 7:30 p.m. E.S.T. in the Lakewood Masonic Temple, corner of Andrews and Detroit Avenues, Lakewood (Cleveland), Ohio. Admission: \$.99, which covers a full course dinner. Plenty of entertainment, good speakers, music by hams, hundreds of fine prizes, are some of the features offered by the "hamfest association" of the Lakewood Club. It behooves hams in the vicinity of Cleveland to plan to be present at this get-together. Anyone with "ham" in his (or her) blood is welcome!

... at Rochester, N. Y., February 9th

The Rochester Amateur Radio Association announces its annual hamfest. The date: February 9th, Saturday. The time: Contests start at 3:00 p.m., banquet at 7:30 p.m. The place: Columbus Civic Center, Lawn and Chestnut Streets, Rochester, N. Y. Speakers: W8CPC, Toastmaster; W1SZ, *QST*; W8CMP, Director, A.R.R.L. Atlantic Division; Bern O'Brien, WHEC; G2KB and all the regular Western New York gang. Tax: \$1.50. General: Contests for everybody; a bowling tournament between Buffalo and Rochester. Prizes and a good time for all! It will be too good to miss!!

... at Mountainside, N. J., February 16th

The annual dinner of the Central Jersey Radio Club will be held Saturday evening, February 16th, at the Mountainside Inn, located on New Jersey State Highway No. 29 near the center of Mountainside, N. J. In addition to the dinner there will be an entertainment and bowling. Admission will be \$.50 to "paid-up" members and \$1.50 to "non-paid-up" members and visitors. All amateurs are cordially invited to attend; a good time is promised! It is suggested that those planning to attend get in touch with Raymond Sutcliffe, W2DKA, 159 Belvidere Ave., Fanwood, N. J., or Robert Morris, W2LV, 22 Mountain View Rd., Millburn, N. J.

... at Wilmington, Delaware, March 2

The Delaware Amateur Radio Club is planning to hold its second annual banquet on Saturday evening, March 2d, in the Gold Ball Room of the Hotel duPont, Wilmington, Del. Complete details are expected for the next issue of *QST*.

### CERTIFICATE FOR CLUB WINNERS IN DX COMPETITION

See complete details on the Seventh International Relay Competition elsewhere in this issue. Besides the Section Award, in each affiliated club group where *three or more* hams take part, A.R.R.L. will make a special certificate award, which will be given through the local affiliated club and countersigned by the club president or club activities manager as a permanent trophy to the local DX champion. Last year 21 affiliated clubs took advantage of the special Club Award and entered at least three members or prospective

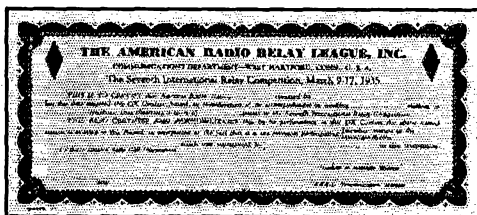

THE CERTIFICATE TO BE AWARDED CLUB WINNERS IN THE INTERNATIONAL DX COMPETITION

members. The number of A.R.R.L.-affiliated clubs has increased substantially until now there are more than 400 clubs on the active list of affiliates. Attention of all clubs is invited to the announcement of the March DX Contest so that local DX competitions may be sponsored by

clubs. Club officers! Which of your club members can bring honors to your association by winning the award made by A.R.R.L. through your society? Ask your gang about it.

#### A GOOD SUGGESTION

W. F. Soules, W9DCM, President of the Minneapolis Radio Club, offers a fine idea: "We did not have a regular meeting place and could not afford to rent club rooms. Our club is sponsoring a division convention in the spring, so we arranged with a hotel for accommodations during that time. The convention will be held in the hotel, and the hotel will be the official hotel during the convention. We presented our plan to the hotel eight months ago and said we would hold our convention and banquet there, if they would provide a free meeting place for us for a year. Perhaps this idea may help other clubs looking for a meeting place. Even local banquets or ham-fests might be an inducement for the hotel to provide a meeting place."

#### PUBLIC SERVICE!

Members of the Hannibal (Mo.) Amateur Radio Club performed a noteworthy piece of public service when a snow storm in early December disrupted all communication between Hannibal and Brookfield, Mo. W9PYF and W9GBC, H.A.R.C. members, cooperated in maintaining contact with W9RTG, Brookfield, until normal communication channels were reopened. Traffic was handled for the Chicago, Burlington & Quincy Railroad, Southwestern Bell Telephone Co., and Western Union. The Hannibal Club through its members and its station, W9KEM, aims to "be ready" when an emergency arises . . . not a bad aim for all clubs!

The Providence (R. I.) Radio Association elected the following officers for 1935: W1GTN, president; W1DSZ, vice-president; T. E. Fletcher, secretary; W1HRC, treasurer; W1AFO and W1BES, executive committee.

#### VISIT THE CLUBS

At A.R.R.L. headquarters there are recorded the addresses of the several hundred amateur radio clubs affiliated with the League, their places and times of meetings. Clubs are splendid places to get acquainted with other amateurs and to participate in interesting discussions on amateur radio. Why not drop in at your local club and "meet the gang"? Address the Communications Manager (enclosing 3¢ stamp, please) for data on affiliated Clubs in your vicinity.

#### FELLSWAY RADIO CLUB—W1ZO

How many amateurs believe in Santa Claus? The entire membership of the Fellsway Radio Club of Medford, Mass., does! At least it is convinced that Mr. Roger Sullivan, Medford, is that club's "Santa." It happened in the spring of

1932. An amateur went to Mr. Sullivan, who is a notary, to have his license sworn to. Though not an amateur himself, Mr. Sullivan was found to be very much interested in amateur radio and suggested that this amateur, who came to have his license fixed up, collect the representative amateurs in the surrounding area and form a club. Furthermore, he offered the club the use of an entire three-and-one-half-acre lot on one of the highest spots in Medford, and offered to erect a club house on any part of it that suited the mem-

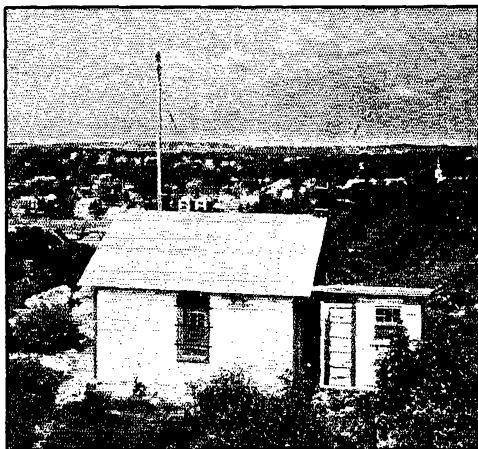

AN ENVIABLE LOCATION—OVERLOOKING THE CITY!

Home of the Fellsway Radio Club (Medford, Mass.) and W1ZO, the club station. This club house consists of two rooms, an operating room (6 ft. x 18 ft.) and a lobby (12 ft. x 18 ft.); a separate building (8 ft. x 10 ft.) houses the fuel supply and chemical closet.

bers. Within two months a fine club house was erected, built for year 'round use (furniture and heating equipment were also supplied gratis!). Present transmitters include crystal-controlled fifty-watters on 7 mc., crystal-controlled RK-18 on 3.5 mc., and a 56-mc. rig. Both c.w. and 'phone are used. A thirty-foot mast on the main shack and a fifty-foot mast on a hill behind the shack provide the main antenna supports—and mighty satisfactory ones at that! An operator is on watch at W1ZO every evening except Sunday. A chief operator, elected each year, organizes the "watch list," runs contests within the club, and checks the operating procedure of all club operators. A technician, also elected, has complete charge of all equipment, supervises new construction and all major adjustments. This arrangement has worked out excellently and is recommended for clubs that operate a station. Present officers of the F.R.A.: W1HHW, president; W1AIW, vice-president; Roger Sullivan, trustee; W1BME, secretary-treasurer; W1FAX, chief operator; W1HMK, technician.

(Continued on page 70)

# The Seventh International Relay Competition

March 9th<sup>1</sup>—17th

A.R.R.L.'s Annual DX Contest—All the World (with W/VE)—Swap Self-Assigned Numbers in DX QSOs—New! 90-hour Total-Time Limit. Extra 500 to 8000 points will also be Added, Depending on Number Bands Used—Certificates for Winners

By F. E. Handy\*

**T**HE A.R.R.L. invites you to take part with amateur operators everywhere in . . . **THE SEVENTH INTERNATIONAL RELAY COMPETITION.** Get on the air . . . any amateur frequency . . . March 9th<sup>1</sup>—17th inclusive 1935. Contest is for most DX QSOs. Worldwide! Advance entry not required. Try your luck and report.

## GENERAL PLAN OF CONTEST

Amateurs with the prefixes W and VE will be taking part in a QSO Party with stations in all parts of the world. When they effect DX QSOs, self-assigned serial numbers will be exchanged and noted in the contest report. From this record each station will submit its score. From the scores (which the Contest Committee will verify by cross-examination of logs) the winners will be determined for each locality, and certificates awarded.

Stations outside<sup>2</sup> the U. S. and Canada will try to work as many W and VE stations as possible to exchange serial numbers. Stations in all localities need only take part on the dates announced and report results at the end of the tests to receive credit in *QST*, and be eligible for awards.

The main competition each operator must consider comes from operators in his immediate A.R.R.L. Section in the case of W and VE stations,<sup>3</sup> and in the case of all other amateurs it comes from the individual operators in their country or locality using the same prefix.<sup>4</sup> The W/VE awards are for the operator running up the best record for each Section.

## NEW CREDIT FOR DX ON ALL BANDS

Indications are that DX is going to be extremely good on all bands this year. In addition

\* Communications Manager, A.R.R.L.

<sup>1</sup> 6:01 p.m., C.S.T., March eighth—see discussion under "the contest period."

<sup>2</sup> Alaska, Hawaii, Philippine Islands, Cuba, Porto Rico, and Newfoundland, in fact, all localities using PREFIXES other than W or VE will receive *QST* mention and awards based on their work with W/VE stations.

<sup>3</sup> Page 5 of this *QST* carries a complete list of the Sections of the A.R.R.L. Field Organization.

<sup>4</sup> Consult the list of call-prefixes for different countries of the world as given in the Twelfth Edition of *The Radio Amateur's Handbook*.

to fine conditions on 7- and 14-mc. bands many 1750-kc. stations have received cards from "across the pond." HB9Y, G6RB, ON4AU, ON4JB, D4BAR, PAØXU, PAØDC, PAØHR, PAØASD, PAØLR, OE7JH, F8UT, D4BMJ and K6LHK have and are now working dozens of W/VE hams using the 3500-kc. band. F8VS, D4BMJ, HB9AQ, G6WY, OK1VA, CN8MN and G6BS have been heard by W9ABS, W8EUY and W2ABS. W1CEJ, VE3JT, W8AQ, W1DIJ, W1DBU, W1CJD, W1IJB, W1ABN, W2ABS, W3DUK, W8UW, W8KKG, W1APU, W8EUY, W2EJZ, VE3GT, VE3JW, VE3LC, W1UE, W9AEH, and W9NNZ have all worked one or more of the DX stations listed. Between December 10th and 25th W8EUY worked G6RB ten times and had 17 European QSOs. We suspect that VK's and ZL's can be worked at will from the west coast U. S. A., too, as soon as some of them make use of this band. Since we are anxious that all hams realize and make use of the fine DX characteristics of the low frequency bands when used over an "all dark" path, an extra contest credit, a bonus to be added to the score kept under the usual well known system, will be given for work on more frequency bands. This year we are introducing a fixed credit, to be added to scores (after multiplier), this 500 point credit to be doubled, each time DX contacts with your transmitter on an additional frequency band are completed. Thus, add 500, 1000, 2000, 4000 or 8000 points to the completed score for successful number exchanges indicated in the contest log on one, two, three, four, or five different amateur bands!

## NEW TIME LIMIT

Operate as much as you want to during the contest period, and report all your DX contacts. Keep track of the time you start and stop operating your station, however, and when you report, don't forget to include the "number of hours station operation in the contest" by totaling up these periods. Up to and including 90-hours' total contest operation there is no penalty, and nothing to be done when computing your score. Should you find that you operated a total of 100 hours (for example), your Grand Total Score should be

multiplied by the fraction  $\frac{9.0}{100}$  to give your "corrected score".

You can operate 6 hours per day, 12 hours each Saturday, and 16 hours each Sunday, working DX in the contest, and you will still have put in only 86 hours total. The 90-hour factor is designed to permit everyone to enjoy DX possibilities to the maximum throughout the whole 9-day period. This plan permits the average ham to plan for his working day, for meals, for 8 hours' daily sleep, etc. Cross examination of logs makes it possible to check the operating time submitted as may be necessary, of course. We hope you like the new "time" scheme. We could have shortened the contest period, but then a few days of poor general DX conditions might ruin all our fun and results. The new time limit puts contestants on a fair basis whether employed or having full time to apply to the contest.

In counting up your total contest time please be fair and honest. We know you will. What constitutes "contest operating hours"? Not the hours you traffic hounds spend keeping local skeds with each other within the U. S. A. and Canada. Not the time spent in local rag chews, swapping DX results, scores, and other dope. Not hours idly listening-in on different bands for amusement during slack time in your daily occupation or when away from your transmitting controls. But if you listen for DX with the ability to call DX stations if, as, and when, you hear them, that time counts, whether you do any calling or working or not. The whole period is to be charged against "contest operating time", and not just the time after you started transmitting. That phase of ham radio which brings DX thrills in world-wide and international terms appeals to the sporting blood in every amateur, so we know you will be fair and both note down and report all the time you spend looking for, and calling, and working, the elusive DX.

#### THE CONTEST PERIOD

To avoid misunderstanding and possible confusion the exact local starting and ending time for our DX competition is given in the following table. These times are based on "Greenwich" and should be computed for any part of the world from the Greenwich meridian. The contest runs from Saturday, March 9th, through Sunday, March 17th (until Monday, March 18th, G.T.).

Time	Starts	Ends
Greenwich	March 9th 001 (12:01 a.m.)	March 17th 2359 (11:59 p.m.)
A.S.T.	8th 8:01 p.m.	17th 7:59 p.m.
E.S.T.	8th 7:01 p.m.	17th 6:59 p.m.
C.S.T.	8th 6:01 p.m.	17th 5:59 p.m.
M.S.T.	8th 5:01 p.m.	17th 4:59 p.m.
P.S.T.	8th 4:01 p.m.	17th 3:59 p.m.

#### AWARDS

Green-bordered certificates, a high-class lithographed job of striking appearance, will be awarded<sup>6</sup>: (1) one in each remotely located country or territory—all hams using the same prefix compete for an award, and (2) in each of 64 A.R.R.L. Sections, mainland U. S. A. and Canada (see page 5, *QST*).

Since the certificate awards will be made to the operator of the highest scoring station in each country, this puts all operators using the same prefix in competition with each other—and similarly each A.R.R.L. section-boundary circumscribes a competing group. DX-transmission

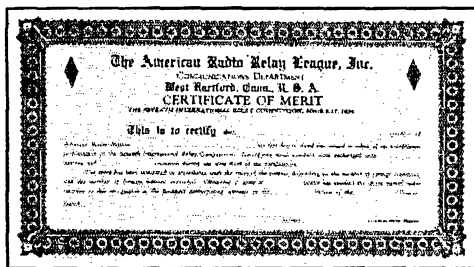

AWARD TO WINNER IN EACH W/VE SECTION

characteristics being the same for all operators in each award-area, the chances of being a winner depend on operating ability and stations and are equally fair to all. Shall we reserve one of these certificates for your station?

#### AFFILIATED CLUB PARTICIPATION

To encourage local participation, additional certificate awards (besides the A.R.R.L. Section awards) will be made through each club where three or more individual club members, or new local hams invited by such a club, take part. Reports must be made direct to A.R.R.L., West Hartford, mentioning the name of the club, to be eligible for the affiliated-club-award. There is nothing more fascinating than to plan local competitions and swap results in a friendly way with the ham-across-town as the operating goes along. Entrants who mention their club will be eligible for both club and Section certificate awards.

#### SCORING

Both the W/VE station, and the station in the remote locality receive one point when the W or VE serial number is acknowledged by the station in the remote locality. Each operator, similarly, may add two points further when a six-figure number (to U. S. A./Canada) is acknowledged or OKed by a W/VE station.

<sup>6</sup> A ruling of the A.R.R.L. Board of Directors permits stations of A.R.R.L.-*QST* staff members to participate in contests with the provision that the operators of such stations shall be ineligible to receive any League awards.

After all the individual points have been added together, this sum, in the case of W or VE participants, is to be multiplied by the number of countries or localities (prefixes) worked to give the score. In the same way, those taking part in other different countries (remote), multiply their total of points by the number of U. S. and Canadian districts (licensing areas) they have succeeded in contacting, to give the score. There are nine U. S. and five Canadian licensing areas making a possible multiplier of fourteen!

To this score is added the fixed credit (500, 1000, 2000, 4000, or 8000) depending on the number of different frequency bands used for your transmitter on which at least one DX QSO (number swap) is indicated in the log and can later be confirmed if necessary. This fixed credit is of course added last, after all multiplying of Sections or districts, and gives the Grand Total. Except for this frequency-band-credit, scoring is exactly the same as in past years. Only when the Grand Total required more than 90-hours contest operation will this be reduced proportionately in determining the final score.

All competitors are requested to submit their lists, even if they only show a small score. In so doing they are supporting claims made in logs from other stations, and they will receive full credit for their work in QST.

The summary of score must show all stations worked, and the operators "sine" for each QSO if there is more than one operator. Awards will be based on the station total and will be made to the individual operator making the largest part of this total.

#### THE SELF-ASSIGNED SERIAL NUMBERS

Any amateur station, anywhere, can take part without advance entry. Each operator taking

part will assign himself a distinctive three-numeral group and use this throughout the contest as the first part of each number exchanged. Numbers exchanged will have six figures, the latter three taken from the first half of each number-combination received. To confirm your first contact, since no numbers will then have been received, the six-figure group sent will consist of the three numbers which identify you in each log, followed by three "naughts."

"Handling" a serial number includes the transmission and receipt of radio acknowledgment (QSL) of same, and the entry of date, time and station call, and numbers as handled, for purposes of record. There is no object in working the same station more than once in the contest period if three points have been earned by a full exchange during a QSO. If but one (or two) point(s) result(s) from a first contact with a station, you can complete the three points (maximum that can be secured with any one station) by working this amateur later in the contest period, and handling a serial number in the opposite direction.

#### PRACTICAL IDEAS

Bill Conklin, W9FM, points to the good operating of ZL's in the last DX contest including in their CQs information on how they would tune their receivers in looking for replies. Bill asks, "Why not devise four abbreviations to indicate how one will tune after a call?" We are indebted to Art Bates, W9FO, for suggesting the following in answer to this manifest need:

- QHM—Will start to listen at high frequency end of band and tune towards middle of band.
- QMH—Will start to listen in the middle of the band and tune toward the high freq. end.
- QLM—Will start to listen at the low frequency end of band and tune towards middle of band.

#### EXAMPLE OF CONTEST LOG

STATION W4YXZ					SERIAL NUMBER 543		
Date and Time	Station Worked	Country	Continent	Frequency	Serial Nr.		Points
					Sent	Received	
March 8th 7:02 p.m., E.S.T. (or 0002 G.T.)	G6RB	G. B.	Europe	3.5 mc.	543,000	765,000	3
March 9th 7:38 p.m.	VK3WL	Aust.	Oceania	7 mc.	543,765	855,887	3
8:50 p.m.	ZL2CI	N. Z.	Oceania	7 mc.	543,858	398,667	3
11:50 p.m.	J2GX	Japan	Asia	14 mc.	543,398	395,984	3
March 9th 12:05 a.m., E.S.T.	PY2BN	Brazil	So. America	7 mc.	543,398	777,000	3
3:10 a.m., E.S.T.	VK5PK	Aust.	Oceania	7 mc.	543,777		1
16 x 5 (countries—prefixes) = 80 (total)							16
+Special credit for work on three bands = 2,000							
<b>GRAND TOTAL SCORE</b>							<b>2,080</b>

QML—Will start to listen in the middle of the band and tune toward the low frequency end.

It is unnecessary and undesirable to crowd our stations into the few kc. at the band edges. In this DX test try the above, you operators in remote localities. Use "MH" and "ML" tuning, and take your pick of the flock of answers you get! By using these signals properly stations at one end of the 20-meter band can readily get calls from stations working at the other end. More QSO's, less wasted time, shorter calls, and less QRM are all among the advantages.

The R-S-T<sup>6</sup> system of signal reporting, adopted by A.R.R.L. because of its general popularity and increasingly widespread use among all amateurs, has proved a great time-saver in other A.R.R.L. contests at the same time it makes unusually complete reports possible. Use of R-S-T should make it easy to follow G6NJ's suggestion that all hams include full reports of signals along with their number exchanges in the DX contest.

W8DED, W9CPQ and several others would have us "prohibit the use of CQ for W/VE contestants" to do away with needless QRM. That's too big a thing to enforce, and not every amateur approves entirely. We urge the view that the smartest operators will refrain from sending unnecessary CQs anyway (within W/VE) in their own best interest. We urge all remotely located DX stations to make it a point to increase their own use of CQ, and to refrain from answering any unrestrained, unintelligent, several-minute CQ-DX calls from W/VE's, giving preference instead to the keen operators who call individually.

#### REPORTING

Reports or summaries from participating stations must be received at A.R.R.L. Hdq. from

<sup>6</sup> See, "A New Standard System of Reporting Signals" page 18, October QST, 1934. Other references: October 1934 T. and R. Bulletin; November QST 1934, page 72 chart; page 211, Twelfth Edition, *The Radio Amateur's Handbook*; also, first inside cover, A.R.R.L. Station Log (3rd Edition, Pub'n 7).

#### LOG, SEVENTH A.R.R.L. INTERNATIONAL RELAY COMPETITION

Name.....  
 Address.....  
 Nr. Frequency Bands on which at least one successful DX exchange was made.....  
 (On logs from W or VE show:)  
 A.R.R.L. Section.....  
 Nr. DX stations QSOed.....  
 Nr. countries (prefixes) QSOed.....  
 (by I.A.R.U.-WAC list)

Call Signal.....  
 Transmitter Tubes.....  
 Plate watts (input last stage).....  
 Number Hours station operation\* in contest.....  
 (On logs from remote points indicate:)  
 Nr. W/VE stations QSOed.....  
 Nr. USA-Canada licensing areas QSOed.....

Date	Time (local)	Station Worked	Country	Continent	Frequency	Serial Number		Points (1) or (2)
						Sent	Received	
TOTAL.....								

all W/VE stations on or before noon April 23, 1935, to be counted in the results or to be considered in the awards. From all outlying localities, reports must be received on or before May 28, 1935. Play safe . . . mail your report immediately at the end of the contest period to avoid delay and insure that your results are credited. Show your claimed-score in full, follow-

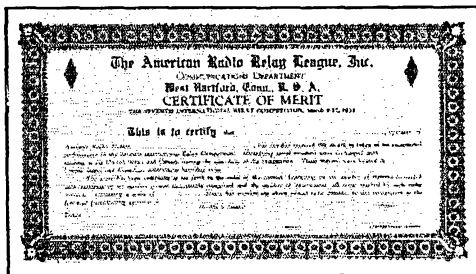

#### AWARD TO FOREIGN WINNERS

ing a tabulation of points in the log-form indicated with this announcement.

#### CONTEST NOTES

You can't help but work a new bunch of stations, run up some new DX records for your station, get a new bunch of QSL-cards, have a whale of a lot of fun, and perhaps rate an A.R.R.L. award at the conclusion. Any neatly kept tabulation in the form given with this announcement will be an acceptable and welcome report. Any operator you work that doesn't know "what it's all about" can be referred to these pages of QST.

Results in previous relay competitions indicate that the majority of stations worked were raised, not by sending CQ, or testing on a half-dozen frequencies—but by first listening and locating foreign amateur stations, then going after them. No excuse for ten-minute CQ's. The stations in remote localities, not W/VE stations, are the ones using CQ most effectively. The planning of best use of frequencies and operating hours for most effective participation and real operating skill are necessary to successful DX-work.

Operators of all stations have equal opportunity insofar as this can be arranged in this contest. Much depends on the judgment of the individual operators in determining the times and frequencies of operation of each station as well as on operating ability itself. Low power apparatus succeeds as often as high power on 14,000 kc.

(Continued on page 86)

# Band Switching in the Universal Exciter Unit

By F. G. Southworth,\* W5EOW

**A**FTER reading W2AOE'S article on band switching in December 1934 *QST*, it occurred to me that some of the gang might be interested in the method of band switching in my rig. You see, when I devised it I wanted to really cover all of the most used bands, both c.w. and 'phone, without plug-in coils or any major operations on the rig. The set-up shown is the result. Of course it is only the exciter unit,<sup>1</sup> the maximum power output needed being on the order of three watts with which to feed a pair of 46's in the final. This unit seems to be really worth the money for 20, 80 and two different spots in the 40-meter c.w. band, and for 160-, 80- and 20-meter 'phone band coverage—with but the flip of a switch.

Fig. 1 shows the circuit of the unit. Three crystals are used, 1961-, 3526- and 7123-kc. These are shown in the order named as *x*, *y* and *z*. The tubes used are both 59's and it was found unnecessary to neutralize the second 59 even when using it as a straight amplifier. With the exception of the switching arrangement the circuit is orthodox. The coils are tapped but it will be noticed that in each case when only a portion of any coil is used the remainder is short circuited.

The switches are merely double-arm rotary switches mounted on small pieces of bakelite, fourteen switch points being used to give a seven-position switch. All three of these switches are controlled as a unit by a single quarter-inch bakelite rod. The layout of one of these switches is also shown in Fig. 1.

Coil A is wound for full use on the 1750-kc. band with taps for the 3500- and 7000-kc. bands. In the total coil and the tapped portions, slightly fewer turns were used than is usual in order that a high-C circuit would result.

Coil B is wound for low-c at 1750-kc. and tapped for low-c on 3500, 7000 and 14,000 kc.

Coil C is wound for low-c at 3500 kc. and tapped for low-c on 7000 and 14,000 kc.

The different switch positions are as follows:

No. 1—1961-kc. crystal, first 59 straight crystal

oscillator, second 59 not used. Output, 160-meter 'phone band.

No. 2—1961-kc. crystal, first 59 Tri-tet crystal oscillator-doubler, second 59 straight r.f. amplifier. Output, 80-meter 'phone band.

No. 3—3526-kc. crystal, first 59 straight crystal oscillator, second 59 not used. Output, 80-meter c.w. band.

No. 4—3526-kc. crystal, first 59 Tri-tet crystal oscillator-doubler, second 59 straight amplifier. Output, low-frequency end of 40-meter c.w. band.

No. 5—3526-kc. crystal, first 59 Tri-tet crystal oscillator-doubler, second 59 doubler. Output, 20-meter c.w. band.

No. 6—7123-kc. crystal, first 59 straight crystal oscillator, second 59 not used. Output, high-frequency end of 40-meter c.w. band.

No. 7—7123-kc. crystal, first 59 Tri-tet crystal

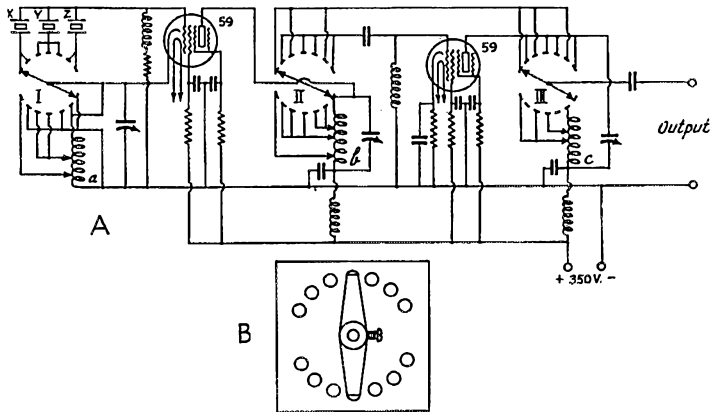

FIG. 1

oscillator-doubler, second 59 straight amplifier. Output, 20-meter 'phone band.

It will be noticed that in all but one case the second 59 is used as a straight r.f. amplifier; and, further, that in each of these cases the first 59 is used as a Tri-tet. This was done because the first 59 alone did not have the needed power output when used as a Tri-tet oscillator and doubler. The output in all cases, with the exception of the fifth position, is between 3 and 3.5 watts. Since greater output was not needed, and because of the ease of band changing, this unit has been found to give very satisfactory results.

**Strays**

Ship Excellency has the call KISS.

—Capt. Paul F. Johnson

\* 5623 East Side Ave., Dallas, Texas.

<sup>1</sup> See *QST*, Oct. and Nov. 1933; also *The Radio Amateur's Handbook* (12th Edition), Chapter Seven.





## Automatic Carrier Switching

Phone operators who have fairly good superhet receivers can, by the addition of a relay or two, easily fix up an automatic switching arrangement by means of which the transmitter is put on the air as soon as the other party to a QSO cuts off his carrier. A diagram of the scheme, suggested by Fred L. Seufert, W2AOG, is given in Fig. 1. The chief essential of the control circuit is the relay  $Ry_1$ , which must be capable of operating

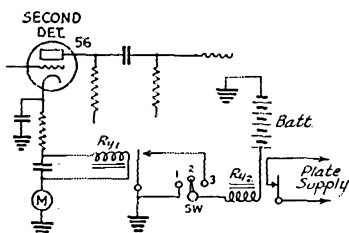

FIG. 1—AUTOMATIC SWITCHING CIRCUIT BY WHICH A RECEIVED CARRIER CONTROLS THE TRANSMITTER

on about .7 ma. and releasing on .5 ma. — in other words, remaining idle under normal detector plate current conditions when no carrier is being received, and operating as soon as a carrier of appreciable strength causes the detector plate current to rise. W2AOG finds a W.E. type B145 relay to be quite satisfactory.

The operation of the system is as follows: With the switch Sw set at position 2, tune in a signal which causes the detector plate current to rise appreciably — say to 1 ma. Next set the switch in position 3; the power relay,  $Ry_2$ , is now in the circuit but does not operate because the control-relay armature is held open. As soon as the received carrier goes off, however, the detector plate current drops and the relay armature is released, closing the contacts and actuating the power relay, thus putting the transmitter on the air. To cut off the transmitter, move the switch to position 2. When the other fellow's carrier comes on again, the switch can be moved to position 3 and the process repeated.

For complete manual operation, the switch is moved between positions 1 and 2.

## Suppressor-Grid Keying

Although keying of the suppressor-grid in a pentode-type tube used as a power amplifier has

been previously suggested in *QST*, the circuit of Fig. 2, suggested by Jim McEwen, W8EWC, has some features which are worthy of consideration from a practical standpoint, since no additional negative bias source is required for keying. Suppressor bias with the key open is secured from the drop across the grid leak caused by the flow of grid current when the tube is being excited. W8EWC writes as follows concerning the circuit:

"The grid bias on the amplifier must be high to make the most of this system, but experience shows that such bias is not in the least damaging to output and efficiency. The more scrupulous, who wish to use normal bias, may add a battery in series with  $R_2$  for more negative bias on the suppressor. The 250,000-ohm resistor is used to keep from shorting the grid leak when keying; in effect it becomes part of the grid leak when the key is down. It must be high to keep the battery and grid leak from fighting about the control grid bias. Neither the negative nor positive potentials should be obtained from a power supply voltage divider, since that would make no load voltages high, resulting in bad sparking at the key; also, no relay is needed with this system.

"In my particular case, using an RK-20, a current of about 7 mils flows through the grid leak,

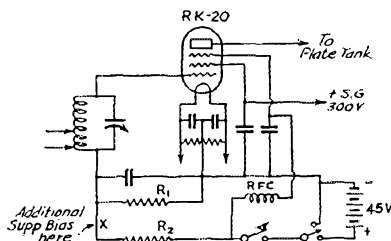

FIG. 2—KEYING SUPPRESSOR-GRID TUBES WITHOUT ADDITIONAL BLOCKING-BIAS SUPPLY

the resistance of which is between 20,000 and 24,000 ohms, so that the bias, with the key up, on both control and suppressor grids is between 140 and 168 volts. With the key down the bias on the control grid is somewhat lower, while the positive suppressor bias is determined by the battery voltage. A switch is provided to place the suppressor at ground potential when desired, but better plate efficiency seems to be obtained with the positive potential.

"Since the keyed current is about 4 mils there is a minimum of sparking at the contacts of the

key, and keying is free from chirps and clicks since there is no great shock or stress on any part of the circuit."

### Automatic Microphone Battery Switch

L. A. Stafford, W2DIB, has a good suggestion for those fellows prone to forget to turn off the mike battery when the station goes off the air. The idea is shown diagrammatically in Fig. 3. A relay is arranged with its contacts in series with the microphone battery circuit and the winding

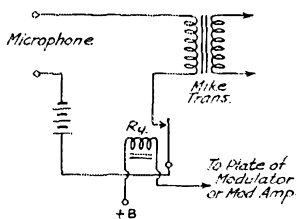

FIG. 3 — RELAY CIRCUIT FOR AUTOMATICALLY CUTTING THE MICROPHONE BATTERY CIRCUIT WHEN TRANSMITTER IS INOPERATIVE

in series with the plate supply for the modulator (if Class A) or the modulated amplifier. The battery circuit is thus automatically closed when the transmitter is in operation, but opens as soon as the plate supply is cut off.

The relay itself must be one which will operate on the plate current taken by the stage to which it is connected, and its characteristics naturally will vary with the type of transmitter in use. It is desirable that it should not introduce too much resistance in the circuit.

### Washing Out the B.C. Interference

The following note from C. W. Roth, W9DOU, may prove of value in cases where keying interference is caused in nearby broadcast receivers — especially when investigation shows that the trouble is caused by overloading of the receiver:

"Here at W9DOU we had some trouble with slight clicks in our own broadcast receiver, and complete blocking of a neighbor's receiver. The description of the effect on our own set was that it was 'clicking,' but a careful check revealed that it was very slight blocking, fading the signals

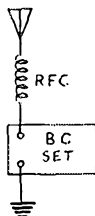

FIG. 4 — CHOKE IN SERIES WITH RECEIVING ANTENNA TO REDUCE INTERFERENCE TO B.C. RECEIVERS

being received on the set when the key was pressed. Someone's seemingly foolish suggestion

was followed, and a radio-frequency choke of the receiver type was connected in the antenna lead of the b.c. set, with the result that nothing was received. Next a choke consisting of No. 26 enamel wound solid for about 3 inches on a piece of broomstick was tried, connected as shown in Fig. 4, and the difficulty was cured. This was on 80 meters.

"Finally the neighbors got tired of having holes chopped in their programs so they spoke up, and investigation showed that the 160-meter transmitter was causing their trouble. Accordingly a choke was again wound on a broomstick with No. 26 enamel, but between four and five inches long; it was tried close to the receiver in the antenna lead and everything was jake.

"No investigation has been made to determine whether or not the length of the choke is critical, but it apparently is not, for other hams having

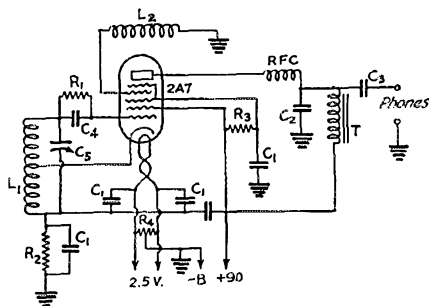

FIG. 5 — ELECTRON-COUPLED FREQUENCY-METER MONITOR USING 2A7 TUBE

L<sub>1</sub> — 90 turns No. 28 d.c.c. on 1-inch form, tapped 30 turns from ground.

L<sub>2</sub> — See text.

R<sub>1</sub> — 10,000 ohms.

R<sub>2</sub> — 250 ohms.

R<sub>3</sub> — 50,000 ohms.

C<sub>1</sub> — .01- $\mu$ fd. mica condenser.

C<sub>2</sub> — .0005- $\mu$ fd. mica.

C<sub>3</sub> — .006- $\mu$ fd. mica.

C<sub>4</sub> — .0025- $\mu$ fd. mica.

C<sub>5</sub> — See text.

T — Audio transformer with primary and secondary in series.

RFC — See text.

this same trouble, identified as 'clicks,' have cured it by winding chokes of the approximate dimensions given, with no case of failure to date."

### Single-Tube E.C. Freqmeter-Monitor

Some time ago while reading an article explaining the operation of the 2A7 tube, I was struck with the idea of adapting this tube for use as an e.c. frequency meter-monitor. Inasmuch as this tube was designed for a very similar purpose, it seemed quite logical to suppose that this tube might have some advantages not possessed by other tubes commonly used in frequency meters. What experiments I have made seem to bear out this supposition.

The circuit used is shown in Fig. 5. Condenser C<sub>4</sub> is a homemade one, the capacity of which is

unknown to me. However its capacity is without doubt close to that of the General Radio 556, since the inductance which it tunes is the same as that used in the frequency meter described in the *Handbook*. The radio frequency choke is a 3 to 1 a.f. transformer with the primary and secondary connected in series. Incidentally, it makes a difference in the effective impedance which way they are connected; I used an a.c. voltmeter to determine the right way.  $L_2$  is the pick-up coil, and various sizes were tried here. As I use the frequency meter only for 80-meter band a coil of 65 turns (1-inch diameter) seemed to give the best results, but for other bands other sizes might prove to be better.

From my experiments the size of the pick-up coil doesn't seem to affect the frequency of the oscillator; indeed, it is possible to tune this coil with a variable condenser without affecting the frequency. The coil or even the grid cap of the tube may be touched with the hand without causing enough change in frequency to throw the oscillator off zero beat with either transmitter or receiver, and plugging headphones in or out has no apparent effect. The pick-up coil may be left outside the frequency meter-monitor shield box in order to obtain a good loud signal in the headphones.

— Lloyd L. Thornton, W8KDM

### Matched-Impedance Coupling to the Zepp

(Continued from page 24)

the hand. After all adjustments have been completed, the connections should be made permanent by soldering.

For the benefit of those amateurs who may happen to have an ammeter or a lamp in the center of the antenna proper, the procedure for making the above adjustments is similar but the field strength indicator is not a necessity. The procedure for adjusting is the same except that the adjustments are made for maximum antenna current, as indicated by the meter in the center of the antenna, and for the condition of no standing waves on the feeders.

It may be of value to point out also that it is not strictly necessary for the feeders to go out from the quarter-wave section at right angles, although this is advantageous when the line can be so constructed. If the feeders make even an acute angle with respect to the quarter-wave section it seems to make little difference, as long as the adjustments are made with the feeders in this position.

#### OPERATING PROOF

It may be of interest to give a brief account of some practical results obtained with an antenna of this type. In order to determine whether or not this antenna had any advantages over the

conventional Zeppelin arrangement with tuned feeders, as far as radiation efficiency was concerned, the following test was made:

The frequency used was in the 14-mc. 'phone band, the radiator itself being cut to a length of exactly 33 feet and mounted vertically on a 40-foot wooden pole. The field strength indicator was set up at quite a distance from the antenna, and the antenna was arranged to be fed by means of the conventional Zeppelin feeder arrangement with series tuning. With the transmitter properly loaded and the antenna brought into exact resonance, the pick-up wire on the field strength indicator was shortened until a reading of a little less than half-scale was obtained. Without changing the adjustment of the field strength indicator in any way, the new antenna coupling scheme was tried out. With the same value of input to the final stage and with everything else in proper adjustment, it was found that the reading of the field meter had increased by approximately 50% over the value with the Zeppelin arrangement. Upon comparing the two antennas, with the cooperation of a distant receiving station, it was found that the new antenna gave an increase in audibility of from 2 to 3 points on the old *R* scale. Needless to say, this amount of improvement is worthwhile under any condition.

This antenna has been used with a great deal of success by W3COT and W3VX on 56 mc. and by the writer and W3IS on 14-mc. 'phone. It also has been adopted by the RCA Victor Company for use in their "Terra-Wave" transmitters operating in the 7-8 meter police band. There is no reason at all why this antenna cannot be constructed to give better operation on the lower frequency bands as well, particularly when a horizontal radiator is used. If the user wishes to go to the trouble, it is possible to construct an antenna of this type for multi-band operation—provided he is willing to construct the quarter-wave section so that its length and the position of the feeders on it could be changed for each band. All matched impedance systems, it should be remembered, work best on only one frequency.



Have you ever met A. Ham, W6BLR?

—W6KBY

### The Cover

The cover illustration this month shows some of the radio antennas and wind velocity measuring equipment at the Mount Washington, New Hampshire, observatory. Since wind speeds of anything up to 175 miles per hour are relatively common, the antennas can hardly be strung up in the usual ham way. We wonder that there is a way of putting up antennas to stand a typical Mount Washington draught.



# Amateur Radio STATIONS



## W9KJF, Indianapolis, Ind.

**C**OMPACTNESS is the watchword at W9KJF, owned by Eugene Van Sickle, 1115 DeQuincy St., Indianapolis. The two main units shown in the photograph are two separate 'phone transmitters, each with built-in power supply, the one on the right even having the receiver on the same frame.

The set at the left is a 75-meter 'phone of fairly high-power output. Starting from a 160-meter crystal, a 59 Tri-tet doubling in its plate circuit

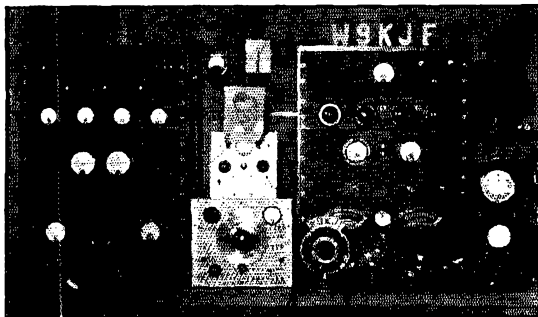

is used to excite an 841 buffer stage, which in turn drives the final amplifier, a 203-A. This part of the set occupies the upper deck. The middle section houses a Class-B modulator using 830-B tubes with appropriate input and output transformers, and also a low-voltage power pack which supplies plate voltage for the 59 and grid bias for the 203-A. At the bottom is the main power supply which takes care of the modulator, modulated amplifier and the buffer stage. It uses 866-A rectifiers and a single-section filter consisting of a 10-henry choke and a 5- $\mu$ fd. condenser.

The outfit at the right is a lower-power rig used for 160-, 75- and 20-meter 'phone. Its r.f. line-up includes a 59 Tri-tet, 59 neutralized buffer, and a pair of 10's in parallel, all in the upper deck. The middle shelf holds the speech amplifier, 59 Class-B modulator, and the single heavy-duty power supply which takes care of the whole set. The bottom section of this frame is occupied by the Patterson PR-10 receiver. That the small set gets out is proved by the fact that an R9 report on its signals has been received from Hawaii.

The aluminum box on the table between the

two frames houses an electron-coupled frequency meter. On top of it is a microphone and mixing panel. Both carbon and crystal mikes are used, the former being preferred for its tone and the latter for its carrying qualities in QRM.

## W8HWR, Utica, N. Y.

**A**NOTHER b.c. station operator who doesn't get enough of radio in working hours is Lawrence W. Briggs, owner of W8HWR. Like many others of the same profession, too, he seems to depend on c.w. for his amateur activities, since we see a couple of keys but no microphone on the operating table. Space has been left on the transmitter rack to take care of a future modulator, however.

The transmitter at W8HWR is crystal-controlled, having a 59 Tri-tet oscillator, a 46 buffer, and a pair of 510's in push-pull. The final stage is coupled to the antenna through a filter network of the type described by Collins in a past issue of *QST*. Two power supplies, one for the 59 and 46 and the other for the final stage, are mounted on the rack. Blank panels are provided for a Class-B modulator and the third power supply which will be required when the modulator is installed. At present the transmitter is used principally for c.w. work in the 3500-kc. band,

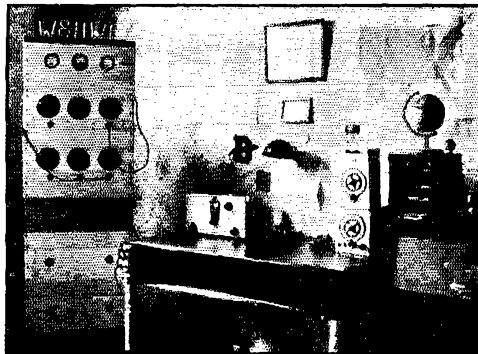

with an input of about 60 watts. The antenna is 100 feet long, with 36-foot feeders.

The receiver, at the left on the operating table, is a home-built outfit using a 58 untuned r.f.

(Continued on page 72)

# • I. A. R. U. NEWS •

Devoted to the interests and activities of the

## INTERNATIONAL AMATEUR RADIO UNION

President: H. P. MAXIM

Vice-President: C. H. STEWART

Secretary: K. B. WARNER

Headquarters Society: THE AMERICAN RADIO RELAY LEAGUE, West Hartford, Conn.

### MEMBER SOCIETIES

American Radio Relay League  
Associazione Radiotecnica Italiana  
Canadian Section, A.R.R.L.  
Československá Amatérská Vysílací  
Deutscher Amateur Sende-und-Empfangs  
Dienst  
Experimenterende Danske Radioamatører  
Irish Radio Transmitters Society  
Liga Mexicana de Radio Experimentadores

Nederlandsche Vereeniging voor Internationaal Radioamateurisme  
Nederlandsch-Indische Vereeniging voor  
International Radioamateurisme  
New Zealand Association of Radio Transmitters  
Norsk Radio Relas Liga  
Polski Związek Krotkofalowcow  
Radio Society of Great Britain

Rede dos Emissores Portugueses  
Reseau Belge  
Reseau des Emetteurs Français  
South African Radio Relay League  
Suomen Radioamatööriliitto r.y.  
Sveriges Sandareamatörer  
Unión de Radioemisores Españoles  
Union Schweiz Kurzwellen Amateur  
Wireless Institute of Australia

Conducted by Clinton B. DeSoto

### Peace:

Copy for this department is late this month. We've been getting out the semi-annual Calendar of the Union (the medium through which official I.A.R.U. business is conducted), and what with that and the effort to clean up tag ends of the year's activities, not to mention the holiday season—well, anyway, here it is, the day after New Year's Day, and these pages should have been at the printer's a week ago.

Notwithstanding, we're going to take the time to comment on a letter sent in here some time ago by Jerry Mathis of W3BES, and brought to mind again by conversations with a number of radio people, amateur and commercial. Here is the letter:

"I seldom spill any ink, but one of the things that really interests me most is international radio friendship. This sudden splurge is brought about by the FB picture of LU2CA'S ether buster. I am in possession of a few intimate details regarding this station.

"The rig was thrown together by Atilio Alzona, LU1BW, who is a big shot with one of the large radio manufacturers and one of the best informed radio men in those parts. While in Philly on business LU1BW visited my humble shack quite a few times for skeds with LU2CA. We handled much interesting traffic with amazing ease. LU1BW knew no English and I no Spanish, so even in spite of an interpreter there was much arm-waving. I took him over to see W3BVX, who 'set them up,' and he was truly appreciative of the hospitality. . . .

"CM1AM also visited my shack when the Cuban mail was on strike, and QSO'ed his brother in Cuba.

"Most of the boys do not realize the possibili-

ties of service we amateurs can render to the stranger within our gates, nor the pleasure of a job well done."

Now the activities described in the foregoing are not extraordinary. They are, in fact, relatively commonplace; the sort of thing that almost any of us has or can expect to have the opportunity to accomplish. The point is that such activities *are* accomplishments; that the interna-



F3AK RECEIVING POSITION

The transmitter is a remotely-controlled Mesny with 20 watts input.

tional amity and goodwill that can be created by such simple acts is of important consequence not only to amateur radio but to the civilization of the world.

QST has carried many preachments on this

subject. In the past ten years what was once an aphorism has become a banality. But at the same time that which was true about the worth of amateur radio from the international standpoint then is ten times more true to-day; we've ten times as many amateurs, ten times as many countries in which amateurs are found, ten times as much activity—and ten times as much recognition.

Recently the old cry of the betterment of international understanding has been raised in connection with short-wave broadcasting. Throughout the world, broadcast receivers are being sold that predominantly have high-frequency tuning ranges as well as the standard broadcast ranges. Set manufacturers and high-frequency broadcasters, flushed with the lucrativeness of this field, are shouting with wild abandon of the escape from locally nationalistic censorship, the broader international understanding, the better international relationships that will result from this craze.

This is largely poppycock. In the first place, everyone who knows the least thing about international broadcasting, especially on the European continent, knows that the most rigid censorship prevails with regard to broadcast material. When revolutions arise, one of the first strategic moves these days is to seize control of broadcasting and alter the policy of propaganda. Most short-wave broadcasters, when they present political news, are literally and exactly propagandists—nothing more. What gain to international amity and peace can arise from the *buncombe* of politicians and governmentally-mouthed "commentators," whether spouting national jingoism for intranational or spewing insincere and misleading blandishments for extra-national consumption? Of what more avail is it to hear one lie from a foreign broadcaster than to read another lie in your morning newspaper? No, the use of short-wave broadcasting as a medium for nationalistic propaganda (the only politico-social use to which it is now being put) won't mean peace among nations or the building up of better international relationships.

But in amateur radio—the direct communication between two individuals, with no more censorship than that attending normal public conversation—removed from political influence and carried on solely as a personal social gesture—there lies a different destiny. It is yours to command.

And now, back to work.

#### General:

QSL information: The new address of the Reseau Belge, for QSL cards as well as all other services, is 312 rue Royale, Brussels, Belgium . . . . The R.E.F., as the parent society, offers a QSL service for Morocco and all African colonies (CN and FM8) via the newly organized

A.A.E.M., B.P. 50, Casablanca, Maroc . . . . . Australian QSL cards can be sent via VK4US, 77 Moreton St., New Farm, Brisbane, Queensland, as well as to Box 1524V, G.P.O., Brisbane . . . . .

I.A.R.U. headquarters takes this opportunity of acknowledging, on behalf of staff members of the Union and the A.R.R.L., holiday greetings from many of its international friends . . . . . Especially grateful are we for messages from S. G. Waite, Hon. Sec'y of the N.Z.A.R.T., and Harry Caldicott, VK2DA, traffic manager of the N.S.W. Division, W.I.A. . . . .

Active Iraq stations have been reduced to two at the present time, according to Vernon Dameron, W8HGA . . . . . One is E. Goodwin, YI6GF, at Mosul; the other is L. A. C. Lewis, YI5GL, of the No. 1 A.C.C., R.A.F., Hinaidi, Baghdad . . . . . ON4UF's new QRA is L. Richard, Chateau, Belgium . . . . . Absolutely unique among the cities of the United States is Oshkosh, Wisconsin . . . . . Every licensed amateur in the city is WAC, we are told by Erwin Rasmussen, W9FAV; a 100% WAC town; reminds us of Czechoslovakia when there were more WAC's than licenses; FB! . . . . . W9FAV says further. "Some 75 countries have been heard this year and over 50 worked. Not bad, considering that this isn't a location that was any good for DX until this year. It seems to bear out the observations made in the I.A.R.U. News about characteristics varying in different locations. For years it was impossible to hear foreign signals; now contacts can be made with R9 reports on both ends, including R9 from Japan. The most unusual contact was made with XU3FU, the Russian icebreaker "Krassin" off Wrangell Island, who has been contacted several times. . . . ."

Many in the world of amateur radio are mourning the passing way on November 22nd of Louis A. Era, ON4BC, after a long and painful illness. ON4BC is recalled by a great many old time amateurs as an outstanding DX man, having made friends the world over. In the later stages of his illness, when it was impossible for him to stay in his shack, he arranged his station for remote operation from his room; radio was his only hobby. Two days before his death he was still at his receiver. Amateurs in the Antwerp area, in particular, feel the loss of a very dear friend. (Thanks, ON4GW, ON4AC, W1LZ.)

#### Special:

"QTC," official organ of the South African Radio Relay League, in two months will have achieved the mature age (among amateur magazines) of seven years. That we have had occasion to admire its conduct, views, and progress in the past is demonstrated by the fact that on occasion we have taken the liberty of quoting from its columns in *QST*. The "QTC" of to-day is the

(Continued on page 72)



# OPERATING NEWS



Conducted by the Communications Department

F. E. Handy, Communications Manager

E. L. Battey, Asst. Communications Manager

**I**LLEGAL operation, called "bootlegging" and the like, we immediately think of as of concern to the Federal Communications Commission. In the minutes of the F.C.C. we note with increasing frequency the names of persons denied amateur licenses and on whom are imposed the penalties as provided by law for violation—persons not eligible to become amateurs because they have been apprehended as mixed up in cases of unauthorized transmission. These things are as they should be. In the U.S.A. licenses are granted free to those qualified, and a fair examination system to determine the qualified is available to all on application. Let this mention of the subject be sufficient warning to all potential bootleggers of radio calls and frequencies, that their disregard of the requirements and rights of others will not be tolerated, either by the F.C.C., or by an aroused amateur public opinion!

The average amateur becomes indignant when someone borrows his call. We have read letters from many such, sympathized, and given advice. We fear, however, that the average ham operator is much too tolerant, until his particular reputation hangs in the balance for some non-amateur's indiscretion! Let us each, here and now, do our part to help ourselves, the licensing authority, and better the whole amateur fraternity by adopting a non-compromising attitude toward those making up the really small percentage of "bootleggers" that our ingenuity will enable us to discover working in our midst—trying to pass as amateurs! This problem was cited in the January issue of the Amateur Transmitters Association (W. Pa.) News. We quote therefrom:

"You may know one person bootlegging on 160 meters; W8XYZ may know another on 40-; W8ZYX may know a case on 80-. Taken altogether we have knowledge of many cases. On these bands calls are borrowed, on 5-meters they are coined. Why a tendency to wink at non-licensed operation in this band? The unlicensed operators working there are not even, for the most part, interested in becoming amateurs. They just want the thrill of 'personal broadcasting,' having got a cheap transmitter, or followed those details given in 'popular' magazines that get persons of six-year mental age on the air. (Such periodicals rarely mention the legal requirement to obtain a license.) The question is this: ARE WE TO TOLERATE OR CONDONE NON-AMATEUR AND BOOTLEG OPERATION IN OUR AMATEUR BANDS, SUCH CAUSING AN APPRECIABLE PORTION OF THE OFF-FREQUENCY OPERATION AND A GREAT DEAL OF QRM OF THE POOR SIGNAL VARIETY?"

One logical spot for action is in and through the Enforcement Committees of and mass action taken by the local amateur radio club, and there is a representative ham club in practically every large community. We fear that many clubs that might assume a position of local leadership in correcting local difficulties are shirking duties and opportunities. But it is not too late to correct these things. It is our personal observation that many radio clubs are too much "all-sufficient unto themselves." Organized for social contact or educational betterment within a small group, there are some associations that seldom invite or draw new members to meetings, that do not so much as think about assuming any position of leadership in their particular ham community, or accept any particular responsibility with respect to the operating ethics of either members or non-members. But the A.T.A., and many another live-wire club is really doing something on this, and other operating problems (local QRM, public relations, off-frequency harmonics). As the

A.T.A. suggests, by reason of our numbers we can by our patronage cause the manufacturers in their advertising, and the non-amateur editors, in their articles, to stress the necessity for licenses for any transmission work. To individual club members we suggest that it is time to get busy and talk the subject out at the very next meeting. Pool all knowledge that can be contributed by various members regarding unlicensed operation in your locality! See that an enforcement program is worked out and started functioning. Make it a friendly helpful program to amateurs. Assist in solving problems by co-operation and technical advice. Advise non-amateurs how application forms for station and operator licenses may be procured—and how necessary such licenses are! After this information is known to non-licensed men there is not the slightest excuse for any illegal operation or evasion, and the cooperation of the local F.C.C. office should, in our opinion, be solicited as non-compliance, stubbornness, and lack of qualifications make necessary, in the opinion of those the club places in charge of this work.

Whether you belong to a club or not, bootleg operation is, or should be, the pressing concern of every licensed operator. Let us make it a personal pledge to each do our share to check up on unlicensed operation, and to cast the call bootlegger (we know no lower form of animal life) from our midst. To "borrow" a call is to pose under someone else's name, and identity, to pass ones self off falsely as another person. For such despicable practices let there be no quarter!

—F. E. H.

## Amateur Radio Scores Again!

By Henry Jenkins, W7DIZ

A tribute to the ingenuity and resourcefulness of radio amateurs! Working under handicaps seldom experienced in any kind of emergency, W7DIZ constructed an operative station from a broadcast receiver, and salvaged parts, "door-knobs to wall telephone gear." We present this story as an outstanding example of amateur emergency work. This first hand account is by W7DIZ, first assistant keeper of the U. S. Light Station on Tillamook Rock, Oregon, and tells just how he established communication with the mainland during the severe and damaging storm of October 21, 1934.—EDITOR.

**T**HIS record concerns the violent storm that swept the North Pacific, causing most severe damage to the light station on Tillamook Rock on October 21, 1934. At 10:00 p.m. on October 20th, a fresh southeast wind was blowing, with light rain. During the night the wind increased to gale force and changed to southwest. About 3:00 a.m. on October 21st, seas were extremely high, swells hitting the base of the Rock from southwest and spray coming over the Rock. At 9:30 a.m. I was awakened with a sudden jar. Water completely covered me, all my clothes and bedding completely wet. The seas at this time had started over the entire tower and pounded against the window shutters of my room until the catch let go, opening them and flooding the room. The wind was

blowing at an estimated 100 miles per hour or more. Seas covered the entire lighthouse carrying with it large rocks, debris and fish which were smashed through the lantern plate glass, breaking 16 panes and flooding all quarters. In endeavoring to replace glass panes with emergency wooden shutters, Hugo Hanson's right hand was deeply cut. While assisting dressing his wound, I read the barometer reading, which was 28.92 inches. Each time the tons of water would cover the building, coming down with terrific impact on the roof, the barometer would drop immediately to 28.72 inches, returning as soon as the impact was over.

Impacts from tons of water and rocks would occur at most every three seconds, lasting from about 10:00 a.m. to noon. About 10:15 a.m. a terrific impact occurred in which the tower and building were enveloped with giant seas. After this it was noticed that the large 80-foot derrick and telephone cable had been swept away.

That was, in my opinion, the wave that did most of the damage. In addition to the derrick and cable, it broke off about six feet of the west end of the Rock, hurling rocks weighing as high as 50 pounds through tower and the roof, smashing shutters although they were made of half-inch wood. It carried the shutters at the base of the building away, flooding under all floors and breaking the piping of the heating system, thereby cutting off heat, which was badly needed at this time. We were all soaked and walking in water, cold and extremely tired. The lantern and fog signal were now inoperative, both greatly needed by mariners. If we were to put out a different light and they came up close enough to identify it, the consequences might be disastrous. Nevertheless, a fixed white light was set up and a crude short-wave transmitter and receiver built up consisting of parts from an Atwater Kent broadcast receiver on hand at the station, batteries, scraps of tinfoil, copper and brass.

At 6:50 p.m., October 23rd, I made the first call for W7CXX and was picked up by W7WR, who was QSO W7CXX and notified him someone was calling him, although W7WR could not tell who was calling, as the signals were so weak and chirpy. A message informing the lighthouse superintendent of damage, etc., was the first traffic handled.

### The Transmitter

When things around here got half dry, I immediately got two boards approximately 10 by 12 inches. Not having any tube sockets, I drilled holes in each board for sockets and I took the two type 30 tubes out of the broadcast set and soldered leads on the prongs of the tubes. On the transmitter board I placed a tank inductance which I made out of some bell transformer wire. The wire was wound on the case from the regular NR6 "A" battery. I used 14 turns. The tuning condenser was a three-gang condenser taken from the BC set, but I only used the middle section. I made the series fixed condensers for the antenna out of tin foil and bread wax paper. I used no grid condenser or leak. The plate blocking condenser was swiped out of the BC set. I made the R.F. choke from one of the regular BC chokes by removing turns, etc. This junk when finally assembled completed a T.N.T. circuit but, as noted, used no grid condenser or leak. I used the batteries out of the telephone for the filaments, using two NR6 "A" batteries in series. The three "B" batteries from the BC receiver were down to 80 volts. For a key I just broke battery connection with my hand at first, but later found a piece of spring brass and made a hand key. I sent my first four messages with my fingers breaking the connection on the "B" batteries. After that I used the home made hand key. My transmitting antenna consisted of 40 feet of salvaged antenna wire that was left from the BC set.

### The Receiver

Not having a spark of anything to work with, the receiver was a crude affair. For the coil I found an old regular telephone receiver and used the shell as the form on which to wind the 3.5-mc. band coil, used 45 turns

of wire I swiped from BC set for the grid coil. There were 20 turns of plate coil. As I had no means of controlling oscillation I put enough plate turns to keep it oscillating at all times. For antenna series condenser I just twisted two feet of insulated wire together, and the capacity of their separation by the insulation served as the series condenser, between the grid coil and the antenna. I used a tin-foil condenser made up for the grid condenser, but no grid leak. The tuning condenser was made from two brass plates that I took off the door knob. I fastened one plate on the receiver base and the other was separated by a piece of bread wax paper. Tuning was accomplished by shoving one plate over the other with a pencil. The values of these parts were unknown but, due to past experience, I finally found the 3.5-mc. band. The first station I heard was W7RT in Seattle. Then I knew where I was and, tuning by shoving around with a pencil, found W7CXX working W7WR. I left the receiver tuned on W7CXX, and while he was transmitting I tuned my transmitter to his frequency by listening to him with my transmitter oscillating. At 6:50 p.m., October 23rd, I called W7CXX, and W7WR informed W7CXX someone was calling him. That was the way QSO was made with the Mainland and God's country. Shipping was warned by notifying the superintendent of lighthouses via message through W7CXX, who relayed to the superintendent, Portland, via Western Union.

In addition to W7CXX and W7WR, who handled the Portland traffic from Tillamook Rock, credit is due W7BXQ and W7BOO of Astoria, Oregon, who handled all the Astoria QRR traffic to the Lighthouse Service supply depot and to the master of the Lighthouse tender Rose, such as weather reports, landing conditions, medical advice, etc. The emergency traffic from and to Tillamook Rock resulted in (1) vessels navigating these treacherous waters being warned of the lighthouse being darkened; (2) repair supplies shipped to the lighthouse; (3) medical treatment to injured and ill light tenders; (4) the Coast Guard life-saving crew and boat going to the rescue of those at the isolated lighthouse. Schedules were maintained for several days, until repairs could be made.

### The "No-Guess" System

In line with the new "Q" signal suggested by W9FO to indicate over what portion of an amateur band you intend to tune after calling CQ, W3DVC, Philadelphia, Pa., suggests a similar system. His indications are the same as W9FO's except that the "Q" is left off: "HM" means "I am tuning from the high-frequency end of the band to the middle of the band"; "LM" means "from the low-frequency end to the middle"; "MH" means "from the middle to the high-frequency end"; and "ML" means "from the middle to the low-frequency end." He also suggests two additional indications, to show that you intend to cover the entire band: "HL," meaning "I am tuning over the entire band, starting at the high-frequency end and tuning towards the low-frequency end," and "LH," meaning "I am tuning over the entire band starting at the low-frequency end." An example of the use of these various abbreviations is "CQ de W3DVC LM K," indicating that W3DVC will tune from the low end to the middle. The use of signals to show where you are going to tune should help reduce unnecessary calling and save every one's operating time.

A QSO of 7 hours and 40 minutes duration is claimed by W9OLW and W9PSP on 1.75-mc. phone. The QSO, starting at 10:20 a.m. and ending at 6:00 p.m., ranged from two-way to five-way. Anyone causing QRM, was promptly taken into the QSO. Stations worked were W9PTR, W9FFP, W9IMN, W9KYW, W9NXA, W9HPI, W9NLP, W9PBM, W9MEV, W9PVM.



The following contribution by Mr. James O. Wood, wins C.D. article contest prize for this month. Your articles on any phase of amateur communication activity are likewise solicited and may win you a bound Handbook, six logs, or equivalent credit applied toward other A.R.R.L. supplies. Let us have your article, and mark it "for the C.D. Contest," please. -- F. E. H.

## Beginners, QRM and Restrictions

By James O. Wood \*

MUCH is said about beginners these days in conjunction with QRM on various popular DX bands. The Old-Timer has perhaps forgotten the day he went into the R.I.'s office, drew a diagram of a simple crystal detector and spark or possibly a one-tube receiver and Hartley, read a bit of code, was almost invariably handed an amateur ticket; he did his own share of pestering those who were before him until he got enough actual operating experience to qualify as one of the gang. I have a weak feeling towards the beginner, for well I remember my first few contacts and punk sending which was due more to nervousness than to lack of practice.

Those of you hollering for restriction of beginners on certain amateur bands, stop a moment and think back some years ago. Would you care to have been restricted to a certain band probably with a bunch of beginners as new and nervous as yourself? Is that a recommended method for development? No. Modern methods of teaching put the weaker students amid the well trained and experienced. Rightly so, "example" is a good method of teaching. The average beginner is no lid. He usually knows as much theory before he gets his ticket as some of you knew in five or six years of experience! Granted there is more available information today than a few years ago. There is information available for higher knowledge of amateur radio which is not taken advantage of by a great many of the old-timers who spend their time working DX and complaining of QRM. Beginners have to learn a good part of all you knew from years of hamming before they get a ticket. Why then any restriction to one band? A month or two of mingling with a few good operators will make the newcomer almost your equal in amateur operating technique. Restrictions are not necessary. Restrictions are not the solution to our QRM problem.

Are you an old-timer? If so you probably have \$200 worth of high-power transmitting gear. But is not your receiver in the same class with the one you started in with back in the "good old days"? Many old-timers have to blush slightly when confronted with that question. It is much easier to get a high-power transmitter working and on the air than it is to build a good receiver. With such an outfit have you the right to holler about restrictions and QRM when you have not met present conditions with an up-to-the-minute receiver? Most of us who are honest admit that the time is here when some form of superhet is essential for selectivity. Yet we hang to our old stand-by, the T.R.F. set, because its sensitivity is good and cost very low. If you are unable because of lack of funds to own a good receiver you should make the best of it until a time that you have met the prevailing congestion with equipment suitable to cope with conditions. Until that time be friendly and tolerant of the beginner who only represents a small part of the QRM after all.

Bring your receiver up to date. Use any form of "superhet," the simplest if necessary. It will be superior to any of the common T.R.F. jobs now in use, at least in selectivity. Most of you can have a super if you make the same effort that you make towards an increase in your transmitter (part at a time). The 5-tube "S.S." simplified version is certainly not too expensive for the

DX man and the Old-Timer who has many times its cost sunk in a high-power transmitter. Made even of the cheapest parts, it outplays the T.R.F. job especially in eliminating QRM, yes, even the local high-power stations. It is a real receiver worthy of every bit of effort necessary to get it going. It is easy to convert your present T.R.F. job! After you have met conditions with such a receiver, I dare say talk of QRM and restrictions of different kinds will be lessened on the part of those really fair-minded and willing to admit that possibly some of the trouble was on their end.

So, gang, lay off the yelping about beginners, QRM and restrictions and get busy. Forget that contemplated increase in power this coming year. The money spent for a 1935 receiver that will discriminate between two signals a few kilocycles apart will prove an excellent investment. Better DX will be possible. You will be able to read weak DX successfully. Better feeling in amateur radio will result.

### 1.75-mc. DX Tests

Data on "160-meter" DX test plans has been received via G5WU and W1DBM: United States and Canadian hams transmit on the hour and half hour for a fifteen-minute period calling "CQ-G," beginning at midnight and ending at 2:00 a.m. E.S.T. Saturday and Sunday mornings during February and March. The British stations will transmit during our listening periods, or from the quarter hour to the half and from the three-quarter to the hour. British stations will call "Test USA" and will be between 1715 and 1800 kcs.

### 1935 R.E.F. Cup Contest

On the occasion of the 10th anniversary of the formation of the "Reseau des Emetteurs Francais" and its acceptance as a member-society of the I.A.R.U., the R.E.F. announces an International Contest, known as the "R.E.F. Cup Contest."

Points will be scored for each contact established with an amateur station located in France, its colonies or its protectorates (all F and CN prefixes). All contacts may be established by means of telegraphy or telephony on any of the amateur frequency bands. Only one contact with a specific French competitor will be permitted to count.

Competitors will be required to exchange a five-letter code word chosen by themselves; this code must be exchanged for each contact. One point will be scored for each complete contact.

The competitor scoring the greatest number of points of entrants in his country will be awarded a commemorative diploma and a free subscription to "Radio-R.E.F." for a period of three months. The competitor scoring the greatest number of points in the world will receive a special diploma and a year's subscription to "Radio-R.E.F."

The contest will start at 0000 Greenwich, Sunday, March 24th, and will conclude at 2400 Greenwich, Sunday, March 31st. Entries must reach R.E.F., 17 Rue Mayet, Paris 6, not later than Sunday, May 19, 1935. The report should cover the following information: Name, address, call sign, input, and total score. For each contact show: Date, Greenwich time, call, codes, frequency band. A short description of the competitor's station is also required. Acceptance of these rules is the only stipulation; the R.E.F. Committee's decision must be accepted as final in all cases of dispute.

W6KBY's uncle lay seriously hurt as a result of a wreck in an auto race. Wishing to get a message to the hospital in New York, he called "CQ Urgent East." VP5PA in Port Maria, Jamaica, answered, and relayed the message to the Jamaica Hospital, Long Island—all in a matter of minutes!

\* Winter Street, Millis, Mass.

## BRASS POUNDERS' LEAGUE

(Nov. 16th-Dec. 15th)

Call	Org.	Del.	Rel.	Total
W9RYD	273	320	920	1513
W9BMC	13	20	1411	1444
W9ETL	118	303	1008	1429
W2BCX	38	50	1261	1349
W9IQI	690	294	274	1258
W9ILH	34	101	1002	1137
W9ANT	105	542	370	1017
W9EHW	594	129	304	927
W9E8A	86	284	549	919
W9JWI	174	153	592	919
OMITB	463	68	382	913
W9KJY	106	142	612	860
W9BND	107	637	99	843
W9CEZ	117	130	596	843
W9FLG	92	121	690	803
W9MZD	46	24	642	712
W9QQV	100	142	437	679
W9FWW	26	65	582	673
W9ERQ	252	57	356	665
W9IOL	63	97	489	649
W9E0U	68	68	510	646
W5MNN	53	102	484	639
W8FTW	70	28	534	632
OM2RX	176	59	390	625
W9GUF	27	23	566	616
W9IEL	65	75	442	582
W9BHV	18	64	495	577
W9BWT	105	102	362	569
W9DI	25	45	456	526
W9CHK	61	196	259	516
W9JTT	40	42	426	508
AC2RT	201	139	176	506
W9FXZ	7	14	479	500

### MORE-THAN-ONE-OPERATOR STATIONS

W8ZG	824	1081	351	2256
W9BNT	468	741	970	2179
KAIHR	620	225	978	1923
K6EWQ	171	160	1030	1361
W9OW	59	391	259	709
W3CXL	251	37	361	649

These stations "make" the B.P.L. with totals of 500 or over. Many "rate" extra credit for one hundred or more deliveries. The following one-operator stations make the B.P.L. for delivering 100 or more messages; the number of deliveries is as follows: Deliveries count:

W9H8K, 222	W9IQW, 144	W9EGQ, 118
W6CVF, 181	W8FCV, 144	W8KKG, 112
W5CUC, 176	W2ELLS, 138	W9BMA, 105
W8CIO, 173	KAILG, 135	W1UE, 103
W4MS, 172	W9RQE, 128	W9CWG, 103
	WIMK, 122	

### A.A.R.S. STATIONS

Call	Org.	Del.	Rel.	Total
WLMF (W9RYD)	227	90	496	813

### MORE-THAN-ONE-OPERATOR STATIONS

WLM (W3CXL)	621	422	3054	4097
WVQB (K6EWQ)	268	160	620	1048
WLJ (W5OW)	171	109	476	756

A total of 500 or more, or just 100 or more deliveries will put you in line for a place in the B.P.L.

## O.B.S.

The following is a supplement to the list of A.R.R.L. Official Broadcasting Stations in October QST (page 49): W2GNK, W6FQY/KG, W6HEW, W9AXH, W9IQI, VE1EF, VE1GL.

## Briefs

"It's rumored about town" that W2FHS of Clifton, N. J., after two years of trying to get his YL interested in ham radio (without results), will finally win his point as the YL's initials are H.A.K., and W2FHS' are L.G.M. --so, the Mrs. will be a H.A.M.!

### Chicago Dance and Hamfest

Amateurs of the Chicago Area will participate in the annual Spring Dance and Hamfest under the auspices of the Midwest Radio Mart on March 30th. Program includes prizes, dancing and entertainment. Prizes will range from fifty-watters to complete sets. Admission is

fifty cents. YLs, OWs, etc., invited. The place: the Congress Hotel, Chicago. Interest is high in this coming affair. Plans are under way to charter a special car or bus to bring about fifty hams from Fort Wayne, Ind.! Plan now to take in this dance-hamfest.

### The Oldest Ham

Believed to be the oldest ham is Mr. C. R. Stedman, Sr., W9CAB, Denver, Colo. W9CAB is 77 years old and has been on the air for four years. He maintains a regular schedule with his son, W7ASQ, Helena, Mont. The next oldest is Mr. C. J. McClure, W7NE, Leavenworth, Wash., who is a few months past 76.

W6HOP, Atascadero, Calif., reports a contact on November 20, 1934, with the Bol-Inca Expedition in Bolivia, South America—CP1GB, in the 14-mc. band.

### The Haywire Net

The "Haywire Net" is a group of 3.9-mc. radiotelephone operators organized for the purpose of rectifying irregularities in the operation of stations within the 3.9 to 4-mc. band. In general, its operation is directed toward the criticism of over-modulated, lopsided and distorted signals, improper carriers, off-band operation, in fact any violation of the radio regulations, with a view to improving radiotelephone operating conditions. The "net" consists of the following members: W3BFZ, W3CKD, W3BJG, W3CRO, W3ADQ, W8AAC, W3AXR, W8IDJ, W2BO, W2CGY, W2ADF, W2AMB, W3SJ.

### Bachelors' Club

From the Illinois Bulletin we learn that traffic men in that section of the country have formed a "Bachelors' Club." The only requirement is that a member be single and desire to remain that way. In order that none of the membership slip into the marital yoke, it is planned to impose a severe penalty on those who do. Members to date are W9DOU, W9RNN, W9KJY, W9LEZ, W9ACL, W9H8K, W9JRK and W8FTW. Those interested and possessing all the necessary qualifications should write or radio W9KJY, Glen Ellyn, Ill., or any of the amateurs listed.

W6LBI worked W6ZZH, an XYL. The next night he worked her OM, W6CRF! He wonders if CRF was checking up on him.

W9KEI suggests: If QRM is known to be on your frequency, sign your call at intervals during a QSO—it helps the other fellow keep track of your signals.

A game of checkers was played via 3.9-mc. radiophone between L. J. Ryan, W9CNS and Frank Miksa of Aurora, Ill. Mr. Miksa was at W9EDW, station of Harold Nelson. W9CNS won the game.

K6CGK held a QSO of two hours and five minutes with MX2B in Manchuria. The QSO was carried on in Japanese, both operators transforming Japanese phonetics into Continental Morse.

### The Royal Order of Acorns

1.75-mc. 'phone operators in Illinois have organized a club known as the "Royal Order of Acorns." Membership is about thirty so far. W9KXE is "The Coconut" (president), W9SHP, "Walnut" (vice-president), W9NOV, "Chestnut" (secretary). The aims of the club are to help beginners and act as official observing stations. Meetings are held on the air every Saturday in the wee sma' hours.

Howard Seefred, W6EA, announces the arrival on December 30, 1934, of an eight-pound baby daughter. Mrs. W6EA is the sister of W7CY.

June 22 and 23, 1934 were two big days in Orlando, Florida: the Florida State Amateur Radio Convention was in progress! The affair opened with a program by the "Knights of the Kilocycles." Talks were given on the A.A.R.S. and the Naval Reserve. W4PL was crowned "King of Liars" after telling the tallest one. 56-mc. tests from plane to ground were very successful; W4ACZ and W4CAM did the operating. Various stunts and contests were held; in an elaborate trial W4AAQU was convicted of "home-wrecking" and was sentenced to "four lashes." The banquet was attended by seventy-five hams, YLs and YFs. W4CLW, Capt. Glen Cole, U.S.M.C., was the "head man" of the show, and much credit for the success of the convention is due him. The gang is looking forward to "another!"

## DX Briefs

### 3.5-mc. Trans-Ocean Work!!

Trans-Atlantic contacts on "eighty meters" are becoming a common occurrence with a return of conditions similar to those in 1924-25. Many amateurs in eastern and central states report contacts with Europeans. Among the signals from "across the pond" are those of CN8MN, CT1KR, D4BAR, D4BDR, D4BMY, D4BJP, F8UT, FM8LX, F8VS, G6BS, G6RB, G6WY, HB9AQ, HB9Y, OE7JH, OK1VA, ON4AU, ON4JB, PA0ASD, PA0DC, PA0HR, PA0LR, PA0XU, ON4DG, CT1KR, VO4K, EI5F, OK2RR, OK2HP. Some of the "W" and "VE" gang who have worked or heard these are: WIABN APU BDI BKL CJD DBU DIJ EAF ES GOG IJB MK QP SK SZ TS UE ZS W2ABS ADO AZL CAV AUP BDN BII BJP DUP EAR GMN DYP ELK EZJ FXC W3DUK BGO CUT DRO W8AQ UY BAS CMI DHQ ESY BQ LKH AKV FIP AXE CNC EUY HKT KKG UW W9ABS MIN AEH NNZ VE1FL VE3GT 3JT 3JW 3TF 3QJ 3LC. As for trans-Pacific work, reports are but few. W2EZJ has worked K6LHK. W9PLM has heard ZL4GR, K6DV and several VK's. More data on trans-Pacific DX work on 3.5 mc. will be appreciated. Midnight to 3:00 or 4:00 a.m. E.S.T. is a favorable time for "30-meter" trans-Atlantic contacts.

### F8VP on 3.9-mc. 'Phone!

F8VP, Port-du-Chateau, France, announces that he will call United States amateurs on 3.9-mc. 'phone (during January and February) every Tuesday and Friday at 2400 Greenwich. Here is an opportunity for trans-ocean 'phone work on 3.9 mc. Who will be first to work F8VP?

### 1.75-mc. 'Phone Heard in England

WIHUIJ, Cromwell, Conn., has received a report on his "160-meter" 'phone signals from G5BI. Before the winter is over there should be considerable two-way trans-Atlantic work on "160" as well as "75-meter" 'phone. Let's hear about it.

### 7 and 14 mc.

Using a single 01A with less than three watts input on 14 mc., W7RT worked several W6's, W9's, a W3 and K6LHK. . . . W3QP's 7-mc. schedules with VK5HG are still flourishing Tuesdays, Thursdays and Saturdays at 7:45 a.m. E.S.T. . . . W8HWE, Pittsburgh, Pa., on December 19, '34, at 4:55 p.m. E.S.T., worked J2JJ on 7 mc. "J" QSO's are not "usual" at that time of day on 7 mc. . . . W8KIU, Morgantown, W. Va., was QSO four ZL's and five VK's all in one morning (Dec. 6th) on 7 mc.

Word of an earthquake in Honduras in early December afforded an excellent chance to test the Detroit Police/Amateur Radio affiliation (see Nov. QST). In a very short time after word had been received, W8SS, W8HUD, W8LFE, W8WA, W8KNT, W8LZV, Mrs. W8DYH,

W8BIU, W8FTW, W8FEE, W8CAT and others had been notified of the chance for QRR work; although nothing definite developed, it was a good drill and proved that the Detroit police/amateur tie-up works! HRIAA was on the job, ready to cooperate in Honduras.

## P.A.R.A. Ready for Typhoons

At the October meeting of the Philippine Amateur Radio Association, Father Depperman of the Weather Bureau made a request that amateurs assist the bureau in gathering data when typhoons are in the P.I. area. He explained that the data necessary would be barometer readings, direction of wind and velocity of wind. President Grove of the P.A.R.A. appointed a committee of three, KA1XA, Lt. Burns KA1HR, and KA1AN to meet with Father Depperman and give him a list of all amateur stations in the P.I., their locations and power. From this list stations that should report during the typhoon season are being selected. An extensive "Weather Net" is being organized.

## 28-mc. Band Opening Up

The 28-mc. band shows signs of opening up to DX. W4AJY, Alabama, on December 23rd and 30th, worked W6CAL, San Francisco, between 1:00 and 2:20 p.m. C.S.T. W1CUN, New Hampshire, worked W5WG, Louisiana, at 11:30 a.m., and W6CAL worked W9GFZ, Illinois, at noon on Christmas day. Signals were strong. ON4AU, Belgium, worked VE3PT. W6CAL is on 28 mc. each Sunday. ON4AU is on daily from 8:30 to 9:30 a.m. E.S.T. W1CKF spends many Sundays on the band. W9JGS has worked W6JNR. W9NY worked the following during December: W4MR, W6JNR, W6DGV, W6CAL, W9GKE, W9DII. Among other stations active on 28 mc. are VE2AC, W9GBJ, W4TZ, W1ZB, W8SS, W9ACN.

W2GVZ claims the DX record in using VE3JW's "human voltmeter." He got across 1350 volts and went "half way to heaven!"

## 56-mc. Experiments

On December 9, 1934, W2GFD and two other members of the Colonial City Radio Club (Kingston, N. Y.) traveled to the top of Overlook Mountain. The altimeter reading was 3150 feet above sea level, temperature zero in the morning, four below in the afternoon. A 56-mc. directional array was in operation by 11:20 a.m. Stations worked were W2QY, W2HUI, W2HBW, W2DPN, heard: W2MQ, W2JZ, W2DZE, W2CUZ, W2AG. Throughout the remainder of the winter the C.C.R.C. will experiment extensively with directional antennae on both 56 and 114 mc. As soon as weather permits a listening post will be maintained atop Overlook Mountain, with members taking tricks each Saturday and Sunday.

W9WC, new Phone Activities Manager, Illinois A.R.R.L. Section, announces definite hours during which he will look for prospective O.P.S. to enable them to make their contact with him. The schedule is: Daily from 11:00 p.m. to 2:00 a.m. C.S.T. Contacts can also be arranged between 9:00 a.m. and 12:00 noon. Any frequency may be used.

## VK DX Contest Results

Word reaches us by radio via VK3RJ-VK2EL-W1SZ that final scores in the VK DX contest have not yet been compiled. VK3ML, who is in charge of contest results expects to have the VK scores finished by January 25th, and the foreign ones by February 25th. The unofficial leaders, in order of unchecked scores are VK3GQ, VK3MR, VK2XU and VK3JQ. VK3GQ's claimed score is over 100,000! A QSL card received by W9FM shows that VK3JO used only a 59 m.o.-doubler and a 59 final in the VK contest! Yet he worked quite a few DX stations.

## ELECTION NOTICES

To all A.R.R.L. Members residing in the Sections listed below: (The list gives the Sections, closing date for receipt of nominating petitions for Section Managers, the name of the present incumbent and the date of expiration of his term of office.) This notice supersedes previous notices.

In cases where no valid nominating petitions have been received from A.R.R.L. members residing in the different Sections in response to our previous notices, the closing dates for receipt of nominating petitions are set ahead to the dates given herewith. In the absence of nominating petitions from Members of a Section, the incumbent continues to hold his official position and carry on the work of the Section subject, of course, to the filing of proper nominating petitions and the holding of an election by ballot or as may be necessary. Petitions must be in Hartford on or before noon of the dates specified.

Due to resignations in the North Carolina, Idaho and Northern Minnesota Sections nominating petitions are hereby solicited for the office of Section Communications Manager in these sections and the closing date for receipt of nominations at A.R.R.L. Headquarters is herewith specified as noon, March 1, 1935.

Section	Closing Date	Present SCM	Present Term of Office Ends
Maritime*	Jan. 15, 1935	A. M. Crowell	Jan. 18, 1935
Maine	Feb. 1, 1935	Reg Strong	Feb. 15, 1935
Sacramento Valley	Feb. 1, 1935	George Woodington	Feb. 15, 1935
Nevada	Mar. 1, 1935	K. L. Ramsey	Aug. 15, 1934
Saskatchewan*	Mar. 1, 1935	Wilfred Skafte	June 15, 1934
Alaska	Mar. 1, 1935	Richard J. Fox	Feb. 16, 1934
N. Carolina	Mar. 1, 1935	G. H. Wright, Jr.	.....
Idaho	Mar. 1, 1935	Don D. Oberbillig (resigned)	.....
N. Minnesota	Mar. 1, 1935	Robert C. Harshberger (resigned)	.....
Western Fla.	Mar. 1, 1935	Edward L. Collins	Mar. 20, 1935
N. Texas	Apr. 1, 1935	Glen E. Talbutt	Apr. 15, 1935
New York City and L. I.	Apr. 1, 1935	Edward L. Baunach	Apr. 15, 1935
Maine	May 15, 1935	John W. Singleton	May 25, 1935

\* In Canadian Sections nominating petitions for Section Managers must be addressed to Canadian General Manager, Alex Reid, 169 Lokan Ave., St. Lambert, Quebec. To be valid such petitions must be filed with him on or before the closing dates named.

1. You are hereby notified that an election for an A.R.R.L. Section Communications Manager for the next two year term of office is about to be held in each of these Sections in accordance with the provisions of By-Laws 5, 6, 7, and 8.

2. The elections will take place in the different Sections immediately after the closing date for receipt of nominating petitions as given opposite the different Sections. The Ballots mailed from Headquarters will list the names of all eligible candidates nominated for the position by A.R.R.L. members residing in the Sections concerned. Ballots will be mailed to members as of the closing dates specified above, for receipt of nominating petitions.

3. Nominating petitions from the Sections named are hereby solicited. Five or more A.R.R.L. members residing in any Section have the privilege of nominating any member of the League as candidate for Section Manager. The following form for nomination is suggested:

Communications Manager, A.R.R.L.  
38 La Salle Road, West Hartford, Conn.  
We, the undersigned members of the A.R.R.L. residing in the ..... Section of the ..... Division hereby nominate ..... as candidate for Section Communications Manager for this Section for the next two-year term of office.

(Five or more signatures of A.R.R.L. members are required.)  
The candidates and five or more signers must be League members in good standing or the petition will be thrown out as invalid. The complete name, address, and station call of the candidate should be included. All such petitions must be filed at the headquarters office of the League in West Hartford, Conn., by noon of the closing date given for receipt of nominating petitions. There is no limit to the number of petitions that may be filed, but no member shall sign more than one such petition.

4. Members are urged to take initiative immediately, filing petitions for the officials for each Section listed above. This is your opportunity to put the man of your choice in office to carry on the work of the organization in your Section.

—F. E. Handy, Communications Manager

## ELECTION RESULTS

Valid petitions nominating a single candidate as Section Manager were filed in a number of Sections, as provided in our Constitution and By-Laws, electing the following officials, the term of office starting on the date given.

Quebec	Stan Comach, VE2EE	Dec. 14, 1934
Ch.-S. C.-Cuba-Isle of Pines-		
P. R.-V. I.	Rannie L. Stewart, W4CE	Dec. 14, 1934
Arkansas	Henry E. Vette, W5ABY	Dec. 15, 1934
Louisiana	W. J. Wilkinson, Jr., W5DWW	Dec. 15, 1934

In the Colorado Section of the Rocky Mountain Division, Mr. Glen Glasscock, W9FA, and Mr. Marvin E. Juza, W9FY, were nominated. Mr. Glasscock received 46 votes and Mr. Juza received 38 votes. Mr. Glasscock's term of office began Dec. 17, 1934.

Add to W9FO's "Radio-crew": W6CVV, O. M. Watt; W6KHV, D. C. Mast; VE3TJ, Hartley; W1BNB, Lugg; W8GUL, Fix.

Father and Son schedules: W9CAB (father)-W7ASQ (son); W8DES (father)-Hal, W1MK (son). Any others?

## STATION ACTIVITIES

### ATLANTIC DIVISION

**E**ASTERN PENNSYLVANIA—SCM, Jack Wagenseller, W3GS—R.M.'s 3EZ and ALX. EER is traffic manager of Beacon Club and reports for BGD, CCD, DLY, ENX, EXE, EER and BUK. VR and ECD report via radiogram. DYX was elected president of Reading High School Radio Club. BYS got 73-88 for his new auto tags. QV got VY73 for his tags. 8ASW is in daytime Army Net. 3CPV has '52 final. 8FLA is looking for skip and QRM eliminator for FB7, 3DUI reports for first time. EPJ has new zepp. EOP and ECD are new O.R.S. GS is experimenting on 224 and 112 mc. FAR just moved in from the ninth district; he is chief engineer of KYW. QM with pair 10's in T.N.T. was heard in China. MG works 56, 14- and 3.9-mc. 'phone and c.w. 8EU is on at new QRA in Wilkes-Barre. 3MC is still acting as "sparks" on the briny deep. ADE says SS Contest and Copying Bee F. B. Do you want a section contest? If so, let's hear from you regarding the kind of contest you desire. GS will furnish suitable prizes, but we want to have the kind of a contest that you want.

Traffic: W3VR 60 ECD 159 DYX 2 BYS 319 AQN 18 BGD 2 CCD 2 DLY 1 ENX 2 EXE 4 EER 5 BUK 1 ABZ 10 CPV 18 DUI 8 ADM 430 EPJ 15 EZ 434 CL 264 EOP 38 GS 32 W8CVS 21 ASV 20 FLA 207 IWT 12.

MARYLAND-DELAWARE-DISTRICT OF COLUMBIA—SCM, Edgar L. Hudson, W3BAK—CXL, CQS, R.M.'s. BWT, Chief R.M. WLM/CXL handled 109,461 words during the month. BND will use '04A in the new transmitter. BAK and EYX are on 1.75-mc. 'phone and 3.5-mc. c.w. EDS is getting O.P.S. CDG is rebuilding. BHE enjoyed Code Copying Bee. WZ has T.P.T.G. '52's.

Traffic: W3CXL 649 (WLM 4097) BND 843 EOU 646 BWT 569 ASO 228 CIZ 63 CMS 60 ABA 52 BAK-23 FDS 21 CDG 12 BHE 4 EIL 4 WZ 2 EYX 2 OZ/EHW 1.

SOUTHERN NEW JERSEY—SCM, Gedney M. Rigor, W3QL—ZI reports new hams in Trenton: FBT and EZD. AVJ is keeping successful 7-mc. schedule. DNU will handle traffic regularly for Atlantic City and vicinity on 3.5 mc. O.P.S. AYZ will handle traffic on 'phone anytime for this Section and relay. NF blew transformer. EDP worked ZU6P 'phone on his new Comet. HIR reports 56 mc. picking up in Trenton. APV reports Trunk B progressing. S.C.M. recommends NF and APV work up Traffic Net for So. N. J. All stations interested write APV or NF. VE holds his own on daily schedules. The S.J.R.A. had annual election with ZX new proxy, BGP vice-pres., BET sec. secy., IS corr. secy., John Birch treas. All amateurs wanting O.R.S. kindly note they must report consistently to get their certificate. An application with one or two reports is NOT sufficient to get O.R.S. ticket.

Traffic: W3AEJ 7 AVJ 22 DNU 12 AYZ 3 NF 13 EDP 4 BIR 3 APV 179 VE 78 ZI 96 ZX 9 QL 7 BYR 6 EWF 6 ATJ 7.

WESTERN NEW YORK—SCM, Don Farrell, W8DSP—The Adirondack Amateur Radio Club reports in full. ISQ, DGR, FSG are building new c.c. transmitter. LL is on 1.75-mc. 'phone. VE3XS, UO, MB visited Malone gang. 8KJW blew power transformer. DSA is on 3970-c. 'phone. DEJ will be on 3.5-mc. c.w. on Jan. 15th. HB is on 56 mc. only. ELU has new zepp. LKL has new transmitter. MAH has been rebuilding. ELF has 1-kw. on c.w. and 600 watts on 'phone. LN has an '03A in final. CPC entertained XIG at his home. KCM has low power 'phone. DSB is rebuilding into a rack. AVI is still on. BGM has been drawing plans for a year for a new transmitter. KYR, Buffalo YL op, is on 1.75-mc. 'phone. AOM has new transmitter nearly completed. PE is at new

QRA. The Tri-County Radio Club has been organized at Glens Falls: DRZ pres., GPT vice-pres., LUJ secy-treas. MVJ-MYE: new calls. The Fort Stanwix Club raised initiation fee from \$1.00 to \$2.50. JLG, BRH, VJ, AAN, IBU had fine trip in the country with portable rig on 3.5 mc. They plowed through the snow and had their transmitter in DOA's abandoned shack which is situated on a high hill 20 miles from nowhere. HI. EUY is working plenty of European stations on 3.5-mc. c.w. JTT, R.M., is high traffic man for the month; he is planning a three months' trip to New Mexico this next summer. GWY and DSS (R.M.) are busy with traffic. Oneida Amateur Radio Transmitting Assn. has been organized: CQU pres., DSS secy. BWY has daily schedule with Syracuse. MBY, new ham, has gone in for traffic. AYD is working plenty DX. KMC has new receiver. FYF is laying for "J" on 14 mc. AQE had fine SS score with low power. EBR rebuilt entire station. AAR has new PR-12. GZM is busy with A.A.R.S. BR is rebuilding final in M.O.P.A. EWP uses 211's in final. DZF has new transmitter. GWT reports DX FB. LGR is going on 'phone exclusively. AKX is still using a 10 final. FYC uses 211's in final, grid bias modulated. DHU was back in Glens Falls for the holidays and is now in Hartford, Conn., for the winter. HWR has been dabbling with 56 mc. AWX has been in hospital with broken ankle received in a school football game. KXA has new SW3. The Mohawk Valley Club moved club rooms to I.O.O.F. Temple on Morgan Street. AFM is on again. EOA has trouble with new rig. GPS is building new 3.9-mc. 'phone. BHW is engaged to be married. Congrats, OM.

Traffic: W8JTT 508 GWY 158 DSS 131 BWY 39 MBY 36 AYD 32 AWM 22 EUY 16 KMC 15 FYF 14 BQJ-BHW 12 AQE-EBR 11 AAR 7 GZM 6 LUJ-BR-EWP-DZF 4 GWT-LGR 3 AKX 1 KJW 14 DSA 43.

WESTERN PENNSYLVANIA—SCM, C. H. Grosarth, W8CUG—GUF is still leading the way: "Hap" is using c.c. now. KWA visited 3SN and 3BND. FCV comes through with nice total. ADY has been appointed D.N.C.S. for Penna 5. CUG and R.M. DWA visited GUF. EZT is newly appointed O.R.S. IUU is active with A.A.R.S. work. LOQ started radio club at Sewickley High School. UK reports the passing of 8LDP of Glendale, Pa. We extend our sympathies to his family. KQK wants a 1 or 2 MFD 10,000 volt filter condenser! KOB handled most of his on 7 mc. AXD says FKQ put his finger over the end of his gun barrel to see if it was loaded. Loss, one finger! CQA is trying new antennae. GJM says IRK is working 14-mc. c.w. JZZ is building a.c. receiver. GSH says GMU will soon be on high power. IOI is rebuilding and IOH wants higher power. AYA is playing with 56 mc. KNB is new O.R.S.

Traffic: W8GUF 616 KWA 430 FCV 302 YA 223 (WLMA 221) ADY 194 CUG 157 EZT 99 IUU 84 LOQ 89 KQK 26 KOB 83 AXD 15 CQA 14 GJM 12 FKU 11 LIG 7 JZZ-GSH 6 IOH 4 AYA 2 KNB 5 KYW 1 UK 36 KNB 9.

#### CENTRAL DIVISION

ILLINOIS—SCM, Fred J. Hinds, W9WR-W9APY—R.M.'s: KJY, ILH, ERU. Winner of the first Illinois QSO Contest is KJE with 86 points. His prize is a 14-mc. antenna coupling coil. Second place was made by ILH with 52 points. There are 34 ham stations in Waukegan, among which are TEG and TEQ. NN has a direct outlet via 6AOR for west and Oriental traffic. NUF has been on 56 mc. PCI is to increase power with a 50-watter. KEH made 57,310 points in SS. CUH has been on 1.75 mc. DRN is now W.A.C. LIV has a 50-watter in final. GSB tried 56 mc. and worked across the street to OBS. FTX was in an auto accident, but everything is OK now. KJX is back from C.C.C. New bug and monitor at SKF. CKC is working hard on Trunk Lines. 1.75 mc. is fine at DBO. RVB is applying for O.R.S. WC is working with 56-mc. equipment to operate in conjunction with 3.9-mc. 'phone. KRE is in Blaine, Oregon, signing W7 from C.C.C. DOU has been 5 years in A.A.R.S. MRQ rebuilt. New rig at PFJ and EZV. ACU works duplex QSOs on

1.75-mc. and 3.9-mc. 'phone. MCC took only 20 minutes to relay a message from 6FYK to 4CYU in Miami. There were three steps in the relay, and K4SA had a hand in it. Transmitter trouble at HUX. KZV worked NY1AA with antenna 12 feet high at open end. RBR put a '45 P.P. T.N.T. on 1.75 mc. to get some occupants for the "dead space" on that band. DDO scored 4000 points in SS. ICN says Trunk Line "L" is going well. NXZ is calibrating. IPT is training a group of ten hams-to-be in a class at Junior High School in Wheaton. NGG dedicated his new shack with a party. KA received 13 foreign QSL cards in one day. HI. PLL and RBR are going after daylight traffic. IYA says he won't miss the next Illinois QSO party. RJ has moved East with KYW. He will use 3FAR at Cold Point, Pa. PTW is building high-power rig. RLH QRM the neighbors with his 'phone. ITA sent his first report as O.P.S. The 1.75-mc. 'phones have a club of the air called "The Royal Order of Acorus," and meets every Saturday night at 12:30 a.m., C.S.T. KXE is "The Coconut" (pres.), SHP is "Walnut" (vice-pres.), and NOV is "The Chestnut" (secy.). Aims of club are to help new beginners and act as O.O. stations. SRC and SQY are reporting again. HUM is a marvellous piano player. KXD rang in Logan square district of Chicago is rebuilding. COW says local 14-mc. 'phone QSOs are now had for the first time in three years. NXG is installing 825 for final. AEH worked a G on 3.5 mc. three mornings last month. MIN is DXing. FYZ says the "Illinois" Bulletin is an FB sheet. AIU, Egyptian Radio Club, is going well. New vibroplex at OXA. OJA and RHZ are on 'phone. PVH can make an RK20 blush. EVJ found a job. PNE heard VK2AP calling WR one morning on 7 mc. STG says the local boys are talking about organizing a club. AND made 29,835 in SS. CKM is recovering from an appendicitis operation. New hams in Rockford: TBP and TET. AAK and EXN are on again. Mr. Geo. Lorentzen, 2342 So. Homan Ave., Chicago, who is doing experimental 'phone work, would like to hear from 'phone hams in vicinity of Chicago.

Traffic: W9LH 1137 KJY 860 DOU 258 (WLT 245) OXA 158 KEH 141 FYZ 109 HPG 122 KXD 82 EZQ 70 HQH 66 KZV 63 DBO 58 SG 51 PTK 49 STG 41 ICN 40 CKC 36 PCI 32 NXG 31 EVJ-SRC-SQY 29 NPM 25 AND 22 NXZ 21 DRN 18 FST-KJX 15 MIN 14 ANQ-MCC-PLL 10 LNI 8 BRZ 7 CUH 6 HUX-DDO 5 IEP-WR-NUF-BRX 4 ACU-ABR 3 IPT-OLA-EQX 2 CEO-MRQ-SKF 1.

INDIANA—SCM, A. L. Braun, W9TE-9FQ Chief R.M.—IRK does nice job on A.A.R.S. YB moved to new QRA. HSF is new O.P.S. RE and DET are rebuilding. ARK is spending winter in Fla. AXH plans new 240-ft. ant. AEB is on 56 mc. MQV is giving 1.75 mc. a try. HUO keeps traffic schedules on c.w. SDP is on 7 mc. HPQ has trouble with new rig. EGQ worked VO8 on 3.5 mc. with 24 watts. HUV is DXing on 7 mc. LLV is teaching radio for F.E.R.A. DFE worked OM1, K6, VK, ZL for DX this month. TE is building new rack and panel. Please note new QRA of 9TE is 5211 Brookville Rd. Send reports there. More O.R.S. are needed; send in applications to-day.

Traffic: W9JRK 286 DET 30 HSF 7 RE 2 AXH 4 AEB 72 MQV 1 HUO 114 SDP 10 HPQ 33 HUF 20 EGQ 313 HUV 2 DFE 27 TE 52.

KENTUCKY—SCM, G. W. Mossbarger, W9AUH—BWJ is getting around to ham work again. CDA is showing the way to the rest of the boys. FZV says school and work at Police Station keep him busy. PAZ reports C.C. with pair '10's. OX is again on the air. CDA is fathering new rig at Centre College along with GGB. KCZ goes Army as regular. KOX reports late account accident. SDG has rig on 1762 kcs. PLM is hearing lots of DX on 3.5 mc. BZS sez "My name on O.R.S. Cup for January, herewith my application." BAZ, back from southern trip swears activity and at Ye S.C.M. We elected him Alternate, didn't we? FGK buys a new ranch. MN also wants O.R.S. Cup. CNE has to go to Atlanta for six weeks. FQK reports from Washington, D. C. Six stage ARU is still building that 'phone. Old Mae West reports two times in a row. EOM sex 50% 'phone 50% c.w. All

O.R.S. failing to report two times in succession this year are to be automatically cancelled. Kentucky parties continue, see your bulletins. 73.

Traffic: W9EOM 10 AUH 53 OMW-AR U20 CNE 123 MN 18 FGK 10 FZV 3 BWJ 40 BAZ 56 BZS 11 HBQ 106 PLM 25 KOX 18 GGB 3 EDQ 56 EDV 24 SDC 5 CIM 12 PXX 1 ACD 30 HAX 17 CDA 186 OX 16 PAZ 5.

MICHIGAN—SCM, Kenneth F. Conroy, W8DYH—Congrats to our new Director, S8C! New officers at M.C.R.C.: COW pres., LU vice-pres., LTH secy. and GTZ money-man. D.A.R.A. announces election of AKN pres., CAT vice-pres., and CSR secy.-treas. CAT suggests that the Bug used by our former S.C.M., the late 8DMS, be used as an incentive to better operating and let the leading man use it for one month. The bug is the property of the D.A.R.A.—awaiting formal action from the D.A.R.A. Executive Board. What do you think? DPE (charge of C.C.C./Amateur coordination) reports following men lined up with Bell. tel. connection with various C.C.C. camps: 9RHM, 8LDS, KOX, AEQ, GOV, 9SOS, FSK, PDE. MORE help needed! KNP recuperated from Thanksgiving feast and under from Christmas feast! MPT made a real score in SS with 10 watts. EDO gets congrats and ham radio gets the air! EGI QRT's as E. Mich. R.M. with DVC filling the shoes. BMG had to quit as W. Michigan R.M. and DWB fills his shoes. MUW is new reporter. FTW makes B.P.L. and then runs into a job! AEQ missed B.P.L. by a mere 15. JO tours the state with FUQ. Inglewood, Calif., is going try Police/Ham affiliation same as Detroit's. Detroit had good drill on Honduras Quake. IWM's receiver was christened "AC HUM Special." BTP says he is dedicating his new book, "How to Get Along with the Women," to AIJ and FRW. IKZ still plugs for more O.P.S. Men whose primary interest is radio-telephone work are invited to join up. By the way—Doctor W8PCP, head of the new Nat'l Radio-telephone Club, has offered to pay his own expenses to speak at the M.C.R.C.—understand that M.C.R.C. has accepted and will announce date very shortly. Mrs. DYH still plugs her code-practice on 3838 kc. Sunday at noon—Tues. and Fri. 5 p.m. E.S.T. QSL. LZV got nice publicity in *Detroit News* on his high school exhibit. BRS gets his old O.R.S. back. CUX prefers warm house to cold shack. FEE is proud possessor of O. P. S. IOR completed rebuilding. Any station desiring a copy of the Bulletin containing info. on the Michigan, can obtain one free by reporting activities to S.C.M. SS sends O.B.S. on 3526 kc. Sundays and Monday at 11 p.m.—QSL? ARR reports 58-mc. contacts with ZN, BJ, QH, CYX—!C.W. JZD reports St. Joseph High School coming on the air. LSF, LYS and MCZ are new O.R.S. NQ keeps O.O.-ing. JIU's new operating position is in kitchen. AYO's s.s. super perks great. DED reports ex-8CP is now MYF. QT, our A.A.R.S. R.M., wants more stations for A.A.R.S. Net—especially in Pt. Huron and Saginaw District. HUD was in SS. MICHIGAN NINES: The YL's at PCU lead the nines with ADY (R.M.) a close second! Congrats. PJZ is new reporter. PIG and MGY are active in Haton. YX is active at School of Mines. DDK handles newspaper stories from Isle Royale. BWU is getting 1.75-mc. rig perking. LUU is knocking 'em cold on 3.5 mc. KS is instructor at College of Mines. GXE, located at Honolulu farm, lost his grass pants! The South Range gang are all on 1.75 mc. HSQ, secy. Marquette C.R.A., reports cooperation with Isle Royale work. EGF is back—nice total. SOS still thinks and thinks. PDE and GQF change QRA's. CE is very QRL. OZM reports RIT up for ham exam. RHM is going places. CWR is experimenting with antennae! The SCM invites more reports from all stations on all forms of activity. 73.

Traffic: W8FTW 632 AEQ 485 DVC 292 GUC 253 LZV 187 DYH 134 QT 133 HBZ 82 KNP 80 LYS 67 CPY 81 DPE 56 HUD-LSF 52 FX 51 GRB 46 DED 43 EGX 30 EKT-JO 27 BTP 24 ARR 16 GQS-HRC 15 GBB 14 KLR 13 AYO-GRN-ICM-IOR 10 DSQ 7 ENQ- JIU 6 FEE-IFI-KYS-LTT 5 BRS 4 JCS 6 NQ 4 GSP 3 ECI-SS 2 EGI-JZD 1. W9PCU 105 ADY 101 OZM 87

PDE 85 HK 72 EGF 49 RHM 36 CE 9 CWR-HSQ 4 PJZ-YX 2.

OHIO—SCM, Robert P. Irvine, W8CIO—GSO has radio telegraph second and radiotelephone first. HCS has plenty of schedules. LUS works traffic with six watts input. IET worked 33 sections for total of 17,820 points in SS using pair of 33's with 180 volts of "B" battery. LCV handles traffic for Oberlin College students to folks back home. BZB is now A.A.R.S. UW worked HB9Y on 3.5 mc. DVL blew plate supply filter. ATN reports by radio. LEM is rebuilding. EFT just recovered from sickness. BBH says A.A.R.S. takes most of his time. New Lakeview hams: MXL, MCV, MWC and MWE. LZK will be O.R.S. soon. AQ worked five Europeans on 3.5 mc. on Dec. 15th, between 1:30 a.m. and 5:00 a.m. KWJ worked ON4CJJ. BKM is experimenting with RK20's and 2-53's in Tri-tet. BKE's auto license tag is --19 CQ. ITR is new O.R.S.; ditto MQC. ICF handled all traffic on 'phone. ISK was in SS. AMF got back on after being sick. HCL moved to Warren from Wheeling, W. Va. KEV and JFZ are new reporters. MAE is going after "Flea" power record. DZO has new 'phone. KVD is experimenting with inverted speech. EVF has new Junior Op. LAU is always open for a good rag-chew. GUL is experimenting with 58-mc. 'phone. DIH has trouble due to visitors filling up his shack so he can't get at transmitter. KLP reports new East Liverpool ham: MPG. RN leads the State with only three schedules. AQ is the winner of this month's delivery contest, with a percentage of 85. Very well done, OM, and let's see who is the winner next month. Trunk Line "L" is completed through Cleveland and working well. New O.P.S.: HMS at Cincinnati. AQ, Wadsworth, is new O.B.S. A ham-fest given by the Buckeye Short Wave Radio Ass'n at Akron was held Dec. 18th, and was well attended by about 200. Among those present was Lt. Sam Townsend, U.S.N.R., of NIC-8WY, who gave a splendid talk on U.S.N.R. activities. The Cleveland Wireless Ass'n held its opening meeting with a big feed. Among those present was 4LU of Signal Mt. A farewell party was given to 8EX, who has gone back to live in New England. This party was given by Hams Limited of which 8EX is a member. We extend our sincere sympathy to 8LER in the loss of his brother. DND became a Radiotelephone First operator on Dec. 19th. NAB is new call and license for an old ham—Dent Stieg, Bellefontaine.

Traffic: W8RN 343 GSO 290 HCS 269 CIO 265 (WLHC 96) LUS 244 IET 186 LCV 147 BZB 110 UW 102 (WLHI 370) DVL 94 HGE 72 ATN 71 LEM 69 PO 64 HMH 58 BDY 47 BBH 45 (WLHA 190) BON 45 LZK 40 JFZ 34 AQ 33 KWJ 19 BKM 18 FGA-BKE 15 ITR-MQC 14 ICF 11 DAT 10 ISK 8 HSX 6 AMF-HCL 5 KEV 3 MAE 2 EEZ 1.

WISCONSIN—SCM, Harold H. Kurth, W9FSS—IQW starts climb for high traffic in Wisconsin. HSK finds T. L. operation interesting. Radio Club at men's dorms on Campus of Univ. of Wisc.—GWK pres. OXP finds skating a detriment to traffic work. SHN uses 20 watts for DX. AKT pounds brass at N.C.R. station. KQL broke crystal trying to grind it down. HDP took Class "A" exam. SJF sends first report. BXZ is going on 14 mc. HTZ let license expire. SZL is new ham. HFL was appointed Alternate Control in N.C.R. AHJ has the urge to get back. IFL is building 1.75-mc. 'phone. CFP, HFL, and SZL had a hamfest at BXZ. FAA is back after long absence. PFQ is on at last. JDP and NAV are experimenting with 'phone. The S.C.M. thanks all the fellows for Christmas cards and greetings. NPU and CJU, operators at WIBA, work 'phone exclusively.

Traffic: W9IQW 419 HSK 260 GWK 91 OXP 85 RQM 22 SHN 18 KQL-HDP 3.

#### DAKOTA DIVISION

SOUTH DAKOTA—SCM, Mike Strahon, W9PFI—SHW and OQV make B.P.L. SHW uses pair of '04A's final. OQV is new R.M. Please send a list of your schedules to him. GTG is handling C.C.C. traffic from Hill City. ALO is trying Collins coupler. NCN at Custer is handling C.C.C. traffic. TY worked a K6 on 3.5 mc.

CFU reports Huron Club meeting again. DIY has new rig with '03A final on c.w. and 'phone. OED says Miller Club 100% A.R.R.L. PGV is building new rig. SMZ made 10-tube s.s. super. PPE at Brookings comes to us from N. Dak.

Traffic: W9HHW 937 OQV 679 GTG 360 HSY 101 FOQ 39 ALO 34 PFI 17 TY 16 CFU 6 BLZ 7.

NORTHERN MINNESOTA—SCM, Robert S. Harshberger, W9JIE—OMI is nominated for S.C.M. BMX has worked all continents. JIE is on 14-mc. 'phone. IGZ has 5 watts on 14 mc. LAY blew tubes in entire transmitter during SS. FTJ works A.A.R.S. and N.C.R. Drills. IBD has new rig. OYC has RK20.

Traffic: W9IGZ 29 RJF 17 JIE 10 OMI 4 000 53.

SOUTHERN MINNESOTA—SCM, Francis C. Kramer, W9DEI—EFK worked 63 Sections in SS. BN is Section's most consistent traffic station. DH operates BN besides his own rig. DVH, and RKG are new O.R.S. GFA has new rig with '10 final. HCC handled Alaskan traffic. XT took State Board exam in Pharmacy. FNK has 40 watts on 7 mc. RAB replaced '46's with '10's. ATD has new receiver. BNN renews his O.R.S. SNW is building new receiver. STK has 28-mc. vertical directional antenna. STB sent a message from Ill., and beat it home. DCM expects to be on 3.5 mc. for traffic. DMA got callouses on his ears and elbows during SS. AIR is home and anxious to work his old friends. IJN is on 1.75-mc. 'phone. SNW has B.C.L. troubles. DGE is back from the river. CRW is announcer at KGPR. PJA is QRL Mexico. Oil-Burner QRM is bad at GTE. JEQ is back with us. SYQ is QRL Dunwoody. KVI blew his 511. LOG has trouble with 14-mc. 'phone. IKN put in high power. Ice boating keeps STB busy. SJX likes c.c. SKW says 7 mc. isn't big enough for all of us! AYA works wonders with pair of '45's. ITQ has F.B. 1.75-mc. rig. LS has beautiful 80-foot mast. KDI, FCS were home for Christmas vacation. DEI will soon have new rig going. Owatona will have radio club soon. The Fairbault Club is extremely active, and reports its members are receiving much publicity in the daily paper. Mpls. World-Chamberlain airport has installed 56-mc. ham equipment. Mpls. Club is going strong and meetings are well attended. SEE YOU AT THE "MID AMERICAN."

Traffic: W9EFK 53 BN 173 DEI 133 DH 61 DVH 15 GFA 11 HCC 8 FMA 6 ZT 5 FNK-RAB 4 BNN-SNW 3 DCM 2.

#### DELTA DIVISION

LOUISIANA—SCM, W. J. Wilkinson, Jr., W5DW—LHR is new O.P.S. DVP schedules 6KKG. BPL is new P.A.M. LA is new O.O. BPN is working on 1 KW. BI is on 7220 kc. BID keeps lots of schedules. EDY is going strong on DX. EDZ blew his 211. BZR visited in south. CMQ likes to QSO on 'phone. AOZ blew pair '10's. DKR again asks that all 5th district hams sends their DX card envelopes to him at 2749 Myrtle St., New Orleans. CTR moved to New York. AVO visits New Orleans. EMS is another Shreveporter. OZ and ACV are still at sea. ST is doing well as club A.M. DWC is active in N.O. AEH is on 7045 kc. DMF uses Tri-tet. DIQ is active in Algiers, La. DYR is key station for New Orleans activities. DES operates at Mackay station. JW is building c.c. rig. CJO has club receiver working F.B. NM is home again. AXU spends lots of time on 'phone. DAQ is back on the air. DXW is fooling with 'phone. BYY has been rebuilding. Thanks to the Louisiana fellows for reelection as S.C.M. Let's have your criticisms, for they may help to better our Section.

Traffic: W5HR 1 DVP 4 BPL 7 CWX-LA-BPN 8 BI-BID 16 KC 18 EDY 19 CXQ 25 EDZ 28 BZR 40 CMQ 16 AOZ 44 DKR 88 EMS 1 AXU 4.

MISSISSIPPI—SCM, J. H. Weems, Jr., W5CWQ—CUU gives up remote control. ESE has new Junior Op. EGE is on with pair '45's. EKV worked first European. GQ is working at Miss. State College. DEJ made nice SS score. CJB built Tri-tet. CWQ works good schedules. The North Miss. A.R.C. holds hamfest in Okolona. CLD is QRL Ylitis. AKP is on in Booneville. QQ, BQX and ELS are on 1.75-mc. 'phone.

Traffic: W5DEJ 96 CWQ 87 EGE-EKV 4.

TENNESSEE—SCM, Merrill B. Parker, Jr., W4BBT—AFM tops the traffic list. OI is doing relay work on 56 mc. CU and BMH have new 3.5-mc. antennas. BWH, SW, CTW and KH spent week-end in Shelby, Miss. GX contemplates embarking on sea of matrimony. PL is on his annual six weeks' fishing trip to Fla. BCA is chasing DX on 7 mc. AEP is new O.R.S. and R.M. Another new O.R.S. is CXY, ex-9MW. AYV was held down by heavy QRM during SS. BBT can't raise better DX than K6. BOZ is back after year's absence. BFZ can't get c.c. rig to perk. 9NKH visited LU. CBS has new gas buggy. CDC is constantly bothered by bad power leak. The Tennessee Section hereby accepts Arkansas' challenge to a Traffic Handling Contest, and advises 5ABI and his gang to be prepared to be taken for a grand and glorious ride. Send in those traffic reports now, fellas, and we'll show the Arkansas boys that they're not the only traffic handling section in the Delta Division!

Traffic: W4OI 36 GX 27 ALM 5 BMH 12 PL 37 BAO 27 BCA 28 AEP 138 R 35 (WLRJ 11) AFM 344 (WLRH 188) BBT 9 CDC 1.

#### HUDSON DIVISION

EASTERN NEW YORK—SCM, R. E. Haight, W2LU—Happy New Year. Let us make 1935 a record year for E.N.Y. R.M. BZZ ends 1934 breaking all records with big total. EGF joins Trunk Line "L" with schedules with SCIO and 2BCX. LU was promoted to Ensign U.S.N.R. FQG does fine job with traffic. GPB is building rack and panel. BJX is out for traffic on 3.5 mc. UL got R9 on 3.5 mc. from 7ALP. ATM hit high in SS. GNI worked CT3, G, ON for DX. FXC worked HB9Y and HBGY on 3.5 mc. ACY got 8200 SS. points on 7 mc. ESO worked first "6" on 3.5 mc. DC is active on 3.9-mc. 'phone. S.A.R.A. elects DHS pres., DC vice-pres., HRS, secy., HCV treas., CJP, ACB, LU, Directors, for 1935. CBN got c.c. perking. DDW joined A.A.R.S. KW had trouble with gassy 860's. QY extends seasons greetings to E.N.Y. CJS was QRL playing Santa Claus. GFD reports for Colonial City Radio Club. DPW is learning to fly. HUI is on 56 and 224 mc. HUB is on 3518 kc. HUM is building c.c. for 3.5-mc. c.w. CC ended 1934 with DX schedule perking 100 per cent. GNI worked CT3, G2, G5, ON4, Z12, VO8. HNU dropped '10 and it broke. HMT has ant. trouble. HCJ signs for N.C.R. FFX was given surprise party by the gang. HMM is on 1.75-mc. 'phone. FEQ is awaiting PR12. CSM is on 56 mc. HJX is on 3.5 mc. EVJ is on 3.9-mc. 'phone. M.H.A.R.C. elected new officers 1935: GXE pres., GWY vice-pres., BJX sec., HVS treas. HVS is on 3.5 mc. BJX, GXE, CGT, DOS, CDM were in SS. AEQ has new rack and panel. CVT is planning improved "Go-Devil." DWO will be on from new QRA, Brooklyn, soon. 2GWY operates Club station 2GZP. 2GCT starts new Xtal rig. BJA is perking on Trunk line "G."

Traffic: W2BZZ 433 EGF 221 FQG 105 BJX 39 DDN 33 UL 19 ATM 15 GPB-GNI 9 DSH 7 FXC 5 ACY 4 GFD 3 ESO-DC-CLL 2 CBN 1 LU 151.

NEW YORK CITY AND LONG ISLAND—SCM, Ed. L. Baunach, W2AZV—In a past report it was stated that 1CNA is now HBQ; it should have read HQB. BNY is now O.P.S. in Brooklyn. HDG, HTI, HWS sends first reports. HLD is adding crystal. CCD is looking for U. S. and British Colonies stamp collections; write him if you have any. A big time was had at DBQ's annual Christmas hamfest. BRB has worked 3½ miles on 75 mc. BLH and BTF are both working at radio. CSO is QRL radio and electrical business. BEG received card from England, heard on 3.9-mc. 'phone. BSR works the J's. CSY is on 3.9-mc. 'phone. US schedules 8MAH regularly. DOG works at Radio City. HBO reports the TUBORO Radio Club: BMW, pres.; LG, vice-pres.; and HMG, secy.-treas. DJP expects to change QRA. CYX made 100 contacts with 1HRC without a miss. TC is now 3.9-mc. 'phone using 212D modulator. ESK keeps nightly schedule with UP5MIC; chief op is CDJ. ELK worked G6RB on 3.5 mc. CJY reports new officers Sunrise Radio Club for 1935: ANJ, pres.; CJY, vice-pres.; DRK,

secv.; HDG, treas. CHK reports BMB out for O.R.S. AYJ contemplates '61 final. DXO has 300 Watts into S42 final. FO, the resistor man, uses 211 final. EVA had X1G as visitor. AZV has F.B. results with 841 final; worked every state on 3.5 mc. GEI of the Crystal League reports: ATB's ant. was cut by BCL's; GND is experimenting with all bands; GMI is trying to get super to perk. GEI worked K5AM. EYQ is trying 3.9-mc. 'phone. FDQ is out for DX. DUP found a new use for ham radio; a friend of his lost the QRA of his YL in Phila, so they raised a Philly station who looked up the QRA and all was OK again. EAR has Class "A" ticket. New officers for Radio Club of Brooklyn for 1935: TI, pres.; BKP, secy.; AZV, treas.; B. Slater, vice-pres. EYS enjoyed the SS. GDF gets out F.B. on 3.5 mc. with pair of 801's. SF was married Dec. 1st and is going to make the Mrs. a ham.

Traffic: W2CHK 516 EYQ 315 ELK 258 (WLNJ 31) BGO 110 FDQ 98 DBQ 89 (WLNJ 47) ESK 66 AZV 58 (YX 33 GEI 29 FF 28 BMB 26 GDF 20 EYS 22 PF 48 US 24 BPJ 14 BYL 10 ADW 10 BKP 10 CP 10 DJP-ALZ-CIT-WK 9 DXO 8 EAR 7 AOV-BIK 6 ATU 4 DUP 5 BTF 4 KI 4 BNY 2 GSF-BFA 3 FKO-C80-LG 1 AA 6 HDG 3 HDP-HGE 1 LC-ATT 3 ENS 2 GZ-BVT-ACG-FS 1 ASG-HBO 2 EVA-FLD 1.

NORTHERN NEW JERSEY—Acting SCM, Charles J. Hammersen, W2FOP—BCX keeps up his record traffic work. CGG is rebuilding. 3ETX operates daily on 3552 kc. GGW increased power. FOP is building pair '46s in par. for operation on 3.5 mc. DCP. new O.B.S., transmits on Mon., Wed., and Fri., at 10:30 p.m., Sundays at 11:00 a.m. HRN enjoys 7-mc. gang QSO's. ABS worked 51 sections in SS. Tri-County Radio Assn. gives code practice on 56 mc. through BTZ and CQX. AMB is new P.A.M. CIM, GPH, EXQ, GFF, AMF, BXM, FKF, DLF, AFB are active on 56 mc. HMP is active on 7 mc. DEE is on the air after long vacation. BPG will soon look for new experiences on the ultra-high frequencies. CLM is experimenting with new antennas. CW is building new rig with '03A final. HFO worked first VK. ECO put in Class "B" 'phone on all bands.

Traffic: W2LKE 159 CGG 76 ETX 57 GGW 35 FOP 20 DCP 18 GMN 9 HRN 2 ECO 15 BCX 1349 (WLNF 327).

#### MIDWEST DIVISION

IOWA—SCM, Phil D. Boardman, W9LEZ/WLUD—1 9ABE, CWG, HCH, HMM, LCX—R.M.'s. The Northeast Iowa Ham Club has been very active. The club has been donated the use of a park building by the city of Decorah. The Iowa City and University of Iowa Amateur Radio Clubs put on a short ham course with some very interesting talks given by prominent university instructors. LEZ works seven daily schedules. LCX was promoted to new position. CWG's transmitter gave up in middle of SS. HMM has Traffic Net working fine. GWT has been on 56- and 28-mc. 'phone. HCH is reorganizing Army Net. ACL likes 1.75-mc. c.w. FYC handled Red Cross traffic. RCR is looking for DX on 7 mc. PAH and TAR applied for O.R.S. RQR made 20,000 points in SS. NDN reports via radio. ERY was unable to hear stations in Copying Bee. GXU is loaded with troubles. SWZ and STA are new hams in Decorah. RDK is back on 3.5 mc. NTW has 50-foot masts. KMJ moved to Cresco. MXC gets out with battery flea power! LY is now living in Decorah. ADD catches a wife. FDL is hunting a "J" for W.A.C. Miss Barbara Jean Pitner arrived Dec. 2d; congrats to her daddy, FZO.

Traffic: W9LEZ 452 LCX 279 CWG 208 HMM 130 GWT 84 HCH 82 ACL 54 FYC 45 RCR-ABE 27 NNM 23 PAH 8 RQR 4 NDN 3.

KANSAS—SCM, O. J. Spetter, W9FLG—KG and IOL, R.M.'s. ESL, P.A.M. IOL is doing a great job of being R.M. IQI reports for his Section. Following B.P.L.: IQI, FLG, IOL, IEL, RQE. RIZ is chief O.R.S. PXW is in Sylvania QSL contest. AWP visited hams in Okla. City. BYV sent report via Western Union. RQE has an RK20. KUP is on again. GXV is servicing on week-ends. PIW is in N.C.R. IFF is building 3.9-mc. 100-watt

'phone. AWQ runs radio service shop. IQI is O.B.S. on 3.5-mc. c.w. MUY reports new club being formed at K.U. The H.R.O.S. has a committee drawing up a new constitution to conform with the regulations of the League. Club secretaries, please give the S.C.M. dope on your club activities. Thanks. The Kansas O.R.S. Round Table is being held every Sunday morning beginning at 9:30 a.m. Get in, gang; IOL in charge. IEL bemoans the fact he has been counting "relays" as one message! Wichita news: ABJ has new rig. OEH is getting rig started. TBR and TCT are new calls. BEZ has new speech amplifier on 14-mc. 'phone. DMF is to be on 14-mc. 'phone. 5DVG is getting new license in Wichita. W.A.R.C. adopted new constitution. Also is giving crystal to every new ham. CVN is getting Class "A" license. GML shows activity. LVZ is having trials and tribulations with B.C.L.'s. LKD has rig on 1.75 mc. RDW has two new sky hooks after others blew down. PGL is on again. DAL is busy with the cops building 9-meter transmitters and receivers. W.A.R.C. had 16 at Topeka Convention. BSX got a new bottle. BDB is selling out.

Traffic: W9IQI 1258 FLG 803 IOL 649 IEL 582 RQE 473 RIZ 337 NJS 103 BYV 63 EYY 57 CMV 56 OAQ 45 NI 33 AWP 30 FRC 26 HSN 25 CDM 22 BYM 20 KFP 12 LVS 6 MUY-SJV 4 PKD 3 PCF-KTJ 1.

MISSOURI—SCM, C. R. Cannady, W9EYG-JPT—JWI reports TCR new Independence ham. MZD gets lots of traffic from TL "B." BMA reports LBB won K.C. QSL contest. AIJ is building c.c. rig for SRE. NNZ is trying DX on 3.5—6GRB and K7PQ. KCG plays checkers via 1.75 mc. with DIC at Moberly. KEI is trying "bk-in" for traffic. ASV reports OSL in Calif. attending college—schedule with him every Tues. TDB is new Joplin ham. MLR is interested in O.R.S. HUG is getting ready for 56-mc. work. RJP uses Tri-tet with pair '46's. OLC applies for O.R.S. JAP renews O.R.S. KEF uses suppressor grid mod. MZF had lots of fun in SS. GBJ is trying 28 mc. a lot. St. Joseph Amateur Radio Club recently organized with NIS, pres.; BLU, vice-pres.; IAC, treas.; LCG, secy.; KBV, reporter. Sedalia amateurs organized Sedalia Amateur Radio Club Dec. 19th with LVA, pres. and OWQ, secy. More men are needed to complete Missouri State Net!

Traffic: W9RYD 1513 (WLMF 813) JWI 919 MZD 712 BMA 271 DHN 276 AIJ 247 NNZ 131 ENF 43 KCG 41 CRM 36 DIC 24 CJR 34 KEI-ASV 17 MLR 14 HUG-RJP 10 OLC 9 JAP-TCR 4 KEF-MZF-LCG 2 GBJ 1.

NEBRASKA—SCM, S. C. Wallace, W9FAM—BNT is going strong as usual. DI keeps bunch of daily schedules. KPA is doing well on Trunk Line "L." FYP, O.P.S., is handling nice bunch of 'phone traffic. FAM schedules 9ICN, Alton, Ill., east on T.L. "L." EHW plans 14- and 7-mc. rigs. RUJ works both c.w. and 'phone. KVZ schedules 6FXL, 5EFK and 9HQV. KJP has bunch of local schedules. FWW is still battling over 600. FZX runs another high score. FWC reports A.A.R.S. work being interfered with by 1.75-mc. 'phones. MKG reports. TBD reports new Tri-tet c.c. transmitter. IFG is remodeling ham shack. DHA says no room for sky wire at present QRA.

Traffic: W9BNT 2179 (WLU 42) DI 526 KPA 315 FYP 184 FAM 155 EHW 55 RUJ 40 KVZ 19 BQR 18 KJP-OPP 7 FWW 673 FZX 500 IFE 96 FWC 81.

#### NEW ENGLAND DIVISION

CONNECTICUT—SCM, Frederick Ells, Jr., W1CTI —MK and UE B.P.L. on deliveries. GME hang on to the Banner. DBU works traffic on 14 mc. with LA's. CVL canceled schedules because of death in his family. Sure sorry, O.M. CJD and YF were sick with gripe. HYF is joining A.A.R.S. BDI reports that 8AQE did some fast work in delivering a message to bus terminal at Rochester in time to reach and stop a passenger on a bus there. AMG is very busy at new farm. FIO is again holding down the Eastern end of the Star Trunk Line. EAO worked all districts and 26 sections out of only 34 contacts in the SS. NE is building a gas station. APA is active on 7048 KC. HPI suggests that we list our occupa-



tious and hobbies (outside of radio) in these reports. Let's have the dope, gang, if you are interested. Clay is Plant Manager at WTIC, and his hobby is hunting and fishing. Milt Mix, relief op at WTIC, has installed IPI at Avon. GKM needs Canadian traffic for schedule with VE2BU. The gang at YU are experimenting with Reinartz's antenna system. This year's officers of Yale Radio Club are: pres., DBP; secy., 3DKT. DLX has new power supply. APZ attends A.A.R.S. drill. CEJ worked a W6 on 3.5 mc. during the SS with 60 watts input. HXZ moved. HZE gets out well with 675 volts on a pair of '46s. BQS says 7-mc. conditions F.B. BNB is on 3.5-mc. and 1.75-mc. c.w. EAF worked CTIKR on 3.5 mc. with 35 watts input. GTW is joining D.A.S.D. IJD is new ham in Middletown. TS raised power to 500 watts input. IGR in Branford operates on 3.5 mc. Reports from those trying to win the C.B.A. Traffic Banner now held by GME should reach CTI by the 19th and should list traffic so as to show number of messages originated, delivered and relayed.

Traffic: WIMK 349 UE 248 CJD 227 GME 130 DBU 97 CVL 89 (WLG1 46) IYF 87 BDI 61 AMG 60 FIO 40 CTI 35 BHM 30 NE 16 APA 14 HPI 13 DOW 12 DEP 12 GKM 11 YU 9 HSX-DLX 8 APZ 6 CEJ 4 HXZ 2 HZE-BQS-BNB 1.

MAINE—SCM, John W. Singleton, WICDX—OR has been appointed Alt. S.C.S. for Maine A.A.R.S. CRP is busy on Trunk Line schedules. DHH plans to work on four bands. EFA is installing 212D in locked amplifier. BTG has been giving 56 mc. a tryout. CHF is alternate control on Trunk Line. GOJ has nice daily schedules. IBM says lots of interest in Augusta. ERB devotes most of his time to traffic work. EZR has new a.c. receiver. INW is new Lewiston ham. BNC renewed O.R.S. HSE sends first report. FNG is building c.c. portable. IJF gets out well on 3.5 mc. IMM is old IUU now located in Bangor. IDN has 1.75-mc. 'phone nearly ready. HUX is on 3562 kc. IEH is converting to c.c. CDX has 211 in final. WIEY entertained the 73 Club with a Christmas tree party. ALO has peach of a signal. IKC gets out fine with '10 in final. The S.C.M. wishes the gang a very happy new year.

Traffic: WIOR 83 CRP 73 DHH 73 EFA 63 BTG 63 CHF 58 GOJ 47 IBM 33 CDX 45 ERB 32 EZR-BNC 25 HSE 18 FNG 9 HUX-IPT 1.

EASTERN MASSACHUSETTS—SCM, Joseph A. Mullen WIASI—ASI is confined to 56 mc. KH worked his 45th state in SS. WV bowed to his twin for first time in SS. EVJ scored 52,400 in SS. BMW is on 1.75 mc. DFS will be on c.w. soon. CEL is leaving for warmer climate for winter. LM is active in N.C.R. HKY finds osc. keying FB for Army drills. SW has '52 perking at last. ADF sends code on Sun., Mon., Wed. and Fri., 7:15 p.m., 1785 kc. RF is building two-way jobs for police circles. CGM is active on 56 mc. AKN works in conjunction with CGM. ZK and AKY are making ready for the big Boston Hamfest late in Feb. FRO is Boston station on A.R.R.L. Trunk Line "C."

Traffic: WIASI 40 KH 54 WV 4 EVJ 3 BMW 36 DFS 8 RE 3 VS 34 GCL 8 CEL 16 LM 27 HKY 12 SW 35 FRO 38.

WESTERN MASSACHUSETTS—SCM, Percy C. Noble, W1BVR/WLG—ASY worked all Ve districts in SS. GZL has new Nat. Oscilloscope. BVR had his annual attack of la grippe! BWY is busy sending O.B.'s. APL is busting the ether with 250 watts input. AWW is trying to entice the S.C.M. into 56-mc. work. ADF sends code practice from 7:15 to 7:45 p.m. on Sun., Mon., Wed., and Fri., on 1785 kc. DUS built t.r.f. receiver. GXL joined A.A.R.S. ZB was forced off the air due to O.W. taking possession of the shack. AJD won crystal holder at the club. BAP is on 56 mc. daily except Saturday. BNL is rebuilding. BSJ has new receiving antenna that is a wow. Chief R. M. DVW had to return to hospital and is again on the way to recovery. Some of our O.R.S. aren't going to be O.R.S. anymore pretty soon. Other sections require reports regularly, and don't see as we are any better than they are.

Traffic: WIASY 7 GZL 104 BVR 78 (WLG 275) BWY

28 APL 18 AWW 12 ARH 9 DCH 7 ADF-COI-CTK-DUS-GXL 2 EOB 1 ZB 1.

NEW HAMPSHIRE—SCM, Basil Cutting, WIAPK—SK and IJB worked PAØASD on 3.5 mc. 100 is new Jefferson ham. GOB will be new O.R.S. DMI is exclusive c.w. now. GHT moved into winter quarters. HQE built rack and panel job for 3.5 mc. AGO has beam antenna on 56 mc. IGI is QRL sick sister. HTO does good job with Army traffic. DMD is rebuilding. AVJ built special shack in cellar. GKE has had trouble with '46s with 900 volts on their plates. HOU is experimenting with antennas. HJI has his 'phone on 1.75 mc. UN has been busy with XR on 56 mc. CCM's XYL took her Class B exam. CCM worked HI7G in West Indies three mornings in succession on 3.9-mc. 'phone. FFL is doing good job with Army Net. ANS is experimenting on duplex 56 and 1.75 mc. IDY was busy for Christmas deliveries. GEY says, "Nothing like married life." 8HYC of Mich. is new op at WLNH. Welcome to our Section. BGZ says, "All records are phonograph at WLNH." ERQ is on Trunk Line "C." PFZ renews O.R.S. BJJ has a fine low-power 'phone. The New England Radiophone Association has broadcasts and roll call on 1.75 mc. at 7:30 a.m. Sundays, with APK as N.C.S. on 1895 kc., and this broadcast and roll call repeated on 3.9 mc. by AUY and CWH at 9:00 a.m. All 'phone stations in New England welcome. Things are under way for New Hampshire Convention at Hotel Carpenter in Manchester some time in April, under the direction of N. H. Section State Committee, consisting of HPM, FTJ, GMH, AVJ and APK.

Traffic: WIERQ 665 DMD 651 FFL 258 (WLG 109) IJB 97 FFZ 38 UN 134 GHT 13 DMI 20 GOB 8 SK 115 CCM 2 IDY 3 GEY 1 BGL 2.

RHODE ISLAND—SCM, Albert J. King, W1QR—GOG has new 56-mc. rig. CAB has trouble on 14 mc. at new QRA. HRC has been inactive due to sickness in family. IMY has schedules on 7 mc. GTN says Q8T coil winding idea FB. BLL drives 50-watter with double doubler.

Traffic: W1GOG 51 HRC 4 CAB 68 IMY 2 QR 25.

VERMONT—SCM, Harry Page, WIATF—EFC applies for O.P.S. FPS has "Class A" ticket. DQK has 300 watts input! GAE has new Tri-tet. AXN has an SW3. GNF lost two tubes, a bleeder, and acquired toothache during the SS. CGV is c.c. on 3567 kc. BJJ gave two aspirants exams for temporary licenses. BD successfully demonstrated the gentle art of radio communication in a teacher's convention. His emergency rig works FB.

Traffic: W1AXN 68 (WLG 9) FPS 63 DQK 30 BJJ 18 ATF 18 CGV 5 GNF 4 GAE 2.

#### NORTHWESTERN DIVISION

ALASKA—SCM, Richard J. Fox, K7PQ—BNW went south for medical treatment. ANQ visited PQ. BOE uses tens P.P. DWM has new power supply. ENA is rebuilding. ATT has gross transmitter and PR-10 receiver. DWM has FB 1000-V. power supply.

Traffic: K7AFT 1 DWM 3 PQ 23 CHP 40 BOE 83.

IDAHO—Acting SCM, Nellie Hart, W7NH—DBP joined A.A.R.S. AVP has new YF. BMF is alternate S.N.C.S. for A.A.R.S. of Idaho. ASA, CSP, DAW, DBP, ABK are coming on 3.9-mc. 'phone. EES is QRL KIDO. AXY loaned car to joy-riders. CZO is remodeling house. CUG has new crystal. BCU has new rig for all bands. CP's YF is in hospital. CHT works 3.9-mc. 'phone. ATN schedules ALY, CGW, AYP: active. BAR's new super perks F.B. KJ is located at Payette. BRU has station at Junior College. DKY builds transmitter for KG. EMT gets F.B. results with new super. BAA is busy with 6ZG. Shoshone County hams are organizing club. DCG takes Class "A." EKV and BKK are 1.75-mc. 'phone. EEX is awaiting PR-12. BZU is back from Alaskan trip. BDX is on all bands. CFX is on with ¼-watt 'phone. DEB is building power supply. AVZ is trying to grid modulate a 212A. EFL is fishing for DX. Where are IDAHO's traffic hounds?

Traffic: W7AVP 61 DBP 6 NH 18.

MONTANA—SCM, O. W. Viers, W7AAT—ASQ takes

traffic honors. TU is back on the air. BIZ let his operator license expire. BVE reports these new Great Falls stations: EOB, EOD, ETA, EOI and EMW. AOD says 14 mc. is good. AQN gets out F.B. with new rig. CRH is lining up early morning schedules on 3.5 mc. AFS will soon have more power. AHF is working at KFBB. CEG is making room for a '52 in his shack. BOZ and BMX returned from C.C.C. camp for Christmas vacation. DSN was home from the Navy for Christmas vacation. BSU did himself proud in the SS. BDJ will soon be on after five months' absence. BJZ does lots of experimenting. EPM and DHW of Billings visited Roundup gang. ESI and EPM have new rigs. DHW plans on installing a new S30. CPY is on 3.9-mc. 'phone. BYE is building new shielded rig. EDJ applied for A.A.R.S. AAT/COX is back on 3.5 mc. after five months' vacation. Thanks for all the reports. Please keep them coming, gang.

Traffic: W7AAT 4 AOD 43 ASQ 138 BVE 8 BDS 7 EDJ 37 (ASQ 100 Oct.-Nov.).

OREGON—SCM, Frank L. Black, W7AMF—R.M., UJ, heads traffic list. 52 stations reported to the S.C.M. this month. Portland gang is going strong on 56 mc., the following being heard nightly: DZL, DIU, VS, AXJ, BEC, BTF, and CSQ. Portland Club Station, AJW, will be on the air by the first of the year. COB, OP on the General Sherman, takes new job with Mackay Radio Station KEK. DIS and ENU have doubled power to 100 watts. DP's family had bad auto crack-up on Armistice Day and are still in hospital. Deforest Club of Grant High School, Portland, has seven operators. Two of them are YLs. BUB and BPJ have combined stations to make tests with G6CL. KV, Director N.W. Division, is new O.P.S. Eugene reports a new YL ham. AXJ is new liaison between A.A.R.S. and A.R.R.L. P.A.M., AHZ, reports phone net going strong. DTG finished radio school. Rebuilding: CHB, HD, DNP. Corvallis Communication Club is open for anyone interested in electrical communication.

Traffic: W7UJ 341 AXJ 165 CXK 118 DUE 87 DTG 77 (WLVP 47) WR 46 BUB 39 CTL 26 BRH 20 DP 19 AMF 24 KL 12 DIS 8 ENU 8 AHZ-DAA-DBY 2 BDU 1 BWD 50.

WASHINGTON—SCM, Stanley J. Belliveau, W7AYO—ETW is new Everett ham. DGY made 5200 pts. in SS. EHU is new reporter. ACS wants some stations to test with on 28 mc. Washington Section announces a six months' progressive contest. Started December 16th, but still not too late to win one of the many worthwhile prizes under the very simple rules. For all the dope see the December issue of the *Brasspounder*. Remember to send in a report and get a copy of the *Brasspounder*. Keep up with all the latest news within the Section. Remember Washington Section QSO Party, the third Sunday of every month, 8 a.m.—8 p.m.

Traffic: W7CQI 381 WY 314 CZY 254 DLN 192 DGY 122 DRY 61 LD 57 CSK 54 APS 49 CND 46 AZI 43 EHU 35 BRT 25 AHQ 24 CHH 24 ECM 22 ALH 19 IG 15 DRK 14 DZX 13 DJJ 13 DDO 12 AIT 10 DPU-AW-BIW-AG 9 RL 8 AYO 7 DCJ-BBK-ACS 6 EFZ-AQ 5 APR-BF 4 EAW 3 AEA-CJN 2 AUP-CDD-UE-ANI-EKA-ABU/7 1 (AZI 42 Oct.-Nov.).

#### PACIFIC DIVISION

HAWAII—SCM, A. O. Adams, K6EWQ—GZI raises coffee. COG is awaiting transformer. EWA, EWQ, LEX, KTF, AGI, KKP, ETF, JRN, LCV and DV have lots of fun on 56-mc. 'phone. JPT has new Comet Pro. KFB has trouble with rig. KPJ has ten in final. EWQ is awaiting new HRO. 8AOR and EWQ stood by for tidal wave that never showed up. ETF has YLitis. IBW is doing nice traffic work. FJF and MV are going H.P. EDH and CIB are rebuilding.

Traffic: K6EWQ 1361 (WVQB 1048) JPT 403 IBW 96 GZI 27 FJF 8 EDH 2.

NEVADA—SCM, Keston L. Ramsey, W6EAD—GYX keeps three daily schedules. IKJ lost antenna poles in wind. KVQ gets out F.B. with new rig. AJP worked some F.B. DX. LOD is N.C.R. control station. AAX is building 56-mc. rigs for use on Naval Reserve Rifle

Range. ATM was visitor at AAX. GGO works F.B. DX. JVH is on 14 mc. BYR is on 14-mc. 'phone every Sunday. KGS is experimenting with low angle radiation. KWO's ears are peeled for DX. KLW announces new 2nd operator. JFB was transferred to airways station at Bitter Creek, Wyo. Good luck, O.M.! BTJ operates N.C.R. station LOD with DSD and EAD. FKY visited N.C.R. unit in Salt Lake City. IEN at Elko worked FKY's rig during his absence. FUG sold his 'phone rig to HCE of Hawthorne. KBZ visited VESLQ—EP and several other VE's on visit to Vancouver, B. C. The Nev. Amateur Radio Assn. held F.B. Hamfest Jan. 12th, 1935, in Reno. The N.C.R. units of Reno and Elko are holding rifle practice regularly. Portable 7UB is on 1.75-mc. 'phone. BIC added Class "B" mod. to 'phone rig.

Traffic: W6GYX 328 AJP 80 LOD 20 UO 22 GGO 12. LOS ANGELES—SCM, Howell C. Brown, W6BPU—Ed Taylor, W6GNM, CRM. Two make B.P.L.: ETL, CVF. New hams: LOR, LPF, LPG. CVF is rebuilding rack and panel. GXM had 12-hour shift during street car strike. IOX is new O.R.S. AM has 171-ft. tower with eight antennas. IIK says Trunk "D" is working F.B. KBY is rebuilding. DEP is moving station to larger quarters. HEW is new O.B.S. BZF and HAH are trying 56 mc. CVV got Pyrex arm in SS. ERT has 25 watt portable 56-mc. rig. JNE is trying to get on 14-mc. c.w. IRD has new job. ANN has 200-ft. antenna on 7 mc. MA has 13 transmitting antennas and beams. UP says lots of fun on 56 mc. portable. CV is experimenting on 14-mc. 'phone. AIF says SS wore him out. HDV joins A.R.R.L. LLM is new reporter. BGF will be in Berkeley from Jan. to Aug. CU was in hospital with appendicitis. Better now. Report, but no traffic: COF, DUX, DZI, FMO, GM, JTF, KJO.

Traffic: W6ETL 1429 (WLVG 158) EDW 349 EBK 295 CVF 249 BPU 159 GNM 103 IDZ 92 AKW 74 GXM 73 FXL 70 IOX 64 AM 55 DNA 51 FYW 43 IIK 38 KBY 26 EK 25 DEP 23 JJI-HEW 22 DBF 19 ALR 18 BZF-CVV 16 LXL 15 DWP 16 ERT-JNE 13 KNP 11 DJC-GKZ-HEM-KBF 10 HAH 9 CTT-IRD-JGA-JSK 8 CAH-DFO-EUV-JAG-TN-ZBJ 6 ANN-MA 5 BWG-FVD-HWM-JUL-KA-KUQ-PD-UP 4 CV-GZQ-JGL-KEI-VO 3 AIF-CKR-DOK-HDV-INC-JSD-KML-LFC-LLM-WT 2 AAN-AGF-BGF-BVZ-CZT-LCO 1.

SANTA CLARA VALLEY—SCM, Chas. J. Camp, W6BMW—JTL complains of 3.5-mc. QRM. BSO was busy with final ex's. AZC received W.A.C. certificate, and made 25,620 in SS. BCF went home for Holidays. YX, Stanford Univ. Radio Club, has 7-mc. rig going. LLW is new Salinas reporter. JJJ from L.A. is up with portable rig. LFG sends good report. YG, Santa Cruz High School, is putting up new transmitting towers. BMW put up new tower and radiating system.

Traffic: W6JTL 1 BSO 9 AZC 64 LLW 12 LFG 124 BMW 32. YG 91.

EAST BAY—SCM, P. W. Dann, W6ZX—RJ is still QRL Army Net. EJA is still keeping schedules with KA. New club at Richmond is coming along F.B. EHM is QRL traffic nets. HRN worked 60 sections in SS. AF now uses circuit à la Grammer in Jan. '34 QST. ITH has new G.E. receiver. S.C.M. would appreciate non-member reports as well as member reports. 73, gang, and Prosperous and Happy New Year.

Traffic: W6RJ 218 EJA 129 HEM 37 HRN 33 YM 16 AF 5 ZX 38.

SAN FRANCISCO—SCM, Byron Goodman, W6CAL—ZG B.P.L.'s. HRY's station was unfortunately destroyed by fire. LIE is on T.L. "B" and handling HRY's T.L. "F." JXK worked RH's schedule by remote control over 56-mc. circuit. NK is U.S.N.R. control. JNI sends holiday greetings to gang from Petaluma. JVV has 56-mc. itch. JDG says final working 76.5% efficient. GPB has antennaitis. JPA is looking for W4 on 3.5 mc. HJP is coasting on 56 mc. KNQ joined N.C.R. JMR has 211 final. CAL is eating, sleeping, and swearing s.s. super. BIP is 28-mc. bound. IPH is looking for bugs (in his rig). DDO has new speech amplifier. GQA has new c.c. rig with "flat" '10 final. CIS is back after traffic. KBM is going after traffic. JAL is on 56 mc. UL is in line for

congrats on new Jr. op. CWR is rebuilding into metal cabinet.

Traffic: W6ZG 2256 (WLV 371) HRY 367 LIE 360 JXR 230 NK 105 (NDH 20) JNI 68 JUV 22 JDG 20 GPB-JPA 12 HJP 11 KNQ 13 JMR 9 CAL 8 BIP-IPH 5 DDO 4 GQA 2 CIS 1.

SACRAMENTO VALLEY—SCM, Geo. L. Woodington, W6DVE—I am sorry to have to tell the gang that I cannot accept another term as S.C.M. Please nominate your favorite amateur and send the dope to F. E. Handy before the closing date, Feb. 1, 1935. KQQ has a pair of RK20's in P.P. IZE is going to 1.75-mc. 'phone. KCA has '52. IMV has '03A. John and Bill of BYB have radio store in Oak Park. Nice card from EFM.

Traffic: W6DVD 45 (WLV 6) GZY 22 CGJ 18 DVE 9 FRP 3.

ARIZONA—SCM, Ernesto Mendoza, W6BJF-QC—KOL has c.c. HCX works east coast doubling on '01A's. IQY made 20,000 points in SS. KOK has new high zepp antenna. CQF is QRL B.C. station KGAR. FGG is going in for 3.9-mc. 'phone. GUQ and DHR say one kw. to pair of '03A tubes isn't good for 'em! JFO and BYD have good luck on 1.75-mc. 'phone DX. DNP is rebuilding. LDC is all set on 3.5-mc. c.w. ALU is awaiting new HRO. JPH attends Los Angeles Radio School. AEK was burnt out by fairgrounds' grandstand loss! CTI used DIE's equipment while latter was at Tucson. AND copies code news for KOY at 40 per! IIF is building 75-watt c.c. four-stage job. IIG and FZQ sold their PR-10 receivers in favor of PR-12. HEU returned from Ohio with pair of 250-watt "Q" tubes! GGS operates at one "dam" power plant after another! GCU is corporal in radio section, N.G. CKF is active on portable 56-mc. 'phone. JYQ uses huge QSL by cartoonist 8EA! BRI finds little time for radio while employed in store. QC is collecting parts for new c.c. two-stage portable all-wave. JRK employs '45 to push '11-D in c.c. circuit. IMR, ex-6AAM, courageously ventures again into matrimony! JHV won RK-20 raffled off at Phoenix Club. CDU held lucky number on crystal door-prize!! KGL will swap couple of 860s, or anything else, for what have you? DSQ would like to know which corner the depression is just around! HKX is employed at Tovrea, just a stone's throw from his QRA. DIE left employ of KGAR for preferred Phoenix druggist position. KQT doubles in final of c.c. osc.-final. GJC has to contend with 25-cycle supply for rig. Phoenix Radio Club is sponsoring low-power type 30-tube transmitter contest, with SW3 as first prize. New calls: JJN Glendale, JEM, JOW Prescott, KOA Ganado, KQT Phoenix. KOL and IIG are newly appointed O.R.S. A bigger and better year to you all, these coming months!!

Traffic: W6KOL 113 HCX 5 IQY 4 KOK 2.

PHILIPPINES—SCM, Newton E. Thompson, KA1XA—R. G. Meyer of KA1HR sailed for the States Dec. 4th. OM2RX and OM2BC are organizing radio club on Guam. First meeting was held on Dec. 22d. Two new stations on Guam: OM2BC and ON2PI. KA1LG will be on soon with big rig, 500 watts c.c. KA1AN was appointed Official Observer P.A.R.A. at last meeting.

Traffic: KA1HR 1923 LG 420 RC 382 CS 259 AN 166 CO 117 US 61 XA 44. KA9WX 30. OM1TB 913. OM2RX 625.

SAN DIEGO—SCM, Harry A. Ambler, W6EOP—BMC makes B.P.L. as usual, also operates WLVH on A.A.R.S. BHV makes B.P.L. first time since 1922. He is leaving for sea duty. IYL, his XYL, will take over some of the schedules. FQU says R.M. Net is working F.B. HEX was in SS contest. AXN, R.M., for the Valley, has new c.c. rig with RK20 final. BLZ has new c.c. rig. EOP has 56-and 28-mc. transceiver. GNT blew rectifier in SS contest. ACJ reports Helix Radio Club is going strong. BAM reports JZD now in Santa Ana. LHN is new station. LD will soon have two new transmitters.

Traffic: W6BMC 1444 (WLVH 20) BHV 577 FQU 126 HEX 38 AXN 34 BLZ-EOP 4 GNT-ACJ-BAM-LD 1.

SAN JOAQUIN VALLEY—SCM, Clyde C. Anderson, W6FFP—The Manteca Club has emergency battery-operated portable. The Stockton Club reorganized with IKG as manager (not president). INP won Stockton 7-mc.

DX contest with EXH copping 3.5 mc. Second prizes for both were crystals so AOZ and JSG will soon be on two c.c. frequencies. FFU is 56-mc. nuts. GXL asked Santa for a '52. KEV has 830 in final. EXH is building new shack. EJE lost his license so JIK has new transmitter. Old JJ is back at Dinuba with KPI. DT has rig on air again. CYY blew an 825. The S.C.M. traded his FBXA for stamps. KFU, the wandering section control call for the Navy, is residing in Fresno for three months. KPW has 'phone rig working. KPM's FBXA (the S.C.M.'s ex-) occupies most of his time. CVT and CVL handled all traffic between Fresno and Northfork during recent storm that caused power and communication failure. Both are A.A.R.S. with CVT retiring as 11th Dist. Control. DQS, from Glendale, invades the section taking charge of the Northfork C.C.C. camp. JHM and JIC joined N.C.R. KGO almost equalled traffic totals of the other S.C.M.'s.

Traffic: W6KGO 236 FFU 99 EXH 90 FYW 62 DZN 40 JSG 33 KEV 9 IKG 4 SF 2 AGV 31.

#### ROANOKE DIVISION

NORTH CAROLINA—Acting SCM, N. M. Patterson, W4EG—Answers to the questionnaire designed to settle the argument on 'phone vs c.w. space requirements insofar as North Carolina is concerned are slow in coming in. All N.C. amateurs are urged to answer the following question and mail it to the S.C.M. at once. Estimate as near as possible the per cent of your operating time that you have spent on each of the amateur bands during the past year, also the PROBABLE per cent you will use each of the bands during the coming year. 1.75-mc. 'phone —, 1.75-mc. c.w. —, 3.9-mc. 'phone —, 3.5-mc. c.w. —, 7-mc. c.w. —, 14-mc. 'phone —, 14-mc. c.w. —, 28 mc. —, 56 mc. —. Total 100% for each year. Please cooperate with us in this. The results will be published in the *Tar Heel Ham*. The 1.75-mc. 'Phone Net is doing fine work. All 1.75-mc. 'phones are invited to get in it. Write W. N. Bray, Box 354, Winston-Salem. AAU is master of ceremonies. BV is building a rig that will knock us all off 1.75 mc. CDX got that rig of his sounding fine. CVQ keeps rebuilding. CDQ rebuilds every week. BX got bitten by the 'phone bug and is on 1.75 mc. with a pretty signal. Wilmington: Other 1.75-mc. 'phones: CBI, CXI, CYB, CDX, AZP, BJU. BRK and BPL are the only two reporting traffic. EE is back on the air. ATY is up on Government Dredge. Charlotte: ALD has schedule with K5AG on 3.5 mc. BLN has schedule with C.C.C. Camp in Va. The Club reports that it cost \$33 to get incorporated after a lot of bargaining. Concord: Reports only three active stations: TJ works on 7 and 14 mc. CTD is trying to sell his motor-cycle. AAU is active on 1.75-mc. 'phone. Winston-Salem: BOH says COK has trouble with parasites. BYA can now work 'phone or c.w. on four bands, OG appears to be slated for S.C.M. Robersonville: BLU reports that 9HZL has gone back to Kentucky. AMC is QRL YL. Tarboro: ALT reports a new SW3 and a blown filter condenser. ALK has rig going fine. BV managed some traffic despite the sickness of his mother. BHR still has that power leak. ZH hooked UIBL, ZEJJ and VQ4CRP. Raleigh: Nice traffic reports from DW and BTC. EG was QRL Christmas rush. VI will be on with a very FB 100 watt 'phone shortly.

Traffic: W4BTC 75 DW 74 ALD 53 BRK 38 CXC 13 BV 9 BHR 6 ALT 6 ZH 6 BXF 5 BLU 5 BYA 4 BPL 2 BLN 40 ACY 4.

VIRGINIA—SCM, Neil E. Henry, W3BRY—EPH wants Canal Zone traffic. ELB reports three new Danville stations. EBD now O.R.S. DWP schedules K5AM twice weekly. EGD placed high in the SS. DQD keeps schedules on 3809 kc. DCU is active in A.A.R.S. GY has swell 'phone on 3973 kc. CYW spends 90% time on 56 mc. CSY is on 3785 kc. CHEE worked 49 sections in SS. BZE worked Utah with '45 T.N.T. WM reports new Portsmouth station. DHZ. BWA's eyes went bad. BIW works plenty DX on 14 mc. BEB and APU are on 1.75-mc. 'phone. ANT leads Section in traffic. BRY is fooling with Tri-tet. AMB is on 3680 kc. ALF had nice score in Va. contest. AAF is chewing rag on 'phone and c.w. AHQ has F.B. 3.9-mc.

'phone. CFV likes "Va. Ham." CNY has high-power 'phone. DRK is on air from CAH. DWE is experimenting. ELA is laid up with bum foot. EOX is on 7096 kc. EUL is active in A.A.R.S. UVA made 11,840 points in SS. ECQ puts 800 v. on pair '46's. EHL enjoyed SS. EPK is 100% c.w. AAJ is new Chief R.M.; visited S.C.M. DZW is building rack and panel rig. FJ controls A.A.R.S. Net, 2 p.m., Sundays. CPN likes 14 mc. CQW transferred to EPW (WVGM). EVO is on 7 mc. EVN applied for A.A.R.S. Club news: Meetings: Richmond, Tues., Y.M.C.A.; U. of V., first and third Fridays, Madison Hall; Lynchburg, Tues., Y.M.C.A.; Petersburg, Y.M.C.A., Thursday. New calls: FAP, FAT, FBW, Danville; FBL, FBR, Lynchburg; DHZ, Portsmouth; EZR, Norfolk. Norfolk Club has code class every night. BIG wants Sunday 'Phone Net. EAP has new 100% mod. Jr. opr. EOO is on 7 and 14 mc. ELJ is building 830 amplifier. DAM is on 7270 kc. COO is 100% c.w. CGR is experimenting on 56 mc. CCU works DX on 14 mc. BAN is still world's best O.O. AFF is on 14-mc. 'phone. AEW is on 3990-kc. 'phone. BTR has trouble with Tri-tet. HZ has bad power leak QRM. CA works on 3.5, 7 and 14 mc. CYM is rebuilding. MQ is building hi-fidelity B.C. set. BPI is on 3820 kc. DGT sends article for "Va. Ham." EMX is on 3580 kc. FBL has '47-801-'03A rig. EBK reports. EEN is active in U.S.N.R. ENJ wants Virginia schedules.

Traffic: W3EPH 1 ELB 3 EBD 16 DWP 8 EGD 2 DQD 13 DCU 12 GY 5 CYW 4 CSY 5 CHE 60 BZE 1 WM 6 BWA 1 BIW 10 BFW 7 BEB 17 APU 3 ANT 1017 BRY 17 AMB 6 ALF 10 AAF 4 AEQ 12 CFV 7 CNY 40 DRK 4 DWE 2 ELA 2 EOX 2 EUL 48 UVA 14 ECQ 29 EHL 5 EPK 2 AAJ 54 DZW 7 FJ 174 CPN 10 CQW 3 EVO 10 EVN 26 EEN 14 ENJ 56.

WEST VIRGINIA—SCM, C. S. Hofmann, W8HD—KKG worked HB9Y on 3.5 mc. and J3EU on 14 mc. ELJ and HD are QRL W. Va. A.A.R.S. Net. FQB offers crystal to W. Va. O.R.S. making highest score in January O.R.S. contest. CDE moved to Richlands. Bluefield Amateur Radio Club is again active. HCL visited Wheeling. 56-mc. tests are conducted at West Va. Univ., using calls DSJ-TI; KIU will be used on 14 mc. KDP worked 36 states in two months. AKQ moved to Lumberport; applies for A.A.R.S. ANU, FQB, BTV, BOW report being home over Christmas holidays. LSK has BCL trouble with 1.75-mc. 'phone. MCL is on jury duty. FVU's operator's license expired. Radio Communications Assn. of Wheeling have a prospective club house. If satisfactory, will later install club room, and ham station. Stations on the W. Va. A.A.R.S. Net will listen for non-W. Va. Net stations who may have traffic to move. Between 6:15 and 6:30 p.m. daily; and right after roll call, which is shortly after 6:30 p.m. daily. The Net stations are all c.c. "one-spot," on 3700 kcs. NDE, U.S.N.R. station in Wheeling, is now in operation. EIK is rebuilding receiver. LTD recovered from a bad case of YL-itis! CHEM has 'phone schedule with HRT.

Traffic: W8KKG 133 ELJ 35 HD 70 (WLHF 74) OK 121 (WLHB 15) EZR 14 KDP 28 AKQ 11 LSJ 6 HWT 26 EIK 16 (WLHG 2) LTD 2.

#### ROCKY MOUNTAIN DIVISION

UTAH-WYOMING—SCM, Arty W. Clark, W6GQC—Utah: 6FRN is on test schedule with K6FAB. KKG has better luck with K6DV. BSE does nice job as D.N.C.S. A.A.R.S. Unit One, Utah. DPO moved to Byron, Wyo. AFN works at O'Loughlin Radio. KOP is chasing bugs out of transmitter. HWI moved to Blanding, Utah, is on 1.75-mc. 'phone and keeps schedule with 5DVH, ex-6EEM. JVB gets R9 in N.Y.C. with 2 watts output on 14 mc. HVU has new rig with c.c. DTB is getting used to married life. Better results at JYD with pair of '46's in final. LOH is Moroni, Utah, call for KVC of Chester. DGR is working hard to keep TL "L" going. This marks the end of a splendid year of activity in Utah and Wyoming. Your S.C.M. is more than pleased and wishes all of you a successful 1935. Wyoming: Assistant S.C.M., T. J. Rigby, W7COH—Sheridan: 7ARK was QRL with Prize Cattle at International Livestock Show in Chicago.

CSE is disturbing the ether from coast to coast on CCC's new 1.75-mc. 'phone as CCC is busy with radio service. DCO is on 7 mc. CPL is on 3.5- and 1.75-mc. voice. EKR

COLORADO—SCM, T. R. Becker, W9BTO—

### In Memoriam

FORREST LAVERN SEVERS (W9BYK)

We have lost one of the finest amateurs we have ever been privileged to have in our midst. Forrest LaVern Severs (W9BYK), who passed away on his birthday, Dec. 23, 1934.

Words cannot express the depth of our loss. LaVern was one of the most ambitious amateurs in this section. To his wife, daughter, mother, and brother we express our deepest heart-felt sympathy. His voice will be sadly missed on the 3.9-mc. band. His crystal 3997 kc. is silent.

Traffic: W9PWU 8 ESA 919 DQD 4 EHC 21.

is QRL working. Casper: AMU has new antenna. BXB is new president of club. EDG is vice-pres. A new ham, name Thomas, secy. NY hears Berlin BC on new super. ADF is building new 'phone. Glenrock: CDV has new SS. receiver. Rock Springs: DIE is trying to line up T.L. schedules. Midwest: CLG is still fighting 1.75-mc. 'phone. COH gave a talk to the Boy Scouts on Amateur Radio. He was assisted by CLG demonstrating with a portable rig. Evanston: COO moved into new home.

Traffic: W6GQC 490 KDI 222 DGR 113 FYR 100 BSE 24 AFN 20 HWI 9 LCM 4 JVB 2 KOP 1 FRN 1 W7ARK 5 AMU 33 DIE 25 COH 165. AXG 2.

#### SOUTHEASTERN DIVISION

ALABAMA—SCM, L. D. Elwell, W4KP—BOU and KP handled emergency traffic. BJA is on 7 mc. CIU has cold shack. DEQ is new ham on 3.5 mc. DS and APU are busy with schedules. CYW is out for QSLs.

Traffic: W4BOU 23 APU 25 BJA 3 CIU 2 KP 5.

EASTERN FLORIDA—SCM, Phil McMasters, W4BCZ—CQD's small brother lost his crystal. BIN reports that DFU is new call of U. of Fla. Club station. CFC has new R.C.A. ham receiver. JO is building new rig with '03A final. Miami Club has new rig on 1.75-mc. 'phone. 9IUX will be BT-4 soon. BDD works VE with 46 amp. on 3.9 mc. BVM is building new rig. BVX is on 1.75-mc. 'phone. KM is now on 1.75-mc. 'phone. AKI lost rig in fire. "Harmonics," Miami weekly ham sheet, is soon to enter third year. DGW is new Gainesville ham. DHD in new St. Pete ham. CQZ works FB DX on 1.75-mc. 'phone. DER has lots of fun using '01A's in triple push-pull. BBG and DBG are working 56 mc. CMN reports new 14-mc. current-fed antenna. AKW pounds brass for Goodyear Blimp. QY takes care of AKW's traffic. Studios are replacing shacks at WS and COS. BNI visited CQJ, IC and AVQ. Tampa stations active on 56 mc.: BDY, ALP, BNR, DDM, IZ, BN.

Traffic: W4ASR 52 CQD 6 COV 3 DBA 6 CWR 3 BCZ 7 BNI 6 CQZ 16.

WESTERN FLORIDA—SCM, Eddie Collins, W4MS—R.M.'s, 4ACB and 4AUW. CTA is selling out. BGA located an FB QRA. QK is building Tri-tet. CDE keeps several schedules. BKD at Ga. Tech. is working the gang. HOW returned to the air. CTZ gets heard cards from Europe. DGG is our newest ham from Perry. AUW made W.A.C. under two hours. CRU should make an FB O.R.S. AFT is heard again. CMJ has some RK20's. BMJ has power troubles. COG has an eye on c.c. Tri-tet. DAO is proud owner of an FB7A. CQF confines his work to U.S.N.R. AQY is QRL State Highway work. KB has 3.9-mc. 'phone QSO card from ZL. QU is busy with NDD. BGA is kept busy at HQ. DBL is rebuilding. AUA

has new QRA. ACB is QRL at the P.O. MS handles KA traffic.

Traffic: W4KB 52 DAO 8 QK 4 ACB 6 CDE 32 AUW 24 COG 8 VR 7 CTZ 15 MS 368.

GEORGIA-SOUTH CAROLINA-CUBA ISLE-OF-PINES-PORTO RICO-VIRGIN ISLANDS-SCM. Bannie L. Stewart, W4CE-AZT is working on types of modulation. DEF is on 3.5 mc. BBV moved to Gainesville, Ga. BCN is building new 1.75-mc. 'phone. DGD is new in Marion, S. C. CWE is building new 'phone. TL has '03A final. ACH uses 801 final. BAT is new O.B.S. CXE is building new amplifier. ANK holds down eastern end of 'Trunk Line "D." BDT is now O.R.S. BW is active in Macon. CPB gets out FB on 1.75-mc. 'phone. BZX is moving in house with rig. MN has RK 18's in final. CPG uses pair of 825's. GB has neat multi-band exciter unit. DGB is new in Columbia. DDO is on in Camden, S. C., with 1.75-mc. 'phone. IR carries high traffic total for Section. DFC is new in Charleston, S. C. EY formerly of Fernandina, Fla., is now in Charleston, S. C. CZA was accused of being a YL. Hi. Vivian is very much a man. CPZ plans to get Asia. CIR uses a hand generator for power. DL has gone in for high power. CCT has been working VK's and ZL's. CFD is active in N.C.R. BCT is on 3.9-mc. 'phone. CWY is active on 7 mc. AFQ is new O.R.S. CE has new antenna 51 feet in air. Please report all traffic handled, A.A.R.S., U.S.N.R., or regular to the S.C.M. each month. CRH is new O.R.S. on 'Trunk Line "D." The Charleston Amateur Radio Club is holding regular meetings. In Gainesville, Ga., the "Queen City Radio Club" has been organized. Officers are: Rev. Hinshelwood, BBV, pres.; ACH, secy.-treas.; R. Bailes, technical instructor, and Alan Hinshelwood, BBV-Code inst. President Bass, CQG, of the "Palmetto Amateur Radio Club" of Columbia reports plans for a new club room and club transmitter.

Traffic: W4AZT 7 ANK 13 BDT 38 IR 424 CIR 18 CFD 5 AFQ 68 CE 10.

#### WEST GULF DIVISION

NORTHERN TEXAS-SCM, Glen E. Talbutt, W5AUL-BII is Texas station on Trunk "D." AZB has hopes! CPB QSO'd 45 sections in SS. DXA is a good traffic station. We thank Bill, BKE, for the fine traffic prize he donated for '34, and congrats to AW as the winner. EDB wants to join A.A.R.S. CHJ works hard in A.A. Net. BXA is now O.R.S. ARV is "daddy" of Section QSO Party. NW is new Director of West Gulf Division. Congrats, OM, we are with you, and plenty of credit to DUR in helping the O.M. IA has turned 'phone man, maybe. EEW is still candidate for O.R.S. EPU is new Eastland ham. CMS is rebuilding "again." CZR has new SW3. SP was called to Calif. due to father's illness. AW has a cow. AUJ, QA: rebuilding. "Flash"! The new assist. S.C.M. arrived on Dec. 20th! His name is "Bill," and he calls CQ all night long. The O.M. also has a new "Detroit rattle." See last month's QST for details of the Section QSO Party, Feb. 9th-16th, and meet the gang. Thanks for the fine reports of 1934, gang, and let's make 1935 a bigger and better year. Nominations for S.C.M. are in order, so make sure your man's name will be on the ballot. AUL will not be a candidate.

Traffic: W5BII 220 AZB 108 ZD 107 BEY 102 CPB 88 DXA 74 CPT 41 ARS 36 BKH 32 EDB 25 CHJ-BXA 24 ARV 10 NW 15 IA 8 EEW 5 EPU 4.

OKLAHOMA-SCM, Carter L. Simpson, W5CEZ-CEZ has Trunk "K" schedules working F.B. CUX made F.B. total in the SS. BKK is trying a PR-10. ASF works hard on A.A.R.S. BAR reports Trunk "D" working F.B. west connecting with California R.M. Net and Trans-Pacific Trunk. DZU is pinch hitting for BKK. BWN put the old '03A back on. DDW's traffic total continues to improve. BLG solved A.A.R.S. cipher message in unknown key. DSM is newest addition to Oklahoma WX Net. CVA's new QRA: Route 6, Box 154. ASW has '52 perking F.B. KZ is operating 'phone 100%. LR at the club shack, has a winter's supply of wood stored for any who wish to spend a night pounding brass. ERU, new ham in Erick, was visited by 9AQL. ESG is new Ponca

City ham. AIR spent the month between shifts dismantling the rig and moving to new QRA. The Key Clickers are drawing up plans for State Convention in the Spring. Route Managers and S.C.M.'s of Oklahoma and N. Texas have a round table QSO every other Sunday a.m. YOUR S.C.M. WILL AWARD A CRYSTAL TO HIGHEST TRAFFIC REPORTING STATION IN THE SECTION FOR THE FIRST SIX MONTHS OF 1935. LET'S HAVE MORE AND BETTER TRAFFIC REPORTS. WHO WILL WIN THE CRYSTAL?

Traffic: W5CEZ 833 CUX 372 AMT 233 BKK 201 ASF 171 BAR 155 BJG 117 DZU 106 BWN 56 DDW 51 BLG 41 DSM 29 CVA 22 DTC-ASQ 18 ASW 8 KZ 7 LR 2 AJF 5.

SOUTHERN TEXAS-SCM, Bradfield A. Beard, W5ADZ-YH is A.A.R.S. BEF worked VP4. CVW is to be O.R.S. BHO is exp. with 56 mc. VV has pair new Eimac 150T in rig; 800 input. DWN is going on trip. BB has '10s P.P. final. ADZ worked OK1LN, J2GX, ZU6P. BJ is moving to new QRA. DPX, P.A.M., has been on 7 mc. BYV wants schedules with 56-mc. hams with directional rigs. PF is on at college. BWM uses portable in Louisiana. DYV reports Valley gang gets together in 1.75-mc. 'phone meetings. DB and AUC are to be new O.R.S. AUC has 1-KW rig. Active: EKL. DVK. Corpus Christi Club is planning big 1935 W. Gulf Convention. BFA is A.D.N.C.S. in A.A.R.S. PC is coming on 1.75- and 14-mc. 'phone. DTJ has crystal for Comet Pro. AUC is fully recovered from effects of airplane crash which laid him up for three months. Glad to have you back, O.M.! CUJ worked ZC6T, D4, EA, and J4. Many 56-mc. rigs in Houston-Only CTC with S01's P.P. and QST beam ant. doing very much DX work.

Traffic: W5OW 709 (WLJ 756) MN 639 BFA 145 YH 64 BEF 57 CVW 21 BHO-VV 20 DWN 10 BB 8 ADZ 7 BJ 6 DPX 4 BYV 6 PF-BWM-DYV 2 EBU 1.

#### CANADA

##### MARITIME DIVISION

MARITIME-SCM, A. M. Crowell, VE1DQ-Nova Scotia: GL is high traffic man. EP snagged AUIAK. HG made high score in SS contest. AQ schedules VP5PA. ET is piling up the DX on 14 mc. EX has new Class B rig on 14 mc. HH is new O.R.S. BL and DB are on 3.9-mc. c.w. BZ uses 'phone and c.w. EY is investigating all bands. HO and GZ are new men. DR got his W.A.C. DM is rebuilding to rack and panel. FV is putting in c.c. FG is changing QRA. FI says he'll get him an 830. AB is new 'phone. DL is building new c.c. job. FW is QRL work around the house. ER and FL, new O.R.S., hold down east end of trans-Canada Trunk Line "I." GN is on 1.75-mc. 'phone. GR rebuilt his 1.75-mc. 'phone. The Newfoundland Amateur Radio Association has been organized with VO8AW, pres.; VO8Z, vice-pres., and VO8H, secy.-treas. FT is starting New Year right by rebuilding completely.

Traffic: VE1GL 44 EP 1 HG 2 HH 10 FT 7 FL 24 ER 5 VO8W 8.

##### ONTARIO DIVISION

ONTARIO-SCM, S. B. Trainer, Jr., VE3GT-TM, on Trunk Line "M," takes the traffic lead this month with JT second. GT, JW and LC worked G6RB and JT worked HB9Y on 3.5 mc. EM has c.c. GG, latest O.R.S., is doing fine work on Trunk Line "I," the trans-Canada Route. WK has been trying to locate FL missing on the high seas. Welcome to AAV, ACZ, ACX and ACS (ex-3YL). UA worked 1200 miles with three watts input. GS worked a "G" on 14-mc. 'phone. HA and GX operate in the north woods for CFB. CFJ, SR blew bottles, TF put them in. SA, TF, PP, MB visited Montreal Hamfest. MA is on after two years. LI is on his way. SZ is interested in VP's YL. JV worked 38 "G's" in 1934. QN, RM, KR and PL get out F.B. 9AL's 14-mc. 'phone was heard in Missouri. II, Ontario P.A.M., reports Canadian Radio-Phone Association coming along fine with able help of

AZ, JI, and JG—latest O.P.S. NX awaits the R.I. for unlimited 'phone license. RO, Ontario O.O., reports there are still some VE3 notes that could be improved. QR is alternating for TM on Trunk "M." JT handled 113 this month with one eye, and under doctor's orders not to write. BC was heard on 3.5 mc. SG has been QRL Signal Corps. The S.C.M. would like to hear from every one, whether they are traffic handlers or not. The S.C.M. wishes to thank the many VE3's who sent Christmas Greetings, and is pleased to report dozens of VE3's turning crystal control each month.

Traffic: VESTM 252 JT 205 GG 128 WK 106 RK 104 WX 71 QK 70 GT 37 DJ 29 MX 13 ABN 6 TF 5 NX 4 ACS 3 ACX 1 MB 10. VE9AL 41.

#### QUEBEC DIVISION

QUEBEC—SCM, J. A. Robertson, VE2GA—The Montreal Amateur Radio Club Hamfest was a great success. Film of A.R.R.L. Headquarters much appreciated. 2AP's film of 22 of the local amateurs in action in their respective shacks had Hollywood's best beaten to a frazzle—at least so the gang thought! Congrats, M.A.R.C. Wanted to know—what the C.G.M. does with all the "Hi-Power" transformers he wins, and has he insured them against burglary? EK is new O.P.S. HK, our R.M., wants complete list of your schedules. Please comply, gang. DR did well in SS contest. CG is the ladies' man. CO will have 'phone soon. HG says FBXA is the receiver. HF is new O.R.S. BU visits VE3WK and VE3SG. BT finds Collins System big improvement. FG likes rag-chewing. BG sure puts out a wallop. DU had bad tire at shack. Whoever your new S.C.M. is, give him a rousing welcome—flood him with reports next month. Don't rely on your memory, stick a notice on top of your receiver—January 16th. GA hopes 1935 will be a year of happiness and prosperity for you all.

Traffic: VE2CO 162 BU 24 CG 11 DR 141 HK 179 CA 8.

#### VANALTA DIVISION

ALBERTA—SCM, J. Smalley, Jr., VE4GD—LX leads in traffic in Alberta. OG gave him a good run for his money. QK and LX report from Calgary. PH went north to operate CZQW. Lorne of EA is at the other end, VDD. OF sticks to 1.75-mc. 'phone. EO worked five X's in two weeks. OZ bagged a K6. SW and HK keep Standard on the map. OA was a Calgary Christmas visitor. LG installed '10's. HM is still "Old Reliable" in Edmonton. The Edmonton gang held a hamfest with good attendance. The Vegreville gang attended in full force. For full details on Alberta activities read the "Kalgary Kea Klix."

Traffic: VE4LX 55 OG 44 PH 23 QK 13 LG 9 QX 3. BRITISH COLUMBIA—SCM, R. K. Town, VE5AC—HR blew rectifier. JA had electrolyte explode on him. HF is QRL commercial oping. FM is doing fine work on T.L. "F." KA has lusty signal on 3.5 mc. EP holds two schedules. KU on 3.5 c.w. now. MD is trying remote control. DZ schedules FT. FG schedules K7BVN. 9AJ is station of B.C.A.R.A. EU moved walk to North Vancouver. KB is active on 7 mc. GT walks a mile to keep 6:30 a.m. schedule. HA was Kiwanis Hobby Show station. HV was outside contact for show. B.C.A.R.A. held elections: C. Longley, pres.; R. Tufnail, secy.; W. Rowan, vice-pres. HC is first VE5 in B. C. to become W.A.C., when he works ZS2X. BI follows three days later. Congrats to both! EJ reports that IO schedules his YL in Victoria. JI has snappy break-in system. KN has been dubbed the "Rajah of Razberries." LI has grief with a Tri-tet. HW suggests the use of neon bulbs to detect r.f. currants in Christmas cookies. DO has new heap. EV threatens to shatter the 1.75-mc. 'phone band with new heap. AE is getting the 224-mc. band bug—look for him, fellows. BC and MP continue good work on 56 mc. DC is full of plans for big 1.75-mc. 'phone heap. G6UN sent a message to VE5HJ which was delivered in less than 20 hrs. via G5YL, VE3GT, VE5FG, VE5KV. FB, OMs. CX reports one power supply up in

smoke. Did you report this month? If not, don't forget to next month. 73.

Traffic: VE5HR 47 JA 58 HP 25 FM 64 KA 1 KV 9 AL 19 EF 10 KU 1 HC 12 MD 5 DZ 14 FG 19 EU 17 KB 9 AC 49 GT 25 HA 125 HV 60. VE9AJ 3.

#### PRAIRIE DIVISION

MANITOBA—SCM, Reg. Strong, VE4GC—An enjoyable banquet was held by M.W.E.A. in St. Charles Hotel. DU holds DX Trophy and Cummings Award. AG won traffic banner again. AC is on 3.5 mc. PR is getting modulated again. CP has 500-watt rig. DZ has pair of 860's on 7 mc. KU has a T250. HL KX has 200-watt c.c. LH is active on 7 mc. MV had a T250. NW is at Gods Lake. OX uses a pair of 10's. QA and QY are going strong on 7 mc. RM and EK are on 1.75-mc. 'phone. RO is looking for DX. Listen at 7 p.m. daily for the 56-mc. wolves. They are SS, UX, UA, IT, GC, CD, GL, AG, BG, HP and TJ.

Traffic: VE4AG 94.

SASKATCHEWAN—SCM, Wilfred Skaife, VE4EL—QS would like schedule with anyone on 56 mc. FA gets out fine on 1.75-mc. 'phone. HS was off owing to no wind for charging bats. The Regina Club propose building field strength meter, frequency meter, and mobile rig for 28-mc. 'phone. AO is active. EB had shack burgled and lost some junk. OC is working with ES and KJ on 1.75-mc. 'phone. New club formed: Saskatoon Radio Operators. RI pops lots of tubes. UH gets out well. UD has new receiver. TN has M.O.P.A. 'phone. RB has new rig. PW has c.c. rig. EL—built transformer for Class B mod. MN makes SS score of 8850 points with '01A transmitter with 220 volts. FW and IG have great time on 'phone.

Traffic: VE4CM 187 MH 77 MN 53 QS 28 PM 14 LI 4 EL 12 PW 4 QZ 2 GA 22 FW 35.

Canal Zone: K5AF/WZAL reports a total of 247 messages handled during the Nov.-Dec. month.

#### All-Canadian QSO Contest

The Canadian Tire Corporation, Ltd., announces final rules for the All-Canadian QSO Contest under its auspices to be held from 12:01 a.m. E.S.T., February 9th to 11:59 p.m. E.S.T., February 19th. An unusually long list of prizes will be awarded and will include filter condensers, transformers, tubes of various types, loud speakers, microphones, chokes, resistors, shielded cable, headphones, crystal holders, meters, relays, soldering irons and other useful pieces of radio apparatus, all worth working for! The rules follow:

- (1) The contest is open only to licensed amateurs in Canada.
- (2) No more than one operator can operate the station for which points are to be scored.
- (3) The stations are divided into two classifications: those using 50 watts input or less, and those using more than 50 watts.
- (4) Stations using less than 50 watts are to multiply their scores by 1.5.
- (5) Operators who have to confine their operating periods due to silent hour restrictions or who are at business 40 hours per week, are to multiply their scores by 2.
- (6) Scoring is as follows: QSO's in the same district but outside the city or town in which the competitor resides, count 5 points. QSO's in adjoining district count 10 points. QSO's two districts away count 20 points. QSO's three districts away count 40 points. QSO's four districts away count 80 points.
- (7) A copy of the station log is to be sent in and will be checked for time of QSO with the contacted station's log. To avoid confusion, please use standard A.R.R.L. log set-up and be sure to mark the time belt in which you are located.
- (8) Two groups of prizes will be donated: one for the 'Phone stations, and one for the C.W. group. 'Phone-C.W. contacts are encouraged and can be scored.
- (9) All logs must be mailed before midnight, February 28, 1935. Mail logs to Canadian Tire Corp., Ltd., attention Mr. T. Locheed, 625-637 Yonge St., Toronto, Ontario.



# CORRESPONDENCE

The Publishers of *QST* assume no responsibility for statements made herein by correspondents

## L' Envoi

818 Southport St., Elmira, N. Y.

Editor, *QST*:

Most of us have read of Warren Eaton's last flight over Biscayne Bay—the last flight of that smiling man who that day shared the controls with the Dark Angel. We, and you, who knew him, will always remember his generosity and sacrifice, and be proud to have served with him.

Few, outside of the Elmira gang, realize just how much Warren meant to amateur radio. Though not an amateur himself, but intending to be this summer, it was he who gave the Elmira club its big break in the First Annual Soaring Contest. His understanding and far vision saw the tremendous value of amateur radio in the gliding field. It was he who smoothed away the difficulties as they arose, and kept enthusiasm at the constructive level when things went wrong.

Prior to the last meet, Warren flew to Washington to make personal application for us, and obtained the special experimental licenses necessary for our equipment. Warren's interest in equipping gliders with radio was the initial cause of the ultra-high-frequency experiments of the Elmira club. He was one of the first to use radio to communicate with the ground from his Franklin glider in which we installed radio. Not one out of the thousands who saw him will ever forget that man riding the winds and the clouds, with such a superb faith in himself and his Maker, nor the clear, calm voice coming down to them from out of the heavens, unfolding a new world.

The Elmira gang will never forget him.

—T. J. Sweeney, W8JU

## Lisbon

Delegation of the United States of America,  
December 18, 1934

Dear Mr. Maxim:

As chairman of the delegation of the United States to the Third Meeting of the International Radio Consulting Committee which convened in Portugal, September 22 to October 10, I have the honor of bringing to your attention the highly meritorious services of your organization's representatives in that meeting.

Mr. Warner's wide experience in the problems before the conference and his skill in discussion were of the greatest value to the American delegation as well as to the conference as a whole. He

labored indefatigably throughout the meeting and was especially helpful on the committee which dealt with organization problems.

Mr. Lamb contributed extensive technical experience and many practical ideas of value in the committee discussions. He was distinguished by zeal for reaching correct solutions and for genuine advancement of the radio art.

Your organization's representatives were concerned primarily with the representation of amateur interests, in which they were highly effective. In addition, however, they cooperated fully with the delegation of our government. Their collaboration and that of the American company representatives with the government delegation was of considerable mutual benefit. An advance draft of the delegation's report has recently been put in the hands of your representatives.

—John Howard Dellinger, Chairman, Delegation of the United States, International Radio Consulting Committee.

PRESIDENT'S NOTE.—Over K.B.W.'s objection, I have insisted that this letter be published in *QST*. It means a lot to all of us. Our representatives looked after our interests and inspired the respect of those whom they had to convince of the justice of our cause. To sell your ideas to a delegation, and have the boss of the delegation come back and give you a pat on the back for doing it, is to do a fine job. Warner and Jim Lamb deserve the thanks of every one of us.

HIRAM PERCY MAXIM

## On 7-mc. 'Phone

241 Kelso Rd., Columbus, Ohio

Editor, *QST*:

. . . The Latin American countries have been accusing us of imperialism for some time, and may or may not be justified in that, but now comes a ham, a W5, and tries to dictate to them what bands they shall use for 'phone, with entire disregard of the fact that the radio regulations of a foreign country are just none of his business. As an American, I resent his attitude. If I were a resident of Mexico I would resent it even more. He assumes that the hams in all countries should be subject to our U. S. regulations.

W5AAQ is misinformed on two points. First, it is *not* "generally conceded" that 40 meters is

reserved for c.w. In support of this see *QST* for August, 1934, page 52. Of 13 countries, 10 European, one American, one African, and New Zealand, seven specifically authorize 'phone on all bands (including 7 mc.), two forbid all 'phone, one limits 'phone to 160 and 80 meters (but the whole of these bands are permitted), and three give no information. In addition, practically all South American countries permit 'phone on 7 mc., if not on all bands. From which it is seen that, of the major countries of the world, the U. S. and Canada are practically the only ones which permit 'phone at all and still forbid it on 7 mc. It is we who are out of step, not the South Americans.

In the second place, he is wrong when he says there is plenty of room for 'phone on 3.9 and 14 mc. There isn't! I have seen letters in *QST* quite frequently, of late, howling about the crowded condition of the 7-mc. band. Well, how about the 3.9-mc. 'phone band? It is far worse. I use a 9-tube superhet, and it is a good one, and I can hear great open spaces on the 7-mc. band at almost any time of day.

In the United States the 7-mc. band is reserved for c.w. Why? Mainly because of an old prejudice, and because of extreme selfishness on the part of the c.w. operators, coupled with the fact that the A.R.R.L. has never had anything to do with 'phone. The c.w. boys want to keep all the best frequencies for themselves, which is natural, but they can't get away with it forever. On their record of achievement, the 'phone operators are entitled to a portion of the 7-mc. band. The c.w. men cannot show as much occupancy of their bands, on the whole, as the 'phone men, as witness the dead silence between 1715 and 1800 kc. and the blank spaces in the high end of the 7-mc. band. You don't hear any silence in the present 'phone bands! They are all occupied, and more space is needed, space which is now assigned to c.w. but not used. And the 'phone men are not selfish, the 'phone assignment is not exclusive like the c.w. assignment. At certain hours of the day the 3.9-mc. 'phone band is pretty well crowded with A.A.R.S. stations, working c.w.!! Have we kicked about that? But one foreign 'phone, operating perfectly within his rights, calls forth a large howl from the c.w. brethren!

I have spoken of achievement. In recent emergencies it has always been the 'phones that got the first word through. In the last earthquake in California it was very striking to listen in on the 'phone band and hear a dead silence except for the stations handling traffic. When any other station came on someone promptly told him to shut up, and he did. And then we tuned down to the c.w. band and heard all the CQ hounds going right on grinding out QRM. You notice in the reports that the traffic came through on 'phone! And at air races, regattas, and all the public appearances of ham radio, you will notice that it is practically all 'phone for quick and reliable communication! That is achievement which entitles the 'phones to a share of the good frequencies as well as the bad.

1.75 mc. is good only for local work, 3.9 is good only for moderate distances, 14 is good on the East coast, but for the bulk of the country it is unreliable and good for DX only at intervals. The consistently good band for both DX and moderate distance is 7 mc. The 'phones are entitled to a just share of this band, and will get it sooner or later. Our goal is 75 kilocycles, the same proportion as we have on 14 mc.

And at last the A.R.R.L. has recognized 'phone. For a long time it didn't, and listen any day to the talk on 3.9 mc. and you can see the amount of support it lost when the 'phone men got disgusted. It will take a long time to repair the damage, but the A.R.R.L. cannot do without the support of the 'phone men at this time, and it will not get that support until the 'phones get a square deal on the matter of frequencies.

—R. B. Jeffrey, W5GDC

EDITOR'S NOTE.—A.R.R.L. has always stood for a square deal for both 'phone and c.w. The objective of the A.R.R.L. Board of Directors in making recommendations for 'phone band allocations has ever been to equitably distribute facilities according to occupancy and utilization. Time lag in effecting revision of regulations has inevitably crept in, of course, but impartiality, based on the latest available surveys, has always been the goal.

Facts: Analysis of work during six emergencies during

1934 shows 'phone used principally in two, c.w. used principally in two, and 'phone-c.w. used 50-50 in the remaining two.

2850 W. 19th Ave., San Francisco, Calif.

Editor, *QST*:

As a ham and a League member of fourteen years standing may I call attention to the change in the relative distribution of 'phone and c.w. men throughout our frequency assignments? This change has been going on steadily for the last four years. This shift toward increased 'phone activity has not only included most of the new men entering the field but also a surprising number of old time brasspounders.

As one who remembers an all-too-short taste of 40-meter 'phone some years ago when, for a few short months, we could do about as we pleased, I offer for consideration the suggestion that holders of Class A licenses be allowed to operate 'phones in the 50 kc. between 7075 kc. and 7125 kc.

A recent unofficial, though quite authoritative, band occupancy check on the 7-mc. band showed that the portion of the spectrum between 7075 and 7125 kc. contained less than one sixtieth of the total stations observed in the band. As this 50 kc. portion of the band is one sixth of the total band it is seen that it contains only about 10% of the number of c.w. stations that it would contain if all the 7-mc. stations were evenly distributed over the entire 300 kc.

One explanation for this lack of c.w. stations may be the fact that crystals oscillating or doubling into this particular 50 kc. are useless for 14-mc. c.w. work as they would double into the 14-mc. 'phone band.

In my humble opinion, the recent growth in numbers and knowledge of the average Class A 'phone man justifies our requesting this territory for joint 'phone and C.W. use. Allocation of this particular portion of the 7-mc. band to 'phone would cause the minimum of change for the present 14-mc. 'phone man as he already has a crystal that either oscillates or doubles into this territory.

I quite well appreciate that this suggestion will probably start another war, the like of which has not been seen since the old spark vs. c.w. days. Nevertheless, I think that progress and equity both justify giving the Class A 'phone man the opportunity to taste some of the year-round 7-mc. DX that has kept our mouths watering for years.

I must emphasize that I do not subscribe to the idea that c.w. is doomed. I have heard many ill-considered statements recently to the general effect that some day we will all use 'phone exclusively. I have pounded my share of brass in the past and will continue to do it in the future but I have a great desire to get one of ON4AU's justly famed phonograph records of my voice and if it will ever be done at all it will have to be done on 7 mc. as Europe and 14 mc. 'phone and I just won't click from my particular location.

—J. N. A. Hawkins, W6AAR

EDITOR'S NOTE.—At 7 mc., 50 kc. represents 16 $\frac{2}{3}$ % of the band. Recent official band occupancy checks show between 14% and 18% of the occupancy of the 7-mc. band to be between 7075 and 7125 kc., indicating approximately normal occupancy of this region. In fact, the only spot at which occupancy drops down appreciably is in the center of the band, DX men displaying a congenital tendency to congregate near the edges; even here, occupancy averages 75% of the maximum.

222 W. 83rd St., New York, N. Y.

Editor, *QST*:

Last month VE5EU suggested that the A.R.R.L. ask for more 'phone frequencies. He specified these frequencies as 3800-3900 kc. . . . the c.w. band is crowded and there is plenty of QRM; so why make the situation any worse?

. . . My suggestion is that if the amateurs are going to ask the League to get them more frequencies, they should ask for a new 'phone band. This band would be situated from 7300 kc. to whatever higher frequency is allotted by the Federal Communications Commission. In other words, a 'phone band extended from the high frequency end of the



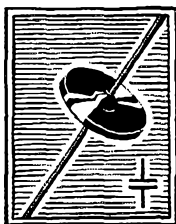

ALTHOUGH in many respects the art of radio communication is more highly developed in this country than in other parts of the world, we cannot afford to ignore the new developments in equipment and technique that originate abroad. For example, to England and Holland must be credited the pioneer work on audio pentodes and magnetic phonograph pickups. In Germany multi-scale dials mechanically tied-in with wave-changing switches were quite common before appearing on American "All-Wave" Receivers. In Germany also, large high-sensitivity cathode ray tubes were first made available to the general public.

And, of course, the work of the Curies of France with crystals paved the way for the modern crystal-control of transmitters and the crystal-filters for our Single Signal receivers.

We do not intend to belittle American research. In our opinion, each important foreign development can be matched by an even more important American development. Furthermore it has generally been necessary to redesign and otherwise perfect foreign developments before they became suitable to our advanced communication practice, and often only the fundamental idea could be salvaged. The audio pentodes now available in this country are certainly radically different in performance from their early English ancestors. The same is true of our phonograph pickups, our commercial cathode ray tubes and high-percentage-Steatite dielectrics. The National Steatite-body American-made insulators are hardly comparable in either appearance, accuracy or low-loss characteristics with the original samples submitted by the European inventor.

During the past year or so, at least two European laboratories have developed materials of great promise. These materials are ceramics quite similar in appearance to Steatite, but for them the European developers claim a dielectric constant very closely approaching 100 (Air = 1, Steatite = 5, Mica = 16), and in addition high dielectric strength and low losses. A good material of this type would obviously be extremely useful. A small disc of such material, metal-coated on both sides, would provide a high voltage, non-inductive condenser that would be ideally suited to such purposes as plate blocking, R.F. bypass, etc. Such condensers are now available in the German retail market, and one type is illustrated above.

Unfortunately, however, tests made in our laboratories on samples so far submitted have not borne out the statements of the European developers and manufacturers, and the condensers are quite disappointing. For this reason we do not feel that we are justified in placing such units on the market at the present time. There is a practical difficulty, also; the new material is reputed to require a firing temperature of 3100° C., which is beyond the capabilities of most of the American kilns, which are commonly gas or oil fired, and designed to operate at about 1400° C. The European process is reported to employ electric arc kilns, which are of course capable of producing the high temperature.

As mentioned above, condensers of this new type are already available on the German market, and we consequently felt that our comments regarding the new material might be of general interest. We have been following its development for over a year, and sincerely hoped that the new product would be suitable for production here by this time. As it is we must look to the future. There is certainly a need for such a material in radio engineering practice, and we also hope to be the ones to make it available to the American radio industry; — but only after we are thoroughly convinced the material has the proper technical merit and we are able to secure the facilities for manufacture in this country from American made or mined materials.

JAMES MILLEN



# Compare Them with RACKS Selling at Any Price

Constructed of very heavy gauge U steel (about  $\frac{1}{4}$ " thick). Finished thruout in black Shrivel Lacquer — Complete with all panels. Made in two sizes.

Type R7: — with 7 panels  $8\frac{1}{2}$ " x 19". Overall size  $21\frac{1}{2}$ " wide, 66" high.  
Price..... **\$16.95**

Type R4: — with 4 panels  $8\frac{1}{2}$ " x 19". Overall size  $21\frac{1}{2}$ " wide 39" high.  
Price..... **\$11.45**



**DUE TO EXTREME LOW SELLING PRICE, PLEASE INCLUDE 75 CENTS FOR PACKING CHARGE**

## 866 TUBES 99c

Insulantite tops — Heavy duty rectifiers.

A SPECIAL buy makes it possible for us to give you at this price, the same tube we previously sold for \$2.15. These also carry our full guarantee.

### THORDARSON CASED TRANSFORMER

600 volts each side of C.T. 200 MA  $2\frac{1}{2}$  V. 10 amps, C.T., 5 V. 3 amps.,  $7\frac{1}{2}$  V. 3 amps. C.T.

**\$2.79**

**THORD. CHOKE 12 H 250 MA. . . . . \$1.99**

## Announcing the CB-70

A new 70-watt Radiophone and CW transmitter — Value that will astonish you — available in kit form. Descriptive Literature on Request.

### CARDWELL CONDENSERS

Tank Condensers				Neut. Condensers			
Type	Cap.	Spacing	Price	Type	Cap.	Spacing	Price
164-B	220	.070	\$2.35	511-B	23	.171	\$1.77
147-B	440	.070	\$4.12	513-B	50	.171	\$3.53
T-199	330	.084	\$5.88	Split Stator			
T-183	110	.171	\$5.29	197-B	*80	.070	\$2.94
				157-B	*210	.070	\$4.70

\*per section

### OUTSTANDING!! GROSS CRYSTAL HOLDER

WHITE CERAMIC commercial type crystal holder — priced at less than ordinary holders. Adjustable pressure, dust proof, no tools required to open. Takes crystal to  $1\frac{1}{2}$ " square. Plugs standard  $\frac{3}{8}$ " spacing. Most efficient job yet. **\$1.00**

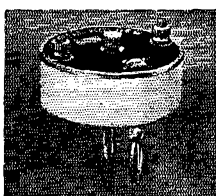

**GROSS RADIO, INC., 51 VESEY ST., N. Y. CITY**

40 meter c.w. band. There is no 'phone in that whole area of ham activity, and it seems to me that this section of the radio spectrum would be an ideal spot for a 'phone band. I don't think this is a great deal to ask for, and if it were granted it would be a great relief from the QRM on the other bands.

—Nathaniel E. Margolis, W2FDR

1008 W. 6th St., Coffeyville, Kans.

Editor, QST:

... One thing offers a serious menace to our 40-meter band, that is the Mexican 'phone problem. Cannot some plan be worked out with their government whereby the 'phones are barred from 7 mc. . . . or at least concentrated at one end instead of spoiling the DX in the whole band as now. There is no part of the band that is not being hurt.

—Charles A. Pine, W9CWW

## CQ DX? ND

Acton House, Felton, Northumberland, England

Editor, QST:

In November QST, page 60, I have just read a letter from VE3IG, with the wording "CQ DX," and as my experience is the exact opposite of his perhaps he may be interested to hear the views of a real low-power G station! I note that VE3IG says his transmitter "having less than 100 watts input may be said to be in the low-powered class," and his own experience has shown "that the low-powered ham has a much greater chance of contacting foreign DX by calling 'CQ DX' than by calling an individual station."

I entirely disagree with VE3IG. With an input never exceeding 8 to 10 watts at my station it has been my experience that by far the most of my DX contacts have been made by calling an individual DX station, and not by calling "Test DX" myself. In this case I am not ranking East Coast U.S.A. stations as DX but am meaning VK, W6, ZS, VE4, CM, CX, PY, etc., on the 14-mc. band. None of these was raised by "Test DX" calls. But, after all, if everyone thought alike we should all be waiting in vain for the other stations "CQ DX" calls! And, as VE3IG remarked, "What is poison in one call may be duck soup in another!" I think I can claim a right to disagree with VE3IG, as I have worked 76 countries, and WAC and WBE with an input never exceeding 10 watts. I hope other low-power enthusiasts will reply to VE3IG and give us their views.

—Barbara Dunn, G6YL

## Puzzle: Find the Swish

R.F.D. No. 1, Oak Harbor, Ohio

Editor, QST:

I built one of the 5-meter receivers for which you furnished the plot.

In experimenting with it I connected a piece of wire about  $8\frac{1}{2}$  feet long to the set for an aerial. It didn't work so I took it off and was tuning over the dial without using any aerial, trying to pick up ignition noises from passing automobiles.

About 30 on the dial I heard a gentle swish swish repeated slowly. Not knowing what a cosmic ray sounds like my attention went over to R9, just like that.

To be brief—I had hung the  $8\frac{1}{2}$ -foot wire over a nail on a shelf, both ends hanging down equally. The ends were swinging. To a ham everything *must* have an explanation. My mental index ran across the axiom "every antenna has inductance and capacity" and hasn't every oscillating circuit also? So, the super-regeneration on the receiver must build up a strong electrical field around it—enough to produce an oscillating current in the piece of wire I hung over a nail seven feet away. I hung the wire over my finger and rotated it, like turning a loop antenna. At two points the effect was loudest and 90 degrees from there it was not detectable. This was at 30 on the dial. By adding a two-inch piece to the wire it changed the dial setting to 80. It's no wonder that 5-meter aeriels and reflectors are specified to quarter-inch tolerance.

Some day when I meet Mr. Milliken I want him to let me hear cosmic rays so I won't get all het up when I build that one meter set.

—R. F. Cutting, W8KQZ

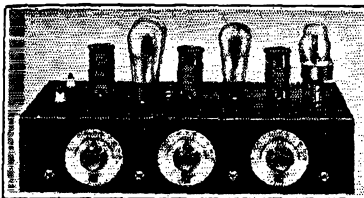

## GROSS C C TRANSMITTER—OUTPUT 25-30 WATTS

The "CW-25" transmitter kit due to its low cost makes it possible for anyone to own a modern crystal controlled station. A schematic hook-up and parts layout sheet as well as tuning instructions are furnished, thus enabling the most inexperienced operator to wire and put the set on the air, for real results. The "CW-25" is supplied with a shrivel finished sturdy metal chassis under which all parts are mounted, making the wiring and components dust-proof. A plug-in crystal holder is furnished with the kit. Only one milliammeter is required for tuning the transmitter and each stage is provided with a jack for this purpose. The "CW-25" uses one '47

as crystal oscillator, one '46 as buffer or doubler and two '46's in the amplifier stage, set of three coils supplied with kit for 20, 40, 80 or 160 band. Additional coils 75c each. **\$13.95**  
Complete kit, less tubes and crystal.....

### Nickel Silver Name Plates

Black background with silver letters and border. Size 1/2" x 1 1/4". Following markings:

Gain Buffer	Speech Modulator	Doubler Class-B Filaments
Amplifier Stand-By	Class C Plates	Grid Crystal Plate
Oscillator	Neutralizer	Antenna
Microphone		

10c each 6 for 50c

### EXTRA SPECIAL!!!

**GROSS CASED 20 H. 350 MA CHOKE**  
Limited quantity, special price. ....\$3.95

Thord. Choke 15 H 250 MA. ....\$2.95  
Gross Cased Choke 30 H 125 MA. \$ .95  
Gross Cased Choke 30 H 200 MA. \$1.94

### UNIVERSAL ANTENNA COUPLING SYSTEM INDUCTANCES

Wound on threaded double X natural bakelite tubing, can easily be tapped, with clip supplied, ea. ....\$1.50  
(Use one coil for single-wire feed and two coils for two-wire systems)

**Low C 40-80-160 Meter Amplifier Coils**  
(See transmitter by GRAMMER page 46 May QST) Plug-in, wound on threaded natural bakelite tubing, will tune with 50 or 60 mmf. condenser, any size, each. ....\$1.50

### 200 WATT VITREOUS RESISTORS With Variable Sliders

1000 ohms. ....	\$ .99
2500 ohms. ....	1.05
5000 ohms. ....	1.05
10000 ohms. ....	1.11
15000 ohms. ....	1.20
25000 ohms. ....	1.29
35000 ohms. ....	1.35
50000 ohms. ....	1.44
60000 ohms. ....	1.49
80000 ohms. ....	1.59
100000 ohms. ....	1.65

### Hoyt Milliammeters and Voltmeters

Perfectly damped meters at a price. These are not to be confused with the usual inexpensive meters. 2" mounting hole, flange 2 3/4" diameter, supplied in the following sizes: 10 ma, 25 ma, 50 ma, 100 ma, 150 ma, 250 ma, 300 ma, 4 V. AC, 10 V. AC, 15 V. AC, 10 V. DC. Price each \$1.30, 3 for. ....\$3.60

### FILAMENT TRANSFORMER FOR BRIDGE RECTIFIERS

Using 83 tubes 5 v-5 v-5 at 3 amps C.T. —3000 v insulation. ....\$2.25  
For 466 tubes 2 1/2 v-2 1/2 v-2 1/2 v C.T. 10,000 volt insulation. ....\$4.50

### GROSS CASED POWER TRANSFORMERS

650 v ea. side C.T. 350 ma. fila. 2-7 1/2 v C.T. and 1-5 v will give 500 v with choke input using 83 or 5Z3 tubes. You can run your entire R.F. and class B off this trans. ....\$5.50  
750 v ea. side C.T. 300 ma fila. 2-7 1/2 v C.T. and 1-5 v. ....\$5.75  
750-1000 v ea. side of C.T. 300 watts. \$6.65  
850-1350-1500 v ea. side of C.T. 400 watts. ....\$8.70  
(the ideal job to give 750-1000-1250 v D.C. with choke input)  
850-1350-1500 v ea. side of C.T. 550 ma. ....\$12.50  
1500-2000 v ea. side of C.T. 800 watts \$11.70

### EXTRA SPECIAL MOUNTED, UNCASED TRANSFORMERS

500-750-1000 volt each side of C.T. 300 watts. ....\$5.50  
400-800 volts each side of C.T. 160 ma. ....\$3.40

### MOUNTED CENTER TAPPED FILAMENT TRANSFORMERS

2 1/2 v 8 a — 2 1/2 v 3 a — 5 v 3 a. ....\$1.29  
2 1/2 v 4 a — 7 1/2 v 2 1/2 a — 7 1/2 v 2 1/2 a. \$1.29  
2 1/2 v 4 a — 5 v 3 a — 7 1/2 v 2 1/2 a. 1.29  
5 v 3 a — 7 1/2 v 2 1/2 a — 7 1/2 v 2 1/2 a. 1.29  
2 1/2 v 6 a — CT (midget). .... .74  
5 v 3 a — CT (midget). .... .74  
6.3 v 1.5 a — CT (midget). .... .69  
7 1/2 v 3 a — CT (midget). .... .89

### Filament Transformers shielded in metal cases, center tapped secondaries

2.5 Volt 10 amperes for 866's. ....\$2.25  
10 to 12 Volts at 8 amperes. .... 2.25

### Cased Combination Filament Transformer

2 1/2 V. C.T. 10 amps for 866's.  
10 V. C.T. 7 amps for '50's or '52's.  
10,000 Volt Insulation. ....\$3.24

### the MACKEY

The perfect semi-Automatic and Straight Key. ....\$10.50  
(circular on request)

### General Electric Pyranols

We have been appointed distributors of this famous commercial line of capacitors now for the first time available to the amateur.

	1000 V.	1500 V.	2000 V.
	D.C.	D.C.	D.C.
1 mfd. ....	\$1.78	\$2.23	\$3.12
2 mfd. ....	\$2.67	\$3.71	\$4.75
4 mfd. ....	\$4.16	\$5.35	\$6.53

### RCA ACR-136 Receiver

Complete with self contained power supply, tubes and speaker. ....\$69.50

PEAK Pre-Selector and Pre-Amplifier 14-200 meters. Less tubes. ....\$19.80

### Eimac Tubes

Performance — Ruggedness — Power — Price

50-T Output 75 to 250 watts. ....\$12.00  
150-T Output 150 to 450 watts. ....\$24.50  
(Immediate delivery)

### FILAMENT TRANSFORMERS FOR EIMAC TUBES

Cased 5 volts CT 12 Amps. ....\$2.95  
Cased 5 volts CT 20 Amps. .... 5.95

### GROSS CASED CLASS "B" TRANSFORMERS

Heavy Duty — for use with 10's, 46's or 4-46's in push-pull par. per pr. ....\$7.50  
For use with two 46's, per pr. ....\$3.95

### NEW!! RAYTHEON RK-23

The new small addition of the RK-20 (in stock). ....\$5.95

### RAYTHEON RK-20

The New RF Pentode Power Amplifier Tube in stock. ....\$15.00  
(see page 14 June QST)

### SPECIAL TUBES!!

510-A Tube Thoriated Tungsten Filament Graphite Plate — Isolantite Base. ....\$2.45  
210 Tube — Thoriated Tungsten Filament Special. ....\$1.15  
1/2 and 1 watt Neon Bulbs. ....\$2.29

## The "EAGLE" Three-Tube Short-Wave Receiver

"Band Spread" over any portion of the tuning range — only finest material used thruout. Employs one '32 R.F., one '32 detector and one '33 Pentode Audio — 15 to 200 meters — four coils, supplied. The "EAGLE" is economical — two dry cells will operate the filaments. See March or April 1933 QST for full description of this most excellent value in short-wave receivers.

"Eagle" completely wired and tested. . \$11.95 Three tubes tested in your receiver. . \$3.00

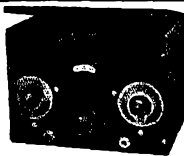

20% DEPOSIT WITH ALL C. O. D. ORDERS. REMIT BY M. O. INCLUDE POSTAGE

Cable Address: GROSSINC.

# GROSS RADIO, INC., 51 VESEY STREET, NEW YORK CITY



# Announcing an Important Development..



Unretouched photo of improved Lynch Resistor, taken under 80-power microscope. Note the uniformity which gives greater current-carrying capacity — freedom from heat . . . noise . . . change!

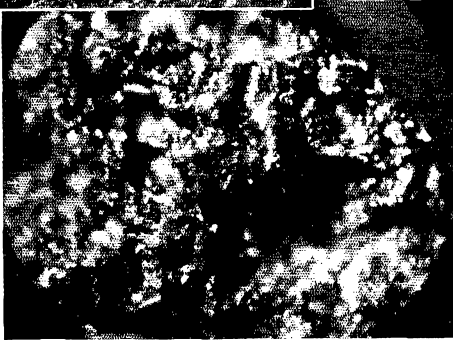

Ordinary resistor under 80-power microscope (unretouched photo) . . . Note rough surface which causes excessive heating; — gradual change in resistance.

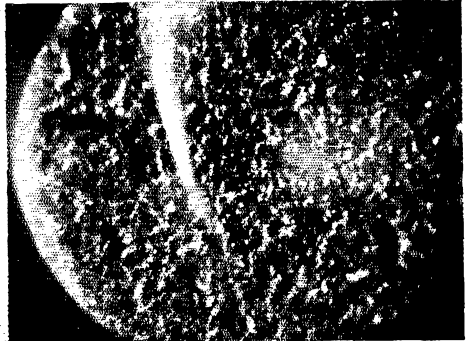

Another ordinary resistor under 40-power microscope (unretouched photo). Lower current-carrying capacity is due to many voids . . . in such a porous mass, contact is point contact only.

## The Improved **LYNCH** RESISTOR

### The Most Important Advance in Resistors in more than 10 Years

AFTER more than five years of exhaustive laboratory work and many months of proving in actual service in the field, we are pleased to present a resistor with marked advantages . . . and, at no advance in prices.

Born at dazzling yellow heat, this new ceramic composition possesses the rugged dependability of Gibraltar. Extruded to exacting specification, its uniform texture ensures far greater current-carrying capacity and permanent, noiseless accuracy.



The Gold Standard of Resistors

Absolutely guaranteed against open-circuiting or change in resistance value. . . Moisture-repellent!

We invite you to demonstrate for yourself the great superiority of these Triple-tested Resistors. Connect them into circuit, overload them heavily, as we have done for hours, days, weeks! Then make your own measurements for accuracy; noiselessness. If, after your own tests you are dissatisfied, return the resistors to your jobber, or to us and your money will be cheerfully refunded.

Ask your jobber also for our new low prices on Lynch "Bluejackets" and "Selectohms" — the wirewound resistors with a reputation.

**LYNCH MANUFACTURING CO. INC.**

R. A. Sayres, Pres., C. G. Cullin, Vice-Pres., L. R. Beardslee, Sec.-Treas.

405 LEXINGTON AVENUE

NEW YORK, N. Y.

Laboratory and Factory, Cranford, N. J.

Say You Saw It in QST — It Identifies You and Helps QST



# THE IMPROVED CATHODE-RAY OSCILLOSCOPE

Linear sweep model for broadcast stations  
and advanced amateurs, physics labs., etc.

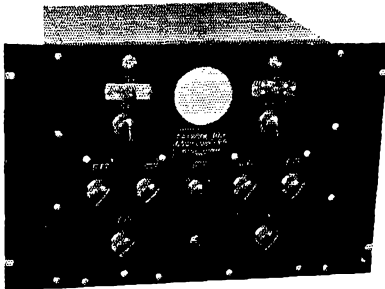

★ Controlled linear sweep. ★ Controlled external sweep.  
★ Freq. locking device for sweep frequency. ★ Picture  
centering adjustments. ★ Wide range focus adjustments.  
★ Complete component shielding. ★ Unit is self contained  
and includes batteries and 110V-60 cycle power supply.  
★ Tubes RCA 906-885-234-281-280. ★ This instrument  
embodies all features ordinarily contained in only the  
highest priced Cathode Ray equipment.

Completely Equipped Ready to Use  
**F.O.B. Newark — \$97.50**  
Literature now available

## R.F. Reactors

As announced last month we now offer for sale a  
complete line of R.F. REACTORS.

Type	RFR-1	RFR-2	RFR-3
Suggested Operating Band — mc. ....	1.7— to 4	3.5 to 14.4	7.0 to 30
Inductance Value — #h. ....	170	70	30
DC Ohms. ....	5.5	3.5	1.5
DC Current-amps. ....	2	?	2
Price. ....	\$1.05	\$ .90	\$ .75

Compare these values —  
With your tank inductance.  
With the DC resistance of the R.F. chokes you are now using.  
With the **CURRENT** rating of your present RF Chokes.

These units are practically indestructible: impervious to moisture, oxidization and heat.

Fitted with mounting brackets and terminal screws.

WE INVITE INQUIRIES FROM  
RADIO MANUFACTURERS  
AND DISTRIBUTORS

## TUBES

210

15W

Large  
Plate

\$ 1.15

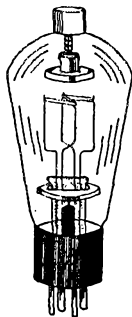

866

1000 hr.

Guarantee

New  
Construction

\$ 1.35

We are specializing in transmitter construction to customers' orders and specifications. Write for quotation on your favorite transmitter.  
Special code classes for beginners. No charge. Telephone for appointment.

**KALTMAN & ROMANDER**  
26 Court St. Newark, N. J.

## Standard Frequency Transmissions

Date	Schedule	Station	Date	Schedule	Station
Feb. 1	A	W6XX	Mar. 8	B	W9XAN
Feb. 8	B	W9XAN		B	W6XX
	B	W6XX	Mar. 13	C	W9XAN
Feb. 13	C	W9XAN	Mar. 15	B	W9XAN
Feb. 15	B	W9XAN		A	W6XX
	A	W6XX	Mar. 20	BB	W9XAN
Feb. 20	BB	W9XAN	Mar. 22	BB	W6XX
Feb. 22	BB	W6XX		A	W9XAN
	A	W9XAN	Mar. 23	BX	W6XX
Feb. 23	BX	W6XX	Mar. 24	C	W6XX
Feb. 24	C	W6XX	Mar. 29	A	W6XX
Mar. 1	A	W6XX			

### STANDARD FREQUENCY SCHEDULES

Time (p.m.)	Sched. and Freq. (kc.)		Time (p.m.)	Sched. and Freq. (kc.)	
	A	B		BB	C
8:00	3500	7000	4:00	7000	14,000
8:08	3600	7100	4:08	7100	14,100
8:16	3700	7200	4:16	7200	14,200
8:24	3800	7300	4:24	7300	14,300
8:32	3900		4:32		14,400
8:40	4000				

Time (a.m.)	Sched. & Freq. (kc.)	
	BX	
6:00	7000	
6:08	7100	
6:16	7200	
6:24	7300	

The time specified in the schedules is local standard time at the transmitting station. W9XAN uses Central Standard Time, and W6XX, Pacific Standard Time.

### TRANSMITTING PROCEDURE

The time allotted to each transmission is 8 minutes divided as follows:

- 2 minutes—QST QST QST de (station call letters).
- 3 minutes—Characteristic letter of station followed by call letters and statement of frequency. The characteristic letter of W9XAN is "O"; and that of W6XX is "M."
- 1 minute—Statement of frequency in kilocycles and announcement of next frequency.
- 2 minutes—Time allowed to change to next frequency.

W9XAN: Elgin Observatory, Elgin National Watch Company, Elgin, Ill., Frank D. Urie in charge.

W6XX: Don Lee Broadcasting System, Los Angeles, Calif., Harold Peery in charge.

## New Schedules for WWV

**B**EGINNING February 1 and continuing each Tuesday and Friday thereafter (except legal holidays), the National Bureau of Standards station WWV will transmit on three frequencies as follows: noon to 1:00 p.m., E.S.T., 15,000 kc.; 1:15 to 2:15 p.m., 10,000 kc.; 2:30 to 3:30 p.m., 5000 kc. These emissions are accurate to better than 1 part in five million at all times and are readily useful for calibrating amateur-band frequency meters by harmonics from an auxiliary 100-kc. oscillator, as described in previous QST articles (June and October, 1933; February, 1934).

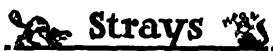

It has been reported by W8KSJ that Adolph Czajka in Chicago has been interested in amateur radio for several years, in spite of his handicap of being deaf and mute. He has built himself a tape recorder by which he watches incoming signals, and sends SWL cards to hams all over the world.

# "As Ripley Says"

**WE QUOTE** from a letter received from a Ham (he happens to be a physician as well) who found a simple solution after having had difficulty with a multi-band transmitter:

"After rechecking the entire job and finding nothing wrong I felt that loss must be occurring in the oscillator, so hit upon the idea of replacing an inexpensive capacity in the plate circuit of the 59 with a small CARDWELL I happened to have on the shelf". As Ripley says, "believe it or not" the excitation mills in the grid of the RK 20 just doubled without any other change whatsoever.

"I consider this a tribute to the low loss construction of your product and believe that it is a good reminder to brother Hams that it pays to use good parts, particularly when operating in the higher frequencies".

"I am glad that I had a CARDWELL on the shelf".

## **MORAL:**

To avoid trouble take the Doctor's advice, don't leave CARDWELLS on shelves — yours or anybody else's — use 'em.

*Send for Literature*

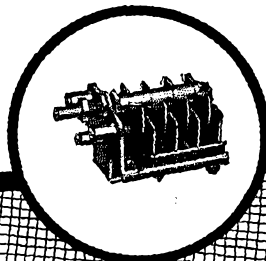

- CARDWELL "TRIM-AIR" MIDGET CONDENSERS
- CARDWELL "STANDARD" MODELS FOR RECEIVERS and MEDIUM POWER TRANSMITTERS
- CARDWELL MIDWAY "FEATHERWEIGHT" CONDENSERS, RECEIVING and TRANSMITTING
- CARDWELL 16-B TRANSMITTING CONDENSERS FOR LARGER TRANSMITTERS
- CARDWELL HIGH VOLTAGE CONDENSERS FOR COMMERCIAL RADIO-TELEGRAPH and BROADCASTING STATIONS
- CARDWELL S-2244 OIL DIELECTRIC FIXED CONDENSERS FOR HIGH FREQUENCY FURNACES and TUBE BOMBARDERS

**THE ALLEN D. CARDWELL MFG. CORP'N.**  
83 PROSPECT STREET, BROOKLYN, N. Y.

**"THE STANDARD of COMPARISON"**

Say You Saw It in *QST* — It Identifies You and Helps *QST*

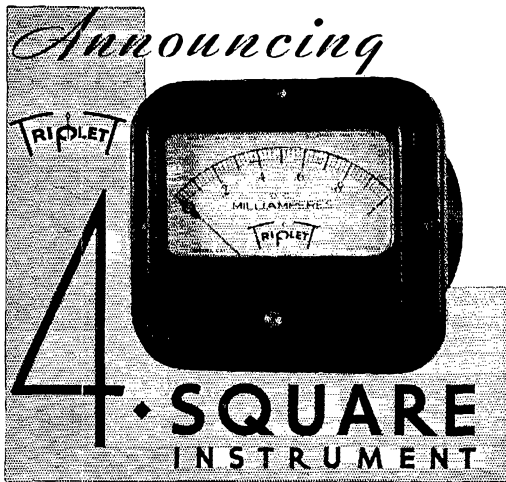

No. 421

HERE is another Triplet achievement—an exclusive Triplet development that is being received enthusiastically by engineers, experimentors and instrument users everywhere, because it offers these outstanding advantages:

1. Maximum scale length;
2. Minimum mounting space;
3. Spacious scale reading opening;
4. Symmetrically designed Bakelite case.

This 4-Square instrument makes it possible to secure the same scale length that is offered only with a 5-inch instrument—yet it uses one inch less panel space. This important advantage makes it easier to read the scale and adds a new note of modernity to the complete unit.

The 4-Square Instrument is 4 inches to the side. It requires only a 2- $\frac{1}{4}$ " mounting hole . . . has 3- $\frac{1}{8}$ " and 2- $\frac{7}{8}$ " AC scale length and is furnished with a spade or knife-edge pointer. It may be used wherever electrical measurements are required. Supplied in all popular ranges for: Voltmeters, AC and DC . . . Millivoltmeters . . . Ammeters, AC, DC and RF . . . Microammeters . . . and Milliammeters, AC and DC.

See Your Jobber

**WRITE FOR FREE LITERATURE**

The Triplet Electrical Instrument Co.

118 Main Street

Bluffton, Ohio, U. S. A.

Triplet Electrical Instrument Co.  
118 Main St., Bluffton, Ohio

Please send me data on the new Triplet 4-Square Instrument No. 421.

Name .....

Address .....

City .....

State .....

## Getting Cooperation from the Antenna Systems

(Continued from page 22)

$\lambda/2$  in length and the layout should be arranged accordingly. Losses on this type of feed line for lengths up to several thousand feet are practically negligible for frequencies upwards to 20 mc., the efficiency greatly exceeding that possible with the "Zepp" or other resonant feed lines of equal length.

A word of caution with regard to feed lines: Be sure the wire is of the proper size and the spacing correct. For a 600-ohm impedance the spacing should be 75 times the diameter of the wire when the line is designed for use with the various antenna-to-line impedance matching systems that presume this impedance.

In conclusion, the author believes that the suggestions outlined in this article represent new fields for thought in the construction and operation of our more simple types of antenna systems. A specific discussion of any one type has been avoided in the desire to cover as much ground as possible in a practical manner and references have therefore been added freely—in connection with which the bibliography on page 21, January 1934 *QST*, is well worth reviewing.

A little thought with regard to the height, compass direction, length, feed line, feed-line terminations at antenna and transmitter, and tuning of our antenna, will go a long way toward making that 200-watt station perform like a 1000-watt installation.

## Strays

Some foul-souled varmint up and climbed my 35-foot antenna pole and swiped the end insulator (price 10¢) of the 66-foot antenna. The villainous blackguard also stretched said skywire fully six feet in his attempt to dislodge feeders and all off the housetop. Would you suggest a Rettysnitch?

—W9IUO

## With the Affiliated Clubs

(Continued from page 33)

MISCELLANY

The Montreal Amateur Radio Club in early December held a very successful hamfest with a record attendance of 150 . . . one of the interesting features was the showing of a movie film taken by VE2AP, wherein twenty-two of the local amateurs are shown in action. . . Lansdowne (Pa.) Radio Association officers for 1934-35 term: W3BQP, president; Jess Ehley, vice-president; W3BIK, recording secretary; W3EOI, corresponding secretary; W3ASD, W3DQA, W3AV and Hank Nichols, directors. . . The November '34 meeting of the Jackson (Mich.) Amateur Radio Association was held in the form of a hamfest for the University of Michigan Radio Club, local amateurs and members . . . a talk on frequency measurements by Mr. W. G. Marburger of Western State Normal, contests, prize distribution and "eats" helped make the evening the enjoyable one it was. . . The Providence (R. I.) Radio Association's new



# A. C. RELAYS

Made by

## Allen-Bradley

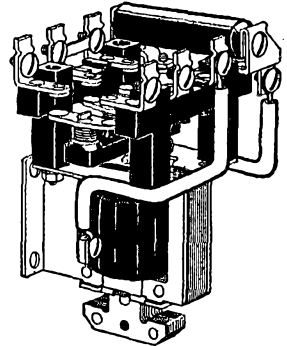
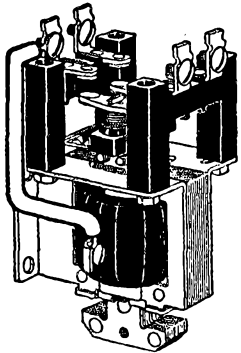

These A. C. solenoid relays are ideal for remote control of transmitters, for control of crystal ovens, and for any general remote control application except for keying. THESE RELAYS WILL NOT OPERATE IN KEYING SERVICE. Silver-to-silver double break contacts are used throughout.

The maximum contact rating is 10 amperes at 220 volts. The relay coils are wound for 115 volts 60 cycle alternating current. Relays for other voltages can be supplied on special order. Use coupon below when ordering.

Type No.	Poles	Nor- mally	Circuit Diagram	Price		Type No.	Poles	Nor- mally	Circuit Diagram	Price	
				Open	In Cob.					Open	In Cob.
A107	1	Open		\$3.50	\$4.50	A177	1	Closed		\$7.50	\$8.50
A117	1	Closed		4.50	5.50	A207	2	Open		4.00	5.00
A127	1	Open and Closed		5.00	6.00	A217	2	Closed		6.00	7.00
A137	1	Open		4.00	5.00	A227	2	Open and Closed		7.00	8.00
A147	1	Closed		5.00	6.00	A237	2	Open		4.50	5.50
A157	1	Open and Closed		5.50	6.50	A247	2	Closed		6.50	7.50
A167	1	Open		6.50	7.50			<p><b>Radiostat</b>—A stepless graphite compression rheostat for primary of 550 watt filament or plate supply transformer. Range 4 to 150 ohms. <b>Price \$6.50</b></p>			

### ORDER BLANK—MAIL WITH REMITTANCE TO

Allen-Bradley Co., 108 W. Greenfield Ave., Milwaukee, Wis.

Enclosed find money order for \$..... for which please send me, shipping charges prepaid, the following items:

..... for..... Volts..... Cycles

Name.....

Address.....

# Thank You!

You have waited most patiently  
We can now make prompt delivery of this fine receiver

## The New PR-12

# PATTERSON

## All-Wave Radio

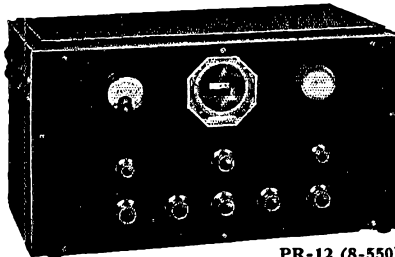

PR-12 (8-550)

### ADDED FEATURES NOT PREVIOUSLY DISCLOSED

3 Stages I. F. Amplification  
Accurate Logging Band Spread  
15 inches on 75 Meter Band

#### NET DELIVERED PRICES COMPLETE

(absolutely nothing else to Buy!)

PR-12 Crackle cabinet without crystal	\$83.70	PR-12 Crackle cabinet with crystal...	\$89.70
PR-12 Console without crystal	101.70	PR-12 Console with crystal...	107.70

Chassis also available

**SHIPPED PREPAID** If Full Purchase Price Accompanies Your Order

#### OUR NEW

### 100 WATT PHONE C.W. XMITTER

Many exclusive "MARINE" features ● Power Output (conservative rating) 100 WATTS PHONE and C.W. ● 20-40-75 and 160 meter bands ● CRYSTAL CONTROLLED FREQUENCY ● PERMANENT NEUTRALIZATION ● BUILT-IN BIAS SUPPLY ● HIGH-FIDELITY AUDIO CHANNEL ● Input Designed for Crystal Microphone

### VISUAL DISTORTION INDICATOR MODULATION PERCENTAGE INDICATOR

Self Contained Antenna Matching Network  
CABINET DIMENSIONS

(Baked wrinkled enamel finish — with rear door)  
60" high 19½" wide 15" deep

ONE YEAR UNCONDITIONAL GUARANTEE

Send stamp for descriptive folder with detailed information and photographs. You will be astounded at what we are offering at such an extremely moderate price.

## L. I. MARINE & ELECTRIC CO.

W2GOT — W2GRO

163-18 JAMAICA AVENUE JAMAICA, NEW YORK

Telephones: JAmAica 6-2925. Night (long distance) LAurelton 8-0400

Cable Address: "ELEC MARINE NEWYORK"

station has been assigned the call W1INM. . . . The Iowa-Illinois Amateur Radio Club is now located in its own club rooms on the fourth floor of the Eisfield Bldg., Burlington, Iowa . . . in order to make the club membership 100% A.R.R.L. those members with the wherewithal loan to the less fortunate, enabling them to maintain League membership, paying back whatever they can in monthly installments. . . . The 73 Radio Club, Wilton, Maine, had a "Christmas" meeting, Christmas tree, Santa and all . . . after the "presents" were distributed contests were held: Liars, CQ Whistling, Cracker Eating and Radiogram . . . the radiogram contest was unique . . . the first initial in the name of every one present was put down in order, and the one who could make up the best radiogram from words starting with these letters won the prize. . . . The Heart of America Radio Club, Kansas City, Mo., is installing 1-kw. rig in new club house. . . . The Southern Missouri Association of Radio Amateurs is planning on sponsoring a state convention at Joplin, Mo., in 1935 in connection with the Ozark Radio Club. . . . The Sunrise Radio Club of Long Island installed the following officers at a dinner-dance on December 8th: W2ANL, president; W2CJY, vice-president; W2DRK, secretary; W2HDG, treasurer . . . this club meets at Jamaica, N. Y., Y.M.C.A. first, third and fifth Friday evenings . . . visitors welcome. . . . A newsy club paper is issued its members by the Union County Amateur Radio Association, Inc., of Elizabeth, N. J. . . . 228-mc. activity is interesting members of the U.C.A.R.A. these days. . . . "Loudspeaker," monthly publication of the Northern Nassau Wireless Association, continues to make its appearance with W2DUA as editor, W2GZS, W2AYJ, W2DPQ, staff representatives, and W2DXO, staff artist. . . .

—E. L. B.

### W8HWR, Utica, N. Y.

(Continued from page 42)

stage, 58 detector, and 56 audio. The gadgets in aluminum boxes at the right on the table are a monitor, using a Type 30 tube, and an absorption wavemeter. Beside the message file on top of the bookcase is an early Zenith receiver used for copying 600-meter stations. A 5-meter transceiver is also part of the station equipment, although it does not appear in the photograph.

W8HWR is a former ship operator and is a member of the NCR.

### I.A.R.U. News

(Continued from page 44)

time-tried and tested result of those seven years of development. Its 16 monthly pages are judiciously filled with assorted technical and organization news—and the technical information comes up to a high standard. The magazine comes as a part of membership in the S.A.R.R.L.; the annual membership dues are £1. The publication office is at Box 7028, Johannesburg, South Africa.

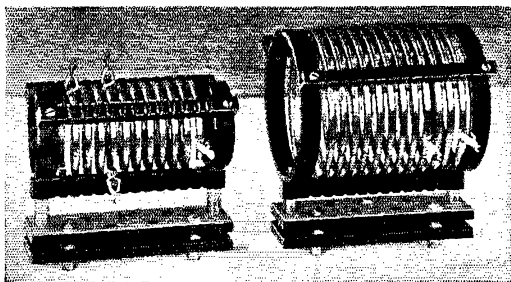

TYPE 679-B

TYPE 679-A

## High Power Transmitting Inductors

THESE two inductors cover all of the amateur bands to 10 meters and have current-carrying capacity for the highest power amateur transmitter. Plug-in — wound with heavy plated copper tubing — mounted in rigid supporting frame — glazed porcelain insulation — outside of mounting ribs notched for extra coupling coil — supplied with copper clips formed to fit the tubing — three Jumbo-type G-R plugs supplied with each coil.

### Specifications

	TYPE 679-A	TYPE 679-B
Turns . . . . .	12	7 and 4
Number of sections . . . . .	1	2
Inductance . . . . .	10 $\mu$ h	2 $\mu$ h and 1.5 $\mu$ h
Clips supplied . . . . .	3	4
Outside diameter of coil . . . . .	5 $\frac{3}{4}$ in.	3 $\frac{1}{4}$ in.
Length, over-all . . . . .	7 $\frac{1}{4}$ in.	7 $\frac{1}{4}$ in.
Height, over-all . . . . .	8 $\frac{1}{4}$ in.	6 $\frac{3}{4}$ in.
Depth, over-all . . . . .	6 $\frac{1}{2}$ in.	4 $\frac{1}{2}$ in.
Price . . . . .	\$7.50	\$6.50

Type 680-J Jack Base for use with the Type 679 Inductors, with three Jumbo Jacks, mounting holes and holes for four additional jacks. Dimensions 7  $\frac{1}{4}$  inches long, 2  $\frac{1}{2}$  inches wide, 1 inch thick.

Type 680-J Jack Base . . . . . \$1.25

Order direct from this advertisement, sending cash

with order and we will ship prepaid anywhere in the U.S. and Canada.

Write for our Amateur Bulletin No. 936-Q2 describing the complete line of General Radio experimental and amateur accessories.

## GENERAL RADIO COMPANY

30 State Street

Cambridge A, Massachusetts

# R A D I O

**ENGINEERING,** broadcasting, aviation and police radio, servicing, marine radio telegraphy and telephony, Morse telegraphy and railway accounting taught thoroughly. Engineering course of nine months duration equivalent to three years of college radio work. School established 1874. All expenses low. Catalog free.

DODGE'S INSTITUTE, Day Street, Valparaiso, Indiana

## BOUND VOLUME XVIII of QST

(1934 Series)

WE have now a limited number of copies of Bound Volume XVIII of QST. Vol. XVIII comprises the entire 1934 series of QST. This volume is made up of two books or sections, each containing six issues of QST. This volume is handsomely bound in red cloth and with gold imprint. The complete volume is priced at \$5.00, postpaid. Better act quickly — only a few copies available.

*QST*

38 LA SALLE ROAD  
WEST HARTFORD, CONNECTICUT

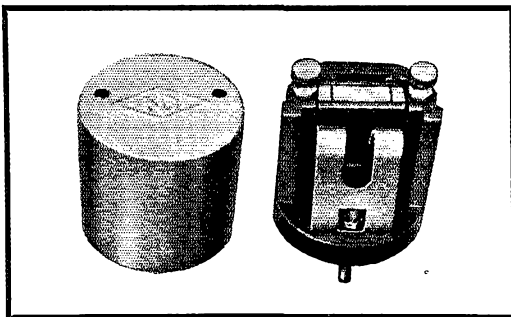

The new National Crystal Holder possesses a number of desirable features. The crystal is held in a vertical position, which permits it to vibrate more freely. Crystals may be changed very readily, making it feasible to use the holder with different crystals as required. The cover is of metal and is used for protection and shielding only. It is not used for clamping the crystal or plates. The body of the holder is molded R-39, and has two prongs on the base for connections. When ordering specify whether for transmitting or resonator (single-signal) crystals. Type CH, without crystal.

List Price, \$2.50

Usual Discounts apply

**NATIONAL COMPANY, INC.**  
MALDEN, MASS.

## Another New Outstanding Gross Value—GROSS CB-100

A 100-Watt Radiophone and C.W. Transmitter completely housed in an entirely enclosed floor rack of ingenious design. All units are fully accessible through the removable front gates, for coil changing, antenna network adjustments, etc. Incorporates everything from microphone jack to impedance matching antenna network.

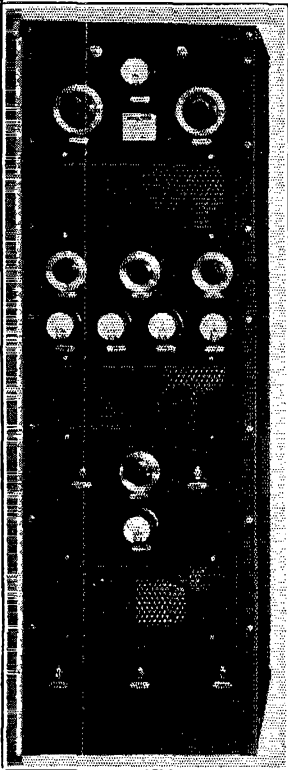

● **R. F. LINE UP** — 47 crystal oscillator, two 45's buffer, 03-A amplifier.

● **FREQUENCY COVERAGE** — 1.7, 3.5, 7 and 14 MC Bands.

● **POWER SUPPLIES** — 1050 and 1200 volts at 400 MA choke input, 8 mfd Pyronal condenser used and 400 volts at 300 MA.

● **SPEECH AMPLIFIER** — Special four stage high gain speech amplifier self contained from microphone jack to gain control.

● **MODULATOR** — Two 800's are used in the Class B Modulator. 100% modulation.

● **ANTENNA UNIT** — Impedance matching network supplied for use with any type of antenna available.

● **OPERATING CONTROLS** — Terminations provided for operating all switches from operating table.

● **SIZE** — 60" high, 19½" wide, 16" deep.

Descriptive Literature Sent Upon Request

**GROSS RADIO, INC.**

51 VESEY STREET • NEW YORK CITY

## Grinding and Finishing Quartz Crystal Plates

(Continued from page 28)

unintentionally and to grind the edges faster than the center.

The first operation in grinding a rough blank is to finish one face as a reference. If the blank is thicker at one edge than at the other, it is necessary to grind approximately one-half of this wedging from that reference face before finishing it. This removal of more material along one edge than along another of the same face is accomplished by pressing with the finger more on the thicker edge while grinding. A fairly coarse grade of carborundum such as No. 200 may be used for rapid grinding. To finish the reference face, a finer grade such as No. 600 should be used and a somewhat thinner mud made of it. This grinding should be carefully done so that the finished face will be as flat as possible, the above mentioned precautions against rolling the blank and grinding the edges lower than the center being especially important.

Knowing whether the blank is an "X-cut" or a "Y-cut," the approximate thickness to which it must be ground can be found by referring to the curves or the formulas of Fig. 1. The next operation is to grind the blank (on the unfinished face) to approximately that thickness, stopping when its thinnest part is within five one-thousandths of an inch of the desired final thickness. In doing this, a fairly coarse grade of carborundum may be used, and the grinding may be done without any special care, except to see that it all be done on the unfinished face.

To finish this second face, after the plate has been ground to approximately the correct thickness, requires a duplication of the efforts above described to finish the reference face. Careful measurement of the blank after each short period of grinding is necessary to determine that it is being ground to the point at which it is exactly the same thickness throughout. When this condition is reached the faces are parallel and the second of the four requirements of a good oscillator has, we hope, been met.

There are a number of ways to check whether a face of a blank is perfectly flat. The first is to measure the thickness of the blank at many points over its entire area and see if this thickness varies. If it does, and this variation is not regular from one edge to another, then there are definite high or low spots on at least one face and that face will need more grinding to level it off. In case any doubt exists as to which side has these high or low spots, each side may be tested by covering it with pencil marks and then rubbing it carefully on a clean flat surface of glass. The pencil marks will be worn off on the high spots, leaving the low spots still covered. By grinding this side carefully in a thin mixture of fine carborundum, the progress of the job of bringing the high spots down to the same thickness as the lows may be watched, as the pencil marks on the low spots will last until that part of the face starts to be ground away.

Too much emphasis may not be placed on the

## BARR CERAMIC BOWLS

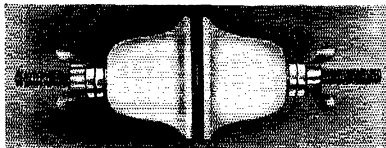

Type No. 25 consists of two 2-inch white ceramic bowls, complete with nicked brass hardware, wing nuts, 5-inch threaded rod and rubber gaskets. List price 65c, 40% discount to amateurs. Order direct from this advertisement if not stocked by your dealer.

Dealers and Jobbers are invited to write for territory

**BARR LABORATORIES, INC.**

1476 Broadway

Dept. 306

New York City

74

Say You Saw It in QST — It Identifies You and Helps QST

# YOU CAN DEPEND ON G-E

## Pyranol Capacitors

THEY'RE inexpensive, too, and scientifically designed. Years of experience in manufacturing capacitors for leading broadcast and short-wave communication stations and the government are built into them. Big, cumbersome capacitors need no longer use valuable space in your transmitter. Nor do you have to worry about fire—Pyranol won't burn. You can use more voltage—G-E Pyranol capacitors will stand the ripple, in addition to the rated d-c. voltage. They make possible better signals and have longer life. Get them from your dealer. Radio Department, General Electric, Schenectady, N. Y.

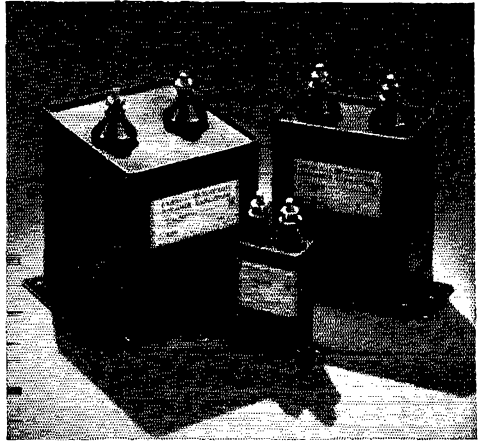

# GENERAL ELECTRIC

## RADIO ENGINEERING

 RCA Institutes offers an intensive course of high standard embracing all phases of Radio. Practical training with modern equipment at New York and Chicago schools. Also specialized courses and Home Study Courses under "No obligation" plan.

Illustrated Catalog on request.

**RCA INSTITUTES, INC.** Dept. ST-35

75 Varick St., New York 1154 Merchandise Mart, Chicago  
Recognized Standard in Radio Instruction Since 1909



# 28 Mc.

Ten Meter Amateur-Band-Spread coils, utilizing the design principles developed for the HRO, are now available for both the FB and AGS receivers. The serial number of the receiver should be given when ordering the AGS or AGSX coils. Purchases should be made through your regular National distributor.

**NATIONAL COMPANY, INC.**  
MALDEN, MASS.



## Here It Is! MARTIN JUNIOR

For Limited Time  
ONLY \$10

Think of it:  
A Genuine  
MARTIN  
Vibroplex  
for only \$10

All standard features. Heavy contact points. 2 3/4 pound black japanned base. The only difference is in size. Ideal for radio. Easy to use. A bargain at this low price. Don't wait—order **YOURS NOW!** Remit by money order or registered mail.

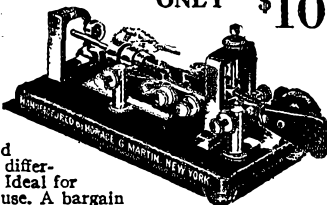

**BUY NOW!**

### OTHER VIBROPLEX MODELS

Famous Improved Vibroplex, Black or Colored, \$17; Nickel-Plated, \$19. Easy-Working Vibroplex No. 6, Black or Colored, \$17; Nickel-Plated, \$19. Write for catalog.

**THE VIBROPLEX CO., INC.**  
825 Broadway New York, N. Y.



**"SO! you wont talk eh?"**

"Where were you on the night of December 13th?" Silent . . . silent as a door knob. . . Here's a tip, Inspector . . . call a good serviceman and have him bring along some Centralabs . . . chances are that's all your SuperIodyne needs to make it tell all it knows.

For a mere handful of Centralab Radiohm Replacement parts will service almost every known make of radio . . . and make it perk better than before.

**RADIOHMS RESISTORS SUPPRESSORS**

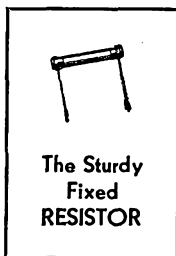

**Centralab**

Division of  
Globe Union Mfg. Co.,  
**MILWAUKEE**

necessity of having a smooth and flat surface on which to grind. The process of grinding on the plate of glass wears away the glass as well as the quartz; therefore, unless the grinding is done uniformly over a large surface, the face of the glass will wear away into hollows which in turn will wear the quartz into convex surfaces instead of flat surfaces as desired. Because of this it is advisable to use different plates of glass for rough and finish grinding, and especially one which is not suspected of being dished when taking out hollows and high spots.

To remove nicks, chips, sharp corners, etc., from the edge of the plate, it is held upright between the fingers and ground on these edges in coarse and then in fine grinding compound. It is also good practice to put a slight bevel around all of the edges of the plate by holding it at an angle and grinding in a similar manner. This will remove small irregularities and chips which might not otherwise be noticed. The corners of the blank may also be rounded slightly and beveled, all for the same purpose.

If the crystal still refuses to oscillate after it has been ground to the same thickness throughout and the edges have been ground and beveled to eliminate trouble from that source, then the trouble still remains in the grinding of the blank or in the original crystal itself. In thin crystals it is not uncommon that the pressure which is applied to the top center while grinding actually causes excessive grinding of the center of the under face. If the top face is "high" in the center by the same amount the plate will be bowl-shaped instead of flat and so will not be a good oscillator. This condition can be found by the same method as was previously mentioned for determining which side contained certain known high or low spots, and can be corrected by careful light grinding in fine compound.

Sometimes a crystal will be a good oscillator, but instead of controlling the transmitter on one particular frequency it can be made to operate on any one of two, three, or more different frequencies fairly close together. This "twin frequency" effect may be due to any one of several causes. If the blank is slightly wedge-shaped instead of being the same thickness throughout this will sometimes happen; or if there are two or more definite local areas of uniform thickness but of different thickness from each other. This second condition is called "stepping," and is sometimes brought about purposely so that the crystal can be used to control on any one of the frequencies as determined by the different thicknesses, independent of the others. Twin-frequencies which are caused by either one of these conditions are eliminated by further grinding to eliminate the cause.

Other twin-frequencies are sometimes caused by mechanical coupling effects peculiar to the crystal itself. These may be eliminated by a careful grinding of the edges of the blank in the same manner as was used to remove nicks. A careful truing up of each edge, to straighten it and to take out any curving or bulging, may also be all that is necessary for this. Such slight edge grind-

# COMPARE BLILEY CRYSTAL PERFORMANCE

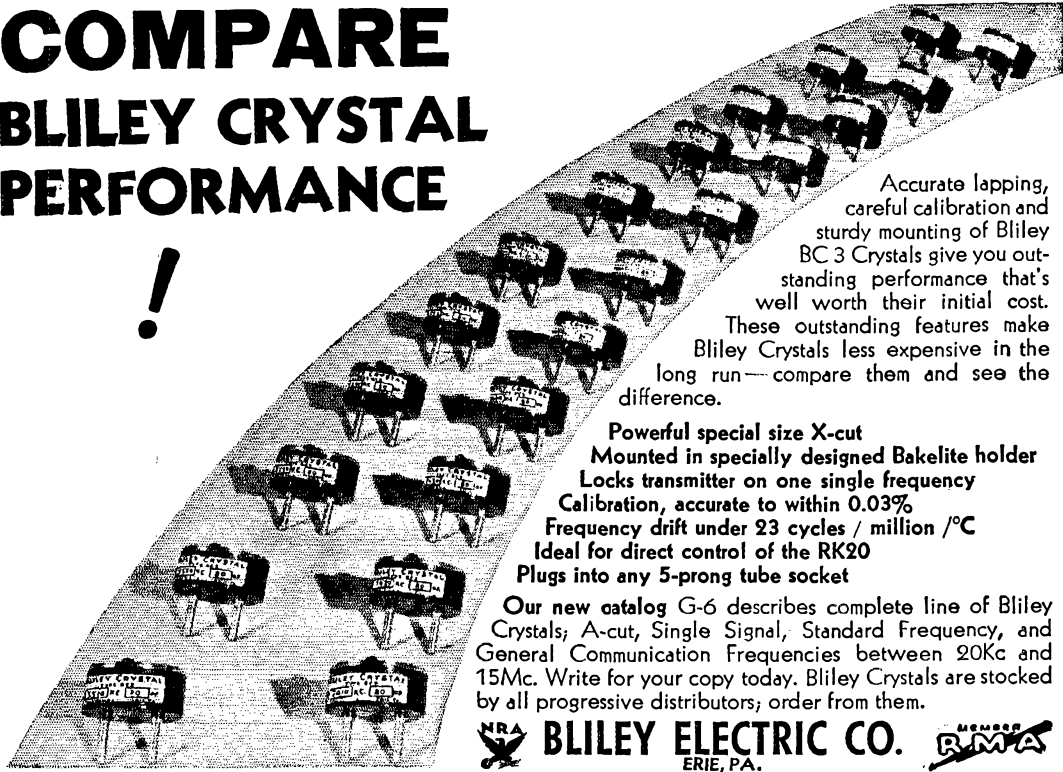

Accurate lapping, careful calibration and sturdy mounting of Bliley BC 3 Crystals give you outstanding performance that's well worth their initial cost. These outstanding features make Bliley Crystals less expensive in the long run—compare them and see the difference.

- Powerful special size X-cut
- Mounted in specially designed Bakelite holder
- Locks transmitter on one single frequency
- Calibration, accurate to within 0.03%
- Frequency drift under 23 cycles / million /°C
- Ideal for direct control of the RK20
- Plugs into any 5-prong tube socket

Our new catalog G-6 describes complete line of Bliley Crystals; A-cut, Single Signal, Standard Frequency, and General Communication Frequencies between 20Kc and 15Mc. Write for your copy today. Bliley Crystals are stocked by all progressive distributors; order from them.



**BLILEY ELECTRIC CO.**  
ERIE, PA.



## PERSONIFY YOUR QSO's

Send 'em a DEL-RAD "HAM-STAMP"

Send us your Photo and \$1.50 for  
100 SPECIAL "HAM-STAMPS"  
SENT POSTPAID

**DELAWARE RADIO SALES CO.**  
405 Delaware Ave. Wilmington, Delaware

## HOW TO LEARN CODE

YOU can learn Code — or step up your w.p.m. amazingly — this surer way. No experience needed. Beginners, amateurs, experienced ops get ahead faster with Teleplex. It doesn't merely "show" you code — it IS Code! You actually HEAR dots-dashes any speed you want. Sends you practice messages and SENDS BACK your own key work, which no other system can do. For quicker license find out about this better way used by U. S. Army, Navy, R.C.A., A.T.&T. and many others. We give you complete course, lend all equipment, give personal service on MONEY-BACK GUARANTEE. Low cost, easy terms. Without obligation write for booklet Q26.

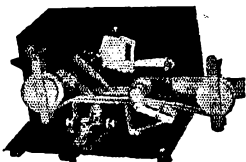

### TELEPLEX COMPANY

76 Cortlandt Street

New York, N. Y.



Say You Saw It in QST — It Identifies You and Helps QST

## New CRYSTAL MICROPHONES

### From "MICROPHONE HEADQUARTERS"

Shure Crystal Microphones are more than just "good microphones" — for they contain that full measure of performance and reliability which is the result of years of experience in microphone development.

The Model 70H is a diaphragm-type crystal microphone, with the new, exclusive Shure "cantilever" action — and is designed for mounting either directly on stands, or in existing carbon microphone rings. Heavy cast-metal chromium plated case of distinctively modern bevel-edge design. Furnished complete with EF "close-fitting" ring and screws, and four "Quick-way" hooks — also seven feet of special shielded, rubber-jacketed cable.

List Price..... \$22.50  
Shure Crystal Hand Microphones also available.



**SHURE MODEL 70H**  
(Licensed Under Patents of The Brush Development Co.)  
Your Regular Jobber can give you complete information about Shure Carbon, Condenser and Crystal Microphones.

### SHURE BROTHERS COMPANY

"Microphone Headquarters"

215 W. HURON ST. CHICAGO, U. S. A.



## A.R.R.L. EMBLEM

— *insignia of the radio amateur*

**I**n the January, 1920, issue of *QST* there appeared an editorial requesting suggestions for the design of an A.R.R.L. emblem — a device whereby every amateur could know his brother amateur when they met, an insignia he could wear proudly wherever he went. There was need for such a device. The post-war boom of amateur radio brought thousands of new amateurs on the air, many of whom were neighbors but did not know each other. In the July, 1920, issue the design was announced — the familiar diamond that greets you at the top of this page — adopted by the Board of Directors at its annual meeting. It met with universal acceptance and use. For fourteen years it has been the unchallenged emblem of amateur radio, found wherever amateurs gathered, a symbol of the traditional greatness of that thing which we call Amateur Spirit — treasured, revered, idealized.

### Do You Wear the A.R.R.L. EMBLEM?

*The League Emblem, in heavy rolled gold and black enamel, is available in either pin or button type .*

There are three special colors for Communications Department appointees. . . .

- ▶ Red background for the SCM
- ▶ Blue background for the ORS
- ▶ Green background for the RM

*Red and green available in pin type only, blue may be had in either pin or button style. All Emblems priced the same*

**\$1.00 POSTPAID**

**American Radio Relay League  
West Hartford, Connecticut**

ing is also sometimes helpful in getting a crystal to oscillate strongly which previously would work only weakly or not at all.

In all of the above, it has been assumed that the blank is still thicker than is known to be required for the desired final frequency. The last operation in this crystal grinding job is to find out definitely on what frequency the crystal oscillates "as is," and then carefully to grind one side with fine carborundum until the frequency comes near enough to that desired. All final grinding should be done a little at a time, with frequent checks of the frequency, and should be done on the same face at all times.

If a very accurate final grind is desired, to within a fraction of a kilocycle of some special frequency, then the faces of the blank may be finished with jeweler's rouge. This will wear away the crystal very slowly and at the same time will take off the ground-glass effect left by the carborundum. In grinding a crystal this close it should be tested each time under the actual conditions and in the same oscillator in which it is to be used. This is important, because changes in oscillator circuits, holders, tubes, voltages, temperatures, tank coils and tuning, all have their effect in changing the operating frequency of a crystal in a crystal-controlled oscillator. It is not sufficient merely to grind the crystal to the specified frequency when tested in a laboratory oscillator. It must still be on that frequency when put to use in your transmitter. This is sometimes a different matter.

### Amateurs Aid in Lost-Plane Search

*(Continued from page 18)*

rescued soon for it was known that they did not have warm clothing or food. When 24 hours had passed and the wreck had still not been located, many rescue parties entered the search on different clues. Planes from five states were assisting in the search over a radius of 50 miles.

Saturday evening a group of amateurs in Schenectady organized a "General Electric" expedition to provide radio communication between searching parties and planes in flight. The night was spent gathering suitable portable radio gear, proper clothing and supplies. Early Sunday morning the party consisting of G. M. Brown, W2CVV; E. H. Fritschel, W2DC; G. W. Fyler, W2HLM; R. A. Lash, W2CBO; W. J. Purcell, ex-8JS; R. W. Williamson, ex-9AHH; W. R. David and R. W. Orth, set forth in three cars and a service truck loaded with the portable gear. The first base was at the Gloversville, N. Y., airport. H. E. Hotaling, W8DKK, joined the party here. At the request of American Airways the call GE1000 was used and the rig operated as a portable emergency base station of the airways system. A gas-driven generating equipment supplied power for both transmitter and receiver. From this base Albany, Buffalo, Newark and Boston airports were contacted, and many times the station relayed dope from airports to and from planes.

Not until late afternoon did word of the



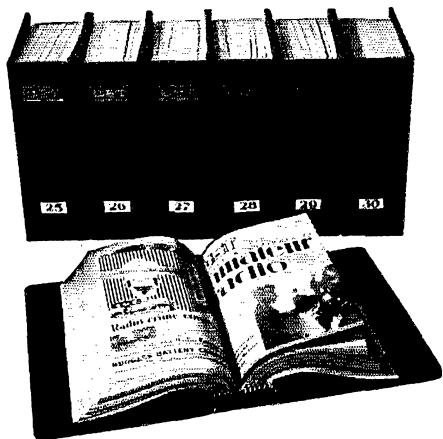

• NOTE •

The illustration shows each binder with a yearly mark. This marking is not stamped on the binder. Simply cut the year label from a calendar, or paste on a piece of paper, marking it in your own handwriting.

TO

- ▶ enhance the appearance of your station
- ▶ facilitate your reference work
- ▶ preserve the records of the advancement of the radio art

YOU NEED

QST  
Binders

One for this year's issues and one for each of the accumulated year's issues that you have. It will accommodate twelve issues of QST and a yearly index. The QST Binder is covered in deep maroon cloth. It is cleverly designed to take each issue as received and hold it firmly without mutilation. It permits the removal of any desired issue without disturbing the rest of the file.

A GOOD INVESTMENT AT

\$1.50 POSTPAID

AMERICAN RADIO RELAY LEAGUE, WEST HARTFORD, CONN.

GULF RADIO SCHOOL

Radiotelegraphy Radiotelephony  
Radio Servicing

SECOND PORT } 1007 Carondelet Street  
U. S. A. } NEW ORLEANS, LA.

A GOOD DOUBLET  
WON'T DO ITS STUFF  
WITHOUT A GOOD COUPLER !

The NEW

LYNCH  
— HAM BANDS —

RECEIVER COUPLER  
IS GUARANTEED

TO

- Reduce Interference
- Increase Signal Strength
- Outperform Anything Else  
Regardless of Location
- Give Satisfaction or Money Back

Designed for use with the famous Lynch Giant-Killer Cable Transmission Line. Works satisfactorily with any two wire line and makes changes in the receiver input circuit unnecessary. Send for free ham antenna bulletin for latest dope on better aerials for all bands.

ARTHUR H. LYNCH, Inc., 227 Fulton St., N. Y.  
PIONEER OF NOISE-REDUCING AERIALS

"WORDS TO THE WISE OMs"—  
HEADQUARTERS  
for

STANDARD SETS AND PARTS  
MADE BY REPUTABLE AND  
RESPONSIBLE MANUFACTURERS

Our reliability gives us the privilege of representing  
the following leading manufacturers:

NATIONAL COMPANY  
HAMMARLUND MFG. CO.  
RCA-VICTOR COMPANY  
GENERAL ELECTRIC COMPANY  
PATTERSON RADIO CO.  
COLLINS RADIO COMPANY  
RADIO MFG. ENGINEERS  
AND MANY OTHERS

Satisfaction Guaranteed—Full Credit Allowed in  
Exchange for Another Make within Ten Days

Write for full details on the  
DEL-RAD EASY PAYMENT PLAN  
DELAWARE RADIO SALES CO.  
405 DELAWARE AVENUE  
WILMINGTON (W3DQ) DELAWARE

New York Branch Canadian Representative  
11 W. 42nd St., N. Y. C. Est. J. L. Walker (VE3JJ)  
W2KR 1920 Rockcliffe, Ont.

# The TURNER (Type G) Crystal Mike

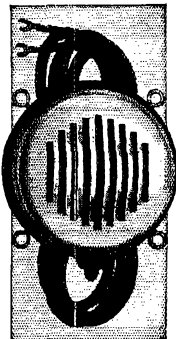

THE Crystal Microphone is the ideal instrument for amateur stations. No field current, no adjustments, no delicate parts. New diaphragm damping is exclusive Turner feature. Fully guaranteed. The Turner Type G Crystal Microphone (Brush Patents) lists at \$20.00. Discount to amateurs, 40%. New list price effective Feb. 1, \$22.50. Descriptive circular on request.

Radio Amateurs! There are good profit possibilities selling, installing, and operating public address systems. Write for complete details.

**THE TURNER COMPANY**  
CEDAR RAPIDS, IOWA

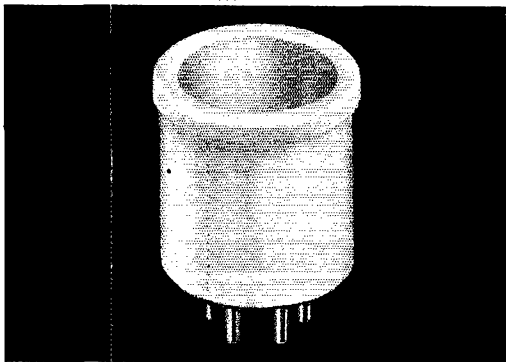

**STEATITE COIL FORM:** Though lower in price than standard R-39 forms, the Steatite form illustrated above offers a highly efficient support for tuning coils in receivers, doublers, etc. It is available with four, five or six prongs to fit standard tube sockets, and is drilled for leads. The winding surface is unglazed, to provide a tooth for cement. Catalog Symbol XR-20.

List Price \$ .35

Usual Discounts Apply

**NATIONAL COMPANY, INC.**  
MALDEN, MASS.

grounded plane's actual location come over the system. Breaking camp in ten minutes the expedition headed over ice-covered roads, for the location designated. After the well-travelled roads were left to start up a wood road at the base of the mountain, snow impeded progress. But at 9:15 a cabin at the end of the road closest to the wreck was reached. Four miles northeast a plane circled continuously. Straining eyes watched until it released a flare—the signal agreed to mark the exact location of the crack-up. Immediately all hands turned out to convert the cabin as the base for radio traffic, and within fifteen minutes the portable was in operation.

State troopers and other parties soon arrived at the cabin. Searching parties left on foot while the operators took tricks during the night. Heavy winds and snow waist-deep with the sub-zero temperature made progress through the thickly wooded mountain very difficult. Not until 11:00 p.m. did a searching party reach the wrecked plane—fifty hours since the forced landing. All during the night a vigil was kept at GE1000.

After dawn a relay of planes flew between Albany and the accident, at which time radio traffic became really heavy. Operation continued throughout the morning until two parties could be seen returning slowly down the mountain with the injured fliers. During the afternoon operations were continued to help direct various searching parties back to civilization. The station was no longer needed so packing was in order and the return trip started immediately, as some of the operators had not slept for 36 hours and others had not eaten for 26. Excitement provided the necessary stimulant.

Chalk up another case of amateurs stepping into the breach and helping in an emergency.

## What the League Is Doing

(Continued from page 27)

figures are in agreement with the statement frequently made in previous election reports in *QST*, that between 80% and 85% of the ballots were cast by licensed amateurs.

The percent of ballots returned was 47.4 in the Central, 47.8 in the Hudson and New England, 45.5 in the Northwestern and 61.8 in the West Gulf Division.

We might look for a minute at this 18.1% who relied upon prior membership for their voting right. This is a figure which will be steadily reduced with the passage of time. There was only about six months between the amending of the by-law and the casting of these ballots. As every amateur knows, there is a heavy turnover in amateur radio, every year seeing thousands of fellows dropping out as they get married, go away to college, get new jobs, or have something happen to them that prevents their continuation—while thousands of new fellows each year enter the game. Many of this 18.1% are old-timers not at the moment in possession of a license, and numerous of them doubtless will continue their membership indefinitely, but on the other hand it is certain that with the passage of time the bulk

**THE AMERICAN RADIO RELAY LEAGUE**  
**RADIOGRAM**

VIA AMATEUR RADIO

TO: \_\_\_\_\_

FROM: \_\_\_\_\_

DATE: \_\_\_\_\_

TIME: \_\_\_\_\_

CLASS: \_\_\_\_\_

REMARKS: \_\_\_\_\_

RECEIVED BY: \_\_\_\_\_

STATION: \_\_\_\_\_

OPERATOR: \_\_\_\_\_

## RADIOGRAM

The radiogram blank has been revamped to allow for that much needed room for the body of the message and to facilitate copying of messages. 7½ x 8½ sheet padded 100 sheets to the pad.

35c each      3 for \$1.00

## MESSAGE FILE

The F. C. C. requires amateurs to keep messages handled for a period of one year. The message file has been designed to facilitate compliance with that regulation. An expanding file of thirteen compartments (one for each month and one for extra papers), it provides for more messages per month than the average station will handle. On the face of the FILE, space is provided for a complete and accurate record of traffic handled. It will accommodate a year's traffic. For a practical and convenient solution of the regulation, you can't beat it.

40c each      3 for \$1.00

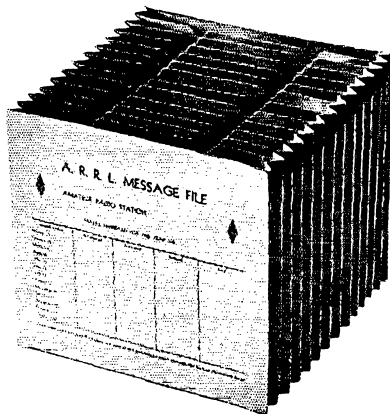

AMERICAN RADIO RELAY LEAGUE, WEST HARTFORD, CONNECTICUT

*Antenna Dope ... Valuable Map*

**FREE**



The most comprehensive and helpful treatise on antenna since Auntie came back into prominence! Map o'creation, with all the foreign and American short-waves charted ... call letters and kilocycles, too! Complete diagrams and illustrations of latest CORWICO Antenna jobs and how to install 'em. Really, this is one of the outstanding bits of technical literature for 1934-5. Be sure to write for your copy ... QUICK.

**CORNISH WIRE CO.**

30 Church Street

New York City

**IN THE WEST**

The AMATEUR'S Headquarters  
are at the

**RADIO SUPPLY CO.**

912 So. Broadway, Los Angeles, Calif.

All the latest Nationally Advertised  
Parts and Kits in stock at all times

9 Licensed Amateurs on our staff at your service

# PEAK

Regenerative Preselector — Preamplifier Predates  
and Modernizes Your PRESENT Receiver

The enthusiastic praise of Hams who already have tried PEAK tells the story! If you are in doubt as to what PEAK P-11 will do for your receiver, we urge you to try it. Your Dealer and ourselves guarantee results as stated in this advertisement!

The PEAK brings weak, unreadable phone, CW and foreign broadcast signals up to R-9, thus predating and modernizing your present receiver at small cost.

List \$33.00 — 40% discount to Hams; your cost, less tubes: \$19.80 at all Radio Supply Houses. Write for literature and name nearest dealer.

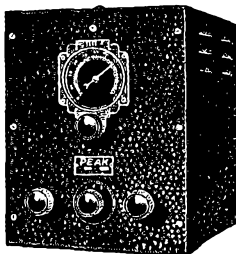

110-120 V. ac 50-60 Cycles

—Here's What PEAK Gives!

1. Tremendous Increase in Signal Strength
2. Increase in Sensitivity
3. Rejection of Image
4. Considerable Increase in Selectivity
5. Reduction of Noise to Signal Ratio

**OTHER FEATURES:** Built-in coils covering 14-200 M. in 3 steps; low resistance, low capacity, silvered Band Selector Switch; 2 HI-Gain stages for type 58 tubes; smooth, electron-coupled regeneration; self contained filament supply; heavy gauge black crystal finish chassis and cabinet.

EASTERN RADIO SPECIALTY CO.  
Manufacturers of PEAK Products  
1845 Broadway, Dept. Q-25, New York, N. Y.

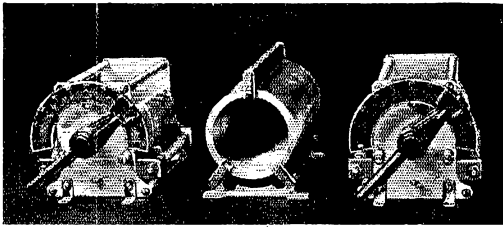

## Impedance-Matching Networks

Pi-Section Impedance-Matching Networks provide convenient and efficient means for coupling transmitter output to transmission line or feeders. Poorly designed networks, however, may be even less efficient than conventional coupling systems.

New Johnson Edgewise-Copper Inductors have been specially designed for amateur impedance-matching networks. They are efficient, compact, sturdy and convenient. With the proper Johnson Type "D" Condensers, they make an ideal output circuit.

Write today for Bulletin 130 — it gives valuable data on Impedance-Matching Networks.

(As illustrated above, Johnson No. 204 Handle-Pointers and Scales may be directly attached to Type "D" Condensers even when no panel is employed. Bulletin 950 tells about these Handle-Pointers.)

Available from Authorized Johnson Distributors

## E. F. JOHNSON COMPANY

Manufacturers of Radio Transmitting Equipment

WASECA, MINNESOTA, U. S. A.

## HIPOWER CRYSTALS

Now available at your dealer  
Accept no other

**HIPOWER "A" CUT**  
HANDLES 300% MORE POWER

HIPOWER "A" CUT in 1700-3500 Kc. Bands	\$3.90
within 10 Kc. or choice of dealers stock	
HIPOWER "X" CUT in 1700-3500 Kc. Bands	\$2.35
within 10 Kc. or choice of dealers stock	
HIPOWER "Y" CUT in 1700-3500 Kc. Bands	\$1.35
within 10 Kc. or choice of dealers stock	

You cannot buy a better crystal  
than HIPOWER at any price!



TYPE M molded bakelite holder plugs in tube socket..... **\$1.00**

**FREE** plug-in mounting with each holder

If your dealer cannot supply you  
order direct and enclose dealer's name

For complete data on "A" cut and other HIPOWER crystals, write for Bulletin E. Broadcast crystals supplied with less than 1/2 cycle drift per million, per °C.

**HIPOWER CRYSTAL CO.**

3607 NO. LUNA AVE., CHICAGO, ILL. TEL. AVE. 5170

of these men not now actively engaged under license will lose their interest and let their memberships lapse. Their numbers will be steadily decimated until finally they virtually disappear from our list, and we prophesy that in this year's elections this 18.1% will show a sharp reduction.

It is ridiculous to suggest that our League doesn't want as a member any person who is not at the moment a licensed amateur. Why not? We do want our affairs controlled by licensed amateurs and we want all the efforts of the League devoted to the improving of amateur radio, never otherwise. We have that assured by the present system that puts the determination of our policies in the hands of elected directors, themselves amateurs, which is a system that makes it positive that A.R.R.L. will always be a ham outfit. If ex-amateurs and future amateurs and even plain non-amateurs want to join the League *without* the right to vote, even a million of them, that's just swell. Their financial support helps the League to do a bigger and better job for amateur radio, and the fact that the directors are amateurs chosen by the licensed membership assures the course of the League as an organization devoted purely to the interests of the licensed amateur.

## 'Phone-C.W. Contest

(Continued from page 20)

swap QSL's and become more understanding of the problems of our fellow amateurs. Whether you enter a 'phone station, or a telegraph station, give the QSO party your attention. Start a sheet listing your QSO's. Send in your score, large or small, so your work can receive full credit in QST. The previous contest of this type was most successful, 'phone scores running higher than c.w. scores. 'Phone participants clicked off the QSO's rapidly, finding dozens of telegraph ops literally "standing in line" to QSO. We think every ham entering will have some good QSO's and a swell time. Try it!

It is suggested that operators exchange and confirm the name of their A.R.R.L. Section \* during the QSO, especially where a state is split into one or more A.R.R.L. Sections so this cannot be ascertained from the call book. Two contest periods (different week-ends) have been provided. If you can make both of 'em do so, but if not your report on work during any part of the time provided will be acceptable. Of course QSO's must all be within the days and hours specified to count for points.

*To take part:* Get on the air on any of the bands assigned by F.C.C. to your type of operation. If you use voice, work all the telegraph stations you can. If you pound brass, work all the 'phone stations you can. Only stations located in the 69 A.R.R.L. Sections count points in the score. Within ten days of the close of the contest's second period, mail your results to A.R.R.L., 38 LaSalle Road, West Hartford, Conn., so the QST report will give your results.

—F. E. H.

# PYRANOL TRANSMITTING CONDENSERS 2 MFD 2000 V.



These filter condensers impregnated and filled with Pyranol have been designed to meet the needs where used in high voltage filter circuits. They have a safety factor heretofore unknown in filter condensers. While we rate these at 2000 volts working we know of cases where they are in use at a 50-75% overload. Made by one of the world's largest manufacturers of electrical apparatus. Guaranteed to be satisfactory or your money back.

## \$2.50

Immediate Delivery  
on All Orders

## International Transformers

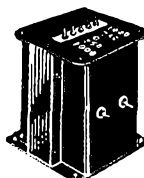

You can depend on INTERNATIONAL plate transformers to provide 100% satisfactory service under the most severe operating conditions. These transformers are especially designed for CW, amplifier, or modulator plate supply service. Rugged construction, correct electrical design, convenient mounting provisions, ample insulation, and the appearance of much more expensive units combined to make INTERNATIONAL transformers as great a value as has ever been offered the amateur trade. The models listed below will deliver 300 M.A. for CW or 250 M.A. for amplifier or modulator plate supply.

Model 2000 — 1000 and 750 volts each side of C.T. .... \$5.95  
 Model 3000 — 1500, 1000 and 750 volts each side of C.T. .... \$8.95  
 Model 2000 — Overall size 7 1/4" x 5 1/2" x 5 1/2"  
 Model 3000 — Overall size 7 1/2" x 5 1/2" x 5 1/4"

866's H.D. \$1.69	866 Fil. Trans. 2.5 Volts 12 Amps \$1.25
Baldwin Type C Phones \$2.50	Ohmite 200 watt Bleeders 100 Ohm to 100,000 \$1.50
10 Volt—6.5 Amps Trans. \$2.10 For 203A tubes	The Mac-Key A perfect Semi Automatic Key. \$10.50
Triplet D.C. 3 1/2" Mill Meters — 0-25 to 500M 0-15 AC Volts (bake-lite) \$3.75. Thermo-Ammeters \$6.66. 0-1, 2.5, 5 Amps. Complete Line.	

**Peak Pre Selector.**  
**Real Signal Hop \$19.80**  
 Two stages of pre-selection.  
 Ask the man that owns One.

The tube Sensational —  
 Eimac.  
 50 T (50 Watts) \$12.00  
 150 T (150 Watts) \$24.50  
 (Eastern Distributors.)

Raytheon RK 20 \$15.00  
 Raytheon RK 23 \$5.95  
 Complete Line on hand.

**NATIONAL 40%**  
**CARDWELL**  
**HAMMARLUND Discount**

Triad 210 \$1.25  
 Triad 81s-50S \$1.25  
 Send for Free Tube Chart.

Mail orders filled to any place in the U. S. Send check or money order — include postage. Prompt service.  
 Foreign Friends: We cannot ship C.O.D. Please send money order or draft, including shipping charges.

**THE RADIO SHACK — BOSTON**  
**46 BRATTLE STREET**  
*(Not connected with any firm bearing a similar name)*

**R.C.A. Hand Mike \$1.50**  
**Turner Crystal Mike \$12.00**

## SEND FOR YOUR COPY TODAY



Every amateur and shortwave fan should have a copy of this new catalog showing Na-Ald quality products. See the new VICTRON parts. Coils, Forms, Plugs, Connectors, Cases, Switches, Dials, Knobs, Cables, Test Accessories, etc.



**ALDEN PRODUCTS CO.** Dept. Q2  
 715 Centre St. Brockton, Mass.

**PEAK PRE-SELECTOR PRE-AMPLIFIER \$19.80**  
 Mail orders filled—Send Postage—Prompt Service  
 SOLD IN NET PRICE

NEW ENGLAND BY  
**THE RADIO SHACK**  
 46 BRATTLE STREET BOSTON, MASS.

## TRIMM FEATHERWEIGHT HEADSETS

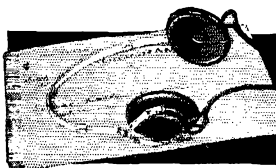

are not low in price, but it is a significant fact that they are being purchased in increasing numbers. The proved performance and sound engineering design of these phones get and keep satisfied users. Ask your dealer for the Special 24,000 ohm impedance phone for "Hams."

**TRIMM RADIO MFG. CO.**  
 1528 Armitage Ave., Chicago, Ill.

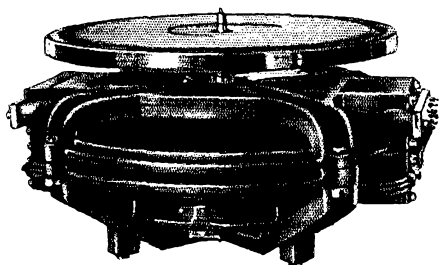

## Your Opportunity to Secure New Western Electric-Crocker Wheeler Synchronous Motors

New 92 pole, 78.2 r.p.m. non-g geared reproducer motors as used by broadcasting stations, for high fidelity reproduction. These motors are ideal for making recording equipment for voice or signals. The speed is constant and there are no gears to introduce variations. The power is ample to make records of any type on aluminum and other recording discs. Weight 60 lbs.

Price, in original cartons, complete with blueprint. .... \$6.00

**LEROY M. E. CLAUSING, 5509 1/2 Lincoln Avenue, Chicago, Illinois**

...here it is!

## The New LOW-LOSS 72 OHM TYPE EO-1 TWISTED-PAIR FEEDER CABLE

(Designed by Robert C. Graham, E. E., W8LUQ, and described by him in the January QST.)

A scientifically designed twisted-pair feeder system for matched-impedance doublet type TRANSMITTING ANTENNAE.

Increased Efficiency—Duplex Operation—Effectively Reduces QRM to BCL Receivers—Greater DX—Ability to Withstand High Power—Accurately Matches Impedance at Center of Half-Wave Hertz Antennae—Low-Loss Construction, (Dielectric constant of rubber compound insulation = 2.7.)—Untuned Line, Therefore May Be of Any Desired Length—Easily Installed.

### NET PRICES TO RADIO AMATEURS

Up to 50 feet @ .07 per foot  
50 to 100 feet @ .06½ per foot  
100 to 500 feet @ .06 per foot  
500 feet and over @ .05½ per foot

20% deposit is required with all C.O.D. orders. Remit by Certified Check or M.O. Include postage. Shipping weight per 100 feet, 7½ pounds.

Write for circular

**RUSSELL A. GRAY (W8AAC)**  
HOMER, NEW YORK

## QST—QST—QST

DE

**M & H—Eastern Ham Hdqtrs.**  
**ANNOUNCING**

OWING TO THE TREMENDOUS INCREASE IN BUSINESS IN OUR HAM DEPT., WE HAVE ADDED TO OUR STAFF OF EXPERIENCED RADIO & SOUND ENGINEERS—3 of the best trained Amateurs in the business—*with long years of standing as ARDENT HAMS.*

## W3PB—W3BES—W3BSC

When in trouble or in doubt don't fail to write in; let these boys iron out your problems.

EASTERN HEADQUARTERS for the

### PATTERSON P-R-12 RECEIVER

if in the district come in and listen in on this revolutionary ham receiver. The talk of HAMLAND.

**DON'T MISS OUR BIG 1935 HAM CATALOG—**  
fill out this coupon for your copy

Name \_\_\_\_\_  
Address \_\_\_\_\_  
City \_\_\_\_\_ State \_\_\_\_\_

**M&H Sporting Goods Co., 512 Market, Phila., Pa.**

## The 1934 Pacific Division Convention

CQ Fresno! Here we come!" filled the ether from all directions as the incoming hams worked the five-meter station on top of the Pacific Southwest Building in Fresno the night before the 15th Annual Pacific Division Convention. . . . Hams rolled in from every direction until the final registration reached 584. . . . The entire second floor of the Fresno hotel was given over to displays, committee rooms, contest rooms, and organizations such as the U.S.N.R. and A.A.R.S. . . . First thing Saturday morning there were code sending and receiving contests. . . . At 11:00 the convention was officially opened by Chairman Ralph A. Jack at a general meeting in the White Theatre, Mayor Leymel of Fresno and Director Culver giving addresses of welcome. . . . Frank Jones opened the afternoon session with an ultra high frequency talk, later winning the Heintz ¾-meter contest. . . . At 2 p.m. everyone was taken out to the Santa Lucia, said to be the world's largest winery, where samples were given out; the flavor of the trip seemed to suit everyone. . . . The afternoon featured technical talks by Jack McCullough and Clayton Bane.

Saturday evening a Convention Frolic was held at the White Theatre. . . . Jim Warner told of his experiences as radio operator on the Southern Cross Flight to Australia. . . . Tumbling and dance numbers, a part of the Headquarters' film, and club stunts continued the program. . . . Breakfast Sunday morning found 48 Naval Reservists in one group, S.C.M.'s, O.R.S. and R.M.'s in another; later, a 56 mc. contest was run off. . . . Technical talks by Charles Perrine, Don Wallace, and a Multi-Arc Rectifier demonstration by George Becker were features of the morning program.

The official A.R.R.L. meeting was held early Sunday afternoon, Director S. G. Culver presiding and A. L. Budlong representing League headquarters. . . . Resolutions were passed concerning the creation of a new Southwest Division, the issuance of WAC certificates, expansion of the 7-mc. band, and changing the 1-kw. power limit to an output rather than an input basis. . . . Following the open forum, Norris Hawkins spoke on "Class B Prime Modulation". . . . At 6:30 p.m. all delegates assembled in the auditorium of the San Joaquin Power Building for the banquet. . . . With Clyde Anderson, W6FFP, as toastmaster, short talks were given by A. L. Budlong, S. G. Culver, and Bernard H. Linden. . . . Los Angeles was selected as the site of the 1935 convention. . . . Prizes of unprecedented value were given away, the climax being reached with the presentation of a complete 75 watt 'phone station. . . .

Convention highlights: The entertainment provided for OW's and YL's; they were given a theatre party, sight-seeing tour, and a card party, along with many prizes. . . . The great number of mobile 56 mc. outfits in operation. . . . The consolation prize of a live duck, at the banquet.

# PERFECTION OF PERFORMANCE

IS ATTAINED ONLY BY CAREFUL ATTENTION TO EACH MANUFACTURING DETAIL

**T**HE electrodes used in Premier Crystal Holders are typical of our strict adherence to minute details. A crystal ground flat and perfect in every other respect is worthless unless used between electrodes that **STAY FLAT**.

To make an electrode stay flat is not as easy as it sounds. Strains in the metal, possibly caused while the blanks are being stamped out, often produces distortions the bad effects of which do not become evident for weeks or even months. Ultimately, the twisting of the plates, even though very slight, causes destruction of the crystal through arcing, reduces the output, shifts frequency and sometimes destroys the crystal entirely by fracturing it. It took much longer to overcome these difficulties than it takes to tell about them. Brass would not behave and was discarded. We developed a nickel silver alloy which is specially heat treated to relieve the surface stress and aged by a unique process.

Determination of the correct thickness of the electrodes and the extraordinary pains taken to produce them, enable us to offer permanently flat and perfect electrodes. This important detail, in addition to many others, brings to the amateur, Crystals and Crystal Holders much nearer perfection than have ever before been produced.



PREMIER "AT" CRYSTAL IN TYPE 180-A SEALED ISOLANTITE HOLDER

Write for Bulletin 103 describing sixteen types of new Isolantite holders, "AT"-cut crystals, etc.



## PREMIER CRYSTAL LABORATORIES, INC.

53 PARK ROW, NEW YORK, N. Y.

**LOOK** at your modulation with a **CLOUGH-BREngle** Cathode Ray Oscilloscope

**Write Today** Get the most from your transmitter. Check modulation, filters, etc., with this low cost, easy-to-use equipment. Write for full particulars.

**The CLOUGH-BREngle Co.**  
1130-J W. Austin Ave., Chicago, U.S.A.

## LEARN RADIO

70% Placement Last Three Years

At the oldest, largest and best equipped privately owned radio operating school in the East. Western Electric and RCA tube transmitters; 180 licensed graduates placed in past three years in broadcasting, shipping, police radio, aviation, service work, etc. Course prepares for all U. S. Government Telegraph and Telephone licenses. Send for 40-page catalog. Investigate. New classes every six weeks from Sept. 10th. Open all year around.

MASS. RADIO SCHOOL, 18 Boylston St., BOSTON  
R. F. TROP, Treas.—EST. 1899—G. R. ENTWISTLE, Pres.

ONE OF AMERICA'S LEADING RADIO SCHOOLS

A REAL NEW DEAL FOR ALL U.S.A. HAMS!

**\$7.50 TO \$10.00 DOWN**  
PUTS THESE SETS IN YOUR STATIONS  
10 MONTHS TO PAY BALANCE

**MCMURDO SILVER 5C  
PATTERSON PR12  
PFANSTIEHL S.S.**

**WRITE—WIRE—CALL—PHONE**  
for technical bulletins on these sets and dope on our "painless" payment plan

All amateur parts in stock

**WILCOX RADIO SALES**  
(W9DDE—W9CRT—W9APY—W9WR)  
506 S. Wabash Avenue Chicago

WEBster 4101

# EIMAC

## TRANSMITTING TUBES ARE HUSKY AND EFFICIENT

Use EIMAC'S in your new rig and put yourself up among the leaders in the forthcoming International DX Contest.

With two 150T's in the final you can obtain a high plate efficiency without exceeding reasonable values of negative bias, grid excitation and plate voltage. This minimizes harmonic generation and concentrates your signal on the fundamental frequency. Why spread it over four or more harmonics?

Get that efficient kilowatt input with only 2500 volts on the plates of two 150T's. Twice cut-off bias is plenty.

TYPE 150T — Net price **\$24.50**  
at leading dealers

Note: New price of 50T, **\$13.50**

— "COMPARE AND REFLECT" —

**EITEL-MCCULLOUGH, INC.**  
SAN BRUNO, CALIFORNIA, U.S.A.

## New QUIET VOLUME CONTROLS and RESISTORS for Every Amateur Purpose

Write Dept. Q  
for Catalog.

175 Varlok St., New York, N.Y.  
**ELECTRAD**

## PRECISION CRYSTALS

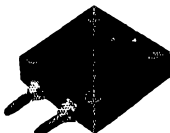

Crystal Holder—\$1.00

'X' and 'AT' cut crystals one inch square carefully ground for frequency stability and maximum output. Be sure of your transmitter frequency — use PRECISION CRYSTALS. Guaranteed to be the highest quality obtainable.

'X' cut PRECISION Crystals carefully ground for maximum power supplied to your specified frequency accurate to 0.1% and calibrated to within 0.03% are priced as follows:

1750 and 3500 kc. bands—\$3.00 each. 7000 kc. band—\$3.50. Add \$1.00 to above prices if plug-in, dustproof holder is desired. Jacks to plug holder into — \$.15 pair.

The 'AT' cut crystal recently developed has a temperature coefficient of practically zero and will handle more power than ordinary crystals. 'AT' cut crystals ground to your specified frequency accurate to 0.1% and calibrated to within 0.03% are priced as follows: 1750 and 3500 kc. bands — \$6.00 each. 7000 kc. band — \$9.00. Crystal holder — \$1.00. Jacks for holder \$.15 pair.

Crystals and ovens for commercial use quoted on at your request. When ordering our product you are assured of the finest obtainable. Now in our sixth year of business.

PRECISION PIEZO SERVICE

427 Asia Street

Baton Rouge, La.

. . . The fellows who carefully stalked five bottles of wine for 15 minutes at the winery, only to find that they could have had them simply by asking



for them. . . . The generally amiable time at the open forum, and the hilarity when Don Wallace asked for a vote on his high power motion (perennial) only to find it had already been passed. . . . The formal presentation ceremony in Room 716 at which "Bud" was presented with 45 pounds of Santa Clara prunes by the San Jose gang (yes, he got 'em home, too! — see photo). . . . Those canes!

— W6FPW + A.L.B.

## International Relay Competition

(Continued from page 37)

The contest offers a special incentive to W/VE amateurs to qualify for membership in the WAC Club. We wonder how many W/VE's will work all continents in the nine days of our contest? Of course many more will complete QSO's with continents most difficult to work, which operation supplementing present achievements will put them in line for "WAC"!

Stations using 14 mc. for the first time are cautioned to use care to keep in the band—slight tuning capacity changes, antenna changes, etc., can change frequency over very wide limits—interference with A.T. and T's 14,440-kc. channel (GBW) from off-frequency amateur operation will be decidedly out of order. We don't want to be obliged to make disqualifications again on these grounds this year!

Both public opinion and government regulations have ruled against "prehistoric" signals, "ac" and unduly broad notes, so we hope there will be "none such." Good notes and stable frequencies should make your work in this contest more successful and enjoyable. A.R.R.L. Official Observers are requested to put in all time possible notifying amateur stations observed off-frequency or with improper-type signals, operating during the contest period. Observers' reports should be sent in through S.C.M.s at the conclusion of the contest.

Stations with good d.c. notes and real frequency stability will have the "edge" over those with poorly adjusted or otherwise inadequate equipment. But more than station equipment will be required to win! Most effective use of the available operation hours, intelligent choice of the different amateur bands, and a high degree of operating proficiency will take one a long way toward superlative results in this contest—or in any amateur radio work for that matter. The



# Super SKYRIDER



*"has everything"*

Acclaimed by Prominent Short-Wave Authorities and Amateurs Everywhere!

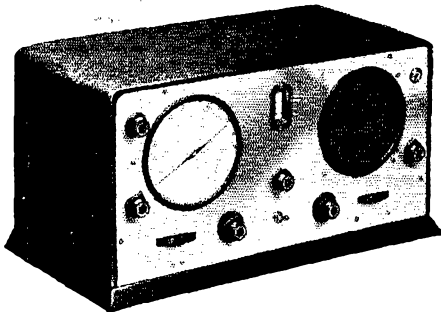

### FEATURES:

- Built-in Power Pack and Speaker
- 4 Short-wave Bands
- Exceptionally wide band-spread — spreading actually 7" on 40 meter band
- Pre-selection
- No Plug-in Coils
- Less than 3 Microvolts Sensitivity
- 3 Watts Power Output in the Speaker
- Tone Control

These unsolicited testimonials, and many others like them, from such famous personalities as Lt. Com. R. H. G. Matthews (famous "Matty" of W9ZN), and T. P. Jordan of Syracuse, can mean but one thing—the Super SKYRIDER is at the very peak of short wave receivers. Write for particulars.

G. A. JOYCE (W9RA)

Pres. Chicago Radio Apparatus Co. Pioneer amateur since 1909 and short-wave distributor says:

"Remarkable enunciation, making it ideal for phone, as well as c.w. . . . Sensitivity and band-spreading superior to any set I've seen. . . . The Super SKYRIDER certainly has it!"

R. S. KRUSE

Technical editor of R/P, and for years technical editor of Q.S.T., says:

"General operation very good. . . . Valuable special features. . . . The set is mechanically solid. . . . Unlike many short-wave receivers the Super SKYRIDER does not permit c.w. tones to change every time any control is touched."

REX MUNGER

Genuine old timer among amateurs and sales engineer. Law Bonn and Co., Minneapolis, Minn.

"Congratulations. Yesterday we received first Super SKYRIDER. Took it home and tried it on couple of QSO'S on 75 meter phone band. To say I was pleased with performance is putting it mildly. Consider the Super SKYRIDER as fine a performing set as I have ever run across."

ROBERT HERTZBERG

Editor of Short Wave Radio, formerly technical editor of Radio News, says in the Dec. 29th issue of the New York Sun:

"This receiver is recommended for its simplicity and utter reliability. It requires no delicate internal adjustments or balancing, and in the hands of the patient operator it will bring in most everything worth hearing on the short waves."

W. J. Halligan, Pres.

the hallicrafters, inc.

3001-C Southport Ave.

Chicago, U. S. A.

a hallicrafters product

## BIRNBACH

All-Wave

## ANTENNA

IMPROVES reception, strengthens signals, reduces interference and noise on all wavelengths.

Complete kit includes all parts — new type coupler, requiring no wave-change switch, wire, new-type insulators, accessories and instructions—only \$5.75 list.

Write Dept. Q-8 for FREE data on Antenna Kit, Aerial and Hook-up Wire, Standoff Insulators, etc.

BIRNBACH RADIO CO., Inc.

145 HUDSON STREET NEW YORK CITY



## ACR-136



AMATEUR RECEIVER

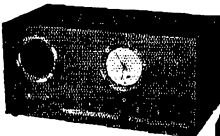

A 7-Tube Super with a range from 540 to 18,000 kc. Band change switch on front panel. Built-in coils. Airplane dial calibrated for positive loggings. It has Stand-by switch, Beat frequency on-off switch, Dual ratio tuning and all other necessary controls. Built-in Power supply and 5-inch Dynamic Speaker. Supplied complete with tubes.

NET PRICE \$69.50 COMPLETE

Write for our new 1935 catalog

**CAMERADIO**

603 GRANT ST. PITTSBURGH - PA.

## Versatility



Aerovox Condensers and Resistors meet your transmission and reception needs. For instance:

- Oil-Filled Condensers . . . aluminum container, round or rectangular . . . genuine high-tension insulators . . . generous safety factor . . . and new low prices (e.g. 2 mid. 2000 v. \$6.50 list; your cost, \$3.90).

- Mica Condensers . . . wide variety . . . quality design, materials, workmanship at mass-production prices.

- Resistors . . . adjustable and fixed wire-wound vitreous enamel . . . carbon . . . lavite . . . grid leak . . . holders.

Free Data write for copy of 1935 Catalog covering entire Aerovox line. Also sample copy of monthly Research Worker.

# AEROVOX

CORPORATION

73 Washington Street

Brooklyn, N. Y.



## ... Exacting

We guarantee our Crystals to be ground to an Accuracy of **BETTER** than .03%. . . BUT . . . No Crystal ever leaves our Laboratories unless it is ground to an Accuracy of **BETTER** than .01% of your specified frequency in order to meet **OUR OWN Specifications**.

### AMATEURS

Crystals are supplied to within 5KC of your specified frequency in either 80 or 160 meter band, \$15.00 each unmounted. Calibration supplied accurate to *Better* than .03%.

#### "THE CRYSTAL SPECIALISTS"

Send for Booklet and Price List

*Scientific*  
**RADIO SERVICE**

124 Jackson Avenue, University Park  
Hyattsville, Maryland, Q-2-35

### 28 and 56 M.C. TWIN-TRIODE

- TRANSCEIVERS
- DUPLEX UNIT TRANSMITTER-RECEIVERS

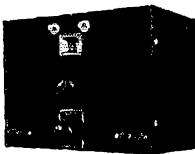

TRANSCEIVERS, each employing push-pull oscillator, Class B modulator. 19, 53 or 6A6 tubes, 10" x 7" x 5".  
\$22.50 and \$26.50

COMBINATION-TRANSMITTER-RECEIVER UNITS, each with push-pull oscillator, Class B modulator transmitter and separate receiver employing r.f. stage. Built-in dynamic speaker. 10" x 14" x 5", 19, 53 or 6A6 tubes.  
\$36.75 and \$39.75

Bulletins on Request

#### RADIO TRANSCIEVER LABORATORIES

8427 105th Street

Richmond Hill, N. Y.

### A.C. Electric Generating Plants

ONAN ALTERNATING CURRENT ELECTRIC PLANTS furnish the same current as city service — 110 volt, 60 cycle, A.C. Operate Radios, Water Systems, Refrigerators, all household appliances.

#### Size 300 to 50,000 Watts

Operate on Gasoline, Gas or Distillate. No battery used except to start engine. Ideal for places remote from electric service. For Public Address, Sound Amplification, Portable Lighting and Standby Equipment.



Also a complete line of D.C. Models

Some Dealer's Territory Available

#### D. W. ONAN & SONS

458 Royalston Ave., Minneapolis, Minn.

best equipment is only as useful for communicating as the man behind the key or "mike" can make it. Use any amateur frequency band, more than one if you wish. Take your pick of operating hours, 'phone or c.w. equipment. All active ham stations are invited to take part and report.

"Total" multiplied by number of

(1) Countries or localities (prefixes)

OR

(2) U. S. and Canadian licensing areas

worked plus fixed credit (500, 1000, 2000, 4000, or 8000) depending on number bands on which QSOs were made equals the **GRAND TOTAL** or **FINAL SCORE** . . .

I hereby state that in this contest, to the best of my knowledge and belief, I have not operated my transmitter outside any of the frequency bands specified in, or in any manner contrary to, the regulations my country has established for amateur radio stations; also that the scoring points and facts as set forth in the above log and summary of my contest work are correct and true.

.....  
Signature of operator(s)

(1) For W/VE entries. In computing points, each "received" serial number group counts 2. Each serial "sent" and properly QSL-ed counts 1.

(2) For entries from stations using any prefixes other than W or VE. In computing points, each 6-figure number "received" counts 1 point, and each number "sent" (with proper acknowledgment) counts 2 points.

#### EXAMPLE OF CONTEST WORK

Every operator taking part in the contest assigns himself a distinctive three-numeral group, used by him throughout the contest as the first part of each number exchanged (sent). All numbers exchanged are **SIX** figure groups. The last three digits of the serial number sent are always taken from the first half of the number group just received (the one from the last participating operator with whom a two-way exchange in the contest has taken place).

Since no exchanges have taken place at the start of the contest (and whenever a "partial" or incomplete exchange has been made so no "foreign" identifying number is available), the **FIRST** (or next) foreign or remote station worked will receive from you a six figure group made up of **YOUR** three-figure identification plus three zeros, constituting the six figure group.

Assume that these are some self-assigned identifying numbers: W4YXZ 343, G6RB 765, VK3WL 856 (he has already QSO W8ZXY 287), ZL2CI 398 (he has just received a number from VE3YY 657), J2GX 395 (who last worked W1YXZ 984), PY2BN 777 and just starting his contest work, also VK5PK 852.

At the beginning of the contest W4YXZ contacts G6RB. He works all the other stations we have named above, and exchanges numbers with each during the contest period. W4YXZ's log (page 36) will show (by italic figures) just how the "first half" of numbers received are used as the "last half" of subsequent transmitter serial number groups.

\* If over 90-hours multiply Grand Total by 90 and divide by the number of hours shown here to give your final score.



Another addition to the BC might well be W2GAS—being necessary for the tractor.

—W2GPI

# ACME-DELTA

COMPLETE POWER SUPPLIES  
REALLY HANDLE CLASS B I  
(As used by James Millen. See Oct. '34 QST)

AD-60

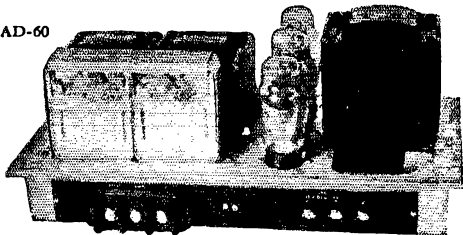

Standard Input 115 V., 60 Cycle, A.C.

Cat. No.	D.C.		Rect.	Ripple %	Reg. %	List Price
	Volts	Amps.				
AD60	1000 & 500*	.250 total	3-83	0.20	11	\$100
AD63	1250 or 1000	.400	2-66A	0.15	10	\$160

\*Note: No filter included for 500 Volt tap. Auxiliary filter required—two AD44 Chokes and one 2 x 8 mid. Electrolytic Condenser. List prices are less tubes and subject to change without notice. Authorized distributors extend 40% discount to amateurs and experimenters. We also sell components. Send for Bulletin DL-48-13. Also DL-48-34 on Class B Amplifiers.



**RAYTHEON MANUFACTURING CO.**  
ELECTRICAL EQUIPMENT DIVISION  
190 Willow Street, Waltham, Massachusetts  
Successor to Delta Manufacturing Co.

## LITTELFUSES

- INSTRUMENT LITTELFUSES, for meters, 1/200 amp. up.
- HI-VOLT. LITTELFUSES for transmitters, etc., 1,000, 5,000 & 10,000 volt ranges, 1/2 amp. up.
- NEON VOLTAGE FUSES & Indicators (TATTELITES), 100, 250, 500, 1,000 & 2,000 volt ratings.
- AIRCRAFT FUSES, AUTO FUSES, FUSE MOUNTINGS, etc. Get new Cat. No. 6.

Littelfuse Labs., 4509 Ravenswood Ave., Chicago, Ill.

**PANELS — BAKELITE — RUBBER — ALUMINUM**  
All Sizes Cut to Order BAKELITE TUBING & RODS  
*Drilling, Engraving & Special Work*  
ALUMINUM CANS—Stock sizes. Special sizes, made to order.  
ALUMINUM CHASSIS—Threaded brass studs for 6/32 screws.  
Length from 1/2" to 6"—price 3c to 30c.

Insulating bushings for all size shafts  
Couplings in brass or Bakelite—15c  
Bakelite Tubing Threaded to Specifications.

**UNITED RADIO MFG. CO.** *Transmitting frames and racks*  
Est. 1923 191 Greenwich St., New York

## BE A GOOD RADIO OPERATOR

Learn to Send and Read Code at Home with

### Instructograph Code Teacher



Experienced Operators, Amateurs and Beginners say there's no better way to get regular, systematic code practice necessary to become a good operator, than with Instructograph. Sends real code just as an expert operator would—it is available day or night, and costs less than most methods. Complete Book of Instruction explains each step as clearly as an instructor would do. Machines, Tapes and Book of Instruction for sale or rent. Cash or terms as low as \$3 per month. Special for three months rental. Rental applied on purchase price if desired. Rent for a month. If Instructograph meets your requirements, buy it. If not, send it back. Send postcard for full details. No obligation.

INSTRUCTOGRAPH COMPANY, Dept. Q-14  
912 Lakeside Place Chicago, Illinois

## THE HAM'S DREAM COME TRUE

### THE TYPE 9 MICA X-MITTING CONDENSER

Constructed of the finest selected mica and foil—moulded at a predetermined pressure, which insures constant and accurate capacity. Ideal as high current blocking (plate to grid) unit—also as by-pass for R.F. around any device.



## LOOK TO C-D IN 1935!

Free for asking—Catalogue No. 126

## CORNELL-DUBILIER CORPORATION

4373 BRONX BOULEVARD  
NEW YORK



## "E. H. Rietzke SPEAKING!"

Mr. E. H. Rietzke, President of CREI, and originator of the first thorough course in Practical Radio Engineering.



## DID YOU GET YOUR "CUT" BACK — OR GET A REAL RAISE?

Radio business is GOOD . . . and if you're not getting anywhere it's your own fault! There's quite a difference between "just getting along" and working toward a goal! The foremost engineers in the country will tell you that TECHNICAL TRAINING is necessary for those who want the big jobs and the salaries that go with them.

### CREI WILL HELP YOU GET AHEAD

The man who isn't capable of better performance than his job requires, will never get a chance at more important duties. CREI is no "diploma mill." Each student receives individual, conscientious instruction, in either the home study or residence courses.

Write Now — for Free 44-Page Illustrated Booklet

CAPITOL  
ENGINEERING



RADIO  
INSTITUTE

14th and Park Road, N. W.  
Dept. Q-2

Washington, D. C.

# HAM-ADS

(1) Advertising shall pertain to radio and shall be of nature of interest to radio amateurs or experimenters in their pursuit of the art.

(2) No display of any character will be accepted, nor can any special typographical arrangement, such as all or part capital letters be used which would tend to make one advertisement stand out from the others.

(3) The Ham-Ad rate is 15c per word, except as noted in paragraph (6) below.

(4) Remittance in full must accompany copy. No cash or contract discount or agency commission will be allowed.

(5) Closing date for Ham-Ads is the 25th of the second month preceding publication date.

(6) A special rate of 7c per word will apply to advertising which, in our judgment, is obviously non-commercial in nature and is placed and signed by a member of the American Radio Relay League. Thus, advertising of bona fide surplus equipment owned, used and for sale by an individual or apparatus offered for exchange or advertising inquiring for special equipment, if by a member of the American Radio Relay League takes the 7c rate. An attempt to deal in apparatus in quantity for profit, even if by an individual, is commercial and takes the 15c rate. Provisions of paragraphs (1), (2), (4) and (5) apply to all advertising in this column regardless of which rate may apply.

**Having made no investigation of the advertisers in the classified columns, the publishers of QST are unable to vouch for their integrity or for the grade or character of the products advertised.**

**QUARTZ**—Direct importers from Brazil of best quality pure quartz suitable for making piezo-electric crystals. Diamond Drill Carbon Co., 719 World Bldg., New York.

**RADIO** engineering, broadcasting, aviation and police radio, servicing, marine and Morse telegraphy taught thoroughly. All expenses low. Catalog free. Dodge's Institute, Byrd St., Valparaiso, Ind.

1000W transformers (GE) 1100-2200-4400 volts each side centertap. Same as hundreds sold A.R.R.L. members. Dawson, 5740 Woodrow, Detroit, Mich. \$13.50.

**HAM** equipment bought, sold or traded. Distributors of all nationally known ham apparatus. Write for catalogue. Walter Ashe Radio Co., St. Louis, Mo.

**WANTED:** for ham antique collection—Radiola 2—portable. DeForest Audion Panel, bulb. Any other early radio equipment. Answer all letters. W6LM.

**QSLs**—SWLs, W6DOU, Hayward, Calif.

**GENERAL** Electric 24/750 volt 200 mill dynamotors, \$25. Two machines for 1500 volts, \$40. Westinghouse, 27 1/2/350 80 mills, \$10. 500 watt 500 cycle, \$7.50. List. Henry Kienzie, 501 East 84th St., New York.

**NATIONAL** FB7A and FBXA receivers and coils, slightly used, guaranteed A-1 condition—60% off list prices. Willard Wilson, W3DQ, Wilmington, Del.

**QSLs!** America's finest! Don't buy cheap, trashy QSLs. They are detrimental to amateur radio! Stamp for samples. W8DED, Holland, Mich.

**COMET** Pro. AVC-Xtal-Wright DeCoster speaker, 15 to 350 meters. Used 2 months, \$80, complete. J. D. Avery, 40-25 196th St., Flushing, L. I., N. Y.

**RCA** UP1016 transformer 1000-1500 each side \$11. Want larger transformer. Also FB7. W8BR.

**QSLs.** Free samples. Printer, Corwith, Iowa.

**QSL** cards, two color, cartoons, message blanks, stationery, snappy service. Write for free samples to-day. W1BEF, 16 Stockbridge Ave., Lowell, Mass.

**QSLs! QSLs!** See mine before ordering. W2AEY.

**NATIONAL** Pre-selector and FB7, 40 meter B.S. coils, RCA tubes. First \$48. m.o. W3BEN.

**POWER** supply for 32v hams. 32 volt 3 amp. input, delivers 350v 100 mil., 2.5v a.c. Two 2v d.c. receivers. Want medium power transmitting equipment. Ralph Senechal, Anamoose, N. D.

**AMATEUR** equipment manufactured to order. Holmes C. Miller, Box 105, Palo Alto, Calif.

**JANETTE** AC 300 gasoline engine converter, 110 a.c. 60 cycle, 300 watts, brand new. W2GYL, Hempstead, L. I.

**SELL!** January 1933 QST dynamon frequency meter monitor. National vernier dial. Aluminum shielded—complete self contained power supply—tubes, \$15. W8GWF.

**CLASS B** transformers—Universal for two or four 46's, 210's, 800's, RK18's, etc., \$7.75 pair postpaid anywhere in United States. 70 watts of audio from 46's. Write for details. W8UD, Douglas, Michigan.

**CRYSTALS:** Guaranteed excellent oscillators, 160 or 80 meters, your approximate frequency \$1.35 postpaid. Crystal Maker's blanks 1"—65¢, dozen \$6.00. Irregular shapes 25¢. Improved dust-proof Bakelite holders, non-exposed 1 1/4" silvered electrodes, plugs into G.R. or tube socket mountings, any position. 75¢. Fisher Laboratory, 4522 Norwood, San Diego, California. "Pioneers of low priced crystals."

**QSLs**, samples, 2143 Indiana Ave., Columbus, Ohio.

**CRYSTALS**—160-80 meters, within three kc., \$1.50. Guaranteed strong oscillators. Vollmer Radio Lab., 5126-35th St., San Diego, Calif.

**CRYSTALS**, guaranteed excellent oscillators, 80-160 meters, your approximate frequency, \$1. W9FHS, 4433 North Kilbourn, Chicago.

**BEST** offer takes Gross Eagle bandspread receiver, tubes, all coils. Paul Lesser, St. Marys, Penn.

**QSLs** by Maleco. Finest in country. Free samples. Maleco, 1512 Eastern Parkway, Brooklyn, N. Y.

**SELL**—ACSW3, 6 sets coils, tubes, power supply second audio stage, choke-condenser output, used about 100 hours. \$24. John Lodge, 61 Norwood Ave., Upper Montclair, N. J.

**CRYSTALS:** Dependable X cut, 1" sq. Fully finished and guaranteed. Specify frequency desired. 160-80, \$2. W8DLM, Rochester, Mich.

**SALE**—50 watt output xmtr with tritrit exciter, monitor, SW-5 receiver with 4 sets coils. W9RAB, Faribault, Minn.

**TELEPLEXES**, Vibroplexes, Omnigraphs, receivers, meters, crystals. Bought, sold, traded. Ryan Radio Co., Hannibal, Mo.

**QSLs**. New, attractive cuts. W6FZQ, Box 1804, Phoenix, Arizona.

**SELLING** out. Three-band transmitter with PP. 210s in final. Rack mounted bak of panel. Good receiver. W3BDS, N. Custer Ave., New Holland, Pa.

**QSLs**, 75¢ a 100. Two colors. W9DGH, 1816 5th Ave., N., Minneapolis, Minn.

**FOR** sale. Latest 1935 model Postal receiver, also three stage two fifty Webster amplifier. Glenn Watt, Chanute, Kans.

**GE** K80-X, \$50. C70, \$40. Grebe 9 tube, \$20. Grebe two tube short wave \$10. RCA amplifier \$10. Western Electric dynamic speaker, \$10. Zeiss binocular \$25. Zeiss Miroflex B F.2/8 (offer). Weston light meter, \$20. Bargains new Winchester, a.c. motors and generators. English "Brown" headphones. Hohner accordion, \$10. C. Mack, 21-52 44th Drive, Long Island City.

**SWAP**—Graflex f4.5 3 1/4 x 4 R.B. camera, very slightly used, for FB7, what have you? W8IR, Grand Rapids, Mich.

**IN** stock—lowest prices: All National, Silver, Hammarlund, Patterson, RME9D, Sky-rider receivers. Trade in your receiver. All Collins, Sylvania, Thordarson, National, Hammarlund, Cardwell, Taylor, Triplett, Trimm, Johnson, Cornell-Dubilier, Biley, others. Guaranteed 866s, \$1.49. All types RCA and Western Electric transmitting tubes. Code machines rented. Used apparatus sold, traded. Save money by writing. Henry Radio Shop, W9ARA, Butler, Mo.

**YOUR** name and call letters painted in Neo-ItE letters on 7x10 card. Special 30¢ postpaid. W5DTM, El Paso, Texas.

**CRACKLE** enamel 75¢, SW3, SW58 coils cheap. Victron dope 30¢. Crackle cabinets. Catalog, Radio Specialties, 433 Monroe, Brooklyn, N. Y.

**INSURE** station performance. Equip with QST specification power, filament, class B, special transformers, reactors. Add that finishing touch with relay racks. Edison batteries. Rectifier Engineering Service, 4837 Rockwood Rd., Cleveland, Ohio.

**CONNECTICUT** hams: time payments on National, Hammarlund, RCA receivers, etc. Test equipment for servicemen. Write for terms. Hatry & Young, Hartford.

**QSLs**, free samples. Printer, Corwith, Iowa.

**QSLs**, SWLs, special time offer 200, \$1. W8ESN, 1827 Cone, Toledo, Ohio.

**NEW** 845 six fifty five meter DeForest H, five dollars. Mc-Shaffrey, Monessen, Pa.

**SELL** two hundred watt rack and panel complete, \$35. Harrison, Brookings, S. Dak.

50 watters, \$7.50; 203As and 854s, new. Amateur Service, Fairview, N. J.

**CRYSTALS**, guaranteed. 160-80 meter, less than 1", X or Y, plus or minus ten kilocycles, \$1.35. Plus or minus two kilocycles, 1", \$2.25. Blanks. 60¢. Odds and ends five for \$1; oscillating 85¢. Grinding instructions 25¢. Holder, \$1. Speedy service. Wm. Threm, W8FN, 4021 Davis Ave., Cheviot, Ohio.

**CRYSTALS:** 160-80 meter; trade for tubes, meters, transformers. Wm. Threm, W8FN, 4021 Davis Ave., Cheviot, Ohio.

**PATTERSON** PR-12, \$87.90 prepaid. Skyrider, National, Hammarlund, Biley xtal. Cardwell, Ward-Leonard, Speed-X, Signal, Raytheon, Sylvania, others. Used receivers. Vinson Radio Co., W5VK, 2123 Broadway, Little Rock, Arkansas.

**PREPAID**—Patterson PR-12 Crackle cabinet complete, \$32.00; With crystal \$37.90—Console \$99.65; With crystal \$105.55. Sargent 8-34 Complete \$49.50; Marine model (15 to 1500 meters) \$57.50. Patterson Pre-Selector \$17.64; Peak \$19.80. All shipped prepaid. Our honest to goodness 100 watt phone-cw transmitter now ready. See our display ads this issue. L. I. Marine & Electric Co., 163-18 Jamaica Avenue, Jamaica, N. Y.

**CRYSTALS**: A-cut, new type crystals insuring maximum power capacity, and minimum frequency drift, supplied in 80-160 meter bands within 5kc. \$5.00. Power ground X-cut crystals 80-160 meters supplied within 25kc. \$1.75; 5kc. \$2.00; exact kc. \$2.50. 40-meters 25kc. \$3.00; 5kc. \$3.75. 450-550kc. filter crystals \$3.00. 100kc. standard frequency bars \$7.50. Commercial prices on request. Insure satisfactory operation of your transmitter by using these better crystals. Gentry Laboratories, 803 W. Maple, Independence, Mo.

**QSLs!** FB designs. 75¢ per hundred. Everything in ham printing. Free samples. W2FJE, 145 Lafayette Ave., Brooklyn, N. Y.

**BUY on terms**; time payments for Connecticut hams. Service equipment for servicemen. Hatry & Young, Hartford.

**STAMP size pictures for QSLs**, 25 for 25¢. Rolls developed for amateurs, 8 prints 25¢. Other photo needs priced accordingly. Dixie Photo Service, Box 230, Port Orange, Fla. W4BRY.

4000V (working) 2 mf condensers, \$5. 2500V 2 mf, \$3. Isolantite transposition blocks, 15¢. W9HYO, 1057 Pratt Blvd., Chicago.

**CRYSTALS**:—Power ground. 80 meters, 1", "X," within three kilocycles, \$1.95. Standard Holders, \$75. "Ham Crystals," 1104 Lincoln Place, Brooklyn, N. Y.

**THERMO-couples** replaced for \$2. and up. Satisfaction or money back. Wright's Laboratory, 5214 S.E. 87 Ave., Portland, Ore.

**WILLIAMMETERS**—new triple range, 40-80-200 mls. Jewell movements, \$2.75 (allow postage insurance 2 lbs.). W9SXF, 1237 "C" St., Lincoln, Nebr.

**AT cut saw blanks** made from finest quality Brazilian quartz. Guaranteed as to quality and cut. \$1.25 each. 6 for \$6. R. B. Cunningham, 1332 N. 12th St., Philadelphia, Pa.

**AT crystals and blanks**. Harry Sonneborn, W9APV, LaPorte, Ind.

**GENERATOR**—Emerson 1000 volt d.c., 400 watts, 3450 R.P.M. Excellent condition. First \$12. takes it. A. L. Dunn, W9AQO, 536 S. 31st Ave., Omaha, Nebraska.

**SELL**—Royal Olympic 5 tube receiver complete; power supply, amateur band spread and broadcast coils, \$13. W. Dort, 1142 Sunset Point, Clearwater, Fla. W4CGV.

**FOR cash or swap**. RCA860, W.E.212D. Want SW3 or SW5 complete. R. Earnstein, 3107 Derbyshire, Cleveland, Ohio.

**CASH for SW3AC or super**. Erwin Hoering, Amityville, L. I. **CRYSTALS** x cut 1" sq., 80-160 meters. Within 3-kc. of frequency ordered, \$2. Ransom & Horn Lab., No. Syracuse, N. Y.

## The Radio Amateur's LICENSE MANUAL

(No. 9 in the series entitled  
The Radio Amateur's Library)

A NECESSITY for the beginner—equally indispensable for the already licensed amateur. Going after your first ham "ticket"? You need the manual for its instructions on where to apply, how to go about it in the right way—and, most important of all, for the nearly 200 typical license exam. questions and answers. Already got a license? The manual is still necessary—for its dope on renewal and modification procedure, the Class A exam. (with questions and answers), portable procedure, etc.

All the dope on every phase of amateur licensing procedure, and, of course, the complete text of the new regulations and pertinent extracts from the basic radio law.

ORDER YOUR COPY TODAY

25c postpaid (no stamps, please)

AMERICAN RADIO RELAY LEAGUE  
West Hartford, Conn.



### WIRELESS KEYS

Signal Standard Wireless Keys are now equipped with Navy type key knob. They are available in 3/16", 1/4" and 3/8" coin silver contacts.

Write for illustrated circular.

SIGNAL ELECTRIC MFG. CO.  
Menominee, Michigan

OFFICES IN PRINCIPAL CITIES

# SIGNAL

MANUFACTURERS OF ELECTRICAL APPLIANCES

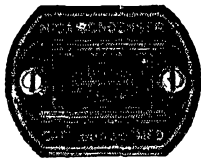

## SANGAMO ACCURATE CONDENSERS

A quality product for the amateur who wants the best results. Available in 1000, 2500, and 5000 volt construction

Write for catalog sheet

SANGAMO ELECTRIC CO.  
SPRINGFIELD, ILLINOIS

## RADIO COURSES

Radio Operating  
Prepare for Gov't license exam.

Radio Amateur Code

Radio Servicing  
Including short wave receivers.

Resident Courses  
Write for Booklet

NEW YORK YMCA SCHOOLS  
4 West 63rd Street, New York City



# Your Nearest Dealer

Your nearest dealer is entitled to your patronage. You can trust him. He is equipped with a knowledge and understanding of amateur radio. He is your logical and safe source of advice and counsel on what equipment

**Patronize the dealer nearest you—**

<p><b>ALLENTOWN, PENNSYLVANIA</b> Radio Electric Service Co. 1024 Hamilton Street Complete stocks transmitting equipment</p>	<p><b>CHICAGO, ILLINOIS</b> Mid-West Radio Mart 520 S. State Street All standard lines carried in stock</p>
<p><b>BALTIMORE, MARYLAND</b> Radio Electric Service Co. 303 W. Baltimore Street Everything for the amateur</p>	<p><b>CLEVELAND, OHIO</b> Northern Ohio Laboratories 2073 West 85 Street Wholesale Distr. for National, Hammarlund, Thordarson, Cardwell</p>
<p><b>BOSTON, MASSACHUSETTS</b> Nutter &amp; Cross, Inc. 99A Milk Street All OMs, OWs, and YLs welcome — W1HRF</p>	<p><b>DENVER, COLORADO</b> Inter-State Radio &amp; Supply Co. 1639 Tremont Place Amateur Radio Headquarters in the Rocky Mountain Region</p>
<p><b>BROCKTON, MASSACHUSETTS</b> Ware Radio Supply Company 913 Centre Street Hammarlund, Sylvania, Ohmite, Raytheon, Triplett Meters</p>	<p><b>DETROIT, MICHIGAN</b> Radio Equipment Sales Co. 14036 Woodward Avenue, Highland Park A complete stock of amateur, shortwave and service parts</p>
<p><b>BUFFALO, NEW YORK</b> Dymac Radio 216 E. Genesee St. — Tel. Cl. 2080 Complete Stock Amateur Parts — Standard Discounts — W8AWK</p>	<p><b>DETROIT, MICHIGAN</b> Radio Specialties Company 171 E. Jefferson Avenue Ham Supplies — National &amp; Hammarlund Sets and Parts</p>
<p><b>BUFFALO, NEW YORK</b> Kronson Service Company 143 East Genesee Street Western New York's largest wholesale distributors — W8EHF</p>	<p><b>DETROIT, MICHIGAN</b> Serlin 1419 Broadway Detroit's Pioneer Radio Merchants</p>
<p><b>CHICAGO, ILLINOIS</b>  Allied Radio Corporation 833 West Jackson Blvd.  Complete standard lines always in stock — W9NRV — W9RZI</p>	<p><b>ERIE, PENNSYLVANIA</b> Jordan Radio Laboratory 2512 Peach Street Amateur, service parts, including Bliley, National, Raytheon. W8CXG</p>
<p><b>CHICAGO, ILLINOIS</b>  Chicago Radio Apparatus Company 415 South Dearborn Street (Est. 1921)  W9RA and W9PST — Amateurs since 1909</p>	<p><b>HARTFORD, CONNECTICUT</b> Radio Inspection Service Company 227 Asylum Street What do you need? We have it</p>
<p><b>CHICAGO, ILLINOIS</b>  Chicago Radio Apparatus Company 415 South Dearborn Street (Est. 1921)  W9RA and W9PST — Amateurs since 1909</p>	<p><b>HOUSTON, TEXAS</b> Straus-Frank Company Distributors for nationally advertised amateur products RCA-DeForest transmitting tubes</p>
<p><b>CHICAGO, ILLINOIS</b>  Newark Electric Company 226 W. Madison Street  Chicago's oldest radio parts store — established 1921 John T. Wallace, Technical Adviser</p>	<p><b>JACKSONVILLE, FLORIDA</b> Glover Weiss Co. Radio Headquarters for Southeast Distributors: RCA Victor, Stromberg-Carlson, Standard Ham Lines</p>
<p><b>CHICAGO, ILLINOIS</b>  Newark Electric Company 226 W. Madison Street  Chicago's oldest radio parts store — established 1921 John T. Wallace, Technical Adviser</p>	<p><b>KANSAS CITY, MISSOURI</b> Burststein-Applebee Company 1012-14 McGee Street "Specialists" in supplies for the Amateur and Serviceman</p>
<p><b>CHICAGO, ILLINOIS</b>  Newark Electric Company 226 W. Madison Street  Chicago's oldest radio parts store — established 1921 John T. Wallace, Technical Adviser</p>	<p><b>KANSAS CITY, MISSOURI</b> Radio Laboratories 1515 Grand Avenue Amateur Headquarters — Complete Stock — Quality Parts</p>

*This advertisement is paid for by the firms listed above. Qualified dealers*

# Is Your Best Friend

you should buy. His stock is complete. He can supply your needs without delay. His prices are fair and consistent with the high quality of the goods he carries. He is responsible to you and interested in you.

You can have confidence in him

<p><b>LOS ANGELES, CALIFORNIA</b></p> <p>Pacific Radio Exchange, Inc. 729-31 South Main Street</p> <p><i>Most completely diversified stock of amateur equipment in the West</i></p>	<p><b>ST. PAUL, MINNESOTA</b></p> <p>Lew Bonn Company 2484 University Avenue Rex L. Munger, W9LIP, Sales Engineer</p> <p>Radio Wholesaler <span style="float: right;">Complete Stock</span></p>
<p><b>MANCHESTER, NEW HAMPSHIRE</b></p> <p>Radio Service Lab. of N. H. 1008 Elm Street — Tel. 218-W Branches — Portland, Me. and Barre, Vt.</p>	<p><b>SAN ANTONIO, TEXAS</b></p> <p>Straus-Frank Company Distributors for nationally advertised amateur products RCA-DeForest transmitting tubes</p>
<p><b>MILWAUKEE, WISCONSIN</b></p> <p>Radio Parts Company, Inc. 332 West State Street Complete stock Nationally Known products</p>	<p><b>SAN FRANCISCO, CALIFORNIA</b></p> <p>Offenbach Electric Company, Ltd. 1452 Market Street</p> <p>"The House of a Million Radio Parts"</p>
<p><b>NEWARK, NEW JERSEY</b></p> <p>Kaltman &amp; Romander 62 Court Street Drop in for an over-counter QSO</p>	<p><b>SIoux CITY, IOWA</b></p> <p>Warren Electric Co. Standard Lines and Discounts T. J. Morris, W9SSN, Mgr. Parts Dept.</p>
<p><b>PEORIA, ILLINOIS</b></p> <p>Klaus Radio &amp; Electric Co. 707 Main Street Amateur Radio Department</p>	<p><b>SPRINGFIELD, MASSACHUSETTS</b></p> <p>T. F. Cushing 349 Worthington Street An amateur, endeavoring to sell good parts</p>
<p><b>PHILADELPHIA, PENNSYLVANIA</b></p> <p>Consolidated Radio Corp. 612 Arch Street Ham receivers, Transmitting tubes, Collins Transmitters, etc.</p>	<p><b>SYRACUSE, NEW YORK</b></p> <p>Roy C. Stage, W8IGF Complete stock of standard Ham &amp; BCL parts Standard Discounts. Free technical service</p>
<p><b>PHILADELPHIA, PENNSYLVANIA</b></p> <p>Freeland Radio Supply Co. 5 N. 7th Street "If it's radio we have it"</p>	<p><b>TORONTO, CANADA</b></p> <p>A &amp; A Radio Service Supply 101 Queen Street, West Canada's foremost radio supply house</p>
<p><b>PHILADELPHIA, PENNSYLVANIA</b></p> <p>Radio Electric Service Co., Inc. N. E. Cor. Seventh &amp; Arch Sts. All nationally advertised lines in stock</p>	<p><b>TORONTO, CANADA</b></p> <p>Wholesale Radio Company, Limited 1133-39 Bay Street Canada's Largest Amateur Supply House</p>
<p><b>PHILADELPHIA, PENNSYLVANIA</b></p> <p>Eugene G. Wile 10 S. Tenth Street</p> <p>Complete Stock of Quality Merchandise</p>	<p><b>TRENTON, NEW JERSEY</b></p> <p>American Radio Co. 5 N. Broad Street Central Jersey's leading radio parts store</p>
<p><b>PROVIDENCE, RHODE ISLAND</b></p> <p>W. H. Edwards &amp; Company 32 Broadway, Room 23 Amateur Equipment — National, Hammerlund, RCA Tubes</p>	<p><b>WASHINGTON, D. C.</b></p> <p>George's Radio Co. 816 F Street, N.W. Washington's largest distributor of radio parts</p>

are invited to apply for rates, etc., to Advertising Department, QST

Say You Saw It in QST — It Identifies You and Helps QST

# You Are Protected When You Buy From QST Advertisers

“Advertising for QST is accepted only from firms who, in the publisher’s opinion, are of established integrity and whose products secure the approval of the technical staff of the American Radio Relay League.”

Quoted from QST’s advertising rate card.

Every conceivable need of a radio amateur can be supplied by the advertisers in QST. And you will know the product has the approval of the League’s technical staff.

## For Your Convenience QST’S INDEX TO ADVERTISERS IN THIS ISSUE

Aerovox Corporation .....	87
Alden Products Company .....	83
Allen-Bradley Co. ....	71
A.R.R.L. Application Blank .....	66
Binder .....	79
Bound Volumes D. ....	73
Emblem .....	78
Handbook .....	4
License Manual .....	91
Supplies .....	81
Barr Laboratories, Inc. ....	74
Birnback Radio Company .....	87
Biley Electric Company .....	77
Burgess Battery Company .....	2
Cameradio Company .....	87
Capital Radio Engineering Institute .....	89
Cardwell Mfg. Corp., Allen D. ....	69
Central Radio Laboratories .....	76
Clausing, Leroy M. E. ....	83
Clough-Brengle Company .....	85
Collins Radio Company .....	Cov. 2
Cornell Dubilier Corporation .....	89
Cornish Wire Company .....	81
Delaware Radio Sales Company .....	77, 79
Dodge’s Institute .....	73
Eastern Radio Specialty Co. ....	81
Eitel-McCullough, Ltd. ....	86
Electrad, Inc. ....	86
General Electric Company .....	75
General Radio Company .....	72
Gray, Russell A. ....	84
Gross Radio, Inc. ....	64, 65, 74
Gulf Radio School .....	79
Hallicrafters, Inc., The .....	87
Hammarlund Mfg. Company .....	1
Hipower Crystal Company .....	82
Instructograph Company .....	89
Johnson Company, E. F. ....	82
Kaltman and Romander .....	68
Leeds .....	96
L. I. Marine & Electric Co. ....	72
Littelfuse Laboratories .....	89
Lynch, Inc., Arthur H. ....	79
Lynch Manufacturing Company .....	67
Massachusetts Radio School .....	85
M & H Sporting Goods Company .....	84
National Company, Inc. ....	63, 73, 75, 80, Cov. 3
New York Y.M.C.A. School .....	91
Onan & Sons, D. W. ....	88
Precision Piezo Service .....	86
Premier Crystal Laboratories .....	85
RCA Institutes, Inc. ....	75
Radiotron Company, Inc. ....	Cov. 4
Radio Shack .....	83
Radio Supply Company .....	81
Radio Transceiver Laboratories .....	88
Raytheon Production Corporation .....	89
Sangamo Electric Company .....	91
Scientific Radio Service .....	88
Shure Brothers Company .....	77
Signal Electric Mfg. Company .....	91
Teleplex Company .....	77
Trimmm Radio Manufacturing Company .....	83
Triplet Electrical Instrument Corp. ....	70
Turner Company .....	83
United Radio Manufacturing Company .....	89
Vibroplex Company .....	75
Wilcox Radio Sales .....	85
Yaxley Manufacturing Company .....	95



*it's Complete!*  
*it's Authoritative!*  
*it's Invaluable!*

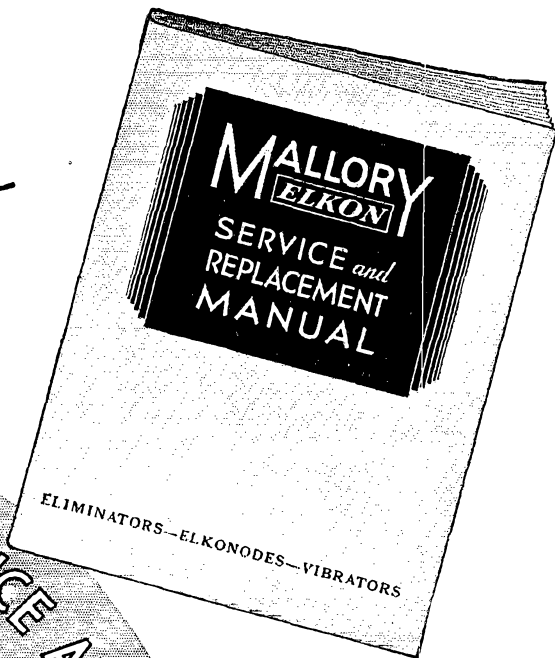

WHEN YOU SERVICE RADIO SETS... and Money with this BOOK... Save Time AUTOMOBILE

Mallory put information in this manual that will put *money* in the pockets of any man who wants to meet the ever-increasing requirements of the automobile radio industry with greater ease and greater profit! Mallory created a sensation in the vibrator field when it created the famous Mallory Elkonode. Mallory scored again with this remarkable manual which marks a great advance over all former publications. Surely you've heard about it. Certainly you'll want to profit by it—and sending for your copy today is a real move in the direction of *starting the new year right!*

**IT'S FREE!**

**JUST MAIL THE COUPON**

Think of it—28 big pages of information that will make every working day of 1935 a more profitable day! Get it—read it—use it! Mail the coupon now and get *your* copy of this money-making manual *absolutely free.*

**P. R. MALLORY & CO., Inc.**  
**INDIANAPOLIS, INDIANA**  
 Cable Address—Palmallo

P. R. MALLORY & Co., Incorporated  
 Indianapolis, Indiana  
 Gentlemen :

As a legitimate authorized service man, I am interested in securing a copy of your Mallory Service and Replacement Manual which I understand is free. Please send this to me quickly without charge.

Name \_\_\_\_\_

Address \_\_\_\_\_ (City) \_\_\_\_\_ (State)

My Jobber is \_\_\_\_\_



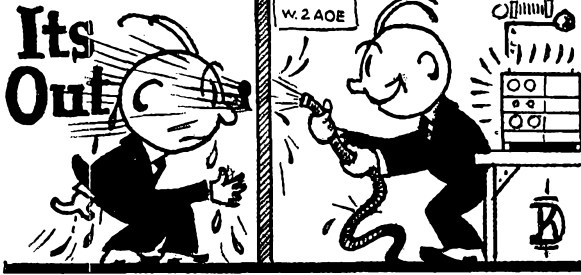

Yes sir! After all these years transmitters by LEEDS will be available by the time this reaches you. Convenient operation on the four popular amateur bands is the keynote of our unique designs. Quality parts, high efficiency and reasonable prices.

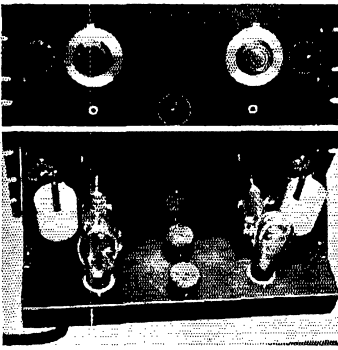

### Here's the First New Unit

On a standard 7 x 19" rack panel, back of panel depth 8". A 247 crystal oscillator operating on 1.7 mc; 3.5 mc; and 7.0 mc drives an 841 buffer doubler giving ample excitation for 2-RK 20's on 4 bands on six frequencies. As illustrated, switches provide means for changing crystals and the amount of inductance in the circuits from the front panel. Link or capacity coupling to the next stage is provided. At last excitation where you want it when you want it in 10 seconds. Type 4X exciter, less tubes and crystals..... **\$25**

LEEDS Racks, Panels and Bases are designed for the maximum amount of convenience in construction, appearance and flexibility.

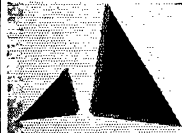

We are rounding out our construction line advertised last month with two new types of brackets, made of 18 gauge steel with dull black finish. They are ideal for fastening panels to bases or demi bases where heavy apparatus is employed. 4" high, 5 3/4" deep, 1/2" bend for mounting; pair..... **25c**  
7 1/2" high, 9 3/4" deep, 1/2" bend for mounting; pair..... **35c**

### SPECIAL CRYSTAL OFFER!



Carrying our regular guarantee of 100% satisfaction. 3 mounted crystals, one 1.7, one 3.5 and one 7.0 mc priced at

**\$10** when purchased with our 4-X unit — you pick the frequencies. AT cut crystals — your choice of frequency in the 1.7 and 3.5 mc bands, unmounted ..... **\$5.00**  
7.0 mc band..... **\$6.50**  
Socket type crystal holder..... **\$1.00**

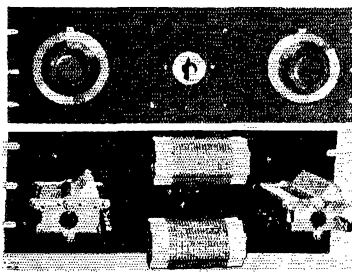

Type AIM-4 (illustrated) for transmitter employing modulated 203's; 852's using two wire feed antennas for 3.5; 7.0; 14.0 and 28 mc operation. Deduct \$2.50 from above prices if 4" bakelite dials are substituted for the General Radio 4" dials illustrated.

Here are four antenna impedance networks made in the LEEDS convenient manner, standard 7x19 panels are employed. Front of panel switching with positive low resistance connections to the network coils, eliminate unstable back of panel clip adjustments. All controls are where you want them, out in front. Antenna Meters? Wait until you see our new meter panel next month.

Type AIM-1 for transmitter employing 210's — 46's, etc. using single wire feed antennas for 1.7; 3.5; 7.0 and 14.0 mc operation..... **\$13.50**  
Type AIM-2 for transmitter employing 203-A's — RK-20's, 852's using similar antennas for 4 band use..... **\$21.50**  
Type AIM-3 for transmitter employing 210's; 46's, etc. using two wire feed antennas for 3.5; 7.0 and 14.0 and 28 mc operation..... **\$13.50**

### LOW LOSS COILS

You can easily "roll your own" coils with our new "air wound" inductance used in our 4-X exciter as illustrated above. Coil diameter 2" employing No. 16 DCC wire. It is available in two styles — close wound, 16 turns per inch and space wound, 9 turns per inch. 20" length **\$2.85**, by the linear inch..... **15c**

### The New NATIONAL HRO

receiver now in stock, with crystal filter and coils covering from 1.7 mc to 30 mc..... **\$139.80**

### NATIONAL COIL FORMS

XR-10A Steatite; 2 1/2" x 5"; 26 turns **\$1.50** List. Special..... **\$.90**  
XR-12A Steatite; 4" x 6 1/2"; 28 turns **\$2.25** List. Special..... **\$1.35**

### The New RCA ACR-136

In stock. A real ham superhet receiver, plus broadcast reception. A descriptive bulletin is yours for the asking on this remarkable receiver. Price, complete..... **\$69.50**  
*Nothing else to buy*



NATIONAL steatite lead through bushings for lowest losses. Type WXS-1 (small size)..... **36c**  
Type WXS-2..... **48c**

General Radio forms; No. 677-U..... **50c**  
No. 677-Y..... **75c**  
General Radio split stator cond..... **\$1.25**  
*Described fully in December issue*



**LEADS THE FIELD**

World Wide Service to Amateurs

45 Vesey Street  
New York City

Cable Address, "RADLEEDS"

Frost lightweight phones, 20,000 ohm impedance..... **\$2.50**

### The New GENERAL RADIO

3 1/4" dial now in stock. We are using them on our new Exciter unit. Each..... **\$1.25**

### Navy Type Telegraph Key

List **\$3.60** Navy knob — 3/8" Tungsten contacts. Only a few left at..... **\$1.15**  
With regular knob..... **.95**  
Leeds transmitting key, special..... **.65**

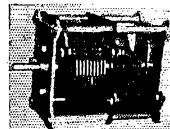

### General Radio

S.L.F. split stator condenser; 175 mmf per section; ideal for antenna networks and medium power **\$1.25**

25 manufacturers folders and our own bulletin B-73 all for a thin dime. Send for yours today.

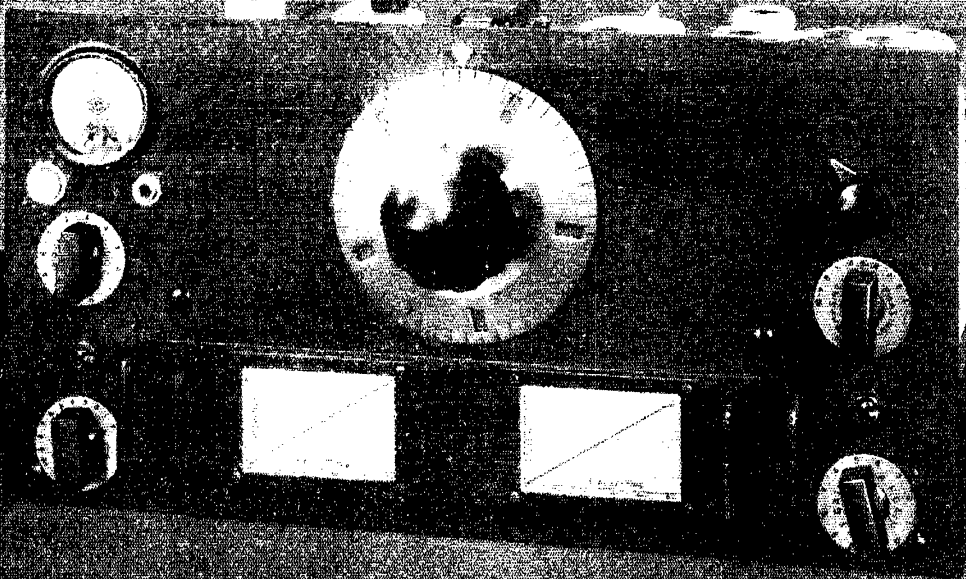

### SINGLE SIGNAL

The completely shielded single signal unit has a front-panel selectivity control with sufficient range for phone reception, as well as a front panel phasing control for heterodyne elimination. The crystal is of a new type, virtually eliminating side peaks. The holder, also new, mounts the crystal vertically, permitting free oscillation. And when turned "off," the unit becomes a conventional I.F. coupling unit which contributes its full share to the remarkable overall selectivity of the HRO.

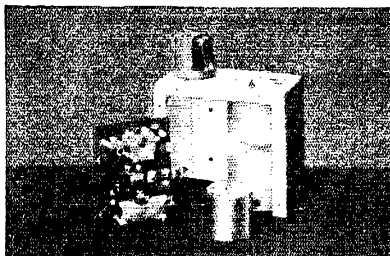

### WORM DRIVE TUNING

The HRO employs the new PW precision condenser with worm-drive tuning. Smoother and more sensitive than a friction drive, it permits swift, accurate tuning and precise calibration. The micrometer dial has an effective scale length of twelve feet, direct-reading to one part in 500. The electrical characteristics are of the same high order, each of the four sections having low-loss Steatite stator insulation, insulated rotors and individual non-inductive rotor contacts.

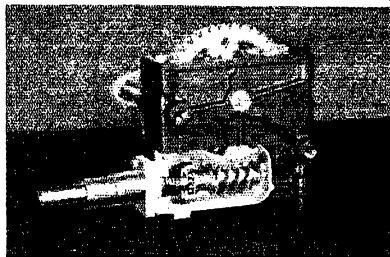

### GANGED PLUG-IN COILS CALIBRATED BAND-SPREAD

The plug-in coils of the HRO are ganged for easy handling, and individually shielded for stability. Used as general coverage coils, each range includes two amateur bands and the spectrum between. By a simple switching device, the same coils are changed to band spread the respective amateur bands, spreading them over a uniform span of 400 divisions. All ranges are accurately calibrated at the factory.

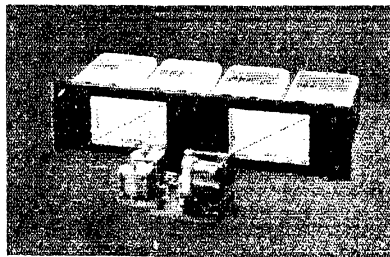

### HIGH PERFORMANCE CIRCUIT

The nine-tube circuit employed in the HRO is remarkable for level gain from 1.7 to 30 mc. Two stages of tuned R.F. amplification preceding the tuned detector provide the notable signal-to-image ratio of 1000 to 1 at 14 mc., as well as exceptional usable sensitivity. The HRO is designed for either double or single wire antenna. Other features include separate audio and R.F. gain control, AVC, Beat Frequency Oscillator, Signal Strength Meter, Phone Jack and B-voltage switch.

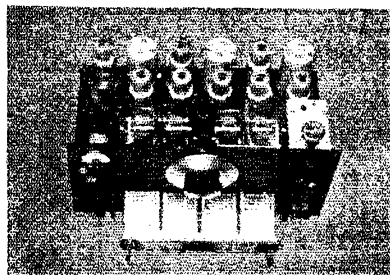

# THE H R O SINGLE SIGNAL SUPERHET

**NATIONAL COMPANY  
MALDEN, MASS.**

# NOW

# \$4<sup>50</sup>

DESIGNED ESPECIALLY  
FOR THE AMATEUR  
★ THE NEW RCA 801 ★

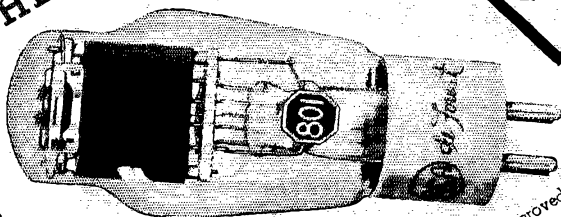

The RCA 801 is a new transmitting tube of improved design and construction. Interchangeable with the type 10 in amateur transmitters, the RCA 801 is capable of considerably greater plate dissipation and output and is rated at 600 maximum plate volts. ¶ Incorporating many advanced features of design, the RCA 801 will find ready application in and bring improved performance to amateur stations. ¶ The RCA 801 may be operated under maximum rated conditions of input at frequencies up to and including 60 megacycles. ¶ For characteristics and technical information on the RCA 801, or other RCA types, see your RCA de Forest Distributor, or write to:



*de Forest* AMATEUR RADIO DIVISION  
RCA RADIOTRON COMPANY, INC.  
CAMDEN NEW JERSEY