

February, 1938
25 cents

QST

devoted entirely to

amateur radio

In this issue—

- Simplified
Transmitter
Designs**
- Coaxial
Feeder
Construction**
- Television
Sweep
Circuits**



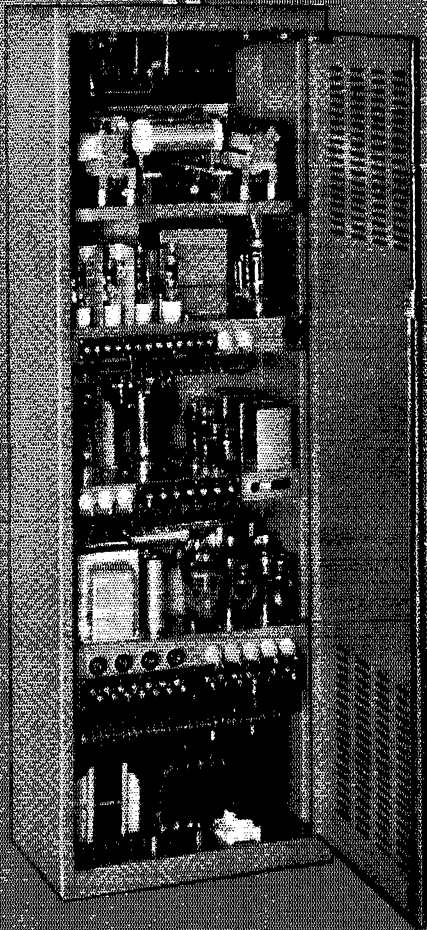

We Think We Have Done a Very Good Job With the 30J.

Mechanical details which we have had in mind have been perfected and many useful gadgets and niceties have taken form. For instance, the r-f output circuit is built as an integral assembly on a machined cast aluminum frame. Excitation tank circuits are "pre-tuned" units which are plugged in and adjusted through the front door. The cabinet with its inter-locked doors is a very neat job. Electrically, the 30J Transmitter has every refinement and desirable feature which our long experience has suggested. The output is 250 full sized watts, and the set works as smoothly at 60mc. as it does at 1.5mc.

COLLINS RADIO COMPANY

CEDAR RAPIDS, IOWA - NEW YORK, N.Y. 11 WEST 42 ST.

Say You Saw It in QST — It Identifies You and Helps QST



*Announcing
the*

SKY CHALLENGER II

With the New Hallicrafters Infinite Image Rejector

the hallicrafters inc., 2611 Indiana Ave., Chicago, U.S.A. • Cable Address: HALLICRAFT, Chicago

WORLD'S LARGEST BUILDER OF AMATEUR COMMUNICATIONS RECEIVERS

*Patent Applied For

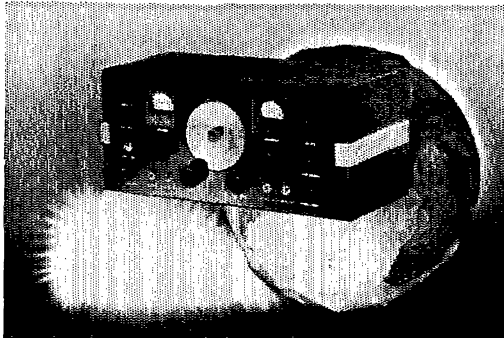

the SKY CHALLENGER II

*With the New Hallicrafters Infinite Image Rejector**

A FEW DAYS AGO, Hallicrafters' dealers throughout the country received their first models of the Sky Challenger II.

My associates and I are proud to offer this receiver to the amateur radio world, not as just another new receiver, but as a definite contribution to amateur radio. The New Sky Challenger, like most new Hallicrafters' models, incorporates not only all the usual features of a communications receiver with a new and higher standard of performance, but several exclusive developments that have never before been offered on any receiver at a comparable price. It includes the new Hallicrafters Infinite Image Rejector, that eliminates annoying image interference, especially prevalent

on the 10 and 20 meter bands, and that offers a quality of reception that will add a new thrill to any QSO. It is needless to point out the advantages of this device to any experienced amateur. Also included is the same famous 1000° Spiral Band Spread System used on the SUPER SKYRIDER and many other refinements in design that make the Sky Challenger II an outstanding value at a new low price.

We, at the Hallicrafters, wish to extend our personal invitation to all radio amateurs, to visit their dealer and inspect the New Sky Challenger II.

W. J. Halligan
Pres.

- ★ Tubes
- ★ Infinite Image Rejector
- ★ Recessed Main Tuning Dial
- ★ 1000° Spiral Band Spread

- ★ 38 MC to 540 KC (7.9 to 545 meters)
- ★ Iron Core I.F.'s

- ★ "S" Meter Terminals
- ★ Doublet or Marconi Antenna
- ★ Crystal Filter Circuit

*Patent Applied For

the hallicrafters inc.

2611 Indiana Ave., Chicago, U. S. A. • Cable Address: HALLICRAFT, Chicago

WORLD'S LARGEST BUILDER OF AMATEUR COMMUNICATIONS RECEIVERS

QST

devoted entirely to

AMATEUR RADIO

PUBLISHED, MONTHLY, AS ITS OFFICIAL ORGAN, BY THE AMERICAN RADIO RELAY LEAGUE, INC., AT WEST HARTFORD, CONN., U. S. A.; OFFICIAL ORGAN OF THE INTERNATIONAL AMATEUR RADIO UNION

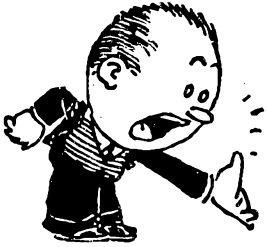

FEBRUARY
1938

Volume XXII
Number 2



Kenneth B. Warner, General Manager of A.R.R.L. Publications; Ross A. Hull, Editor; James J. Lamb, Technical Editor; George Grammer, Assistant Technical Editor; Clark C. Rodimon, Managing Editor; David H. Houghton, Circulation Manager; Ralph T. Beaudin, Assistant Circulation Manager; F. Cheyney Beekley, Advertising Manager; Charles Brunelle, Assistant Advertising Manager.

Editorial and Advertising Offices

38 La Salle Road
West Hartford, Connecticut

Subscription rate in United States and Possessions and Canada, \$2.50 per year, postpaid; all other countries, \$3.00 per year, postpaid. Single copies, 25 cents. Foreign remittances should be by international postal or express money order or bank draft negotiable in the U. S. and for an equivalent amount in U. S. funds.

Entered as second-class matter May 29, 1919, at the post office at Hartford, Connecticut, under the Act of March 3, 1879. Acceptance for mailing at special rate of postage provided for in section 1103, Act of October 3, 1917, authorized September 9, 1922. Additional entry at Concord, N. H., authorized February 21, 1929, under the Act of February 28, 1925.

Additional second-class entries to cover sectional editions authorized March 20, 1935. Copyright 1938 by the American Radio Relay League, Inc. Title registered at United States Patent Office.

The Contents

Editorial	7
Future DX and the Ionosphere Trends <i>George Grammer, W1DF</i>	8
The First Interamerican Radio Conference <i>K. B. Warner, W1EH</i>	9
A Low-Cost 100-Watt Transmitter <i>Vernon Chambers, W1JEQ</i>	12
A Regenerative Receiver with High Audio Selectivity <i>F. Malcolm Gager and Arthur F. Graham</i>	16
Inexpensive Coaxial R.F. Transmission Line <i>Douglas A. Smith, W2BZR</i>	19
28-Mc. Preselection <i>James Millen, W1HRX and Dana Bacon, W1BZR</i>	21
The "QSL Forty" <i>Fred Sutter, W8QBW</i>	24
A.R.R.L.'s Tenth International DX Competition <i>F. E. Handy, W1BDI</i>	26
What the League Is Doing	29
Plate Modulation of Screen-Grid Tubes <i>Francis M. Dukat, W1BOD</i>	30
Cairo. Part II <i>A. L. Budlong</i>	32
Grid-Controlled Rectifiers for Amateur H.V. Supplies	34
Army-Amateur Radio System Activities	35
Navy Day Competition — 1937	36
Sweep Circuit Considerations in the Television Receiver <i>Marshall P. Wilder, W2KJL</i>	38
How Would You Do It?	42
A Simple 56-Mc. Transmitter with Cathode-Bias Modulation <i>Everett C. Geiger, W2FZQ and Edward McGrath, W2GNL</i>	44
The Harmonic Tank Circuit <i>B. P. Hansen, W9KNZ</i>	45
Television Transmissions from Los Angeles	47
A Statement from Hygrade-Sylvania	47
Hints and Kinks	48
I.A.R.U. News	51
Operating News	53
Correspondence Department	61
A.R.R.L. QSL Managers	106
Hamads	123
QST's Index of Advertisers	126

Section Communications Managers of the A.R.R.L. Communications Department

All appointments in the League's field organization are made by the proper S.C.M., elected by members in each Section listed. Mail your S.C.M. (on the 16th of each month) a postal covering your radio activities for the previous 30 days. Tell him your DX, plans for experimenting, results in 'phone and traffic. He is interested, whether you are an A.R.R.L. member or get your QST at the newsstands; he wants a report from every active ham. If interested and qualified for O.R.S., O.P.S. or other appointments he can tell you about them, too.

			ATLANTIC DIVISION		
Eastern Pennsylvania	W3QP	John Buck Morgan	8527 Germantown Ave.	Chestnut Hill, Philadelphia	
Maryland-Delaware-District of Columbia	W3BAK	Edgar L. Hudson		Laurel, Delaware	
Southern New Jersey	W3BET	W. W. Wilson	247 E. Atlantic Ave.	Audubon	
Western New York	W8CSE	Ed Preston	10 Lincoln Ave.	Fully	
Western Pennsylvania	W8OFO	Kendall Speer, Jr.		Lower Merion	
			CENTRAL DIVISION		
Illinois	W9KJY	L. John Huntoon	327 Brandon Ave.	Glen Ellyn	
Indiana	W9OG	Noble Burkhart	R. 4, Box 1	Indianapolis	
Kentucky *	W9ARUJ	Darrell A. Downard	116 N. Longworth Ave.	Louisville	
Michigan	W8DPE	Harold C. Bird	R. F. D. 2	Pontiac	
Ohio	W8AQ	E. H. Gibbs	405 Broad St.	Wadsworth	
Wisconsin*	W9UIT	Aldrich C. Kraines	3288 S. Illinois Ave.	Milwaukee	
			DAKOTA DIVISION		
North Dakota	W9RZA	Ernest Bloch	Box 202	Thompson	
South Dakota	W9SEB	Andrew J. Esar	221 West Prospect Ave.	Pierre	
Northern Minnesota	W9IGZ	Edwin L. Wicklund	R. F. D.	Kensington	
Southern Minnesota	W9DCM	Webster F. Soules	3549 36th Ave., So.	Minneapolis	
			DELTA DIVISION		
Arkansas	W5ABT	H. E. Velte	4415 West 12th St.	Little Rock	
Louisiana	W5DKR	Eugene H. Treadaway	2749 Myrtle St.	New Orleans	
Mississippi *	W5GHF	Robert E. Barr		Memphis	
Tennessee	W4DEP	B. G. Lowrey Smith	673 Hillcrest St.		
			HUDSON DIVISION		
Eastern New York	W2LU	Robert E. Haight	511 South Holmes St.	Scotia	
N. Y. C. & Long Island	W2AZV	E. L. Banauch	102 Central Ave.	Massapequa, L. I.	
Northern New Jersey	W2GMN	Fred C. Read	1014 North Ave.	Elizabeth	
			MIDWEST DIVISION		
Iowa *	W9LEZ	Phil D. Boardman	325 Kirkwood Blvd.	Davenport	
Kansas	W9PTE	Harry E. Legler	304 Miami St.	Hiawatha	
Missouri	W9OJD	Miss Letha Altendorf	1015 W. 3rd St.	Joplin	
Nebraska	W9FAM	Samuel C. Wallace	Green St.	Clarks	
			NEW ENGLAND DIVISION		
Connecticut	W1CTI	Frederick Ellis, Jr.	19 Merrill Rd.	Norwalk	
Maine	W1EFB	Winfield A. Ramadell	1188 Washington Ave.	Portland	
Eastern Massachusetts	W1IWC	Sam Gross	Pleasant St.	Lowell Hills	
Western Massachusetts	W1IAH	William J. Barrett	239 Columbia St.	Adams	
New Hampshire	W1BFT	Carl B. Evans	80 No. State St.	Concord	
Rhode Island	W1HRC	Clayton C. Gordon	192 Washington Ave.	Providence	
Vermont	W1GNF	Alvin H. Battison	1 Central St.	Windsor	
			NORTHWESTERN DIVISION		
Alaska	K7ENA	Leo E. Osterman	Customhouse	Wrangell	
Idaho	W7EMT	Carl Eichelberger	2810 North 26th St.	Spokane	
Montana *	W7CRE	Dick Beasley	446 Edith St.	Missoula	
Oregon	W7ATV	Eugene N. Lovejoy	3013 N. E. Clackamas	Portland	
Washington	W7WY	Robert H. Voraw	Route 1, Box 398	Vancouver	
			PACIFIC DIVISION		
Hawaii*	K6OQE	Harold C. Smith	P. O. Box 150	Honolulu	
Nevada	W6BIC	Edward W. Heim	309 Claremont St.	Reno	
Santa Clara Valley	W6FBW	Elbert Amarantes	454 Washington St.	San Jose	
East Bay	W6JIV	Harold J. Burchfield	2240 106th Ave.	Oakland	
San Francisco	W6SG	Alan D. Whittaker, Jr.	79 Elinor Ave.	Mill Valley	
Sacramento Valley	W6GZY	J. L. C. Buckenham	2931-23th St.	Sacramento	
Philippines	KA1GR	George L. Rickard	Box 849	Manila	
San Joaquin Valley	W6LPE	Angelo V. Astone	729 Safford	Fresno	
			ROANOKE DIVISION		
North Carolina	W4OG	H. S. Carter	P. O. Box 111	Winston-Salem	
South Carolina	W4BDE	Ted Ferguson	1213 College St.	Columbia	
Virginia	W3IWA	Charles M. Waff, Jr.	2014 Monument Ave.	Richmond	
West Virginia	W8HD	C. S. Hoffmann, Jr.	47 Lynwood Ave.	Wheeling	
			ROCKY MOUNTAIN DIVISION		
Colorado	W9FA	Glen Glasscock	2164 So. Corona St.	Denver	
Utah-Wyoming	W7COH	Townsend J. Rigby		Midwest, Wyoming	
			SOUTHEASTERN DIVISION		
Alabama	W4DGS	James F. Thompson	102 Narrow Lane Rd.	Montgomery	
Eastern Florida	W4DVO	L. A. Connolly	719 So. Willow Ave.	Tampa	
Western Florida	W4BSJ	Ellis R. Curry	Box 425	Madison	
Georgia-Cuba-Isle-of-Pines-Porto Rico-Virgin Islands	*W4PM	Charles W. Davis	2156 N. E. Boulevard Dr.	Atlanta Ga.	
			SOUTHWESTERN DIVISION		
Los Angeles	W6GXM	Don M. Draper	4421 West 63 St.	Los Angeles	
Arizona	W6KFC	Victor C. Clark	747 E. Park St.	Phoenix	
San Diego	W6JRM	Howard K. Breedlove	R. 2, Box 636	San Diego	
			WEST GULF DIVISION		
Northern Texas	W5DXA	Lee Hughes	125 N. Main St.	Childress	
Oklahoma	W5CEZ	Carter L. Simpson	2010 So. 4th St.	Ponca City	
Southern Texas	W5BHO	Dave H. Calk	6726 Ave. Q	Houston	
New Mexico	W5CGJ	Joseph M. Eldodt		Chamita	
			MARITIME DIVISION		
Maritime	VE1DQ	A. M. Crowell	69 Dublin St.	Halifax, N. S.	
			ONTARIO DIVISION		
Ontario	VE3SG	Fred H. B. Saxon	302 Lee Ave.	Toronto, Ont.	
			QUEBEC DIVISION		
Quebec	VE2EE	Stan Comach	780 Brault Ave	Verdun, P. Q.	
			VANALTA DIVISION		
Alberta *	VE4GD	Jas. Smalley, Jr.	611 First Ave., N. W.	Calgary	
British Columbia	VE5HP	James Hepburn	335 Foul Bay Road	Victoria	
			PRAIRIE DIVISION		
Manitoba	VE4RG	A. J. R. Simpson	635 Garfield St.	Winnipeg	
Saskatchewan	VE4EL	Wilfred Skaife	2040 McTavish St.	Regina	

* Officials appointed to act until the membership of the Section choose permanent S.C.M.'s by nomination and election.

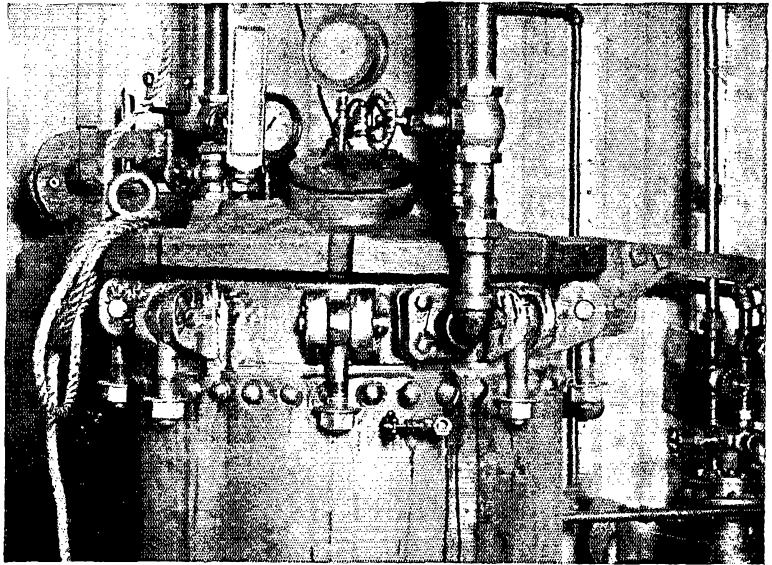

Kandid Ken-O-Talk, No. 3

• IMPREGNATION •

LET us quote the old adage that "A chain is no stronger than its weakest link." Inasmuch as impregnation is one of the most important links in the life of a transformer, the following procedure will explain the care which is taken by us to make all links strong. We all know that paper insulation and cotton contain moisture at all times, the amount depending upon the humidity of the atmosphere.

Every coil is put in a ventilated oven for a period of 12 hours and pre-heated to drive off the bulk of the moisture. The coils are then placed in a large vacuum tank at a higher temperature where the remainder of the moisture is drawn off with a powerful pump capable of a vacuum of 29.75 inches. After this vacuum is attained, hot varnish is allowed to flow in the vacuum tank, completely covering the coils, maintaining all the time the 29.75 inches of vacuum. After this the vacuum is released and pressure of 100 lbs. per square inch is applied to force the varnish into all the possible crevices.

The varnish is then drawn off and the coils drain and dry in the vacuum tank for five hours, with a vacuum of 29.75 inches imposed on them once every hour.

The next step is to place these coils in an oven for 12 hours for their final drying and heat treatment.

From the preceding paragraphs it will be noted that all coils are under a continuous heat treatment for a period of 36 hours, thereby insuring our users of transformers that they have had a transformer's worst enemy (moisture) taken away, and sealed out by a protective coating of varnish baked into the coil. Following this the coils are laminated and clamped, then heated again for four hours to get rid of the surface moisture on all metal parts and are placed in their containers and poured with compound, while hot.

F. P. Kenyon

The American Radio Relay League



THE AMERICAN RADIO RELAY LEAGUE, INC., is a non-commercial association of radio amateurs, bonded for the promotion of interest in amateur radio communication and experimentation, for the relaying of messages by radio, for the advancement of the radio art and of the public welfare, for the representation of the radio amateur in legislative matters, and for the maintenance of fraternalism and a high standard of conduct.

It is an incorporated association without capital stock, chartered under the laws of Connecticut. Its affairs are governed by a Board of Directors, elected every two years by the general membership. The officers are elected or appointed by the Directors. The League is non-commercial and no one commercially engaged in the manufacture, sale or rental of radio apparatus is eligible to membership on its board.

"Of, by and for the amateur," it numbers within its ranks practically every worth-while amateur in the nation and has a history of glorious achievement as the standard-bearer in amateur affairs.

Inquiries regarding membership are solicited. A bona fide interest in amateur radio is the only essential qualification; ownership of a transmitting station and knowledge of the code are not prerequisites. Correspondence should be addressed to the Secretary.

HIRAM PERCY MAXIM, FIRST PRESIDENT

OFFICERS

President.....EUGENE C. WOODRUFF, W8CMP
State College, Pa.

Vice-President.....GEORGE W. BAILEY, W1KH
Weston, Mass.

Secretary.....KENNETH B. WARNER, W1EH
West Hartford, Connecticut

Treasurer.....ARTHUR A. HEBERT, W1ES
West Hartford, Connecticut

Communications Mgr....F. EDWARD HANDY, W1BDI
West Hartford, Connecticut

General Counsel.....PAUL M. SEGAL
1026 Woodward Building, Washington, D. C.

Address all general correspondence to the administrative headquarters at West Hartford, Connecticut

DIRECTORS

President
EUGENE C. WOODRUFF.....W8CMP
234 W. Fairmount Ave., State College, Pa.

Vice-President
GEORGE W. BAILEY.....W1KH
74 Webster Road, Weston, Mass.

Canadian General Manager
ALEX REID.....VE2BE
169 Logan Ave., St. Lambert, P. Q.

Atlantic Division
WALTER BRADLEY MARTIN.....W3QV
Box 612, Roslyn, Pa.

Central Division
R. H. G. MATHEWS.....W9ZN
100 East Ohio St., Chicago

Dakota Division
FRED W. YOUNG.....W9M2N
228 1/2 Willard St., Mankato, Minn.

Delta Division
E. RAY ARLEDGE.....W5SI
P. O. Box 286, Pine Bluff, Ark.

Hudson Division
KENNETH T. HILL.....W2AHC
115 Willow St., Douglaston, L. I., N. Y.

Midwest Division
FLOYD E. NORWINE, JR.....W9EFC
120 South Fourth St., St. Louis, Mo.

New England Division
PERCY C. NOBLE.....W1BVR
37 Broad St., Westfield, Mass.

Northwestern Division
RALPH J. GIBBONS.....W7KV
c/o United Air Lines, Pendleton, Ore.

Pacific Division
J. L. McCARGAR.....W6EY
66 Hamilton Pl., Oakland, Calif.

Koanoke Division
H. L. CAVENESS.....W4DW
State College Station, Raleigh, N. C.

Rocky Mountain Division
EDWARD C. STOCKMAN.....W9ESA
618 So. Williams St., Denver

Southeastern Division
BENNETT R. ADAMS, JR.....W4APU
1512 Grove Place, Homewood, Ala.

Southwestern Division
CHARLES E. BLALOCK.....W6GG
443 Main St., El Centro, Calif.

West Gulf Division
WAYLAND M. GROVES.....W5NW
c/o Humble Pipe Line, Talco, Texas



THE EDITOR'S MILL

IT HAS always seemed a pity to us that some bright fellow didn't have the idea, 'way back when, of making a series of disc recordings of the ham bands at intervals of a year or so with the particular idea in mind of building a history of the progress of ham transmitting and receiving technique. It would surely be good if, in one of our relatively morbid moments, when we feel that there is still so much rotten in the game, we could crank up the machine and listen to a cold, clear winter night in 1924. The mess of blurry, squashy notes spluttering across the dial of our hopelessly broad-tuning receiver would most certainly jerk us into the realization that, in spite of all the things still left undone, we have taken terrific strides in the basic business of putting signals on the air and getting them out of it. This may seem a trite sort of observation, particularly since we have so recently been crabbing about the infernal complexity of modern ham equipment. But it is an inescapable fact and one that's good to think about.

It so happens, of course, that we have no recordings of the old-time signals, and without them we find our recollection of earlier days unavoidably rose-tinted by fond thoughts of problems licked and impossibilities achieved. But a good makeshift is to tune somewhere up above 14 Mc. and park for a few minutes on one of the available diathermy signals, preferably using a good old detector and two-step for the job. One then only has to think of a series of ham bands populated by hideous noises of this kind, interspersed with raspy r.a.c. notes and twittery near-d.c. burbles slithering across channel after channel, in order to get the idea fairly accurately. For even in 1925, impossible though it now seems, raw a.c. as a plate supply was widely used even by the crack stations of the day. Rectifier tubes, let alone filter condensers, were expensive luxuries available only to the few. Crystal control was virtually unknown. As to 'phone, unfortunately there is no satisfactory way to gain a picture of the best 'phone signals of even ten years ago. Some of the poorest transceivers still to be heard on the ultra-high frequencies may bear some points of similarity but they are surely much too good.

No, the historical recordings don't exist and even our keenest recollections are distorted. But

no ham who was close to the technical problems of earlier periods can possibly tune across to-day's bands without getting some semblance of a warm feeling around the cockles of his heart. The amateur has done a miraculous technical job. Exceptions will always rise to plague us but, by and large, the ham gives an example to the world of just how signals should be sent and received.

I'M GOING to revert now to the first-person-singular long enough to make an announcement of some interest to our readers. It's easier that way because it is a subject pretty close to me.

If you'll inspect the mast-head of this issue you'll notice that *QST* has a new editor. I have named Mr. Ross A. Hull, long our associate editor, as the editor of *QST*. I retain for myself a title based upon the specification of the League secretary's duties in our constitution, that of general manager of A.R.R.L. publications. Since that first dim year back in the early 20's when *QST*'s staff first embraced more than one editor, I have been known as the editor-in-chief. For many years that was a perfectly proper description of my editorial duties, but for the last several years it has not been accurate. We have, I think, the most competent editorial staff with which ever a magazine was blessed, and it handles things in its stride. The stage in our development has been reached where I am no more the editor-in-chief of this journal than I am its advertising manager or its circulation manager or its credit manager—all of which I used to be. Mr. Hull has been in fact its chief editor for years back, as he has been of the *Handbook*, so let us put the credit where it is due.

Ross Hull needs no introduction to *QST* readers. He is as ardent and as complete an amateur as I have ever known. He tears into new ideas with an unbelievable fervor. In 1928 he directed with magnificent success our special technical program which developed new apparatus and methods to meet the technical restrictions which came upon us in 1929 when the Washington Convention took effect. He is largely responsible for the successful amateur attack on the ultra-high frequencies and his personal investigations in that field have brought him to world eminence. He was the first to demonstrate the bending of

such waves in the lower atmosphere as a function of meteorological conditions, and to establish a correlation between u.h.f. reception and air-mass weather phenomena. He has versatility and brilliance as well as the splendid old amateur spirit and plenty of editorial experience. Somewhere in this country there's a firm named Ross that makes steering gears for large trucks. Some years ago they published an advertisement that illustrated the use of their equipment under particularly trying conditions and they headed it with the slogan "Ross steers these difficult jobs with ease." Better bywords for Ross Hull could not be imagined; they describe him perfectly.

Let no one think this is my valedictory speech to *QST*. Of all the activities of the A.R.R.L. staff *QST* is my first and greatest love. It always will be. And as I said above, this is not a change in

QST personnel; it is a simple recognition of the facts that have existed for some years. I shall continue not only to worry as *QST*'s business manager but, as secretary of the League, to act as the intermediary between the Board of Directors and the staff to insure the pursuit of editorial policies in accordance with the Board's wishes and shaped to meet our members' needs under changing conditions. There are doubtless some readers of this great journal of the American shack whose hearts, as they read these lines, leap with the hope that they are hereafter to find a new writer of this page. But not so, OM's. I shall also continue my monthly effort to concoct words of cheer, warning or quasi-wisdom for this page, with the w.k. Bud pinch-hitting here in my absences; without that, I admit, I'd feel quite excommunicated. So I'll BCNU.

K. B. W.

Future DX and Ionosphere Trends

By George Grammer,* W1DF

ALTHOUGH there probably isn't much we can do about it, it is interesting now and then to sit down and speculate about probable future DX conditions, basing our speculations on the expected behavior of the ionosphere in the years immediately before us. The future is not an entirely uncharted sea, but neither is our coming voyage wholly over familiar waters.

As most amateurs know, it is generally accepted that long distance transmission is possible because of the existence of an ionized region, called the ionosphere, in the upper atmosphere. Radio waves entering this region are refracted, or bent, to an extent depending upon the frequency and the density of ionization. The ionosphere actually is divided into several strata, each "layer" being more or less effective in refracting or reflecting waves of different frequencies. The subject was covered quite thoroughly in Dr. Kenrick's paper in September, 1936, *QST*,¹ which every amateur interested in long-distance transmission ought to read.

The state of the ionosphere has been definitely correlated with sunspot activity through observations made over a considerable period of years. The critical frequencies of the F_2 layer²—the layer of chief interest for DX transmission on 14

Mc. and higher—show marked increases with increases in the number of sunspots, and since the F_2 critical frequency is a measure of the highest frequency on which communication over long distances is possible, it follows that the greater the sunspot activity the better conditions will be for 14-, 28- and even 56-Mc. DX work. Conversely, when sunspots are relatively few the critical frequencies are lower and transmission conditions on the higher frequencies are poor. So much for a rather hasty review.

Now scientists have been looking at the sun for hundreds of years, and it is known that sunspot activity rises and falls in regular cycles. Between any two periods of maximum or minimum activity there is an average stretch of about eleven years; the actual time between maxima has been known to be as short as seven and as long as seventeen years. The alternative periods are not exactly similar, so that identical conditions would not be expected to prevail at times eleven years apart. Nevertheless, the maxima and minima come and go with regularity, and radio transmission conditions can be expected to vary accordingly. Hence the assertion that the future is not entirely uncharted.

Getting down to dates, the last sunspot minimum occurred about 1933. It is impossible to be very specific—or even to limit the time to one year—because the maxima and minima are quite broad; the curve is filled with irregularities

(Continued on page 120)

* Assistant Technical Editor, *QST*.

¹ G. W. Kenrick. "The Kennelly-Heaviside Layer," *QST*, September, 1936.

² These terms are explained in Dr. Kenrick's article.

The First Interamerican Radio Conference

Seventeen Nations at Habana Applaud and Support Amateur Radio—'Phone Bands Standardized—Friendly Message Traffic To Be Encouraged

By K. B. Warner,* W1EH

A NEW kind of conference has entered the life of the American radio amateur—inter-american radio conferences. The first of these has just been concluded at Habana as I write, and the second is scheduled for Santiago, Chile, in 1940. Being administrative conferences with the right to deal with frequencies and write regulations binding upon the signatory administrations, they will be of much importance to us—much more important, for example, than the meetings of the C.C.I.R. In authority they will fit midway between the world conferences (such as Madrid and Cairo) and the domestic regulations of each country, such as are written by our F.C.C. The Madrid Convention encourages regions to make regional arrangements that may deviate slightly from the world plan, provided interference is not caused to other regions. Of course there have been regional agreements in both North and South America before the Habana meeting, but never before one whose effect extended through all of the Americas.

The Habana conference was characterized by a very fine recognition of the value of amateur radio, a complete willingness to assign our frequency bands to us exclusively, and a whole-hearted pledge to support our bands at the Cairo conference. The nations there represented agreed to the present widths of the amateur bands and the portions thereof available for 'phone operation. Moreover—and I think this is strikingly important—with a few exceptions they all agreed to permit the interchange by amateurs of friendly messages on behalf of third parties, by a special arrangement that relaxes the restrictions of the present world regulations. The contrast of philosophies between the New World and the old was never better exemplified!

Representatives of seventeen nations assembled in Habana for this conference which lasted from November 1st to December 13th: Argentina, Brazil, Canada, Chile, Colombia, Cuba, Dominican Republic, Guatemala, Haiti, Mexico, Newfoundland, Nicaragua, Panama, Peru, United States of America, Uruguay and Venezuela. When the conference was concluded, four documents were signed by the delegates, all to become effective July 1, 1938. Two of these

are treaties requiring ratification by the governments: one a North American regional treaty concerning broadcasting on frequencies below 1600 kc., the other setting up a continuing inter-american arrangement for interchanging technical data and for holding future conferences. The other two documents are administrative agreements between the *communications administrations* of the respective countries, not requiring formal ratification by the *governments*. One of these deals with miscellaneous things, the most important item in which is the recommendations to the Cairo conference. The fourth deals with allocations and regulations on behalf of services operating on frequencies above 1600 kc. and is, therefore, of the highest interest to us. The Newfoundland representative was obliged to retire early from the conference, and the Argentine representative did not receive authority to sign, so that these two nations are not yet party to the compacts, but it is understood that they will announce their adherence. We understand that all the other nations signed all the documents.

With the Cuban government as gracious host, the conference was welcomed by the President of



R.C.C. LUNCHEON TO OA4Z AND W1EH

Officers and prominent members of the Radio Club de Cuba assembled for a luncheon given to Mr. Tudela, the Peruvian delegate, and Secretary Warner. Mr. E. Anca, president of the club, stands in white suit behind the club pennant.

Cuba at an opening plenary session held in the House of Representatives. Part of his remarks deserve quotation here. After discussing some of the problems before the conference he said:

"Finally, you are confronted by the question of radio amateurs, and with the responsibility of preparing their defense before the forthcoming world conference at Cairo. It is impossible to forget the extent to which radio amateurs can

*Secretary, A.R.R.L.

contribute towards the brotherhood of peoples. To them we also owe, from its beginning, the greater part of the progress made in the technique of radio-electric communications, as well as the discovery of the unlimited field of short waves. While defending them we no more than pay homage to the memory of Marconi, that amazing amateur who gave humanity his marvelous invention which, destroying the barriers for the exchange of thought, creates an intimate understanding amongst the peoples, linking them through arts and intellects."

This conference differed from any other I have ever attended in that the representatives of "private interests," of which I was one, were not permitted to participate but were present only as ob-



JUSTO MAHÍA Y RIVAS, CO-CM2JM

Chief of the transmitters' section of the Radio Club de Cuba and technical advisor on amateur matters to the Cuban delegation, photographed with K. B. Warner, W1EH, League Secretary, at the Habana Conference.

servers, permitted to sit at the back of rooms and listen; this was strictly a conference between government people. However, we "camp followers," as we called ourselves, were able to do very useful work by discussing matters with foreign delegates out of meetings, and in actively working with the members of the U.S.A. delegation who had our matters in tow. It will be different at future inter-american conferences, for the new arrangement setting up the Interamerican Radio Office provides that at future conferences we and the other representatives of recognized special interests will have deliberative voices, although, of course, the actual voting will be the privilege only of governments.

It is time to report some of the detailed results of the conference. Like any radio conferences to-day, the greater part of the energy of this one was consumed with broadcasting matters. Although doubtless a very important matter, it did not concern me and I did not have time to follow it, so there is nothing of importance I can tell you about it. A good starting point seems to be the recommendations to the Cairo conference.

There is now a pleasingly well-developed consciousness of the need for Pan-American unity in radio matters, particularly as before the rest of the world. This conference adopted a series of recommendations to the Cairo meeting, dealing with matters both technical and otherwise and

concerning numerous services. By a unanimous vote the American nations recommended that the 7-, 14-, 28- and 56-Mc. bands remain allocated as exclusive amateur bands for use all over the world; and they recommended that the Cairo conference continue the 1715-2000 and 3500-4000 kc. bands in regions other than Europe in their present status. This present status is a shared assignment between amateurs, fixed and mobile, but it is the intention of the American regions then to assign these bands exclusively to amateurs. The plans adopted with respect to a possible expansion of h.f. broadcasting at Cairo are such as to offer minimum hazard to our frequencies.

A conference such as the Habana one is important to us because it may yield or withhold certain lower frequencies within limits set by the world conferences. The Madrid regulations make certain frequency bands available for amateurs, but in some cases only on a permissive basis: they might be shared with other services. In any continent where there is a regional agreement it is necessary for that agreement to repeat the world-wide allocations before the individual nations are authorized to devote these bands to amateur use. Consequently it is good news of the first order that the administrative agreement signed at Habana assigns all the bands we now use from 1.75 Mc. to 60 Mc. exclusively for amateurs in every country participating. Moreover, they adopted "as a guide" the u.h.f. allocation which we recently reported as just adopted in the United States, which scheme includes the new amateur bands 112-118 and 224-240 Mc. Every amateur frequency may be used for c.w. telegraphy; this a sort of basic consideration. However, largely for our own good, they adopted recommendations addressed directly to us amateurs: "that the Administrations should point out the desirability that amateurs use the bands from 1750 to 2050 and from 3500 to 4000 kc. preferably for short-distance communication; that the Administrations recommend that the bands from 7000 to 7300 kc. and from 14,000 to 14,400 kc. should not be used for short-distance communication between amateur stations." Only one change was made in our allocations, and that one to which we had previously given our assent, as reported months ago in *QST*: the 1.75-Mc. band is to be changed in the Americas to 1750-2050 kc. instead of 1715-2000. Remember that non-harmonic "overhang" we have in our spectrum diagrams from 1715 to 1750? Well, it is going to be taken off the "left-hand edge" and put on the "right-hand edge" some day when the F.C.C. gets around to amending our domestic regulations.

In recent years there have been regional agreements in both North and South America. The North American one expired a few years ago. The South American one was originally negotiated in Buenos Aires in 1935 and, we believe, then related only to broadcasting matters. At a conference in

Rio de Janeiro in June of 1937, this agreement was revised and expanded to take effect the first of 1938. It covered not only broadcasting but several other services, including amateurs. It recognized and perpetuated all of the frequency bands we now use but opened all of them to 'phone operation except the frequencies 7150-7200 and 14,300-14,400 kc. The Habana conference had to take into account this Rio agreement. To make a long story short, the outcome is that the Rio agreement stands so far as concerns broadcasting as a South American regional proposition, but in all of its other manifestations, including amateur matters, it is abandoned and gives way to the new interamerican agreements of Habana.

The Habana conference, in my estimation, established a new mark for intelligence in international conferences by creating a sub subcommittee of "amateur experts" to deal with the amateur problems and make recommendations to it. The only thing the matter with the s.s.c. was that I wasn't a member of it myself—hi! There was the usual subdivision of work: the plenary session set up certain committees, including a technical one; the technical committee divided into broadcasting matters and matters other than broadcasting; the latter subcommittee, when an appropriate stage in its work was reached, set up the s.s.c. of amateur experts. This was headed by Señor Don Carlos A. Tudela of Peru, who happens to be OA4Z and the chief technical expert of the Peruvian administration. Its other members were Messrs. Gerald C. Gross, W3GG, of the F.C.C.; Eduardo Noguera, HK3EN, of Colombia; Don Fernando Sánchez A., Mexican inspector of radio; and Don Alfonso Hernandez Catá y Galt, chief of the Cuban radio laboratory. An excellent group it was, with a good appreciation of amateur problems. This was the group which recommended the reaffirmation of our bands and their defense at Cairo, and it was in this group that the very difficult question of subdividing the amateur bands for 'phone was considered and resolved. Cuban amateurs, through the *Radio Club de Cuba*, were active participants in the conference, and the amateur s.s.c. had the assistance of additional practical amateurs in the persons of Messrs. Justo Mahia, CM/CO2JM, Rafael Bordenave, CM2RW, and Lieut. Enrique S. Morales, of the Cuban signal corps, all of whom were members of the Cuban delegation.

This question of 'phone in fact was the main problem of the amateur committee. There was this Rio agreement, opening almost everything to 'phone, effective the first of the year. There was a rather widespread recognition that the Rio plan was unwise to an extreme. There was the existent hit-or-miss policy of the Latin countries, resulting in the distribution of 'phone signals at random through all the bands. Finally, there was the definite proposal originated by the Cuban government and backed by the Mexican government,

that 100 kc. of the 7000-7300 band be made available for 'phone in the Latin countries. This was the opening situation. The final decisions were as follows:

1.75-Mc. band is available in its entirety for 'phone, at the discretion of individual administrations. In the 3.5 band, only the frequencies be-

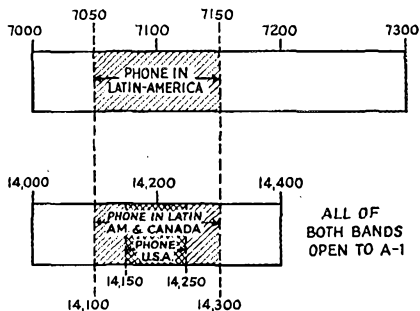

THE H.F. 'PHONE PROVISIONS OF THE I.R.C.

tween 3800 and 4000 are available for 'phone. In the 7-Mc. band the frequencies between 7050 and 7150 kc. may be assigned for 'phone work in the Latin-American countries but not in the United States, Canada or Newfoundland. In the 14-Mc. band, the frequencies between 14,100 and 14,300 kc. are available for telephony and may be so used in the Latin-American countries, Canada and Newfoundland. The United States obligates itself to confine telephony in this band to the present frequencies 14,150-14,250 at least until December 31, 1939. No mention of 'phone was made on frequencies above 28 Mc. The conference recommended to the governments that 'phone in the 14-Mc. band be permitted only after an adequate probationary period in which to acquire experience, plus a technical and practical test—in other words, that something like a Class A license be required.

The United States has no present intention of expanding 4-Mc. 'phone. This agreement simply means that all the nations undertake to have no 'phone operating below 3800 kc. in this band. Thus Mexican amateurs possibly may be permitted to operate between 3800 and 4000, and, of course, Canadian amateurs already enjoy 3750-4000. But after July 1st we are to be spared the murderous interference from Mexican and Canadian 'phone stations in the lower portion of this important traffic band: the Mexican 'phones will move up in the band and the Canadian 3500-3550 assignment will be eliminated.

The most illuminating characteristic of the Habana conference was the insight it provided the northern nations into the differences in communication which exist in the tropical and subtropical regions in all radio services. It seems to be a physical fact that their natural noise level is so

(Continued on page 68)

A Low-Cost 100-Watt Transmitter

Three-Band Rig Using 6L6's and Push-Pull 809's

By Vernon Chambers,* W1JEQ

NINE times out of ten the word "inexpensive," when used as a transmitter adjective, implies that the piece of gear is of the low-power variety. Now, however, several manufacturers are supplying us with tubes that permit moving these low-cost rigs up into the medium-power class. The transmitter to be described falls into this classification, since it will deliver at least 100 watts output, although costing only about twenty-five dollars to build, exclusive of power supply. A pair of new RCA 809's in the final, three-band operation with one crystal, inductive coupling between the driver and final stages and ease of construction are some of its features—besides low cost.

THE CIRCUIT

The circuit, shown in Fig. 1, uses a 6L6 Tri-tet oscillator followed by a 6L6 doubler, with either of these circuits, depending on the frequency, feeding into the push-pull 809's. For 3.5-Mc., the oscillator output is fed to the final grid circuit; on this band the doubler tube is entirely cut out. For 7- or 14-Mc. output all three stages are used, the doubler being excited at either the fundamental or second harmonic of the crystal frequency; the doubler drives the final grids at the output frequency.

The method by which the circuit changes for operation on different bands are brought about will become clear from inspection and comparison of Figs. 1 and 2. The actual coil form and socket connections for the oscillator and doubler are shown in Fig. 1, while Fig. 2 shows the essential r.f. circuits for the two sets of operating conditions. When a 3.5-Mc. coil is

used at L_3 , no coil is used in the L_2 socket. In this case the oscillator plate, through the coil form wiring indicated in Fig. 1, is connected to the primary coil of L_3 , while the 6L6 doubler plate is disconnected. With L_2 open, the doubler control-grid and screen circuits also are disconnected.

For 7- and 14-Mc., L_2 is plugged into its socket, when the jumpers in the coil form automatically connect the doubler control grid and screen in circuit. Either the 7- or 14-Mc. L_3 coil makes the proper connection to the doubler plate. The 3.5-Mc. L_3 coil should not be used when L_2 is in place. It will be noted that the primary of L_2 is tuned only on 3.5 Mc.; on the other two bands the primary is untuned.

The circuit is arranged so that the cathodes of the oscillator and doubler are keyed simultaneously. Since the 809's are high- μ tubes, their plate current is quite low at zero bias without excitation, and therefore no fixed bias is necessary to protect the tubes when the key is open.

THE OSCILLATOR

The oscillator circuit and constants are practically identical with those described on page 162 of the 1938 *Handbook*. Actually the only change is in the plug-in band-changing arrangement described above. Since the set is intended for use with 3.5-Mc. crystals, the cathode circuit has a fixed coil. It could be made plug-in if crystals ground for other bands are to be used. A 100,000-ohm gridleak is used to give good harmonic output. The plate voltage is dropped to a suitable value for the screen through resistor R_3 . An inexpensive 100- μ fd. receiving condenser provides feed-back control in the cathode circuit. By-passing has been made inexpensive by

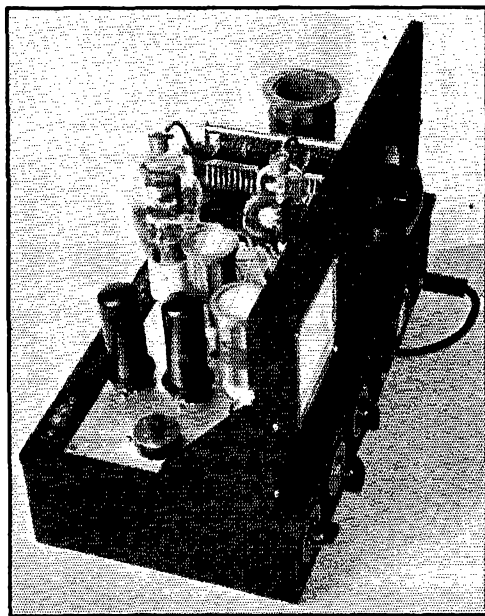

THIS INEXPENSIVE RIG WILL DELIVER BETTER THAN 100 WATTS ON THREE BANDS

A pair of 809's in push-pull is driven by 6L6's used as crystal oscillator and doubler.

*QST Laboratory Assistant.

the use of paper condensers. Desirable features of this type of oscillator are break-in keying and the fact that only one crystal is needed for three-band operation.

THE DOUBLER

As previously explained, the doubler goes into operation only when 7- or 14-Mc. output is desired from the amplifier. Its plate supply is from the same source as for the oscillator. The plate coil (primary of L_3) is an untuned affair closely coupled to the final grid coil (secondary of L_2). The screen resistor, R_4 , is connected between the screen grid and pin No. 2 on the oscillator plate coil socket, the d.c. connection being made by a jumper in the coil form when L_2 is plugged in. The grid coupling condenser, C_{15} , is connected to the No. 3 pin on the socket for L_2 ; a second jumper in the coil form completes the connection to the oscillator plate when L_2 is in the socket. C_{10} , C_{11} and C_{12} are the plate, screen and cathode by-pass condensers respectively. R_5 is the grid-leak resistor.

THE FINAL AMPLIFIER

The push-pull 809's are wired in the conven-

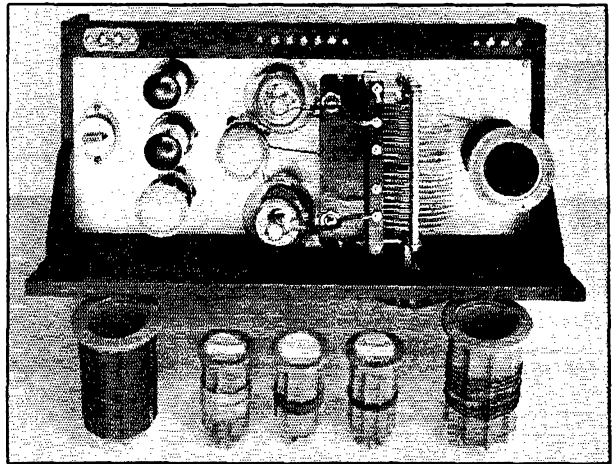

THE LAYOUT AND COILS ARE CLEARLY SHOWN IN THIS TOP VIEW

An aluminum sheet on the wooden baseboard substitutes for a metal chassis.

tional cross-neutralized circuit with split-stator plate tank condenser. Plug-in coils are used in both the final and grid circuits, and all by-passing is done with paper condensers. It is a common experience with symmetrical push-pull circuits to encounter parasitic oscillations, and this amplifier as originally laid out was no exception. In this

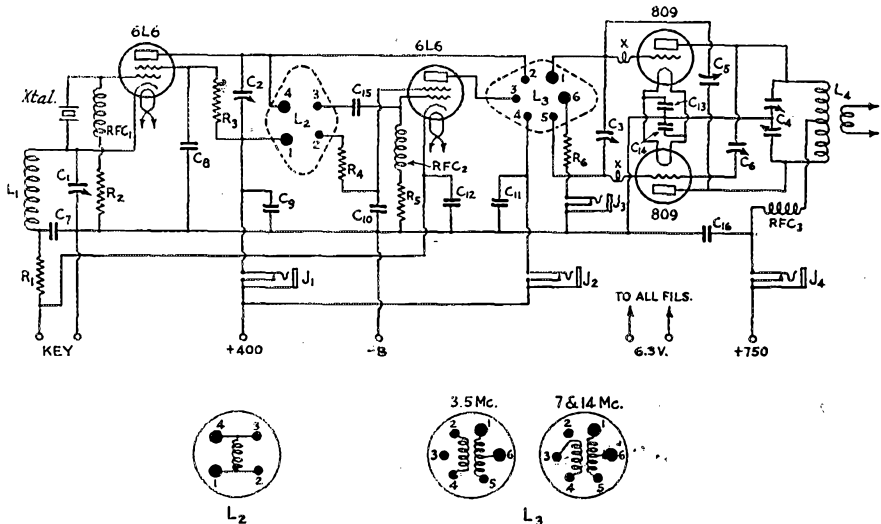

FIG. 1—TRANSMITTER CIRCUIT DIAGRAM

- L_1 —10 turns No. 16, diameter 1 inch, coil length $1\frac{1}{4}$ inches.
- L_2, L_3, L_4 —See coil table.
- C_1 —100- μ fd. receiving condenser (Star).
- C_2 —100- μ fd. receiving condenser (National SE-100).
- C_3 —50- μ fd. receiving condenser (National SE-50).
- C_4 —210 μ fd. per section, 0.07" air

- gap, split-stator (Cardwell XT-210-PD).
- C_5, C_6 —18- μ fd. neutralizing condensers (National STN).
- C_7 to C_{14} , inc.—0.01- μ fd. 600-volt paper (Aerovox 684).
- C_{15} —100- μ fd. mica (Aerovox 1468).
- C_{16} —0.002- μ fd., 1500-volt paper (Sprague SW-22).
- R_1 —400 ohms, 10-watt (Ohmite).

- R_2, R_5 —0.1-megohm, 1-watt (IRC).
- R_3 —25,000 ohms, 10-watt (Ohmite).
- R_4 —15,000 ohms, 10-watt (Ohmite).
- R_6 —1500 ohms, 10-watt (Ohmite).
- RFC_1, RFC_2 —2.5-mh. r.f. chokes (National R100).
- RFC_3 —Transmitting-type choke (Coto CI-20).
- J_1 to J_4 , inc.—Midget closed-circuit jacks (Utah).

case the insertion of a small coil in each grid lead, combined with a slight change in one of the neutralizing condenser leads, cured the oscillation; the lead was moved from the grid to the far side of the parasitic choke. Changing both leads, inci-

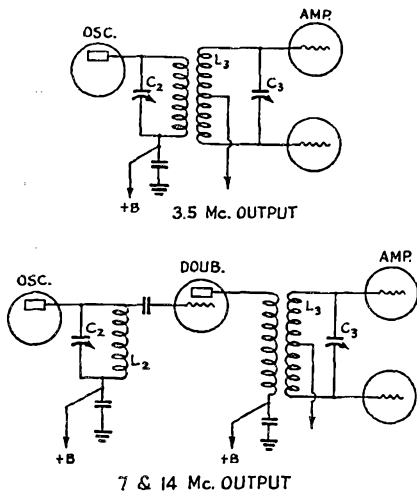

FIG. 2—THE ESSENTIAL R.F. CIRCUITS FOR OPERATION ON DIFFERENT FREQUENCY BANDS
The circuits are automatically switched when the coils are changed, as explained in the text.

dentally, only tended to bring the oscillation back again. The final arrangement of leads and chokes is shown in the circuit diagram, but it is quite likely that the reader may find a different arrangement desirable should parasites be encountered.

A closed-circuit jack is in the plus-B lead for metering; similar jacks are in the plate supply leads of both 6L6's. A fourth jack is in series with the final grid resistor. A 0-300-ma. meter, with cable and plug, permits current readings in any of the four circuits.

CONSTRUCTION

With cost and ease of construction the paramount considerations, the use of a metal chassis was given no more than a passing thought. Instead, a housing in the form of a breadboard layout was built up. Except for a thin sheet of aluminum along the top and a masonite panel along the bottom at the front, the housing is entirely of wood. The aluminum sheet allows better and shorter ground connections, while the masonite, being only a quarter-inch thick, permits easy mounting of receiving

condensers, jacks and meter. For the baseboard, panel, end pieces and panel brackets, clear $\frac{1}{2}$ -inch white pine is used. All of the necessary pieces may be cut from a $\frac{1}{2}$ by 12 inch board measuring not more than 60 inches long. These pieces are as follows: base $8\frac{3}{4}$ by 17 inches; end pieces, $8\frac{3}{4}$ by $3\frac{1}{2}$ inches; panel, 7 by 17 inches. The triangular-shaped panel brackets measure $3\frac{1}{2}$ by 4 by $5\frac{1}{4}$ inches. The aluminum, cut from $\frac{1}{32}$ -inch stock, is $6\frac{1}{4}$ inches wide by $16\frac{1}{8}$ inches long.

The small variable condensers, C_1 , C_2 and C_3 , the meter and the jacks are mounted on the masonite panel. The cathode condenser, C_1 , is at the left-hand side, $1\frac{3}{8}$ inches in from the edge. The oscillator plate and amplifier grid tuning condensers, C_2 and C_3 , are mounted in order to the right. The spacing is $2\frac{1}{8}$ inches between shaft centers. The meter, also centered vertically on the panel, is located 5 inches from the right-hand edge. The jacks are $\frac{3}{4}$ inch from the bottom edge, two on either side of the meter.

On top of the baseboard are the tube, coil and crystal sockets, the final tank and neutralizing condensers, and the terminal strips for power, keying and antenna connections. The sockets (National CIR) for the 809's and the oscillator and doubler coils are provided with small standoff insulators which permit mounting above the base with the aid of only one machine screw. Sub-base octal sockets are used for the two 6L6's. Old-type five-prong ceramic sockets are used for the crystal and final coil, the one for the coil on the metal pillars provided, and the other counter-sunk into the base. Holes are drilled along the rear edge of the base to accommodate the three terminal

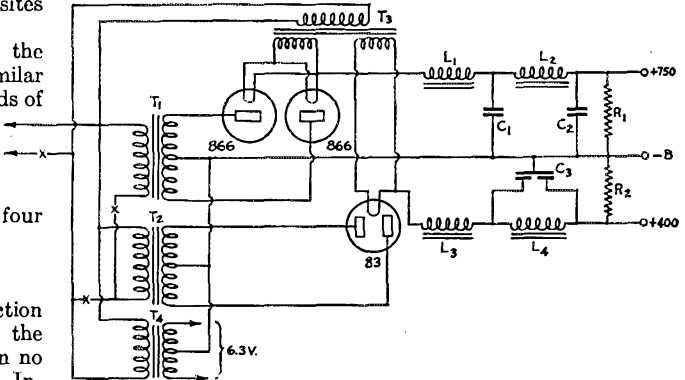

FIG. 3—SUGGESTED POWER SUPPLY DIAGRAM
T₁—Plate transformer, to deliver 750 volts d.c. at 200 ma. through choke-input filter (900 volts a.c. each side center-tap).
T₂—Plate transformer, to deliver 400 volts d.c. at 150 ma. through choke-input filter.
T₃—Rectifier filament transformer; 2.5 volts at 10 amp. for 866's; 5 volts at 3 amp. for 83.
T₄—Filament transformer, 6.3 volts at 7 amp. (See text).
L₁, L₂—Swinging choke, 5/20 henrys, 200 ma.
L₃, L₄—Smoothing choke, 12 henrys, 200 ma.
C₁, C₂—2- μ f. 1000-volt filter condensers.
C₃—Dual 8-8- μ f. electrolytic, 450-volt working.
R₁—20,000 ohms, 50-watt.
R₂—20,000 ohms, 25-watt.
Control switches, denoted by "X," are s.p.s.t.

strips. The ones in the corners are the keying and r.f. output strips while power leads are brought to the center one.

The actual layout can be seen plainly in the top-view photograph. A few details may prove helpful, since with one or two points located, the correct layout will follow naturally. The tank condenser is centered above the meter on the panel below. A hole is drilled to pass the shaft, 5 inches in from the right-hand end of the upper panel and 3 inches up from its bottom edge. The condenser mounting holes must then be drilled in the base so that the condenser is supported with the rotor plates swinging toward the right.

A bakelite shelf fastened to the tank condenser supports the neutralizing condensers. Running along the under side of the tank condenser is a long spacing rod held in place with a machine screw at either end. A strip of bakelite, 1½ inches by 5¾ inches, is clamped to the condenser by two angle brackets which are held in place by the spacing rod screws. The neutralizing condensers are mounted through holes drilled at either end of this shelf. All the wiring between C_4 , C_5 and C_6 should be done before the assembly is bolted to the panel, since this will avoid a great deal of poking and twisting later on. Leads going to the tubes and coil may be left floating temporarily.

The grid prongs of the 809 sockets should point toward the socket for L_3 to give short and symmetrical connections. The sockets should be placed so that the rotors of the neutralizing con-

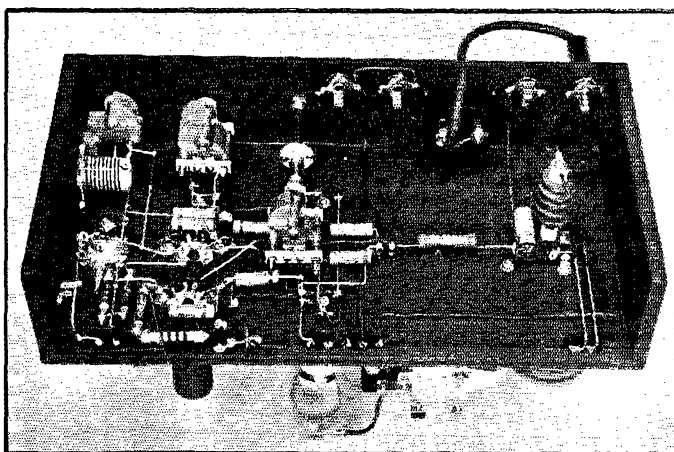

THE BOTTOM VIEW SHOWS PARTS AND WIRING
The dimensions of the set are such that it can easily be adapted for rack mounting.

densers will clear the tubes comfortably. The two 6L6's and the oscillator plate coil form a straight line between the front and rear of the base, the first tube toward the front being the oscillator tube. The crystal and L_3 sockets are to the left and right, respectively, of this line. At the far right is the socket for L_4 , the final tank coil.

All other parts are mounted below the base, as shown in the bottom-view photograph. The cathode coil is screwed to one of the wooden end pieces in a position close to the cathode condenser. The wiring should be as direct as possible, with ground connections going directly to the aluminum sheet. Soldering lugs slipped under any nut that holds a bolt in direct contact with the metal will be convenient ground connections.

COIL CONSTRUCTION

In describing the coils we shall refer to the various connections by their socket-prong numbers. These numbers, which appear on the diagrams, are as viewed from the tops of the sockets. Five coil forms are needed for the two 6L6 circuits; three of the forms are equipped with six prongs and the remaining two with four prongs. All coils are made with No. 20 d.s.c. wire, close-wound. The oscillator 3.5- and 7-Mc. coils (L_2) used in conjunction with the doubler are wound on the four-prong forms, with the ends of the winding going to the No. 1 and No. 4 prongs. When the windings have been completed jumpers are placed inside the form between Nos. 1 and 2 and 3 and 4.

The coils labelled L_3 are wound on the six-prong forms. As shown in Fig. 1, on 3.5 Mc. the plate winding is connected to the oscillator tube, while on 7 and 14 Mc. the corresponding winding is arranged to plug into the doubler plate circuit,

(Continued on page 64)

Coil Data	
L_2 and L_3	
3.5 Mc. L_2	Plate 45 turns No. 20 d.s.c., close-wound 1" diameter
	Grid 27 " " " " " " " 1½" "
3.5 Mc. L_3	Plate 22 " " " " " " " 1½" "
	Grid 12 " " " " " " " 1½" "
7 Mc. L_2	Plate 32 " " " " " " " 1" "
	Grid 12 " " " " " " " 1½" "
7 Mc. L_3	Plate 12 " " " " " " " 1½" "
	Grid 19 " " " " " " " 1" "
14 Mc. L_2	Plate 19 " " " " " " " 1" "
	Grid 6 " " " " " " " 1½" "
L_4	
3.5 Mc. 23 turns No. 16 enam. wire single-spaced 2¼" dia. 3" long	
7 Mc. 14 " " " " " " " 2¼" " 2¼" "	
14 Mc. 8 " " " " " " " 2¼" " 1½" "	

A Regenerative Receiver With High Audio Selectivity

A Tuned R.F. Unit Incorporating Some Unusual Features for Improved Performance

By F. Malcolm Gager* and Arthur F. Graham**

THE simple—though effective—r.f. receiver described here should appeal to the many amateurs who still get their thrills in amateur radio through the use of inexpensive equipment. Descriptive material for effective tuned r.f. receivers has been given in many publications too numerous to mention. The par-

parent that the conventional r.f. circuits were considerably affected by a swinging antenna, so that the beat note swept in and out of Selectosphere resonance. This difficulty was eliminated by the installation of a link circuit between the antenna input and the radio-frequency amplifier. An alternative circuit also is shown, and when used the L_2 's of each radio-frequency amplifier coil must be arranged to resonate with C_5 almost out.

Another unconventional addition is the use of a 6F5 as an audio amplifier with variable regenerative gain. This added gain is useful for both speakers, and particularly so with the Selectosphere. It will be noted that when the volume control in the grid circuit of this tube is in the minimum position the regenerative voltage fed back from the plate load circuit of the 6F5 is negligible. When the variable arm is moved toward the grid the regenerative action is brought into play, simultaneously with an increase in gain. The plate load of the 6F5 consists of a tuned circuit inductively coupled to the 6F5's grid, as indicated in the circuit diagram. The transformer used in the present receiver is a push-pull output

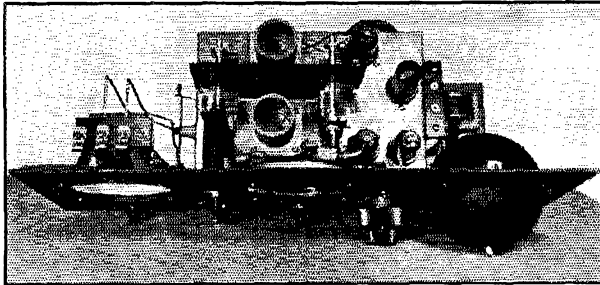

THE TOP VIEW OF THE RECEIVER SHOWS THE STRAIGHT-FORWARD R.F. LAYOUT
The chassis occupies about half the panel width; the remainder of the space is available for the two speakers.

ticular receiver about to be described has, in addition to the regularly accepted components,¹ several advantageous features which were necessitated by the incorporation of a high-selectivity amplitude-limiting acoustical unit, the Selectosphere,² as an integral part of the receiver. Ordinarily, with a high-selectivity acoustic device of Selectosphere character, it would not be considered good practice to permit mechanical coupling to the remainder of the receiver, yet the design and construction shown in this paper have proved very satisfactory.

Fig. 1 is the wiring diagram of the receiver proper; Fig. 2 the detailed output switching circuit. With the Selectosphere in use it became ap-

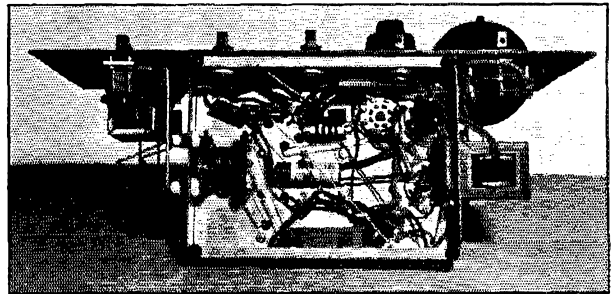

A BELOW-CHASSIS VIEW
The r.f. input transformer, L_sL_s , is mounted at the left edge of the chassis alongside the feedthroughs. The antenna condenser, C_5 , is at the left on the panel. The revamped transformer which gives regeneration in the first audio stage is fastened to the right-hand chassis edge.

* Dept. of Physics, Boston College, Chestnut Hill, Mass.

** Selectosphere Company, Box 3, Newtonville, Mass.

¹ The fundamental circuit diagram is similar to that given on page 117, *The Radio Amateur's Handbook*, Fifteenth Edition.

² *Radio*, October, 1936.

transformer from a Jensen D8G with the voice coil winding removed and about 60 turns replaced for a tickler coil. The polarity of this coil

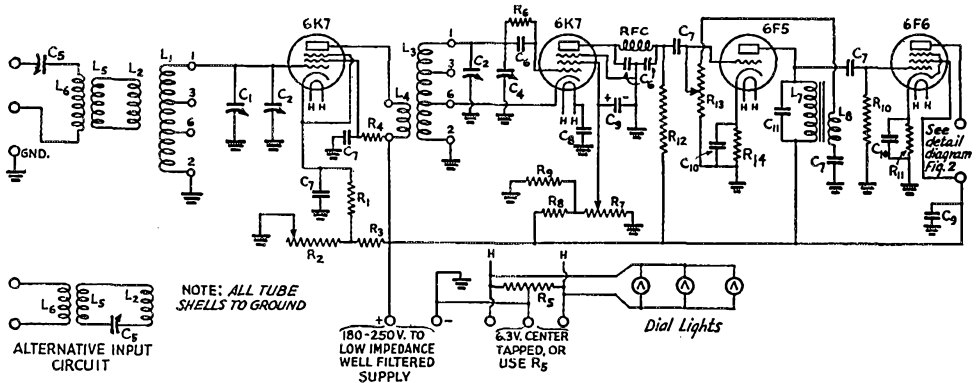

FIG. 1—CIRCUIT DIAGRAM OF THE RECEIVER

- $L_1, L_2, L_3, L_4, L_5, L_6$ —See Coil Data Table.
 L_7, L_8 —See text.
 C_1, C_2 —Double-gang band-spread tuning condenser 100- μ fd. per section (Hammarlund MCD-100S).
 C_3, C_4 —Band-set tuning, same as above.
 C_5 —75- μ fd. midget (National UM-75).
 C_6 —100- μ fd. mica.
 C_7 —0.01- μ fd. 400-volt tubular paper.
 C_8 —0.001- μ fd. (optional) r.f. by-pass.
 C_9 —4- μ fd. 450-volt (Aerovox, Type PBS5).
 C_{10} —10-10 μ fd. electrolytic, 50-volt.
 C_{11} —0.001 mica (see text).
 R_1 —300-ohm, 1/2-watt cathode resistor.
 R_2 —10,000-ohm variable resistor (r.f. gain control).
 R_3 —50,000-ohm, 2-watt bleeder.
 R_4 —100,000-ohm, 1/2-watt resistor.
 R_5 —75-ohm filament center-tap resistor.
 R_6 —0.5 to 5-megohm.

- R_7 —50,000-ohm potentiometer (regeneration control).
 R_8 —20,000-ohm, 10-watt voltage divider.
 R_9 —2500-ohm, 1-watt.
 R_{10} —0.5-megohm, 1/2-watt.
 R_{11} —400-ohm, 1-watt resistor.
 R_{12} —60,000-ohm, 1-watt.
 R_{13} —0.5-megohm volume control.
 R_{14} —6500-ohm, 1/2-watt.
R.F.C. 2.5-mh. r.f. choke (National Type 100).

The detector grid leak, R_6 , should be adjusted between the values given to obtain maximum sensitivity and smoothest control of regeneration. R_9 , the final resistor of the detector screen voltage divider, likewise may be varied somewhat for optimum results; the screen normally should operate at about 30 volts. Higher values of detector plate resistor, R_{12} , may be used for somewhat greater signal output.

is important, as is also the value of the tuning condenser, C_{11} . The latter condenser should resonate with the full winding of the transformer at the Selectosphere's resonant frequency, approximately 1000 cycles. The correct adjustment is for the circuit to go into self-oscillation when the grid control of the 6F5 just reaches the full-on position. This regenerative feature is particularly effective when using the Selectosphere to boost weak signals, and no instability is encountered even when the 6F5's grid control is adjusted to a point just below that for self-oscillation.

The audio power amplifier is a 6F6. Its load circuit, indicated in detail in Fig. 2, incorporates a selector switch allowing a combination of outputs on four of the five positions available. Position 1 connects the receiver output to the dynamic speaker. In Position 2 this speaker is paralleled with the Selectosphere; Position 3 connects in the Selectosphere by itself and in Position 4 the headphone terminals are connected and the speakers silenced. The speaker-silencing circuit shown is suitable if the speaker has a clean air gap and a well-varnished coil—otherwise, fireworks will result. A snap switch can be included in series with the voice coil if such difficulty arises.

The second position, using the Selectosphere and dynamic speaker in parallel, is a helpful operating position when hunting over the bands. A host of signals can be heard on the dynamic, and

when one is selected the tuning can be set to give the approximate beat note for Selectosphere operation. When the output switch is thrown to position the desired signal is on, or very near, the Selectosphere's peak response frequency.

Coil data for four bands are given in Table I. The r.f. and detector coils are identical. The coils should be doped to keep the turns in position.

TABLE I

COIL DATA

Band	Total Pri. T.	Total Sec. T.	Cathode Tap	Band-Spread Tap
1.75 Mc.	20	60	6	33
3.5 Mc.	15	27	1 1/2	14 1/2
7 Mc.	10	13	3/4	4 1/2
14 Mc.	5	7	1/2	1 1/4

Primary Windings: All close-wound at bottom of coil form, with No. 36 d.s.c. wire.

Secondary Windings: No. 24 d.s.c. wire, the length of each coil being 1 1/4 inches.

Taps are counted from the ground terminal of the coil. Coil Forms: National XR-6.

L_5, L_6 : Input transformer; both coils close-wound with 7 turns of No. 24 d.s.c. wire spaced 3/16" apart on tube 1 1/4" long by 1 1/4" outside diameter.

CONSTRUCTIONAL DETAILS

Top and bottom views of the receiver are given in the photographs. The panel is standard relay-rack stock 19 by 8 3/4 inches. The chassis, 9 by 7 by 2 inches, is secured to the panel by two bolts,

plus the clamping effect of three variable-resistor units. The left-hand speaker (looking at the front) is conventional 5-inch dynamic. The particular one shown is the type having a separately-excited field, but permanent-magnet dynamic or magnetic units can be substituted.

The high-selectivity speaker on the right is the regular Selectosphere minus the mounting base

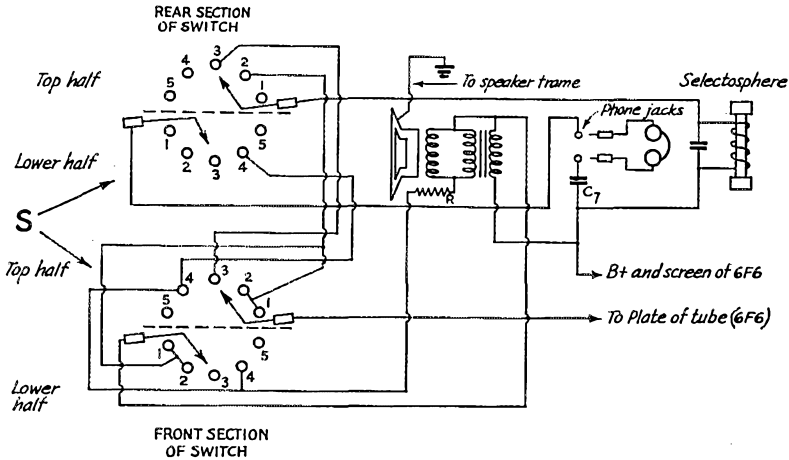

FIG. 2—OUTPUT SWITCHING CIRCUIT TO USE 'PHONES, SPEAKER OR SELECTOSPHERE, OR THE LATTER TWO IN COMBINATION

S—Yaxley 4-pole, 5-point, 2-section, 2-gang switch (No. 1325).
R—100 ohms, approximately. Value should be adjusted to give satisfactory speaker silencing.

and the support stem. The rear half of this unit is secured to the panel by three angle brackets, allowing the front half free motion back and forth.

The central dial is a Crowe 11 to 1, 270°, fitted on the front panel side with a Crowe double-control vernier mechanism which appears behind the two G.R. knobs. Tuning with the small knob gives approximately 55-to-1 ratio for Selectosphere use, and less than one-quarter turn of this knob is enough to bring a desired signal in and out of audibility when the high-selectivity speaker is used. The dial scale is secured to the dial back frame with liquid solder to eliminate any buzzing when the speakers are used. The small central bushing which backs the pointer was removed and a small felt washer cut and placed as a buffer between the dial scale and the pointer. The top-view photograph shows the dial gear train and vernier separated from the radio-frequency ground by an insulated sector on the band-spread tuning condenser. This arrangement gets rid of tuning noise on the higher frequencies. Ordinary vaseline is used on the gear train to permit damping and free motion.

Between the regular speaker and the dial are the ganged band-setting condensers and their

panel control. The five lower control units, starting with the left-hand unit, are the antenna or link trimmer, the r.f. volume control, the detector regeneration control, the audio regeneration control, and the receiver output selector switch. The dial plates of these controls are secured by the central lock nuts of the variable resistance units, with the addition of an application of liquid

solder at the four corners. This solder gives the effect of small rivets at the corner holes, but care must be taken in using it so as not to remove the paint from the panel.

The shield between r.f. and detector circuits is self-supporting from the condenser shields by soldering. This shield goes directly to the common r.f. ground. The two tuning condensers are mounted from

the base by angle brackets. This sets them up from the chassis, makes for shorter leads to the raised coil sockets and eliminates vibration. The input arrangement to the receiver is indicated on the top of the dynamic speaker. To the right of this speaker and above the band-setting condenser is seen a short section of wood dowel through which a bolt catches the main panel with the band-setting condenser's mounting clamp. This precaution makes the assembly very rigid and either rack or table mounting can be used. The four corners of the chassis are fitted with rubber feet to cushion the receiver.

VIBRATION HINTS

When a receiver of this character incorporates speakers along with regeneration, it is excellent practice to tie things down fairly tightly with lock washers. The tube sockets in this receiver were mounted away from the lower side of the chassis by their washers and as an added precaution the "deadpin" holes in the sockets had their contact wipers removed. Vibration problems should not be tolerated in any receiver because often what one calls a poor note is traceable to some receiver defect. The top of chassis layout can be changed to suit the individual; the amateur is known to be resourceful in these matters and if the constructor does not care to follow this layout exactly, no harm will result. Lastly, where the three volume controls and two holding-down bolts grip the panel to the chassis, thin fibre washers were inserted so that there would be no

(Continued on page 57)

Inexpensive Coaxial R.F. Transmission Line

Low-Loss Low-Impedance Line Which Can Be Built for Ten Cents per Foot

By Douglas A. Smith, W2BZR*

Lest recent mention in the technical press of coaxial cable in connection with television development has created the impression that a "coaxial" line is something very special while our familiar "concentric" lines are a different breed, we hasten to explain that the two terms are practically synonymous, both implying that the two conductors have a common geometric center or axis. After consulting Webster, we've come to the conclusion that of the two words, "coaxial" probably is more accurately descriptive, hence deserves preference. The television cable is special—but not because the conductors are coaxial.—EDITOR.

THE peculiar situation at W2BZR which prompted the use of coaxial transmission line was this: The station is surrounded by trees and is at the base of a knoll. Up on the plateau at the top of the knoll is an excellent antenna location—wide-open spaces and plenty of good tall trees. Last winter a 14-Mc. aluminum-tubing vertical radiator was erected on the plateau, mounted on a 40-foot mast. The greatest problem was how to feed it, as the radiator was about 200 feet from the transmitter.

Some will say, "That should have been easy; just use a 600-ohm line with a matching section at the antenna." More easily said than done. Such a line and matching section were tried, but the results were very discouraging. Finally, a single-wire matched impedance line tapped 11 feet 9 inches from the base of the vertical antenna was tried, and then we started to get results.

However, the open-wire lines had two unfortunate features: They were unsightly and they passed directly under a 2300-volt feeder line operated by the local power company. Needless to say, when our line was discovered it was promptly condemned and had to be taken down. So there we were with a perfectly good antenna 200 feet from the transmitter—and no way of feeding it. But, no, there must be some way of getting soup up that hill to such a grand antenna location, and there was a solution—coaxial cable buried under the ground.

The biggest drawback to the lines commercially available was cost. In one instance 250 feet of line would have cost \$250. The lowest-priced cable we could locate was a few cents less than a quarter per foot—this still ran to too much money. So we decided to build the line ourselves.

BRASS VS. COPPER

Most commercial lines are made of copper tubing; we actually bought 250 feet of this $\frac{3}{8}$ -inch thin-walled tubing in 50-foot coils, and found it

* Allen D. Cardwell Mfg. Co., 81 Prospect Ave., Brooklyn, N. Y.

filthy on the inside. At least a good tablespoonful of muck and copper filings was swabbed out (in the same manner as cleaning a gun), and we realized that this type of tubing would never do for high-frequency work. So we lugged it back to the metal supply house, and while trying to get a line on cleaner copper tubing with fewer irregularities in the inside, we saw some thin-walled brass tubing. The inside of this brass tubing was as clean and shiny as the inside of a shot-gun

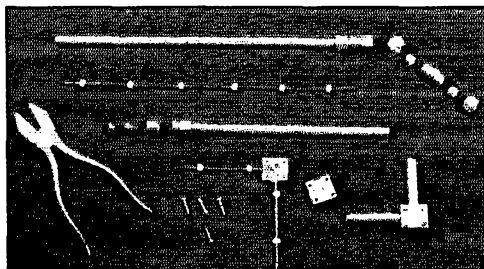

FIG. 1—ALL THE GADGETS USED IN CONSTRUCTION OF THE LINE ARE SHOWN IN THIS PHOTOGRAPH

barrel. It fitted our $\frac{5}{16}$ -inch Isolantite beads perfectly, with only about 0.01 inch play between the bead and the tubing. One disadvantage (we thought, before asking the advice of a Bell Laboratory man) was that the brass tubing only came in 14-foot lengths. Another question we had in mind was whether the brass would be as efficient a conductor as copper. This fear also was quelled by our Lab friend. Either copper or brass tubing can be used with equal success. Of course we realize that the conductivities of copper and brass are different, but in r.f. transmission the skin effect is the same.

But how about bending this hard-drawn brass tubing? The answer is to use right-angle coaxial joints. These are pictured in Figs. 1 and 2. With such a gadget geometrical layout of the line is possible. However, it is possible to obtain a good

deal of flexibility when the line is completely assembled. Our line wends its way between trees and bushes and through the brow of the knoll leading to the plateau, much like a long snake—underground of course, about six inches.

Those unfamiliar with concentric-line construction can readily get the idea from Figs. 1 and 2. The inside conductor, a piece of No. 12 wire with Isolantite beads crimped into position every two

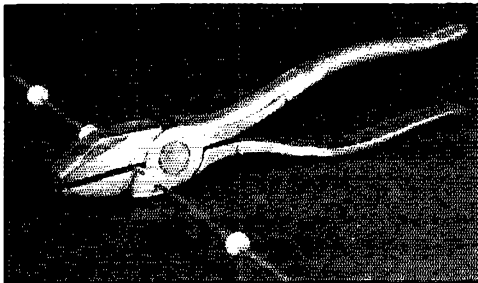

FIG. 2—THE CRIMPING TOOL (REVAMPED PLIERS) READY TO TAKE A BITE

The crimps, on each side of the insulating beads, keep the latter from sliding out of position.

inches (approximate eye measurement), is slid into the brass tubing. The resulting line has a characteristic impedance between 72 to 75 ohms, which is approximately the impedance at the center of a half-wave antenna.

The advantages of this type of line over open-wire lines are many. With coaxial cable the impedance is constant. Second, the losses are negligible at frequencies up to 14 Mc. Even at 28 and 56 Mc. the losses are so trivial over the average length feeder that they might as well not be considered. However, for the sake of those who really want the facts the tabulation below is taken from information compiled by Bell Laboratories:

LOSS IN DB FOR VARYING LENGTHS OF COAXIAL LINE (3/8" O.D.)			
	Per Mile	Per 1000 Ft.	Per 100 Ft.
2 Megacycles	8.5 db	1.6 db	.16 db
4 "	12.0 "	2.2 "	.22 "
7 "	16.0 "	3.0 "	.3 "
14 "	22.0 "	4.1 "	.4 "
30 "	34.0 "	6.4 "	.64 "
40 "	40.0 "	7.5 "	.75 "
56 "	56.0 "	10.6 "	1.06 "

Third, with a coaxial line complete grounding of the outer conductor can be obtained, either by a typical ground connection at one or both ends or at the middle, or by burying it underground. Thus there is no possibility of transmission line radiation and its attendant highly undesirable features.

Now for the actual construction of the line. Figure out how many feet of wire will be needed and get a little extra. Use hard-drawn or semi-hard No. 12 bare copper wire; the impedance will be off slightly if enamelled wire is used. Next procure the Isolantite beads or spacers. For 3/8-inch outside diameter 0.02-inch wall brass tubing, a

head approximately 5/16 inch in diameter should be used. The tubing and bead sizes are readily available and will give an impedance of 75 ohms, according to the *Handbook* formula for designing coaxial lines.

String the beads loosely on the wire. If you have a long length to work it is best to construct two reels, winding the wire on one and having the other available for the finished beaded wire. The problem is to crimp the wire on each side of the individual beads to keep them from slipping, and yet not break or distort the wire. After about two weeks of experimenting with all sorts of gadgets, a 50-cent pair of pliers (Woolworth's best) as shown in Fig. 2 was decided upon. Simply file the cutting edge to a point where the pliers will no longer cut wire. Leave a slight space, of the order of 0.01 inch, between the edges. Then procure a key file at the local hardware store and file two square notches opposite each other in the two old cutting edges, these notches to be just a hair or two less in width than the diameter of the No. 12 wire. The depth should be such that when the wire is squeezed in the notches it will have a tendency to be flattened and two little bulges will fill out at either side of the notches into the 0.01-inch gap left between the old cutting surfaces. These bulges will keep the beads from sliding along the wire. The "crimps" as they are termed, must be made on each side of the bead, and should be as close to the bead as possible to keep it from sliding back and forth. Be sure the notches in the "crimper" are filed square and not round. It is not necessary to take the temper out of the 50-cent pliers before filing; they will file very easily "as is."

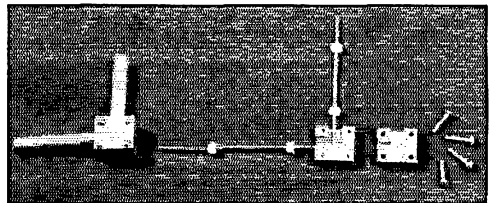

FIG. 3—LEFT—A COMPLETED RIGHT-ANGLE COAXIAL JOINT RIGHT—THE JOINT READY TO BE ASSEMBLED

After a few evenings spent crimping the beads on the wire you are probably either ready to call the whole thing off, go to the doctor to have your thumb cured of arthritis—which happened here!—or else you're ready to slide the brass tubing on.

I say "slide" because that is exactly what we did here. We¹ kept our center conductor (250 feet) all in one piece and slid the 14-foot sections of tubing, together with the necessary fittings, over the beads already crimped on the wire. Not a single bead chipped or broke. This method makes

¹ Thanks to help from W2HZR.

(Continued on page 74)

28-Megacycle Preselection

Circuit Hints and Practical Construction

By James Millen,* W1HRX and Dana Bacon,** WIBZR

FOR the past year or more the 28-Mc. band has been particularly hot; signals from all continents have been coming through with good regularity and many amateurs have been quick to take advantage of the chance to make WAC under almost ideal conditions.

There was little QRM at first and a simple regenerative receiver was satisfactory. During the Summer and Fall of 1937, however, two changes occurred; ten meters got even hotter and the American 'phone band was shifted to its present position. These events brought out the shortcomings of many receivers and the merits of others. The better conditions increased QRM alarmingly, the regenerative receiver became inadequate from the standpoint of selectivity, and many proud owners of superhets were disagreeably surprised at the performance of their equipment. Many of the simpler and cheaper receivers having 28-Mc. coverage were found to

i.f. channels. After the 'phone band was changed to include frequencies from 29 to 30 Mc., the low-frequency half became full of images, which were particularly objectionable since most of the

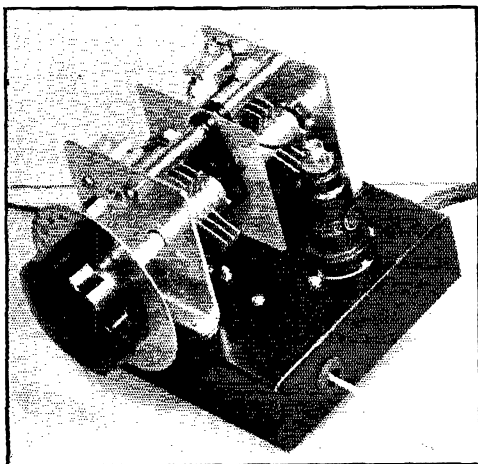

FIG. 1—THE SINGLE-STAGE 28-MC. PRESELECTOR
No vernier dial is necessary, as a band-spread tuning condenser is used with but two tuned circuits.

be lacking in sensitivity, with images indistinguishable from real signals.

On the old 'phone band, 28 to 28.5 Mc., images had not been bothersome as there were very few signals above 29 Mc. to cause trouble, and only those signals between about 28.9 and 29.4 Mc. could appear as images in supers having 456 kc.

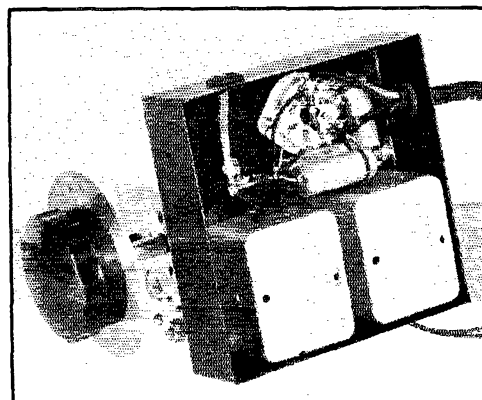

FIG. 2—BOTTOM VIEW OF THE SINGLE-STAGE UNIT

Simple, isn't it? The two rectangular shields house only the coils. Note the shielded output lead.

foreign amateurs chose to operate between 28 and 28.5 Mc.

ELIMINATING IMAGES

A preselector would seem to be the only means for overcoming the difficulty, but it soon became apparent that the commercial preselector had exactly the same shortcomings as the receiver, both being designed primarily for lower frequency operation, and the results were, of course, disappointing. This was to be expected as no particular effort had been made to reduce the circuit losses nor to compensate for the low grid impedance of conventional tubes above 15 Mc.

One solution for the image problem is to use a receiver having a high-frequency i.f. channel, for in such a receiver the signal-to-image ratio automatically will be quite high, and furthermore no signal in the 28-Mc. band can appear as an image interfering with any other signal between 28 and 30 Mc.¹ Another solution is to employ a preselector built especially for 28-Mc. operation. In considering the design of such a preselector the characteristics of the receiver with which it is to be used are very important. A few of the very

¹"A New Quartz Crystal Filter of Wide-Range Selectivity," *QST*, Sept. 1937.

*Malden, Mass.

**41 Bellington St., Arlington, Mass.

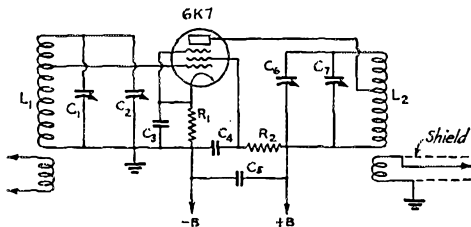

FIG. 3—DIAGRAM OF THE SINGLE-STAGE UNIT

C_1, C_7 —3-30 $\mu\text{fd.}$ mica trimmers.
 C_2, C_6 —Tuning condensers, two gang, 25 $\mu\text{fd.}$ per section (National Type 81X).
 C_3 —0.1 $\mu\text{fd.}$, 200-volt, tubular paper.
 C_4, C_5 —0.1 $\mu\text{fd.}$ 400-volt, tubular paper.
 R_1 —350-ohm $\frac{1}{2}$ -watt.
 R_2 —50,000-ohm $\frac{1}{2}$ -watt.
 L_1, L_2 —Tuned winding: 6 turns of No. 20 E. $\frac{9}{16}$ " diameter, $\frac{1}{2}$ " long. Pick up winding: 3 turns of No. 30 d.s.c. close wound, spaced about 1;16" from low end of tuned winding.

best communications receivers have good sensitivity on ten and the only improvement desired is some stepping-up of the signal-to-image ratio with comparatively little voltage gain. There would be no point in using a high-gain preselector with such receivers, since they already go down to the noise level. The majority of sets will, however, need considerable gain as well as reduction of images, and these requirements automatically indicate the use of acorn tubes. One ordinarily thinks of acorn tubes as being primarily built for ultra-high frequency operation; that is, above 56 Mc. As a matter of fact, there is a surprising difference between the acorn pentode (956) and the corresponding conventional tube (6K7, 6D6, etc.) even on 14 Mc., and at 28 Mc. the difference is still more marked.

PRACTICAL PRESELECTORS

Figs. 1 and 2 show an extremely simple and inexpensive preselector employing one 6K7. In view of some of the statements above the choice of this tube might seem illogical. The reason for its use is to demonstrate the possibility of overcoming grid loading effects and to show that adequate performance is obtainable with elementary circuits (Fig. 3). This unit, as constructed, has a voltage gain of about 8 and a signal-to-image ratio of 7, when used with a receiver having an intermediate frequency of 456 kc. It is entirely suitable for use with receivers of the better class which already possess fairly good sensitivity. Such receivers will have signal-to-image ratios between 5 and 30, and the addition of the preselector will therefore increase the ratio 7 times.

The detrimental grid-loading effect cannot be completely eliminated, although it may be reduced considerably by tapping the grid about one-third of the way down the coil. By so doing, the Q of the tuned circuit can be maintained at a

value much higher than that ordinarily obtainable, and at the same time voltage on the tube grid is not cut down appreciably. The explanation is simple: The more efficient tuned circuit develops higher impedance with attendant higher signal voltages, and the tapped coil is in reality a matching transformer, the grid impedance of a 6K7 at 30 Mc. being about 30,000 ohms. Circuits employing acorns do not require such treatment, the grid impedance of the 956 being over one-quarter megohm at this frequency.

Figs. 4 and 5 show a more elaborate two-stage preselector employing acorn tubes and probably representing the best unit of its type that would be practical for home construction. With the gain control wide open, the voltage amplification is about 300 and the signal-to-image ratio is 100 when used with a receiver having an intermediate frequency of 456 kc.

When properly connected, it will transform a decidedly mediocre receiver into one having exceptionally fine 28-Mc. characteristics. The circuit diagram is shown in Fig. 6. The acorn preselector will of course effect some improvement when connected to a high-quality receiver, but naturally the improvement will be much less marked and the gain control of the receiver must be retarded to hold background noise down to a

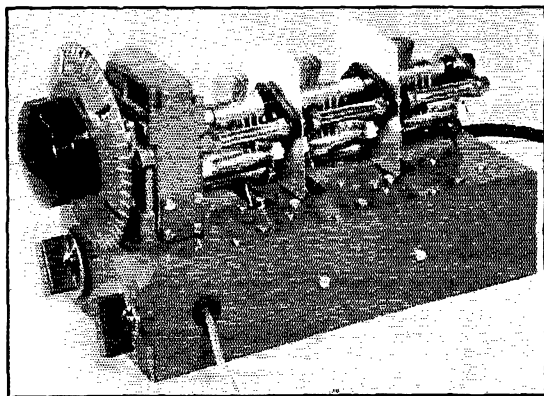

FIG. 4—THE TWO-STAGE ACORN JOB

The vernier dial is advisable in this case, as tuning is fairly sharp.

reasonable level. Since a signal-to-image ratio of 300 or 400 to 1 usually is ample, a two-stage unit completely solves the image problem except on the very poorest receivers; for instance, if the receiver alone has a signal-to-image ratio of 4.5 to 1, the ratio becomes 450 to 1 when the preselector (with 100 to 1 ratio) is added.

The reader has probably noticed that the two circuits are unconventional in only one respect: The use of a tuned output-circuit link coupled to the receiver input. This arrangement appears to be just as effective in coupling the preselector to the receiver as it is in coupling between various

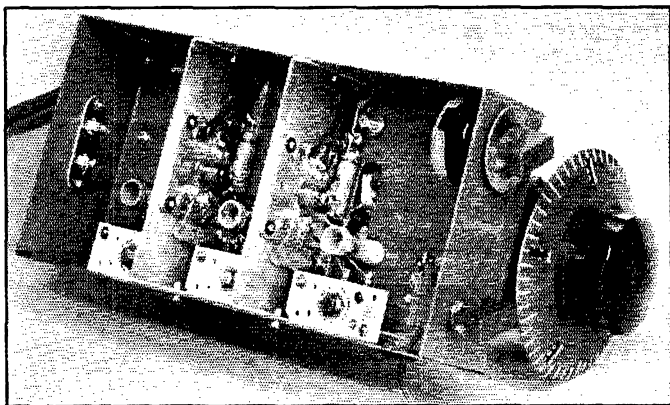

FIG. 5—BELOW-CHASSIS VIEW OF THE TWO-STAGE PRESELECTOR

Cathode by-pass is furnished by connecting the cathode terminal to the copper socket (standard National type XMA) plate, which is insulated from the shield partition by the piece of mica furnished with the socket. The capacity is about 0.001 μ fd.

stages of a transmitter. It must be pointed out, however, that output tuning has some disadvantages; it cannot be employed satisfactorily when the preselector is to be used with certain types of receivers, particularly those wherein impedance changes at the input circuit react on receiver tuning. Such receivers usually exhibit hand-capacity effects (without the preselector) and are very sensitive to any change in antenna characteristics. While most superhets do not have these defects, there are a few which are so constructed that the antenna is coupled directly to the first detector circuit and this circuit, in turn, reacts upon the high-frequency oscillator. When used with a preselector having a tuned output, the combination becomes almost impossible to handle since any attempt to peak up the preselector will detune the signal. In general, however, the tuned output circuit adds greatly to the performance of the preselector, increasing both gain and signal-to-image ratio.

COMBINATION UNITS

The two preselectors so far described were chosen to represent two extremes. The amateur who contemplates the construction of such equipment would do well to consider a combination unit embodying the various features of each which will be best suited to his plans. For instance, a 956 substituted for the 6K7 in Fig. 3 will increase the gain from about 8 to 17 and the signal-to-image ratio from 7 to 20. Conversely, 6K7's could be substituted for the acorns in the two-stage model. In this case over-all gain could be made as much as 70 with a signal-to-image

ratio of 50 to 1. Simply by tapping the grids of the 6K7's down the coil about one-third of the way, the signal-to-image ratio would be double but gain would be decreased only about 25%. A two-stage acorn circuit minus the tuned output would give performance approximately equivalent to that of two 6K7's with three tuned circuits, since it is very difficult to transfer the r.f. voltage directly from the plate of a tube to the input of the receiver without introducing considerable loss and undesirable feedback.

With regard to the matter of gain control, it may be seen that the first acorn tube is operating wide open at all

times, gain adjustment being made at the second tube. This is done to provide the best signal-to-circuit-noise ratio under the assumption that receiver and preselector together would be too noisy if both were operated at full gain and, furthermore, that fairly strong signals might overload the receiver input circuit if the preselector gain were not limited in some manner. Without going into the matter too deeply, it may be said that the tube to which the antenna is coupled should always operate at

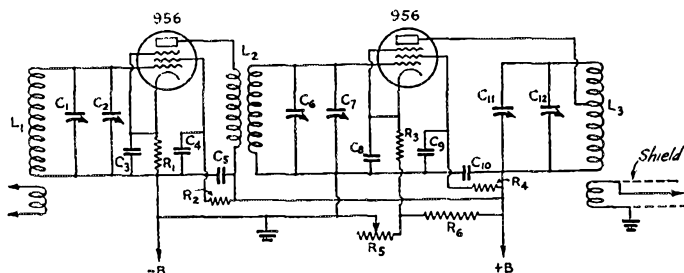

FIG. 6—CIRCUIT OF TWO-STAGE UNIT

- C₁, C₆, C₁₂—35- μ fd. air trimmers.
- C₂, C₇, C₁₁—Tuning condensers 3-gang, 25 μ fd per section (National NPW-X).
- C₃, C₈—See caption under Fig. 5.
- C₄, C₅, C₉, C₁₀—0.01 μ fd. 400-volt tubular paper.
- L₁, L₃—Same as L₁ and L₂ of Fig. 3.
- L₂—Same secondary as L₁, Primary 4 turns of No. 30 d.s.c. interwound, starting from bottom.
- Tube sockets—National XMA.
- Coil forms—National XR-3.
- R₁, R₃—500 ohms, 1/2-watt.
- R₂, R₄—100,000 ohms, 1/2-watt.
- R₅—10,000-ohm wire-wound gain control.
- R₆—Gain control bleeder, 100,000-ohm 1/2-watt.
- B + — 250 volts maximum.

maximum gain in order to provide best ratio of signal to circuit noise. It follows, then, that no gain control is needed on the single-stage model.

(Continued on page 80)

The "QSL Forty"

A Compact and Inexpensive 3.5- and 7-Mc. Transmitter

By Fred Sutter,* W8QBW-W8QDK

IN THE June, 1936 issue of *QST* appeared an article by Mr. Frank Edmonds, W2DIY, which to the present writer's way of thinking is highly inspirational. (But let's drop this "present writer" stuff and have a real ham talk in the first person singular. OK?) In fact it is even more than inspirational; it fairly stampedes one into action. At any rate it stampeded me, and there resulted here at W8QBW rig after rig using 6L6

the little fellow went to town both here at W8QBW and at W8QDK the big tube idea faded down to about $S\frac{1}{2}$ and the 2000-volt transformer went on the shelf and is still there. R.I.P.

Now, as to results. On 40 meters the rig has worked all W districts from this QTH, which is in Grosse Pointe, Mich., along the shore of Lake St. Clair. A report of S7 is unusual, S8 and S9 being rather the rule. The poorest report so far is S4 from W7GAF in Stanfield, Oregon, about 1775 miles, and the next poorest is S5 from W6KBZ, Reno, Nevada, about 1950 miles. When W8QDK went on the air for the first time in July, 1937, the first 29 CQ's resulted in 24 QSO's, on 40 meters, all during daylight hours. Surely no reasonably minded ham can demand more from a \$1.35 bottle.

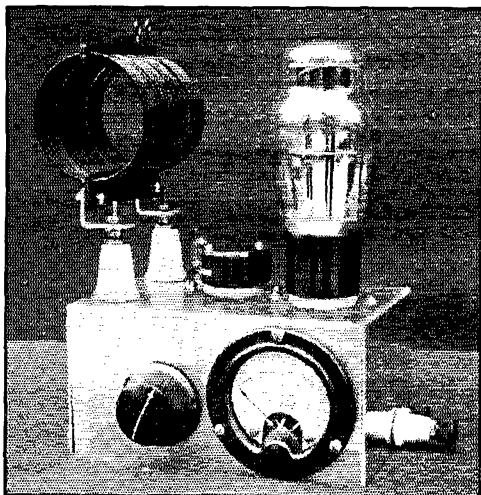

WITH CHASSIS AREA THE SAME AS THAT OF A POSTCARD, THIS LITTLE RIG PACKS QUITE A WALLOP

and 6L6G tubes, Tri-tet, mongrel and straight circuits with all kinds of values and coils. And Came the Dawn! A tiny transmitter using the 6L6G tube, straight circuit, on a wee chassis $3\frac{1}{2}$ by $5\frac{1}{2}$ inches, which would light a 40-watt G. E. Mazda dummy load to more than full brilliancy. Now if you will measure your QSL card and find that it is $3\frac{1}{2}$ by $5\frac{1}{2}$ inches you will see why this one was christened the "QSL 40."

My original thought in this was to arrive at a simple oscillator with soup enough to excite that Big Tube which is the dream of every new ham. A 6L6G running a 300-watt amplifier—as Mr. Edmonds puts it in his article, "this two stage set-up would be a nice rig for c.w.," a very miracle of understatement! But when I found out how

THE PHOTOGRAPHS

Looking at the photographs it will be noted that in front is the plate-condenser knob and the plate meter. On the side are the key binding posts, at the back a 5-prong socket for the power and on top are the coil, tube, crystal and protective pilot bulb. Underneath is an r.f. choke, a resistor, three tubular condensers and, of course, the meter and 100- μ fd. midget. There isn't much which could be left out except perhaps the pilot bulb, but as this with its socket costs but 14 cents it is good inexpensive crystal insurance. The cost of all this exclusive of crystal, which every ham

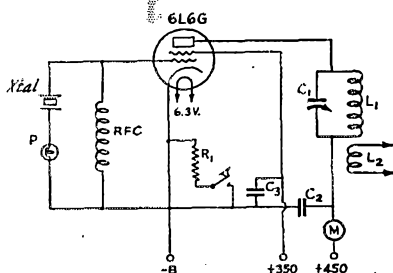

FIG. 1—THE TRANSMITTER CIRCUIT DIAGRAM

- C₁—100- μ fd. midget (Hammarlund MC-100-S).
- C₂, C₃—0.1- μ fd. paper tubular, 1000-volt (Aerovox 1084).
- C₄—0.1- μ fd. paper tubular, 600-volt (Aerovox 684).
- RFC—2.5-mh. r.f. choke (National R-100).
- R₁—200 ohms, 10-watt (Ohmite Brown Devil).
- M—0-300 d.c. milliammeter (Triplett 221).
- P—Mazda Type 40 pilot bulb.
- L₁—7 Mc.: 15 turns No. 14 enamelled, diameter $2\frac{1}{4}$ inches, length $1\frac{3}{4}$ inches.
- 3.5 Mc.: 21 turns No. 14, diameter $2\frac{1}{8}$ inches, length $2\frac{3}{4}$ inches.
- L₂—6 turns No. 14 at end of L₁. Same on both bands.

* 1000 Kensington Road, Grosse Pointe, Mich.

already has, is about \$7.50. If the builder possesses a meter and a 100- μ fd. midget, the outlay drops to about \$2.50.

THE CIRCUIT

The circuit is that of the Edmonds article with a few changes (of course!). The glass 6L6 was used instead of the metal tube, R_2 was omitted, R_1 was changed from 400 ohms to 200 ohms and a space-wound coil was used instead of the form wound coil. It is more than probable that a technician (which I am *not*) can point to many offenses against theory and practice, but the fact remains that the rig delivers 40 watts and it does get out. I have not lost a tube except one which, being defective, was replaced without charge by the manufacturer. A few words regarding this "overload" bugaboo may not be amiss. Any electrical device used intermittently for short periods will carry heavy overloads because it does not have time to heat up, and has plenty of time to cool down between loads.¹ On c.w. a keyed oscillator has an input consisting of dots and dashes, little time to heat up and plenty of time to cool down. A demonstration of this may be seen in the

¹ With tubes, the total cathode emission available is also an important factor. If the emission is not great enough, the efficiency under a heavy overload will be poor, more than the normal proportion of heat will be developed, and even though the overload may not last long gas may be released which will poison the cathode. Most tubes are rated conservatively enough to stand a reasonable overload, even the receiving types under discussion.—EDITOR.

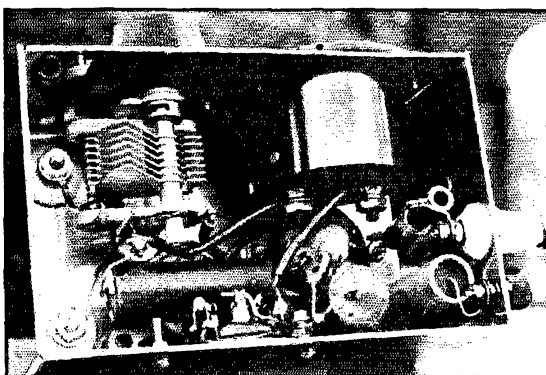

THE BOTTOM VIEW SHOWS LITTLE SPACE TO SPARE
The socket for the power leads is on the lower chassis edge, slightly to left of center.

above rig where the pilot bulb, on 40 meters, key down, burns dull yellow. When the rig is keyed, the pilot bulb does not light at all. The current flows, but it is interrupted before the bulb has time to heat to visibility. This applies also to the plate and screen of the 6L6G tube. However, a voltage overload is a matter of insulation, which may, or may not, withstand the excess voltage. If it does stand up then evidently the voltage "overload" is not an overload after all.

THE CHASSIS

Use light aluminum, No. 16 gauge or lighter, 9 by 11 inches with the corners cut out $2\frac{3}{4}$ by $2\frac{3}{4}$ inches and bent to form a top $3\frac{1}{2}$ by $5\frac{1}{2}$ inches. The plan, Fig. 2, is looking down on the top of the not-yet-folded chassis. As there is little if any waste space it is best to follow the dimensions accurately. You can make the chassis bigger, if desired, but this one is so small that there is practically no wiring, the parts themselves reaching from

"here to there." The plate condenser is insulated from the chassis, being mounted on a bit of bakelite. Don't forget that.

THE COILS

Quite a comprehensive article could be written on "how to make" these spaced-turn coils, but most of it is in the *Handbook* and the photograph ought to tell the rest. You will probably make quite a few of these coils at one time or another, so had better make a drilling template about five inches long of $\frac{1}{8}$ -inch strip steel. Space the holes eight to the inch, using a No. 44 drill for No. 14 wire, and do

(Continued on page 84)

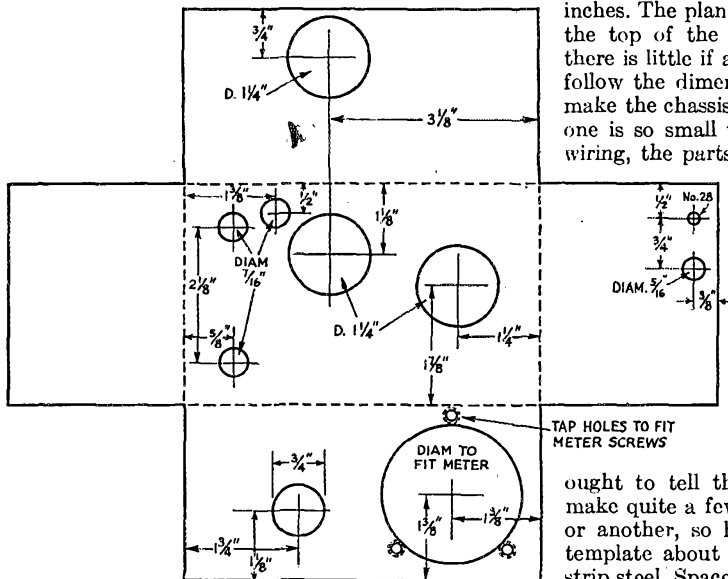

FIG. 2.—WORKING DRAWING OF CHASSIS BEFORE FOLDING

A.R.R.L.'S Tenth International DX Competition

Radiotelegraph Contest, March 5th¹ to 13th; 'Phone DX Contest, March 19th¹ to 27th

Medallions to CW-DX and to 'Phone-DX Winners in each Section⁶—Swap Number Groups (RST² Report³—Self-Assigned Serial Nr.) in DX QSOs—Operating Time 90 Hrs. in the 9 Days—Score is Sum of DX Contact Points Times Number of Official Countries Worked (or Number of W-and-VE Districts, for Others)—Gavel Trophy to Leading Club!—W-VE's Invite All the World Take Part

By F. E. Handy* WIBDI

TWO separate periods for competitive work by either radiotelegraph or radiotelephone operation are again provided this year.

Both come in the month considered to offer the ultimate in the DX that the season affords! The time-tested rules for contest exchanges will be the same for both periods, except that no quota plan applies in the 'phone period. We expect entries to be in one period or the other—but one can take part in both, if he likes. Scores of course are independent for each period.

Suggestions for changes have been carefully considered. At the request of radiotelephone amateurs, contacts by voice with telegraph stations will no longer be considered legitimate for contest exchanges. All reports in this section of the contest must be voice-to-voice. This is really just a clarification of rules, since in practice just about 99 per cent of QSOs have always been with stations working in

the mode indicated by the designation for a section of the contest. It has been wasteful of time to hook stations of the "other" mode to explain what was wanted. Since operating c.w. in a 'phone sector has been considered unethical by many, we add that in addition to the 'phone contest recording for credit only the voice-voice QSOs, that the telegraph contest period will contemplate only telegraph-telegraph QSOs.



DISQUALIFICATIONS

Remember the disqualifications made last March for off-frequency operation, improperly modulated notes, and the like? *Violations of government regulations will again be penalized.* There must be no repercussions about poor amateur operating at Cairo! Official Ob-

servers will be asked to hew to the line, reporting all violations to the contest committee. Special cooperation is being requested of the F.C.C.

* Communications Manager, A.R.R.L.

¹ 6:01 P.M., C.S.T., March 5th or 19th, see discussion under "the contest period."

² For R-S-T definitions of "readability, strength and tone" in that order: See 1938 A.R.R.L. Handbook, page 398, Operating an Amateur Radio Station, page 12, or drop postal for list. Scales correspond to W-R-T of European systems approximately.

³ In 'Phone exchanges only two numerals will be given in the report, the first always the "readability" and the second the "strength." In other words, telegraph entrants will send and receive six figure groups, and 'phone entrants will receive five figure groups.

⁴ QHM—Will start to listen at high frequency end of band and tune towards middle of band.

⁵ QMH—Will start to listen in the middle of the band and tune toward the high frequency end.

⁶ QLM—Will start to listen at the low frequency end of band and tune towards middle of band.

QML—Will start to listen in the middle of the band and tune toward the low frequency end.

⁷ Phone operators should not use Q code or telegraph procedure when a few properly chosen words will inform the transmitting operator in what part of the band they will be listening first! The idea also is to make the 'phone report part of the five numeral groups, so it will be quite unnecessary to say "readability" and "strength" or other indication before the first two numbers in the serial number group.

⁸ Alaska, Hawaii, Philippine Islands, Cuba, Porto Rico, and Newfoundland, in fact, all localities using PREFIXES other than W or VE will receive QST mention and awards based on their work with W/VE stations.

⁹ Page 4 of this QST carries a complete list of the Sections of the A.R.R.L. Field Organization.

¹⁰ Consult the list of call-prefixes for different countries of the world as given in Jan. '38 QST, page 45. This will be used as the official list.

<i>Time</i>	<i>Starts</i>		<i>Ends</i>	
	March		March	
Greenwich	5th	19th 0001 (12:01 A.M.)	13th	27th 2359 (11:59 P.M.)
A.S.T.	4th	18th 8:01 P.M.	13th	27th 7:59 P.M.
E.S.T.	4th	18th 7:01 P.M.	13th	27th 6:59 P.M.
C.S.T.	4th	18th 6:01 P.M.	13th	27th 5:59 P.M.
M.S.T.	4th	18th 5:01 P.M.	13th	27th 4:59 P.M.
P.S.T.	4th	18th 4:01 P.M.	13th	27th 3:59 P.M.

itself. We shall ask the monitoring stations to give the DX bands redoubled attention. Any stations known to have been logged in violations by the F.C.C. during the contest will also be disqualified automatically. The interest of *all* amateurs requires strict observance of frequencies, d.c. power supply regulations, etc.

The Cairo meetings will be in session as we amateurs take part in our contest. Amateurs of all nations must work in the frequency bands assigned them, or regardless of nationality, must be disqualified if checked in the contest period as off-frequency with sufficient evidence to prove a deviation to the award committee. It makes little difference *what* nationals are out of bounds, we are not going to allow any practices to be built up that would constitute grounds for complaint against the amateur service. The interests of *all* amateurs in their frequency bands are too precious to risk by any yielding to selfish desires of the few to build contest scores by unfair means.

For more at length on "DX competition policy" see page 21, May 1937 *QST*.

HINTS FOR DX SUCCESS

Intelligent listening is a first essential. You have to hear them before you can work them. Tuning specifically "from the middle to the end" as well as "from either end toward the middle" should be a useful practice. Don't crowd band edges—that's just an invitation to be disqualified!

Use all bands that you can! Operating points, personal efficiency, and the "man behind the station" (most of all) count! W/VE hams not wanting to show themselves "lids" will avoid all use of "CQ DX." No distant stations will waste time answering such calls when one call from "outside" will bring hundreds of answers from more efficient operators. All stations should try to work BREAK-IN for real operating efficiency. Hams outside W/VE urge more speed, asking W/VEs to shoot the number along first before anything else. U. S. and Canadian amateurs approve continued use of CQ by all stations in remote localities, but plead that these CQs be made shorter—when so many U.S.A.—Canadian stations are competing for each one! CQ DX is "out" for W/VEs. Remotely located participants: Please sign often in CQs or calls. Use QHM, QML, QLM, QMH⁴ as a guide of when or how long to call.

GENERAL CONTEST PLAN

Amateurs with the prefixes W and VE will be taking part in a QSO Party with stations in all parts of the world. When they effect DX QSOs, they will exchange self-assigned serial numbers (two³ or three-figure reports plus three self-assigned numbers that stay the same for all stations). This whole group is entered in the contest report. From this record each station will submit its score. From the scores (which the Contest Committee will verify by cross-examination of logs) the winners will be determined for each locality, and medallions awarded. Three points can result from a full

exchange in any band, but no more can be obtained from the same station unless both stations connect in another band for additional exchanges. Contacts with non-participants can count, where you explain the system, refer to this announcement if necessary, and the operator assumes (and sends you) a serial number for his records and your report.

Stations outside⁵ the U. S. and Canada will try to work as many W and VE stations as possible to exchange serial numbers. Stations in all localities need only take part on the dates announced and report results at the end of the tests to receive credit in *QST*, and be eligible for awards.

The main competition each operator must consider comes from operators in his immediate A.R.R.L. Section in the case of W and VE stations,⁶ and in the case of all other amateurs it comes from the individual operators in their country or locality using the same prefix.⁷ The W/VE awards are for the operator running up the best record for each Section under the Rules.

Separate certificates will be awarded the c.w. winner, and the 'phone winner, for each country, and likewise for each A.R.R.L. Section. It's a chance for 14- and 28-Mc. 'phone hams to do their stuff in the second period—but it will in no sense be a competition of 'phone with c.w. operators. *Select either period; try your luck and DX, and report results one and all!*

Logs on the first period will be marked "C.w. station work," and those for the second period, "Phone work." The transmitter must be kept on c.w. or 'phone, too. It is unethical to shift to c.w. to call a station, or send numbers, when taking part in the 'phone period (and vice versa), and disqualification will be made of offending stations. Likewise, whistling of code for numbers (or similar means) is regarded as improper. Counting of consecutive numbers, spelling of the letters that constitute numbers, using word lists from the Handbook, etc., are regarded as the proper methods.

THE CONTEST PERIOD

To avoid misunderstanding and possible confusion, the exact local starting and ending time for our DX competition is given in the above table. These times are based on "Greenwich," and should be computed for any part of the world from the Greenwich meridian. The contest runs (First Period) from Saturday, March 5th, through Sunday, March 13th (until Monday, March 14th, G.T.); (Second Period) from Saturday, March 19th, through Sunday, March 27th (until Monday, March 28th, G.T.).

SERIAL NUMBERS

The first digits of the serial number sent shall constitute the Readability³—Strength³ and Tone³ reports of the station to which the number is sent. Every operator taking part in the contest assigns himself a distinctive three-numeral group, used by him throughout the contest as the last part of each number exchanged (sent). Try to send and receive one complete serial number with each DX station.

TIME LIMIT

Up to and including 90 hours' total contest operation (for *either* period) there is no penalty, and nothing to do when computing your score. Should you find that you operated a total of 100 hours (for example), your gross score should be multiplied by the fraction $\frac{90}{100}$ to give your net or "corrected score."

You can operate 6 hours per day, 12 hours each Saturday, and 16 hours each Sunday, working DX in the contest, and come out about right. This plan permits the average ham to plan for his working day for meals, for 8 hours' daily sleep, etc. Cross examination of logs makes it possible to check the operating time submitted as may be necessary, of course.

The time limit puts contestants on a fair basis whether employed or having full time to apply to the contest. Operate as much as you want to during the contest period. Keep track of the time you start and stop operating your station. This must be shown in your log report.
(Continued on page 114)

LOG, NINTH A.R.R.L. INTERNATIONAL RELAY COMPETITION (Example, W1XYZ, Serial No. 545)

C.W. Entry	March 5th-13th	Bands	1.7	3.5	7	14	28 Mc.	Total
Call Signal.....	Logs from W or VE, show, for each band:							
Name.....								
Address.....	Nr. DX Stations QSOed.....			3	4	1	1	9
Transmitter Tubes.....	Nr. Countries (prefixes) QSOed..			2	3	1	1	7
Plate watts (input last stage).....	Logs from remote points indicate; for each band:							
Nr. Hours Station Operation ¹ (14 h. 29 m.)	Nr. W/VE stations QSOed.....							
A.R.R.L. Section (for W/VE's).....	Nr. U. S. A.—Canada licensing areas worked.....							

Station Time Record	Operating Time	Date and Time	Station Worked	Country	Worked Record of New Countries ² for Each. Freq. Band					Serial Nrs.		Points	
					1.7	3.5	7	14	28	Sent	Received		
On 7:01 P.M.		Mar. 4th 7:02 P.M. E.S.T. (or 0002 G.T. Mar. 5th) 7:15 P.M. E.S.T. 9:40 P.M. E.S.T.	G6RB G2SZ ON4AU	G. B. G. B. Belgium		1					568,543 488,543	478,001 488,111	3 2 3
Off 10 P.M.	2 h. 59	Mar. 6th 7:38 P.M. 8:50 P.M. 11:50 P.M.	VK3WL ZL2CI J2GX	Aust. N. Z. Japan			1				579,543 487,543 349,543	579,287 398,857 588,984	3 3 2
On 12:00		Mar. 13th 12:05 A.M. E.S.T. 3:10 A.M. E.S.T.	VK7RC VK5PK	Aust. Aust.			2 ¹⁰				586,543 499,543	577,000	3 1
Off 4:05 A.M. On 1:30 P.M. Off 4 P.M.	4 h. 05 2 h. 30	2 P.M. E.S.T.	PY2BN	Brazil			3				487,543	468,852	3

14 h. 29

Multiplier = 2 + 3 + 1 + 1

24 × 7 (countries) = 168 Score

"Points" multiplied by the number of

1) Countries or localities (prefixes) for all bands

OR

2) U. S. and Canadian licensing areas for all bands equals the SCORE..... (This is the final score unless the operating time exceeds 90 hours).

I hereby state that in this contest, to the best of my knowledge and belief, I have not operated my transmitter outside any of the frequency bands specified in, or in any manner contrary to, the regulations my country has established for amateur radio stations; also that the scoring points and facts as set forth in the above log and summary of my contest work are correct and true.

Signature of operator(s)

¹ Add second column in log to give total operating time.

² "Countries" for W/VE Participants. Change this to read "Districts" or "Licensing Areas" on all reports from other parts of the World.

¹⁰ A progressive record of the number of new countries (or licensing areas) is kept in these columns. A notation is made for each station worked but the figure increases numerically only as additional prefixes (or lic. areas) are added on a certain band. These columns are not added, but the last number notation in each column added to similar numbers in other columns gives the "multiplier." Counting the "number of notations" in each of these columns gives the number of different contacts with "DX" stations or "WE/VE stations" on each band, as the case may be, so the information at the beginning of the log-record may be filled in.

What the League Is Doing

League Activities, Washington Notes, Board Actions—For Your Information

Election Results

Two former directors have been returned to office and one new one elected to the A.R.R.L. Board as the result of balloting in the 1937 elections in the Atlantic and Dakota Divisions and in Canada.

CANADA

In a comparatively light vote, our Canadian brothers returned Alex Reid to office as Canadian General Manager by an almost two-to-one vote over his opponent, Leonard W. Mitchell. The story:

Alex Reid, VE2BE..... 202
Leonard W. Mitchell, VE3AZ..... 114

As reported previously, Alex Larivière, VE2AB, becomes the alternate by reason of the withdrawal of his only opponent, John C. Stadler, VE2AP.

ATLANTIC DIVISION

The Atlantic Division similarly decided it wants to retain its present director and reelected Brad Martin by a thumping majority over his two opponents; in a close race for the alternate position, Raymond E. Macomber, W3CZE, nosed out his only opponent. The balloting:

For Director:
Walter Bradley Martin, W3QV..... 679
Roy C. Corderman, W3ZD..... 281
Edward L. Thompson, W3CQS..... 79
For Alternate:
Raymond E. Macomber, W3CZE..... 540
Herbert M. Walleze, W8BQ..... 495

DAKOTA DIVISION

With the previous director, Carl Jabs, not a candidate, the race was between Fred W. Young, W9MZN, and Frank A. Vowles, W9BBL, with the former winning handily:

Fred W. Young, W9MZN..... 127
Frank A. Vowles, W9BBL..... 57

Mr. Young, the new director, is 32 years old, is an instructor in mathematics and science at the State Teachers' College at Mankato, Minn., and is already familiar to some extent with directorial problems, having been the alternate director of the division in 1936 and 1937. He was president of the Southern Minnesota Radio Association in 1934 and 1935 and is at present an O.P.S.

As reported in the previous issue, the Pacific Division has a new director in the person of J. L. McCargar, W6EY, of Oakland, Calif. Mr.

McCargar, 41 years of age, is in the Freight Traffic Department of the Southern Pacific Co., and is a real old-timer, having been in ham radio since 1911 and a member of the League virtually from its start. He has been both a commercial radio and wire operator and spent five years in the Navy as a Chief Radioman. All this, coupled with the fact that he has for the past several years been the alternate director for the Pacific Division, as well as representing it at board meetings on two occasions, insures the division a representative of wide experience in communications problems and League affairs.

Year by year, the voting in League director elections comes closer to being 100 per cent by licensed amateurs. As most members are aware, the by-laws were changed in 1934 to specify that thereafter no new members of the League could vote in elections unless, at the time of voting, they were licensed amateurs. However, since no member of the League who was a member in good standing at the time of this change could be deprived of his voting privilege, it has been necessary to permit voting of unlicensed members who were then members and who have since maintained continuous membership, without any lapses. As the years go by, this unlicensed "prior membership" percentage steadily drops, and from an 18 per cent figure in the 1934 elections has fallen to an average of just over 6 per cent in the contests just held. As a matter of interest, we cite the figures by divisions:

Division	Licensed Amateur	Relying Upon Prior Membership.
Atlantic.....	93.46%	6.54%
Canada.....	94.31	5.69
Dakota.....	96.20	3.80
Average.....	93.96%	6.04%

Cairo Secretary Warner sailed for Cairo from New York on January 4th, and will be on the scene by the time this issue reaches members. He will be joined there by Arthur Watts, of the Radio Society of Great Britain, and also, a few weeks later, by Paul M. Segal, the League's general counsel and the other member of the American amateur delegation; the trio will combine to make up the official delegation of the I.A.R.U.

The official U. S. government delegation to Cairo was announced by President Roosevelt a

(Continued on page 81)

Plate Modulation of Screen-Grid Tubes

Notes on Operation Without Simultaneous Screen Modulation

By Francis M. Dukat,* WIBOD

PLATE modulation of screen-grid tubes, whether of the tetrode or pentode variety, has long been considered impossible,¹ although linear operation can be secured by modulating plate and screen together. Recently linear plate modulation up to 100 per cent has been claimed for the new aligned-grid (beam) transmitting tetrodes.² The conventional pentode and the aligned grid types are not radically different in characteristics, but the following is submitted to demonstrate the existence of certain peculiarities which permit the aligned-grid tubes to be plate-modulated more successfully than pentodes.

First, it may be stated that it is not entirely impossible to plate-modulate the ordinary pentode. The characteristic curves of an ideal pentode are shown in Fig. 1. For fixed control-grid and screen voltages the plate current is constant for any value of plate voltage. Suppose such a tube were operating Class-C at a d.c. plate potential, E_b , a constant peak excitation, E_{p4} , and a fixed screen voltage and load, so that the plate current pulse flowed over some line, *A*, and the peak of the pulse occurred at (1). If the d.c. plate voltage is doubled the plate current pulse will flow over line, *B*, and peak at point (2). The peak current is unchanged, the fundamental component will be relatively unchanged, and there would be no increase in output. However, if the d.c. voltage is decreased to the value, $\frac{E_b}{2}$ the plate current

pulse will operate over *C*, and when the pulse reaches the zero plate voltage line at (3), there can be no further increase in output. Therefore, the peak of the plate current pulse will be limited, the fundamental component will be reduced, and the output reduced proportionately. In such a tube, the modulation would be possible if the carrier were set originally at $\frac{E_b}{2}$ and modulated up to E_b and down to zero. Modulation at higher plate voltages would be possible if the peak excitation were increased to E_{p5} or E_{p6} .

On this basis it would seem that there should exist some value of plate voltage at which the ordinary pentode could be plate modulated. Curve (1) in Fig. 2 is a plot of the output of a Type

RK-20 operating under normal conditions of excitation and screen voltage as the plate voltage is varied. Linear plate modulation under these conditions of operation would be possible at a plate voltage of 600 volts. The carrier power is only about 12 watts, which is considerably less than the carrier power possible with suppressor modulation. Supposedly, if the excitation could be increased, the carrier plate voltage could be increased for the same distortion, and proportionately greater output obtained. Unfortunately, increased excitation will result in excessive screen current and overloading of the screen. In the aligned grid tubes, however, the screen current-space current ratio is considerably less than in the

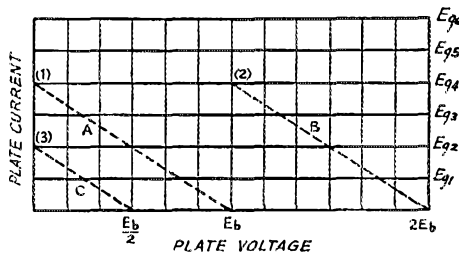

FIG. 1—PLATE FAMILY OF AN IDEAL PENTODE

Plate current curves are simply horizontal lines, indicating that the plate current is independent of plate voltage for fixed values of excitation voltage. Fixed screen voltage also is assumed.

ordinary pentode. Therefore, more excitation can be applied before the screen overloads. Another factor that acts to advantage in the aligned grid tubes is the fact that the plate of this type of tube has some control itself over the total space current. Thus, if a Type RK-47 is operating under normal Class-C conditions and the screen voltage is reduced to zero, it will be found that the output is not zero and that the plate current at 1250 volts is of the order of 15 to 20 milliamperes. This will help on the modulation peaks where the screen begins seriously to limit the plate current. The net result of these two factors is to permit the aligned-grid tubes to be modulated at a plate voltage that approaches the maximum allowable from a voltage-breakdown standpoint. Modulation of the RK-47 is possible at 900 volts plate and of the RK-48 at 1500 volts plate if the excitation is adjusted for the maximum allowable screen current and the plate current kept within rating. This plate cur-

* Raytheon Production Corp., Newton, Mass.
 1 Grammer, "Plate Modulation of Pentodes," *QST*, September, 1935.
 2 Rodimon, "Beam Tubes in a Push-Pull Amplifier," *QST*, September, 1937.

rent rating is one based on the increased screen current and reduced maximum plate dissipation under carrier conditions.

Since the required excitation is higher, the driving power is increased slightly. The driving power for the RK-47 is about 1.3 watts for plate-modulated 'phone as compared to about 1 watt for combined screen and plate modulation under the same bias conditions. On the other hand, the modulator requirements are less for plate modulation.

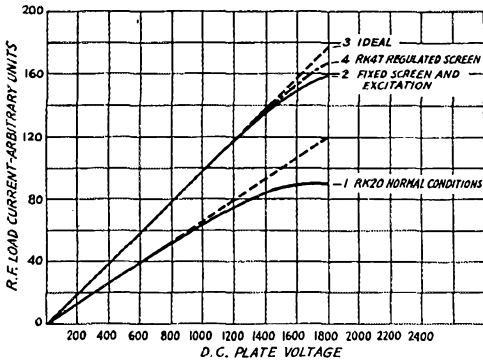

FIG. 2.—TYPICAL OPERATING CHARACTERISTICS OF RK-20 AND RK-47 WITH PLATE MODULATION

Optimum operation is secured with the RK-47 when the screen voltage rises slightly on modulation peaks. This is accomplished by obtaining screen voltage from the d.c. plate supply through a dropping resistor by-passed only for r.f.

lation since the screen does not have to be modulated.

The following are recommended operating conditions for the RK-47, RK-48 and RK-39/41:

	RK-47	RK-48	RK-39/41
E_b plate d.c.	900	1500	400 volts
E_{c2} screen d.c.	300	400	200 volts
E_{c1} control grid d.c.	-100	-100	-45 volts
I_b plate d.c.	80	150	60 ma.
I_{c2} screen d.c.	50	50	17.5 ma.
I_{c1} control grid d.c.*	8	9	4.0 ma.
Peak r.f. input *	175	180	70 volts
R.f. input power *	1.3	1.4	0.25 watts
Carrier output.	50	162	17 watts
Audio power (plate modulation—Mod. factor of 1.0)	36	112.5	12 watts
Peak power output—Mod. factor of 1.0.	200	648	68 watts
Plate load of modulator.	11,200	10,000	6700 ohms
Screen resistor.	12,000	22,000	11,400 ohms
Max. screen dissipation.	15	20	3.5 watts

* Approximate values only. Adjust for rated screen dissipation.

Curve (2) shows a typical plate modulation characteristic for the RK-47. The modulation begins to fall off slightly from the ideal, Curve (3). However, if the screen voltage is supplied from the d.c. plate supply through a dropping resistor by-passed for r.f. only, the screen voltage will rise at the high modulation peaks and tend to straighten out the characteristics. Measurements

made using a screen supply of this sort, Curve (4), show that the characteristic varies little from the ideal. Increasing the bias and excitation in such proportion as to maintain rated screen dissipation will improve the linearity but at the expense of driving power. Usually there is an optimum value of screen voltage. Too-high screen voltage will result in excessive screen dissipation before the excitation is optimum, while too-low screen voltage will not only reduce the output, but will also cause increased distortion because of the limiting action of the screen on the plate current.

What the League Is Doing

(Continued from page 29)

week before Christmas. It is made up of Senator Wallace H. White, Jr., of Maine, as chairman, Capt. S. C. Hooper, of the Navy, F.C.C. Commissioner T. A. M. Craven, F.C.C. Chief Engineer E. K. Jett, and Francis C. De Wolf, of the State Department. With the exception of Commander Craven, who will not leave until early in February, the delegation sailed early in January; it was, of course, accompanied by a corps of advisors, translators, secretaries and stenographers.

As we go to press, we learn of a belated Cairo proposal by our old friend Japan, who will be recalled as one of the most persistent enemies of amateur radio at past conferences. The latest proposal is quite the worst that country has ever advanced, however, and is certainly a lulu! On the pretext of gaining new territory for the aeronautical services, Japan would calmly wash out our 160-meter band and would strip us to a meagre 100 kilocycles in each of the 80- and 40-meter bands! At 20 meters we would be permitted 200 kilocycles, but a joker is inserted here by Japan's suggesting that these 200 kc. be shared between amateur, fixed and mobile services (we have our present assignment at "20" on an exclusive amateur basis). Above 28-Mc. amateurs would be eliminated.

Nice people!

We hasten to assure readers that this proposal is not anything to worry about unduly; although never before confronted with anything quite so drastic, even from Japan, we know from past experience that ways can be found to neutralize such proposals. Nevertheless, it furnishes an excellent example of what might very likely happen to amateur radio were it not organized, and represented at both national and international conferences by people who know from long experience just how to deal with these things.

Jett It is a real pleasure to be able to announce the appointment of Lt. E. K. Jett as Chief Engineer of the F.C.C., effective the first

(Continued on page 114)

Cairo

In Two Parts—Part II†

By A. L. Budlong*

IN the previous section we outlined, as rapidly as was consistent with the facts, the history of amateur frequency allocations, both internationally and here in the United States.

Now we come to the question of the forthcoming Cairo conference itself. Since this conference, like all its predecessors, will have the power to make a complete change in all the international regulations, involving even so drastic a step as the complete abolishment of frequency assignments for any particular service, it becomes a matter of great interest to us amateurs. Most amateurs, however, aside from knowing there is such a thing as an international conference and knowing it can do these things and that it meets from time to time, have very little idea how the sessions are conducted, how we amateurs, for instance, get represented and get our wishes placed before the conference group, and to what extent we participate and vote in the sessions. In this second half of our article we propose to sketch in the conference picture.

As a starter, let's take the simplest of all questions: why is the conference being held in Cairo, why is it being held in 1938, and who is entitled to participate?

It is being held in Cairo because the group which met at the Madrid conference in 1932 voted then to hold the next meeting at Cairo. Each conference customarily decides upon the location for the next. In recent years there has been a tendency to hold these in the smaller countries. The time of meeting is similarly agreed upon by the previous conference. Actually, the Cairo meeting should have been during the latter part of 1937; it was postponed to the winter of early 1938 for no other reason than the one that the participating nations didn't like the idea of going to Egypt in the summer! Postponing the date of a conference doesn't postpone the date on which the conference agreements go into effect; that was and still is January 1, 1939.

As to those who may participate, it may be said, generally speaking, that any nation in the world which wishes to participate in one of these conferences may do so. The cost is prorated among participants. In addition to governments, the present treaty provisions provide that certain accredited private operating agencies and international organizations may participate in

the sessions "in an advisory capacity" if the participating government agencies vote to let them do it. As of this writing, the United States government, at the request of the A.R.R.L., has formally proposed that representatives of the I.A.R.U. and A.R.R.L. be admitted to the sessions of the Cairo conference on this basis. The Egyptian government, the first hurdle to be jumped after our own government, has similarly acquiesced. It is anticipated that there will be no objection to our representatives participating.

At this point it is well to point out that regardless of what other agencies may participate, only *governments* vote. Groups such as the I.A.-R.U. and the A.R.R.L. may be admitted to participation but they cannot vote. We will have more to say about voting later on.

CONFERENCE PREPARATIONS

Theoretically, the conference can draft an entirely new treaty and regulations. And by the way, since we're talking about the treaty, it might be well to get an idea what the document looks like.¹ In its entirety, it bulks several hundred pages of normal-size type. Of this, the *treaty* takes up only about one-third; the other two-thirds is occupied with the *regulations* hitched to the treaty. The whole thing might be likened to a constitution and by-laws, the treaty being the constitution and the annexed "general radio regulations" being the by-laws. The treaty portion is of no particular concern to us, since it is concerned with such generalities as the organization and functions of the International Telecommunications Union, provisions for the ratification of the convention, approval of the regulations, relations with non-contracting governments, rules for arbitration, a section setting up the C.C.I.R. and others providing for the maintenance of the Berne Bureau, and other similar generalities. All the dirty work, from our standpoint, is contained in the regulations; it is in these that services are defined, regulations of procedure specified, frequency allocations set forth, etc. So far as Cairo is concerned, the *treaty* is not under discussion; it is satisfactory as it is and needs no alteration. Cairo will confine itself to a revision of the *regulations*.

Now it is quite true, as we have said, that the

¹ A copy can be secured from the Government Printing Office, Washington, D. C., for 30 cents; ask for Department of State Conference Series No. 15, "International Radiotelegraph Conference, Madrid, 1932."

* Assistant Secretary, A.R.R.L.

† Part I appeared in January QST.

conference has the authority to junk all the previous regulations and write up an entirely new set, but from a practical standpoint it is not necessary to go to such extremes. Many of the regulations adopted at Madrid are perfectly all right even to-day and there is no sense junking those only to rewrite them in the same language. So what happens at Cairo is that everybody scans the Madrid regs, argues about such changes as this or that nation may think necessary, and finally agrees upon a final new set which, actually, may differ in only occasional items from the Madrid regs. The idea is to leave alone such regulations as may be ok "as is" and to change only those that need changing.

However, although only the regulations will be under discussion at Cairo and although the conference will revise, rather than rewrite a new set, the meeting will drag out anywhere from two-and-a-half to four months! And it would drag out even longer, were it not for a system whereby everybody had advance knowledge of what everyone else expects to revise and just how they propose to revise it. We are referring to the business of "proposals" and here is how it works, taking Cairo as an example:

The conference is scheduled for early 1938. As early as November, 1936, every nation expecting to be present is supposed to mail to the Berne Bureau, in Switzerland, a complete summary of the changes in the old regulations which it wants to suggest at Cairo. The idea is that all these "proposals" will promptly be printed by the Berne Bureau in book form and a copy sent back to each participating nation during the spring of 1937; the obvious purpose is to provide every participant with full knowledge of what to expect, to determine, in advance, who agrees with whom and to prepare arguments against such proposals as may be regarded as unfavorable.

THIS PROPOSAL BUSINESS

Now we're going to look into this proposal business somewhat closely. It is of real concern to us, for it is in these advance proposals that we get the first indication of the attitude to be expected from our own and all other governments with respect to intentions at Cairo on amateur matters. We have already, in the July 1937 *QST*, page 22, listed the actual Cairo proposals touching on amateur matters. How did the other nations decide on them? For that matter, how did the United States go about formulating its own proposals, including amateur proposals, and what opportunity was provided for us to inject ourselves into the argument and state our views?

We'll dismiss the other nations of the world by saying that, since with most of them all communications are government monopolies, the proposals almost invariably result from conferences

limited pretty strictly to government officials.

In the United States, however, radio is not a government monopoly; we do things differently. It is true that our proposals are issued in the name of the United States government and, in the last analysis, are what our government thinks best, but it is the practice of our authorities to call in representatives of all the radio interests in the country to help draft the proposals. This provides every interest an opportunity to state its own case. The A.R.R.L., representing amateur radio, was given full opportunity to participate with other agencies and to seek to have incorporated in the U. S. proposals whatever we wanted to change at Cairo. Let's see how we did it.

The proposals were due in Berne in November, 1936, you will recall. Early in the Spring of 1936 our government let it be known that it was going to inaugurate a series of meetings to formulate its Cairo proposals, and it invited everybody who had any stake in radio to come to Washington to help draft them. Anybody who had a legitimate interest in these proceedings could attend. The A.R.R.L., as usual, was present as the representative of amateur radio.

So Spring, 1936, saw several score representatives of dozens of U. S. radio interests assembling in Washington at the call of the government for the purpose of formulating proposals. The work, logically, was split up into various groups, each of which handled some specific subject or section. There would be a group studying technical matters, another doing a job on administrative details, one tackling frequency allocations, etc., with various subcommittees under these main groups when necessary. Members were appointed to these various committees and all went off to their own corners for several weeks or months, as the work might require, to do their jobs. In our case, we were interested in the group having to do with definitions and the committee on frequency assignments: the first, because we think the Madrid definition of an amateur is faulty and the second . . . well, it is hardly necessary to point out our interest in that subject! We will dismiss our participation in the definitions matter right now by saying that the amateur definition we wanted was adopted and incorporated into the formal U. S. proposals. We'll also dismiss all the other preparatory committees in which we had no interest by saying that most of them had finished their work by late Spring.

But what about the allocations committee and, specifically, the high-frequency allocations in which we have so much interest? More to the point, since the A.R.R.L. Board authorized the League's officers to make every effort to secure a widening of our amateur bands at Cairo (which meant they first had to get into the U. S. proposals), were we successful in securing the adop-

(Continued on page 88)

Grid-Controlled Rectifiers for Amateur H.V. Power Supplies

THE possibility of using thyratron tubes to combine rectification with a keying system has intrigued more than one amateur, but the idea has never gotten very far because suitable tubes have not been readily available. Now comes an announcement from Eitel-McCullough, Inc., of a new grid-controlled mercury-vapor rectifier tube to be known as the KY21, a tube designed specifically for this purpose. The KY21 is a heavy-duty rectifier, a pair of them being capable of delivering 3000 volts at 1 ampere d.c., using a choke-input filter.

A peculiar characteristic of the mercury-vapor tube with a grid is the fact that once the tube starts conducting the grid loses control. Thus, it

is possible to block off plate current provided sufficient negative bias is applied to the grid *before* application of plate voltage, but if the bias is afterwards reduced to the point where plate current begins to flow and the mercury ionizes, the space charge disappears and the grid has no effect. When such a tube is used as a rectifier, the alternating plate voltage of course reaches zero and becomes negative during half of the cycle, during which period the grid again assumes control. Hence it is possible to use grid control at keying speeds, with the advantages that the keying is positive and that but negligible power need be broken in the actual keying circuit.

Several circuits suitable for use with the tubes are shown in Fig. 1. A fundamental arrangement is shown at the top; the battery simply represents a source of bias voltage, which may actually be furnished by a simple power pack. In this case the bias transformer secondary must be insulated from the core and primary for at least the peak power transformer voltage, which in the case of the usual choke-input supply will be about 60% higher than the d.c. output voltage. A keying relay similarly insulated must be used.

The second circuit shows a suitable bias supply using an ordinary b.c.l. power transformer and an 80 rectifier. The 2.5-volt winding (which usually is heavy enough to handle all the power necessary—about 15 watts) is used as a primary, and since it gets its power from the rectifier filament transformer, no special insulation is necessary except to see that the whole transformer is well insulated from ground. The keying relay, however, must still be insulated as before.

The lower diagram shows an all-a.c. circuit using a transformer with high-voltage insulation. The secondary is center-tapped, with its outside ends connected to the grids of the rectifier tubes. The polarity must be such that when the transformer primary is energized the induced voltage will place a negative potential on a rectifier grid at the same time that the power transformer is running the plate positive. The resistor in the center tap is to limit grid current. The lamp in series with the a.c. line limits the current flow when the primary is shorted out by the key. Alternatively, a back-contact key or relay can be used in series with the primary.

The grid voltage required to prevent plate-current flow depends upon the plate voltage employed. The tubes have a rather low μ , since the lower μ has been found to give more desirable all-around operating characteristics. At 2000 volts, about 100 volts negative on the grid is re-

(Continued on page 37)

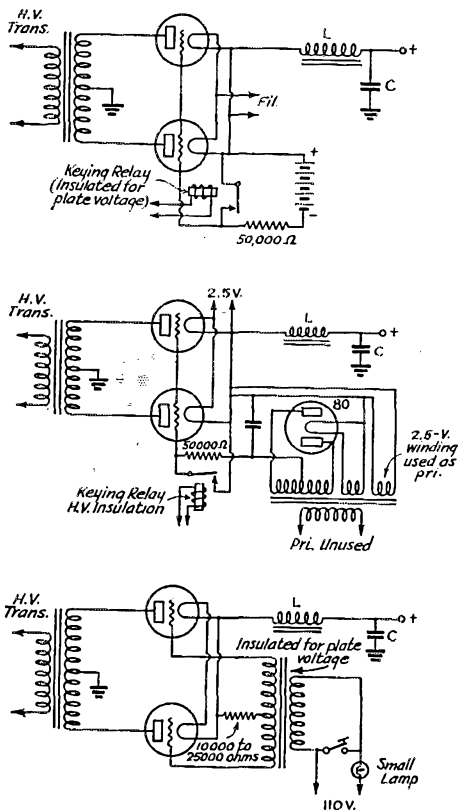

FIG. 1—TYPICAL CIRCUITS FOR GRID-CONTROLLED RECTIFIERS

Since the power handled by the keying relay is negligible, almost any kind of contact will be satisfactory. Workable ones were made from old trickle-charger automatic switches by W6UF-W6CHE, who supplied the diagrams. The contacts were remounted on bakelite "outriggers" to provide the essential high-voltage insulation.

● ARMY-AMATEUR RADIO SYSTEM ACTIVITIES ●

SEVERAL months ago you will remember, the general exodus of Americans from Shanghai started. Many people were trying to get in touch with friends and relatives. Amateur radio came to the rescue as usual and many messages were handled between Shanghai, Manila and the United States. Around the first of November, the Liaison Officer, AARS, sent a message to XU8CR in Shanghai and requested a report of amateur radio activities. He replied immediately but it was well over a month before his letter reached the United States.

XU8CR is owned and operated by Mr. C. R. Shekury, of Bills Motors, Shanghai. Before things started popping in Shanghai, XU8CR says his schedules included K6OCL, Guam, and XU3MA, Chefoo. When traffic began pouring in at the rate of fifty per day sent, and forty received, two other stations were added; VS6AH in Hongkong and KA1AX-WLXR in the Philippines. VS6AH, being on British territory, had to get special permission from the Government to handle refugee traffic since British amateur stations are not normally permitted to handle messages. KA1AX-WLXR is an A.A.R.S. station, owned and operated by army personnel in their off-duty hours. A list of operators at KA1AX is not available so we can only credit the station with good work done in aiding the refugees from Shanghai. For a period of one month XU8CR and KA1AX worked from nine in the evening to one or two in the morning, handling over two thousand messages during the period. KA1AX went off the air but was replaced a short time later by KA1HR-WLXP, Manila, with KA1SL also standing by. KA1HR needs no introduction.

With the arrival of the Sixth Marines, Shekury says, traffic really did pick up and he averaged about one hundred messages on the hook at all times. This he hoped to clear before long.

Traffic originated at XU8CR averaged, at the time of his letter, November 14, 1937, about as follows: fifty per cent Marine, twenty-five per cent mission institutions and twenty-five per cent for the rest of the community. Received messages averaged about the same. K6OCL, Guam, handled the bulk of the traffic for the United States, with KA1HR-WLXP, handling a part of it along with all Philippine traffic.

The A.A.R.S. channel to the United States from Manila is via WLXB-K6OGD, Hawaii, to WLM-W3CXL, Washington, D. C., for the east coast traffic and via WLMI-W6GXM, Los Angeles, California, and WLMW-W7NH, Twin Falls, Idaho, for the west coast.

XU8CR daily schedules:

6:15 P.M. XU3MA, Chefoo

6:30 P.M. VS6AH, Hongkong.

7:00 P.M. K6OCL, Guam.

7:30 P.M. WLXP-KA1HR, Manila.

8:30 P.M. KA1SL, Manila.

10:30 P.M. K6OCL, Guam.

XU8CR traffic to date (November 14th); sent 2890 and received 2000 since January first 1937.

While information is not complete, it is believed that K6OCL contacted W6FWJ in San Diego, California, and W6CII in Los Angeles for his United States outlet.

This is another instance where amateur radio has come to the aid of others in distress, and much credit is due Mr. Shekury and those who helped him during this critical period.

The Shanghai *Times* says: "Many residents of Shanghai are singing the praises of a modest man who has unselfishly devoted nearly all his spare time since the beginning of the crisis to the sending of personal messages out to all parts of the world with a small short-wave radio set. This man is Mr. C. R. Shekury, of Bills Motors, who, although there has been nothing in it aside from a measure of personal satisfaction, has been devoting himself to his hobby for the last few weeks. This hobby has brought infinite comfort to others and ample testimony of this statement lies in the expression of appreciation of those who have been served."

* * *

Results of the Armistice Day Message competition are listed below. This year 759 amateurs copied this message broadcast on November 11th by WLM on the frequencies 3497.5 kcs and 6990 kcs.

The winner of this competition is the Fourth Corps Area, which made a total of 300 points with 100 members submitting correct copies.

Corps Area Participants Handicap Total Points

<i>Corps Area</i>	<i>Participants</i>	<i>Handicap</i>	<i>Total Points</i>
IV	100	3.0	300
IX	216	1.0	216
VII	105	1.8	189
V	79	2.0	158
III	69	2.1	145
VIII	33	2.9	96
II	77	1.2	92
VI	51	1.5	76
I	29	1.9	55

This message from the Chief Signal Officer of the army is a subject of annual competition between Corps Areas. The handicap factor is applied to determine the total score in order to compensate for Corps Areas having a smaller population of amateurs.

Navy Day Competition—1937

FOR the thirteenth consecutive year radio amateurs of the United States participated in the celebration of Navy Day on October 27, 1937, by copying a message from the Secretary of the Navy in A.R.R.L.'s annual Navy Day Receiving Competition. Letters of commendation, signed by Secretary Swanson, were offered to all operators making perfect copy of the message text.

374 operators, or 57% of the 653 participants, submitted perfect copies and each will receive one of the letters. The message, sent by NAA (Washington) and NPG (San Francisco), was copied in 45 states, the District of Columbia, Hawaii, Puerto Rico and Canada.

The Honor Roll lists all participants by Naval Districts in the order of rating within their respective Districts. Congratulations to those whose proficiency places them among the letter-winners! The NAA and NPG transmissions were at approximately 20 words per minute instead of the 15 w.p.m. of previous years. A number of familiar calls are found on the Honor Roll. Among them is W5BMI, who has won a letter in the Navy Day competition for five consecutive years.

As a matter of general interest a tabulation is presented showing participants by Naval Districts, number of N.C.R. members copying the message, number of copies of NAA, NPG, etc.

Once again may we urge all participants in copying contests—do not recopy . . . do not guess! Copy what you hear and submit that "for better or for worse."

—E. L. B. and T. W. Y.

1937 NAVY DAY MESSAGE

For many years Navy Day has been observed throughout the nation on 27 October, the birthday of Theodore Roosevelt. Likewise for many years a radio message has been broadcast on that day to our good friends the American radio amateurs, many of whom are also members of our Naval Communication Reserve. In these times of great international unrest the Navy is particularly gratified to know that its Naval Reserve has reached the highest state of efficiency and readiness for duty that has existed since the World War. The maintenance of a strong and efficient Naval Reserve will do much to strengthen our Navy and assist us in the maintenance of peace and the protection of our own citizens at home and abroad.

CLAUDE A. SWANSON
Secretary of the Navy

(This is the text of the message transmitted from NAA; it is not, however, presented as an identical copy of what was sent—punctuation differs from the original. NPG's text was a paraphrase of NAA's.)

1937 Navy Day Honor Roll

Letter Winners

First Naval District: W1ABG W1AJ W1AN W1APR W1AWU W1BB W1BFT W1BL W1BZO W1DCF W1DGN W1DIZ W1DUJ W1EOB W1EVA W1FAK W1FI W1FNY W1FPF W1FSV W1GAE W1GEN W1HCB W1HVH W1HI W1IC W1IIN W1IKU W1IMD W1ISH W1KH W1KHA W1KIN W1NP W1NS W1PQ W1RR Frank L. Butler, Donald E. Hinds, Chester L. Keene, Joseph E. Reagan. Third Naval District: W1AFB W1AHC W1AMQ W1DMK W1EBT W1ES W1GKM W2AA W2AJ W2ALD W2APO W2AZM W2BDR W2BJX W2BZJ W2CJI W2CJX W2CUG W2CYD W2CVQ W2CYX W2DLJ W2DNS W2ESO W2FAR W2FFN W2GGW

Naval District	Number of Participants			Number Making Perfect Copy			% Perfect Copies	Number of Copies Submitted		
	N.C.R. ¹	Non-N.C.R. ¹	Total	N.C.R. ¹	Non-N.C.R. ¹	Total		Of NAA	Of NPG	Total
First	34	29	63	21	20	41	66	63	5	68
Third	46	48	94	29	26	55	59	94	6	100
Fourth	39	45	84	25	27	52	62	84	3	87
Fifth	15	30	45	10	18	28	62	44	2	46
Sixth	8	9	17	3	5	8	47	17	1	18
Seventh	5	10	15	3	8	11	78	15	2	17
Eighth	46	26	72	26	9	35	49	71	10	81
Ninth	51	83	134	34	44	78	58	130	25	155
Eleventh	30	10	40	18	6	24	60	15	35	50
Twelfth	33	11	44	18	5	23	52	10	39	49
Thirteenth	30	10	40	13	4	17	44	8	35	43
Fourteenth	2	1	3	1	1	2	67	..	3	3
Miscellaneous	1	1	2	1	1	2
Totals	341	312	653	202	172	374	57	552	167	719

¹ The number of N.C.R. and non-N.C.R. member participants was determined as accurately as possible by examination of copies received.

W2GVX W2GVZ W2HAK W2HQG W2HZJ W2IEZ
W2JEQ W2JTC W2KFB W2LR W3DIA W3EWI W3FCQ
W8ABN W8AIE W8DOD W8EMW W8EWP W8JGX
W8KXA W8LDA W8NVK W8PSM W8PWU W8QCH
W8QIR W8RAO Gordon S. Gregory. *Fourth Naval District:*
W2DDY W2FRF W2GRY W3ABE W3ADE W3AKB
W3ANZ W3BYR W3COV W3CRS W3DGC W3DGM
W3EDC W3EFH W3EHZ W3EON W3EWT W3EYT
W3FGX W3FIG W3FKJ W3FKT W3FFM
W3FTX W3FZH W3GJT W3GUD W3HAT W3MH
W3QV W3CUG W8EU W8FQL W8FUW W8IUY W8JZ
W8KRT W8LUG W8MQL W8MOT W8NCJ W8NZR
W8OEM W8OFO W8QAN W8RQ Arthur C. Jacoby, Lester
W. Krute (W8CVS), Donald Leslie, P. Frederick Long,
Eldon Stanford, Edward Tong. *Fifth Naval District:* W3AU
W3BJX W3BWT W3CDG W3CJT W3CPM W3EEN
W3FNG W3FPX W3FSP W3FYJ W3FYQ W3GKN
W3GKZ W3GRX W3GXV W6OME-3 W8CYV W8IGO
W8MCL W8NLE W8PSR R. Bradley, Edward Day, Joseph
A. Haefner, J. C. Harper, William Y. McPherson, Elbert
R. Puffenbarger. *Sixth Naval District:* W4AGI W4CQ
W4DW W4EBA W4ECZ W5GOH S. L. Diggie, Jr., Orbra
Harrell. *Seventh Naval District:* K4KD K4RJ W4AFC
W4AGR W4AIJ W4CZS/EMK W4DVO W4DYZ W4EFM
W4EZ Daniel S. Griffin. *Eighth Naval District:* W1ART-4
W4ABY W4CRP W4CQ W4DQW W4EOY W4ETN
W4EUT W4OI W5ASQ W5BCW W5BMI W5BNO
W5BWN W5CEZ W5CPB W5DAK W5DAQ W5DDJ
W5DGB W5DWN W5ESK W5FAJ W5FNV W5FVJ
W5GER W5GJW W5KC W5OJ W9IHO W9SOB Lyman
M. Edwards, Samuel L. Miller, Madison Monroe, Milburne
O. Sharpe. *Ninth Naval District:* W1BGL-9 W8AXV
W8BKM W8CHO W8FX W8HRA W8LAG W8LCR
W8NDL W8OON W8PP/UT W8QLO W9AA W9AGQ
W9AHY W9AIR W9ANV W9ARH W9AUH W9BQM
W9CDA W9CTZ W9DEB W9DI W9DJA W9EGS W9ELL
W9EMN W9EYH W9FEU W9FFD W9FNQ W9FYX
W9GFL W9GHR W9HDP W9HPG W9KJX W9KJY
W9KUI W9LEZ W9LGZ W9LQU W9LWV W9MFF
W9MYL W9NGS W9NMZ W9NNM W9NVF W9PYF
W9QAB W9RKV W9RLB W9RQR W9RTN W9SIL
W9SKR W9TGN W9TH W9THD W9TKX W9TWV
W9UEU W9VEE W9VWY W9VZS W9WDD W9WGU
W9WYA W9YPI W9ZQW W9ZTN W9ZUO J. H. Cartwright,
Phil G. Hill, W. W. Read, W. J. Wagner. *Eleventh Naval District:* W5ENI W5ZM W6ALO W6BII W6CGY
W6CLY W6EC W6HBD W6HG W6HOS W6IHK W6JAR
W6LDM W6LKB W6LRF W6MGS W6MHX W6MLJ
W6MRT W6NDF W6NXT W6NYN R. B. Walling, Raymond
A. Wood. *Twelfth Naval District:* W6ADB W6AHK
W6BLZ W6CUZ W6DHE W6ECW W6EJA W6FYM
W6JAT W6NKQ W6OBK W6CIW W6ESA W6FA
W6LZA W6RTQ W6SBB W6TDS W6TSQ W6TTD
W9WTW Fred M. Hoehn, Robert S. Howland. *Thirteenth Naval District:* W7ATN W7AZY W7BKZ W7BMX
W7DJS W7EBS W7EGG W7EQC W7ER W7ESV W7GCO
W7GDF W7GGW W7LD Luther L. L. Dilley, John D.
Hertz, H. E. Thomas. *Fourteenth Naval District:* K6MV
W. K. Harris.

The remaining 279 participants on the Honor Roll follow. They are classified by Naval Districts and are listed under their respective districts in the order of rating. Where calls or names are connected by dashes, it indicates that these participants have equal ratings and are listed in a group, alphabetically and numerically.

First Naval District: W1ATK-W1DUK-W1EF-W1FPS-W1GDI-W1HML-W1JID-W1JOW-W1JSK-Boardman H. (Chace)-Leslie T. Malmgren W1EPE-W1IWC-W1YCW-W1YK-George F. Cook W1DGW-W1FQP-W1IVG-W1JGP-W1KBC W1VF. *Third Naval District:* W1ADW-W1HXZ-W1ITI-W1KAA-W2AER-W2BOT-W2FIP-W2JFB-W2KHN-W3ZI-W8ABX-W8BDC-W8GWY-W8JQE-Stephen M. Fox-Wm. Scullion-Wm. C. Tooker W1BHM-W1BYW-W1JLJ-W2AUP-W2HOA-W2JGE-W8COD-W8DT-W8LGR-W8NUA-W2HGL-W2HTD-W2VG-W8QKM W2JWT W1JXP-W2JUC W1APW W2KVC W2JBN-W2KZF W2BAF. *Fourth Naval District:* W3ATJ-W3CHL-W3DNU-W3DXK-W3EBO-W3ELI-W3FEG-W3FI-W3FPC-W3FPG-W3FZO-W3GYY-W3ID-W8OML-

W8QBK-Edwin B. Rhoads W3CNP-W3GJQ-W8BKS-W8FLA-W8VI W3AR-W3DYB-W3FFE-W3SB W3AEJ-W8NPNQ W3CTJ W3FYK-W3GMK W3BGD W3GYB. *Fifth Naval District:* W3GBC-W3GMC-W3GPC-W8JA/3-W8LBI-W8OHW W3GWF-W8ELO-W8OLV-W8PTJ W8NCD W8OFE W8BWK W3HGB W3CYV-W8MLW W9WNK-3. *Sixth Naval District:* W4AGF-W4DEF-W4DFC-W4EOJ-W4EUX-B. E. Ketchie W4AAR W4CSO W4DKM. *Seventh Naval District:* W4AOZ-W4DQA-W4KY W4JO. *Eighth Naval District:* W4APU-W4DXQ-W4QU-W5BAM-W5BKH-W5BRQ-W5CEE-W5ELM-W5EOE-W5FBQ-W5FHA-W5FTW-W9SMV W4DGC-W4DIX-W4RO-W5CWW-W9PAN-H. L. DeWalt-Arthur P. Kay, Jr. (W4ACC)-Lena E. Kay (W4ACC)-Francis Wm. Taylor (W4PBW/HQ)-J. F. Sullivan (W4PBW/HQ) W5CVO-W5DOM-W5EOW W5DXQ-W5EZY W4CDE-W4EUC-Jerome H. Codington-Fritz Ossenbeck W5FRB-C. G. Lodel-Robert Rudesill W4AXP W5ERV. *Ninth Naval District:* W1JHU-8-W8BKE-W8FTW-W8FWU-W8HMH-W9AKT-W9CGY-W9FOQ-W9GMT-W9GWT-W9LLD-W9ORP-W9PCC-W9QDP-W9RSJ-W9SO-W9SQC-W9WJV-W9ZGB-W9ZMP-W9ZTR-J. Russell Thorburn W9AZR-W9EPT-W9FAI-W9FWS-W9LGR-W9NUR-W9NVX-W9RZU-W9YGF-W9ZHD-W9ZOO-W9JG Harry Anderson W8AFK-W8BRS-W8DWP-W9DBO-W9IGZ-W9IMV-W9RWS-W9VKN W9TCM-Rudolph Joseph Blaho-W. J. McGuffage W9JTF-W9PB W9HUB-W9UEG-W9YMX-Joseph Takacs W9PDS W8RFF-Milton O. Kangas W9GEN W9KJ. *Eleventh Naval District:* W6AEE-W6KHK-W6KNL-W6NDV-W6NSQ-W6OON-John E. Pitts, Jr. W6DSN-W6EGL-J. J. Sluiter W6MMO W6PAY W6OIN Eric Laue W6GST W6CIW. *Twelfth Naval District:* W6AOA-W6DIY-W6JZJ-W6LGE-W6MUC-W9JFD-Julio Sannazzari-Jamieson D. Vawter W6AK-W6JAC-W6KDM-W6MCR-W6NTA-W9GLL-W9LQO-W9USP-Homer D. Jagers-Donald Sturtevant-Allan Brodnax W6PN W6GRB. *Thirteenth Naval District:* W7ACF-W7AFX-W7DJJ-W7EHO-W7EWR-W7FFQ W7AND-W7BOZ-W7CBT-W7TK-Arthur W. Emigh-William Samuelson W7BCV-W7ESO-W7OS Ralph W. Lindahl-Frank A. Kalberg-Fred B. Dyer W7DPW 7AMG W7AUV W7CWN W7BIR. *Fourteenth Naval District:* L. D. Paulson. *Miscellaneous:* VE4CQ Albert Freeman.

Grid-Controlled Rectifiers

(Continued from page 34)

quired for cut-off, with other plate voltages calling for proportionately higher or lower bias.

As compared with straight primary keying, it is said that the "tails" are considerably less with this system for the same amount of filter, possibly because of elimination of transformer lag and arcing at key contacts. The method is noteworthy for its elimination of key clicks with high power.

The cathodes of the new tubes take approximately 10 amperes at 2.5 volts. Rectifiers of similar ratings but without grids are also soon to be made available. These will be the Type RX21.

-G. G.

Regenerative Receiver

(Continued from page 18)

possibility of metal surfaces in contact producing a buzzing sound.

Like all receivers this one presupposes a reasonable antenna and a suitable power supply. Since most amateurs have their own receiver power supplies, it is not considered necessary to describe a particular design. For minimum hum, a well-filtered supply should of course be used for head phone and voice reception.

Sweep Circuit Considerations in the Television Receiver

The Design and Operation of Saw-Tooth Oscillation Generators

By Marshall P. Wilder,* W2KJL

IF THE true significance of the basic requirements in a television receiver has been grasped fully, it will be apparent that, with one important exception, there is nothing fundamentally new in a video receiver. It is true that the receiver must be bigger and better in regard to band width and phase shift but, in general, the design is an extension of well-known circuits of the past.

The important exception is in the sweep circuits which generate voltages or currents to be used in deflecting the cathode-ray beam over the surface of the screen in exact synchronism with the scanning beam used to produce the picture at the transmitter. The necessity for sweep circuits is quite new and altogether foreign to communi-

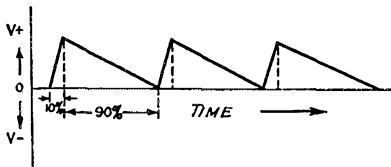

FIG. 1

cation art. Some of us have had experience with sweep circuits in our cathode-ray oscilloscopes, but for the benefit of those to whom the words "sweep circuit" are both confusing and unfamiliar, a few lines of explanation are in order. When a beam of electrons is caused to move across a cathode-ray screen linearly with time, we are, in effect, sweeping a point of light across the screen and, as far as the eye is concerned, ruling a line. When the beam has reached the end of one line, it must return to the other side of the screen without being seen. This return movement is sometimes called the "fly-back" and is set in a modern television receiver to occupy approximately 10 per cent of the time taken to draw the line (or trace) itself. If we plot the voltage against time of such a trace we find that the voltage may rise very rapidly from zero in a short space of time and then fall off steadily to zero, rising rapidly again and falling off uniformly in a continuous sequence. Such a curve, as in Fig. 1, is called a positive saw-tooth oscillation. If the voltage falls very rapidly and then rises slowly the oscillation is called a negative saw-tooth. The genera-

* 55 Kendall Ave., Maplewood, N. J.

tion of such oscillations is the work of the sweep circuit, two such circuits being required in the television receiver. One of these circuits generates the high-frequency saw-tooth oscillation which moves the electron beam in the horizontal direction. The second sweep circuit generates a much lower frequency and serves to move the beam (and the spot of light created by it) in the vertical direction.

Saw-tooth oscillations are produced in practice by the use of gas triodes, such as the 885, by multivibrator oscillators or by feed-back oscillators of a special type. All of these systems rely upon the charging and discharging of a condenser to produce the necessary wave shape.

The simplest but probably the most unstable form of saw-tooth oscillator is that employing a gas triode, the grid of which acts as a trigger and the cathode as a source of electrons to insure ionization of the gas at a reasonably low potential. Figure 2 shows such a circuit. The voltage "B" charges "C" to some critical value at which the grid loses control and the gas in the tube ionizes, thus shorting the condenser "C". This momentarily removes the voltage from the plate of the tube and allows the grid to regain control. This slow charging of "C" and the sudden discharge is, of course, a continuous process and results in the production of a saw-tooth voltage. A second type of saw-tooth generator makes use of a multivibrator—an arrangement of two tubes operated as a sort of resistance-coupled amplifier and provided with some means of feedback to produce

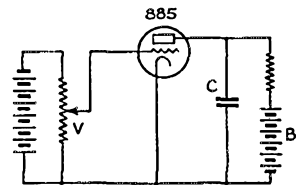

FIG. 2

oscillation. The circuit of one such saw-tooth generator, due to Bedford and Puckle, is outlined in Fig. 3. This sweep circuit employs two high-vacuum triodes, 76's for example. With the particular constants given in Fig. 3, the circuit will oscillate in the neighborhood of 400 cycles per second. By suitable modification of the val-

ues in the tank circuit C_2, R_5 , the circuit can be made to operate at higher or lower frequencies. The ratio of charge to discharge time can be controlled by using higher values of R_5 across lower values of C_2 to give a shorter discharge or fly-

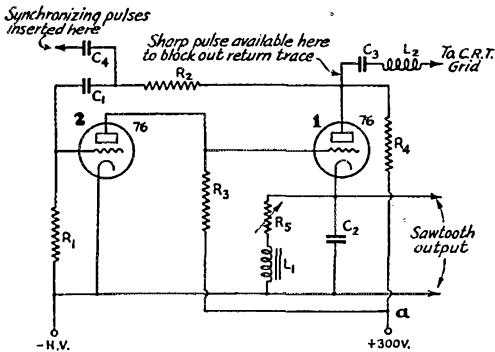

FIG. 3—A TYPICAL MULTIVIBRATOR-TYPE SAW-TOOTH GENERATOR

- R_1 —1 megohm.
- R_2 —4000 ohms.
- R_3 —100,000 ohms.
- R_4 —2000 ohms.
- L_1 —1000-henry choke (Thorndarson T-29C27). This choke is necessary to insure linearity if electrostatic deflection is employed. It will not be needed if magnetic deflection is to be used.
- R_5 —100,000 ohms.
- C_1 —0.002 μ fd.
- C_2 —0.01 μ fd.
- C_3, C_4 —0.002 μ fd.

back time, or vice versa. The circuit functions in the following manner:

The operation is started by any irregularity at the grid of the tubes, say Tube No. 1. This will be amplified by both tubes and fed back to Tube No. 1 in a very much enlarged form. If this irregularity were in the positive direction, the plate current of Tube No. 1 would climb very fast, the current through R_5 causing the cathode to become so positive that the tube cuts off, sending a positive pulse around to Tube No. 2 which, when amplified by that tube, appears as a very negative voltage on the grid of Tube No. 1, insuring cut-off. With Tube No. 1 cut-off, the charge in C_2 will discharge through R_5 until the cathode falls so negative that plate current once more can flow and with this first rise in current, a negative pulse will pass around to be amplified by Tube No. 2 and to aid the rise in plate current of Tube No. 1 until cut-off once more occurs due to the high positive polarity of the cathode of Tube No. 1. The cycle now repeats itself in a continuous sequence. A small synchronizing impulse through C_4 will set the exact point where cut-off is reached and the frequency of the output will then be that of the synchronizing impulses.

A third type of saw-tooth oscillator using a high-vacuum type tube is shown in Fig. 4. This arrangement is generally known as a "blocking oscillator." The feed-back transformer T_1 is arranged so that the tube would oscillate in the conventional fashion if a steady and relatively limitless plate supply were available. In this arrangement, though, the plate voltage is that

available across the "reservoir" condenser C_1 supplied at a relatively slow rate through the constant current device indicated on the diagram. With C_1 charged to its maximum, a positive impulse arriving at the grid of the tube will cause plate current to flow and this, because of the feedback through T_1 , will drive the grid further positive and initiate an oscillation. At this stage, however, the plate current has risen so high that the condenser C_1 is discharged. The plate current will therefore drop to a low value and the drop, again because of the feed-back, will drive the grid negative. This polarity will be maintained by the grid circuit condenser, effectively blocking the tube while C_1 charges steadily through the constant current device. The voltage across C_1 , starting from the charged condition, will show a sudden drop as the tube breaks into oscillation, then a slow linear rise during the recharging period.

A somewhat similar sweep circuit is described in the RCA pamphlet 1801-10-37 entitled "Kinescope 1800." This pamphlet should be studied carefully by anyone interested in more detailed information on the operation of saw-tooth oscillators of this type.

While all these sweep circuits are used in practical television equipment, it is the belief of the present writer that the Puckle circuit is perhaps the simplest to build and the easiest to synchronize. It will be used, therefore, as the basis for the complete circuits to be described.

The multivibrator as shown in Fig. 3 is only part of the complete sweep unit. Though its output is in the form of a saw-tooth, we are to find that some modifications of the basic circuit and many critical adjustments will be necessary before a truly satisfactory wave-shape is had. A first problem is offered, for instance, by the fact that when a charged condenser discharges through a resistor, it does not discharge with complete linearity—that is, the current does not leave the condenser at a constant rate. The discharge is at

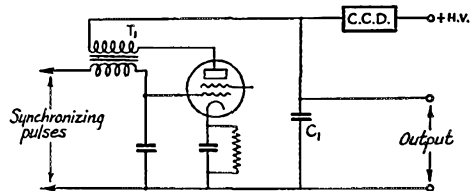

FIG. 4—ONE TYPE OF SWEEP CIRCUIT USING A BLOCKING OSCILLATOR

first quite rapid and then, as the condenser approaches the discharged condition, the rate at which it discharges becomes slower. This means that the cathode-ray beam deflected across the screen by the saw-tooth voltage would not move across the screen at a uniform speed. It would move faster at first and then more slowly, resulting in a picture broadened at one side and

squeezed together at the other. In order to correct this type of non-linearity, three methods may be applied. The saw-tooth voltage may be amplified by a tube which is operating on a non-linear portion of its grid characteristic, the amount of distortion so produced correcting the defect in the original wave shape. Alternatively, the current, as it discharges from the condenser, may be passed through a pentode operating on the part of its characteristic known as the "constant current portion"—a pentode so operated being one type of constant current device to which reference was made in discussing Fig. 4. A third method, developed by the writer, is quite simple and requires no tubes. It employs a high-inductance choke in series with the discharging resistor. Such a choke is indicated as L_1 in Fig. 3.

In the television receiver we require two separate sweep oscillators, one to generate a frequency of 60 cycles (for the vertical sweep) and another to generate approximately 13,000 cycles (for the horizontal sweep). Circuits of the two sweep oscillators may be almost exactly the same, the difference in generated frequency resulting from the choice of values in the tank circuit C_2 , R_5 of Fig. 3. The inductance of the choke used to correct the wave-shape should be approximately 2000 henrys in the low-frequency sweep and approximately 100 henrys in the high-frequency unit. The value of inductance is not critical and its d.c. resistance will not change the frequency of the tank circuit appreciably.

So far we have dealt only with the means of generating saw-tooth oscillations. We shall now consider the methods of applying them to produce the necessary deflection in the cathode-ray tube. If we are to use electrostatic deflection, the necessary voltage may be had directly from the terminals of the tank condenser in a circuit of the type shown in Fig. 3. One important difficulty with some types of cathode-ray tubes will be the so-called "trapezium" distortion. This causes a pattern, which should be a square, to appear on the screen as a keystone. An explanation of the cause of this distortion is beyond the scope of this paper, but it is readily avoided by using a push-pull arrangement such as that shown in Fig. 5. A portion of the voltage generated in the tank circuit of the second tube is obtained across the voltage divider R_{16} , R_{17} and applied to the grid of an amplifier. The voltage in the output of this stage can be made equal in amplitude to that generated in RC tank circuit but its phase will be 180 degrees different. When these voltages are applied as indicated in Fig. 5, the deflection will be linear and any trapezium distortion will be balanced out. With this circuit it is necessary to generate only half as much voltage for com-

plete deflection of the beam as is required if two of the deflection plates are tied back to the anode—as is often done in conventional cathode-ray tube circuits. Naturally, all four plates of the cathode-ray tube must be free

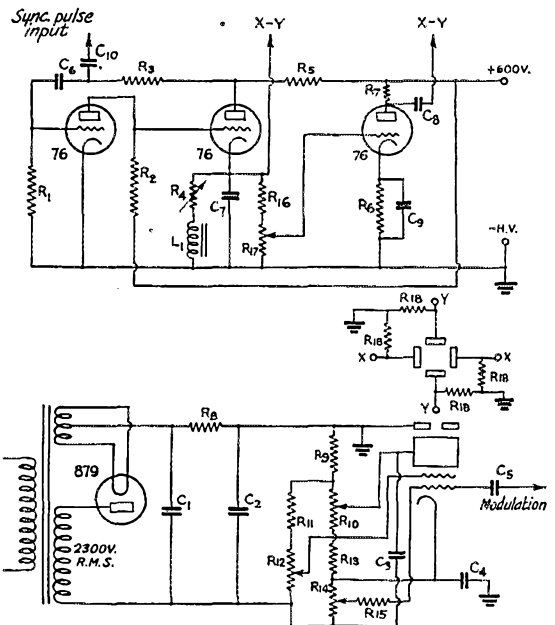

FIG. 5—A PUSH-PULL SWEEP CIRCUIT FOR ELECTROSTATIC DEFLECTION TOGETHER WITH THE CATHODE-RAY TUBE ARRANGEMENT

Constants for the High-Frequency Sweep

- R_1 —1 megohm.
- R_2 —100,000 ohms.
- R_3 —4000 ohms.
- R_4 —50,000 ohms.
- R_5 —2000 ohms.
- R_6 —1500 ohms.
- R_7 —150,000 ohms.
- R_{16} —500,000 ohms.
- R_{17} —25,000 ohms.
- C_6 —0.002 μ fd.
- C_7 —0.001 μ fd.
- C_8 —0.01 μ fd.
- C_9 —50 μ fd.
- C_{10} —0.002 μ fd.
- L_1 —100 henrys (Kenyon T-155).

Constants for Low-Frequency Sweep

- R_1 —1 megohm.
- R_2 —100,000 ohms.
- R_3 —4000 ohms.
- R_4 —250,000 ohms.
- R_5 —2000 ohms.
- R_6 —1500 ohms.
- R_7 —150,000 ohms.
- R_{16} —500,000 ohms.
- R_{17} —250,000 ohms.
- C_6 —0.002 μ fd.
- C_7 —0.25 μ fd.
- C_8 —0.2 μ fd.
- C_9 —50 μ fd.
- C_{10} —0.01 μ fd.
- L_1 —2000 henrys (two Thordarson T-29C27 in series).

Constants for Power Supply and C.R. Tube Circuits

- R_8 —100,000 ohms, 5-watt.
- R_9 —1 megohm, 10-watt.
- R_{10} —250,000-ohm, 5-watt.
- R_{11} —500,000-ohm, 1-watt.
- R_{12} —500,000-ohm, 1-watt.
- R_{13} —150,000-ohm, 5-watt.
- R_{14} —50,000-ohm, 1-watt.
- R_{15} —500,000-ohm, 1/2-watt.
- R_{18} —2 megohm, 1/2-watt.
- C_1 , C_2 —0.5 μ fd., 3000-volt.
- C_3 —2 μ fd., 750-volt.
- C_4 —0.5 μ fd., 3000-volt.
- C_5 —0.25 μ fd., 3000-volt.

before push-pull electrostatic deflection can be used.

The alternative method of applying the saw-tooth output for deflection purposes is by the use of electromagnetic deflection. This is the type of deflection most to be recommended for television reception. Although excellent pictures

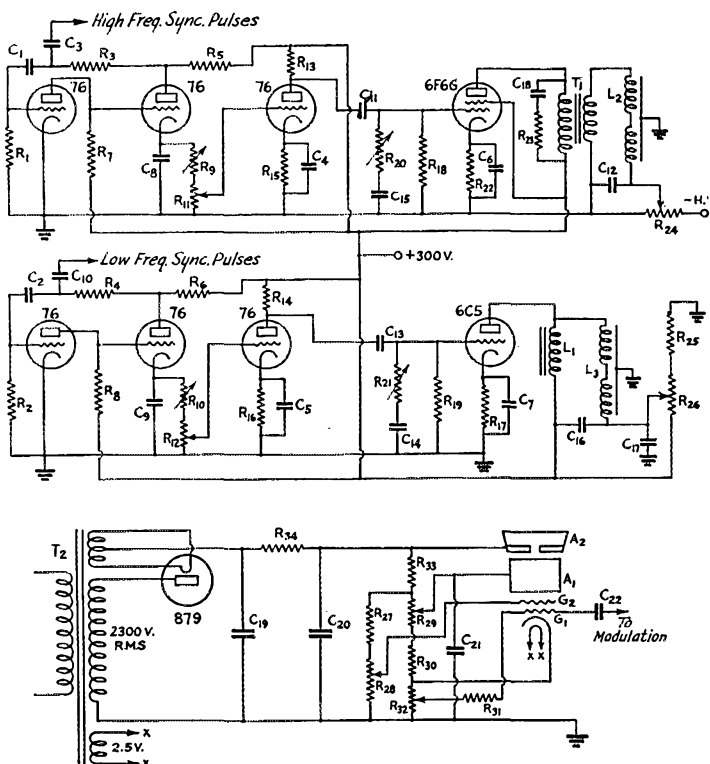

FIG. 6—A PAIR OF SWEEPS FOR MAGNETIC DEFLECTION TOGETHER WITH THE HIGH-VOLTAGE POWER SUPPLY AND C.R. TUBE

- C1, C2, C3—0.002 μ fd.
- C4, C5, C6, C7—50 μ fd.
- C8—0.001 μ fd.
- C9, C10—0.25 μ fd.
- C11, C12—0.01 μ fd.
- C13—1 μ fd.
- C14—0.5 μ fd.
- C15—0.004 μ fd.
- C16, C17—8 μ fd. electrolytic.
- C18—0.0005 μ fd.
- C19, C20—0.5 μ fd., 3000-volt.
- C21—1 μ fd., 1000-volt.
- C22—0.1 μ fd.
- R1, R2—1-megohm.
- R3, R4—4000 ohms.
- R5, R6—2000 ohms.
- R7, R8, R9—100,000 ohms.
- R10—250,000 ohms.
- R11, R12—10,000 ohms.
- R13, R14—50,000 ohms.
- R15, R16, R17—2500 ohms.
- R18, R19—1-megohm.
- R20, R21—25,000 ohms.
- R22—300 ohms.
- R23—35,000 ohms.
- R24—12 ohms.
- R25—100,000 ohms.
- R26—30,000 ohms.
- R27, R28—500,000 ohms, 1-watt.
- R29—250,000 ohms, 5-watt.
- R30—150,000 ohms, 5-watt.
- R31—500,000 ohms.
- R32—50,000 ohms.
- R33—1-megohm, 10-watt.
- R34—100,000 ohms, 5-watt.
- L1—100 henrys (RCA Type 9833 or Kenyon T-155).
- L2, L3—RCA Type 9831 or Kenyon Type T-700 Yoke.

T1—RCA Type 9836 or Kenyon T-111.

can be obtained by using electrostatic deflection, there are several disadvantages at the present time. Most electrostatically-deflected tubes do not focus as well at the extreme end of the trace as they do in the center. This distortion is not apparent when electromagnetic deflection is employed. Also, the power necessary to generate the deflecting current in the coils is not as great as that required to generate the high voltages for electrostatic deflection. Then, the cathode of the cathode-ray tube, as well as those of the sweep oscillators, can be at ground potential when electromagnetic deflection is employed.

But there are plenty of problems in electromagnetic deflection, also. To obtain linear deflection of the beam employing magnetic sweep circuits, we must have current flowing in the deflection coils or yokes which is itself linear. A saw-tooth voltage applied to the coils will not result in a linear current flowing in the coil because of the back e.m.f. from the coil when shocked by the applied voltage. It is therefore necessary so to distort the voltage waveform entering the coil that a linear current flow will result. This is commonly known as supplying an impulse riding on the leading edge of a saw-tooth. This impulse plus the saw-tooth will result in a linear current flow through the yoke winding. To obtain this waveform it is necessary to gener-

ate first the saw-tooth and then to add a suitable impulse to the saw-tooth voltage as it is applied to the grid of an amplifier. The output of the amplifier will then have the necessary impulse riding on a saw-tooth. In the case of the high-frequency sweep, this current is applied through a transformer because the impedance of the yoke coil is very much lower than that of the plate of the output tube and a sad mismatch would result if the transformer were not used. In the case of the low-frequency deflection coil, a transformer or a choke may be used to couple between the amplifier and the yoke. The necessary deflecting coils or yoke can be purchased from RCA or Kenyon at the present time while the very important transformer necessary to couple the output of the high-frequency sweep to the yoke is also available from the same sources.

The complete circuit for magnetic deflection is shown in Fig. 6. The Puckle type of multivibrator is employed followed by a third Type 76 tube which serves a double purpose: It inverts the phase and adds an impulse to the saw-tooth waveform generated by the multivibrator. It will be noted that a 6F6G tube is used as the output amplifier for the high-frequency sweep while a

(Continued on page 58)

How Would You Do It?

Suggestions on Displaying QSL Cards

IN presenting Problem No. 12, little did we realize how vital the question of displaying QSL cards is to the modern amateur. His receiver tubes may burn out when he operates his transmitter, he may risk his life operating an exposed transmitter, his antenna relay may be noisy and he may catch pneumonia from draughty lead-in openings, but—by gosh!—he's extremely finicky about the way he cares for his QSL's and how he shows them off to visiting firemen! At least that's the impression we gained from the avalanche of responses to Problem No. 12.

In writing a summary of the various ideas and combinations of ideas, we have deemed it impracticable to make specific mention of the sources, in most cases, because most of the ideas were duplicated many times. The interest displayed in the problem is highly appreciated, nonetheless.

The problem resolved itself into three major portions, the first dealing with that of protecting the cards against dust, etc.; the second, that of devising a suitable mounting which would prevent marring walls; and third, methods of fastening the cards to the mounting with as little damage to the cards as possible.

Cellophane was chosen as a protective covering by the majority. Some wrapped each card in cellophane, fastening it at the back with glue or Dupont cement. Others used a large sheet to cover a group of several cards. Another scheme consisted of strips of heavy cellophane or celluloid the width of a card. Diagonal slits were cut in the cellophane strip to receive the corners of a card in a manner similar to that used in old-style photo albums. The use of adhesive photographic art corners was also suggested. In both latter cases, the cards were mounted on the cellophane strips with the faces of the cards against the cellophane. These strips, containing the cards, were suspended from the picture moulding. Still another scheme consisted of long horizontal pockets of cellophane made of a strip, somewhat wider than the height of a card, cemented at the ends and lower edge only. A series of these long pockets was mounted, one

above the other on a suitable background. The cards may be inserted from the top. In a slightly modified form, both top and bottom edges were fastened and the ends left open so that a string of cards fastened together could be pulled through from end to end.

Several samples of wrapping were submitted and we tried some of our own. The chief objection to the use of cellophane seems to be that most of the inexpensive light-weight grades are affected seriously by changes in temperature and humidity. From the condition of most of the samples received, it seems very advisable to wrap cards very loosely to prevent buckling of the card when the cellophane shrinks. Ready-made envelopes in standard sizes are available at most stationery stores and were suggested by several. Perhaps the selection of a size which will fit the card loosely is the most satisfactory way of using cellophane for protection.

While we did not try the idea of a large sheet for covering a group of cards, it seems that wrinkling or bulging would still be a problem. A wrinkled or ripply surface makes it difficult to find any position from which the cards may be viewed without glare from reflected light.

To our minds, the most satisfactory method of protecting cards against soiling is that suggested by the second largest group. This consists of brushing or spraying the cards with a protective waterproof preparation. We doubt if the process would be any more tedious than that of preparing a cellophane covering. It should be less expensive, the problem of wrinkles is avoided and the cards are furnished with a permanently preserved finish which permits washing the cards, if necessary, without damage to the cards. Clear lacquer, clear shellac, French lacquer, clear varnish, map varnish, clear liquid celluloid, water glass and drawing fixer

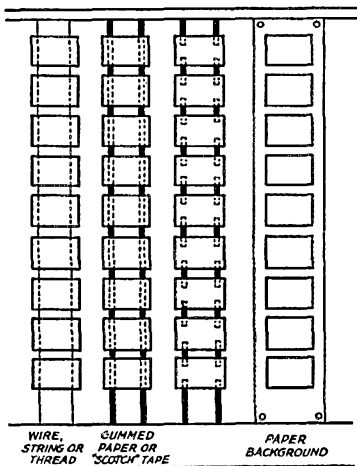

FIG. 1—FOUR METHODS OF SUSPENDING QSL CARDS
Each is explained in the text.

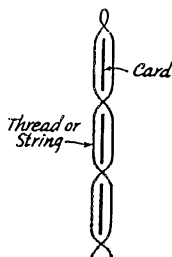

FIG. 2—A NOVEL WAY OF LINKING CARDS TOGETHER

are suggested as being satisfactory for the job. Most of these preparations produce a glossy surface. W1BYJ suggests a solution of 40 per cent clear metal lacquer and 60 per cent lacquer thinner. Two coats seemed to change the original surface of the card but little. W1BYJ coats the cards by dipping them vertically into a container of the solution, holding the card with a pin at one corner to prevent finger marks. The cards are suspended by means of the pin while drying which requires about seven minutes. He cautions against smoking or any open flame in the vicinity of the solution which, like most lacquer preparations, is highly inflammable.

W5ASD suggests a solution made by dissolving clear celluloid in airplane "dope" or by thinning down "liquid celluloid."

Care must be used with any of these solutions to provide a uniform surface when applied with a brush. Perhaps the best method of application is by means of a small atomizer or "blow" type sprayer, either of which may be obtained at little cost from art or stationery stores.

Several schemes for mounting the cards without marring the wall were suggested. Perhaps the most popular scheme of all consisted of a pair of strings, thread, small diameter wire, gummed paper strips or strips of so-called "Scotch" tape or masking tape. ("Scotch" tape may be obtained in rolls at any stationery store. It is coated on one side with a permanently adhesive surface somewhat similar to that of adhesive medical tape but is less expensive. It is obtainable in a variety of forms, colors and sizes. One type is transparent.) Each pair of strips is run vertically from the top to the bottom of the wall with a separation somewhat less than the length of a card. By means of Dupont cement, stamp hinges, bits of "Scotch" tape or adhesive tape, the cards are fastened, one above the other, to the strips. (See Figs. 1A and 1B.) In the case of gummed paper strips or "Scotch" tape strips, additional fastening is unnecessary, of course. If the cards are wrapped in cellophane, they may be attached to the wires or strings by folding the cellophane over the string or wire before fastening the cellophane at the back of the card.

Another popular method is to arrange the cards in chain fashion, each card being fastened to the one above it by two small pieces of adhesive material such as those mentioned above. (See Fig. 1C.) With either of these methods, when necessary, the rows of cards may be taken down and folded into compact packs. A variation in this method involves punching four holes in each card and suspending one card from the one above it by means of small wire hooks. Others suggest sewing the cards in long strips with needle and thread. A rather novel method of linking the cards together is shown in Fig. 2. This scheme was suggested by ON4CC.

Another group preferred mounting cards in

Problem No. 14

OUR Hero is looking for something new and novel in the way of transmitter construction. He is particularly desirous of finding new arrangements which will provide a minimum of accessibility for coil changes or minor alterations and yet permit enclosing the apparatus against dust accumulation and tampering by visitors or other members of the household. He has found that the accessibility of the popular rack-and-panel system is often restricted unless space is available on all four sides of the rack. He believes there is room for entirely new slants on the business of constructing transmitters for greatest utility from the strictly amateur angle.

If the unit can be made sufficiently attractive to remove objections to operation in the living room of a small apartment, so much the better.

groups on backgrounds of studio board, drafting paper, wall board, plywood, cardboard, quarter board and similar material with the surface covered with colored paper, cloth or oilcloth. A suitable frame or moulding was often suggested. The cards were fastened to the mounting by means of thumbtacks, Dupont cement, bits of "Scotch" tape, stamp hinges or photographic art corners. As an alternative, some suggested slitting the background material for the corners of the cards where this was practicable. W9YRF assembles several cardboard squares, on which his cards are mounted, in "calendar" form so that cards on any particular sheet may be examined by lifting the sheets above it.

An idea which seems to come halfway in between the two preceding methods consists of strips of colored shelf paper or wrapping paper, somewhat wider than the length of a card, extending from top to bottom of the wall, on which the cards are mounted. (See Fig. 1D.) W9TCK suggests a paper roller shade as a mounting.

Several others suggested albums made up from "dime store" loose-leaf scrap books.

Prize winners for this month are as follows:

First Prize: Fred Lindquist, W1BYJ

Second Prize: Miss Amy Medary, W1KRO

We wish also to thank the following for their assistance: W1GMM, GZX, IMV, IXC, KSK, 2DIJ, HTV, IOZ, IZX, KCC, 3AHK, BBV, EYM, GEO, GQZ, 4EPH, JO, 5EZA, 6AOI, NAL, PGG, 7AZD, CMY, 8AVF, BTP, INK, LCO, OMM, PCM, QVR, 9EUZ, KYE, NBV, OLN, PCZ, VDG, VWO, WMP, K4KD, K7GLL, VE2IA, 3GZ, 5PW, 5UI, G6GH, E. J. Drumm,

(Continued on page 110)

A Simple 56-Mc. Transmitter with Cathode-Bias Modulation

By Everett C. Geiger,* W2FZQ, and Edward McGrath,** W2GNL

THE little 56-Mc. transmitter here described is the result of a considerable period of experimentation and "bug chasing" in the search for an efficient and economical rig for local rag-chews. In it is incorporated a modernized version of "center-tap" modulation; namely, cathode-bias modulation. Here we have a companion for our old cronies, plate modulation and grid-bias modulation.

We thought the idea was good, but the performance of the finished transmitter far exceeded anything we had hoped for. It combines improved frequency stability, fair output, small modulator power and good audio quality. Without exception, all reports on quality of speech have been "crystal" and "broadcast." Running the oscillator at 28 watts input, it is possible to modulate it fully with the output of a 56 tube.

The foregoing claims have been fully proven by over three years' use of two rigs built to these specifications. And, incidentally, W2GNL has verification of the reception of his signals in the Middle West when the "skip" was on. Consistently good results have been obtained in numerous contacts in the 1st and 3rd districts.

As shown in the diagram of Fig. 1, the radio frequency portion of the rig is a conventional TNY oscillator using the twin-triode 53. The usual values of inductance and capacitance are employed. The audio portion employs a 56 speech amplifier transformer-coupled to a 56 modulator. The modulation coupling transformer T_3 is a 3:1 audio transformer with the secondary removed and 200 turns of No. 26 wire wound in its place. This forms the secondary, which must carry the cathode current, and across which the cathode bias voltage for the 53 is developed. Be sure that the grid end of this secondary is at ground potential.

The antenna coupling method is quite important. It was found that the tuned antenna tank method, as shown in the diagram, was most satisfactory, because the loading by the antenna could be more easily controlled. Accurate control of antenna loading is quite necessary for proper output and modulation of the oscillator, as outlined in the following paragraph.

When the plate and grid circuits of the oscillator are adjusted for best oscillation without load it will be found that the plate current rises instead of dipping as in the more usual oscillator circuit. This is perfectly proper, however, and at maximum there should be about 100-ma. plate current flowing. Then it is advisable to detune the plate tank condenser until the current drawn is about 90 ma. With antenna tank loosely coupled to the oscillator and tuned to resonance, the coupling should be adjusted until the plate current dips to 80 or 85 ma. Field strength tests indicate that a dip of 5 to 10 mils produces greatest signal output. With everything adjusted properly the plate current (and output current) will kick

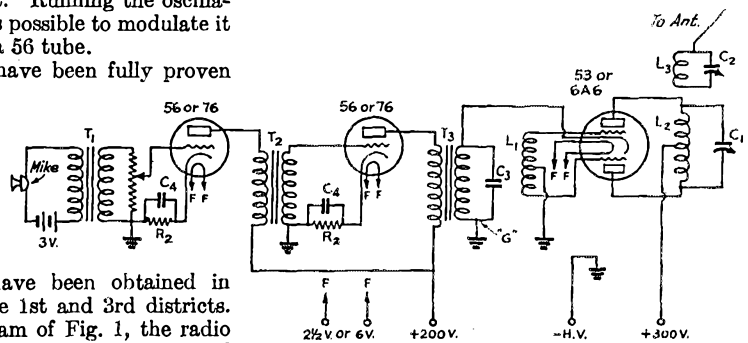

FIG. 1—CIRCUIT OF THE CATHODE-BIAS MODULATED TRANSMITTER

- L_1 —6 turns No. 12 wire, 1 inch diameter.
- L_2 —4 turns No. 12 wire, 1 inch diameter.
- L_3 —2 turns No. 12 wire, 1 inch diameter.
- C_1, C_2 —50- μ fd. midget variables.
- C_3 —0.001- μ fd. by-pass.
- C_4 —0.5- μ fd. by-pass.
- R_1 —500,000-ohm volume control.
- R_2 —2000-ohm 1-watt cathode resistors.
- T_1 —Single-button microphone transformer.
- T_2 —3:1 audio transformer.
- T_3 —3:1 audio transformer with secondary removed and replaced by new secondary consisting of 200 turns No. 26 wire wound around primary.

up under modulation. If it kicks down, the plate tuning should be adjusted for lower plate current.

The power supply for the oscillator is conventional and should be capable of delivering 300 volts at 100 ma. The mike used in all work with this rig is a high-quality single-button carbon type. The antenna is a half-wave vertical with single-wire feed. Other types of antennas may be used successfully.

* Glen Manor, Park Ridge, N. J.

** 235 Cypress Ave., Bronx, New York City.

The Harmonic Tank Circuit

Increased Transmitter Efficiency at Ultra-High Frequencies

By B. P. Hansen,* W9KNZ

THE circuit device about to be described is the result of an effort to effect improved performance with tubes of conventional design at higher than ordinary frequencies. In its basic theory it is by no means new; in fact it represents the indecent disinterment of one of those dead things Warner recently wished buried—in his November Editorial, to be exact. It has existed for years in the familiar—to the *real* old timer—Tesla or Oudin coil, from which Gorgon-headed monster the suppressed ham of war days drew great streaming sparks to astonish his visitors.

A five-meter transmitter usually is operated at rather poor efficiency simply because the tank circuits must necessarily be of very small dimensions. This limitation particularly restricts the amount of inductance that can be used. The output capacitance of the tube or tubes used to excite the final tank usually limits the size of such a tank coil to two or three small turns. If we could establish some means of transferring the energy output of a tube to a tank circuit whose constants were independent of the tube constants, it might be possible to realize an improvement in the performance of our high-frequency equipment. Such an operating condition is brought about by the circuit trick under discussion.

A tank coil is constructed of such dimensions that its fundamental frequency will be relatively low. The dimensions also are chosen so that the tuning condenser used across this entire coil is of about the capacity that would be used for the much higher operating frequency that we hope to get. Instead of designing the coil with well-spaced turns, we wind the turns rather closely together to get as much distributed capacity as possible. If now the circuit is tuned to say 20 Mc., but is excited at its third harmonic or 60 Mc., it will give very much the same sort of performance that our Hertz antennas give when operated at harmonics of their fundamental frequencies. In connecting the plate of the exciting tube to this tank coil, however, we find that we must connect it at a point on the coil where the impedance of the loaded tank circuit will equal the optimum load impedance for the tube. Another way of saying the same thing: We must connect the plate of the tube to the coil very near a voltage node when the coil is considered as operating only at the desired harmonic frequency. This point is readily determined experimentally; for a third

harmonic tank it will actually be close to a third of the way down from the hot end of the coil. This point found, and the plate connected, the circuit will operate nicely at its third harmonic (or any other harmonic for that matter), and the tuning effect of the tube capacity will be negligible.

Actual experiment with the device has shown that, for operation in the amateur five-meter band at least, most generally satisfactory results are obtained when the circuit does operate at the third harmonic.

The push-push doubler circuit employing the harmonic plate tank which is shown in Fig. 1 will solve quite a few problems that usually confront

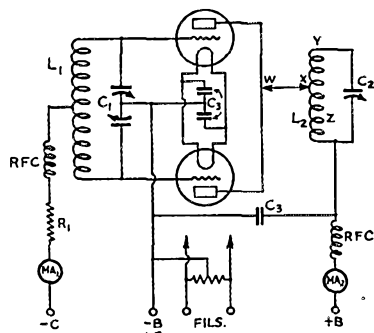

FIG. 1—PUSH-PUSH 56-MC. DOUBLER USING THIRD-HARMONIC PLATE TANK CIRCUIT

- C₁—Split-stator, 35 μ fd. per section, double-spaced.
- C₂—25 μ fd., triple spacing.
- C₃—0.005- μ fd. mica.
- L₁—14 turns No. 12, coil diameter $\frac{3}{4}$ inch.
- L₂—9 turns No. 12, coil diameter $2\frac{1}{2}$ inches, coil length $3\frac{1}{2}$ inches.
- RFC—Two-inch winding of No. 26 d.c.c., $\frac{3}{8}$ -inch diameter, turns spaced wire diameter. No form used.
- R₁—50,000 ohms, 50-watt.
- MA₁—0-50-ma. d.c.
- MA₂—0-500-ma. d.c.
- Tubes used by W9KNZ were W.E. 242-A's.

the operator of a five-meter station. This type doubler can be made to give performance equal to that of the same tubes working at the same output frequency as Class-C amplifiers. Since it does not depend upon excessive values of bias and excitation for its doubling action, it can actually be operated under Class-C conditions, and can therefore be properly modulated. The grids of the two tubes are in push-pull and are operating at one-half the output frequency. An actual advantage over a straight-through amplifier is gained here in that excitation requirements are more easily met

* 3800 Colfax Ave., Denver, Colo.

and the charging current flowing to the grids (that r.f. grid current that the manufacturers mention, in terms of *ampres* on their dope sheets) is considerably smaller than it would be for a straight-through amplifier. True, the plates of the tubes are in parallel—and at 60 Mc. at that—but the use of the harmonic tank circuit reduces that problem to zero. No neutralization is needed. Any ordinary tubes can be used. The one thing that must be watched closely is the danger of stem failure due to dielectric losses. Plate dissipation, for all ordinary triodes at least, is not a limiting factor, since the stems of nearly all conventional triodes will soften and fail long before the plates begin to show colour.

If the tubes do not draw the same current, as shown by one plate running hotter than the other, move the point "W" along the lead between the two plates until the load is equalized. If this lead from plate to plate is made about six or eight inches long, it will be easy to match up any pair of tubes.

For this particular set of parts, point "X" comes exactly four turns down from the hot end, "Y," of the coil.

R.f. chokes in all leads will reduce pickup in nearby b.c.l. sets. They should be of such dimensions that they represent about a quarter wave at operating frequency. Excitation is supplied to L_1C_1 at 30 Mc.; circuit L_2C_2 tunes to 20 Mc. but operates at 60 Mc. While a nice, long arc can be pulled from point "Y," there won't be much in the way of fireworks at the plate leads of the tubes. But by going on down the coil a little way farther toward the ground end, at point "Z" will be found another point of high voltage. The apparent voltage at this point is less than at the end of the coil, of course, due to the loading effects of the adjacent portions of the coil, but this point "Z" offers some interesting possibilities as a starting point for regenerative feedback.

Actual performance of a typical setup using 242-A's may be enlightening. With a grid leak R_1 , of 50,000 ohms and with 90 volts fixed bias, the maximum d.c. grid current was 20 ma. Maximum plate voltage was 650 and plate current 250 ma., which represents an input of about 160 watts. A half-wave antenna coupled to this tank showed better than 1.5 amps at its center. Unloaded, the off-resonance plate current would run around 350 ma. and would dip to about 100 ma. "on the nose." Unloaded and tuned to resonance, a fat arc a half-inch long could be pulled from the hot end of the tank. With the input reduced to 40 watts, this outfit still puts out the strongest signal, according to a good many reports, than any piece of five-meter equipment had ever put over the Denver area. The signals were reported S9-plus in Boulder, a distance of about 40 miles over irregular country. W9GBQ at Sedalia, 20 miles away over a series of ridges, can hear some Denver five-meter stations (average Denver input around

60 watts) when he uses a directional antenna for receiving. The 40-watt signal from this equipment was readable at his place on a three- or four-foot piece of wire, while the 160-watt signal gave S9 strength on the same scrap of wire. These distances do not appear formidable to some of the five-meter crowd who will read this, but we fellows here in Colorado merely suggest that the problems offered by this part of the country will fill anybody's vacation with all the five-meter headaches he will want to meet.

The failure of the author's health brought the experimental work on this device to an abrupt halt. However, its performance on 120 Mc. was checked and gave promise of some interesting results. As a matter of fact, the outfit performed just about as well on 120 Mc. as it did on 60 Mc. Only one report on the 120 Mc. signal was had, from W9VXX of Denver, but he received it S9 plus on a superhet consisting of a converter feeding a t.r.f. receiver.

For smaller tubes, care *must* be exercised to prevent stem failures. Probably some of the larger tubes with grid and plate leads brought through the sides of the envelope would give much better performance. It would be interesting to see how some of the older large tubes would behave—the 204-A for example.

We were able to operate a pair of Taylor 825's at the following operating values: grid leak, 50,000 ohms; grid current, 15 ma. (*no more*—the stems will fail); plate volts, 500; plate current, 100 ma. Other constants were the same as for the larger tubes. For a pair of 45's: grid leak 50,000 ohms; grid current, 12 ma. (*no more*); plate volts 300, plate current 60 ma.

When we hear of someone operating a pair of 45's on five meters at an input of 60 watts or so, we have to grin; if the efficiency of the setup was anything at all, the stems in the little bottles would melt!

In conclusion, one experiment that was tried might be of interest. During a contact with a local station, and running 40 watts input to the harmonic-tank setup, we were getting an S9 plus report. The harmonic tank coil was then removed and a conventional coil with the plate connected to the hot end substituted, and the input adjusted to exactly the same value as for the original setup. The report dropped to S3 or S4. Only one conclusion can be drawn from such a direct comparison.

The author wishes to express his gratitude and appreciation to W9GBQ and W9ESA for their help in developing and testing this equipment.

Correction

In the article "A Five-Band Exciter with Front-of-Panel Coil Changing," January, 1938, *QST*, the common connection between the oscillator plate coils in Fig. 1 should be grounded to the common negative bus. The diagram shows the coils floating.

Television Transmissions from Los Angeles

AMATEURS in the vicinity of Los Angeles are particularly fortunate in that television transmissions are available daily on a regular program basis. In this respect, the Los Angeles fellows are, as far as we can discover, more fortunate than those in any other city in the United States. Source of the transmissions is W6XAO operated by the Don Lee Broadcasting System. The station operates daily except Sundays and Holidays starting at 6:30 P.M. In addition, daylight programs are transmitted according to the following schedule: Monday, 9 to 10 A.M.; Wednesday, 11 to 12 A.M.; Saturday, 2 to 3 P.M. Special programs are transmitted frequently and are announced at the conclusion of the preceding scheduled transmission.

The vision signal is transmitted on 45 Mc., the accompanying sound on 54.3 Mc. The image is a 300-line picture with a frame repetition frequency of 24 per second. Interlacing is avoided in order to allow equally successful reception on either 50 or 60-cycle home electric power — which power frequencies are divided about fifty-fifty within the service range of the transmitter (of the order of twenty miles).

Mr. Harry R. Lubcke, Director of Television for the Don Lee System has stated that he will appreciate the cooperation of amateurs in the vicinity in checking the daily transmissions and explains that suggestions and circuit data on suitable receiving equipment are available to anyone mailing a stamped, self-addressed envelope to the Television Division, Don Lee Broadcasting System, 1076 West Seventh Street, Los Angeles.

A Statement from Hygrade-Sylvania

A RECENT advertisement of the Sylvania Radio Tube Division of the Hygrade-Sylvania Corporation, which appeared in a number of radio trade publications, has been the matter of much comment. Entirely without our knowledge, intent or purpose, there appeared in this advertisement, in a semi-concealed state, certain coarse and offensive phrases.

"In this advertisement there is a cut of what purports to be a newspaper containing certain body text which was supposed to be illegible and meaningless. The rough layout of this advertisement, which was prepared by our advertising agency, Cecil, Warwick & Legler, was turned over to the S. W. Benson Studios, a commercial art firm, for finished lettering and drawing. This art firm delegated the work to a free-lance artist. As to just what happened, we cannot be certain, although we have a letter from Mr. S. W. Benson, president of the art firm, in which he assumes entire responsibility for the act that was committed. The lettering, whose ever it is, is obvi-

ously the work of an unbalanced mind or the result of a perverted sense of humor.

"No one who subsequently handled this advertisement as it went through the various stages of engraving, proving and final printing of the publications noticed that the supposedly illegible type, when placed under a magnifying glass, revealed the questionable material referred to.

"To our thousands of friends and acquaintances in the industry it is unthinkable that our company could have possibly had any conscious part in such a deplorable incident, and we hope that this explanation will make the whole situation clear in the mind of anyone whom it reaches.

"The matter has already been called to the attention of the inspector in charge of the General Post Office in New York City, who now has all the circumstances under investigation.

"We realize, in making this statement, that we may be bringing the matter to the attention of many who otherwise would not have been advised of it; however, we feel that complete candidness is called for and we feel confident that our good faith will be unquestioned and our good-will unimpaired."

HYGRADE SYLVANIA CORPORATION

B. G. Erskine
President

The Cover

WE HAVE to thank Mr. William P. Schweitzer, W2JKQ, for the photograph used up front on this issue. The shot was taken by Mr. Schweitzer during the construction of a new rotatable directive antenna at his station.

56-Mc. Transatlantic Reception of W1KH

W1KH heard by Bill Mulliss, Neerholm, Bath, Somerset, England, on Dec. 12, 1609 GMT, on 56.2 Mc. CW; report is QSA4 R7-5, slightly chirpy. Bailey says checks with log and also his note is slightly chirpy. W1KH using xtal rig, 250 watts, feeding into vertical half-wave through Collins coupler and Zepp feed. No reflectors.

All-Continent QSO Sets New Record

W4DLH and his gang of all-continent round table cohorts really went to town on January 4th. From 1318 to 1321 GT W4DLH talked to VU2CQ, VU2CQ to G5ML, G5ML to HK5AR, HK5AR to VK4JU, VK4JU to SU1SG and SU1SG completed the circuit back to W4DLH. All continents were in contact and a span of 54,100 miles had been covered in 3 minutes and 20 seconds. These contacts were made by radiotelephone on the 14-Mc. band. Tie that one!

HINTS and KINKS

for the Experimenter



Audio Peak Limiter for Speech Amplifiers

AUTOMATIC volume compression as a means of preventing overmodulation in 'phone transmitters has been advocated in a number of articles in recent *QST* issues.¹ A rather simple and easily-installed system, involving operation only over a single stage, is shown in Fig. 1. It was worked out by M. C. Bartlett, W9JHY, and has proved to be quite satisfactory in practice, since overmodulation is practically impossible once the operating conditions are set. There is no perceptible effect on the speech quality.

A pair of 802's, operating as Class-AB amplifiers, is used to drive the Class-B grids. In W9JHY's case the driver is coupled to the Class-B input transformer through a 200-ohm line, and the audio voltage appearing across the line is applied to the primary of transformer T_2 , whose

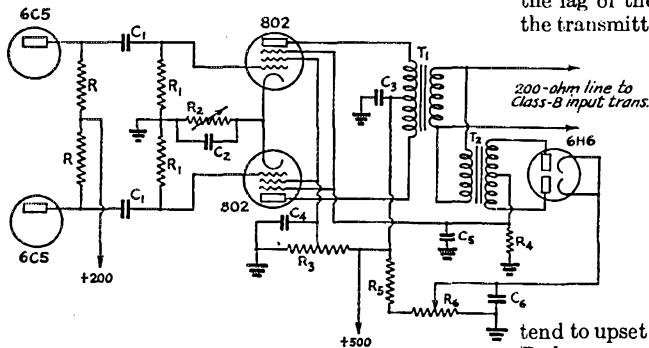

FIG. 1—AMPLITUDE LIMITING CIRCUIT FOR PENTODE SPEECH AMPLIFIERS

- C_1 —0.1 μ fd.
- C_2 —1.0 μ fd.
- C_3 —4- μ fd. electrolytic.
- C_4 —1.0- μ fd. electrolytic.
- C_5, C_6 —0.1- μ fd. paper (C_6 optional).
- R —250,000 ohms, 1-watt.
- R_1 —500,000 ohms, 1-watt.
- R_2 —1000-ohm variable.
- R_3 —40,000 ohms, 25-watt semi-variable.
- R_4 —0.1 to 1.0 megohm (time constant).
- R_5 —150,000 ohms, 2-watt.
- R_6 —5000-ohm potentiometer.
- T_1 —Class-AB to line transformer.
- T_2 —Class-B input or push-pull interstage, 3:1 ratio or higher.

¹ Hansen, "A.V.C.-Controlled Pre-Amplifier," *QST*, September, 1937; Bullock and Jacobs, "An Electronic Volume Compressor," *QST*, September, 1937; Plummer, Waller, "Negative-Peak Automatic Modulation Control," *QST*, October, 1937.

center-tapped secondary is connected to the plates of a 6H6 used as a full-wave rectifier. The rectified audio voltage is suitably filtered and applied as bias to the suppressors of the 802's. Thus the greater the output signal the greater the bias developed, and in turn, the lower the amplification in the 802 stage. The 6H6 cathode is given some initial bias through R_6 so that the automatic control does not function until the signal reaches a predetermined level.

In connection with adjustment of the circuit, W9JHY writes:

"Adjust R_2 until the two tubes draw 60 ma. (no signal), which gives about Class-AB operating conditions.

"Now, with constant tone input, measure the voltage appearing from suppressor to ground. This should be about 1 volt, on a high resistance voltmeter, when the Class-C stage is being modulated 75 per cent to 80 per cent. Then, when the lag of the R_4C_5 circuit is taken into account, the transmitter will not go over 90 to 95 per cent modulation. The setting of R_6 controls the threshold bias on the 6H6, which, if being fed a high enough voltage by T_2 , will nicely control the gain of the 802's.

"As an indicator of modulation percentage, or rather of the operation of the compression circuit, a voltmeter (0-100 volts d.c.) can be connected from suppressor to ground, although this will make the gain-change more rapid and tend to upset the C_5R_4 ratio, which must be right. Perhaps a variable resistor at R_4 might be a good idea. It is desirable to set the gain control at some point where the compression is *not* brought into play, since, after all, this system is only intended as a protective measure, and probably better quality will result if no compression voltage appears on the suppressor.

"If this plan is employed where the 802's are driving the Class-B stage grids directly, it stands to reason that the higher voltage which appears at the Class-B grids will necessitate a higher threshold voltage, obtainable with a potentiometer of a proportionately higher resistance at R_6 . With voltages of this value, an 80 rectifier could be used to advantage, in place of the 6H6.

"The transformer T_2 is the only part that proved troublesome. I finally picked on an old

high-ratio General Radio transformer that has bumped around the junk box since the days of two-filament audions. I believe it is either 6:1 or 10:1 ratio, but almost any high ratio transformer will work; it should develop about 150 volts audio across the secondary terminals on external peaks."

In W9JHY's speech amplifier, the 80Z's simply replaced a pair of 2A3's formerly used in the driver stage.

Regeneration Control

THE performance of the two-tube receiver described in the October *QST*,² can be markedly improved by operating the screen of the detector at a constant voltage and varying the r.f. feed-back as shown in Fig. 2.

The semi-variable resistor replacing the potentiometer and fixed resistor may be of almost any convenient value, but should be of such

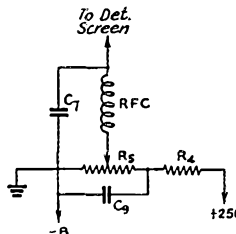

(A)

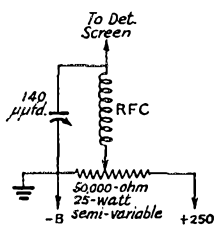

(B)

physical dimensions that the screen voltage may be easily controlled. A screen voltage of about 25 volts was found to be optimum, a higher voltage causing an annoying and persistent fringe howl.

The electrolytic condenser C_9 was found unnecessary in the modified circuit, since there is no possibility of scratch from moving contacts.

The advantages of this method of controlling regeneration are: greater stability, since the detector is operating under constant conditions; noiseless control of regeneration with no moving contacts; fewer parts necessary, making for greater compactness. There is an almost im-

² Chambers, "Modernizing the Simple Regenerative Receiver," *QST*, October, 1937.

perceptible transition into and out of oscillation, with complete absence of back-lash.

This method of regeneration control may be adapted to any regenerative circuit with but minor circuit changes.

—Edmond L. Piesen, 48 Franklin Ave., Saranac Lake, N. Y.

Inexpensive Crystal Selector Switch

ALTHOUGH there are several types of crystal-selector switches on the market, they are relatively expensive; the simple switch assembly described here easily can be constructed from

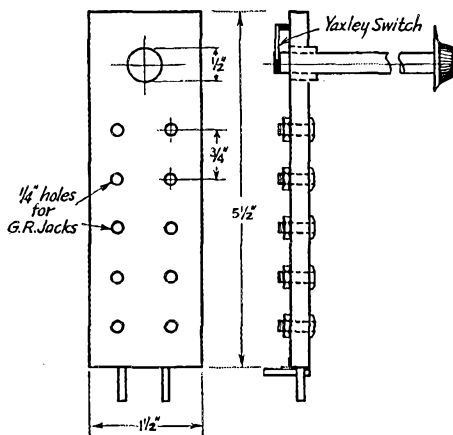

FIG. 3—EASILY-CONSTRUCTED PLUG-BASE AND SWITCH FOR CRYSTALS

spare parts on hand in the average amateur station. The materials required are:

- 10 General Radio type jacks (see note below).
- 1 Single-gang 6-point switch (Yaxley No. 6263).
- 1 $3/16$ " bakelite strip $1\frac{1}{2}$ " by $5\frac{1}{2}$ ".

NOTE: These jacks will fit the standard pin plugs used on the plug-in type of crystal holder. If a round-type crystal holder is used which plugs into the standard 5-prong tube socket, tube-pin type jacks should be used.

The jacks are assembled on the bakelite strip as shown in Fig. 3 and are spaced $3/4$ " apart—standard spacing for five-prong socket. The distance between adjacent levels of jacks will depend on the thickness of the crystal holders used. The

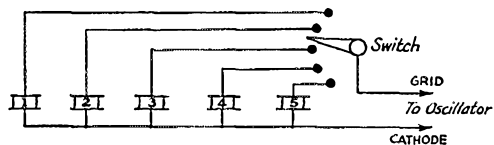

FIG. 4—WIRING DIAGRAM OF THE CRYSTAL SWITCH AND PLUG-BASE

$\frac{3}{4}$ " separation shown in Fig. 3 is based on the thickness of the regular rectangular type of holder.

Fig. 4 is the schematic diagram for the wiring of the switch. All leads should be kept as short as possible, especially the wire to the crystal oscillator grid, in order to minimize the distributed capacity.

If your present transmitter is already equipped with a five-prong socket mounting for the crystal holder, this crystal selector switch can be arranged to plug into the socket by adding a 1 by 1 inch bakelite strip, equipped with two tube pins for plugging into the socket. This small bakelite strip is attached to the bottom of the switch mounting by two small brass angle brackets.

The crystal selector switch described above has been used at W2PF-WLNA for the past year and a half without any trouble. It is indispensable in changing almost instantaneously from the special Army Amateur 3497.5-kc. frequency to the 3510-kc. amateur frequency and back again, which is often required during AARS drills or in handling traffic. Adjustments of tank condensers are not usually required for frequency shifts not exceeding 20 kc.

—David Talley, W2PF

— . . . —

Rhombic Antenna at HH4AS

HH4AS was constructed with a view to maintaining contact with relatives living in Connecticut while the writer was on a two-year assignment with RCA Communications. It was necessary to decide whether to erect a high-power

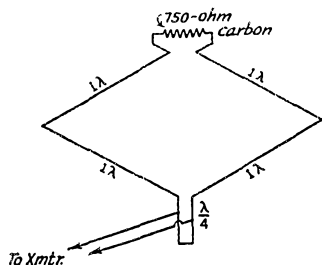

FIG. 5—RHOMBIC ANTENNA USED BY HH4AS
Built for 14-Mc. operation, each leg is approximately 65 feet long.

rig and pay ten cents per watt to the Government or to use low power with a beam antenna. The latter was decided upon.

As a preliminary experiment a very small transmitter was made using crystal on 7 Mc. into a 41 which doubled to 14 Mc., with a 79 receiving tube in the final. Power output was three watts. This flea-power rig was connected to a half-wave doublet and experiments started. During this month a station was located (W1GCX) who lived only a mile from the writer's relatives. W1GCX

fortunately is a splendid operator, but it was necessary to give him a readable signal at all times if we were to keep a Haitian circuit open.

After much wandering around the nearby fields looking for space, a "V" antenna was decided upon. This "V" was two wavelengths on each leg, with an angle of 95 degrees at its apex. Feeders were matched to the antenna through a quarter-wave stub. With this "V" HH4AS began putting in commercial signals to W1GCX, and schedules were kept faithfully with 100 per cent success. However, after a visit to the A.T. & T. 'phone station in Haiti and observing operations with the rhombic, the idea persisted that I could fold one wave on each leg of my "V" and, with a resistor in the center, form a rhombic with very little trouble. I had never seen reports on a one-wave rhombic, but experiments would prove or disprove its efficiency. This was done a short time ago, and on the first night I got reports of 579 579, 589, 569 from Hartford, and stations along the center line without solicitation commented on my signal strength increase. The W1GCX-HH4AS circuit is operating as well as most commercial circuits. Very seldom do I have to furnish an RQ. On several occasions I have received reports of 599 in Ottawa. The general layout is shown in Fig. 5.

My purpose in writing this is to try and show that one-wave rhombics are easy to construct and have decidedly unidirectional qualities. Hams with rhombic minds need not wait until they find space for three and four waves on each leg to get an efficient signal squirter. For verification, stations north of Haiti may hear what five watts sounds like with a one-wave rhombic and judge for themselves whether it is worth the trouble. HH4AS is on every night at 8 p.m. on 14,400 kc. and now uses one 6L6 in the final with an output of 5-6 watts.

—L. F. Sherwood, Supt., RCA Communications, Inc., Port Au Prince, Haiti

— . . . —

FB7 Receiver Changes

HERE are some suggestions from G. N. Dugonis, W3COZ, for slight changes in FB7 and FBX receivers which will make operating more convenient and possibly effect some improvement in performance. He writes: "These changes, although not radical, will be beneficial. First, the beat oscillator control is inside the case, and it is annoying to have to lift the lid to make a change in the pitch of the signal. The circuit of Fig. 6 shows how to eliminate this. A 50- μ fd. variable condenser is connected from the cathode of the beat oscillator to ground. The best place to put this extra control is in place of the b.o. switch. Be sure the lead is in a well-grounded shield. To stop the b.o. for 'phone reception, bend

(Continued on page 110)

• I. A. R. U. NEWS •

Devoted to the interests and activities of the

INTERNATIONAL AMATEUR RADIO UNION

Headquarters Society: THE AMERICAN RADIO RELAY LEAGUE, West Hartford, Conn.

MEMBER SOCIETIES

American Radio Relay League
Asociația Amatorilor Romani de Unde Scurte
Associazione Radiotecnica Italiana
Canadian Section A. R. R. U.
Československá Amatérská Vysílací
Deutscher Amateur Sende-und-Empfangs
Dienst
Experimental Radio Society of Egypt
Experimenterende Danske Radioamatører
Federation des Emetteurs Belges
Irish Radio Transmitters Society
日本アマチュア無線聯盟 Japan

Liga Colombiana de Radio Aficionados
Liga Mexicana de Radio Experimentadores
Magyar Rövidhullámú Amatőrök Országos
Egyesülete
Nederlandsche Vereeniging voor Internationaal Radioamateurisme
Nederlandsch-Indische Vereeniging voor
Internationaal Radioamateurisme
Newfoundland Amateur Radio Association
New Zealand Association of Radio Transmitters
Norsk Radio Relæ Liga
Österreichischer Versuchssenderverband

Polski Związek Krotkofalowcow
Radio Club Venezolano
Radio Society of Great Britain
Rede dos Emissores Portugueses
Reseau des Emetteurs Français
Reseau Luxembourgeois des Amateurs d'Ondes Courtes
South African Radio Relay League
Suomen Radioamatööriyhdistys r.y.
Sveriges Sandareamatörer
Unión de Radioemisoras Españolas
Union Schweiz Kurzwellen Amateurs
Wireless Institute of Australia

Conducted by Byron Goodman

Calendar:

The December copy of the biannual Union Calendar is being transmitted to the member-societies as this is being written. Three new societies have been unanimously voted into the Union: the *Reseau Luxembourgeois des Amateurs d'Ondes Courtes* (R.L.), Luxembourg, the Experimental Radio Society of Egypt (E.R.S.E.), Egypt, and the *Asociația Amatorilor Romani de Unde Scurte* (A.A.R.U.S.), Roumania. Speaking on behalf of the other members of the Union, the Headquarters extends these new members a cordial welcome and hearty good wishes. By unanimous consent, the *Federation des Emetteurs Belges* (F.E.B.) is declared to be the member-society of the Union for Belgium. This is the result of a request by the *Reseau Belge*, since the F.E.B. represents a combination of the R.B. and the Flemish-speaking *Vlaamsche Radio Bond*. The Union now totals 32 member-societies.

A proposal by the R.E.F. to add another delegate to the Cairo Conference was voted down, and the delegation consists of Messrs. K. B. Warner, Arthur E. Watts, and Paul M. Segal. They will be assisted by members of the Experimental Radio Society of Egypt. Mr. Warner, as Secretary of the Union, is named chairman of the delegation. The delegation is instructed to endeavor to obtain additional frequencies and other privileges to as great an extent as circumstances will permit, without endangering present frequencies and regulations. Messrs. Warner and Segal are en route for Cairo at the time of writing; they will meet Mr. Watts in Cairo.

It is possible that the I.A.R.U. delegation will not be the only amateur representation at Cairo.

There is a possibility that a member of the R.C.V. will be appointed to the official delegation from Venezuela.

A clarification of the QSL-card forwarding policy was effected by the adoption of an amendment to Miscellaneous Rule No. 3 which reads: "Member-societies shall agree to accept QSL cards addressed to non-members of the national society, provided that such non-members collect or pay for the reforwarding of the cards to them." Prior to this, some societies had been reluctant to forward cards for non-members, and the amendment will insure delivery in those countries.

Proposal No. 35, to prohibit relationships between member-societies and rival, competitive or dissenting societies within the territory of other member-societies, was adopted by an almost unanimous majority.

Two new societies have been proposed for membership: the *Esti Raadio Amatoride Uhing* (Estonia), and the *Radio Club de Cuba* (Cuba).

Some discussion resulted from the proposal by the W.I.A. to hold each year six large international continental contests. Several of the societies are strongly in favor of such a move, feeling that if each continent is given a chance to run their own DX contest each year, under the auspices of one or two of the member-societies of that continent, a much better all-around arrangement will result. When more societies have been heard from, it will be possible to formulate a majority opinion, and it is quite possible that some such system of handling DX contests will be used during 1939 and afterwards.

Further discussion on the systems of signal-reporting resulted in a more-or-less general ac-

ceptance of the present scale. Discussion seems to center on the "T" portion of the system, several societies feeling that it is not an accurate index to the quality of one's signal. For example, the S.A.R.R.L. suggests a "T" system reduced to B, G, and X, standing for bad, good, and crystal, respectively. Thus a signal report would be 57X, 46G, etc. If a detailed report of the sender's note is asked for after having received a "B" note report, then some scale such as the one suggested by the D.A.S.D. could be used.

Australia:

The W.I.A. informs us that their amateur convention will be held at Sydney on April 12-18, 1938. This date corresponds with the World Radio Convention, being held from April 4th to April 14th, under the auspices of the I.R.E. (Australia), and the whole thing is part of the celebrations associated with the 150th anniversary of Australia. Many overseas engineers are expected to attend the radio convention, and all amateurs will be more than welcome.

South Africa:

After March 1, 1938, all call signs in the Union of South Africa will be confined to the ZS group, and the groups ZT and ZU will no longer be used for amateur call signs. New ZS calls have been issued to amateurs whose call signs commenced with ZU or ZT, but they cannot be used until March, 1938. The change has been brought about by the S.A.R.R.L. as a result of representations made to the Postmaster General, wherein it was pointed out that it is desirable to differentiate between amateur call signs and all other call signs. ZS3 will still be the prefix for Southwest Africa.

QSL:

Corrections in the QSL Bureau list of October, 1937, are given below:

Australia: Ray Jones, 23 Landale Street, Boxhill, Victoria.
Austria: Willy Blaschek, O.V.S.V., Bahngasse 29, Klosterneuberg.
Italy: A.R.I., Viale Bianca Maria 24, Milan.
New Zealand: N.Z.A.R.T., Box 489, Wellington.

Awards:

For those of you who like to add certificates to the wall, we list two new awards.

The Wireless Institute of Australia offers a W.A.S. (Worked All States) award, with the following rules:

1. Applicants must be financial members of W.I.A.
2. The following are considered as states: VK2, VK3, VK4, VK5, VK6, VK7, VK8 and VK9.
3. QSL cards must show clearly that any six

states have been worked on each of any four bands.

4. The 24 cards must be forwarded to the Divisional Secretary for perusal and he will notify Federal Headquarters of the decision of his council on the suitability of the presented cards. On the receipt of this advice FHQ will mail the certificate direct to the applicant.

This award should be worth working for, since it is not easy for someone outside of Australia to work six districts on four different bands.

The WBCN (Worked British Commonwealth of Nations) award, offered by the S.A.R.R.L., has practically the same rules as WBE, with the exception that the applicant must be a member of the S.A.R.R.L. (For details of the WBE award, see page 50, March, 1937 *QST*.) Also, all contacts must have been affected after Jan. 1, 1937.

Sweep Circuit Considerations

(Continued from page 41)

6C5 proves adequate for the low frequency. The amplitude available from these circuits and their linearity make them completely suited for the television receiver. They are very "sure-fire" in operation and do not require any special transformers in the pulse-generating portion. In circuits of this type a sharp negative pulse can be obtained from the plate of the second tube—a pulse which may be applied to the grid of the cathode-ray tube to bias it negative during return traces. The connection is shown in Fig. 3. This is a highly desirable feature for some work as it removes the return trace from the pattern and allows the ratios of trace to fly-back time to be much lower without marring the pattern by diagonal lines. It is not necessary to use this pulse when receiving television pictures, of course, as special pulses of the proper amplitude and phase are transmitted for this purpose in the television signal itself. Incidentally, this type of sweep circuit has been used by the writer to generate sweep frequencies as high as 6 megacycles.

It is suggested that the experimenter work first with the basic circuit of Fig. 3 before proceeding to the construction of the complete sweep circuit. Without a thorough understanding of their operation, the adjustment for proper amplitude and complete linearity is an extremely difficult procedure. But the circuits, in spite of the large number of tubes used, are actually inexpensive to build and completely satisfactory in their operation.

In the discussion of Fig. 7 in Mr. Wilder's article in the January issue, several obvious errors were made (by the printer!) in referring to the RC circuit R_{13} , C_8 . The resistor was described incorrectly in several places on page 33 as R_8 while the condenser was miscalled C_9 . Also, the R_{10} mentioned in line 8 on the right column of the same page should have been R_{14} . Sorry!



OPERATING NEWS



Conducted by the Communications Department

F. E. Handy, Communications Manager

E. L. Batley, Asst. Communications Manager

THE opening period of A.R.R.L.'s Tenth International Contest, March 5th, will mark a decade of growing interest in international tests. The first was held in May 1927, the second held in February 1928, and in latter years all have been scheduled in March. The earliest contest resembling in any fashion to-day's product followed first general transatlantic and transpacific working by three or four years. Participation? A success from the start, more hams have taken part with every passing year, with but one or two exceptions. From 180 logs in its first season the "ninth" brought us 1391 telegraph and 376 radio-telephone logs. This is indicative of even much wider participation, since large success and larger scores tend to reduce the number of logs that come from men with limited time who are just taking a crack at some of the elusive DX that always comes out of hiding for the fracas.

The DX highlight of the year is matched in its W-VE appeal only by the Sweepstakes. Changes in rules have become increasingly rare of late years, the DX competition holding to the form of exchange proved most efficient in bearing vital station reports and contest identification. This stability in system of working is, of course, vital and important in insuring that all amateurs understand fully and quickly how to take part. Other amateur societies have adopted several points of the system used in our March activity, in recent years in devising popular contests along parallel lines, no mean compliment in itself. Disqualifications based on competent observation have been made from the start, to insure necessary adherence to government regulations and enforce sportsmanship in so far as practicable. The problem of supervision increasing with greater participation, we are asking Uncle Sam to assist in this policing effort this year through every one of his several monitoring stations.

This portion of the long-term solar cycle is calculated to give excellent DX transmission conditions. Radio weather is, of course, like terrestrial weather more or less unpredictable at times. But the favorable seasonal factors, and the tested rules for this activity that make for enjoyment and success, are all along customary lines.

Ten years of DX contests is a lot, in anyone's life. With curiosity and interest we dig back in the QST file and note the participants in the early

DX affairs. We wonder how many hams who take part in *this* one will be taking part in their *tenth*? Probably not many, but a few we hope! At least one or two calls in the early lists ring familiar—and the pages fairly glow with the listings of DX records of past years. A.R.R.L. strives constantly to bring success and enjoyment to its members in their pursuit of amateur radio. The tests held in March have to be announced a month early so the announcement can reach amateurs on the other side of the globe in time. The auspices are right. The plans are announced. May we wish each participant a good measure of success in this activity dedicated to the DX group! There may be only one c.w. or 'phone winner for your Section or continent—but every ham who works some DX and reports his work is sure of personal pleasure, and is adding his accomplishment to the history of amateur radio.

— . . . —

Speed! How fast can the human voice span the globe? From Coral Cables, Florida, just as we go to press, comes a report that Official 'Phone Station W4DLH, with VU2CQ, G5ML, HK5AR, VK4JU and SU1KG set up a new *all-continent* round table, January 4th, beating the past record for completing such a get-together by making it in just three minutes and twenty seconds!

— . . . —

Speaking of shattering records, some were broken in the A. R. R. L. Sweepstakes. Sixteen operators topped last year's high of 403 contacts. All 70 League Sections were worked by W6MVK (c.w.) of the San Joaquin Valley, who made 469 QSO's, 96,180 points. All 70 Sections were also worked by W6ITH O.P.S., East Bay Section, with 343 QSO's, 48,020 points. Here are the stations that appear to have topped last year's highest score:

W6MVK	W8BYM	W9TYF	W5KC
W3BES	W9FFU	W9IU	W1RY
W2IOP	W9RQM	W4CYC	W9RSO
W1EZ	W8OFN	W8DOD	W9VKF

They are each likely to prove Section winners, and more power to them. When claimed scores are checked, all winners can be announced. The above stations are not, strictly speaking, in competition with each other at all, each striving for separate Section and club awards. Stations in different Sections have different transmission condi-

tions, different "accessibility" to other Sections and different problems in getting out. Work between remote Sections, therefore, cannot be accurately compared by scores. Note that both stations to achieve honor in working 70 Sections were on the west coast, and "just" made P. I. to get under the wire. At last something that is proved to be done with greater ease from the coast? We refuse to say it until definite check of the licensed station distribution has been made and our records of issuing W.A.S. tickets to all and sundry have been consulted. Hi.

—F. E. H.

Try 56-Mc. DX!

DON'T forget that M.R.A.C.—A.R.R.L. Trophy that is offered for the first certified U. S. A. intercontinental two-way work on the 56-60 Mc. band. Work over great circle distances in excess of 2000 miles counts. See page 35 of July 1937 QST for details. The time is near, we think, when someone will lay claim to that fine Trophy Cup.

Speaking of coast-to-coast and possible transocean work on 56 Mc., it is interesting to note that recent Bustan measurements of layer height and a tabulation of normal incidence critical frequency as taken at Washington at noon give promise, in analyzing weekly records, that this is the logical season to try for new records. In the winter the F-layer critical frequencies in the daytime exceed any values found in the summer. A broad diurnal maximum occurs centered at about 1:00 p.m. local time. Early December measurements indicated a maximum useful frequency (for F-layer transmission) of 38,700 and 48,000 kc. The measurement released for December 22nd indicated 51,000 kc. as the maximum useful. A trifling extension of the condition indicated on this date should permit long distance 56-Mc. work.

The possibilities for 2500- or 3000-mile success are even greater than for 2000-mile work. So we suggest that at the time when the sun is in the zenith, attempts to establish coast to coast communication utilizing 56-60 Mc. frequencies should be well worthwhile. The best time might well be 1:30 p.m. EST, 12:30 p.m. CST, 11:30 a.m. MST, 10:30 a.m. PST, or two hours before and after this time, for serious workers to break through to a new 56-Mc. DX record!

A class in Amateur Radio will be conducted at Crane Evening School, Jackson & Oakley Blvds., Chicago, starting early in February—Room 301, 7:45-9:45 p.m., Tuesday and Thursday. Code and theory will be covered.

Briefs

The Naval Communication Reserve, Third Naval District, is conducting a series of sixteen weekly broadcasts over station WNYC, New York. The first of these Sunday afternoon broadcasts was on January 9th; the time is 2:15 p.m. EST. Every amateur will find the series interesting, whether an N.C.R. member or not.

W9LEZ heard a very loud "160-meter 'phone" harmonic on 3725 kc. He listened to see what call was signed. In his own words:—"You could have blown me over with a zephyr when he said, . . . 'This is W9—operating portable in Grand Island, Nebraska' . . . "!!

And then there is the fellow who wants to know if a "QSL" (a colored one) from Grand Island counts for Nebraska towards W.A.S.

W9ZDZ, Steamboat Springs, Colo., is conducting code practice on 1875.5 kc. on Tuesdays from 5:30 to 5:50 p.m. MST.

QRR Work in Oklahoma

ONCE more did amateur radio play an important part in an emergency. Once more were the amateurs of Oklahoma given an opportunity to demonstrate their ability to be of great assistance. Another achievement can be chalked up for Amateur Radio. The occasion was one of those mid-western sleet storms, with wires covered with ice and power and communication by land wire disrupted. On December 12th, Oklahomans arose to behold a cloudy, misty day with the ceiling some 200 feet and visibility less than a half mile. By Monday morning, the 13th, the mist had changed to a steady drizzle of rain and the wind had changed to the north, bringing the temperature down to the freezing point. By Monday evening the ice formation was becoming heavy and landwire communication began to falter. At this time, Harold Hartman, W5QL, got a rig on 3.5-Mc. c.w. and established contact with W5CWL of Enid, who was using 3.9-Mc. 'phone. Since the Oklahoma Gas and Electric Company leased telephone line failed at this time, these two stations maintained contact throughout the night.

Since W5CWL was not accustomed to working c.w., it was decided matters would be facilitated by use of 'phone at both ends. Oklahoma's P.A.M., Jerry Sears, W5AIR, volunteered his services. W5AIR went on the air at 8:00 a.m., Tuesday, with W5QL doing the most of the operating, and was on continuously until midnight, Wednesday. Communication was maintained with W5CWL, and a portable self-powered outfit was loaded on a truck and sent to El Reno, where it was operated as a portable by W5CXU. Contact was next established with W5EFV at Alva. These three stations worked through the day handling traffic for O.G. & E. W5CEZ was out hurriedly constructing a new antenna when he was called by the O. G. & E. Ponca City plant, stating that their telephone line had gone out and they wanted to get in touch with Oklahoma City. An antenna was gotten up to replace the one broken down with ice, and contact was established with W5AIR. Contact between W5CEZ and W5GFT in Enid was also established, as well as with W5DTU and W5CVA in Oklahoma City. At this time W5CEB came on the air at Enid and relieved W5CWL to let him get some rest. More operators were pressed into service at W5AIR. In addition to W5AIR and W5QL, W5ARB and W5CJC assumed relief roll at W5AIR. Two operators stayed on the job at W5AIR all the time, one at the transmitter and one at the telephone. W5AIR maintained communication with W5EFV, W5CEB and W5CUX until midnight, Tuesday, when skip interfered. They were able to maintain contact with W5CXU throughout the night. W5CEB and W5GFT got a rig on 1.75-Mc. 'phone and cleared some important traffic with W5EON while skip was still on 3.5 Mc. Since it was possible to get through to Oklahoma City from Ponca City by telephone, W5CEZ, W5CEB and W5EFV turned in at midnight and resumed again at 6 a.m. On Wednesday the rain had ceased. It warmed up around noon, ice began to fall and troubles increased. Power failed to El Reno and Enid at noon, but was restored around 4 p.m. At this time there were as many as 44 towns in the vicinity of Enid and El Reno that were without means of communication, and many were without power. Enid was completely isolated except for contact by radio. Contact was maintained all day Wednesday and through the evening up to midnight between Oklahoma City, El Reno, Enid, Ponca City and Alva. W5AIR had been on the air continuously since 8 a.m. the day before, with two operators on duty all the time.

Radio contacts were resumed Thursday morning and continued throughout until 9 p.m. The O. G. & E. got their leased line in operation from Ponca City to Oklahoma City, and were able to get through on a toll line once an hour to Enid. W5AIR, CXU, CEB and EFV secured their watches and turned in for some badly needed rest. W5CEZ and W5GFT continued until 11 p.m. Thursday, with traffic between Enid and Oklahoma City coming by radio between Enid and Ponca City, and by telephone from Ponca City to Oklahoma City. At 11 p.m. these two stations were advised that no further necessity for radio communication existed.

Approximately 200 messages were handled for the O.G. & E., as well as a number of personal messages from men out with repair crews to their families at home. Much credit is due W5QL for his work in organizing the radio set-up and for the manner in which he stuck to the job of operating, since the major part of the operating at W5AIR and W5QL was by him. The occasion demonstrated a further need for emergency equipment in every community, equipment that is capable of working on 7, 3.5 and 1.75 Mc. Everyone did a fine job. W5EFV had Alva to take care of all by himself, and he did splendidly. W5QL, AIR, CUX, ARB, CJC, CEB and CWL put in some long hours of operating. W5CEZ, GFT, CVA and EON spent many long hours of watching and listening in, functioning when needed.

—Carter L. Simpson, W5CEZ, S.C.M., Oklahoma

Susquehanna Emergency Net

THE Susquehanna Emergency Net membership is now complete and includes the Susquehanna River, Chenango River, Chemung River, the Juniata River and their tributaries. The primary purpose of the net is to furnish communications to cities and towns along these watersheds should any disastrous floods occur, resulting in the loss of normal communications.

It is hoped that the S.E.N. will prove to be a contribution to the general safety of all against the perils of devastating floods such as have occurred in the past. The readiness of this net to serve has an important bearing upon the work of the American Red Cross because the S.E.N. not only backs up the systematic reporting of river stages, but also can act as an official channel of communication between the heads of the local chapters and the headquarters in Washington.

Interconnected electric companies have a vast system of land and carrier communications that may be of great value during disasters. Information relative to the progress of future floods will be thus transmitted. Also should telephone and telegraph fail, these sections will be patched up either by amateur radio or by privately owned communications circuits. The utility companies will, of course, use their grapevine of telephone circuits as a second line of defense and amateur radio as a last resort, because the utility operators are conversant with their requirements. On the other hand, the amateur radio circuit can be worked for normal relief, etc., having the utility circuits as a second line of defense.

It will be impossible for the Weather Bureau to make forecasts of river stages at various points along the river unless data pertaining to rainfall, weather and river stages are received from index points along the river promptly. From these data, the Weather Bureau will be able to follow future floods and make more accurate estimates. Unfortunately, when a flood is forming, the normal communications systems may become burdened with various types of traffic which delays these reports. To preclude this situation, photographs of easily identifiable structures or buildings in the flooded area were made. These photographs were marked with a scale by which gauge heights could be ascertained. A series of these photographs will be made available to the amateur and other responsible persons in each locality. From these photographs, it will be possible to get stage readings after the river leaves its bounds. With the data collected and curves of the 1936 flood passage, fairly accurate estimates can be made of the flood progress.

Key stations in the various localities are being instructed to make their services known to their local relief agencies. The American Red Cross headquarters at Washington has also instructed their relief administrators in the localities of this service.

The S.E.N. operates on a frequency of 3910 kc, about 75 per cent 'phone, the remainder c.w. All stations appointed for this work were chosen for their past experience, availability during disasters and their location to the centers they serve. Serious thought was given to power supplies at such points where past experience has shown that utilities have failed. Where there is not a reasonable margin of safety from loss of power, the key stations have built emergency transmitters and receivers; some to operate from batteries and

others from gasoline engine-driven alternators and, in one instance, there is available a steam engine. Following is a list of key stations by call: W8DHO, W8CHU, W8MFD, W8AYG, W8CVS, W8EA, W8MAH, W8LMY, W8QJP, W8DEC, W8VI, W8BKT, W3WX, W3UR. Where possible, alternate stations have been appointed: W8CNA, W8KQ, W8AVK, W8CEX and alternate control station W3AVX. A supporting membership, which takes no part in the drills but has come forward offering service during disasters by doing patrol duty and to relieve the net of traffic, is as follows: W2BZR, W2LV, W3FJU, W3QV, W3BEI, W3ADM, W8HLM, W8BRC, W8FER and W8QWH.

The first drill took place on November 28, 1937, at 8:00 A.M., and required but twenty-eight (28) minutes, with only two stations not reporting. After official business, the net was turned over to the key stations, resulting in a round table of general discussions. It is the purpose of the net to operate bi-weekly on Sundays at 8:00 A.M. until after the spring freshets; drills will then be reduced to once a month to keep the net active.

—Chas. G. Landis, W3UA

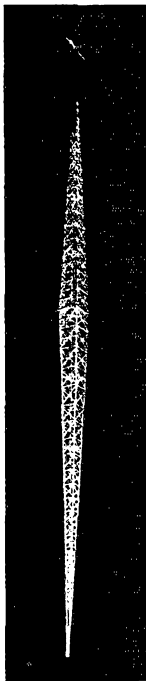

THE MAST AT WIDHT, BRISTOL RADIO CLUB, SOUTH MOUNTAIN, BRISTOL, CONN.

It is exactly 100 feet high, being built of wood, square cross section, 4 ft. square at the middle (50 ft. height) and tapering at both ends to 5 inches. Corner pieces $\frac{1}{8}$ -inch by 2-inch, lattice work or diagonal pieces ordinary building lathes. It is supported on two eyebolts, one sunk into rock ledge, the other in base of mast and joined together by bolt. Guy wires at 50 and 100 ft.

1.75-Mc. DX Tests

A preliminary report on the 1.75-Mc. DX Tests held on each week-end during December and January lists contacts between W1BB and G2DQ, G2PL and G6SQ. Contacts between G2PL and W1BB were on December 11th and December 18th. W1BB worked G2DQ and G6SQ on the week-end December 18th-19th. G2PL has heard W3GCK, W3DAE, W2JON and W3EM? (believed to be W3EMM). G6SQ heard W3GCK and W2JON. W1EZ heard G2PL, G6SQ and G2DQ. W1BB lists the following W participants in the tests: W1KXA, W1LJY, W9FOC, W2JEX, W1EZ, W9ENQ, W8MIS, W2HBO, W1BMW, W3GLV and W3DUE.

— * * * —

The following is a supplement to the list of A.R.R.L. Official Broadcasting Stations in October QST (page 50): W1AXL, W4EBZ, W6GTM, W8HCS, W9DEA, W9SEL, W9YWE, VE2HL, VE2HT.

PRIZES FOR BEST ARTICLES

The article by Mr. Eric Adams, VE3ALG, wins the C.D. article contest prize this month. Each month we print the most interesting and valuable article received marked "for the C.D. contest." Contributions may be on any phase of amateur operating or communication activity (DX, 'phone, traffic, rag-chewing, clubs, fraternalism, etc.) which adds constructively to amateur organization work. Prize winners may select a 1938 bound *Handbook, QST* Binder and League Emblem, six logs, eight pads radiogram blanks DX, Map and three pads, or any other combination of A.R.R.L. supplies of equivalent value. Try your luck. Send your contribution to-day!

Does This Mean You?

By Eric Adams, VE3ALG*

THERE are among the many operators frequenting the ham bands to-day those who produce much gnashing of teeth on the part of other operators. We have the fellow who sends a series of badly distorted CQ's for two minutes solid and then, after signing once in an equally sloppy fashion, stands by to look over the band. Another common curse is the lid of many frequencies who commences his call on, say 3710 kc. and shifts in the middle of the procedure to 3700 kc., where we develop a triple headache trying to separate him from an example of scourge number three, the amateur who is supposedly operating on 1.8-Mc. 'phone but who, for all practical purposes, is generously devoting most of his output to the 3.5-Mc. c.w. boys. Then we must not forget that member of the ham fraternity whose note is a close imitation of someone tearing oilcloth. He is a little too common to ignore. We have our friend who places the dictionary on the key and then diddles with his rig for at least twenty minutes, quite ignoring the fact that he is doubtless interfering with a good many others who are using the air in a more sensible fashion. Who hasn't worked the ham whose idea of a QSO is, "Ur sigs RST 599 hr in Lidville, QRM, QRN, QSB, QRU, QSL? 73." And we cannot overlook the over-modulation expert, the 'phone counterpart of the oilcloth ripping c.w. man.

The reader may be wondering as to the cause of this review of ham radio pests. Why remind us of these people when so little can be done about them? It is there that a great misunderstanding occurs. A good deal can be done, and if all hams would only get together it might have some practical effect. It is logical to believe that these improperly operated stations are on the air for exactly the same reason as anyone else, i.e. to get contacts. When Johnny Lid calls a long CQ with his T3 note, someone promptly works him and obligingly supplies a T8X report. That is the rub. To give reports so carelessly simply encourages poor notes. Have the strength of your convictions. If the note is T3, report it as T3; if it's T6, report T6 and don't ever say T9 unless it really is T9! By the simple process of getting together and absolutely refusing to call, or answer a call, from any operator who knowingly is not operating decently, much could be done toward eliminating one of our major annoyances.

When the operator of an offending station found that he simply could not raise anyone, he would be forced to conclude his efforts sooner or later. Possibly, if of the impatient type, he would wrathfully deposit his transmitter in the nearest ash can and turn his attentions toward such perplexing and intellectual problems as the creating of paper dolls or butterfly chasing. Regardless of what particular pursuit caught his fancy, he would be removed from the air which, after all, is the major item. Perhaps the operator of the QRM generator would conclude that all was not right

* 509½ Yonge St., Toronto, Ontario, Canada.

and, after suitable adjustments or changes, would return to the air to gather in his full quota of QSO's the same as anyone else. Simply because a ham has slipped is no reason why he should be forever boycotted, if he will correct his ways. Neither, though, is there any reason why he should be encouraged to continue with his chirpy note, over-modulation, or whatever his particular offense may be.

How do you feel when just after hearing that elusive J or ZS, a station with a buzz-saw note hogging ten times its proper share of frequency comes pounding in, hopelessly covering your desired DX contact? Why not immediately start a campaign to eliminate as much as possible of the QRM caused by the carelessness of our own numbers? Surely we have no right to complain about the occasional noises made by Mr. Jones' furnace blower or Mrs. Smith's vacuum cleaner when we submit to much more obnoxious QRM disguised as a signal from some ham rig. If each and every ham will commence an absolutely 100 per cent drive against every station which is in any way knowingly operating against proper ham traditions, we will accomplish much toward clearing up our bands.

One of the most important parts of this drive must be the adoption of the policy of giving *honest signal reports* (and this refers to both notes and modulation). We must recognize the dilemma in which an operator finds himself when the majority of the fellows he works say "T9" and on almost negligible percentage say "T6" (or whatever the true report happens to be). Who is he to believe? He usually coasts along with the majority. We will never win the battle against bad notes and overmodulation until we all take pains to give accurate reports. And, of course, we must practice what we preach—a good listening monitor seldom lies.

Trans-Pacific and Other DX Schedules

THE following data will aid in routing traffic to Hawaii, P. I., Guam, Alaska, Canal Zone, etc.

W6CUU, Beverly Hills, Calif., schedules KA1HR daily except Saturday and Sunday at 6:00 A.M. PST. . . . W6IOX, Santa Barbara, Calif., schedules K6ONF and K6NXX daily at 1:00 A.M. PST. . . . W7DUE, Portland, Oregon, schedules KA1HR. . . . W7NH, W6GXM and W6ETL each schedule K6OGD/WLXB and KA1HR/WLXP on A.A.R.S. channels. . . . W7FPN, Aberdeen, Wash., schedules K6OHX three days per week. . . . W6LNS schedules KA1HR daily except Sunday. . . . W6LUJ schedules KA1HR. . . . K6NXX connects daily with K6OGD, K6OCL and KA1HR. . . . W6DH, Los Angeles, schedules K6OHX. . . . W6ITH schedules KA1ME on 14-Mc. 'phone. . . .

W7FVK, Longview, Wash., W6DH, Los Angeles, Calif., and W7EBQ, Astoria, Ore., schedule K7FSX, Seward, Alaska. . . . W6JTV, Oakland, Calif., has a schedule of long standing with Alaska. . . . W7GGM, Bellingham, Wash., and W6PCK, Los Angeles, also schedule Alaska. . . . W6BQO, Los Angeles, schedules XU8AG at 4:30 A.M. PST daily, and KA1SL at 5:00 A.M. PST, Wednesday and Sunday. . . . W6FWJ, San Diego, schedules K6OCL, Guam, thence to XU8AG. . . . A new route to Guam will soon be open via W6FKB, San Diego. . . .

W4PL, Shepherd, Tenn., schedules K5AA daily except Sunday at 5:30 P.M. CST. . . . K5AA in turn schedules OA4U, Huancayo, Peru, at 3:00 P.M. EST daily except Sunday. . . . W1AJ, Montague City, Mass., schedules NY1AA, Balboa, C. Z., Mondays at 8:00 P.M., Thursdays at 7:00 P.M. EST. . . .

W3QP, Philadelphia, schedules W6CUU daily except Sunday at 10:00 P.M. EST, thereby completing a circuit from the east coast to P. I. . . . W3QP also schedules W9ESA, Denver, who provides another trans-Pacific circuit via A.A.R.S. channels. . . . Traffic for Canal Zone via W1AJ, may be routed via A.R.R.L. Trunk Lines to W1IOR, Worcester, Mass., who schedules W1AJ. . . . W4PL may also be reached via the trunk lines and other A.R.R.L. traffic routes through his connections with numerous outstanding traffic handlers. . . .

The OA4U-K5AA-W4PL circuit is an interesting one. The complete circuit includes W3CIZ, Silver Spring, Md.,

and works as follows. OA4U is the station of the Carnegie Institute Magnetic Observatory at Huancayo, Peru. Considerable traffic is handled between Peru and the Institute in Washington, D. C. Leaving Peru at 3:00 p.m. EST, traffic reaches W4PL at 5:30 p.m. CST, and goes to W3CIZ (the Washington delivery station) at 4:00 a.m. the next morning. 14 Mc. is used from OA4U to W4PL and then 3.5-Mc. or cross-band 7/3.5 Mc. to W3CIZ. Schedules are daily except Sunday. This circuit is known as the Southern Branch of the "Hit and Bounce Trunk Lines" . . . the traffic hits a station and bounces right along to the next without delay!

The Western Branch of the "Hit and Bounce Trunks" consists of W3CIZ-W4PL-W5MN-W6IOX-K6ONF/K6NXD/W6LBB. W6IOX meets the K6 stations at 3:00 a.m. CST. At 5:00 a.m. CST, using 7 Mc., he contacts W4PL. Also listening in are W5MN and W3CIZ, but their rigs are on 3.5 Mc. W4PL copies all messages. Those for the Southwest are sent first, and then W4PL, working cross-band, gives W5MN his fills, if needed. Then W6IOX puts through those that go to the eastern areas, and W4PL fills the gaps for W3CIZ. Lastly come those for the South, Middlewest, Canal Zone, etc. By using this system, traffic leaving the mid-Pacific after midnight is spread out across the U.S.A. and up and down the Atlantic seaboard that same night (or morning)!

The A.R.R.L. Trunk Lines can connect with all the schedules mentioned above, so a message handed to any trunk liner for specific routing via a given station will receive the best of attention.

— * * * —

New W.A.S. Members

Worked All States Club membership now totals 414. The "WAS" award has been made to amateurs in every state except Nevada! This is rather singular since Nevada is one of the most difficult states for W.A.S. aspirants to get. It should be a simple matter to make the club in Nevada. Who will be the first Nevadan W.A.S.? The following have qualified for the club since August 4, 1937: W1EBF (No. 349) W9TLF W3EPV XE1AM W2BRV W3CDG W9UAI W9YEZ W3AIZ W5YJ W8LXF W9WCE W8NXN W9WUZ W3BXG W4EFM CM2OP W6KKM CO2EP W9ANZ W9VWL W9YCR K6JPD W8QYR W4GB W2DVV W1EH W9MWH W5GGX W4EIS W9MLF W7CPY W3FUF W9DHO W8GER W8IBU W8KAU W6OTE W8LCN W6KJV W8MZH W6NJK W9AA W9UAZ W7AXS W1JTD VE3HP W8CUY W3GY W9VLP W5KC W8PTD W9KJY CO2JB W3FGK W4BHY W9EC W5GKZ W6IWS W5ENI W9WBW W8WT W7AOL W1GJQ W8GDH OE3AH (No. 414).

CO2EP, W3GY, CO2JJ and W5GKZ (1.75 and 28 Mc.) qualified using radiotelephone only. Club members outside the "States" and Canada are, in order of membership: OA4J, K6CGK, XE2C, XE2N, K6MVV, VK6SA, XE1AM, CM2OP, CO2EP, K6JPD, CO2JJ and OE3AH.

That only 414 amateurs have qualified for W.A.S. in a two-year period bespeaks the fact that it is a real achievement. Forty-eight confirmations submitted to the A.R.R.L. Communications Department as proof of contacts with the forty-eight United States will make you eligible for the W.A.S. certificate. Sufficient postage must be sent with the confirmations to take care of their return. Contacts may be made on any of the amateur bands and at any number of different addresses, provided no two addresses are more than twenty-five miles apart. A special rule permits a confirmation from either the District of Columbia or Maryland itself to count for the state of Maryland. Send your confirmations as soon as you can qualify.

— * * * —

Night Owl Net

Rag Chewers' Club members will be interested in the organization of a rag chewers' net operating on a spot frequency of 3512 kc. Meetings are held each Friday at midnight, CST. All stations are invited to join the fun. W9ACL, W9AA and W8DYB are charter members of the net, which has been appropriately christened the "Night Owl Net."

Fire Prevention Week

THE week in October which contains October 9th, the anniversary of the great Chicago fire, is annually proclaimed "National Fire Prevention Week" in the United States. Fire Prevention Week has become an event of International observance. For the past three years radio amateurs throughout the world have played an important part in the observance of this important event.

1935's observance was aided by the amateurs through station W6HXP, owned by the late Paul Potter, when Fire Chief Ralph J. Scott of the Los Angeles Fire Department exchanged greetings and methods of fire prevention with Fire Department Chiefs and Civic Executives in Buenos Aires, Argentina; Chanarai, Chile; Sao Paulo, Brazil, and Birmingham, England, through a relay from Pittsburgh, Pa.

Again, in 1936 during Fire Prevention Week, Chief Scott compared notes on a nation-wide hookup of amateurs arranged by Henry Harris, W6LIQ, and composed of W9CUD, W2HUQ, W4AKY, W9FJ, W9UJS and W9WE.

1937's Fire Prevention Week was observed with the aid of radio amateurs on October 6th with Official Phone Station, W6MYO, owned by E. E. (Red) Wyatt, Jr., of Los



The scene at W6MYO, A.R.R.L. Official Phone Station, Los Angeles, during Fire Prevention Week demonstration on October 6, 1937. Seated, left to right: Fire Commissioner Edward W. Lewis and Deputy Chief Bert M. Blake of the Los Angeles Fire Department. Standing: E. E. Wyatt, Jr., W6MYO.

Angeles acting as key station. Fire Commissioner Edward W. Adams, Deputy Chief Bert M. Blake and Captain Orville J. Emory of the Los Angeles Fire Department, and Willinson Pierce, Jr., President of the Los Angeles Junior Chamber of Commerce, were present at W6MYO. R. H. Morse, W5CRQ, of Dallas, Texas, had present at his station Chief Sidney Hanson and Fire Marshal L. M. Funk of the Dallas Fire Department. Fire Chief Springer of Texarkana, Texas, was present at W5BEK, Frank Martin, Texarkana. Bill Seymour, K6NZQ, Hilo, Hawaii, had at his station Fire Chief Johnson Kahili of Hilo and Deputy Sheriff Peter N. Pakele of Hawaii County.

Due to the hook-up arranged by O.P.S. W6MYO, these different Fire Department Executives were able to successfully discuss matters of mutual interest and benefit to each other in their never-ending fight against destruction by fire. A large number of listeners have reported reception of this demonstration to W6MYO. Special QSL's will be sent to all those who have sent in reports.

—Don M. Draper, W6GXM, S.C.M. Los Angeles

— * * * —

During the month of May W6OML had the interesting experience of operating a 56-Mc. portable-mobile rig aboard a large purse-seiner, the *Pop Ernest*, which transported the Monterey Sea Scouts from Monterey to Santa Cruz to attend the Sea Scout Regatta. Communication was maintained with W6NTU, W6COO and W6JRU in Monterey. Amateur radio received good publicity from this work; parents of the Scouts thought it an excellent safety measure.

How's DX?

How:

The revised list of countries run last month in the I.A.R.U. News seems to have met with the general approval of all concerned. We are pleased to hear it, and to those who have written asking about some small island or place that was omitted, we say that only countries that have or had active amateurs were included, as well as some larger countries that were included because of their political importance. If and when some of the omitted places break into ham radio, they will be added. Then too, islands are usually counted as groups, so don't write in asking to list every little island in the Leeward or Windward group or something like that. Naturally, the line has to be drawn somewhere.

Where:

Well, maybe you aren't interested in adding Tristan da Cunha to your list, but if you were the smart thing to do would be to look around on 40 and 20 for ZU9AB. A Norwegian expedition, we only know that any reports on them would be greatly appreciated by the N.R.R.L. and A.R.R.L. And while you're adding to the list, PX2B (14,360 kc., T8), G8MF (14,100 kc., T9c) in the Channel Islands, and ZB2A (14,280 kc., T8) in Gibraltar, are all good bets. Credit PX2B to W2DTB, G8MF to W1DF, and ZB2A to W2GVZ and W2BEW A man biting a dog isn't news at all compared with W8CRA working a new country. But here it is: I7EY (14,040 kc.) in Addis Ababa, Ethiopia. On Jan. 7, 9, 10th he was on 14415 and said he would sign I7AA after Jan. 15th. QSL via A.R.I., Italy That guy VU2AN (14,090 kc., T9) that you've been calling each morning is in Baluchistan, in case you're thinking of giving up W8DFH pops in with a couple of pips: ST6KR (14,145 kc., T9) at Khartoum ex-YI6KR, ex-ZC6KR; and VQ3TOM (13,995 kc., T7), ex-G2TM, gives his QRA as Millar Radio Station, Moshi, Tanganyika For some of those Pacific islands, W6ITH says to look for K6BAZ (14,200, 14,380, and 7100 kc.) on Howland Island, K6OGD on 20 and 40 for Jarvis Island, and K6OSF on 40 for Baker Island VE5ACS, at Resolution Island, N.W.T., will be back home in July, and will not QSL until then, according to W2KAK. The QRA then is H. L. Baxter, P.O. Box 937, Yarmouth, Nova Scotia The expeditions OX2QY (14,370 kc.) and VP3THE (14,300 kc.) were heard working each other a few evenings ago. A far cry from the days when expeditions weren't heard from for months. Now the equator and the poles trade experiences the same day they happen Your QSL for XSV1SM can be sent care of LU2CW, according to W8CMH G6YL sends a QRA you might want sometime: AC4AA, Tsing-Ho, Kan Postal Office, Lhasa, Tibet You know by now that G3 is an additional prefix in England but not a new country. Also, South Africans will be using ZS only, after March. For that Southwest Africa contact, look for ZS3F (14,080 kc.) on phone or c.w.

When:

We're really starting the New Year right. Instead of having only a few 20-meter stations to tell you about, we have reports this month of DX on every one of the popular bands. We hope it's a sign of the times.

W1EZ reports G6SQ, G2PL, and G2DQ on about 1730 kc., coming through around 12:30 a.m., E.S.T. W1BB got S7 from G2DQ when he worked him. How's for a few more taking a crack at 160-meter DX?

Europe seems to be duck soup on 80 for the W1's and W2's, but how about some of the VK's and ZL's the W6's work? We'd like to hear about them For example W21JU worked HB9AS, HB9SE, HB9AK, and heard HA2L Then, W3AGV worked I1TKM (3538 kc.)

for the I's first 80-meter W. D4ORT (3510 kc.) was also worked W1TS took a look at 80 and worked HA2F, GW5FI, HB9S, D4SSH, and heard a flock of others, including SM6WL W1EPE heard HH1EL (3475 kc.) working G2DB one morning around 4 W2JHB worked D3CFH (3595 kc., T9) To top it all, W1EZ heard ZL4BU (3500 kc.) one morning at 6. Which makes it seem as though 80 has some possibilities.

The lads did themselves proud in reporting some of their 7-Mc. efforts, and we find that there really is stuff on the band. One of the most consistent signals on the band is I1EC (7300 kc., T7). Then there's YV1AK (7030 kc., T9) reported by W1EZ; HA2Q, U5KS, and U5YH at around 7120 kc., reported by W21JU and U2NE, HA2L, VP7NC, and EI4J, worked by W1JVS W21OP sat down for a few hours and worked a mess of Europeans and ZL2BD, ZL2UV, K6OPL, K7CHP, ZL3FP, and heard FA8PW (7005 kc.) W1TS submits U6WB, U2NE, LU4BH, K6OVJ, and a lot of the more common Europeans G15FA (7065 kc.) writes that he hears ZL, VK, LU, HK, PY, YV, W6, W7, and K6 on 40, but has trouble getting them to listen In passing, W4ZZ mentions SX3A (7000 kc., T7), SU1KT, LU5LA, and G6WY.

On 20, such luminaries as F18AC (14,265 kc., T9), and AA5CN (14,445 kc., T7) in Tangier Zone, are worked by W2CYS. F18AC is especially anxious to work more east coast W's J5CC (14,410 kc., T8) has been coming through to W1 around 5:45 p.m., which is also a good time to look for PK1WI (14,390 kc., T9), and FY3AA (14,410 kc., T7) One worth going after is VQ5AF (14,260 kc.) in Uganda And, if you haven't worked OX2QY, try OX2ZA (14,070 kc., T4) W4ZZ has set his cap for U8IB, VR2FR, FK8IA (?), and CR7AJ, but doesn't tell us much about them Random stuff is HRO (14,410 kc., T8) in Honduras, VS8AK (14,160 kc., T9), KA7EF (14,100 kc., T9), and TF2C (14,380 kc., T8)

Ten is good but we don't get many reports. W1SZ has been keeping a sked right along with VK2GU, with good signals at both ends. How's about it?

VK2NO, who has been knocking around on 5 for many moons, writes to tell us that he has a confirmed report of his 56-Mc. signals from Wellington, N. Z. The report was Q4 R5 What with short skip showing up on 10 from time to time, and the R.S.G.B. 56-Mc. Contest, 1938 should produce some real 5-meter DX. Give it a try.

What:

There still seems to be some prejudice against the use of a crystal filter in receiving, even by those that have them in their receivers. We feel sorry for those of you who have good filters and don't use them. Just to see how good the thing really is, we ran some measurements. We found that with the crystal there was a reduction in noise of 15 db, while the drop in signal couldn't be measured. Too many fellows say their filters are no good because the noise drops so fast that it sounds as though the set had lost overall gain. They're awfully wrong. Of course, a poor crystal filter is worthless, and you'll do much better by using a regenerative i.f. to set selectivity.

A suggestion: if you have a "V" beam with legs one or two wavelengths long, you can gun up the gain very easily by using another "V" $\frac{1}{2}$ -wave behind it, and feeding the two out-of-phase. I.e., you'll have a double-V that looks like the chevrons of a corporal, and with the spacing even less than that for the "flat-top" beam now becoming so popular.

Who:

Johnny Moyle, VK2JU, well-known to the 14-Mc. 'phone lads, is coming to the States sometime in March Lew Bellem, W1BES, is going to Pitcairn Island

with Granville Lindley, chief electrician of Commander Byrd's last expedition. They plan to be on from Pitcairn after March 1, on 14,346 and 7245 kc. Dunno the call yet, but probably P1TC W6NRE doesn't agree with W8OMM's figure of 10 miles/watt on 1.75, and has him topped with a 10-watt QSO with W9UNQ, figuring up to 120 m.p.w. K7GLD, at Shegong Creek, is a real Eskimo, and a fine operator W4PL and W4AM sked OQ5AE weekly, but complain of the W's swishing across with their ECO's, trying to attract the OQ's attention. Frankly, it's a lousy practice, and some of them might show a little more consideration. The thing to do of course is to

urged to refrain from answering "Test BERU" calls. This courtesy will be appreciated by all B.E. amateurs.

The Second Annual Dinner Meeting of the Westlake Amateur Radio Association will be held February 19th (6:00 p.m.) at Guild Hall, opposite the Union Terminal, Cleveland, Ohio. An excellent program is offered, consisting of talks by technical authorities, motion pictures of interest to radio operators and entertainment. The principal speaker will be Dr. J. R. Martin, Professor of Electrical Communication, Case School of Applied Science, Cleveland. All amateurs are invited to attend. The price will be \$1.50, including dinner and entire program. Reservations should be made at least one week in advance to facilitate dinner arrangements. Apply to Harold J. Tune, W8LZE, 1287 Giel Avenue, Lakewood, Ohio.

DX Century Club

WE welcome six new members to the DX Century Club this month—W1LZ, W1TS, W2GW, W2GTZ, HB9J and F8RJ. Congratulations to each! With the appearance of the new list of countries (Jan. QST), nearly everyone on the 75-or-more countries list has advanced several countries. Changes in relative positions among members of the club are noted. W8CRA now leads the list with 118. We rather suspect, however, that G6WY has some more confirmations on the way now that the new list is out! G2ZQ advanced eight countries, now placing third with 114.

Forty-four amateurs now have submitted proof of contacts with 75-or-more countries; thirteen of them are members of the DX Century Club. Check over your confirmations in accordance with the list in January QST and send them in just as soon as you can show 75 or more. When sending in your confirmations, please accompany them with a list of claimed countries and stations representing each country to aid in checking and for future reference after your confirmations have been returned to you. Please send postage to cover the return of your confirmations.



YOU CAN'T HANG AROUND ON THE HIGH END OF 20 VERY LONG WITHOUT RUNNING INTO CE4AD, THE STATION OF LUIS ADALBERTO BRITO R.

The rig shown above is a pair of self-excited '10's in parallel, but the new one will, be c.c. on 14,082 kc. with an 804 in the final. In two years, CE4AD has worked over 2300 W's.

give the boys a chance to clear their traffic and then go after him W9KG, who used to use W9ALV but no more, deserves a fate worse than he gets. Just when we think DX has been fair around here he drops in with a worked-list a mile long, including HS1BJ, F18AC, CR7AW, OX2QY, HC2MR, VP4CF, U9MN, FY8AC, HI9I, ZB2A, VP8FO, and KA1AF. On 40, U9AV, LU3DE, LU5LA, and a bunch of Europeans W8CMH doesn't believe the legend that his neck of the woods (Port Huron, Mich.) is n.g. for DX. In 39 days he worked 165 DX contacts in 41 countries, and shows no sign of weakening As unobtrusively as possible, W5KC gets in his deadly licks by calmly informing us that the latest there are VS4CS, CT2BC, J2CL, ZE1JI, PK6HR, PK1VX, PK3MP, SV1RX, FP8PX, and FT4AG Then, too, W9NNZ has it too easy. He calls ZS2AC without luck, tunes over the band and finds that ZS6EQ is carrying on a QSO with W9NNZ. Conditions got worse, so NNZ never did find out how he got hooked up WIWV has a new QTH, good enough for WAC within 7 days. Stations were ZU8U, G8BS, J2JJ, VK2EO, PY2KT, and a W9 And K7RT worked ZU5Q for his WAC, and 11WV for another country. Johnny reports UPOL at 83° 45' N, 2° E on Nov. 4.

—W1JPE

The B.E.R.U. Contest will be held on February weekends. This affair is for British Empire stations only. W's are

MEMBERS, DX CENTURY CLUB

	Different Countries
Frank Lucas, W8CRA	118
H. A. Maxwell Whyte, G6WY	116
John Hunter, G2ZQ	114
Douglas H. Borden, W1BUX	112
Jefferson Borden IV, W1TW	110
Henry Y. Sasaki, W6CXW	108
Clark C. Rodimon, W1SZ	105
Harry G. Burnett, W1LZ	104
Don H. Mix, W1TS	104
Walton H. Bostwick, W2GW	101
Reeve O. Strook, W2GTZ	101
Guy Grossin, F8RJ	100
Jan Lips, HB9J	100

The following have submitted proof of contacts with 75-or-more Different Countries:

EI5F	93	W9ADN	83
W9KA	90	W8OQF	82
W1DF	89	W2CYS	81
W1WV	89	G5QY	80
W9EF	89	W4CCH	79
W1ZI	88	G2DZ	78
W8OSL	88	W1JPE	77
W6FZL	88	W1RY	77
W3BES	86	W6ADP	77
W3EVL	86	W3EPR	77
W6GAL	86	W9KG	77
W1DUK	84	W4AJX	76
W8JMP	84	W3BVN	75
W8KKG	84	W6BAM	75
VE2EE	83	W9UM	75
W2GVZ	83		

BRASS POUNDERS' LEAGUE

(November 16th-December 15th)

Call	Ortg.	Del.	Rel.	Extra Del. Credit	Total
K60CI	291	146	1130	42	1609
W8HCS	60	218	680	170	1128
W2BCX	10	15	1098	—	1123
W6IOX	39	75	940	69	1121
W4PL	12	9	1074	3	1098
W2BCX**	11	6	935	—	952
W1INU	59	38	730	—	827
W8QAN	86	58	646	23	813
W1IP	22	19	734	—	783
W8KWA	19	30	700	—	749
W6BMC	4	14	720	5	743
W1IOT	58	107	507	21	693
W6JTV	111	189	193	164	657
W8LSF	—	—	640	—	640
W6LLW	36	33	554	4	627
W5MN	20	140	404	59	623
W1UE	138	246	138	97	619
W1IHI	59	175	356	15	605
W8OFO	15	49	503	35	602
W3BWT	71	96	355	62	544
W3EN	5	87	403	—	545
W1KNB	8	33	460	33	534
W6IMI	81	146	187	112	526
W1IWC	64	70	380	9	523
W2JHB	36	130	271	73	510
W9PTU	32	124	350	—	506

MORE-THAN-ONE-OPERATOR STATIONS

Call	Ortg.	Del.	Rel.	Extra Del. Credit	Total
W5OW	160	782	188	77	1207
W9BNT	94	228	601	—	923
W1GOJ	49	62	606	49	756
K6NXD	340	191	36	—	617

These stations "make" the B.P.L. with total of 500 or over. One hundred deliveries + Ex. Del. Credits also rate B.P.L. standing. The following one-operator stations make the B.P.L. on deliveries. Deliveries count!

W6ITH*, 328	W2GVZ, 166	W8MQM, 110
W6LUI, 316	W9KJ, 134	W1FSV, 107
W9ESA, 274	W1IOR, 131	W5FPO, 107
W3CIZ, 266	W1AKS, 124	W2DBQ, 104
W3EML, 248	W9HPG, 122	W3AKB, 103
W3QP, 241	W1JCK, 120	W1EPE, 101
W8DH, 201	W1DMP, 119	W5CEZ, 101
W6LBB, 159	W6MDI, 118	W6BQO, 100
	W5DKR, 111	

A.A.R.S.

Call	Ortg.	Del.	Rel.	Extra Del. Credit	Total
WLMI (W6GXM)	75	142	628	136	981
WLNF** (W2BCX)	24	10	639	—	673
WLNF (W2BCX)	9	9	642	—	660
WMLL (W3NF)	—	—	606	—	606
WLHA (W8BBH)	8	60	422	34	597
WLMA (W7A)	7	2	491	1	501
WLR (W4IR)	23	113	508	71	715

MORE-THAN-ONE-OPERATOR STATIONS

Call	Ortg.	Del.	Rel.	Extra Del. Credit	Total
WLM (W3CXL)	189	180	1222	—	1591

A total of 500 or more, or 100 deliveries Ex. D. Cr. will put you in line for a place in the B.P.L.

* All traffic handled by two-way radiotelephone.
** October-November.

ELECTION NOTICES

To all A.R.R.L. Members residing in the Sections listed below: (The list gives the Sections, closing date for receipt of nominating petitions for Section Manager, the name of the present incumbent and the date of expiration of his term of office.) This notice supersedes previous notices.

In cases where no valid nominating petitions have been received from A.R.R.L. members residing in the different Sections in response to our previous notices, the closing dates for receipt of nominating petitions are set ahead to the dates given herewith. In the absence of nominating petitions from Members of a Section, the incumbent continues to hold his official position and carry on the work of the Section subject, of course, to the filing of proper nominating petitions and the holding of an election by ballot or as may be necessary. Petitions must be in West Hartford on or before noon of the dates specified.

Due to resignations in the Iowa, Kentucky and Hawaii Sections, nominating petitions are hereby solicited for the office of Section Communications Manager in these Sections, and the closing date for receipt of nominations at A.R.R.L. Headquarters is herewith specified as noon, Tuesday, February 15, 1938.

Section	Closing Date	Present SCM	Present Term of Office Ends
Alberta *	Feb. 1, 1938	Alfred D. Kettenbach	Feb. 18, 1938
Washington	Feb. 1, 1938	Robert H. Votaw	Feb. 17, 1938
Maritime*	Feb. 15, 1938	Arthur M. Crowell	June 14, 1937
Nevada	Feb. 15, 1938	Edward W. Helm	June 14, 1937
Gal.-Cuba-r. of P.-P. R.-V. I.	Feb. 15, 1938	Bannie L. Stewart	Dec. 14, 1936
Alabama	Feb. 15, 1938	James F. Thompson	Jan. 17, 1938
Iowa	Feb. 15, 1938	Owen Williams (resigned)
Kentucky	Feb. 15, 1938	G. W. Mossbarger (resigned)
Hawaii	Feb. 15, 1938	Otis Hill (resigned)
Montana	Mar. 1, 1938	Russell U. Richmond	Mar. 13, 1938
Vermont	April 1, 1938	Alvin H. Battison	April 15, 1938
So. Minnesota	April 1, 1938	Webster F. Soules	April 16, 1938
South Dakota	May 2, 1938	Andrew J. Kjar	May 18, 1938

* In Canadian Sections nominating petitions for Section Managers must be addressed to Canadian General Manager, Alex Reid, 169 Logan Ave., St. Lambert, Quebec. To be valid such petitions must be filed with him on or before the closing dates named.

1. You are hereby notified that an election for an A.R.R.L. Section Communications Manager for the next two year term of office is about to be held in each of these Sections in accordance with the provisions of the By-Laws.

2. The elections will take place in the different Sections immediately after the closing date for receipt of nominating petitions as given opposite the different Sections. The Ballots mailed from Headquarters will list in alphabetical sequence the names of all eligible candidates nominated for the position by A.R.R.L. members residing in the Sections concerned. Ballots will be mailed to members as of the closing dates specified above, for receipt of nominating petitions.

3. Nominating petitions from the Sections named are hereby solicited. Five or more A.R.R.L. members residing in any Section have the privilege of nominating any member of the League as candidate for Section Manager. The following form for nomination is suggested:

Communications Manager, A.R.R.L.
38 La Salle Road, West Hartford, Conn.
We, the undersigned members of the A.R.R.L. residing in the Section of the Division hereby nominate as candidate for Section Communications Manager for this Section for the next two-year term of office.

(Five or more signatures of A.R.R.L. members are required.)
The candidates and five or more signers must be League members in good standing or the petition will be thrown out as invalid. Each candidate must have been a licensed amateur operator for at least two years and similarly, a member of the League for at least one continuous year, immediately prior to his nomination or the petition will likewise be invalidated. The complete name, address, and station call of the candidate should be included. All such petitions must be filed at the headquarters office of the League in West Hartford, Conn., by noon of the closing date given for receipt of nominating petitions. There is no limit to the number of petitions that may be filed, but no members shall sign more than one.

4. Members are urged to take initiative immediately, filing petitions for the officials for each Section listed above. This is your opportunity to put the man of your choice in office to carry on the work of the organization in your Section.

—F. E. Handy, Communications Manager

ELECTION RESULTS

Valid petitions nominating a single candidate as Section Manager were filed in a number of Sections, as provided in our Constitution and By-Laws, electing the following officials, the term of office starting on the date given.

Connecticut	Fred A. Ellis, Jr.	WICTI	Dec. 4, 1937
Western New York	Ed. Preston	W8CBE	Dec. 6, 1937
Saskatchewan	Wilfred Skalte	VE4EL	Dec. 16, 1937
San Diego	Howard K. Breedlove	—	Dec. 16, 1937
Virginia	W6JRM Charles M. Waff, Jr.	W3UVA	Jan. 17, 1938

In the Wisconsin Section of the Central Division Mr. Aldrich C. Krones, W9UIT, and Mr. Karl R. Medrow, W9AKT, were nominated. Mr. Krones received 90 votes and Mr. Medrow received 87 votes. Mr. Krones' term of office began December 6, 1937.

In the British Columbia Section of the Vanita Division Mr. James Hepburn, VE5HP, and Mr. Marshall Threau, VE5OT, were nominated. Mr. Hepburn received 41 votes and Mr. Threau received 28 votes. Mr. Hepburn's term of office began December 20, 1937.

In the Southern Texas Section of the West Gulf Division, Mr. Dave H. Calk, W5BHO, and Mr. James B. Rives, W5JC, were nominated. Mr. Calk received 88 votes and Mr. Rives received 86 votes. Mr. Calk's term of office began December 23, 1937.

In the Alaska Section of the Northwestern Division Mr. Leo E. Osterman, K7ENA, and Mr. Richard J. Fox, K7FO, were nominated. Mr. Osterman received 26 votes and Mr. Fox received 25 votes. Mr. Osterman's term of office began December 31, 1937.

Station Activities on page 104



CORRESPONDENCE

The Publishers of *QST* assume no responsibility for statements made herein by correspondents

Sharpening the Signal

4022 No. 13 St., Milwaukee, Wis.

Editor, *QST*:

A letter about sideband limitation from WIBWS got me thinking. Here's what I think:

1. The higher tones, generating sidebands farther from the carrier frequency, cause most of the trouble.

2. The low tones, whose sidebands are quite close to the carrier frequency, do not broaden the signal much.

3. Poor quality is caused more by distortion and harmonics than by low-range frequency response.

4. High distortion and harmonic content cause the signal to splash around and mess things up more than high-range response does.

Therefore a low-pass filter would serve the purpose as well as a band-pass, and at the same time would keep the signal more natural sounding. It would be simpler, too.

But we could probably dispense with the filter altogether, if enough fellows would cooperate by forgetting high-range frequency response and concentrating on eliminating distortion. This would mean considerable saving on microphones and transformers too. If cooperation is lacking we can try filters later.

—Keith Hayes, W9ZGD

Past and Present

3800 Colfax Ave., Denver, Col.

Editor, *QST*:

This is by way of reply to your editorial in *QST* for November. I hope that it will be taken by you in the same open spirit I felt toward your editorial. You said some pretty sharp things and so shall I.

Your second paragraph wonders if we don't hang on to dead things long after they should have been buried. I think not. I think the trouble with the young squirt element, be his age sixteen or sixty, is not enough background. He has been plunged right into immediate enjoyment of the game without having had to pass through years of experience and learning to tolerate and respect the rights of the other fellow. . . .

I still think that the fellow who never wound miles of wire on three or four large Quaker Oats tubes in order to hear old POZ has missed some-

thing that he will never be able to buy with all his chromium-plated modern junk. Remembering back over the years, I find that one of the deepest sources of enjoyment that I get out of this game comes from contrasting the old game with the new—old equipment with modern.

Strangely enough, the older some of our ideas and equipment are, the more actually modern they turn out to be, to the fellow who refuses to do as you suggest—forget the past. If we must quote names and dates and places, it might startle some of the boys to know that the very first demonstrations of radio transmission, by old Heinrich Hertz himself, were carried on in what is now called the "ultra-short" wave region. As for the equipment, I still find use for an old 43-plate Murdock moulded "mud" variable condenser in spite of its losses and age. It turned out to be indispensable in a recent study of super-regenerative receivers I made.

And that mention of super-regeneration gives me a chance to throw your own words back at you. In your editorial in *QST* for July, 1922, you gave a description and a discussion of super-regeneration that still stands as a source of inspiration and information to many of us. In spite of what are now apparent as a few technical faults, it is still a good piece of writing although it is more than 15 years old. In it you stated a challenge which I do not believe has ever been answered. It is found on page 8 where you say, "There is no reason why the very weak signal of an amateur station across the continent may not be fed into a 250-watt power tube and a quarter kilowatt of signal-modulated output made available if desired." "If desired," indeed! Has anybody done it? Has any one of the thousands of greenhorns who have broken into the game first as five-meter bootleggers and later as phonograph-playing pests on the air ever so much as read that article? Not on your life. They have no attics or basements full of the accumulations of years. They start from scratch with their heads filled, perhaps, with new ideas about impedance matching and beam antennas, but they don't know the difference between decrement and electrose. If they need a variable condenser they buy one, new and shiny. They don't have to cut up a couple of different sized tomato cans to make a clumsy makeshift to do the job.

There's another point that rubs a lot of us pretty raw. It is true that a lot of dust accumulates on the junk in my basement. But when I

need some little gadget for some dirty little job that no shiny modern product will fit, I can usually find it or the raskins' down in that junk heap. And when, as is always the case with me, the family budget won't permit the purchase of equipment for a new experiment or piece of gear, I go down into that mess and dig out enough junk to work over into something that will do. I'm a poor man like a lot of other hams. Your attitude in this respect is hardly in good form, to my way of thinking, because you fellows there at headquarters have clean, modern parts to use for any job that comes up, whether it be along the line of developing something for ham radio, which is your job, or for flying model airplanes which certainly isn't. You don't have to worry about every penny—W1AW doesn't have to close down for an indefinite period because just one 866 goes out. But a lot of us fellows do have to contend with problems of this sort. Those of us who do, have a feeling that we ought to be telling you who, in this game of ours, is getting soft.

I agree that the average xtal-controlled transmitter is far too complicated. I agree that we keep on doing things the same way, year after year—that is, most of us do. But there are a few who not only remember the lessons of the past but who try continually to build upon them. Through all the ages filled with the suffering and misery that comes from war, men have as yet to learn how to live together without fighting. Through all the scant half century that we have had radio we have yet to exhaust the possibilities opened up by the work of the very first workers in our field. If our minds are filled with moss-covered theory and our conduct with rust filled practices, let it be said to our shame that we have been poor stewards of the talents that have been entrusted to us—that we have buried them in the ground when we should have kept them polished with activity to the glory of God and for the happiness of our fellow men.

—B. P. Hansen, W9KNZ

Anti-Television Club

34 Pennsylvania Ave., Port Jervis, N. Y.

Editor, QST:

What kind of a scheme is this that you are trying to get up now?

Why all the sudden publicity on television? Can't you see that the commercials are trying to bite off a piece, if not take all, of our ultra-high frequency bands?

Any ham who develops the use of television on the ultra-highs is but a traitor to the cause. Let's get together on this thing and nip it in the bud! I elect myself, W2GTW, as Number 1 member of the Anti-Television Club. All you hams that have any comment on this opinion write in and express yourself. If you want to join the club let me know. I think that the majority of the hams are opposed to this new racket and see no reason why we should put up with it.

We need all of this radio spectrum that we can get our hands on and can't afford to lose even a kilocycle right now.

—John McKinney, Jr., W2GTW

EDITOR'S NOTE.—Of course, it has not occurred to W2GTW that were it not possible for amateurs to claim such accomplishments as opening up the short- and ultra-short waves to public occupancy, not to mention numerous other technical contributions, we would probably now not have any kilocycles to lose. Or that television can be just another such accomplishment to add to our record.

Two Watts Max

Hildingsbraaken, Ranch Atalanita, Culp Creek, Oregon
Editor, QST:

I know, I haven't worked any ZS's or VK's, but I want to tell you a few of the things behind the two watts here at W7FHZ.

I operate spasmodically, whenever the "A" battery will hold up. The darn thing won't take more than half a charge, and even that requires two days of motherly attention to the gasoline motor which runs the old make-unknown generator which gets as hot as old '10 with 1500 on the

plate I used to own. This gas motor really belongs to the washing machine, but I use it every day except Monday, so it's really part of my power supply.

The rig is a 6L6, Tri-tet, working 3570 kc. and 7140 kc. with the same coils: I just short out the cathode coil and re-tune. The antenna is an end-fed Hertz, 133 ft. long and supported by a 60 ft. cedar pole, purloined from the hill back of the house. (The station is located on a ranch in the Calapooya Mountains, 40 miles SE of Eugene, Oregon.) The receiver is a 30 and a 19 two-stage.

On 80 the input is 1.8 watts and on 40 2.0 watts. The darn rig puts out more on its harmonic!

Well, as I started to say, I've not worked any ZS's or VK's, but I did work a W3—W3GVE—with an S6 sig in Washington! This was on 7140. Any night—if I stay up long enough—I can hear VP6, VK, K6, ZL, J's etc.; and any night—if I stay up late enough—I can work both coasts. All of which shows that 2 watts can do just about what a W6 kw. will, and without half the QRM. I forgot to mention that the "A" battery runs a worn-out auto vibrator (cost \$5) with a hot 150 v. at 20 ma. to the 6L6, about half of which I use, holding the rest in reserve when I get a good loud VK that seems like he won't answer—which he doesn't.

—D. von Ruysdael Drenner, W7FHZ

Stamps, Again

St. Pauls Rectory, Dera Creek, N.S.W.

Editor, QST:

I am an old timer, having been at radio since 1917 (old Army spark rigs in the A.I.F., Palestine and Egypt) and have made hosts of friends through this marvelous hobby. Now I am trying to find what hams are interested in stamps. I am a collector of all British Colonials and U.S.A. Pictorials. Strange, but out of the 1500 W's I've contacted only a few are stamp fiends. Send a sample few with your requests for VK stamps though please don't ask for too many over 5/- in value. Hi!

—The Rev. Wilber Brooke, VK2BR
Chaplain Morisset Mental Hospl.

Deadwood

Whiting, Indiana

Editor, QST:

Some time ago W8RFG expressed curiosity as to what the F.C.C. would do about the scarcity of W9 calls after W9ZZZ was reached. The editor answered that they would not start over with W9AAAA. Assuming that Mr. Editor knew whereof he spoke, then what? Well, that time has come and went. The F.C.C. went back to the front and passed out the W9CQ calls and now I believe the W9Q calls are being gobbled up. But then what? Will future applicants find it necessary to stand in line, waiting for someone to die so his call may be passed on? Let's hope not! However, it is easily possible to keep right on giving out calls till doomsday and never resort to four letter calls. Oh, they can't, eh? Well, I say they can! OK, then, here's how.

Start a new system of renewing licenses. Things are far too easy now. Just dash over to Hank's house at the end of three years, work three guys and send it in. Nothing to it. I wonder how many of these fellows are just weeds—dead timber—excess baggage? Hundreds of the calls now outstanding are absolutely idle, haven't been used for years! Just oodles of these gents haven't even got a transmitter or receiver, couldn't possibly pass the Class B exam, don't even know the code and don't give a whoop! So what? OK, Mr. F.C.C. here's what. The next Jasper that applies for renewal can just send in the old log along with his ticket! Well, then, if that's too much, submit the log for the past year, or if that is too much, for any six months during the life of the present license. And are you going to be surprised when you find just how many of these lads aren't keeping a log at all, or only about ¼ of the QSO's are logged, or the log fails to show all information required by law!

(Continued on page 64)

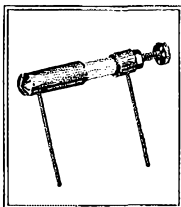

SINCE their first appearance about two years ago, 6L6's have found wide use in amateur circuits for crystal oscillators, doublers and the like. Their characteristics make them quite suitable for such purposes. This, of course, is an old story now. In these applications they require some neutralization, because the shielding between grid and plate is not adequate for the purposes described. This is also an old story, judging from the number of amateurs who have written us asking for a special 6L6 neutralizing condenser. That is why we are writing this page.

To be perfectly frank, there is no need to buy neutralizing condensers for 6L6's. The required capacity is only about 6 mmf. and can be easily obtained by some simple method such as twisting two pieces of insulated bus together. As a guide, two pieces of No. 14 bus $4\frac{1}{2}$ inches long, each covered with spaghetti for its whole length, were found to have a capacity of 6.4 mmf. when twisted together lightly. Untwisted and parallel, but touching, the capacity was 4.2 mmf. Spaced $\frac{1}{2}$ inch apart, the capacity was 1.9 mmf.

We found that this suggestion did not satisfy many of our customers, even though it did work. We aim to please, so we set out to make a regular, bona-fide neutralizing condenser specially for 6L6's. Obviously nothing expensive or pretentious was in order, and we searched our memories for methods once used in similar cases. Back in the dear dead days when we were busy making Browning-Drake kits, and nearly everyone else was busy wiring them, a device known as a "penny" was often used. This was a small copper disk facing part of the coil winding, and adjusted in or out by a screw. The coil itself served as one plate. This gadget gave noble service once, and in fact is still used in modified form. We were tempted to dust it off and use it again, but somehow one copper disk and a screw does not look like much of a condenser, and we feared that it would have no more appeal than the bus wire and spaghetti.

Another old device consisted of two heavy bus wires end to end, covered with spaghetti, and provided with a sliding sleeve for adjustment. This seemed to have more promise. Brought up to date and adapted to 6L6's, it takes the form shown above. The "frame" of the condenser is practically an R-100 choke without a winding; in other words an Isolantite tube with metal caps and pig-tails at each end. The cap at one end is extended to cover a little more than half the Isolantite tube. The other cap supports a screw which can be advanced down the inside of the tube for capacity adjustment. The whole thing is light enough to be supported by the pigtails quite safely.

As a matter of fact, it is a very nice little condenser, neat, convenient, and inexpensive. We are almost tempted to urge you to buy them instead of using bus wire, pennies or whatnot.

JAMES MILLEN



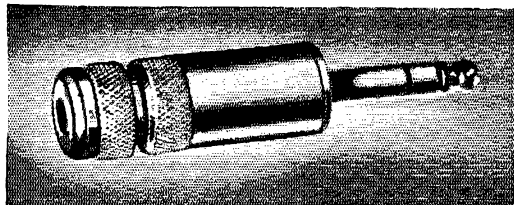

Three Way Microphone Plug
 With Bakelite Shell No. 76 \$1.00
 With Polished Nickel Shell No. 76A, \$2.50

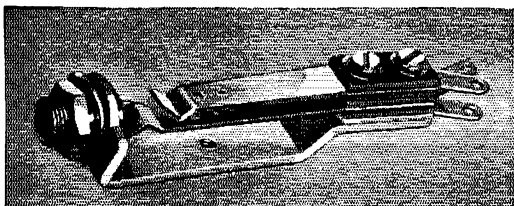

Three Circuit Microphone Jack No. 2B, 60c

There are 38 types of YAXLEY Jacks, Extension Jacks and Plugs

The illustrations show but two items in this famous Yaxley line.

Yaxley Jacks are made in four models—the new “X” type incorporating a special dust protector; the standard Yaxley Long Frame type; the Junior (in which the springs are parallel to the panel for compactness); and the Midget.

A variety of spring combinations are available for practically any application, and special models can be furnished on order.

Ask your distributor to show you.

P. R. MALLORY & CO., Inc.
INDIANAPOLIS INDIANA
 Cable Address—PELMALLO



Correspondence

(Continued from page 68)

I feel safe in saying that just about half of the present holders of W9 calls will have to go ahead with their stamp collecting without an amateur call. Won't that be terrible?
 —Amos Utterback, W9PB

A Low-Cost 100-Watt Transmitter

(Continued from page 16)

since at these frequencies the oscillator has its own plate coil, L_2 . The plate, or primary, windings are not on the coil forms themselves but are self-supporting coils fitting inside the coil form, movable with respect to the secondary so that the coupling can be varied. A 1-inch mandrel, a small sheet of paper and some Duco cement are needed for the construction of these coils. The paper is wrapped around the mandrel to keep the wire from sticking to it when the cement is applied. The required number of turns of wire is then wound around and cemented. When dry, the coil is slipped from the mandrel and the leads connected to the appropriate pins inside the six-prong form. Care should be taken to leave the leads long enough to permit sliding the coil up and down once the ends have been soldered to the prongs, so that the coupling can be adjusted for optimum power transfer. The leads for the 3.5-Mc. plate coil go to the prongs numbered 3 and 4. Both the 7- and 14-Mc. plate coils are wired to prongs numbered 2 and 4.

The grid coils, wound on the outsides of the six-prong forms, also are close wound with No. 20 d.s.c. wire. The pin connections are the same for all three grid windings, the ends going to Pins 1 and 5 and the centertap to No. 6.

Hammarlund TCF-5 transmitting forms are used for the final coils. These forms have a diameter of $2\frac{1}{4}$ inches and a winding length of $3\frac{1}{2}$ inches. A three-turn double-spaced link is wound in the center of each form. The link ends are connected to two of the prongs and thence to the two terminal strips at the rear edge of the base. After the links have been completed the center-tapped plate windings may be put on. Winding data are given in the coil table. In each case half of the stated number of turns is wound on each side of the link with the whole winding, including the link, spaced out to the length specified. No. 16 enamelled wire is used for all final-amplifier coils.

TUNING AND ADJUSTMENT

After a crystal has been selected and the various voltages are available the tuning procedure is as follows: For 3.5-Mc. output, the 3.5-Mc. coil is plugged in the L_2 socket, and the meter plug in J_2 . (Since there is no coil in the L_2 socket at this frequency, oscillator plate current cannot flow through J_1). With condensers C_2 and C_3 set at about half capacity, apply voltage and close the key. The oscillator tube should draw approximately 100 ma. C_2 and C_3 are rotated until resonance is reached, indicated by a dip in current to the vicinity of 20 or 25 ma. C_1 may



RIDING THE CLOUDS WITH



ROESLER

Along the great circle route, or across uncharted jungles, Bendix equipped ships ride the clouds . . . and in more peaceful and prosaic pursuits, Bendix ground stations and beacons will make positive contact with their winged companions aloft. In these various installations, CENTRALAB Volume Controls, Fixed Resistors, and Switches play a dependable part.

Centralab
CRI
 DIVISION OF GLOBE-UNION INC., MILWAUKEE, WIS.

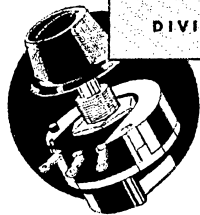

Say You Saw It in QST — It Identifies You and Helps QST

THE SUPER SKYRIDER
THE SKY CHIEF
THE SKY CHALLENGER



THE ULTRA SKYRIDER
THE SKY BUDDY
THE SKYRIDER COMMERCIAL

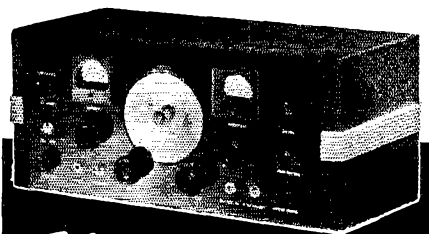

The SKY CHALLENGER II

with the amazing NEW HALLICRAFTERS INFINITE IMAGE REJECTOR

THE HALLICRAFTERS have done it again. The New Sky Challenger II is another real advance in amateur radio reception, an absolute knock-out of a receiver with several striking new features, at a sensational new low price. It has the Infinite Image Rejector, that eliminates image interference, performing the same function as 10 or more exclusive pre-selectors.

1000° BAND SPREAD

You'll find it has the same Spiral Band Spread System that is used on the Super Stryder, so that you can really spread out the bands. You'll find razor-sharp selectivity, better sensitivity and a dozen other features, all at a new low price that makes this receiver an outstanding value in amateur radio equipment.

AT THIS SENSATIONAL LOW PRICE

\$77.00 LESS SPEAKER
LESS CRYSTAL

Come in to see it or write for
complete details

FEATURES

- ★ 9 Tubes
- ★ 1000° Spiral Band Spread
- ★ Full Coverage 38 MC to 540 KC (7.9 to 545 meters)
- ★ "S" Meter Terminals
- ★ Infinite Image Rejection Circuit
- ★ New Recessed Main Tuning Dial
- ★ Tone Control
- ★ Iron Core I.F.'s

CONSOLIDATED RADIO CORP.
612 Arch Street Philadelphia, Pa.

the hallicrafters inc.

be left at minimum capacity for practically all crystals; the lower the capacity the less the feedback and the lower the crystal current.

The meter is now shifted to the amplifier grid circuit, J_3 , and the grid current noted. Very likely the current will be small because the coupling between the two coils probably is not optimum. Coupling between the two circuits is controlled by the position of the plate coil with respect to the grid winding, so the plate winding should be moved up and down inside the form (with simultaneous retuning of C_3 and C_2) until a grid current of about 75ma. is obtained. To prevent the possibility of a 400-volt shock, move the coil with a small stick or else shut off the plate voltage when touching it. When the correct coupling has been secured, a few drops of Duco cement between the plate winding and the form will prevent handling or jarring from shifting the winding.

Neutralizing the final is the next job. With a neon bulb held against the plate of one of the 809's, the tank condenser C_4 is rotated until the bulb glows. This is the resonance point. C_5 and C_6 are now turned simultaneously until all indication of r.f. at the plates disappears. Condenser C_4 should be readjusted from time to time to bring the tank circuit back into resonance, since the neutralizing adjustments will change the original resonance point slightly. The neutralization can be checked by watching the grid current while C_4 is rotated; there will be only a very slight flicker on the meter, or none at all, when C_4 passes through resonance if the amplifier is properly neutralized. Once completed, the neutralization will hold for all bands, so this adjustment need not be repeated.

For 7-Mc. output, use the 3.5-Mc. coil in the oscillator plate circuit at L_2 , and the 7-Mc. coil in the doubler circuit at L_3 . With the meter plug in J_1 , C_2 is tuned to resonance, again indicated by minimum plate current. The meter is then shifted to J_3 , the amplifier grid circuit, and C_3 adjusted for maximum grid current. Here again the plate coil must be correctly coupled to the grid winding, requiring the same treatment as the 3.5-Mc. L_3 coil. When a grid current of 70 ma. has been secured the doubler plate current should be checked (meter plug in J_2) to determine if this tube is correctly loaded.

For 14-Mc. output, the second-harmonic output of the oscillator drives the doubler, therefore the 7-Mc. coil is used at L_2 . At L_3 , the 14-Mc. 6-prong coil is used. On 14 Mc. the doubler output is not as high as on 7 Mc., hence the grid current will be lower—in the vicinity of 50 ma. This is still ample to drive the 809's satisfactorily. For maximum excitation, it may be desirable to increase the setting of C_1 , although the crystal current is lower when C_1 is at minimum. The adjustment should be made with the amplifier delivering power to a load, and appreciable capacity should not be used at C_1 unless a worth-while increase in output results.

On all three bands, the final-stage tuning procedure is the same. With maximum excitation,

(Continued on page 118)

THE SUPER SKYRIDER
THE SKY CHIEF
THE SKY CHALLENGER



THE ULTRA SKYRIDER
THE SKY BUDDY
THE SKYRIDER COMMERCIAL

THE SKY CHALLENGER II

wipes out **IMAGE** INTERFERENCE



\$77.00

LESS SPEAKER · LESS CRYSTAL

The new Sky Challenger II is a good buy at its price. Completely modern, with the new Hallicrafters Infinite Image Rejector that wipes out image interference, the 1000° Spiral Band Spread, not to mention its many other exclusive features and mechanical improvements, the Sky Challenger II offers an entirely new standard of performance in communications receivers.

BUY ON BOB HENRY'S OWN TIME PAYMENTS!

You can enjoy the superior performance of a Sky Challenger II while you pay for it by payments arranged to suit you with only 6% interest charge. I finance my own paper so I can sell to you with less interest cost and less red tape and bother. Write today, let me send you complete information on the Sky Challenger II and other receivers and my liberal time payment plan.

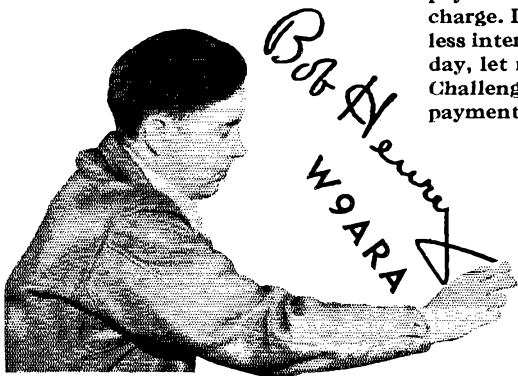

HENRY RADIO SHOP

211 NO. MAIN ST., BUTLER, MISSOURI

the hallicrafters inc.

THE SUPER SKYRIDER
THE SKY CHIEF
THE SKY CHALLENGER



THE ULTRA SKYRIDER
THE SKY BUDDY
THE SKYRIDER COMMERCIAL

THE SKY CHALLENGER II



\$7700 LESS SPEAKER
LESS CRYSTAL

ONE OF THE GREATEST VALUES
EVER OFFERED IN AMATEUR RADIO

We have never seen so much for the money. This new Sky Challenger II has more features, more real value, packed into its cabinet than were thought possible at its price.

NEW INFINITE IMAGE REJECTOR

Wipes out all image interference completely. It's brand new and exclusive with the Sky Challenger II, a genuine advance in amateur reception.

1000° BAND SPREAD

The Sky Challenger II has the same 1000° Spiral Band Spread that was the sensation of the amateur world when first introduced on the Super Skyrider. Offers the maximum useable band spread on any band.

NEW SELECTIVITY and SENSITIVITY

Sensitivity and Selectivity are both better than ever before, and it has been refined mechanically into the "smoothest" operating receiver you've ever seen.

The Sky Challenger II has a lot of other features — you have to see it to appreciate what a value it is. Come in today and look it over — or mail the coupon for complete details.

Mail This Coupon Now!

Gentlemen:
Please rush me complete Hallicrafters dope and copy of Tydings' 1938 Serviceman's Amateur Catalog.

NAME.....CALL.....

ADDRESS.....

E. J. TYDINGS CO.

AT TWO CONVENIENT STORES
114 NINTH ST. 230 NO. FOURTH ST.
PITTSBURGH, PA. STEUBENSVILLE, PA.

the hallicrafters inc.

The First Interamerican Radio Conference

(Continued from page 11)

immensely greater than ours that they are obliged to choose frequencies that we normally would regard as undesirably high for a given service. Thus the amateurs in the Latin nations are interested in 7-Mc. 'phone for the very excellent reason that the natural noise level experienced on the lower-frequency bands does not permit successful 'phone work with the authorized power. We have low-frequency 'phone assignments for short-distance work, but they are almost worthless to them. It is the traditional W-VE-VO view that there should be no 'phone in the 7-Mc. band, but it is to be admitted that every nation has a sovereign right, under the Madrid regulations, to open as much of this band to 'phone as it wishes, including the actual exclusion of c.w.! And here was this Rio agreement opening this band to 'phone except for 50 kc. Obviously, neither the amateurs of these countries nor their governments were to be dissuaded from their intention to use some 'phone in this band, and I think it is physically demonstrable that they need it. The problem, therefore, was how much and where? The A.R.R.L. Board was of the belief that 'phone should be confined to 100 kc. of this band, and that seemed reasonable.

It may be asked why the Cuban and Mexican governments were asking anyone's permission to put 'phone in 100 kc. of that band. They were not; they were asking for 100 kc. exclusively for Latin-America, and exclusively for 'phone; they wanted W-VE amateurs to give up 100 kc. completely! They, of course, get exceedingly severe QRM from our c.w. operation and they felt that they had a moral right to some 'phone territory free of c.w. interference, considering that we have lower-frequency bands on which we may operate 'phone. The northern nations, of course, were obliged to say that they could not contemplate giving up any of the band to the Latin countries exclusively. After a long discussion, a 100-kc. non-exclusive assignment was agreed upon, after the United States had pointed out that any 'phone allocation tends in practice to be self-exclusive and after it was agreed that there would be no 'phone in those 100 kc. in W, K, VE and VO. This was not done by pulling the wool over the eyes of the Cuban amateurs; Mr. Catá and his associates realize exactly what it means in the way of probable interference and are definitely uneasy about it, but they were simply good sports and exceedingly coöperative and willing to do the right thing. I believe that the arrangement will work very successfully for the Latin-American amateurs. To W amateurs who are inclined to query any Latin 'phone in this band, I would remark that it is a right of governments that no one can take away from them, and that a compromise was therefore the only possible solution; that tropical conditions warrant the assignment; and that the operating position of W amateurs will be better with Latin 'phones confined to 100 kc. of this band instead of causing interference all through it as at present.

(Continued on page 70)

THE SUPER SKYRIDER
THE SKY CHIEF
THE SKY CHALLENGER



THE ULTRA SKYRIDER
THE SKY BUDDY
THE SKYRIDER COMMERCIAL

IT'S UNBELIEVABLE!

LOOK AT THIS
RECEIVER!

LOOK AT THE
PRICE!



It's entirely beyond our understanding how Hallicrafters can put so much real value in a communications receiver for so little money. The Sky Challenger II is a fine communications receiver, precision-built, with selectivity and sensitivity far above average and fine all-around performance. If this were all it had, it would be a bargain at its price!

It's easy to own a Sky Challenger II with our liberal time payment plan! Every receiver we sell is personally checked by us to guarantee satisfactory performance for our customers. You can be assured of personal, intelligent service by experienced amateurs when you deal with Radio Shack!

\$77⁰⁰

LESS SPEAKER
LESS CRYSTAL

SKY CHALLENGER II

But, look, it's got the NEW Hallicrafters Infinite Image Rejector, used on the Sky Challenger II for the first time on any receiver. You know what you would pay for enough pre-selection to cut out image interference on the 10 and 20 meter bands. This new patented Image Rejector does this job, does it perfectly and it's part of the receiver.

Then there's the famous Hallicrafters 1000° Spiral Band Spread System, until now used exclusively on the SUPER SKYRIDER. It, too, is included on the New Sky Challenger II. These two features alone put the Sky Challenger II in a class by itself among communications receivers. Come in to see it today, or write at once for complete details.

NEW ENGLAND'S OLDEST AMATEUR SUPPLY HOUSE

THE RADIO SHACK

46 BRATTLE STREET • BOSTON, MASS.

the hallicrafters inc.

THE SUPER SKYRIDER
THE SKY CHIEF
THE SKY CHALLENGER



THE ULTRA SKYRIDER
THE SKY BUDDY
THE SKYRIDER COMMERCIAL

We Have It!

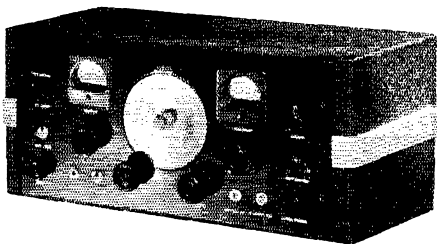

the **NEW** **\$77.00**

SKY *Less Speaker
Less Crystal*
CHALLENGER II

with the
**NEW INFINITE
IMAGE REJECTOR**

Again, Hallicrafters ring the bell with a new, and different, communications receiver, with several new exclusive features, better all around performance and greater mechanical perfection — all at a new low price! The Sky Challenger II has the new Hallicrafters Infinite Image Rejector that wipes out image interference and the same 1000° Spiral Band Spread System used on the SUPER SKYRIDER, two advanced developments that are ordinarily found only on much higher priced receivers.

With finer performance and numerous structural and mechanical refinements, the Sky Challenger II lives up to every Hallicrafters tradition. See the Sky Challenger II at our store today or write for complete details.

- ★ 9 Tubes
- ★ Infinite Image Rejector
- ★ 1000° Band Spread
- ★ New Recessed Tuning Dial
- ★ 38 MC to 540 KC (7.9 to 545 Meters)
- ★ Iron Core I F
- ★ "S" Meter Terminals
- ★ Doublet or Marconi Antenna

DELAWARE RADIO SALES CO.

405 Delaware Avenue
Wilmington, Delaware

the hallicrafters inc.

Determining the location of the 100-kc. 'phone segment was more difficult. It was obvious that it ought to be harmonically-related to a 14-Mc. assignment, in which the Latins are nearly as much interested. Obviously the Rio agreement opening 14,000-14,300 to 'phone would not do; obviously a band of this world-wide effect should not have more than half its width devoted to 'phone. It was rather plain that it should be that half in which the W-YE amateurs are already established: 14,100 to 14,300 in which the Canadians operate, containing in its center our W allocation. The VE amateurs are accustomed to working in a band twice as wide as the W one, but avoiding the W's in the center and generally regarding their assignment as 50 kc. on either side of the W's. To the Latin amateurs this was a new idea and they did not like it in two slices. Of course it would have been much more desirable if it could have been arranged so that the Latins and the Canadians, say, could have had 100 kc. in one continuous range, while the U.S.A. had another 100. But unless more than half of the 14-Mc. band were opened to 'phone, which everyone admitted was undesirable, this would have involved moving either U.S.A. or Canadian 'phones on behalf of Latin stations not yet established. It was a very difficult question, as the 'phone matter always is. But finally it became apparent to everybody that the only solution was for the Latin 14-Mc. 'phones to use the same frequencies as the Canadians, and thus the place in the 7-Mc. band for the 'phone segment became indicated as the subharmonic of 14,100-14,300, or 7050 to 7150 kc. But in order to prevent 'phones from overrunning more than half of the 14-Mc. band and in order to displace the Rio figures with a new agreement providing, in effect, two separate slices of 50 kc. each for the Latins, it was necessary for the representatives of the United States administration to agree that this country, temporarily at least, will not expand its 14-Mc. 'phone allocations into the territory the Latins are to occupy, and it did pledge itself not to do so before the first of 1940 at the earliest. The relations of these two bands are shown perhaps a little clearer in the diagram.

Incidentally, it is probable that the action of the Habana conference permanently locates the 'phone sub-bands in the middle portion of the general bands, and eliminates further speculation about the movement of the 'phone sub-bands to one end or the other of the 14-Mc. band.

THIRD-PARTY TRAFFIC

While the 'phone matter was the most important one, the most interesting was a decision by the governments to permit international handling of the third-party "unimportant" traffic. Our readers may remember that the handling of international messages emanating from third parties is forbidden by the current world regulations unless special provisions to the contrary have been made by interested administrations. We have such arrangements already with Canada, Chile and Peru, but these individual arrangements are but laboriously negotiated. Months ago it occurred to the

THE SUPER SKYRIDER
THE SKY CHIEF
THE SKY CHALLENGER



THE ULTRA SKYRIDER
THE SKY BUDDY
THE SKYRIDER COMMERCIAL

WORKS
like 10 Pre-Selectors



The NEW Hallicrafters Infinite IMAGE REJECTOR CIRCUIT of the SKY CHALLENGER II \$77.00

You'll get a new kick out of the 10 and 20 meter bands when you work them with the NEW SKY CHALLENGER II. How many times have you had a QSO on these bands go sour due to image QRM! That's a thing of the past with the new Hallicrafters Image Rejector, as you'll find out the first time you operate the New Sky Challenger II. For this new circuit will give you better image rejection than 10 expensive stages of pre-selection, and it's built right into the New Sky Challenger II, an integral part of the receiver.

You'll find the same 1000° Spiral Band Spread System used in the SUPER SKYRIDER, to really spread out the bands for you. You'll find new and better selectivity and sensitivity — refinements throughout the entire receiver and — all at a price you would gladly pay for an ordinary receiver. Get the complete dope on the New Sky Challenger II. Mail the coupon today!

Less Speaker and Crystal

PURCHASE YOUR
SKY CHALLENGER II
ON
HINDS & EDGARTON
EASY TIME
PAYMENTS

Don't wait for better reception. Buy your Sky Challenger II on payments that you'll scarcely miss every month. Write today for full particulars on the HINDS & EDGARTON Easy Payment Plan.

W9APY HINDS & EDGARTON W9WR

19 SOUTH WELLS STREET, CHICAGO, ILLINOIS

Please rush me complete story on new Sky Challenger II and Edgerton Time Payment Plan.

Name..... Call.....

Address..... City.....

the hallicrafters inc.

GOING PLACES

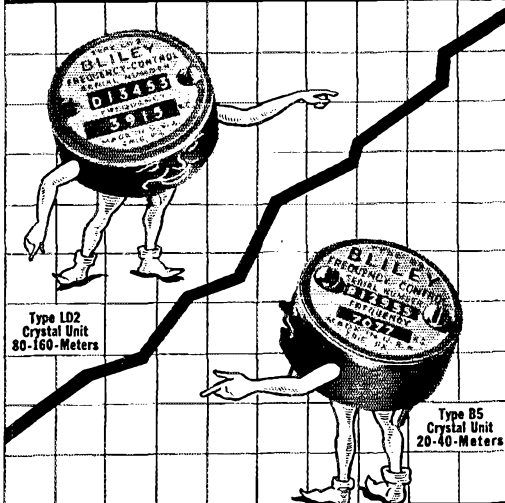

DOING THINGS

THESSE two "fellows" are really going to town in a big way — and why shouldn't they? Amateurs, the world over, appreciate their superior characteristics and full dependability.

For the 80- and 160-meter bands, the LD2 unit is outstanding in its high activity, full dependability and its drift of less than 4 cycles/Mc./°C. You'll find at least one of these units in almost any ham shack you may visit.

40- and 20-meter crystals have been pioneered by Bliley. The 40-meter LD2 unit needs no introduction, yet the new B5 unit for 40 meters, which replaces it, is even better. With greater activity and 35% more R.F. current carrying capacity, it leaves little to ask for at such a reasonable price. For 20-meters, the new B5 unit brings greater frequency stability to the high frequency bands at a new low cost.

Hop on the Bliley Band-Wagon — get an LD2 or B5 unit from your regular distributor. Bliley Electric Company, Erie, Pa.

BLILEY CRYSTALS

A.R.R.L. that this might be made an item in the regional arrangement of Habana, so through the efforts of the League the subject was proposed by the United States government for consideration there. A formal document was introduced, explaining the proposal, and suggesting a multi-lateral agreement. When the subject came up for consideration in subcommittee, it was expertly presented by Mr. Gross of the U.S.A. delegation. Probably the subject is not of vast practical importance, but it has great significance as a symbol of high idealism. Any amateur is aware of that vast potential ability of amateur radio to improve international understanding through the contacts between amateurs. We all know the appreciation that our contacts give us of the ideals and aspirations of other peoples. There would undoubtedly be great improvement in Pan-American understanding if this "international visiting" by amateurs could be expanded to embrace communications on behalf of third parties. That was the idea: that all the American nations agree mutually, by one clause in their treaty, to set aside the Madrid restriction and demonstrate in the New World a new sympathy and understanding between peoples.

It has been adopted! The governments of Mexico and Venezuela regret that their basic laws prohibit them from accepting the idea, and it is intimated that the same situation prevails in the Argentine. But all the other countries, so far as we are aware, embrace the project; and it is our understanding that on July 1st the list of countries with whom we are permitted to interchange traffic as we do now with Canada, Chile and Peru will be greatly expanded. It was beautiful to see the administrations represented at Habana seize upon that ideal—there was something tremendously significant about it. It was not necessary for the United States to battle on behalf of its proposal. That was done by numerous other delegations who were sincerely fired with zeal for the project and who laced into the few recalcitrants, so that it was accepted in subcommittee by eleven votes to none, with three abstentions. The final language provided an "out" for those countries whose internal regulations prohibit such international exchange, so that everybody was able to sign the document without reservations. The provision reads as follows:

WHEREAS, the General Radio Regulations annexed to the International Telecommunication Convention of Madrid provide that unless modified by special arrangements between interested countries amateur stations are forbidden to transmit international communications emanating from third persons; and

WHEREAS, it is apparent that the community of interest of the peoples of all the Americas would be fostered by encouraging the exchange, by amateur stations, without charge, of friendly messages emanating from our citizens;

Be it resolved, by the Inter-American Radio Conference, that:

In the interest of close and friendly contacts between the peoples of the Americas, the administrations of the contracting countries whose internal legislation permits it agree that amateur radio stations in their respective countries and possessions may internationally exchange messages emanating from third parties; provided, however, that such messages shall be of a character that would not normally be sent by any other existing means of electrical communication and

WANTED!

By every ham in the world

Do You Know Any of These Men?

They are the Thordarson Engineers—All full-fledged "Hams" who have compiled this

ARRESTING NEW EDITION

48 pages-ALL NEW Tested circuits, data and general information on transmitters.

CHIEFS OF POLICE

Sheriffs, "G" men and amateurs appreciate the value of accurate information.

\$10,000

may be the value of this new guide to you, but it's yours for only 15c list at your jobber's or 15c postpaid from the factory direct.

Here's the Evidence

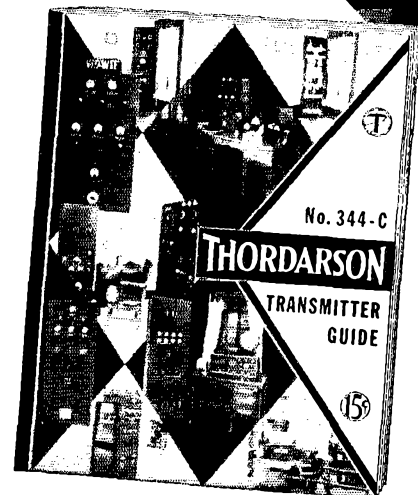

4th Edition



THORDARSON ELECTRIC MFG. CO.

500 W. HURON STREET CHICAGO, ILL.

NA-6-NS TYPE ADN
XR-500-PD XC-75-XD
ZR-10-AS MG-35-NS

Some amateurs seem to be confused by the type numbers used on CARDWELL condensers. These designations are necessary and tell the complete story on any individual condenser.

CARDWELL has available a mimeo sheet, "Key to Cardwell Type Numbers," to interpret these seemingly incoherent letters and figures.

If you do not have a CARDWELL catalog No. 40 with its valuable voltage breakdown chart, L.C. chart for designing tank circuits and a chart for determining peak voltages across tank condensers — get one now — free — at your dealers or write direct to CARDWELL.

While on the subject of CARDWELL condensers, let us again bring to your attention our new ADN* and BDN* disc neutralizers; remembering that the NA series of neutralizers still offers the convenience of a compact 180 degree variable for those tubes for which the capacity ratings of the NA series are correct. A constant voltage rating is of course an obvious advantage of this type.

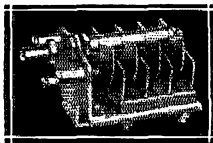
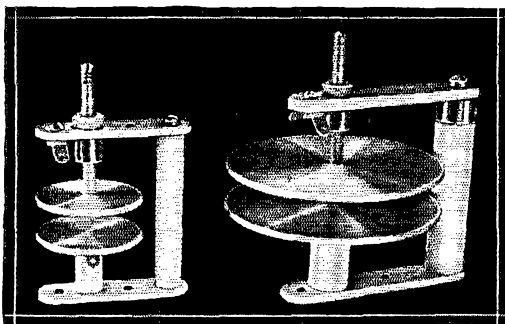

ADN (top left). Capacity range: 5 to 4 Mmfd. Net to amateurs. \$1.80
BDN (top right). Capacity range: 2 to 12 Mmfd. Net to amateurs. \$3.00
NA-16-NS (left). Capacity range: 7 to 16 Mmfd. Net to amateurs. \$3.00

Also ask your dealer for our sheet listing proper Cardwell condensers for the splendid transmitters described in "Stancor Hamanal," "Taylor Tube Manual," General Transformer's "Progressive III" and "Streamliner," and Utah kits, as well as identification table of Cardwell units used in the "Radio" Handbook.

**THE ALLEN D. CARDWELL
MANUFACTURING CORPORATION**
83 PROSPECT STREET, BROOKLYN, NEW YORK

on which no compensation may be directly or indirectly paid.

For the success of our efforts at Habana much credit must be given to the understanding work of the amateur s.s.c.; to the U.S.A. delegation, particularly to Mr. Gross, who was outstanding and indefatigable in his efforts on our part; to Dr. Nicolas G. de Mendoza and to Mr. Catá of the Cuban delegation. But for this successful outcome we are perhaps chiefly indebted to the fine ham spirit of the Cuban amateurs, who were splendidly cooperative and willing to "let live" as well as live.

I met many of the Cuban amateurs, whose organization, *Radio Club de Cuba*, has its headquarters in Habana. They are the same swell gang that one meets in amateur circles anywhere in the world. Shortly after I arrived they gave me a reception, and a few weeks later they tendered a luncheon in honor of OM Tudela, OA4Z, and myself. They have some pretty stations and they possess the true ham spirit. There are about 225 licensed amateurs in Cuba and about 300 members of the R.C.C. As one collateral result of my visit there, we have had the pleasure of receiving an application from the R.C.C. to become the Cuban member of the I.A.R.U. and we hope that, before many months, the name of the *Radio Club de Cuba* will be appearing each month in the mast-head of the I.A.R.U. section of *QST*.

Brief

W2HNH had an odd operating experience recently on 7 Mc.—it seemed nigh impossible for him to raise the stations he called, although he did work somebody after each call. First he called W8QZB and was answered by W8MWY, who lives near QZB. Later in the day he called W8KFFV and, on listening for KFV's reply, was called by W8EWT. Then, to top it off, after calling W8BBW and standing by, back comes W3FFY. All the calls were made in the usual manner and W2HNH found it quite surprising to hear entirely different stations pop up and work him each time. In none of the cases did the station actually called come back!

Inexpensive Coaxial R.F. Line

(Continued from page 20)

for higher efficiency since no soldering is required to connect the center conductor wire from 14-foot lengths into the required footage. Of course before any tubing was put on we had soldered the center conductor of the end seal to the center conductor of the line, and the first piece of tubing on the wire was made fast to the end seal with gas-tight fittings. In our particular case spark plugs (Y-4 Champions) were used for end seals. As they are threaded for $\frac{3}{8}$ -inch threads it was easy to tap and cut one of the brass fittings in such a way as to allow the small plug to be coupled. However, as it is rather a ticklish job to take out the spark plug's center conductor without cracking the porcelain, we suggest procuring end seals now made available by several manufacturers. Simply ask for an end seal for a $\frac{3}{8}$ -inch outside diameter concentric or coaxial line.

With gas-tight fittings of the type commonly used on gas lines in automobiles and refrigeration units, it is not necessary to sweat joints—heretofore the customary method of connecting sections

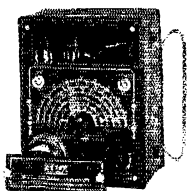

Ranger

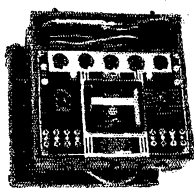

Simpson

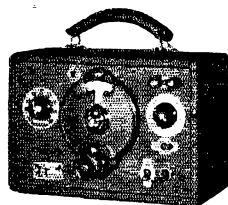

R. C. A.



Clough-Bregle

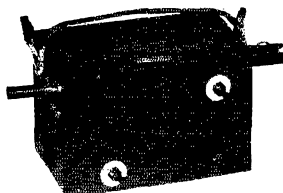

Million

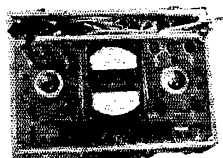

Supreme

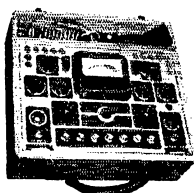

Precision



Triplett

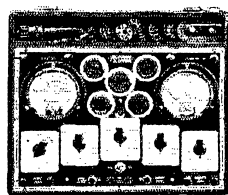

Precision

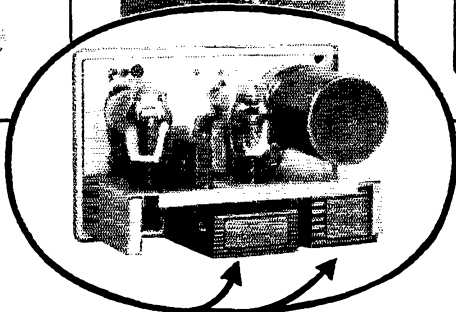

INSIDE

PROOF

of Dependable Test Instruments

Many famous trade-marks identify the leading test instruments used in radio service laboratories. These trade-marks give us confidence in the stamina, precision, and dependability of this equipment. We use them with confidence in the accuracy of the delicate measurements they indicate.

But underneath the trade-mark—inside the box—lies the reason for their satisfactory service—good workmanship—quality materials. It is significant, therefore, that

Burgess Batteries are chosen to power practically all the better known, modern radio test equipment. When you renew cells in your test equipment, buy Burgess for continued accurate performance, just as the manufacturer intended. Use Burgess Batteries in all your experimental work for the same reason. They give the greatest efficiency—lowest cost.

BURGESS BATTERY COMPANY
Freeport Illinois

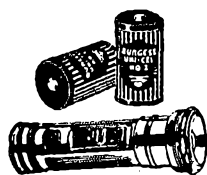

BURGESS



Say You Saw It in *QST* — It Identifies You and Helps *QST*

FOR THE TOUGH JOBS— THE *New* "SUPER-PRO"

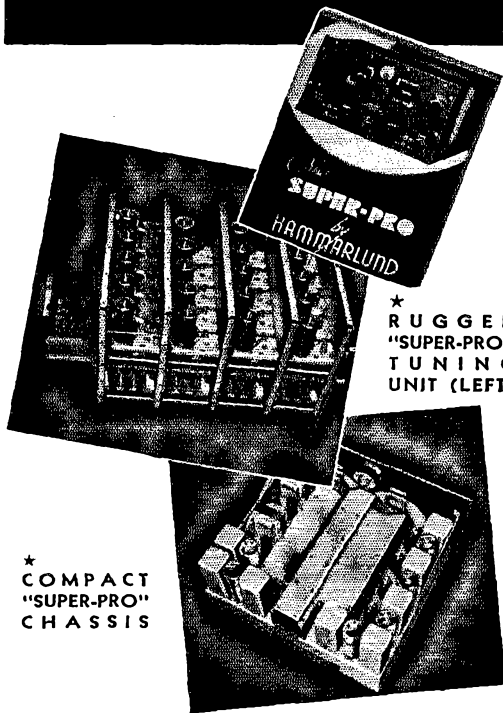

★ RUGGED
"SUPER-PRO"
TUNING
UNIT (LEFT)

★ COMPACT
"SUPER-PRO"
CHASSIS

"THE Hammarlund 'Super-Pro' has certainly proved itself a gem on my toughest expedition assignments," says Len Hammond, Fox Movie-tone News. "At all times, the 'Super-Pro' provided truly remarkable results. I wouldn't be without it." Throughout the world countless others are also finding the "Super-Pro" a grand set for the toughest jobs. "Super-Pro's" feature — 2 R.F. on all bands; 4 air tuned I.F.; electrostatically shielded input; direct tuning; calibrated panel controls; 3 A.F.; stand-by switch; relay terminal strip; variable crystal filter, etc. Mail coupon below for further details on this ideal set for the tough jobs.

HAMMARLUND MFG. CO., INC.
424-438 W. 33rd St., N. Y. C.

Q-2-38

- Please mail me "Super-Pro" bulletin
 Please mail new "38" catalog

Name.....

Address.....

City.....State.....



HAMMARLUND

Canadian Office: 41 WEST AVE., NO., HAMILTON, ONTARIO

of tubing in coaxial lines. In sweating such joints solder often would leak into the line and cause shorts or arc-overs. Don't solder the line together if you want trouble-free operation.

RIGHT-ANGLE JOINTS

Assuming that the line is completed as far as the wall or window where it is to be brought into the transmitter, perhaps it is necessary to make a sharp bend to make a neat installation. Being brass tubing, the line refuses to bend, so now you use a right-angle coaxial joint, Fig. 2. This joint, believe it or not, maintains the 75-ohm impedance even though the center conductor is bent at a 90-degree angle.

These joints are made of brass stock $\frac{3}{16}$ inch thick by 1 inch wide. Two squares of this stock 1 inch to the side are clamped in a vise and drilled and tapped for whatever thread size you have available, one section being drilled and the other

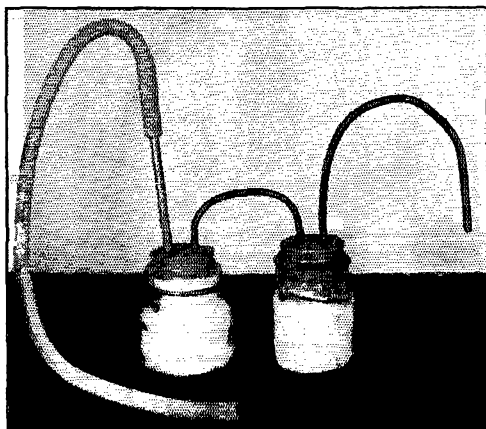

FIG. 4—THE AIR-DRYING APPARATUS

Air is pumped through calcium chloride, a drying agent, and thence into the line.

tapped so that when screws are inserted and tightened the two blocks will fit together snugly. This must be an accurate job, and we would suggest you have it done by a local machine shop unless you are well equipped to do it. Next, place the two sections in a vise and drill, accurately, $\frac{3}{8}$ -inch holes through two sides halfway through the two sections. You then have two $\frac{3}{8}$ -inch holes drilled at a 90-degree angle to each other, meeting in the center of the two sectional blocks of brass. Now coat the inside surfaces between the blocks with Duco cement, bend the wire accurately so it does not touch either wall of the right-angle hole, insert the $\frac{3}{8}$ -inch brass tubing into each hole about $\frac{1}{4}$ inch and tighten up the four screws holding the two brass sections together.

PREVENTING MOISTURE CONDENSATION

An end seal must be used at both ends of the line. Outlet and inlet fittings and a 0-80 pound pressure gauge should also be mounted in the line if it is to be filled with nitrogen gas. However, we have had no occasion to use gas in our line,

DX ARE THE TUBES FOR CHAMPIONS

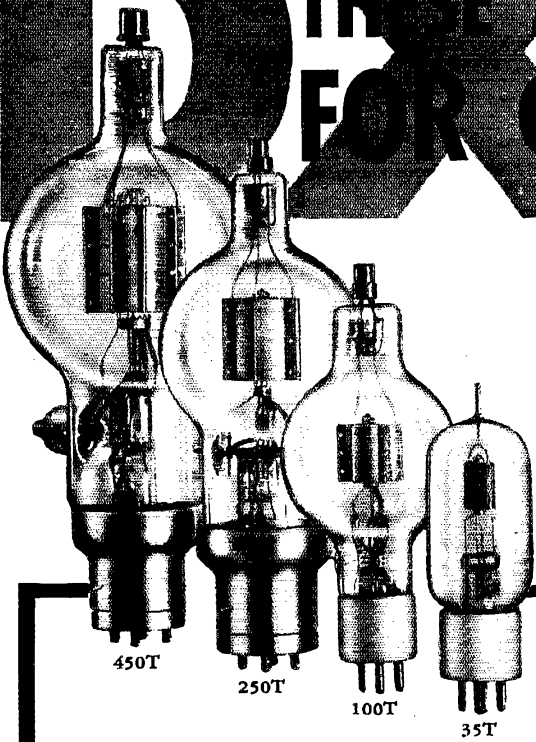

450T

250T

100T

35T

THE WORLD'S MOST NOTABLE AMATEURS USE EIMAC TUBES BECAUSE...

1. *Tantalum plates and grids fabricated and exhausted by an exclusive Eimac process.*
2. *Complete severe exhaust; "getter" entirely eliminated.*
3. *No internal insulators to break down under excessive heat.*
4. *Vertical bar grid, with high insulation, low capacity support.*
5. *Improved thoriated tungsten filament having unusual thermionic efficiencies with a special support assembly.*
6. *Lowest interelectrode capacities for equal power rating or capabilities.*
7. *Unconditionally guaranteed against gas.*

YOU CAN GET THESE TUBES
AT YOUR DEALERS TODAY

W6QD Herb Becker renowned authority on DX work whose articles are widely read. Continually on the air . . . uses Eimac Tubes.

W9ARA Bob Henry won the 1937 phone DX contest. Popular phone man of the mid-west who uses Eimac Tubes for greater performance.

W4DHz Dave Evans won first place in 1936 and fourth place in 1937 DX contests. One of the best known East Coast Hams. An ardent Eimac fan.

W6CUH Charlie Perrine . . . an Eimac user. Everybody knows of his exploits in technical and DX fields. His ideas have revolutionized amateur radio.

W6CXW Henry Sasaki won second place in the 1937 DX contest. Has been using Eimac tubes for over three years. One of the most consistent West Coast signals.

G5BY Hilton L. O'Heffernan is one of the better known English amateurs. Was the first English station to be heard across the Atlantic on 5 meters. G5BY used Eimac Tubes.

VK2NO Don Knock holds the world's DX record for 5 meters. Confirmed report of his 5 meter signals being heard in Wales. Another Eimac triumph.

[We could fill a book with names of enthusiastic Eimac users, but space does not permit.]

Eimacs record breaking success in attracting radio's outstanding Hams from all over the world is something more than mere luck. The owners, executives and workers (every one) in the Eimac shops, are "Hams"; all young people; all vitally alive and enthusiastic about tube performance as a personal hobby. They talk your language and feel your problems. It is their pride and glory to s-t-r-e-t-c-h tube performance far in excess of normal ratings. No wonder Eimac tubes are in such demand by the outstanding DX Hams throughout the world . . . no wonder, too, that the rank beginner who starts with Eimac soon outstrips many oldtimers, who continue with outmoded rigs.

Eimac
TUBES

EITEL & McCULLOUGH, INC. • San Bruno, California



Jefferson Electric Co.
Bellwood, Ill.

Gentlemen:

I am sending you a picture of a 100-watt amplifier built from a diagram you issued some time ago and using your product. The amplifier has been built for some time and I want to tell you that it proved to be the cause of it and I have not reported that will compare with it.

The top part has a base control amplifier speaker and another control. The second part has a base control and a frequency for two or four miles. A later master control and a master control or communication built like the common diagram. The third part has two milliamperes and a meter for the line current. The third part has three sections, a master switch filament and plate voltage sections. The output is so that 200 filament and plate voltage can be used to it.

Sincerely yours,
Ted Govern
2nd Street



"For Best Results— Use Jefferson Transformers"

No. 467-451
Transformer for
Class B Driver.

Those who have had widest radio experience with receivers, transmitters, amplifiers—know that the transformers used make a big difference—as Ted Govern confirms.

Jefferson Transformers have become the recognized standard for those demanding the highest efficiency and the most reliable service. . . . You can get Jefferson Transformers from your Parts Jobber—and if you want our complete catalog and manual of Amplifier Circuit Diagrams, just clip and mail the coupon below. JEFFERSON ELECTRIC COMPANY, Bellwood, Illinois. Canadian Factory: 535 College Street, Toronto, Ontario.

Get our latest Catalog 372-R and Manual of latest Amplifier Circuit Diagrams . . . Free for the asking.



JEFFERSON RADIO TRANSFORMERS

JEFFERSON ELECTRIC COMPANY
Bellwood, Illinois. (C.)

Mail latest catalog 372-R and your free manual of new amplifier circuit diagrams to:

Name

Address

City State

and it has been lying six inches underground now for three months. Gas is used in these lines when they are installed for broadcast stations, but we know of many ultra-high-frequency police installations that have been operating perfectly for many months without gas.

The purpose of the gas (nitrogen drawn off through oil) is to give the line a greater voltage-breakdown factor between center and outer conductor, and also to keep out water and prevent condensation within the line. The average pressure maintained should be in the vicinity of 25 pounds.

A much easier system² to use for clearing out condensation (if you ever do get any—we haven't yet) is to fill a Mason jar not quite full of calcium chloride. Push a brass or copper tube down through a rubber stopper almost to the bottom of the jar. Then put another brass tube through the stopper so it just projects on the other side. This is bent over and similarly connected to a second Mason jar filled with cotton batting, as shown in Fig. 4. This tubing goes to the bottom of the second jar. A third tube goes down through the stopper of this jar to the top of the cotton batting and is then connected to the line. The first tube is connected to a bicycle pump and air is pumped into the first jar through the calcium chloride out into the next jar up through the cotton batting and out through a hose to the coaxial line. You then have air free of moisture content pumped into the line's inlet valve and out through the outlet valve near the end of the line. Any moisture in the line will be dried up.

Thus, you have a workable coaxial line. Any amateur can build it. Except for the coaxial joints, which were made in a local ham's machine shop (W2FL) no tools are required other than those ordinarily found in any amateur station, plus a couple of wrenches out of the "flivver's" tool kit.

COUPLING TO ANTENNA AND TRANSMITTER

Since we were mainly interested in 'phone, the antenna with which the line is used was designed with three-band 'phone operation in mind. It consists of a half-wave on 75 meters fed in the center with the coaxial line. Each side of center (which is supported by a 40-foot pole) insulators are inserted to give the required half-wave flat tops for both 20 and 10 meters. Jumpers are connected across these for 75-meter operation and are removed for either 20- or 10-meter operation simply by letting down both ends of the antenna, which is suspended on pulleys. A ladder of cross arms on the center pole allows us to go about halfway up the pole and either connect or disconnect the jumpers for whatever half-wave antenna we choose to use. This antenna system really works well on 75, 20 and 10.

Coupling the coaxial line to the antenna is simple. Merely anchor each section of the antenna to the pole and run flexible copper braid or soft-drawn copper wire leads neatly from the end seal connections at the end of the coaxial line. One side of the flat top is soldered to the brass tube, the

² Thanks to W2DAC, chemist on the job.

THE CALL OF THE BATON ROUGE POLICE depends on DELCO-REMY

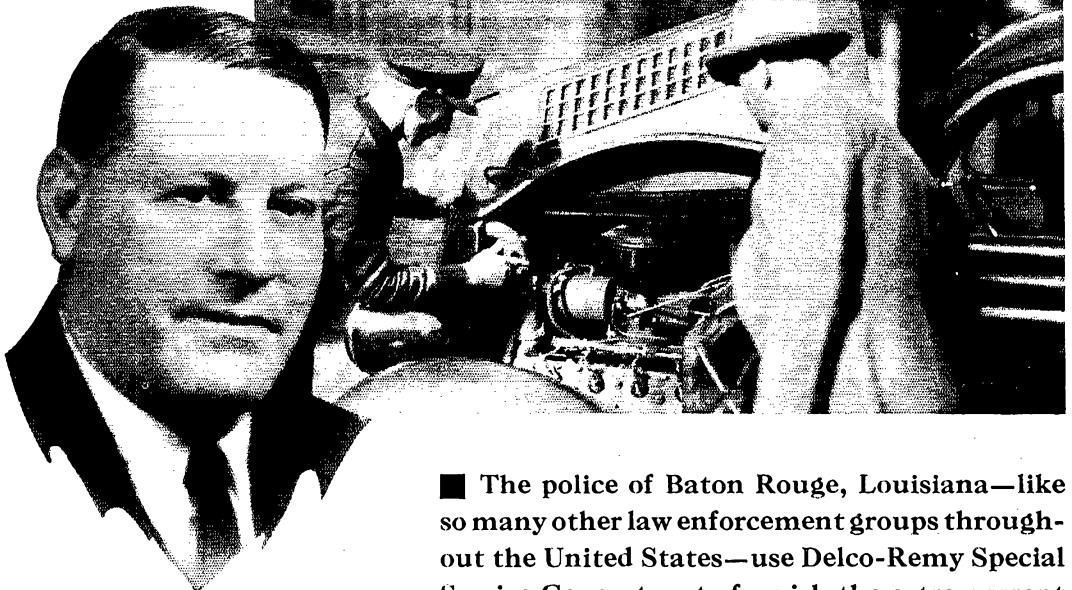

"We have received splendid results from the Delco-Remy generators in service on more than 20 of our radio-equipped police cars. We chose Delco-Remy generators for their dependable operation under the toughest twenty-four-hour grind, and they have proven worthy of every trust."

K. H. STRENZKE, Commissioner
Baton Rouge, La., Police Dept.



S. S. ARRIGHI
Supervisor of Radio
Baton Rouge, La., Police Dept.

■ The police of Baton Rouge, Louisiana—like so many other law enforcement groups throughout the United States—use Delco-Remy Special Service Generators to furnish the extra current required for police radio work. These municipal and state police departments find that Delco-Remy High-Output Generators and Delco-Remy Current and Voltage Regulators keep radio-equipped scout cars and cruisers in service the maximum amount of time—and at minimum cost. Amateurs, too, find that these same generators provide ample current for two-way radio service and experimental work in their own cars.

Any Branch or Electrical Service Station of United Motors Service will be glad to recommend a Delco-Remy High-Output Generator specifically adapted to your needs.

Delco-Remy

ANDERSON, INDIANA



Delco-Remy products are sold and serviced by United Motors Service Stations everywhere . . . wherever you see this sign.

World's Largest Manufacturer of Automotive Electrical Equipment

Say You Saw It in QST — It Identifies You and Helps QST

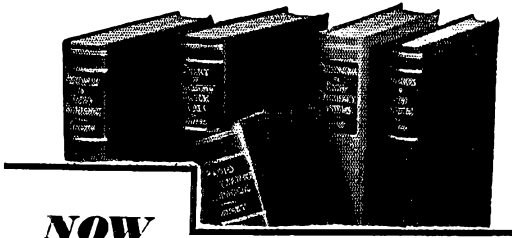

NOW
this high-powered radio engineering library

sent to you for 10 days' trial—
 at a special price and terms

These books cover circuit phenomena, tube theory, networks, measurements, and other subjects—give specialized treatment of all fields of practical design and application. They are books of recognized position in the literature—books you will refer to and be referred to often. If you are a researcher or experimenter—if your interest in radio is deep-set and based on a real desire to go further in this field—you want these books for the help they give in hundreds of problems throughout the whole field of radio engineering.

RADIO ENGINEERING LIBRARY

—especially selected by radio specialists of McGraw-Hill publications
 —to give most complete, dependable coverage of facts needed by all whose fields are grounded on radio fundamentals

For home-study and reference. Contains a revised selection of books culled from latest McGraw-Hill publications in the radio field.

5 volumes, 3064 pp., 2000 illustrations

1. Glasgow's PRINCIPLES OF RADIO ENGINEERING
2. Terman's MEASUREMENTS IN RADIO ENGINEERING
3. Chaffee's THEORY OF THERMIONIC VACUUM TUBES
4. Hund's PHENOMENA IN HIGH-FREQUENCY SYSTEMS
5. Henney's RADIO ENGINEERING HANDBOOK

Special Low Price and Easy Terms

Bought singly, the five volumes comprising this library would cost you \$25.00. Under this offer you save \$1.50 and, in addition, have the privilege of paying in easy installments beginning with \$2.50, 10 days after receipt of the books, and \$3.00 monthly thereafter. Take advantage of these convenient terms to add them to your library now.

SEND THIS ON-APPROVAL COUPON

McGraw-Hill Book Co., Inc.
330 W. 42nd St., New York, N. Y.

Send me Radio Engineering library, 5 vols., for 10 days' examination on approval. In 10 days I will send \$2.50, plus few cents postage, and \$3.00 monthly till \$23.50 is paid, or return books postpaid. (We pay postage on orders accompanied by remittance of first installment.)

Name.....

Address.....

City and State.....

Position.....

Company.....QST-2-38
 (Books sent on approval in U. S. and Canada only.)

inner conductor going to the opposite half. No fanning is necessary.

Coupling to the transmitter is likewise easy; use a coupling coil at the cold end of the tank inductance or, in the case of push-pull stages, at the center of the inductance. Tune the final stage to resonance before coupling the coaxial line, then connect your coupling coil to the line and vary the number of turns until the proper amount of plate current is drawn by the tube or tubes.

You can't beat this type of line when it only figures a fraction over 10 cents per foot to construct!

28-Mc. Preselector

(Continued from page 85)

CONNECTIONS

Heater and "B"-voltages for the preselector may be obtained from the receiver except in the case of a.c.-d.c. receivers, where special provision must be made for heater current. The B + leads of the preselectors themselves are well by-passed, as shown in Figs. 3 and 6, and it should always be possible to connect the lead to some part of the receiver power supply where it will not introduce feedback or make additional filtering necessary.

Connections between preselector and receiver might appear to be extremely simple; actually this is the most critical point of the installation. The various photographs clearly show one lead of the output link grounded to the chassis and the high side completely shielded by means of flexible wire braid. This braid must be solidly grounded to the receiver chassis and it is sometimes necessary to select the grounding point with considerable care in order to avoid oscillation. To put it another way, the chassis of both preselector and receiver must be at exactly the same r.f. potential, and this potential should, of course, be as close as possible to zero.

The difficulty arises from the fact that the various B + circuits and grid returns of the receiver are not sufficiently filtered for operation at fairly high gain levels and consequently a certain amount of r.f. potential is present on the chassis, speaker leads, a.c. cord, etc. Without the preselector, these potentials would do no harm, since the gain of the receiver is "down" at ten meters, but with the high-gain preselector connected, the potentials are sufficient to cause feedback and oscillation in the added r.f. circuits, even though the preselector itself is perfectly filtered. The most bothersome feedback occurs between the speaker leads (connected directly to the B + circuits) and the antenna lead-in or feeders near the preselector input. In addition to bonding the two chassis, as mentioned above, it may be necessary to by-pass the various speaker leads and a.c. cord with 0.001- μ fd. mica condensers. In particularly stubborn cases, the plate return leads of the first detector, high frequency oscillator, and r.f. stage (if any) of the

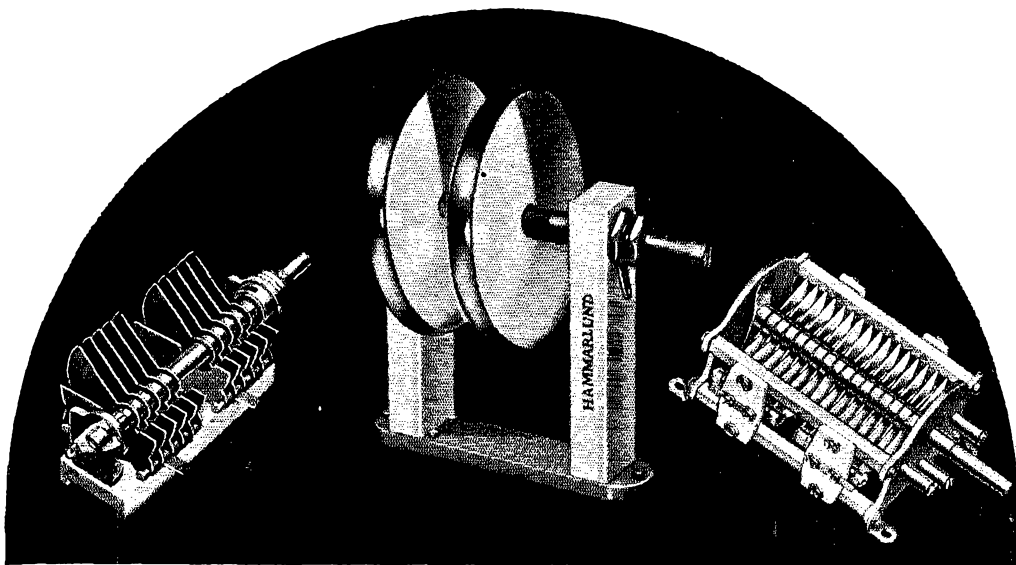

THREE GREAT PARTS

For Quality Transmission

THROUGHOUT the world, amateurs and professionals proudly proclaim the superiority of their transmitters using great parts by Hammarlund that insure such quality transmission. Each of these items has a host of distinctive features that hit a new high in standards of design. For instance, the "N-20" (illustrated above, center) one of the newest additions to the Hammarlund transmitting condenser family, is an ideal heavy duty high voltage neutralizing condenser with many new features, such as, micrometer adjustment with a heavy finely threaded machine screw; heavy round edged aluminum plates, polished on all surfaces, and a special lock for permanent adjustment. A stop is provided to prevent all possibility of shorting. Insulation is B-100 Isolantite. Like the "N-10" this condenser has been also designed for horizontal adjustment, with a 2-hole mounting. Its capacity range is from 2 to 20 mmf. with an air gap range of from $\frac{1}{8}$ " to 2". The plates are 4" in diameter.

The "MTCD" (shown at right) is another recent development that provides the high operating efficiency demanded by critical amateurs and professionals. Designed for universal mounting, it can be mounted on a panel flat, on a chassis with either side up on its edge, thus fitting any possible arrangement of parts. Heavy aluminum plates are accurately wedged into deep slots in supporting bars. An accurately machined stainless steel shaft fitted to a long bronze front bearing mounted on a Beryllium cushion disc provides a free floating action for

consistently smooth operation and perfect bearing. Isolantite insulation and silver plated Beryllium contact wipers assure lowest losses and lowest series resistance. Available in a number of convenient sizes from 20 mmf. to 265 mmf. with a wide variety of operating voltages from 1000 to 5500 volts.

The Hammarlund "MCDX" (at left) is well-known to the amateur who builds and operates quality ultra-high frequency transmitters. It is the accepted standard for tuning ultra-high frequency transmitters where a well insulated split stator condenser is required. Its design is such that the inductance with which it is used can be soldered directly to the terminals eliminating further support. A new split type rear bearing and noiseless wiping contact assure smooth, quiet operation. Cadmium plated non-corrosive soldered brass plates are used. Available with midline or semi-circular plates with a maximum capacity of 31 mmf.

Assure yourself of superior results by using Hammarlund precision products in your transmitter. Mail coupon below for new "38" catalog for full details on all Hammarlund products.



HAMMARLUND MFG. CO., INC. Q-2-38
424-438 W. 33 St., N. Y. City

Please send me "38" catalog

Name.....

Address.....

City.....State.....



MODERN TEST EQUIPMENT FOR THE AMATEUR

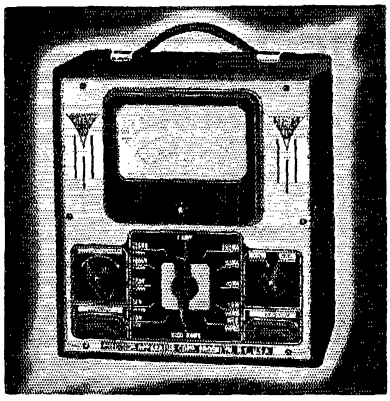

"PRECISION" Series 840L
A.C. — D.C. — VOLT — OHM —
DECIBEL — MILLIAMMETER
including a
2500 VOLT A.C. and D.C. RANGE
and a 1000 M.A. RANGE

SPECIFICATIONS

- * 5 A.C.-D.C. Voltage Ranges from 0 to 2500 volts at 1000 ohms per volt.
- * 4 D.C. Current Ranges from 0 to 1 amp.
- * 5 Output Ranges.
- * 3 Resistance Ranges from 0 to 10 megs. (provision for self-contained batteries).
- * 5 Decibel Ranges from -10 to plus 63DB.

Net price to amateurs **\$19.95** Less batteries and test leads

SERIES 840P incorporates same specifications as the black leatherette covered portable case with removable cover. Size 9 x 10 x 6. Net to amateurs. **\$21.95**

AVAILABLE AT LEADING DISTRIBUTORS

Following is a partial list

- | | |
|---------------------|---------------------------------|
| Boston, Mass. | RADIO SHACK, Inc. |
| Charlotte, N. C. | SHAW DISTRIBUTING CO. |
| Chicago, Ill. | LIJKKO SALES CORP. |
| Denver, Col. | INTERSTATE RADIO and SUPPLY CO. |
| Bagerstown, Md. | ZIMMERMAN WHOLESALERS |
| Houston, Texas. | STRAUS-FRANK CO. |
| Miami, Fla. | WALDER RADIO and APPLIANCE CO. |
| Modesto, Cal. | WHOLESALE RADIO SERVICE |
| New York, N. Y. | TERMINAL RADIO CO. |
| Norfolk, Va. | RADIO SUPPLY CO. |
| Philadelphia, Pa. | CENTURY RADIO CO. |
| Pittsburgh, Pa. | TYDINGS CO. |
| Pottsville, Pa. | SYLVESTER RADIO and SUPPLY CO. |
| Reading, Pa. | GEORGE D. BARBEY CO. |
| San Antonio, Texas. | OLSEN RADIO SUPPLY |
| St. Louis, Mo. | WALTER ASCHÉ RADIO CO. |
| Texarkana, Ark. | MIMS RADIO CO. |
| Washington, D. C. | RÜCKER RADIO WHOLESALERS |

PRECISION APPARATUS CORP.

821 EAST NEW YORK AVENUE
BROOKLYN, NEW YORK



receiver will require additional filtering. Often-times a 0.1- μ fd. condenser connected from one side of the first detector heater to chassis will do the trick.

At 28 megacycles electrostatic shielding between the antenna primary and the first tuned circuit does not appear to be particularly helpful in reducing such feedback. This may be due to the fact that complete shielding of this type is very difficult to obtain at these frequencies, the situation being further complicated by the presence of electromagnetic or inductive feedback from standing waves on the various external leads.

ALIGNMENT

The amateur who has not previously constructed equipment of this type may hesitate to do so, because he feels that the circuits will be difficult to gang properly or that the added tuning control will make tuning too complicated. Neither of these objections is valid. Since the preselector covers only a narrow range of frequencies and tuning of all circuits is the same, it is necessary to make the secondary windings of the coils only approximately identical. For instance, in building the single-stage unit the coils were space-wound by eye on a half-inch form and were merely adjusted so that the overall dimensions were the same, as nearly as could be judged by holding the coils side by side. The coils should, of course, be mounted symmetrically with respect to the shielding, although here again dimensions are not critical.

In the absence of feedback discussed above, alignment of the preselector circuits is absurdly simple. Merely tune the receiver to the high frequency end of the band with the various gain controls advanced sufficiently to make background noise plainly audible, then starting at the preselector output circuit and working back toward the antenna adjust the trimmer condensers for maximum background noise. No signal is necessary and the antenna need not be connected. To check ganging, tune the receiver to the low-frequency end of the band and swing the preselector dial until the background noise peaks up; then check the trimmer adjustments to see that all circuits are exactly in tune. The antenna should now be connected and the input-circuit trimmer checked again. If it requires readjustment, the antenna coupling is too tight and the primary should be backed away from the secondary or one of the turns removed. If the link-circuit coupling between the preselector output and the receiver is too tight, the output-circuit trimmer will tune very broadly or will, in extreme cases, have a double peak. Best coupling will generally be obtained when the output-circuit trimmer adjustment is only very slightly broader than that of the grid-circuit trimmers.

After the preliminary work has been done and the combination is set to go, the preselector can always be kept in step with the receiver by the background-noise peak and there is no possibility, therefore, of missing weak signals because the preselector is out of tune.

ANNOUNCING

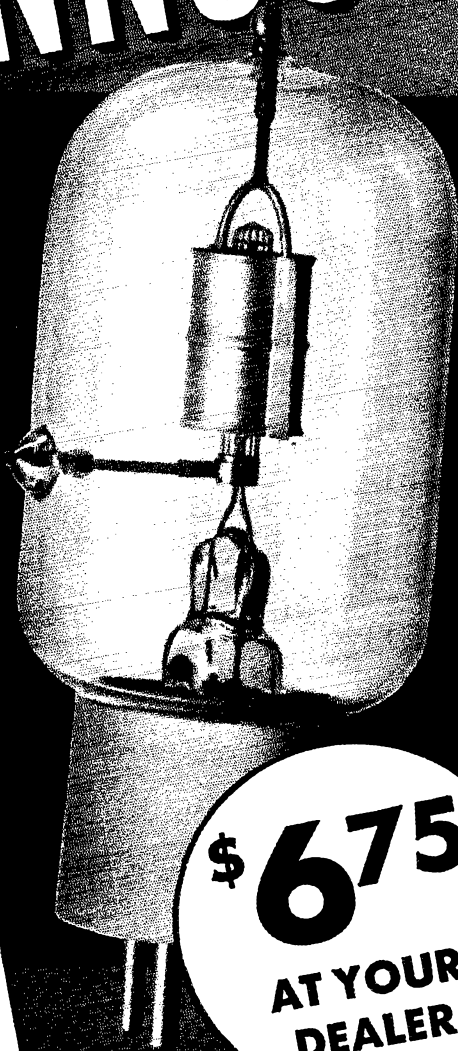

THE TYPE **54** **GAMMATRON**

A NEW LOW PRICE
HIGH POWER TRIODE

- Tantalum plate
- Tantalum grid
- Nonex envelope
- No "getter"
- 50 watt plate
- Mu-27
- Max. plate ma-150
- Max. pl. volts-2000
- Full ratings to 100 megacycles

\$ 675

**AT YOUR
DEALER**

SEE THIS SENSATIONAL VALUE TODAY

HEINTZ AND KAUFMAN
SOUTH SAN FRANCISCO LTD CALIFORNIA U.S.A.

Say You Saw It in QST — It Identifies You and Helps QST

TWINS

IN VALUE!

This outstanding pair of RCA Amateur Receivers gives you full value for your money... in features, in performance, in downright pleasure

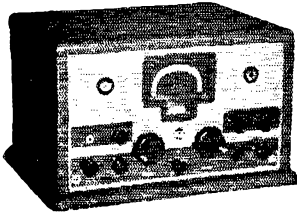

ACR-111
"Custom-Built"
Performance
at Low Cost

This 16-tube receiver is professional in design and appearance as well. Its razor-like selectivity and exceptional sensitivity will bring in stations you never heard before. It has in addition, electrical band spread, noise suppressor, two r-f and i-f stages, high signal-to-noise ratio and more than ten other features—every one of which means real satisfaction to every owner. All this RCA engineering accomplishment available to the amateur at only... **\$189.50**

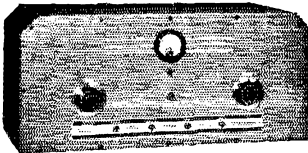

ACR-155
New Low
Price!

Here is a buy you cannot afford to pass up —9 tubes, one stage r-f, high-ratio tuning with oversized knob, separate calibration-spread dial, built-in speaker, all controls on front panel, 550-22,000 k. c., two-tone gray cabinet that is easy on the eyes! A real amateur communication receiver at the unbelievable new net cost to you, **\$44.50** ready for operation

For full details about either of these receivers, see your nearest distributor or write to the address below

FOR MAXIMUM PERFORMANCE AT MINIMUM COST... USE RCA RADIO TUBES

Listen to "Magic Key of RCA" Sundays, 2-3 p. m., E. S. T., on NBC Blue Network



FOR AMATEUR RADIO

AMATEUR RADIO SECTION

A Service of the Radio Corporation of America
RCA Manufacturing Company, Inc., Camden, N. J.

The "QSL Forty"

(Continued from page 27)

it accurately. You can then turn out the bakelite strips in short order. When drilling a strip, back it up with a piece of steel so that the point only of the drill shows through the bakelite, then run the drill through from the back, thus avoiding bad breaking out between holes.

The 40-meter coil in the photograph has two strips $2\frac{1}{8}$ inches long, one being $\frac{3}{8}$ inch wide, the other $\frac{1}{4}$ inch wide, each with 22 holes. Make up a coil on a tin can or a bottle so that it will spring to $2\frac{1}{4}$ -inch diameter. Feed this through the strips till you have 15 turns for the plate coil and 6 turns for the coupling coil. The 15 turns "use up" 16 holes in the bottom strip and 15 holes in the top strip. The 6 turns use 6 holes in

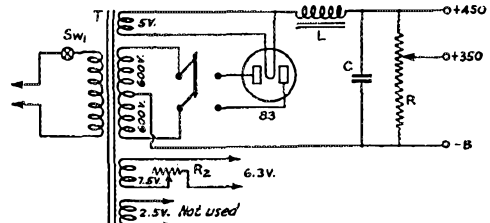

FIG. 3—CIRCUIT DIAGRAM OF THE POWER SUPPLY

T—Power transformer, 600 volts each side c.t., with 5-, 7.5- and 2.5-volt windings (Thoradson T-6878).
L—Filter choke, 15 henrys, 250 ma. (Thoradson T-6877).
C— $2\mu\text{fd}$, 1000-volt (G.E.).
R₁—20,000-ohm, 55-watt bleeder (Ohmite 0584).
R₂—2-ohm, 1-amp. rheostat.
Sw₁—S. p. s. t. toggle.
Sw₂—Porcelain-base knife switch, d. p. s. t.

the bottom strip and 7 holes in the top strip. Note that L_1 and L_2 are not one continuous coil. To steady the floppy coil while a drop of Duco cement is put into each hole, roll up some heavy paper, thrust it through the coil and let it unroll till it holds things snugly. The little aluminum brackets with the banana plugs are shown clearly, and should be fitted before threading the coil. For larger coils use three strips instead of two. Bend the ends of L_2 into little loops for handy connection to the leads from the antenna feeders.

POWER SUPPLY

Any power supply which will deliver 450 volts, loaded, at not less than 200 ma. will operate the rig. Use a 20,000-ohm voltage divider of 50 watts rating, and set the slider so as to get about 350 volts, loaded, for the screen. The power supply diagrammed in Fig. 3 is satisfactory and inexpensive. If a transformer with a 6.3-volt tap, which is now available, is used the rheostat in the $7\frac{1}{2}$ volt circuit may be omitted. A 5-and-10-cent store porcelain base d. p. s. t. switch is in the high-voltage leads so that the 83 may warm up before the voltage is thrown on by closing the switch. This may be mounted above the power supply chassis on four small feed-throughs, the long studs of which replace the screws holding the switch.

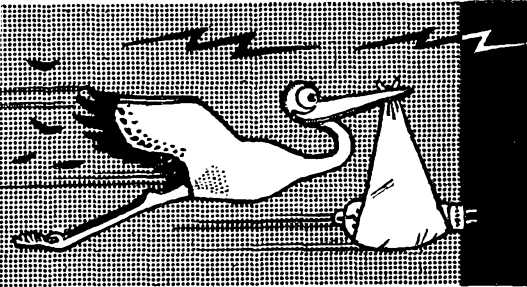

NEW...
CONSTRUCTION
DESIGN
PERFORMANCE
PRICE

FOR AMATEUR RADIO

CONSTRUCTION

Large, sturdy GRAPHITE ANODE with lead out of top. High quality insulating material throughout. Heavy four-way supports. Thoriated tungsten filament, and low loss ceramic base.

RATINGS CLASS C TELEGRAPHY

DC Plate Voltage	1000 Max. Volts
DC Plate Current	155 Max. MA.
Plate Input	155 Max. Watts
Plate Dissipation	65 Max. Watts
Filament Voltage	7.5 Volts
Filament Current	3.25 Amps.
Amplification Factor	27.5
Mutual Conductance	6000 Umhos.

Secure type HY51A from your distributor. See him or write us for additional data and characteristics of this and other Hytron Power Tubes.

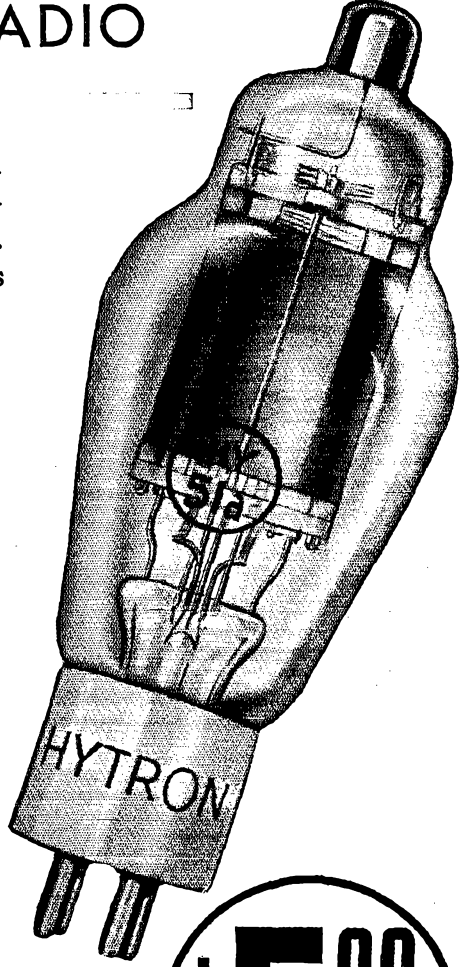

HYTRONIC
LABORATORIES

SALEM - MASS.

MADE IN U. S. A.

A DIVISION OF THE HYTRON CORP.



**"MY
QUESTIONS
ARE
ANSWERED"**

"UNTIL RECENTLY
I was hazy about
tube information
that every amateur
should know. Then
I sent for the
Sylvania Technical
Manual. Now my
questions are an-
swered!"

Technical
MANUAL
25

THE Technical Manual can solve your tube problems too. It lists over 200 tube types . . . gives full information on glass, metal, "G" type, Sylvania "Ballast" tubes, and those for Majestic receivers. Includes typical circuit diagrams, bias resistor charts, and a wealth of other data valuable to amateurs.

This "amateur's friend" should be part of your reference library. Send 25c and the coupon . . . *today!*

SYLVANIA

Set-Tested Radio Tubes

HYGRADE SYLVANIA CORP. Q.S.T.-28
Emporium, Pa.

Here is 25c. Send me my copy of the new
Sylvania Technical Manual.

Name _____

Address _____

City _____ State _____

AMATEUR SERVICEMAN
 DEALER EXPERIMENTER

FITTINGS

For the transmitter you need two Amphenol steatite sockets, 5-prong for the crystal and power and one octal for the tube. Use two Birnbach jack feed-throughs No. 478-J and banana plugs for the coils, and one feed-through No. 458 for the insulated key binding post. For the power supply use one steatite 4-prong socket for the 83 tube and six No. 458 feed-throughs for the choke and condenser and for mounting the porcelain-base switch. It may be necessary to grind the edges of the feed-throughs for the switch, depending on the jaw spacing of the latter.

When installing the pilot bulb socket be sure that the correct terminal is grounded or else the bulb will not be in circuit.

ANTENNAS—COUPLING

I don't know of any "best rule" about this. My own antennas are 80-meter, half-wave Zepps, about 40 feet up. At W8QBW the feeders are about 55 feet long and at W8QDK these are about 44 feet long, both tuning parallel on 40 and 80 meters. The r.f. antenna meter on 80 reads about 1.3 amperes and on 40 about 0.6 amperes, the difference being due to the location of current loops.

BAND CHANGING

This is a matter of a moment only. Lift out the coil and crystal, replace with the ones desired and tune up. Anyhow this "instantaneous band change" idea is the bunk and not worth the complications and expense it involves.

The rig has been run, key-down, for an hour at a time, on a 25-watt Mazda dummy, 100-ma. plate current, and seems to like it. This will shed some light on using it as a continuously-running exciter. When used in this way, however, better reduce the screen voltage as much as possible and still get the 25 watts output.

Results from this or any other transmitter depend largely on reasonable operation. If you hear a half dozen stations just about your frequency, then you will be merely a part of the QRM and the chances for a QSO rather slim. If you have a very good receiver you will do better calling CQ than answering calls. Should any one of the many listening hams answer, you are pretty sure to hear him and a QSO result. If your receiver is not much good, then answer the other fellow's CQ. You *know* you can hear him and if he hears you and chooses to answer, again a QSO results. At least this seems to check with common experience.

Strays

In making up coils with turns threaded through strips of bakelite, sometimes trouble is encountered in making the strips stay put while the Duco cement is being applied. If a roll of heavy paper is thrust axially through the coil and allowed to unroll, it will hold things snug. The strips may then be spaced and cemented without slipping.

—W8QBW

**LESS HEAT
MORE WATTS
WITH GRAPHITE**

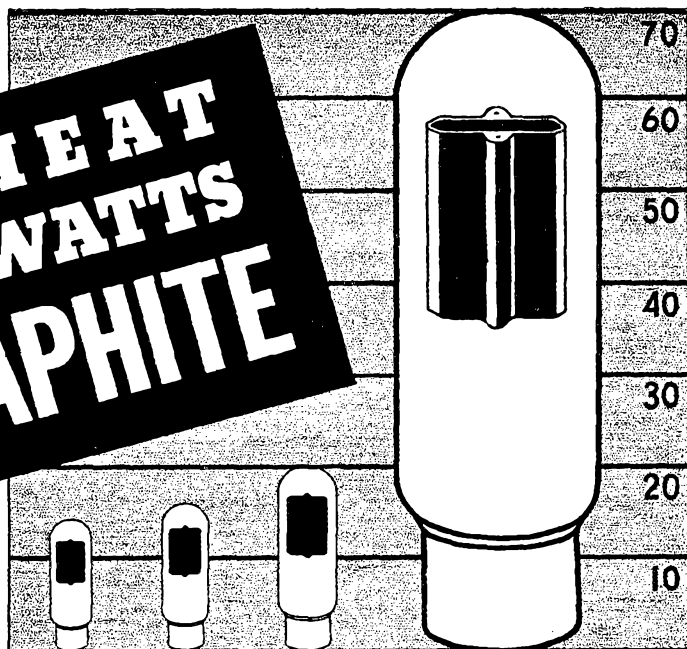

No heat's too high for Speer Graphite Anodes. Even at 3400° F., far beyond the melting point of glass . . . far above any temperature to which any anode will be operated, graphite still does not melt or even soften . . . does not crack or distort. Though graphite stands extreme temperature, it operates at lower temperatures than any metal anode because it dissipates heat more readily.

For example, a tube with a tantalum anode will get red hot when dissipating 14 watts, a molybdenum anode at 16 watts, a tungsten anode at 20 watts and a carbon anode at 70 watts.

This means that when you buy tubes with Speer Graphite Anodes, the plates will run cooler, and will not melt, soften, crack or warp. Speer Graphite Anodes stand heavier overloads and last longer.

Speer Graphite Anodes are sold only to tube manufacturers and used by the leaders. For list and Graphite Anode Booklet, write us.

SPEER CARBON COMPANY ST. MARYS, PA.



SPEER GRAPHITE ANODES

GROSS CP-55 and CB-55 TRANSMITTERS

- Full 95 Watts input ● New Taylor T20 tubes
- Ten Meter operation ● Built-in power supply
- For operation on 10-20-40-80-160 meters
- 3 stages, 42 Osc, 6L6 buffer, 2-T20's in final

KIT \$42.70

Less tubes, meters, crystal — One set coils included in price

The "CP-55" uses the marvelous new T-20's in the output stage. These real transmitting tubes will give outputs and performance not possible with ordinary receiving tubes — their price is very low.

The ideal unit for the beginner or the "Old Timer" desiring an additional Transmitter for operation on 10 meters, or any other band. In the CP-55 you have available an Xmitter having real power at a marvelously low price.

Compare the construction of the "CP-55" with units selling at many times its price. Only finest components are used such as Cardwell Condensers, Steatite Sockets, IRC Resistors, Cornell Dubilier and Aerovox Condensers, etc.

The CP-55 is converted into a fine **RADIOPHONE TRANSMITTER** by merely adding an available modulator unit.

Descriptive Bulletin on Request

"CW-55" RF Unit only as used in the CP-55 including one set coils, less tubes, xtal, meters. Kit **\$18.95**
 Two full size surface type meters..... **\$7.00**
 Coils, any amateur band listed in features, per set..... **2.25**
 Kit of Matched tubes for RF Unit..... **6.60**
 One 83 Tube for power supply..... **.65**

"CB-55"

The Radiophone version of the "CP-55" — Also sensationally low priced. All Bands including 10 Meters. Bulletin gives Details

NEW! "CB-130"

Radiophone Transmitter. Floor Cabinet Model. 120 Watt-Phone Transmitter.

Bulletin gives full details and amazingly low price

"THE STANDBY" (2 to 2000 Meters) 3 TUBE A.C. AND D.C. RECEIVER

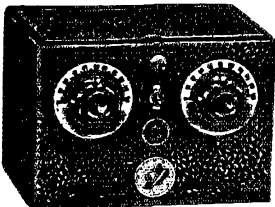

This excellent 2 to 2000 meter receiver is offered with full realization of the present-day need of the amateur for a dependable "stand-by" receiver which will cover practically all of the radio bands in use today. Super regeneration, which is the most efficient form of detection at these frequencies, is used from 2 to 15 meters. By throwing a toggle switch, straight regeneration and higher wavelenghts up to 2000 meters may be had. Throughout the entire tuning range, there are no skips or dead spots. Loud speaker volume is available from practically every station received.

● Power supply incorporated. ● Individual antenna tuning for high and low wave ranges. ● 1-76 super regenerative detector, 1-6J7 regenerative detector, 1-12A7 audio amp. and rectifier.

Complete kit of parts less coils, tubes, cab..... **\$7.59**
 2-5-10 meter coils (set of 3)..... **.39**
 9½ to 15 meter coil..... **.39**
 15-200 meter coils (set of 4)..... **1.30**
 200-310 meter coil..... **.39**
 310-550 meter coil..... **.36**
 550-1050 meter coil..... **.60**
 1000-2000 meter coil..... **1.50**
 Metal cabinet..... **1.50**
 Kit of three tubes..... **2.40**
 Wired and tested in our lab., additional..... **2.00**

GROSS RADIO, INC.

51 VESEY STREET NEW YORK

Cable Address: GROSSINC

Standard Frequency Transmissions

Date	Schedule	Station	Date	Schedule	Station
Feb. 4	A	W6XK	Mar. 11	A	W9XAN
Feb. 11	A	W9XAN		B	W6XK
	B	W6XK	Mar. 18	A	W9XAN
Feb. 25	BB	W6XK		A	W6XK
	A	W9XAN	Mar. 25	BB	W6XK
Feb. 26	BX	W6XK		A	W9XAN
Feb. 27	C	W6XK	Mar. 26	BX	W6XK
Mar. 4	A	W6XK	Mar. 27	C	W6XK

STANDARD FREQUENCY SCHEDULES

Time (p.m.)	Sched. and Freq. (kc.)		Time (p.m.)	Sched. and Freq. (kc.)	
	A	B		BB	C
8:00	3500	7100	4:00	7000	14,000
8:08	3600	7100	4:08	7100	14,100
8:16	3700	7200	4:16	7200	14,200
8:24	3800	7300	4:24	7300	14,300
8:32	3900		4:32		14,400
8:40	4000				

Time (a.m.) Sched. and Freq. (kc.) BX

6:00	7000
6:08	7100
6:16	7200
6:24	7300

TRANSMITTING PROCEDURE

The time allotted to each transmission is 8 minutes divided as follows:

2 minutes—QST QST QST de (station call letters).

3 minutes—Characteristic letter of station followed by call letters and statement of frequency. The characteristic letter of W9XAN is "O"; and that of W6XK is "M."

1 minute—Statement of frequency in kilocycles and announcement of next frequency.

2 minutes—Time allowed to change to next frequency.

W9XAN: Elgin Observatory, Elgin National Watch Company, Elgin, Ill., Frank D. Urie in charge.

W6XK: Don Lee Broadcasting System, Los Angeles, Calif., Frank M. Kennedy in charge.

WWV Schedules

EACH Tuesday, Wednesday and Friday (except legal holidays), the National Bureau of Standards station, WWV, transmits with a power of 20 kw. on three carrier frequencies as follows: 10:00 to 11:30 A.M., E.S.T., on 5000 kc.; noon to 1:30 P.M., E.S.T., on 10,000 kc.; 2:00 to 3:30 P.M., E.S.T., on 20,000 kc. The Tuesday and Friday transmissions are unmodulated c.w. except for 1-second standard-time intervals consisting of short pulses with 1000-cycle modulation. On the Wednesday transmissions, the carrier is modulated 30% with a standard audio frequency of 1000 c.p.s. The standard musical pitch A = 440 c.p.s. is also transmitted from 4:00 P.M. to 2:00 A.M., E.S.T., daily except Saturdays and Sundays, on a carrier frequency of 5000 kc., power 1 kw., 100% modulation. The accuracy of the frequencies of the WWV transmissions is better than 1 part in 5,000,000.

Cairo

(Continued from page 33)

tion of such wider-band proposals from the United States?

We'll answer the questions first and then give the story. We were not successful in getting recommendations for wider amateur bands into the

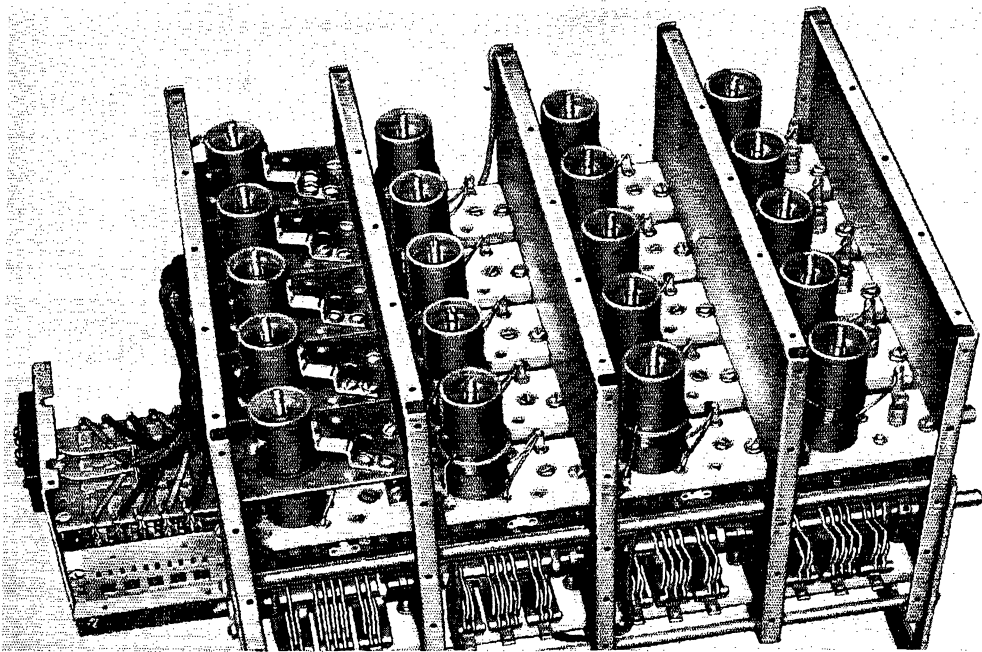

Photos courtesy of The Hammarlund Manufacturing Company, Inc.

FOR MODERN RECEIVERS— ISOLANTITE

Modern receiver designs employ ceramic insulation in an increasing number of applications. Hammarlund's "Super-Pro", an excellent example of up-to-date design, uses Isolantite* liberally.

Greater precision in dimensions, high mechanical strength, and low electrical losses are factors which make Isolantite insulation the choice of the leading manufacturers of both amateur and commercial radio equipment.

*Registered Trade-name for the products of Isolantite Inc.

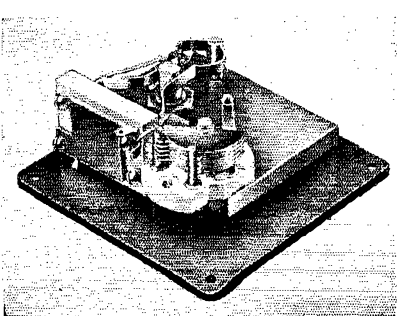
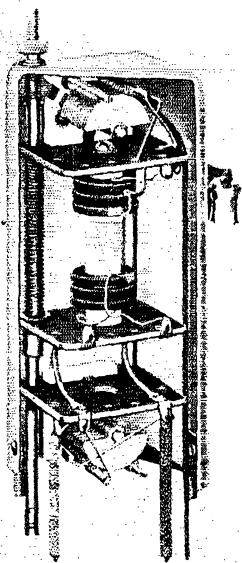

ISOLANTITE INC.

CERAMIC INSULATORS

Factory: Belleville, New Jersey • Sales Office: 233 Broadway, New York, N. Y.

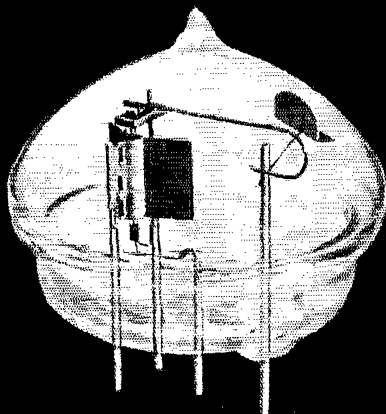

WHAT A TUBE for the ultra-highs!

Go up as high as you like. The 316A takes you all the way!

Everywhere amateurs interested in ultra-high frequencies are using the Western Electric 316A. Read its features — you'll want to build a transmitter around it.

It's designed specially for use in circuits at frequencies up to 750 mc. It delivers 6.5 watts at 500 mc.

Important features producing higher efficiency are: absence of conventional glass press; close electrode spacings, reducing time of electronic transit; short heavy leads; low inter-electrode capacities.

Upper frequency limit.....	750 mc.
Nominal power at 500 mc.....	6.5 watts
Maximum plate voltage.....	450 volts
Maximum plate dissipation.....	30 watts
Maximum plate current.....	80 ma.
Filament voltage.....	2 volts
Filament current.....	3.65 amps.

The booklet enclosed with each 316A gives typical circuit details and complete operating instructions. For full information on this and other Western Electric tubes for amateur use, consult your dealer — or write Graybar Electric, Graybar Building, New York.



Western Electric
* **BROADCASTING EQUIPMENT**
Distributed by **GRAYBAR Electric Company**

U. S. proposals; the United States, therefore, is not proposing any increase of amateur territory at Cairo.

Now for the story: we go back to June, 1936; the allocations committee still has not met. The reason? That the F.C.C. had announced it would hold an entirely separate hearing at Washington, for the advertised purpose of securing data which would enable it to make domestic assignments in the still-unassigned ultra-high frequencies. Now, at first hand it may seem there is very little connection between Cairo proposals for the high frequencies and a domestic hearing on ultra-high frequencies; we assure you, however, that there was a very close connection! We say the "advertised" purpose of the F.C.C. hearing was ultra-high-frequency matters. Actually, it was far more than this. You see, the matter of short-wave allocations is an extremely difficult and controversial subject. Just about every radio interest in the country had been making loud noises ever since Madrid as to their respective needs for more territory. As the F.C.C. saw it, it might very well happen that the Cairo preparatory group would become so hopelessly bogged down on this subject that it would be found necessary to turn the whole thing over to the government agencies for decision, and in this case the F.C.C. would have a major share of the responsibility. Before the Commission found itself in any such delicate position, it wanted to have accurate knowledge of the actual needs of each service; this June hearing was an ingenious solution to the problem. Each user of radio who showed up at the "ultra-high" hearing was going to have to prove not only his case for u.h.f. assignments but, in addition, his case for what he wanted in the normal short-wave spectrum. Indeed, more than that, he was going to have to establish his reasons for keeping what he already had! As an F.C.C. official stated shortly before the hearing (he cannot be quoted since his remarks were off the record) it was a case of putting it right up to each service to scratch down and prove its right to the air, as of the present time. With particular respect to us amateurs, for instance, we had to justify ourselves in terms of present day accomplishments; ancient history and past triumphs, while interesting, were not going to be good enough.

So at this point we see everybody dropping all immediate thought of Cairo preparatory work and, instead, going to work like the very dickens to make a bang-up case for themselves at the F.C.C. June hearing. The League's job for the amateur at this hearing was the now well-known "Presentation for the Amateur Service," a document of some 20,000 words and thirteen charts, a copy of which was sent to every A.R.R.L. affiliated club last year and which is still available to individual members at fifty cents a copy. (If you've never seen this job, you should!) In this we made out the very best case we could for the amateur, for fair assignments in the u.h.f. spectrum when such assignments were made by the F.C.C. in this country and, furthermore, for

A. C. RELAYS

Made by

Allen-Bradley

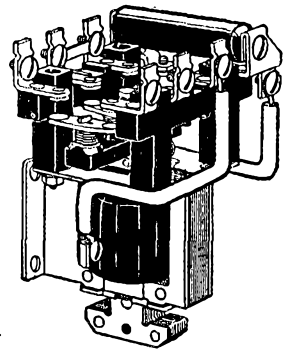
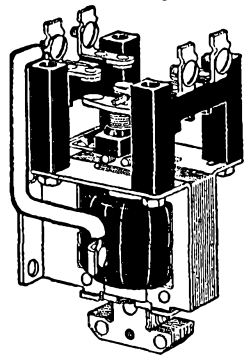

These A. C. solenoid relays are ideal for remote control of transmitters, for control of crystal ovens, and for any general remote control application except for keying. THESE RELAYS WILL NOT OPERATE IN KEYING SERVICE. Silver-to-silver double-break contacts are used throughout.

The maximum contact rating is 10 amp. at 220 v. or 3 amp. at 550 v. The relay coils are wound for 115 volts 60 cycle alternating current. Relays for other voltages can be supplied on special order. Use coupon below.

Type No.	Poles	Nor- mally	Action	Circuit Diagram	Price		Type No.	Poles	Nor- mally	Action	Circuit Diagram	Price	
					Open	In Cab.						Open	In Cab.
A107	1	Open	SP ST		\$3.50	\$4.50	A177	1	Closed	SP ST		\$7.50	\$8.50
A117	1	Closed	SP ST		4.50	5.50	A207	2	Open	DP ST		4.00	5.00
A127	1	Open and Closed	SP DT		5.00	6.00	A217	2	Closed	DP ST		6.00	7.00
A137	1	Open	SP ST		4.00	5.00	A227	2	Open and Closed	DP DT		7.00	8.00
A147	1	Closed	SP ST		5.00	6.00	A237	2	Open	DP ST		4.50	5.50
A157	1	Open and Closed	SP DT		5.50	6.50	A247	2	Closed	DP ST		6.50	7.50
A167	1	Open	SP ST		6.50	7.50	<p>Radiostat—A stepless graphite compression rheostat for primary of 550 watt filament or plate supply transformer. Range 4 to 150 ohms. Price \$6.50</p>						

ORDER BLANK—MAIL WITH REMITTANCE TO

Allen-Bradley Co., 108 W. Greenfield Ave., Milwaukee, Wis.

Enclosed find money order for \$..... for which please send me, shipping charges prepaid, the following items:

..... for..... Volts..... Cycles

Name.....

Address.....



NEW ARRIVALS in **RK** *Amateur Tubes!*

RK-11 20 MU Class C Triode. 20% more powerful filament (6.3 volts) than nearest competitive type. Longer life, higher output and efficiency. Designed particularly for RF operation.

RK-12 Zero Bias Class B Modulator. Filament 6.3 volts. Particularly adapted to AF amplifier-modulator service—requiring no bias. Excellent RF characteristics. Output 100 watts (2 tubes).

RK-51 20 MU Class C Triode. Heavy 7.5 volts filament. 60 watts dissipation. Excellent RF operation. Highest ratio of output to input drive power than any triode of its class. 165 watts.

RK-52 Zero Bias Class B Modulator. Particularly suitable for frequency multiplier applications, and in AF amplifier-modulator service. Filament 7.5 volts. 60 watts dissipation. Low idling current—high “standby efficiency.” 250 watts (2 tubes.)

See your parts jobber—or write
for free technical data

RAYTHEON AMATEUR TUBES

420 Lexington Ave., New York 445 Lake Shore Drive, Chicago
55 Chapel St., Newton, Mass. 555 Howard St., San Francisco
415 Peachtree St. N. E., Atlanta

“WORLD'S LARGEST EXCLUSIVE TUBE MANUFACTURERS”

our dire need for more territory at 3.5 and 7 Mc. We included the specific plea that our 3.5-Mc. band should go from 3500–4500 kc. and that our 7-Mc. band should go from 7000–7500 kc., if amateur needs were adequately to be served. It should not be assumed that we hoped for some sort of favorable recommendation by the F.C.C. on these points; the hearing resulted in no recommendations or findings by the Commission with respect to such matters. It merely “heard” the various services, noting the information against possible future need. (It is true that the u.h.f. portion of the testimony was subsequently used in formulating a set of domestic u.h.f. assignments in the Fall of 1937.)

With the June hearing out of the way, we now go back to the allocations group of the Cairo preparatory committee. A meeting of this committee was called; and now, at last, we are right down to bedrock! If amateurs were to get more frequencies at Cairo, it was just about essential that the United States, at least, should propose them; if increases were to appear in the U. S. proposals, they had first to be adopted by the committee on allocations of the main Cairo preparatory committee.

So here we are at the first meeting of the allocations committee; the question is what proposals, if any, are to be made for change in the Madrid table of high-frequency allocations. It is a big moment for us. The meeting is open. Any proposals for changes? Yes indeed!—the League immediately proposes a widening of the amateur 3.5 and 7-Mc. bands to the figures suggested by us at the June hearing, and for the reasons given then. The matter came to a vote—and, with one exception, every single radio interest present at the meeting (commercial, government, Army and Navy) voted against it; our own vote and that of the representative of the Department of State were the only ones in favor. We were turned down flat.

Now, right here we want to make a most important point: that turn-down by the allocations group was not in any sense a discrimination against us as amateurs. We mean this: it is not to be assumed from that vote against us that our request for more space was denied whereas other services were granted all or part of their requests for more space. The fact is that no service secured so much as a single additional kilocycle. Not one. The outcome of the committee's deliberations was that not a single change of any kind was proposed for any service in the territory above 1715 kc. In other words, the attitude of the United States with respect to the Cairo table of allocations in the short-wave spectrum is to maintain the present Madrid assignments intact.

Why?

Merely this: by the time the June hearing was over and by the time of the preparatory meetings, it had become the unanimous feeling among the representatives of practically every radio interest in the country that the only way to avoid a hopeless snarl on high-frequency assignments at

NEWARK MOVES TO NEW AND LARGER QUARTERS!

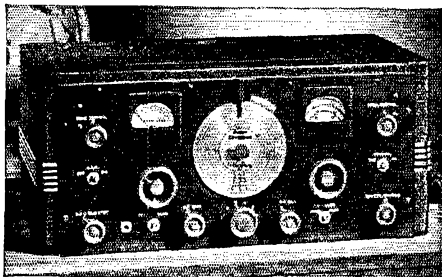

1938 HALLCRAFTER Super Sky Rider

ONLY \$23 DOWN and \$9.02 monthly for 12 months (or \$17.74 monthly for 6 months, or \$11.93 monthly for 9 months) . . . buy this 1938 Super Sky Rider, complete with tubes, crystal and speaker, CASH PRICE **\$123**

THOUSANDS SOLD — but we still have a few of these well known makes Oil Filled, Oil Impregnated FILTER CONDENSERS

We started with 10,000 and are now sold down to a limited stock of the four capacities listed below. ALL WELL KNOWN MAKES. Guaranteed at rated voltages. No more at these amazing low prices when these are gone. Get your order in TODAY and be sure!

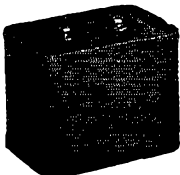

2 mfd., 2000 V. DC $4\frac{1}{2} \times 3\frac{1}{4} \times 1\frac{1}{4}$, 1 $\frac{1}{4}$ lbs. . . \$1.50
3 mfd., 1250 V. DC $3\frac{1}{2} \times 3\frac{1}{4} \times 1\frac{1}{4}$, 1 $\frac{1}{4}$ lbs. . . 1.25
8 mfd., 2000 V. DC $5 \times 3\frac{1}{2} \times 3\frac{1}{4}$, 2 $\frac{1}{4}$ lbs. 2.75
4.4 mfd., 1500 V. DC $5 \times 3\frac{1}{4} \times 1\frac{1}{4}$, 1 $\frac{1}{4}$ lbs. . . 1.75

BUY NOW — PAY LATER

Newark's Easy Payment Plan permits you to enjoy these receivers now on small monthly payments that you hardly miss. We can supply any amateur receiver you want. We ship 10 days after receiving down payment. Order today direct from this ad.

TIME PAYMENTS ON PARTS!

EASY TERMS on orders for your Parts and Tubes, of \$60.00 or more. Stock up now, pay later! Orders for Parts and Sets can be arranged under ONE easy payment contract. It's easy to pay the NEWARK way!

NEW 1938 CATALOG just off the press. Hundreds of bargains for hams! You get exactly what you want and you pay less . . . much less. 4-HOUR SERVICE from complete stock always ready to ship. Write today for your copy of this big catalog . . . **FREE!**

323 W. Madison Street IS OUR NEW CHICAGO ADDRESS

. . . just half a block west of our old location and on the other side of the street. Greatly increased floor area here will permit us to carry a larger and more complete stock on hand at all times, with better facilities for demonstration and service. New Streamline Trolleys stop almost in front of our store. Visit these modern show rooms when in Chicago. Watch Our Window Displays.

And be sure to address your mail to
323 W. Madison St., Chicago

NOW! IMMEDIATE DELIVERY Guaranteed!

NATIONAL

NC 80X

AND NC 81X

★

Order Now

\$18.00
Pay Only Down

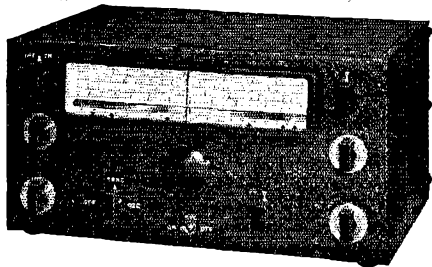

Balance on easy terms. Only \$6.44 monthly for 12 months, or \$8.53 a month for 9 months, or \$12.68 a month for 6 months. Complete with Tubes, Crystal Filter, 8" P.M. Speaker Chassis. (Speaker Cabinet to Match, \$4.80 extra)

\$88.00
CASH PRICE

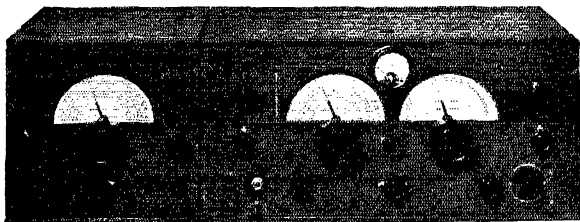

PAY ONLY \$11.25 PER MONTH

TAKE 12 MONTHS TO PAY FOR THIS

RME 69. Or \$14.77 a month for 9 months, or \$21.94 monthly for 6 months. Pay only \$26.20 Down. Price includes Tubes, Crystal, and Speaker in Cabinet. COMPLETE! DB 20 Pre Selector \$151.20 \$42.60 Extra. CASH PRICE

NEWARK

Electric Company

323 W. MADISON ST.
Dept. Q CHICAGO, ILL.

ADD TO YOUR TRANSMITTER

with



Easily Adapted To Your Layout

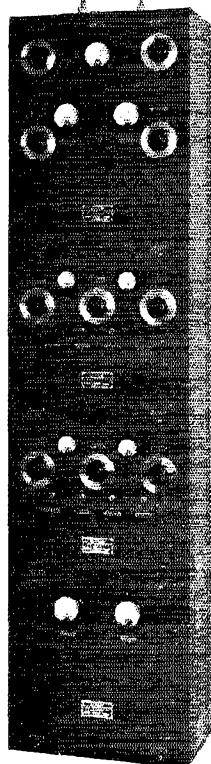

No. 3.... \$13.95
Antenna
Coupling Kit

No. 4.... \$49.75
500-Watt RF
Amplifier

No. 1.... \$49.75
A complete
80-Watt CW
Transmitter

No. 2.... \$44.50
50-Watt
Modulator

No. 5.... \$49.75
250-Watt
Class B
Modulator

★ Prices do not include tubes, meters or crystal.

HERE'S the logical way to add to your transmitter. Do it with UTAH kits. Economical because in addition to high efficiency circuits and parts, you need never discard a single part. Every step brings you closer to a professionally styled 500-watt rig. See your jobber or write Dept. Q-2 for details.

UTAH RADIO PRODUCTS CO.

CHICAGO, U. S. A.

TORONTO
ONTARIO, CANADA

BUENOS AIRES
(UCOA RADIO PRODUCTS CO.)

"16 YEARS OF LEADERSHIP"

Cairo was to hold out for the *status quo* and maintain it, if humanly possible to do so. It was not a question of merit; everybody knows that certain services in this country urgently need more space than they now have; it is quite possible, too, that most everybody would be found in pretty general agreement on the fact that some people have too much. But that is not the point. The point is that the entire spectrum is already assigned "full up" under the Madrid table; any increase in the space to one service must inevitably result in a decrease in space to others. Were the problem confined to this country we might iron things out, nevertheless, but the problem is not confined to this country at Cairo; it involves every nation in the world. Just what would happen if a general re-shuffling of the short-wave table took place at Cairo no one knows. But everybody here agrees, from intimate experience with past conferences, that such a thing is to be avoided so far as possible. There are entirely too many foreign interests itching to jump into just such a situation with all sorts of complicating requests and demands. Somebody would be sure to lose and, with the matter beyond our control, nobody wants it to be themselves who get short-changed. The U. S. view, then, is to stick to what we have, if we can.

When these recommendations reached the main preparatory committee, however, A.R.R.L. filed a minority report disagreeing with the allocations committee findings, and appealing for our requested extensions of space. We were turned down by the main committee, which reaffirmed the allocations group recommendations in every particular. From the main preparatory committee, the U. S. proposals (now in complete form but not yet "final") went to the government for study; specifically, to the F.C.C. and a group of representatives of government radio interests known as the Interdepartmental Radio Advisory Committee. At the direction of the League's Board, we made an appeal for the granting of our frequency-band increases to this group, but were subsequently advised that the F.C.C. and I.R.A.C. did not feel justified in departing from the recommendations of the preparatory committee. It must be said this was rather to be expected; changes are rarely made at this stage. Nevertheless, when the U. S. proposals (now having the approval of the F.C.C. and I.R.A.C.) went to the State Department for final approval, we made an appeal there. We were eventually advised that our plea could not be granted. The State Department then transmitted the proposals to Berne in the name of the U. S. government.

The complete book of proposals of all the nations was then issued by the Berne Bureau in April of this year and, as we've already mentioned, extracts of those portions affecting us amateurs were printed in the July 1937 issue of *QST*. Since they are matters of record we will not repeat them here. During the Fall of 1937 the groups represented in the preparatory committee meetings met again at Washington to

Higher Quality!

**MORE
WATTS
PER
DOLLAR**

**THESE TAYLOR CHAMPS
HIT NEW LOW PRICES**

T-20 \$2.25

TZ-20 \$2.25

T-55 \$7.00

203-Z \$8.00

Lower Prices!

Once again Taylor, "More Watts Per Dollar," smashes through for the Amateur!! As usual Taylor leads the way, offering lower priced, higher quality Amateur Transmitting Tubes. The sensational price slash on the four tubes listed above is proof of Taylor's unceasing fight to bring "Hams" everywhere the benefit of "More Watts Per Dollar." Each of these tubes has proven its

right to sales leadership. Long life, dependable service, value-plus prices and Taylor's irrevocable guarantee of satisfaction have brought the Amateur a new idea in transmitting tube values. Taylor "More Watts Per Dollar" now SAVES YOU MORE MONEY. There's a reason for Taylor leadership—You will find that reason in RESULTS.

ATTENTION, AMATEURS, ATTENTION

On or before February 1st, Taylor Tubes will announce a new tube in the low price field that will give you a new conception of "More Watts Per Dollar." Watch for the announcement in this magazine. ASK your Parts Distributor for the facts.

Taylor Tubes are sold only through leading Amateur Parts Distributors.

"More Watts Per Dollar"

Taylor HEAVY **CUSTOM BUILT** DUTY **Tubes**

TAYLOR TUBES, INC., 2341 WABANSIA AVE., CHICAGO, ILLINOIS

"EXCELLENT
SUCCESS..."

SAYS OX2QY

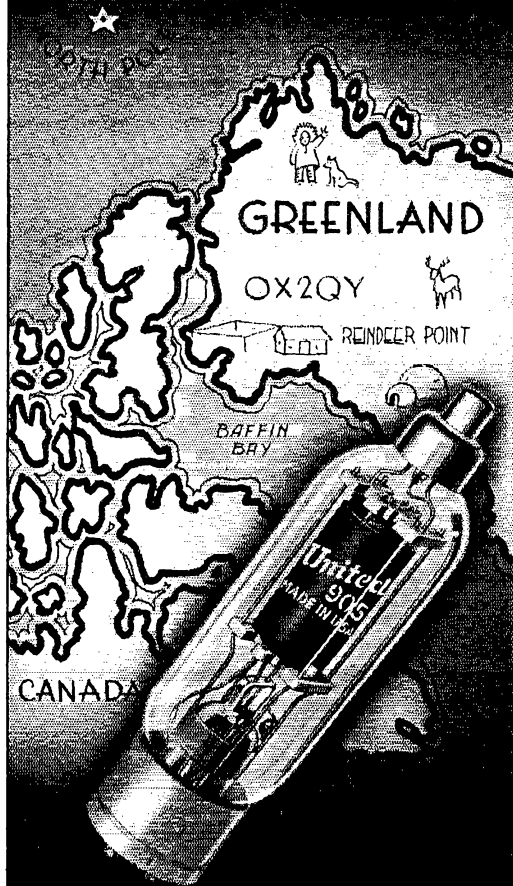

As usual, where dependability is vital, UNITED tubes are on the job.

This time it is the UNITED 905's in the MacGregor Expedition transmitter. Through the New York Times receiver, in the heart of Manhattan, we hear from Greenland:

"Excellent success with UNITED Electronics 905 and 966 tubes under very adverse conditions. Handled over 1000 messages to date and had several NBC broadcasts with splendid success. Season's Greetings."

Capt. C. J. MacGregor and A. G. Sayre
If your dealer does not stock UNITED tubes, your order will be cheerfully handled by the factory, and all the more power to you.

Type 905 is interchangeable with Type 805 — Price \$13.50.

UNITED ELECTRONICS COMPANY

42 SPRING STREET · NEWARK, NEW JERSEY

study all these proposals. We are not concerned with this, however, since the result has been to reaffirm the U. S. stand on matters affecting us.

THE CAIRO CONFERENCE

We're finally ready to follow our fortunes across the Atlantic to the Cairo conference itself. Presumably, this conference will behave very much as did the two previous, the Madrid, 1932, affair and the gathering at Washington in 1927; readers who are particularly interested in a detailed treatment of these meetings are referred to the February, 1933, and January, 1928, issues of *QST* respectively, for complete stories.

The last step to be made on this side of the water in connection with U. S. participation at Cairo is the appointment of the U. S. government delegation. As we write, in early November, no announcement of the make-up of this delegation has been made; it is customary to wait until the last month or so before this is done. The delegation will consist of government people—usually four or five men. With them will go a corps of technical advisors, translators, clerks and stenographers to a total of perhaps twenty-five people. Also from the United States will go some twenty to thirty representatives of the various private interests in this country. Among these latter will be the League's two representatives, jointly representing the A.R.R.L. and the I.A.R.U.² At Cairo, our group will join with similar delegations and representatives from 75 or 80 different nationalities, a total of many hundreds of dignitaries, large and small.

At Cairo, the first thing is the holding of the opening plenary meeting—a plenary meeting being a full meeting of the whole conference group. At this meeting, representatives from the host nation (Egypt, in this case) will greet the delegates. Then the delegates will rule on the other than the government delegations; our own participation (ARRL-IARU) will not be a question here, however, since we had arranged to have the question circulated in advance and have already been notified of admittance, by the Egyptian government. Then committees will be formed, chairmen for them elected, decisions made as to which nations may wish to participate in the workings of which committees and the work parcelled out by topics, after which the plenary session will adjourn and let the committees go to it. What happens thereafter is best described, briefly, by a paragraph incorporated in the article on the Madrid Conference by Secretary Warner, which we quote:

"The conference spent the first week getting organized, adopting internal rules, appointing committees and bureaus and assigning subjects to its five main committees—and in the organization meetings of the committees to divide themselves into subcommittees and parcel out the work. The second week things started moving, with some real talk in subcommittees, countless people shooting off un-

² The I.A.R.U. delegation will also include the representatives of other member-societies.

OHMITE

goes to Pitcairn Island

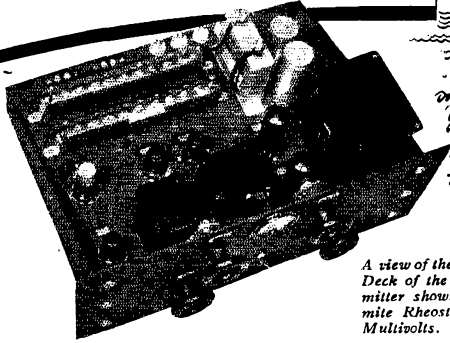

A view of the Audio Deck of the Transmitter showing Ohmite Rheostats and Multivolts.

BAND-SWITCH

Quick change from one frequency to another, with really low-loss efficiency, is easy with Ohmite Band-Switches.



RHEOSTATS

Ohmite Rheostats make tubes last longer — permit exact adjustment of filament voltage for long life and peak performance.



BROWN DEVILS

Ohmite "Brown Devils" are extra-sturdy vitreous-enamelled resistors that will stand up under extreme humidity. 10 and 20 watt sizes.



MULTIVOLTS

Voltage-divider construction is easy, convenient, flexible with Ohmite "Multivolt" tapped units. Wide range of resistance and wattage ratings available.

OHMITE DEPENDABILITY IN NEW "PITC" RIG

Pitcairn Island, romantic scene of "Mutiny on the Bounty," a tiny dot in the Pacific thousands of miles from nowhere, will soon have its first really efficient radio transmitter. Seldom visited by passing ships, "PITC" will rely exclusively on this transmitter for outside contact. Since components must not fail, even under adverse tropical conditions, OHMITE Resistors, Rheostats, and Band-Switches were the choice of the designing engineers.

You may not have to depend on radio alone for vital contacts with the outside world — but you can depend on the proper Ohmite units to solve your radio resistance problems once and for all — surely, economically, conveniently. Do the job right with Ohmite!

HANDBOOK
PAGES
538-539
CATALOG
SECTION

See your Jobber or Write for Complete Catalog 16
OHMITE MANUFACTURING COMPANY

4831 Flournoy Street, Chicago, Illinois

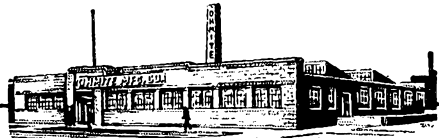

The modern Ohmite "daylight" factory where every facility is provided for the production of high quality rheostats and resistors under rigid laboratory standards — assuring consistent uniformity and dependability in every unit as well as prompt, accurate service on stock and special orders.

OHMITE

Rheostats • Resistors • Tap Switches

● THE ● SCOPE OF THE BOOKLET

"BUILDING AN AMATEUR RADIO TELEPHONE TRANSMITTER"

This booklet is addressed primarily to readers who have at least read our companion booklet, "How to Become a Radio Amateur," and have, perhaps, built a simple telegraph transmitter and receiver, have received their license, have acquired some skill and experience as a code operator, and who now feel the urge to explore the possibilities of radio telephony. These people should find this booklet the exact answer to their needs.

Absolutely the first requisite in either building or operating a 'phone transmitter is a solid understanding of what we are attempting to do when we accomplish voice transmission. Understanding the functions of the various parts, we shall avoid difficulties. The saddest thing in amateur radio is a 'phone amateur who does not understand the operation of his apparatus. The book begins, therefore, with a discussion of the principles involved and makes every effort to make this discussion perfectly clear so that the reader can easily make it a part of his own knowledge. It then goes on to the actual construction and operation of an inexpensive but efficient 'phone transmitter.

Priced at 25 cents per copy, postpaid

AMERICAN RADIO RELAY LEAGUE
West Hartford, Connecticut

believable hours of speeches and arm-waving, thus disclosing the actual problems and resulting in the creation of subcommittees to study them. From there on, for about half the duration of the conference, it was a process of study, hit a snag, appoint another subcommittee, study, hit another snag, appoint a subsubcommittee, until finally much of the work was in the hands of a large number of these *petites comités*, the schedule of whose daily meetings filled the blackboard. There the real work got done. Then came the day when some of these little groups were finishing their jobs, reporting to the parent committees and being discharged; then the parents would finish and report to the grand-parents; and so the process of recombination took the place of subdivision, until finally the main committees were making their combined reports to the whole conference. The wording thus arrived at for the new treaty had to be read twice before the entire conference in plenary assembly, for which purpose it was set in type and printed first on blue sheets and then, with the modifications made, on rose sheets. When the rose sheets were finally adopted, the delegates signed the parchment copy and the conference was over."

We'll let that stand as the briefest possible outline of how a conference does its work, leaving the detailed description of Cairo to Secretary Warner's report later this Spring when the complete Cairo story is told.

In the meantime, some sidelights may not be amiss. For instance, how do we amateurs figure in all this business and how do we get a chance to keep tabs on what is happening that concerns us? There are three ways: first, by means of conferences between our League representatives and the U. S. delegation "after hours" on matters affecting us; second, by the actual participation of the A.R.R.L.-I.A.R.U. representatives in the discussions which take place in the committees, subcommittees, subsubcommittees, etc.; third, by informal discussion between our representatives and representatives of other countries at lunches and dinners, over coffee tables, and so on. It is all very logical and works out nicely.

Now about voting which, you will recall, we promised we'd have something to say about before we finished. It isn't possible to talk very concretely about the voting question because it is such a perpetual bone of contention that it really never has been settled in all its details. Of course, as we've said, governments are the only ones entitled to vote. But how many votes per country? Ah!—now the fight is on! Well, in theory, each country has a vote. On the other hand, the early conferences agreed that countries which had colonial possessions (those which were not represented separately) could have additional votes, one per possession. Whoa!—some countries have lots of possessions; all right, they put a limit on this angle by saying that in no case could the number of such additional votes exceed six. Then came the day when, after the

QRT . . . all 5-Meter Amateurs . . . QRV?

Did you read the editorial in December issue of *QST* relative to ultra high frequency operation and the great importance attached to the 5-meter band? Television interests, with their millions invested, immediately bordering the low frequency side, and the government occupying the immediate range beyond 60 megacycles!

Yes! It's going to be important to play the game according to the rules! Very important!

RME as one of the leaders in amateur communication equipment is "placing the first long-range gun" in the interest of 5-meter operation by introducing the

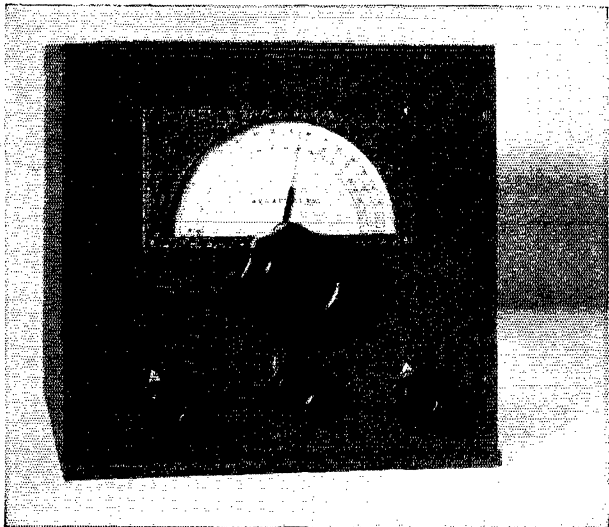

510X FREQUENCY EXPANDER

What Is It?

— A specially designed unit to be used in conjunction with your present receiver, especially the RME-69, in order to expand the range for *real* operation on 5 meters. You must know whether you are in or out of the band! Consequently, the tuning range of the 510X is continuous from 27.8 megacycles to 70 megacycles. (You will note it covers 5 and 10 meter amateur bands.)

What Does It Do?

— Provides an over-all sensitivity of better than one microvolt when used in conjunction with any modern receiver such as the 69 . . . features excellent stability, complete shielding, calibrated dial, finger-tip tuning control mechanism, and incorporates its own power supply . . . meets all requirements for 5-meter operation in a manner never before provided.

Why the 510X Expander?

— With your present superhet as a basic double IF receiver, the *510X Expander* gives you an excellent U.H.F. instrument at a nominal cost without having to invest in expensive ultra-high-frequency-designed supers. RME thus gives to the radio amateur and the 5-meter enthusiast and experimenter the lowest cost, highest over-all sensitive, calibrated method of working 5-meters ever offered. The new unit will be ready for delivery during the early part of February.

LITERATURE IS AVAILABLE ON REQUEST

RADIO MFG. ENGINEERS PEORIA ILLINOIS, U.S.A.

Increase Transmitter Efficiency

with New **TRIPLET**
ILLUMINATED THERMO-AMMETERS

Model 446 with Front Illumination
NEW FOUR INCH SQUARE modernistic instrument featuring extra long scale. Available also in ammeters, milliammeters, microammeters, voltmeters, millivoltmeters, etc. A.C. and D.C.

TO ANTENNA

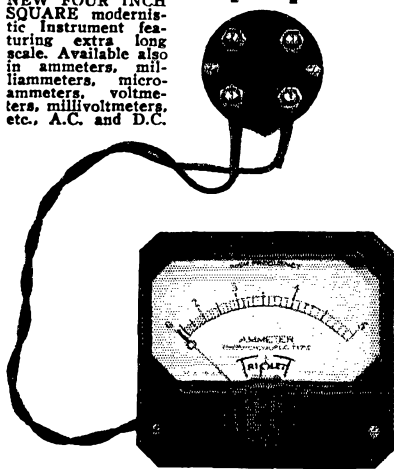

PRICES GREATLY REDUCED

All amateurs know that the sure way to get the most out of your rig is to install a Thermo-Ammeter in your antenna circuit. Now you can get a Thermo-Ammeter with front illumination. Illumination attachment is extra. Does not affect meter, and light bulb can be easily replaced. Perfect distribution of light.

Triplett Thermo-Ammeters are sturdily built to carry high overloads, and to give long life. The thermo couples are external to the meter and connected to it by 2 ft. leads. The thermo couple can be located where convenient while the ammeter is placed on the panel.

All Thermo Couples are designed to work on any size Triplett Thermo-Ammeters.

2" Model No. 241 complete with Thermo Couple, not illuminated\$5.83

4" Model No. 446 as illustrated with Thermo Couple, not illuminated\$7.83

Thermo Couple for all sizes, each\$2.67

Thermo-Ammeters are available in the following ranges: 0-.5, 0-1, 0-1.5, 0-2.5, 0-5.



THE TRIPLETT ELECTRICAL INSTRUMENT CO.,
252 Harmon Drive, Bluffton, Ohio

.....Please send me more information on Model 426:

.....I am also interested in.....

Name

Address

City.....State.....

Great War, countries such as Germany were still major powers but had lost their colonies in the War. What to do? We seem to recall that at Washington Germany was arbitrarily allowed six votes, even though she didn't have the colonies—but that doesn't end the trouble; the voting question got squabbled over all over again at Madrid. Well, it's about time we put an end to all this by saying what, perhaps, we should have at the start—that as a matter of actual practice, hardly any question is ever submitted to vote! And that statement goes for everything right up to and including the plenary sessions themselves! The way things work, nobody would think of putting a matter to vote until the sentiment has been thoroughly determined and hashed out and everybody lined up—and when that is done no voting is necessary. Consequently, it is almost never resorted to; decisions are made in terms of the obvious consensus of opinion, and that ends the matter.

We've been asked how far into the u.h.f. spectrum the Cairo conference will make assignments: the existing Madrid table does not go above 30,000 kc. for general assignments. Of course, the answer to this one will be more apparent in a couple of months. However, it is quite possible that Cairo will go fairly well up into the u.h.f.'s—perhaps as high as 100 Mc. This subject is logically one for regional agreement rather than world-wide agreement, but Cairo may go into it simply because of such things as consideration of air-navigation aids, etc., which should be uniform over the world from an equipment standpoint.

So far, we've not said anything about our prospects at Cairo; we have purposely avoided discussion of this point, as a matter of fact. After all, it is rather profitless to speculate on the outcome; we'll know it soon enough. However, it is probably safe to say that the chances of our acquiring any additional territory are virtually zero; they'd be bad enough, in the face of world opinion against it, even if the U. S. were committed wholeheartedly to such expansion—and as we have pointed out, the U. S. is not proposing any such expansion. Can we keep our present frequencies? Well . . . the chances are just about as good (and bad) as they were prior to the Madrid conference in 1932. We kept them at Madrid. It is not going to be easy sailing, however, any more than it was there. Inspection of the foreign proposals should indicate that. Most of our trouble will likely be with the low-frequency bands at 80 and 160 meters, just as at Madrid; this territory is earnestly desired by most foreign countries for all sorts of mobile and other services. So far, the shared-band principle³

³ An arrangement whereby two or three services are jointly assigned a given set of frequencies on equal shares, under the international table, with specific assignment left to "regional agreements" between groups of adjacent nations. For instance, our 3.5-Mc. band is assigned jointly to amateur, mobile and point-to-point, under the Madrid treaty. European nations agree how much of the band each service shall have, but without affecting the right of North American nations to come to some other agreement.

The shared-band principle applies only to the lower-

INDEX*

PAGE

PAGE

Transmitters:
 150-Watt Output 6L6G-RK47 Three-Band 192-194

Power Amplifiers:
 25-Watt Output 6L6G Amplifier 178-179
 150-Watt Output T-55 Amplifier 181-183
 200-Watt Output P.P. 35T's 195-196
 300-Watt Output P.P. HK-154's 198-197
 300-Watt Output 806's, 203A's, etc. 197-198
 400-Watt Output P.P. 100TH's 199-200
 500-Watt Output 250TH or 806 200-201
 750-Watt Output P.P. 806's or 250TH's 201-202
 750-Watt Output P.P. T-200's 202-203

Crystal Control 157-161
 Crystals, Cutting and Grinding 155-156
 Crystals, Mounting 157
 Efficiency 171-172
 Electron-Coupled Circuit 207-208
 Excitation 170-171
 Filament Center-tap 155
 Frequency Multipliers 179-181
 Frequency Stability 208
 Grid Bias 155, 171, 204-205
 Grid Neutralization 168
 Grounds 208
 Harmonic Generation 179-180
 Harmonic Suppression 172
 Hartley Circuit 207
 Interstage Coupling 165-167
 L-C Ratios 172-174
 Link Coupling 51-52, 166-167
 Load Impedance 172
 Metering 205-207
 Neutralizing 167-170, 175-176, 205
 Oscillator Circuits 153, 207-208
 Parallel Feed 154
 Parallel Operation 161, 164-165
 Parasitic Oscillations 205, 216
 Pentode Crystal Oscillators 158-160
 'Phone (see "Radiotelephony")
 Plate Neutralization 168
 Portable (see "Portable")
 Power Supply (see "Power Supply")
 Push-Pull Operation 161, 164-165, 194-195
 Rack Construction 96-99
 Screen-Grid Amplifiers 170
 Self-Controlled Oscillator Circuits 207-208
 Series Feed 154
 Tank Circuits 153-154, 172-174
 Tetrode Crystal Oscillators 158-160
 Triode Crystal Oscillators 157
 Tri-Tet Circuit 160
 Tubes 79, 183
 Tubes (Table of Characteristics) 81-87
 Tuned Grid-Tuned Plate Circuit 207
 Tuning 159-160, 175-178, 181
 Ultra-High Frequency (see "Ultra-High Frequency")

Triode 57-58
 Triode Crystal Oscillators 157
 Tri-Tet Oscillator 160
 Trouble Shooting (Receivers) 150-152
 Trouble Shooting (Transmitters) 205
 Trunk Lines 416
 Tubes (see "Vacuum Tubes")
 Tuned Circuits 35-37
 Tuned Grid-Tuned Plate Circuit 207
 Tuning Arrangements and Band-Spreading 104-105
 Twisted Pair Feeders 303

Ultra-High Frequencies:
 Antenna Systems 319-320
 Coil Trimming 265-266
 Converters, U.H.F. Frequency 262-265
 DX 262
 Filament Circuit 273-274
 Frequency Modulation 272
 General 251-252
 Linear Oscillator Circuits 272-273

Modulators:
 General 284-285
 10-Watt Class-A Modulator 285-286
 10-Watt High-Gain Class B 286
 Oscillator Circuits 270-271
 Oscillator-Amplifier Systems 278
 R.F. Amplifiers 258-260

Receivers:
 General 252-253
 Metal-Tube Self-Quenched Receiver 253-255
 Acorn-Tube Self-Quenched Receiver 255
 Midjet Self-Quenched Receiver 255
 Metal-Tube Separately-Quenched 257-258

Ultra-High Frequencies:
 Metal-Tube Superhet Converter 262-263
 Acorn-Tube Superhet Converter 263-264
 C.W. Superhet Converter 264-265
 General Purpose Superheterodyne 266-267
 Resonant-Line Construction 274
 Self-Quenched Receivers 253
 Separately-Quenched Receivers 255-257
 Short-Line Control 274
 Superheterodyne Receivers 260-262, 268
 Superinfragenerator Receivers 267-268
 Superregenerative Receivers 253
 Transceivers 286

Transmitters:
 General 269-271
 Acorn-Tube Midget Transmitter 271-272
 Practical Open-Line Transmitters 274-277
 Concentric-Line Transmitter 277
 Trough-Line Transmitter 277-278
 5-Watt Mobile Oscillator-Amplifier 282-283
 8-Watt Mobile Oscillator-Amplifier 279
 15-Watt Crystal-Controlled Transmitter 281-282
 25-Watt Crystal-Controlled Transmitter 282-284
 150-Watt Resonant-Line Oscillator-Amplifier 279-281

Underwriters Rules 389-390
 V Antennas 315-316
 V-Cut Crystals 156
 Vacuum Tube Voltmeters 376-377

Vacuum Tubes:
 Beam Tubes 65
 Cathodes 66
 Characteristic Curves 57, 59
 General 57-58
 Multi-Purpose Tubes 66
 Numbering 68

Operation:
 As Amplifiers 57-60
 Class A 61
 Class B 61-62
 Class C 62
 Other Classifications 62
 As Detectors 63-65
 As Oscillators 62-63
 Pentodes 65-66
 Preferred Receiving Types 69
 Ratings and Characteristics 68
 Rectifiers 70, 79
 Socket Connections 67-70
 Space Charge 29, 57
 Symbols 429

Tables:
 Receiving (Glass) 71-74, 76-79
 Receiving (Metal) 75
 Rectifiers 80
 Transmitting 81-87
 Tetrodes 65
 Transmitting 79, 183
 Variable- μ Tubes 66

Variable Selectivity 125-126, 138-139
 Velocity Microphone 226, 227-228
 Velocity of Radio Waves 37
 Vibrator-Transformers 355
 Volt 34
 Voltage Amplification 60
 Voltage Dividers 344-345
 Voltage-Regulated Power Supply 363-364
 Voltmeters 35
 Volunteer Code Practice Stations (for Beginners) 22
 W1AW, W1MK, A.R.R.L. Hq. Station 417
 WAC Certificates 12, 15-16, 417
 WAS Certificates 417
 Watt 41
 Wavelength 37, 53-54
 Wavelength-Frequency Conversion 37, 54
 Wavelength Performance 17-19
 Wavelengths, Amateur 18
 Wavemeter (see "Frequency Meters and Monitors")
 Wave Traps 218
 Windchargers 356
 Winding Coils 90-95
 Wire Table 431
 Word Lists for Accurate Transmission 396
 Workbench 94
 Wouff-Hong 16
 X-Cut Crystals 155
 Y-Cut Crystals 155
 Zepp Feed for Antennas 298-300, 300-301

446 INDEX

*see page 102



ONE OF THE SIX INDEX PAGES
FROM THE 1938 EDITION OF

The Radio Amateur's Handbook

Reprinted to give you some idea of the scope of the current edition and the ease with which you may find the answer to any radio construction, theory or operating problem.

\$1.00 Continental U.S.A. **\$1.25** Elsewhere
Buckram bound, \$2.50 Spanish edition, \$1.50

AMERICAN RADIO RELAY LEAGUE
West Hartford, Connecticut

* See page 101.

which applies to these low frequencies has enabled us to come through OK so far as this country and Canada are concerned; we can only hope for a continuance. Lately, there appears to be excellent likelihood of trouble at 7 Mc., due to the demands of short-wave broadcasting and aviation for greater assignments in this territory. If the conference goes into the u.h.f., we might very likely have difficulty with our five-meter and other such bands because of the pressure of television, were it not that here again the subject is probably one for regional agreements.

That, we think, just about winds up the story. It has been impossible, obviously, to touch on the hundreds of details and "angles" with respect to legislative history and interpretation, and international conferences. Interested students on these subjects are invited to ask for details, or further references. However, we hope the average amateur has a more complete picture of the situation and an improved understanding of what is behind the makings of legislative history.

As of the time of the appearance of this second half of the article, the Cairo conference will be in session (barring emergency postponement because of international complications not now foreseeable) with the prospect of lasting until May, at least. However, look for an article on the complete story of the conference from Secretary Warner, along about the June or July issue of *QST*. Needless to say, we all hope the news will be good!

frequency bands, where transmissions are continental rather than world-wide in effect. Our 3.5 and 1.7 bands are shared bands; so are the 28 and 56-Mc. bands; 7 and 14 are exclusive to amateurs.

As a matter of interest, wherever we have "shared" bands with other services under the international table, we have always secured such bands exclusively to ourselves under our own U. S. laws and in the subsequent North American regional agreement.

Strays

New Receiving Power Amplifier Tube

A new 250-volt power tube, suitable for Class-B applications and as a dynamic-coupled power amplifier, has been announced by RCA-Radiotron. Designated as the type 6AC5G, it is an octal-based high- μ triode with heater taking 6.3 volts at 0.4 amp. In Class-B, a pair of the tubes will deliver an audio output of 8 watts with 250 plate volts, using a load resistance (plate to plate) of 10,000 ohms. In this application it works with zero bias, the plate current for a pair of tubes without excitation being 5 milliamperes.

As a dynamic-coupled power amplifier (circuit similar to that contained in the 6B5 type tube) with a 76 driver, an output of 3.7 watts can be obtained with 10% distortion.

The 6AC5G has an amplification factor of 125, transconductance 3400 micromhos at 13 volts positive grid bias.

Quotation from a newspaper description of a radio system installed by a Southern fire department. "The receiver has built a 'noise squelcher' circuit which eliminates static. The only noise is that of a broadcast."

HYVOL

HIGH-VOLTAGE CAPACITORS

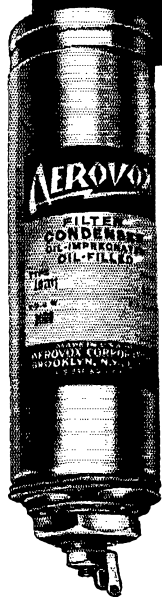

- ★ Handy. Inexpensive. Genuine oil-filled units for high-voltage filter circuits.
- ★ Compactness due to HYVOL — the super-dielectric oil.
- ★ Inverted screw mounting. 1½" dia. Either 2½" or 4½" tall.
- ★ .5 to 4 mfd. 600, 1000 and 1500 v. D.C. working. A lot of high-voltage capacity for little money.

New CATALOG . . .

Covers transmitting components. Ask your jobber for copy — or write us direct.





TEMCO

AGAIN SHOWS THE WAY IN MODERN TRANSMITTER DESIGN!

In a specialized industry where the announcement of new developments constantly taxes the ingenuity of the most exacting radio research laboratories, the continued supremacy of TEMCO Transmitters has been a highlight of 1937. Again for 1938, the same skilled hands and engineering foresight which originally conceived this famous line, have created two new transmitters—the "350A" and "50".

The 350A is an entirely new transmitter, being similar to the original 350 in only one respect—that of power classification. It incorporates many advanced features which make it the most modern unit of its power in the field.

*All New Beam Tubes in the RF Circuit.
Crystal Holders Accommodating 4 Crystals with Front of Panel Change-over.*

*Multi-Frequency Band Switching up to Final Amplifier.
250 Watts Output.
Peak Limiting Speech Amplifier, with Two Channel Mixer.*

*Variable Link Output Circuit.
No Neutralization.
Zero Bias Modulator Tubes.*

The new TEMCO "50" has been developed only after months of research in an effort to produce a low power, reasonably priced transmitter embodying modern features which would be in keeping with the high standards for performance and quality which distinguish TEMCO Transmitters of higher power rating.

Both models will be ready for delivery about March 1st. We predict that these, too, will be highlights of the New Year. We invite your inquiries for complete technical data.

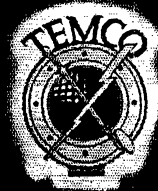

Transmitter Equipment Manufacturing Co., INC.

130 CEDAR STREET • NEW YORK, N. Y.

Designers and Manufacturers of Radio Transmitting and Accessory Equipment

Station Activities ROANOKE DIVISION

NORTH CAROLINA SECTION—SCM, H. S. Carter, W4OG—Your S.C.M. wants to thank the gang for the nice Christmas cards, and to extend best wishes for 1938. BX is doing good work on 14 Mc. with a pair of '10's. DLX applied for O.R.S., DSY for O.P.S. The Kings Mtn. gang is 51 per cent A.R.R.L. members now; FB, gang. DOQ is putting up new antenna. DOV awaits U9 card for W.A.C. CEI took part in the SS Contest. EYC visited CEI. ANU has been appointed P.A.M. and is trying to get a 'Phone Net going on 3.9 Mc. Give him your support, fellows. 4NG/WLMC has started out with a bang; he led the State in traffic his first month to report in N. C. He is Chief Radio Aide in A.A.R.S. now. DZS is getting out well on 14-Mc. 'phone. ALL has added an X to the YL's title. Congratulations. OM. ESO had a good time in the SS. ESB is on 1.75 Mc. with increased power. CPT made his 24th consecutive monthly report for the Wilmington gang. Your S.C.M. congratulates you on your fine work. EC is building a receiver that should out-receive any commercial set. DGV is working 28 and 3.9-Mc. 'phone. DWB is handling the A.A.R.S. for ABT while the latter is rebuilding his rig into a kw. job. 4NC held a Christmas party. AHF is finishing new rig. Santa Claus brought CFR a pair of 801's.

Traffic: W4NG (WLMC 159) DWB 108 DW 53 BVD-CVQ 14 ANU 11 DZS 7 ESO-DLX 5 DGV 2 NC 8.

SOUTH CAROLINA—SCM, Ted Ferguson, W4BQE—CPB is working 28-Mc. 'phone. EOP on 7 and 14 Mc. wants local schedules. EDQ says 28-Mc. DX is FB. DQY has new rig working. CQU and BDT are active on c.w. CQG had as a visitor K6OQE from Koko Kahi, T.H. DGD is working 1.75-Mc. 'phone. EZF's 27 watts are doing fine job on 1.75-Mc. 'phone. EJK likes his 130-foot vertical. EGH's 16 watts are FB on 1.75-Mc. 'phone. BPD finds the new beams "the stuff" for DX. DNR is O.R.S. and is active on 3.5-Mc. c.w. CZA says he and CZN are working a few of the gang cross-band. DLE is being transferred to the Philippines. Luck to you, OM. CWY is back on the air. EXP has a new Jr. operator. ECG is increasing power. Gang, let's start 1938 off with a "Bang." Don't fail to take part in the 3.5-Mc. C.W. Net 9:00 A.M. each Sunday, or the 1.75-Mc. 'Phone Net 8:30 A.M. each Sunday. They are having lots of fun. Won't you take part?

Traffic: W4CZA 62 ALT 29 EWB 22 CZN 12 CQU 9 BYA 8 EJK 7 DQY-EOP 6 EGH 4 DGD 2 EZF 1.

VIRGINIA—SCM, Charles M. Waff, Jr., W3UVA—P.A.M.: 3AJJ—R.M.'s 3GPC, GJP, GTS, DQB, BJX. GWP is new O.R.S. GPC is using 30 watts input for traffic schedules. GTS schedules the Canadian Trunk Line, so traffic may be reliably relayed by him. BFW is on with 350 watts input to 100TH final. GBC schedules DNY, FSP and GTS daily. EZL is back in his original shack. GJP schedules GPC and FSP daily. GCO would like to get in touch with hams interested in a 56-Mc. Net, especially those in or near Richmond. HAD uses an SW-3 receiver and a '46 osc. UVA has been on 3.5 Mc. BSY returned to Univ. of Fla. We all sympathize with Neil Henry, W3BRY, in the death of his wife.

Traffic: W8GPC 350 GTS 271 (WLQE 157) (WLMG 239) GJP 118 GBC 70 GCO 4 GWP 3.

WEST VIRGINIA—SCM, C. S. Hoffmann, Jr., W8HD-W8NS—To date three men have been recommended by radio clubs for Emergency Coördinator appointments. They are 8DYB, for Wheeling and Ohio County; 8BOK, for Clarksburg-Fairmont, or the district served by the Mountaineer Amateur Radio Assn.; and 8QQZ for Logan. The S.C.M. hopes these E.C. appointments will give the Section better coverage and cooperation in future disasters. The Black Diamond Radio Club (Logan) suffered a \$5000 loss when a fire destroyed their log cabin house, their 1-kw. 'phone transmitter and receiving equipment; a re-building program has begun; a fine spirit of perseverance. QQZ wants a 1.75-Mc. 'Phone Net. Well, there's PHY, new 1.75 'phone man; and maybe BDD (P.A.M.) can lend some assistance. LCN has gone to 1.75-Mc. c.w. "fer fun." MOP and MOL are interested in 3.9-Mc. 'Phone Net, and BDD (P.A.M.) wants ideas and suggestions from the gang on it; he believes it can be extended down the Ohio River, possibly from Pittsburgh, to Cairo, Ill. New officers of Huntington Radio Club: PSR, Pres.; QFN, Vice-Pres.; RGB, Secy.-Treas. QPZ got Radio Telephone and Radio Telegraph 3rd licenses. It is reported ELJ is boasting of a new transmitter—! PSR

has new W.A.S. certificate. MZT is on 3.9-Mc. 'phone. KKG is back! He attended Salisbury meeting of N. C. Floating Club. NZA visited Wheeling Radio Club. DYB is new O.R.S. acting as alternate to HD on Trunk "E." MIS schedules MIT, now in Parkersburg. QBS operated from C.C.C. Game at Sugar Grove. QPZ uses 211 in final. KYJ is lining up schedules. OXO mails his messages to HD for the A.R.R.L. Trunks. Mountaineer Amateur Radio Association is forming a 1.75-Mc. 'Phone and C.W. Net and have 18 already enrolled. OXO has worked 54 countries. HSA, EP and GBF have new receivers. EP needs 3 states for W.A.S. on 1.75-Mc. 'phone! KLP visited Wheeling. RDC is modulating a '03 final. LGB has new 14-1.75-Mc. rig, and is building portable equipment. The S.C.M. has been spending three hours per night on A.R.R.L. Trunks and National Trunk Net. He would be glad to recommend schedules for stations desiring the handling of traffic. KIU is building an amplifier; he schedules V011. MLW, MNX and PHY work a round-table schedule. Don't forget to report the news.

Traffic: W8DYB 15 KYJ 10 PSR 6 QPZ 1 HD 158 LCN 5 OXO 20 PHY 1 KIU 13.

NEW ENGLAND DIVISION

CONNECTICUT—SCM, Frederick Ellis, Jr., W1CTI—UE leads the Section in traffic with B.P.L. total. JMY now holds call WLQG in A.A.R.S. JXP takes part in Nutmeg, Humdingler and A.A.R.S. nets. Plenty of traffic outlets there! DMP made B.P.L. on deliveries. KFN is learning to copy traffic on a mill. GKM changed QTH January 1st. JBJ enjoyed his first European DX on 28,060 kc. BNB experimented on 28 Mc. AMQ relieves UE as N.C.S. of the Nutmeg Net three nights a week. Out of 27 stations reporting traffic this month, only 6 included comments suitable for this column. Come on, gang, let's have a little dope if possible. B.A.R.A. entertained C.B.A. at the spacious B.A.R.A. Club rooms on December 13th. IQP was the speaker of the evening, and talked on a variety of subjects including N.C.R., antennae and tubes. February 19th and 20th have been reserved for a Connecticut QSO party. We hope for a large attendance and lots of Connecticut contacts that week-end. Plan to attend. Full details will be sent by mail.

Traffic: W1UE 619 JMY 478 (WLQG 80) JXP 404 AXB 372 AFB 333 HSX 276 DMP 229 ITI 223 KFN 192 JQD 135 KV 115 (WLGJ 46) ES 70 AJB 70 (WLGJ 24) GKMC-TI 66 BDI 57 GMR 53 JYE 52 KQY 47 AMQ 43 JFN 30 AW-FAJ 28 TS 15 JTD 14 JBJ 6 BNB 3.

MAINE—SCM, Winfield A. Ramsdell, W1FBJ—JJN had his 1.75-Mc. 'phone rig at the Rockland Hobby Show, Dec. 7th and 8th, and originated over three hundred messages. GKC and FZD assisted in getting the traffic off. This kind of work helps, as the radio station was the most popular exhibit at the show. EWN is forming net on 1.75-Mc. 'phone to cover entire Section. GOJ and KNB handled most of the traffic from the Rockland Hobby Show. IQM is operating portable from U. of M. at Orono. AHJ now at Livermore Falls is active on 14 Mc. JUV applied for O.R.S. We need plenty more applications, fellows. EFR sends first traffic report. KKB and BX are building new rigs for 1.75-Mc. 'phone. ASG and BJY are attending radio school in Mass. KNJ has new end-fed hertz. GPJ was recent caller at DHH. CPT has Class A license. KRZ is operating on 3.5 Mc. using a 59 crystal osc. EUL has joined the ranks of married men. FCE and DEG recently obtained first-class commercial radiotelephone tickets. KRK is new ham at Boothbay Harbor. Rifle clubs through the State are looking for interested amateurs to handle matches by radio. This has already been worked out successfully between Portland and Damariscotta, IIE taking care of the radio work in Damariscotta and the P.A.W.A. (KV1) in Portland. Any operator wishing detailed information should get in touch with IIE or FBI. What do you think of making the Section QSO party an annual or bi-annual affair? Any comments regarding this will be very much appreciated. Again we urge all stations that handle any messages by radio to report same to the S.C.M. by the 20th of each month.

Traffic: W1GOJ 756 KNB 534 JJN 360 FBJ 171 ISH 126 IST 74 EFR 38 IBR-KNJ 22 HSE 19 EWN 10 JUV 8 CFO 236 INW 107.

EASTERN MASSACHUSETTS—SCM, Sam Gross, W1IWC—The emergency organization in the Section is taking shape under the direction of W1BEF, Emergency Coördinator for Eastern Mass. Coördinators have been ap-

pointed as follows: HXE—Lawrence; KBQ—Haverhill; JJJ—New Bedford. A 56-Mc. Emergency Net along the Merrimack River drills every Tuesday at 7 p.m. Radio Clubs that have not sent recommendations for an Emergency Coördinator in their community to W1BEF are urged to do so at once. The entire Section should be organized as soon as possible, as emergencies give no warning. IHI leads Section in traffic again. AKS has new 7-Mc. skyhook. IHI, IWC, JCK, AKS and EPE make B.P.L. this month. Nice going, guys. EPE heard HS1EL on 3.5 Mc. KMY is new Ass't Emergency Coördinator. JMS puts 400 watts into new T-125. JNF moved to Lynn. DMF rebuilt high-voltage power supply. The entire Section extends its sympathy to INA in the loss of his mother. FCR is active on "Nutz Net." BMW was on N.C.R. duty aboard the destroyer *Hamilton* for two weeks. IN gets out FB on 56 Mc. KMY believes in 89 super-regen. receiver. OQ has new rotary beam ant for 28 Mc. IZE and JJE enjoyed visit to WEEI; they were shown around by HON. ILD lost his mast in high wind. EPZ, KMY and HXE had six-hour 'phone QSO. JNU is back on 56 Mc. after stay in hospital. A few SS scores: IQH—23,400; IWC—18,018; BEF—13,335; ABG—11,373. Looks like the M.V.A.R.C. is high club in this Section with score of about 60,000. How about you other clubs getting even next year, or in the coming DX contest? Who got the gong for describing HXE's 12-foot gong last month? (shuda been 12 INCHES). KXN is new ham in Squantum. The M.V.A.R.C. had one of the best talks ever when Messrs. Bramley, Cooper and Henry of N.E. Tel. and Tel. described, with the aid of slides and talkies, how radio was used in conjunction with world-wide telephone service. BVL spoke to the S.S.A.R.C. on "Design Considerations for Transmitting Tubes," giving the boys the dope on what happens to an overloaded tube and what can be done to bring some dead ones back to life. ALP is rebuilding 56-Mc. receiver and rig. WV worked his 97th country (J2JJ-14,324 kc.—5 p.m., Dec. 15th). The HI-Q Radio Club reports 26 are attending their school; and an SS contest score of 15,083. ALB was on 'phone for SS. ALG is building 28-Mc. 'phone rig. BSG finds triode crystal oscillator easier on his crystals. GZI is active on 56 Mc. HA is back after 3-year layoff. JBO hooked his first ZL on 14 Mc. JIX has new 28-Mc. 'phone. JQZ has rig rebuilt after its bout with the baby. KDM has taken the fatal step. Congrats and best wishes to you and the XYL. KKO joined the R.C.C. IPK is adding pair of tens to 6L6G exciter. HIL, FOI, DVU, IKP, GAO and JGQ have formed a net on 1952 kc. for local rag chewing and reduction in QRM. IAV rebuilt rig during Christmas holiday.

Traffic: W1HI 605 IWC 523 AKS 437 JCK 360 EMG 338 EPE 263 KMY 185 BEF 179 JMS 171 JNF 164 (WLGY 116) DMF 137 HXE 133 QA 129 JYJ 128 JTM 122 HWE 99 INA 105 KCT 92 HRE 75 AGX 73 KKM 72 FCR 53 HFJ 51 KBO 42 BMW 41 ABG 40 KBQ 38 IUQ 37 ASI 22 QW 20 (CC1C 24) KMS 4 HKY 2. (Oct.—Nov.: W1JNF 166 (WLGY 87) HRE 61.)

WESTERN MASSACHUSETTS—SCM, William J. Barrett, W1JAH—IOT made B.P.L. with plenty to spare. IOT and KON are new O.B.S., on 3.5-Mc. c.w. and 1.7-Mc. 'phone respectively. IOR made B.P.L. on deliveries. JXN, KJO, EAX and JLM are new A.A.R.S. members in Central Mass. Net. KUQ has gone back to East Pa. after too brief stay with us—Good luck. Despite duties as our Director and Radio Aide and C.A.N.C.S. for 1st C.A., BVR manages to handle traffic. BIV is running nice bunch of schedules. Pres. reports for the Chair City Radio Club of Gardner, which recently became affiliated with the League. How about some news from the other clubs? AJ reports emergency outfit well under way. Better get 'em built, fellers—we're not asking for another flood, but if one comes we don't want to be found wanting. KJK is working up a Ski and WX Net with 2BGO. Your S.C.M. would welcome applications for O.P.S. and O.R.S. from qualified stations. GZL reports quite a few 1.75-Mc. 'phones active in our Section. HJR goes back to school in Indiana in January; he would like to work the gang on 14-Mc. 'phone. COI has whole flock of poles up. BNL switched schedules to 7 Mc. AJD reports from Nashua, N. H. Sorry to have you leave the Section, Ed, but best of luck in your new location. Every bit of news helps out, fellows. A card on the 16th will do the trick.

Traffic: W1IOT 693 (WLGN 283) IOR 357 KUQ 86 BVR 74 (WLG 205) BIV 61 KOQ 102 AJ 49 HSK 46 JAH 23 KJK 18 GZL 15 JQJ-IZW 3 BKG 98 DIE 18 ZB 151.

NEW HAMPSHIRE—SCM, Carl B. Evans, W1BFT—

The NHN on 3840 kc. has increased membership by several stations: AEF, AXL, BAC and JDP. BCT reports the 56-Mc. antennas on Pack Monadnock are down, due to heavy winds this last fall. KIN has started a club named "Granite State Radio Club" for future hams. EAL is now on 56 Mc. and schedules IUI to connect the 3735-kc. A.R.R.S. Net with the 56-Mc. A.A.R.S. Net. KBR is adding P.P. '45's to the final. IMB is working DX on 28 Mc. EDN is building a new 56-Mc. transmitter. ESB is building a new transmitter with a 6L6 driving an RK-28. BAC is located at a ski camp on Mt. Cardigan and handles WX and ski reports for the newspapers. HOU is building a 28-Mc. 'phone transmitter. KPL is operating on 56 Mc. with a 600-foot transmission line to his antenna way up on a hill in back of his shack. ANS has an RME receiver now.

Traffic: W1IP 783 TA 462 BFT 342 FFL 303 (WLG 5) GMM 204 KIN 198 GHT 103 HTO 85 IDY 74 JDP 57 ANS 55 JGI 42 EAL 37 AXL 30 ICS 27 JBM 21 CMR 18 AP-HGV 6 EDN-AEF 3.

RHODE ISLAND—SCM, Clayton C. Gordon, W1HRC—BIT has H-73 for auto plates and HRC is sporting G-7388 for his 1938 plates. FOV has completed modulator and speech amplifier for 14-Mc. 'phone. KIV (ex-K6AUQ) has a pair of T200's for his final. Arthur O'Brien of the Woonsocket Police has dug up his ham ticket and is heading for 28-Mc. 'phone. KCG presented himself with an RK-20 for Christmas. ETD had a KM-12 ST-380 Peri-Dynamic speaker kit given him by the XYL for Christmas. AQ went as a body (9 members comprised the party) to visit the New Bedford Radio Club gang on Nov. 19th, and had the best of a bowling match and enjoyed coffee, sandwiches and cup cakes. The AQ Club station was on the air continuously during the SS with CPV, AOP, JGB and BOY operating. HJ has hooked modulator unit on his exciter for 'phone work on 14 and 28 Mc. HPE got auto plates B-73. JNO has 28-Mc. vertical on 25-30-foot fishpole. He has been appointed Emergency Coördinator for the Newport Region. JEZ has accepted appointment as Emergency Coördinator for the Providence Area. We want to appoint E.C.'s for Westerly and Woonsocket, as well as Pawtucket, if somebody will please help us out with some suggestions as to who the executives are in those territories. JXA rebuilt receiver. The P.R.A. had its annual Christmas party on Nov. 17th. GTN was presented with a new "Handbook" as a token of the esteem in which he is held. There is a strong and apparently well-founded rumor around that the 56-Mc. bootleg gang has moved down to "2½ meters." They are reported to have high technical skill and some are said to be well equipped with knowledge of the code. It isn't sporting, boys, to play a game and break the rules. Why not get a ticket and become an "honest woman"? We visited 1KQY and the New Haven gang the 4th and 5th of December and played guest operator on the Nutmeg Net and also attended the RM-NITE party from there. GTN heard the first and spotted us before he even heard us signal!

Traffic: W1INU 827 GTN 475 IEG 327 IMY 134 JWE 94 JXQ 65 INT 51 HRC 27 KTH 20 IQF 16 KOG 7 KUA 5 KCS 4 ETD 3.

VERMONT—SCM, Alvin H. Battison, W1GNF—C.R.M.: 1FSV. R.M.: 1EZ. P.A.M.: 1AVP. KXL is a new amateur in Johnson. KOO would like schedules with any Vermont amateur. KVB applied for O.R.S. ELR has a new Sargent pre-selector; he is running tests with Boston amateurs on 28 Mc. DPO found his antennae chopped into fine pieces one morning! KIE is using a semi-automatic key. FPS is trying to complete W.A.S. on 3.5 Mc. GAZ is attending radio school in Boston. Ex-BCK is now a married man. GNF is DXing on 3.5 Mc. HOW is experimenting. FSV signs WLGU in the A.R.R.S. JVS built an emergency generator, as of Nov. QST. IQG visited GNF. IDW has a new modulator using 803's. FSV made the B.P.L. on deliveries. FB. KJG is pushing traffic in great style. EZ is renewing traffic schedules. FSW is recovering from an appendicitis operation. GAN and CBW visited BNS. GAE visited FSV. AHN and AVP were active in the O.P.S. party. KWC is trying to get a 6L6 perking on 28 Mc. FPS has been appointed Emergency Coördinator for Windham and Bennington Counties, AHN for Windsor and Rutland Counties, JVS for Addison, Chittenden and Franklin Counties. Appointments for the other counties will be announced in the next issue.

Traffic: W1FSV 394 KJG 43 GAE 16 GNF 12 KVB 8 AHN-KOO 2.

(Continued on page 108)

CHECK



QUALITY

Any way you wish . . . you can check Stancor and the answer is always the same—"It's quality that counts."

Sometimes Stancors cost a few cents more than other transformers of the same characteristics . . . BUT THEY'RE WORTH IT.

NOTE CHECK THESE POINTS AGAINST THE FIELD •

1. Cores of highest grade, laminated silicon steel. ✓
2. Windings checked after each operation. ✓
3. Positive vacuum impregnation with special equipment. ✓
4. Triple Tested on dummy loads for perfect performance. ✓
5. The most modern factory in the industry. ✓
6. Finest appearance. Newest finishes. Embossed nameplates. Concealed connections. ✓

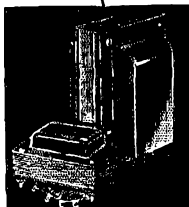

Then You'll
**BUY
STANCOR**

STANDARD TRANSFORMER CORPORATION

850 BLACKHAWK STREET • CHICAGO

A.R.R.L. QSL Bureau

FOR the convenience of its members, the League maintains a QSL-card forwarding system which operates through volunteer "District QSL Managers" in each of the nine United States and five Canadian districts. In order to secure such foreign cards as may be received for you, send your district manager a standard No. 8 stamped envelope. If you have reason to expect a considerable number of cards, put on an extra stamp so that it has a total of six-cents postage. Your own name and address go in the customary place on the face, and *your station call should be printed prominently in the upper left-hand corner.*

- W1—J. T. Steiger, W1BGY, 35 Call Street, Willimansett, Mass.
- W2—H. W. Yahnel, W2SN, Lake Ave., Helmetta, N. J.
- W3—R. E. Macomber, W3CZE, 418 10th St., N. W., Washington, D. C.
- W4—G. W. Hoke, W4DYB, 328 Mell Ave., N. E., Atlanta, Ga.
- W5—E. H. Treadaway, W5DKR, 2749 Myrtle St., New Orleans, La.
- W6—D. Cason Mast, W6KHV, 423 East E St., Ontario, Calif.
- W7—Frank E. Pratt, W7DXZ, 5023 So. Ferry St., Tacoma, Wash.
- W8—F. W. Allen, W8GER, 324 Richmond Ave., Dayton, Ohio.
- W9—Roy W. McCarty, W9KA, 11 South Michigan Ave., Villa Park, Ill.
- VE1—J. E. Roue, VE1FB, 84 Spring Garden Rd., Halifax, N. S.
- VE2—C. W. Skarstedt, VE2DR, 236 Elm Ave., Westmount, P. Q.
- VE3—Bert Knowles, VE3QB, Lanark, Ont.
- VE4—George Behrends, VE4RO, 186 Oakdean Blvd., St. James, Winnipeg, Manitoba.
- VE5—E. H. Cooper, VE5EC, 2024 Carnarvon St., Victoria, B. C.
- K4—F. McCown, K4RJ, Family Court 7, Santurce, Puerto Rico.
- K5—Norman F. Miller, K5AF, 15th Air Base Squadron, Albrook Field, Canal Zone.
- K6—James F. Pa, K6LBH, 1416D Lunalilo St., Honolulu, T. H.
- K7—Leo E. Osterman, K7ENA, Customhouse, Wirangell, Alaska.
- KA—George L. Rickard, KA1GR, P. O. Box 849, Manila, P. I.

Brief

When is a QSO? When one lasts all day long it is certainly worthy of mention! On Armistice Day, 1937, W5BEH of Galveston, Texas, strolled over to the local club station, W5DIG (Galveston Amateur Radio Club), for a QSO or two. At 8:35 A.M. W5FXS of Beaumont, Texas, was raised. After two hours of rag chewing the subject turned to record QSO's. It was decided to stick to the controls as long as possible. It turned into an all-day party at W5DIG, with various club members taking tricks. On the Beaumont end W5FXS rode the key unaided. The contact ended after a solid eight hours and thirty-five minutes! At W5DIG the following participated in the contact: W5FWE, W5FOY, W9RYQ, W5BEH and W5AUX.

Speaking of long QSO's, the longest continuous rag chew on record is one that took place between W7WY and W7HD on January 28th-29th, 1933—20 hours, 2 minutes!

¡Queridos Señores!

La edición 1938 del "THE RADIO AMATEUR'S HANDBOOK" se puede ahora conseguir en lengua española traducido por la Revista Telegráfica de Buenos Aires, Argentina, reconocida como la más antigua establecida y la más importante publicación de literatura de Radio en Sudamérica.

El "Handbook" (libro manual) está reconocido como el libro modelo en su clase. El por tanto tiempo esperado y sugestionado libro manual (Handbook) estamos seguros que su edición en español encontrará una acogida extraordinaria. Ha sido cuidadosa y escrupulosamente traducido. Ha sido impreso en una imprenta que está reconocida como la mejor de Sudamérica.

Nosotros estamos orgullosos del hecho que la Revista Telegráfica haya producido este trabajo y estamos seguros al mismo tiempo que es una contribución notable para la literatura técnica en la lengua española.

Se pueden conseguir ejemplares en "The American Radio Relay League, West Hartford, Connecticut, U. S. A." a \$1.50 cada ejemplar, franco, o si es más conveniente directamente de la Revista Telegráfica, Perú 165, Buenos Aires, Argentina, a cinco pesos, en moneda argentina.

AMERICAN RADIO RELAY LEAGUE

(Continued from page 106)

ATLANTIC DIVISION

EASTERN PENNSYLVANIA—SCM, Jack Morgan, W3QP—R.M.'s: 3AKB, 3AQN, 8ASW; P.A.M.: 3EOZ. Call and frequency charts locating each O.R.S. of this Section have been mailed to each O.R.S. and to neighboring S.C.M.'s to help to speed up deliveries throughout the Section. Route your traffic via O.R.S. listed on this chart. 3AKB, EDC, EML, EWJ, QP, 8ASW and FLA were all swamped by Christmas traffic. 3AKB hooked a ZL during SS. 3AQN gave 56 Mc. a whirl but says 3.5 and 7-Mc. traffic is better sport. 3BGD worked lots of VK/ZL's. 3DPU is working traffic with WAWG regularly. 3EHZ was QSO Germany and Italy on 3.5 Mc. Some B.C.L. pulled down 3EML's mast and ant. 3GDI uses separate transmitters for each band—5 of them! 3GJY joined A.A.R.S. 3QP acted as relief operator for 3AMS on his VK6MO schedule while AMS was moving. 8ATF has antenna with a pair of 240-ft. feeders.—Remote control as applied to the ant. 1 8BQ visited 8EU and sliced his ant. into something smaller than one-mile lengths so it could be tuned! 8EU, 8RQ and 8CDT gave 8AVK a lift with an extension for his mast. 8DHT has a new line to the coast that is working well. 3QP has two lines into the far east, both speedy; one via 6CUU, the other via 9ESA at Denver. 8QXW is moving rig from attic to cellar.

Traffic: W3ADE 27 AGK 7 AKB 251 (WLQP 35) AQN 73 BGD 2 DGC 75 DGM 18 DPU 80 DXC 33 ECA 65 EDC 126 EHZ 2 EML 368 BTM 2 EWJ 148 (WLQH 23) GDI 63 GJY 37 GMK 36 GUB 4 NF 18 (WLML 606) QP 320 W2ITX-3 72 W8ASW 178 ATF 4 BQ 15 CDT 8 DHT 87 EU 7 FLA 258 OML 5 QXW 7.

MARYLAND, DELAWARE, DISTRICT OF COLUMBIA—SCM, E. L. Hudson, W3BAK—R.M.'s: 3CQS, 3CXL. Chief R.M.: 3BWT. SN has a new marine transmitter. CDG heard ZL1DI on 3.5 Mc. CYV is moving to Virginia. EPD has second-class Commercial Radiotelegraph ticket. EYX visited New York and Philadelphia hams. CDQ has ½-kw. rig and new HRO receiver. Following notes from EZN of the Washington Radio Club: The Washington Radio Club held a gala Christmas party Dec. 29th. After rebuilding to 1 kw. EZN finds that a traction company a block away from his shack runs 100 or more busses at all times during the cold weather to keep them from freezing!

Traffic: W3CXL 84 (WLM 1591) BWT 584 SN 545 CIZ 408 FSP 70 GKN 44 EIV 36 GKZ 27 BAK 18 FPQ 9 CDG 5 EHW 3.

SOUTHERN NEW JERSEY—SCM, W. W. Filson, W3BEI—BYR and EFM turn in swell totals as a result of being eastern terminal stations of Trunk "B." ZI, VE, EEQ, DCQ and CCO journeyed to Gov. Island on invitation of Col. Stanely, Sig. Officer 2nd Corps Area. GCU, FBT, AWH, AIR and EDP of the Trenton Radio Society participated in the recent "SS." The Trenton Radio Society paid a return visit to the York Road Radio Club. We regret that BIR is selling out. FPA, a new O.R.S., has gone to N. Y. C. for three months. ZX schedules K4ENY and VE2LOI GWW, a new station in Wildwood, turns in first report. DNU moved to another QTH in P-Ville. The Greater Camden Radio Ass'n elected officers for 1938: Pres., GFL; Vice-Pres., AGK; Treas. and Rec. Sec., BYK; Cor. Sec. and Sgt.-at-Arms, CZN; Directors, FZP, CNI, DJR, H. Fox and C. O'Neil. The club meets at Community Center, 28th and River Road, Camden, and expects to install a transmitter under the club call HEB. BGP schedules K4ENY and VP3THE. BAY, BEI, BGP, CES, QL and ZX of the South Jersey Radio Ass'n journeyed to the regular Dec. meeting of the Del. Valley Radio Ass'n and enjoyed as the speaker of the evening Mr. Bud Waite, one of the radio ops. with the Byrd Antarctic Exp. The South Jersey Radio Ass'n elected officers for 1938: Pres., QL; Vice-Pres., BGP; Treas., John Birch; Rec. Sec., BWR; Cor. Sec., IS; Directors, BEI-BQC-DAJ-FCB-PDF-KW and FBH. BWR has moved back to Haddonfield. BEI is journeying to the different clubs lining up a Coordinator in the different localities for emergency communication groups. FBG is busy with new super and helping local hams get on 28 Mc.

Traffic: W3BYR 338 EFM 256 (WLNJ 125) ZI 197 QL 56 BEI 21 DNU 16 GWW 10 AEJ 7 FBM 6 ZX 4 BGP 3.

WESTERN NEW YORK—SCM, H. E. Preston, W8CSE—R.M.'s: 8JTT, 8BJO, 8AQE, 8DSS; P.A.M.: 8CGU. The W.N.Y. O.R.S. Net is working in fine style. BJO is doing a

good job in Trunk Line "G"; he has a new receiver and pair of '52's in final. PCW is heard now and then at the Univ. of Cincinnati station 8YX. CJJ schedules OX2QY and EI.2A weekly. DZC, PVG, ADV, CJJ and KBS ran up nice scores in the SS. The Elmira Club Glider Radio Committee under PVG is working on new ultra-high equipment for the next meet. GWY needs help to turn all the knobs on his new 101X receiver. PLA is the busiest station in W.N.Y.; he heads our traffic list this month. JTT is heard on Saturday nights. DHU would like to get the gang in the northeastern part of the Section organized. DSS is on nearly every day. CGU is only O.P.S. reporting this month. How about the rest of you?

Traffic: W8GWY 115 JTT 10 JQE 15 CSE 252 (WLNW 104) BJO 136 PLA 318 FCG 125 DHU 54 QMR 28 CGU 8 DSS 32 ABN 18 PWU 4 CTX 31.

WESTERN PENNSYLVANIA—SCM, Kendall Speer, Jr., W8OFO—R.M.'s: 8KUN, 8KWA, 8MOT, 8GBC. P.A.M.: 8QNQ. Emergency Coordinators: Pittsburgh, 8QAN; Butler, 8DDC; Ohio River Region, 8BBV. A.A.R.S. Liaison R.M.: 8UK. N.C.R. Liaison R.M.: N8KOB. "Flash"—Western Penna. Section led all other sections in traffic totals for the months ending October 15th and November 15th. Let's keep Western Penna. up there, fellows. QAN leads the Section this month with a nice total. BPL's: QAN, KWA, OFO and with A.A.R.S. traffic WLMA / 8YA. QAN is building an RK36 and pair of 150-T's final 56-Mc. rig for emergency work. KWA has been bearing quite a few HB9's on 3.5 Mc. QAN won the '52 tube donated by KWA for the highest O.R.S. score in the Section in the last O.R.S. party. Congrats. OFO is QRL trunk line work, etc. NDE is active with the Humdinging Net. IOH says REE will soon be on with a new Stancor rig. UK attended A.A.R.S. Conference at Baltimore to discuss reorganization of the A.A.R.S. in the Third Corps Area. George Hart is the only active operator at YA; the rest are busy experimenting and DXing. HBG says Amateur Radio performed some speedy service concerning a death in Clearfield and helped notify friends of the deceased. GUF gets on several nights a week. MOT and GBC have been organizing an N.C.R. unit in DuBois. N.C.R. has been taking up LGD's time. QXF hopes to be an O.R.S. soon. FXK is active on 56 Mc. QHS has a new 56-Mc. rig. QYJ has rig on 3.5 Mc. CJB moved rig downstairs. IYQ is working DX on 14 Mc. OAJ is rebuilding 28-Mc. phone. MWV is rebuilding. FCO is on 1.75-Mc. phone. 9SOK moved to Pittsburgh. NEA is working some DX with 460-foot skywire 50 feet in the air. IRK now has a real shack and is rebuilding for high power. DFT is recuperating from a severe illness. Best wishes. NCJ since going W.A.C. is working some 3.9-Mc. phone. 9YXD/8 is experimenting with a totally automatic key. A sixteen-year-old chap, RIK, is a new amateur in Pittsburgh. NFS, who is attending M.I.T., complains that a bootlegger is using his call on 7 Mc. Anyone having any idea who the violator is, please advise your S.C.M. BOG gave an interesting talk on "antennas" at meeting of the Amateurs Transmitters Assn. of Western Penna. Complaints have been coming in concerning amateurs operating c.w. in the 'phone bands. Why not be GOOD amateurs and work together? Let code be confined to the c.w. channels, thus helping the 'phone men, and the 'c.w. men clean up some bad harmonics they have in the c.w. channels, thus helping the c.w. men.

Traffic: W8QAN 813 KWA 749 OFO 602 KUN 303 MOT 222 NDE 174 IOH 110 DDC 102 UK 97 CMP 82 YA 64 (WLMA 501) HBG 57 GUF 75 GSH 40 GBC 34 KOB 18 LGD-QXF 16 MJK 13 AXD 10 MWV 24.

HUDSON DIVISION

EASTERN NEW YORK—SCM, Robert E. Haight, W2LU—W2EGF schedules 8DSS daily. LU is active with N.C.R. Congrats to GTW and the YF on arrival of Jr. YL opr born Dec. 9th. KXF, new Port Jervis ham is on 3.5 Mc. KFB is new O.R.S. He is 15 yrs. old and wants to know if any younger hams hold Class A ticket in E.N.Y. ITK reports HUB has FB all-band exciter unit. IUR has new HF-100 on 7 and 14 Mc. IJG is new O.P.S. ACB is newly appointed Emergency Coordinator for Schenectady area. ACB holds the office of President in the S.A.R.A. for 1938. Your S.C.M. is waiting to hear from Clubs in regard to recommendations for appointment of Emergency Coordinators. Let us make 1938 a big year and put E.N.Y. back in the lead.

Traffic: W2EGF 262 LU 37 GTW 29.

NEW YORK CITY AND LONG ISLAND—SCM, Ed. L. Baunach, W2AZV—HYL is O.O. in Staten Island. KLN and KVV send first reports. LXY is now using two HRO's, and schedules South America and Europe. KVH is out for O.R.S. appointment. PF arranged a visit for A.A.R.S. members and their friends to Governors Island to see the new equipment of 2SC WLN, WVP, movies, etc. which were enjoyed by all. OQ delivered a message to the President of Postal Telegraph. KKW is looking for Delaware and Kentucky for W.A.S. on 7 and 14 Mc. EC is working with 8DHT on a coast to coast Trunk Line on 3630 kc. HGO operates 7 and 56 Mc. for traffic. EBO is now 8RDG on 14 Mc. 'phone. CHK worked 125 stations on 14 Mc. 'phone in one month. JXJ delivered a lecture on the subject "Propagation of Radio Waves" at the American Museum of Natural History. ELK got a present of a '52 used only ten hours. KCV had a 50 minute QSO with HC1PZ on 7208 kc. If you think SN has any foreign QSL cards for you, contact JHB on 3582 kc. and he will let you know. ELN is back on. KPK is working on new rig. IYR continues to work portable from Syracuse, N.Y. ESO has three doublets on 14, 7 and 3.5 Mc. using same EO1 cable. JUX is experimenting with 6L6 regenerative oscillator. HMJ is on 7 and 14 Mc. HRB is rebuilding. IXQ is building new e.c. oscillator and frequency meter. JBL got on during the holiday vacation. VG is rebuilding P.P. final amplifier in a rack and panel job. IJU got a kick out of the SS. HAK is trying for O.R.S. again. Visitors are always welcome at AZV's new shack. DXO has 56 Mc. rig perking. Inter-club bowling schedule is to start shortly among Federation Clubs. HBO has 6L6G-801 on 1771 kc. Tu-Boro Radio Club officers for 1938: BVE, Pres., HVD, Vice Pres., JWE, Sec.-Treas. The club is going to have a C.W. net on 1750 kc. JEQ operates on 7200 kc. The next A.R.R.L. meetings will be held on February 28 and April 29 at 8:00 p.m. at the Army Building, N.Y.C.

Traffic: W2JHB 510 DBQ 233 (WLN 96) OQ 204 PF 111 BGO 73 DXO 40 IHT 32 AZV 32 KCV 22 GDF 20 IOP 17 EC 15 EXR 14 IXY 12 EYB-HAK 11 ESO-KVH 8 AA-CIT 7 HMJ 6 KVV-CHK-IXQ-HGO-BYL 4 HYL 3 FLD-HRB-JDF-US-BKP-DLR-FIP-ADW 2 BFA 1.

NORTHERN NEW JERSEY—SCM, Fred C. Read, W2GMN—The Northern New Jersey QSP Club met Dec. 16 at the home of GGE in South Orange. Emergency work was discussed. CMC is active in N.N.J. traffic net. GVZ added two more countries. GSI is in the market for a 28 Mc. receiver. AOG is working on new 28 Mc. beam antenna. HRZ is back on 1.7 Mc. 'phone. IOZ is on again. JJP reports from Weehawken for first time. KEJ has 44 states toward W.A.S. The North Newark Amateur Radio Club named its new bulletin "Bandspread." The Dec. issue contains some interesting notes on amateur activities of its members. GDB is having lots of fun with new 1.7 Mc. rig. The Original Tri-County Radio Club had its annual Christmas dinner on Dec. 20. HZR is active as an O.O. JPK of the N.C.R. is back with a 300 watt transmitter for all bands. Some N.C.R. members this year are HNP, HIT, IWY, JSX, JBI and JUN. 8NSG, newcomer to Elizabeth, will soon have W2 call. IYG is doing good work on 1.7 Mc. phone. BYD received bad burns from high voltage power supply.

Traffic: W2BCX 1123 (WLN 660) GVZ 343 CGG 314 HZY 259 GGE 118 HQL 111 (WLN 123) HOZ 73 GMN 23 CMC 21 JUC 20 IZV 8 CIZ 5 JMX 2. (Oct.-Nov.: W2BCX 952 (WLN 673).)

SOUTHEASTERN DIVISION

ALABAMA—SCM, James F. Thompson, W4DGS—R.M.'s: 4DS, 4CRF, 4APU, P.A.M.'s: 4DHG, 4BMM. CUE, station of the B'ham Amateur Radio Club, really went to town in the Dec. Ala. QSO Party. ECI did the operating and a total of 57 points was made. Cross-band 'phone-to-c.w., which counted 4 points, got most of the points. APU was second, and also found that cross-band c.w.-to-'phone helped his score along. ERX took third place by operating mostly from 1.75-Mc. 'phone, though contacts with CYC, DD, CUE and AG, who were on 3.5-Mc. c.w., gave him a nice total. CYC and BMM held fourth and fifth places. The party this time seemed to have a goodly number of participants, though the number of logs sent in was small. If you want another one before the DX contest, let me know. I have been thinking about a QSO Party to take in the whole Southeastern Division. If we hear from all of the S.C.M.'s we have written, it might be tried. The B'ham Club announces: Reduction in dues, two rigs operating, two

more rigs contemplated, election of officers, new antenna going up with ERX erecting the masts and ECI stringing the wire, and a big welcome to all old members and all active hams. Believe it or not—APU, that sage of the 3.5-Mc. c.w. band for years, was heard on 'phone! EKI is rolling up a mess of DX on 28-Mc. 'phone. DS reports that Trunk Line "D" is running plenty sweet right out to the west coast, and says to route your traffic through him. FB is on in B'ham and likes to work old OA and CIQ back home in Mobile. EQM has worked 23 countries and 43 states. FAZ is new 1.75-Mc. 'phone call in Greenville. CYC reports for East Ala.: EPA, EHB, DPR, AZH, DUQ, EAB, CYC and 8GCF/4 are the hams at Ala. Poly better known as Auburn, this year. The Auburn Radio Club has 28-Mc. 'phone with an 801 final. EAB has a TNT '10 on 7 Mc. In Phoenix City—EMP has P.P. 35T's on 7 and 14 Mc. AUS has new antenna tied onto his P.P. 250TH's on 14-Mc. 'phone. EGI works 7 Mc. CCJ is going to town with new T20 par. on 3.5 and 7 Mc. CYC ran up 55,600 in the SS. BZA was a visitor in Montgomery. HB has a new crystal mike, a Christmas gift from the XYL. BLL, another Mobile guy, moved to B'ham and got his rig going on 14 Mc. AJY needs a mechanical engineer and plenty of man power to raise his new mast. DID has been assigned call FBB for the portable at Flat Creek, so he has it on 28 Mc. with 400 watts. BMM still is an old faithful on the 3.9-Mc. A.A.R.S. Net. He's RS' best customer in more ways than one, with BCU running second. ECF has a 28-Mc. Johnson "Q" just a mere 70 ft. in the ozone. EHH has 400 watts to P.P. T55's on 14,316 and 28,756 kc. EBZ is O.O. and O.B.S. EBZ reports for Tusky: ETL is building a 6L6 rig. ELX rebuilt into new metal cabinet. CRG is at new QTH. EUI built himself a superhet. FAJ is EYV's new "assistant." EBZ has new P.P. 801 final and worked ERQ/2 (ex-2ESC). EVS has new shack, rig and antenna. AEQ has new G.E. receiver. ECI is the first "E.C." (Emergency Coordinator) to be appointed. In case this is my swan song, I have enjoyed worrying you all as your S.C.M. and, in case it isn't, I hope that I can do better during the next two years. Your support has been most appreciated in every activity. 73—Jim.

Traffic: W4DS 53 EBZ 12 APU 10 EVS 4.

EASTERN FLORIDA—SCM, Lewis A. Connolly, W4DVO—Assistant SCM, John B. Dodd, W4CQD—R.M.: 4COB, P.A.M.: 4DDB. Jo has pair of 211's on 7 Mc. DWI received official commendation from Chief Signal Officer, U. S. Army, for making a perfect copy of Armistice Day message, in Braille. Congratulations, Henry, may your accomplishments be a standard for us all. EPV has new 101X receiver. ACZ is back on 3.9-Mc. 'phone after a long absence. DU is very active on the same band. DDB visited hams in Miami and West Palm Beach. DNU visited DDB in De Land. DUE has pair of T55's on 7 Mc., also new Breting 12 receiver. BYS is Sparks on "WFCK" plying between Boston and Savannah. EEP spent 28 hours rag chewing during the last month. AFZ has 100 watts on 7 Mc. Santa Claus brought COB an Astatic T3 mike. DUG expects to handle a record amount of traffic at Booth at the Florida State Fair. EBF quit the briny deep to be a landlubber again on 7 Mc. 8QMR is arriving in Tampa, Jan. 3d, to spend the winter. DVO worked Wyoming on 3.5 Mc. for state number 42. How about some more reports to help Ye Olde S.C.M. fill this space? 73.

Traffic: W4COV 26 JO 24 BYR 1 EEP 15 EPV 2 COB 26 DVO 85.

WESTERN FLORIDA—SCM, Ellis R. Curry, W4BSJ—R.M.: AXP, ACB renewed Class A license. CDE is master of ceremonies on West. Fla. Net. MS has two new 65-foot poles. EQR works 7 and 14 Mc. DXQ, QU, HQ and PBW are active in Naval work. SZ is building 6L6 oscillator. QK has schedule on Thursday nights. AXP's traffic report is excellent.

TENNESSEE—SCM, B. G. L. Smith, W4DEP—R.M.'s: W4CXV and W4AYE. Through 4PL we have one day service on messages from Hawaii and Canal Zone. ENE likes his rag chewing and DX. ESK cured his key clicks by putting in a pair of '45 keying tubes. DIJ has gone back to McMinnville. DEP's antenna rope broke in the pulley and, as there was snow on the ground and no more rope at the time, he just tied the loose end to the fence. That made half the antenna vertical and the other half horizontal, and only twelve inches off ground; it worked, and net business was carried on just the same.

Traffic: W4PL 1098 RO 193 CBA 70 HK 490 BQK 55 DEP 52.



A New Thrill FOR THE AMATEUR

ASTATIC's New Acorn Model T-3 Microphone "has what it takes" to thrill the ham as well as those engaged in public address, recording and broadcast circles. Exclusive design swivel mount permits convenient positioning of microphone head and prevents cable breakage. Interchangeable plug and socket connector makes possible quick change to desk or floor standard. Beautifully designed. Full year guarantee.

LIST PRICE \$25.00

Write for Literature

ASTATIC

Astatic Microphone
Laboratory, Inc.
Dept. G-6
YOUNGSTOWN, OHIO
*Licensed Under Brush
Development Co. Patents*

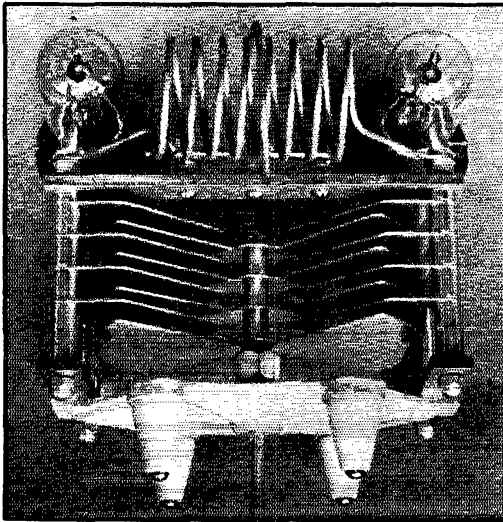

COMPACT—

HALF AS LONG for their airgaps and capacities, these A & B condensers will make your transmitter more efficient than ever. May be had with neutralizing condensers and plug-in coil mounting built-in. Shown is model ABC5625.

Write for bulletin

w6vx ATKINS & BROWN w6wb
215 Fourteenth St., Oakland, Calif., U. S. A.

How Would You Do It?

(Continued from page 45)

F. K. Foster, Bertram Green, E. P. Haines, Jr., Frank Kasal, C. D. MacLauchlan, Julius Ozick, H. E. Rice, Jr., F. P. Vasquez and Vincent Whaley.

Rules for the Problem Contest are repeated below:

1. Solutions must be mailed to reach West Hartford before the 20th of the publication month of the issue in which the problem has appeared. (For instance, solutions of problem given in the April issue must arrive at *QST* before April 20th.) They must be addressed to the Problem Contest Editor, *QST*, West Hartford, Conn.

2. Manuscripts must not be longer than 1000 words, written in ink or typewritten, with double spacing, on one side of the sheet. Diagrams and sketches may be in pencil, but must be neat and legible.

3. All solutions submitted become the property of *QST*, available for publication in the magazine.

4. The editors of *QST* will serve as judges. Their decision will be final.

Prizes of \$5 worth of A.R.R.L. station supplies or publications will be given to the author of the solution considered best each month, \$2.50 worth of supplies to the author of the solution adjudged second best. The winners have the privilege, of course, of stating the supplies preferred.

Hints and Kinks

(Continued from page 50)

the tip of one rotary plate of the condenser so that when turned to maximum capacity it shorts.

"An audio gain control is a useful addition to the set. A 500,000-ohm volume control can be mounted in place of the other toggle switch ("B" on-off). It can be connected across (or replace) the grid resistor in the 2A5 stage. The B switch can be mounted on the control.

"In the high-frequency oscillator, a 57 tube often will give better results than the 24A. It is hard to get a 24A which does not put a.c. modulation on signals on 14 and 48 Mc.; the 35 and 58 also seem to have this characteristic. The suppressor of the 57 should be grounded; all other

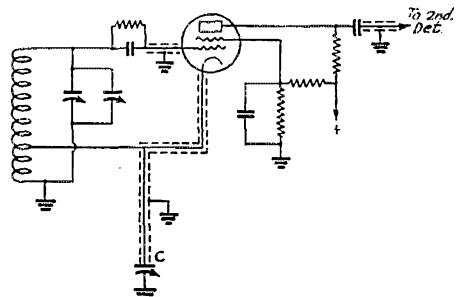
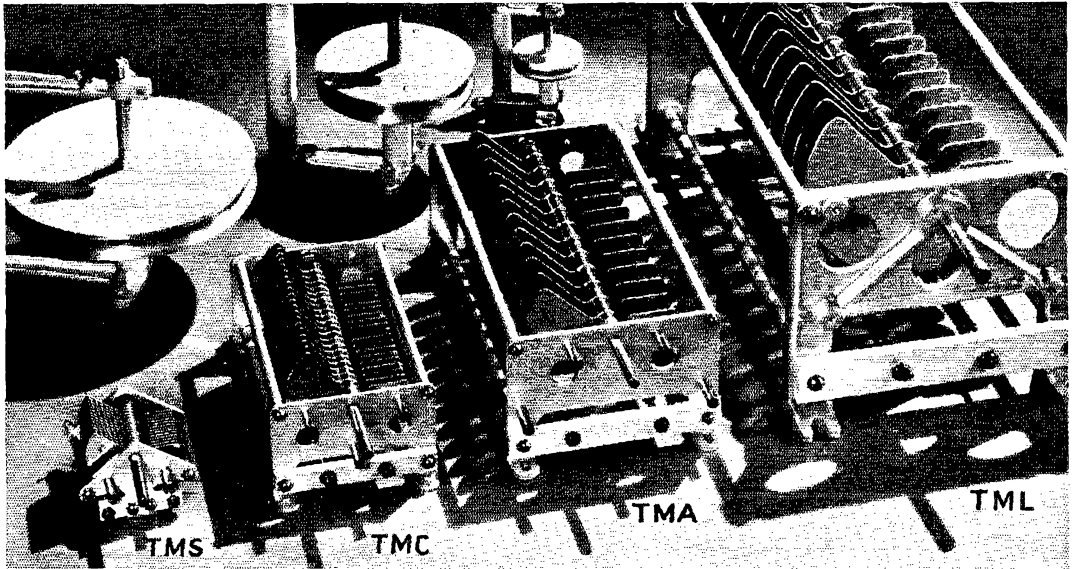

FIG. 6—"REMOTE CONTROL" OF BEAT OSCILLATOR FREQUENCY FOR FB7 AND FBX RECEIVERS
Condenser C is 50- μ fd. maximum.



These are the condensers which you see so often in illustrations of outstanding transmitters, and hear so much about in articles describing high-performance gear. They have an enviable record

for efficient, dependable operation, for conservative operation, for ability to stand punishment. You do not have to "ask the man who owns one"; he will want to tell you anyway.

NATIONAL COMPANY, INC., MALDEN, MASS.

GORDON NAME PLATES **ANTENNA TUNING**

A complete line of 122 everlasting, chromium plated name plates for Transmitter, Sound and Test equipment. Available in two sizes. Write for listing and low prices.

GORDON SPECIALTIES COMPANY
440 S. Dearborn Street • Chicago, Illinois

Unconditional Guaranteed	PR CRYSTALS	Powerful Reliable
X cut 7000 KC ± 5 KC . . . \$1.85	3500 or 1750 . . . \$1.65	
Low Drift ± 5KC 40-80-160 2.20		
PETERSEN RADIO CO. Ex		
W9JRY	COUNCIL BLUFFS, IOWA	W7AHE
Formerly Omaha Crystal Labs.		

**Radio Operator's
Course**
**Telegraphy—
Telephony
Aviation**

**Practical
Experience
Studio—
Transmitter—
Announcing**

PORT ARTHUR COLLEGE has been teaching Radio for twenty-eight years, and during this time it has never been our policy to guarantee positions to prospective students, directly or indirectly. We believe it wisdom at this time, however, to go on record in our QST advertising to say that it is impossible for us to even come near to supplying the demand for Radio Operators received by our Employment Department. We do not mean by this that all students who enroll will automatically secure positions. The demand is for graduates — good men who deserve and are qualified to hold positions. The graduates of our Radio School, so far as we know or can learn, are employed 100%.

It is possible for every student who enters the P. A. C. Radio School and completes the course in keeping with our standards to receive employment as a Radio Operator for our station

K P A C at the transmitter, in the control room, as trans-radio press operator, or announcer, and not only earn more money than he pays for the training but to also continue his training as a post-graduate student in advanced work and prepare himself to secure and hold operating positions in the upper bracket of broadcasting, marine work, announcing, or airways.

Port Arthur College advertises primarily to Radio Amateurs and the training is too technical for the average student who has not selected Radio as his life's work. We know the opportunities for positions and advancement are unlimited for men who are interested in Radio and who plan to make this their career and are willing to make the sacrifice and effort necessary to master our training. P. A. C. maintains strict collegiate rank — only high school or college graduates are eligible for enrollment.

If interested in details about Radio Course, write for bulletin R

PORT ARTHUR COLLEGE • PORT ARTHUR (World-known port) TEXAS



Gerry Sayre, of the Mac Gregor Arctic Expedition, Greenland, is producing clear signals heard the world over. He is using Ward Leonard Plaque Resistors as terminating resistors in his Rhombic Antenna.



W.L. Plaque Resistors are non-inductive and non-capacitive. Circular 507 gives full data.

**WARD LEONARD
RADIO SPECIALTIES**

WARD LEONARD ELECTRIC COMPANY

41 South Street, Mount Vernon, New York
Please send me Circular 507.

Name

Street

City State

Call Signal



TRANSOIL

for transmitting

**HIGHEST QUALITY
OIL CAPACITORS**

Ask for new complete
Transmitting Catalog
describing

TRANSOIL—SOLAREX—TRANSMICA

SOLAR
MFG. CORP.



599 BROADWAY
NEW YORK CITY

connections are the same as to the 24A. The oscillator coils will need re-setting when this change is made. The 57 also eliminates the jumping of signals often noticed with the 24A tube."

Neon Oscillation in Regulated Plate Supplies

TROUBLE is sometimes experienced with an audio oscillation set up by the neon bulb in regulated plate supplies using the bulb to obtain cathode drop for the regulator tube. One method of curing such an oscillation was described in November *QST*.³ Now comes W4AHP with the suggestion that reversing the connections to the neon bulb often will cure the trouble. We've tried it in one supply and found that it does help to a considerable extent, although there may still be a tendency to oscillate when the supply is loaded to such an extent that the regulator is close to the point where control is lost. At any rate, it's an easy thing to try.

The characteristics of the circuit into which the supply is working have a considerable influence on these neon-bulb oscillations. The same supply, for instance, will give no trouble on one receiver, but will sometimes howl on another. Any suggestions the gang may have for complete cures will be welcome.

³ "Regulated Plate Supplies," Hints and Kinks, November, 1937, *QST*.

Scratch-Paper Feeder

H. W. CASTNER, W1IIE, has a kink which should appeal to those who want their scribbling paper handy but not all over the operating table. The idea is simplicity itself—just a

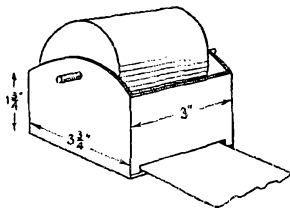

FIG. 6—SCRATCH PAPER HOLDER
The paper is an adding machine roll.

small box of about the dimensions shown in Fig. 6, containing a roll of adding machine paper. W1IIE puts the gadget behind his receiver, with the strip of paper pulled out underneath where it is always close at hand. When a section gets filled up with notes it is first folded over so the other side can be used and finally torn off.

Briefs

If you like to chew the rag, watch for those stations signing "RCC" after their calls. This sign-off indicates membership in the Rag Chewers' Club, that group of fellows who are pledged enemies of the "QRU CUL" type of contact. There are now over 1900 active R.C.C. members.

W6NGT, operating 56 Mc. on Pilot Peak in the Sierra Nevada Mts., near Yosemite, elevation 6115 feet, worked W6OAB on Mt. Diablo, a distance of 130 miles airline. He also worked W8UF on Mt. Hamilton, 100 miles distant.

SOCKETS

National Socket Types include a model for every tube commonly used by amateurs, from acorns to transmitting pentodes. All have low losses. All have dependable trouble-free contacts that keep filaments up to rating and signal circuits noise-free. All are convenient to use — witness the copper acorn socket with built-in by-pass condensers, and the general purpose receiving types that can be rotated to the best wiring position and locked there in their metal mounts. Complete listings and prices are given in the Catalogue. National Company, Inc., Malden, Mass.

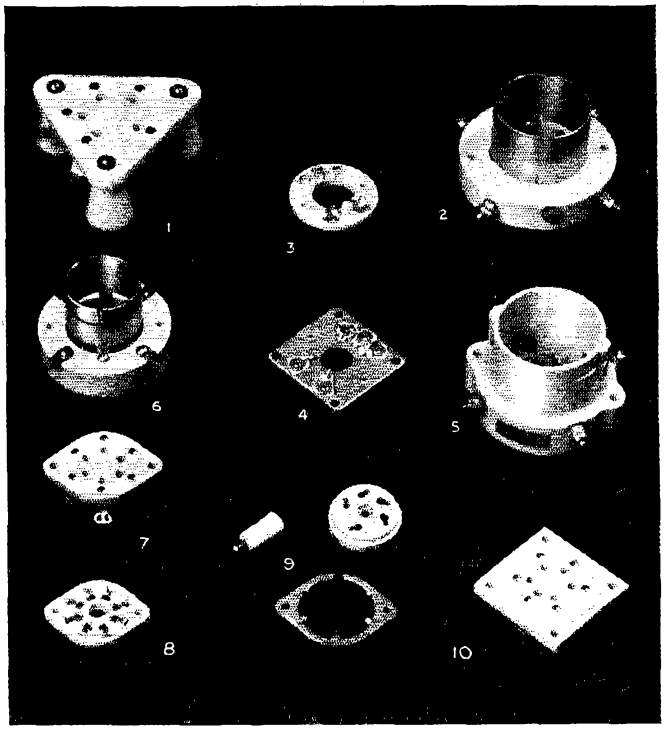

NATIONAL

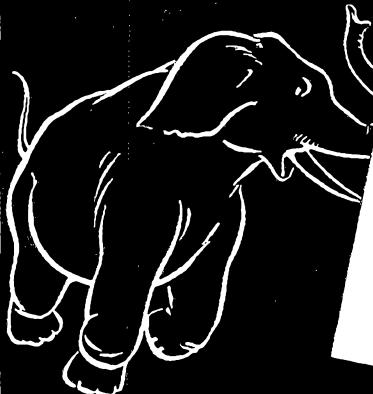

AN ELEPHANT IN A RADIO AD?
 Yes... because an elephant never forgets
 ... and WE never forget that to hold your
 good will we must be on the job every min-
 ute. Thousands of "hams" and engineers
 waited on each month, and never a complaint
 of shabby merchandise or shabby service! Get
 the habit of calling on us when in the district
 ... and keep our catalog handy.

TERMINAL
Radio Corporation

80 CORTLANDT STREET, NEW YORK, N. Y.

TELEPHONE • BARCLAY 7-0622

Say You Saw It in QST — It Identifies You and Helps QST

From Any Angle

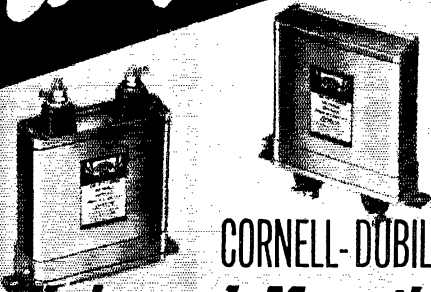

CORNELL-DUBILIER

Universal Mounting

DYKANOL
TRANSMITTING
CAPACITORS

Type TJ-U

Are best!

FULL DETAILS
AT YOUR DEALER



**AHOY
THERE!**

TAKE A LOOK
AT THE **SCRULOK**
developed by

BIRNBACH

Always a pioneer, Birnbach again leads with the new *Scrolok* solderless connection. Test leads and prods using this new principle need no soldering or tightening with wire-cutting screws. Every part is assembled with a tight mechanical and electrical contact.

Ask your jobber for the new Birnbach Test Prods, Test Leads, Banana Type Plugs, Insulated Pin Tips, etc., featuring the *Scrolok* principle. If he cannot supply you, write direct to us.

BIRNBACH RADIO CO.
145 HUDSON ST. **BIRCO** NEW YORK, N. Y.

Brief

What do you make of this? W9EC badly needed a Mississippi card for W.A.S., so he mailed a certain W5 a self-addressed postal, all made out for the QSO in question and requiring only a few blanks to be filled in by the W5. He got the card back all right . . . but in exactly the same condition that he sent it—none of the blanks had been filled in! Cooperation?

What the League Is Doing

(Continued from page 31)

of this year. Lt. Jett, who has been acting chief engineer since Commander T. A. M. Craven was appointed to a commissionership last fall, has long been regarded as the logical selection for the post he now occupies. Forty-four years old, he has been on the staff of the F.C.C. (and its predecessor the F.R.C.) since 1929, has had extensive experience in radio with the Navy—and has been an amateur in former years. As reported in a previous section, he has been appointed as one of the delegates of the United States to the Cairo Conference. Such gatherings are by no means new to him, however; he has just recently returned from the Habana conference, where he was the principal technical advisor to the American delegation, he was a delegate to the C.C.I.R. meeting at Bucharest last May, and has attended a number of previous North American radio conferences.

DX Contest Announcement

(Continued from page 30)

In counting up your total contest time, please be fair and honest. What constitutes "contest operating hours"? Not hours keeping local skeds within the U.S.A. and Canada. Not time spent in local rag chews, swapping DX results. If you listen for DX with the ability to call DX stations if, as, and when, you hear them, that time counts, whether you do any calling or working or not. The whole period is to be charged against "contest operating time," not just the time after you started transmitting!

AWARDS

A striking bronze medallion award will be given: (1) Two in each remotely located country⁷—to one c.w. winner, and one 'phone winner. In either contest section, all hams in the one territory 5 and 7 defined in the official country list compete for an award. (2) Two medallions in each of the 67 A.R.R.L. Sections, mainland U. S. A. and Canada, one to the telegraph, and one to the voice-operated station winner.

All operators in the same country⁷ will be in competition with each other—and similarly each A.R.R.L. section-boundary circumscribes a competing group. DX-transmission characteristics being the same for all operators in each award-area, and in each period, the chances of being a winner depend on operating ability and stations and are equally fair to all.

CLUB PARTICIPATION

To encourage local participation, additional certificate awards (besides the A.R.R.L. Section awards) will be made through each club where three or more individual club members, or new local hams invited by such a club, take part. For a club to rate a c.w. winner's certificate awarded on behalf of the club group, at least three reports from c.w. club-member (First Period) participants must be sent to Hq. Similarly, a club 'phone winner's certificate will be issued only when three 'phone (Second Period) entries mentioning the club have been received. Reports must be made direct to A.R.R.L., West Hartford, mentioning the name of the club, to be eligible for the affiliated-club-award. Entrants



WANT SPEED . . . and Professional Technique? GET CANDLER TRAINING

The Exclusive Sound System
That Produces Champions!

It takes more than merely the sending and receiving of code to become a skilled radio telegraph operator. The New CANDLER SYSTEM teaches you quickly the technique of Fast, Accurate telegraphing by simplifying the same world-famous principle that has trained many of the outstanding telegraphers and champions during the past 25 years. If you are sincere in your desire to be a skilled operator, find out how easily and inexpensively your ambitions can be realized — right in your own home! Mail the coupon and get all the surprising facts.

Candler Trains You Personally

Candler methods will give you surprising speed and accuracy. You will be amazed at your progress the first week. And you improve with every hour of code work. Don't postpone this thrill any longer. Mail the coupon now!

CANDLER SYSTEM CO.

Dept. Q-2

ASHEVILLE, N. C., U. S. A.

MAIL COUPON TODAY FOR FREE BOOK

CANDLER SYSTEM CO.

Dept. Q-2, Asheville, N. Carolina, U.S.A.

Send me your FREE book right away! My present speed is wpm.

Name

Address

City State



NEW HOLDER DESIGN

15 SECONDS TO
INSTALL CRYSTAL

For All Bands
GREATER STABILITY
Plugs in 5 prong tube socket

Beautiful Appearance

MODEL AH HOLDER \$1.00 At your dealer
or direct

HIPOWER LOW DRIFT CRYSTALS:
within 10 kc. or Choice of stock

AH-10, 1700-3500 Kc. bands \$2.35

AH-10, 7000-7300 " bands 3.90

WRITE FOR NEW LITERATURE

Hipower "Low Drift" Broadcast and Commercial
Crystals Are Approved by F.C.C.

Hipower Crystal Co., 2035 Charleston St., Chicago

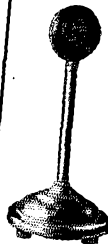

COMPARE IT WITH ANY MICROPHONE!

You'll appreciate the smooth performance of the T-9. It has a well extended frequency response without peaks. High output level—53 DB. The new shock proof cartridge means noise and breakage eliminated. T-9 is semi-directional—can't blast and won't feed back readily. A real performer that will save you money. Come in or order by mail.

TURNER
MODEL
T-9

former that will
save you money.
Come in or
order by mail.

\$11.47

NET

CHICAGO RADIO APPARATUS CO.
415 SOUTH DEARBORN ST.
CHICAGO, ILLINOIS

Licensed under patents of the Brush Development Co.



- ADVANCED ENGINEERING
- PRECISION MANUFACTURE
- PERFECT RECEPTION

Ken-Rad Radio Tubes

KEN-RAD TUBE & LAMP CORPORATION - OWENSBORO, KY.
Makers of Ken-Rad Radio Tubes and Ken-Rad Electric Light Bulbs

Say You Saw It in QST — It Identifies You and Helps QST

HARVEY'S

CONVENIENT to EVERYWHERE

NEW PRICES ON THE FOLLOWING TAYLOR TUBES

T-20	\$2.25	TZ-20	\$2.25
T-55	\$7.00	203-Z	\$8.00

We carry a complete line of TAYLOR, RAYTHEON, EIMAC, AMPEREX and RCA tubes

HARVEY SPECIAL Power Supply Components. All fully guaranteed. Mounted in attractive metal housings with standoff insulators.

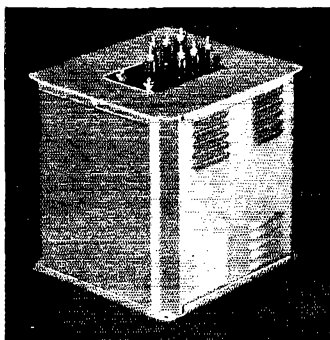

20462A — 1000-750-0-750-1000 AC at 300 MA. DC.	\$5.20
20462B — 1500-1250-1000-0-1000-1250-1500 AC at 300 MA. DC.	\$6.75
20462C — 2500-2000-1500-0-1500-2000-2500 AC at 300 MA. DC.	\$10.95
20462D — 1500-1250-1000-0-1000-1250-1500 AC at 500 MA. DC.	\$10.95
20462E — 575-525-0-525-575 AC at 500 MA. DC.	\$5.20

FILAMENT TRANSFORMERS

Primary 115 volts—tapped at 105 volts, 50/60 cycles AC	
22283 — Secondary 2 1/4 V.C.T. at 10 amps. 5000 volts insulation for 2-866's	\$1.65
22284 — Secondary 5 1/2 V.C.T. at 13 amps. 2500 volts insulation for Eimac tubes	\$4.00
22285 — Secondary 7 1/4 V.C.T. at 8 amps. 2500 volts insulation for T-20, TZ-20, and 809 tubes	\$1.90
22286 — Secondary 10 V.C.T. at 8 amps. 2500 volts insulation	\$2.30

The following condensers are oil impregnated and conservatively rated.

1000 V., D.C. Working Voltage	2000 V., D.C. Working Voltage
1 mfd. Special \$1.10	1 mfd. Special \$1.75
2 mfd. Special 1.50	2 mfd. Special 2.45
4 mfd. Special 2.00	4 mfd. Special 4.65
1500 V., D.C. Working Voltage	3000 V., D.C. Working Voltage
1 mfd. Special \$1.45	1 mfd. Special \$2.50
2 mfd. Special 2.00	2 mfd. Special 4.95
4 mfd. Special 3.25	
W2GW E	W2KJ Y
W2JL L	W2KX F

OUR *Best* VALUE IS OUR RECORD OF LOYAL SERVICE

HARVEY

Radio Company of New York

103 WEST 43rd STREET • NEW YORK, N. Y.

CABLE ADDRESS: "HARADIO"

who mention their club will be eligible for both club and Section awards.

Besides this, the sum of the scores of all club participants ('phone and c.w.) may be added, and reported by the club secretary, to count for the club itself. A genuine gavel, with engraved sterling silver band, is offered as an award to that club whose officers or activities manager submits the greatest collective score in A.R.R.L.'s 10th International DX Competition. The club station may be operated as one of the group of club member-stations, but the idea is not to operate that station so much as to have individual members all working at their own stations.

RULES

- All contest work must take place in the contest period.
- Reports must show each time of starting and stopping station operation in the log submitted to A.A.R.L., and if the total time of station operation exceeds 90 hours (in either period) the proper factor must be applied to the gross score as shown under "time limit."
- Logs must include date, time of QSO, call of station worked, serial numbers exchanged and other information required tabulated neatly with the claimed score. (See the log examples for required data.)
- Scoring: Both the W/VE station, and the station in the remote locality receive one point when the W or VE serial number is acknowledged by the station in the remote locality. Each operator similarly, may add two points further when a serial number (to U. S. A./Canada) is acknowledged by a W/VE station.
 - For W/VE entries. In computing points, each "received" serial number group counts 2. Each serial "sent" and properly QSL-ed counts 1.
 - For entries from stations using any prefixes other than W or VE. In computing points, each serial number "received" counts 1 point, and each number "sent" (with proper acknowledgment) counts 2 points.
- Logs must be marked for "phone" or "c.w." transmissions with work in a single entry all by one method for one period. Separate entries may be made for both periods if desired. This is optional.

W/VEs:

First Period (C.W.). Quota of three stations per country (prefix) may be worked in each different band and is the limit to count points toward the score, except that if one way exchanges with some of these three have been made, more stations can be worked to give not more than 9 points (basic) per country. This quota shall be permitted in each different band.

Second Period ('Phone). No quota limit on stations per country.

6. Multiplier shall consist of the number of countries (prefixes) worked on one band plus those worked on a second band, plus those worked on a third band, etc.

All Others:

- No quota limit on stations.
- Scoring points shall be multiplied (for total) by the number of U. S. A. and Canadian licensing areas contacted (a possible 14). The multiplier is also increased further by working the same areas on additional frequency bands. (Example: All districts are worked on two bands, possible multiplier is 28; 10, 8, 6, and 5 licensing areas are worked on four bands. The sum, 29 licensing areas, is the multiplier to use to get the gross score.)

9. All entrants agree to be bound by the Rules and Contest Announcement and the regulations of their licensing authority. In a contest of this magnitude, no correspondence can be entered into regarding Award Committee Decisions.

10. The highest scoring individual operator's score is the official score for all awards. Other operator scores must also be submitted separately if more than one operator worked a station. The station score (all points by all countries) may be stated for purposes of comparison, but will not have official significance in making awards.

11. More than one receiver and receiving operator in use at one time to log available DX is not permissible and shall be grounds for disqualification.

12. The same station can be worked in more than one band, provided the quota of three (per country, per band) which applies in the first period only is not exceeded.

13. Cross band work does not count in this contest.

14. Reports and logs from participating stations must be received at A.R.R.L. Hq. from all W/VE stations on or

SOLID or FLEXIBLE — METAL or INSULATED

★ Whichever you need, you'll find a Johnson unit just right for the job.

Johnson Flexible Couplings really provide a new conception of flexibility, but with absolute freedom from backlash.

Hubs cannot turn or loosen, and two set screws 90° apart in each hub assure positive drive.

Spring material is non-rusting phosphor bronze and all metal parts are cadmium plated.

Insulation is Alsimag 196, so designed that creepage path and arcing distance are the maximum possible.

Two sizes identical in features provide for different voltage peaks and accommodate practically all shaft combinations.

No. 250, 1 3/8" diameter for 1/4" shafts List \$ 80

No. 251, 2 1/4" diameter for 3/8" or 1/4" shafts List 1.25

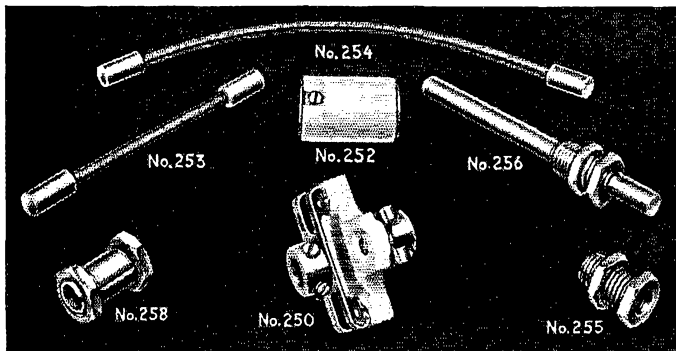

Other Johnson coupling units include a solid coupling for 1/4" shafts insulated with Alsimag 196 (No. 252), phosphor bronze flexible shafts with 1/4" hubs in 3" (No. 253) and 6" (No. 254) lengths, compression shaft coupling (No. 258 of cadmium plated brass for 1/4" shafts and panel bearings (No. 255) with 3" (No. 256) and 6" (No. 257) 1/4" shaft extensions.

★ For these and other Johnson products, ask your Jobber or write for Catalog 964J.

E. F. JOHNSON COMPANY
 MANUFACTURERS OF *Radio Transmitting Equipment*
 WASECA MINNESOTA U.S.A.
 Export Office: 25 Warren St., New York. Cable "SIMONTRICE"

Be a Good, Fast Sender

Get a NEW Improved

VIBROPLEX

Semi-Automatic Key



THE BUG trade mark identifies the Genuine Vibroplex

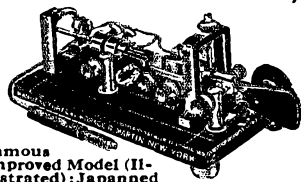

JUNIOR
 ONLY \$12.50

Famous Improved Model (Illustrated); Japanned Base, \$17; Nickel-Plated, \$19.

A little smaller and more compact but in every other detail the same as large model. Large points. Japanned base. Complete with wedge and cord.

Be popular. A good, fast sender is always popular whenever he comes on the air. The New Improved Vibroplex develops a degree of sending proficiency seldom attained by users of the old type straight key. Don't envy good, fast senders — be one! Get a New Improved Vibroplex semi-automatic key — standard the world over for clarity, speed and sending ease. Easy to learn.

Vibroplex does the rest. Costs no more than imitations. So why not get the best? Insist on the Genuine Vibroplex. Your old Vibroplex accepted as part payment on a new Vibroplex. Money order or registered mail. Write for FREE catalog.

THE VIBROPLEX CO., INC.
 832 Broadway New York, N. Y.

PRACTICAL RADIO ENGINEERING

Don't "sit down" on the job! Get busy and prepare yourself for the bigger jobs in store for technically-trained men. A post card brings you our 48-page book of interesting facts about your future in Radio.

Dept. Q-2, 14th & Park Road, Washington, D. C.



SEND FOR FREE CATALOGUE

CAPITOL RADIO ENGINEERING INSTITUTE

Radio Digest
 HIGHLIGHTS FROM THIS ISSUE
 NOVEMBER, 1937

Sensation OF THE RADIO FIELD!

- It's the ONLY magazine with the best from ALL branches of radio (except business and entertainment)
 - Digests, extracts, reprints from QST, Radio, All Wave Radio, Radio News, Elec. News, Service, Communications, Bell System and R.C.A. papers, house organs, over 100 journals
 - Twelve issues for \$2.50 in U.S.A., Canada, and Pan American countries. Elsewhere, \$3.00 or 12s 6d. Sample copy, 25c
- RADIO DIGEST**
 7460 Beverly Blvd. Los Angeles

LEARN CODE RIGHT

Tapes for Every Need — Send You Typical Messages by **INSTRUCTOGRAPH**

It's easy and practical to learn or improve your Radio or Morse Code, any speed. Senior model with 10 tapes and Book of Instructions — \$20.25. (Rented at low cost) Junior model with 5 tapes and Book of Instructions — \$12.00. (Not rented). Complete oscillator equipment, less battery, \$6.50. Write for details today.

INSTRUCTOGRAPH CO., Dept. Q-2
 912 Lakeside Place Chicago, Ill.
 Radio College of Canada
 863 Bay St., Toronto



BUY ON CASH OR TERMS: HALLICRAFTER AND R.M. E. SHORT WAVE RECEIVERS, SPEED-X AND VIBROPLEXES, Telegraph Instruments.

Really HANDY

This New Shure "Military-Type" Hand Microphone

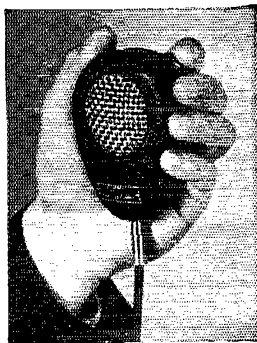

★ Here's the answer to a long-felt need for a microphone that would fit naturally, firmly, in the palm of the hand. Small, light, compact—yet rugged and dependable. No bothersome handle. Slips easily into pocket. Takes minimum space in portable equipment. Optional locking press-to-talk switch. Relay contacts can be furnished. Unusually high output level plus famous Shure "high-efficiency" speech characteristic.

Crystal and Carbon types are available in standard and "anti-noise" close-talking models.

List prices from... \$15 to \$31.50

Ask your Jobber or Write for Bulletin 144Q.

Shure Patents Pending. Licensed under patents of the Brush Development Company.



RADIO ENGINEERING



RCA Institutes offer an intensive course of high standard embracing all phases of Radio and Television. Practical training with modern equipment at New York and Chicago schools. Also specialized courses and Home Study Courses under "No obligation" plan.

Illustrated Catalog on request

RCA INSTITUTES, INC. Dept. ST-38

A Radio Corporation of America Service

75 Varick St., New York 1154 Merchandise Mart, Chicago

PRECISION CRYSTALS

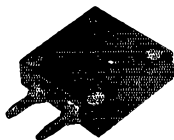

Crystal Holder

Highest quality crystals, one inch square, carefully ground for frequency stability and maximum output. Be sure of your transmitter frequency—use PRECISION CRYSTALS.

Low frequency drift crystals (Type L T C) supplied within 0.1% of your specified frequency and calibrated to within 0.03% are priced as follows: 1750 and 3500 kc. bands — \$3.50 each. 7000 kc. band \$4.00 each. Holder \$1.00.

(Holder as illustrated to fit G.R. jacks or round holder to plug into a tube socket can be furnished. G.R. jacks to plug illustrated holder into — \$1.15 pair.)

'X' cut PRECISION Crystals carefully ground for maximum power supplied within 0.1% of your specified frequency and calibrated to within 0.03% are priced as follows: 1750, 3500 and 7000 kc. bands — \$3.00 each. Add \$1.00 if holder is desired.

'AT' cut crystals for commercial use quoted on at your request. When ordering our product you are assured of the finest obtainable. Now in our seventh year of business.

PRECISION PIEZO SERVICE

427 Asia Street

Baton Rouge, La.

before noon, April 22, 1938, to be considered for awards. From all outlying localities, reports must be received on or before May 27, 1938. Play safe... mail your report immediately at the end of each contest period to avoid delay and insure that your results are credited in QST. Show your claimed-score in full, following a tabulation of points in the log-form indicated with this announcement.

15. The entries received after the competition will be passed upon by an A.R.R.L. Award Committee whose decision will be final in all cases.

WARNING!

Good notes, not ragged ones are advisable. The F.C.C. monitoring station personnel are acquainted with the dates of our DX contest, and will be on the job. You do not want to be disqualified! Nor do you wish discrepancy reports for poor notes and overmodulated signals! Better lose out in some operating hours rather than jeopardize your amateur standing. Let's make it a contest with *no bum signals*.

All competitors are requested to submit their lists, even if they only show a small score. In so doing they are supporting claims made in logs from other stations, and they will receive full credit for their work in QST.

A Low-Cost 100-Watt Transmitter

(Continued from page 66)

apply plate voltage and rotate C_4 rapidly for the dip in plate current which indicates resonance. The minimum plate current probably will be about 80 ma. With the key up (no excitation to the final) the plate current should drop to 30 ma. or less. For testing purposes, a 100- or 150-watt lamp can be used as a dummy load, connected to a few turns of wire looped over L_4 . The coupling should be adjusted, either by the number of turns in the loop or by moving the loop with respect to L_4 , until the rated plate current of 200 ma. is drawn. When a change in coupling is made, C_4 should always be retuned for minimum plate current. With full input, a 100-watt lamp should be at full brilliance.

No antenna-tuning apparatus has been described because antennas require different approaches. The A.R.R.L. Handbook antenna chapter contains information which will enable the builder to construct a suitable coupler. A link-coupled unit will fit in nicely with the transmitter construction.

POWER SUPPLY

Fig. 3 is a suggested diagram for a power supply for the transmitter. It will be noted that separate plate supplies for the amplifier and drivers are recommended, instead of a single supply with a voltage divider. The use of two plate supplies avoids the plate-voltage changes on the 6L6's with tuning, or when the doubler is cut in or out of the circuit, which would be inevitable with a single supply and a voltage divider. At the moment, the catalogs do not show a 6.3-volt transformer having sufficient amperage to handle the filaments of all four tubes, which leaves the alternatives of using two transformers of the proper output voltage or else a 7.5-volt unit of ample current-carrying capacity with a turn or two removed from each side of the winding to drop the voltage to 6.3. Under present circumstances the latter probably is the less expensive.

The various components needed for the power supply are available from several manufacturers

200-R TRANSMITTER

with Redesigned RF Section

1,500-30,000 kilocycles — 325 Watts Input — 6L6 Oscillator — 6L6 Frequency Multiplier — RK-28 Amplifier — Band Switching — Crystal Selection — Carrier Control.

The 200-R is but one of a complete line of transmitting units varying in power output from 10 to 750 watts and bearing the name HARVEY which is your guarantee of satisfaction.

Write for catalog 52 which gives full details and prices

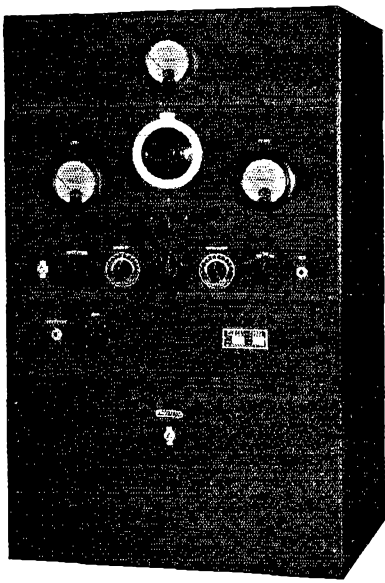

HARVEY RADIO LABORATORIES, INC.

25 Thorndike St., Cambridge, Mass.

SPECIAL TO AMATEURS
Piezo-Electric Crystals — \$2.50 EACH POSTPAID
 Until supply is exhausted . . . we offer 80 meter band crystals unmounted; accurate calibration, excellent oscillators. Limited quantity.
SCIENTIFIC RADIO SERVICE
 "The Crystal Specialists Since 1925." University Park, Hyattsville, Md.

RADIO

ENGINEERING, broadcasting, aviation and radio telegraphy and telephony, police radio, servicing, marine accounting taught thoroughly. Engineering course of nine months' duration, equivalent to three years of college radio work. School established 1874. All expenses low. Catalog free. **DODGE'S INSTITUTE, Day Street, Valparaiso, Indiana**

SPEED THE COMPLETE LINE OF TELEGRAPH KEYS

Model 312 Key
 A new amateur's practice key mounted on a mahogany finished wood base. Black enameled metal key base. Arm black Oxidized and all other parts finished in natural brass. Includes circuit closing switch. 1/4 inch silver contacts.
 No. 312 Key List Price \$2.25
 Other models of hand keys from \$1.50 to \$3.50 list. Available at leading jobbers everywhere.
 Write for new literature and amateur discounts

LES LOGAN CO.
 646 Jessie Street San Francisco

MEMORANDUM

✓ You need a copy of the new Bigger-than-ever 1938 Handbook.

✓ You need a binder for your 1937 QST's — and another for 1938.

FEBRUARY, 1938

Free

TO ALL AMATEURS!!

THIRD EDITION OF STANCOR'S NEW

HAMANUAL

Here's a book that's very much in demand . . . but you can get your copy FREE at Sun Radio! 44 pages of information. Complete descriptions with diagrams of 16 modern x'mtrs from 10 watts to one K.W. Also data on all Stancor transformers and chokes. ANOTHER SCOOP! The new Stancor Amplimanager — 24 pages describing 10 new audio amplifiers ranging in power from 3 to 60 watts. It, too, is FREE! Come in and pick up your copies.

THERE'S A REASON FOR THE FAST GROWING POPULARITY OF SUN RADIO

Always a leader . . . it's only natural that amateurs should look to Sun Radio to set the pace. If you want the newest numbers of every leading manufacturer; if you want fast, dependable service and merchandise backed by a guarantee of satisfaction that has stood the test of 16 years . . . swing to Sun! Don't take our word for it — try us on your next order!

RCA ACR 155 AMATEUR RECEIVER. **\$44.50**
COMPLETE WITH TUBES. Was \$74.50. Now

RCA TMV 135A CRYSTAL and HOLDER, "V" CUT. 3500 to 4000 Kc only. Quantity **\$3.95** limited. Formerly \$9.85. Special at

1938 HALLICRAFTER SUPER SKYRIDER

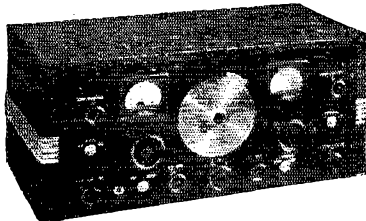

Complete with tubes, crystal and speaker

\$123

Write for time payment plan

HALLICRAFTER 1938 SKY CHALLENGERS with speaker, crystal and tubes in stock.

- NATIONAL RECEIVERS IN STOCK. HRO, NC100, NC80X, HRO Jr., NC101X, for immediate delivery.
- WESTERN ELECTRIC Keying Relays. Each95c

NEW LOW PRICES ON TAYLOR TUBES!!

T-20 @ \$2.25 TZ-20 @ \$2.25 T-55 @ \$7.00 203-Z @ \$8.00

- SYLVANIA 211C — Guaranteed! \$6.75
- The new RCA 814 in stock \$17.50
- AMERICAN CODE READER \$12.00
- STANCOR TRANSFORMERS IN STOCK.
- AMATEUR X'MITTING TUBES BY TAYLOR, RCA, EIMAC, RAYTHEON, W.E.
- AMERICAN TELE-KEY with adjustable side-swiper . . \$2.94
- BLILEY B5 40 M. crystals. Your choice of a huge stock. \$4.80
- TRIMM Commercial Phones, 17,000 ohms \$9.41
- STANCOR 3-stage X'mtr kit, complete \$49.95



RADIO CO.

227 Fulton Street, New York, N. Y.

Cable Address: SUNRADIO NEW YORK

and the trend over a short period is not marked. Since 1933 sunspots have been on the increase and can be purchased quite inexpensively, hence only electrical specifications are given and no particular brands specified. The total cost of the power supply probably will be about the same as that of the transmitter, in the neighborhood of twenty-five dollars. The two units together figure out to about fifty cents per watt of r.f. output, which is quite reasonable for transmitters of the 100-watt class.

DX and the Ionosphere

(Continued from page 8)

and the F₂ critical frequencies have been rising. At the present time we are riding the crest, the period between minima and maxima being about 5½ years. Since the maxima also are broad, it seems safe to assume that long-distance transmission on the higher frequencies will be at its best during 1938 and may be expected to stay there for a goodly portion of 1939. Then the downhill slide to about 1944, when sunspots and DX conditions probably will again have reached the 1933 low. There will be plenty of variations along the route, of course, because there are seasonal and short-period variations as well as the long-time trends. We are only concerned with the latter at the moment, however.

What, specifically, can we expect of DX during the next five or six years? How good is a high and how poor is a low? Since we are probably in the midst of a high, we can expect 1938 to be about the same as 1937. But for forecasting 1944 conditions we have only past experience to guide us, and the guideposts are not too reliable. Amateur radio has changed too fast in the past five years; conditions other than those existing along transmission paths show to-day a very different picture than they did in 1933. Not only has the general level of equipment, both transmitting and receiving, been greatly improved but to-day there are far more stations, in more parts of the globe, operating more hours per day. DX has been good, and good DX generates more and more interest and activity.

The picture since 1933 is fairly clear. Speaking personally, we can well remember when Asian signals first began to be heard generally in New England; Asia, at least the Eastern part, is about the hardest place to work from this area. Since activity at that time in Western As'a was practically negligible, a New England W.A.C. was rare indeed. But Asian signals started filtering through in early 1935, and have been with us in ever-increasing quantities since. Early 1935, too, saw the revival of inter-continent 28-Mc. communication; the coincidence of the two events is surely significant. Only a year between good DX and an undoubted low! The fact that the preceding two years had shown practically no inter-continent work only makes us wonder whether lack of activity gives the

(Continued on page 122)

Where to buy it

A directory of suppliers who carry in stock the products of these dependable manufacturers.



ALBANY, N. Y. Uncle Dave's Radio Shack 356 Broadway
BALTIMORE, MD. Radio Electric Service Company 3 North Howard St.
BOSTON, MASS. Radio Shack 46 Brattle Street
BOSTON, MASS. Wholesale Radio Service Company, Inc. 110 Federal Street
BRONX, N. Y. Wholesale Radio Service Company, Inc. 542 East Fordham Rd.
HARTFORD, CONNECTICUT Radio Inspection Service Company 227 Asylum Street
JAMAICA, L. I. Wholesale Radio Service Company, Inc. 90-08 166th Street
NEWARK, N. J. Wholesale Radio Service Co., Inc. 219 Central Ave.
NEW YORK, N. Y. Gross Radio, Inc. 51 Vesey St.
NEW YORK, N. Y. Harrison Radio Co. 12 West Broadway
NEW YORK, N. Y. Wholesale Radio Service Co., Inc. 100 Sixth Ave.
NEW YORK, N. Y. Terminal Radio Corp. 80 Cortlandt Street
POTTSVILLE, PENN. E. Norwegian & George Sts. Sylvester Radio & Supply Co., Inc.
READING, PENN. George D. Barbey Company 404 Walnut St.
READING, PENN. Sylvester Radio & Supply Co., Inc. 104 North Ninth Street
SPRINGFIELD, MASS. T. F. Cushing 349 Worthington St.
WASHINGTON, D. C. Sun Radio & Service Supply Co. 938 F Street, N. W.

RME
RECEIVERS -- PRE SELECTORS
AMATEUR RADIO EQUIPMENT
RADIO MFG. ENGINEERS, Inc.
PEORIA ILLINOIS

ALBANY, NEW YORK Uncle Dave's Radio Shack 356 Broadway
BINGHAMTON, NEW YORK Radio Testing Station 25-27 Sturges Street
CONCORD, NEW HAMPSHIRE Rear, 80 N. State Street Evans Radio
HARTFORD, CONNECTICUT Stern Wholesale Parts Company 210 Chapel Street
NEW YORK, N. Y. Harrison Radio Co. 12 West Broadway
NEW YORK, N. Y. Terminal Radio Corp. 80 Cortlandt Street
ROCHESTER, NEW YORK Radio Parts & Equipment Co. 244 Clinton Ave., N.



ALBANY, NEW YORK Uncle Dave's Radio Shack 356 Broadway
BOSTON, MASS. The Radio Shack 46 Brattle Street
BOSTON, MASS. Selden Radio Company 98 Brattle Street
BOSTON, MASS. Wholesale Radio Service Company, Inc. 110 Federal Street
BRONX, N. Y. Wholesale Radio Service Company, Inc. 542 East Fordham Rd.
BUFFALO, NEW YORK Radio Equipment Corp. 326 Elm Street
CONCORD, NEW HAMPSHIRE Rear, 80 N. State Street Evans Radio
JAMAICA, L. I. Wholesale Radio Service Company, Inc. 90-08 166th Street
NEWARK, NEW JERSEY Wholesale Radio Service Co. 219 Central Avenue
NEW YORK, N. Y. Harrison Radio Co. 12 West Broadway
NEW YORK, N. Y. Wholesale Radio Service Co. 100 Sixth Avenue
WASHINGTON, D. C. Sun Radio & Service Supply Co. 938 F Street, N. W.

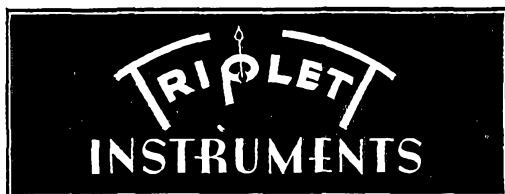

ALBANY, N. Y. Uncle Dave's Radio Shack 356 Broadway
BOSTON, MASS. Radio Shack 46 Brattle Street
BOSTON, MASS. Selden Radio Company 28 Brattle St.
BOSTON, MASS. Wholesale Radio Service Company, Inc. 110 Federal Street
BRONX, N. Y. Wholesale Radio Service Company, Inc. 542 East Fordham Rd.
JAMAICA, L. I. Wholesale Radio Service Company, Inc. 90-08 166th Street
MONTREAL, CANADA 285 Craig Street, West Canadian Electrical Supply Co., Ltd.
NEWARK, N. J. Wholesale Radio Service Company 219 Central Ave.
NEW YORK, N. Y. Wholesale Radio Service Company 100 Sixth Avenue
POTTSVILLE, PENN. E. Norwegian & George Sts. Sylvester Radio & Supply Co., Inc.
READING, PENN. George D. Barbey Co. 404 Walnut Street
READING, PENN. Sylvester Radio & Supply Co., Inc. 104 North Ninth St.
WASHINGTON, D. C. Sun Radio & Service Supply Co. 938 F Street, N. W.

RCA OSCILLOGRAPH PRICES REDUCED!

These fine new instruments, excellent for use with amateur transmitters, now yours at amazingly low cost.

WAS \$84.50 NOW \$63⁹⁵

Stock No. 9545 RCA 3-inch
Cathode Ray Oscillograph



Thousands have been sold during the three short years since this splendid instrument was introduced. Its sensitivity is 0.7 volts (R.M.S.) per inch—linear saw-tooth sweep oscillator, 10 to 18,000 cycles . . . 2 wide range amplifiers, 10 cycles to 90 kilocycles. Gain 40 . . . Complete with Tubes.



WAS \$47.50 NOW \$39⁹⁵

Stock No. 151 RCA
1-inch Cathode Ray Oscillograph

This Oscillograph will give you "big time" performance. Its sensitivity is 1.75 volts (R. M. S.) per inch—amplifier range—30-10,000 cycles. Gain 50—Linear timing axis (horizontal sweep) —30-10,000 cycles . . . All controls on front panel . . . Gray wrinkle lacquer finish with nickel trimming . . . Complete with Tubes.

Over 300 million RCA Tubes have been bought by radio users . . . In tubes, as in the equipment, it pays to go RCA ALL THE WAY! Listen to the Magic Key of RCA every Sunday, 2:30 P.M., E. S. T., on NBC Blue Network.



Test Equipment

RCA Manufacturing Co., Inc., Camden, N. J.
A Service of Radio Corporation of America

READ AND
SEND

CODE

Learn Easily at Home this Quicker Way:

No experience needed. Beginners read code quickly, copy accurately. If already an op, speed up your wpm this approved way. "Almost human!" experts call the amazing New All Electric Master Teleplex. Only instrument ever produced which records your sending in visible dots and dashes on specially prepared paper tape—then sends back your own key work at any speed you wish. Fascinating, fool-proof, gets results because you learn by HEARING as well as seeing. That is why thousands agree this method is surest and quickest. We furnish Complete Course, lend you the New Master Teleplex, and give you personal instruction with a MONEY-BACK GUARANTEE. Low cost, easy terms. Write today for folder Q2; no obligation.



The "Ham"
SPECIAL

Standard Teleplex—a highly efficient code teacher using heavy specially prepared waxed paper tape, having two rows of perforations. Write for Free folder Q2-2.

We are the Originators of this type instrument

**TELEPLEX CO. 72-76 CORTLANDT ST.
NEW YORK, N. Y.**



THE NEW EARCAPS

Improve the quality of your head-phone to give results of a dynamic speaker. Immediate delivery for Ambassador, Baldwin, Brandes, Cannonball, Globe, Kellogg, Murodock, Radlocar, Solid, Trimm, Featherweight and Professional, and Western Electric phones.

Send for illustrated literature giving complete information.

Inventor and Manufacturer, Dept. Q-2
PAUL JARNAK, 69 West 83rd St., NEW YORK CITY

answer; the ionosphere data show better average conditions.³

The low period of 1933 can also be considered to have extended over most of 1932. Experience is not of much value to us for the preceding five years; there were fewer amateurs, especially in foreign countries; before 1929 amateur radio had no official existence in many of them and it took years to gain a real foothold subsequently. Considering all these factors, our speculations lead us to the conclusion (it may only be a hope!) that the coming low will not reach the depths that the last one did. Considering the period since 1933, it is reasonable to expect that the worst part will not last longer than about two years. With better antennas and a background of experience, we should not be surprised to find the DX gang doing the same old business at the same old stand—in 1944. The digging no doubt will be harder, but there may be something to dig for. At any rate, the postman should be busy carrying W.A.C. cards until 1942 at least.

As a sidelight, the ionosphere conditions which make good DX possible on 14 and 28 Mc. also tend to spoil long-distance communication on the medium-high frequencies. The greater density of ionization tends to cause greater absorption of these frequencies in the lower layers.⁴ Best conditions, therefore, do not prevail over all bands at once. The DX activity on the different bands definitely reflects these trends.

Those interested in the current state of the ionosphere will find it profitable to pick up the broadcasts from the Bureau of Standards' station WWV, which are transmitted each Wednesday. The bulletin is sent by voice on three different frequencies: on 10,000 kc. at 1:30 P.M., on 5000 kc. at 1:40 P.M., and on 20,000 kc. at 1:50 P.M. Data on critical frequencies and virtual heights of the various layers, with maximum usable frequencies corresponding to several skip distances up to 2500 kilometers, are given, based on measurements made at noon of the same day. Corresponding data also are given for the previous night, with a short discussion of ionosphere conditions during the previous week. Comparison of existing transmission conditions with the broadcast data is both interesting and instructive. In recent weeks the calculated maximum usable frequency at noon has several times been in the vicinity of 50 megacycles, which certainly brings 56-Mc. DX within the realm of possibility.

Some years ago when ten meters started to open up, we had a working rule that when skip was short on 20 the chances of hearing something on 10 were pretty good. The ionosphere data bears this out. But now if you hear S9 signals on 20 from stations within a hundred miles or so, especially around noon, look out for 56-Mc. DX. If inter-continents 56-Mc. QSO's are ever to be pulled off, 1938 should be the year.

³ E. B. Judson, "Comparison of Data on the Ionosphere, Sunspots, and Terrestrial Magnetism," Proc. I. R. E., January, 1937.

⁴ Gilliland, Kirby, Smith and Reymers, "Characteristics of the Ionosphere and Their Application to Radio Transmission," Proc. I. R. E., July, 1937.

HAM-ADS

(1) Advertising shall pertain to radio and shall be of nature of interest to radio amateurs or experimenters in their pursuit of the art.

(2) No display of any character will be accepted, nor can any special typographical arrangement, such as all or part capital letters be used which would tend to make one advertisement stand out from the others.

(3) The Ham-Ad rate is 15c per word, except as noted in paragraph (6) below.

(4) Remittance in full must accompany copy. No cash or contract discount or agency commission will be allowed.

(5) Closing date for Ham-Ads is the 25th of the second month preceding publication date.

(6) A special rate of 7c per word will apply to advertising which, in our judgment, is obviously non-commercial in nature and is placed and signed by a member of the American Radio Relay League. Thus, advertising of bona fide surplus equipment owned, used and for sale by an individual or apparatus offered for exchange or advertising inquiring for special equipment, if by a member of the American Radio Relay League takes the 7c rate. An attempt to deal in apparatus in quantity for profit, even if by an individual, is commercial and takes the 15c rate. Provisions of paragraphs (1), (2), (3) and (5) apply to all advertising in this column regardless of which rate may apply.

Having made no investigation of the advertisers in the classified columns, the publishers of *QST* are unable to vouch for their integrity or for the grade or character of the products advertised.

QUARTZ—direct importers from Brazil of best quality pure quartz suitable for making piezo-electric crystals. Diamond Drill Carbon Co., 719 World Bldg., New York City.

RADIO engineering, broadcasting, aviation and police radio, servicing, marine and Morse telegraphy taught thoroughly. All expenses low. Catalog free. Dodge's Institute, Byrd St., Valparaiso, Ind.

QSL'S, W2SN, Helmetta, N. J.

CALLBOOKS—new DX calls, new prefixes, thousands of new W and V calls, in the Winter, 1937 Radio Amateur Call Book. Sent postpaid \$1.25, or a whole year (four issues) for \$4. (In foreign countries \$1.35 and \$4.35.) Your call and QRA printed in large type \$1 per year. Radio Amateur Call Book, 610 S. Dearborn, Chicago.

QSL'S, all colors, cartoons, snappy service. Write for free samples today. W1BEF, 16 Stockbridge Ave., Lowell, Mass.

COMPLETE training for all amateur and professional radio licenses. New York Wireless School, 14 E. 44th St., N. Y.

USED receivers. Bargains. Price list 3¢. W3DQ, 405 Delaware Ave., Wilmington, Del.

GENERAL Electric dynamotors 24/750 volts 200 mills, \$20. On twelve volts deliver 375. Westinghouse 27 1/2/350, \$10; 200 Watts 900 cycles, \$15; 8-15 volts 500 watts Aircraft, \$10. Simon 500 watt 500 cycles with exciters, \$8. Slightly used, \$6. List, Henry Kienzle, 215 Hart Blvd., Staten Island, N. Y.

QSL'S, Cartoons. Free samples. Theodore Porcher, 7708 Navajo St., Philadelphia, Pa.

TRADE: 35-T, two 0-100 Weston 301 milliammeters, good condition, for Kelsey or other handpress with equipment. H. Cary, W9TOF, 122 W. Liberty, Mankato, Minn.

SELL: Esco generator, 1000 volt 300 watt separately excited 32 or 16 volt field. Bruno kit Velocity mike with transformer. General Electric generator, 500 volt 100 watt self excited. Wayne Faith, Montpelier, Ohio.

BILLEY crystals: DX frequencies like 7001, 7199, etc. stocked by W8DED.

QSL'S? SWL's? DX cards that bring returns. Samples? W8DED, Holland, Mich.

HIGH powered portable power supply 1/2 H.P. Johnson engine coupled to 750 volt 200 mill. d.c. generator. Sell \$40. Harry Sherwood, 3 E. Ave., Larchmont, N. Y.

SWAP: pair RK20's in perfect condition, slightly used, for good ham receiver. W5GEA, Box 612, Greenwood, Miss.

QSL'S. Free samples. Printer, Corwith, Iowa.

SELL cash only: 500 watt 500 cycle alternators with exciters, \$7. each, two machines, \$13. Westinghouse 27 1/2-350 volt 80 mill. \$7.50 each, three for \$20. All five machines for \$30. All brand new—never used. Address R. T. Duncan, W9WB/7, 1320 15 St., Lewiston, Idaho or 1124 E. Division St., Lombard, Ill.

MUST sell for best cash offer: Supreme Diagonoscope 555, combination AF oscillator, RF oscillator, 3 inch oscilloscope—Supreme Diagonometer 585, combination tube tester and set tester. Above items used five months—A-1 condition. Beaver Radio Service, Beaver Dam, Wis., W9RHS.

GUARANTEED plate and filament transformers designed to your specifications—very reasonable. Michigan Electrical Lab., Muskegon, Mich.

350 WATT phone and five meter mopa plus big bargain list. W2JKB.

SWAP: Leica D with 3.5 lens for communications superhet. J. F. Hefton, 3524 Lee Blvd., Arlington, Va.

CRYSTALS: Zero cut. New low drift, 160-80-40 meters, \$1.85; 20 meters, \$3, postpaid. Plug-in mountings, 75¢. Fisher Lab., 4522 Norwood St., San Diego, Calif.

QSL cards, neat, attractive, reasonably priced. Samples free. Miller, Printer, Ambler, Pa.

QSL'S, 300 one-color cards, \$1. Samples. 2143 Indiana Ave., Columbus, Ohio.

SELL: Few new Chevrolet steering wheels—just the thing for rotary antenna control, \$1. each. W9WTE, Salem, Wis.

QSL'S of distinction. W2AEY, 338 Elmora, Elizabeth, N. J.

TWO 1/2 k.w. 2500 v. CT transformers, \$9. each. W8ADU.

QSL'S, Beautiful designs. Free samples. Maleco, 1512 Eastern Parkway, Brooklyn, N. Y.

LONGLINES 5 meter oscillator. Beautiful workmanship, powerful, stable, efficient, inexpensive. Bulletin ready. QSL to Paradio, 124 Garrison, Jersey City, N. J.

SUPER-regenerator 5 meter receiver. Beautiful workmanship and non-radiating with preselection, self-quenching detector, powerful audio. Modern, selective, inexpensive. Bulletin ready. QSL to Paradio, 124 Garrison, Jersey City, N. J.

DEALERS should carry our present and future 5 meter developments. Your letterhead to Paradio, 124 Garrison, Jersey City, N. J.

MANUFACTURERS but not salesmen? Let this live-wire agency sell for you. Write Paradio, 124 Garrison, Jersey City, N. J.

QSL'S—75¢ for 100 two colors. Rush your order to W9DGH, 2005 N. Third Ave., Minneapolis, Minn.

FBXA, Peak preselector, dynamic, pack, all ham coils, \$55. Four k.w. transformer variable d.c. to 6000, \$60. Perfect RK-20's, \$10. each. Winsor, Pleasantville, N. Y.

WANTED: Navy receiver IP500 or similar. Cash or trade. W8GWA.

TELEPLEXES, instructographs, omnigraphs, typewriters bought, sold. Ryan's, Monroe City, Mo.

WANT 500 volt generator. W9ARJ.

CRYSTALS: Power ground 80M X cuts, unconditionally guaranteed, \$1.50. 40M V, four cycle drift, \$2.75. Catalog. Ham Crystals, 1104 Lincoln Place, Brooklyn, New York.

QSL'S, SWL's. 100 3-color. 75¢. Lapco, 344 W. 39th, Indianapolis, Ind.

SELL: All band 150 watt phone; PR-16 receiver. Accumulated xmitter parts. \$200. List. W9CSN.

SELL: FB7A bandspread and general coverage coils for all bands \$2.95 pair. W9ARA, Butler, Mo.

913 oscilloscope without tubes, \$8.50. W8QZR.

CRYSTALS, X cut, 80-160, \approx five kilocycles, \$1.50. Spot frequency, \$2.50. Three small 80 meter blanks, including carborundum, \$1.20. Holders, \$1. Wm. Threm, W8FN, 3071 Moosewood Ave., Cincinnati, Ohio.

OUR large three inch oscillograph complete and ready to work with linear sweep circuit, synchronization circuit, tubes, etc., only \$39.50. Money-back guarantee. Order now. International Standards, 5307 Ravenswood, Chicago.

REM9DS—rebuilt at factory by RME test engineer to RME69 circuit. Contains all six bands. Complete. Guaranteed O.K., \$75. cash. W9DQH, Peoria, Ill.

SELL: New 1938 Super-Skyrider complete with crystal filter, speaker, \$100. Absolutely like new, write for details. W8PJQ.

CRYSTALS: unconditionally guaranteed. Supplied within five kilocycles. 1715-2000 or 3500-4000 kilocycles, X-cut \$1.50. A-cut \$2.25; 7000-7300 X-cut \$1.85. A-cut \$2.25. Spot frequencies \$1. additional. I.F. crystals 465 or 1600 kilocycles \$3.25. Above crystals supplied mounted molded bakelite holder (fits tube socket) only 75¢ additional. Wright Radio Labs., 5859 Glenwood Ave., Chicago, Illinois.

QSL'S—highest quality—lowest prices. Radio Headquarters, Ft. Wayne, Ind.

EIDSON'S T9 crystals are equal in output to any crystal at any price. 40 and 80 meter bands \$1.60, 7301-7500 k.c. range \$2. Rugged X cut, fully guaranteed. Follow the lead of thousands of enthusiastic users and buy fracture-resisting T9 crystals—accept no substitute. T9 ceramic holders \$1.10. Prices postpaid. C.O.D.'s accepted. Sold by: Hieronymus Radio, 88-34 209 St., Queens Village, N. Y.; Henry Radio Shop, Butler, Mo.; Pemberton Labs., Ft. Wayne, Ind.; or Eidson's, Temple, Texas.

FREE: 3 high-grade, porcelain case, mica transmitting condensers, 2000 volt test, any capacity up to .001 mfd with every order of 100 two-color, modern QSL cards—price \$1.—large selection. Samples. W3DGS, 6417 Tulip St., Philadelphia, Pa.

LOCAL hams—new tantalum 852s. fully guaranteed, \$8. W9HYO.

QSL'S—SWL's—new rainbo effects. Samples. Frits, 455 Mason, Joliet, Ill.

203A new, with socket and filament transformer, \$5. W2EXR. MICROPHONES—W.E. and RCA condenser with amplifier, cord, plugs, \$10. Easily converted for a.c. operation. Excellent frequency response. Write for details, R. Brooks, 4700 Montgomery, Downers Grove, Ill.

DOUGLAS Universal class B transformers. Match all tubes—50 watts audio \$4.95 pr.—100 watts audio \$7.75 pr. delivered—guaranteed. For details write W9IXR, Weyerhaeuser, Wis.

A mounted crystal near your frequency 80-160 meter bands \$1.25. Same unit 40 meters \$2.25. R9 Crystals, 338 Murray Ave., Arnold, Pa.

BRAND new: Acr-155s \$44.50; ACR-175s \$89.; SX11 eleven tube Super-Skyriders with crystals \$79.50; \$7.50 model Mac-Keys for \$5.95. W9ARA, Butler, Mo.

RECONDITIONED sets shipped on ten day trial: NC100Xs \$99.; NC100s \$89.; PR-15s \$79.; ACR-175s \$89.; PR16Cs \$64.; Breting 12s \$59.; Breting 14s \$69.; Scott XV Deluxe \$59.; Super-Skyriders \$29.; PB7s \$19.; All Stars \$17.50; SW5s \$9.; other sets. List free. W9ARA.

SELL: Collins 4A transmitter complete ready to operate \$39. Also Collins 45A, 30FX, 32F. Write. W9ARA.

WHO said it can't be done? Fabradio is, after years of profitable manufacturing, still selling Y-cut 160 and 80 meter crystals at 75¢ each. Our dealers are making money, too. X-cut \$2.25. A-cut \$2.75. Catalog 37 is ready. Fabradio, Sandwich, Ill.

FOR sale: Mod. & speed amp. 57-56-46—pr. 46's. Class B pwr supply & mike. W8FBC.

RME products. W8ANT.

HALLICRAFTERS. W8ANT.

USED ACR136. W8ANT.

USED Comet-pro crystal. W8ANT.

USED RK20. W8ANT.

USED RK28. W8ANT.

USED Jackson oscilloscope. W8ANT.

AUTO transformers. W8ANT.

EIMAC tubes. W8ANT.

RELAY racks, cabinets, panels. W8ANT.

ALL lines of new and used amateur equipment bought, sold, exchanged. Write to Southern Ohio's only amateur owned amateur business. Jos. N. Davies, W8ANT, 2767 N. Bend Rd., Sta. A, Cincinnati, Ohio.

1000 watt transformers (G.E. on marble bases 1100-2200-4400 each side center. Hundreds sold hams last eleven years—guaranteed unconditionally. Dawson, 6740 Woodrow, Detroit, Mich.

RADIO COURSES

RADIO OPERATING: Prepare for Gov't. License Exam.
RADIO SERVICING: Including Short Wave • AMATEUR
CODE • ELECTRONICS • TELEVISION •

Day and Evening classes—Booklet upon request

NEW YORK YMCA SCHOOLS

4 West 63rd Street, New York City

—UNSOLICITED Reports on the TR-6A*

Duplex 5 Meter Transmitter-Receiver

"I would not hesitate to recommend them to any other National Guard unit."
— (sig.) H. T. B., Dorchester, Mass.

"We have heard W9CLH 160 miles away every night but one from R5 to R9. We also worked W5EHM Dallas and were heard by W2ICY New York."
— (sig.) W. J. P., Newaygo, Mich.

"I sincerely believe that I have never seen as fine a 5 meter portable mobile rig as your TR-6A-M."
— (sig.) R. P. B., Southborough, Mass.



Radio Transceiver Laboratories

8627-115th St.

Richmond Hill, N. Y.

124

Say You Saw It in QST — It Identifies You and Helps QST

DO YOU WANT TO LEARN WIRELESS and TELEGRAPHY?

TWO BOOKS EVERY AMATEUR
SHOULD HAVE —

Send Now!



**10¢
Each**
POSTPAID
COIN, OR
STAMPS

Hundreds of amateurs have learned from these books, so can you.

These books give you the fundamentals of wireless and telegraphy. They contain the codes and how to learn them. Mail your order now to:

SIGNAL ELECTRIC MFG. CO., Menominee, Michigan

ESTABLISHED
1892



LEARN RADIO

— TELEVISION —

New Beginners' Class Jan. 17th. Send for 48-page catalogue, explains fully, 500 licensed graduates placed in last six years in broadcasting, shipping, police radio, aviation, etc. Oldest, largest and best equipped school in N. E. We teach all branches of radio. Tel. HAN. 8184.

Ten operators placed with Pan-American Airways in one week.

Radio Service Instructions Given

MASS. RADIO SCHOOL

18 Boylston Street, Boston

YOUR POWER

Increase your power with this new voice transmissions type microphone. Model VT-73 is built for voice and emphasizes the frequencies which give intelligibility. You actually get more power and cut through QRM better with a VT-73. Here is a mike, stand, handle combination with anti-resonant cable and full R.F. shielding. High level means less amplification needed. Order now and enjoy broadcast quality reports. This and other Turner crystal microphones in stock.

\$14.85
NET

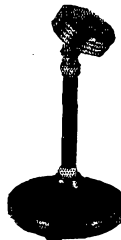

Turner VT-73

HENRY RADIO SHOP

211 North Main Street, Butler, Mo.

Licensed under patents of the Brush Development Co.

Your Nearest Dealer Is Your Best Friend

Your nearest dealer is entitled to your patronage. You can trust him. He is equipped with a knowledge and understanding of amateur radio. He is your logical and safe source of advice and counsel on what equipment you should buy. His stock is complete. He can supply your needs without delay. His prices are fair and consistent with the high quality of the goods he carries. He is responsible to you and interested in you.

Patronize the dealer nearest you—You can have confidence in him

ATLANTA, GEORGIA

Wholesale Radio Service Company, Inc.
265 Peachtree Street
"The World's Largest Radio Supply House"

BALTIMORE, MARYLAND

Radio Electric Service Co.
3 N. Howard St.
Everything for the amateur

BOSTON, MASS.

Wholesale Radio Service Company, Inc.
110 Federal Street
"The World's Largest Radio Supply House"

BRONX, NEW YORK

Wholesale Radio Service Company, Inc.
542 East Fordham Road
"The World's Largest Radio Supply House"

BUFFALO, NEW YORK

Radio Equipment Corp.
326 Elm Street
W80BK — Ham, service and sound equipment

BUFFALO, NEW YORK

Dymac Radio
216 E. Genesee Street
Complete Line Ham and BCL Equipment CI. 2080

ELMIRA, NEW YORK

Miller's Radio Shack
205 Railroad Avenue
Fine equipment for amateurs

JAMAICA, L. I.

Wholesale Radio Service Company, Inc.
90-08 166th Street (Merrick Road)
"The World's Largest Radio Supply House"

MONTREAL, CANADA

Canadian Elec. Supply Co., Ltd.
285 Craig St., W.
Quality parts and equipment for discriminating buyers

NEWARK, N. J.

Wholesale Radio Service Company, Inc.
219 Central Avenue
"The World's Largest Radio Supply House"

NEW YORK, N. Y.

Gross Radio, Inc.
51 Vesey Street
Fair dealings plus fair prices. Anything in radio

NEW YORK, N. Y.

Wholesale Radio Service Company, Inc.
100 Sixth Avenue
"The World's Largest Radio Supply House"

NEW YORK, N. Y.

Harrison Radio Company
12 West Broadway
"The Friendly Ham Supply House"

PHILADELPHIA, PENNSYLVANIA

Eugene G. Wile
10 S. Tenth Street

Complete Stock of Quality Merchandise

PROVIDENCE, RHODE ISLAND

W. H. Edwards Co.
32 Broadway
National, Taylor Tubes, Hallicrafters. Complete amateur supply house

RICHMOND, VIRGINIA

The Arnold Company
527 W. Broad Street
W3EHL—"The Virginia Ham Headquarters"—W3FBL

ROCHESTER, NEW YORK

Radio Parts & Equipment Co.
244 Clinton Avenue, North
Complete stock amateur-BCL parts. Standard discounts

You Are Protected When You Buy From QST Advertisers

“Advertising for QST is accepted only from firms who, in the publisher’s opinion, are of established integrity and whose products secure the approval of the technical staff of the American Radio Relay League.”

Quoted from QST’s advertising rate card.

Every conceivable need of a radio amateur can be supplied by the advertisers in QST. And you will know the product has the approval of the League’s technical staff.

The Advertisers

Aerovox Corporation	102
Allen-Bradley Company	91
Astatic Microphone Laboratory, Inc.	110
Atkins & Brown	110
Birnback Radio Company, Inc.	114
Billie Electric Company	72
Burgess Battery Company	75
Candler System Company	115
Capitol Radio Engineering Institute	117
Cardwell Mfg. Corp., Allen D.	74
Centralab	65
Chicago Radio Apparatus Company	115
Collins Radio Company	Cov. 2
Cornell-Dubilier Corporation	114
Delco-Remy Corporation	79
Dodge’s Institute	119
Eitel & McCullough, Inc.	77
Gordon Specialties Company	111
Gross Radio, Inc.	88
Hallcrafters, Inc., The	1, 2, 66, 67, 68, 69, 70, 71
Hammilund Manufacturing Co., Inc.	76, 81
Harvey Radio Company	116
Harvey Radio Laboratories, Inc.	119
Heintz & Kaufman, Ltd.	83
Henry Radio Shop	124
Hipower Crystal Company	115
Hygrade Sylvania Corporation	80
Hytronic Laboratories	85
Instructograph Company	117
International Resistance Company	127
Isolantite, Inc.	89
Jarnak, Paul	122
Jefferson Electric Company	78
Johnson Company, E. F.	117
Ken-Rad Tube & Lamp Corporation	115
Kenyon Transformer Company, Inc.	5
Logan Company, Les.	119
Mallory & Company, Inc., P. R.	64
Massachusetts Radio School	124
McGraw-Hill Book Company	80
Mims Radio Company	116
National Company, Inc.	Cov. 3, 63, 111, 113
New York Y. M. C. A. Schools	124
Newark Electric Company	93
Ohmite Manufacturing Company	97
Petersen Radio Company	111
Port Arthur College	111
Precision Apparatus Corporation	82
Precision Plezo Service	118
RCA Institutes, Inc.	118
RCA Manufacturing Company, Inc.	Cov. 4, 84, 122
Radio Digest	117
Radio Mfg. Engineers, Inc.	99
Radio Supply Company	113
Radio Transceiver Laboratories	124
Raytheon Production Corporation	92
Scientific Radio Service	119
Shure Brothers	118
Signal Electric Mfg. Company	124
Solar Mfg. Corporation	112
Speer Carbon Company	87
Standard Transformer Corporation	106
Sun Radio Company	112
Taylor Tubes, Inc.	95
Telex Company	112
Terminal Radio Corporation	113
Thordarson Electric Mfg. Company	73
Transmitter Equipment Mfg. Company	103
Triplett Electrical Instrument Co., The	100
United Electronics Company	96
United Transformer Corporation	128
Utah Radio Products Corporation	94
Vibroplex Company, The	117
Ward Leonard Electric Company	112
Western Electric Company	90
Yazley	64



A FEW DO'S AND DON'TS ON POWER WIRE WOUND RESISTORS

LAST MONTH we discussed the reasons why we make our IRC Cement Coated Wire Wound Resistors that way. This month it will be some hints on how to use them in a power supply. For a starter we can't think of a better subject than:

POWER RATING. The basis of our rating is the standards of the A.I.E.E. and N.E.M.A. These ratings correspond to the watts dissipation which will cause a temperature rise of 482 degrees Fahr. when the resistor is operated in "free air." By this we mean that the resistor under load will be 482 degrees hotter than the surrounding air when that air has plenty of room to circulate around the unit.

The "loss" in a resistor — the number of watts it must dissipate — can be calculated easily if you know its resistance and either the current through it or the voltage across it. Either square the current in amperes and multiply it by the resistance in ohms, or square the voltage and divide it by the resistance in ohms. In either case, the answer will be the number of watts the resistor must dissipate.

Now, in commercial equipment, it is considered good practice to use wire wound resistors at not more than 50 per cent of their rating to take care of the fact that air circulation is not so good, and other component parts such as transformers, etc. are also giving out heat. Since the *maximum temperature* is the limiting factor, you shouldn't take a "50 watt" resistor and put 50 watts into it if it is jammed in a small space above your hot rectifier tubes.

You have already guessed the answer — mount your heavy wattage bleeders

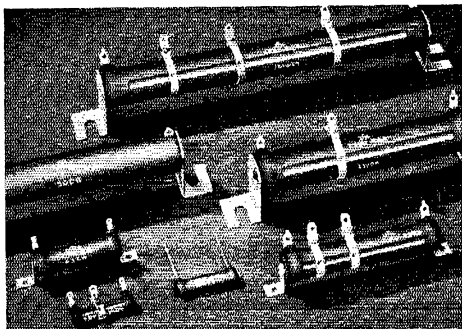

near the rear of your chassis where the air will circulate around them. We even know one chap who successfully put 600 watts into a "100 watt" resistor by sticking an old piece of hose in each end and running tap water through the hole in the tube! We don't recommend this as a general practice. That water is at ground potential, don't forget, and besides we would rather sell more resistors.

The best bet is to put some thought into the design of your power supply just as you do into the R.F. portion of your rig. It will save you money in the end.

A FEW MORE TIPS. Don't move the slider on an adjustable unit with the juice on. An arc is harsh treatment for fine resistance wire and 1000 volts or so is uncomfortable to the touch.

If you are using a wire wound for your grid resistor, don't forget that it has some inductance. Put a good choke on the grid side of it, and be darned sure it is not mounted in the R.F. field.

If you want a neat arrangement for metering the rig, try some small "AB Type" resistors of 10 to 20 ohms in the circuit shown on Page 206 in the new Handbook. It saves a lot of meters, jacks (and jack).

INTERNATIONAL RESISTANCE COMPANY

401 NORTH BROAD STREET, PHILADELPHIA, PA.

ADVERTISEMENT — Say You Saw It in *QST* — It Identifies You and Helps *QST*

Audio and Power equipment for medium and low power rigs

HANDSOME, STURDY CONSTRUCTION ★ GOOD REGULATION
★ PRICED FOR THE MODERATE POCKET-BOOK ★

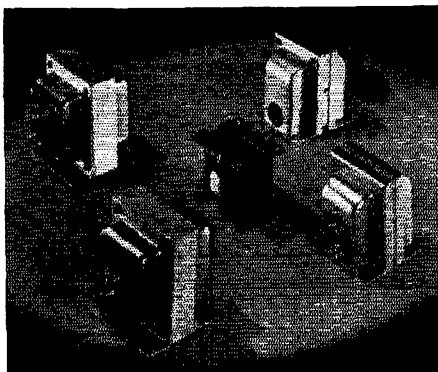

PLATE TRANSFORMERS

CS-200 450 each side of center at 150 MA.; 5V-3A; 2½ V-10A. CV mtg. Net to Amateurs.....	\$3.90
CS-201 500 each side of center at 200 MA.; 2½ V.C.T. 14 A; 5 V.C.T. 3 A; CD mtg. Net to Amateurs.....	\$4.80
CS-202 600 each side of center at 200 MA.; 2½V-10A; 7½V-3A; 5V-3A. CD mtg. Net to Amateurs.....	\$6.00
CS-203 800 each side of center at 150 MA.; 600 V. D.C. CD mtg. Net to Amateurs.....	\$4.50
CS-204 800 each side of center at 250 MA.; 650 V. D.C. CD mtg. Net to Amateurs.....	\$6.60

FILAMENT TRANSFORMERS

LM-1 2½ V.C.T. 20 A; 2500 V. insulation. OT mtg. Net to Amateurs.....	\$1.80
LM-2 7½ V.C.T. 6.5 A; 2500 V. insulation. OT mtg. Net to Amateurs.....	\$2.10
LM-3 10 V.C.T. 6½ A; 2500 V. insulation. OT mtg. Net to Amateurs.....	\$2.40
LM-4 6.3 V.C.T. 5 A; 5 V.C.T. 6 A; 2500 V. insulation. OT mtg. Net to Amateurs.....	\$2.40
LM-5 2½ V.C.T. 12 A; 5000 V. insulation. OT mtg. Net to Amateurs.....	\$2.10
LM-6 5 V.C.T. 3 A; 5 V.C.T. 3 A; 5 V.C.T., 6A; 2500 V. insulation. OT mtg. Net to Amateurs.....	\$2.40
LM-7 Three 7½ V.C.T. 2½ ampere windings; 2500 V. insulation. OT mtg. Net to Amateurs.....	\$2.40
LM-8 2½ V.C.T. 5 A; 2½ V.C.T. 5 A; 5 V.C.T. 3 A; 2500 V. insulation. OT mtg. Net to Amateurs.....	\$2.10
LM-9 2½ V.C.T. 5 A; 5 V.C.T. 3 A; 7½ V.C.T. 3 A; 2500 V. insulation. OT mtg. Net to Amateurs.....	\$2.40
LM-10 2½ V.C.T. 5 A; 7½ V.C.T. 3 A; 7½ V.C.T. 3A; 2500 V. insulation. OT mtg. Net to Amateurs.....	\$2.40
LM-11 5 V.C.T. 3 A; 7½ V.C.T. 3A; 7½ V.C.T. 3 A; 2500 V. insulation. OT mtg. Net to Amateurs.....	\$2.40
LM-12 2½ V.C.T. 5 A; 5 V.C.T. 3 A; 6.3 V.C.T. 3 A; 2500 V. insulation. OT mtg. Net to Amateurs.....	\$2.40
LM-13 6.3 V.C.T. 3A; 7.5 V.C.T. 4A; 5 V.C.T. 3A. 2500 V. insulation. OT mtg. Net to Amateurs.....	\$2.40
LM-14 6.3 V.C.T. 3A; 7.5 V.C.T. 6.5 A, 2500 V. insulation. OT mtg. Net to Amateurs.....	\$2.40

Gleaming chromium plate! Welded cases! Vacuum treated and humidity proof. Transformers fully clamped internally. All outputs with a variety of impedances! Trim professional units all physically symmetrical and with uniform mounting arrangements.

The new chromshield VARIMATCH modulation transformer incorporates a modified VARIMATCH coil structure making possible universal matching from all the popular modulator tubes to a 5,000 or 3,500 ohm if load. It will handle 20 watts of audio.

A PRIME AND CLASS B OUTPUT TRANSFORMERS

CS-R designed for class A, AB and B tubes like the 45, 50, 2A3, 42, 59, 46, 47, 2A5, 6F6, 6V6, 6B5, 6A0, 53, 79 and similar tubes to an r_L load of 5000 and 3500 ohms. C-4 case. Net to Amateurs **\$2.10**

CS-L will match same tubes as above but to a 500, 15, 8, 4 or 2 ohm line. C-4 case. Net to Amateurs..... **\$2.25**

CS-V will match same tubes as CS-R but to a 15, 8, 4 and 2 ohm line. C-4 case. Net to Amateurs..... **\$1.95**

A PRIME AND CLASS B INPUT TRANSFORMERS

CS-29 Driver plate to 53, 6A6, 49, 79 or 89 grids. C-4 mtg. Net to Amateurs..... **\$1.65**

CS-30 Driver 46 or 59 plate to 46 or 59 grids. C-4 mtg. Net to Amateurs..... **\$1.65**

CS-291 Single 2A3, 45, 42, 2A5, 6F6, 6D5 triode plate to push pull A prime 2A3, 45, 42, 2A5, 6F6, 6D5 grids. C-3 mtg. Net to Amateurs..... **\$2.25**

CS-292 Push pull 53 or 6A6 triode plates to two or four class B 53 or 6A6 grids. C-3 mtg. Net to Amateurs..... **\$1.95**

CS-293 Push pull triode 56, 37, 57, 77, 6C6, 6CS plates to two or four A prime 45, 2A3, 42, 2A5, 6F6, 6D5, 6L6 grids. C-3 mtg. Net to Amateurs..... **\$2.10**

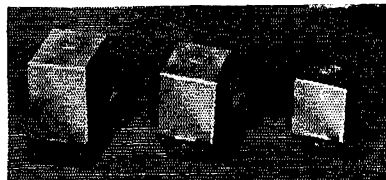

UNITED TRANSFORMER CORP.

72 SPRING STREET

NEW YORK, N. Y.

EXPORT DIVISION: 100 VARICK STREET NEW YORK, N. Y. CABLES: "ARLAB"

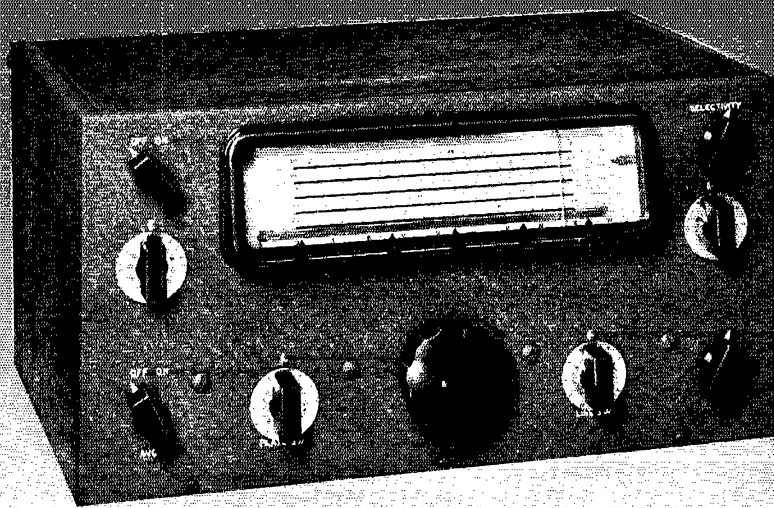

In these few short months the NC-80X and NC-81X receivers have become part of the National tradition. Their advanced circuit details, including the wide-range crystal filter and high IF frequency for image rejection, have brought a new standard of performance to the low priced field. Their thoroughbred construction keeps that performance consistently high. And their convenience makes operation swift, accurate, and tireless.

NATIONAL COMPANY, INC.

NATIONAL NC-81X

Effective February 15th the net price of the NC-80X and the NC-81X receivers complete with crystal, tubes, and speaker will be \$99

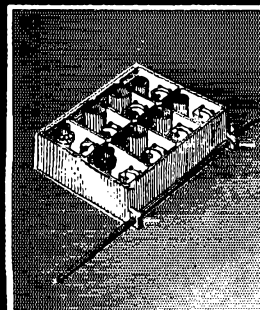

17 YEARS OF RCA PROGRESS

**Boosts Performance,
Cuts Cost of Transmitting Tubes**

Here's Proof!

RCA pioneered the development and sale of transmitting tubes in 1921. Since then, RCA has greatly increased performance capabilities of these tubes, thereby insuring greater sales, which have consistently lowered price levels!

★ 1921 ★

These transmitting tubes were developed and sold by RCA.

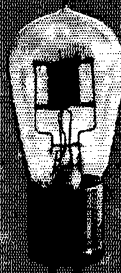

★ 1938 ★

These RCA transmitting tubes give better performance at lower cost.

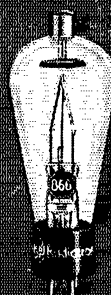
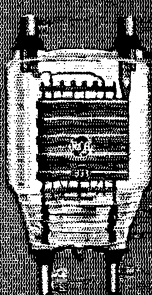

Radiotrons

RCA MANUFACTURING CO., INC. CAMDEN, N.J. U.S.A.

A Division of the Radio Corp. of America

FIRST IN METAL
FOREMOST IN GLASS
FINEST IN PERFORMANCE