

# QST

march, 1938  
25 cents

devoted entirely to

# amateur radio

*In this issue—*

**Simplified  
superhet**

**New Ideas  
in Exciter  
Design**

**More on  
television**

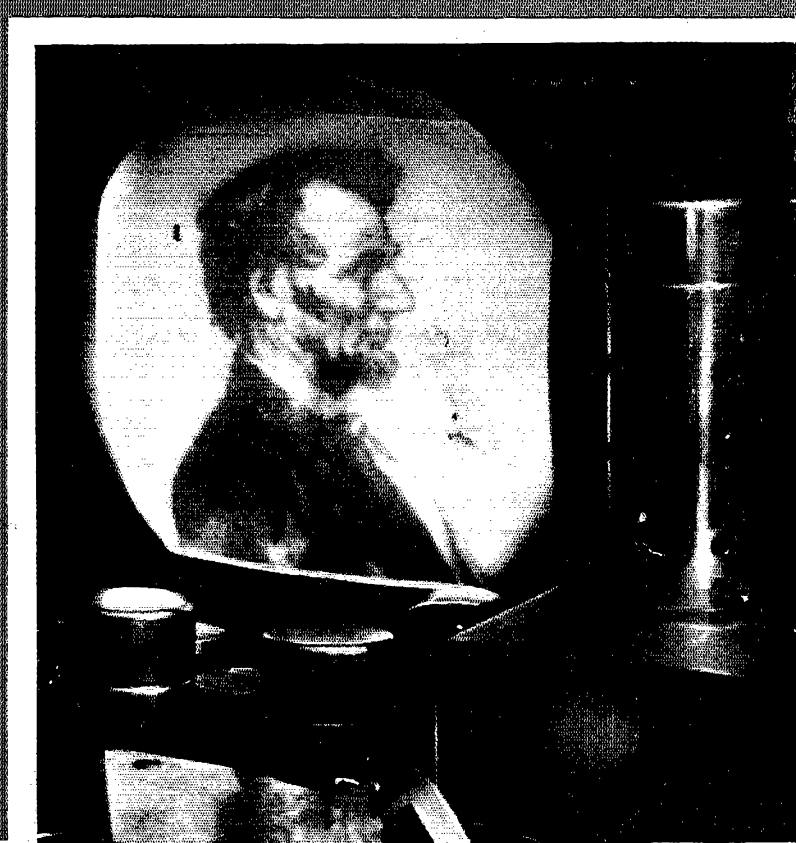

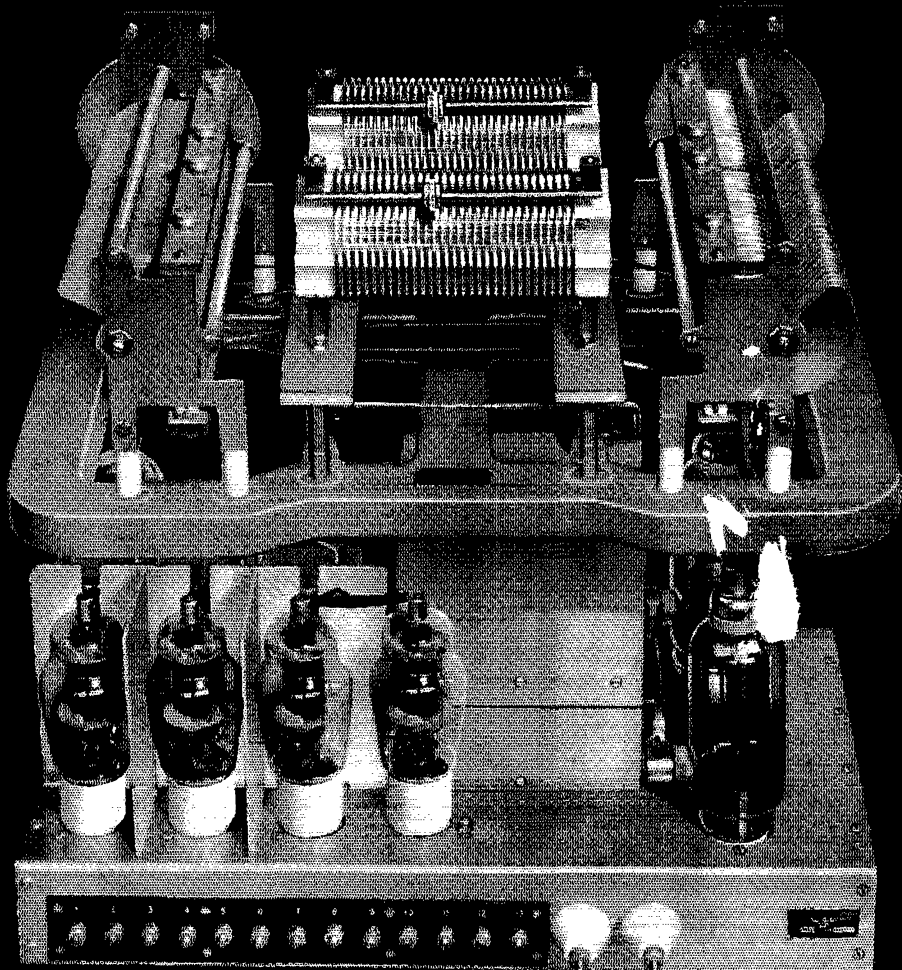

## A Hound's Tooth . . .

is not as clean as the design of the 30J r-f section. Every piece of metal and ceramic bespeaks simplicity and performance.

# COLLINS RADIO COMPANY

CEDAR RAPIDS, IOWA

NEW YORK, N. Y.: 11 WEST 42 STREET

# Infinite

## Image Rejection\*

### with the New SKY CHALLENGER II

**T**HE INFINITE IMAGE REJECTOR\* is just one of the features of the NEW SKY CHALLENGER II that makes it unique among communications receivers. Where ordinary amateur receivers are designed to reduce image ratio to the minimum level, the Hallicrafters have gone a step further, and provided the means to effectively eliminate image interference. Any amateur can appreciate the value of this new Hallicrafters circuit, especially when working the 10 and 20 meter bands. Combined with the 1,000° Spiral Band Spread, its razor-

sharp selectivity, and rigid, smooth-operating, mechanical superiority, this feature accounts for the instantaneous popularity and acceptance of the New Sky Challenger II by the amateur radio world. See it at your dealers or write for complete information.

*\* Patent applied for*

- ★ 9 Tubes
- ★ Infinite Image Rejector
- ★ 1000° Spiral Band Spread
- ★ 38 MC to 540 KC (7.9 to 545 Meters)
- ★ Extreme Selectivity
- ★ Recessed Main Tuning Dial
- ★ "S" Meter Terminals
- ★ Iron Core IF's

*All Hallicrafters Receivers available on Liberal Time Payments*



the hallicrafters inc.

2611 Indiana Ave., Chicago, U. S. A.  
Cable Address: "Hallicraft" Chicago

**"WORLD'S LARGEST BUILDERS OF AMATEUR COMMUNICATIONS RECEIVERS"**

Say You Saw It in QST — It Identifies You and Helps QST

# The DEALER'S CHOICE



## the SUPER SKYRIDER\*

▼ Ever since the announcement of the 1938 Super Skyrider, this receiver has had the enthusiastic support of the Hallicrafters dealers. During the short period that it has been available, our dealers have sold more Super Skyriders than any other Hallicrafters receiver and we believe more than any other communications receiver built. This has been extremely gratifying, for we appreciate the unique position of the dealers in amateur supplies and the invaluable service they are performing for amateur radio.

Most dealers are experienced amateurs themselves, and their advice and counsel on technical subjects and equipment is eagerly sought. They act as a clearing house for information on new developments and in general do everything in their power to further the cause of the radio amateur.

Because we value the amateur supply dealers' judgment so highly we are happy to receive their support of the 1938 Super Skyrider and accept it as the highest form of approval. Ask your dealer about the Super Skyrider and the Hallicrafters Time Payment Plan.

\* A short time ago we built, on special order, a limited number of 1938 Super Skyriders with 2 Stages of Pre-Selection and a built-in Noise Limiter. We have had a number of requests for similar receivers and are now prepared to supply them upon order. Ask your dealer about Model SX-17.

**ALL HALLICRAFTER RECEIVERS SOLD ON LIBERAL TIME PAYMENTS**

# the hallicrafters inc.

2611 Indiana Ave., Chicago, Ill., U.S.A. • Cable Address: HALLICRAFT, Chicago

**WORLD'S LARGEST BUILDER OF AMATEUR COMMUNICATIONS RECEIVERS**

# QST

devoted entirely to

# AMATEUR RADIO

PUBLISHED, MONTHLY, AS ITS OFFICIAL ORGAN, BY THE AMERICAN RADIO RELAY LEAGUE, INC., AT WEST HARTFORD, CONN., U. S. A.; OFFICIAL ORGAN OF THE INTERNATIONAL AMATEUR RADIO UNION

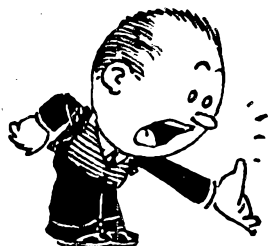

## MARCH

## 1938

### Volume XXII

### Number 3



Kenneth B. Warner, General Manager of A.R.R.L. Publications; Ross A. Hull, Editor; James J. Lamb, Technical Editor; George Grammer, Assistant Technical Editor; Clark C. Rodimon, Managing Editor; David H. Houghton, Circulation Manager; Ralph T. Beaudin, Assistant Circulation Manager; F. Cheyney Beekley, Advertising Manager; Charles Brunelle, Assistant Advertising Manager.

Editorial and Advertising Offices

38 La Salle Road  
West Hartford, Connecticut

Subscription rate in United States and Possessions and Canada, \$2.50 per year, postpaid; all other countries, \$3.00 per year, postpaid. Single copies, 25 cents. Foreign remittances should be by international postal or express money order or bank draft negotiable in the U. S. and for an equivalent amount in U. S. funds.

Entered as second-class matter May 29, 1919, at the post office at Hartford, Connecticut, under the Act of March 3, 1879. Acceptance for mailing at special rate of postage provided for in section 1103, Act of October 3, 1917, authorized September 9, 1922. Additional entry at Concord, N. H., authorized February 21, 1929, under the Act of February 28, 1925.

Additional second-class entries to cover sectional editions authorized March 20, 1935. Copyright 1938 by the American Radio Relay League, Inc. Title registered at United States Patent Office.

## The Contents

Editorial . . . . .	9
Canada-U.S.A. Contest . . . . .	10
CQ WCFT . . . . . Alan R. Eurich, WCFT, W8IGQ	11
A Feed-Back Compensator for R.F. Circuits H. O. Talen, W9PYQ	14
Double-Regenerative Superhet . Byron Goodman, W1JPE	15
What the League Is Doing . . . . .	19
The Infinite Rejection Principle Applied to Image Attenuation . . Karl W. Miles and J. L. A. McLaughlin	20
New Approach to Amateur Transmitter Design James Millen, W1HRX	24
Compact Construction with High Power T. M. Ferrill, Jr., W5CJB-1	27
A Home-Built Velocity Microphone Norman E. Gibbs, W1JXP	32
Army-Amateur Radio System Activities . . . . .	34
Speech Versus Sine Waves . . Earl I. Anderson, W8UD	35
A Universal Test Unit for Study of Television Images Marshall P. Wilder, W2KJL	37
A Pack Set for 200 and 300 Mc. . L. C. Sigmon, W9YNJ	40
Amateur Radio Stations . . . . . W9AXH	43
A Continuously-Rotatable 28-Mc. Beam A. F. Neuenhaus, W2BSF and M. E. Schreiner, W2AJF	45
A Solution to the Tank Circuit L-C Ratio Problem Frank Lester, W2AMJ	47
Silent Keys . . . . .	48
R.F. Interference from Power Circuits Robert Y. Chapman, W1QV	49
How Would You Do It? . . . . .	50
Hamdom . . . . .	51
Hints and Kinks . . . . .	52
I.A.R.U. News . . . . .	55
Operating News . . . . .	57
Correspondence Department . . . . .	65
A.R.R.L. QSL Bureau . . . . .	98
Standard Frequency Transmissions . . . . .	102
Hamads . . . . .	123
QST's Index of Advertisers . . . . .	126



# TWO NEW WONDER TUBES

## TZ-40

A high Mu zero bias Triode offering wide possibilities in Class B Audio operation and as a high power doubler and buffer.

175 watts of Class B Audio output with 3 watts drive! As an exciter it will drive efficiently an amplifier stage to 700-800 watts input. Complete technical bulletin for the asking — at your Distributor or write us.

## TZ-40

### GENERAL CHARACTERISTICS

Filament .....	7.5 volts
Filament current .....	2.5 amps.
Amp. factor .....	.62
Plate to Grid cap.....	4.5 MMF

### CLASS B AUDIO OPERATION (Values for 2 tubes)

Plate Volts .....	1000
Bias .....	0
Peak A.F. Grid to Grid voltage.....	220
Zero signal DC plate current.....	44 MA
Max. Sig. plate current.....	280 MA
Plate to plate load.....	6800 ohms
Av. Driving Power .....	3 watts
Power output .....	175 watts

### CLASS C OPERATION

Plate volts .....	1000
Plate current .....	115 MA
Grid volts .....	-45
Grid current, Max. ....	35 MA
Driving power, Max. ....	10 watts

### OVERALL DIMENSIONS

Max. length .....	6½
Max. diam. ....	2

**Taylor Tubes, Inc.**

**MORE WATTS PER DOLLAR**  
Manufacturers of Vacuum Tubes  
2341-43 WABANSIA AVE., CHICAGO, ILL.  
TELEPHONE, ARMITAGE 1720-1

To the Amateur:

I honestly believe that the T-40 and the TZ-40 represent the best values ever offered to an amateur.

When you use these tubes you will get a new conception of quality, stamina, dependability and performance.

We are proud to be able to offer you these wonder tubes.

Yours for MORE WATTS PER DOLLAR.

*Frank J. Hajek*  
FRANK J. HAJEK - W9ECA  
SECRETARY & TREASURER

*Comparison Sells Taylor Tubes*

**Taylor** HEAVY **CUSTOM BUILT** DUTY **Tubes**

Say You Saw It in QST — It Identifies You and Helps QST

# TAYLOR CHAMPS

## T-40 TZ-40

A pair of WONDER TUBES—setting an entirely new standard of value. Experienced Radio Distributors, Tube Builders and Engineers, marvel at Taylor's aggressiveness and ability to continually produce better transmitting tubes at "More Watts Per Dollar" values. You, the amateurs of the world will wonder at the more efficient results of these truly amazing WONDER TUBES. Read the characteristics and remember that the rugged carbon anodes used in these and other Taylor tubes operate at red heat without injury to filament emission. The T-40 and TZ-40 operate efficiently in all transmission services on all amateur frequencies. These new WONDER TUBES are destined to be the outstanding sales champs of 1938. See them before you buy—comparison sells Taylor Tubes.

### T-40

A general purpose Triode with characteristics that make possible super-efficient performance in all Class C services on all Amateur Frequencies. Extremely easy to drive—the ratings given here are maximum requirements for high level modulated amplifiers. For CW or buffer operation the drive required is 50% less. Ask your distributor or write us for complete technical bulletins.

### T-40

#### GENERAL CHARACTERISTICS

Filament ..... 7.5 volts  
 Filament current ..... 2.5 amps.  
 Amp. factor ..... 25  
 Plate to Grid cap. .... 4.5 MMF

#### CLASS C OPERATION (1.7 MC. to 60 MC.)

Plate volts ..... 1000  
 Plate current ..... 115 MA  
 Grid volts ..... -80  
 Grid current, Max. .... 35 MA  
 Driving power, Max. .... 10 watts

**\$3.50**

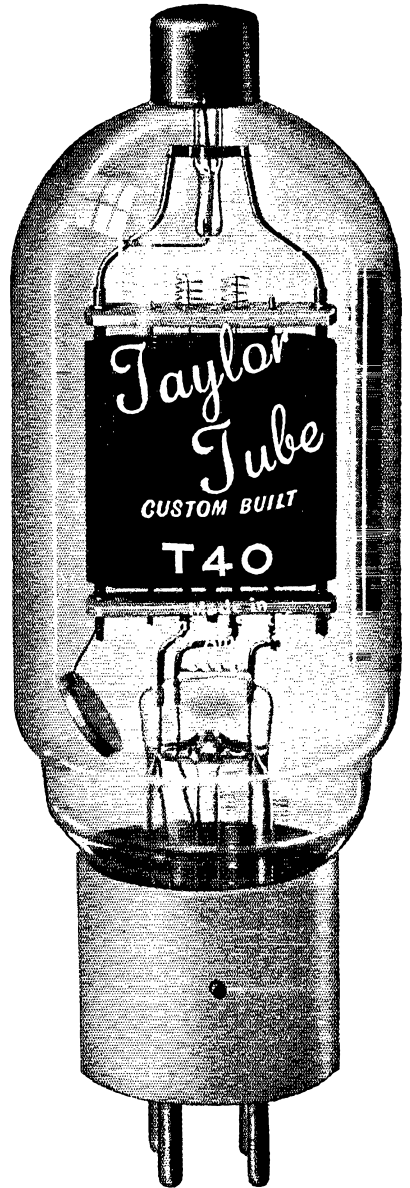

Actual Size

*Recommended by Leading Parts Distributors*

*"More Watts Per Dollar"*

**TAYLOR TUBES, INC., 2341 WABANSIA AVE., CHICAGO, ILLINOIS**

## Section Communications Managers of the A.R.R.L. Communications Department

All appointments in the League's field organization are made by the proper S.C.M., elected by members in each Section list. Mail your S.C.M. (on the 16th of each month) a postal covering your radio activities for the previous 30 days. Tell him your DX plans for experimenting, results in 'phone and traffic. He is interested, whether you are an A.R.R.L. member or get your QST at the newsstands; he wants a report from every active ham. If interested and qualified for O.R.S., O.P.S. or other appointments he can tell you about them, too.

Eastern Pennsylvania Maryland-Delaware-District of Columbia Southern New Jersey Western New York Western Pennsylvania	W3QP W3BAK W3BEI W8CSE W8OFO	<b>ATLANTIC DIVISION</b> John Buck Morgan Edgar L. Hudson W. W. Wilson Ed Preston Kendall Speer, Jr.	8527 Germantown Ave. R. 4, Box 1 247 E. Atlantic Ave. 10 Lincoln Ave.	Chestnut Hill, Philadelphia Laurel, Delaware Audubon Tully Lowber
Illinois Indiana Kentucky * Michigan Ohio Wisconsin	W9KJY W9QG W9XRU W8DPE W8AQ W9UIT	<b>CENTRAL DIVISION</b> L. John Huntoon Noble Burchart Darrell A. Downard Harold C. Bird E. H. Gibbs Aldrich C. Krones	327 Brandon Ave. R. 4, Box 1 116 N. Longworth Ave. R. F. D. 2 405 Broad St. 3288 S. Illinois Ave.	Glen Ellyn Indianapolis Louisville Pontiac Wadsworth Milwaukee
North Dakota South Dakota Northern Minnesota Southern Minnesota	W9R7A W9SEB W9IGZ W9DCM	<b>DAKOTA DIVISION</b> Ernest Bloch Andrew J. Kiar Edwin L. Wicklund Webster F. Soules	Box 202 221 West Prospect Ave. R.F.D. 3 3549 36th Ave., So.	Thompson Pierre Kenington Minneapolis
Arkansas Louisiana Mississippi * Tennessee	W5ABI W5DKR W5GHF W4DEP	<b>DELTA DIVISION</b> H. E. Velte Eugene H. Treadaway Robert E. Barr, B. G. Lowrey Smith	4415 West 12th St. 2749 Myrtle St. 673 Hillcrest St.	Little Rock New Orleans Lucaedale Memphis
Eastern New York N. Y. C. & Long Island Northern New Jersey	W2LU W2AZV W2GMM	<b>HUDSON DIVISION</b> Robert E. Haight E. L. Baunach Fred C. Read	511 South Holmes St. 102 Central Ave. 1014 North Ave.	Scotia Massapequa, L. I. Elizabeth
Iowa * Kansas Missouri Nebraska	W9LEZ W9FB W9OUD W9FAM	<b>MIDWEST DIVISION</b> Phil D. Boardman Harry E. Lexter Miss Letha Allendorf Samuel C. Wallace	325 Kirkwood Blvd. 304 Miami St. 1015 W. 3rd St. Green St.	Davenport Hiawatha Joplin Clarks
Connecticut Maine Eastern Massachusetts Western Massachusetts New Hampshire Rhode Island Vermont	W1CTI W1FBI W1IWC W1JAH W1BFT W1HRC W1GNF	<b>NEW ENGLAND DIVISION</b> Frederick Ellis, Jr. Winfield A. Ramsdell Sam Gross William J. Barrett Carl B. Evans Clayton C. Gordon Alvin H. Battison	19 Merrill Rd. 1183 Washington Ave. Pleasant St. 239 Columbia St. 80 No. State St. 192 Washington Ave. 1 Central St.	Norwalk Portland Marshfield Hills Adams Concord Providence Windsor
Alaska Idaho Montana * Oregon Washington	K7ENA W7EMT W7CRE W7ATV W7WY	<b>NORTHWESTERN DIVISION</b> Leo E. Osterman Carl Eichelberger Dick Beasley Eugene E. Lovejoy Robert H. Votaw	Customhouse 2810 North 26th St. 446 Edith St. 5013 N. E. Clackamas Route 1, Box 398	Wrangell Boise Missoula Portland Vancouver
Hawaii * Nevada Santa Clara Valley East Bay San Francisco Sacramento Valley Philippines San Joaquin Valley	K6OOE W6HC W6FBW W6ITV W6SG W6GZY KA1GR W6LPE	<b>PACIFIC DIVISION</b> Harold C. Smith Edward W. Heim Robert Amarantes Harold J. Baulreind Alan D. Whittaker, Jr. J. L. C. Buckenham George L. Rickard Angelo V. Astone	P. O. Box 150 509 Claremont St. 454 Washington St. 2240 106th Ave. 79 Elinor Ave. 2931-24th St. Box 849 729 Safford	Honolulu Reno San Jose Oakland Mill Valley Sacramento Manila Fresno
North Carolina South Carolina Virginia West Virginia	W40G W4BQE W3UVA W8HFA	<b>ROANOKE DIVISION</b> H. S. Carter Ted Ferguson Charles M. Waff, Jr. C. S. Hoffmann, Jr.	P. O. Box 111 1213 College St. 2914 Monument Ave. 47 1ynwood Ave.	Winston-Salem Columbia Richmond Wheeler
Colorado Utah-Wyoming	W9FA W7COH	<b>ROCKY MOUNTAIN DIVISION</b> Glen Glasscock Townsend J. Rigby	2164 So. Corona St.	Denver Midwest, Wyoming
Alabama Eastern Florida Western Florida Georgia-Cuba-Isle-of-Pines- Porto Rico-Virgin Islands	W4DGS W4DVO W4BSJ *W4PM	<b>SOUTHEASTERN DIVISION</b> James F. Thompson L. A. Connolly Ellis R. Curry Charles W. Davis	102 Narrow Lane Rd. 719 So. Willow Ave. Box 425 2136 N. E. Boulevard Dr.	Montgomery Tampa Madison Atlanta, Ga.
Los Angeles Arizona San Diego	W6GXM W6KFC W6JRM	<b>SOUTHWESTERN DIVISION</b> Don M. Draper Victor C. Clark Howard K. Breedlove	4421 West 63 St. 747 E. Polk St. R. 2, Box 636	Los Angeles Phoenix San Diego
Northern Texas Oklahoma Southern Texas New Mexico	W5DXA W5CEZ W5BHO W5CGJ	<b>WEST GULF DIVISION</b> Lee Hughes Carter I. Simpson Dave H. Calk Joseph M. Eldott	125 N. Main St. 2010 So. 4th St. 6726 Ave. Q	Childress Ponca City Houston Chamita
Maritime	VE1DQ	<b>MARITIME DIVISION</b> A. M. Crowell	69 Dublin St.	Halifax, N. S.
Ontario	VE3SG	<b>ONTARIO DIVISION</b> Fred H. B. Saxon	302 Lee Ave.	Toronto, Ont.
Quebec	VE2EE	<b>QUEBEC DIVISION</b> Stan Comach	780 Brault Ave.	Verdun, P. Q.
Alberta British Columbia	VE4GE VE5HP	<b>VANALTA DIVISION</b> C. S. Jamieson James Hepburn	581 W. Riverside Drive 335 Foul Bay Road	Drumheller, Alta. Victoria
Manitoba Saskatchewan	VE4BG VE4EL	<b>PRAIRIE DIVISION</b> A. J. R. Simpson Wilfred Skaife	635 Garfield St. 2040 McTavish St.	Winnipeg Regina

\* Officials appointed to act until the membership of the Section choose permanent S.C.M.'s by nomination and election.



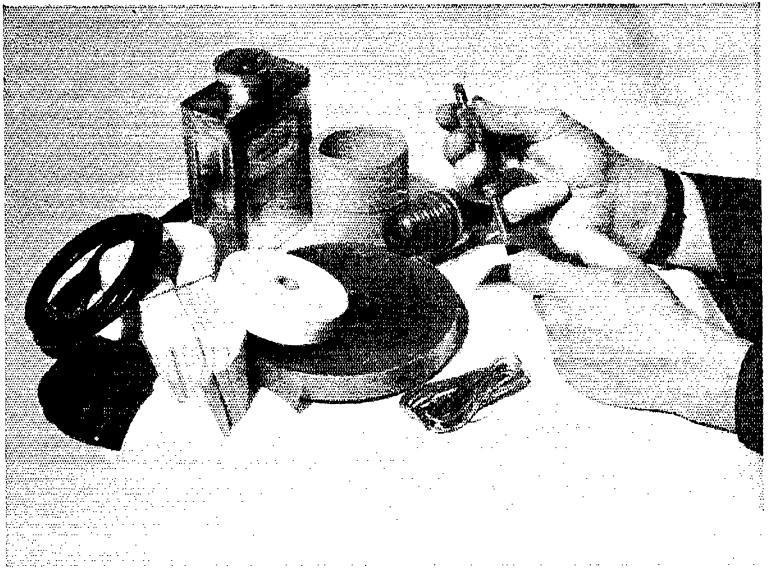

## Kandid Ken-O-Talk, No. 4

### • MATERIAL (a) •

LET us consider the material that enters into the building of good transformers and associated products. We will first consider insulation of the various kinds, such as paper, cloth, varnish, compound and bushings, as well as solder which has an important bearing on their effectiveness.

*Paper*, the first to be considered, must not be confused with ordinary paper, but must be of special electrical grade, free from all metallic specks and acid or alkaline reaction. When a new supply is received, all this type of material is tested in a commercial laboratory to be sure that it has a neutral reaction.

*Varnish* beside being neutral must be able to withstand heat, and its solvent must not attack the enamel on the wire or oxidize at any of the soldered joints. In fact the varnish must penetrate to all points and deposit a film over paper and all insulating material so as to keep moisture out after the impregnating process as well as to insulate the coil electrically.

*Compound* must have all of the preceding characteristics and in addition must be so made that it will not oxidize under the presence of ozone, or in itself absorb moisture. Furthermore this compound must be of such a type that the heat developed by the transformer will be equally transferred to all parts of the metal container. If this were not so the outside of the container would be cool and the coil very hot and would burn out from lack of heat transfer.

*Bushings* offer a wide choice, from the low voltage type, made of composition, to the Ceramics of the dry process type and glazed, to the better grade of the wet process type of which some are glazed and some plain. This latter type for high voltage and non-moisture absorbing qualities are the best.

*Solder* is another factor in the ability of a transformer to stand up. In no case should acid soldering paste, compounds or acid core solder be used on electrical joints inside or outside. Only the best grade of rosin core solder should be used.

Furthermore, the operator's hands or fingers should not come in contact with any soldered joints for the acid present on the skin is often enough to start corrosion. Gummed stickers should never be moistened in the mouth for saliva very often contains sufficient acid to do irreparable damage to the coil.

In the above discussion the major precautions necessary to protect transformers from their natural enemies, acid and moisture, are pointed out.

*F. P. Kenyon*

# The American Radio Relay League



• **T**HE AMERICAN RADIO RELAY LEAGUE, INC., is a non-commercial association of radio amateurs, bonded for the promotion of interest in amateur radio communication and experimentation, for the relaying of messages by radio, for the advancement of the radio art and of the public welfare, for the representation of the radio amateur in legislative matters, and for the maintenance of fraternalism and a high standard of conduct.

It is an incorporated association without capital stock, chartered under the laws of Connecticut. Its affairs are governed by a Board of Directors, elected every two years by the general membership. The officers are elected or appointed by the Directors. The League is non-commercial and no one commercially engaged in the manufacture, sale or rental of radio apparatus is eligible to membership on its board.

"Of, by and for the amateur," it numbers within its ranks practically every worth-while amateur in the nation and has a history of glorious achievement as the standard-bearer in amateur affairs.

Inquiries regarding membership are solicited. A bona fide interest in amateur radio is the only essential qualification; ownership of a transmitting station and knowledge of the code are not prerequisite. Correspondence should be addressed to the Secretary.

HIRAM PERCY MAXIM, FIRST PRESIDENT

## OFFICERS

*President*.....EUGENE C. WOODRUFF, W8CMP  
State College, Pa.

*Vice-President*.....GEORGE W. BAILEY, W1KH  
Weston, Mass.

*Secretary*.....KENNETH B. WARNER, W1EH  
West Hartford, Connecticut

*Treasurer*.....ARTHUR A. HEBERT, W1ES  
West Hartford, Connecticut

*Communications Mgr.*...F. EDWARD HANDY, W1BDI  
West Hartford, Connecticut

*General Counsel*.....PAUL M. SEGAL  
1026 Woodward Building, Washington, D. C.

Address all general correspondence to the administrative headquarters at West Hartford, Connecticut

## DIRECTORS

*President*  
EUGENE C. WOODRUFF.....W8CMP  
234 W. Fairmount Ave., State College, Pa.

*Vice-President*  
GEORGE W. BAILEY.....W1KH  
74 Webster Road, Weston, Mass.

*Canadian General Manager*  
ALEX REID.....VE2BE  
169 Logan Ave., St. Lambert, P. Q.

*Atlantic Division*  
WALTER BRADLEY MARTIN.....W3QV  
Box 612, Roslyn, Pa.

*Central Division*  
R. H. G. MATHEWS.....W9ZN  
100 East Ohio St., Chicago

*Dakota Division*  
FRED W. YOUNG.....W9MZN  
228½ Willard St., Mankato, Minn.

*Delta Division*  
E. RAY ARLEDGE.....W5SI  
P. O. Box 286, Pine Bluff, Ark.

*Hudson Division*  
KENNETH T. HILL.....W2AHC  
115 Willow St., Douglaston, L. I., N. Y.

*Midwest Division*  
FLOYD E. NORWINE, JR.....W9EFC  
120 South Fourth St., St. Louis, Mo.

*New England Division*  
PERCY C. NOBLE.....W1BVR  
37 Broad St., Westfield, Mass.

*Northwestern Division*  
RALPH J. GIBBONS.....W7KV  
c/o United Air Lines, Pendleton, Ore.

*Pacific Division*  
J. L. McCARGAR.....W6EY  
66 Hamilton Pl., Oakland, Calif.

*Roanoke Division*  
H. L. CAVENESS.....W4DW  
State College Station, Raleigh, N. C.

*Rocky Mountain Division*  
EDWARD C. STOCKMAN.....W9ESA  
618 So. Williams St., Denver

*Southeastern Division*  
BENNETT R. ADAMS, JR.....W4APU  
1512 Grove Place, Homewood, Ala.

*Southwestern Division*  
CHARLES E. BLALACK.....W6GG  
443 Main St., El Centro, Calif.

*West Gulf Division*  
WAYLAND M. GROVES.....WSNW  
c/o Humble Pipe Line, Talco, Texas

# "It Seems to Us — —"

THE critical season when most communications emergencies occur is again upon us. Floods, hurricanes, sleet storms—the threat of broken wires and consequent intelligence gaps in the last months of winter imposes heavy responsibility on amateur radio.

Amateurs have provided emergency communications at such times for nearly two decades. Until recent years, theirs have been largely performances of individual heroism—deeds of valor performed single-handed or by comparatively small groups. It is only in the past two or three years that the concept of amateur radio, as an entity, taking over the bulk of emergency communications activities whenever existing services are overloaded or disrupted, has achieved form. Now that concept is coming to be accepted, not only among amateurs but by other radio services and government and relief agencies as well.

It should perhaps be stated, parenthetically, that in speaking thus of "amateur radio" we are using the broadest definition. Amateurs have many affiliations; much "amateur" emergency activity is nominally directed by such authorities as the Signal Corps, Naval Reserve, National Guard, even the Coast Guard and Army Engineers, as well as municipal and semi-private agencies. But in a realistic sense these groups are all affiliates of amateur radio; they are dependent upon amateurs for operating personnel; and to a major extent they utilize amateur frequencies and operate under amateur status. Their sole connecting link is amateur radio. The amateur is the yeast that leavens the whole batch of bread; without him the individual groups could not exist.

The keynote of all our emergency communications system is, therefore, the amateur. The responsibility is likewise his. This responsibility makes imperative the exercise of forethought and preparedness. Occasionally one hears optimistic assertions on the part of private or governmental agencies that professional emergency communications corps are being or will be organized, to avoid the haphazardness of amateur methods. A little simple arithmetic will show the impracticability of any such ambitious plan; the facilities simply aren't available. To establish a system of minimal utility several thousand units would be required. More or less regular drills would be essential to provide the consistent practice essential for proficiency. The cost would be staggering.

Apart from that, the wastage in radio channels would be prohibitive.

But the fact that such plans are even broached indicates a lack in the amateur system, however. Further evidence of such a lack is the implied desire on the part of certain agencies following the Ohio River flood last year to take over the administration of amateur facilities in future emergencies.

And there lies the key to the lack. It is one of administration—*organization*. Our facilities have been more than adequate; we have thousands of skilled operators, we have permanent stations located in nearly every community, and we have many hundreds of units of portable self-powered equipment developed in recent years as a result of A.R.R.L.'s Emergency Corps and Field Day campaigns. Beyond that, we have amateur and amateur-affiliated networks covering the entire country.

All that has been lacking has been centralized organization—*coördination*. In past emergencies such centralized, coördinated control has evolved spontaneously in some regions; in others, inefficiency, duplication of effort, and confusion and delay have prevailed. In the future we cannot depend on accident. We must have efficiency and reliability and complete coverage from the very start. We must prepare adequately, not only with personnel and equipment, but with organization.

For the past seven months A.R.R.L. has been working on this problem. For the most part it has been a process of working out details in the broad general plan, expanding the program of the A.E.C. of the past several years, providing a skeleton framework of organization to serve as a rallying point for mobilization in time of emergency need. Recommendations to the F.C.C. to aid the amateur service in its organized capacity to serve the public were made by the Board last May. About December 15th the nucleus of the plan—the appointment of Emergency Coördinators in all communities of sufficient size—was gotten under way; by the end of January some fifty coördinators had already been appointed.

The details of this plan have already been circulated through Communications Department bulletins, and will be the subject of a detailed article in the next issue of *QST*. Every amateur should examine this article with care, for it is of great importance to the future of amateur radio.

—C.B.D.

# Canada—U. S. A. Contact Contest

April 14th, 15th, 16th, 17th and 18th

**W**HAT a glorious weekend of operating that will be, 102 hours for renewing old friendships. Records of previous years should be topped this year. Last year VE3GT won a lovely trophy fourteen inches tall, which was donated by Canadian Marconi Co. This year, The Canadian General Electric Co. is donating a cup to go to the highest scoring Canadian station. Other Canadian manufacturers are donating prizes in equipment to go to the next three or four highest stations. Canadian General Manager Alex Reid, VE2BE, has heartily endorsed this year's contest, which is being sponsored by the Section Communications Manager of Ontario, Fred H. B. Saxon, VE3SG. Logs should be mailed to him at 302 Lee Ave., Toronto, Ontario, not later than midnight April 30, 1938.

## THE CONTEST RULES

Dates: Starts—Thursday, April 14th, 6 P.M. local time. Ends—Monday, April 18th, midnight, local time.

Duration: 102 hours.

Frequency: Any or all amateur bands may be used.

Object: Each VE will work as many W stations as possible in as many United States A.R.R.L. sections (see list page 6, QST) as possible. Each W will work as many VE stations in as many VE sections as possible.

Scoring: The same log form as used for last year's contest will be used. Message preambles will be exchanged. Each preamble sent will count one point and each one received will count one point. It is not necessary for preambles to be exchanged BOTH ways before a contact may count, but one must be sent or received before credit is claimed. All preambles must be handled under approved A.R.R.L. procedure. Mark each new section as it is worked. The "check" portion of the preamble will be the RST report of the station worked. Sample preamble: NR 1 VE3GT CK 579 Toronto, Ont. 6.02P Apr. 14. W Stations multiply number of points by the number of VE sections worked and multiply the final score by nine, there being nine times as many U.S.A. sections. VE stations multiply the number of points by the number of U.S.A. A.R.R.L. sections worked.

## POWER AND OPERATOR HANDICAP

Each station having less than 100 watts input to the final stage shall multiply the score by  $1\frac{1}{2}$ .

Where more than one operator normally operates a station the total score of the station shall be accepted, providing a certificate is attached to the log giving the names and call signs of the operators making the score.

## PRIZES

A.R.R.L. Certificates of Merit will be awarded to the leader in each of the 70 A.R.R.L. sections in the U.S.A. (and possessions) and Canada. Suitable prizes for a limited number of Canadian leaders will be available. The Canadian General Electric Co. are donating the main prize this year, a cup, which will be known as The C. G. E. Trophy. The sponsor will not be in the running for a prize, but will be on the air to give points to aid W stations in obtaining a higher score.

## OPERATOR'S CERTIFICATE

The following certificate is requested on each log submitted:

"I hereby state that in this contest I have not operated my transmitter outside any of the frequency bands specified on my station license, and also that the score and points set forth in the above summary are correct and true."

— . . . —

In checking the logs of last year's contest it was noticed that every A.R.R.L. section had active participants, yet there were six sections from which no logs were received. This year the sponsor would like to be able to issue certificates of merit to each of the 70 sections. W6ITH led the U. S. contingent last year with 101 contacts, 93 of which were made on 'phone, all seven Canadian sections being worked. This was splendid work, but, never being satisfied, we are looking forward to some one bettering it this year.



# CQ WCFT\*

## Further Adventures Aboard the "Yankee"

By Alan R. Eurich,\*\* WCFT-W8IGQ

**B**ACK in 1936, just before spring started thinning the ranks of the brethren, while slaving away trying to absorb a little book knowledge I read an article written by Captain Irving Johnson recounting some of the experiences he had had with a crew of young fellows on his schooner circumnavigating the globe two years before. The idea of his cruise had been to take boys, mostly of college age, on what amounted to a "share-the-cost" basis, and sail around the world. These fellows also served as the crew.

Having a bit more than the usual touch of adventurous spirit in his blood, Irving Johnson took his ship into many of the out of the way places seldom visited in recent years. Among other things he did on that first cruise was to discover five new islands in the Pacific and chart them, to weather an Indian Ocean cyclone, and to discover a major waterfall in British Guiana over five-and-a-half times as high as Niagara. However, from my point of view, one serious error had been made—they carried no radio. In fact, several times during the cruise folks at home began to worry over them when the *Yankee* was unable to follow the schedule that had been laid out before leaving America.

Captain Johnson's closing words were: "I hope to leave Gloucester (Mass.) again with another group of boys November 1st, 1936, for a similar cruise." I inquired for further details. The idea sounded good to me as I had become rather fed up with classes and the like.

After due preliminary negotiations, during which I looked over the boat and was looked over, I finally signed on for the coming world cruise. As a ship the *Yankee* was a 92-foot, two masted schooner, built some forty years ago by the Dutch Government for pilot service on the North Sea. The old pilot service orders were to stay out until no other vessel could. By that time the pilot ship

could not risk coming in close to shore, so she was literally built for all kinds of weather. In those days she had no power and had to rely on her sailing ability alone. To-day she is as sound as the day she was commissioned though time has seen a few minor changes. Below, she has been refitted to make living conditions more comfortable on long cruises in the tropics. A 35-h.p. semi-Diesel motor makes for easier maneuvering at docks and through narrow passes. Another addition to the ship's original gear is the radio antenna, which runs from the lead-in bowl in the deck near the base of the mainmast to the main spreader. The antenna is a vertical 55-foot Marconi.

I had been told before signing that if I finally went on the trip, the "Skipper," as I soon came to call Captain Johnson, would see that there was radio equipment on board. Some personal friends of his had been trying to sell him the idea that

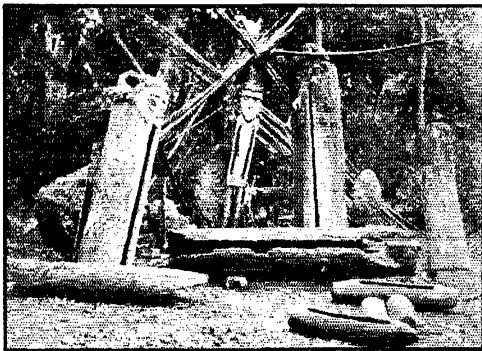

Photos by Edmund Zacher

### NATIVE DRUMS KEPT THE CREW AWAKE ONE NIGHT IN THE NEW HEBRIDES

Investigation the next day disclosed these offenders.

high-frequency radio on a small boat was very practical, but Captain Thompkins of the *Wander Bird*, KMUP, whom the Skipper knew well, had not had much success with his attempt. We ended up with a compromise between what I wished to have and the Skipper's idea of cost. This amounted to an old m.o.p.a. designed for service ten years ago on 100-meter c.w., which I rebuilt to work on the high-frequency ship bands. With an 801 driving p.p. 801's

I was supposed to get an output of about 75 watts. The receiver was a Sargent model 12 which I chose because Walter Evans of Westinghouse Radio Division warned me from his experiences that moisture troubles would be very bad. The makers advertised the model 12 as having been made primarily for shipboard use. Now, I wish that I had bought two receivers—keeping one in the oven drying out while using the other.

Previous to sailing I had decided that here was a good chance to see what amateur radio could do when it came to rendering daily long-haul traffic contacts without the aid of high power and

\* Written on board the schooner-yacht "Yankee" in mid-Indian Ocean.

\*\* 4138 Oak Knoll Drive, Youngstown, Ohio.

directional antennas at both ends. I made arrangements with several stations in various parts of the world for schedules and spread the word in general that while legally WCFT was a ship station licensed for communication with amateurs, actually she was an amateur station operated by an amateur and would be in communication with amateurs. Unfortunately, even after making some trips to Washington to see the F.C.C. people personally, I was unable to get permission to operate in the amateur bands. The best they could do for me was to indorse the licenses in the same way as for Byrd—permitting amateur contacts under the call WCFT but requiring us to operate on regular ship frequencies. Therefore, many stations who would have liked to have carried schedules were unable to, because their receivers were made to tune the amateur bands only.

When we sailed on November 1, 1936, I had skeds with the following: W8PH, W1ZB, W3BQP, W8IUF, G6NJ, K5AI and VP5JB. In addition I was to work VS1AA and ZS2X when I got within range of them. Unfortunately, difficulties with the installation required that I carry a skeleton schedule with W1ZB only.

Right here Carl Madsen, W1ZB, should come in for his bow. He heard of the *Yankee's* cruise shortly before we sailed and wrote offering his services, as he felt that, aside from having a good station with a modest DX record, he was in a position to give WCFT quick service to our home office which was in Springfield, Mass. He came down to Gloucester while we were outfitting, to say "Hello," and made a flying trip the day we sailed, to calibrate the transmitter. Since then he has given far better cooperation than I could have hoped for. He has been on daily for over a year right on schedule. Once a breakdown threw us off the air for a week, but he was still faithfully at it when we got back on. If for some reason he had to leave town he would get W1FTR or W1CC to fill in for him. However, it was usually ZB who was there. No matter what time it was or what condition that New Year's celebration had left him in, he would still be there when the clock rolled around to sked time. This was a fine example of the true ham spirit that so many people claim is dying out.

I also want to thank Oakes Spaulding, W1FTR, who spent so many early mornings standing by in Hartford when my signals got so weak that his slightly superior location often made the differ-

ence between getting a message or having W1ZB struggle to hear it through a maze of electric shaver QRM again. W8IUF receives our thanks for giving a wonderful QSP to many of the families of those on board. The same applies to W8AAU. K5AG, with operator Snow behind the controls, spent many early hours handling traffic to and from the *Yankee*. W6LPZ and W5FSE made possible several direct chats with my folks while they were on an extended trip and some personal business needed attention. To W1TS, W1SZ and W1NI I want to give thanks for many a pleasant chat. It was a great pleasure to chat for a minute or two in good old ham style with various stations and I am only sorry that the supply of energy in the ship's batteries wasn't large enough to permit some old-fashioned rag chewing. The following also did their part to render various bits of assistance in one way or another during the course of the cruise: W8HAR, W8PH, W9ALV, K5AA, K5AV, KA1FM, K6NXD, K6OJG, NY2AC, FO8AA, VS1AD, VS3AE and ZE1JG.

I had had doubts of what the little 75 watts could do on such long haul contacts, and while its performance far exceeded even my wildest hopes, there were times nevertheless when I was unable to work through. In fact, no amount of power would have broken down the barrier. A

synopsis shows that from Gloucester, Haiti, Panama, Galapagos Islands, Easter Island, Pitcairn Island to Tahiti we had S9 or better signals from the U. S. A. Our signals in turn were sufficient to insure good solid contacts except when broken up by the heaviest QRM in the ship bands. Naturally we reached Panama a little better than the U. S. A. but the QRM from all the shipping passing through the Canal made matters even worse than in New England. At Papeete, Tahiti, we experienced our first slump in the strength of U. S. signals. This, however, I lay to local conditions, for as soon as we left there and went on towards Christmas and Fanning Islands the signals came back up to their former

level. However, by the time WCFT reached Pago Pago the signals had dropped off again and, combined with very poor local conditions from surrounding mountains, caused the first break we were to experience. Nevertheless we continued to have contact by combined use of 36 and 18 meters. After experiments early in the trip, during which we tried 8.2, 11, 12.4 and 16.5 Mc. and both 7 and 14 Mc. for the home end, we found

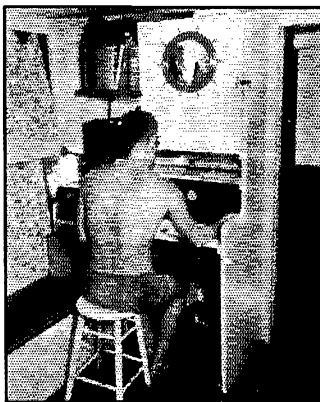

**THE AUTHOR HARD AT WORK  
MOVING TRAFFIC FROM WCFT  
TO W1CC**

*This picture was taken while in the  
Aru Islands in the Dutch East Indies.*

that 8.2 and 16.5 Mc. used in conjunction with 7 and 14 Mc. respectively gave us the best results. Gradually, as summer static increased during May, 1937, on 36 meters in the U. S. A. we shifted all of our operation to the higher frequencies. For the first time during the trip the signals at both ends began to show the effects of the "DX Cycle." While they did not conform exactly to Perrine's findings they did show that there was a definite cycle. Finally, after calling at the New Hebrides, Solomons, New Britain and Papua, we cleared through Torres Straits and that night, entering the Arafura Sea, we had our last contact with the States on 36 meters. Strangely enough, it was with my own station, W8IGQ, using only 100 watts on 40 meters. Two nights later not even West Coast signals came through. From then on, as we progressed through the Netherlands Indies, we had difficult contacts at intervals on 16.5 Mc. We still heard W1ZB, and alternates, on 14 Mc. but only S3 and 4. At this time we started to clear traffic through KA1FM in Manila. We continued to have occasional contacts with the East Coast direct until the *Yankee* left Semarang, Java, which was the last time we were to hear the New England gang for some time.

After a lay-off at Singapore while I left the ship for a trip to Siam, I continued to work KA1FM, but I was unable to hear the United States at all on any frequency. I am referring to amateurs, for KPH and KFS came through, although weakly in comparison to the power they are using. As the *Yankee* rounded the north end of Sumatra, however, the signals from the U. S. just burst through on 14 Mc., not at the 1000 to 1300 GT period that we had been using up to this time but about 0000 GT. 'Phone and c.w. came through equally loud. I notified W1ZB as soon as I felt certain that these conditions were not temporary. In mid-Indian Ocean I suddenly lost KA1FM. All KA signals dropped out. Five days later I raised W1FTR on 16.5 Mc. and had a solid QSO. Daily contact was established and, though the time that W signals came in shifted very rapidly as WCFT moved across the Indian Ocean, the strength of signals at both ends remained good for some time. The Chagos Islands found the peak on 14 Mc. about 2230 GT while the area off northern Madagascar found it some place between 2100 and 2215. About this stage of the trip KA signals started to come in again, but very weak in comparison to their former strength. Also W's came in during the 1200 GT period, but not nearly so well as the other way around. For that matter W's could be heard on 14 Mc. any time from 1200 through to 0400 GT on good days. This may all sound rather confusing but it should serve as a fairly accurate guide to help those figuring the correct time to listen for those sparsely settled areas of the globe. As this is being written the *Yankee* is approaching the island of Zanzibar. Here conditions have taken a drastic



THE "YANKEE" LIES AT ANCHOR AT BARTHOLOMEW ISLANDS IN THE GALAPAGOS

shift and no signals except South Americans, which are strong, are heard between 2000 and 0300 GT on 14 Mc. Conditions are similar on 7 Mc. This sudden slump is probably due, however, to the approaching winter solstice.

Now let's get away from the subject of radio and look at the other side of the cruise. Here was a year and a half of good fun with no worries. Room and board had been paid at the start and would not bother us until the cruise was over. Just think of a chance to forget two winters and slide quietly along in the tropics, literally on the wings of the wind! After the first few days of getting used to such minor items as the motion of the ship, we got out of the North Atlantic, just beginning to feel winter's hoary finger, and soon sailed into Cape Haitien, Haiti, famous as a rendezvous of Christophe, the black Napoleon of French Colonial days. Then we sailed to Panama for last-minute supplies. This seemed to us to be the final jumping-off place. Here we would leave all civilization such as we had known and drop into a world totally new. In our passage down we had had a taste of sailing. We had sometimes drifted lazily along with hardly steerage way. The hot tropical sun beating down made us lazier every minute. At times we tore along through the night with the deck lashed by driving spray, the wind howling in the rigging. Suddenly all hands would be roused out of a sound sleep to rush on deck, dressed just as they slept, to fight flaying canvas and gear—one hand for themselves and one hand for the ship. Oh, this trip was varied enough to suit anyone.

From Panama we eased slowly down across the Gulf of Panama to the strange Galapagos Islands, which Beebe truly called "The world's end." They are a great natural zoological garden, marine aquarium and geological wonderland all rolled into one.

Then we crossed the great Pacific to Easter, Pitcairn, Manga Reva and Tahiti.

At Tahiti and some of the other Society Islands such as Moorea we found some of the beauty spots of the Pacific. Here was the home of beautiful,

(Continued on page 84)

# A Feed-Back Compensator for R.F. Circuits

## Controlled Negative Feed-back in the Receiver R.F. Amplifier

By H. O. Talen,\* W9PYQ

IN receivers using a tuned radio-frequency amplifier, the design usually includes no deliberate feed-back from the succeeding stage to the first grid circuit. Sometimes a regenerative feed-back coupling is provided, with marked advantages under certain, but not all, conditions. There seems to be a perennial argument as to whether a regenerative r.f. stage is "constitutional" or not, particularly in a super-heterodyne using more than two or three tubes. There is little doubt that feed-backs do occur except when the r.f. stage is neutralized either by accident or by careful adjustment. Let us consider the question further in terms of a circuit in which we can choose any required degree of positive or negative feed-back, in addition to those already existing.

### THE CIRCUIT

In Fig. 1 we have a tuned radio frequency stage followed by a regenerative detector, probably the world's toughest spot for a tuned amplifier. The cathode is connected to potentiometer  $R_1$  (500 ohms) across a small winding coupled to  $L_1$  and having its center point grounded. For lack of a better handle, we call the potentiometer and associated circuit a "feed-back compensator." By swinging the arm to "A" the cathode is in effect tapped up on  $L_1$ , and the result is a regenerative electron-coupled circuit of the Hartley type, if the coils are wound in the same direction. Swung to the other end, the arm connects the cathode to the coil at "B" in such a way as to feed back *degeneratively* any signal impressed on the grid. As expected, the latter setting reduces the signals to a degree which experience shows is dependent upon the voltage and phase of other feed-backs. Of course, the potentiometer can be set at any intermediate point desired, with corresponding results.

### CONDITIONS AFFECTING OPERATION

The first grid circuit is affected by several factors, among which is the antenna "load." Like the weather, we rarely do anything about it. If the antenna is resonant at the received frequency,

the grid circuit tunes broadly and usually behaves itself with almost any degree of regeneration in the next stage. Not so when the antenna frequency or a harmonic differs from the received signal. By appropriate setting of the feed-back compensator, it is possible to offset a heavy antenna load with regeneration, and to nullify any dead spots in the tuning range. By a different setting, any unwanted oscillation of the r.f. stage due to a light load and advanced regeneration in the detector can be eliminated.

In unneutralized high-frequency amplifiers there is always a transfer of energy through the grid-plate capacity of the tube. The phase of this feed-back depends upon the relative tuning of the two circuits; if the plate circuit is tuned to a higher frequency than the grid circuit, regeneration or oscillation will result; with the opposite condition as to tuning, there can be a decidedly degenerative effect on the signal in the grid circuit.

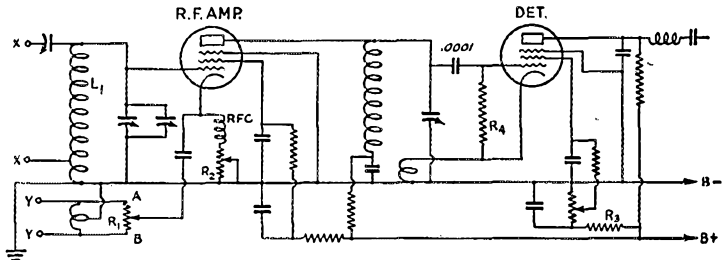

FIG. 1—ESSENTIALS OF THE FEED-BACK COMPENSATOR CIRCUIT

$R_1$ —500-ohm potentiometer (feed-back compensator).  
 $R_2$ —R.f. gain control.  
 $R_3$ —Regeneration control.  
 $R_4$ —1-megohm leak.  
 $X-X$  and  $Y-Y$ —Alternative antenna connections.

Published tube data show that the plate-cathode impedance of an r.f. pentode is higher than the load impedance furnished by even the best of parallel-tuned circuits. Part of the disparity can be eliminated by regeneration in the second stage. In order to take full advantage of the gain obtainable from an r.f. stage, the regeneration in the second stage must be carried somewhat farther than is usually permitted because of trouble from oscillation in the first stage. The desired result can be secured by stabilizing the first r.f. stage with a judicious bit of negative feed-back.

By gradually introducing more negative feed-

(Continued on page 68)

\* 5532 Tennessee Avenue, St. Louis, Mo.



# A Double-Regenerative Superhet

## Low-Cost Five-Tube Receiver with Stability and Selectivity

By Byron Goodman,\* W1JPE

ONCE upon a time all amateurs built their own receivers, simply because that was the only way they could get them. But that was once upon a time, and nowadays, with the many excellent receivers available on the market, a fellow has to have a fairly good reason for building one. One's pocketbook usually supplies a very good reason; sometimes it's a fellow's pride, and every once in a while it's because some upstart thinks that the commercial receivers are still not as perfect as they might be from an amateur's viewpoint.

Let's take the case of the fellow with the small pocketbook. Likely as not he is using a t.r.f. or even a detector-and-one-audio, both excellent receivers when there isn't too much Q.R.M. But when the going gets tough one really needs a superhet—not necessarily because of any greater sensitivity but because of increased selectivity plus the fact that a superheterodyne won't lock up on strong signals the way an oscillating detector will. But our friend with the already-strained pocketbook can't afford an elaborate receiver, and therefore must compromise as much as possible. And although he can compromise still further than was done in the receiver to be described, it is our feeling that the technical disadvantages will outweigh the few economic advantages.

### CIRCUIT FUNDAMENTALS

From the compromise standpoint, it seems that the receiver should have at least five tubes. The mixer and h.f. oscillator are of course essential and should be separate tubes. The customary i.f. amplifier can be eliminated and only a regenerative second detector used for gain and selectivity, but a separate beat-frequency oscillator should be used if we are to avoid the "locking-up" trouble that is the disadvantage of oscillating detectors. An audio stage is necessary as a suitable coupling to the headphones or speaker, and provides an excellent place for the volume control. The receiver should use a 1600-kc. i.f. to reduce the image response, and a regenerative mixer to increase the gain in the all-important "front end." One more thing: a high-*C* high-frequency oscillator circuit should be used for stability, but a low-*C* signal circuit should be used for maximum gain, ganged together by the

system described in an earlier issue of *QST*.<sup>1</sup> That the high-*C* oscillator is well worthwhile is shown by the fact that the plate voltage on the set can be varied 50 volts with a resultant change in signal beat of only about 500 cycles on 14 Mc.

The tubes practically selected themselves for this receiver. The 6L7G seemed to be the only choice for the mixer because of its excellent characteristics and lack of necessity for critical adjustment of oscillator voltage. A 6J7 might have been used, but the oscillator coupling would have been more critical.

Previous experience had shown the 6J5G to be an excellent high-frequency oscillator tube, and its use in this receiver again justified its reputation.

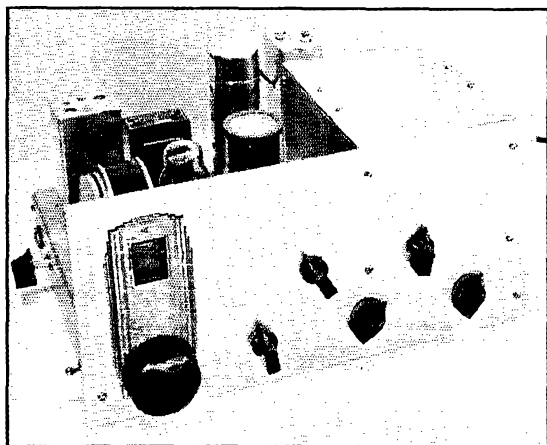

THE DOUBLE-REGENERATIVE SUPERHET

A simple five-tube receiver for the amateur who wants a maximum of receiver performance with a minimum of cost. A larger knob has been placed on the drum dial to facilitate tuning. The b.f.o. adjustment can be seen at the rear of the receiver, on the left-hand side.

A 6K7G was used for the second detector because it goes in and out of oscillation a little more smoothly than a 6J7G. A metal 6K7 was used for the b.f.o. tube, and the 6C5 seemed logical for the audio tube, although no doubt a 6F6 or even a 6L6 could be used if real audio watts were desired. However, for usual headphone reception the audio volume control is set at about  $\frac{2}{3}$  off, so the audio output was considered to be ample.

<sup>1</sup> Goodman, "A 56-Mc. Converter of High Stability," *QST*, August, 1937.

\* Assistant Secretary, A.R.R.L.

ELECTRICAL DETAILS

A glance at the circuit in Fig. 1 will show that most of the details are straightforward and conform with usual practice. The No. 3 grid of the mixer tube is coupled directly to the grid of the high-frequency oscillator, and the tight coupling doesn't seem to impair the stability at all. The mixer and oscillator tuning circuits are bandspread by the usual tapped-coil method, with the additional feature of a high-*C* oscillator circuit for stability and a low-*C* signal circuit for gain. Very little difficulty was experienced in winding the coils, although the completeness of tracking will depend entirely on the patience of the builder. However, since the mixer padding circuit is adjustable from the panel, it is not necessary to make the two circuits track exactly. If the coil dimensions given are followed closely, the tracking will be quite good.

It will be noted that the regeneration control for the mixer is a variable resistor placed between two fixed resistors. This gives a variation in screen voltage in the mixer of from 50 to 200 volts

instead of the usual 0 to 200 volts, and gives a slight "vernier" effect to the regeneration control.

The second detector employs a tuned cathode circuit for regeneration, saving the trouble of winding a special i.f. transformer. The detector is coupled to the audio tube by means of a 0.1- $\mu$ fd. condenser and a 500-henry choke. Suitable r.f. filtering is used before the high-inductance choke, and there is no "motorboating" or "howling."

One thing may appear a little unusual. There is no connection between the b.f.o. and the second detector. This results in slightly-below-optimum coupling between oscillator and detector for strong signals, with consequent "limiter" action. However, the coupling is just about right for weak signals, with the result that the signal-to-noise ratio appears to be exceptionally good, and always brings forth the comment that the receiver seems to be nice and quiet. Such is of course the case, and on strong signals it is only necessary to back off the front-end gain by reducing the regeneration or detuning the mixer, and increasing the audio gain to give excellent signals for copy. If it

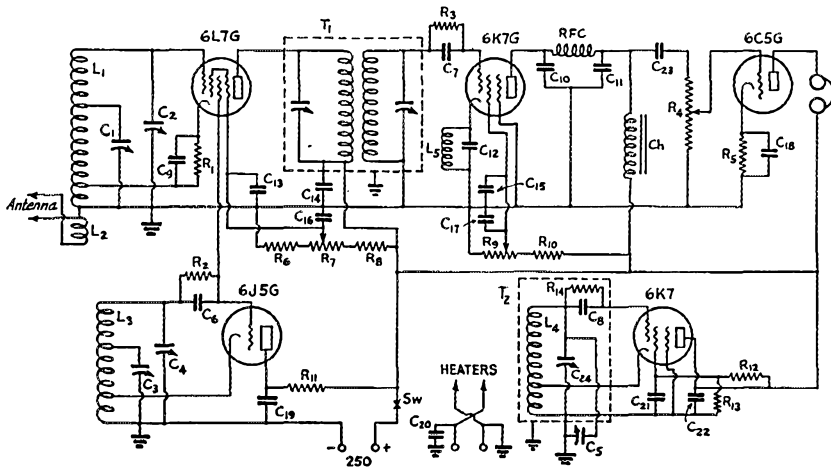

FIG. 1—CIRCUIT DIAGRAM OF THE RECEIVER

- C<sub>1</sub>—15- $\mu$ fd. tuning condenser (Hammarlund HF15).
- C<sub>2</sub>—35- $\mu$ fd. bandset condenser (Hammarlund HF35).
- C<sub>3</sub>—35- $\mu$ fd. tuning condenser (Hammarlund MC-35-S).
- C<sub>4</sub>—100- $\mu$ fd. bandset condenser (Hammarlund HF100).
- C<sub>5</sub>—2-plate midjet variable for beat-note adjustment (Sickles ATR-21).
- C<sub>6</sub>, C<sub>7</sub>—100- $\mu$ fd. mica.
- C<sub>9</sub>, C<sub>10</sub>, C<sub>11</sub>, C<sub>12</sub>—250- $\mu$ fd. mica.
- C<sub>13</sub>—0.005- $\mu$ fd. mica.
- C<sub>14</sub>, C<sub>15</sub>—0.01- $\mu$ fd., 400-volt paper.
- C<sub>16</sub>—0.1- $\mu$ fd., 400-volt paper.
- C<sub>17</sub>—0.5- $\mu$ fd., 400-volt paper.
- C<sub>18</sub>—5- $\mu$ fd., 50-volt electrolytic.
- C<sub>19</sub>—0.005- $\mu$ fd. mica.
- C<sub>20</sub>, C<sub>21</sub>, C<sub>22</sub>—0.01- $\mu$ fd., 400-volt paper.
- C<sub>23</sub>—0.1- $\mu$ fd., 400-volt paper.
- R<sub>1</sub>—500 ohms, 1/2-watt.
- R<sub>2</sub>—40,000 ohms, 1/2-watt.
- R<sub>3</sub>—0.25 megohm, 1/2-watt.
- R<sub>4</sub>—0.5-megohm potentiometer.

- R<sub>5</sub>—1000 ohms, 1-watt.
- R<sub>6</sub>—25,000 ohms, 1/2-watt.
- R<sub>7</sub>, R<sub>9</sub>—15,000-ohm wire-wound potentiometer. (Yaxley C15MP. Rotor must be insulated from panel.)
- R<sub>8</sub>—500 ohms, 1-watt.
- R<sub>10</sub>—30,000 ohms, 10-watt wire-wound.
- R<sub>11</sub>—10,000 ohms, 1-watt.
- R<sub>12</sub>, R<sub>13</sub>—15,000 ohms, 2-watt.
- RFC—2.5-mh. choke.
- L<sub>1</sub>, L<sub>2</sub>, L<sub>3</sub>—See coil table.
- L<sub>5</sub>—2.5-mh. choke.
- T<sub>1</sub>—1600-kc. air-tuned i.f. transformer. (Sickles 8084. The grid lead, which is tapped down on the coil in the transformer as it comes from the manufacturer, must be moved to the stator plates of the grid tuning condenser before the transformer is used.)
- T<sub>2</sub>, (L<sub>4</sub>, C<sub>24</sub>, R<sub>14</sub>, C<sub>8</sub>)—1600-kc. b.f.o. unit (Sickles 6631).
- Ch—500-henry audio impedance (Thordarson T-3736).

is found that too much oscillator voltage reaches the second detector, the voltage to the plate of the b.f.o. can be reduced, and if too little oscillator voltage is being fed to the detector the coupling can be increased by draping a piece of insulated wire somewhere between the two circuits. The b.f.o. is made to turn off, for 'phone reception, by bending over one corner of the rotor plate of  $C_5$ , which shorts with the stator plate in the extreme position.

#### CHASSIS CONSTRUCTION

To facilitate home construction, the shielding was reduced to a minimum. It was decided that the first detector was the portion of the set that required shielding, if any was to be used, and so it was housed in a separate box,  $4\frac{3}{4}'' \times 6\frac{1}{4}'' \times 4\frac{3}{8}''$  high, with a removable lid for changing coils. The chassis itself was made by bending a  $9\frac{1}{2}'' \times 18\frac{1}{4}''$  piece of  $3/32''$  aluminum into a shallow "U" with  $2\frac{1}{8}''$  sides and fastening on a rear strip and the  $\frac{1}{8}'' \times 6\frac{1}{2}'' \times 13''$  panel with  $\frac{1}{4}''$  square brass rod. The photographs show the construction better than any words. Care was taken to make the chassis rigid, to insure stability. After all the holes have been drilled, the chassis and panel may be given a dull finish by soaking them in a lye solution for about fifteen minutes.

We ran into a condition in this receiver that might easily have been avoided. The completed receiver showed a tendency, especially on the higher-frequency bands, to "jump" from signal to signal instead of tuning smoothly. The grounded rotor-shaft of the oscillator tuning condenser was connected directly to the drum dial, and for some time we refused to believe that the dial was responsible for the "jumping." However, after everything else had been tried, we finally isolated the rotor from the dial by means of an insulated coupling, and our troubles disappeared. The erratic behavior had of course been caused by the several variable ground paths shunting the heavy supporting pillars of the tuning condensers. As the dial was rotated, these shunt paths varied and affected the frequency just enough to make things awkward. This has been pointed out several other times, but it had always sounded like so much "hokum." We know better now, and therefore recommend that any high-frequency oscillator tuning condenser be grounded at only one or two points and not shunted by the dial to ground.

#### LINING UP

Actually lining up the receiver takes only a short while. If a modulated oscillator is available,

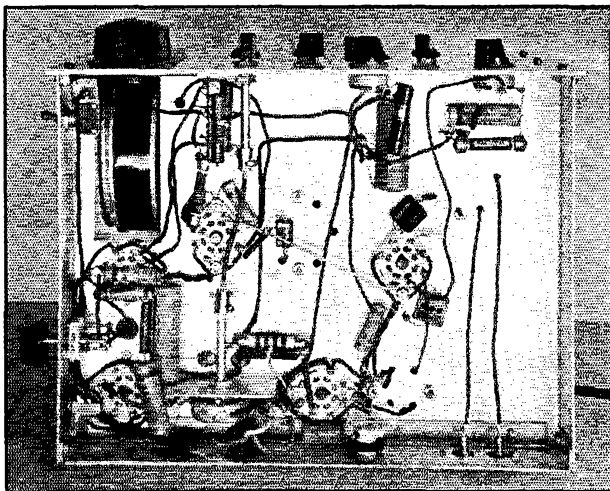

**BOTTOM VIEW OF THE RECEIVER**

*A flexible shaft is used to turn the audio volume control at the rear of the set. Any stray coupling is avoided by thus mounting the audio volume control near the audio tube. The r.f. choke fastened to the back of the chassis is used to make the second detector regenerative. The switch near the drum dial turns off the plate voltage.*

set it at around 1600 kc. (the exact frequency is unimportant) and connect its output to the grid of the 6L7 mixer. Then tune the i.f. transformer until the signal is the loudest. The b.f.o. condenser (on the side of the chassis) is set at half scale and the trimming condenser in the shield can is adjusted until a beat is obtained between the b.f.o. and the 1600-kc. signal from the signal generator. If no signal generator is available, set the second-detector regeneration control to the point where the detector oscillates and then adjust the b.f.o. until a beat is heard. The primary tuning of the i.f. transformer is next adjusted to the point where the regeneration control must be advanced the farthest to maintain oscillation. The primary will then be in tune with the secondary. If later it is found that the i.f. frequency selected falls on some broadcast harmonic or other unwanted signal, a slight readjustment will be necessary.

Adjustment and trimming of the coils is relatively simple. With a mixer and oscillator coil wound according to the table and placed in the receiver, set the tuning dial at the low-frequency end of its scale and tune around with the oscillator band-set condenser  $C_4$  until a familiar marker or amateur signal at the low-frequency end of the particular band is heard. This adjustment should be with  $C_4$  set at about  $\frac{3}{4}$  full capacity. Tune to the other end of the band to check for the bandspread of the oscillator. If the band doesn't occupy enough space on the dial, move the tap that goes to the tuning condenser  $C_3$  down on the coil. If there is too much bandspread, move the tap up on the coil.

To make the mixer circuit track with the os-

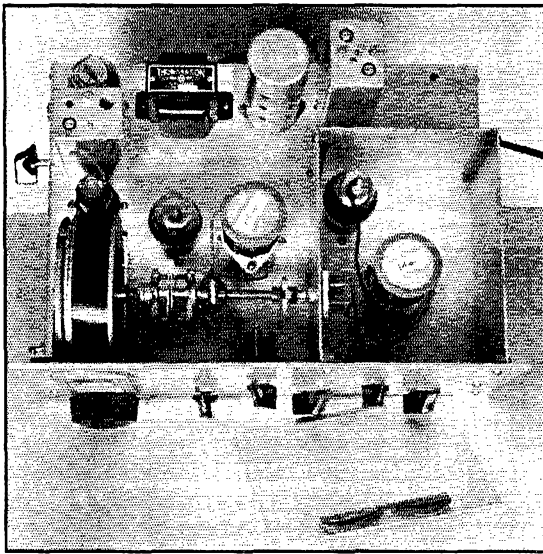

A TOP VIEW OF THE RECEIVER

The high-frequency oscillator tuning condenser, in the center foreground, is ganged to the mixer circuit in the shield compartment. The i.f. transformer is directly in back of the mixer tube, and the grid leak and condenser are mounted directly on the grid lead to the second detector. The audio coupling choke and audio amplifier tube are to the left of the second detector. The b.f.o. unit and tube are directly in back of the drum dial.

The oscillator tuning condenser is supported above the chassis by two brass posts. Since the photograph was taken, the oscillator tuning condenser has been isolated from the dial by an insulated coupling, for reasons described in the text.

collator, first tune in a signal at the high-frequency end of the band and peak the signal with the mixer band-set condenser  $C_2$ . Then tune in a signal at the low-frequency end of the band and see whether  $C_2$  has to be increased or decreased to peak the signal. If the capacity has to be increased at the low-frequency end of the band the tuning tap should be moved *up* on the coil. If the capacity has to be decreased to peak the signal, the tap should be moved *down*. The adjustments should be not more than a quarter-turn at a time on the 14- and 28-Mc. ranges, but can be half-turns at the other frequencies. The tracking can be made as complete as one cares to go—it is simply a matter of patience. The total number of turns is right if  $C_2$  resonates at about half-scale.

Adjustment of the cathode tap on the mixer

coil comes next. It is desirable to have the cathode tap and the antenna coil so proportioned that the mixer goes into oscillation with the regeneration control set at about  $\frac{2}{3}$  scale. If the mixer goes into oscillation too soon, i.e., with the regeneration control set at something much less than  $\frac{2}{3}$  scale, the cathode tap should be made lower on the coil. The point at which oscillation takes place can also be varied by loosening the antenna coupling, either by reducing the number of turns in  $L_2$  or by moving it farther away from  $L_1$ . All antenna-coil adjustments should be made with the antenna connected to the receiver.

When the "front end" of the receiver is working smoothly it may be worthwhile to experiment a little with the second-detector cathode condenser  $C_{12}$ . If oscillation of the second detector takes place at something less than  $\frac{2}{3}$  setting of the regeneration control,  $C_{12}$  should be made slightly smaller. It will be found that the two regeneration controls interlock slightly when both detectors are being run too close to the oscillating point, but this can be avoided by running the mixer in a slightly less regenerative condition.

#### NOTES ON OPERATION

In operation, the second detector is run in a regenerative condition but *not* oscillating. The b.f.o. is not tuned exactly to the same frequency as the regenerative second detector, but about 1000 cycles to either side. When this is done, a "single-signal" effect is noticed, i.e., the signal on one side of zero beat will be louder than on the other side. This condition is only achieved when the second detector is almost oscillating, and proves very useful in separating two signals quite close together. Although the single-signal effect obtained in this receiver does not approach that which results from the use of a crystal filter or regenerative 450-kc. amplifier, it does result in an S7 signal on one side of zero beat being reduced to an S4 signal on the other side. A little experimenting with the adjustment will make the operator familiar with the process of adjusting for maximum single-signal effect. Incidentally, it will be noticed that more

(Continued on page 106)

#### COIL TABLE

Band	Total Turns and Wire Size	$L_1$ Length of Winding	Cathode Tap*	B.S. Tap*	$L_2$ Total Turns and Wire Size	Total Turns and Wire Size	$L_2$ Length of Winding	Cathode Tap*	B.S. Tap*
3.5 Mc.	39 No. 24 d.s.c.	1 1/4"	1/2	36	4 No. 24 d.s.c. closewound	15 1/2 No. 20 enam.	1 1/4"	5	14
7	26 1/2 No. 20 enam.	1 3/8"	1/2	8	4 No. 32 d.s.c.	14 1/2 No. 20 "	1 1/4"	5	12
14	12 1/2 No. 18 "	1 1/4"	1/2	3 1/2	2 No. 24 d.s.c. "	6 1/2 No. 18 "	1 1/4"	2	3 3/4
28	5 1/2 No. 18 "	3/4"	1/2	2	3 No. 32 d.s.c.	2 No. 18 "	1"	1/2	1 3/4

All coils wound on 1 1/2" diam. Hammarlund forms.  $L_1$  and  $L_2$  wound next to each other except on 7 Mc. where spacing between  $L_1$  and  $L_2$  is 1/2". All coils except 3.5-Mc.  $L_1$  are spacewound to occupy winding length given.

\* Tap turns counted from grounded end of coil.

# What the League Is Doing

League Activities, Washington Notes, Board Actions—For Your Information

## Examination Schedule

The F.C.C. announces its schedule of amateur examinations for 1938. Consult the following list when you need to know when and where examinations will be held. Where exact dates or places are not shown, information may be obtained, as the date approaches, from the Inspector-in-Charge of the district. It should be noted that no examinations are given on national holidays or state holidays. All examinations begin promptly at 9:00 A.M., local time except for New Orleans and Honolulu, where they begin at 8:30 A.M.

### DISTRICT NO. 1

Boston, Mass., Customhouse, 7th floor, every week day except Thursday.

### DISTRICT NO. 2

New York City, 1024 Federal Bldg., 641 Washington St., Tuesdays, Thursdays and Saturdays.  
Schenectady, N. Y., sometime in March, June, September and December.

### DISTRICT NO. 3

Philadelphia, Pa., Room 1200, Customhouse, 2nd and Chestnut Sts., every Wednesday.

### DISTRICT NO. 4

Baltimore, Md., Ft. McHenry, Wednesdays and Saturdays.

### DISTRICT NO. 5

Norfolk, Va., Room 402, New P. O. Bldg., every Friday.  
Winston-Salem, N. C., February 5th, May 7th, August 6th and November 5th.

### DISTRICT NO. 6

Atlanta, Ga., 411 Federal Annex, Tuesdays and Fridays.  
Nashville, Tenn., February 18th, May 20th, August 19th and November 18th.  
Savannah, Ga., 208 Post Office Bldg., *Class A only, for time being*; examinations given at convenience of the inspector by arrangement with the office.

### DISTRICT NO. 7

Miami, Fla., Room 312, Federal Bldg., each Monday and Friday, by appointment.  
Jacksonville, Fla., June 4th and November 5th.  
Tampa, Fla., 201 Stovalls Professional Bldg., *Class A only, for time being*; examinations given at convenience of the inspector by arrangement with the office.

### DISTRICT NO. 8

New Orleans, La., 326 Customhouse, every Monday.  
Little Rock, Ark., March 22nd and September 13th.

### DISTRICT NO. 9

Galveston, Tex., Room 404, Federal Bldg., Wednesdays and Saturdays.

### DISTRICT NO. 10

Dallas, Tex., 302 U. S. Terminal Annex Bldg., every Tuesday.  
Oklahoma City, Okla., February 19th, May 21st, August 20th and November 19th.  
San Antonio, Tex., March 12th, June 11th, September 10th and December 10th.  
Albuquerque, N. M., April 30th and October 22nd.

### DISTRICT NO. 11

Los Angeles, Calif., 1105 Rives-Strong Bldg., Mondays and Saturdays.

Phoenix, Ariz., two days in April and two days in October.  
San Diego, Calif., 503 New California Bldg., *Class A only, for time being*; examinations given at convenience of the inspector by arrangement with the office.

### DISTRICT NO. 12

San Francisco, Calif., 328 Customhouse, Class B, Mondays only; Class A, daily.

### DISTRICT NO. 13

Portland, Oregon, 207 New U. S. Courthouse, every Friday  
Boise, Idaho, sometime in April and October.

### DISTRICT NO. 14

Seattle, Wash., 808 Federal Office Bldg., every Friday.  
Butte, Mont., sometime in May and November.  
Spokane, Wash., sometime in May and November.  
Juneau, Alaska, P. O. Box 2719, *Class A only, for time being*, examinations given at convenience of the inspector by arrangement with the office.

### DISTRICT NO. 15

Denver, Colo., 504 Customhouse, first and third Saturday of each month.  
Salt Lake City, Utah, sometime in March and September.  
Billings, Mont., sometime in April and October.

### DISTRICT NO. 16

St. Paul, Minn., 927 Main Post Office Bldg., first and third Saturdays of each month, and by appointment.  
Bismarck, N. D.; dates can be secured from the Inspector-in-Charge at St. Paul.

### DISTRICT NO. 17

Kansas City, Mo., 609 Pickwick Bldg., 903 McGee St., first and third Friday and Saturday of each month, and by appointment.  
Des Moines, Ia., April 8th and 9th, July 8th and 9th and October 14th and 15th.  
St. Louis, Mo., May 13th and 14th, August 12th and 13th and November 11th and 12th.

### DISTRICT NO. 18

Chicago, Ill., 246 U. S. Courthouse Bldg., every Saturday.

### DISTRICT NO. 19

Detroit, Mich., 1025 Federal Bldg., every Saturday.  
Cincinnati, Ohio, sometime in May, August and November.  
Columbus, Ohio, sometime in March, June, September and December.  
Cleveland, Ohio, sometime in April, July and October.

### DISTRICT NO. 20

Buffalo, N. Y., 514 Federal Bldg., first Friday of each month and by appointment. If the first Friday falls on a holiday, the examinations will be given on the following Friday.  
Pittsburgh, Pa., sometime in March, June, September and December.

### DISTRICT NO. 21

Honolulu, T. H., Aloha Tower, Mondays and Saturdays.  
Hilo, T. H., July 22nd.  
Wailuku, Maui, T. H., July 20th.  
Lanai City, Lanai, T. H., July 19th.  
Kaunakakai, Molokai, T. H., July 18th.  
Lihue, T. H., August 12th.

### DISTRICT NO. 22

San Juan, P. R., 303 Ochoa Bldg., *Class A only, for time being*; examinations given at convenience of the inspector by arrangement with the office.

### HEADQUARTERS

Washington, D. C., F.C.C. offices, every Thursday; other days by appointment.

# The Infinite Rejection Principle Applied to Image Attenuation

A New Method of Eliminating Images in Superhet Receivers

By Karl W. Miles and J. L. A. McLaughlin\*

**A**N inherent peculiarity of the superheterodyne is its ability to respond simultaneously to signals of two different frequencies which are separated by *twice* the frequency of the i.f. amplifier. Where the oscillator, mixer and r.f. amplifier tuning condensers are ganged together, as is now accepted modern practice, and the oscillator is tuned i.f. frequency higher than the frequency of the desired signal, the undesired signal of the other response frequency, commonly referred to as the image, will be more or less attenuated because of the selective action of the tuned circuits between the antenna and mixer. The amount of this attenuation, in terms of voltage, is called the *image ratio*, and will depend on the shape of the selectivity curve of the input circuits. The i.f. amplifier selectivity will in no way affect this ratio.

Now at a frequency of, say, 1000 kc., the image ratio of a superheterodyne with an r.f. stage ahead of the mixer will be of the order of 10,000 or better. That is, the image signal will have to be

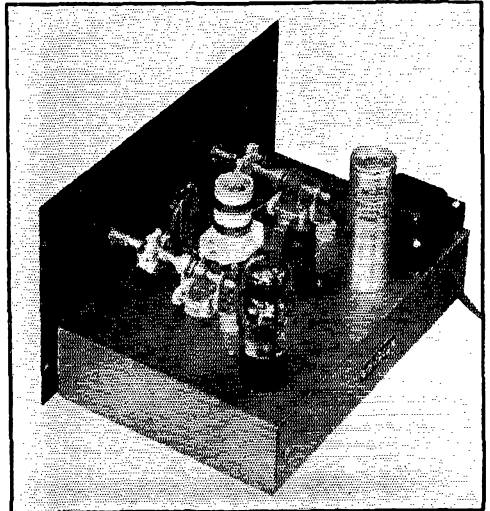

AN INEXPENSIVE AND EASILY-BUILT PRESELECTION WITH IMAGE REJECTION

The range covered is 9 to 16 Mc. The nearer variable condenser is the image rejection control; that on the far side the regular tuning condenser. The power-factor correction resistor is mounted on the panel.

10,000 or more times as strong as the desired signal to give the same output. At 2000 kc. the ratio will be down to something like 1000 and at 7 Mc. to about 200. At 14 Mc. a ratio of about 50 is usual and at 30 Mc. a ratio of two or three is considered pretty fair.<sup>1</sup>

Now why does the image ratio become so poor at the higher frequencies? Simply because as the frequency goes up the percentage difference between the signal and image frequencies grows less; in other words, the image frequency is climbing nearer the nose of the resonance curve and approaching par with respect to the signal frequency. If we persist in our attempt to eradicate the image by means of purely selective devices at frequencies in the neighborhood of 30 Mc. and higher, we will find that progress is comparatively slow. We can go on adding preselection to the

<sup>1</sup> The image ratio figures are based on an i.f. of the order of 465 kc. and the use of ordinary tubes and circuits at signal frequency. At the higher frequencies, some improvement in performance can be secured by using acorn tubes because of their lesser loading effect on the tuned circuits.—EBRON.

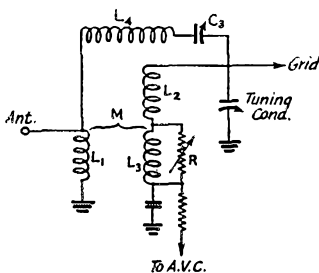

FIG. 1—THE IMAGE REJECTOR CIRCUIT

Values of the components labelled will depend upon the tuning system and other features of the receiver with which the rejector is used. Experimental values determined in one type of receiver are as follows:

C<sub>2</sub>—7 and 14 Mc.: 15- $\mu$ fd. variable; 28 Mc.: 10- $\mu$ fd. variable.

L<sub>1</sub>—7 and 14 Mc.: 4½ turns No. 34 d.s.c., diameter ¾ inch.

28 Mc.: 2½ turns No. 34 d.s.c., diameter ¾ inch.

L<sub>2</sub>—7 and 14 Mc.: 10½ turns No. 22 d.s.c., diameter ¾ inch.

28 Mc.: 2 turns No. 20 d.s.c., diameter ¾ inch.

L<sub>3</sub>—7 and 14 Mc.: 3 turns No. 22 d.s.c., diameter ¾ inch.

28 Mc.: 2 turns No. 20 d.s.c., diameter ¾ inch.

L<sub>4</sub>—7 and 14 Mc.: 15 turns No. 34 d.s.c., diameter ¾ inch.

28 Mc.: 8 turns No. 34 d.s.c., diameter ¾ inch.

R—1000-ohm rheostat.

These will serve as a basis for experimental work with a particular set-up. The main tuning condenser is assumed to cover 7 and 14 Mc. at opposite ends of its scale.

\* The Hallcrafters, Inc., 2611 Indiana Ave., Chicago, Ill.

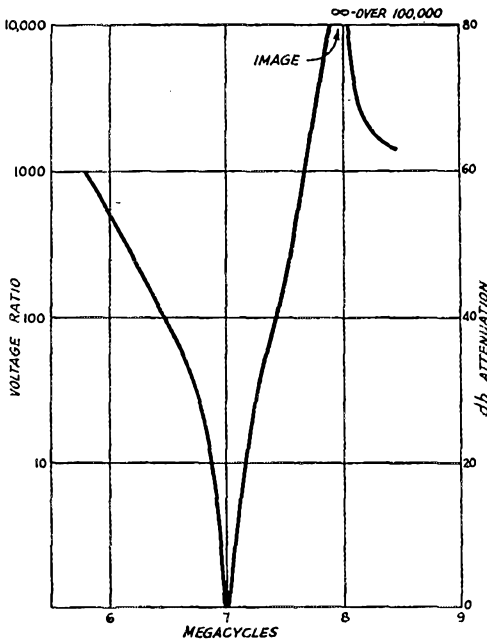

FIG. 2—SELECTIVITY CURVE OF R.F. END WITH RECEIVER TUNED TO 7 MC. AND IMAGE REJECTOR ADJUSTED TO 7.93 MC.

The i.f. selectivity of the receiver is not included in this curve nor in the curves of Figs. 3 and 4.

point where the number of stages becomes impracticable to handle and still not duplicate the performance given by a few stages at the lower frequencies.

Some other means of improving image ratios at the higher frequencies obviously is needed. One method which shows promise is a variation of the i.f. infinite rejection system recently described in *QST* by the present authors.<sup>2</sup> Similar coupling devices can be made infinitely selective in rejecting the image frequencies.

Fig. 1 shows the fundamental circuit. As in the i.f. system, we have a primary  $L_1$  which couples to  $L_2$  through the mutual  $M$  and capacity  $C_3$ .  $L_2$  and  $L_3$  together form the signal-frequency tuning coil;  $L_1$  and  $L_4$  the image-rejection circuit inductance. The reason for using  $L_4$  will be explained later on. The coupling between the antenna (or interstage) input and the grid circuit is the product of  $M$  and  $C_3$ . For the signal frequency the circuit behaves very much the same as a straight inductively-coupled stage with small capacity coupling at the high-potential side. But for the image frequency, the voltage through  $C_3$  equals the voltage induced in the mutual  $M$  and, being of opposite sign, cancels out. To make the null infinite, the power-factor corrector  $R$  is necessary. With proper

<sup>2</sup> Miles and McLaughlin, "A New I.F. Amplifier System with Infinite Off-Frequency Rejection," *QST*, November, 1937.

power-factor correction, no coupling exists at the image frequency. In practice, because of stray coupling or through direct pickup in some part of the circuit beyond the rejector stage, some image signal may leak through, but with careful design the signal-to-image ratio can be made better than 100,000 at frequencies as high as 36 Mc. This is the highest frequency so far attempted.

Experimental work has been done on single-stage application and on two standard receivers. In one instance, in which the rejector system was inserted in the mixer circuit of a receiver having no r.f. stage, image ratios of over 2000 were achieved at frequencies as high as 16 Mc. Stray couplings by-passing the rejector circuit prevented greater rejection. This gives some idea of the effectiveness of the rejector circuit, however, because an image ratio of 2000 at 16 Mc. is higher than can be obtained in a good receiver with two or three stages of preselection ahead of the mixer.

Figs. 2, 3 and 4 are curves showing the front-end performance of a receiver having one r.f. stage ahead of the mixer, the rejection being applied to the r.f. grid circuit. The i.f. selectivity of the receiver is not included in these curves. In each case the rejector is adjusted to signal frequency plus twice the i.f., the signal circuit being tuned to resonate at 7 Mc. in Fig. 2, 14 Mc. in Fig. 3 and 30 Mc. in Fig. 4. The power-factor correction resistor,  $R$ , is in all cases adjusted for maximum attenuation of the image. The plots extend to

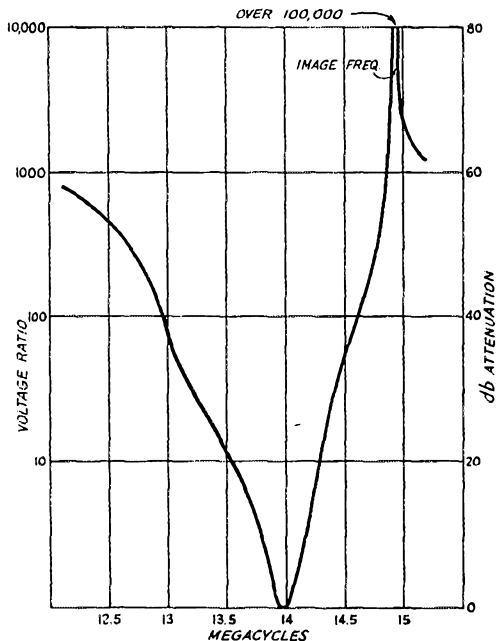
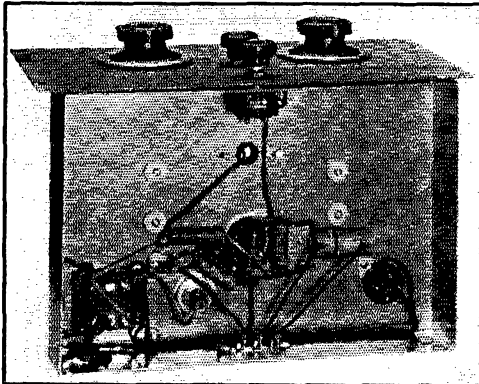

FIG. 3—RECEIVER TUNED TO 14 MC. AND IMAGE REJECTOR ADJUSTED TO 14.93 MC.



**BELOW CHASSIS VIEW OF THE PRESELECTOR**

The variable resistor is the gain control. The output transformer,  $L_1L_2$ , is mounted close to the tube socket.

only a ratio of 10,000, or 80 db; the actual signal-to-image ratio is over 100,000 in all cases.

**AN IMAGE-REJECTING PRESELECTOR**

Because of the worth-while improvement in the complete wiping out of image frequencies that this radically different coupling circuit offers, some practical information should be included in this article. So that interested amateurs and experimenters may be able to adapt such a device to their present equipment, we have built up a simple r.f. stage which may be connected to any receiver. The parts are few and the construction is simple. The frequency range is from 9 to about 16 Mc. and the unit is intended for use on the 14-Mc. band. This is the range in which the average image starts to become bothersome. The circuit diagram and constants are given in Fig. 5.

To get the rejector circuit working properly pick out some band where you know there are images, for example, the region around 13 Mc. Tune over this band until you pick up the image of some 14-Mc. amateur 'phone, and peak up the circuits by means of  $C_2$  and  $C_4$ . Then slowly turn the rejector condenser,  $C_3$ , until a spot is found where the 'phone drops out or is greatly attenuated. Finally, adjust resistor  $R_2$  for maximum attenuation. When you are sure the system is working properly on this frequency, the receiver and preselector can be tuned to the 14-Mc. band and the rejector adjusted to wipe out bad images in this range.

If no rejection point can be found, it may be because  $L_1$  is reversed,  $C_3$  may be too large,  $R_2$  may be too large or too small, or there may be no images at the frequency to which the preselector and receiver are tuned. If a rejection point is found and the image is still audible, see if the image can be picked up with the antenna disconnected. If so, the image signal is getting in at some point past the rejector circuit and shielding should be tried to reduce this pickup.

We should like to give coil information for use on the 30-Mc. band because this is where the rejector is certainly most needed. However, it is difficult to give constants which would have much practical value at these frequencies. The coils have so few turns that the wires leading to them are apt to have as much inductance as the coils themselves, and since  $C_3$  may become less than 1  $\mu\text{fd.}$ , duplication therefore would become quite difficult. Another reason for not doing so is that at this frequency the rejector preferably should be built into the receiver itself, so that maximum efficiency may be achieved and proper shielding employed to prevent the image signal from being picked up on the output side of the rejector circuit.

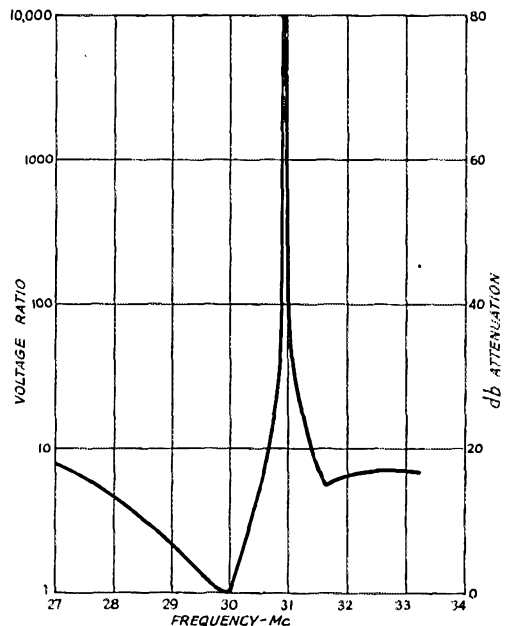

**FIG. 4—RECEIVER TUNED TO 30 MC. AND IMAGE REJECTOR ADJUSTED TO 30.93 MC.**

The incorrigible experimenter, we know, will wind coils for other ranges—perhaps with happy results. To him we offer this advice. Couple the plate of the r.f. stage to the input of the receiver with the shortest possible lead, and on the 30-Mc. range tune the plate circuit of this tube and couple to the receiver through a low-impedance line. It is important to build up the greatest gain possible at these frequencies. The image frequency is so close (in percentage) to that of the signal that with complete rejection of the image there may be appreciable loss of signal strength. At 30 Mc. the gain may drop to about one-tenth of what it was without rejection, so if the r.f. stage gain is kept high—and a gain of ten can be had at



these frequencies—the desired signal (with the rejector set to the image frequency) will be at about the same level at the receiver as it was before the selector-rejector stage was added. A great deal of this loss can be overcome by careful circuit construction in attaining maximum  $Q$  in the tuned circuit, together with the optimum degree of antenna coupling. For example, in a production model of the receiver in which this system is used, there is only a 20 per cent loss in gain with the rejector circuit set for maximum attenuation; with an image ratio of 2000 there is no perceptible loss of desired signal.

At 14 to 30 Mc. the rejector condenser capacity ( $C_3$ ) ranges from a fraction of a  $\mu\text{mfd.}$  to a few  $\mu\text{mfd.}$  and resistor  $R$  is from 250 to 1500 ohms. The higher the frequency the lower the resistance needed. Some interaction between the rejector control and the selector control may be experienced; in a single stage this is of little consequence, but when built into a receiver with all the tuning controls ganged together may be quite serious. To overcome this defect  $L_4$  (Fig. 1) is employed. The use of this coil increases the voltage in the rejector circuit and reduces the effect of  $C_3$  on the signal-tuning circuit. When  $L_4$  is used  $C_3$  becomes considerably smaller.

Although the value of resistance used for power factor correction must be carefully adjusted for maximum rejection, in practice it has been found that a fixed resistor of optimum value for the band over which the circuit is to work will permit dispensing with one control without undue sacrifice of image attenuation. Provided the proper value of fixed resistance is used, highly effective image suppression can be obtained—not the full capabilities of the system, but still capable of relegating practically all image signals to the background. The fixed resistor could be incorporated in the plug-in coils (or switched with the coils in a band-switching receiver) after the optimum value for each range has first been obtained experimentally by the use of a variable resistor.

To give practical information on coil design and the incorporation of this circuit into existing manufactured receivers is out of the question. No two manufacturers' receivers would require the same treatment and coil design. Also, without the proper laboratory equipment and knowledge the performance of an otherwise perfectly good receiver might be greatly impaired. Third, most manufacturers void their guarantee if any tinkering is done with "innards" of their receivers. There is no reason, however, why the circuit could not be tried out on home-built jobs.

The majority of curves and coil information

contained in this article are taken from the work done on the application of the infinite image rejector to a standard "Challenger" type receiver. A rejector was inserted in the r.f. stage and was made to operate over the range from 7 to 30 Mc. The gain of the receiver with and without the rejector in operation is the same for all frequencies up to 20 Mc. Beyond 20 a slight loss of signal is

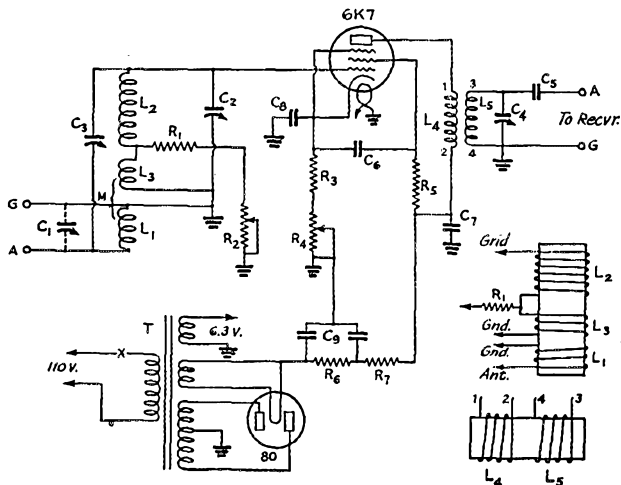

FIG. 5—CIRCUIT DIAGRAM OF IMAGE-REJECTING PRESELECTOR FOR 9- TO 16-MC. RANGE

- $L_1$ —10 turns No. 34 s.e.
- $L_2$ —5 turns No. 20.
- $L_3$ —3 turns No. 20.
- $L_1, L_2$  and  $L_3$  on same form, diameter  $1\frac{1}{4}$  inch (Hammarlund);  $L_2$  and  $L_3$  spaced  $\frac{7}{8}$  inch,  $L_1$  and  $L_3$  closely coupled. Note winding direction in drawing.
- $L_4$ —15 turns No. 36 s.e.
- $L_5$ —5 turns No. 20.
- $L_4$  and  $L_5$  on same form, diameter  $\frac{3}{4}$  inch,  $\frac{1}{8}$  inch between coils.
- $C_1$ —100- $\mu\text{mfd.}$  variable (optional).
- $C_2$ —100- $\mu\text{mfd.}$  variable, input tuning (Hammarlund).
- $C_3$ —20- $\mu\text{mfd.}$  variable, image rejection (Hammarlund).
- $C_4$ —150- $\mu\text{mfd.}$  padder, output tuning.
- $C_5$ —200- $\mu\text{mfd.}$  fixed.
- $C_6, C_7, C_8$ —0.05- $\mu\text{mfd.}$  paper.
- $C_9$ —Dual 8- $\mu\text{mfd.}$  electrolytic.
- $R_1$ —600 ohms,  $\frac{1}{2}$  watt.
- $R_2$ —100-ohm variable (power factor correction).
- $R_3$ —500 ohms,  $\frac{1}{2}$  watt.
- $R_4$ —10,000-ohm variable (gain control).
- $R_5$ —100,000 ohms,  $\frac{1}{2}$  watt.
- $R_6, R_7$ —20,000 ohms, 1 watt.
- T—Power transformer to deliver 250 volts d.c., with 6.3-volt filament winding (General No. 1657).

observed when the rejector is adjusted to the image frequency.

The design of an r.f. amplifier is generally a compromise between gain and image rejection. In the conventional cascaded selective coupling circuits gain and image ratio are inversely related because of the broadening of the resonance curves of the individual circuits when the coupling is adjusted for maximum gain. Since in this system the two functions are distinct and separate, the gain of the r.f. stage can be made considerably

(Continued on page 98)

# New Approach to Amateur Transmitter Design

By James Millen,\* W1HRX

**T**HE r.f. exciter in a transmitter can have high "survival value" if it is properly designed. Final stages, buffers, and modulators may come and go (and they usually do, in most amateur stations), but the exciter, like the receiver, should be designed carefully and built as a long-time investment. Such an exciter should be capable of operating at any predetermined frequency in the amateur bands, and the operation of selecting a frequency should be rapid and convenient. If these specifications are completely filled, such a unit can become part of the permanent equipment of the shack to the same extent that a good receiver does.

In the 'phone transmitter, the same considerations apply to the audio preamplifier. If it has an output of about 15 watts, it will serve very nicely either as a complete voice end for grid or suppressor modulation, or as a driver for a Class-B stage. A pair of 838's (these tubes are particularly convenient because they need no fixed bias) require only 7.5 watts of driving power for 260 watts output; where more power is needed a biased tube such as the 806 will supply 660

watts (per pair) with 10 watts of driving power. So 15 watts of driving power is ample.<sup>1</sup> The other important requirement of the preamplifier is voltage gain. The amplifier will be satisfactory if it delivers full output with an input of not more than 0.005 volts at the grid of the first tube.

For some time it has been our feeling that it would be a perfectly swell thing if we could have some kind of gadget containing a solution to all of the headaches normally encountered in the construction of a transmitter. The bulk of the so-called headaches are pretty well confined to the speech amplifier and the exciter, consequently if these two could be combined once and for all in one compact cabinet, along with all the necessary power supplies, switches, and accessories, the construction or reconstruction of the rest of the transmitter would be just plain fun.

With this in mind, we took a chassis, cabinet and other parts normally used to make an NC-100 receiver, and tried to build such a device. While from a circuit point of view the results were reasonably satisfactory, the unit was somewhat of a monstrosity mechanically. Certainly

it seemed foolish to shift a large catacomb back and forth for band changing when most of the compartments were empty and the contacts therein were used simply for switching purposes.

About this time we became very much intrigued by a type of switch used in the telephones now furnished with the Western Electric automatic exchanges. One of our engineering associates, W1HSV, designed a very compact switch using the same principles which would do everything that the shifting catacomb did, and do it much more quickly and conveniently. Around this switch developed the circuit and mechanical arrangement which is the subject of the present discussion, and which is illustrated in the accompanying diagram and photographs. This particular model is intended for the man who wants especially to operate in the four 'phone sub-bands in the 3.5-, 14-, 23- and 56-Mc. amateur bands. Any one of the four can be selected by pushing in the appropriate button. With one possible exception noted below, all tank

circuits are pretuned, so that no additional operations are required to get "on frequency."

## THE EXCITER CIRCUIT

Basically, the exciter circuit is conventional enough. It employs a crystal-controlled 6L6G

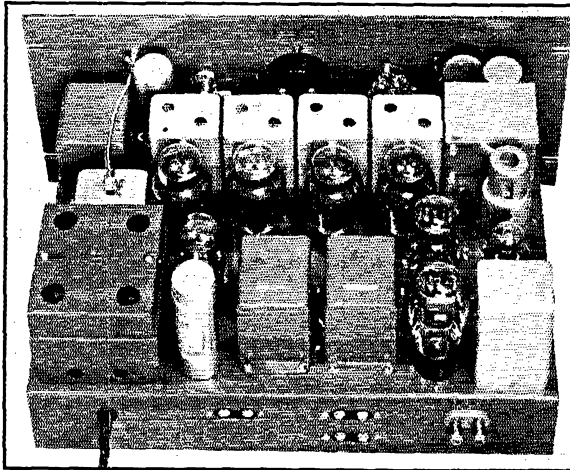

A COMBINATION R.F. AND AUDIO EXCITER  
R.f. output on four bands with push-button control, as well as a speech-amplifier and driver for a Class-B modulator.

\* Malden, Mass.

<sup>1</sup> An excess of driver power always is desirable, especially when the driver works into tubes requiring fixed bias, because better voltage regulation is obtained than when the driver is loaded to its maximum capabilities. The driving power figures given in the tube manuals are approximate, while output figures are tube output and do not include losses in coupling devices.—EDITOR.

oscillator operating at 3.5 Mc., followed by three frequency-multiplier stages, also employing 6L6G's. Its unusual features are in the details. For instance, single, multiple, or variable-frequency type crystal holders can be used, since adequate space has been provided around the 5-prong crystal socket, and provision has been made for controlling the crystal switch or movable top plate from the front panel by means of a flexible shaft. The use of either of these versatile crystal systems makes it possible to select a convenient operating frequency within the band simply by turning a knob, a convenience whose importance we do not have to enlarge upon here. In most cases the oscillator and doubler tanks are broad enough to require no retuning, but in the special case where crystals of widely different frequencies are chosen for the multiple holder a slight adjustment of the oscillator tank is desirable. For this purpose a tuning control and a meter are provided on the panel. This control also permits securing the best adjustment for any particular crystal and for best keying conditions when using the outfit on c.w. A jack is provided on the front panel for plugging in the key; it is connected in the cathode circuit of the oscillator.

As will be seen from the wiring diagram, Fig. 1, and the bottom view of the chassis, each section of the switch has a small mica trimming condenser mounted on it. The condensers serve as compensators and are automatically cut in or out of the circuit by the switch. When shifting from the 28-Mc. to the 14-Mc. band, for instance, the 28-Mc. doubling tube is cut out of the circuit. To avoid detuning the 14-mc. tank, the small trimming condenser is switched across it.

One of the fundamental problems in exciter design is that of maintaining uniform output on different bands. As a matter of fact, it is usually desirable so to arrange the circuits that output increases with frequency, since the larger tubes to which the exciter is connected ordinarily will require increasing driver power. With tubes of the high-mu triode type (53's, etc.) it is possible to maintain nearly constant output but the desired increase is not available, particularly at 14 and 28 megacycles. The 6L6G's, on the other hand, have the ideal characteristic of requiring extremely low excitation for full output, and it is possible to quadruple with practically no loss in power and to obtain an actual increase when doubling, except at 56 Mc. The line-up of the 'phone-band model will, therefore, do everything that is asked of it, its output being essentially the same at 3.5 and 14 Mc., with a definite increase at 28 and 56 Mc. The output is sufficient

to drive all of the common pentodes and beam tubes used in amateur work, as well as the low- and medium-power triodes. Large triodes will require additional power, but since the driving tube would require high voltage, it seemed more logical to locate it near the final, rather than to attempt to incorporate it in the exciter.

#### THE METER CIRCUIT

As an aid in tuning the oscillator and doubler tanks, a meter and selector switch are provided on the front panel. A voltmeter with a range of 200-300 volts is used for this purpose, rather than

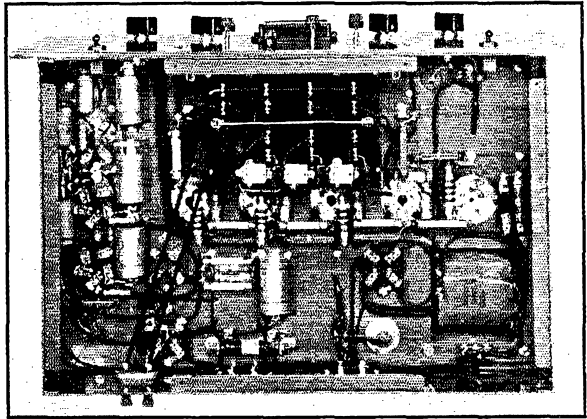

BOTTOM VIEW OF THE EXCITER

The works of the cam-operated push-switch are behind the bakelite panel in the upper foreground.

the customary plate milliammeter. Reference to the wiring diagram will show that this meter is switched across the grid bias resistor of the following stage and consequently measures grid voltage. This is a convenient measure of the excitation, since the d.c. voltage being measured is produced by grid rectification of the exciting signal. In fact, the combination of grid, cathode, grid resistor and meter can be regarded as a conventional rectifier-type a.c. voltmeter. In use, the tuning is adjusted for *maximum* swing of the meter, not minimum swing as in the case of the milliammeter in the plate circuit.

#### THE AUDIO CIRCUIT

To get sufficiently high gain to handle the now popular crystal microphone and still secure an output of the order of 10 watts or so to drive the average Class-B modulators, it was necessary to use four stages. These consist of a 6C6 pentode resistance coupled to a 76, which in turn is resistance-coupled to the 76 driver for the push-pull 2A3's. It is necessary, of course, to filter each plate circuit separately, and this filtering must be effective in eliminating r.f. as well as in preventing audio feedback.

It would hardly be worth while to describe in detail the experimental work necessary to obtain completely stable performance with both r.f. and audio channels in operation at the same time, since any such discussion would necessarily apply only to this particular unit and would be of little value to an amateur attempting to construct a similar piece of equipment with a slightly different layout. There are, however, a few points which it might be well to mention. The treatment

of the circuit elements associated with the 6C6 tube requires special care; all by-pass condensers and resistors must be grounded at the correct point (found experimentally) on the chassis and all elements, including the cathode resistor and by-pass condenser, must be mounted in a tightly-fitting metal shield. Even the grounding of this shield is rather fussy, and it should preferably be isolated from the front panel. In using any high-

(Continued on page 118)

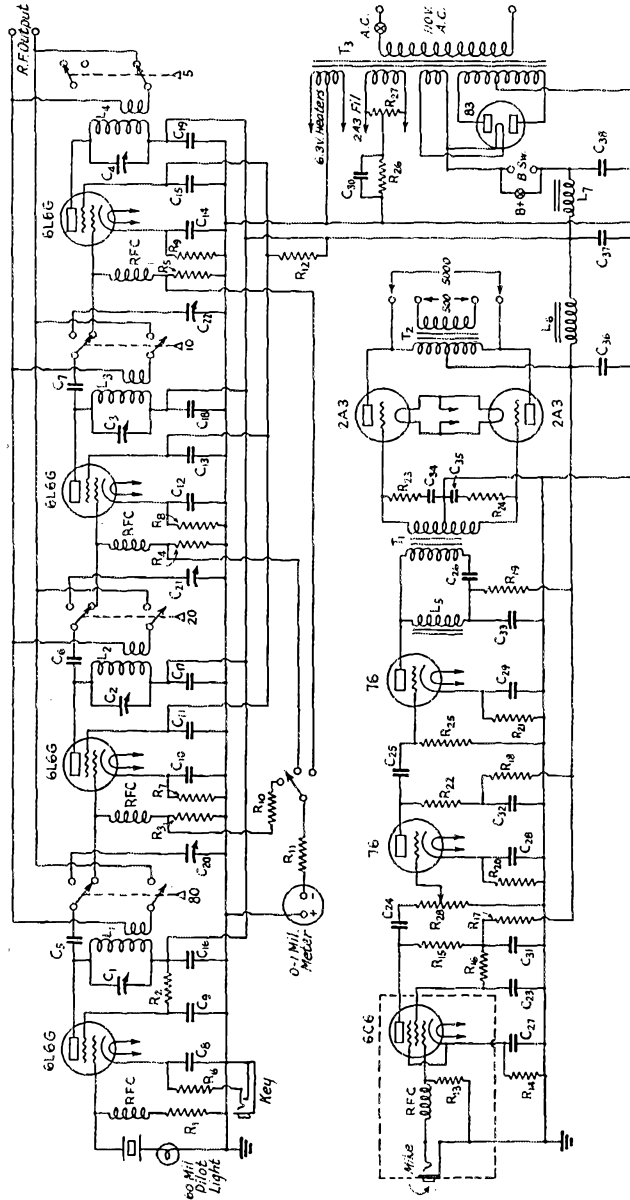

FIG. 1—CIRCUIT DIAGRAM OF THE COMBINATION EXCITER

- L<sub>1</sub>—32 turns No. 28, on 1" form, 60 turns per inch (3.5 Mc.).
- L<sub>2</sub>—8 turns No. 24, on 1" form, 24 turns per inch (14 Mc.).
- L<sub>3</sub>—3 1/4 turns No. 24, on 1" form, 24 turns per inch (28 Mc.).
- L<sub>4</sub>—4 turns No. 24, on 3/8" form, 24 turns per inch (56 Mc.).
- Links 2 turns in each case.
- L<sub>5</sub>—30-henry, 20-ma. choke.
- L<sub>6</sub>—10-henry, 80-ma. choke.
- L<sub>7</sub>—10-henry, 160-ma. choke.
- R<sub>1</sub>—20,000 ohms, 1-watt.
- R<sub>2</sub>—20,000 ohms, 10-watt.
- R<sub>3</sub>, R<sub>4</sub>, R<sub>5</sub>—20,000 ohms, 1-watt.
- R<sub>10</sub>—100,000 ohms, 1-watt.
- R<sub>11</sub>—200,000 ohms, 1-watt.
- R<sub>12</sub>—7500 ohms, 10-watt.
- R<sub>13</sub>—5 megohms, 1/2-watt.
- R<sub>14</sub>—1000 ohms, 1/2-watt.
- R<sub>15</sub>—250,000 ohms, 1/2-watt.
- R<sub>16</sub>—1 megohm, 1/2-watt.
- R<sub>17</sub>, R<sub>18</sub>, R<sub>19</sub>—20,000 ohms, 1/2-watt.
- R<sub>20</sub>, R<sub>21</sub>—2500 ohms, 1/2-watt.
- R<sub>22</sub>—100,000 ohms, 1-watt.
- R<sub>23</sub>, R<sub>24</sub>—100,000 ohms, 1/2-watt.
- R<sub>25</sub>—1 megohm, 1/2-watt.
- R<sub>26</sub>—750 ohms, 15-watt.
- R<sub>27</sub>—60-ohm c.t. resistor.
- R<sub>28</sub>—500,000-ohm volume control.
- C<sub>1</sub>, C<sub>2</sub>, C<sub>3</sub>, C<sub>4</sub>—Double 25-μfd. variables (in National FXT exciter tank assembly).
- C<sub>5</sub>, C<sub>6</sub>, C<sub>7</sub>—100 μfd. mica.
- C<sub>8</sub> to C<sub>15</sub>, inc.—0.1 μfd., 400-volt paper.
- C<sub>16</sub> to C<sub>19</sub>, inc.—0.001-μfd. mica.
- C<sub>20</sub>, C<sub>21</sub>, C<sub>22</sub>—30-μfd. (National M-30).
- C<sub>23</sub> to C<sub>26</sub>, inc.—0.25 μfd., 400-volt paper.
- C<sub>27</sub> to C<sub>30</sub>, inc.—10-μfd. electrolytic, 50-volt.
- C<sub>31</sub>, C<sub>32</sub>, C<sub>33</sub>—8-μfd. electrolytic, 450-volt.
- C<sub>34</sub>, C<sub>35</sub>—0.01-μfd., 400-volt paper.
- C<sub>36</sub>, C<sub>37</sub>, C<sub>38</sub>—4-μfd. oil-filled, 600-volt (Aerovox).
- T<sub>1</sub>—Interstage audio 3:1, with c.t. secondary.
- T<sub>2</sub>—Class-AB output, push-pull 2A3's to 500-ohm line.
- T<sub>3</sub>—Power transformer, 400 volts, 250 ma., with fl. windings.
- RFC—2.5-mh. chokes (National R-100).
- Switch—Cam-operated, s.p.d.t. and s.p.s.t. (National ACS-4)

# Compact Construction with High Power

A Complete 500-Watt C.W.-'Phone Transmitter of Small Dimensions

By T. M. Ferrill, Jr.,\* W5CJB-1

**T**HE transmitter herein described was built with two objects in view: First, to provide a completely self-contained transmitter of large output, so small that it could be crated and shipped conveniently, carried in a car or small truck in case of emergency, or installed in small living quarters; second, as an experiment to determine how practical in operation a transmitter built in this manner would be.

The advantages of compactness in transmitter design are obvious. Portability and convenience of operation are two of the major features; in fact, this transmitter is usually placed on the operating desk beside the receiver, where controls directly on the transmitter panels are within easy reach of the seated operator. Relays for switching power supplies, and separate speech amplifiers for convenient control of audio amplification, are thus eliminated. The disadvantages of extreme compactness remained to be found by actual use of the finished unit. Some guess as to the troubles to be expected was made, but their extent and the best methods of overcoming them provided more than sufficient incentive for the undertaking.

For the benefit of those who might be attracted by some of the features of this transmitter to duplicate it, it must be pointed out that the compact design necessitated the sacrifice of other desirable features ordinarily considered important. Furthermore, the composite nature of the transmitter required many hours of painstaking work to adapt commercially-available apparatus to fit into the very limited space. The plate tank tuning condenser of the final r.f. amplifier required eight alterations, each of which involved cutting metal. To install the insulators supporting the final amplifier tank coil, new pieces had to be substituted in the bases, decreasing the space required for the feed-through insulators below the chassis, and allowing mounting of the associated tuning condenser directly beneath the plate coil. Similar fitting was employed in the construction of the power supplies; indeed, the greater part of the work was made necessary by the attempt at extreme compactness. It was necessary to use the smallest number of amplifying stages consistent with good design practice in both the radio-frequency and audio-frequency equipment.

\*Massachusetts Institute of Technology, Cambridge, Mass.

## APPARATUS LAYOUT

The transmitter is divided into three units; radio frequency equipment, audio frequency equipment, and power supplies. The r.f. section consists of one rack-panel and chassis containing all the r.f. equipment, all meters except that indicating modulator plate current, and the filament transformer heating all filaments of r.f. tubes. The second unit, built likewise on one panel and chassis, contains all audio equipment, power supply for the speech amplifiers, filament transformer for the modulator tubes and in addition, one of

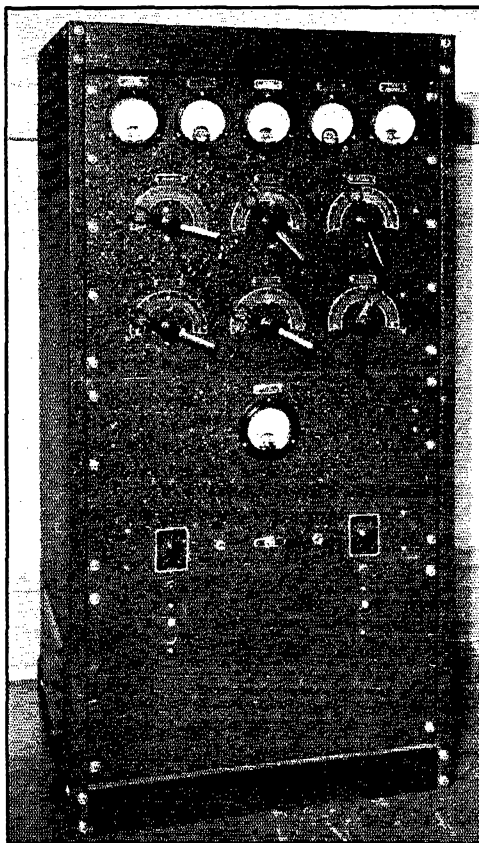

THE COMPLETE HALF-KILOWATT 'PHONE AND C.W. TRANSMITTER

Occupying a total volume of less than 7.5 cubic feet, the overall dimensions are 42 by 20.5 by 15 inches, everything included except microphone and key.

the high-voltage power transformers, which is connected to one pair of 866 tubes in the bottom unit. On the panel of the modulator unit are the gain controls and input jacks, the switch controlling the a.c. supply to the audio equipment, and the modulator plate milliammeter. The third unit consists of one power supply for oscillator plate and grid-bias on buffer and final amplifier, one supply for buffer and final amplifier plates, and one supply for the modulator tubes. This unit was built directly on the base of the cabinet. A separate panel was mounted on the front of the cabinet to hold power switches, overload relays, and pilot lights.

To provide adequate driving power for the final amplifier operating as a plate-modulated Class-C stage, it was necessary to use a crystal oscillator with high harmonic output and to realize high power gain in the buffer stage. At the time the transmitter was being designed, an RK23 tube was chosen for the oscillator, an RK23 tube was chosen for the oscillator, to be used as a Tri-tet at all times. One of the beam-power tubes of corresponding size would probably have been the choice for the oscillator, had these tubes been developed. Both RK20 (with proper circuit alterations) and T55 tubes have been used in the buffer stage, and either is perfectly satisfactory. An HF100 tube would also be a very suitable tube for this application, and one of the new beam tubes of the fifty-watt size

would be admirable here. It was necessary to use conservatively rated tubes in this transmitter, and to operate them well within their ratings, since the cooling is none too effective at best. An HF300 tube was chosen for the final, after some experimentation with smaller tubes which ordinarily should handle the power which the HF300 takes. The smaller tubes were operated within their ratings but failed to withstand the strain.

#### CIRCUIT DETAILS

For the particular tube arrangement shown in Fig. 1 the most desirable method of coupling between stages would ordinarily be adjustable link coupling, with oscillator and buffer on one chassis and final amplifier on another. Here, space consideration dictated the use of either capacity coupling or inductive coupling with coils built in pairs. Both methods of coupling—capacity and inductive—have been used in this transmitter with almost equal results; the latter, however, gave slightly more efficient power transfer and helped to maintain balance of the tuned circuits, as would be expected.

The keying arrangement shown is used because of its simplicity and lack of undesirable keying characteristics. As the keyed circuit operates at a high negative potential with respect to the metal cabinet, a relay is provided to isolate the key. This method of keying is very suitable for break-in

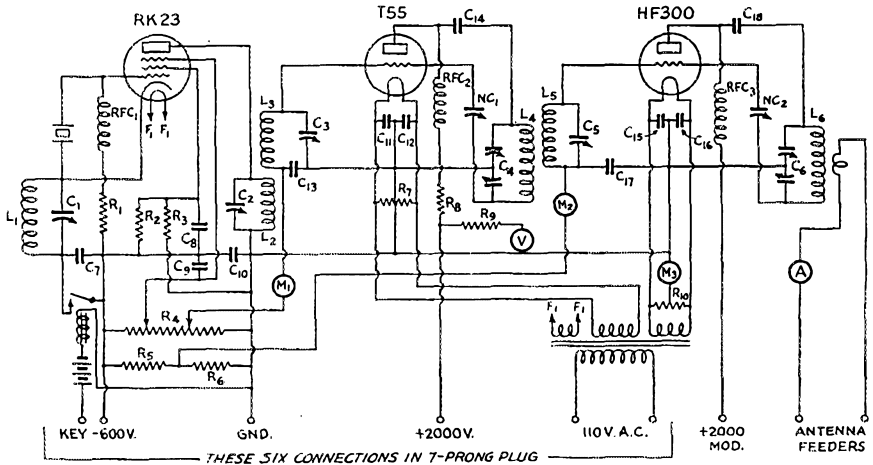

FIG. 1—THE RADIO-FREQUENCY SECTION

- C<sub>1</sub>—140  $\mu$ fd. (Cardwell ZU-140-AS).
- C<sub>2</sub>, C<sub>3</sub>—150  $\mu$ fd., 0.07" spacing (Cardwell MT-150-GS).
- C<sub>4</sub>—210  $\mu$ fd. per section, 0.07" spacing (Cardwell XT-210-PD).
- C<sub>5</sub>—220  $\mu$ fd., 0.07" spacing (Cardwell XT-220-PS).
- C<sub>6</sub>—150  $\mu$ fd. per section, 0.17" spacing (Cardwell TJ-150-UD).
- C<sub>7</sub>—0.002- $\mu$ fd. mica, 1000-volt.
- C<sub>8</sub>—0.006- $\mu$ fd. mica, 600-volt.
- C<sub>9</sub>—0.01- $\mu$ fd. mica, 600-volt.
- C<sub>10</sub>—0.01- $\mu$ fd. mica, 1000-volt.

- C<sub>11</sub>, C<sub>12</sub>, C<sub>13</sub>—0.01- $\mu$ fd. mica, 600-volt.
- C<sub>14</sub>—0.002- $\mu$ fd. mica, 5000-volt.
- C<sub>15</sub>, C<sub>16</sub>—0.01- $\mu$ fd. mica, 600-volt.
- C<sub>17</sub>—0.002- $\mu$ fd. mica, 1000-volt.
- C<sub>18</sub>—0.002- $\mu$ fd. mica, 12,500-volt.
- NC<sub>1</sub>—2-6  $\mu$ fd., 6000-volt.
- NC<sub>2</sub>—5-14  $\mu$ fd., 8000-volt.
- R<sub>1</sub>—50,000 ohms, 2-watt.
- R<sub>2</sub>—12,500 ohms, 25-watt.
- R<sub>3</sub>—10,000 ohms, 25-watt.
- R<sub>4</sub>—10,000 ohms, 75-watt.
- R<sub>5</sub>—10,000 ohms, 40-watt.
- R<sub>6</sub>—6000 ohms, 75-watt.

- R<sub>7</sub>, R<sub>10</sub>—100 ohms, center-tapped 10-watt.
- R<sub>8</sub>—4000 ohms, 200-watt.
- R<sub>9</sub>—Voltmeter multiplier.
- RFC<sub>1</sub>—2.5-mh. r.f. choke (National R100).
- RFC<sub>2</sub>, RFC<sub>3</sub>—2.5-mh., 500-ma. r.f. choke (Hammarlund CH-500).
- M<sub>1</sub>—0-25 d.c. milliammeter.
- M<sub>2</sub>—0-200 d.c. milliammeter.
- M<sub>3</sub>—0-500 d.c. milliammeter.
- A—0-5 r.f. ammeter.
- V—0-2500 d.c. voltmeter.

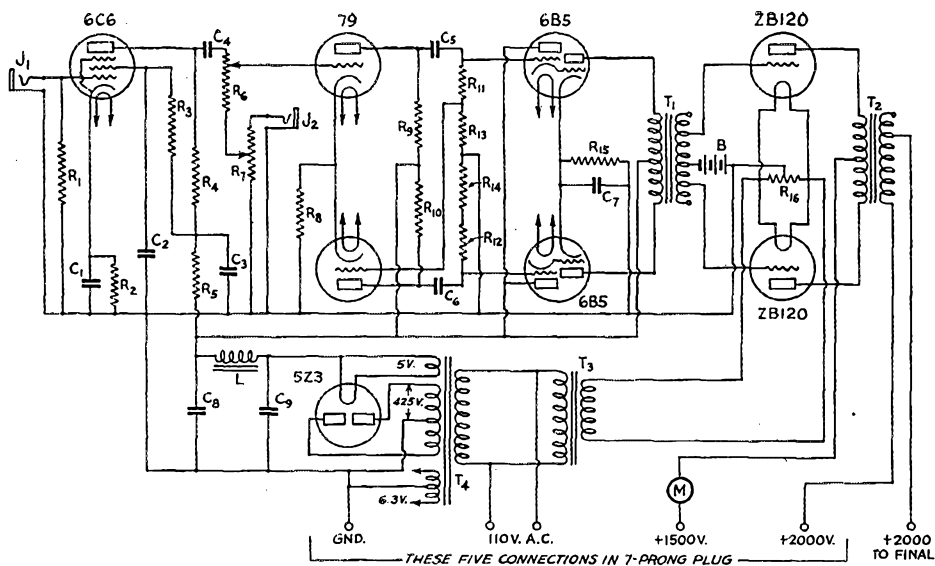

FIG. 2—WIRING DIAGRAM OF THE AUDIO-FREQUENCY SECTION

C<sub>1</sub>—10- $\mu$ d. 25-volt electrolytic.  
 C<sub>2</sub>, C<sub>3</sub>—1- $\mu$ d. 600-volt paper.  
 C<sub>4</sub>, C<sub>5</sub>, C<sub>6</sub>—0.01- $\mu$ d. mica, 600-volt.  
 C<sub>7</sub>—10- $\mu$ d. 50-volt electrolytic.  
 C<sub>8</sub>, C<sub>9</sub>—12  $\mu$ d., 800-volt.  
 L—30 henrys, 150-ma.  
 R<sub>1</sub>—5 megohms, 1/2-watt.  
 R<sub>2</sub>—1600 ohms, 1-watt.  
 R<sub>3</sub>—1 megohm, 1-watt.  
 R<sub>4</sub>—200,000 ohms, 1-watt.  
 R<sub>5</sub>—50,000 ohms, 1-watt.

R<sub>6</sub>—500,000-ohm volume control (mike gain).  
 R<sub>7</sub>—200,000-ohm volume control (line gain).  
 R<sub>8</sub>—1500 ohms, 2-watt.  
 R<sub>9</sub>, R<sub>10</sub>—100,000 ohms, 2-watt.  
 R<sub>11</sub>, R<sub>12</sub>—500,000 ohms, 1-watt.  
 R<sub>13</sub>, R<sub>14</sub>—12,000 ohms, 1-watt.  
 R<sub>15</sub>—120 ohms, 10-watt.  
 R<sub>16</sub>—100 ohms, center-tapped, 10-watt.  
 J<sub>1</sub>—Open-circuit jack (microphone).

J<sub>2</sub>—Open-circuit jack (line).  
 B—9-volt battery.  
 M—0-500 d.c. milliammeter.  
 T<sub>1</sub>—Class-B input transformer (U.T.C. FA-53-AX).  
 T<sub>2</sub>—Variable-ratio Class-B output (U.T.C. VM-4).  
 T<sub>3</sub>—Filament transformer, 10-volt.  
 T<sub>4</sub>—Power transformer, 425 volts each side c-t., 200-ma., with rectifier and 6.3-volt windings.

operation. It will be noted from the circuits that fixed bias is applied to the buffer and final grids when the key is open, preventing no-signal plate current, although most of the bias is obtained from grid-leak action when the excitation is applied.

The lack of plate-current milliammeters in oscillator and buffer circuits is a bit unusual, but not a great disadvantage. A portable milliammeter was inserted in these circuits when the first adjustments of the equipment were being made, and it is used each time a major change in the circuits is made. For tuning the transmitter, as when changing from one band to another, the grid-current meters are adequate indicators of operating conditions, since it is known from previous measurement that plate-current values accompanying resonance are safe. The meters used for measuring grid current could easily be switched to measure plate current of the first two stages. The voltmeter in the final-amplifier plate supply serves as a bleeder.

In the audio system as well as the r.f. portion of the transmitter, care had to be exercised to allow margins of safety for the components used, to provide for the more than usual heat in which the parts would be operated. First, modulator

tubes capable of modulating 500 watts input without difficulty were needed, with required driving power and bias two important considerations. The ZB120 tubes seemed very suitable for this purpose, and were selected for the final audio stage. A simple speech amplifier which would give sufficient gain for the modern crystal microphones, and would easily drive the ZB120 tubes without too much distortion, was the next step. Type 6B5 tubes were chosen for the driver stage, reducing space requirements with the direct-coupled triode drivers, and providing characteristics suited to Class-B driver operation. With the concentration of magnetic fields unavoidable in such a transmitter it was considered important to avoid the use of any transformers for audio coupling, other than the Class-B input and output transformers. This suggested the use of either push-pull speech amplifiers throughout, or a phase-inverter such as one section of a Type 79 tube. The latter was chosen, chiefly because of space limitations, as well as the fact that the other section of the 79 tube used as a triode amplifier, together with the usual pentode first amplifier, would provide ample gain.

Reduction of size of power supplies, without sacrificing quality or the expectation of long,

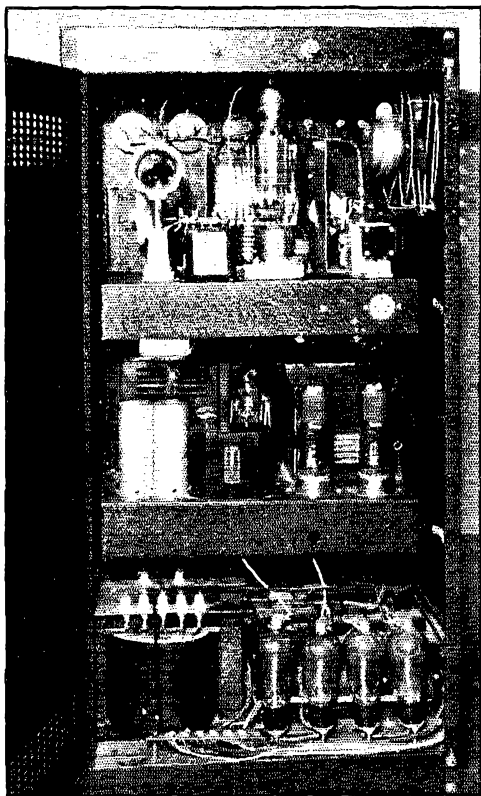

**REAR VIEW, SHOWING THE THREE DECKS**

*R.f. at the top, speech amplifier and modulator in the center, power supply at bottom. Note the ventilating fan on the upper right side of the cabinet.*

trouble-free service, is a real problem. The choice of compact, oil-filled filter condensers accounted for greatest saving of space in the power supplies. The oscillator power supply was used also to provide grid bias voltage for the buffer and final amplifier when the excitation was removed from these stages. The loads of the modulator and the high-voltage radio-frequency stages could have been placed on one power supply, but the use of a separate supply for the modulator tubes is preferred. Common sense indicated that power transformers which would run at high temperature while operated in open air would not be at all suitable in such a transmitter as this.

#### TEMPERATURE CONSIDERATIONS

Although this transmitter was operated for many periods of several hours each before a fan was installed, with the door closed and the room at a comfortable temperature, using modulation with full input power, such operation is very improper. The temperature within the transmitter rose to very high values during these tests, and

although no equipment was lost it is reasonably certain that much longer continuous operation of the transmitter would cause very destructive heat and that short life of the equipment could be expected. The transmitter cabinet is provided with louvres at top and bottom of each side; and in addition, the door at the back is punched, top and bottom, giving a cane-like area directly behind the rectifier tubes and the large tubes in the r.f. section. While convection currents were of considerable aid in removing heat from the transmitter, a fan was found to be a necessary addition. After thorough tests of the transmitter without special cooling aid were completed an eight-inch fan was obtained, and after some experiment to determine the position which would give most efficient cooling it was placed as shown in the back view, directly against the top louvres on the warm side of the transmitter. It is operated as an exhaust fan, causing a strong draft of heated air from the transmitter. The induction motor is connected so that it operates continuously while the filaments are heated. Even with the fan, the internal temperature in the transmitter is quite high, and for this reason the remarks in connection with conservative operation apply with the fan as used. A power of 200 watts is dissipated from the filaments alone, and all of 1750 watts except the actual average power delivered to the antenna transmission line is dissipated by the transmitter when it is operated as a 'phone unit.

#### COUPLING

It is very important that the coupling between the oscillator plate coil and buffer grid coil, and the coupling between the buffer plate coil and final amplifier grid coil, be very carefully adjusted to obtain optimum operation of these three stages. Once set, this adjustment remains fixed for all future operation, since the grid and plate coils mutually coupled are wound as single plug-in units, one for each band, for each coupling position. Thus, the optimum coupling is automatically obtained by simply plugging in the proper coils for any frequency band. As used in this transmitter, the coupling is so close that a very noticeable interaction of tuning exists between coupled tanks. In order to adjust the circuits to resonance, therefore, the two condensers—plate condenser of one stage and grid condenser of the succeeding stage—are adjusted simultaneously, the grid current of the succeeding stage being observed during the process. With this one exception, the usual process of tuning applies to this transmitter.

The antenna coupling arrangement is simply a single turn of wire placed inside each final-amplifier plate-coil form and located centrally within the winding. The coupling is varied by rotating the turn. The ends of the antenna coil are brought out through holes in the top of the form and are cut off so as to leave half-inch



lengths of wire protruding for terminals. The transmission lines used with the transmitter are of the low-impedance untuned type, concentric and twisted-pair, varying from 40 to 100 ohms impedance.

This transmitter as described, has been operated on the 3.5-, 7- and 14-Mc. bands. For output on any of these three bands, a crystal of either the output frequency or half the output frequency may readily be used, supplying sufficient excitation to the buffer to drive the final amplifier adequately for 'phone or code operation. For code work alone, frequency doubling may be used in both the Tri-tet oscillator and the intermediate amplifier, making it possible to operate the transmitter on twenty-meter c.w. with full half-kilo-watt input, using an eighty-meter crystal in the oscillator.

The power which the transmitter may be expected to deliver to the antenna transmission line varies from 300 to 400 watts, depending on the care taken in making adjustments, and the frequencies of output and crystal.

To give definite information on the compactness of this transmitter, the following specifications are listed:

- Height . . . . . 42 inches, overall
- Width . . . . . 20.5 inches
- Depth . . . . . 15 inches
- Weight . . . . . 350 pounds, equipped for operation

Although it was originally feared that a transmitter as compact as this would be erratic in operation and require frequent repair, this unit

COIL DATA

Frequency		L <sub>1</sub>	L <sub>2</sub>	L <sub>3</sub>	Separation L <sub>2</sub> -L <sub>3</sub>	L <sub>4</sub>	L <sub>5</sub>	L <sub>6</sub>
3.5 Mc.	Turns	11	14	14	1/2"	15	19	24
	Length	3/4"	3/4"	3/4"		3"	2 1/2"	3 1/4"
7 Mc.	Turns	6	9	9	1/2"	15	19	12
	Length	5/8"	3/4"	3/4"		3"	2 1/8"	3 1/4"
14 Mc.	Turns		6	6	7/8"	8	9	5
	Length		1/2"	1/2"		3"	2 3/4"	2"

L<sub>1</sub>, L<sub>2</sub>, L<sub>3</sub> — No. 18 wire on 1 3/4" diameter ceramic form.

L<sub>4</sub> — No. 12 wire on 4" diameter ceramic form.

L<sub>5</sub> — No. 12 wire on 2 1/2" diameter ceramic form, concentric with L<sub>4</sub>.

L<sub>6</sub> — No. 10 wire on 3" diameter ceramic form.

has been giving consistent and dependable service. It made a very interesting experiment, with satisfactory results. If equipped with component parts specially suited to this type of construction, there is little doubt that extremely compact transmitters could be built to give complete satisfaction, using effective cooling means.

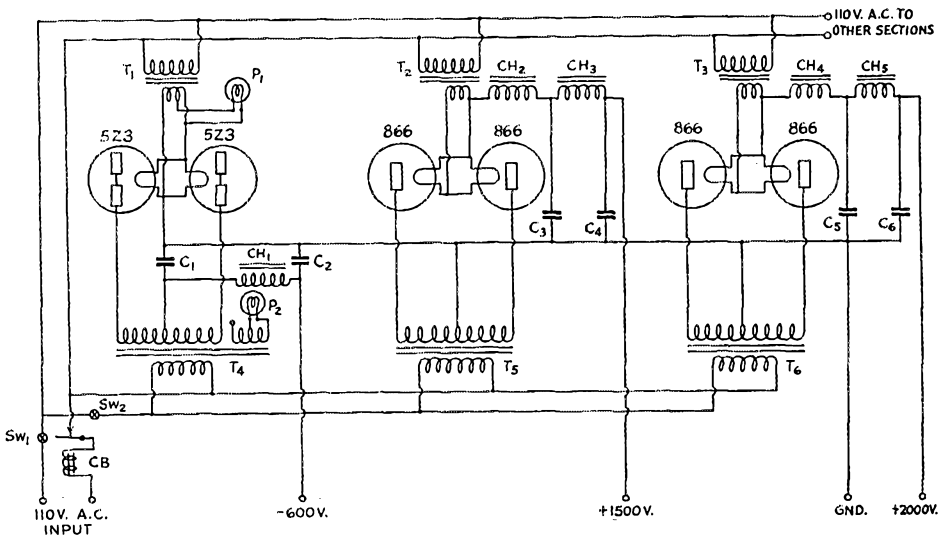

FIG. 3—POWER SUPPLY DIAGRAM

- C<sub>1</sub>, C<sub>2</sub>—4-μfd., 1000-volt oil condenser.
- C<sub>3</sub>, C<sub>4</sub>—2-μfd., 2000-volt oil condenser.
- C<sub>5</sub>, C<sub>6</sub>—2-μfd., 3000-volt oil condenser.
- CH<sub>1</sub>—20-henry, 200-ma. choke.
- CH<sub>2</sub>, CH<sub>4</sub>—18-henry, 300-ma. swinging choke.
- CH<sub>3</sub>, CH<sub>5</sub>—12-henry, 300-ma. smoothing choke.
- CB—20-ampere circuit breaker.
- T<sub>1</sub>—Filament transformer, 5 volts, 6 amp.
- T<sub>2</sub>, T<sub>3</sub>—866 Filament transformer, 2.5 volts, 12 amp.

- T<sub>4</sub>—Plate transformer, 600 volts each side c.t., 200 ma., with 5-volt winding.
- T<sub>5</sub>—Plate transformer, to give 1500 volts d.c. at 500 ma. through filter.
- T<sub>6</sub>—Plate transformer, to give 2000 volts d.c. at 400 ma. through filter.
- P<sub>1</sub>, P<sub>2</sub>—2.5-volt pilot lights.
- Sw<sub>1</sub>, Sw<sub>2</sub>—Filament and plate control switches, s.p.s.t.

# A Home-Built Velocity Microphone

## Constructional Details of a Unit Built from Magneto Parts

By Norman E. Gibbs, WIJXP\*

**R**IBBON microphones have always appealed to the writer because of their simplicity, ruggedness, and good frequency response. Construction of most types of ribbon microphones is quite simple. In essence the microphone consists of a metallic ribbon suspended between the poles of a magnet. Sound waves by their pressure cause the ribbon to move. It thus becomes a tiny

least some lead as it was quite soft. A new one might effect a cure, so our experiments began at that point. The new ribbon made a new microphone out of the apparent "dud," but still the pickup was not as much as competing makes afforded. The idea of making an attempt at home construction became most attractive.

At the start several demands must be recognized:

1. The expense of construction must be low.
2. Only ordinary tools found in the usual home shop should be required.
3. The proper material must be utilized or success is nearly impossible. By proper materials of course is meant high-quality magnets, high-permeability steel for the pole pieces, and a foil from which to cut the ribbons which possesses proper mechanical and electrical characteristics.

### SELECTING RIBBON FOIL

In the hunt for suitable foil for the ribbons, all sorts of metal sheet and foil were inspected. A good source which yields a surprising variety is blown filter and by-pass condensers (paper type). The following properties are demanded:

1. Lightness—a suitable foil is from one-third to three-quarters of a thousandth thick. Usually the thinner ribbons are more sensitive as there is less force required to move their lighter bulk—provided, of course, they possess the quality of elasticity.
2. Elasticity—springiness. Suitable foil makes a tinkling noise when a strip of it is waved with the hand. The noise is distinctly metallic and usually a foil giving this noise will have good tensile strength. A lead foil will not have the proper springiness, but may stretch if put under slight strain. A good foil, if slightly wrinkled, can be stretched in the same manner as a coil spring, provided the stretching is not too violent.

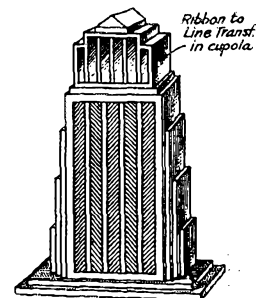

FIG. 2—SKETCH OF THE MICROPHONE CASE  
It is made of wood, as described in the text.

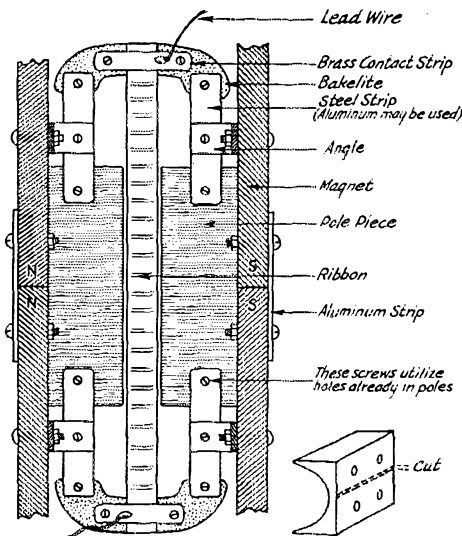

FIG. 1—VELOCITY MICROPHONE CONSTRUCTION DETAILS

Dimensions will depend upon the magneto parts used.

generator, since it is a conductor moving in a magnetic field.

The assemblies to be described were made as a result of an unhappy experience with a commercial velocity microphone purchased for use with a 'phone transmitter. The response was very poor and the hum level most annoying. Compared with other types it was a dismal failure. With the feeling that matters could not be made much worse the "mike" was pulled apart, the general idea being to see if the ribbon were correctly centered or if some reason could not be found for the poor operation.

The ribbon in question seemed rather lifeless and apparently was made of foil containing at

\* Old Lyme, Conn.

tin foil will not have the proper springiness, but may stretch if put under slight strain. A good foil, if slightly wrinkled, can be stretched in the same manner as a coil spring, provided the stretching is not too violent.

3. High conductivity—a bright surface means good conductivity. Tin foil possesses this as well as the other properties. Aluminum foil is

covered with a transparent coat of aluminum oxide which prevents good electrical contact. This oxide, by the way, causes the difficulties experienced in attempts to solder aluminum, as it forms almost instantaneously.

All in all, that "tinkle" sound is the best rule of thumb to use in judging material. Such foil keeps its bright surface, is easy to provide with proper contacts, and its springiness means lively response in the "mike."

As a start it was assumed that, within limits, the better and stronger the magnets used the better would be the results. Also it was assumed that the material to be used for the pole pieces would have to be of high magnetic permeability. Obviously the cost of having steel pole pieces machined to order from a high-grade cobalt steel was out of the question.

At hand were two defunct marine magnetos; the magnets and pole pieces were obtained from these.<sup>1</sup> The poles are especially adaptable to our purpose and are of high-permeability steel anyway. Only a hack saw, emery wheel, hand drill, soldering iron, and the other usual and miscellaneous tools were at hand, nor are special tools required. The emery wheel is a necessity.

The following description of the steps taken in construction, together with the sketches and photographs, should give sufficient detail to enable any mechanically inclined person to build a presentable microphone.

#### MECHANICAL CONSTRUCTION

The magnetos are torn down, care being taken to keep all the machine screws. If desired your

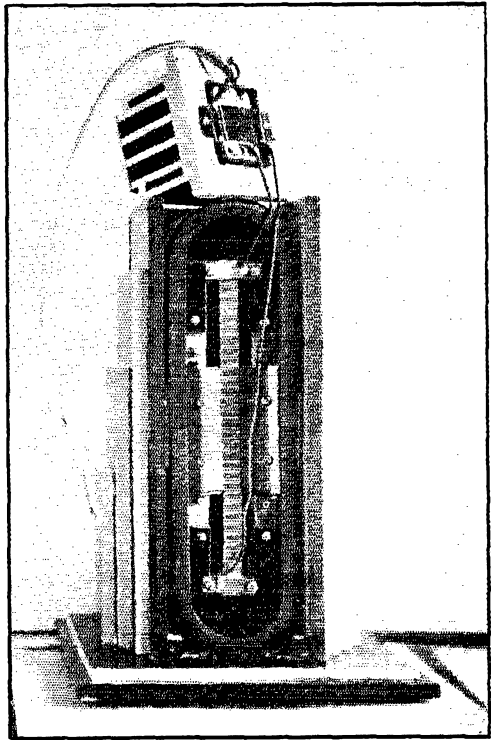

ASSEMBLED IN THE CASE, WITH THE FRONT GRILLE REMOVED

Note the ribbon-to-line transformer in the "penthouse."

magnets tend to oppose one another. If your magnets tend to draw together you have them in the wrong position. In proper position we have a flat oval magnet with the poles at the junction (on each side) of the assembly. An aluminum strip is used to fasten the magnets together, the holes used being those already drilled for us.

We are now ready to prepare the pole pieces. Fortunately the poles are shaped down to a narrow edge, ideal for our purpose. Our task is to cut one of the magneto poles in half to furnish a pair for the microphone. This is accomplished with the emery wheel. With care a straight and fairly narrow cut can be made. The edges of the pieces should be ground as perfectly straight as possible so that when they are mounted the ribbon slot will have straight sides and not be wider at one end. The sketch shows where the cut is made.

Forming the pole and ribbon assembly is best explained by the drawings and photographs. A number of pieces of strip steel of the type used to bind the cores of b.c.l. power transformers, or strip brass or aluminum, together with angles of the same material, provide means for fastening the assembly rigidly. In the models built by the writer the clearance between the pole pieces was

(Continued on page 78)

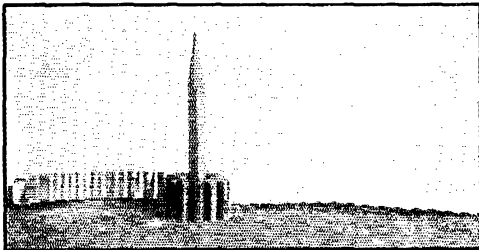

#### RIBBON AND CRIMPING TOOL

The tool is a small gear with a pencil stub as a handle. The crimping is done on a piece of soft felt.

local garage and ignition shop can boost the strength of your magnets by placing them in the field of a very strong electromagnet. In assembling the magnets to form an elongated oval be careful to place similar poles together so that the

<sup>1</sup> Almost any good-sized garage where electrical repair work is done should provide at least a source of information for tracking down a defunct magneto. There is no reason why types of magnetos other than marine could not be used as effectively. As to cost, the probability is that the price of old "mags" will be quite nominal and the entire unit can be built for less than \$10. If the magneto is picked up for a song, \$5 should suffice.

# ● ARMY-AMATEUR RADIO SYSTEM ACTIVITIES ●

## Speed Contest Results

THE Seventh Corps Area is to be congratulated on winning the Code Speed contest (of December 6, 1937) with a total score of 482.4 points. They had ninety-one members participating with an average speed of 29.7 words per minute. The highest speed attained by them was 45 words per minute.

Complete scores for all Corps Areas are listed below.

CA	Total Points	Participants
I.....	112.1	20
II.....	158.0	41
III.....	289.8	54
IV.....	309.0	29
V.....	116.0	20
VI.....	112.5	30
VII.....	482.4	91
VIII.....	295.8	26
IX.....	268.0	96

W5GEY won first place in the individual scoring, having copied accurately sixty-five words per minute. He was awarded a "MacKey," which was donated by Terminal Radio Co., New York City. W4AFQ was second with a speed of fifty words per minute. He did not wish to compete in the individual scoring, having won a prize in last season's contest. The second prize, a Bliley Crystal, type LD2, donated by Harvey Radio Co., New York City, was awarded to W2BCX, who was next high with a speed of fifty words per minute.

The highest scoring A.A.R.S. members in each Corps Area are as follows, listed according to the length of copy made accurately at speeds indicated: First C.A.—W1BVR 40, W1AKS 40, W1JMS 40. Second C.A.—W2BCX 50, W2GGE 45, W2DBQ 40. Third C.A.—W3AKB 45, W3DNY 40, W3GKZ 40. Fourth C.A.—W4AFQ 50, W4AWO 45, W4AGI 40. Fifth C.A.—W9NGS 45, W8QLO 40, W8PWY 35. Sixth C.A.—W9DOU 40, W9YPI 40, W9SZL 35. Seventh C.A.—W5BMI 45, W9BNT 45, W9KCG 45. Eighth C.A.—W5GEY 65, W6KFC 50, W5OW 45. Ninth C.A.—W6GXM 45, W6BMC 40, W6CVL 40.

Non-member W9HUM of the Sixth Corps Area made best copy submitted, having copied one hundred words perfectly at sixty-five words per minute.

Following is quoted from the Eighth Corps Area Bulletin:

"We all have heard this recognized phrase, 'He is a fine op,' and we all would like to have this said about us. We have read about the ham who can copy fifty, and some of us have had the pleasure to know personally such operators. The height of every radio enthusiast's ambition is to make a real operator of himself, but very often the motive is speed only. The 'fast' boys

will tell us that speed is all right only as long as accuracy is primary. The foregoing may seem rambling, but it ties up very definitely with what is to follow.

"In the A.A.R.S. are certain signals which are for convenience in operating. They are for the most part purely 'procedure' signals and are used in A.A.R.S. operations to save time. One Army man will doubtless think another a good operator if he is always on his toes and able to use correctly these signals.

"If you have been a careful listener, you have doubtless heard the above-mentioned signals used in drills which have no relation to the Army. It is this incorrect use of forms which will hurt many otherwise good men. When in a drill, or a net, please use the form that is set as standard for that particular net, and when operating in another net use the method prescribed for its operation. Do not mix operations. It will pull down your operating ability in the eyes of the fellows you work with.

"Another thing that seems to have a strong hold upon the activity this year is indifference towards schedules. One does not have to make schedules with a fellow ham just because he is asked to do so, but if the schedule is made, then keep it as regularly as possible. There are times when it is humanly impossible for us to make a program click, but a little time spent on a systematic arrangement of our working time, our radio time and our sleeping time will result in well organized system by which not only will the radio operating become more enjoyable and efficient, but also will the rest of the outside activities. It might be added that even though you are not so 'hot' when speedy operation is desired, regularity in operating will undoubtedly give you an excellent standing with other fellows."

## NOTES AND COMMENTS

From reports submitted for a period of one month, the average amount of traffic originated, relayed and delivered by A.A.R.S. members is 1.58 messages per station per day.

Traffic reports submitted to Corps Area Signals should include all traffic handled by the station. Reports to A.R.R.L. should separate ham-band traffic from that handled on the special frequencies. The A.A.R.S. uses A.R.R.L. method of counting traffic.

The main defect in many portable emergency rigs is that they are not portable.

"Accuracy First," and, "Reduce Delay Time" are written in neon lights in the War Department Message Center.

(Continued on page 82)

# Speech Versus Sine Waves

## A Discussion of Class-B Modulator Capabilities

By Earl I. Anderson,\* W8UD

"A little knowledge is a dangerous thing". That, unfortunately, seems to sum up the situation with respect to the modulating capabilities of Class-B audio amplifiers. The fact that speech wave-forms contain, on the average, only about half the power of a pure tone having the same peak amplitude has led too many amateurs to jump to an erroneous conclusion. The author here reiterates, with examples, statements made in *QST* some two years ago—principles which have been overlooked in the search for something for nothing. Every 'phone man should read it.—EDITOR.

IT is a well-known fact that with a sine-wave signal in plate modulation, the audio power required for 100% modulation is 50% of the d.c. input to the Class-C stage. With voice input, however, the average audio power requirements are in the vicinity of 25%,<sup>1</sup> a condition which has led many amateurs to believe that a given Class-B audio stage will modulate twice as much r.f. input with voice as it would with a pure tone. For example, it is assumed that a modulator rated to deliver 100 watts of audio will modulate a 200-watt Class-C amplifier with sine-wave input, and a 400-watt amplifier with voice input.

Unfortunately, this is not true. Average output is no indication of the peak output if the wave-form is not known, and peak power is the important consideration. However, the shape of voice waves is such that, in general, the average power for a given peak power is only about half that for sine wave having the same peak power. But the peak power requirements for 100% modulation are the same regardless of wave form, so the same peak power is required whether the input wave form is that of a pure tone or speech. This means that a given modulator set-up can modulate 100% without distortion only a definite Class-C stage power input; this input remains constant and is not a function of wave-form or average power.

However, since with voice input the average power is less, it follows that the average plate dissipation is less. Consequently, if plate dissipation is the only limiting factor, the operating conditions can be revised to secure more output with voice input than with sine-wave input, because excessive heat will not be developed on the plates. On the other hand, not only plate dissipation but also filament emission and insulation in the tube must be taken into consideration. If the filament emission is adequate, the peak current value may be increased until either it or the plate dissipation become the limiting factors; or if the insulation in the tube is sufficiently good the plate voltage may

be increased until either it or the dissipation become the limiting factors. Whether or not the peak plate current and plate voltage may be increased depends upon the characteristics of each individual tube type. Operation in excess of ratings should not be attempted in the absence of positive knowledge that it is permissible in the individual instance, and will not result in tube failure or increased harmonic content.

In other words, if the sine-wave ratings are conservative from the standpoint of voltage or current, or both, new operating conditions may be chosen to permit greater output with voice than with sine-wave input, by taking advantage of the reduced plate dissipation with voice. The correct operating conditions would be the same as for the same peak output with a sine-wave signal, and would be calculated exactly as described in a previous article.<sup>2</sup>

The essential formulas needed for any Class-B calculation are reproduced here for convenience:

$$I_{pmax} = \frac{I_{pav}}{0.636}$$

where  $I_{pmax}$  = peak plate current to each tube  
 $I_{pav}$  = max. average plate current to both tubes with sine-wave input

$$ER_p = I_{pmax} \times R_p$$

where  $ER_p$  = peak voltage developed  
 $R_p$  = reflected load impedance to one tube (one-fourth plate-to-plate value)

Minimum voltage drop across tube =  $E_b - ER_p$   
where  $E_b$  = plate supply voltage

$$\text{Power output} = \frac{ER_p \times I_{pmax}}{2} = \frac{I_{pmax}^2 \times R_p}{2}$$

$$R_p = \frac{ER_p}{I_{pmax}}$$

$$\text{plate-to-plate load} = 4R_p$$

\* Douglas, Michigan.

<sup>1</sup> Grammer, "Greater Economy in Class-B Modulator Design for Speech," *QST*, August, 1935.

<sup>2</sup> Anderson, "Class-B Audio Design," *QST*, August, 1937.

SOME PRACTICAL EXAMPLES

In general, tubes such as 203-A's with all leads out the base cannot be operated at greatly increased voltages because breakdowns in the base or socket, if not in the tube, may result. It may be possible to increase the peak plate current for increased output. At the maximum rating for 203-A's we find the following:

D.c. plate voltage.....	1250 volts
Max. average plate current (2 tubes).....	306 ma.
Optimum load impedance (plate-to-plate).....	9000 ohms
Power output.....	260 watts

Analyzing these figures, we find:

$$0.306/0.636 = 0.482 \text{ amp. peak plate current to each tube}$$

$$0.482 \times 9000/4 = 1080 \text{ peak volts developed}$$

$$1250 - 1080 = 170 \text{ volts minimum drop across tube}$$

From the curves it seems safe enough to run the peak plate current up to about 0.7 amp. At the increased current the drop across the tube would be proportionately greater,<sup>3</sup> so

$$170 : x = 0.482 : 0.7$$

$$x = 250 \text{ volts drop across tube at 700 ma.}$$

$$\text{Power output} = \frac{(1250 - 250) \times 0.7}{2}$$

$$= 350 \text{ watts}$$

$$R_p = \frac{(1250 - 250)}{0.7} = 1430 \text{ ohms}$$

$$1430 \times 4 = 5720 \text{ ohms, plate-to-plate}$$

By increasing the peak plate current and changing the operation conditions we have made it possible to modulate 700 watts input instead of the 520 watts possible under the sine-wave setup. Under these new conditions the maximum average plate current with sine-wave input for full output would be  $0.7 \times 0.636$ , or 445 ma. With voice input for the same peak output the maximum average plate current would be only about 50% as great. The 203-A filament will handle the 0.7-ampere peak plate current in good shape, and with voice input the average plate dissipation will be well below the ratings.

With a tube on which the plate voltage as well as the peak current may be increased, a much greater ratio of voice output to sine-wave output may be obtained. The T20 is an example of such a tube. Because its plate lead comes out the top the voltage may be increased greatly without fear of breakdown, and reference to the curves indicates that the filament is capable of emission far in

<sup>3</sup> This assumption is not strictly correct, since the proportionality will depend upon the tube characteristics. In practice, however, no error of any importance is introduced, since the load resistance and excitation changes necessitated by the new operating conditions operate to maintain the minimum plate voltage fairly close to its original value.—Error.

excess of the requirements at the maximum rated output. The maximum sine wave ratings are as follows:

D.c. plate voltage.....	800 volts
Max. average plate current (2 tubes).....	137 ma.
Optimum load impedance (plate-to-plate).....	12,000 ohms
Power output.....	70 watts

Analyzing these figures, we find:

$$0.137/0.636 = 216 \text{ ma. peak plate current to each tube}$$

$$0.216 \times 12,000/4 = 650 \text{ peak volts developed}$$

$$800 - 650 = 150 \text{ volts drop across tube}$$

Suppose we increase the plate voltage to 1000 without increasing the peak current.

$$\text{P.O.} = \frac{(1000 - 150) \times 0.216}{2} = 91.8 \text{ watts}$$

$$R_p = \frac{850}{0.216} = 3940 \text{ ohms}$$

$$3940 \times 4 = 15,760 \text{ ohms, plate-to-plate}$$

Inspection of the curves shows that the peak plate current may be increased to 0.3 ampere safely. The drop across the tube will be proportionately greater

$$0.216 : 300 = 150 : x$$

$$x = 208 \text{ volts drop across tube at 300 ma. peak}$$

At the increased plate voltage and current the calculation would be

$$\text{P.O.} = \frac{(1000 - 208) \times 0.3}{2}$$

$$= 119 \text{ watts}$$

$$R_p = \frac{792}{0.3} = 2640 \text{ ohms}$$

$$2640 \times 4 = 10,560 \text{ ohms plate-to-plate}$$

With sine-wave input the maximum average plate current would be  $0.3 \times 0.636$  or 191 ma. and the plate dissipation would be greatly in excess of the rated value, but with voice input for the same peak output the maximum average plate current would be only about 100 ma. and the plate dissipation should be approximately the rated value.

In conclusion, it is possible to modulate more input to the final stage with voice than with tone modulation, but the operating conditions must be altered to permit increased peak output—and definite knowledge of the tube capabilities is absolutely essential. The assumption that twice as much input to an r.f. amplifier can be modulated with voice as with sine-wave input in the same setup is entirely without basis in fact, and can only result in serious distortion if attempted. For distortionless 100% modulation the input to the modulated amplifier must not exceed twice the audio capabilities of the modulator.

# A Universal Test Unit for the Study of Television Images

Sweep Circuits, Video Amplifier and an Image Generating Tube Combined in a Unique Set-Up

By Marshall P. Wilder,\* W2KJL

AT this stage the reader of this series of articles will have a general idea of modern television technique together with enough circuit data to permit him to build a complete receiver. The circuit material has been made intentionally very general in nature in order to facilitate the description of the functioning of the various components. We could, at this stage, proceed with a detailed constructional type of article describing a complete receiver. Since regular scheduled transmissions are still (at the time of writing) unavailable and since the sincere experimenter will demand a still more detailed understanding of practical circuit and adjustment procedure, we have decided to devote this article instead to the description of what can be considered a universal experimental set-up, built around inexpensive equipment and suited for use either as portion of a receiver, as a "test set" capable of producing a complete picture signal for the adjustment of receiving apparatus, or as the basis of an experimental transmitter.

This experimental equipment is built around a most fascinating device, recently perfected for television work, which is actually a test picture generator tube. The device, under the name "Monoscope," was described by Mr. C. E. Burnett of RCA at a recent convention of the Institute of Radio Engineers. The original tube was a very beautiful affair designed for use in the testing of commercial studio and transmitter equipment and was rather out of the reach of the amateur. The very great usefulness of this device, however, has led other manufacturers to undertake development work aimed at the production of a small and inexpensive unit. Two such tubes under development are the "Monotron" of National Union and the "Phasmajector" of the Allen B. DuMont Laboratories.

These test picture generator tubes consist

\* 55 Kendall Ave., Maplewood, N. J.

essentially of an electron gun similar to that used in conventional cathode-ray tubes. This gun focuses a beam of electrons upon an aluminum disk mounted in the position ordinarily occupied by the fluorescent screen of a cathode-ray tube. The picture to be reproduced is printed on this disk. The electron beam is deflected with normal sweep circuits and as the beam crosses the picture, variations in secondary emission from the picture disk result. The secondary electrons emitted are either gathered on a conductive coating inside the tube or on a special collector element, and the video output voltage is obtained either from the picture plate or from the collector.

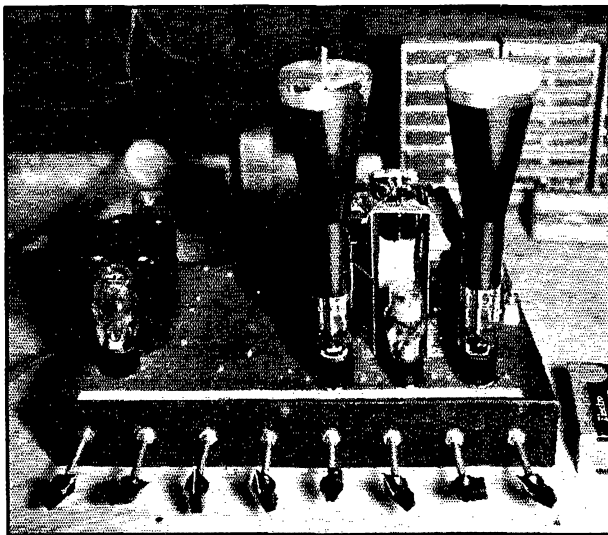

THE COMPLETE PICTURE GENERATING EQUIPMENT TOGETHER WITH A VIEWING TUBE: AN EXPERIMENTAL SET-UP OF THE EQUIPMENT DESCRIBED

Power supplies for the video amplifier, the sweeps and generating and viewing cathode ray tubes are at the left. The video amplifier (with one tube upside down to shorten wiring) is between the C.R. tubes. Sweep circuit gear is at the right rear. The plentiful controls are, of course, to facilitate experiment.

The output of the device is surprisingly high and the gain of an amplifier used to bring the signal up to a sufficient level to operate the control grid of the C.R. tube need not be greater than 25.

The important feature of the whole development from the amateur point of view is that we are to have available an inexpensive method of producing a television signal which is certain to be of enormous benefit in facilitating experimental work. No longer need we wait for commercial transmitters nor, for that matter, need we give up hope of participating in television experiment just because we live beyond the range of the transmitters now operating. Even when we do have a commercial signal available, the new picture tube will make available a test picture of fixed and known quality with which accurate comparative work may be done. It is fortunate also that the necessary associated apparatus is relatively simple. And it is still more fortunate that the equipment built to operate the new tube is all entirely suitable for use in an experimental receiver.

In Fig. 1 is the complete circuit of a picture generating unit. It includes two sweep units, of the type described in the last article of this series, together with a two-stage video amplifier. Also, there is the necessary wiring for the picture tube itself. This unit, with a conventional three-inch cathode ray tube in place of the Monotron, becomes a television receiver by the addition of an r.f. section and a synchronizing pulse separation unit. On the other hand, it becomes a demonstration unit to allow the visual examination of the picture in the Monotron tube by connecting a

three-inch cathode-ray tube to the 1000-volt supply, providing a separate voltage divider for focusing, then connecting the control grid of the cathode-ray tube to the output of the video amplifier. The output of the sweep circuits is connected, of course, both to the deflecting plate in the Monotron and in the cathode-ray tube.

Examination of the circuit will show that the sweep unit and the video amplifier correspond very closely to the circuits given in previous articles. Also, the arrangement of the Monotron portion follows exactly conventional cathode-ray tube practice. The only unconventional feature is in the arrangement used to extract from the sweep circuit suitable pulses for synchronizing and blanking. These pulses are obtained from the plate of the second tube in each sweep unit. In order to avoid interlocking between the two oscillators and to insure proper mixing of the two synchronizing pulses, the pulses are passed through a double diode before being mixed. They are then fed directly to the control grid of the Monotron in order to prevent the generation of any video voltage during the return traces of both sweeps. If this were not done, the video voltages would cause irregularities in the amplitudes of the synchronizing pulses. In order to get these pulses in the output of the complete unit, a small portion of the available pulse voltage is picked off a voltage divider and injected into the grid of the first

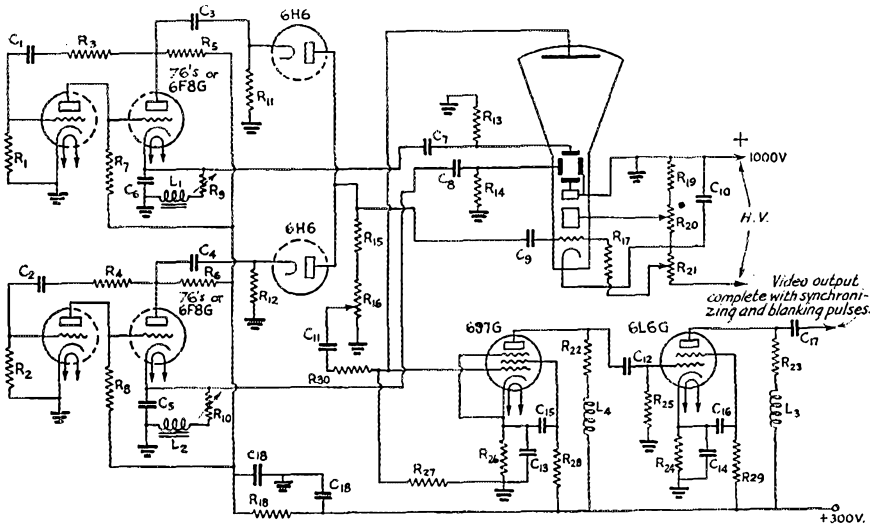

FIG. 1—THE COMPLETE CIRCUIT OF THE STANDARD PICTURE SIGNAL GENERATOR UNIT

- |  |   |  |
|--|---|--|
| R <sub>1</sub> , R <sub>2</sub> , R <sub>11</sub> , R <sub>12</sub> , R <sub>13</sub> , R <sub>14</sub> , R <sub>25</sub> —1 megohm. | R <sub>19</sub> —150,000 ohms.                | C <sub>5</sub> —2 μfd.   |
| R <sub>3</sub> , R <sub>4</sub> —4000 ohms.  | R <sub>20</sub> —75,000 ohms.                 | C <sub>6</sub> —0.001 μfd.   |
| R <sub>5</sub> , R <sub>6</sub> —2000 ohms.  | R <sub>22</sub> , R <sub>23</sub> —2500 ohms. | C <sub>7</sub> , C <sub>8</sub> , C <sub>12</sub> , C <sub>17</sub> —.5 μfd. |
| R <sub>7</sub> , R <sub>8</sub> —100,000 ohms.   | R <sub>24</sub> —220 ohms.                    | C <sub>9</sub> , C <sub>10</sub> —1 μfd.                                     |
| R <sub>9</sub> —50,000 ohms.   | R <sub>26</sub> —1500 ohms.                   | C <sub>11</sub> —25 μfd.   |
| R <sub>10</sub> —150,000 ohms.   | R <sub>27</sub> —25,000 ohms.                 | C <sub>13</sub> , C <sub>14</sub> —50 μfd.                                   |
| R <sub>15</sub> —200,000 ohms.   | R <sub>28</sub> —250,000 ohms.                | C <sub>15</sub> , C <sub>16</sub> , C <sub>18</sub> —8 μfd.                  |
| R <sub>16</sub> , R <sub>21</sub> —10,000 ohms.  | R <sub>29</sub> —30,000 ohms.                 | L <sub>1</sub> —100 henrys.  |
| R <sub>17</sub> —.5 megohm.  | R <sub>30</sub> —250,000 ohms.                | L <sub>2</sub> —2000 henrys.   |
| R <sub>18</sub> —1500 ohms.  | C <sub>1</sub> , C <sub>2</sub> —0.002 μfd.   | L <sub>3</sub> , L <sub>4</sub> —100 microhenrys.                            |
|  | C <sub>3</sub> , C <sub>4</sub> —0.01 μfd.    |  |



video amplifier tube along with the signals from the Monotron. The output of the video amplifier thus contains the picture voltages plus the synchronizing and blanking pulses. In other words, the output of the unit corresponds very closely to that obtained from the final video amplifier in a receiver tuned to a normal television signal. In setting up the equipment it is as well to have a three-inch cathode-ray tube available. This tube is placed in the socket ordinarily occupied by the picture generating tube and the sweep circuits are then adjusted until the usual scanning lines cover the desired area. Some workers will find it worthwhile to add adjustable positioning controls to permit centering the pattern—the necessary circuits being available in many pamphlets and books dealing with cathode-ray tube technique. With this setup the voltages on the cathode-ray tube may also be adjusted to give the desired brilliance and focus. The operation of the blanking pulses can be checked by removing the diode tube, in which case the return traces will be visible on the screen. All of this suggests that the device, in addition to serving its prime purpose of a picture signal generator, is also an excellent cathode-ray oscilloscope. Additional condensers may be provided in the cathode circuit of the sweep units to give a wide variety of frequencies and the video amplifier may be used to provide amplification of the voltage whose waveform is to be studied. Should the experimenter already have a complete oscilloscope it will not be necessary to build the entire rig. One additional sweep unit may be added to that already in the oscilloscope and the only additional item will then be the video amplifier.

In our experimental work the unit shown in the photograph has been used for a variety of interesting jobs. In its complete form it allows, in the first place, a very excellent demonstration of the fundamental principles of transmission. Also, it immediately permits an examination of the capability of both the Monotron and the cathode-ray tube in resolving a television image. The pattern provided on the picture tube is sufficiently complex in its drawing so that it is possible to receive all the details present only if the equipment is excellently adjusted. Incorrect sweep amplitudes immedi-

ately become apparent as a distortion in the breadth or height of the image. Poor high-frequency response in the video amplifier is indicated by poor definition on the edges of lines—particularly when they are vertical. Phase shift is indicated by the edges being reversed in color or by the lines themselves being shifted slightly to the right—giving a ghost of the pattern displaced slightly from the original. Then, the ability of the screen, tube and coupling circuit to reproduce good tone values can be tested by observing whether or not any halftones in the original can be duplicated in the final picture.

The unit is essentially a device for facilitating the construction and adjustment of television receivers, but one needs little imagination to visualize it as a source of modulation for a ham television transmitter. Indeed, such equipment has already been used by some of us for preliminary experimental work with considerable success. This is not to say that the day of practical amateur television transmission is here. This gadget permits the transmission of a single picture only and we must await the development of inexpensive Iconoscopes before the reproduction and transmission of moving images becomes possible. It is important to realize, though, that the necessary technique is being given close study and that before very long we shall find amateur television transmission to be not much more complicated nor much more expensive than 'phone transmission is to-day.

In the meantime, we firmly suggest that the television enthusiasts should study and possibly duplicate a unit such as that described. Its operation will give him a very intimate picture of many of the details of television technique which are so difficult to assimilate in any other fashion and will provide him with units suitable for immediate application to experimental reception.

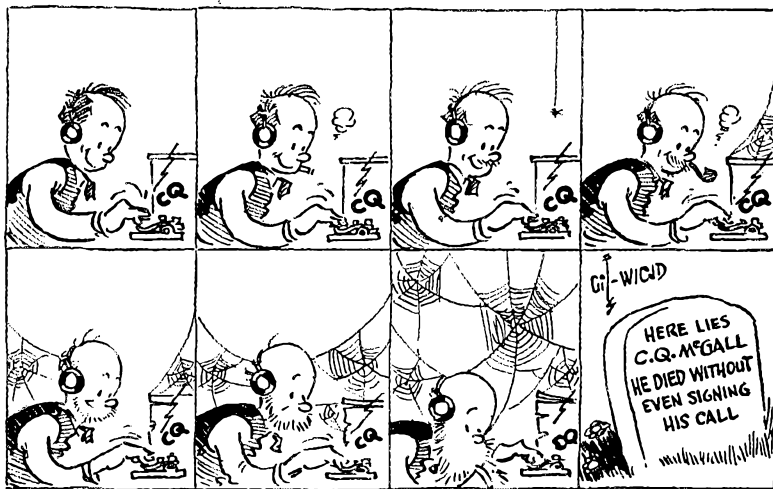

# A Pack Set for 200 and 300 Megacycles

Completely Portable Transmitters Using Acorn Tubes

By L. C. Sigmon,\* W9YNJ

**A**LTHOUGH the 300- and 200-megacycle transmitters to be described were designed primarily to be used in a relay broadcast pack transmitter, I believe the description and results obtained will be of interest to every amateur interested in the development of the ultra-high frequencies.

Experimental work was first started in the early part of the summer of 1937 under my amateur license. At that time breadboard models of the ultra-high-frequency transmitters and receivers were constructed. The results obtained were so promising that two experimental licenses were applied for by the KCMO Broadcasting Company for relay broadcasting purposes. The license called for four experimental frequencies—100, 200, 300 and 500 megacycles. To date all frequencies except 500 megacycles, or 0.6 meter, have been used with excellent results for relay transmissions over short distances, the distance depending upon the frequency, power and location.

At the present time not enough work has been done on the 500-megacycle receiver and transmitter to go into details about it, except to say that the most promising receiver so far constructed seems to be of the type having tuned lines in the plate and grid circuits, similar in construction to the 300-Mc. transmitter shown in Fig. 3.

The complete pack set consists of the main case containing a receiver, modulator and "A" and "B" batteries, and separate transmitters which can be attached to the top of the case. The same transmitter

circuit is used for both 200 and 300 Mc., the difference being simply in the size of the linear tank circuit. The complete circuit diagram is given in Fig. 2.

## LAYOUT DETAILS

Fig. 1 is a picture of the pack set with the 300-megacycle transmitter attached to the projecting pipe. Each end of the pipe is fitted with a four-prong plug so that transmitters of different frequencies may be plugged in. The antenna projecting out of the transmitter is a quarter-wave rod. The antenna to the right, for receiving, also is a quarter wave. All transmitting controls are locked in place after the transmitter is set on frequency. The modulating unit is enclosed in the upper left-hand corner of the pack transmitter proper; the upper right-hand part contains the receiver. The meter on the front reads the total plate current of both transmitter and receiver, the current being approximately 19 ma. The left-hand dial is the regeneration control and the right-hand dial is the receiver tuner. The central bar knob is the audio gain control. The switch breaks both the "A" and "B" voltages. The lower part of the pack transmitter contains three Burgess "B" batteries, No. Z30P, each battery 45 volts, and two Burgess No. F2BP "A" batteries, these being 3 volts each. The total weight of the batteries is only four pounds, eight ounces. In testing the pack transmitter a small power supply was constructed to replace the batteries.

The jacks for the microphone and headphones are located in the left- and right-hand corners on top of the



FIG. 1—THE COMPLETE PACK SET

The 300-Mc. transmitter is in the small box on top of the pipe. The main case contains a receiver, modulator and batteries for plates and filaments.

\* Chief Engineer, KCMO, Kansas City, Mo.

pack unit. The back plate of the transmitter pack is attached with self-tapping screws. Four rubber sponges are provided, one on each corner of the back plate, so that the pack will fit comfortably on one's back. A double-button carbon microphone is used. The reason for elevating the transmitter above the pack is so that the antenna projecting from the top of the transmitter will be clear of the person wearing it, and also others in the vicinity.

**THE TRANSMITTER CIRCUITS**

Fig. 3 shows the 300- and 200-Mc. units uncased. The construction is almost self-explanatory from the pictures. The tuned line in the grid and plate circuits was used to provide the degree of frequency stability required by the Federal Communications Commission, as well as to obtain maximum circuit efficiency. The rods used are  $\frac{3}{8}$ -inch solid brass, and less than  $\frac{1}{8}$ -wavelength long. The spacing between centers of the brass rods is  $\frac{3}{4}$  inch. The distance between the rods can be varied, but with greater spacing longer rods will be required.

The problem of insulation is not serious at the ultra-high frequencies with the type of

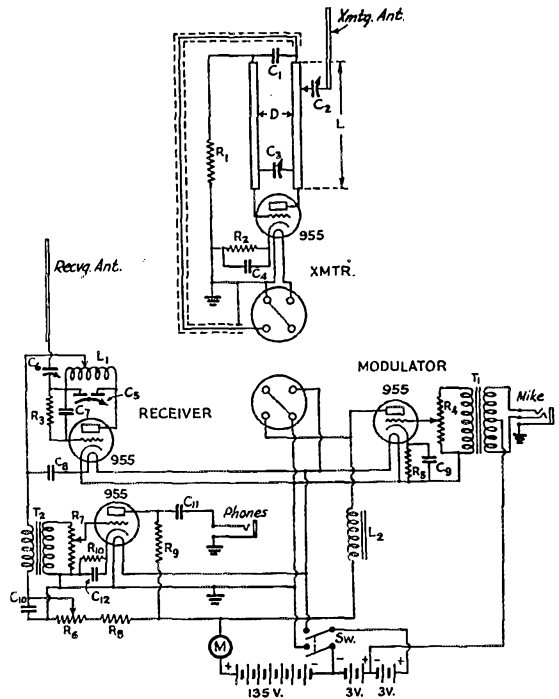

**FIG. 2—CIRCUIT DIAGRAM OF THE PACK TRANSMITTER AND RECEIVER**

- C<sub>1</sub>—100- $\mu$ fd. (Cornell-Dubilier with low-loss case).
- C<sub>2</sub>—30- $\mu$ fd. padder (National M-30).
- C<sub>3</sub>—Tuning condenser. (See text and photos.)
- C<sub>4</sub>—0.01- $\mu$ fd. paper.
- C<sub>5</sub>—Special split-stator (Cardwell ZR-15-AS with stator cut in center).
- C<sub>6</sub>—30- $\mu$ fd. padder (National M-30).
- C<sub>7</sub>—50- $\mu$ fd. fixed (Cornell-Dubilier with low-loss case).
- C<sub>8</sub>—0.003- $\mu$ fd. mica.
- C<sub>9</sub>—25- $\mu$ fd. electrolytic.
- C<sub>10</sub>—0.5- $\mu$ fd. paper.
- C<sub>11</sub>—0.01- $\mu$ fd. paper.
- C<sub>12</sub>—25- $\mu$ fd. electrolytic.
- L— $\frac{3}{8}$ -inch brass rods, length  $3\frac{3}{4}$  inches for 300 Mc., 6 inches for 200 Mc., spaced  $\frac{3}{4}$  inch.
- L<sub>1</sub>—4 turns No. 18, diameter  $\frac{1}{4}$  inch, tapped at center.
- L<sub>2</sub>—A. f. choke (Stancor C-1003).
- R<sub>1</sub>—5000 ohms,  $\frac{1}{2}$ -watt.
- R<sub>2</sub>—450 ohms, 1-watt.
- R<sub>3</sub>—10 megohms.
- R<sub>4</sub>—100,000-ohm midget variable (Centralab N-117).
- R<sub>5</sub>—1000 ohms, 1-watt.
- R<sub>6</sub>—50,000-ohm midget variable (Centralab N-114).
- R<sub>7</sub>—500,000-ohm midget variable (Centralab N-103).
- R<sub>8</sub>—20,000 ohms, 1-watt.
- R<sub>9</sub>—75,000 ohms, 1-watt.
- R<sub>10</sub>—5000 ohms, 1-watt.
- T<sub>1</sub>—D.B. microphone transformer (U.T.C. CS-5).
- T<sub>2</sub>—Audio transformer, 3:1 ratio.
- M—0.25 d.c. milliammeter (Readrite).
- Sw—Battery switch, d.p.s.t.

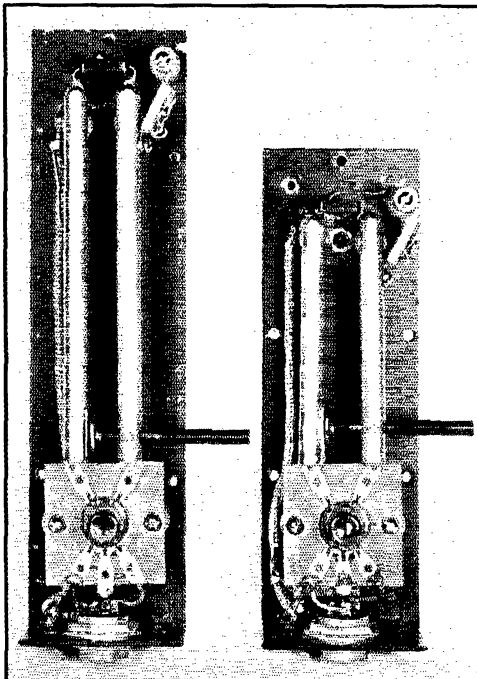

**FIG. 3—THE 200- AND 300-MC. TRANSMITTERS**  
 Either may be plugged into the top of the main case. Both use resonant-line oscillator circuits with 955 acorn tubes.

construction shown. The voltage is slightly less than maximum at the tube socket and is minimum (a voltage node) at the ends of the rods. A standard Mycalex socket is used for the 955 acorn tube. The insulators at the end of each rod are inexpensive ameroid pillars. The condenser shunted across the ends of the grid and plate rods is a special high-frequency unit, but a standard mica postage-stamp-size condenser will work as well.

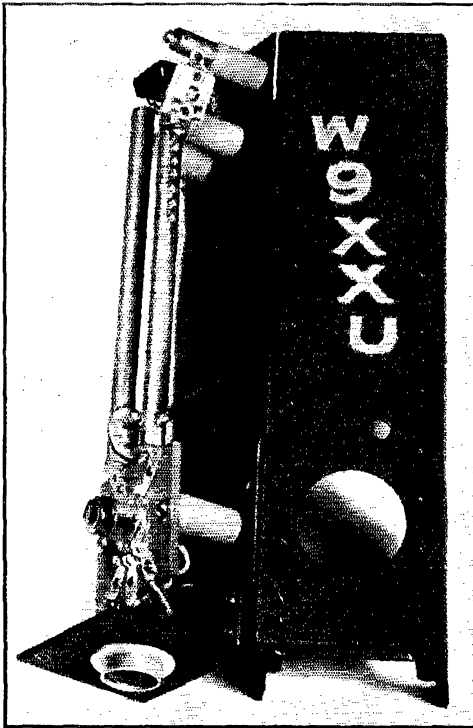

FIG. 4—A SIDE VIEW OF THE 200-MC. TRANSMITTER

Showing how the assembly is mounted to the base plate.

It was found necessary to shield the plate voltage lead. If this is not done standing waves will appear in power leads, and a number of undesirable effects may be expected. The transmitter should only be grounded at one place on the chassis, this being near the grounded filament lead. The shield over the plate voltage lead should also be grounded at the filament lead and the remaining part of the shielded lead insulated from the chassis.

Tuning of the transmitter is effected by means of a penny soldered off center to an 8/32 threaded brass rod. The reason for the penny being soldered off center is to give a vernier tuning effect. Another small plate is soldered to the grid rod to complete the tuning condenser. The details of this construction are shown clearly in Figs. 3 and 4. The plate rod is also tapped for 6/32 screws at intervals of a quarter inch, for a length of approximately an inch and three-quarters from the low-voltage end. This is to locate the proper coupling point for the antenna condenser. Some difficulty was experienced when the oscillator was encased, and those not intending to encase the oscillator will find it necessary to extend the length of the rods slightly. The transmitter proper is constructed on No. 16 gauge

aluminum, but copper is preferable when weight is not an important factor. The main case of the pack transmitter is made of No. 22 gauge cold rolled steel.

The modulator unit is of the Heising type, using another 955 tube. The rest of the circuit is self-explanatory.

#### OPERATING DATA

The quality of voice transmission from the transmitter is good, provided the transmitter is not modulated too heavily. The chief source of distortion is the non-linear characteristic of the regenerative detector used in the receiver. If a low percentage of modulation is used the distortion is not objectionable. All programs broadcast from the relay pack transmitter go through an equalizing circuit which also helps to improve the quality of transmission from the pack.

The greatest distance so far tried for reception was three-quarters of a mile over open country. No doubt greater distances can be covered with higher power. The approximate power of the transmitters is 0.1 watt.

The purpose of the 300- and 200-Mc. pack transmitter at KCMO is not to cover a great distance, but for use inside large auditoriums and for man-on-the-street broadcasts, etc., where it is ordinarily necessary to use several hundred feet

(Continued on page 88)

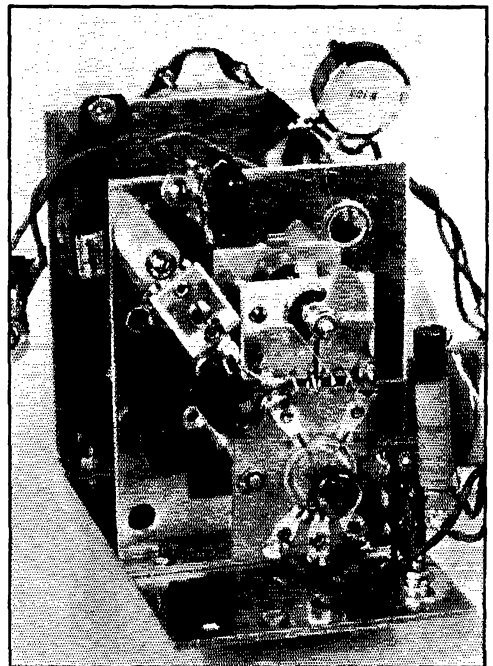
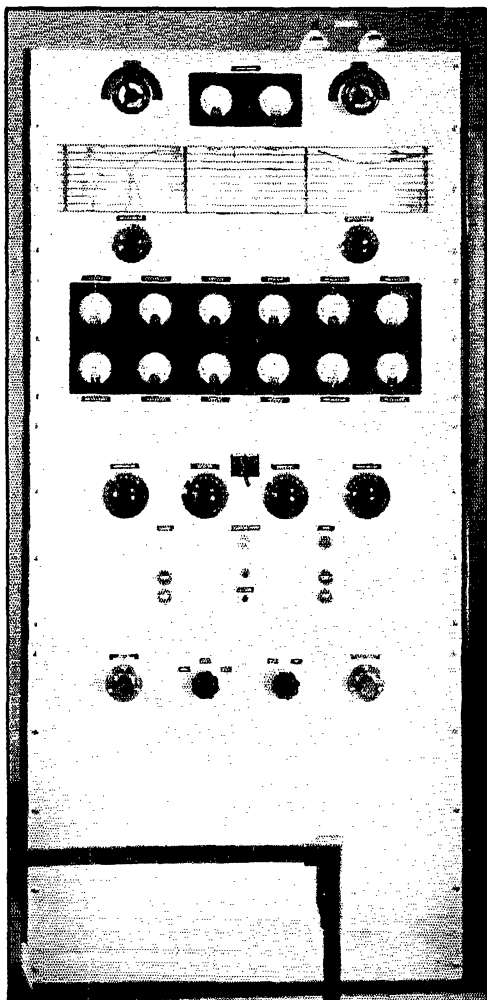

FIG. 5—THE RECEIVER REMOVED FROM THE MAIN CASE

The superregen tube is a 955.



# Amateur Radio STATIONS



BLACK BAKELITE CONTRASTS STRIKINGLY WITH THE ALUMINUM PANELS OF W9AXH'S TRANSMITTER

*The meter panels are set behind glass windows.*

## W9AXH, Indianapolis, Indiana

WHILE all of us admire commercial-built equipment and usually try to emulate it in our own construction, comparatively few are

adept enough to reach the point where visiting hams refuse to believe our rigs are home-made. That, however, is the case with the transmitter recently constructed by W9AXH, Robert E. Stuart, of Indianapolis, Ind., of which two views are shown in the accompanying photographs.

The complete transmitter, used for both 'phone and c.w. in the 80-, 40- and 20-meter bands, is contained in a metal cabinet 78 inches high by 37 wide and 17 deep; three shelves and the base hold the various sections of the outfit. The front panels are made of 3/16-inch aluminum, each 36 inches wide. The final stage, using two 150T's in push-pull, can be operated at inputs from 350 watts to a kilowatt, and is modulated by a second pair of 150T's. A 53 oscillator-doubler, 801 buffer, and 100TH driver complete the r.f. line-up. The audio end built into the transmitter consists of two 76's in push-pull followed by four 2A3's in push-pull parallel which feed the modulator grids.

Looking into the back of the transmitter, the top shelf carries the antenna tuning condenser (used only on 80 meters), final stage and the modulators. A homemade dual fixed condenser, 50  $\mu$ fd. per section, is beside the variable plate tank condenser, a Johnson 50- $\mu$ fd. per-section unit, and can be connected in to increase the tank capacity for 80-meter operation. The tank coil plugs in directly below the tank condenser. The neutralizing condensers and filament transformer also are on this shelf. The grid tank for the final is underneath the shelf, link-coupled to the 100TH driver on the next deck below.

All r.f. stages except the final are on the second shelf. At the left is a crystal oven containing four air-gap holders which are adjustable through the top of the oven. The 53 oscillator-doubler with its tank coils, and the 801 buffer and tank, occupy the space between the oven and the shield which separates the 100TH driver from the exciter. Between the exciter and front panel is a shielded compartment containing the audio driver for the modulator, and also power supplies for the driver and the r.f. exciter. The Class-B input transformer is mounted underneath the top shelf and is fed through a shielded line from the 2A3 plates.

Filter components are contained on the third shelf. At the left are two 3500-volt 2- $\mu$ fd. oil-filled condensers which are connected in parallel

to form the filter output; the input condenser consists of two 3000-volt 2- $\mu$ fd. units connected in series. The input swinging choke is 5-20 henrys at 1 amp., the smoothing choke 20 henrys at the same current. The panel to the right on this shelf holds several control relays; that at the left is a Ward-Leonard time-delay for the 872 rectifiers, followed by a Leach keying relay and a Dunco 30-amp. unit for primary control of the plate circuits. On the other side of the panel (not visible in the photograph) are a second 30-amp. Dunco relay for filament control, a homemade relay for the crystal temperature oven, underload relay for the bias circuit, overload relay for the final-amplifier plates, and overload relay for the modulator. The round can below the shelf contains a switch, operated simultaneously with a voltage-changing switch on the high-voltage supply, which changes the bias on the 150T's to correspond with the plate voltage in use.

The largest item on the bottom shelf or base is the plate transformer, specially built for this transmitter. It is a 3-kva. job with 110-220 volt primary, giving secondary voltages of 3200, 2500 and 1870 each side of the center tap for d.c. voltages of 2500, 2000 and 1500 volts, at a maximum current of 1 ampere. Additional plate-voltage variation in steps of 100 volts to a maximum of 500 either way from these main voltages can be secured by means of an auto-transformer connected in the primary circuit of the plate transformer. The 872 rectifiers are between the transformer and the large baffle. Homemade 1-amp. high-voltage fuses are in series with the rectifiers for protective purposes. The 110-220-volt power connections, remote-control and keying leads, and the 500-ohm audio line are brought in the bottom through appropriate plugs. The transformer at the left is the UTC Class-B output transformer, wound for three different impedances to take care of the power inputs at the three main plate voltages available. The rear doors, four in number, are interlocked with the high-voltage so that the power is cut off when a door is opened.

The front view shows the layout of controls. Radiostats are provided for filament-voltage adjustment on the 872's and 150T's; these, with the plate-voltage change switch, are on the bottom panel. In addition, a switch is provided for shorting the Class-B output transformer for c.w. operation. The square plate in the center of the second panel is a four-position switch for selecting various crystals in the oven. The exciter tuning controls, along with filament and plate on-off controls, also are on this panel. The power controls are duplicated on the operating table.

Meters for the various stages are behind the glass window in the third panel. All significant grid and plate circuits are metered, along with the filaments of the larger tubes. The tuning knobs for the final stage and antenna are on the top



THE REAR VIEW IS TAKEN THROUGH A DOORWAY WHICH IS NOT PART OF THE TRANSMITTER

Four doors, with safety interlocks, give access to the inside of the metal case.

panel. Antenna ammeters are behind the glass insert.

The grill through which the 150T's are visible consists of a number of 3/8 by 3/16-inch brass strips separated by brass blocks. Rods run through the blocks to hold the assembly together, and the whole grill is chromium plated.

The operating desk at W9AXH, not shown in the photographs, is directly in front of the transmitter. The receiver, an HRO, is mounted at the bottom of a 30-inch desk-type relay rack. Additional units mounted on the rack include a power supply for the receiver and speech pre-amplifier; a permanent-magnet speaker; the preamplifier, consisting of a 6J7 pentode-connected working into a second 6J7 triode-connected, the latter feeding a 500-ohm line to the

(Continued on page 106)

# A Continuously-Rotatable 28-Mc. Beam

Rapid Rotation—No Stops—Stationary Feeders

By A. F. Neuenhaus,\* W2BSF, and M. E. Schreiner,\*\* W2AJF

**D**URING the winter of 1935, twenty-meter QRM drove W2BSF and W2AJF to the five-meter band for local QSO's in an effort to alleviate the situation, and it proved a most interesting and instructive experience. Our work there proved to us that though the "big kilowatt" will usually plough through, a certain bit of skywire called the "antenna" has more to say in getting out than most of us are willing to concede.

The ten-meter band was opening up with its splendid possibilities, but our experience with 20 and 40 had taught us what to expect when it began humming. Here was a band that surely would place the world at our "mike-tips," but again the big kilowatt signals, which we could not afford, cast a menacing shadow across our anticipations. (We take no issue with the truth that high power, properly adjusted, causes less QRM outside its own frequency than a carelessly-adjusted rig of a few watts.) However, what five meters had taught us could be put to work on ten, and we had convinced ourselves there that the power we cannot afford in the transmitter can certainly be built into the antenna at a cost well within the reach of the average ham's pocketbook.

Of all the arrays and beams we had tried, seen, heard or read of, the one that seemed to have the greatest possibilities for enhancing our chances of successful QSO's in any desired direction with a moderate amount of power, was the reflector-director type. It had a particular appeal to us, especially from the viewpoint of its unidirectivity, which very effectively eliminates QRM in undesired directions, and under normal conditions it has worked out exactly the same way on the reception of signals here. In other words, the incoming signal at which the array is pointed is built up while signals from other directions are attenuated to a considerable degree.

Rotatable beams and more of them have put in their appearance and many a fine signal from them has buffeted our speakers around, but most of the designs were too cumbersome for our locations and expensive for our purses. Then, too, the everpresent problem of dangling feeders makes it impossible to rotate these beams completely and continuously through 360 degrees. Stops of various kinds were annoying for the reason that it very often proves necessary to rotate these antennas through 300 degrees to effect a 60-degree change in directivity. Motors, of course, may be used to do most of the work, but they must be

reversible in one form or another, thus adding expense.

After all these considerations, it occurred to us that the vertical reflector-director set-up afforded a means of overcoming all of these handicaps and also provided a splendid method for avoiding the usual dangling feeder. In addition, it would give us our long-sought continuous and complete rotation right through 360 degrees in either direction. Instead of rotating the antenna, why not simply rotate the reflector and director around a stationary half-wave "J" antenna and feed through the conventional open-wire transmission line? We immediately got to work and constructed such an affair, and it has been in operation at W2BSF

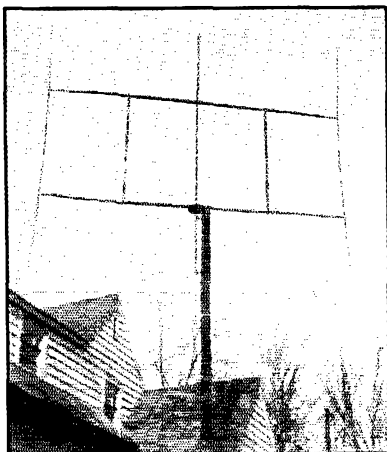

THE 28-Mc. ROTARY BEAM INSTALLED AT W2BSF

*A unique feature of this arrangement is the stationary antenna, with the reflector and director rotating around it. This construction simplifies the feeding problem.*

for the past two or three months. To make a long story short, we have been so completely satisfied and gratified with the results, that our immediate thought was to pass it along to our fellow-hams through the medium of our old friend *QST*.

Actual measurements and, above all, received S-meter readings in all parts of the country and as far away as Honolulu, have shown the beam to have a gain of 4 db over the regular di-pole at the same elevation and with the same power. The front-to-back ratio is at least 16 db. To appease those fellows who entertain worries about vertical polarization, let us say that tests have proved that, outside our own district, the vertical

\* 34 Sylvester Ave., Hawthorne, N. J.

\*\* Prospect St., Little Falls, N. J.

polarization effects are negligible, the signal strength maintaining the same level with both horizontal and vertical receiving antennas at the same station. Locally—within a 25 or 30 mile radius—vertical polarization effects are noticeable, but do not seriously affect the signal strength.<sup>1</sup>

A duplicate of this antenna is in process of construction at W2AJF at the present time and will include some minor improvements and refinements which are shown in the accompanying drawings. Incidentally, this beam can very easily be rotated completely through 360 degrees in either direction, or stopped at any intermediate point, in less than five seconds! Following is a description of the details of construction:

The dimensions of all elements of the system are calculated strictly in accordance with formulas (for desired frequency) contained in the 1938 A.R.R.L. Handbook.<sup>2</sup> The 4-inch by 4-inch mast is

<sup>1</sup> In sky-wave transmission, the polarization of the received waves seldom bears any definite relation to the polarization of the transmitting antenna. From this standpoint, it is a matter of indifference whether horizontal and vertical antennas are used. Ground losses are probably lower when the wire is horizontal, and there is less likelihood of interference with nearby receivers.—*Editor*.

<sup>2</sup> The recommended director spacing in the Handbook is  $\frac{1}{2}$  wavelength; optimum spacing, however, usually is obtained only after a period of cut-and-try. In connection

20 feet high so that when complete the antenna will be one-half wave above ground. The half-wave antenna portion consists of a 12-foot length of 1-inch O.D. aluminum pipe,  $\frac{1}{8}$ -inch wall, with a brass reducer fitted to the top. A  $\frac{1}{2}$ -inch I.D. brass nipple is fitted with two set screws and screwed into the reducer. The  $\frac{1}{16}$ -inch O.D. aluminum can be cut to any length above 5 feet and will slide nicely into the brass nipple, making it possible to adjust the half-wave antenna to the proper length and fasten the sliding section with set screws. The 1-inch aluminum pipe will fit through the insulator-block bushings and pulley, which are bolted to the lower horizontal member.

(Continued on page 118)

with element lengths and spacings, there is the possibility of improving the gain of an array of this type by using the spacings and tuning conditions derived by G. H. Brown and described in the *Proceedings of I.R.E.* for January, 1937. For example, when only a single parasitic element is used, maximum gain is secured with spacings of the order of 0.1 wavelength, the parasitic elements being adjusted to have the proper reactance for either forward or backward radiation. In the special case of self-resonant parasitic elements (length same as that of antenna) optimum spacing for functioning as a "director" is 0.1 wavelength; as a "reflector," 0.2 wavelength; in both cases the gain is quite near the maximum possible. Where more than one parasitic element is used, the mutual impedances between all elements of the array must be considered in determining optimum spacings and tuning conditions.—*Editor*.

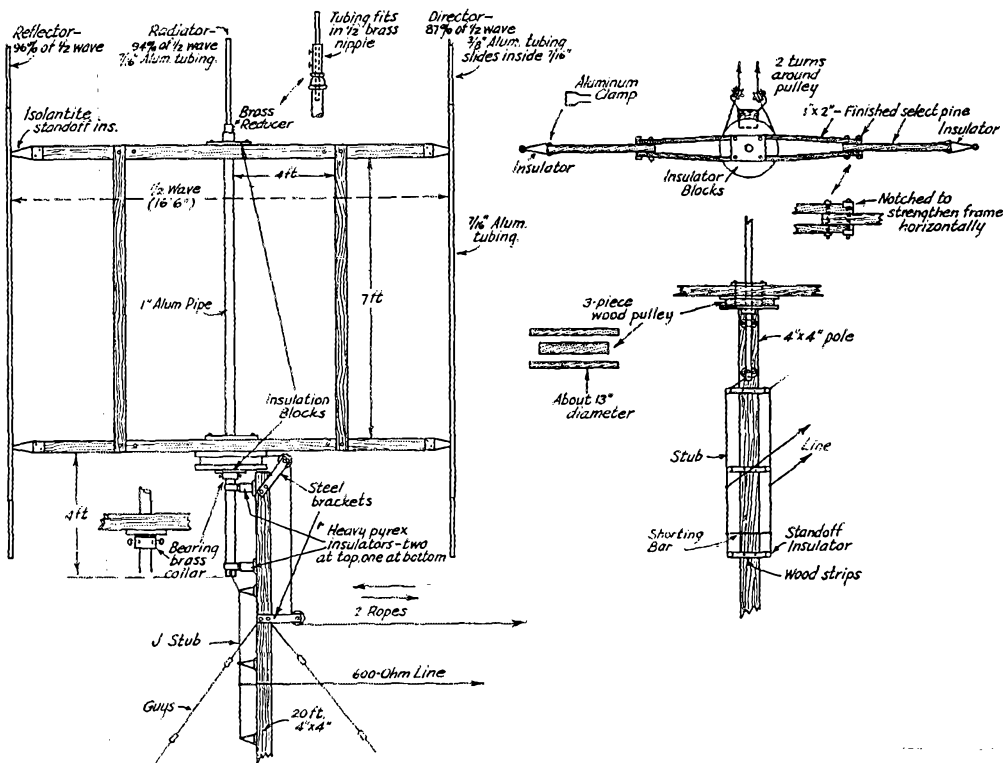

FIG. 1—DETAILED DRAWINGS OF THE ESSENTIALS OF THE ROTATING BEAM



# A Solution to the Tank Circuit L-C Ratio Problem

## Variable-Range Condenser for Multi-Band Transmitters

By Frank Lester,\* W2AMJ

**T**HE old adage, "necessity is the mother of invention," applies in this case for it was because of a job given to the writer that this idea developed. To the best of my knowledge the plan about to be discussed has not appeared in print, nor has it been applied to amateur transmitters. Why this should be so is rather puzzling, for the idea is so simple that it is a wonder several of us have not thought of it previously.

It is a well-known fact—only too well known—that we require an entirely different order of tank capacity for 56 Mc. than for 1.75 Mc. It is also common knowledge that lead lengths and stray capacities play an increasingly important part the higher in frequency we go. Heretofore, because of the fact that maximum efficiency is always the ham's requirement, two or more amplifiers have been necessary when such a wide frequency range was desired. The plan to be discussed tends to eliminate the need for separate final amplifiers when a wide frequency range is to be covered.

Now to get down to business. In this case it is advisable to reverse the usual procedure and consider the low-frequency end first. Let us assume that we want to operate on 1.75 Mc., and also that a fairly good L-C ratio will result if we have approximately 100  $\mu\text{fd.}$  of effective tuning capacity, utilizing a split-stator condenser (i.e., 200  $\mu\text{fd.}$  per section). Usually it will be found that the minimum capacity of such a condenser is too high to permit good L-C ratio on 56 Mc. There is, however, nothing to

prevent our taking each one of the sections of this large condenser and splitting it into two parts, which means that we will have three capacity ranges available to cover the six amateur bands. This is just exactly what has been done, and when the construction of the majority of popular variable condensers is considered it can readily be appreciated that the job is not a difficult one. Therefore the cost is small and at the same time one amplifier can be made to function with good efficiency where two or three previously had to be employed.

Fig. 1 shows the entire circuit. All that is needed in addition to the special condenser is a new plug-in coil assembly. This should have seven plugs to take care of connecting in the desired capacities throughout the frequency range from 56 to 1.75 Mc. Obviously, on 56 Mc. the pair of small sections of the variable condenser will be employed. The same capacity also may be used for 28-Mc. operation, although the designer has the choice of using these or the larger sections, depending upon whether a low-C or a high-C circuit is desired. Depending on the wiring of the plug-in coil strips, we may use either the small sections, the large condenser sections or the two in parallel on each side. Each section should be cut so that optimum capacity values can be obtained throughout the frequency range.

With the cooperation of the Hammarlund Manufacturing Company, a sample condenser was made up to the writer's specifications. To give an idea of the capacity ranges possible, these are the actual measurements of the sample condenser:

Using the high-frequency condenser sections, the minimum capacity is 8, the maximum capacity 24.5  $\mu\text{fd.}$  The capacity range of the larger sections—which we will term the "middle frequency" condenser—is from a minimum of 11½

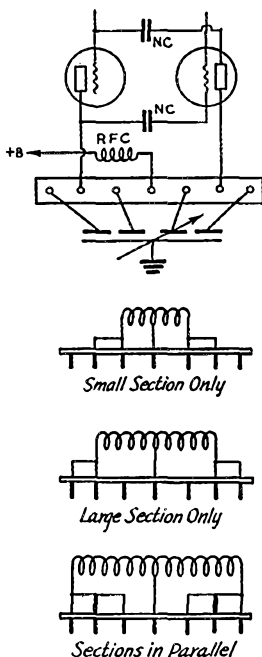

**FIG. 1—THE FOUR-SECTION CONDENSER CAN BE USED TO GIVE THREE CAPACITY RANGES IN CONJUNCTION WITH COIL STRIPS HAVING SEVEN PLUGS**

The wiring shown automatically cuts in the desired capacity when the appropriate coil is plugged in.

\* 103 Williamson Road, Bergenfield, N. J.

<sup>1</sup> Aside from greater ease of tuning at the higher frequencies with condenser of small capacity range, the merit of the scheme can be judged by comparing the minimum capacity of the smaller sections in series with the minimum capacity of the condenser as a whole without alteration. In the condenser discussed, this "improvement ratio" is better than 2 to 1. —EDITOR.

to a maximum of 82.5  $\mu\text{fd.}$ , while with the two sections connected in parallel on each side the range is from 19.5 to 103  $\mu\text{fd.}$ <sup>1</sup>

These capacity ranges are not to be confused with the capacity of each section, but represent the net capacity obtained when the condenser is employed in the usual split-stator fashion. The

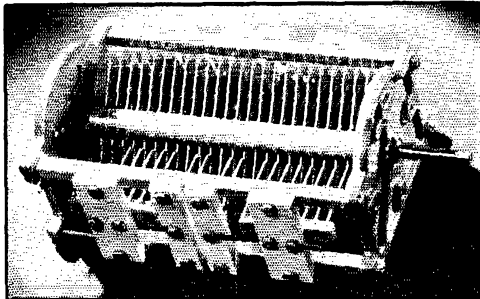

FIG. 2—THE "DOUBLESPLIT" CONDENSER DISCUSSED IN THE TEXT

measurements also take into account the effect of the unused sections which are left floating.

The photograph of the sample condenser clearly illustrates what may be termed a revamped 225  $\mu\text{fd.}$  per section split-stator condenser. The following information should prove helpful to those who may wish to adapt one of their present condensers to this circuit:

The rotor plates are not changed in any way. In order to increase the spacing between the two separate sections of the condenser, one stator plate is removed. In addition to increasing the spacing, this also allows two rotor plates to be employed as the outside plates, forming a more or less effective shield between each of the sections. This decreases the capacity effect between sections, depending on the position of the rotor. As the unused section is left floating, some r.f. current will flow into the plates because of their proximity to the active section; this will increase the minimum capacity slightly, but introduces no particular power loss.

In designing the plug-in coil assembly to be used with this condenser, short leads are readily obtained for the higher frequencies because the two small condenser sections have been located in the center with the two larger sections at each end. As shown in Fig. 1, it is readily possible to vary the length of the coil without having long leads, since it is necessary to employ the entire length of the plug-in coil strip only when the entire capacity of the condenser is to be used.

This same setup may be used in the grid circuit, although in many cases it may not be required because a lower  $L-C$  ratio often may be used without any great sacrifice in efficiency.

This idea will undoubtedly appeal to the high power men who must of necessity use large con-

densers that present quite a problem when 56- or 28-Mc. operation is contemplated.

## Strays

### By-Pass Condenser Needed in "QSL Forty" Circuit Diagram

In Fig. 1, the circuit diagram of the 6L6 oscillator in the article "The 'QSL Forty,'" February *QST*, the cathode by-pass condenser,  $C_4$ , was inadvertently omitted from the drawing, although

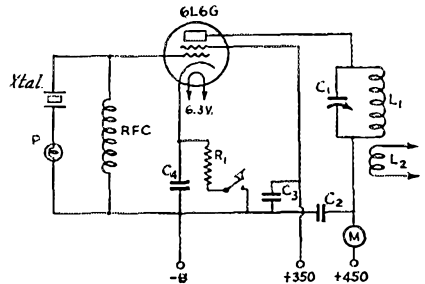

included in the list of parts. This resulted in short-circuiting the cathode resistor and key. The correct diagram, with  $C_4$  in its proper place, is reproduced herewith.

### Silent Keys

IT IS with deep regret that we record the passing of these amateurs:

William J. Albert, W6KPU, Whittier, Calif.

J. W. Bush, Jr., W5ZD, Dallas, Texas

Robert H. Cowan, W5EED, El Paso, Texas

T. J. Findley, W6BBN, Los Angeles, Calif.

John B. Goddard, W8AEX, Fayetteville, W. Va.

Fred W. Kinne, W8EOH, Towanda, Penna.

William I. Lovett, W7GBJ, Aberdeen, Wash.

B. C. Osborne, W1JZX, Worcester, Mass.

Robert S. Rose, W9DRR, Marquette, Mich.

Samuel R. Smith, W6MNT, Long Beach, Calif.

Bennie Stein, W2ILU, Irvington, N. J.

Raymond J. Taylor, ZL1BA, Auckland, N. Z.

Robert L. Travis, W4CWH, Demarest, Ga.

Anthony G. Wingerter, W9SAT, St. Louis, Mo.

# R.F. Interference From Power Circuits

## Identifying and Curing Radio Noises

By Robert Y. Chapman,\* W1QV

**T**HERE is no doubt that if it were not for noise we all would be able to hear much more DX.

The writer is a firm believer in the old slogan which goes, "let's clean house at home first." So let's talk about the noises that can originate in the operator's establishment. First we must remember that any form of noise external to the receiver is highly-damped r.f. with a peak in some particular frequency region, and when associated with power lines, will be modulated at a frequency depending on the line frequency and voltage involved. Most noise seems to resonate on about 1700 kc. with an average modulation frequency of about 120 cycles on 110-volt lines and about 400 cycles on 2300-volt lines.<sup>1</sup> The easiest forms of noise to locate are the steady buzzes which sound like bumble bees loving a rose.

The major causes of interference originate on the secondary side of the transformer which supplies the affected district. From the reception standpoint, homes can be divided into three classes. The poorest is the type with open wiring and the meter in the attic, plus gas and electric combination fixtures. Let's discuss this type of location from an operating angle.

First, we have no a.c. line shielding, which means that we have open lines to resonate with the output frequency of the transmitter. Regardless of the transmitting frequency we are practically certain of resonance in some part of the wiring. The unmistakable sign is lighting the lights when they are not turned on. The cure is install a small by-pass condenser across the a.c. line at the light fixture.

The most common source of noise in such an installation arises as the result of the light fixtures being grounded to the gas-line fixtures. This arrangement never gives a solid ground and the least vibration results in loud cracks like the snapping of a whip.

Another form of noise results from poor conduction in corroded soldered connections; the greater the load on the circuit the more noise produced. Sounds like a baritone taking a gargle.

If you live in this type of house your chances of causing b.c.l. interference are five times as great as if you lived in a newly-wired house.

The next type is the house having open wiring but with the meter board in the cellar, and having

no gas-fixture combinations. The main fault is that when the wiring was done there was no respect for polarity. This installation was in the era of load fuses; they put them all over the house. The fuse blocks get badly tarnished with age; as a result the contact gets poor, and as the load increases heat is generated and the composition boils out and runs all over the connections. This results in a bad noise that sounds like an old '23 Ford throttled down.

Another common source of interference in this type of home is the ceiling fixture having link chain suspension. The only cure is to bond the links. The noise can be identified as a series of snaps with slight buzzes. It must be remembered that in houses with old wiring, bad fixtures and loose connections are almost certain to be found. Also, check the ground connections on all fuse blocks of the type known as "Not-a-fuse". These get loose and cause a bad noise. The water-pipe ground clamp from the a.c. light line also should be inspected.

Next, let's go to the newly-wired homes, complete with BX. Here we do find everything pretty well bonded, but if it is not we are likely to get common a.c. hum interference in the receiver. A prevalent cause of noise in houses wired with BX is the cable chafing against water pipes, resulting in clicks like those caused by keying. This type of interference is often blamed on some innocent ham.

Incidentally, many a buzz can be traced to a wall-socket that has become burned as a result of poorly-fitting lamp plugs.

When you check your home for noise, tighten all loose connections in the fixtures and replace those that are not positive in action—for instance, where you have to snap the switch several times

(Continued on page 88)



\* 20 Raymond St., New London, Conn.

<sup>1</sup> The higher pitch may be associated with three-phase supply or possibly harmonics in the waveform.—Editor

# How Would You Do It?

## Non Short-Circuiting Coil Clips

**I**N Problem No. 13, our Hero asked for some ideas on coil clips which, among other things, would not flop over and short-circuit turns. A glance at the drawing will show that his wishes were more than fulfilled. Some of the schemes are simplicity itself while others are not so simple — take your choice.

A very simple and effective clip is shown in Fig. A. This idea was submitted by W2HNX who wins first prize. The clip itself is of the simple type described some time back in the Hints and Kinks section of *QST*. It may be made by folding a strip of phosphor bronze or similar material and forming the end around a nail or drill of suit-

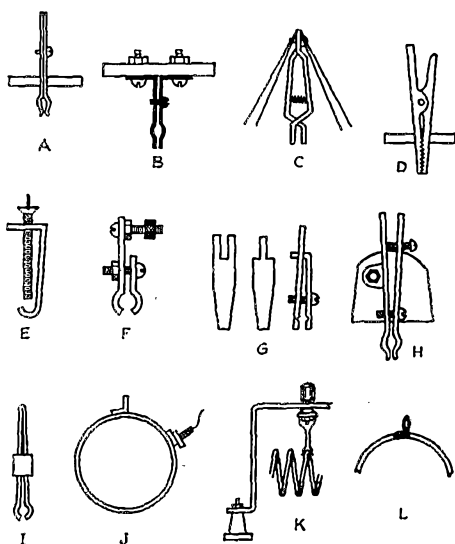

able size. Similar clips are obtainable from certain manufacturers.

To prevent the clip from twisting far enough to short-circuit turns, a hole is drilled about halfway up the clip and a small rod of insulating material such as bakelite or celluloid from a knitting needle is inserted in the hole and cemented fast.

In Fig. B is a somewhat different arrangement utilizing the same principle, suggested by VE4AJQ. The clip, in this case, is made of two pieces of heavy spring brass or phosphor bronze bent at right angles, formed at the ends and fastened with machine screws to a strip of insulating material.

W8QPS uses a "pee-wee" clip of the "bulldog" type with the jaws filed down to permit use on coils with closely-spaced turns. The clip is fitted

with celluloid strips as shown at C to prevent tipping too far. The same idea was suggested by W8OWL.

Along the same line is the "alligator" type clip, shown in Fig. D. Each jaw is fitted with a peg of insulating material. The design was submitted by Harold W. Hartman of Los Angeles.

Three types of "pressure" clips are shown in Figs. E, F and G. In each case, sufficiently firm clamping is possible to prevent the clip turning and short-circuiting turns, even when subjected to a strong pull. The design shown at E was submitted by K4EDS. The metal piece is  $\frac{1}{4}$  to  $\frac{3}{8}$  inch wide. The whole at the top is tapped to accommodate the flat-head machine screw. A small piece of sheet metal is soldered in the screw-driver slot to form a wing-screw which may be turned by hand. Two simple types which require the use of a screwdriver are shown in Figs. F and G. The first was submitted by W2DC and the second, which is designed to prevent any possible twisting while tightening, was suggested by W2BXJ.

In case anyone feels that he must have absolute insurance against twisting, the design of Fig. H by W9SZN should fill the bill. The metal pieces should be cut from stiff brass of as great thickness as practicable. An "ear" is cut as shown on one of the pieces to permit fastening to the small piece of insulation which effectively prevents tipping. The bottom screw should not be tightened completely as it is only a sort of pivot. The clamping action is obtained chiefly by means of the upper screw.

A rather novel clip is suggested by W6GFK and is shown in Fig. I. The clip itself is first formed from a piece of spring brass. A narrow band of soft brass is then bent around the upper part of the clip. Sliding this band up and down on the clip will loosen or tighten the clamping.

Another highly satisfactory tapping arrangement is shown at J. This idea was suggested by W4PL and E. Ottney, Peterboro, Ontario. We believe it merits second prize which goes to W4PL because of his more complete treatment. Its most serious drawback is that it requires soldering, although it has the advantage over all other schemes in that it may be used with coils of very closely-spaced turns. While an ear or tab of No. 12 or 14 wire may be used for the tap, W4PL prefers to file down the head of a No. 6-32 machine screw and also to file out the screwdriver slot to fit the wire and solder the head to the wire at the point where the tap is desired. A standard 'phone tip is just the right size to take a

*(Continued on page 114)*

# H A M D O M



AT first glance it may appear an odd thing that this page has not previously presented a word portrait of Dr. Eugene C. Woodruff, the president of the League. After all, Hamdom's most distinguished citizen is surely a personality of interest to amateurs everywhere.

But that is, actually, somewhat a superficial view. This Hamdom page, as it happens, has been primarily a space for facts and figures, where biographical data and vital statistics are condensed into a swiftly-paced pen picture. Dr. Woodruff is not the sort of personality that can be fitted into such compass. His life does not lend itself to being measured with dates and sliced into neatly-packaged sections comprising distinct eras. His philosophy is that of the individualist, and his career reflects that philosophy, and you can't squeeze him into ordinary molds for he just doesn't fit.

It is with the consciousness of considerable temerity, therefore, that we at long last attempt to do this much toward presenting Dr. Woodruff on this page; that we attempt to convey the *feeling* of the kind of man he is. In order that the light and shadow may have a backdrop on which to play this is the skeletal record of his career: Born in St. Clair, Michigan, in 1871, schooled largely at Ann Arbor, graduating a B.Sc. from the University of Michigan there in 1894, followed by a master's degree in chemistry, physics and music in 1896 and a Ph.D. in physics, mathematics and chemistry in 1900, he chose pedagogy as his life work. Invention has been his avocation, or perhaps better, his other life work. He has taught practically every scientific subject in schools and colleges in various locations including Bozeman, Mont., Decatur, Ill., Chicago, and, for the past 25 years, Pennsylvania State College. There he is currently head of the Departments of Electric Railways and Radio, senior classes, and teaches the junior class in general E.E. He is a former athlete and has coached in football, basketball, track and baseball at various institutions. He is a fellow of the American Association for the Advancement of Science and a member in the A.I.E.E. and I.R.E. He belongs to several fraternities and other societies. He was a 1935

medallist for Pi Eta Sigma for scientific attainment.

But to attempt to describe a man in such terms is but to caricature, coldly and lifelessly. The impress of the personality is not gauged by the names and dates. The bloodless symbols of the record book do not vivify the intangibles that are the man; there must be other words to breathe feeling into the portraiture. Dr. Woodruff is a small man, but with a breadth of shoulder befitting an ex-football player of the mauve decade. Sitting or standing—standing he is as comfortable as sitting—he is in repose. There are no meaningless gestures of the hand, no wasted motions. His eyes are bright and deep when he looks at you; but mostly he gazes into the distance as he considers what is said.

His mind is like a complex tool; not a general-purpose tool, but a highly specialized tool, shaped for one purpose only, to perform one function superlatively well. His mind shears off superfluous and retains only essentials. He cannot remember the names of his students, but he knows their features, and identifies them on the mental chart of his classroom which he constantly carries, and he grades the seats rather than the names. He does not forget the grades. At a reunion dinner of old students given him recently he could not recall a name of the forty ex-students present, but he could recall the grade of each and every one.

This is an index. Time was when he could remember the names perfectly well; at Millikan College at Decatur, Ill., and even in the early years at Penn (where he went in 1913) he could remember whole classes, for several years back. But as time went on there were so many names. They became a burden. And they were unimportant; it wasn't the name, but the character, the attitude, the response that mattered. The face was the crux of physical individuality, the grade

labelled the mentality. So he remembered the faces and the grades and forgot the names.

Dr. Woodruff is an aloof man, yet a kindly and intimate man. This is the paradox. He is a retiring man, and he shrinks from the light of popular inspection. He is often torn between the

(Continued on page 108)



# HINTS and KINKS for the Experimenter



## Universal Antenna Coupler

WICAB has been active in Naval Reserve Communications since 1927, and this made it necessary to have a transmitter capable of working in the 80- and 160-meter bands. Also, like a good many other hams, the urge to hunt

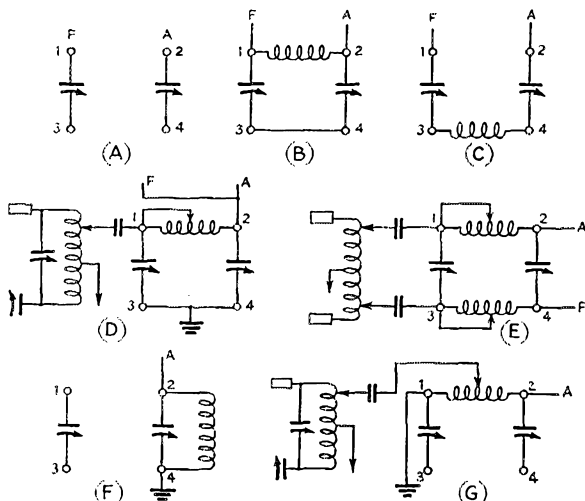

FIG. 1—UNIVERSAL ANTENNA-COUPLING ARRANGEMENT

Using four jack-top stand-offs for connection posts, practically any antenna-coupling system can be used with a few simple changes in plugs. Several representative coupling methods are shown above.

for DX is quite strong, necessitating an antenna system that will work fairly well on all bands. Having acquired a new QRA recently, and desiring to keep the antenna system on my own property, I arrived at the conclusion that a 67-foot antenna with Zepp feeders would probably be the best type to use.

For a number of years a Collins network has been a standard piece of apparatus at this station, but with the advent of Zepp feeders it seemed desirable to use the regular series-parallel method of tuning them. Having only the two variable condensers in the Collins network available meant that if they were used for Zepp feeders the Collins network would have to be torn apart.

After a little thought the system shown in Fig. 1, which I have christened a "universal antenna coupler," was devised. Four standoff insulators

with banana plug sockets in their ends are mounted in the form of a square about 5 inches on a side (the spacing of these coils is determined by the length of the coils), and connected as in Fig. 1 (A) with two variable condensers between Nos. 1 and 3 and Nos. 2 and 4 insulators. For the sake of convenience the feeders are marked A and F, A being the one attached to the antenna and F the dead-end feeder. By plugging a coil in sockets 1 and 2 and a shorting bar in sockets 3 and 4 the feeders are parallel tuned, as in (B).

For series tuning, remove the shorting bar from 3 and 4 and plug the coil in these two sockets, as in (C). For Zepp feeder tuning the coil is link-coupled to the final amplifier.

(D) shows the single-ended pi-section network. Place the coil in sockets 1 and 2, connect F and A to 2, ground 3 and 4, and couple the plate tank through a by-pass condenser to socket 1.

By using two coils, as shown in (E) a two-wire line can be coupled to a push-pull amplifier.

When a Marconi antenna is needed the coil may be placed between 2 and 4, 4 being grounded as in (F). An antenna counterpoise system may be used in a like manner by attaching the counterpoise to insulator 4 instead of to ground.

(G) shows a Western Electric antenna coupler that has worked very well on 2000 kc. The coil is untuned and the coupling is varied by tapping down on both the antenna coil and the plate inductance.

This universal coupler has been used quite successfully at station WICAB for operation on 10 to 160 meters inclusive, and it is hoped that these suggestions will help solve antenna-coupling problems for those who like to work all bands.

—Horace Young, WICAB

—...—

## Band Checker

HERE is a description of a gadget which I have found handy to have around the station. It is the old absorption wavemeter in new form, and consists simply of a cardboard tube from a flashlight cell, on which a coil of No. 22 d.c.c. wire is

wound, with a mica condenser of capacity anywhere between 100 and 250  $\mu\text{fd}$ . held inside by Duco cement. Pasteboard disks are cemented to the top and bottom of the tube, and a hole is

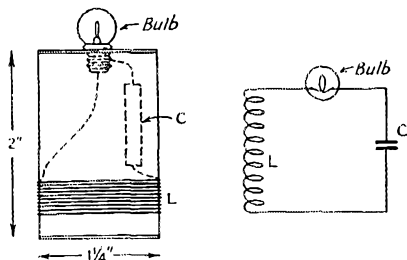

FIG. 2—TUNED-LOOP BAND INDICATOR

Useful for checking the band to which a stage is tuned, also as a neutralizing indicator. C is a midget mica condenser of any convenient capacity, L a coil with turns adjusted to resonate with C at about the middle of a band.

drilled in the top disk for a flashlight bulb, to which wires are soldered. The bulb is held by more cement inside. All three are connected in series, as shown in Fig. 2. The turns are juggled until maximum brilliancy of the bulb is obtained when placed near a transmitter tank operating on the desired frequency. When the correct number of turns has been determined the coil is heavily doped. Final adjustment is made by squeezing the coil together or spreading turns before the dope sets. One can be made for each amateur band used, and also for troublesome harmonics such as 53 meters, 27 meters, etc.

These pickups are considerably more sensitive than the usual loop and flashlight bulb. An indication can be obtained from a low-power transmitter about 7 inches from the tank, using the proper coil. The wrong coils have to be placed almost inside the tank coil before the bulb will light. Likewise, if there is any doubt as to the crystal harmonic to which the tank is tuned, the answer is quickly obtained by holding the indicators near it.

—Theo. J. Mesh, W1CCO

### A T.R.F. Stage for the Two-Tube Receiver

THE circuit diagram of Fig. 3, contributed by Adolfo Dominguez, Jr., CM2AD, shows a simple method of constructing a tuned r.f. stage to be used in conjunction with the QST two-tube receiver (see recent *Handbooks*). It has been quite successful in increasing selectivity as well as signal strength, and in eliminating the "dead spots" often encountered when the detector is coupled directly to the antenna.

The circuit is arranged so that the detector coils in the receiver need not be rewound. The

plate of the 58 r.f. tube is fed through a 2.5-millihenry r.f. choke, and is coupled to the detector grid through  $C_5$ , a 50- $\mu\text{fd}$ . trimmer condenser. The trimmer should be connected close to the detector coil, not more than two or three inches from the coil socket. The trimmer capacity must be adjusted carefully for maximum signal transfer without making the r.f. stage oscillate.

No band-spread is used on the r.f. stage since the tuning is not critical. The grid coils,  $L_2$ , are identical with the detector coils except that they are not tapped. The antenna coupling coils,  $L_1$ , are wound as described under the diagram. CM2AD's r.f. stage is enclosed in a metal box measuring 4 1/2 by 7 by 6 1/2 inches. A shielding container is of course necessary to avoid oscillation.

The r.f. gain control is useful in preventing overloading of the detector by strong signals, in addition to the other advantages already mentioned.

### Junk-Box 160-Meter 'Phone for Local QSO's

MOST of us have in our junk boxes parts for which we have very little use. Being among

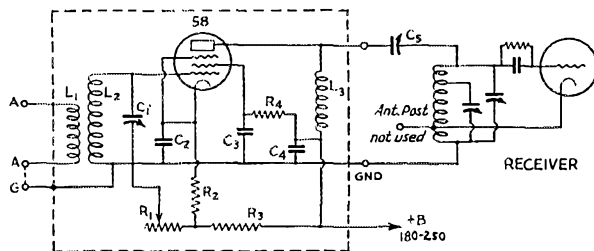

FIG. 3—T.R.F. STAGE FOR THE TWO-TUBE RECEIVER

- $C_1$ —100- $\mu\text{fd}$ . variable.
  - $C_2, C_3, C_4$ —0.01- $\mu\text{fd}$ . paper.
  - $C_5$ —50- $\mu\text{fd}$ . trimmer.
  - $R_1$ —10,000-ohm potentiometer (r.f. gain control).
  - $R_2$ —300 ohms, 1/2-watt.
  - $R_3$ —50,000 ohms, 2-watt.
  - $R_4$ —100,000 ohms 1-watt.
- $L_1, L_2$ — $L_2$  same as detector coils in receiver;  $L_1$ : 3.5 Mc., 15 turns; 7 Mc., 10 turns; 14 Mc., 5 turns; 28 Mc., 3 turns; all No. 30 d.c.c. wire close-wound at bottom of  $L_2$ .

those mentioned, I decided to do something about it. So with pencil and paper and with the thoughts of a simple 160-meter 'phone rig in mind, I started. The rig turned out to be simple, as I had hoped, and was made entirely from the junk box, except for two flashlight cells for the microphone. Not long after going on the air with it I was confronted with "how about the dope on your rig, OM?" and before long these little sets began to sprout locally on the 160-meter band.

The boys say they're FB because excess power isn't needed for local work, more of them can be squeezed in the band with less QRM to ham as well as b.c.l.—and of course the low cost makes them attractive.

The rig here is laid out in breadboard style, although many other ways will prove satisfactory. Little difficulty should be experienced in

getting it "perking," as the circuit, Fig. 4, is almost fool proof. Values, of course, are not absolutely critical. Any satisfactory antenna

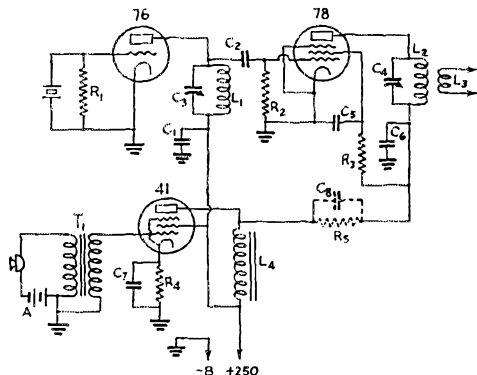

FIG. 4—LOW-POWER 160-METER 'PHONE

- $C_1$ —0.002- $\mu$ fd. mica.
- $C_2$ —100- $\mu$ fd. mica.
- $C_3, C_4$ —100- $\mu$ fd. variable.
- $C_5, C_6$ —0.001- $\mu$ fd. mica.
- $C_7$ —5- $\mu$ fd., 25-volt electrolytic.
- $R_1, R_2$ —50,000 ohms, 1/2-watt.
- $R_3$ —20,000 ohms, 1-watt.
- $R_4$ —400 ohms, 2-watt.
- $L_1, L_2$ —60 turns No. 24 enamelled on 1 1/2-inch diameter coil form.
- $L_3$ —10 turns of No. 24 enamelled on 2-inch diameter tubing.
- $L_4$ —30-henry choke.
- $T_1$ —S.B. microphone transformer (a bell-ringing or dynamic speaker output transformer will work).
- $A$ —3-volt battery.
- $C_8, R_5$ —See text.  $C_8$  should be 5  $\mu$ fd. or more;  $R_5$ , 750 ohms, if used.

system will be OK for this outfit, the one here being a revamped 80-meter Zepp, with 25 turns of antenna wire on a 3-inch diameter form in series with the dead feeder and a series antenna condenser in the live one. The antenna coupling coil is wound on a bakelite tube that slides over the tank coil.

The rigs so far have only been in operation a short time and results are starting to speak for themselves. My own, with 1.6 watts input, has worked 75 miles with S7. One of my friends has worked 135 miles with 2.5 watts input.

—Floyd Gribben, VE3LR

On the basis of a 250-volt plate supply, the audio output of the 41 is 3.4 watts when working into a 7600-ohm load. For minimum distortion, the plate and screen input to the 78 amplifier should be adjusted to represent a load of this value. Using 250 volts on the 78, this means that the combined plate and screen current should be 33 ma. Lower current values will increase distortion and lead to overmodulation unless the microphone input is reduced. For 100 per cent modulation the dropping resistor  $R_5$  and by-pass condenser  $C_3$  must be used, in which case the combined plate and screen current should be 30 ma. Under the circumstances this seems a rather

unnecessary refinement since the circuit without the dropping resistor will give 90 per cent modulation.—EDITOR.

### VE2EE's Freqmeter-Monitor

THE circuit diagram of the freqmeter-monitor described by VE2EE in "Hints and Kinks" in December *QST* showed a connection between the lower end of  $R_7$  and the cathode of the 56 which should not have been there, since it shorts the resistor. Also, the cathode by-pass condenser on the 56, marked " $C_3$ " in the diagram, should have been labeled " $C_8$ ."

Several fellows have written in asking about  $R_4$ , which appears in the list of parts but not in the diagram. This resistor was originally in the place occupied by  $L_2$ , which replaced it, and should be ignored. VE2EE also advises that the 2A7 plate resistor,  $R_3$ , will be somewhat better if the value is reduced to 1000 ohms.

### The HH4AS Rhombic Antenna

THE angles at the sides of the rhombic antenna shown in Fig. 5 in February "Hints and Kinks" should be 40 degrees. This dimension was not shown in the drawing.

### Protection Against Bias Failure

THE following may be of some help to those amateurs using bias packs who would like to protect their amplifiers against bias failure, but cannot afford to buy overload relays.

This system requires an automobile generator cutout, a resistor and one-quarter pound of No. 34 enameled magnet wire. Remove the old wind-

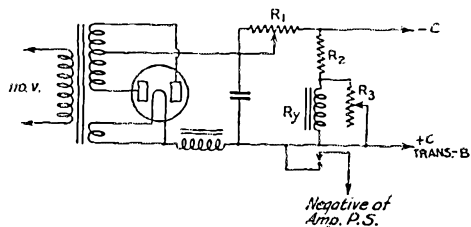

FIG. 5—INEXPENSIVE RELAY PROTECTION IN CASE OF BIAS FAILURE

- $R_1$ —15,000 ohms.
- $R_2$ —7500 ohms.
- $R_3$ —2000-ohm wire-wound potentiometer.

ings from the cutout and rewind with the magnet wire. The value of the shunt resistor ( $R_2$  in Fig. 5) can be determined by calculation or experiment. The characteristics of the cutout are such that the contacts will close on 12 ma. and open on 3 ma. approximately. The 3-ma. opening current is the reason for using the shunt resistor, as will be explained later.

(Continued on page 118)



# • I. A. R. U. NEWS •

Devoted to the interests and activities of the

## INTERNATIONAL AMATEUR RADIO UNION

Headquarters Society: THE AMERICAN RADIO RELAY LEAGUE, West Hartford, Conn.

### MEMBER SOCIETIES

American Radio Relay League  
Asociația Amatorilor Romani de Unde Scurte  
Associazione Radiotecnica Italiana  
Canadian Section A.R.R.L.  
Československá Amatérský Vysílací Ústředí  
Deutscher Amateur Sende-und-Empfangs Dienst  
Experimental Radio Society of Egypt  
Experimenterende Danske Radioamatører  
Federation des Emetteurs Belges  
Irish Radio Transmitters Society  
日本アマチュア無線連盟 Japan

Liga Colombiana de Radio Aficionados  
Liga Mexicana de Radio Experimentadores  
Magyar Rövidhullámú Amatőrök Országos Egyesülete  
Nederlandsche Vereeniging voor Internationaal Radioamateurisme  
Nederlandsch-Indische Vereeniging voor Internationaal Radioamateurisme  
Newfoundland Amateur Radio Association  
New Zealand Association of Radio Transmitters  
Norsk Radio Relæ Liga  
Österreichischer Versuchsenderverband

Polski Związek Krotkofalowcow  
Radio Club Venezolano  
Radio Society of Great Britain  
Rede dos Emissores Portugueses  
Reseau des Emetteurs Français  
Reseau Luxembourgeois des Amateurs d'Ondes Courtes  
South African Radio Relay League  
Suomen Radioamatöörlitto r.y.  
Sveriges Sandareamatörer  
Union de Radioemisores Españoles  
Union Schweiz Kurzwellen Amateur  
Wireless Institute of Australia

## Conducted by Byron Goodman

### Contests:

We mentioned last month that several of the societies are in favor of the proposals by the W.I.A. and the D.A.S.D. to have six large international continental contests each year, under the auspices of one or two of the member-societies of that continent. It can be pointed out that the A.R.R.L., DJDC, and VK/ZL contests almost amount to that now. The idea certainly seems to have merit, and we rather imagine most of the DX men throughout the world are hoping that some such arrangement is made. It should encourage some of the less active countries to be on the air.

Meanwhile, we will list some of the contests planned for 1938. Complete rules will appear in QST as they are received from the societies.

During January, the S.A.R.R.L. held its second annual DX contest. This was followed in February by the B.E.R.U. tests of the R.S.G.B., which ran concurrently with the N.A.R.A. contest, and the *Coupe du R.E.F.* and the *Coupe des Pays de Culture Française* of the French society. During March the A.R.R.L. holds its 10th annual contest, the c.w. portion running from March 5-13 and the 'phone portion from March 19-27. On weekends in May the M.R.A.O.E. (Hungary) will hold its contest, and the Polish DX Contest, conducted by the P.Z.K., will run from May 16 to May 30. The Third Annual DJDC Contest will be held during August, with exact rules and times to be announced later. The VK/ZL Contest, conducted this year by the W.I.A. with the assistance of the N.Z.A.R.T., is scheduled for October.

### Australia:

By radio via VK2EL we learn of a decided improvement in the amateur regulations in Australia. The W.I.A. has been successful in raising the power limit of VK stations, and they now have a 50-watt maximum power limit without special license instead of the old 25-watt limit. Furthermore, the special licenses for increased power are now good for 24 hours a day, instead of from midnight to 6 A.M. as was formerly the case.

### QSL:

The following correction should be made to the October list of QSL Bureaus:

Luxembourg: Service QSL de Reseau Luxembourgeois, 164 Av. de la Fayencerie, Luxembourg.

### Periodicals:

We don't know if everyone is familiar with the fact that practically all of the member-societies have their own monthly publications. These range from full-size magazines to small mimeographed sheets. However, every one is interesting to other amateurs, and just in case a few of our readers might be interested in amateur radio periodicals of other countries, we are going to review some of them for you. This month we'll talk about the ones written in English.

One of the oldest and most firmly established is the "T & R Bulletin" of the R.S.G.B. The January, 1938, issue (the latest at hand) is a well-organized magazine of 64 pages, printed on

good stock, with several photographic illustrations and a large number of sketches. Technical articles on antennas and receivers, feature articles, book reviews, and a number of departments giving personalized news of both English and British Empire stations round out a balanced issue. The "T & R Bulletin" is issued free of charge to members of the R.S.G.B. The annual membership fee is 12/6 for overseas members (about \$3.50); the office is at 53 Victoria Street, London, S.W. 1.

Members of the W.I.A. read "Amateur Radio," a compact magazine of 32 pages (the October, 1937, issue). It contains technical articles on break-in operation and a low-power transmitter,



**THE "WORKED BRITISH COMMONWEALTH OF NATIONS"**

Certificate offered by the S.A.R.R.L. to members who have worked British Empire stations on each of the five continents (North and South America count as one continent).

announcements of contests, a station description, and divisional notes on the active stations, as well as notes on 2S- and 56-Mc. conditions. The editorial address is Box 2611W, G.P.O., Melbourne, and the subscription price is 6/- per annum (about \$1.50).

The December issue of "Break-In," the official publication of the N.Z.A.R.T., is a 36-page booklet, printed on good paper with a heavy cover page, with technical articles on series modulation, power amplifiers, parasitic oscillations, and a five-band exciter unit, as well as contest announcements, a station description, personal news and other department articles. There are very few photographs but a number of sketches illustrate the articles adequately. The annual subscription is 7/6 (about \$2.00); the address is Box 837, Dunedin.

The first issue (October, 1937) of the "E.R.S.E. Journal," the official publication of the Egyptian society, was the only one at hand. It is mimeographed on letter-size paper, and carries 15 pages. There are technical articles on transformers and 2S-Mc. problems, as well as editorial

material and personalized news of the members. The subscription rate is P.T.50 per year; address all inquiries to F. H. Pettitt, SU1SG, P. O. Box 254, Cairo, Egypt.

For a number of years the S.A.R.R.L. published "QTC," a monthly magazine that enjoyed an excellent reputation. However, it recently became financially unfeasible to continue with the publication, and the news of the League is now circulated by a monthly mimeographed bulletin of 10 pages or more. It deals mainly with official and social aspects of the League, leaving technical development problems to the foreign amateur magazines that are read also by the membership. Address any inquiries to Box 7028, Johannesburg.

**WAC:**

The following WAC certificates were issued during the period from July 1 through December 31, 1937: John B. Power, W3AXU; Kenneth Bryant Warner, W1EH; D. S. Dirden, W6ABE; Z. T. Chang, XU8ZT; Donald Powell, G5MD; Stanislaw Bancser, SP1FU; J. Srocynski, SP1BR; R. K. Sheargold, G6RS; L. F. Viney, G2VD; C. F. Soruby, G5YU; Jan Simons, ON4AW; D. Jenkins, ZL2SM; J. R. Smith, ZL1JI; F. G. Bell, ZL2SX; J. D. Parminter, ZL2OU; Roger Baffereau, F3LE; A. P. F. Willems, PK3WI; Cap. Luis Lasaga, XE1AK; Herman Nielsen, OZ9A; Leon Martin, ON4LM; G. A. James, G8CT; T. B. Wimbush, SU2TW; Egl W. Aagaard, LA2X; Richard Utikal, D4OUT; Rolf Tschanter, D4KEJ; C. Florian, YR5CF; G. Wanzel, YR5OR; Percy Feng, XU6LN; R. H. Overn, VE3QI; Dan Summers, W6KQH; Sam D. Gross, W1IWC; H. D. Bamford, W1APU; Harry X. Geitz, W2HW; Henry L. Goodloe, W3GAP; Fred W. Watkins, W6FBM; Vernon Dameron, W8HGA; J. P. Jones, W8ASI; William M. Allison, W1FFK; George Robert Stewart (Okla. A & M), W5YJ; Jack C. Shuler, W6KUR; C. S. Hollenbeck, W2BQK; Edward W. Stroets, W2AEP; Frederick R. Lambrecht, W9YEG; G. C. Giberson, W3PC; G. C. Giberson, W3PC (phone); Theodore R. Jacobs, Jr., W6LHW; Joe H. Harms, W2JME (phone); Robert E. Henry, W9ARA (phone); Ross L. Bateman, W7AO (phone); Kenneth C. Bryan, K6MVV (phone); Pedro R. Casellini, LU4BH (phone); Mario Wallace Simonsen, PY2GJ (phone); Clement E. de Silva, VP2CD (phone); B. B. Bachelder, W6JPW (phone); Leslie M. DeVoe, W9LQ (phone); Lucien Champnois, F3JD (phone); Abdoel Rachman Saleh, PK1RA; G. H. Diesselborg, PK5GD (phone); J. F. B. Rancuret, PK1ZZ (phone); H. H. Vrouwes, PK4VR (phone); Louis Regnier, F3CP (phone); Maurice Dirac, ON4VU (phone); Pierre Gibert, F8DW (phone); Maurice Harp, W6KJG; J. G. Lammers, PK1GL (phone); J. van Eysbergen, PK4DG (phone); J. F. Verschuyl, PK1VY; O. A. F. Spindler, VU7FY; George Gathman, W2DOE; Golden W. Fuller, W5FR; Wm. A. MacKenzie, W1FDN; Thomas Sue Chow, W6MVK; Pier Luigi Bargellini, IKS (phone); John C. Wildner, W8NQC; R. C. Schmidt, W9VDY; J. Gilbert Smith, W4AMC; C. E. Asch, W9BIY; Regimental Amateur Radio Station, K5AA; Larry J. Barton, W6OCH (phone); Paul Krelick, W8QQE; Jerome F. Cerny, W9LOJ; Harold S. Dix, W2DPA; Robert L. Poucel, W2AYJ; E. M. Washburn, W3AVJ; P. B. White, Jr., W3FPQ; George W. Goodwin, VE2DQ; C. L. Robinson, W6KJV; Robert Engleman, W9OEG; Jack P. Blindbury, W6AMQ; Winston-Salem Amateur Radio Club, Inc., W4NC; Clyde Kirby, W5FES; Jess Y. Bowman and Jerry Stover, W5YF; John E. Nelson, W6LMZ; Lloyd C. Hoffman, W5JW; J. P. Furrer, W1PZ; Chas. E. Spitz, W6FZQ (phone); Mayo McAllister, W9UQU; A. E. Goldman, W1CSR; Marc Espinel, F8CP; R. P. Freeman, W1LY; J. G. Zuiderwijk, PA0ZJ; H. B. Gortz, PA0GN (phone); C. H. Ranft, G5RF; D. A. Richardson, ZS1B (phone); H. Haycox, ZS1AV; Rene Jourdan, F8LO; Yasu-

(Continued on page 88)



# OPERATING NEWS



Conducted by the Communications Department

F. E. Handy, Communications Manager

E. L. Battey, Asst. Communications Manager

**T**HE Maxim Memorial Station building will be progressing rapidly toward completion during March. The equipment for W1AW, according to present plans, will be installed during April and May. Many of the several transmitter units are already completed in the League's workshops. The seven-acre site for the new Headquarters station was purchased by the League last summer after exhaustive studies of the available locations. The Executive Committee in the latter months of 1937 opened a large number of bids on the approved architect's specifications. These details and recommendations were placed before your Board of Directors for examination. With studies and opinions completed, the President authorized the work to proceed; 65-foot masts of western red cedar (five of 'em) were set before cold weather. These provide for several long wire antennas besides which there will be erected a 350-foot per side diamond. Those who receive our field organization "family" bulletins have already noted the news on the project from the date of breaking ground in December to the point of completing the foundation in January 1938.

When completed, the station will have four complete separate transmitters, with full amateur power capability for each amateur band and provision for radiotelephone and radiotelegraph work included for each. It will be a station of which any member may well be proud.

Only four miles from the Headquarters offices of A.R.R.L., the site is in relatively open country adjacent to Hartford, in Newington, Conn. The brick and stone building is large enough to allow later addition of more equipment for frequency "marker transmissions" or other purposes. As we write these lines, we're looking forward to favorable weather that will permit climbing those masts to complete the antenna systems. As you can guess, there are a pile of problems to be solved at every step of a station project. But within the next few months, in May surely, we'll be seeing you via the new W1AW instead of operating on a curtailed schedule in temporary quarters.

Your Board's purpose has been to rehabilitate your station washed out in the 1936 floods (W1MK) and at the same time set up a fine, suitable, and lasting memorial, to keep alive indefinitely the memory and inspiration of the

League's First President. W1AW (H.P.M.'s old call), in lieu of W1MK, will soon be ready to carry on the duties and program of your A.R.R.L. stations. This advance information is in response to many inquiries from members on the progress. It will be encouraging to know that the rafters are up and the work on the radio end is well advanced.

**Copying Bee** participation was up 52.7 per cent, according to reports on that December activity, with interest near the all-time high! In late March those who took part will be getting back their individual reports to enable comparison with the transmitted material. Full results will appear in the next issue of *QST*, or the following issue.

**On Harmonic Interference:** It is timely to suggest that all amateurs look into adjustment of transmitters and re-check them carefully! In accordance with the regulations (Par. 381) amateur transmitters must be "as free from harmonics as the state of the art permits" . . . and that is today a very low value of harmonic intensity indeed.

One S.C.M. writes, "It's time for another warning to 75-meter 'phone members about their second harmonics falling at about 7900 kcs. Heard at least 15 yesterday. QSOed several and advised them of the dangers. One was S9. I listened to him on 7958 (!) and transmitted on 3925." From another, "Telephone harmonics have completely washed out our Corps Area net frequency of 3725 kcs. at times, and the Signal Office advises me that amateurs throwing an unnecessarily strong harmonic on this frequency should be reported to the F.C.C. Can't you treat this matter in *QST*? Trouble also on Trunk G (3625 kc.) frequency, but unable to identify them yet." The R.C.A.C. office in Washington report some difficulties with c.w. band harmonics from 3.5 Mc. likewise and amateur radiograms are being filed to notify offenders and request remedies in the speediest possible fashion.

We suggest that effort be made to clear these adjustments up, to avoid citations and F.C.C. trouble for individuals and in line with the high standards of the amateur service which has a splendid record of coöperation in giving immediate attention to such things. Improperly high grid bias and excessive plate voltage, high modula-

tion transients, and coupling to antennas of harmonic energy generated by such things is often the source of trouble. Local listening, tests with other amateurs, and careful analysis of transmitter outputs should *always* prove profitable . . . to all amateurs. Get the energy into your antenna on the *desired* frequency, operate tubes on the proper sections of their characteristic curves and get better tube life and results!

—F. E. H.

#### PRIZES FOR BEST ARTICLE

The article by Mr. I. L. Tilden, M.D., K6PGQ, wins the C.D. article contest prize this month. Each month we print the most interesting and valuable article received marked "for the C.D. contest." Contributions may be on any phase of amateur operating or communication activity (DX, 'phone, traffic, rag-chewing, clubs, fraternalism, etc.) which adds constructively to amateur organization work. Prize winners may select a 1938 bound *Handbook, QST* Binder and League Emblem, six logs, eight pads radiogram blanks DX, Map and three pads, or any other combination of A.R.R.L. supplies of equivalent value. Try your luck. Send your contribution to-day!

### "I Don't Want QSL from W's"

By I. L. Tilden, K6PCQ\*

SOMETIME ago I happened to run across this statement following the call of a prominent station in the Western Hemisphere—"I don't want QSL's from W's." My interest was immediately aroused.

I call to mind a very good friend of mine, a boy permanently crippled by infantile paralysis. Born and raised in the heart of Chicago's great west side, he found, not only a fascinating hobby, but a means of livelihood in amateur radio.

I will always remember my first visit to his station. Surrounded by two- and three-story tenement houses, with the roar of the elevated in my ears, I was ushered into his small, second-story backroom. Upon the wall were framed membership certificates in the A.R.R.L., Rag Chewers' Club, and Chair Warmers Club. His Class A license was displayed in a prominent place on the wall.

And then he showed me the pride and joy of his life, a homemade C.W. rig, made up breadboard style of second hand parts with a pair of tens in the final, yet electrically sound in every principle. Last but not least, we spent a pleasant hour going over his QSL cards which were carefully indexed alphabetically, according to station and district, and kept in a box file. His greatest DX was a W6 and he had never worked outside the United States and Canada. His twenty-five-foot antenna (the best that he could manage under the circumstances) was hemmed in by power lines.

Several weeks later he managed to contact K5AA. This QSO was the big topic of conversation on our daily six o'clock schedule for weeks following and I'm sure he considers that K5 card (which arrived in due course) as one of his most valuable possessions. This Canal Zone station with its many operators has had a soft place in my heart from that time on.

To digress a little: I one morning heard a station outside the United States calling CQ DX. I was able to contact him and the only thing he could say was QSL. I sent my card at once but am still waiting for his. The same thing has hap-

\* Queens Hospital, Honolulu, T. H.

pened on numerous occasions. It seems that many foreign stations do not care to work W's, especially W9's. And if contact is established, they cut the QSO as short as possible and are reluctant to QSL, although most of them promise to very faithfully. While in the W9 district, I could call CQ and listen in vain for an answer. Here in the K6 district with the same rig and a much less efficient antenna, I can call CQ and take my pick of W's, VK's, ZL's and an occasional K7, J, XE, etc.

So pity the poor W and especially the W9. (There are so many of them.) If you XE's, PY's, LU's, K7's, K7's, K6's, VK's and ZL's hear a weak, wavery signal coming from W9, please remember that it may be emanating from the shack of one such as my friend (and there are hundreds like him). Give him a break and by all means QSL. It is a small thing to do and you may rest assured that your card will occupy the place of honor on the wall of his shack. Though you may be tired of W cards and perhaps regard the practice of exchanging cards as a pernicious habit, still, it is done by the majority of amateurs, and, especially to one just starting out, is a big part of the game. It seems to me that you would gain more lasting pleasure from your hobby if you would make it a point to work some of these W's who are starved for DX. What may be an everyday occurrence to you is usually a rare event to them.

"I don't want QSL's from W's." Just a bare statement of fact, and yet it calls to my mind the story of hundreds of chaps such as my friend, scattered throughout the great cities and farms of the middle west, to whom a foreign card would mean a great deal. To me it is not in keeping with the spirit of amateur radio.

EDITOR'S NOTE.—The thought behind this article might well be carried further—to the exchange of QSL's between W's. The majority of U.S. amateurs enjoy receiving QSL's from other W's. Although they may not confirm DX contacts, they convey the same spirit of fraternalism. Perhaps the chap you QSO'd is working for W.A.S. He will need your QSL card for this purpose. But QSL cards are not merely a confirmation of contact—they are a symbol of the true amateur spirit. . . . they provide welcome mementos through the passing years of pleasant associations with brother amateurs, whether those amateurs happen to be located in Timbuctoo or "next door."

— . . . —

### Oregon Emergency Service

Radio amateurs of Astoria, Oregon, banded together at the headquarters of the local N.C.R. unit, provided communications for that city when a storm in the Northwestern portion of the country destroyed regular wire facilities in late December, 1937. Under the leadership of Ensign Frewitt, W7AGP, N.C.R. unit commander, efficient service was rendered without a let-up for nearly two whole days and nights.

W7BDR at the key of W7GKP, the Astoria N.C.R. station, made contact through a Portland amateur with the N.C.R. personnel in that city and N7ATP in Portland was on the job. The Seattle N.C.R. station and individual N.C.R. members throughout Washington were also standing by to assist. W7BBO's transmitter was brought to the Astoria headquarters and BBO and W7ALM had it going in little better than an hour (coils had to be wound for the correct frequency, etc.). As radiograms piled up W7EBQ took the surplus traffic to his station and put it on the A.A.R.S. networks. Most of the Oregon A.A.R.S. members were on the air, as well as several Washington members and numerous non-members so W7EBQ had no trouble in keeping his hook clear. Among those active were W7BGM, DDZ, WR, BLN, FNO, ABB, FVK, EOY, FLF and WY. At N.C.R. headquarters activity went steadily forward. W7CBA took another batch of the surplus traffic to his station and moved it via 1.75-Mc. 'phone. Regular Navy operators from NPE took a postman's holiday, taking tricks at W7GKP after standing their regular watches at NPE. The National Guard kept a supply of hot coffee always ready for the operators. Wire service was partially restored in about two days, although amateurs remained ready to service for the remainder of a week due to danger of floods and slides. It was a job well done—in orderly, efficient fashion.

## Briefs

Radio amateur members of the employees club of the San Joaquin Light and Power Corporation have banded together in the interests of their hobby. They have a station in Fresno, California, operating under the call W6HYG. Two nets are maintained, one on 1866-kc. 'phone, one on 3732-kc. c.w. Members of the group are W6OBT FNK LDZ BKC KOB MHU LQU AHL NFW LBZ QK LMW JDU CVL IYLDXG EAEDT OHI PLI. An independent power source is being planned for the Fresno control station (W6HYG) to improve emergency facilities.

A hook-up consisting of W9YPX, Isle Royale, Mich., W9BBN, Grand Marais, Minn., W9DOQ, Duluth, Minn., and W9DCM, Minneapolis was functioning on December 31st, ready to render whatever service was needed in the worst storm that section of the country had seen for some thirty years. The circuit brought news of the safety of Isle Royale residents and reports on flood conditions and damage at Grand Marais. Ice covered all communication and power lines but the wind let up before more serious damage could be done.

With wire communication disrupted by a severe sleet storm on New Year's Eve a family at Gillsrock, Wisconsin, obtained a doctor's advice for its sick baby by amateur radio. W9GIS at Gillsrock made contact with W9JM at Sturgeon Bay. The latter communicated with the physician, received instructions and sent them back to W9GIS.

Jammed into Times Square, New York City, engaged in the New Year's Eve celebration, W5BTX was surprised by a lusty CQ from a tin horn at his elbow. The natural inquiry, "Say, bud, are you a ham?" brought the reply, "Sure, 2JIN—who are you?" . . . and thus started a QSO amid the bedlam of the occasion.

Due to the fast work of amateur radio, VE1EB, who is Division Supt. of Government Telegraphs, was able to complete the installation of cable between Grand Manan Island, Bay of Fundy, and the mainland before winter arrived in earnest. His order for submarine cable, two miles of it, weighing about ten tons, had been delayed in shipment. As weather conditions were getting worse daily no time could be lost. VE1EB went to the shack of VE1IE at Castalia on Grand Manan and succeeded in contacting VE1BF, St. John. Ascertaining that the cable would be in St. John the following morning, arrangements were made by VE1BF for shipment by Diesel freighter the following night. The cable arrived at the island none too soon, but in time to enable the installation to be completed on the last suitable day of the season.

On December 28, 1937, due to a sudden moderation in temperature in Western Canada, numerous and severe snowslides in the Rocky Mountain district resulted in disruption of wire communications. The C.P. and C.N. Railways each had but one line from Toronto to Vancouver and amateur radio was called upon to assist with the traffic load. A group of 14-Mc. 'phones provided communication from morning until late afternoon when wire service was restored. Stations cooperating were VE3IX and VE3EO, Toronto; VE3AHA, Dryden; VE4TM, Calgary, Alta.; VE4NI, Winnipeg, Man.; VE4BD, Biggar, Sask.; VE5CR, Vancouver, B. C. Every message handled was checked back to the sender, making a 100% efficient circuit.

Traffic for OX2QY, the MacGregor Arctic Expedition, Reindeer Point, Greenland, is routed via A.A.R.S. nets as follows. From WLM/W3CXL, the Washington control station, messages go to WLNf/W2BCX, Elizabeth, N. J., on 3497.5-kc. W2BCX then shifts to 14 Mc. and relays to W2BCR, Newburgh, N. Y. at 8:00 p.m. EST each night. W2BCR jumps into his car and drives to W2CIF, about four miles away. W2CIF has a 14-Mc. beam directed towards OX2QY with a good 1 kw. of power. Schedules are kept nightly between W2CIF and OX2QY at 7:30 p.m. EST, or

as soon as OX2QY clears his commercial traffic with WCC OX2QY uses 14,368-kc. and also schedules W8CJJ.

W2FF handled a rush message for N. Y. C. from VO3X, originating at the Grenfell Mission and concerning breakdown of a heating plant there. VO3X stood by while W2FF delivered the message and received a reply, which concerned precautions necessary in repairing the boiler to insure safety. The complete message exchange took only twenty minutes.

## South Carolina 'Phone Net

South Carolina has a "160 meter" 'phone net operating on 1960-kc. each Sunday at 8:30 A.M. EST. W4EOZ is Net Control Station. Divided into four divisions, Northwestern, Central, Eastern and Southern, the net includes W4EJK, W4ETC, W4EZF, W4DKB, W4EOO, W4EGH, W4CHD, W4ETF, W4DQY (OPS), W4EOZ, W4BNN, W4BGD, W4EHF, W4DPN, W4CUS and W4FAL. W4EOZ calls the division control stations and receives report on all stations present, then any traffic coming through is handled, being relayed to stations in the most advantageous locations. Control stations maintain schedules with W4DVZ, North Carolina, W4OX, Georgia and W4DOG, Florida, as outlet stations. A number of the net members also operate 28 Mc. 'phone and relay distant traffic on that band.

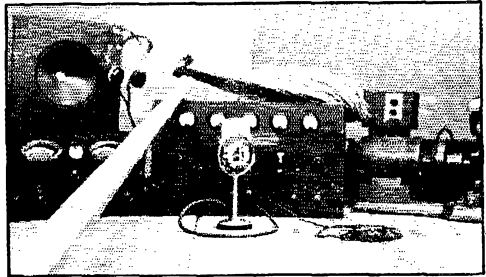

## A DE LUXE EMERGENCY LAYOUT

This is station KINT, complete in every detail and ready for emergency service, including 50-watt transmitter, receiver, gas-driven a.c. power plant, collapsible dural antenna masts, and all associate gear. KINT is one of the several stations in the emergency network of the Los Angeles County Flood Control District. Maurice E. Kennedy, W6KQ, is radio engineer for this network, which comprises both fixed and portable stations. The key station is KIIV, located in downtown Los Angeles; 2726 kc. is used for voice work, with a special frequency of 3190 kc. for c.w. operation from the small stations when they cannot be received on voice during the daytime.

W8KJ feels that more careful identification should be made by operators on the ultra-high frequencies. Not only should the call be clearly identified but mention of location would also be helpful.

A new city ordinance in Detroit, Mich., requires that any device or machine which causes interference to radio reception, or to transmission of any program broadcast by radio, must be corrected by suitable filters, shielding, etc., or the use of said device or machine must be discontinued. This ordinance is not directed against radio transmitters and does not affect transmitting radio amateurs or other F.C.C.-licensed stations. Detroit listeners (amateurs and BCL's alike) who are troubled by man-made interference can obtain relief by notifying the Supervisor of Radio, Detroit Police Department.

## O.B.S.

The following is a supplement to the list of A.R.R.I. Official Broadcasting Stations in October QST (page 50): W2HZL, W4DQY, W4DSY, W5BN, W5ECE, W5EST, W5KC, W7GLEH, W8BOK, W8IHN, W8JRL, W8NEU, W9EC, W9OXC.

## BRASS POUNDERS' LEAGUE

(December 16th-January 15th)

Call	Orig.	Del.	Rel.	Extra Del.	Total
K6OCL	693	288	1397	132	2510
W4PT	41	35	232	25	337
W8HCS	246	370	1244	260	2120
W6IOX	33	77	1744	70	1924
W2BCX	11	19	1573	—	1603
W1IP	21	20	1194	11	1246
W4CYP	155	54	984	28	1221
W8GAN	110	230	810	143	1093
W8LEF	72	54	882	28	1036
W7EBQ	43	102	784	43	972
W3CIZ	64	237	431	227	959
W4CKY	62	86	770	40	938
W3QP	115	386	2	—	384
W8OFO	33	21	774	62	880
W9ESA	91	237	424	113	865
W7FVK	17	34	766	19	836
W8VSN	53	128	641	—	822
W9RMYN	21	47	707	36	811
W8BWT	159	148	392	—	774
W4NG	33	104	634	—	771
W1AKS	94	112	520	41	767
W8KWA	7	75	657	—	739
W1AXB	30	27	662	8	727
W8WAZ	40	61	582	36	719
W5CEZ	58	98	543	15	714
W1UE	161	286	128	130	705
W1IOT	49	113	521	19	702
W2GGE	9	19	640	15	683
W6LBB	87	123	356	114	680
W8C1L	38	24	610	—	672
W6ZM	50	155	306	155	666
W9AZR	30	28	588	7	653
W6LUJ	64	205	180	202	651
W4HK	45	20	566	18	649
W8FLA	119	82	400	48	649
W5CHH	7	10	616	6	639
W6BMC	7	12	609	9	635
W6MGL	7	21	583	19	630
W9RWS	36	26	550	13	625
W5ROE	26	41	536	21	624
W1IHI	62	129	409	16	616
W5DNE	102	93	370	48	613
W3EML	60	78	389	78	605
W1IWC	71	117	396	19	603
K6ONF	125	223	178	45	571
W6JTW	58	164	182	152	556
W1AFB	47	55	427	37	551
W1EMG	34	48	424	38	544
W9ZJS	105	87	294	41	527
W6LMD	3	13	502	47	525
W6KFC	52	365	63	41	521
W9OUD	51	60	389	30	520
W6COH	18	30	448	23	519
W2GVZ	57	130	212	119	518
W5DXA	36	23	392	20	511
W9NFL	20	65	453	12	510
W4AXP	—	—	508	—	508
W1CKK	25	78	342	60	505
W9PTU	21	85	384	15	505

### MORE-THAN-ONE-OPERATOR STATIONS

Call	Orig.	Del.	Rel.	Extra Del.	Total
W5OW	259	184	1030	134	1807
K5AA	821	172	34	129	1156
W9BNT	82	341	630	22	1075
K6NXD	581	125	71	—	777
W1GOJ	40	80	571	51	742
W3CXL	46	21	522	—	589
W5FPO	125	98	154	154	531
W5FSK	55	52	380	33	520
W4AWO	18	57	374	53	502

These stations "make" the B.P.L. with total of 500 or over. One hundred deliveries + Ex. Del. Credits also rate B.P.L. standing. The following one-operator stations make the B.P.L. on deliveries. Deliveries count!

W9PLL, 274	W5FDR, 174	W6NQB, 128
W9KJY, 269	W2DBQ, 169	W3AKB, 123
W2OQ, 264	W9HFG, 157	W1OR, 121
W6QMG, 263	W1KH, 150	W8IAT, 109
W8CEU, 218	W4DVO, 148	W8JQE, 109
W6IMI, 213	W5BN, 137	W1MY, 106
W2HOZ, 209	W3DGC, 135	W6FOU, 106
W8OUF, 206	W2JHB, 132	W7FZB, 105
W9EDQ, 201	W5AG, 131	W2PP, 103
W6ITE*, 194	W1BFT, 128	W7HD, 103

### A.A.R.S.

Call	Orig.	Del.	Rel.	Extra Del.	Total
W1MI (W6XKM)	127	285	1356	257	2025
W1R (W4IR)	27	205	1000	164	1369
W1MM (W7NH)	7	21	694	2	724
W1MG (W4NG)	26	43	444	—	513

WLVV (W6KDI) made the B.P.L. on 138 deliveries.

### MORE-THAN-ONE-OPERATOR STATIONS

Call	Orig.	Del.	Rel.	Extra Del.	Total
W1M (W3CXL)	398	323	3819	167	4707

\* All traffic handled by two-way radiotelephone.

## Michigan Emergency

**D**URING the afternoon of December 31st a steady rain was freezing as it fell. By nightfall all wires had a coating of ice at least one inch in diameter. W8FTW was so advised. Because of acquaintance with the operators at WPV, the Detroit Edison Co.'s radio station, it was decided that this was the best place to get information on ice conditions in the district. The Port Huron District Supervisor of this company has offices in the same building as the radio station, so through this office and the telephone switchboard in the radio station, the following conditions were determined: (1) Several high-voltage transmission lines were down in the Thumb district. (2) There was no wire communication with towns to the North. (3) The power company was not very concerned about the breakdown at 11 p.m., December 31st.

W8JKO and W8DPE got together at 12:55 p.m., January 1st, and immediately a broadcast was put on the air clearing all channels for emergency. The 1.75, 3.5 and 7-Mc. bands were monitored for any possible weak signal from any amateur who might be trying to get out. W8BRS and W8NIV worked together; while one operated the station on 3.5 Mc., the other monitored the 1.75-Mc. band. An amateur in Deckerville, Mich., one of the stricken points, did his best to inform the public as to conditions. W8DPE contacted the W. U. Traffic Department and found that they had several messages they would gladly turn over to radio, if a reliable contact could be made. W8NIV and W8CSX were immediately notified of this. While W8JKO, W8BRS and W8DYH were attempting to get through, W8CSX received a personal call from W8GHP of Pigeon, Mich., which is located in the stricken area. When informed of the need of his station he immediately left for home, arriving around 2 a.m. Upon his arrival he immediately contacted W8CSX and made a schedule for the next morning.

At 9:30 a.m. on January 2nd, W8DPE was informed that a direct contact had been made with the stricken area through W8GHP. Western Union filed a number of messages with amateur radio. W8DPE took this traffic to W8CSX and assisted him in getting it through to W8GHP. After W8GHP had cleared the traffic he drove two miles into Pigeon and contacted the Western Union Manager at Bad Axe over the only 'phone line working, and succeeded in getting the messages to him for delivery.

On the afternoon of January 1st, W8IM reported that the power company desired to get in touch with its Bad Axe, Mich., power house very badly. He considered taking a portable rig up there. W8JKO notified the members of the 3663-kc. A.A.R.S.-A.R.R.L. Net. This net then established contact with both 3.9 and 1.75-Mc. 'phone stations. W8IBH and W8JKO gathered together a portable transmitter and genemotor power supply, together with a battery-operated receiver, and prepared to go to Bad Axe. However, they were advised that the State Police had forbidden travel on the highways, and that the Detroit Edison had decided against sending any portable. So W8JKO returned to 3663 kc. and advised W8FTW, who had taken over control, that we were not going. The fact that W8BUD had been contacted in Bad Axe also figures in abandoning our early plans. About 7 p.m. January 1st, we were notified that the Detroit Edison now had telephone contact with Bad Axe and that the Western Union wires were back in service. W8FTW was notified and he transmitted the information to the net. Some traffic was originated for the power company and the set-up was capable of handling more.

W8DPE (S.C.M.) and W8JKO

## Briefs

Alphabetical QSO's are the latest in the coincidence line. At 1:50 a.m., one morning, W6NRE signed off with W6IWY on 1.75-Mc. 'phone. One minute later he was in contact with W6JWY.

Frank Chiron Spoon, K7GLD, at Shegong Creek, Alaska, is believed to be the first Eskimo amateur. He maintains several schedules and is reported as being an FB operator.

## Code Practice

W9NNA, Terre Haute, Indiana, is transmitting code lessons throughout February, daily except Saturday and Sunday from 6:30 to 7:30 p.m. CST on 1875-kc. W8LCN, Wheeling, W. Va., announces code practice transmissions on 1756-kc. each Thursday at 8:30 p.m. EST. W1ASD, Hartford, Conn., announces change in schedule of code lesson transmissions to 7:30 p.m. EST, Monday, Tuesday and Friday on 1882-kc. The schedules announced by W9ZDZ in February QST have been discontinued.

Station WRTD, Richmond, Va., 1500-kc., broadcasts a code class each Thursday from 6:45 to 7:00 p.m. EST with W3AMB as instructor.

— . . . . —

An attempt to "use" New Orleans amateurs in an illegal manner did not prove profitable to the proponents of the idea. Due to the fact that amateurs respect their regulations and value their rights the "racketeers" involved shortly found themselves in jail. The scheme was to station a man at a point of vantage near the race track, from which point the winning horse could be seen. The second the winner crossed the finish line this information was to be phoned to an amateur station and then sent by radio to six listening stations in New York State, where bets were to be placed on the winning horse before the official news could be flashed by wire. W5FMO and W5FPO were offered \$50.00 to \$75.00 a day for the use of their stations, but refused and notified the Radio Inspector, who placed the matter in the hands of the police.

— . . . . —

## A.A.R.S. Speed Contest

Complete details on A.A.R.S. members' participation in the December, 1937, A.A.R.S. Speed Contest appear elsewhere in this issue. Among the non-A.A.R.S. members participating in the contest the following made the highest ratings in each Corps Area: First C.A.—W1UE 45 w.p.m., W1TS 40 w.p.m. Second C.A.—W2CJI 40 w.p.m., W2KBM 35 w.p.m. Third C.A.—W8OKS 40 w.p.m., W3CRS 40 w.p.m. Fourth C.A.—W4BIH 40 w.p.m., W4EBA 35 w.p.m. Fifth C.A.—W8BKM 45 w.p.m., W8KQS 20 w.p.m. Sixth C.A.—W9HUM 65 w.p.m. (with best report submitted by anyone), W9RLB 40 w.p.m. Seventh C.A.—W9CMF 35 w.p.m., W7FRV-9 35 w.p.m. Eighth C.A.—None submitted. Ninth C.A.—W6MUR 40 w.p.m., W7CRH 40 w.p.m. The only Canadian report was from VE3HP, 30 w.p.m. In the case of those having equal speeds within any C.A., they are listed in order according to the length of copy made accurately at those speeds.

Letters of commendation from A.R.R.L. President Woodruff to the highest scoring eligible member League in each Corps Area have been awarded to W1BVR, W2BCX, W3AKB, W4AFQ, W8BKM, W9NGS, W9HUM, W5BMI, W5GEY and W6GXM.

— . . . . —

Amateur radio was represented at the Hobby Show in Augusta, Maine, October 25 and 26, 1937, by a very impressive exhibit. Two complete stations were set up, one a 50-watt 'phone on 1.75 Mc., the other a 300-watt rig on 3.5-Mc. c.w. No antennas were used on the transmitters since they worked with W1BE, the N.C.R. station located directly over the auditorium where the show was held. A sizeable total of messages was handled, being relayed to W1BE. Most of the traffic went from W1BE to W1BIG, who maintained a schedule with W1LP for connection to the A.R.R.L. Trunk Line system. Credit for the success of the exhibit goes to W1BWR, W1BE, W1BIG, W1KCO, W1JOA, W1EFA and W1BUH, all of whom cooperated in the preparation and booth maintenance.

— . . . . —

While QSO with W9IAG, Peoria, Ill., on November 6, 1937, W5FSH mentioned the fact that he had a brother living somewhere in Peoria from whom he had not heard for over four years. The following Saturday contact was again established with W9IAG, and W5FSH was very happily surprised to hear his brother's voice over the ether. Thus two brothers were reunited after a long separation, thanks to amateur cooperation.

Here's a cross-band contact that was made against the will of the participants. W2HRN had just completed a 6L6 oscillator and was trying 3.5 Mc. for the first time, using a 3617-kc. crystal. Hearing W2KMS call CQ near his frequency, he gave him a call. KMS came back with an RST 579x report, much to HRN's satisfaction. KMS' signals were 569x. HRN went on to explain that this was his first QSO on 3.5 Mc., whereupon KMS inquired what frequency HRN is using. It developed that KMS was listening to HRN on 7 Mc., and KMS thought his transmitter was putting out on 7 Mc. We think the simplest way out of the dilemma would have been for the lads to swap transmitters! But there's a sadder ending to this little story. HRN figured that if he were getting out so well on 7 Mc. with the rig working as a straight 3.5-Mc. oscillator, he should get out much better if he were to double, so he made the necessary adjustments, closed the key and blam! . . . broke his crystal into four pieces. "No more eighty meter experimenting for me," says W2HRN, "I'm going back to forty and stay there."



The Montreal Amateur Radio Club's booth at the "Produced in Canada Exhibition," November, 1937, is a lesson in good planning and execution. The M.A.R.C. and Les Amateurs Canadiens-Francais de la TSF combined their efforts in representing amateur radio at the Exhibition. Each club installed a separate station so that dependable communication for demonstration purposes could be maintained between the two stations in event conditions were not favorable for outside contacts. VE2JY loaned his station for the L.A.C.F. booth, while the entire shack of VE2EE, Quebec S.C.M., was transported to the Exhibition as the M.A.R.C. exhibit. The usual messages were handled and various members of the public were permitted to "talk on the air." Ham parts were on display as well as numerous signs (out of view of the camera) regarding messages being accepted, the object of amateur radio clubs, etc. Amateur radio was given added prestige in the Montreal area due to the efforts of the two clubs.

## Hams Afloat

W7FTL is aboard the U.S.S. *Tatnuck*, NETQ . . . W4BYS is Sparks on the Tug *Cadmus*, WQBL . . . W4CPL is on the S.S. *Colorado* . . . Chief on the S.S. *Seminole*, WNCX, is W1CDF . . . W1FOH operates WHCB, S.S. *Bravo* . . . W1FBX is on S.S. *Osage*, KJTK . . . The rigs on the S.S. *Shawnee*, WOBG, are a 500-watt Spark and 50-watt tube set—i.c.w.; W1UW is Chief, W1JOB second opr., W4EBK third opr . . . W8CLL was on the Tug *Sulphite*, KENQ, on the Great Lakes for the third consecutive year . . . W1MS is third mate on the freighter S.S. *Tillian*, out of N. Y. C. . . . W9QV is operator on S.S. *Padanay*, KUGQ, plying between New York and about twenty ports in Western Africa . . . W9AUQ is third operator, S.S. *Excambion*, New York and Mediterranean Sea ports . . . W9ETB is third opr. on S.S. *American Banker*, New York and London . . . W6HSG is operator on WLFF, a fishing boat out of San Diego.

— . . . . —

VE3LY is reputed to be the only ham in the world who has worked all four members of the "Caveny Family": VE3GG VE3KH, VE3BB and VE3ADZ.

# How's DX?

## How:

The month of March may mean various things to various kinds of people, but to a ham it means only one thing: the DX Contest! And since you people have been so kind in helping out this column with your reports and tips, we felt that we would like to tell you how to win the contest. We aren't kidding when we say that you'll surely get somewhere if you follow our suggestions, but we aren't saying where you'll get. . . .

First of all, you'll want an electric razor. After seeing some of the advertisements, we're sure that it will be just the thing to use, shaving while you're pounding brass with the other hand. Connect the razor across the primary of your plate transformer so it will shut off when you turn off the transmitter, or else you will QRM yourself. If the ads are right, you can even wear your dinner jacket, but this is no real advantage from a radio standpoint.

However, with your well-groomed appearance (and possibly the dinner jacket) your YF or mother should have no objections to serving all of your meals at the operating table. It's really amazing how her attitude will change as long as you remain neat and tidy, and you'll gain time by having all of those meals at the table. Be honest: can you sit through a whole meal at the dinner table when you just *know* that you're missing some prime DX? Of course you can't.

Another good trick is to build up a beautiful friendship with a doctor and then get him to testify that the reason you didn't show up at the office that week was because you were very sick. In this way you won't lose a week's pay, and it will help to explain the black circles under your eyes on Monday morning.

However, from the operating standpoint, there is one very simple way to beat your competitors, and that is to score more points. This can be done in a number of ways, but we can't tell you now because there's a man come to see us. A strong man, in a gray uniform. . . .

## Where:

That 7-Mc. gang really kicked through this month, and a couple of the best-looking ones are reported on 40. W3ATR reports contacts with LX1AS (7142 kc.) at around 4:30 p.m., and FO8AA (7135 kc.) at 3:30 a.m. . . . Someone may be kidding us, but W4BRB reports FU2X (7040 kc., T3) as an officer in the French Foreign Legion. QSL via F3BX . . . . W8DPY reports FQ8AB (14,255 kc.) as a fellow who doesn't like to be called slowly but at about 25 w.p.m. He tunes from the middle towards the high end . . . . Many are wondering about the authenticity of I7AA, ex-17EY (14,410 kc. T9), at Addis Ababa, Ethiopia. He's OK, and your card can be sent care of the Italian QSL Bureau . . . . For the 'phone men, W5FIY recommends VR2FR (14,145 kc.) at around 6:30 a.m., CST . . . . J2JJ (14,300 kc., T9) tells us to look for VR4AD (14,280 kc.) and VQ5A (14,370 kc.) . . . . ZB2A (14,270 kc., T9) reported by Tom, and supposedly in Gibraltar, is quite possibly a phoney. At any rate, the RSGB knows nothing about him, and they're supposed to be forwarding his cards. According to G6WY, it is very difficult to get permission to operate a ham station in Gibraltar. "Ham" also tells us about EA9AI, CR6AF, PX2A and SV6SP (Crete), all on 7 Mc. . . . . W5GKZ says to get on 10 if you want Guatemala: TG9AA (28,450 kc., 'phone) . . . . HRIUZ will be on again soon, on 40 with a pair of 204A's. He says VP4AA (7025 kc., T9) is the station of the British Guiana Expedition, in the Amazon River valley about 1000 miles south of Georgetown . . . . YN1AA (14,405 kc., T8) says you can save yourself money by not sending him U. S. stamps or international reply coupons. The U. S. postage is of course n.g. and the postoffice does not honor the reply coupons. He has about \$5.00 worth of

the latter right now . . . . There has been quite an influx of "phoney's" the past month or so. Some of them, like B4UP, B2A, and the like, make no pretense and freely admit that they are aboard a ship somewhere. Incidentally, B4UP told us the other day that he's retiring soon, after 5 years of brass-pounding on the seven seas. But the guys that are in our hair are ones like the fellow somewhere around Washington, D. C., who was signing YI2RJ on 20, or the youngster in Richmond, Va., who has been signing OX2ZA, HR5AK and K6DEN, on 20. We also learn that VR2AB and VQ1AB were phoney's. We hope these smarties will be sporting enough to stay out of the DX Contest and not waste everyone's time . . . . They don't all get away with it. The fellow who used TF1A for a while has been turned over to the F.C.C.

## When:

That 3.5-Mc. band we have is turning out to be OK as far as DX goes. W9LEZ worked ZL1DI, D4ORT (3515 kc.), and a number of K7's . . . . W7FPN worked ZL1DI (3625 kc.) and ZL2TP, and heard ZL3IN (3670 kc.), ZL2FG, and ZL2FR (3625 kc.); and W7FBK worked ZL1DI, ZL2TP, and ZL1HQ . . . . W8PWU heard ZL1DI, ZL2FR and ZLAAF (3600 kc.) around 5 a.m. and has worked G6WY (3545 kc., T9). Europeans heard there include G6HB, G6RB, D4GAD, HB9C, HB9U, HB9AA, HB9AS, HB9BG, HB9CK and ON4AU, between 3500 and 3650 kc. . . . . W3EPD worked D4ORT and HB9AS

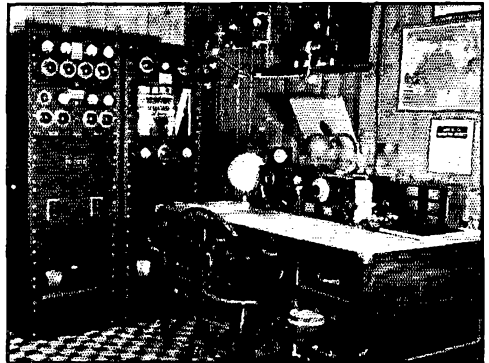

## W2GTZ SPECIALIZES IN ASIAN CONTACTS

Reeve Strock, W2GTZ, is an old-timer in ham radio. He started in 1913 with a spark coil and the call 9UY, and ended up with W2GTZ and a pair of 46's in 1932. The present rig uses either crystal or ECO, and ends up with a pair of T200's in the final, feeding either a 2- or 1/2-wavelength Zepp. The 1/2-wave Zepp slants, and is used for Asia mostly, the longer wire filling-in in the other directions. A sked with VK6SA has been kept for over a year with only 2 misses, and Reeve made 114 Asian contacts last year, which isn't too bad for a W2.

(3525 kc.), and W8KWA got ON4AU and G6RB . . . . W1ZL worked 16 countries on the band last winter with 25 watts to a 6L6G oscillator, and bids fair to surpass the performance this time. Most consistent so far are G6WY, D3FVI, HB9AS, G2ZP and G6RB (worked 8 times) . . . . The 75-meter 'phones boom in over there according to G80G and ON4HS, and they remind us that most of the Europeans are not allowed to operate as high as 3900 kc. They suggest that the W 'phones look around once in a while for some of the DX that hears them.

It almost appears that the 7-Mc. bunch is ganging up on



this column and trying to force us to eat our belittling words about their band. All of which is OK with us, and our only comment is "Have at it, men" . . . . . Besides the ones we mentioned, W3ATR has worked ZB1P (7035 kc.), OK1CX (7025 kc.) HA2L (7070 kc.), HB5G (7060 kc.) and many others. Heard were PZ1RL (7015 kc.), CT1QJ (7190 kc.), LU1AB (7105 kc.), PY2CQ (7165 kc.), OZ9NH (7085 kc.), YR5EV (7080 kc.), HK5JD (7095 kc.), and others . . . . . W3BGD, a club-mate of W3ATR's, worked LU5AN (7045 kc.), ZS1CX (7015 kc. T7), and ON4HC (7020 kc.) one night between 10 and 12 . . . . . W4BRB worked VP7NC (7180 kc. T9x), VP7NL (7130 kc., T6), VP7NR (anywhere, T9e), YV1AK (7030 kc., T9x), YV4AX (7225 kc., T9x) and VK6SA (7030 kc., T9x) . . . . . W9AIC knocked off F3KH (7035 kc.), OK2PN (7045 kc.), D4NXR (7030 kc.), HK5JD, ZL1LZ, ZL1BR, VK3CW and many more, while W9JKX has worked ZB1P, and W9HQH has raised OK1BC (7295 kc., T9) and D4ATT (7325 kc. T7) . . . . . Upin Canada, VE3ALM helps us out by listing LU4BH (7185 kc.), PY2HH (7180 kc.), SM6UJ (7150 kc.), VO1D, VO1M and VO1W (7070 kc.), and HR4AF, and in the low end of the band, YS1FM, VS7AG1, HZ2LD, and YV5AA on 'phone. This at what VE3ALM claims is the noisiest QRA there is . . . . . W8DPY worked CN1CR (now CN1AA) on 40, about the middle of the band . . . . . Another W9 who must be reckoned with is W9WCE, who worked XE, YV, K6 and ZL, and sends in a long list of stations heard, including OE3AH, F3KH, GM8AT, G2PL, HK3AL, K6, ZL and VK . . . . . Count on the W6's, of course. W6CIS reports G2PL (7050 kc.), ON4AU (7000 kc., T8); J2NF, J8CG and J2KJ all at 7150 kc., and OK1BC (7280 kc., T9), also reported by W6KUT . . . . . Up north a ways W7ENW knocks off HA2L, OK1BC, PAOAC, VP1DM, YV2MS and VK's . . . . . W8QHL contributes FA8BG (7145 kc., T9), OK2JR (7165 kc., T9), HC1FG (7145 kc., T8x), and many of those previously mentioned. He says Europeans from 9 p.m.-2 a.m., K6's after 11 p.m., ZL's after 2:30 a.m., and DX good up to 7 a.m. These can all be stretched out a bit, with Europeans breaking through in late afternoon . . . . . W2HZS is no piker either when it comes to finding the good ones. His include FA8PM (7110 kc.), VP5CK (7055 kc.), VP6TR (7040 kc.), LU5BL (7115 kc.), and F3AM (7200 kc.), but Bob still needs a "G"! . . . . . If you still aren't convinced about 40, W2FJH tells about SP1MF (7100 kc.), LA6K (7100 kc.), OZ1B, SM5MZ, 11EC and SP1IA; W2DIJ reports working 20 countries on 40 during evenings the past two months; W2GMM worked PAOPN with a 47 xtal oscillator; and W2IOP reports J3FJ at 7120 kc. . . . . Taking all the evidence into consideration, it simply appears that the 40-meter gang has been too taciturn, and there is plenty of DX kicking around all the time. So let's hear about it.

The VU's as well as other Asians have been fairly consistent on 20 in the east lately. Some of the better ones worked at W1TS include VU2LK (14,010 kc., T9), VU2EO (14,060 kc., T9), VS8AG (14,055 kc., T9), UR8IA (14,300 kc., T7) and U9AW (14,410 kc., T8), XZ2DY (14,100 kc., T9) and U81B (14,440 kc., T8) were heard at 7:45 a.m. . . . . W8LZK manages to squeeze plenty of DX out of the band between T.L. schedules on 80, and worked ST6KR (14,160 kc., T9x), KA1AF (14,140 kc., T9x), ZS3F (14,080 kc., T8x), U5OL (13,395 kc., T9x), CR7AW (14,300 kc., T9x), VU2AN (14,060 kc., T9x) in Baluchistan, VS8AG (14,050 kc., T9x), and VQ8AS, VQ8AE, VQ8AB. Some of those heard include U6WB (14,400 kc., T8), VS7RF (14,340 kc., T9x), VS2AE (14,030 kc., T9), XUBAM (14,090 kc., T9), VQ4CHS (14,035 kc., T9), VQ3TOM (13,395 kc., T6), and VQ4CRI (14,150 kc., T7) . . . . . Another U6 to look for is U6ST (14,350 kc., T8) . . . . . W2HHP still sneaks in some good ones, the latest including I7AA, CR7AY (14,030 kc., T9), and XU8RL (14,330 kc., T9). Among those heard: VQ4KTC (14,360 kc., T8), UX5AE (14,410 kc., T9), FB8AA (14,130 kc., T8c), and ZE1JV (14,280 kc., T9) . . . . . Latest at W7ENW include ZT6V, ZS2F, ZS2X, ZU1T, ZU5AQ, SU1WM, ES5D, PY2KX, UK1CC, PAOAZ, D4NRF and others . . . . . J2KX (14,340 kc.), J2OV (14,340 kc.), ZB1R (14,430 kc.), and U9AV (14,425 kc.) have been coming through in W9, according to W9AIC . . . . . W3ZX doesn't let much get past him. His latest include U6AH (14,420 kc., T7), U1AD (14,415 kc., T9),

CN8MS (14,410 kc., T6), CN8AR (14,290 kc., T7), CN8AX (14,400 kc., T7), SU5NK (14,300 kc., T9x), PK1RI (14,360 kc., T9) and VP1JR (14,410 kc., T8) . . . . . W3GAU reports VP3TEV (14,410 kc., T9), QSL via VP3BG. Incidentally, the VP3's fat is hard to read, and the boys are still arguing whether his call is 3TEV or 3TEST. At least he doesn't have to go to "swing school"! . . . . . Just in time to make this issue, W2CYS drops in with KA1QL (14,366 kc., T9), VS6AO (14,340 kc., T9), and G8DO (14,300 kc., T9) in the Channel Islands. Heard was ZD7H (14,390 kc., T9) in St. Helena. Jeeves, warm up transmitter No. 7 and swing the beam to 75° east of south!

Reports on 28 Mc. are practically nil this month but we feel that it is because there is nothing really startling coming through, with the exception of one or two mentioned above. However, the band is in good condition, as evidenced by a long list submitted by W3AKX. The list includes stuff in five continents and some nice ones like HR5C, SV1CA, CE2BE, HJ4EA and a raft of Europeans and K6's. Ten will probably be pretty hot during the Contest.

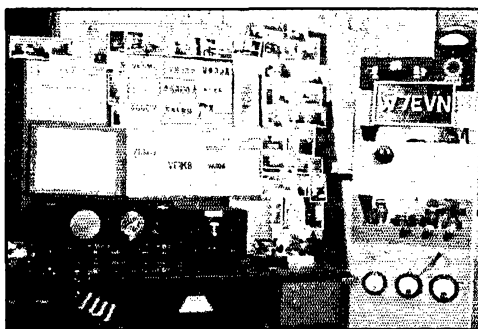

W7EVN, CASPER, WYOMING, HOLDS W.A.S. TICKET NO. 271

All but three states were worked on 3.5 Mc. Rhode Island, Nevada and Vermont were snagged on 7 Mc. Transmitter uses a '47 crystal, '46 doubler, P.P. '10's final, running at 60 watts input. W7EVN is also an enthusiastic R.C.C. member.

Nothing much of DX contacts on 5, but the boys are still at it. CM7AB has tald down there, on 57,600 kc., and will be looking for W's . . . . . W2KRB is on in the mornings looking for Europeans, and is anxious to arrange test schedules.

### What:

W9ZJ brings up a topic that may bear a little discussing. It is this business of the fellows with the rotatable "beams" on 10 and 20, and whether or not they are worth the effort. The average gain is usually not more than one or two "S" points, and ordinarily that won't make much difference. Remember, this is the gain over a straight antenna, not the front-to-back ratio. The front-to-back difference is of course quite useful for both sending and receiving, reducing QRM considerably in many instances. But if the intent is to extend your operating time and work stations when no one else can, you'll probably need a fixed array with its greater gain. Or don't you agree?

### Who:

W6ITH ran into a 'phone signal on 14,120 kc. the other evening, and the operator had a marked Oxford accent. "Ah," says Reg, "a G." When the fellow signed it was J2NG, in Tokyo. Reg raised him and found that the accent had been acquired during seven years of school in Australia . . . . . The first WAS in Argentina will go to LU7AZ if he gets a card from the New Mexico station he worked the other day . . . . . Maybe you've wondered about these stations in Hejaz and Bahrein, and why they don't seem to

answer many calls. A letter from De Mont Stevens, at Jeddah says that he is on the air for a mining company with three 30FXC transmitters, but you're wasting your time if you call him when you hear him testing. The Arabian government only licenses them if their transmissions are confined to within the country. Woe is us! . . . . OA4AB, well-known 'phone, is back in the States and will be signing a W2 call soon . . . . W6JMR now has 457 different Europeans to his credit, including 185 different C's. And incidentally, he has worked G2YL, J2IX, HC1FG, VE5YL and K6MZK—all he needs is an African YL for a YL WAC . . . . Some nice work at W6KUT includes contacts with YN2AB, HC1PZ, YV1AK and YS2AB, bringing his total to 77 countries . . . . With his usual nonchalance, W9KG tells us that he has completed WAC on 40 with stuff like U9AV, J2MO, HR4AF, YS1FM, ZS1CX, HK5JD, a flock of LU's, and Europeans including ES, I, EA2, and HB. The 14-Mc. list is a mile long, and includes VU2FX at 9 P.M., VQ4CHS, OQ5AE, VS7MB, YV4AX, CN1CR, KA1AX and HI2T. Keat still has a "Missouri KW" of 95 watts to a pair of T20's, and an even 100 countries . . . . HK1Z is now HK5AR . . . . W2IXY keeps a 'phone sked with VU2CQ three times a week, and says she didn't sked VP3THE as erroneously reported here, but did sked OX2QY . . . . The other morning W8JSU hauled up to 40 and worked GM8AT, daylight all the way. He spent the day 100 miles away, pulled back in the evening, got on 20 and his first contact was GM8AT, darkness all the way. It looks like he needs a new receiver and the advice that 40 is a darkness band and 20 a daylight band, or something . . . . W9HQH worked U9ML (14,435 kc., T9c) for WAC at his new QTH . . . . A welcome report from W5VV tells of his latest, such things as TF2C (14,290 kc., T7), ZE1JZ (14,400 kc., T9), VU2EO (14,380 kc., T9), VQ8AS (14,125 kc., T9), FR8VX (14,440 kc., T9), I7AA and others. His total is 107 countries worked, with only 68 confirmed. The thing has reached the point where he is practically off the air—in an effort to raise money to buy postage to send letters to get those delinquent cards Wilmer has sold most of his transmitting gear! . . . . Here's another new one, reported by W3CBT: ZM4AD (28,190 kc., 'phone) in British Samoa. Boyd also worked TG9AA . . . . Some of the W1's have decided to enter the contest after all. Yes, W1FH, that perennial threat, should be out of this year's contest. Wedding bells ring Feb. 27th, and to our congratulations and best wishes we add a sigh for another good man gone wrong . . . . Here's hoping all youse guys have a grand time in the Contest. Personally, we're going fishing—for a few new countries!

—W1JPE

### A.R.R.L. Headquarters Operators

Hal Bubb, "Hal," Chief Opr. W1AW.

The following calls and personal sines belong to members of the A.R.R.L. Headquarters gang:

W1AL, J. J. Lamb, "jim"  
 W1AW, A.R.R.L. Headquarters Operators Club  
 W1BAW, R. B. Beaudin, "rb"  
 W1BDI, F. E. Handy, "fh"  
 W1CBD, C. B. DeSoto, "de"  
 W1DF, George Grammer, "gg"  
 W1EH, K. B. Warner, "ken"  
 W1ES, A. A. Hebert, "ah"  
 W1GS, F. C. Beekley, "beek"  
 W1JBJ, Thomas W. York, "tom"  
 W1JEQ, Vernon Chambers, "vc"  
 W1JFN, A. L. Budlong, "bud"  
 W1JPE, Byron Goodman, "by"  
 W1JTD, Hal Bubb, "hal"  
 W1SZ, C. C. Rodimon, "rod"  
 W1TS, Don Mix, "don"  
 W1UE, E. L. Battey, "ev"  
 W5CJB-1, Thomas M. Ferrill, Jr.

## DX Century Club

CENTURY CLUB membership now totals fifteen, W6GRL and W8DFH having recently received their certificates. Congratulations to these new members! "Ham" Whyte, G6WY, is back at the top of the list with a healthy lead. W8CRA has a good grasp on second place. A number of the "under 100" group are moving rapidly towards the century mark, W9KG having only three more to go. We look for several new club members within the next few months.

Check over your confirmations in accordance with the January QST list of countries and send them in as soon as you can present 75-or-more. When sending your confirmations, please accompany them with a list of claimed countries and stations representing each country to aid in checking and for future reference after your confirmations have been returned to you. Please send postage to cover the return of your confirmations.

### MEMBERS, DX CENTURY CLUB

	Countries
H. A. Maxwell Whyte, G6WY	126
Frank Lucas, W8CRA	119
Jefferson Borden IV, WITW	114
Douglas H. Borden, W1BUX	114
John Hunter, G2ZQ	114
Henry Y. Sasaki, W6CXW	108
Clark C. Rodimon, W1SZ	106
Harry G. Burnett, W1LZ	106
Don H. Mix, W1TS	105
Walton H. Bostwick, W2GW	105
Reeve O. Strock, W2GTZ	102
Jean Lips, HB9J	102
C. E. Stuart, W6GRL	102
Guy Grossin, F8RJ	100
E. L. Walker, W8DFH	100

The following have submitted proof of contacts with 75-or-more Countries:

W9KG	97	W3EVW	88	W1JPE	82
E15F	96	W6ADP	87	W1RY	82
W9PST	95	W8OQF	87	W8EUY	82
W8LEC	94	W6GAL	86	W2CYS	81
W8JMP	93	G2DZ	86	W4CCH	80
W8OSL	93	W2GVZ	86	W3EPR	79
W9EF	92	W4DRD	85	W4CFD	79
W1WV	92	W1DUK	84	W3EVT	78
W1DF	90	W2HHF	84	W8ADG	77
W9ADN	90	W3JMM	84	W8BSF	77
W9KA	90	W8KKG	84	W3AIU	77
W1ZI	89	VE2EE	83	W4AJX	76
W6FZL	88	G5QY	83	W6BAM	75
W3BES	87	G5RV	83	W9UM	75

### Delaware

For the information of those searching for a Delaware contact for W.A.S., we print a list of Delaware stations: W3SL HC WJ DQ AIS AIW AKH AOP ARM BBP BAK BTQ CPG CIY CHJ CLU CER CWF DIA DKO DMO DMP DNC DNF DNH DNI DNN DNP DOA DOH DPA DQG DRD DRE DSQ DTD DTK DUA DUK EGN EGV EIH EIX EJA EJU EEB EPT EYM FLA FNI FFF GCO FGW PHK FJK FKI FKT FUO FVW GAU GEN GFD GGO GGW GVQ GYQ GZH HBE HBR HDA HF MA DTQ DZF.

W2KGN points out that QRK? means, "Do you receive me well? Are my signals good?" . . . This does not necessarily call for an RST report. QRK? can well be used during long QSO's to check occasionally on whether the other fellow is receiving you O.K. QRK (without the question mark) means, "I receive you well. Your signals are good." W2KGN suggests RST? when we desire an actual signal report.

W2SB worked UPOL, the Russian North Pole Expedition, on November 3, 1937, 8:52 to 9:10 P.M. EST. The expedition's frequency was around 13,990-14,000 kcs., c.w. W2FSN made contact immediately following W2SB.

Station Activities on page 100



# CORRESPONDENCE

The Publishers of QST assume no responsibility for statements made herein by correspondents

## "The Amateur Is Progressive"

251 Lafayette Ave., Grantwood, N. J.

Editor, QST:

I agree heartily with your reply to the letter by W2GTW in your February issue. When I read such letters it makes me wonder just what some of these boys are getting out of their hobby. If the old adage, "You only get out of a thing what you put into it," holds true in these cases, they certainly can't be getting much. Luckily for them, however, A.R.R.L. is putting in enough to make up for their failure to do so. They spend their time worrying about losing a kilocycle and criticizing the activities of the League, which has made possible the comparatively large number of kilocycles that we now have, without doing anything themselves to warrant the use of same. I hate to think just how many kilocycles we would now enjoy if all amateurs had been, and were now, as selfishly non-progressive as such letters indicate.

The third rule of the amateur's code is, "The Amateur Is Progressive." This should mean, I believe, not only that the amateur should keep his station abreast of science but also that he should keep himself abreast of the times by digestion of as much of the knowledge of the science as is practical, and by as much personal experimentation as his finances will permit. Where would the amateur be now if he had taken such an attitude toward 'phone in the pre-'phone days as this writer (W2GTW) takes toward television?

I believe that I have as much authority as W2GTW and a much more scientific attitude when I say that most amateurs are heartily in favor of the "publicity" on television as well as articles on model airplane control by radio. The amateur will never lose a kilocycle through his aid in the development of television, but he is very apt to lose several if he fails to keep up the good work of technical advance. The advancement of the science and aid in communication emergencies are the only excuse for the amateur's being. Lacking these, the amateur must gradually give way to more pressing services. With these, he will last indefinitely and need waste no time by worrying over a lost kilocycle.

—H. G. McCann, Jr., W2KWK, ex-W1KAM

## Vote of Thanks

85 Overland Ave., Bridgeport, Conn.

Editor, QST:

I wonder how many of us realize the swell job being done for us by our QSL bureaus throughout the country.

If all the rest do their volunteered duty as well as our WIBGY, I sincerely believe we all owe each and every one of them a hearty vote of thanks.

We can all do a small part to help our respective district bureau by seeing that he has one of our stamped, self-addressed envelopes in his office, that he may attempt to keep his files up to date.

You might say, "I do not work any DX; there are no cards for me." But don't forget, there may be a few "heard" cards for you.

Nothing brings quite as much happiness and enthusiasm to the "non-DXer" as a heard card from some remote country.

So fellows, let's get behind our local QSL bureaus and send them some envelopes and take advantage of this really fine service.

—Charles A. Taylor, W1DOV

## Maybe It Was Two Other Fellows

14 Britton St., Jersey City, N. J.

Editor, QST:

. . . It is not very unusual for stations to work each other on schedule using their second harmonic, but when a harmonic and an image frequency come into the picture through the medium of QSO's then you have something. The 160-meter c.w. band is dead enough at night, but in the afternoon hours it is even deader than dead. However, I used to operate there quite a bit. One day I heard a CQ going on and decided to call the fellow. I got him and he turned out to be a fellow cityite living a little more than a mile away. As I have said, we had about twenty chats when one night he decided to drop over and carry on a ragchew in person. Well, our conversation led us to learn that all the time he was transmitting and receiving on 80-meter c.w. and I, at the same time, was transmitting and receiving on 160 c.w. It turns out that he was copying my harmonic and I was getting his image frequency. Neither had any knowledge of this, and at no time did we make a schedule. When one heard the other calling

a CQ he gave him a shout. At all times the signals were R99 plus at both ends. . . .

—Charles M. O'Brien, W2EQS/W3DPY

## They Do Work

16 Windsor Road, Somerville, Mass.

Editor, QST:

Who says that directional "CQ's" do not produce results? While QSO with ZS2A this afternoon on 14 mc. he asked me to QSP three messages concerning schedules, particularly on 28 mc. to W9DXX, W6JJU, and W7AMX. At my consent, the messages wiggled off ZS2A's "bug" in one—two—three order.

After a short rag-chew we signed off, and I tackled the job of delivering the messages immediately, so that the schedules proposed therein might be kept by the recipients. Starting up the transmitter (the buffer being used as the output stage with only 165 watts input) I tried a directional "CQ" as follows: CQ CQ CQ CQ tfc de ZS2A for W9DXX W6JJU W7AMX de W1LZ W1LZ W1LZ. This was repeated three times and then the receiver was turned on again. Imagine the glow of satisfaction when back came W9DXX. "Alice" took her message solid the first time through the nerve-wracking racket of a parked truck's motor. Who says that the "YL's" cannot show the "OM's" how to operate?

A bit more of rag-chewing with W9DXX, and the other two messages were tackled. A CQ similar to the first one brought no results. Then I remembered that the transmitter was on 14,008 kc. Since both W6JJU and W7AMX are usually to be found on the other end of the band, the transmitter was shifted to 14,388 kc. Listening on this end of the band neither of the desired stations could be heard, so I decided to try another directional CQ. Back to the receiver after this CQ, and W7FH was heard on the edge of the band coming back to me. He took the message with no "fills" and advised me that W7AMX himself was calling me on my own frequency. Tuning a bit further into the band, W7AMX was located. During the three-way QSO that followed W6JJU's message was easily forwarded with assurances of an immediate QSP by W7AMX. . . .

—Harry G. Burnett, W1LZ

## 120 Mc. for Beginners

724 West 44th St. Terrace, Kansas City, Mo.

Editor, QST:

The Tulsa Amateur Radio Club in the January, 1937, issue suggested a method of bringing unlicensed 5-meter operators within the law and aiding prospective amateurs in learning the code by issuing a special short term license to permit operation on this band.

I doubt if the 5-meter operators would be willing to compete with the hundreds of additional inexperienced operators whose noisy transceivers would add to the congestion on the already crowded 5-meter band.

If this proposed class were assigned to still higher frequencies, for instance above the 112- to 120-Mc. band, they would not interfere with 5- or 2½-meter work and would at the same time promote investigation of these unexplored bands.

The following plan is a modification of the one submitted by the Tulsa Amateur Radio Club:

1. The exam should be easy, consisting of questions on ultra-high-frequency theory, transmitters, antennas and on amateur procedure as well as knowledge of the code including numerals and some punctuation marks.
2. The term of the license should be no more than one year during which period the operator would be required to pass the Class B exam or forfeit amateur privileges until he does.
3. The band should extend from 120 to 130 Mc. With further development of equipment even higher frequencies could be used.
4. Only c.w. (types A-1 and A-2 emission) should be permitted with 100 watts maximum power since the purpose is to enable the operator to learn the code—not DX.

5. The call could be designated by four numerals, the first being the number of the call area.

Even with low power and directional antennas distances of 10 miles or more could be worked. Perhaps "bootleggers" would be reluctant to leave 5 meters but radio clubs would be much more willing to report "bootleggers" if they could go to the higher frequency band.

Perhaps modifications of this and the other plan would be acceptable to the A.R.R.L. and the F.C.C. if enough support were given it. It would be valuable in training future hams and would aid greatly in cleaning up the 5-meter band and stimulate interest and investigation of frequencies above 60 Mc. . . .

—John C. Dodds

## DX Test Technique

Tarboro, North Carolina

Editor, QST:

. . . The proper way to work DX is to listen and then call the station with which contact is desired. If this simple method is carried out I feel certain that the station seeking DX will realize several times the benefits of his station when using this method as by trying to call the DX to him.

. . . Unless conditions change considerably from what they have in the last two months it will be necessary that the above method be followed (in the International Tests.—En.) DX has been very, very scarce in this part of the United States during this period. What with the ever increasing number of stations the openings in the band are forever dwindling. After several QSO's within a radius of one thousand miles nearly every amateur tells me that he, like myself, isn't making any contacts with DX stations. So, fellows, when March rolls around let's all have a chance at the DX by listening and not clutter up the band by useless "CQ DX" calls.

—J. M. Carstarphen, Jr., W4CUI

## World Peace and World Friendship

730 N. 6th St., Grand Junction, Colo.

Editor, QST:

That letter "Hams and Peace," by W8QN, on page 52 of June QST, with its accusation that hams were doing nothing at all to further the cause of peace, would rather make it appear that the W.F.S.R.A. has been lying down on the job as far as advertising itself is concerned. . . . We have been coming along lately, now having members in 15 countries and 4 continents, and expect to go WAC in membership shortly. In England things have been going even better than here, and there are now more members of the W.F.S.R.A. in England than there are in the United States, much as I blush to have to admit it. In England Mr. Arthur H. Bird, G6AQ, is in charge of W.F.S.R.A. affairs, with the title of Hon. Secretary for Great Britain and Ireland. His QRA is 35 Bellwood Road, Waverley Park, Nunhead, London, S. E. 15. I am still the world secretary, but G6AQ acts in all matters relating to W.F.S.R.A. affairs in the British Isles.

You probably recall the requirements of membership from the item on page 74 of July, 1935, QST. The rules are still just the same: It is necessary simply to copy and sign the pledge and forward to me (or to G6AQ, for G members). . . .

The W.F.S.R.A. is doing something to promote peace, W8QN to the contrary notwithstanding! I am enclosing a copy of the Membership Pledge, in case you wish to quote it.

—Duane Magill, W9DQD

EDITOR'S NOTE.—The pledge: "I hereby promise that I will, to the best of my ability, make such use of my amateur station as will be conducive to international friendships; that I will never voluntarily permit my station to be used as the tool of selfish nationalistic interests; and that I will do what I can, as a radio amateur and as an individual, to promote world peace and understanding."

(Continued on page 122)



One of the large radio tube manufacturers recently went on record with the statement that radio tubes had a longer period of service with the filaments always hot than when they were shut off when not in use. The principal reason given for this was that the temperature strains caused by alternate heating and cooling were the most common cause of tube failure. For instance, these strains may lead to strange secondary effects such as leakage from cathode to filament, due to rubbing when parts expand and contract. On the other hand filaments are not harmed by running hot with plate current off and may even have their emitting qualities improved.

This is in line with our own experience. It certainly agrees with the experience of the commercials, many of whom have their HRO's turned on all the time. They do this not so much to save the tubes, however, as to simplify remote control and operating procedure. For instance, some of the airlines have their HRO's located a mile or so from the operating position, where they operate on fixed frequency, unattended. Once thoroughly warmed up the temperature drift of an HRO is negligible, so that by operating with filament power always on no adjustment of the tuning control is necessary. This simplifies remote control to the ultimate degree, for there is no "control," just a stable receiver with an off-on switch in the B-supply lead.

Amateurs do not operate on fixed frequency of course, but it seems to us that this idea of continuous tube heater operation has a number of advantages for the amateur. In addition to long tube life and very high frequency stability, there is the further advantage that the set is always ready to operate with full efficiency at a moment's notice. During DX contests or other heavy schedules this technique is particularly worth while. The power consumption is not an important consideration. At W1HRX (where the power is now per KWH and not per gallon of gasoline, thanks to the new pole line) the rate is about  $3\frac{1}{2}$  cents. On this basis filament power for an HRO is about \$7.25 for a full year, twenty-four hours a day, every day. This is also the approximate life of a set of tubes when operated as described above.

Of course, where the set is operated only occasionally, it is hardly worth while to leave the power on. Also, not all sets are designed for continuous duty, and our suggestions above are not a blanket recommendation. All National receivers can be operated continuously however, and we advise doing so. The One-Ten is a possible exception to this rule, because it uses acorn tubes.

The cost figures given above are for receiver filaments only, not including the rectifier. There is no particular virtue in leaving the rectifier on when it is in a separate power supply.

Speaking of fixed frequency, many amateurs operate in one band exclusively. Our experience has been that for this kind of work the HRO Junior is by far the best bet. When purchased with one coil range, it provides a de luxe single range receiver at no more cost than a less efficient general purpose set. Furthermore, extra equipment, such as a crystal filter, or an S-meter, or more coil ranges, can be added at any time. You can choose just exactly the equipment you need, thus getting maximum performance at minimum expense, "tailored" to fit your requirements.

JAMES MILLEN



Use  
**YAXLEY**  
 APPROVED RADIO  
 PRECISION PRODUCTS

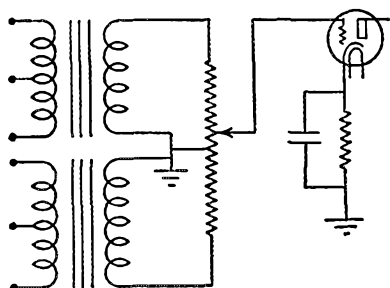
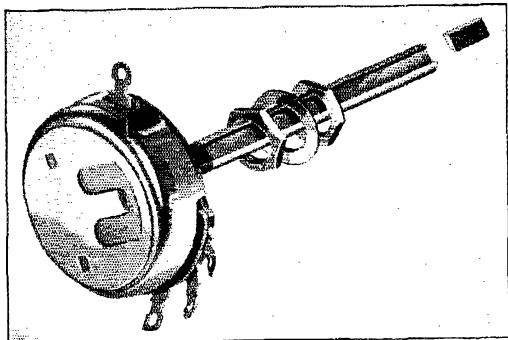

## Fader Control for Electronic Mixers

The Yaxley TRP 609 control, a special one megohm center-tapped potentiometer with a combination right and left-hand taper has won well-deserved popularity as a means of fading two high impedance circuits into the grid of a following tube.

This control embodies the new Yaxley SILENT features of construction and is well-adapted for use in high gain amplifiers because of its noise-free characteristics.

The price is \$1.50 list, less knob. You can procure this part from your Mallory-Yaxley Distributor.

**P. R. MALLORY & CO., Inc.**  
**INDIANAPOLIS INDIANA**

Cable Address—PELMALLO

Use  
**MALLORY**  
 APPROVED RADIO  
 PRECISION PRODUCTS

## A Feedback Compensator

(Continued from page 14)

back and simultaneously increasing the detector screen voltage, a stage is reached where signals are amplified very greatly and with perfect stability. The regeneration control is not in the least critical, which contradicts previous experience when raising the output from a regenerative rig. This result was not the one particularly sought for in our experiments, but may easily prove to be the most desirable advantage of the type of control described here. The process can be carried on past the point where the grid-leak detector is an efficient rectifier, judging from results with the experimental set-up.

### SELECTIVITY

Examination of the circuit diagram shows that there are several common impedances between the first and second tuned circuits. It follows that the effective selectivity of the rig depends on the degree of coupling and the tuning of the two circuits. The feed-back compensator introduces a controllable degree of coupling in addition to previously existing couplings. Oscilloscope observation of the output, using an r.f. oscillator modulated at 20 kc. as the signal source, shows that the selectivity curve can be modified from a single rounded hump to a "square-shouldered" curve, and finally into a double-peaked curve. These are easily recognized as the series of curves obtained when the coupling of two tuned circuits is gradually increased from less than critical to more than critical values.

It would be impossible to specify the exact conditions under which any one type of curve might be produced in the receiver; suffice it to say that any one of them can be recognized by careful attention to the side bands heard, particularly when tuning through two "adjacent" signals in an amateur 'phone band. Certainly a 'phone signal sounds better with a square selectivity curve than with the sharp peak usually associated with regenerative detectors, and also found in superhets with conventional intermediate-frequency amplifiers.

### C.W. RECEPTION

There appear to be at least two other effects obtainable with the circuit described above, but they were somewhat difficult to establish with any degree of certainty in practice. The first concerns only the c.w. addict with a conventional 3 or 4 tube receiver. When the feed-back compensator is carefully set in a position which substantially neutralizes the r.f. stage, it is possible to tune in a signal with the r.f. stage "right on the nose," and to have the detector oscillating at a slightly different frequency for the beat note. This trick, comparable to the single-signal effect used in all good superhets, practically eliminates one of the two beat notes heard with an autodyne detector. A small panel-controlled trimmer condenser in the first tuned circuit is very helpful in getting the exact setting required.

## NEWS PICTURES MAKE THE DEADLINE

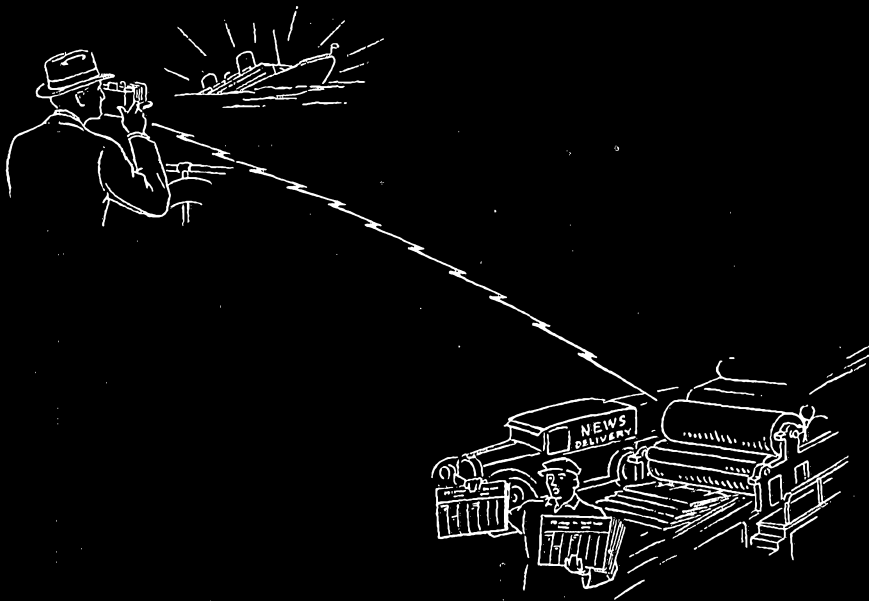

**T**HE reporter and the camera-man join hands in bringing to the public the news of the day. And as telegraph wires and radio flash the reporter's story from city to city with the speed of light, the camera-man's pictures travel at the same speed, ready to make the same deadline—ready to appear in the same edition with the story.

The electron tube makes possible the transmission of news pictures by wire and radio—and in every electronic circuit—in the moderate frequencies of wire transmission or in the high frequencies of radio—the insulation must

be of the highest quality. In the commercial transmission of pictures Isolantite\*-insulated circuits and equipment contribute to the dependability of the service.

In this comparatively new field, Isolantite's long experience in the design of ceramic insulators for every application is at the service of its customers.

\*Registered Trade-name for the products of Isolantite, Inc.

# ISOLANTITE INC.

**CERAMIC INSULATORS**

Factory: Belleville, New Jersey • Sales Office: 233 Broadway, New York, N Y

Say You Saw It in QST — It Identifies You and Helps QST

# T W O

## Eimac TUBES

### RX21 MERCURY VAPOR RECTIFIER

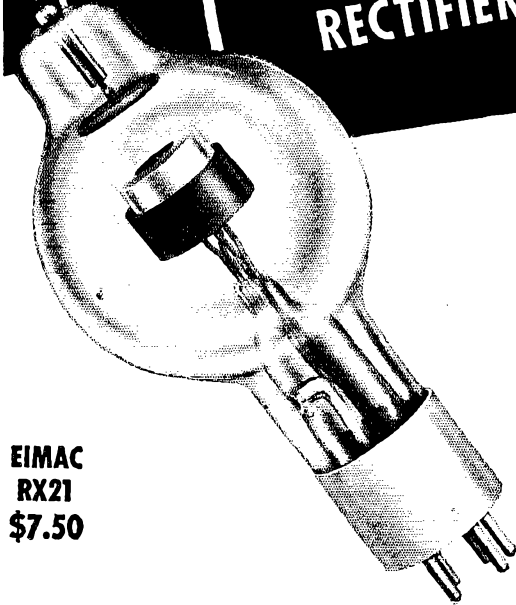

**EIMAC  
RX21  
\$7.50**

The same unique construction and outstanding design principles that account for the tremendous success of Eimac in the power tube field, are incorporated in this new rectifier. RX21 is a tube for the amateur who demands the very finest equipment obtainable; yet in cost it is well below the average for rectifiers of the same rating . . . (1½ amperes at 3500 volts). Ask your dealer for complete information about RX21, then compare it to others of the same calibre.

**SEE FACING PAGE ADVERTISEMENT FOR  
AN IMPORTANT EIMAC ANNOUNCEMENT**

**EITEL McCULLOUGH, Inc.**

#### DYNAMIC SELECTIVITY

The other effect which seemingly occurs at some settings of the controls is that of complete suppression of adjacent channel signals. That happens to be the goal of a lot of miscellaneous experimenting with receiver circuits here, although we have strayed occasionally into noise-suppressors, automatic gain controls, etc. The basic idea seems to be somewhat like this:

Certain adjacent-channel signals are passed through the tube to the second tuned circuit and may be considered to drain off through either the condenser or the coil, depending on whether they are high or low in frequency as compared to the desired signal. If these side frequencies could be fed back negatively to the grid circuit without feeding back the desired signal degeneratively, there should be a definite gain in effective selectivity. Study of the plate circuit impedances shows that, outside of the tuned circuit, the least current flows at the resonant frequency, and relatively larger currents for other frequencies. This discrimination against the resonant frequency can be employed usefully if the currents involved are passed through an impedance representing a noticeable fraction of the total impedances in series in the complete plate circuit.

In the circuit shown in Fig. 1, these currents must flow through the feed-back coil in order to complete the circuit from plate to cathode. The coupled impedance of the grid circuit constitutes the load for the feed-back currents. In a circuit using a separate primary winding for the second tuned circuit, the by-pass condenser from the low potential end might be connected permanently to point "A" in the circuit, leaving the screen-grid by-pass condenser connected to ground as shown. A previous trial of this circuit trick in various stages of a superhet failed to give a result which was not obscured by the effects of automatic gain control, circuit tuning, etc.

#### SOME RESULTS

The experimental three-tube receiver, using the feed-back compensator, included a pentode audio stage working into a dynamic speaker. The frequencies covered were from 12 Mc. to 17 Mc. Most domestic and several foreign short-wave broadcast stations within this range drove the audio stage to capacity. Incidentally, the set exhibited a remarkable tolerance of fading and signals of different levels, possibly because of the automatic gain action of the grid-leak detector. The r.f. tube was a 954 acorn having a sharp cut-off characteristic. There was no noticeable cross-modulation from strong signals when degenerative feed-back was used, except from transmitters within a half mile. Perhaps the substitution of a variable-mu pentode or introduction of an extra tuned circuit between antenna and receiver would help to reduce blanketing by these local stations.

#### AN ADDED CONTROL

The feed-back compensator described here may seem an unnecessary added control, since the same effects can be produced by other means. But



# NEW TUBES

## KY21 GRID CONTROL (MERCURY VAPOR) RECTIFIER

*This Newest Eimac Development  
Fills a Long Felt Need!*

A pair of Eimac KY21 tubes operating in the conventional full-wave rectifying circuit, provides a D.C. output power of 3500 volts at 1½ amperes; regulates the flow of current by means of the grid control; provides the means to key 3 K.W. of power with the simplest *low power* circuit; eliminates heavy, arcing relays; permits high power operation in congested areas, by practically eliminating all "key clicks."

Eimac KY21 is essentially a mercury vapor rectifier tube to which has been added a control grid, the only tube of its kind available to amateurs, designed and rated for maximum utility, in amateur equipment. The advantages of keying through KY21 tubes is immediately apparent. Since the primary of the transformer is constantly energized, "blinking lights" are minimized. Elimination of arcing relays removes "tails" from signals more completely than an equivalent filter for primary keying. The main filter smooths the R.A.C. and eliminates "key clicks" simultaneously. Such a filter consisting of 8 henries and ½ to 2 mfd. will give T9X signals and permit "weights off" bug operation.

"Hams" everywhere are discarding ordinary rectifiers . . . replacing with Eimac KY21. Place your order today . . . there's bound to be a shortage.

**YOUR EIMAC DEALER HAS KY21 AND RX21 TUBES NOW**

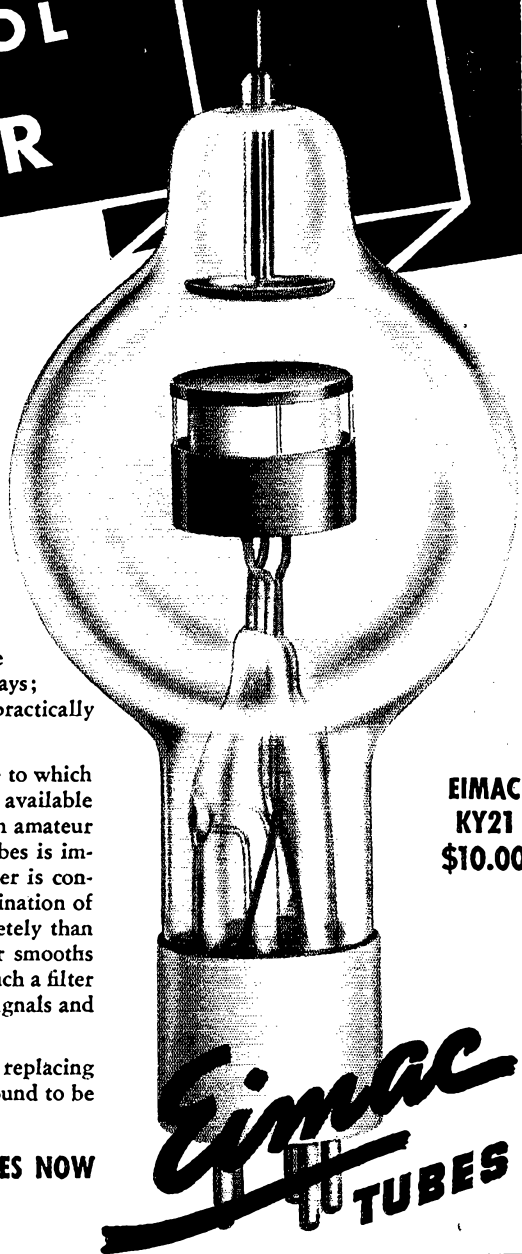

**EIMAC  
KY21  
\$10.00**

**Eimac  
TUBES**

**EITEL McCULLOUGH, INC. • San Bruno, California**

Made by the men who build  
Commercial Communications  
Equipment ...

## THIS RCA AMATEUR TRANSMITTER IS A TOP-NOTCH VALUE

The Model ACT-150 is a top-notch performer at a price that shouts value! Made by the same skilled RCA engineers who create commercial communications equipment, it offers features that *prove* its quality ... features born of RCA's experience and research in every phase of radio! Look them over — see for yourself.

### FEATURES

Conservative 150 watts output (c.w. and 'phone).

Tube line up of modern acclaim: R.F.—RCA 807, 802, two 807's, two 808's; Audio—RCA 6J7, two 6C5's, two 2A3's, two 808's; Rectifiers—RCA 83, 5Z3, 80, two 866's.

Isolated speech amplifier of special design.

10 to 160 meter operation.

Circuits fully metered including modulation indicator.

Switch for "Tune-up" protection or power output reduction.

Transformers given special impregnation.

Interlock switch for safety to operator.

Neutralized at factory.

Pleasing two-tone gray finish and handsome escutcheon plates on cabinets.

Low tube and extra coil costs.

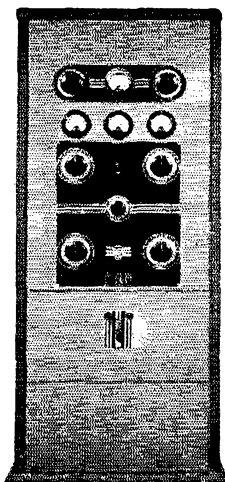

### MODEL ACT-150

Amateur's net price F.O.B. factory with speech amplifier and one set of coils but less tubes, microphone, crystal. Extra set of coils \$13.50 **\$625**

For maximum performance at minimum cost — use RCA Radio Tubes.

RCA presents the "Magic Key" every Sunday, 2 to 3 P. M., E.S.T., on the NBC Blue Network



## FOR AMATEUR RADIO

AMATEUR RADIO SECTION

A Service of the Radio Corporation of America  
RCA Manufacturing Company, Inc., Camden, N. J.

hams cannot all apply laboratory methods to hook those elusive DX stations. So the added control is suggested as a means of balancing up the unknown quantities with another one. It is offered up to the tender mercies of the set builders, to be modified, moved thither and yon, replaced by double variable condensers or tapped coils, and changed into a link circuit, or Colpitts feed-back. Variations which we have tried all seemed to have possibilities.

For application to the front end of a superhet, the feed-back compensator should be helpful in removing erratic action, whether deliberate regeneration is used or not. Perhaps combined control of the feed-backs in both r.f. and detector circuits can be developed to the point of being reasonably fool-proof. Certainly the first circuits in a superhet are subjected to most of the conditions affecting the simple circuit discussed here.

Acknowledgment is due and offered to anyone whose circuit design, textbook, handbook or magazine article may have suggested some part of the "feed-back compensator." Certainly, H. S. Black's contribution of the "Stabilized Feed-back Amplifier" was largely responsible.

### Homebuilt Velocity Microphone

(Continued from page 33)

approximately one-half inch and the ribbon so cut as to leave approximately a sixteenth inch or less spacing on each side.

The bakelite pieces at the ends support the ribbon and are drilled to accommodate the machine screws holding the brass clamps which provide contact with the ribbon. These clamps are so bent that the ends are turned up, thus putting strong pressure upon the ribbon. A very important point is to be sure to use only well-polished brass for these contacts. If the brass is lacquered, be sure to remove the lacquer with fine sandpaper. The use of aluminum or other metals — aluminum especially — will result in poor response and low sensitivity because of contact resistance.

#### FORMING THE RIBBON

The task of cutting the ribbon demands a little patience, and you must expect to gouge and rip a few trial ribbons until you acquire the right touch. A half-microfarad condenser will furnish plenty of material for a great many attempts.

Place a foot-long strip of the foil upon a piece of flat and rather heavy cardboard. If there are any wrinkles, smooth them out with light, long strokes of the fingers. Place a straight edge — a brass-edged rule is ideal — over the foil so as to leave the desired width of ribbon. Press the straight edge down firmly so that the ribbon will not slip and with a steady, slow motion draw a razor blade along the straight edge. Practice on a few odd pieces will give you the knack and let

(Continued on page 76)

For  
**TROUBLE-FREE**  
 Dependable Service

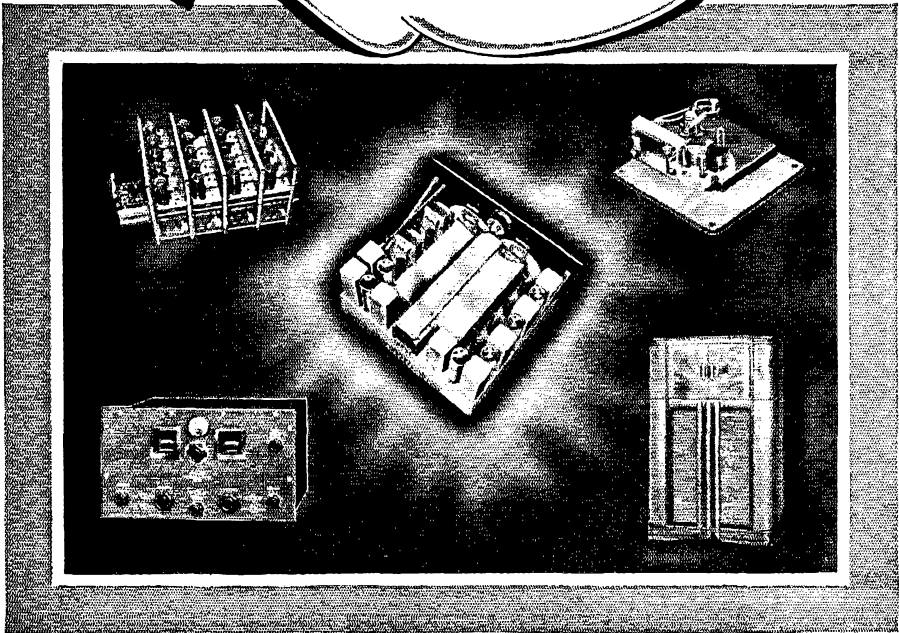

## THE NEW "SUPER-PRO"

THE new "Super-Pro" with its distinctive design and rugged construction, provides "trouble-free, dependable service" so essential to the critical amateur and professional for his important and exacting air activities. Among the "Super-Pro" features that contribute to this superior efficiency is the husky, self-contained tuning unit, with its unique noiseless band-change cam knife switch. In addition, the tuning unit has 20 separate coil assemblies, with coils wound on highest grade bakelite and mounted on Isolantite bases. The tuning unit also has a shielded 4-gang tuning condenser and 12-gang band spread condenser with soldered brass Midline plates, stainless steel rotor shaft, and steel ball bearings affording smooth and accurate tuning.

Other features of the "Super-Pro" are — two R.F. stages on all bands; calibrated band width (3 to 16 kc.); available in table model, rack panel, or console for 7½ to 240 or 15 to 560 meters. Console model has a bass reflex sealed sound chamber and a 15" high fidelity speaker.

### MAIL THIS COUPON!

HAMMARLUND MFG. CO., INC.  
 424-438 W. 33d St., N. Y. City

- Please send me "Super-Pro" bulletin.
- Please send me "Super-Pro" Console bulletin.
- Please send me dealer listing.

Name.....

Address.....

City.....State.....Q-3-38



# HAMMARLUND

# NEWARK'S BIG NEW STORE PARADE OF "HAM" VALUES

**Only \$19 down**

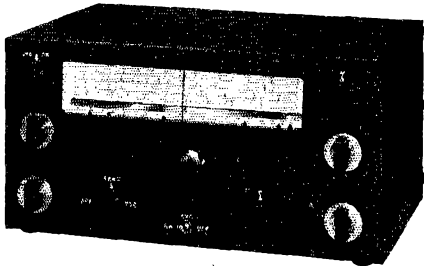

ONLY \$7.30 MONTHLY for 12 months buys this NATIONAL NC 80X (or NC 81X) Or you can pay \$9.66 per month for 9 months or \$14.36 monthly for 6 months. Complete with Tubes, Crystal Filter, and 8" P.M. Speaker mounted in Cabinet to match. Cash price.....\$99.00

**ORDER NOW DIRECT FROM THIS AD**



Simply send down payment with your order, own one of these fine National receivers NOW, and pay balance at your convenience. Everything we advertise is carried in stock for prompt delivery. We can ship your set within 10 days after receiving down payment. Order parts, too, all under one simple extended payment plan. Write for catalog.

ONLY  
**\$29.70**  
DOWN

★  
1 Year to Pay  
Pay only \$26.14 a month for 6 months; or \$17.67 a month for 9 months; or \$13.45 a month for 12 months.

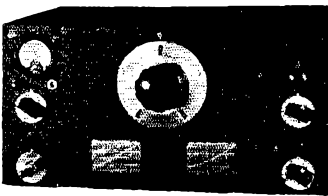

**HRO DE LUXE**

Complete Band Spread coverage, 1700 KC to 30,000 KC. Nine Tubes (not including rectifier). Two pre-selector stages. Strictly single-control tuning. Four gang precision condenser with pre-loaded worm drive tuning, 20-1 ratio. Two I. F. stages with Litz-wound coils, air condenser tuned. Beat Frequency Oscillator for "offset" C. W. tuning. Single Signal (Crystal Filter) standard equipment. Direct reading micrometer dial spreads tuning over 500 divisions, numbered every 10 divisions. Buy now on NEWARK'S easy 6% Credit Plan.

**\$179.70**  
CASH PRICE

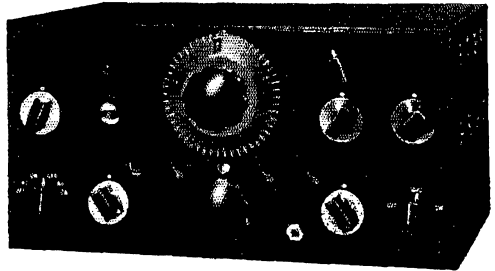

**NATIONAL NC 101X**

**\$24 DOWN** and \$9.47 a month pays for this famous National Model NC-101X. And you can take a year to pay! Or, if desired, pay \$18.58 a month for 6 months or \$12.50 a month for 9 months. Cash Price, complete with Tubes, Crystal, and Speaker.....\$129.00

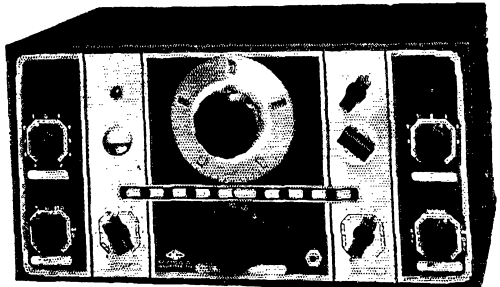

ONLY  
**\$20**  
DOWN  
Balance  
**\$9.02**  
Per Month  
1 YEAR  
TO PAY

Or \$17.74 a month for 6 months; or \$11.93 a month for 9 months.

**NATIONAL NC 100**  
Complete (Cash Price) **\$120.00**

... NATIONAL NC-100 ... the "Perfected" Super-Het! Amazingly selective, high sensitivity, low noise level. A wonderful performer. Full coverage, individual built-in plug-in coils, shifted by knob on front panel. 540 to 30,000 KC coverage in 5 ranges. 12 tubes, one stage RF, two IF, P.P. Pentode 10 w. audio output. Full AVC circuit. Built-in power supply. Single and double antenna connections. "Electric Eye" tuning indicator. Large, latest type *Dynamic Speaker*.

**YOU CAN DEPEND ON NEWARK TO HAVE ALL NEW SETS AS RELEASED AND ANNOUNCED BY THE NATIONAL CO.**

# NEWARK

*Electric Company*  
323 W. MADISON ST.  
Dept. Q CHICAGO, ILL.

# OPENS WITH ASTONISHING ..LOW PRICES..EASY TERMS!

**THOUSANDS SOLD — but we still have a few of these well known makes**  
Oil Filled, Oil Impregnated  
**FILTER CONDENSERS**

We started with 10,000 and are now sold down to a limited stock of the four capacities listed below. ALL WELL KNOWN MAKES. Guaranteed at rated voltages. No more at these amazing low prices when these are gone. Get your order in TODAY and be sure!

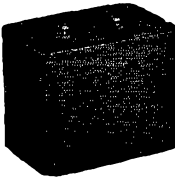

2 mfd., 2000 V. DC 4 3/4 x 3 3/4 x 1 3/4, 1 3/4 lbs... \$1.50  
3 mfd., 1250 V. DC 3 3/4 x 3 3/4 x 1 3/4, 1 3/4 lbs... 1.25  
8 mfd., 2000 V. DC 5 x 3 3/4 x 3 3/4, 2 3/4 lbs... 2.75  
4.4 mfd., 1500 V. DC 5 x 3 3/4 x 1 3/4, 1 3/4 lbs... 1.75

## HAM BARGAINS TRANSFORMERS Made by UTC

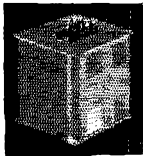

Increase your power at half the former expense. Get one of these New UTC Special Transformers... fully cased with universal mountings and stand-off bushing terminals. Quality at low prices... Buy Now! Transformers are same as the illustration and ratings are AC values.

20462A — 750-1000 each side of center, AC, at 300 mills, weight 20 lbs. .... \$5.20  
20462B — 1000-1250-1500 AC each side of center, 300 ma., weight 25 lbs. .... \$6.75  
20462C — 1500-2000-2500 each side of center, AC, at 300 mills, weight 31 lbs. .... \$10.95  
20462D — 1000-1250-1500 AC each side of center, at 500 mills, weight 31 lbs. .... \$10.95  
20462E — 575-525 AC each side of center, at 500 MA., weight 18 lbs. .... \$5.20

## New Aerovox "Hyvol" Oil-Filled Condensers

In Extremely Compact Metal Cans

Selected paper section condensers filled and impregnated with "Hyvol," the new super-dielectric oil. Hermetically-sealed, leak-proof containers. Mounting lugs. Compact, much smaller than others, yet ideal for heavy-duty service.

Type	D.C. Volts	Cap. Mfd.	Size — in.	Price
			L. — W. — D.	
609	600	1	2 1/8 x 1 13/16 x 1 1/16	\$1.62
609	600	2	2 7/8 x 1 13/16 x 1 1/16	2.06
609	600	4	3 3/8 x 2 1/2 x 1 3/16	2.65
1009	1000	1	2 1/8 x 1 13/16 x 1 1/16	1.76
1009	1000	2	4 x 1 13/16 x 1 1/16	2.65
1009	1000	4	4 3/4 x 2 1/2 x 1 3/16	2.94
1509	1500	1	4 x 1 13/16 x 1 1/16	2.21
1509	1500	2	4 1/4 x 2 1/2 x 1 3/16	3.23
1509	1500	4	4 3/4 x 3 3/4 x 1 1/4	4.70
2009	2000	1	3 3/8 x 2 1/2 x 1 3/16	2.65
2009	2000	2	4 x 3 3/4 x 1 1/4	3.53

## 323 W. MADISON ST. IS OUR NEW CHICAGO ADDRESS

Come to our Big New Store... just 1/2 block west of our old location, and across the street. More Floor Space. Bigger Stock on Hand. Better facilities for demonstration and Service. New streamline Madison Street Trolleys stop a few steps from our door. Plenty of parking Space FREE to all Newark Customers. Newer... Better... Lower Priced Parts and Supplies... Buy Now... Easy Terms if your order is for \$60 or more!

## FB7 Owners Look at this Scoop! COILS AT 1/2 PRICE

National's FB 7 Coils. Regularly listed at \$6.00 per pair. They'll go fast at our low price. Stock is Limited... and no more when these are gone. Very Special at... **\$3.00** Pair

Only the following numbers available at our give-away prices!

TYPE AB — 160-meter band spread  
TYPE AB — 80-meter band spread  
A — 15-26 general coverage  
C — 41-72 general coverage  
D — 70-125 general coverage  
E — 120-200 general coverage

## PRE SELECTOR COILS TO MATCH

Regularly priced at \$3.60. Newark Special Price, only... **\$1.75**

## FREE CATALOG

Just off the press. Hundreds of bargains for ham! You get exactly what you want and you pay less... much less. 4-HOUR SERVICE from complete stock always ready to ship. Write today for your copy of this big catalog.

## SCHOOLS, LABORATORIES and POLICE DEPTS.

We will gladly furnish any reasonable quantity of our catalogs for your entire staff, for classroom and laboratory use, etc.

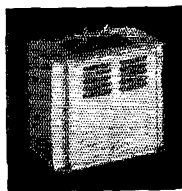

WRITE NOW!

## SPECIAL HAM BARGAIN CHOKES — BY UTC

Chokes to match transformers. Fully enclosed as pictured. Just the thing for that new rig.

20462F — Smoothing choke 20 hy. — 200 MA., weight 5 lbs.	
20462FS — Swinging choke 5-25 hy. — 200 MA. — 2500 volts — Insulation. Each.	<b>\$1.45</b>
20462G — Smoothing choke 20 hy. — 300 MA. — weight 8 lbs.	
20462GS — Swinging choke 5-25 hy. — 300 MA. — 3500 volts — Insulation. Each.	<b>\$2.85</b>
20462H — Smoothing choke 20 hy. — 400 MA. — weight 13 lbs.	
20462HS — Swinging choke 5-25 hy. — 400 MA. — 5000 volts — Insulation. Each.	<b>\$3.45</b>
20462I — Smoothing choke 20 hy. — 550 MA. — weight 17 lbs.	
20462IS — Swinging choke 5-25 hy. — 550 MA. — 6000 volts — Insulation. Each.	<b>\$4.95</b>

## BARGAIN PLATE AND FILAMENT TRANSFORMERS

20757 — 600-0-600 V. AC., 200 MA., 2.5 V. Ct. 10 A., 7.5 V. 3 A., 5 V. 3 A. Wt. 11 lbs.	\$2.95
21647 — 500-425-0-425-500 V. AC., 250 MA., 7.5 V. 3 A., 6.3 V. 3 A., 5 V. 3 A. Wt. 12 lbs.	\$2.95
23160 — 600-525-0-525-600 V. A. C., 300 MA., 7.5 V. 3 A., 6.3 V. 5 A. Wt. 16 lbs.	\$5.50
22283 — 2.5 V. Ct. 10 A. Wt. 3 lbs.	\$1.65

# NEWARK Electric Company

323 W. MADISON ST.  
Dept. Q CHICAGO, ILL.

Say You Saw It in Q87 — It Identifies You and Helps Q87

# BETTER CONDENSERS

'MTC-D'

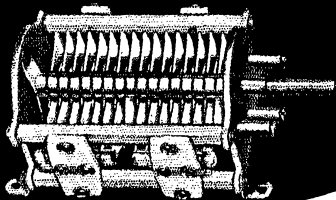

SPLIT-STATOR

for

'N-10'

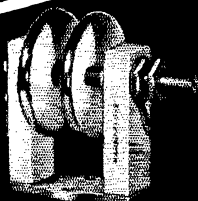

NEUTRALIZING CONDENSER

# BETTER RADIO

FREE →



THESE two precision products by Hammarlund are intended for medium-power transmitters of compact design. The "MTC-D" is built for universal mounting and is available in capacities ranging from 20 to 265 mmf. with voltage ratings of from 1000 to 5500. — The "N-10" is an ideal companion to the "MTC-D." It is compact, rugged, and has a capacity range of 2 to 10 mmf. Both items are Isolantite insulated.

### Mail Coupon

HAMMARLUND MFG. CO., INC.  
424-438 W. 33d St., N. Y. City.

Q-3-38

Please send me new "38" catalog.

Name.....

Address.....

City.....State.....



# HAMMARLUND

## Homebuilt Velocity Microphone

(Continued from page 78)

you determine for yourself how much pressure to use so that the ribbon will cut rather than tear. Cut the ribbon at least a couple of inches longer than necessary.

Assuming that you have cut a ribbon of desirable width, i.e., about  $\frac{1}{16}$  inch narrower than the ribbon slot, the next problem is to put a crimp in it. This wrinkles the ribbon slightly and gives

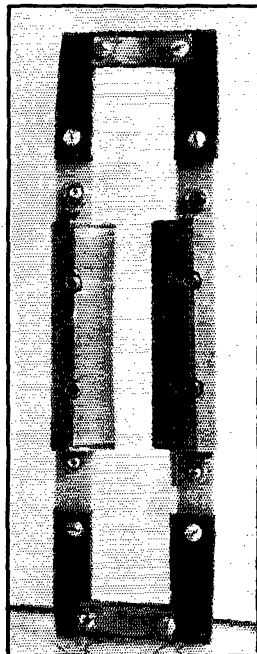

MAGNETS, POLE PIECES AND RIBBON SUSPENSION BEFORE THE RIBBON IS PLACED IN POSITION

it extra springiness so that it can be stretched when mounted and yet will respond to very slight sound pressure. The wrinkling process gathers the ribbon together and it will stretch like a coil spring. In mounting the ribbon we make use of this property to keep the ribbon snug so that the changes in position of the microphone do not cause it to sag. After crimping, a ribbon will withstand considerable pull but be careful not to make it too tight. The photograph should be self-explanatory as to method of crimping. Only slight pressure is used on the gear which is run over the ribbon. The felt mat allows the ribbon to give and accommodate itself to the teeth.

Now that you have the ribbon ready and the entire pole assembly rigidly mounted to the magnets, you are ready for placing the ribbon in position. The pole pieces should be "dodged" around slightly by loosening the machine screws in the assembly so that the ribbon slot will be straight and of constant width. The brass contacts should be in position but sufficiently loose to enable the ribbon to be slipped beneath them. Slip each end of the ribbon under the contacts. Leaving an inch or so over-extension, clamp the ribbon into the proper position at one end. You will have to pull



## 7 MEGACYCLES *and up* . . . .

**Y**OU HAVE, no doubt, found out that it is impossible to make an inductor or capacitor with zero resistance.

For reasons, which we shall try to clarify, it is also impossible to make a perfect resistor without any inductance or capacitance in it. If you just want to change electrical energy into heat you can run current through most anything, a hunk of baling wire or a barrel of salt water, and they'll both give off B.T.U.'s. But if you want a real *resistance*, one that has constant impedance from DC up to 30 megacycles or higher, you've asked for something.

Most people think of any carbon resistor as pure resistance. Extremely delicate measurements of several types of carbon units indicate that they have negligible inductance (if you keep the leads short) but considerable distributed capacity. This is caused by the relatively large amount of "binder" material used in most types of carbon resistors to hold the particles together in a solid mass. We have reduced this distributed capacity in the IRC "Type F" resistor by making it in the form of a thin film, less than three thousandths of an inch thick, bonded to the outside of an insulating cylinder, which is then encased in a protective Isolantite sleeve.

The result of this design is a resistor with very small changes in impedance when operated at high frequencies. Many of the "pill", molded, or extruded types of carbon resistors change appreciably and this becomes more severe the higher the resistance value; at twenty megacycles a representative molded carbon "one megohm" resistor measures only 0.17 megohm! An IRC "F-1 Type" resistor of the same initial value measures 0.7 megohm at the same frequency.

Now we also make the BT Type insulated resistor and it is an excellent job for audio or broadcast frequencies. It is at least the equal of the ordinary carbon resistor at high frequencies, but if you want an exceptional high frequency resistor we recommend the "F Type."

What good is all this? Well, try some "F Type" resistors in the R.F., oscillator, and mixer circuits of your superhet and see if they don't improve the performance. Regardless of which band you're on you can be sure that your 50,000 ohm grid resistor isn't behaving like a 10,000 ohm.

If your R.F. amplifier is cursed with U.H.F.

parasitics it can sometimes be cured by inserting in the grid circuit as close as possible to the grid connection of the socket a 100 ohm Type F-1 resistor with eight turns of No. 18 wire wound on the body and soldered to the metal ends.

It will often improve the A.V.C. action of a receiver (even a broadcast receiver) to replace the decoupling resistor in the A.V.C. circuit, if it is a molded carbon or insulated type, with an F-1 of the same value.

We saw a neat little grid condenser in an U.H.F. job. It consisted of two small copper plates bolted to the body of the F-1 grid resistor and connected to the ends, thus taking advantage of the insulating sleeve as a support.

Don't infer from the above discussion that you should use resistors with a flat frequency characteristic throughout a set. The insulated resistor (IRC Type BT) is fine up to, say, 10 megacycles, but for operation at higher frequencies do what the leaders do, use IRC "Type F".

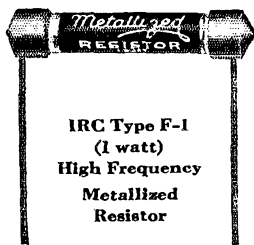

### INTERNATIONAL RESISTANCE COMPANY

401 NORTH BROAD STREET, PHILADELPHIA, PA.

ADVERTISEMENT

Say You Saw It in QST — It Identifies You and Helps QST

# "I'M THE BOY WHO'S SATISFIED!"



"I paid 25c for a Technical Manual that's worth far more . . . a real bargain in tube information."

AMATEURS need the Sylvania Technical Manual . . . for it contains the fundamentals of tube characteristics and performance that every amateur should know.

The Manual lists over 200 tube types . . . with circuit application information on each. Tells all about glass, metal, "G" type, Sylvania "Ballast" tubes, and tubes for Majestic receivers. Contains bias resistor charts, typical circuit diagrams, and many other important items.

Send the coupon below and 25c for the Sylvania Technical Manual . . . today! You'll be the boy who's satisfied.

*Hygrade Sylvania Corp. also manufactures the famous Hygrade Lamp Bulbs*

## SYLVANIA

Set-Tested Radio Tubes

HYGRADE SYLVANIA CORP. Q.S.T.-38  
Emporium, Pa.

Here is 25c. Send me my copy of the new Sylvania Technical Manual.

Name \_\_\_\_\_

Address \_\_\_\_\_

City \_\_\_\_\_ State \_\_\_\_\_

AMATEUR

SERVICEMAN

DEALER

EXPERIMENTER

the ribbon taut with the fingers at the opposite end and juggle it around slightly to get it centered properly. With one end clamped the juggling is repeated at the opposite end and adjustment of tension so made that when the entire assembly is laid flat, ribbon parallel to table top, the ribbon does not sag. Leads may be now soldered directly to the brass strips without danger to the ribbon. The excess ribbon may be cut off to the ends curled over the edge of the bakelite.

### OUTPUT CONSIDERATIONS

The impedance of the ribbon is on the order of half an ohm. This must be matched to the impedance of the input circuit of your amplifier. If you are going to use the "mike" in close proximity to the preamplifier, say within 6 feet or so, it is possible to run the leads from the ribbon to a ribbon-to-grid transformer. In general, it is preferable to utilize a ribbon-to-line transformer, matching the ribbon to a 50- or 200-ohm line. This was mounted in the little cupola of the case, as shown in the photograph. Lines may be up to a thousand feet long without heavy losses.

The cable should be shielded and this shielding bonded to the magnet assembly and the core of the ribbon-to-line transformer. Lacking a transformer of this type, a working substitute may be found in a universal output transformer such as is used in coupling speaker voice coils in receivers. By connecting the ribbon to the lowest-impedance taps and the line to the primary of the transformer, a suitable combination may be found. A good transformer costs but little, and the better performance and hum-free operation from use of correctly designed units and good grade microphone cable are well worth the extra expense. Shielded wire may be utilized for cable, but a definite increase in gain will be observed when using the microphone cable.

Success of velocity microphones depends also upon the preamplifier used, and the manner in which the lines are coupled or matched has considerable to do with not only the gain but the hum level. A good input transformer, line-to-grid, is desirable. If you cannot afford one of the better balanced-winding types which tend to minimize magnetic pickup, use an ordinary one and if necessary place it in extra shield cans and even mount it in a position a few inches from the chassis in a spot which gives minimum hum pickup. Shielded leads, well-grounded preamplifier, and a decent input transformer mean low hum level, surprisingly good pickup, and freedom from "headaches."<sup>2</sup>

As to results, the following method was used in making comparisons with other types of microphones, including commercially-available products of both high and low cost. A speaker in a remote room in the house was connected to the output of the amplifier. A number of individuals listened to the various tests. A regular alarm clock can be heard ticking some 20 feet away

<sup>2</sup> The preamplifier used with these mikes incorporated a 6C6 pentode followed by a 6C6 triode connected. Output level at plate of latter is pleasing headphone volume.



**HERE  
THEY  
ARE!**

# RCA Television Parts

## FOR KINESCOPE DEFLECTING CIRCUITS

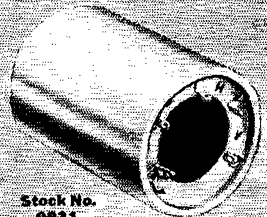

Stock No. 9831

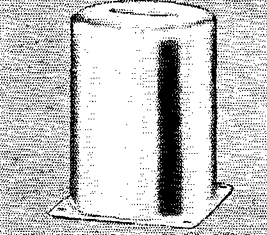

Stock Nos. 9832, 9834, 9835, 9836, 9838

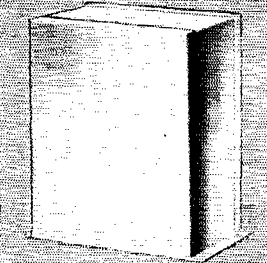

Stock Nos. 9832, 9839

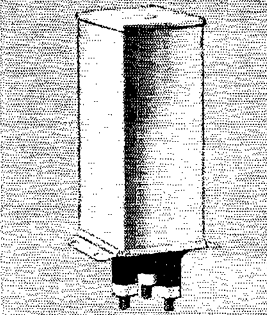

Stock Nos. 9837, 9840

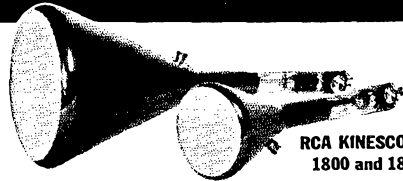

RCA KINESCOPES  
1800 and 1801

Again RCA encourages the amateur and television experimenter by making available the basic units for the construction of Kinescope deflecting circuits. These parts are of traditional RCA design, include the finest engineering features and are manufactured to give long service. They are for use with RCA 5- and 9-inch Kinescopes, Types 1800 and 1801.

**DEFLECTING YOKE . . .** For RCA 1800 and 1801 Kinescopes. Has windings for both horizontal and vertical deflecting circuits. Designed to have uniform flux distribution. Size: Outside diameter, 2½ inches; Inside diameter to fit RCA 1800 and 1801 Kinescopes. Length: 3¾ inches. Stock No. 9831. . . Net Price **\$10.00**

**POWER TRANSFORMER . . .** Includes all windings necessary for a complete power supply for the deflecting circuits of RCA 1800 Kinescope. Insulated for high voltage. Plate winding of 6,000 volts and two 2.5 volt heater windings. Stock No. 9832. . . Net Price **\$12.50**

**POWER TRANSFORMER . . .** For 1801 Kinescope, plate winding of 2300 volts and two 2.5 volt heater windings. Stock No. 9839. . . . . Net Price **\$10.00**

**VERTICAL OUTPUT REACTOR . . .** A fine auto-transformer for matching output of deflecting circuits to deflecting yoke vertical circuit. 120 henries inductance. 3800 ohms DC resistance. Stock No. 9833. . . . . Net Price **\$3.00**

**VERTICAL OSCILLATION TRANSFORMER . . .** For low frequency blocking oscillator circuit. Gives best efficiency at 60 cycles. Stock No. 9834. . . . . Net Price **\$3.00**

**HORIZONTAL OSCILLATION TRANSFORMER . . .** For high frequency blocking oscillator circuits. Has high efficiency at 13,200 cycles. Stock No. 9835. Net Price **\$3.00**

**HORIZONTAL OUTPUT TRANSFORMER . . .** Has extremely wide frequency response and special characteristic to pass a 13,200 cycle saw-tooth voltage. Matches output of horizontal deflecting circuit to horizontal winding of deflecting yoke. Stock No. 9836. . . . Net Price **\$9.50**

**POWER SUPPLY CAPACITOR . . .** For RCA 1800 Kinescope. A high quality, 6,000 volt unit containing two .03 mfd. capacitors. Oil filled construction to insure long life. Stock No. 9837. . . . . Net Price **\$11.75**

**POWER SUPPLY CAPACITOR . . .** For RCA 1801 Kinescope. Contains one .025 mfd. 4,000 volt unit and one .05 mfd. 3,500 volt unit. Oil filled. Stock No. 9840. . . . . Net Price **\$5.50**

**POWER SUPPLY REACTOR . . .** Newly designed for Kinescope filter circuits. Insures good regulation in power supply circuit when used with Stock Nos. 9837 and 9840, shown here. Stock No. 9838. . . . . Net Price **\$4.75**

**RCA KINESCOPES 1800 and 1801 . . .** Especially designed for television reception. They provide a clear picture of slightly yellowish hue. RCA 1800—9-inch Kinescope, **\$60**. RCA 1801—5-inch Kinescope, **\$40**.

Over three hundred million RCA radio tubes have been purchased by radio users . . . In tubes, as in parts and test equipment, it pays to go RCA All The Way.

RCA presents the "Magic Key" every Sunday, 2 to 3 P.M., E. S. T. on the NBC Blue Network. Ask your distributor, or send 10 cents to Camden, N. J., for a commemorative advertisement on RCA's television tube announcement.



# Parts

RCA MANUFACTURING CO., INC., CAMDEN, N. J.  
A SERVICE OF THE RADIO CORPORATION OF AMERICA

# ANOTHER NEW CARDWELL TYPE "J" FIXED AIR CONDENSERS

Have you ever wanted to make the tank condenser you use on 40, 20, or 10, resonate an inductance designed for 80 or 160 meter operation? With the new fixed capacitors by Cardwell—(plug in type)—such procedure is practical. The correct L to C ratio can be obtained on any frequency, yet you use only one variable capacity. Note that plates are readily removable for fixed capacity adjustment. Procure the Cardwell Catalog No. 40 and peruse the data therein on L to C ratios. The two capacitors shown in this ad are a starter—do you fellows want more like them? Tell us about it.

JCO-45-OS

"JB"

JD-80-OS

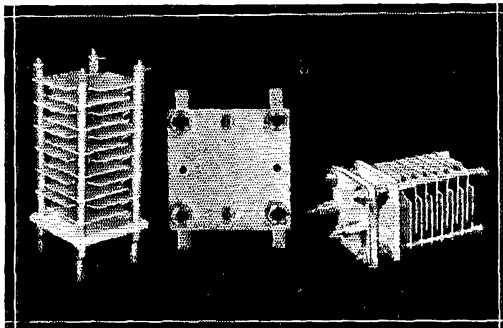

TYPE JD-80-OS fixed air condenser, 80 mfmfs., .125" airgap, 5000 V., Alsmag 196 insulation. List price.....\$5.50

TYPE JCO-45-OS fixed air condenser, 45 mfmfs., .250" airgap, 7500 V., Alsmag 196 insulation. List price.....\$5.50

TYPE "JB" — Jack Base' or fixed air condensers. Fits either unit. Alsmag 196 high frequency insulation. List price.....\$1.00

## CARDWELL ACCESSORIES



Many amateurs and experimenters will welcome the parts and accessories made available by Cardwell. Mounting brackets, Hexagonal Posts, Extension Posts, Mounting Pillars, Mounting Brackets, Connecting Clips (especially good in connection with air wound Inductances) and the new Cardwell Alsmag Insulated flexible shaft couplings, are among the "gadgets" available. All items on this counter card strictly in accord with Cardwell high quality standards. See these items at your dealer's.

**THE ALLEN D. CARDWELL  
MANUFACTURING CORPORATION**  
83 PROSPECT STREET, BROOKLYN, NEW YORK

from the mike. The breeze blowing through the window screen is plainly audible. In fact nearly all sounds such as those made by birds in the garden outside the window, cars going by on the road, people talking and moving about in the next room, are readily picked up and recognized. A person speaking in a medium-sized room can be heard from any position in the room. When used on a P.A. job outdoors excellent pickup was experienced in reinforcing dialogues and group singing.

Fidelity and frequency response were checked by placing the mike in the same room with an electric phonograph and picking up the actual sound emitted from it. Using a frequency test record giving notes continuously variable from 10,000 to 30 cycles, the microphone picked up and carried all frequencies from 7000, the upper reproduction limit of the phonograph, to the deepest recorded. Similar tests on the air yielded similar results.

In direct comparison with an RCA PB-90 velocity microphone (this is the type formerly used with the 20-watt portable public address equipment and at Radio City) the home-made microphones gave a creditable performance, although the commercial product is somewhat more brilliant and has slightly higher output. All in all, the comparison was very favorable to the home product, and, considering the difference in cost, the results are most satisfactory and highly pleasing to the constructor.

A few precautions must be taken in using microphones of this type on the operating desk. They will, of course, pick up hum by induction from near-by power transformers and speaker fields. Accordingly they must be so located as to pick up minimum hum when used near receivers. Generally a three-foot separation will reduce hum to a negligible level from this cause.

However, they do allow the operator to sit back in his easy chair, to make notes at his leisure, without the necessity of holding the mike to his lips, and if visitors are present all can take part in the conversation from their chairs without stirring. At W1JXP two of these mikes are used, connected in parallel, giving a pleasing binaural effect. The pair so connected can hardly be distinguished in performance from the RCA mike previously mentioned.

Room echo and reverberation, of course, enter the picture prominently if full sensitivity is utilized. For close talking purposes the gain can cut to reduce background and room noise. Curtains, wall drapes, and bare windows all exert influence either by sound absorption or reflection. A rug hung on the wall at the rear of the operating desk and directly behind the microphone prevents, to a great degree, the reflected sound wave from the wall entering the rear of the mike and causing echo effect.

The cases shown were made from basswood, the rods are dowel sticks and the grill cloth thin silk. Little, if any, cavity response or boominess seems evidenced from the use of four instead of two magnets to increase magnetic intensity, nor from the housing.

# OFF THE PRESS

## THE NEW 1938

## THORDARSON

## TRANSMITTER

### GUIDE No. 344-C



**W9GKU**  
R. E. DAVY



**W9UVP**  
W. C. HOWE



**W9UVC**  
J. D. FORTUNE



**W9EYU**  
L. A. STINEMAN



**W9DCQ**  
L. J. FOHR, JR.



**W4CBD**  
A. D. MAYO, JR.

Get  
Your Copy  
NOW

# 15c

From the factory post-  
paid or at your jobber's,  
less regular discount.

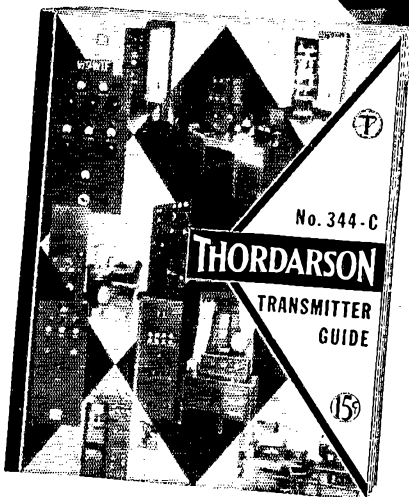

Six  
Thordarson  
Engineers, all  
Hams, who pro-  
duced this guide.

# THORDARSON ELECTRIC MFG. CO.

500 W. HURON STREET CHICAGO, ILL.

4th Edition



## Imagine the kick . . .

sitting on board your "Little Betsy," 20 miles at sea and talking by telephone (just like the one at home) with your friends, your office — and other ships. Think of the safety it affords — keeping you constantly in touch with shore stations all along the coast — and then, too, — if your prize dog has pups they can call you directly from home with up-to-the-minute details. This is what our mariner looks like —

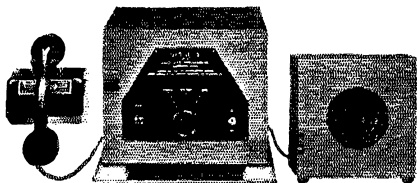

## HARVEY *Marine 12*

Ship Radiotelephone is licensed for use on ships under patents of the American Telephone & Telegraph Company. It is compact, with crystal controlled transmitter and receiver in one cabinet — easy to operate, only one master control — range, 50-100 miles. For a more complete description write to Harvey Radio Laboratories, Inc., 25 Thorndike Street, Cambridge, Mass., for folder M12.



All in all, from pleasing appearance to fine pickup and faithful reproduction, the home-made velocity microphone is well worth the effort and trouble demanded in its construction.

The writer wishes to extend his thanks to his brother for his assistance in solving various mechanical details of construction.

### A.A.R.S. Activities

(Continued from page 84)

One of the most interesting phases of the Army Amateur System is cryptanalysis, which is taught and conducted by each Corps Area Signal Officer, with experts in each Corps Area. Cryptanalysis in itself is a very fascinating hobby.

During the Christmas Holiday traffic season, KA1HR numbered originated messages consecutively from 1 to over 2000.

Using information obtained by radio, several Corps Areas work problems in locating unknown stations.

3.8% of the total number of amateurs in the United States are A.A.R.S. members; 80% of the A.A.R.S. members are also members of A.R.R.L.

On December 13, 1937, Oklahoma City vicinity suffered a severe sleet storm with ice-covered power, telephone and telegraph wires. The situation was efficiently handled by local amateur operators.

On February 5th, amateur traffic handling in Shanghai, China, was discontinued.

Another speed contest is contemplated this season, the transmission to be made from both the East and West Coast. Details will be announced later.

### Briefs

W8PAJ, Clarksburg, W. Va., worked all states within about three months after getting his call; he uses a pair of tens in the final stage.

— . . . —  
An example of the real spirit of amateur radio is given by W1EHT. He writes, "On the summit of South Pack Monadnock, Peterborough, N. H., there have been erected two masts about twenty-five feet in height. On one is mounted a Pickard, on the other a matched impedance antenna, both complete with spaced feeders of sufficient length that by parking a car in the right position both can be used, one for receiving, the other for sending. These were erected by W1CJT and an S.W.L. named Sawtelle, and are left there all summer for any ham who wishes to use them. It is an excellent 56-mc. location, the mountain being 2280 feet above sea level, and only about 50 miles from Boston. Here's a chance for some good portable work, thanks to W1CJT and his friend."

— . . . —  
The membership list of the League is not available for commercial circularizing but may be made available, in a Section or an area not exceeding one Division, for pro-amateur and non-commercial purposes, upon the application of any member and at his expense. Thus for some years past the headquarters office has supplied lists of names or has addressed envelopes for convention committees, candidates in A.R.R.L. S.C.M. and Director elections, etc., whenever requested to do so. The service is available of course to all candidates in elections, or for other worthy pro-amateur purposes. The actual cost of materials and labor is charged. Because this section of our office is heavily burdened, however, we require at least two weeks' notice to do the work.

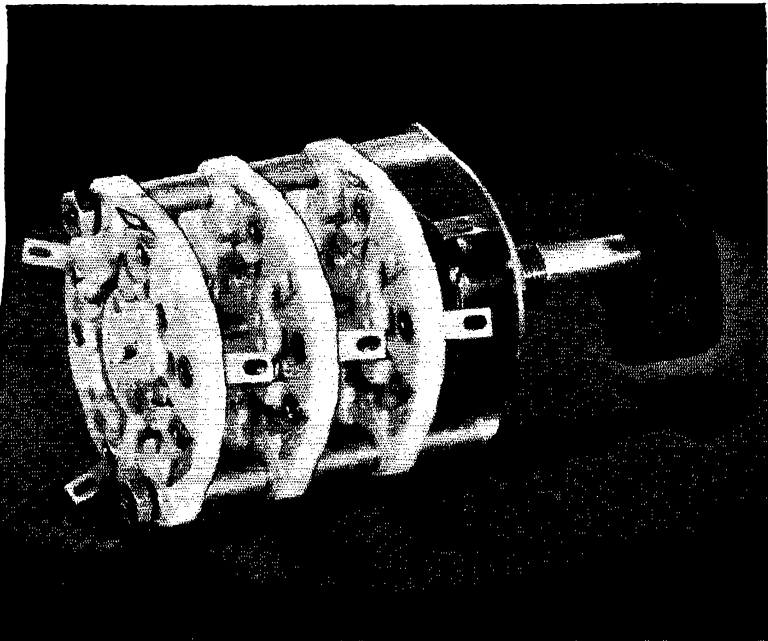
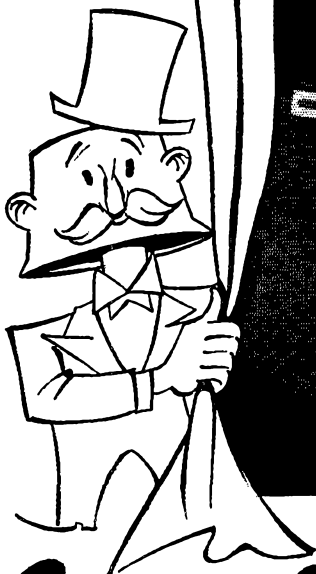

# Centralab ANNOUNCES ISOLANTITE SWITCHES *for*

## Amateur Use

### TRANSMITTERS

- *Crystal Frequency Selector* from one band to another — or within the band to dodge QRM.
- *Amplifying or Doubling Stages* selects the proper coil or tap on one coil — or correct tank coil on final stage.
- *Antenna Coupling* in series or parallel for matching antenna to given frequency.
- *Transceivers* send and receive switch.

### RECEIVERS

in either preselectors or receivers wherever wave changes are required.

- Low Power Factor — High Efficiency
- Low Dielectric Loss — Good Circuit Stability
- Low Moisture Absorption — Better Performance. » »

**MAIL NOW**

**CENTRALAB — Div. of Globe-Union Inc.**  
**MILWAUKEE, WISCONSIN**

Please send me descriptive literature on your new Isolantite Selector Switches.

Name \_\_\_\_\_

Street \_\_\_\_\_

City \_\_\_\_\_

State \_\_\_\_\_

QST.

# Centralab

## GRAPHITE DOES NOT MELT

TUNGSTEN      MELTS AT 6098° F

TANTALUM      MELTS AT 5162° F

MOLYBDENUM   MELTS AT 4748° F

NICKEL          MELTS AT 2646° F

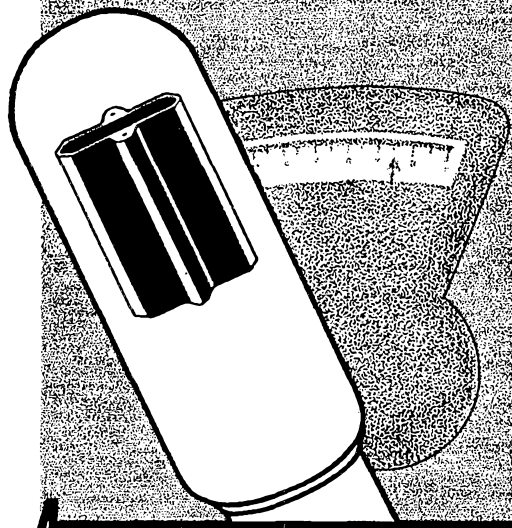

## Another reason why GRAPHITE ANODES are best.....

You can't melt graphite, but all metals melt — and before metals melt they soften. Just another good reason why Speer Graphite Anodes make better tubes. Speer Graphite Anodes do not fuse, warp or distort at any temperature. They carry heavier loads and last longer in continuous service.

When you buy tubes, buy tubes with Speer Graphite Anodes. Leading manufacturers make them. Write us for list and Graphite Anode Booklet 80.

## SPEER CARBON CO.

ST. MARYS, PENNA.



8066

## CQ WCFT

(Continued from page 13)

vari-colored coral reefs, tall, stately coconut palms, and the easy-living brown-skinned islanders. Before long the spell of the islands began to take hold. Time was meaningless. The motto was "Never do to-day what can be done to-morrow." It is really a pity that modern civilization is doing so much to ruin the natural beauties of these pearls under the Southern Cross.

Turning northward, we soon reached the little atoll of Pen Rhyn. Captain Viggo, who is ending his days as the British Resident here, welcomed us warmly. He is one of the last of the old South Sea traders left alive, and he kept us entertained with his stories of days gone by. It was he who supplied the basis for Nordhoff and Hall's story, "Hurricane," which recently appeared on the screen. The book was dedicated to him. Interestingly enough, he had been through seven hurricanes—four at sea on his schooner and three on low atolls. He claimed that the storm depicted in the book was only a small one and hardly worthy of the name "hurricane."

After calling as far north as the Line Islands, Christmas and Fanning, where wrecks of Spanish galleons bound from the Philippines to the Mother Country laden with treasure lie side-by-side with modern steamers loaded with coal and lumber, the *Yankee* turned southwestward through the Phoenix Group, now famous as the possible grave of Amelia Earhart Putnam. They are just tiny coral atolls—deserted—surrounded by some of the worst shark-infested waters I have ever seen.

Then, after calls at Tokelau, Swains Island, Upulu (Apia), we reached the American Naval Station, Pago Pago, on Tutuila. What a pleasant relief to see fellow countrymen again and to enjoy ice cream, clean and orderly settlements, and movies! While here we found Samuel Goldwyn, Inc., doing some location work for their coming picture, "Hurricane." They were badly in need of a schooner to take part in the story, but the ship that they had bought for the purpose was in California and the job of "faking" shots back in Hollywood would not be too satisfactory. The *Yankee* turned up just in time and moved out on location a few days later to make most of the shots showing the schooner of the story sailing along off the reef and going through it. It gave us quite a kick to suddenly "break into pictures" in such an unusual way.

From American Samoa we worked our way slowly out of the Polynesian region, past the islands of Niuatobutabu, Niuafoou, Uea and many others famous in the romantic lore of the South Seas, into that of the Melanesians to New Hebrides, one remaining stronghold of cannibalism. The interior of the larger islands here have never been visited by the white man. To-day, 1938 A.D., the few coastal settlements of Malekula and Santos hear rumors of great cities and even nations of natives living inland that have never been seen and that don't know any world other

# BLILEY CRYSTALS

*for Every Amateur Band*

## 5-10-20 Meter Bands



HF2 20-METERS  
\$5.75



HF2  
10-METERS  
\$5.75

B5 20-METERS  
\$7.50

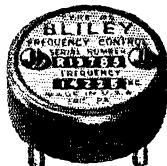

**B**ILILEY has brought precision frequency control to the higher amateur frequencies. Look at the new B5 20-meter unit — it brings the advantages of low drift to this popular band and costs only \$7.50. Then there's the medium drift HF2 20-meter crystal unit, priced at \$5.75, that provides economical frequency stability. And for working 5-meters there's only one answer — the HF2 10-meter (28 Mc.-30 Mc.) crystal unit. It simplifies the construction of stable 5-meter transmitters and assures more DX by concentrating the carrier power on a single frequency. See your nearest distributor for complete information on these and the other Bliley Crystals described on this page. Bliley Electric Co., Erie, Pa.

## 40-80-160 Meter Bands

LD2 80-160 METERS \$4.80

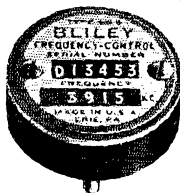

B5 40-METERS \$4.80



VF1 80-METERS  
\$7.50

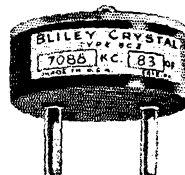

BC3 40-80 METERS  
\$3.35

**T**HE 40, 80, and 160-meter bands are covered by four precision Bliley Crystal Units. The B5 40-meter unit is a superior mounted 40-meter crystal priced at \$4.80. For the same low price, the time-proven LD2 low drift crystal unit stands first with amateurs in the 80 and 160-meter bands. With the VF1 80-meter variable frequency crystal unit, dodging QRM is easily performed by a mere twist of the control knob . . . When quadrupling to the 20-meter band, instantaneous frequency shift of 22 Kc. is readily obtainable. Last, but not least, the BC3 X-cut crystal units are an excellent buy at \$3.95 for the 40 and 80 meter bands.

## THESE BEAM POWER TUBES . . .

THEY LOOK ALIKE  
THEY'RE PRICED ALIKE



**BUT . . .**

## ONLY RAYTHEONS GIVE RK PERFORMANCE!

. . . No "SOFTIES" in the RK Line

None of us can resist that urge to crowd the plate past its normal rating. So RAYTHEON tubes are built with an extra margin of safety. Just look inside an RK-47. Here's what you'll find:

### BEAM POWER TUBES

**RK-47**—Hard Glass Bulb, 10 Volt, 3.25 Amp. Filament, 1250 Volts Plate, Driving Power, 1 Watt, Output Power, 120 Watts.

Amateur Net Price . . . \$17.50

**RK-48**—Hard Glass Bulb, 10 Volt, 5 Amp. Filament, 2000 Volts Plate, Driving Power 1.2 Watts, Output Power, 250 Watts.

Amateur Net Price . . . \$27.50

**RK-39**—6.3 Volt, 0.9 Amp. Filament, 500 Volts Plate, Driving Power 0.3 Watts, 35 Watts Output.

Amateur Net Price . . . \$3.50

1. A HARD GLASS BULB. Prolongs tube life. No pin pricks when operated at high temperatures. Also enables us to produce a tube that is much more gas-free.

2. MOLYBDENUM PLATE—not iron. "Moly" costs 10 times more, but it assures gas-free operation.

3. CERAMIC INSULATION—no mica. Mica is a gas supplier. It is not used in RK-47 tubes.

Even RK tubes should not be overloaded. But they WILL stand more abuse, they WILL last longer. You will ALWAYS get your money's worth if you will ALWAYS ask for RAYTHEON!

See your RAYTHEON jobber or write for FREE technical data

# RAYTHEON RK

## AMATEUR TUBES

420 Lexington Ave., New York 445 Lake Shore Drive, Chicago  
55 Chapel St., Newton, Mass. 555 Howard St., San Francisco  
415 Peachtree St. N. E., Atlanta

"WORLD'S LARGEST EXCLUSIVE TUBE MANUFACTURERS"

than the mountain fastnesses where they live. In the Solomons, islands which have probably the bloodiest history of any, we met old traders and recruiters who could spin yarns of the past that alternately shook us with laughter and then made our hair curl. Some of the islands in these parts were discovered by the Spanish explorers shortly after Magellan made his world-circling trip. Then they were lost for years and remembered only as the myth of a few crazy explorers, only to be re-discovered in comparatively recent times.

We left the Pacific Islands at last and sailed on to New Guinea, where it may take an experienced bushman seven months to walk from one side of the island to the other. Here, far back in the mountainous interior, one can find natives who have never seen the sea. Strangely enough, they use sea shells brought to them by intertribal barter as a medium of exchange. Here a sharp contrast between the new and the old exists, for with the discovery of gold in the interior the white man has brought the latest scientific instruments and conveniences to wrestle this precious metal from the ground and has moved right into primitive surroundings where the people are living in the stone age.

The *Yankee* continued on to visit the pearling center of Dobo in the Aru Islands, Banda the old spice port from whence the East Indies got the name "Spice Islands," Ambonia, Flores, Komodo, where the only dragons in the world are found, Bali ("nuf sed!"), Java and Singapore. Here, because labor was cheap, the Skipper decided to have some alterations and repairs made. This necessitated a lay-over of about a month, which left ample time for me to see some of Asia on my own. A quick trip overland through Johore and the other Malay States, Siam with its historic and interesting Bangkok, Indo-China and its famous Angkor Wat, and return, more than justified the expense of money and time.

After this brief rest, if it may be called that, the *Yankee* sailed on once again. This time the winds took her to Sumatra and Nias. The latter is a small island off the west coast of Sumatra with very interesting native life. These people are intensely proud of their athletic prowess and fighting ability. Next we headed off across the Indian Ocean for Zanzibar. As the winds carried us near to both Diego Garcia and the Farquhar Islands, we called briefly at them to see what they might hold of interest.

As this article is being written at sea between the Farquhar Islands and Zanzibar, it will be some time yet before the final chapter of the cruise is written. Briefly, present plans are to go from Zanzibar to Beira, Lourenco Marques, Capetown, Rio de Janeiro, Georgetown, British Guiana, St. Thomas, Virgin Islands and on back to Gloucester to complete the circumnavigation. Our plan is to arrive back home at 2:00 P.M. on May 1, 1938, exactly a year and a half after we sailed. Barring unforeseen accidents there is no reason why we shouldn't make it.

If there is any ham healthy and not afraid of work, with some money, here is the bang-up



The

# NC-800

NEUTRALIZING CONDENSER

— BUILT LIKE A MICROMETER —

LONG BEARINGS, threaded bearing is 1-9/32 inches long preventing eccentric operation, wobble, etc.

MICROMETER TYPE LOCK does not require screw driver or other tool for operation.

3/16 Inch thick, rounded and polished aluminum plates provide for maximum breakdown voltage with a minimum of between plate spacing.

Fine, accurately machined threads — no wobble.

Heavy aluminum base with three mounting holes.

Rugged cast aluminum bearing support.

Convenient terminal locations.

Genuine Isolantite insulation.

Convenient! — Requires a minimum of chassis space.

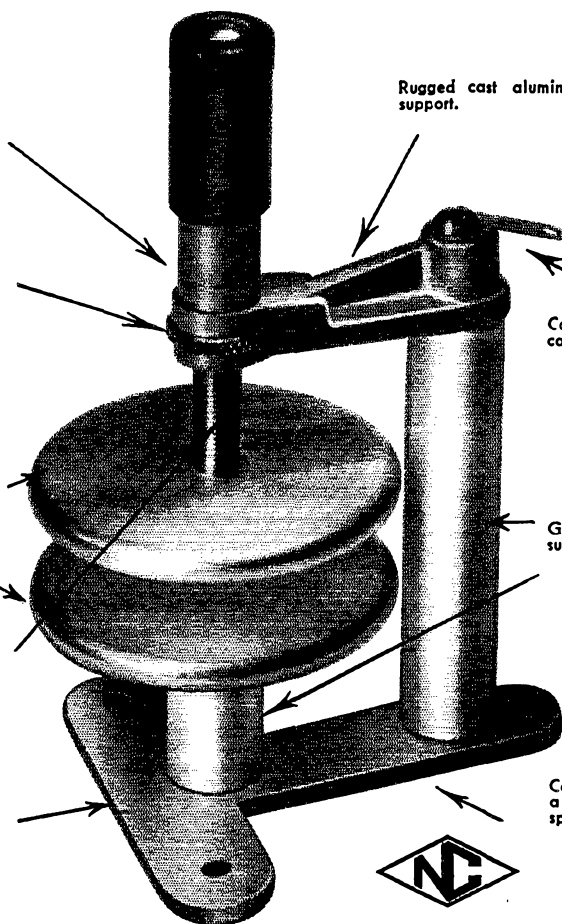

We not only are continually striving to develop and originate new and advanced products, but we are also continually trying to improve and better our older products. See the improved NC-800 at your dealer's today! — No increase in price!

NATIONAL COMPANY, INC., MALDEN, MASS.



## CONSTRUCTION

Sturdy GRAPHITE ANODE with lead out of top.

High quality insulating material throughout.

Heavy four way supports. Thoriated tungsten filament. Low loss ceramic base. Low interelectrode capacities.

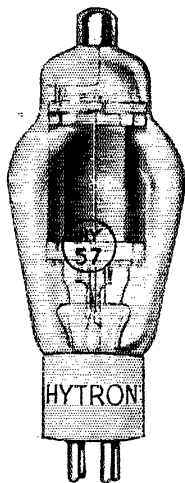

## RATING CLASS C TELEGRAPHY

DC Plate Voltage:  
750 max. volts  
DC Plate Current:  
110 max. ma.  
Plate Input:  
85 max. watts  
Plate Dissipation:  
40 max. watts  
Filament Voltage:  
6.3 volts  
Filament Current:  
2.0 amps  
Amplification Factor:  
45  
Mutual Conductance:  
3500  $\mu$ mos.



Type HY57 is also excellent for high frequency and Class B Audio.

*Secure type HY57 from your distributor. See him or write us for additional data and characteristics of this and other Hytron Power Tubes.*

## HYTRONIC LABORATORIES

76 LAFAYETTE STREET  
SALEM, MASSACHUSETTS  
A DIVISION OF HYTRON CORP.

Export Office: 11 W. 42nd St., New York  
Cable Address: "Hytron" New York

chance of a lifetime. He should hold a commercial second-class telegraph license, have had plenty of experience working both DX and TFC, "know his onions" when it comes to ingenuity in making the parts available do the trick in repair work, and be able to live congenially with eighteen people in close quarters for a year and a half. Sailing experience is useful but by no means necessary; as this boat is run entirely by an amateur crew it is best to be as well-equipped as possible. Many people meet a few of these requirements but the person who is versatile has just that much better chance when it comes to competing for the berths. On the present cruise the party is made up of eighteen in all; the skipper, his wife, a small son, the cook, two girls and twelve boys. The latter were chosen from over a thousand applications. The average age of the whole crew is 22 years.

So remember, WCFT sails again in the fall of 1939 and is in need of an operator who will be chosen from amateur ranks. If anyone is interested in sailing on her get in touch with me.

## A Pack Set for 200 and 300 Megacycles

(Continued from page 48)

of clumsy microphone cable. The signal received is piped back to the station through a remote amplifier and telephone lines.

The reason for the receiver in the pack set is so that the one wearing the pack can receive instructions from the remote engineer, or so that when two pack transmitters are used in conjunction, each announcer carrying the pack will know what the other is saying and doing.

The receiver used in the pack transmitter was designed after an article in November, 1934 *QST*.<sup>1</sup> The circuit diagram is shown in Fig. 2. The receiver used for picking up the signal from the pack transmitter is a National 1-10. It was found necessary to make some slight changes in the 1-10 receiver so that it could be tuned more conveniently at 300 megacycles. The removal of two stationary plates from each of the tuning condensers, plus spreading the turns of each coil, usually will accomplish this. Output transformers also were added to match 50- or 500-ohm lines, these transformers being shunted across the plate circuit of the 6C5 audio tubes. The antennas used with the 1-10 receiver are of the tuned type, being made from a 72-ohm concentric transmission cable. The outside copper tubing is an odd number of quarter wavelengths, the projecting wire being half wavelength long. In our first test quarter-wave antennas were used on both transmitter and receiver. It was found that by using half-wave antennas on the receiver and the transmitter about 4 or 5 db gain could be expected. The antennas now being used are one-quarter

<sup>1</sup> Hull, "Practical Communication on the 244-Mc. Band," *QST*, November, 1934.

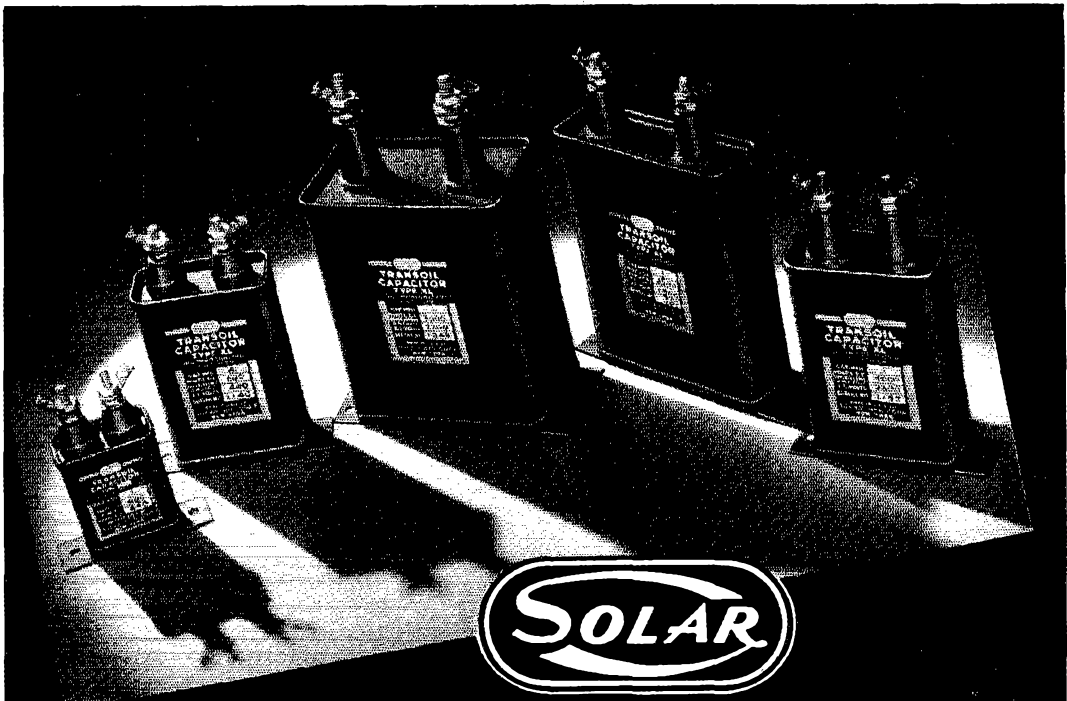

# TRANSOIL

*for transmitting*

**HIGHEST QUALITY  
OIL CAPACITORS**

*Ask for new complete  
Transmitting Catalog  
describing*

TRANSOIL—SOLAREX—TRANSMICA

**SOLAR MFG. CORP., 599-601 BROADWAY, NEW YORK, N. Y.**

# NOW—Electronics theory and applications at your fingertips

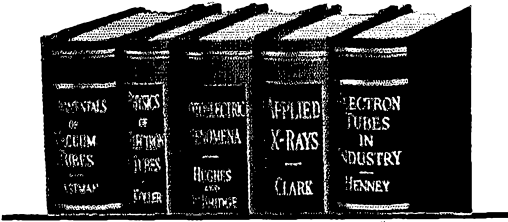

## The Library of ELECTRONICS

**F**UNDAMENTAL laws and principles—theoretical discussions—tube and circuit descriptions—diagrams and data—design information—practical applications—a modern reference and special-study library of electronics for the industrial engineer, communications man, and physicist—brought to you in this newly assembled group of five authoritative and detailed volumes.

**5 volumes, 2212 pp., 1406 illustrations**

1. Eastman's FUNDAMENTALS OF VACUUM TUBES
2. Koller's PHYSICS OF ELECTRON TUBES
3. Hughes and DuBridge's PHOTOELECTRIC PHENOMENA
4. Clark's APPLIED X-RAYS
5. Henney's ELECTRON TUBES IN INDUSTRY

Books selected by specialists of the McGraw-Hill Publications to give the broadest view, a detailed coverage, of advanced electronics engineering. Replete with the sort of information to which you will refer often in both ordinary and special work. A thousand pages on electronics applications in industry and technology.

### Special Low Price and Easy Terms

Bought singly, the five volumes comprising this library would cost you \$22.00. Under this offer you save \$2.50 and, in addition, have the privilege of paying in easy installments beginning with \$3.50, 10 days after receipt of the books, and \$4.00 monthly thereafter. Take advantage of these convenient terms to add them to your library now.

#### SEND THIS ON-APPROVAL COUPON

**McGraw-Hill Book Co., Inc.**  
330 W. 42nd St., New York, N. Y.

Send me THE LIBRARY OF ELECTRONICS, 5 vols., for 10 days' examination on approval. In 10 days I will send \$3.50, plus few cents postage, and \$4.00 monthly till \$19.50 is paid, or return books postpaid. (We pay postage on orders accompanied by remittance of first installment.)

Name .....

Address .....

City and State .....

Position .....

Company ..... QST-3-38

(Books sent on approval in U. S. and Canada only.)

wavelength long on the receivers feeding the remote amplifier.

Among tests of interest that have been made was one of enclosing the pack transmitter in a completely copper-plated cabinet. The receiver was at a distance of approximately two hundred feet. There was very little drop in signal when the transmitter was completely enclosed, either on 200 or 300 megacycles. One of the most remarkable things about the 300-Mc. signal is that no interference of any kind has been received, and very, very little on 200 megacycles. The reason the above frequencies were chosen was because of the lack of interference and the greater compactness possible in construction as compared with frequencies in the vicinity of 40 megacycles.

One of the most serious problems so far experienced on 200 and 300 megacycles is the variation of signal strength because of interference effects in and around metal structures. This condition seems to be more severe on 300 than on 200 megacycles. It is not noticed in the open until the transmitter is a half mile or more away from the receiver. Rapid physical movements of the person wearing the pack transmitter had no effect on the reception within reasonable distances. A tap dance was even done and described by the announcer with the pack on the back with perfect reception.

Twenty fifteen-minute periods of broadcasting using the 300-Mc. transmitter have just been completed for the Kansas City 1938 Auto Show, held in the Exposition Hall of Kansas City's Municipal Auditorium. The conditions under which the ultra-high-frequency equipment worked are undoubtedly as severe as will ever be generally experienced, due to the number of large metal posts, balconies, and steel auto bodies. It was found necessary on several occasions to move the receiver to different locations during certain broadcasts. Another interesting experience was that the reception of the 300-Mc. signal was very spotty even at close distances when working under low ceilings that contained a great deal of steel construction. It was found that reception was more dependable during our 6:00 P.M. broadcasts when the crowds were lightest.

HIGH STRENGTH LIGHT WEIGHT

## STEEL TOWERS

Especially designed for

Radio Antennas Ladder Masts

Triangular shape — each side 13 inches overall — braced every 30 inches with horizontal and diagonal members — full 12 inch ladder on one side — legs cold rolled special shape thin section — square head 5/16 inch bolts with hex nuts — tower steel all rust resisting copper bearing galvanized after fabrication — shipped in 10 foot sections either assembled or knocked down to domestic points but knocked down only to foreign destinations —

PRICES REASONABLE  
For information write to

### WIND TURBINE COMPANY

West Chester, Pennsylvania

Manufacturers also of POWER TOWERS and  
STAINLESS STEEL WIND TURBINE PROPELLERS  
for 6-volt wind driven battery chargers

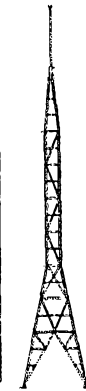

← WIDE BASE



PIN BASE →

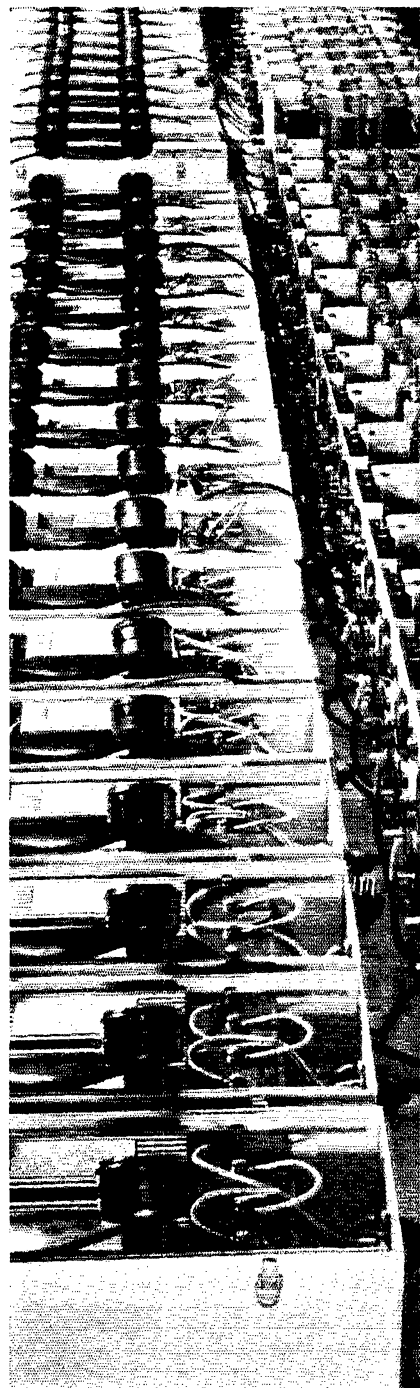

**Burgess Batteries**  
**ON DUTY**  
IN THE **NATIONAL PARK SERVICE**

Here the same Burgess batteries that you use serve National Park Service.

These Burgess campaigners are standard in the new portable radio sets specially designed by National Park Service. National Park Rangers use this equipment where no other means of communication is possible. It keeps them in constant contact with headquarters and greatly facilitates fighting dangerous forest fires.

National Park Service Technicians have found in Burgess batteries that dependability and reliability characteristic of their own service to the country.

You can have the same economical, dependable portable power. Buy Burgess when you buy batteries.

**BURGESS BATTERY COMPANY**  
FREEPORT, ILL.

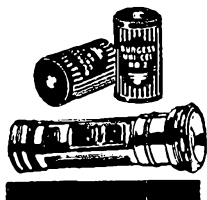

**BURGESS**



Say You Saw It in QST — It Identifies You and Helps QST

(Continued from page 68)

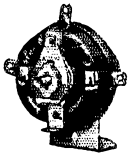

Ohmite Band Switch



Ohmite Rheostat



Ohmite Brown Devil



Ohmite Multivolt

● Maybe you can "get by" with less than OHMITE quality in your equipment. But it will cost you no more for that extra quality — that extra dependability that made OHMITE standard equipment with discriminating manufacturers of radio transmitters and receivers.

Do the job right with OHMITE resistors, rheostats, band switches, and chokes. And be sure you have that handiest Ham help, the Ohmite Amateur Handbook. Your jobber has it for a dime.

See your Jobber or Write for complete Catalog 16.

Pidanos el nombre del distribuidor de Ohmite mas cercano y el Catálogo Completo 16S.

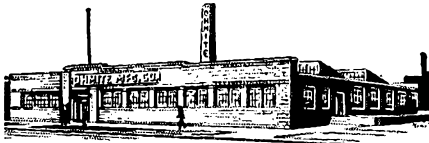

OHMITE MANUFACTURING COMPANY  
4831 W. Flourney Ave., Chicago, Ill. U.S.A.



taro Takada, J8CF; A. Reid, GM5YN; D. B. Fry, G5UY; Otto Buchelt, D4XJF; Gerhard Ouvrier, D4SBG; Henry R. Pemberton, W3DPU; Wlodzimierz Graffstein, SP1JC; S. R. Green, SU1KG; G. Maurer, HB9AI; Philippe Recordon, HB9K; William F. Lightfoot, W9TXG; Bela Galdi, HA7H; Bruce Read, W9WKU; F. R. Warnick, Jr., W8KYO; Willard F. Hunton, W6ODD; R. B. Green, W3BEN; F. D. Bornman, W8QDU; Charles C. Larcom, KA1US; Charles F. Fitzgerald, W1AAK (phone); Harold G. Lewis, W9TH; Norman LaVoo, W9RUW; J. A. Farrer, VQ3FAR; Edwin Page, W6AQV; John G. Campbell, W2OC; Richard L. Paige, W9NST; Fernand Baptiste, ON4TA; M. A. Sira, Jr., YV5AK (phone); Gerd Wahl, D4YVM; Slavomir Stoklasek, OK2FO; Kurt Lange, D4DHC; Mr. Hoefnagels, ON4HF; Helmut Diel, D3BJK; John H. Fitzgibbon, W7DNP (phone); Keith Highley, W6NCZ; Douglas Walters, G6CV (phone); R. J. Bee, VS2AG (phone); R. S. Harvey, ZL1KJ; J. W. T. Mooney, GM6IJ; John Clarricoats, G6CL (phone); R. Herbert, G2KU; V. M. Desmond, G5VM (phone); Karl Heinz Guttner, YM4AD; M. Pedersen, OZ5P; B. Helmer Hansen, OZ8B; Jan Kuchar, OK2HK; D. H. Wijkman, PA0IDW (phone); Hans P. Twick, D4VGH; Stig Erik Petersson, SM6QN; Max Hempel, D4HNG; Wallace Cloake, W7EZX; Harold E. Davis, W5FFW; Ray Smith, W3FAM (phone); J. Gillson, W3GAU; Jesse Bieberman, W3KT; Louis D. Gadoury, VE2HG (phone); J. F. Wise, W3AIZ; Donald Lauderdale, W9RJ; Reno Rosellini, W8LJE; Carl H. Rogatsky, W6LUJ; Owen J. McCabe, W1COJ (phone); William E. Owen, W5WG; W. H. Faulkner, Jr., W3BSY/4; Albert Steffens, W6LWS; George Sue Chow, W6OPD; H. R. Blain, W6AFH; Walter R. Chittenden, W6NEP; Dr. Pohl, D4ICG; Herbert Steffen, D4YCF; Cenek Vostry, OK1DX; J. Reid, W4CJN; Josef Cupr, OK1JC; H. Caunce, G6K8; Jack Thorpe, G5TO; Rudolf Micka, OK1MB; George W. Ewing, W6GM; Roy Usher, VE4EA; Richard LeRoy Smith, W4DRD (phone); Harry Gross, W6FZL; Dan H. Smith, W3CIE (phone); Ildefonso Franco, XE1LK (phone); A. J. H. L. Rosenquist, PK1VH (phone); J. M. van Heusden, PK1VH (phone); L. G. Watts, G6WO; Dr. Desso Horvath, HA8I; W. O. Wright, G6FQ; G. C. Proctor, G5PR; A. Weber, D4YXM; Kurt Brink, D3DRF; Adam Muller, D3GKR; Elvin Feige, W6TT (phone); Ph. J. Huis, PA0AD; J. H. Koen, PA0CX; Hr. P. J. H. Roell, PA0WG; Hugh D. Ross, ZL2NG; F. H. Hoy, ZK2QF; George E. Billson, Jr., ZL3KG; P. Clark, ZL4FS; Philip W. Blakeley, ZL2CV; Arthur W. Bailey, ZL2QA; Pedro R. Casellini, LU4BE; William Kemp, LU7BH; Luis M. Persico, LU6AX; Dr. Martin L. Hidalgo, LU6AN; Dr. Martin L. Hidalgo, LU6AN (phone); Ernesto L. Guerrini, LU9AX; L. A. Carter, G5AQ; Robert B. Holland, PY2JO; Robert B. Haner, W2FBA; Max Isoard, Jr., W6DJJ; James Smalley, Jr., VE4GD (phone); Rudy Majeske, W8NJP; Charles Zierman, W6GTM; William G. Baird, Jr., W9RCQ; Carl F. Mueller, W8GIZ (phone); C. W. Chapman, Jr., W6LOY; W. B. Thompson, W8OKC; J. B. Smith, W4CYY; Thorus E. LaCroix, W6LN; Raymond T. Hight, W4BVD; John L. Webb, W4DDQ; John Woerner, W8ONQ; John E. Bickel, W6BKY (phone); Alva A. Smith, W9DMA; W. C. Uzzell, W2BNX; Sam Roth, W9RIA; Harvey G. Bennett, W8PHD; Richard A. Gilson, W4DOO; J. Lee Smith, W6AWP; Captain Ben Wallich, G8BW (phone); Fok Sut Chung, XU6SW; Juan Antonio Moro, CM2AG; Golden W. Fuller, W8EWS; Glenn G. Godwin, W8QHX; Gleb Kruglowski, SP1MX; Wladyslaw Mozier, SP1LN; Dean R. Spires, W5ESZ; John L. Simpson, W6MYD; Earl M. Reichman, W8NBK; Richard V. Schneider, W8AVB; Valeriu Vasilescu, YR5VU; Earnest Groos, YR5IG; A. E. Gilbeau, W6HIP; Walter T. MacKenzie, W3EJU; Donald E. Hedin, W9HGN; Henry Peter Meisinger, W3GHB; D. B. Nelson, W6LHF (phone); Nelson M. Foulter, W1DQC (phone); R. H. Bewick, W4EEV (phone); Henry W. Hart, W5FHJ (phone); Robert H. Killion, W3FVO (phone); H. M. Buroker, W7QC (phone); D. L. O'Brien, W6PB (phone); William Good, W3IFD (phone); Rollins O. Plummer, W6CNA (phone); E. M. McNair, VE4WJ (phone); Mrs. Erika Capelle, D4KAK; Lwowski Klub Krotkofalowcow, SP1LW; Raymond R. Randall, K7EVM; Neal Bakker, W2HFN; Robert O. Morris, W8FKW; F. Blair Webster, W8QOK; Shurley McClara, W6AKB; O. U. Tatro, W7FWD; Walter Rininsland, W2IUD; Robert M. Stephens, W1JLT; William E.

# Low Power!

## A New 50 Watt Transmitter to Uphold Traditional TEMCO Superiority

- **Band Switching Exciter with Variable Excitation Control**
- **Complete Coverage from 10 to 160 Meters**
- **High Fidelity Speech Amplifier with Inverse Feed Back**
- **Low Impedance Swinging Link Output**

Here at last is a low power transmitter for both phone and C. W. which really is outstanding. Although we have never made claims for any TEMCO model beyond an enumeration of its features, it is our belief that the "50" represents the finest value in its power classification on the market today.

TEMCO "50" is the result of months of research in an effort to produce, not just another "50 watter," but a unit which would be in keeping with the high standards of performance and quality which has distinguished other TEMCO models.

We are confident that amateurs with limited budgets who have appraised TEMCO high power units and expressed a desire for their ownership, will welcome the opportunity to purchase this new TEMCO "50" which sacrifices none of the modern features, engineering and efficiency which characterizes the TEMCO 1,000, 600, 350, and 100.

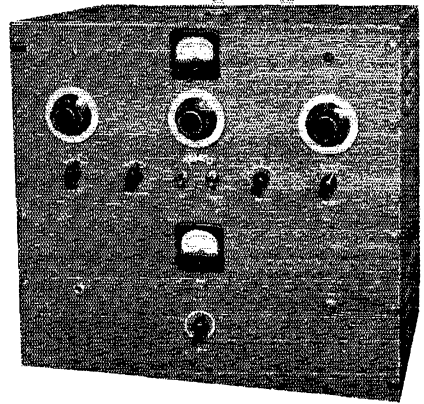

### PRICED SENSATIONALLY LOW

TEMCO "50" for phone and C. W., less crystal, tubes, microphone but including band switching exciter unit for 5 bands and 1 power amplifier coil for any 1 band..... **\$195**  
 TEMCO "50" for C. W. only, in single deck cabinet, less accessories as described above..... **\$125**

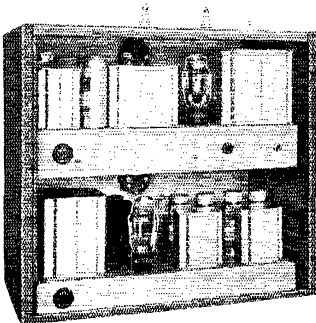

The units contained in the TEMCO "50" each have their individual power supply. Therefore the R.F. unit may be furnished in a single cabinet when transmitter is desired exclusively for telegraph operation. The modulator unit may be added at any time without making any wiring changes whatsoever. Though not shown, unit comes with rear door. A personal inspection at your dealers will convince you of the merit which we claim for TEMCO "50." Dealers can make immediate delivery from stock.

### THE NEW TEMCO 350-A IS ALSO READY

It incorporates the following advanced features: All new beam tubes in the R.F. circuit, Crystal holders accommodating 4 crystals with front-of-panel changeover, Multi-frequency band-switching up to final amplifier, 250 watts output, peak limiting speech

amplifier, with two channel mixer; variable link output circuit, no neutralization, Zero bias modulator tubes. Complete technical data available. Price with coils for 5 bands, less tubes, crystals and microphone..... **\$650**



**Transmitter Equipment Manufacturing Co., INC.**

130 CEDAR STREET • NEW YORK, N. Y.

*Designer and Manufacturers of Radio Transmitting and Accessory Equipment*

# NEW!! GROSS CB-200 RADIOPHONE TRANSMITTER

Gross presents a new beautifully constructed floor model transmitter having real power at an amazingly moderate price. The new Taylor TZ-40's are used in the output stage. You will be proud to own the CB-200.

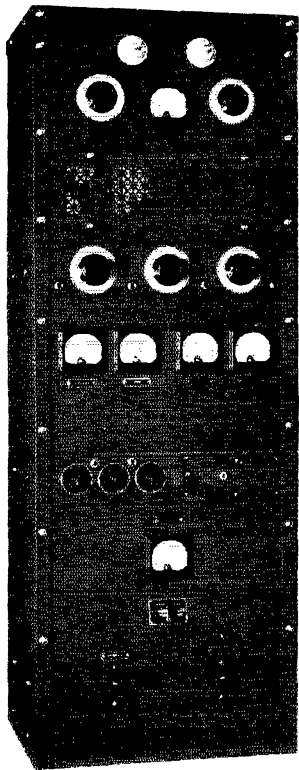

- \* R.F. LINE UP — 42 oscillator, 6L6G buffer, two Taylor TZ-40's amplifier
- \* SPEECH AMPLIFIER — 6C5, 6N7, 6N7, two 42's
- \* MODULATOR — Two RK-12, separate power supply
- \* ANTENNA UNIT — Self contained antenna tuning unit
- \* FREQUENCY COVERAGE — 1.7, 3.5, 7, 14, 30 mc
- \* POWER — Radiophone 170 watts input CW 200 watts input
- \* CABINET — Floor model, extremely compact size, finished in rich gray wrinkle lacquer

Write for Descriptive Literature Giving Full Details

## GROSS RADIO, INC.

51 VESEY STREET

NEW YORK

Cable Address: GROSSINC

Russell, W6MTC; R. A. Herold, W8MOK; N. K. Maxwell, W5FOH; George R. Cannon, W6LXI; J. L. Tavener, W9GNU; Frank P. Kennedy, W9LXX; Burton S. Waldron, W9ZT; L. W. Siebothem, W9COH; Jan Switalski, SP1MJ; Norman C. Hurter, W4DBF; Elmer F. Bond, W8MAH; D. W. Wells, W6OEH; W. W. Simpson, W8KPL; Andy H. Fuchikami, K6JPD; Harold C. Smith, K6OQE; H. W. Holt, W4TP; Roy G. Walters, Jr., W9LUV; George Dery, W6HG; R. J. Bradley, G2FO; J. D. Cameron, GM8CN; R. C. Kaye, G6RO; W. W. Field, G2GC; H. J. Chater, G2LU; R. E. M. de la Pole, VS7RP; Robert G. Ling, W1IBF; Elmer Rahmes, W3JFC (phone); G. McLean Wilford, G2WD; A. P. F. Willemse, PK3WI (phone); E. Th. Vermast, PK1VM (phone); C. A. LeCotey, PK3IC; Gale B. Sells, W7AMQ; Hans Klotz, D4GDF; L. Hill, G5WI; Pierre Doche, F8JL; Carlos Navia Osorio XE1LC (phone); L. A. Moxon, G6XN (phone); R. Madjid, PK1MJ; J. F. Verschuyl, PK1VY (phone); A. Te Riet, PK1RI (phone); R. T. Dealey, G6DT (phone); L. W. Parry, G6PY (phone); Jean Nagues, F8KI (phone); Ch. J. Tijdgat, PA0TY; L. J. van der Toolen, PA0NP (phone); R. J. McIntyre, PA0EO (phone); C. V. D. Maagdenberg, PA0QB; Peter Kadvany, HA8N (phone); Jozsef Boer, HA3B; Endre Zerinvári, HA6N; Sandor Monda, HA2N; T. T. Winkler, Jr., PA0AX; J. Meyer, PA0EA; J. F. A. Verzijl, PA0KZ; V. R. Krause, ZS6AU; A. Sachs, ZT6AU; P. W. Keens, ZT6AL; D. J. McDonald, GM6KH; Josef Koch, D3DFN; Otakar Halas, OK2RR; Stanislav Pohl, OK2IR; Rudolf Schulze, D4CBM; Wilfried Onnen, D4SGK; Heinrich Fischvoigt, D3AUK; J. M. Kirk, G6ZO; E. Breaud, FA8JO; E. R. Henman, G6HM; C. Gregg, G5CG; F. G. Whinfrey, G8IW; J. R. Letts, G8IL; Kenji Nishi, J2CF; T. O. I. Pick, G8GL; D. W. H. Paterson, FN1C; Richard S. Briggs, W1BVL; James M. Bruning, W3EZ; William V. Pock, W8MPD; William Edward Rice, W1IKT; Mynard Taylor, W6NLI; E. P. Chase, Jr., W2KAK; E. C. Atkinson, W4ECI; Simpson B. Adler, W1IEK; W. L. Rust, W8ADM; W. L. Weihofen, W6JGQ; Henry H. Wilson, W6NCT; M. F. Reed, W6GJP; Orville E. Johnson, W9JJR; Charles M. Berry, W9WBT; Harry J. Kuhlemeier, W8HA; David Stockham, W6NPY; Ray Bloemer, W6QG; Moises Tapiero, LU4DQ; Hansjürgen Schwartz, D4SZK; Donald M. MacBeth, W9KDF; Craig S. Nunan, W6LCA; Reno W. Goetsch, W9RQM; Walter Hampel, W9UYD; Kenneth Leiner, W8LCN; Kazys Karkauskas, LY1KK; Albert Savage, W1CPV; Leonard Ball, W8OII; A. M. Lundeen, W9PZI; Art Ferguson, VE3HP; Sandor Czeller, HA3G; Peter Kadvany, HA8N; Elmer Grabb, W8DOD; John Crosby, W6MCG; Sidney D. Shaw, W7AOL; Cadet Amateur Radio Club, W2KGY; C. Hoffman, W2APU; Harold R. Kaiser, W8MQE; A. B. Morgan, VE3OI; R. V. Galle, VK5QR; W. N. Govan, VK5WG; C. W. Hodder, VK5LY; C. L. Irving, VK4WL; A. S. Mather, VK2JZ; C. F. A. Luckman, VK2JT; J. B. Corbin, VK2YC; G. W. Thornton, VK2IP; A. M. Thackeray, VK2TA; L. B. Husher, VK4UL; G. Kempton, VK2CI; W. Stirling, GM6RV; J. Dale, G5VD (phone); E. J. Laker, G6LK (phone); Marcel Wallace, F8FM (phone); C. H. Oliver, W6FPF (phone); W. R. Neal, W4DAY (phone); John R. Lally, W9LVG (phone); R. C. Higgy, W8LFE (phone); Chester R. Ashby, W6DTB; Chester E. Ashby, W8DTB (phone); Folke Thor, SM6PA; G. Werkema, PA0APX; C. Taylor, G2ZT; J. Hum, G5UM; Martin Schurig, D4PCU; Alfons Duchene, ON4DA; J. H. Emmerson, G8HA; C. A. Butler, G2YB; V. D. Morse, G8IK; F. Bodigheimer, D4ATT; Etienne Faitrop, F3AU; Gottfried Kaiser, D4GLF; M. Havlicek, OK3TW; C. F. Turner, ST2CM; Kaarlo Sainio, OH2NM; A. H. Eckstein, OH2NE; Erkki Kairenius, OH2ND; Armas Valste, OH2NB; Armas Hakkanen, OH2NQ; Tatu Kolehmainen, OH2NT; Holger Jalander, OH2NX; Voitto Eloranta, OH2OB; Lars Nyberg, OH2OD; Frans Makela, OH2OG; A. R. Ohman, OH2OI; Hrjo Vuorinen, OH2OT; Paavo Aikala, OH2OW; Goran Tigerstedt, OH2PM; Hugo Malm, OH3NA; Osmo Toivryla, OH3NG; Toviio Vehonieni, OH3NK; Martti Viljanen, OH3NQ; Kaarlo Heikkila, OH3OI; Veikko Kirsimaa, OH3OJ; Toviio Koponen, OH5NF; Kalervo Suhonen, OH5NK; Eino Kirsi, OH5NR; Eino Metso, OH5NZ; Yrjo Perho, OH5OA; Eugen Autere, OH5OC; Hilmer Sinisalo, OH5OD; Jorma Norola, OH5OH; Runar Gronholm, OH6NG; Gunnar Stendahl, OH6NS; Helmer Osterblad, OH6NN; Taavi Kinnunen, OH7NC; Leo Antman, OH7ND; Eino Toivanen, OH7NF; B. Saharo, OH7NI; Olli Snellman, OH8NB; Olavi Kaattari, OH8NF; Vaino Vestu, OH1NJ; Yrjo Juhari, OH1NF; Raino Jaykka, OH1NS; Lenna Suominen, OH1NL.



# HOWARD

announces a new communication receiver

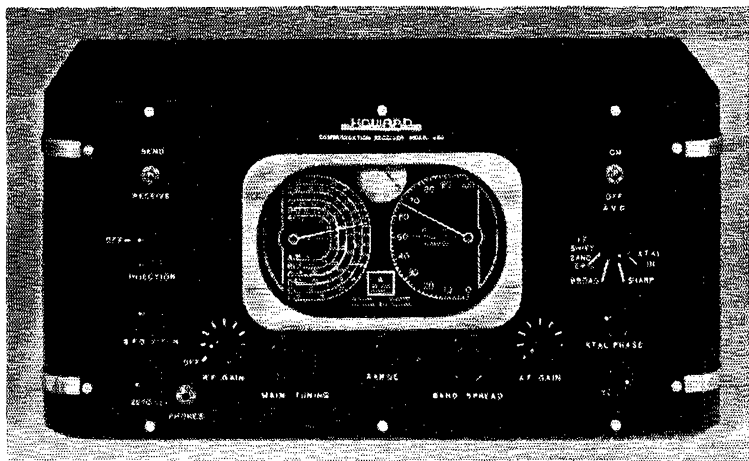

**AT A PRICE WITHIN THE MEANS OF THE AMATEUR AND INCORPORATING MANY INTERESTING NEW FEATURES**

- Frequency Coverage 65 MC to 540 KC in Six Bands
- Twelve Tubes, eight metal, four glass
- Electrical Band Spread two three-gang condensers
- Illuminated Dual-Dial accurately calibrated
- Flywheel Tuning on both tuning controls
- Calibrated R Meter
- Band-In-Use Indicator
- R.F. Stage On All Bands except five-meter band
- R.F. Coil System Coaxially Designed With Band Switch, eliminating coil secondary leads
- Air-tuned R.F. and oscillator circuits
- Iron Core I.F. Coils
- Dual Channel, Variable Selectivity I.F. Circuits, providing crystal switching, 1560 KC I.F. for the five- to ten-meter bands, broad and sharp for other bands, all accomplished with one control knob
- High Gain Antenna Coils
- High Translation Mixer Circuit
- Push-pull Beam Power Output
- BFO with amplitude and pitch controls
- Output Terminals for 5 and 500 ohms
- Headphone Jack
- Terminals for standard and doublet aerials
- Separate Five-meter Antenna Connection
- Relay Connection For Break-In-Work
- Send-Receive Switch
- Full Floating tuning condensers
- Stabilized Power Supply
- Heavy Copper plated chassis
- Modern Cabinet Design, finished in brushed silver and telephone black
- Speaker In Cabinet To Match Design Of Receiver

BUILT BY AMERICA'S OLDEST RADIO MANUFACTURER—BACKED BY YEARS OF EXPERIENCE IN BUILDING PRECISION RADIO EQUIPMENT

See this receiver at your jobber's or write for Bulletin No. 450

## HOWARD RADIO COMPANY

1731-35 BELMONT AVENUE

CHICAGO, ILLINOIS

# PREFERRED by AMATEURS

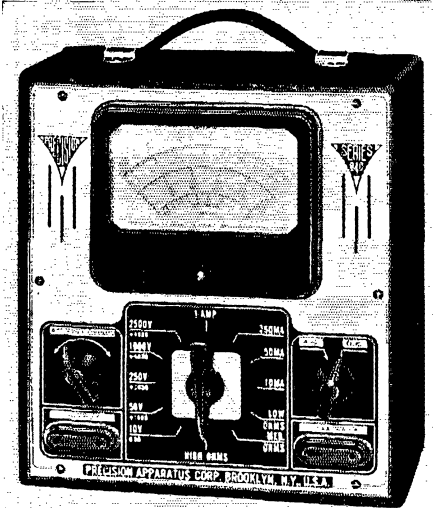

## "PRECISION" Series 840L A.C.—D.C. VOLT—OHM— DECIBEL—MILLIAMMETER including a

**2500 VOLT A.C. and D.C. RANGE  
and a 1000 M.A. RANGE**

### SPECIFICATIONS

\* 5 A.C.—D.C. Voltage Ranges from 0 to 2500 volts at 1000 ohms per volt.

\* 4 D.C. Current Ranges from 0 to 1 amp.

\* 5 Output Ranges.

\* 3 Resistance Ranges from 0 to 10 megs. (provision for self-contained batteries).

Net price  
to amateurs

**\$19.95**

Less batteries  
and test leads

\* 5 Decibel Ranges from -10 to plus 63DB.

\* Large 4 1/4" D'Arsonval meter, 2% accuracy.

\* Wire wound shunts 1% accuracy.

\* Matched multipliers 1% accuracy.

\* Guaranteed close accuracy on all ranges.

**SERIES 840P** incorporates same specifications as the 840L but is housed in an attractive black leatherette covered portable case with removable cover. Size 9 x 10 x 6. Net to amateurs. **\$21.95**

### AVAILABLE AT LEADING DISTRIBUTORS

Following is a partial list

Atlanta, Ga.	SPECIALTY DISTRIBUTING CO.
Baltimore, Md.	RADIO ELECTRIC SERVICE CO.
Birmingham, Ala.	E. E. FORBES & SONS CO.
Boston, Mass.	RADIO SHACK INC.
Chicago, Ill.	NEWARK ELECTRIC CO.
Cleveland, O.	PROGRESS ELECTRIC CO.
Columbia, S. C.	DIXIE RADIO CO.
Denver, Colo.	INTERSTATE RADIO & SUPPLY CO.
Dobersville, N. Y.	ADIRONDACK RADIO SUPPLY
Lincoln, Neb.	HICKS RADIO CO.
Los Angeles, Calif.	KIERULFF & CO.
New York, N. Y.	HARVEY RADIO CO.
Saginaw, Mich.	RADIO PARTS CO.
San Antonio, Texas	A. B. FRANK CO.
San Jose, Calif.	WHOLESALE DIST. CO.
Scranton, Pa.	SCRANTON RADIO SUPPLY CO.
Springfield, Mo.	RADIO ENGINEERING SERVICE
Steubenville, O.	LEVINSON'S RADIO SUPPLY
Tulsa, N. Y.	VARTH ELECTRIC CO.
Vancouver, B. C.	HYGRADE RADIO SUPPLIES

# PRECISION APPARATUS CORP.

821 EAST NEW YORK AVENUE  
BROOKLYN, NEW YORK

EXPORT DIVISION:— 458 BROADWAY, NEW YORK

## R. F. Interference from Power Circuits

(Continued from page 40)

before you can get the light to stay on. Go to the meter board in the cellar and check to see if any of the fuses are warm; if so, remove the fuse and clean the contacts or put in new ones. Don't let two pieces of BX cable run together or touch any pipes. Check the bell transformer for secondary and primary connections. Check the condition of the switch blades in the main switch.

Now on the distribution transformer secondary or in other houses in the neighborhood, the causes of noise other than those already described will probably be from some of the following:

Source of noise	Sound Produced
1. Secondary wires in trees	Snapped fingers
2. Loose taps at the transformer	Bronx cheer
3. Guy wire in the secondary lines	Same cheer, twice as many people
4. Appliances:	
a. Electric razor	Bumble bee
b. Oil burners	Ten airplane motors
c. Water pumps	Grinding crystal
d. Floor sanders	Man humming a tune
e. Electric train	Horse fly trying to get out of a window
f. Thermostats	Machine gun

Now the transformer pole; first, check all connections on both sides of the transformer, primary and secondary, next the lightning arrester, then the insulators. Dry-process porcelain insulation will cause a low-pitched interference in dry weather, but in wet weather there will be no noise because of direct grounding. Cut-out boxes often leak, and occasionally the fuse in the box becomes loose.

Last but not least, check the ground connection on the transformer.

On the line, check for guy wires rubbing the primary line, burned insulator pins, loose underground services and trees which the primary line runs through. Tree noises are worst when the sap is in.

On the street-lighting circuit look for safety coils, bad lamps, bad insulators, swinging fixtures and loose fixture heads. Remember that few noises pass from the secondary lines to the primary lines, but all primary noises are heard over several secondaries. If your noise is only on in the evening, check house wiring and look for street-light circuit trouble.

The writer still uses the "persuader" system for finding the source of interference on the primary lines, and this is it:

Material: one large heavy wooden mallet, good auto radio installation.

Procedure: Smack every transformer pole and listen for results. They usually respond nicely. I have had everything from the noise disappear to transformers fall at my feet.

Results: Equipment replaced either because defective or missing.

## Brief

Did you know that W8DAM lives in Niagara Falls?  
—W8K5Y.

# MOVE OVER, FOLLOW!

GET OUT FROM UNDER THAT

## Q - R - M

MAKE YOUR QSO'S 100%  
YOU CAN! WITH THE NEW

### *Meissner Signal Shifter*

—providing Remote Frequency Control from operating position.

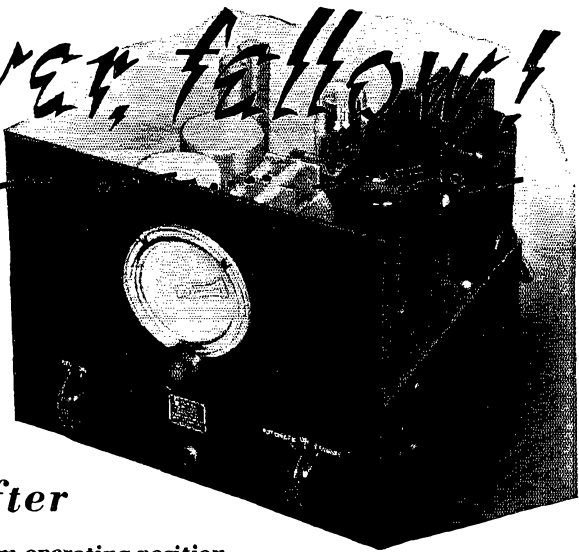

The Meissner "Signal Shifter" is a variable-frequency, electron-coupled exciter unit with oscillator and buffer circuits ganged together for single dial control. It is designed for use with Amateur transmitting equipment to enable the operator to conveniently change frequency from his operating desk. Five sets of plug-in coils, three to a set, provide for operation on the 10, 20, 40, 80, and 160 meter Amateur bands. Accurate tracking and proper design hold output constant over entire range of each band.

Two frequency doubling circuits on all bands (except 160) minimize effects of load on oscillator frequency resulting in maximum stability.

Eliminates one or two doubler stages in your transmitter as power output is more than sufficient to drive a low-power stage such as RK-20's, 802's, 210's, 807's or similar tubes—directly on the frequency you wish to work.

Unbelievable frequency stability—superior to that of many crystals—obtained by use of special Hi C electron coupled oscillator circuit and dual buffer arrangement to isolate load. Rigid, fool-proof construction insures against changes due to ordinary handling and usage. Maximum variation of calibration observed during 21-day actual operation at W9WWI under varying conditions of temperature and humidity was .008% or 300 cycles at the operating frequency of 4,000,000 cycles (75 meters). Frequency shift with load variation, tested during this period, was less than 500 cycles from full-load to no-load.

Entirely revolutionary stand-by system, never before used in apparatus of this type—permits tubes to remain at essentially constant operating temper-

ature whether exciter is in use or standing-by thus eliminating all possibility of thermal frequency-drift.

Selective-Automatic operation—internal relay system permits exciter (1) to be "killed" with transmitter by present "stand-by" switch; (2) to remain in operation independent of transmitter for frequency-check, etc.; or (3) to remain "dead" independent of transmitter as when crystal exciter is being used although kept in operating condition and ready for instant use when desired. Any of the three operating conditions instantaneously available by a 3-position selector switch on front panel of unit. Only other control besides tuning adjustment is a simple "On-Off" switch.

Fully assembled including cabinet; wired and completely adjusted in the laboratory—not a factory-built product—yet priced within the means of the average amateur.

Every unit laboratory-tested for operation and frequency-stability on all bands.

Available with or without built-in power supply.

Coils furnished separately in sets of three for each band. Purchase only those you need for bands in which you operate.

Write for full particulars and prices to address below.

#### 1938 CATALOG

now being prepared; 10 pages devoted exclusively to complete line of amateur equipment. Get your name in now for free copy.

## MEISSNER MANUFACTURING CO.

150 Belmont Avenue • Mt. Carmel, Illinois, U.S.A.

Say You Saw It in QST — It Identifies You and Helps QST

# IF THE MOUNTAIN CAME TO MOHAMMED



he would joyously accept this supernatural event as a reward to his implicit faith. And as Faith moves mountains—Faith in his source of supply moves the consumer. Consistently and effectively satisfying the consumer, creates an acceptance of a merchant's products. LEEDS RADIO has, for 16 years, consistently given the amateur merchandise of the highest quality at the lowest possible price. Our constant endeavor to improve our relations with you insures your receiving the utmost in service.

For your T-20 — TZ 20 — and 809; The Kenyon T 378; 7.5 v. or 6.3 v. at 7 amps C.T. 2000 v. test. **\$3.00**

LEEDS LD-5 Crystals are being used by satisfied amateurs all over the world. Cut to your specified frequency (at no extra cost) in the 40, 80 and 160 meter bands; mounted in a holder; unconditionally guaranteed. **\$3.50**

For your Cathode bias requirements in the X-mitter. Ohmite 50 watt rheostats, 700 ohms; special each. **59c**

Have you received your copy of the Kenyon Engineering News No. 20 showing experimental Television circuits? A card will bring it.

We carry a complete stock of

RAYTHEON Transmitting Tubes

RCA Transmitting Tubes

TAYLOR Transmitting Tubes

CARDWELL Condensers

HAMMARLUND Condensers

NATIONAL Condensers

## LEEDS CONDENSERS

Oil Impregnated: Non Inductive: Hermetically sealed

2 mfd. 1000 v. Net. **\$1.50** 4 mfd. 2000 v. Net. **\$4.65**  
4 mfd. 1000 v. Net. **2.00** 1 mfd. 3000 v. Net. **2.50**  
2 mid. 2000 v. Net. **2.45** 2 mfd. 3000 v. Net. **4.95**  
Unconditionally guaranteed

## LEEDS TRANSFORMERS

COMPLETELY SHIELDED — HIGH VOLTAGE

1500-1000-1250 each side C.T. at 300 ma. Net. **\$6.80**  
2500-2000-1500 each side C.T. at 300 ma. Net. **11.00**  
500-425 each side C.T. at 250 ma. 5 v. at 3 amp; 2-6.3 v. at 3 amp. **\$3.00**  
2.5 v. C.T. at 10 amps; 5000 v. insulation for 2-866 tubes. **\$1.70**

## LEEDS SHIELDED CHOKES

to match the above transformers

20 H. 200 MA 115 ohm **\$1.50** 5/25 H. 200 MA 115 ohm  
20 H. 300 MA 95 ohm **2.90** 5/25 H. 300 MA 95 ohm  
20 H. 400 MA 85 ohm **3.50** 5/25 H. 400 MA 85 ohm  
20 H. 550 MA 55 ohm **5.00** 5/25 H. 550 MA 55 ohm

## OVERSEAS AMATEURS ATTENTION

There is a satisfied Leeds customer near you, regardless of your QRA. Leeds export service is being constantly used by amateurs and commercials in over 80 countries. One shipment will convince you.

Our technical department welcomes your inquiry



**LEADS THE FIELD**

45 Vesey Street  
New York City

Tel. COrlandt 7-2612

Cable Address: "RADLEEDS"

World Wide Service to Amateurs

## Image Rejection

(Continued from page 28)

higher than is normally permissible, thus compensating for slight attenuation of the signal when the rejector is in use in the 30-Mc. band.

With higher than normal gain in the first tube, a better signal-to-noise ratio can be obtained over the frequency range below 30 Mc., with complete freedom from images.

## A.R.R.L. QSL Bureau

FOR the convenience of its members, the League maintains a QSL-card forwarding system which operates through volunteer "District QSL Managers" in each of the nine United States and five Canadian districts. In order to secure such foreign cards as may be received for you, send your district manager a standard No. 10 stamped envelope. If you have reason to expect a considerable number of cards, put on an extra stamp so that it has a total of six-cents postage. Your own name and address go in the customary place on the face, and your station call should be printed prominently in the upper left-hand corner.

- W1—J. T. Steiger, W1BGY, 35 Call Street, Willimansett, Mass.
- W2—H. W. Yahnel, W2SN, Lake Ave., Helmetta, N. J.
- W3—R. E. Macomber, W3CZE, 418 10th St., N. W., Washington, D. C.
- W4—G. W. Hoke, W4DYB, 328 Mell Ave., N. E., Atlanta, Ga.
- W5—E. H. Treadaway, W5DKR, 2749 Myrtle St., New Orleans, La.
- W6—Horace Greer, W6TI, 414 Fairmount Ave., Oakland, Calif.
- W7—Frank E. Pratt, W7DXZ, 5023 So. Ferry St., Tacoma, Wash.
- W8—F. W. Allen, W8GER, 324 Richmond Ave., Dayton, Ohio.
- W9—Roy W. McCarty, W9KA, 11 South Michigan Ave., Villa Park, Ill.
- VE1—J. E. Roue, VE1FB, 84 Spring Garden Rd., Halifax, N. S.
- VE2—C. W. Skarstedt, VE2DR, 236 Elm Ave., Westmount, P. Q.
- VE3—Bert Knowles, VE3QB, Lanark, Ont.
- VE4—George Behrends, VE4RO, 186 Oakdean Blvd., St. James, Winnipeg, Manitoba.
- VE5—E. H. Cooper, VE5EC, 2024 Carnarvon St., Victoria, B. C.
- K4—F. McCown, K4RJ, Family Court 7, Santurce, Puerto Rico.
- K5—Norman F. Miller, K5AF, 15th Air Base Squadron, Albrook Field, Canal Zone.
- K6—James F. Pa, K6LBH, 1416D Lunalilo St., Honolulu, T. H.
- K7—Dean Williams, K7ELM, Box 2373, Juneau, Alaska.
- KA—George L. Rickard, KA1GR, P. O. Box 849, Manila, P. I.

# Jensen

## PERI-DYNAMIC REPRODUCERS

... with *Bass Reflex*

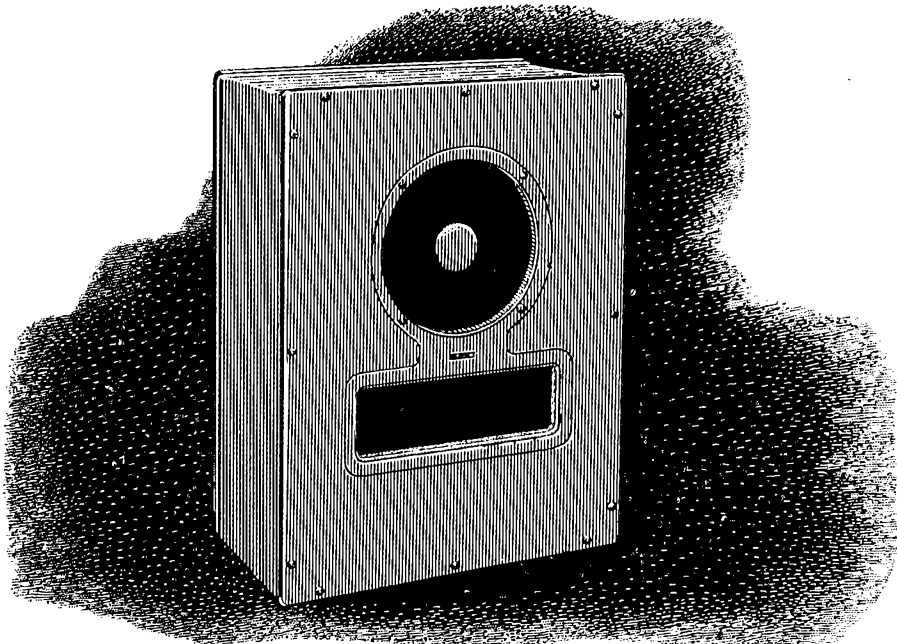

Now  
Offered  
With

## Jensen Auditorium and 18" Speakers

The outstanding performance of these "Standard of the World" speakers is now improved by the advanced acoustic principles, incorporated in these

new reproducers, which add new octaves of low frequency response and exceed in ability even an infinite baffle.

**AND . . .** as separate enclosures correctly designed for the thousands of these speakers already in use and inefficiently "baffled."

Enclosures are shipped in knock-down kit form for convenience and low cost. Those who know the performance improvement, convenience and low cost of Jensen *Peri-dynamic* Reproducers for 8,

10, 12 and 15-inch speakers will cheer the addition of these new models. Write for new descriptive literature describing the complete line of Jensen *Peri-dynamic* Reproducers.

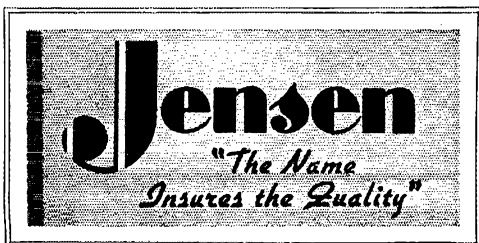

JENSEN RADIO MFG. COMPANY QS 3-38  
 6601 S. Laramie Avenue, Chicago, Illinois

Please send me new literature describing Jensen *Peri-dynamic* Reproducers for Auditorium and 18" Speakers.

Name .....

Address .....

City ..... State .....

## NEW ENGLAND DIVISION

**C**ONNECTICUT—SCM, Fred A. Ellis, Jr., W1CTI—AXB, UE and AFB made B.P.L. AXB has schedules covering all U.S.A., Hawaii and Canada. AFB got his B.P.L. total from Trunk Line "C." JXP reports for Connecticut A.A.R.S. that AJB has a new YL operator. New A.A.R.S. members: KAY, AMQ and AXB. KFN and HSK keep New Haven on the map. JYE takes care of West Haven. AMQ, N.C.S. for Nutmeg Net three nights a week, says his year-and-a-half-old YL operator runs around saying "dit-dah" and "hello" into his mike. ES keeps six schedules and is going strong. KQY and KKS applied for O.R.S. BDI attended Horsetraders meeting held at Middletown. His new week-end hobby is cutting down 35-year-old trees on new WIAW site that are in the way of "antennas to be." EFW came through with a nice report and registered for A.E.C. BHM has been appointed Emergency Coördinator for New Haven, APA for Bridgeport and HYF for Norwalk. Hal runs WIAW only for official broadcasts, contests and RM nights. His own station JTD was awarded W.A.S. certificate. AW is also a new W.A.S. Club member. JBJ is rebuilding modulator with two '10's Class B to modulate his 125 watts r.f. DWP has new rig for 'phone and c.w. with 300 watts input on c.w. Our sympathy to BNB; his father passed away Dec. 30th. BFS says everything rather haywire, but it works. TD is testing on dummy antenna. KKS, new Nutmeg Net member, reports on the gang around Manchester. BEQ is grid-modulating a pair of '52's on 14 Mc. DJC has 100 watts on 14 Mc. remotely controlled. JNJ installed crystal control. BAX is back on the air. IYI has moved to Wichita, Kans., and has W9 call. CLG is an engineer at WTHH. HZK schedules 60TE (ex-IJGO). New officers of Manchester Radio Club; BEQ, Pres.; EJI, Vice-Pres.; DJC, Secy.-Treas. New officers of Connecticut Brass Pounders Association (ICBA): BCG, Pres.; CTI, Vice-Pres.; HYF, Secy.; S. Shepperd, Treas. APZ took a trip down south, and sails for England on business trip this month. BCG is building a new rig with 808 final. GBX is building a new home and will have a special room for radio. IOV is planning a new transmitter and figuring how to erect a couple of masts. UE received rating of 45 w.p.m., TS 40 w.p.m., ITI 25 w.p.m., and JYJ 20 w.p.m. in A.A.R.S. speed contest. HAX worked 1BVR on 3.5-Mc. c.w., the signals from BVE being relayed back to HAX on 56 Mc. via KJC. This was not prearranged, but the hookup worked out on the spur of the moment.

Traffic: W1AXB 727 UE 705 AFB 551 JXP 443 HSK 431 JMY 350 (WLGQ 40) KFN 270 KV 246 (WLGJ 49) JYE 165 AMQ 133 ES 119 JQD 94 DMP 93 GMR 72 KQY 60 ITI 57 BDI 41 EFW 26 CTI 25 BHM 23 AW 12 JFN 10 JYJ 9 JTD 8 HYF-JBJ 7 DQP 3 KKS 2 APW-CJD 6.

**MAINE**—SCM, Winfield A. Ramsdell, W1FBJ—The Maine QSO party was certainly a success. About 75 stations took part and, from the reports that have come in, all had a grand time. Plans are under way for another party in the fall. Any suggestions which would make the affair more enjoyable will be greatly appreciated. The three high scores were made by DEG, 152 points; FIV, 125 and GOJ, 121. DEG contacted the old home town for the first time in several years during the QSO party. IQZ operated KFE in the contest on 3.9-Mc. 'phone and made 94 points. DHE is radio operator at Riverhead, L. I. IRB is rebuilding. IQZ scored 31,000 points in SS and is preparing for the DX contest. KRK is working the middle west on 3.5 Mc. with single 6L6 osc. ASQ is increasing power. HSW moved to Woolwich. Boothbay Harbor hams are interested in forming a Lincoln County Radio Club. CRP has renewed the O.R.S. ticket. IEB is operating 3.9-Mc. 'phone and was active in QSO party. HSE has been appointed O.R.S. FZD has arranged schedule with KOU to handle traffic. JUV is new O.R.S. EWN gets daily reports on winter sports conditions from the White Mts. for the local newspaper on 1.75-Mc. 'phone. KZE is new ham in Woodland operating on 1.75-Mc. 'phone, using 6L6 osc. and 807 amp. FJP and KSL are giving 28 Mc. a try. AHJ is operating at Livermore Falls. KNB gave amateur radio some very good publicity, when he was able to assist the Coast Guard in the search for the disabled fishing schooner *Richard J. Nunan*. Radio conditions were so poor that the Coast Guard were unable to contact their stations along the coast. First information as to the vessels plight was relayed to the Coast Guard through KNB. EFR and IQM are getting in line for O.R.S. TE, CRP, JRS, KQX, KRZ and BX were some of the boys using crystal

oscillators for rigs in the QSO party. BX had 50 volts at 10 mills, and did a fine job. IYP is building a 28-Mc. rig. KHU is operating portable at Scarborough. DOZ has 28-Mc. rig about ready for installation in car. The Portland Amateur Wireless Assn. had its annual election of officers, Jan. 4th, with following results: TE, Pres.; FIV, Vice-Pres.; CRP, Secy.; GVS, Treas.; FBJ, Chief Operator. HSE says new NC-81X perks FB. KNJ reports boys around Penobscot Bay are forming net meetings to be held over the air, Sundays. KEZ is new O.R.S. prospect. There has been plenty of activity in getting new O.R.S. lined up, as can be seen from the above report. Now that the ball has been started, let's all stay together and keep it in motion. There is a feeling with the boys generally that traffic reports are only accepted from Official Stations. Please take every opportunity to change this feeling and urge all stations you hear handling traffic to report same on the 16th of each month.

Traffic: W1GOJ 742 KOU 286 ISH 210 EWN 134 INW 114 IST 110 IBR 64 KNB 62 KNJ 45 EFR 41 JUV 28 HSE 23 FIV 3 DHH 1 KRK 4 FBJ 30 CFO 237.

**EASTERN MASSACHUSETTS**—SCM, Sam Gross, W1IWC—AKS kept schedules with emergency rig during Christmas rush. IWC is rewinding 32v. d.c. generator for 110 a.c. JCK runs 200 watts to a T-55. EPE needs N. Mex. and Nevada for W.A.S. on 3.5 Mc. KH was heard in England on 56.2 Mc. BEF wishes clubs would send him recommendations for Emergency Coördinators. HXE is doing swell job as Emergency Coördinator for Lawrence. JYJ had chance to do some real emergency work. ASI is getting schedules lined up. KMY's antenna let go during Christmas traffic rush. KBQ is getting Asst. Coördinators lined up in Haverhill. FDB has FB first report. FJN is new E. Mass. Traffic Net member. BMW is on U.S.S. *Hamilton* for two months. HIL is new O.P.S. HKY has 52 countries toward Century Club. ALB is coming on 1.75-Mc. 'phone all the way from 28 Mc. ALG was the lucky one this month congratulations to you and the missus. ERH would like list of stations on 3935 kc. IQO is getting out well with 45 watts on 7 Mc. JIX finished 28-Mc. rig. JQZ found keyer tube really works. JYB is rebuilding. The HI-Q Radio Club is having a club W.A.S. contest for 1938. The leader at present is IGO. IZF has new rig perking on all bands. IKU, JYJ, and EVJ had emergency network all ready from Nantucket Island to New Bedford when telephone and wire circuit failed. FXH drills with N.C.R. on 1.75 and 3.5 Mc. AWD operates on 14-Mc. 'phone. AGW keeps daily schedule with K4DDH on 14-Mc. 'phone. The Radio Operators Club of New Bedford had a club Sweepstakes Contest with AGW, AWD, CBZ, HQL, IKU, EJJ, UJ and KHE taking part. FXB is back on after a year's lay-off. AZY is putting a pair of 808's in new rig. KVVU is working 7-Mc. DX with single 6L6. WV is still working the DX in spite of poor conditions. AKS, IHI, IWC, EMG, JCK and KH made B.P.L.

Traffic: W1AKS 767 IHI 616 IWC 603 EMG 544 JCK 505 (WLGV 24) EPE 297 JFB 283 KH 222 BEF 220 HWE 190 JMS 182 QA 179 KCT 130 HXE 117 KMQ 115 JYJ 107 DMF 101 ASL-KMY 88 KBQ 84 HRE 76 JSM 75 AGX 74 FDB 69 QW 71 (CCIC 25) JNF 63 (WLGJ 77) IUQ 60 HFJ 40 FJN 17 BMW-BFR 14 HIL 3 HKY 3 TY 210 JBI 91 JNU 86 JRM 75 KKM 47 JTM 17.

**WESTERN MASSACHUSETTS**—SCM, William J. Barrett, W1JAH—IOT leads the traffic parade with nice total. IOR is B.P.L. on deliveries. BVR is active on 1st C.A. A.A.R.S. 'Phone Net-QRG 1995 kc. Perce is also new O.P.S. ZB raised country total to 124 with HSI1BJ, FI8AC and Z83F. Carl breaks the news that he is soon to move to Maryland. AZW and BKJ are active on 3.5 Mc., Milt reporting satisfactory progress on the Super. EOB reports a new bug. AJ threatens to forsake 7 Mc. long enough to work some of us up on 3.5 Mc. KJO sends first report since joining A.A.R.S. JAH is on when time permits, which is too seldom. KJK visited Racine gang while on business trip to Wisconsin. KFV has joined Army and gone to Canal Zone. BNL has new band-switch exciter—per Oct. QST. BKQ is confining activities to 56 Mc. AJD is still up in Nashua, with the rig in Holyoke. IRI reports that Holyoke Amateur Radio Club visited A.R.R.L. Hdq. Jan. 14th. APL is selling out and rebuilding from scratch. COI says cards from CQ5AQ and SVIKE got New Year off on right foot. He reports 5EHS working in Pittsfield. How about some news from the rest of the gang?

Traffic: W1IOT 702 (WLGJ 179) IOR 416 BVR 198

(WLG 225) BIV 164 ZB 126 AZW 98 EOB 56 AJ 45 KJO 34 JAH 15 KJK 13 BNL 7 DUZ 5.

**NEW HAMPSHIRE**—SCM, Carl B. Evans, W1BFT—The NHN on 3840 kc. now includes HTJ in Plymouth. We are still looking for Laconia, Hanover and Woodsville. JCA has rebuilt this "super-gainer" with a stage of i.f. and reports much more sensitivity, selectivity and stability. ESB is now proud owner of an RME-69 receiver. HJM has left for Ohio to work. FCI is sending traffic covering ski and weather reports on the Eastern Slopes Region. FAB is on the staff of Radio Today in New York City. 2FDD moved to Concord and is active on 3.5 Mc. HOV has a new RK-47 "beam" tube in the final. BFT finally worked Nevada in the A.R.R.L. QSO Party, which means W.A.S. at last.

Traffic: W1IP 1246 BFT 461 TA 349 FFL 312 (WLG 29) GMM 283 FCI 235 KIN 181 IDY 83 EAL 75 IUI 68 ANS 66 AXL 54 CEA 51 JDP 50 CMR 49 AEF-GHT 29 KMH 22 HGV 18 HJM 12 AP 11 JGI 10 ITF 7 HRP 3 HTO 1.

**RHODE ISLAND**—SCM, Clayton C. Gordon, W1HRC—CPV and KYK signed up with A.A.R.S. HCW is thinking of same. IMY has new Mac Key and has been put on as S.N.C. 3 in charge of Pawtucket Net of A.A.R.S. JNO is on 7 Mc., working 11EC, YR5ML, PY1DL, YR5VC, D4IZI and YR5PB with good reports. BVI and JFF are getting on 56 Mc. The Providence Radio Association held its annual election; GTN is again Pres., with HRC Vice-Pres., JDX Treas. and Mr. Earnshaw Secy. BES, who did the big job of assembling the new radio equipment for PITC, is accompanying the equipment to Pitcairn Island. HRC and JXA have built a muck-saw and are building a grinding wheel, experimenting with crystal sawing and grinding. Which brings up the thought—those Polariscopes sold in the toy stores at Christmas time make FB sources of polarized light for examining quartz. GTN was favored with a visit from the Jamaica Plain representatives of the N. E. Radio Club Council, Jan. 9th (Jack Ferguson and Fred Goode). JXQ had Hallicrafter from Santa. The Naval Reserve gang have a tape-sending machine for Morse practice.

Traffic: W1NU 427 IMY 311 IEG 246 GTN 235 JUE 110 INT 63 KWA 61 JXQ 52 QR 40 KTH 38 KCS 35 HRC 24 KOG 13 IQF 7 JNO 4 ETD 2.

**VERMONT**—SCM, Alvin H. Battison, W1GNF—C.R.M.: 1FSV. R.M.: 1EZ. P.A.M.: 1AVP. KIE is operating portable at St. Albans indefinitely. GAE built a new transmitter using 59-6A6-807. FPS schedules KOO. FSV advises all stations with Vt. traffic to look on 3715 kc. at 7:00 p.m. where CBW, FSV, GAE, JRU, JVT, KJG and KIE are waiting to route traffic to the different sections of the state. GAE and his A.A.R.S. gang are working on cipher texts. 10A-3GWV visited at GNF. CGT and EJF are once again on 3.5 Mc., CGT from N. Ferrisburg and EJF from Kimball. KOO is keeping four schedules and sending code practice. JVS made W.A.C. and has worked 70 countries with his new T125. 2JBL is now a Beta Kappa man at Middlebury. KVB and HEV apply for O.R.S. JXS is hoping for Class A license. BZS has moved from Maine to commence his duties at WCAX, Burlington. ELR is trying a new PR15 receiver. FN is rebuilding 14-Mc. rig. 2BAQ is operating at WCAX, Burlington. HEV has one of the neatest stations we have yet seen. IQG visited at FSV, AVP, AHN and GNF.

Traffic: W1FSV 405 KJG 61 KVB 8 GNF 4 AHN 2 DPO 1.

#### HUDSON DIVISION

**EASTERN NEW YORK**—SCM, Robert E. Haight, W2LU—W2LU has weekly schedule with 2AHC. HYC on 3515 kc. schedules 2KAK, 8DSS, 1AXB and 3EDC. BLU reports activities of Port Jervis boys. UL installed new keying system, keying in osc. stage permitting bk-in. KFB uses 807 e.c. osc. on 7 and 3.5 Mc. with 15 to 60 watts input. FQG hold O.P.S. No. 13 and O.R.S. No. 13. ITK, new O.R.S., reports BDB has traffic schedules with K5AN and K5AU. HUB has 35T on 14, 7 and 3.5 Mc. CJP, S.A.R.A.'s staff photographer, is active on 14 and 7 Mc.

Traffic: W2LU 58 HYC 52 BLU 13 HCM 10 IKV 9 UL 6 KFB 3 FQG 5.

**NEW YORK CITY AND LONG ISLAND**—SCM, Ed. L. Baunach, W2AZV—JYL is out for O.P.S., ESO for O.B.S. appointments. BGO has a weather net going on 3.5 Mc. Anyone interested should get in touch with him. KYO and KTH sent their first reports. IBT is back in the Section after spending a year in Los Angeles. DXO joined A.A.R.S. JZX received new Class "A" ticket. HNJ dusted off his rig

after a long shutdown. EVA is putting a kw. on 7 Mc. KSI's new rack and panel job has a T-55 final on 7191 kc. FJH is putting 250 watts into his RK-36 on 7073 kc. JDF built an FB rig for KXJ using 809's final. KPK has new 6L6 rig. BYL is rebuilding using a Pierce oscillator, RK-25 and pair of 50T's final. KYH is using a T-125, 250 watts input on 7136 kc. JEQ is experimenting with a pair of tens in TNT. CHK is going to take the final step July 2nd. PF uses break-in on 'phone as well as on c.w. AZV's new 40-foot mast completes his new station. HGO has a number of pupils for code practice on 56 Mc. JFU received his first card from Cuba. TC is now in Rockville Center with 1-kw. rig on 14 Mc. DR in Merrick is using a 30-FXC on 1.7 and 28 Mc. GDU can be heard from Freeport on 14 Mc. with 700 watts input. CHK's motto is one QSO a day on 14 Mc.; he has had 238 QSO's since Nov. 14th. HBO tried a 14-Mc. beam. IXY is trying 56 Mc. using long lines oscillator, 22 watts input to a rotary beam antenna. EXR has new HRO and rig. IXQ participated in 1.75-Mc. DX tests. ELK is secretary of N. J. QSO Club. ITN, EFI and JFM are trying 28 Mc. IHT has started a 56-Mc. club at school. IJU put up a new antenna for DX tests. JEB is looking for 7 states for W.A.S. DOG got a new ACR-155 since the YF found the receiver had a BC band on it; it is now up in the living room. KVV says that HDO is being bootlegged on 56 Mc. EC's Atlantic-Pacific Trunk Line operates nightly on 3630 kc. at 10 p.m. HAK schedules 9HBQ every Sunday on 3670 kc. KI schedules 1GOJ daily at 8:45 a.m. on 3674 kc. APM, BVE, HVD and JSV are operating c.w. on 1.75 Mc. The Radio Club of Brooklyn elected following officers for 1938: AQQ, Pres.; HOH, Vice-Pres.; AAZ, Treas.; KIU, Secy. TI has moved to Washington, D. C., where he works for the Naval Research Lab. KYU is new Brooklyn station, operating on 14 Mc. HHT took the final step and is now one of the Benedicts.

Traffic: W2JHB 418 OQ 357 DBQ 290 (WLNB 54) PF 177 BGO 161 DXO 131 EC 52 AZV 40 AHC 39 IBT 36 KIF 28 ESO-EXR 21 JZX 17 BYL 15 HAK 14 IJU-IHT 11 KI-IXQ 9 CHK 8 KVH 7 EYS 4 ELK-HBO 2 DOG-HGO-KSI-FLD-DLR 1.

**NORTHERN NEW JERSEY**—SCM, Fred C. Read, W2GMN—BCX, HOZ and GMN attended the annual dinner of American Signal Corps Association at Governors Island. HXI enjoyed working the transmitter during vacation. GGW has been active in traffic work. HFB gets out twice as well with 801's in final. HYI has new receiver. CJX is active again. HRZ is active on 1.7 and 28-Mc. 'phone and 14-Mc. c.w. JUC has become active traffic man. GVZ is all-around active ham; made B.P.L. and has 103 countries to date. CGG has been doing fine traffic work. JCT has high power on 3.5 Mc. ISU, JXY and HZY are on 56 Mc. The Bloomfield Radio Club is building transmitter. IBX is back on 1.7-Mc. 'phone. CEE is on 14 Mc. GBY has been making recordings. ICJ gets on only for drills. KTR reports for first time. JMX has a T-125 with 190 watts input on 1.7 Mc. GSI is building a 28-Mc. transmitter and receiver. AOG has been busy on 28 Mc. JV, KON and ALC have been working on radio system for local Police Department. JNS has pair of T-55's in final. MW lost antenna in sleet storm. JYK is active on 1.7 Mc. HNP is new 'Phone Activities Manager. JQK is prospective O.P.S. ILE is new O.R.S. JKQ has new 1000-watt transmitter. BCX, GGE and GVZ made B.P.L. on total points. GVZ and HOZ on deliveries.

Traffic: W2BCX 1603 (WLNF 953) GGE 683 (WLNQ 105) GVZ 518 CGG 452 HOZ 284 GGW 163 97 HZO 69 CIZ 8 IZV 7 HXI 29 JMX 6 HRZ-ICJ 4 HDJ-GMN 3 CJX 2 HQL 135 (WLNK 263) HZY 261 JUC 121. (Nov.-Dec.: W2GGW 97.)

#### ATLANTIC DIVISION

**EASTERN PENNSYLVANIA SECTION**—SCM, John Buck Morgan, W3QP—P.A.M.: 3EOZ, R.M.'s 3AKB, 3AQN. Mid-winter season brought a large turn-out; 38 stations reporting. 3CXE is trying 28-Mc. flea power. 3GXX has a new mast and 28-Mc. beam. 3GFK is giving 3.9-Mc. 'phone a whirl with good success. 3CZS has a very effective line-up in his new 41 Pierce Osc., 42 buffer/doubler and 807 final. Christmas traffic was unusually heavy at 3CHH, 3DGC, 3ECA, 3EDC, 3EML, 3EWJ, 3QP, 8ASW and 8DHT with good percentage of deliveries. Emergency Co-ordinator plans are developing nicely; a list of E.C.'s appears in O.R.S. Bulletins. 3EML installed a pair of 808's and runs 600 watts input with excellent results; his K5AA schedule works very well. 3EOZ crashed 28 Mc. with a 1/2-kw. job.

(Continued on page 104)



# Say, Radio Amateur!

## RIGHT NOW

at

# CAIRO

EGYPT

## Your LEAGUE

IS REPRESENTING

## Your HOBBY



**ARE YOU  
A MEMBER  
OF YOUR LEAGUE?**

*Board of  
Directors*

## Standard Frequency Transmissions

Date	Schedule	Station	Date	Schedule	Station
Mar. 4	A	W6XK	Apr. 8	A	W9XAN
Mar. 11	A	W9XAN		B	W6XK
	B	W6XK	Apr. 15	A	W9XAN
Mar. 18	A	W9XAN		A	W6XK
	A	W6XK	Apr. 22	BB	W6XK
Mar. 25	BB	W6XK		A	W9XAN
	A	W9XAN	Apr. 23	BX	W6XK
Mar. 26	BX	W6XK	Apr. 24	C	W6XK
Mar. 27	C	W6XK	Apr. 29	A	W6XK
Apr. 1	A	W6XK			

### STANDARD FREQUENCY SCHEDULES

Time (p.m.)	Sched. and Freq. (kc.)		Time (p.m.)	Sched. and Freq. (kc.)	
	A	B		BB	C
8:00	3500	7100	4:00	7000	14,000
8:08	3600	7100	4:08	7100	14,100
8:16	3700	7200	4:16	7200	14,200
8:24	3800	7300	4:24	7300	14,300
8:32	3900		4:32		14,400
8:40	4000				
Time (a.m.)	Sched. and Freq. (kc.)				
	BX				
6:00	7000				
6:08	7100				
6:16	7200				
6:24	7300				

The time specified in the schedules is *local standard time* at the transmitting station. W9XAN uses Central Standard Time, and W6XK, Pacific Standard Time.

### TRANSMITTING PROCEDURE

The time allotted to each transmission is 8 minutes divided as follows:

2 minutes—QST QST QST de (station call letters).

3 minutes—Characteristic letter of station followed by call letters and statement of frequency. The characteristic letter of W9XAN is "O"; and that of W6XK is "M."

1 minute—Statement of frequency in kilocycles and announcement of next frequency.

2 minutes—Time allowed to change to next frequency.

W9XAN: Elgin Observatory, Elgin National Watch Company, Elgin, Ill., Frank D. Urie in charge.

W6XK: Don Lee Broadcasting System, Los Angeles, Calif., Frank M. Kennedy in charge.

### WWV Schedules

**E**ACH Tuesday, Wednesday and Friday (except legal holidays), the National Bureau of Standards station, WWV, transmits with a power of 20 kw. on three carrier frequencies as follows: 10:00 to 11:30 A.M., E.S.T., on 5000 kc.; noon to 1:30 P.M., E.S.T., on 10,000 kc.; 2:00 to 3:30 P.M., E.S.T., on 20,000 kc. The Tuesday and Friday transmissions are unmodulated c.w. except for 1-second standard-time intervals consisting of short pulses with 1000-cycle modulation. On the Wednesday transmissions, the carrier is modulated 30% with a standard audio frequency of 1000 c.p.s. The standard musical pitch A=440 c.p.s. is also transmitted from 4:00 P.M. to 2:00 A.M., E.S.T., daily except Saturdays and Sundays, on a carrier frequency of 5000 kc., power 1 kw., 100% modulation. The accuracy of the frequencies of the WWV transmissions is better than 1 part in 5,000,000.

### Brief

W5NW, West Gulf Division Director, reports that in 1924 he had worked all states with a 202 and received all cards except from Nevada. W5NW has worked 10 of the A.R.R.L. Directors and all headquarters officers.



# ANNOUNCING

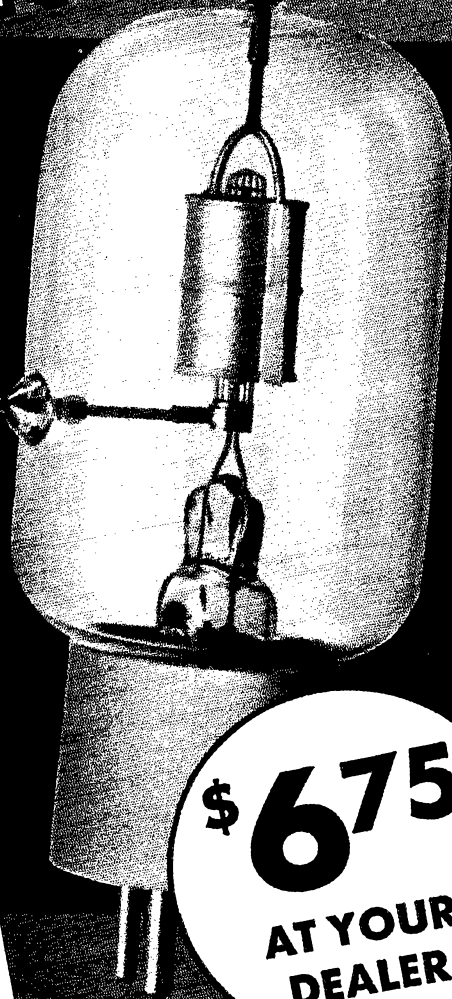

THE TYPE **54**

## GAMMATRON

A NEW LOW PRICE  
HIGH POWER TRIODE

- Tantalum plate
- Tantalum grid
- Nonex envelope
- No "getter"
- 50 watt plate
- Mu-27
- Max. plate ma-150
- Max. pl. volts-2000
- Full ratings to 100 megacycles

\$ **675**

AT YOUR  
DEALER

SEE THIS SENSATIONAL VALUE TODAY

HEINTZ AND KAUFMAN  
SOUTH SAN FRANCISCO LTD CALIFORNIA U.S.A.

Say You Saw It in QST — It Identifies You and Helps QST

(Continued from page 101)

3EZ has a glorified oscilloscope arrangement whereby he may demonstrate variation effects of rectification, inductance, capacity, etc., by throwing a few switches from operating position. 3GJY and 3BGD find DX good on 7 Mc. 3GMK joined N.C.R. 8ATF has job of building a complete rig for a medical missionary to British Guiana and is teaching him the game at the same time. 8HKS has a new Utah code 'phone rig which is very satisfactory. 8OML is trying for Class A ticket. 8QXW is operating from the parlor while his house is being rewired. Additions or corrections to E. Pa. O.R.S. frequency list should be sent in promptly.

Traffic: W2ITX/3 12 3ADE 40 3AGK 6 3AKB 380 3AOC 10 3AQN 150 3BBV 21 3BGD 1 3BYB 69 3CHH 639 3DGC 304 3DPD 82 3DXC 7 3ECA 227 3EDC 130 3EML 605 3EON 22 3EWJ 204 3EZ 3 3FVJ 1 3GAG 157 3GDI 116 3GJY 58 3GMK 31 3GUB 109 3QP 887 8ASW 356 8ATF 6 AXH 2 8CDT 13 8DHT 240 8HKS 18 8QXW 17 3NF 83.

MARYLAND, DELAWARE, DISTRICT OF COLUMBIA—SCM, E. L. Hudson, W3BAK—R.M.'s: 3CXL, 3CQS. Chief R.M.'s: 3BWT, 3CIZ gives 36-hour traffic service under normal conditions to Peru, Panama, Hawaii, P. I. and Alaska. 3BKZ has 6L6-6L6-100TH 28-Mc. 'phone rig. The Washington Radio Club held its annual Christmas party, Dec. 29th. The affair was held at the Coast Artillery Armory, there being adequate space for holding the initiation of new members as well as dancing. The party was a huge success and lasted until far into the wee small hours of the night, and topped off with de luxe sandwiches made by a member of the club. GXO has been elected President of the Baltimore Mike and Key Club, and with the assistance of DWC has organized a 28-Mc. club. FN, Annapolis, has new 'phone on the air using PP HF-100's. GEB is rebuilding to a band-switching rig with a 250TH final and is building a new e.c. osc. WLM/3CXL handled 533 messages on Dec. 23rd. From Dec. 20th to Dec. 23rd, inclusive, 1885 messages were handled!

Traffic: W3CIZ 959 SN 822 BWT 774 CXL 589 (WLM 4707) 8JA-3 205 3BKZ 198 ETE 78 GKZ 60 FPQ 43 GKN 39 BAK 11 CQS 9 EZN 8 CDG 5 GXO 5.

SOUTHERN NEW JERSEY—SCM, W. Walter Filson, W3BEI—Honors for the Section in traffic go to BYR, who has really been doing a fine job on Trunk "B." The S.J. Net welcomes GIA and BAY, the latter striking for an O.R.S. ZI had a 56-Mc. contact with 3CUD (ex-3EH), the first since Spark days. BEI is looking for responsible A.R.R.L. men for Coördinator appointments. FBM gets home occasionally to answer net roll call. DNU settles back in his new QTH. GWW, another addition to Wildwood, sends in first report. W3FCQ did a nice job with a round trip message in 1½ hours. BAY, a former O.R.S. from the dark ages, breaks out with a big layout using an ACT150 transmitter and an ACR-11 receiver. Then after the gang (7 of us) raised a 43-ft. tower on top of his three-story house, the rope broke and reeved free through the pulley. BGP has used his "V" beam to good advantage in So. Amer. and is now picking up the loose ends of intermediates heard down that way. ZX keeps to his weekly schedules with VE2LO and K4ENY. A couple new hams in Trenton are HAZ and HEV.

Traffic: W3BYR 488 EFM 210 (WLNJ 49) ZI 132 BEI 28 QL 23 FBM-AEJ 22 DNU 17 GWW 10 FCQ 5 BAY 3 BO 1.

WESTERN NEW YORK—SCM, H. E. Preston, W8CSE—R.M.s: 8DSS8BJO. P.A.M. 8CGU. The Utica Amateur Radio Club put on a grand hamfest on January 15th at the Imperial Hotel in Utica. Every one present had a good time and is looking forward to the next convention. PLA, our star traffic man, made the B.P.L. with plenty to spare. Good for you, Fred. JQE takes second place with plenty of originations. DSS was very active during the Christmas message rush. GWY keeps the "Far East" corner of the Section on the map. DHU is doing a mighty fine job; he would like to contact more stations in northern New York. CTX was a busy man with Utica Hamfest, but managed to handle a few. QXS, our newest O.R.S., gives us a much needed outlet at Geneva and nearby places. PWU is working DX on 3.5 Mc. BUN in Oneonta is a great help in taking care of traffic for that Section. CGU is having pretty good luck on 14 Mc. PLA found time to attend the Utica Hamfest and to work England on 3.5 Mc. MMV keeps 1845 kc. busy with a mighty nice sounding 'phone; he is a star station in the A.R.R.L. Emergency Corps. QWA and RBW joined N.C.R. NNJ plans on a little 14-Mc. DX. JHI is on 14 Mc. with 150

watts. DSU will take traffic for Auburn; he is on approximately 3800 kc. PFM is rebuilding rig for DX contest. LUJ had a good time at the Utica Hamfest. RKA, a newcomer, reports from East Randolph. The entire Section extends deepest sympathy to W8IH in the death of his wife. The S.C.M. appreciates the way you have started supporting him. A report of your activity is a great help. How about more reports? We need traffic station in Buffalo, Jamestown, Rochester, Syracuse and Watertown. What say, some of you fellows?

Traffic: W8PLA 649 JQE 397 CSE 361 (WLNM 100) DSS 218 FCG 178 GUY 139 BJO 80 DHU 79 CTX 55 QXS 48 PWU 24 BUN 22 JTT 15 CGU 14 ABN 12 RBW 6 WVA 5 PCW 4 LUJ 4 RKA 5.

WESTERN PENNSYLVANIA—SCM, Kendall Speer, Jr., W8OFO—R.M.'s: 8KUN, 8KWA, 8MOT, 8GBC. A.A.R.S. Liaison R.M.: 8UK. N.C.R. Liaison R.M.: N8KOB. Emergency Coördinators: Pittsburgh; 8QAN, McKeepore; 8DNF, Erie; 8AQJ, St. Mary's; 8NDE, Butler; 8DDC, Ohio River Region; 8BBV, New appointment—O.O.: 8GJM. Prospective O.R.S.: PFW, QXF. Amateurs Transmitters Assn. Banquet—Feb. 26th at Pittsburgh. Cameradio Hamfest—Feb. 27th at Pittsburgh. Dr. E. C. Woodruff, W8CMP, John L. Reinarts, W1QP, and James Millen, W1HRX, are expected at the hamfests. QAN made a fine total, with one week off for moving to new QTH. B.P.L.'s on totals: QAN, OFO and KWA. GUF made B.P.L. with a nice bunch of deliveries. KWA is busy with the A.R.R.L. Planning Committee which is studying the uses we make of our various bands. OFO still finds time to work some VK's, ZL's and YV's. GBC has a fine bunch of schedules and promises B.P.L. next month. KUN is rebuilding. DDC is getting an emergency outfit going at Butler. NDE has two new rigs about completed, one with 6F6-T20-P.P. T20's, the other with 6F6-10-P.P. 825's. The new rig at UK is completed with 802-T55-P.P. T55's. IOH says IFY got married. Congrats. New N.C.R. member—RAW. KOB is active again. MOT is swinging into action again. LGD is back in the O.R.S. Net and A.A.R.S. FCO has a new HRO. NCJ received a QSL from Hong Kong and is now W.A.C. RGN was laid off, and is back at JTT again. QVQ moved to new QTH and has completed rebuilding. GUY has a new half-wave vertical using aluminum tubing fed by a 550-ohm line. DGL is working 28 Mc. with P.P. T20's to vertical antenna. YA has W.A.C. now and needs New Mexico and Nevada for W.A.S. NEA works 1.75-Mc. 'phone. Ex-8JSY is active every evening on 14,030 kc. as 4ETX, Miami, Fla. Attention is called to unnecessary phonograph record broadcasting, rebroadcasting of broadcast station programs and air parties of questionable character being broadcast by 'phone stations. A new O.O. has been appointed to monitor this type of illegal operation, so WATCH YOUR STEP.

Traffic: W8QAN 1221 OFO 880 KWA 739 GUF 353 GBC 274 KUN 213 DDC 169 MOT 159 UK 132 NDE 125 IOH 103 CMP 94 YA 57 (WLMa 448) HBG 23 MJK 18 AXD 13 KOB 10 LGD 8 GJM 3.

#### ROANOKE DIVISION

NORTH CAROLINA—SCM, H. S. Carter, W4OG—The New Year got under way with a bang with the largest traffic total of any month since OG has been S.C.M. Thanks, fellows. 4NG/WLMG is Chief Radio Aide for A.A.R.S., and handled more traffic than any other station in the state. DGU had AAK as a visitor. DZS has a new ACR-175, and is working plenty of DX. EMV is working on 28-Mc. 'phone using a rotary beam antenna. CYB in new home promises plenty of activity. The Chapel Hill Club has as members AVE, CXM, CZC, DKF, DVV, CYX, COC, UM, 1JBW, 2HVO, HZS, JXR, FLL and ESA; the club call is WE. ANU has the 3.9-Mc. 'Phone Net going with six on the list now. They meet at 9:00 a.m. each Sunday. Help make this net a success, fellows. DW plans on rebuilding his high-power rig before the DX Contest. ATC is very active on the air. ECH will have more power soon. ESO and DLX are new O.R.S. ESB puts out a nice signal on 1.75-Mc. 'phone. DSY is now O.B.S. and O.P.S. BXF is Emergency Coördinator for Charlotte. Help him, fellows. AEN and ALD are on 14-Mc. 'phone. EFL has a new rig on 14 Mc. BX is on 14-Mc. 'phone. DST is going to take Class A. BXB is working on 56 Mc. CEL moved to Greenville, S. C. FT is increasing power. EC completed new receiver. NY is on 28 Mc. with low power. BQZ is member of the Emergency Corps. BJV is on 14 Mc. with T200. EWP is on 7 Mc. CPT has about 75 watts input on 28 Mc. with his bi-push rig. EAA

and EYA are on 7 Mc. EXX has a new NC-81X. DSQ keeps the club transmitter busy on 1.75-Mc. 'phone. The W4NC gang enjoyed having the fellows there for the Floating Club meeting. OG worked the O.R.S. Party from 4NC. DGV is having good luck on 28 Mc. and does some work on 3.9 Mc. DWB is doing a good job with the A.A.R.S. and Trunk Line "C." DCW is having plenty of fun on 3.9-Mc. 'phone. DCQ is back on after rebuilding; all his speech equipment is now in rack and panel. ABT got his kw. on the air; he plans to give the other fellows a fit during the DX Contest. AHF, who lives next door, also plans to give the fellows a fit in the contest!

Traffic: WANG 772 (WLMG 513) DWB 90 ECH 43 ABT 44 EZV 41 AGF 18 NC 10 DLX 9 BVD 12 ANUWE 8 DW-DHR 7 DGV-DZS 6 OG-CXM 4 CYB-EAM 2.

SOUTH CAROLINA—SCM, Ted Ferguson, W4BQE—CZA did a nice job in the A.R.R.L. Contest. DFC is active on 7 Mc. CKW, DMX and FAL are rebuilding. DNK has taken his 4 watts to law school in Tenn. DRG and DXJ work 3.5 Mc. GB is dividing time between 28 and 1.75-Mc. 'phone. ETF has a new beam antenna. ERF joined the N.C.R. DNR is doing nice job on 3.5 Mc. ERB is working 1.75-Mc. 'phone. DRS is active at Moultrieville. DTU has new rig on the air. EOZ is active on 1.75-Mc. 'phone. CQU has new e.c. frequency meter and monitor. CE has pair of TZ-20's in final. EOP is on 7 and 14 Mc. EPJ has his O.R.S. and is looking for schedules. EZF is active on 1.75-Mc. 'phone. EDQ has his O.P.S. and is working 28-Mc. 'phone. CZN on 3.5 Mc. wants more schedules. ALT is active on 3.5-Mc. c.w. and not on 'phone as reported by S.C.M. last month. My error; sorry, OM. EGH is active on 1.75-Mc. 'phone. DQY has his O.P.S. and works 1.75 Mc. BDT did an FB job in traffic this month. There are two things this Section needs! *More activity and everyone to become a member of the League.* Do your part by becoming a member of the League to-day.

Traffic: W4BDT 146 CZA 95 EWB 37 DNR 29 ALT 24 EPJ 17 EOP 17 EDO-EOZ 15 BQM 14 EGH 10 CQU-EZF 6 CE 5 DQY-EMB 4 CZN 2.

VIRGINIA—SCM, Charles M. Waff, Jr., W3UVA—P.A.M.: W3AIJ—R.M.'s: W3GPC, 3GJP, 3GTS, 3DQB, 3BJX—The S.C.M. wishes to express here his appreciation to those who nominated and elected him. At the same time thanks are extended to all who during the past two years have cooperated by reporting. It is only in this way that some measure of success has been attained; will you continue to report regularly and thus help the Virginia Section to forge ahead. Thanks. GTS again leads the Section in traffic. FHF is mostly rag-chewing. FMY has a new rig with P.P. 100-TH's almost ready. FQY has new QTH; 8EPY is his second op. EZL is on 28 and 3.9-Mc. 'phone and would particularly like to contact Va. 'phones on 3.9 Mc. HBO is on 1.75-Mc. 'phone with 50 watts. GCZ is increasing power from 50 to 100 watts. BFW is on 7 and 14 Mc. GJP is doing well with new Emergency Coördinator appointment. GPC handled all his traffic in two weeks after the New Year's Day. AHK is installing new 100-TH final. FBL moved to new QTH. EPK has been operating portable in Washington with a 6L6 on 7 Mc. GBC has been hearing some good DX on 14 Mc. GWP would like schedules between 6 and 7:30 p.m. on 3.5 Mc. GKL contacted 88 stations in the A.R.R.L. member contest. HBF has worked all districts with 6L6 osc. AHK, FBL, GPV, UVA and ZA attended the N. C. Floating Club meeting at Winston-Salem on Jan. 9th. WS has been ill in hospital with rabbit fever for over a month. GKT has moved to Covington from Wilmington, Del. Welcome, OM.

Traffic: W3GTS 352 (WLMG 282 WLQE 92) GPC 134 GJP 61 GBC 59 GWP 26 FBL 5 FHF 2.

WEST VIRGINIA—SCM, C. S. Hoffmann, Jr., W8HD/W8NS—January has seen the realization of a Section O.R.S. Net in this State. Each night at 7 p.m. on 3700 kcs. HD, OLV (R.M.) or DYB (Alternate for HD on Trunk schedule) will call O.R.S. and take any traffic. Even though you are not an O.R.S., you are invited to participate; the rag-chew afterward you will enjoy. We will see you on 3700, or write the S.C.M. for further particulars. Section Net certificates will be issued shortly to active members, and a prize will be offered at the close of the season for the best station. Emergency Coördinators are being appointed, and to date are: DYB, Wheeling and Ohio County; BOK, Fairmont-Clarksburg district; CZ, Charleston area; QZZ, Logan. The Huntington and Wheeling radio clubs are studying emergency power equipment and its construction, especially alternators. FB, fellows. The S.C.M. wishes to thank the

Mountaineer Amateur Radio Club for its whole-hearted cooperation with the S.C.M. and the A.R.R.L. A committee of two members visited the S.C.M. to see what appointments were left vacant in the State and which should be filled to best further amateur radio and the A.R.R.L. spirit in the State. Accordingly, the Club has nominated the following: O.B.S.; BOK, JRL ('phone), NEU (c.w.). O.O.: OJI. BOK and JRL already have been appointed by the S.C.M. New O.R.S.: PTJ. Officers for 1938 Wheeling Radio Club: CWY, Pres.; BWK, Vice-Pres.; Ex-W8EEO, Secy.-Treas.; DYB, Corresponding Secy. CZ is new Pres., Charleston Radio Club. PUA, former Pres., moved to Louisville, Ky. Other officers: BKKI, Vice-Pres.; HI, Treas.; KYJ, Secy. The 1.75-Mc. 'Phone-C.W. Net is getting under way. Those who have not yet joined, write OXO. The 3.9-Mc. 'Phone Net is also being organized, and MOL is appointed Control Station by P.A.M. BDD. Both these nets, as well as the W. Va. O.R.S. Net, will have as their primary purpose storm emergency work and Emergency Coördinators should consider them as their "right-hand bowlers." NEU, KHB, OXO and EP are DXing on 28 Mc. BOK visited Marietta Club. JRL, MZD, PEJ and LO visited Wheeling. KKG has 84 countries verified towards DX Century Club; his new QTH is Box 335, Romney. PSR worked his first Cuban and Mexican! LCN has a new 4-band transmitter! DTL, KWI, OJI, KLP, QPZ, DYB and CWY are on 56 Mcs. NKZ is moving to Wheeling. ELJ attended his father's funeral in Lynchburg. PNE, QZZ, and RGP have new receivers. Black Diamond Radio Club (Logan) is rebuilding its club house; has \$800 already appropriated since the fire! HHH and KPX have a 1-kw. 'phone rig. MOP attended Winston-Salem Hamfest. FQA is located at Keyser. OXO and HD handled traffic to W.V.U. Football Team during Sun Bowl game in Texas. New stations on 3700 kc.: DYB, WK, MJJ and GOQ are back on the air. Old TI is now 2KVM in N.Y.C.! RFP is new Morgantown ham. PQQ was home from 8YX for vacation. AEC joined Silent Keys. HD is member of A.R.R.L. National Trunk Line Net.

Traffic: W8BWK 2 DYB 75 HD 350 KIU 15 KYJ 3 LCN 10 LII 26 LXF 12 OK 49 OLV 36 PHY 8 PSR 47 QPZ 1 PQQ 10 QZZ 6.

#### DELTA DIVISION

LOUISIANA—SCM, Eugene H. Treadaway, W5DKR—R.M.'s: 5BN, 5DWW. P.A.M.'s: 5BMM, 5FUM. E.C.: 5FPO O.O.: 5DXK. ACA is going places on 14 Mc. KC is active O.R.S. BMM is champ DX man. GPE reports new homemade receiver perking FB. FVC schedules GPE. Ex-5AFW awaits a W8 call. EGQ wants O.R.S. BN, a real old-timer and a swell op, is now our So. Louisiana R.M., O.R.S., O.B.S. and very active in A.A.R.S. work; he is also a member of Trunk Line "H" and will handle any traffic; look for him on 3.5 Mc. EVZ and BRR are doing their bit on 14 and 7 Mc. FUM has a new Patterson PR-15. GAL is putting together 1.75-Mc. 'phone. EPY and EKU visited FUM. GUK gets nice reports with his P.P. '45's. GIA says his new NC-81X is the berries. A0Z is building a 28-Mc. rig. JW, EDY, EVS and CJO report activity FB on 28 Mc. FPO has new antenna which he just invented; write him for information. FHH is looking for activities for the N.O. gang. BPL, an old 'phone man, is now on 3.5-Mc. c.w. FMO is building a peak selector. EBB is helping GND get on 28 Mc. 4ENA, 5FRN, 5ASD, 8REL, 9SRJ, 9WIC, 9TTZ, 9WCP, 81FY, 5SI and 1CBD were visitors and did some oping at 5FPO. 5SI, Dir. Arledge, made one of his many visits to N.O. and visited with the gang. Always glad to have you with us, OM. 3BRA is a regular op at FUM. DGB with his 1 kw. are tearing up 7 Mc. GCM has a 211D final. EGK gets his 7's in the early afternoons. FVD has an automatic CQ'er. EUK of San Antonio, Texas, is now active in Shreveport. DXB and DHE are active in Vivian. AKI and ML completed new rigs. ZS goes in for 56 Mc. CEN reports from Carnegie Tech. CMQ, BZR, BBW and GCS are active in Minden. FSX is 30-Mc. fiend. DU, the R.I. at N.O., is a real ham and a swell fellow. ECO has FB new homemade receiver. FDA is the Fortier High School station. ACV operates GIW at L.S.U. AXU has a 1-kw. 'phone. EBZ has been working DX. EAY is heard about town on 28 Mc. Active N.C.R. stations in Louisiana: DAQ, FSI, DPR, BUK, FWO, KC and FCZ. DXK is rebuilding. GDU says his FB7 is a great receiver. 4AXN and 9BEP are active in N.O. FLM reports from Reserve. ACY has 300 watts on 7 Mc. FZQ has a FB new rig. JM of Dallas, Texas, is active in Jennings. DIQ reports several new hams in Algiers. GAD is receiving some nice DX cards. EML works his bit of VK's. FXP likes 28 Mc.

# YOU NEED THIS BOOK

... and it's FREE!

**JUST MAIL THE  
COUPON**

**NEW 1938 EDITION**



## Valuable Information for Beginners and Advanced Radio Telegraphers

What is the right way to learn code ... the quickest way to step up your speed and improve your technique? Why should you pay even a small sum for code instruction? What is there about code that you can't dig out for yourself — that good hard practice won't overcome?

Get the answer to these and many other important questions. This New Book of Facts has 52 pages of information for every radio operator. See what the Code Champions have to say about stepping up your speed. Find out who gets the good jobs in radio, and why. What questions will be asked in your code exam? What is there about the Candler System that, in 30 interesting minutes, teaches you more than hours of practice any other way?

Mail the coupon today, and you will soon have at your fingertips, the combined experience of thousands of radio amateurs ... information that can make you a top notch operator. It may be just what you need for a successful radio career. Don't delay. This is too important to put off. Tear out the coupon right now! You'll always be glad you did.



Walter H. Candler ... "the man who knows the short cuts to true code skill."

## CANDLER SYSTEM CO.

Dept. Q-3 Asheville, No. Carolina

### MAIL THIS COUPON TODAY!

CANDLER SYSTEM CO.  
Dept. Q-3, Asheville, North Carolina, U. S. A.

Name .....

Address .....

City.....State.....

## A Double-Regenerative Superhet

(Continued from page 18)

signal is obtained by using a regenerative detector and a separate b.f.o. than is obtained by turning off the b.f.o. and making the second detector oscillate, another argument in favor of the separate b.f.o.

No trouble should be experienced with image response. The presence of images simply indicates that the antenna coupling is too tight, and loosening it should cure the trouble. A separate tuned antenna circuit<sup>2</sup> also will help reduce image response, but it adds another control and also makes the regeneration setting of the mixer more critical, and is therefore not recommended except where absolutely necessary.

This receiver was designed for the fellow who now owns a regenerative receiver and wants something better. In order to get the reaction of that type of amateur, the receiver was "farmed-out" to a W1 who has worked considerable DX in spite of having only a t.r.f. receiver. He was asked to be as critical as possible, giving his honest reaction and experiences. After a few days he brought the receiver back to complain about the "jumpy" tuning previously mentioned, a fault that hadn't shown up in our laboratory adjustments. The fault was corrected as described, and our friend returned to his shack. He tells us that the signal-to-noise ratio is much better than with his t.r.f., that he can hear many signals he couldn't touch before, and that he can now work right up close to the big fellows without their locking him up. There is only one thing he didn't tell us. He failed to mention when he will return the receiver.

<sup>2</sup> Exp. Section, "Tuning the Receiving Antenna," QST, June, 1936. Also Chapter Seven, *The Radio Amateur's Handbook*, 1938.

## W9AXH

(Continued from page 44)

transmitter; and a Triplett modulation indicator and carrier-shift indicator. The microphone is a Brush Type BRS-2.

Two Q antennas are used, one a half wave on 14 Mc., the other a full wave. They run at right angles to each other and are supported by two 65-foot telephone poles plus a smaller iron pole. A Ward-Leonard antenna relay is used to shift the antenna in use from transmitting to receiving.

Since the latter part of April, when the transmitter was finished and put on the air, contacts have been made with many foreign countries, most of them being the "100%" type. Most of the operation is carried on with an input of 650 watts, although the full kilowatt is frequently used. At the maximum input the final r.f. tubes show so little color that the glow on the plates can be seen only in a darkened room.

The call W9AXH was issued to its present owner in March, 1923, and a station of one type or another has been on the air ever since. The transmitter shown here is a far cry from the lone 202 which comprised the first outfit!

# The New 1938 Edition of the RADIO AMATEUR'S HANDBOOK

**T**WELVE men, each a specialist in some phase of amateur radio, collaborated four months in the production of the 1938 edition of **THE RADIO AMATEUR'S HANDBOOK**. Virtually thousands of hours of effort have been expended in a thorough-going re-writing of the book. Larger than ever before and still more profusely illustrated, the **HANDBOOK** is without question the most comprehensive ever produced. Further, the selection of the material and its arrangement have resulted in the most understandable presentation. ● Two entirely new chapters have been added — the first a thorough treatment of workshop practice covering the problems faced in working with raw material, assembling and wiring the component parts of station equipment. It includes designs for work benches and operating tables. The second new chapter is devoted to the ever-important field of emergency and portable equipment. Designs are given for the last word in emergency gear and special attention is paid to the power supply problem. ● In response to wide demand, an entirely new chapter has been written on the general subject of fundamental principles. The new chapter is aimed at those individuals, young or old, who have absolutely no knowledge whatever of electrical and radio phenomena but who demand a painless introduction to the subject. ● The remaining chapters have all been vigorously rewritten, involving an entirely new text. Those dealing with apparatus construction have benefitted from a three-months' laboratory program devoted to the design and construction of modern transmitters, receivers and power supplies, incorporating modern tried and proven circuits. In all these circuits and in the equipment built around them, a special attempt has been made to avoid anything freaky or unusual. Indeed, the work has been greatly that of selecting from the maze of good, bad and indifferent circuits only those which comply strictly with modern practice. In contrast to previous editions of the Handbook, many of the apparatus designs were prepared especially for the book and are exclusive to it.

**\$1 postpaid in Continental U.S.A. — \$1.25 postpaid elsewhere**  
**Spanish edition \$1.50 postpaid**

**American Radio Relay League • West Hartford, Conn.**

# NEW LOW PRICES

TAYLOR TUBES		RAYTHEON TUBES	
T-20.....	\$2.25	RK11.....	\$2.50
TZ-20.....	2.25	RK12.....	2.50
T-55..	7.00	RK51.....	8.00
203Z.....	8.00	RK52.....	8.00
866.....	1.50	866.....	1.50

★ **The New H-K 54** ★

Plate MA-150  
Plate Volts — 2000  
At 100 Megacycles

\$6.75

★

## U. T. C. AMATEUR SPECIALS

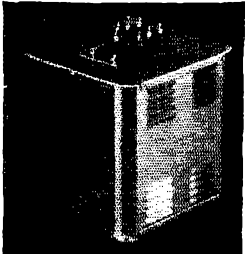

20462A—1000-750-0-750-1000 AC at 300 MA. DC. —	\$5.20
20462B—1500-1250-1000-0-1000- 1250-1500 AC at 300 MA. DC.	6.75
20462C—2500-2000-1500-0-1500- 2000-2500 AC at 300 MA. DC.	10.95
20462D—1500-1250-1000-0-1000- 1250-1500 AC at 500 MA. DC.	10.95
20462E—575-525-0-525-575 AC at 500 MA. DC.	5.20

20462F—Smoothing Choke— 20 Hy.-200 MA. 115 ohms DC Resistance. 2500 Volts Insula- tion	\$1.45
20462FS—Swinging Choke— 5-25 Hy.-200MA. 115 ohms DC Resistance. 2500 Volts Insula- tion	1.45
20462G—Smoothing Choke— 20 Hy.-300 MA. 95 ohms DC Resistance. 3500 Volts Insula- tion	2.85
20462GS—Swinging Choke— 5-25 Hy.-300 MA. 95 ohms DC Resistance. 3500 Volts Insula- tion	2.85
20462H—Smoothing Choke— 20 Hy.-400 MA. 85 ohms DC Resistance. 5000 Volts Insula- tion	3.45
20462HS—Swinging Choke— 5-25 Hy.-400 MA. 85 ohms DC Resistance. 5000 Volts Insula- tion	3.45
20462I—Smoothing Choke—20 Hy.-550 MA. 55 ohms DC Resi- stance. 6000 Volts Insula- tion	4.95
20462IS—Swinging Choke— 5-25 Hy.—550 MA. 55 ohms DC Resistance. 6000 Volts In- sulation	4.95

... New ...

**CHALLENGER II** \$77.00  
**HALLICRAFTERS**

In Stock for Delivery  
Time Payments

**Inventory Mark-Downs**

*Send for List*

Everything under the sun at some very  
substantial savings

Include P.P. with M.O. on Mail Orders

**THE RADIO SHACK**  
46 Brattle Street, Boston

## Hamdom

(Continued from page 51)

desire to please by public appearances and the wish to withdraw to his blessed privacy. His college class is like a family, and they live with an astonishing community of interest and experience and inspiration. He eschews ponderous professional formalities. His radio class, indeed, spends many of its hours (in class and out) in his private ham shack (it is really a laboratory). These are his intimates, and with all such he is regarded as the king of choice spirits. Strangers find his reserve a bit difficult to penetrate; this is not because he wishes it so, but because the contours of his thought processes fall in lines too lofty and direct for immediate understanding.

He is a man who will be a legendary figure. About him legends have already arisen—legends perpetrated by students, by colleagues. These legends are not malicious, nor are they wholly untrue. They are bits of fiction erected on small bases of fact. They are entertaining mosaics which are built and re-built as they are told, and to which new pieces are constantly added—it being but natural to add bright, shiny pieces to so fascinating a pattern. This situation disturbs the good doctor at times, but he consoles himself with the reflection that it doesn't do any real harm.

The cause is probably that highly-selective memory of his again. People ask him for details as to what he has done, and he can tell them of the technical ramifications, but such puerilities as names and dates and places he cannot tell them. He was honored, once, for his inventive genius, with an elaborate banquet, and speeches, and a medal. Before that, they asked him for biographical details; but he could not please them. So they went to the dean, and he prepared a long and impressive list, and the doctor was as interested as anyone to hear it. It was probably accurate enough, at least in broad outline, he feels; at any rate he hopes so. They gave him a medal, but it was lost, and now he has difficulty recalling the name of the society. He belongs to several Greek-letter fraternities, and has turned down bids from others; but he cannot immediately recall the names of any of them. Why burden himself? There are so many more important things to remember and to think about.

An ideal breeding-ground for legend, that attitude. It leads to attempts at interpretation, and interpretation leads to theorizing, and theorizing leads to romancing. Apart from the legends, however, his career has been extraordinary. He has held numerous patents, but his major contributions (mostly in the field of electric railway engineering) he has never patented. He has given them into the public domain. He has not even sought the publicity attendant upon the presentation of formal papers (sometimes to the dismay of the college authorities). He merely tells his ideas to other people. In this informal way he has served as consultant to many railroads and manufacturing firms. For the most part he passes his

# HEAR HIM *and* RAISE HIM with a JOHNSON "Q" ANTENNA

★ Your success in DX work is largely dependent on your antenna system. The Johnson "Q" Antenna, because of its extremely high efficiency, radiates nearly 100% of the transmitter output. For this reason, the Johnson "Q", now in its fifth year, is more popular than ever.

Because of its adjustable "Q" section insulators, the Johnson "Q" can be used with various directional systems including the "long wire" harmonic radiator, "V" beam, half-waves in phase, director-reflector systems, etc. Use of the units in this connection utilizes the gain of the directive system and retains the extremely high "transfer" efficiency of the "Q."

The unit is as outstanding when used for receiving as for transmitting, the exceptional efficiency of

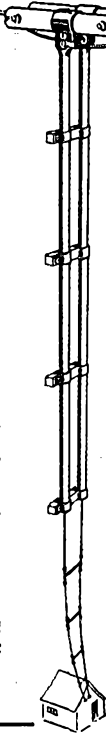

the system resulting in an extremely high signal to noise ratio.

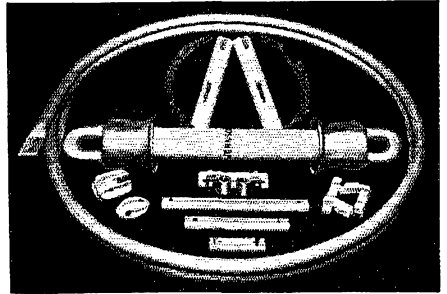

Other Johnson Antenna equipment includes Johnson high tensile strength, non-stretch enameled Copperweld wire, antenna insulators, feeder spreaders and transposition insulators.

If you have a special application for the Johnson "Q", full information will be supplied at your request.

★ For general information on the "Q" and other Johnson Products, ask your Jobber or write for Bulletin 100J and Catalog 964J

**E·F·JOHNSON·COMPANY**  
 MANUFACTURERS OF *Radio Transmitting Equipment*  
 O WASECA MINNESOTA U.S.A.  
 Export Office: 25 Warren St., New York. Cable: "SIMONTRICE"

**Radio Operator's  
 Course  
 Telegraphy—  
 Telephony  
 Aviation**



**Practical  
 Experience  
 Studio—  
 Transmitter—  
 Announcing**

PORT ARTHUR COLLEGE has been teaching Radio for twenty-eight years, and during this time it has never been our policy to guarantee positions to prospective students, directly or indirectly. We believe it wisdom at this time, however, to go on record in our QST advertising to say that it is impossible for us to even come near to supplying the demand for Radio Operators received by our Employment Department. We do not mean by this that all students who enroll will automatically secure positions. The demand is for graduates — good men who deserve and are qualified to hold positions. The graduates of our Radio School, so far as we know or can learn, are employed 100%. It is possible for every student who enters the P. A. C. Radio School and completes the course in keeping with our standards to receive employment as a Radio Operator for our station

K P A C at the transmitter, in the control room, as trans-radio press operator, or announcer, and not only earn more money than he pays for the training but to also continue his training as a post-graduate student in advanced work and prepare himself to secure and hold operating positions in the upper bracket of broadcasting, marine work, announcing, or airways. Port Arthur College advertises primarily to Radio Amateurs and the training is too technical for the average student who has not selected Radio as his life's work. We know the opportunities for positions and advancement are unlimited for men who are interested in Radio and who plan to make this their career and are willing to make the sacrifice and effort necessary to master our training. P. A. C. maintains strict collegiate rank — only high school or college graduates are eligible for enrollment.

*If interested in details about Radio Course, write for bulletin R*

**PORT ARTHUR COLLEGE ■ PORT ARTHUR (World-known port) TEXAS**

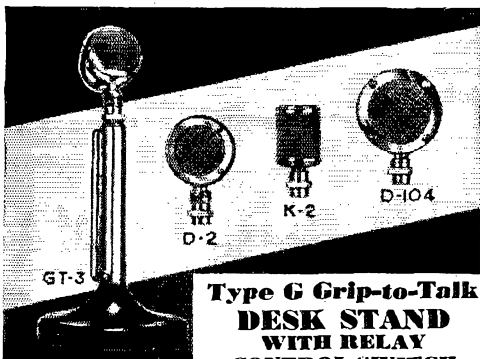

**Type G Grip-to-Talk  
DESK STAND  
WITH RELAY  
CONTROL SWITCH**

Astatic Engineers now offer a new Desk Stand with relay operating switch for remote control of amplifiers and transmitters through suitable relay systems. Interchangeable socket connector to accommodate microphones illustrated. Most practical combination stand made. Chrome and black. Be first to own one.

**Combination List Prices**

- GT-3 Mic. & Stand \$30.00
- GD-2 Mic. & Stand 30.00
- GK-2 Mic. & Stand 32.50
- GD-104 Mic. & Stand 27.50

**TYPE G STAND  
ALONE — \$10.00**



**Astatic Microphone  
Laboratory, Inc.**

Dept. G-7  
YOUNGSTOWN, OHIO  
*Licensed Under Brush  
Development Co. Patents*

**A D J U S T O H M**

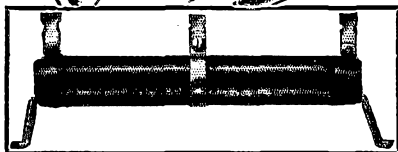

**Adjusts Power by Adjusting Resistance**

There is no more convenient gadget around the radio shack than a Ward Leonard Adjustohm Resistor. The adjustable contact saves purchasing an assortment of fixed resistors. Available in watt ranges, 10 to 200 watts. Described in NEW circular 507.

**WARD LEONARD ELECTRIC CO.**

41 South Street, Mount Vernon, New York  
Please send me FREE copy of 507 and 507B.

Name .....

Address .....

City ..... State .....

Call Signal .....

ideas on to his students, and they work them out. Many times they become final theses. His work and his ideas are spontaneous and often ingenious. In 1913, just before coming to Penn State, he evolved an automatic street car control system for interurban train service. In 1914 he sketched out an improvement, and his senior class made a model and tested it. It seemed appropriate to call the early version the 1913 model and this the 1914 model. But in two or three weeks the 1915 model was out, and by the time America entered the war they already had the 1939 model on the bench. Then they stopped, but it has always been a question whether there were no more improvements possible or whether the prospect of an eventual futuristic Frankenstein daunted them.

This species of dry, indeed at times quaint, humor is ordinarily remarked as Dr. Woodruff's most notable characteristic, especially in amateur circles. At times it is a depth bomb, exploding only slowly in the consciousness of his hearer. At other times it is a skyrocket, sizzling upward and gaining momentum until it, too, achieves full meaning and explodes. But never is it labelled, obvious.

The freedom with which he contributes his ideas to the world and the reserve in which he holds his private affairs are in sharp contrast. When the State of Pennsylvania inaugurated the licensing of engineers not long ago, he refused to make application. The examiners required the submission of details concerning previous commissions and activities, and he would not tell these things. Nor did he believe any engineer should be forced to do so. His conviction was that the relationship of consultant to client was like that of any other professional man—lawyer, or doctor—a confidential one. He still does not have the license.

Of course it is always appropriate to tell of a man's interests. Dr. Woodruff has had many, and has pioneered in several fields. He has been an amateur photographer since 1899. He has owned twenty-three cars since 1908 and has driven across the continent twenty-five times; travelling over long routes at high speeds has always been to him a major satisfaction. He is a trained musician, having graduated from the University School of Music in Ann Arbor; his particular musical interest is the pipe organ.

But radio has for some years past been increasingly the focal point of his life. He began it in 1897, thus encompassing practically the entire history of the art. On his wall still hangs an elaborate spark gap constructed in 1910—operated at 40,000 volts and capable of a 4-inch spark. The call 8CMP was issued just after the war, and it has since been consistently active. The recent handicap of arthritis does not deter Dr. Woodruff from religious maintenance of several traffic schedules and active participation in all A.R.R.L. operating activities. At that, he usually finds time for a little extra rag-chewing with new stations on the side, swinging his bug with enthusiasm rivalling that of the newest ham. During the winter he plans to invade the realm of 10- and 20-meter 'phone, planning thus



# My Creed

**To** give you specialized personal service of genuine value that is not available from other jobbers.

**To** sell all equipment on terms to suit you financed by myself with less interest cost, less red tape, quicker delivery.

**To** take your equipment in trade at a fair value on other equipment.

**To** allow you to try any receiver for ten days without obligation and to cooperate with you in every way I can to see that you are entirely satisfied.

## DX CONTEST IS COMING—GET THAT NEW EQUIPMENT FROM W9ARA

### Compare Bob Henry's Terms with others

Model of Receiver	Cash Price	Down Payment	12-Month Payments
NC80Xs and NC81Xs	\$ 99.00	\$19.80	\$6.99
NC101Xs	129.00	25.80	9.11
HROs	179.70	35.94	12.70
Breting 14AX and Super Skyrider	99.00	19.80	6.99
ACR-155 and Sky Chief	44.50	8.90	3.27
1938 Sky Challenger II	77.00	15.40	5.44
RME-69s	151.20	30.24	10.69

Similar terms on PR-15, NC100, NC100X, HRO Jr., Super Pro, ACR-111, Sargent receivers. And on Harvey, RCA, RME, Temco transmitters and Utah, Progressive, Stancor, All Star kits.

You can reach me by letter, telegram, phone, or visit nearly 24 hours a day, 365 days a year. Write for any information. Your inquiries are invited.

**HENRY RADIO SHOP**  
211 North Main St.      Butler, Missouri

*Robert Henry*  
W9ARA

SELECTED BEST TELEVISION SPECIALS

## Radio Digest

**HIGHLIGHTS FROM THIS ISSUE**

• The only magazine with the best from ALL branches of radio (except business and entertainment!)

• Digests, extracts, reprints from QST, Radio, All Wave Radio, Radio News, Electronics, Service Communications, Bell System and R.C.A. papers, house organs, overseas journals.

• Twelve issues for \$2.50 in U.S.A., Canada, and Pan American countries. Elsewhere, \$3.00 or 12¢ 6d sample copy, 25¢.

RADIO DIGEST

7460 Beverly Blvd.      Los Angeles

Sensation  
OF THE RADIO FIELD!

25¢

NOVEMBER, 1932

SPEED

THE COMPLETE LINE  
OF TELEGRAPH KEYS

Model 312 Key

A new amateur's practice key mounted on a mahogany finished wood base. Black enameled metal key base. Arm black oxidized and all other parts finished in natural brass. Includes circuit closing switch, 1/4 inch silver contacts.

**No. 312 Key**.....List Price **\$2.25**

Other models of hand keys from **\$1.50 to \$3.50** list. Available at leading jobbers everywhere.

Write for new literature and amateur discounts

LES LOGAN CO.

646 Jessie Street
San Francisco

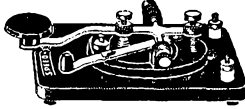

## A Good Name Goes a Long Way

The name Ken-Rad, stands for finest engineering, quality manufacture and perfect performance. Ken-Rad offers a complete line of dependable radio tubes.



# Ken-Rad Radio Tubes

KEN-RAD TUBE & LAMP CORPORATION - OWENSBORO, KY.

Makers of Ken-Rad Radio Tubes and Ken-Rad Electric Light Bulbs



**A NEW  
B & W  
"BABY"  
THAT DOES A  
MAN-SIZED  
JOB! . . .**

**TYPE BVL  
"AIR INDUCTOR"**

**SMALLER . . . MORE COMPACT  
. . . STURDILY CONSTRUCTED . . .  
PRACTICAL . . . HIGHLY EFFICIENT**  
— that's the new B & W Type  
BVL Air Inductor! . . . Ideal  
for operation in the final stages  
of 50-100 watt Xmitters or with  
B & W Fixed Link Coils in inter-  
stage coupling. Provides unusu-  
ally accurate control of excitation  
for most 1KW jobs up to the  
strid of the final stage.

The BVL Swinging Link and  
Jack Bar is equipped with four  
jacks, designed for direct mount-  
ing on condenser. Six interchange-  
able coils available. A complete  
range from 5 to 160 meters.

Write today for full details

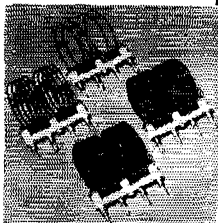

**BVL BASE AND  
INTERCHANGEABLE COILS**

BVL Base . \$2.50 40 BVL . \$1.65  
160 BVL . 2.10 20 BVL . 1.45  
80 BVL . 1.90 10 BVL . 1.40  
5 BVL . \$1.35

**BARKER & WILLIAMSON**

Radio Manufacturing Engineers • ARDMORE, PENNSYLVANIA

**IF**

You are an experienced radioman;

You are ambitious to get ahead rapidly in radio;

You realize the necessity of a directed training in the engineering principles of radio but are unable to take advantage of college training,—

**Then**

send for our new illustrated book "A Tested Plan for a Future in Radio." It will give you complete details of an advanced home study course in Practical Radio Engineering *Written for the Experienced Radioman.*

**Capitol Radio Engineering Institute**

Dept. Q-3

14th and Park Road, N.W. Washington, D. C.



to satisfy himself concerning certain technical problems arising there.

President Woodruff is doubtless best known to hams in general for his famous "bag o' tricks." He is an indefatigable constructor of unique pieces of apparatus with novel and ingenious applications—all of which he builds himself, to the last detail—and these he has exhibited at conventions and hamfests in practically every state. Indeed, Doc Woodruff and his blue Duesenberg with the call W8CMP on the trunk, in which he accomplishes his convention hegiras, have become a tradition at ham conventions.

His connection with A.R.R.L. dates back to 1925, in which year he was elected director of the Atlantic Division, succeeding such well-known figures as the late Horace Beale and Dr. G. E. Bidwell. Consistently re-elected, by 1936 he had become the dean of the League's Board. As such he was chosen as the chairman of the Board for its first meeting following the double loss of President Maxim and Vice-President Stewart. So effective was his performance in this capacity that he became the Board's choice for the presidency, and he took office immediately upon election in May, 1936.

As was said before, Dr. Woodruff is an individualist. He believes in individualism. His creed is that the mass cannot rise higher than the individual unit, and it is therefore the unit that must be trained and developed. The keystones of civilization and culture are enterprise and ingenuity, he feels. It is this conviction which forms the basis for his intense faith in amateur radio as a force for good. He sees in the training which the art of amateur radio has afforded so many thousands—young and old, of all walks of life, in lines of thought and action—a concrete force of incalculable good. He recognizes that there must be an outlet for latent energies above and beyond those required for the simple acts of living, and he believes that these outlets can be made to lead in any direction—good or bad—solely through the pressure of environment of habit. The cultural discipline of amateur radio in shaping such outlets is, inevitably, certain to advance the broad front of civilization as a whole.

Such is the destiny he envisions for amateur radio. The amazing counterpoint is that his own life and accomplishments so ably illustrate that vision.

—C.B.D.

**SELECTOSPHERE**

High Selectivity. Noise and static reducing loudspeaker. Rivals XTL filter reception. Designed for pentode audio output. Approx. 1000-cycle peak. Suitable for TRF or superhet. Approx. 7" high, 4" dia. Black crackle finish. Kit with instructions for assembly and use. Amateur Net \$7.50, shipped post-paid in U. S. Shipping weight 8 lbs. Simple to assemble.

Selectosphere Company, Box 3, Newtonville, Mass.



**IT IS AS EASY AS PIE**  
 for the amateur and engineer to be sure of accurate replacements, utmost savings consistent with **QUALITY** and follow-through service that slips no cogs . . . but to enjoy ALL these advantages you've either got to come to **TERMINAL** or find another outfit as good. Ask the Radio folks who shop here!

# TERMINAL Radio Corporation

80 CORTLANDT STREET, NEW YORK, N. Y.

TELEPHONE • BARCLAY 7-0622

## LEARN RADIO — TELEVISION —

500 Licensed graduates placed in past 7 years in shipping, broadcasting, aviation, police, etc.; we also teach radio servicing and repairing; new term Mar. 14, May 9, day or eve.; 52-page catalog free; oldest, largest and best equipped.

### MASS. RADIO SCHOOL 18 Boylston Street, Boston

G. R. Entwistle, Pres.  
Established 1899

R. F. Trop, Treas.  
Hancock 8184



### Compare It With Any Microphone!

You'll appreciate the smooth performance of the T-9. It has a well extended frequency response without peaks. High output level—53 DB. The new shock proof cartridge means noise and breakage eliminated. T-9 is semi-directional—can't blast and won't feed back readily. A real performer that will save you money.

**TURNER MODEL T-9** **\$11.47**  
 Come in or order by mail. **NET**

### SCOTT WHOLESALE RADIO

344 EAST 4th STREET  
LONG BEACH, CALIFORNIA

Licensed under patents of the Brush Development Co.

## HINTS & KINKS

Amateurs are noted for their ingenuity in overcoming by clever means the minor and major obstacles they meet in their pursuit of their chosen hobby. An amateur must be resourceful and a good tinkerer. He must be able to make a small amount of money do a great deal for him. He must

frequently be able to utilize the contents of the junk box rather than buy new equipment. Hints and Kinks is a compilation of hundreds of good ideas which amateurs have found helpful. It will return its cost many times in money savings — and it will save hours of time.

Price 50¢ postpaid . . . No stamps

**AMERICAN RADIO RELAY LEAGUE, INC.** WEST HARTFORD CONNECTICUT

**Whether It's**



**HOT OR COLD**

**WET OR DRY**

**C-D CAPACITORS**  
*Can take it!*



Upon the continuous operation of C-D capacitors depends, to a certain measure, the success of the Mac Gregor Arctic Expedition's radio communication system. The reliable operation of C-D capacitors for radio and cosmic-ray equipment on stratosphere flights and scientific expeditions has demonstrated the unfailing dependability of C-D condensers. Write for catalog No. 160 to 1013 Hamilton Blvd., So. Plainfield, N. J.  
Cable Address: CORDU  
MICA • PAPER • DYKANOL  
WET AND DRY ELECTROLYTIC

**CORNELL-DUBILIER**  
ELECTRIC CORPORATION  
South Plainfield, New Jersey

**How Would You Do It?**

(Continued from page 50)

6-32 tap so the tip may be threaded onto the screw. If a tap is not available, the threads of the screw may be filed off until the 'phone tip may be slid on over the screw and soldered in place. Contact to the tap is made by means of a standard 'phone jack which will also fit on the No. 12 or 14 wire.

Still another scheme is shown at K. This idea comes from W2GSI. A contact from a small knife switch, properly formed to fit the wire, is fitted to a standard Eby binding post. This post has a

**Problem No. 15**

**T**HANKS to the suggestions of his many friends, Our Hero's radio equipment is working very smoothly (for the time being, at least), in fact, perhaps a little too smoothly for one of his nature who delights in tinkering. It now happens that he would like to install his rig in the basement or in that special shack he has had in mind for so long. The YF, however, visualizes climbing flights of stairs or long trips to the shack whenever she would have a word with him. Our Hero thinks he ought to be able to find most of the necessary material in his junk box with which to build an inter-communicating telephone system between the shack and the house, thus solving the difficulty. He would like to see diagrams with all values of the simplest system which will work satisfactorily on lines up to 100 or 150 feet in length.

hole passing through the shaft which will pass No. 12 wire. The clip may be slid along the wire to the desired point and tightened by the clamping action of the binding post. The wire support, which also serves as the lead to the tap, holds the clip at right angles to the axis of the coil.

We believe the idea shown at L deserves honorable mention. While it seems that the idea must have been used before we have never happened to see it. An ordinary small soldering lug is soldered to the wire and then almost any type clip will provide good contact with little danger of falling over on adjacent turns, or the wire may be fastened on with a machine screw. If taps must be made on every turn, the lugs may be staggered. This idea comes from W8NDV.

Thanks also to the following whose schemes could not be presented because of space limitations: W2DOD, 2GNE, 3BFK, 6JEI, 8GWF, 8HKT, 9BSP, 9EGE, 9IKY, 9YZH, VE1KE and H. C. Hawkins.

Rules under which the contest is conducted are as follows:

1. Solutions must be mailed to reach West Hartford before the 20th of the publication month

**SAY FELLOWS!**

**OUR 10% DOWN PAYMENT AND LOW MONTHLY PAYMENTS SHOULD INTEREST YOU. IMMEDIATE DELIVERY ON ALL THE BEST RECEIVERS AND TRANSMITTERS.**

~~~~~  
Latest Price List and Details 3c Stamp  
~~~~~

National—RME—Hallicrafters—Temco  
—Hammarlund—Harvey—Patterson—  
Breting—RCA—Taylor, etc.

Also All Parts, Tubes, etc.

~~~~~  
**WILLARD S. WILSON-W3DQ**  
DELAWARE RADIO SALES COMPANY  
405 Delaware Avenue Wilmington, Del.

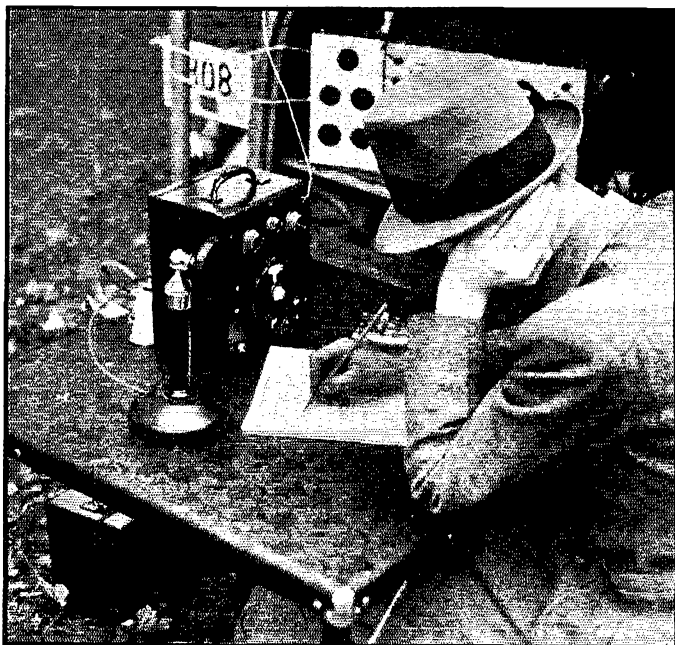

# HAVE YOU A LOG

for your  
Portable  
and Mobile  
operation?

35c each  
3 for \$1

**A.R.R.L.**  
West Hartford, Conn.

# RADIO

**ENGINEERING,** broadcasting, aviation and police radio, servicing, marine radio telegraphy and telephony, Morse telegraphy and railway accounting taught thoroughly. Engineering course of nine months' duration, equivalent to three years of college radio work. School established 1874. All expenses low. Catalog free. **DODGE'S INSTITUTE,** Day Street, Valparaiso, Indiana

Unconditionally  
Guaranteed

**PR  
CRYSTALS**

Powerful  
Reliable

X cut 7000 KC  $\pm$  5 KC . . \$1.85    3500 or 1750 . . \$1.65  
Low Drift  $\pm$  5 KC 40-80-160 . . . . . 2.20

**PETERSEN RADIO CO.** Ex

W9JRY    COUNCIL BLUFFS, IOWA    W7AHE  
Formerly Omaha Crystal Labs.

## WORLD TIME at a Glance!

No guesswork with the **GORDON WORLD DX CLOCK.** Instantly tells GMT or local time of stations you contact. Available for 110 or 220 volts; 25, 40, 50 and 60 cycles. 24 hr. colored dials. Self-starting Waltham movement. Can be mounted flush in a panel. See your jobber today!

**GORDON SPECIALTIES CO.** 440 S. Dearborn St. CHICAGO, ILLINOIS

## Be a Good, Fast Sender

Get a **NEW Improved**

# VIBROPLEX

Semi-Automatic Key



THE **BUG** trade mark identifies the Genuine Vibroplex

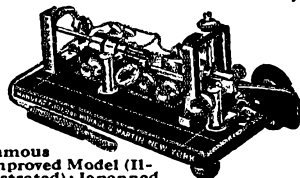

## JUNIOR ONLY \$12.50

A little smaller and more compact but in every other detail the same as large model. Large points. Japanned base. Complete with wedge and cord.

Famous Improved Model (Illustrated); Japanned Base, \$17; Nickel-Plated, \$19. Be popular. A good, fast sender is always popular whenever he comes on the air. The New Improved Vibroplex develops a degree of sending proficiency seldom attained by users of the old type straight key. Don't envy good, fast senders — be one! Get a New Improved Vibroplex semi-automatic key — standard the world over for clarity, speed and sending ease. Easy to learn.

Simply press lever — Vibroplex does the rest. Costs no more than imitations. So why not get the best? Insist on the Genuine Vibroplex. Your old Vibroplex accepted as part payment on a new Vibroplex. Money order or registered mail. Write for **FREE** catalog.

**THE VIBROPLEX CO., INC.**  
832 Broadway    New York, N. Y.

## NEW HOLDER DESIGN 15 SECONDS TO INSTALL CRYSTAL

For All Bands  
GREATER STABILITY  
Plugs in 5 prong tube socket

Beautiful Appearance



**MODEL AH HOLDER \$1.00** At your dealer or direct

**HIPOWER LOW DRIFT CRYSTALS:**  
within 10 kc. or Choice of stock

AH-10, 1700-3500 Kc. bands \$2.35  
AH-10, 7000-7300 " bands 3.90

WRITE FOR NEW LITERATURE

Hipower "Low Drift" Broadcast and Commercial Crystals Are Approved by F.C.C.

Hipower Crystal Co., 2035 Charleston St., Chicago



# AHOY THERE!

TAKE A LOOK  
AT THE SCRULOK  
developed by  
**BIRNBACH**

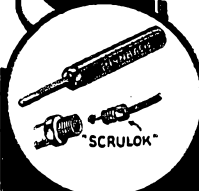

Always a pioneer, Birnbach again leads with the new *Scrulok* solderless connection. Test leads and prods using this new principle need no soldering or tightening with wire-cutting screws. Every part is assembled with a tight mechanical and electrical contact.

Ask your jobber for the new Birnbach Test Prods, Test Leads, Banana Type Plugs, Insulated Pin Tips, etc., featuring the *Scrulok* principle. If he cannot supply you, write direct to us.

**BIRNBACH RADIO CO.**  
145 HUDSON ST. / **BIRCO** NEW YORK, N. Y.

## ¡Queridos Señores!

La edición 1938 del "THE RADIO AMATEUR'S HANDBOOK" se puede ahora conseguir en lengua española traducido por la Revista Telegráfica de Buenos Aires, Argentina, reconocida como la más antigua establecida y la más importante publicación de literatura de Radio en Sudamérica.

El "Handbook" (libro manual) está reconocido como el libro modelo en su clase. El por tanto tiempo esperado y sugestionado libro manual (Handbook) estamos seguros que su edición en español encontrará una acogida extraordinaria. Ha sido cuidada y escrupulosamente traducido. Ha sido impreso en una imprenta que está reconocida como la mejor de Sudamérica.

Nosotros estamos orgullosos del hecho que la Revista Telegráfica haya producido este trabajo y estamos seguros al mismo tiempo que es una contribución notable para la literatura técnica en la lengua española.

Se pueden conseguir ejemplares en "The American Radio Relay League, West Hartford, Connecticut, U. S. A." a \$1.50 cada ejemplar, franco, o si es más conveniente directamente de la Revista Telegráfica, Perú 165, Buenos Aires, Argentina, a cinco pesos, en moneda argentina.

**AMERICAN RADIO RELAY LEAGUE**

of the issue in which the problem has appeared. (For instance, solutions of problem given in the April issue must arrive at *QST* before April 20th.) They must be addressed to the Problem Contest Editor, *QST*, West Hartford, Conn.

2. Manuscripts must not be longer than 1000 words, written in ink or typewritten, with double spacing, on one side of the sheet. Diagrams must be neat and legible.

3. All solutions submitted become the property of *QST*, available for publication in the magazine.

4. The editors of *QST* will serve as judges. Their decision will be final.

Prizes of \$5 worth of A.R.R.L. station supplies or publications will be given to the author of the solution considered best each month, \$2.50 worth of supplies to the author of the solution adjudged second best. The winners are requested to specify the supplies preferred.

### Hints and Kinks

(Continued from page 54)

Fig. 5 shows the connections. The values shown are for the rig used here, a 59 keyed oscillator and push-pull RK-20 amplifier. Assuming that  $R_1$  and  $R_2$  are proportioned to give the desired bias, the adjustment of the relay operating current is simple. Turn on the bias supply and apply normal excitation to the amplifier. Leave the plate voltage off so you won't run the risk of becoming a Silent Key. Adjust the shunt resistor until the relay just closes. If the relay does not close, the resistance of  $R_3$  is too low. The system is now ready for use. Turn the excitation and bias supply on and off a few times to make sure the relay works every time.

It can be seen that the amplifier plate voltage cannot be applied until the bias and excitation have reached the proper value. Thus, if the excitation or bias fail when the power is turned on, the amplifier won't go up in smoke.

Now we come to the disadvantage of the 3-ma. opening current of the relay and the reason for the shunt resistor. Taking the rig here as an example, assume the shunt resistor disconnected, no excitation, the power is on and the relay contacts are closed. Now suppose a partial short develops in the bias supply. Depending on the resistance of the short, the current through the relay will be between zero and the normal bleeder current of 12 ma. At the relay opening current of 3 ma., the bias on the amplifier will be around 22 volts, which would allow the plate current to climb way above normal. Now assuming the same conditions, but with the shunt resistor connected, the bias will be around 45 volts. By applying excitation now, the resulting grid current will bring the bias up to around 67 volts, which is a little over half the normal bias used on this amplifier. This would hold the plate current to a reasonable value. The higher the ratio of shunt resistor current to relay current, the higher the bias voltage will be at the time the relay opens. Any dead shorts or opens occurring in the bias supply will cause the relay to open immediately.

— Norman C. Hunter, W4DBF

# HARVEY'S

CONVENIENT to EVERYWHERE

features  
**THE "PRECISION"  
SERIES 840L**

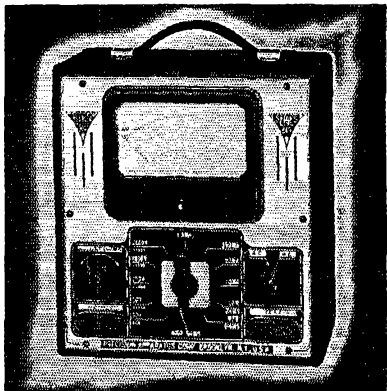

A.C.—D.C. VOLT—OHM—  
DECIBEL—MILLIAMMETER  
including a  
**2500 VOLT A.C. and D.C. RANGE  
and a 1000 M.A. RANGE**

Accuracy guaranteed by use of wire wound shunts of 1% tolerance and matched resistors of 1% tolerance.

Endorsed and used by leading engineering concerns, broadcast stations, institutions, amateurs and servicemen.

Complete line of "PRECISION" testing equipment available. See these and other instruments in our store.

**SPECIFICATIONS**

- \* 5 A.C.-D.C. Voltage Ranges from 0 to 2500 volts at 1000 ohms per volt.
- \* 4 D.C. Current Ranges from 0 to 1 amp.
- \* 5 Output Ranges.
- \* 3 Resistance Ranges from 0 to 10 mega. (provision for self-contained batteries).
- \* 5 Decibel Ranges from — 10 to plus 63DB.

Net price to amateurs **\$19.95** Less batteries and test leads

**SERIES 840P** incorporates same specifications as the 840L but is housed in an attractive black leatherette covered portable case with removable cover. Size 9 x 10 x 6. Net to amateurs. **\$21.95**

OUR *Best* VALUE IS OUR RECORD OF LOYAL SERVICE

# HARVEY

*Radio Company of New York*

103 WEST 43rd STREET • NEW YORK, N. Y.

CABLE ADDRESS: "HARADIO"

Say You Saw It in QST — It Identifies You and Helps QST

# HARVEY'S

CONVENIENT to EVERYWHERE

WE CARRY A COMPLETE STOCK  
OF ALL NATIONAL PRODUCTS  
including the popular  
**NC-80X and NC-81X**

Advanced circuit details, including wide-range crystal filter and high IF frequency for image rejection. These receivers have set a new standard of performance in the low priced field. IN STOCK . . . come in, listen and taken them with you . . .

AVAILABLE FOR IMMEDIATE DELIVERY  
the 2 LATEST TYPE TUBES

**TAYLOR T-40 and TZ-40**

They fill the gap between the T-20 and the T-55.

## New—CARDWELL type "J" Fixed Air CONDENSERS

These "plug-in" type fixed capacitors can make the tank condenser you use on 40, 20, or 10, resonate an inductance designed for 80 or 160 meter operation. The correct L to C ratio can be obtained on any frequency, using only one variable capacity.

**Type JD-80-OS**—80 Mmfds., .125" airgap, 5000 V., Alsimag 196 insulation. Net price . . . **\$3.30**

**Type JCO-45-OS**—45 Mmfds., .250" airgap, 7500 V., Alsimag 196 insulation. Net price . . . **\$3.30**

**Type JB**—Jack base for fixed air condensers. Fits either unit—Alsimag 196 insulation. Net price . . . **60¢**

### Our TAYLOR T-20, T-55 TRANSMITTER KITS

are satisfying the many amateurs who purchased them. They are still available. See our ad in the November issue, QST, page 108.

### THOUGHT OF THE MONTH

SALESMANSHIP is the art of selling products which will not come back . . . to customers who WILL.

W2I JL

W2K WY

W2K XP

OUR *Best* VALUE IS OUR RECORD OF LOYAL SERVICE

# HARVEY

*Radio Company of New York*

103 WEST 43rd STREET • NEW YORK, N. Y.

CABLE ADDRESS "HARADIO"



FOR  
**BOTH**  
**AC**  
**AND**  
**DC**  
**TESTING**

USE  
**Model 666**  
**DEALER PRICE**  
**\$15**

## Pocket Volt-Ohm Milliammeter

Uses large 3" sq. Triplet Instrument. Has molded case, selector switch and all necessary accessories. A complete instrument for all servicing needs. Size—3 1/16" x 5 7/8" x 2 1/8". See Your Jobber—Write for Catalog.

The Triplet Electrical Instrument Co.  
253 Harmon Dr., Bluffton, Ohio

Please send me Name.....  
more information Address.....  
on Model 666. City.....State.....

## GET YOUR NEW SKY CHALLENGER II

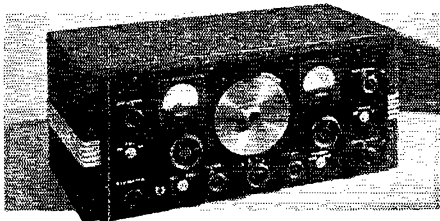

at H & E Easy Time Payments

**\$77.00**  
CASH PRICE  
(Less Speaker, Crystal)

**\$10.00** DOWN  
**\$6.10 PER MONTH**  
(12 Months)

**10  
DAY  
TRIAL**

Enjoy the superior performance of the New Sky Challenger while you're paying for it at H & E liberal terms. Friendly, personal service you'll enjoy, with satisfaction guaranteed. Ask any H & E customer.

**MAIL THIS COUPON NOW!**

Please send me complete information about the New Sky Challenger II and your easy time payment plan.

Name \_\_\_\_\_ Call \_\_\_\_\_

Address \_\_\_\_\_

**HINDS & EDGARTON**

19 South Wells St.  
Chicago, U.S.A.

**W9APY**

**W9WR**

## A Continuously-Rotatable Beam

(Continued from page 48)

The brass collar should be fastened about 3 feet 9 inches from the bottom of the 1-inch aluminum pipe to allow 3 feet 6 inches for fastening to the mast and 3 inches clearance for the pulley and ropes. The 1-inch aluminum pipe supports the whole affair and is anchored to the two upper pyrex insulators with a heavy-gauge brass strap which completely encircles the pipe. The bottom end of the pipe is anchored to a single pyrex standoff insulator with a heavy brass mounting screw through the pipe. Also, a hole is drilled at this point and tapped for a 10/31 brass machine screw which connects the stub to the antenna. The four vertical bracing members (two each side) are bolted in place to make the entire framework rigid, and they eliminate the possibility of the top horizontal member's lagging behind the bottom one and snapping the director and reflector from their support. Lengths of both reflector and director are adjustable.

Wherever possible, brass hardware is used to withstand the weather, and all wood members are heavily varnished. The rope used is a good grade of hemp. From the bottom pulleys the rope ends come into the shack, where the rig can be operated merely by pulling the ropes. Alternatively, the rope can be fastened to a wheel for more convenient rotation; you will most likely want to incorporate your own ideas in the rotating control. Since only a few pounds of tension are necessary to rotate the beam, we simply pull the ropes here. Our indicating device consists of two flashlight bulbs tapped across a few inches of the director and reflector—a green bulb in the director and a red one in the reflector.

The drawings and photograph clearly show all other details. The methods for adjusting the quarter-wave linear transformer and coupling the transmission line are described in the *Handbook*.

## New Transmitter Design

(Continued from page 26)

gain amplifier of this type the importance of carefully shielding the mike cord and plug is generally realized. Many microphones are now furnished with a shielded plug and cord as standard equipment.

### POWER SUPPLY

The single power supply which serves both the exciter and the audio amplifier has to be considerably huskier than if individual supplies were used. The cost of building a single husky power supply offers quite a saving over that of two separate power supply units, however, even with the special heavy filtering required. Aside from being designed to handle the combined power requirements of the audio and r.f. circuits, it is quite conventional. Oil condensers are used, rather than electrolytic, as the operating voltage



# AMATEUR RADIO *Map of World*

I.A.R.U.—W.A.C.

All known districts

Principal cities  
of the world

Divisions

Six colors  
and black

and sub-divisions

Countries designat-  
ed by prefixes

180 prefixes in  
large red letters

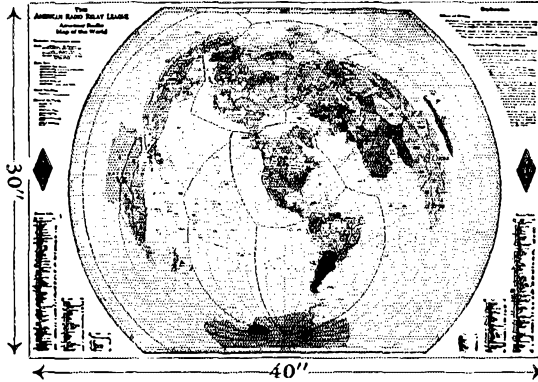

U. S. inspection  
districts  
and examining  
points

230 countries  
indexed

**PRICE**  
**\$1.25**  
**POSTPAID**

2% accuracy for dis-  
tance measures in  
miles and kilometers

Time zones — legal  
and Greenwich

**A. R. R. L.**  
**W. HARTFORD**  
**CONNECTICUT**

## RADIO ENGINEERING



RCA Institutes offer an intensive course of high standard embracing all phases of Radio and Television. Practical training with modern equipment at New York and Chicago schools. Also specialized courses and Home Study Courses under "No obligation" plan.

Illustrated Catalog on request

**RCA INSTITUTES, INC.** Dept. ST-38

A Radio Corporation of America Service

75 Varick St., New York 1154 Merchandise Mart, Chicago

## COMMERCIAL HEADSETS

IDEAL FOR

Amateurs and commercial operators — ruggedly constructed, yet extremely lightweight.

Write Dept. R-4 for Information

**TRIMM RADIO MFG. CO.**

1770 W. Berteau Ave.

Chicago, Ill.

## LEARN CODE

the way you'll be using it—

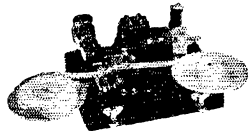

by SOUND

PROBABLY the best way to learn to read code is by listening to code. Probably the best way to learn to send code is by hearing your own sending repeated

back to you. With the New All Electric Master Teleplex Code Teaching Machine you learn code the natural, easy, fascinating way. Only instrument ever produced which records your sending in visible dots and dashes — then SENDS BACK your own key work at any speed you desire. We furnish complete course, lend you the New All Electric Master Teleplex, give you personal instruction with a MONEY BACK GUARANTEE — all at a surprisingly low cost per month. Write today for FREE catalog Q. 3. No obligation.

**"HAM SPECIAL"**

Standard Teleplex — a highly efficient code teacher using heavy specially prepared waxed paper tape, having two rows of perforations. Write for Free folder "Q.T.-3."

We are the originators of this type instrument

**TELEPLEX CO.** 72-76 CORTLANDT ST.  
NEW YORK, N. Y.

## SPECIAL TO AMATEURS

Piezo-Electric Crystals — \$2.50 EACH POSTPAID

Until supply is exhausted . . . we offer 80 meter band crystals unmounted; accurate calibration, excellent oscillators. Limited quantity.

## SCIENTIFIC RADIO SERVICE

"The Crystal Specialists Since 1925." University Park, Hyattsville, Md.

## GET RID OF FEEDBACK!



TURNER MODEL T-9

Model T-9 has no peaks to start feedback. Its response is honestly flat. You can work it close to speakers with less danger of howl. Sound from the back of T-9 is sharply reduced. This means less noise pickup. It's high level too — minus 52 DB.

Here is a mike that really takes abuse. The shock proof cartridge prevents breakage and noise.

Compare it with any higher priced microphone. Hear it at our store. Come in or send in your order by mail — today.

**\$11.47**  
NET

## NORTHERN RADIO CO.

2208 4th AVE., SEATTLE, WASHINGTON

Licensed Under Patents of the Brush Development Company

# WE ARE GOING TO MOVE

## SO WE CELEBRATE A MONTH OF VALUES!

In another month we leave our present home to move into our own newly built 2-story building where every modern facility will be available to amateurs, experimenters and technicians. All departments will be enlarged . . . but more about that later. In the meantime we are reducing stocks before removal. You'll find it well worth while to visit us this month or if you live too far away, send us your list of requirements and we will be happy to quote you. Hundreds of BARGAINS every day . . . all month long!

**STANCOR TRANSMITTER KIT**  
48 circuit combinations available from one kit. Special at... **\$49.95**

Write for Free literature and HAMANUAL

● **SPECIAL! DOUBLE BUTTON CARBON MICROPHONE.** Modern-istic finish. Excellent response. Special at... **\$2.75**

● **RCA-ACR 155.** Formerly \$74.50. Reduced to... **\$44.50**

● **TAYLOR - EIMAC - RCA - RAYTHEON - AMPEREX X'MITTING TUBES IN STOCK.**

● **NATIONAL NC80X AND NC81X** in stock. Price with tubes, crystal and speaker... **\$99.00**

● **HALLICRAFTER 1938 SUPER SKYRIDER.** Com-plete... **\$123.00**

● **A COMPLETE STOCK OF PAR-METAL PRODUCTS IN STOCK. WRITE FOR BIG FREE CATALOG**

● **NATIONAL, HRO, HRO Jr., NC 100X, NC 101X** and the complete National line of parts carried in stock. Write for Free Catalog.

● **HEAVY DUTY R.F. CHOKES.** 1000 M.A. .... **88¢**

● **RCA TMV 135 "V" cut CRYSTAL** complete with holder. 3500 Kc to 4000 Kc... **\$3.95**

Have you received the latest copy of "The SUN"—our Periodical Bargain Sheet? If not, get on our mailing list!

### THE NEW TEMCO "50"

We are among the first to show this job!

For phone and C. W. less accessories... **\$195**

For C. W. exclusively... **\$125**

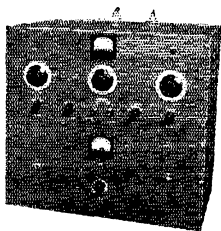

## RADIO CO.

227 Fulton Street, New York, N. Y.

Cable Address: SUNRADIO NEW YORK

is of a value that is slightly in excess of what may safely be used when complete freedom from breakdown or failures is desired, especially after long periods of inactivity.

The switch on the front panel for interrupting the plate supply without interfering with the filament heating, for use when receiving, is provided with additional contacts at the rear of the cabinet so that it may also be used either directly or by means of relays to turn off and on the standby switch on the receiver and the plate supply to the final amplifier.

#### APPLICATION NOTES

For convenience, the exciter-speech amplifier unit really belongs on the operating table, alongside the receiver. This permits locating the final amplifier, modulator and power supply at relatively remote points, for instance in the basement, in a closet or similar available space. If only one final amplifier is used, then of course it is necessary to shift plug-in coils or go through some other such maneuver in order to change bands. With all the band-switching convenience built into the exciter, it is felt that there is considerable merit in the idea of having more than one final stage—at least one for each of the most-used bands. Then by means of a relay, remote lighting of the filaments in the stage desired can be controlled from the operating position, and band-switching in the final accomplished with as much facility as in the exciter.

The investment in equipment for such a setup is not as great as might be thought at first, inasmuch as the same modulators and power supply would be used for all bands.

### The Cover

THE photograph this month was taken in QST's laboratory where Ross Hull is working toward the development of some simplified ham television gear. The image on the Kinescope suffers several obvious faults but at least it is an actual un-faked, unretouched image. Some of the fuzziness is due to the very long exposure (one minute) made necessary by the use of a small stop to give adequate depth of focus. The source of the image is a standard picture generator tube made by the Allen B. DuMont Laboratories.

NOW! A Perfected

## AUTOMATIC SENDER

Let the Automatic Sender raise your stations. Repeats calls or messages indefinitely. Sends 2 to 70 words a minute. Entirely automatic. Built-in tape perforator. Complete with 4 rolls of tape and full instructions. No extra equipment needed. Fully Guaranteed. **\$12.50**  
\$18.50 West of Denver  
Postpaid in U.S.A.

A New RELAY

Faster — More Compact — Quieter  
Moisture Proof — More Applications

Plug-in base fits UX socket. Only 1 inch wide, 3 inches tall. Ideal for use with vacuum tube. Follows perfectly at speeds far above professional "bug." Perfect as keying relay. Available in 0, 25, 50, 100, 150 volts. **\$4.50 to \$6.**  
Postpaid in U.S.A.

**GARDINER-LEVERING Co.** Haddon Heights New Jersey, U. S. A.

# Where to buy it

A directory of suppliers who carry in stock the products of these dependable manufacturers.



**ALBANY, N. Y.** Uncle Dave's Radio Shack 356 Broadway  
**BALTIMORE, MD.** Radio Electric Service Company 3 North Howard St.  
**BOSTON, MASS.** Radio Shack 46 Brattle Street  
**BOSTON, MASS.** 110 Federal Street  
 Wholesale Radio Service Company, Inc.  
**BRONX, N. Y.** 542 East Fordham Rd.  
 Wholesale Radio Service Company, Inc.  
**HARTFORD, CONNECTICUT** 227 Asylum Street  
 Radio Inspection Service Company  
**JAMAICA, L. I.** 90-08 166th Street  
 Wholesale Radio Service Company, Inc.  
**NEWARK, N. J.** 219 Central Ave.  
 Wholesale Radio Service Co., Inc.  
**NEW YORK, N. Y.** Gross Radio, Inc. 51 Vesey St.  
**NEW YORK, N. Y.** Harrison Radio Co. 12 West Broadway  
**NEW YORK, N. Y.** 100 Sixth Ave.  
 Wholesale Radio Service Co., Inc.  
**NEW YORK, N. Y.** Terminal Radio Corp. 80 Cortlandt Street  
**POTTSVILLE, PENN.** E. Norwegian & George Sts.  
 Sylvester Radio & Supply Co., Inc.  
**READING, PENN.** 404 Walnut St.  
 George D. Barbey Company  
**READING, PENN.** 104 North Ninth Street  
 Sylvester Radio & Supply Co., Inc.  
**SPRINGFIELD, MASS.** T. F. Cushing 349 Worthington St.  
**WASHINGTON, D. C.** 938 F Street, N. W.  
 Sun Radio & Service Supply Co.

**RME**  
**RECEIVERS -- PRE SELECTORS**  
 AMATEUR RADIO EQUIPMENT  
 RADIO MFG. ENGINEERS, Inc.  
 PEORIA ILLINOIS

**ALBANY, NEW YORK** Uncle Dave's Radio Shack 356 Broadway  
**BINGHAMTON, NEW YORK** 25-27 Sturges Street  
 Radio Testing Station  
**CONCORD, NEW HAMPSHIRE** Rear, 80 N. State Street  
 Evans Radio  
**HARTFORD, CONNECTICUT** 210 Chapel Street  
 Stern Wholesale Parts Company  
**NEW YORK, N. Y.** Harrison Radio Co. 12 West Broadway  
**NEW YORK, N. Y.** Terminal Radio Corp. 80 Cortlandt Street  
**ROCHESTER, NEW YORK** 244 Clinton Ave., N.  
 Radio Parts & Equipment Co.



**ALBANY, NEW YORK** Uncle Dave's Radio Shack 356 Broadway  
**BOSTON, MASS.** The Radio Shack 46 Brattle Street  
**BOSTON, MASS.** Selden Radio Company 28 Brattle Street  
**BOSTON, MASS.** 110 Federal Street  
 Wholesale Radio Service Company, Inc.  
**BRONX, N. Y.** 542 East Fordham Rd.  
 Wholesale Radio Service Company, Inc.  
**BUFFALO, NEW YORK** Radio Equipment Corp. 326 Elm Street  
**CONCORD, NEW HAMPSHIRE** Rear, 80 N. State Street  
 Evans Radio  
**JAMAICA, L. I.** 90-08 166th Street  
 Wholesale Radio Service Company, Inc.  
**NEWARK, NEW JERSEY** 219 Central Avenue  
 Wholesale Radio Service Co.  
**NEW YORK, N. Y.** Harrison Radio Co. 12 West Broadway  
**NEW YORK, N. Y.** 100 Sixth Avenue  
 Wholesale Radio Service Co.  
**WASHINGTON, D. C.** 938 F Street, N. W.  
 Sun Radio & Service Supply Co.

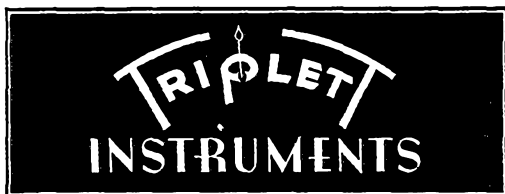

**ALBANY, N. Y.** Uncle Dave's Radio Shack 356 Broadway  
**BOSTON, MASS.** Radio Shack 46 Brattle Street  
**BOSTON, MASS.** Selden Radio Company 28 Brattle St.  
**BOSTON, MASS.** 110 Federal Street  
 Wholesale Radio Service Company, Inc.  
**BRONX, N. Y.** 542 East Fordham Rd.  
 Wholesale Radio Service Company, Inc.  
**JAMAICA, L. I.** 90-08 166th Street  
 Wholesale Radio Service Company, Inc.  
**MONTREAL, CANADA** 285 Craig Street, West  
 Canadian Electrical Supply Co., Ltd.  
**NEWARK, N. J.** 219 Central Ave.  
 Wholesale Radio Service Company  
**NEW YORK, N. Y.** 100 Sixth Avenue  
 Wholesale Radio Service Company  
**POTTSVILLE, PENN.** E. Norwegian & George Sts.  
 Sylvester Radio & Supply Co., Inc.  
**READING, PENN.** George D. Barbey Co. 404 Walnut Street  
**READING, PENN.** 104 North Ninth St.  
 Sylvester Radio & Supply Co., Inc.  
**WASHINGTON, D. C.** 938 F Street, N. W.  
 Sun Radio & Service Supply Co.

FOR A  
*Smooth, Quiet*  
POWER SUPPLY

use

*Utah* "NO BACK TALK"  
TRANSFORMERS

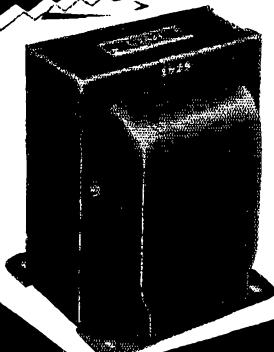

**UTAH RADIO PRODUCTS CO.**  
CHICAGO, U. S. A.

BUENOS AIRES-UCOA RADIO PRODUCTS CO.

**"16 YEARS OF LEADERSHIP"**

**DO YOU WANT TO LEARN  
WIRELESS and TELEGRAPHY?**



TWO BOOKS EVERY AMATEUR  
SHOULD HAVE —

*Send Now!*

**10¢  
Each**  
POSTPAID  
COIN, OR  
STAMPS

Hundreds of amateurs have learned from these books, so can you.

These books give you the fundamentals of wireless and telegraphy. They contain the codes and how to learn them. Mail your order now to:

**SIGNAL ELECTRIC MFG. CO., Menominee, Michigan**

ESTABLISHED  
1892



Correspondence Department

(Continued from page 68)

Did You Say QRM?

1215 Rodman, N. E., Massillon, Ohio

Editor, QST:

... If all those guys who howl about traffic conditions and QRM on the 40-meter band would try to copy on the 124-meter police band, and I mean really do some traffic work on that band, 40 meters would sound like the 10-meter band. Why not a police traffic net and trunk line to handle long haul traffic requests for information and descriptions? This would be a real service. We could use one right here in Ohio just to handle traffic between the major cities now that the F.C.C. is enforcing Rule 331.

—W. Hinman, W8UX

QSL Troubles

La Paz, Bolivia, South America

Editor, QST:

Here is a pack of trouble for your "QSL YL" at Hq plus a long wail. We all like to think that we are a bit more honest than the "other guy," but I have heard more kicks from W stations that they never received my QSL cards from old CT2BK. At least 70% of the stations worked from here that were also worked from CT2BK complain of non-receipt of CT2BK's card. Well, I think that I can honestly say that a card has been sent to every station with whom either CT2BK or the present CP2AA has ever QSO'd.

This QSL business is a pretty expensive one for DX stations in any case, as practically every contact is DX. I, myself, have sent 126 cards since the 24th of last month. Cost of printing, mail, etc., has cost me over \$3.00 just for this lot. When fellows ask me why I only use a type 46 in my final with 20 watts they might care to know that since 1934 I have spent over \$34.50 on the QSL side of running my rig and have no money left to buy equipment! Why in heck don't some of these lads get in touch with their A.R.R.L. QSL Bureaus? That arrangement was set up for this specific purpose but I really think that rafts of my cards are awaiting the addressees at these Bureaus.

In future I send one card and no more, not even if I get a direct letter from a station asking for the card for a QSO. I am here for several years and hope during that time to effect two or more thousand QSO's and at approximately 8 cents per QSO this runs into real money.

Let the boys ask their QSL bureaus for cards.

—H. E. J. Smith, CP1AA—ex-CT2BK

To End CQ

P. O. Box 3804, Phoenix, Ariz.

Editor, QST:

We seem to yet have much unnecessary QRM and difficulty in identifying a signal in a desired area with a minimum of time and effort, with even directional CQ's striking a low average.

I would like to suggest to amateurs at large a discontinuance of what I believe is now obsolete—the use of CQ for calling practice—and in its place substitute a continuously identifying type of call. This can be the prefix of the country in which the calling station is located; where a single letter is used, the district number may follow:

W6 W6 W6 de W6FZQ W6FZQ W6FZQ AR  
ZL ZL ZL de ZLIHH ZLIHH ZLIHH AR  
VK VK VK de VK3XP VK3XP VK3XP AR

Of course in raising a particular locality not heard at the time of transmission, for example a W1, we could alternate the letters CQ with W1, repeating as deemed necessary.

In this manner, the origin of the station in its general inquiry call is easily known, with little time lost by any one desiring to contact the area of the caller, or hunting for him over the band. I am sure this would stop the present abuses of long CQ's and CQ DX, as no one would then have to listen to such rot. The ease with which our English brethren are so easily recognized is a known fact. We could also then with the use of this system tell whether or not we would wish to follow an inquiry call or not through a barrage of R9 QRM.

—Charles E. Spitz, W6FZQ

# HAM-ADS

(1) Advertising shall pertain to radio and shall be of nature of interest to radio amateurs or experimenters in their pursuit of the art.

(2) No display of any character will be accepted, nor can any special typographical arrangement, such as all or part capital letters be used which would tend to make one advertisement stand out from the others.

(3) The Ham-Ad rate is 15¢ per word, except as noted in paragraph (6) below.

(4) Remittance in full must accompany copy. No cash or contract discount or agency commission will be allowed.

(5) Closing date for Ham-Ads is the 25th of the second month preceding publication date.

(6) A special rate of 7¢ per word will apply to advertising which, in our judgment, is obviously non-commercial in nature and is placed and signed by a member of the American Radio Relay League. Thus, advertising of bona fide surplus equipment owned, used and for sale by an individual or apparatus offered for exchange or advertising inquiring for special equipment, if by a member of the American Radio Relay League takes the 7¢ rate. An attempt to deal in apparatus in quantity for profit, even if by an individual, is commercial and takes the 15¢ rate. Provisions of paragraphs (1), (2), (4) and (5) apply to all advertising in this column regardless of which rate may apply.

Having made no investigation of the advertisers in the classified columns, the publishers of *QST* are unable to vouch for their integrity or for the grade or character of the products advertised.

**QUARTZ**—direct importers from Brazil of best quality pure quartz suitable for making piezo-electric crystals. Diamond Drill Carbon Co., 719 World Bldg., New York City.

**RADIO** engineering, broadcasting, aviation and police radio, servicing, marine and Morse telegraphy taught thoroughly. All expenses low. Catalog free. Dodge's Institute, Byrd St., Valparaiso, Ind.

**QSL'S**, W2SN, Helmetta, N. J.

**CALLBOOKS**—new DX calls, new prefixes, thousands of new W and VE calls, in the Spring, 1938 Radio Amateur Call Book. Sent postpaid \$1.25, or a whole year (four issues) for \$4. (In foreign countries, \$1.35 and \$4.35.) Your call and QRA printed in large type \$1 per year. Radio Amateur Call Book, 610 S. Dearborn, Chicago.

**QSL'S**, all colors, cartoons, snappy service. Write for free samples today. WBEF, 16 Stockbridge Ave., Lowell, Mass.

**USED** receivers. Bargains. Cash only. No trades. Price list 3¢. W3DQ, Wilmington, Del.

**GENERAL** Electric dynamotors 24/750 volts 200 mills, \$20. On twelve volts deliver 375. Westinghouse 27 1/2/350, \$10; 200 Watts 900 cycles, \$15; 8-15 volts 500 watts Aircraft, \$10. Simon 500 watt 500 cycles with exciters, \$8. Slightly used, \$6. List. Henry Kienzie, 215 Hart Blvd., Staten Island, N. Y.

A mounted crystal near your frequency 80-160 meter bands \$1.25. Same unit 40 meters \$2.25. R9 Crystals, 338 Murray Ave., Arnold, Pa.

**CASH** for used National NC100X. H. Afton, Box 2122, Boise, Idaho.

**RADIOMAN**, 25, married, commercial first fone-cw tickets, merchant-marine, coastguard, amateur, and some tape reading experience; wants shore job. Available March 18th. W6PZ.

**QSL'S**. Samples—stamp. Printer, Corwith, Iowa.

**WANTED**: Used Collins, Temco or Harvey transmitter, phone-cw, 350-500 watts; also RME. Details first letter. Box 83, Leesburg, N. J.

**WANTED**: pair RCA Photophone 4606 oil damped phonograph pickup heads or someone who will repair my burned-out ones. W2FUU, 243 Jamaica Ave., Flushing, N. Y.

**QSL'S?** For particular hams. Samples? W8DED, Holland, Mich.

**CRYSTALS**: Biley. Patronize W8DED (LD2, 7183, 7030, \$2.95 each).

**SPEECH** amplifier complete, tubes and power supply—xtal input—2A3's, 18 watt output to 500 or 200 ohms—\$12. W9ULJ, Emerson, Iowa.

**QSL'S**—200 for \$1.25. Barry, Babylon, N. Y.

**QST**—one bundle, good condition: '33, '34, '35 complete; '32 complete except Jan.; '31 complete except Jan. and Aug. Also have March, May and Aug., 1930, good condition. Sept. '30, Oct. '30, and Dec. '29 good condition except covers. Complete lot, \$19. F.O.B. Dallas, Texas. E. M. Shook, 227 W. Woodin Blvd.

**QSL** cards, neat, attractive, reasonably priced. Samples free. Miller, Printer, Ambler, Penn.

**CHOKER**: best cash offer takes Thordarson T2073 twenty-six henries, five-hundred mills, three thousand volt insulation, twenty-four pounds. W2AXP.

**QSL'S**. Cartoons. Free samples. Theodore Porcher, 7708 Navajo St., Philadelphia, Penn.

**SELLING** out: pair of 50T's, Thor. trans., Nat'l condensers; write for list. W3FQE.

**TWO** Western Electric 212E, three Sylvania 212D, five 113A sockets. W3HL, Harrisonburg, Va.

**REMOTELY** controlled enclosed rack and panel transmitter. Also miscellaneous parts and rack. No shipments. Stanley Peck, 80 Maryland Ave., Freeport, L. I., N. Y.

**BEST** offer takes several 500 watt, self-excited 110 volt, 60 cycle generators, fitted for belt drive. These were wound over old auto generators, and are fully guaranteed electrically and mechanically. W3AAO-W3BBV, 434 N. Beaver St., York, Penn.

**FREE**: 164-page A-W-R Practical Radio Manual featuring a complete personalized course for the newcomer. Also construction articles on receiver and transmitters; photos of ham stations, etc. Over 110 illustrations. Absolutely free with a year's subscription to All-Wave Radio (12 issues) at \$2.50. Descriptive circular on request. Write—All-Wave Radio, Suite 601A, 16 E. 43 St., N. Y.

**AMATEUR** stationery printed in 2 colors—100 sheets and envelopes, \$1.25. W3BYK, 923 N. 27 St., Camden, N. J.

**QSL'S**. Free samples. Cards supreme. Maleco, 1512 Eastern Parkway, Brooklyn, N. Y.

**SURPLUS**—8" microphone rings silver crackle, 69¢ postpaid. Globe Radio Co., 401 W. State St., Milwaukee, Wis.

**CRYSTALS**: zero cut. New low drift. 160-80-40 meters, \$1.85; 20 meters, \$3. postpaid. Plug-in mountings, 75¢. Fisher Lab., 4522 Norwood St., San Diego, Calif.

**HRO**, latest relay rack model, gray, in original case, first \$150. takes it. W3AFR.

**WILL** trade 101X for 35mm camera, Zeiss or Leica preferred. Donovan, Box 63, Chattanooga, Tenn.

**SURPLUS**: new 804's, 830's, used ACR175, PR10, preselector, 85¢, etc. Want multiarc. W6MVK, Modesto, Calif.

**SELL**: TRF receiver. W8JQE.

**W8HCN** selling out. Wanted, silicon steel. 250 Washington, Bluffton, Ohio.

**OUR** large three-inch oscillograph complete and ready to work with linear sweep circuit, synchronization circuit, tubes, etc., only \$39.50. Money-back guarantee. Order now. International Standards, 5307 Ravenswood, Chicago.

**SELL**: Patterson PR-10, good condition, \$39. W3CDG.

**QSL'S**, SWL's. 100—3 color—75¢. Lapco, 344 W. 39th, Indianapolis, Ind.

**RECEIVERS**: Write for list of used bargains, National, Halli-crafter, PR-10, etc. New RCA-ACR155—\$44.50. Van Sickle Radio, W9KJF, Indianapolis, Ind.

**WANTED**: QST Volumes I, II, III and IV complete. Must be in good condition. State price particulars. Arthur Grolz (W8DK), 43 Butler St., Mt. Clemens, Mich.

**MUST** settle an estate. Nineteen thirty-seven Stromberg, Model 160L, original box. List price, \$275.; sacrifice, \$125. cash. W4WL.

**CRYSTALS**: unconditionally guaranteed. Supplied ± 5 kilocycles. 160-80 meters, X-cut \$1.50, A-cut \$2.25; 40 meter X-cut \$1.85. Wright Radio Labs., 5859 Glenwood Ave., Chicago, Ill.

**MORE** than 5000 Fabradio Y-cut crystals are now in use. The price is 75¢ each. 24-hour service. See February QST for details. Fabradio, Sandwich, Ill.

**METER** repair service—all types repaired and recalibrated. This month's special—Weston 301 milliammeters repaired or range changed, \$1.50. Weston or similar types thermo-couple meters repaired, \$2.25. Braden Engineering Co., 305 Park Dr., Dayton, Ohio.

**TRY** us first—radio supplies. Loughnane & Co., Decatur, Ill.

**QSL'S**—prices, samples for stamp. W2AEY, 338 Elmora, Elizabeth, N. J.

**FBXA** complete, preselector, fifteen coils, \$50. W6MYK, Tucson, Arizona.

**BETTER** QSL's—SWL's. Samples. Fritz, 455 Mason, Joliet, Ill.

**FREE**—while they last—3 high grade porcelain case, mica transmitting condensers, 2000 volt test, any capacity up to .001 mfd. with every order of 100 QSL cards—all for \$1. Send for samples—choose from my selection of modern cards. W3DGS, 6417 Tulip St., Philadelphia, Penn.

**CRYSTALS**, X-cut, 80-160, ± five kilocycles, \$1.50. Spot frequency, \$2.50. Three small, 80 meter blanks, including carbonium, \$1.20. Holders, \$1. William Threm, W8FN, 3071 Moosewood St., Cincinnati, Ohio.

**SELL** all or part 30 Western Electric 600-A double button carbon microphones, \$6. each. Money order. Station WNEW, N. Y. C.

EIDSON'S T9 crystals will put you in the running in the forthcoming DX contest. Our reasonable prices allow more frequencies, thereby increasing your chances. 40 and 80 meter bands \$1.60, 7300-7600 k.c. range \$2. Rugged X cut, fully guaranteed. Accept no substitute. T9 ceramic holders \$1.10. Prices postpaid. C.O.D.'s accepted. Sold by Pembleton Labs., Ft. Wayne, Ind.; W9ARA, Butler, Mo.; Hieronymus Radio, 88-34 209 St., Queens Village, N. Y.; or Eidson's, Temple, Texas.

USED RK20. W8ANT.

USED FBXA. W8ANT.

COMET-Pro—crystal model. W8ANT.

KENYON transformers. W8ANT.

NATIONAL one-ten, used. W8ANT.

USED 180 meter phone, 25 watts. W8ANT.

USED 150T. W8ANT.

USED 50T. W8ANT.

PLATE transformers. W8ANT.

FILTER condensers, specials. W8ANT.

RCA ACR111, used. W8ANT.

ALL lines of new and used amateur equipment bought, sold, exchanged. Write to Southern Ohio's only amateur owned amateur business. Jos. N. Davies, W8ANT., 2767 N. Bend Rd., Sta. A., Cincinnati, Ohio.

LONG and short line control systems for 5 meters, by Remco. Either assembled or kit forms now available. Free bulletins ready. QSL to Paradio, 124 Garrison, Jersey City, N. J.

RECEIVERS for 5 meters, by Custombuilders of N. Y. Free bulletin ready. QSL to Paradio, 124 Garrison, Jersey City, N. J.

MORE dealers should stock our 5 meter developments. Paradio, 124 Garrison, Jersey City, N. J.

QSL'S—highest quality, lowest prices. Radio Headquarters, Ft. Wayne, Ind.

CRYSTALS: 80M X cuts, \$1.50. Complete line amateur crystals and holders. Reasonable prices. Request catalog. Ham Crystals, 1104 Lincoln Place, Brooklyn, New York.

3 tube 6 volt transceiver with motorgenerator and speaker, \$10. W8NNJ.

THOUGHTFUL amateurs install Precision guaranteed transformers. 1/2 k.w., 2500 v. c.t., 400 ma., \$9. Michigan Electrical Lab., Muskegon, Mich.

FOR sale: pair RK28's; factory sealed cartons; \$25. each or both for \$45. W9DII.

TANTALUM can take it. Kilowatt to pair Ewing 100s. No report of failure in eighteen months. \$8. guaranteed. W9HYO.

CRYSTALS: Eidson's T9 fracture-resisting X-cut 80-40 meters, \$1.60. Rig-test one, you'll agree they're unbeatable. Van Radio, 464 E. 117th, No. 7, Cleveland, Ohio.

FOR SALE; two Esco 3 unit motor generator sets in fine condition at a real bargain. First machine 1600 v. d.c., .73 amps: Low voltage 14 v. d.c. 36 amps; motor 220 a.c. 60 cycles 3.5 HP. 3 phase 10 amps 1750 RPM. Second machine 2000 v. d.c., .75 amps: Low voltage 18.5 v. d.c. 36 amps; motor 220 v. a.c. 3 phase 4 HP. 11 amps 1750 RPM. Both sets compound wound. High voltage machines both have double commutators. Included with each set is a fine magnetic starter with overload protection and two heavy-duty field rheostats with each set. One machine cost \$418. and the other about \$850. Either set priced at \$65. F.O.B. Flint subject to prior sale. More information on request. F. D. Fallain, 1626 Union Industrial Bldg., Flint, Mich.

SALE or trade: Carter genemotor model 255-351 X, new—never used, 250 volts at 50 MA., 350 volts at 100 MA., Filtered for ultra hi-freq. List, \$60. Best cash offer. W8NGY c/o W8DXW, 14834 Euclid Ave., E. Cleveland, Ohio.

DOUGLAS Universal Class B transformers match all tubes, including new TZ40-809-RK12. 50 watts audio, \$4.95 pair. 100 watts audio, \$7.75 pair, postpaid, guaranteed. Write W9IXR, Weyerhaeuser, Wis.

TELEPLEXES, instructographs, omnigraphs, bought, sold. Ryan's, Monroe City, Mo.

RECONDITIONED guaranteed sets shipped on ten day trial: HROs \$129.70, RME-69s \$99., NC100s \$89., HRO Jrs. \$69., SX11s \$69. ACR-175s \$69., PR16Cs \$64., Breting 12s \$59., RME9Ds \$59., PR-10s \$39., FBXAs \$29., FB7As \$23., Super-Skyriders \$29., All-Star Supers \$17.50, Skyriders \$17.50, other sets. List free. Write. W9ARA, Butler, Mo.

FBXA coils \$2.95 pair, SW3 coils \$1.75 pair, Kaltman & Romander oscilloscope with tubes \$29., Shure 70s crystal microphone \$7.95, WE276As \$5.95, carbon plate RCA-203-As and 211s \$6.95, RCA-852s and 860s \$7.95. W9ARA.

QSL'S? Patronize W8DED.

BILEY crystals. W8DED.

SELL RCA frequency modulator; RCA transceiver; Peak preselector; radio magazines; two 845's. W8DT.

WANTED: Coils for SW58. W8NOW.

QSL'S—quality—2 color—\$1. hundred; \$1.75, 200. Samples. W8NOS.

SACRIFICE: standard make super-het receiver, fine condition, inquire. W5AMK.

CRYSTALS: high-grade, guaranteed—write. VE1KS.

## LEARN CODE RIGHT

Tapes for Every Need—Send You Typical Messages by INSTRUCTOGRAPH

It's easy and practical to learn or improve your Radio or Morse Code, any speed. Senior model with 10 tapes and Book of Instructions—\$20.25. (Rented at low cost) Junior model with 5 tapes and Book of Instructions—\$12.00. (Not rented). Complete oscillator equipment, less battery, \$6.50. Write for details today.

INSTRUCTOGRAPH CO., Dept. Q-3  
912 Lakeside Place Chicago, Ill.  
Radio College of Canada  
863 Bay St., Toronto

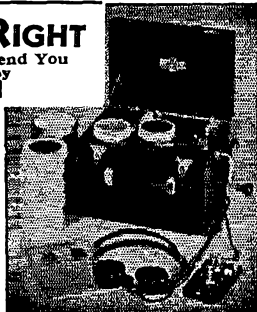

BUY ON CASH OR TERMS: HALLICRAFTER AND R.M. E. SHORT WAVE RECEIVERS, SPEED-X AND VIBRO-PLEXES, Telegraph Instruments.

## GORDON NAME PLATES

## ANTENNA TUNING

A complete line of 122 everlasting, chromium plated name plates for Transmitter, Sound and Test equipment. Available in two sizes. Write for listing and low prices.

## GORDON SPECIALTIES COMPANY

440 S. Dearborn Street • Chicago, Illinois

## RADIO COURSES

RADIO OPERATING: Prepare for Gov't. License Exam. ●  
RADIO SERVICING: Including Short Wave ● AMATEUR CODE ● ELECTRONICS ● TELEVISION ●

Day and Evening classes—Booklet upon request

## NEW YORK YMCA SCHOOLS

4 West 63rd Street, New York City

## PRECISION CRYSTALS

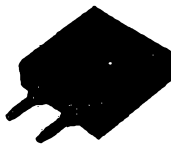

Crystal Holder

Highest quality crystals, one inch square, carefully ground for frequency stability and maximum output. Be sure of your transmitter frequency—use PRECISION CRYSTALS.

Low frequency drift crystals (Type L T C) supplied within 0.1% of your specified frequency and calibrated to within 0.03% are priced as follows: 1750 and 3500 kc. bands—\$3.50 each, 7000 kc. band \$4.00 each. Holder \$1.00.

(Holder as illustrated to fit G.R. jacks or round holder to plug into a tube socket can be furnished. G.R. jacks to plug illustrated holder into—\$1.15 pair.)

'X' cut PRECISION Crystals carefully ground for maximum power supplied within 0.1% of your specified frequency and calibrated to within 0.03% are priced as follows: 1750, 3500 and 7000 kc. bands—\$3.00 each. Add \$1.00 if holder is desired.

'AT' cut crystals for commercial use quoted on at your request. When ordering our product you are assured of the finest obtainable. Now in our ninth year of business.

## PRECISION PIEZO SERVICE

427 Asia Street

Baton Rouge, La.

# Your Nearest Dealer Is Your Best Friend

Your nearest dealer is entitled to your patronage. You can trust him. He is equipped with a knowledge and understanding of amateur radio. He is your logical and safe source of advice and counsel on what equipment you should buy. His stock is complete. He can supply your needs without delay. His prices are fair and consistent with the high quality of the goods he carries. He is responsible to you and interested in you.

Patronize the dealer nearest you—You can have confidence in him

|                                                                                                                                                           |                                                                                                                                                              |
|-----------------------------------------------------------------------------------------------------------------------------------------------------------|--------------------------------------------------------------------------------------------------------------------------------------------------------------|
| <p><b>ATLANTA, GEORGIA</b><br/>Wholesale Radio Service Company, Inc.<br/>265 Peachtree Street<br/>"The World's Largest Radio Supply House"</p>            | <p><b>NEWARK, N. J.</b><br/>Wholesale Radio Service Company, Inc.<br/>219 Central Avenue<br/>"The World's Largest Radio Supply House"</p>                    |
| <p><b>BALTIMORE, MARYLAND</b><br/>Radio Electric Service Co.<br/>3 N. Howard St.<br/>Everything for the amateur</p>                                       | <p><b>NEW YORK, N. Y.</b><br/>Gross Radio, Inc.<br/>51 Vesey Street<br/>Fair dealings plus fair prices. Anything in radio</p>                                |
| <p><b>BOSTON, MASS.</b><br/>Wholesale Radio Service Company, Inc.<br/>110 Federal Street<br/>"The World's Largest Radio Supply House"</p>                 | <p><b>NEW YORK, N. Y.</b><br/>Wholesale Radio Service Company, Inc.<br/>100 Sixth Avenue<br/>"The World's Largest Radio Supply House"</p>                    |
| <p><b>BRONX, NEW YORK</b><br/>Wholesale Radio Service Company, Inc.<br/>542 East Fordham Road<br/>"The World's Largest Radio Supply House"</p>            | <p><b>NEW YORK, N. Y.</b><br/>Harrison Radio Company<br/>12 West Broadway<br/>"The Friendly Ham Supply House"</p>                                            |
| <p><b>BUFFALO, NEW YORK</b><br/>Radio Equipment Corp.<br/>326 Elm Street<br/>W80BK — Ham, service and sound equipment</p>                                 | <p><b>PHILADELPHIA, PENNSYLVANIA</b><br/><br/>Eugene G. Wile<br/>10 S. Tenth Street<br/><br/>Complete Stock of Quality Merchandise</p>                       |
| <p><b>BUFFALO, NEW YORK</b><br/>Dymac Radio<br/>216 E. Genesee Street<br/>Complete Line Ham and BCL Equipment Cl. 2080</p>                                |                                                                                                                                                              |
| <p><b>ELMIRA, NEW YORK</b><br/>Miller's Radio Shack<br/>205 Railroad Avenue<br/>Fine equipment for amateurs</p>                                           |                                                                                                                                                              |
| <p><b>JAMAICA, L. I.</b><br/>Wholesale Radio Service Company, Inc.<br/>90-08 166th Street (Merrick Road)<br/>"The World's Largest Radio Supply House"</p> | <p><b>RICHMOND, VIRGINIA</b><br/>The Arnold Company<br/>Broad at Harrison St.<br/>W3GPV—"The Virginia Ham Headquarters"—W3FBL</p>                            |
| <p><b>MONTREAL, CANADA</b><br/>Canadian Elec. Supply Co., Ltd.<br/>285 Craig St., W.<br/>Quality parts and equipment for discriminating buyers</p>        | <p><b>ROCHESTER, NEW YORK</b><br/>Radio Parts &amp; Equipment Co.<br/>244 Clinton Avenue, North<br/>Complete stock amateur-BCL parts. Standard discounts</p> |

# You Are Protected When You Buy From QST Advertisers

“Advertising for QST is accepted only from firms who, in the publisher’s opinion, are of established integrity and whose products secure the approval of the technical staff of the American Radio Relay League.”

Quoted from QST’s advertising rate card.

Every conceivable need of a radio amateur can be supplied by the advertisers in QST. And you will know the product has the approval of the League’s technical staff.

## The Advertisers

|                                        |                |
|----------------------------------------|----------------|
| Astatic Microphone Laboratory, Inc.    | 110            |
| Barker & Williamson                    | 112            |
| Birnbach Radio Company, Inc.           | 116            |
| Billey Electric Company                | 85             |
| Burgess Battery Company                | 91             |
| Candler System Company                 | 106            |
| Capitol Radio Engineering Institute    | 112            |
| Cardwell Mfg. Corp., Allen D.          | 80             |
| Centralab                              | 83             |
| Collins Radio Company                  | Cov. 2         |
| Cornell-Dubilier Corporation           | 114            |
| Delaware Radio Sales Company           | 114            |
| Dodge’s Institute                      | 115            |
| Eitel McCullough, Inc.                 | 70, 71         |
| Gardiner Levering Company              | 120            |
| Gordon Specialties Company             | 115, 124       |
| Gross Radio, Inc.                      | 94             |
| Hallcrafters, Inc., The                | 1, 2           |
| Hammarlund Mfg. Company, Inc., The     | 73, 76         |
| Harvey Radio Company                   | 117            |
| Harvey Radio Laboratories, Inc.        | 82             |
| Heints & Kaufman, Ltd.                 | 103            |
| Henry Radio Shop                       | 111            |
| Hinds & Edgarton                       | 118            |
| Hipower Crystal Company                | 115            |
| Howard Radio Company                   | 95             |
| Hygrade Sylvania Corporation           | 78             |
| Hytronic Laboratories                  | 88             |
| Instructograph Company                 | 124            |
| International Resistance Company       | 77             |
| Isolantite, Inc.                       | 69             |
| Jensen Radio Corporation               | 99             |
| Johnson Company, E. F.                 | 109            |
| Ken-Rad Tube & Lamp Corporation        | 111            |
| Kenyon Transformer Company, Inc.       | 7              |
| Leeda                                  | 98             |
| Logan Company, Les.                    | 111            |
| Mallory & Company, Inc., P. R.         | 68             |
| Massachusetts Radio School             | 113            |
| McGraw-Hill Book Company               | 90             |
| Meissner Manufacturing Company         | 97             |
| Mims Radio Company                     | 108            |
| National Company, Inc.                 | Cov. 3, 67, 87 |
| New York V. M. C. A. Schools           | 124            |
| Newark Electric Company                | 74, 75         |
| Northern Radio Company                 | 119            |
| Ohmite Manufacturing Company           | 92             |
| Petersen Radio Company                 | 115            |
| Port Arthur College                    | 109            |
| Precision Apparatus Corporation        | 96             |
| Precision-Piezo Service                | 124            |
| RCA Institutes, Inc.                   | 119            |
| RCA Manufacturing Company, Inc.        | Cov. 4, 72, 79 |
| Radio Digest                           | 111            |
| Radio Mfg. Engineers, Inc.             | 127            |
| Radio Shack, The                       | 108            |
| Radio Supply Company                   | 113            |
| Raytheon Production Corporation        | 86             |
| Scientific Radio Service               | 119            |
| Scott Wholesale Radio                  | 113            |
| Selectosphere Company                  | 112            |
| Signal Electric Mfg. Company           | 122            |
| Solar Mfg. Corporation                 | 89             |
| Speer Carbon Company                   | 84             |
| Sun Radio Company                      | 120            |
| Taylor Tubes, Inc.                     | 4, 5           |
| Teleplex Company                       | 119            |
| Terminal Radio Corporation             | 113            |
| Thordarson Electric Mfg. Company       | 81             |
| Transmitter Equipment Mfg. Company     | 91             |
| Trim-Radio Mfg. Company                | 119            |
| Triplet Electrical Instrument Co., The | 118            |
| United Transformer Corporation         | 128            |
| Utah Radio Products Corporation        | 122            |
| Vibroplex Company, The                 | 115            |
| Ward Leonard Electric Company          | 110            |
| Wilson, Willard S.                     | 114            |
| Wind Turbine Company                   | 90             |
| Vaxley                                 | 68             |



# The 510X Frequency Expander by RME

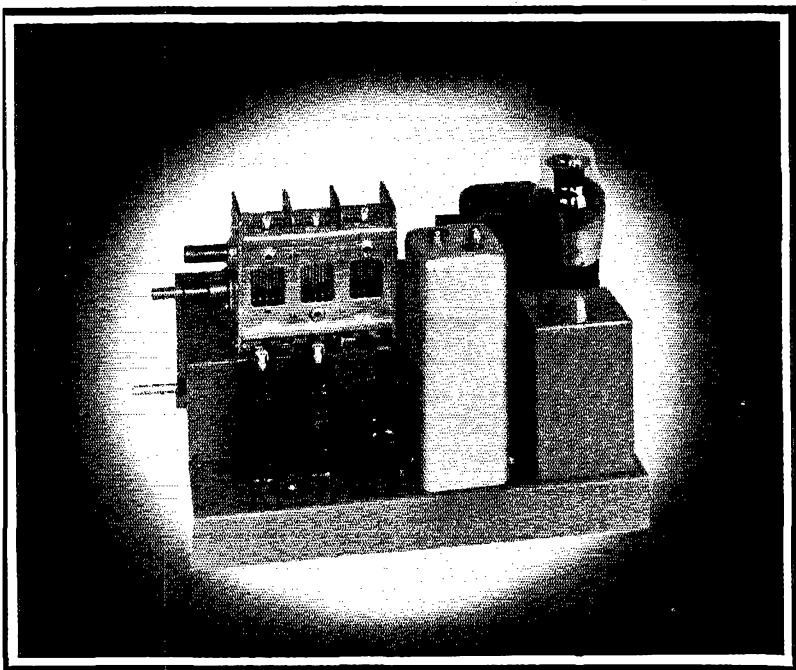

For the  
5-Meter  
Band

*Literature  
on Request*

A practical and economical unit introduced to put the ultra-high frequency band to work.

Connect the frequency expander ahead of your present RME-69, set the controls of the 69 per instructions accompanying the new unit, and tune the 510X to cover the frequency range from 27 to 70 mc.

*Real* sensitivity, *real* selectivity, *real* calibration at a price well below anything now available to obtain *real* results.

And there will be *real* exploring going on in this five-meter band.

**RADIO MFG. ENGINEERS, PEORIA, ILLINOIS**

**R M E - 6 9**

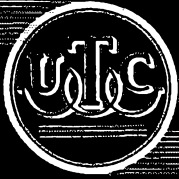

Most Complete Transformer  
Line in the World

QUALITY • RELIABILITY

# VARITRAN VOLTAGE CONTROL UNITS

REG. U. S. PATENT OFFICE



Other sizes

Automatic VARITRANS are available to maintain line voltage constant. Details and prices on request.

Licensed under U. S. Patent No. 2009013

### FEATURES

- ★ Smooth control
- ★ High efficiency
- ★ Excellent regulation
- ★ Low cost

### APPLICATIONS

- ★ Motor control
- ★ Heat control
- ★ Rectifier control
- ★ Light control
- ★ Line voltage control

The UTC VARITRAN makes possible continuously variable output voltage, using a sliding contact riding over the turns of an auto-transformer.

Standard units are designed for 115 volts input, 0-130 volts continuously variable output.

**Model V-1.** 570 Watts — 5 amp. maximum rating, complete with cord, plug and switch, net. . . . . \$10.00

**Model V-2.** Same as V-1, but uncased, with terminal strip for rack or panel mounting, net. . . . . \$9.00

**Model V-3.** 850 watts maximum rating, 7.5. amps., uncased, with terminal board and provisions for mounting, net. . . . . \$14.00

**Model V-4.** 1250 watts — 11 amps. maximum rating, uncased, net. . . . . \$20.00

**Model V-5.** 2000 watts maximum rating, 17.5 amps., uncased, net. . . . . \$32.00

## ULTRA COMPACT HIGH FIDELITY AUDIO UNITS

| Type No. | Application                                                                                                      | Primary Impedance                | Secondary Impedance                           | Your Cost |
|----------|------------------------------------------------------------------------------------------------------------------|----------------------------------|-----------------------------------------------|-----------|
| A-10     | Low impedance mike, pickup, or multiple line to grid                                                             | 50, 125, 200, 250, 333, 500 ohms | 50,000 ohms                                   | \$6.00    |
| A-12     | Low impedance mike, pickup, or multiple line to push pull grids                                                  | 50, 125, 200, 250, 333, 500 ohms | 80,000 ohms overall, in two sections          | \$6.00    |
| A-14     | Dynamic microphone to one or two grids                                                                           | 30 ohms                          | 50,000 ohms overall, in two sections          | \$5.40    |
| A-16     | Single plate to single grid                                                                                      | 8,000 to 15,000 ohms             | 60,000 ohms, 2:1 turn ratio                   | \$4.80    |
| A-18     | Single plate to two grids                                                                                        | 8,000 to 15,000 ohms             | 80,000 ohms overall, 2.3:1 turn ratio overall | \$5.40    |
| A-20     | Mixing, low impedance, mike, pickup, or multiple line to multiple line                                           | 50, 125, 200, 250, 333, 500 ohms | 50, 125, 200, 250, 333, 500 ohms              | \$6.00    |
| A-24     | Single plate to multiple line                                                                                    | 8,000 to 15,000 ohms             | 50, 125, 200, 250, 333, 500 ohms              | \$6.00    |
| A-26     | Push pull low level plates to multiple line                                                                      | 8,000 to 15,000 ohms each side   | 50, 125, 200, 250, 333, 500 ohms              | \$6.00    |
| A-27     | Crystal microphone to multiple line                                                                              | 100,000 ohms                     | 50, 125, 200, 250, 333, 500 ohms              | \$6.00    |
| A-30     | Audio choke, 300 henrys @ 2 MA 6000 ohms D.C. 75 henrys @ 4 MA 1500 ohms D.C. inductance with no D.C. 450 henrys |                                  |                                               | \$4.20    |

The UTC Ultra compact audio units represent the acme in small, light-weight units where portability or size is of paramount importance. Through the use of new design methods, high fidelity is obtainable in all individual units, the frequency response being ± 2 DB from 30 to 20,000 cycles on all units. There is no need to resonate one unit in an amplifier to compensate for the droop of another unit.

All units employ true hum balancing coil structure, which combined with a high conductivity outer case, afford a maximum of inductive shieldings.

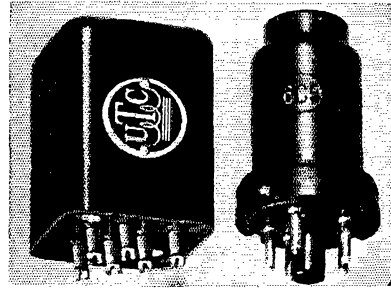

## UNITED TRANSFORMER CORP.

72 SPRING STREET

NEW YORK, N. Y.

EXPORT DIVISION 100 VARICK STREET NEW YORK, N. Y. CABLES "ARLAB"

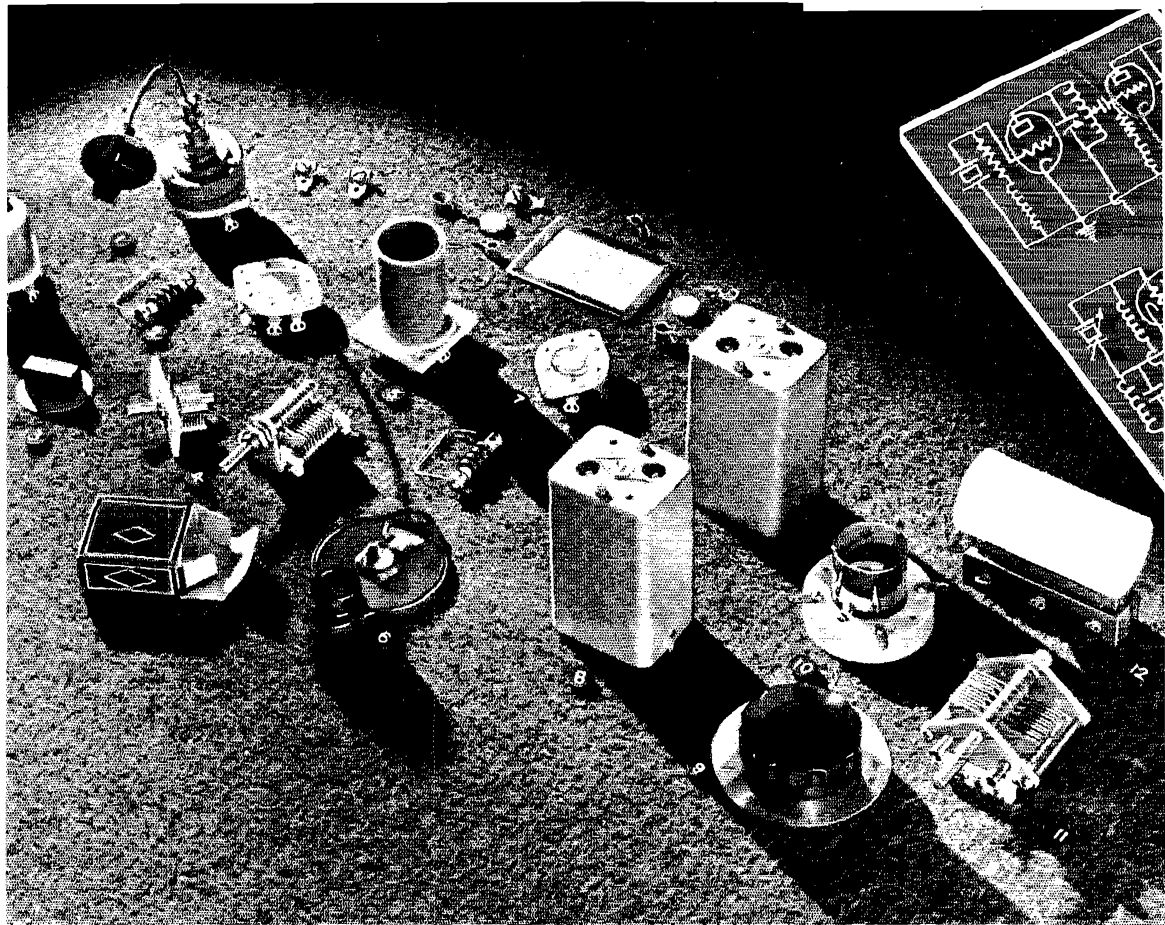

## NOTHING LESS WILL DO

*The numbered parts shown above are as follows:*

1. CHT and CHV Crystal Holders
2. R-100 R.F. Choke
3. HRO Dial, Type 10-0
4. UM and ST Condensers
5. XR-6 Coil Form with Square Socket
6. BM Dial
7. 6-prong Socket
8. FXT Fixed Tuned Exciter Tank
9. O Dial, Type 0-100
10. XM-10 Transmitting Socket
11. TMSA-50 Condenser
12. UR13 Buffer Coil Form Assembly

**W**HEN building or remodeling your transmitter, remember there is no substitute for National Radio Products, either in quality or in price. Genuine National parts will insure better performance of the old rig and peak operating efficiency of the new. A highly efficient exciter may be built around the group of parts illustrated above. They are ideally suited in every particular for this application. Nothing less will do.

The parts shown are described in our catalog No. 370 (which is bound into the NRP 121 Handbook). A catalog may be had from any office, National distributor or by mail direct from us.

# NATIONAL



# COMPANY

# RCA Announces MAJOR PRIZE WINNERS IN AMATEUR CONTEST!

For the best statement on "Why I Use RCA Tubes"

## FIRST PRIZE

Mr. Philip Rosenblatt, W2AKF  
P. O. Box 905  
Hoboken, N. J.

Mr. Rosenblatt wins a new RCA Amateur Receiver—ACR-111

## SECOND PRIZE

Mr. Wm. Leonard May, W3APJ  
11 W. Kirk St.  
Chevy Chase, Md.

Mr. May wins a new RCA Amateur Transmitter—ACT-20

For the best statement on "Why I Don't Use RCA Tubes"

## FIRST PRIZE

Mr. Paul E. Kreilick, W8QQE  
322 Garland Ave.  
Kalamazoo, Mich.

Mr. Kreilick wins a new RCA Amateur Receiver—ACR-111

## SECOND PRIZE

Mr. Dwight Stebbins, W9WLK  
614 Atlantic Ave.  
Morris, Minn.

Mr. Stebbins wins a new RCA Amateur Transmitter—ACT-20

THE OTHER 196 WINNERS HAVE BEEN NOTIFIED DIRECT BY MAIL.

RCA takes this opportunity to thank all who entered this contest. Naturally, we are gratified to know that RCA Radiotrons are held in such high regard by so many. (We received four entries giving reasons for using RCA Radiotrons to every one telling us why these tubes were not used.)

We are grateful, too, to those who went to the trouble of telling us why they do not use our tubes. We admit we are not perfect. We want to correct any shortcomings. That's why we offered prizes for your objections to RCA Tubes in order that we might do everything in our power to correct the faults you found.

Again, we thank you. We are going to use many of the suggestions you sent in, so that in the future, all amateurs will proclaim RCA Tubes "the tops"!

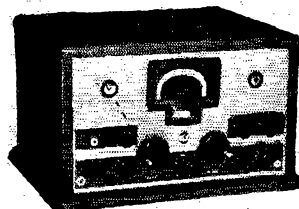

## FIRST PRIZE! RCA Amateur Receiver ACR-111

Won by Messrs.  
Rosenblatt and Kreilick

This RCA Receiver gives you custom-built performance at low cost. Has 16 tubes—is professional in design and appearance. Offers razor-like selectivity and exceptional sensitivity. Brings in stations you never heard before. Other features include Electrical Band Spread, Noise Suppressor, 2 r-f and i-f stages, high Signal-to-Noise Ratio. We know Messrs. Rosenblatt and Kreilick will be pleased with this instrument's excellent performance.

For maximum performance at minimum cost—  
use RCA radio tubes

RCA presents the "Magic Key" every Sunday, 2 to 3 P. M.  
E. S. T., on the NBC Blue Network

Ask your distributor or send 10c to Camden for a commemorative  
advertisement on RCA's television tube announcement



# Radiotrons

RCA MANUFACTURING CO., INC., CAMDEN, N. J. • A SERVICE OF THE RADIO CORPORATION OF AMERICA