

**POST**

April, 1938  
26 cents

devoted entirely to  
**AMERICAN  
RADIO**



*...to know—*  
**Novel Ideas  
in Portable  
Equipment  
Practical  
Speech  
Amplifier  
Design**

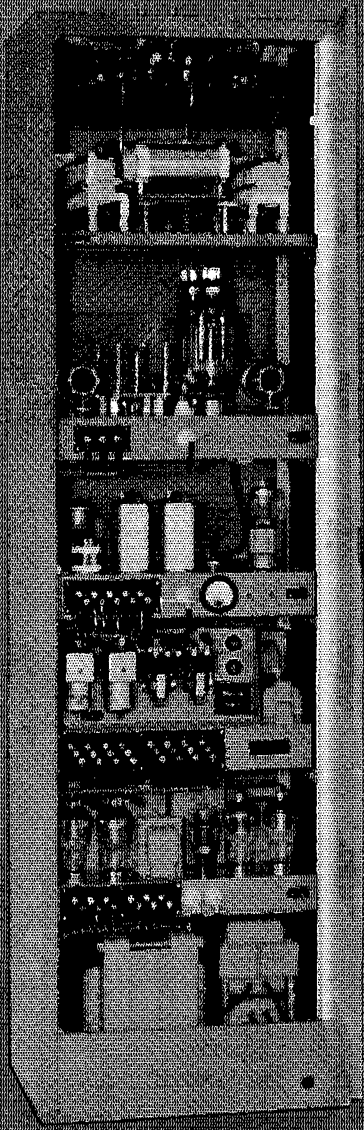
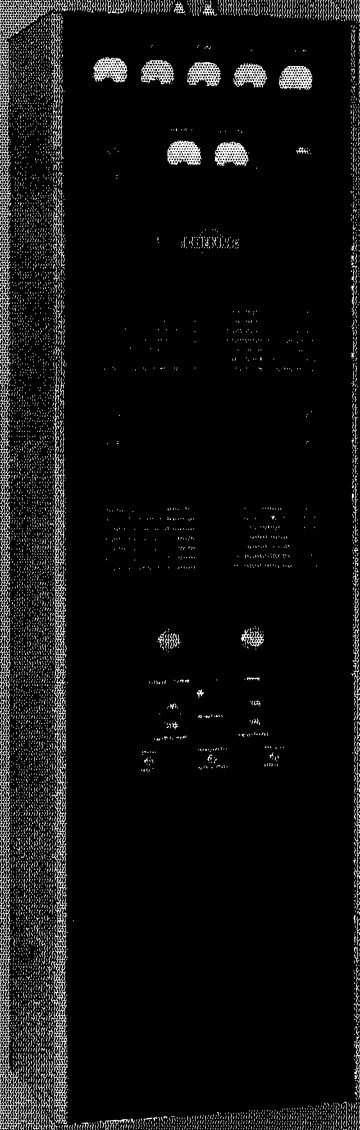

## **COLLINS 600A-2 TRANSMITTER**

600A TRANSMITTERS during the past two years have proved themselves to be extremely serviceable and to be capable of exceptional performance. The 600A-2 (250 watts PH, 750 watts CW) is the new model which retains the basic 600A design and incorporates many new electrical and mechanical developments.

# **COLLINS RADIO COMPANY**

CEDAR RAPIDS, IOWA-NEW YORK, N.Y.: 11 WEST 42 ST.



Mrs. C. J. McGregor and her daughter  
with their Super Skyrider.

*From*  
**Philadelphia**

*to the* **ARCTIC**

Capt. C. J. McGregor  
of the McGregor  
Arctic Expedition.



**HALLICRAFTERS RECEIVERS  
WITH THE MCGREGORS IN  
THE ARCTIC AND AT HOME**

● At home, with the head of the family locked in the frozen wastes of the Arctic, Mrs. C. J. McGregor and her daughter are cheered by his voice as it comes through the speaker of their Super Skyrider. And in the far North, Captain McGregor and the members of the McGregor Arctic Expedition keep in daily touch with the world through another Hallicrafters receiver.

Thus the scientific expeditions to the far places of the world, the research laboratories in the great universities, and hundreds of other stations where dependable short wave reception is not only desirable but imperative, are selecting Hallicrafters receivers for their fine performance under all conditions of service.

This same high standard of performance is the factor that is influencing thousands of amateurs in their selection of Hallicrafters receivers.

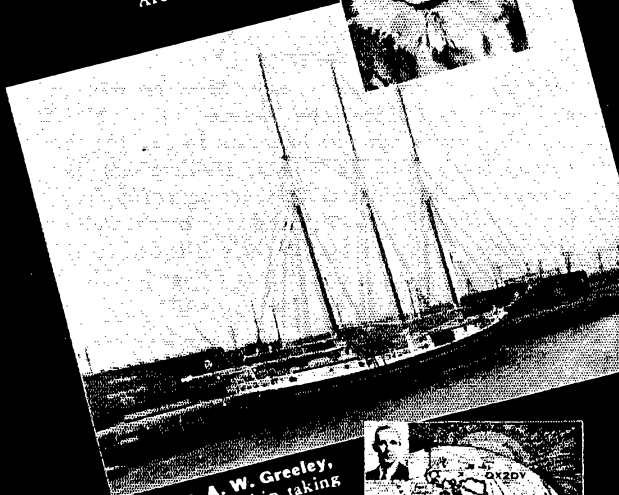

The Gen. A. W. Greeley,  
the McGregor ship, taking  
on supplies.



The McGregor Expedition  
QSL card, with Mr. A. G.  
Sayre, radio operator for  
the expedition.

All Hallicrafters Receivers now available on Liberal Time Payments.

**the hallicrafters inc.**

2611 Indiana Ave., Chicago, U. S. A.  
Cable Address "Hallicraft" Chicago

**"WORLD'S LARGEST BUILDERS OF AMATEUR COMMUNICATIONS RECEIVERS"**



by  
**POPULAR REQUEST**  
*the* **SX17**  
**A SPECIAL MODEL SUPER SKYRIDER**



At the request of a few Hallicrafters dealers, we built a limited number of *Super Skyriders* with an additional stage of pre-selection and a built-in Noise Limiter. It was not our intention to include this special receiver in the regular Hallicrafters line. However, without formal announcement of any kind, the news about the SX17 spread as its owners talked about it over the air and to their friends. To our amazement, we found ourselves deluged with inquiries and orders.

With such a situation, and with the Hallicrafters policy of building what the amateur wants, we have no choice but to include the SX17 in our line. Here it is. Your Hallicrafters dealer can tell you about it, or write us today for complete information.

**Features of the SX17 Super Skyrider**

- ★ 5 to 550 Meters Coverage
- ★ 2 Stages Pre-Selection
- ★ Built-in Noise Limiter
- ★ 13 Tubes
- ★ Wide Range Variable Selectivity
- ★ 1000° Electrical Band Spread
- ★ 6 Bands
- ★ "S" Meter
- ★ Better than 1 Microvolt Average Sensitivity on all Bands

**A Few**

**Unsolicited Comments on the SX17**

*From a real Old Timer—*  
 "Best receiver I have ever owned. Can't be beat."

HERBERT A. BEERING  
 W1GDV (Pre-War 1KW)  
 West Roxbury, Mass.

*Another from the 1st District—*  
 "Have used Skyriders since 1935. SX17 very satisfactory."

M. LANGDON HILL, W1EWN  
 Portland Me.

*From the 2nd District—*  
 "I find this receiver superior to all other receivers I have heard so far ... Noise Silencer really works."

FRED D. PATTI, W2JIE  
 New York City

*From the 9th District—*  
 "The performance of my SX17 is 100% plus on all frequencies from 550 KC to 62 MC. I marvel at its capabilities."

C. H. NICHOLS,  
 W9P2V—O. B. S. Phone,  
 Staples, Minn.

*From an embryo amateur, just taking exams.—*

"Picked up an F3, G5 and G8 on 10 meters in first half hour of use."

GEORGE E. DOWNER,  
 Washington, D. C.

**the hallicrafters inc.**

2611 Indiana Ave., Chicago, U. S. A.  
 Cable Address "Hallicraft" Chicago

All Hallicrafters' Receivers available on liberal time payments

**"WORLD'S LARGEST BUILDERS OF AMATEUR COMMUNICATIONS RECEIVERS"**

# QST

devoted entirely to

# AMATEUR RADIO

PUBLISHED, MONTHLY, AS ITS OFFICIAL ORGAN, BY THE AMERICAN RADIO RELAY LEAGUE, INC., AT WEST HARTFORD, CONN., U. S. A.; OFFICIAL ORGAN OF THE INTERNATIONAL AMATEUR RADIO UNION

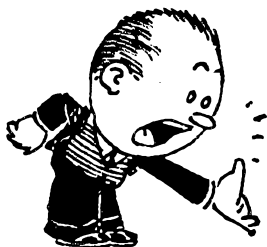

APRIL

1938

Volume XXII

Number 4



Kenneth B. Warner, General Manager of A.R.R.L. Publications; Ross A. Hull, Editor; James J. Lamb, Technical Editor; George Grammer, Assistant Technical Editor; Clark C. Rodimon, Managing Editor; David H. Houghton, Circulation Manager; Ralph T. Beaudin, Assistant Circulation Manager; F. Cheyney Beekley, Advertising Manager; Charles Brunelle, Assistant Advertising Manager.

Editorial and Advertising Offices

38 La Salle Road  
West Hartford, Connecticut

Subscription rate in United States and Possessions and Canada, \$2.50 per year, postpaid; all other countries, \$3.00 per year, postpaid. Single copies, 25 cents. Foreign remittances should be by international postal or express money order or bank draft negotiable in the U. S. and for an equivalent amount in U. S. funds.

Entered as second-class matter May 29, 1919, at the post office at Hartford, Connecticut, under the Act of March 3, 1879. Acceptance for mailing at special rate of postage provided for in section 1103, Act of October 3, 1917, authorized September 9, 1922. Additional entry at Concord, N. H., authorized February 21, 1929, under the Act of February 28, 1925.

Additional second-class entries to cover sectional editions authorized March 20, 1935. Copyright 1938 by the American Radio Relay League, Inc. Title registered at United States Patent Office.

## The Contents

Editorial . . . . .	7
Amateurs Mobilize in Southern California Flood Emergency . . . . . <i>Clinton B. DeSoto</i>	8
A Tuned Loop for 80- and 160-Meter Reception <i>John P. Tynes, W6GPY</i>	10
Some Practical Aspects of Speech Amplifier Design <i>Dana H. Bacon, W1BZR</i>	12
Putting the Harmonic Generator to Work <i>John L. Reinartz, W1QP</i>	15
What the League Is Doing . . . . .	18
DeLuxe Battery-Operated Portable Stations <i>R. D. Waterhouse and W. C. Hilgedick</i>	20
The Construction of Television Receivers <i>Marshall P. Wilder, W2KJL</i>	23
Modernizing the 56-Mc. Transceiver <i>A. S. Burke, W3VVR and T. Leaf</i>	28
"You Said a Mouthful" . . . <i>Lawrence E. Hauck, W9CYV</i>	30
Shock-Proofing the Transmitter . . . <i>L. C. Waller, W2BRO</i>	31
A Simple 110-Volt A.C.-D.C. Code-Practice Oscillator <i>T. M. Ferrill, Jr., W5CJB-1</i>	34
When Emergency Strikes . . . . . <i>F. E. Handy, W1BDI</i>	35
How Would You Do It? . . . . .	39
Hints and Kinks . . . . .	41
A.A.R.S. Activities . . . . .	44
1.75- and 28-Mc. Operation with the Low-Cost 100-Watt Transmitter . . . . .	45
A Crystal-Controlled 5- and 10-Meter Portable <i>Frederick F. Sylvester and E. F. Dillaby</i>	46
Transmitting Tube Manual . . . . .	47
I.A.R.U. News . . . . .	58
Amateur Radio Stations . . . . . <i>W9FQU</i>	50
Silent Keys . . . . .	50
Operating News . . . . .	51
Correspondence Department . . . . .	59
Book Review . . . . .	68
Standard Frequency Transmissions . . . . .	90
New Receiving Tubes . . . . . <i>1851, 6K8</i>	98
Hamads . . . . .	107
QST's Index of Advertisers . . . . .	110

# Section Communications Managers of the A.R.R.L. Communications Department

All appointments in the League's field organization are made by the proper S.C.M., elected by members in each Section listed. Mail your S.C.M. (on the 16th of each month) a postal covering your radio activities for the previous 30 days. Tell him your DX, plans for experimenting, results in 'phone and traffic. He is interested, whether you are an A.R.R.L. member or get your QST at the newsstands; he wants a report from every active ham. If interested and qualified for O.R.S., O.P.S. or other appointments he can tell you about them, too.

Eastern Pennsylvania Maryland-Delaware-District of Columbia Southern New Jersey Western New York Western Pennsylvania	W3QP W3BAK W3BEI W8CSE W8OFO	<b>ATLANTIC DIVISION</b> John Buck Morgan Edgar L. Hudson W. W. Filson Ed Preston Kendall Speer, Jr.	8527 Germantown Ave. 247 E. Atlantic Ave. 10 Lincoln Ave.	Chestnut Hill, Philadelphia Laurel, Delaware Aubudon Tully Lowber
Illinois Indiana Kentucky * Michigan Ohio Wisconsin	W9KJY W9QG W9ARU W8DPE W8AQ W9UIT	<b>CENTRAL DIVISION</b> L. John Huntoon Noble Burkhart Darrell A. Downard Harold C. Bird E. H. Gibbs Aldrich C. Krones	327 Brandon Ave. R. 4, Box 1 116 N. Longworth Ave. R.F.D. 2 405 Broad St. 3288 S. Illinois Ave.	Glen Ellyn Indianapolis Louisville Pontiac Wadsworth Milwaukee
North Dakota South Dakota Northern Minnesota Southern Minnesota	W9RZA W9SEB W9IGZ W9DCM	<b>DAKOTA DIVISION</b> Ernest Bloch Andrew J. Kjar Edwin L. Wicklund Webster F. Soules	Box 202 221 West Prospect Ave. 3549 36th Ave., So.	Thompson Pierre Kensington Minneapolis
Arkansas Louisiana Mississippi * Tennessee	W5AB1 W5DKR W5GIF W4DEP	<b>DELTA DIVISION</b> H. E. Velte Eugene H. Treadaway Robert E. Barr B. G. Lowrey Smith	4415 West 12th St. 2749 Myrtle St. 673 Hillcrest St.	Little Rock New Orleans Lucedale Memphis
Eastern New York N. Y. C. & Long Island Northern New Jersey	W2LU W2AZV W2GMN	<b>HUDSON DIVISION</b> Robert E. Haight E. L. Baunach Fred C. Read	511 South Holmes St. 102 Central Ave. 1014 North Ave.	Scotia Massapequa, L. I. Elizabeth
Iowa * Kansas Missouri Nebraska	W9LEZ W9PB W9OUD W9FAM	<b>MIDWEST DIVISION</b> Phil D. Boardman Harry E. Legler Miss Letha Allendorf Samuel C. Wallace	325 Kirkwood Blvd. 304 Miami St. 1015 W. 3rd St. Green St.	Davenport Hiawatha Joplin Clarks
Connecticut Maine Eastern Massachusetts Western Massachusetts New Hampshire Rhode Island Vermont	W1CT1 W1FB1 W1GFC W1IAH W1BFT W1HRC W1GNF	<b>NEW ENGLAND DIVISION</b> Frederick Ella, Jr. Winfield A. Ramsdell Sassaparilla William J. Barrett Carl B. Evans Clayton C. Gordon Alvin H. Battison	19 Merrill Rd. 1188 Washington Ave. Pleasant St. 239 Columbia St. 80 N. State St. 192 Washington Ave. 1 Central St.	Norwalk Portland Marblehead Hills Adams Concord Providence Windsor
Alaska Idaho Montana Oregon Washington	K7ENA W7EMT W7FL W7ATV W7WY	<b>NORTHWESTERN DIVISION</b> Leo E. Osterman Carl Eichelberger G. A. Woodhouse Eugene E. Lovejoy Robert H. Votaw	Customhouse 2810 North 26th St. Holter Dam 5013 N. E. Clackamas Route 1, Box 398	Wrangell Boise Wolf Creek Portland Vancouver
Hawaii * Nevada Santa Clara Valley East Bay San Francisco Sacramento Valley Philippines San Joaquin Valley	K6OOE W6BIC W6BEW W6FTY W6SG W6GZY KA1GR W6LPE	<b>PACIFIC DIVISION</b> Harold C. Smith Edward W. Heim Elbert Amarantes Harold J. Burchfield Alan D. Whittaker, Jr. J. L. C. Buckenham George L. Rickard Angelo V. Astone	P. O. Box 150 509 Claremont St. 454 Washington St. 2240 106th Ave. 79 Elinor Ave. 2931-24th St. Box 849 729 Safford	Honolulu Reno San Jose Oakland Mill Valley Sacramento Manila Fresno
North Carolina South Carolina Virginia West Virginia	W4OG W4BQE W3UVA W8HD	<b>ROANOKE DIVISION</b> H. S. Carter Ted Ferguson Charles M. Waff, Jr. C. S. Hoffmann, Jr.	P. O. Box 111 1213 College St. 2914 Monument Ave. 47 Lynwood Ave.	Winston-Salem Columbia Richmond Wheeling
Colorado Utah-Wyoming	W9FA W7COH	<b>ROCKY MOUNTAIN DIVISION</b> Glen Glasscock Townsend J. Rigby	2164 So. Corona St.	Denver Midwest, Wyoming
Alabama Eastern Florida Western Florida Georgia-Cuba-Isle-of-Pines- Porto Rico-Virgin Islands	W4DGS W4DVO W4BSJ *W4PM	<b>SOUTHEASTERN DIVISION</b> James F. Thompson L. A. Connolly Ellis R. Curry Charles W. Davis	102 Narrow Lane Rd. 719 So. Willow Ave. Box 425 2136 N. E. Boulevard Dr.	Montgomery Tampa Madison Atlanta, Ga.
Los Angeles Arizona San Diego	W6GXM W6KFC W6JRM	<b>SOUTHWESTERN DIVISION</b> Don M. Draper Victor C. Clark Howard K. Breedlove	4421 West 63 St. 747 E. Polk St. R. 2, Box 636	Los Angeles Phoenix San Diego
Northern Texas Oklahoma Southern Texas New Mexico	W5DXA W5CEZ W5BHO W5CGJ	<b>WEST GULF DIVISION</b> Lee Hughes Carter L. Simpson Dave H. Calk Joseph M. Eldodt	125 N. Main St. 2010 So. 4th St. 6726 Ave. Q	Childress Ponca City Houston Chamita
Maritime	VE1DQ	<b>MARITIME DIVISION</b> A. M. Crowell	69 Dublin St.	Halifax, N. S.
Ontario	VE3SG	<b>ONTARIO DIVISION</b> Fred H. B. Saxon	302 Lee Ave.	Toronto, Ont.
Quebec	VE2EE	<b>QUEBEC DIVISION</b> Stan Comach	780 Brault Ave.	Verdun, P. Q.
Alberta British Columbia	VE4GE VESHP	<b>VANALTA DIVISION</b> C. S. Jamieson James Hepburn	581 W. Riverside Drive 335 Foul Bay Road	Drumheller, Alta. Victoria
Manitoba Saskatchewan	VE4BG VE4EL	<b>PRAIRIE DIVISION</b> A. J. R. Simpson Wilfred Skiffe	635 Garfield St. 2040 McTavish St.	Winnipeg Regina

\* Officials appointed to act until the membership of the Section choose permanent S.C.M.'s by nomination and election.



## Kandid Ken-O-Talk, No. 5

### • HIGH QUALITY AUDIO SYSTEMS •

**T**HE words "High Quality" are purely comparative. A high quality modulator amplifier today is quite different from one of fifteen years ago. But what do we mean by a high quality modulator amplifier today? We must go on and furnish some standard against which we may make comparisons before any definite impression is conveyed by two such indefinite words. Before we set up this standard, it will be well to look a little further into the requirements of the device to be qualified. Its function is to transmit intelligence. Of what nature, we may ask? Is it for speech, music, or television? If it is to be used for television, the range of frequencies to be transmitted is very wide, and the phase shift must be held to narrow limits. We are, at the present, primarily interested in the transmission of spoken intelligence, so we will disregard the requirements for transmission apparatus of other types.

The first requisite for our amplifier is that its amplitude distortion be low. Since, with proper design, this may easily be minimized, let us set our requirements at a maximum figure corresponding to six percent RMS harmonic distortion.

The second requirement is one that will be set with different degrees of severity, largely by personal opinion. This requirement is for the ability of the device to pass a certain minimum band width of frequencies with no discrimination.

The quality of the voice, which makes it possible for us to identify friends and acquaintances on hearing them speak, is likely to be spoiled if the band of frequencies transmitted is too narrow. If it is desired to transmit this quality let us set our minimum band width from 60 to 6000 cycles. On the other hand if voice quality is unimportant and only intelligibility is required we may narrow our band width considerably.

The third requirement is that there be a minimum of unwanted frequencies transmitted. In this class would come power supply hum, pickup-hum and so on.

In addition to these requirements of course will be those of over-all gain and power output which vary with the type of microphone used and the size of the transmitter to be modulated.

With these specifications confronting him, the amateur has many important decisions to make. He is the chief engineer on the job. It is up to him to decide exactly what requirements must be met, and then to go about meeting them in the most economical manner. The economy with which he may meet a given standard of excellence is a measure of his ability.

Many of our "chief engineers" give much thought and do a great deal of original work on antennae and R. F. problems. Many now realize what results may be obtained by spending a like amount of thought on their modulators. Next month we will cite an example of one who gave his modulator the thought it deserves. We will show the circuit he used, the standard of excellence he attained, and the money he saved the "broadcasting company at W2—" on a thirty-watt unit.

*F. P. Kenyon*

# The American Radio Relay League



**T**HE AMERICAN RADIO RELAY LEAGUE, INC. is a non-commercial association of radio amateurs, bonded for the promotion of interest in amateur radio communication and experimentation, for the relaying of messages by radio, for the advancement of the radio art and of the public welfare, for the representation of the radio amateur in legislative matters, and for the maintenance of fraternalism and a high standard of conduct.

It is an incorporated association without capital stock, chartered under the laws of Connecticut. Its affairs are governed by a Board of Directors, elected every two years by the general membership. The officers are elected or appointed by the Directors. The League is non-commercial and no one commercially engaged in the manufacture, sale or rental of radio apparatus is eligible to membership on its board.

"Of, by and for the amateur," it numbers within its ranks practically every worth-while amateur in the nation and has a history of glorious achievement as the standard-bearer in amateur affairs.

Inquiries regarding membership are solicited. A bona fide interest in amateur radio is the only essential qualification; ownership of a transmitting station and knowledge of the code are not prerequisite. Correspondence should be addressed to the Secretary.

HIRAM PERCY MAXIM, FIRST PRESIDENT

## OFFICERS

**President**.....EUGENE C. WOODRUFF, W8CMP  
State College, Pa.

**Vice-President**.....GEORGE W. BAILEY, W1KH  
Weston, Mass.

**Secretary**.....KENNETH B. WARNER, W1EH  
West Hartford, Connecticut

**Treasurer**.....ARTHUR A. HEBERT, W1ES  
West Hartford, Connecticut

**Communications Mgr.**...F. EDWARD HANDY, W1BDI  
West Hartford, Connecticut

**General Counsel**.....PAUL M. SEGAL  
1026 Woodward Building, Washington, D. C.

Address all general correspondence to the administrative headquarters at West Hartford, Connecticut

## DIRECTORS

*President*  
EUGENE C. WOODRUFF.....W8CMP  
234 W. Fairmount Ave., State College, Pa.

*Vice-President*  
GEORGE W. BAILEY.....W1KH  
74 Webster Road, Weston, Mass.

*Canadian General Manager*  
ALEX REID.....VE2BE  
169 Logan Ave., St. Lambert, P. Q.

*Atlantic Division*  
WALTER BRADLEY MARTIN.....W3QV  
Box 612, Roslyn, Pa.

*Central Division*  
R. H. G. MATHEWS.....W9ZN  
100 East Ohio St., Chicago

*Dakota Division*  
FRED W. YOUNG.....W9MZN  
228 1/2 Willard St., Mankato, Minn.

*Delta Division*  
E. RAY ARLEDGE.....W5SI  
P. O. Box 286, Pine Bluff, Ark.

*Hudson Division*  
KENNETH T. HILL.....W2AHC  
115 Willow St., Douglaston, L. I., N. Y.

*Midwest Division*  
FLOYD E. NORWINE, JR.....W9EFC  
120 South Fourth St., St. Louis, Mo.

*New England Division*  
PERCY C. NOBLE.....W1BVR  
37 Broad St., Westfield, Mass.

*Northwestern Division*  
RALPH J. GIBBONS.....W7KV  
c/o United Air Lines, Pendleton, Ore.

*Pacific Division*  
L. McCARGAR.....W6EY  
66 Hamilton Pl., Oakland, Calif.

*Roanoke Division*  
H. L. CAVENESS, JR.....W4DW  
State College Station, Raleigh, N. C.

*Rocky Mountain Division*  
EDWARD C. STOCKMAN.....W9ESA  
618 So. Williams St., Denver

*Southeastern Division*  
BENNETT R. ADAMS, JR.....W4APU  
1512 Grove Place, Homewood, Ala.

*Southwestern Division*  
CHARLES E. BLALACK.....W6GG  
443 Main St., El Centro, Calif.

*West Gulf Division*  
WAYLAND M. GROVES.....WSNW  
c/o Humble Pipe Line, Mt. Pleasant, Texas



# "It Seems to Us — —"

WE suppose that most of us, in explaining amateur radio to friends, have dwelt on the benefits it can bring to the shut-in. Here, surely, is a group to which it can mean much: friendly contact with their fellows to those whose friendships must be few; visits to others in far countries by those to whom little or no traveling is possible; the enjoyment of competitive effort in contests for those to whom such things are normally denied.

Four years ago, a typical Chair-Warmer heard about amateur radio, learned the code, turned to literature on the subject—and brought up against a blank wall. For the man was blind, and there was no amateur radio literature in Braille.

He wrote to the Service for the Blind of the New York Chapter of the American Red Cross about the problem, and their interest was aroused. This was an interesting coincidence; at that same time, the League was engaged in correspondence with the Braille Division of the Library of Congress (which sponsors printing for the blind under a special yearly appropriation from Congress) concerning the possibilities of amateur literature in Braille. Thus it came about that we were asked what was this Handbook, of which the inquirer had spoken, and would we give permission for a single copy to be made in Braille? We gladly gave the permission, but it must have been something of a shock for the Red Cross people in New York when they saw the Handbook. For here was no easily-transcribed pamphlet, but an unusually long, word-packed text! If that were not enough, there was the problem of diagrams; essential to the text, they represented a new and difficult problem in Braille work.

The American Red Cross, however, has not gained its world-wide reputation by lying down when confronted with difficult jobs. The laborious task of transcription was confidently undertaken and a year later was finished—nine large volumes of it! For a year thereafter, that single set enjoyed a steady demand, not only in the New York area but all over the East.

Watching this demand, and perceiving in the results a powerful force for good among the blind, the Red Cross and the Library of Congress finally decided to tackle another transcription, this time on plates for multiple printing, so that sets could be distributed to libraries carrying Braille literature. The cost of materials would be paid out of the Library's special appropriation; the New York Chapter of the Red Cross would do the work.

That was two years ago. To-day, just as we go to press with this issue of *QST*, it is our pleasure to announce that 54 copies of the complete 12th edition of the A.R.R.L. Handbook, together with the same number of copies of the latest edition of the License Manual (which will be kept up-to-date with "change sheets" when required) have just been bound and distributed to 27 branch libraries around the country, where they will henceforth be available on a loan basis to any blind person. That list of libraries will appear in next *QST*; in the meantime, anyone interested may secure it from the Library, the Red Cross or League headquarters, on request.

Nor is that all! With the 54 government-paid-for copies distributed, the New York Chapter is ready to fill individual orders, for those who may wish them, at \$10 for the complete 8-volume combination of Handbook and License Manual, or at \$1.25 for individual volumes, postage to be added in either case. These prices, we may say, represent the bare costs of production; neither the Red Cross nor the A.R.R.L. realizes any profit whatsoever from the books. Orders can be sent to the A.R.R.L., but preferably should go direct to the Braille Service of the New York Chapter, American Red Cross, 315 Lexington Ave., New York City.

These are the facts. Yet, inspiring as they are, they fail utterly to convey the true story of this project; only one who has visited the New York offices of the Red Cross and seen the spirit which characterizes those who have put in so much unselfish effort on this work can remotely appreciate what has been accomplished. The amount of labor and care poured into this relatively stupendous task of transcribing—for this is one of the most ambitious Braille projects ever attempted by this agency—is inconceivable, yet it has been done entirely by volunteer workers. Everywhere in the Braille department of the New York Chapter is the most inspiring enthusiasm for "our book," as they have come to call it. And indeed, considering the enormous effort they have expended on it, it is impossible not to feel that it is their book; our part has been no more than that of a well-wishing by-stander.

Amateurs everywhere can feel particularly proud that the cause of amateur radio as a hobby and recreation for the blind has been so enthusiastically espoused by these authorities. It is a glowing tribute!

—A. L. B.

# Amateurs Mobilize in Southern California Flood Emergency

Many Isolated Cities Linked Solely by Amateur Radio;  
A.R.R.L. Emergency Plan Receives First Test

By Clinton B. DeSoto\*

**D**URING the first days of March southern California's most destructive flood disaster gave radio amateurs in the region their greatest opportunity for public service since the Long Beach earthquake of 1933.

The raging waters, rising to flood heights with almost incredible speed, were matched by the mobilization of amateur communications resources within the six beleaguered counties—Ventura, Los Angeles, San Bernardino, Orange, Riverside and San Diego.

The angry Santa Ana River, starting high in the mountains and plunging 6000 feet to sea level in 30 miles, overflowed with the relentless five-day rainfall (26.85 inches in Pasadena) and became seven miles wide near the sea. Dry most of the year, the Los Angeles River became a raging monster that tore out railway and highway bridges in the industrial area, paralyzing transportation and communications. High water throughout the rest of southern California created emergency situations critical in varying degree. Practically every bridge and road in western San Bernardino County, largest in area in the country, was washed out or blocked by slides. A death toll exceeding 100 and property damage approaching \$25,000,000 totalled the extent of the catastrophe.

The torrents struck quick, furious blows that annihilated wire communications in many cities. San Diego, El Centro, Riverside, Redlands, San Bernardino, Filmore—in these and other places radio was the sole remaining link. The San Fernando valley and most of the coastal communities south of Long Beach relied on amateur operators with emergency equipment when other means failed. Long Beach itself was isolated in many respects, as were Canoga Park, Van Nuys, North Hollywood, Venice. Throughout the entire southern California area hundreds of amateurs went to work, either at their own stations or with emergency gear in devastated sections.

#### THE LOS ANGELES AREA

Flood stage was reached on Wednesday, March 2nd. There was little advance warning of the probable extent of the calamity. Only when the Boulder Dam power line was taken out by a slide,

\* Assistant Secretary, A.R.R.L.

causing the loss of power in many sectors, did the major proportions of the disaster appear. In the space of a few hours portable, mobile and emergency-powered equipment was set up at key points.

Relief communications in the Los Angeles area and San Fernando valley were organized by S.C.M. Don Draper, W6GXM, aided by his Emergency Coördinators, Ralph S. Click, W6MQM, for Los Angeles, C. H. Haas, W6EAH, for Hollywood and Beverly Hills, Mal F. Meacham, W6KLN, for the Pasadena territory, and Click's assistant in Los Angeles, Matt Murray, W6OJL.

W6OJL established headquarters at the Red Cross building on Menlo Avenue in Los Angeles and served as net control on the 5- and 160-meter bands, dispatching relief and rescue parties. Supply and equipment orders for the police, railroad traffic for the Union Pacific and Southern Pacific, missing persons reports, etc., were handled. A. E. Gram, W6NXW, participated in the formation of the Red Cross net. Wilbert J. Jewell, W6NAH, got himself excused from school so he could operate the Red Cross Net control station.

There were 50 stations on the network, tying in the California Forestry Service and medical and other organizations as well as the Red Cross. Samuel W. Wolfe, W6LRO, Howard L. Johnson, W6PAK, James Parker, W6OZV, Benton T. Jayne, W6JWY, Victor W. Lonberger, W6NIU, W6EZA and Olen W. Lewis, W6BVA operated under portable status. A number of these stations were on continuously for 50 hours or more, with George A. McDaniel, W6MGO, W6OJL, Cal D. Smyth, W6OPM and Johnny Goodman, W6LVL, still going on March 6th. David Josephson, W6HDR, and W6LVL operated the key station on 1.7-Mc. 'phone, while W6OPM and W6OJL manned the key outlet on 5 meters. Exceptional work was performed by all stations on this network, approximately 3000 messages being handled.

W6GXM in Los Angeles and R. T. Warner, W6MRT, in Victorville, handled traffic on 75-meter 'phone for the California Highway Patrol and National Guard, as well as general service messages, from 3 P.M. on March 2nd through the week-end. These stations also scheduled W6KDI

in Cedar City, Utah, W6DSB in Independence, W6BMC in El Centro, W6MBJ in Riverside, W6CDA in Oakland and W6GQC in Salt Lake. They handled traffic for the Union Pacific, Southern Pacific and Santa Fe railroads. This network also provided valuable service for the Bureau of Power and Light.

Other railroad orders and also general traffic were handled through W6NXW and Andrew H. Abraham, W6MQS, these stations working W6DEP and W6RO in Long Beach, W6MOR in Daly City, W6DSB and W6CUY in Lone Pine, W6BXQ in Laguna Beach, W6LFC in Willowbrook and W6NYS in Santa Clara. The message total was approximately 800.

W6MQM lost his antenna mast, but relayed through George D. Whittet, W6BQI, and Howell C. Brown, W6BPU, in Pasadena (all A.A.R.S.), with the XYL holding down the land 'phone. Speaking of XYL's, those at W6MQS, W6NXW, W6GXM, W6MQM, W6BQI and many others deserve credit, manipulating telephones with one hand and coffee pots with the other.

Arthur H. Potts, W6MMQ, concentrated on traffic for the Southern California Telephone Company, and Stuart P. Dalton, W6FJ, worked with the Associated Press. Forrest H. Wright, W6LFC and Lanford W. Sorenson, W6JWQ, were also active in the Los Angeles area, as was Kenard D. Moore, W6PDB. Cecil F. Dickinson, W6JSX, transmitted United Press correspondence to W6ITH in San Francisco. The John S. Marshall High School Radio Club, W6YBH, handled 136 messages with replies to 42 in four hours.

Lonin Grignon, chief of sound at Paramount, placed J. N. A. Hawkins, W6AAR, in charge of a crew with a 500-watt portable on a 1-ton truck, fitted with auxiliary equipment, but the truck was unable to get into the flooded area. Also standing by on call with self-powered gear were Stanley E. Hyde, W6IAH, Perry F. Backus, W6HUX and W6MQM.

The Los Angeles area proved a particularly fertile source of emergency gear, the motion picture studios—Metro-Goldwyn-Mayer, Fox, Paramount, Columbia—and the radio parts stores—Leo J. Meyberg, Radio Doc, Pacific Radio Exchange, Radio Supply, Radio Television—furnishing needed equipment.

#### HAM CONTACTS COVER ENTIRE AREA

One or more amateur stations were active in practically all the smaller cities around Los Angeles, most of them operating in spontaneous networks coöperating with A.R.R.L. Coördinators. W6EAH had a 10-meter mobile unit in the field, operating through W6JFM at the Red Cross Net control in Los Angeles. Press traffic was handled with W6MMV and W6KW, San Diego, and W6BKY, Whittier.

Jack Prather, W6KJP, was active in North

Hollywood, as was R. D. Nagel, W6CAH. W6KJP handled traffic for the police with the San Fernando valley, together with W6MQS and W6JWY. Edward F. Munnell, W6PCP, was on in Hollywood, and James Neubauer, W6LVX, in Tujunga. W6NIU operated in Van Nuys. Reginald M. Bradshaw, W6NAY, handled Beverly Hills. In the Pasadena region there were Herschel B. Calvert, W6EAN, Cecil W. Woods, W6JSB and George W. Parr, W6BWG.

When the situation became generally threatening the Long Beach Emergency Committee, headed by Larry Lynde, W6DEP, met at the local armory at the request of the Police Department. It was there decided to station amateur stations on the west side of the "flood control"—as the Los Angeles River is termed—before the bridges, and accompanying telephone wires, were washed out.

W6DEP, whose emergency equipment comprises a gasoline-driven power plant, all-band transmitter and two 5-meter transceivers, undertook the job. Locating the transceivers at strategic points, including the Southern California Edison plant which powered the city, W6DEP maintained a constant 160-meter circuit to W6RO and W6EWK in Long Beach. Dwight Williams, W6RO, relayed by land telephone to relief headquarters, while Dr. L. J. Trowbridge, W6EWK, policed the channel and served as alternate contact.

The major emergency anticipated in Long Beach did not materialize, however, for the San Gabriel River burst a levee ten miles up the valley, relieving the pressure along the Los Angeles. Even so, there was plenty of work for the hams. Martin E. Corcoran, W6GOY, took his portable to the overflowing banks of the San Gabriel and provided invaluable communication. Don C. Wallace, W6AM, established a number of hook-ups, including one between National Guard headquarters at Long Beach and Sacramento, another with Vical Merrington, W6HGN, Hondo, to the *Rancho de los Amigos* (county poor farm), and still another for International News Service to Chicago whereby the first flood picture out of the area was transmitted by facsimile!

Albert Hansen, W6HHU, provided communication with San Bernardino. Elmer H. Lincoln, Jr., W6HTE, served as a relay point to the police. The Long Beach police were thoroughly amateur-conscious, by the way, Foster Strong, W6MK, being chief of police radio. The same was true of the City Emergency Committee, for John Mead, ex-W6JE, is head of that. Other amateurs were also active in Long Beach, including A. K. Edgerton, W6EDF, of Glendale, who was visiting in the city at the time and used the 5-meter mobile in his car at a bridge lookout station.

San Bernardino was isolated for a period of days. A 40-foot wall of water, which came roaring

(Continued on page 72)

# A Tuned Loop for 80- and 160-Meter Reception

## Compact Directivity for Improving Portable and Emergency Operation

By John P. Tynes,\* W6GPY

**T**HE interesting developments of the day—new circuits, new equipment and new ideas, come so fast that we are all hard pressed to keep up with the procession. In the rush we sometimes forget, or perhaps merely overlook, some of our old friends. This is somewhat the case with loop antennas, such as were used quite extensively on broadcast receivers a few years back.

When the word "loop" is used we generally think of direction-finding equipment. Loops are still used to a great extent on the longer wave bands for this purpose, but for direction finding or beam operation on the higher frequencies, they have been replaced almost entirely by the larger multi-element antenna systems used by many of the airways stations.

An important use for the loop lies in the field of noise elimination—"noise" being any background disturbance that tends to obscure the wanted signal. It may be caused by a station operating on the same frequency, but not in the same line of direction as the station you are trying to receive, or it may result from a leaky insulator on a power pole a block or so away. The loop has advantages in combating these noises that are not present in any of the more popular noise suppressors, such as the crystal filter and the Lamb noise silencer, because it can help prevent them from getting into the receiver at all. It is not claimed that the loop is a cure for all the ham's troubles, but we do believe that its addition to the receiver will make the operating job more pleasant under some conditions.

The loops described have been used very successfully by the SARO (a Pacific Coast emergency network) for a number of months. Most of these stations are low-powered and designed to work with gasoline-driven a.c. supplies. The small amount of power in the carriers makes for very difficult operation during bad QRM and QRN conditions. The use of loops on the receivers when working these stations has caused a vast improvement in the operation of the network. It has made possible contacts that previously were out of the question.

The loop has another very practical advantage for use with emergency equipment, in that it eliminates the necessity for erecting a receiving antenna, which is a requirement in duplex operation.

### PRELIMINARY EXPERIMENTS

The design of a loop antenna for use on the 160- and 80-meter bands was something new to all of us. In fact most of us had never operated a loop before, and others were not even familiar with the theory of its operation. A little time was spent in reading the available literature on the subject, especially the information given in

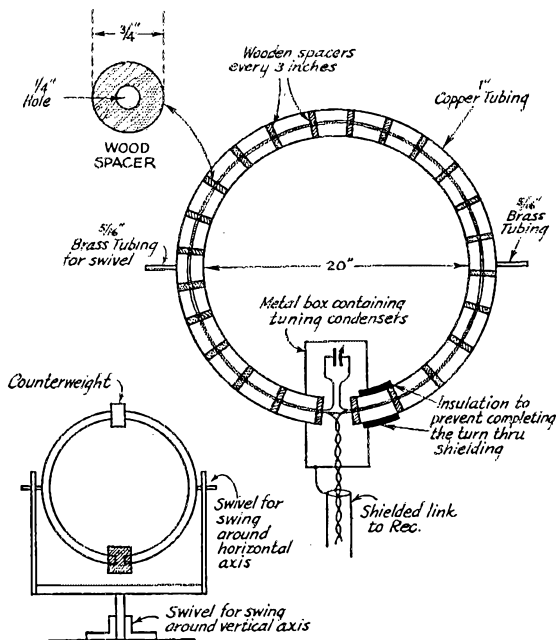

FIG. 1—DETAILS OF LOOP CONSTRUCTION

The spacers, cut from 3/4-inch round stock and drilled in the center, are spaced every three inches along the wires, and taped in place. Five separate wires, of length sufficient to run through the tubing with a little to spare, are used. The wire and spacer assembly is pulled through the tubing and four of the wires spliced at the opening to form the loop proper. The fifth wire is the link for coupling to the receiver. The insulation at one end of the tubing is essential, since a continuous circuit would prevent signal pickup.

\*3044 1/2 Telegraph Ave., Berkeley, Calif.

Terman's "Radio Engineering" and also Morecroft's work on the same subject.

The first trial loop constructed was a cumbersome affair made out of two-inch copper stove pipe, welded into a two-foot square open at one corner. Wooden discs were cut on the drill press with a panel cutter and these discs were fitted into the pipe so as to support the wires of the loop. These wires were threaded into the discs before the welding job was done. The open corner of the square provided a separation so that the tubing would not form a shorted turn, and at the same time provided a place to splice the wires of the loop.

Six turns of wire were used in this loop, and they were tuned by a regular broadcast variable condenser. Connections were made from each side

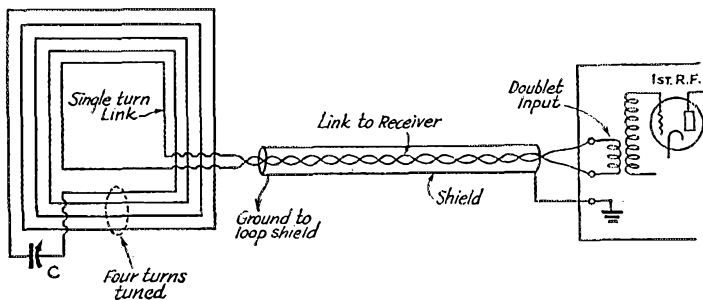

FIG. 2—THE LOOP CIRCUIT

The four-turn loop is tuned by condenser C, a broadcast-type variable, having a maximum capacity of about 370  $\mu\text{fd}$ . The loop resonates to the 160-meter band with C near maximum capacity, and to 80 meters with C near minimum.

of this condenser to the grid and ground of the first r.f. or input stage of the receiver. This worked very well, but the coupling method was inconvenient since it required going into the receiver and lifting the grid cap. It was not so good from a shielding standpoint, either, so other methods of coupling were sought. The system which seems to work best is to place an additional turn of wire in the loop and connect it to the doublet input of the receiver by means of a twisted pair of wires. The wires of this link can be shielded, with the shielding tied to the receiver at one end and to the copper shield of the loop at the other end.<sup>1</sup>

Six turns proved to be too many to resonate on both the 160- and 80-meter bands, so the number was cut to four. The fifth turn was used for the link, and the sixth turn was left open and unused.

A second loop was constructed in an effort to cut down the size and make it more convenient for use in portable work. This new loop was made out of half-inch soft copper tubing, bent into a fifteen-

inch circular shape. No spacers were used in this loop, with the result that the capacity of the wires to the grounded copper shield greatly reduced its effectiveness. Another lesson learned—keep the capacity of the loop to ground as small as possible.

#### FINAL CONSTRUCTION

The third loop was started with the idea of including as many as possible of the good points of the first two loops and at the same time eliminating the bad features. This third loop was made out of one-inch copper tubing bent into a circle about twenty inches in diameter, with the wires supported in the center of the tubing by small wooden spacers. Four turns were used in the loop proper, tuned with a condenser as in the first loop. The fifth turn was used for link-coupling the loop to the receiver. This loop worked exceptionally well and was of satisfactory size.

At this point in the construction, it was decided to mount the loop so that it could be rotated in either the vertical plane or the horizontal plane. This last change really brought home to use the nicest feature of loop operation. By swinging the loop in both planes and taking into account the polarization of the received wave, it was possible to reduce any signal to the inaudible, or nearly so, and still hear the desired signal. The constructional and electrical features are shown fully in the two figures.

Loop antennas have very broad tuning characteristics when turned to the maximum signal position, but are very sharp when turned to the minimum signal position. This means that the sharp minimum can be placed on an interfering signal or noise, and the broad maximum will allow the desired signal to come through. The signal received from the wanted station will not be as loud as when tuned in on a regular antenna, but the signal-to-noise ratio will have been improved to the point where the signal can be copied solid.

Other loops have been constructed, of the non-shielded type, using wooden strips for the framework. These loops have all proved their worth, but they are harder to build into compact form, and perhaps not quite as rugged for portable use.

There is a fertile field for further work with loops and it is hoped that others will take it up. We have had very gratifying results with these loops on the 160- and 80-meter bands, but we have only tried them on these two bands. Whether they can be made to work as well on the higher frequencies remains to be seen.

<sup>1</sup> Shielding of both loop and receiver is essential if the directive properties of the loop are to be realized. The loop and receiver input circuit also should be balanced to ground; the doublet connection recommended by the author provides a means for doing this.—EDITOR.



# Some Practical Aspects of Speech Amplifier Design

## Considerations in Obtaining Wide Frequency Response and Low Hum Level

By Dana H. Bacon,\* W1BZR

**C**OMPARATIVELY little has been written on the practical problems encountered in the design and construction of a high-gain high-fidelity speech amplifier of the type required in the up-to-date amateur 'phone installation. The fundamental requirements of such an amplifier are, of course, well understood; briefly, it must have an input system built for a high-impedance microphone, an overall gain of about 125 db, and a flat frequency response from about 30 to 10,000 cycles. There must be sufficient power output to drive a good-sized modulator, if necessary, and hum level, distortion, etc., must be so low as not to be noticeable.

The average amateur has neither the time nor the laboratory facilities for doing the experimental work required and it is hoped, therefore,

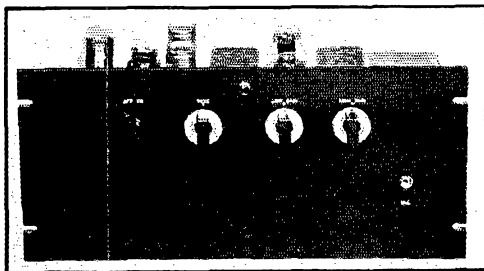

THE AMPLIFIER DISCUSSED IN THE TEXT

*The right-hand gain control is for the microphone amplifier channel, while the one on the left controls the auxiliary low-gain channel, which is suitable for a phonograph pickup or similar comparatively high-level apparatus.*

that the following discussion will be helpful to those who are confronted with the task of building an amplifier having the characteristics outlined above.

### CHOOSING THE TUBES

The output requirements should first be considered. Class-B modulator tubes are now available which will deliver 500 or 600 watts of audio when operated Class-B with driving power of only 10 or 12 watts. If the speech amplifier will deliver 15, it will, therefore, be capable of handling a modulator which will work with a full kilowatt input to the Class-C r.f. stage.

Since most of the screen-grid tubes and pen-

todes are quite fussy as regards load impedance and since their plate impedances are high, making the Class-B coupling transformer quite critical in design, the obvious choice is low-impedance triodes, such as the 2A3's. Two of these tubes when operated in push-pull with fixed bias will deliver 15 watts with only about 2.5 per cent distortion. Inasmuch as the same tubes self-biased with a cathode resistor will deliver only 10 watts with 5 per cent distortion, it is well worth while to use a separate fixed bias supply, as shown in the schematic diagram, Fig. 1. Voltage for the half-wave rectifier is obtained from a tap on one side of the high-voltage secondary winding of the power transformer. A rectifier tube must be selected which will heat up as soon as the 2A3's, otherwise they would be damaged by lack of bias. Suitable economical rectifiers are not available, but the Type 26 has all the necessary requirements.

### VOLTAGE AMPLIFIERS

A single Type 56 will drive 2A3's to full output without difficulty, and it remains, therefore, to obtain sufficient voltage amplification between the microphone and the grid of the 56. Unfortunately, this gain cannot be obtained in a single stage, even when using a screen-grid tube.

Perhaps before going farther it might be well to consider the input circuit. The conventional crystal microphone is built to work directly into the grid of the tube, the grid return of which usually consists of a 5-megohm resistor. The actual input capacity of a tube is not simply the grid to cathode capacity; due to the manner in which the tube functions, the grid-to-plate capacity, multiplied by the amplification of the tube, shows up as a capacity in parallel with the grid-to-cathode capacity. Suppose, for instance, a high- $\mu$  triode, such as the 6F5, is analyzed; the normal input capacity is listed as 6  $\mu\text{fd}$ ., but the grid-to-plate capacity of 2  $\mu\text{fd}$ . multiplied by the voltage amplification, say 55, gives a total shunting effect of about 115  $\mu\text{fd}$ ., and this would of course be sufficient to attenuate seriously the higher audio frequencies across the 5-megohm grid circuit.<sup>1</sup>

<sup>1</sup> The extent of the high-frequency attenuation depends upon the type of device feeding into the amplifier; the crystal microphone, fortunately, is fairly tolerant in this respect because electrically its output circuit looks like a moderate-sized capacitance, and shunting additional capacitance across it does not change the frequency response to as great an extent as with other types of input devices.—EDITOR.

\* 41 Bellington, Arlington, Mass.

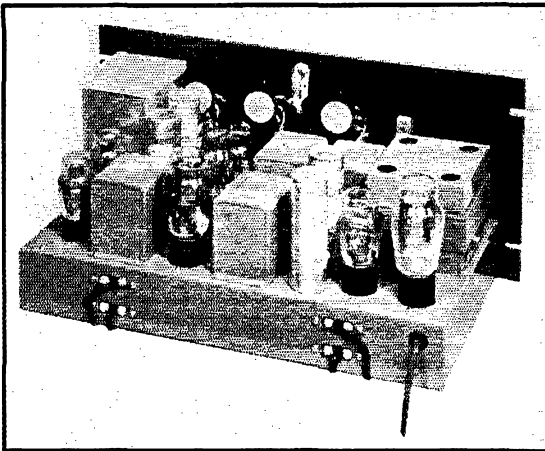

#### A TOP VIEW OF THE CHASSIS

*The power transformer and rectifier tubes should be mounted as far as possible from the voltage amplifier stages. It is not necessary to shield the 83 rectifier.*

It follows, therefore, that the best tube to use is one of the screen-grid type, since screen-grid tubes have such an extremely low grid-to-plate capacity that the shunting effect is negligible. The Type 57 is entirely satisfactory.

A 2A6 was chosen to fill in between the screen-grid input tube and the 56. Another 56 could have been used instead with about 10 db less gain, and this is satisfactory if the full 125 db gain is not required. The use of a high- $\mu$  triode in the second stage does not cause attenuation of high frequencies as it would in the first stage, since the impedance of the grid circuit is considerably lower. The diode plates are not used.

#### 2.5-VOLT VS. 6.3-VOLT HEATERS

The reader may have wondered why 2.5-volt tubes were used instead of the 6.3-volt types. As a matter of fact, the first experimental models of the amplifier were built with the latter tubes, but it soon became apparent that the hum level was excessively high. Most of the hum was found to originate in the heater circuit of the input tube and of the many types tried the 6J7 was the best, being considerably better than the 6C6. A more thorough investigation showed, however, that there are two types of heaters used in the 6J7's. One of these is of a double-spiral construction which overcomes the hum problem pretty well but is subject to microphonism, while the other employs a folded heater wire with no provision for balancing out hum. The latter is, however, very good from the microphonic standpoint. Even when using the 6.3-volt tubes having the spiral heater, it is usually necessary to center-tap the heater winding carefully and run it at a potential of 10 to 40 volts positive with respect to the cathode in

order to prevent electrons emitted from the heater itself from reaching the grid. (Point "X" in the schematic.) The situation is even more involved, however, since different tube manufacturers use different methods of heater construction and the dealers have no way of telling how any particular tube is built. All of these problems can be very easily avoided by using tubes with 2.5-volt heaters, since they are of uniform construction, and of the large number tested even the worst were considerably better than the average corresponding 6.3-volt type. Hum from the heater circuit is apt to be bothersome in the second stage as well as in the input, and although the effect is much less objectionable, substitution of a 2.5-volt type in this circuit position was a very definite improvement.

#### FREQUENCY CHARACTERISTIC

We come now to the choice of circuit elements and their effect on frequency response.

The values shown in Fig. 1 are such that there is less than 1 db variation in gain between 25 and 10,000 cycles, and the gain at 20 cycles is down only two or three db. As a matter of fact, it is a fairly simple matter to obtain an excellent frequency characteristic; there are only three or four points that must be watched. Cathode bias resistor bypasses must be at least 20  $\mu$ f.; 8 or 10 is not enough. Furthermore, these condensers should be of the low-voltage type in order that they will maintain their characteristics at the low potential at which they are used. Coupling condensers between stages are not fussy; if the grid leak resistor is at least one-half megohm, a 0.1- $\mu$ f. condenser will be large enough. Units of 0.25  $\mu$ f. are available at approximately the same price, however, and may be used if desired.

The push-pull audio input transformer must be of good quality, and even the best transformer will be working at a disadvantage if the plate current of a tube is passed through its primary.

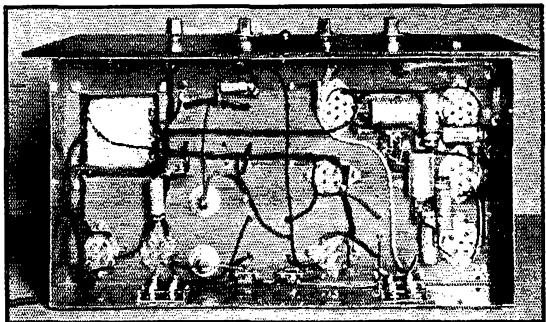

#### NOT MANY PARTS SHOWING HERE

*Careful layout and good workmanship are always worth while and make the complete job look much simpler than the schematic diagram would indicate.*

The simple shunt-feed arrangement which supplies the plate of the 56 was found to be entirely satisfactory and with the particular transformer employed extended the lower frequency limit from 50 to 20 cycles. While it is customary to use a choke instead of a resistor for shunt-feeding the plate of a tube, the resistor is to be preferred in this particular circuit. Inasmuch as the 2A3 grids are never swung positive, the 56 is not called upon to deliver any appreciable power and it may be considered for all practical purposes as being a voltage amplifier. If a choke were used its reactance would have to be several times greater than that of the transformer primary in order to maintain amplification at low audio frequencies, but almost any resistor may be used and the fact that it is a resistor helps to flatten the frequency characteristic.

The transformer secondary should be balanced with respect to the primary, in order to obtain uniform high-frequency response. One of the inexpensive transformers that was tested had a secondary of conventional construction wherein one grid terminal was next to the primary and the other was at the outside end of the coil. This transformer had a rather peculiar characteristic since the end of the secondary that was nearest

the primary had considerable shunt capacity which gave a dip in the frequency-response curve in the neighborhood of 6000 or 7000 cycles, while the outside end of the secondary contributed to a peak which showed up at about 10,000 cycles. While it would be possible to tune this peak to fill in the hollow, such practice is an unnecessary complication in view of the high-quality transformers that are available at reasonable prices.

#### STABILITY

Strangely enough, and very luckily, the same means used to obtain stability or freedom from motor-boating will, at the same time, minimize hum and improve the frequency characteristic. The plate circuits of the three low-level stages are each individually filtered with 20,000-ohm resistors and 8- $\mu$ fd. condensers. These were found to be entirely adequate and will eliminate any trace of motor-boating. At the same time, they constitute extremely effective power-supply filters which prevent any ripple from the plate supply from reaching the signal circuits. Similarly, the 25- $\mu$ fd. cathode by-pass condensers, in addition to their function of extending the low-frequency response of the amplifier, serve to remove any 60-

(Continued on page 108)

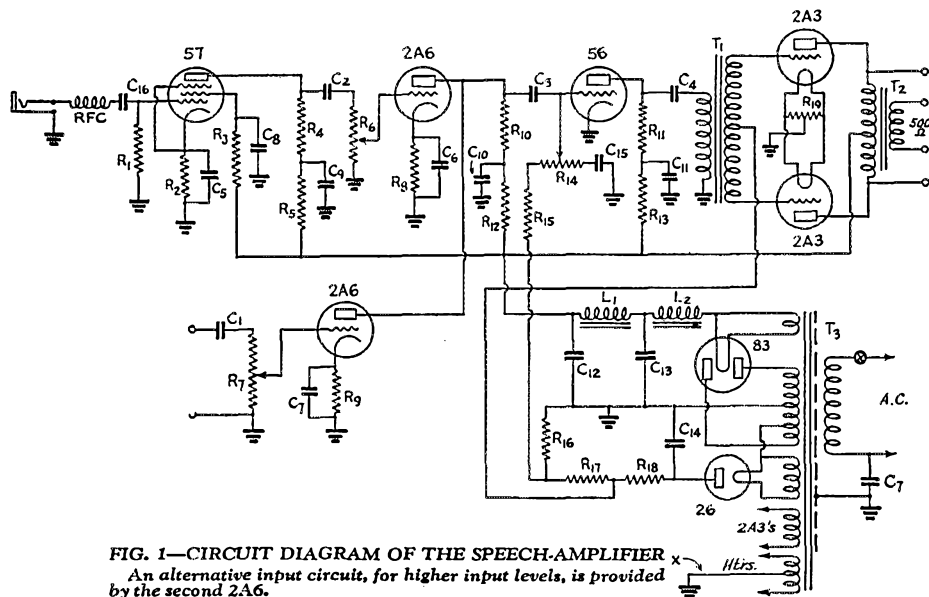

FIG. 1—CIRCUIT DIAGRAM OF THE SPEECH-AMPLIFIER  
An alternative input circuit, for higher input levels, is provided by the second 2A6.

- C<sub>1</sub>, C<sub>2</sub>, C<sub>3</sub>, C<sub>4</sub>—0.25- $\mu$ fd. 400-volt paper.
- C<sub>5</sub>, C<sub>6</sub>, C<sub>7</sub>—25- $\mu$ fd. 25-volt electrolytic (Aerovox MM25).
- C<sub>8</sub>—0.5- $\mu$ fd. 400-volt paper.
- C<sub>9</sub>—C<sub>14</sub>, inc.—8- $\mu$ fd. 450-volt electrolytic.
- C<sub>15</sub>—0.005- $\mu$ fd. 400-volt paper.
- C<sub>16</sub>, C<sub>17</sub>—0.1- $\mu$ fd. 400-volt paper
- R<sub>1</sub>—5 megohms, 1/4-watt.
- R<sub>2</sub>—1000 ohms, 1/4-watt.
- R<sub>3</sub>—1 megohm, 1/4-watt.
- R<sub>4</sub>—0.25 megohm, 1/4-watt.

- R<sub>5</sub>—0.1 megohm, 1/4-watt.
- R<sub>6</sub>, R<sub>7</sub>—0.5-megohm volume control.
- R<sub>8</sub>, R<sub>9</sub>—2500 ohms, 1/4-watt.
- R<sub>10</sub>, R<sub>11</sub>—50,000 ohms, 1/4-watt.
- R<sub>12</sub>, R<sub>13</sub>—20,000 ohms, 1/4-watt.
- R<sub>14</sub>—0.5-megohm volume control.
- R<sub>15</sub>—10,000 ohms, 1/4-watt.
- R<sub>16</sub>—2700 ohms, 1-watt.
- R<sub>17</sub>—11,000 ohms, 1/4-watt.
- R<sub>18</sub>—26,000 ohms, 1-watt.
- R<sub>19</sub>—10-ohm ct. (Yaxley).
- T<sub>1</sub>—Audio transformer, single-plate

- T<sub>2</sub>—Class-AB output transformer, 2A3 plates to 500-ohm line (National HFO).
- T<sub>3</sub>—Power transformer, 400 volts each side c.t., with bias tap at 145 volts; with 5-volt, 1.5-volt and 2.5-volt windings (National HFA).
- L<sub>1</sub>, L<sub>2</sub>—12 henrys, 125-ma. (National 80).
- RFC—2.5-mh. r.f. choke.

# Putting the Harmonic Generator to Work

## Four-Band Transmitter With 814 Final

By John L. Reinartz, \*W1QP

**A**T my attendance at amateur meetings during 1937 someone usually asked for more information about the "harmonic generator" circuit which I had described in *QST* a while back.<sup>1</sup> A typical question was, "What tubes for the final stage?" This question is easily answered by the medium-power beam tube, the 814. A complete transmitter embodying the harmonic-generator circuit and capable of operation on all amateur bands down to 10 meters has been built in a fashion that can be easily duplicated.

It will be remembered that in the harmonic-generator circuit the crystal oscillator was operated on the crystal frequency only, and that the following tube was used to generate the even and odd harmonics up to the 11th and 12th. For our present purpose, the 8th harmonic is sufficient; that is, 28 Mc. from an 80-meter crystal. The tubes originally used in the crystal-oscillator and multiplier circuit were an 802 and an 807. It is appreciated that these tubes are a little larger than necessary and for this reason the unit described uses two 6L6 tubes. However, if the 6L6 tubes are to be operated so that the d.c. plate input is never more than the safe plate dissipation, it is advisable to operate only to the 4th harmonic of the crystal frequency. This makes it necessary to use two crystals for operation on all bands between 28 and 3.5 Mc. One crystal at 3.5 Mc. is suitable for operation at 3.5, 7 and 14 Mc.; a 7-Mc. crystal, for operation at 7, 14 and 28 Mc. This arrangement gives a choice of two frequencies at 7 and 14 Mc.

The beam power tube has so many desirable features that it may be well to list a few. First, and probably the most valuable characteristic, is the low driving-power requirement of the tube. Expressed in terms of power output and power input, the ratio is 130 watts to 1.5 watts. Second, it requires no neutralization, even at 10 meters. Third, plate modulation can be used with a modulation factor of 1 with good linearity. In addition, the tube requires but 1250 volts when used for Class-C telegraphy, for 130 watts output; this means an economical plate-voltage supply. In

many cases, the rated efficiency can be exceeded and the output consequently increased without exceeding the plate-dissipation rating of the tube.

In the transmitter pictured, nothing was sacrificed even though compactness was a requirement. Because relay-rack mounting is nearly universal, provision is made for that detail. Above the chassis are mounted the tubes and coils, along with the crystal, while underneath are mounted the condensers, transformers, resistors, and associated wiring. It will be seen that the tank condensers are fairly large. This is necessary in order to obtain a "Q" of 12 for the final tank at 3.5 Mc. While the condensers shown are all of the same size, this is not a necessary design feature. The coil forms used in the transmitter may also be modified or commercial coil forms substituted. The ingenuity of the average

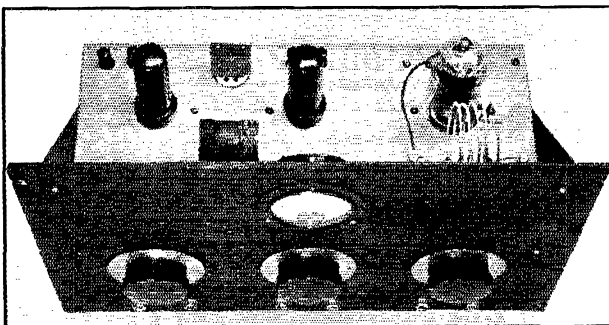

**TWO 6L6'S IN THE HARMONIC-GENERATOR CIRCUIT DRIVE THE 814 IN THIS TRANSMITTER TO FULL OUTPUT ON THREE BANDS**

*The oscillator and harmonic-generator plate coils are mounted on a common form, in this case fastened horizontally to a plug-in base.*

amateur can come into play here with the consequent satisfaction of having improved appearance. It is suggested that the layout be followed as nearly as practicable in order that the wiring will not depart too much from that used in the transmitter pictured. Too many deviations may cause a change in the performance characteristics.

### HARMONIC-GENERATOR CIRCUIT

As indicated in Fig. 1, the crystal-oscillator circuit and that of the following tube must be treated as one, because their combined action accounts for the generation and amplification of the desired harmonics. Beginning with the cathode circuit, it should be noted that the fixed

\* 176 Wadsworth St., Manchester, Conn.

<sup>1</sup> Reinartz, "A Fundamental-Reinforced Harmonic-Generating Circuit," *QST*, July, 1937.

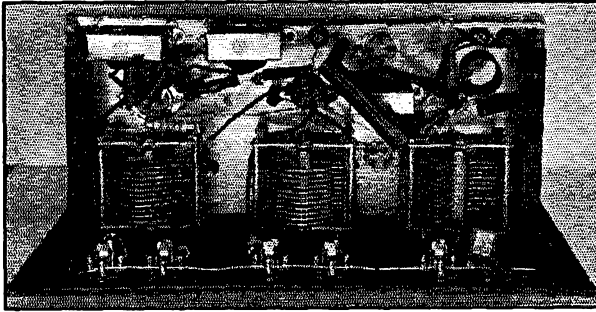

**BOTTOM VIEW OF THE TRANSMITTER**

As explained by the author, variable condensers with lower voltage rating can be used in the low-power circuits. The jacks for metering are connected in the cathode and grid circuits.

condenser across the cathode inductance must not be larger than 100  $\mu\text{fd.}$ , but that the inductance itself should be quite large so that the circuit will tune approximately to *one-half* the fundamental frequency of the crystal. This inductance need not be changed once the cathode circuit is adjusted to tune to half the frequency of the lowest-frequency crystal; this corresponds to 1.75 Mc. for a 3.5-Mc. crystal, or to approximately 950 kc. for a 1.75-Mc. crystal. The cathode circuit will then be suitable for any higher-frequency crystal, even including one made for 28 Mc. The crystal is always connected between the No. 1 grid and the *bottom* of the cathode tuned circuit. While a low-resistance grid leak of the type indicated will allow the greatest power output, the circuit will function with other types of resistors. The use of less than 100,000 ohms in series with the screen is not recommended. A lower value will not appreciably raise the power output, but may cause the plate input (in case the crystal stops oscillating) to exceed the plate dissipation rating of the tube.

It will be noted that the 6L6 harmonic multiplier is connected as a high- $\mu$  triode, with the control and screen grids tied together. With this type of connection the plate current is extremely small when the tube is not being excited. The same thing may be done in the oscillator circuit, if desired, as shown by the alternative oscillator diagram in Fig. 1. The tubes work equally well with either method of connection, but with the grids tied together the plate dissipation is negligible when the crystal is not oscillating.

The plate-circuit connections are unique in that the plate circuit of the frequency multiplier is inductively coupled to the plate circuit of the crystal-oscillator. The two plate coils are, in fact, wound on the same form; they *must be in the proper phase relation* in order to function properly. When connected correctly, the plate circuit of the second 6L6 feeds back into the plate circuit of the oscillator the harmonic corresponding to the operating frequency; this, in turn, is fed back to the grid of the second tube in an amplified

condition, be it the second, third, fourth, or higher harmonic. When the two coils are wound in the same direction, the plate of the first tube should be connected to the beginning of its coil and the high voltage to the other end. The plate of the second tube should then be connected to the beginning of its coil, and the plate voltage to the other end. Fig. 1 shows the connections for the proper phase relation as well as the spacing between the two coils for proper coupling.

When operating on the same frequency as the crystal, the second 6L6 has no tendency to oscillate, since the feedback is degenerative rather than regenerative at the fundamental frequency. Neutralization therefore is not required.

#### FINAL AMPLIFIER

The connections to the 814 will offer no difficulties since there is no need for neutralization. Capacity coupling is used from the driver stage. While the coupling capacitance can be fixed, it is better to use a midget variable condenser in order that better control of the driving power and d.c. grid current can be obtained. The 814 requires very little d.c. grid current; any value from 9 to 12 ma. will be found sufficient. It should be remembered that effective by-passing with good low-voltage condensers is a necessity at the screen and filament terminals of the socket. Those who have experienced a disconcerting decrease in grid current when plate voltage was applied to a screen-grid final amplifier may not know that it was partly due to insufficient by-pass capacitance at either the screen or filament connections of the tube. Such a condition causes a degenerative effect which acts to reduce the grid current and output of the final stage. In some instances, it is even advantageous to use a series-tuned circuit at the screen of a tetrode to make sure that the screen-to-filament impedance is low. Of course, every precaution should be taken to keep the plate-circuit wiring away from the grid-circuit wiring to minimize r.f. feed-back and resulting instability.

#### ADJUSTMENT

In the tuning-up process, the crystal-oscillator plate condenser is adjusted to the dip in plate current at the fundamental frequency of the crystal. The tuning of the second tube is done similarly, but the correct frequency will be determined by the coil combination being used. If the coil combination is for a 3.5-Mc. crystal and the fourth harmonic (14 Mc.) for the second tube and the final, then the second tube must be tuned to the dip at the fourth harmonic. The frequency must be carefully checked to make sure that the circuit is not tuned to the third or fifth harmonic.



When the correct frequency is once determined, the dial settings of the last two tank condensers should be noted and recorded. These dial settings might well be attached to or marked on the plug-in coil form. When the grid current of the 814 is at or near 10 ma., the plate voltage may be applied and the plate circuit tuned to resonance. The same tuning procedure is used for all coil combinations, such as 3.5-3.5, 3.5-7 and 3.5-14, or 7-7, 7-14, and 7-28 Mc. The 814 plate coil, of course, always corresponds to that used in the second 6L6 stage.

If an 802-807 combination is employed for the first two stages, the transmitter will go directly from 3.5 to 28 Mc., so that only a 3.5-Mc. crystal is required. The rig will then be capable of operating on 3.5, 7, 14 and 28 Mc. from one 3.5-Mc. crystal—which is something!

#### MODULATION

There is no need to worry regarding the modulation capabilities of the 814 on any of the amateur bands where 'phone is allowed (down to 28 Mc.). Clean, 100 per cent modulation is obtainable. The transmitter described has been in use at W1QP with voice modulation on 28, 14 and 4 Mc. with remarkably fine results. At normal tube ratings in this type of service, the power output is approximately 90 watts.

For 100 per cent modulation, it is necessary that the screen voltage be supplied through a series resistor from the modulated plate supply. While this means that a bit more audio power is needed, because both screen and plate are modulated, the difference in power is very small. Cathode-ray patterns of the modulated carrier show that modulation of a beam power tube (when the screen is also properly modulated) provides the same quality and completeness of modulation that are obtained when a triode is used. A beam power tube is even better in this respect than a triode if the latter is not adequately neutralized.

This unit will be used as a demonstration transmitter by the writer at such amateur meetings as he may attend during 1938, so that the manner in which the circuit functions to drive an 814 on all bands up to 28 Mc. may be investigated at first hand.

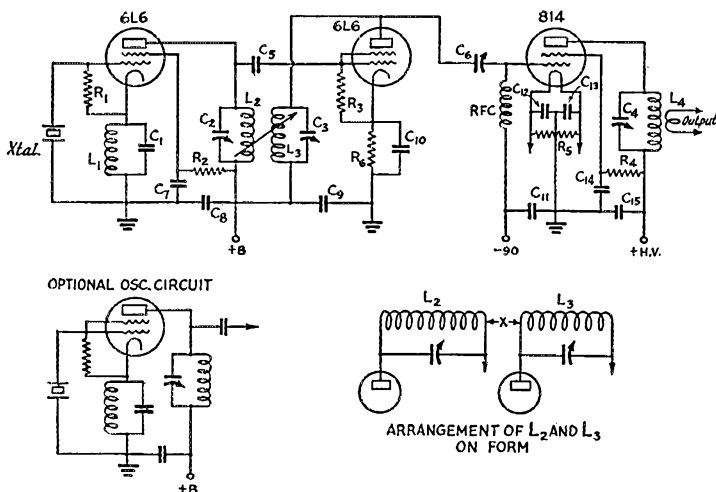

FIG. 1—CIRCUIT DIAGRAM OF TRANSMITTER USING THE HARMONIC-GENERATING CIRCUIT

- L<sub>1</sub>—1½-inch winding of No. 24 d.c.c. on 1½-inch diameter form.  
 L<sub>2</sub>—3.5-Mc. crystal; 15 turns No. 20 d.c.c. close-wound on 1½" form.  
 7-Mc. crystal; 7 turns No. 20 d.c.c. close-wound on 1½" form.  
 L<sub>3</sub>—3.5 Mc.: 15 turns No. 20 d.c.c. close-wound.  
 7 Mc.: 7 turns No. 20 d.c.c. close-wound.  
 14 Mc.: 5 turns No. 16 d.c.c. space-wound.  
 28 Mc.: 3 turns No. 16 d.c.c. space-wound.

L<sub>8</sub> wound on same form as L<sub>2</sub>. Spacing between coils as follows:

L <sub>2</sub> Freq.	L <sub>3</sub> Freq.	Spacing, Inches
3.5 Mc.	3.5 Mc.	3
3.5 Mc.	7 Mc.	2
3.5 Mc.	14 Mc.	1
7 Mc.	7 Mc.	2
7 Mc.	14 Mc.	1
7 Mc.	28 Mc.	½

- L<sub>4</sub>—Inductance adjusted so capacity is 1 μfd. per meter on each band.  
 3.5 Mc.: 16 turns No. 14, diameter 2½ inches, length 3 inches.  
 7 Mc.: 8 " " " " " " " " " "  
 14 Mc.: 4 " " " " " " " " " "  
 28 Mc.: 2 " " " " " " " " " "

- C<sub>1</sub>—100-μfd. mica.  
 C<sub>2</sub>, C<sub>3</sub>, C<sub>4</sub>—225-μfd. transmitting variable (see text).  
 C<sub>5</sub>—100-μfd. mica.  
 C<sub>6</sub>—50-μfd. variable.  
 C<sub>7</sub>—C<sub>13</sub>, inc.—0.01-μfd. paper, 600-volt.  
 C<sub>14</sub>, C<sub>15</sub>—0.005-μfd. paper, 2000-volt (0.01-μfd. 1000-volt units in series).  
 R<sub>1</sub>—5000 ohms, 1-watt.  
 R<sub>2</sub>—100,000 ohms, 2-watt.  
 R<sub>3</sub>—20,000 ohms, 1-watt.  
 R<sub>4</sub>—40,000 ohms, 25-watt.  
 R<sub>5</sub>—100 ohms, center-tapped.  
 R<sub>6</sub>—7000 ohms, 10-watt.  
 RFC—2.5-mh. r.f. choke.



Use of an old 0-50-volt battery tester of the low-resistance type for filament voltmeter and plate milliammeter indicator in the low-power transmitter is suggested by W2GTA.

The use for coil forms of the wooden forms on which 28-foot lengths of 35-mm. Agfa photographic film are obtained is suggested by J. E. Greenbaum, Bridgeport, Conn. These forms are of one-inch diameter and 1¾-inch length.

# ● What the League Is Doing ●

## League Activities, Washington Notes, Board Actions—For Your Information

---

**Cairo News** The battle is still to be fought at Cairo, as of the time of writing, but the preliminary skirmishes have been won. The conference officially opened on February 1st. In all, some 285 delegates from 71 countries and colonies were registered. In addition, there were present 79 representatives from 42 operating organizations, and 27 observers from non-operating organizations (including I.A.R.U. and A.R.R.L.), making a total of some 400 official participants—plus personnel from the Berne Bureau, the Egyptian secretariat, and some hundreds of office workers.

Following the opening session, which was honored by a message from King Farouk, and a reception for the delegates in the royal palace, the radio section of the conference proceeded to work, exactly as outlined in the recent Cairo article. At the opening plenary session on the afternoon of the second day, three major committees were set up, chairmen designated for them, and their work parcelled out. Senator White, chairman of the U. S. delegation, was named chairman of the important Technical Committee; the other two main committees are those on Regulations and Tariffs & Traffic. The Technical Committee split up into a subcommittee on allocations and one on the classification of waves and miscellaneous subjects. The Allocations Committee is, of course, the one of most significance to us; it is headed by Colonel Angwin, of Great Britain.

So far, very few amateur matters have received attention resulting in conclusive action. Foremost of those considered was the Japanese proposal to limit amateur power to 50 watts input to the antenna. This proposal was successfully defeated, and is not likely to be heard from again in this conference. U. S. Representative Gross attacked the Japanese argument that the proposal would reduce interference, pointing out that the United States had experienced no unfortunate interference effects from 48,000 amateurs over a period of 26 years, with 1000 watts input as a power limit; he asked for maintenance of the *status quo*. His motion was immediately seconded by a large group of nations. As a result of this showing, we understand, Japan was prevailed upon to withdraw the proposal. In consequence, Article 8 remains unchanged and each nation continues to be free to set the power limitation of its amateur stations. It is not expected that this article will be given any further attention by the conference.

The amateur allocations themselves have not yet been considered, with the exception that, following a spirited discussion over the appropriation of some of our 28-Mc. territory for the meteorological service, the preservation of the 28 and 56-Mc. bands seems reasonably assured at this writing. It is apparent, however, that a major battle on the lower-frequency bands looms. Already there is much argument on the question of how to get increased space for aeronautical and broadcast stations in the short-wave spectrum, with the Japanese proposal for acquiring it from amateur territory representing one attitude. Most European nations are definitely proposing inroads on one or more of our bands and real trouble is anticipated. It is too early to speculate on the outcome, except to point out that the partisans of amateur radio outside of Europe will try to keep any undue threats confined to the European continent. We can only hope that territory for these other services can be found outside the amateur bands. The problem of the amateur representatives (Warner, Watts and Segal are now all on the job) will be to keep the support of amateur radio's proponents stronger than its opponents.

— . . . —  
**Rumor** From many sections of the country this past month we've had inquiries regarding a rumor that the code-speed requirement in the amateur examination had been raised from 13 w.p.m. to 17 w.p.m. We're happy to torpedo the rumor. Nothing to it, gang; the speed is still 13 w.p.m.

— . . . —  
**Keeping Your Log** The amateur regulations require that you log *each* transmission from your station. This doesn't mean you have to make a separate entry every time you go back at a given station during the course of a single QSO, but it does mean each different QSO or call has to be logged. On a visit to the F.C.C. a few weeks ago, it was called to our attention that a lot of hams don't log the sending of a CQ unless it happened to get a reply, and we were asked to tell the gang that this isn't correct practice, which of course it isn't. So watch your log entries, fellows; you never know when your log or portions of it may be called in for examination.

— . . . —  
**Habana** The documents of the Habana conference, known as the "Inter-American Arrangement Concerning Radiocom-

munications" have been issued in an English translation and we reprint portions affecting amateur matters for their interest to amateurs on the two American continents. Remember, as pointed out in Secretary Warner's article in the February *QST*, that these provisions are not yet in effect, however.

Under Table III (giving the general frequency allocation to services between 1600-4000 kcs.), 1750-2050 kcs. and 3500-4000 kcs. are designated as exclusively amateur frequencies for all three zones covered by the treaty—the North American, South American and so-called Central zones. Similarly, in Table IV, covering frequencies between 4000-25,000 kcs., exclusive amateur bands are agreed to for 7000-7300 kcs., and 14,000-14,400 kcs., and in Table V, we get 28,000-30,000 kcs. This is as high as definite assignments go under the treaty. However, the conference set up a Table VI "as a guide to planning, research and the experimental use of" the frequencies between 30 Mcs. and 300 Mcs., and in this table we have been given exactly the same bands as recently outlined by the F.C.C. for future U. S. amateur use in the u.h.f. spectrum, at 56-60 Mcs., 112-118 Mcs., and 224-230 Mcs.

Note 7, attached to the tables of allocations, is interesting: "Existing services operating within the present authorized bands shall not be displaced therefrom unless suitable replacement frequencies are provided; therefore, it is important that the recommendations to Cairo contain specific recommendations on this subject." And now for some of the real meat of the conference, as it dealt with us: we refer to Section 8 of the agreement and we suggest it be read in its entirety:

"Section 8. *Amateurs.*

"The following provisions concerning amateurs were unanimously agreed upon in addition to the allocation tables:

"1. That the band from 1750-2050 kc. be allocated for A-1 and A-3 emissions.

"2. That, after a study of the recommendations issued by the Radio Conference at Buenos Aires (revised at Rio de Janeiro, 1937), (e) and (f) of Recommendation number 10, they have agreed to amend them, without altering the spirit thereof, substituting in their stead, the following:

"(e) That the Administrations should point out the convenience that amateurs use the bands from 1750 to 2050 and 3500 to 4000 Kc/s preferably for short distance communication.

"(f). That the Administrations recommend the bands from 7000 to 7300 Kc/s and 14,000 to 14,400 Kc/s should not be used for short distance communications between amateur stations.

"3. That frequencies included between 3500 to 4000, 7000 to 7300 and 14,000 to 14,400 be

available for allocation in accordance with the following table.

3500 to 3800 Kc/s for A-1 only.

3800 to 4000 Kc/s for A-1 and A-3.

7000 to 7050 Kc/s for A-1 only.

7050 to 7150 Kc/s for A-1 and A-3.

(A-3 for Latin-American only.)

7150 to 7300 Kc/s for A-1 only.

14,000 to 14,100 Kc/s for A-1 only.

14,100 to 14,300 Kc/s for A-1 and A-3.

14,300 to 14,400 Kc/s for A-1 only.

"Emission type A-1 may be used in the entire frequency band comprised between 14,000 and 14,400 Kc/s. The Latin-American countries, Canada and Newfoundland may use type A-3 in the frequencies comprised between 14,100 and 14,300 Kc/s. The United States will operate with emission type A-3 on frequencies 14,150 to 14,250 Kc/s., at least until December 31, 1939.

"4. The bands from

1750 to 2050 Kc/s

3500 to 4000 Kc/s

7000 to 7300 Kc/s

14,000 to 14,400 Kc/s

28,000 to 30,000 Kc/s

56,000 to 60,000 Kc/s

shall be amateur bands.

"5. In order to make a better use of the 14-megacycle band insofar as radiotelephone communication is concerned, and to avoid at the same time any undue congestion which may be caused by the operation of beginners not familiar with the use of high frequencies, it is recommended that an adequate probationary period in which to acquire the necessary experience, as well as a technical and practical test, be required before an amateur will be granted a license to operate on the 14 megacycle band for radiotelephony." (In other words, something like our Class-A requirements and special examination is endorsed as a good idea for all American countries for 14-Mc. 'phone.—Ed.)

"6. The amateur bands lately assigned shall not be used for any type of broadcasting fixed or mobile service."

And then we come to the third-party message section:

"Section 9. *Amateur Third Party Messages.*

"Whereas the General Radio Regulations annexed to the International Telecommunication Convention of Madrid provide that unless modified by special arrangements between interested countries amateur stations are forbidden to transmit international communications emanating from third persons; and

"Whereas it is apparent that the community of interest of the peoples of all the Americas would be fostered by encouraging the exchange, by amateur stations, without charge, of friendly messages emanating from our citizens.

(Continued on page 64)

# De Luxe Battery-Operated Portable Stations

Field Sets Used by the National Park Service

By R. D. Waterhouse\* and W. C. Hilgedick\*\*

*Although the portable set described in this article does not work on amateur frequencies, the circuits can be adapted readily to our work. This is truly emergency equipment, portable to locations where cars and storage batteries cannot be taken. Its reliability has been proved by daily operation under adverse conditions. There are good ideas here for the taking.—EDITOR*

SO much interest has been displayed in the issues of *QST* on portable emergency radio transmitter-receiver equipment that it was decided to offer descriptions and data on the latest type of National Park Service field set as a contribution toward better portables. This set was presented to two radio conventions during the past summer, as well as to radio clubs, and each time much interest was displayed in its unique features.

The development of this specialized equipment started in 1928 with '01A tubes and a battery supply that would break the back of any mule. Year by year the bugs have been taken out and weight and volume reduced by the coordination of efforts of manufacturers' development engineers, telephone company engineers, University of Washington Radio School, and the National Park Service engineers, until a set has been evolved that has the minimum of weight and bulk possible for the output. Its construction is such that accidental rough usage or handling does no damage, it can be put on the air in five minutes, and it works, even in the hands of an inexperienced operator. The output is approximately three watts, and we are getting 100 miles consistently. However, our usual set-up requires covering five to fifty miles, so it can be seen that reliable communication is obtained.

As many as 1600 men have been maneuvered, fed and equipped at a fire lasting over a month, with radio communication serving as the

means of contact. During the 1937 Mississippi flood these sets were in operation handling many messages in the Memphis area on the levees, in the boats, and in the offices of the operating agencies. In Grand Canyon National Park one of these sets furnished 100 per cent communication on the Temple of Shiva climb. Another expedition taking a two months' geological survey trip down the Colorado River through the deep narrow gorges of the Grand Canyon from Lee's Ferry to Pierce's Ferry set up one of these sets each evening and talked to the Park headquarters on the South Rim. Communication was established and reports exchanged each night except one—and that was when the cook, who was not familiar with the operation of the set, was the only man left in camp. The maximum distance covered was 110 miles. Lehman Cave National Monument reports to Zion National Park, a distance of 200 miles, each morning with this type of set.

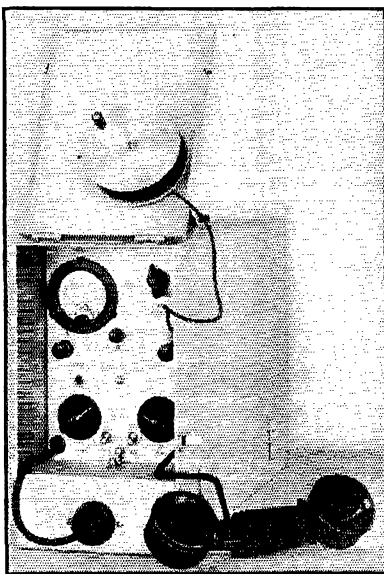

THE COMPLETE PACK SET

*Containing a three-stage crystal-controlled transmitter and modulator, and a four-tube superhet receiver, all dry-battery operated. The antenna reel is on the raised cover. The flat compartment at the bottom, into which the cable is plugged, is a tray containing "A" and "B" batteries.*

## REQUIREMENTS

The requirements of a field set for our use are briefly as follows:

1. It must be as light-weight as possible because a man going to a fire or on a rescue party must not have his speed hampered by a heavy pack.
2. It must be complete, including antenna and power supply.
3. It must be compact and easy to handle.
4. It must be sturdy and able to take the knocks—then work.
5. It must utilize voice transmission so that any of the personnel besides trained radio men can operate it.

\*Regional Engineer, Region Four, National Park Service.

\*\*Radio Engineer, National Park Service.

6. It must cover frequencies between 2400 and 3500 kc.

#### COMPLETE SET ASSEMBLY

The set consists of the transmitter-receiver compartment proper and three different sizes of power supplies, which are made up in two sizes of battery trays that clamp to the bottom of the set and a separate heavy-duty battery box. The larger of the battery trays carries regular portable batteries, the smaller holds a set of very light-duty batteries where extreme portability is required, and the separate box contains large-size batteries where longer duration of service is desired and where time has allowed packing a heavy unit into the field.

The following tabulation gives the size and weight of these various units complete with batteries. All units contain 180 volts "B" and 3 volts "A":

1. Set with small tray— $17\frac{1}{2}$  by 6 by  $10\frac{1}{2}$  inches, weight 22 pounds.
2. Set with large tray— $17\frac{1}{2}$  by 6 by 13 inches, weight 36 pounds.
3. Heavy duty box—20 by 15 by 10 inches, weight 85 pounds.

The approximate length of service of each supply is:

#### Larger battery tray:

Receiver on continuously . . . . .	60 hours
Receiver on 6 hours per day . . . . .	100 hours
Receiver on 3 hours per day . . . . .	110 hours
Receiver on 1 hour per day . . . . .	120 hours

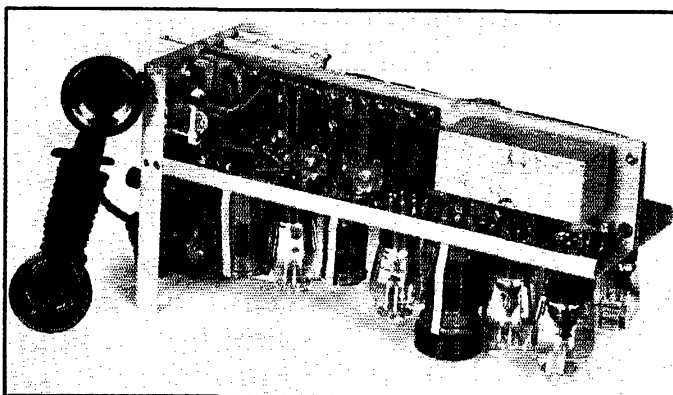

#### THE TRANSMITTER SIDE

The chassis is the same size as that for the receiver. The rectangular metal box contains the audio transformers. The output is in the vicinity of three watts, on frequencies from 2400 to 3500 kc.

#### Separate battery box:

Receiver on continuously . . . . .	60 days
Receiver on 6 hours per day . . . . .	75 days
Receiver on 3 hours per day . . . . .	90 days
Receiver on 1 hour per day . . . . .	150 days

No data were obtained on the smaller battery tray because these batteries will give service only for a short period, and should not be relied upon for power for over one-half day's continuous service or two days' intermittent service.

#### THE TRANSMITTER

The transmitter combines a crystal oscillator and buffer in a single 19 tube, and uses a second 19 with the elements in parallel as a power amplifier. This is modulated by a 19 tube in Class-B driven by a 1F4. The 1F4 provides sufficient audio gain to permit operation of the microphone without additional batteries besides that used for the "A" battery supply. Bias for the 1F4 driver is obtained from the power-amplifier grid leak, with suitable filtering to prevent r.f. feedback.

Unity-coupling plug-in coils are used which cover a restricted range of frequencies. The picture may be confusing on this point because the insulating cloth between windings extends below the coil on top.

The output coil,  $L_3$ , contains a fixed condenser to give a pi-section output for the "L" antenna post. The value of this condenser has been chosen to match correctly the antenna on the reel.

The "S" antenna post is connected to the high side of

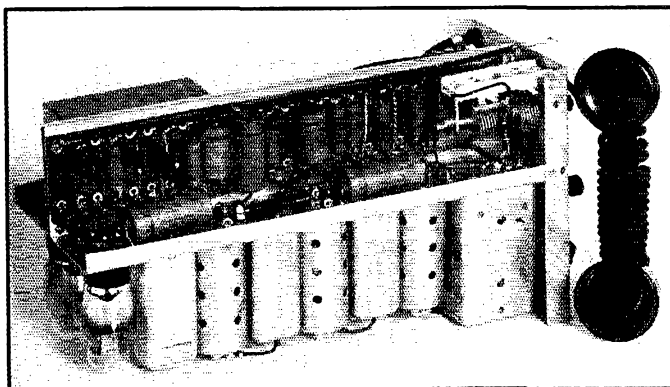

#### THE RECEIVER SIDE OF THE CHASSIS

R.f. coils are in the can at the extreme right. Note the neatness of the wiring job. Since the receiver is used exclusively for 'phone reception, no beat oscillator is incorporated, but one could be included readily in an amateur adaptation of the layout.



the output-tuning condenser through a series condenser. This condenser has been adjusted to match correctly a 500-ohm load such as the single-wire-fed antenna recommended. However, the circuit will match approximately any impedance between 200 and 1000 ohms. An adjustment of the series capacity, which is mounted directly behind and below the p.a. meter, will provide closer matching.

A side fone is supplied to the handset from the

output of the 1F4 through  $R_{26}$ . This serves as a check on the operation of the speech section.

#### THE RECEIVER

The receiver is a conventional superheterodyne with automatic volume control. A 1A6 tube is used as a frequency converter to the intermediate frequency of 465 kc.; a 1A4 tube as an intermediate frequency amplifier; a 1A4 tube as a second

(Continued on page 68)

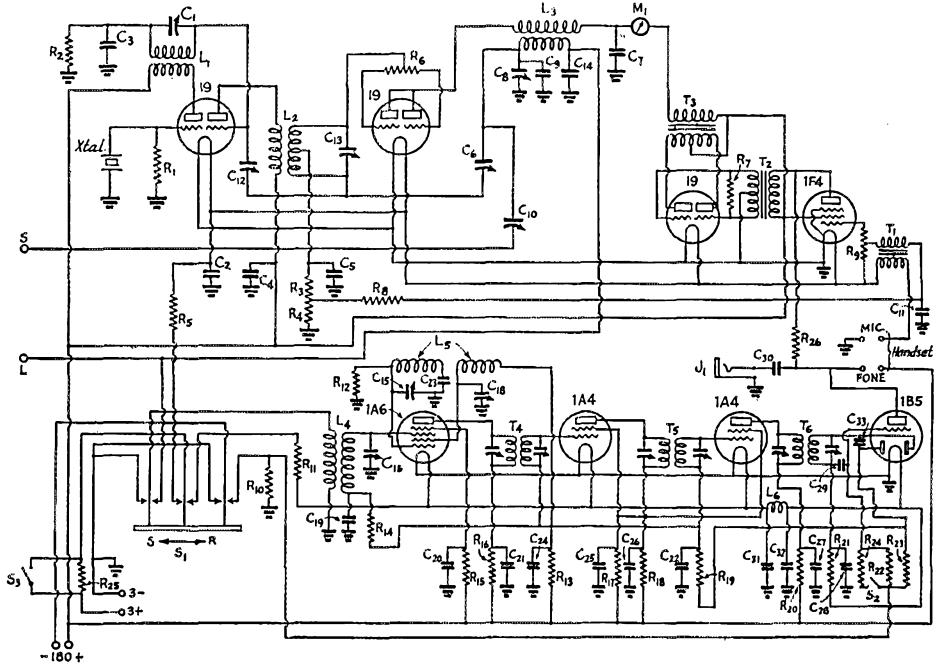

FIG. 1—COMPLETE CIRCUIT DIAGRAM OF THE NATIONAL PARK SERVICE PACK SET

- C<sub>1</sub>—Oscillator plate tuning, 35- $\mu$ fd. trimmer.
- C<sub>2</sub>, C<sub>3</sub>, C<sub>4</sub>, C<sub>6</sub>—0.01- $\mu$ fd. paper.
- C<sub>5</sub>—Amplifier neutralizing, 35- $\mu$ fd. trimmer.
- C<sub>7</sub>—Amp. plate by-pass, 0.002- $\mu$ fd. mica.
- C<sub>8</sub>—Amp. plate tuning, 100- $\mu$ fd. variable (Hammarlund MC-100-S).
- C<sub>9</sub>—Amp. tuning trimmer, 70- $\mu$ fd.
- C<sub>10</sub>—Antenna coupling, 70- $\mu$ fd. trimmer.
- C<sub>11</sub>—Audio driver, bias filter, 0.1  $\mu$ fd.
- C<sub>12</sub>—Buffer neutralizing, 35  $\mu$ fd. trimmer.
- C<sub>13</sub>—Buffer tuning, 140- $\mu$ fd. trimmer.
- C<sub>14</sub>—Antenna coupling, 200- $\mu$ fd. mica.
- C<sub>15</sub>, C<sub>16</sub>—Receiver tuning, 100  $\mu$ fd. (Hammarlund MCD-100-M).
- C<sub>17</sub>—70- $\mu$ fd. trimmers, in parallel with C<sub>15</sub> and C<sub>16</sub>. Not shown in diagram.
- C<sub>18</sub>—Oscillator vernier, 15  $\mu$ fd. (Hammerlund SM-15).
- C<sub>19</sub>, C<sub>20</sub>, C<sub>21</sub>—0.01- $\mu$ fd. paper.
- C<sub>22</sub>, C<sub>23</sub>—0.1- $\mu$ fd. paper.
- C<sub>24</sub>—Oscillator padder, 0.001- $\mu$ fd. mica.
- C<sub>25</sub>, C<sub>26</sub>, C<sub>27</sub>, C<sub>28</sub>—0.01- $\mu$ fd. paper.
- C<sub>29</sub>, C<sub>30</sub>, C<sub>31</sub>—0.25- $\mu$ fd. paper.
- C<sub>32</sub>—0.001- $\mu$ fd. mica.
- C<sub>33</sub>—250- $\mu$ fd. mica.
- R<sub>1</sub>—20,000 ohms, 1/2-watt.
- R<sub>2</sub>—10,000 ohms, 1/2-watt.
- R<sub>3</sub>—3000 ohms, 1/2-watt.
- R<sub>4</sub>—1000 ohms, 1/2-watt.
- R<sub>5</sub>—1/2 ohm.
- R<sub>6</sub>—100 ohms each section (parasitic suppressor).
- R<sub>7</sub>—30,000 ohms, 1/2-watt.

- R<sub>8</sub>—20,000 ohms, 1/2-watt.
- R<sub>9</sub>—100,000 ohms each section.
- R<sub>10</sub>—150 ohms, 1/2-watt (bias resistor)
- R<sub>11</sub>—2 ohms.
- R<sub>12</sub>—50,000 ohms, 1/2-watt.
- R<sub>13</sub>, R<sub>17</sub>—20,000 ohms, 1/2-watt.
- R<sub>14</sub>, R<sub>19</sub>, R<sub>22</sub>—1 megohm, 1/2-watt.
- R<sub>15</sub>, R<sub>26</sub>—50,000 ohms, 1/2-watt.
- R<sub>16</sub>, R<sub>18</sub>, R<sub>20</sub>—5000 ohms, 1/2-watt.
- R<sub>21</sub>—250,000 ohms, 1/2-watt.
- R<sub>23</sub>—0.5 megohm, 1/2-watt.
- R<sub>24</sub>—10,000 ohms, 1/2-watt.
- R<sub>25</sub>—1 ohm.
- L<sub>1</sub>, L<sub>2</sub>, L<sub>3</sub>—Oscillator, buffer and amplifier plate coils; constants depend upon band to be used. With receiving-type forms, dimensions for the tuning capacities given can be found from the chart in the Transmitter Design chapter in the Handbook. Primaries are same as secondaries, the latter being wound over the former with a layer of insulation between.
- L<sub>4</sub>, L<sub>5</sub>—Oscillator and mixer coils. Standard coil sets may be used for the purpose.
- L<sub>6</sub>—1/2 to 1 microhenry.
- T<sub>1</sub>—Single-button microphone transformer.
- T<sub>2</sub>—Class B input transformer for coupling 1F4 to 19.
- T<sub>3</sub>—Class-B output transformer for 19.
- T<sub>4</sub>, T<sub>5</sub>, T<sub>6</sub>—465-kc. i.f. transformers.
- Sw<sub>1</sub>—3-pole d.t. switch (Yaxley No. 63).
- Sw<sub>2</sub>, Sw<sub>3</sub>—S.p.d.t. toggle.
- M<sub>1</sub>—0-50 d.c. milliammeter.

# The Construction of Television Receivers

## Basic Circuit Details and a Preliminary Outline of Two Experimental Models

By Marshall P. Wilder,\* W2KJL

*After an extended period of experiment, Mr. Wilder presents us with preliminary details of two very practical television receivers. It must be admitted that even the simpler circuit is quite a fearsome affair, and it is obvious that a full understanding of the function of the various components will be possible only after careful study. The material has been prepared on the assumption that the interested reader has already made a close study of the previous articles in this series and that he is familiar with modern high-frequency receiver practice.*  
—EDITOR.

AT the beginning of this series, a promise was made to describe a television receiver that, once built, would work. Now that we have covered all the important circuit considerations and now that there is a good possibility of television signals being available, we can proceed to fulfill that promise.

In order to cover the subject adequately, the constructional details of two separate receivers will be given. Both of these are experimental assemblies and while they are both capable of effective operation, it is not suggested that they represent perfection. They are so arranged, however, that general experimental work is made readily possible. The first receiver is a relatively simple one employing straight r.f. amplification of the signal and a three-inch cathode-ray tube electrostatically deflected. The second receiver is actually a modern high-fidelity unit using a superheterodyne r.f. section and a viewing tube

\*55 Kendall Ave., Maplewood, N. J.

in which electromagnetic deflection is employed. The simpler receiver will doubtless have the greater appeal. The picture is, of course, quite small and the available definition will be only fair. However, it is our belief that once a picture of some kind is resolved, the fascination and challenge it presents will quickly lead to more simplification and refinement until a truly worthwhile receiver results.

From the photographs of the t.r.f. receiver it can be seen that the apparatus is divided into two units: one containing the power supplies and sweep circuits; the other including the r.f. amplifier, the video amplifier and synchronizing separation circuits and the cathode-ray tube itself. The r.f. end of this receiver consists of three stages and a diode detector. This is followed by two stages of video amplification and the double-diode synchronizing impulse separation circuit. The sweep circuits are of the multivibrator type, a single tube of the double-triode type being used

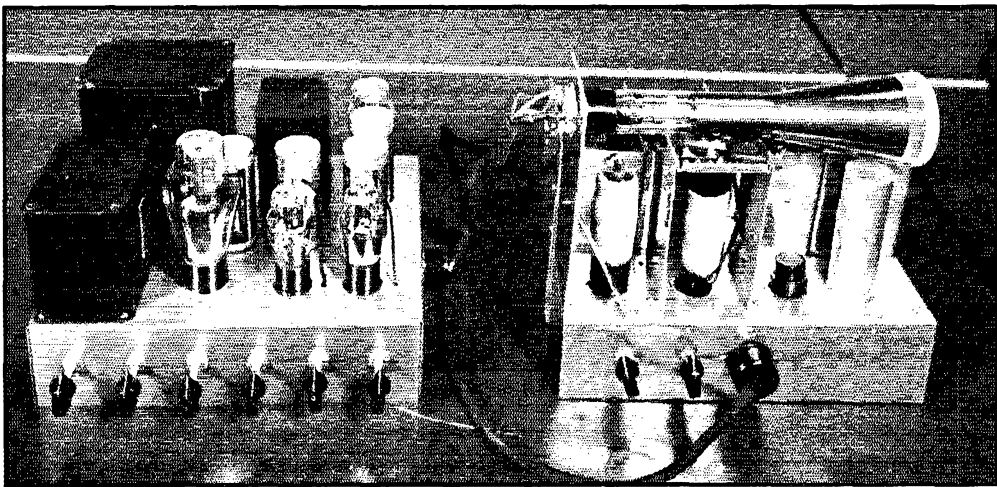

THESE TWO UNITS COMPRISE THE SIMPLE T.R.F. TELEVISION RECEIVER

A three-inch cathode-ray tube provides an inexpensive viewing device and the remaining equipment has been reduced to a practical minimum. Power supplies and sweep circuits are on the left chassis, the r.f. amplifier, video amplifier, sync. separator and c.r. tube being on the right-hand chassis.

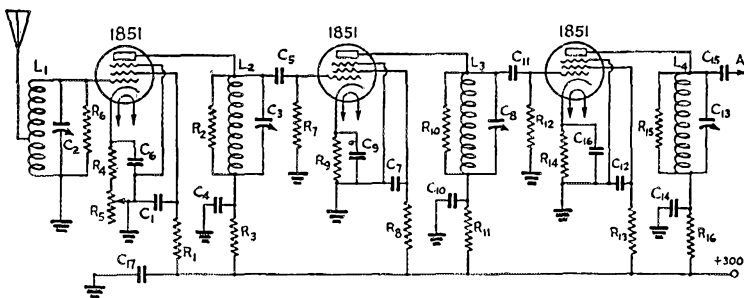

FIG. 1—CIRCUIT OF THE R.F. SECTION OF THE T.R.F. RECEIVER

- R1, R8, R13, R10, R23—60,000 ohms.
- R2, R6, R10, R15, R20, R24, R28—2000 ohms.
- R3, R11, R16, R17, R45, R46—5000 ohms.
- R4, R9, R14, R18, R21, R25—160 ohms.
- R5, R28—10,000-ohm variable.
- R7, R13, R23—25 megohm.
- R7—15,000 ohms.
- R9—200,000 ohms.
- R10, R32—25,000 ohms.
- R21, R34—50,000-ohm variable.
- R33—30,000-ohm variable.
- R34, R47, R48—100,000 ohms.
- R45—100,000-ohm variable.
- R36, R39, R40, R41, R42—5 megohm
- R37, R38—1-megohm variable.
- R43, R44—1 megohm.
- R49, R50—2500 ohms, 5-watt.
- R51—500 ohms.
- R52—150,000-ohm variable.
- R53—10,000 ohms.
- All resistors are I. R. C.
- C1, C4, C8, C7, C9, C10, C12, C14, C16, C17, C18, C21, C24, C28 and C30—0.01- $\mu$ fd. mica.
- C2, C3, C8, C13—15- $\mu$ fd. mica.
- C5, C11, C37—0.0001- $\mu$ fd. mica.
- C15, C36, C38—0.001- $\mu$ fd. mica.
- C19, C23, C39—8- $\mu$ fd. electrolytic.
- C20, C25—50- $\mu$ fd. electrolytic.
- C22, C31—0.1- $\mu$ fd. paper.
- C37—0.0015- $\mu$ fd. mica.
- C29, C29—1- $\mu$ fd. paper.
- C29—0.1- $\mu$ fd., 1000-volt.
- C38, C34—0.002- $\mu$ fd. mica.
- C35—0.2- $\mu$ fd. paper.
- C10—0.01- $\mu$ fd. paper.
- C41, C42—0.5- $\mu$ fd. paper, 1000-volt.
- C43, C44—16- $\mu$ fd. electrolytic.
- L1, L2, L3, L4—6 turns  $\frac{3}{8}$ " inside diameter No. 14 wire with turns spaced  $1\frac{1}{2}$  times wire diameter.
- L5—30 henrys, Kenyon T-153.
- L6—1000 henrys, Thordarson T29C27.
- L7—2000 henrys, two Thordarson T29C27 in series.
- L8—100 henrys, Kenyon T155.
- L9, L10, L11—75 microhenrys (one pie of a National R-100 choke with approximately 9 feet of wire removed from that pie).
- Ch.—25 henrys.
- R.F.C.—30 turns on  $\frac{1}{2}$ " bakelite rod, No. 25 wire.
- T1—Kenyon T-208.
- T2—Kenyon T-206.

vision is made for centering the pattern on the cathode-ray screen by adjustment of potentiometers included in the power pack. There are no controls for the amplitude of the sweep voltages since with the constants given, the sweep amplitudes are such as to fill substantially the whole screen and to provide approximately the proper aspect ratio. Controls for focus and grid bias of the cathode-ray tube are provided in the high-voltage power supply unit. The power supplies are built as a separate assembly not only to facilitate experimental work but to avoid distortion of the image on the cathode-ray tube which would result should the tube be close to the fields generated by the power supply transformers.

in each. Two high-voltage supplies are made available—one for the cathode-ray tube and the other for the sweep circuits and the receiver proper.

The cathode-ray tube used may be a National Union Type 2003 or the new RCA Type 906. Both of these three-inch tubes employ electrostatic deflection and the electron gun has been designed so that a small enough trace can be obtained to effect a reasonable job of resolving the complete 441-line picture. With the voltage supplied by the power supply specified, sufficient brilliance will be obtained to produce a fairly bright picture in a darkened room. The image is, of course, entirely unsuited for demonstration to the lay public but is adequate for experimental work. No provision has been made in the receiver for d.c. restoration to set automatically the average brightness of the picture. It has been found that manual adjustment of the picture brightness is satisfactory for a simple receiver of this type. Pro-

Since both receivers were completed immediately prior to the release of the new RCA 1851 steep-slope pentode, it was necessary to use the British tubes of that type. Also, a British low-resistance diode was employed as a detector. It will be noted that the new Type 1851 is specified in the r.f. and video amplifier circuits and that a 955 or a 6H6 is specified for the detector. The normal pentode receiving tubes are incapable of providing sufficient gain and it will be found that the use of the steep-slope pentodes is really essential.

Reviewing the circuits of the power supply and

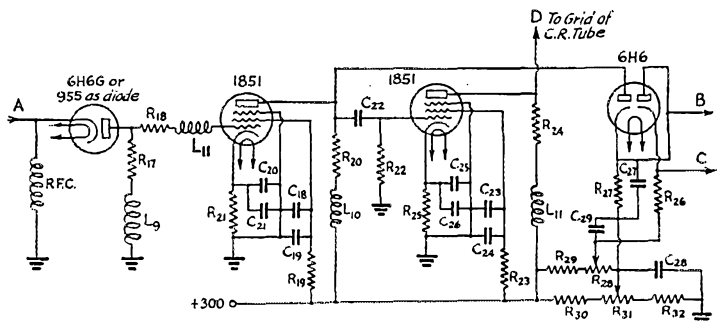
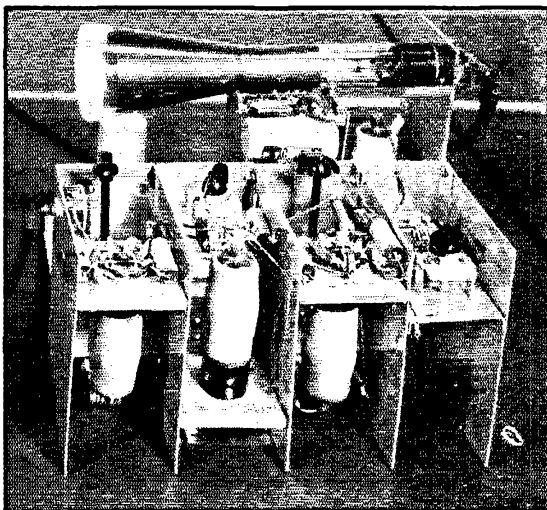

FIG. 2—THE DETECTOR, VIDEO AMPLIFIER AND SYNCHRONIZING IMPULSE SEPARATOR OF THE T.R.F. RECEIVER

For constants see under Fig. 1.

sweeps for the t.r.f. receiver, we find that the general arrangement is quite similar to that already described in previous articles. As is normal practice with cathode-ray tubes using electrostatic deflection, the positive of the high-voltage supplies is grounded. This means, of course, that the focusing and grid-bias control, together with the grid itself, are "hot" with respect to ground. It will be noted that the coupling condenser from the output of the video amplifier to the cathode-ray tube control grid has a rating of 1000 volts for this reason. The 300-volt supply for the remainder of the receiver follows conventional practice. The sweep circuits are very similar to those described in the February issue of *QST*, except that, in the actual receiver, the double-triode 6F8G is used in place of the pair of 76's.

The r.f. portion of the receiver uses three Type 1851 tubes as straight r.f. amplifiers. The circuit arrangement is quite similar to that commonly used in the usual r.f. amplifier for an ultra-high-frequency receiver. The most important difference is in the use of loading resistors across the four tuned circuits to permit the amplifier to pass a sufficiently wide band of frequencies. The circuit comprising the detector, the video amplifier and the synchronizing impulse separator follows very closely the arrangement described in the January issue. One minor difference is that instead of using a triode



SHOWING THE R.F. SECTION OF THE SIMPLE RECEIVER

The somewhat unusual arrangement of the tubes permits very short plate-to-grid wiring. Each stage is tuned separately in order to avoid mechanical complications.

phase inverter to feed the synchronizing impulse separator, the input to that section is derived from the plate circuit of the first video tube.

Since it is impractical to present at this time the complete description of the assembly and, more particularly, the adjustment of the various sections of the receiver, we shall pass to a review

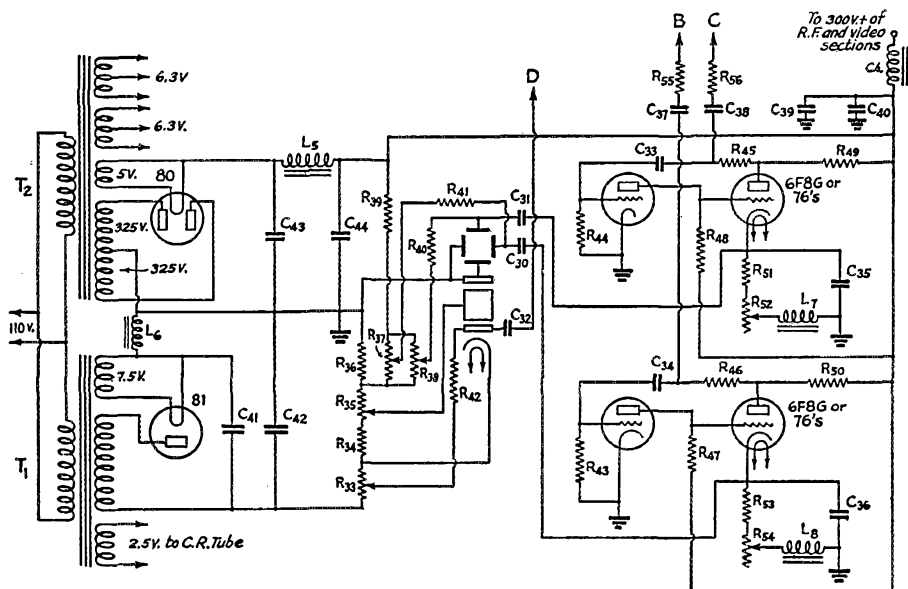
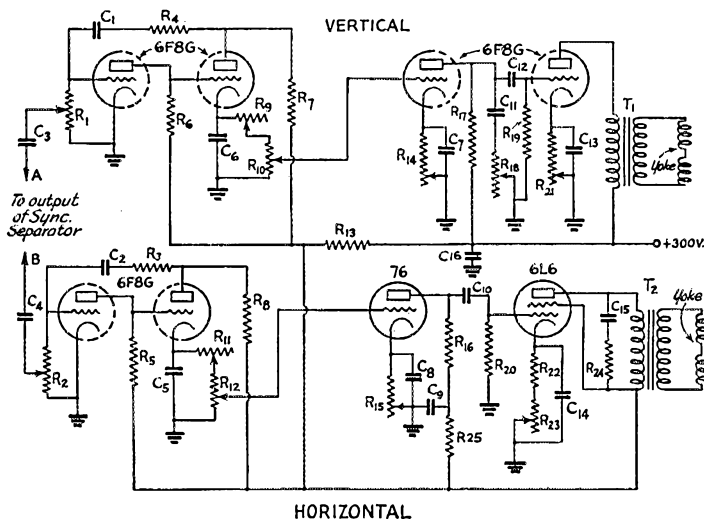

FIG. 3—THE SWEEP, POWER SUPPLY AND CATHODE-RAY TUBE CIRCUITS OF THE T.R.F. RECEIVER

For constants see under Fig. 1.



- R11—100,000-ohm variable.
- R12—10,000-ohm variable.
- R13—35,000-ohm, 1-watt.
- R14—50,000-ohm variable.
- R15—10,000-ohm variable.
- R16—50,000-ohm, 1-watt.
- R17—5-megohm, 1-watt.
- R18—100,000-ohm variable.
- R19, R20—5-megohm, half-watt.
- R21—10,000-ohm variable.
- R22—250-ohm, 1-watt.
- R23—1000-ohm variable.
- R24—35,000-ohm, 1-watt.
- R25—25,000-ohm, 1-watt.
- C1, C2—.002- $\mu$ fd. mica.
- C3—.1- $\mu$ fd. paper.
- C4—.005- $\mu$ fd. mica.
- C5—.001- $\mu$ fd. mica.
- C6—.01- $\mu$ fd. paper.
- C7—.25- $\mu$ fd. 50-volt electrolytic.
- C8—.25- $\mu$ fd. paper.
- C9—.8- $\mu$ fd. 450-volt electrolytic.
- C10—.005- $\mu$ fd. mica.
- C11—.5- $\mu$ fd. paper.
- C12—.1- $\mu$ fd. paper.
- C13, C14—25- $\mu$ fd. 50-volt electrolytic.
- C15—.0005- $\mu$ fd. mica.
- C16—8- $\mu$ fd. 450-volt electrolytic.
- T1—Low frequency deflection coupling transformer—Kenyon T112.
- T2—High-frequency deflection transformer—Kenyon T111 or R.C.A. No. 9836.
- Yoke—Kenyon T700 or R.C.A. No. 9831.

FIG. 4—THE SWEEP CIRCUITS FOR THE SUPERHET RECEIVER

R1, R2—1-megohm variable.  
 R3, R4—4000-ohm, 1-watt.  
 R5, R6—100,000-ohm, 1-watt.

R7, R8—2000-ohm, 5-watt.  
 R9—250,000-ohm variable.  
 R10—25,000-ohm variable.

of the basic elements of the superheterodyne receiver. It is suggested that the reader should study all these circuits very closely in conjunction with the explanation given in previous articles. Absolute familiarity with the circuit arrangement and the function of its components is an essential before successful construction or adjustment can be hoped for.

To provide a preliminary description of the superheterodyne receiver, two photographs are given together with the circuits of the power

supplies and sweeps. In the first photograph of this receiver the video amplifier and sweep circuits are on the left-hand chassis. The five tubes on the right-hand side with the two output transformers are the magnetic sweep generator tubes and coupling transformers. Along the top of the receiver is the cathode-ray tube with the magnetic deflection yoke in position on the neck of the tube. This mounting is convenient for applying sweeps and modulation but the equipment must be treated with considerable respect because

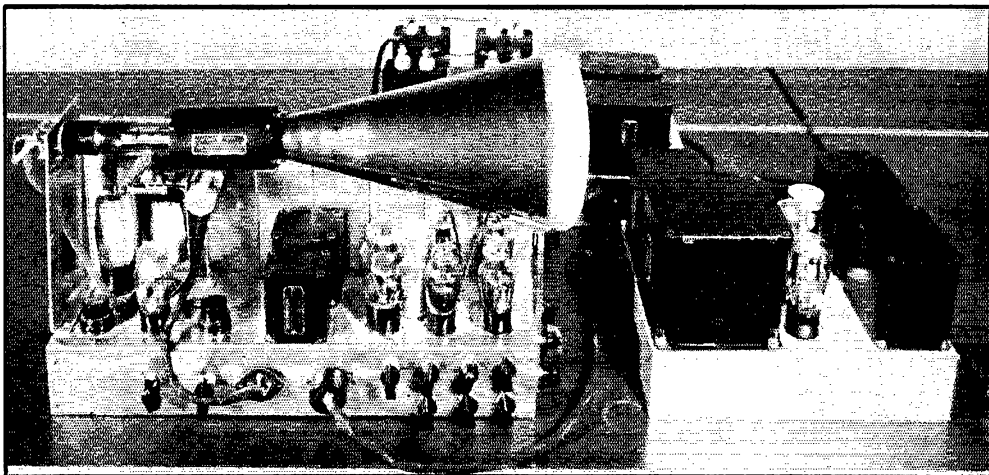

THE ADVANCED SUPERHET-TYPE TELEVISION RECEIVER

A magnetically-deflected viewing tube is used. Below it are to be seen the sweep circuits and video amplifier. The low-voltage power supply is at the right.

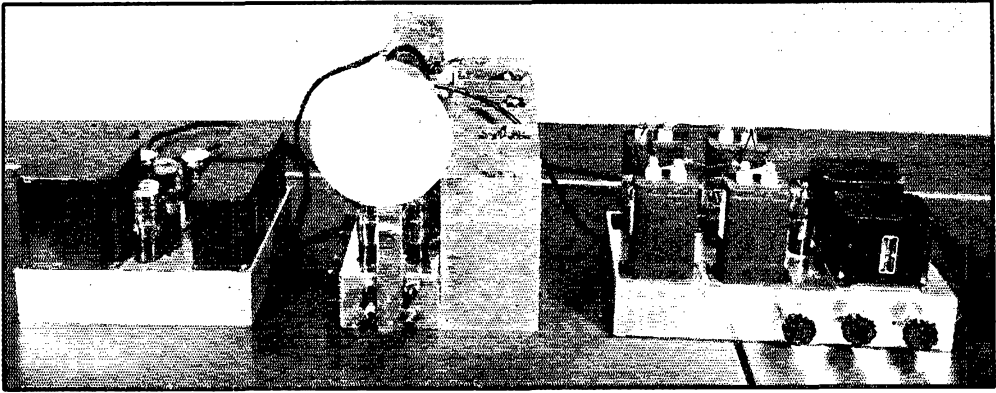

A GENERAL VIEW OF THE SUPERHET-TYPE RECEIVER

The chassis at the right contains the high-voltage supply for the c.r. tube. The r.f. section of the receiver is immediately to the right of the c.r. tube.

of the all too-readily available high-voltage anode tap. The sweep output socket is on the left and the power supply socket on the right. The seven controls near the sweep tubes and four controls on the front of the chassis are for controlling the sweep circuits. Experience in handling these controls will soon indicate which can be left alone and which must be adjusted more or less frequently to provide proper synchronizing. The two controls on the left are for setting the potentiometers in the synchronizing impulse separation circuit so that both the high- and low-frequency synchronizing impulses can be separated from the complex picture signal.

The two 6H6's are the d.c. restoring diode (on the left side) and the synchronizing impulse separation tube. The 6G5 is the triode amplifier following the d.c. restoring circuit and feeding the 6H6 impulse separator. The video amplifier is directly behind these three tubes. One tube is mounted in the normal manner and the next inverted. Inversion of one tube with respect to the other facilitates wiring and greatly shortens all leads from grid to plate. It might be mentioned that high transconductance pentodes should never be operated horizontally because of the extremely small spacing between grid and cathode.

To the right of the receiver is the low-voltage power supply which provides filament and plate voltages for the receiver proper and sweep circuits. The high-voltage power supply for the cathode-ray tube is also shown.

The diagram of the sweep circuits for this receiver will be seen to differ considerably from those described in the February issue. The number of tubes has been cut from eight to five and the number of controls increased to aid

in precise adjustment of the sweep voltages.

The details of the r.f. end of the superheterodyne receiver will be given in the next article together with a complete description of the assembly and the adjustment of both receivers. However, it might be mentioned at this point that the r.f. arrangement consists of two stages of straight radio-frequency amplification followed by a heptode mixer tube and four stages of intermediate-frequency amplification. These are followed by the usual diode detector, two stages of video amplification and a synchronizing separator.

Both of these receivers have been given a preliminary test but since transmissions have been so scarce up to this time it is entirely probable that some minor modifications will be indicated when the opportunity is had for further experiment with the equipment.

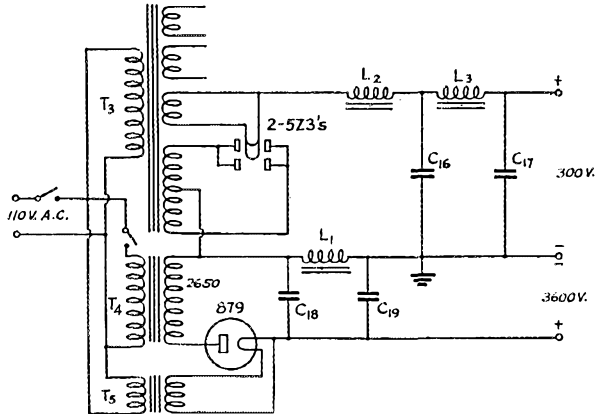

FIG. 5—POWER SUPPLIES FOR THE SUPERHET-TYPE TELEVISION RECEIVER

T<sub>3</sub>—Kenyon T244.  
T<sub>4</sub>—Kenyon S7038.  
T<sub>5</sub>—Kenyon S7039.  
L<sub>1</sub>—Thordarson T29C27.  
L<sub>2</sub>, L<sub>3</sub>—Kenyon T151.

C<sub>16</sub>, C<sub>17</sub>—16- $\mu$ fd. 450-volt electrolytic.  
C<sub>18</sub>—1- $\mu$ fd. 4000-volt.  
C<sub>19</sub>—0.1- $\mu$ fd. 4000-volt.

# Modernizing the 56-Mc. Transceiver

## Crystal Control With Non-Radiating Receiver

By A. S. Burke, W3VR,\* and T. Leaf\*

**C**RYSTAL-CONTROLLED transmitters on 56 Mc. are not only desirable but rapidly becoming a necessity. They are desirable because tests have proved that the concentration of power resulting from the improved frequency

transceivers are highly useful pieces of equipment, especially for portable or portable-mobile operation. Constructional details are presented herewith for building a modern transceiver, the transmitting section of which is crystal-controlled and the receiving section of which is of the non-radiating type, thus eliminating the undesirable features of the older type units. The transmitter is always on the same frequency regardless of receiver adjustments and you *know* what that frequency is. The signals are stable and can be copied on even the most selective superheterodyne receiver. The power output is sufficient for highly-satisfactory operation as a fixed unit in the station when operated from an ordinary power pack, and on the other hand for portable operation the power-supply requirements are within the capabilities of small vibrator units or dynamotors.

The circuit, shown in Fig. 1, follows standard practice. An RK34 is used in the transmitting portion, with one triode section as the crystal oscillator, using a 28-Mc. crystal, and the second section as a doubler-amplifier on 56 Mc. The second section is modulated by a 6F6 pentode. Using a single-button microphone, more than

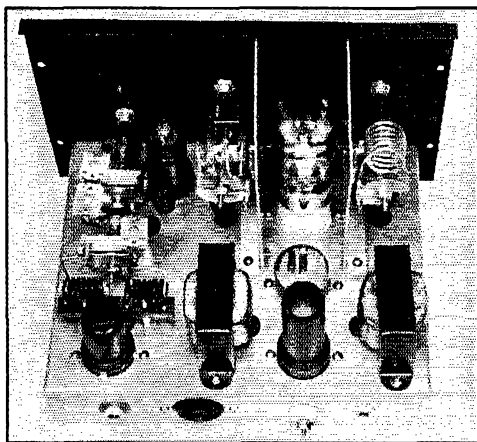

A TOP VIEW, SHOWING THE COMPLETE LAYOUT

The 6F6 and its input transformer and output choke are in the foreground. The crystal is between the 6F6 and RK34.

stability permits reliable communication over greater distances. The necessity arises from the fact that increasing commercial and government occupancy of frequencies on each side of our 56-Mc. band, as pointed out in the editorial in December, 1937, *QST*, will not tolerate the out-of-band operation which can occur so easily when self-excited oscillators are used.

The use of crystal-controlled equipment on 56 Mc. also permits the utilization of more sensitive superheterodyne receivers, which again helps to increase the effective working distance of the transmitter.

One of the most conspicuous offenders in the way of out-of-band operation on 56 Mc. is the ordinary transceiver, with its self-excited oscillator and ever-changing transmitting frequency. However,

\*General Engineers, 2241 Garrett Road, Upper Darby, Pa.

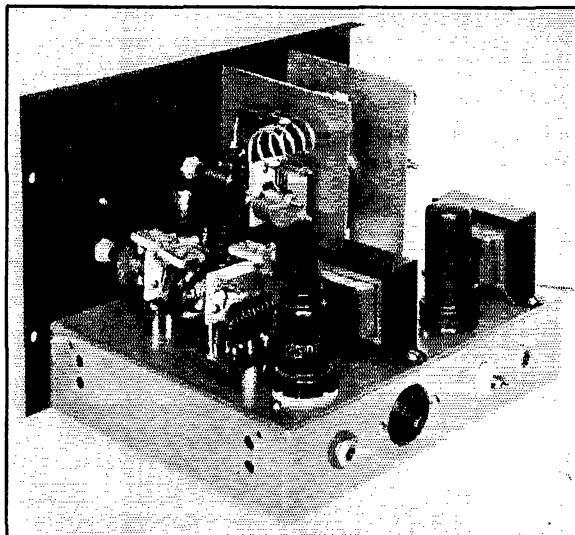

A VIEW OF THE TRANSCEIVER FROM THE RECEIVER SIDE

The receiver section proceeds from the panel towards the back of the chassis along the rear edge. The circuit mounted on the vertical shield is the transmitter output tank.

ample audio gain and power are available for 100 per cent modulation of the amplifier.

The receiver section uses a 6C5 tube in a self-quenched superregenerative detector circuit, with a 6K7 tuned r.f. stage to eliminate radiation and increase selectivity. A band-spread of approximately sixty divisions on a 100-division dial can be expected with tuning capacities and inductances as given. All parts are standard and readily obtainable.

The entire unit is constructed on a 7 by 9 by 2-inch metal chassis with a 7 by 10-inch front panel. The assembly will fit into a standard metal cabinet. Looking at the rear view, the transmitter portion of the unit is constructed on the right end of the chassis and the receiver portion on the left end, while the combination modulator and audio amplifier is located in the foreground near the transmitter components. The two tuning condensers for the transmitter are mounted on the vertical metal partitions on each side of the RK34 tube, the oscillator condenser at the right and the doubler condenser at the left. These partitions act as shields between the two tank circuits, and at the same time permit convenient mounting of the tuning condensers and coils for short plate leads to the RK34. The coils are mounted directly

on the tuning condensers and are made of No. 12 bare wire. All r.f. leads should be extremely short and all r.f. ground returns connected to one point on the chassis.

The arrangement of the various parts becomes clear from a comparison of the circuit diagram and photographs. The microphone and speaker jacks are mounted on the rear chassis edge, as are also the midget stand-off insulator which serves as an antenna post, and a four-prong socket to which the power-supply connection plug is brought. The two tuning condensers in the receiver section are ganged through a midget flexible coupling; the interstage coupling condenser,  $C_{13}$ , is mounted directly on  $C_{14}$ . The antenna-coupling and r.f. trimmer condensers,  $C_8$  and  $C_{10}$ , are similarly mounted on  $C_9$ .  $C_8$  and  $C_{13}$  should be adjusted for optimum performance when a signal is being received.

It will be noted that a comparatively high-C oscillator tank circuit is used in the transmitter. This is desirable for maximum power output and maximum stability. The output of the transmitter is a little over three watts, but since it is crystal-controlled the results are comparable to those obtained from 10- or 12-watt self-excited trans-

(Continued on page 88)

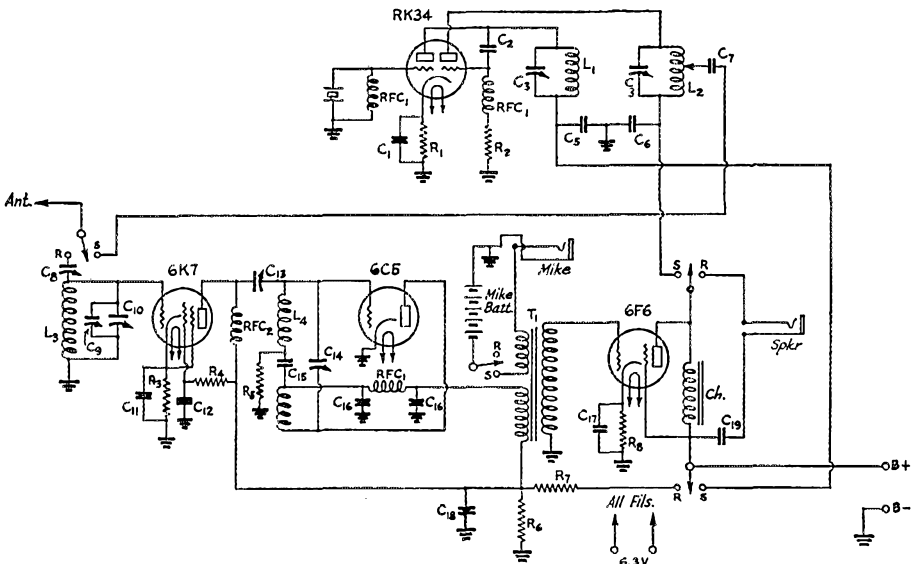

FIG. 1—CIRCUIT DIAGRAM OF THE CRYSTAL-CONTROLLED TRANSCEIVER

$C_1, C_5, C_8$ —0.005- $\mu$ fd. midget mica.  
 $C_2$ —0.002- $\mu$ fd. midget mica.  
 $C_3$ —75- $\mu$ fd. midget variable (Cardwell ZR-75-AS).  
 $C_4$ —35- $\mu$ fd. midget variable (Cardwell ZR-35-AS).  
 $C_7$ —0.001- $\mu$ fd. midget mica.  
 $C_8, C_{10}, C_{12}$ —3-30- $\mu$ fd. trimmers (National M-30).  
 $C_9, C_{14}$ —15- $\mu$ fd. midget variable (Cardwell ZR-15-AS).  
 $C_{11}, C_{12}$ —500- $\mu$ fd. midget mica.  
 $C_{15}$ —100- $\mu$ fd. midget mica.

$C_{16}$ —0.001- $\mu$ fd. midget mica.  
 $C_{17}$ —10- $\mu$ fd. 25-volt electrolytic.  
 $C_{18}$ —0.25- $\mu$ fd. 400-volt paper.  
 $C_{19}$ —0.01- $\mu$ fd. 400-volt paper.  
 $RFC_1$ —2.5-mh. r.f. choke.  
 $RFC_2$ —R100 choke (National).  
 $R_1$ —400 ohms, 10-watt.  
 $R_2$ —30,000 ohms, 2-watt.  
 $R_3$ —1500 ohms, 1/2-watt.  
 $R_4, R_5$ —100,000 ohms, 1/2-watt.  
 $R_6, R_7$ —50,000 ohms, 1-watt.  
 $R_8$ —450 ohms, 10-watt.

$L_1$ —6 turns No. 12, diameter 3/4 inch, spaced wire diameter.  
 $L_2$ —4 turns same as  $L_1$ .  
 $L_3$ —7 turns No. 14, diameter 1/2 inch, spaced wire diameter.  
 $L_4$ —56-Mc. receiver coil (Sickles No. 1203).  
 $T_1$ —Transceiver input transformer (Kenyon KA-114-M).  
 $CH$ —30-henry, 70-ma. choke.  
 Switch—4-pole double-throw (Yaxley 3242J).



# "You Said a Mouthful"

By Lawrence E. Hauck,\* W9CYV

**B**ACK in February, 1937, *QST* carried, on page 21, the following meaty piece: "W9HHT tunes his transmitter by holding his tongue to the antenna lead!" The thing has stuck in my crop ever since. That certainly was a tasty dish to set before the kink trier-outer! As a matter of fact the late Prof. Bernie Tonsiloff, instructor in physics at the Squirtkill School on the Hudson, always advocated using various parts of the human anatomy as r.f. indicators! To quote from Prof. Tonsiloff:

"Touching the tongue to the antenna binding post is really equivalent to hooking a dummy antenna to the transmitter! It is the only known method of matching the impedance of the final tank circuit with the impedance of the operator!"

To mouth a few practical applications, we find the tongue as an r.f. indicator quite useful for (1) testing the efficiency of the feeder system, (2) loading the final tank circuit, (3) neutralizing the stubborn amplifier!

It is regrettable that Prof. Tonsiloff never lived to experiment with the two latter possibilities. After much success in detecting r.f. leakage in various lead-in wires, the professor was accidentally dispatched to another world while conducting an experiment in his classroom. He was illustrating the electrolysis of saliva, using his tongue as cathode and his gold dental-work as anode, when a surplus accumulation of hydrogen in his sinus passages ignited and blew out his brains. Otherwise the experiment was a success.

To get back to this r.f. tasting business, there is scant need for buying expensive instruments when, with a little practice, the average ham can taste the output of his transmitter. Try loading up the final tank circuit with your tongue clipped on the hot end—or the cold end if you prefer. Just a matter of how you like it—hot or cold! Yum-yum, you can almost taste the currents in it. Maybe your transmitter is a push-pull affair. Try tasting the center tap of the tank coil. If the circuit is out of balance, one eye will fly shut and the ear on that side of your head will glow to a blushing red! Simply tune up by watching your eyes resemble the Roman numeral twenty!

For the lads who don't care for sissy games there is always the stubborn amplifier to tongue-tie—as neat a neutralizing trick as has been devised for those who relish baked-tongue! Just take a firm grip on the plate terminal and try tasting the difference that effervesces from the grid post! You're right! It's toasted, and you can taste the difference! The grid to plate capacity is then measured only by your capacity to

take it! When you finally absorb all of the r.f. and none remains in the circuit, it is high time to call the thing neutralized and walk away. It may be necessary to leave a portion of the tongue stuck on the grid terminal if you leave in a hurry.

Ouch! who tharted this thasting bithnith anyway! My thung hurth thow bad now I muth theece thith dithcourth. Thee you later and beth theventy threeth!!!

## Strays

I gave Tommy, the junior op at my station, a bum switch. Being of a mechanical turn of mind, he promptly proceeded to build a transmitter and receiver around it. They were made of cardboard, but had dials and pilot lights, meters, and vent holes, and had a real honest-to-goodness switch!

The next day Tommy met me at breakfast with his face wreathed in smiles, and said, "Russ, gee did I ever have a swell QSO with a VK this morning. It lasted one hour and five minutes."

"That's fine, son; I can't do that well."

"But Russ, there is one thing wrong with the rig," he said, "the receiver doesn't work very well. I wish you would go down town and buy me a whistle so I can have some heterodynes in my receiver, like yours."  
—W9RNX

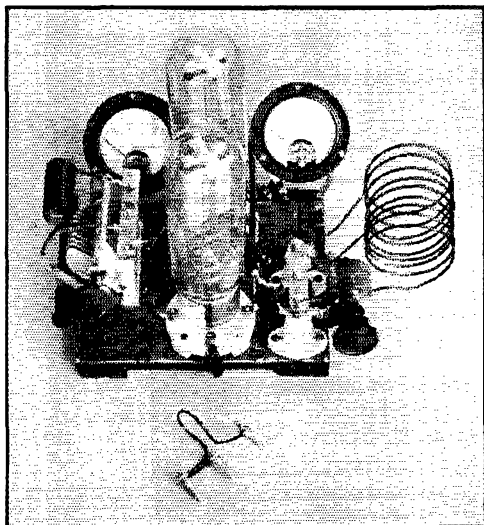

A VIEW OF THE PUSH-PUSH 56-MC. DOUBLER USING THIRD-HARMONIC PLATE TANK CIRCUIT OF FEB. *QST*, PAGE 45

The photograph was received too late for publication in the February issue.

\* 435 East 4th St., Newton, Kansas.

# Shock-Proofing the Transmitter

A Novel Tank-Circuit Arrangement and Miscellaneous Suggestions for Reducing Danger of Injury from High Voltages

By L. C. Waller, W2BRO\*

SEVERAL years ago, shortly after my wife had had the misfortune to acquire me, I was operating a breadboard-type transmitter on 14-Mc. 'phone, using two 800's with a 1250-volt supply. The 800's were series fed, which nearly proved to be my downfall. With the carbon mike (using a grounded metal frame and handle) in my left hand, I very cautiously pushed my "modulation indicator" (a thermogalvanometer with a one-turn pick-up loop) a little closer to the plate tank coil of the final stage to make it read a bit higher. Using only the tip of my right-hand index finger as a "pusher," I carefully watched to see that the loop did not touch the copper-tubing tank coil. It didn't, but the metal case of the meter brushed against the shaft of the near-by single-section tank condenser. The full 1250 volts thus passed through my body from arm to arm. The feeling, for the benefit of those hams who haven't yet suffered the experience, was as if a Gargantuan giant had struck me squarely on the top of the head with a 20-pound iron maul. Momentarily I was unconscious, but the first violent, muscle-breaking, nerve-shattering shock broke the slight contact and I regained consciousness just as I was about to tip over backwards in my chair. Perspiring all over like a cotton-picker on a July day, I felt weak and numb. The mike was scattered in various pieces over the floor. I had thrown it down so hard that most of the springs were decoupled and the mike head was out of the frame.

I never thought such an accident could possibly happen to me. For was I not a radio engineer by profession, had I not been an active amateur since 1922, had I not constructed every section of the transmitter, had I not had years of experience with both amateur and commercial transmitters employing high-voltage tubes? No, accidents like that could only happen to novices, to fellows who weren't very sure just what it was all about anyway. Phooey! To all brother hams who are similarly positive that they too know too much about their apparatus to make precautions essential, I say phooey, bosh, and tommyrot! The "rattlers" will get you sooner or later if you don't take care. In this business, an ounce of prevention is likely to be better than all the cure in the world. *The most insidious feature of this ever-present danger is that, after such an experience,*

\* 57 Monona Ave., Rutherford, N. J.

*we hams immediately proceed to continue operation without doing one little thing in the interest of safety.*

To attack any problem scientifically, it is well to review the problem, the known factors and, in this case, the solutions or partial solutions that others have offered. Unquestionably, the big commercial companies have found the best answer theoretically. That is, of course, the complete enclosure of all high-voltage apparatus in strong cages equipped with multiple interlocks so that no access to the apparatus can be secured without the primary circuit of the high-voltage supply being opened, and kept open, until the doors are again safely shut and locked. Even then, one interlock switch is no positive guarantee of

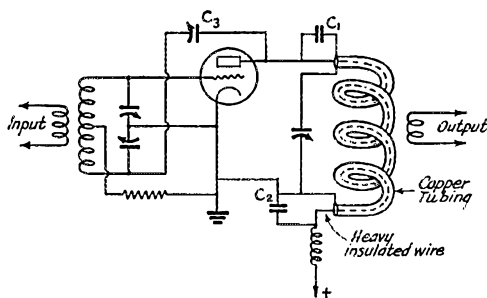

FIG. 1—SHOWING THE USE OF "CONCENTRIC FEED" TO KEEP HIGH D.C. VOLTAGE OFF THE PLATE TANK COIL AND TUNING CONDENSER

C<sub>1</sub> 0.002  $\mu$ f., rated at two to four times plate voltage; C<sub>2</sub> 0.002  $\mu$ f., rated at one to two times plate voltage. In many cases C<sub>1</sub> and C<sub>2</sub> may be omitted.

safety. History demonstrates that interlocks are not infallible.

So what? Let us first consider the main possible sources of danger. They are:

(A) The power supply itself, including the filter components and the rectifier filament transformer.

(B) Any r.f. stage using a high-voltage tube, especially the final amplifier.

(C) The modulator and associated equipment, in 'phone transmitters.

(D) The antenna circuit, where the antenna coupling system may be such as to allow it, accidentally or otherwise, to receive the high d.c. plate voltage.

(E) The keying circuit in telegraph transmitters, where the keying is done in the cathode return to ground (the high voltage is across the key contacts through the series resistance of the keyed tube).

(F) Other places you and I may not think of.

As regards (A), the power supply, the following ideas are conducive to longevity:

(1) Place a rectangular, box-like cover over the rectifier tubes. This can be made of a few pieces of wood for a framework, the latter covered with

(4) Use *twin* red pilot lights (two in parallel) wherever their use might help to warn the operator that the high voltage is on—especially where he cannot see the rectifiers' glow. Both lights are not likely to burn out simultaneously, if our hero is worried about that angle. The lights should be operated from a small transformer whose primary is permanently connected across the primary of the high-voltage supply, so that they go on together.

(5) Make all high-voltage leads, d.c. and a.c., as inaccessible as possible, and insulate all terminals by means of bakelite cover strips or, if nothing else, with a heavy wrapping of rubber and friction tape. Use nothing but heavily insulated, high-voltage wire for all dangerous leads. Auto ignition cable is fine in most cases, and is worth the extra expense if one considers it as life insurance.

(6) Leave no secondary terminals of high-voltage transformers unprotected. They can always be taped or covered. Always use rubber tape first, in generous quantity, and then friction tape. The treatment depends entirely on the transformer terminal design.

Next, I skip to (C), the modulator and associated

equipment. The procedure should be similar to that for the power supply. Cover the tubes with a suitable screened box. Use h.v. cable for all dangerous leads. Adequately tape or cover all wiring joints, output transformer terminals, modulation choke terminals, etc. Use bakelite-case meters for all high-voltage plate circuits. In addition, if the meter is panel-mounted, place a clear glass plate over its entire face, so that even the "zero-adjust" screw can't be touched. The glass-plate cover should be used even for bread-board layouts.

As to point (D), the antenna coupling circuit, it is taken care of automatically by the answer to (B), which is to come later. In other cases, the use of a well-insulated link coil coupled to the voltage-minimum point on the plate-tank coil will be satisfactory. Another link coil can then be used to couple to the tuned circuit associated with the antenna or feeders; ordinary twisted lamp cord or EO-1 can be used between the two low-impedance links. This system has several other advantages, one of which is that it will readily take power from a balanced tank circuit, with either single or push-pull tubes. It also minimizes

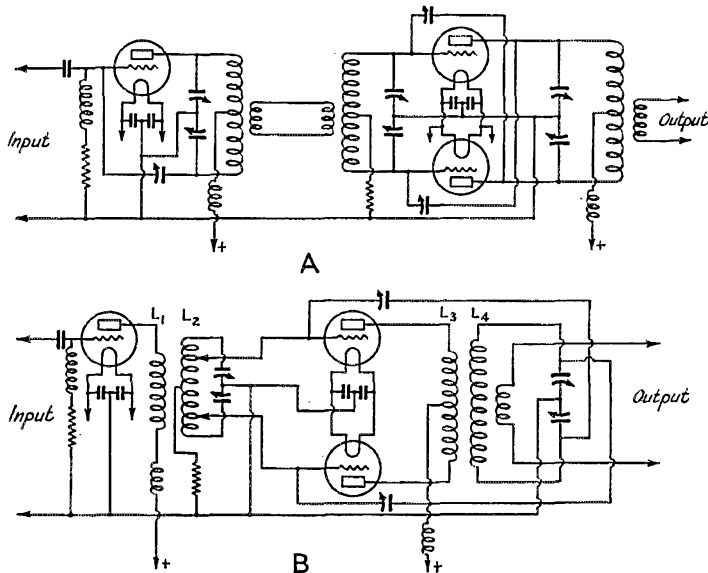

FIG. 2—(A) THE USUAL CIRCUIT FOR A PUSH-PULL AMPLIFIER AND DRIVER

(B) The concentric-feed circuit.  $L_1$  is wound inside  $L_2$  and  $L_3$  inside  $L_4$ .

heavy copper screen such as is used for windows in a house. The box should clear the tubes by at least one inch on all sides and by about two inches at the top. It should be fastened firmly, by hinges or otherwise, to the base, so that it cannot be slid about. Ground the copper screen, which may help to eliminate r.f. hash disturbances due to the electrostatic shielding effect. This precaution should keep "Junior" from poking his hands around the rectifiers. The screen allows ample ventilation for the tubes. The tube leads can be brought through heavily-insulated wire under the box, by means of a cut-away.

(2) Use mercury-vapor tubes wherever possible, even on the low-voltage supplies, because their blue glow gives a nice visual warning when any current is flowing.

(3) Use a bleeder resistor across *all* h.v. supplies, both to make the mercury-vapor rectifiers glow when there is no tube load, and to discharge all filter condensers. A condenser jolt may be fatal.

harmonic radiation, electrostatic coupling, and final-tank detuning with load variations.

Next, we come to point (E), the keying circuit. If the keying is done in the cathode return to ground, an ordinary key should never be used directly, but only in conjunction with a keying relay. A terrific jolt can be obtained across the key contacts when the key is open, through the series resistance of the keyed tube, if the key is directly in the cathode circuit. The keying relay should be used, or else keying should be done by some other method which is not so dangerous. The A.R.R.L. *Handbook* covers this subject adequately (name an amateur radio subject it doesn't cover!).

And now, if you have had the patience to read this far, we come to point (B), the r.f. stages. These are the *most dangerous* of all points considered and, unfortunately, the most difficult animals to de-tooth. It is this problem which has, for the most part, defied even amateur ingenuity to date.

The writer started with a simple sketch of an r.f. power amplifier, using a single tube for simplicity's sake. The plate tank coil and the tuning condenser are obviously the components about which we have to worry most. How, then, are we to remove the d.c. plate voltage from these parts and still get it to the plate of the tube? Two facts are evident—the plate must have its d.c. voltage, and the tank must have its r.f. voltage from the plate. It looks almost as bad as the old static problem did for many years—separating the black sheep from the herd, etc. Of course, parallel-choke-and-condenser feed is an old stunt, and does the trick well enough for low-power, single-ended stages. It can be used for medium power too, if a special, high-quality, well-designed r.f. choke is available (which it usually isn't). Also, the idea of the r.f. choke is not so hot when one considers push-pull stages, especially stages handling appreciable power. The chokes may unbalance the stage, cause a loss of r.f. power, etc. After a few minutes of puzzling, the writer remembered the old co-axial oscillator stunt, and the co-axial input-coupling idea. Hence, the "concentric-feed" circuit of Fig. 1 was immediately evolved. The figure is self-explanatory. The plate coil is made of large copper tubing, the inside diameter of which is big enough to take a heavily insulated wire. The wire itself can be very small, but the insulation must be excellent. The plate gets its d.c. voltage and current through the center-wire, and the r.f. tank circuit gets its r.f. through d.c. blocking condenser  $C_1$ . The by-pass condenser  $C_2$  is not usually necessary,

but it will help to hold the lower end of the d.c. coil at zero r.f. potential. Even  $C_1$  was found unnecessary in the 14-Mc. stage in which concentric feed was actually tried by the writer, although it may be required at lower frequencies.

The concentric-feed arrangement not only keeps the d.c. plate voltage off the tank circuit but also allows the rotor of the tuning condenser to be connected directly to ground, or to chassis. Its main disadvantage is that the coils are a bit more trouble to make and do not lend themselves quite so easily to plug-in design. Coil-shortening schemes are just as practical, however, since shorting the outer coil effectively shorts the same portion of the inner coil at radio frequencies.

The construction of the coils is not very difficult if the copper tubing is large enough in comparison with the size of insulated wire that must be used. The inner wire should be pulled through the tubing by means of a small iron wire, the latter being pushed through first. The tubing should not be wound into a coil, of course, until the insulated wire is in place. Terminals or plugs can be soldered to the ends of the outer tank coil for mounting either on stand-off insulators or in jacks. The coils can be made 100 per cent plug-in, but a special coil base will be necessary with two extra pins for the inner coil.

The concentric-feed idea can be applied with even greater advantages to a push-pull stage. In this case, the d.c. wire must be pulled through an elongated hole cut in the center of the copper-tubing coil, for connection to the positive high voltage.

Wishing to change my final stage from one 806 to push-pull 806's, I drew up the usual circuit of Fig. 2A. This is a rather clumsy, bulky arrangement, requiring *two* split-stator condensers. Then, thinking of the "concentric-feed" idea with respect to the buffer stage, I worked up the circuit of Fig. 2B. Note that it requires only *one* split-stator condenser and *one* copper-tubing coil of the concentric-feed type. The copper coil, having no d.c. plate voltage applied, can be direct-connected to the push-pull grids. Either grid or plate neutralization can be used on the buffer stage, which can, of course, be either single or push-pull. In Fig. 2B is shown a single 203-A driving push-pull, 806's, with concentric feed throughout. Variation of grid excitation for the 806's can easily be accomplished by clips on the copper or outer coil,  $L_2$ .

Although the circuit of Fig. 2B is the essence of simplicity and is much better than the conventional one of Fig. 2A in most respects, it should

(Continued on page 78)

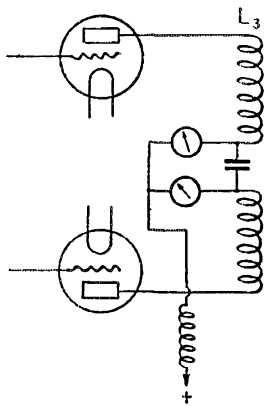

FIG. 3—SHOWING A METHOD FOR MEASURING PLATE CURRENT OF EACH TUBE IN A PUSH-PULL AMPLIFIER

# A Simple 110-Volt A.C.-D.C. Code-Practice Oscillator

By T. M. Ferrill, Jr.,\* W5CJB-1

**T**HE code-practice oscillator shown in Fig. 1 was developed in response to popular demand for such a device. Since the construction of this oscillator requires only a tube and socket, transformer, two condensers, two carbon resistors, and a resistor line cord, the total cost is very reasonable.

The tube selected for this oscillator is a 12A7, which combines in one envelope a half-wave rectifier and a pentode. The connection from the suppressor grid—the grid shown next to the plate in the diagram—to the cathode of the pentode section is made within the tube, and only the cathode of the tube is connected to a pin in its base. The screen grid, the grid shown in the diagram as the second below the plate, is connected separately to one of the tube pins, and a connection must be made between this terminal and the plate. The heaters of the two sections are connected in series within the tube, and only two terminals are used for these connections. The heater voltage required for this tube is 12.6 volts, and may be a.c. or d.c. Each section of the tube has a separate cathode connection.

The 12.6 volts for the heater is obtained from the 110-volt source by means of a resistor line cord, a special cord containing a resistor in addition to the usual two wires from the plug. The resistor is connected

\*Technical Dept., A.R.R.L.

to one of the plug blades, and the opposite end is terminated at the oscillator. Hence, there are three leads emerging from the cord. Only two of

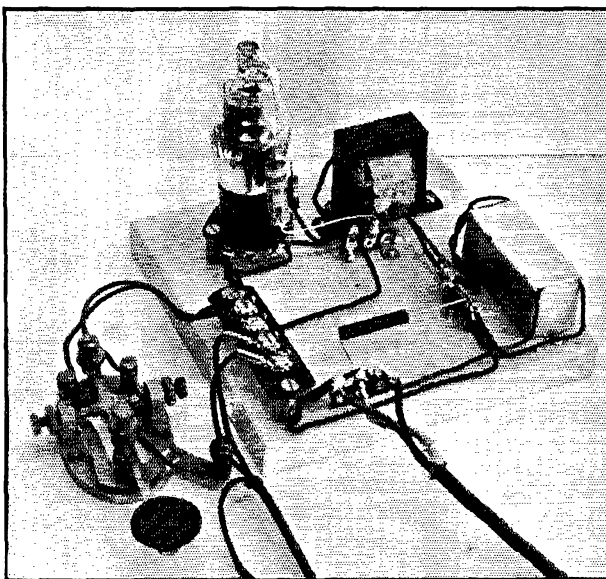

THE 110-VOLT CODE-PRACTICE OSCILLATOR

The grid-leak and grid condenser,  $R_1$  and  $C_1$ , may be seen in front of the tube. The transformer is beside the tube, with the filter condenser in the right foreground. The connection of the line cord resistor is shown in the foreground, while the four screw terminals include two for a key and two for headphones.

the three connections of the line cord are used with this set, the third being soldered to a lug on the strip shown in the photograph. In the cord used, this wire left disconnected at the set—the one to which the line cord resistor is connected at the plug—is denoted by black insulation. The 110-volt line terminal which is wired in the set to the rectifier cathode and to one of the two heater connections is marked by red insulation, while the

(Continued on page 108)

FIG. 1—CIRCUIT DIAGRAM OF THE CODE-PRACTICE OSCILLATOR

$C_1$ —0.01- $\mu$ fd., 600-volt tubular condenser (Sprague).  
 $C_2$ ,  $C_3$ —2-section midset electrolytic condenser, 10  $\mu$ fd. each section 25 volts working (Sprague).  
 $R_1$ —3-megohm,  $\frac{1}{2}$ -watt resistor (IRC).  
 $R_2$ —3000-ohm, 1-watt (IRC).  
 $R_3$ —Line cord resistor, 360 ohms.  
 T—Transformer 3:1 midset push-pull input transformer (Thoradson L-6907).  
 Total cost of equipment approximately \$2.25, exclusive of tube.

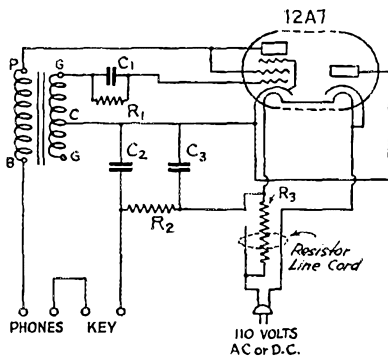

# When Emergency Strikes

## Plans for Your Emergency Operating

By F. E. Handy,\* WIBDI

The League's Emergency Corps presents an opportunity and challenge to every active amateur. If you are licensed you should be a member of the A.E.C. The A.R.R.L. plan for rendering public service in emergencies is based on (1) Registrations of station facilities in the Emergency Corps, not by A.R.R.L. members alone, but by every licensed amateur operator; (2) Community studies, by Emergency Coordinators and local amateur planning committees; (3) Complete coordination of all amateur operator and station facilities to give best service with least interference through use of most suitable stations and nets and creation of operator reserves.

This article explains how amateur radio functions best in both isolated and general emergency. Vital preparedness needs, that each of us should take care of at once, before emergency strikes are first treated. Then follows the equally important principles of operating during emergencies that these may be available in the scope of one article for consultation if and whenever needed.—EDITOR

THE numbers and location of amateurs in nearly all communities of our country constitute opportunity and assurance that the amateur service will be called upon to render necessitous service to the public in communications emergencies of every description. This article is not another of the type that dwells on our amateur usefulness and glorious history of past accomplishment in emergencies, even though that history is one of which we may be proud. These paragraphs will be directed at the matter of making best disposition of our stations and operators to render *most effective and useful service in future emergency*. It will cover the expansion and new aims in A.R.R.L. emergency organization over the past year.

Whenever wire circuits are overloaded or disrupted or non-existent, varying degrees of need may develop for radio communication. If the need is great we have what is known as a communication emergency. Any of several radio services may be able to help, especially some of the more numerous amateur stations. In the case of isolation of an individual or small group, amateurs must function under normal operating conditions.

A call should be directed at a desired station for handling a message if possible. If not available, there should be little trouble in getting attention of another station, and assistance by the general inquiry (CQ) method with thousands of stations constantly combing the amateur bands for calls at all hours. This is especially true for calls made near the band

\* Communications Manager, A.R.R.L.

edges, which are suggested as suitable points for designation for emergency calling, at any time. In the event ordinary specific calls and CQ's do not work as expected and a situation is importantly serious, use of the signal "QRR" becomes justified. QRR is the official A.R.R.L. "land S.O.S." . . . a *distress call* for use by stations in emergency zones *only*. It shall never be employed by any station other than one in an emergency situation. The most vital radio service takes place where both communication and power circuits are paralyzed—so let us emphasize right at the start that self-powered apparatus is necessary in every ham station, for *full* preparedness!

If a general relief emergency develops, this is usually accompanied by radio calls from isolated small communities, and in addition by a growing radio communication emergency traffic load on the low frequency amateur bands. Wire circuits are called upon to carry peak loads at a moment when power supply may be disrupted or communication wires themselves are out. Public and private organizations have more than normal traffic to send, and dislocations in housing arrangements and normal living conditions may be

responsible for generating thousands of individual messages. Some agencies may take their own communication with detachments sent to a relief area, but relief, military agencies, public utilities, etc., with a remote headquarters or extensive system requiring interchanges of data between offices or units will generate a large amount of official traffic of high priority in addition.

Conditions in emer-



HAVE YOU YOUR MEMBERSHIP CARD IN THE EMERGENCY CORPS?

Get a blank from S.C.M. or E.C. and register today—every licensed amateur is eligible. The aim is A.R.R.L. Emergency organization in every community.

gency are such that every available channel must be used effectively. Naturally the telephone and telegraph wires are going to be used first when they are available for use. In the interest of suppression of interference, radio should not be used where wire service is available, except to line up additional avenues for communication to fall back on as a situation deepens. Broadcasting stations should be used only for transmitting information to large groups of people. Some amateurs have actually written us to ask how they arrange to connect with the audio channels to the local broadcasting station "that they may be ready for emergency." The chance that an amateur station will have to transmit over the local broadcast station, or will have his station used in place of that station in emergency is extremely

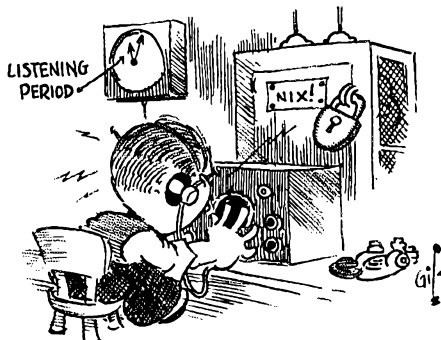

KEEP THE TRANSMITTER OFF THE AIR DURING LISTENING PERIODS

remote! Amateurs have important emergency functions, *not* in reaching the general public, but in handling necessary point to point communications effectively—as nearly like the service given by the local telegraph office as possible. The agencies we served in past emergencies tell us that they want messages to be accurate, secret and fast, and reliably recorded in writing whenever practicable. Amateur networks will be depended on to form an invaluable secondary communications system to wire services whenever they conform to these specifications.

#### A.R.R.L. RECOMMENDATIONS

1. That frequencies *at the band edges* be utilized for all emergency calls, with emergency present but not yet recognized or generally declared. The idea is to lend point and specification to builders of emergency equipment. This spot on all bands is well covered continuously by receivers. It gives hope to the isolated operator that he can be heard. Such frequencies are suggested as spots for all listeners to hunt for weak signals in any periods in general emergency for taking account of the isolated and making new station alignments.

2. That *whenever F.C.C. shall have recognized and declared a general communications emergency*

*exists, 1975–2000, 3500–3525, and 3975–4000 kcs. shall be reserved as emergency "calling" channels . . . prohibited to all stations except for first emergency or QRR calls, and initial or very important emergency relief traffic. All stations using such channels for contact shall as rapidly as practicable shift to inner-band "working and calling" frequencies, to leave these emergency channels clear for important calls of this type.*

3. That in the designated and recognized emergency areas, *all general amateur stations observe a silent or listening period for the first five minutes of each hour (0000–0005) on all amateur channels (3500–4000 kcs. 1715–2000 kcs.), tuning through the emergency calling and other channels for any QRR or initial-important calls from weak or isolated stations previously unable to effect contact in the interference.*

#### INFORM LOCAL AGENCIES OF FACILITIES

How do the agencies served know about us? How do we get the traffic? Some amateurs take the attitude that "when called upon" they can serve. Perhaps so, but the duty of the good amateur to himself and the whole amateur service is to see that local agencies such as the Red Cross chapter, mayor's office, utilities, military, railroad, weather forecaster etc. are all informed *now* of our availability. If you are in a small community you ought to inform these agencies about amateur radio, your facilities, and file with them your name and telephone number. Officials change and records get lost in files so a letter or visit about three times a year reaffirming or bringing data up to date will richly reward both the individual amateur and the amateur service. In communities where there is an A.R.R.L. Emergency Coördinator your A.E.C. registration<sup>1</sup> of equipment with him is earnestly requested. He will then handle the informing of all agencies, as one of his duties. There are plenty of problems in a widespread emergency that will make it doubtful if any amateur will be hunted up or called upon unless he has taken the proper advance steps to prepare himself and make his availability known.

#### A.R.R.L. PROGRAM CREATES OPERATOR RESERVE TO MAN BEST LOCAL STATIONS

This brings us to the subject of League organization and amateur preparedness for the emergency of the future. A.R.R.L. organization depends on your support and the advance preparedness of every licensed amateur!

- (1) Have you registered your equipment in the Emergency Corps? Every amateur should —whether you have special emergency

<sup>1</sup> AEC registration is open to *all*. The membership card shown in one illustration is sent to every registered member. No limitation as to A.R.R.L. members is made. The League's emergency program is open to every amateur. This form of amateur organization is regarded by us as Public Service. Write for a blank to return to your SCM. Let us make you a member.

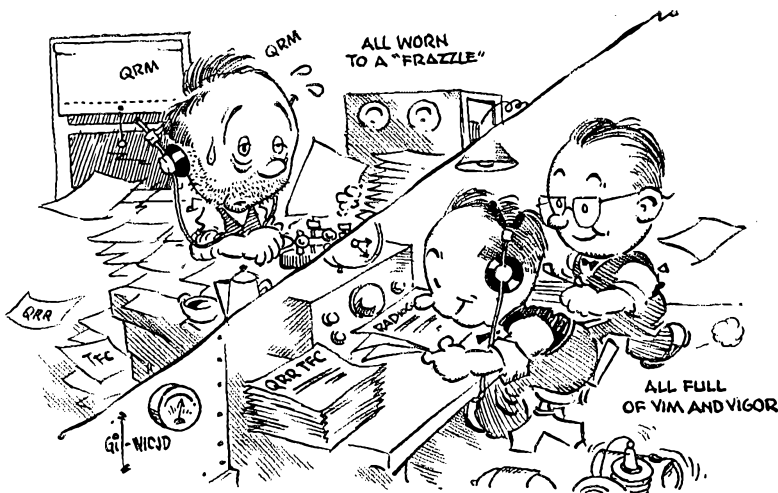

COOPERATIVE OPERATING DOES A BETTER JOB WITH GREATER EFFICIENCY ALL AROUND "INSTEAD OF HARASSED, OVERWORKED INEFFICIENT OPERATORS . . . PUT KEY STATIONS ON 6- OR 8-HOUR BASIS . . . WITH RELIEF AND SECOND OPERATORS FOR EFFICIENCY DURING INTENSIVE OPERATION. . . ."

gear or not—whatever band or bands you work.

(2) Do you have self-powered equipment for receiver and transmitter?

Whatever happens in emergency, you will find hysteria, and some amateurs who are activated by the thought that they must be sleepless heroes. So activated, a situation can result that approaches chaos. In some past general emergencies we have had too many stations and operators on the air—too much meaningless communication! The point has already been reached where the Federal Communications Commission had to invoke a general limiting order restricting communications<sup>2</sup> in the low-frequency bands to important relief work. But even that did not prevent too many stations doing relief communication work in some cases! Instead of operating almost all the local stations full time or more in emergencies, how much better it would be to man the best located, and best equipped stations, suitable for the work in hand, and man these by relief shifts of the best qualified amateurs. This is the way to reduce interference. This is the way to secure well operated stations, too. Instead of

<sup>2</sup> It is likely that the F.C.C. will take similar action in case of similar future occasion. The Red Cross and government services conferred Feb. 14th and 16th on emergency communication policies, with the writer representing amateurs, and the need for restricting and policing the amateur bands in widespread emergency was generally recognized.

Do you recollect that the F.C.C. order and nationwide policing was handled by three score of appointee stations in the Ohio Valley flood period? See page 52, March 1937, and page 98, April 1937 *QST* for details. Tentative plans call for an official system similar to that to function as part of amateur operations, supplementing the F.C.C.'s administrative action by giving a definite means of policing in future emergency, with the penalties of Sec. 502 of the Communications Act a force behind the policing!

harassed, overworked operators who are inefficient and make mistakes, we need to put our operating on a 6- or 8-hour basis for each operator, and make it possible to keep the key stations on the air two or even three shifts per day (by relief operators) if and when required.

Each station ought to have a second man to telephone messages, keep log, prepare traffic for transmission, etc., during intensive operation in emer-

gencies. It ought to be the aim of all amateurs everywhere, to voluntarily register the equipment they have and information on the bands they work with the A.E.C.,<sup>1</sup> and stand ready to cooperate in any plans developed for their communities.

#### LOCAL EMERGENCY PLANNING, JOB OF E.C.'S

For years the A.R.R.L. has encouraged the building of self-powered equipment. The June Field Days dedicated to emergency preparedness have become famous in their own right. The Emergency Corps likewise has an honorable history. Since the Ohio Valley flood steps have been taken to greatly enlarge the Corps, to expand membership and registrations in it, to create local leadership and cooperative planning for the Corps, the object to give us emergency planning, and to create as nearly as possible the actual picture of 100 per cent cooperation of all amateurs in *planned* operating effort in future emergencies. The desirable situations of the above paragraph, with relief operators, the best fitted stations on the job, other stations quiet, are what we aim at! By sufficient concentration and push on this problem every amateur should have opportunity to attend a local club meeting where emergency work and plans will be discussed. Every amateur should have the local picture defined, and *know his job* for emergency, whether flood, earthquake, or tornado. It is realized that no situation is ever exactly as it is visualized in advance. Force of circumstances may make changes in plans necessary at the last minute, or from day to day during a crisis of changing situations. Without plans no approach to the problem can be had. With plans it is easy to make modifications and changes to



fit a changing situation and effective work is possible. The clear sensible approach with reasoned planning is required. Let us leave the heroics and hysteria to others who have no plans.

#### TRAINING ESSENTIAL

Nothing takes the place of trained people in real emergencies. Operator training is vital and the man who knows how to write down a message accurately and affix the handling data to make an official record of the time and station at the same time he checks the number of word groups for accuracy has a big start on his fellows in giving the type of service most desired. One lesson from previous emergencies is that all amateurs should align themselves with A.R.R.L. operating organization, or A.A.R.S. or N.C.R. organization, to familiarize and train themselves to rise above the level of haphazardness and mediocrity. Proficiency comes *only* with practise.

#### COMMITTEES AND CORRELATION OF EFFORT

One of the crying needs of any organization with widespread units is a message center. In future emergencies the local Red Cross committees on "communication" will quite likely have a man who keeps track of the facilities of all wire and radio and other communication agencies. Municipalities may establish message centers for all their agencies if a situation becomes serious enough. At any rate they need to know how to get message facilities they will need. On examination of our facilities a year ago we reported in *QST* right after the flood work that what we felt was needed was increased coördination. The amateur service with its numerous bands, radiotelephone and radiotelegraph groups, and largest number of stations of any radio service most of all needs an officer to keep track of local amateur facilities, to correlate all individual schedules—equipment—effort. This permits reducing interference, cuts out unnecessary duplication of facilities. The functioning of such a coördinating officer should make amateur station work doubly effective when his work is properly carried out.

#### A.R.R.L. EMERGENCY COÖRDINATORS

So we have had, in A.R.R.L. field organization, since last October, the new appointment of Emergency Coördinator. Scores of coördinators have been appointed by S.C.M.'s in different communities to take charge of continuing club and area studies. Each coördinator (with the exception of Regional Coördinators) is a local community coördinator.

The Emergency Coördinator for the amateur service invites local amateurs, one from each group of amateurs, to become members of a local amateur emergency planning committee. Such men have the title of Assistant Coördinator and are specialists for organizing facilities in the particular frequency-groups that they represent.

Coördinators do not organize continuing networks like Route Managers and Phone Activities Managers. Their job is to coördinate existing facilities, not to set up new unless required. The Coördinators' function is to plan skeleton organizations of all the local amateur facilities in line with the picture we have described. The best stations in each group, the fastest and most accurate operators, the location of those stations, how to call the operators day or night if needed, the times the operators could handle stations in emergency, those are the things made a matter of record by each Emergency Coördinator. How is this done? By arranging meetings of local amateurs and distribution at such meetings or by mail, of our Emergency Corps registration-application blanks, so each individual puts his own facilities and information on record in an official manner. Coördinators will arrange such tests of facilities as desired by amateurs and as seem desirable to local agencies, and such, if practicable, are well worth while. *Plans* for station and operator utilization in emergency, and full registrations of facilities in all amateur groups are the first duty of an E.C.

#### REGIONAL COÖRDINATORS

A number of appointments as Regional Coördinator have also been made. Instead of tackling registrations and skeleton organization plans for a *community*, these to be placed in effect in the event of a widespread communications emergency, as just described, the Regional Coördinator is an amateur assigned to promote a net or special line of radio communication paralleling a railroad, or a watershed, or connecting branches of a relief or utility or other organization. Regional Coördinators are appointed only when a particular agency or agencies request or desire special facilities. Such coördinators are located near the central or important point requiring amateur lines of communication. Their net organizations may extend beyond Section boundary lines. In this event, they will receive full coöperation and help in getting recommendations and surveying available active stations from S.C.M.'s and community Emergency Coördinators.

*Self-Powered Equipment.* All amateurs who can do so are encouraged to build self-powered equipment, or better yet provide means of plugging over the regular receiver and transmitter to gas driven units or battery-supply. Instead of struggling with insensitive or non-selective receivers during emergency how much better it is to shift the 6-v. heaters over to battery supply with a few B-blocks or convenient vibrapacks for full performance! By all means acquire gas-driven 110 v.a.c. units or rewind Dodge generators<sup>3</sup>

(Continued on page 76)

<sup>3</sup> See page 26, November 1937 *QST*, on portable-emergency equipment; also Chapter 15 in the Radio Amateur's Handbook.

# How Would You Do It?

## Unusual Ideas in Transmitter Construction

**I**N presenting Problem No. 14, it was hoped that it would unearth something refreshingly new and novel in the way of transmitter construction. Apparently, however, most of us are just catching up with the rack-and-panel idea and it is yet too early to be looking for something to take its place. Nevertheless, we did succeed in picking up a few unusual, if not new, ideas which may serve to spur thought on transmitter designs which will more completely fill the bill in amateur construction.

The question of a simple and inexpensive design which will afford protection against dust and most accidents is at least partially answered by G. P. Anderson of G2QY. The essentials of construction are shown in Fig. 1. The transmitter consists of a series of chassis bases for the various units mounted on a simple arrangement of shelves. The unusual feature is the depth of the bases which is sufficient to accommodate all cir-

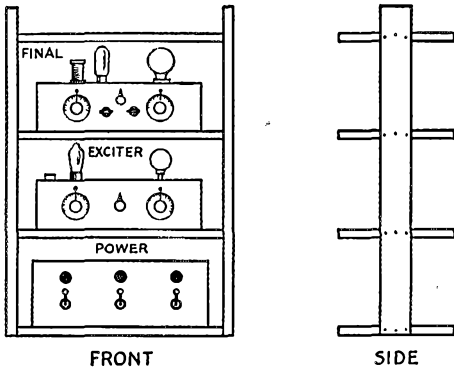

FIG. 1—A SIMPLE DESIGN FOR LOW- AND MEDIUM-POWER TRANSMITTERS WHICH AFFORDS PROTECTION FROM DUST AND PROVIDES EASY ACCESS FOR ALTERATIONS

cuit components except the tubes and the tank coils which are accessible for changing. With the tubes and coils removed, the tops of the bases present comparatively smooth surfaces which may be easily dusted. Power supply connections are made through cables with attached plugs so that each unit is readily removed if servicing becomes necessary.

Perhaps the most novel and neat arrangement of those suggested is that depicted in Fig. 2, described as follows by Ernest L. Moline, W9SWT:

"It so happens that the current dilemma of Our Hero parallels one from which I have, in my own opinion at least, emerged victorious after

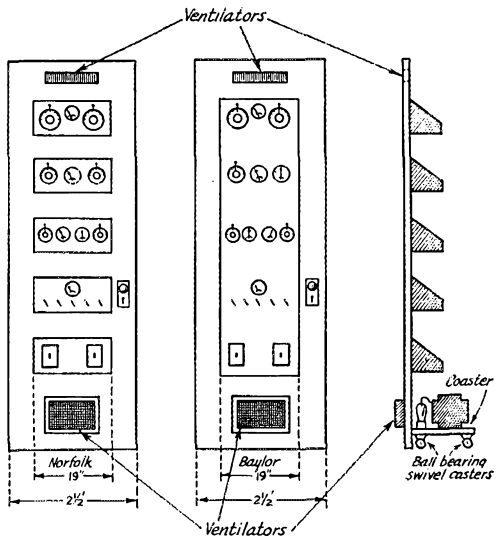

FIG. 2—A SPARE CLOTHES CLOSET ADJACENT TO THE OPERATING POSITION MAKES AN IDEAL LOCATION FOR A TRANSMITTER

having been plagued by it for months. Though our problem is mutual, there might be a vast difference between the architectural arrangements of our respective homes which would prevent operation in the living room; but if he is fortunate enough to have a clothes closet adjacent to his living room, or for that matter any unoccupied anteroom, I'm sure he will benefit from what I am about to do.

"While actual construction has not been commenced, the closet door has been measured and its cost meditated upon, as have the prices of costumers which must inevitably carry the burden of the evacuated clothes closet. After careful perusal of various mail order catalogs, it has been found that the combined costs of a new door and a costumer is far below that of a commercial relay rack.

"It may not be absolutely necessary to purchase a new door, but in most cases it will be much safer to stow the old door away somewhere in the attic for future replacement in the event that the experiment goes awry, and equip the closet or anteroom with a new door of identical style and finish. The reason for this precaution is obvious after it is learned that the door is to become the victim of drills, chisels and what not; and will eventually emerge from the operation full of meter holes and the like. With the anti-

pation of such mutilation in the mind of whoever must grant permission, that permission is more easily gained if the disfiguring is done to something besides an old heirloom or the property of a disagreeable landlord. In the end, if the work is painstakingly done, there is no reason why it shouldn't be attractive; and the chances are that the old door will be permitted to rest peacefully in the attic.

"Door styles best suited to transmitter mounting are the Norfolk and the Baylor. If something more fancy is desired the Windsor, which is basically the same as the Baylor, may be used. The Norfolk has five individual panels framed by the door proper and run horizontally while the Baylor has only one vertical panel approximately four-fifths as long as the door and similarly framed. The width of the panels between the vertical parts of the frame on a door two and one-half feet wide is exactly nineteen inches, which makes this size door readily adaptable to the standard relay rack panels, if those are desired.

"Various methods of mounting the chassis can be employed and are best decided upon by the individual constructor. If the Baylor type door is used, the panelling may be broken up into separate panels for mounting each deck from the front in conventional relay rack fashion; or the mounting may be done from the rear, leaving the door panel intact, and presenting a much neater appearance. An example of the latter type of construction can be clearly understood and appreciated by reference to the article by George F. Wunderlich, W6DUW, on page 38 of the November 1937 issue of *QST*.

"Now that the method of mounting has been decided upon, let's see if we can find any disadvantages. Possibly the only objectionable feature of mounting a transmitter on a door is the strain exerted on the hinges by the weight of the power supplies in high power rigs, but this strain may be alleviated by mounting the power supplies permanently in the closet since there are no coils to change in a power supply. As an alternative, the power supplies could be mounted on a coaster and be pushed and towed back and forth into and out of the closet by the door.

"With the power supply angle successfully knocked in the head, this method of mounting the transmitter can offer nothing but advantages. Everything is flush with the wall and does not clutter up the room as a superfluous piece of furniture and, when adjustments need be made, the entire rig can be swung in an arc of 180 degrees for ease of accessibility. The high voltage is in a safe place during operation and away from inquisitive visitors; and it may also be kept away from the

## Problem No. 16

OUR Hero has been reading up on band-changing systems for transmitters. He has found plenty of material published on various schemes, each one of which seems to have satisfied the requirements of the writer. And yet, with all of these systems before him, he is in a dilemma. Should he switch doubler stages in and out, switch coils or tank circuits in various circuits, use separate final amplifiers or some other system? Or should he be content with the time-worn plug-in coil system? He would like to see some conclusive general arguments for each of the various methods of band-changing.

To place some limit upon the scope of the problem, we shall say that he will be satisfied with c.w. operation in three bands. Cost, simplicity or complexity, speed of changing (if speed is considered to be of prime importance), and all other points including the antenna problem should be taken into consideration. Select any pet system you wish and put up the best possible argument for it. It should be remembered that the prize is offered for the best *argument* and not particularly for the best mechanical or electrical arrangement.

operator by providing interlocking switches to cut out the primary voltage to the hot stuff when the door is opened. Likewise interlocking switches may be provided for connecting tuned feeders in the event that they are used. And when the rig is put off the air a master switch inside the closet may be opened and the door locked with the key hidden safely in the operator's pocket, insuring a thoroughly disabled rig until he returns to pound out another CQ."

William M. Hildebrand, W8LOF, describes his rig which is built into a cedar chest:

"Very few mothers or wives, who are obliged to tolerate the presence of a 'ham' in the home, would object to an attractive cedar chest full of radio apparatus even in the living room. Although

it might not be their idea of good furniture arrangement to have such a chest in the living room, it would be much preferred to that of any other type of construction in which many dials, switches and other gadgets would protrude from the panel.

"The chest may be purchased at a surprisingly low cost at nearly any furniture

(Continued on page 84)

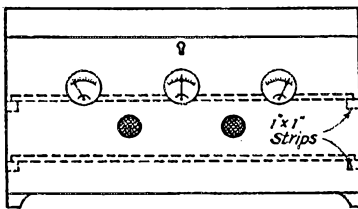

FIG. 3—W8LOF OVERCAME FAMILY OBJECTIONS BY BUILDING HIS RIG IN A CEDAR CHEST

Tuning controls are under the cover.

# HINTS and KINKS for the Experimenter



## Electrolytic Interrupters for D.C. Districts

THE suggestion of use of transformer power supplies on d.c. supply lines with the use of an electrolytic interrupter comes from B. P. Hansen, W9KNZ, Denver, Colo., who made use of this device to supply UV-202 tubes in years past.

The sketch of Fig. 1, taken from the book "Induction Coils," H. S. Norrie (Spon and Chamberlain, 123 Liberty St., New York, 1909), shows a simple electrolytic interrupter. The cur-

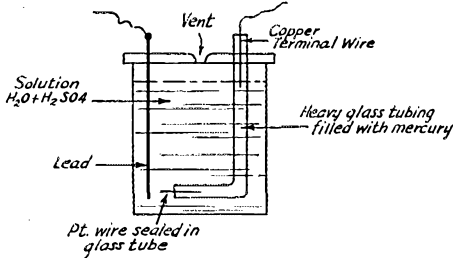

FIG. 1—BASIC ELECTROLYTIC INTERRUPTER

rent carrying capacity of this type is lower than that of Fig. 2, and in addition, the frequency of the interrupter of Fig. 1 is difficult to adjust.

The interrupter of Fig. 2 was taken from a picture in an old catalog of the Electro Importing Company. A large earthenware crock (approximately  $\frac{1}{2}$  gallon capacity) is used for the con-

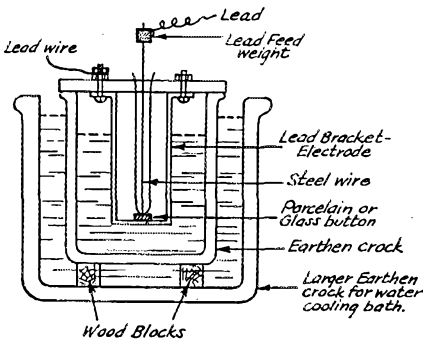

FIG. 2—PRACTICAL ELECTROLYTIC INTERRUPTER

This type should bear investigation by amateurs in d.c. districts.

tainer. Since the electrolytic solution reaches a high temperature when in operation, with resultant change in resistance, means must be provided for cooling the crock and its enclosed ap-

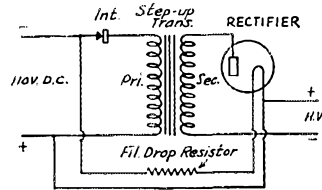

FIG. 3—CIRCUIT SHOWING APPLICATION OF THE INTERRUPTER IN PRIMARY CIRCUIT OF TRANSFORMER

A fuse must be provided in series with the primary.

paratus. The crock is therefore set up inside a larger container partially filled with water, and in cases of extreme heat, provision might be made for use of circulating water in the outer container.

The electrolytic solution has a specific gravity of 1280 to 1300, obtained by use of eight parts water with one part sulfuric acid. The current-carrying capacity of the solution increases with its strength, but a stronger solution has shorter life.

The lead bracket shown in Fig. 2 serves a double purpose; it supports the small glass or porcelain spacer which in turn holds the end of the small electrode, and it also forms the second electrode. A strip of lead about  $\frac{1}{2}$ -inch thick by  $1\frac{1}{2}$  inches wide should be adequate for this bracket. The bolts which support this bracket should be heavily plated with lead or cadmium.

The lid should be made of paraffin-soaked wood, and must be provided with a vent hole.

The small electrode is a piece of steel wire. The steel wire is contained in a short length of  $\frac{3}{16}$ -inch o.d. heavy glass tubing, drawn down to a small point at the lower end. There must be a hole left at this end of the tube, so small that the wire cannot quite pass through. When the assembly has been placed in operation, the end of the wire will be reduced to a long, tapered point by the electrolytic action, and it will then protrude through the hole and rest on the glass or porcelain spacer. The distance from the top of the spacer to the bottom of the glass tube should be approximately  $\frac{1}{16}$  inch; a greater distance

allows the passage of more current but results in lower frequency operation.

A fuse or other protective device must be used in series with the interrupter. One possible circuit using this device is shown in Fig. 3. It must be warned that 110-volt d.c. primary supply,

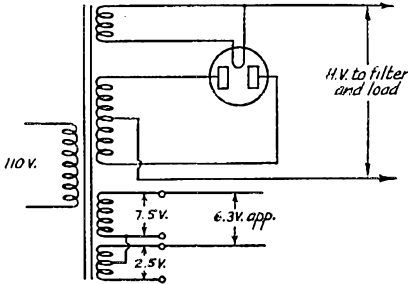

FIG. 4—METHOD FOR OBTAINING 6.3 VOLTS FROM OLD-TYPE TRANSFORMERS

with interrupter, will not in any circumstances be equivalent to 110-volt a.c. supply.

### 6.3-Volt from 7.5-Volt and 2.5-Volt Windings

THE use of a center-tapped 2.5-volt winding, and a 7.5-volt winding to obtain 6.3 volts for heater-type tubes is suggested by Edwin Kirchhuber, W2KJY, Brooklyn, N. Y.

Fig. 4 shows the circuit suggested. The voltage between center-tap and one side of the 2.5-volt winding is connected in phase opposition with the 7.5-volt winding, and the series combination is used to supply the heater voltage required. As the 7.5- and 2.5-volt windings were designed for these voltages at loads greater than that usually required for 6.3-volt tubes, the voltage to be expected should be quite close to the desired value.

### Information on Pulleys for Amateur Antenna Use

NEARLY every person interested in radio is confronted, at some time, with the problem of the type of pulley best suited to antenna erection. Since in antenna applications, the pulley is often so situated that it remains for weeks exposed to all weather conditions, and in many cases, the halyard remains in one position, failing to exercise the pulley, the results of tests with five common types should prove valuable to many readers. *QST* is therefore indebted to D. Reginald Tibbetts, W6ITH, Berkeley, Cal., for this data.

The five pulleys placed in use in the same conditions were:

1. Ordinary cheap galvanized iron awning pulley; cost, 10¢.

2. Better grade galvanized iron with bronze shaft; cost, 25¢.
3. Bronze awning pulley, boat supply; cost, 65¢.
4. Hardwood block with steel shaft; cost, 90¢.
5. Hardwood block with bronze roller bearing shaft; cost, \$1.50.

After several months of use, winter and spring, the test yielded the following comparison of the different types:

1. This pulley was completely out of operation. It had "frozen" within two months.
2. This pulley could be turned, but corrosion which had taken place on the inside face of the pulley caused binding.
3. The bronze awning pulley could be turned, but it showed some stiffness as a result of corrosion. This type was considered to be a satisfactory one for the purpose, if cleaned periodically; however, the usual position of the antenna pulley makes this an impractical solution to the problem.
4. The hardwood block pulley with steel shaft was inoperative, owing to rusting of the steel shaft which caused the latter to "freeze" in the block bearings.
5. The fifth type, hardwood block with bronze roller-bearing shaft, was found best suited to this use. Operation of this pulley compared favorably with that of a new one.

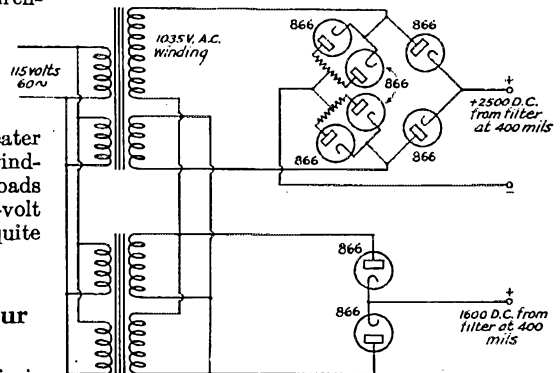

FIG. 5—1600- AND 2500-VOLT POWER SUPPLY USING BRIDGE-RECTIFIED POLE TRANSFORMERS

Filter equipment is not shown; the conventional filter arrangements used with full-wave rectifier supplies are applicable here.

Application of grease to the pulley bearings is recommended.

### Dual Power Supply Using Two Pole Transformers

THE circuit arrangement shown in Fig. 5 was designed by Fenton Priest, W3EMM, Norfolk, Va., to fill the need for 2500-volt 400-mil and 1600-volt 400-mil plate supplies. The 1600-volt

supply is used for a Class-B modulator and buffer, while the 2500 volt supply is connected to a 1-kw. final amplifier. Each of the two transformers used has two separate 115-volt windings, and two separate 1035-volt windings. These transformers can either be used on 115 volts, as

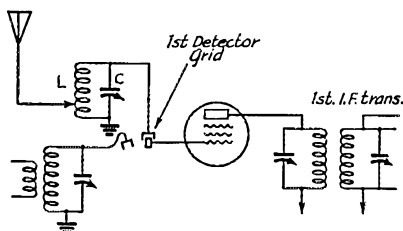

FIG. 6—CIRCUIT FOR ADDITION OF HIGH-FREQUENCY TUNING CIRCUIT FOR INCREASING THE RANGE OF SUPERHETERODYNE RECEIVER TO COVER AN ADDITIONAL HIGH-FREQUENCY BAND

*Tuning of the added circuit is not critical.*

shown in the diagram, or the two 115-volt windings may be connected in series on each of the two transformers, in which case the system is equally well adapted to use on a 230-volt line. In this circuit, the four 115-volt coils are connected in parallel. The high-voltage coils on transformer B are connected in parallel and are then connected between the two high-voltage coils of transformer A. The phasing of the primary and secondary windings must be carefully arranged as shown. In Fig. 5 pairs of 866 rectifiers are shown paralleled to handle the combined loads at the two voltages. With the rectifiers, center-tapped resistors of 50 ohms are used to balance the currents of the parallel tubes. An alternative arrangement would be the use of 872 type tubes at the two points of paralleled 866's.

With reference to regulation of the dual supply, W3EMM writes: "With the final amplifier

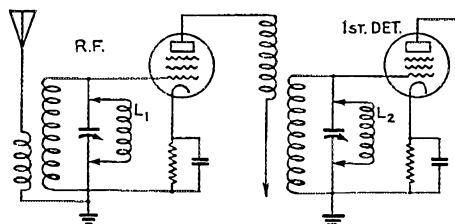

FIG. 7—CIRCUIT DIAGRAM SHOWING ADDITION OF HIGH-FREQUENCY COILS BY CLIPPING ACROSS CONDENSER SECTIONS

drawing 400 mils at 2500 volts, the buffer drawing 75 mils at 1600 volts and the Class-B static plate current 100 mils at 1600 volts, in addition to the load of the two bleeder resistors, the voltage regulation is excellent, varying only 50 to 60 volts on the 1600-volt supply, with modulation."

W3EMM further advises that these trans-

formers (rated at 3 KVA each) are often obtainable when being regularly replaced by the local power companies, and that they are sold at the price of discarded metal.

—...—

## Use of Modern Superhets for Reception of High-Frequency Bands

SUGGESTIONS have come almost simultaneously from Chauncey Coston and W7ENR, of Hoquiam, Washington, and William L. Smith, W3GKP, Washington, D. C., that compact coil-and-condenser tank circuits, with tuning range suited to the band next higher than the highest reached by receivers of a particular type, be added to the receiver without any major circuit changes, as shown in Fig. 6. This adaptation is obviously limited to receivers which use fundamental frequency output of the oscillator to tune through the entire receiver range, so that use may be made of second-harmonic oscillator output to tune the band next higher than the receiver's highest band.

Referring to the circuit of Fig. 6, *L* and *C* represent coil and condenser of suitable size for tuning through the desired higher-frequency band. This coil-and-condenser assembly is connected in the receiver only when this particular band is desired, and the connection is made by grounding one end of the tank and connecting the other end to the grid cap of the first detector tube, removing the regular grid cap entirely. In this way, damage to the receiver is avoided, and the versatility of the receiver is increased.

Although this method adds another control to the receiver, the tuning of this new circuit is not critical, the actual reception-frequency of the receiver being adjusted by the regular tuning dial which controls the fundamental and second-harmonic frequencies of the oscillator. Of course, the adjustment of the added tank to the exact frequency of the received signal should result in a slight increase in received-signal strength.

An alternative suggestion which has been received is the use of similar coils of a few turns each, one of which may be clipped across the first detector tuning condenser, another across the r.f. tuning condenser, etc. For receivers having r.f. amplifier stages, requiring the use of more than one clipped coil, care should be taken that the coils have as nearly as practicable equal inductance and distributed capacity characteristics. A circuit illustrating this suggestion is included in Fig. 7. The coils would be added to the receiver only for operation on the high-frequency band, and would be simply clipped to ground and each condenser section, the oscillator condenser section excluded. With the use of either the first or the second method, a receiver tuning through the 10-meter band could be used to receive the 5-meter band, or one tuning through the 20-meter band could be used to receive 10-meter signals.

# ● ARMY-AMATEUR RADIO SYSTEM ACTIVITIES ●

THE following is quoted from a recent issue of the Ninth Corps Area monthly bulletin:

"From my slight experience with Army field sets, the first requisite of a portable set is that it really be portable. Our dictionary gives the definition of portable: 'Capable of being borne or carried; easily transported.' Notice that word 'easily.' A man who has been flooded out of his normal shack has neither the time nor the inclination to carry a huge rig, perhaps cross country, for a mile or more, slipping, sliding through the mud and water, or breasting his way through snow or rocks or something, to a new location. This set must be light and small and entirely independent of any outside source of power.

"This class of rig does not need to be so very powerful. A two-tube rig using batteries and receiving tubes will normally be sufficient. There is seldom a distance of over a hundred miles to be covered to the edge of the emergency area where contact can be made with someone with a permanent set-up. This man will have his regular super or other rig, capable of building up a very small signal to readable strength.

"The same goes for the portable receiver. A two-tube blooper will bring in many signals from fellows outside the emergency area who still have their California (?) kilowatt rigs going. The man in the emergency area is not so much interested in working the other fellow in the same circumstances as he is; what is wanted most is connection with the outside fellows and through them, Government, Red Cross and other relief agencies.

"There is another class of emergency, such as

W6CC encountered last winter. His shack was still intact, his rigs and home were there, as always, but the heavy snows had broken down all power and other lines into his city. He had a good car but could not get it out of the garage. His need was not so much an emergency rig such as described above as it was for emergency power. He had a good battery from the car that he could not use. What he needed was some way of putting that power to use to get him contacts with other parts of the state. He had the means and was in contact with San Francisco and Sacramento, the state capital. Through him the city's newspapers got their press news from the rest of the country and through him, if there had been need for such, the Red Cross could have been notified to send serum and other relief supplies. Luckily, these were not needed, but he had done his part. He was ready for the emergency. This winter he has added a phone rig to increase his usefulness.

"What about you? Could you do the same for your city?"

Not long ago WLM was in contact with WLYY-W6CDA on 6990 kcs. At the same time WLNF-W2BCX was in contact with WLM on 3497.5 kcs. WLYY informed WLM that he had quite a few messages, most of which were for the Second Corps Area. WLM requested WLNF to tune his receiver to 6990 to receive WLYY. WLNF's 3497.5-kc. signals were then plugged through the switchboard into a tube keying repeater and back into WLM's 6990-kc. set, thus enabling him to key both circuits simultaneously. There is no doubt that WLYY was somewhat confused by this arrangement, but the traffic was

Station	City	Time Filed (EST)	Time Received	Relaying Stations	Elapsed Time
W4NF	St. Augustine, Fla.	7:35P 2nd	7:47P 2nd	W4IR	12 mins.
W5FDR	Houston, Texas	6:30P 31st	6:52P 31st	W5MR WLJ	22 mins.
W6LKU	Glendale, Calif.	9:00P 1st	10:03P 1st	W6CVL WLVH	1 hr. 3 mins.
W1FAP	Old Orchard, Me.	5:45P 2nd	6:14P 2nd	W1BVR	1 hr. 9 mins.
W9VTH	Willmar, Minn.	7:00P 2nd	8:12P 2nd	W9PTU WLUD	1 hr. 12 mins.
W8KUN	Homer City, Pa.	6:30P 1st	7:04P 1st	W8UK WLQL	1 hr. 14 mins.
W8CSG	Chelsea, Mich.	7:25P 4th	9:40P 4th	W8FTW WLTJ	1 hr. 15 mins.
W6OUU	Safford, Ariz.	8:30P 2nd	10:06P 2nd	W5DXA W5MN WLJ	2 hr. 16 mins.
W1FSV	Rutland, Vt.	5:25P 1st	9:45P 1st	WLG	4 hr. 20 mins.
W9QG	Indianapolis, Ind.	6:45P 2nd	12:10A 3rd	WLHL WLHA	6 hr. 5 mins.
W5QJ	New Orleans, La.	5:33P 3rd	4:10P 4th	W5GHF W8YA	22 hr. 37 mins.
K7FSX	Seward, Alaska	11:30A 12th	1:20A 13th	W7EBQ W6CDA	10 hr. 50 mins.

\* \* \* \*

handled in a very expeditious manner while the operator at WLM leaned back and enjoyed a cigarette, very much pleased with himself for working himself out of relaying these messages another time.

\* \* \* \*

A recent survey of the occupations of members of the A.A.R.S. shows them engaged in all types of work. Reports were received from approximately 825 members. A list of the more numerous occupations follows:

Students . . . . .	21%	Radio Engineers . . . . .	4.2%
Radio Servicemen . . . . .	17%	Teachers . . . . .	4.3%
Radio Operators . . . . .	10%	Merchants . . . . .	4.3%
Clerks . . . . .	8.4%	Mechanics . . . . .	4.1%
Electricians . . . . .	6.6%	Telegraphers . . . . .	3.2%
Telephone Employees . . . . .	4.5%	Soldiers . . . . .	3.2%
Electrical Engineers . . . . .	4.5%	Printers and Publishers . . . . .	4.7%

To test the accuracy and speed of our system, on January 27th, fourteen messages were mailed to different members in all sections of the country with instructions to file as soon as possible for transmission to WLM. Those received were en-

tirely accurate with a remarkably short elapsed time enroute. Only two of these messages failed to arrive at WLM.

A list of stations where these messages were originated and relay conditions appear on the preceding page.

Starting with this issue, we will run a series of cipher messages. No solutions or instructions in methods of breaking these down will be printed, but all are invited to try to "bust" these messages. Solutions should be forwarded to the Liaison Officer, A.A.R.S., 3441 Munitions Bldg., Washington, D. C. If you submit a correct solution you will be so advised by letter or radiogram.

The following is very easy: UFRWO SGFMH SCAF L JLIJU UHGJB JTVOB JUHRH BGJHI FVSEF MUEOA QEFOE OWSJU UNOUE FDHGB JHEAO DNJBJ YDJBE XHUHU QJLLV BOSGE NJGBJ HEXHB NFXIH SCIEJ NFLUN JUVJL OSKBJ HQOSG LFXSM OWJEN FVUHS LAODN JBIJU UHGJU UEFDN OUBJD RCXHU MOWJE NFVUH SLUEF DXXXX.

## 1.75- and 28-Mc. Operation with the Low-Cost 100-Watt Transmitter

EVIDENTLY, from the considerable amount of correspondence generated by the description of the 6L6-809 transmitter in *QST*,<sup>1</sup> a large percentage of those contemplating the construction of this outfit is anxious to extend the frequency range beyond the three bands for which it was designed. Also, many want information concerning a modulator suitable for the transmitter.

Originally, the outfit operated on 3.5, 7 and 14 Mc., using one crystal for all three bands; operation on 1.7 and 28 Mc. was not contemplated at that time. In the new set-up we have a range of five bands, starting at 1.7 Mc. and ending at 28 Mc. Operation with 3.5-Mc. crystals can still be carried on as before, but alternatively the two lower bands can be covered with a 1.7-Mc. crystal and the last three with a 7-Mc. crystal.

All that is needed for working on the two additional bands is the construction of a few extra coils. Actually, anyone already having built the rig would have an extra coil or two if he constructed both the coils described in the original article and those shown in the accompanying table. Although the coil forms used are inexpensive, anyone wishing to do so can very easily figure out the minimum number after a little study of the two coil tables.

<sup>1</sup> Chambers, "A Low-Cost 100-Watt Transmitter," *QST*, February, 1938.

The general method of operation is the same as originally outlined; that is, the oscillator is coupled to the amplifier, the doubler being cut out of the circuit, when the amplifier works at crystal frequency. In such case no coil is used at  $L_2$ . For output at twice the crystal frequency, a fundamental coil is used at  $L_2$  and the second-harmonic coil at  $L_3$ ; at four times the crystal frequency, a second-harmonic coil at  $L_2$  and fourth-harmonic

### COIL DATA

L <sub>1</sub>	
1.7 Mc. . . . .	Plate 90 t. No. 22 d.s.c. close-wound 1" dia.
	Grid 40 t. No. 20 d.s.c. close-wound 1½" dia.
L <sub>2</sub>	
14 Mc. . . . .	L <sub>2</sub> Plate 4 t. No. 18 enam. single-spaced 1½" dia.
L <sub>3</sub>	
28 Mc. . . . .	Plate 10 t. No. 20 d.s.c. close-wound 1" dia.
	Grid 5 t. No. 18 enam. single-spaced 1½" dia.
L <sub>4</sub>	
1.7 Mc. . . . .	46 turns No. 16 enam. wire, 2¼" dia., 3¾" long
28 Mc. . . . .	4 turns No. 14 enam. wire, 1½" dia., ¾" long

coil at  $L_3$ . The tuning procedure is similar to that described in the February article. The amplifier should remain neutralized on all bands, although the apparent neutralization may not be quite as complete on 28 Mc., partly because of the

(Continued on page 64)



# A Crystal-Controlled 5- and 10-Meter Portable

## Three-Tube Transmitter for Mobile Work

By Frederick F. Sylvester,\* Ex-W2ACU and Edwin F. Dillaby,\* WIDWY

**M**ANY amateurs have long considered the construction of a crystal-controlled portable u.h.f. rig but have hesitated, thinking the job too complicated and the results questionable. The apparatus pictured herewith may be constructed inexpensively and affords excellent results, comparable to those obtainable from commercial low-power, two-way communication systems. All of the component parts are obtainable from the current stock of parts dealers except the transmitter case, which may be purchased at low cost.

The Hytron 6J5GT "Bantam" triode (a miniature 6J5G) and the HY60 beam-tetrode tubes were chosen for use in this transmitter as they are new types specially designed for portable use. The HY60, which is a beam-tetrode type power tube similar to the many beam power tubes already on the market, with the exception that the bulb size and heater power consumption are greatly reduced, makes possible high operating efficiency at relatively low plate inputs.

The transmitter is entirely self-contained in a cast-iron box, easily obtainable at any iron foundry from rough patterns. The transmitter

\* Engineering Department, Hytronic Laboratories, 78 Lafayette St., Salem, Mass.

unit is shelf-mounted on a panel which also serves as a shield between the oscillator and doubler-amplifier circuits. The cast-iron case is mounted by means of strap iron brackets to the rear bumper of the car, and the antenna fish pole is plugged into a standoff insulator provided at the top of the transmitter unit. Connections are made to the rig through a multiple plug entering the bakelite bottom cover of the box. A multi-wire cable carries the plate, filament and audio power to the plug connections at the rear of the car. The modulator as well as the "B" supply are mounted inside the car wherever convenient. The receiver uses a separate antenna which mounts on the side of the rear bumper opposite the transmitting antenna.

The transmitter circuit is rather unique insofar as it is simple yet very effective. A Type 6J5GT tube is used as a triode oscillator in connection with a Bliley 10-meter crystal. The plate tank of the crystal stage is capacity coupled to the HY60, which works as a doubler-amplifier on 56 Mc. or on 28 Mc. as a straight r.f. amplifier. The Marconi antenna is inductively-coupled to the final plate tank. The accompanying circuit diagrams show the modulator as a separate unit, which is probably the better arrangement since

it need not be shielded and requires but a single 6V6G.

Extremely small size and the low inter-electrode capacities of the Bantam tube make it desirable for use in the 10-meter crystal stage. Sufficient output is obtainable from the crystal stage alone to light a  $7\frac{1}{2}$ -watt 110-volt lamp to about one-fourth of its normal brilliancy. Several makes of crystal holders were tried for maximum output and stability in transmit and it was found that a good crystal holder was well worth the investment.



THE MODULATOR AND R.F. END ARE SEPARATE UNITS IN THIS 28-56-MC. PORTABLE-MOBILE TRANSMITTER

The modulator unit, at the left, is mounted inside the car. The r.f. end fastens to the rear bumper, with the antenna fishpole mounted on a standoff which protrudes through the back of the cast-iron box. The detachable plate, of bakelite, faces downward when the assembly is in place on the bumper.

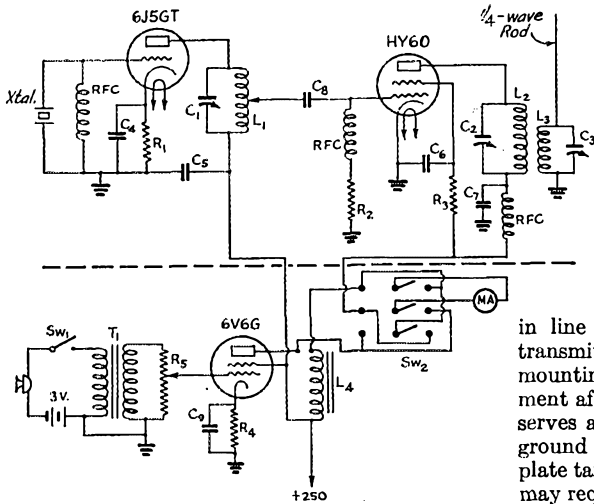

FIG. 1—CIRCUIT DIAGRAM OF THE CRYSTAL-CONTROLLED 28- AND 56-MC. MOBILE TRANSMITTER

The transmitter unit is the part above the dotted line. The modulator, which may be installed in any convenient spot in the car, is below.

C<sub>1</sub>—75- $\mu$ fd. air trimmer (Hammarlund APC-75).

C<sub>2</sub>—15- $\mu$ fd. variable (Cardwell ZR-15-AS).

C<sub>3</sub>—100- $\mu$ fd. variable (Hammarlund APC-100).

C<sub>4</sub>, C<sub>5</sub>, C<sub>8</sub>—0.002- $\mu$ fd. mica.

C<sub>7</sub>—0.001- $\mu$ fd. mica.

C<sub>6</sub>—100- $\mu$ fd. mica.

C<sub>9</sub>—5- $\mu$ fd. 50-volt electrolytic.

R<sub>1</sub>—200 ohms, 1-watt.

R<sub>2</sub>—50,000 ohms, 1-watt.

R<sub>3</sub>—50,000 ohms, 10-watt.

R<sub>4</sub>—250 ohms, 10-watt.

R<sub>5</sub>—500,000-ohm volume control.

L<sub>1</sub>—7 turns No. 12 enamelled, diameter  $\frac{7}{8}$  inch, spaced wire diameter.

L<sub>2</sub>—28 Mc.: 6 turns No. 12, diameter  $1\frac{1}{8}$  inches, spaced wire diameter.

56 Mc.: 3 turns No. 12, diameter  $1\frac{1}{8}$  inches, spaced wire diameter.

L<sub>3</sub>—3 turns No. 14, diameter 1 inch.

L<sub>4</sub>—15-henry choke (U.T.C. CS-40).

T<sub>1</sub>—Microphone transformer (Thordarson T-7259).

RFC—2.5-mh. r.f. choke (National R-100).

Sw<sub>1</sub>—S.p.s.t. switch.

Sw<sub>2</sub>—3-pole d.t. key switch.

The amplifier tube drives very easily and makes an excellent power doubler. The entire current drain for both tubes in the transmitter totals less than 60 ma. at 250 volts. Better than 5 watts of modulated carrier can be obtained with only 7.5 watts input to the final stage. The total plate power input for the rig, including the modulator, is approximately 23 watts.

The modulator consists of 200-ohm-to-grid input transformer coupled directly into a 6V6G. A good handset with a 3-volt supply will drive the modulator to full output. The HY60 is plate-and-screen modulated through the connecting cable from the modulator unit within the car. The total current drain from the "B" pack does not exceed 95 ma., and any good rotary or vibrator power supply designed for the purpose may be used. It is generally best to place the power supply under the front seat to afford short

connection leads to the car battery. For convenience in tuning the transmitter, a 0–100 ma. plate-current meter is assembled in the front panel of the modulator unit. A triple pole-double throw switch makes it possible to measure the plate current of the 6V6G modulator or the plate and screen current of the HY60.

Tuning is accomplished through the iron case with an insulated extension screw driver. Tapped holes, with plugs to fit, keep out water and are drilled in line with the tuning condenser shafts. The transmitter may be tuned on the bench before mounting it on the car, but may require readjustment after installation since the car body, which serves as a counterpoise, may not be exactly at ground potential. Tuning of the crystal stage plate tank circuit generally remains constant, but may require some adjustment. Tuning of the final stage is easily accomplished with the aid of the plate-current meter, which indicates resonance current accurately. It is then simply necessary to retune the antenna trimmer condenser to full plate load. Modulation can be checked by throwing over the key switch to read modulator plate current.

The modulator unit may be installed under the dash or in the glove compartment. Tone-modulated c.w. signals on 5 meters are easily achieved by using a high-frequency Signal buzzer and key in the primary circuit of the microphone input transformer. The receiver used by the authors is a National 1–10, but any good superhet or superregenerative unit is satisfactory.

## Transmitting Tube Manual

THE familiar receiving-tube manual which has been a useful member of the library of many an amateur in the past few years now has a companion in the recently-announced "Technical Manual TT-3", published by RCA Manufacturing Company, Inc., Harrison, N. J. Somewhat similar in plan to the receiving-tube book, the opening chapters cover fundamentals of tube design, construction and application, followed by detailed operating specifications for the various RCA transmitting tubes of particular interest to amateurs, and ending with sections on such subjects as transmitter design considerations, rectifiers and filters, and circuits. A number of formulas and charts of utility to the transmitting amateur are included. The book is comprehensively indexed.

The TT-3 contains 192 pages, of which about 110 are devoted to specific tube types, the remainder being general information. The price is 25 cents.

# ● I. A. R. U. NEWS ●

Devoted to the interests and activities of the

## INTERNATIONAL AMATEUR RADIO UNION

Headquarters Society: THE AMERICAN RADIO RELAY LEAGUE, West Hartford, Conn.

### MEMBER SOCIETIES

American Radio Relay League  
Asociatia Amatorilor Romani de Unde  
Scurte  
Associazione Radiotecnica Italiana  
Canadian Section A.R.R.U.  
Ceskoslovenski Amatérni Vysilaci  
Deutscher Amateur Sendo-und-Empfangs  
Dienst  
Experimental Radio Society of Egypt  
Experimenterende Danske Radioamatører  
Federation des Emetteurs Belges  
Irish Radio Transmitters Society  
日本アマチュア無線聯盟 Japan

Liga Colombiana de Radio Aficionados  
Liga Mexicana de Radio Experimentadores  
Magyar Rövidhullámú Amatőrök Országos  
Egyesülete  
Nederlandsche Vereeniging voor Interna-  
tionaal Radioamateurisme  
Nederlandsch-Indische Vereeniging Voor  
International Radioamateurisme  
Newfoundland Amateur Radio Association  
New Zealand Association of Radio Trans-  
mitters  
Norsk Radio Relæ Liga  
Oesterreichischer Versuchssenderverband

Polski Zwiasek Krotkofalowcow  
Radio Club Venezolano  
Radio Society of Great Britain  
Rede dos Emissores Portugueses  
Reseau des Emetteurs Francais  
Reseau Luxembourgeois des Ama-  
teurs d'Ondes Courtes  
South African Radio Relay League  
Suomen Radioamatööriyhdistys r.y.  
Sveriges Sandareamatörer  
Unión de Radioemisores Españoles  
Union Schweiz Kurzwellen Amateurs  
Wireless Institute of Australia

## Conducted by Byron Goodman

### Periodicals:

Last month we told you about the monthly publications of the English-speaking member-societies of the Union. In describing the other publications we can only give you impressions; our knowledge of languages falters badly as it gets to English and becomes practically non-existent after that.

Members of the O.V.S.V. (Austria) read "OEM," a mimeographed bulletin averaging 18 or 20 pages, written in German. A recent issue carried a thoroughly technical article on the Magnetron, a station description, results of tests and announcements of others, DX notes and routine announcements. The membership fee in the society is 12 Austrian shillings (about \$2.40).

The official publication of the F.E.B. (Belgium) is "QSO," a well-printed full-size magazine. The issue on hand (October) runs 24 pages, and it includes many small news items, both of a personal and general nature, technical articles on series modulation, reduction of harmonics, monitors, high-frequency amplifiers, and crystal oscillators, a station description, a DX column, DX test results, and several pages devoted to personalized section reports. The magazine is written in French; membership in the society costs 8 belgas annually (about \$1.35).

The Danish magazine "OZ" is also a full-size publication. The February, 1938, issues gives a very favorable impression, and its 32 pages contain technical articles on an advanced 28- and 56-Mc. receiver, propagation data on 28 Mc., translations of several technical articles appearing in other publications, and a number of articles

that have no illustrations and so your reviewer can't guess their subject material. Membership in the EDR is 12 kroner per year (about \$2.50).

"Radio REF," the monthly magazine of the French society, is the largest (72 pages) of the foreign society magazines. The February issue contains much general news material, articles for the beginner, an extensive DX section, a section devoted to high-frequency experiments, section reports, and one of a series of articles on telephony. Most of the technical material, aside from the telephony article, is contained in several complete station descriptions. Other issues of the magazine that we have examined have carried a large number of original technical articles. The annual membership fee is 55 francs, equal to about \$2.55.

It is difficult to look at "CQ," the publication of the DASD, and not regret that you don't read German. The February issue contains an interesting-looking article on a modern superhet receiver, a very complete article on measurements and the associated equipment, and several general articles. The issue on hand has 20 large pages. Membership in the DASD costs 12 RM per year, equal to about \$4.75.

Since Italy nominally has no amateurs, the magazine of the Italian society of necessity confines its treatment to articles of a more or less general nature. The January issue of "il Radio Giornale" carries articles on power supplies, a translation of *QST*'s radio-controlled sailplane story, digests of recent patents and contemporary magazine articles. The 24-page magazine carries quite a few advertisements, an indication that the radio trade is not exactly at a standstill!

Membership in the A.R.I. costs 30 lire per year (about \$2.00).

"Onda Corta," the official magazine of the L.M.R.E. (Mexico), is fairly well known in this country. Its technical standard has always been high, and for that reason it is read by many W hams. The January issue has 44 pages, with technical articles for beginning and advanced amateurs, DX notes, an extensive account of the recent *Convencion Nacional* held at Monterrey, and the usual departments. The subscription price is \$5.00 Mexican per year (about \$1.40).

Those who read Dutch should find "CQ-NVIR," the Netherlands society magazine, very interesting. It is apparently a very complete magazine, although the reviewer's language shortcomings are again responsible for an incomplete impression because there aren't many photographs or diagrams in the 32-page February issue. However, there are several technical articles treating u.h.f. equipment, oscillators, etc., a section devoted to DX and another to activity reports, a correspondence section, and several miscellaneous departments. The make-up of the magazine is clean and orderly, and the cover design is very pleasing. The membership fee in the N.V.I.R. is 3.50 Dutch guilders (about \$1.90).

Although it is a mimeographed publication, "CQ-PK," the monthly magazine of the N.I.V.-I.R.A., contains much excellent material. The pages are quite large (8½ x 13"), and those in the January issue numbered 15. Several pages are devoted to an annual report of the society's activity, and several more are devoted to advanced systems of remote-control tuning. "CQ-PK" generally contains an interesting up-to-date technical article, and we always look through it with interest, even if we can't read Dutch. The rest of the January issue contains miscellaneous technical notes, dope on QRA and QSL Bureaus, and some "ham-ads." No commercial advertising is carried.

"LA," the paper of the NRRL (Norway), is a printed bulletin. Several technical articles, contest results and announcements, DX notes, and personal reports are included in the 8 pages (October). The membership fee is Kr. 8, about \$2.00.

If some of the other languages slowed us up, Polish stops us completely. However, "Krotkofalowiec Polski" gives the impression of being a very up-to-date technical publication. The December issue of 26 pages contains an article on thyatron control, a treatment of half-wave dipole antennas, a constructional article on a bug key, information on a stabilized power supply, contest announcements and results, and general department articles. The subscription rate is 9 zloty (about \$1.75).

The Swedish paper, "QTC," is somewhat similar to the Norwegian one. It is printed six times a year, usually runs about 8 pages. The January issue carried articles on a portable transmitter, swinging chokes, DX, contests, and a good deal of personal news. The membership fee is 10 Swedish crowns (about \$2.50).

The Swiss magazine, "Old Man," is written mostly in German, but carries some passages in French. This, of course, presents no serious problem to a reviewer who reads neither language with equal ease. However, this publication of the U.S.K.A. gives a very favorable impression to one who can only scan through it. The January issue carries 32 pages, and is made up mainly of short items dealing with contests, miscellaneous activity, editorial comment on problems of the day, and section reports. The membership fee is 7 Swiss francs (about \$1.60).

If anyone is further interested in any of the publications of the member-societies, we will be pleased to give what information we can, or to transmit your inquiry directly to the society.

## Strays

WIHRC says, "Those Polariscope sold in the toy stores make excellent sources of polarized light for examining quartz."

— — —

"Copper tubing in any of the standard sizes and in lengths up to 100 feet may be had with inside bright, smooth, and clean," writes L. W. Florman, who suggests that tubing for the construction of coaxial transmissions be obtained from refrigerator supply houses.

## Canada—U. S. A. Contest

THE period April 14th-18th has been announced for the Canada-U. S. A. Contact Contest. See March *QST* (page 10) for complete details. Starting Thursday, the 14th, at 6:00 p.m., VE-W QSO's will be the "order of the day" up to midnight on Monday, the 18th. The Canadian General Electric Company is donating a cup to the highest scoring Canadian station. Certificates of Merit will be awarded to the leader in each of the 70 A.R.R.L. sections. Read up on the rules and get in on some enjoyable VE-W contacts.



# Amateur Radio STATIONS



## W9FQU, Park Ridge, Ill.

**A** SPAN of twenty-two years separates the one-quarter-inch spark coil days of 9ANI and the present up-to-the-minute station W9FQU owned and operated by Mr. M. L. Potter of Park Ridge, Ill.

During the intervening years, the station has progressed through the various stages so familiar to every old-timer. Immediately after the war there was the 1-kw. "sink" spark "rock-crusher" well known as 9ABL, then the first hesitating chirps from 5-watt 9DMI in the days when the Hartley and "sure-fire" circuits held sway.

W9FQU itself dates back to 1930. It is now primarily a 'phone station operating at various frequencies in the 14- and 4-Mc. bands. The three transmitter racks, left to right, contain the five-stage, 500-watt 4-Mc. r.f. section with push-pull 860's in the

final; the 250-watt Class-B modulator, used to modulate either r.f. section; and the 14-Mc. transmitter using push-pull HD203-A's in the final, normally operated also at 500 watts input.

The relay rack scheme is carried to the receiving position shown in the second photograph. At the bottom of the rack is a series of switches which control the entire operation of both the transmitters, including connecting of either the 16/4 wavelength Bruce or the full-wave Zepp antenna and switching of the modulator to either r.f. section. The two receivers will be recognized as the RME69 with pre-selector and the Hallicrafters' Ultra-Skyrider. Immediately above the RME receiver is the speech amplifier which is connected to the input of the modulator through a 500-ohm line.

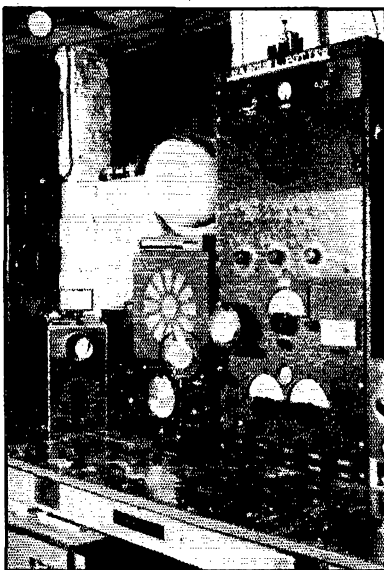

OPERATING POSITION AT W9FQU

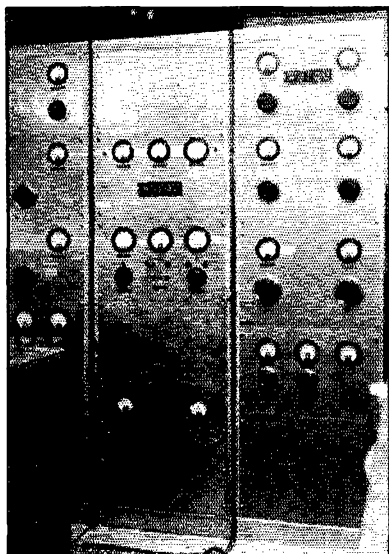

W9FQU

### Silent Keys

**I**T is with deep regret that we record the passing of these amateurs:

Arlie V. Davis, W5EVP, Dallas, Texas  
Ralph F. Miller, W8HQH, Massillon, Ohio  
Ernest A. Richardson, Bronx, N. Y.  
D. R. Sheehan, VE2DR, Montreal, Quebec  
Lindsay F. Towler, Victoria, B. C.  
Robert E. L. Travis, W4CWH, Demorest, Ga.  
Howard M. Vinson, W9DIU, Conde, S. D.  
A. G. Wingenter, W9SAT, St. Louis, Mo.



# OPERATING NEWS



Conducted by the Communications Department

F. E. Handy, Communications Manager

E. L. Battey, Asst. Communications Manager

**Flood emergency!** As we are proud to report in detail elsewhere in this issue, Southern California amateurs, true to amateur tradition, rose to the occasion in the flood emergency of early March. The Los Angeles Section Manager and all A.R.R.L. Emergency Coördinators in the area found it necessary to translate their facts (from station registrations) into actual organization. Advance amateur meetings dedicated to emergency planning proved their value in terms of practical preparedness to serve! It is probably true that the advance skeleton plans, which it is the duty of every community coördinator to produce for assumed contingencies, required modifications to fit circumstances. The point is that amateur planning and preparedness pays dividends. As we have said to each coördinator, we say to amateurs individually, **HAVE A PLAN.**

When the flood waters rose, self-powered set-ups were placed in operation—u.h.f. sets deployed on opposite river banks to prevent isolation—portables and networks operated to fixed station centers to serve particular needs of Red Cross, police, utilities, railroads and others. See the flood story for details. May we congratulate and thank every amateur for his flood effort and the very real coöperation between all concerned in the interest of giving the best public service in this emergency.

After wire service had been reëstablished in a limited way, this was overloaded for several days. With official traffic back on the wires the secondary load of family inquiry messages built up to a peak following the emergency by about three days, as people informed of ten- to twenty-hour delays in telephone calls turned to other means of getting facts to allay anxiety. Practically all amateur bands got a share of this traffic. The Trunk Lines did nobly. Wherever answers to messages were secured, amateurs may be assured that amateur radio won tremendous approbation and gratitude for the effort expended.

**Other emergencies.** This month we also take pride in recounting the facts on amateur operating accomplishment in the wake of a wind storm that did serious damage in northern California. Likewise amateur emergency service was extended in Oklahoma. Following a sleet storm wires became heavily coated. Wires down, amateurs filled the breach well. *The same thanks and*

*congratulations* are due the particular amateurs concerned in these events. It does not detract from their effort in the slightest that the emergency work was utilitarian without the emotional appeal that accompanies relief emergencies! It is not the size of an emergency condition that counts necessarily. The fact that whether one wire or a thousand are disrupted, and amateurs in each case successfully assume radio communication responsibilities is something in which all amateurs may take pride.

**"Get off my frequency . . ."** How often in tuning various bands we hear such words, or variations of the theme. Quite probably these result from the yearning we all have for a sure-fire circuit without any inconvenience from interference. Often we get letters from indignant amateurs who have just about decided to give up ham radio. They have received a real or fancied insult from a fellow ham—were cut short—or had to parry a tactless remark made on the impulse. Perhaps it was an argument about the use of a frequency. Perhaps not. But such things often leave a badly bruised sense of justice in their wake. Like other problems, we must look at the facts, and individual differences and the practical answers, and learn to take such things in our stride. Getting back to the *frequency* argument, it may be one ham who discovers a neighbor with a crystal of the same frequency, or it may be a member of a spot frequency net who argues with another ham with equal rights to use of this frequency.

As far as the expressed sentiments are concerned, a moment's reflection will make clear the fact that frequencies are not allocated to amateurs for individual "exclusive" use. Every amateur station license is an authorization of the F.C.C. to use any choice of frequencies within the limits of the several amateur bands, at will. No amateur has either more or less right to a particular frequency than any other similar licensee. All licensees having authorizations from Uncle Sam have equal complaint against any bootlegger or unauthorized station that appears in the bands without proper qualifications. The only way to amateur results which is sure-fire and effective is through courteous, brotherly, systematic, and coöperative use of the transmitting medium by all concerned. Some common sense

must be used, too. For example, an individual who carelessly acquires a crystal that happens to be right "plunk" on a ten-station net must note that the simplest way to insure himself minimum interference will be to grind it higher, or get another, or operate at times when the net is not operating. Crystals are quite cheap in this country in this enlightened day and age. The use of an amateur band by an amateur may be likened to that of the public streets by the public. Mutual tolerance and cooperation are required to avoid collisions and conflicts.

The approach or attitude with which one approaches his amateur operating has much to do with the effectiveness of results. Selfishness and intolerance are sometimes the companion of the amateur who sticks too close to his hobby objectives, or who places a little too much emphasis on his private "results" and cares not enough about the building of what may be a valuable and lasting friendship! A little less "high pressure" in the getting of results, a little more thoughtfulness and thought . . . operating courtesy in the place of intolerance. Let's try it!!!

—F. E. H.

#### PRIZES FOR BEST ARTICLE

The article by Mr. John Girand, W6KVL, wins the C.D. article contest prize this month. Each month we print the most interesting and valuable article received marked "for the C.D. contest." Contributions may be on any phase of amateur operating or communication activity (DX, 'phone, traffic, rag-chewing, clubs, fraternalism, etc.) which adds constructively to amateur organization work. Prize winners may select a 1938 bound *Handbook*, *QST* Binder and League Emblem, six logs, eight pads radiogram blanks, DX Map and three pads, or any other combination of A.R.R.L. supplies of equivalent value. Try your luck. Send your contribution to-day!

### Limit QRM

By John Girand, W6KVL\*

**I**T might be well to stop and analyze the amateur as an individual to see if he is getting—and giving—the full measure of real amateur radio.

Numerous letters to the Editor of *QST* complain about "lids," long CQ's, QRM and bum fists and there the matter rests; nothing is done about it. In most cases the principal cure lies in individual action. A dozen "letters to the Editor" will not do as much good towards reducing long CQ's, for example, as a friendly contact with the offending station and an explanation that more QSO's will result from short and snappy CQ's.

And as for the so-called "lids" . . . Much as it is painful to say it, there was a time in every

\*405 Ellis Bldg., Phoenix, Ariz.

amateur's life when he, too, could only copy 10 w.p.m., and his fists may have been a pain to the then older amateurs. These "lids" of to-day will be the operators of to-morrow, and good operators, too, if you will help them to-day. In 21 years of "ham" radio, I have yet to encounter a "lid" who was not appreciative of friendly advice. A visit to those who live nearby, and perhaps a discarded tube socket or condenser to help the "lid" build a better filter will pay big dividends: in better operators on the air with better signals.

The average amateur complains of QRM on his band, then winds up his rig and adds some more! For a long time I have had a one tube "stand-by" receiver tuned to my transmitting frequency which I use just before transmitting to see if my channel is clear; it's been a big help, too, and saved me many a call that would have been wasted because of QRM on my channel. A shift of a few kilocycles can be easily made on most amateur transmitters, and many times you can slide out from under heavy QRM, instead of adding more and more with your own signals.

"Sorri OM QRM hr vy bd" . . . and so on far into the night. With 65 stations trying to get through on 7001 kc. and nary a cheep from any station on the high end of the band. The amateur bands aren't crowded beyond endurance; the amateurs all are crowded into one part of the band. And a letter to the Editor won't move them out, either.

Individual effort will go a long way towards clearing up many of the amateurs' difficulties. Help one newcomer every day; avoid QRM'ing another ham just once every day; try one QSY every day; and it won't be long until the "gripe" letters to the Editor in *QST* will be few and far between, and wouldn't that be Great!

During QSO's every amateur can do much towards QRM reduction by tactfully condemning improper operating practices and by pointing out the correct procedure, at the same time explaining the benefits to be gained by "thoughtful" operating. A station is no better than its operator, and the real source of QRM is the operator—the signal is controlled by the operator. Friendly hints on profitable operating habits, passed along during actual contacts will not only help the whole fraternity, but also will aid the offenders to get the most out of their amateur radio.

— . . . —

There was quite a rush on the part of Headquarters staff members to join the A.E.C. when a recent bulletin to members of the Emergency Corps came off the mimeograph reading, in part, "In smaller communities where for any reason Coördinators have not been appointed, individual A.E.C. members must be responsible for carrying out the *cuties* specifically assigned to a Coördinator in the best manner possible." The typographical error was corrected before the bulletin was mailed, but we believe the A.E.C. would make more rapid strides if the word were really "cuties" instead of "duties"! Hi!!

## California Wind Storm

ON the evening of February 9th the Mission Trail Net, "180 meter" 'phone traffic net operating on 1804 kc., was interrupted by a QRR call, which started the net stations off on some mighty fine communications emergency work. At 7:15 P.M. W6NTU, acting N.C.S., requested all stations to QRX as a weak c.w. QRR call had been heard on the net frequency. It was W6GUK, Yuba City, operating his battery-powered emergency rig and calling with QRR traffic. W6OUM, Westwood, was also attempting to raise the net. W6KUS, Los Molinos, being well located for reception of the stations in the emergency area, was designated N.C.S. to receive the traffic and distribute it among the net stations.

A wind storm raging in the interior of California was wrecking power and transmission lines, causing serious damage and leaving many towns and cities without communication. Sacramento had but one power line left into the city, all lines north being out; Westwood, Yuba City and Grass Valley were without power and communication; all lines out of Colusa were down. The Mission Trail Net swung into action in earnest.

W6PBQ, San Francisco, handled traffic for the power company, and with W6OAE sent A.P. news items to Grass Valley for the local paper. W6ONP, San Francisco, was hooked up with W6PBQ via 56 Mc., handling the land-line, as PBQ had no telephone. Much traffic was handled for the Southern Pacific and Western Pacific regarding railroad service and dispatching in the isolated areas. Some traffic was also handled for the telegraph companies. The worst of the rush was over shortly after midnight, although many localities were still without communication as late as the next evening. Repair work was greatly facilitated by amateur radio message service. Snow was falling rapidly throughout the stricken areas and drifting was bad, necessitating constant checks on conditions. The work demonstrated the great value of trained amateur circuits, the Mission Trail gang putting into practice the experience gained through its regular net sessions.

Net stations aiding in the work and outside stations assisting included W6KUS, W6ONU, W6MRQ, W7CJL, W6OV, W6JDN, W6KUN, W6OMC, W6ZM, W6OAO, W6FOC, W6OUE, W6BF, W6JTE, W6PBQ, Q8OAE, W6GZ, W6JUQ, W6NTU, W6NAL, W6NOG, W6OND, W6LMF, W6HGN and W6OOQ.

On 3.5 Mc. other circuits were also performing splendidly. At Sacramento, with communication lines crippled, W6KME was on the job with a portable-emergency rig, aiding the highway police, press, Western Union and the power company in getting word to and from the isolated towns. W6LMD, Sonora, assisted W6KME in establishing contact with W6CW, Reno, Nevada, and other points. W6CW was cooperating with the police in Reno.

At 2:00 P.M., February 10th, W6KME was taking W.U. traffic from W6NKT, Placerville. Conditions were unfavorable, so W6LMD took over for KME, keeping schedules with W6NKT from then until 3:00 P.M., February 12th. All types of traffic were handled, totalling about 100 actual messages. W6KME was on hand throughout this entire period to handle Sacramento traffic. Close to 1000 words of press were handled. Placerville was without communication until the afternoon of February 12th. Sacramento was without power until that evening.

At Sonora, conditions were similar to those at Placerville and W.U. traffic, etc., was handled on 3.9-Mc. 'phone by W6FV and W6CQI to Q8BVZ at Fresno, who was on 3.5-Mc. c.w. Schedules were maintained between these stations from February 10th to 12th.

W6NMQ of the isolated mountain town of Bishop was able to help his town through QSP with W6CW, Reno. W6JTS, Rio Vista, handled traffic of great importance concerning supplies for emergency workers on levee duty. Due to his work the supplies arrived in time to prevent additional destruction. W6CC, Colusa, and W6NEH, Sacramento, were on the job doing their part in moving emergency traffic.

With the Yosemite National Park isolated by storm conditions, W6ITH, Berkeley, maintained regular schedules for

six days with the government radio station at the park. A total of 183 messages were handled. Most of these were of an emergency nature; orders for supplies, snowplow orders, advice to a hospital stating that a nurse was snowbound and unable to report for duty, instructions for trucks and stages, many messages to persons advising that certain individuals were snowbound and unable to get home for several days, reports for automobile clubs regarding road conditions, etc. Communication was by 1.75- and 3.9-Mc. 'phone.

Our thanks to W6BF, W6LMD, W6ITH and W6GZY for the bulk of the above report on emergency work. It tells the usual story of the important part radio amateurs play "when disaster strikes." Are you ready to do your part when called upon? Emergency power supplies are one of the most important features of preparedness. Could you perform if regular power sources should fail? Give thought to both equipment preparedness and operator preparedness. Register your facilities in the A.R.R.L. Emergency Corps.

## Motorcycle Endurance Run

THE Oakland (Calif.) Radio Club furnished communication for the Oakland Motorcycle Club during an endurance run held in January 1938. It was decided to set up one transmitter on the 145-mile figure-eight course, at the crossing point at Clayton, Contra Costa County, and one at the start and finish line at 31st and San Pablo in Oakland, the station on the course working into another station in Oakland by 1.75-Mc. 'phone, and from there to the starting point by 56-Mc.

The event was set for January 29th-30th. On the afternoon of the 29th, W6EGM and the writer went to Clayton with W6EGM's transmitter and the writer's receiver and portable transmitter (in case of break-down of the main rig), and proceeded to string up an antenna from a windmill tower to the store where we were to establish our station. We set up the transmitter and receiver and testing started. Things were finally whipped into shape and contact was made with W6ELW, the relay station between W6EGM at Clayton and W6OT at the starting point.

The first rider left Oakland at 12:03 A.M., and one every minute after until 42 riders got started on their way. At 1:28 A.M. they started to roll into Clayton, and from that time on we were sure busy. Every time a rider came in, the name, number and time was handed to the operator for transmission by 1.75-Mc. 'phone to W6ELW (Oakland), who relayed to W6OT at the starting point by 56-Mc. 'phone, and vice versa for the answers and queries. After all the riders came through on the first lap there was a short respite until they started through on the return lap. Then the fun started all over again about 4:30 A.M. They drifted through until about 7:00 A.M. and then started through again about 9:00 A.M. on the second lap. This continued until almost noon. We closed down at 11:57 A.M., after 12 hours and 32 minutes of almost continuous transmission. The various stations were manned by the following operators: At Clayton: H. E. (Mickey) Lewis and W6ZM. W6EGM was operated by W6EGM and Frank Reed. W6OT was operated in relays by George Campbell, W6LVS, W6MMK, W6OMC and others.

—W6ZM





# How's DX?

## How:

The April edition of this pillar is usually the toughest to put out. It has to be done during the first or second day of the DX Contest so we can't talk about that. It comes out around April first, but if we try to organize a "DX Expedition" or something, for a rib, someone will take us seriously and try to hold us to it.

As a matter of fact, this business of trying to be a smarty can be very embarrassing. Last month we mentioned the use of an electric razor as a time-saver in the Contest. We have a birthday around the first part of March, and what should we receive but a nice new electric razor! Who's kidding who?

## Where:

A number of fellows have reported hearing and working RUPUL (14,300 kc., T7) and RUPULB (14,356 kc., T9). According to the dope we have, RUPUL is a 2-watt station at Aklavik, N.W.T., connected with the Wilkins Expedition searching for a lost Russian flyer, and RUPULB is the call used with the 50-watt rig in their plane. No dope so far on the operator, or the authenticity of these stations, so please let us know if you hear any more . . . . . W5BB tells us that TG9AA (28,400 kc., 'phone) is the only licensed amateur down there, that he will QSL every contact, that he uses 54 watts input, and that his address is: 7th Avenue South, Number 94, Guatemala City, Guatemala . . . . . Although ZB2A seems to be a phoney, you can still get Gibraltar for your list if you work OXVC, a ship doing salvage work in the Mediterranean, on 14 Mc. QSL via RSGB . . . . . A good bet for Honduras is HR4AF (28,312 and 29,060 kc.). Send us your QSL in a stamped envelope and we'll address it for you; the station is under cover . . . . . If you worked EL2A after Jan. 25, 1937, send your card to Lloyd Neville, Duside, Liberia, and not to W8BIS . . . . . ZC6AQ (14,020 kc., T7) in Palestine is one of those tantalizing fellows that gets on once in a blue moon. WITS and W8BII got him this time . . . . . YV5AK, the QSL Bureau for Venezuela, writes to say that cards on hand for YV3LO, YV3GS, YV5TL, YV2MS, YV6AL and YV2CU, cannot be delivered because the stations are apparently phoney. That may be true of all except YV2CU, who is very much DX, except that he isn't in Venezuela—he uses the YV prefix to escape detection. We'll forward your card and give you his country if you've worked him . . . . . From Cairo, WIEH writes to say that HAM is a station at the Budapest Airport, using 200 watts and working anywhere in the 7- and 14-Mc. bands. KB also says that, according to Arthur Watts, the India office (part of the British government at London), in response to the pleas of the RSGB, is now going to consider licensing in VSS. Apparently V88AA was stretching the regs a little when he was on before . . . . . G6WY recently got a rare one when he worked CR6AF (7226 kc.) in Angola. The putsouter runs only 6 watts, so you'll probably have to dig for him . . . . . W8JSU wants to know about ZC6AY (14,380 kc., T7). He sounded like the McCoy, but QRM prevented JSU's getting his QRA . . . . . W3CKY is wondering also, this time about TA2J (14,285 kc., T8), worked around 4 P.M. . . . . W2CYS has a nice one here: CR1OZS (14,300 kc., T8), in Timor. Go ahead, look it up. We had to . . . . . XUBAZ, who boomed through on various occasions, is apparently a phoney. W3EVT tracked him down with a couple of directive antennas, and he just doesn't come from Asia . . . . . W4YC sends the QRA of CNSAV (28,300 kc., 'phone): Jack Oemichen, Villa Darna, Rue Montaigne, Meknes, French Morocco.

## When:

Not many reports on 80 this month, but what there are are mighty fine. We told you about W1ZL and his 6L6 last

month—his latest is a contact with K6CGK (3505 kc.), which leaves only Asia for Carl's 80-meter WAC. W2ECL and W8LMI also worked the K6 . . . . . W8PWU sent in a complete DX Time Table for 3.5 Mc., but we're going to save it for next year because April is a little late for DX on 80. Curly has been hearing a flock of ZL's and K7's on the band, as well as the European stuff. G6HB has been heard S8 . . . . . Sorry, but the W7FBK credited with the 80-meter ZL's last month should have been W7FVK.

The 7-Mc. gang went easy on us this month, and didn't snow us under as they did last month. W9WLB reports several Africans coming through, including ZS2A (7000 kc.), ZS1AH (7005 kc.), ZS1AN (7000 kc.) and ZU3Z (7050 kc.) . . . . . W1JVS, who says Vermont is a good QTH when the DX is looking for WAS, reports G8FF, YR5VX, D4AFF, OA6U, HK5JD, HB9CG and G8RL . . . . . W6PGL says Asians are good, including XU9CF and MX2B, and W7BCV reports a QSO with HR1JR (7300 kc.).

The 14-Mc. band is the old reliable, of course. Asian DX has been pretty good on the east coast lately. W2GTZ sends in a swell list, the cream of which includes VS1AA (14,015 kc., T9), XU8CK (14,240 kc.), VU2AN (14,080 kc.), XZ2DX (14,030 kc., T9) and U9BC (14,460 kc., T6) worked, and V87WR (14,110 kc., T9c), XU8RB (14,060 kc., T9) and KA4LH (14,095 kc., T9) heard . . . . . That fellow W2CYS is always right in there, and his this month include

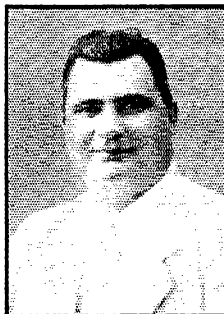

MR. R. LEBON, FISAC

During the past six months, FISAC has given many their first contact with French Indo-China. The receiver is a 10-tube b.c. superhet, the antenna a 1/2-wave Zepp, and the final runs 50 watts input.

AC4AA (14,375 kc., T9), VQ8AA (14,400 kv., T7), KA1ZL (14,280 kc., T9), VS7AR (14,290 kc., T7), and a mess of XU's and J's . . . . . WITS, whose ECO walks in where angels fear to tread, gets around a little. Don reports XU6MK (14,110 kc., T8), XZ2DY (14,100 kc., T9), VU2LJ (14,100 kc., T9), VU2BG (14,275 kc., T9), PZ1AB (14,410 kc., T7), and CT3AN (14,140 kc., T9) . . . . . W9GFE worked G5MW on 20 'phone at 6:30 P.M. the other day, an unusual time for Europe there . . . . . Speaking of 'phone, W8AAJ has a mile-long list of 'phones he has worked recently. The choicest include F18AC (14,265 kc.), PK1GL (14,275 kc.), KA1HS (14,255 kc.), KA1CS (14,268 kc.), ZS3F (14,075 and 14,300 kc.), a flock of ZS, CE, PY and LU, CX2AK (14,045 kc.), VP8TR (14,050 kc.) and HC2HP (14,260 kc.). Howard had some tough luck; with DX running like that a sleet storm took down two 60 footers . . . . . No need for not hearing Asians in Nebraska. W9FWW reports VU2AU (14,090 kc.), VU2FH (14,150 kc.), VU2OJ (14,145 kc.), VS6AG (14,100 kc.), and F18AC . . . . . W3EMA adds CR7MF (14,090 kc., T9) and U9AV (14,440 kc., T9) to the literature of the day . . . . . W2GVZ worked G8MF (14,360 kc., T8) in the Channel Islands for his 105th.

Ten is long on DX but short on reports. W1KKS tells us about everything but Asia coming through down there, with HR4AF, mentioned before, the best bet for a new country

... W8DST mentions that very short skip has been appearing again on 10, which is our cue to remind you that that is the time to listen on 5 if you're DX-minded about 56 Mc. Signals have been heard both ways across the drink; it's simply a matter of time before the first two-way will be made. Remember, there is a big gold cup collecting dust here at HQ that goes to the first W who works between continents on 5.

**Who:**

Next to working a new country, one of our greatest pleasures is being able to tell about some good low-power work. W9AHR is the same sort, and he tells us about a fellow in Kansas you ought to know. W9DSR, using 1 1/4 watts input on 160 'phone, worked 32 states, including California, Vermont and Florida. Just to rub it in a bit, the work was done during the evening and not during the less crowded early morning hours. The final is a 19, modulated by a 49. QRO to 9 watts, and moving to 28 Mc., he has worked K6MVV, VK2GU and such. Jeeves, what was our power bill last month? It was? Hmmm. . . . Better drop the input to 990 watts . . . . Speaking of low power, we were always a great admirer of the 210 DX Club idea, so we set out to find why we weren't hearing about it lately. The grapevine hath it that W8GQB, the guiding hand, became YL-conscious some time back and hasn't been heard from since. It's a pity, because the club was going nicely, with a monthly news bulletin, nice competition among the members, and a good spirit. Requirements for membership were a final input under 150 watts, tubes of 210 rating or less, and at least 50 countries worked. W8OSL, W6GAL and several other well-known DX men were members. We hope the club gets going again . . . . Speaking of W8OSL, UK8IA recently gave him his 118th country . . . . If you live in Nevada, you'll make F8RR happy by working him on either 10 or 20. That's all he needs for his WAS . . . . That fellow W7AHX that we told you about some time back has gone sissy. You remember him as the fellow who worked DX with a Ford engine-driven generator. Well, now he's just one of the boys, having moved into town and a house with a.c. But it means that he'll probably be knocking them over in still greater style . . . . Speaking again of low power, W6NPU out in Ogden, Utah, has some sort of a record. He worked J2OV for his first Asian the other night and collected an S7, only to find that his Zepp had blown down in a wind storm two nights previous! . . . . W4ELQ claims a record: Worked More J's in One Hour than Any Other Alabama Station. He uses a T55 in the final, and worked J2LL (14,300 kc., T8), J2OV (14,280 kc., T9x), and J5CV (14,255 kc., T9x). Other DX there includes ZB1J, FB8AB, UIAD (14,450 kc., T7x), VU2FH, and ZS2F . . . . W1BFA worked OK1LN on Christmas but wasn't fooled—he corresponds with the real OK1LN and knows he was off the air. Now who would bootleg that call? Why not pick a more juicy one? If you're going to be a rat, be a big one or not at all . . . . CM2AO was calling I7AA without much success the other night when he heard some loud signal calling him. He almost passed it up, but it turned out to be ZB1H, so he missed one country and got another. It must be nice to be a country like that. There just doesn't seem to be any appeal in a W1 call. At least no one breaks an arm trying to raise us . . . . W6JMR has a neat one here. The other day he heard a guy CQ-ing merrily and signing a "G" call. Almost everyone knows that G's call "TEST" and aren't permitted to call CQ, but this dope had an "E" in the call as well, and there aren't any G calls with E's in them, OK, look it up. (We checked Wally on it too!) . . . . W2IXY was in on a novel QSO the other day when she and G8MA on 14-Mc. 'phone tied in with W2DKJ who was operating 56 Mc. in a plane about 10,000 feet up. Which reminds us of the time last year when we received VK2MV at W1JPE on 20 and piped him on 5 to W1SZ who shot him back to VK3OC on 20, a total distance of about 20,000 miles. A VK who could hear both VK2MV and W1SZ said that the time lag was quite noticeable, as one might expect . . . . W6ITH tells us that the ruling that Chilean stations must use Spanish applies only to commercial stations. Reg mentions hearing a VK9 on 40.

**Century Club:**

Several fellows have asked about counting countries in that list printed in the January issue, in connection with the Century Club rating. It's simple; each line counts as a country, except the line that says Soviet Union.

**BRASS POUNDERS' LEAGUE**

(January 16th-February 15th)

Call	Orig.	Del.	Rel.	Extra Del. Credit	Total
W4PL	10	47	3184	30	3251
K6OCL	229	175	1393	68	1865
W3CZ	47	147	1097	141	1432
W5GHF	34	46	919	32	1031
W2HYC	126	56	808	20	1010
W6LUJ	87	245	400	242	974
W7EBQ	13	38	788	20	859
W5MN	88	180	518	54	840
W10EX	104	39	104	29	826
W2BCX	5	12	801	—	818
W8JQE	58	51	667	24	800
W3BYR	16	20	749	8	793
W5CEZ	40	108	613	13	774
W8KWA	8	53	662	—	723
W7DUE	4	—	658	50	712
W3EML	69	60	506	60	695
W7FVK	48	65	552	12	677
W8OFO	71	51	514	27	663
W1IP	13	21	610	13	657
W6ITH *	20	300	30	280	630
W8CLL	20	13	593	—	628
W1IOT	20	63	538	5	626
W4NBR	2	4	612	4	622
W8HCS	12	81	468	56	617
W6IOX	19	104	434	57	614
W6LMD	14	68	463	67	612
W4HK	12	9	580	9	610
W9RMM	9	27	550	10	596
W3BWT	54	50	451	34	589
W9RWS	32	32	502	15	581
W2JHB	28	107	354	83	572
W1IHT	41	117	412	—	570
W5BN	10	10	550	—	570
W1AKS	86	79	372	12	549
W1UE	53	238	141	116	548
W6FYR	35	20	467	12	534
W8QAN	26	25	460	17	528
W8QGD	71	10	441	1	523
W9KJY	24	203	133	163	523
W3AQN	95	70	326	31	522
W4DWB	13	149	272	81	515
W8FTW	25	18	471	1	515
W8ISK **	31	30	412	27	500

**MORE-THAN-ONE-OPERATOR STATIONS**

Call	Orig.	Del.	Rel.	Extra Del. Credit	Total
K4IDG	3575	5	6	3	3589
KAIER	732	564	762	544	2602
W5OW	164	132	1116	67	1479
W9BNT	49	177	584	14	824
W1GOJ	25	88	477	41	631

These stations "make" the B.P.L. with total of 500 or over. One hundred deliveries+Ex. Del. Credits also rate B.P.L. standing. The following one-operator stations make the B.P.L. on deliveries. Deliveries count!

W3QP, 313	W2JWT, 168	W7CCR, 116
W8CEU, 263	W9PLG, 164	W2FP, 110
W8NUV, 220	W8CSE, 159	W5ZM, 108
W6JTV, 216	W6NQB, 146	W4EBP, 106
W2GVZ, 212	W3GPC, 137	W5AAJ, 106
W6AXN, 207	W1HRE, 135	W1BNS, 105
W6IMI, 196	W1JCK, 135	W2BCO, 103
W3DGC, 183	W6NLL, 134	W8DYH, 103
W6DH, 182	W2OQ, 130	W7FZB, 102
W6KDI, 176	W6FQU, 130	More-than-one-opr.
W6PFR, 174	W9HPG, 125	K5AA, 238

**A.A.A.S.**

Call	Orig.	Del.	Rel.	Extra Del. Credit	Total
WLR (W4IR)	13	90	1100	60	1263
WLMA (W8YA)	14	21	651	21	707
WLNF (W2BCX)	13	1	663	—	677

WLMI (W6GXM) and WLNB (W2DBQ) made the B.P.L. on 244 and 178 deliveries respectively.

**MORE-THAN-ONE-OPERATOR STATIONS**

Call	Orig.	Del.	Rel.	Extra Del. Credit	Total
WLM (W3CXL)	155	322	2792	73	3342

A total of 500 or more, or 100 deliveries Ex. D. Cr. will put you in line for a place in the B.P.L.

\* All traffic handled by two-way radiotelephone.  
\*\* Dec.-Jan.

## October O.R.S.-O.P.S. Parties

ALTHOUGH operating conditions were rather adverse, the October quarterly O.R.S.-O.P.S. Parties were very successful and enjoyable. The "camaraderie" of these affairs is fully realized only by active participation. Competition is intense, but friendly. The next parties are scheduled for April 23rd-24th.

In the lead in the October O.R.S. Party are W1AW, W4DWB and W6KFC. W8LUQ again leads the O.P.S. group with 6216 points, with W4DCQ and W1FBJ next in line. But the listings below tell the complete story.

The April parties are the last to count in the All-Season O.R.S.-O.P.S. Competitions, which are nearing completion. These competitions cover all phases of work included in the two appointments. Qualified amateurs are invited to join the ORS/OPS groups. Get in touch with your S.C.M., if interested in signing up.

### Official Relay Station Scores

Station	Score	Different Stations	Different Sections	Heard	Power	Section
W1AW (Hal)	7,230,970	166	45	40	200/500	Conn.
W4DWB	6,701,730	147	47	32	25/50	N. C.
W6KFC	6,497,832	114	49	20	.....	Aris.
W4NC (W4OG)	5,469,728	136	40	28	500-250	N. C.
W1TS	5,058,087	140	43	29	300	Conn.
W8JTT	4,765,260	128	44	40	200	W. N. Y.
W8OFO	4,461,912	145	44	8	300/500	W. Pa.
W2HZY	3,862,890	124	38	10	55	N. N. J.
W3GKZ	3,326,610	117	38	22	200	M.-D.-D. C.
W4APU	3,311,816	116	48	34	200-300	Ala.

Station	Score	Stations	Sections	Station	Score	Stations	Sections
W8BYM	3,167,946	121	36	W5EOE	1,635,531	80	43
W9LEZ	3,065,062	110	44	W2GVZ	1,602,118	104	29
VE9OI	3,059,856	123	39	W9OUD	1,482,800	68	42
W5WG	2,947,832	101	46	W1GME	1,468,404	95	31
W3GDI	2,923,830	108	39	W1AXB	1,461,252	86	30
W8JKO	2,663,583	126	37	W3PPQ	1,426,336	85	31
W8NKU	2,662,200	105	40	W2DXO	1,361,625	101	24
W2JEB	2,512,832	102	40	W1AFB	1,313,886	90	33
W5DXA	2,448,808	101	47	W2HMJ	1,273,836	85	29
W1UE	2,224,180	110	30	W1BFT	1,227,198	93	29
W3NF	2,211,865	106	31	W9MYL	1,217,123	79	34
W1EOB	2,931,445	103	32	W8WGY	1,211,430	84	26
W3ADE	1,903,984	95	32	W5CEZ	1,148,984	73	40
W8PWU	1,877,500	92	33	W2AHC	1,125,643	78	31
W1LOT	1,793,073	103	32	W2EYX	1,006,740	78	27
W3BYR	1,762,536	94	30	VE3PE	1,013,985	85	26
W8NVU	1,702,375	90	35				

### Official 'Phone Station Scores

Station	Score	QSO's	Sections	Heard	Power	Section
W8LUQ	6216	43	24	22	350	W. N. Y.
W4DCQ	5544	48	21	12	350	N. C.
W1FBJ	5145	35	21	35	250	Maine
W2CBO	5016	40	22	14	500	E. N. Y.
W9TTA	4465	39	19	20	225	Ind.
W3FGJ	4320	42	20	3	450-500	Va.
W8CGU	4302	43	18	12	200	W. N. Y.
W3CHE	3720	36	20	3	1000	Va.
W8PUN	3456	38	16	13	140	Ohio
W4QI	3451	35	17	14	250	N. C.

Station	Score	QSO's	Sections	Station	Score	QSO's	Sections
W2IKV	3306	32	19	W1DWP	2093	21	13
W1COI	3196	28	17	VE3KM	2041	20	13
W8BQA	3094	37	14	W8MBW	1781	21	13
W8KNF	2910	32	15	W9FNV	1778	24	14
W8ICQ	2907	33	17	W8HFR	1771	27	11
W2DC	2822	30	17	W8MZT	1737	25	9
W8MOL	2580	32	15	W6ITH	1625	23	13
W2HNA	2400	28	16	W9NHF	1624	20	14
W8PFM	2142	25	14	W6CQI	1521	21	13

## Briefs

The 20-hour QSO record established in 1933 by W7WY and W7HD on c.w. could hardly stand indefinitely, and it is not surprising that it was broken by 'phone operators. . . . W2HRZ, Nutley, N. J., and W2IWY, Newark, N. J., were in continuous communication for 22 hours, 4 minutes, on January 23th, using "160" 'phone . . . . And on the heels of this performance, two British Columbia 'phones took 24 hours and 10 minutes to get "talked out" on February 1st-2nd. This was a cross-band QSO between VE5II, New Westminster, on 3850 kc., and VE5UD, Queensboro, on 1793 kc. . . . Then climaxing anything on record for long contacts, W8PYS, W8PYY and W8QZH got together on 1889 kc. 'phone at 9:00 p.m., February 11th, to start a three-way QSO that lasted for 37 hours, 15 minutes. W8MPR was "relief operator" at W8PYS, W8PGJ assisted at W8PYY and W8QK at W8QZH . . . . It makes our tonsils ache to even think of these QSO's . . . . the proverbial "sewing circle" has nothing on ham operators, apparently!

W5CVA, Oklahoma City, a member of the Oklahoma Section Net, received several messages for delivery in Oklahoma City, but the addresses had no telephones. W5GFG, W5EMP and W5FRL happened by CVA's shack and conceived a new idea in message delivery. W5GFG had a portable 28-Mc. rig in his car. W5CVA put his transmitter on 28-Mc. 'phone, and W5GFG and EMP drove to the home of the first addressee, called the party to the door and had him come out to the car, where contact was made with W5CVA and delivery made on the spot by radio. This was repeated on several other messages, and ham radio got a big hand each time.

WANC, special emergency station of the Ira Lou Spring Post, American Legion, Jamestown, N. Y., is on the air for test transmissions each Monday from 8:00 to 10:00 p.m. EST. 2726 kc. is used for voice work, 3190 kc. for c.w. and WANC is always glad to make test contacts with amateurs. Watch these frequencies on Monday nights.

Radio amateurs at Princeton University, W3DH, excel in sport activities at the university. W3EFN, a member of the swimming team, is a world record holder in the breast stroke. W2FOQ ran the 220-yd. low hurdles on the 1939 freshman track team. W2HBB rowed No. 2 on the 1939 freshman crew. W2DQT is a member of the varsity football team and W2ECT is on the varsity wrestling team.

Something of a record in "working all states" has been made by W9NST, Elmhurst, Ill., who was recently awarded a W.A.S. certificate. Competing in a local club contest, W9NST worked all states in approximately 40 hours of operating over a nine-day period! This was all on 7 Mc. An inspection of the QSO confirmations shows 19 states worked on January 1st, 9 on the 2nd, 5 on the 3rd, 3 on the 4th, 2 on the 5th, 3 on the 7th; 2 on the 8th and 5 on the 9th. The outstanding thing of this work is that all contacts were made by general operation and not by participation in any national contest.



## Oklahomans Repeat Emergency Work

FOR the second time in two months, amateurs in Oklahoma had an opportunity to demonstrate their ability to render service in time of emergency when another sleet and ice storm hit in mid-February. On February 17th steady rains were prevalent over most of the state. By 8 a.m. the temperature had dropped below freezing from Oklahoma City north and west. W5CEZ and W5QL were contacted by representatives of the Oklahoma Gas and Electric Company before noon, since the rain was quite heavy and ice was forming rapidly. W5CEZ and W5QL, with W5FRC standing by to help if needed, made contact at noon on 3.5 Mc. and made arrangements to get the State Net in operation that afternoon.

By 4 p.m. the O. G. & E. leased telephone lines were practically all out between Ponca City, Enid, Oklahoma City, El Reno and Garber. Garber was also without power and any form of communication. W5CEZ came home to find his antenna pulled in two, but it was soon spliced, the ice knocked off and back in operation. W5GFT of Enid was contacted, and he in turn called out the boys there. W5CEB of Enid loaded up the self-powered rig owned by W5CPC and went to Garber, about 15 miles northeast of Enid, and set up the station at the O. G. & E. Garber Tap. Contact by radio was established between the following stations at 6:30 p.m.: W5CVA, W5DAK, W5EGP, W5EMD, W5FOJ, W5FOM, W5FRB, W5FRC, W5FSK, W5GFT, W5MK, W5YJ, W5QL, W5CEB and W5CEZ on the State Net frequency of 3682 kc. Power failed early in the evening at Enid and left W5GFT in the dark. He was soon back on with a gasoline engine-driven a.c. generator with two outfits, one on 1.75-Mc. phone and c.w., the other on 3.5-Mc. c.w. W5CEB in Garber was using 1.75 Mc. due to skip. W5QL, CEZ, CEB and GFT remained in contact throughout the night. W5CXU left Oklahoma City for El Reno with a portable layout, early Friday morning, and joined the Net. W5ASQ operated in relief roll at W5CEZ and W5ARB helped out at W5QL along with W5CJS in Oklahoma City. W5GVV and W5GVS helped W5GFT keep the station going in Enid. W5CEB operated single-handed at Garber. Contact was maintained throughout the day between the five stations.

Power was restored to Enid on the morning of the 18th and all telephone lines were out between Enid and Ponca City and Enid and Oklahoma City. It was still possible to reach Oklahoma City by Bell Telephone from Ponca City. By midnight the storm had broken, and things began to look better. A telephone line from Ponca City to Oklahoma City and from El Reno to Oklahoma City was in operation, so W5CXU and W5CEZ with W5EIA operating secured their watch until 6 a.m., Saturday. A relief operator, W5BKD, was sent from Oklahoma City to relieve W5CEB. W5CEZ and W5CUX resumed contact Saturday morning and continued through the day. The relief operators at Enid in the meantime were obliged to go to work at their civil jobs, which left W5GFT without any help and no rest. W5QL, W5CXU and W5CEZ shut down Saturday evening. Garber was still without communication, and W5CEB and W5GFT continued throughout the night and all day Sunday.

Many dispatches were handled, principally for O. G. & E. for the dispatching of men and materials and of direction repair work. Two dispatches were handled for the Oklahoma State Highway Patrol Thursday night. This was in addition to personal messages from workmen out on the job to their families at home along with weather conditions, ice formation, etc.

—W5CEZ, S.C.M., Oklahoma

August 22, 1937. . . "CQ de K5AA K." . . . "K5AA, de W6KIN AR." . . . "Have two messages for east coast, but cannot raise that area. DE W6KIN." . . . "Have schedules two east coast stations tomorrow night. Will QSP. DE K5AA." . . . Both messages were from XU8LR, Shanghai. Later W2JN, Upper Montclair, N. J., was raised by the K5AA second operator. The chief operator nearly jumped out of his shoes at this, for one of the messages was for that town! "QTC1 Upper Montclair de K5AA." . . .

## DX Century Club

KEAT CROCKETT, W9KG, is a recent addition to the Century Club roster. Known also as W9ALV, which call he used for some time, Keat has cut some fancy DX capers with moderate power. Congratulations, OM! Club membership is now sixteen, with G6WY still in the lead. Many of the under 100 fellows are advancing steadily towards their goal, and with the conclusion of the DX Contest the listings below will be in for some marked changes.

Check over your confirmations in accordance with the January QST list of countries and send them in as soon as you can present 75-or-more. When sending your confirmations, please accompany them with a list of claimed countries and stations representing each country to aid in checking and for future reference after your confirmations have been returned to you. Please send postage to cover the return of the confirmations.

### MEMBERS, DX CENTURY CLUB

		Countries
H. A. Maxwell Whyte, G6WY (No. 5) . . .	129	
Frank Lucas, W8CRA (No. 1) . . . . .	119	
John Hunter, G2ZQ (No. 6) . . . . .	118	
Jefferson Borden IV, W1TW (No. 3) . . . . .	117	
Douglas H. Borden, W1BUX (No. 2) . . . . .	114	
Clark C. Rodimon, W1SZ (No. 7) . . . . .	109	
Henry Y. Sasaki, W6CXW (No. 4) . . . . .	108	
Harry G. Burnett, W1LZ (No. 10) . . . . .	108	
Don H. Mix, W1TS (No. 9) . . . . .	105	
Walton H. Bostwick, W2GW (No. 11) . . . . .	105	
Reeve O. Strock, W2GTZ (No. 12) . . . . .	103	
C. E. Stuart, W6GRJ (No. 15) . . . . .	103	
Jean Lips, HB9J (No. 13) . . . . .	102	
Guy Grossin, F8RJ (No. 8) . . . . .	100	
E. L. Walker, W8DFH (No. 14) . . . . .	100	
Keat Crockett, Jr., W9KG (No. 16) . . . . .	100	

The following have submitted proof of contacts with 75-or-more Countries.

EI5F . . . . . 98	W8OQF . . . . . 87	W8BOX . . . . . 81
W9PST . . . . . 95	W2GVZ . . . . . 87	W9AEH . . . . . 81
W8LEC . . . . . 94	G2DZ . . . . . 86	W4CCH . . . . . 80
W8JMP . . . . . 93	W6GAL . . . . . 86	W3EPR . . . . . 79
W8OSL . . . . . 93	W1RY . . . . . 85	W4CFD . . . . . 79
W1DF . . . . . 93	W4DRD . . . . . 85	W5BB . . . . . 79
W1WV . . . . . 92	W2HFF . . . . . 84	W8FJN . . . . . 78
W9EF . . . . . 92	W3JM . . . . . 84	W9FLH . . . . . 78
W3EVW . . . . . 92	W8KKG . . . . . 84	W3AIU . . . . . 77
W1DUK . . . . . 92	W1JPE . . . . . 83	G6GH . . . . . 77
W9ADN . . . . . 90	VEZEE . . . . . 83	W8ADG . . . . . 77
W9KA . . . . . 90	W3EVT . . . . . 83	W8BSF . . . . . 77
W1ZL . . . . . 89	G5QY . . . . . 83	W8CJJ . . . . . 77
W6FZL . . . . . 88	G5RV . . . . . 83	W9UM . . . . . 77
W2GT . . . . . 87	W6BAM . . . . . 83	W1EWD . . . . . 76
W3BES . . . . . 87	W8EUY . . . . . 82	W4AJX . . . . . 76
W6ADP . . . . . 87	W2CYS . . . . . 81	W3BVN . . . . . 75

"QRV de W2JN." . . . The message was delivered by telephone that same night, the 22nd . . . and it had left the station of origin on the 21st. Schedules make snappy relaying an everyday occurrence, but these unexpected things add lots ofumph to traffic work. FB.

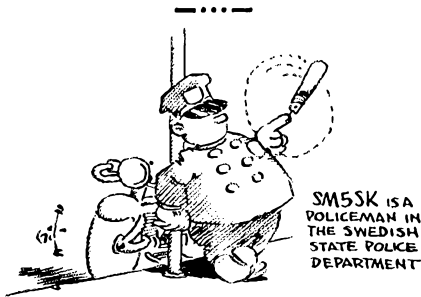

## Hamfests Scheduled

*At Framingham, Mass.:* The Framingham Radio Club announces its Fifth Annual Hamfest to start at 2:00 P.M. April 23rd, at the Hotel Kendall, Irving Street, Framingham. Registration, \$2.00, includes banquet, well-known speakers, 56-Mc. treasure hunts and other features, including something of particular interest to those interested in photography. Everyone is welcome!

*At Wichita Falls, Texas:* The Annual Banquet and Hamfest of the Wichita Falls Amateur Radio Club will be held at Wichita Falls on Saturday evening, April 23rd. A cordial invitation is extended to every amateur, radio enthusiast and "Ham-2-B" . . . and their ladies. Reserve the evening of April 23rd for a real get-together.

*At Baltimore, Md.:* The Mike and Key Club will stage its Fifth Annual Tri-State Hamfest at the Emerson Hotel, Baltimore, on April 30th. "Bigger and Better" is the promise.

*At Charleston, W. Va.:* Make your plans now to attend the annual "Charleston Hamfest" to be held at the Ruffner Hotel on May 22nd. Meetings of A.A.R.S. and A.R.R.L. nets and A.E.C. members are being planned. "Speeches" will be of limited length to avoid boredom. Banquet and big prize drawing will wind up the activities.

-----

## Briefs

W5EWZ, Harlingen, Texas, on February 13th worked all W districts in two hours and forty minutes on 7 Mc. Stations were W6OUK, W5FVN, W8WA, W1JXU, W7DNW, W4DHN, W3FYO, W9WJV and W2IGE, worked in the order listed. Power used was 50 watts to the final stage.

-----

VE3QB, 14,304 kc., offers a cake of maple sugar to the first ham with whom he makes contact and from whom he receives a QSL card in Montana, North Dakota, Idaho, Wyoming, Nevada, Utah, Arizona and New Mexico. The offer is good until the end of the 1938 maple sugar season. It is difficult to get some of the brethren to send QSL cards, but have things come to such a pass that we must resort to "bribes" to make the lads loosen up? Hi.

-----

## Worked All Bands

A unique stunt was staged by the Greater Buffalo Five Meter Club on January 23rd, when amateurs on all active bands were linked together in an all-band QSO; 32 amateurs participated in this QSO, which started at 1:00 P.M. and wound up at 5:18. Stations on each of the various bands were picked up by W8QLK, W8RV and W8PAN and retransmitted to all participants via 1.75-Mc. phone. Each operator was given an opportunity to talk to all the rest. Termed the "Octa-Plex WAB" hook-up, each participant has received a special QSL card from the Greater Buffalo Five Meter Club as a verification of his part in the affair. Those taking part were: On 1.75 Mc.—W8RV QLK IHO IHG PLJ LFK QBU QEE NTZ PAN; On 3.5 Mc.—W8BHQ GGY IUF POL; On 7 Mc.—W8KYR NWH CL NMI OWT OZU QUQ FYH DYX; 14 Mc.—W8TR DLU EXX; 28 Mc.—W8BSM OWE; 56 Mc.—W8CDM PTV HQC; "2½ meters"—W80BK.



## ELECTION NOTICES

To all A.R.R.L. Members residing in the Sections listed below: (The list gives the Sections, closing date for receipt of nominating petitions for Section Manager, the name of the present incumbent and the date of expiration of his term of office.) This notice supersedes previous notices.

In cases where no valid nominating petitions have been received from A.R.R.L. members residing in the different Sections in response to our previous notices, the closing dates for receipt of nominating petitions are set ahead to the dates given here-with. In the absence of nominating petitions from Members of a Section, the incumbent continues to hold his official position and carry on the work of the Section subject, of course, to the filing of proper nominating petitions and the holding of an election by ballot or as may be necessary. Petitions must be in West Hartford on or before noon of the dates specified.

Due to resignations in the Iowa, Kentucky and Hawaii Sections, nominating petitions are hereby solicited for the office of Section Communications Manager in these Sections, and the closing date for receipt of nominations at A.R.R.L. Headquarters is herewith specified as noon, Friday, April 15, 1938.

Section	Closing Date	Present SCM	Present Term of Office Ends
Vermont	Apr. 1, 1938	Alvin H. Battison	Apr. 15, 1938
So. Minnesota	Apr. 1, 1938	Webster F. Soules	Apr. 16, 1938
Washington	Apr. 15, 1938	Robert H. Votaw	Feb. 17, 1938
Maritime *	Apr. 15, 1938	Arthur M. Crowell	June 14, 1937
Nevada	Apr. 15, 1938	Edward W. Heim	June 14, 1937
Ga.-Cuba-Isle of Pines	Apr. 15, 1938	Bannie L. Stewart	Dec. 14, 1936
Iowa	Apr. 15, 1938	Owen Williams (resigned)	-----
Kentucky	Apr. 15, 1938	G. W. Mossbarger (resigned)	-----
Hawaii	Apr. 15, 1938	Otis Hill (resigned)	-----
Alabama	Apr. 15, 1938	James F. Thompson	Jan. 17, 1938
South Dakota	May 2, 1938	Andrew J. Kjar	May 18, 1938
Utah-Wyoming	June 1, 1938	Townsend J. Rigby	June 15, 1938
Los Angeles	June 15, 1938	Don M. Draper	July 1, 1938
W. Penna.	July 1, 1938	Kendall Speer, Jr.	July 10, 1938
Illinois	July 1, 1938	L. John Huntoon	July 10, 1938

\* In Canadian Sections nominating petitions for Section Managers must be addressed to Canadian General Manager, Alex Reid, 169 Lozan Ave., St. Lambert, Quebec. To be valid such petitions must be filed with him on or before the closing dates named.

1. You are hereby notified that an election for an A.R.R.L. Section Communications Manager for the next two year term of office is about to be held in each of these Sections in accordance with the provisions of the By-Laws.

2. The elections will take place in the different Sections immediately after the closing date for receipt of nominating petitions as given opposite the different Sections. The Ballots mailed from Headquarters will list in alphabetical sequence the names of all eligible candidates nominated for the position by A.R.R.L. members residing in the Sections concerned. Ballots will be mailed to members as of the closing dates specified above, for receipt of nominating petitions.

3. Nominating petitions from the Sections named are hereby solicited. Five or more A.R.R.L. members residing in any Section have the privilege of nominating any member of the League as candidate for Section Manager. The following form for nomination is suggested:

(Place and date)

Communications Manager, A.R.R.L.,  
38 La Salle Road, West Hartford, Conn.  
We, the undersigned members of the A.R.R.L. residing in the . . . . . Section of the . . . . . Division hereby nominate . . . . . as candidate for Section Communications Manager for this Section for the next two-year term of office.

(Five or more signatures of A.R.R.L. members are required.) The candidates and five or more signers must be League members in good standing or the petition will be thrown out as invalid. Each candidate must have been a licensed amateur operator for at least two years and similarly, a member of the League for at least one continuous year, immediately prior to his nomination or the petition will likewise be invalidated. The complete name, address, and station call of the candidate should be included. All such petitions must be filed at the headquarters office of the League in West Hartford, Conn., by noon of the closing date given for receipt of nominating petitions. There is no limit to the number of petitions that may be filed, but no members shall sign more than one.

4. Members are urged to take initiative immediately, filing petitions for the officials for each Section listed above. This is your opportunity to put the man of your choice in office to carry on the work of the organization in your Section.

—F. E. Handy, Communications Manager

## ELECTION RESULTS

Valid petitions nominating a single candidate as Section Manager were filed in a number of Sections, as provided in our Constitution, and By-Laws, electing the following officials, the term of office starting on the date given.

Alberta	C. B. Jamison, VE4GE	Feb. 18, 1938
Montana	G. A. Woodhouse, W7FL	Mar. 13, 1938

Station Activities on page 83



# CORRESPONDENCE

The Publishers of *QST* assume no responsibility for statements made herein by correspondents

## 'Phone QRM

312 Slaughter St., Dallas, Texas

Editor, *QST*:

During the past year there has been an unprecedented growth in the number of amateur phones in operation. As each new phone comes on the air interference grows steadily worse. Additional frequencies would be but a temporary remedy at best. They, too, would soon fill and we would be faced with the same situation. The answer lies not in more space but through conservation of present allotments by common sense operating procedure. An hour of listening on any phone band will convince the most sceptical that unnecessary interference caused by operating malpractices constitute an enormous part of the trouble.

Amateur phone operators must learn to remove their carriers from the air when not being usefully modulated. The other evening a twenty-meter phone station carrier continued for 23 minutes while the operator talked on the telephone. Twenty-three minutes of useless QRM for absolutely no reason at all. Please, OM's, cut the switch when you are called away from the mike. It will save on your light bill and make your brother hams a whole lot happier.

Another source of much unnecessary interference is the so-called "Duplex" operation or maintaining carriers constantly during a QSO. Usually this is done on separate bands, one transmitter on 80 and the other on 20, etc. A contact of an hour, therefore, causes exactly one hour of interference instead of 20 to 25 minutes as would be the case in normal operation. This situation is growing to an alarming degree and constitutes a real menace to amateur phone operation. Listen to some of the better stations operate push-to-talk for a real treat. In those cases the carriers are on for only about 40 per cent of the time and 60 per cent needless QRM is eliminated.

It is also interesting to find the Federal Communications Commission interprets the "superfluous signal" regulation as an absolute barrier to duplex phone operation. Their interpretation is very sensible because the receiving station's carrier is not being usefully modulated and is, therefore, a "superfluous signal." In a majority of cases duplex operation also violates the "minimum power" regulation. The reason for this is that the blanketing effect of the transmitter renders the receiver inoperative except in respect to

strong local signals. It follows, therefore, that each station must, while working duplex, use many times the minimum power necessary to work a given distance.

Several years ago it was well-nigh impossible to complete a contact because of "testing" on the air. This practice has been reduced to a minimum chiefly through the efforts of the A.R.R.L. It now seems in order for the League to take definite steps to squelch this later but equally annoying practice.

—F. G. Southworth, *W5EOW*

## Television: Pro and Con

46 Orange St., Port Jervis, N. Y.

Editor, *QST*:

In reference to the article on television in the correspondence section in February's *QST*, we were amazed regarding the formation of an Anti-Television Club in this vicinity.

As far as we know, the members of our club are the only occupants of the ultra-high frequencies in this locality. Our membership is composed of amateurs from the second, third and eighth districts, and some were active in radio before W2GTW wore three-cornered pants.

Any ham with common sense knows that the government is not keeping the amateur for the sake of cluttering up part of the short-wave spectrum. . . .

Those of us who have interested ourselves in radio know that television is in its infancy as radio was in its early stages. Television is here. He who stands in the way of progress is doomed. So come on, amateurs. Let's get busy on this new field and keep the membership of the Anti-Television Club down to one.

—Tri States Radio Club, *W3GKI*  
Ben Swartwout, *W2FRU*, Secretary

81 Church St., Spring Valley, N. Y.

Editor, *QST*:

Reading in February 1938 *QST* the letter Johnnie (W2GTW) wrote started me thinking a little. Why should anyone be interested in having the hams step into the "Television Picture"?

Let us suppose someone has a car to sell. He will try to interest some other party in that car in order to dispose of it. . . . The more the demand increases the more he can sell. The more he sells the more he fills his pockets. . . .

We all know that it is quite costly to do much experimenting. In spite of all the improvements resulting from research work in television, it is a tremendous expense and must be considered as an investment that will bring large profits later on. Therefore, in order to make research "investments" profitable, the selling price of the manufactured products must be enough to cover cost of experimentation, plus cost of manufacture, plus a reasonable percentage of profit on the investment. If part of that experimenting is conducted by hams and the expense sustained by them, the manufacturing companies of ready-built television equipment will save plenty! Then, too, manufacturers of parts used by the hams in their experiments in television construction will realize large profits on the material sold to hams.

Perhaps ham radio can "brag" about their accomplishments on short and ultra-short waves, but won't the great majority of hams honestly admit that they are the losers in the end? Our U. S. A. might boast that in being victorious in the war of 1914-18 she has a great accomplishment to her credit. However, we all know that though we won in the war we actually were the biggest losers. The ham who may discover something of great value to television is probably the one who has studied the subject diligently, spent every available penny on parts, and on the whole has deprived himself of many other pleasures in order to devote as much time as possible to his main interest. If his discovery should be worthy of a patent it wouldn't be of much use, because what chance would he have in a fight against a big company with millions? We can recall the fights for the patents on the telephone and other inventions. . . .

An employee in a research laboratory of a large concern is compensated for his discoveries by his salary. Is it no more than fair that a private individual should receive some form of compensation for some intricate circuit of great value or any other discovery or invention he might make which would be of value to a company?

. . . I firmly believe that this idea of hams in the television "picture" is nothing more than a form of propaganda to stimulate interest in television in order to sell more parts for construction along television lines.

Johnnie, you can count me as the next member of the *Anti-Television Club!*

—Nicholas Hlipala, W2HYC

Rockmart, Ga.

Editor, *QST*:

In the correspondence department of February issue of *QST*, I note that W2GTW wished to organize an Anti-Television Club. From his remarks, I gain that he has not been long in the ranks of experimental and amateur radio work, else he would have known that television experiments have been carried on by the rank and file (average ham) for the last eight or ten years. A friend and I received television pictures with fair success from Washington, D. C., as far back as 1930. Television is by no means a new thing. Commercial interests and amateurs alike are working side by side in experiments to perfect it to an extent that it may be used in the homes as radio receivers are used today.

The commercial interests are not trying to "hog" our bands used for television. . . . I feel confident that our interests will be protected by the A.R.R.L. if past records and history mean anything. History usually repeats itself.

Amateur radio exists only for the potential development of new uses of the radio, especially in the transmission of signals and of the great help to the public and the authorities in times of disaster. . . .

Let us stop this wrangling among ourselves and concentrate our best efforts on experimental work and, if we are not interested in that, do our regular schedules and QSO work with clean cut signals.

—G. W. Dickerson, W4BIA

7342-71st Pl., Ridgewood P. O., Brooklyn, N. Y.  
Editor, *QST*:

The letter of W2GTW in February *QST* is in complete accord with my own sentiments. I am in this game for 25 years and never howled about anything. However, the open-

faced, bald audacity of the television people when they seek amateur cooperation reminds me of the days when commercial broadcasting put on its first panties. They would make us the guinea pigs of their experiments and then slaughter us for their commercial profit.

I am not opposed to the development of television as an art, but I resent exploitation of amateur radio. Let there be produced an outfit which is practical and economical enough to be put on the market like any other commodity. The problem is that of the television interests, not that of the amateur-consumer.

The editor's note to W2GTW's letter is hackneyed. Most of us know the amateurs' "claim" to accomplishment and we also know that the graveyard of radio below 200 meters is territory to which the amateur has a greater proportional right than he has received at the hands of commercial radio. The tone of the editorial comment is as if our existence was merely being tolerated because of our "claim to such accomplishments," much the same as an experimental animal is kept in a cage and fed only until it is of no further use. What then?

Let the televisionists solve their own problems without amateur experimenters. They then will have at least some slight justification to snatch from us our few kilocycles—in the interests of public service. It has happened. It can happen again. I hope not.

—Harry C. Stenger, W2DQW-WLNT

3933 Elmwood Road, Cleveland Heights, Ohio

Editor, *QST*:

In reading through *QST* as per usual I came across an article written by W2GTW in which he stated that any ham that works on television is a "traitor to the cause." This statement got me so burned up that I am writing to you for the first time.

Although I do like to chew the rag with the fellows as much as any normal ham does, there is another side to the matter which I don't believe W2GTW has looked into. Is there any other excuse for amateur radio except for the development of radio and radio communications? Think it over, W2GTW.

I believe that is the opinion of practically all of the hams that I have talked to.

—A. R. Mueller, W8OYW

## Re: Standard Frequency Transmissions

103 E. Maple St., Wenonah, N. J.

Editor, *QST*:

. . . Recently you published an article, stating that W9XAN was about to discontinue its service. For heaven's sake, can't we prevent the suspension of this vital service to amateur radio?

. . . My hat goes off to the men who supply this service to us, but I would like to boot the daylights out of the most unnecessary interference from the nitwits that hang all over the key, right smack on the standard at the crucial period. I logged five stations on the 3600 and four on the 3700-kc. frequencies during recent transmissions. Of the nine microbes four of them gave the usual ten-minute CQ. There have been many articles written on this subject, but why do these individuals persist in ruining the transmissions that are really vital to we who boast of the amateur radio hobby? . . .

Can't we of the League actually do something to force some sort of quiet period during these standard transmissions?

I utilize the transmissions of W9XAN whenever it is possible and I miss the M.I.T. transmissions. I believe we could use more of these stations and I for one would gladly pay for the use of this service. Why couldn't the A.R.R.L. dues be increased say, 50¢ per year and have the headquarters station transmit standard frequency checks? How about advancing the idea to the membership? . . .

—Albert M. Weber

(Continued on page 68)



THE versatility of the FXT (Fixed-Tuned Exciter Tank) Units has caused them to be used in all sorts of strange applications. Nevertheless, such a large number are used (as we intended) in exciters that it seems like a good idea to give some definite data on coil winding and other details. The table below gives the details of coils which we have actually wound for our own use, and which are based on experiment, of course. The exciter diagram shown is old stuff, and it is given here merely to make the data complete.

A few comments are in order. The data as given is for the standard FXT unit which has two small condensers at the top of the shield. For ten meters one condenser is used. For 20, 40, and 80 meters both condensers are wired in parallel. There is ample tuning range in the condensers to take care of normal stray capacitance in the wiring and to allow for small variations in the coils and still completely cover any of the amateur bands so that there is nothing critical about building an exciter with these units.

Where the plug-in base is used (FXTB assembly), it is necessary to ground the shield. One of the contact pins can be used for this purpose. This can be connected to the shield most easily by using the scheme illustrated at the right. A solder lug between the shield and the base (located where it will be gripped by one of the screws) is fastened to the pin by a bus wire jumper. While soldering, the screw is used to hold the lug in proper position. Once soldered, the shield can be removed at will without breaking connections. The lug should be of the "Shakeproof" variety, so that there will be good contact. Often a smooth lug will not bite through the oxide film that is present on aluminum surfaces.

Possibly you may prefer to get a handful of parts and make your own special assembly, such as that illustrated in one of our several advertisements elsewhere in this issue of *QST*. In certain cases, such as for the 60 mc. band, such special assemblies may be preferable to the standard FXT or FXTB unit, but as a general rule the standard unit is the best. Five meter band coils can be made by using the XR-3 (9/16" dia.) form with 4 or 5 turns (1/4" winding length) depending upon capacity and the length of the leads, etc. Only one condenser is then used.

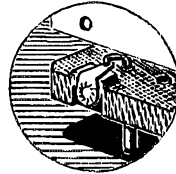

When using Beam tubes, such as 6L6s, excitation for following tube is taken from plate end of coil — no tap.

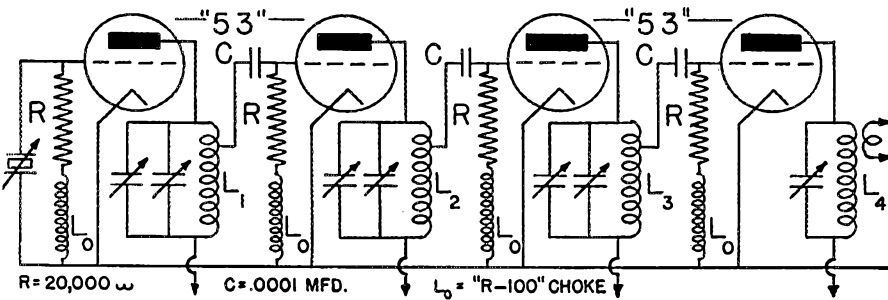

POSITION	BAND	TURNS	LENGTH OF WINDING	TAP (TURNS FROM TOP)
L <sub>1</sub>	80 Meters	32	1 Inch	11
L <sub>2</sub>	40 Meters	16	1 Inch	3
L <sub>3</sub>	20 Meters	8	1/2 Inch	3
L <sub>4</sub>	10 Meters	4	1/4 inch	2 TURN LINK

JAMES MILLEN







# YAXLEY Switches

## ...and the difference between shorting and non-shorting types

Many of our customers have written, asking that we explain the difference between shorting and non-shorting types of switches.

On a shorting type switch, the moving arm overlaps each contact, so that when the switch shaft is rotated from one position to another, the second circuit is closed before the first circuit is opened. This type of construction is used in band change switches to prevent an annoying noise in the loudspeaker which otherwise would occur when the grid circuits were momentarily opened during the operation of the switch.

Non-shorting switches do not have this overlap, and are preferred for test equipment service. In this type switch adjacent circuits are not momentarily contacted during the rotation of the switch.

Write us for information on your switch problems. Yaxley Switches are sold by leading radio parts distributors.

**P. R. MALLORY & CO., Inc.**  
**INDIANAPOLIS INDIANA**  
Cable Address—PELMALLO



## Correspondence

(Continued from page 60)

### Rho Epsilon

5822 E. Green Lake Way, Seattle, Wash.

Editor, *QST*:

We would like to spread the word around about an active amateur radio organization for college students.

*Rho Epsilon Fraternity* is an inter-collegiate amateur radio fraternity organized "to encourage experimental radio activity among American college students; to foster orderly operating; and to exchange news items for the college papers through local short wave stations." We believe it to be the oldest organization of its kind, having been founded at Washington State College in 1911. In addition chapters have been established at the University of Washington, the University of Idaho, and the University of Virginia.

Membership is open to amateurs at institutions where a chapter has been organized and granted a charter. A chapter may be established by petitioning for a charter. We would like to hear from college radio clubs with regard to affiliation with *Rho Epsilon*, and from any college student interested in organizing a chapter at his school. Information may be had by writing the national secretary.

—Nilo E. Koski, W7LD  
National Secretary

### Thanks

Norfolk, Va.

Editor, *QST*:

Of course you have received a copy of the ruling of the F.C.C. in regards to the decision reached pertaining to amateur interference referred to in the hearing of Parrish vs. Dudley, and I want to take this opportunity to thank the A.R.R.L. in general and the headquarters staff in particular for the extra effort they went to in my behalf and to assure them that we are all satisfied that only through your efforts and that of our very excellent attorney, Mr. Paul M. Segal, were we able to obtain such a favorable decision.

All the fellows seem to be quite jubilant over the results, and from the messages of "sympathy" received via amateur radio and through the mails I know that for the next month I'll be busy with many more expressing the happiness of the "gang" at the outcome. . . .

—(Dr.) A. D. Dudley, W3ADD-W3AEY

### Is This a QSO?

1520 W. 18th St., Chicago, Ill.

Editor, *QST*:

Recently I have listened to several stations outside the U. S. apparently trying to see how many QSL's they can collect or else how many stations they can contact in one evening.

Take, for example, a CX station, who will come on in the evening with a nice lusty lengthy CQ. Naturally quite a few W's hear him, so when he comes back the QSO's run something like this: W1—, W4—, W8—, W2—, W9—, de CX— RRR tnx ur all RST 579 hr— QRM QRU oul 73 SK CQ QRZ CQ QRZ de CX—. This keeps on for any length of time, so that in an evening the CX operator has managed to contact (?) a good 35 to 50 W stations.

Now the point I am trying to bring out is the fact that nobody benefits from such QSO's. It stands to reason that the report 579 has no significance since every W gets the same report, whether he is T4 or T9X.

Every so often I read where some foreign operator claims he can't answer QSL's, because of the large number of cards he receives.

If our CX friend receives 35 cards (or more) a day, I see where it would be financially impossible for him to answer all of his QSL's. Of what use is a shack papered with QSL cards when we know that none of those cards have been answered? I know that I would not get any pride from such a shack. Wouldn't it be much better if some foreign amateurs would try to make friends with some of our W's?

# LEADING MANUFACTURERS CHOOSE EIMAC for important Ultra High Frequency work

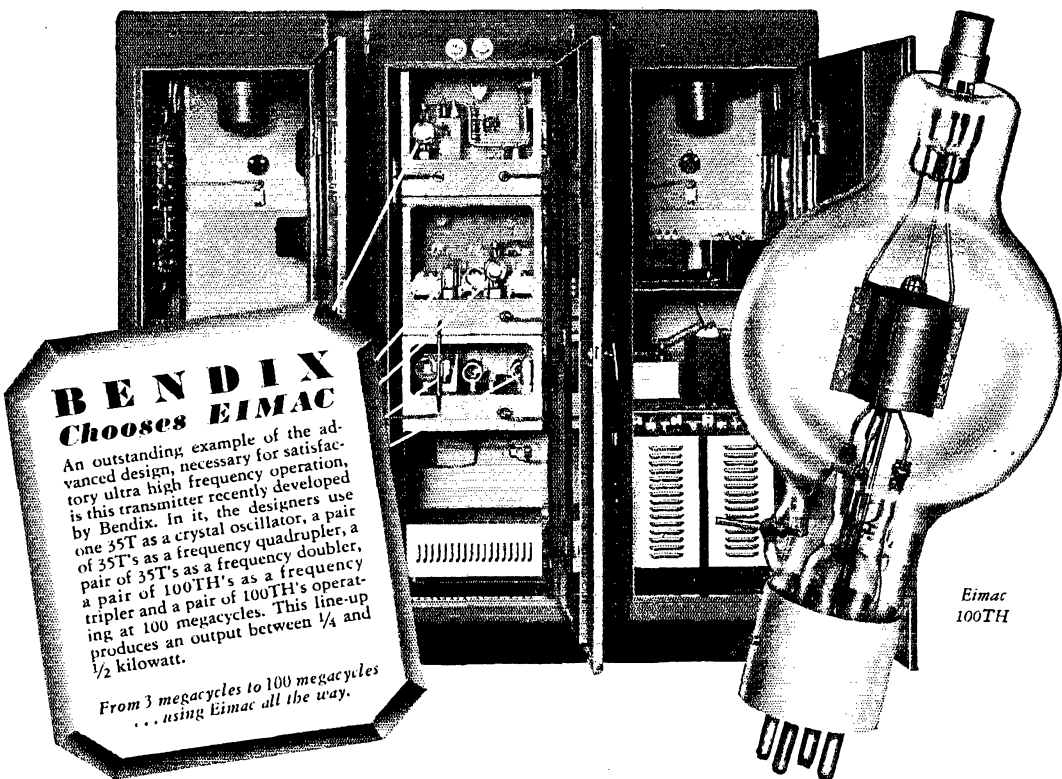

## BENDIX Chooses EIMAC

An outstanding example of the advanced design, necessary for satisfactory ultra high frequency operation, is this transmitter recently developed by Bendix. In it, the designers use one 35T as a crystal oscillator, a pair of 35T's as a frequency quadrupler, a pair of 35T's as a frequency doubler, a pair of 100TH's as a frequency tripler and a pair of 100TH's operating at 100 megacycles. This line-up produces an output between  $\frac{1}{4}$  and  $\frac{1}{2}$  kilowatt.

From 3 megacycles to 100 megacycles  
... using Eimac all the way.

Eimac  
100TH

For the past two years the nation's leading radio engineers have been carrying on extensive experiments in the field of Ultra High Frequencies. Among other outstanding achievements, has been the development of a group of powerful transmitters which will enable transport and other aircraft to accomplish a safe blind landing. The importance of *dependability* in an instrument of this type is obvious.

Equipment for this work must perform its function perfectly all the time. It must work without the help of the operator, for it is sealed from the weather and handled by remote control. The tubes, as in all transmitters,

are the most vital part. They must be rugged, dependable and highly efficient.

It is significant to note, that practically every firm now engaged in this difficult task, uses Eimac tubes. Certainly this endorsement should mean much to the radio amateur. It offers convincing proof that Eimac tubes will give superior performance in your transmitter.

# Eimac TUBES

EITEL-McCULLOUGH, INC. • San Bruno, California

Say You Saw It in QST — It Identifies You and Helps QST

Made by the men who build  
Commercial Communications  
Equipment . . .

## THIS RCA AMATEUR TRANSMITTER IS A TOP-NOTCH VALUE

The Model ACT-150 is a top-notch performer at a price that shouts value! Made by the same skilled RCA engineers who create commercial communications equipment, it offers features that *prove* its quality . . . features born of RCA's experience and research in every phase of radio! Look them over — see for yourself.

### FEATURES

Conservative 150 watts output (c.w. and 'phone).

Tube line up of modern acclaim: R.F.—RCA 807, 802, two 807's, two 808's; Audio—RCA 6J7, two 6C5's, two 2A3's, two 808's; Rectifiers—RCA 83, 5Z3, 80, two 866's.

Isolated speech amplifier of special design.

10 to 160 meter operation.

Circuits fully metered including modulation indicator.

Switch for "Tune-up" protection or power output reduction.

Transformers given special impregnation.

Interlock switch for safety to operator.

Neutralized at factory.

Pleasing two-tone gray finish and handsome escutcheon plates on cabinets.

Low tube and extra coil costs.

### MODEL ACT-150

Amateur's net price F.O.B. factory with speech amplifier and one set of coils but less tubes, microphone, crystal. Extra set of coils \$13.50 **\$625**

For maximum performance at minimum cost — use RCA Radio Tubes.

RCA presents the "Magic Key" every Sunday, 2 to 3 P. M., E. S. T., on the NBC Blue Network



**FOR  
AMATEUR RADIO**

AMATEUR RADIO SECTION

A Service of the Radio Corporation of America  
RCA Manufacturing Company, Inc., Camden, N. J.

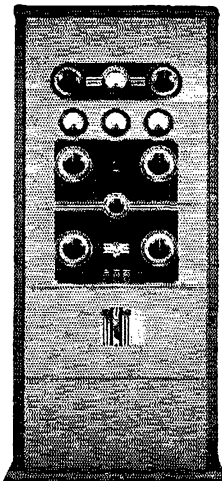

Just because I am a member of the R.C.C. does not mean that I want to see every QSO last far into the night. The fact is I enjoy a nice snappy QSO as much as anyone else, but let's get something out of these QSO's, and not just some resentment at a brother ham for not giving us a chance to tell him how the weather is, or how conditions are, or how we missed the 7:15 train this morning when we couldn't break away from that VK.

—George Vesely, W9SKR

### 1.75 and 28-Mc. Operation

(Continued from page 46)

unbalance caused by touching a neon bulb to one plate.

In case the builder does not care to have the 809's draw approximately 100 milliamperes plate current when the key is open, as is the case with no fixed bias on the tubes, a "C" battery of 22½ volts can be inserted in series with the grid leak, R<sub>6</sub>. This will cause the plate current to drop to zero, thus avoiding unneeded power dissipation in the tubes during keying spaces. The bias will have no noticeable effect on the operation of the amplifier, even on 28 Mc., since there is plenty of excitation on all bands.

The parasitic chokes, marked "X" in the circuit diagram in February *QST*, should be four turns of No. 14 wound on a pencil, with spacing equal to the wire diameter.

Larger wire (No. 18) than on lower frequencies has been used on the 14- and 28-Mc. driver coils, to reduce losses at these frequencies. Another point worth mentioning is that the 1.7-Mc. plate coil is wound with No. 22 wire instead of the No. 20 used for the other coils. The No. 22 wire is used to permit winding a coil no longer than the grid-coil form, since with larger wire the inner coil would protrude out of the other, making a mechanically unstable arrangement.

### MODULATION

For those interested in modulating the transmitter it is recommended that the speech system on page 233 of the 1938 A.R.R.L. *Handbook* be used. The output from the 6L6's described is 50 watts, which is exactly the power needed to modulate a pair of 809's at the maximum recommended operating conditions for plate modulation (600 volts and 166 ma. for the pair). The r.f. output will be approximately 75 watts. The modulator output transformer should match the 6L6's (optimum plate-to-plate load 3800 ohms) to the 3600-ohm Class-C load. A 1:1 transformer should be near enough for all practical purposes.

—V. C.

### What the League Is Doing

(Continued from page 19)

"Be it resolved, by the Inter-American Radio Conference, that:

"In the interest of close and friendly contacts between the peoples of the Americas, the administrations of the contracting countries whose internal legislation permits it agree that amateur radio stations in their respective countries and possessions may internationally exchange mes-



## MEASUREMENTS MADE EASY

Just about the handiest instrument you can have around the shack is a good 0-1 milliammeter with the following accessories: 1. A few accurate resistors, fixed and variable. 2. A type 30 tube with midget "A", "B" and "C" batteries. 3. An understanding of the many applications of this multi-purpose instrument.

To make a d.c. volt meter, you will need a resistor in series with the milliammeter whose ohmage is 1,000 times the full scale voltage — that is, a 10,000-ohm resistor will make a 0-10 volt meter, 1-megohm will make a 0-1,000 volt meter.

We have manufactured for some years now Precision Wire Wound Resistors for such service. They are non-inductively wound with low temperature-coefficient wire on grooved Isolantite forms, are well impregnated and finished, and are normally supplied to plus or minus 1% accuracy. On special order they can be supplied to tolerances as close as plus or minus 1/10%. You will find the type "WW" units carried by your jobber simple to mount and worthy of a place in your most accurate measuring equipment.

If you don't need such high accuracy (and few hams do for ordinary adjustments), we would suggest the familiar Type BT, Insulated Metallized Resistors. These resistors have been developed to a state where they remain stable to within 2% of their original value over long periods of time. They have a temperature coefficient of less than minus .03% per degree Fahrenheit. We have recently made these units available to the jobbers with a plus or minus 5% tolerance, and they are the answer to your need for inexpensive volt meter multipliers. It is advisable to operate them well below their ratings in order to keep the temperature low. Use a BT-1 or BT-2 for voltages up to 500, and two BT-1's or BT-2's in series for 1,000 volts.

For measuring currents greater than 1 milliampere, a shunt is connected across the terminals of your milliammeter so that only a portion of the current flows through the meter. The resistance of this shunt is as follows: Resistance of the shunt equals resistance of meter divided by (N-1),



Type WW-1

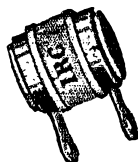

Type WW-3

Two of the most popular IRC Precision Wire Wound Resistor types. Twelve additional types are also available.

where N is the number of times you wish to increase the full-scale reading. For instance, suppose you find your meter has a resistance of 45 ohms. If you wish to multiply its full-scale reading by 10 you will need a 5-ohm resistor. For small currents an IRC Wire Wound Type BW in 5% tolerance will make a satisfactory shunt, or the more accurate type "WW".

To switch various shunts of this type across your meter, use a switch of low and constant contact resistance — otherwise your calibration may be seriously affected. By this means a single meter will serve to measure everything from grid current to the full plate current in the final of your transmitter.

This brings us to the use of this meter in measuring (or rather, indicating) R.F. There have been numerous articles in *QST* and other magazines on the construction and use of simple field strength meters using a type 30 or other triode tube. One is described in the new Radio Amateurs Handbook on page 378. It is simple to construct and will tell you more about what your rig is doing than any single instrument you could own — neutralization, relative antenna output, relative field strength in different directions, etc.

This same gadget can be used as a v.t. volt meter for measuring a.c. peak voltages. Eliminate the tuned input circuit and include "B" and "C" batteries with a potentiometer adjustment. This, too, is described under "Instruments and Measurements" in the Handbook in more detail than we can give here. Suffice to say that this meter draws no current from the circuit being measured and can be used on anything from an R.F. circuit to checking a.c. filament voltage. (Don't forget to divide the peak voltage by 1.4 to get the R.M.S. voltage).

P.S. All of the above equipment can be put together for less than ten dollars.

### INTERNATIONAL RESISTANCE COMPANY

401 NORTH BROAD STREET, PHILADELPHIA, PA.

ADVERTISEMENT

Say You Saw It in *QST* — It Identifies You and Helps *QST*

# ANOTHER NEW CARDWELL TYPE XE-160-70-XQ

W2AMJ called the turn in his article on a Variable Range Condenser for multi-band transmitters in March QST, page 47.

Many of you have written to us over the past few years asking us why such a unit was not available.

## HERE IT IS . . . BUILT TO YOUR ORDER

CARDWELL high quality construction throughout. Airgap (per section), .100 inches. General Electric Mycalex insulation.

List Price **\$22.00**

Effective balanced capacity ranges available by proper connections to coil.

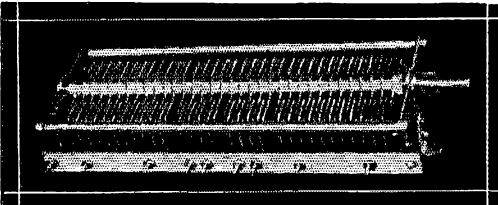

Notice how popular air wound coils such as Coto and B&W readily adapt themselves to these effective capacity ranges for push-pull balanced circuits, and flexibility of ranges for you fellows who "roll your own" tank coils in an effort to get the optimum L C combination.

- 2 small sections in series, for high frequency bands . . . . . 9 to 34 mmfds.
- 2 large sections in series, for medium frequency bands . . . . . 13.5 to 83 mmfds.
- 1 large and 1 small section parallel for each half of a dual condenser for 160 meters. . . . . 19 to 114 mmfds.

If you already have a good final for 20, 40 and 80 M., use a CARDWELL "J" plug-in Fixed Condenser (See our Feb. QST ed.) to load up your split stator capacitor for 160 meters. JD-80-OS, 80 mmfds. .125" airgap, 4" long x 2 1/2" square, 5000 V. JCO-45-OS, 45 mmfds. .250" airgap, 5 3/8" long x 2 1/4" sq., 7500 V. Alsimag 196 insulation. List price, each . . . \$5.50 "JB" Jack base for either type. List price . . . . . \$1.00

CARDWELL offers for your convenience GENUINE ALSIMAG NO. 196 CERAMIC BEADS for 3/8 inch O.D. coaxial lines, straight brass tube like W-2BZR used (Feb. QST) or soft drawn copper "water" tubing which bends swell on an 8" radius and doesn't require the square coupling blocks.

Beads are .295" O.D. with center hole for No. 12 B&S copper wire. Pkg. 250 beads (enough for 50 feet of line). List price, per pkg. . . . . **\$2.30**

## Cardwell presents G.E. MYCALEX

- H.F. insulation in stock bar sizes, you can saw and drill. Make your own special inductance mountings, R.F. terminal blocks, etc. . . . with a real H.F. low loss material. Here are some of the best buys:
- Item "ME" 4 5-16" x 1/2" x 1/4". List . . . . . \$0.35
  - Item "MG" 6" x 1/2" x 1/4". List . . . . . \$0.55
  - Item "MH" 6 1/4" x 1/2" x 1/4". List . . . . . \$0.60
  - Item "MM" 12" x 1" x 1/4". List . . . . . \$1.95
  - Item "MJ" 10" x 3/4" x 1/4". List . . . . . \$1.65
  - Item "MK" 12" x 1/2" x 1/4". List . . . . . \$1.35
  - Item "ML" 12" x 3/4" x 1/4". List . . . . . \$1.75

Ask your dealer for these new  
**CARDWELL QUALITY PRODUCTS**

**THE ALLEN D. CARDWELL MANUFACTURING CORPORATION**  
83 PROSPECT STREET, BROOKLYN, NEW YORK

sages emanating from third parties; provided, however, that such messages shall be of a character that would not normally be sent by any other existing means of electrical communication and on which no compensation may be directly or indirectly paid."

**Financial Statement** The League showed a profit of something over nine thousand dollars from ordinary operations in the last quarter of 1937. By order of the Board, the operating statement is here published for the information of the membership:

### STATEMENT OF REVENUES AND EXPENSES, EXCLUSIVE OF EXPENDITURES CHARGED TO APPROPRIATIONS, FOR THE THREE MONTHS ENDED DECEMBER 31, 1937

REVENUES	
Membership dues . . . . .	\$18,261.91
Advertising sales, QST . . . . .	25,754.46
Advertising sales, Handbook . . . . .	6,936.98
Newsdealer sales, QST . . . . .	11,037.71
Handbook sales . . . . .	23,568.86
Booklet sales . . . . .	2,873.05
Calculator sales . . . . .	428.59
Membership supplies sales . . . . .	2,749.37
Interest earned . . . . .	407.94
Cash discounts received . . . . .	277.61
	<b>\$92,296.48</b>
<b>Deduct:</b>	
Returns and allowances . . . . .	\$3,399.60
Collection and exchange . . . . .	7.47
Cash discounts allowed . . . . .	575.57
	<b>\$3,982.64</b>
Plus increase in reserve for newsdealer returns of QST . . . . .	156.48
	<b>4,139.12</b>
<b>Net revenues . . . . .</b>	<b>\$88,157.36</b>

EXPENSES	
Publication expenses, QST . . . . .	\$17,044.43
Publication expenses, Handbook . . . . .	19,704.68
Publication expenses, booklets . . . . .	1,007.05
Publication expenses, calculators . . . . .	208.05
Salaries . . . . .	25,700.34
Membership supplies expenses . . . . .	1,709.51
Postage . . . . .	2,417.14
Office supplies and printing . . . . .	3,123.75
Travel expenses, business . . . . .	1,583.32
Travel expenses, contact . . . . .	671.36
QST forwarding expenses . . . . .	926.03
Telephone and telegraph . . . . .	817.13
General expenses . . . . .	1,068.09
Insurance . . . . .	43.77
Rent, light and heat . . . . .	1,164.73
Provision for depreciation of furniture and equipment . . . . .	346.27
General Counsel expenses . . . . .	262.27
Communications Dept. field expenses . . . . .	196.35
Headquarters station expenses . . . . .	44.10
Alterations and repairs expenses . . . . .	775.05
Bad debts written off . . . . .	125.60
<b>Total expenses . . . . .</b>	<b>78,939.02</b>

Net gain before expenditures against appropriations . . . . . **\$9,218.34**

## Modernizing the Transceiver

(Continued from page 29)

mitter. A 6E6 tube was tried in the original setup, but the RK34 was found to give slightly higher output and more satisfactory operation over long periods.

For full power output, a plate voltage of 300

# Now - FOR AMATEUR USE

3 Band Switching Turret  
using Centralab Isolantite  
Switch made by BARKER  
and WILLIAMSON  
Ardmore, Pa.

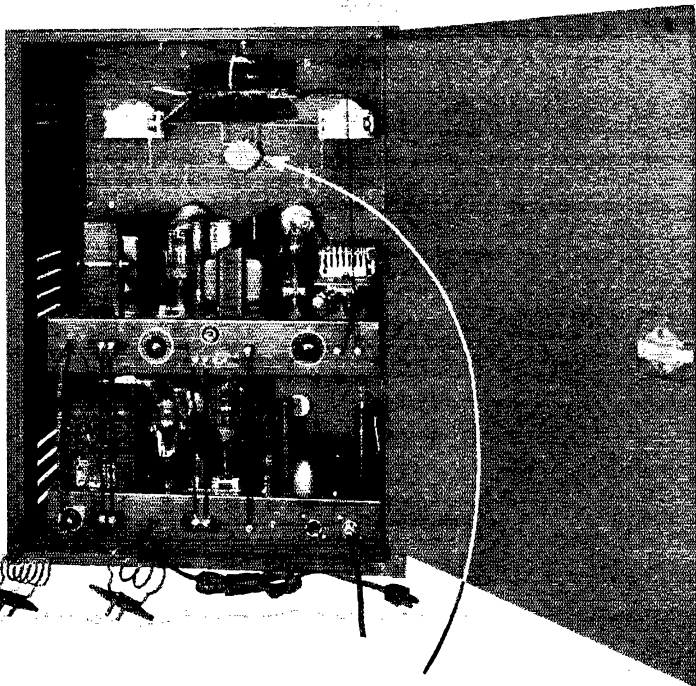
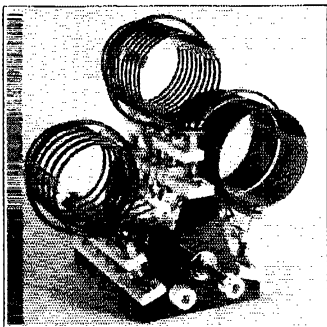

Centralab Antenna Matching  
Switch on 5B 40W Transmitter  
made by WHOLESALE RADIO  
of New York, N. Y.

# ISOLANTITE SWITCHES

## TRANSMITTERS

- *Crystal Frequency Selector* from one band to another — or within the band to dodge QRM.
- *Amplifying or Doubling Stages* selects the proper coil or tap on one coil — or correct tank coil on final stage.
- *Antenna Coupling* in series or parallel for matching antenna to given frequency.
- *Transceivers* send and receive switch.

## RECEIVERS

in either preselectors or receivers wherever wave changes are required.

**MAIL NOW**

**CENTRALAB — Div. of Globe-Union Inc.**  
MILWAUKEE, WISCONSIN

Please send me descriptive literature on  
your new Isolantite Selector Switches.

Name \_\_\_\_\_

Street \_\_\_\_\_

City \_\_\_\_\_

State \_\_\_\_\_

QST.

# Centralab

*Greater*  
**OUTPUT**  
with  
**LOWER DRIVING POWER**

when you use

**RAYTHEON**  
**RK**  
**LOW COST TRIODES**

RK tubes are easy to drive. Just check the figures below. And remember, RAYTHEON ratings are very conservative. But we don't stint when it comes to *Value!* Hard glass bulbs, carbon plates, Isolantite bases, extra large thoriated tungsten filaments—all contribute to the longer life and higher efficiency you can always expect, and get, from Raytheons. And they are built to take heavy momentary overloads, too. When you need a Power Amplifier, Oscillator or Frequency Multiplier, get the extra watts and longer life that come with RK Triodes.

**RK-11** —20 MU Class C Triode. Filament 6.3 volts. Plate 750 volts. Excellent R-F characteristics. 55 watts output with only 3.2 watts drive. **\$2.50**

**RK-12** —A high mu triode. Filament 6.3 volts. Plate 750 volts. A very efficient zero bias Class B modulator with extremely low distortion—even at 100 watts (two tubes) 3.4 watts drive. **\$2.50**

**RK-51** —20 mu Class C triode. Filament 7.5 volts. Plate 1500 volts. Excellent R-F characteristics. 170 watts output with only 10 watts drive. **\$8.00**

**RK-52** —A high mu triode. Filament 7.5 volts. Plate 1250 volts. Very efficient zero bias Class B modulator with 250 watts output (two tubes) and only 7.5 watts driving power. **\$8.00**

See Your Raytheon Jobber or Write for Detailed Characteristics on These and Other R-K Tubes.

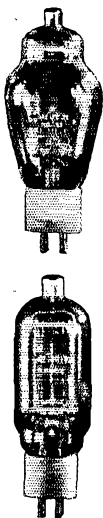

**RAYTHEON**  
**RK**  
**AMATEUR TUBES**

420 Lexington Ave., New York 445 Lake Shore Drive, Chicago  
55 Chapel St., Newton, Mass. 555 Howard St., San Francisco  
415 Peachtree St. N. E., Atlanta

"WORLD'S LARGEST EXCLUSIVE TUBE MANUFACTURERS"

should be used. Higher voltages are not recommended. At this voltage the entire plate-current drain in the "transmit" position is 95 milliamperes; in the "receive" position it is 65 milliamperes. The total filament drain is 2.1 amperes at 6.3 volts.

A little trouble was experienced with 28-Mc. crystals as received from the factory. None of the crystals tried would oscillate until cleaned, but after cleaning all were persistent oscillators. Unlike those for lower frequencies, 28-Mc. crystals are rated at comparatively high r.f. crystal current. They are harmonically-operated units, the fundamental frequency being around 5.6 Mc., and operate best when low- $\mu$  triode tubes are used.

Any conventional antenna as used on the average transceiver will operate satisfactorily with this unit.

**BOOK REVIEW**

*Fundamentals of Radio*, by F. E. Terman, McGraw-Hill Book Company, New York; 458 pages, including index; \$3.75.

A new "Terman" always is of special interest to amateurs as well as engineers, the author's well-known clarity of style and comprehensiveness of treatment having made his volumes not simply works for occasional reference but practical assistants to those engaged in the design of equipment. The present text, written by Prof. Terman with the collaboration of Lt. F. W. MacDonald, U.S.N., is, in the words of the publishers, "an elementary version of the author's well-known *Radio Engineering*, designed for a one-term course in radio . . . a carefully unified and almost wholly new text, emphasizing basic principles and their practical applications."

The plan of the book is similar to that of the larger *Radio Engineering* and covers much of the same ground. The treatment is simplified, however, and is designed to meet the requirements for an introductory course in radio. A large number of problems for classroom work features each chapter. A knowledge of complex quantities is not required.

Not intended for those who know and use *Radio Engineering*, *Fundamentals of Radio* will meet the needs of readers whose mathematical ability is not great enough for complete understanding of the former. An excellent book for home study by the amateur. High-school mathematics is sufficient for working out the problems.

—G. G.

**De Luxe Battery-Operated Portable Stations**

(Continued from page 28)

intermediate frequency amplifier; and a 1B5 duo-diode-triode as a diode detector, a.v.c. supply, and audio amplifier. The rectified voltage from the diode is applied to the grids of the converter and i.f. amplifier tubes. This controls the volume so effectively that no additional control is provided except for the Hi-Lo switch on the panel.

The antenna circuit is connected to the transmitter output tuning circuit so that the antenna impedance is matched to the receiver input at the transmitting frequency. This increases the gain

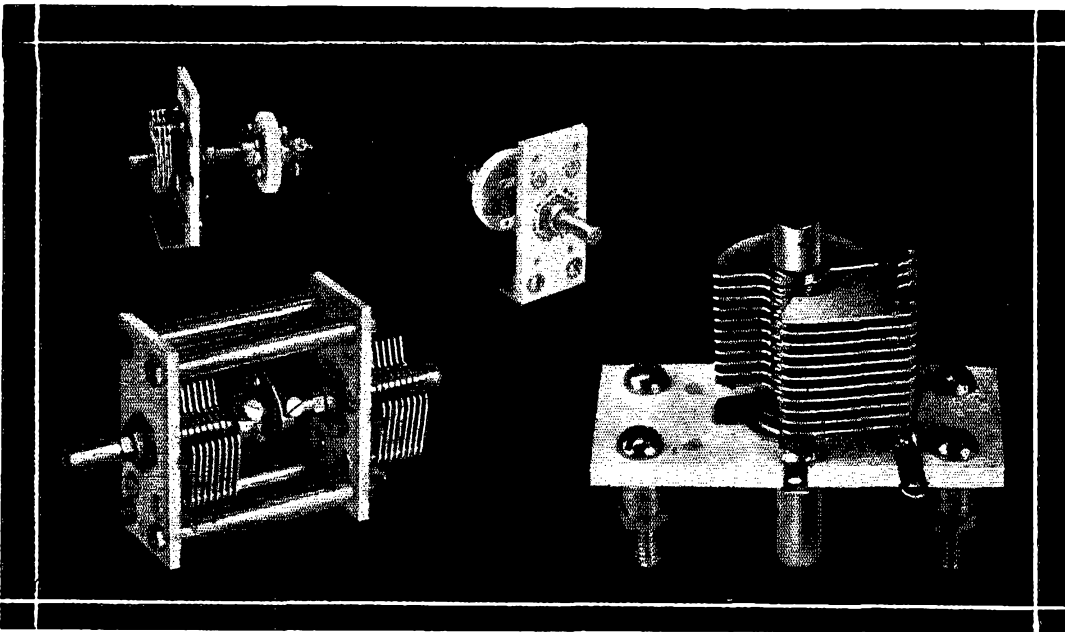

## A SEASONED DESIGN

The type UM Ultra Midget Condenser is designed for use in ultra high frequency receivers, transmitters or exciters where a small efficient padding or tuning condenser is needed. Its wide acceptance for such use is founded on its small size for mounting in shield cans, on its shaft extensions on each end of the rotor for convenient ganging, and on its universal type of mounting. These features when used in conjunction with our flexible couplings (a few from our complete line are illustrated below) make a unit that is easily adaptable to unusual layouts. At the right in the illustration above, is one model of the UM condenser (a balanced stator model is also available). At the left are two of the many convenient methods of mounting and ganging. Other features include a staked and soldered construction which, together with the "self locking" rotor design, makes the UM condenser virtually proof to vibration. Prices are extremely low, ranging from \$.75 (net) for the 15 mmf size to \$1.14 (net) for the 100 mmf size.

**NATIONAL COMPANY, INC., MALDEN, MASS.**

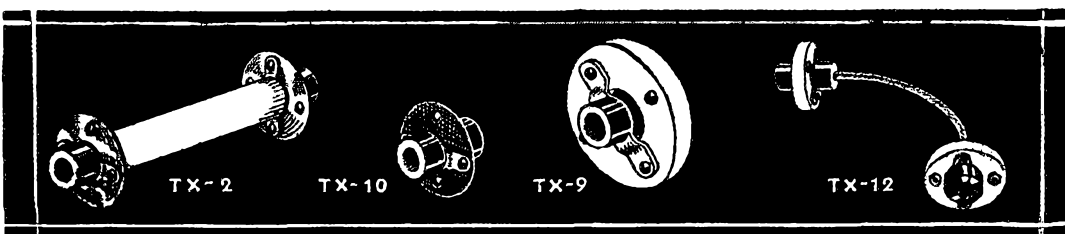



# NEW JOHNSON SOCKETS

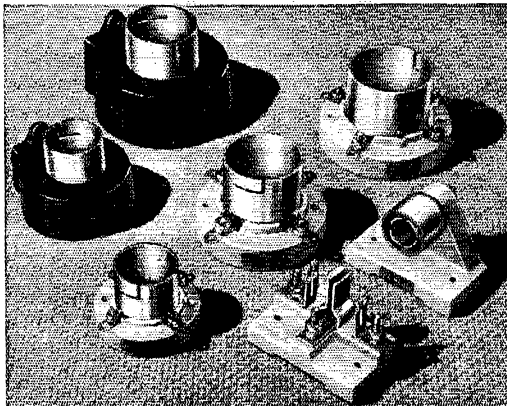

★ The most famous transmitting tube sockets in the world, the Johnson "50 watt" (center) and UX base (lower left) are now available with many new features.

- Choice of *steatite\** or porcelain base.
- Choice of *beryllium copper\** or phosphor bronze contact springs — cadmium plated, side wiping, with integral soldering terminal.
- Design refinements providing maximum voltage breakdown.
- Heavy nicked brass shell with bayonet slot is retained, supporting the tube by its base rather than its prongs.

*\*As specified for Government and other transmitters in severe service.*

Other Johnson Sockets are available for "250 watt" tubes, pentodes such as RCA 803 and RK28, and for vertical panel mounting of "50 watt" and UX base tubes.



Johnson wafer sockets of Alsi-mag 196 are ideal for use in either transmitting or receiving. Exceptionally efficient at high and ultra high frequencies and

built for high voltage service. Available for all tubes.

**Ask your Jobber or Write for Catalog 964J**

Visit our Booth at 111 Bell Street, National Radio Parts Trade Show, Stevens Hotel, Chicago, June 8-11

**E-F-JOHNSON COMPANY**   
 MANUFACTURERS OF *Radio Transmitting Equipment*  
 WASECA MINNESOTA U.S.A.  
 Export Office: 25 Warren St., New York. Cable: "SIMONTRICE"

at the transmitting frequency and introduces some loss at other frequencies.

## CONTROLS

Simplicity is paramount so controls are kept to minimum. On the front panel are only three variable adjustments; namely, a condenser in the final tank circuit, a receiver gang condenser, and a one-plate vernier on the receiver oscillator for close tuning, which incidentally is very useful.

Also on the control panel is a 0-50 d.c. milliammeter reading final plate current, a change-over switch, a filament switch, a volume switch, two antenna binding posts, and a jack for loud-speaker use, such as in a fire camp, where several men may be gathered around to get reports.

The filament and volume switches are of the small toggle type with high and low positions. The filament switch shorts out or introduces a one-ohm resistor to compensate for terminal voltage drop in the batteries. The volume switch is a 10,000-ohm audio shunt. These two switches give a simple and adequate control of these circuits, as proved by eighteen months' use.

## THE ANTENNA

The antenna reel is mounted on the inside of the cover. On this reel is a 50-foot length of insulated wire to be laid on the ground as a counterpoise. Following this, as the wire is unwound from the reel, is a lead weight, then about 30 feet of twine which ties to a small airplane-type insulator. Tied to this insulator is a 90-foot length of insulated flexible antenna wire which is soldered to the drum of the reel. The length of antenna can be varied by winding it on in the drum for a few turns, thus forming an inductance and essentially a loaded quarter wave. The correct adjustment is obtained when the amplifier draws 25 ma.

## ADJUSTMENTS

A terminal strip can be seen on the bottom of the chassis, transmitter side, directly above the transformer bank. These terminals are the "B" common, oscillator plate, buffer plate, and power amplifier plate, and allow easy access to these circuits for inserting a milliammeter during shop adjustments. The neutralizing condensers can be seen mounted at the side. All of the adjustments are conventional for these circuits.

For receiver alignment a meter is inserted in the battery lead in the tray or case for use in indicating correct trimmer settings, since the a.v.c. varies the plate current of the tubes.

One of the most frequently-heard comments is about the lack of hookup wire and the usual spider-web characteristic of many sets crowded into a small space. This is due both to the placement of parts and to the use of the capacitor and resistor units themselves as the connecting links between the sockets and the ground or "B" plus bus that is laced along the bottom of the chassis.

# DELCO-REMY GENERATORS

## help Cincinnati fight crime

● The Cincinnati Police Department has built one of the most efficient police broadcasting stations in the country as an added weapon in its war against crime. To get full benefit from this radio equipment, Cincinnati has installed Delco-Remy special service generators and Delco-Remy current and voltage regulators in its radio-equipped police cars. For the Queen City Police, like so many other law enforcement agencies, have found that this Delco-Remy special service equipment is designed and built to furnish the extra current necessary for continuous, trouble-free operation of cruisers and scout cars. Amateurs, too, find that Delco-Remy high-output generators provide ample current for two-way radio service and experimental work in their own cars.

Any Branch or Electrical Service Station of United Motors Service can recommend and supply the proper generator and current and voltage regulator for your own use.

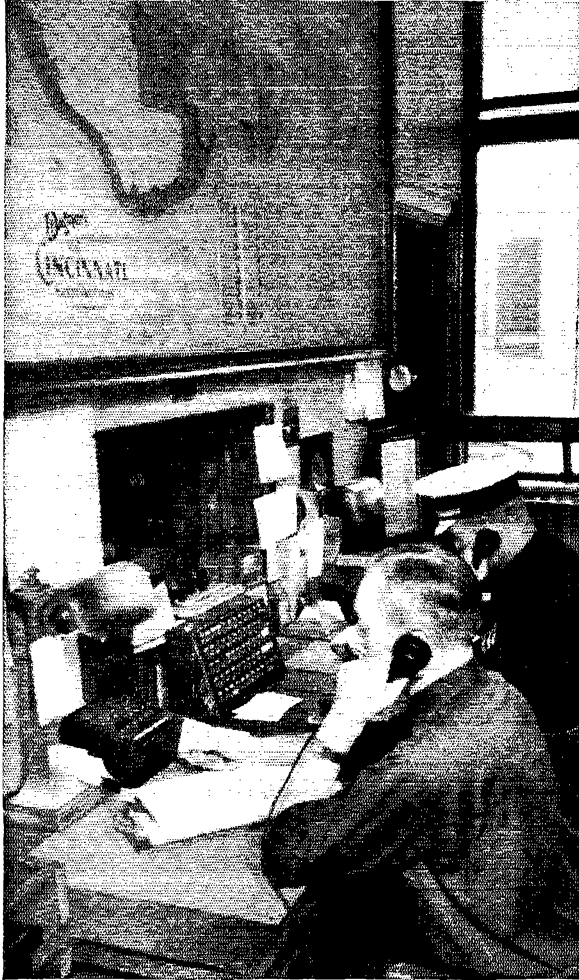

The relay room, where incoming calls are received and movements of scout cars are controlled. Through the opening in the wall may be seen the panel of the speech amplifier, which carries the voice of the dispatcher to the transmitter in Eden Park, some three miles away.

★ ★ ★

"We have been using Delco-Remy high-output generators for the past three years on all our radio cars and find them satisfactory in every way. We have eliminated all B-battery sets, and our battery trouble is now at a minimum."

E. T. WEATHERLY, Chief of Police  
Cincinnati, Ohio



# Delco-Remy

ANDERSON, INDIANA



Delco-Remy products are sold and serviced by United Motors Service Stations everywhere . . . wherever you see this sign.

**World's Largest Manufacturer of Automotive Electrical Equipment**

Say You Saw It in QST — It Identifies You and Helps QST

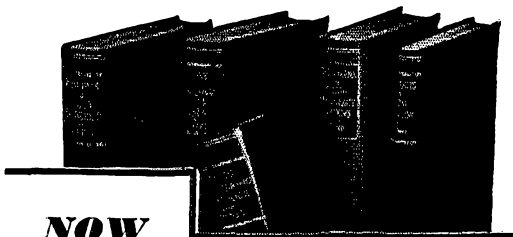

**NOW**  
**this high-powered radio engineering library**

sent to you for 10 days' trial—  
 at a special price and terms

These books cover circuit phenomena, tube theory, networks, measurements, and other subjects—give specialized treatment of all fields of practical design and application. They are books of recognized position in the literature—books you will refer to and be referred to often. If you are a researcher or experimenter—if your interest in radio is deep-set and based on a real desire to go further in this field—you want these books for the help they give in hundreds of problems throughout the whole field of radio engineering.

**RADIO ENGINEERING LIBRARY**

—especially selected by radio specialists of McGraw-Hill publications  
 —to give most complete, dependable coverage of facts needed by all whose fields are grounded on radio fundamentals

For home-study and reference. Contains a revised selection of books culled from latest McGraw-Hill publications in the radio field.

**5 volumes, 3064 pp., 2000 illustrations**

1. Glasgow's PRINCIPLES OF RADIO ENGINEERING
2. Terman's MEASUREMENTS IN RADIO ENGINEERING
3. Chaffee's THEORY OF THERMIONIC VACUUM TUBES
4. Hund's PHENOMENA IN HIGH-FREQUENCY SYSTEMS
5. Henney's RADIO ENGINEERING HANDBOOK

**Special Low Price and Easy Terms**

Bought singly, the five volumes comprising this library would cost you \$25.00. Under this offer you save \$1.50 and, in addition, have the privilege of paying in easy installments beginning with \$2.50, 10 days after receipt of the books, and \$3.00 monthly thereafter. Take advantage of these convenient terms to add them to your library now.

**SEND THIS ON-APPROVAL COUPON**

**McGraw-Hill Book Co., Inc.**  
**330 W. 42nd St., New York, N. Y.**

Send me Radio Engineering library, 5 vols., for 10 days' examination on approval. In 10 days I will send \$2.50, plus few cents postage, and \$3.00 monthly till \$23.50 is paid, or return books postpaid. (We pay postage on orders accompanied by remittance of first installment.)

Name .....

Address .....

City and State .....

Position .....

Company ..... QST-4-38  
 (Books sent on approval in U. S. and Canada only.)

**Shock-Proofing the Transmitter**

(Continued from page 35)

be noted that the insulation between the d.c. coil  $L_1$  and the r.f. coil,  $L_2$ , must be adequate. A short-circuit between  $L_1$  and  $L_2$  will place the buffer plate voltage directly on the grids of the final tubes, and blow them up in short order.  $L_2$  should be made of 1/4-inch copper tubing and  $L_1$  should be covered with a very high grade of high-voltage insulation. The potential difference between the two coils is the h.v. on the buffer added to the negative bias voltage on the final.

**Southern California Emergency**

(Continued from page 9)

down on the city following a cloudburst in the mile-high mountains to the west, wiped out all communications and transportation. Harvey Gillette, W6IRX, and Louis C. Sample, W6MHW, served as relief links, handling much traffic.

Winifred St. John, W6ATP, furnished an invaluable relay for stranded citizens at Greenwood through her station at Mont-Eton Mines. Harry Wolf, W6NKT, supplied Placerville's emergency contact, serving Western Union and the California Highway Patrol.

Traffic from San Bernardino, Riverside and San Diego was relayed by W6MVG at Oceanside and W6BXQ, Laguna Beach. W6PFQ at Point Loma and W6EWV, La Jolla, relayed from San Diego until lines were reestablished on March 6th. John C. Serwe, W6NLS, furnished communication for Sunland when power was on. W6GG, W6CB and W6MMW operated a 'phone net for the southern part of the region. W6EZA and W6BVA, located at Olive View, tried to relay sheriff's orders to Sagus and New Hall; when they had trouble getting through to the sheriff's office W6PDB assisted. All were using 28-Mc. 'phone. G. R. Southerlen, W6DUF, La Habra, got the first news of the extent of the Orange County emergency through to United Press, via W6ITH.

Although there were doubtless many other amateur stations active at other points in the emergency zone, this is the extent of the information available at the time of writing—the emergency having barely ended.

But the foregoing gives the picture as we have it. For the information herein contained we are indebted to telegraphic reports by Emergency Coördinators Click, Haas and Meacham, and by W6AM. Additional details will be given later.

Despite the fact that A. T. & T., RCA and Mackay opened radio circuits between Los Angeles and San Francisco, enabling the clearance of telephone and telegraph communications, all facilities were overloaded and there was need of general amateur message handling beyond the actual emergency communication with isolated points. This was effectively supplied by the Army and Navy Nets and the A.R.R.L. Trunk Lines. WLM cleared a considerable quantity of California traffic, collected on Corps Area Nets (the 2nd Corps Area Net, for one, was ordered to

(Continued on page 100)

NOT ~~\$12.50~~

NOT ~~\$7.50~~

NOT ~~\$6.00~~

NOT ~~\$5.00~~

NOT ~~\$4.00~~

NOT ~~\$2.25~~

NOT ~~\$1.75~~

**BUT \$1.50**



## TAYLOR LEADS

*Read! Trace the history of the 866, most widely used amateur tube. It proves Taylor leadership. In 1932 Taylor Tubes smashed existing tube prices by announcing the sale of quality 866's at the then fabulously low price of \$1.65. Naturally there were many who doubted the quality of this tube. The Bronx cheers of doubters turned to acclaim, when Amateurs — Engineers and Scientists, found Taylor 866's better tubes. For five years the sales of Taylor 866's have led by a wide margin. And so it is with other types. Taylor pioneered lower prices on all transmitting tubes. Following Taylor's lead, the price on all types of amateur tubes have steadily decreased and at the same time, a broader guarantee on transmitting tubes has been established. The result of this tireless fight for the Amateur is easily seen. "More Watts per Dollar," has become the magic slogan to greater Amateur accomplishment. Taylor Tubes is proud of its loyal Amateur friends. Taylor accepts and holds high its leadership in the fight for genuine value on transmitting tubes. Taylor Tubes will never fail in its trust.*

**FLASH!** • Over 2000 Wonder Tubes—T-40  
A New Record and TZ-40—sold in one month

*"More Watts Per Dollar"*

**Taylor** HEAVY **CUSTOM BUILT** DUTY **Tubes**

TAYLOR TUBES, INC., 2341 WABANSIA AVE., CHICAGO, ILLINOIS

# YOUR COPY IS READY

52 PAGES  
OF VITAL INFORMATION  
TELEGRAPHER HAS  
BEEN WAITING FOR

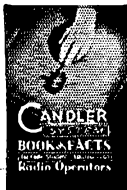

NEW EDITION

## IT'S FREE GET YOURS TODAY

Whether you are trying for your license, any grade, or just learning code, here is the answer to all your questions. Contains new F. C. C. rules and regulations, examination questions and answers, valuable advice by leading authorities on how to pass your examinations, etc. World's fastest operators give you speed tips. It took a lifetime to acquire the facts now available for

the first time in this free book. To every man interested in radio as a career, this information is essential. If radio is your hobby, by all means take advantage of this opportunity to add countless hours to your enjoyment.



You'll find his experiences interesting reading . . . and a valuable aid to mastering code and acquiring professional technique. Read what McElroy, World's Code Champion, has to say about gaining speed.

L. R. McDonald, W8CW — Winner Code Contest, A.R.R.L. Detroit Convention, Sept. 6, 1937. Copied 60 wpm. without error. "Practice alone will not develop a fast op. Code is a mental process. Candler's Exclusive Mind Training is essential to fast code. And Candler knows the short cuts!"

WRITE FOR YOUR  
FREE BOOK NOW!

**CANDLER SYSTEM CO.**  
DEPT. Q-4 ASHEVILLE, NORTH CAROLINA, U. S. A.



The only other points of high voltage left to worry about are the plate meter, the condensers  $C_1$  and  $C_2$ , and the plate connection to the tube itself. The meter and the fixed mica condensers can easily be taken care of by the usual methods, already discussed. The plate connection, if it is at the top of the tube, cannot easily be covered or taped, due to its irregular shape and to the high temperature at which the bulb operates. Therefore, if our hero does not want to put a screened box over the final amplifier tube, then about the best he can do is to improvise a light-weight covering from some sheet fibre or other thin insulating material which can stand high temperatures. Such a covering might be made in the shape of a tiny, rectangular box, which when inverted will just slide over the tube cap and the connecting strap. This box can be held in place by silk thread—if the tube doesn't get too hot. Clumsy as this may seem, it will effectively prevent Hon. Knuckles from touching the plate terminal when the hand is placed nearby for some legitimate purpose.

The neutralizing condenser  $C_3$  does not have the d.c. plate voltage on its plate side, since it is connected to the r.f. tank only. The same holds true for plate neutralized circuits, single or push-pull. Thus, the voltage rating necessary for  $C_3$  is reduced by 50 per cent,—another advantage of concentric feed over series feed.

If a little common sense and a lot of "elbow grease" are applied, any of us can fix our transmitters so that it is virtually impossible to receive accidentally a fatal shock—and this at a cost of only a few dollars. Many of us owe it to our wives and families, if we don't care about ourselves, to take more precautions, irrespective of how familiar we are with the equipment. If the danger is there in numerous places, it takes only one slight slip, one error of judgment, one mental lapse, one slight oversight, or one small accident over which we have no timely control to add a new name to the list of Silent Keys.

In conclusion, the writer wishes to point out that half-protection is much worse than no protection at all. One may forget *which* half is fixed, and in any event one is likely to acquire a feeling of false security and subsequently become careless. If nothing is protected, at least the operator knows that he should be constantly on his guard, and he stands some chance of surviving. (This probably explains why there have been relatively so few cases of electrocution among amateurs.) Therefore, if you start to danger-proof your rig, do a complete job while you are at it; and when you are through, be able to look it over and say, "How the devil am I going to measure the d.c. plate voltage now?"

**Strays**

The use of amateur abbreviations, Q signals, call prefixes, and other amateur language for construction of cross-word puzzles is suggested by W9WLE, who has successfully carried out this idea.

# Of What is the ANODE Made?

It is not the shape of the anode that makes transmission tubes stand overloads and last a long time, it is the material of which the anode is made — SPEER Graphite Anodes, whatever their shape, have these fourteen advantages over any other material:

- 1 **Increase** allowable plate power dissipation.
- 2 **Lower** temperatures of associated tube parts.
- 3 **Withstand** severe overloads.
- 4 **Defy** warping.
- 5 **Prevent** hot spots or fused holes.
- 6 **Minimize** bulb darkening and insulator leakage.
- 7 **Improve** degassing qualities.
- 8 **Decrease** gas troubles.
- 9 **Enhance** tube appearance.
- 10 **Provide** precise anode dimensions.
- 11 **Produce** uniform tube characteristics.
- 12 **Retain** original dimensions in service.
- 13 **Maintain** normal tube characteristics.
- 14 **Allow** wide latitude of anode design.

*Speer Anodes are supplied only to manufacturers*  
Buy and use transmission tubes with SPEER Graphite Anodes. Write us for a list of manufacturers of such tubes and for Anode Booklet No. 80.

**SPEER CARBON CO.**

ST. MARYS —  — PENNA.

# SPEER GRAPHITE ANODES

# MORE POWER AT A LOWER PRICE

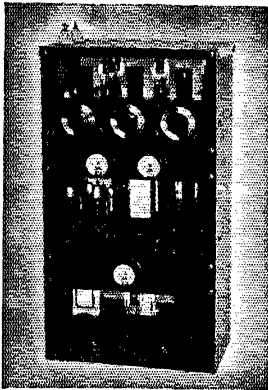

## GROSS CB55

### Radiophone Transmitter

FB. FOR 30 MC. — Input: 95 watts. Uses: 2-T20 tubes in R.F. and 6L6's in modulator. Coils available for 30, 14, 7, 3.5, and 1.7 mc. Descriptive bulletin on request.

## GROSS CB200 200 Watt Transmitter

See March *QST*. Write for descriptive Bulletin — and remarkably low price.

## "THE STANDBY" (2 to 2000 Meters) 3 TUBE A.C. AND D.C. RECEIVER

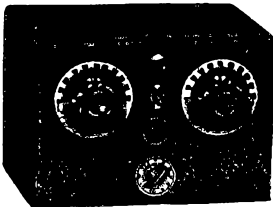

This excellent 2 to 2000 meter receiver is offered with full realization of the present-day need of the amateur for a dependable "stand-by" receiver which will cover practically all of the radio bands in use today. Super regeneration, which is the most efficient form of detection at these frequencies, is used from 2 to 15 meters. By throwing a toggle switch, straight regeneration and

higher wavelengths up to 2000 meters may be had. Throughout the entire tuning range, there are no skips or dead spots. Loud speaker volume is available from practically every station received.

- Power supply incorporated.
- Individual antenna tuning for high and low wave ranges.
- 1-76 super regenerative detector, 1-6J7 regenerative detector, 1-12A7 audio amp. and rectifier.

Complete kit of parts less coils, tubes, cab. ....	\$7.59
2-5-10 meter coils (set of 3) .....	.39
9 1/4 to 15 meter coil .....	.39
15-200 meter coils (set of 4) .....	1.30
200-310 meter coil .....	.39
310-350 meter coil .....	.36
550-1050 meter coil .....	.60
1000-2000 meter coil .....	.60
Metal cabinet .....	1.50
Kit of three tubes .....	2.40
Wired and tested in our lab., additional .....	2.00

## GROSS RADIO, INC.

51 VESEY STREET NEW YORK

Cable Address: GROSSINC

## When Emergency Strikes

(Continued from page 38)

if you can arrange to do so. Plan on full operation from 6 volts if you cannot. Automobile batteries and no end of man power may be requisitioned cheaply in most widespread emergencies. Generators and vibrapacks are entirely practical and useful. Note the recommendations of another section for band-edge calling frequencies, and plan emergency equipment to aim at proper calling and working frequencies for greatest utility.

### Emergency Operating Fundamentals

**Aim, Point-to-Point Effectiveness.** Some of the lessons of past experience are sufficiently digested to make some remarks relative to conditions possible. All agencies filing messages must

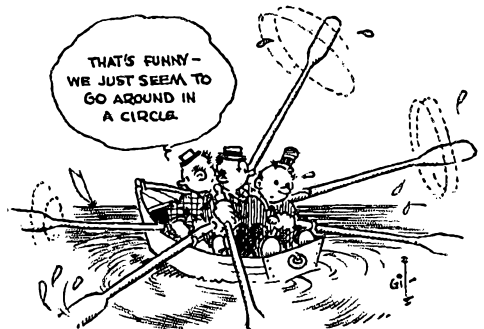

YOU'VE GOT TO HAVE COORDINATION AND COOPERATION!

"THE AMATEUR SERVICE . . . NEEDS AN OFFICER . . . TO CORRELATE INDIVIDUAL SCHEDULES, EQUIPMENT, EFFORT. . . COORDINATION IS ESSENTIAL"

be served courteously, efficiently, accurately and with maximum of secrecy, not only in line with our obligations with respect to the Communications Act and the secrecy of correspondence provisions—but to prevent dame rumor from getting any assistance from our amateur efforts! Our messages, unlike those of broadcasting stations, are *not* for the public, but in fact are best handled as undramatically as possible and kept from the public in every manner possible. False rumors have been started, the F.C.C. has pointed out, through garbled reception of entirely proper telephone messages. Extra precautions then must be taken by any voice operators to overcome such dangers, and above all, unnecessary discussions of messages handled and conditions in general should not be permitted. Information should be transmitted in regular message form with complete address and signature, and after handling no future reference should be made to the information except as may be specifically requested by the addressee for the sender.

**Priority.** Amateur stations must have proper regard for priority of communications. While absolute determinations of priority can be made only at points where the fullest extent of disaster needs are known, highest priority is required for

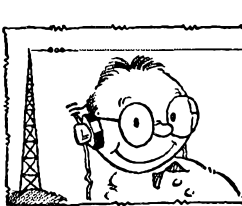

# DX DAN

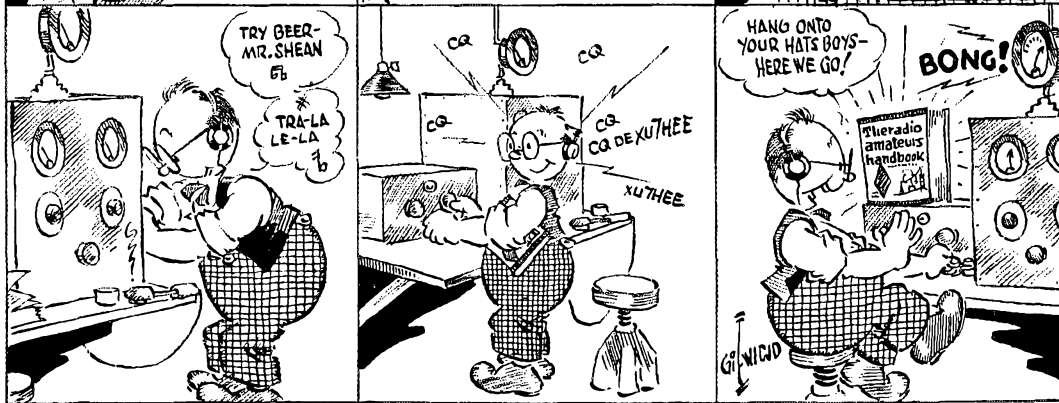
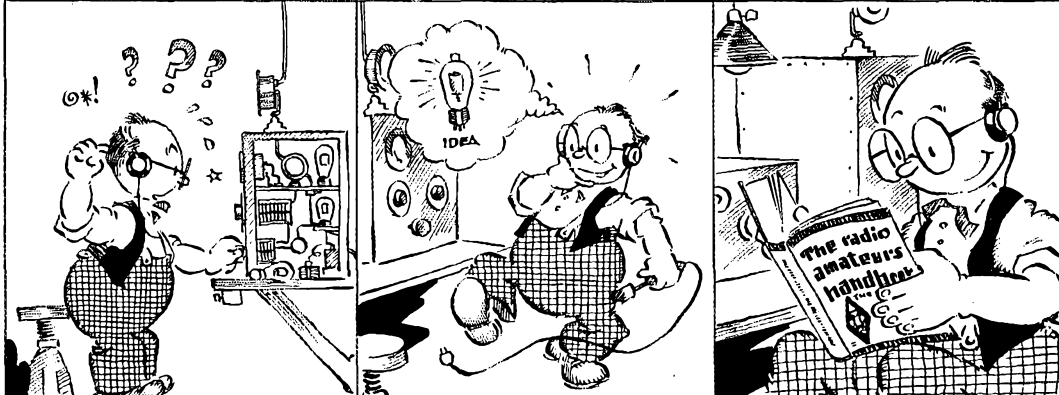
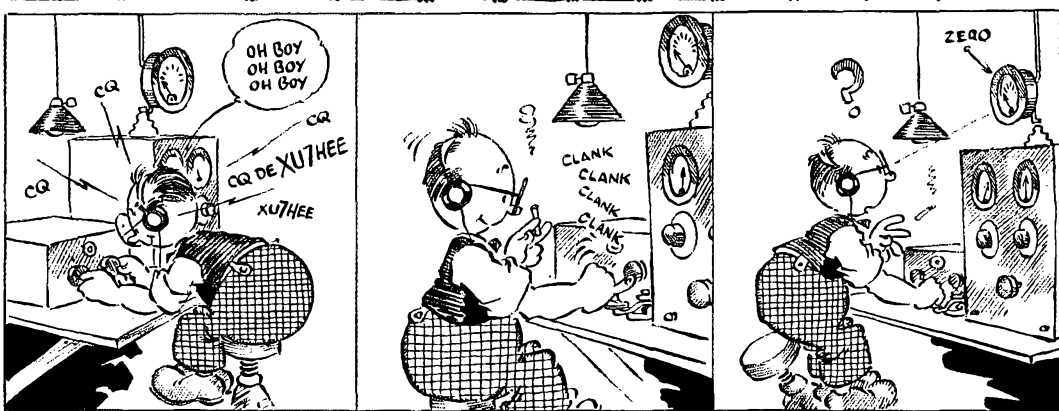

\$1 postpaid in Continental U. S. A. — \$1.25 postpaid elsewhere  
Spanish edition \$1.50 postpaid

**American Radio Relay League • West Hartford, Conn.**



# 7 GOOD BUYS FOR AMATEURS

## 304B TRIODE

Upper frequency limit—300 megacycles. Maximum voltage—1250 volts. Nominal power output, Class C—unmodulated—85 watts.

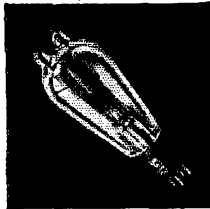
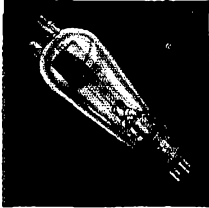

## 305A SCREEN GRID

Full ratings up to 50 megacycles. Maximum voltage—1000 volts. Nominal power output, Class C—unmodulated—85 watts.

## 306A PENTODE

Full ratings up to 50 megacycles—reduced ratings up to 70 megacycles. Maximum voltage—300 volts. Maximum power output 8.8 watts.

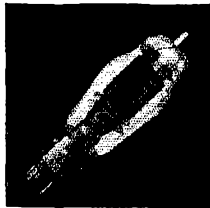
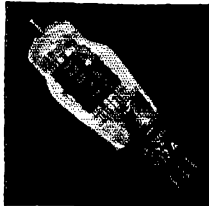

## 307A PENTODE

Full ratings up to 40 megacycles—reduced ratings up to 70 megacycles. Maximum voltage—500 volts. Carrier power output—20 watts.

## 316A TRIODE

Upper frequency limit—750 megacycles. Maximum voltage—450 volts. Nominal power output at 500 megacycles—7.5 watts.

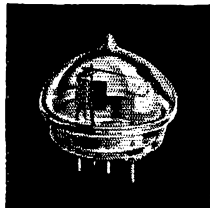
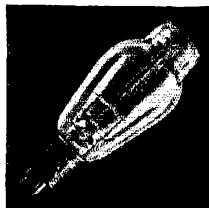

**300A TRIODE** High quality audio. Maximum voltage—450 volts. Maximum output—17.8 watts.

## Power Amplifier 242C TRIODE

Maximum voltage—1250 volts. Approximate carrier output, Class B, 100% modulated—50 watts. 100% modulated—Class C Nominal power output—130 watts.

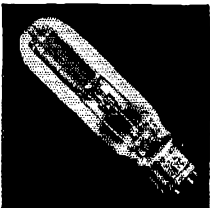

For full information, consult your dealer—or write Graybar Electric Co., Graybar Building, New York.

**Western Electric**  
BROADCASTING EQUIPMENT

official, public service, and semi-official agencies. Personal matters, whether concerning relief or not must await handling of public matters.

Stations should keep quiet (QRX) to prevent and reduce interference, when they have no public agency or official traffic rating priority. Priority is determined by emergency zone conditions. It is a senseless procedure to direct or solicit traffic for areas where large sections of the population are in temporary housing arrangements in the early stages of general emergencies. Such messages cause interference and unavoidably delay important circuits and messages, and worst of all, they cannot in most instances be delivered. If accepted, take them subject to delays and possible non-delivery at all due to emergency area conditions.

In the later stages of emergencies they can sometimes be handled. It is much better to have stations in an emergency area start personal messages of reassurance coming out of the area to people with fixed residence where conditions for delivery are assured. Neither type of personals constitute *priority* traffic. Both types can be handled, but care should be taken to respect the wishes and directions of emergency area stations, and to handle such things as they can be fitted into periods when no traffic of importance appears to be in the offing, and then with due precautions. Tremendous personal public good will comes from handling such messages where they can be delivered, so amateurs should aspire to assist, but only after the official and priority traffic permits.

**Responsibility.** Vital information on local conditions should be released only when verified and signed by proper authority. Make your operation in connection with official agencies such as the Red Cross, civil and military authorities, and have messages signed by officials in as many cases as possible. An amateur is engaged in providing *communication*. He must not assume responsibility to any extent beyond his personal knowledge on penalty of being held liable for the information! Always confirm the authenticity of reports. If a matter is hearsay it should be reported as such or labelled as a rumor. All messages should have complete addresses and signatures.

**Avoiding Duplication.** At least two important agencies served recently are unhappy about the duplication of messages received by amateur channels. In one case an amateur after handling a message direct is reported to have sent it to a score of other stations for relay so that the agency was pestered many times with duplicate deliveries and demand for reply at times when it could ill afford time for explanations. It has also been intimated that a few voice stations imitated the little-recommended broadcasting station practice of sending messages broadcast with request for anyone to deliver. While *perhaps* a nice publicity stunt for a broadcaster, the idea is decidedly not to be dignified as a certain system of communication! Amateurs should number messages carefully, send them complete, make sure they are

# PRECISION PARTS

*Joe*

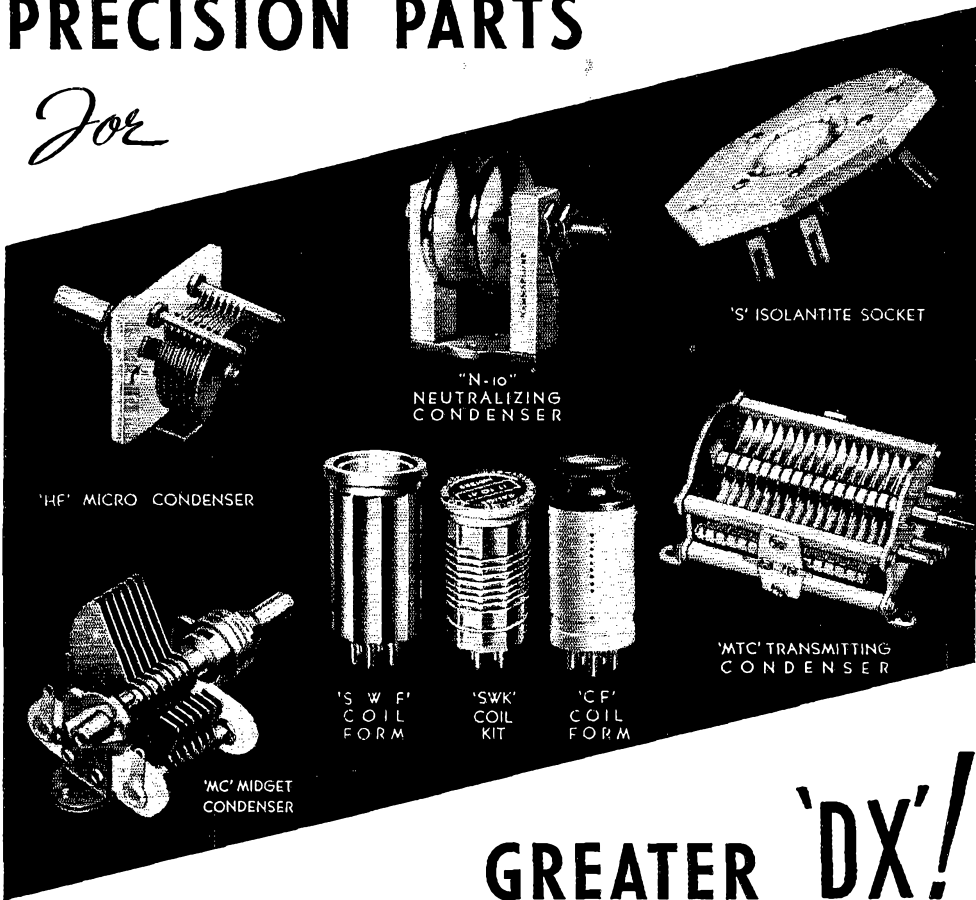

'HF' MICRO CONDENSER

"N-10"  
NEUTRALIZING  
CONDENSER

'S' ISOLANTITE SOCKET

'MTC' TRANSMITTING  
CONDENSER

'S W F'  
COIL  
FORM

'SWK'  
COIL  
KIT

'CF'  
COIL  
FORM

'MC' MIDGET  
CONDENSER

## GREATER 'DX'!

FOR over a quarter of a century, amateurs and professional operators have been using Hammarlund "precision products" in their receivers and transmitters. The unflinching service of these thoroughly engineered parts has made them the choice of experts. As an example, you will find "MC" midgets, and "HF" micro condensers built into nearly every amateur receiver and low-power exciter unit. These condensers are solidly constructed with heavy brass plates which are soldered into place and cadmium plated for highest possible efficiency. Isolantite insulation makes these condensers ideal for high and ultra-high frequency work.

"MTC" and "N-10" condensers, with their highly polished round edged plates are companion units designed for medium power

amplifiers requiring husky tank condensers and really effective neutralizing condensers.

For real "DX" incorporate these condensers, as well as Hammarlund coils, coil forms, R.F. chokes and sockets in your new rig. Be safe, go Hammarlund all the way! Send for complete 1938 catalog.

### MAIL THIS COUPON!

HAMMARLUND MFG. CO., INC.  
424-438 W. 33 St., N. Y. City

Q-4

Please send me new "38" catalog

Name.....

Address.....

City.....State.....



# HAMMARLUND

# BASSETT RADIO



A COMPLETE LINE OF  
ULTRA MODERN  
RADIOTELEPHONE EQUIPMENT

HF-1000W  
HF- 500W  
HF- 150W

AT A PRICE THE  
AMATEUR CAN AFFORD

*Designed  
by the makers of*

**BASSETT CONCENTRIC FEEDER**

BCF-64	1000 WATT LINE
BCF-64	500 WATT LINE
BCF-JR.-64	100 WATT LINE
BCF-34	1000 WATT LINE

FROM 5¢ TO 17¢ PER FOOT

**BASSETT RESEARCH CORP.**

211 SERVICE COURT  
SOUTH BEND, INDIANA, U. S. A.

accurate, and record handling and delivery data on forms if they wish to have their service accorded the highest degree of respect. Numbering messages at originating stations helps avoid duplicating any, aids identification. Authentic duplicates, when necessary to use two channels or repeat messages to assure action, should be marked **DUPLICATE** plainly and the word transmitted with the number so all handling stations and the addressee are properly informed.

**Fit Service to Needs.** Enthusiastic amateurs who happen to operate on a common frequency often like to dedicate their net to some emergency purposes. In one case we have noted such a net desiring to unite with other nets close to the same frequency, remotely located, all with the thought that this strengthened the potential emergency usefulness. For training purposes, the nets handling specific communications that give practice, build accuracy, serve the public etc. do excellent service. We doubt whether any net of stations located without regard to needs of a specific communication problem or agency can reach the fullest usefulness for emergency. Bigness or size, or extension into a large area can even impair service possibilities from a given net unless there is a definite reason assignable for the action. We have nothing against set-ups dedicated to emergency planning, are all for them. These remarks are made to suggest that each group and net should "hitch its wagon to a star." Aim to serve those who will have to be served in certain eventualities. Extend your net to cover the cities and points logical or desired by the agency served.

**All Amateur Groups Register Facilities.** The utilization of frequencies and modes for coverage for which they are best suited to make best use of all amateur facilities, and minimize interference by proper distribution of assignments to different nets and in the proper ratio to 'phone and telegraph should be planned. Since several agencies prefer telegraph service and telephone channels are sensitive to interference and overload quickly with 6 kc. per channel required, logic would indicate that more of the communications should be set up to operate using telegraph. Irrespective of the intrinsic merits of radiotelegraph and radiotelephone, organization of each mode and group for 100 per cent preparedness in each is important. Choice of stations and line up of nets will often depend on the stations volunteering and ready and whether stations in a sufficient number to cover points by a given mode or on a given band can be mobilized. See page 15 (9) and (10) of *Operating an Amateur Radio Station*. Local studies in every case determine exact emergency plans and skeleton line-ups of stations.

**Limiting Interference.** Stations in the area of an emergency will transmit to the outside as specifically as needs direct. General calls and CQs by remote stations may interfere, are worse than wasted, and so activity of such stations is practically prohibited, *except responsive to calls and direction* of the stations at vital emergency centers.

# ONLY \$19 CASH

brings you this Famous hallicrafter's custom-built

## SKY CHALLENGER II

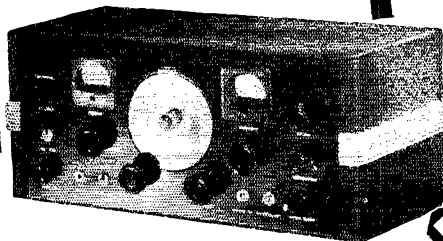

Balance payable in easy installments

**Only \$7.30 a month and 1 year to pay!**

Or you can pay \$9.66 a month for 9 months, or only SIX monthly payments of \$14.36 Each! This Hallicrafter's masterpiece features the new *Infinite Image Rejector*. Set comes complete with tubes, crystal and speaker mounted in cabinet to match. Think of it! You only send \$19.00 down payment with your order. **\$99.00**  
Mention your Call letters. CASH PRICE.....

## hallicrafter's SX-16 SUPER SKY RIDER

**\$23 DOWN** is all you need to buy this super-selective SX-16. You pay only \$9.02 a month for each, or 6 payments of \$17.74 per month. Hallicrafter's Super Sky Rider features the new *central tuning dial*, accurately calibrated for all 6 bands. No charts or graphs needed to read this dial. Automatic band pointer always indicates the frequency band on which you are tuning. Complete with tubes, crystal and 12" PM Dynamic speaker mounted in cabinet to match. CASH PRICE **\$123**

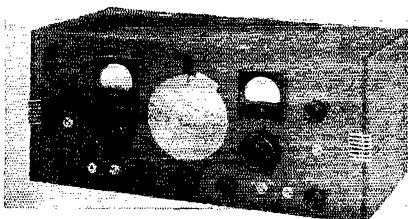

HAMS! GIVE YOUR CALL LETTERS WHEN YOU WRITE!

## hallicrafters SPECIAL MODEL SX-17 SUPER SKY RIDER

Pay only \$10.36 per month for 12 months . . . \$34.50 Down!

Features of the SX-17 are like the SX-16, including 3 to 550 meters coverage, 13 tubes, Wide Range Variable selectivity, 1000° Electrical Band Spread, 6 bands, "S" meter, and better than 1 microvolt average sensitivity on all bands. In addition, the SX-17 offers *TWO stages Pre-selection and a Built-in Noise Limiter*. Take a year to pay the Newark Way, or 6 monthly payments of \$20.26 or 9 payments at \$13.64. Complete with tubes, crystal and 12" PM Hallicrafter's Dynamic Speaker in modern \$149.50 design cabinet to match. CASH PRICE

**HAMS ATTENTION!**

Give Your Call Letters When You Write

**BUY NOW—PAY LATER**  
It's Easy to Pay the Newark Way!

Simply send your down payment with your order and mention your call letters. We ship within 40 days. Enjoy one of these fine receivers now, on small monthly payments you'll never miss. We can supply any amateur receiver you want . . . on our famous 6% Credit Plan. You can depend on Newark to have all new sets as released and announced by the manufacturers.

**TIME PAYMENTS ON PARTS!**  
See our last ad for Newark Specials

**EASY TERMS** on orders for your Parts and Tubes, of \$60.00 or more. Stock up now, pay later! Orders for Parts and Sets can be arranged under ONE easy payment contract. Be sure to mention your call letters.

**NEW 1938 CATALOG**. Fully illustrated. Hundreds of Bargains for Hams. You get exactly what you want and you pay less. Orders shipped within 4 HOURS after receipt. Complete stock on hand always. Write today tell us your call letters and **FREE!** ask for our big catalog.....

# NEWARK

Electric Company  
323 W. MADISON ST.  
Dept. Q CHICAGO, ILL.

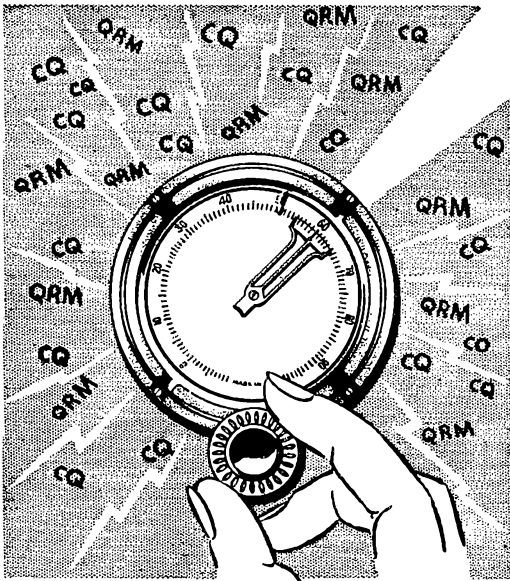

## Shift Your Signal into the Clear

**EASILY . . . QUICKLY . . . Without Leaving Operation Position**

WITH the Meissner Signal Shifter you can shift your frequency at will to find a clear channel for your signal by simply adjusting the single dial which controls the ganged oscillator and buffer circuits. Five sets of plug-in coils, three to a set, provide for operation on the 10, 20, 40, 80 and 160 meter bands. Accurate tracking and proper design hold the output constant over the entire range of each band.

Unbelievable frequency stability results. Many amateurs say this unit is superior to crystals. In one test, under varying conditions of humidity and temperature, the maximum variation of calibration was .008% or 300 cycles at the operating frequency of 4,000,000 cycles (75 meters). Frequency shift with load variation, tested during this period, was less than 500 cycles from full-load to no-load.

The Meissner "Signal Shifter" is not built by mass-production methods. Each unit is assembled, wired and adjusted in the laboratory to assure proper operation and complete frequency-stability. It is mounted in a black-crystal finished cabinet and requires 1-6F6, 1-6L6, and 1-80. Coils are furnished separately in sets of three for each band. The built-in power supply operates from 110 volt 60 cycle line. Also available without power supply; require 2.0 amps at 6.3 volts and 80 ma at 360 volts.

See it at your Parts Jobber at once, or write today for complete details. This is something new you will want to know about.

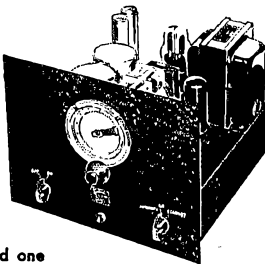

Complete with Power Supply and one set of coils for one band.

Less Tubes.....

Less Power Supply, \$31.95 Net

**\$39.95**  
NET

ANOTHER  
*Meissner*  
IDEA!

**MEISSNER MANUFACTURING CO.**

**151 Belmont Avenue**

**Mt. Carmel, Ill.**

New 1938 catalog ready soon . . . Reserve your copy now

82

Say You Saw It in QST — It Identifies You and Helps QST

**Correlation of Net Frequencies.** Insofar as possible networks in adjacent areas may well operate on adjacent, but different channels. Care should be used by all in a common locality that might become part of a large flood area, for example, not to duplicate frequencies exactly, as common interference is then unavoidable. Duplication of low frequencies in remote sections of the country is recommended. Net organization is the immediate problem of only Regional Coördinators, and the community Emergency Coördinators have the prime function of securing amateur registrations of operator and station facilities, perfecting amateur planning committees and completing studies of best theoretical disposition of these facilities in assumed emergencies, and the coördination of existing known net facilities and study of frequencies used.

A.R.R.L. Hq. maintains full lists of net frequencies utilized by A.R.R.S. and A.R.R.L., and to the extent possible, by the N.C.R. Our records are available for consultation of any amateur or group of amateurs, and to assist regional planning we are glad to note proposed net frequencies, and suggest time division, or known net frequencies of prior registration that might conflict. The effect of consultation avoids duplication and conflict, and permits duplication of frequencies in remote areas for most economical and efficient practical amateur service operation. We urge all interested parties to write us fully listing their proposed frequencies, so we can operate as a clearing house for information of mutual value.

**Restraint.** More listening, less transmitting, is the proper role of the many stations adjacent to emergency areas. Transmitting participation should, in general, be limited to that required by the stations working under actual emergency loads and handicaps.

**No Authority to Repeat Broadcasts. Policing.** Policing and observer stations recommended by A.R.R.L. or appointed by F.C.C. in communications emergencies may report any failure to observe the F.C.C.'s emergency orders or rules for disciplinary action. Addressed transmissions to amateurs (broadcasts) should include their source. They should be repeated exactly, if at all, and *may not be repeated* without specific authority for so doing. Rumors are started by expansion, or contraction, and subsequent repetition of broadcast dispatches. To delete qualifying words, expand, exaggerate, or alter meanings is criminal.

**Radiotelephone Policy.** Voice operators should be brief, talk as fast as good reception permits, should *not* comment casually about official texts, should number messages, and show originating point in standard form to insure accuracy and avoid duplications.

**Results Count.** The important thing is to get the message through. As long as there are wires they should carry the main load. Wires should be used as often as possible from secondary points, to reduce interference. Results, with as little noise and heroics as possible, are what count.

**Assignment of Nets to Agencies.** The spirit

# "Sprig is combig . . ."

and are we cold sufferers glad. No mittens and mufflers to keep track of and we can actually leave the house without galoshes. Then too — spring means we will want to be out-of-doors so we should make plans to take our transmitter with us. The "one and only" for that purpose

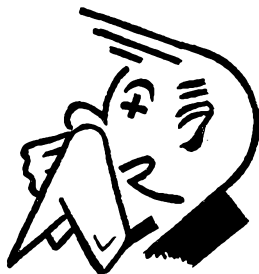

is the improved HARVEY UHX-10 (Portable) Transmitter featuring 1,500 to 60,000 kc. coverage. . . . AC or Battery operation. . . . New oscillator circuit. . . . Better excitation control. . . . Gray wrinkle finish. . . . Complete panel engraving. . . . Compact. . . . Light. . . . Rugged. Write to Harvey Radio Laboratories, Inc., 25 Thorndike Street, Cambridge, Mass., for complete information.

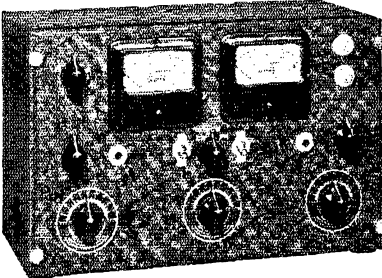

## UHX-10 TRANSMITTER

Radio Operator's  
Course  
Telegraphy—  
Telephony  
Aviation



Practical  
Experience  
Studio—  
Transmitter—  
Announcing

PORT ARTHUR COLLEGE has been teaching Radio for twenty-eight years, and during this time it has never been our policy to guarantee positions to prospective students, directly or indirectly. We believe it wisdom at this time, however, to go on record in our QST advertising to say that it is impossible for us to even come near to supplying the demand for Radio Operators received by our Employment Department. We do not mean by this that all students who enroll will automatically secure positions. The demand is for graduates — good men who deserve and are qualified to hold positions. The graduates of our Radio School, so far as we know or can learn, are employed 100%. It is possible for every student who enters the P. A. C. Radio School and completes the course in keeping with our standards to receive employment as a Radio Operator for our station

K P A C at the transmitter, in the control room, as trans-radio press operator, or announcer, and not only earn more money than he pays for the training but to also continue his training as a post-graduate student in advanced work and prepare himself to secure and hold operating positions in the upper bracket of broadcasting, marine work, announcing, or airways. Port Arthur College advertises primarily to Radio Amateurs and the training is too technical for the average student who has not selected Radio as his life's work. We know the opportunities for positions and advancement are unlimited for men who are interested in Radio and who plan to make this their career and are willing to make the sacrifice and effort necessary to master our training. P. A. C. maintains strict collegiate rank — only high school or college graduates are eligible for enrollment.

*If interested in details about Radio Course, write for bulletin R*

**PORT ARTHUR COLLEGE ■ PORT ARTHUR (World-known port) TEXAS**

**SPECIAL TO AMATEURS**  
Piezo-Electric Crystals — \$2.50 EACH POSTPAID  
Until supply is exhausted . . . we offer 80 meter band crystals unmounted; accurate calibration, excellent oscillators. Limited quantity.

**SCIENTIFIC RADIO SERVICE**  
"The Crystal Specialists Since 1925." University Park, Hyattsville, Md.

**WORLD TIME at a Glance!**



No guesswork with the GORDON WORLD DX CLOCK. Instantly tells GMT or local time of stations you contact. Available for 110 or 220 volts; 25, 40, 50 and 60 cycles, 24 hr., colored dials. Self-starting Waltham movement. Can be mounted flush in a panel. See your jobber today!

**GORDON SPECIALTIES CO. CHICAGO, ILLINOIS**  
1104 S. Wabash Ave.



**SERIES 840L**  
**A.C.—D.C. VOLT—OHM—**  
**DECIBEL—MILLIAMMETER**  
 including a  
**2500 VOLT A.C. and D.C. RANGE**  
**and a 1000 M.A. RANGE**

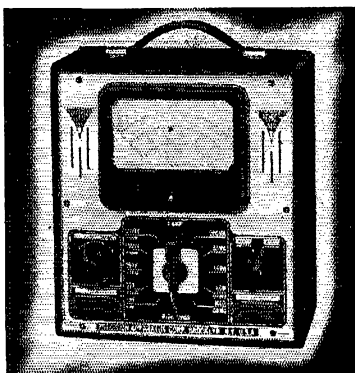

**SPECIFICATIONS**

- ★ 5 A.C.—D.C. Voltage Ranges from 0 to 2500 volts at 1000 ohms per volt.
- ★ 4 D.C. Current Ranges from 0 to 1 amp.
- ★ 5 Output Ranges.
- ★ 3 Resistance Ranges from 0 to 10 megohms. (provision for self-contained batteries).
- ★ 5 Decibel Ranges from —10 to plus 63DB.
- ★ Large  $4\frac{1}{4}$ " D'Arsonval meter, 2% accuracy.
- ★ Wire wound shunts 1% accuracy.
- ★ Matched multipliers 1% accuracy.
- ★ Guaranteed close accuracy on all ranges.

Net price to amateurs **\$19.95** Less batteries and test leads

**SERIES 840P** incorporates same specifications as the 840L but is housed in an attractive black leatherette covered portable case with removable cover. Size 9 x 10 x 6. Net to amateurs. **\$21.95**

**AVAILABLE AT LEADING DISTRIBUTORS**  
 Following is a partial list

- Akron, O. — Summit Radio Supply Co.
- Allentown, Pa. — Wholesale Radio Service Co., Inc.
- Baltimore, Md. — Wholesale Radio Parts Co.
- Boston, Mass. — Radio Shack, Inc.
- Chicago, Ill. — Chicago Radio Apparatus Co.
- Dallas, Texas — Southwest Radio Supply
- Denver, Colo. — Inter-State Radio & Supply Co.
- Jacksonville, Fla. — Radio Parts Co.
- Knoxville, Tenn. — Tele Radio Supply Co.
- Los Angeles, Cal. — Kierulff & Co.
- New York, N. Y. — Sun Radio Co.
- Norfolk, Va. — Radio Supply Co.
- Philadelphia, Pa. — Century Radio Co.
- Pittsburgh, Pa. — Tydings Co.
- San Francisco, Cal. — Wholesale Radio & Electric Supply Co.
- St. Louis, Mo. — Walter Ashe Radio Co.
- Texarkana, Ark. — Mims Radio Co.

**PRECISION**  
**APPARATUS CORPORATION**  
 821 EAST NEW YORK AVE., BROOKLYN, N. Y.  
 EXPORT DIVISION—458 BROADWAY, NEW YORK

of getting the job done by joint efforts, the willingness to subjugate self to the plan in the community interest, during the emergency period, is what counts. In actual emergency, and plans for emergency, responsible amateur leaders in all groups put aside petty rivalry in favor of working together. A.R.R.L., A.A.R.S. and N.C.R. groups all function with amateur licenses, amateur frequencies, amateur status, excepting for special government frequencies for some N.C.R.—A.A.R.S. affiliated stations. In using amateur frequencies facilities should be pooled for best results while minimizing interference. If the single "best" net cannot be utilized and extended by pooling operator reserves, we suggest careful assignment or division of nets between (a) different agencies served or (b) between certain groups of cities or points covered for a specific purpose.

The assignment of particular net facilities to special contact jobs to cover points beyond the capabilities of a single net, and traffic distribution from a single local routing agency to cities for which a particular net has responsibility must be agreed upon between responsible leaders. In large emergencies the communication picture and needs change from operating shift to operating shift. Exchange of schedule and routing data between all communication leaders or through a coordinating center at least twice per day is essential. In actual emergency the basic principle should be that one joint net, or numerically smaller facilities added to the support of the more strongly organized groups in a joint plan, should be created. Detached individual station schedules to particular points for particular agencies may be permissible with intermittent operation to cut interference, but all should be catalogued and part of the plan known to all official leaders, and particularly to the American Red Cross local communications desk or chairman.

**Message Centers.** Establishment of local message routing and distributing agencies or other system must be organized by amateurs if not properly arranged by local authority. This, with proper filing and numbering of traffic should prevent duplication of messages by several channels with overload, interference, confusion and consequent delays and irritations.

**In General.** Ask yourself these questions: Can you, off hand, put a message into proper form, complete with preamble, number, call, place of origin etc. . . the way officials and agencies such as engineers and Red Cross like to have their traffic? Have you equipment that will operate emergency-powered? If so, how long would it take to get it going after a power failure? Are you all lined up direct or via a Coördinator with local officials? Do you know what points the mayor, the Red Cross office, the military units, the local weather forecasting office, the public utilities . . . would need to handle vital communications with should their circuits become overloaded or fail? What would be the volume of traffic with each of these cities? Have plans been made to establish amateur circuits to such points and test them periodically? Who should take

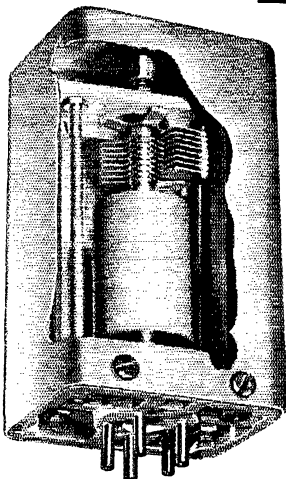

## SHIELDED PLUG-IN COILS

WITH the PB type plug-in base, it is extremely easy to build high performance gear — whether it be for experimental receivers, bread board layouts, monitors, exciters or what have you.

The low-loss R-39 base, with prongs moulded in to fit standard sockets, has mounting holes for our type UM Air Dielectric Condensers and our R-39 coil forms. The illustration shows the effective assembly that is possible with these units. This PB-10 base fits our Fixed Tuned Exciter Tanks, thus making them available for plug-in mounting. Attachment to the shield can is easily made by four screws.

The generous shield and the low-loss base offers you the best assurance of satisfactory operation of whatever gear you may mount inside.

**NATIONAL COMPANY, INC.**  
MALDEN, MASS.

Plug-in Base and Shield, Type PB-10 (either 5 or 6 prong).  
Net price . . . . . \$ .45  
Plug-in Base (only 5 or 6 prong) Type PB-10A. Net price . . . . . 24  
Fixed Tuned Exciter Tank, with PB-10 Base.  
Type FXTB (either 5 or 6 prong).  
Net price . . . . . 2.94  
Midget Coil Forms (R-39).  
Type XR-2 (1" dia. x 1 1/4" long).  
Net price . . . . . 21  
Type XR-3 (9/16" dia. x 3/4" long).  
Net price . . . . . 18  
Ultra Midget Condenser, Type UM. Net prices from . . . \$ .75 to \$ 1.10

### IN CHOOSING A SCHOOL

Be sure and investigate the many advantages offered by our 36 weeks comprehensive course.

#### EASTERN RADIO INSTITUTE

899 BOYLSTON STREET BOSTON, MASS.

## SAVE YOUR TUBES

★ with OHMITE  
Vitreous-Enameled  
RHEOSTATS

Every tube manufacturer will tell you that tube life will be unnecessarily shortened if you exceed the rated voltage. On the other hand, running tube filaments below rating seriously impairs efficiency and lowers output.

There is only one right voltage for transmitter tube filaments — the rated voltage. And it's easy to "put them on the head" with Ohmite Vitreous-Enameled Rheostats. Models and ratings for all tubes and transmitters.

Ask your Jobber or  
Write for Catalog 16

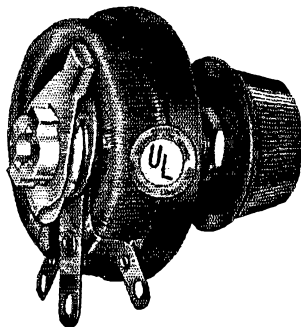

OHMITE MANUFACTURING COMPANY  
4831 West Flournoy Street, Chicago U. S. A.

**OHMITE**

RHEOSTATS RESISTORS TAP SWITCHES

## FASTEST WAY TO LEARN CODE

Easy, Fascinating — LEARN BY EAR to be a GOOD OP.



The New All Electric Master Telex Code Teaching Machine is exactly what thousands are looking for. No experience needed. Ideal for beginners — steps up WPM

for ALL Ops. There is no guesswork with Master Telex, because it records your sending in visible dots and dashes. You SEE and HEAR exactly how you are making your signals. You learn code the way you'll be using it — by SOUND. Complete course included at no extra charge. Used by many schools for teaching code. Low cost, easy terms. MONEY BACK GUARANTEE. Send now for booklet Q-4, no obligation. Post card will do.

The "Ham" Special Standard Telex — a highly efficient code teacher using heavy specially prepared waxed paper tape, having two rows of perforations. Write for Free folder Q-T-4

We are the originators of this type instrument

**TELEPLEX CO.** 72-76 CORTLANDT ST.  
NEW YORK, N. Y.



# LEEDS Does the Job Right

Whether you buy over the counter or send your order in from the farthest point on the globe you are assured of the same quick and efficient service that has made LEEDS' name a "Buy-word" throughout Hamdom.

## LEEDS' HAM SPECIALS

### TRANSFORMERS— Completely Shielded

1500-1000-1250 each side C.T. at 300 MA. Net.....	\$6.80
2500-1500-1000 each side C.T. at 300 MA. Net.....	11.00
1500-1250-1000 each side C.T. at 500 MA. Net.....	11.00
1000-750 Volts each side C.T. at 300 MA. Net.....	5.25

### CONDENSERS—Oil-Impregnated: Non-Inductive

2 Mfd. 1000 V. Net....	\$1.50	4 Mfd. 2000 V. Net....	\$4.65
4 Mfd. 1000 V. Net....	2.00	1 Mfd. 3000 V. Net....	2.50
2 Mfd. 2000 V. Net....	2.45	2 Mfd. 3000 V. Net....	4.95

*Unconditionally Guaranteed*

### CHOKES — Completely Shielded

20 H. 200 MA 115 ohm.....	\$1.50	5/25 H. 200 MA 115 ohm	
20 H. 300 MA 95 ohm.....	2.90	5/25 H. 300 MA 95 ohm	
20 H. 400 MA 85 ohm.....	3.50	5/25 H. 400 MA 85 ohm	
20 H. 550 MA 55 ohm.....	5.00	5/25 H. 550 MA 55 ohm	

NATIONAL NC-80X and NC-81X in stock. Complete with Tubes, Crystal and Speaker..... \$99.00

### General Radio Variacs for Voltage Control

Type 200 CU; 850 VA; 0-135 Volts; 7½ Amps.....	\$14.50
Type 100K; 2 KVA; 0-115 Volts; 17½ Amps.....	40.00
Type 100L; 2 KVA; 0-230 Volts; 9 Amps.....	40.00

*A descriptive Bulletin will be sent upon request*

Don't forget that LEEDS LD-5 Crystals are cut to your exact specified frequency in the 40- 80- and 160-meter band at NO EXTRA CHARGE. Mounted in metal holder to fit standard 5 prong socket and unconditionally guaranteed. Net..... **\$3.50**

### The New GENERAL RADIO OCTAL SOCKET

can be mounted above board or sub-base. Each contact separated by a thick bakelite wall. By far the finest octal socket.

Type 688, each net 40c; 10 for \$2.75

### General Radio Coil Forms

Notched to provide permanent winding space for wire up to No. 10 B & S; forms 4¾" long.

Type 677-U, 2¼" diameter.... 50c

Type 677-Y, 3¼" diameter.... 75c

A Complete Stock of KENYON TRANSFORMERS on hand. A catalog will be sent upon request

### Raytheon Tubes

RK-11.....	\$2.50
RK-12.....	2.50
RK-51.....	8.00
RK-52.....	8.00
RK-49.....	2.10

### R. C. A. Tubes

Type 809.....	\$2.50
Type 866.....	1.50
Type 913.....	4.00
Type 954.....	5.00
Type 955.....	3.00

### OVERSEAS AMATEURS, ATTENTION!

There is a satisfied Leeds customer near you, regardless of your QRA. Leeds export service is being constantly used by amateurs and commercials in over 80 countries. One shipment will convince you.

*Our technical department welcomes your inquiry*



**LEADS THE FIELD**

45 Vesey Street  
New York City

Tel. COlrland 7-2612

Cable Address: "RADLEEDS"

World-Wide Service to Amateurs

responsibility for reporting flood heights, number of dead or injured, general conditions? Why should you *not* do this, yourself? Are you experienced in writing messages legibly — in avoiding errors over telephone circuits — giving others the proper impression of respect for the amateur service by your efficiency and dependability and practise in regular amateur work? Have you had a meeting with other local amateurs to discuss which stations would be the best ones (in different frequency-mode groups) to man in time of emergency? Will you and others agree to refrain from operating stations that might cause unnecessary interference and use up operator reserve strength that should be available to man better stations in 8-hour shifts for 15- to 24-hour periods? What operators would be best fitted to assist in handling telephone and messenger circuits? What local links on 28 Mc. or 56 Mc. could be offered if all local telephone service folded up? What local agencies would need this and where would the stations locate? What A.A.R.S./NCR frequencies are used in your district? These questions will give you the idea of the problems to be worked out. How many questions can you conscientiously answer? This article is to suggest local meetings to discuss these things. Ask your Emergency Coördinator or S.C.M. for a form to register your equipment in the Emergency Corps today!

### The ACE SELF-SUPPORTING VERTICAL RADIATOR

- Low angle radiation for extreme DX
  - Heavy ground wave for local contacts
  - Reduces skip and fading
  - Non-directional for world-wide coverage
- Substantially constructed of heavy zinc-coated tubing finished in metallic lacquer. Requires NO guy wires! Self-supporting in winds up to 115 MPH. Sturdy 65,000 volt glazed porcelain base insulator.
- Shipped complete with all fittings and hardware and detailed erection and feeder blue-prints.
- 16 feet high — for 5-10-20 bands..... \$13.50
- 33 feet high — for 10-20-40 bands..... \$19.50
- (Also works well on 80 and can be loaded for 160)
- Base insulator only for those who wish to "build their own," with full constructional blue-print, \$9.50.
- FOB SEATTLE, WASH. At your dealers or order direct.

Remit with order or C.O.D. on receipt of \$5.00 deposit

W7AXS ACE PRODUCTS CO. W7ASL  
809A Terminal Sales Building, Seattle, Wash., U. S. A.

### NOW! A Perfected

## AUTOMATIC SENDER

Let the Automatic Sender raise your stations. Repeats calls or messages indefinitely. Sends 2 to 70 words a minute. Entirely automatic. Built-in tape perforator. Complete with 4 rolls of tape and full instructions. No extra equipment needed. Fully Guaranteed. **\$12.50**

\$18.50 West of Denver Postpaid in U.S.A.

### A New High-Speed RELAY

Faster — More Compact — Quieter  
Moisture Proof — More Applications

Plug-in base fits UX socket. Only 1 inch wide, 3 inches tall. Ideal for use with vacuum tube. Follows perfectly at speeds far above professional "bug." Perfect as keying relay. Available in 6, 25, 50, 100, 150 volts. **\$4.50 to \$6**

Postpaid in U.S.A.

GARDINER-LEVERING CO. Haddon Heights New Jersey, U. S. A.

*Never Before!*

# FREQUENCY CONTROL with QUARTZ CRYSTALS

*a storehouse of valuable information available for the first time . . .*



You'll want a copy of this authoritative booklet that tells the "why's and wherefore's" of quartz crystal frequency control. Theory, application and operating notes are effectively presented in a simple straightforward manner. Complete, yet not too technical, this new booklet is invaluable to engineers, amateurs and experimenters.

You need FREQUENCY CONTROL WITH QUARTZ CRYSTALS—you've been waiting for it a long time. Now, a copy is yours for the small charge of 10¢ (in Canada 15¢) —just a fraction of the actual cost of publication. It is obtainable only through your Bliley Distributor. Since the supply is limited and the demand will be large, get your copy as quickly as possible. Bliley Electric Company, Erie, Pa.

*Some of the chapters:*

- Frequency Standards . . . Crystal Activity . . . The Multivibrator
- Effects of Temperature . . . General Operating Notes
- Standard and Special Crystal Oscillator Circuits

*10¢ at your Bliley dealer*

## RADIO COURSES

**RADIO OPERATING:** Prepare for Gov't License Exam. • **RADIO SERVICING:** including Short Wave • **AMATEUR CODE** • **ELECTRONICS** • **TELEVISION** •

Day and Evening classes—Booklet upon request

**NEW YORK YMCA SCHOOLS**

4 West 63rd Street, New York City

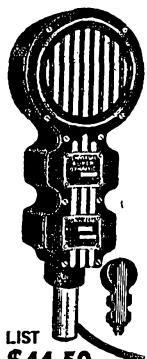

## New UNIVERSAL DYNAMIC MICROPHONE

100% SATISFACTION OR 100% REFUND

Self-energizing. Not affected by heat or climate. An amazing sound development. Impedances 33 or 50 or 200 ohms; also high impedance direct to grid. Frequency response 40-8,000 CPS. Output —58db.

LIST \$44.50 with 25 ft. cable

Microphone Division

**UNIVERSAL MICROPHONE CO., LTD.**

424 Warren Lane

Inglewood, Calif., U. S. A.

Oil-filled capacitors for steady, cool operation.

Paper, mica and electrolytic units. All types, sizes.

Also a line of essential fixed and adjustable resistors.

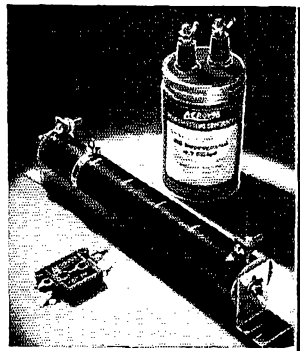

# Sturdy!

AEROVOX condensers and resistors have an enviable reputation for sturdiness. They incorporate extra safety factors. That's why they are chosen by builders of "rigs" for steady going.

Ask . . . your jobber or us for new transmitting component catalog.



## Station Activities

### NEW ENGLAND DIVISION

**C**ONNECTICUT—SCM, Frederick Ells, Jr., W1CTI—HSX and UE made the B.P.L. Take a look at HSX's total! JXP handles A.A.R.S. reports for this Section. AMQ gave K5AA two-hour service on delivery and answer to New Haven. CCF has daily schedule to Phila. and Canal Zone plus feeder to T.L. "E." BDI spent three days in Washington conferring with Red Cross and F.C.C. on emergency communication plans. HIM went to Florida on a vacation. The new station equipment for AW is nearly finished. EFW got a third-class 'phone ticket to use at Meriden Airport in aviation service. QP was in Pittsburgh during the Conn. QSO Party and says sorry to miss it. DWP has a new crystal for 3705 kc. BGIJ has a Harvey 80T. CTB uses two 6L6's in crystal osc. 9RLF is doing graduate work in Electrical Engineering at Yale University. TD got on with osc. and buffer stages for O.R.S. Party. EAO has been appointed Emergency Coordinator for Hartford. JHM runs 500 watts to a pair of T55's on 28 and 14 Mc., 250 watts on 1.75 Mc. GB has 250 watts on '52 final on 1.75-Mc. 'phone. They have code classes and instruction on Class A and B license data each Tuesday. CBA is rebuilding power supply for c.w. rig. CTB and KKS are new members of the Nutmeg Net. HYF, E.C. for Norwalk, contacts Norwalk A.E.C. members on the air on the 10th, 20th and 30th of each month, at the same time testing emergency equipment and training operators in procedure.

Traffic: W1HSX 826 UE 548 JXP 476 AMQ 400 AXB 337 JMY 325 (WLGQ 53) JYE 237 AJB 218 (WLGQ 152) CCF 218 KV 166 (WGLI 24) DMP 142 CTI 121 BDI 85 GMR-BS 83 KQY 82 JQD 80 JYJ 73 KAY 67 KFN 34 BHM 32 KKS 25 JTD 23 AW-EFW 22 HYF 15 QP 9 GKM 8 APW 7 DWP-BGJ-CTB 4 TS 4 ITI 73 KXM 21 JBJ 4 JFN 6 FAJ 38.

**MAINE**—SCM, Winfield A. Ramsdell, W1FBJ—R.M.'s: 1GOJ, 1INW, 1ISH, 1IST, 1HSD. C.R.N.: 1GOJ, Emergency Coordinators: TE, Portland Area; JYU, Bar Harbor. New O.R.S.: EUL, KEZ, KOH, O.P.S.: DEG, JYU, O.B.S.: INW, E.C.: JYU. There is room for several more Emergency Coordinators in the Section. This department should be built up and kept in an active condition so that we won't be found lacking in any case that may come up. GVS joined the A.A.R.S. IJF has been covering the Augusta territory for the P.T.N. IIE schedules GOJ twice weekly. KCO is new member of the P.T.N. JJN is working in Portland. ATS has held schedule with JXU, Quincy, Mass., for over two years. AUC returned from Florida. DOZ has been appointed temporary pres. of the N.E.D.R.A. FWA is operating on 3.5 Mc. using a 6L6 crystal, 211 final with 100 watts input. DAS has an 807 final on 14 Mc. BGU moved to Farmington and is operating on 3.9-Mc. 'phone. EWN has new SX-17 Skyriider receiver. LMP has new rig, putting 400 watts into the final. KMM reports for the first time. Another Maine QSO Party will be held some time in May. There will be some change in the method of scoring to make it more interesting. Exact details and the date will be announced in a later issue. Let's all talk it up and get ready for a much larger and better party than the last one:

Traffic: W1GOJ 631 ISH 263 INW 238 KOU 128 CFO 185 IST 115 FBJ 49 IBR 31 GVS 30 HSE 28 KMM 29 IIE 26 JUV 10 FIV 8 DYH 1 EFR 19 EWN 75.

**EASTERN MASSACHUSETTS**—SCM, Sam Gross, W1IWC—We have four B.P.L.'s this month: IHI, AKS, JCK and HRE. HRE applied for O.R.S. BEF has new vertical antenna for 28 Mc. IYU proves traffic can be handled on 1.75-Mc. 'phone. DMF has new rig completed. KCT missed B.P.L. on deliveries by a thin whisker. JYJ handled traffic for New Bedford Hobby Show. JSM has 6L6G-807 going on 3.5 Mc. KPW applied for O.P.S. KQA is back with new rig. KKO is trying new vertical "J" antenna for DX. IAV is working on new rig. WV has 92 countries toward Century Club. ALB is trying beam antenna on 28 Mc. BSM's new rig: 59-RK39-pair HY51B's on 28, 14 and 7 Mc. INO has rig working on 14, 7 and 3.5 Mc. JQZ has i.c.w. for N.C.R. 56-Mc. drills. FJN is studying for first-class 'phone ticket. The S.S.A.R.C. had an auction last month. The Merrimack Valley Emergency Net has discontinued Tuesday night drill, due to QRM. Schedules are now kept daily, but at different times. Congratulations this month to BQR; he is the proud poppa of a brand-new Jr. op. KB has new receiver under construction. KOI is new ham in Lawrence. EPZ is back on 28-Mc. 'phone with a couple of 808's. The M.V.A.R.C. is sending code practice a half hour

before each club meeting. Anyone interested is invited to get in touch with JJP. As a further incentive, S.W.L. members who get their ham ticket will be presented with the latest A.R.R.L. Handbook as a gift from the club. Do you know that you may report your activities to your S.C.M. whether you are a League member or not? Others are just as interested in what you are doing as you are in their activities. You don't need to handle traffic to report. Let's hear from you each month sometime between the 16th and 20th, please.

Traffic: W1IHI 570 AKS 549 IWC 481 JCK 458 (WLGV 53) HRE 278 EPE 249 BEF 215 IYU 205 DMF 174 HWE 165 KCT 156 JYJ 155 KMY 145 QA 132 EMG 130 JFS 114 AGX 102 KH-IUQ 98 KTE 95 KMQ 93 AAR 91 JSM 81 ZK 59 PI 57 JBI 56 KPW 51 JNF 50 (WLGV 64) JLQ 46 HXE 45 HFJ 33 ASI 32 CCL 23 EGR 12 COL 9 IIM 8 KQA 4 HKY 2.

**WESTERN MASSACHUSETTS**—SCM, William J. Barrett, W1JAH—IOT continues the B.P.L. habit. IOR is now WLGJ in A.A.R.S. Chet reports a very successful open house by the Worcester Radio Ass'n. Among those present were JOP, KWS, DYI, CFQ, DIE, IOT, LDK, GFS, KWG, DJU, ZJ, JFA, EDO and a dozen S.W.L.'s. A talk on rotary beams was followed by movies and refreshments. Nice going, fellows. How about some news of the activities of the other clubs? BIV reports Chair City Radio Club running Club DX contest, with separate contests and prizes for licensed and unlicensed members—the latter being a receiving test. EOB keeps A.A.R.S. schedules. DUZ has nice score for traffic on 1.75-Mc. 'phone net. BNL is building transmitter-receiver for 56-Mc. mobile. KOJ and KJS not Class A tickets. BKG is doing lots of building these days. AZW is pounding brass. BVR is new O.P.S. AJ moved to new QTH. Hams wishing to put traffic into Springfield will find FPP on 3840 kc. KJK is moving to Wisconsin. IEI reports great interest in DX contest among his gang. HJR/9 has new Sky Challenger to go with his suitcase portable. COI has new 400-watt rig and rhombic on 14 Mc. KJS reports from Buffalo. AJD reports from Nashua. Don't forget, fellows, your cards are welcome, traffic or no traffic.

Traffic: W1HOT 626 (WLGN 188) IOR 370 (WLGJ 13) BIV 182 EOB 162 DUZ 108 BVR 106 (WLG 180) HSK 76 HKG 68 BNL 21 JAH 12 FPP 8 AJ 5 I/W 1.

**NEW HAMPSHIRE**—SCM, Carl B. Evans, W1BFR—In the case of any flood emergencies arising this spring, all active stations are requested to listen on and tune as close as possible to the 3840-kc. NHN Net frequency or the 3735-kc. A.A.R.S. Net frequency and cooperate to give us as much coverage over the state as possible. On 3840 kc. listen for the control stations and try to contact them so as to advise them that you are on, and arrange regular schedules, if possible, during the duration of the emergency. HFT is master control on 3840 kc. and GMM, TA and AEF alternate controls, in that order. KLV in Littleton is now on the NHN on 3840. CME and GDE in Manchester have crystals for that frequency and are with us occasionally. KKL has been doing some interesting duplex work on 29-Mc. 'phone, having as many as five or six stations hooked up on a duplex, retransmission arrangement so that all stations could be copied by all the others. CMB is using a new RME receiver. KMH is increasing power. ITF joined the Farmers' Net on 1840 kc. EAL is tying in the 56-Mc. A.A.R.S. Net with the 3735-kc. Net. HJM is back from Ohio and on 3560 kc. JNO is new O.P.S. FJF has a pair of new RK-11's in final. GMD is new O.P.S. in Berlin. FCI is operating 29-Mc. 'phone. KEX has a new Bliley 28-Mc. crystal and is going to use it on 28 and 56 Mc. AXL is now O.B.S. on 1840 kc.

Traffic: W1IPI 657 TA 350 FFL 306 (WLBG 79) GMM 235 FCI 232 KIN 206 BFT 198 IDY 148 HGV 100 KMH 89 AXL 73 JDP 64 CEA 60 ANS 59 AEF 55 CMB 36 GHT 21 HTO 20 JGI 19 EAL 18 ICS 15 AP 11 GDE-ITF 8.

**RHODE ISLAND**—SCM, Clayton C. Gordon, W1HRC—AQ had annual election, results as follows: Pres., AOP; Vice-Pres., CPV; Treas., George Hunter; Sec'y, BOY; Social Committee, AKA; Membership Committee, FXC. Feb. 18th saw the second annual bowling meet between the P.R.A. and AQ. AQ's first team consisting of HXV, Hunter, AKA, DYB and CPV took 3 points to P.R.A.'s 1 point with ISI, IQF, HRC, FAH and GTN making up P.R.A.'s first team. Total pin fall 1280 to 1162. The second teams were AQ: LAB, AOP, AVH and 2CB; P.R.A.: KYK, Bonneau, KCS and KTH. Total pin fall 989 to 789 in favor of AQ which took all 4 points. High single—IQF with 112. IPU is

back with 6L6 and T-55. ETD needs only Montana, Utah and Nevada for W.A.S., and Africa and Asia for W.A.C. GTN attended N.E. Radio Club Council meeting in Boston, Feb. 12th, representing the P.R.A. HRC and JXA have acquired motor-generator set and rebuilt for independent power source for emergency use of P.R.A. JAR, JDX, EZW, DAH and ETD are regulars on 28 Mc. Almost all of the A.A.R.S. gang now hold ratings as "Privates" or better. JNO has left Newport and taken job with B.C.L. station in Laconia, N. H. JEZ is working hard as E.C. in Providence. CH, who uses '01-A's and storage batteries in receiver for hooking DX, has baby daughter. EX is on 14-Mc. 'phone. AOF completed super-super-special-temperature-controlled c.c. oscillator.

Traffic: W1INU 348 IMY 308 GTN 267 JEG 212 KWA 169 JUE 137 CPV 127 INT 122 KTH 79 JXQ 63 QR 57 KOG 45 HRC 31 HCW 28 IQF 27 IPU 18.

VERMONT—SCM, Alvin H. Battison, W1GNF—BNS, former Vt. ace traffic man, has returned; look at the total FSV leads again. KJG with his 7 watts made a nice total also. KOO received visits from BJP, ITE and KTB. JLF is running the 1.9-Mc. Net in DPO's absence. KXL has his 100-watt set on 3.5 Mc. JVS mounted his emergency-power generator on his automobile engine. JXS needs Africa for W.A.C. KUV joined the A.A.R.S. The amateurs of Rutland and vicinity announce the forming of "The Green Mountain Radio Club." IDM is putting an '03A on 1.9-Mc. 'phone. JVS is doing the structural work. EHB is building a 28-Mc. 'phone. BD is rebuilding his high-power transmitter. HFV is operating on 14-Mc. c.w. FPS schedules KOO. KJG has been appointed Emergency Coordinator for Washington, Lamoille, and Orleans Counties; JLF for Caledonia, Essex, and Orange Counties.

Traffic: W1FSV 287 BNS 201 KJG 78 GNF 5 AHN 4 DPO-KOO 2.

#### HUDSON DIVISION

**EASTERN NEW YORK**—SCM, Robert Haight, W2IU—E. N. Y. congratulates HYC on FB total! HYC is building  $\frac{1}{2}$ -kw. rig. JWT made B.P.L. on deliveries. LU renewed membership with A.R.R.L. for eleventh consecutive year. KFB used 807 crystal osc. in A.A.R.S. drills. BLU was appointed E.C. IKV is also new Emergency Coordinator. ITK says IUR has new modulator. HCM reports GJK moved next block to him. CJS increased voltage on HF100 from 700 to 1000. ACB is getting net tuned up for emergency work. ALP is running 800 watts input. JG's operating is confined to 3.9-Mc. 'phone and 3.5-Mc. c.w. HNH operates on high end of 3.5 and 14-Mc. bands. LBB is new ham in Albany. JRX and CYW are on 56 Mc. with crystal. KXF, new ham in Port Jervis, works all U. S. dists. with 45-watt transmitter on 3.5 Mc. Note, traffic men: 9YWE, Jack C. Andrews, 206 West John St., Knox, Ind., wants good traffic schedule with N. Y. State, 3.5 Mc. How, OM's?

Traffic: W2IHYC 1010 JWT 337 LU 160 KFB 11 BLU 7 IKV 6 ITK 5 HCM 2 CJS 1.

**NEW YORK CITY AND LONG ISLAND**—SCM, Ed. L. Baunach, W2AZV—DVU, GSC, and JZX are now O.P.S. A Jr. op arrived at PF's, February 8th. FF did some FB work with VORX. After June IYR will be on from his new QTH in N. Y. C. IHT gets on 1.75-Mc. with 30 watts input. JBJ is going to Cornell U. and will soon be an eight; he is looking for N. Y. C. schedules on 7298 kc. EC is looking for stations in Brooklyn on 3.5 Mc. for schedules for A-P Net. AWX sends first report since 1927. LAP is a new station at 105 W. 168th St., N. Y. C. SM5UU is now FFV and would like to contact some of his old friends on 14,015 and 28,288 kc. HAY is out for O.R.S. HGO is busy arranging schedules on 7096 kc. Portable 1AA in Brooklyn has a Class A ticket. TC is now located in Rockville Centre. HXT is settling down to ham radio. HMJ joined the A.A.R.S. KWB is operating on 7159 kc. using a 6L6 tritet. IJU received W.A.C. JUW is operating on 7178 kc. with a single 6L6 trying for W.A.S. KXJ has worked all districts on 1.75-Mc. 'phone since Jan. 1st. CHK received a R5 89 from Capetown, S. A., on 1417 kc. ESO finds working ZL's easy on 14 Mc. KVV is operating on 56 Mc. while rebuilding his 7-14-Mc. rig. HBO and HVD are trying 1.75 Mc. KIF is using rig described by 8DPY in QST. BGO is on 3510 kc. at 3:00 p.m. daily. IOP finished rig with P.P. 100TH final. HNJ works out FB with low power on 7 Mc. ELK rearranged his FBXA with excellent results. IXQ built new power supply. HRB is building new rig. The next and last Hudson Division A.R.R.L. meeting will be held April 29th at the Army building. Watch for the Hudson

Division Convention to be held in June. AZV is trying 805's. 2SV, The Sunrise Radio Club, located at 196-08 Hillside Ave., Hollis, L. I., invites all members or prospective members of the amateur fraternity to visit its club house on Friday evenings and meet some of the lads you have talked to but never met. Come out and chew the fat with the gang and get some of the wrinkles ironed out of that new rig. Something special on the 1st Friday in each month. Make it a date.

Traffic: W2JHB 572 BGO 266 PF 175 LIU 145 IBT 110 KI 66 DQW 65 JZX 60 EC 55 AZV 42 GDF 34 HAK 30 FF 26 KCV 17 IHT 14 HNJ 13 CHK 12 AWX-EXR 10 HNJ-HAY 9 KVA 7 BYL-RIF-JDF-IOP-EYS 6 AA-CIT-ADW 5 HBO-HGO-ESO-DLR 4 HXT 3 FIP-ELK-LR-HYL 2 FLD 1 OQ 274 DXO 216 DBQ 150 (WLNB 251).

#### NORTHERN NEW JERSEY SECTION QSO PARTY

Attention of amateurs in the Northern New Jersey Section is directed to a QSO Party to be held on the evening of April 14th, to promote better acquaintance among the operators of this Section. The rules will be as follows:

**Date:** The contest begins at 6 p.m., Thursday, April 14th, and ends at 1 a.m., Friday, April 15th, E.S.T.

**Qualifications:** All operators of stations located in the Northern New Jersey Section of the Hudson Division, including the counties of Bergen, Essex, Hudson, Middlesex, Monmouth, Passaic, Ocean and Union, who send in copies of their logs with final score are eligible for prizes.

**Call Procedure:** Calling procedure for use by all stations in the contest shall be "CQ NNJ de W2—".

**Completion of Contact:** A contact shall be considered complete when one message has been sent and one received. Each message shall consist of the usual preamble (number, call letters of originating station, check, place, time, and date) with no text. The check shall consist of three numbers, the "RST" report for the station being worked. If necessary, a contact may be completed in two QSO's instead of one.

**Scoring:** Two points are allowed for each completed contact with another station in the Northern New Jersey Section. Only completed contacts count, and only one contact with each station counts, even if different bands are used for each contact. The total score obtained in this way is multiplied by the number of different towns, townships, boroughs, etc., worked. It is not essential for the station worked to turn in a log in order for the contact to count. No score will be allowed for stations heard.

**Power:** The power used shall have no effect on the score. Low power for local contacts is recommended.

**Frequency:** Any frequency may be used. Either c.w. or 'phone may be used.

**Log Sheets:** Each operator shall turn in a copy of his log, mailing it before midnight, April 25th, to Ray Cronshy, W2HOZ, 77 Oraton St., Newark, N. J. Each item shall consist of a copy of the message sent. Where a station has more than one operator each shall submit a separate report.

**Prizes:** Prizes have been donated by the Northern New Jersey QSP Club, Wholesale Radio Service, Harrison Radio Company, Gross Radio Company, Terminal Radio Company and others.

**NORTHERN NEW JERSEY**—SCM, Fred C. Read, W2GMN—The QSP Club had a well attended and interesting meeting February 10th at the home of HOZ. JUC has a new receiver. CGG is alternate for HZY on Trunk Line "M." GVZ made B.P.L. second month in succession. KHA turned in first traffic report. BZJ had his antenna blown down by a storm. KTR is active in the R.C.C. IVJ has a new power supply for his 56-Mc. 'phone. JKG has a new antenna for 28-Mc. 'phone. CMC has been getting reports of skiing conditions from 1FCI for several department stores in New York. HDJ has joined the A.A.R.S. The Original

(Continued on page 92)

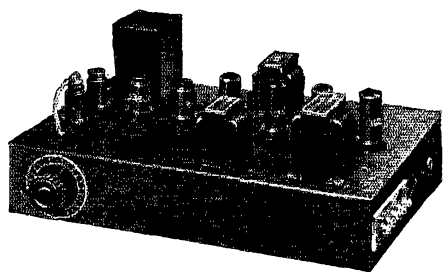

# New Amplifier for Direct Current Circuits

Added to the long list of amplifier circuits developed in the radio research laboratories of the Jefferson Electric Company is the Jefferson 10 Watt 25L6 Amplifier.

This may be connected to the usual 110-115 Volt direct current source of supply found in many sections — and makes unnecessary the use and expense of a converter.

Metal tubes are used throughout, including four 25L6's in the final stage. The extremely high gain of 139 decibels is attained with perfect stability of operation. . . . Mikes of the lowest output levels swing the amplifier to full output of 10 Watts.

## Bulletin PA-15 — Free

This describes all parts, including chassis and complete large circuit diagram. . . . Use the coupon below. . . . JEFFERSON ELECTRIC COMPANY, Bellwood, (Suburb of Chicago), Illinois. Canadian Factory: 535 College St., Toronto, Ont.

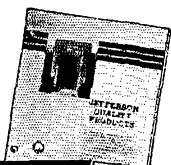

## JEFFERSON RADIO TRANSFORMERS

JEFFERSON ELECTRIC COMPANY

Bellwood, Illinois

Please send new Radio Catalog 372-R, Bul. PA-15 and Manual of Amplifier Circuit Diagrams. (Q)

Name.....

Address.....

City and State.....

## Standard Frequency Transmissions

Date	Schedule	Station	Date	Schedule	Station
Apr. 1	A	W6XX	May 6	A	W9XAN
Apr. 8	A	W9XAN		B	W6XX
	B	W6XX	May 13	A	W9XAN
Apr. 15	A	W9XAN		A	W6XX
	A	W6XX	May 20	BB	W6XX
Apr. 22	BB	W6XX		A	W9XAN
	A	W9XAN	May 21	BX	W6XX
Apr. 23	BX	W6XX	May 22	C	W6XX
Apr. 24	C	W6XX	May 27	A	W6XX
Apr. 29	A	W6XX			

### STANDARD FREQUENCY SCHEDULES

Time (p.m.)	Sched. and Freq. (kc.)		Time (p.m.)	Sched. and Freq. (kc.)	
	A	B		BB	C
8:00	3500	7100	4:00	7000	14,000
8:08	3600	7100	4:08	7100	14,100
8:16	3700	7200	4:16	7200	14,200
8:24	3800	7300	4:24	7300	14,300
8:32	3900		4:32		14,400
8:40	4000				

Time (a.m.)	Sched. and Freq. (kc.)	
	BX	
6:00	7000	
6:08	7100	
6:16	7200	
6:24	7300	

### TRANSMITTING PROCEDURE

The time allotted to each transmission is 8 minutes divided as follows:

- 2 minutes—QST QST QST de (station call letters).
  - 3 minutes—Characteristic letter of station followed by call letters and statement of frequency. The characteristic letter of W9XAN is "O"; and that of W6XX is "M."
  - 1 minute—Statement of frequency in kilocycles and announcement of next frequency.
  - 2 minutes—Time allowed to change to next frequency.
- W9XAN: Elgin Observatory, Elgin National Watch Company, Elgin, Ill., Frank D. Urie in charge.  
W6XX: Don Lee Broadcasting System, Los Angeles, Calif., Frank M. Kennedy in charge.

## WWV Schedules

EACH Tuesday, Wednesday and Friday (except legal holidays), the National Bureau of Standards station, WWV, transmits with a power of 20 kw. on three carrier frequencies as follows: 10:00 to 11:30 A.M., E.S.T., on 5000 kc.; noon to 1:30 P.M., E.S.T., on 10,000 kc.; 2:00 to 3:30 P.M., E.S.T., on 20,000 kc. The Tuesday and Friday transmissions are unmodulated c.w. except for

(Continued on page 94)



## TURNER Model 38 Crystal Mike gives you Top Performance

Clean-cut signals, reliability and absence of background noise make the Turner model 38 a favorite with nationally known operators. You can run long mike circuits without losing signal strength. No blasting when held close to speaker. Shock-proof crystal mounting protects crystal and eliminates handling noise. High level . . . high capacity . . . freedom from R.F. bugs. A beautifully designed mike you'll be proud to show with the finest rig. Supplied with eight foot cable and polarized connector. Modernize your rig now. Order a Turner model 38 today.

**\$13.23**

Turner Model 38 NET

## TERMINAL RADIO

80 Courtlandt Street, New York City

Licensed Under Patents of the Brush Development Company

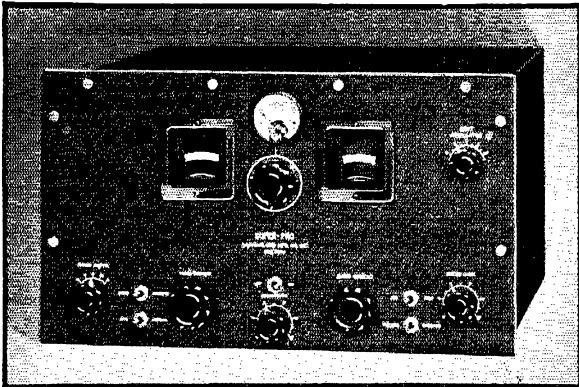

# BUILT FOR CROWDED PHONE BANDS

## SUPER- PRO

- 7½—240 METERS
- 3-16 KC. SELECTIVITY
- FULL SPREAD ON ALL BANDS
- 2-STAGES OF HIGH GAIN PRESELECTION
- 16-TUBES; FRACTIONAL MICRO-VOLT SENSITIVITY

**HAMMARLUND MANUFACTURING COMPANY, INC.,**  
424-428 WEST 33RD STREET, NEW YORK

WRITE DEPT.  
O4 FOR  
BULLETIN



Unconditionally Guaranteed	<b>PR CRYSTALS</b>	Powerful Reliable
X cut 7000 KC ± 5 KC . . \$1.85	3500 or 1750 . . \$1.65	
Low Drift *5 KC 40-80-160 . . . . .	2.20	
<b>PETERSEN RADIO CO. Ex</b>		
W9JRY COUNCIL BLUFFS, IOWA W7AHE		
Formerly Omaha Crystal Labs.		

## ● FOR SALE

### Broadcast Equipment at Ham Prices!

A rare opportunity to modernize your phone transmitter with broadcast equipment. One of America's leading radio stations is moving into new quarters and offers for sale its present studio and control room equipment at sacrifice.

Composite equipment now in use has been maintained to highest standards of present-day efficiency. Components include such famous names as Daven, U.T.C., Kenyon, Ferranti, Cornell-Dubilier, Aerovox, Westinghouse, General Radio, Western, R.C.A., Stromberg-Carlson, I.R.C., etc.

Studio and Master Control racks can be sold complete or knocked down.

Also available are a number of R.C.A. condenser microphones and Western Electric 600A microphones.

*Write or wire for itemized list. Equipment can be inspected in actual operation*

**QST—Box K**  
**West Hartford, Connecticut**

## The "BUG" You've Always Wanted

NEW Improved



# VIBROPLEX

Semi-Automatic Key

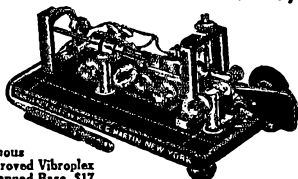

THE BUG trade mark identifies the Genuine Vibroplex

### JUNIOR ONLY \$12.50

A little smaller and more compact but in every other detail the same as large model. Large points. Japanned base. Complete with wedge and cord.

Famous Improved Vibroplex Japanned Base, \$17  
Nickel Plated Base, \$19

Search where you will, we don't think you will find this famous Vibroplex's equal in clarity of signal, range of speed or in sending ease. Beautifully finished in glistening nickel plate and mounted on a polished black japanned base — this finer Vibroplex not only adds class to your radio room, but also provides an easier, faster and better way to send. That's why over 100,000 of the world's finest operators use and recommend this type of key. Easy to learn. Simply press lever — Vibroplex does the rest. Treat yourself to a New Improved Vibroplex now! Insist on the Genuine Vibroplex. Accept no substitute. Costs no more than imitations. So why not get the best? Your old Vibroplex accepted as part payment on a New Vibroplex. Money order or registered mail. Write for FREE catalog.

**THE VIBROPLEX CO., INC.**  
832 Broadway New York, N. Y.

Say You Saw It in QST — It Identifies You and Helps QST

(Continued from page 89)

Tri-County Radio Association is planning a social evening for some time in April. KAK reports for the first time from Teaneck. ICJ devotes his time on air to A.A.R.S. and N.C.R. KSW of Hoboken, ex-W3FAU, reports for first time; he is heard on 7 and 14-Mc. c.w. LAO is new station at Oakhurst; he will use 7 Mc. to start. The Esso Radio Club recently formed at the Bayway plant of the Standard Oil Co. has 15 members. CAY and CAX spent a midwinter in Bermuda. The "Arabian" network is a new 'phone net on 1970 kc. BXU, ex-K5AY, has his old call back. LAG, ex-W8NSG, is active station in Elizabeth. BTZ's 150 (?) watts are doing yeoman service on 3.9-Mc. 'phone. IEP of Keyport is operating portable rig on 3541 kc. at Syracuse, N. Y. WZ is on 14 Mc. from his new QTH at Union. CQX has new directional antenna. GCV is using 14 Mc. FKI has new 500-watt rig on 1.75-Mc. 'phone. GDB is back on 3.5 Mc. with increased power. The North Newark Radio Club had a talk on television by Marshall P. Wilder, who writes for QST. The club had a very successful social evening which they called a "Nickelodeon Night" with movies, on January 19th, with an attendance of 65. HRZ and IWY of the N.N.A.R.C. established a new record of 22 hours, 10 minutes continuous QSO, beating by 2 hours, 8 minutes the previous record made in 1933. The N.N.A.R.C.'s "Bandspread" is one of the best amateur club newspapers that we have seen. The A.E.C. has a considerable number of new members in the Section.

Traffic: W2BCX 818 (WLNF 677) GYZ 407 CGG 379 HCO 150 HQL 106 (WLNR 122) JPK 92 JUC 85 CMC 45 KAK 42 KHA 21 BZJ 16 JKG 26 (Previous period JKG 25) KTR 11 HNP 14 CIZ-ICJ 6 GMN 5 HOZ 61 GGW 158.

### ATLANTIC DIVISION

**E**ASTERN PENNSYLVANIA—SCM, Jack Morgan, W3QP—R.M.'s: 3AKB, 3AQN, 8ASW. P.A.M.: 3EOZ, Asst. S.C.M. in charge of Emergency Coördination: 3AKB, E.C.'s: 3DGM, 3DPU, 3NF, 3UA, 3UR, 8HHO. Section traffic ratio of originations to deliveries was healthy with 528 to 829. 3ADE has a new 101X. 3AOC joined A.A.R.S. 3AQN turned in an impressive total, and has schedules in all directions. DX has been good on 7 Mc. at 3BGD and 3ATR. 3GXX has a new 28-Mc. beam. 3DDM worked 17AA at Addis Ababa for a new country. 3DGC finds plenty of traffic and DX. Chester Radio Club staged a QSO party which was most successful. 3DPU works WAWG regularly. Yeadon Boro Council has allotted space in the Boro Hall for the Yeadon Radio Association transmitter. 3EML won the traffic laurels for the month; Bill works K5AA twice per night. 3EON's new tritet gives fine results. 3EOZ built some good field equipment for Main Line Radio Club. 3EZ has gone N.C.R. 3GYY is snapping traffic around with his 12-watt 6L6G osc. on 3.5 Mc. 6CTU went to Europe, so 3QP now QSP's KA1HR via 6LUJ daily except Saturday. 8AXH is going 'phone-conscious; he runs 55 watts to a 6L6 osc.!!

Traffic: W3ADE 39 3AGK 1 3AOC 11 3AKB 174 3BBV 17 3AQN 522 3BES 10 3BGD 5 3CHH 21 3DDM 9 3DGC 244 3DGM 3 3DPU 45 3DXC 38 3ECA 91 3ECP 43 3EML 695 3EON 8 3EJW 219 3EZ 2 3GAG 157 3GDI 178 3GMK 63 3GUB 162 3GYY 7 3NF 45 (WLML 374) 3QP 415 8ASW 269 8ATF 11 8AXH 2 8DHT 203 8EU 4 8FLA 315 8NPK 17 8OML 2 8QLW 4.

**MARYLAND-DELAWARE-DISTRICT OF COLUMBIA**—E. L. Hudson, W3BAK—R.M.'s: 3CXL 3CQS. Chief R.M. 3BWT. The Atlantic Division Convention will be held in Washington on June 24th-25th. BKZ has new traffic rig with 100TH in final, 600 watts. EIV is experimenting with antenna. CAB is having an FB time playing chess by radio. BAK is building a new rig.

Traffic: W3CXL 255 (WLM 3342) CIZ 1432 BWT 589 BKZ 135 GKN 40 EIV 36 CAB 30 CDG 18 FPQ 9 BAK 8 EZN 4.

**SOUTHERN NEW JERSEY**—SCM, Walter Filson, W3BEI—The S.C.M. is gratified to be able to place one of the gang in the B.P.L.—BYR! Nice work, Vic! The S.C.M. enjoyed a pleasant evening at the Greater Camden Radio Club. CNI and CZN are now members of the U.S.N.R. HCE, stationed aboard the U.S.S. *Mohawk*, is on the air with a single 6L6G crystal osc; he is ex-K5AR and K5AJ. BO is back on day work, and glad to be back in the net. FBW worked his first VK on 7 Mc.; he has also received his ticket from the second district which he uses during the week at work, 2LBM. FML is P.O.I.C. of Atlantic City's U.S.N.C.R. Unit. UT is a daddy, and it's a girl. Nice work, Smitty. ZI keeps us in touch with North Jersey through his

several schedules. The Delaware Valley Radio Ass'n is running a series of lectures and events in Trenton in an endeavor to raise funds for new centrally located club quarters in down-town area. BEI lost his 40-foot pole in a light breeze. The South Jersey Club had the pleasure of listening to Amory (Bud) Waite, one of the party with Admiral Byrd on his last Antarctic Expedition, who told in detail the experiences of his year and a half and all the dope on the radio gear and the re-broadcasts which were heard over the C.B.S. In March the speaker will be on China.

Traffic: W8BYR 793 (WLNJ 66) ZI 169 EFM 150 (WLNJ 50) DNU 25 BEI 22 FBM 10 BO 9 BAY 5 FCQ 4. **WESTERN NEW YORK**—SCM, H. E. Preston, W8CSE—Chief R.M.'s: 8BJO, R.M.'s: 8JTT, 8DSS. P.A.M.: 8CGU. JQE and PLA completed their W.A.S., entirely on 3.5 Mc. JQE is our star traffic man with a nice score. (SE has a T220 buffer stage that remains neutralized regardless of the setting of the neutralizing condenser! PXB plans a new final with a pair of T55's. RMR is putting Mt. Morris on the map on 7255 kc. RKA joined A.E.C. and is active on 3560 and 7165 kc. LOV is heard daily on 7250 kc. NNJ plans on a mobile 'phone-c.w. rig for 28, 14 and 3.5 Mc. Our P.A.M., CGU, is getting results. DSS has a good list of schedules. QGW is working nice DX on 14-Mc. 'phone with new seven half wave antenna. (TX has a new 100TH in rig and plans on using KY21 rectifiers soon. OEH is on 3775 kc. from Burke. EIJ will be on from new QTH at Ticonderoga.

### WESTERN NEW YORK QSO PARTY

A Western N. Y. QSO Party will be held from 6 p.m., April 9 to midnight, April 10. All bands and both 'phone and c.w. may be used. All stations in W. N. Y. are urged to participate. Prizes will be given to the W. N. Y. stations working the greatest number of other stations in Western New York. Stations worked outside of the Section do not count. It is a project to create interest and activity in Western New York. Further details may be obtained by writing to the contest manager, Francis Orcutt, W8GWT, 127 South Ave., Penn Yan, N. Y. All reports of activity in this contest must be sent to the contest manager BEFORE April 20th.

BJO has a new "Bi-Push" exciter driving the '52's, and he works DX on 7 Mc. with the greatest of ease. QXS, our newest O.R.S., is doing fine work from Seneca Castle. FUG has come back to life in Rochester. FCG is the most regular member of the O.R.S. Net. BUN in Oneonta is heard from once a week. CP is working on that kilowatt (?) 'phone. MEY is knocking 'em off on 14-Mc. 'phone. APU is on 1.75-Mc. 'phone late at night. NXQ's neighbors get a great kick out of his remote-controlled rotatable beam antenna. PXA and CYT keep the 28-Mc. 'phone band hot. FEJ in Cortland is working on a one kilowatt 'phone for 1.75 Mc., using a pair of 100TH's final and a pair of ZB120's in Class B. IUF is doing a wonderful piece of work in the "Yankee Net" which handles traffic from the yacht *Yankee* and other far places. ISX and GZP are interested in O.P.S. MMV is getting to be a most familiar call on 'phone. IY now lives in Norwich. REM writes a nice letter from Buffalo; he operates on 3588 kc. most of the time, but takes a fling at 56-Mc. 'phone. Please get your reports to the S.C.M. BEFORE the 20th of each month if you want to be included in this Section report. DON'T FORGET THE W. N. Y. QSO PARTY APRIL 9TH AND 10TH. 8NA has 71 QSO's on 1.75-Mc. 'phone between Jan. 16th and Feb. 15th using 1860 and 1960 kc. PWU can't get on except in the wee small hours. He has heard all ZL Districts on 3.5 Mc. and has worked some nice DX. He joined the R5GB. ROI, a new ham in Auburn, writes a nice letter, telling of two weeks' activity on 7 Mc. in which he worked all districts but W6 with 30 watts input to an RK49 Crystal Oscillator. Not bad for a two-weeks-old ham. RNG is another new ham in Auburn. RME is a new ham in Syracuse on 1.75-Mc. 'phone grid-modulating a pair of 211's.

Traffic: W8JTT 99 GWY 62 FCG 307 FUG 49 JQE 800 QXS 32 BJO 4 CSE 316 (WINM 123) GWT 15 CTX 37 LUQ 4 RKA 3 DSS 217 PLA 342 DHU 55 CGU 9.

**WESTERN PENNSYLVANIA**—SCM, Kendall Speer, Jr., W8OFO—R.M.'s: 8KUN, 8KWA, 8MOT, 8GBC. A.A.R.S. Liaison R.M.: 8UK. N.C.R. Liaison R.M.: 8KOB;

Emergency Coördinators: Pittsburgh, 8QAN; McKeesport, 8DNG; Erie, 8AQJ; St. Marys, 8NDE; Butler, 8DDC; Ohio River Region, 8BBV, New O.R.S.: QXF, Prospective O.R.S.: BBW. KWA leads the Section in traffic with a nice total. B.P.L.'s: KWA, OFO, QAN and WLMA/8YA with A.A.R.S. traffic. KWA is busy gathering data for the A.R.R.L. Planning Committee. OFO added PA to his new countries worked list. QAN had a fine emergency meeting of Pittsburgh amateurs and will hold emergency tests each Sunday morning. GBC is moving to another part of town. DDC has emergency rig in operation. UK says there is more activity in Pa5 since the Third Corps Area A.A.R.S. reorganization. LGD is busy with N.C.R. work. MJK is running a hundred watts to a pair of T20's. KNB says his homemade bug works better than his factory one. QXF is active in the W.P.A. O.R.S. Net. KOB is back. Mon-Yough Transmitter Assn. at McKeesport had a 90 per cent turn-out, with OVY winning the door prize. NVQ is running a kilowatt to a pair of 250-TH's. OVW is active with a 50T final. GJM with the South Hills Brass Pounders has their 2-kw. 110-volt a.c. power supply ready for any emergency. DGL is operating on 14 and 28 Mc. Two new XYL amateurs for Western Penna.: ROP, the XYL of RED of Erie and the XYL of QES of Pittsburgh. (Congrats.) QES is running 350 watts to a '60 final. WANTED—live wire and active amateurs to serve as O.O., O.R.S., O.P.S., and O.B.S. in Western Penna. Write to the S.C.M. Let's help double the A.R.R.L. membership. Make your motto—Every member get a new member—stay a member—support the organization that is supporting you.

Traffic: W8KWA 723 OFO 663 QAN 528 GBC 484 KUN 207 DDC 156 UK 116 IOH 101 LGD 97 CMP 90 NDE 81 HBG 49 YA 57 (WLMA 707) MJK 39 KNB 29 QXF 20 KOB 13 AXD 12.

#### ROANOKE DIVISION

WEST VIRGINIA—SCM, C. S. Hoffmann, Jr., W8HD\* W8NS—MOL is Emergency Coördinator for Huntington. Assistant Emergency Coördinators appointed: By DYB: BWE, CDV, CXR, CWY, LCN; By QQZ: ELJ, KHB, LGB, New O.R.S.: PTJ, New O.B.S.: NEU (on c.w.). JRL sends Official Broadcast on 'phone each Tuesday and Thursday, 6:30 P.M., 1810 kc. NEU sends O.B. on c.w. each Tuesday and Thursday, 8 P.M., 3750 kc., after which is sent code practice at 5, 10 and 15 w.p.m. LCN sends code practice on 1756 kc., Thursdays, at 8:30 P.M. MCR resigned as R.M. Southern Dist. due to U.S.N.R. duties; PTJ was recommended by Huntington Radio Club and appointed in his place. OLV resigned in Northern District, due to ill health; DYB was appointed in his place. Charleston Radio Club is having hamfest May 22nd, Ruffner Hotel, 1 P.M. until 7 A.M.! RDH and RFD apply for R.C.C. BLE, BWK, DYB, and PTJ are on 56 Mc. PTJ takes Inter-Section O.R.S. schedule with Ohio, daily; likewise DYB takes Inter-Section O.R.S. schedule with Penna., giving the State O.R.S. Net a daily direct contact into these two adjoining states. MOP worked HI7G. PSR and EZR are installing U.S.N.R. station in P. O. Building. RJG, a shut-in for 21 years, will be on with a 'phone rig soon. BKI, QFN and NRX are building beam antennas. KIU has advanced classes in radio at W.V.U. with RFP, KJT, JBY and DWZ as pupils! PHY reports the 7040 Round-table QSO is getting bigger 'n bigger. Members now: MLW, MNX, FEO, FCU, PQZ. PHY takes traffic, giving it to HD for A.R.R.L. Trunks. QPZ and MLW apply for O.R.S. QPZ is now R.C.C. and has Radiotelephone first, Commercial and Class A ham tickets. FB! O.R.S. in good standing: BDD, CDV, DYB, ELO, HD, KIU-DSJ, KKG, KYJ, LCN, LII, LXF, MCL, NSE, NLE, OLV, OHW, OFE, PHY, PQQ, PSR, PTJ. O.P.S.: KIU-DSJ, KKSJ, BDD, MOL, MOP, MZT.

Traffic: W8HD 148 DYB 98 LII 87 PTJ 81 KIU 54 PSR 73 KYJ 52 OLV 11 BWK 8 PHY 6 PQZ 1.

VIRGINIA—SCM, Charles M. Waff, Jr., W3UVA—P.A.M.'s: 3AIJ—R.M.'s: 3GPC, 3GJP, 3GTS, 3DQB, 3BJX—FGJ likes O.P.S. contests. HBO has receiver going again and would appreciate calls. GPC made the B.P.L. on deliveries, the first Va. station to do so in many months. HDQ wants to become O.R.S. EMA uses an 8JK beam on 7 Mc. with FB results. FMY finished new rig, P.P. 100TH's with 700 watts 'phone and 1-kw. c.w. GWP worked Vt. for his 44th state in O.R.S. party. GJP had to cancel all sched-

ules due to doctor's orders. Sorry, OM. FBL is setting up at new QTH. FCU has new Bruce beam for 14 Mc.

Traffic: W3GPC 308 GJP 63 GWP 49 GTS 25 (WLQE 4) (WLMG 19) EMA 10 FMY 2.

SOUTH CAROLINA—SCM, Ted Ferguson, W4BQF—ETF is installing a rotating beam. GB says 28-Mc. 'phone DX is FB. CQG is active on 3.5 Mc. ERF is active in local N.C.R. unit. DMX has O.P.S. and is active on 3.5 Mc. CE rebuilt final and is working 3.9-Mc. 'phone. CQU got the bugs out of his a.c.-e.c. frequency meter. CZA and the gang are doing a fine job with traffic. CZN has O.R.S. and has been elected to the "Dew Drop Net." FB, OM, DNR schedules BDT and CZA. ALT, BQM, EDO and EWB did a nice job in traffic. EZF worked his first VE on 1.75-Mc. 'phone with 27 watts input. DXJ wants state schedules. EPJ is grinding his own crystals. DQY has a new receiver and is going to work 28-Mc. 'phone. ECG increased power and is active on 3.5 Mc. AUW is now active in this Section (Georgetown). Welcome, OM. Portable W3FQQ is working 3.9 and 28-Mc. 'phone. Your attention is called to the fact that Sunday, April 3rd, is the date set for the S.C. State meeting. It is the desire of the Palmetto Amateur Radio Club that all the fellows in this Section attend. See you there.

Traffic: W4CZA 323 BDT 236 CZN 133 BQM-EWB 24 ALT 21 DNE 20 CQU 19 DQY 12 EPJ 11 EDO 7 CE 5 DXJ 3 EZF-3FQQ 2.

NORTH CAROLINA—SCM, H. S. Carter, W4OG—The 3.9-Mc. 'Phone Net is getting along fine with 15 members and ANU, P.A.M., at its head. DW plans to join the 3.9-Mc. Net. The Asheville gang organized a fine club. HX is pres.; TO vice-pres.; GW secy. BNG is on 1.75 and 28-Mc. 'phone. QA uses his '04A to heat his shack. FCY and FCB are new hams. BC operates the police transmitter. OVC is now in Asheville. ESO is looking for schedules anywhere; get in touch with him. DLX is getting some good schedules lined up. CAY is active on 3.5 Mc. DSY has some good schedules which include VK's and VO's. BX says the gang is busy with plans for a big hamfest in March. BXF has been appointed Emergency Coördinator. Line up with him, fellows. DHW is moving to Memphis. AID has good luck with 14-Mc. beam. DMW was transferred from Miami and is in the N.C.R. BKT moved from Greensboro to Charlotte. DST is rebuilding. CLB completed his exciter unit. BHS is moving to 3.9 Mc. DQ is trying to get some new states for W.A.S. EQF moved from 1.75-Mc. 'phone to 7-Mc. c.w. DGU reports that CWH died some time ago. Our sympathy to his family. CYB has been experimenting with 8JK beam on 14 Mc. DSO is on 14 Mc. with 400 watts. DOV received U9 card for W.A.C. DOZ has new Junior op. DOQ has a rotating beam. EYA is Emergency Coördinator for Salisbury and vicinity. DKF is increasing power. DOR is going strong with 30 watts input. QI returned from a visit in Cuba. NY is working out well on 28 Mc. with an increase in power. EWP moved to new QTH in suburbs. BYA get on for the 3.9-Mc. 'Phone Net. DWB made B.P.L. FB, OM. DCW works 3.9-Mc. 'Phone Net on Sunday, and 3.5-Mc. c.w. the rest of the time. DGV is going strong on 3.9 and 28-Mc. 'phone. CFR, ABT, AHF, RA and OG have increased power. Your S.C.M. received a card from EZN, who is operating at Mount Hermon School in Massachusetts.

Traffic: W4DWB 515 ECH 154 DSY 3# DLX 21 ABT 16 CQV 12 NC 10 CZN 8 DGV 6 ESO-ANU 5 BVD 6 EYA 5 BYA-BX 4 AGF 3 EQF-DGU-DW 1.

#### SOUTHEASTERN DIVISION

ALABAMA—SCM, James F. Thompson, W4DGS—R.M.'s: 4DS, 4CRF, 4APU. P.A.M.'s: 4DHG, 4BMM. We would like to earnestly request that you cooperate in every way you can with the Emergency Coördinators in their endeavor to set up an emergency organization. The cyclone and flood season is on now, and we never know when it will strike in our locality. DHG has a new RME 6-volt model which may be used as an emergency receiver; he also has a portable transmitter. FB has 300-watt 1.75-Mc. 'phone. BLL has new P.P. 860 600-watt c.w. final going up. CQY has turned to 'phone a little down in Geneva; he is old EA's son. EUJ has a kw. on 28 Mc. in Dothan. LT is 3.9-Mc. 'phoning again. APU is on 1.75 and 3.9-Mc. 'phone quite a bit now.



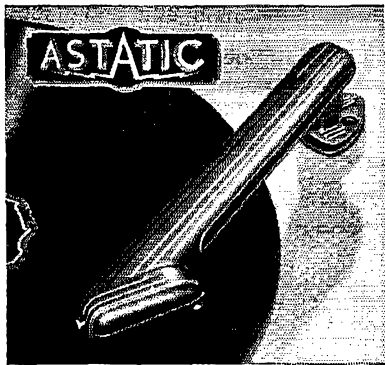

## The Arm That Rests on a Cushion

In the new streamlined Model 0-7 Crystal Pickup, Astatic Engineers have incorporated Axial Cushioning, insulating the playing arm from its supporting base to reduce motor noise and speaker pickup feedback. Other features include Offset Head design to reduce tracking error, Triangular Groove needle loading and free stylus movement. An ideal Pickup for improved amplifier and radio phonograph combinations. Full year guarantee.

New List Price, \$10.00  
Write for Literature



Astatic Microphone Laboratory, Inc.  
830 Market St.  
YOUNGSTOWN, OHIO  
Licensed Under Brush Development Co. Patents



## A JOB . . . or a FUTURE — which for YOU?

We want men who want a future. Radio wants men with ABILITY and is willing to PAY for it . . . If you have the TECHNICAL TRAINING necessary for advancement. Prepare yourself for big opportunities by applying yourself to CREI training. It's helped others and can help you — let us tell you how.

### Practical Radio Engineering

offered in three study plans to meet the needs of everyone. Home Study Course . . . Residence Training . . . Combination Home-Study and Residence Course.

Write today for the CREI "TESTED PLAN"

Mail or paste the coupon below on a penny post card and receive your free copy of this interesting and inspiring booklet.



### CAPITOL RADIO Engineering Institute

#### MAIL THIS COUPON TODAY

CAPITOL RADIO ENGINEERING INSTITUTE  
Dept. Q-4, 14th & Park Rd., Washington, D. C.

Please send me complete details and illustrated 48-page booklet — "A Tested Plan for A Future in PRACTICAL RADIO ENGINEERING."

Name.....

Address.....

City.....

## WWV Schedules

(Continued from page 80)

1-second standard-time intervals consisting of short pulses with 1000-cycle modulation. On the Wednesday transmissions, the carrier is modulated 30% with a standard audio frequency of 1000 c.p.s. The standard musical pitch A = 440 c.p.s. is also transmitted from 4:00 P.M. to 2:00 A.M., E.S.T., daily except Saturdays and Sundays, on a carrier frequency of 5000 kc., power 1 kw., 100% modulation. The accuracy of the frequencies of the WWV transmissions is better than 1 part in 5,000,000.

## How Would You Do It?

(Continued from page 40)

store, or it may be built if one is particularly apt in the construction of such things. Neatness in appearance is the prime factor in the mind of the mistress of the household, and this factor should be reckoned with in the decision as to whether to buy or make the chest.

"The exterior appearance is very appealing, as shown in Fig. 2. Only the meters, name plates, and jewel lights are to be seen. The insulators for feeder connection may be mounted on the end, while all wires leading to the chest should enter from the rear.

"For the greatest accessibility the transmitter is constructed on removable breadboards. The breadboards are supported at each end by 1-inch by 1-inch wooden strips, and are securely fastened to the inside of the chest with screws. The condensers are mounted on end so that the dials will face upward and the plug-in type of coils are used.

"All connections to the meters, key and power leads should be made with plugs and jacks to facilitate the removal of the breadboards from the chest. The breadboards need be only as wide as the apparatus requires and the remaining space may be used advantageously by building in small boxes in which to store the extra coils, soldering iron, reserve tubes, screw driver, neon lamp, and other items that are convenient to have at hand. The power supply unit is mounted on the bottom breadboard and the r.f. unit on the top breadboard. By merely raising the lid the necessary tuning or coil changes may be accomplished with the minimum of effort.

"It is necessary to bore small holes in the bottom of the chest and others toward the top of the back panel to furnish the necessary ventilation. The short legs of the chest raise it far enough above the floor to permit air to circulate freely through the chest; thus keeping the apparatus at a moderate temperature.

"A transmitter in a chest of this design would not only overcome the undesirable appearance of the usual transmitter, but would provide accessibility for coil changes or minor alterations and

# TEMCO 50 WATTS OUTPUT

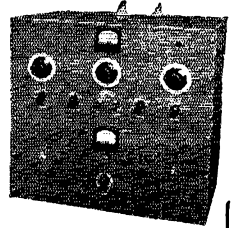

- Band Switching Exciter with Variable Excitation Control.
- High Fidelity Speech Amplifier.
- Complete Coverage from 10 to 160 Meters.
- Low Impedence Swinging Link Output.

You asked for it — so TEMCO has produced a transmitter that is the answer to a multiplicity of communication problems. This newest TEMCO Transmitter perpetuates the modern features, engineering and efficiency which characterizes other TEMCO models. ● R.F. Line Up: 1-6L6 Oscillator, 1-807 Buffer Doubler, 1-T40 Class "C" Amplifier, 2-866 Rectifiers. Speech Amplifier and Modulator Line Up: 1-6J7, 1-6C8G, 2-6L6's and 1-5Z3 A personal inspection at your Dealer will convince you of its superiority

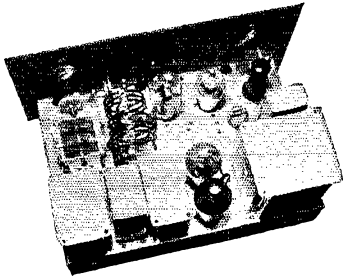

## PRICED SENSATIONALLY LOW

TEMCO "50" for telegraph operation only in single deck cabinet less tubes, crystal, but including band switching exciter unit for 5 bands and 1 power amplifier for any one band..... **\$125**

TEMCO "50" for telegraph and telephone operation (illustration above) less accessories as described above as well as microphone.....\$195

*Note:* The modulator unit may be added at any time without making any wiring changes whatsoever to permit both C.W. and phone operation.

*Technical information on this or other TEMCO Transmitters will gladly be sent upon request.*



## Transmitter Equipment Manufacturing Co., INC.

130 CEDAR STREET • NEW YORK, N. Y.

*Designers and Manufacturers of Radio Transmitting and Accessory Equipment*

## RADIO ENGINEERING



RCA Institutes offer an intensive course of high standard embracing all phases of Radio and Television. Practical training with modern equipment at New York and Chicago schools. Also specialized courses and Home Study Courses under "No obligation" plan.

Illustrated Catalog on request

**RCA INSTITUTES, INC.** Dept. ST-38

A Radio Corporation of America Service

75 Varick St., New York 1154 Merchandise Mart, Chicago

## PRECISION CRYSTALS

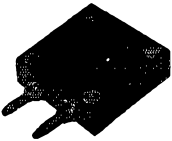

Crystal Holder

Highest quality crystals, one inch square, carefully ground for frequency stability and maximum output. Be sure of your transmitter frequency — use PRECISION CRYSTALS.

Low frequency drift crystals (Type L T C) supplied within 0.1% of your specified frequency and calibrated to within 0.03% are priced as follows: 1750 and 3500 kc. bands — \$3.50 each. 7000 kc. band \$4.00 each. Holder \$1.00.

(Holder as illustrated to fit G.R. jacks or round holder to plug into a tube socket can be furnished. G.R. jacks to plug illustrated holder into — \$1.15 pair.)

\*X' cut PRECISION Crystals carefully ground for maximum power supplied within 0.1% of your specified frequency and calibrated to within 0.03% are priced as follows: 1750, 3500 and 7000 kc. bands — \$3.00 each. Add \$1.00 if holder is desired.

\*AT' cut crystals for commercial use quoted on at your request. When ordering our product you are assured of the finest obtainable. Now in our ninth year of business.

**PRECISION PIEZO SERVICE**

427 Asia Street Baton Rouge, La.

## SAY FELLOWS!

**OUR 10% DOWN PAYMENT AND LOW MONTHLY PAYMENTS SHOULD INTEREST YOU. IMMEDIATE DELIVERY ON ALL THE BEST RECEIVERS AND TRANSMITTERS.**

~~~~~  
 Latest Price List and Details 3c Stamp  
 ~~~~~

National—RME—Hallicrafters—Temco  
 —Hammarlund—Harvey—Patterson—  
 Breting—RCA—Howard—Taylor, etc.

*Also All Parts, Tubes, etc.*

~~~~~  
**WILLARD S. WILSON-W3DQ**

DELAWARE RADIO SALES COMPANY

405 Delaware Avenue Wilmington, Del.

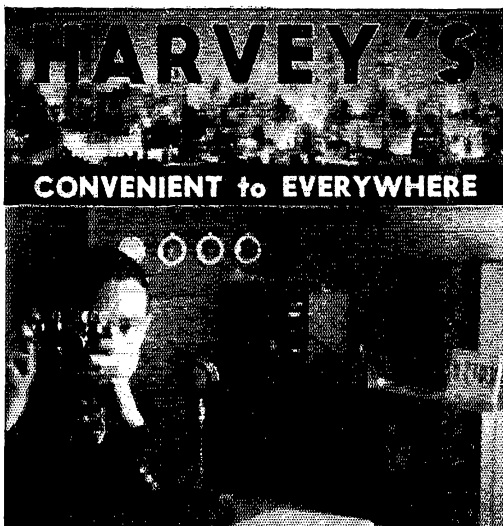

**"HOLD ON, Glenn . . . We're supposed to be taking YOUR picture . . ."**

Excuse us, fellows, but Glenn Pickett, W2IDV, is one of the thousands of satisfied Harvey customers . . . and we thought we'd like to vary the monotony a bit by breaking loose with a picture that wasn't selling anything . . . OK . . . ?

But getting back to business . . . there's little in the way of radio that we haven't got

## IN STOCK

Complete lines of National, Bliley, Amperex, Cardwell, United Transformer, Hammerlund, Precision, Hallicrafters, etc. . . etc. . . (Adv. Agency note: We'd like to taper off . . . you know how many and which manufacturers we can list . . .)

And let's not overlook the fact that those new

## TAYLOR T-40 and TZ-40 Tubes and HEINTZ & KAUFMAN Type 54

are on our shelf . . . They sure are a whale of a lot for the money . . . Only **\$3.50** for the **TAYLOR TUBES** . . . and only **\$6.75** for the **GAMMATRON**.

**TRANSMITTER KITS?** Look back at some of our recent ads in *QST* . . . They're still available . . . and selling . . .

**INCIDENTALLY** . . . If you're interested in cameras, or have camera or radio equipment that you want to "swap" . . . we sell both . . . and can talk "trade-in" . . .

OUR *Best* VALUE IS OUR RECORD OF LOYAL SERVICE

# HARVEY

*Radio Company of New York*

103 WEST 43rd STREET • NEW YORK, N. Y.

CABLE ADDRESS: "HARADIO"

yet permit enclosing the entire unit against dust accumulation and tampering by visitors or other members of the household."

Prize winners this month are:

First, G. P. Anderson, G2QY

Second, Ernest L. Moline, W9SWT

We wish to thank the following also for their contributions: W1KFN, 2KNN, 7FRC, 8BIE, 80MM, 9AHR, 9DXY, 9OJM, 9RED, G5SR, Julius Ozik and Bertram Green.

Rules for the Problem Contest are repeated below:

1. Solutions must be mailed to reach West Hartford before the 20th of the publication month of the issue in which the problem has appeared. (For instance, solutions of problem given in the April issue must arrive at *QST* before April 20th.) They must be addressed to Problem Contest Editor, *QST*, West Hartford, Conn.

2. Manuscripts must not be longer than 1000 words, written in ink or typewritten, with double spacing, on one side of the sheet. Diagrams and sketches may be in pencil, but must be neat and legible.

3. All solutions submitted become the property of *QST*, available for publication in the magazine.

4. The editors of *QST* will serve as judges. Their decision will be final.

Prizes of \$5 worth of A.R.R.L. station supplies or publications will be given to the author of the solution considered best each month, \$2.50 worth of supplies to the author of the solution adjudged second best. The winners have the privilege, of course, of stating the supplies preferred.

## Brief

W1EVJ, Nantucket, Mass., provided communication from Nantucket Island when a snow storm disrupted telephone and telegraph lines on January 13th. Press and several Western Union messages were handled. Among stations working with EVJ were W1JY, New Bedford, and W1KU, Fairhaven.

## THE NEW TURNER 30-30 Crystal Mike Gives You

**Streamline Design—Broad-cast Quality—Low Price**

This new semi-directional Turner crystal mike greatly reduces feedback troubles because of its streamline design. Absence of peaks permits operation close to loud speaker. Output level, minus 52DB, permits use of low gain amplifiers. Hum problems minimized because no input transformer required. Not affected by wind in outdoor setups and will not blast. Crystal interior suspended in shock absorbing material to prevent breakage and eliminate handling noises.



Turner 30-30



Showing Removable Cable

**\$13.23**

NET Cable Included

New cable connector makes lengthening cable easy. A simple soldering operation replaces cumbersome splices. Fits any standard desk or floor stand. A smart, modern mike at low cost. Order today.

Amateur Radio Headquarters in Indiana

**VAN SICKLE RADIO SUPPLY CO.**  
34 W. Ohio, Indianapolis, Ind.  
Licensed Under Patents of the Brush Development Co.

# A New Thrill for RADIO AMATEURS!

For 16 years Radio Amateurs, Engineers and Experimenters have made Sun Radio their headquarters. Many of them bought parts for their first rigs from us and we're proud to number hundreds of you fellows among those who have been coming to us for years! The confidence which you placed in us, the increasing numbers of your fellow Hams whom you have sent to us have made it necessary to expand.

Today we are proud to issue an invitation to you to make the greater Sun Radio Company your headquarters. Here in our own new two story home we have every modern facility to service your needs: A far greater stock of all nationally known lines, than ever before, many new lines, sound proof booths for comparing the relative merit of S.W. receivers, a modern X'mtr in operation which licensed Hams may operate! There's plenty of room, too, to browse around.

You'll find the old familiar faces here to smile a welcome to you and serve you effi-

ciently and well. So come visit us if you can, and if you can't — you'll find our Mail

Order Dept. today, is second to none! You'll get *what* you want *when* you want it.



### KEY TO ROUTES TO SUN RADIO

- 1 — 8th Ave. Subway
- 2 — B.M.T. Subway
- 3 — I.R.T. West Side Subway
- 4 — 9th Ave. El
- 5 — Hudson Tubes



## SUN Radio Co. 212 Fulton St. New York, N. Y.



## SPEED-X

The Complete Line of Telegraph Keys  
"HI-SPEED"  
Semi-Automatic  
Key

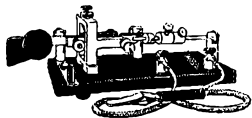

Model No. 510

Complete with switch cord and plug. List price \$10.75.

Other models from \$9.25 to \$17.50. Available at leading jobbers everywhere. Write for new literature and Amateur Discounts.

### LES LOGAN COMPANY

646 Jessie Street

San Francisco

## LEARN CODE RIGHT

Tapes for Every Need — Send You

Typical Messages by

### INSTRUCTOGRAPH

It's easy and practical to learn or improve your Radio or Morse Code, any speed. Senior model with 10 tapes and Book of Instructions — \$20.25. (Rented at low cost.) Junior model with 5 tapes and Book of Instructions — \$12.00. (Not rented.) Complete oscillator equipment, less battery, \$6.50. Write for details today.

INSTRUCTOGRAPH CO., Dept. Q-4  
912 Lakeside Place Chicago, Ill.  
Radio College of Canada  
863 Bay St., Toronto

BUY ON CASH OR TERMS: HALLICRAFTER AND R.M.E. SHORT WAVE RECEIVERS, SPEED-X AND VIBROPLEXES, Telegraph Instruments



## "I've Been a Ham for 10 Years"

Says Larry Bradenburg, W2DZL

"BUT I'VE NEVER FOUND A LOW-POWER RIG  
THAT EVEN COMES CLOSE TO THE UTAH JR."

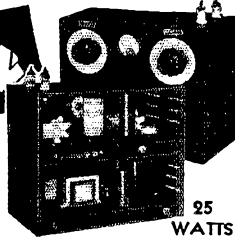

JUNIOR KIT  
only \$15.95

25  
WATTS

"Since purchasing the kit I have verified reports from all but six states, and have been in contact with stations in Cuba, Mexico, Colombia and recently was QSO with Brazil — getting from him an R6 report. My worst report has been R5, and I've had higher power rigs that wouldn't do as well. I believe that with a good antenna and receiver, it is highly possible to work all countries with the Utah Jr."

Write department Q-4 for all the  
Surprising Facts, or see your jobber

## UTAH RADIO PRODUCTS CO.

CHICAGO, U. S. A.

BUENOS AIRES — UCOA RADIO PRODUCTS CO.

## "16 YEARS OF LEADERSHIP"



# AHOY THERE!

TAKE A LOOK  
AT THE **SCRULOK**  
developed by  
**BIRNBACH**



Always a pioneer, Birnbach again leads with the new *Scrulok* solderless connection. Test leads and prods using this new principle need no soldering or tightening with wire-cutting screws. Every part is assembled with a tight mechanical and electrical contact. Ask your jobber for the new Birnbach Test Prods, Test Leads, Banana Type Plugs, Insulated Pin Tips, etc., featuring the *Scrulok* principle. If he cannot supply you, write direct to us.

**BIRNBACH RADIO CO.**  
145 HUDSON ST. BIRCO NEW YORK, N. Y.

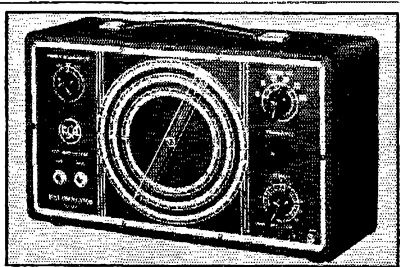

## New RCA OSCILLATOR PROVIDES ONE-VOLT R-F OUTPUT!

This fine, new AC Oscillator sells at lowest price ever . . . . . only **\$2995**  
Stock No. 153, complete with RCA Metal Tubes

**GIANT DIAL!** Wide frequency range—100  
**ONE-VOLT OUTPUT!** to 30,000 kcs. Harmonics of  
**RCA METAL TUBES!** last band may be used for ultra-  
high frequency testing. Three  
attenuator taps plus fine control give continuous control of output from zero to 0.25 volts. See your RCA Parts Distributor for full details.

Over three hundred million RCA radio tubes have been purchased by radio users. . . . . In tubes, as in parts and test equipment, it pays to go RCA ALL THE WAY.

**RCA** Test Equipment  
RCA Manufacturing Co., Inc., Camden, N. J.  
A Service of Radio Corporation of America

## New Receiving Tubes

### Type 1851 Television Tube

A NEW television amplifier pentode intended for use in experimental television receivers has recently been made available through the transmitting-tube distributors of RCA.

This new pentode, identified as the 1851, features extremely high grid-plate transconductance (9000 micromhos). It is recommended for use in the r.f. and i.f. stages of the picture amplifier as well as in the first stages of the video amplifier when several video stages are used.

Tentative characteristics and ratings are given below:

|                                                  |                                 |                                  |
|--------------------------------------------------|---------------------------------|----------------------------------|
| Heater voltage (a.c. or d.c.) . . . . .          | 6.3 volts                       |                                  |
| Heature current . . . . .                        | 0.45 amp.                       |                                  |
| Inter-electrode capacitances: *                  |                                 |                                  |
| Grid-plate . . . . .                             | 0.02 $\mu$ fd. max.             |                                  |
| Input . . . . .                                  | 11.5 $\mu$ fd.                  |                                  |
| Output . . . . .                                 | 5.2 $\mu$ fd.                   |                                  |
| Max. plate voltage . . . . .                     | 300 volts                       |                                  |
| Max. screen voltage . . . . .                    | 150 volts                       |                                  |
| Max. screen supply voltage . . . . .             | 300 volts                       |                                  |
|                                                  | <i>Condition I</i> <sup>2</sup> | <i>Condition II</i> <sup>3</sup> |
| Typical operation:                               |                                 |                                  |
| Plate voltage . . . . .                          | 300                             | 300 volts                        |
| Suppressor voltage . . . . .                     | 0                               | 0 volts                          |
| Suppressor-supply voltage <sup>1</sup> . . . . . | 150                             | 300 volts                        |
| Screen series resistor . . . . .                 | 0                               | 60,000 ohms                      |
| Cathode-bias resistor <sup>4</sup> . . . . .     | 160                             | 160 ohms, min.                   |
| Amplification factor,                            |                                 |                                  |
| appr. . . . .                                    | 6750                            | 6750                             |
| Plate resistance, appr. . . . .                  | 0.75                            | 0.75 megohm                      |
| Transconductance . . . . .                       | 9000                            | 9000 micromhos                   |
| Plate current . . . . .                          | 10                              | 10 milliamperes                  |
| Screen current . . . . .                         | 2.5                             | 2.5 milliamperes                 |

\* With shell connected to cathode.  
<sup>1</sup> Screen-supply voltages in excess of 150 volts require use of a series dropping resistor to limit the voltage at the screen to 150 volts when the plate current is at its normal value of 10 milliamperes.  
<sup>2</sup> Condition I with fixed screen supply gives a sharp cutoff characteristic.  
<sup>3</sup> Condition II with series screen resistor gives.  
<sup>4</sup> The d. c. resistance of the grid circuit should not exceed 0.25 megohm.

The base pins of the 1851 fit the standard octal socket which should be installed to hold the tube in a vertical position, with the base either up or down. A pin cap terminal is used for the grid terminal, and connection is made to it by means of a clip, for which one receptacle from an octal socket is satisfactory. The clip and clip lead must be kept away from the shell of the tube.

Base connections of the 1851 are as follows: Pin 1, shell; pin 2, heater; pin 3, plate; pin 4, screen; pin 5, suppressor; pin 7, heater; pin 8, cathode.

### 6K8

Raytheon and RCA simultaneously report the Type 6K8, a multi-unit type of metal vacuum tube incorporating a triode unit and a hexode unit. It is intended primarily for use as a converter in superheterodyne receivers, especially those of the all-wave type. In such receivers, performance of the 6K8 is characterized by improved frequency stability in the high-frequency bands. This tube may be used satisfactorily in a.c.-d.c. receivers, inasmuch as the



*Bulletins GEA-201A and GEA-2818  
sent on request*

RADIO DEPARTMENT  
GENERAL ELECTRIC COMPANY  
SCHENECTADY, N. Y.

## HE'S MAKING CERTAIN That You Get a Better Capacitor

**T**HIS engineer is making the final check on Pyranol before it is used in treating G-E capacitors. It must conform to rigid standards. This is just one of many check tests of materials entering into G-E Pyranol capacitors.

Pyranol has very high dielectric strength and will not burn. Because of its better electrical stability, as compared with ordinary insulating oils, G-E hermetically sealed Pyranol capacitors will retain their excellent quality year after year. For trouble-free operation, install G-E capacitors in your set.

# GENERAL ELECTRIC

Filing No. 5700

900-9

### How to Modernize Your P.A. Equip- ment with TURNER'S New 30-30 Crystal Mike

A brand new streamline crystal mike that gives you semi-directional operation, genuine absence of peaks, greatly reduced feedback trouble and trustworthy response . . . 30 to 8000 C.P.S. High level, minus 52DB, allows use of economical low gain amplifier. Hum problems are minimized because no input transformer required. The 30-30 is not affected by wind on outdoor set-ups and will not blast. Crystal interior suspended in shock absorbing material to prevent breakage and eliminate handling noises. Smooth ebony \$13.93 and sparkling chrome finish.



Priced right. Order today. *Net. Cable Included.* Model 30-30.  
**PORTLAND RADIO SUPPLY CO.**  
1300 W. Burnside Street Portland, Oregon  
*Licensed Under Patents of the Brush Development Co.*

### With FRONT or REAR ILLUMINATION

FAN TYPE  
ROUND  
SQUARE

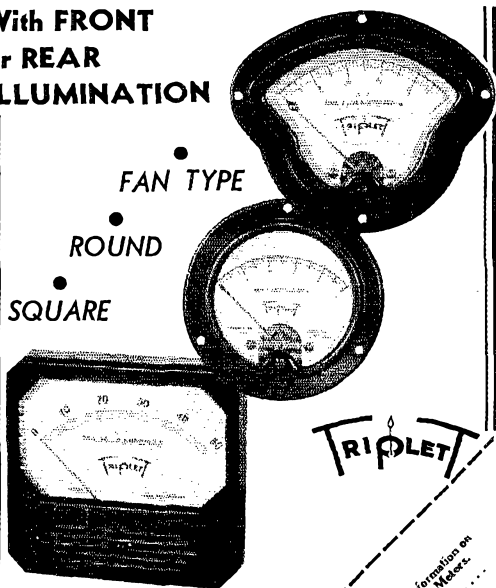

Sensitive and ultra-sensitive electrical indicating instruments. D.C. Moving Coil . . . . A.C. the Repulsion Type. Sizes — 2" to 7".

Specify TRIPLET for the finest, most up-to-date instruments in appearance, performance and economy.

The Triplet Electrical Instrument Co.  
Please send me more complete information on  
251 Harrison Ave., Hudson, Ohio  
Triplet Fan Type, Round and Square Models.  
Name \_\_\_\_\_  
Address \_\_\_\_\_ City \_\_\_\_\_ State \_\_\_\_\_



### NEW HOLDER DESIGN 15 SECONDS TO INSTALL CRYSTAL

For All Bands  
GREATER STABILITY  
Plugs in 5 prong tube socket  
Beautiful Appearance

**MODEL AH HOLDER \$1.00** At your dealer or direct

**HIPOWER LOW DRIFT CRYSTALS:**  
within 10 kc. or Choice of stock

AH-10, 1700-3500 Kc. bands \$2.35  
AH-10, 7000-7300 " bands 3.90

WRITE FOR NEW LITERATURE

Hipower "Low Drift" Broadcast and Commercial Crystals Are Approved by F.C.C.

Hipower Crystal Co., 2035 Charleston St., Chicago

HERE THEY ARE

AT NEW **LOW** PRICES



2 MFD — 2000 VOLT  
OIL IMPREGNATED  
**TRANSMITTING  
CONDENSERS**

**\$1.25**

Because . . . a nationally known manufacturer has discontinued this round can for the square type . . . **YOU PROFIT!** Only a limited quantity at this low price.

**TRIAD 866's**

**90c**

FIRST QUALITY! RUGGED! LONG LIFE!

*Never before sold at this low price!*

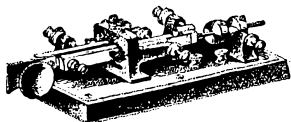

**KENCO KEYS**

Another lot . . . at a special price concession from the manufacturer. At this price you cannot afford not to have one of these automatic keys.

**\$2.95**

**40M  
7200—  
7500  
XTALS**

Regular 40 meter "X" cut xtals made by nationally known manufacturer. Ideal for new 28.5 30 MC fone — Fm stock.

**99c**

**NEW  
TAYLOR  
TUBES**

T-40 TZ-40

Two new WONDER TUBES that are breaking all records.

**\$3.50**

*Include P.P. with M.O. on Mail orders*

**The RADIO SHACK**

**46 BRATTLE STREET**

**BOSTON**

screen, oscillator plate, and mixer plate may all be operated from the same 100-volt supply.

Typical operating conditions for the 6K8 for 250-volt plate supply are as follows:

|                                                                                   |               |
|-----------------------------------------------------------------------------------|---------------|
| Mixer plate voltage (hexode) . . . . .                                            | 250 volts     |
| Mixer screen voltage (hexode) . . . . .                                           | 100 volts     |
| Mixer control grid bias (hexode) . . . . .                                        | —3 volts      |
| Oscillator plate voltage (triode) . . . . .                                       | 100 volts     |
| Oscillator grid resistor (triode) . . . . .                                       | 50,000 ohms   |
| Mixer plate current (hexode) . . . . .                                            | 2.7 ma.       |
| Mixer screen current (hexode) . . . . .                                           | 6.5 ma.       |
| Oscillator plate current (triode) . . . . .                                       | 3.5 ma.       |
| Oscillator grid current (triode) . . . . .                                        | 0.15 ma.      |
| Mixer plate resistance, appr. (hexode) . . . . .                                  | 0.6 megohm    |
| Conversion transconductance . . . . .                                             | 400 micromhos |
| Conversion transconductance at mixer control-grid bias = —30 volts, appr. . . . . | 2 micromhos   |

Connections of the 6K8 are as follows: Pin 1, shell; pin 2, heater; pin 3, hexode plate; pin 4, hexode screen (grids number 2 and 4); pin 5, triode grid and hexode grid number 1; pin 6, triode plate; pin 7, heater; pin 8, cathode; cap, hexode grid number 2.

**Southern California Emergency**

*(Continued from page 78)*

stand regular watch). An N.C.R. emergency circuit between San Diego, Los Angeles and San Francisco was placed in operation for the Red Cross on March 3rd by the Commandant of the 11th Naval District. The Trunk Lines handled quite a load of Los Angeles area traffic during the period from the 3rd to the 6th, mostly of a personal nature. Some official messages were handled, but for the most part these were put on wire lines near the emergency zone. Due to the character of the disaster national radio communications aid was not the vital essential it has been in recent eastern floods.

The bands most used were 160- and 75-meter 'phone within the area and 40- and 80-meter c.w. for national relaying. Five-meter mobile units also proved intensely useful, with 28-Mc. mobiles covering the longer jumps. The principal lack appeared to be an adequate number of emergency-powered portables at strategic points. Los Angeles had a surplus; in other regions they were badly needed, but transportation difficulties left no way to effect the exchange.

A particularly outstanding feature of the amateur work was the cooperation given the press. With more than a score of California cities isolated, newspaper correspondents were dependent on amateur communication. All AP and UP dispatches from San Diego, El Centro, Riverside, Redlands, San Bernardino and Filmore for the first 24 hours came via amateur radio. This performance, although not in itself widely ballyhooed, will unquestionably aid amateur prestige.

This emergency has given the new A.R.R.L. emergency plan its baptism of fire. For the first time the principle of coordinating amateur activities under centralized control by local appointees has been tried out. Although the plan is so new that there had been little opportunity for detailed planning, it is evident from the

*(Continued on page 108)*



## HAPPY FAMILY—IS RIGHT

Adolph Gross and Bill Filler and our clerks and our delivery boys . . . all think of themselves as members of a hustling, bustling family . . . with good merchandise to sell, service to perform, FRIENDS to make and to hold. You don't have to know French to recognize esprit de corps as manifested here every hour of every day. New catalog ready.

# TERMINAL Radio Corporation

80 CORTLANDT STREET, NEW YORK, N. Y.

TELEPHONE • BARCLAY 7-0622

Depend on a Good Name

. . . because it means good materials, good engineering, and excellent performance. You'll be satisfied with dependable Ken-Rad Radio Tubes.



## Ken-Rad Radio Tubes

KEN-RAD TUBE & LAMP CORPORATION - OWENSBORO, KY.  
Makers of all types of Radio Tubes and Ken-Rad Electric Light Bulbs

## LEARN RADIO — TELEVISION —

500 Licensed graduates placed in past 7 years in shipping, broadcasting, aviation, police, etc.; we also teach radio servicing and repairing; new term Mar. 14, May 9; day or eve.; 52-page catalog free; oldest, largest and best equipped.

### MASS. RADIO SCHOOL

18 Boylston Street, Boston

G. R. Entwistle, Pres.  
Established 1899

R. F. Trop, Treas.  
Hancock 8184

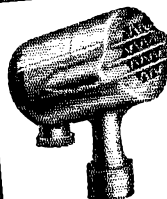

## The New "Clipper" Dynamic

Another American Moving-Coil Microphone. Featuring High Output, Small Size, Ruggedness, Fidelity, Trim, Efficient Design, Long Life, Stability. D7 and D7T Microphones come complete with 12 1/4' R/J cable and Amphenol plug. Chrome finish. 5/8-27 Connector. Over-all height, 2 3/4". Diameter, 1 1/4". Net weight, 8 1/4 ounces.

D7T — High Impedance 10,000. List Price . . . . . \$22.50  
D7 — Low Impedance 30 to 50 Ohms. List Price . . . . . \$20.00

Request Catalogue No. 27 for Complete Details

AMERICAN MICROPHONE CO., INC.  
LOS ANGELES, CALIFORNIA

Say You Saw It in QST — It Identifies You and Helps QST



*quality above all*

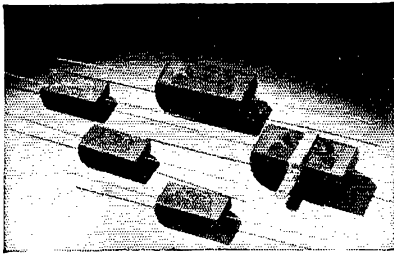

**TYPE XB  
Mica Transmitting Capacitor  
WITH LEADS . . .**



NOW, for the first time, high voltage mica condensers with convenient wire leads! Low-loss Bakelite; excellent i.f. characteristics; individually packaged.

Order through your jobber

**SOLAR MFG. CORP.**  
599-601 Broadway New York, N. Y.

**"PITC"** — *Pitcairn Island*

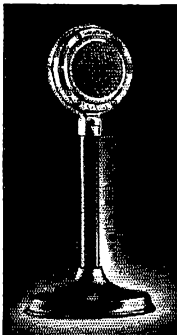

**Goes on the Air with  
the SHURE 70SW  
"Communications-Type"  
Crystal Microphone**

"Way out on this little isle in the South Seas, where atmospheric conditions are plenty tough, where the signals must get thru — clearly, intelligibly, consistently — the Voice of Pitcairn will talk to the world thru this famous Shure hi-efficiency "speech" microphone.

The MODEL 70SW, complete with desk stand and cable, lists at **\$25**

Ask your Jobber or Write us for Catalog 144Q

**HOLD IT . . . in the  
Palm of your Hand**

New Shure "Military-Type" Hand Microphone! Small, light, compact. Optional locking press-to-talk switch. Carbon and Crystal types, in standard or "anti-noise" close-talking models.

List Prices . . . . **\$15 to \$31.50**

Shure Patents Pending; Licensed under patents of the Brush Development Company.



**Speech Amplifier Design**

(Continued from page 14)

cycle component that is picked up by the cathodes from the heaters.

It may seem peculiar that fixed bias was not used on all stages when a supply would be available simply by adding a few small resistors to the voltage-divider circuit in the output of the bias filter, especially since fixed bias would automatically eliminate the large-sized cathode condensers and hum troubles in the cathode circuits, the cathodes being grounded. It was found, however, that the additional filters required for each individual grid circuit with fixed bias were considerably more complicated than the cathode-biasing arrangement, particularly in the input stage; furthermore, the amplifier as a whole had a tendency to "squawk" as the tubes were warming up, or at the instant the a.c. switch was turned off.

**HUM ELIMINATION**

Even though all the precautions mentioned so far regarding hum elimination are carefully followed, it will probably be necessary to do some experimental work in order to reduce the hum to the lowest possible level. The best way to attack the hum elimination problem is to start with the output stage, all other tubes being removed from the circuit. The 2A3's must be approximately balanced in their characteristics, and even so it is desirable in some cases to have a variable center-tapped resistor across the filament circuit so that the point which gives minimum hum can be easily found. This adjustment should be made with the 2A3 grids connected together (the push-pull input transformer secondary shorted). Then, remove the short and if the hum level increases twist the transformer around on the chassis until the point of minimum pickup is found. During this test, the primary should be open.

Next, proceed to the 56 stage and check the plate filter, bias supply leads, etc., for possible sources of hum. Work back in this manner until the input stage is reached, for it is here that most of the hum troubles originate and it will be quite impossible to overcome them effectively if there are other sources of hum in the following stages. The reason for this is that the hums introduced at different circuit points will not add up in phase and it is quite possible, therefore, that an experimental circuit change that actually increases hum in one portion of the circuit will tend to buck out hum in the output. Such a condition is most unsatisfactory. If this bucking out action is allowed, the hum level will vary with the setting of the gain control, tone control, etc., and the residual hum level cannot be reduced to the absolute minimum. Furthermore, fundamental hum frequencies may buck each other while harmonics may add.

Several special precautions must be taken in wiring the input stage; the tube and all circuit elements associated with the grid and cathode must be completely shielded; this includes the microphone jack, coupling condenser, r.f. choke,

# INDISPENSABLES

√ your receiver    √ your transmitter    √ your F.C.C. licenses  
 √ your LICENSE MANUAL

It's against the law to operate an amateur radio station without the required federal licenses for station and operator. The maximum penalty for so doing is a \$10,000 fine and two years in a federal penitentiary.

That's the broad basic picture. But within the scope of the federal licensing machinery are many detailed regulations, the violation of any one of which can lead to suspension, cancellation of licenses, or even fines or imprisonment. These regulations change frequently, in step with the rapidly developing art of radio.

There is only one way for the amateur to keep at his finger tips these changing legal requirements — short of maintaining his own Washington legal bureau. That is to keep the latest edition of the Radio Amateurs License Manual in the shack at all times. New editions always contain the latest regulations — and when a new edition appears it means that changes in federal regulations have made its predecessor obsolete.

WE ARE NOW SUPPLYING THE EIGHTH EDITION  
 TAKE A LOOK AT YOUR COPY!

TWENTY-FIVE CENTS POSTPAID

AMERICAN RADIO RELAY LEAGUE, WEST HARTFORD, CONN., U.S.A.

## RADIO

**ENGINEERING,** broadcasting, aviation and police radio, servicing, marine telegraphy and telephony, Morse telegraphy and railway accounting taught thoroughly. Engineering course of nine months' duration, equivalent to three years of college radio work. School established 1874. All expenses low. Catalog free. DODGE'S INSTITUTE, Day Street, Valparaiso, Indiana

THE NAME



ON

RADIO AND TELEVISION  
*Power* TRANSFORMERS

IS YOUR ASSURANCE  
 OF HIGHEST OPERATING  
 PERFORMANCE . . .

THE ACME ELECTRIC & MFG. CO.  
 38 WATER ST. CUBA, N.Y.

Acme  Electric  
 TRANSFORMERS

### DU MONT PHASMAJECTOR

PROVIDES A STANDARD VIDEO SIGNAL SOURCE  
 TO PROMOTE TELEVISION DEVELOPMENTS

The Du Mont Phasmejector Type No. 1 eliminates the dependence of the television experimenter on erratic and variable signals from the scattered television transmitters. This tube generates a video test signal with an output of 0.2 volt across a 10,000 ohm load. Price: \$40.00

#### DEMONSTRATES TELEVISION

The Phasmejector Type No. 1 may be used with two Du Mont Types 164 or 168 oscillographs with minor circuit changes for demonstration of the principles of television.

ALLEN B. DU MONT LABORATORIES, INC.  
 Upper Montclair, New Jersey

STOP  
 WASTING POWER  
 ON 5 METERS



Concentrate your carrier with a Bliley HF-2 10 meter crystal. At Bliley Dealers, \$5.75. Ask for Bulletin E-5.

BLILEY HF2 Crystals

# QST

## YEARLY BINDERS



THOSE who take pride in the appearance of their lay-out and wish to keep their reference file of *QST*'s in a presentable manner, appreciate the *QST* binder. It is stiff-covered, finished in beautiful and practical maroon fabricoid. Cleverly designed to take each issue as received and hold it firmly without mutilation, it permits removal of any desired issue without disturbing the rest of the file. It accommodates 12 copies of *QST* and the yearly index. Opens flat at any page of any issue.

With each Binder is furnished a sheet of gold and black gummed labels for years 1919 through 1938. The proper one can be cut from the sheet and pasted in the space provided for it on the back of the binder.

A file of several years of *QST*, kept in order in binders, is a most valuable reference library for any Radio Amateur.

Price **\$1.50** postpaid

Available only in United States and possessions, and Canada.

**THE AMERICAN RADIO RELAY LEAGUE**  
West Hartford, Conn.

grid leak, cathode resistor, and cathode resistor by-pass. All these parts can be conveniently mounted in a rectangular shield can, as shown in the photographs. The common ground point of the cathode resistor and by-pass condenser, the microphone jack, and the grid leak must be inside the shield and if the input stage, as a whole, is fairly close to the power transformer, this grounding point must be selected experimentally with considerable care.

The shield compartment itself must be solidly grounded to the chassis and should not touch the front panel or cabinet, as any such connection may cause circulating currents in the shield which will, in turn, introduce objectionable hum or r.f. feed-back.

The gain control must be of the non-inductive type and its leads must be completely shielded.

### tone control

Reference to the circuit diagram will show a tone control connected in the grid circuit of the 56 tube. This control is of the type that will attenuate either the high- or the low-audio frequencies. Little need be said concerning the action of the control since it is quite conventional in its operation. It constitutes, however, a worth-while addition to the amplifier since it may be used to compensate to some extent for peaks in the high frequency range of the microphone or, on the other hand, to weaken the bass voice frequencies and by so doing to effect a much higher level of modulation on frequencies in the middle range which are most necessary from the standpoint of intelligibility.

### R.F. FEEDBACK

The problem of eliminating r.f. feedback is very easy to solve; in fact, there will be no problem if filtering and shielding technique, as employed in receiver construction, is applied to the speech amplifier. The amplifier as a whole should be completely shielded. All external leads; i.e., the microphone cable, the a.c. supply cord, and the output leads, either must be well filtered or thoroughly shielded. In the case of the a.c. cord, a 0.1-ufd. condenser connected from one side of the line to the chassis will suffice. In addition, the power transformer should have an electrostatic shield to separate the primary from the other windings. The output circuit, being of fairly low impedance (not over 5000 ohms), can be bypassed to chassis with small mica condensers, although this will not be necessary unless the r.f. field around the equipment is exceptionally strong.

### CONCLUSION

Equipment built in accordance with the above suggestions will constitute a complete and self-contained unit which may be used with almost any microphone pickup, loud speaker, or transmitter. An amplifier of this type does not become obsolete and it is a worth-while addition to any radio shack, even though it may sink to the level of being used for p.a. work!

# Where to buy it

A directory of suppliers who carry in stock the products of these dependable manufacturers.



**ALBANY, N. Y.** Uncle Dave's Radio Shack 356 Broadway  
**BALTIMORE, MD.** 3 North Howard St.  
 Radio Electric Service Company  
**BOSTON, MASS.** Radio Shack 46 Brattle Street  
**BOSTON, MASS.** 110 Federal Street  
 Wholesale Radio Service Company, Inc.  
**BRONX, N. Y.** 542 East Fordham Rd.  
 Wholesale Radio Service Company, Inc.  
**HARTFORD, CONNECTICUT** 227 Asylum Street  
 Radio Inspection Service Company  
**JAMAICA, L. I.** 90-08 166th Street  
 Wholesale Radio Service Company, Inc.  
**NEWARK, N. J.** 219 Central Ave.  
 Wholesale Radio Service Co., Inc.  
**NEW YORK, N. Y.** Gross Radio, Inc. 51 Vesey St.  
**NEW YORK, N. Y.** Harrison Radio Co. 12 West Broadway  
**NEW YORK, N. Y.** 100 Sixth Ave.  
 Wholesale Radio Service Co., Inc.  
**NEW YORK, N. Y.** Terminal Radio Corp. 80 Cortlandt Street  
**POTTSVILLE, PENN.** E. Norwegian & George Sts.  
 Sylvester Radio & Supply Co., Inc.  
**READING, PENN.** 404 Walnut St.  
 George D. Barbey Company  
**READING, PENN.** 104 North Ninth Street  
 Sylvester Radio & Supply Co., Inc.  
**SPRINGFIELD, MASS.** T. F. Cushing 349 Worthington St.  
**WASHINGTON, D. C.** 938 F Street, N. W.  
 Sun Radio & Service Supply Co.



**ALBANY, NEW YORK** 356 Broadway  
 Uncle Dave's Radio Shack  
**BINGHAMTON, NEW YORK** 25-27 Sturges Street  
 Radio Testing Station  
**CONCORD, NEW HAMPSHIRE** Rear, 80 N. State Street  
 Evans Radio  
**HARTFORD, CONNECTICUT** 210 Chapel Street  
 Stern Wholesale Parts Company  
**NEW YORK, N. Y.** Harrison Radio Co. 12 West Broadway  
**NEW YORK, N. Y.** Terminal Radio Corp. 80 Cortlandt Street  
**ROCHESTER, NEW YORK** 244 Clinton Ave., N.  
 Radio Parts & Equipment Co.



**ALBANY, NEW YORK** 356 Broadway  
 Uncle Dave's Radio Shack  
**BOSTON, MASS.** The Radio Shack 46 Brattle Street  
**BOSTON, MASS.** Selden Radio Company 28 Brattle Street  
**BOSTON, MASS.** 110 Federal Street  
 Wholesale Radio Service Company, Inc.  
**BRONX, N. Y.** 542 East Fordham Rd.  
 Wholesale Radio Service Company, Inc.  
**BUFFALO, NEW YORK** Radio Equipment Corp. 326 Elm Street  
**CONCORD, NEW HAMPSHIRE** Rear, 80 N. State Street  
 Evans Radio  
**JAMAICA, L. I.** 90-08 166th Street  
 Wholesale Radio Service Company, Inc.  
**NEWARK, NEW JERSEY** 219 Central Avenue  
 Wholesale Radio Service Co.  
**NEW YORK, N. Y.** Harrison Radio Co. 12 West Broadway  
**NEW YORK, N. Y.** 100 Sixth Avenue  
 Wholesale Radio Service Co.  
**WASHINGTON, D. C.** 938 F Street, N. W.  
 Sun Radio & Service Supply Co.

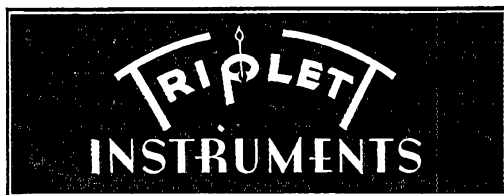

**ALBANY, N. Y.** Uncle Dave's Radio Shack 356 Broadway  
**BOSTON, MASS.** Radio Shack 46 Brattle Street  
**BOSTON, MASS.** Selden Radio Company 28 Brattle St.  
**BOSTON, MASS.** 110 Federal Street  
 Wholesale Radio Service Company, Inc.  
**BRONX, N. Y.** 542 East Fordham Rd.  
 Wholesale Radio Service Company, Inc.  
**JAMAICA, L. I.** 90-08 166th Street  
 Wholesale Radio Service Company, Inc.  
**MONTREAL, CANADA** 285 Craig Street, West  
 Canadian Electrical Supply Co., Ltd.  
**NEWARK, N. J.** 219 Central Ave.  
 Wholesale Radio Service Company  
**NEW YORK, N. Y.** 100 Sixth Avenue  
 Wholesale Radio Service Company  
**POTTSVILLE, PENN.** E. Norwegian & George Sts.  
 Sylvester Radio & Supply Co., Inc.  
**READING, PENN.** George D. Barbey Co. 404 Walnut Street  
**READING, PENN.** 104 North Ninth St.  
 Sylvester Radio & Supply Co., Inc.  
**WASHINGTON, D. C.** 938 F Street, N. W.  
 Sun Radio & Service Supply Co.

They're  
**ULTRA-COMPACT!**



**SUITABLE FOR EVERY SERVICE NEED**

Cornell-Dubilier type BR dry electrolytics (illustration actual size) are the last word in efficient compact filter capacitors. Hermetically sealed in aluminum containers, these condensers are completely protected against heat and humidity. Size is fully 1/8 that of corresponding types.

C-D BR's are now at your dealer — Single sections only in capacities 4, 8, 12, 16, 20 and 40 mfd., 150 Volts D.C. and up to 3 mfd., 450 Volts D.C.

Complete details in catalog flyer No. 154A. Write Today to 1013 Hamilton Blvd., South Plainfield, N. J.  
Cable Address: "CORDU"

**CORNELL - DUBILIER**



**ELECTRIC CORPORATION**  
South Plainfield, New Jersey

## My Creed . . .

TO give you specialized personal service of genuine value that is not available from other jobbers.

TO finance all my time sales myself so that I can sell all receivers, transmitters, and parts to you on terms arranged to suit you with less interest cost.

TO take your equipment in trade at a fair value.

TO allow you to try any receiver for ten days without obligation and to cooperate with you in every way I can to see that you are entirely satisfied.

### Compare Bob Henry's Terms with Others

| Model and Receiver     | Cash Price | Down Payment | 12 Monthly Payments |
|------------------------|------------|--------------|---------------------|
| NC80X and NC81X...     | \$99.00    | \$19.80      | \$6.99              |
| NC101X.....            | 129.00     | 25.80        | 9.11                |
| HRO.....               | 179.70     | 35.94        | 12.70               |
| RME-69.....            | 151.20     | 30.24        | 10.69               |
| Breting 14AX.....      | 99.00      | 19.80        | 6.99                |
| Sky Challenger II..... | 77.00      | 15.40        | 5.44                |
| Super Skyrider.....    | 99.00      | 15.40        | 6.99                |

Also Super Pro, ACR-111, PR15, Sky Chief, others.

Similar terms on Harvey, RCA, RME, Temco transmitters and Progressive, Utah, Stancor, All Star kits.

**IN STOCK:** RME 510X Expander \$42.00, Meissner Frequency Shifter \$39.95, T40s and TZ40s \$3.50, all other latest equipment at wholesale prices. Get quickest delivery of the latest equipment from W9ARA. Your inquiries invited.

**HENRY RADIO SHOP**

211 North Main Street Butler, Missouri

## A Simple 110-Volt A.C.-D.C. Code-Practice Oscillator

(Continued from page 34)

resistor wire is distinguished by white covering. It is important that the proper-resistance cord be obtained, since cords of several different resistance values are made for different tubes and tube combinations.

The filter condenser,  $C_2$  and  $C_3$ , is a two-section midget electrolytic condenser having a common negative lead and separate positive leads. The common negative lead is connected in the oscillator to the cathode of the pentode section of the 12A7, and to the  $C$  connection of the transformer secondary. One of the positive leads of the condenser is connected to the resistor terminal of the line cord and to the resistor  $R_2$ . The other positive lead connects to the opposite end of the resistor, and through key and headphones to the  $B$  terminal of the transformer. The opposite end of the transformer primary winding,  $P$ , is connected to the plate of the pentode section of the 12A7. The grid resistor and grid condenser,  $R_1$  and  $C_1$ , are connected between the grid terminal of the tube (the top cap) and one of the secondary terminals marked  $G$ . If the oscillator is completed according to the wiring diagram, and all connections have been carefully checked, failure of the set to oscillate when the key is closed will indicate that the incorrect  $G$  terminal of the transformer was chosen, in which case it will merely be disconnected and the other  $G$  lead will be substituted. This applies with operation on a.c., and on d.c. if closing the key causes a distinct click in the headphones after the tube has warmed for a minute. If a d.c. source is used with the oscillator, the polarity of the plug must be correctly fixed by plugging it in so that the click of the 'phones may be produced by keying the oscillator.

If the pitch produced by the oscillator is found to be too low or too high, it may be varied over a wide range by varying the resistance value of the grid resistor,  $R_1$ .

In the operation of this code-practice oscillator, care must be taken that neither the wiring of the oscillator, nor the key nor 'phones be allowed to come in contact with ground. Also, the operator must use caution to refrain from being connected between the oscillator or key and a ground connection.

## Southern California Emergency

(Continued from page 100)

reports so far at hand that facilities were conserved, duplication and undue waste of effort avoided, and the troubles of multiple deliveries and inadequate cooperation between networks minimized by its operation.

It is clear that a difficult job was successfully performed. We feel a surging pride at the accomplishments of our southern California brethren; they have upheld the amateur tradition in noble fashion indeed.

# HAM-ADS

(1) Advertising shall pertain to radio and shall be of nature of interest to radio amateurs or experimenters in their pursuit of the art.

(2) No display of any character will be accepted, nor can any special typographical arrangement, such as all or part capital letters be used which would tend to make one advertisement stand out from the others.

(3) The Ham-Ad rate is 15c per word, except as noted in paragraph (6) below.

(4) Remittance in full must accompany copy. No cash or contract discount or agency commission will be allowed.

(5) Closing date for Ham-Ads is the 25th of the second month preceding publication date.

(6) A special rate of 7c per word will apply to advertising which, in our judgment, is obviously non-commercial in nature and is placed and signed by a member of the American Radio Relay League. Thus, advertising of bona fide surplus equipment owned, used and for sale by an individual or apparatus offered for exchange or advertising inquiring for special equipment, if by a member of the American Radio Relay League takes the 7c rate. An attempt to deal in apparatus in quantity for profit, even if by an individual, is commercial and takes the 15c rate. Provisions of paragraphs (1), (2), (4) and (5) apply to all advertising in this column regardless of which rate may apply.

Having made no investigation of the advertisers in the classified columns, the publishers of *QST* are unable to vouch for their integrity or for the grade or character of the products advertised.

**QUARTZ**—direct importers from Brazil of best quality pure quartz suitable for making piezo-electric crystals. Diamond Drill Carbon Co., 719 World Bldg., New York City.

**RADIO** engineering, broadcasting, aviation and police radio, servicing, marine and Morse telegraphy taught thoroughly. All expenses low. Catalog free. Dodge's Institute, Byrd St., Valparaiso, Ind.

**QSL'S**, W2SN, Helmetta, N. J.

**CALLBOOKS**—new DX calls, new prefixes, thousands of new W and VE calls, in the Spring, 1938 Radio Amateur Call Book. Sent postpaid \$1.25, or a whole year (four issues) for \$4. (In foreign countries \$1.35 and \$4.35). Your call and QRA printed in large type \$1 per year. Radio Amateur Call Book, 610 S. Dearborn, Chicago.

**QSL'S**, all colors, cartoons, snappy service. Write for free samples today. WIBEF, 16 Stockbridge Ave., Lowell, Mass.

**USED** receivers. Bargains. Cash only. No trades. Price list 3¢. W3DQ, Wilmington, Del.

**RECEIVERS**: Write for list of used bargains. National, Halli-crafter, PR-10, etc. New RCA-ACR155—\$44.50. Van Sickle Radio, W9KJF, Indianapolis, Ind.

**QSL'S** Cartoons. Free samples. Theodore Porcher, 7708 Navajo St., Philadelphia, Penn.

**WANTED**: QST Volumes I, II, III and IV complete. Must be in good condition. State price particulars. Arthur Grols (W8DK), 43 Butler St., Mt. Clemens, Mich.

**QSL'S**—200 for \$1.25. Barry, Babylon, N. Y.

**QSL'S**—quality—2 color—\$1. hundred; \$1.75, 200. Samples. W8NOS.

**WANTED** for experimental purposes: defunct transmitting tubes. Cash or trade used radio parts. Write W6BYW.

**QSL'S**, SWL's, 65¢ hundred, two color. Samples. W1FTM, 268 Piedmont, Waterbury, Conn.

**WANTED**: Collins transmitter, 16 mm. camera. W9MLB, Gothenburg, Neb.

**QSL'S**. Samples. Stamp. Printer, Corwith, Iowa.

**SW3**—a.c.—five sets coils—10, 20, 40, 80 and BC. less power supply. First \$16. takes it. W1BGY.

**QSL** cards, neat, attractive, reasonably priced. Samples free. Miller, Printer, Ambler, Pa.

**QSL's?** QSL's? Patronize a brother ham. Samples? (stamp). W8DED, Holland, Mich.

**HLILEY**, patronize W8DED.

**METERS** new 3/5" flush bakelite cased. Pattern 88 200 microamperes \$5, 300 to 500 microamps \$4, 1 milliamp \$3.50, any range 5 to 1000 ma. \$2.95. Pattern 68 R. F. thermocouple type 10 or 50 ma. \$7.50, 100 ma. \$5., 5 to 20 amperes \$4.50. Also a.c. and d.c. voltmeters and ammeters. W2CXY, Hillside, N. J.

**BEST** offer: 90 watt phone transmitter, new; crystal mike. Box K, Oakley, Kans.

**SELL**: Collins 32B, \$60. cash. Write W1FPPS.

**WANTED**: Riders Manuals. Clarence Pate, Sampson, Ala.

**GENERAL** Electric 24/750 volt 200 mill dynamometers \$20. On 12 volts delivers 375. Two in series for 1500. Westinghouse 27 1/2/350 volt \$10. 500 watt 8-15 volt Aircraft \$10. 900 cycle 200 watts \$15. Simon 500 watt 900 cycle \$10. Henry Kienzle, 218 Hart Blvd., Staten Island, N. Y.

**SACRIFICE**: 200 watt phone transmitter. Also portable multi-band transmitter. Commercial appearance. Quality apparatus. Details, photographs on request. Camera, photographic equipment considered in trade. D. M. Gallagher, W2AEH, 1125 Paul Ave., Schenectady, N. Y.

**SELL**: One new 100TH, \$7.; almost new 50T, \$4.; used 50T, \$3.50; 800-0-800 200 ma. Thordarson, \$2.; 7 1/2 7 1/2 3.5 amp. Thordarson; 2 mfd. 1500 volt Dubilier, \$2.50. W7MCO, San Francisco.

**QSL'S**—W3BYK—923 N. 27 St., Camden, N. J.

**TRANSFORMERS**, chokes, custom built. Write for list. 36 lb. 1/2 KVA plates—\$11.; 47 lb. 1 KVA—\$15. Baker Engineering, Ft. Wayne, Ind.

**NEW** 20 watt fone, 80 watt c.w. portable 20-40-80, details on request, \$95. Two Eimac 150Ts, never used, \$20. pair. RCA ATR-219 5 meter transceiver, tubes and batteries, \$14.75; Wing 5 meter transceiver, tubes, \$7.50. Westinghouse 27.5/350 dynamotor, \$5. W1AYG.

**CRYSTALS**: X cut, 80-160, ± five kilocycles, \$1.50; spot frequency, \$2.50. Special prices to Army, Navy, Red Cross and other round table nets. Three small, 80 meter blanks, including carborundum, \$1.20; holders, \$1. William Threm, W8FN, 3071 Moosewood St., Cincinnati, Ohio.

**FREE**—catalog. Fabradio crystals and associated equipment. Prices from 75¢ to \$75. Dealers and users are enthusiastic. Fabradio, Sandwich, Ill.

**SACRIFICE**: sell 250 watt phone transmitter complete with separate speech amp. and crystal mike, \$150. W4EWO.

**QSL'S**. Finest designs. Free samples. Maleco, 1512 Eastern Parkway, Brooklyn, N. Y.

**WANTED**—half or one kw. Thordarson or other type high voltage spark transformer in good condition. Florman, Onekama, Mich.

**TRY** us first—radio supplies. Loughnane & Co., Decatur, Ill.

**QSL'S** of high quality. W2AEY, 338 Elmora, Elizabeth, N. J.

**W8IPF** selling out FB7 rcvr. 600 watt c.w. rig. Send for list.

**CRYSTALS**: 80M X, \$1.50. 160M-80M V, \$2.25. 40M V, \$2.75. Four cycle coefficient. Holders, \$1. Catalog. Ham Crystals, 1104 Lincoln Place, Brooklyn, New York.

**SELL** at discount: brand-new RME69 with noise suppressor, special band-spread, and break-in controls. W9ZT, 1623 Irving, Minneapolis, Minn.

**CRYSTALS**—unconditionally guaranteed. Supplied—five kilocycles. 160-80 meter X cut, \$1.50; A cut, \$2.25; 40 meter X cut, \$1.85. Wright Radio Labs., 5859 Glenwood, Chicago, Ill.

**QSL'S**—SWL—samples. Fritz, 455 Mason, Joliet, Ill.

**CRYSTALS**: Zero cut. New low drift. 160-80-40 meters \$1.85, 20 meters \$3. postpaid. Plug-in mountings 75¢. Fisher Lab., 4522 Norwood St., San Diego, Calif.

**SELL** 300 watts c.w. on 4 bands \$95., grid modulator \$12., 9 tube Sky-Rider \$55. All in new condition. W9ORY.

**USED** RME DB20. W8ANT.

**USED** NC100Xs. W8ANT.

**T40s**—TZ40s. W8ANT.

**NEW** Eimac rectifier tubes. W8ANT.

**GAMMATRONS**. W8ANT.

**USED** oscilloscope. W8ANT.

**WARD** Leonard antenna relays. W8ANT.

**BLILEY** crystals. W8ANT.

**FILTER** condensers, bargains. W8ANT.

**RME** frequency expanders, 510X, in stock. W8ANT.

**ALL** lines of new and used amateur equipment bought, sold, exchanged. Write to Southern Ohio's only amateur owned amateur business. Jos. N. Davies, W8ANT, 2767 N. Bend Rd., Sta. A., Cincinnati, Ohio.

**QSL'S**, SWL's. 100, 3 color, 75¢. Lapco, 344 W. 39th, Indianapolis, Ind.

**FREE**: 3—2000 volt, mica transmitting condensers—with every order of 100 QSL cards—price \$1. Large selection. Samples. W3DGS, 6417 Tulip St., Philadelphia, Pa.

**HERE** again—those snappy relay racks, panels, chassis. Edison Bs. Motorized duplex rotary beams—teerable horizontal and vertical directivity. W8ML.

**CRYSTALS**: Eideon's powerful X cut 80-40 meters, \$1.60. Try us for one. You can't beat these at any price. Van Radio, 464 E. 117th, No. 7, Cleveland, Ohio.

RELAY racks—standard 6 ft. steel. Special \$7.75. Circular. Eastern Technical Service, Oriskany, N. Y.

COAXIAL line—circular. Eastern Technical Service, Oriskany, N. Y.

CRYSTALS, mounted, 80-160 \$1.25, V-cut 40 \$2.25. R9 Crystals, 338 Murray Ave., Arnold, Pa.

SELL: motor-generator 110 a.c. 60-60 cycles to 500 volts 75 milliamperes plus 7½ volts 2.8 amperes, \$7.50, Bos Hess, 7118 Benson, Huntington Park, Calif.

CRYSTALS: are you tired of paying high prices for so-called fancy crystals only to see them soon fracture? Then turn to Eidson T9 crystals, they are more durable, are highly active, strong in harmonic output and reasonably priced—thousands of satisfied users will vouch for this. 40 and 80 meter bands \$1.60, 7301-7600 kc. range \$2. Rugged X cut, fully guaranteed, close frequency supplied. T9 ceramic holders \$1.10. Prices postpaid, C.O.D.'s accepted. Sold by: W9ARA, Butler, Mo.; Hieronymus Radio, 88-84 209th St., Queens Village, N. Y.; Pemberton Labs., Ft. Wayne, Ind.; or Eidson's, Temple, Texas.

F.C.C. approved combination per cent modulation meter and monitor. Direct reading Triplett meter tells you modulation level at any instant. In beautiful black crackle steel case. C.O.D., \$14.75 complete. Test Equipment Labs., W9GZ-W91BA, 2722 S. 59 Ave., Cicero, Ill.

SELL: Weston meters, National 5880 pack, condensers, other spare parts—list. W8AAJ.

QSL's—highest quality—lowest prices. Radio Headquarters, Ft. Wayne, Ind.

FOR sale: modern high fidelity radio broadcasting transmitter, 100-250 watts. Approved by F.C.C. under Rule 132. Complete a.c. operation, Class B modulation. Special price—send for photo. WHBI, Newark, N. J.

QSL's. Better designs, better stock, better workmanship. Free samples to hams only. W2FJE, 101 Hanson Place, Brooklyn, N. Y.

RELAY racks, standard, 73¼ inches, ½ inch steel, spot welded, undrilled, shipping weight 60 lbs., \$5. each. W4EDH-4, Johnson City, Tenn.

LONGLINES 5 meter oscillator. Beautiful workmanship, powerful, stable, efficient, inexpensive. Bulletin ready. QSL to Paradio, 124 Garrison, Jersey City.

SUPER-regenerator 5 meter receiver. Beautiful workmanship, and non-radiating, with preselection, self quenching detector, powerful audio. Modern, selective, inexpensive. Bulletin ready. QSL to Paradio, 124 Garrison, Jersey City.

SWELL QSL's: two colors; one hundred, \$1.; snappy service. W8CTC, Allegan, Mich.

TELEPLEXES, instructographs, omnigraphs, vibroplexes, receivers bought, sold, traded. Ryan's, Monroe City, Mo.

OPPORTUNITY to buy, sell or exchange used ham equipment. A plan that will appeal to you. Write for information—now. E. L. Glassford, W2EQK, 1934 University Ave., N. Y.

KITS assembled. Transmitters or any type of special equipment built to order. Radio Supply Co., 2114 Main St., Joplin, Mo.

SELL or swap for firearms QST file Jan., 1920; Oct., 1920—Jan., 1935 inclusive. Make offer. Pascal, 80 Nassau, N. Y. C.

DOUGLAS Universal Class B transformers. More audio, flexibility, quality, satisfaction, at the lowest possible price. Guaranteed—postpaid—for details write W9LXR, Weyerhaeuser, Wis.

FOR SALE: rack and panel 450 watt c.w. xmitter. T55's final. Cost over \$200—sell for \$80. Also 1938 Super Skyrider xtal and speaker \$80. Both hardly used. Photo and details on request. W1GOD, 131 Court St., Dedham, Mass.

SELL: complete set QST's 1930 through 1937, \$15. W8QXM, Capital University, Columbus, Ohio.

178 QST's 1917 to date, incomplete, \$15. lot. Lots of parts. Send for list. A. P. Southworth, Sheffield Rd., Wakefield, Mass.

RECONDITIONED guaranteed sets shipped on ten day trial: HROs \$129.70, NX100Xs \$99., RME-69s \$99., NC100s \$89., HRO Jrs. \$69., Breting 14s \$69., ACR-175s \$69., PR-16Cs \$69., Breting 12s \$69., RME9Ds \$59., SX15 Sky Challengers with crystal \$49., PR-10s \$39., Silver 5CXs \$34., Super-Sevens \$29., Sky Chiefs \$29., FBXAs \$29., FB7As \$23., Sky Buddies \$19., Sargent 10SA \$17.50, many other sets. List free. Write W9ARA, Butler, Mo.

GENUINE National FBXA coils \$2.95 pair, SW3 coils \$1.75 pair, Weston and Jewell RF meters \$3.95, new Dynamic mike \$6.95, RCA-800s \$4.95, RCA-872s \$6.95, RCA-204As \$17.50, 275 watt gas engine generator, 500 watt 110 volt a.c. generator, 1500 volt generator, other bargains. W9ARA.

SPECIAL brand-new SX15 Sky-Challengers with crystal filters \$59., brand-new SX11 Super-Skyriders with crystal \$69., new Mac-Key bugs \$5.95. W9ARA.

CODE machines rented and sold. W9ARA.

# NOW..... THE RECEIVER THEY'RE ALL TALKING ABOUT!

## the hallicrafters SX17

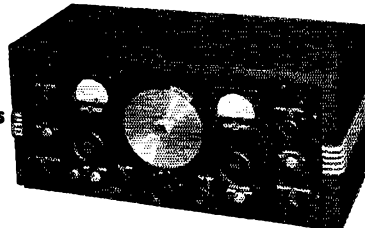

### A SPECIAL SUPER SKYRIDER

THE SX17, a special Super Skyrider with TWO stages of Pre-Selection and a Built-In NOISE LIMITER, is the communications receiver of the hour! Let us send you a complete description of this popular new receiver and full information on the H & E Time Payment Plan. Enjoy the splendid reception that you can get with an SX17 for only a small down payment and low monthly easily met payments. You'll like H & E friendly, personalized service, too, that has made us friends all over the country. Mail the coupon today.

**THE H & E TIME PAYMENT PLAN MAKES IT EASY TO OWN A NEW SX17**

#### MAIL THIS COUPON HINDS & EDGARTON

19 South Wells St., Chicago, Ill.

Please send me information on the SX17

Name.....Call.....

Address.....

City.....State..... Ill-6A

# DO YOU WANT TO LEARN WIRELESS and TELEGRAPHY?

A BOOK EVERY AMATEUR SHOULD HAVE —

*Send Now!*



**15¢ POSTPAID COIN, OR STAMPS**

Hundreds of amateurs have learned from this book, so can you.

This book gives you the fundamentals of wireless and telegraphy. It contains the codes and how to learn them. Mail your order now to:

SIGNAL ELECTRIC MFG. CO., Menominee, Michigan

ESTABLISHED 1892



# Your Nearest Dealer Is Your Best Friend

Your nearest dealer is entitled to your patronage. You can trust him. He is equipped with a knowledge and understanding of amateur radio. He is your logical and safe source of advice and counsel on what equipment you should buy. His stock is complete. He can supply your needs without delay. His prices are fair and consistent with the high quality of the goods he carries. He is responsible to you and interested in you.

Patronize the dealer nearest you—You can have confidence in him

## ATLANTA, GEORGIA

Wholesale Radio Service Company, Inc.  
265 Peachtree Street  
"The World's Largest Radio Supply House"

## BALTIMORE, MARYLAND

Radio Electric Service Co.  
3 N. Howard St.  
Everything for the amateur

## BOSTON, MASS.

Wholesale Radio Service Company, Inc.  
110 Federal Street  
"The World's Largest Radio Supply House"

## BRONX, NEW YORK

Wholesale Radio Service Company, Inc.  
542 East Fordham Road  
"The World's Largest Radio Supply House"

## BUFFALO, NEW YORK

Radio Equipment Corp.  
326 Elm Street  
W80BK --- Ham, service and sound equipment

## BUFFALO, NEW YORK

Dymac Radio  
216 E. Genesee Street  
Complete Line Ham and BCL Equipment  
Cl. 2080

## ELMIRA, NEW YORK

Miller's Radio Shack  
205 Railroad Avenue  
Fine equipment for amateurs

## JAMAICA, L. I.

Wholesale Radio Service Company, Inc.  
90-08 166th Street (Merrick Road)  
"The World's Largest Radio Supply House"

## MONTREAL, CANADA

Canadian Elec. Supply Co., Ltd.  
285 Craig St., W.  
Quality parts and equipment for discriminating buyers

## NEWARK, N. J.

Wholesale Radio Service Company, Inc.  
219 Central Avenue  
"The World's Largest Radio Supply House"

## NEW YORK, N. Y.

Gross Radio, Inc.  
51 Vesey Street  
Fair dealings plus fair prices. Anything in radio

## NEW YORK, N. Y.

Wholesale Radio Service Company, Inc.  
100 Sixth Avenue  
"The World's Largest Radio Supply House"

## NEW YORK, N. Y.

Harrison Radio Company  
12 West Broadway  
"The Friendly Ham Supply House"

## PHILADELPHIA, PENNSYLVANIA

Eugene G. Wile  
10 S. Tenth Street

Complete Stock of Quality Merchandise

## RICHMOND, VIRGINIA

The Arnold Company  
Broad at Harrison St.  
W3GPV—"The Virginia Ham Headquarters"—W3FBL

## ROCHESTER, NEW YORK

Radio Parts & Equipment Co.  
244 Clinton Avenue, North  
Complete stock amateur-BCL parts. Standard discounts



# You Are Protected When You Buy From QST Advertisers

“Advertising for QST is accepted only from firms who, in the publisher’s opinion, are of established integrity and whose products secure the approval of the technical staff of the American Radio Relay League.”

Quoted from QST’s advertising rate card.

Every conceivable need of a radio amateur can be supplied by the advertisers in QST. And you will know the product has the approval of the League’s technical staff.

## The Advertisers

|                                          |                    |
|------------------------------------------|--------------------|
| Ace Products Co.                         | 86                 |
| Acme Electric & Mfg. Company             | 103                |
| Aerovox Corp.                            | 87                 |
| American Microphone Company, Inc.        | 101                |
| Astac Microphone Company, Inc.           | 94                 |
| Bassett Research Corp.                   | 80                 |
| Birnback Radio Company, Inc.             | 98                 |
| Bliley Electric Company                  | 87, 103            |
| Candler System Company                   | 74                 |
| Capitol Radio Engineering Institute      | 94                 |
| Cardwell Mfg. Corp., Allen D.            | 66                 |
| Centralab                                | 67                 |
| Collins Radio Company                    | Cov. 2             |
| Cornell-Dubilier Corp.                   | 106                |
| Delaware Radio Sales Company             | 95                 |
| Delco Remy Corp.                         | 71                 |
| Dodge’s Institute                        | 103                |
| DuMont Laboratories, Allen B.            | 103                |
| Eastern Radio Institute                  | 85                 |
| Eitel-McCullough, Inc.                   | 63                 |
| Gardiner-Levering Co.                    | 86                 |
| General Electric Company                 | 99                 |
| Gordon Specialties Company               | 83                 |
| Gross Radio, Inc.                        | 76                 |
| Hallcrafters, Inc., The                  | 1, 2               |
| Hammarlund Mfg. Company, Inc.            | 79, 91             |
| Harvey Radio Company                     | 96                 |
| Harvey Radio Laboratories, Inc.          | 83                 |
| Henry Radio Shop                         | 106                |
| Hinds & Edgarton                         | 108                |
| Hipower Crystal Company                  | 99                 |
| Instructograph Company                   | 97                 |
| International Resistance Company         | 65                 |
| Inter-State Radio & Supply Co.           | 100                |
| Jefferson Electric Company               | 90                 |
| Johnson Company, E. F.                   | 70                 |
| Ken-Rad Tube & Lamp Corp.                | 101                |
| Kenyon Transformer Company, Inc.         | 5                  |
| Leads                                    | 86                 |
| Logan Company, Les                       | 97                 |
| Mallory & Company, Inc., P. R.           | 62                 |
| Massachusetts Radio School               | 101                |
| McGraw-Hill Book Company                 | 72                 |
| Melnsner Mfg. Company                    | 82                 |
| Mims Radio Company                       | 96                 |
| National Company, Inc.                   | Cov. 3, 61, 69, 85 |
| New York Y. M. C. A. Schools             | 87                 |
| Newark Electric Company                  | 81                 |
| Ohmite Mfg. Company                      | 85                 |
| Petersen Radio Company                   | 91                 |
| Port Arthur College                      | 83                 |
| Portland Radio Supply Company            | 99                 |
| Precision Apparatus Corp.                | 84                 |
| Precision Piezo Service                  | 95                 |
| RCA Institutes, Inc.                     | 95                 |
| RCA Mfg. Company, Inc.                   | Cov. 4, 64, 98     |
| Radio Mfg. Engineers, Inc.               | 111                |
| Radio Shack, The                         | 100                |
| Radio Supply Company                     | 97                 |
| Raytheon Production Corp.                | 68                 |
| Scientific Radio Service                 | 83                 |
| Shure Brothers                           | 102                |
| Signal Electric Mfg. Company             | 108                |
| Solar Mfg. Corp.                         | 102                |
| Speer Carbon Company                     | 75                 |
| Sun Radio Company                        | 97                 |
| Taylor Tubes, Inc.                       | 73                 |
| Teleplex Company                         | 85                 |
| Terminal Radio Corp.                     | 90, 101            |
| Transmitter Equipment Mfg. Company       | 95                 |
| Triplett Electrical Instrument Co., Inc. | 99                 |
| United Transformer Corp.                 | 112                |
| Universal Microphone Company             | 87                 |
| Utah Radio Products Corp.                | 97                 |
| Van Sickle Radio Supply Company          | 96                 |
| Vibroplex Company, The                   | 91                 |
| Western Electric Company                 | 78                 |
| Wilson, Willard S.                       | 95                 |
| Vaxley                                   | 62                 |

# MONEY SAVING SERVICE TO RME OWNERS

To all amateurs and commercial operators, who own RME-69 Receivers, Radio Manufacturing Engineers wish to call attention to the fact that your purchase of an RME-69 constituted an investment in which you desired to obtain maximum benefit and service for the longest possible period of time. You purchased an RME with the intention of realizing the benefits of our service whenever it became necessary and desirable.

RME has repeatedly stated that the 69 is complete, modern, up-to-date! We have kept our promise. As the radio industry progresses in newer developments of components and circuits, we have also progressed. No RME-69 owner need sacrifice his investment because of newer developments. They may be incorporated in any 69 at a nominal cost and the receiver continue to retain its high value and usefulness.

The following service on alterations may be obtained:

1. Installation of the LS-1 noise suppressor as described in our literature. Net, **\$15.40**
2. \* Replacement of the present crystal filter circuit for variable phasing control in which case only "on" and "off" positions are provided when using the crystal filter circuit. Net..... **\$6.70**

\* Note: If type BC-3, 465 KC crystal is in receiver, this will have to be changed over to the newer CF-1 vertical type. Additional charge for this type crystal. Net, **\$2.75**

3. Installation of new type air-tuned IF transformers which have recently been developed and approved. Net..... **\$10.75**

*On all of the above installations a complete check-up and calibration is included without additional charge.*

4. Complete overhaul and check-up less replacement of worn parts. (These parts are charged for at net prices when replacement is authorized.) Net..... **\$2.00**

5. Installation of extra pair of binding posts on rear of chassis apron and special relay control contacts provided on monitor switch for special break-in operation to control transmitter. Net..... **\$2.70**

*Additional band spread may be had on the band spread dial at no additional cost.*

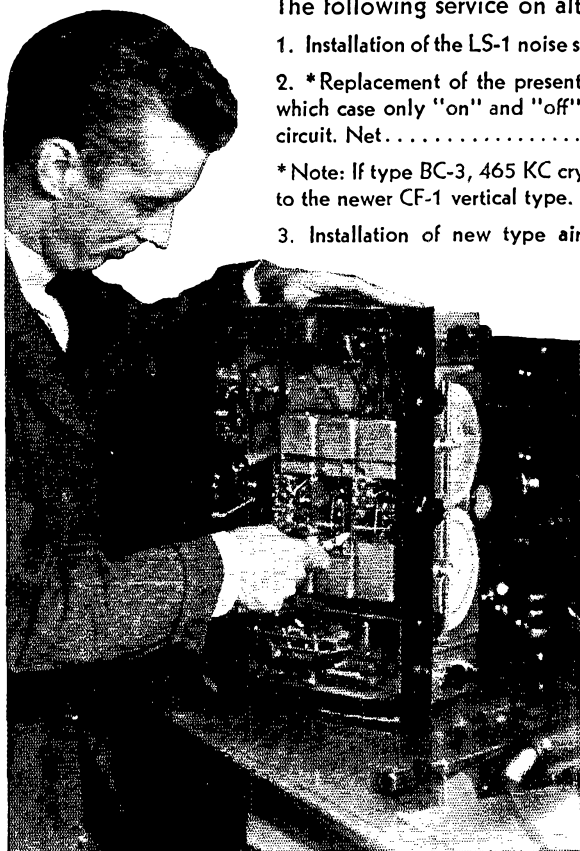

Your receiver is valuable to you. Pack it accordingly! Use a wooden box in every instance. Transportation damages are difficult to collect and delay the return of your receiver unreasonably. Equipment must be sent to us transportation charges prepaid. Always mention the serial number when writing about your receiver. It facilitates service.

**RADIO MFG. ENGINEERS, inc., PEORIA, ILLINOIS**

# RME - 69

# VARIMATCH

ALL UTC transformers are designed for maximum flexibility. The Varimatch series are noteworthy in that they will match any audio tubes to any RF tubes within their output rating, eliminating the possibility of obsolescence as new tubes are announced. All you have to decide is the DC input to your RF stage. Then just pick the VARIMATCH output transformer that will handle the maximum audio power required. These transformers will also match the line impedance output of PA or similar amplifiers direct to the Class C tubes. ALL VARIMATCH outputs matching RF stages will carry DC in the secondary.

THE VARIMATCH TRANSFORMER NEVER BECOMES OBSOLETE

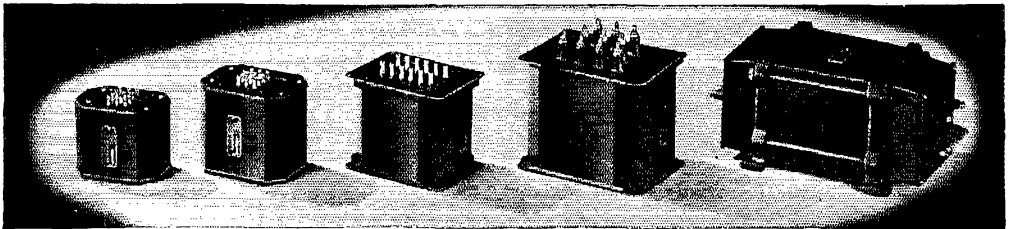

## VARIMATCH MODULATION TRANSFORMERS

UTC VARIMATCH Modulation Transformers Will Match ANY Modulator Tubes to ANY RF Load . . .

|                                               |         |
|-----------------------------------------------|---------|
| VM-0 Maximum audio output 20 watts . . . . .  | \$3.00  |
| VM-1 Maximum audio output 30 watts . . . . .  | \$4.80  |
| VM-2 Maximum audio output 60 watts . . . . .  | \$7.50  |
| VM-3 Maximum audio output 125 watts . . . . . | \$12.00 |
| VM-4 Maximum audio output 300 watts . . . . . | \$19.50 |
| VM-5 Maximum audio output 600 watts . . . . . | \$42.00 |

## VARIMATCH INPUT TRANSFORMERS

Varimatch Input Transformers will take care of practically every driver requirement.

PA-50AX Single 89, 53 56, 6C5, etc. to class B 53, 6A6, 89, etc. . . . . \$3.30

PA-51AX Single 56, 6C5, 45, 59, 6L6, 2A3, etc. to class B 46, 59, 79, or A prime 42's, 45's, etc. . . . . \$3.30

PA-52AX Push Pull 45, 59, 2A3, etc. to class B 46, 49, 841, etc. . . . . \$3.90

PA-53AX Push Pull 45, 59, 2A3, 6L6, etc. to class B 210, 801, 800, 35T, 8K-18, 203A, ZB-120, etc. . . . . \$4.50

PA-59AX 500 ohms line to 805, 838, 203A, 210, 800, ZB-120, etc. . . . . \$4.50

PA-538AX Push Pull Parallel 45, 2A3, 6L6, etc. to push pull parallel 838, 203A, ZB-120, or to class B 204A, HF-300, 849, etc. . . . . \$10.50

PA-512 500 ohms line to class B, 150T, HF-300, 204A, etc. . . . . \$12.00

## PA VARIMATCH TRANSFORMERS

The new UTC PA Varimatch transformers will match practically any tube in their power range to a 200-500 ohm line or to any voice coil.

PVM-1 For all audio tubes up to 12 watts. \$3.00

PVM-2 For all audio tubes up to 30 watts. \$4.80

PVM-3 For all audio tubes up to 60 watts. \$7.50

PVM-4 For all audio tubes up to 125 watts. \$12.00

PVM-5 For all audio tubes up to 300 watts. \$19.50

## LINE VARIMATCH TRANSFORMERS

The UTC LINE VARIMATCH units will match any single or group of voice coils to a 500 ohm line. Impedance range is from .2 to 75 ohms in 50 combinations . . . UTC LINE VARIMATCH AUTOFORMERS will match one to ten 500 ohms lines or LVM 500 ohm windings to the 500 ohm output of an audio amplifier.

LVM-1 12 watt Line Varimatch unit. . . . . \$2.70

LVM-2 30 watt Line Varimatch unit. . . . . \$4.20

LVM-3 50 watt Line Varimatch unit. . . . . \$6.00

LVM-10 12 watt Line Varimatch Autoformer 500, 250, 167, 125, 100, 83, 71, 62, 50 ohms. . . . . \$2.70

LVM-11 30 watt Line Varimatch Autoformer. . . . . \$4.20

LVM-12 60 watt Line Varimatch Autoformer. . . . . \$6.00

LVM-13 125 watt Line Varimatch Autoformer. . . . . \$10.80

LVM-14 300 watt Line Varimatch Autoformer. . . . . \$15.00

ALL PRICES SHOWN ARE NET TO AMATEURS

# UNITED TRANSFORMER CORP.

72 SPRING STREET

NEW YORK, N. Y.

EXPORT DIVISION: 100 VARICK STREET NEW YORK, N. Y. CABLES: "ARLAB"



*The NC-101X*  
*and the*  
**NTE**

The new National NTE Exciter-Preamplifier Unit is the ideal answer to transmitter control at the operating position. It is not a transmitter in itself, but it does eliminate most of the headaches in building a transmitter. It includes a versatile multi-band exciter unit with a choice of frequencies in each band and a high-gain hum-free preamplifier with plenty of output to modulate low power finals or to drive high-power Class B Modulators. The power supply is self contained, and the push button switch makes band-switching as easy as on the NC-101X Amateur Receiver (which needs no introduction here). The NTE Unit is a basic element in the 600 watt De Luxe transmitter featured in the new Thordarson Transmitter Guide. A special National Catalogue supplement and an Engineering Bulletin obtainable from our dealers list and describe the NTE Unit as well as new Transmitter foundation units and associated gear.

**NATIONAL COMPANY**



**LOW IN COST — HIGH IN PERFORMANCE**

# 3

## RCA LEADERS FOR HIGH-EFFICIENCY TRANSMITTERS

These RCA tubes are of the high-mu type, having low bias-voltage requirements. This means greater economy since it is not necessary to provide high bias voltages or have excessive plate-supply voltages in order to compensate for loss in effective plate voltage

due to bias requirements. Other important features of these tubes include extra heavy duty filaments for long life and reserve emission, and high perveance characteristics which mean high efficiency at moderate plate voltages and resultant economy of power supply equipment.



**\$1750** RCA-814 Beam-Power Amplifier. D.C. plate voltage, 1250 volts. D.C. screen voltage, 300 volts. D.C. grid voltage, -80 volts, max. D.C. grid current, 10 ma. D.C. plate current, 144 ma. Plate input, 180 watts max. Plate dissipation, 50 watts max. Driving power (Approx.), 1.5 watts. Power Output (Approx.), 150 watts. Filament, 10 volts, 3.25 amperes.

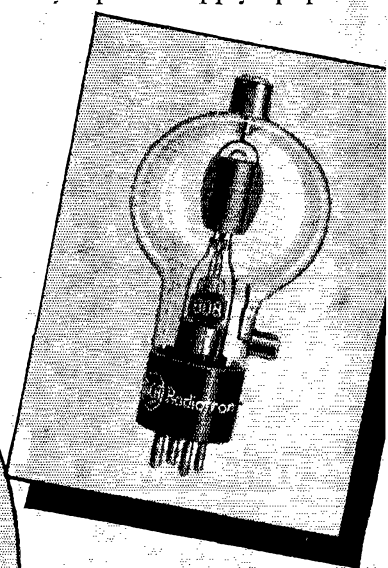

**\$250** RCA-809 High-Mu Triode. D.C. plate voltage, 750 volts max., D.C. grid voltage, -60 volts. D.C. plate current, 100 milliamperes max. Plate input, 75 watts max. Plate dissipation, 25 watts max. Driving Power (Approx.), 2.5 watts. Power Output (Approx.), 55 watts. Filament, 6.3 volts, 2.5 amperes.

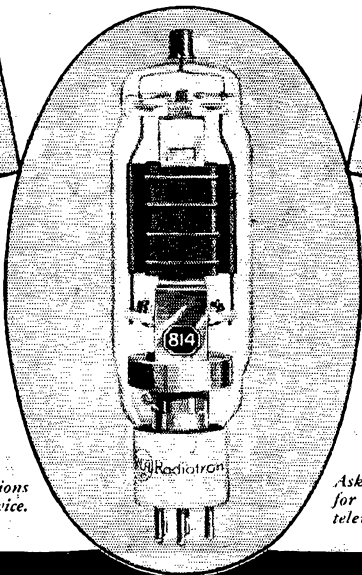

**\$775** RCA-808 Tantalum-Plate High-Mu Triode. D.C. plate voltage, 1500 volts. D.C. grid voltage, -200 volts. D.C. plate current, 125 ma. Plate input, 200 watts max. Plate dissipation, 50 watts max. Driving Power (Approx.), 9.5 watts. Power Output (Approx.), 140 watts. Filament Rating, 7.5 volts, 4 amperes.

*All data for typical operating conditions in Class C telegraph service.*

*Ask your distributor, or send 10c to Camden, for a commemorative announcement of RCA's television tubes. A real decoration for your shack.*



# Radio Tubes

**FIRST IN METAL  
FOREMOST IN GLASS  
FINEST IN PERFORMANCE**

RCA MANUFACTURING CO., INC., Camden, N. J. • A Service of the Radio Corporation of America