

QST

may, 1938
25 cents

devoted entirely to

amateur radio

In this issue—

**New Systems
for Quick
Frequency
Change**

**DX Contest
Highlights**

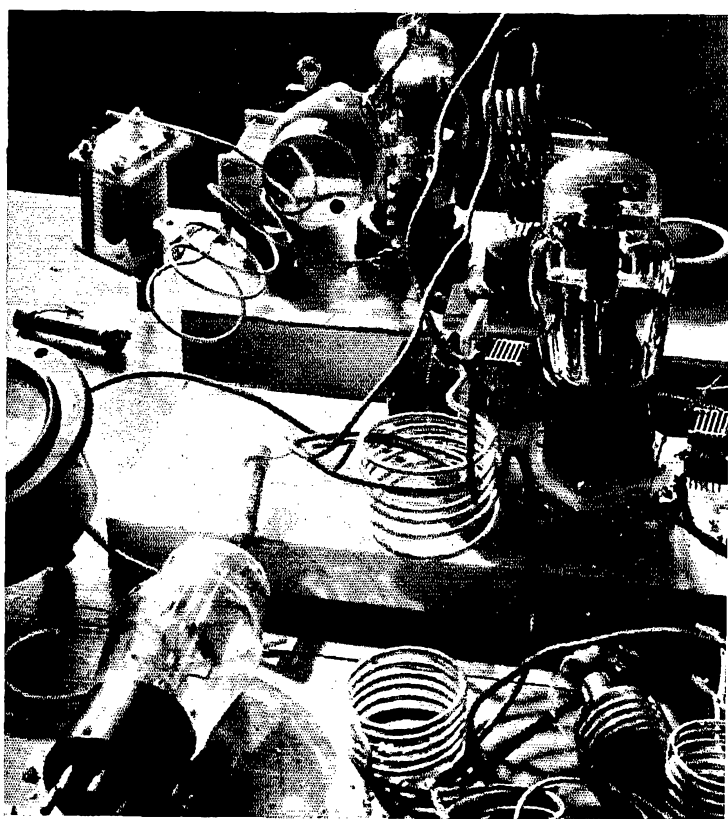

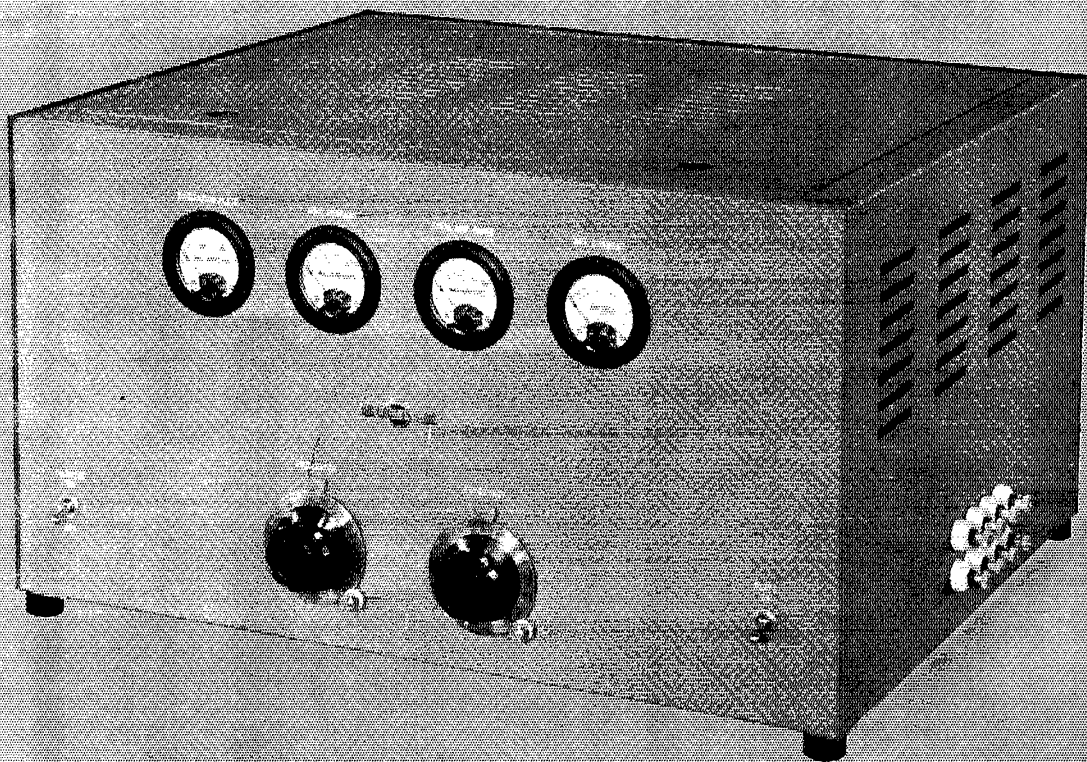

COLLINS 32RA

This transmitter, one of Collins popular 32 Series is a compact, low power unit entirely self-contained.

Any four frequencies in the range from 1.5 mc. to 15 mc. may be selected instantly. A single dial selects frequency and provides for connecting individual antennas for each frequency, or a single antenna may be used for a group of frequencies. Either balanced two-wire or grounded antennas may be used.

Mechanical details and panel controls have been greatly simplified. Construction is neat and very rugged. All parts are readily accessible for maintenance and inspection. The power output is 40 to 50 watts telephone and telegraph.

COLLINS RADIO COMPANY

CEDAR RAPIDS, IOWA NEW YORK, N.Y. 11 WEST 42 ST.

Introducing
2 NEW Hallicrafters Receivers
the SKY BUDDY and the
SKY CHAMPION

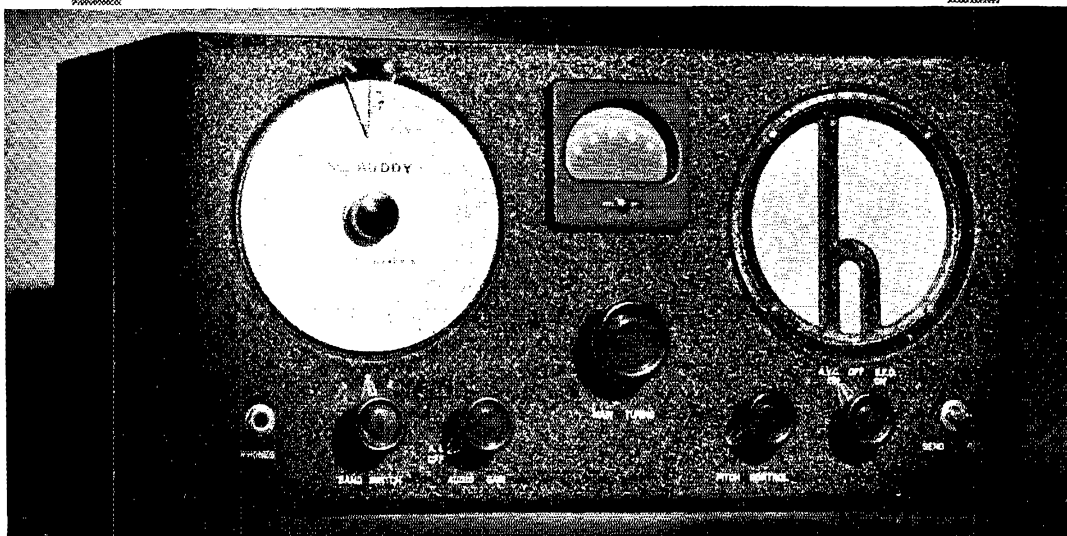

A PRACTICAL, QUALITY BUILT COMMUNICATIONS RECEIVER AT A NEW LOW PRICE

Only an organization with the facilities, experience and resources of the Hallicrafters could build a practical communications receiver to sell at this low price.

The 1938 SKY BUDDY is an amateur's receiver in every respect, covering everything on the air from 18.5 MC to 545 KC, including the 20, 40, 80 and 160 meter amateur bands, with a degree of sensitivity and selectivity usually found only on communications receivers selling at many times its modest price. It's an AC set, of conventional Power Transformer construction. All the components of the SKY BUDDY are only of the finest, and it has all the basic controls required for amateur communications, including built-in speaker — there is nothing else to buy. The separate Band Spread is better than the A.R.R.L. Handbook recommendations for band spread against scale calibration on all the amateur bands.

Any experienced amateur will be delighted at its fine performance — it has all the painstaking careful engineering, the thorough workmanship found in all Hallicrafters receivers. See the New 1938 SKY BUDDY at your Hallicrafters dealer today.

THE SKY BUDDY

- 5 Tubes ● Complete Coverage 18.5 MC to 545 KC ● Built-In Speaker ● Phone Jack ● Send-Receive Switch ● A V G Switch ● 3 Bands ● Separate Band Spread Dial ● Beat Frequency Oscillator ● Pitch Control ● Easily adapted for Battery operation.

AMATEUR'S NET PRICE

\$29.50

including speaker and tubes

FOR DETAILS OF THE
SKY CHAMPION
 SEE NEXT PAGE

the hallicrafters inc.

2611 Indiana Ave., Chicago, U. S. A. • Cable Address: "HALLICRAFT," Chicago

"WORLD'S LARGEST BUILDERS OF AMATEUR COMMUNICATIONS RECEIVERS"

THE SKY CHAMPION

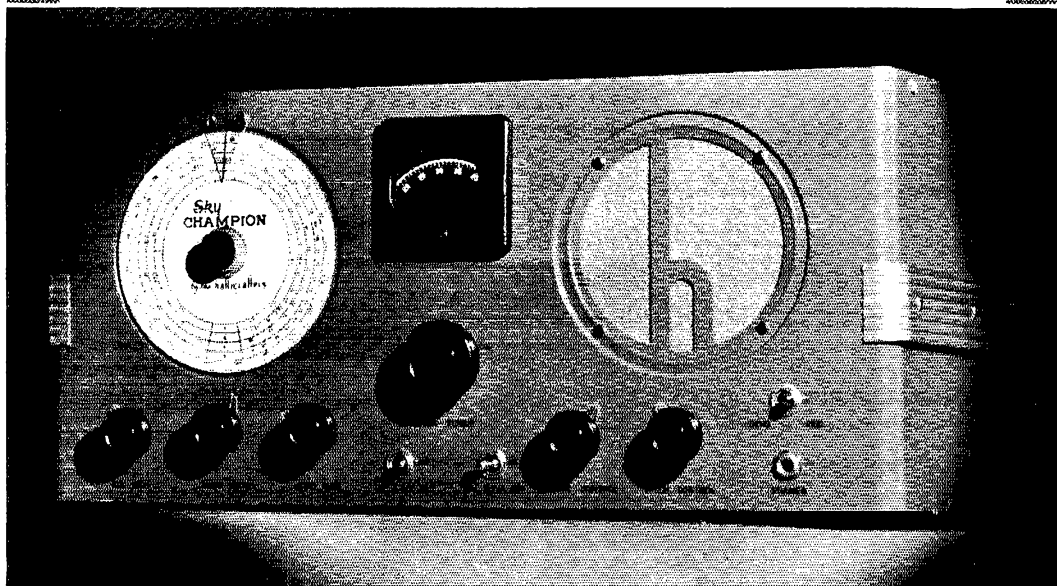

There has always been a need for a real communications receiver at this lower price range. The Hallicrafters have recognized that need and have endeavored to fill it in the past. The SKY CHAMPION is their most highly successful effort in this direction, for, at no time previously, has the amateur with a limited purse, been offered so much for so little.

The SKY CHAMPION is an 8 Tube, A.C. Receiver with Pre-Selection, 4 Band complete coverage from 44 MC to 545 KC (6.8 meters to the top of the B. C. Band), and Built-In Speaker, a COMPLETE communications receiver in every respect. Its sensitivity and selectivity are that of much higher priced receivers; it has every essential control for amateur reception and a Band Spread better than A.R.R.L. Handbook recommendations.

The SKY CHAMPION has had the same careful design and attention to detail that are found on the better Hallicrafters receivers, its components are of the finest, the workmanship of the best — it's a true Hallicrafters receiver, worthy of a place in the Hallicrafters Line. Your Hallicrafters dealer has it. See it there or write for complete specifications.

- 8 Tubes
- Complete Coverage 44 MC to 545 KC
- For AC or Battery Operation
- 4 Bands
- Separate Band Spread Dial
- Individual Coils for each Band
- Beat Frequency Oscillator
- AVC Switch
- Tone Control
- Sensitivity Control

\$49⁵⁰

*Amateurs' Net Price
Complete with Speaker
and Tubes.*

A Champion Endorses the SKY CHAMPION

Mr. T. R. McElroy, Famous World's Champion Code Operator, says: "Congratulations on the SKY CHAMPION! It's got performance you can't get for twice the price elsewhere!"

SEE PRECEDING PAGE
FOR DETAILED DESCRIPTION
OF NEW 1934

● **SKY BUDDY**

the hallicrafters inc.

2611 Indiana Ave., Chicago, U. S. A. • Cable Address: "HALLICRAFT," Chicago

"WORLD'S LARGEST BUILDERS OF AMATEUR COMMUNICATIONS RECEIVERS"

QST

devoted entirely to

AMATEUR RADIO

PUBLISHED, MONTHLY, AS ITS OFFICIAL ORGAN, BY THE AMERICAN RADIO RELAY LEAGUE, INC., AT WEST HARTFORD, CONN., U. S. A.; OFFICIAL ORGAN OF THE INTERNATIONAL AMATEUR RADIO UNION

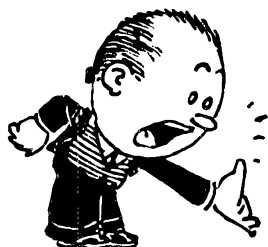

MAY
1938

Volume XXII
Number 5



Kenneth B. Warner, General Manager of A.R.R.L. Publications; Ross A. Hull, Editor; James J. Lamb, Technical Editor; George Grammer, Assistant Technical Editor; Clark C. Rodimon, Managing Editor; David H. Houghton, Circulation Manager; Ralph T. Beaudin, Assistant Circulation Manager; F. Cheyney Beekley, Advertising Manager; Charles Brunelle, Assistant Advertising Manager.

Editorial and Advertising Offices

38 La Salle Road
West Hartford, Connecticut

Subscription rate in United States and Possessions and Canada, \$2.50 per year, postpaid; all other countries, \$3.00 per year, postpaid. Single copies, 25 cents. Foreign remittances should be by international postal or express money order or bank draft negotiable in the U. S. and for an equivalent amount in U. S. funds.

Entered as second-class matter May 29, 1919, at the post office at Hartford, Connecticut, under the Act of March 3, 1879. Acceptance for mailing at special rate of postage provided for in section 1103, Act of October 3, 1917, authorized September 9, 1922. Additional entry at Concord, N. H., authorized February 21, 1929, under the Act of February 28, 1925.

Additional second-class entries to cover sectional editions authorized March 20, 1935. Copyright 1938 by the American Radio Relay League, Inc. Title registered at United States Patent Office.

The Contents

Editorial	7
Highlights of 1938 DX Contest <i>Byron Goodman, W1JPE</i>	8
Applying Band-Pass Couplers to Amateur Transmitters <i>Clinton B. DeSoto</i>	12
Simple Directional Arrays Using Half-Wave Elements <i>Nick C. Stavrou, W2DFN</i>	17
New Ideas in Rotatable Antenna Construction <i>L. H. Whitney, W1EER and G. W. Whitney, W1JYQ</i>	20
What the League Is Doing	22
Intra-Band Quick Frequency Change for Transmitters <i>Byron Goodman, W1JPE</i>	23
Vacuum-Type Fixed Condensers for Transmitter Tank Circuits	26
A 5-, 10- and 20-Meter Converter <i>T. M. Ferrill, Jr., W5CJB-1</i>	27
A Self-Contained Speech Amplifier, Monitor and Control Unit <i>Howard C. Lawrence, W2IUP</i>	30
Kansas State Convention	32
More New Tubes <i>RK-56, 6S7, 6W7G, 6J8G</i>	32
A Desk-Type Push-Button Frequency-Control Unit <i>Clark C. Rodimon, W1SZ</i>	33
A Portable-Mobile Crystal-Controlled U.H.F. Transmitter <i>Louis R. Padberg, W9FPA</i>	37
The Construction of Television Receivers <i>Marshall P. Wilder, W2KJL</i>	39
A Simplified Exciter Circuit. <i>Carl C. Drumeller, W9EHC</i>	42
Improved Thermo-Ammeter Construction to Increase Accuracy on Ultra-High Frequencies . <i>John H. Miller</i>	44
New England Division Convention	45
Hudson Division Convention	45
Atlantic Division Convention	45
Eighth A.R.R.L. S.S. Contest <i>E. L. Battey, W1UE</i>	46
A.A.R.S. Activities	51
How Would You Do It?	52
Hints and Kinks for the Experimenter	54
Silent Keys	56
I.A.R.U. News.	57
Operating News	59
Correspondence Department	67
Book Review	102
Standard Frequency Transmissions	102
Hamads	123
QST's Index of Advertisers.	126

Section Communications Managers of the A.R.R.L. Communications Department

All appointments in the League's field organization are made by the proper S.C.M., elected by members in each Section listed. Mail your S.C.M. (on the 16th of each month) a postal covering your radio activities for the previous 30 days. Tell him your DX, plans for experimenting, results in phone and traffic. He is interested, whether you are an A.R.R.L. member or get your QST at the newsstands; he wants a report from every active ham. If interested and qualified for O.R.S., O.P.S. or other appointments he can tell you about them, too.

Eastern Pennsylvania Maryland-Delaware-District of Columbia Southern New Jersey Western New York Western Pennsylvania	W3QP W3BAK W3BE1 W8CSE W8OFO	ATLANTIC DIVISION John Buck Morgan Edgar L. Hudson W. W. Wilson Ed Preston Kendall Speer, Jr.	Blue Bell Laurel, Delaware Aubudon Tully Lowber	
Illinois Indiana Kentucky * Michigan Ohio Wisconsin	W9K1V W9QG W9ARU W8DPE W8AQ W9JTT	CENTRAL DIVISION L. John Huntoon Noble Burkhart Darrell A. Downard Harold C. Bird E. H. Gibbs Aldrich C. Krones	327 Brandon Ave. R. 4, Box 1 116 N. Longworth Ave. R.F.D. 2 405 Broad St. 3288 S. Illinois Ave.	Glen Ellyn Indianapolis Louisville Pontiac Wadsworth Milwaukee
North Dakota South Dakota Northern Minnesota Southern Minnesota	W9RZA W9SEB W9IGZ W9DCM	DAKOTA DIVISION Ernest Bloch Andrew J. Kjar Edwin L. Wicklund Webster F. Soules	Box 202 221 West Prospect Ave. R.F.D. 3 3549 36th Ave., So.	Thompson Pierre Kensington Minneapolis
Arkansas Louisiana Mississippi * Tennessee	W5ABI W5DKR W5GHF W4DEP	DELTA DIVISION H. E. Velte Eugene H. Treadaway Robert E. Barr B. G. Lowrey Smith	4415 West 12th St. 2749 Myrtle St. 673 Hillcrest St.	Little Rock New Orleans Lucedale Memphis
Eastern New York N. Y. C. & Long Island Northern New Jersey	W2LU W2AZV W2GMN	HUDSON DIVISION Robert E. Haight E. L. Baunach Fred C. Read	511 South Holmes St. 102 Central Ave. 1014 North Ave.	Scotia Massapequa, L. I. Elizabeth
Iowa * Kansas Missouri Nebraska	W9LEZ W9PH W9OUD W9FAM	MIDWEST DIVISION Phil D. Boardman Harry E. Lester Miss Letha Allendorf Samuel C. Wallace	325 Kirkwood Blvd. 304 Miami St. 1015 W. 3rd St. Green St.	Davenport Hawatha Joplin Clarks
Connecticut Maine Eastern Massachusetts Western Massachusetts New Hampshire Rhode Island Vermont	W1CTI W1FBJ W1IWC W1IAH W1BFT W1HRC W1GNF	NEW ENGLAND DIVISION Frederick Ellis, Jr. Winfield A. Ramsdell Sam Gross William J. Barrett Carl B. Evans Clayton C. Gordon Alvin H. Battison	19 Merrill Rd. 1188 Washington Ave. Pleasant St. 239 Columbia St. 80 No. State St. 192 Washington Ave. 1 Central St.	Norwalk Portland Marshfield Hills Adams Concord Providence Windsor
Alaska Idaho Montana Oregon* Washington	K7ENA W7EMT W7EL W7FNO W7WY	NORTHWESTERN DIVISION Leo E. Osterman Carl Eichelberger G. A. Woodhouse J. R. MacManiman Robert H. Votaw	Customhouse Route 2 Heller Dam 1545 N. E. 48th Ave. Route 1, Box 398	Wrangell Kuna Wolf Creek Portland Vancouver
Hawaii* Nevada Santa Clara Valley East Bay San Francisco Sacramento Valley Philippines San Joaquin Valley	K6OQE W6B1C W6FBW W6JTV W6SG W6GZY KA1CR W6LPE	PACIFIC DIVISION Harold C. Smith Edward W. Heim Elbert Amarantes Harold J. Burchfield Alan D. Whittaker, Jr. J. L. C. Buckenham George L. Rickard Angelo V. Astone	P. O. Box 150 509 Claremont St. 454 Washington St. 2240 106th Ave. 79 Elinor Ave. 3931-24th St. Box 849 729 Safford	Honolulu Reno San Jose Oakland Mill Valley Sacramento Manila Fresno
North Carolina South Carolina Virginia West Virginia	W4OG W4BQE W4B1G W8HD	ROANOKE DIVISION H. S. Carter Ted Ferguson Charles M. Waff, Jr. C. S. Hoffmann, Jr.	P. O. Box 111 1213 College St. 2914 Monument Ave. 47 Lynwood Ave.	Winston-Salem Columbia Richmond Wheeling
Colorado Utah-Wyoming	W9FA W7COH	ROCKY MOUNTAIN DIVISION Glen Glasscock Townsend J. Rigby	2164 So. Corona St.	Denver Midwest, Wyoming
Alabama Eastern Florida Western Florida Georgia-Cuba-Ile-of-Pines- Porto Rico-Virgin Islands	W4DGS W4DVO W4BSJ *W4PM	SOUTHEASTERN DIVISION James F. Thompson L. A. Connolly Ellis R. Curry Charles W. Davis	102 Narrow Lane Rd. 719 So. Willow Ave. Box 425 2136 N. E. Boulevard Dr.	Montgomery Tampa Madison Atlanta, Ga.
Los Angeles Arizona San Diego	W6GXM W6KFC W6JRM	SOUTHWESTERN DIVISION Don M. Draper Victor C. Clark Howard K. Breedlove	4421 West 63 St. 747 E. Polk St. R. 2, Box 630	Los Angeles Phoenix San Diego
Northern Texas Oklahoma Southern Texas New Mexico	W5DXA W5CEZ W5BHO W5CGJ	WEST GULF DIVISION Lee Hughes Carter L. Simpson Dave H. Calk Joseph M. Eldodt	125 N. Main St. 2010 So. 4th St. 6726 Ave. Q	Childress Ponca City Houston Chamita
Maritime	VE1DQ	MARITIME DIVISION A. M. Crowell	69 Dublin St.	Halifax, N. S.
Ontario	VE3SG	ONTARIO DIVISION Fred H. B. Saxon	302 Lee Ave.	Toronto, Ont.
Quebec	VE2EF	QUEBEC DIVISION Stan Comach	780 Brault Ave.	Verdun, P. Q.
Alberta British Columbia	VE4GE VESHP	VANALTA DIVISION C. S. Jamieson J. Hepburn, Jr.	581 W. Riverside Drive 335 Foul Bay Road	Drumheller, Alta. Victoria
Manitoba Saskatchewan	VE4BG VE4EL	PRAIRIE DIVISION A. J. R. Simpson Wilfred Skaife	635 Garfield St. 2040 McTavish St.	Winnipeg Regina

* Officials appointed to act until the membership of the Section choose permanent S.C.M.'s by nomination and election.

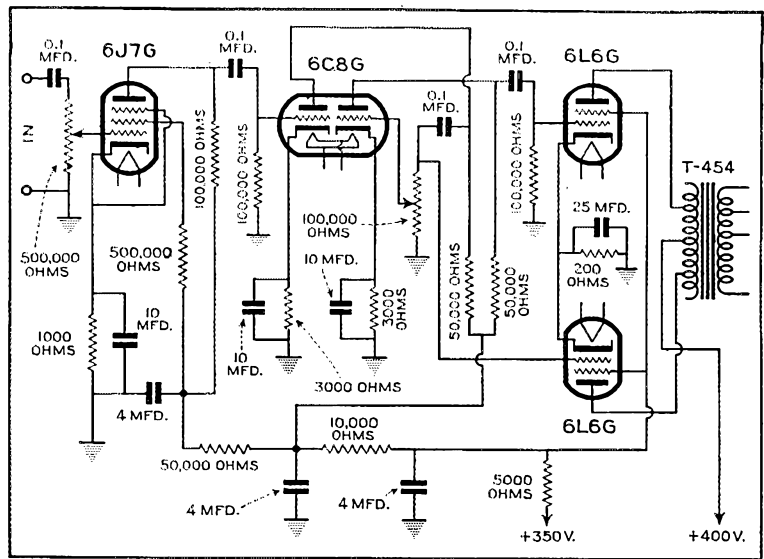

Kandid Ken-O-Talk, No. 6

• HIGH QUALITY AUDIO SYSTEMS •

CONTINUING our discussion of the thirty watt modulator at W2—, we see that our amateur "chief engineer" has decided to use a conventional circuit. This is shown above.

The only thing which deserves special attention is the duo-triode phase inverter tube. This is a type which is constructed with two separate cathodes. The amplification factor is relatively high (38), making it possible to obtain sufficient gain to work out of a crystal microphone, with only two voltage amplifier stages.

Simplicity is the first characteristic of this circuit to catch the eye. The input stage consists of a pentode, resistance coupled. The second stage is a standard phase inverter. This stage drives the output tubes. Here we have an amplifier with about 100 D.B. gain, capable of delivering 30 watts, using only four tubes. All the circuits are of the "tried and proven" type. There is nothing new or tricky, but yet, the result is a better than average example of the possibilities of the compact and efficient amplifier design possible, using tubes now available.

In this amplifier, careful attention was given to the placement of parts and shielding. The result is absolute stability, and a hum level which leaves nothing to be desired. The chief source of hum is the heater of the 6J7, and this is not found to be serious when the center tap of the filament is grounded.

The values of grid and plate resistors chosen do not give the highest gain possible to obtain from the tubes used. This was found to be unnecessary. The values were, however, chosen to give a flat frequency response from 60 to 6000 cycles. Tests with an oscillator and oscilloscope have proven the wisdom of this choice.

W2— plans to use his present modulator unit as a driver for a high power stage in the future. In order to do this he says he will replace the 6L6G's with 6A3's. The latter tubes will deliver 10 watts when operated with self bias. This is ample for driving most any modulator tubes. The 6A3's are much more suitable, for this purpose, than the 6L6G's because of their low plate resistance. Low plate resistance is essential in driver tubes to insure good audio voltage regulation at the grids of the class B stage.

The first circuit contemplated for this modulator used a 57 resistance coupled to a 56 — the 56 transformer coupled to a pair of 56's — the 56's transformer coupled to four 2A3's. The saving achieved consisted of the elimination of four tubes, two transformers, and a reduction of power consumption. The cost of the amplifier constructed was but little over one half of the one originally planned on.

F. P. Kenyon

The American Radio Relay League



DIRECTORS

- President*
EUGENE C. WOODRUFF.....W8CMP
234 W. Fairmount Ave., State College, Pa.
- Vice-President*
GEORGE W. BAILEY.....W1KH
74 Webster Road, Weston, Mass.
- Canadian General Manager*
ALEX REID.....VE2BE
169 Logan Ave., St. Lambert, P. Q.
- Atlantic Division*
WALTER BRADLEY MARTIN.....W3QV
Box 612, Roslyn, Pa.
- Central Division*
R. H. G. MATHEWS.....W9ZN
100 East Ohio St., Chicago
- Dakota Division*
FRED W. YOUNG.....W9MZN
228 1/2 Willard St., Mankato, Minn.
- Delta Division*
E. RAY ARLEDGE.....W5SI
P. O. Box 286, Pine Bluff, Ark.
- Hudson Division*
KENNETH T. HILL.....W2AHC
115 Willow St., Douglaston, L. I., N. Y.
- Midwest Division*
FLOYD E. NORWINE, JR.....W9EFC
120 South Fourth St., St. Louis, Mo.
- New England Division*
PERCY C. NOBLE.....W1BVR
37 Broad St., Westfield, Mass.
- Northwestern Division*
RALPH J. GIBBONS.....W7KV
c/o United Air Lines, Pendleton, Ore.
- Pacific Division*
J. L. McCARGAR.....W6EY
66 Hamilton Pl., Oakland, Calif.
- Ranoke Division*
H. L. CAVENESS.....W4DW
State College Station, Raleigh, N. C.
- Rocky Mountain Division*
EDWARD C. STOCKMAN.....W9ESA
618 So. Williams St., Denver
- Southeastern Division*
BENNETT R. ADAMS, JR.....W4APU
1512 Grove Place, Homewood, Ala.
- Southwestern Division*
CHARLES E. BLALACK.....W6GG
443 Main St., El Centro, Calif.
- West Gulf Division*
WAYLAND M. GROVES.....W5NW
c/o Humble Pipe Line, Mt. Pleasant, Texas

THE AMERICAN RADIO RELAY LEAGUE, INC., is a non-commercial association of radio amateurs, bonded for the promotion of interest in amateur radio communication and experimentation, for the relaying of messages by radio, for the advancement of the radio art and of the public welfare, for the representation of the radio amateur in legislative matters, and for the maintenance of fraternalism and a high standard of conduct.

It is an incorporated association without capital stock, chartered under the laws of Connecticut. Its affairs are governed by a Board of Directors, elected every two years by the general membership. The officers are elected or appointed by the Directors. The League is non-commercial and no one commercially engaged in the manufacture, sale or rental of radio apparatus is eligible to membership on its board.

"Of, by and for the amateur," it numbers within its ranks practically every worth-while amateur in the nation and has a history of glorious achievement as the standard-bearer in amateur affairs.

Inquiries regarding membership are solicited. A bona fide interest in amateur radio is the only essential qualification; ownership of a transmitting station and knowledge of the code are not prerequisite. Correspondence should be addressed to the Secretary.

HIRAM PERCY MAXIM, FIRST PRESIDENT

OFFICERS

- President*.....EUGENE C. WOODRUFF, W8CMP
State College, Pa.
- Vice-President*.....GEORGE W. BAILEY, W1KH
Weston, Mass.
- Secretary*.....KENNETH B. WARNER, W1EH
West Hartford, Connecticut
- Treasurer*.....ARTHUR A. HEBERT, W1ES
West Hartford, Connecticut
- Communications Mgr.*...F. EDWARD HANDY, W1BDI
West Hartford, Connecticut
- General Counsel*.....PAUL M. SEGAL
1026 Woodward Building, Washington, D. C.

Address all general correspondence to the administrative headquarters at West Hartford, Connecticut



"It Seems to Us — —"

THE major trend in amateur radio during the past decade seems to have been toward an increasing maturity. Whether or not that's a desirable thing offers room for considerable debate. Here are the facts:

In 1926 the average age of the licensed amateur membership of A.R.R.L. was about 22 years. In 1928 it was an estimated 23. In 1934 it was perhaps 25. In mid-1937 it was about 27. To-day it is an even 30.

This last figure is disclosed by the latest check-up on the returns from the Perpetual Survey questionnaire, which has for nearly a year been sent to new and renewing members. Broken down into component parts, we find that the Class A licensees have an average age of 31.5, the Class B licensees average 28, Class C are up to 30 again, while the non-amateur members average 27 and the foreign licensed membership peaks at 32.

Parenthetically, the percentages of Class A and Class C members are somewhat disproportionate in terms of national averages, the proportion of Class A members running about a third higher than the national percentage of license issuances while Class C is about 50 per cent less. Class B proportions are about equal. The probable answer to this situation lies in economic factors.

The obvious conclusion from this array of evidence is that the growing complexity and cost of amateur radio is slowly restricting its pursuit to those of broader experience and training and greater financial responsibility. The day of amateur radio as the hobby of "attic experimenters" and "basement" laboratorians, the art of lads of high-school age or younger who dabble with it as a diversion from Meccano or Erector sets or a Gilbert's "hoy chemist" kit, is passing. Indeed, it is already past.

Partial evidence of this, added to the rising average age, is the increased *minimum* age. A few years back we had licensed amateurs of 8 and 9 years of age; little Jean Hudson was only nine when she got her ticket in 1933. Lads of 12 or 13 were veterans. To-day all that has changed. The youngest licensed amateur of whom we know is 12, and in all the country there are only a handful under 15.

In the editorial in September 1937 *QST*, K.B.W. pointed out that there existed two peaks in amateur age groups, one denoting the apex of youthful enthusiasm, the other the return to the

air after the young man had established himself in the world. The first peak centered between 17 and 21, the second between 28 and 33. We have become accustomed to referring to these as the 20-30 peaks. But our more recent figures tend to shift those points: the first now runs 19-24, with a maximum at 21. The second covers 29-35, with a maximum at 32. Furthermore, there is now an intermediate peak at 27 that overshadows the one at 21.

So it can be seen that from every vantage point for analysis the pattern moves up the age scale. Obviously, there must be underlying causes for this state of affairs, and it does not do merely to say that amateurs are growing older. The percentage of turn-over in amateur ranks has not lessened appreciably. The average tenure of license on the part of our membership runs between 6 and 7 now, close to what it was in the last check-up. The peak in the years' licensed curve occurs at about 3 years in both cases.

Nor is all of the answer to be found in increasing technical complexity or in the higher cost of station equipment. True, our elaborate receivers and multi-stage transmitters are monstrosities beside the 1-, 2- and 3-stage rigs of a decade ago. But there has been some simplification in recent times; and beyond that, better understanding of circuit behavior reduced to elementary rules of thumb; and above all there is the availability of detailed technical literature on a scale undreamt of a few years back. So far as cost is concerned, the minimum initial cost of an adequate station is lower by half now than it was ten or even five years ago. In 1926 a 100-watt rig with a 210 took most of a couple of weeks' wages for Mr. Average American; now he can run 100 watts to a pair of 6L6's for less than the cost of a suit of clothes. Perhaps the youngsters of to-day are wiser than we were; perhaps they prefer the suit of clothes.

But this is a subject that leads to endless speculation, and this page is not endless. Whatever the causes, the facts are these: Amateur radio is growing older, more mature. It has long been more than just a hobby for the youngsters; it has now gotten well beyond their reach. It is the pursuit of men of affairs, who, stabilized, in their normal vocational activities, have found it the ideal avocation. To-day, more than ever, the character of its adherents lends the institution of amateur radio character, prestige, and responsibility.

—C. B. D.

Highlights of the 1938 DX Contest

New Records, Both Phone and C.W.—Greatest Interest Ever

By Byron Goodman,* W1JPE

A VERY peculiar thing has been happening around HQ for the past week or two. Many hams have been sending in sheets of paper with stacks of numbers and station calls on them. We paid no attention to the first few, but when they kept coming in we did a little investigating. We found out plenty.

It seems that there was a DX Contest! Not just an ordinary sissy contest where fellows hang around and take life easy, working stations now and then as they please, but a toe-to-toe slugfest, a knock-down-and-drag-out affair, the old "here a number, there a number" that left the weaklings gasping by the wayside and the huskies wishing they had eaten more spinach! Yes sir, the 1938 contest ran true to form in only one respect: It was bigger and better than any of the previous ones.

Saying that the DX Contest was "bigger and better" than any previous one is getting to be a trite expression, but it is true nevertheless. This is the third year that the Contest has been conducted under the same rules, and yet the scores are even higher than the modified country-list could account for.

So again it boils down to just one thing: There are some mighty smart operators in these contests who recognize all of the problems and are prepared to solve them.

Conditions were excellent during both the c.w. and 'phone portions of the contest. Although not very many rare countries showed up in the c.w. section, there was always more than enough DX to go around, and the striking thing about the 'phone portion was that many of the DX stations that have never been known to operate on voice showed up with 'phone signals for the first time. As a matter of fact, there were a number of countries in the 'phone contest that didn't get in the c.w. melée, much to the chagrin of some of our more confirmed brass-pounders. This was particularly true of the Central American VP group and some of the South American countries.

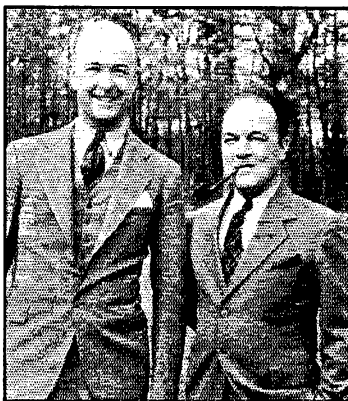

"MATTY" REHM, W2HNY (L.) AND
"TOMMY" THOMAS, W2UK

Last year antennas played a large part in the contest. They did again this year, of course, but another factor showed up, an apparently harmless but actually horrible little thing called an "ECO." Yes sir, the frequency-swishing that went on was really something! But it worked well on 10 and 20, and wonderfully on 40 and 80. In fact, the smarties with the ECO's in the lower-frequency bands did quite a job of raising their percentage of "calls answered" by picking the right frequencies on which to call. Of course this isn't the first year they've been used, but they were more prevalent this year than ever before.

The C.W. Contest

FOR the third consecutive time the highest score was turned in by a DX station, and for the second time in that period by a young fellow named Juan Loby y Lobo, of Mexico City, Mexico. Just about everyone in the contest guessed correctly that XE1A was none other than old XE2N, and the reason

* Assistant Secretary, A.R.R.L.

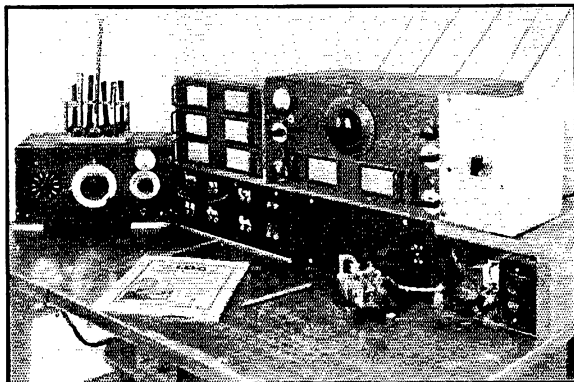

OPERATING POSITION AT W2UK

Ec. oscillator and crystal selector at the left makes a handy pipe stand! All controls are at the fingertips for transmitter operation and antenna selection.

for the correct guesses was the excellent operating practice used, which is a splendid tribute to Mr. Lobo's skill. XE1A could only put in 75 hours and 40 minutes during the contest, so he was only able to work 1419 stations for a score of 236,322! It figures out to be something like 18.7 contacts per hour, which means that you don't waste time wondering whether or not you're getting out when you work them like that! XE2N worked 5 stations on 160 meters, 113 on 80, 257 on 40, 533 on 20, and 491 on 10. The rig is compact, band-switching, and runs 150 watts input to the HF-100 final.

The second highest foreign score reported so far is that of K4KD, who ran up 131,895 points in 86 hours. Operating on four bands, his best time was 22 contacts in one hour, which is really batting 'em out. The rig is 100 watts to a 35T final.

Not many foreign scores have come in yet, but some of the higher ones to date are: K4DTH, 109,466; CM2AD, 107,320; OK1BC, 100,000; LU7AZ, 99,295; EI8B, 97,500; G6NF, 91,696; GI6TK, 80,000 and OA4J, 60,044.

It may be that some of the Europeans worked W6's on 3.5 Mc. No QSO's have been reported yet, but EI8B heard W6HK and was heard by W6JBO on 80 meters.

Last year we thought we knew the high-scorer among the W's, and gave him a big blast, only to have a topping score come in too late for publication. That *may* happen again this year, but it will have to be a very, very dark horse. It is a pleasure to introduce the first *two-time* high scorer among the W's: Tommy Thomas, W2UK! Yep, Tommy was high last year and is practically certain to repeat this year, with the almost unbelievable score of 176,000 points! He ran up that score by working practically everything on the 10-, 20-, 40- and 80-meter bands. Broken down, it amounts to 329 contacts in 76 different countries, with a total multiplier of 179. Last year's score seemed incredibly high, but this year's skyrocketed to unforeseen heights. Congratulations, Tommy!

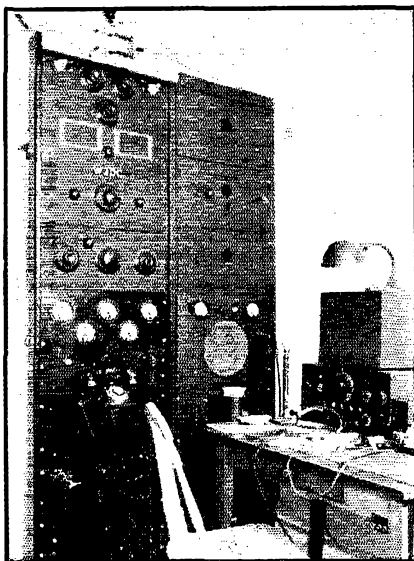

W2DC, SCOTIA, N. Y.

Transmitter (r-f. section) in the left rack with 805's in the final and power supplies and modulator in the right rack. "Fritz" had all the operating he wanted in the c.w. contest, however. An NC-101-x with noise silencer was used.

Running second in mighty fine style comes Fenton Priest, W3EMM, who collected 321 contacts in 70 different countries, a multiplier of 165, and a grand total of 157,905 points. W3EMM has a mighty nice station down in Norfolk, Va., but, like all of the high-scoring boys, it was his operating that placed him up among the toppers.

And just to prove that Virginia has more than one good DX man, Clement Goo On, W3EVT, runs quite close to W3EMM with 150,720 points, made by working 325 stations for a multiplier of 157. W3EVT is a small Rocky Point when it comes to antennas, having one for 80, one for 40, 3 for 20 and 3 for 10, with the result that he doesn't miss very much. The antennas range

from simple half-waves on 80 and 40 to "flat-top" and horizontal "H" types on 20 and 10. And just to prove *Norfolk, Va.*, has another DX man, Dan Smith, W3CHE, rolled up 128,000 points.

"Roddy" of W1SZ, perennial threat in these contests, ran up 137,000 points by working 281 stations for a multiplier of 163. The next highest score we've heard of is from W9ARL, John Marshall out in Kansas City. Johnny is a consistent DX-er whose work gets better every year, and this time he made 135,020 points and

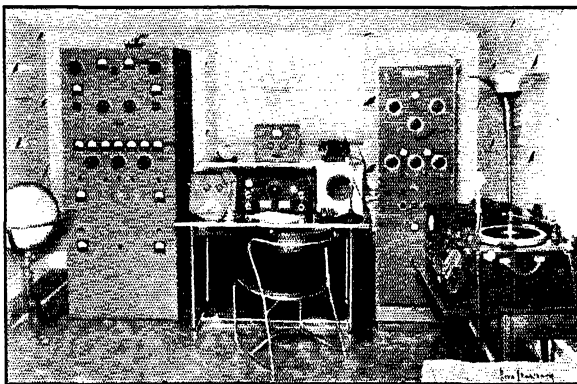

W1CND, AMHERST, MASS.

The large rig at the left ends up in a pair of H.F. 300's—modulated by another pair. The smaller rig uses a pair of RK-38's in the final modulated by a pair of the same. Electrical rotation of 10- and 20-meter antennas is controlled from the operating position.

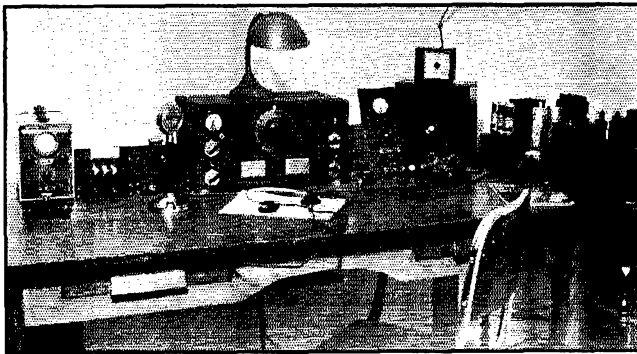

WHERE W3EMM BLASTED AWAY FOR 178 HOURS

worked 71 different countries, which reads like swell work for his part of the country. He had four-band contacts with ON4AU and GI6TK as well as many North American stations.

These W3's crop up everywhere. Next highest score is from W3PC at Port Republic, N. J., Clem

THIS EQUIPMENT SIGNS W3EMM

Features of this station include two V-beams and a rhombic over water that are switchable from the operating position; a pair of 250TH's in the final driven by a pair of 100TH's, not to mention a rack containing 20 crystals! When on 'phone a pair of 805's serve as modulators.

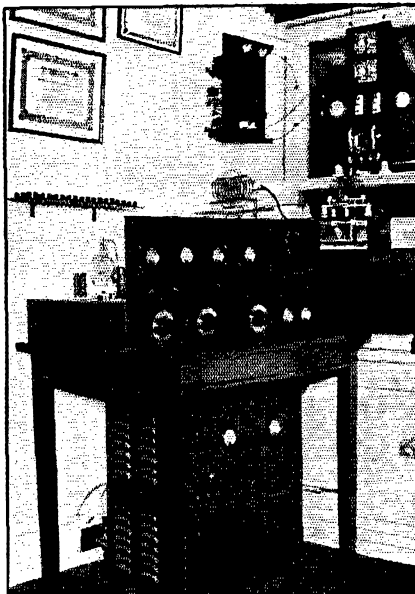

actually worked two more countries than W2UK did, but his score was down to 120,324 because he didn't work on 3.5 Mc. At that, he had 272 contacts and a multiplier of 148.

W6CXW also showed the boys that "lightning can strike twice." Last year Henry was 2nd U. S. A. high scorer and this year apparently leads the West Coast with a score of 118,000.

W1TS, by working 252 stations with a multiplier of 143 in 60 countries, ended up with 108,110 points. W2DC, at Scotia, N. Y., came through with 107,520 points, with W1TW right behind with 100,110 points. The grapevine tells us that W2JME has "over 104,000," but we can't

W3EOZ, BRYN MAWR, PA.

Three transmitters are used: 160- and 75-meter 'phone rig ends up with 4 852's in p.p. parallel. The 20-meter 'phone uses a pair of T200's and the 28-Mc. rig ends up with T55's.

give an accurate figure. The second highest W6 we've heard of is W6JBO and his 99,236 points, swell work from there in view of the fact that the Westerners don't get the break on running up multipliers on 80 meters. Other good scores reported so far are: W6HX, 94,635; W4AH, 90,500; W8LEC, 86,198; W9AEH, 85,140; W2BYP, 84,000; W4AJX, 83,500; W2CBO, 75,815; W3BES, 74,472; W8NJP, 72,540; W6CUY, 71,572; W2DSB, 71,000; W2CJM, 67,976; W1ME, 65,670; W6QD, 62,640; W4CBY, 60,216; W9LOJ, 58,644; W8LUQ, 56,175; W1AVJ, 55,650; W6GCX, 54,400; W1BFT, 52,700; W6AM, 51,670; W9NNZ, 51,156; W1DZE, 50,796.

The 'Phone Contest

DON'T ever make the mistake of assuming that there isn't plenty of smart operating going on in the 'phone bands. Any such ideas along those lines that you might have had will be quickly dispelled when you take a look at some of the 'phone scores. We haven't had enough time to be sure that we have the high men in the proper order, because there



may be several more logs that will modify the relative standings, but the ones now available look very good.

For a while it seemed as though Bob Henry, W9ARA, was going to repeat last year's performance and come out on top, with his 82,000 points, but then W4CYU popped in with the announcement that he had put together enough contacts to add up to 93,350. Then we heard from W3EMM! Fenton Priest, all fresh from the c.w. fracas, sailed through with 97,092 points. W3EMM contacted 371 stations with a multiplier of 87. Fenton used three bands and only operated 89 hours and 3 minutes—a total of 178 hours and 53 minutes for the two contests—no wonder we haven't heard W3EMM since the 'phone battle!

W3EMM is another strong booster for directional antennas and attributes to them much of his success in both sections of the contest. He used a rhombic and two "V" type antennas, all of modest dimensions as long wire antennas run. The rhombic, however, was erected over a salt-water river which might have helped to produce the excellent results obtained. This antenna is only 145 feet on each leg with side angles of about 60 degrees and only 32 feet high at high tide. It was directional toward the northeast. The two "V" antennas each had legs of 175 feet at an average height of 45 feet. One was directional E-W and the other in the NNW and SSE directions. Any antenna could be selected for transmitting or receiving by means of toggle switches on the operating table.

W4CYU worked 360 stations in 55 different countries for a multiplier of 91 on 10 and 20 meters. Bob only used between 500 and 700 watts, but has four Vee beams and an 8-element array that really laid down signals. So it looks as though you have to live on Long Island or down South to have the "world's best radio location."

W9ARA worked 341 stations for a multiplier of 81. We have no accurate information on W6GRL, but we believe he ran up 82,000 points before the close of the contest with W4DHZ doing the operating on 'phone.



THE MODULATOR AND KILOWATT TRANSMITTER OF W3PC, PORT REPUBLIC, N. J.

Clem Giberson uses a pair of 852's in the final running at a kilowatt input. On 'phone he modulates it with push-pull-parallel 242A's in Class B. For antennas a 400 foot leg diamond is used for Europe, 4 half-waves in phase for Australia and Africa, and a rotary 28-Mc. beam with reflector and director. The control wheel for the rotary can be seen under the operating table. The receiver is a Comet Pro with a two-stage preselector. Clem added his 136th country in the contest.

Tommy Thomas caught up on his sleep and let W2HNY operate at W2UK during the 'phone test, with the result that W2UK has 69,000 points in the tonsil marathon; 296 contacts in 54 countries, for a multiplier of 78, did it.

We're ashamed of the W1 representation. Here this fellow W1CND ran up 58,000 points in only 40 hours of operation, but wasn't able to put in the time that would have been necessary to run up a bigger score and possibly bring the bacon into the First District. CND is the kind that works stuff like F18AC, J, PK, VS6 and such in a contest.

In the 'phone section, W3PC scored 54,288, while W4BYY down at Fargo, Ga., made 54,242 points by working 247 stations for a multiplier of 70. Then comes W4AH of Charlotte, N. C., with 51,800. W6ITH follows close behind with 51,240 points. Reg worked on

four bands, and worked KA1ME on 3.9 Mc. and K6CGK, K7PQ, and XE2HN on 1.8 Mc.

W9ARL made 50,922 points in the 'phone test

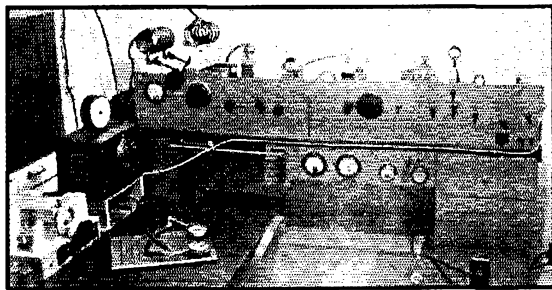

THE RIG AT W8LEC, DETROIT, MICH., IS DESIGNED FOR QUICK BAND AND FREQUENCY-CHANGE

The black box above the key houses a 47 crystal oscillator with 6 crystals and a 59 ECO that is used to drive the #7 when c.c. isn't used. A concentric line feeds the output of this unit to the input of the first doubler. Coil switching is used throughout, including the HF-200 final amplifier stage which runs at a kilowatt input. W8LEC used three different antennas during the competition, a vertical 28-Mc. doublet, a 14-Mc. rotary beam, and a horizontal 7-Mc. doublet.

and other good scores include W8NJP, 49,296; W4CDG, 48,868; W3EOZ, 46,860; W9YGC, 45,000; W4YC, 44,154; W1TW, 43,608; W2IUUV, 39,324; W6OCH, 37,758; W3CHE, 36,000,

(Continued on page 84)

Applying Band-Pass Couplers to Amateur Transmitters

A Continuous-Coverage Transmitter with 100 Watts Output on Four Bands

By Clinton B. DeSoto,* W1CBD

THE trend in transmitter design these days is toward quick frequency- and band-change methods. There's no doubt of that. Band-switching has become widely accepted in the past two or three years; multiple crystal or e.c.o. operation is standard, and we even have complicated structures with motor-driven ganged tuning and similar elaborate means designed to short-circuit the tuning operation.

This transmitter is an attempt at providing complete flexibility in the matter of frequency choice. In sum total, it enables the selection of any desired frequency in several amateur bands with direct-reading accuracy of better than 0.1 per cent or five spot frequencies with an error within 0.03 per cent. These changes are made with a minimum of controls, saving time and effort.

Basically, the transmitter consists of an optional e.c.o. or crystal oscillator, the output of which drives an RK-47 125-watt beam-power tube direct or through a series of band-pass-coupled RK-25 doublers. The only controls that must be manipulated in changing frequency are the e.c.o. grid tuning condenser or crystal switch and, for appreciable changes, the plate tank or antenna circuit (depending on the output arrangement).

The principal feature contributing to the simplified handling of this transmitter is the use of band-pass coupling elements, requiring no re-tuning within a given amateur band.

DESIGNING BAND-PASS COUPLERS

It is a source of won-

*Assistant Secretary, A.R.R.L.

der that band-pass-coupled circuits have not been more generally used in amateur transmitters. There are doubtless good reasons for this, apart from the fact that relatively little information on practical applications has been made available. For one thing, power is always precious, and the loss of an appreciable amount in a band-pass circuit usually outweighs the inconvenience of re-tuning when changing frequency.

With the current trend toward flexible quick-frequency-change transmitters, however, band-pass circuits become constantly more attractive. Power in moderate quantities has become so cheap these days, too, what with the economical high-performance tubes now available, that reduced efficiency is no longer very important.

The design of band-pass couplers is a relatively straight-forward procedure. No elaborate multi-section filters are required to cover the amateur bands; ordinary transformer-coupled double-tuned circuits are entirely adequate. Indeed, the sole special requirement of a band-pass coupler of this type as against ordinary inductive coupling is that the degree of coupling must be closely controlled.

It is a basic element of coupled circuit theory that there is a single degree of coupling for any given coil combination that will give the maximum transfer of energy from primary to secondary. This condition is called critical coupling. At this point the resistance coupled into the primary circuit at the resonant frequency equals the primary circuit resistance, satisfying the condition for maximum power. In this condition

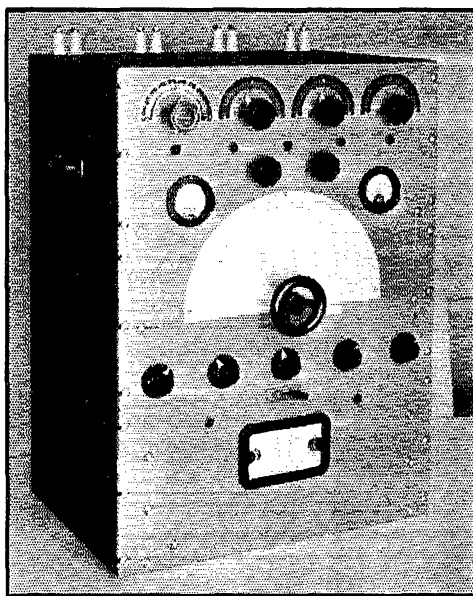

THE 100-WATT CONTINUOUS-FREQUENCY-COVERAGE TRANSMITTER

The large tuning dial is direct-reading in frequency. Along the top are separate output tank circuits for each band (with separate links coming through the feed-thru's), the output tank band-switches being just below. Pilot lights indicate the band and oscillator in use. The lower row of switches provides exciter band-changing, meter switching, crystal or e.c.o., frequency calibration re-set vernier, and crystal switch. The anti-capacity switch on the power panel has 'phone, c.w. and tune-up positions.

the primary resonance curve (r.f. current measured in the primary tank circuit—not d.c. plate current dip) shows a double hump, the coupled reactance serving to neutralize the primary reactance at frequencies slightly off resonance. At critical coupling this serves only to broaden the over-all curve, but when the coupling is increased still further the two humps or peaks spread and become more pronounced as the coupled reactance is matched farther down the primary resonance curve. At the same time the secondary curve also broadens, with two peaks located symmetrically about the resonant frequency at about the same points as the primary peaks. Owing to the lower impedance of the secondary at resonance, the secondary resonance curve does not show peaks until the coupling is on the order of 50 per cent greater than "critical."

By taking advantage of these characteristics—double-peaked primary and broadened single-peaked secondary curves—a curve of substantially equal response over a wide range of frequencies can be achieved. The degree of coupling must be quite carefully controlled, however; critical coupling or less, as normally used in amateur transmitters, results in a fairly sharp curve requiring retuning every few kilocycles, while twice critical coupling will give peaks 50 to 100 per cent greater than the center response—not to mention lowered transfer efficiency.

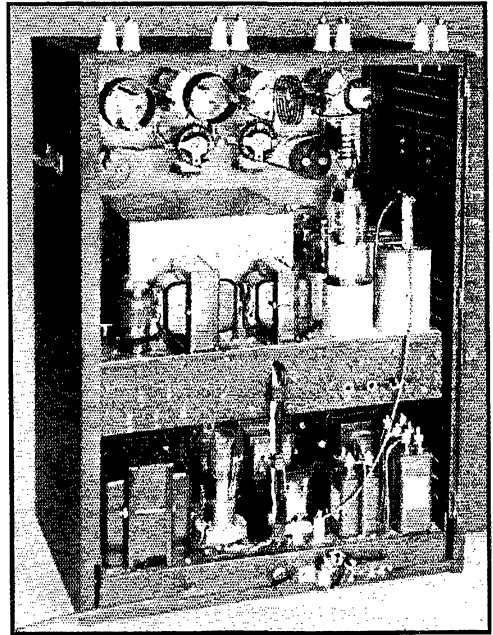

REAR VIEW OF THE BAND-PASS-COUPLED TRANSMITTER

The electron-coupled oscillator is housed in the large shield can, with the crystal oscillator at left and the band-pass stages along the right. Pre-set crystal tank condensers mounted on the rear panel are tuned with a screwdriver, while the doubler grid currents are read through jacks on the same panel. The high-voltage lead trailing down at the right normally is conducted through a shield to an external modulation transformer. Knobs on the power chassis control oscillator voltage and a key-click filter circuit.

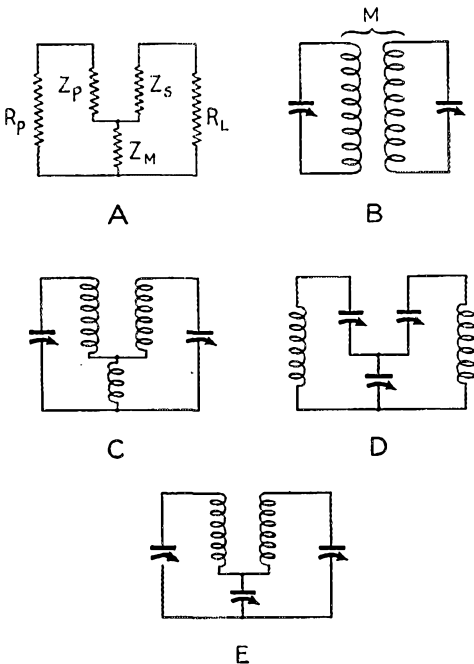

FIG. 1—BASIC FORMS OF BAND-PASS COUPLER CIRCUITS

Although it is possible to assemble band-pass couplers by strictly experimental methods, the two essential factors—coupling and effective Q —are hard to compare simultaneously, and in the end it will be found simpler to perform certain basic computations which indicate the desired conditions with reasonable accuracy. These theoretical considerations can be summarized as follows:

It may be assumed that the essential elements of a band-pass coupler are shown in the equivalent circuit, Fig. 1-A. For practical purposes, Z_p and Z_s can be considered quite separate tuned circuits, whose resonant frequency is the center of the pass-band, while Z_m is a common coupling impedance—either mutual inductance, or common capacity or inductance. Since, as has been shown, the extent to which Z_s is coupled into Z_p determines the separation of the double peaks, Z_m is the element whose value determines the width of the pass-band.

The value of Z_m is customarily denoted by the expression for coefficient of coupling, k . A rough approximation of the value of k required to produce a given pass-band can be secured from the following simplified relationship:

$$\frac{\text{Width of pass-band}}{\text{Resonant frequency of tuned circuits}} = k$$

An ideal band-pass filter provides equal response over the desired pass-band with sharp cut-off on either side. This sharp cut-off is not as essential for purposes of selectivity in transmitters as in receivers, but it does improve the efficiency of the coupler because the response within the desired band is higher. The use of the minimum required pass-band is therefore desirable.

The term "width of pass-band" is an approximation with limits just outside the actual peaks of the primary resonance curve. In practice the curve usually is extremely broad with a single peak, due to the effect of the secondary. The term is merely an indication of the area over which substantially uniform response may be expected.

The actual degree of uniformity of response is controlled by the effective Q of the circuits in relation to the coefficient of coupling. Although the location of the peaks in the curve is substantially independent of resistance in the circuit, the proportionate response at the peaks and in the center is directly controlled by the resistance. Too low a value of Q will have the effect of permitting the secondary to dominate, giving a rounded single peak; the efficiency will be poor and the response over the pass-band uneven. Too high an effective Q , on the other hand, raises only the peaks, again resulting in unequal response. The ideal provides for an over-all variation not greater than 10 or 20 per cent, with sharp drop-offs at the sides. With proper design, this can be achieved with a loss such that the resonant voltage rise is about half that obtained with critical coupling.

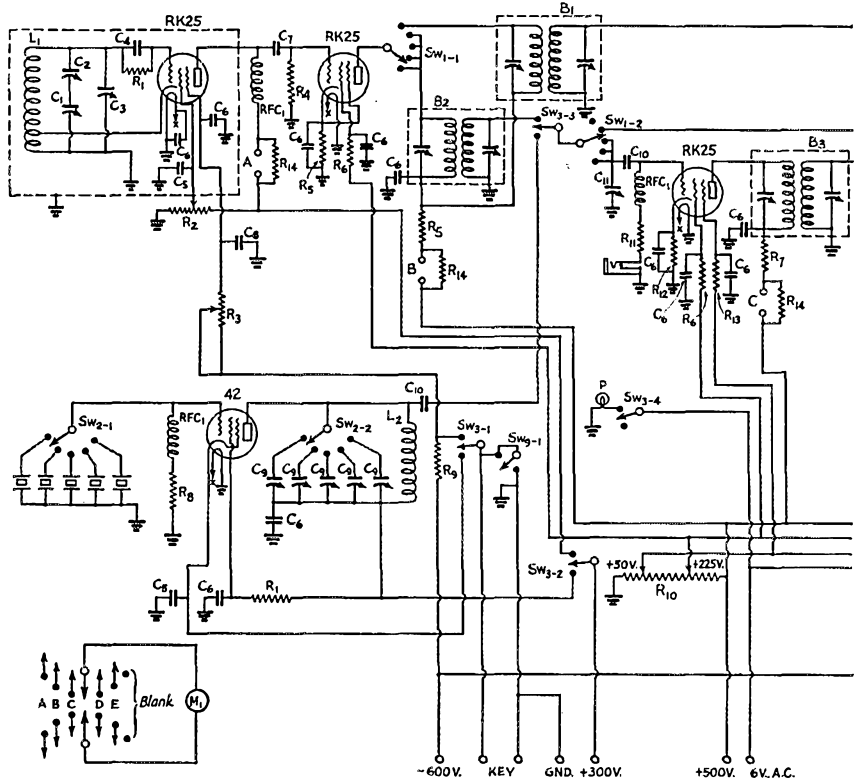

FIG. 2—CIRCUIT DIAGRAM OF THE CONSTANT-FREQUENCY-CHANGE TRANSMITTER

- | | | |
|--|---|--|
| L_1 —25 turns No. 14 tinned wire, 1.75" dia., 2.5" long. | C_1 —150- μ fd. main tuning variable (National TMC-150). | C_9 —50- μ fd. midget variable (Hammarlund APC-50). |
| L_2 —28 turns No. 20 d.s.c. wire, 1.5" dia., 1" long. | C_2 —350- μ fd. series padding variable (National MEC-350). | C_{10} —0.002- μ fd. 1000-volt mica. |
| L_3 —3 turns No. 10 enamel, 2" dia., 8" long (1-turn link). | C_3 —500- μ fd. parallel padding variable (National EMC-500). | C_{11} —30- μ fd. midget mica trimmer (National M-30). |
| L_4 —6 turns No. 14 enamel, 2.5" dia., 1.5" long (2-turn link). | C_4 —250- μ fd. 1000-volt mica. | C_{12} —0.001- μ fd. 2500-volt mica. |
| L_5 —12 turns No. 16 enamel, 2.5" dia., 1.5" long (3-turn link). | C_5 —0.01- μ fd. 400-volt mica. | C_{13} —35- μ fd. transmitting variable (Cardwell MG-35-NS). |
| L_6 —13 turns No. 16 enamel, 2.5" dia., 1.6" long (4-turn link). | C_6 —0.01- μ fd. 600-volt (working) tubular paper. | C_{14} —200- μ fd. transmitting variable (Cardwell MT-100-GD). |
| | C_7 —100- μ fd. 1000-volt mica. | R_1 —50,000-ohm 1-watt carbon. |
| | C_8 —0.5- μ fd. 600-volt (working) tubular paper. | R_2 —25,000-ohm 25-watt wire-wound semi-variable. |

The proper value of Q to satisfy this condition is that which, with the degree of coupling specified, results in equal currents in the secondary at the resonant frequency and at the primary peaks. Terman has shown¹ that the value of Q required to realize this condition is about 50 per cent greater than the Q required for critical coupling (the value of k being constant). Therefore:

$$Q = \frac{1.5}{k}$$

The effective Q of the circuit depends primarily upon the effect of the coupled load resistance. Both the actual value of this resistance and the degree of coupling participate in its effect. Since the degree of coupling is set by the pass-band, the

¹ F. E. Terman, "Radio Engineering," second edition, page 88.

coupled load resistance must be varied to control Q . In practice, this can be accomplished by assuming a set of probable power requirements (on the basis of experience, tube charts, *Handbook* information, etc.) and solving the following equation:²

$$L = \frac{(0.8 E_b 0.7)^2 / 0.7 P}{6.28 f Q}$$

where

L = inductance in μ h
 E_b = plate voltage

² J. L. Reinartz, "How Much C?" *QST*, March, 1937. Although the accuracy of this simplified equation is limited in the present application, the factors for efficiency and operating angle being arbitrary values taken for average Class-C amplifiers, the result is not sufficiently critical to justify the complication of more elaborate expressions.

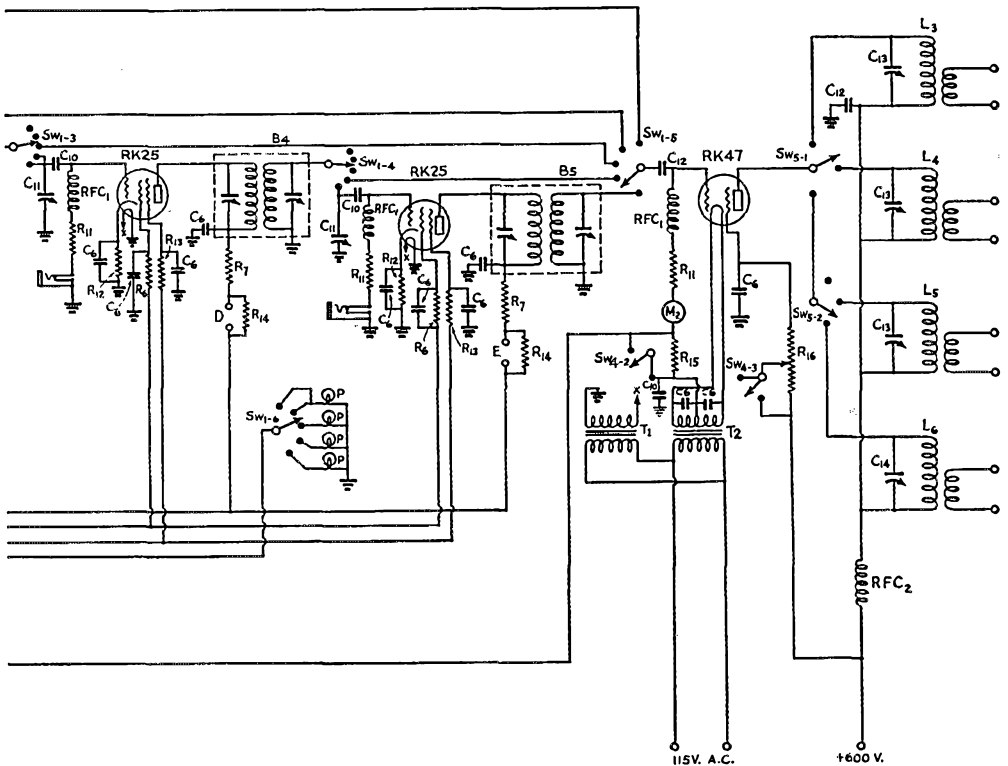

- R₃—100,000-ohm potentiometer.
- R₄—100,000-ohm 1-watt carbon.
- R₅—500-ohm 1-watt carbon.
- R₆—500-ohm ½-watt carbon.
- R₇—500-ohm 2-watt carbon.
- R₈—20,000-ohm 1-watt carbon.
- R₉—1-megohm 1-watt carbon.
- R₁₀—60,000-ohm 50-watt wire-wound semi-variable.
- R₁₁—10,000-ohm 1-watt carbon.
- R₁₂—1000-ohm 10-watt wire-wound.
- R₁₃—10,000-ohm ½-watt carbon.
- R₁₄—100-ohm ½-watt carbon.

- R₁₅—400-ohm 25-watt wire-wound.
- R₁₆—60,000-ohm 25-watt wire-wound semi-variable.
- T₁—6.3-volt, 5-amp. filament transformer (Thordarson T-73F60).
- T₂—10-volt, 3.25-amp. filament transformer (Thordarson T-64F15).
- RFC₁—2.5-mh. r.f. choke (National R-100 or Hammarlund CH-X)
- RFC₂—1-mh. transmitting r.f. choke (National R-154U).
- P—6-volt pilot light.
- M₁—100 ma.

- M₂—25 ma.
- Sw₁—10-section 5-position band-change switch (Centralab, see text).
- Sw₂—2-section 5-position crystal switch (Yaxley 1315).
- Sw₃—4-section 2-position oscillator switch (Yaxley 1312).
- Sw₄—3-section 2-position 'phone-c.w. switch (Federal).
- Sw₅—3-position band switch (Ohmite).
- Sw₆—2-section 6-position meter switch (Yaxley 3226-J).

P = power input in watts
 f = mid-band frequency in Mc.
 Q = effective Q , as arrived at by previous equation

The two significant values are now available—the coefficient of coupling and the inductance required to give the proper effective Q . The next requirement is to translate the coupling coefficient into usable terms.

There are several ways of coupling the tuned circuits in a band-pass filter, as shown in Fig. 1. Each method may have advantages in specific circumstances. The actual choice will depend on the electrical and mechanical layout. The circuit of Fig. 1-B is recommended for most applications as the simplest to construct and adjust; it is the type used in the transmitter being described.

Fig. 1-B relies on mutual inductance for coupling. The value of this inductance required to provide the necessary coupling is readily determined:

$$M = kL$$

The calculation of the actual mutual inductance of two coils is not quite as simple, but it can

be accomplished by the use of the following formula when the two coils are nearly identical and are coaxial but not concentric, with "cold" ends adjacent:³

$$M = \frac{a^2 n^2}{l} \left(\frac{D + \frac{1}{2}}{\sqrt{(D + \frac{1}{2})^2 + a^2}} - \frac{D - \frac{1}{2}}{\sqrt{(D - \frac{1}{2})^2 + a^2}} \right)$$

where

l = length of one coil in inches
 a = radius of one coil in inches
 n = number of turns in one coil
 D = distance between centers of coils in inches, coaxially (l plus spacing)

The computation for Fig. 1-C is somewhat easier, although the result is more difficult to achieve in practice. Here it is necessary only to make the common inductance equivalent in

(Continued on page 110)

³ This is a simplified formula. The basic equations, covering coils of all shapes and characteristics, are given on pages 269-283 of Bureau of Standards Circular C74, "Radio Instruments and Measurements."

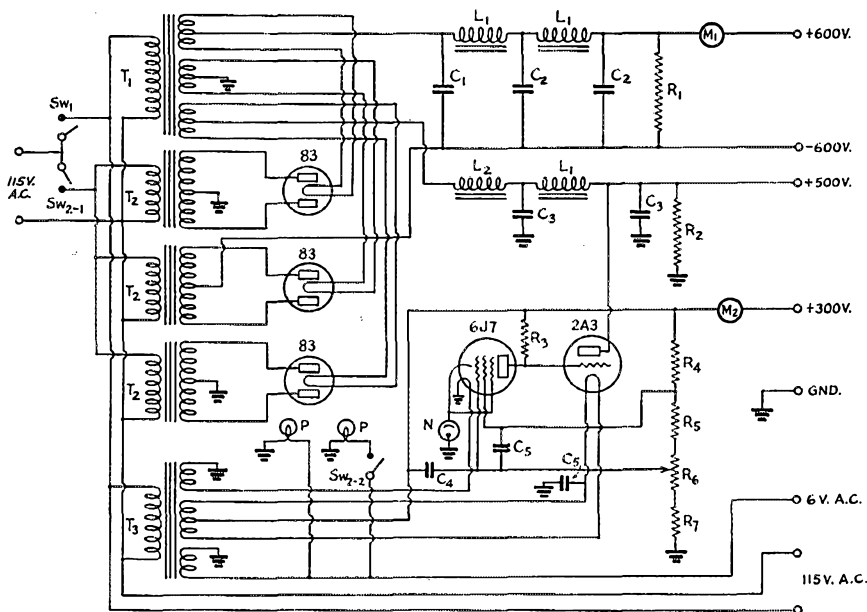

FIG. 3—POWER SUPPLY WIRING DIAGRAM

L_1 —Filter choke, 200-ma. 12-henry (Thoradson T-16C25).
 L_2 —Input choke, 200-ma. 5-henry (Thoradson T-67C49).
 C_1 —1- μ fd. 2000-volt filter condenser.
 C_2 —2- μ fd. 1500-volt filter condenser.
 C_3 —2- μ fd. 600-volt filter condenser.
 C_4 —0.5- μ fd. 400-volt tubular paper.
 C_5 —0.25- μ fd. 200-volt tubular paper.
 R_1 —50,000-ohm 50-watt wire-wound.
 R_2 —100,000-ohm 10-watt wire-wound.

R_3 —0.5-megohm 1-watt carbon.
 R_4 —30,000-ohm 1-watt carbon.
 R_5 —25,000-ohm 1-watt carbon.
 R_6 —10,000-ohm wire-wound potentiometer.
 R_7 —5000-ohm 1-watt carbon.
 T_1 —Filament transformer, three 5-volt 3-amp. windings (Thoradson T-70F46).
 T_2 —Plate transformer, 600-volt 200 ma. (Thoradson T-16P00).

T_3 —Filament transformer, 2.5-volt 2.5-amp., 6.3-volt 0.3-amp. and 5-6-volt 2-amp. (Thoradson T-79F84).
 N —1-watt neon bulb, type G-10 (with base resistor removed).
 P —6-volt pilot light.
 M_1 —200 ma.
 M_2 —100 ma.
 Sw_1 —S.p.s.t. filament canopy switch.
 Sw_2 —D.p.s.t. plate canopy switch.

Simple Directional Arrays Using Half-Wave Elements

A Résumé of Data on Gain Variation with Spacing

By Nick C. Stavrou,* W2DFN

THERE seems to be a lack of general understanding regarding some of the important aspects of the operation of antennas using phased elements which, we believe, can be attributed to the fact that information on the subject is to be found only in widely scattered tech-

Generally too much attention is paid to horizontal directivity and not enough to vertical directivity, which is equally important from the standpoint of raising the signal level. Here is an example: We have a sharp beam directed at London which gives us S9 reports there and in other parts of the world in line with the beam, but which may give us only S5 to S6 in Portugal or Finland, which are removed only about 15 degrees from the beam. If the antenna is not rotatable, obviously such sharpness is not suited to the needs of the ordinary amateur, who does not desire point-to-point service only. If the horizontal directivity is made broad, however, the general impression is that we lose in gain, but in many cases this gain can be brought up again by lowering the angle of radiation. Then we can put an S8 to S9 signal over most of Europe, whereas before we pumped it all into one spot. The theoretical gain of the sharp horizontal beam with broad vertical directivity may be higher but in real results, particularly under poor conditions, the

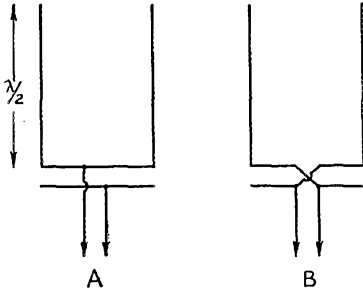

FIG. 1—TWO HALF-WAVE ELEMENTS IN-PHASE (A) AND OUT-OF-PHASE (B)

The theoretical gains over a single half-wave element similarly oriented are given in Table 1.

nical papers or compiled, more or less completely, in the more expensive books. Hence the ordinary amateur cannot always have the information at his finger tips. The purpose of this paper is to summarize the pertinent facts about directional antennas consisting of half-wave phased elements, giving the theoretical gains with each combination based on the work of Sterba¹ and Brown.² Although these theoretical gains probably are slightly higher than most amateur locations can give, nevertheless the figures can be used for comparison of gain between different arrangements.

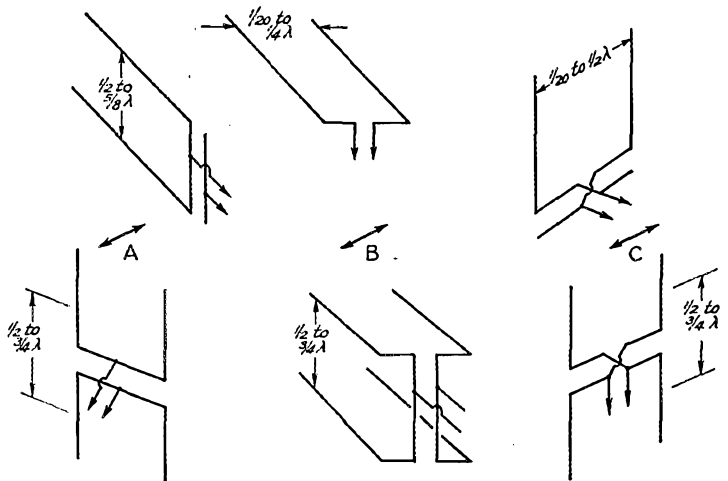

FIG. 2—HALF-WAVE COMBINATIONS WHICH CONCENTRATE THE RADIATION AT LOW ANGLES

Arrows indicate the direction of maximum radiation in horizontal plane. In the upper row, A is a broadside in-phase array, while B and C are end-fire out-of-phase arrays. The lower row shows methods of stacking to improve the vertical directivity without affecting the horizontal directivity to any considerable extent.

* 51 South Orange Ave., Newark, N. J.
¹ Sterba, "Directional Transmitting Systems," *Proc. I.R.E.*, July, 1931.
² Brown, "Directional Antennas," *Proc. I.R.E.*, January, 1937.

"broader" beam with sharp vertical directivity will be equally as good.

Until recently, end-fire arrays (radiation in line with antennas) have been sadly neglected. This was probably because two half waves spaced a half wave and fed out of phase have a theoretical gain of 2.2 db (see Table I) and the same antennas fed in phase give a gain of 4 db; also, it had been thought that spacing out-of-phase elements closer than a half wave caused partial cancellation of radiation. Recently it has been shown by G. H. Brown ² that not only does the expected cancellation not take place, but that the gain actually increases, up to a certain point, with closer spacings.

Let us consider for a moment the half-wave spacing mentioned in the preceding paragraph. If the radiators are vertical, it would seem that the broadside array gives over one and a half times the power gain. On the other hand, the vertical pattern is the same as that of a single half-wave antenna, while the out-of-phase vertical radiators give a lower effective angle of radiation. In proof of the value of vertical directivity many DX'ers will recall the signal of low-powered PAØLL in the Spring of 1934; this station used two vertical end-fire half waves spaced a half wave apart, and had one of the most consistent European signals here in the East as well as on the West Coast.

Table I is interesting in showing how gain varies when spacing is varied for both out-of-phase end-fire arrays and in-phase broadside arrays. It must be noted that this table is for two antennas only. The maximum gain figure for the in-phase arrays, which occurs at $\frac{5}{8}$ -wave spacing, does not hold for three or more elements in line, where the maximum gain occurs at $\frac{3}{4}$ -wave spacing. The gain of end-fire arrays increases with reduced spacing, with a maximum occurring at $\frac{1}{2}$ wave. Even $\frac{1}{2}$ -wave spacing gives practically the gain of a $\frac{1}{2}$ -wave spaced broadside array. The $\frac{1}{2}$ -wave spacing at 14 Mc. amounts only to three and a half feet, so a quite compact array can be built. However, it must be kept in mind that at such close spacing the radiator currents are large and provision should be made to keep wires rigid, since the detuning will be considerable with slight changes in spacing.

Fig. 2 shows combinations of two half waves for

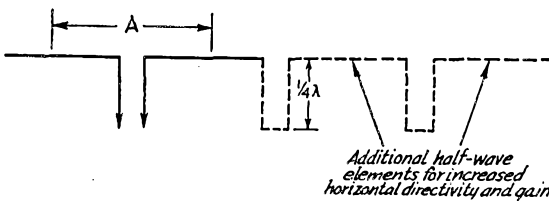

FIG. 3—COLINEAR HALF-WAVES IN PHASE

Theoretical gains over a single element are given in Table II for a number of elements with two different spacings.

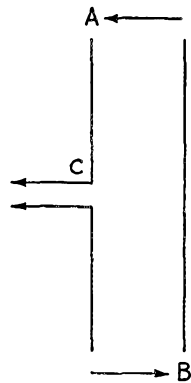

FIG. 4—HALF-WAVE ANTENNA WITH PARASITIC REFLECTOR

Depending upon the spacing and the reactance of the parasitic element, the direction of maximum radiation may be either as shown by arrow A (parasitic element a reflector) or by arrow B (parasitic element a director).

low-angle radiation and how they should be stacked to improve still further the vertical directivity, without increasing the horizontal sharpness to any great extent. Bearing in mind that maximum radiation occurs from the central (high-current) portion of a half-wave element, the end quarters may be bent at right angles. The loss in the desired direction that ensues is quite small, and a rotary beam only 16 feet square at 14 Mc. can be quite effective.

TABLE I
THEORETICAL GAIN OF TWO HALF-WAVE ANTENNAS AT DIFFERENT SPACINGS

180° Out of Phase (End Fire)		In Phase (Broadside)	
Separation in Fractions of a Wavelength	Gain in DB	Separation in Fractions of a Wavelength	Gain in DB
$\frac{1}{8}$	4.3	$\frac{5}{8}$	4.8
$\frac{1}{40}$	4.1	$\frac{3}{4}$	4.6
$\frac{1}{4}$	3.8	$\frac{1}{2}$	4.0
$\frac{3}{8}$	3.0	$\frac{3}{8}$	2.4
$\frac{1}{2}$	2.2	$\frac{1}{4}$	1.0
$\frac{5}{8}$	1.7	$\frac{1}{8}$	0.3

To arguments that too low an angle of radiation can defeat its purpose, we can only answer that such a thing as too low an angle is not possible at the average antenna heights used by amateurs. The lower the frequency the lower the height in wavelengths; since the angle of maximum radiation increases with decreasing height, and since high radiation angles are relatively more effective on the lower frequencies, it all works out to the advantage of the operator.

An antenna which has no special vertical directivity though it can be made quite sharp (from the amateur viewpoint) by increasing the number of elements is commonly known as "half-waves in phase." This system is shown in Fig. 3, with gain figures in Table II. It is not commonly known that when the half-waves are separated so that the centers are $\frac{3}{4}$ -wave apart

instead of $\frac{1}{2}$ wave the gain increases approximately 1.4 db.

PARASITIC ANTENNAS

Now we come to the explosion (for which Brown is again responsible) of another long-accepted idea—that parasitically-excited reflectors should be spaced $\frac{1}{4}$ wave and directors $\frac{3}{8}$ wave from a driven antenna.

Let us take the familiar antenna-reflector setup, shown in Fig. 4, which has become popular on the higher-frequency bands, particularly in rotatable antennas. The reflector is generally made a bit longer than a half wave (about two percent) but in many installations it is found that a somewhat

ated by the antenna without a reflector. In other words, the front-to-back ratio is only 5.3 db, approximately. This relatively small difference has been observed by many amateurs having rotatable antennas.

When the reflector is made a little longer than the resonant length, a point will be reached where the power gain in the desired direction is 3.2 db and the power radiated in the backward direction is 6 db less than from a comparison single half-wave radiator, giving a front-to-back ratio of 9.2 db. If, however, the reflector were shortened by a similar amount, the radiation from the system would be nearly the same in both directions; in other words, the system becomes bi-directional.

Now we come to the interesting part. Let us shorten the spacing between the parasitic and driven antennas to a tenth wavelength. We adjust the length of parasitic antenna D, Fig. 4, to resonance, noticing that adjustment of D affects the tuning of the antenna C. After tuning to resonance (a few inches may mean a lot) we find that our reflector has changed its job and is now a director. Maximum radiation is now toward arrow B and the power gain is now 5.6 db, which is even better than any arrangement shown in the tables for two driven antennas. The backward radiation is about the same as from a single half wave, so the front-to-back ratio is about 5.6 db. Let us try changing length of D. First we try lengthening it, and soon the parasitic antenna decides to be a reflector again. At its optimum (maximum gain) length as a reflector the gain is 4.8 db and the front-to-back ratio is also 4.8 db.

Next we shorten the combination director-reflector right through self-resonance to a point where wire D (now being a director) causes the system to have a gain of about 4.6 db and a front to back ratio of 17 db. So, there you have it, take your choice: A power gain of 5.6 db and less than 6 db drop in signal toward the rear, or one decibel less gain forward and 17 db attenuation backward.

One may well ask at this point how one knows how much to lengthen or shorten the reflector-director, as the case may be, for maximum attenuation to the rear. The method described by Mims³ is about the simplest and best for the amateur. Commandeer a brother ham, not too close, who has a receiver with an S meter and adjust wire D for greatest front to back ratio.

As a director, optimum spacing occurs at one-tenth wave when the parasitic radiator is cut for self-resonance, and the gains are as noted in the preceding paragraphs. As a self-resonant reflector, maximum gain is about 4.8 db at $\frac{1}{2}$ wavelength, and the front-to-back ratio is only around 3.7 db, a barely noticeable difference in actual reception. Optimum front-to-back ratio, with the

(Continued on page 108)

³ Mims, "The All-Around 14-Mc. Signal Squirter," QST, December, 1935.

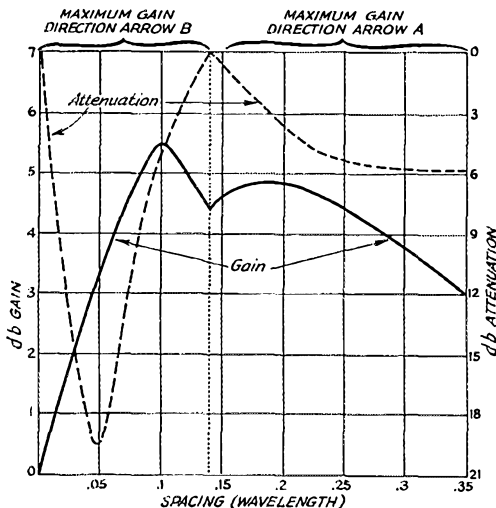

FIG. 5—FORWARD GAIN AND BACKWARD ATTENUATION FOR A HALF-WAVE ANTENNA WITH A SINGLE PARASITIC ELEMENT, AS A FUNCTION OF SPACING

The parasitic element is self-resonant.

shorter reflector is preferable. With quarter-wave spacing, the forward gain, in the direction of arrow A, is approximately 4.3 db when the reflector is resonant, while the backward radiation (arrow B) is nearly the same as the power radi-

Spacing Between Centers of Adjacent Half Waves (A)	Number of Half Waves in Array Gain in DB				
	2	3	4	5	6
$\frac{1}{2}$ Wave	1.8	3.3	4.5	5.3	6.2
$\frac{3}{4}$ Wave	3.2	4.8	6.0	7.0	7.8

New Ideas in Rotatable Antenna Construction

Improved Feeder Contacts for Continuous Rotation

By L. H. Whitney,* W1EER and G. W. Whitney,** W1JYQ

WITH a little patience, a few sticks of wood, some nails, bolts, insulators, wire, tubing and a *Handbook* (not to mention a good strong back!) one can construct an efficient antenna system. The results to be secured are two-fold, since a well-designed transmitting antenna turns out to be just as good for receiving. After all, a station is no better than its antenna system, regardless of power, operator or receiving apparatus.

With this thought in mind, about a year ago we decided to design and erect a tower upon which could be installed various types of skywires, in order to learn which would bring about the most effective results. The outcome of a whole winter's work gave rise to the present 128-foot wooden structure, weighing some two and one-half to three tons, shown in the accompanying photograph.

At the time, we were operating on 40-meter c.w., and 5-meter 'phone, so the first antenna to be attached to the tower was a $\frac{1}{2}$ -wave 40-meter vertical Zepp, which proved very satisfactory and which is still in use to-day. Our chief efforts about then were in the direction of the ultra-high frequencies, and although we had achieved very gratifying results with a 5-meter $\frac{1}{2}$ -wave vertical, we didn't really know what a good antenna meant until a 5-meter vertical Johnson "Q" was installed at the top of the tower. Our ability to receive was improved many times and, from the reports, one would think we had increased the power immensely when it came to transmitting. We worked many DX stations on 5 meters located in the 1st, 2nd, 3rd, 4th and 9th Districts, and we were also reported several times in the British Isles on 5-meter 'phone.

Of course, ham fashion, not being satisfied with just operating on one or two bands, we became inquisitive about 10 meters and constructed a transmitter for that frequency, but after playing around for about six months or so we found out that the type of antenna to be employed at this frequency also had a tremendous bearing on the

results. We installed a 10-meter vertical "J" at the top of the tower just under the 5-meter "Q," and after calling our heads off for some weeks—and, of course, doing some heavy listening—came to the conclusion that a different antenna had to be used not only to get out but to receive those stations which we knew were on the air.

After some deliberation, we decided to tear down the "J" and install a horizontal 10-meter "Q," and sure enough, true to form, the old boy did his stuff! Before we had time to put the rig on the air, we were hearing 10-meter signals that we never knew existed before, coming in S9. It proved to be just as efficient for transmitting, but we felt sure we could go further yet if we could devise some way of rotating the antenna. So we debated the matter, and after some further listening to our fellow-hams' experiences it appeared that equal, if not better, results could be obtained with a rotating directional array even if mounted somewhat nearer the earth.

Again, things began to hum, and there developed the 10-meter rotating directional array now in use on this band. We again used the "Q" horizontal, with one director and one reflector, in order to make a real comparative study of both types of antennas regarding mounting heights, as well as signal strength and radiation pattern.

This beam has been the means of increasing our signal strength on an average of 3 to 4 S points. The results are equivalent on receiving. One of the unexpected results accom-

plished was the lowering of car-ignition QRM, a most important factor to us since the shack is only 500 feet from the Boston Post Road.

During the recent DX Contest, we made WAC twice on 10-meter 'phone, and have worked some twenty countries. Among the distant stations worked were VK2GU, VU2CQ, ZE1JR, LU9BV, LU1DA and K6MNV.

Aside from special features for rotating, the beam itself differs very slightly from other rotary beams. But we think we have licked the problem when it comes to the contacting device to be used on a beam that is rotatable either clock-wise or counter-clock-wise 360°, continuously.



WILK AND LLOYD WHITNEY,
W1EER

* P. O. Box 473, Noroton Heights, Conn.

** P. O. Box 426, Stamford, Conn.

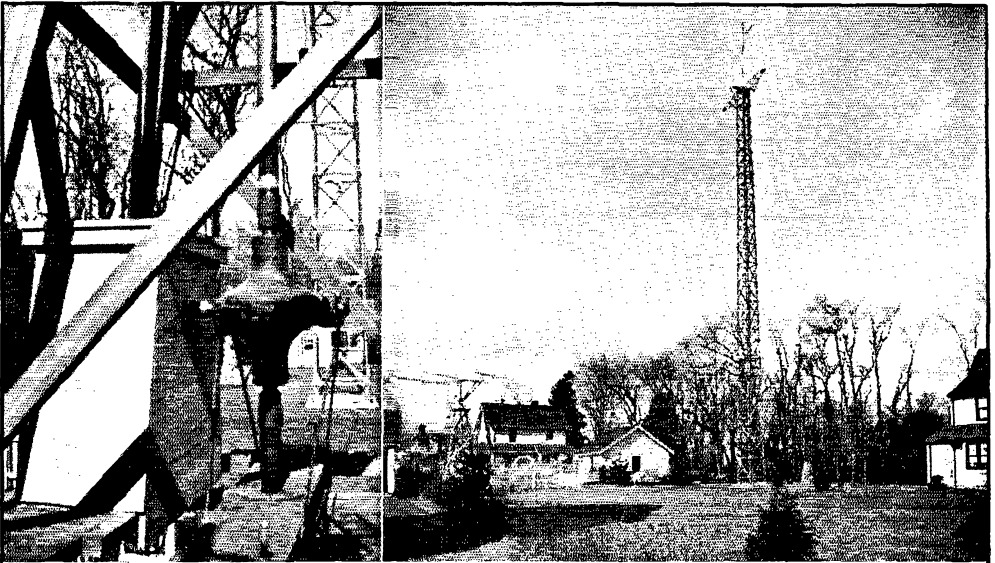

THE ROTARY BEAM, AT LEFT, IS DWARFED BY THE 128-FOOT TOWER, BUT NEVERTHELESS OUTPERFORMS THE TEN-METER HALF-WAVE MOUNTED ON THE CROSS ARM AT THE TOWER'S TOP

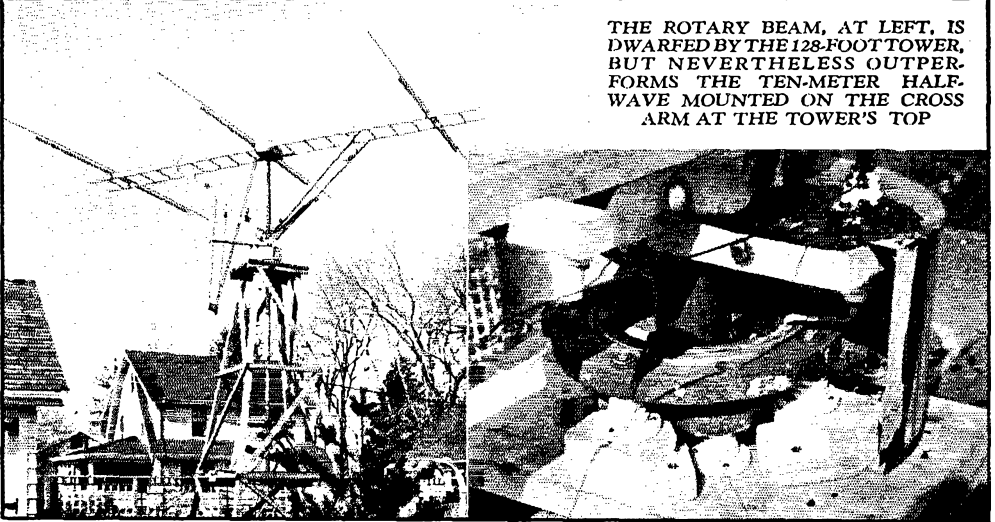

LEFT—THE ROTATING SYSTEM, WITH ITS "Q" ANTENNA, DIRECTOR AND REFLECTOR

The antenna elements are 22 feet above the ground. The important constructional features are described in the text. Note the "drum" just above the platform; it serves as a protective cover for the contactors.

RIGHT—CLOSE-UP OF THE MERCURY CONTACTS

Part of the lower cast-iron flange is visible between the two stand-off insulators supporting the near side of the upper flange. Contacts are steel rods dipping in mercury-filled troughs in the flanges.

TOP LEFT—THE ROTATING AND SUPPORTING MECHANISM FOR THE BEAM

The heart of the system is an automobile rear end. The driving motor is mounted inside the "house" which protects it from the weather.

MECHANICAL CONSTRUCTION

The 20-foot ladder mounting for the beam, seen in the photograph, is an original idea which accomplishes weight reduction, increases the strength, and at the same time provides a struc-

ture upon which any type of directional antenna can be built. The beam is designed so as to permit tilting at a later date if desired. The antenna, reflector and director are made of half-inch copper tubing, mounted on stand-off insulators, and

(Continued on page 98)

What the League Is Doing

League Activities, Washington Notes, Board Actions—For Your Information

Cairo By the time this issue of *QST* reaches readers' hands, the Cairo Conference will be history, and doubtless every informed amateur will know the outcome. At the moment of writing, though, it is not possible to predict surely what that outcome may be. However, the latest reports from the front indicate that:

In the western hemisphere amateur radio has been successfully defended. All our existing bands will remain intact, without compromise. Based on the loyal support of the United States delegation, entrenched in the firm resolve of the Habana conference that American amateur radio must be maintained, on this side of the world we will have emerged unscathed.

Our brothers elsewhere will probably not have fared so well. Pressure on practically all the existing amateur bands except 14 Mc. and higher (the threat against our u.h.f. assignments was mentioned last month), particularly on the part of many of the European delegations, is so great that some losses on a regional basis are inevitable. The 1.7- and 3.5-Mc. bands will, it is expected, be retained on a nominally shared basis, with the probability that in actual practice European amateurs will in future be allowed to use these bands even less than in the past.

The biggest fight unquestionably revolves around 7 Mc. At this moment, frequency allocations in the Technical Committee (still subject to plenary action and adoption) assign the entire 7-Mc. band to amateurs as at present, but permit short-wave broadcasting in the high-frequency 100 kc. outside the Americas. In other words, in Europe and possibly other continents hams will have to share 7200-7300 kc. with B.C. stations.

It seems apparent that the crucial issue in all the conference has been the problem of securing additional international broadcasting channels. Numerous plans to this end were proposed, some of them Machiavellian in their ingenuity; practically all hit at the amateur "reservoir." One by one, each was resisted and defeated by the proponents of amateur radio. In the end, however, it seems likely that our best efforts from this side of the world cannot entirely save our friends on the other. The social and political implications of this struggle will undoubtedly bear historical significance.

But this is no place for the detailed story. That will come, following upon the return of Secretary Warner and General Counsel Segal to this country. Watch the official broadcasts and the next issues of *QST*!

Braille Handbook Last month in our editorial comment we stated that the list of libraries to be provided with copies of the *Braille Handbook* published by the New York Chapter of the American Red Cross would be given in this issue. Here it is (the numerals in parentheses indicate the number of copies supplied):

Albany—New York State Library (2)
Atlanta—The Victor H. Kriegshaber Memorial Lighthouse for the Blind, Carnegie Library (3)
Austin—Texas State Library (1)
Chicago—Chicago Public Library (2)
Cincinnati—Cincinnati Public Library (3)
Cleveland—Cleveland Public Library (3)
Denver—Denver Public Library (3)
Detroit—Wayne County Library (2)
Faribault—Minnesota School for the Blind (1)
Honolulu—Library of Hawaii (1)
Indianapolis—Indiana State Library (1)
Jacksonville, Ill.—The Illinois Free Circulating Library for the Blind (1)
Los Angeles—Braille Institute Library (2)
New Orleans—New Orleans Public Library (1)
New York—New York Public Library (1)
Oklahoma City—Oklahoma Library Commission (1)
Philadelphia—Free Library of Philadelphia (3)
Pittsburgh—Carnegie Library of Pittsburgh (2)
Portland, Ore.—Library Association of Portland (1)
Sacramento—California State Library (3)
Saginaw—Michigan State Library for the Blind (1)
St. Louis—St. Louis Public Library (5)
Salt Lake City—Salt Lake City Public Library (1)
Seattle—Seattle Public Library (1)
Washington, D. C.—Library of Congress (2)
Washington, D. C.—National Library for the Blind, Inc. (3)
Watertown, Mass.—Perkins Institution Library (3)

Madrid Ratifications The Department of State advises that the instrument of ratification by Norway of the Madrid Convention was deposited with the Spanish Ministry of State at Barcelona on December 15th. The instrument of ratification by Sweden, on the other hand, was deposited with the Ministry of State at Valencia on June 23, 1937. These ratifications do not have any tangible effect on amateur radio, inasmuch as these countries adhered to the Washington Convention, the provisions of which were substantially identical.

Strays

We call attention to an error made in the continuation in the story in April *QST* entitled, "Shock-Proofing the Transmitter." The part of this article on page 72 should have been placed at the bottom rather than the top of the column, so that the reader would not miss the last three paragraphs of the story on page 74.

Intra-Band Quick Frequency Change for Transmitters

Combining Band-Pass Action with Relay-Controlled Padders for Frequency Shift without Manual Retuning

By Byron Goodman,* W1JPE

ABOUT two and a half years ago when we were at a Pacific Division Convention, W6CUH put the problem of quick frequency-change up to us point blank. It sounded like a swell idea, a necessary part of any new transmitter, and so it was given much thought. The result evolved as a weird contraption utilizing four of the old push-button units that were used on the 1927 (or thereabouts) Zenith broadcast receivers. These units were connected to ganged shafts of tuning condensers and a crystal selector switch, and the units were mounted one above the other so that, by connecting the corresponding push-buttons together with cables, the bottom push-button would throw three others. The rig also included band switching. It was as cumbersome as it sounds and had the disadvantage that the operator had to go to the transmitter to change frequency within the same band. Electrically it was an efficient system but mechanically it just wasn't good enough to suit our particular taste.

In the meantime W6CUH had gone ahead along a different line with the excellent outcome

* Assistant Secretary, A.R.R.L.

that was described in *QST*.¹ This of course started us thinking along similar channels, with the result that three different models were built before we arrived at the transmitter to be described.

This particular version, while not nearly so complete as that of W6CUH, has only one final amplifier instead of three, and, although it does take as much time to change bands as with any plug-in coil transmitter, it can go from one end of the band to the other as quickly as one can throw a switch. On 20 and 40 this means that you can watch the whole band instead of just the portion near the frequency to which the transmitter happens to be tuned.

CONTROL UNIT

The control unit, which sits on the operating table, is nothing more than an RK-25 Tri-tet oscillator housed in a metal box, with the 3.5-Mc. crystals plug-in on the top of the box. This permits changing crystals very easily or adjusting variable-gap crystal holders when they are used. The crystal-switch has two sections; one section in the padding



A MODERN BREADBOARD TRANSMITTER DESIGNED FOR QUICK INTRA-BAND FREQUENCY CHANGE

Plug-in coils are used for changing bands, but a combination of semi-band-pass filters and relay-connected padding condensers makes it possible to set the operating frequency from the operating table.

The concentric coils in the center of the transmitter constitute one of the band-pass filters. They are made concentric in order to obtain the close coupling necessary. The two coils are plugged in as a unit.

The final amplifier has quite short leads, obtained by using home-made neutralizing condensers and mounting the tank condenser vertically. The padding condenser and r.f. relay can be seen to the right of the final amplifier tank coil. A similar unit is used at the antenna tuner to shift the tuning from one end of the band to the other.

lects the crystal and the other cuts in the padding

¹ Perrine, "More DX Per Dollar," *QST*, February and March, 1937.

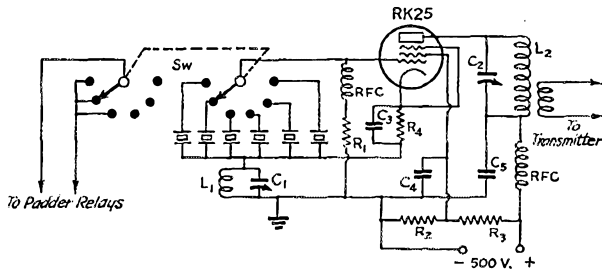

FIG. 1—CIRCUIT DIAGRAM OF THE CONTROL UNIT

- C₁—75- μ fd. variable (National ST75).
- C₂—35- μ fd. variable (National ST35).
- C₃, C₄, C₅—0.005- μ d. mica.
- R₁—50,000-ohm, 1-watt.
- R₂—40,000-ohm, 2-watt.
- R₃—20,000-ohm, 10-watt.
- R₄—300-ohm, 1-watt.
- RFC—R. f. choke, receiving type.
- L₁—15 turns No. 24 wound on 1-inch diameter form to occupy 1"
- L₂—24 turns No. 20, 1 1/2" diameter, 2" long. Coupling link is 7 turns No. 20.
- Sw—2-section 6-position broadcast type switch (Yaxley).

relays in the final and antenna tank circuits when working at the low-frequency end of a band. The tube is mounted upside down in the box to give short leads. The plate tank coil is permanently tuned to about 7100 kc., and is tightly coupled to the next stage by a link of 7 turns. Although the line runs about twelve feet to the transmitter, there is plenty of excitation.

THE TRANSMITTER

We have always been partial to breadboard arrangements, so it was decided that the main unit should be built along these lines. A clincher to this argument was the fact that earlier rack and panel models of the same lineup had demonstrated that it was not easy to change coils. The "breadboard" in this case, however, is a piece of 1/8-inch thick aluminum with quarter-round bends at the ends to give a smooth and modern appearance. The panel, which is used only as a mount for the meters and has no controls on it, is made of black crackle-finished Masonite drilled and tapped for the 4-36 screws with which it is fastened to the aluminum. The rear edge of the chassis is braced by a piece of 3/4-inch brass angle bar, necessary because the filament transformers are mounted on the underside of the chassis. The quarter-round bending of the aluminum was done in a machine shop; the other work was done with regular tools. The aluminum of the chassis was given a dull finish by swabbing with strong lye solution.

The 7-Mc. excitation from the crystal oscillator is coupled into an 807 buffer-doubler tube through a fixed-tune grid circuit. By using a link of more than the usual number of turns, the close coupling between this grid circuit and the oscillator plate

circuit forms, in effect, a band-pass filter, with the result that the excitation is practically constant over the whole operating range.

The plate tank of the following 100TH driver stage are wound on the same coil form to give very close coupling and consequent band-pass action. A National FXTB fixed-tune exciter tank unit is used here, the unit being plug-in because it must work on either 7 or 14 Mc. The problem of making suitable connections to the 807 plate and the 100TH grid

COIL DATA

- L₁—15 turns No. 24 d.s.c. space-wound on 1" dia. to occupy 1"
- L₂—24 turns No. 20 enam., 1 1/2" dia., 2" long, self-supporting
- L₃—22 turns No. 24 d.c.c. close-wound. Link is 7 turns, close-wound
- L₄— 7 Mc.: 20 turns No. 24 d.c.c. close-wound
14 Mc.: 11 turns No. 22 d.c.c. close-wound
- L₅— 7 Mc.: 21 turns No. 24 d.c.c. close-wound
14 Mc.: 12 turns No. 22 d.c.c. close-wound
L₄ and L₅ are wound on 1" diam. forms. Spacing between L₄ and L₅ is 1/2"
- L₆— 7 Mc.: 20 turns No. 16 enam., 3 1/2" diam., 2" long
14 Mc.: 10 turns No. 14 enam., 3 1/2" diam., 1 3/4" long
28 Mc.: 5 turns No. 12 enam., 2" diam., 1" long
- L₇— 7 Mc.: 32 turns No. 18 enam., 2" diam., 2" long
14 Mc.: 17 turns No. 16 enam., 2" diam., 2 1/2" long
28 Mc.: 6 turns No. 12 enam., 2" diam., 1" long
- L₈— 7 Mc.: 24 turns No. 12 enam., 3 1/2" diam., 6" long
14 Mc.: 12 turns No. 10 enam., 3 1/2" diam., 6" long
28 Mc.: 8 turns 1/2" tubing, 2 1/2" diam., 7 1/2" long
- L₉—B & W Type HDA Antenna-matching coil
L₉ is tapped across 2 turns on 7 Mc. and across 1 turn on 14 and 28 Mc. for the padding condenser
L₆, L₇, L₈ and L₉ are Barker & Williamson coils
L₃ is mounted in National FXT unit; L₄-L₅ is in a National FXTB unit

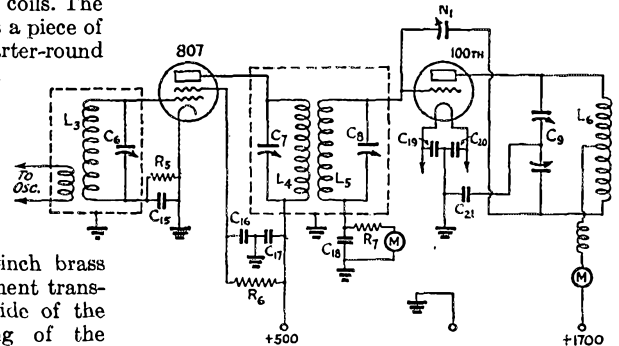
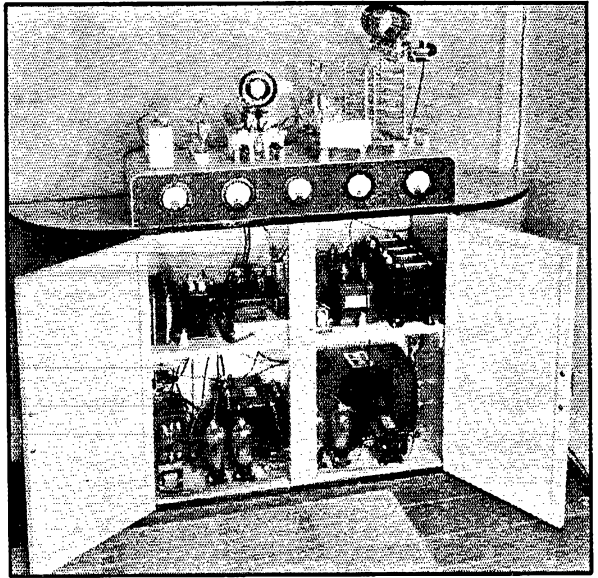

FIG. 2—THE TRANSMITTER CIRCUIT DIAGRAM
 C₆, C₇, C₈—25- μ fd. variable, 2000-volt spacing.
 C₉, C₁₀—35- μ fd. per section split-stator variable, 3000-volt spacing (Cardwell NF-35-ND).
 C₁₁—44- μ fd. per section split-stator variable, 1/2" spacing (Atkins-Brown ABC445).
 C₁₂—100- μ fd. variable, 0.2" spacing (Cardwell XC-100-XS).
 C₁₃, C₁₄—100- μ fd. receiving-type variable (Hammarlund MC-100-S).
 C₁₆, C₁₉, C₁₇—0.01- μ fd. 600-volt paper.
 C₁₈—0.006- μ fd. receiving type mica.

was not solved very well, but flexible leads making direct contact to the terminals were used rather than bringing out all of the connections to the plug-in base. A high-resistance (40,000-ohm) grid leak is used with the 100TH because the tube is used as a doubler when going to 28 Mc., and the high grid resistance gives more efficient doubling.

Another plug-in band-pass unit is used to couple the 100TH to the push-pull 250TH final amplifier. By making the circuits quite low-*C* and by coupling them closely, it is possible to maintain enough excitation at both ends of the 20- and 40-meter bands to drive the final amplifier. The excitation rises to greater values at the centers of the bands, as would be expected, but it was considered satisfactory when it didn't drop to too low a value at the edges. For the purist, a padding condenser and suitable relay could be used here (across the plate coil only, because the circuits interlock) to give greater efficiency and consequently more excitation. The band-pass filters used here are made up from Barker & Williamson coils mounted on National PB5 plugs. Fortunately, the sockets for these plugs fit nicely on the variable condensers used.

The final amplifier is straightforward, with components mounted for short leads and convenience. The neutralizing condensers are homemade from scrap aluminium and mount directly on the tank condenser. The Micalox mounting bar that comes with the tank condenser has its hardware removed and a small bakelite platform



THE TABLE HOUSES THE COMPLETE POWER SUPPLY

fastened to it. An r.f. relay and 100- μ fd. condenser are mounted on this platform. Two G.R. jacks on the platform take two plugs that are connected to a turn of the tank coil by flexible leads. It is this turn, with the condenser across it, that changes the tuning of the final amplifier when going from the high-frequency end of a band to the low. The coil is a special B & W mounted on their regular fittings.

The fly in the ointment of all this quick-change business is the antenna system. We cast about for weeks trying to find some way to eliminate a relay and padding condenser in the antenna system (tuned feeders are used), but we finally had to give it up. The antenna tuner also had to tune several different lengths of feeders when different antennas were used, so it had to be a flexible system. It boiled down to a B & W swinging-link assembly and another r.f. relay and padding condenser, mounted with the suitable tuning condenser, antenna ammeter and antenna change-over relay. Possibly its only merit is that we have yet to find a piece of wire that won't take power when connected to the unit.

POWER SUPPLY

Of course it wouldn't do to let a transmitter like this go to waste just anywhere, and therefore a suitable setting had to be made. This ended up by emerging as the table shown in the illustration. Although it does look slightly out of place in a New England farmhouse, now that we think of it, it has the merit of housing a fairly large power supply and furnishing a decent place for the extra

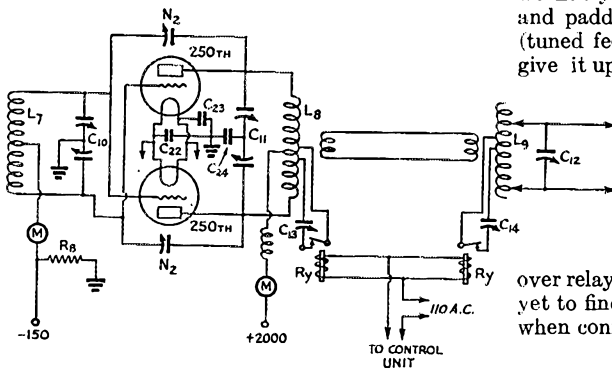

(FIG. 2—Continued)

- C₁₈—0.006- μ fd. receiving type mica.
- C₁₂, C₂₀, C₂₂, C₂₃—0.002- μ fd. postage-stamp mica.
- C₂₁, C₂₄—0.002- μ fd. 5000-volt mica.
- R₃—60,000-ohm, 2-watt.
- R₆—30,000-ohm, 10-watt wire-wound.
- R₇—40,000-ohm 20-watt wire-wound.
- R₈—2000-ohm 100-watt wire-wound.
- R₉—R.f. relay (Guardian R-100).
- N₁—Neutralizing condenser (National NC-800).
- N₂—Neutralizing condenser, homemade. Plates are x.
- L₃—L₅—See coil table.

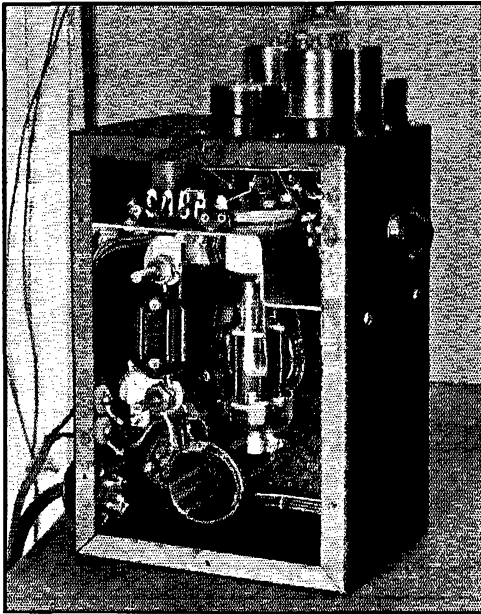

THE FREQUENCY-CONTROL BOX ALSO HOUSES THE CRYSTAL OSCILLATOR

The switch on the front panel selects the proper crystal and connects the r.f. relays when necessary.

Short leads are obtained by mounting the oscillator tube upside down. The circuits are tuned by an insulated screw driver after the side of the box has been replaced.

coils that aren't in use. It was made of pine, finished off with four coats of gray enamel and then the facing edges were trimmed with black enamel. The power supplies deliver 500 volts for oscillator and buffer-doubler, 1750 for the 100TH driver, 2000 volts for the final amplifier, and 150 volts of grid bias for the final amplifier. The table also houses a power contactor relay, a high/low-power relay, a circuit breaker, and an auto-transformer used to adjust filament voltages.

(Continued on page 84)

Vacuum-Type Fixed Condensers for Transmitter Tank Circuits

THAT the conventional air-dielectric variable condenser is at some disadvantage when high-voltage operation is contemplated is well known; wide plate spacing to take care of high peak voltages greatly increases the bulk and cost of the condenser because of the greater plate area, and also magnifies the structural difficulties. If there were no gas between the plates to break down under intense electrostatic stress, the necessity for wide spacing would disappear.

It follows, therefore, that quite a lot of capacity can be put into a small space if the condenser is mounted in an evacuated container. This has been done in a new type of tank condenser developed by Eitel-McCullough, Inc., and soon to

be marketed. About the size of a medium-power vacuum tube, the new condenser somewhat resembles a tube in appearance except for the end mountings. Intended particularly for use in high-voltage, low-current circuits, where high $L-C$ ratios can be used for reasonable "Q" values, the new condensers are made in four capacity values, $6\frac{1}{2}$, 12, 25, and $50 \mu\text{fd.}$, for operation through 28 to 3.5 Mc. Tests have indicated that the voltage which can be handled is limited by the distance between terminals (about $3\frac{1}{2}$ inches) rather than between the plates, since an external flashover occurs before the breakdown is reached in the vacuum. On this basis, the manufacturers are tentatively rating them for tank circuits used with amplifiers running at d.c. plate voltages up to 4000 with plate modulation, when push-pull is used, and about 6000 volts, plain c.w. With single-ended amplifiers, higher voltages can be used.

Since the capacity value is fixed, tuning must be accomplished by some such means as a variable shorted turn inside the coil or an auxiliary midget condenser of ordinary construction and lower voltage rating connected across a turn or two of the coil. In either case the coil itself probably will require some preliminary adjustment to bring the tuning range over the band desired. The condenser and coil can be fastened together as a unit

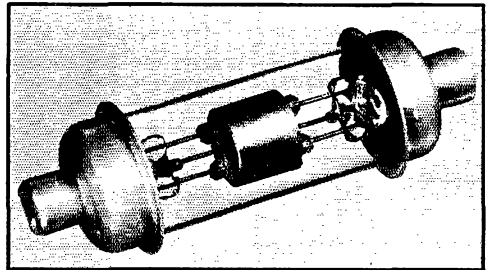

and plugged into fuse clips or similar mountings so that the proper capacity is used on each band. Since there are no large masses of metal, stray capacities are minimized, and short tank leads likewise are possible.

—G. G.

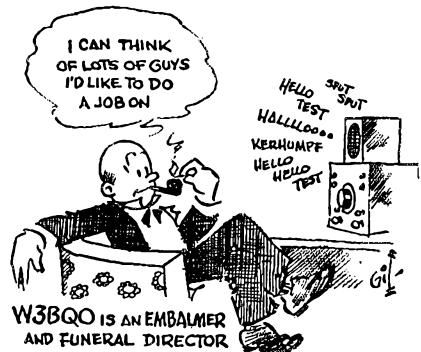

A 5-, 10- and 20-Meter Converter

Band-Spread Tuning, Effective Preselection, and Stable Operation with Only Two Tubes

By T. M. Ferrill, Jr.* W5CJB

MANY amateurs are the possessors of receivers which fail to meet completely their requirements for reception on the higher-frequency amateur bands, either through insufficient rejection of images or because of instability which makes the received signals sound so "wobbly" as to be difficult to read. The same receivers often are limited to reception of the 14-Mc. and lower-frequency bands, either because of limited tuning range, or because of low sensitivity on 10 meters.

Many others have available good broadcast-type receivers to which c.w. beat oscillators have been or can be added, and are in need of some means for receiving in the high-frequency amateur bands with good selectivity, sensitivity, stability, and—fully as important as the other considerations—good band-spread.

These needs may be met by constructing a converter such as the one described here. Making use of only two tubes to perform the functions of r.f. amplifier, first detector, and oscillator, this unit represents a simple and economical arrangement for use with existing receivers.

It is highly desirable to have combined in the receiver, in addition, some means of tuning through the 5-meter band. Obviously, for regular work on 5 meters, the best receiver is one designed specifically for 5-meter reception, with none of the compromises so likely to be present in the design of a multi-range receiver. While this converter is at 60 megacycles admittedly not an equally satisfactory substitute for the converters and receivers which have been designed specifically for 5-meter reception, it will at least give the operator a means of "keeping in touch" with 5-meter activity.

An intermediate-frequency range of 1.4 to 1.8 megacycles was chosen for the converter, making it suitable for use with almost any type of receiver, and giving a good signal-to-image ratio.

* Technical Department, QST.

An ordinary broadcast receiver may be used with the converter for 'phone reception, and for c.w. reception with the addition of a beat oscillator. Even this type of receiver has little creeping at the frequency at which it is operated, and lack of band-spread in it is of no consequence since its dial is set to the intermediate frequency used and left permanently adjusted while the converter is operated. The selection of stations is done entirely with the band-spread dial on the converter.

CIRCUIT

There are no freakish circuits; the first stage is

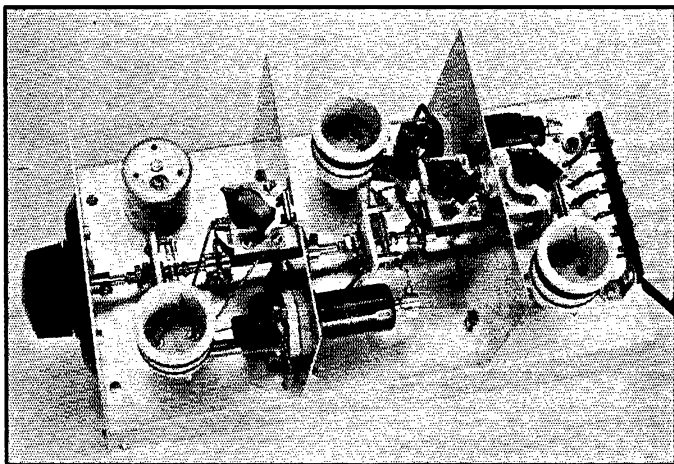

A TOP VIEW OF THE CONVERTER

The oscillator coil, L_5-L_6 , is in the right foreground, with the intermediate-frequency output coil and condenser in the shield can opposite. The baffle shield near the front panel supports oscillator padding condenser and socket of 6K8 tube, shown in foreground. The baffle shield at rear of chassis supports r.f.- and detector-padding condensers, as well as the 6K7 r.f. tube.

a conventional high-gain amplifier using a 6K7, the oscillator is a simple triode tickler-regeneration circuit, making use of the separate triode section in a 6K8 which also contains a hexode first-detector using first-grid oscillator injection and application of the received and amplified signal to the third grid. Second and fourth grids of the hexode are internally connected together and used as its screen. The 6K8 tube is a new type, a description of which appeared in April QST. The tube contains a special triode designed to be used as high-frequency oscillator in converters, with

the grid of the triode and first grid of the hexode (four-grid) section common.

The choice of the 6K8 tube as the oscillator-first detector was the result of tests which showed its operation at these frequencies to be satisfactory for ordinary purposes, and of the constructional simplicity afforded by its use.

Inductive coupling was used throughout, providing good circuit isolation. At the highest frequency to which the converter tunes, many types of condensers which might be used for coupling between the r.f. circuits would possess appreciable inductance in addition to their capacity.

One interesting feature in the design is the lack of elaborateness of the tracking arrangement. Since the problem of obtaining sufficiently true tracking through the bands covered using the i.f. chosen between 1.4 and 1.8 megacycles is only $\frac{1}{16}$ as great as the corresponding problem involved with a receiver tuning across the 160-meter band using an i.f. of 465 kc., it was considered advisable to add to the simplicity of the converter by using slightly increased spacing of turns on the oscillator coil to raise the oscillator frequency, using approximately equal capacity settings of the three padding condensers. By setting the padding condensers while receiving a station near the middle of a band, tuning by means of the band-spread dial alone is used, with no noticeable need for realignment of the padding condensers (if the use of the converter is limited to amateur-band tuning). If reception on frequencies far removed from the amateur bands is desired, a complete resetting of the padding condensers is necessary.

CONSTRUCTION

The chassis for the converter is made by folding

down 2-inch sides on a 10-inch by 12-inch piece of $\frac{1}{16}$ -inch aluminum, making a channel-shaped base 6 inches wide, 12 inches deep, and 2 inches high. The two baffle shields are 5-inch by 6-inch sections, and the front panel is 7-inch by 6-inch sheet—all made of the same sheet stock as is used for the base. The band-spread tuning condenser is made by ganging three Cardwell Trim-Air condensers, each of which is mounted separately on the mounting bracket provided. Half-inch holes are drilled in the baffle-shields before assembly, and bakelite rods and flexible couplings are used to connect the condensers, which are mounted with the stator plates turned up in order to get the terminals away from the chassis. The sockets for the plug-in coils are mounted on pillars made by sawing $\frac{3}{8}$ -inch copper tubing into 1 $\frac{1}{4}$ -inch lengths. With the sockets mounted in this manner, the coils are held well away from the chassis and condenser, while the connections of the socket are placed quite near the other parts of the circuit.

The unusual method of mounting the two tubes was used to facilitate short connecting wires in the r.f. circuits. With the tubes arranged as shown, the grid cap of the 6K7 tube, variable condenser terminals, antenna input connections, and coil-socket connections form a compact group, making short wires possible. At the same time, the plate and cathode connections of this tube extend through the baffle shield and thus allow very short connections to the plate coil, L_4 . The connections of L_3 , C_3 , C_4 and the signal input grid of the 6K8 are exactly similar to those of the 6K7 tube, coil, and condensers, again providing for short connections. The circuits of the plate, oscillator grid, oscillator plate, and cathode of the 6K8 are terminated at its base, making it possible

to use short connecting wires in the oscillator circuit with the coil and condensers grouped as shown. This layout of parts might truly be called one designed for "short circuits"—short circuits being used in a strict literal sense. It will be noted from the photographs that the wiring above the chassis is direct—that is, that each wire goes straight from one point to the next. This is highly desirable in a unit of the frequency range which this converter covers. The direct connecting wires in the r.f. circuit

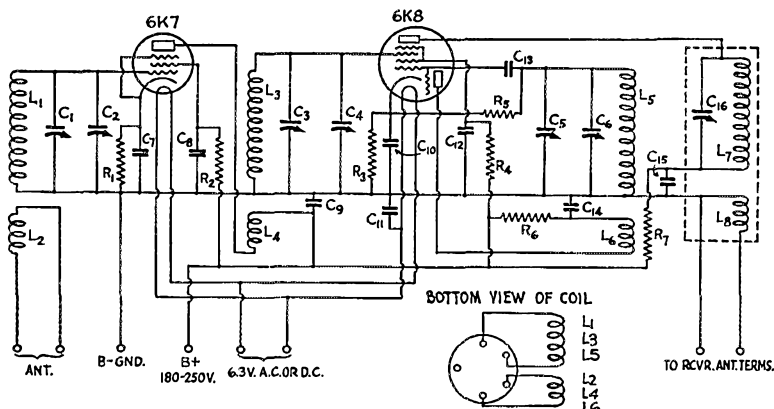

FIG. 1—CIRCUIT DIAGRAM OF THE CONVERTER

- | | | |
|--|---|---|
| C_1, C_3, C_8 —75- μ fd. midget variables (Cardwell ZU-75-AS). | C_7, C_{12} , inc.—0.01- μ fd. paper, 400-volt. | condenser (see text). |
| C_2, C_4, C_6 —2-plate midget variables (see text), ganged. | C_{13} —100- μ fd. mica. | R_1, R_2 —300-ohm, $\frac{1}{2}$ -watt. |
| | C_{11}, C_{15} —0.01- μ fd. paper, 400-volt. | R_3 —100,000-ohm, 1-watt. |
| | C_{16} —Air or mica padding | R_4 —25,000-ohm, 2-watt. |
| | | R_5, R_6 —50,000-ohm, 1-watt. |
| | | R_7 —2000-ohm, 1-watt. |

are pieces of No. 14, which wire size not only has low r.f. resistance, but also lends mechanical rigidity to the assembly.

The screen and cathode bypass condensers for each of the two tubes are connected directly between the socket lugs and a soldering lug held in place by the socket mounting screw nearer the heater and cathode connections. These soldering lugs provide two common ground points, one for each of the two tubes and associated circuit; and the ground connections from the corresponding coil and condenser tank circuit are made to this lug. In the photographs, the small tubular paper bypass condensers and the cathode bias resistors will be seen grouped about the sockets. Insulated wires are then carried from heater and screen socket connections, and from r.f. amplifier and oscillator plate coils, through holes in the chassis, to the proper lugs and resistors beneath the base. Solder-lug mounting strips are used for the purpose of holding the resistors firmly in place, in preference to having them supported by the wiring. Another insulated wire is run through a chassis-hole from the detector plate to the C_{16} - L_7 intermediate frequency output tank.

The intermediate frequency tank used in this converter was an old 465-kc. i.f. transformer with a single mica trimmer, C_{16} , and a wood core on which were mounted a multi-section coil and a layer winding, loosely coupled. All but one of the pies of the sectional winding were removed, and

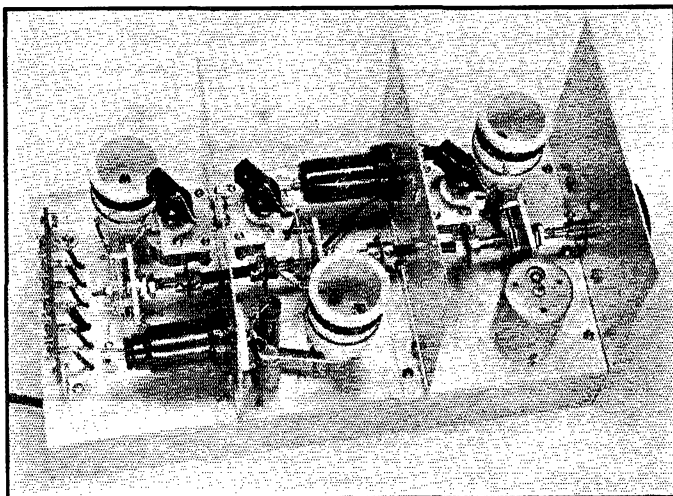

ANOTHER VIEW SHOWING THE GANGED BAND-SPREAD CONDENSERS

The close arrangement of the screen and cathode bypass condensers for the 6K7 tube (in foreground) may be seen in this view. The coil sockets are the new one-hole mounting type.

the layer winding was moved up against the remaining pie. The single pie, L_7 , was then connected across the mica condenser, and the layer winding was used as L_8 .

The problem of obtaining an intermediate-frequency output assembly is simplified by use of such a transformer as the Meissner type 8100. This transformer has two tuned windings, such that both L_7 and L_8 have condensers connected in parallel. For receivers which have condenser antenna input, the transformer may be used with no alterations; one of the two windings and parallel condenser are used as L_7 - C_{16} , and the other coil and parallel condenser are used as L_8 , it being unnecessary in this case to remove the condenser from its position in the secondary circuit. For those sets having antenna-coil input, the secondary circuit may again be used, unaltered, but in this case, with somewhat decreased efficiency. Improved performance with this type of set may be obtained by removing approximately two-thirds of the secondary winding, and leaving the condenser originally connected across this winding out of the circuit.

It will be noted from the circuit diagram that one of the two connections of L_8 is grounded in the converter. A lug strip mounted directly beneath the intermediate-frequency output tank receives this connection, a ground connection to the chassis, and the shield of the shielded microphone cable (type used for crystal microphones). The center conductor of the cable is connected to the other end of L_8 . At the opposite end of the cable, the shield is connected to the ground post of the receiver, and the center conductor is connected to

(Continued on page 86)

Band Mc.	14-14.4	28-30	56-60
No. turns..... L_1, L_2, L_5	6	3	3
No. turns..... L_2, L_4, L_6	2	2	7
Total coil length..... L_1, L_3, L_5	$\frac{1}{2}$ "	$\frac{1}{2}$ "	$\frac{3}{8}$ "
Total coil length..... L_2, L_4, L_6	$\frac{1}{4}$ "	$\frac{1}{4}$ "	$\frac{1}{2}$ "
Space between primary and secondary.....	$\frac{3}{8}$ "	$\frac{1}{4}$ "	Windings Concentric
<i>Wire Size</i>			
14- and 28-Mc. bands: All windings No. 20, enamel.			
56-Mc.: No. 18, bare, for L_1, L_3 and L_5 , $\frac{1}{2}$ " i.d.			
No. 22, enamel for L_2, L_4 and L_6 , $\frac{1}{4}$ " i.d.			

A Self-Contained Speech Amplifier, Monitor and Control Unit

By Howard C. Lawrence, Jr.,* W2IUP

ONE of the important pieces of equipment in any radiotelephone station is the speech amplifier. When this speech amplifier is mounted in a small cabinet complete with its own power supply, an overmodulation indicator, a voice level indicator, a variable-frequency audio oscillator for modulated c.w. or testing, and a set of controls to operate the complete transmitter, it becomes an even greater asset to the station. Since it is self-contained the unit may be shifted easily from one rig to another for experimental work, and it can also be used

back of the chassis at which all other outside connections except the 110-volt power cable terminate. When the switch Sw_1 is in the m.c.w. position the output of the audio oscillator is fed into the last amplifier tube. Gain controls have been arranged so that the gain from the microphone and oscillator channels can be controlled independently.

AUDIO OSCILLATOR

The audio oscillator is of the conventional type. The feedback transformer, T_3 , is an interstage audio transformer with a 3:1 turns ratio. If the polarity of the windings is not correct the tube will not oscillate. Should this happen it can be corrected by reversing the connections to either (not both) the primary or secondary windings. Putting the tone control in the cathode lead of this oscillator was found to be the most satisfactory way of controlling the pitch. By using a voltage divider consisting of R_{16} and R_{17} to supply the plate voltage, and keying as shown, all traces of key clicks and back wave are eliminated.

MAGIC EYE INDICATORS

Probably the most interesting part of this unit is the 6E5 voice-level indicator and the 6E5 overmodulation indicator. These tubes will tell almost as much as meters would, and their cost is much lower. In the voice-level indicator, the voltage applied to the grid of the 6C5G is also applied to the grid of a 6Q7G triode—double diode tube. The triode section is used as an amplifier feeding into the diode section, which rectifies the signal and causes a negative bias to be developed across the potentiometer R_{21} . Part of this bias voltage is then applied to the grid of the 6E5 through the filter R_{22} and C_{12} . This filter slows down the movement of the pattern on the

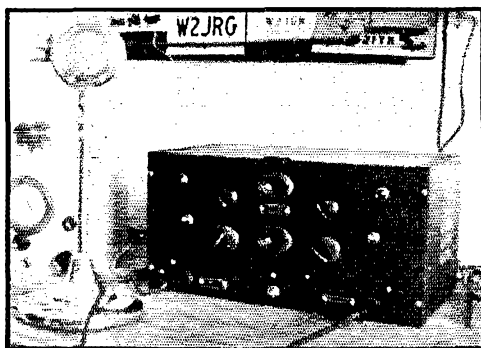

THE SPEECH-AMPLIFIER, MONITORING AND CONTROL UNIT IN ITS PLACE ON THE OPERATING TABLE

with a broadcast receiver to take care of those small p.a. jobs the amateur is often asked to take. With the overmodulation indicator, high levels of modulation may be maintained without fear of overmodulation, while the voice level indicator will tell, among other things, how much background noise is getting through on the carrier. The variable-frequency audio oscillator can be used to give a test signal while making field strength measurements, while adjusting the transmitter, or while another amateur adjusts his receiver, or it may be used for m.c.w. on the ultra-high-frequency bands where such signals are permitted.

The circuit of this unit is shown in Fig. 1. The 6J7 high-gain amplifier tube feeds into a 6C5G second amplifier stage. The output of this stage goes to a jack on the back of the chassis so that headphones may be plugged in to monitor transmissions, and also to an octal tube socket on the

* 518 M.I.T. Dormitories, Cambridge, Mass.

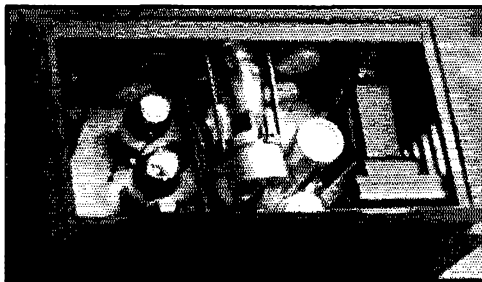

LOOKING INSIDE THE CABINET

6E5 screen so that it is easier to follow with the eye. R_{21} may be adjusted so that the pattern on the 6E5 just closes with 100 per cent modulation. The pattern may be made to change faster by using smaller values of R_{22} and C_{12} , while larger values will slow down the speed of operation. If one of the commercial mountings for the 6E5 is used, R_{23} will in most cases come with the mounting. Using the resistor R_{20} as a dropping resistor for the plate voltage of the 6Q7G as well as a load resistor for the 6E5 does not affect the operation of these tubes, and saves an extra resistor. If the plate supply voltage to the 6E5 is too high the screen will not last as long as it should and the tube will be less sensitive.

The 6E5 overmodulation indicator is controlled by the bias voltage developed across R_{15} by the current that flows in the rectifier tube VT on negative peaks of overmodulation. The movement of the pattern is slowed down for observation by the condenser C_{12} . Larger values of this condenser will cause the pattern to change more slowly. The sensitivity of the indicator is controlled by adjusting the potentiometer R_{16} . Fig. 2 shows the part of the indicator installed in the transmitter. Tube VT can be any diode capable of withstanding an inverse peak voltage of twice the plate voltage used on the modulated r.f. amplifier. For small transmitters using under 750 volts on the plate, a Type 45 tube with the grid and plate tied together will be satisfactory. This tube must be supplied from a separate filament

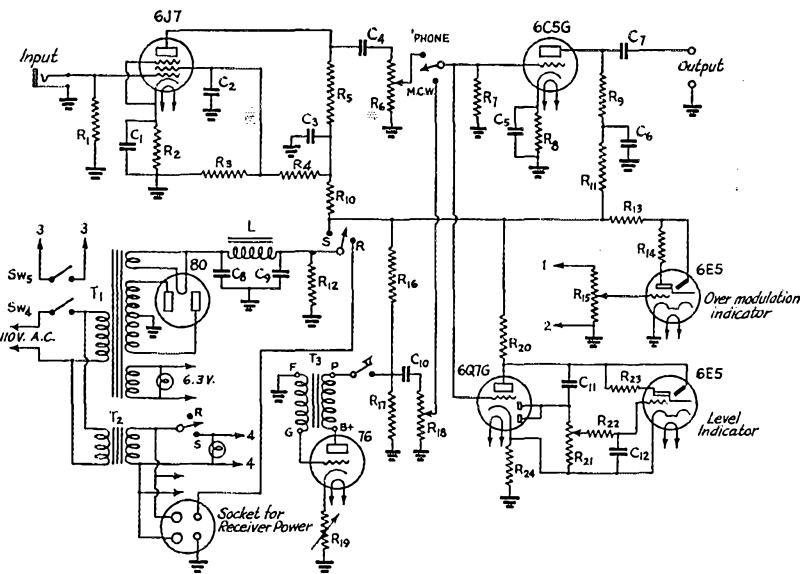

FIG. 1—CIRCUIT DIAGRAM OF SPEECH AMPLIFIER AND MONITORING UNIT

- C_1, C_5 —10- μ fd., 25-volt electrolytic.
- C_2 —1- μ fd., 200-volt electrolytic.
- C_3, C_6 —2- μ fd., 200-volt electrolytic.
- C_4, C_{10} —0.01- μ fd., 400-volt paper.
- C_7, C_{11} —0.05- μ fd., 400-volt paper.
- C_8, C_9 —8- μ fd., 400-volt electrolytic.
- C_{12} —0.1- μ fd., 400-volt paper.
- $R_1, R_7, R_{14}, R_{16}, R_{23}$ —1 megohm, 1/2-watt.
- R_2, R_8 —3500 ohms, 1/2-watt.
- R_3, R_9 —50,000 ohms, 1/2-watt.
- R_4, R_5 —250,000 ohms, 1/2-watt.
- R_6, R_{18}, R_{21} —500,000-ohm potentiometer.
- R_{10} —50,000 ohms, 1-watt.
- R_{11} —10,000 ohms, 1/2-watt.
- R_{12} —50,000 ohms, 10-watt.
- R_{13} —20,000 ohms, 2-watt.
- R_{15} —500,000-ohm potentiometer.
- R_{17} —20,000 ohms, 1/2-watt.
- R_{19} —1-megohm potentiometer.
- R_{20} —100,000 ohms, 2-watt.
- R_{22} —3 megohms, 1/2-watt.
- L —30-henry, 50-ma. choke (shielded).
- T_1 —Power transformer, 685-volt, c.t., 55 ma.; 6.3-volt and 5-volt windings, shielded (Thordarson T-7078).
- T_2 —6.3-volt, 2-amp. transformer, shielded.
- T_3 —Audio transformer, 3:1
- Phone-MCW—S.p.d.t. toggle switch.
- S_R —D.p.d.t. toggle switch (one unit).
- Sw_4, Sw_5 —D.p.s.t. toggle switch (one unit).

Terminals 3-3 control filaments of transmitter. Terminals 4-4 connect to 6.3-volt relay controlling transmitter plate supply. See Fig. 2 for connections of terminals 1-2.

winding insulated to withstand twice the power-supply voltage.

POWER SUPPLY

The built-in power supply uses a Type 80 rectifier and condenser-input filter. By using a shielded choke and transformers, and twisting the heater leads to the tubes, it was possible to eliminate completely all trace of hum in the output signal. During the time that the transmitter is not on the air there is no drain on the high-voltage power supply, and therefore it may be used to operate a small receiver or a preselector. To facilitate this a four-prong tube socket was installed on the back of the chassis. To take care of the heaters of this receiver or preselector and to help provide for the large current drain of heaters, pilot lights, and relay, a separate shielded 6.3-volt transformer is used. The d.p.d.t. switch Sw_2 and Sw_3 is used to apply the plate voltage to the proper place

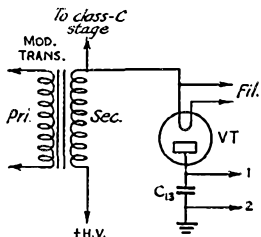

FIG. 2—REVERSED RECTIFIER CIRCUIT AT TRANSMITTER FOR ACTUATING OVERMODULATION INDICATOR

- C_{13} —0.02- μ fd., 400-volt paper.
- VT—Suitable diode (see text).

and to control the relay in the plate supply of the transmitter. One section (Sw_5) of the double-pole single-throw switch turns on the heater power while the other section (Sw_4) is used to turn on the filaments of the transmitter.

This unit was built on a 1/16-inch aluminum chassis 12 by 7¼ by 1½ inches. The black wrin-

(Continued on page 122)

Kansas State Convention

(Midwest Division)

Wichita, Kansas, May 7th and 8th

THE Wichita Amateur Radio Club is sponsoring the Kansas State A.R.R.L. Convention in Wichita, Kansas, at the Hotel Lassen, on Saturday and Sunday, May 7th and 8th. The convention will feature Amateur Emergency Preparedness, and all surplus funds will be used for the construction of portable amateur equipment to be used solely for emergencies and emergency work.

An unusual, different, and highly entertaining program is planned with only a few speeches and lots of action. Prizes??? of course—even if we have to purchase most of them. Registration fee is \$1.99 per person and will include a "Dutch Lunch" on Saturday evening and a banquet on Sunday. A special treat is in store for the ladies—so don't hesitate to bring them. YL's, XYL's and the OW are all welcome.

A cash prize of \$5.00 will be given to the Radio Club that sells the most pre-registration tickets. Make your registration with A. B. Unruh, W9AWP, 1617 South Seneca St., Wichita, Kansas.

See you in Wichita, May 7th and 8th.

More New Tubes

RK-56, 6S7, 6W7G, 6J8G

THE Type RK-56 beam-power tube has recently been announced by Raytheon. This tube makes use of aligned grids to reduce the ratio of screen current to plate current and allows more efficient utilization of the total space current. The deflector plates in the RK-56 are connected internally to the cathode. This is a heater-type tube with top-cap plate terminal and 5-prong isolantite base—an amateur version of the 6V6G.

Connections, specifications, and ratings are given below:

Bulb: ST-14, glass.

Base: Medium 5-pin, isolantite.

Cap: Small, metal.

Overall length: 5¼ inches.

Diameter, Max.: 1 1¼ inches.

Base Connections (RMA numbers):

Pin 1.....Heater
Pin 2.....Screen

Pin 3.....Control grid
Pin 4.....Cathode
Pin 5.....Heater
Cap.....Plate

Interelectrode capacities:

Grid to plate.....0.25 mmfd.
Input.....10 mmfd.
Output.....9 mmfd.

R.F. Power amplifier or oscillator, Class C, telegraphy ratings:

Heater Voltage.....6.3 volts
Heater Current.....0.55 amp.
D.C. Plate Voltage.....Max. 300 volts
D.C. Screen Voltage.....300 volts
D.C. Plate Current.....60 ma.
D.C. Screen Current.....14 ma.
D.C. Control Grid Current.....5 ma.
Plate Dissipation.....5.5 watts
Screen Dissipation.....4.5 watts

Typical Operating Conditions:

D.C. Plate Voltage.....300 volts
D.C. Screen Voltage.....300 volts
D.C. Control Grid Voltage.....40 volts
D.C. Plate Current.....60 ma.
D.C. Screen Current.....14 ma.
D.C. Control Grid Current.....3.0 ma.
Peak R.F. Input Voltage.....60 volts
R.F. Driving Power.....0.15 watts
Power Output.....12.5 watts

6S7 AND 6W7G

RCA has just announced a new triple-grid super-control amplifier to be known as the 6S7. This tube is a pentode type metal tube intended for service in the r.f. and i.f. stages of radio receivers designed for low heater-power consumption. Its heater requires 0.15 ampere at 6.3 volts. This tube is essentially similar in its other characteristics to the Type 6K7 now in common use, except that its screen voltage and current ratings are reduced approximately 25 per cent, and the amplification factor is approximately 1750 compared to a value of approximately 1000 for the 6K7.

Raytheon has also announced a new tube of low heater consumption, the 6W7G. This tube is a counterpart of the 6J7G in all its characteristics except the heater consumption, which is 0.15 ampere at 6.3 volts.

6J8G

Ken-Rad announces a new converter tube including in one envelope a triode and a heptode. This is a glass-envelope, octal-base tube much similar to the 6K8 tube, its greatest difference being a plate resistance of 4.0 megohms of the heptode, compared to 0.6 megohm resistance of the hexode. The heptode section of the 6J8G tube has a cathode, five grids, and a plate. The No. 1 grid is the r.f. input grid, the No. 2 and No. 4 grids serve as the screen, the No. 5 grid is the suppressor, and the No. 3 grid is the mixing grid. The No. 3 grid is internally tied to the oscillator grid of the triode section, and the No. 5 is internally tied to the cathode.

The high plate resistance of the tube should result in a quite appreciable gain when used with a high-Q intermediate-frequency transformer.

A Desk-Type Push-Button Frequency-Control Unit

Finger-Tip Selection of Crystals or Electron-Coupled Oscillator at the Operating Table

By Clark C. Rodimon,* WISZ

FLEXIBILITY in changing frequency within a band from the operating table has always been lacking at WISZ. The announcement of a new 8-position push-button switch, offering new possibilities along the lines of remote control, created a desire to make some improvements. One attractive suggestion for using the switch was to incorporate it in a combination frequency-changing and transmitter-control unit, using seven of the buttons for seven different crystals and the eighth position for an electron-coupled oscillator. The idea hit home inasmuch as the 11th International DX Contest was only a few days away.

This gadget would be on the operating table and switch any one of seven crystals into use depending on the button pushed. The e.c. oscillator, on the eighth button, would be used as a last resort to reach a frequency the variety of crystals would not produce. The output of the device would plug directly into the grid circuit of the crystal oscillator tube of the existing exciter, replacing the usual crystal. The only demand to be made of the e.c. oscillator was that its output should be T9 and at least comparable to a crystal in stability. The finished product would have to be compact and small enough to fit on the operating table, and it must have a self-contained power supply.

CIRCUIT

It was considered that an 89 as oscillator tube and a 6L6 as isolating buffer amplifier would provide a satisfactory tube line-up. The success or failure of an e.c. oscillator depends greatly on the loading on the oscillator, and consequent reaction between oscillator and amplifier. To reduce reaction between these stages impedance coupling was used, with an ordinary receiving type choke in the plate circuit of the 89. A low-capacity mica condenser gave sufficient coupling between the 89 plate and 6L6 grid. Special shielding was only deemed necessary on the oscillator cathode coil, inasmuch as the metal box provided enough shielding for the output plate circuit. After doing some figuring with a Lightning Calculator it seemed that with e.c.o. the best way to cover the

entire 3.5-Mc. band, and still not cramp front-panel tuning too greatly, would be to divide the coverage into two sections, using padding condensers to pick the range desired. An FXT unit with its two 25 μmf . condensers fitted these requirements very well.

Across the cathode coil at all times is a fixed capacity of 300 μmf . This lumped capacity makes a fairly high- C circuit, which is necessary for good dynamic stability. This condenser is one of the plated-mica type, comparable to air condensers in stability with changes in temperature and humidity.

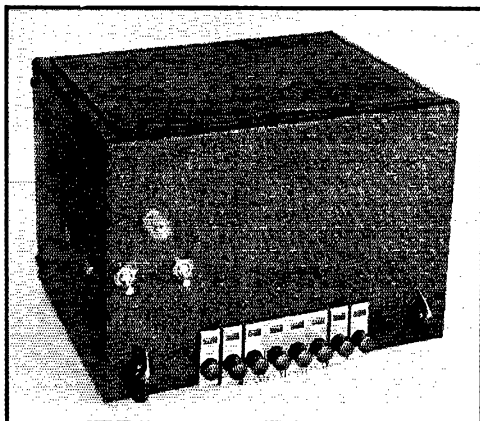

FRONT VIEW OF FREQUENCY CONTROL UNIT

The insulated output terminals are shown on the left side. The neon tube indicator is directly above the toggle switches. The left knob tunes the output and the right control sets the frequency—when used as an e.c.o.

The only tricky part of the circuit is in the cathode coil, L_1 , which has two taps. This is necessary because part of the coil must be shorted out when using crystal control so that the circuit can be tuned to a higher frequency for tri-tet operation. L_1 , C_2 and C_3 in the cathode circuit comprise the FXT shielded unit. Care must be exercised in the construction of L_1 so that shorted turns do not occur in the process of making the taps.

The push-button switch is actually a group

* Managing Editor, Q.S.T.

ing is recommended by the manufacturer to provide sufficient heat conduction away from the divider. Holes for the bolts on both the front and back lips of the sub-base were countersunk so the screw heads would not protrude. The switch is mounted under the sub-base and is securely bolted to the front lip with 1¼-inch bolts and 1½-inch mounting pillars. Mounting the switch calls for some filing for each slot on the sub-base. The sub-base was raised ¾ inch in the cabinet. It is necessary to drill eight half-inch holes through the panel of the cabinet to allow the buttons to move far enough in the "push" position. An escutcheon plate fits over the push rods and panel holes.

One tuning condenser is mounted on either side of the push-button switch. The condenser tuning the cathode circuit of the 89 is a midget type picked to fit the space. This condenser must be of good construction and should be mounted rigidly.

The wiring is all sub-base save for the lead to the control grid of the 89. For stable e.c.o. operation it is most important that all leads in the r.f. portion of the oscillator be direct and supported so there is no vibration. R.f. chokes and resistors should be fastened solidly to mounting lugs so there is no chance of vibration. The paint should

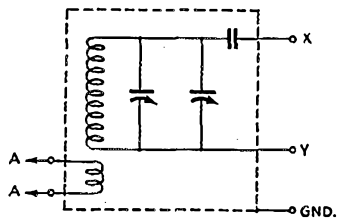
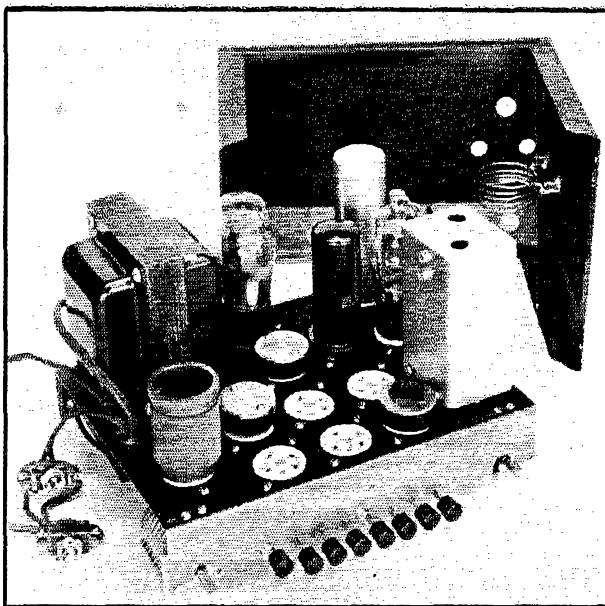

FIG. 2—OUTPUT COUPLER

See text for details.

be scraped from the sides and bottom of the box around the screw holes so a good electrical joint is secured when the box is assembled. If this is not done the user may find himself with an e.c. oscillator that "burbles" and is anything but stable. The unused prongs on the crystal sockets should be bent so that they cannot touch any exposed wiring; an even better scheme would be to ground all unused socket connections. Ground connections should be made to soldering lugs under nuts and bolts coming through the sub-base, making sure that there is a good contact between lug and base.

Coupling coil L_2 is a 3-turn coil 2 inches in



INTERIOR OF THE UNIT

The output coil is at the left, unshielded. The cathode coil is at the right in the FXT unit. It can be seen there is not much room to spare. At the rear is the cabinet with the fixed link L_2 attached to the output terminals. The photograph shows 5 turns, but this was later cut down to 3 turns. When the unit is assembled the plate coil fits inside the fixed output link.

diameter, self-supporting on two insulating jack-type bushings that serve as output terminals. The coil is so arranged that L_2 fits inside L_3 when it plugs into its socket. The output terminals connect to a two-wire line terminating in the output coupler.

OUTPUT COUPLER

The coupler for plugging into the crystal socket of the exciter was made from an FXT unit with 60 turns of No. 20 wire across the two fixed padders as shown in Fig. 2. A 0.002- μ f. isolating condenser was placed inside the can to prevent grounding the grid of the first tube in the exciter proper. The coupler is tuned to a considerably higher frequency than the output of the control unit since the internal shielding in the ex-crystal oscillator tube was not sufficient to permit tuning the grid and plate circuit to the same frequency without self-oscillation. Also, the output would have been greater than necessary. The coupler tuning was adjusted so that the dip on the plate meter of the former crystal tube was the same as when a crystal was used in the grid circuit.

Since the keying of the transmitter was already taken care of it was not necessary to worry about the chirp problem, so often a bugaboo of e.c. oscillators. Tuning the next stage after the e.c. unit itself had no effect on the frequency; there was no reaction save a change in transmitter output.

OPERATION

When all wiring has been completed and checked and the voltages at tube terminals measured, the gadget is ready for a trial run. Try a crystal first for oscillation. Crystal frequencies must be between 3500 and 4000 kc. Push the button which connects the desired crystal into the circuit; oscillation will be indicated by an in-

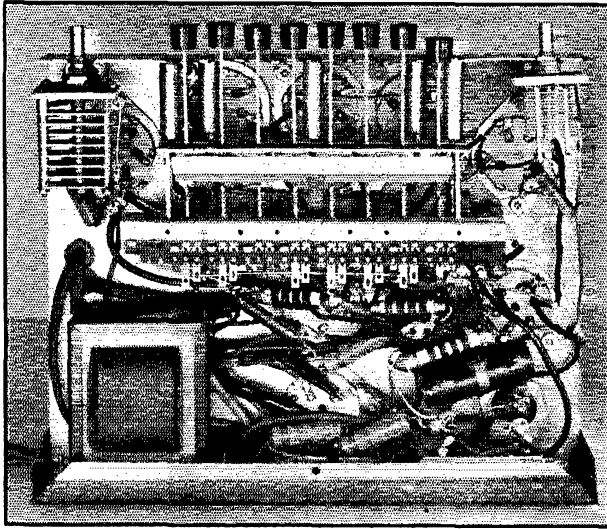

WIRING IS ALL UNDERNEATH

The 300- μ fd. fixed mica condenser is directly in back of the cathode condenser at the right. Rf. chokes are jammed in with by-pass condensers, but all wires are vibration-proof. The filter choke is at the left. At the right of the choke is the voltage divider, almost hidden by the lip of the box.

crease in the brilliancy of the indicator tube. Set the output condenser, C_6 , for maximum brilliancy and the tuning is finished. Crystals within 200 kc. in frequency may be selected without resetting C_6 .

When C_6 is set for maximum lamp brilliancy for one of the crystals, use the receiver as a monitor and push the e.c. button. Adjust the cathode condenser, C_5 , until a beat is heard, indicating that the e.c. oscillator is now tuned to the same frequency as the crystal. The brilliancy of the indicator tube will be less, as will be the output, but this is no factor to worry over. If a beat is not heard but the oscillator is working properly, as indicated by a change in brilliancy in the indicator tube as C_5 is varied, the e.c. oscillator is not capable of tuning to the crystal frequency. If this occurs set trimmer condensers C_2 and C_3 at minimum and, with the receiver, note what frequency range a complete rotation of C_5 will give. It should hit 4000 around the minimum setting of C_5 and tune to about 3600 kc. with maximum setting. Now, set C_2 and C_3 at maximum capacity and check the range of the oscillator when rotat-

ing C_5 . It should be possible to go a trifle lower in frequency than 3500 kc. at maximum setting of C_5 . With C_1 and C_2 set at minimum capacity it will be possible to tune above 4000 kc., so that complete coverage of the 3.5-Mc. band is available.

Using the padders in this way gives more band spread, with the value of C_5 specified, than if the whole band were covered on a single variable.

This allows easier resetting to match frequencies, but even so a good vernier dial for C_5 would be a worthwhile asset.

The cathode condenser setting is changed only when the e.c. oscillator is used for frequency control. When the crystals are used the setting of this condenser is immaterial. The coil and condenser combination, L_2C_6 , in the plate circuit of the 6L6 more than covers the entire range from 3500 to 4000 kc. The setting of C_6 is not critical either, but for frequency changes of 200 kc. or more it is advisable to reset for maximum brilliancy of the indicator tube.

STABILITY

As there is a considerable amount of heat thrown off by the tubes and transformer it is suggested that during operation the lid of the box be open. With the lid closed the box gets quite warm—too warm for any but low-drift crystals to operate on a given frequency.

Some words should be said concerning the drift of the e.c. oscillator.

From a cold start until the end of a 4-hour period the total change in frequency was 3 kc. on 80 meters. Most of this change was in the first ten minutes. After that time, the frequency crept down quite gradually for the first hour, after which the change was very slight. However, during the DX Contest it was never turned off—the unit ran constantly, as did the receiver.

The stability was better than we had hoped for. Whether the frequency at a given condenser setting changed a few kc. from day to day did not worry us, since the frequency would be changed frequently during contest operation. It was merely necessary to maintain a fairly even rate of climb for on and off periods of transmissions. At first a switch in the "B" supply lead was tried to turn the gadget off while receiving. However, this did not work out well because with the switch turned off the tube elements would cool. It was then decided to cut off the screen voltage on the 89. This can be accomplished either by opening the circuit or grounding the screen, as shown by Sw_1 . Either method worked out very well.

(Continued on page 98)

A Portable-Mobile Crystal-Controlled U.H.F. Transmitter

15-Watt Output Unit Which Can Be Adapted to 28- and 56-Mc. Work

By Louis R. Padberg,* W9FPA

THE portable-mobile transmitter described here is the outgrowth of several years' work with mobile equipment in the u.h.f. police-communication field. While designed primarily for mobile use in the 30- to 40-Mc. region, it can be readily adapted for other uses, such as for the 28- and 56-Mc. amateur bands. The circuit is based on fundamentals and is simplicity in itself; all parts not absolutely necessary have been omitted without sacrificing efficiency. It represents the result of endless experimenting with combinations of tubes and parts, to determine the most suitable layout for this type of work.

The circuit diagram is given in Fig. 1. A 6N7G is used as a crystal oscillator and doubler, followed by the final amplifier, an 807. The final may be used either as a straight amplifier or doubler, depending upon the circumstances. For police work, a 36-meter crystal is used, the final being a doubler to the 9-meter operating wavelength. The constants given in the circuit diagram are for 20- and 10-meter crystals, however, for work in the amateur bands. For 28-Mc. operation, a 14-Mc. crystal should be used, in which case the 807 is used as a straight amplifier. With the same crystal, the 807 can be used as a doubler to 56 Mc. Alternatively, a 28-Mc. crystal can be used for straight amplification on 56 Mc.

Either metal or glass tubes can be used, but the author finds the glass type slightly superior. A 6L6G may be substituted for the 807, although the output is lowered slightly and neutralization is required.

It will be noted that the first triode section has no resistance in the grid circuit. The cathode is at ground potential and a National R-100 choke is used across the crystal. The plate current does not creep as might be expected; the d.c. resistance

of the r.f. choke perhaps supplies a small amount of grid bias.

The second triode section is a conventional

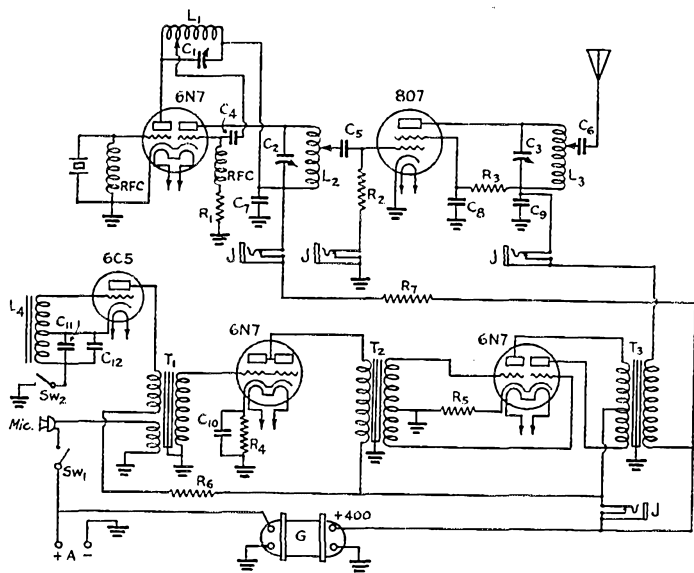

FIG. 1—CIRCUIT DIAGRAM OF THE PORTABLE-MOBILE TRANSMITTER

- C₁—100- μ fd. air trimmer (Hammarlund APC-100).
- C₂, C₃—50- μ fd. air trimmers (Hammarlund APC-50, in coil forms).
- C₄—100- μ fd. mica.
- C₅—300- μ fd. mica.
- C₆—100- μ fd. mica.
- C₇, C₈, C₉—0.01- μ fd. mica.
- C₁₀—25- μ fd. 50-volt electrolytic.
- C₁₁—0.003 μ fd.
- C₁₂—0.05 μ fd.
- L₁*—14-Mc. crystal—18 turns No. 18, length 1 inch, diameter 1 1/2 inches.
- 28-Mc. crystal—4 turns No. 18, length 1 inch, diameter 1 1/2 inches.
- L₂,* L₃*—28-Mc.: 4 turns No. 18, length 1 inch, diameter 1 1/2 inches.
- 56 Mc.: 2 turns No. 18, length 1 inch, diameter 1 1/2 inches.
- L₄—Center-tapped choke (primary of Thordarson T-6125 output transformer). Oscillator frequency adjusted by C₁₁ and C₁₂.
- T₁—Transceiver-type microphone-audio transformer (UTC-UPMG).
- T₂—Class-B input, parallel 6N7 driver to 6N7 Class-B grids.
- T₃—Class-B output, 6N7 to 8000-ohm load.
- Sw₁, Sw₂—S.p.s.t.; on-off switches for microphone and audio oscillator. Lw₁ in microphone-receiver handset.
- J—Closed-circuit jacks.

* Suggested specifications for amateur-hand work. Slight modification may be required.

* 1028 Fairmount Ave., St. Louis, Mo.

doubler. Since the 807 is extremely easy to drive, quadrupling in the second triode of the 6N7G can be done, and usually provides sufficient excitation. For the particular frequency desired in this case (33,100 kc.) doubling twice proved most satisfactory. Care must be taken not to over-excite the grid of the final, as reduced output and shorter tube life result. A grid meter should be used to determine the correct grid current. With a 10,000-ohm grid leak the grid current was 16 ma. at 375 volts on the plate of the final. The best grid resistor was found to be about 100,000 ohms, and with this value the grid current is 3 ma.

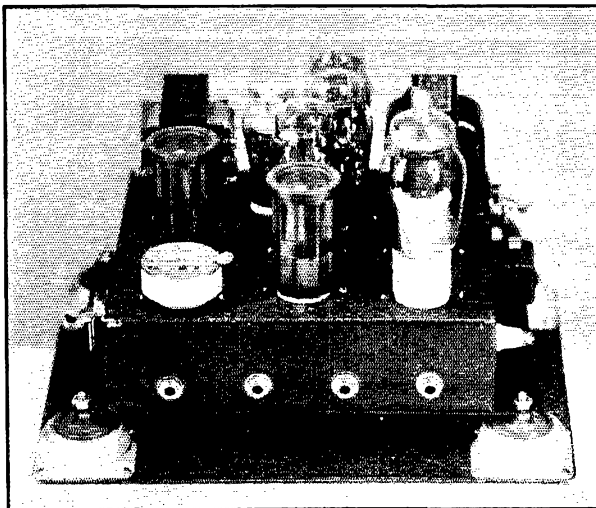

THE CRYSTAL-CONTROLLED U.H.F. TRANSMITTER WITH ITS SHOCK-PROOF MOUNTINGS

Designed primarily for mobile police work, the circuit readily can be adapted to amateur use.

No r.f. choke is used either in this circuit or in the plate circuits. Better results were actually obtained without them, although they were originally placed in the circuits.

The modulator uses a 6N7G driven by another 6N7G connected as a triode. A 100-ohm resistor connected between the center tap of the Class-B input transformer and cathode serves to lower the current without causing any appreciable distortion. Between 350 and 400 volts are used on the plates of these tubes. At this voltage the audio output is sufficient to modulate fully 25 watts input to the final r.f. stage.

A 6C5 tube is used in an audio oscillator circuit feeding into the modulator; this tube of course can be eliminated if not desired. In police work it serves as a calling tone, and on 56 Mc. it could be used for modulated c.w.

All circuits are metered by means of a plug and jack system, using a 0-100 ma. meter. All tubes are operated at 375 volts except the oscillator, which is run at 275 volts. The plate supply is a dynamotor rated at 225 ma. at 400 volts, using

5.8 volts input. The microphone is a high-grade single-button type and the quality compares favorably with more expensive types.

The layout of parts is shown in the photograph of the transmitter. The crystal, doubler plate coil, and 807 are along the front edge of the chassis. Directly behind are the oscillator plate coil, the 6N7G oscillator-doubler, and the final plate coil; the latter is hidden by the 807. The modulating equipment is along the rear edge. The transmitter is on rubber shock-proof mountings, which are advisable, even essential, for mobile work in a car or aircraft. In some portable applications the transmitter is mounted, with a receiver, in a carrying case, with a separate transformer-rectifier type power supply which is operated from a small gasoline-driven a.c. source.

Several antenna systems have been used with satisfactory results. The one now in use is a quarter-wave vertical fishpole mounted on the rear bumper. This can be grounded against the car frame at the base and a single-wire feeder tapped about 25 inches (for 33,100 kc.) above the base,¹ or the base can be insulated and the antenna fed at the bottom. The feeder is capacitively-coupled to the final. The tapping point is rather critical and should be done with the aid of a field strength meter. Very loose coupling will usually be found best.

The range of the transmitter will depend upon the power input and the nature of the country over which it is working. Communication has been established for 35 miles over flat country, using 20-25 watts input. In a city, consistent range should be figured at about five miles. The sky wave has been picked up several thousand miles away.

With crystal-controlled apparatus as simple as this there is no excuse for using modulated oscillators.

¹ Should this type of feeder be used on an amateur-band antenna, the optimum point for attachment can be found with the aid of a field-strength meter.—*ERRON.*

Strays

“Before installing 866 and 866A tubes, a tiny hole should be drilled in the base of each, between the small pins. This allows the air in the base to remain at atmospheric pressure, reducing the tendency toward increased pressure (resulting from high temperature) causing the solder to leave the ends of the filament pins.”

—WJPE

— . . . —

There is nothing deeply significant about the cover this month—just a fine sample of hay-wire.

The Construction of Television Receivers

Circuit Details of the Experimental Superhet Model Together with Suggestions for the Adjustment of Both Receivers

By Marshall P. Wilder* W2KJL

In this sixth and final article of the present series by Mr. Wilder further suggestions on the assembly and adjustment of experimental equipment are given. Additional material dealing with the practical problems of modern television is scheduled to appear in the early future.—EDITOR.

IN continuing the description of the two experimental television receivers, it would be well, first, to round out the general outline of the superheterodyne version. The arrangement of the two r.f. stages is given in Fig. 1 and differs in no important respect from the r.f. section of of the t.r.f. receiver. The steep-slope pentode 1851 is used in both stages and all tuned circuits are heavily damped with resistance to provide the necessary band width. The output of the second stage feeds the 6K8 mixer, the circuits of which are so arranged that a 6J8 or 6A8 may be substituted without any change in wiring. The 6K8 is, however, the preferred tube. The output of the first i.f. transformer in the plate circuit of this mixer feeds the four-stage i.f. amplifier shown in Fig. 2. This section is quite conventional in its circuit arrangement and employs the 1851 in each stage. It will be noticed that the Aladdin type U100 i.f. transformers have the trimmer condenser across the primary winding and that the loading resistor is across the secondary winding only. Experiment and measurement has indicated that this arrangement provides sufficient band width (at least for experimental purposes). In attempting a still further increase in the band width it would appear to be desirable to reduce the resistance of the loading resistors across the secondary winding and not to include additional resistors across the primary winding. The last i.f. transformer, T_5 , feeds the second detector—a diode connected rather unconventionally across the secondary terminals. The output of this diode feeds directly to the input of the two-stage video amplifier which also employs the 1851. One feature of this amplifier is that no by-pass condensers are used across the cathode resistors. Higher gain may be had by using by-pass

condensers but their value must be at least several hundred μ f. before effective low-frequency response and freedom from phase distortion are had. Practice suggests the much simpler procedure of omitting any by-pass.

The output of the video amplifier is capacity coupled to the control grid of the 1801 cathode-ray tube across which circuit is connected a diode d.c. restoring circuit. The synchronizing separator unit, which is somewhat similar to that described in the January issue, is connected directly to the plate of the first video amplifier. This connection avoids the necessity for a phase-changing triode as indicated in the original circuit and, because the d.c. component is still available in the first video plate circuit, assures a constant level for synchronizing impulses. Aside from these details, there is nothing likely to confuse anyone familiar with the previous articles of this series.

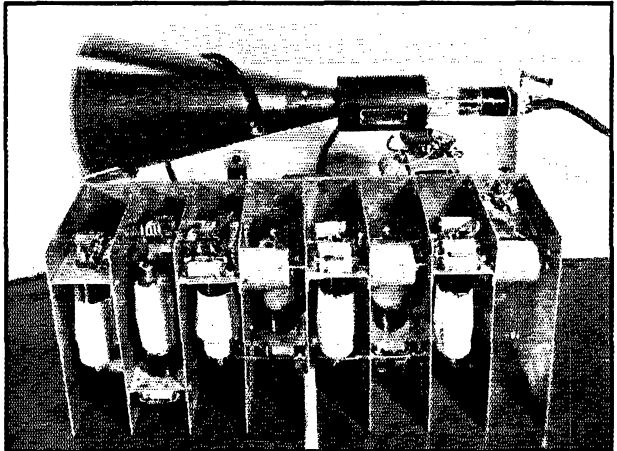

ILLUSTRATING THE R.F. AND I.F. SECTIONS OF THE SUPERHET TELEVISION RECEIVER

The two r.f. amplifiers are at the left, the tuning condensers being manipulated with a bakelite tuning rod. The cut-down i.f. transformers can be seen between the upper corners of the partitions. This photograph, like those presented with the article in the April issue, was taken before the advent of the 1851 pentode. The English tubes shown have since been replaced with the new American type.

* 55 Kendall Ave., Maplewood, N. J.

Turning now to details of construction and adjustment, we will first review the t.r.f. receiver which was illustrated and described in general terms in the previous article. Of first importance, of course, is the problem of mechanical layout. That shown in the illustration is an entirely practical one but, it must be insisted, by no means the ideal one in all cases. It is firmly suggested that the experimenter should first obtain all the essential components, then juggling with them and making sketches until the elements of the mechanical design have been evolved. In the r.f. amplifier section it is extremely important to provide a very short and direct path from the plate circuit of one r.f. amplifier to the grid of the next. The method of inverting every other tube, as exploited in the design of both receivers, is one good method of assuring such short leads but the procedure, it must be admitted, does involve mechanical complication and it does virtually prevent ganging of the four tuning condensers. This last limitation is not important at the moment (it will probably be many years before we have a band full of transmitters operating simultaneously) but it does constitute one of the

problems to be overcome. There is comfort in the thought that most amateurs have already developed considerable skill in the design of purposeful and practical mechanical assemblies and we feel that the problem will be solved in a dozen different ways in quick time.

In the original model, the video amplifier and sync. separator, together with the cathode-ray tube, were assembled on the one folded channel and back plate. Then, the r.f. section was bolted alongside. A similar principle was observed in the construction of the superhet receiver, the additional length made necessary by the extended i.f. amplifier being utilized, on the other side of the chassis, by the sweep circuits. It will be noticed that the i.f. transformers in the superhet receiver have been cut down to permit mounting them horizontally on the vertical partitions. This greatly facilitates the provision of direct wiring but calls for the addition of extension pieces on the tuning screws of the trimmer condensers.

THE SWEEP GENERATORS

After completing the assembly and wiring of either receiver, the first problem is to insert the

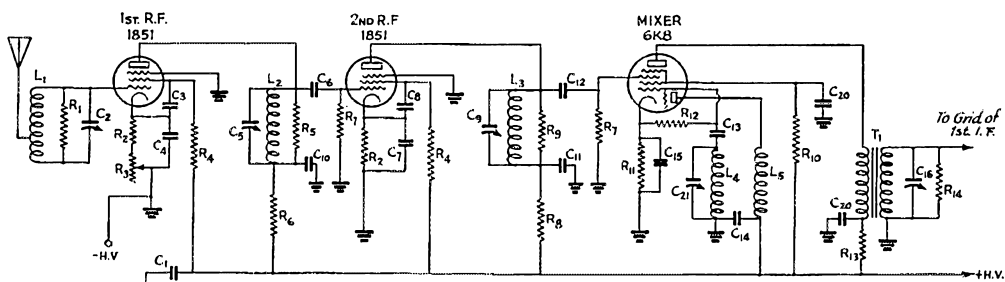

FIG. 1—THE CIRCUIT OF THE TWO R.F. STAGES AND MIXER OF THE SUPERHET RECEIVER

- R1—1000-ohm, 1/2-watt.
- R2—150-ohm, 1/2-watt.
- R3—1000-ohm variable.
- R4—60,000-ohm, 1/2-watt.
- R5—1000-ohm, 1/2-watt.
- R6, R8—1000-ohm, 1/2-watt.
- R7—0.25-megohm, 1/2-watt.
- R9—1000-ohm, 1/2-watt.
- R10—20,000-ohm, 2-watt.
- R11—300-ohm, 1-watt.
- R12—50,000-ohm, 1/2-watt.
- R13—2000-ohm, 1-watt.
- R14—2500-ohm, 1/2-watt.
- R15—150-ohm, 1/2-watt.
- R16—60,000-ohm, 1/2-watt.
- R17—2000-ohm, 1/2-watt.
- R18—150-ohm, 1/2-watt.
- R19—60,000-ohm, 1/2-watt.
- R20—2000-ohm, 1/2-watt.
- R21—2500-ohm, 1/2-watt.
- R22—150-ohm, 1/2-watt.
- R23—60,000-ohm, 1/2-watt.
- R24—2000-ohm, 1/2-watt.
- R25—2500-ohm, 1/2-watt.
- R26—150-ohm, 1/2-watt.
- R27—60,000-ohm, 1/2-watt.
- R28—2000-ohm, 1/2-watt.
- R29—2500-ohm, 1/2-watt.
- R30—5000-ohm, 1/2-watt.
- R31—150-ohm, 1/2-watt.
- R32—60,000-ohm, 1/2-watt.
- R33—2000-ohm, 1-watt.
- R34—0.25-megohm, 1/2-watt.
- R35—150-ohm, 1/2-watt.

- R36—60,000-ohm, 1/2-watt.
- R37—2000-ohm, 1-watt.
- R38—1.0-megohm, 1/2-watt.
- R39—50,000-ohm variable.
- R40—200,000-ohm, 1-watt.
- R41—500,000-ohm variable.
- R42—3-megohm, 3-watt.
- R43—15,000-ohm, 1/2-watt.
- R44—2000-ohm, 1/2-watt.
- R45—0.2-megohm, 1-watt.
- R46—10,000-ohm variable.
- R47—25,000-ohm, 1-watt.
- R48—50,000-ohm variable.
- R49—25,000-ohm, 1-watt.
- C1—0.01 paper.
- C2—35-μfd. Cardwell trim-air.
- C3, C4—0.01 paper.
- C5—35-μfd. Cardwell trim-air.
- C6—100-μfd. mica.
- C7, C8—0.01 paper.
- C9—35-μfd. Cardwell trim-air.
- C10, C11—0.01-μfd. paper.
- C12—100-μfd. mica.
- C13—100-μfd. mica.
- C14—0.0025-μfd. mica.
- C15—0.01 paper.
- C16—1-f. trimmer.
- C17, C18, C19—0.01 paper.
- C20—0.01 paper.
- C21—35-μfd. Cardwell trim-air.
- C22—1-f. trimmer.
- C23, C24, C25—0.01 paper.
- C26—1-f. trimmer.
- C27, C28, C29—0.01 paper.

- C30—1-f. trimmer.
- C31, C32, C33—0.01 paper.
- C34—1-f. trimmer.
- C35—5-μfd. mica.
- C36—8-μfd. electrolytic.
- C37—1-μfd. paper.
- C38, C39—0.01 mica.
- C40—0.25-μfd. paper.
- C41—8-μfd. electrolytic.
- C42, C43—0.01-μfd. mica.
- C44—1-μfd. paper.
- C45—0.1-μfd. paper.
- C46—8-μfd. electrolytic.
- C47—0.01 mica.
- C48—1-μfd. paper.
- C49—0.0015-μfd. mica.
- C50—1-μfd. paper.
- L1—8 turns No. 14 tinned wire, 1/2" inside diameter occupying 1 1/4" of length.
- L2, L3—7 similar turns.
- L4—12 turns No. 14 tinned wire, 5/8" inside diameter occupying 1 1/4" of length.
- L5—12 turns No. 22 silk-covered wire wound on a form to fit inside L4.
- L6, L7—No. 34 silk-covered wire close-wound on a 5/16" diameter form to occupy 13/16" of length.
- T1 to T5, incl.—Aladdin type U100 i.f. transformers.

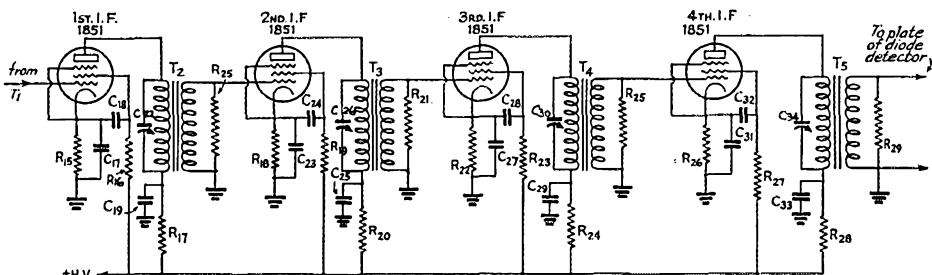

FIG. 2—THE COMPLETE CIRCUIT OF THE I.F. AMPLIFIER

For constants see under Fig. 1.

tubes of the sweep oscillators and check their performance. The work is enormously facilitated if a cathode-ray oscilloscope (provided with the usual linear sweep) is available. With such an instrument, the operation of the sweep oscillators and the wave shape available from their output circuit may be examined. Adjustment of the sweep oscillators in the t.r.f. receiver is, of course, simplified by the fact that controls for frequency are the only ones provided. With the constants given, the sawtooth output can hardly fail to be of reasonably satisfactory shape and amplitude. The magnetic sweep circuits of the superhet receiver involve a much more serious problem since all of the many controls influence the final waveshape. In this case, a particularly effective procedure is to insert a 10-ohm resistor in series with the output transformer and the yoke winding, then observing the voltage across this resistor on the oscilloscope. The amplitude of this voltage is quite small and it will be essential to use an oscilloscope fitted with an amplifier of good frequency response. It is impractical to attempt to describe the effect of the various adjustments on the waveshape but, fortunately, a clean sawtooth can be had by pure cut-and-try adjustment of the various variable resistors. It is suggested that the vertical sweep unit be adjusted first and that a search should then be made for any evidence of the sawtooth voltage in the plus B lead to the horizontal sweep unit. Further ex-

periment with the circuit given in Fig. 4 of the article in the April issue suggests that more effective separation of the two circuits may be had by eliminating the resistor R_{13} and by inserting a 3000-ohm resistor in the lead joining the high voltage leads of the two sections of the sweep unit. An additional 8- μ fd. by-pass condenser is then placed between the plus B wiring of the horizontal sweep and ground.

With the sweep circuits in operation, high voltage may be applied to the cathode-ray tube and the luminous rectangle or raster focussed and examined carefully. Poor waveshape in the horizontal sweep immediately will be made apparent by unevenness in the brilliance in a horizontal direction. Poor linearity in the vertical sweep is made evident by irregularity in the luminosity in a vertical direction or in irregular spacing of the fly-back trace. Naturally, the amplitude should be sufficient to fill the screen of the cathode-ray tube. Further adjustment of the sweep circuit may be made just as soon as the video amplifier and sync. separator are put into commission. At this time, the output of a conventional serviceman's test oscillator may be connected to the input of the video amplifier. With the oscillator running at, say, 500 kc., vertical bands will be produced on the screen. The spacing between these bands should be substantially the same all the way across the screen if the horizon-

(Continued on page 96)

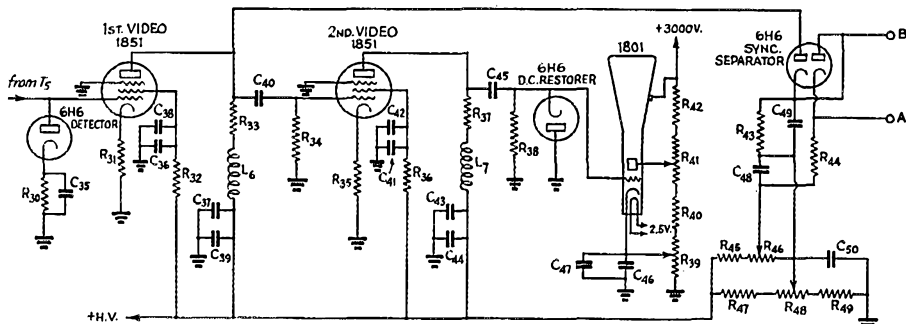

FIG. 3—THE SECOND DETECTOR, VIDEO AMPLIFIER, SYNC. SEPARATOR AND CATHODE-RAY TUBE CIRCUITS

For constants see under Fig. 1.

A Simplified Exciter Circuit

Low Crystal Current, Good Harmonic Output, Minimum Controls

By Carl C. Drumeller,* W9EHC

AFTER shedding a few tears over a little box containing the shattered remains of some thirty dollars' worth of defunct crystals that had departed this life by way of "high-output" oscillators, the writer decided that forever hereafter the crystals used at W9EHC would function in an oscillator that would be called upon to do duty as a frequency-control device *only*, and that all frequency multiplication and power amplification would be done in

the r.f. choke in the cathode circuit was replaced by a tuned circuit. This circuit showed great promise; it was a ready oscillator, taking off with any crystal from 160 to 40 meters inclusive, it was very stable, the crystal current was moderate, the power output was enough to excite properly the next stage, and the tuning was quite uncritical. In fact, it was so uncritical that the output seemed to be best with the tuning condenser at minimum capacity, so the condenser was removed. The output promptly went up. A larger coil was plugged in, and the output still went up. Finally a 2.5-mh. r.f. choke was soldered in, and the output still went up, exciting the tube following the oscillator very well. To make matters more interesting, it now became possible to use a 6L6 as a buffer without bothering to neutralize it.

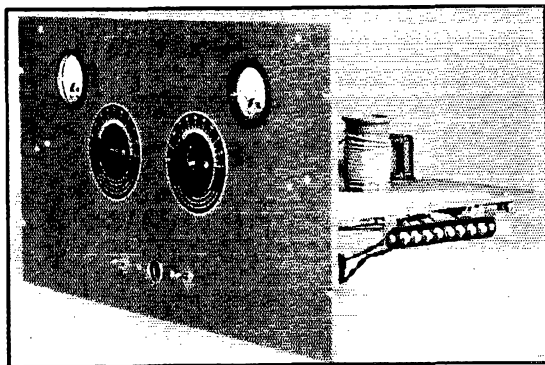

A PANEL VIEW OF W9EHC'S EXCITER-TRANSMITTER
With only two tuning controls and two plug-in coils, several hands can be covered with one crystal.

The circuit finally worked out, the next step was to determine constants. The soldering iron came in for plenty of wear and tear while dozens of different combinations of capacity and resistance were tried and different tubes were tested. The values given in the diagram resulted after much experimentation, and it is not advisable to depart from them with one exception; the cathode-resistor by-pass condenser of the 6L6 stage may be reduced to as low a value as 100 μfd . with a steady

subsequent stages. That decided, the next question was: What type of oscillator should be used? A survey of crystal oscillators showed two fundamental types; the more common grid-cathode (t.p.x.g.) Fig. 1-A and the less-used grid-plate, Fig. 1-B. From these a number of familiar variations have been evolved.

A breadboard layout was set up and a number of different types of oscillators were built and tested. A thermocouple milliammeter in series with the crystal measured its r.f. current, and the same meter could be loosely-coupled to the plate circuit to measure the comparative output. Since it had been pre-determined that the oscillator was to be used for frequency control only, it was coupled to an amplifier tube, and all output measurements made in the plate circuit of that tube.

After a series of tests of different circuits, one similar to that shown in Fig. 1-C was tried, the difference lying in the fact that in the original,

* 441 No. Franklin St., Colorado Springs, Colo.

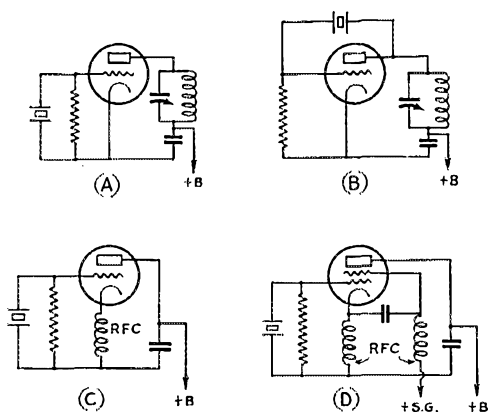

FIG. 1—FUNDAMENTAL CIRCUITS AND THOSE USED BY THE AUTHOR

At A is the ordinary tuned-plate crystal-grid circuit; at B the grid-plate type. Circuits C and D are the author's development of the latter, adapted to triodes and tetrodes.

increase in output (especially at the higher harmonics) but with a sacrifice in stability.¹

The choice of tubes is wide, but certain ones are somewhat better than others. For the oscillator, the 6V6G and the 41 are equally good, with the 2A5, 24A, 59, 6L6G, and the 42 lagging a bit. For the buffer-doubler, the metal 6L6 is considerably better than its nearest rival, the 6L6G, which in turn is far ahead of the 59, 2A5, 24A, 41 or 42.

A series of readings was taken, recording the crystal current with differing crystals and with the output circuit tuned to the fundamental frequency and to various harmonics. With 375 volts on the plate and 250 volts on the screen, the crystal

¹ The larger capacitive reactance with smaller values introduces regeneration, especially at the higher frequencies. This method of increasing output at higher harmonics was used in the frequency-multiplying circuit of the original Tri-tet exciter, and the same arrangement also has been used to give feed-back in u.h.f. oscillators.—EDITOR.

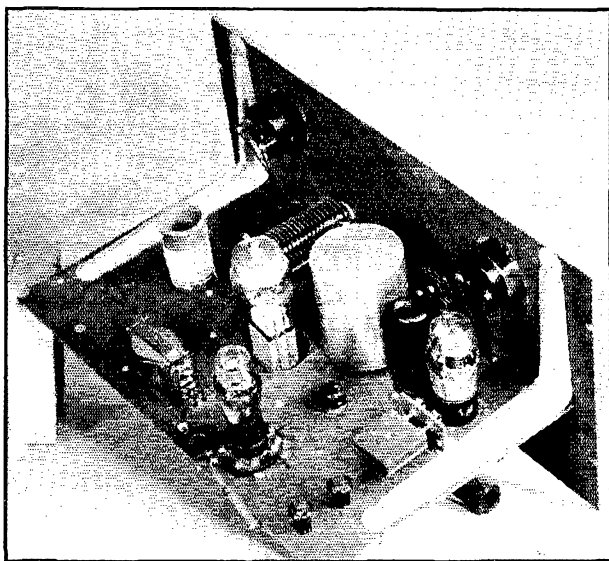

THE CHASSIS LAYOUT

The 6V6G and 6L6 multiplier are mounted close together. The shielded coil is that for the 6L6 plate and RK-20A grid. The small knob between the crystal and RK-20A controls the excitation. The audio oscillator for monitoring keying is along the near edge.

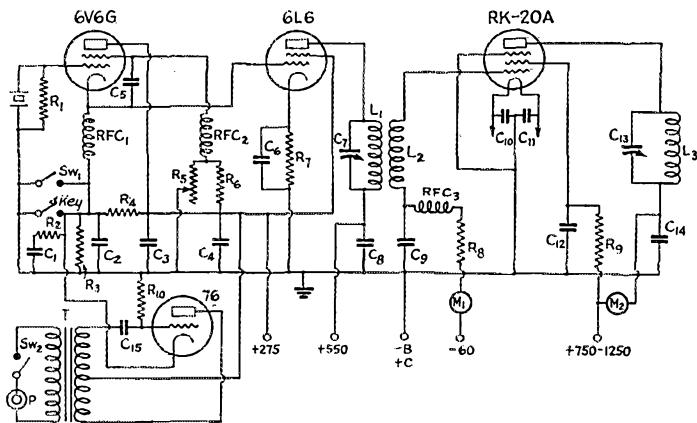

FIG. 2—CIRCUIT DIAGRAM OF THE COMPLETE EXCITER

- C₁—0.1- μ f. paper.
- C₂—0.002- μ f. mica.
- C₃—0.006- μ f. mica.
- C₄—2- μ f. electrolytic, 400-volt.
- C₅, C₆—0.006- μ f. mica (see text for discussion of C₆).
- C₇—50- μ f. midjet variable.
- C₈—0.015- μ f. mica.
- C₉—0.006- μ f. mica.
- C₁₀, C₁₁—0.002- μ f. mica.
- C₁₂—0.01- μ f. mica.
- C₁₃—100- μ f. transmitting variable.
- C₁₄—0.015- μ f. mica.
- C₁₅—0.002- μ f. mica.
- R₁—0.5 megohm, 1-watt.
- R₂—750 ohms, 2-watt.

- R₃—50,000 ohms, 1-watt.
- R₄—30,000 ohms, 75-watt.
- R₅—250,000-ohm variable, 20-watt.
- R₆—100,000 ohms, 20-watt.
- R₇—2000 ohms, 20-watt.
- R₈—15,000 ohms, 2-watt.
- R₉—20,000 ohms, 40-watt.
- R₁₀—75,000 ohms, 1-watt.
- L₁, L₂, L₃—Usual values to resonate at desired frequency with tuning condensers specified. Dimensions for various types of

- coil forms may be taken from charts in the Handbook. L₂ is the same as L₁ in each case, with interwound turns.
- Sw₁, Sw₂—S.p.s.t. switch.
- T—Audio transformer, single plate to push-pull grids.
- RFC₁, RFC₂, RFC₃—2.5-mh. r.f. choke, 125 ma.
- M₁—0-20 d.c. milliammeter.
- M₂—0-100 d.c. milliammeter.
- P—Headphone unit.

current in no case exceeded three scale divisions on the 100-division scale of a 115-ma. thermo-couple current-squared galvanometer. It is quite important that the plate circuit of the frequency-multiplier tube be tuned to exact resonance with the fundamental frequency or some harmonic thereof. If it is off resonance the crystal current goes up, but never to a figure that is dangerous even to X-cut crystals. If the output is too great reduce the screen grid voltage of the oscillator tube.

The circuit of the complete exciter unit is shown in Fig. 2. It will be noticed that a keying monitor is incorporated, since it is the writer's belief that no c.w. transmitter should be operated without one. A listening period on any c.w. band will convince even the most skeptical that something is needed to improve many of the fists that infest the amateur bands.

No construction notes will be given, for every true amateur is capable of designing a layout that will meet his individual needs. A few words need be said in explanation of the resistors in the oscillator circuit. R_2C_1 comprise a key-click filter that functions perfectly. R_3 is needed to enable the bias voltage produced by the IR drop across R_7 to be impressed upon the grid of the 6L6 when the key circuit is open. R_4 is a bleeder that draws current through R_3 and thereby applies high grid bias to the 76, via R_{10} , when the key is open; this was found to be necessary to prevent the audio oscillator from functioning while the key is open. Sw_1 and Sw_2 are used to short the key and to cut off the a.f. oscillator while using 'phone or while tuning up. It is important to place Sw_2 where it is shown, and not in the plate circuit, as it would then affect the plate voltage of the oscillator and the screen-grid voltage of the 6L6. R_5 and R_6 comprise a voltage divider that enables the screen voltage of the oscillator tube to be adjusted properly. This control should be used to adjust the power output of the unit, and it will be found that it will never be necessary to run more than 8 milliamperes rectified grid current through M_1 . C_4 keeps the audio oscillator from modulating the 6V6G and the 6L6.

It will be noticed that no plate meter is em-

ployed in either of the first two stages, and that L_1 and L_2 are interwound to give "unity coupling." This is not by accident. A meter in either of those two plate circuits gives a reading that has no bearing on the power output, and it is necessary to read the rectified grid current of the amplifier in order to determine when L_1C_7 is properly tuned. It is therefore impractical to employ link coupling, for then the amplifier grid current would also be dependent upon the tuning of its grid circuit as well as on the 6L6 tuning. Capacity coupling could be employed, of course.

In cases where high power output is not desired, a smaller tube can be used in place of the RK-20A. At W9NRZ, and also at W9ZCX, a 6L6G is used as the final tube of the exciter and enough output is realized to excite fully any tube up to and including a T55. The RK-20A was used at W9EHC simply because there was one available in the shack.

This circuit will oscillate with 160-, 80- and 40-meter crystals; it has never been tried with 20-meter crystals. It works as well as a quadrupler from an 80-meter crystal as it does as a doubler from a 40-meter crystal. The output on ten meters, using an 80-meter crystal, is used at W9EHC to excite an RK-38 final amplifier to full output. What more can one ask of an exciter.

Improved Thermo-Ammeter Construction to Increase Accuracy on Ultra-High Frequencies

By John H. Miller*

IT has been known for some time that errors have existed in thermal instruments functioning on very high frequencies, and a number of articles on this general subject have been published in the technical press.¹ The essence of all of these studies of the response of thermal instruments to ultra-high-frequency currents has been that in the higher ranges they tend to read high. Thermo ammeters function by reason of a heater wire which is heated by the current passing through it; to this heater is welded a small thermocouple which produces a voltage proportional to the temperature

of the heater, and in turn actuates a very sensitive d.c. meter movement. Since at the ultra-

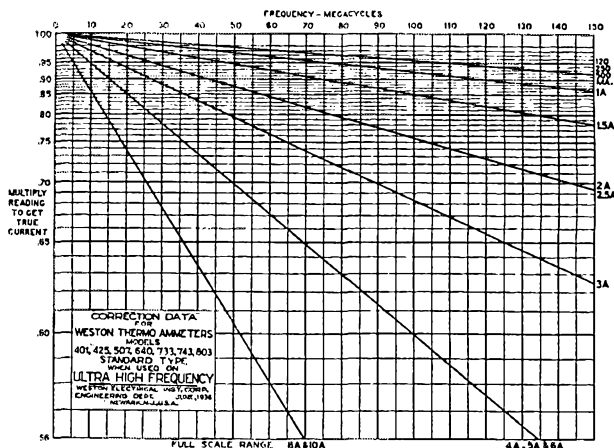

FIG. 1

* Weston Electrical Instrument Co., Newark, N. J.

¹ "Frequency Errors in Radio Frequency Ammeters," by J. D. Wallace and A. H. Moore, I.R.E. Proceedings, March, 1937, and "Thermocouple Ammeters for Ultra-High Frequencies," by John H. Miller, I.R.E. Proceedings, December, 1936.

high frequencies the effective resistance of a wire is somewhat higher than at low frequencies, it is obvious that the total heat, I^2R , is greater at the high frequencies and as a result the instrument reads higher on its scale.

Most studies of this error indicate that the skin effect is practically the entire effect, and Fig. 1 shows a correction sheet applying to standard Weston Model 425 thermo ammeters. It will be noted that the error increases with both frequency and full-scale current range, and this might be expected because for the higher ranges the diameter of the heater wire increases.

This difficulty has been satisfactorily solved through the use of a tubular heater element formed from extremely thin platinum foil, to which is welded the thermocouple which actuates the direct-current movement proper. The tubular heater element is so dimensioned that the effective resistance at the ultra-high frequencies is very little different from that at low frequencies, this dimensioning being carefully worked out in terms of all factors such as specific resistance of the material, diameter, wall thickness, and so on. Through the use of high-resistance platinum alloys and these tubular heaters, the errors have been brought to the rather small values of 1 per cent at 50 megacycles, 3.5 per cent at 100 megacycles, and 6.5 per cent at 150 megacycles. Even at 300 megacycles the maximum error is 16.5 per cent, and this is probably far less than the error occasioned by the actual physical placement of an instrument in a one-meter transmitter.

It is most interesting to place one of the new instruments of, say, 10 amperes capacity, in series with one of the older instruments and check them at 1 megacycle and at some higher frequency above 50 megacycles. At 1 megacycle they will read the same, but at the higher frequency the older instrument will read much higher.

It is quite possible that figures as to antenna current from ultra-high-frequency transmitters will have to be materially revised now that these new instruments are available, inasmuch as in many cases the true currents are perhaps only $\frac{2}{3}$ of those indicated by the older instruments. By the same token, our transmission efficiencies are probably somewhat greater than had been previously considered.

New England Division Convention

Hartford, Conn., May 21st and 22nd

HHEY, fellers! A real two-day old-fashioned New England Division Convention is to be held at Hartford, Conn., May 21st and 22nd, at the Hotel Bond, under the auspices of the Hartford County Amateur Radio Association. The dates come on Saturday and Sunday, and the big

banquet will be Sunday afternoon and will enable everyone to reach home that night and be ready for work Monday morning.

Remember Hartford is the headquarters of *QST* and the A.R.R.L. Trips have been arranged to visit Headquarters, also the new Memorial WIAW station which will have been dedicated by that time.

The best of technical meetings, Navy and Army gatherings will be held. The N.E.D.R.A. will also hold its annual phone meeting. A big initiation of the Royal Order of the Wouff Hong will take place.

Registration fees: \$3.50 complete; without banquet, \$2.50; banquet only, \$1.50. Ladies, \$2.00; without banquet, \$1.00; banquet only, \$1.50. Make your reservation in advance by writing to the convention secretary, F. H. Norman, W1JZB, 314 Park Road, West Hartford, Conn.

See you there!

Hudson Division Convention

New York City, June 17th and 18th

THE annual Hudson Division Convention is at last back in New York. It is an old adage that changes are good, and this year the committee appointed by Director Ken Hill have decided to have a real old-fashioned two-day affair and the Hotel Astor at Broadway and 44th St., one of the most centrally located hotels in New York City, has been chosen for all activities of the convention.

There will be manufacturers' exhibits, a technical program to satisfy those interested in those meetings and plenty of hamfesting. All that the committee asks for is your attendance. Old timers remember those real ham conventions that were held in New York City years ago. The committee is working to give you that kind of a convention. The price will be only \$3.00 per person, including the big banquet with its entertaining features. Ed. Berliant is the chairman, and he can be reached at 227 Fulton St., New York City. Get your Clubs to attend in a body and make your reservations early.

Atlantic Division Convention

Washington, D. C., June 24th and 25th

ALL roads will be leading to Washington, D. C., for the annual Atlantic Division Convention to be held at the Washington Hotel, Friday and Saturday, June 24th and 25th, under the auspices of the Washington Radio Club. The best of technical talent from the Bureau of Standards, Naval Research Laboratory and Industrial Research Laboratory will be present. Motor trips, tea parties and movies will entertain the ladies.

(Continued on page 86)

Eighth A.R.R.L. Sweepstakes Contest Results

All Sections Worked on Both 'Phone and C.W.

By E. L. Battey,* W1UE

THE Eighth A.R.R.L. Sweepstakes Contest, November, 1937, was the most outstanding "SS" ever held—and that is saying something!! 1013 operators submitted 926 c.w. scores and 102 'phone entries. We don't know the correct abbreviation for the word "success," but "SS" (Success) would do very nicely!

There is but one thing that surpasses the actual results of the Eighth SS and that is the enthusiasm of the contestants. And the only thing that might possibly surpass this enthusiasm is "what they are going to do next time." Here are some typical comments of participants: "Sure get a kick out of the SS."—W7CMB. "This was my first contest, but it won't be my last."—W9WTW. "Enjoyed it very much; ought to be more frequent. Hi."—W3FMY. "Great fun even though the other fellows' numbers were usually much higher than mine."—W7FXF. "CU next year. Watch my smoke."—W1GEJ. "This was my eighth Sweepstakes—some fun."—W1BEF. "Had a fine time and am already planning a few changes to make the rig perk better for next contest."—W1JEA.

* Assistant Comms. Manager, A.R.R.L.

"The '37 contest was the most enjoyable SS I have ever been in."—W9RSO. "Lost lots of sleep but it was worth it."—W1ITI. "Wotta contest! I'm sure glad it's over, but wish there were another for next week. Hi."—W9TPH. "It was a lot of fun, my wife still loves me, and the gas and light companies call me 'pal.'"—W9AHR. "Wow."—W9YRS. "It was a good experience, which I hope will improve my operating ability."—W4DDJ. "This was my fourth consecutive SS and have enjoyed each one more than the previous."—W9RQM. "Hate to wait a whole year for the next one."—W9KXX. "Had a swell time even though I didn't pile up a big score."—W8MOH. "First time I ever entered this type of contest. The set-up was fair for all."—W8CSX. "Sometimes those '46's surprise me!"—W9MGN. "It would be fine if we could see such efficient operating all the time."—W3FFE. "Enjoyed the operating practice."—W3FDF. "Low score but lots of fun."—W3CWQ. "This is one time I can smile when the electric light bill comes through."—W2AYJ. "Thanks for 36 hours of misery, suspense, delight, surprise and elation."—W2HNN.

"This was my fifth SS, and as usual enjoyed it very much."—W9IVD. "The contest was perfect as a proving ground for testing the skill of the individual operator."—W5BTS. "Message preambles are now known so thoroughly I can send them backwards and forwards without making a mistake."—W4ESO. "Secm to live from one Sweepstakes contest to the next."—W3AAF. "Wouldn't miss another SS."—W6GPB. "To me the SS represents the most enjoyable 40 hours of the year 1937."—W9TYF.

WINNERS

Disproving the theory that "nobody wins a contest but the power company," medallion awards are being made to the 67 c.w. and 44 'phone winners throughout the 70 A.R.R.L. Sections. Entries were received from every Section except Alaska, Nevada and P. I. Hearty congratulations to the following, winners in their respective Sections: C.W.—W1BFT W1EOB W1EZ W1GBO W1GKJ W1GME W1RY W2HNN W2IOP W2PY W3AWH W3BES W3FMY W3QZ W4ALT W4BSJ W4COV W4CYC W4DW W4ECZ W4PL W5AQE W5ASG W5BTS W5CPB W5GEA W5GEY W5KC K6CGK W6BXL W6GPB W6HZT W6ITY W6KFC W6KOP

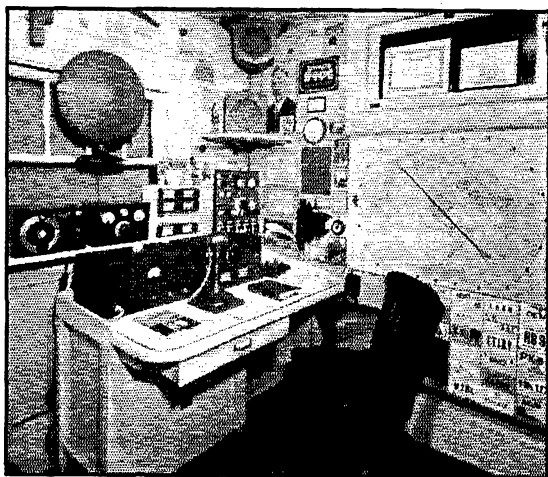

THE OPERATING CORNER AT W4OC, DURHAM, N. C.

There's something efficient about the appearance of this shack! And W4OC won the 'phone award for North Carolina. On the table at the left is the speech amplifier, with HRO receiver at the right. Under the speaker in the window is a frequency meter, modulation meter and receiver coils. On the right hand wall is an A.R.R.L. map of the world with 24 lights around the outer edge. These lights show the position of the Mims signal squitter, which is started, stopped and reversed by the switch at the bottom left of the map. The transmitter, which sits in another part of the room, is a Collins 600A.

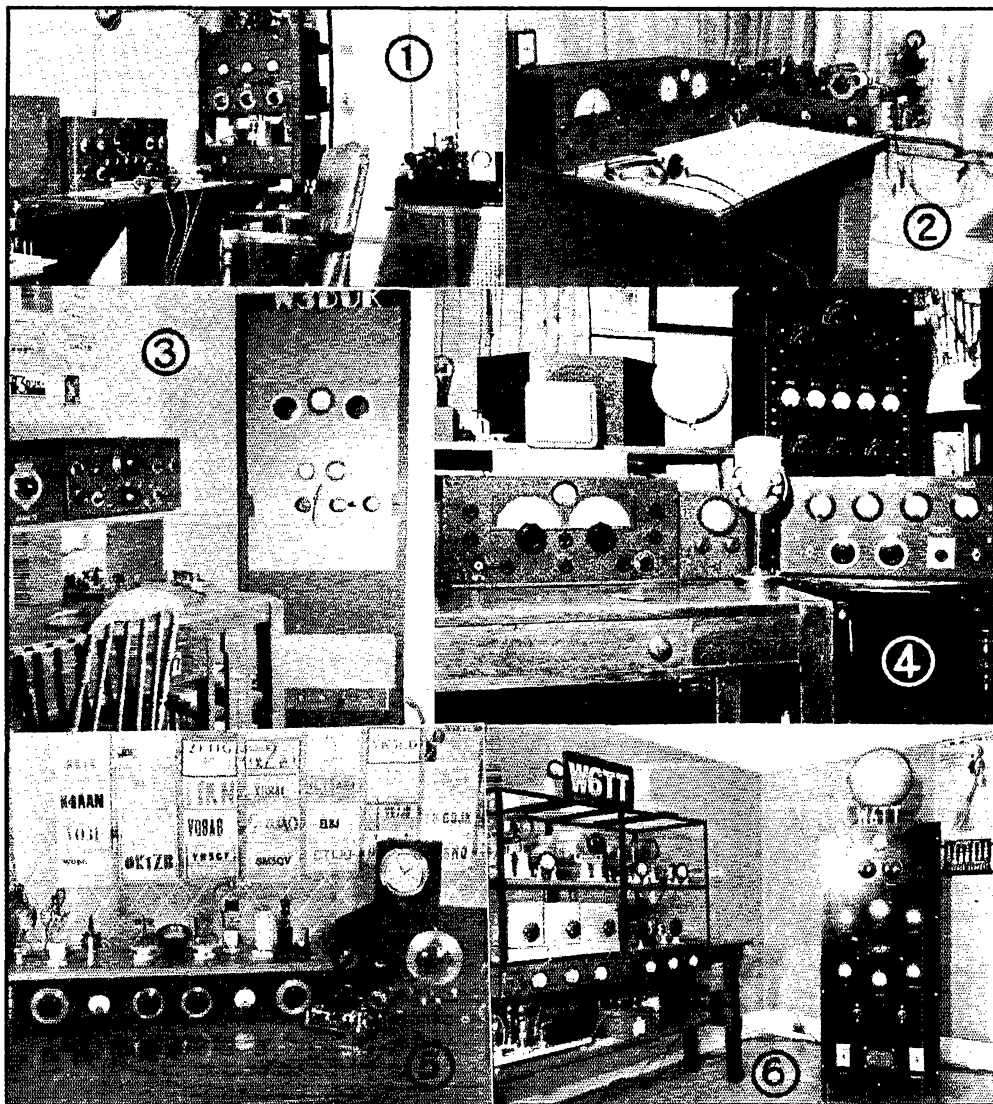

THESE STATIONS WENT TO TOWN IN THE "SS"

1 W2IOP, N. Y. C.—L. I. c.w. winner and fourth highest national scorer. On the operating table is the speaker, NC-101X, phones and keys. The large homemade rack and panel rig carries a 6L6-RK39-P.P. HF100's. At the right behind the chair is the set that did the work in the contest: 6L6-RK39-T55. The shack is on the third floor of a 21-story house, the antenna running to a 32-story building. 2 Plenty of elbow room is a feature of W9VKF's operating table. The RME DB20 box contains the frequency meter and a 56 output limiter. The transmitter uses a pair of '46's in the final, running at 25 watts; antenna tuning unit is at the right. W9VKF was high man in Southern Minnesota. 3 W3DUK, Wilmington, Del., worked 365 stations in 58 sections for a score of 42,224. Note that the receiver and freq-meter-monitor are placed on a shelf above the main operating position, which carries only the keys and control switches. The transmitter line-up is 6A6-6A6-807's-100TH, 350 watts input. 4 W9PWU was second highest 'phone scorer with 39,411 points. At the right of the RME-69, the oscilloscope and the mike is the portable transmitter used in the SS. The line-up is 6L6-807 with high-level plate/screen modulator from a Class B 6N7G with a 6C5 resistance into a 6N7 Class A as a driver. An 83 power pack runs the whole outfit. The complete rig, power supply and all, is housed in 8 3/4 x 19 x 13 cabinet. The larger transmitter is a 500-watt all-band 'phone-c.w. rig. 5 This is the neat layout used by W8LZK, Toledo, Ohio. 95 watts input was run to the P.P. RK-37 amplifier, which is preceded by 6L6G osc. and T-20 buffer. LZK QSO'd 250 stations in 65 sections. 6 Something out of the usual run is the transmitter construction plan at W6TT, c.w. winner in the East Bay Section. The tube line-up is '47-6L6-801-100TH-P.P. 250TH's. 1-kv. input is used on 7, 14 and 28 Mc. Voice is also used with 6F5-6C5-P.P. 6N7-four 2A3's-two 250TH's mod.

W6MDI W6MVK W6TT W7CMB W7EWR
 W7EYB W7GFN W8BYM W8DOD W8GUF
 W8OGV W8OXO W9AHR W9FFU W9LEZ
 W9RBN W9RCQ W9RQM W9RSO W9TYF
 W9UBB W9VKF W9YCR W9YEZ W9ZAR
 VE1EP VE2IN VE3JT VE4GE VE4KX VE4ZC
 VE5FG. 'PHONE—W1APK W1BEF W1DAY
 W1DYA W1ITI W2FQG W2JDG (W2JZX
 opr.) W2JME W3AED W3AIR W3AVX
 W3GDX W4BQE W4HZ W4OC W5BQD
 W5BRW W5CTC W6AM W6CQI W6EJC
 W6ITH W7CPY W7EYD W7FRA W7GKJ
 W8EMP W8FIP W8KWS W8LCO W9BAQ
 W9BTJ W9PUW W9PZI W9SFF W9TQL
 W9YGC W9YQN CO2WM VE2KX VE4IU
 VE4PK VE4QO VE9AL (VE3BC opr.).

WORKED ALL SECTIONS

With the addition of South Carolina (made a separate section in the summer of '37) to the list of A.R.R.L. Sections, there were 70 Sections to be worked in the Eighth Sweepstakes. W6MVK, using c.w. on 7 and 14 Mc., worked all 70 within the period of the contest! It took an alert operator

to do this, and others who have tried will join us in complimenting Tom, W6MVK. Using radio-
 phone on all amateur frequencies W6ITH set out to duplicate his 1936 feat of working all sections. He succeeded in working 69 Sections plus a hoot-
 leg station, which gave QTH as Filtrao, in North-
 ern Minnesota, the 70th Section. This station
 was signing W9VJO's call, and research does not
 disclose a Minnesota town named Filtrao.

W6HJT (W6HJT opr.) worked 69 Sections,
 all but P. I. So near and yet so far! W3BES
 snagged 67, W6BXL W8BYM W8OFN W9AHR
 66, W1EZ W4CYC W8GUF W8LZK W9RSO
 65, W1TS W4PL W5CPB W6KFC W7EK
 W8DOD W9IU W9RCQ W9RQM W9UIT 64.
 In all, 51 operators worked 60 or more sections.

LEADERS IN CONTACTS

Evidence of the amount of activity during the
 SS is the fact that twenty-four participants
 worked 300 or more stations! Leading the list and
 apparently breaking all Sweepstakes "stations
 worked per hour" records is W6MVK with 469
 stations, an average of 12 per hour. W3BES is

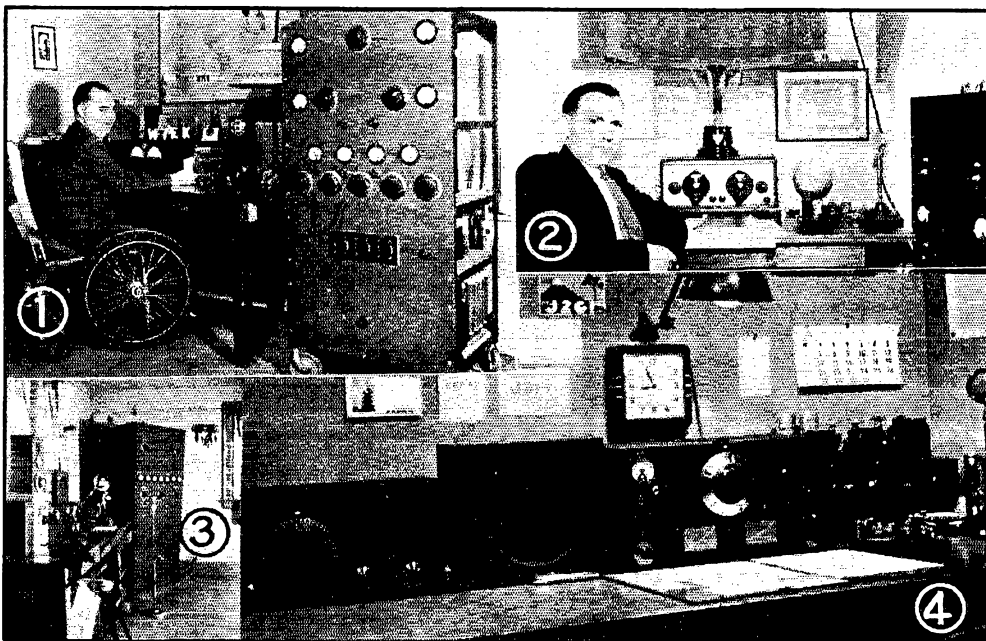

FOUR HIGH SCORERS

1 A well-known old-timer is Everett Kick, W7EK, of Everett, Wash. Here we have him at his operating position, where he rolled up contacts with 249 stations in 64 sections and a score of 31,552. P.P. 150T's, running at 900 watts, grace the final of the classy looking rig. Receiver is RME-69. 2 Dr. H. J. Hocking, VE5FG, won the British Columbia award with 29,250 points. The puts-outer uses a 59 tri-tet, c.c. or c.c., a 24A buffer and an RK-20 final, with approximately 100 watts input. 3 Looking down the operating table at VE9AL, where VE3BC made the third highest 'phone score and won the Ontario 'phone award. From left to right on the table are such items as bound volume of QST, frequency meter and absorption type wavemeter, HRO receiver and coils, neon tube regulated power supply, loud speaker, heterotone oscillator and preamplifier for the transmitter. The transmitter consists of RK-23 tri-tet osc.-RK-20-P.P. RK-38's Class C, 500 watts input. With the exception of the final, the rig is completely band-switching. The modulator uses 805's Class B, microphone is a BR2S two sound cell crystal. 4 The operating post at W3AIR, Princeton, N. J., Southern New Jersey 'phone winner. Left to right: Speech amplifier, speaker, HRO, and home built 56-Mc. receiver. The transmitter line-up is 6A6-802-P.P. 807's-P.P. 100TH's, 400 to 500 watts input. Modulator uses 830B's. The exciter is built up as a portable, driven from a gas-driven unit.

second with 438, or 11.2 per hour, followed by W2IOP 433, 10.8 p.h., W8OFN 431, 10.7 p.h., and W9RCQ 410, 10.2 p.h. Others with over 300 stations worked: W3CHH 389, W6KFC 386, W1EZ 382, W1AW (W1JTD opr.) 382, W6HJT (W6HJT opr.) 371, W3DUK 365, VE3JT 351, W8BYM 347, W6ITH (phone) 342, W9FFU 336, W3ENX 327, W9TYF 318, W8ADV (2 oprs.) 312, W1BFT 310, W9RQM 307, W1RY 304, W9VKF 303, W5KC 301, W8IAW 300.

HIGH SCORERS

Although competition for SS awards is only within each individual A.R.R.L. Section and each winner is only a winner over the other contestants in his own Section, there is much rivalry for the highest score of *all* contestants—the highest score in all 70 Sections. In the 1937 contest this honor goes to Thomas Sue Chow, W6MVK, who reached the dizzy heights of 96,180 points with 469 contacts in all 70 sections!! All contacts were made on 7 and 14 Mc. with the aid of *eleven* antennas, all directive arrays, and *eleven* crystals; 90 to 100 watts input was used to an RK-20 final. MVK used to advantage the knowledge gained in previous Sweepstakes. He has established a real goal for other SS-ers!

In second place is Jerry Mathis, W3BES, a perennial SS threat, with 87,837—438 contacts, 67 sections. Using 90–100 watts input Jerry bettered his '36 performance (403 contacts, 64 sections, 1-kw. input) and says he got a bigger kick out of working with reduced power.

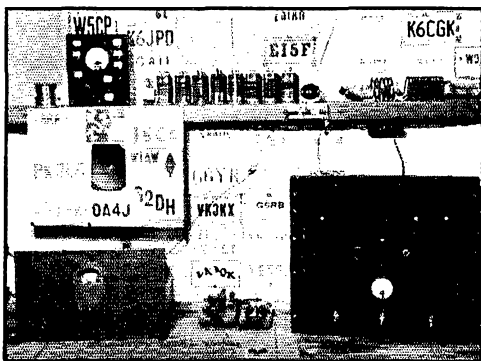

W5FZD, AUSTIN, TEXAS

There is no wasted space here. The receiver is a home-constructed six-tube super, the transmitter a 59 c.c. oscillator and RK-39 amplifier. W5FZD placed second in Southern Texas with 42,579 points.

It wouldn't seem like an SS, if Hal Pratt, W1EZ, wasn't up with the top-notchers, and we're not surprised to find Hal in third place with 74,295 on the basis of contacts with 382 stations in 65 sections. The e.c. oscillator was a big help. In fourth and fifth positions and worrying W1EZ more than a little we find W2IOP, 74,264 (433 stations, 63 sections), and W6KFC, 74,112 (386

stations, 64 sections). W6KFC is a familiar contest call and is always watched closely by SS contestants. W2IOP made a big jump forward and apparently deserves his share of attention in future competitions.

W8BYM, Ohio, placed sixth among the national highs with 68,706 (347 stations, 66 sec-

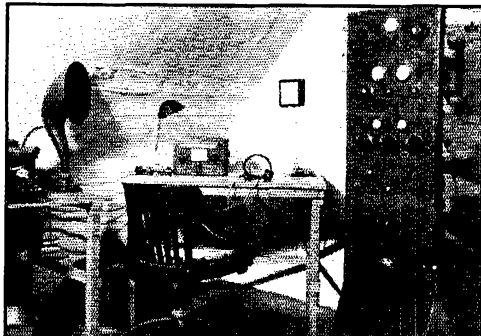

HIGHEST SCORING VE

VE3JT, Toronto, was the highest scoring VE participant in the SS. Receiver is an FBXA; power supply for this is at the left under the "mill." Behind the panels is a 59 tri-tet, choice of c.c. or e.c.o., an 807 buffer-doubler and 838 final, running at 225 watts. At the top of the rack is a Collins antenna tuning unit.

tions), and W9FFU, Colorado, closed the contest with 62,496 (336 stations, 62 sections) for a good claim on seventh place.

F. W. Hartley, VE3JT, was the highest scoring Canadian participant—42,060 points; 351 stations, 60 sections; 225 watts input to an 838 final did the business.

Fifty-four contestants scored over 40,000 points. Following the high seven we find W9RQM 58,656, W8OFN 56,562, W9TYF 56,109, W9IU 55,872, W4CYC 55,672, W8DOD 55,584, W5KC 55,428, W1RY 55,175, W9RSO 54,990, W9VKF 54,450, W9RCQ 52,480, W9GWK 52,392, W6BXL 51,777, W2AYJ 51,773, W8NLQ 51,684, W8IAW 51,300, W9NUF 51,125, W3ENX 50,700, W6HJT (W6HJT opr.) 49,749, W1TS 49,728, W9RBN 48,888, W8LZK 48,750, W9LEZ 48,372, W1BFT 48,126, W5WG 47,700, W9MUX 47,610, W3CHH 46,620, W1AW (W1JTD opr.) 46,482, W5CPB 45,978, W6ITY 45,360, W9AHR 45,243, W3FQZ 44,457, W3BET 43,648, W4PL 43,584, W5FZD 42,579, W2PY 42,510, W9CFB 42,456, W9EYH 42,294, W3DUK 42,224, VE3JT 42,060, W9CWW 41,958, W3GAU 41,490, W1AVJ 41,292, W3CBF 41,150, W5AQE 40,992, VE3GT 40,824, W9VES 40,236. All of these operators have discovered the SS formula—watch out for them in future contests!

RADIOPHONE PARTICIPATION

One hundred and two operators submitted 'phone entries in the Eighth SS. As a result of this increase in participation 'phone scores are considerably higher than in previous years. Twenty-

five voice operators have scores of over 3000 points. Reg Tibbetts, W6ITH, has the highest score for the second consecutive year—47,196, 342 stations worked, his work in contacting all sections has already been reported. Once again he succeeded in making a contact on each band (1.7, 3.9, 14, 28, 56 and 112 Mcs.). W6ITH's performance on 'phone equals many a good c.w. score and certainly shows what can be done by voice.

Richard Hyde, W9PWU, Colorado, made a healthy stab at highest 'phone honors with 39,411 points from contacts with 228 stations in 58 sections. He used his portable rig, running from 15 to 30 watts input to an 807 plate/screen modulated by a 6N7G Class B, on the 1.8, 3.9, 14 and 28 Mc. bands. Regarding the use of such low power, PWU says, "Sometimes I found the going hard, but as a whole I was surprised the way the contacts rolled in." Nice going, OM.

Bruce Carveth, VE3BC, operating VE9AL in Toronto, is third high among the 'phones with 16,536 (162 stations, 53 sections). Power used was 500 watts to a pair of RK-33's. Next comes W2JME, Northern New Jersey, with 13,995

(156 stations, 45 sections); W6OCH, East Bay, 12,336 (129 stations, 48 sections); W2JV, Northern New Jersey, 12,291 (121 stations, 51 sections); W4OC, North Carolina, 11,804 (114 stations, 52 sections); and W9FUH, Colorado, 10,253 (126 stations, 47 sections).

Other good 'phone scores are those of W3AIR 9588, W8FIP 8772, W6CQI 8237, W6IWU 7766, W9YGC 7544, W5CTC 6952, W9YQN 6750, W2IUV 6240 and W2JUV 5169.

High radiophone operators, after W6ITH, in number of sections worked are W9PWU 58, W6CQI 54, VE9AL (VE3BC opr.) 53, W4OC 52, W2JV and W3AIR 51, W6OCH 48, W9FUH 47, W9YGC 46, W2JME 45 and W5CTC 44. Twenty-two voice operators worked 30 or more sections.

Eighteen 'phones worked 80 or more stations, the leaders in contacts being W6ITH 342, W9PWU 228, VE9AL 162, W2JME 156, W6OCH 129, W9FUH 126, W2JV 121, W4OC 114, W2JUV 100, W6CQI 98 and W3AIR 94.

(Continued on page 56)

SCORES

Eighth All-Section Sweepstakes Contest, 1937

(Scores are grouped by Divisions and Sections. . . . The operator of the station first-listed in each Section is winner for that Section. . . . Asterisks denote stations not entered in contest, reporting to assure that stations they worked get credit. . . . The number of sections and number of stations worked by each station are given following the score. . . . Likewise the "power factor" used in computing points in each score is indicated by the letter A or B. . . . A indicates power up to and including 100 watts (multiplier of 1.5), B indicates over 100 watts (multiplier of 1). . . . The total operating time to the nearest hour is given for each station and is the last figure following the score. . . . Example of listings: W3BES 87,837-67-438-A-39, or, Final Score 87,837, number of sections 67, number of stations 438, power factor of 1.5, total operating time 39 hours. . . .)

ATLANTIC DIVISION		W3ALB	22101-53-209-B-24
W3BES	87837-67-438-A-39	W3BQJ	21432-38-188-A-1
W3XEN	50700-52-327-A-39	W3GUB	21318-38-187-A-38
W3CHH	46620-60-389-B-40	W3CNP	20064-44-152-A-35
W3BET	43648-55-263-A-40	W3DUI	20022-47-145-A-39 ²
W3FLY	39114-53-249-A-40	W3FTQ	19065-41-160-A-32 ²
W8OKC	38106-58-222-A-37	W3DGC	18354-38-161-A-39
W3GDI	32594-51-213-A-38	W3BGD	17424-44-132-A-17
W3ATR	32400-48-225-A-39	W3ADE	17172-53-162-B-32
W3DGM	30816-48-215-A-39	W3GJY	17082-39-146-A-40
W3GHM	30665-47-218-A-40	W3AGY	16500-50-161-B-30
W3ECA	29280-40-244-A-35	W8AXH	15810-34-155-A-38
W8FDA	29040-55-177-A-39	W3NFI	13005-45-145-B-19
W3EDC	24660-40-206-A-32	W3EFH	12900-40-109-A-30
W3DRJ	23880-40-199-A-25	W3AKB	11579-31-126-A-20
W3KTC	23868-52-233-B-36	W3GUV	8640-32-90-A-19 ⁴⁰
W3FZA	23027-43-179-A-38	W3ECP	5973-22-91-A-24
W3FRY	22770-55-138-A-33	W3FLH	5926-26-77-A-16
W3DPU	22672-52-220-B-29	W3DDM	5876-36-96-B-18
			5270-31-85-B-16

W3FWH	3150-25-42-A-12	W3DRE	49-4-4-A-4
W3GYV	1998-18-37-A-14	W3FJE*	2-1-1-1-1-1
W3EMR	1824-16-38-A-7	Phone	
W3CWQ	1470-21-35-B-19	W3AED	2-1-1-1-1-1
W3GKS	1402-14-34-A-20		
W3GRF	1302-14-31-A-12		
W3GJX	1207-17-36-B-11	<i>Su. New Jersey</i>	
W3GNJ	780-10-26-A-10	W3AWH	26244-54-164-A-40
W3EON	432-9-10-A-1	W3PAX	21460-58-186-B-40
W3GRS	171-6-10-A-2	W3EYT	19364-52-192-B-38
W3CPL*	30-2-5-A-4	W3BOG	12832-37-117-A-35
W3GVR*	8-2-2-1-1-1	W3BYR	11840-37-160-B-36
Phone		W3CMT	9936-36-93-A-31
W3AVX	2-1-1-1-1-1	W3CRR	8745-32-132-B-37
		W3IFE	7956-34-70-A-14
		W3BEI	5580-30-93-B-25

<i>Md.-Del.-D.C.</i>		W3DNU	5228-26-87-A-17
W3FQZ	44457-58-258-A-39	W3EHE	3500-28-65-B-1
W3DUK	42224-58-365-B-38	W3GUS	3120-20-40-A-16
W3GUA	41490-60-235-A-40	W3BTT	1454-17-29-A-20
W3CBF	41150-60-229-A-40	W3GHF	1200-16-25-A-13
W3FPQ	36762-44-266-A-39	W3FCQ	756-12-21-A-9
W3EJU	33384-52-217-A-37	W3FDF	756-14-19-A-9
W3EIV	24622-49-169-A-32	W3AEJ	180-9-10-B-1
W3HC	22565-49-155-A-30	W3GEO	126-6-7-A-4
W3FSP	19305-39-166-A-27	W3GUV	60-4-5-1-1
W3BKZ	19050-50-191-B-36	W3CWU	27-3-3-A-2
W3MGJ	16800-40-140-A-33	Phone	
W8JA-3	15152-39-130-A-35	W3AIR	9588-51-94-B-23
W3EIL	14036-44-160-B-31	W3FFE	3-1-1-A-1
W3GKZ	13350-50-136-B-25		
W3EHW	9360-39-82-A-12		
W3ETE	9000-30-101-A-19	<i>Western New York</i>	
W3GOB	8400-40-71-A-23	W8DDO	55584-64-203-A-39
W3FEW	7970-33-81-A-23	W8ADV	33072-53-312-B-39 ⁴
W3FIO	5387-27-67-A-14	W8EWT	31293-57-183-A-40
W3DQZ	4914-26-64-A-19	W8EMW	30600-50-204-A-39
W3DRD	4000-32-63-B-31	W8NWH	27324-44-209-A-32
W3GKP	3528-21-56-A-18	W8KAU	24750-55-150-A-22
W3FNG	1995-19-35-A-8	W8DSU	24111-57-226-B-36
W3HBE	1800-15-40-A-12	W8PKA	22500-40-189-A-34
W3GYQ	855-15-20-A-8	W8NQC	18180-40-152-A-32
W3CYV	743-15-17-A-4	W8QKM	14850-33-150-A-37
W3DKO	446-11-14-A-4		

(Continued on page 74)

¹ W3EMR opr. ² W3DYU opr. ³ Three oprs. W3FTQ, W3DTR, W3GWO. ⁴ Two oprs. W8ADV 13760, W8KBS 2840. ⁵ Two oprs. ⁶ Both power factors. ⁷ Four oprs. W8NWX, W8HWK, W8OKY, W81V1. ⁸ Both power factors; high—6757, low—995. ⁹ W9TWC opr. ¹⁰ Both power factors. ¹¹ Both power factors; high—7992, low—1392. ¹² Both power factors; high—704, low—73560. ¹³ Two oprs. Alex & Steve Eklblad. ¹⁴ W2JZX opr. ¹⁵ Both power factors; high—6240, low—5288. ¹⁶ Both power factors; high—3753, low—1416. ¹⁷ Two oprs. W2JSE, Alfred Harada. ¹⁸ Both power factors; ¹⁹ Both power factors; high—2440, low—9918. ²⁰ Trinity College Radio Club, W1LLA opr. ²¹ Aero Radio Club, W1BQI, W1KXB, W1JLL oprs. ²² HQ staff members, not eligible for awards. ²³ W1LTD opr. ²⁴ Both power factors; high—4800, low—3003. ²⁵ The Associated Radio Amateurs of Southern New England, Inc.; oprs., W1CPV 2940, W1BOY 1938, W1JGB 378, W1AOP 126. ²⁶ Two oprs., W1KVB, W1KIE. ²⁷ W7VQ opr. ²⁸ Both power factors; high—1824, low—858. ²⁹ Both power factors; high—8237, low—969. ³⁰ Both power factors; high—338, low—6510. ³¹ Both power factors; high—8600, low—1653. ³² Two oprs., W4DCZ, Milton Adams. ³³ Two oprs. ³⁴ W5GOH opr. ³⁵ Two oprs., W6OWC, W6KZJ. ³⁶ Both power factors; high—2958, low—18. ³⁷ VE3BC opr. ³⁸ VE2MV opr. ³⁹ Unofficial; outside of 70 A.R.R.L. Sections. ⁴⁰ Two oprs., Richardson & Moore. ⁴¹ W3DRW opr. ⁴² Two oprs., W9ZMG & W9NWE. ⁴³ W6HJT opr.

● ARMY-AMATEUR RADIO SYSTEM ACTIVITIES ●

AS READERS of this section are aware, the Army Net of the A.A.R.S. comprises the Army station (WLM) located in Washington, and a secondary station of this net representing each of the nine Corps Areas and three over-seas departments. Each of these secondary stations normally is located at the military headquarters of the Corps Area or Department and heads up as N.C.S., the member stations located within each respective command. As all general instructions as to policies, organization and operation emanate from the office of the Chief Signal Officer, the activities of each Corps Area or Department are conducted in a generally uniform manner with the details of the activities decentralized under the jurisdiction of the Corps Area or Department Signal Officer.

One of these Corps Areas, the Second, comprises the States of New York, New Jersey and Delaware and the Territory of Puerto Rico. The headquarters of the Corps Area is at Governors Island, N. Y., at which point is located the Corps Area net control station WLN-W2SC. This is a well-equipped, modern station operated by military personnel under the same standards of efficiency as required of station WVP, the Second Corps Area control station of the War Department Radio Net. Station WLN-W2SC, which is equipped with a gasoline-electric generator, is prepared for operation on all assigned War Department frequencies, as well as amateur frequencies.

The Second Corps Area is divided territorially into five nets, each under the direction of an N.C.S. and all supervised and coordinated by the Corps Area N.C.S. Continuous efforts are being made to improve the operating efficiency of the nets and provide the membership the fullest possible measure of instruction and training.

At the outset of the current operating season the major problem confronting the Corps Areas was the change in net organization to conform to the new policy of the Chief Signal Officer requiring the abolition of the District and Local nets wherever practicable and having all stations within a state net operate on the state net frequency. Under the previous plan of operation, state nets comprised in turn several district nets, each operating under a different frequency. Some of the many disadvantages of this arrangement were that each district N.C.S. was required to have two crystals, one for the District and one for the State net; if a district N.C.S. was absent from a drill, the net stations of that district had no way of reporting into the State net; messages had to be twice relayed in passing from a secondary district station to the Corps Area N.C.S.; and in case of emergency, there was no definite

direct contact with all stations on account of various frequencies assigned.

Under the modified net organization all secondary stations in each State net operate on the same frequency, whereas the State N.C.S. and alternates are equipped for operation on both the state and corps area frequencies. This arrangement eliminates virtually all of the above mentioned difficulties under the old plan and offers more interest and satisfaction to the members.

Illustrative of the advantages and possibilities in the application of this new policy, the details of the very satisfactory and successful plan of operation of the Southern New York State Net (N.C.S.-W2DBQ) should be mentioned. All stations are required to operate on a spot frequency of 3710 kcs. which permits direct, instantaneous channels between all stations in the net. With this number of stations operating in one net, operators not having traffic may, upon occasions when the traffic load is heavy, be unable to engage very actively in net operation if required to stand by during the full period of the drill.

To overcome this difficulty and to offer a greater number of stations opportunity for experience as N.C.S. the members of this net are now divided into three groups, designated as Battalions 1, 2, and 3. Battalion 1 operates from 7:45 to 8:15 P.M.; 2 from 8:30 to 9:00 P.M.; and 3 from 9:00 to 9:30 P.M. The former district N.C.S.'s are now SNC2, 3, 4, 5 and 6. These alternates assist in handling the Battalion nets and as tie-ins with the Corps Area Net. The period from 8:15 to 8:30 P.M. is designated as the Executive Period in which all alternates report to the S.N.C.S. and receive their instructions for the evening.

After 9:30 P.M. the net is free and stations not cleared in their Battalion net may report in.

Each alternate is furnished with a Battalion membership list in alphabetical order, by which method stations are called up.

This plan is in effect on Monday nights only; during the week all members may report in on 3710 kcs. at 8:00 P.M. The alternate NCS3, etc., assume control of the net in rotation throughout the week, thereby giving each equipped member station training as a net control station.

* * *

The following message in unknown key is presented for those interested in the art of cryptanalysis. Send answers to the Liaison Officer, A.A.R.S., 3441 Munitions Bldg., Washington, D. C.

CDLL SEEB IEDS COOTT AMTA AVRDE
EIMIE TBSAD AOLCI EOTET IWGOT YDYAA
FNUNA RRCSB BNOTN FRNVB AEACP ILPIM
IAIOI NCRUE LYECB IIAVI MISAD TEBBS
NCISY TEIYH CEPNG YMNEO NEHNS NEALS

How Would You Do It?

Intercommunicating Telephone Systems for Use Between Station and Family

AN intercommunicating telephone system can hardly be classed as amateur radio equipment. We have discovered, nevertheless, that a surprisingly large number of amateurs consider it an essential part of the station. It may not add a mile to the range of the transmitter, but it often preserves peace in the household when it becomes necessary to communicate with the operator when the station is located in some remote corner of the house or in a shack in the back yard.

The solutions which were submitted in response to Problem No. 15 include descriptions of both the simple telephone systems and those more complicated systems employing speech amplifiers and loudspeakers. We have selected the best examples of each type. Some systems are so weird that we rather doubt that they have ever been tried out, while others show definite indication of use under practical conditions because they include switches for opening the circuit in case

the operator does not wish to be disturbed!

Four different schemes for simple telephone systems are shown in Fig. 1. In each case a head-phone unit is used for the transmitter instead of a microphone. Complete success is reported with lines considerably longer than the distance suggested in the problem. In view of this, those more complicated systems requiring microphones, batteries and transformers were eliminated.

Problem No. 17

(Suggested by W8JGR)

WITH the approach of summer weather, Our Hero's head is full of plans for new antenna construction. One of the most important projects on the program is the erection of a rotatable antenna. Already he has many of the details worked out, but one thing stumps him. He would like to see complete descriptions of satisfactory and practical ideas on direction indicators. He wants to be able to rotate the antenna from the operating position and have some indicating device conveniently located which will tell him in what direction the antenna is pointed at any given time.

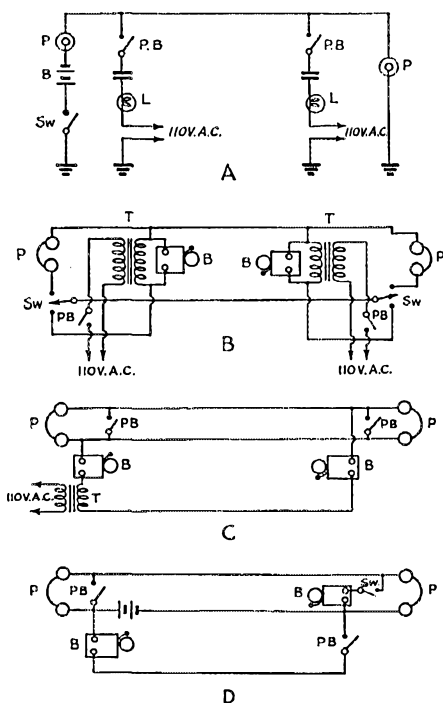

FIG. 1—SIMPLE LINE TELEPHONE CIRCUITS

In most cases, the system will work satisfactorily if a good ground connection is substituted for one of the talking lines. B—Battery, bell or buzzer, as indicated, L—110-volt lamp, P—Headphone unit or set, PB—Push-button switch, T—Bell-ringing transformer.

The simplest idea submitted was that of Winfred C. Lowe, of New Brunswick, N. J. It is shown at A of Fig. 1. The system operates with only a single wire and ground connection. The 60-cycle "buzz" in the single head-phone at either end when either push-button is operated is used for calling. The size of the series condensers may be varied to produce the best results. The single head-phone unit is used both as microphone and receiver. The 110-volt lamps are used as a precaution against short circuits. Care should be taken to arrange the 110-volt plug so that the grounded side of the 110-volt line is connected to ground to prevent a short circuit of the line. The danger of a short circuit if the 110-volt line is reversed could be eliminated by placing another fixed condenser between the 110-volt line and ground. The battery indicated for energizing the talking circuit is not always necessary.

Several ideas requiring two and three lines were submitted. When using but two wires (or one wire and a common ground, such as a water pipe), a power supply is required at each end of the line for ringing as shown at B. Switches are also required at each end to switch from the

ringing circuit to the talking circuit. Both switches are normally thrown in the downward direction. With the switches in this position, either push-button may be used to call the other station. When the second station answers, both switches are thrown in the upward position for talking after which the switches must be returned to the original position. In this particular case, bell-ringing transformers are used to supply the calling circuit. Ordinary headphones are used at each end, one unit being used at each end as the microphone. This particular arrangement was submitted by J. T. Simpson, New Orleans, La., although very similar schemes were suggested by others.

A three-wire system requiring but one supply is shown at C. This circuit was submitted by W9TO and has the advantage that no switching is necessary.

The circuit suggested by W9DFD and shown at D is rather novel in that the same battery is used for both ringing and talking circuits. The switch at one end is normally closed to complete the ringing circuit. In the arrangement described, this is a hook-type switch on which the headphones are hung. It opens when the headset is removed from the hook for talking.

Turning to more elaborate installations of the speech-amplifier-loudspeaker variety, a popular

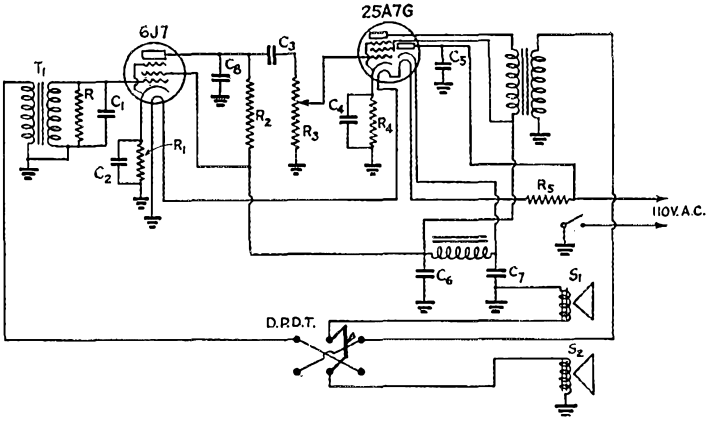

FIG. 2—LOUDSPEAKER SYSTEM INCLUDING POWER SUPPLY

- C₁—0.001 μ fd.
- C₂, C₃—0.1 μ fd., 200-volt.
- C₄—10 μ fd., 25-volt.
- C₅—0.01 μ fd., 200-volt.
- C₆—16 μ fd., 200-volt.
- C₇—12 μ fd., 200-volt.
- C₈—0.001 μ fd.
- R₁, R₂—100,000 ohms,
- 1/2-watt.
- R₃—500,000 ohms, variable.
- R₄—600 ohms, 5-watt.
- R₅—290 ohms, Candohm or Ohmite resistance cord.
- T₁—Line-to-grid transformer.
- T₂—Plate-to-line transformer.
- Sw₁, Sw₂—Magnetic speakers.
- SW—D.p.d.t. switch.

circuit is shown in Fig. 2. This circuit was supplied by Harry Moreton, Jr., of Cincinnati, Ohio, who, incidentally, made the original suggestion of the subject for this problem. The 25A7G is one of the more recently announced tubes somewhat similar to the 12A7 and includes rectifier for the power supply. The capacity of C₈ may be changed to suit personal preference as to tone quality. The chief disadvantages of this type of circuit are that it may be operated from only one end of the line and that it is necessary to switch from "send" to "receive."

A circuit which requires no switching is shown in Fig. 3B. It is a circuit commonly used in tele-

phone "repeater" service and is described by G. Smith of Chicago, Ill. For the benefit of those who are not familiar with the principles involved, a brief explanation is given.

Referring to diagram A, T₁ and T₂ are the input and output respectively of the amplifier. It will be noted that they are on opposite sides of a

(Continued on page 106)

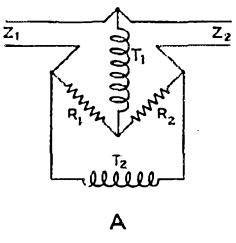

A

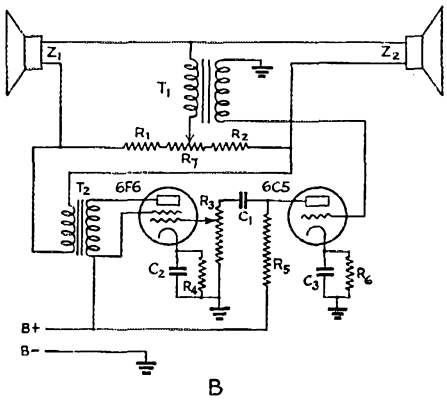

B

FIG. 3—LOUDSPEAKER SYSTEM REQUIRING NO SWITCHING

- R₁—10,000 ohms
- R₂—10,000 ohms
- R₃—500,000-ohm volume control
- R₄—400 ohms
- R₅—50,000 ohms
- R₆—2500 ohms
- R₇—5000 ohms
- R₈—5000 ohms (see text)
- R₉—10,000 ohms
- C₁—0.01 μ fd., 400-volt
- C₂, C₃—25 μ fd. electrolytic, 25-volt

T₁, T₂—See text
 Note: In the diagram, the wire between R₂ and Z₂ should not connect to grid of 6C5

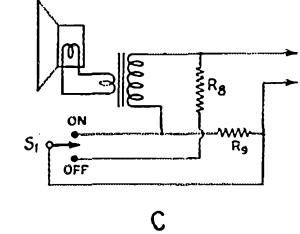

C

HINTS and KINKS for the Experimenter



Crystal Oscillator Requiring No Tuning Adjustment

AN OSCILLATOR which is particularly suited to crystal grinding and fixed-tune exciter applications is shown in Fig. 1. Making use of only two 2-watt carbon resistors, two 600-volt

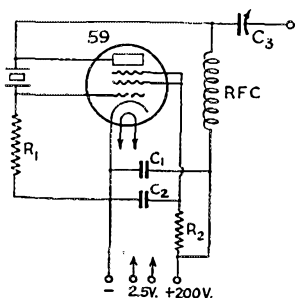

FIG. 1—CIRCUIT OF THE FIXED-TUNED CRYSTAL OSCILLATOR

0.01 paper condensers, an R100 r.f. choke, and a tube and socket, this unit provides much flexibility and economy for crystal testing or universal exciter designs.

The use of a crystal as the only tuned circuit in the oscillator makes tuning adjustment unnecessary, and in this arrangement, the output of the crystal may be measured without harmonic worries.

C_1 and C_2 are the 0.01 μ d. condensers mentioned above, while R_1 is 100,000 ohms and R_2 is 20,000 ohms. Condenser C_3 is an optional output condenser which may be used to give variable coupling to succeeding stages or to output or frequency-measuring devices. A plate milliammeter may be used in series with the positive lead to the plate for making rough tests of the crystal activity.

To test the stability of this oscillator, the author tuned a communication-type receiver to zero beat with the oscillator. Increasing the coupling of the oscillator to the external circuit from almost no load to a point at which the plate current approximated that taken by the oscillator circuit without a crystal had no apparent effect on the output frequency. For a further test, the plate and grid terminals of the crystal holder were grasped in the author's fingers, still with no noticeable change in the operation of the oscillator.

This oscillator should aid in overcoming the problems introduced into the design of band-switched exciters by possession of crystals on different bands, and in addition, crystals of widely different frequencies in one amateur band.

The circuit shown is adaptable to any low power tetrode or pentode vacuum tube. The use of the following types of tubes will afford satisfactory operation: 59, 46, 47, 6K7, and 6F6. The circuit constants are not critical. The radio frequency choke may be any type receiving choke at hand, provided it has a fairly high impedance at the frequencies of the crystals used.

—C. M. Ault
Lincoln, Nebr.

Calibration Graphs for Panels

AMATEURS using calibration curves on the front panels of their station equipment to facilitate tuning or to improve appearance will find this kink contributed by Director Bennett R. Adams, Jr., W4APU, Homewood, Alabama, of the utmost value. Mr. Adams writes, "... A professional-looking job can be made by first drawing the chart on ordinary thin cross-section

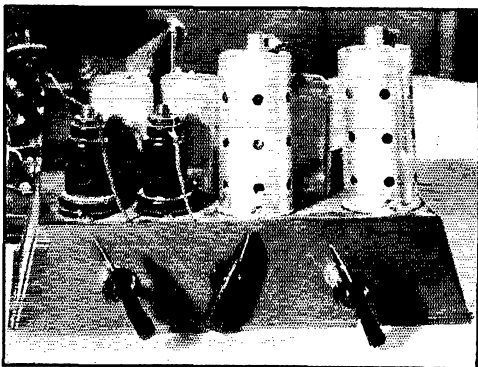

TYPICAL BREAD-PAN LAYOUTS

paper using India Ink, or pencil with blue carbon paper (turned up) under the cross-section paper, and then having a photographic print made of the graph, with the graph paper replacing the usual negative. The result is a chart of excellent appearance and nice finish, having a black background and white lines, and it will not fade as

would a blue print. The cost should be in the neighborhood of five or six cents each for prints of the usual snapshot size."

Judging by the favorable comment which Mr. Adams' sample received, this type of front-panel graph card will receive wide usage.

Bread-Pan Vs. Bread-Board

THE accompanying illustration shows two bread-pan hookups, modernized versions of the old familiar bread-board arrangements. This new use of inexpensive kitchen utensils is recommended by C. A. Donaldson, Del Rio, Texas. Mr. Donaldson writes, "These small pans from the dime store are just the thing for small chassis as they are fairly stiff and still it is easy to punch holes in them. Small holes may be punched with an ice pick, and larger ones with any type of punch or hole-cutter. Then, if the circuit and layout prove satisfactory, a permanent chassis may be built using the same hole centers. In the photograph the unit is an experimental 500-kc. generator.

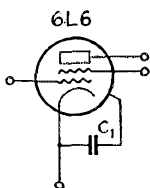

FIG. 2—METHOD OF SAFE GUARDING AGAINST SHORTED B-SUPPLY

Shielding the Microphone Plug

A COMMON cause of r.f. feed-back in 'phone transmitters is inadequate shielding of the microphone circuit. Recently manufacturers have brought out microphone plugs which are made entirely of metal (with the exception of small insulating parts in the sleeve and terminal mounting within the plug) and hence are completely shielded. The ordinary bakelite-shell plug may be shielded easily in the following manner:

For shielding material, use a small piece of tinfoil taken from an old paper condenser. Do not detach the tinfoil from the waxed paper; instead, cut both paper and foil to size so that when formed in a cylindrical shape, a snug fit inside the bakelite shell of the plug will result. When forming the cylinder, make sure that the paper will be turned to the inside, so that there will be no chance of the foil shorting the microphone connections. When the bakelite is screwed back on the plug, the thread will bite into the foil, thus grounding it and making the shielding effective.

—W. B. Thompson, W3OKC
410 W. Pine St., Shamokin, Pa.

Preventing Voltage Breakdown in 6L6 Oscillators

A METHOD for preventing arc trouble in 6L6 tubes, and thus saving power supply components, is shown in Fig. 2. Trouble was experienced with a 6L6 operating with 400 volts plate,

indicating that the power supply was being shorted within the tube itself. Since the operation was normal (the tube was used as a tetrode crystal oscillator with medium load), an arc within the elements was considered highly improbable. Therefore, the connection between the shell and ground was removed, and this was found to remove the shorting load. Since the point of lowest breakdown voltage in this type of tube seems to be between connections for the elements and the shell, use of a 0.01 $\mu\text{f.}$, 600-volt condenser between metal shield and ground is recommended.

—Edwin F. Ehlinger, W8BBP
Utica, N. Y.

LC Constants for Intermediate, Broadcast and Amateur Bands

A TABLE of much interest to amateurs is that given below. The results listed are the values given by accurate computation for the product of inductance and capacity corresponding to each of the frequencies listed. Each value of LC is given in terms of microhenrys ($\mu\text{h.}$) and micro-microfarads ($\mu\mu\text{f.}$)

Band	Frequency	LC Constant
Intermediate	455 kc.	122355.
Broadcast	540 kc.	36866.4
Broadcast	1500 kc.	11257.9
160 M. amateur	1715 kc.	8612.4
160 M. amateur	2000 kc.	6332.57
80 M. amateur	3500 kc.	2067.73
80 M. amateur	4000 kc.	1583.14
40 M. amateur	7000 kc.	516.944
40 M. amateur	7300 kc.	475.339
20 M. amateur	14000 kc.	129.236
10 M. amateur	28,000 Mc.	32.3090
10 M. amateur	30,000 Mc.	28.1448
5 M. amateur	56,000 Mc.	8.07726
5 M. amateur	60,000 Mc.	7.03620

For other frequencies:

$$LC = \frac{25330.3}{(\text{Freq.})^2} (\text{Freq. in Mc.})$$

This table should prove helpful in the selection of circuit elements.

—Henry R. Hesse, W2ERY
Brooklyn, N. Y.

Switched 6L6G Oscillator for Grid-Plate Crystal and E.C.O. Operation

THE oscillator of Fig. 3 makes use of a double-throw, double-pole switch to obtain e.c.o. operation using the grid-plate crystal oscillator circuit from page 161 of *The Radio Amateur's Handbook*.

For crystal operation, the cathode coil, L_1 , is tuned to approximately half the crystal frequency by means of condenser C_1 . The plate tank circuit, C_2-L_2 , is dipped to resonance in the usual manner.

When the switch is changed to the other position, the tube works as a conventional e.c.o.,

giving excellent stability due to the frequency doubling action in the circuit.

High output is realized, since the crystal current in this type oscillator is low. Making use of the same circuit constants for e.c.o. operation as are used for crystal, the oscillator gives approximately equal amounts of power with crystal oper-

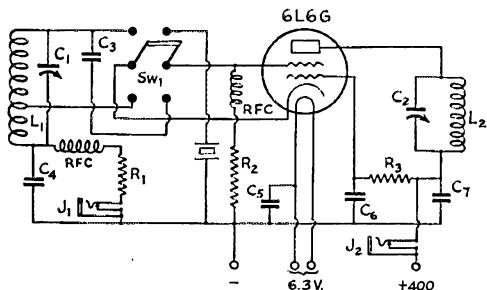

FIG. 3—CIRCUIT OF THE E.C.-XTAL OSCILLATOR

C₁—500-µfd. variable.

C₂—100-µfd. variable.

C₃—100-µfd. mica.

C₄—0.01-µfd. mica.

C₅, C₆—0.002-µfd. mica.

C₇—1.002-µfd. mica.

R₁—250-ohm, 2-watt.

R₂—100,000-ohm, 1-watt.

R₃—25,000-ohm, 5-watt.

Sw—D, p.-d.t. jack-type (Yaxley).

L₁—3.5-Mc. coil, 1 1/4-inch diameter, 15 turns No. 20

d.c.c., close-wound, tapped 2 turns from ground.

L₂—7-Mc. coil, 1 1/4-inch diameter, 14 turns No. 20 d.c.c.,

close-wound.

RFC—R-100 chokes.

ation and electron-coupled operation, and is quite

stable when operated in the latter arrangement.

—Charles McCarthy, EI6G

St. Clares Ave., Cork, Ireland

—R. Newman, EI8M

Passage, Cork, Ireland

Eighth S.S. Contest

(Continued from page 50)

CLUB SCORES

Once again the Frankford Radio Club of Philadelphia is winner of the gavel trophy offered to the club whose members submitted the highest aggregate score. More than tripling their '36 total, the Frankford participants ran up 335,559 points! The president should be able to maintain order now, with a gavel in each hand!! Second time runner-up is the Merrimack Valley Amateur Radio Association of Concord, N. H., whose score of 202,763 more than doubles the '36 total. The Westlake Amateur Radio Association (Cleveland, Ohio) is third with 158,223, followed by Montreal Amateur Radio Club, 140,493; VE Operators Association (Toronto), 121,082; Delaware Amateur Radio Club (Wilmington), 118,342; York Road Radio Club (Glenside, Pa.), 117,745; Lane Technical High School Radio Club (Chicago), 114,815; Hamfesters Radio Club, Inc. (Chicago), 112,470; Chattahoochee Amateur

Radio Association (Georgia-Alabama), 112,005; Beacon Radio Amateurs (Philadelphia), 110,304; Washington Radio Club, 109,349; 100 What Club (Modesto, Calif.), 96,222; Milwaukee Radio Amateurs' Club, Inc., 82,501; Oakland (Calif.) Radio Club, 79,415; Wichita (Kans.) Amateur Radio Club, 79,131; High Park Radio Club (Ontario), 60,735; Birmingham (Ala.) Amateur Radio Club, 59,613; Bridgeport (Conn.) Amateur Radio Association, 59,485; Elmira (N. Y.) Amateur Radio Association, 58,305; Pasadena (Calif.) Short Wave Club, 53,412; Egyptian Radio Club (E. St. Louis, Ill.), 52,485; Richmond (Va.) Short Wave Club, 50,752; Finger Lakes Transmitting Society (Auburn, N. Y.), 48,751; Merrimack Valley Amateur Radio Club (Lowell, Mass.), 48,654; Trenton (N. J.) Radio Society, 37,313; Wheeling (W. Va.) Radio Club, 23,850; Providence (R. I.) Radio Association, Inc., 20,740; Hi-Q Radio Club of Lynn, Mass., 14,986; Hartford County (Conn.) Amateur Radio Association, 14,202; Tampa (Fla.) Amateur Radio Club, 14,123; Connecticut Brass-pounders Association (Noroton, Conn.), 14,112; Trinity College Radio Club (Hartford, Conn.), 12,318; The Greater Cincinnati Amateur Radio Association, 11,037; Starved Rock Radio Club (Ill.), 10,468.

The above-mentioned thirty-five clubs had three or more members submitting scores. The following amateurs receive certificate awards for making the highest score in their respective clubs: W3BES, W1BFT (c.w.); W1APK ('phone), W8BYM, VE2IN (c.w.); VE2KX ('phone), VE3GT, W3DUK, W3EDC, W9NUF, W9MWU, W4CYC, W3FLY, W3FPQ, W6MVK, W9UIT, W6ITH ('phone); W6TT (c.w.), W9AHR, VE3AET, W4ELQ, W1CLH, W8KGG, W6BXL (c.w.); W6BWG ('phone); W9RCQ, W3FMY, W8DSU, W1IQH (c.w.); W1BEF ('phone); W3AWH (c.w.); W3AIR ('phone), W8LCN, W1KCS, W1ERH (c.w.); W1ALB ('phone), W1EAO (c.w.); W1ITI ('phone), W4DCZ, W1AXB, W1ILA, W8PBX (c.w.); W8NDN ('phone), W9NGG. Awards are made only in clubs having three or more reporting participants. If any club finds that it actually had three

(Continued on page 68)

Silent Keys

IT IS with deep regret that we record the passing of these amateurs:

Les. Allitt, VE4EB, Regina, Sask.

Edwin R. Fisk, W1ADV, West Springfield, Mass.

Walter J. Pike, W8QMF, Newaygo, Mich.

D. R. Sheehan, VE2DG, Montreal, Que.

● I. A. R. U. NEWS ●

Devoted to the interests and activities of the

INTERNATIONAL AMATEUR RADIO UNION

Headquarters Society: THE AMERICAN RADIO RELAY LEAGUE, West Hartford, Conn.

MEMBER SOCIETIES

American Radio Relay League
Asociația Amatorilor Romani de Unde
Scurte
Associazione Radiotecnica Italiana
Canadian Section A.R.R.L.
Československá Amatérská Vysílací
Deutscher Amateur Sende-und-Empfangs
Dienst
Experimental Radio Society of Egypt
Experimenterende Danske Radioamatorer
Federation des Emetteurs Belges
Irish Radio Transmitters Society
日本アマチュア無線聯盟 Japan

Liga Colombiana de Radio Aficionados
Liga Mexicana de Radio Experimentadores
Magyar R6vidhullámú Amat6rök Országos
Egyesülete
Nederlandsche Vereniging voor Interna-
tionaal Radioamateurisme
Nederlandsch-Indische Vereniging Voor
Internationaal Radioamateurisme
Newfoundland Amateur Radio Association
New Zealand Association of Radio Trans-
mitters
Norsk Radio Rel6 Liga
Oesterreichischer Versuchssenderverband

Polski Zwiasek Krotkofalowcow
Radio Club Venezolano
Radio Society of Great Britain
Rede dos Emissores Portugueses
Reseau des Emetteurs Francais
Reseau Luxembourgeois des Ama-
teurs d'Ondes Courtes
South African Radio Relay League
Suomen Radioamat6urilitto r.y.
Sveriges Sandareamat6orer
Unión de Radioemisores Españoles
Union Schweiz Kurzwellen Amateure
Wireless Institute of Australia

Conducted by Byron Goodman

Cairo:

Developments at Cairo and the experiences of the delegation are reported elsewhere in this issue, under "What the League is Doing."

British Isles:

Because you are probably interested in knowing what some of the hams in the British Isles are like, we are taking the liberty of quoting from a letter from William Rice, W1IKT, who recently returned from a trip to the British Isles.

"... Although ham radio was not the object of my trip, I succeeded in making some very interesting 'personal QSO's' with hams I had talked to over the air. The warm hand of amateur radio friendship that was extended to me added enormously to the enjoyment of my trip.

"My first call was at R.S.G.B. headquarters where I was greeted most cordially by Mr. Clarricoats, G6CL, Secretary of the society. G6CL is a keen ham, and in spite of his many activities in connection with the society has found time to get his WAC and WBE on both c.w. and 'phone. In response to his kind invitation, I spent a pleasant evening at his home and station in the company of a VK who happened along.

"We next visited 'Ham' Whyte, G6WY, the renowned DX-er who heads the Century Club. His walls display some very rare QSL's. He has four transmitters in all, c.w. and Class AB 'phone, running with an input of 250 watts, an excellent example of the QRO 'G'. The receiver is a 6-tube superhet, and his antenna is a 7-Mc. full-wave Hertz. 'Ham' is a member of the R.S.G.B. Council, and QRA Manager.

"In North England at New-Castle-on-Tyne I

ran down G5QY, a most energetic person whose call is quite well known all over the world. He is also a keen Century Club aspirant, and I spent a most interesting evening in his shack. He uses ECO rigs with about 100 watts input, and a 'Windom' antenna. In 1931 he made WAC with only 5 watts input. G6MK, another active North Britisher and an ECO fan, looked in for a rag-chew before I left New-Castle.

"Some miles north of New-Castle-on-Tyne, in the seclusion of the bleak and wind-swept Northumbrian country, I found England's first YL amateur station, the unique G6YL of QRP fame. Here I found ample proof that 'flea-power' really does work if given a fair chance, for Miss Dunn has done remarkable things with low power (6 to 10 watts). In fact the cards and certificates that adorn the walls of the 'radio den' would put to shame many a kilowatt outfit. The plate supply for the tiny transmitters, one for each band including 56 Mc., is supplied by a generator run from storage batteries. The two-tube battery receiver (36 volts on plate, 2 volts on filaments) and a single-wire A.O.G. antenna complete the station equipment. I was much impressed by the wonderful efficiency so in evidence everywhere. I found Miss Dunn most hospitable, and I enjoyed immensely her great interest and enthusiasm.

"My pilgrimage next carried me across the rough and unpleasant Irish Sea to Dublin, where I got in touch with EI5F and EI8G. EI5F and I first became acquainted in the days of war clouds, spark transmitters, and magnetic detectors.

"A two-hundred mile trip west to the sea-washed shore of County Mayo brought me to Capt. Noblet of EI9D. He is a very keen 'phone man', and I found him a real 'dyed-in-the-wool'

ham. He is a most resourceful chap, and his isolated QTH must have tested his resources to the full when he started in the amateur game. I wound up my hamming in EI with a telephone call to EI9J. It was after hours (8 P.M.), and the call had to go through the Civic Guard Barracks (the constabulary). EI9D stood in and we had a three-way, with the guards standing by and wondering what it was all about. That ham language had them guessing about spys and secret service!

"Back in London I just had time to say 'cheerio' to G6CL and R.S.G.B. before going to Southampton and the *Queen Mary*.

"... I would like to express my thanks and appreciation to the G and EI hams for the fine comradeship extended to a wandering W1."

QSL Bureaus:

Following is the latest revised list of the foreign QSL Bureaus to which QSL cards may be sent for distribution. Many of these bureaus now refuse to handle SWL cards and reports, and therefore listener reports should be sent directly to the station.

Alaska: Dean Williams, Box 2373, Juneau.
 Antigua: A. Tibbits, Box 43, St. John's.
 Argentine: Radio Club del Argentina, Rividavia 2170, Buenos Aires.
 Australia: Ray Jones, 23 Landale Street, Boxhill, Victoria.
 Austria: Willy Blaschek, O.V.S.V., Bahngasse 29, Klosterneuberg.
 Barbados: *see* Antigua.
 Belgium: Baron Bonaert de la Roche, ON4HM, Chateau de Marchiennes, Harvengt nr. Mons.
 Bermuda: Alfred E. Redman, "Elsing," Middle Road, Devonshire.
 Bolivia: Henry E. J. Smith, c/o Standard Oil Co. of Bolivia, La Paz.
 Borneo: *see* Malaya.
 Brazil: L.A.B.R.E., Caixa Postal 26, São Paulo.
 British Guiana: *see* Antigua.
 British Honduras: D. Hunter, Box 178, Belize.
 Canal Zone: John J. Carr, 78th Pursuit Squadron, Albrook Field.
 Ceylon: Radio Club of Ceylon and South India, P. O. Box 282, Colombo.
 Chile: Luis M. Desmaris, Casilla 761, Santiago.
 China: I.A.R.A.C., Box 685, Shanghai.
 Colombia: L.C.R.A., Apartado 330, Bogota.
 Costa Rica: Federico Gonzalez, Box 384, San José.
 Cuba: Adolfo Dominguez, Milagros 66, Vibora, Habana.
 Czechoslovakia: C.A.V., Post Box 69, Praha I.
 Denmark: Arne Hammer, OZ7D, Norre Aaby.
 Dominican Republic: H. H. Gosling, Calle Cesar Nicolas Penson, Ciudad, Trujillo.
 Ecuador: Carlos Cordovez, Box 30, Rio Bamba.
 Egypt: F. H. Pettitt, Catholic Club, Mustapha Barracks, Alexandria.
 England: R.S.G.B., 53 Victoria St., London, S. W. 1.
 Estonia: E.R.A.U., Box 220, Tallin.
 Federated Malay States: *see* Malaya.
 Finland: S.R.A.L., Pohjola, Box 42, Helsinki.
 France (and any country with prefix beginning with "F"):
 Réseau des Emetteurs Français, 6 Square de la Dordogne, Paris, 17^e.
 Germany: D.A.S.D., Schweinfurthstr. 78, Berlin-Dahlem.
 Greece: C. Tavaniotis, 17-a Bucharast St., Athens.
 Guam: C. R. Spicer, Naval Communication Office, Agaña.
 Haiti: L. F. Sherwood, c/o R.C.A., Port-au-Prince.
 Hawaii: James F. Pa, K6LBH, 1416D Lunallo St., Honolulu.

Hong Kong: H.A.R.T.S., Box 651.
 Hungary: National Union of Hungarian Short Wave Amateurs, VIII, Maytaster 6, Budapest.
 India: B. M. Tanna, Satya Sadan, Santa Cruz.
 Irish Free State: I.R.T.S. 23, Sth. William St., Dublin.
 Italy: A.R.I., Viale Bianca Maria 24, Milan.
 Jamaica: Cyril M. Lyons, 2-B North St., Kingston.
 Japan: J.A.R.L., P. O. Box 377, Tokyo.
 Java: *see* Netherland East Indies.
 Jugoslavia: Stephen Liebermann, Meduleceva 9, Zagreb.
 Kenya: R.S.E.A., Box 570, Nairobi.
 Latvia: L.R.B., Post Box 201, Riga.
 Lithuania: L.R.M., Post Box 100, Kaunas.
 Luxembourg: Service QSI, de R.B., 164 Av. de la Fayette, Luxembourg.
 Madeira: *see* Portugal.
 Malaya (and Borneo): J. MacIntosh, c/o Posts & Telegraphs Dept., Penang, Straits Settlements.
 Mexico: L.M.R.E., Sinaloa 33, Mexico City.
 Morocco: A.A.E.M., BP 50, Casablanca.
 Netherlands: N.V.J.R., Post Box 400, Rotterdam.
 Netherlands East Indies: Ir. J. M. van Heusden, N.I.V.I.R.A., Palmenlaan 1, Bandoeng.
 Newfoundland: Newfoundland Amateur Radio Assn. c/o F. S. Holden, P. O. Box 650, St. John's.
 New Zealand: N.Z.A.R.T., P. O. Box 489, Wellington.
 Nicaragua: Ernest Andress, YN1OP, Estacion Radio-difusora Bayer YNOP, Managua.
 Norway: N.R.R.L., P. O. Box 2253, Oslo.
 Republic of Panama: R. D. Prescott, Box 32, Panama.
 Palestine: Frank H. Pettitt, Catholic Club, Mustapha Barracks, Alexandria, Egypt.
 Peru: Radio Club of Peruano, Apartado 538, Lima.
 Philippine Islands: George L. Rickard, P. O. 849, Manila.
 Poland: P.Z.K., Bielowskiego 6, Lwow.
 Puerto Rico: Francis M. McCown, Family Court No. 7, Santurce.
 Portugal: R.E.P., Rua Das Chagas 35, Lisbon.
 Roumania: Victor Cantunari, Str. Matei Basarab, 3 bis Bucharest IV.
 Salvador: J. Frederico Mejia, 7a Calle Poniente 76, San Salvador City.
 South Africa: S.A.R.R.L., P. O. Box 7028, Johannesburg.
 Southern Rhodesia: *see* South Africa.
 Spain: U.R.E., Apartado 262, Madrid.
 Straits Settlements: *see* Malaya.
 Sudan: c/o Frank H. Pettitt, Catholic Club, Mustapha Barracks, Alexandria.
 Sweden: S.S.A., Stockholm 8.
 Switzerland: U.S.K.A., Bern.
 Tanganyika: *see* Kenya.
 Trinidad: *see* Antigua.
 Uganda: *see* Kenya.
 Uruguay: U.S.W.C.G., Box 37, Montevideo.
 U.S.S.R.: C.B.S.K.W., I Samoteahny, 17, Moscow.
 Venezuela: R.C.V., Torre a Madrices No. 8, Caracas.

SWL QSL Bureaus:

SWL acknowledgments are not handled by the Bureaus, but we are fortunate in having a bureau for those coming into the United States. Amateurs acknowledging United States SWL cards should send them as follows:

Eastern U. S. (corresponding to W1, W2, W3, W4, and W8): H. S. Bradley, 66 Main Street, Hamilton, N. Y.

Western U. S. (corresponding to W5, W6, W7, and W9): Warren B. Mayes, 1438 South 11th Street, Maywood, Ill.



The Type 902 is a new 2-inch low-voltage cathode-ray tube in the RCA line.



OPERATING NEWS



Conducted by the Communications Department

F. E. Handy, Communications Manager

E. L. Battey, Asst. Communications Manager

Station Distribution of operating amateurs determines the occupancy of all our amateur bands. Analysis of the interest registered by some ten thousand League members who have classified their individual operating uses of their assignments shows present day occupancy with high accuracy.

To show *trends* in the last year in amateur radio, we present, following, the figures that show the division of interest, and the per cent change in occupancy, plus or minus, in the territory indicated over the last 12-month period:

Bands (m) (Mc.)	1937-1938 Occupancy	Per Cent Change
160 1.7	9.63%	- 9%
80 3.5	27.05	- 6.5%
40 7	26.86	+ 6.64%
20 14	25.18	+ 5.54%
10 28	6.01	+27.5%
5 56	5.06	-17%
v.h.f.	.21
	100.00%	

The first observable fact noticeable in the above is that three of our bands may be classed as "major interest" bands. Those at 3.5, 7, and 14 Mc. contain nearly 80 per cent of all our operating! Increases are to be noticed in work in the higher frequency bands, 28, 7, and 14 Mc., where the sun spot cycle has brought continued favorable results and DX. There has been a continued gain in 28-Mc. interest, amounting to 25 per cent gain on the amount of ten meter operating observed a year ago. Ten meter interest itself was then a 584 per cent increase over the lower level of activity of two years previous! The gain in work in the 7-, 14-, and 28-Mc. bands was at the expense of some drop in 1.7-, 3.5- and 56-Mc. interest. This is of course no commentary on total activity which may be assumed to be substantially constant, but merely on the *division* of all recorded activity in our different bands.

It has taken three years for the extent of work on 14 Mc. to place this band in the "major interest" classification. In 1935 interest amounted to but 16 per cent instead of 25.18 per cent! A similar future for the 28-Mc. band might be predicted were it not for the important long term changes in transmission conditions which appear to follow the sun spot cycle.

Future trends may also depend on regulations and frequency allocation. For example, with 7050-7150 kc. open to Latin-American radio-telephone after July there will be shifts in utilization through the band, and possibly extending to other bands.

28 Mc. is still a "best bet"—for antenna experimenting, for local coverage with minimum spot-tiness and shadows, for DX with modest power, for operating with more elbow room or less congestion, for the satisfaction that comes from licking the engineering problems in circuits at this frequency. This band with five times as many kilocycles as our 14-Mc. band can handle ten times its present occupancy, and then we doubt if the congestion index will equal that of low-frequency bands because "skip" is more helpful in reducing "local" QRM.

Shortly after you receive this *QST*, A.R.R.L. directors will be bound for Hartford to attend their annual meeting at which League policy is formulated. As a member, it is your place to inform your Director, as your representative, of your opinions and ideas concerning any matters that affect your interest.

Your Director will appreciate it if you will send him your thoughts and observations. Unless your Director does hear from you, or you are in direct contact with your elected Director or his assistants and alternates, it will be difficult for him to know your wishes. This is then to renew our annual suggestion. After due deliberation on various issues before amateur radio, and considering the best future for the fraternity, as well as immediate desires, we suggest, if you have not already done so that you "write your Director." His address is on page 8 of this issue. Address him personally *care of A.R.R.L. Headquarters* after May first.

—F. E. H.

Briefs

Mr. Edward J. Day, formerly of WLM-W3CXL, has been appointed A.A.R.S. Chief Radio Aide to the Chief Signal Officer of the Army. His present address is Kernersville, N. C., where he operates WLMC-W4NG and is active in the Fourth Corps Area.

— . . . —

W9WIB reports that in the Mechanized Cavalry at Fort Knox, Ky., there are two radio operators: Key, a c.w. op. and Chinn, a 'phone op!

PRIZES FOR BEST ARTICLE

The article by Mr. Pierre Basset, F3LB, wins the C.D. article contest prize this month. Each month we print the most interesting and valuable article received marked "for the C.D. contest." Contributions may be on any phase of amateur operating or communication activity (DX, 'phone, traffic rag-chewing, clubs, fraternalism, etc.) which adds constructively to amateur organization work. Prize winners may select a 1938 bound *Handbook*, QST Binder and League Emblem, six logs, eight pads radiogram blanks, DX Map and three pads, or any other combination of A.R.R.L. supplies of equivalent value. Try your luck. Send your contribution to-day!

To See Ourselves as Others See Us

By Pierre Basset, F3LB*

SINCE I've been working as a merchant service op and in a big land station, I've learnt a tremendous lot of things, and I've gone through some rough but excellent schooling.

About a fortnight ago I came home on leave and, of course, I made a bee-line for the shack and began some knob-twiddling on the 14-Mc. band. I skipped half a dozen chaps CQing their arms off, and stopped on a couple of nice DX signals, almost on the same frequency. One of them was ending a QSO of the "RST xxx QRU" type. The other was calling CQ wildly, without a break—at last he stopped, out of sheer exhaustion I suppose, and incidentally heard the other chap calling him. They were both DX for me, but their QTH's were not more than 150 miles from each other. They gave each other a report of "RST 589 vy fb es ok es whatnot," which indeed sounded quite good considering the band and the distance involved, and started chewing the rag.

No. 1's bug certainly had no weights on—I even doubt whether it had a pendulum at all—and it certainly needed a high-speed ear to read his rather slow sending. I managed, somehow, to understand that he was using a fat kw., that his feeders were stuffed with healthy amps of r.f., everything was OK but he would now retune a wee bit his antenna tuner, and did you notice any change? The other waited a couple of minutes, probably thinking over the rather messy bit of paper he had before him, and, after calling a dozen times, answered: "R R R R OK OK OK but pse rpt hr vy QRM" (you see he meant QSD QRS but he had mixed up his Q code). Then he stopped to scratch his head, called again and signed off. No. 1 came back in due course with a straight key and one of the most crooked fists I've heard, and started his lecture all over again sending words twice. It lasted a full 14 minutes with never a break! After that I heard a string of

dots poured forth by a very ill-adjusted bug, and then "AR K." Quoth the other, "QRM pse rpt" and I cut off my receiver with a jerk and went for a walk in the nice cool air.

Why must these pests with their wasted kws. jam up a valuable channel in one of our best DX bands? All these people should be dragged to a special school where they would listen to the splendid snappy traffic on 500 kc. and the smooth balanced work of the big land stations. They might learn how to work efficiently, using BK, and asking for BQ after a long and partly QRM'd message. They might also be taught what is really accurate traffic at 30 w.p.m. After that course they would be delivered back to the air, and we should then hear some of this hi-speed traffic and those QSO's which sound just like fast conversations, and which are a joy to the heart of any true operator. And all that on our ham bands!

Unfortunately (many of us would say "happily") it means a lot of hard work and grim determination to become a good op. Nobody can say he has reached the highest standard, nor even a "very good" one, because the first thing you learn is to notice all your defects—and this is precisely what many of us need.

Briefs

W9ARL (1415 points) and W1SZ (1218 points) were the two highest scorers outside of South Africa in the South African DX Contest held in January. District winners in the U. S. are W1SZ, W2GNQ, W3DDM, W4DMB, W5BRR, W6HTT, W8JMP and W9ARL. South African winners: ZU6P, 46,310; ZT2Q, 44,415. Winners in other countries: VQ8AF FB8AA CR7AY VS7RP LU6BK LU7AZ HA8C IIT SPLAR SM5UM YR5AA G6RH HB9J PA1AZ YM4AA FA8ZZ EI5F ZL1HY K4DTH K6CGK ON4CO GM5YC VU2EO OK2XX D3CSC PK3WI 1Y1J VK2DG VK5LD VK7CM. This information was received by radio at W5BEN-9, Glenview, Ill., from ZS6DW.

— — — —

On March 6th W1GHQ, Boston, originated a message destined to the son of a person near death with heart disease, transmitting it to W1WI, Lexington, Mass., who had contact with a W6 in California, where the message was bound. Western Union and the telephone company had been unable to make delivery. On March 7th a reply was received that the son was on his way home. Although the fellow's exact address was unknown, amateurs succeeded in tracking him down. FB.



* 23 rue Felix-Faure, Le Havre, France.

Briefs

Inquiries are being received on this "Seek You" call heard so often in the amateur 'phone bands!

The Massachusetts Institute of Technology Radio Society (W1MX) assisted in the intercollegiate sailboat races held at M.I.T., November 7, 1937, by maintaining contact between the boat house and the three committee launches by 56 Mc. Three mobile rigs relayed racing results and fouls to the station on shore, which announced them over a P.A. system to the spectators. As there were eighteen college crews represented, the radio network greatly facilitated in tabulating results. The rigs were installed and operated by W1KRD, W2INQ, W2JOI and W7DGN.

W3EMJ and W3FSM will transmit test signals on 114 Mc. and 116 Mc. respectively on Tuesday, Thursday and Saturday nights from 11:45 P.M. to 12:15 A.M. EST. They are interested in hearing from other amateurs in the second or third district in regard to activities on "2.5 meters."

WSATT supervised the installation of a system of carrier current radio communication in the coal mines at Nellis, W. Va. Units are installed in each section of the mine and on each train motor. A control unit in the timekeeper's office connects with all other points.

When a tornado struck sections of Illinois on March 15th, amateur radio was on the job to do its part. Amateurs assisted in handling traffic at South Pekin, in the center of the stricken area, using portable W9PBI, W9LNY was on the job at Belleville, offering his services to the Red Cross. W9TCB, Highland, W9UZK, Woodriver, and W9DJG, Alton, brought portable equipment to Belleville. W9TCB set up 50 watt 1.75-Mc. 'phone rig at W9LNY's shack. W9UZK worked on 28 Mc. Others assisting were W9WDZ and W9PDD.

W6MRQ, who drives the Inland Stage between Reno, Nevada, and Bishop, Calif., was snow-bound with his stage and ten cars in the high Sierras near Leving, Calif. He had his emergency rig with him and hooked it up, using the baggage rack on top of the bus as an antenna. He made contact with W6IP at Cain Ranch, who relayed messages from the snow-bound tourists to the Mission Trail Net.

The Stuyvesant High School Radio Club, New York City, dates back many years. The club has been going strong for twenty-five years. With one of the first radio licenses, call 2YS, commercial operating was carried on within a radius of 30 miles. The transmitter was a 1/2-kw. spark. At present the club operates under the call W2CLE on 56-Mc. 'phone.

On March 15th the tenth game of chess by radio was played between W3CAB, Washington, D. C., and W8OKL, Pittsburgh. The player at the Washington end was Mr. J. B. Beadle of the Federal Communications Commission. Mr. B. H. Saxton, W8OKL, handled the Pittsburgh end single-handed. He resigned the game to Mr. Beadle in the 16th move.

The 4th Annual Hamfest and Banquet of the Nashville Amateur Radio Club, held in Nashville, Tenn., on January 15th, proved to be the most enjoyable affair in the club's history. Among those present were Mr. E. Ray Arledge, W5SI, Director, A.R.R.L. Delta Division, who addressed the meeting; Mr. J. B. Wathen, W9BAZ, Kentucky Route Manager; W9ARU, Net Control of the L. & N. Railroad Net; and Mr. R. O. Kessack, organizer of the net. Other visitors were W9SRJ, W9EI, W9TFK, W9KVE, W4HWN, W4DLQ, W4DLA, W4CHW, W4BWF, W4EBC, W4NL, W4AYE, W4BBC, W4DQH, W4DRI and W4AQF, from Illinois, Indiana, Kentucky, Arkansas, Georgia and Tennessee. Club members and the ladies brought the attendance to 75. The climax of the occasion was the prize drawing, which provided one or more items for all. The usual amount of "shack-visiting" preceded and followed the get-together.

BRASS POUNDERS' LEAGUE

(February 16th-March 15th)

Call	Orig.	Del.	Rel.	Extra Del. Credit	Total
W2HYC	96	60	1684	6	1846
W4PL	16	18	1400	5	1439
W6LJ	123	265	445	263	1096
W6MEO	290	316	132	316	1054
W7BQ	16	48	850	130	1044
W6IOX	6	128	622	124	944
W61MID	6	9	867	5	887
W3SN	62	127	627	—	816
W1TH	46	123	599	—	768
W9ESA	58	184	426	87	755
W1IWC	69	73	600	—	742
W7CCR	68	19	596	22	735
W2JHB	22	157	384	165	728
W6KFC	41	560	77	50	728
W3BYR	16	16	665	11	708
W8OJO	50	21	604	30	705
W1BSX	69	40	548	18	675
W4EHT	39	48	582	26	665
W6CDA	11	45	572	37	665
W6ITH*	97	227	168	169	661
W6BMC	16	30	594	19	659
W6DH	42	121	354	121	638
W6JTV	69	196	214	154	633
W6MQS	95	167	190	158	610
W6FYR	24	13	560	9	606
W3CIZ	24	65	447	65	601
W4CXY	52	36	484	25	597
W2CGG	40	27	506	14	587
W7FTL16	35	63	428	57	583
W61LW	31	29	502	20	582
W3EML	54	80	360	50	574
W1KMY	65	40	452	—	557
W1IOT	16	70	453	8	547
W5EOE	23	95	420	4	542
W9OUD	41	20	455	12	528
W1JYE	58	47	326	11	527
W3BWT	52	61	365	43	521
W5BN	14	55	220	220	509
W9AZR	37	63	404	2	506
W9EC	53	50	394	9	506
W9EKK	76	10	407	10	503

MORE-THAN-ONE-OPERATOR STATIONS

Call	Orig.	Del.	Rel.	Extra Del. Credit	Total
W5OW	143	139	1114	105	1501
W6MRT	178	103	362	78	721
W6CV	70	31	530	25	656
W1GOJ	28	77	497	47	649
W4AWO	26	47	336	40	649
W1JY	65	101	410	51	627
W9BNT	82	154	370	19	625

These stations "make" the B.P.L. with total of 500 or over. One hundred deliveries+ Ex. Del. Credits also rate B.P.L. standing. The following one-operator stations make the B.P.L. on deliveries. Deliveries count!

W3QP, 332	W1KH, 132	W9KJY, 114
W6LAK, 300	W7APS, 132	W6NLL, 110
W3DQH, 207	W6FQU, 131	W6ZM, 107
W9FTG, 198	W6LCX, 131	W1BFE, 106
W4WB, 193	W6BPU, 130	W1JGE, 104
W6PFR, 192	W6EAB, 130	W1EPE, 103
W6OQH, 180	W3EDC, 127	W6BWI, 102
W2HOZ, 163	W1JCK, 125	W6IGO, 102
W1FE, 160	W5CEZ, 123	W6CH, 100
W8UK, 148	W6MDQ, 120	W6HDR, 100
W2GVZ, 145	W5GPT, 117	More-than-one-opr.
W6RZF, 140	W6JWY, 117	W5FPO, 238
W6NXO, 134	W6OUU, 116	W5FEK, 129

A.A.R.S.

Call	Orig.	Del.	Rel.	Extra Del. Credit	Total
WLMI (W6GXM)	230	539	574	525	1868
WLMA (W8YA)	17	38	683	36	774

WLJG (W5ZM) made the B.P.L. on 106 deliveries.

MORE-THAN-ONE-OPERATOR STATIONS

Call	Orig.	Del.	Rel.	Extra Del. Credit	Total
WLM (W3CXL)	193	177	3036	64	3470

A total of 500 or more, or 100 deliveries Ex. D. Cr. will put you in line for a place in the B.P.L.

* All traffic handled by two-way radiotelephone.

O.B.S.

The following is a supplement to the list of A.R.R.L. Official Broadcasting Stations in October QST (page 50): W1INW, W1IWC, W1JY, W2GSC, W2IJU, W2JKG, W2KIF, W5AOZ, W5TO, W6KNZ, W7DIS, W8NNJ, W8RNO, W9GY, W91PN, VE3PE, VE5BJ

How's DX?

How:

Now is probably as good a time as any to explain a few things that don't seem to be straight in the minds of everyone. For example, a lot of fellows send in their DX Contest logs and request that a WAC certificate be issued on the strength of their Contest work. That's fine, and we're pleased to do it, but remember that your log can't be checked until the foreign stations send in their logs. So if you had only one Asian contact, for example, and that Asian doesn't send in his log, we won't be able to check for you, and you'll think we just don't care about your WAC. Therefore the best thing to do is to wait until the final results come out in *QST*—then you'll see whether or not all of the stations you worked submitted logs. All of which is a swell reason why some of those rarer countries should submit their Contest logs. Of course, you can still get a WAC by sending in the cards.

Last month we promised to forward cards to a certain DX station for you and also to give you his country. A lot of cards came in and were forwarded, but we must apologize for not telling the name of the country. We jumped the gun a bit, and promised to tell before we had permission to disclose the facts. So those mutterings under your breath are justified—we're everything you say we are.

Perhaps you'd like to know why we make so much of such a little thing. Well, every country isn't like the United States, and some of them aren't particularly fond of amateur radio. This fact doesn't occur to a lot of fellows, who blithely send cards addressed to "Amateur Radio Station Whoozis, Box 00, Unfriendly, Country," with the result that Mr. Undercover Ham gets investigated and possibly juggled. There are still countries where cards should be sent to the hams with absolutely no mention of radio on the envelope, and cards should never be sent except in an envelope. You'll be giving the foreign station a break if you observe these simple rules. And you'll be keeping some of that good DX on the air for us!

One more thing. Some of the QSL Managers are receiving cards from W stations to be sent to foreigners. The Managers are not for that purpose at all—they distribute incoming cards via the stamped envelopes you send them—and under no circumstances should they be imposed upon to the extent of being asked to handle outgoing cards. Send your foreign cards to the bureaus listed in this month's I.A.R.U. column.

Speaking of QSL's, a sweeping investigation of the QSL card racket is being made, and next month some startling revelations will be made. Don't miss it!

Where:

It's going to be a dirty trick to tell you about VR6AY (14,360 kc., T9 or 'phone) at Pitcairn, who has been rapping through, because if you haven't worked him by now your chances are slim. The dope we have is that WIBES, who has been doing the operating, is leaving there around the middle of April, and Andrew Young, the fellow for whom the gear was installed, won't operate in the ham bands. It may be that he will later on, but not according to the dope we got. If you were one of the many that did work him, send your card, a self-addressed envelope, and a 5-cent International Reply Coupon to VR6AY, Pitcairn Island, South Pacific W2LXY worked one on 'phone that looks good: ZC2OP (14,360 kc.) on Cocos Island. That is, if it isn't a phoney. They told Dorothy they were treasure hunting and that it took 40 hours to get back to Costa Rica by boat, but they don't read their *QST*. The Cocos Island they're thinking of uses the prefix "TI"; the Cocos Islands, ZC2, are out near Java, and 40 hours from there to Costa Rica is mighty good time, except for a flight of imagination! But good DX still crops up in spite of the wise guys. One that W1FTR pulled out of the hat the other

evening was FG8AH (7150 kc., T6) in Guadeloupe. He gets on around 10 p.m., E.S.T., and you'll be right in if you can speak French. W1FTR also worked VQ2FJ on 14040, T9. And W8CRA, who doesn't work much DX any more (because there isn't much he hasn't worked already), dove down and came up with a contact with FO8AA (14,200 kc.), in French Oceania Another slick one, worked by W1KKS, is YS1MS (14,080 kc., T6) in Salvador Sorry if we gave the impression last month that OXVC would count in the Century Club. We wanted to say that the guy was in Gibraltar and worded it ambiguously—the rules of the CC specifically say "no ships." VE3QB contributes the QRA: A. Nissen, Danish Salvage SS, *Geir*, Gibraltar Speaking of Gibraltar, W2GW wrote to his father, who lives at Gibraltar, and asked him to look up this ZB2A and arrange a schedule. W2GW's OM looked high and low, but the closest he came to finding him was hearing a story that one of the local radio service men had operated an unlicensed station a while and was caught. He was lucky to escape a jail sentence. W2GW thinks this was ZB2A and, although not a phoney, the chances of a QSL are about nil K6TE (14,300-14,375 kc., T8) at Wake Island is back on again. W2GTZ, W8LEC, and W8PHD were among those working him W7LD says that RUPUL and RUPULB were Soviet Search Expedition bases at Aklavik, N.W.T., and Point Barrow, Alaska, respectively, supplementing and correcting last month's information HR7WC is under cover, but cards will be forwarded by W2IYO W3FLH reports working UONG (14,290 kc., T9x) during the Contest. The QTH is Verchneindinsk, Asia W6KIP has a nice one here: VK9DM (14,300-14,400 kc., T7) in New Guinea G6WY and others report that PJ3CO (14,300 kc., T7) in Curacao is ex-PA0XX. You might send your card care of the Netherlands QSL Bureau, but don't send it to Curacao. They don't like amateurs down there! They don't like hams in Surinam either. That's why PZ1AB (14,390-14,490 kc., T7) is under cover. But he QSL's everyone, so wait for his card and you'll get his address. Or we'll give it to you if you'll drop us a card W5DAQ corrects our April statement about YV6AL, and furnishes his address: Pedro Yvelli, P.O. Box 35, Bolivar, Venezuela W6ITH worked one of those scarce Nicaraguans on 'phone: YN3BG (14,262 kc.). Reg. get the address as Dennis Gallo, P.O., Leon, Nicaragua Don't get too worked up about FN4FX (7150 kc., T8). He isn't in French India as the prefix would lead you to believe but somewhere off the coast of Brazil last time we heard Dunno for sure, but we imagine the ZZ2X and ZZ4M that have been kicking around in the 20-meter band are ships or too-smart W's.

When:

If we felt like being punny we could say that conditions were "DXcellent" during the Contest. Oh, well, a fellow should be allowed a little relaxation after having W6QD parked on top of him during the Contest! This isn't the place to go into details about the competition, but you'll be interested to know that Europeans heard, and were heard on, the west coast on 3.5 Mc. A brief glance through the logs on hand show no QSO's, however The 7-Mc. band was good, although we haven't heard of its bringing out any rare countries 20 and 10 were anybody's bands, and no matter where you were the stuff came through. W6DTB reports hearing VQ9AT on 20, and he worked HS1BJ on 28,270 kc., which is the first report we've had of 1BJ being on 10.

Except for that FG8 there doesn't seem to be anything very startling on 40 these days. But on 20, if you want to believe W1IYM, who really has no reason to kid us, you can grab off stuff like VR2FF (14,060 kc., T8x), XUBAM (14,110 kc., T9), VQ4CRO (14,080 kc., T9), SU2TW

(14,015 kc., T7c), ZBJJ (14,020 kc., T9), or CN8AX (14,025 kc., T7c) Or XU9KK (14,410 kc.) in Tibet, heard by WITW Or if that doesn't satisfy you, peek over the shoulder of W2GTZ and look at his log. It includes stuff like VP7NT (14,410 kc., T9), J2LK (14,315 kc., T8), J2LL (14,030 kc., T9), J3FJ (14,050 kc., T9), XU6LN (14,120 kc., T9), XU2BM (14,240 kc., T9), XU6MK (14,130 kc., T9), XU8AG (14,290 kc., T9), KA1AA (14,030 kc., T9), KA7EF (14,170 kc., T9), and others Or W8LEC's shoulder, whose log has U8ID (14,440 kc., T9), U6WD (14,420 kc., T8), XU8AP (14,100 kc., T8), and KAIYL (14,275 kc., T9) W8DOD and his 100 watts are still accounting for things like KAIQL (14,280 kc., T9), KA1AX (14,260 kc., T7), KA1SL (14,260 kc., T7), VS6AG (14,080 kc., T9), PK1VX (14,115 kc., T9) and CT3AN (14,120 kc., T9) W8OSL, who wants to start a crusade to make diathermy machines use p.d.c., adds J8CD (14,360 kc., T9), G8MF (14,350 kc., T8), and U6WB (14,385 kc., T6) W6NKT gives us SP1HH (14,280 kc.), ZU6E (14,070 kc.), XU7BB (7100 kc.), PK1PK (14,000 kc.), VS1AI (14,040 and 14,100 kc.), XZ2DP (14,030 kc.), ZS1Z (14,045 kc.) and ZU6K (14,040 kc.) J2LL (7100 kc., T9) came through on the east coast during the Contest W9CWW donates VU7FY (14,380 kc.) and XU8RL (14,340 kc.), while W8HCR adds VU2CQ (28,360 kc., 'phone).

Who:

W9WSY has a 4-wavelength Vee beam for Europe but that isn't all. He has a low-power record that is something: a QSO with G6YR on 10 meters using 22½ volts at 2 mils to the final 807, which figures out to be .045 watts! Lee was RST579 with 50 watts, 559 with 0.5 watts, and 439 with .045 watts. The only way to beat that one is to work somebody with the filaments turned off! Nothing could be called low power after that one, but YV5AO does well at that. He has kept a daily sked with K6MOJ for five months on 7 Mc., and he only uses 45 watts input Outside of Africa W9ARL was first and W1SZ second in last year's S.A.R.R.L. Contest, and ZU6P and ZT2Q finished 1-2 at home You would expect WIWV to pop up with one like this. He claims the unique record of being the only one to work a station whose call changed during the QSO. Yep, he was working ZU6C just before midnight on February 28th, but the South African calls changed over at midnight so he finished up working ZS6DM. He doesn't mention how he recorded it in the log! It's good to see people happy—sorta warms your heart and stuff. Like hearing that WIAPA, after only 18 years, has finally worked himself several Asians all at once and is in line for a WAC. Oh, boy, wait until Gil hears that those Asians he worked don't QSL! We received a radiogram from U3DZ to the effect that the operator of UPOL arrived in Moscow on March 17th. We don't know, but you might get a card if you sent yours care of the S.K.W. W7DXZ, the 7th District QSL Manager, worked WAC twice on 20 and once on 10 during the Contest, and now has 87 countries Another one of these fellows who works a lot of stuff but no J's is W2IYO, who has F18AC, ST2LR, FR8VX, U8IB, U9AC, VQ4KSL, ZPIAX, ZS3F, and FQ8AB among his latest. The total is 88 countries now, and will be higher when he raises some of the stations he has been hearing, which include VQ3FAR, TG2A, VR5CD on 20, and VU2CA on 10 Who has the dope on CR6PG? Sounds too good to be true on 14,415 kc. HK5JD (7090 kc., T9) only needs New Hampshire for WAS, and requests that some of the boys up that way give him a shout W9AIC can't understand those eight good years during which he never worked an Asian. He worked U9AW, U9AV, U9ML in 19 minutes during the Contest and U9BC shortly after it! If you've wondered about those VP3's not coming back to you on c.w., the answer, according to WITS, is that they all use supers with no BFO's. However, this is not advanced as an

argument for T4 notes among W's! VP3BG is on 14-Mc. 'phone, VP3TEST is on c.w., and VP3NV is on 28-Mc. 'phone occasionally W7AYO had a tough break in the DX Contest. A bad head cold left him deaf for two days. (We called plenty of fellows who must have had head colds!) Stan has 81 countries, and some of the latest are CR7AC, ZS2AL, U5AH, VP9L, J8CHE, I1KKN, SM7YE, and GW6JW W9KG claims he didn't have much time for the Contest, but he worked 24 Europeans on 10 one Sunday morning at 25-30 w.p.m. without a repeat. Not bad, and neither are YN1AA (14,404 kc., T9), VU2AN (14,110 kc., T8), and FM8AD (3515 kc., T9). Keat's latest countries VK6MW (14,110 kc., 'phone) has a rotatable beam I7AA has moved into the band, and last we heard could be found around 14,340 kc. . . . VU2AN has moved and has no a.c. now, with the result that his power is only 10 watts, furnished by a small gener-



HERE'S SOME DX FOR YOU
A shot of the shack at SVIKE, showing SVICA at the rear left, SM7YT, SUIKG, and SVIKE in the middle row, and SVIAZ wearing the glasses. The others are friends and relatives.

ator, according to W8OSL W2IOP is just an old hold-out for 7 Mc. He had much better going there than on 20, he says, and worked 22 countries there the first night of the Contest W2GVZ worked PX2A during the tests but is kind of doubtful as to his authenticity.

That's about all for this month. Right now we're going to do the conventional thing and call CQ on 40 for about 15 minutes before we eat dinner. It's too much trouble to warm up the receiver too!

—W1JPE

Hidden Transmitter Hunt

The Richmond (Va.) Short Wave Club staged a Hidden Transmitter Hunt on Sunday, January 17th. The club president, W3FMY, assembled a 30-watt 3.9-Mc. 'phone rig and, with the help of W3CGR, installed same at a secret location. Participants gathered at W3FJ's shack in the center of town and started out from there. Twenty-five took part in the hunt; ten cars were used. All types of receivers were used, from one tube regenerative to all-wave broadcast sets; the latter were plugged in at various locations to check volume. Many used loop antennas. W3ZU and W3BPR located the hidden transmitter in about one hour, using signal strength as the only indicator. A two-tube battery set was used with criss-cross wire in top of coupe for antenna. W3WS came in second. The outstanding fact that impressed those taking part in this activity was that a simple battery-operated receiver, in a moving car, under adverse conditions (it had just rained hard prior to the "hunt" and the noise level was high from power lines, etc.) is capable of locating a transmitter in a comparatively short time. It proves that even the most carefully hidden "bootleg" station can be located. The Richmond gang plans further "hidden transmitter" hunts with improved equipment and technique.

DX Century Club

THIS month we welcome four new members, W8DWV, W9ARL, EI5F and W4CBY. Nice going, fellows! Century Club membership now totals 20, and several in the "below 100" group are rapidly pushing toward the century mark. It won't be long now for G6CL and W8JMP, each having 99. Note that G6WY has reached 130!

The Century Club and "75-or-more" listings represent the only official confirmed "countries worked" list in existence. There is no guesswork about the records indicated—confirmations have been presented and checked. The business of QSL's takes on a more important aspect when you consider that the confirmations you send out may be used to substantiate Century Club claims. Remember that the next time a DX station asks you for a QSL—it may be the one he needs to place him in the list! Operators in the "rare" countries particularly should realize this.

Check over your confirmations in accordance with the January QST list of countries and send them in as soon as you can present 75-or-more. When sending your confirmations, please accompany them with a list of claimed countries and stations representing each country to aid in checking and for future reference after your confirmations have been returned to you. Please send postage to cover the return of the confirmations. The DX Contest, recently concluded, should help many increase their totals. If the fellows you worked send in logs, we'll check same for confirmations, provided you have sufficient additional confirmations to make the total 75-or-over.

MEMBERS, DX CENTURY CLUB

	Countries
H. A. Maxwell Whyte, G6WY (No. 5).....	130
Frank Lucas, W8CRA (No. 1).....	120
John Hunter, G2ZQ (No. 6).....	118
Jefferson Borden IV, W1TW (No. 3).....	117
Clark C. Rodimon, W1SZ (No. 7).....	116
Douglas H. Borden, W1BUX (No. 2).....	115
Henry Y. Sasaki, W6CXW (No. 4).....	111
Don H. Mix, W1TS (No. 9).....	109
Harry G. Burnett, W1LZ (No. 10).....	109
Walton H. Bostwick, W2GW (No. 11).....	108
Reeve O. Strock, W2GTZ (No. 12).....	107
C. E. Stuart, W6GRL (No. 15).....	107
Jean Lips, HB9J (No. 13).....	103
Keat Crockett Jr., (No. 16).....	102
John Marshall, W9ARL (No. 18).....	102
Guy Grossin, F8RJ (No. 8).....	101
E. L. Walker, W8DFH (No. 14).....	100
Frances Walcsak, W8DWV (No. 17).....	100
H. Hodgens, EI5F (No. 19).....	100
B. W. Benning, W4CBY (No. 20).....	100

The following have submitted proof of contacts with 75-or-more Countries:

G6CL..... 99	W6FZL..... 88	W4CCH..... 81
W8JMP..... 99	W1JPE..... 87	W3EPR..... 80
W6HX..... 98	W2GVZ..... 87	W4AJX..... 80
W9PST..... 97	W3JM..... 87	W5VV..... 80
W1DF..... 96	W5BB..... 87	W8DGP..... 80
W8LEC..... 95	W6ADP..... 87	W4CFD..... 79
W8OSL..... 95	W9AEN..... 87	W8CJJ..... 78
W1ZB..... 94	W6GAL..... 86	W8FJN..... 78
W8OQF..... 94	W8EUY..... 86	W9FLH..... 78
W9KA..... 94	G2DZ..... 86	W1BFT..... 77
W3EVW..... 93	W1RY..... 85	W3ATU..... 77
W9EF..... 93	W4DRD..... 85	W3EPU..... 77
W1DUK..... 92	W2HHF..... 84	W8ADG..... 77
W1WV..... 92	W8KKG..... 84	W8BSF..... 77
W9ADN..... 92	W6BAM..... 83	W9UM..... 77
W1ZI..... 91	W8BOX..... 83	FB8AB..... 77
F8RR..... 91	VEZEE..... 83	W1EWD..... 76
W2CT..... 90	G5QY..... 83	SU1WM..... 76
W1CC..... 89	G5RV..... 83	W3BVN..... 75
W3BES..... 88	G6CH..... 82	W5ASG..... 75
W3EVT..... 88	W2CYS..... 81	

New Members, 20-Year Club

B. B. Greenleaf, W6VU: "It was along about 1912 that the bug started after me. My first licensed call was 9PQ, which was held until I strutted away to the big War. On my return, and when the ban was lifted, I was again on with the call 9KI. I cannot remember when I lost that call, but for a couple of years or so I traveled with an orchestra. I again returned to radio along about 1924 with the call 9DVX. In 1929 the California fever got me and at that time I was issued the call I now hold, W6VU. I would like to hear about a lot of the old-timers, especially in the middle west. Some that should be roused out of their sleep are old 9GC at Lanark, Ill., and C. H. Fahrney of Polo, Ill. Of course we would like to hear about Johnny Clayton, old 5BV of Little Rock, Mo. B. West of Lima, Ohio, and perhaps you can rouse 5ZA, in Roswell, New Mex." . . . **Arthur A. Hebert, W1ES, A.R.R.L. Treasurer:** "Started in amateur radio in 1903 working or trying to work a coherer that would not decohere. First real transmitter in 1908, with call AH, consisted of one-inch spark coil, all E. I. Co. parts. In 1912 obtained Comm'l First Grade license and amateur station call was 2JM (the wife's initials), and had graduated to a 1-kw. spark rig. The longest transmission of that year was 25 miles, using Galena detector for receiver. In 1914 joined the A.R.R.L. and have been connected with it ever since in official capacities. Have had all types of receivers and transmitters, changing as new developments took place. Calls held: 2JM, 2ZH, 2MP and present W1ES." . . .

E. B. Sisley, VE3UX: "Wonder if I can qualify for the 20 Years-a-ham Club or something? Interest started in 1913, and here are some memories: E. I. Co. catalog, staying up late to hear NAU, NAX, NAR, etc., on crystal. Transmitters shut down for War. Joined wireless section of R.A.F. in 1918. Heard first 'phone sigs, from American-built sub-chasers coming down the lakes in 1918. Licensed end of 1918 as Can. 3BF with $\frac{1}{2}$ -kw. spark from ozone machine, and double filament audiotron detector. QRT college 1920-26. Licensed 1926-29 as Can. 3HJ. Present call of VE3UX received in 1930." . . . **Guy A. Stewart, Jr., W2JRG:** "I started foolin' with wireless back in 1909 in Mt. Vernon, N. Y. The first call I used was GS, and my first license from the Dept. of Commerce was 2AKA. I think the ticket came in 1915. Since going back on the air in April, 1936, which was 19 years to the day from the time I stopped in 1917 when War was declared, I have run up against a flock of hams (particularly on 56 Mc.) who knew the old days of spark coils, rotary gaps, the helix, vario-couplers, galena detectors, etc.—and long 4-wire antennas. I still get a great kick out of wireless, ah, excuse me, radio, but not quite as much fun as in the old days when a kw. in a Thordarson reached Denver one night. But it's still a great game." . . .

Alex H. Knights: W2DZA "Received amateur license on March 30, 1914, at Brooklyn Navy Yard and received station call 2TW. After war received call letter 2UJ. Tube transmitter put on the air on this time using VT2 tubes and chemical rectifiers. Used c.w., i.e.w., and 'phone (Loop modulation). Active until around 1924 when I 'sold out.' Bitten by the bug again in 1932 and received present call W2DZA and have been more or less active ever since." **T. J. Rigby, W7COH (S.C.M., Utah-Wyo.):** "First call in 1906 was 'R' then when they started using 'R' instead of 'OK' (all Morse code then) switched to 'TJ' and used this until Gov't gave me 6DU in 1912 and W7COH in 1930. In 1912 established what so far as I know the first communication from an airplane in flight to ground station. Phil Parmelee, flying a Model 'B' Wright biplane, using a 2-inch spark coil wired to a push button on the right-hand control for a key, sent the following message to me located on the grandstand. He was over Santa Anita race track about 17 miles, as I remember. 'Greetings everyone. Tell Ferris I am going to open the meet in San Francisco. I am coming back now. —Phil.'" **Glen Katzenberger, W7DVS:** "I learned the code in 1915 and the first transmitter on the air was a 1-inch spark coil, home-made condenser constructed of old photographers' plates and a William B. Duck helix. The station was dismantled during the War by government inspectors and put in a large canvas bag which was properly sealed. After the War the next transmitter was a 1-kw. Thordarson trans-

former, large plate-glass condenser, rotary spark gap and ribbon wound helix. Receiver was a Paragon with one detector and two stages of audio, also a William B. Duck loose coupler for the purpose of listening to the old well-known time signals of NAA. In 1921 was experimenting with c.w. using a Marconi VT1 tube. (First c.w., by the way, was cross town QSO by placing key in the antenna lead from receiver.) 1922 found the station with a 20-watt c.w. rig using 4 UV202 tubes in parallel with a chemical jar rectifier. My proudest possessions today are pictures of these old sets. Operation up to this time was in Springfield, Ohio. In 1923 moved to Seattle, Wn., obtained the call of 7QL. Calls held from 1915 to present date are G.K., 8BEN, 7QL and W7DVY." **Wilson E. Weckel, W8QDQ:** "I became interested in amateur radio in 1913 spending my timelisting to the hams on 200 meters and commercial traffic on 600 meters. In 1915 I received my first license and call 8AQW which held until the War started. Of course I did my duty to make this country safe for democracy by enlisting in the Naval Reserve Force. After I received my discharge in 1919 I took and passed the examination for a commercial license. Then, in November, I was issued 8AL as call letters. Used spark at first, then with the advent of c.w. used it until 1930. Working for R.C.A. they moved me to Philadelphia, and while there my license expired and of course my call 8AL. Then the depression started and I moved back home to Canton. Two years ago I became afflicted with a nerve ailment which makes walking extremely difficult, so I applied for a Class 'C' license and now I have had W8QKQ for the past nine months and it sure helps me to pass the time." **David Talley, W2PF:** "In October, 1915, visited a fellow school chum and heard NAH on a galena detector and the time signals from NAA. Immediately persuaded my father to get me one of those two-slide tuning coil receiving set complete. In 1916, got a 1/2 inch spark coil on the air under call 'DT.' In February, 1917, passed my amateur operator's license, but was not issued a call because of impending war with Germany. Closed down station in April, 1917 until February, 1919, when receiving was again permitted. Obtained call 2PF (which I still have) when transmitting was allowed in December, 1919. Soon replaced 1/2-inch spark coil with a 1/2-kw. transformer and added synchronous spark gap in 1920. Bought Grebe CR-13 receiver in 1921. Installed a.c. c.w. in 1922. Sold spark set when I moved in December, 1922, and made-up a 50-watt c.w. transmitter. Installed crystal control in 1924. Joined A.A.R.S. in 1926 and was assigned Army call WLN-1 in 1929. Assigned present Army call WLNA in 1930. Have been O.R.S. since those appointments were first issued and still am O.R.S. No. 10 in Hudson Division. Have been O.R.S., O.O., R.M. and Asst Director." **Wm. F. C. Hertz, Jr., W1FJE:** "I first became interested in Radio late in 1912 or early in 1913. About 1916 first license was secured with assigned call of IABU. Secured Commercial 1st grade in Aug. 1917, and went to work for R.C.A. Sept. 1917. Resigned from R.C.A. in Nov. 1927. During my commercial experience I kept up with ham radio, visiting many hams not only in this country but in foreign countries as well. Also was a visitor at radio clubs in many parts of the world. Secured 1FT in 1927 and W1FJE in 1932." **R. G. Sidnell, W8GYR:** "I started wireless in 1909, using a tuning coil (made from mother's rolling pin), a couple of worn out arc carbons with a darnin needle across them for a detector, and a no-account telephone receiver hooked up to all the various sizes and kinds of wire available as an 'aerial.' For a transmitter at that time, had a Ford spark coil and some batteries of questionable virtue, no tuning. When license became necessary, I took out a first-grade amateur and had call letters assigned 8KS. Shortly, thereafter, had a commercial license and worked for the Marconi Company on the Great Lakes. During the War was in the Navy for Radio duty, keeping the commercial license valid during that time. Immediately after leaving the Navy, set up a 'ham' station again, at that time with a synchronous rotary spark transmitter and a regenerative receiving outfit. Call letters at that time were 8CBW. Inadvertently allowed that license to run out, but re-licensed as soon as a tube transmitter was

constructed, being assigned call letters 8AEA. Interest lagged again, but in 1930 again set up a 'ham' outfit and was assigned call W8GYR, which has been in effect ever since." **S. J. Mallory, W2CJX:** "Have been a ham since 1914 when signing KN—using spark coil and double slide tuner—DX 12 miles. Then the War and shut down followed by a fling at ship oping. This until late 1921 when returned to ham waves as CJX my present call. Just came across my first O.R.S. certificate dated in Sept. 1922. Used a 1+ kw. 'coffin' in those days, and the neighbors all but ran me out of town until c.w. came along. Settled with a 500-cycle i.c.w. HI. All peaceful now due to wave traps I installed and use 14 Mc. most of the time." **D. A. Hoffman, W8FRY:** "Started as a licensed amateur: 1914. First call 8ADU. Other calls: W8UX, W8FRY (present call). Started in Akron, Ohio. First outfit: E. I. Co. and Duck Co. apparatus. One-inch spark coil and loose coupler, galena detector, Brandes phones, 4-wire antenna with Electrore insulators. Later had first rotary spark gap and first Audiotron detector in Akron (tube with wires fastened to binding posts). Was *QST's* first cartoonist (for 8 years). Drew illustrations for early *Old Man* and *Young Squirt* stories, also occupational cartoons. Originated the *QSL* card fad through suggestion printed in *QST*. With Jack Gritton, organized first Akron Radio in 1914. Served in Signal Corps, U. S. Army, for 10 months during latter part of World War. Stationed on Mexican Border. Emerged as corporal. Following War built 5-watt broadcast station with regular programs nightly, mostly records. This was one year before KDKA started under those call letters. Believe played first game of checkers by radio-phone ever played, but date and other proof lost. Still have the checker board, however! In 1930 enlisted in U. S. Naval Communication Reserve. In 1932 received commission as Ensign. Now Executive officer of Youngstown Unit U.S.N.C.R. one of most active units in the nation. Asst. Editor 'QRX,' Ninth Naval District U.S.N.C.R. paper. Hobby: Building 5-meter mobile rigs. Married. No children. President of Youngstown 5 and 10 Meter Club. Biggest surprise of life: When read that Maxim was the 'Old Man.' Always thought it was someone else."

Briefs

One hundred hams, YL's, YF's and S.W.L.'s registered at the Oakland County Radio Club hamfest held November 24th at Sylvan Lake, Pontiac, Mich. W8DPE, Michigan S.C.M., was master of ceremonies. The program included a 56-Mc. hidden transmitter hunt, won by W8QLZ, various talks and sound movies. W8NIT's YL handled the door prize drawing and presentations. At 7:00 p.m. a chicken dinner was served, after which the gang wound up activities with a general rag-chew session.

 Many operators might well ask themselves the following questions, suggested by W6DHS: (1) Is my operation a credit to amateur radio and its traditions? (2) Am I using the present accepted form in message handling? (3) Am I

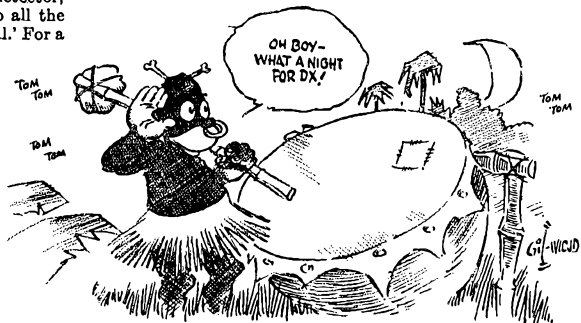

posted on the latest revisions of operating procedure? (4) Do I give a contacted station an honest report, or am I afraid of offending him? (5) Do I send QRM, OM, when he is sending too fast for me? (6) Do I come back with R R OM, when I'm not really sure I received what he sent correctly? (7) Do I hold the key down for testing purposes during the periods when the air is most congested? (8) Do I ignore reports that my note is not of the proper quality, or that I have key clicks? (9) Am I sure that my frequency is within the amateur bands?

— . . . —

W3ESX (14366 kc.) invites QSO's with fellows desiring to converse in Spanish. He has already enjoyed some interesting contacts in Spanish with W3GET, W3BUI, W2IGM and W2JTC. K4ESH (14350 kc.) also offers QSO's in Spanish.

— . . . —

F.C.C. DISCIPLINARY ACTIONS

On March 8th, the F.C.C. *en banc*, acted in cases before it, as follows:

William S. Letch, Moneta, Calif. Suspended for a period of 6 months, amateur radio operator license with Class B privileges, because licensee violated provisions of the Communications Act and the Rules and Regulations of the Commission as follows: Made a false entry in station log, in violation of Rule 386.

Guy A. Stewart, Jr., Westchester, N. Y. Amateur radio station license W2KLI revoked, because applicant made false statements with regard to the ownership of transmitting apparatus to be used in proposed station, in violation of the Communications Act and Rule 386 of the Commission's Rules and Regulations.

Louis G. Fabian, Pittsburgh, Pa. Suspended operator license with Class B privileges, for a period of 1 year, because licensee permitted another person to maintain and operate an unlicensed radio station on the premises identified as the authorized location of amateur station W8QJM, of which Fabian is licensee, and permitted such unlicensed radio station to be falsely identified in radio communications by call letters W8QJM, heretofore assigned to him by the Commission, in violation of the Communications Act.

Harry L. DeBiddle, Gardena, Calif. Suspended operator's license with Class B privileges for a period of 6 months, because licensee made false entries in his application for modification of amateur station license; and made false entries in the operating log of his station W6NDE in violation of Rule 386 of the Commission.

On March 22d, the Commission took the following action:

Robert Earle Haupt, Carlsbad, N. M. Suspended amateur operator license with Class B privileges, for a period of 6 months, because he operated his amateur station without possession of his station and operator license in violation of Rule 221b; he operated his station on amateur frequencies for which he was not licensed in violation of Rule 377.

Attend a Hamfest

May 7th, at Syracuse, N. Y.: The Central New York Radio Club of Syracuse, N. Y., will hold its annual get-together at the Turn Verein Hall in that city on Saturday, May 7th. Registration begins at 3:00 p.m.; an auction will be held at 6:00 p.m. Bring your surplus parts and sell them or swap them for something you need. An interesting program is planned—a minimum of dry speeches, maximum of entertainment. Army and Navy meetings will be held. Dinner is scheduled for 7:00 p.m. Prizes, of course! W8CYT is chairman of the hamfest committee.

May 14th, at Milwaukee, Wis.: The 16th Annual QSO Party-Hamfest of the Milwaukee Radio Amateurs' Club, Inc., will be held at the Milwaukee Athletic Club on Saturday, May 14th. Reservations and complete information may be obtained from the club secretary, Fred Seifert, W9EFX, 3077 North 39th Street, Milwaukee.

May 15th, at Ypsilanti, Mich.: Michigan-A.R.R.I. Hamfest, under the auspices of the Detroit Amateur Radio Assn., is scheduled for Sunday, May 15th, at the National Guard Armory, Ypsilanti. Price, 50 cents. 10:00 a.m. to 6:00 p.m., with prizes, speakers, eats, and special entertainment for the YF's and YL's. Advance purchase of tickets from the club secretary (W8MV, Frank Beechler, 18667 Waltham Ave., Detroit) gives a chance on extra prizes.

May 22d, at Charleston, W. Va.: The "Charleston Hamfest" will be held Sunday, May 22d, at the Ruffner Hotel. Meeting at 1:00 a.m. of A.R.R.L. Net, A.A.R.S. Net and Emergency Corps members and friends. Hamfest proper

starts at 1:00 p.m. and continues until after the banquet and prize drawings. There will be plenty of prizes, including grand prize of an A-1 communications receiver, and plenty of entertainment. Speakers will include such well-known men as Col. Clyde L. Eastman, Signal Officer, 5th Corps Area, L. G. Windsom, W8ZG-W8GZ, "Pat" Hoffmann, W8HD, West Virginia S.C.M. and W8KKG, former S.C.M. Come and bring the family!

August 6th, at Jenny Lake, Wyo.: August 6th, 7th and 8th have been selected for the Sixth Annual WIMU (Wyo., Idaho, Mont., Utah) Hamfest at Jenny Lake, near Moose, Wyo. Jenny Lake is situated at the foot of the Teton Mountains in the Teton National Park, where there is plenty of motor boating, swimming, horseback riding and fishing. Nearly all who attend the meeting come prepared to camp, although there are cabin facilities. There is little formality to this get-together, its primary purpose being to renew old acquaintances, discuss all phases of amateur radio and enjoy an outing. All amateurs are invited to attend and should feel free to bring their families; entertainment is provided for the ladies and children. Further details may be obtained from H. D. McCuiston, W7AYG, or L. E. Crouter, W7CT.

Hungarian DX Contest

The second Hungarian DX Contest will be held on the four week-ends of May under the auspices of the National Union of the Hungarian Shortwave Amateurs. Each period starts Saturday at 1400 GT and ends Sunday at 2400 GT. Six figure serial numbers will be exchanged, one point for receiving, one point for sending, two points if numbers are handled successfully both ways. The serial numbers will be made up as follows: The first three numbers will be the RST report of the station worked, the last three will represent the number of the QSO; thus, in the fifth QSO the number might be 579005, in the one hundredth QSO, 579100, etc. On any given week-end the same station may be worked more than once, if on a different frequency band. The same station may be worked on each week-end. Total points are to be multiplied by the number of different HA stations worked, QSO's with the same station on a different band counting an extra multiplier. At least one participant in every country, but not more than three, will receive a certificate for his contest work. Each district in the U.S.A., Canada, Australia, New Zealand and the Union of South Africa will be considered as separate countries for purposes of the awards. A complete log, containing data on the transmitter and receiver, list of QSO's (with time, call, serial numbers, frequency band, points, etc.) should arrive at the Union not later than August 1st; address: Lendvay-u. 8., Budapest, Hungary. Participants are also asked to send their QSL's for the stations worked along with the logs.

Polish DX Contest

P.Z.K., Polish Section, I.A.R.U., announces a DX contest for Polish amateurs and those throughout the rest of the world. The competition starts at 0001 GT, May 1st, and ends at 2400 GT, May 15th. Polish stations will give a serial number, which must be received correctly and reported via QSL card. If the number is not received, or incorrectly received, or the QSL card is not sent, the QSO will not count for either competitor. Points will be scored as follows: VE1 and VE2 claims six points for each complete SP QSO; W1, W2, W3, VE3 and W8 claim seven points per QSO; W4, W9, VE4 and VE5, eight points; W5 and W7, nine points; W6, eleven points. Points for 28-Mc. QSO's will be quadrupled. Each station may be worked once only on every amateur band. A certificate will be awarded to the highest scoring competitor in each country. The three highest scorers outside of Poland will receive special certificates and prizes. QSL cards should be sent to Polski Zwiasek Krotkofalowcow, Biuro QSL, ul. Bielowskiego 6, Lwow, Poland. Cards received after September 30th will not be considered.

— . . . —

W9ZQB's high school basketball jersey carried number 88; he recently played in a game with W9WVD as referee.

Station Activities on page 100



CORRESPONDENCE

The Publishers of *QST* assume no responsibility for statements made herein by correspondents

"It Can't Happen Here . . ."

305 East Ninth St., Upland, Calif.

Editor, *QST*:

We have had a flood out here in Southern California and a number of places were cut off from the outside world. Here at Upland . . . several hundred people were isolated for days while attempts were made to get in touch by various methods.

One of our local police officers is a good friend of mine and he knew that I had an amateur station and was active. He came to the house one night just after the peak of the flood and asked if I would go up to Camp Baldy with him as both radio man and doctor. Of course I agreed, and started out to see what I could do in the way of assembling radio equipment. . . . I hunted around until about 2:00 A.M. and called a number of amateurs and others out of bed trying to get some parts and power, growing hourly more ashamed of myself and my confrères for not being ready. . . .

Then word was brought that arrangements had been made for some amateurs to bring some portable equipment into town. . . . I waited anxiously to hear from the two operators, and no word was forthcoming. Finally I went up the hill to see what was going on and found that the base station was set up, of all places, immediately under the big Boulder Dam power lines and the ground operator was sitting around complaining of the high noise level and drinking coffee! We proceeded to move him out to a place where he could hear. Even then his portable generator was making so much noise in the receiver that he could hear no weak sigs. I was amazed. . . .

You have probably gathered by now just what I feel so deeply about. It is the old story. I have been reading in *QST* for a number of years the advice of those who have had more experience than I about getting QRR equipment ready. I always thought that was fine for the large centers of population, but it can't possibly happen here in this little country town. It *did* happen, though, and I wasn't ready and no one else was, either. . . .

One thing is certain. We may never have another flood or earthquake or disaster of any sort here in this section, but there will be some good emergency portable equipment prepared for use here or wherever it may be needed, and it's going

to be built and tested to be sure that it will establish the communication that is necessary at these times.

—Robert I. Hodgkin, M.D., W6OOS

Standardized Specifications

27 Avondale St., Valley Stream, L. I., N. Y.

Editor, *QST*:

At a recent meeting of the Nassau Communications Association . . . a very heated discussion was had concerning radio amateur equipment specifications. This letter is written with the thought in mind that a better understanding can be had between amateur and manufacturer, to the benefit of both, if the following information applied:

All equipment should be stamped so that at any time the user may have its specifications available without the trouble of looking for serial numbers and data sheets, or writing the manufacturer. . . . It is apparent that it would be next to impossible to attempt such a thing with vacuum tubes, and it is hardly necessary since some form of standardization is used here and almost every amateur handbook has charts of characteristics. Small fixed resistors, color coded, would also be eliminated since some form of standardization is also used. With respect to other amateur equipment a dire need is felt for accurate detailed specifications. . . .

We believe detailed specifications should be stamped on the following equipment. These specifications should be set forth in advertising and mail order catalogues for the benefit of those amateurs who are not located within traveling distance of distributors.

1. Chokes:
 - a. Inductance rating
 - b. Type (swinging or smoothing)
 - c. Maximum working voltage
 - d. Maximum breakdown voltage and amperage (insulation voltage between core and winding)
 - e. Maximum and minimum current ratings
 - f. Alphabetical code identification of noise effect when used under operating conditions (talk back)
2. Condensers (fixed paper or oil impregnated)
 - a. Voltage working
 - b. Voltage surge

- c. Actual capacity (ofttimes when a replacement type is purchased the label gives the capacity of its electrolytic counterpart, which is not the capacity of the actual condenser purchased)
- 3. Condensers (variable)
 - a. Capacity (actual), maximum and minimum
 - b. Breakdown voltage at various standard frequencies
 - c. Specific statement as to the type of insulation
- 4. Power Transformers
 - a. Primary voltage and current (maximum and minimum at standard temperature rise and safe operating temperature)
 - b. Voltage, secondary
 - c. Amperes, secondary
 - d. Alphabetical code identification of noise effect when used under operating conditions (talk back)
- 5. Audio Transformers
 - a. Type of shielding
 - b. Alphabetical code identification of response and curves governed by a standardization chart
 - c. Clearly marked terminals

It is our belief that if such a system as above outlined were initiated in good faith by the manufacturers as a group, it would bolster their sales of better equipment and be a saving to the amateur, who would purchase the correct component in the beginning instead of buying a piece of equipment which causes him dissatisfaction and annoyance and disagreeable relations with both dealer and manufacturer. Such specifications, firmly affixed to equipment, would also make it possible to identify them for future use when their present need is not felt.

We would request that you publicize the above thoughts with the idea in mind of having honestly manufactured merchandise honestly presented.

—*Nassau Communications Association*
David Lewis, W2IYO, Secretary

Gyp B.C.L. Sets and QRM

Grafton High School, Grafton, W. Va.

Editor, *QST*:

It is generally known that the F.C.C. and other officials are being deluged with complaints concerning amateur interference with broadcast reception. Although the hams, in most cases, may be the innocent victims of poor B.C.L. receivers, the politicians know that the B.C.L.'s have more votes than the hams and so, right or wrong, we are bound to suffer eventually.

The situation has been brought to my attention, locally, by a couple hams on 160-meter 'phone. Being the physics teacher in the local high school and teaching classes in radio fundamentals to student and adult groups, I have been picked out by numbers of the B.C.L.'s as the proper person to tell their tale of woe. As second harmonics of superhet oscillators are hard to explain to the average man and he usually thinks that his radio is above reproach, it makes a tough job.

In the advertising and sales of radios, it is necessary to use some method of describing the receivers and the trade has continued the old custom of rating a machine by the number of tubes, which doesn't mean much with the introduction of multi-element tubes. But the buyer now looks for the radio with the greatest number of tubes for the fewest dollars. This trend was brought to my attention in the last couple weeks by examining several machines in repair shops and "gyp" stores. Dummy tubes are being used merely as resistors with the tube painted to conceal the contents. A 12-tube _____ in a repair shop contained 5 dummies, an 11-tube _____ in a gyp store contained 4 similar tubes with numbers on them which were evidently phoney. Competition with sets like these has put the reputable manufacturers on the spot in their attempts to build sets of "modern design."

Could the F.C.C., through the Bureau of Standards or some high ranking research organization, set up standards for approving the design and operation of receivers on much the same basis as the Fire Underwriters test and ap-

prove equipment? Then let the public know that when they buy a receiver which does not meet the standards, they are doing so at their own risk and complaints on its troubles would be ignored by the R.I.

Although this would not eliminate the offending receivers now in use, it would show the public, more forcibly than anything we can say, that something has been wrong with the present crop, in addition to opening a market for manufacturers who are not ashamed to put their name on their finished product.

—*Lynn Faulkner, W8NTV-W80FD*

Code Test Compulsory

Chicago, Ill.

Editor, *QST*:

The following may be of interest to persons putting forth the idea of a no-code amateur license examination.

Paragraph 3, Article 8, of the General Radio Regulations, annexed to the International Telecommunications Convention of Madrid, 1932, states:

"In amateur stations or in private experimental stations, authorized to conduct transmissions, any person operating the apparatus on his own account or for third persons must have proved that he is able to transmit texts in Morse code signals and to read by aural radiotelegraph reception, texts so transmitted. He can be replaced only by authorized persons possessing the same qualifications."

Therefore our government is bound by treaty to give a code examination to prospective amateurs.

—*H. V. Sarnowicz, W9VPQ*

The "Work" in WAS

81 Elizabeth St., Stratford, Ont.

Editor, *QST*:

In all probability you are just about "fed-up" with these various missiles of woe regarding the QSL card. I'll try to make my complaint as brief as possible.

Nearly every month in *QST* there appears a list of those lucky fellows who happen to snag a WAS certificate. Along with this list is the invitation to the rest of us to get down to some serious brasspounding and do likewise. Personally, I believe that very soon our own word and log will have to be accepted as confirmation of this WAS feat.

I, and probably many others, have worked the entire United States two or three times, but yet need confirmation from around 15 states. My postage bill is running up simply because I get big-hearted and send two or three cards to the same station trying to induce a reply. If they have no cards, why not write a short note confirming the contact? . . .

I realize that work is expected to contact the various states but a fellow has to work twice as hard to get the confirmation for said contact. This should not be. If it is going to be so hard to make WAS because of our brother hams' non-coöperation, this achievement should be discontinued. . . .

—*Edmund C. Skowby, VE3PE*

Eighth A.R.R.L. Sweepstakes Contest Results

(Continued from page 56)

participants, but no award has been made, we shall see that credit is given upon receipt of a list of the club members taking part and submitting scores. The aggregate scores of several clubs having less than three reporting participants are as follows: Northern Nassau Wireless Association (Long Island), 75,965; St. Joseph Valley Radio Club (Indiana), 56,109; Rochester (N. Y.) Ama-

(Continued on page 70)



W5DPY, "Pat" Patterson of Dallas, has suggested a modification of our type STN neutralizing condenser that makes for extremely easy and practical mounting in compact low power final amplifier or buffer installations where tubes such as 210s, 841s, 801s and 809s with moderate plate voltages are used.

Pat took one of the standard condensers and reversed the two screws that hold the stator plate assembly. To the ends he then added two of the little Isolantite cone shaped stand-offs that we furnish with the new CIR sockets. A slot in the end of the condenser shaft completed the assembly so that a Bakelite screw driver could be used for adjusting. We have tried to show the general idea in the illustration above.

We like it so much that from now on all of our STN-18 condensers will come through this way as standard. If you want to mount them in the old-fashioned conventional way, you will just be in a couple of free stand-offs!

Another interesting application "trick" was also shown to us on this same trip through the South by Jim Rives, W5JC, of San Antonio. He constructed and assembled a transmitter, including one of our CRO oscilloscopes on standard 19" panels and then tried to mount the units in one of the enclosed or cabinet style racks. The oscilloscope was too deep, because of the way we mount the power supply transformer on the back of the case. We mount the transformer there for a reason: — so that its field will not distort the pattern on the tube screen. Moving the transformer from the back to the side of the case spoils this effect. By mounting one of the cheap "postage stamp" size b.c. set replacement filament transformers on the opposite side of the case (with its primary connected to A.C. input and secondary open) a position for this transformer can be found that will balance out the evil effects of shifting the mounting of the main transformer from the back to the side. When so arranged, the complete oscilloscope extends only 12 $\frac{1}{8}$ inches behind the panel.

Incidentally, W5JC had a number of other "hints and kinks" including the idea of using one of the special cords made for the AC-DC midget BC sets as the heater element for his crystal oven. The cords are inexpensive, available at all dealers, just about the right length to spiral around the inside of the oven, and, of course, can be connected directly across the 110 volt line (through the thermostat switch).

JAMES MILLEN





Announcing... *New* Mallory Transmitting Condensers

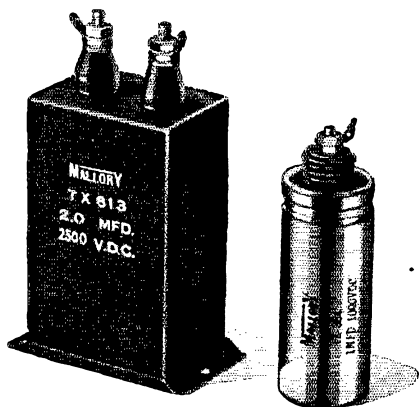

**NEW..in Design..Construction
..Impregnation..and appearance
BUT.. tested and proven in
performance..**

Both types—TX and TZ—are ideal for radio transmitter and high-power amplifier applications. Both are impregnated with Mallory Compound, which is not a wax—is unlike any standard or special impregnating oil now offered and will not leak out of the container. It positively does not contain chlorine either in a free or combined form.

The natural, high dielectric constant of Mallory Compound is combined with unusual heat resistance. Condensers impregnated with Mallory Compound have unusually good power factor and extremely stable DC resistance.

Mallory TX Condensers are housed in rectangular metal cans, with durable black crackle enamel finish, and are provided with two ceramic stand-off terminal insulators.

Mallory TZ Condensers are dual purpose units, for transmitter filters or heavy duty power amplifier circuits. These are supplied in round aluminum cans with threaded necks for inverted mounting. They can also be mounted upright with standard ring brackets.

See your distributor about these new transmitting condensers!

P. R. MALLORY & CO., Inc.

INDIANAPOLIS INDIANA

Cable Address—PELMALLO



teur Radio Association, 55,584; Tri-Town Radio Amateur Club (Illinois), 49,020; Twin Boro Amateur Radio Association (N. Y.), 44,716; Chicago Ether Busters, 36,456; Chester (Pa.) Radio Club, 30,816; Central New York Radio Club, 30,600.

LOW-POWER RECORDS

Different operators have different ideas of just what constitutes "low power." To some, 150 watts seems low, others feel that 75 is about as low as they would care to go, a few think anything above 20 watts is high power. In the SS we find a number of operators using what we consider low power. We think their accomplishments in the contest prove something or other. For example, VE4CQ ran only 4 watts to an '01A TNT, working 60 stations in 35 sections! And W9VOD, with but 5 to 6 watts input, worked 115 stations in 45 sections!! Not to be outdone W8OQU worked 41 stations, 26 sections, with a single type 19 at 1 watt input. Now we're really talking low power! One of our most consistent low power men is W8JA, operating portable in the District of Columbia; he has done some excellent work in O.R.S. Parties and other activities, and in the SS turned in 15,152 points (130 stations, 39 sections) using 6 watts. You'll have a hard time proving to W9VKF that he needs more than 25 watts because he continues to lead the Southern Minnesota Section with that power—he made 54,450 this time, working 303 stations in 60 sections. He has a nice DX record, too. W4COV, also using 25 watts, led the Eastern Florida Section with 25,538 . . . 175 stations, 49 sections. Looking down the list a bit we find W9DBO, 14 watts, with 40 stations, 24 sections. W8FDA, old-time low-power enthusiast, sticks to his '71A with 10-12 watts and worked 177 stations in 55 sections during the contest. Twelve watts brought W9KMN contacts with 91 stations in 48 sections. W8BON's 22 watts worked 82 stations, 32 sections. W8BXC and W8PIH both used 8 watts input, BXC making 30 contacts in 16 sections, PIH making 70 QSO's in 26 sections.

MISCELLANY

There is no better way to add states towards the Worked All States award than to take part in the SS. Many participants increased their totals. Among them are W8FLA, who added three states, W6GPB, who completed his WAS, W6NEN, who brought his total to 47, W6KOP, who added one, W4BHY, who added R. I. and N. Mex., W9VIP, who added three, VE1EP, who worked his 48th, W5DB, W3GAU, W3FFE, who now needs but one, W9VES, W8NDL, W9VZI, W9VFM, W1IDU, W6PBV, who added six states, and many others. W9RQM worked all states except Nevada in the contest. W6BXL worked 46 states, all but Nevada and S. C. Nomination for the most optimistic ham: The fellow who called "CQ No SS." W1HOU and W8JJA exchanged preambles, both Nr. 73. Highlight for W8FKO was when a neighbor's young Daniel Boone brought down the transmitting antenna by scoring a bull's eye on the insulator. W9RSO used

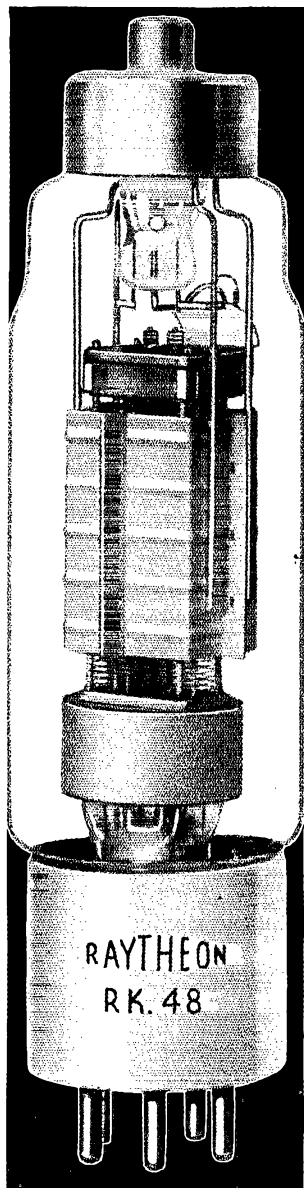

CHARACTERISTICS OF BEAM POWER TUBES

RK-47 Hard glass bulb, 10 volt. 3.25 Amp. Thoriated Filament. 1250 volts plate. 1 watt driving power. — — output power. 120 watts. Amateur net price..... **\$1750**

RK-48 Hard glass bulb, 10 volt. 5 Amp. Thoriated Filament. 2000 volts plate. Driving power 1.2 watts. Output power 250 watts. Amateur net price..... **\$2750**

RK-39 6.3 volts, 0.9 Amp. Filament. 500 volts plate. Driving power, 0.3 watts. 35 watts output. Amateur net price..... **\$350**

Imagine!

250 WATTS OUTPUT

with only 1.2 WATTS DRIVING POWER!

LESS DRIVING POWER

**+ Greater Output at 70% Efficiency
= More Tube Value per Dollar**

What amazing facts for amateurs to know!

IMAGINE 250 watts output with 1.2 watt driving power in the RK-48!

IMAGINE 100 watts output with 1.0 watt driving power in the RK-47!

IMAGINE 35 watts output with .3 watt driving power in the RK-39!

Don't forget that less driving power means using less tubes, getting higher efficiency and building your whole transmitter for less money.

Remember—*all* RK Beam Power tubes are precision-engineered and built for quality—not for price! What's more—they are rated at 70% plate efficiency—not at 85 and 90 percent.

With expensive molybdenum plates both in RK-47 and RK-48—they can be operated at color without producing gas!

Hard (Nonex) glass bulbs permit building a "hard" (gas free) tube, which means longer life and permits operation at hotter temperatures without air leakage. Isolantite bases provide better insulation qualities and permit operation at higher voltages and the maintenance of more constant tube characteristics.

Raytheon RK beam tubes can be plate modulated efficiently!

Raytheon's exhaustive research in pioneering beam power tubes are directly responsible for the exclusive features that make RK tubes a wise investment.

Don't put your money on any other tube. Do as other smart amateurs do. Buy RK's. You, too, will find it pays! See your Raytheon jobber.

**RAYTHEON
RK**

AMATEUR TUBES

CHICAGO • ATLANTA • NEW YORK • NEWTON, MASS. • SAN FRANCISCO

"WORLD'S LARGEST EXCLUSIVE RADIO TUBE MANUFACTURERS"

Made by the men who build
Commercial Communications
Equipment ...

THIS RCA AMATEUR TRANSMITTER IS A TOP-NOTCH VALUE

The Model ACT-150 is a top-notch performer at a price that shouts value! Made by the same skilled RCA engineers who create commercial communications equipment, it offers features that *prove* its quality ... features born of RCA's experience and research in every phase of radio! Look them over — see for yourself.

FEATURES

Conservative 150 watts output (c.w. and 'phone).

Tube line up of modern acclaim: R.F.—RCA 807, 802, two 807's, two 808's; Audio—RCA 6J7, two 6C5's, two 2A3's, two 808's; Rectifiers—RCA 83, 5Z3, 80, two 866's.

Isolated speech amplifier of special design.

10 to 160 meter operation.

Circuits fully metered including modulation indicator.

Switch for "Tune-up" protection or power output reduction.

Transformers given special impregnation.

Interlock switch for safety to operator.

Neutralized at factory.

Pleasing two-tone gray finish and handsome escutcheon plates on cabinets.

Low tube and extra coil costs.

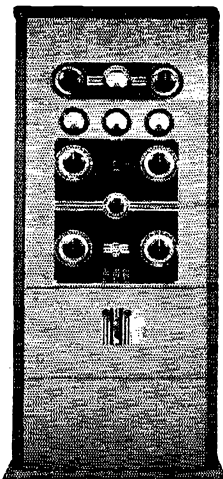

MODEL ACT-150

Amateur's net price F.O.B. factory with speech amplifier and one set of coils but less tubes, microphone, crystal. Extra set of coils \$13.50 **\$625**

For maximum performance at minimum cost — use RCA Radio Tubes.

RCA presents the "Magic Key" every
Sunday, 2 to 3 P. M., E. S. T., on the
NBC Blue Network



FOR AMATEUR RADIO

AMATEUR RADIO SECTION

A Service of the Radio Corporation of America
RCA Manufacturing Company, Inc., Camden, N. J.

his time on the budget plan—he tried to keep a certain average number of QSO's per hour and, if he had any extra QSO's in less than an hour, he spent the time hunting for new sections. It seemed to work! W9ARE went into the contest with the idea of finding out just what could be accomplished by staying on one spot in the 14-Mc. band, and working no other bands. In 20 hours on 14,001 kc., he worked 121 stations in 53 sections. Not a single CQ was sent by W8KAU; his practice was to use e.c.o. and call stations on their own frequency, he worked 150 stations. W7GLH is the champion "traveling SS-er." He has worked in Sweepstakes Contests as W8UC, W4CA (St. Petersburg, Fla.), W4CA-5 (New Mexico), W4CA-9 (Colorado), W9WFV (Colorado), and in the '37 contest as W7GLH (Washington). "The SS surely demonstrated the practicability of short calls, break-in, and short CQ's."—W8IYL. But why didn't more operators use bk-in? A good example of the type of thrill that awaits the SS participant is W9MUX's experience of getting New Mexico two minutes before the close of the contest. Winning an SS award is not always easy. Competition was mighty keen in some sections and we note several close races. In Md.-Del.-D. C. W3FQZ, 44,457, and W3DUK, 42,224, gave blow for blow. W9RCQ, 52,480, in Illinois, had to contend with W9NUF, 51,125. In Indiana it was a close win for W9TYF, 56,109, over W9IU, 55,872. The Washington race was about neck-and-neck with W7CMB, 33,201, and W7EK, 31,552. The lads weren't fooling in East Bay, where W6TT made 19,883, and W6MVQ 19,580. In Alberta, we find VE4GD, 25,281, close on the heels of VE4GE, 26,625. It was by a narrow margin that WIGBO, 22,464, won over W1BBN, 21,624, and W1DIL, 21,218, in Rhode Island. W6IZE, 12,192, gave W6MDI, 12,705, a good battle in Sacramento Valley. In Eastern Florida, W4COV, 25,358, didn't have too much to spare over W4EFM, 24,771. VE3JT, 42,060, and VE3GT, 40,824, made it hot for each other. W2JV, 12,291, was a strong competitor of W2JME, 13,995, for the Northern New Jersey 'phone award. A check of W9AHR's log revealed that he made more QSO's per hour on 14 Mc. than on any other band. In order to keep track of stations worked, W8FLA, ruled a sheet with ten columns, one for each of the nine districts and one for VE's. Each time a contact was made he would jot down the call in its respective column, thereby avoiding chance of duplicating QSO's. Hal Bubb at W1AW also used this system to advantage. "I was very happy to note that many more 'phones were taking part in the SS. It seemed that about 10% of the stations worked were active and only 4% seemed to have no knowledge of what was going on. A new method of timing was used this year to secure the greatest accuracy and efficiency. A Weston hour meter, normally used to check filament life of the tubes, was connected to a switch on the operating desk. This was set in operation whenever operating in the SS. This method gave a cumulative count and made known the hours remaining."—W6ITH.

CU in the '38 SS!

RME TO THE RESCUE DURING LOS ANGELES FLOODS

Snapshot of the RME-69 Receiver and DB-20 Pre-Selector in the Transmitter Station of KNX, at Van Nuys, Calif.—near Los Angeles.

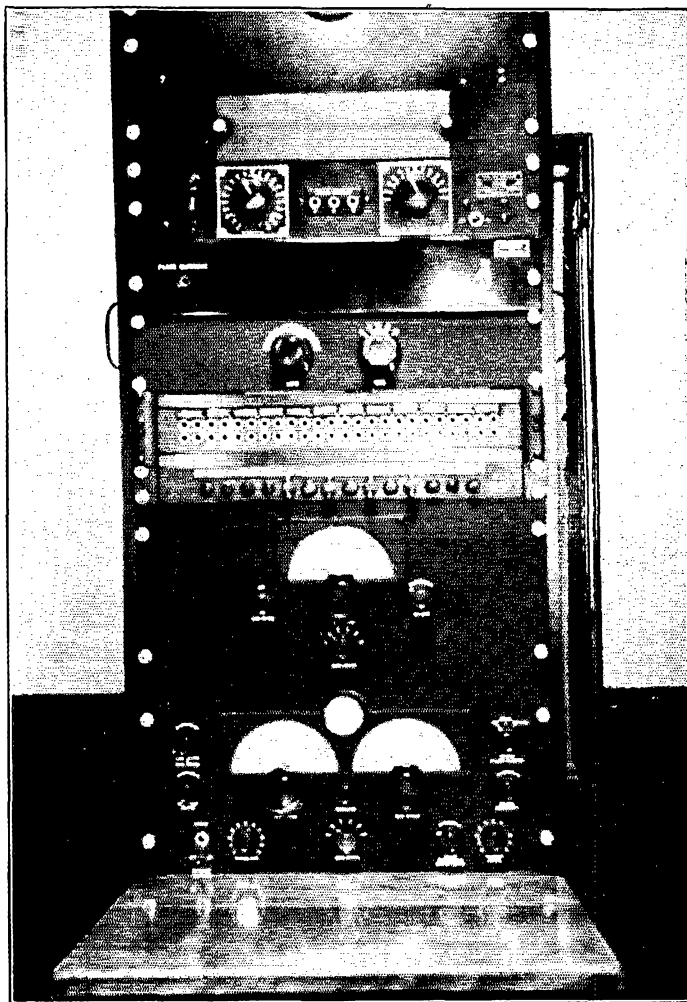

For one and one-half days, during the recent devastating Southern California floods, KNX, the Columbia Station in Los Angeles, was completely cut off by phone from its transmitter station located in Van Nuys, a distance of 12 miles.

But the foresight of the Columbia Broadcasting Co. officials had provided for just such an emergency. One of their three RME-69's, located at the transmitter station, furnished the entire communication channel between the studios and the transmitter, so that KNX was able to carry its program schedule without interruption.

KNX also uses its RME equipment to pick up remote programs, to monitor short-wave transmission from WABC, New York, as well as for local communicating purposes . . . also for special events such as the 2-way network broadcast with Don Budge's ship arriving from Australia, Easter Services from U. S. Navy, Boulder Dam Broadcasts, etc.

Mr. Les Bowman, Chief Engineer of C.B.S. and Mr. Leo Shepard, Transmitter Supervisor, selected RME Equipment because of its high quality, quietness and ease of operation . . . and it may be of interest to *QST* readers that Messrs. Bowman and Shepard are enthusiastic amateurs (W6PQY and W6LS respectively).

RADIO MFG. ENGINEERS, INC.

306 FIRST AVENUE, PEORIA, ILLINOIS

ENTHUSIASTIC USERS PRAISE MEISSNER SIGNAL SHIFTER



INTRODUCED at the Pittsburgh Hamfest in February and at the St. Louis Hamfest in March, the Meissner Signal Shifter "stole the show." When shown to leading jobbers, orders poured in. In thirty days Signal Shifters were in use in nearly all parts of the country. And letters of praise started to arrive with every day's mail.

The Meissner "Signal Shifter" is a variable-frequency, electron-coupled exciter unit with oscillator and buffer circuits ganged together for single dial control. Designed for use with Amateur transmitting equipment it enables the operator to conveniently change frequency from his operating desk. Five sets of plug-in coils, three to a set, provide for operation on the 10, 20, 40, 80, and 160 meter Amateur bands. Accurate tracking and proper design hold output constant over entire range of each band.

Two frequency doubling circuits on all bands (except 160) minimize effects of load on oscillator frequency, resulting in unbelievable stability — actually superior to that of many crystals!

One or two doubler stages may be eliminated as power output is more than sufficient to drive a low-power stage such as RK-20's, 802's, 210's, 807's or similar tubes — directly on the frequency you wish to work.

The Meissner "Signal Shifter" is assembled, wired and adjusted in the laboratory to assure proper operation and complete frequency stability. It is mounted in a black-crystal-finished cabinet and requires 1-6F6, 1-6L6, and 1-80. The built-in power supply operates from 110 volt 60 cycle line. Also available without power supply; requires 2.0 amps at 6.3 volts and 80 ma. at 360 volts.

Your parts jobber has the Meissner Signal Shifter in stock right now. See him at once. Learn what this remarkable new unit can do to improve your QSO's. Write for complete information.

Complete with power supply and set of coils for one band. Less tubes

LESS POWER SUPPLY
\$31.95 NET

\$39.95
NET

ANOTHER
Meissner
IDEA!

MEISSNER MANUFACTURING CO.

152 Belmont Ave., Mt. Carmel, Ill.

S. S. Scores

(Continued from page 60)

W8KGG	14450-39-127-A-31	W9MCC	5274-22-40A-11
W8CJJ	13500-50-135-B-31	W9NRB	1425-19-25-A-5
W8FYH	13117-33-133-A-33	W9KJY	1326-17-39-B-5
W8DZC	12735-45-142-B-33	W9NQP	1248-16-26-A-4
W8AQE	12600-30-141-A-27	W9REC	897-13-23-A-12
W8FMH	12240-48-128-B-41	W9FXW	874-19-23-B-9
W8QXS	11160-40-140-B-34	W9RWS*	689-13-22-A-8
W8PLA	10416-31-112-A-2	W9NIU	660-11-20-A-10
W8BLO	10164-42-121-B-20	W9WJX	594-11-18-A-3
W8NWT	8160-32-85-A-24	W9DSO*	429-11-13-A-2
W8QCH	8516-24-91-A-27	W9NQI	294-7-14-A-7
W8LDA	6460-34-95-B-13	W9YDQ	283-8-12-A-7
W8PNA	5630-27-71-A-21	W9INY	163-7-8-A-3
W8DST	4181-37-57-B-20	W9ZPN	133-7-10-B--
W8PCM	4110-30-71-B-26	W9JU	18-2-3-A-2
W8BCN	3960-24-55-A-19	W9FYZ	3-1-1-A--
W8OQU	3198-26-41-A-13	W9BPN	2-1-1-B--
W8DHU	2850-19-50-A-10	Phone	
W8OQ*	2679-21-33-A-5	W9TQL	4646-19-86-A-27
W8BB*	1554-14-37-A--	W9TSD	162-9-9-B-3
W8OXH	1540-22-36-B-14	W9WXT	72-6-6-B-3
W8PFC	1020-17-30-B-13	W9IKV	4-2-2--
W8QHX	900-15-21-A-7		
W8CPI	546-13-14-A-3*	Indiana	
W8CNH*	478-14-17--6*	W9TYF	56109-59-318-A-39
W8BFG	442-13-17-B--	W9IU	55872-64-291-A-40
Phone		W8SKA	31895-50-219-A-37
W8KWS	8-2-2--	W8EGQ	24525-50-167-A-36
W8CPI	3-1-1-A--	W8ABB	24381-63-129-A--
W8QHX	3-1-1-A-1	W9VWY	6300-30-70-A-17
		W9WCE	5673-31-61-A-19
W. Pennsylvania		W9AET	3968-32-62-B-8
W8GIU*	39780-65-205-A-27	W9CZC	720-18-20-B-12
W8FLA	18942-44-144-A-24	W9SDC	630-10-22-A-3*
W8JMP	15364-46-167-B-31	W9QEU	210-7-10-A-4
W8IYT	11264-44-129-B-7	W9KPN	168-7-8-A-3
W8OML	9240-35-88-A-11	W9GGF	12-2-2-A-1
W8KOB	8512-32-133-B-26	W9SIV	8-2-2--
W8LUG	6804-27-84-A-11	W9TWC	3-1-1-A--
W8KYR	6732-34-102-B-37	W9ZNC	1-1-1--
W8HSN	5616-26-73-A-20	Phone	
W8ZU	4374-27-55-A-36	W9YGC	7544-46-82-B-28
W8JSU	1820-18-30-A-9	W9SDC	1750-25-35-B-9
W8NEK	1590-20-27-A-9	W9MUR	1530-17-30-A-14
W8NRE	741-13-19-A-2	W9LLV	561-11-17-A-7
W8HWK	48-4-4-A-1	W9YCY	14-2-4--
W8QHS*	24-2-4-A--		
W8NNY*	24-3-4--	Kentucky	
Phone		W9HBN	48888-56-292-A-31
W8TJP	8772-34-86-A-34	W9YGR	5829-29-37-A-18
W8KBJ	3564-33-54-B-12	W9MPL	4320-24-60-A-12
		W9IFM	1530-17-30-A-2
		Phone	
		W9YQN	6750-36-65-A-26
CENTRAL DIVISION			
Illinois		Michigan	
W9RCQ	52480-64-410-B-40	W8OCV	28512-48-199-A-27
W9NUF	51125-63-271-A-40	W8CGB	25980-60-203--36*
W9MUX	47610-60-267-A-40	W8PFD	18120-40-151-A-37
W9VES	40236-56-241-A-37	W8NDC	14645-49-152-B-23
W9MWU	38940-55-236-A-35	W8CMB	14384-57-128-B-28
W9UTT	38160-60-214-A-37	W8BML	13860-44-108-A-37
W9WWT	36456-56-217-A-40	W8OQF	12820-56-110-B-29
W9VFX	36300-55-222-A-40	W8ITK	11809-49-122-B-22
W9WFS	34775-53-230-A-31	W8NDL	9730-35-140-B-26
W9TMU	31512-52-207-A-33	W8PKY	9382-41-112--25*
W9MIN	27507-53-173-A-24	W8PHZ	5442-26-69-A-10
W9ZMG	27284-47-194-A-37*	W8NXT	3450-23-50-A-19
W9ZTN	25530-46-189-A-38	W8QGD	2036-19-37-A-9
W9MED	25099-48-175-A-30	W8NUV	1302-14-32-A-9
W9TFY	21420-51-212-B-36	W8QIZ*	1260-21-31-B--
W9MGN	19881-47-142-A-36	W8PG	1000-20-52-B-6
W9UTB	18450-41-151-A-28	W8NQ	147-7-7-A-2
W9VS	18306-54-116-A-31	W8DED	144-6-8-A-1
W9AIC	17384-53-169-B-27		
W9ENQ	15687-42-125-A--	Ohio	
W9TKN	15624-42-126-A-36	W8YIM	68706-66-347-A-37
W9TSS*	15606-51-154-B-23	W8OFN	56562-66-431-B-40
W9HQH	13356-42-106-A-22	W8IAW	51634-50-292-A-40
W9KMN	13104-48-81-A-26	W8LWQ	51300-57-300-A-40
W9NGA	12600-40-105-A-29	W8LZK	48750-65-250-A-38
W9AZP	10998-47-117-B-22	W8BGX	47570-59-210-A-38
W9MRQ	10080-40-127-B-21	W8BKQ	34944-52-225-A-30
W8EUL	9760-50-89-B-26	W8LYQ	33367-61-274-B-39
W8EUT	9603-35-91-A-29	W8LVH	24720-60-209-B-40
W9VOQ	8160-34-80-A-17	W8PKH	22617-42-180-A-29
W9IVD	7752-42-143--37*	W8PKE	22140-45-265-B-40
W9NGT	7036-33-74-A--	W8PNA	16950-50-113-A-23
W9GMT	6177-29-71-A-18	W8WE	14800-50-149-B-30
W9ZIL	5304-34-52-A-22	W8EUQ	14100-47-100-A-22
W9TUV	4422-29-51-A-13		
W9SGL	4350-29-50-A-18		
W9VDX	3190-29-55-B-29		
W9DBO	2772-24-40-A-23		
W9TWL	2760-20-46-A-17		

★
SEE YOUR
JOBBER



NEW!
COMPACT!
SENSIBLE!

★
SEND FOR
DETAILS

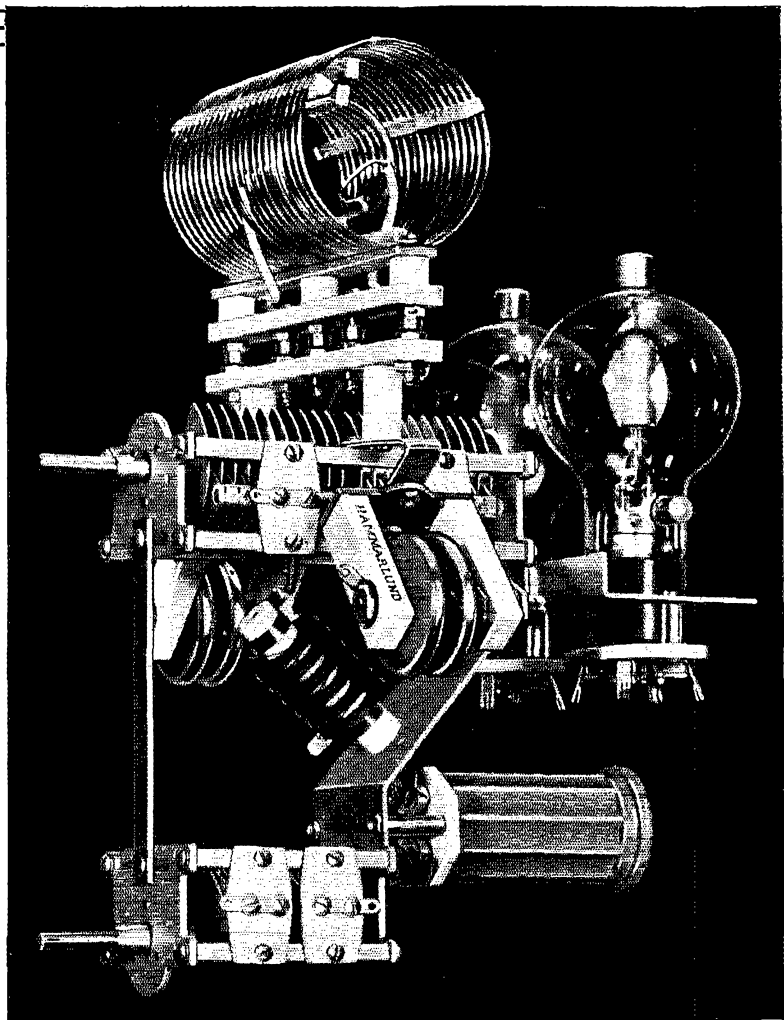

HAMMARLUND's new "foundation kits" are designed to make it easier for the amateur to build neat, efficient, compact apparatus. The 300-watt push pull R.F. amplifier, illustrated, can be built in less than 20 minutes. The only tools necessary are a screw driver and soldering iron.

No chassis is needed; no difficult drilling. The various brackets are shaped and drilled to be used with standard Hammarlund parts, even holes for mounting the R.F. by-pass condensers are provided. All parts are of aluminum and have a silver-like satin finish. The entire unit is designed for greatest efficiency; all leads are short and direct. Compact in size — meas-

ures only 13" x 8½" x 8" overall. Designed for any of the popular triodes from 10's to 808's. For low power, type 10 tubes may be used, and for higher power (around 300 watts) a pair of 808's.

Be thrifty, save time, build better transmitters. See your dealer or write for descriptive literature.

MAIL COUPON TODAY!

HAMMARLUND MFG. CO., INC.	Q-5
424-438 W. 33 St., N. Y. City	
(<input type="checkbox"/>) Send data on "foundation kit"	
Name.....	
Address.....	
City.....State.....	

Canadian Office: 41 West Avenue, No., Hamilton, Ont.



HAMMARLUND

Say You Saw It in QST — It Identifies You and Helps QST

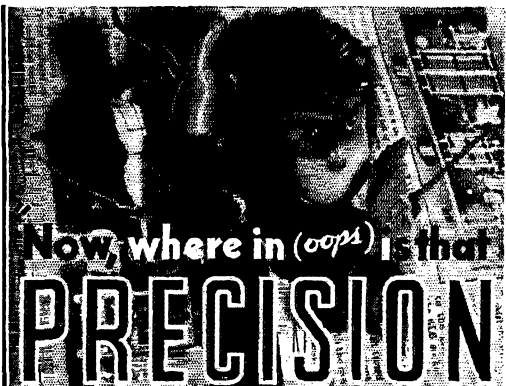

Now, where in (oops) is that
PRECISION

SERIES 840L
A.C.—D.C. VOLT—OHM—
DECIBEL—MILLIAMMETER
including a
2500 VOLT A.C. and D.C. RANGE
and a **1000 M.A. RANGE**

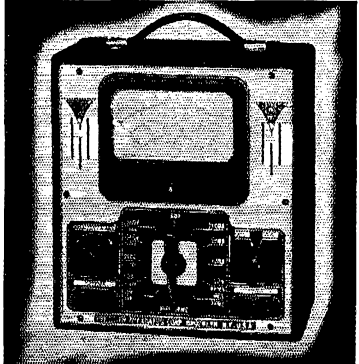

SPECIFICATIONS

- * 5 A.C.—D.C. Voltage Ranges from 0 to 2500 volts at 1000 ohms per volt.
- * 4 D.C. Current Ranges from 0 to 1 amp.
- * 5 Output Ranges.
- * 3 Resistance Ranges from 0 to 10 meg (provision for self-contained batteries).
- * Decibel Ranges from — 10 to plus 60dB.
- * Large 4 1/2" D'Arsonval meter, 2% accuracy.
- * Wire wound shunts 1% accuracy.
- * Matched multipliers 1% accuracy.
- * Guaranteed close accuracy on all ranges.

Net price to amateurs **\$19.95** Less batteries and test leads

SERIES 840P incorporates same specifications as the 840L but is housed in an attractive black leatherette covered portable case with removable cover. Size 9 x 10 x 6. Net to amateurs. **\$21.95**

AVAILABLE AT LEADING DISTRIBUTORS

Following is a partial list

- Akron, O. The Summit Radio Supply
- Alloua, Pa. Hollenback's Radio Supply
- Baltimore, Md. Radio Electric Service Co.
- Boston, Mass. Radio Shack, Inc.
- Chicago, Ill. Allied Radio Corp.
- Columbia, S. C. Dixie Radio Supply Co.
- Denver, Colo. Inter-State Radio Supply Co.
- Hagerstown, Md. Zimmerman Wholesalers
- Jamaica, N. Y. Peerless Radio Distributors
- Johnstown, Pa. Cambria Equipment Co.
- Los Angeles, Cal. Kierulff & Co.
- Miami, Fla. Radio & Electric Supply Co.
- New York, N. Y. Harrison Radio Co.
- Portland, Ore. Radio Supply Co.
- Richmond, Va. The Arnold Co.
- Seattle, Wash. Brandes Gordon Co.
- St. Louis, Mo. Walter Ashe Radio Co.
- Texas, Tex. Mims Radio Co.
- Utica, N. Y. Vaeth Electric Co.
- Winston-Salem, N. C. Brown-Rogers-Dixson Co.

PRECISION
APPARATUS CORPORATION
821 EAST NEW YORK AVE., BROOKLYN, N. Y.
EXPORT DIVISION—458 BROADWAY, NEW YORK

W8BCE	13293-42-106-A-23	DELTA DIVISION	
W8AVH	12192-49-127-B-25	Arkansas	
W8QZR	11433-37-103-A-33	W5ASG	25575-55-155-A-40
W8PWY	11220-34-110-A-20	W5EJL	11970-39-107-A-40
W8BON	7872-32-82-A-17	W5FPD	9546-37-87-A-25
W8PBX	7871-33-81-A-21	Phone	
W8MOH	7533-27-94-A-28	W5BRW	2668-29-57-B--
W8LAG	7140-34-71-A-16	W5BXM	1395-15-31-A-12
W8BMX	6660-37-90-B--	W5GJK*	4-2-2--
W8LQA	6525-29-75-A-12	Louisiana	
W2HWG-8	5832-36-56-A-15	W5K	55428-62-301-A-38
W8PIH	5421-26-70-A-24	W5WG	47700-60-267-A-39
W8DAE	5088-32-54-A-13	W5DWW	6810-39-90-B-22
W8PMS	3795-23-56-A-19	W5GCM	2310-22-35-A-12
W8LYZ	3332-28-60-B-14	W5EUK	1755-18-33-A-32
W8KQK	2864-23-42-A-22	W5FKS	243-9-11-A-3
W8ORM	2160-20-36-A-9	W5DGB	192-8-8-A-2
W8MGD	1530-17-30-A-8	Phone	
W8BXC	1440-16-30-A-8	W5BQD	1786-10-47-B-18
W8NUP	1064-19-29-B-6	Mississippi	
W8CXF	570-15-19-B-2	W5GEA	23655-57-208-B-36
W8QXM	297-9-11-A-2	W5FTT	1481-21-26-A-14
W8MOK	252-9-14-B-2	Tennessee	
W8PHW	240-8-10-A-5	W4PL	43584-64-220-A-37
W8CBF	148-6-14--	W4CXY	10200-34-100-A-16
W8OZE	60-4-5-A-3	W4DDJ	9188-35-91-A-24
W8DWT	12-2-2-A-1	W4DLX	8764-38-89-B-23
W8LCO	936-16-20-A-7	Hudson Division	
W8NDN	234-9-13-B-10	Eastern New York	
W8FBF	176-8-11-B-14	W2HNH	35462-47-253-A-36
W8ODF	162-6-9-A-4	W2HAN	26367-47-187-A-30
W8NZS	2-1-1--	W2HCM	22800-50-152-A-29

Wisconsin		W2HJG	35462-47-253-A-36
W9RQM	58856-64-307-A-39	W2KLP	7128-24-100-A-17
W9GWK	52392-59-296-A-37	W2KLF	2805-17-55-A-18
W9EYH	42294-53-267-A-36	W2BAF	45-3-5-A-3
W9UIT	31744-64-248-B-32	Phone	
W9RH	26019-59-220-B-39	W2FQG	3-1-1-A--
W9VDY	24738-57-220-B-29	N.Y.C.-L.I.	
W9ZFT	8880-32-95-A-29	W2IOP	74264-63-433- -012
W9PTE	7524-44-91-B-14	W2AYJ	51773-59-293-A-39
W9RKP	7344-32-77-A-18	W2HMJ	32154-46-233-A-19
W9PRA	7216-41-88-B-14	W2GUP	30843-46-224-A-30
W9KXK	5439-37-80-B-30	W2IRV	25014-44-191-A-35
W9YMG	3524-27-45-A-9	W2LJU	24260-40-204-A-31
W9VYZ	3510-26-46-A-21	W2AHC	24192-56-216-B-31
W9SJJ	3240-24-45-A-15	W2HAY	18954-54-117-A-33
W9VZL	2243-23-34-A-10	W2ION	17880-40-150-A-33
W9YXH	2174-21-36-A-12	W2FTX	14508-39-128-A-39
W9ZBP	1674-19-31-A-7	W2DXL	13431-37-123-A-35
W9LUC	912-16-19-A--	W2HUG	13358-36-124-A-34
		W2HYA	11988-37-105-A-25
		W2CTI-2	11742-38-103-A-29
		W2JIR	11552-38-154-B-391
		W2PYS	11400-38-150-B-35
		W2JVS	10392-32-114-A-26
		W2FUQ	10095-37-105-A-35
		W2AOD	10179-39-131-B-30
		W2JAU	9367-26-130-A-22
		W2AJL	8046-36-78-A-23
		W2JRG	7869-33-81-A-25
		W2GXS	6930-35-68-A-24
		W2KKW	6138-29-74-A-29
		W2INF	5985-21-96-A-13
		W2EQG	5928-26-78-A-22
		W2BCE	4123-31-67-B-16
		W2AJR	4032-28-48-A--
		W2HBO	3762-22-57-A-14
		W2GP	3588-23-52-A-8
		W2JEB	3150-21-50-A-10
		W2JIN	2898-21-46-A--
		W2DVA	2880-24-40-B-7
		W2KFW	1872-16-39-A-17
		W2ISI*	1862-17-38-A-8
		W2KUB*	1804-22-41-B-11
		W2EC	1287-13-33-A-5
		W2CKX	1254-19-33-B-9
		W2KFM	1218-14-29-A-8
		W2KJY*	900-12-25-A-3
		W2IHE	198-6-11-A-5
		W2PF*	24-2-6-B-1
		W2BMG	21-3-4--
		W2APZ*	8-2-2--
		W2KWM*	2-1-1--
		Phone	
		W2JDG	4814-28-87-B-1611
		W2CMU	1116-18-31-B--
		W2TY*	4-2-2--

DAKOTA DIVISION

North Dakota	
W9UBB	27084-61-222-B-30
W9YJL	20325-50-136-A-33
W9SDQ	7801-29-135-B-36
W9YJO	6846-28-82-A-27
W9DMM	6000-32-63-A-20
W9PRU*	230-10-12-B-5
Phone	
W9BTTJ	1800-27-36-B-19
South Dakota	
W9YEZ	19140-55-119-A-40
W9FOQ	17132-47-122-A-22
W9VOD	15525-45-115-A-36
W9VQN	4500-25-60-A--
Phone	
W9PZI	4815-30-54-A-12

No. Minnesota

W9YCR	32670-55-198-A-39
W9SYX	27666-53-175-A-37
W9YTF	25016-51-167-A-40
W9PPR	16002-42-129-A-33
W9RTN	15120-45-171-B-31
W9YUB	12960-40-110-A-26
W9DNY	11220-44-85-A-33
W9BRA	7344-34-72-A-17
W9ZGI	5520-32-58-A-17
W9IGZ	4790-31-52-A-12
W9HFN	3201-22-49-B-13
W9HKF	2646-27-48-B-8
W9CMA	168-7-8-A-3
W9KYE	128-8-10-25
Phone	
W9SFF	2-1-1--
So. Minnesota	
W9VKF	54450-60-303-A-40
W9EPJ	9984-39-128-B-16
W9VIP	1197-19-22-A-7
W9KUI	27-3-3-A--

MORE WATTS PER DOLLAR

in Audio-FREQUENCY TUBES



TZ-40 ZERO BIAS

UP TO
175 WATTS
Class B Audio Output
\$3.50

Class B Audio Operation

(value for 2 tubes) Max. ratings

DC Plate Voltage.....	1000
Bias.....	0
Peak AF Grid to Grid Volts.....	200
Zero Sig. DC Plate Cur. MA.....	44
Max. Sig. Plate Cur. MA.....	280
Plate to Plate Load, Ohms.....	6900
Av. Driving Power, Watts.....	3
Power Output, Watts.....	175

The leading transformer Manufacturers recognized the usual value of this WONDER TUBE and are announcing special Class B Output units to match. Thordarson T-14-M-49 and Stancor A 3829 transformers are already in your Distributors stock. General, Utah, Kenyon, UTC, Inca and others will announce their units soon. Listen on the Ham Bands for real testimonials.

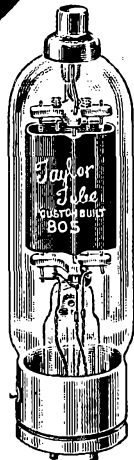

NEW 805 ZERO BIAS

UP TO
450 WATTS
Class B Audio Output
\$13.50

Class B Audio Operation

(value for 2 tubes) Max. ratings

DC Plate Volts.....	1750
Bias.....	-22½
Peak AF Grid to Grid Voltage.....	250
Zero Sig. DC Plate Cur. MA.....	60
Max. Sig. DC Plate Cur. MA.....	390
Plate to Plate, Ohms.....	10,000
Driving Power, Watts.....	8.0
Power Output, Watts.....	450

The 805 operates at zero bias at lower plate voltages. The 805 is also a fine RF Tube. Insist on Taylor 805's. EXCLUSIVE FEATURES — Processed Carbon Anodes — Floating Anode. Complete technical bulletin free for the asking.



822 UP TO 700 WATTS

Class B Audio Output
\$18.50
Class B
Audio Operation

(value for 2 tubes) Max. ratings

Plate Volts.....	2000
Bias.....	-67
Peak AF Grid to Grid Volts.....	345
Zero Sig. Plate Cur. MA.....	60
Max. Sig. Plate Cur. MA.....	545
Plate to Plate, Ohms.....	8000
Driving Power, Watts.....	12
Power Output, Watts.....	700

203Z ZERO BIAS

UP TO
300 WATTS
Class B Audio Output
\$8.00

Class B Audio Operation

(value for 2 tubes) Max. ratings

DC Plate Voltage.....	1250
Bias.....	0
Peak AF Grid to Grid Voltage.....	220
Zero Sig. DC Plate Cur. MA.....	90
Max. Sig. Plate Cur. MA.....	350
Plate to Plate Load, Ohms.....	7900
Average Driving Power, Watts.....	8
Power Output, Watts.....	300

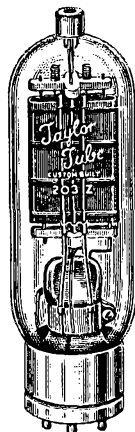

"More Watts Per Dollar"

TAYLOR TUBES, INC., 2341 WABANSIA AVE., CHICAGO, ILLINOIS

MORE NEW PRODUCTS FROM CARDWELL

MORE TYPE "J" FIXED AIR CONDENSERS

Thanks for your letters telling us you like the Cardwell "J" type Plug-In units and the Jack Base for them.

By request we present the "J" family group to date . . . three new ones and a modification.

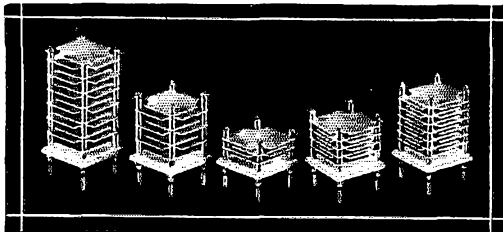

Every Barker-Williamson coil covered by suitable 50-50 mmfd. variable, with either a 50 or 25 mmfd. "J" fixed. Coto Coils for 160 meters use 70-70 mmfd. variable with 50 mmfd. "J" fixed.

Type	Capacity	Airgap	Length	List
JCO-50-OS	50 mmfds.	.250"	5 3/8"	\$5.50
JCO-25-OS	25 "	.250"	3 3/4"	4.00
JD-80-OS	80 "	.125"	4 "	5.50
JD-50-OS	50 "	.125"	3 3/16"	4.00
JD-25-OS	25 "	.125"	2 1/2"	2.80

All "J" types are 2 1/4 inches square

TYPE JB — Jack Base for "J" fixed units. Alsimag 196 — 2 3/8" x 2 3/8" x 1/4". Complete with mtg. posts, screws and nuts, list. . \$1.00

TYPE "E" FIXED MIDGET CONDENSERS

EO-100-F5, list. \$2.10

Complete line of "E" type midget fixed air condensers also available. Send for Cardwell bulletin on these and other new items.

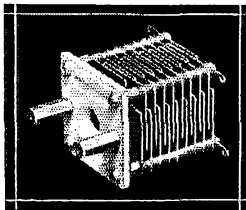

LO-FLEX INSULATED COUPLINGS

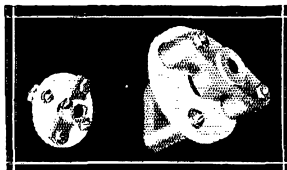

Inflexible, heavy duty couplings, permitting insulated extension or coupling of shafts where flexibility of the insulating member is undesirable.

TYPE CNF. High Power LO-Flex. 15,000 Volts. 1/2" x 2 1/4" diameter glazed Alsimag 196 Insulation, massive nickel plated composition castings. For any shaft up to one half inch. List. \$3.20

TYPE ENF. Medium Power LO-Flex. 10,000 Volts. Insulating disc 1 1/2" diameter Isolantite, wax impregnated. For 1/4" shafts. List \$1.00

Five pages of helpful data free. Ask for Cardwell bulletin "Condensers Used in Popular Manuals, Kits and Handbooks."

THE ALLEN D. CARDWELL MANUFACTURING CORPORATION
83 PROSPECT STREET, BROOKLYN, NEW YORK

No. New Jersey

W2PY	42510-52-273-A-40
W2QL	32501-47-293-A-40
W2JKH	23054-47-166-A-40
W2DZA	22717-49-155-A-30
W2JJE	21662-43-171-A-40
W2GVZ	16403-47-175-B-35
W2HZY	15660-36-145-A-24
W2CWC	15498-41-128-A-36
W2GSQ	15183-42-121-A-33
W2KAK	13926-44-106-A-34
W2IYM	13283-35-129-A-24
W2KHA	12168-39-107-A-37
W2HNT	11528-37-174-36 ¹⁸
W2IVC	11430-30-127-A-26
W2CMC	11184-32-117-A-26
W2JUU	11138-33-113-A-25
W2ECO	11070-41-135-B-28
W2JSS	11051-29-133-A-34
W2AFK	8964-24-126-A-25
W2GBY	6402-33-98-B-19
W2CFW	6090-29-70-A-19
W2DSV	5772-26-75-A-12
W2JUC	5418-21-86-A-19
W2BUT*	3808-32-61-B-18
W2KSM	3024-24-43-A-22
W2IMQ	2088-16-44-A-11
W2HFN	1936-22-44-B-12
W2GHO	1848-21-46-B-9
W2GME	1756-24-37-B-9
W2EIG	1584-16-33-A-9
W2IB	1254-19-33-B-22
W2FLJ	1080-20-30-B-9
W2GMF	864-12-24-A-7
W2JZW	684-12-19-A-11
W2JMS	683-13-19-A-12
W2CFS	420-10-14-A-7
W2JSE	378-9-15-A-7
W2IGE	324-9-12-A-7
W2GGW	126-6-7-A-1
W2GTA	90-5-6-A-7
W2KEG	18-2-3-A-1
W2KIL	3-2-2-1-1
Phone	
W2JME	13995-45-156-B-36
W2JV	12291-51-121-B-38
W2IUU	6240-39-80-B-19
W2JUN	5169-38-100-30 ¹⁸
W2JSE	168-2-28-A-1 ¹⁷
W2JUC	24-2-4-4-4
W2FWE	2-1-1-1-1
W2KNQ	2-1-1-1-1

MIDWEST DIVISION

Iowa

W9LEZ	48372-58-278-A-38
W9CFB	42456-61-233-A-40
W9TIJ	29518-49-196-A-39
W9DOX	13863-45-105-A-20
W9ARE	12614-53-119-B-20
W9MZF	9546-43-74-A-38
W9YXK	8742-38-78-A-26
W9SCZ	8364-41-103-B-23
W9RJE	8268-47-124-24 ¹⁸
W9LDB	7884-36-73-A-23
W9VFM	1728-16-37-A-15
W9VOY	1125-15-26-A-13
W9TGG*	216-9-12-1-1
Phone	
W9BAQ	32-4-4-4-4
W9FGQ	2-1-1-1-1

Kansas

W9AHR	45243-66-229-A-37
W9CWW	41958-63-222-A-40
W9YAH	23265-47-166-A-38
W9AWP	21750-50-145-A-27
W9YRS	12443-37-113-A-32
W9MFB	11172-38-98-A-28
W9PZA	7884-36-110-B-22
W9BYV	6303-33-96-B-22
W9AWR	4872-28-58-A-28
W9OWZ	2741-21-44-A-30
W9WIN*	651-14-16-A-7
W9ZGB	624-13-16-A-7
W9OAG	546-13-15-A-4
W9UEG	420-14-15-B-4
W9ZHH	330-10-11-A-3
W9YGG	315-7-15-A-3
W9SIL	12-2-2-A-1

Missouri

W9RSO*	54990-65-285-A-37
W9GHI	26442-52-170-A-32
W9VLP	25920-45-196-A-40
W9GBJ	22631-61-186-B-31
W9TPR	13662-46-99-A-19
W9JAP	10471-39-90-A-20
W9AUB	9185-39-79-A-29
W9VAV	5265-30-61-A-20

W9PWV	4248-24-59-A-25
W9WCM	3016-29-52-B-19
W9YZH	1607-17-34-A-22
W9KIC	1350-15-30-A-20
W9DIC	90-5-6-A-1

Nebraska

W9ZAR	28292-56-160-A-33
W9DMY	24795-57-145-A-28
W9HRT	75-5-5-A-3
W9ZJH*	2-1-1-1-1

NEW ENGLAND DIVISION

Connecticut

W1GME	32198-45-240-A-39
W1CLE	23814-54-147-A-40
W1AMQ	20535-37-186-A-38
W1KQY	17496-36-182-A-37
W1APA	15136-44-174-B-33
W1KKS	14127-34-141-A-40
W1KIJ	12894-42-155-B-38
W1AXB	12648-28-147-A-26
W1BLH	12462-31-136-A-31
W1CEJ	12426-38-166-B-35
W1BHM	12358-48-148-21 ¹⁹
W1JUD	10404-34-102-A-25 ²⁰
W1IGZ	7252-37-101-B-21
W1EAO	7000-40-88-B-20
W1HTI	5913-27-73-A-17
W1KAY	3825-17-114-B-14
W1JYW	3540-20-61-A-25
W1GKM	1824-16-39-A-6
W1EWF	1575-15-35-A-6
W1CTJ	1392-16-29-A-6
W1KBJ	1200-15-40-B-10
W1KKI	705-10-25-A-18
W1JLL	200-10-10-B-2
W1AFB*	112-7-8-B-1
W1JYJ	105-5-7-A-2
W1LII	90-5-6-A-2
W1HYF	72-4-6-A-1
W1GVK	24-3-4-1-1

W1TS	49728-64-260-A-40 ²³
W1AW	46182-61-382-B-40 ²³
W1UE	6300-28-75-A-14 ²²
W1BJB	1920-16-40-A-15 ²²
W1ES	1190-17-35-B-6 ²²
W1BDI	308-11-14-B-2 ²²

Phone

W1TTI	1176-14-28-A-8
W1EAO	3-2-2-B-1

Maine

W1GKJ	24633-51-165-A-40
W1LMD	20139-49-138-A-30
W1EB	612-12-17-A-8
W1CFS*	27-3-3-1-1

Phone

W1DAY	522-12-16-A-9
W1FBJ	182-7-13-B-1

Massachusetts

W1RY	55175-61-304-A-39
W1GEJ	29625-50-199-A-40
W1BUX	29040-55-177-A-38
W1IQH	23400-40-197-A-40
W1GCJ	23079-49-157-A-37
W1IKU	21210-35-203-A-37
W1IWC	18018-42-144-A-26
W1KHE	17055-45-190-B-38
W1ICA	15375-50-102-A-21
W1IFP	14280-34-140-A-24
W1IDU	12210-37-111-A-28
W1HKY	11985-47-127-B-31
W1ABG	11373-34-112-A-29
W1BEF	10108-28-183-B-33
W1BERH	6324-34-63-A-20
W1BPE	5724-24-80-A-25
W1JEA	5217-37-71-B-32
W1JXU	5022-27-63-A-1
W1JOX	4485-23-66-A-25
W1KPP	4278-31-69-B-11
W1KMS	4095-21-65-A-26
W1ILD	3593-21-57-A-11
W1ALG	3432-26-66-B-12
W1NA	3018-29-52-B-12
W1LPS	2079-21-33-A-15
W1KCV	1608-16-34-A-21
W1JYB	1368-19-24-A-13
W1BZO	1102-15-25-A-6
W1BDU	1092-14-27-A-15
W1BSG	1035-15-23-A-9
W1LIN	968-15-23-A-18
W1BEM	600-10-20-A-13
W1BSM	234-9-12-A-8
W1HA	210-7-10-A-6
W1ALP	200-7-10-A-7
W1JQZ	34-4-7-A-7
W1CTR	64-4-9-B-3

CENTRALAB Ceramic Capacitor

CERAMIC DIELECTRIC FOR LOW POWER FACTOR. COMPOSITION ALLOWS COMPLETE CONTROL OF CAPACITANCE-TEMPERATURE COEFFICIENT

HEAVY COPPER COATINGS MAKE TUBULAR CAPACITOR PLATES

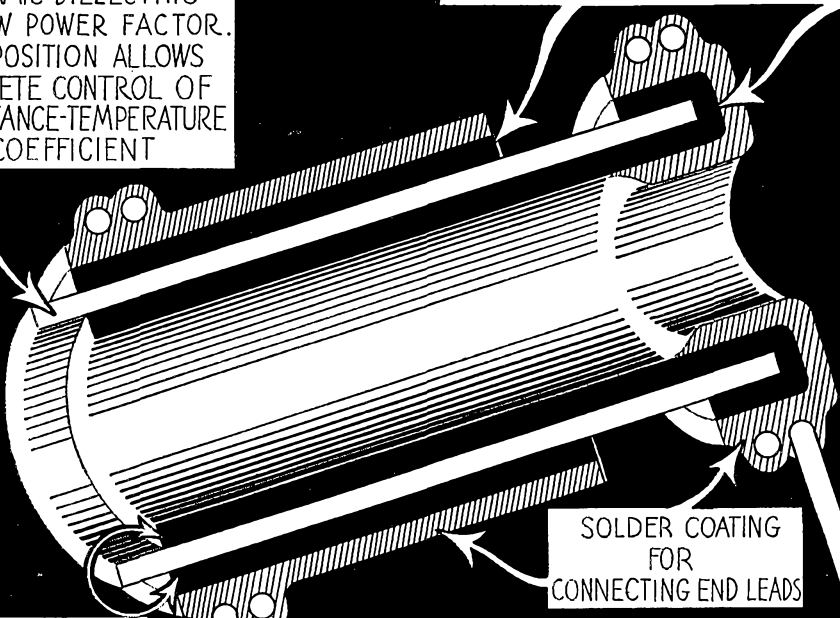

ADEQUATE PROTECTION AGAINST BREAKDOWN AT 1000 Volts

CROSS SECTION OF A CERAMIC CAPACITOR

SOLDER COATING FOR CONNECTING END LEADS

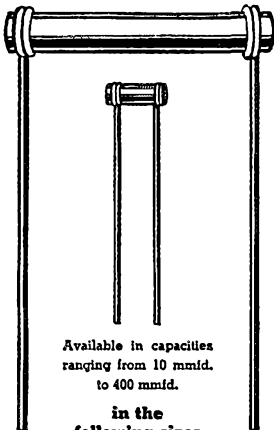

Available in capacities ranging from 10 mmfd. to 400 mmfd.

in the following sizes

- Type 816— $\frac{1}{4}$ x $1\frac{1}{2}$ inch
- Type 814 — $\frac{1}{4}$ x 1 inch
- Type 810— $\frac{1}{4}$ x $\frac{3}{4}$ inch
- Type 813— $\frac{1}{4}$ x $\frac{3}{4}$ inch

Introducing another member of the Centralab family

with the following characteristics and advantages:

- A single capacitor will provide any desired capacitance-temperature coefficient from 0 to a negative coefficient of .0007 mmfd. per mmfd. per degree centigrade.
- Ceramic dielectric has zero porosity. Capacity and power factor unaffected by aging or humidity.
- Low mass allows capacitor temperature to follow the chassis temperature closely.
- Capacitance remains constant at any frequency.
- Low power factor resin coating prevents moisture bridging between capacitor plates.

Manufacturers and set builders are invited to write our engineering department for more detailed data.

Centralab

CRL

Division of GLOBE-UNION INC., Milwaukee

"Spring is here" . . . and with it **PORTABLE MOBILE** operation

We have the **new equipment** to make operating a pleasure. Shown here is our **Type TR-7**, the result of experience with the popular Type TR-6A6 which it replaces. Improvements in all units have been made in step with new developments. The new cabinets are even neater and stronger . . . all chassis cadmium plated.

In addition to the TR-7 we make "The Compact", a five tube 2 v. battery operated portable transmitter . . . the "R510" midget four tube 6 v. loud-speaker receiver and the re-designed "Type HFM" . . . **Xtal Controlled 10 watt Phone-CW-MCW Transmitter for all frequencies** including 56 Mc.

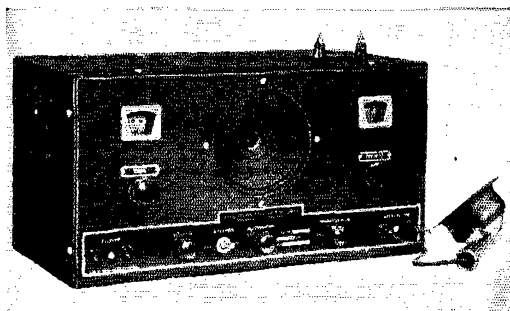

5 Meter Duplex Transmitter-Receiver Type TR-7

- Non-radiating Rec'vr
- 7 Tubes — 5" Dyn. Speaker
- 6E6 Unity Coupled
- 10 watt Carrier

- 100% Modulation
 - Duplex Operation — PHONE — MCW
- TRANSMITTER — RECEIVER**

\$47.70

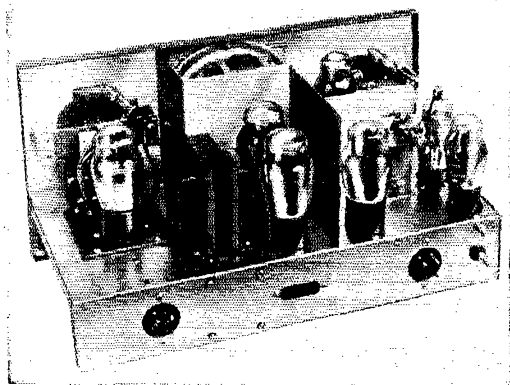

Type TR-7 Chassis

NEW LITERATURE IS READY

RADIO TRANSCEIVER LABORATORIES
8627 — 115 Street, Richmond Hill, New York

W1IGA*	60-6-9--	W7EK	31552-64-249-B-40
W1BB	55-5-6-B-10	W7EGE	29618-50-259-B-39
W1JQZ	44-4-6--	W7GLH	24570-52-158-A-30
W1JBO	41-3-5-A--	W7BYD	23085-45-175-A-38
W1NO	18-2-3-A-2	W7LDA	13734-42-109-A-34
W1HLX*	12-2-2-A-1	W7EFA	7227-33-112-B-24
W1IQO	3-1-1-A--	W7PSD	3744-26-65-A-20
Phone		W7GQW	3519-23-52-A-19
W1BEF	180-9-10--	W7GPN	2700-27-50-B-23
W1ALB	105-5-7-A-14	W7EJP	2682-31-74--22
W1HPB	12-3-4--	W7EHU	1980-20-34-A-12
W1QO	3-1-1-A--	W7GAD	924-14-22-A-9
W. Massachusetts		W7BTO	765-15-26-B-10
W1EOB	34632-52-224-A-32	W7BYK	432-9-16-A-5
W1HNE	9810-30-109-A-19	W7GBF*	432-8-18-A--
W1KQJ	7803-46-149--36	W7PZB	285-5-19-A-4
W1BIV	4389-29-77-A-16	W7CWN	143-5-10-A-4
W1AJ	4060-29-70-B-21	W7AFC	90-5-6-A-3
W1DOH	594-11-19-A-6	W7AFC	68-5-5-A-3
W1KJV*	479-11-15-A-6	W7PKC	24-2-4-A-2
W1GJ	12-2-2-A-2	Phone	
W1KVN	4-1-2--	W7BYD	858-13-22-A--
Phone		W7AXS	112-7-8-B--
W1DYA	4-2-2--		

New Hampshire

W1BFT	48126-52-310-A-40
W1AVJ	41292-62-224-A-40
W1IVU	29046-47-206-A-39
W1IP	16650-30-185-A-27
W1HOU	14490-42-115-A-28
W1FTJ	14001-26-180-A-40
W1JCA	13122-36-122-A-30
W1AWU	9867-26-127-A-22
W1HOV	7308-28-87-A-16
W1LEJ	5304-26-102-B-22
W1GKE	2376-22-36-A-12
W1KIN	1302-14-31-A-7
W1JJD	759-11-23-A-7
W1WL	40-4-5--

Phone

W1APK	420-10-21-B-8
W1LJB	2-1-1-B--

Rhode Island

W1GBO	22464-54-208-B-40
W1BBN	21624-53-204-B-39
W1DIL	21218-41-176-A-28
W1KCS	13596-44-104-A-31
W1AQ	11428-45-136--22
W1KOF	6475-35-97-B-23
W1HRC	3591-27-67-B-12
W1JUE	3245-21-52-A-14
W1AOP	2322-27-44-B-14
W1KIH	975-13-25-A-9
W1IZO	308-11-14-B-5
W1JNO	90-5-6-A-1

Vermont

W1EZ	74295-65-382-A-40
W1PSV	5072-23-74-A-8
W1AXN	1914-22-29-A-11
W1KIE	1277-14-31-A-16
W1KVB	666-12-20-A-15
W1JVS	572-13-22--

NORTHWESTERN DIVISION

Idaho	
W7GFN	19986-42-162-A-39
W7BRU	12150-50-122-B-27
W7FRK*	720-12-20-A-5

Phone

W7FRA	18-3-3-B-2
W7ARS	2-1-1--
W7GGH	2-1-1--

Montana

W7EWR	20288-49-138-A-28
W7EOD	5250-28-61-A-21
W7FXF	1482-19-26-A-11
W7CRH	1242-18-23-A-4

Phone

W7CPY	1620-18-30-A-8
W7FL	2-1-1--

Oregon

W7EYB	27378-54-168-A-38
W7BIM	23135-53-148-A-39
W7EZK	14268-41-117-A-25
W7ASG	9803-33-98-A-31
W7CYU	6897-37-91-B-34
W7BTH	2709-21-43-A-7
W7FXM	1688-15-39-A-14
W7DP	1131-13-30-A-15
W7ELO	585-15-20-B-7

Phone

W7GKJ	429-11-13-A-7
-------	---------------

Washington

W7CMB	33201-62-182-A-40
-------	-------------------

Hawaii

K6CGK	11172-38-100-A-22
K6JPD	9861-38-87-A-15
K6LBH	4836-26-64-A-29

Santa Clara Valley

W6HZT	49749-69-371-B-40
W6NCO	21600-48-151-A-25
W6MUR	17433-39-149-A-26
W7CQO	69324-37-35-A-34
W6PBV	4455-22-68-A-21
W6AMM	3840-32-58-B-11
W6MXE	2-1-1--

East Bay

W6TT	19883-59-169-B-29
W6MVQ	19580-55-179-B-28
W6LMZ	10672-46-116-B-30
W6NGC	8918-29-103-A-32
W6EJA	4500-27-85-B-27
W6DHS	4290-33-65-B-20
W6PFD*	558-12-10--

Phone

W6ITH	47196-69-342-B-40
W6OCH	12336-48-129-B-27

San Francisco

W6GFB	33300-60-185-A-39
W6NEN	20790-42-168-A-38
W6ABB	20250-50-135-A-39
W6IPH	10062-43-116-B-33
W6CIS	1280-20-32-B-7
W6NDS	780-10-26-A-9
W6LCS	741-13-19-A-8
W6OSW	27-3-3-A-1

Sacramento Valley

W6MMD	12705-35-121-A-37
W6IZE	12192-48-130-B-26
W6NEA	7308-42-87-B-17
W6NFD	1824-16-39-A-13
W6NKT	980-20-26-B--
W6KZG	570-10-19-A-10
W6OAA	221-7-13-A-6

Phone

W6EJC	3478-37-47-B-17
-------	-----------------

San Joaquin Valley

W6MVK	96180-70-460-A-39
W6ATH	9760-40-122-B-24
W6NIQ	4048-29-47-A-16
W6OFD	18-3-3-B--

Phone

W6CQI	8237-54-98--35
W6LWU	7766-31-86-A-38

ROANOKE DIVISION

North Carolina

W4DW	18950-50-100-B-31
W4BYD	8652-42-103-B-20
W4ESO	6390-27-81-A-28
W4CFR	5265-27-65-A-21
W4CIE	5032-34-74-B-15
W4DWA	2070-20-36-A-17
W4CQO	465-10-16-A-4
W8KKG-4*	2-1-1--

Phone

W4OC	11801-52-114-B-38
W4TO	507-13-20-B-2
W4RV	8-2-2--
W4AHY	2-1-1--

South Carolina

W4ALT	1425-19-27-A-12
-------	-----------------

4 EIMAC 35T's
 give a "normal" output of
475 WATTS
 with this transmitter

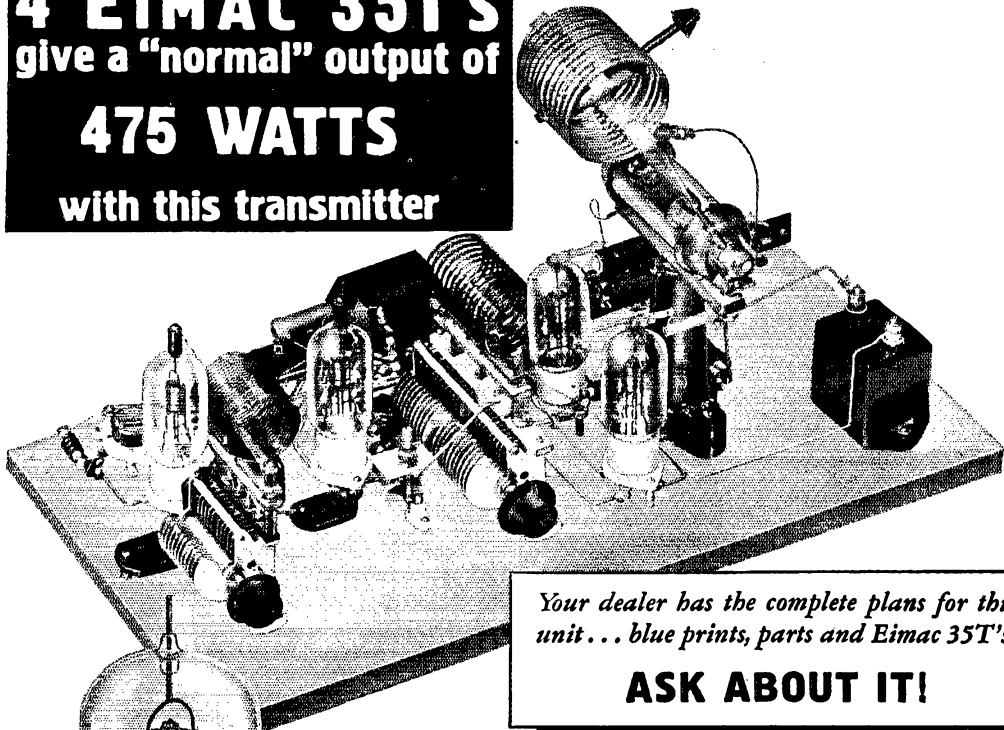

Your dealer has the complete plans for this unit . . . blue prints, parts and Eimac 35T's.

ASK ABOUT IT!

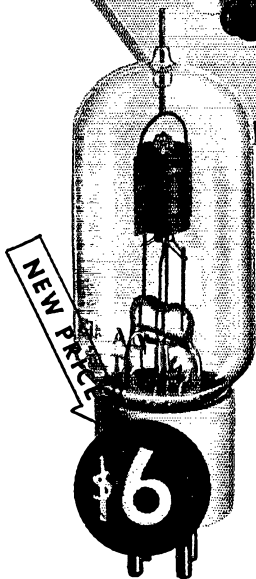

When the first Eimac tubes were placed on the market, thousands of radio operators experienced a new conception of tube performance. This was due to Eimac's radical departure from conventional design, far superior construction, revolutionary technical advances. Eimac changed the old standards; set new marks which have since never been equaled.

Conventional tube appearances were changed; prices cut; ratings boosted; but Eimac has continued to maintain top place. One outstanding example of this is exemplified in the 35T tube.

The transmitter illustrated on this page has been written about, talked about and lectured about, by radio men from coast to coast for the past two years. It was constructed by the Eimac research department in order to test the 35T tube under extraordinary operating conditions. One 35T is used as a crystal oscillator, one as a frequency multiplier and two connected in push-pull in the final.

This little "rig" gives a "normal" output of 475 watts on 160, 80, 40, 20 and 10 meters. A 160 meter crystal being used on 160, 80 and 40 meters, while a 40 meter crystal permits operation on 40, 20 and 10 meters. It operates at 600 watts input to the final, being excited by the fourth harmonic of the crystal by means of the frequency multiplier. As an example of the stamina of Eimac 35T's, this transmitter was operated, through the entire phone contest, with 1000 watts input (4000 volts; 250 milliamperes) to the final; carrier power 850 watts, 100% modulated. No other tube of like power ratings has equaled this performance.

Ask your dealer today for complete details of this assembly. Actual construction plans are available for your use, or your dealer may be equipped to construct the entire transmitter for you.

Eimac
TUBES

EITEL-McCULLOUGH, Inc.
 San Bruno, California

QUALITY ALONE

SELLS THIS RECEIVER



The UNITED 966 (866) became one of the leading tubes of 1937 — not because of its low price, but purely on its easily recognized superior standards.

Pick up a set of UNITED 966 tubes and compare with any other make.

Notice the **deflecting baffle** to keep proper balance between condensed mercury and ambient temperature.

Notice the way the mercury has been introduced in a measured amount — **no free mercury** to splash around the tube and contaminate the elements — no amalgams on baffle, filament or anode.

Put them in your transmitter — don't wait for the usual 15 minutes preheating — they'll start safely in a few seconds. This is only guaranteed with UNITED 966.

Insist on UNITED rectifiers next time. If your dealer is out of stock — send us your order.

Price \$1.50

UNITED ELECTRONICS CO.
42 SPRING STREET
NEWARK NEW JERSEY

Phone W4BQE	4896-36-69-B-27	W6NGD W6MAJ	7964-44-92-B-16 3-1-1-A-1
<i>Virginia</i>		<i>Los Angeles</i>	
W3FMY	29640-57-261-B-39	W6BXL	51777-66-262-A-40
W3EMA	27840-58-160-A-40	W6GAL	20855-55-189-A-32
W3AAF	23922-54-221-B-39	W6MXN	28358-51-187-A-1
W3GWP	12519-39-107-A-36	W6HEW	28500-53-256-B-36
W3FQP	11374-47-121-B-19	W6DIO	15370-53-145-B-28
W3GKL	8640-40-111-B-23	W6MNA	7020-30-78-A-17
W3GTS	7152-32-75-A-11	W6AQJ	6720-42-81-B-21
W3FJ	6848-41-75-18 ³⁰	W6OWC	4992-32-80-B-25 ³⁸
W3CSY	4662-28-55-A-20	W6KSX	4872-28-59-A-23
W3GWQ	3654-29-42-A-28	W6IOX	3927-33-60-B-20
W3FBL	1770-20-30-A-14	W6CPM	3498-22-53-A-12
W3GBK	1351-17-26-A-5	W6LJD	2604-28-47-B-19
W3GPV	200-7-10-A-4	W6PCP	1962-12-55-A-15
W3GD [*]	2-1-1-1-1-1	W6MXC	880-11-40-B-8
Phone		W6NPL	612-17-19-B-1
W3GD ^X	1980-20-33-A-10	W6MQS	585-10-20-A-10
<i>West Virginia</i>		W6LFX	540-8-23-A-7
W8OXO	18075-50-124-A-30	W6NTR [*]	396-11-12-A-2
W8LCN	16560-46-121-A-29	W6DTY	390-10-13-A-7
W8JJA	14456-52-140-B-30	W6LND	192-8-8-A-12
W8HD	3908-31-63-B-15	W6OIU	188-5-13-A-1
W8BHG	2040-20-37-A-15	W6FLS	24-3-4-B-1
W8BWK	1344-14-33-A-10	Phone	
W8KSJ	2-1-1-B-1	W6AM	2976-29-57-7 ³
		W6MPK	2254-23-49-B-22
		W6BWG	1033-23-43-B-14
		W6BUK [*]	2-1-1-B-1
		<i>San Diego</i>	
ROCKY MOUNTAIN DIVISION		W6TTY	45360-60-254-A-39
<i>Colorado</i>		W6EPZ	25960-59-220-B-36
W6FFU	62496-62-336-A-37	W6LVB	19856-43-155-A-33
W6TSS	28210-62-228-B-40	W6GTM	17738-55-108-A-31
W6WTW	25868-54-223-B-38	W6JQB [*]	3480-20-87-B-1
W6RRS	23100-50-154-A-32	W6NGN	2346-17-46-A-16
W6YDW	13992-44-117-A-28	W6OAM	1932-14-46-A-1
W6TDR	2277-23-33-A-7	W6OLU	456-8-20-A-9
W6CAA [*]	656-16-18-B-1		
W6ZNL	348-8-15-A-7	WEST GULF DIVISION	
Phone		<i>Northern Texas</i>	
W6PWU	39411-58-228-A-34	W5BTS	30324-56-184-A-35
W6FUH	10253-47-126-30 ⁸¹	W5ROE	27360-57-242-B-39
		W5FBQ	25872-50-157-A-39
<i>Utah-Wyoming</i>		W5GBC	19272-49-137-A-25
W6KOP	32329-54-204-A-39	W5AMO	8322-38-73-A-20
W6PDV	19264-56-178-B-39	W5FZU	7347-31-70-A-22
W6LXI	18008-49-123-A-30	W5BAM	7193-35-69-A-17
W7DES	7783-43-92-B-26	W5DGP	2880-24-40-A-16
W7GCO	3872-29-45-A-15	W5AWT	1073-13-28-A-18
		W5DXA [*]	270-9-10-A-1
		W5DQD [*]	24-3-4-1-1
		<i>Oklahoma</i>	
SOUTHEASTERN DIVISION		W5AQE	40992-56-245-A-40
<i>Alabama</i>		W5FLU	35496-58-207-A-40
W4CYC	55872-65-287-A-39	W5CJZ	16688-56-150-B-31
W4ELQ	25262-63-201-B-34	W5FFW	12646-45-145-B-29
W4APU	17550-45-131-A-23	W5GOQ	12036-42-96-A-22
W4EDR	16800-40-142-A-33	W5EGP	9078-34-89-A-16
W4AII	7772-33-79-A-23	W5BQA	4176-32-44-A-26
W4BJA	5873-31-61-A-11	W5FOM	3240-24-45-A-15
W4BHY	5408-37-75-B-17	W5KZL-5	1922-21-32-A-22
W4AHP	90-6-8-B-3	W5FRB	1125-15-25-A-8
		W5FFK	609-14-20-A-1
		<i>Southern Texas</i>	
<i>Eastern Florida</i>		W5CPB	45978-64-246-A-38
W4COV	25358-49-175-A-35	W5FZD	42579-57-253-A-39
W4EFM	24771-46-180-A-37	W5DB	28755-54-178-A-31
W4DCZ	10800-45-121-B-20 ⁸²	W5ESL	10320-43-124-B-31
W4COB	9372-44-107-B-20	W5CWW	4848-32-51-A-16
W4DIQ	4901-33-50-A-14	W5FJM	4158-28-49-A-20
W4JO	2400-20-40-A-14	W5ARO	1377-17-27-A-7
W4FGL	2138-19-39-A-14	W5EWF	378-9-15-A-15
W4DBF	1560-20-39-B-12	W5AFL	12-2-2-A-2
W4BYR	660-11-20-A-8	Phone	
W4EVP	594-11-18-A-16	W5CTC	6952-44-82-B-25
W4EFC	525-10-18-A-8	W5DB	216-6-12-A-3
W4EBE	180-8-8-A-6	W5ATW	105-5-7-A-6
W4BYF [*]	27-3-3-A-1		
Phone		<i>New Mexico</i>	
W4HZ	2-1-1-1-1-1	W5GEY	35235-58-203-A-36
		W5CJP	21492-54-203-B-39
<i>Western Florida</i>		W3DPE-5	10646-47-76-A-28
W4BSJ	16110-45-179-B-27	W5ZM	2625-25-35-A-10
W4EPT	10086-41-86-A-21	W5CGJ [*]	192-8-12-B-5
W4EAD	9243-39-79-A-31		
W4MS	3255-35-48-B-1	CANADA	
		<i>Maritime</i>	
<i>Georgia-Cuba-etc.</i>		VEIEP	39447-54-248-A-37
W4ECZ	32505-55-198-A-35	VEICU	2370-20-42-A-25
W4VX	23828-45-181-A-31	VEIKJ	2243-23-33-A-12
KADTH	6192-36-87-B-33	VEIGJ	882-12-25-A-9
W4ABS	5680-32-89-B-33		
CM2OP	4380-30-54-A-9	<i>Ontario</i>	
W4EQI	2508-22-38-A-19 ⁹⁴	VE3JT	42060-60-351-B-40
W4PM	612-17-20-B-5		
K5AA	3304-28-59-B-14 ⁹⁹		
Phone			
CO2WM	144-6-8-A-4		
SOUTHWESTERN DIVISION			
<i>Arizona</i>			
W6KFC	74112-64-386-A-40		
W6LAI	10823-39-94-A-31		



RHOMBIC and DUMMY ANTENNAS

IN MARCH we discussed the frequency characteristic of various low wattage resistors such as are used in receiving sets or other applications where the power dissipation is small. Dig into that page again.

We make a resistor that has negligible change at high frequencies by using an extremely thin film of metallized material, bonded to an insulating cylinder.

For a long time we have realized the need for these same characteristics in a job which would dissipate enough power to be used in a Rhombic antenna. Such a resistor would also be useful as a dummy antenna load in tuning up, testing, and measuring the output of a transmitter.

The humanitarian benefits of such a device are obvious:

ITEM NO. 1. With a terminated Rhombic, the average ham with low power can increase his power gain from 5 to 30 times by concentrating it **where he wants it and nowhere else.**

By the same token, his receiver will have increased gain in that direction only, less interference from other directions, and hence a tremendous increase in ratio of desired signal to undesired. In addition to this, the terminated Rhombic, while limited to 1 direction, can be used on any of the high frequency bands with the same set of untuned feeders. If you have the room, it is more effective to put up 2 or 3 Rhombics than to sink the same money in a high power final.

ITEM NO. 2. If all the hams who ruined your best bit of DX by testing with a long string of "V's" were laid end to end, wouldn't you be happy? A dummy antenna is the answer for tuning up and testing. Modern broadcast transmitters have a dummy antenna built in so that they can be tested without going on the air. It is simply coupled to the final tank circuit in place of the regular antenna.

We have been working on a resistor for this application for many months. The obvious way to make a high power resistor is, of course, to make it of alloy wire or ribbon. There are several "non-inductive" windings on the market that are fine up to 3 megacycles, but tests indicate that they have too much inductance or distributed capacity to hold

LIFE
BEGINS ON 40 WITH A
RHOMBIC

constant impedance at high frequencies.

Our line of development has been in applying our metallized coating directly to large Isolantite cylinders. The results are interesting. They have been successfully

used in high power experimental transmitters operated at 90 megacycles. They will dissipate considerable power, if there is good air circulation around them — certainly in the case of a resistor on the end of an antenna. In a commercial rig, as a dummy antenna, two cylinders 2" in diameter x 18" long have been used to dissipate 5 Kw. by water cooling them. You won't want such an elaborate set-up, but it indicates some of their capabilities. And, most important of all, they are a close approach to a pure resistance.

You will find helpful information on Rhombics in these sources:

Proceedings I.R.E., August 1931, Page 1406, E. Bruce.

Proceedings I.R.E., January 1935, Page 24, Bruce, Beck & Lowry.

Proceedings I.R.E., October 1937, Page 1327, D. Foster.

Bell Laboratories Record, April 1932, Page 291, E. Bruce.

QST, November 1936, Page 28, Hull & Rodimon.

QST, April 1937, Page 21, Moore & Johnson.

QST, May 1937, Page 42, R. C. Graham.

QST, February 1938, Page 50, "Hints & Kinks".

Radio, November 1937, Page 57, Moore & Johnson.

Radio, December 1937, Page 23, C. B. Stafford.

The Radio Amateurs Handbook, 1938 Edition, Page 316.

"Radio" Antenna Handbook. The above articles range all the way from a mathematical analysis of Rhombic antennas (such as Foster's article in the I.R.E. Proceedings) to highly practical articles on their installation and adjustment (such as the ones in QST and Radio).

In another month our power-type high-frequency resistors will be available commercially. Be sure and see your IRC jobber next month for more complete information.

INTERNATIONAL RESISTANCE COMPANY
401 NORTH BROAD STREET, PHILADELPHIA, PA.

ADVERTISEMENT

Say You Saw It in QST — It Identifies You and Helps QST



**A CONTROL GRID, MERCURY VAPOR
KEYING RECTIFIER**

★ HERE is the Keying Rectifier you have been waiting for. The SHELDON KY866 is a new, half-wave mercury vapor keying rectifier with a control grid. It utilizes the same filament voltage and current as any standard 866 tube. What's more, it can replace an 866 without circuit changes because it has a standard base.

"Hams" everywhere recognize KY866 as the best method yet developed for pre-filter keying. It eliminates heavy, arcing relays, prevents "key-clicks" . . . and for the first time makes smooth, trouble-free operation possible.

UNSOLICITED TESTIMONY

W8AU — "I think you have a real tube for the amateur. The remarkable thing to me is the absence of tails and clicks which makes high speed bug and break-in operation a simple matter."

W2BMX — "The keying is entirely free from any chirps or tails. The make and break is positive. Their operation in the "ham" rig is something which just can't be excelled."

To avoid delay, we suggest that you order at once.

SHELDON KY866 - \$4.00 Net Price
SHELDON 866 - 1.50 " "

Made by RECTIFIER SPECIALISTS

SHELDON ELECTRIC CO.

76-82 COIT ST., IRVINGTON, N. J.
626 W. JACKSON BLVD., CHICAGO, ILL.

VE3GT	40824-56-248-A-40	VE2MU	5346-27- 66-A-22
VE3AU	25599-53-161-A-20	VE2LI	2375-25- 49-B-19
VE3HP	19478-53-125-A-34	VE2HI	1385-13- 36-A-14
VE3ATX	17181-46-125-A-30	VE2JZ	710-11- 22-A- 7
VE3VA	170- 8-44-129-A-23	VE2DQ*	32- 4- 4-B- 1
VE3AET	16758-42-135-A-34	Phone	
VE3ZE	15818-37-144-A-35	VE2KX	4104-36- 54-B-15
VE3PE	14544-32-152-A-23	VE2DQ	351- 9- 13-A- 4
VE3HB	14100-40-110-A-33	Alberta	
VE3DV	12750-34-126-A-31	VE4GE	26625-50-183-A-30
VE3TA	12258-36-114-A-19	VE4GD	25281-53-160-A-38
VE3AJB	11520-32-121-A-31	VE4VJ	8550-34- 77-A-21
VE3HE	11078-35-108-A-34	VE4ADW	6485-33- 67-A-29
VE3AKD	8873-35- 85-A-27	VE4WJ	1770-20- 31-A-13
VE3SG	8658-26-111-A-31	VE4TY	660-11- 20-A- 6
VE3QB	7017-29- 82-A-27	Phone	
VE3PL	6034-27- 75-A-26	VE4PK	2- 1- 1- - -
VE3AQB	5438-29- 63-A-25	British Columbia	
VE3IW	3528-28- 43-A-23	VE5FG	29250-52-191-A-39
VE3WK	3245-21- 52-A-18	VE5QP	22658-53-144-A-38
VE3VD	3066-28- 37-A- 8	VE5QA	19305-45-146-A-39
VE3AGP	2864-23- 44-A-17	VE5SW	12444-34-122-A-40
VE3DU	2363-21- 39-A-14	VE5II	8069-33- 83-A-22
VE3ACI	2310-20- 40-A-15	VE5KL	6138-32- 62-A-15
VE3ACB	1767-19- 31-A-19	VE5UK	1238-11- 38-A-26
VE3RF	1566-18- 29-A-10	VE5ABI	3- 1- 1-A- 2
VE3AER	1530-17- 30-A-14	Manitoba	
VE3AE	405- 9- 15-A- 4	VE4KX	17493-49-121-A-22
VE3AJM	273- 7- 13-A- 6	VE4AAW	4032-28- 48-A-23
VE3ACX*	75- 5- 5-A- 3	Phone	
Phone		VE4QO	72- 6- 6- - -
VE3AL	16536-53-162-B-25*7	Saskatchewan	
VE3BF*	8- 2- 2- - -	VE4ZC	15093-43-119-A-40
VE3AGT	2- 1- 1- - -	VE4QZ	12177-41-101-A-35
VE3OC	2- 1- 1- - -	VE4AJA	7104-37- 65-A-36
Quebec		VE4CQ	6195-35- 60-A-21
VE2IN	31164-49-214-A-37	VE4UN	5495-33- 56-A- -
VE2GE	28638-43-225-A-35**	VE4MB	3450-25- 47-A-17
VE2JI	18900-45-144-A-38	VE4PQ	54- 3- 6-A- 2
VE2JD	18000-40-150-A-36	Phone	
VE2DR	15996-62-129-B-27	VE4HU	2- 1- 1- - -
VE2AA	9158-33- 93-A-31		
VE2DJ	7308-28- 87-A-30		
VE2IA	6567-22-102-A-25		

DX Contest Highlights

(Continued from page 11)

W1AXA, 35,000.

It's too soon to have any foreign scores, but we heard that CO2JJ made 48,022 and VK2GU made 42,000.

There was a good deal less out-of-band operation this time than in the previous contest. There will be some disqualifications, perhaps two-thirds as many as before. A few of the reporting stations that would have made this write-up are unavoidably missing, since their early listing in Official Observers' reports points to the likelihood of sufficient weight of evidence to disqualify, when all O.O.'s have reported and all evidence is evaluated. Lists of those disqualified by observer reports will appear with the final write-up this year. The greater observance of authorized frequencies speaks much better for a amateur radio.

To all those who so graciously helped us in compiling this report, we offer our sincere thanks.

Quick Frequency Change

(Continued from page 26)

Tuning the transmitter is not any more difficult than adjusting a more conventional layout. A crystal around 3550 kc. is switched into the oscillator, and the plate circuit of the oscillator and the grid circuit of the 807 buffer doubler are peaked for maximum response. The tuning will be quite broad. The 807 plate-100TH grid unit, *L4L5*, is then plugged in and resonated. With the high value of grid leak used on the 100TH the grid current will only run around 10 milliamperes on 14 Mc. and a little higher on 7 Mc., but this will be quite adequate. The current should

quality above all



SOLAREX

Oil Impregnated

TRANSMITTING CAPACITORS

- Ratings of 1, 2 and 4 mfd. in operating voltages of 1000, 1500, 2000 and 3000 D. C.
- Heavy metal cans, with deeply imbedded insulators.
- Full voltage protection.
- Outstanding value. — Ask your dealer about the **very reasonable** Solarex prices.

Catalog upon request

SOLAR MFG. CORP., 599-601 BROADWAY, NEW YORK, N. Y.

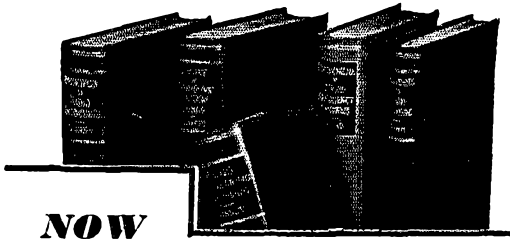

NOW
this high-powered radio engineering library

sent to you for 10 days' trial—
 at a special price and terms

These books cover circuit phenomena, tube theory, networks, measurements, and other subjects—give specialized treatment of all fields of practical design and application. They are books of recognized position in the literature—books you will refer to and be referred to often. If you are a researcher or experimenter—if your interest in radio is deep-set and based on a real desire to go further in this field—you want these books for the help they give in hundreds of problems throughout the whole field of radio engineering.

RADIO ENGINEERING LIBRARY

—especially selected by radio specialists of McGraw-Hill publications

—to give most complete, dependable coverage of facts needed by all whose fields are grounded on radio fundamentals

For home-study and reference. Contains a revised selection of books culled from latest McGraw-Hill publications in the radio field.

5 volumes, 3064 pp., 2000 illustrations

1. Glasgow's PRINCIPLES OF RADIO ENGINEERING
2. Terman's MEASUREMENTS IN RADIO ENGINEERING
3. Chaffee's THEORY OF THERMIONIC VACUUM TUBES
4. Hund's PHENOMENA IN HIGH-FREQUENCY SYSTEMS
5. Henney's RADIO ENGINEERING HANDBOOK

Special Low Price and Easy Terms

Bought singly, the five volumes comprising this library would cost you \$25.00. Under this offer you save \$1.50 and, in addition, have the privilege of paying in easy installments beginning with \$2.50, 10 days after receipt of the books, and \$3.00 monthly thereafter. Take advantage of these convenient terms to add them to your library now.

SEND THIS ON-APPROVAL COUPON

McGraw-Hill Book Co., Inc.
330 W. 42nd St., New York, N. Y.

Send me Radio Engineering Library, 5 vols., for 10 days' examination on approval. In 10 days I will send \$2.50, plus few cents postage, and \$3.00 monthly till \$23.50 is paid, or return books postpaid. (We pay postage on orders accompanied by remittance of first installment.)

Name.....
 Address.....
 City and State.....
 Position.....
 Company..... QST-5-38
 (Books sent on approval in U. S. and Canada only.)

not vary by more than 10 per cent over the full range of the 7- or 14-Mc. bands. Once these units have been adjusted there will never be any further need for tuning them; they are simply plugged in as the occasion demands. The 100TH plate-250TH grids unit, L_6L_7 , is plugged in and resonated for the center of the band being used. Because the tubes are triodes working at relatively high voltages, the response here will not be as flat as is obtained over the bands for the 807 and RK-25, but rated grid current can be obtained for the final amplifier at each end of the bands without exceeding the ratings of the 100TH, and it is therefore considered satisfactory.

The final amplifier and antenna circuits are easy to tune. A crystal near the high-frequency end of the band is selected and the amplifier and antenna tuned in the ordinary fashion. When a crystal near the low-frequency end is selected, the crystal switch also cuts in the small padding condensers, and all of the tuning is done with them for this end of the band. Of course the final output is not uniform over the entire band but it stays fairly constant over 100 kc. on 14 Mc.

When changing bands, it is only necessary to plug in the proper coils and tune the driver plate-final grid and the final plate and antenna circuits. And once they are set you can go scouting around the band without being afraid that you will get caught in the wrong part.

A great deal cannot be said for the present transmitter other than that it does get around. It is still felt that the quick-change transmitters of the future will utilize ganged tuning controls, either manually- or motor-driven, because that is the only way that the tubes can be operated at top efficiency, a requirement quite dear to the heart of any self-respecting ham. However, this particular transmitter is relatively simple, and is still novel-enough looking so that we still wonder who could have built it!

Atlantic Division Convention

(Continued from page 46)

Hamfesting, A.R.R.L., A.A.R.S. and N.C.R. meetings will be held for those interested in these activities. All those desiring to be initiated in the Royal Order of the Wouff Hong will have the opportunity. Further information may be obtained from G. E. Marshall, W3DAP, Secretary, 146 You St. N. E., Washington, D. C.

A 5-, 10- and 20-Meter Converter

(Continued from page 29)

the antenna post. On sets designed for use with doublet type antenna lead-in, the connection of one of the two doublet posts to ground is used, just as it would normally be made to the receiver ground post when used with a single-wire lead-in antenna. This is the type of receiver referred to above as the inductive-coupled antenna type with which best results will be obtained by use of the reduced secondary winding for L_s .

The cable used with this converter is only three feet long, including the length shown running

THE **254** A NEW MEDIUM
PRICE TRIODE

GAMMATRON

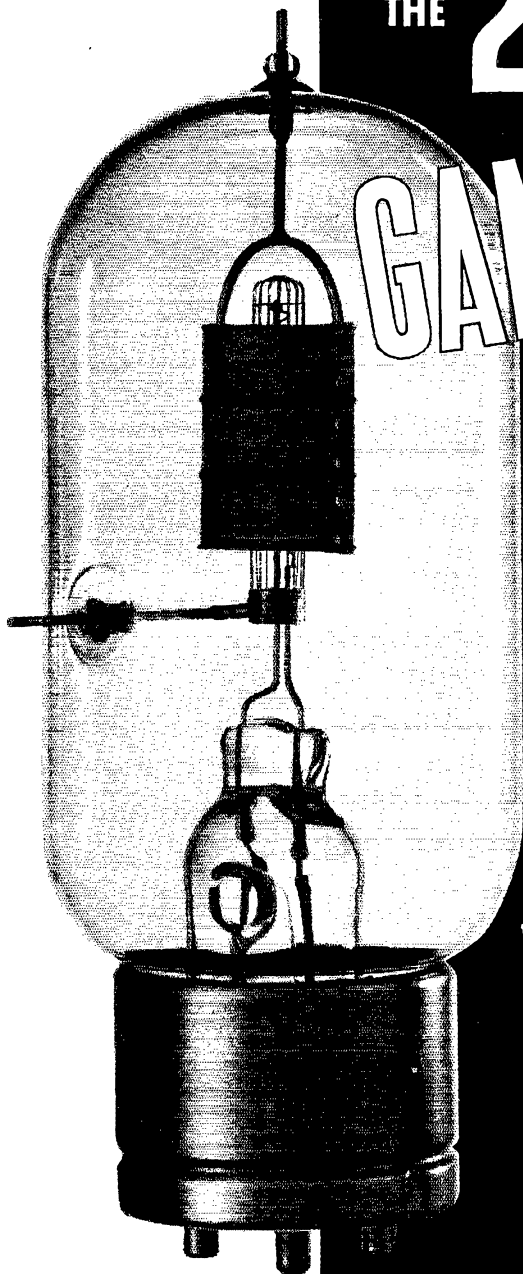

100 Watt Plate

MU = 25

Tantalum Grid
and plate

NONEX envelope

No "Getter"

MAX. plate ma = 200

MAX. plate volts = 3000

A NEW TUBE VALUE

\$12⁵⁰

AT YOUR DEALER

HEINTZ AND KAUFMAN
SOUTH SAN FRANCISCO LTD CALIFORNIA U. S. A.

MORE POWER AT A LOWER PRICE

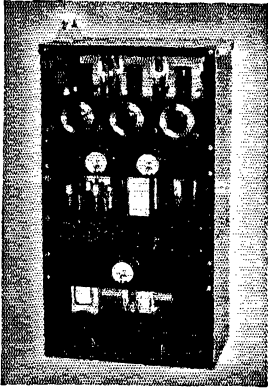

GROSS CB55 Radiophone Transmitter

FB. FOR 30 MC. — Input: 95 watts. Uses: 2-T20 tubes in R.F. and 6L6's in Modulator. Coils available for 30, 14, 7, 3.5, and 1.7 mc. Descriptive bulletin on request.

GROSS CB200 200 Watt Transmitter

See March *QST*. Write for descriptive Bulletin — and remarkably low price.

"THE STANDBY" (2 to 2000 Meters) 3 TUBE A.C. AND D.C. RECEIVER

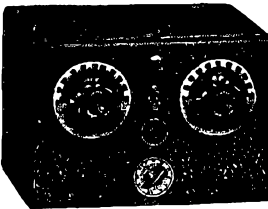

This excellent 2 to 2000 meter receiver is offered with full realization of the present-day need of the amateur for a dependable "stand-by" receiver which will cover practically all of the radio bands in use today. Super regeneration, which is the most efficient form of detection at these frequencies, is used from 2 to 15 meters. By throwing a toggle switch, straight regeneration and

higher wavelengths up to 2000 meters may be had. Throughout the entire tuning range, there are no skips or dead spots. Loud speaker volume is available from practically every station received.

- Power supply incorporated. ● Individual antenna tuning for high and low wave ranges. ● 1-76 super regenerative detector, 1-6J7 regenerative detector, 1-12A7 audio amp. and rectifier.

Complete kit of parts less coils, tubes, cab.	\$7.59
2-5-10 meter coils (set of 3)95
9.4 to 15 meter coil39
15-200 meter coils (set of 4)	1.39
200-310 meter coil39
310-550 meter coil36
550-1050 meter coil60
1000-2000 meter coil60
Metal cabinet	1.50
Kit of three tubes	2.40
Wired and tested in our lab., additional	2.00

GROSS RADIO, INC.

51 VESEY STREET NEW YORK

Cable Address: GROSSINC

along the inside corner in the chassis. It is desirable to keep this cable as short as operating convenience will allow.

The plug-in coils used for 20- and 10-meter reception are wound on National XR20 5-prong forms, while those for 5-meter reception are air-wound and mounted in the pins of 5-prong tube-bases from which the side walls were sawed to leave the flat bottom and pins. This type of plug represents a high loss at 5 meters, and for better results on this band, should be replaced by a similar plug-base sawed from a coil form of R39 or other low-loss material. A large part of the loss to be expected at 5 meters is encountered in the tubes—a loss which would be avoided only by use of tubes designed for high-frequency applications. The grid-windings of the 5-meter coils are made of No. 16 solid bare wire, three turns in each coil, wound on a half-inch dowel, removed, and spaced to occupy $\frac{3}{8}$ -inch winding length. The antenna and plate coils are wound on a pencil, removed, and spaced to occupy $\frac{1}{2}$ -inch winding length. The ends of the grid coil are straightened and inserted directly into the two appropriate pins. The ground end of the antenna or plate coil is inserted in the proper prong, and the plate or antenna end of this coil is returned through the center of the coil to the plate pin of the tube-base. The plate or antenna end of the primary winding is nearest the bottom of the form. The spacing is given between the ground end of the primary and the ground end of the secondary, the grid end of secondary being the connection nearest the top of the form. All primary and secondary windings are wound in the same direction.

The three band-spread condensers ganged and connected to the dial in this unit were Cardwell ZR-15-AS units, having 15- μ fd. maximum capacity. With these condensers, the spread of the three bands ranges from 15 to 25 dial divisions (on a dial calibrated 0-100). A spread of 50 to 90 divisions for the three bands is obtained by use of three type ZR-10-AS (3-plate) condensers from each of which one rotor plate has been removed, leaving one rotor and one stator plate. This degree of band-spreading is considered highly desirable by most amateurs, and for that reason, the latter condenser arrangement is strongly recommended.

OPERATION

To place the converter in operation, the receiver with which it is to be used is first turned on and volume set for normal operation, and the tuning dial is set to receive some frequency between 1.4 and 1.8 megacycles. Then the receiving antenna is disconnected and transferred to the converter antenna post. If a single-wire lead-in is used, the antenna post shown nearer the ground connection in the circuit diagram is connected to the ground post on the converter, and the lead-in is connected to the other antenna post. Next, the connection of the converter output cable is made to the receiver antenna-ground terminals, the 20-meter converter coils are plugged

new low prices on... type TJ-U capacitors

CORNELL-DUBILIER DYKANOL FILTER CAPACITORS

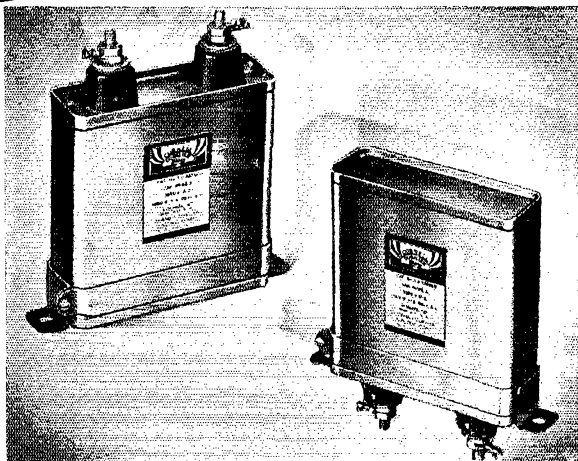

Prices have been substantially reduced on all Cornell-Dubilier DYKANOL universal mounting transmitting capacitors.

No sudden shift in policy is this. No cutting down on C-D high quality standards. Our price reduction is the result of months of careful planning — of enlarged production facilities, to meet an ever increasing demand. Remember — nothing has been cut but the price.

C-D type TJ-U transmitting capacitors are impregnated and filled with DYKANOL—the non-inflammable, non-explosive high dielectric impregnant used in the construction of capacitors for the U. S. Signal Corps. DYKANOL has proven its exceptionally stable characteristics through years of dependable operation in tens of thousands of broadcasting and amateur stations throughout the world.

For complete listing of new type TJ-U prices see your local C-D jobber or write for catalog No. 161.

Cat. No.	Cap. Mfd.	Your Cost
600 V.D.C.		
TJ-U 6010.....	1 Mfd.	\$1.62
TJ-U 6020.....	2 "	2.06
TJ-U 6040.....	4 "	2.65
1000 V.D.C.		
TJ-U 10010.....	1 "	1.76
TJ-U 10020.....	2 "	2.35
TJ-U 10040.....	4 "	2.94
1500 V.D.C.		
TJ-U 15010.....	1 "	2.06
TJ-U 15020.....	2 "	2.94
TJ-U 15040.....	4 "	4.12
2000 V.D.C.		
TJ-U 20010.....	1 "	2.65
TJ-U 20020.....	2 "	3.23
TJ-U 20040.....	4 "	5.29
3000 V.D.C.		
TJ-U 30010.....	1 "	7.06
TJ-U 30020.....	2 "	8.82
TJ-U 30040.....	4 "	12.94
5000 V.D.C.		
TJ-U 50010.....	1 "	14.70
TJ-U 50020.....	2 "	18.82

CABLE ADDRESS: "CORDU"



CORNELL-DUBILIER ELECTRIC CORPORATION

1013 Hamilton Boulevard, South Plainfield, New Jersey

HOW TO LEARN CODE!

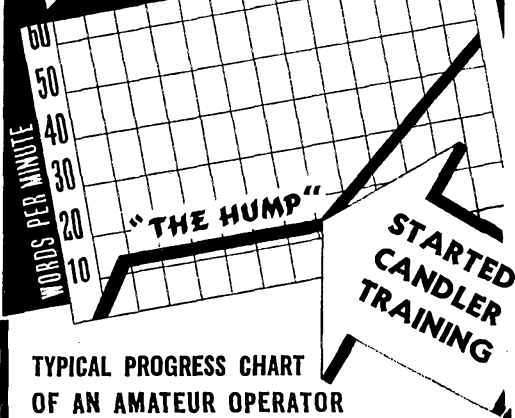

TYPICAL PROGRESS CHART
OF AN AMATEUR OPERATOR

BEFORE AND AFTER CANDLER TRAINING

It's positively uncanny the way a typical amateur reacts to Candler Training! As an absolute beginner he makes progress — up to a certain point. There he sticks with little or no further progress for months or even years regardless of how much he practices — how desperately he works. And then, in despair, he comes to Candler!

Almost at once, under Candler's scientific guidance, he's over the "Hump" and progressing by leaps and bounds until he's taking and reading code with the same effortless ease that he reads print!

Hours of undirected practice won't help! It takes a thorough knowledge of fundamentals and the proper mental training and coordination that Candler gives you to make a skilled operator. Learn code the Candler way — with the same system that made Champions of men like T. R. McElroy and L. D. McDonald, W3CW. It's the quickest way, too — a real short cut to code skill as thousands of Candler-trained operators will testify. Ask any skilled operator about Candler training!

SEND FOR THIS
FREE "Book of Facts"

52 PAGES of vital information every radio telegrapher should know! Contains F.C.C. requirements, principal exam questions, etc. Whether you're trying for a license or just learning code, send for your Free copy now!



CANDLER SYSTEM CO.
Dept. Q5, Asheville, N. C., U. S. A.

in, and the filament and plate supply wires are connected to the converter. For the plate and filament supply, one of the small receiver power packs such as the low-current power supply of Fig. 1420 in the 1938 edition *The Radio Amateur's Handbook* may be used, or the power may be taken from the power supply in the receiver with which the converter is used. If the filament winding is provided with a center tap, this tap should be connected to the "-B" terminal of the receiver; otherwise, a center-tap resistor should be connected across the filament terminals, with center tap grounded. If the power supply of the receiver is used, it is likely that the grounded center tap connection is already provided.

With the connections completed and the receiver running at normal volume, condenser C_{16} is rotated by means of a screwdriver until a position is found at which the noise is increased to a maximum. This indicates that the output of the detector in the converter is tuned to the intermediate frequency to be used. With C_{16} fixed at this adjustment (it will remain properly set when coils are changed for other bands), the oscillator padding condenser, C_6 , is set at approximately $\frac{2}{3}$ total capacity, and the detector padding condenser, C_3 , is slowly rotated until the second increase in output is detected (the first having been produced by adjusting C_{16} to resonance with the receiver). Next, the r.f. padding condenser, C_1 , is rotated until the final increase of sensitivity is noted. The band-spread condenser, $C_2-C_4-C_6$, should now be tuned to some strong signal, and padders C_1 and C_3 should be peaked carefully (one at the time, of course).

If the trial of the converter has proceeded "according to Hoyle" up to this point, the r.f. stage and detector stage are properly tuned to the signal being received. The oscillator frequency may be the sum of the frequency being received and the intermediate frequency (frequency to which the broadcast receiver has been tuned) — the proper adjustment. On the other hand, it may be a frequency i.f. lower than the frequency of the station being received. By very slowly rotating the oscillator padding condenser, C_6 , it will be noted that the output of the converter will reach a peak at two settings very close together. It should be left adjusted at the lower-capacity setting. The band-spread condenser dial should now be tuned through its range in search of 20-meter amateur stations. If the first trial adjustment of the padding condensers fails to fall in the amateur band, a second adjustment of C_3 should be chosen (not far from the first) and the above process should be repeated, until the proper position for receiving the 20-meter band is found. This adjustment should allow the converter dial to tune across the full width of the amateur band and some distance beyond each band limit.

The process for tuning the converter to the 10- and 5-meter bands is exactly similar to that for 20 meters, the choice of the 20-meter band for the first trial of the converter having been made because of the greater dependability of the 20-meter amateur band and neighboring frequencies to

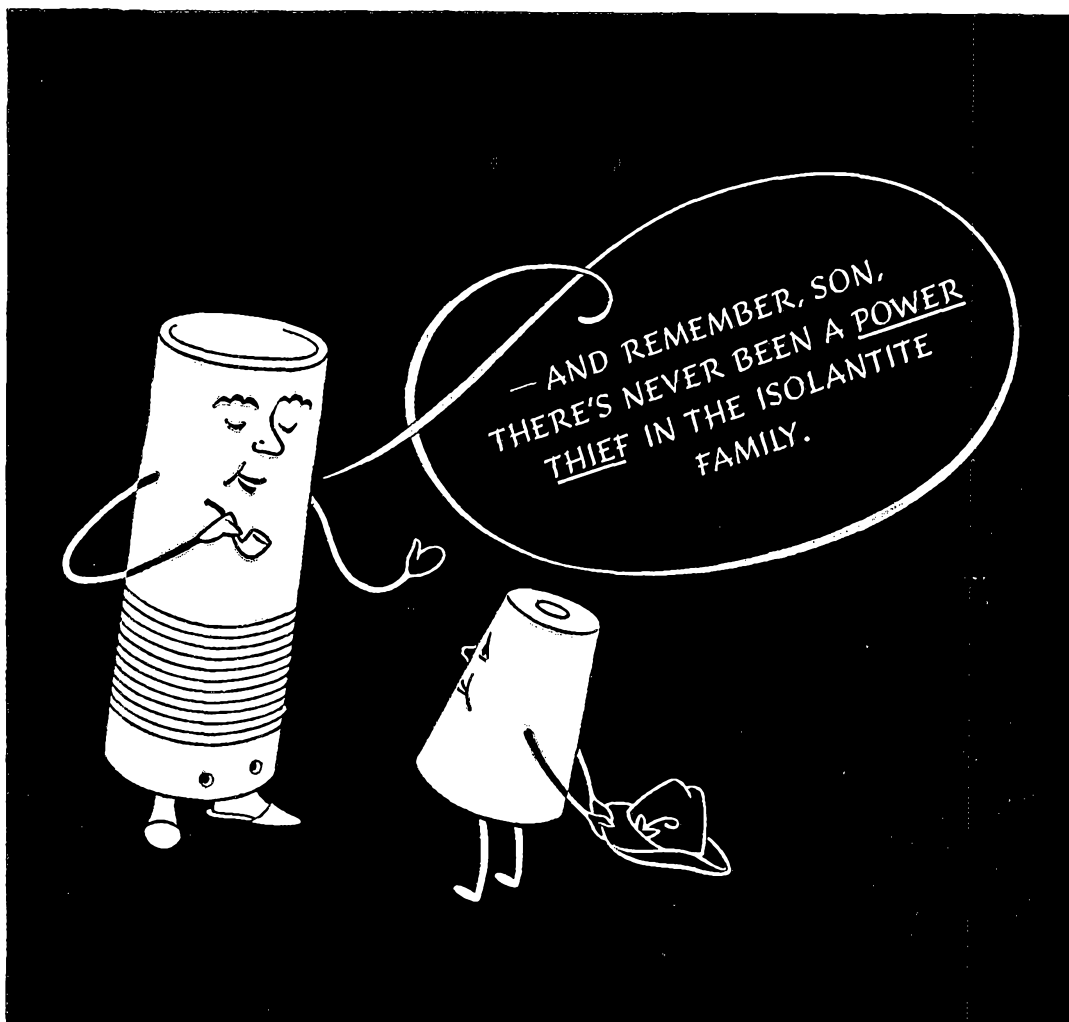

THE small Isolantite* stand-off insulator really has no need of fatherly advice from the big coil form. Isolantite insulators cannot steal power from high-frequency circuits, for their extremely low loss factor keeps their power absorption at a minimum. In every part of a radio circuit, Isolantite ceramic insulation is a safeguard of efficient operation.

High mechanical strength of Isolantite is another important factor in limiting power losses. Comparatively small cross-sections withstand heavy loading, permitting the use of a small volume of dielectric without danger of mechanical failure.

High-temperature firing gives a non-absorbent body which resists the effects of moisture. Isolantite

insulators retain low power factors even when wet. Smooth, glazed surfaces readily shed dust and dirt, avoiding risk of flash-over in exposed locations.

Isolantite is manufactured in many standard forms for most radio applications. Cooperation in the formulation of special designs for new applications is an important aspect of Isolantite's service to its customers.

*Registered Trade-name for the products of Isolantite, Inc.

ISOLANTITE INC.

CERAMIC INSULATORS

Factory: Belleville, New Jersey • Sales Office: 233 Broadway, New York, N. Y.

Say You Saw It in *QST* — It Identifies You and Helps *QST*



ASTATIC
New, Model T-3
MICROPHONE
Highly Praised

A new, general purpose, diaphragm type, crystal microphone of the highest type. Unique tilting mount permits directional or non-directional position. Chrome finish. List price \$25.00.

"See it at the Chicago Show"

Licensed Under Brush Development Co. Patents

ASTATIC MICROPHONE LABORATORY, INC.

DEPT. G-9, YOUNGSTOWN, OHIO

Pioneer Manufacturers of Quality Crystal Devices

My Creed . . .

TO give you specialized personal service of genuine value that is not available from other jobbers.

TO finance all my time sales myself so that I can sell all receivers, transmitters, and parts to you on terms arranged to suit you with less interest cost.

TO take your equipment in trade at a fair value.

TO allow you to try any receiver for ten days without obligation and to cooperate with you in every way I can to see that you are entirely satisfied.

Compare Bob Henry's Terms with Others

Model and Receiver	Cash Price	Down Payment	12 Monthly Payments
NC80X and NC81X . . .	\$99.00	\$19.80	\$6.99
NC101X	129.00	25.80	9.11
HRO	179.70	35.94	12.70
RME-69	151.20	30.24	10.69
Bretling 14AX	99.00	19.80	6.99
Sky Challenger II	77.00	15.40	5.44
Super Skyrider	99.00	15.40	6.99

Also Super Pro, ACR-111, PR15 and the newly announced Sky Champion, Sky Buddy, and Bretling 9.

Similar terms on Harvey, RCA, RME, Temco transmitters and Progressive, Utah, Stancor, All Star kits.

HENRY RADIO SHOP

211 North Main Street Butler, Missouri

provide signals for tuning the converter. In many locations, it will be necessary to make use of a local oscillator to determine the settings for 5-meter band reception.

If the receiver with which the converter is used is one provided with c.w. beat oscillator and pitch control, its use with the converter simply necessitates the few simple connections necessary to move the antenna to the input of the converter, and the output of the converter to the input of the receiver. An additional receiving antenna for use only on the high-frequency bands might well be installed, making it necessary only to switch the input of the receiver from low-frequency receiving antenna to converter output.

This converter, used with a receiver of only ordinary amplification, gives very good sensitivity and stability, and makes a very worthwhile addition to the amateur station.

New Ideas in Rotatable Antenna Construction

(Continued from page 21)

these in turn are mounted on 1 1/4- by 1 1/4-inch white-pine strips. These strips are attached to the ladder by adjustable angle brackets. The antenna is cut for 29,000 kc., and the reflector and director are spaced 1/4-wave from the antenna. Dimensions for cutting and spacing the reflector and director were arrived at after checking many *Handbook* calculations, and enlisting the aid of various amateurs who had had considerable experience in this field.

The ladder upon which all of the elements are mounted is attached to a piece of 2 1/2-inch extra-heavy pipe by means of a 2 1/2-inch flange mounted on a 2- by 12-inch plank. The pipe is inserted through a hole in the top of the tower, which is reinforced by a 5- by 5- by 3/8-inch steel plate acting as a bearing, then in turn is attached to an old worm-drive Ford rear end.¹ The rear end is mounted so as to use the axle for the main shaft and the worm-drive for the driving end. The lower end of the rear end is attached to another piece of extra-heavy pipe, up into the end of which is pressed a double-sealed ball bearing acting as a step thrust bearing. This bearing carries the entire weight of the rotating member, and in turn rides on a pin which is attached to a steel plate bolted to a table constructed of double 2- by 10-inch planking. There is also a plug pressed up into the shaft above this bearing which is drilled and tapped for a 3/8-inch rod. This rod is to be inserted into the plug and a Selsyn motor attached to it, to operate a direction indicator. Direction indication will be accomplished by the use of a second Selsyn motor and an indicating pointer on a great-circle map in the shack in the basement of the house, 135 feet away from the antenna. The circuit between the two motors will be a five-wire line.

The power to rotate the beam is furnished by a quarter-horsepower reversible motor which is

¹ Be sure to spot-weld the gears in the Ford rear end, in order to eliminate differential action, otherwise difficulty will be experienced in rotating the beam by this means.

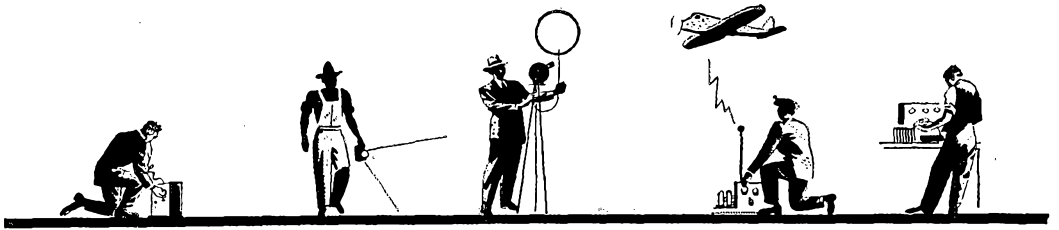

There's a World of Uses for these Burgess Special Purpose Batteries

Now you can have special batteries designed particularly for experimental work, research, or portable equipment.

Burgess provides an extensive line of small, compact, and surprisingly efficient batteries to fit special requirements.

Made to the same high quality that characterizes all Burgess radio batteries, these units will give you economical, dependable service. Some of the more popular numbers are shown below. Write for further information.

BURGESS BATTERY COMPANY FREEPORT, ILLINOIS



Z30N



4F2H



F2BP



X30BP



2F2H



W30BPX



B2BP



W30BP



W5BP

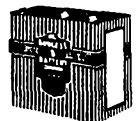

No.	Over-all Size Width Height Depth	Weight	Description and Uses
Z30N	3" x 5" x 1 1/8"	1 1/4 lbs.	A newly developed 45-volt "B" battery. (Z30NX — Special heavy-duty type furnished in same size.)
4F2H	3 3/8" x 5 7/8" x 2 3/8"	2 3/4 lbs.	A 3-volt general utility battery adapted for portable radio "A," lanterns, ignition, and marine lights.
F2BP	2 5/8" x 4 1/16" x 1 3/16"	12 oz.	A 3-volt battery used extensively in test instruments and by the U. S. Forest Service in portable radio.
X30BP	3 1/2" x 4 1/16" x 1 3/8"	15 oz.	A smaller 45-volt "B" battery, featuring more capacity than the midget size and greater economy on higher drains.
2F2H	2 5/8" x 4 3/8" x 2 3/8"	1 3/8 lbs.	A 3-volt "A" battery of more than double the capacity of the F2BP. Used in portable radio.
W30BPX	2 13/16" x 4 1/16" x 1 3/8"	10 oz.	Midget size 45-volt "B" battery. For extremely light weight transmitters or receivers, such as radio controlled aircraft.
B2BP	1 13/16" x 2 13/16" x 1 3/16"	3 oz.	A very light 3-volt "C" battery for portable radio.
W30BP	2 13/16" x 3 13/16" x 1 3/8"	11 oz.	Similar to W30BPX, except that it also has a 22 1/2 volt tap—uses brass knurled nuts instead of insulated nuts.
W5BP	2 13/16" x 1 11/16" x 5/8"	3 oz.	A midget 7 1/2-volt "B" battery used for portable radio grid bias.



BURGESS

Say You Saw It in QST — It Identifies You and Helps QST

GET THE MOST OUT OF YOUR RIG

with Ohmite Vitreous-Enameled Resistors and Rheostats



★ Ask your jobber for Ohmite "Brown Devils" when you need sturdy, dependable (but economical) resistors for voltage-dropping, bias units, bleeders, and a hundred-and-one other transmitter and receiver resistor requirements in your "shack." Remember, Brown Devils are built right from the core out — sealed tight with permanent, vitreous enamel coating! And will they take a "beating."



★ With an Ohmite Vitreous-Enameled Rheostat, you can keep your power tube filament at rated value all the time — increase tube life — attain maximum efficiency. Sizes and ratings for all low and high power tubes.

See Your Jobber or Write for Catalog 16.

OHMITE MANUFACTURING COMPANY
4831 Flournoy Street Chicago, Illinois, U. S. A.

OHMITE
RHEOSTATS RESISTORS TAP SWITCHES

IT'S EASY TO BUY A NEW SKY CHAMPION

The H. & E. Way

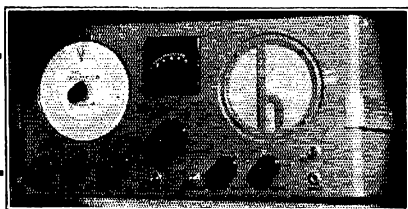

For as little as \$10.00 down and with 9 monthly payments of only \$5.15, you can own one of these sensational new Hallicrafters receivers when you buy it the H and E way. What's more, you'll enjoy your dealings with Hinds and Edgerton.

Amateurs ourselves, we know the needs of amateurs and their requirements for prompt intelligent service. Why be satisfied with mediocre reception when a new receiver costs so little. Mail the coupon for complete details.

- 8 Tubes
- 44 MC to 545 KC Coverage
- 4 Bands
- Built-In Speaker

Amateurs
Net Cash Price..... **\$49.50**
Inc. Speaker and Tubes

MAIL THIS COUPON TO-DAY!

HINDS & EDGARTON
19 So. Wells St., Chicago, U. S. A.

Please send me complete details of New SKY CHAMPION

Name.....Call.....
Address.....

geared down to the Ford rear end by means of three stages of V-belts. The ratio between the motor and the main beam is approximately 1170 to 1. This gives us about one and one-half turns of the beam per minute. The size of the motor is optional, however; a quarter-horsepower was used because we happened to have one on hand, but a $\frac{1}{2}$ 0-h.p. motor would do this particular job equally well, because of the ease with which the beam rotates. The motor is controlled by a four-wire circuit to the shack, and the reversing action is brought about by the use of a four-pole double-throw switch.

CONTACTS

Last but not least (because it is a most important constructional factor in connection with a 100 per cent rotatable beam) is the feeder question. At W1EER an extensive study has been made of this subject. Many types of contacts were made and tested, but every one of them had some fault. We finally conceived the idea of using some kind of liquid material for the connecting medium, and the outcome was mercury, or quicksilver. One of the photographs shows the contact device we made up. It consists of two cast-iron flanges, one above the other, mounted on stand-off insulators; on the surface of each of these flanges was cut a $\frac{3}{4}$ - by $\frac{3}{4}$ -inch circular trough. These troughs were filled to the top with mercury. The 600-ohm feeders from the "Q" are fed into the mercury troughs by means of feed-through insulators, as shown in the picture. Special $\frac{1}{4}$ -inch cold-rolled rods were bent and threaded to travel one within each trough. In order to eliminate any splashing of the mercury when the contacts are started in motion, the ends of the rods coming in contact with the mercury were formed elliptically.

The connection between the flanges and the feeders from the shack is made by drilling and tapping the flanges and inserting a brass screw to which the feeders are soldered. Since the contacting apparatus should be protected from the weather, it is advisable to make a hood to fit over this unit, otherwise snow, and rain in particular, will cause considerable difficulty. The snow and rain will not affect the mercury to any extent, but if moisture collects on top of it, and the temperature goes down to freezing, a layer of ice will form on the surface of the mercury and prevent the contact rods from rotating freely. Such a condition would cause the mercury to fly out, and the contacts would be destroyed.

DON'TS

In conclusion, there are a few "don'ts" in connection with the use of mercury. We give you below the benefits of our experience:

1. *Do not* use any kind of material for troughs that will amalgamate with mercury, otherwise your quicksilver will vanish!

2. *Do not* allow the mercury to become mixed with any other foreign matter—keep it clean. Should the mercury become dirty, however, it may be strained through a good grade of filter paper very satisfactorily. Mercury may become

The Hourly Log — RADIO

Flood Reveals Amateurs As New Group of Heroes

Hams' Unselfishly Devote Efforts to Disaster

By DARRELL DONNELL
When the last word

papers with world and national press reports. Throwing information on their vast life...

Should Be Given Public Service Award

QRP

QRP

QRP

Amateurs— Thordarson Salutes You

It is under conditions such as those recently experienced in the Pacific Coast flood that the "ham" rises to the occasion with his short-wave equipment. Many nights spent contacting other "hams" throughout the world prepared these operators of amateur radio stations for heroic service in times of emergency. When all other forms of communication were practically useless, amateurs carried the load of transmitting messages for authorities, relief agencies, newspapers, and individuals. We deem it a privilege to serve these "hams" and thus have a part in aiding those who take over so magnificently a giant load of responsibility in times of great human need. Amateurs, Thordarson salutes you!

THORDARSON ELECTRIC MFG. CO.
500 W. Huron St. Chicago, Ill.

See us at the National Radio Parts Trade Show, June 8 to 11 inclusive.

Our booth number is 112-114 Coulomb Street



Now YOU CAN HAVE

Bridge-Type Construction and Soft-iron Pole Pieces

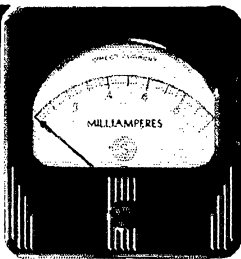

Without the "Bridge-Type" price!

• It's no longer necessary to pay a premium for panel instruments with the finer bridge type construction and soft iron pole pieces. The new Simpson Instruments give you these and other quality features at prices no higher than you have paid for the ordinary run of instruments.

A typical value is illustrated here—a bridge-type instrument in a beautiful, modern 3 x 3½" case with illuminated dial and built-in 6-V. lamp at a net price to amateurs (in most A. C. and D. C.) ranges of only..... **\$4.65**
(Thermo couple types \$7.68)

Ask for new literature covering the finer Simpson line of instruments and testing equipment.

SIMPSON ELECTRIC COMPANY

5216 W. Kinzie St., Chicago, Ill.

SIMPSON Instruments that *STAY accurate*

SPEED-X

THE COMPLETE LINE OF TELEGRAPH KEYS

A new and outstanding development — A general purpose type — Moulded Bakelite Base. Pigtail connections eliminate insulation problems — No current on bearings — Coin silver contacts. All Metal parts nickel plated.



Type 301 Key

- No. 301. Bakelite Key. List Price ..\$2.15
- No. 301S. With Switch. List Price, \$2.50
- No. 302. ¼-inch contacts. List Price, \$2.40
- No. 302S. With Switch. List Price, \$2.75

Other models of Hand Keys from \$1.50 to \$3.50 list — Available at leading jobbers everywhere — Write for new literature and Amateur Discounts.

LES LOGAN CO.

646 Jessie Street

San Francisco

The ACE SELF-SUPPORTING VERTICAL RADIATOR

- Low angle radiation for extreme DX
 - Heavy ground wave for local contacts
 - Reduces skip and fading
 - Non-directional for world-wide coverage
- Substantially constructed of heavy zinc-coated tubing finished in metallic lacquer. Requires NO guy wires! Self-supporting in winds up to 115 MPH. Sturdy 65,000 volt glazed porcelain base insulator. Shipped complete with all fittings and hardware and detailed erection and feeder blue-prints.
- 16 feet high — for 5-10-20 bands.....\$13.50
 - 33 feet high — for 10-20-40 bands.....\$19.50
- (Also works well on 80 and can be loaded for 160)
Base insulator only for those who wish to "build their own," with full constructional blue-print, \$9.50.
FOB SEATTLE, WASH. At your dealers or order direct.
Remit with order or C.O.D. on receipt of \$5.00 deposit

WTAXS ACE PRODUCTS CO. WTASL
809A Terminal Sales Building, Seattle, Wash., U. S. A.

somewhat oxidized due to exposure, but this is no cause for alarm.

3. Do not make the dimensions of your troughs too large. Mercury costs at least \$1.00 per pound,² and if the troughs are cut too big, the expense of filling them will be prohibitive.

² A pound of mercury is slightly over two cubic inches. —Editor.

The Construction of Television Receivers

(Continued from page 41)

tal sweep oscillator is producing a satisfactory sawtooth voltage. Similar adjustment of the vertical sweep may be made by using an input voltage to the video amplifier of about 1000 cycles —producing horizontal bands which should be of similar width and similar spacing.

THE I.F. AMPLIFIER

The adjustment of the i.f. amplifier is carried out with a test oscillator in the usual manner. The oscillator is set on approximately 13.5 Mc., its output connected to the primary of the second-last i.f. transformer and the trimmers then tuned for maximum response. The output from the test oscillator is then moved stage by stage toward the input, tuning, in each case, for maximum output. The result should be an amplifier giving a fairly flat response over something more than 2 Mc. Speaking in terms of high fidelity reception, this adjustment procedure should really only be considered as a start since very careful manipulation of the variables would be needed to provide full response over a 2.5-Mc. band and freedom from phase distortion. In this work, as in the adjustment of everything else in the receiver, the reception of actual television signals will naturally be of tremendous assistance. Adjustment of the r.f. portion of the receiver and the mixer will be facilitated by setting the oscillator, by means of an absorption wavemeter (or by listening to it in a receiver of known calibration), to 32 Mc. (approximately). The tuned circuits of the r.f. amplifiers may then be adjusted for maximum response to the signals from a test oscillator or merely to ignition noises. It is remotely possible that oscillation troubles will be experienced in either the r.f. or i.f. amplifiers. In such cases, the logical procedure is to make a careful check of by-passing and to experiment with the addition of further by-pass condensers at various points in the wiring.

The most important adjustment still remaining is that of the sync. separator—an adjustment which can hardly be made without operating the receiver with an actual television signal or the output from a test unit such as that described in the March issue. The requirement is that the cathode of the first section of the sync. separating diode should be slightly more positive than the plate and that the cathode of the second section should be still more positive. This condition could be checked very roughly with a voltmeter but might well be performed during the first attempt at television reception.

It is inevitable that the construction and ad-

THE RADIO AMATEUR'S HANDBOOK

\$100

postpaid in continental U.S.A.
\$1.25 postpaid elsewhere
Spanish edition \$1.50 postpaid

*The biggest dollar's worth
in the game—available
at your nearest ham store
or direct from*

AMERICAN RADIO RELAY LEAGUE
West Hartford, Connecticut

NEW TRIPLET

ILLUMINATED THERMO-AMMETERS

Model 446 with Front Illumination. New four-inch square modernistic instrument featuring extra long scale. Available also in ammeters, milliammeters, microammeters, voltmeters, millivoltmeters, etc., A.C. and D.C.

Write for Catalog

PRICES GREATLY REDUCED

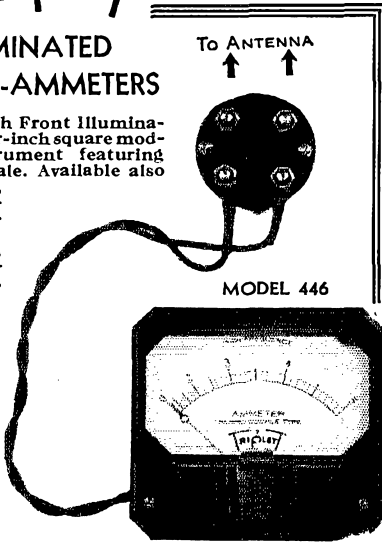

The Triplet Electrical Instrument Co.
255 Harmon Dr., Bluffton, Ohio
Please send me more information on Model 446;
I am also interested in _____
Name _____
Address _____
City _____ State _____

RADIO

ENGINEERING, broadcasting, aviation and police radio, servicing, marine radio telegraphy and telephony, Morse telegraphy and railway accounting taught thoroughly. Engineering course of nine months' duration, equivalent to three years of college radio work. School established 1874. All expenses low. Catalog free. DODGE'S INSTITUTE, Day Street, Valparaiso, Indiana

You Get Broadcast Quality At Low Price With TURNER'S New 30-30 Crystal Mike

This new semi-directional Turner crystal mike greatly reduces feedback troubles because of its streamline design. Absence of peaks permits operation close to loud speaker. Output level, minus 32DB, permits use of low gain amplifiers. Hum problems minimized because no input transformer required. Not affected by wind in outdoor setups and will not blast. Crystal interior suspended in shock absorbing material to prevent breakage and eliminate handling noises.



Showing Removable Cable

\$13.23

NET Cable Included

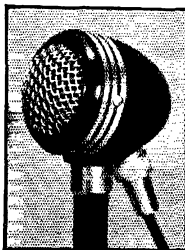

Turner 30-30

New cable connector makes lengthening cable easy. A simple soldering operation replaces bunglesome splices. Fits any standard desk or floor stand. A smart, modern mike at low cost. Order today.

COAST ELECTRIC COMPANY

707 Eighth Avenue San Diego, California
Licensed Under Patents of the Brush Development Co.

justment of either of these receivers will result in many headaches even when the circuit is known to be correct and when the purpose of each component is fully understood. At the same time it is true that if the receiver is functioning at all, if the sweep circuits are producing a fair wave-shape and if the sync. separator is in the circuit, some sort of a picture will be made available. From then on, there remains merely the business of monkeying with each detail until the best possible image is had. The procedure may be tedious but to the experimenter with any interest in the subject it is tremendously fascinating.

A Frequency-Control Unit

(Continued from page 38)

Grounding the screen put slightly more load on the bleeder, but since the dissipation was still within the rating of the unit, this was the method used. In practice the 89 oscillates weakly with Sw_1 closed, though this is not serious. On 14 Mc. the output of the 89 is just audible. If at any time interference results the 89 can be stopped by merely pushing another button just enough to disengage the switch being used and not engaging another. All buttons will then be out.

Switching may look complicated on the diagram. Sw_1 (with switch Sw_2 in the off position) puts the unit in operation without turning on the complete transmitter. This allows you to get your frequency without swooping over the band with a carrier on the air. When you have picked your spot, Sw_1 is flipped to the off position and the whole transmitter, including the frequency-control unit, is then controlled by Sw_2 . The second pair of contacts on Sw_2 goes to a heavy duty relay which controls the transmitter primaries.

RESULTS

The unit was used all during the contest. Originally the e.c.o. was going to be only for emergencies, with the seven crystals doing the heavy work. After the contest was well under way we found the only crystals used were those on the band edges—where angels fear to tread. It performed so well that it will sit constantly on the operating table. If we were doing it over again the only changes would be to use a slightly larger and heavier box, plus a vernier dial to tune the cathode circuit of the oscillator. Possibly a screen-grid tube of the receiving variety would be used instead of a 6L6, because all the power developed by the 6L6 is not needed.

The e.c.o. also has been used for 'phone operation on all bands with excellent results. One only need be extremely careful in the original setting. When checking its operation in radiophone service, monitor the 3.5-Mc. frequency of the gadget and notice whether there is any change in frequency at all. There should be none. Remember, any change in frequency during modulation would be multiplied 8 times if the transmitter output were tuned to 28 Mc. Any frequency flutter on 3.5 Mc. would make the output unusable on 28 Mc. Care in wiring and choice of sturdy components will be well repaid.

A. C. RELAYS

Made by

Allen-Bradley

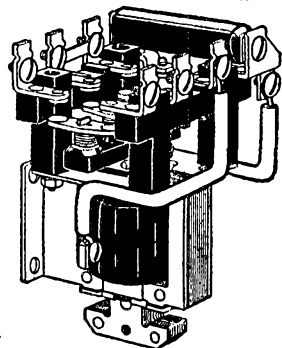
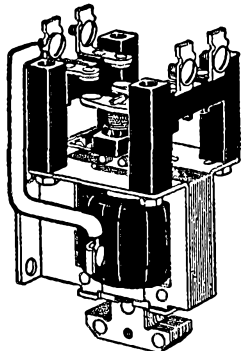

These A. C. solenoid relays are ideal for remote control of transmitters, for control of crystal ovens, and for any general remote control application except for keying. THESE RELAYS WILL NOT OPERATE IN KEYING SERVICE. Silver-to-silver double-break contacts are used throughout.

The maximum contact rating is 10 amp. at 220 v. or 3 amp. at 550 v. The relay coils are wound for 115 volts 60 cycle alternating current. Relays for other voltages can be supplied on special order. Use coupon below.

Type No.	Poles	Nor- mally	Action	Circuit Diagram	Price		Type No.	Poles	Nor- mally	Action	Circuit Diagram	Price	
					Open	In Cab.						Open	In Cab.
A107	1	Open	SP ST		\$3.50	\$4.50	A177	1	Closed	SP ST		\$7.50	\$8.50
A117	1	Closed	SP ST		4.50	5.50	A207	2	Open	DP ST		4.00	5.00
A127	1	Open and Closed	SP DT		5.00	6.00	A217	2	Closed	DP ST		6.00	7.00
A137	1	Open	SP ST		4.00	5.00	A227	2	Open and Closed	DP DT		7.00	8.00
A147	1	Closed	SP ST		5.00	6.00	A237	2	Open	DP ST		4.50	5.50
A157	1	Open and Closed	SP DT		5.50	6.50	A247	2	Closed	DP ST		6.50	7.50
A167	1	Open	SP ST		6.50	7.50	<p>Radiostat—A stepless graphite compression rheostat for primary of 550 watt filament or plate supply transformer. Range 4 to 150 ohms. Price \$6.50</p>						

ORDER BLANK—MAIL WITH REMITTANCE TO

Allen-Bradley Co., 108 W. Greenfield Ave., Milwaukee, Wis.

Enclosed find money order for \$..... for which please send me, shipping charges prepaid, the following items:

..... for..... Volts..... Cycles

Name.....

Address.....

CENTRAL DIVISION

ILLINOIS—SCM, L. John Huntoon, W9KJY—Egyptian and Piasa Amateur Radio Clubs are two of the many units that did good work in the recent southern Illinois tornado. Many of the local boys contributed to the work done in connection with the California flood—mostly by keeping off the air (and during a contest, too!) TSN is running for Congress—best of luck, OM. MRQ's new 6L6 out-classee the old 59 oscillator. A "grasshopper crystal" makes 3.9-Mc. 'phone operation much more enjoyable for BRY. AT5 sends news of EWN's return on vacation from operating on S.S. St. Mihiel—remember "Red" as a traffic handler back in 1932 and 1933? We would hate to lose NFL from the traffic ranks, but hope the new 2nd class commercial ticket helps him to a job. ITH will soon be on 3765. After receiving a green F.C.C. QSL, QKL immediately secured a crystal to prevent any more chirpy signals. MLJ is trying out 1.75-Mc. 'phone with 25 watts. In a club W.A.S. contest for a one-month period, PNW worked 41 states. First report from QKJ is that he is building a new s.s. super and using e.c. on 7 Mc. MWU is kept quite busy organizing the new A.A.R.S. 'Phone Net. The new ZB-120 modulators please NHF. Welcome to CZS, newcomer in Peoria. MKS is recuperating, and a card or letter, or even a QSL, would help cheer him up—address Hoom 104, St. Margaret's Hospital, Spring Valley, Ill. Under the call WLTR, RMN is holding down the traffic end of A.A.R.S. work KJY forsook in favor of the September National Convention Committee work. WSF takes exception to our comment that all Rockford hams are on 56 Mc., and supports his contention by a list of that city's hams on other bands and the DX worked. The 804 tube was finally replaced in KMN's rig. "Almost, but not quite," is the story of RWS' attempt to make the B.P.L. Crystal control is a new feature at NIU. AA is moving—and will be off air for a few months until he gets a 70-foot tower up to clear buildings about that height in all directions from the new location. GSB is getting back on the air. In DBO's opinion, 7 Mc. is a dandy band for local contacts at all times. ACU is now running his entire 'phone transmitter from 180 volts of Edison storage cells, six watts input. OA6U makes a third country for ZEW. We plan a field test of emergency equipment, especially for A.E.C. members but open to anyone in this Section, once or twice this summer, besides the usual League affair; activities will center around 3765 kc. for s.w. and for 'phone on an as yet undetermined frequency; Sunday morning or afternoon will probably be the best time; details later, but any suggestions will be appreciated; in the meantime, line up that portable/emergency equipment, as each participant must actually be operating in the field, away from any power source.

Traffic: W9EC 506 RMN 497 (WLTR 30) RWS 445 NFL 289 KJY 202 (WLTG 162) MRQ 123 HPG 107 (WLTI 24) DDO 71 VEE 66 (WILTO 43) YZE 49 MWU 41 MCC 35 RVF 31 NXG 25 CGV-VS 22 HXC 21 GMT 18 TUV 17 HQH 13 DBO 12 DOU 10 IH-CEO 9 IVD 8 QKJ 7 ATS 6 PNV 5 QKL-MLJ 4 NIU-BRY 3 NHF 2.

INDIANA—SCM, Noble Burkhart, W9QG—AB had 50 DX QSO's. ABB worked 4 new countries for total of 84. AXH worked another country on 'phone. CB is on the air daily. CXD has 200 watts input to T55 final. DET has new low-power rig on 3638 kc. with 9 watts input. DHJ is operating regularly again. DQK is on 3.9-Mc. 'phone. EGQ is open for afternoon schedules on 3505 kc. FB keeps 7-Mc. schedules. FLV is back in Terre Haute. FTQ builds and re-builds. GAT has rig on 14 Mc. using P.P.-RK-20's. GM can be heard from Hagerstown. HKQ works on 1900 kc. HKR was in DX contest. HPQ was in Indianapolis for N.C.R. Conference. HRW is new at Crawfordsville. HUV has worked 74 countries. IU worked a G on 3.5 Mc. JPX had 11 visitors from Kokomo. ICY moved to Indpls. KDD has a new transmitter on 3.5 Mc. with 100 watts to T-20's. KHC moved to Lafayette and got W.A.S. LLV gets on 3.9 Mc., Sunday afternoons. LSZ checks frequency with WVV. LYK is on 1.75-Mc. 'phone. MTZ is fond of e.c. oscillators. NQJ is back on 7 Mc. using the old Vibraplex. PIF's QTH is Bunker Hill. PPB works 7 Mc. PWZ visited Indpls. QCE, QPS and QEI are new hams. QG visited N.C.R. Conference. QIB got a new Temco 100-watt transmitter from KJF. SYJ is new E.C. for Indpls. and Ass't S.C.M. TRN has several schedules. TTA hauled a load of hams to Indpls. Radio Club meeting. TYF is now W.A.S. UNI has been having some fine QSO's on 1.75 Mc. VMG is new E.C. for Ft. Wayne. VXI has an FB 1.75-Mc. skywire. WVO visited Indpls. Radio Club. YWE has new Sky Chief receiver.

ZNC has an auto generator to rewind for 110 a.c. as per QST. ZTG has nice 1.75-Mc. skywire. ZYX helps the Indiana Radio Guard. The South Bend Amateur Communication Society is going to town with lots of interest among the OT's. DLM, AMI and TYF are teaching code to the YS's. HIU, TTA, MIG, ZBT, PIJ, FTQ, YUJ, DJJ, ZUW, Ward Ingels and Bickel, all of Kokomo, visited the Indpls. Radio Club to see CYQ snow his latest travel pictures. There were about 200 others at that meeting. If you fellows don't like what we have in this column about you, please send it in yourself—sometimes the grapevine picks up more dirt along the line than it starts with. The Indiana A.A.R.S. has a daily traffic schedule at 6:30 p.m. on 3656 kc. It is planned to expand this net and make it a state-wide A.R.R.L. Net. If everyone can get a crystal for the above frequency, or grind down one he has, it will help lots. To get the thing started this spring, one or more stations will cover the entire 3.5-Mc. band from 6 to 6:30 and 7 to 7:30 p.m. daily, looking for Indiana or out-of-state traffic. This station will be on 3650-3656 kc. and will call "CQ Indiana." Please let me know your reactions to a net of this kind. There is lots of room for more A.A.R.S., O.R.S. and O.P.S., also for E.C. appointments in many towns. If you are interested, let me know.

Traffic: W9AB 10 ABB 31 DHJ 11 EGQ 5 FB 32 HPQ 18 KHC 3 QG 177 (WLHL 129) SYJ 68 TTA 23 TYF 5 YWE 52 ZNC 6 WCE 2.

KENTUCKY—Acting SCM, Darrell A. Downard, W9ARU—HAX reports all stations active in Bowling Green. MYL is waiting to be transferred to Cincinnati, but carries on schedules. CDA is building new exciter. RBV gets in some DX. LYN has been transferred to the Cavalry School Detachment at Fort Riley, Kans. HBQ and ARU are building mobile and portable 56 and 1.75-Mc. rigs working from 6 volts. MN QSO'ed 36 stations in DX contest. EDQ keeps Ludlow on the map. UUR works plenty DX on 14 and 28 Mc. with P.P. T20's. EDV is working on voice-controlled carrier job. CWZ is building low-power rig for 3.5 Mc. AUH says he is going to devote entire summer to 56 Mc. TXC is handling traffic on 3.9-Mc. 'phone schedules. ELL worked close to 100 stations and 50 countries in DX contest. BEW has been appointed Emergency Coördinator for Ashland. VYY's super works FB. TKO does quite a bit of 1.75-Mc. 'phone work. QLF is doing nicely with a T20. CEE is portable 8 at Clarksburg, W. Va. BKU will be on soon. Quite a few of the fellows have applied for membership in the Emergency Corps. If you have emergency equipment, make application to the S.C.M. for appointment.

Traffic: W9EDQ 304 ARU 164 ZJS 179 HAX 87 CDA 81 MYL 65 HBQ 48 MN 28 ELL 19 RBV 12 TXC 9 VYY 5 CXD 4.

MICHIGAN—SCM, Harold C. Bird, W8DPE—E.C.'s: 8PSH, 80EN, 8AKN, 8JO. R.M.'s: 9CWR, 8GQD, 8LSF. The Michigan QMN Net is endeavoring to run a skeleton net during the summer months and would appreciate hearing from net members interested. It is planned to run the net on Monday and Friday evenings, weather permitting. MICHIGAN EIGHTS: ACU is getting rig together. JKO reports good DX on 7 Mc. QZV hopes to see the gang at the hamfest. RRH is on with a brand-new rig. QHA is on 7 Mc. CMH wants suggestions as to how he can get up 3.5-Mc. antenna with only 30 feet space. NQJ is doing a fine job of monitoring. JUQ had one of the most enjoyable radio seasons, thanks to QMN. NQS is on 3.9-Mc. 'phone with 1 kw.; he reports chess games via radio between two Mich. points. DSQ keeps plugging along. NXT sends his largest report. QGD, our new R.M., is doing nice job. Congrats to QH, new club vice-pres. QDX gets a big kick out of working QMN. RJC is new reporter from Allegan. RCR has started with gang in QMN. LU is getting lined up for QMN. PYT has nice rig. BRS reports Chair Warmers getting 'Phone Net lined up in vicinity of 1920 kc., 2:00 p.m., Mon., Wed., Fri. NDL reports N.C.R. nearly ready for new unit. AKN, one of our new E.C.'s in Detroit, is lining up assistants. HKT reports GKW got license renewed after long inactivity. Twin City Radio Council is getting portable ready for June Field Day. PVB, new reporter from Flint, has nice rig. LND sends nice report. FWU is back from Florida. CEU has been assigned to S.S. Wandotte, WADR. CPY wants schedule for summer on "2½ meters." NUV is plugging at QMN. AIJ is back in the fold with 500 watts. IHH says when he gets Asia he will be on QMN. ROL thanks us for U.R.S. LAK is playing with 1.75 Mc. LXJ reports by radio. MICHIGAN NINES: Ex-9TUZ is located

at Coloma. HSQ is having loads of fun handling traffic in U.P. and QMN. SDG reports following stations in his net: VE3EK, W9QAT, W8QYK, W9SER, and W9VET. IIT reports by radio. GJX, Helen, is O.R.S. again. CE has been doing a little DXing. More Eight's: Ye S.C.M. had enjoyable visit from DYH. PSH also dropped in. DMP reports by radio. CSG sent nice report. FOV is new reporter. CSL says the 52-ft. mast that has been laying on the ground since last November is now skyward. QND went after his Class A ticket. The Annual D.A.R.A. Hamfest will be held at Ypsilanti on May 15th. Something new, something different. Plan to be there and bring the YI's. Prizes, good eats, good speakers. Your S.C.M. requests that all Emergency Coordinators read the instructions carefully as to their duties and responsibilities. By so doing you will avoid embarrassment to yourself and your appointees. Thanks for your fine cooperation, gang. Be seeing you at hamfest. 73.—Hal.

Traffic: W8QGD 402 FTW 335 (WLJT 83) DYH 191 LSF 169 NUV 117 ROL 116 IXJ 108 DPE 88 JUQ 80 NDL 76 NNT 52 QH 48 JKO 47 PVX 41 CPY 37 PYT 30 DSQ 26 LND 23 QDX 21 BRS 18 FX 15 DMP 12 DZ-MBM 9 NQS 8 CMH-CEU-AIJ 5 RJC-RKR-HKT-BML 3 RQA 2 NQ-LHH 1 QGS 46 QND 1 QYK 33 CSG 18 PRA 44. W9HSQ 63 IIT 52 SDG 49 SQB 48 GJX 34 YX 31 CWR-YPX 24 CE 17.

OHIO—SCM, E. H. Gibbs, W8AQ—ISK, mixes some nice DX with traffic, but leads the state this month. LZK, another mixer of DX and traffic, runs a close second in traffic. LVU got his pair of '10's to take 180 watts without a blush. Traffic has picked up at EEQ. PIH will soon blossom out with a '10 final rig. We welcome LVH of Lakewood to the ranks of O.R.S. BAH reports new U.S.N.R. Net on 3555 kc. at 7:30 nightly, with MSP as control. ICC is back in A.A.R.S. Net. DWT built new rig for LUS. GVX got 3710 crystal and joined the Regulars. IWR applied for O.R.S. RFF got going on 14 Mc. and is moving to new QTH with room for a couple of beams. LOF is chief radio technician at O.S.U.R.C. RLX worked VK and arranged schedule with VP2BX. Welcome to the following new O.P.S.: FNX of Elyria, AXQ of Cleveland, GDC of Columbus, PKS of Fostoria, EQN of Springfield, VZ of Marietta. LEN has been appointed Emergency Coordinator for greater Columbus. New end-fed all-band antenna at NYY. CVZ is building new emergency rig for storage battery power. PUN has been getting emergency nets lined up in the southern part of the state. RLO is a new Piqua ham. IEF returned from 28 to 14 Mc. with his kw. 'phone. FHB lost antenna in sleet storm, but has new 280-foot doublet. JFC reports emergency drill with portable rigs at dams up and down river from Cincinnati. PVW has been having success with new 42 oscillator set-up. KKH works out nicely on 14-Mc. 'phone. VZ finished 400-watt rig with '04A final, modulated by '03A's Class B. PNJ reports C.A.R.A. coming out with a quarterly paper. CDR has new NC100X. DXB organized radio club at Chatham High School. OVI is building new 89-RK25-P.P. '10 rig in relay rack. PBX is rebuilding to T40 final. LKU, Assistant Emergency Coordinator, is organizing his Area Net around Ohio U. Radio Club. Old GDC is back in Columbus as 9ZDH/S. MFV bought new Silverstone communications receiver. EDR increased power to 600 watts. JOE is working DX on 14 Mc. KAH is on 28 Mc. again. The Dial Radio Club, Middletown, has station 8ROT with HF100 rig on 3.9 and 14-Mc. 'phone. RME69 receiver. The Aerial Club at Akron has been reorganized, and is getting away to a good start. RRC, uncle of PKS, is a new ham in Fostoria. Three of the town's lawyers are now hams! Fostoria Wireless Ass'n received its charter of affiliation with A.R.R.L.—congrats! IRA is figuring on new rig. IER is busy at Ohio State. KDU has 28-Mc. rig perking. MEA has moved to Portsmouth. LPA has 140-watt grid-modulated job on 1.8 Mc. NAF, only A.A.R.S. in Knox County, returned from a stay in Washn. and Phila. Congrats to OUV on his recent marriage. PIP has 'phone rig on 3.9 and 1.8 Mc. The gang is glad to hear that PGT has completely recovered from a broken back. OUZ has 35T final and new Super Sky rider. NPG likes 7 Mc. GER heard a station on 14 Mc. bootlegging his call several times during the month. EQN worked the first station called on 28 Mc.—F8RR. 56-Mc. activity is booming in Akron, with over 80 locals on that band and some of them working over into western Pa. and western N. Y. That band should open up for some 1000-mile contacts about the time you read this report—nuf sed.

Traffic: W8ISK 254 LVU 193 HCS 152 BBH 129 (WLHA

482) LZE 114 EEQ 101 LZK 99 PIH 82 CIO 69 (WLHC 48) NYY 55 LCK 53 AQ 52 NKU 45 KIM 39 LVH 24 YX 22 MUR 19 BAH 17 ICC 15 EQN 14 DWT-GVX 9 APC 8 CVZ 6 IWR 5 FNX 5 PUN 4 ICQ 3 JFC-PVW-KKH-GNI-VZ 2 LWT-PNJ-CDR 1. (Jan.-Feb.: W8LZK 211 NKU 28.)

WISCONSIN—SCM, Aldrich C. Krones, W9UIT—The Sixth Corps Area Signal Officer is desirous of obtaining several more Wisconsin stations in the A.A.R.S. Anyone interested, contact 9ESM. FAA finally made 'phone W.A.C. using three different kind of beams. YXH worked several VK's and ZL's on 14 Mc. ZBO is keying crystal for break-in. WWD has a new T-125. CNT is new call issued to Steve Zawila, second opr. at WUEN. WGP is on 3.5 Mc. by spasms. ESM has a new SX-17. Wausau Radio Operators Club met at LWX. ZTO is new O.P.S. on 28 and 14-Mc. 'phone with new 250TH. RQM and WJB work the Wausau ham's share of DX. CFT plans an 8JK beam. MWK has a new T55 final. ZWI and WMK run 8 watts for cross-town QSO's on 1.75 Mc., and have worked both coasts by "hitch hiking" with ZTO. PRM, LED and FEO used 56 Mc. very successfully to time ski riders at Rib Mountain Meet. La Crosse hams have a Sunday round table with 1.75, 3.5, 3.9, 14 and 28 Mc. represented on 'phone and c.w. AKT is active in N.C.R., A.A.R.S. and State Net. HSK has been O.R.S. for five years. ZLM left La Crosse for Chicago. FWW runs close to half kw. on 3.9-Mc. 'phone. QDI, tried 7 Mc. DRO, now located in Staples, Minn., visited the La Crosse gang. The La Crosse Radio Club has started building a portable emergency rig. JDP has been working quite a bit of DX on 28 Mc. using a ten final and an 8JK beam. NUJ has a new rig on 14 Mc. using a pair of T-20's. RBO is having a fine time on 1.75-Mc. 'phone. KLL was married recently. DXI needs a truck to move his portable rig. ASQ from Eau Claire was in Superior visiting folks and gang. ONI acquired a new Jr. op. P4Y is active on 7 Mc. RZY is winding transformers and chokes for new rig. 8JF will be on during spring vacation and more O.R.S. parties. 8ZL takes the prize for being one of the most active hams in the State; he is in N.C.R., A.A.R.S., State Net and is R.M. YEG worked 8 new countries in DX contest. HGG is holding down his spot in State Net. GWK took a flog at the DX contest when not handling traffic in T.L. "A" and State Net. NRQ is very dependable in State Net. RLB has new HK-54. VVQ turns in a nice report from West Allis. YDY is working hard for W.A.S. ZGD has worked nine countries with his low-power 'phone. QUD, new Milwaukee ham, is doing fine with low power to a T-20. Thanks, gang, for the fine reports, and hope we can all meet at the M.R.A.C. QSO Party, May 14th.

Traffic: W9SLZ 74 (NCR 20) (WLTF 46) HGG 65 GWK 52 ONI 32 (WLTN 21) IYL 33 NRQ 18 RNX 7 RLB 10 VVQ 4 UIT 2 HSK 17 (WLTD 18) AKT 17.

MIDWEST DIVISION

IOWA—Acting SCM, Phil Boardman, W9LEZ/WLUD—Council Bluffs Radio Operators Club entertained the whole Omaha gang. They expect to have a 56-Mc. treasure hunt in June. Sioux City reports 81 hams there now!! The Iowa-Illinois Amateur Radio Club of Burlington is planning a big hamfest for some time this summer. ICX is going strong with new rig. LEZ received W.A.C. certificate. NVF is recruiting new A.A.R.S. members. JMX operates in early morning net. AWH built new desk for station. PJR reports for Burlington Club. WNL, PHA and WMP are active in QRR Net. ABE was visited by BNT and AIJ. WTD is going strong on 28-Mc. 'phone. KZV and SHY will be on 1.75-Mc. 'phone for summer. QAV is 7-Mc. DX hound. ARE and FSH joined A.A.R.S. QOQ is new ham in Ft. Madison. NIA started spring cleaning by painting shack. TMY is building emergency power plant. LDH snags DX with new 805. VFM worked two K6's for first DX. SQQ is recovering nicely after operation. YRO has new relay rack. ZTV is building 809 final. ZLD moved to Sioux City from Nebr. TJA has new preselector for his Sky rider. UZZ has new receiver. YQY will be on 7 and 14 Mc. with new rig. AJA has worked over 900 different DX stations. NHY is anxious to try 56 Mc. GFQ worked Asia for 'phone W.A.C. Congratulations. UQJ is working plenty DX on 28 Mc. SEE will soon have more power on 7 Mc. CCY is on 3.9-Mc. 'phone. PDM is doing well on 1.75-Mc. 'phone. PDI is on 28-Mc. 'phone. QUF is building 3.5-Mc. rig. QAQ has '10 final. HAQ and RPA can be heard on 28 Mc. IBR gets on 1.75-Mc. 'phone occasionally. REV is active in U.S.N.R.

(Continued on page 104)

**✓ CHECKED
✓ AND DOUBLE CHECKED**



For Greater Efficiency

Utah Transformers work better, last longer, but cost no more.

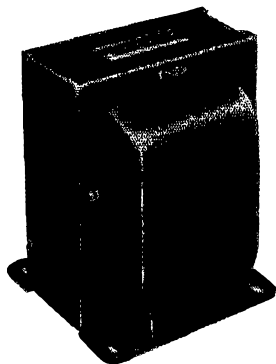

RADIO SHOW

Room 561, Stevens Hotel, and Booths 113-115, Marconi Blvd., Radio Parts City, Stevens Hotel, June 8th to 11th

UTAH RADIO PRODUCTS CO.

CHICAGO, U. S. A.

BUENOS AIRES — UGOA RADIO PRODUCTS CO.

"16 YEARS OF LEADERSHIP"

SICKLES COILS

ALL TYPES OF RF AND IF WINDINGS

Manufactured by

F. W. SICKLES COMPANY

300 Main Street

Springfield, Mass.

PRECISION CRYSTALS

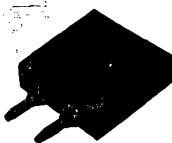

Crystal Holder

Highest quality crystals, one inch square, carefully ground for frequency stability and maximum output. Be sure of your transmitter frequency — use **PRECISION CRYSTALS**.

Crystals can be furnished with square holder as illustrated (fits G.R. type jacks) or with round holder to plug into tube socket. When ordering be sure to state the type holder desired. G.R. jacks to plug illustrated holder into — 15c pair.

Low frequency drift crystals (Type LTC) supplied within 0.1% of your specified frequency and calibrated to within 0.03% are priced as follows: 1750, 3500 and 7000 kc. bands \$3.50 each. Holder \$1.00. (State type desired.)

'X' cut **PRECISION** Crystals carefully ground for maximum power supplied within 0.1% of your specified frequency and calibrated to within 0.03% are priced as follows: 1750, 3500 and 7000 kc. bands — \$3.00 each. Holder \$1.00. (State type desired.)

'AT' cut crystals for commercial use quoted on at your request. When ordering our product you are assured of the finest obtainable. Now in our ninth year of business.

PRECISION PIEZO SERVICE

427 Asia Street

Baton Rouge, La.

BOOK REVIEW

Radio Operator's Manual, by the Radio Department, General Electric Co. 181 pages, 11 photographs, 45 diagrams. Published by the General Electric Co., Radio Department, Schenectady, N. Y. Price, \$1.00.

This is a revised edition of the manual reviewed in the April, 1936, issue of *QST*. It has been considerably expanded, both in size and scope; now there are included not only broadcast transmitters and police radiotelephone and radiotelegraph systems, but also radio systems for land and marine fire departments, transit and electric power companies, and conservation departments. Although intended primarily as a manual to qualify an applicant for the radiotelephone classes of license, it provides much general information of interest to any user of commercial radio equipment.

— C. B. D.

Standard Frequency Transmissions

Date	Schedule	Station	Date	Schedule	Station
May 6	A	W9XAN	June 3	A	W9XAN
	B	W6XX		B	W6XX
May 13	A	W9XAN	June 10	A	W9XAN
	A	W6XX		A	W6XX
May 20	BB	W6XX	June 17	BB	W6XX
	A	W9XAN		A	W9XAN
May 21	BX	W6XX	June 18	BX	W6XX
May 22	C	W6XX	June 19	C	W6XX
May 27	A	W6XX	June 24	A	W6XX

STANDARD FREQUENCY SCHEDULES

Time (p.m.)	Sched. and Freq. (kc.)		Time (p.m.)	Sched. and Freq. (kc.)	
	A	B		BB	C
8:00	3500	7100	4:00	7000	14,000
8:08	3600	7100	4:08	7100	14,100
8:16	3700	7200	4:16	7200	14,200
8:24	3800	7300	4:24	7300	14,300
8:32	3900		4:32		14,400
8:40	4000				

Time (a.m.) Sched. and Freq. (kc.)

Time (a.m.)	BX
6:00	7000
6:08	7100
6:16	7200
6:24	7300

TRANSMITTING PROCEDURE

The time allotted to each transmission is 8 minutes divided as follows:

- 2 minutes—*QST*, *QST QST de* (station call letters).
 - 3 minutes—Characteristic letter of station followed by call letters and statement of frequency. The characteristic letter of *W9XAN* is "O"; and that of *W6XX* is "M."
 - 1 minute—Statement of frequency in kilocycles and announcement of next frequency.
 - 2 minutes—Time allowed to change to next frequency.
- W9XAN*: Elgin Observatory, Elgin National Watch Company, Elgin, Ill., Frank D. Urie in charge.
W6XX: Don Lee Broadcasting System, Los Angeles, Calif., Frank M. Kennedy in charge.

WWV Schedules

EACH Tuesday, Wednesday and Friday (except legal holidays), the National Bureau of Standards station, *WWV*, transmits with a power of 20 kw. on three carrier frequencies as follows: 10:00 to 11:30 A.M., E.S.T., on 5000 kc.; noon to 1:30 P.M., E.S.T., on 10,000 kc.; 2:00 to 3:30 P.M., E.S.T., on 20,000 kc. The Tuesday and Friday

(Continued on page 106)



YOU CAN BUY IN CONFIDENCE FROM A STORE LIKE THIS

Picture shows view of our Big New Store. Note shelves loaded with big stock parts and sets ready for immediate shipment. This established and responsible firm stands behind every purchase you make, either in person or by mail. We have all sets as released and announced by manufacturers.

4 HOUR SERVICE — LOW PRICES
EASY TERMS
on Sets, Parts and Supplies

AS LOW AS \$19.00 DOWN

ACCORDING TO THE SET YOU BUY

EASY PAYMENTS \$7.30 to \$38.08 MONTHLY

These receivers are among the best values money can buy. Our 6% EASY CREDIT PLAN makes it easy to own one. Compare our rates. Send down payment with your order today. Set will be shipped as soon as credit is O.K.'d. Entire transaction 1 week. Order now

	Cash Price	Down Payment	6 Months Payments	9 Months Payments	12 Months Payments
NATIONAL NC-80X-NC-81X complete with Tubes, Crystal, and 8 in. P.M. Speaker.	\$99.00	\$19.00	\$14.36	\$9.66	\$7.30
NATIONAL NC-100X complete with tubes, crystal and speaker in cabinet.	\$147.60	\$27.00	\$21.10	\$14.21	\$10.80
NATIONAL NC-100 complete with tubes and speaker in cabinet.	\$125.10	\$20.10	\$18.58	\$12.50	\$9.47
NATIONAL NC-101X complete with tubes, crystal and speaker.	\$129.00	\$24.00	\$18.58	\$12.50	\$9.47
NATIONAL HRO with tubes and coils.	\$179.70	\$29.70	\$26.14	\$17.67	\$13.45
NATIONAL HRO with tubes, coils and power supply.	\$195.60	\$35.60	\$27.84	\$18.83	\$14.33
RME-69 complete with tubes, crystal and speaker in cabinet.	\$151.20	\$26.20	\$21.94	\$14.77	\$11.25
RCA-111 complete with tubes, crystal and speaker.	\$189.50	\$39.50	\$26.14	\$17.67	\$13.45
HAMMARLUND SUPER PRO complete with tubes and 8" dynamic speaker. Model SP-110 — 15 to 560 meters and Model SP-110S — 7.5 to 240 meters.	\$243.00	\$33.00	\$36.35	\$24.61	\$18.75
Model SP-110X — 15 to 560 meters and Model SP-110SX — 7.5 to 240 meters.	\$261.00	\$41.00	\$38.08	\$25.78	\$19.64
HALLICRAFTER SKY CHALLENGER II complete with tubes, crystal and speaker.	\$99.00	\$19.00	\$14.36	\$9.66	\$7.30
HALLICRAFTER SX-16 SUPER SKY RIDER complete with tubes, crystal and speaker.	\$123.00	\$23.00	\$17.74	\$11.93	\$9.02
HALLICRAFTER SX-17 SUPER SKY RIDER complete with tubes, crystal and speaker.	\$149.50	\$34.50	\$20.26	\$13.64	\$10.36

Only \$19 down

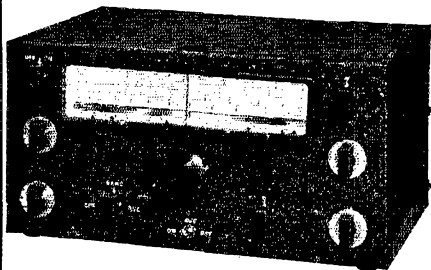

ONLY \$7.30 MONTHLY for 12 months buys this NATIONAL NC 80X (or NC 81X)

Or you can pay \$9.66 per month for 9 months or \$14.36 monthly for 6 months. Complete with Tubes, Crystal Filter, and 8" P.M. Speaker mounted in Cabinet to match. Cash Price . . . \$99.00

Oil Filled, Oil Impregnated FILTER CONDENSERS

ONLY \$1 1500 V. DC
1 1/2 mfd.

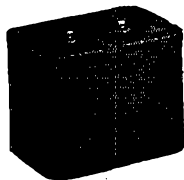

2 1/4" Diameter Round Can
3 3/4" High, Weight 1/2 lb.
WELL KNOWN MAKES. Guaranteed at rated voltages. We've sold 10,000 at these low prices . . . then bought MORE at a lucky price! Quantities limited. First come, first served.

2 mfd., 2000 V. DC	4 3/4" x 3 3/4" x 1 3/4", 1 1/2 lbs.	\$1.50
3 mfd., 1000 V. DC	5 x 3 3/4" x 1 3/4", 1 1/2 lbs.	1.10
3 mfd., 1250 V. DC	5 x 3 3/4" x 1 3/4", 1 1/2 lbs.	1.25
3 mfd., 1500 V. DC	5 x 3 3/4" x 1 3/4", 1 1/2 lbs.	1.50
4.4 mfd., 1500 V. DC	5 x 3 3/4" x 1 3/4", 1 1/2 lbs.	1.75
5 mfd., 2000 V. DC	5 x 3 3/4" x 1 3/4", 1 1/2 lbs.	2.75
10 mfd., 750 V. DC	4 3/4" x 4 3/4" x 1 3/4", 2 lbs.	1.75
14 mfd., 750 V. DC	4 3/4" x 4 3/4" x 1 3/4", 2 lbs.	2.00

NEW FB7 COILS 1/2 IN ORIGINAL BOXES PRICE

National's FB7 Coils. Regularly listed at \$6.00 per pair. They'll go fast at our low price. Stock is Limited . . . and no more when these are gone. *Very Special!*

Only the following numbers available at our give-away prices!

- TYPE AB — 160-meter band spread
- TYPE AB — 80-meter band spread
- TYPE A — 15-26 general coverage
- TYPE G — 41-72 general coverage
- TYPE D — 70-125 general coverage
- TYPE E — 120-200 general coverage

\$3.00
PAIR

PRE SELECTOR COILS TO MATCH

Regularly priced at \$3.60. Newark Special Price, only. . . **\$1.75**

ORDER TODAY FROM THIS AD

PRICES GUARANTEED FOR THIS MONTH ONLY

SEND DOWN PAYMENT WITH ORDER AND MENTION YOUR CALL LETTERS

WRITE FOR BULLETIN

NEWARK

Electric Company

323 W. MADISON ST.
Dept. Q CHICAGO, ILL.

(Continued from page 101)

THC gets out fine on 1.75-Mc. 'phone. QFZ has new 809 on 3.5 Mc. VBY moved from Chicago to Council Bluffs. UZE is now operator at KFAB in Lincoln, Nebr. UFL reports 7-week-old YL modulates 'phone FB. VTQ has sweet station. JRY has 400 watts on 28 Mc. CWG is still bragging over the VK and ZL he worked on 3.5 Mc. years ago.

Traffic: W9LXCX 369 LEZ 114 (WLUJ 143) DEA 117 NVF 36 JMX 29 TGK 24 AWH 11 PJR-WNL 5 PHA-WMP 3 ABE 4 WTD-RZV-QAV 2.

KANSAS—SCM, Harry E. Legler, W9PB—Our Assistant S.C.M., UQX, reports the League's Emergency Organization Program well under way. CVN has been the first E.C. appointed for this Section. RAT reports Coffeyville Club planning emergency equipment and expecting to cooperate in the A.E.C. program. Route Manager UEG again reports fine traffic total from activity on National and "H" Trunks. FLG made B.P.L. and reports A.A.R.S. traffic totals. WIN arranged with QQQ to take traffic that was originated during KSAC Engineer's Open House. MFH is general chairman for the Kansas Section A.R.R.L. Convention to be held at Wichita, May 7th and 8th. The Wichita Club is all organized to entertain the convention in grand style. FRC handled goodly number of messages from California flood area. Capt. Babcock is now in charge of WRK at Ft. Riley. SII's new NC81X makes him long for the DX it brings in. YAH needs only Vermont for W.A.S.; some of his traffic was from California floods. ZFS' traffic was handled on 7 Mc. YRS proudly boasts of W.A.S. ZJA longs for another ham in his town so he can carry on 56-Mc. experiments. YFE is rebuilding for 14-Mc. 'phone and c.w. QHP qualified for R.C.C. with 5EGP. QML plans P.P. 838's final for his Utah Jr. low-power rig. SNZ schedules his brother, QAU, regularly. From the traffic reports of some of those reporting, the S.C.M. believes that the correct method of computing totals is not fully understood. Remember that extra delivery credits can never exceed messages delivered. Study Operating Booklet or instructions on bottom of report cards. Will be looking for you at Wichita Convention.

Traffic: W9UEG 377 FIG 361 EYY 96 WIN 85 OZN 61 MFH 45 FRC 42 WRK-EFE 40 SIL 38 AVW 35 YOS 28 VWT 26 VQ 25 YAH 18 ZFS 13 RAT 10 FER 8 YRS 7 AWR 3 ZJA 2.

MISSOURI—SCM, Letha Allendorf, W9OUD—LBA has gone to Miami to take job with Pan American. DIN finished the rig with P.P. 809's final. ZLE is building a 3.9-Mc. rig. QHL is using flea power on 3.9-Mc. 'phone and 7 Mc. VID has new rig on 3.9-Mc. 'phone using pair of 809's and new NC81X. HHT is making new low-power rig for all bands. OMG and ZAO took Class A exam. EYM is a new O.P.S. and UYD aspires to be. The O.A.R.C. has applied for A.R.R.L. affiliation and is being organized by VMI into an emergency net. RZN schedules Union and St. Clair since moving to Crystal City. ZVL, VLP and UYD attended big hamfest in St. Louis. New calls in the club are UAC and VNG. TZC is working 1.75 and 7 Mc. QLT has new receiver. QMF works 1.75 Mc. TGG is on 3.5 Mc. using Delco power. CJB is on the air from local stations. HVT worked Algeria with 75 watts on 14-Mc. 'phone. RSO has 71 countries with CT1KH, BT3AW, BS5D, EN8AV and HA4H worked in DX contest. ARH added K4KD, F8RR, XE1A, HH1P, HK1PA and YN1AA in ten hours during the contest. PYF is building emergency transmitter and receiver. KEI is plugging away on T.L. "E" and L. & N. line. JAP has more schedules, more traffic and more fun. TCM is working on a new antenna. TGN's new transmitter is progressing slowly. OUD handled a lot of traffic to and from the flood region. JVM is working on the emergency net.

Traffic: W9OUD 528 AIJ 185 TGN 138 KLJ 137 PYF 122 JAP 102 KEI 87 SBR 22 TCM 15 YTW 2 HVT-ZVL 1.

NEBRASKA—SCM, Samuel C. Wallace, W9FAM—DI has FB trunk line hookups. KPA is Alt. on T.L. "B." UHT is handling nice bunch of schedules. FAM has been sticking on Trunk Line "L." The people in Enders, Nebr., were wondering why W9KPA was always climbing around on roofs, and finally came to the conclusion it was caused by the new goat glands received at the last operation. EHW is getting started again after recent fire which destroyed everything he had. ZUM moved his shack. SDL keeps A.A.R.S. schedules. PGA plugs at Trunk "E." WKP reports emergency net progressing nicely. DIX says DX on 3.5 Mc. has been very good. MZF is working on new antenna. EKK handled a lot of traffic to and from California

flood area. MKG reports activity in and around Holdrege. UWA at Atlanta comes down to code classes every Tues. night. VDC is on 7 Mc., WYJ on 3.5 Mc. MKG is on 3.5 Mc. also. QAT is in a net under the supervision of SDG in Houghton, Mich., called the Cross Country Net; the net meets at 6 p.m. daily. WGO is new ham on the air. ZJH has been working DX on 7250 kc. YDZ reports for Norfolk and vicinity. QWU, QWW, YRM, VQO and YDZ handled Calif. flood traffic. The N.E. Nebraska Club is sponsoring a hamfest at Wayne first Sunday in June. QFT has new crystal. QJJ is using YDZ portable. GFI is messing with receiver. CIR is thinking of 14-Mc. 'phone. YRM and VQO dream of 28 Mc. VQO got new Skydrider SX17.

Traffic: W9BNT 625 (WLUJ 202) DI 271 KPA 208 UHT 159 FAM 149 POB 63 EHW 13 UDH 14 ZUM-SDL 10 PGA 9 WKP 8 DIX 4 MZF 1 EKK 503 QAT 18 QGE 4 ZCF 8 ZJH 2.

DAKOTA DIVISION

NORTH DAKOTA—SCM, Ernest E. Bloch, W9RZA—ZGR built two 56-Mc. transceivers. Bismarck hams have organized a radio club, the "Missouri Valley Radio Association." They have about fifteen members. STT is building a '47-801-T5 rig for 7 Mc. NZG went to St. Paul and passed the exam for Radio Telephone First. STJ is trying 7 Mc. PGO is oping for N.W. Airlines. ZRT is giving 14 Mc. a try. VUG has his antenna up again after having it torn down by snow. ZTL is working FB DX with the T20 he won in the Dak. Div. QSO Contest. YVF is rigging up a portable gas-driven power supply for emergency operating; also bought a 913 oscilloscope. YAP built a Phone Test meter with 1.5 ma. Weston meter. PQW stopped in to see RZA, KRS and the gang at GF.

Traffic: W9RZA 56 AEL 22 ZTL 10 VUG 5 DYA 4 ZRT 1.

SOUTH DAKOTA—SCM, Andrew J. Kjar, W9SEB—AZR, R.M.-E.C. OXC, O.B.S. USI and USH are W.A.C. on 28 Mc. CW and USI made W.A.C. on 28-Mc. 'phone. Those boys are really doing things with their 28-Mc. rotary beam antenna. PPE is fooling with 56 Mc. on week-ends. UDI is on 3.5 Mc. WVN is on 7-Mc. and 56-Mc. 'phone. GRY is on 14 Mc. most of the time. USI-USH work all bands, c.w. and 'phone. EUH is on with a 43-6A6-6L6-'O3A rig. IQZ is building his rig in a 19-by-6-inch rack and panel. SRX is putting in the T200 final. WPA gets a big kick out of the State Net schedules. The fellows in Yankton are thinking of organizing a radio club. YNW plans on applying for O.R.S. CRY has 500 watts to a pair of '52's getting his share of DX on 7 Mc. ALO wishes someone would explain why USI and USH hooked Omaha, Nebr., on 56 Mc. by pointing their beam towards the west, Omaha being due south. VOD and VQN are going to try some low-power 1.75-Mc. 'phone. Pierre's eavesdropper, Phil Schultz, is active on 3.5 and 7 Mc. with a 2A5-TZ20 rig with 90 watts input and an SX 16 receiver, and sports the call QVY. PLF is active on 1.75-Mc. 'phone. LBU has an 809 final. WLP is active on 3.5 Mc. giving code lessons to a few local beginners. OXC still makes Sunday morning Official A.R.R.L. Broadcasts at 10:30 a.m., also each Wednesday at 7:00 p.m. on 3931 kc. Please listen for Red for important news. GEU is giving 3.9-Mc. 'phone a try. TBI has a commercial Radio Telephone ticket. SMS tried 7 Mc. and hooked XE for a feeler towards DX. ZCC has 807's going ok and is very active in A.A.R.S. FOQ is rebuilding receiver. QLP's 1-kw. rig blocks the receivers for the gang on A.A.R.S. Net. DIY and ADJ have been appointed Assistant Directors for this A.R.R.L. Section. QAK keeps daily schedule with QVY. The Brookings gang is doing a lot of 56-Mc. experimenting, and it may be possible some of us can bear them some Sunday after 1:30 p.m. C.S.T. If so, please let them know. Oh, well, maybe some day one of the fellows in the State Net will figure out a way to put that wise-cracking AZR in the back seat. 73—Andy.

Traffic: W9AZR 506 (WLUJ 25) SEB 168 VQN 29 FOQ 13 VOD 11 ZCC 9 WPA 8.

NORTHERN MINNESOTA—SCM, Edwin L. Wicklund, W9IGZ—Howdy, gang. How about getting your portable rigs ready for the A.R.R.L. Field Day? It's lots of fun. Let's put this Section on the map with some real activity. YCR is active on 14 Mc. ZGI on 1.75-Mc. 'phone. ZGU is using oscilloscope. ZGT is on 14 Mc. using 41 and RK-49. VED is going in for high power. KKO has a pair of T-40's for modulators. QNI is a St. Paul new ham on 3.5 Mc. WUH hooked a K7. YKD is adding to rig. OSR called on CWB, AND and KQA. ZQB came on 1.75-Mc. 'phone.

ZLH spends most of time on 7 Mc. chewing the rag. LSC and VTH are new O.P.S. AZE has a pair of RK-11's in final. HEO has a pair of 54 Gamatrons in final. YAP bought HEO's T55's, and has them in final. UVA uses a T55 in his 28 and 14-Mc. rig, with his 20-watt rig on 3.9 and 1.75-Mc. 'phone. VVA is on 14-Mc. 'phone and c.w. WLK has a doublet antenna. VTH will be the Phone Activities Manager for this Section. Your S.C.M. has his portable rig going now, getting plate supply from a vibrator and genmotor run off 6-volt battery. The Min-Dak Radio Club will hold summer meetings the third Sunday of each month.

Traffic: W9PTU 389 (WLUC 44) FTJ 4 RJF 14 HEN 80 IGZ 8 ZLH 2 YCR 5.

SOUTHERN MINNESOTA—SCM, W. F. Soules, W9DCM—The cost of electricity prohibits high power at ZAD. MZN, the Dakota Division Director, is sending out a questionnaire to all members, so please return them to him to assist him in getting the views of the whole Division. The Board meeting is soon so send your ideas to MZN right away. UWG moved to Rochester from Canby. The Rochester Radio Club is planning a portable station for field days and emergency purposes. TKX has a new rig with an 807 final. ZMQ is on the air for traffic each day, except Sunday, at 12:30 P.M. QDE has a Hallicrafter Super Seven. KUI is going to rebuild and overhaul his gas-engine power plant. TOF is moving from Mankato to Eagle Lake. OGU is on 14-Mc. 'phone with a vertical antenna. SJK is grinding a 100-kc. crystal for frequency standard. EFK has the rig going again. QMC is trying to get the South High rig on 28 Mc. QLB is on 1.75 Mc. QIN is on 7 Mc. with a T-20. RWH is rebuilding his rig on trays. DCM is on 28, 14 and 3.9-Mc. 'phone along with a little 3.5-Mc. c.w. Don't forget to write to our Director.

Traffic: W9ZAD 6 ZMQ 4 MZN-KUI-QDE-DCM 2.

WEST GULF DIVISION

NORTHERN TEXAS—SCM, Lee Hughes, W5DXA—EOE handled some flood traffic during the Calif. "dew." DXA managed to work three new countries in DX Contest. CDU made few changes in rig. BAM got on for last day of contest and worked two countries. FRE worked T.L. "AP" while DNE was off the air for his health. FZJ is trying Reinartz loop antenna on 14 Mc. ECE was visited by CJF, DLM and VP. AZB, EOE and EOC visited the S.C.M. EES is rebuilding, R.C.A. 814 Class "C," pair 17Z-40's Class "B" and New Turner crystal mike.

Traffic: W5EOF 542 DXA 267 CDU 60 BAM 60 BKH 56 FMZ 51 FRE 36 EYZ 21 FZJ 6 FAJ-ECE 5.

OKLAHOMA—SCM, Carter L. Simpson, W5CEZ—CEZ has new skyhook. GFT ran up traffic total during sleet storm QRR work. YJ was made Oklahoma S.N.C.S. 4 in the A.A.R.S. and assigned special call WLJO. EGP is signing 'em up in A.E.C. FOJ resumed A.A.R.S. activity from new QTH. DTU has new PB-7 receiver. EMD has trouble keying crystal. EST is receiving nice reports on his O.B.S. broadcasts. AIR is running 500 watts to a 200T on 3.9 Mc. EGQ is rebuilding 28 and 14-Mc. 'phone rig. FWZ, ERS, AYF, BOR and EGQ have low-powered rigs on 1.75-Mc. spot frequency for local rag chews. FFW got three new countries during DX Contest. EHY needs Vt. and Del. for W.A.S. GXL and GUA, Ex-W9JBR, are new hams in Okmulgee. GZR and GZU are new hams in Weleetka, and GZA is a new one in Ponca City. Now is the time to get ready for the Field Day tests. See how your emergency-powered rigs work.

Traffic: W5CEZ 488 (WLJC 79) FSK 338 (WLJY 55) GFT 211 YJ 174 (WLJO 16) EGP 86 (WLJJ 41) FOM 82 CVA 60 MK-FOJ 44 DTU 38 EMD 33 FRC 24 BRC 17 GME 16 DAK-GAQ 12 FBI 11.

SOUTHERN TEXAS—SCM, Dave H. Calk, W5BHO—OW leads the traffic count and reports on the Section Net. DWN reports rig in service two years and only replaced one filter choke. FDR has 800 watts input to an HK354. The Section Net is operating on 3657 kc. with FDR as N.C.S. CVQ reports that EJK in Austin has the last thing in portable emergency equipment, mounted in truck with battery charging equipment. HS schedules MN, BN and WLM daily. CCU operates on 14 and 28-Mc. 'phone. DOM works the Navy and A.E.C. Nets. GNX has one schedule daily. DNE visited GNX for three weeks. FDI is off due to operation. Hope you recover soon, OM. Congrats to FGP who took unto himself a wife. AMX works A.E.C. Net and was able to get a report through from the flood district in California. EIN is building 28-Mc. 'phone and c.w. rig and

moved into new shack. FWS, XYL, and FNQ, OM, are both on 28-Mc. 'phone and c.w. GUY applied for O.R.S. AFN is active on 28-Mc. 'phone. DE on 14-Mc. 'phone worked cross-band with XE2RC, letting a mining engineer talk with his wife who was in a hospital in El Paso; also handled some traffic from L.A. flood area. CWD visited some ham shacks in San Antonio. GQH is active on 7 Mc. FRK has worked all districts with a 61.6. FOH has new antenna pole. EVJ has low-power 3.9-Mc. 'phone rig. CWW also has 3.9-Mc. portable 'phone rig. FBR is stacking two 8JK beams on top of each other and is retiring two '10's for T-40's. GDP returned from Port Arthur College with commercial ticket. AFS is active on 28-Mc. 'phone. GUB and GUM are new calls in El Paso. FSQ operates 1.9-Mc. 'phone. MS is building rotary beam antenna; AQK is on 28-Mc. 'phone. UW is building 28-Mc. 'phone for EAE. GWL is using 6A6 with four watts on 14 Mc. GGL is building portable geophysical transmitters. TO is new O.B.S. DZR is on 1.9 Mc. using 809. EWJ works 7, 14 and 28 Mc. BHO works the A.E.C. Net and schedules EOO at Univ. of Texas. Ask all the stations you work to send traffic and activity reports to your S.C.M.

Traffic: W5OW 1501 MN 197 DWN 129 (WLJX 119) FDR 119 CVQ 83 HS 41 CCU 17 GUY 15 DOM 12 GNX 8 REF 7 AMX 10 GWL 6 BHO 61.

NEW MEXICO—SCM, Joseph M. Eldodt, W5CGJ—Our S.C.M. is on vacation in Arizona this month. ENI has fine traffic outlets, being able to get on Trunk Lines "M" and "AP" and National Trunk Line Net, in addition to A.A.R.S. Because of new working hours GEY is dropping principal on Trunk Line "M," but will act as alternate. The Albuquerque Communications Club recently elected new officers: GSJ, pres.; AQ, vice-pres.; Jim Brady, treas.; 3DPE, secy.; CHU, activities mgr.; GEY, traffic mgr. The Southeastern New Mexico Radio Club at Carlsbad meets twice monthly and plans big things for the West Gulf Division Convention at Carlsbad, August 25th-26th-27th. It will be a splendid opportunity for hams from all over the country to visit the famed Carlsbad Caverns, and plans are being formulated to care for a huge crowd. Members of the New Mexico Military Institute Radio Club are enjoying many fine contacts with the new all-phone-band transmitter. Albuquerque now has more A.A.R.S. stations than any other New Mexico city with GPV, GGX, GEY, and newly enrolled members GSJ and CHU. GSJ received special frequency call in A.A.R.S. of WLJK. CSR has a pair of T55's in final on 14-Mc. 'phone. 3DPE, a student at the Univ. of New Mexico, is doing nicely on 14-Mc. 'phone. GUZ and FJE worked lots of DX in contest. GIB recently moved to Albuquerque from Roswell with his Kalifornia Kilowatt. GSA is active on 56 Mc. GMS plans some recordings of code for practice work. AOH in Raton has new all-phone-band rig going, running 200 watts to pair of 756's in P.P. In Roswell, ZA, ZM and DAD are active on 28-Mc. 'phone. ENI is getting set for 56 or 28-Mc. operation from his car; he is just starting a fine new hospital at Lovington. New Mexico A.A.R.S. 'Phone Net meets regularly Tuesdays at 5:45 A.M. on 1805 kc. under DLG, the S.P.N.C.S. The A.A.R.S. C.W. Net meets regularly Mondays between 7-8 P.M., and as either A.A.R.S. or A.R.R.L. Section Net four other nights per week on 3702.5 kc. ZM handles lots of Philippine traffic from 6LUJ with nightly schedules on 7 Mc. The A.A.R.S. C.W. Net, which stresses emergency preparedness, held its second drill using only emergency equipment March 21st. ND is playing with portable receivers and transmitters in Roswell. FQG of Pecos recently joined the A.A.R.S. 'Phone Net in New Mexico.

Traffic: W5ENI 401 (WLJI 4) ZM 292 (WLJG 157) GPV 94 GSJ 42 FSP 31 DLG 31 BHU 24 FUA 14 GEY 6 CHU 3. (Jan.-Feb.: W5GEY 80.)

ROCKY MOUNTAIN DIVISION

COLORADO—SCM, Glen Glasscock, W9FA—The number of reports this month certainly is encouraging, fellows. Keep it up! Look at the number of traffic reports! ESA takes high traffic honors as usual. WWB and TDR do a fine job keeping Pueblo on the map. WVZ is trying hard to make Marshall Pass on the continental divide a well-known spot. EII handles all orders for WVZ from grub to shoestrings, when "Buck" is snowed in for the winter. CAA is on at odd moments. DDF reports for the A.A.R.S. 'Phone Net. HDU is sporting a couple of 100TH tubes. ZJQ replaced the '10's with a T125 final. ZXL is new member of A.A.R.S. 'phone gang. LYV is back to low power.



AHOY THERE!

TAKE A LOOK
AT THE SCRULOK
developed by
BIRNBACH



Always a pioneer, Birnbach again leads with the new *Scrulok* solderless connection. Test leads and prods using this new principle need no soldering or tightening with wire-cutting screws. Every part is assembled with a tight mechanical and electrical contact.

Ask your jobber for the new Birnbach Test Prods, Test Leads, Banana Type Plugs, Insulated Pin Tips, etc., featuring the *Scrulok* principle. If he cannot supply you, write direct to us.

BIRNBACH RADIO CO.
145 HUDSON ST. / **BIRCO** NEW YORK, N. Y.

RADIO ENGINEERING



RCA Institutes offer an intensive course of high standard embracing all phases of Radio and Television. Practical training with modern equipment at New York and Chicago schools. Also specialized courses and Home Study Courses under "No obligation" plan.

Illustrated Catalog on request

RCA INSTITUTES, INC. Dept. ST-38

A Radio Corporation of America Service
75 Varick St., New York 1154 Merchandise Mart, Chicago

READ SEND CODE LIKE AN EXPERT!

Learn Quickly at Home, Get Real Speed

It's easy, fascinating, to become a good op with the NEW ALL ELECTRIC MASTER TELEPLEX CODE TEACHER to help you. Only instrument ever

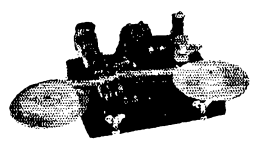

produced which *records* your sending in visible dots and dashes — then *sends back* to you at any speed you desire. Also sends practice work, recorded by an expert. That is why so many schools teaching code prefer Master Teleplex.

That is why thousands agree this method is surest, quickest — has taught more ops in the past few years than all other methods. We furnish Complete Course, lend you Master Teleplex, give you personal instruction with a MONEY-BACK GUARANTEE. Low cost. Send today for booklet Q-5; no obligation.

THE "HAM" SPECIAL

Standard Teleplex — a highly efficient code teacher using heavy specially prepared waxed paper tape, having two rows of perforations. Write for free folder QT-5.

We are the originators of this type instrument

TELEPLEX CO. 76 CORTLANDT STREET
NEW YORK, N. Y.

TELEPLEX — "The choice of those who know"

WWV Schedules

(Continued from page 102)

transmissions are unmodulated c.w. except for 1-second standard-time intervals consisting of short pulses with 1000-cycle modulation. On the Wednesday transmissions, the carrier is modulated 30% with a standard audio frequency of 1000 c.p.s. The standard musical pitch A = 440 c.p.s. is also transmitted from 4:00 P.M. to 2:00 A.M., E.S.T., daily except Saturdays and Sundays, on a carrier frequency of 5000 kc., power 1 kw., 100% modulation. The accuracy of the frequencies of the WWV transmissions is better than 1 part in 5,000,000.

How Would You Do It?

(Continued from page 53)

bridge. When $\frac{Z_1}{Z_2}$ is equal to $\frac{R_1}{R_2}$, the bridge is in balance and none of the voltage across T_2 can appear across T_1 , and therefore the amplifier will not "sing." But, if a signal voltage is impressed across Z_1 , the voltage will divide across R_1 and T_1 , with that part across T_1 being amplified through the amplifier and applied across T_2 . As T_2 is in balance with T_1 through the bridge, it will not feed back, but the signal voltage appearing across T_2 will be impressed across Z_1 and Z_2 in series.

A practical circuit is shown in Fig. 3B. Comparing this with Fig. 3A, Z_1 and Z_2 are permanent magnet speakers which serve as microphones as well. R_1 and R_2 are the same arms of the bridge as those correspondingly numbered in Fig. 3A and are supplemented by the potentiometer R_7 for balancing the bridge. R_3 is a gain control for adjusting the output of the amplifier. T_1 should have a step-up ratio. T_2 should have characteristics suitable for matching the load consisting of Z_1 and Z_2 shunted by the series of R_1 , R_2 and R_7 to the optimum load specified for the output tube used. With speakers of about 5000 ohms and resistances of 10,000, 5000 and 10,000 ohms respectively for R_1 , R_7 and R_2 , T_2 should have a ratio of about one-to-one to provide a proper load for the 6F6. The two speakers used should be identical if possible.

If, for any reason, either speaker needs to be cut out, a double-pole double-throw switch is necessary to remove the speaker and replace it with a resistance equal to the speaker impedance. If this is not done properly, the bridge will become unbalanced and the outfit will "sing." A single-pole double-throw switch in series with resistance can be used, as shown in Fig. 3A, to cause the circuit to feed back and "sing" which may be useful in calling. R_8 and R_9 are placed in each terminal set along with S_1 . When S_1 is closed, both speakers are muted somewhat due to the shunt of R_8 and the voltage-dividing action of R_9 . But, when the switch is changed to the "on" position, the bridge will unbalance and "sing" until the other switch is thrown to the "on" position. R_8 , at the operator's position, should be made variable to allow an additional bridge

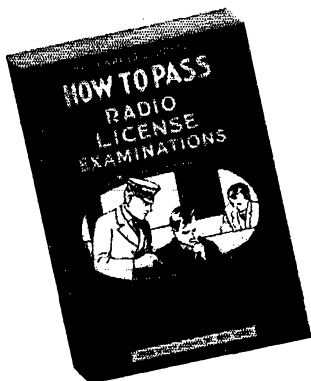

Published March 1938
 201 pages; 6½ by 9⅞
 73 illustrations
 \$2.00

Now Available!

Questions and answers for the amateur who is preparing for commercial exams, for the radiotelegraph operator, the radiotelephone operator, and all prospective commercial radio licensees.

DREW'S

HOW TO PASS RADIO LICENSE EXAMINATIONS

By Charles E. Drew, I.R.E., A.I.E.E.

This book is more than just a new edition of a famous work. It has been completely rewritten. It will serve as an excellent guide to all radiomen, whether interested in broadcasting, marine, aeronautical, or any other field of radio transmission and reception. The concise presentation of the essential questions and answers which the operator must know makes it easy to follow. Important phases of the subject are given thorough treatment, so that the man who understands the content of this book will be well qualified to pass the examination for his commercial license.

Contains new material on—

Rectifier tubes for supplying high-voltage for tube operation

Methods for eliminating or reducing the power in unwanted frequencies

Adjustments of the various classes of amplifiers used in transmitting circuits

The use of equalizers in lines over which speech and music frequencies are carried to the audio input of the transmitter

The procedure for changing operating power and operating on a new transmitting frequency

Circuit conditions and adjustments which affect resonance

General principles of electricity

The location of principal seaports along the coast line of the United States and important ports of call in foreign countries

Radio laws and regulations

ON APPROVAL COUPON

JOHN WILEY & SONS, INC.
 440 Fourth Avenue, New York, N. Y.

Kindly send me a copy of Drew's "How to Pass," on ten days' approval. If I decide to keep it I will remit \$2.00; otherwise, I will return the book postpaid.

Name.....

Address.....

City and State.....

Employed by.....

QST 5-38

JOHN WILEY & SONS, INC.
 440 Fourth Avenue New York

NEW HALLICRAFTERS

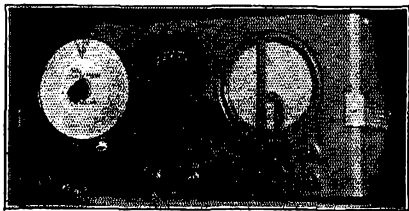

SKY CHAMPION

8 Tube, A.C. Receiver with Pre-Selection, 4 Band complete coverage from 44 MC to 545 KC (6.8 meters to the top of the B. C. Band), and Built-In Speaker, a complete communications receiver in every respect. Has every essential control for amateur reception and a Band Spread better than A.R.R.L. Handbook recommendations.

\$49.50

Amateurs' Net Price
Complete with Speaker
and Tubes.

- 8 Tubes
- Complete Coverage 44 MC to 545 KC
- For AC or Battery Operation
- 4 Bands
- Separate Band Spread Dial
- Individual Coils for each Band
- Beat Frequency Oscillator
- AVC Switch
- Tone Control
- Sensitivity Control

THE NEW 1938 SKY BUDDY

Covers the 20, 40, 80 and 160 meter amateur bands. An AC set, of conventional Power Transformer construction. All the components are only of the finest, and it has all the basic controls required for amateur communications, including built-in speaker — there is nothing else to buy. The separate Band Spread is better than the A.R.R.L. Handbook recommendations for band spread against scale calibration on all the amateur bands.

THE SKY BUDDY

- 5 Tubes
- Complete Coverage 18.5 MC to 545 KC
- Built-In Speaker
- Phone Jack
- Send-Receive Switch
- A V C Switch
- 3 Bands
- Separate Band Spread Dial
- Beat Frequency Oscillator
- Pitch Control
- Easily adapted for Battery operation.

AMATEURS NET PRICE

\$29.50

including speaker and tubes

Get yours at

Radio Specialties Co.

171 East Jefferson Avenue
Detroit, Michigan

balance when both switches are in the "off" position. A similar change in both lines will not affect the balance, and, therefore, one of the shunting resistors may be made variable to compensate for the irregularities of the other.

If it is desired to be able to turn the amplifier on from either end of the line, it will be necessary to run another pair of lines between the two stations with both switches connected in parallel across the line. *Note: In the diagram, the wire between R_2 and Z_2 should not connect to grid of 6C5.*

PRIZES

First—Winfred C. Lowe, New Brunswick, N. J.
Second—George Smith, Chicago, Ill.

We wish to thank also the following for their contributions: W1JLJ, 1K1K, 2CRK, 2IAW, 2IGE, 2JHB, 2KTF, 2KVS, 2KZQ, 3AYZ, 3DBQ, 3FFC, 3FNN, 3GCK, 3GPH, 5CIQ, 5GNV, 6JTN, 6PCP, 6PFX, 8MVQ, 8OAH, 8PEN, 8REM, 9GVL, 9JHY, 9OPA, 9PCZ, 9RRS, 9SKR, E. P. Abrams, J. Althouse, G. W. Clarke, W. Cringan, E. P. Haines, Jr., H. A. Hudson, L. Linnett, R. C. McCown, R. Mens, J. T. Morrow, C. B. Neiman, H. D. Pierce, T. D. Reid, R. F. Scott, D. Smith, D. Sorber, D. S. Swennumson, W. B. Syer.

Rules under which the contest is conducted are as follows:

1. Solutions must be mailed to reach West Hartford before the 20th of the publication month of the issue in which the problem has appeared. (For instance, solutions of problem given in the May issue must arrive at *QST* before May 20th.) They must be addressed to Problem Contest Editor, *QST*, West Hartford, Conn.

2. Manuscripts must not be longer than 1000 words, written in ink or typewritten, with double spacing, on one side of the sheet. Diagrams and sketches may be in pencil, but must be neat and legible.

3. All solutions submitted become the property of *QST*, available for publication in the magazine.

4. The editors of *QST* will serve as judges. Their decision will be final.

Prizes of \$5 worth of A.R.R.L. station supplies or publications will be given to the author of the solution considered best each month, \$2.50 worth of supplies to the author of the solution adjudged second best. The winners have the privilege, of course, of stating the supplies preferred.

Simple Directive Alloys

(Continued from page 18)

parasitic antenna resonant and acting as a director, occurs at about $\frac{1}{20}$ wavelength spacing and the power gain is about 3.25 db. Back radiation is down about 19 db. As a reflector tuned to resonance, the best spacing for maximum front-to-back ratio is 0.3 wave, where the gain is 3.8 db and front-to-back ratio is 5.75 db. *There is no particular reason for favoring the use of a reflector; the advantages of a director are greater.* The impedance of the driven radiator at $\frac{1}{20}$ -wave spacing is about 15 ohms, and at 0.3-wave spac-

TYPE O DIAL

THE O Dial has always been distinguished not alone for its appearance, but also for the very thorough way in which the dial scale is insulated from the shaft on which it mounts. For some applications, as in instrument use, it is desirable to ground the dial. For this purpose a small multi-contact brush is now packed with each dial. This device also provides a smooth friction load that makes adjustments steadier.

Where a positive clamp is desired, the new Type ODL Lock is available at a small extra charge. It is positive in action, and tightening it does not disturb fine adjustments, nor mar the fine finish of the dial.

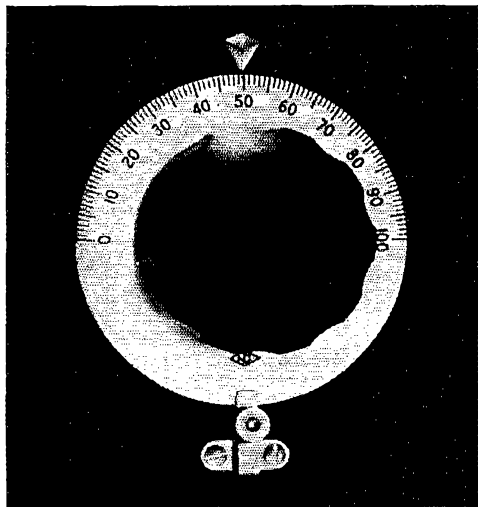

National Type O Dial, complete with index and grounding brush. Net Price... **\$.90**

National Type ODL Lock. Net Price... **\$.30**

NATIONAL COMPANY, INC., MALDEN, MASS.

PRICES REDUCED

On G-E Pyranol Capacitors

For Example:

	WAS	NOW
1000-volt, 4 mu f.....	\$4.20	\$3.00
1500-volt, 2 mu f.....	3.75	3.00
2000-volt, 2 mu f.....	4.80	3.30
2500-volt, 1 mu f.....	8.40	4.80
3000-volt, 1 mu f.....	10.80	7.20

The ever-increasing popularity of G-E Pyranol Capacitors has afforded economies in production which we are passing on to you. • Ask your dealer

for Bulletin GEA-2021A and the new price list on all ratings, or write Radio Department, General Electric, Schenectady, N. Y.

GENERAL  ELECTRIC

REMOTE CONTROL

WARD LEONARD
MIDGET
REMOTE CONTROL
RELAYS

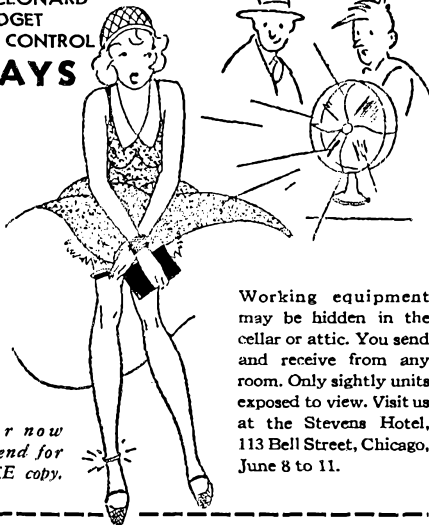

Working equipment may be hidden in the cellar or attic. You send and receive from any room. Only slightly units exposed to view. Visit us at the Stevens Hotel, 113 Bell Street, Chicago, June 8 to 11.

Circular now ready. Send for your FREE copy.

WARD LEONARD ELECTRIC CO.
41 South Street, Mount Vernon, N. Y.
Please send me a free copy of your latest bulletin on Midget Remote Control Relays.

Name _____
Street _____
City and State _____
Call Signal _____

RADIO POSITIONS There are good positions waiting for good-type, well-trained men in radio . . . There are good opportunities for fine futures . . . but an advanced COMPLETE ACTUAL PRACTICAL TRAINING . . . as well as high type theory . . . is essential. Free Bulletin on Positions, Futures and Training.

Frank G. Jones Lecturers Arthur Halloran
Author "Radio Handbook" Author "Cath. Ray & Tel."

PACIFIC RADIO SCHOOL
Dept. A, 735 Larkin Street San Francisco, Calif.

Unconditionally Guaranteed

PR CRYSTALS

Powerful Reliable

X cut 7000 KC ± 5 KC . . \$1.85 3500 or 1750 . . \$1.65
Low Drift ± 5KC 40-80-160 2.20

PETERSEN RADIO CO. Ex

W9JRY COUNCIL BLUFFS, IOWA W7AHE
Formerly Omaha Crystal Labs.

YOU CAN BUY NO BETTER
RADIO AND TELEVISION
Power TRANSFORMERS
. THAN THOSE WHICH BEAR

THE NAME



THE ACME ELECTRIC & MFG. CO.
38 WATER ST. CUBA, N. Y.

Acme Electric
TRANSFORMERS

ing it is about 80 ohms. Therefore low-impedance lines such as twisted pair or concentric cable cannot be used in the conventional manner. The center impedance of the driven antenna is extremely low with the parasitic wire spaced a tenth wave, varying between 10 and 20 ohms.

We suggest that at spacings of a tenth wave or closer the radiators be rigid, preferably tubing, since under certain conditions of adjustment it is possible for the parasitic antenna to alternate between functions of director or reflector if it should swing excessively.

Applying Band-Pass Couplers

(Continued from page 16)

value to M , subtracting that value from the separate coils. The total inductance in each tuned circuit, both separate and common, should be as given by the formula for L . The separate coils should be so located or shielded from each other as to eliminate or at least minimize any stray mutual inductance that might otherwise exist.

An approximation for the value of the common coupling capacity in Figs. 1-D and 1-E can be arrived at by solving the formula for M and translating the result (L) into reactance of opposite sign:

$$C = \frac{1}{39.5 f^2 L}$$

Inasmuch as stray couplings and phase relationships may modify the arrangement considerably this value may vary widely from the optimum. Experimental determination with variable capacities being so relatively easy, it is recommended that the value computed for C above be used only as a guide for experimental investigation.

PUTTING BAND-PASS TO WORK

The value of tuning capacity required to tune the calculated inductance to resonance can, of course, be determined by the same relationship given in the preceding paragraph, or by *Lightning Calculator*. In the case of the higher-frequency bands this value for C may be less than the stray circuit capacities. Obviously, some re-design will then be called for. Within moderate limits the resulting increase in Q will not be disturbing, high-frequency circuit losses being a counter-actant. If the response is too unequal the plate and grid circuits may be tuned to separate frequencies—a condition with inherently unequal response, but which may neutralize undesired peaks—or the grid circuit may be loaded by resistance. Both these methods entail a reduction in transfer efficiency. A better plan is to decrease both plate voltage and grid bias, resulting in higher plate current for the same input, lowering the plate impedance and thereby the effective Q . Fortunately, the circuits are to a considerable extent self-adjusting, the power consumed in the

BE SURE TO READ THIS NEW BOOKLET

NEW AND VALUABLE INFORMATION ON THE THEORY, APPLICATION AND OPERATION OF QUARTZ CRYSTALS . .



Whether you are an engineer, amateur or experimenter, you will want a copy of this authoritative booklet that tells the "why's and wherefore's" of quartz crystal frequency control. Theory, application and operating notes are effectively presented in a simple straightforward manner. Complete, yet not too technical, this new booklet is a storehouse of valuable information.

Nothing like FREQUENCY CONTROL WITH QUARTZ CRYSTALS has ever been published before. Now, for the first time, you can have this much needed information at your fingertips. A copy is yours for the small charge of 10¢ (in Canada 15¢)—a fraction of the actual cost of publication. Your Bliley Distributor has these booklets on hand—obtain your copy from him. The supply is limited and the demand will be large, so get your copy immediately. Bliley Electric Company, Erie, Pa.

Some of the chapters:

Frequency Standards . . Crystal Activity . . The Multivibrator
Effects of Temperature . . General Operating Notes
Standard and Special Crystal Oscillator Circuits

10¢ at your Bliley dealer

HERE'S A REAL "BUY" FOR ALL ACTIVE AMATEURS

THROUGH SPECIAL ARRANGEMENTS WITH RCA-VICTOR, WE PRESENT

THE "VICTOR RECORD SOCIETY" GIFT OFFER

EVERY HAM SHOULD JOIN AT ONCE AND GET THIS

New RCA VICTOR RECORD PLAYER at no cost!

LOOK AT THESE FEATURES—New Type Crystal Pick-up, Quiet Synchronous Motor, Beautiful Moulded Bakelite Case, Volume Control and Switch. Connects to your Speech Amplifier or Radio Receiver. Frequency response 70 to 7,000 C.P.S.

HOW YOU JOIN THE SOCIETY—Write us at once for membership form. Cost of the membership is only \$6.00. Next select \$9.00 worth of Victor Records, any records you choose. Immediately we ship your order, including the R93B, without one penny of additional investment. You also receive Victor Record dividends covering the cost of your membership.

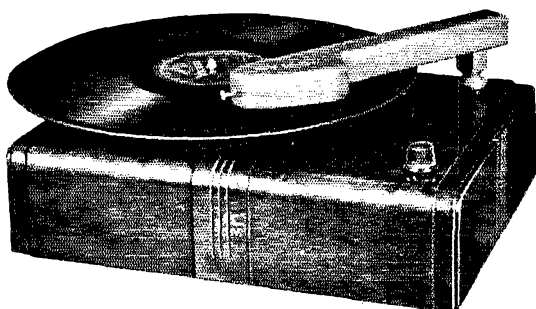

CRYSTAL PICK-UP AND ARM ASSEMBLY

Only \$2.97 (Amateur Net Prices) Only \$3.90

Immediate Delivery on These Parts



SYNCHRONOUS-REACTION MOTOR

Only \$3.90



Model R93-B
LIST PRICE **\$1495**

AMATEUR NET PRICE ONLY **\$897**

Also write for our New Time Payment Plan on all Amateur Equipment. Down Payments less than 10% of total order. For U. S. A. only

DELAWARE RADIO SALES COMPANY

405 Delaware Avenue
Wilmington, Delaware

WILLARD S. WILSON—W3DQ

Established 1922

DO YOU WANT TO LEARN WIRELESS and TELEGRAPHY?



A BOOK EVERY AMATEUR
SHOULD HAVE —

Send Now!

15¢

POSTPAID
COIN, OR
STAMPS

Hundreds of amateurs have learned
from this book, so can you.

This book gives you the fundamentals of wireless and telegraphy. It contains the codes and how to learn them. Mail your order now to:

SIGNAL ELECTRIC MFG. CO., Menominee, Michigan

ESTABLISHED
1892



**GORDON
NAME PLATES**

ANTENNA TUNING

A complete line of 122 everlasting, chromium plated name plates for Transmitter, Sound and Test equipment. Available in two sizes. Write for listing and low prices.

GORDON SPECIALTIES COMPANY
1104 S. Wabash Avenue • Chicago, Illinois

GOING AWAY TO SCHOOL?

Be sure and investigate the many advantages offered by our 36 weeks comprehensive course.

EASTERN RADIO INSTITUTE

899 BOYLSTON STREET

BOSTON, MASS.



NEW HOLDER DESIGN
15 SECONDS TO
INSTALL CRYSTAL

For All Bands
GREATER STABILITY

Plugs in 5 prong tube socket

Beautiful Appearance

MODEL AH HOLDER \$1.00 At your dealer
or direct

HIPOWER LOW DRIFT CRYSTALS:
within 10 kc. or Choice of stock

AH-10, 1700-3500 Kc. bands \$2.35

AH-10, 7000-7300 " bands 3.90

WRITE FOR NEW LITERATURE

Hipower "Low Drift" Broadcast and Commercial
Crystals Are Approved by F.C.C.

Hipower Crystal Co., 2035 Charleston St., Chicago

load varying in accordance with circuit conditions.

Some readjustment of the actual spacing between the coils may be helpful, especially where stray capacity coupling exists. The method of providing variable coupling used in the band-pass couplers in the transmitter described is quite simple. The plate coil is, in each case, wound on the XR-1 coil form contained in the National FXT trimmer and shield assembly which is the structural basis of the units. The bottom half-inch of this form is left empty. The grid coil is wound on a celluloid former which slides on this empty end space. The celluloid former is made by taking a sheet of 1/8th-inch sheet celluloid about 1 1/2 by 4 inches, wrapping it around a blank XR-1 form, and cementing the overlapping ends with Duco cement. It should be tight enough to slide smoothly on the form and yet hold firmly wherever it is set. The wire is then wound on while the celluloid is still on the form, and heavily doped. Finally, the whole coil is covered with Scotch (cellulose) tape, both to further stiffen the structure and to protect the winding.

The coupler is then assembled, with heavy bus leads coming from the trimmer terminals through the bottom of the can for wiring into the circuit. The plate return and grid leads from the respective coils are soldered directly to these busses where they parallel the coil ends. The grid coil connections are made with a small amount of slack to provide sufficient flexibility to enable moving the coil for a fraction of an inch either side of the calculated spacing.

The dimensions for the particular couplers used in this transmitter are given in the accompanying table. The use of coils of nearly identical length and diameter throughout simplifies both calculation and construction. As pointed out above, all these couplers are made in similar fashion. The two higher-frequency units are built in standard FXT assemblies, while the lower-frequency transformers use the can and condenser assemblies from National IFC i.f. transformers, the coils being discarded. The 25- μ fd. trimmers in the standard assemblies do not have enough range on these bands, and the additional cost of the i.f.t.'s is slight.

The couplers are used to tie in successive doubler stages, with output on 7, 14 and 28 Mc., and to couple the Class-A amplifier following the e.c.o. into either the RK-47 on 3.5 Mc. or the 40-meter doubler. No coupler is used in the output of the crystal oscillator, pre-tuned plate circuits being more practicable there.

The basic order comprises B_2 with a nominal range of 3500 to 3750 kc., B_3 with 500-kc. coverage at 7 Mc., B_4 with 1000 kc. at 14 Mc. and B_5 with about 1500 kc. coverage at 28 Mc. High circuit losses and the impracticability of designing the 10-meter coupler for proper Q owing to high circuit capacity make it difficult to secure adequate excitation for the RK-47 over the entire 28-Mc. band without exceeding the dissipation rating of the RK-25 doubler. A slight readjustment of the grid trimmer enables satisfactory coverage of the entire band.

STATION OPERATING SUPPLIES

For full enjoyment of your operating activities
you will want these forms designed to meet
your needs

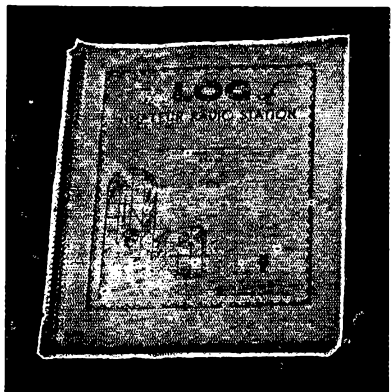

HANDY TO USE

The most interesting feature of the new LOG BOOK is the incorporation of spiral binding. This permits the book to be folded back flat at any page, requiring only half the amount of space on the operating table and making it easy to write on. The log-sheet has been redesigned by the Communications Department so that there is space provided for recording the number of messages handled and QSL's sent and received. General log information (prefixes, etc.) has been brought up-to-date. The LOG BOOK price has been reduced and is now 35c per book, 3 books for \$1.00, postpaid.

FOR PRESTIGE

The radiogram blank is now an entirely new form, designed by the Communications Department to comply with the new order of transmission. All blocks for fill-in are properly spaced for use in typewriter. It has a strikingly new heading that you will like. Radiogram blanks, $8\frac{1}{2} \times 7\frac{1}{4}$, lithographed in green ink, and padded 100 blanks to the pad, are now priced at 25c per pad, postpaid.

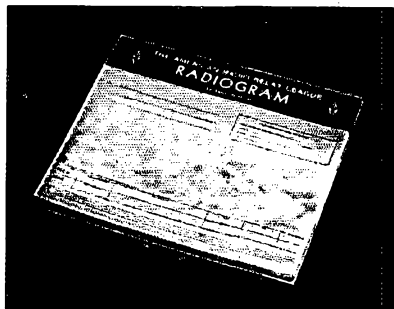

FOR CONVENIENCE

Radiogram delivery cards embody the same design as the radiogram blank and are avail-



able in two forms — on stamped government postcard, 2c each; unstamped, 1c each.

AMERICAN RADIO RELAY LEAGUE, INC.
WEST HARTFORD, CONNECTICUT

E. H. RIETZKE, Pres.



There's Always a Better Job for a Better Man!

CAPITOL RADIO ENGINEERING INSTITUTE

If you're satisfied and contented with your present position in Radio, you won't be satisfied with CREI . . . *but*, if you're ambitious and can realize the opportunities that lie ahead in Radio for specialized, *technically trained* men . . . then, CREI can help you as it has helped others — out of routine jobs into top positions in the Radio industry.

"Invest" One Cent Now . . . Write Today for FREE Illustrated Catalog

Our "Tested Plan for a Future in Radio" will be gladly sent free on your request. Paste coupon on a penny post card and mail for your copy of this interesting, illustrated booklet right away.



MAIL THIS COUPON TODAY

CAPITOL RADIO ENGINEERING INSTITUTE
Dept. Q-5, 14th & Park Rd., Washington, D. C.
Please send me complete details and illustrated 48-page booklet — "A Tested Plan for a Future in PRACTICAL RADIO ENGINEERING."

Name.....

Address.....

City.....

How to Double Your Power Into Antenna with LINN'S E-20 Speech Amplifier . . . at Low Cost

You get actual 100% modulation with this new speech amplifier because of automatic volume compression. Assures increase in average antenna power of about 3dB, or double power. No fear of over-modulation. Wired complete as shown with 8 tubes, ready to operate. Even your DX reports say "Broadcast Quality." Mounts on standard rack. Easy to use. Entirely automatic. Write today for bulletin 1-1. Priced complete at only \$27.50 net. Order today.



LINN ENGINEERING CO.

BOX 457

CEDAR RAPIDS, IOWA



Your dealer has this new unit in stock

THE VALPEY CRYSTALS

HOLLISTON, MASS

NEW

We are pleased to announce the new Valpey type V5 unit embodying features found in only the finest units.

Holder molded from low loss material. PK pins for 5 prong tube socket mounting. Low drift crystal will not exceed 4 C/M° centigrade.

Heat treated stainless steel electrodes. Frequency calibration accurate to within .03% in purchasers equipment.

Supplied in the 1.7, 3.5, 7 Mc. bands. Amateur net cost only.....\$4.80

BAND-PASS COIL DATA

	Frequency	Length	Diameter	Turns	Wire ¹	Spacing ²
B ₁	3.7-4 Mc.	1"	1"	36	No. 22	0.5"
B ₂	3.5-3.8 Mc.	0.8"	1"	36	No. 24	0.5"
B ₃	7-7.5 Mc.	0.8"	1"	23	No. 20	0.4"
B ₄	14-15 Mc.	0.8"	1"	12	No. 20	0.2"
B ₅	28-29.5 Mc.	0.8"	1"	7	No. 20	0.3"

¹ All wire is enamel-covered. The 14- and 28-Mc. coils are space-wound to fill the indicated length.

² Spacing is between "cold" ends of grid and plate coils. Both coils are identical.

B₁ is shown in the circuit as an auxiliary coupler covering the 3750-4000 kc. region, completing the 80-meter band coverage. It is perfectly possible to secure even response over the entire 500 kc. at 80, but the efficiency is correspondingly reduced. In this particular layout the additional sacrifice could not be tolerated. B₂, as shown, can be made to cover the region 3500-3850 adequately — in other words, practically the whole c.w. band. Crystal control is used in the 75-meter 'phone band, the desirability of c.c.o. being less acute there (you can't escape the QRM anyway!).

RK-25's are used as doublers primarily because they were in the shack. Had 807's been available they would probably have been used, particularly in doubling to 28 Mc. Even 6L6G's would doubtless be satisfactory, if initial cost is more important than frequent tube replacements.

The exciter band-change switch was made up to order by Centralab. Its Isolantite insulation, positive contacts and freedom from "whip" despite its length are desirable features. It contains five standard 2-pole 5-position switch plates, assembled with approximately 2-inch spacing between plates. This is a highly adaptable assembly, capable of handling quite a few more circuit variations than are called for in the transmitter described. Similar switches, or special assemblies designed to meet other layout needs, can be secured through most amateur supply houses; manufacturers will fill reasonable needs.

Considerable care was taken with the electron-coupled oscillator. It was felt that a signal somewhat better than "just good enough to get by" — which is about as much as can be said for the bulk of c.c.o.'s now in use, especially when they are keyed — was essential. For this reason the oscillator was built as a separate unit, the mechanical construction being made very rigid, and the whole mounted on rubber within the main assembly. This obviates vibration problems, including the transmission of both hum and keying shocks when the unit is mounted on the operating table. Of particular importance is the reduction of microphonics in both tube and condensers; this is aided by the high-C circuit.

The oscillator is assembled in an 8 by 8 by 6-inch Electralloy box, of the type sold knocked down. The oscillator tube is mounted inverted, with the socket placed at the bottom of a National J-30 coil shield which serves both as a tube shield and ventilating chimney. A number of

NEUTRALIZING CONDENSERS

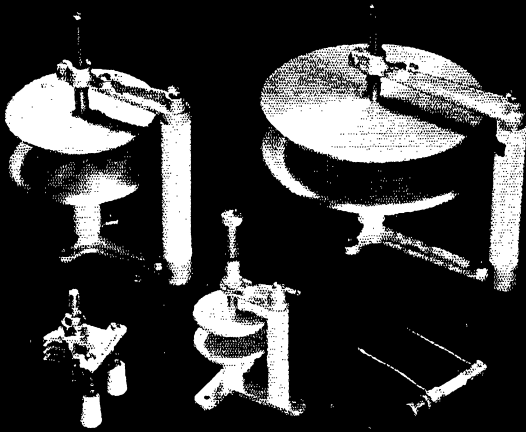

Steady improvements and additions have made National Neutralizing Condensers outstanding in performance and versatility. Recent improvements include micrometer type thimble and clamp for the NC-800 and an insulated mount for the STN. The NC-600 is a new arrival, small and compact enough to be supported by its own pigtail leads and pre-eminently suited to neutralizing 6L6's.

In the group illustrated above in the top row, left to right is the NC-150 (Net Price \$3.90) and the NC-500 (Net Price \$7.50). In the lower row, left to right is the new STN (Net Price \$1.20), the new NC-800 (Net Price \$1.80) and the new NC-600 (Net Price \$2.7).

NATIONAL COMPANY, INC. MALDEN, MASS.

NOW! A Perfected AUTOMATIC SENDER

Let the Automatic Sender raise your stations. Repeats calls or messages indefinitely. Sends 2 to 70 words a minute. Entirely automatic. Built-in tape perforator. Complete with 6 rolls of tape and full instructions. No extra equipment needed. Fully Guaranteed. **\$12.50**

\$18.50 West of
Denver
Postpaid in U.S.A.

A New High-Speed RELAY

Faster — More Compact — Quieter
Moisture Proof — More Applications

Plug-in base fits UX socket. Only 1 inch ideal for use with vacuum tube. Follows perfectly at speeds far above professional "bug." Perfect as keying relay. Available in 6, 25, 50, 100, 150 volts. **\$4.50 to \$6**

Postpaid in U.S.A.

GARDINER-LEVERING CO. Haddon Heights
New Jersey, U. S. A.

LEARN RADIO — TELEVISION —

500 Licensed graduates placed in past 7 years in shipping, broadcasting, aviation, police, etc., we also teach radio servicing and repairing; new term Mar. 14, May 9, day or eve., 52-page catalog free; oldest, largest and best equipped.

MASS. RADIO SCHOOL 18 Boylston Street, Boston

G. R. Entwistle, Pres.
Established 1899

R. F. Trop, Treas.
Hancock 8184

Look for the Good Name

Insist on KEN-RAD Tubes. They give better radio reception. The latest refinements and improvements are incorporated. KEN-RAD, means highest quality.



Ken-Rad Radio Tubes
KEN-RAD TUBE & LAMP CORPORATION - OWENSBORO, KY.
Makers of all types of radio tubes and Ken-Rad Electric Lamp Bulbs

Say You Saw It in QST — It Identifies You and Helps QST

WHEN WE SAY

' LIGHTNING '

We're thinking of that funny stuff that comes zooming out of the skies, right through the QRM, lighting up everything in a flash!

AND WHEN WE SAY

LIGHTNING CALCULATORS

We mean that these gadgets bring an answer right through *mathematical QRM* just like that — in a clear flash!

Type A, \$1.00 Type B, \$1.00

For problems involving frequency, inductance and capacity, in design of radio frequency circuits. Direct reading answers for size of coils and condensers for any range between 400 kc. and 150 mc.

Gives direct reading answers to calculations involving current, resistance, voltage and power with scale for resistance of copper wire and scale for calculating decibel gain or loss.

Type C, \$.50 Type D, \$.50

More information on electrical conductors than you could find in a book full of tables.

Gives decibel gain or loss when input and output voltages, currents or power are known.

Type E, \$.50 Type F, \$.50

Direct reading total resistance of resistors connected in parallel, and total capacity of condensers connected in series.

Permits measurement of resistance, from 1 ohm to 1 megohm by use of a voltmeter. Makes an ohm-meter of your voltmeter.

Prices include postage from the
AMERICAN RADIO RELAY LEAGUE
West Hartford, Connecticut

holes have been drilled in the cover of the box directly above the socket, for the purpose of providing direct upward air conduction.

The tuning system is arranged to provide both band-spread and a straight-line-frequency tuning characteristic, along with high *C*. The series and parallel padders, *C*₂ and *C*₃, are adjusted by an insulated screw-driver through the side of the box, slots having been sawed in the shaft ends and locating bearings placed in the box wall. *C*₄ is a panel trimmer, which enables correction for calibration when rechecking against a standard, and also serves to shift the low- and high-frequency ranges on the 80-meter band.

Since the primary reason for using e.c.o. is to be able to locate precisely on any desired frequency, it seemed logical to provide an accurate and easily-read frequency calibration. Any attempt to use a conventional dial would mean an auxiliary calibration chart of some sort, even if the receiver were used for precise setting. The most effective solution seemed to be to borrow from all-wave broadcast practice and make a large directly-calibrated scale on stiff cardboard fastened to the panel. A celluloid indicator taken from an ancient *Lightning Calculator* and a control wheel completed the tuning assembly.

Calibration is accomplished by the use of a receiver and a 100-kc. oscillator checked with b.c. stations. The band limits are first set on the ends of the scale by adjusting the padding condensers, and then the 100-kc. points marked (on the 28-Mc. band, where there are more of them!).

Simply building up a circuit from a book does not mean a stable, clean-keying electron-coupled oscillator. The use of electron-coupling is not a cure-all for instability, drift or poor-note troubles. Certain design precautions must still be taken.

Frequency changes in an e.c. oscillator are caused primarily by the following changes in operating conditions:

1. Voltage variations (line voltage changes, power supply regulation responding to changes in other circuits).

2. Tuning of the output load tank and the following amplifier (if a Class-C amplifier its tuning controls the power loading of the oscillator).

3. Temperature changes, including both ambient (room) temperature changes that modify the characteristics of the tuned circuit, and tube heating, causing variations in the interelectrode capacities.

These considerations are arranged in the order of their progressive importance. The least important is that of voltage changes, the e.c.o. having as its principal feature the inherent ability to compensate for such variations. However, the use of a voltage-stabilized power supply eliminates most of the small change (perhaps 0.001 per cent for 20 per cent line voltage change) to be expected from this source.

Tuning the output circuit of an e.c.o. will have more or less effect on the frequency depending on the internal screening of the tube. Dow⁴ gives

⁴ J. B. Dow, "Electron-Coupled Oscillator Circuits," *QST*, January, 1932.

Take a look inside

the Harvey UHX-10. You'll find parts by Cardwell, Aero-vox, and Cornell-Dubilier, Centralab, and I.R.C., Kenyon, UTC, Coto-Coil, Arrow-Hart and Hegeman, Yaxley, Triplett, Amphenol, Birnbach, William Brand, Philadelphia Wire, Shakeproof Lock Washer, Alcoa Aluminum. It's a veritable "blue book" of Radio Manufacturers. This

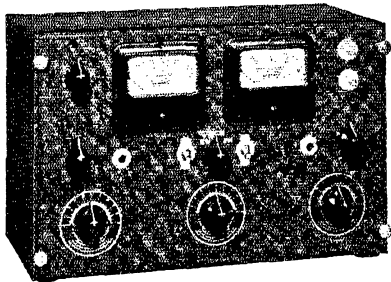

rugged, compact, portable transmitter

has a frequency range of 1,500 to 60,000 kc. . . . AC or Battery Operation . . . New oscillator circuit . . . Better excitation control . . . Gray Wrinkle finish . . . Complete panel engraving. Write to Harvey Radio Laboratories, Inc., 25 Thorndike St., Cambridge, Mass., for more complete information.

Licensed 2-way Equipment Available For Police Services

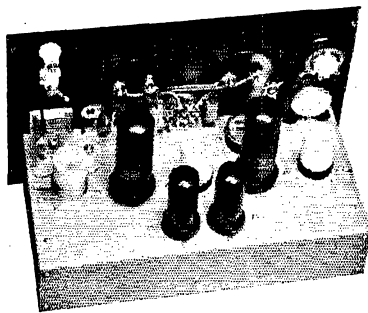

UHX-10 TRANSMITTER

INDISPENSABLES

√ your receiver √ your transmitter √ your F.C.C. licenses
√ your LICENSE MANUAL

It's against the law to operate an amateur radio station without the required federal licenses for station and operator. The maximum penalty for so doing is a \$10,000 fine and two years in a federal penitentiary.

That's the broad basic picture. But within the scope of the federal licensing machinery are many detailed regulations, the violation of any one of which can lead to suspension, cancellation of licenses, or even fines or imprisonment. These regulations change frequently, in step with the rapidly developing art of radio.

There is only one way for the amateur to keep at his finger tips these changing legal requirements — short of maintaining his own Washington legal bureau. That is to keep the latest edition of the Radio[®] Amateurs License Manual in the shack at all times. New editions always contain the latest regulations — and when a new edition appears it means that changes in federal regulations have made its predecessor obsolete.

WE ARE NOW SUPPLYING THE EIGHTH EDITION
TAKE A LOOK AT YOUR COPY!

TWENTY-FIVE CENTS POSTPAID

AMERICAN RADIO RELAY LEAGUE, WEST HARTFORD, CONN., U.S.A.

Short-cuts to the right answers

MATHEMATICS FOR RADIO AND COMMUNICATIONS

By GEORGE F. MAEDEL, Head of Radio Frequency Engineering Dept., R.C.A. INSTITUTE

To master the technicalities of radio — to use engineering literature intelligently, the amateur **MUST** have the mathematics groundwork covered by this absorbing, simplified home-study course. Thoroughly trains you to solve knotty problems quickly, accurately, decisively. Contains hundreds of short-cuts, as well as complete instruction in the algebra, arithmetic, plane and solid geometry necessary to a complete understanding of radio technicalities.

Examine this valuable book on our 5-day **\$3.75**
FREE EXAMINATION OFFER

5 DAYS FREE EXAMINATION

PRENTICE-HALL, Inc.,
Book Division 3, 70 Fifth Ave., New York, N. Y.

Send me a copy of MATHEMATICS FOR RADIO AND COMMUNICATIONS for 5 Days' Free Examination. I enclose \$3.75, plus 6c postage, with the understanding that I may return the book within 5 days and my money will be refunded.

Name.....

Address.....

SPECIAL TO AMATEURS

Piezo-Electric Crystals — \$2.50 EACH
POSTPAID

Until supply is exhausted . . . we offer 80 meter band crystals unmounted; accurate calibration, excellent oscillators. Limited quantity.

SCIENTIFIC RADIO SERVICE

"The Crystal Specialists Since 1925." University Park, Hyattsville, Md.

SELECTOSPHERE \$3.95

Good News. A sensational high selectivity-noise and static reducing loudspeaker for use with any receiver — no alterations. Rivals XTl filter reception. Direct sales gives maximum selectivity per dollar at a new low price, \$3.95 plus postage for 7 lbs. Kit complete with use and assembly instructions. Simple to assemble. Checks and M.O. accepted.

Selectosphere Co., Box 3, Newtonville, Mass.

TURNER'S New 30-30-Crystal Mike

Modernize Your P.A. System
at Low Cost

A brand new streamline crystal mike that gives you semi-directional operation, genuine absence of peaks, greatly reduced feedback trouble and trust-worthy response . . . 30 to 8000 C.P.S. High level, minus 52DB, allows use of economical low gain amplifier. Hum problems are minimized because no input transformer required. The 30-30 is not affected by wind on outdoor set-ups and will not blast. Crystal interior suspended in shock absorbing material to prevent breakage and eliminate handling noises. Smooth ebony \$13.95 and sparkling chrome finish.

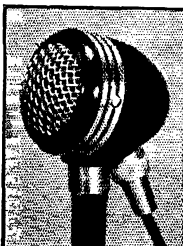

Priced right. Order today. Net. Cable Included. Model 30-30.

RADIO SUPPLY COMPANY

912 South Broadway, Los Angeles, Cal.

Licensed Under Patents of the Brush Development Co.

a figure of 0.004 per cent change in frequency due to tuning the load circuit through resonance, while detuning the resonant plate circuit of the first following amplifier changed it 0.001 per cent and detuning the power amplifier caused a change of 0.0005 per cent. All of these changes are avoided by using an "impedance-coupled" screen-grid Class-A amplifier following the oscillator which uses no tuned load circuit out of the oscillator and can transmit no load circuit variations back from following stages, since it takes no power from the oscillator and input-capacity variations are minimized by the internal shielding in the tube.

The most important effect is due to temperature. The temperature coefficient of tuned circuits depends on a lot of variables, but it averages about 0.005 per cent per degree. Placing the tuned circuit in a temperature control box having a variation of plus or minus 1° F. would keep the drift down to perhaps 100 cycles at 3.5 Mc., but this is hardly practicable. In the transmitter described the chimney arrangement of the oscillator tube tends to keep heat out of the oscillator shield box, aided by the exhaust effect of a cooling fan placed at the top of the cabinet which avoids the accumulation of excessive heated air in the cabinet as a whole. After an initial heating period the temperature variations are small.

There isn't much more one can do with the tuned circuit itself. The same impotence prevails with regard to the variations in interelectrode capacities introduced by tube heating. This may amount to a 0.002 per cent frequency change between on-off periods or during keying, when plate power is off. In the oscillator shown the use of suppressor-grid keying leaves the power dissipated in the actual oscillator circuit more or less constant. Furthermore, the plate circuit is so lightly loaded that there is negligible plate heating, further reducing drift from this cause.

Although the effect of temperature on stability, being the largest cause as well as the hardest to liquidate, may seem discouraging, there is another angle of attack, and that lies in the design of the oscillatory circuit itself. First of all, there is the matter of effective circuit Q —high $C-L$ ratio. Every amateur knows that high- C is desirable in an oscillator in order to mask changes in interelectrode capacities. It also serves to compensate for phase shift resulting from a change in effective plate resistance, such changes being inversely proportional to Q . A high- C circuit that is heavily loaded no longer has high Q , however, so the power output must be kept low. Again, the Class-A amplifier is a virtue.

Proper choice of the grid and plate (screen-grid) blocking condensers, too, will serve to compensate for phase shifts between the grid and plate alternating voltages—the basic cause of oscillator instability.⁵ Suitable values of reactance will serve to isolate the tuned circuit from external changes, i.e., from the tube circuit. The use of a large coefficient of coupling between the grid

⁵ F. B. Llewellyn, "Constant Frequency Oscillators," I.R.E. Proceedings, December, 1931.

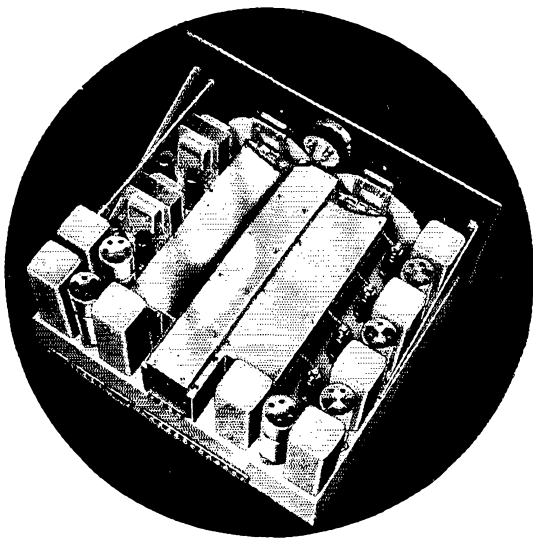

THE ANSWER TO PHONE "QRM"!

Don't let "QRM" spoil your phone "QSO's"! Selectivity of the "Super-Pro" is variable from 3 to 16 kc. and is the answer to crowded phone bands. At maximum selectivity, heterodynes and hash are reduced to practically nil. Unfinished "QSO's" are a waste of time. Use a "Super-Pro" and make your week-ends on 20 meters a real pleasure, not an endurance contest.

Hammarlund Mfg. Co., Inc.
424-438 West 33 Street, New York
Canadian Office: 41 W. Ave., No., Hamilton, Ont.



WRITE DEPT. Q-5
FOR BULLETIN

HAMMARLUND

COMMERCIAL HEADSETS IDEAL FOR

Amateurs and commercial operators—ruggedly constructed, yet extremely lightweight.

Write Dept. R-45 for Information

TRIMM RADIO MFG. CO.
1770 W. Berteau Ave. Chicago, Ill.

LEARN CODE RIGHT

INSTRUCTOGRAPH tapes send you typical messages Radio or Morse any speed. Easy practical way to improve. Senior Model \$20.25 (also rented). Junior Model \$12.00 (not rented). Complete oscillator equipment less battery \$6.50. Write for details today.

INSTRUCTOGRAPH CO., Dept. Q-5
912 Lakeside Place Chicago, Ill.

Radio College of Canada, 863 Bay St., Toronto



**Radio Operator's
Course
Telegraphy—
Telephony
Aviation**



**Practical
Experience
Studio—
Transmitter—
Announcing**

PORT ARTHUR COLLEGE has been teaching Radio for twenty-eight years, and during this time it has never been our policy to guarantee positions to prospective students, directly or indirectly. We believe it wisdom at this time, however, to go on record in our *QST* advertising to say that it is impossible for us to even come near to supplying the demand for Radio Operators received by our Employment Department. We do not mean by this that all students who enroll will automatically secure positions. The demand is for graduates—good men who deserve and are qualified to hold positions. The graduates of our Radio School, so far as we know or can learn, are employed 100%.

It is possible for every student who enters the P. A. C. Radio School and completes the course in keeping with our standards to receive employment as a Radio Operator for our station

K P A C at the transmitter, in the control room, as trans-radio press operator, or announcer, and not only earn more money than he pays for the training but to also continue his training as a post-graduate student in advanced work and prepare himself to secure and hold operating positions in the upper bracket of broadcasting, marine work, announcing, or airways.

Port Arthur College advertises primarily to Radio Amateurs and the training is too technical for the average student who has not selected Radio as his life's work. We know the opportunities for positions and advancement are unlimited for men who are interested in Radio and who plan to make this their career and are willing to make the sacrifice and effort necessary to master our training. P. A. C. maintains strict collegiate rank—only high school or college graduates are eligible for enrollment.

If interested in details about Radio Course, write for bulletin R

PORT ARTHUR COLLEGE ■ PORT ARTHUR (World-known port) TEXAS

¡Queridos Señores!

La edición 1938 del "THE RADIO AMATEUR'S HANDBOOK" se puede ahora conseguir en lengua española traducido por la Revista Telegráfica de Buenos Aires, Argentina, reconocida como la más antigua establecida y la más importante publicación de literatura de Radio en Sudamérica.

El "Handbook" (libro manual) está reconocido como el libro modelo en su clase. El por tanto tiempo esperado y sugestionado libro manual (Handbook) estamos seguros que su edición en español encontrará una acogida extraordinaria. Ha sido cuidadosa y escrupulosamente traducido. Ha sido impreso en una imprenta que está reconocida como la mejor de Sudamérica.

Nosotros estamos orgullosos del hecho que la Revista Telegráfica haya producido este trabajo y estamos seguros al mismo tiempo que es una contribución notable para la literatura técnica en la lengua española.

Se pueden conseguir ejemplares en "The American Radio Relay League, West Hartford, Connecticut, U. S. A." a \$1.50 cada ejemplar, franco, o si es más conveniente directamente de la Revista Telegráfica, Perú 165, Buenos Aires, Argentina, a cinco pesos, en moneda argentina.

**American
Radio Relay League**

and plate circuits—locating the cathode tap for maximum excitation—also aids in this respect by reducing the effect of stray couplings of random phase characteristics.

Although the Class-A amplifier used to couple from the e.c.o. adds still another stage, the improvement in performance makes it worth while. It affords quite a high order of power gain, even though its actual output is low. The use of "impedance coupling" from the oscillator limits the input signal to a low value, the high output capacity of the RK-25 affording a net reactance for the oscillator of only a couple of thousand ohms or so. The operating plate current of the e.c.o. is 6 ma. This is sufficient to drive the Class-A stage to a watt or two—enough to excite either the RK-47 or the 7-Mc. doubler. Had it been necessary, another band-pass coupler could have been used in place of the r.f. choke-resistor combination; in this way the signal voltage required to drive the Class-A stage to its rated 3 or 4 watts output could be secured.

The crystal oscillator circuit is of the standard pentode type, the only unique feature being the pre-tuned plate circuits. These tuning condensers, set to correspond with the crystal frequencies, are switched simultaneously with the crystals, eliminating a tuning operation.

Both oscillators are keyed, enabling break-in operation. Cathode keying is used on the 42 and suppressor-grid keying on the RK-25. Bias for the latter is obtained from the power supply for the RK-47 final, which is grounded at +600 volts rather than negative B. The c.o.-e.c.o. switch changes the necessary connections at the same time it revises the d.c. and r.f. circuits. An adjustable lag circuit is provided, the control resistor, R_3 , being accessible at the rear of the power supply. The keying of the e.c.o. is exceptionally crisp and clean, even cleaner than that of the c.o. This is, of course, due to the complete isolation, both mechanical and electrical—mechanically through the rubber-mounted sub-chassis assembly and electrically through the Class-A coupling amplifier and regulated power supply.

THE FINAL

To facilitate adjustment of the final amplifier separate tank circuits are provided for each band. This ensures proper orders of tank Q without resetting the tuning condenser when changing to frequencies near harmonic relationships. If the transmitter as shown is used on the operating table as the exciter for one or more separate kilowatt finals, the output circuits can be link-coupled to corresponding grid circuits, the coupling being adjusted to provide some band-pass characteristics.

It does not seem practicable to use band-pass coupling to an antenna over any appreciable part of a band. The reactance of the antenna changes so rapidly that constant readjustment is necessary to maintain an impedance match. The use of an external tuned antenna circuit for each band, link-coupled to the respective plate tank circuits,

Where to buy it

A directory of suppliers who carry in stock the products of these dependable manufacturers.



BUTLER, MISSOURI 211-215 N. Main Street
Henry Radio Shop

CHICAGO, ILL. 833 W. Jackson Blvd.
Allied Radio Corp.

CHICAGO, ILL. 901-911 W. Jackson Blvd.
Wholesale Radio Service Company, Inc.

COLUMBUS, OHIO 203 N. Fourth St.
Bell Radio Parts Co.

DETROIT, MICHIGAN 5027 Hamilton Ave.
Rissi Brothers, Inc.

DETROIT, MICH. 171 E. Jefferson Ave.
Radio Specialties Co.

DETROIT, MICHIGAN 11845 Woodward Ave.
Radio Specialties Co.

KANSAS CITY, MO. 1012 McGee Street
Burststein-Applebee Company

OMAHA, NEBRASKA 2855 Farnam St.
Radio Accessories Company

ST. LOUIS, MO. 927 Pine Street
Gordon Radio Company



BUTLER, MISSOURI 211-215 N. Main Street
Henry Radio Shop

CHICAGO, ILLINOIS 833 W. Jackson Blvd.
Allied Radio Corp.

CINCINNATI, OHIO North Bend Road, Mt. Airy
Jos. N. Davies

MINNEAPOLIS, MINNESOTA 1124-26 Harmon Place
Lew Bonn Company



CHICAGO, ILLINOIS 901-11 W. Jackson Blvd.
Wholesale Radio Service Company, Inc.

CHICAGO, ILLINOIS 833 W. Jackson Blvd.
Allied Radio Corp.

CLEVELAND, OHIO 2073 West 85th Street
Northern Ohio Laboratories

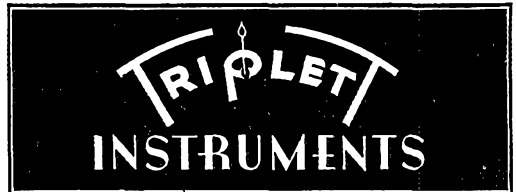

CHICAGO, ILL. 833 W. Jackson Blvd.
Allied Radio Corporation

CHICAGO, ILL. 901-911 W. Jackson Blvd.
Wholesale Radio Service Company, Inc.

CHICAGO, ILLINOIS 25 North Franklin Street
Electric & Radio Supply Co., Inc.

CLEVELAND, OHIO 610 Huron Road
Goldhamer, Inc.

MINNEAPOLIS, MINN. 1124-6 Harmon Pl.
Lew Bonn Co.

● THE ● SCOPE OF THE BOOKLET

"BUILDING AN AMATEUR RADIO TELEPHONE TRANSMITTER"

This booklet is addressed primarily to readers who have at least read our companion booklet, "How to Become a Radio Amateur," and have, perhaps, built a simple telegraph transmitter and receiver, have received their license, have acquired some skill and experience as a code operator, and who now feel the urge to explore the possibilities of radio telephony. These people should find this booklet the exact answer to their needs.

Absolutely the first requisite in either building or operating a 'phone transmitter is a solid understanding of what we are attempting to do when we accomplish voice transmission. Understanding the functions of the various parts, we shall avoid difficulties. The saddest thing in amateur radio is a 'phone amateur who does not understand the operation of his apparatus. The book begins, therefore, with a discussion of the principles involved and makes every effort to make this discussion perfectly clear so that the reader can easily make it a part of his own knowledge. It then goes on to the actual construction and operation of an inexpensive but efficient 'phone transmitter.

Priced at 25 cents per copy, postpaid

AMERICAN RADIO RELAY LEAGUE
West Hartford, Connecticut

is desirable. If the coupling is made quite tight (but only inductive, not capacitive) only the plate tank condenser need be re-set and this adjustment will be non-critical. An effective harmonic filter will thereby be provided, as well.

Constants for the plate tank circuits were chosen with the requirements of reasonably high Q for modulation (plate-and-screen) on 4, 14 and 29 Mc. Low- C is satisfactory on 7 Mc., provided isolated inductive coupling to the antenna is used to minimize harmonics.

The purpose of SW_4 may require some explanation. Since the bias, plate and screen voltages specified for the RK-47 are different in modulated and unmodulated operation, this switch makes the necessary changes—adding cathode bias and reducing the series screen resistor as well as shorting the key. The "open" position of the switch leaves the cathode resistor in but adds the additional series screen resistance, limiting peak plate current when tuning up.

Little need be said about the power supply, except to point out that it uses two transformer-rectifier systems in series for high voltage supply, the juncture being grounded. This offers several advantages: economy, the availability of high negative bias for keying, and reduced insulation requirements. A separate 500-volt supply powers the doubler stages, and, through a voltage-regulating network similar to those described in the *Handbook*, the oscillators.

A Self-Contained Speech Amplifier, Monitor, and Control Unit

(Continued from page 32)

kle-finished steel cabinet is 14 inches long, 7 inches high and $7\frac{1}{2}$ inches deep. The chassis layout is shown in the top view. It will be noted that the power supply was kept as far as possible from the 6J7 amplifier stage. The separate 6.3-volt heater transformer was installed after this picture was taken. A space was left in the back right-hand corner so that an output transformer to a 500-ohm line could be put in later if desired. Glass tubes were used in all except the first stage because they have been found more dependable. If a glass tube had been used in the first stage it would have been necessary to shield it, so a metal tube was used here.

On the front panel, from left to right in the top row, are a red pilot light which indicates that the heaters are on, the sensitivity control for the overmodulation tube, the modulation-level indicator, the modulation-level tube sensitivity control, and the green light that indicates that the transmitter is on the air. In the next row down are the heater power switch, the oscillator gain control, the over-modulation indicator, the microphone gain control, and the plate-voltage switch. In the bottom row are the jack for the key, the m.c.w.-'phone switch, and the microphone jack. The oscillator tone control is on the chassis inside the cabinet near the oscillator tube.

HAM-ADS

(1) Advertising shall pertain to radio and shall be of nature of interest to radio amateurs or experimenters in their pursuit of the art.

(2) No display of any character will be accepted, nor can any special typographical arrangement, such as all or part capital letters be used which would tend to make one advertisement stand out from the others.

(3) The Ham-Ad rate is 15c per word, except as noted in paragraph (6) below.

(4) Remittance in full must accompany copy. No cash or contract discount or agency commission will be allowed.

(5) Closing date for Ham-Ads is the 25th of the second month preceding publication date.

(6) A special rate of 7c per word will apply to advertising which, in our judgment, is obviously non-commercial in nature and is placed and signed by a member of the American Radio Relay League. Thus, advertising of bona fide surplus equipment owned, used and for sale by an individual or apparatus offered for exchange or advertising inquiring for special equipment, if by a member of the American Radio Relay League takes the 7c rate. An attempt to deal in apparatus in quantity for profit, even if by an individual, is commercial and takes the 15c rate. Provisions of paragraphs (1), (2), (4) and (5) apply to all advertising in this column regardless of which rate may apply.

Having made no investigation of the advertisers in the classified columns, the publishers of *QST* are unable to vouch for their integrity or for the grade or character of the products advertised.

QUARTZ—direct importers from Brazil of best quality pure quartz suitable for making piezo-electric crystals.

Diamond Drill Carbon Co., 719 World Bldg., New York City.

RADIO engineering, broadcasting, aviation and police radio, servicing, marine and Morse telegraphy taught thoroughly. All expenses low. Catalog free. Dodge's Institute, Byrd St., Valparaiso, Ind.

QSL'S, W2SN, Helmetta, N. J.

QSL'S, all colors, cartoons, snappy service. Write for free samples today. W1BFF, 16 Stockbridge Ave., Lowell, Mass.

USED receivers. Bargains. Cash only. No trades. Price list 3¢. W3DQ, Wilmington, Del.

QSL'S—200 for \$1.25. Barry, Babylon, N. Y.

FREE—catalog. Faberadio crystals and associated equipment. Prices from 75¢ to \$75. Dealers and users are enthusiastic. Faberadio, Sandwich, Ill.

QSL'S, SWLs, 65¢ hundred, two color. Samples. W1FTM, 268 Piedmont, Waterbury, Conn.

GENERAL Electric 24/750 volt 200 mill dynamotors \$20. On 12 volts delivers 375. Two in series for 1500. Westinghouse 27 1/2/350 volt \$10. 500 watt 6-15 volt Aircraft \$10. 900 cycle 200 watts \$15. Simon 500 watt 500 cycle \$10. Henry Kienzie, 215 Hart Blvd., Staten Island, N. Y.

CRYSTALS, mounted, 80-160 \$1.25, V-cut 40 \$2.25. R9 Crystals, 338 Murray Ave., Arnold, Pa.

QSL'S—W3BYK—923 N. 27 St., Camden, N. J.

CALLBOOKS—Spring edition now on sale containing complete up-to-date list of radio hams throughout entire world. Also world prefix map, press schedules and new time conversion chart. Single copies \$1.25. Canada and foreign \$1.35. Radio Amateur Call Book, 610 S. Dearborn, Chicago.

RCA ACT-20 transmitter like new \$95. with tubes. New ACR-155—\$44.50. Van Sickle Radio, W9KJF, Indianapolis, Ind.

RCA transceivers, phones, mike, tubes, \$15. Stelle, Box 33, Rodessa, La.

QSL'S. Free samples. Printer, Corwith, Iowa.

SWAP: Hammarlund Super-Pro for Contax or Projector. Ortmann, 16 Florence St., Cambridge, Mass.

FOR sale: two RK28s, used very little, \$20. each or both \$30. W3HH, Princeton, N. J.

QSL cards, neat, attractive, reasonably priced. Samples free. Miller, Printer, Ambler, Pa.

GOOD used bug—\$5. C. J. Hanrahan, 314 N. Fourth St., Mechanicsville, N. Y.

WANTED: A used 6 volt input, 400 volt, 200 ma output generator. Black Hills Radio Club, Box 149, Rapid City, S. D.

SWAP: transmitting, receiver parts—candid camera preferred. I. J. Sullivan, C.P.R.R., Lewiston, Idaho.

QSL'S. Free samples. Theodore Porcher, 7708 Navajo St., Philadelphia, Pa.

CRYSTALS: Before you buy write W8DED.

QSL'S, SWL's? Unbeatable. Samples? (stamp) W8DED, Holland, Mich.

DOUGLAS Universal Class B transformers of quality. Designed by W8UD. Sold exclusively by W9IXR. 50 watts audio \$4.95 pair. 100 watts audio \$7.75 pair. Postpaid in U. S. A. Guaranteed. To promote faster service we have moved. Write W9IXR, 17 W. Knapp St., Rice Lake, Wis.

FOR sale: 500 watt rack panel c.w.-phone xmitter PP805 final, coils 160 to 10, built by Hugo Romander. Price \$375. W8NWV, Uniontown, Pa.

WANTED: 1800 rpm 1 1/2-3 k.w. 110 alternator or d.c. equipment suitable for rewinding to a.c. W9ARN, Bartonville, Ill.

DISCONTINUING station—bargains galore. W1JJI.

BLUE print code chart—both codes—dime. W9OC, Spencer, Iowa.

BLUE print (dime) and photostat (quarter) International Q signals—convenient size. W9OC, Spencer, Iowa.

SELL: brand-new ACSW3, tubes, 10 and 20 bandspread coils, \$16.50. W9FZQ, LaPorte, Ind.

BARGAIN: selling 400 watt code, 300 watt fone, rack and panel type transmitter, coils for 80, 40, 20, and 10 meters; r.f., 42, 807, 35T, PP-35Ts; audio, 76, 76, PP-76s, PP-807s; condenser mike with 2-stage pre-amp in head; meters, 42, 807 and 35T plates, and PP-35T grid and plate, audio mod. plates; rack 72 X 19 inches. Price \$200. complete f.o.b. Philadelphia, all tubes but no crystals. Write W3QP.

FOR sale: Collins transmitter—Model 30FXC—200 watts output c.w. or phone. Complete with tubes, crystal microphone, crystal and coils for operation 10 meter ham band. New condition—used less than 100 hours. Cost over \$600.—will sell to first taker for \$300. cash. Shipment f.o.b. Bridgeport, Conn. H. A. Crossland, W5JR, High St., Fairfield, Conn.

CRYSTALS: zero cut. New low drift, 160-80-40 meters, \$1.85; 20 meter crystals, \$3. postpaid. Plug-in mountings, 75¢. Fisher Lab., 4522 Norwood St., San Diego, Calif.

WESTERN Electric condenser microphones with preamplifiers, \$10. each. Various Weston 301 meters, \$3. each. Dismantling Western Electric recording amplifiers. Write for price list of parts available. National Cine Labs., 20 W. 22 St., N. Y. C.

SELL: 300 watt 110 volt a.c. gasoline driven generator. Slightly used. Best cash offer. Reiffin, W2CWP, 2910 Valentine Ave., N. Y. C.

WANTED: power transformer 2500 to 3000 v., also filter and choke. W4DSA.

POLARIZED Relays \$3.95, extremely fast action. Same as used in Mac Auto. Ted McElroy, Boston.

913 oscilloscope. Tubes. Linear sweep. T. Porcher, Chestnut Hill, Pa.

TRANSMITTING tubes—used, 500 watters 7 types. Several smaller types. Rectifiers also. W9OQN, Ritz Radio Co., 1610 Central Ave., Kansas City, Kansas.

VAGABOND South Sea shore—expense cruise June 1938. Wanted—3 radio amateurs, one with first commercial license, also amateurs in other fields. Diesel steel schooner, accommodations for 20. Private staterooms for couples. Mr. P. Luko, 3640 Third, Wyandotte, Mich.

QSL'S. Beautiful designs. Finest quality. Samples. Maleco, 1512 Eastern Parkway, Brooklyn, N. Y.

NEW, unused 3/4 H.P. Lauson gasoline engine. Ball bearings; incorporated magnet; float carburetor. Cost \$47. month ago; sell for \$25. cash—no trades. Palmer Craig, 728 W. Market, Bethlehem, Pa.

NATIONAL oscilloscope small size. Sell best offer. W8KJ.

CRYSTALS; special for May: 160M-80M AT and V cuts, four cycle coefficient, within five kilocycles, \$1.95. Holders, \$1. Catalog. Ham Crystals, 1104 Lincoln Place, Brooklyn, New York.

SELLING 5 meter station complete. Meters, ham parts. W2GNZ, Bronx.

SWAP: 204A and National DX variable condenser. W3BNM.

FREE: 3—2000 volt, mica transmitting condensers with every order of 100 QSL cards. Price—\$1.—large selection—samples. W3DGS, 6417 Tulip St., Philadelphia, Pa.

WANTED: RCA 106 speaker cabinet. J. T. Boyer, Jr., Winston-Salem, N. C.

SACRIFICE: beautiful 200 watt rack and panel c.w. transmitter, 40 and 80. Six Weston meters, \$110. f.o.b. Adel, Iowa. Robert Freeman.

SELL or trade: files of *QST*, Electronics, IRE Proceedings, radio books, meters, RCA aircraft receivers, laboratory equipment. Consider cameras. D. Canady, State Theater, Cleveland, Ohio.

CRYSTALS: X cut, 80-160 five kilocycles \$1.50; spot frequency \$2.50. Special prices to Army, Navy, Red Cross and other round table nets. Three small, 80 meter blanks, including carborundum, \$1.20. Holders, \$1. William Threm, W8FN, 3071 Moosewood St., Cincinnati, Ohio.

COMPLETE station: 450 watt phone transmitter as described Page 49, May 1937 *QST*. RME receiver with silencer, spare parts, accessories. All for \$285. W9SDQ, Indianapolis.

MUST sell 150 watt modulator with power supplies and speech equipment, \$45. 200 watt transmitter complete, \$75. 50 watt modulator with speech and power, \$22. Write for list. Need cash. Radio, 206 N. Main, Blackwell, Okla.

TRY us first for radio supplies. Loughnane & Co., Decatur, Ill. SWAP dismantled station and 160 QST's for 3 1/4 x 4 1/4 Graflex or other good camera. List on request. Apt. GH2, 10 Monroe St., N. Y. C.

WANTED: 100 watt factory-built transmitter for 10, 20, 40, and 80 meter c.w. and phone. Will consider Temco, Harvey, etc. Also want Harvey UHX-10 for mobile use. Give full particulars. C. J. Clark, 925 Montrose Ave., Chicago, Ill.

SELL: 125 watt fone, \$85. Complete Super-Seven Skyrider, \$25. WIIFS.

QSL-SWL, bargains. Outstanding designs. Fritz, 455 Mason, Joliet, Ill.

SELL all or part 1 k.w. phone-c.w. transmitter. Finest parts. Write W9MIQ.

QSL'S, SWL's. 100-3 color-75¢. Lapco, 344 W. 39, Indianapolis, Ind.

IPS rubber crystal, QSY remotely, varies completely 160 to 10 meters. Approximately 20 watts output, \$19.80. Radio Apparatus Mfg., 1522 N. Clark, Chicago. W9IPS.

CRYSTALS: Eidson's T9 power-ground X-cut 80-40 meters, \$1.60. Fracture-resisting and high harmonic output. Fully guaranteed. Van Radio, 464 E. 117th, #7, Cleveland, Ohio.

RECEIVER headquarters, all makes of new and used sets. W8ANT.

TRANSMITTERS and transmitter kits. 10 to 160 meters. 10 to 1000 watts. Phone and c.w. W8ANT.

ALL lines of new and used amateur equipment bought, sold, exchanged. Write to Southern Ohio's only amateur owned amateur business. Jos. N. Davies, W8ANT, 2767 N. Bend Rd., Sta. A., Cincinnati, Ohio.

RECONDITIONED guaranteed sets shipped on ten day trial: RME-69s \$99.; NC100Xs \$99.; NC100s \$89.; Breting 14s \$69.; ACR-175s \$69.; Breting 12s \$59.; PR16Cs \$59.; S11 Super-Skyriders \$59.; Sky Challengers \$49.; S9s \$39.; PR-10s \$39.; Super-Sevens \$29.; Sky Chiefs \$29.; FB7As \$23.; most other models. List free. Write W9ARA, Butler, Mo.

METER repair service—d.c. milliameters: springs \$1.75; new coil \$2.50; new pointer \$1.75. Prices quoted on any repair. Braden Engineering Co., 305 Park Dr., Dayton, Ohio.

TWO 2400 volt transformers—pair delivers 1 k.w. at 2000 d.c.—both, \$10. Used 150T, \$10. W9ULJ, Emerson, Iowa.

DUPLEX rotary beams. Worm drive tilting heads concentrate beam power. Special designs. Telescoping dural tubing elements. Power transformers. W8ML.

QSL'S—highest quality—lowest prices. Radio Headquarters, Ft. Wayne, Ind.

NEW 803 guaranteed, \$20.; five meter receiver three 76s—bargain—\$5.; Trimm phones, \$2. Write for list. W8RSJ, 14220 Rutherford, Detroit.

TRANSMITTERS constructed—complete or sections; your parts or new. Superior workmanship. Write. Howard Radio, 231 Menard, Chicago.

QSL'S—the best. W8NOS, 27 Houston, Buffalo.

INSTALL guaranteed precision transformers with ratings you need. Send specifications for quotations. Michigan Electrical Lab., Muskegon, Mich.

CRYSTALS: one ham tells another about T9 crystals,—you too will be pleased with their performance. Do yourself a favor and try one, you can't lose—they are fully guaranteed. High activity type, fracture-resisting X cut. 40 and 80 meter bands \$1.60, 7301-7500 k.c. range \$2., close frequency supplied. FB T9 ceramic holders \$1.10. Prices postpaid. C.O.D.'s accepted. Various types of fine commercial crystals supplied on order, inquire. Sold by: Hieronymus Radio, 88-34 209 St., Queens Village, N. Y.; Pemberton Labs., Ft. Wayne, Ind.; W9ARA, Butler, Mo.; or Eidson's, Temple, Texas. Note: West coast and Canadian dealer territory available. Write Eidson's.

TELEPLEXES, instructographs, omnigraphs, vibroplexes, receivers bought, sold. Ryan, Monroe City, Mo.

COAXIAL lines. Relay racks. Custom-built equipment. Other specials. Write Eastern Technical Service, Oriskany, N. Y.

SELL—ten 1 mfd. 1500 volt filter condensers, dollar each, postpaid. W6EA.

NEW 81X. Improved dial, (got Super-Pro for birthday) \$85. Latest ACSW3, National power 80, 40, 20, 10 band coils, \$25. cash. W8QMN.

SALE: 1250 v. power supply 300 mls, good condition, \$25. Also amplifier using two T55 in pp, \$25., including tubes less meters. One Radio Transceiver Lab., 12 watt 5 meter xmtr and 4 tube revr in same cabinet, \$10. W4ETS, Gatlinburg, Tenn.

HINTS & KINKS

AMATEURS are noted for their ingenuity in overcoming by clever means the minor and major obstacles they meet in their pursuit of their chosen hobby. An amateur must be resourceful and a good tinkerer. He must be able to make a small amount of money do a great deal for him. He must frequently be able to utilize the contents of the junk box rather than buy new equipment. Hints and Kinks is a compilation of hundreds of good ideas which amateurs have found helpful. It will return its cost many times in money savings — and it will save hours of time.

Price 50c postpaid . . . No stamps

AMERICAN
RADIO RELAY LEAGUE, INC.
West Hartford, Connecticut

Simplified

5-METER

Now you can build that reliable rig that really sets out. Ask your dealer for Bulletin E-5.



CRYSTAL CONTROL

Double to 5 meters with Bliley HF-2 10-meter crystal. (28-30 MC.) \$5.75.

BLILEY HF2 CRYSTALS

New B9 Crystal Microphone



A small, lightweight, crystal microphone, with good response and high output. It is semi-directional and notably free from feedback. This unit has a wide range of applications, enhanced by the available accessories. The B9 is singular in that it is equipped with a plug at the microphone, thus making cable replacement a simple operation. Chrome finish. Complete with plug and 8' cable. Standard 3/4" fitting.

List Price \$29.50

Request Catalogue No. 27 for Complete Details

All crystal microphones licensed under patents of THE BRUSH DEVELOPMENT CO.

AMERICAN MICROPHONE CO., INC.
Los Angeles, California



Your Nearest Dealer Is Your Best Friend

Your nearest dealer is entitled to your patronage. You can trust him. He is equipped with a knowledge and understanding of amateur radio. He is your logical and safe source of advice and counsel on what equipment you should buy. His stock is complete. He can supply your needs without delay. His prices are fair and consistent with the high quality of the goods he carries. He is responsible to you and interested in you.

Patronize the dealer nearest you — You can have confidence in him

CHICAGO, ILLINOIS

Allied Radio Corporation
833 West Jackson Blvd.

Complete standard lines always in stock—W9IBC, W9DDM, W9GEZ

CHICAGO, ILLINOIS

Chicago Radio Apparatus Company
415 South Dearborn Street (Est. 1921)

W9RA and W9PST — Amateurs since 1909

CHICAGO, ILLINOIS

Wholesale Radio Service Company, Inc.
901-11 West Jackson Boulevard

"The World's Largest Radio Supply House"

DES MOINES, IOWA

Iowa Radio Corp.
1212 Grand Avenue

Complete amateur stock, W9OCG—W9EMS—W9KAY

DETROIT, MICHIGAN

Radio Specialties Company
171 E. Jefferson Avenue

Ham Supplies — National & Hammarlund Sets and Parts

DETROIT, MICHIGAN

Rissi Brothers
5027-31 Hamilton Ave. at Warren
WBKXK Manager Amateur Department

FRESNO, CALIFORNIA

Ports Manufacturing Co.
3265 E. Belmont Ave.

Wholesale: RCA-Thordarson-Bliley. All Standard Lines

KANSAS CITY, MISSOURI

Burstein-Applebee Company
1012-14 McGee Street

"Specialists" in supplies for the Amateur and Serviceman

KANSAS CITY, MISSOURI

Radiolab
1515 Grand Avenue
Amateur Headquarters in Kansas City

MILWAUKEE, WISCONSIN

Radio Parts Company, Inc.
538 West State Street
Complete stock Nationally Known products

MINNEAPOLIS, MINNESOTA

Lew Bonn Co.
1124-26 Harmon Place
W9BP—W9TLE—W9HOP—W9DKL—W9LEX

OAKLAND, CALIFORNIA

Offenbach Electric Company
2085 Broadway
"The House of a Million Radio Parts"

SAN FRANCISCO, CALIFORNIA

Offenbach Electric Company, Ltd.
1452 Market Street
"The House of a Million Radio Parts"

SEATTLE, WASHINGTON

Northern Radio Company
2208 Fourth Avenue
W7AVC, W7FRF, W7AWP to serve you

ST. LOUIS, MISSOURI

Van Sickle Radio Company
1113 Pine Street
W90WD invites you to amateur headquarters in St. Louis

TORONTO, CANADA

A & A Radio Service Supply
101 Queen Street, West
Canada's foremost radio supply house

TORONTO, ONTARIO, CANADA

Wholesale Radio Company, Ltd.
1133-37 Bay Street
Canada's Largest Radio Parts Distributors — VE-3XB

WINNIPEG, CANADA

Electrical Supplies, Ltd.
306-10 Ross Avenue
Western Canadian Amateur Headquarters for leading lines

You Are Protected When You Buy From QST Advertisers

“Advertising for QST is accepted only from firms who, in the publisher’s opinion, are of established integrity and whose products secure the approval of the technical staff of the American Radio Relay League.”

Quoted from QST’s advertising rate card.

Every conceivable need of a radio amateur can be supplied by the advertisers in QST. And you will know the product has the approval of the League’s technical staff.

The Advertisers

Ace Products Company	96
Acme Electric & Mfg. Company	110
Allen-Bradley Company	99
American Microphone Co., Inc.	124
Astatic Microphone Laboratory, Inc.	92
Birnback Radio Company, Inc.	106
Biley Electric Company	111, 124
Burgess Battery Company	93
Candler System Company	90
Capitol Radio Engineering Institute	114
Cardwell Mfg. Corp., Allen D.	78
Centralab	70
Coast Electric Company	98
Collins Radio Company	Cov. 2
Cornell-Dubilier Corp.	89
Delaware Radio Sales Company	111
Dodge’s Institute	98
Eastern Radio Institute	112
Eitel-McCullough, Inc.	81
Gardiner Levering Company	115
General Electric Company	109
Gordon Specialties Company	112
Gross Radio, Inc.	88
Hallcrafters, Inc., The	1, 2
Hammarlund Mfg. Company, Inc.	75, 119
Harvey Radio Company	108
Harvey Radio Laboratories, Inc.	117
Heintz & Kaufman, Ltd.	87
Henry Radio Shop	92
Hinds & Edgarton	94
Hipower Crystal Company	112
Instructograph Company	119
International Resistance Company	83
Isolantite, Inc.	91
Ken-Rad Tube & Lamp Corp.	115
Kenyon Transformer Company, Inc.	5
Linn Engineering Company	114
Logan Company, Les.	96
Mallory & Company, Inc., P. R.	70
Massachusetts Radio School	115
McGraw-Hill Book Company	86
Melssner Manufacturing Company	74
Mims Radio Company	108
National Company, Inc.	Cov. 3, 69, 109, 115
Newark Electric Company	103
Ohmite Manufacturing Company	94
Pacific Radio School	110
Petersen Radio Company	110
Port Arthur College	119
Precision Apparatus Corp.	76
Precision Piezo Service	102
Prentice Hall, Inc.	118
RCA Institutes, Inc.	106
RCA Manufacturing Company, Inc.	Cov. 4, 72
Radio Mfg. Engineers, Inc.	73, 127
Radio Shack, The	116
Radio Specialties Company	108
Radio Supply Company	117, 118
Radio Transceiver Laboratories	80
Raytheon Production Corp.	71
Scientific Radio Service	118
Selectosphere Company	118
Sheldon Electric Company	84
Sickles Company, F. W.	102
Signal Electric Mfg. Company	112
Simpson Electric Company	96
Solar Mfg. Corp.	85
Sun Radio Company	120
Taylor Tubes, Inc.	77
Teleplex Company	106
Terminal Radio Corp.	113, 117
Thordarson Elec. Mfg. Company	95
Trimm Radio Mfg. Company	119
Triplett Elec. Instrument Co., Inc.	98
United Electronics Company	82
United Transformer Corp.	128
Utah Radio Products Corp.	102
Valpey Crystals, The	114
Ward Leonard Electric Co.	110
Wiley & Sons, Inc., John	107

COMMUNICATION



AFTER THE NOVELTY WEARS OFF . . .

*Your dealer has
all the information
. . . so have we*

AMATEUR RADIO BECOMES A HABIT. With thousands on the air making their daily schedules . . . working DX contests . . . carrying-on in emergencies . . . it has become a habit for an amateur to say:

"For receiver, I'm using an RME-69, OM" . . .
and many add "with a DB-20 Pre-Selector."

This combination is now available in a single cabinet, either with or without antenna change-over switch and noise-suppressor.

RADIO MFG. ENGINEERS 306 FIRST AVENUE
PEORIA, ILLINOIS

... from the **LARGEST** to the **SMALLEST** ...

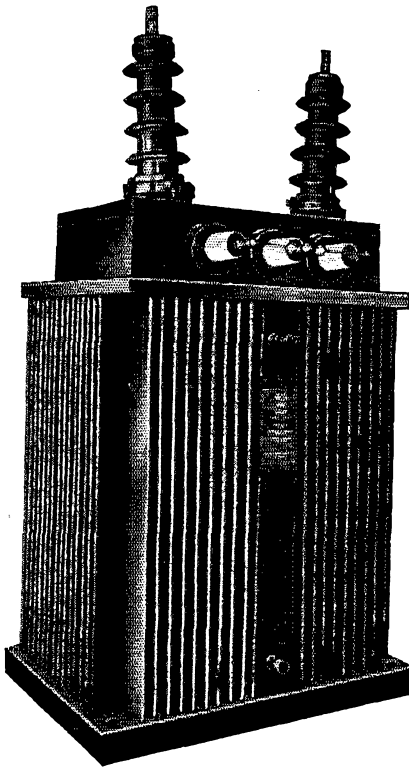

Typical of the large broadcast equipment manufactured by UTC is the filter choke illustrated on the left, designed for a 100 KW broadcast station and weighing about $3\frac{1}{2}$ ton. This unit is 100,000 times the size of the UTC OUNCERS.

The new UTC OUNCER series represent the acme in compact quality transformer practice. These units weigh approximately one ounce and those which do not carry D.C. have high fidelity characteristics suitable for broadcast and similar applications, being uniform in response from 30 to 20,000 cycles. The OUNCER transformers are ideal for hearing aid, aircraft, glider, portable, concealed service, and similar applications.

The OUNCER units have overall dimensions of $\frac{7}{8}$ " diameter by $1\frac{3}{16}$ " height, including lugs. Mounting is effected by two screws opposite the terminal board side.

UTC OUNCER unit compared to smallest bar knob. Illustration, at right, is slightly larger than actual size.

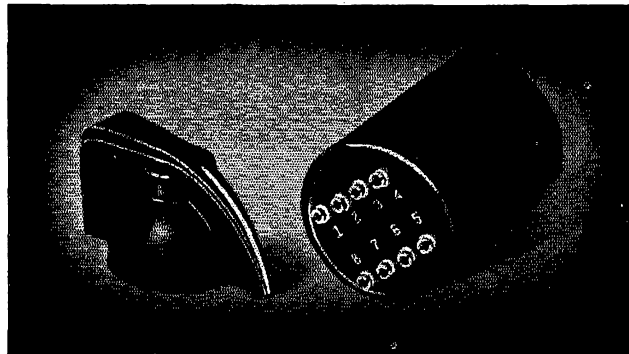

OUNCER HIGH FIDELITY AUDIO UNITS

(max. Level -5 DB)

Type No.	Application	Pri. Imp.	Sec. Imp.	Net Price
0-1	Mike, pickup, or line to 1 grid	50,200,500	50,000	\$6.00
0-2	Mike, pickup, or line to 2 grids	50,200,500	50,000	6.00
0-3	Dynamic mike to 1 grid	7.5/30	50,000	5.40
0-4	Single plate to 1 grid	8000 to 15,000	60,000	4.80
0-5	Single plate to 1 grid, D.C. in Pri.	8000 to 15,000	60,000	4.80
0-6	Single plate to 2 grids	8000 to 15,000	95,000	5.40
0-7	Single plate to 2 grids, D.C. in Pri.	8000 to 15,000	95,000	5.40
0-8	Single plate to line	8000 to 15,000	50,200,500	6.00
0-9	Single plate to line, D.C. in Pri.	8000 to 15,000	50,200,500	6.00
0-10	Push pull plates to line	8000 to 15,000	50,200,500	6.00
0-11	Crystal mike or pickup to line	50,000	50,200,500	6.00
0-12	Mixing and matching	50,200	50,200,500	5.40
0-13	Reactor, 200 Hys. — no D.C.; 50 Hys. — 2 MA. D.C.			4.20

SEE YOUR DISTRIBUTOR . . . OR WRITE FOR CATALOG OF OUR COMPLETE LINE

UNITED TRANSFORMER CORP.

72 SPRING STREET

NEW YORK, N. Y.

EXPORT DIVISION: 100 VARICK STREET - NEW YORK, N. Y. CABLES "ARLAB"

The new National Corporation has made a very real contribution
 to the world's progress in the field of communications. It has
 built a new type of radio receiver, one that is not only more
 efficient and more reliable than any other receiver of its
 kind, but also one that is more economical and more
 convenient to use. This new receiver is the result of the
 research and development work of the National Corporation,
 and it is a true masterpiece of engineering and design.
 The National Corporation is proud to announce the
 introduction of this new receiver to the public. It is
 a true masterpiece of engineering and design, and it is
 a true contribution to the world's progress in the field
 of communications.

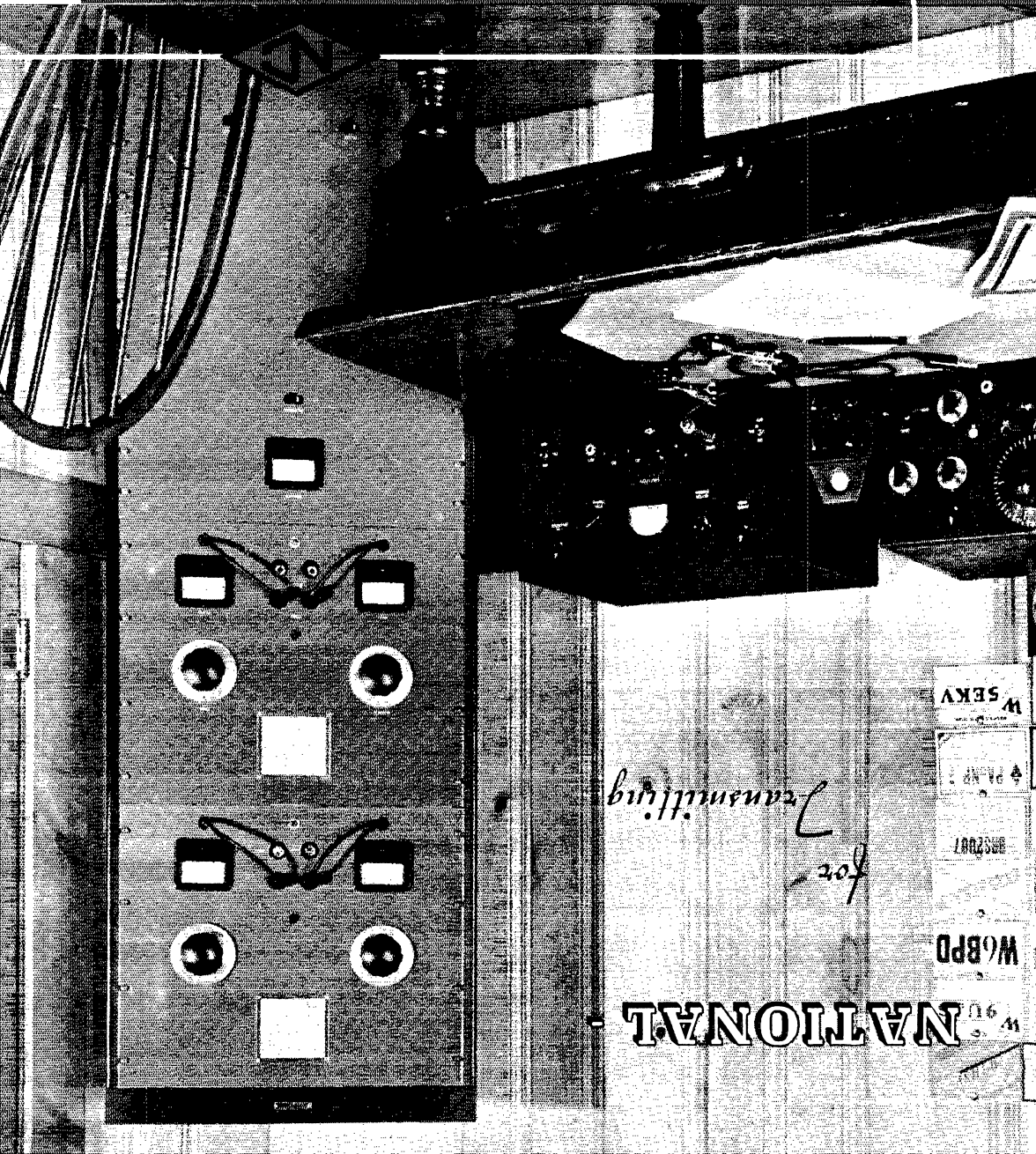

Transmitting

for

NATIONAL

WSEK
 W6BPD
 W6BPD
 W6BPD



A Few Facts About Ratings

RCA Amateur Contest Reveals Your
Approval of Policy which Maintains Tube Ratings
on Consistent, Conservative Basis

RCA tubes are given ratings which will insure satisfactory service and long life. These ratings establish a foundation for reliable tube operation. These ratings determine your true tube cost—which is Watt Hours per Dollar.

We know, from our life tests, breakdown overloads, and other tests, that RCA tubes will perform well above ratings but it is not recommended that tubes be operated in excess of ratings since the difference between the actual capabilities of the tube and the rating is provided as your factor of safety.

While it is probably true that a satisfactory life, less than normal, could be obtained by operating tubes somewhat in excess of ratings, the varying operating conditions imposed by each different application would necessitate a new rating study for each application. Many amateurs were frank in telling us that they were running RCA tubes in excess of our ratings and obtaining good life.

Our ratings were used simply as a guide in deciding how much overload was to be applied. We are familiar with this school of thought and recognize that the tube user following it is probably aware that he is compromising life expectancy for greater tube output. The fact remains, however, that our ratings are set up to insure for you satisfactory performance on the basis of both life and output, and we cannot recommend operation in excess of these ratings.

In RCA Transmitting Tubes we endeavor to give you a well designed, skillfully manufactured product, rated so as to assure you a minimum cost of tube operation.

For a more comprehensive discussion on tube ratings, refer to pages 111, 112 and 143 of your "Air-Cooled Transmitting Tube Manual", TT3. If you haven't a copy, send 25¢ to the Commercial Engineering Section at Harrison, New Jersey, and one will be mailed to you.

RCA presents "Magic Key" Sundays, 2 to 3 p. m., E.D.S.T. on NBC Blue Network.

Ask your distributor, or send 10¢ to Camden, New Jersey, for a commemorative advertisement on RCA's television tube announcement.



Radio Tubes