

# QST

July, 1938  
25 cents

devoted entirely to

# amateur radio

**In this issue—  
Low-Cost  
60-Meter  
Phone  
New Ideas  
in Remote  
Control**

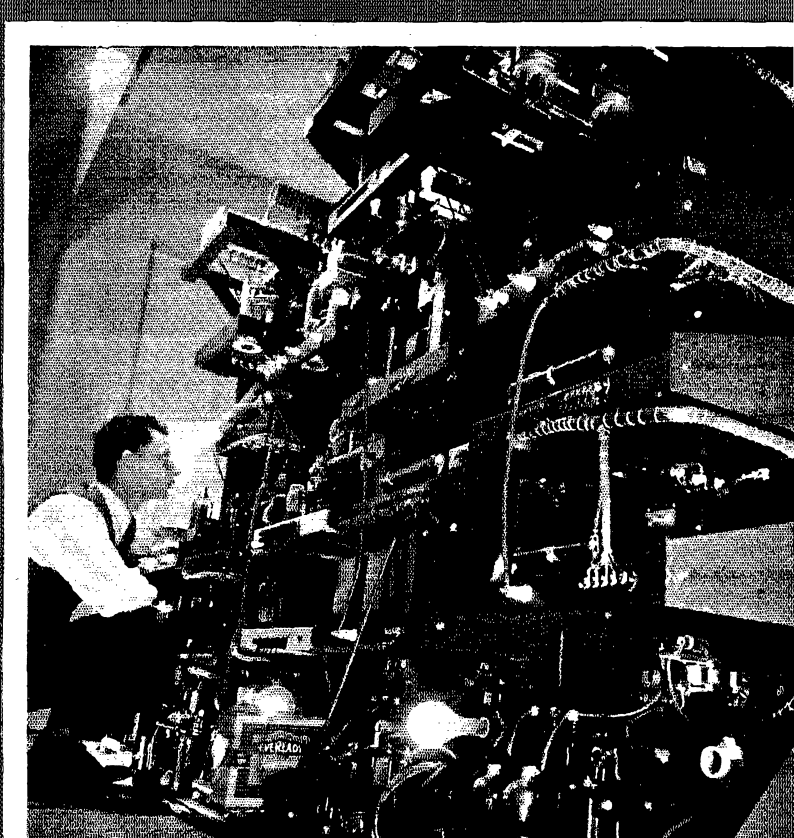

# 30J

The New Synonym  
For Transmitter Performance

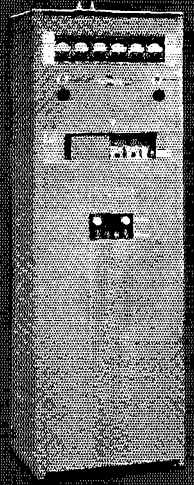

■ Every three or four years a piece of amateur gear makes its appearance which is so well worked out and is so universally useful that its very type number becomes a byword and an accepted standard. For example, no one will forget those old perennials in the receiver field, the SW3 and the Comet "Pro." And more recently, Jim Millen is boasting that he sees no need for changing his HRO for another year. Of course, there is no comparison between receivers and transmitters in respect to the quantities of sets involved, but the principle is the same, namely: that it is a tribute to the builders' judgment, engineering, experience and foresight when he is able to produce a model so excellent that it will hold its leadership for several years without revision in design.

We have something more definite than a "hunch" that the type number, 30J, will remain an important addition to the amateurs' special language for some time to come. By way of ancestry, the 30J has the 30FXC, and before that the 30FXB, as illustrious predecessors. A lot of new developments have gone into the 30J, each of which has been severely tested and proved out with an eye to the future. And then the 30J operates on all frequencies up to 60 mc. and has the right power (250 watts) for a generally useful set. We have been careful not to add any special gadgets to the 30J which are not necessary as far as real results and everyday convenience are concerned. Another reason for type number longevity is that we have arranged to produce the 30J at a very reasonable price. One thing about which we can be entirely certain—the 30J's going into service now will still be pushing good solid signals around the world for many years to come.

## COLLINS RADIO COMPANY

CHICAGO, ILLINOIS 160 VA. NEW YORK, N. Y. 101 WEST 42 STREET

*For the Ultra High Frequencies*

the hallicrafters offer

*The* **SKYRIDER 5-10**

**with Automatic Noise Limiter!**

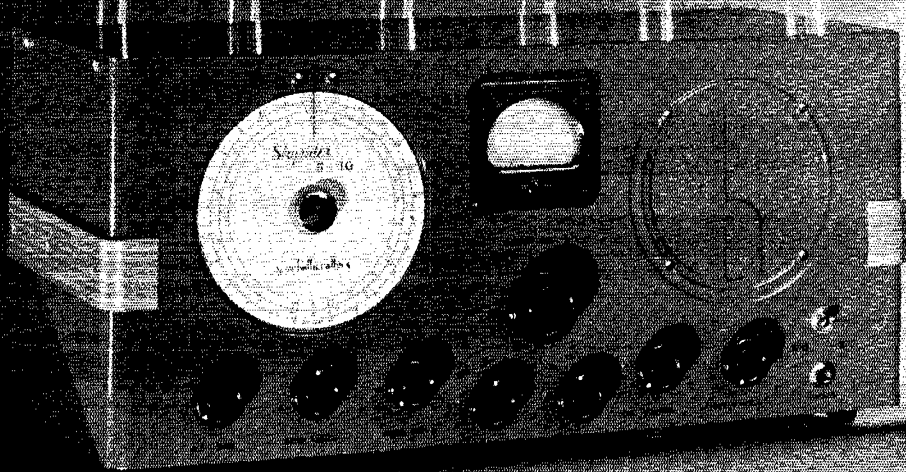

**D**ESIGNED especially for Ultra High Frequency reception, the SKYRIDER 5-10 offers the amateur the exacting performance required for superior reception on the 5 and 10 meter bands.

Through the use of the newly developed RK 1851 tube as an r.f. amplifier, with a gain increase of 6 to 1, an ultra high frequency sensitivity of better than 1 microvolt is obtained. A single stage of 1600 KC i.f. amplification provides a band width of 30 KC at 10 times down; — even frequency modulated 5 meter signals are clearly understandable with this selectivity.

With a built-in Automatic Noise Limiter, coverage from 68 Mc to 27 Mc (4.4 to 11 meters) on two bands, separate inertia-tuned Band Spread Dial, the SKYRIDER 5-10 is a remarkable receiver for ultra high frequency reception.

## *Features*

- ★ 8 Tubes
- ★ RK 1851 pre-selection stage
- ★ Continuous coverage 27 to 68 MC
- ★ 2 Bands
- ★ AVC
- ★ Automatic Noise Limiter
- ★ Improved Band Spread
- ★ Built-in Speaker
- ★ 1600 KC i.f. amplification
- ★ Beat Frequency Oscillator

**the hallicrafters inc.**

2611 Indiana Ave., Chicago, U. S. A. Cable Address: "HALLCRAFT," Chicago

**"WORLD'S LARGEST BUILDERS OF AMATEUR COMMUNICATIONS RECEIVERS"**

*For the Commercial Frequencies*



## *The* SKYRIDER MARINE

A NEW RECEIVER, designed for amateur and professional operators working the commercial frequencies. The SKYRIDER MARINE tunes from 16.2 to 2150 meters (18.5 MC to 140 KC) on 4 Bands, and is especially "hot" on the 600 and 700 meter bands. Overall sensitivity and selectivity are far above average for this type of receiver, and improved image rejection, attained through the use of 1600 KC i.f. transformers, provides better reception on the higher frequencies. The SKYRIDER MARINE is ideal for marine service, and is easily adapted to 6-volt battery operation, offering efficient commercial reception at an extremely modest price. Write for complete information today.

*All Hallicrafters Receivers sold at liberal time payments*

### *Features*

- ★ Tunes 16.2 to 2150 meters (140 KC to 18.5 MC)
- ★ 4 Bands
- ★ 8 Tubes
- ★ Automatic Volume Control
- ★ Tone Control
- ★ Head Phone Jack
- ★ Beat Frequency Oscillator
- ★ Built-in Speaker
- ★ Individual Coils for each band
- ★ AF Gain Control
- ★ Band Switch
- ★ Sensitivity Control

the hallicrafters inc.

2611 Indiana Ave., Chicago, U. S. A. Cable Address: "HALLICRAFT," Chicago  
"WORLD'S LARGEST BUILDERS OF AMATEUR COMMUNICATIONS RECEIVERS"

# QST

devoted entirely to

# AMATEUR RADIO

PUBLISHED, MONTHLY, AS ITS OFFICIAL ORGAN, BY THE AMERICAN RADIO RELAY LEAGUE, INC., AT WEST HARTFORD, CONN., U. S. A.; OFFICIAL ORGAN OF THE INTERNATIONAL AMATEUR RADIO UNION

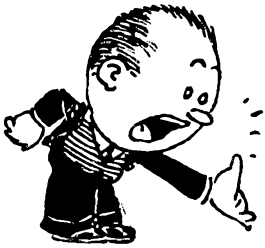

JULY  
1938

Volume XXII  
Number 7



Kenneth B. Warner, General Manager of A.R.R.L. Publications; Ross A. Hull, Editor; James J. Lamb, Technical Editor; George Grammer, Assistant Technical Editor; Clark C. Rodimon, Managing Editor; David H. Houghton, Circulation Manager; Ralph T. Beaudin, Assistant Circulation Manager; F. Cheyney Beekley, Advertising Manager; Charles Brunelle, Assistant Advertising Manager.

Editorial and  
Advertising Offices

38 La Salle Road  
West Hartford, Connecticut

Subscription rate in United States and Possessions and Canada, \$2.50 per year, postpaid; all other countries, \$3.00 per year, postpaid. Single copies, 25 cents. Foreign remittances should be by international postal or express money order or bank draft negotiable in the U. S. and for an equivalent amount in U. S. funds.

Entered as second-class matter May 29, 1919, at the post office at Hartford, Connecticut, under the Act of March 3, 1879. Acceptance for mailing at special rate of postage provided for in section 1103, Act of October 3, 1917, authorized September 9, 1922. Additional entry at Concord, N. H., authorized February 21, 1929, under the Act of February 28, 1925.

Additional second-class entries to cover sectional editions authorized March 20, 1935. Copyright 1938 by the American Radio Relay League, Inc. Title registered at United States Patent Office.

## The Contents

Editorial . . . . .	7
Maritime Division Convention . . . . .	8
The Battle of Cairo <i>Kenneth B. Warner and Paul M. Segal</i> . . . . .	9
A Low-Cost 1.75-Mc. Phone Transmitter <i>Vernon Chambers, W1JEQ</i> . . . . .	13
"Look for Me on — Kc." <i>E. P. Tilton, W1HDQ and Glenn H. Browning</i> . . . . .	18
Minimizing Receiver Frequency Drift . <i>Charles Mayeda</i> . . . . .	21
CQ de W10XDA . . . . . <i>Clifton Foss, W20J</i> . . . . .	23
What the League Is Doing . . . . .	26
Some Faces at the 1938 A.R.R.L. Board Meeting . . . . .	30
The QSL-Forty on 14 Mc. <i>Fred Sutter, W8QBW-W8QDK</i> . . . . .	31
A Ten-Meter Rotatable Alford Beam <i>Don C. Wallace, W6AM</i> . . . . .	32
The California Flood . . <i>Walter W. Matney, W6EQM</i> . . . . .	34
A Versatile Remote-Control Circuit <i>Max L. Hilliard, W9WEE</i> . . . . .	37
West Gulf Division Convention . . . . .	39
Do's and Don'ts in Power Supplies <i>T. M. Ferrill, Jr., W5CJB-1</i> . . . . .	40
An Improved Capacity Bridge . . . <i>Moe Joffe, W2BNY</i> . . . . .	42
New Gear for Radio-Control Systems . . . . .	44
How Would You Do It? . . . . .	47
The Army-Amateur Radio System . . . . .	51
Hints and Kinks for the Experimenter . . . . .	52
I.A.R.U. News. . . . .	55
Operating News . . . . .	57
Correspondence Department . . . . .	65
Silent Keys . . . . .	102
Hamads . . . . .	107
QST's Index of Advertisers . . . . .	110

## Section Communications Managers of the A.R.R.L. Communications Department

All appointments in the League's field organization are made by the proper S.C.M., elected by members in each Section listed. Mail your S.C.M. (on the 16th of each month) a postal covering your radio activities for the previous 30 days. Tell him your DX, plans for experimenting, results in 'phone and traffic. He is interested, whether you are an A.R.R.L. member or get your QST at the newsstands; he wants a report from every active ham. If interested and qualified for O.R.S., O.P.S. or other appointments he can tell you about them, too.

Eastern Pennsylvania	W3QP	<b>ATLANTIC DIVISION</b>	John Buck Morgan	Blue Bell
Maryland-Delaware-District of Columbia	W3BAK	Edgar L. Hudson	247 E. Atlantic Ave.	Laurel, Delaware
Southern New Jersey	W3BEI	W. W. Fison	10 Lincoln Ave.	Audubon
Western New York	W8SE	Ed Preston		Tully
Western Pennsylvania	W8OFO	Rendall Speer, Jr.		Lower Merion
		<b>CENTRAL DIVISION</b>		
Illinois	W9KJY	L. John Huntoon	327 Brandon Ave.	Glen Ellyn
Indiana	W9QG	Noble Burkhart	R. 4, Box 1	Indianapolis
Kentucky	W9ARU	Darrell A. Downard	116 N. Longworth Ave.	Louisville
Michigan	W8DPE	Harold C. Bird	R.F.D. 2	Pontiac
Ohio	W8AQ	E. H. Gibbs	405 Broad St.	Wadsworth
Wisconsin	W9UIT	Aldrich C. Kronos	3127-A West Madison St.	Milwaukee
		<b>DAKOTA DIVISION</b>		
North Dakota	W9RZA	Ernest Bloch	Box 202	Thompson
South Dakota	W9VOD	Dr. A. L. Russell		Wall
Northern Minnesota	W9IGZ	Edwin L. Wicklund	R.F.D. 3	Kensington
Southern Minnesota	W9DCM	Webster F. Soules	3549 36th Ave., So.	Minneapolis
		<b>DELTA DIVISION</b>		
Arkansas	W5ABI	H. E. Vette	4415 West 12th St.	Little Rock
Louisiana	W5DKR	Eugene H. Treadaway	2749 Myrtle St.	New Orleans
Mississippi*	W5GHF	Robert E. Barr		Lucedale
Tennessee	W4DEP	B. G. Lowrey Smith	673 Hillcrest St.	Memphis
		<b>HUDSON DIVISION</b>		
Eastern New York	W2LU	Robert E. Haight	511 South Holmes St.	Scotia
N. Y. C. & Long Island	W2AZV	E. L. Baunach	102 Central Ave.	Massapequa, L. I.
Northern New Jersey	W2GMN	Fred C. Read	1014 North Ave.	Elizabeth
		<b>MIDWEST DIVISION</b>		
Iowa*	W9LEZ	Phil D. Boardman	325 Kirkwood Blvd.	Davenport
Kansas	W9PFI	Harry E. Legler	304 Miami St.	Lawrence
Missouri	W9OUD	Miss Letha Allendorf	1015 W. 3rd St.	Joplin
Nebraska	W9FAM	Samuel C. Wallace	Green St.	Clarks
		<b>NEW ENGLAND DIVISION</b>		
Connecticut	W1CTI	Frederick Ella, Jr.	19 Merrill Rd.	Norwalk
Maine	W1FBI	Winfield A. Ramsdell	1188 Washington Ave.	Portland
Eastern Massachusetts	W1IWC	Sam Gross	Pleasant St.	Marsfield Hills
Western Massachusetts	W1IAH	William J. Barrett	239 Columbia St.	Adams
New Hampshire	W1BFT	Carl B. Evans	80 No. State St.	Concord
Rhode Island	W1HRC	Clayton C. Gordon	192 Washington Ave.	Providence
Vermont	W1GNF	Alvin H. Battison	1 Central St.	Windsor
		<b>NORTHWESTERN DIVISION</b>		
Alaska	K7ENA	Leo E. Osterman	Customhouse	Wrangell
Idaho	W7EMT	Carl Eichelberger	Route 2	Kuna
Montana	W7FL	C. A. Woodhouse	Holter Dam	Wolf Creek
Oregon*	W7FNO	J. R. MacManiman	1545 N. E. 48th Ave.	Portland
Washington	W7FCG	W. Beale	R. 4, School Ave.	Walla Walla
		<b>PACIFIC DIVISION</b>		
Hawaii*	K6OOE	Harold C. Smith	P. O. Box 150	Honolulu
Nevada	W6BIC	Edward W. Heim	509 Claremont St.	Reno
Santa Clara Valley	W6FBW	Elbert Amarantes	454 Washington St.	San Jose
East Bay	W6JTV	Harold J. Burchfield	2240 106th Ave.	Oakland
San Francisco	W6SG	Alan D. Whittaker, Jr.	79 Elinor Ave.	Mill Valley
Sacramento Valley	W6GZY	J. L. C. Buckenham	2720 22nd St.	Sacramento
Philippines	KA1GR	George L. Rickard	Box 849	Manila
San Joaquin Valley	W6LPE	Angelo V. Astone	729 Safford	Fresno
		<b>ROANOKE DIVISION</b>		
North Carolina	W4OG	H. S. Carter	P. O. Box 111	Winston-Salem
South Carolina	W4BOE	Ted Ferguson	1213 College St.	Columbia
Virginia	W3UVA	Charles W. Waff, Jr.	3101 Park Ave.	Richmond
West Virginia	W8HD	C. S. Hoffmann, Jr.	47 Lynewood Ave.	Wheeling
		<b>ROCKY MOUNTAIN DIVISION</b>		
Colorado	W9FA	Glen Glasscock	2164 So. Corona St.	Denver
Utah-Wyoming	W7COH	Townsend J. Rigby		Midwest, Wyoming
		<b>SOUTHEASTERN DIVISION</b>		
Alabama	W4DGS	James F. Thompson	102 Narrow Lane Rd.	Montgomery
Eastern Florida	W4DVO	L. A. Connolly	719 So. Willow Ave.	Tampa
Western Florida	W4BSJ	Ellis R. Curry	Box 425	Madison
Georgia-Cuba-Isle-of-Pines-Porto Rico-Virgin Islands	*W4PM	Charles W. Davis	2136 N. E. Boulevard Dr.	Atlanta, Ga
		<b>SOUTHWESTERN DIVISION</b>		
Los Angeles	W6GXM	Don M. Draper	4421 West 63 St.	Los Angeles
Arizona	W6KFC	Victor C. Clark	747 E. Folk St.	Phoenix
San Diego	W6JRM	Howard K. Breedlove	R. 2, Box 636	San Diego
		<b>WEST GULF DIVISION</b>		
Northern Texas	W5DXA	Lee Hughes	125 N. Main St.	Childress
Oklahoma	W5EZZ	Carl L. Simpson	2010 So. 4th St.	Okmulgee City
Southern Texas	W5BHO	Dave H. Calk	6726 Ave. Q	Houston
New Mexico	W5CGJ	Joseph M. Eldodt		Chamita
		<b>MARITIME DIVISION</b>		
Maritime	VE1DQ	A. M. Crowell	69 Dublin St.	Halifax, N. S.
		<b>ONTARIO DIVISION</b>		
Ontario	VE3SG	Fred H. B. Saxon	302 Lee Ave	Toronto, Ont.
		<b>QUEBEC DIVISION</b>		
Quebec	VE2EE	Stan Comach	780 Brault Ave.	Verdun, P. Q.
		<b>VANALTA DIVISION</b>		
Alberta	VE4GE	C. S. Jamieson	581 W. Riverside Drive	Drumheller, Alta.
British Columbia	VE5HP	J. Hepburn, Jr.	335 Foul Bay Road	Victoria
		<b>PRAIRIE DIVISION</b>		
Manitoba	VE4BG	A. J. R. Simpson	635 Garfield St.	Winnipeg
Saskatchewan	VE4SV	Arthur Chesworth	1071 4th Ave., N. W.	Moose Jaw

\* Officials appointed to act until the membership of the Section choose permanent S.C.M.'s by nomination and election.

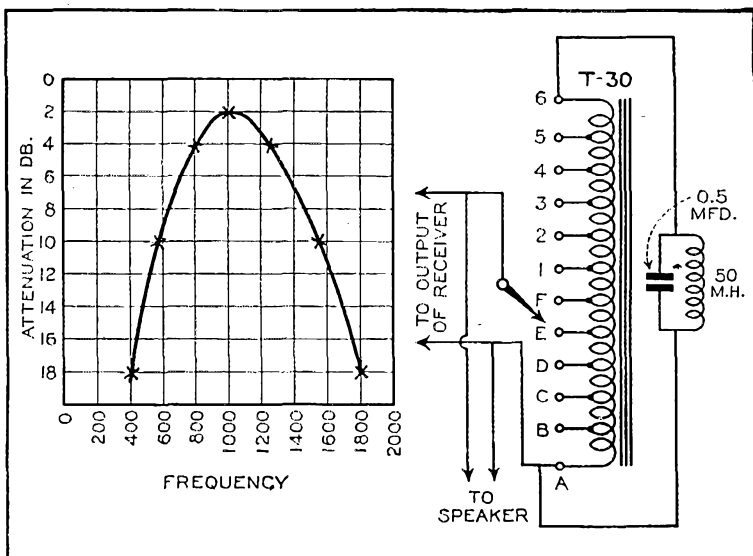

## Kandid Ken-O-Talk, No. 8

### • INTERFERENCE •

W2—, our old friend who built the 6L6 modulator described in Ken-O-Talk No. 6, was over to see us recently. Among other things, he was interested in some sort of an audio filter to pass 1000 cycles only. He said he wanted this to use in his 8-ohm output to the speaker to cut down background noise and to improve selectivity on C. W. reception. We asked him why he didn't use a crystal filter in the I. F. which would be much better than any audio filter. Since his receiver is a T. R. F. type, this would be out of the question, and he doesn't care to invest in a super-het at present.

Upon investigating the coils and condensers necessary for an 8-ohm filter it was found that the condensers would be so large it would be worth about as much as a new receiver. We were about to give the idea up and devise a filter to be used in the grid of the output tube when another possibility occurred to us. Since the size of condenser required is dependent on the impedance of the circuit, why not transform the voice coil up to a value where reasonable size condensers may be used, and then transform it back to eight ohms after the filtering is done? "But," objected W2—, who instead of being interested in selling transformers is interested in not having to buy them, "that's going to take two transformers besides the filter coils." A little further thought indicated that the job could be done with only one transformer, a coil and condenser.

The circuit used is shown above. Type T-30 is an auto-transformer giving impedance ratios of 3000/2500/2000/1500/1000/500 ohms to twelve different voice coil values ranging from .16 to 16 ohms. Thus, the resonant circuit may be shunted across an impedance of 3000 ohms, matched to any voice coil. The proper condenser value for this impedance is approximately  $\frac{1}{2}$  mfd. and to resonate at 1000 cycles the choke should be 50 millihenries.

The selectivity curve obtained is shown above. This was taken using a choke which had a Q of about 12. Higher Q values would of course give a sharper selectivity curve.

The coil may be of the air core type, random wound on a bobbin. A bobbin may be made of a piece of 1" bakelite tubing  $1\frac{1}{2}$ " long, and two square wood blocks, four inches on a side. The wood blocks are held together by means of a BRASS bolt through the center of the bakelite tubing. About 1500 turns of No. 22SCE or No. 22DCC give the required inductance.

W2— has not had much time to test the filter yet, but he tells us that it is decidedly effective in improving signal to noise ratio. It does help in separating two interfering signals as well as eliminating heterodynes, but just how effective it is in this respect remains to be seen after further tests.

*F. P. Kenyon*

# The American Radio Relay League



**T**HE AMERICAN RADIO RELAY LEAGUE, INC. is a non-commercial association of radio amateurs bonded for the promotion of interest in amateur radio communication and experimentation, for the relaying of messages by radio, for the advancement of the radio art and of the public welfare, for the representation of the radio amateur in legislative matters, and for the maintenance of fraternalism and a high standard of conduct.

It is an incorporated association without capital stock, chartered under the laws of Connecticut. Its affairs are governed by a Board of Directors, elected every two years by the general membership. The officers are elected or appointed by the Directors. The League is non-commercial and no one commercially engaged in the manufacture, sale or rental of radio apparatus is eligible to membership on its board.

"Of, by and for the amateur," it numbers within its ranks practically every worth-while amateur in the nation and has a history of glorious achievement as the standard-bearer in amateur affairs.

Inquiries regarding membership are solicited. A bona fide interest in amateur radio is the only essential qualification; ownership of a transmitting station and knowledge of the code are not prerequisites. Correspondence should be addressed to the Secretary.

HIRAM PERCY MAXIM, FIRST PRESIDENT

## OFFICERS

- President*.....EUGENE C. WOODRUFF, W8CMP  
State College, Pa.
- Vice-President*.....GEORGE W. BAILEY, W1KJ  
Weston, Mass.
- Secretary*.....KENNETH B. WARNER, W1EI  
West Hartford, Connecticut
- Treasurer*.....ARTHUR A. HEBERT, W1EJ  
West Hartford, Connecticut
- Communications Mgr.*...F. EDWARD HANDY, W1BD  
West Hartford, Connecticut
- ◆
- General Counsel*.....PAUL M. SEGAL  
1026 Woodward Building, Washington, D. C.
- ◆

Address all general correspondence to the administrative headquarters at West Hartford, Connecticut

## DIRECTORS

- President*  
EUGENE C. WOODRUFF.....W8CMP  
234 W. Fairmount Ave., State College, Pa.
- Vice-President*  
GEORGE W. BAILEY.....W1KJ  
74 Webster Road, Weston, Mass.
- Canadian General Manager*  
ALEX REID.....VE2BE  
169 Logan Ave., St. Lambert, P. Q.
- Atlantic Division*  
WALTER BRADLEY MARTIN.....W3QV  
Box 612, Roslyn, Pa.
- Central Division*  
R. H. G. MATHEWS.....W9ZN  
100 East Ohio St., Chicago
- Dakota Division*  
FRED W. YOUNG.....W9MZN  
228 1/2 Willard St., Mankato, Minn.
- Delta Division*  
E. RAY ARLEDGE.....W5SI  
P. O. Box 286, Pine Bluff, Ark.
- Hudson Division*  
KENNETH T. HILL.....W2AHC  
115 Willow St., Douglaston, L. I., N. Y.
- Midwest Division*  
FLOYD E. NORWINE, JR.....W9EFC  
120 South Fourth St., St. Louis, Mo.
- New England Division*  
PERCY C. NOBLE.....W1BVR  
37 Broad St., Westfield, Mass.
- Northwestern Division*  
RALPH J. GIBBONS.....W7KV  
c/o United Air Lines, Pendleton, Ore.
- Pacific Division*  
J. L. McCARGAR.....W6EY  
66 Hamilton Pl., Oakland, Calif.
- Roanoke Division*  
H. L. CAVENESS.....W4DW  
State College Station, Raleigh, N. C.
- Rocky Mountain Division*  
EDWARD C. STOCKMAN.....W9ESA  
618 So. Williams St., Denver
- Southeastern Division*  
BENNETT R. ADAMS, JR.....W4APU  
1512 Grove Place, Homewood, Ala.
- Southwestern Division*  
CHARLES E. BLALACK.....W6GG  
443 Main St., El Centro, Calif.
- West Gulf Division*  
WAYLAND M. GROVES.....W5NW  
c/o Humble Pipe Line, Mt. Pleasant, Texas





# "It Seems to Us — —"

IT appears to be high time that we cleared away some of the underbrush obscuring the television situation. Not that it is an easy job. Television has been the obscure member of the radio family since the very beginning. It has always been a "secret-development-behind-locked doors" proposition and there has been a "hush-hush" feeling permeating the whole thing.

It is only natural that the large laboratories spending countless thousands of dollars on research and development should protect their work strenuously and it is therefore perfectly understandable that even the simplest circuits, let alone any practical information on adjustment and operation, should have been closely guarded secrets. But it all seemed a little stupid and certainly tantalizing to find that enthusiastic and progressive amateurs were not in a position to pick up the threads and begin work. Realizing, about a year ago, that things in the television picture were rapidly coming to a head and that in spite of all the false starts and tedious delays it was coming to life as a lusty addition to the family, we planned to try to break down some of the mystery and to examine the possibility of developing television as a legitimate and really worth-while field for amateur participation. Wilder's series of six articles was the first result. This series now constitutes the first reasonably complete treatment of the practical aspects of modern television published in this country. Even this series is, of course, only a beginning aimed at providing the amateur with an accurate picture of the background of to-day's technique and enabling him to make that very necessary first step of gaining a practical understanding of how to go about receiving television images. The next logical step, about which we have intentionally said nothing until now, is amateur transmission. Until we can transmit, television is necessarily nothing more than a fascinating side issue—something that no progressive amateur can afford to ignore but something presently available as a field of experiment only to those living in the vicinity of New York City or Los Angeles. From the moment that amateur television transmission becomes practical, the whole field of television becomes as much a part of amateur radio as radiophone now is. It is difficult to conceive of television activity comparing in extent with that now covered by radiophone. But it is becoming

increasingly obvious that the field is one in which the amateur can do many important things. History will doubtless repeat itself in providing a few isolated groups and individuals progressive enough to drive forward as pioneers, criticized by some, ignored by most of the others but producing, in spite of it all, pages for the yet unwritten chapters of amateur radio's history.

Naturally, there will be kicks and criticism and yammering. They will be copy for the history just as they were in the case of spark *vs.* c.w., 'phone *vs.* code, the superhet *vs.* the detector-two-step and, for that matter, every forward move yet made. We anticipate and expect the kicks—without them we should suspect some devitalizing illness in our ranks. But all the indications suggest that we are destined to take a crack at television as an intriguing and significant extension of amateur radio communication.

Frankly, we had no such slant on the picture a year ago. At that time television transmission seemed to be utterly beyond the reach of amateur radio. The equipment apparently was so complex and so expensive and the technical problems so acute that no amateur could possibly attempt practical participation in the field. Aside from that, we could see television only as another undesirable source of interference. We thought we could glimpse, too, the hopeless confusion resulting from lack of agreement on standards of transmission with respect to the number of lines, frames, etc. At this writing we have behind us about six months of practical experience with modern television equipment gained in a *QST* laboratory program aimed to provide a study of the problems of amateur television transmission and its possible future. The program is far from being finished, but already it has demanded an almost complete reversal of our earlier ideas. The amateur television transmitter of the immediate future, we find, need cost little more than the radiophone of to-day. Its "terrifying" complexities can be boiled down, we find, to something only slightly more involved than those of voice transmission. And there is no apparent need for more than the sketchiest standards. What is perhaps more important still is the discovery that the necessary sweep oscillators, synchronizing pulse shapers and video amplifiers offer the same fascination, once one gets started, as did the thousand and one earlier problems of regenera-

tive detectors, Hartley oscillators, Zepp feeders, crystal oscillators and the rest. Of course there are many bugs to be exterminated—healthy tough-skinned ones at that. By far the most important problem is that of the pick-up or camera tube which, in an inexpensive ham version, is still in the early experimental stages. But the problem can be licked—we feel certain of that. Then there is the old problem of bandwidth. A fair picture is to require something more than a megacycle and this, when we think in terms of 'phone, seems tremendous. At the same time it must be realized that even our 112-Mc. band would accommodate five or six transmitters operating simultaneously within a limited radius. Only in very densely populated districts and only in the absence of any cooperative spirit between television workers would this mean serious trouble. But even with problems still unsolved, it has been no puny thrill to find that with something less than two hundred dollars' worth of transmitting equipment (yes, that includes an experimental iconoscope), we have been able to generate, transmit and receive recognizable pictures of some of the Headquarters' crew. Their handsome features suffered somewhat in the process,

admittedly, but no more so than did our voices in the early days of 'phone.

It has needed only a relatively successful experiment of this nature to allow us to cook up quite a vivid mental picture of possible activity on, say, 112 or 224 Mc. among a group of enthusiasts in any one of a thousand towns or cities. One can imagine members of these television circles cranking up their "wireless picture senders" after supper and taking turns in introducing visiting ham friends to the group, displaying their newest QSL cards, drawing circuits for each other and, in the process, developing a hundred and one improved and simplified features for the television technique of the future. That the amateur is to have a part in television development seems to us now to be as logical and as inevitable as was our rôle in all the work of the past.

We have not arrived yet, of course. The stage has not been reached when the amateur can throw together a television transmitter from standard parts and pump his picture into the air. But things are moving along smoothly and we keenly expect to be able to get down to brass tacks and publish practical dope in the early future.

—R. A. H.

### Maritime Division Convention

St. John, New Brunswick, September  
3rd-4th-5th

Auspices of Loyalist City Amateur Radio  
Club.

Watch for the circulars.

A dentist who was listening to the conversation turned to his wife and said, "No wonder there is something wrong with his speech equipment. I have his teeth down at the office for repairs."

—W3HJW

"Justice, in a roundabout fashion, overtook another violator of the F.C.C. regulations when a local 5-meter bootlegger was jailed for breaking into a local library.

"Perhaps a well baited circulating library sponsored by the A.R.R.L. would clean up the bootlegger situation."

—W3EUG

### The Cover

THE shot this month was taken behind four of the new transmitters about to be installed at the Maxim Memorial Station, W1AW. Hal Bubb, who built the transmitters and who is W1AW's chief op., squats at the lower left corner of the picture.

### Strays

The following incident occurred during a 160-meter 'phone QSO:

"I can't tell exactly what is wrong with your rig, but it seems to me that there is something wrong with your speech equipment; the distortion is terrible," reported one of the amateurs to the other.

On page 26, March 1938 QST, R<sub>6</sub> to R<sub>9</sub>, inclusive, should have been given as 300-ohm, 2-watt.

On page 31, May 1938 QST, R<sub>24</sub> should have been given as 700-ohm, 1/2-watt.

Have tube manufacturers suddenly swung to the modest side of the pendulum's course in making claims on their developments? We notice in a new apparatus announcement this month the following statement: "This tube is a high mutual conductance pentode in a metal bulb, which will likely find very general application in high frequency . . . receivers and amplifiers, in order to secure a high gain and a low signal-to-noise ratio."

# The Battle of Cairo

American Amateurs Retain All Frequencies After Terrific Fight; U. S. A. Puts Up Splendid Defense; European Hams Short-Changed by Greedy Governments; European Broadcasting Invades 7-Mc. Band in Late 1939

By Kenneth B. Warner\* and Paul M. Segal\*\*

**A**FTER some years of preparation, the much-heralded international telecommunications conferences were held in Cairo, Egypt, this past winter and spring. We assume that the reader is already familiar with the extensive preparatory meetings that have been reported in *QST*. The story of the amateur's participation at Cairo really goes back to the Habana Conference last autumn, where an inter-American regional agreement was negotiated. As far as amateurs in the Americas are concerned, Habana paved the way for Cairo. The American nations there agreed to continue the present amateur bands and they agreed to defend them jointly at Cairo, subsequently appointing the United States delegation as their spokesman.

We went to Cairo in January at the instructions of the A.R.R.L. Board of Directors to represent American amateur radio. Jointly with Mr. Arthur E. Watts, G6UN, President of the Radio Society of Great Britain, we had also been designated by the International Amateur Radio Union as its representatives, and so had world-wide credentials as well. We three had worked together at Madrid, so this was in the nature of a reunion of an old team. We also had assistance from the Experimental Radio Society of Egypt, whose President, Mr. Wm. E. Marsh, SU1WM, attended some of the early meetings. This article is an attempt to tell you the results of our work.

Cairo represented simultaneous radio and telegraph conferences, with several hundred delegates and representatives and assistants in attendance, representing 74 different national and colonial administrations and several dozen operating companies and other organizations. The meetings ran from February 1st to April 8th,—ten weeks. The organization of the conference to handle its work followed remarkably closely the pattern outlined by Budlong in his recent *QST* article. While there

were many committees, the heart of the whole conference was the technical subcommittee on allocations, which did a mountainous piece of work under the chairmanship of Colonel A. S. Angwin of the British delegation. In its brief life it created nine sub-subcommittees to deal with different parts of its work and, in addition to scores of meetings of these sub-subs, itself held 38 meetings. You'll get some idea of the amount of its work when we tell you that the minutes of the allocation work alone comprised a pile of mimeographed paper about three inches thick. The total work of the conferences is reported in a stack of papers actually some feet high, a nice winter's reading if you care for that sort of thing. The actual results of the radio conference consist of redrafted regulations and protocols and are embodied in a printed book of 124 legal-size

pages of small type. You wouldn't want to read all of it. We'll try not to bother you with the details and tell you only the things interesting to amateurs.

However, there were many matters besides frequency allocation to interest us. Before we talk allocations, suppose we get these little things out of the way:

Perhaps you'll remember that there was a proposal by Japan to limit our power to 50

watts. This item was reached early in the work of the conference and we were able to defeat it easily. We had aligned a large number of administrations in opposition. We suspect that some of them came to our side because they considered 50 watts output entirely too much power for amateurs. At any rate, only Spain and Chile supported the thing when it came up, and the Japanese were obliged to withdraw it.

Rules were adopted governing the participation in future conferences of such organizations as ours—both future administrative conferences such as this one and the meetings of the C.C.I.R. The door has been left open for the I.A.R.U. in both cases, and in fact the Union is mentioned in a footnote to the regulations as one of five organi-

## CAIRO HIGHLIGHTS

*Amateur bands unchanged throughout the Americas.*

*Short-wave broadcasting puts heavy pressure on 7- and 14-Mc. bands, gains non-exclusive right to use 7200-7300 for broadcasting outside the Americas, effective Sept. 1, 1939.*

*European 80-meter band severed and reduced to 3500-3635 and 3685-3950.*

*European administrations hedge on part of 5-meter band in Europe.*

*Proposal to reduce our power defeated; no changes in general amateur regulations.*

*Big fight over amateur matters; United States delegation splendidly supports us but small sympathy from major European powers.*

*Next conference in Rome, spring of 1942.*

\* Secretary, I.A.R.U. and A.R.R.L., WIEH.

\*\* General Counsel, A.R.R.L.

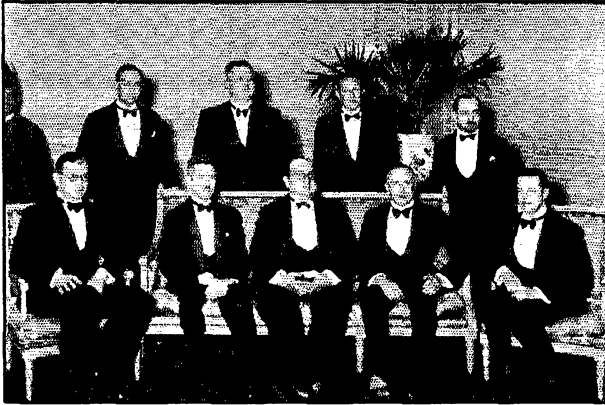

**H. H. PRINCE MOHAMED ABD EL-MONEIM, SU1AM**

Patron and Honorary President of the Experimental Radio Society of Egypt, cousin of H. M. the King of Egypt, entertains at dinner and the evening for the amateur representatives at Cairo and some officers of the E.R.S.E. Sitting, left to right: George Moens, SU1RO, Hon. Secretary, E.R.S.E.; Kenneth B. Warner, W1EH, I.A.R.U. and A.R.R.L. Secretary; His Highness, SU1AM; A. Egerton Watts, G6UN, President of the Radio Society of Great Britain; Wm. E. Marsh, SU1WM, Executive President, E.R.S.E. Standing: Edw. M. Chorlian, SU1CH, Vice-President, E.R.S.E. and President of the Radio Club of Cairo; R.E.A. Disteche, SU1RD, member of the E.R.S.E. council; Frank H. Pettit, SU1SG, QSL Manager and Hon. Editor of E.R.S.E. Bulletin; Paul M. Segal, General Counsel, A.R.R.L.

zations especially accepted into the work of the C.C.I.R.

An interesting change was made in the Q code, effective the first of next year. You are all aware of the confusion in QSA meanings because signal strength and readability are combined in one indication—the situation which impelled amateurs to the adoption of the RST system. The governments have now taken a page from our book by separating these functions, assigning the strength indications to QSA on a 1-to-5 scale and the readability indications similarly to QRK. The following new scales have been adopted:

*Strength*

- QSA 1—barely perceptible
- QSA 2—weak
- QSA 3—fairly good
- QSA 4—good
- QSA 5—very good

*Readability*

- QRK 1—unreadable
- QRK 2—readable occasionally
- QRK 3—readable with difficulty
- QRK 4—readable
- QRK 5—perfectly readable

Because some company's telegraph printers rendered a period as III, the telegraph conference asked the radio conference to concur in making changes in the

international Morse code whereunder a period would be indicated by the old symbol for a comma and a comma would be indicated by the old symbol for an exclamation point. (Nothing was suggested as to how exclamation points might be transmitted in future!) The radio conference decided to concur. The subject is not mentioned in the radio regulations and the United States is not a party to the telegraph regulations. There is some doubt as to whether American practice will be altered in the above-noted respects beginning next year but the consensus is that it will. We never thought we'd live to see the code itself changed, but here it is!

**ABOUT FREQUENCIES**

Now for the part you're really interested in, the business of frequency allocations. It isn't too tough to have to tell you that not only did the Habana Conference continue all the amateur bands but the Cairo Conference reaffirmed them exactly as they are for all the countries of the American region. The amateurs of Europe suffer some reduction of maximum-available assignments but the W/VE membership of the American Radio Relay League will continue in the occupancy of the full widths of its bands. We're

going to experience some inconvenience in DX work because of an almost certain reduction in the frequencies that will be enjoyed by foreign amateurs but that is a European matter beyond our control.

This preservation of our frequencies was attained only after a very severe struggle. It was necessary for the delegation of the United States to exert its full force to attain its end. The fight was an exceedingly bitter one, with many hours of committee meetings over a period of several days devoted almost entirely to the amateur matters. It was something unequalled in our previous experience as representatives of the amateur. Not one amateur band was violated from attack by European administrations, even as concerns our side of the water. That, under these circumstances, every American amateur kilocycle continues to be available is something for which



**WHAT A CONFERENCE WILL DO TO A FELLOW**

One of the authors, as seen en route home by an Italian caricaturist. We like to think that three weeks in an Egyptian hospital had something to do with the goofy look. Or maybe it was that international haircut: a Greek barber's attempt to produce a German haircut in Egypt on an American head.

the American amateur should be everlastingly grateful to the delegation of the United States.

The allocation decisions are best shown in the appended table and its footnotes.

Three factors profoundly affected frequency allocation at Cairo in every part of the spectrum: the growing needs of aviation, the pressure for more broadcasting frequencies, and the preparations Europe is making for war. Almost every change made, every difficulty encountered at Cairo by any interest, was the result of one of these three factors. All of them entered our picture.

#### THE ULTRA-HIGH FREQUENCIES

The first of our bands to receive attention were the u.h.f., when a sub-subcommittee was set up to deal with frequencies above 25 Mc. under the chairmanship of a French delegate. These frequencies experienced great pressure from television, military aviation and *sondage*, i.e., radio soundings of the upper atmosphere for meteorological purposes by means of small balloons. This was a pet of the French and they wanted world-exclusive frequencies for it because of its low power and unstable frequencies. Although the u.h.f. allocation was finally agreed in terms of a European column and one for other regions, many attempts were made to make the division in terms of all of the world except the Habana signatories, indicating the peculiar position occupied by the American countries as against the rest of the world. That Habana agreement insured protection of the amateur position. The United States of course was helpless to dictate the contents of the European column, could only suggest that flexibility should be maintained in the new u.h.f. field. But the Europeans were insistent upon making definitive allocations to services and the U.S.A. could only let them go their unwise way. The Cairo u.h.f. allocation is a bumbling job, based on administrative horse trading, not on engineering considerations. Europe is just awakening to the possibilities of the u.h.f. and there is a gold-rush on, high-lighted by television hysteria and vast military preparations. The plan they have worked out is certainly unsound and cannot long endure; its provisions for the future of European television, as one instance, are plainly inadequate.

The refusal of the United States to agree to a world-wide *sondage* assignment just above 30 Mc. called forth a retaliatory effort by France, Great Britain and Germany to cut our 10-meter band and assign 29.5-30 to *sondage*, using us as a

weapon against the United States: "Sondage is as important as amateurs." The effort was finally averted but it was not possible to get the band exclusively for amateurs and, although intact, it reads as it did before, amateurs and experimental.

A very difficult negotiation extending over several days brought the committee work to 40.5 Mc. after having provided for beacons, aeronautics, etc., and it was then time to provide for television. The agreed plan was for three 6 Mc. channels, each country to use any two for television and the other for "low-power" (i.e.,

chiefly military) stations. The addition of 18 Mc. would bring the frequency to 58.5 Mc., in our band. The band was safe in America but we fought our best on behalf of the European amateurs. We soon learned that a private agreement had been reached between Great Britain, France, Germany and the Netherlands for a detailed allocation and there was no opposing them in the European region. England and France are establishing their television in the lower 40's and could use the upper end of the range for "low-power stations." On the other hand Germany, for example, with no 5-meter amateurs permitted, would use the low end for her military stations, her television at the upper end, stretching up

to 58.5. Great Britain wanted to continue her amateurs in the 56-60 band but would not oppose the plan, feeling that she was protected and that Germany, for instance, had a right to use it for other purposes if she wished. It became apparent that only a shared status was possible for part of the band in Europe, and so it was agreed that 40.5-58.5 would be shared television, low-power and amateurs, and 58.5 to 60 amateur and experimental.

At this point an amazing thing occurred. It will be noticed that the scheme contemplates that the French low-power stations be in the upper 6 Mc., 52.5-58.5. The French military and television representatives asserted that a basic law in France made it incumbent upon the administration to allot to amateurs any and all frequencies that might permissively be available to them, with the administration robbed of all discretion in the matter. To protect the military services it was therefore demanded that outright sharing with amateurs be eliminated between 56 and 58.5 and that there simply be a note to the effect that the administrations might, if they thought it necessary, allow amateurs to work in this portion of the band. We did not for a moment believe that such a law existed in France, nor that this



LIEUT. EWELL K. JETT  
Chief Engineer of the Federal Communications Commission and an ex-amateur, who was the splendid spokesman on amateur frequency matters for the United States delegation.

was the way to handle the situation if it did, but we found ourselves unable to help the European amateurs. Great Britain was content, feeling that her amateurs would be well-enough pro-

Frequencies	General Allocation (if any was made)	Regional Allocation	
		European Region <sup>1</sup>	Other Regions
1715-2000		1715-1925: (a) Amateurs (b) Fixed (c) Maritime mobile 1925-2000: (a) Amateurs (b) Maritime mobile, A3 only	(a) Amateurs (b) Fixed (c) Mobile
3500-4000		3500-3635: (a) Amateurs (b) Fixed (c) Mobile 3635-3685: Non-open <sup>2</sup> 3685-3950: (a) Amateurs (b) Fixed (c) Mobile 3950-4000: Aeronautical	(a) Amateurs (b) Fixed (c) Mobile
7000-7300	7000-7200: Amateurs 7200-7300: (a) Amateurs (b) Broadcasting		
14-14.4 Mc.	Amateurs		
28-30	Amateurs— Experiments		
56-60		56-58.5: Television and Low- Power Stations. <sup>4</sup> Norm. —The administrations may, if they consider it necessary, authorize amateurs to use the band 56-58.5. 58.5-60: Amateurs. Experiments. Low-Power Stations <sup>4</sup>	Amateurs— Experiments
112-120		Low-Power Stations. <sup>4</sup> Norm.—The administrations may, if they consider it necessary, authorize amateurs to use the band 112-120.	Regional <sup>4</sup>

<sup>1</sup> The European Region extends to longitude 40° E. and southwards to latitude 30° N. except for the parts of the Arabian Peninsula lying within these limits. It thus includes African countries bordering on the Mediterranean.

<sup>2</sup> I.e., not open to public correspondence. In some countries may be state services, such as police. In others, will be military. By special arrangement, U.S.S.R. does not here follow the European column but rather the one for "other regions."

<sup>3</sup> A footnote opposite 7200-7300 in the Cairo table reads: "This band can only be used for broadcasting in regions other than the American continent (including the territories and possessions of the countries of that continent)." The term American continent embraces both North and South America.

<sup>4</sup> A footnote defines a low-power station as one of which the power is below 1 kw. Does not state whether input or output meant. Nothing is said about the type of station. This is deliberately vague, meant to cover everything, particularly military installations.

<sup>5</sup> A footnote appears in the "other-regions" column opposite all allocations above 30 Mc. (except the 56-60 band) stating that a table in Appendix 4 indicates an allocation which shall serve as a guide for research and further experiments on the American continent. Appendix 4 then reproduces the figures thus tentatively adopted at Habana as an American guide between 30 and 300 Mc. These include exclusive amateur allocations throughout the Americas of 56-60, 112-118 and 224-230 Mc.

ected by the proposed language, Germany favored the suggestion since she had no amateurs at all in that band, and no other administration would object. The change to the status of a note was made. Then the Dutch delegate insisted that his low-power stations (chiefly aero) had to operate between 58.5 and 60 and he demanded the right to share this half of the band too. His associates of the British, French and German delegations offering no objection, this too was done. Thereby came about the new arrangement for this band in Europe shown in the table. We participated actively in the work of this sub-subcommittee, taking the floor, filing statements, negotiating with delegates outside meetings, and in general did our best to assist the European amateurs. However, with the important European administrations of contrary mind, there was little or nothing that could be accomplished.

The 112-Mc. band is a matter for regional agreement outside of Europe. As concerned the European column, we had agreement to at least a shared status, but again through the perfidy of the French and the inertia of the British the status of the European assignment was reduced to that of a note.

Unable to get what we considered proper consideration for European amateurs in the sub-subcommittee, and feeling properly indignant over the misrepresentation made by the French delegates (since confirmed by the R.E.F.), we made strong objection in the name of I.A.R.U. when the report came up for adoption. Not a single European administration supported us and the report was adopted. However, we have made it a matter of record in the minutes of that subcommittee, for the information of European amateurs, how the matter came about. Naturally there is no compelling European administrations to assign the 56-60 and 112-120 bands to their amateurs if they do not want to. As for European amateurs in countries whose administrations wish to give them these bands, the administrations can simply say that they consider it necessary. However, it is the thin edge of the wedge and it should be understood that European amateurs are in a less satisfactory status than before as concerns 56-60.

#### THE LOW-FREQUENCY SHARED BANDS

Our 1715-2000 and 3500-4000 bands were the next reached, when another sub-subcommittee dealt with the range from 1500 to 5500 kc. At the outset the European nations made a hard drive to establish world-wide exclusive aeronautical bands throughout this portion of the spectrum, moves that attacked both of our bands. When this effort was rejected by the Habana signatories the maintenance of both our bands in their present shared status (fixed, mobile, amateur) was assured for regions other than Europe, and the re-

(Continued on page 45)

# A Low-Cost 1.75-Mc. 'Phone Transmitter

Twenty-Five Watts Output—6L6's in Modulator and R.F. Final

By Vernon Chambers, W1JEQ\*

**B**ECAUSE of its possibilities for local rag-chews and getting acquainted with other amateurs in the vicinity, the 1.75-Mc. 'phone band often is an attractive spot, particularly for beginners. The transmitter pictured and described here has been designed especially for 160-meter 'phone work. Besides being capable of generating the type of signal demanded by existing operating conditions and regulations, it has the merits of low cost, simplicity of construction and practically sure-fire operation. Complete with tubes and power supplies, the cost totals less than fifty dollars, which is quite reasonable for a three-stage transmitter, a two-stage modulating system and individual power supplies for each unit. The pressed-wood bases and panels give neat appearance and still permit the construction work to be of the very simplest type, requiring no special tools. The type of modulation used is easily the least critical in adjustment and therefore the most practical for the beginner or amateur without 'phone experience.

As the photograph shows, the two units are mounted on a small home-made wooden rack, which is built from one- by two-inch white pine. The top section consists of the r.f. stages and the accompanying power supply. Running from left to right in this unit are the power supply, a 6F6 pentode oscillator, a 6F6 buffer and the 6L6 final. Mounting the power supply alongside and on the same base as the transmitter saves a great deal of space and allows all leads to be attached permanently in place. It was found that the screen-grid tubes used in the buffer and final stages, while not the completely-shielded transmitting type, are well enough shielded to be operated without neutralization at this low frequency. No regenerative

effects are present. The lack of need for neutralization is an obvious constructional and operating convenience.

The bottom unit has the power-supply at the left, a push-pull 6L6 modulator in the center and the 6C5 speech-amplifier at the right. Possibility of hum pick-up from the power supply has been eliminated by mounting this section and the speech-amplifier at opposite ends of the base.

## OSCILLATOR

The oscillator circuit uses a Type 6F6 tube with pentode connections. The crystal is tied between the control grid and ground, with the grid leak,  $R_1$ , and the r.f. choke connected between the same two points. The cathode is connected directly to ground and the screen voltage is obtained from the same source as the plate. The tank circuit,  $C_1L_1$ , is connected with the stator side of the condenser tied to the plate and the rotor end to plus "B." A jack,  $J_1$ , in the positive d.c. lead permits the insertion of a meter plug into the plate circuit. Condenser  $C_8$  is a short length of insulated wire soldered to the plate terminal of the tube socket and bent around so that it is near the grid prong, adding a small amount of capacity between the

plate and grid of the tube to increase feed-back. The additional feed-back improves the operation of the oscillator.  $C_7$  and  $C_8$  are the plate and screen by-pass condensers.

## BUFFER STAGE

The buffer stage is a straight power amplifier; its chief purpose, however, is to provide isolation of the oscillator from the final, a practice that should always be followed whenever an amplifier is to be modulated. The grid leak and the r.f. choke are connected between the control grid and

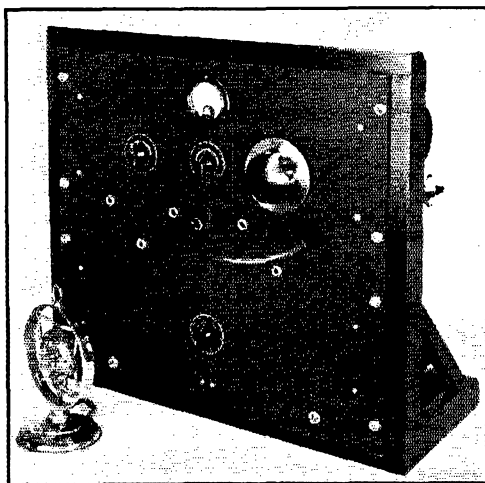

THE COMPLETE 160-METER 'PHONE TRANSMITTER

*A 6L6 final r.f. amplifier is driven by two 6F6 stages and is modulated by a pair of 6L6's. The r.f. output is approximately 25 watts.*

\*QST Laboratory Assistant.

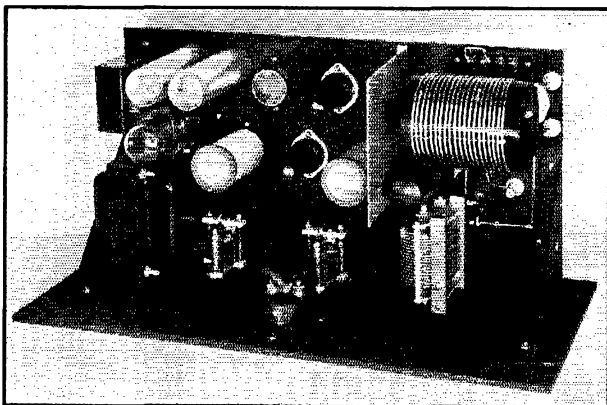

TOP VIEW OF THE R.F. SECTION

The power-supply is on the same base as the transmitter. A small shield helps to prevent interstage coupling.

ground.  $R_3$ , the cathode resistor, is tied between the cathode and ground and is by-passed by  $C_9$ .  $C_2$  and  $L_2$  form the tank circuit.  $L_2$  is a center-tapped coil and the plate voltage is applied at the tap. The plate and screen are by-passed by condensers  $C_{10}$  and  $C_{11}$ . Screen voltage is obtained from the same source as that for the plate. As in the oscillator circuit, a jack,  $J_3$ , is inserted in the positive plate-voltage lead. Coupling between the oscillator and buffer is made through the coupling condenser  $C_4$ . The stage is free from regeneration, thus there is no need for a neutralizing system.

#### FINAL AMPLIFIER

A 6L6 tube is employed in the final stage. This circuit is a straight power amplifier. The tank circuit,  $C_3$ ,  $L_3$ , makes use of a center-tapped coil, which requires some explanation. In planning the transmitter it was expected that 6L6's would require neutralizing, and the coil therefore was made with the center-tap. When we learned that neutralization was unnecessary we switched over to straight series feed, with the plate voltage fed in at one end of the coil. It was found that with this connection the tank condenser setting for best output did not coincide with the setting for resonance, indicating too-high load resistance. With the center-tap, the "double tuning" disappeared. Also, the center-tap provides a simple means of neutralizing in the event that the builder should desire to

install such a system. If a large knob is used for the tank condenser it will keep the hand far enough from the condenser shaft to minimize any hand-capacity effects. In the final arrangement the high-voltage first goes through the secondary of the modulation transformer and then to the coil's center-tap.

The plate voltage is dropped to the correct value for the screen grid through resistor  $R_5$ .  $C_{13}$  is the screen by-pass condenser. Since the screen grid is modulated along with the plate, it is necessary to read the total current of the two elements. In order to do so, the screen-voltage lead is tapped at a point between  $J_4$  and the center-tap of the plate coil. The cathode is tied to ground through  $C_{12}$  and a pair of leads across this condenser will provide a keying or switching channel.  $R_4$  is the grid leak and  $RFC$  the grid choke. Jacks  $J_3$  and  $J_4$  permit metering of the grid and plate circuits. A toggle switch in the negative supply lead allows cutting off the plate voltage while still maintaining filament power.

#### POWER SUPPLY

Located at the extreme left of the base is the power supply, a standard condenser-input affair using a Type 83 rectifier. Condensers with a working voltage of 600 are used, since it was found that the ordinary 450-volt type would not stand the surges at the output voltage of the power transformer used. There are no terminal strips for output voltages since the wiring goes

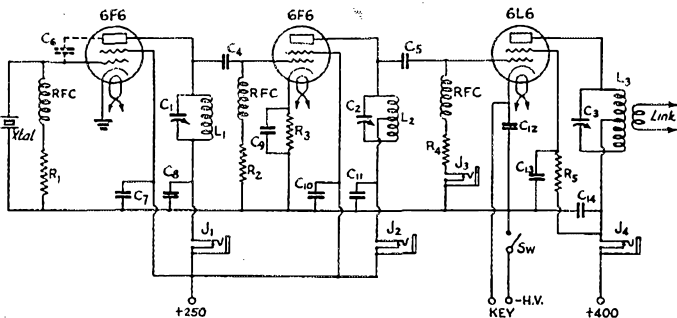

FIG. 1—CIRCUIT DIAGRAM OF R.F. SECTION

- $C_1, C_2$ —200- $\mu$ fd. receiving condensers (National STH-200).  
 $C_3$ —365- $\mu$ fd. receiving condenser (Cardwell MR-365-BS).  
 $C_4, C_5$ —50- $\mu$ fd. midget mica condensers (Cornell Dubilier, Type 2).  
 $C_6$ —See text.  
 $C_7$  to  $C_{14}$ , inc.—0.01- $\mu$ fd. 600-volt paper (Aerovox 684).  
 $R_1$ —50,000-ohm, 1-watt (IRC).  
 $R_2$ —10,000-ohm, 2-watt (IRC).  
 $R_3$ —400-ohm, 1-watt (IRC).  
 $R_4$ —30,000-ohm, 1-watt (IRC).  
 $R_5$ —10,000-ohm, 10-watt slider (IRC).  
 $RFC$ —2½ m.h. r.f. chokes (National R-100).  
 $J_1, J_2, J_3, J_4$ —Midget closed-circuit jacks.  
 $Sw$ —S. p. s. toggle switch.  
 $L_1$ —45 turns No. 20 d.c.c., close-wound, 1½" diameter, 2½" long.  
 $L_2$ —45 turns No. 20 d.c.c., close-wound center-tapped, 1½" diameter, 2½" long.  
 $L_3$ —20 turns No. 14 wire, center-tapped, 3" diameter, 3" long.



directly to its allotted place.

#### CONSTRUCTION

The r.f. components and their power supply are mounted on a tempered masonite base measuring  $8\frac{3}{4}$  by 17 inches. The panel measurements are  $8\frac{3}{4}$  by 19 inches. A study of the top view photograph will make the layout of parts quite clear. Holes for the oscillator and final condensers should be drilled so that each is centered  $5\frac{1}{2}$  inches from the side and  $3\frac{5}{8}$  inches from the bottom edge.

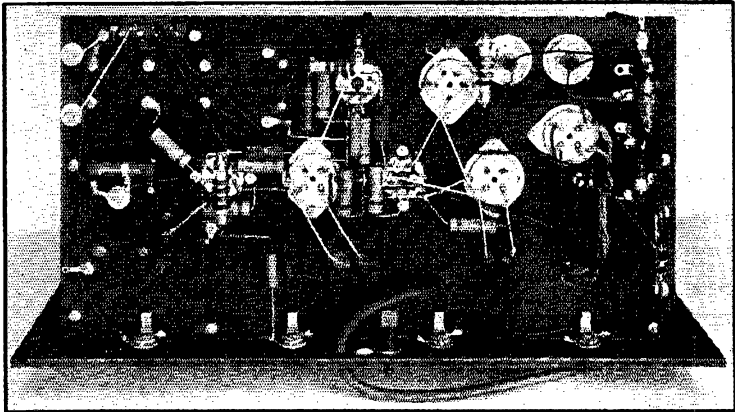

BOTTOM VIEW OF THE R. F. SECTION

The layout of the smaller parts mounted below the base is clearly shown.

The buffer condenser is then mounted from the bottom edge. The buffer condenser is then mounted on a line with and midway between the other two. All three condensers mount directly on the panel. Next, the socket holes should be drilled with the various tubes and coils arranged to the rear of their respective condensers as shown in the photograph. A four-screw terminal strip is mounted at the right-hand rear side of the base. The key leads are brought to two of the terminals and the output tank coil link is connected to the other two. This link is fastened to the two feed-through insulators at the right of the coil; these insulators simply act as a support, and the output leads are brought from underneath to the terminal strip. Because of the final tank coil size and the compactness of the rig, a small shield is placed between the final and buffer stages to prevent undesired coupling. This shield is a sheet of thin

aluminum measuring 5 by 5 inches with  $\frac{3}{8}$ -inch lip to permit fastening to the base. The shield should be connected to the common ground circuit. Resistors and condensers, mounted below the base, are placed to give short and direct leads between the various parts. The power supply is arranged compactly at the left.

On the panel are the plate milliammeter, a hole for the meter cable, a switch and the four jacks. The meter is centered above the buffer condenser and the four jacks are all on a line one inch from the bottom edge. The switch and cable hole are centered between the middle two jacks. A pair of small panel brackets serves to hold the base and panel together. When the base is attached, it should be fastened so that the panel will protrude beneath the base about  $1\frac{1}{8}$  inches.

#### TESTING THE R.F. SECTION

After the construction of the r.f. section has been completed, it is a good idea to test it before going on with building the modulating equipment. With a crystal and the coils in place, and plate voltage disconnected from the final, insert the meter plug in  $J_1$  and put the toggle switch in the "on" position. Rotate  $C_1$ , the oscillator condenser, until resonance is reached, indicated by a drop in plate current, which will be about 50 ma. non-oscillating, to a value of 35 ma. or so. The meter plug is then placed in  $J_2$  and the buffer tuned to resonance; for this circuit the plate current should drop from the

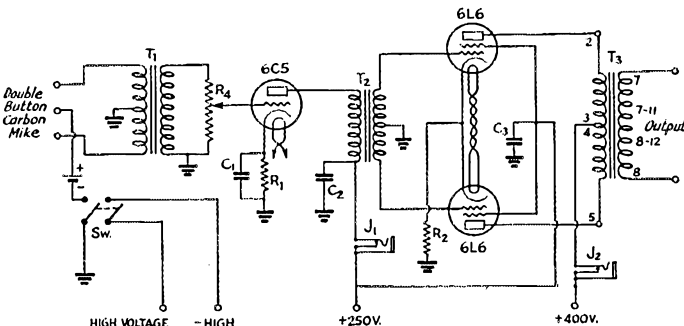

FIG. 2—SPEECH AMPLIFIER AND MODULATOR DIAGRAM

- $C_1$ —25- $\mu$ fd. 25-volt electrolytic.
- $C_2$ —2- $\mu$ fd. 450-volt electrolytic.
- $C_3$ —2- $\mu$ fd. 475-volt electrolytic.
- $R_1$ —2000-ohm,  $\frac{1}{2}$ -watt.
- $R_2$ —200-ohm, 10-watt.
- $R_4$ —50,000-ohm volume control.
- $J_1, J_2$ —Midget closed circuit jacks.
- Sw—D.p.d.t. toggle switch.
- $T_1$ —Mike transformer, double button to grid (Thordarson T-58A37).
- $T_2$ —Push-pull input transformer (Thordarson T-13A35).
- $T_3$ —Multi-Match modulation transformer (Thordarson T-11M74).

off-resonance value of 50 ma. to about 15 ma. Then move the meter plug to  $J_3$  and check the final grid current, which should be in the neighborhood of 3 or 4 ma.

To check the final amplifier, clip a 25-watt lamp across four or five turns of the plate coil and connect a switch or key across the "key" terminals, Fig 1. The lead which later will run from the positive high-voltage tap on the power supply to the modulation transformer, is for the time being connected directly to the plate-coil center-tap. One of the lamp leads should be connected to the center of the coil. With the meter plug inserted in  $J_4$ , close the key or switch. The tuning procedure is the same as with the preceding stages, except that the total plate and screen current should drop to 100 ma. at resonance with the amplifier fully loaded by the lamp. It may be necessary to tap the load across more or less turns of the coil to reach the correct value of current. Without a load, the current should be about 140 ma. when the final is not tuned to resonance and about 50 ma. when it is.

If, as these adjustments are carried through, it is found that the final amplifier is unstable, it may be because the various parts have been laid out differently and that there is unwanted

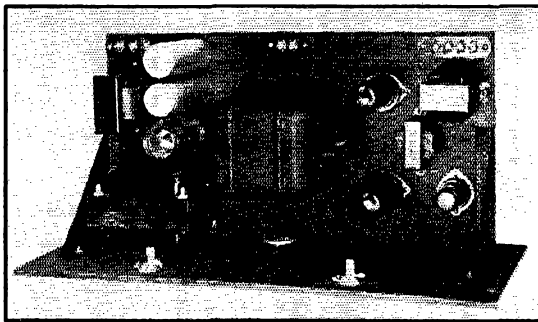

**THE MODULATOR UNIT**  
A double-button microphone works into a 6C5 speech amplifier which in turn drives a pair of Class-AB 6L6's.

be connected between the 6L6 grid and the rotor side of the tank condenser without making any other changes. However, with reasonable care in construction there should be no necessity for neutralizing.

#### SPEECH AMPLIFIER

In the speech amplifier circuit, Fig. 2, a double-button microphone works into  $T_1$ , a microphone-to-grid transformer. The two outside primary leads of the transformer go to the two microphone buttons and the center-tap goes to ground. A 50,000-ohm potentiometer, the gain control, is in parallel with the transformer secondary, one lead of which is also grounded. The rotor contact of the gain control is tied to the grid of the 6C5.  $R_1$ , a 2000-ohm resistor, is the bias resistor and is by-passed by  $C_1$ . A single-plate-to-push-pull-grid transformer,  $T_2$ , is used to couple this stage to the modulator. The high end of the primary of

this transformer goes to the 6C5 plate and the plus-"B" connects through  $J_1$  to the positive 250-volt tap of the power supply.  $C_2$  is the plate by-pass condenser. The outside ends of the secondary winding of  $T_2$  are connected to the two 6L6 grids and the center-tap is grounded. One section of the d.p.d.t. toggle switch is put to use in this circuit. The frame of the microphone is connected, through the mike cable, to the positive terminal of a 1½ volt dry cell, the microphone battery. From the negative terminal of the battery a lead is run through the toggle switch and then to ground, furnishing a means of opening the battery circuit when desired.

#### THE MODULATOR

The modulator consists of two 6L6's in push-pull, operated Class-AB without grid current so that no power is required from the 6C5 driver. The tubes are self-biased,  $R_2$  being the cathode-bias resistor. Since the modulator screen voltage is of the same value as the speech amplifier plate

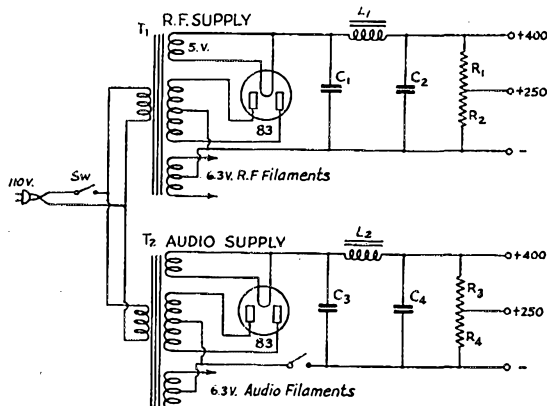

**FIG. 3—DIAGRAM OF POWER SUPPLIES**

- $C_1, C_2, C_3, C_4$ —8- $\mu$ fd, 600-volt electrolytic (Mallory HS-693).
- $R_1$ —4000-ohm, 25-watt (Ohmite).
- $R_2$ —25,000-ohm, 10-watt (Ohmite).
- $R_3$ —5000-ohm, 25-watt (Ohmite).
- $R_4$ —10,000-ohm, 10-watt (Oh-

- ite).
- Sw—S.p.s.t. toggle switch.
- $L_1, L_2$ —8-henrys, 150 ma. (Thordarson T-13C30).
- $T_1, T_2$ —Plate and filament transformers, 750-volt, 150 ma. c.t.; 6:3-volt, 5 amp. c.t., 5-volt, 3 amp. (Thordarson T-13R15).

voltage, it may be obtained from the supply as shown in the diagram.  $C_3$  is the screen bypass condenser. The two plates are connected to the outside terminals of the primary of the modulation transformer,  $T_3$ . The numbers marked at different points on  $T_3$  indicate the tap numbers on the Multi-Match transformer used. In our case the plate-to-plate impedance should be approximately 8000 ohms, while the r.f. stage looks like a load of 4000 ohms. If the connections marked on the diagram are used the match will be as close as is possible. Nos. 2 and 5 are the plate connections. Positive high-voltage is fed through  $J_2$  to Nos. 3 and 4 tied together. Nos. 7 and 8 are the output terminals, while Nos. 7 and 11, and also 8 and 12, are respectively connected together. The second half of the d.p.s.t. toggle switch,  $Sw$ , is used to switch voltages either on or off the tubes of the entire audio system. This half of the switch is connected between the high-voltage transformer center-tap and the negative side of the filter.

#### MODULATOR CONSTRUCTION

Panel and base measurements of the modulator are the same size as those used for the r.f. section. Panel brackets are also used to fasten the two together. Little need be said about the layout, because with the small number of parts used, a glance at the photograph will give the needed information. The power supply is at the right-hand end of the base with the power transformer next to the panel. In the exact center of the base is the modulation transformer, with the 6L6 tubes and the speech amplifier to the right. Terminal strips along the rear provide means for connecting the microphone and for connecting the secondary of  $T_3$  to the transmitter. The four-terminal strip is for the microphone, mike ground connection and the microphone cable shield. Plate voltage for the r.f. final amplifier is brought from the meter jack,  $J_4$ , in Fig. 1, to the two-terminal strip to the rear of the modulation transformer and then back again to the center-tap of  $L_3$ . The terminal strip is of course connected to the output winding of the modulation transformer. At the right-hand end of the base there is a three-terminal strip for the 110-volt a.c. input. One side of the a.c. line goes to a lug strip fastened below the base, and then through the s.p.s.t. toggle switch mounted at the right-hand end of the panel. From there it continues on to one of the strip terminals. The other

side of the a.c. line is brought to the second terminal. From these two points a twisted pair is run to the primary of the r.f. power-supply transformer. The third terminal is used to make a common ground connection between the two units.

The panel holds the remaining five parts. The two toggle switches are at the bottom edge just in line with the two outside jacks of the transmitter. The jacks for reading the audio plate currents are at the top of the panel and the gain control a little below its center.

#### TESTING THE MODULATOR

The modulator preferably should be tested with a 4000-ohm 25-watt resistor connected across the output terminals. (Do not attempt to run the modulator without a load because of the possi-

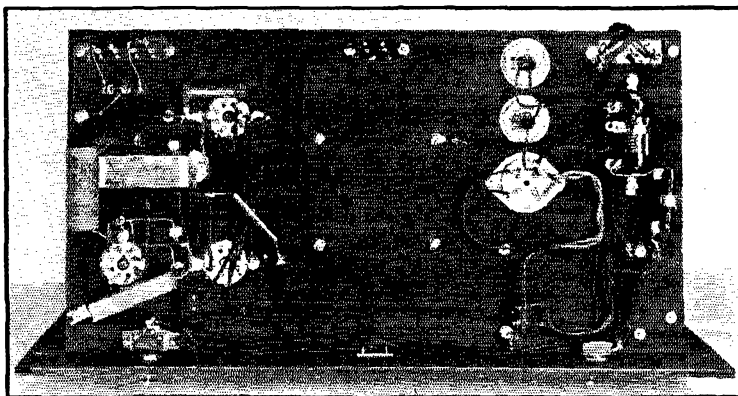

THE UNDER SIDE OF THE MODULATOR

The power-supply wiring is at the right and the audio wiring at the left.

bility of breaking down the insulation of the modulation transformer.) This resistor represents the load that the r.f. tubes will offer to the modulator. A pair of headphones across a resistor of 100 ohms or so, connected in series with the load resistor, will afford a means of checking the quality of the output. With the microphone and battery in place and an external ground attached, talk into the microphone. The plate current of the 6C5 should remain constant both with and without speech. The meter plug is then moved to the modulator plate circuit and a reading made of the plate current. Without excitation, the 6L6's should draw approximately 95 ma. Set the gain control so that the plate current will rise about 12 or 15 ma. when the microphone is spoken into. The gain control is left at the point that permits proper operation, and a check of the quality is made by listening in the headphones.

With the two units mounted in the rack, the a.c. and d.c. connections should be made between the

(Continued on page 72)

# "Look for Me on --- Kc."

## A Simplified All-Band All-Frequency Exciter Unit

By E. P. Tilton,\* W1HDQ, and Glenn H. Browning\*\*

**A**NOTHER 'universal exciter'? So what!" Such is the anticipated reaction of the average amateur to the above title, for surely all-band exciters have come in for their full share of treatment in the various ham publications of late. But the countless variations of the quick QSY idea which have appeared recently seem to be lacking in one or more of the qualities listed below, all of which seem desirable to the writers.

If carefully designed, the exciter may be considered as a long-term investment, and should therefore be so laid out as to perform as many useful functions as possible. With this thought in mind, and with an ever-watchful eye on the total cost, we set about to design an exciter unit which would incorporate the following features:

1. Power enough to drive a reasonably husky final.
2. Output on all bands from 160 to 5 meters, with crystal or self-controlled oscillator, and with quick changeover from one method to another and from one band to another.
3. Thoroughly stable self-controlled oscillator, with complete frequency coverage, easily calibrated, in all bands.
4. Oscillator keying for snappy break-in operation, without the "twerp" so common to keyed crystals.
5. Greatest possible simplicity, for flexible operation and low cost.

How well the unit about to be described fills the above requirements may be judged from the fact that the output is at least 35 watts on all bands from 160 to 10 meters, with 15-20 watts on 56 Mc., using three

crystals and one set of plug-in coils. The note from the electron-coupled oscillator is of such quality that it is impossible to identify it as such when it is tested against a crystal on the same frequency. Either oscillator may be keyed without the slightest sign of chirp. The simplicity and resultant low cost are obvious from the photographs and schematic diagram. As will be seen everything is straightforward without any frills.

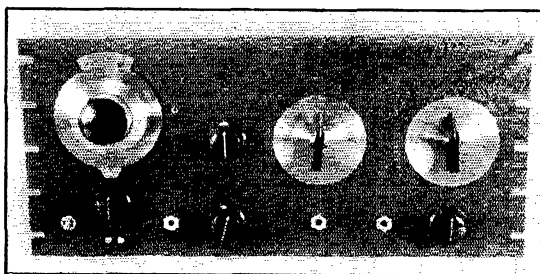

PANEL VIEW OF THE EXCITER

The vernier dial at the left is the e.c.o. control. The switches have plain knobs without dial plates.

### THE E.C. OSCILLATOR

Inasmuch as the oscillator is the chief point of interest in the layout, we will start the description at that point. One had to listen on any band for but a few minutes during the 1938 DX contest to realize that variable frequency control by means other than crystal is enjoying

increasing acceptance among the more progressive amateurs. In fact a number have been heard to remark that while the use of self-excited oscillators used to be confined to beginners, with

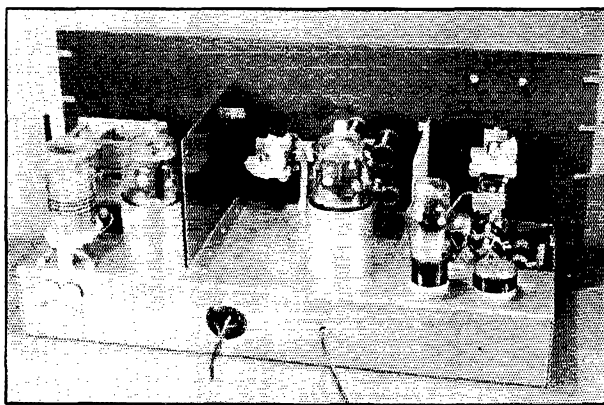

THE TOP-OF-CHASSIS LAYOUT IS SHOWN IN THIS REAR VIEW

The coil assembly for the e.c.o. grid circuit fits in a cut-out in the chassis at the right-hand edge; a baffle shield between this and the plate-coil assembly helps prevent coupling. A similar shield is between the 807 output circuit and the front end of the exciter. The two feed-throughs at the left are the output terminals.

\* 62 Oswego St., Springfield, Mass.

\*\* Browning Laboratories, Winchester, Mass.

crystal control the accepted hallmark of the experienced amateur, it is now the "old timer" who is using the e.c. rig, with the straight crystal job being considered ideal for the newcomer.

This is quite as it should be, for the self-controlled oscillator calls for a certain amount of finesse in both design and operation, which makes

crystal control safer for the inexperienced amateur. There are certain precautions which must be taken in the design of electron-coupled oscillators if their full value is to be realized. Though these factors are well known it may be well to reënumerate them at this point. First and foremost, the e.c. oscillator is *not* a cheap substitute

for crystal control and should not be treated as such. Power supply requirements call for good regulation and excellent filtering, and the power supply should be used for the oscillator alone. The plate circuit should be isolated from the grid circuit and should be operated on a harmonic, never on the fundamental, of the grid circuit. The grid circuit should be "high-*C*" for all frequencies

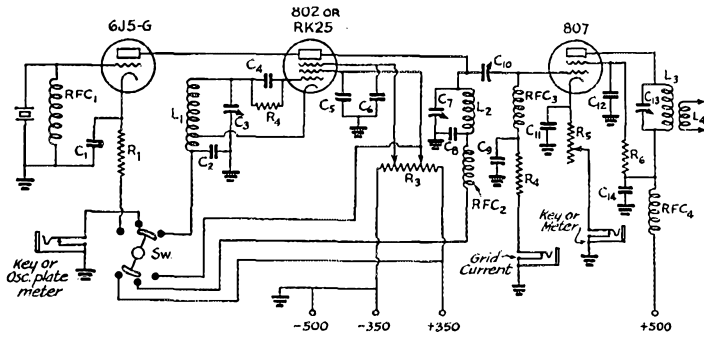

FIG. 1—THE EXCITER CIRCUIT DIAGRAM

See Fig. 2 for the detail of switching.

- C<sub>1</sub>, C<sub>2</sub>—0.005 to 0.02- $\mu$ fd. mica.
- C<sub>3</sub>—100- $\mu$ fd. variable (see coil data).
- C<sub>4</sub>—100- $\mu$ fd. fixed (see coil data).
- C<sub>5</sub>, C<sub>6</sub>—0.005 to 0.02- $\mu$ fd. mica.
- C<sub>7</sub>—50- $\mu$ fd. variable (see coil data).
- C<sub>8</sub>, C<sub>9</sub>—0.005 to 0.02- $\mu$ fd. mica.

- C<sub>10</sub>—80-120- $\mu$ fd. trimmer (Sickles ATF-111010).
- C<sub>11</sub>, C<sub>12</sub>—0.005 to 0.02- $\mu$ fd. mica.
- C<sub>13</sub>—100- $\mu$ fd. variable, double-spaced (National).
- C<sub>14</sub>—0.005 to 0.02- $\mu$ fd. mica.
- R<sub>1</sub>—300 ohms, 10-watt (Ohmite).
- R<sub>2</sub>—50,000 ohms, 1/2-watt (see coil data).

- R<sub>3</sub>—25,000 ohms, 30-watt with two sliders (Ohmite 0389).
- R<sub>4</sub>—50,000 ohms, 1-watt (IRC).
- R<sub>5</sub>—5000-ohm, 30-watt (Electrad).
- RFC<sub>1</sub>, RFC<sub>2</sub>—2.5-mh. r.f. choke (National R-100).
- RFC<sub>3</sub>—Sickles No. 1225 or other dissimilar chokes.
- RFC<sub>4</sub>—Sickles No. 1226 or other dissimilar chokes.

COIL DATA

L<sub>1</sub>—E.C. Oscillator grid circuit

Freq.	Turns	Wire	Tap	Turns Per In.	Shunt Cap., $\mu$ fd.
875-1000 kc.	104	33 enam.	20	Close-wound	225
1.75 Mc.	53	28 enam.	10	60	225
3.5 Mc.	27	24 enam.	6	34	200
7 Mc.	14	22 tinned	2 1/2	16	200
14 Mc.	6	16 tinned	1 1/2	8	200

All coils wound on 5/8-inch diameter forms. With hand winding, some adjustment may be necessary; turns should be adjusted so that the low-frequency band limit is reached with maximum capacity on oscillator tuning condenser, C<sub>3</sub>. Shunt capacitors are Sickles Silver-Cap Type 11-883.

Coils, padding condensers, C<sub>2</sub>, C<sub>3</sub>, C<sub>4</sub>, R<sub>2</sub> and Sw<sub>1</sub> (see Fig. 2) are available in one complete assembly (Browning BL-5-G).

L<sub>2</sub>—802 or RK-25 plate circuit

Band	Turns	Wire	Turns Per In.
1.75 Mc.	108	31 enam.	Close-wound
3.5 Mc.	53	26 enam.	Close-wound
7 Mc.	31	24 enam.	34
14 Mc.	14	18 tinned	16
28 Mc.	7	16 tinned	8

1.75- and 3.5-Mc. coils wound on 3/4-inch diameter forms; all others on 5/8-inch forms. Adjust turns so that high-frequency end of band is reached with C<sub>7</sub> near minimum capacity.

Coils, C<sub>7</sub>, C<sub>8</sub> and Sw<sub>2</sub> (see Fig. 2) are available in one assembly (Browning BL-5-P).

L<sub>3</sub>—Output coils

Band	Turns	Wire	Turns Per In.	Link Turns, L
1.75 Mc.	68	28 enam.	44	15
3.5 Mc.	38	24 tinned	24	8
7 Mc.	18	20 tinned	12	6
14 Mc.	9	16 tinned	7	4
28 Mc.	4	16 tinned	4	2
56 Mc.	2	12 tinned	*	2

1/2-inch between turns; turn diameter 1 1/4 inches. The 56-Mc. coil is self-supporting, mounted in a sawed-off tube base.

All coils except that for 56 Mc. wound on Hammarlund receiving forms, diameter 1 1/2 inches. Coil length 1 1/2 inches. The actual coils used are a manufactured set (made for receivers); with hand winding, the use of enameled wire throughout may be advisable to prevent shorted turns. Links may be of any convenient insulated wire, interwound between L<sub>3</sub> turns at cold end.

and be mechanically stable. The oscillator tube must be operated far below its rated plate dissipation to guard against tube heating and resultant frequency drift. These considerations, while applying to crystal control to a certain extent as well, are of paramount importance if the signal from the e.c.-controlled rig is to have "crystal" characteristics.

A word about the choice of tubes: Just any pentode is not good enough for the electron-coupled oscillator. The various audio pentodes such as the 59, 2A5, 42, 89, and 6L6 may be used, but the need for high stability and sufficient output for operation on all frequencies dictates the use of transmitting pentodes of the 802 or RK-23 and RK-25 variety. The more perfect shielding and higher output of these tubes makes them ideal for this service. If output from the oscillator is not desired on frequencies above 14 Mc., the 89 and 6L6 (metal type preferred) may be used with good results. Whatever tube is used it should be borne in mind that the e.c. oscillator is operated at low plate efficiency; consequently, it must be operated at a fraction of the manufacturer's plate voltage and current ratings in order to hold the plate dissipation well below the rated value. If the tube heats during operation, frequency drift will occur, regardless of how well the rest of the oscillator circuit is designed.

The basis of the electron-coupled oscillator in our exciter is a set of five cathode-tapped coils,

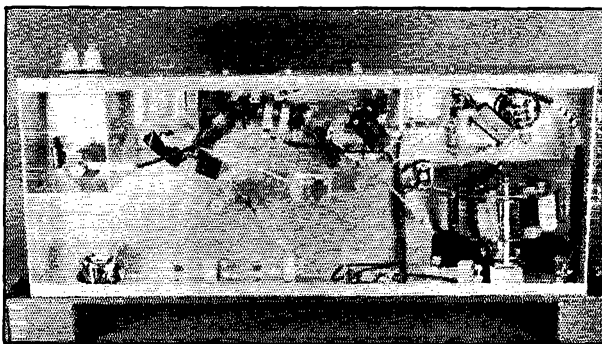

THE COMPONENTS BELOW THE CHASSIS ARE SHOWN IN THIS PHOTOGRAPH

Note the shielded compartment for RFC<sub>4</sub> and C<sub>14</sub>. Filament transformers are mounted on the chassis.

cover the 14-, 7-, 3.5- and 1.7-Mc. bands, with a special coil covering 875-1000 kc. for doubling into the 160-meter band. Thus the oscillator plate may be operated on the second or fourth harmonic for all bands. The fixed condensers used across the coils are the recently introduced silver-plated mica type, which show practically no capacity variation under widely varying conditions of temperature and humidity. The stability of these condensers makes possible an accurate and permanent calibration of the oscillator for all frequencies.

The oscillator plate circuit consists of a coil-switching assembly similar to that used in the grid, except that the circuit is "low-C," without padding condensers, and its frequency, with the band switch in the same position as that of the grid circuit, is one band above that of the grid circuit.

#### CRYSTAL OSCILLATOR

The crystal oscillator is simplicity itself. Almost any cathode-type triode may be used, but the 6J5G seems to be the most adaptable of those tried. It works well with all types of crystals, including the "harmonic" 28- and 14-Mc. variety, its r.f. current is low, and crystal keying may be used with any crystal without the

slightest suggestion of chirp. The method of changing from crystal to e.c. control is novel but effective. The cold end of the cathode circuit of the e.c. oscillator and the cathode of the 6J5G are both by-passed to ground, a panel switch being used to complete electrically the circuit of whichever oscillator is desired. This switch also takes the plate voltage for the 6J5G from the

(Continued on page 56)

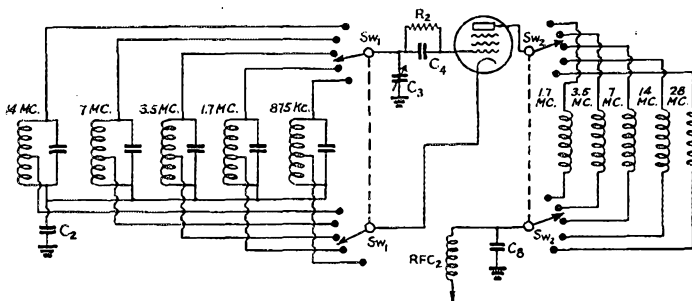

FIG. 2—DETAIL OF COIL SWITCHING CIRCUITS

See Fig. 1 for constants. Sw<sub>1</sub> and Sw<sub>2</sub> are two-section 5-point tap switches (Yaxley Type RM-2-gang).

each with a fixed condenser across it. These coils are mounted on a two-section switch which permits the desired frequency range to be selected at will, tuning being accomplished with a 100- $\mu$ fd. variable condenser which is common to all bands. A band spread of from 40 to 80 degrees, easily calibrated, is thus obtained and the capacity in the grid circuit is never less than 225  $\mu$ fd., assuring maximum frequency stability. The coils

# Minimizing Receiver Frequency Drift

## An Easily Constructed Capacity Compensator for Overcoming "Warm-Up" Effects

By Charles S. Mayeda\*

WITH the increasing use of our higher frequency bands, frequency drift in receivers has become an important problem. The average receiver drifts, from "cold" to its final operating temperature, approximately 0.1 to 0.2 per cent of its operating frequency. This frequency drift is always in the negative direction (or a decrease in frequency) while the receiver's temperature is increasing. At 7 Mc. and lower, the drift of 7 to 14 kilocycles does not cause a great deal of trouble; but at 30 megacycles, where the drift can be as high as 60 kilocycles, even a broad-tuning receiver cannot escape being affected. The home-made receiver on which these experiments were performed drifted approximately 50 kilocycles at 30 megacycles; with the crystal filter set at maximum selectivity, the resonance peak could not be held for more than a few seconds while the receiver was warming up. Incidentally, the "fire-up" drift is not necessarily an indication of receiver quality, since various tubes have different effects on the frequency, and the oscillator  $L/C$  ratio must be taken into consideration. Many high-quality communication receivers were found to have a greater "fire-up" drift than some cheap all-wave receivers.

In the high-frequency oscillator circuit, a change of either capacitance or inductance is the only cause of a change in frequency. This change can be brought about indirectly as well as directly, as in the case of plate resistance and load impedance affecting the input capacity of the tube. By careful design, inductance changes can be greatly reduced, and certain capacity variations can be practically eliminated. However, changes in tube capacity cannot be controlled readily. The offender is the heater inside the oscillator tube, which causes an expansion of certain elements with respect to others, bringing about a considerable change in input capacity. The effect of this capacity variation can be reduced by increasing the  $C/L$  ratio of the oscillator tuned circuit, but with present-day methods of circuit tracking there is a limit to the amount of  $C$  that can be used, especially at the higher

frequencies. With first-detector coupling to the tuned circuit of the oscillator, capacity changes in this tube must also be considered.<sup>1</sup>

### CAPACITY COMPENSATION

If the input capacity of the tube increases a certain amount in a given time, a special variable capacitor so made that, in the same amount of time, its capacity will decrease by an amount equivalent to the increase in tube capacity and with exactly the same speed can be connected in the circuit, so that actually the net input capacity will be constant. Thus the frequency drift can be eliminated, regardless of  $L/C$  ratio. With a little juggling of pencil, paper and a *Lightning Calculator*, we arrived at a figure of 0.12- $\mu\text{fd}$ . effective increase in capacity with the particular 6K7 used for the oscillator, from cold start to period of stable operation. However, a portion of the frequency drift was caused by an increase in inductance, a quantity which will vary in different receivers; also, various tubes have different values of capacity change, so the above figure, although representative, will not be exactly true in all cases.

It is not so hard as it might seem to make such a special condenser. We thought of using some type of thermostat, but this idea was discarded in favor of a plain metal rod of sufficient length that its expansion and contraction would move a metal disc toward or away

from a similar stationary disc, causing a capacity change dependent upon changes in temperature. If the "rotor" and "stator" plates are placed so that expansion of the rod increases the spacing between plates, satisfactory compensation for

<sup>1</sup> The drift caused by expansion of tube elements, while appreciable, usually is quite rapid since the tube reaches a stable temperature within a comparatively short time. Circuit components, however, warm up slowly and at rates depending upon their exposure to the source of heat, as well as their individual characteristics. Paradoxically, a receiver so constructed that the critical circuit elements are fairly well removed from the heat source may take the longest time to "settle down," simply because a greater time is required for that part of the receiver to reach a stable temperature. The total drift, of course, will be less than in the case of a set having the oscillator circuit near tubes or power supply components. Fixed padding condensers with negative temperature coefficients are being introduced to give automatic compensation for this type of drift.—EDIRON.

*So long as tubes, resistors and what-nots develop heat, just so long will there be temperature effects in tuned circuits and consequent frequency drift while receivers are warming up. But something can be done to minimize this annoyance—something relatively simple. Read how.—EDITOR.*

\* Route 2, Box 564, Vacaville, Calif.

variation of tube capacity can be achieved. The drawing of the device, Fig. 1, indicates clearly the position of the discs, brackets, etc.

#### CONSTRUCTIONAL CONSIDERATIONS

On inspecting the table of coefficients of linear expansion for various solid bodies, we find that the value for copper is 0.000017 and for brass 0.000019, per degree Centigrade. Although copper was used in the experimental model, brass is preferable. Either of these metals has sufficient expansion for our purpose. A copper rod 3 inches long would have an expansion of 0.000017, or 0.000051 inch per degree Centigrade increase of temperature. By increasing the temperature 30° C. the rod would expand 0.00153 inch. A pair of discs of 1 square inch area (approximately 1 1/8 inches in diameter) with a spacing of 0.04470 inch would have a capacity of 5  $\mu$ fd. An increase of 0.00153-inch spacing would reduce the capacity by 0.17  $\mu$ fd., a bit more than would be required. Exact capacity variations can be obtained by adjusting the spacing between plates.

An attempt was made to utilize the heat radiated from the tubes to actuate the compensator, but the heat does not begin to have an effect until after five minutes or so, and considerable drift would occur during this period. To overcome this, some method of heating the device immediately on switching on the receiver is necessary. Instead of the rod first tried, a length of tubing was obtained. To heat this tubing a 6-inch section of voltage-dropping resistor cord, commonly used in a.c.-d.c. sets, was placed inside the tubing, and the length of the heater resistor was adjusted so that the tubing's increase in temperature would be near the value formerly contemplated.

#### TESTS AND RESULTS

After the rotor plate was properly soldered to the tubing and the stator rigidly mounted, the assembly was placed in the receiver. In the first trial 3/16-inch copper tubing was used. With this size tubing the expansion, instead of being too slow—as was the case with the plain rod—was too fast, resulting in an initial drift in the opposite direction (about 10 kilocycles plus); after a time the tubing would reach its final temperature and the receiver, not yet having warmed up, would gradually drift back to its former frequency. When considering calibration after 30 minutes, everything would be o.k., but a drift in first direction and then the other is worse than drifting in one direction. A somewhat larger-sized tubing (1/4 inch), which would result in more gradual heating, because of the greater spacing between the heating element and the tubing wall, was tried. The dissipation of the heating

element was also increased slightly. With this size tubing the effect was still present, but was a great deal smaller. Without the compensator, the frequency change after 30 minutes from a cold start was approximately 20 kilocycles at 14 megacycles. With the compensator adjusted so that the calibration was the same whether the receiver was warmed up or cold, the compensator got ahead of the receiver in the first five minutes and the receiver drifted 3 kilocycles (plus); after a few minutes, the frequency gradually drifted to its former position and became stable in about

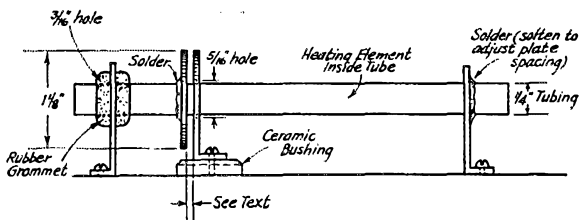

FIG. 1—CONSTRUCTIONAL DETAILS OF THE COMPENSATING CONDENSER

*Slight modifications in plate spacing may be necessary to fit the characteristics of individual receivers, as pointed out in the text.*

10 minutes. The tests were made with a room temperature of 60° F. The room temperature has some effect on the amount of drift; the drift due to a 10-degree (F.) increase in room temperature without the compensator was approximately 10 kilocycles, and with the device, for the same temperature excursion, was 2 1/2 kilocycles. Exact compensation for room temperature variations can easily be made, but room temperature variations are usually so slow that no difficulty is encountered. The "fire-up" drift, being most serious, should be given the greatest attention.

With the not-quite perfect results from the copper tubing, we set about to obtain a metal tubing that would have lower heat conductivity so that the temperature rise would be more gradual. Brass has a relative conductivity of 21 compared to 92 for copper; steel has 6-11. Unfortunately, at the time of writing no tubing of either brass or steel was available. However, the experimenter can readily substitute brass in the compensator since the expansion is practically the same as that of copper.

#### ADJUSTMENTS

For a trial use about four or five inches of 1/4-inch tubing. Place the bracket and moving disc so that the active length will be about 3 inches; increasing this length will increase the expansion. The spacing between the two plates should be about 1/32 to 1/16 inch. The stator plate should be mounted as solidly as possible, so that the mechanical stability of the receiver will not be impaired. The complete device should be placed

*(Continued on page 72)*



# CQ de W10XDA

## Adventures on Board the "Morrissey" on the 1937 Trip North

By Clifton Foss, W2OJ\*

**F**EW people there are who have not heard of that intrepid Arctic explorer, Bob Bartlett.

Captain Bob has sailed in the Arctic region for so many years that it is sufficient to just mention that he was navigator for Peary on his discovery of the North Pole in 1909. Since that time, he has spent at least a portion of each year in the Arctic. For the past two years, it has been my good fortune to have accompanied him on his annual trips to the North in the capacity of radio

operator of W10XDA. In addition to the scientists, photographer and doctor, we also had on board last year eleven young students who acted as crew and helped to share the cost of the expedition. I've received a great number of requests for a description of the trip and the equipment used on the Schooner *Morrissey*, and since it would be almost impossible to reply individually to these inquiries, I thought that a story of the trip might prove of general interest in *QST*. As the 1938 expedition will probably be under way when this article appears, I hope more amateurs will become interested in keeping contact with W10XDA throughout the summer.

Because it is necessary to keep the radio installation very compact, equipment must be chosen with care. The power, 110 volts d.c., is derived from a bank of Exide cells which are kept charged by a Diesel d.c. generator. To convert the d.c. to 110-volt a.c., we use a rotary converter which is rated at 600 watts, so you can see that our power must be used conservatively. The transmitter was constructed by Boe Moe for his previous trips as radio operator on the *Morrissey* to the Arctic and from time to time has been altered as radio practice advances. The present line-up is a 47 crystal oscillator feeding an 804 buffer and an 805 in the Class-C amplifier stage, running at 150 watts input. This is modulated by a pair of heavy-duty carbon-plate 210's in Class-B. The speech pre-amplifier consists of two 30's in cascade and is a self-contained battery-operated unit. This feeds through a 500-ohm line to a 46 which in turn feeds a pair of 45's as the drivers for the Class-B modulator stage. The reason for the odd tube line-up is that it is necessary to start and stop the generator with each transmission and therefore tubes with directly heated filaments must be used. The microphones used were the Astatic D-2 and K-2, which were entirely satisfactory. The receiving equipment consisted of an RME-69 with DB-20 presclector, battery-operated model, and we found this particular receiver very stable despite the heavy vibration from the Diesel engine. For long-wave reception, we used the Kennedy receiver which has been with us many years.

A good antenna is an important item but a difficult thing to erect, particularly on a sailing vessel. We tried to improve on the vertical Marconi type previously used by installing a vertical stub type antenna cut to 12,862 kc., our main experimental frequency, and by leaving the stub

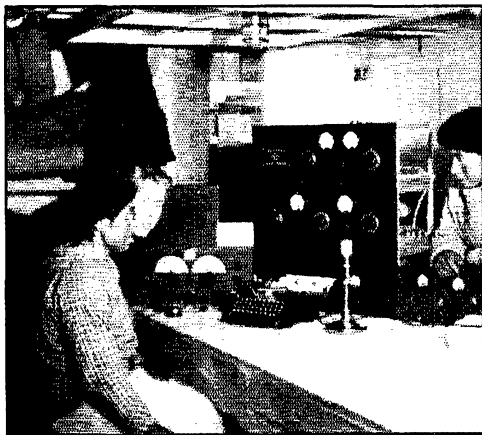

W10XDA EQUIPMENT HAULED OUT TO THE MAIN SALON

W2OJ (white face) is explaining what it is all about to a couple of Eskimos.

operator of W10XDA. In addition to the scientists, photographer and doctor, we also had on board last year eleven young students who acted as crew and helped to share the cost of the expedition. I've received a great number of requests for a description of the trip and the equipment used on the Schooner *Morrissey*, and since it would be almost impossible to reply individually to these inquiries, I thought that a story of the trip might prove of general interest in *QST*. As the 1938 expedition will probably be under way when this article appears, I hope more amateurs will become interested in keeping contact with W10XDA throughout the summer.

Because it is necessary to keep the radio installation very compact, equipment must be chosen with care. The power, 110 volts d.c., is derived from a bank of Exide cells which are kept charged

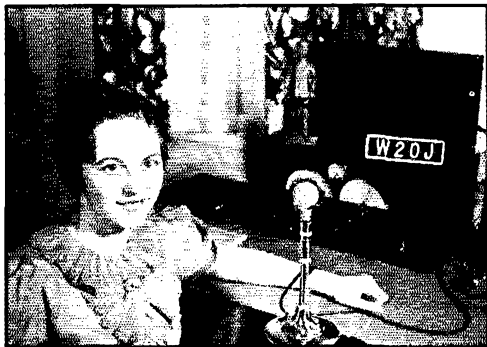

MRS. FOSS, W2OJ KEPT THE HOME STATION ON THE AIR

\* 8214 11th Ave., Brooklyn, N. Y.

unshorted and feeding it at the low end with EO-1 cable, we discovered that the antenna was not at all critical as to frequency and that the voltage and current nodes shifted about very conveniently. As a matter of fact, we used this one antenna over a range of 8,280 kc. to 17,310 kc. covering the spectrum of frequencies useful to us in the Arctic region.

As you all know, expeditions depend almost entirely on contacts with ham stations for the disposition of their traffic, and we were no exception. However, this year we planned on having a more organized traffic circuit, and since my wife, W2JZJ, had obtained her ticket the previous year, we planned to use our home station, W2OJ, as the New York base. We prepared by erecting beam antennas aimed to direct the maximum signal to the center of our proposed itinerary, or slightly north of Newfoundland. We hoped this would help make our contacts more consistent than those of the previous year. At W2OJ we had a 300-watt transmitter operating on 20-meter 'phone, and an RME-69 as the receiving unit. An arrangement was also made so that the output of the land lines could be retransmitted and the output of the receiver plugged into the land line.

On June 22nd, with hardly a square inch of space left on the decks of the *Morrissey*, we left



**VO1I AT HIS RECEIVING POSITION**

*This station with both Oscar and Marge operating is well-known to the 14-Mc. gang.*

New York for the Arctic. Stopping briefly at City Island to pick up some of the students who were to accompany us on this voyage, we sailed in high spirits.

After an uneventful trip, we arrived at Brigus, Newfoundland, Captain Bob's home town, and I took an overland jaunt to St. John's to visit this fellow VO1I whom we hear so often on the 20-meter band. VO1I, Oscar, as the gang on 20 knows him, is the chief operator of the Newfoundland Broadcasting System, and has the privilege



*Upper Left—"Ootah" and his daughter talking with W2OJ. "Ootah" is said to be the last living man who went with Peary to the North Pole. Upper Right—The "Morrissey" in pack ice at Cape York, N. W. Greenland. Bottom Left—Skirting a small iceberg is often ticklish business. Bottom Right—As a last resort a pair of pants can usually swing a deal when it comes to trading with the Eskimos.*

of locating his transmitter at the same QTH as the broadcast transmitter, which is two miles from his home. Over one twisted pair from his home to the station, Oscar manages to operate on 10, 20, 40 and 80 meters, shift frequency, run speech input, and completely remote-control his transmitter. The transmitter is 200 watts input to a pair of 203-A's and consists mainly of home-made parts such as home-wound Class-B transformers, etc. My brief visit with VOII proved to be very instructive as well as enjoyable.

Without further ado, we pushed off from Brigus for the frozen North. The weather remained remarkably fair, but before long we began to see the first signs of ice as we crossed Davis Strait to the southern coast of Greenland and approached Godhavn, which is the seat of the Danish Government in Greenland. Just before reaching Godhavn, we observed the midnight sun, and from then until our return to Godhavn, we had no darkness. In Godhavn, much fun was had trading with the Eskimos, obtaining souvenirs, but as we were in a hurry to get North, we stayed only long enough to take on fresh water. The icebergs became quite numerous then as we pushed gingerly through them for Cape York, where we were to visit the Peary Monument which Captain Bartlett erected a few years ago in memory of the grand old explorer, Robert Peary. As we neared the Cape the Monument, which is ninety feet high, could be sighted a long way off by virtue of its bright metal cap reflecting the sun.

Leaving Cape York our next objective was to secure two live walrus pups for the Chicago Zoo. We had to sail much farther North to obtain these, but finally we came upon a rare sight—a herd of several hundred walrus. Putting out in a whaleboat with the intention of lassoing a couple of pups, we met with unexpected resistance on the part of the bulls of the herd. Since we hadn't realized the potential danger of their tusks, we were frantically alarmed when one of them hooked his tusks over the gunwale of the whaleboat and would have successfully capsized us had not the boatswain had the presence of mind to clip him over the head with an axe. His strategy saved us from being dumped into the midst of these half-ton monsters, but meanwhile the other walrus had been beating their heads against the sides of the boat which caused it to leak like a sieve, so that we had to make a hasty retreat to the *Morrissey*. Those walrus didn't daunt us,

however, so we put out in the other whaleboat and this time were successful in capturing two of the pups without further damage.

We headed back for Disco Island and on the way ran across a large polar bear with her cub. Though we had no accommodations ready for a live bear, the opportunity seemed too good to miss, so we dispatched the mother and hauled the cub aboard. There was plenty of excitement while the cub whipped back and forth on the deck with just a single rope around his middle, and the rigging was the favorite—and safest—spot for observation. Finally we managed to bind him securely and we all felt more comfortable, but it was some time before the young walrus in their cage on deck were convinced that the bear they sensed wasn't hungrily roaming around.

During this part of the trip, radio conditions remained quite good on the 20-meter band until we reached our northernmost point, 78.45° N. Lat., which was the farthest north the *Morrissey* had ever been in all her exploration. At this time all radio signals faded out, and even the British broadcasting stations which had been putting in S9 signals on 19 and 25 meters were not heard from. Not one signal could be heard over the spectrum from 10 to 500 meters. This condition existed for two days but on the third day signals made a slow comeback. Later, we received information from the Bureau of Standards explaining this as due to storms in the ionosphere.

On our way down the coast of Greenland, we had contacts with W8XNR, at the University of West Virginia, with whom we conducted tests, and also contacted W2APT who took the bulk of our c.w. traffic for the remainder of the trip, and who is one swell operator, copying as many as 47 messages at a clip and asking for more!

We arrived at Godhavn, Disco Island, where we were to stay for a day or so and do a bit of trading with the natives. The Eskimos at Godhavn are really quite well educated, all but one of the radio operators being Eskimo and the Greenland newspaper being printed entirely by Eskimos. They were very friendly and invited us

to play them a game of football. Football à la Eskimo is a combination of football, soccer and rugby all rolled into one. Since all Eskimos are short and small, we thought we'd go a bit easy on them as we had the advantage of size and thought we surpassed them in skill. We tramped

(Continued on page 98)

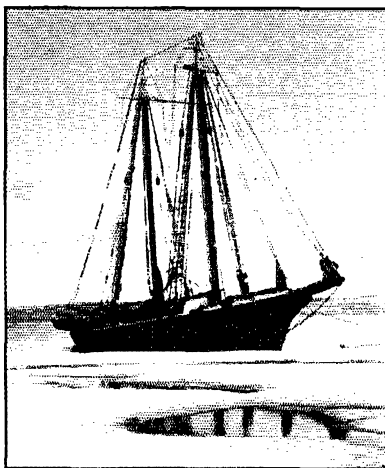

THE "MORRISSEY" IN ICE AT ETAH

# ● What the League Is Doing ●

League Activities, Washington Notes, Board Actions—For Your Information

---

## Membership Poll

At its May meeting, the A.R.R.L. Board of Directors ordered the taking of an advisory informative poll, through the columns of *QST*, as to the wishes of the members of the League concerning two requests proposed to be made of the Federal Communications Commission for changes in amateur regulations.

Here are the two proposed requests, and an explanation of them, and instructions as to how members of the League may express their wishes on each of these topics:

**Proposal No. 1—That the League request the Federal Communications Commission to extend as high as 60,000 kc. the rules regarding the quality and stability of signals now applying up to 30,000 kc.**

The question is whether the 5-meter band should not now have the same rules as are applied to 10 meters and up, concerning the stability of signals and their freedom from harmonics, spurious radiations generally, overmodulation, etc., and with the same requirement to use adequately-filtered direct-current power supply. The change in regulations would probably be effected by changing the stipulated figure in our Rules 381 and 382 to read 60,000 kc. instead of 30,000 kc. A great many amateurs now feel that the time has been reached, in our exploitation of the 56-Mc. band, when directly-modulated oscillators, unstable and creeping signals, wobulation and overmodulation should go. The Board of Directors wants to know whether you agree. There is some question whether the adoption of such rules would work an unfair hardship on the development of portable-mobile equipment or on general amateur work in localities remote from the congestion of large cities. What do you think?

**Proposal No. 2—That the League request the Federal Communications Commission to expand the "160-meter 'phone-band" allocation from 1800–2000 kc. to 1800–2050 kc. after the 1715–2000 kc. band is shifted to 1750–2050 kc.**

At this writing, our band is 1715–2000 kc. All of it is open to c.w., and 'phone may be used between 1800 and 2000 kc. As a result of the Habana administrative agreements, this band is soon to be changed to 1750–2050 kc. All of the band will still be open to c.w. and the portion from 1800 to 2000 will continue to be open to 'phone also. The question is about the new frequencies be-

tween 2000 and 2050. The Board of Directors wants to know whether you think that that last 50 kc. should be opened to 'phone or should be confined to c.w. The argument for confining it to c.w. is that there are times in the solar cycle when skip interferes with reliable relay work in the 3500–4000 band, at which times it would be very useful to have 50 kc. on either end of this lowest-frequency band free from 'phone interference. The argument for opening it to 'phone is that c.w. men do not make any great use of this band and would not adequately occupy the frequencies, whereas the 'phone band is crowded and would quickly populate the new sub-band and put it to use. What do you think?

**How to express yourself:** Here are two numbered proposals, on each of which the Board would like to have a yes or no answer from each licensed member of the League. Simply address one of your station QSL cards to the American Radio Relay League, West Hartford, Conn. At some convenient place on the face of the card, write, "I am in favor of proposal No. 1" if you would like to have the League endeavor to extend the usual rules about the quality of signals to cover the 5-meter band as well; or write, "I am not in favor of Proposal No. 1" if you are opposed to the League's making this endeavor. Below your answer on this question, write, "I am in favor of Proposal No. 2" if you would like to have the League request the assignment of the new frequencies 2000–2050 kc. to 'phone; or write, "I am not in favor of Proposal No. 2" if you prefer to see 'phone excluded from the use of these frequencies. If you do not have a station QSL card you may use a plain postcard, then signing your name and address and call if any.

Answers may not be qualified: the poll is on the question of approving or disapproving the projects as formulated by the Board. The poll is open only to members of the League. Responses, to be tallied, must reach the headquarters of the League by noon on September 1, 1938.

Here is an opportunity, arranged for you by the Board, to state your wishes on two pending matters. The Board hopes that there will be a large and immediate response.

## By-Laws Reprinted

The constitution and by-laws of the League have been reprinted to show all changes made up to the conclusion of the last meeting of the Board. Interested members may obtain a copy without charge upon application to the Secretary.

## Financial Statement

The League showed a good husky profit from operations during the first quarter of 1938, generally the best of the year. The detailed operating statement is here published for the information of the membership.

### STATEMENT OF REVENUES AND EXPENSES, EXCLUSIVE OF EXPENDITURES CHARGED TO APPROPRIATIONS, FOR THE THREE MONTHS ENDED MARCH 31, 1938

REVENUES			
Membership dues.....	\$15,182.18		
Advertising sales, <i>QST</i> .....	23,397.78		
Advertising sales, Handbook.....	10,450.98		
Newsdealer sales, <i>QST</i> .....	11,156.84		
Handbook sales.....	12,265.17		
Spanish edition Handbook revenues.....	3,820.95		
Booklet sales.....	3,355.36		
Calculator sales.....	365.63		
Membership supplies sales.....	2,617.37		
Interest earned.....	568.62		
Cash discounts received.....	519.20		
Bad debts recovered.....	439.70	\$84,139.78	
<i>Deduct:</i>			
Returns and allowances.....	\$ 3,010.08		
Cash discounts allowed.....	473.97		
	\$ 3,484.05		
Plus increase in reserve for newsdealer returns of <i>QST</i> .....	47.41		
	\$ 3,531.46		
Less exchange and collection charge credit.....	10.67	3,520.79	
Net revenues.....		\$80,618.99	
EXPENSES			
Publication expenses, <i>QST</i> .....	\$16,804.82		
Publication expenses, Handbook.....	8,166.39		
Spanish edition Handbook expenses.....	1,575.20		
Publication expenses, booklets.....	1,140.83		
Publication expenses, calculators.....	423.55		
Salaries.....	24,457.76		
Membership supplies expenses.....	1,455.80		
Postage.....	2,204.44		
Office supplies and printing.....	1,299.23		
Travel expenses, business.....	592.74		
Travel expenses, contact.....	348.02		
<i>QST</i> forwarding expenses.....	945.68		
Telephone and telegraph.....	729.14		
General expenses.....	891.88		
Insurance.....	572.31		
Rent, light and heat.....	1,153.38		
Provision for depreciation of furniture and equipment.....	325.72		
General Counsel expenses.....	431.49		
Communications Department field expenses.....	175.65		
Headquarters station expenses.....	44.07		
Alterations and repairs expenses.....	379.27		
Bad debts written off.....	27.00		
Total expenses.....	64,144.37		
Net gain before expenditures against appropriations.....		\$16,474.62	

## Board Meets

Last month we gave you an account of the important actions taken by the A.R.R.L. Board of Directors at its annual meeting in May. We now present the com-

plete minutes of the session. More than that, they are followed by the minutes of four meetings of the Executive Committee held during the preceding year, which the Board now orders printed for your information. Minutes are admittedly dry reading but you will learn much about the scope of work of your organization if you will study them carefully.

### MINUTES OF 1938 ANNUAL MEETING OF THE BOARD OF DIRECTORS, AMERICAN RADIO RELAY LEAGUE

May 13-14, 1938

In compliance with the Constitution and responsive to due notice, the Board of Directors of the American Radio Relay League, Inc., convened in regular annual meeting at The Hartford Club, Hartford, Conn., on May 13, 1938. The meeting was called to order by Dr. Eugene C. Woodruff, President, at 10:06 a.m., D.S.T. The roll was called, showing the following directors present:

Eugene C. Woodruff, President  
 George W. Bailey, Vice-President  
 Alex Reid, Canadian General Manager  
 Bennett R. Adams, Jr., Southeastern Division  
 E. Ray Arledge, Delta Division  
 Charles E. Blalack, Southwestern Division  
 Hugh L. Caveness, Roanoke Division  
 Ralph J. Gibbons, Northwestern Division  
 Wayland M. Groves, West Gulf Division  
 Kenneth T. Hill, Hudson Division  
 J. L. McCargar, Pacific Division  
 W. Bradley Martin, Atlantic Division  
 R. H. G. Mathews, Central Division  
 Percy C. Noble, New England Division  
 Floyd E. Norwine, Midwest Division  
 Edward C. Stockman, Rocky Mountain Division  
 Fred W. Young, Dakota Division

Thus all divisions were represented. There were also present Secretary K. B. Warner, Treasurer A. A. Hebert, Communications Manager F. E. Handry, General Counsel Paul M. Segal, Assistant Secretary A. L. Budlong, Assistant Secretary Clinton B. DeSoto and, as technical adviser to the Board, George Grammer, Assistant Technical Editor of *QST*. At the invitation of the Board there was also in attendance, as a non-participating observer, Alternate Director Raymond E. Macomber, Atlantic Division.

On motion of Mr. Caveness, after discussion, the minutes of the 1937 annual meeting of the Board of Directors were approved in the form in which they were issued by the Secretary.

On motion of Mr. Noble, unanimously VOTED that the annual reports of the officers to the Board of Directors are accepted and the same placed on file.

On motion of Mr. McCargar, unanimously VOTED that the election of President and Vice-President is placed as the last item on the agenda for this meeting.

On motion of Mr. Hill, after discussion, VOTED that all acts performed and all things done by the Executive Committee since the last meeting of the Board, and by it reported to the Board, are ratified and confirmed by the Board as the actions of the Board. Mr. Young requested that he be recorded as voting opposed.

On motion of Mr. Caveness, unanimously VOTED that the Board, having considered its mail act in which it decided to hold the next annual meeting of the Board in May, as usual, and there to further consider the question of national conventions, now ratifies the action taken and decides to take this action as of September 13, 1937.

On motion of Mr. Martin, unanimously VOTED to defer until the morrow, May 14th, receipt of the report of the Membership Committee of the A.R.R.L. Board.

On motion of Mr. Bailey, unanimously VOTED that the report of the Planning Committee is received and that consideration of its recommendations is deferred until the morrow.

Mr. Reid presented his report as Canadian General Manager. In turn, every division director rendered a report on the conditions in his division.

On motion of Mr. Blalack, unanimously VOTED that the Board now proceeds to a consideration of subjects raised by individual directors at their own initiative, by alphabetical order of divisions.

Proceeding to a consideration of such items, on motion of Mr. Mathews, of the Central Division, unanimously VOTED that the Communications Manager of the League is instructed to consider a revision of the present QSL-card handling system in order to provide relief from present detail work of divisional QSL Managers, in divisions where such relief is found necessary.

Moved, by Mr. Mathews, that By-Law 7 of the A.R.R.T. Constitution & By-Laws be amended by inserting after the second sentence thereof the following:

"Subject to the approval of the Communications Manager, the Section Communications Manager may appoint such Assistant Section Communications Managers as may be desirable."

But, discussion bringing out that such appointments are permissible under the terms of the present by-laws, Mr. Mathews, with unanimous consent, withdrew the motion.

Moved, by Mr. Mathews, that the first sentence of By-Law 12 be amended to read as follows:

"12. Any candidate for the office of Director must have been both a member of the League and a licensed radio amateur operator for at least four years during the five years last preceding the receipt by the Secretary of his petition of nomination, as hereinafter provided."

But after extended discussion, the yeas and nays being ordered, the said question was decided in the negative: Whole number of votes cast, 16; necessary for adoption, 12; yeas, 5; nays, 11. Those who voted in the affirmative are Messrs. Adams, Arledge, Mathews, McCargar and Young; those who voted opposed are Messrs. Blalack, Caveness, Gibbons, Groves, Hill, Martin, Noble, Norwine, Reid, Stockman, and Bailey. So the motion was rejected.

On the question of amending the by-laws in such fashion as to permit the holding of national conventions, moved, by Mr. Mathews, to amend By-Laws 48 and 50 as follows:

In By-Law 48, after the word "Division," add the words "or Divisions." In By-Law 50, amend the first clause of the first sentence to read "Before a division convention is held." After the third sentence, add a new sentence, "Before a convention of all or a group of Divisions is held, the same shall receive the approval of a majority of the Directors concerned." In the fourth and final sentence of By-Law 50, eliminate the word "such."

During this discussion the Board recessed for luncheon at 12:57 p.m., reconvening at 2:29 p.m., with all directors and other officials in attendance. After further discussion Mr. Mathews, by unanimous consent, withdrew the motion. Moved, by Mr. Mathews, that the by-laws be amended by the adoption of a new by-law to follow By-Law 50 and to be known temporarily as By-Law 50a, as follows:

"50a. Notwithstanding the provisions of By-Laws 48-49 and 50, the Board of Directors may, at any meeting, authorize or direct, upon such terms as it may prescribe, the holding, as a national convention, of a meeting of persons interested in amateur radio from throughout the operating territory of the League."

The yeas and nays being ordered, the said question was decided in the affirmative: Whole number of votes cast, 16; necessary for adoption, 12; yeas, 16, nays, 0. Every director voted in the affirmative except the Chair, who did not vote. So the new by-law was adopted.

Moved, by Mr. Mathews, that, pursuant to the amendment just adopted, this Board authorize a national convention to be held in the fall of this year at Chicago, Ill., in accordance with the request of the Chicago Area Radio Club Council and under such regulations as the Board may provide. But, after discussion, with unanimous consent, Mr. Mathews withdrew the motion. On the further motion of Mr.

Mathews, VOTED that this Board authorizes a national convention to be held in the fall of this year at Chicago, Ill. Mr. Gibbons requested to be recorded as voting opposed.

Moved, by Mr. Mathews, that the application of the Chicago Area Radio Club Council to hold a national convention in Chicago be now considered. After discussion, on motion of Mr. Bailey, unanimously VOTED that a special order is made of this subject for 9:30 a.m. the following day, to consider a draft contract between the Board and the Council to be prepared by General Counsel Segal and Mr. Mathews.

On motion of Mr. Mathews, unanimously VOTED that the sum of thirty-two hundred dollars (\$3,200.00) is hereby appropriated from the surplus of the League, as of this date, for the purpose of defraying the expenses of holding this meeting of the Board of Directors, any unexpended remainder of this sum to be restored to surplus.

Moved, by Mr. Young, that the Board direct the editor of QST to publish not more than one letter each issue signed by any director, or which he approves by indicating with a footnote which he signs, providing a director may care to use the space; the editor may refuse to publish a letter only in case that he judges it to be libelous. But, after discussion, the said motion was rejected, Messrs. Young and McCargar asking to be recorded as having voted for adoption.

Moved, by Mr. Young, and seconded by Mr. Gibbons, that the Board request the Federal Communications Commission to make a reasonable increase in the assignment of frequencies to be used for A-3 emission in the 3500-4000 kc. amateur band. But, after discussion, by unanimous consent Mr. Gibbons withdrew his second. No other second occurring, the motion fell.

On motion of Mr. Arledge, after discussion, unanimously VOTED that there is hereby appropriated from the surplus of the League, as of this date, the sum of one thousand dollars (\$1,000.00) for the purpose of defraying the traveling expenses of the Section Communications Managers of the League within the continental limits of the United States and Canada to attend their respective divisional or state conventions once yearly; reimbursement to be made at the rate of two cents per mile via the shortest commonly-traveled route, plus one night's hotel accommodation at \$2.50, and an allowance of \$2.00 for convention registration fee; allowance of these expenses to be subject to approval by the Communications Manager upon examination of detailed report of the activities of the Section Communications Manager at such convention, to be submitted with his expense account; any unexpended remainder of the said appropriation to be restored to surplus.

Moved, by Mr. McCargar, that Article III, paragraph 2, of the Constitution, be amended to read as follows:

"2. The President and Vice-President shall be elected by the voting membership of the League in the manner provided in the By-Laws and shall hold office for two years or until their successors are elected and qualified. The Secretary, the Communications Manager and the Treasurer shall be appointed by the Board."

The said motion was ruled out of order by the Chair on the grounds that the required legal notice had not been given; but, on appeal, the decision of the Chair was reversed. After discussion, the yeas and nays being ordered, the said question was decided in the negative: Whole number of votes cast, 16; necessary for adoption, 12; yeas, 4; nays, 12. Those who voted in the affirmative are Messrs. Adams, Arledge, McCargar and Young; those who voted opposed are Messrs. Blalack, Caveness, Gibbons, Groves, Hill, Martin, Mathews, Noble, Norwine, Reid, Stockman and Bailey. So the motion was rejected.

Moved, by Mr. McCargar, that whereas the President and Vice-President are not elected by the members and do not represent any division of the League, the Constitution be amended to provide that neither the President nor Vice-President has any voting power except where it is necessary for either of these officers, when presiding at Board meetings, in order to break a tie vote, and that only division directors and the Canadian General Manager have voting power at Board meetings except as indicated above. After discussion, unanimous consent being given, Mr. McCargar withdrew

the motion and moved to amend Article IV, paragraph 1, of the Constitution by adding at its end the following new sentence:

"Only members of the Board elected by members of the League may vote on matters before the Board except that, when acting as presiding officer, the President or Vice-President may vote to break a tie vote."

The yeas and nays being ordered, the said question was decided in the negative: Whole number of votes cast, 15; necessary for adoption, 12; yeas, 6; nays, 9. Those who voted in the affirmative are Messrs. Adams, Arledge, Blalack, McCargar, Stockman and Young; those who voted opposed are Messrs. Caveness, Gibbons, Groves, Hill, Martin, Mathews, Noble, Norwine and Reid. The President and Vice-President did not vote. So the motion was rejected.

On the motion of Mr. McCargar, VOTED that all minutes of the Executive Committee meetings shall be incorporated in the minutes of the Board of Directors meetings and published in QST.

Moved, by Mr. McCargar, that a complete and unaltered verbatim stenographic report be taken of the proceedings of the Board of Directors meetings, and that copies be made available to the members on demand. But, after discussion, the said motion was rejected.

Moved, by Mr. McCargar, that all League expenses be submitted to the Board in budget form, for consideration and incorporation in a budget adopted by the Board. But, after discussion, the said motion was rejected.

Moved, by Mr. McCargar, that the membership of the League be organized into local units similar to other societies. But, after discussion, the said motion was rejected.

Moved, by Mr. Caveness, to amend By-Law 47 by shifting the item now reading "(4) Appointments and Elections" to be the last item in the tabulation thereof. On motion of Mr. McCargar, VOTED, 9 to 6, to amend the said motion by incorporating therein a provision for the insertion of a new item of business to be known as "Directors' Motions," to follow the item "Reports of Division Directors." The question then being on the adoption of the amended motion, the yeas and nays were ordered and the said question was decided in the affirmative: Whole number of votes cast, 17; necessary for adoption, 12; yeas, 17; nays, 0. Every director voted in the affirmative. So By-Law 47 was amended to read as follows:

"47. The regular order of business at meetings of the Board of Directors shall be as follows:

- (1) Roll-call.
- (2) Consideration of Minutes of last meeting.
- (3) Reports of Officers.
- (4) Ratifications.
- (5) Special Orders.
- (6) Reports of Standing Committees.
- (7) Reports of Special Committees.
- (8) Report of Canadian General Manager
- (9) Reports of Division Directors.
- (10) Directors' Motions.
- (11) Unfinished Business.
- (12) New Business.
- (13) Appointments and Elections.

The above order or any part of it may be suspended by a two-thirds vote at any meeting."

Moved, by Mr. Caveness, that By-Laws 19 and 27 be amended by altering the date stipulated in the first sentence of each by-law to read "twentieth day of October" in each case instead of "first day of November." The yeas and nays being ordered, the said question was decided in the affirmative: Whole number of votes cast, 17; necessary for adoption, 12; yeas, 17; nays, 0. Every director voted in the affirmative. So the by-laws were amended.

On motion of Mr. Caveness, unanimously VOTED that the sum of three thousand three hundred and seventy-five dollars (\$3,375.00) is hereby appropriated from the surplus of the League, as of January 1, 1939, for legitimate A.R.R.L. administrative expenses, said amount allocated to the Canadian General Manager and to the Division Directors as follows:

Canadian General Manager.....	\$250.00
Atlantic Division Director.....	200.00
Central Division Director.....	300.00
Dakota Division Director.....	200.00
Delta Division Director.....	200.00
Hudson Division Director.....	200.00
Midwest Division Director.....	225.00
New England Division Director.....	200.00
Northwestern Division Director.....	250.00
Pacific Division Director.....	250.00
Roanoke Division Director.....	200.00
Rocky Mountain Division Director.....	200.00
Southeastern Division Director.....	200.00
Southwestern Division Director.....	250.00
West Gulf Division Director.....	250.00
	\$3,375.00

any unexpended remainders of these funds at the end of the year 1939 to be restored to surplus.

Moved, by Mr. Stockman, that there be incorporated in all members' copies of QST, all section reports submitted for publication by the SCM's of the United States and Canada. But, after a discussion of the sectionalized printing of QST, the said motion was rejected.

Moved, by Mr. Adams, that the annual reports of officers and the tentative agenda for annual Board meetings be placed in the hands of directors by April 1st of each year. But, discussion developing that the Board had already issued orders on this subject, Mr. Adams, with unanimous consent, withdrew the motion.

On the question of better control of A.R.R.L. conventions, after discussion, on motion of Mr. Blalack, VOTED that the Secretary and Communications Manager are directed to draft a complete outline of desirable rules for the government of A.R.R.L.-sponsored conventions, said outline to be submitted to the Board for its consideration and recommendations.

The Board recessed for dinner at 6:27 P.M., reconvening at 8:00 P.M. with all directors and other officials in attendance.

On the question of appropriating funds for the completion of the headquarters station W1AW, after extended discussion and examination of accounts and estimates, on motion of Mr. Bailey, VOTED that there is hereby appropriated from the surplus of the League, as of this date, the sum of eleven thousand dollars (\$11,000.00) for the purpose of defraying the expenses of completing the headquarters radio station W1AW, in accordance with a special report made to the Board by the Communications Manager, any unexpended remainder of this sum to be restored to surplus; and that the Board expresses to Communications Manager Handy its appreciation for his splendid execution of this task, a credit to the memory of Hiram Percy Maxim. Mr. Young asked to be recorded as voting opposed.

General Counsel Segal and Secretary Warner reported orally to the Board in supplementation of their written report concerning the Cairo international radiotelegraph conference, and were interrogated by various members of the Board. On motion of Mr. Mathews, unanimously VOTED that the Board expresses its appreciation to Messrs. Segal and Warner for a very complete and successful job at Cairo.

On motion of Mr. Gibbons, the Board, by unanimous vote, extended a cordial expression of thanks and appreciation to the QSL Managers and to the Standard Frequency Stations for their splendid services to amateur radio.

Moved, by Mr. Norwine, that the Board refrain from adopting any policy tending to confine speaking over amateur radiotelephone stations to licensed operators only. But, after discussion, Mr. Norwine, unanimous consent being given, withdrew his motion. After further discussion, on motion of Mr. Gibbons, the subject was laid on the table.

On the desirability of seeking an amendment of regulations to preclude the operation of amateur television transmitters in the 1.7- and 56-Mc. bands, after discussion, on motion of Mr. Young, unanimously VOTED that the Board requests the Federal Communications Commission to amend the amateur regulations in such manner as to delete the

(Continued on page 76)

# Some Faces at the 1938 A.R.R.L. Board Meeting

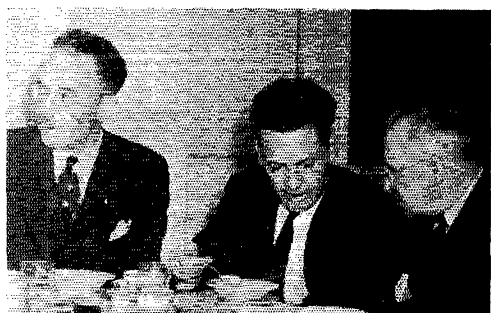
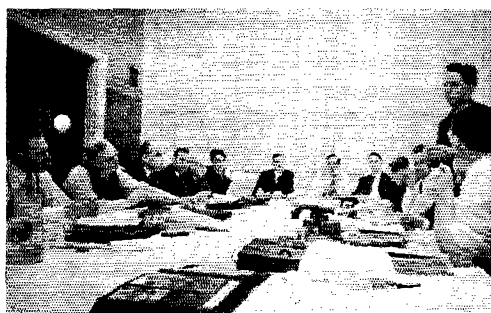

*Candid shots by Paul Segal, general counsel and unofficial photographer-extraordinary to the Board, grabbed at the 1938 meeting. Names down the columns, left-hand one first: The C.G.M., Alex Reid, and Mathews, south side; Arledge in foreground, then Caveness and Blalock; deSoto absorbs, Hebert smiles; luncheon corner with Woodruff, Warner and Segal. Next column: Young addresses a warm afternoon session; Warner and Young at the secretary's corner; "Soupy" Groves eats soup, flanked by Hill and Hebert; concentration by Mathews, Reid, Bailey and Noble.*



# The "QSL Forty" on 14 Mc.

## Further Developments in the Popular L.P. Transmitter

By Fred Sutter,\* W8QBW-W8QDK

AMONGST the fellows who have written me regarding the "QSL Forty" a number asked the question, "Will it work on twenty meters?" The way to find out, of course, is the usual ham way — try it and see; so with that idea in view I have done this and present the dope herewith.

The answer to the above question is, "certainly," with the qualifying statement, however, that the output drops 15 to 20 per cent. That is, with a 14,020-ke. crystal the transmitter lights a 25-watt Mazda dummy antenna to more than full brilliancy but does not light the 40-watt

No. 12 enamel and  $L_2$  3 turns. The new coil is  $2\frac{1}{4}$ " diameter, 2" in length,  $L_1$  having 8 turns of No. 14 enamel and  $L_2$  3 turns. The coil lengths given are for  $L_1$  only. The performance with either coil was the same, both on lamp load and connected to the antenna. The new coil differs slightly in construction, it will be observed, from the original coil shown in the February article. The lower bakelite strip is  $\frac{5}{16}$ " thickness and the banana plugs screw into 6-32 holes tapped into this strip, thus doing away with the aluminum brackets. If anyone has made a drilling template as recommended he can use it, skipping every other hole and thus making the turn spacing  $\frac{1}{4}$ " instead of  $\frac{1}{8}$ ".

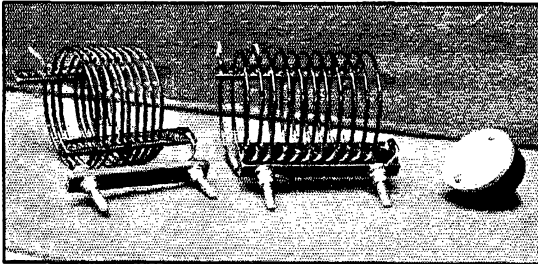

ALTERNATIVE 14-MC. COILS FOR THE "QSL FORTY"

lamp quite fully. The plate current drops from 170 ma. to about 140 ma. when the transmitter is coupled to an 80-meter half-wave Zepp with 55-foot feeders. Without going into too great refinement of measurement I should say that the input is about 62 watts and the output about 33 watts on 14,020 kc., and it might be added that probably the 33 watts will give a better account of themselves on 20 meters than 40 watts will on 40 meters.

The crystal current appears to be safely within the 150 ma. rating of the Bliley HF2 14,020-ke. crystal which was used, so far as might be determined from the pilot bulb (6.3 v., 150 ma.) in series with the crystal. This burns a fairly bright yellow on load and about normal brilliancy not loaded.

### COILS

Two different coils were tried, as shown in the photograph; one was a cut-down experimental 40-meter coil and the other a newly-designed coil. The specifications are as follows; cut-down coil,  $2\frac{1}{4}$ " diameter,  $\frac{3}{4}$ " length,  $L_1$  having 6 turns of

\*1000 Kensington Road, Grosse Pointe, Mich.

### VOLTAGES

The same plate and screen voltages used in the "QSL Forty" were employed, namely 450 and 350 volts. Possibly some slight improvement would result from changing the screen voltage a little, but in ordinary use, changing bands, this would hardly be worth bothering about. Anybody who is curious can try it and see.

### OSCILLATION

Not the slightest difficulty was encountered in securing oscillation. The crystal did its stuff precisely as smoothly as the 40- or 80-meter crystals.

(Continued on page 100)

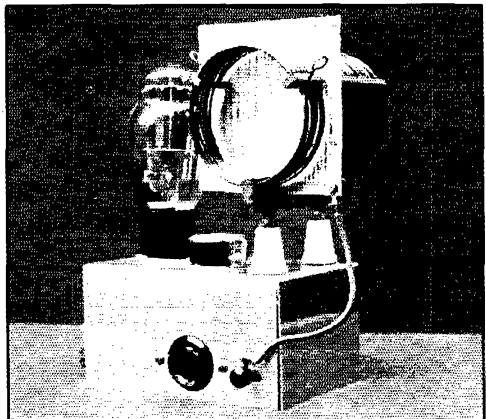

A SIMPLE AND EASILY-MADE FARADAY SCREEN

It can readily be used on other types of transmitters as well as on the "QSL Forty."

# A Ten-Meter Rotatable Alford Beam

Extended Double Zepp and Reflector Requiring No Special Supports

By Don C. Wallace,\* W6AM

Here is an "experience story" on a ten-meter directive antenna following the principles outlined by W2NB in June QST. It has been in use long enough for a real idea of its capabilities to be obtained. If you already have an ordinary antenna of sufficient height, do as W6AM does and hang one of these from it.—EDITOR

WHEN Hugo Romander, W2NB, was here three years ago, we decided that a twenty-meter schedule once a week was desirable. To facilitate contact, a twenty-meter beam was put up during Hugo's visit and this beam has been successful in maintaining 100 per cent weekly QSO's with New Jersey throughout the entire three years.

Since that time later developments, particularly the Alford principle of beam construction,<sup>1</sup> have come forth and it was deemed advisable to try one of these for ten-meter work. Although Hugo had suggested that the antenna be put up horizontally, it was decided as a starter to make it vertical so it could be rotated easily.

The complete antenna consists of an extended double-Zepp<sup>1</sup> and reflector, mounted on spreaders as shown in Fig. 1. It can be suspended from any antenna now in existence, inasmuch as the overall length (or height if it is to be considered as such) is only 44 feet, approximately. Any antenna that is 50 feet or more high readily can be adapted as a support. Two swordfish swivels (which hold 260 lbs.) allow the unit to rotate very nicely. At present the rotation is accomplished simply by throwing the two-pound weights, which are tied to light ropes at the bottom, into different bushes. This holds the antenna in place and it is quite steady even in a heavy wind.

## TUNING

The construction is such that the entire antenna can be made on the ground, then suspended horizontally at a height of say 8 or 10 feet above the ground. If it is built in this manner, the tuning can be done with a stepladder and later the entire beam hoisted into its final position.

Although slightly better tuning might be secured if a little more time were spent on it, the antenna has worked very well with the following procedure. With the unit in a horizontal position just a few feet above the ground, the transmitter was hooked on any aerial which happened to be in the vicinity so that radiation would occur at

28,600 kc. First the radiator wires were tuned to resonance, with the quarter-wave matching stub at the bottom disconnected. Resonance was secured by moving a 6-inch shorting bar along the radiator tuning stub at the center until the maximum reading occurred in a thermo-couple r.f. meter in the bar. Then the quarter-wave matching stub at the bottom of the beam was attached and the 6-inch shorting bar on it was moved back and forth until maximum reading again occurred on the meter. Then the meter was taken out of circuit and placed in the shorting bar for the tuning stub for the reflector wires, and the procedure repeated until maximum current existed in the reflector.

Next, the 600-ohm line to the station was connected, as shown in Fig. 1, on the quarter-wave matching stub, and moved along until the meter in the shorting bar in the radiator tuning stub showed maximum current. It was noted that this point, which was 16 inches from the closed end of the matching stub, coincided with the point where a resistive load was indicated at the transmitter; in other words, where the resonance dip on the final tank condenser was at the same setting regardless of whether or not the 600-ohm line was connected. Finally, the meter was again placed in the shorting bar in the reflector tuning stub and the latter was once more adjusted for maximum current.

Then the whole array was hoisted vertically (all the tuning up to this point had been done with it in a horizontal position) and corrections of 1 inch made to see if there was any change. The change was so slight as to be negligible, so for all practical purposes the antenna can be tuned up at a distance of say 8 or 10 feet above the ground in a horizontal position by use of a stepladder. This is considerably more convenient than hoisting the whole system up and down each time a change is made.

The dimensions of the radiating sections are the same as the reflecting sections and corrections are made to the stubs rather than by changing the lengths of the active wires. It also will be noted that the radiating section is approximately 0.66 wavelength, which closely resembles the top

\* 4214 Country Club Drive, Long Beach, Calif.  
<sup>1</sup> Romander, "The Extended Double Zepp Antenna," QST, June, 1938.

RESULTS

When tests were made with stations using receivers equipped with db meters, the change from maximum to minimum (front-to-back ratio) varied between 12 db and 18 db. Tests have been made with stations as far away as England and Asia on the rotatable feature and their reports agree quite closely with those in the immediate vicinity. The ratio would be greater if the antenna were horizontal, no doubt, but the vertical position is very convenient for rotation, inasmuch as the turning radius is but 3½ feet for the whole system. In fact it takes but little more space than a plain vertical antenna.

The operation of the antenna is indicated somewhat by the following: From April until September, W6AM tried to be on the air three times a week, whenever travel permitted. K6MNV sent a daily call from Hawaii just prior to 3 P.M., P.S.T., listened for United States stations between 3:00 and 3:05, and then reported all stations heard. On many days only three or four stations in the United States could be heard, while on some days fifteen or twenty might be reported. W6AM was, nine times out of ten, very close to the loudest one reported, and in many cases the loudest.

The important thing was this: Only once during that entire time of supposedly poor ten-meter conditions was it impossible both to hear and get a report from K6MNV. On the particular day when the report was not forthcoming, a station in Denver was worked immediately thereafter, thus showing that ten meters has been consistent every day the station has been in operation during the months from April to September. This, we feel, is in a large measure due to the operation of the beam. Prior to this, such results were far from obtainable at this location.

With the beam properly pointed there has never been an exception to the rule that W6AM is louder than any ten-meter 'phone within a radius of 100 miles from the station. It is of course true that a great many of the stations get into the same localities very well and are using less power, but the fact that the system does work the way it's supposed to—namely, a one-kilowatt transmitter with a four-element beam—indicates its utility for ten-meter work. We plan on duplicating it for five meters (with additions to fill up the space available) and to make some sort of twenty-meter rotary beam, using some of the principles as outlined by Alford.

It is equally as useful in receiving as in transmitting and, like other beam antennas, when used for receiving indicates which stations are getting the transmitter best. Consequently, the user immediately knows just whom to call.

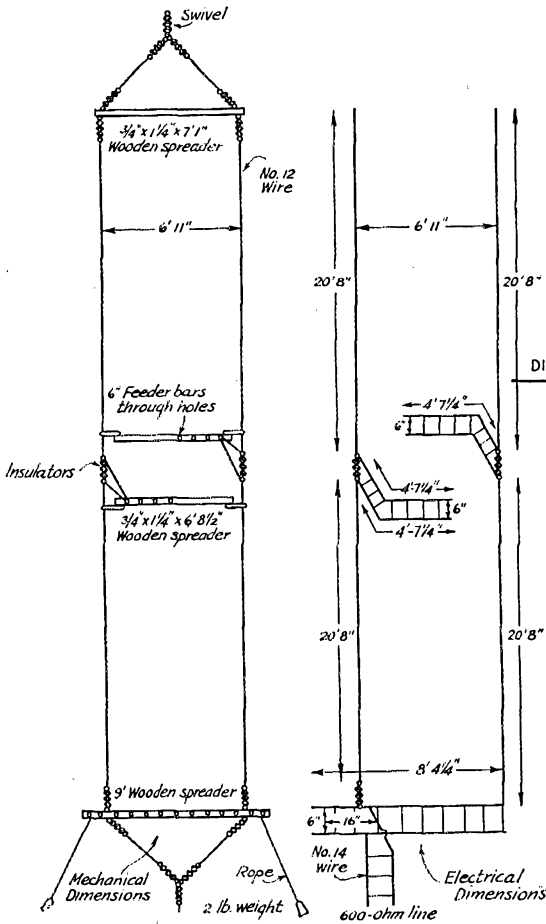

FIG. 1—THE ROTATABLE ALFORD ANTENNA AT W6AM

Designed for a frequency of 28,600 kc., it is useful over most of the 10-meter band. Antenna at the right, parasitic reflector at the left.

figure for the maximum output radiator used by broadcast stations. The length gives the proper spacing as outlined by Alford; that is, two half-wave radiating sections, considered as such, should be spaced 0.28 wavelength. Of course all the dimensions are subject to "end effect"; corrections are automatic when the tuning stubs in both radiator and reflector wires are adjusted.

The beam described here was designed for 28,612 kc. before the ten-meter 'phone band was shifted. It works noticeably better on this frequency, although no particular reduction in loading is noticed up to 28,500 or 28,700. It is still useful at 29,000 but diminishes in utility beyond that because of improper matching. On the whole it can be considered exceptionally good for about one-quarter of the band and useful over the whole band.

# The California Flood

By Walter W. Matney,\* W6EQM

*Much additional detail concerning the performance of amateur radio during California's March flood disaster has been made available since the initial report in April QST. This story by Mr. Matney, which has been augmented by several individual reports received at A.R.R.L. Headquarters, comprises a reasonably complete supplement on the splendid service rendered by Southern California operators.—EDITOR.*

FOR the benefit of our Eastern friends who, when they have floods, expect to have ample warning, indicated by rising rivers, and plan upon being inconvenienced for a week or so while the waters subside, we should like to describe a Southwestern "flood." In a land of "dry" rivers the lines of drainage are generally defined by dusty, gravel-covered channels, which, even during the spring months, seem far, far too wide and deep for the small stream flowing down the center. Of course, the surface flow is not any reliable indication of the total flow of the river, as, due to the peculiar porous substrata, there is a continuous, all-year flow, oftentimes extending for many feet below the apparent surface of the "river" bed. But, during storm periods the picture changes abruptly. In a short time, often not more than a few minutes, these channels become raging torrents from bank to bank, carving great indentations in the banks, overflowing to form new auxiliary channels, and destroying everything in their paths. Of late years, much splendid work has been done in the construction of flood control dams and debris basins, which under ordinary conditions are fully capable of controlling the huge volumes of water which are headed for the ocean, with a drop of 2000 feet or more in 25 miles. On March 2nd, these dams had been constantly filling for three days, in order to hold back the torrents which otherwise would be added to those pouring into the channels at lower levels. It became necessary, in some instances, to release water at the rate at which it was flowing into these reservoirs, in order to maintain the proper safety factor.

The Los Angeles metropolitan area suffered a minimum of damage in comparison with other

\* Assistant Director, A.R.R.L. Southwestern Division, 6008 Monte Vista Street, Los Angeles, Calif.

districts. In the suburbs and in adjacent cities and towns damage was heavy, accompanied by loss of life, flooding of homes, complete disruption of transportation and complete destruction of all communication facilities, except radio, to points outside the stricken area and even within the limits of the same towns. Again, that Amateur Radio proved its value in "public interest, convenience, and necessity" had not been overestimated.

Isolated communication line failures began in the morning of Wednesday, the 2nd. Many amateurs inspected their portable equipment, began looking for emergency power supplies, and offered their services to the various official agencies. The result was that several stations were in actual contact at the time that flood crest was reached in the higher portions of the area, around 3:00 P.M. Many locations in the hills and mountains

reported rainfall of over 26 inches for the four days preceding. As the runoff descended, increasing number of reports were received of critical conditions, until practically all of Los Angeles, San Bernardino, Riverside, Ventura, San Diego and Orange Counties were known to be suffering the worst flood of record for that territory.

Amateurs then went into full-fledged action as one by one the lines failed. Law and Order groups, the Red Cross, the railroads, power

concerns, broadcast systems, press services and many other important agencies were served. This condition of paralyzed land line service existed for several days, during which time scores of amateur stations were in constant operation, many maintaining continuous watch for periods of 72 hours or more.

On 1.75 Mc. on voice and code, was an impressive array of stations, all cooperating. There were W2FIO/6, W2KNZ/6, W6AAR, AYP, BHP, BVA, BXQ, CGY, CIW, CQK, CUY, DEP, DFO, DZR, ETI, EWV, EYJ, EZA,



"CLIFF" AND "OLLIE" KIMBALL, W6MMV AND W6PLN RESPECTIVELY

*Both gave splendid service in emergency nets on both 3.9- and 1.75-Mc. 'phone during the Southern California flood.*

FJ, GKX, GNU, GOU, GVX, HBD, HDR, HUX, IGO, ILL, IVG, JFM, JJB, JMP, JPN, JWY, KJP, LFA, LFC, LMF, LVL, LVX, MBF, MCI, MDQ, MEP, MGQ, MHD, MNC, MPR, MQS, MTL, MWG, NAH, NFB, NGQ, NLS, NIU, NNJ, NNP, NPQ, NRD, NSW, NWG, NWM, NXW, OJC, OJL, OLD, OLM, ONC, OPF, OWF, OXR, OZV, PEP, PFG, PDY, PMT, PNW, POV, RO, W7CEG/6. The individual story of each of the men who worked 1.75 Mc. would make many volumes, all well worth reading, but limited space allows us to mention but a few of the highlights. W6LVX took his portable equipment farther up into Big Tujunga Canyon close to the big dam that controls the water flow. W6AYF, a member of the Amateur Radio Emergency Council of Los Angeles, accompanied by W6BNO, carried his battery-powered 1.75-Mc. c.w. rig 12 miles over unbroken trail to Camp Currie, in the shadow of Mount Baldy, where 85 people were marooned without food and medical supplies. There they contacted W6IVG and W6MDX, located at the base of the canyon and in constant touch with the Uplands Police Department. Tragically humorous was the time, en route to the camp, when AYF lost his footing and slipped perilously close to the brink of a 25-foot fall into a roaring stream. A lucky tree branch saved him, but when he rejoined the posse, he found that he had lost his precious bug, which had been reposing in his hip pocket. Too late to go back, they continued on to camp, where, lacking any kind of key and after burning their fingers by breaking 300 volts, he, with the aid of W6BNO, contrived a key out of a table knife and a carpet tack. This was used for two days while handling emergency traffic!

The Mission Trail Net on 1.75-Mc. 'phone handled a large quantity of emergency traffic. In fact, traffic was so heavy it was necessary to operate in two groups, one on the regular net frequency of 1804 kc., the other on 1827 kc. Close contact was maintained with the Alameda County Police Station, KPDA, which monitored the net twice each hour until danger of loss of regular service was past. The XYL at W6HGN took down traffic and all information on a dictograph, while the OM did the operating. Stations cooperating with the Mission Trail Net included W6PGZ, W6ITH, W6NTU, W6LMF, W6HGN, W6NOG, W6OND, W6KUS, W6ZM, W6AM, W6OMC, W6PBQ, W6OUM, W6OVB, W6IGO, W6OJX, W6JUQ, W6HHE, W6ONU, W7FNJ, W6NQJ, W6JAC, W6JTE and W6BF.

The San Diego area was very well covered. W6LYY (3.9-Mc. 'phone), assisted by W6PGE, was one of the first on the air with emergency traffic, handling press for the *San Diego Union* with W6MEO, Los Angeles. W6MMV, assisted by W6PLN, and W6KW, aided by W6BHF, W6OAN, W6CNB and Louie St. Martin, were also outstanding San Diego stations. W6KW op-



FRED REINEKING, LOS ANGELES MANAGER, INTERNATIONAL NEWS PHOTOS, AND DON WALLACE, W6AM, AT W6AM

*This equipment was set up to transmit the first picture by facsimile from the affected area to W9QDA, Chicago.*

erated continuously for 27½ hours, W6LYY and W6MMV also putting in long stretches at their mikes. W6OVE on 1.75-Mc. 'phone, assisted by his XYL, handled large amounts of traffic, getting but little sleep during the emergency. W6BXQ (1983 kc.) at Laguna Beach provided an important relay point between San Diego (W6OVE and W6EWU, La Jolla) and Los Angeles (W6MQS). W6PFQ, San Diego, cooperated with this circuit. Outlets to San Bernardino were provided by W6NOL and W6FHQ. W6BEX, San Pedro, was also on the job. W6LYY and W6KW handled about 3000 words of press for the Associated Press, *San Diego Union & Tribune* and *San Diego Sun*. W6LIP, Beverly Hills, was northern contact for the *Tribune*. W6FQU/WLYF on 3.5-Mc. c.w. furnished the A.A.R.S. nets with San Diego contact, handling scores of messages and press via those channels. In addition to the stations mentioned the following were also active in handling San Diego communications: W6BWI, W6NDD, W6APG, W6MMW, W6GG, W6BMC, W6DBV, W6BZR, W6NOD, W6JRM and W6FGU. A fact worthy of mention is that W6OVE, W6LYY and W6MEO are all shut-ins.

On March 15th broadcast station KFSD in San Diego honored the San Diego amateurs for their flood work by a special fifteen-minute broadcast in which W6MMV, W6PLN, W6LUB, W6KW, W6EWU, W6APG, W6BHF, W6FQU and W6CNB participated.

W6CV and W6NRD, Redlands, proved of real value to that city. W6NRD on 1830-kc. 'phone acted as police broadcast station, Redlands police receivers being tuned to that frequency, as well as handling regular emergency traffic. W6CV operated on 3.9-Mc. 'phone handling dispatches for the Southern California Gas Co. and Southern California Edison Co. Principal contacts were with W6MHW, San Bernardino, W6MMV

and W6LYY, San Diego, W6MMW and W6GG, El Centro, W6MEO, Los Angeles, and W6BKY, Whittier. W6NRD was later moved to the Redlands Police Station, continuing broadcasts to police cars and maintaining a radio link to KSBC, the San Bernardino police transmitter. Clifford Vansel assisted in keeping a 24-hour service at W6NRD until sufficient wire service was restored. W6CV took over the KSBC contact when the line again went out. W6BFW, W6CMS and Ben F. Kessler assisted in the operation of W6CV, while L. R. Stephens, an S.W.L., performed an invaluable service in handling telephone calls and delivering messages. W6KJO, also of Redlands, was in operation on 3.5-Mc. c.w. W6CV is in receipt of a letter from the City of Redlands expressing appreciation for the work of radio amateurs during the disaster.

On 3.9-Mc. 'phone, the band was covered by stations handling personal messages for frantic relatives. Among the stations known to have actively engaged in official work were W6BKY, W6CAH, W6DPT, W6EAH, W6CV, W6GG (Southwestern Division A.R.R.L. Director), W6GM, W6BVA, W6EZA, W6LAK, W6LYY and W6MEO. W6GM did major work for the city of San Bernardino, which was practically totally inundated for a long period. W6MMV and W6MMW were active for two days without rest.

R.C.A.'s transmitting and receiving station at Huntington Park was washed out, leaving them without communication in and out of Southern California. Messages handled by W6ITH, Berkeley, led to the establishment of an emergency receiving post in the R.C.A. downtown Los Angeles office, which was used to receive "blind" from the San Francisco R.C.A. station. Frequent service messages via amateur radio advised whether transmissions from S.F. should be slowed down or speeded up, what messages were missed, requested repeats, etc. Amateur stations on the Los Angeles end were W6MEO, Los Angeles, on 3.9-Mc. 'phone and W2FPT/6, Beverly Hills, on 14-Mc. 'phone.

W6ILJ and W6KMI, Riverside, also cooperated in the handling of traffic for KSBC. W6ILJ, using 1.75-Mc. 'phone, was operated by Roy Heckman, Tom Patterson and Homer Deal, while W6KMI on 3.9-Mc. 'phone was manned by Julian Faas, A. H. Des-Mazes and Doris Harbaugh, assisted by Charles Hunter and Carlton Caldwell.

On 3.5 Mc. longer haul traffic was handled, much of it of the utmost priority. The military reserve organizations did wonderful work. A.A.R.S. members handled much important traffic. In the A.A.R.S. active nets were: W6AKW, ARO, AXN, BLD, BMC (WLVH), BPU (WLVI), BQI, CDA, CII, CVL, CZO, DH, DKN, DSB, DVD, EFK, EFY, FQU (WLYF), FS, GXM (WLMI), HAG, HIR, KDI, KNP, KSY,

KTQ, LLW, MBR, MRT (WLYD), MSN, MTR, MXO, NBD, NKR, NLL, ODQ, OIE, OJQ, OQH, PAQ, PJR, PGJ. Among those serving as control stations of the principal A.A.R.S. nets were W6FQU, W6MRB, W6LLW, W6BMC, W6BPU and W6FS. Non-A.A.R.S. members who assisted the A.A.R.S. nets included W6AOJ, CV, CVO, DHM, DOB, DQV, DSN, EK, ELC, EPM, ESA, FMJ, GQC, GSX, IY, KST, KNK, MQE, MBJ, MHW, MMW, NXO, PAV, PNH.

W6AKW, A.A.R.S., operated portable at the base of Little Rock Dam, near Palmdale, using W6KST's emergency outfit. His contacts were with W6CZO, W6AAN, W6GXM, W6BQI, W6LLW, W6NKR, W6HIR, W6MBR, and W6PJR, all on 3.5-Mc. c.w. Much important information was handled concerning conditions at the dam.

Two of the busiest stations during the flood were W6GXM/WLMI, Los Angeles, and W6MRT/WLYD, Victorville. Almost continuous contact was maintained between these stations. Operation was practically entirely with A.A.R.S. stations and nets. A continuous watch of 81 hours was maintained at W6MRT, ex-W6PAQ and Calvin Tabor acting as relief operators. Relief operators at W6GXM were W6CII/WLMH, W6OJQ, W6OQH and W6FJM. It was necessary to operate W6GXM on emergency power for a total of eight hours. At the request of stations KIIE of the Department of Water and Power, W6MRT established contact with W6DSB at Independence on 7 Mc. W6BLU, Big Creek, and W6CVL, North Fork, assisted in relaying information. W6MRT maintained hourly schedules with KIIE, W6GXM and W6DSB, handling traffic for the Department of Water and Power, Red Cross, Sheriff's office, railroads, bus companies, local papers and individuals. W6DSB kept these hourly schedules single handed for over 24 hours, materially aiding the restoration of power lines.

Lake Gregory Dam, above Victorville, a town of 3000 people and the home of W6MRT/WLYD, was reported as being on the verge of collapsing. It was arranged to blow the town's fire siren in the event of the dam's failure, so as to warn the populace. At about 7:00 P.M., March 4th, the siren was blown for a small fire in a store building. Some hysterical youth, in his automobile, drove madly up and down the streets blowing his horn and shouting, "The dam is out." A message was originated at W6MRT, routed through W6GXM/WLMI (S.C.M.) and W6BMC/WLVH to the San Bernardino police, where the condition of the dam was being carefully checked. An answer, to the effect that there was absolutely no danger, was returned within a few minutes, thus preventing what probably would have been a serious panic.

(Continued on page 82)

# A Versatile Remote-Control Circuit

Filament and Plate Control, Frequency-Changing, Speech, Monitoring and Overmodulation Indication on a Two-Wire Line

By Max L. Hilliard,\* W9WEE

HOW many times have we all carried on with our end of a ragchew only to find when we stand by that we have been hopelessly covered with QRM or have faded out of the picture. Also it is rather discouraging to call an elusive DX station and find when we stand by that he is calling our friend across town who

areas to minimize b.c.l. interference or to secure more adequate antenna facilities.

The remote control circuit described here provides complete control of a 'phone rig with the transmitter located at any reasonable distance up to several miles from the control point. The control circuit consists of only two wires between the

transmitter and control point, with the earth acting as a third conductor or common return for all circuits except the talking circuit which is full metallic. In this circuit the following features are provided:

- Talking circuit.
- Filament control.
- Plate control.
- Monitoring.
- Modulation checking.
- Frequency changing.

## DESCRIPTION OF EQUIPMENT

The circuit in detail is shown in Fig. 1. Transformers  $T_1$ ,  $T_2$ ,  $T_3$ , and  $T_4$  are 1:1 ratio transformers which match an impedance of approximately 500 ohms. The d.c. resistance of each of the four windings on each transformer is approximately 13 ohms and the particular type used is known as Western Electric No. 77-A repeating coil. Most telephone supply houses handle repeating coils suitable for this circuit, at a cost comparable to that of a good-grade audio transformer. In fact, ordinary audio transformers with the same electrical characteristics may be substituted, provided that the midpoints are brought out to permit transformers  $T_1$  and  $T_2$  to be wired as shown.

Transformer  $T_5$  in the modulation indicator, Fig. 2, is a filament transformer for the half-wave rectifier tube  $V_1$ . Both this transformer and the rectifier tube should be selected to withstand the

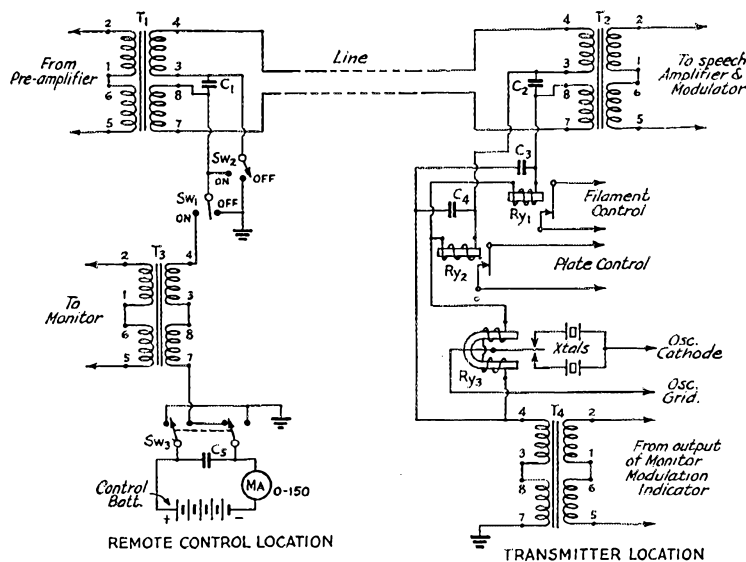

FIG. 1—CIRCUIT OF THE REMOTE-CONTROL SYSTEM

$C_1$ —0.1- $\mu$ fd. paper, 400-volt.  
 $C_2$ —4- $\mu$ fd. paper, 400-volt.  
 $C_3$ ,  $C_4$ —2- $\mu$ fd. paper, 400-volt.  
 $C_5$ —4- $\mu$ fd. paper, 400-volt.

$Sw_1$ ,  $Sw_2$ —S.p.d.t. toggle.  
 $Sw_3$ —D.p.d.t. toggle.  
 $Ry_1$ ,  $Ry_2$ ,  $Ry_3$ —Control relays; see text.  
 $T_1$ ,  $T_2$ ,  $T_3$ ,  $T_4$ —1:1 audio transformers with split windings; see text.

already has a W.A.C. certificate. If we could have had our receivers in operation while transmitting and told our rag-chewing friend to break in on us when the going got tough we might at least have saved our breath.

Effective break-in operation is usually not possible on medium- and high-powered 'phone rigs unless considerable separation exists between the receiver and transmitter. This of course necessitates remote control of the transmitter or receiver. Besides providing effective break-in operation, a remote control circuit permits the transmitter to be located away from congested

\* Room 1905, Telephone Building, St. Louis, Mo.

modulated plate voltage of the final amplifier plus a suitable safety factor.

Relays 1 and 2 are Western Electric No. 100-A telegraph line relays and are the type usually used in telegraph and railroad stations on Morse telegraph lines. They are d.c. relays having a resistance of 100 ohms each, and operate with proper adjustment over a current range of 25 to 100 ma. Any relay which will operate on a reasonable amount of current will work in this circuit. The resistance is not critical, but it is very important that Relays 1 and 2 have the same electrical characteristics in order that the talking circuit will not be unbalanced to ground.

Relay 3 is a Western Electric No. 215-FA polarized relay. The action of this relay is similar to a zero-center ammeter. Current flowing through the winding in one direction will pull the armature in one direction and when the polarity of the current is reversed the armature, or needle in case of an ammeter, will pull in the opposite direction. There are many types of polarized relays, which, while fundamentally the same, have characteristics that vary over a wide range. They usually operate on low current values of from 1 to 10 ma. and have a d.c. resistance of 500 to 1500 ohms or more. The effective resistance of this type of relay should be lowered when used in this circuit to 50 or 75 ohms by placing an external shunt across the winding. This shunt serves the dual purpose of lowering the resistance of the control circuit and lowering the value of current through the winding of the polarized relay. In case the crystal switching circuit is not desired, Relay 3 and Switch 3 may be omitted.

Relay 4 is also a sensitive d.c. relay with a d.c. resistance of from 100 to 1000 ohms, capable of operating on 5 to 10 ma. A polarized relay can be used to an advantage in this circuit because of the low operating current required. If a polarized relay is used, only one of the contacts will be required and the winding must be connected to pull the armature to the desired contact.

All of the relays described above have contacts which will carry only a small amount of current, and the voltage on the contacts should not exceed 200 volts. Relays 1 and 2 are intended to control other heavy-duty power relays, but the contacts on Relays 3 and 4 may be used to control their respective circuits directly.

The a.c. tone supply shown in the modulation indicator can be any source of a.c. tone such as an audio oscillator. The purpose of this tone is to indicate at the control point that a predetermined percentage of modulation has been reached.

#### OPERATION

Make certain that Switch 2 is in "off" position, and operate Switch 1 to "on" position. This will operate Relay 1 and close the filament circuits. Relay 3 will also be operated to one contact or the other, depending upon whether positive or nega-

tive battery is used as determined by the position of Switch 3. After the rectifier tubes have attained operating temperature, Switch 2 can be operated to the "on" position which closes the plate supplies and places the transmitter on the air. The transmitter is then controlled by Switch 2, Switch 1 being left in the "on" position when standing by. A close inspection of the circuit will reveal that some current is flowing through Relay 2 when Switch 1 is in the "on" position, even when

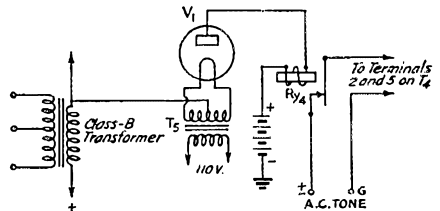

FIG. 2—OVERMODULATION INDICATOR

V<sub>1</sub>—Rectifier; any tube with insulation capable of standing twice the Class-C plate voltage.  
Ry<sub>4</sub>—See text.  
T<sub>5</sub>—Rectifier filament transformer, insulated for at least twice Class-C plate voltage.

Switch 2 is in the "off" position. The amount of current will be small, however, and no false operation will result if Relay 2 is adjusted to release when Switch 2 is in the "off" position.

In case it is desired to change crystals, operate Switch 2 to the "off" position and operate Switch 3 quickly. This will reverse the polarity of the control battery and pull the armature of Relay 3 to the opposite contact, thereby selecting another crystal. Switch 2 may then be operated as described above to place the transmitter on the air again. Obviously the crystals used should be sufficiently close in frequency to permit operation without retuning the transmitter.

#### EXPLANATION OF CIRCUIT

The talking circuit is full metallic, and when Switches 1 and 2 are in the "on" position it is ready for operation. The monitoring circuit is obtained by using both of the talking circuit wires in parallel, with the earth acting as a common return. The audio by-pass condensers around Relays 1, 2, and 3 and the control battery are to provide an audio path for the monitoring circuit. Condenser C<sub>2</sub> across the mid-points of transformer T<sub>2</sub> serves as an audio path for both the talking and monitoring circuits as well as a blocking condenser for direct current in the control circuit. Condenser C<sub>1</sub> across the mid-points of transformer T<sub>1</sub> also serves as a direct-current blocking condenser and is shorted out for talking purposes when Switch 2 is operated. This monitoring circuit in telephone usage is known as a grounded phantom. Any grounded circuit is inherently unbalanced and some noise may be expected. To offset this noise the monitor at the



transmitter should have a rather high output level.

If the resistance of each wire of the talking circuit together with Relays 1 and 2 is the same and good audio transformers are used, no interaction or cross talk should result between the talking, monitoring, or control circuits.

The control battery should be adjusted as required, the actual voltage depending upon the resistance of the control line, transformers and relays, and the operating current required. A small well-filtered power supply may be substituted for this battery if desired.

The modulation indicator is similar to the negative-peak indicator described in the *Handbook*. Relay 4 has been substituted for the meter, and a battery in series with the relay winding has been added. This battery may be adjusted so that the relay will operate at any predetermined percentage of modulation. A tap from any low voltage power supply may be used in place of this battery if desired.

When Relay 4 operates, the a.c. tone will be closed through to the monitoring circuit. The volume of this tone should be adjusted to a value somewhat higher than the monitor in order that it will be easily noticed in the monitor at the control point. Several methods of monitoring may be used at the control point. A combination of headphones and volume indicating meter is very satisfactory, as this permits both aural and visual monitoring. An a.c. voltmeter constructed from an 0-1 ma. milliammeter and a small copper-oxide rectifier makes a very satisfactory volume indicator for this circuit. If used it should be adjusted so that ordinary speech will operate it to about one-half scale on peaks, and the tone from the modulation indicator should be adjusted to operate the meter to approximately full scale.

The monitor at the transmitter should be stable and sufficiently selective to detect frequency deviations of any great magnitude. If such a monitor is used, frequency deviations will be detected by a loss of volume or no signal in the monitoring circuit at the control point. In most cases, of course, the remotely-controlled transmitter will be sufficiently close to the control point to permit additional monitoring of the signal over the air. In this connection it appears that the use of one of the recently described a.m.c. circuits in the speech amplifier will give further assurance that the modulation capability of the transmitter is not exceeded.

Where the control line is exposed to the elements or to power lines, suitable lightning arrestors should be installed at each end of the line. The wiring should be made as shown on Switches 1 and 2 in order that both sides of the line will be grounded when it is not in use. This minimizes the possibility of false operation should the control line become crossed with a foreign voltage. The control battery has been placed purposely at

the control point, because a ground on the control line might cause false operation if the battery were at the transmitter end.

While it is not the purpose of this article to discuss the speech characteristics of various types of lines, in general it will not be necessary to equalize the control line to secure a satisfactory frequency response for voice-only operation if the control line is only a mile or two long. On long lines, and more particularly on long lines located in cables, some equalization may be required if a range of frequencies as high as 5000 cycles is desired. In case equalization is necessary, standard so-called loss circuits are usually used. These circuits are merely band-pass filters consisting of an audio choke coil and parallel condenser tuned to a frequency slightly higher than the highest frequency desired. This filter in series with a variable resistor is bridged across the input of the speech amplifier at the transmitter and adjusted until the desired frequency range is secured. As mentioned above, this is a loss circuit to the lower frequencies and any loss inserted must be compensated for by additional gain in the amplifiers.

The gain of the amplifier at the control point should be sufficient to insure an output of from 6 to 15 milliwatts or from zero to plus 4 db. Higher outputs may be used when the line is not adjacent to other speech circuits such as telephone or broadcast circuits.

The versatile ham will find many modifications possible in this circuit. In one known case, Relay 3 was used with additional relays to switch from a 20-meter 'phone rig to an 80-meter c.w. rig. Keying of a low-powered stage may be accomplished by using a marginal relay in series with terminal 7 on transformer  $T_4$  and ground. For those interested, the operation of marginal relays is covered in the *Handbook*.

---

## West Gulf Division Convention

Carlsbad, N. M., August 25th-26th-27th

IT has been said that the West Gulf Division always does things in a big way. It is apparent that the Southeastern New Mexico Amateur Radio Club intends to carry out that legend by extending a cordial invitation to all radio amateurs to trek to Carlsbad, N. M., for the annual West Gulf Division Convention which it is sponsoring on August 25th-26th-27th. The reason for a three-day affair is the Cavern trip which will consume one entire day, and this is planned for Friday, the 26th. On Saturday, the 27th, technical and business meetings morning and afternoon, with the banquet Saturday evening. The registration fee for the three days, \$5.00; for Saturday only, including the banquet, \$1.50. Just write Ted Fitzsimmons, Secretary, Box 341, Carlsbad, N. M., for further details.

# Do's and Don'ts in Power Supplies

By T. M. Ferrill, Jr.,\* W5CJB-1

SOME careless and mistaken practices often creep into power supply design; particularly in the selection and operation—or misoperation—of components, despite very clear and dependable information published in standard reference books. This incomplete understanding of all the factors involved frequently leads to disappointment and to unnecessary correspondence with manufacturers of transformers and chokes, especially in the case of the lower-priced units which carry ratings having little or no margin of safety. Probably this is more often true of cases in which inexperienced amateurs “graduate” to medium and high-power installations, but even

he may later learn to his regret (or the manufacturer's regret, for it is often the sad experience of this much-mistreated person to receive a tearful letter insisting, “. . . and it was operated within your rating, so I feel that I am entitled to a new one”).

In Fig. 1 is shown the power-supply circuit, just as it probably would be in this representative case. The components selected are as follows:

$L_1$ —Swinging choke, rated at 5–25 henrys, 90 ohms d.c. resistance, 300 ma.

$L_2$ —Smoothing choke, rated at 20 henrys, 100 ohms d.c. resistance, 300 ma.

$T_1$ —Transformer, rated at 2000 volts a.c. each half of secondary winding at 300 ma. load.

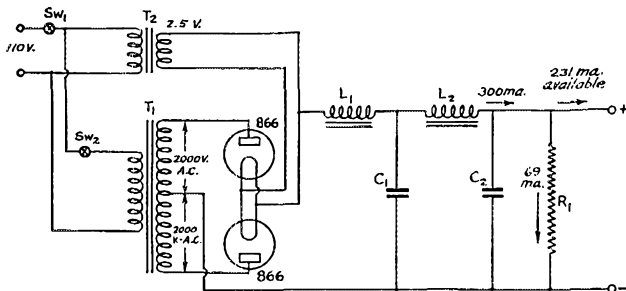

FIG. 1—THE POWER SUPPLY CIRCUIT UNDER DISCUSSION

The condensers  $C_1$  and  $C_2$  do not enter into the discussion, since in a circuit of this type they have little to do with average voltage regulation. They must have sufficient capacity, of course, to reduce the ripple content in the d.c. output voltage to a negligible value, and in 'phone transmitters  $C_2$  must have negligible reactance at voice frequencies.

more experienced amateurs—presumably better informed—also have trouble from time to time, trouble which easily could be avoided with a little forethought.

Let us take a representative case, with requirements worked out, to show just what properly could be expected from the component parts. A typical amateur has just completed a transmitter requiring 2000 volts at 300 ma., a 600-watt continuous load when used for 'phone. Accordingly, he thumbs through his latest catalog and finds, much to his satisfaction, that the catalog lists a transformer rated to supply 2000 volts a.c. at 300 ma., the voltage specified being for one-half secondary winding. In the same manner, he finds a swinging choke and a smoothing choke also rated at 300 ma., and blissfully proceeds to obtain this apparatus, thinking himself quite fortunate, indeed, to have found listed just the apparatus needed. However, there is more here than meets the eye of the careless designer, as

The problem now is to determine the output voltage and power available without overloading any of the units.

Fig. 2 shows an approximate drawing of the rectified but unfiltered output voltage from the 2000-volt transformer under consideration. The rating of 2000 volts is given in “r.m.s.” voltage, a figure which corresponds to the voltage of a direct current source which would develop the same power, or heating effect, in the resistor connected to the rectifier output. When the rectifier output is applied to a choke-input filter, however, the resulting d.c. output voltage is approximately the average value of the a.c. voltage. The average voltage output of the transformer-rectifier combination is represented by the 1800-volt line shown on the graph, and it is this latter value which would be given by a d.c. voltmeter connected across the output of the system. The ratio of average to r.m.s. voltage is 0.9, and this value is used in the computation below:

$$2000 \times 0.9 = 1800 \text{ volts} = \text{d.c. output voltage}$$

A further drop in voltage will occur because of the resistance of the choke windings. This drop readily can be computed by Ohm's Law:

$$I (R_{L1} + R_{L2}) = 0.300 (90 + 100) = 57 \text{ volts}$$

In addition there is a constant drop of approximately 15 volts in the mercury-vapor rectifiers, so that the net output voltage becomes:  $1800 - 15 - 57 = 1730$  volts, approximately.

The resistance of the bleeder,  $R_1$ , is now computed from the 25-henry critical value of the in-

\* Technical Department.

put choke, by use of the formula,<sup>1</sup>  $L_{input} = \frac{R_1}{1000}$

$$R_1 = 25 \times 1000 = 25,000 \text{ ohms}$$

$$\text{Bleeder current} = \frac{E}{R_1} = \frac{1730}{25,000} = 0.069, \text{ or } 69 \text{ ma.}$$

$$\text{Bleeder power} = 0.069 \times 1730 = 119.2 \text{ watts (120)}$$

The bleeder power rating should be at least this value, and higher if the resistor is mounted near other components.

The 69-ma. current taken by the bleeder obviously must come out of the 300-ma. transformer and choke ratings, so that the results can be summed up as follows:

$$\text{Net output current} = 300 - 69, \text{ or } 231 \text{ ma.}$$

$$\text{Net output voltage} = 1730 \text{ volts}$$

$$\text{Net output power} = 0.231 \times 1730 = 400 \text{ watts approximately}$$

In other words, the power supply is quite suitable for supplying a load requiring 400 watts under the conditions (1730 volts at 231 ma.) which result from computations above. However, it should not be expected to deliver 600 watts, as might have been anticipated in the selection of the component parts. As a matter of fact, use of this power supply at a 600-watt load would mean that the ratings of not only the power transformer were exceeded, but also those of the two chokes, since the total current would be well over 400 ma. The 400-watt external load produced by use of a 230-ma. current would cause the transformer and the chokes to operate at just their rated power—no more or less.

In view of the result obtained by the "snap judgment" method of selecting power supply components, it would seem advisable to start with the desired load and work back to the required transformer and choke ratings. The method is simply the reverse of that just used, and we shall carry it through to determine the ratings of the power supply transformer, chokes, and bleeder to meet the 2000-volt 300-ma. requirement originally set up.

Since it is obvious from the foregoing that the current supplied to the bleeder is going to add some figure between 50 and 100 ma. to the 300-ma. load requirement, chokes with 400-ma. or greater current rating will first be selected, so that the representative ratings below may be obtained:

$L_1$ —Swinging choke, rated at 5–25 henrys, 75 ohms d.c. resistance, 400 ma.

$L_2$ —Smoothing choke, rated at 20 henrys, 75 ohms d.c. resistance, 400 ma.

Computations based on the 25-henry critical value of inductance for the new swinging choke again result in the selection of a 25,000-ohm bleeder resistance.

<sup>1</sup> Power Supply Chapter, *The Radio Amateur's Handbook* (Page 332, 1938 Edition.)

$$\text{Bleeder current} = \frac{2000}{25,000} = 0.080, \text{ or } 80 \text{ ma.}$$

The current rating for the transformer and chokes should, therefore, be at least 300+80, or 380 ma. Choke voltage drop is then computed by the method used previously— $I(R_{L_1} + R_{L_2}) = 0.380(75 + 75) = 57$  volts. Adding the choke and rectifier drops to the desired voltage,  $2000 + 57 + 15 = 2072$  volts = average gross voltage required (not to be confused with any of the values published

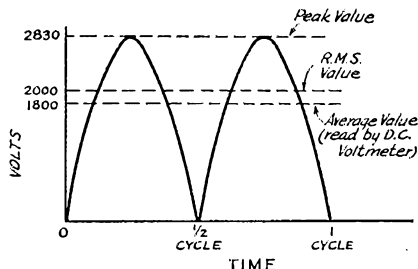

FIG. 2—WAVE-FORM OF FULL-WAVE RECTIFIED OUTPUT VOLTAGE SHOWING THE RELATIONSHIP BETWEEN R.M.S., PEAK AND AVERAGE VALUES OF THE OUTPUT VOLTAGE

on transformers as their a.c. output voltage, which is an r.m.s. value).

$$\text{Changing the average to an r.m.s. value, } \frac{2073}{0.9}$$

= 2300 volts = a.c. rating, center-tap to one rectifier plate, on transformer loaded to 380-ma. d.c. Hence, the following parts are suitable for the power supply for the 600-watt load:

$L_1$ —Swinging choke, rated at 5–25 henrys, 75 ohms d.c. resistance, 400 ma.

$L_2$ —Smoothing choke, rated at 20 henrys, 75 ohms d.c. resistance, 400 ma.

$T_1$ —Transformer, rated at 2300–0–2300 volts, a.c., at 380 ma. d.c. (current rating should be 380 ma. or more).

$R_1$ —25,000 ohms, power rating at least 0.080 × 2000, or 160 watts.

It is interesting to note that in the first case the power supply using a "600-watt" transformer at full rating delivered a net power of 400 watts, whereas a power supply for delivering 600 watts net power would, in the case discussed, require an "875-watt" transformer (the product of 2300 volts and 380 ma.). Actually, the first transformer output power rating is 540 watts, given by  $0.300 \times 2000 \times 0.9$ . Similarly, the total power delivered by the second transformer is  $0.380 \times 2300 \times 0.9$ , or 785 watts.

Finally, it may well be mentioned that the methods of calculation described do not take into account all losses, peculiar wave-shapes, or phase-

(Continued on page 94)

# An Improved Capacity Bridge

## V.T. Tone Generator and Output Amplifier for Better Null Indications

By Moe Joffe,\* W2BNY

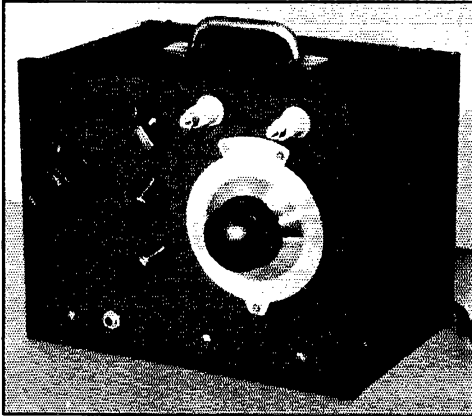

PORTABLE CAPACITY BRIDGE WITH VACUUM-TUBE OUTPUT AMPLIFIER AND TONE GENERATOR

The knob on the left controls the balancing condenser which compensates for capacity of leads to the external condenser whose capacity is to be measured. The feed-throughs are the connections to the unknown capacity.

IN these days of amateur experimentation with receiver and transmitter construction based on something more concrete than cut-and-try methods, an inexpensive means of checking nominal capacitance values would be a welcome adjunct to the amateur laboratory.

Fixed capacitors often can be substituted for variable units, even when cut-and-try methods seem to offer the quickest way to arrive at the proper value for a given purpose. An experimental but unknown value may sometimes be arrived at quickly, but to label that value properly for future reference requires the services of a simple capacity bridge. The writer, having felt the need once too often, decided to do something about it, and the result was the unit described here. It may be of interest to others, since it has been a source of satisfaction to the constructor.

The useful range of the

\* 1492 E. 12th St., Brooklyn, N. Y.

bridge is 1000  $\mu\text{fd}$ . This value was chosen because condensers above that capacity are generally classed as by-pass type and are not critical in value. The circuit is one fundamentally familiar to all, and its construction and operation are simple. It consists of a good fixed mica or air capacitor of about 1250  $\mu\text{fd}$ ., two precision resistors of equal value, and a variable condenser with a linear capacity characteristic, i.e., one with an equal change of capacity per dial division over the greater part of the scale. There is also a small vernier capacitor, to aid in balancing the bridge, and a single-pole double-throw switch to throw the phasing resistors from one side of the capacity arm to the other. The tone source may be either a buzzer or a tube oscillator as shown in the diagram, Fig. 1. The oscillator,  $V_1$ , is followed by an amplifier,  $V_2$ , which serves to isolate the bridge from the oscillator. A second amplifier,  $V_3$ , following the bridge serves a double purpose. First, since the impedance of small capacitors at 1000 cycles is high—for instance, that of a 100- $\mu\text{fd}$ . condenser is of the order of 160,000 ohms—and that of a pair of sensitive 'phones at the same frequency is relatively low—about 20,000 ohms—it is evident that this mismatch is too great for an accurate indication. Therefore it is necessary to use a high impedance null indicator. Second,

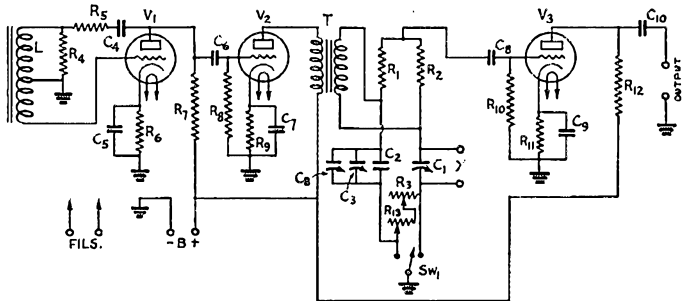

FIG. 1—CIRCUIT DIAGRAM OF THE CAPACITY BRIDGE

- $C_1$ —1500- $\mu\text{fd}$ . variable (Cardwell XR-1500-PS).
- $C_2$ —1250- $\mu\text{fd}$ . fixed mica.
- $C_3$ —100- $\mu\text{fd}$ . variable (Cardwell ZU-100-AS).
- $C_B$ —25- $\mu\text{fd}$ . variable (Cardwell ZR-25-AS).
- $C_4$ —0.01- $\mu\text{fd}$ . paper.
- $C_5, C_{10}$ , inc.—0.1- $\mu\text{fd}$ . paper.
- $R_1, R_2$ —5000-ohm precision resistors (IRC).
- $R_3$ —10,000-ohm potentiometer.
- $R_4$ —12,500 ohms,  $\frac{1}{2}$ -watt.
- $R_5$ —0.5 megohm,  $\frac{1}{2}$ -watt.
- $R_6$ —850 ohms,  $\frac{1}{2}$ -watt.
- $R_7$ —0.25 megohm,  $\frac{1}{2}$ -watt.
- $R_8$ —0.5 megohm,  $\frac{1}{2}$ -watt.
- $R_9$ —1500 ohms,  $\frac{1}{2}$ -watt.
- $R_{10}$ —0.5 megohm,  $\frac{1}{2}$ -watt.
- $R_{11}$ —3500 ohms,  $\frac{1}{2}$ -watt.
- $R_{12}$ —0.25 megohm,  $\frac{1}{2}$ -watt.
- $R_{13}$ —1000-ohm potentiometer.
- $SW_1$ —S.p.d.t. switch.
- $C$ —Center-tapped audio choke.
- $L$ —Interstage audio transformer.
- $V_1$  and  $V_2$  are the two sections of a 6F8G double triode (this tube has separate cathodes);  $V_3$  is a 6C5.

the amplifier increases the sensitivity of the instrument, permitting greater accuracy in determining the null or no-signal point of the "standard."

The oscillator circuit is of the inductive feedback type. Two resistors,  $R_4$  and  $R_6$ , are critical in adjustment for sine-wave output, and those owning an oscilloscope will find it of considerable value in adjusting the circuit of the oscillator for best wave shape. However, should no oscilloscope be available, it will be necessary to listen with a pair of 'phones and vary the resistors until a clean note results. The variable air condenser "standard" used in this bridge has a capacity change of 15  $\mu\text{fd.}$  per dial division over 90 percent of the dial, providing that the dial has 100 divisions per 180 degrees of rotation. By using a vernier dial such as the National type "N," a change of 1.5  $\mu\text{fd.}$  can be read. In the construction of the bridge, points to remember are to tie all components down as solidly as possible, and to insulate both condenser arms from ground.

After constructing the bridge and getting a good tone from the oscillator, it is ready for a preliminary test. Set the dial so that with the condenser plates all in, the dial will be on the zero-degree mark. Now turn the condenser gradually until the tone seems to get weaker or disappears. After finding the point where the weakest response is obtained, slowly turn the phasing resistors  $R_3$  and  $R_{13}$ . If the response gets louder, switch them over to the other leg of the bridge and vary them again until a point is reached where the loud tone has disappeared altogether. This is known as the null point. If it seems impossible to get a good null indication, harmonics generated by the oscillator may be responsible. It will be necessary to vary the oscillator resistors

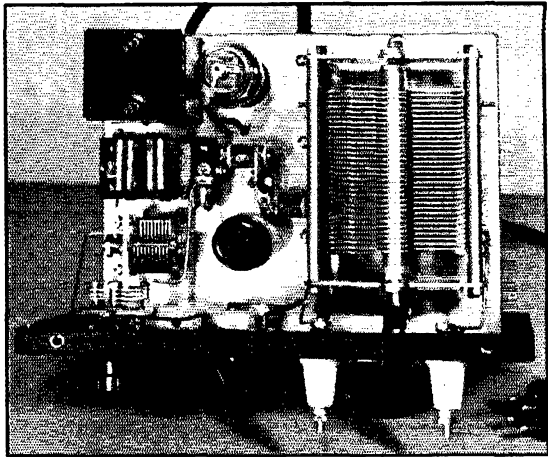

TOP VIEW SHOWING THE CHASSIS LAYOUT

The large condenser is  $C_1$ .  $C_B$  is mounted on the panel, but insulated from it, and  $C_3$  is similarly mounted on the chassis.

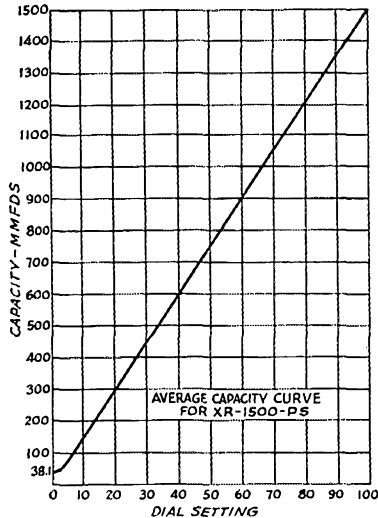

FIG. 2—AVERAGE CALIBRATION CURVE OF THE BRIDGE CONDENSER

TABLE I  
AVERAGE CAPACITY VALUES OF XR-1500-PS  
(Assuming 180 degree rotation over 100 division scale)

Degrees	Capacity
90	150 $\mu\text{fd}$
80	300 "
70	450 "
60	600 "
50	750 "
40	900 "
30	1050 "
20	1200 "
10	1350 "

again until the harmonics are reduced, at which time a good null point will be obtained.

With the vernier condenser  $C_B$  in the midway position, balance the bridge with the main variable condenser  $C_1$ , and note the dial setting. It should be on the 10-degree position. If not, reset it to 10 degrees and vary the auxiliary condenser,  $C_3$ , until balance reoccurs. Lock  $C_3$  in that position. During this adjustment it must be remembered to leave the balancing vernier  $C_B$  in the midway position.

The last mentioned condenser has a very definite purpose in the bridge. In order to measure the capacity of the unknown condenser alone, the capacity of the leads to which the capacitor will be connected must be balanced out. This is accomplished by first connecting the leads to the "X" posts and placing them in the approximate position they will assume when the actual measurement is being taken, the "standard" being then set on the reference point, 10 on the dial. The circuit is then balanced to the null point by varying the balancing vernier,  $C_B$ . The condenser to be measured is now attached and the circuit once more balanced by rotating the "standard," leaving all other adjustments alone, until the best null is obtained. Now try to vary the phasing resistors to get a still better null.

(Continued on page 94)

# New Gear for Radio-Control Systems

## A New Gas Triode and a New Relay at Last Permit One-Tube Operation

**L**AST October we ran a story on radio-control systems for model aircraft and in the process released a flood of correspondence on the subject the like of which we haven't seen in many a moon. It appears that virtually hundreds of amateurs are dreaming up model airplanes or boats on the side or are offering their technical knowledge and their transmitting privileges for the benefit of specialists in the model field.

In the original story we deplored the apparent need for a three-tube receiver to do any sort of a reliable job. "Surely there must be some way of

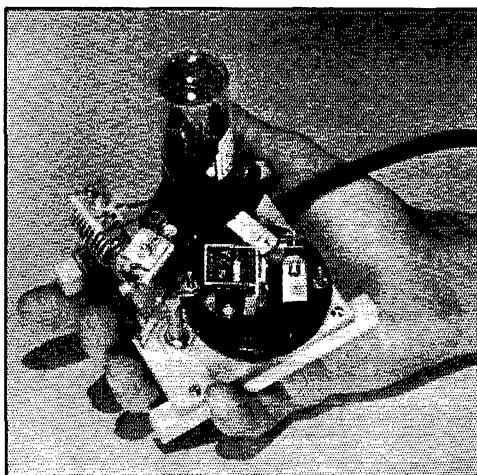

THE NEW ONE-TUBE RECEIVER BUILT IN A FORM SUITABLE FOR MODEL AIRCRAFT

Weight of the equipment shown is approximately 8 oz. The padding condenser used for tuning is mounted on the coil itself, the other "padder" being for antenna coupling. The variable plate resistor and by-pass condenser are under the ply-wood base.

building a simple one-tube receiver," we said, "a receiver capable of operating an inexpensive relay." Hot news of the moment is that there is a way of building such a receiver and that the new developments on which it is based result in pulling down the weight of the complete equipment from something over three pounds to about one pound. We have had an opportunity to make extended experiments with the new equipment in QST's Lab and though we have not had it in the air we are sufficiently confident of its worth to term it "the nuts." Here's the dope: Raytheon Production Corporation, with Robert Packard, W1ISJ, the engineer directly interested in the work, has developed a new gas-filled triode known,

for the moment, as "QY-4" and resembling a type-30 but capable of very much more. In a super-regenerative detector circuit the tube provides a plate current change of at least one milliampere upon receipt of even a very weak signal. Companion Discovery is a honey of a relay made by Sigma Instruments, Inc., Belmont, Massachusetts, known as Model 2-A of 8,000 ohms resistance and weighing around two ounces—almost six ounces lighter than any other successful relay we have tried.

The accompanying circuit and photograph show a receiver built with these two components. The circuit is seen to be quite a normal super-regenerative affair, the only important difference being in the use of a very large by-pass condenser,  $C_4$ . The only other really important item is the variable resistor  $R_2$  with which the plate voltage is adjusted—the adjustment being fairly critical. The receiver itself follows conventional ultra-high-frequency practice in that leads are short and the few components are mounted in close proximity. The adjustment is a little trickier than with the old-type control receiver, filament-voltage, plate-voltage, and antenna-coupling playing the important rôles. In our own work we kept the filament voltage at about 2.2 volts then fiddling with the antenna coupling condenser and plate resistor until the idling plate-current was approximately 1.7 mills and the current with signal about 0.5 mills. With this order of plate-current change the Sigma relay operates with extraordinary reliability.

Our work with the new gear is by no means

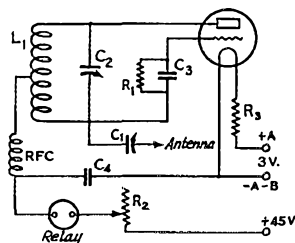

THE CIRCUIT OF THE RADIO-CONTROL RECEIVER

- L1—Eight turns No. 14 wire  $\frac{1}{2}$ " inside diameter, tap approximately at center of coil but requiring adjustment.
- C1, C2—National M30, 30- $\mu$ fd. padding condensers.
- C3—100  $\mu$ fd., mica.
- C4—0.25  $\mu$ d. paper.
- R1—2 megohms in original receiver but experiment with other values suggested.
- R2—10,000-ohm variable.
- R3—12 ohms in original receiver but experiment with other values suggested.
- R.F.C.—40 turns of No. 30 d.s.c. wire on  $\frac{3}{16}$ " former.

completed. But we tell this much of the story for the benefit of the many who are eager to get moving in this fascinating field. —R. A. H.

## The Battle of Cairo

(Continued from page 12)

maining problems of these bands were confined to Europe.

There were initially a great many proposals affecting the 1.7 band in Europe, ranging all the way from isolated bald demands to eliminate amateurs to an agreement by many nations to establish an exclusive aero band near 1800 kc. There were some proposals to establish exclusive narrow bands for *sondage* and for ionosphere measurements. With France and Great Britain initially supporting these proposals, it seemed at first that they would go through. However, some difficulties were encountered with the primary European use of the 1.7 band which is by the small-boat telephony service and a ten-nation private meeting was held to adjust the difficulties under the sponsorship of Sweden, which is friendly to amateur radio. When the compromises were worked out the aviation and other demands had been shifted, and with unanimous agreement the 1715-2000 band was retained in Europe in its Madrid status—the only one of our bands to go through easily in “both columns.”

When the work reached the 3.5 band another snag was encountered. Many European countries give their amateurs but 100 kc. of this band. Germany in particular had established what were claimed to be rather extensive “non-open” services closely above 3600 and demanded that some 50 kc. in that vicinity now be an exclusive non-open assignment, freed not only of amateur QRM but of that from other fixed and mobile stations. Great Britain, which assigns amateurs 3500-3730, tried to hold the space non-exclusively for amateurs but, the negotiating proving generally difficult and compromises being essential, yielded and agreed, promising Mr. Watts they would make it up to British amateurs by expanding their band a similar amount. Mr. Watts was reluctantly forced to agree to accepting his band in two sections. At this time it was expected that all the remainder of the band to 4000 would be kept on the Madrid shared status but a complication arose concerning another aero band, originally destined to be 4000-4050. Private European talks were again resorted to and at the next meeting the group reported several conclusions, one of them the exclusive European assignment of 3950-4000 to aviation. Despite U.S. urging that the amateur band be continued to 4000 in Europe, it was accepted.

The available European amateur frequencies in this band are now to be 3500-3635 and 3685-

3950, and another European amateur band is narrowed below that allowed in the rest of the world. Only six European countries are known to have given amateurs the full 3500-4000 and it is of course true that if American amateurs can get along with 500 kc., Europeans can do with 400. Because the frequencies are admittedly regional in effect, the United States could not actively fight for the European amateurs. We did missionary work on this band but were obliged to conclude that no support was available in Europe for amateurs in any guise in the 50-kc. segments of this band now exclusively allotted to non-open stations and to aeronautics. There is no way to sway European administrators on a purely European matter when they are finally in agreement.

### THE LONG-DISTANCE BANDS

The first examination of the range from 5 to 25 Mc. was made by a sub-subcommittee searching for aviation frequencies. Considering particularly the hostile Japanese and U.S.S.R. proposals, this was a danger, but they passed by both our 7- and 14-Mc. bands, taking their frequencies from the mobile bands. That left broadcasting as the other danger but the first survey of this field by a broadcasting group recommended that the h.f. broadcasting bands be expanded at their present locations rather than invade new territory. However, when a special sub-subcommittee was appointed for broadcasting allocations, it immediately touched us, the Italian chairman proposing that the 6000-6150 broadcast band be widened 100 kc. by the novel expedient of shifting all stations between 6150 and 7000 kc. a hundred kilocycles upwards in frequency and reducing our band to 7100-7300. This was instantly supported by Germany and Switzerland but the United States of course objected, with the result that recourse was had to the usual informal conversations outside the meetings.

In the private group it became apparent that Great Britain also wanted to reduce us 100 kc.

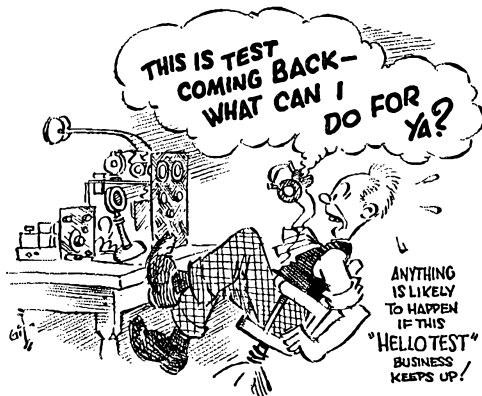

and that there were similar aspirations towards our 14-Mc. band. When the United States declined to yield, the British proposed that majority opinion be followed and the amateur band be reduced, the United States taking a reservation on it, inasmuch as it was being found impossible to get anywhere near the necessary amount of broadcasting channels from other sources because of objections from this nation or that. Since other services were being obliged to give up frequencies, it was demanded that amateurs also relinquish some, and the private group agreed to propose that European broadcasting be permitted between 7200 and 7300 by derogation, i.e., by mutual consent. The United States advised us to acquiesce in this or we would have the frequencies definitely allocated to broadcasting, with the U.S.A. in the weak position of simply reserving. It became plain that the actual intent of Europe was to get from a third to a half of both our 7- and 14-Mc. bands exclusively for broadcasting. We decided that we had better permit broadcasting in Europe by derogation in a third of the 7-Mc. band if we in America could be protected from broadcasting QRM and provided the 14-Mc. band could be saved intact.

When the sub-subcommittee next met the Italians at first accepted this situation but France, angered because widening proposals concerning a 9-Mc. broadcast band touched some of her essential services, again proposed getting the needed broadcast frequencies at amateur expense. She referred to her proposal to widen the amateur band to 7500 kc. but, in view of the circumstances, would now withdraw that proposal and instead propose that 100 kc. of the amateur band be devoted exclusively to broadcasting. There was quarreling and general disagreement on most of the proposed new broadcast bands. Great Britain then proposed that 7200-7300 be devoted to broadcasting and let the U. S. reserve, and France and Germany and Italy jumped instantly to her support. The Italians in fact proposed that the same thing be done to the 14-Mc. band, Switzerland and Germany at once seconding. The U. S. fought back splendidly, being willing to agree only to European derogations in 7200-7300 provided American amateurs weren't interfered with. This caused France and Germany to demand that the protection be reciprocal, that W amateurs not interfere with their broadcasting reception. At this point Great Britain, with plans in mind anent Egypt and India, suggested a footnote opposite the amateur allocation permitting the use of 7200-7300 for broadcasting outside the Americas between 0800 and 2400 G.M.T. To her credit at this point, despite pressure from associates, she would not go beyond that. Agreement concerning 7 Mc. seeming impossible, talk turned to the 14-Mc. band. It was eventually agreed that, from the technical standpoint, the sharing of this band by broadcasting was simply impos-

sible because of its worldwide effect. France and Italy then demanded that the United States assent to giving up some of the band outright and were decidedly indignant at her refusal. The sub-subcommittee was hopelessly deadlocked and it was agreed that the whole matter of what to do about the amateur 7- and 14-Mc. bands would have to be referred to the main subcommittee on allocations. The United States annexed to the minutes a very strong statement in support of amateur radio, absolutely refusing to yield any of the 14-Mc. band.

Overnight, before the subject reached the allocations committee, a petition was circulated demanding 150 kc. of our 14-Mc. band exclusively for broadcasting. The British refused to sign it and the British chairman succeeded in killing it, Great Britain having decided (to our certain knowledge) that our 14-Mc. band should be held in reserve as something to take away from us at the next conference when the world's needs are greater! As things got under way in the allocations committee, with the outlook quite black, we took a bold step: we made a deal with the British, agreeing to accept a footnote permitting broadcasting 7200-7300 outside the Americas, Great Britain agreeing to line up its associates, including the Empire, to accept just that and to affirmatively support the integrity of our 14-Mc. band. As the fireworks got under way, Rumania, Germany and Switzerland bitterly attacked the United States' statement defending amateur radio and demanded exclusive broadcast bands at 7 and 14 Mc. When the talk quieted a little the British, following their agreement with us, put forth the agreed proposal. Australia seconded it as a reasonable compromise. The United States accepted. France, protecting its other services, made a last-gasp attack, thinking it incredible that the United States would refuse to give up parts of 7 and 14 outright. Italy then, and New Zealand and Brazil, supported the U. S. and Great Britain, and it was shortly adopted on the basis that 7000-7300 would be amateur, with a footnote permitting broadcasting outside the Americas in the portion 7200-7300.

But when the minutes appeared they showed 7000-7200 amateur, 7200-7300 amateur and broadcasting, with a footnote that the broadcasting could be done only outside the Americas. Technically the same, the psychology was different. The United States demanded that it be changed back to the agreed basis, and at once released more fireworks. France demanded that it be left as reported, with broadcasting shown in the table. The U.S.S.R. supported France, saying that was logical since the exception is for the Americas. The United States pushed its point all possible, but Europe was angry, adamant. Any more pressure would have meant 7000-7200 amateurs, 7200-7300 broadcasting, with a foot-

*(Continued on page 104)*



# How Would You Do It?

## Some Hot Ideas on Direction Indicators for Rotatable Antennas

**B**ECAUSE the rotatable array antenna system can provide appreciable gain over a simple half-wave antenna and yet requires a comparatively small amount of space, it is becoming increasingly popular, especially with those amateurs located in the more populous areas. One of the minor problems involved in the installation of an antenna system of this type is that of providing a suitable device to give an indication of the direction in which the antenna is pointed. This indicator should be located at the operating position where it may be observed most conveniently. The object of Problem No. 17, as

pulley may be used to take up any slack in the line.

Another simple mechanical system by Bert Green is shown in Fig. 1B. It is applicable to the rope-and-pulley method of antenna rotation. An indicating pointer of metal is attached to the control rope at an appropriate point and a scale of compass points is placed alongside the rope as shown in the sketch. As an alternative, a sliding contact could supplant the pointer and the contact used to switch on a system of lights indicating the compass points.

Either of these mechanical arrangements may be used to drive the novel indicator suggested by M. J. Fickas, W6BIH. He suggests that the cable between antenna and operating position be used to rotate a world globe mounted on an axis running through the station location. The axis is placed vertically with the station location at the top. Strings outlining roughly the path of the radiation lobe are stretched between a pin at the station location and some convenient fastening points near the bottom of the globe.

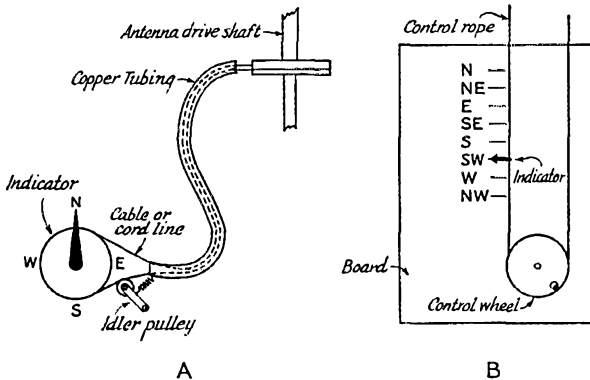

FIG. 1—TWO SIMPLE MECHANICAL SYSTEMS  
In A, a cable runs between the antenna and indicator through copper tubing. In B, an indicating pointer is attached to the rotating ropes.

set forth in *QST* for May, was to reveal some of the more successful schemes employed by those who have solved the problem for themselves. Several excellent solutions were suggested by the contestants and we shall describe a few of them.

### MECHANICAL SYSTEMS

A rather simple mechanical scheme is suggested by Charles S. Fleming, ex-W5DYL. It is shown in Fig. 1A. The rotating shaft of the antenna system is fitted with a pulley. This pulley is coupled to a similar pulley located at the operating position by means of a well-greased cord, belt or cable running through a length of copper tubing extending from one pulley to the other. The second pulley, which must be of the same diameter as the first, or greater, is fitted with a pointer and suitable scale of compass points. If the line is very long, it may be necessary to make an extra turn around each pulley to prevent slipping. An idler

ELECTRICAL LAMP INDICATOR  
A simple and reliable electrical indicating system is shown in Fig. 2. This was suggested in various forms by Andrew Randall, W1KVP; C. J. Roberts, W9EWN; Alfonso Sanchez, K4EJF; W. Scheitler, W9UZG; Russell Stott, W6PHZ and V. J. Sullivan. The shaft or spindle on which the antenna system rotates is fitted with a rotary switch which serves to operate a system of indicator lights at the operating position. The lamps may be arranged in a circle according to

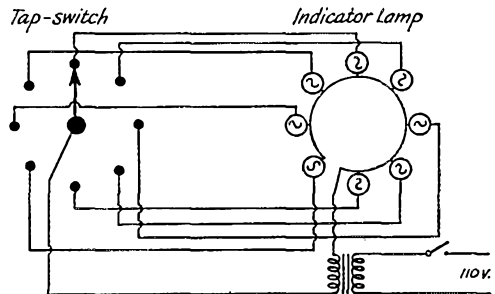
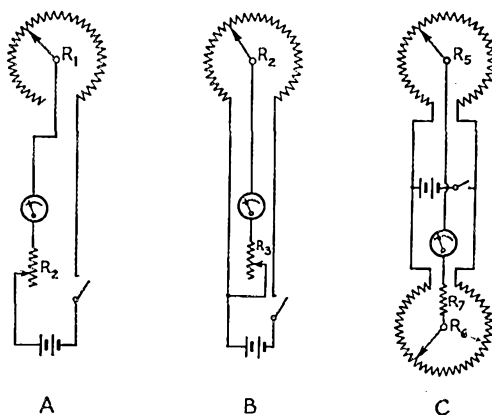

FIG. 2—SIMPLE ELECTRICAL SYSTEM  
The switch on the antenna shaft operates the lamps at the operating position. Lamps may be of flashlight or miniature type operating from step-down transformer.

the points of the compass and connected to the switch points in such a manner that the lamp which is selected to indicate any particular position of the antenna will light when the antenna is in that position. The construction of the switch must be suited to the style of rotating scheme used. In most cases the contact arm may be mounted on the rotating member and the points on a stationary ring surrounding the rotating shaft. K4EJF has fitted his with a Ward Leonard multi-point rotary switch. The switch should be inclosed to prevent damage from rain or snow. The number of contacts and lamps to be used will depend upon the accuracy of determination of direction desired. Many seem to think the four cardinal compass points are sufficient. K4EJF gets down to fine points by using 28 indicator lamps. The chief disadvantage of this system seems to be the large number of wires required between the antenna structure and the operating position.

**MILLIAMMETER OR VOLTMETER AS INDICATOR**

Three systems which use a milliammeter or voltmeter for the indicator are shown in Fig. 3. These have the advantage of requiring only two or three wires. The one at A requires but two



**FIG. 3—IN THESE THREE CIRCUITS, A MILLIAMMETER OR VOLTMETER IS USED AS INDICATOR**  
 A—Simple series resistance circuit. B—Potentiometer method. C—Bridge method. See text for suggested values.

wires or one wire and ground. It was suggested by Harry E. Adams, W9KZR; Elmer F. Blanchard, W1CHB; Clyde Burt, Jr., W6LFI; Austin H. Crane; Bob Foote, VE3AOR; Reed Fulton; C. F. Glass, W6OXQ; George L. Kemp, W2HNP

and Milton W. Raymond. The variable resistance  $R_1$  is arranged to operate with rotation of the antenna system. With  $R_1$  set at zero resistance,  $R_2$  is adjusted to bring the milliammeter reading to full scale. Rotation of the antenna will cause additional resistance to be inserted in series, de-

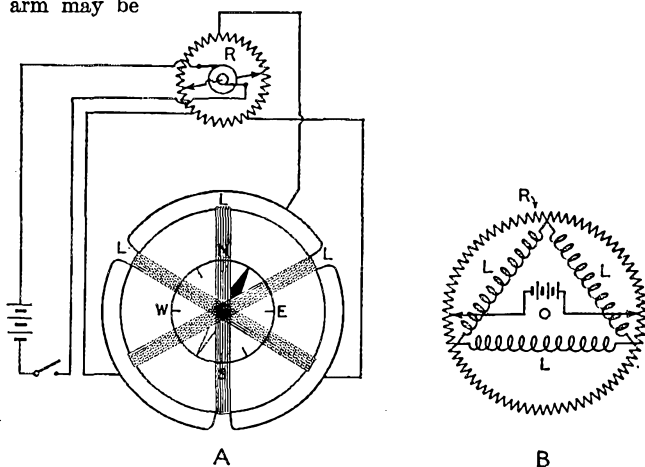

**FIG. 4—IN THIS CIRCUIT, THE COMPASS NEEDLE FOLLOWS THE ROTATING MAGNETIC FIELD CREATED BY THE BATTERY AND FIELD COILS (L) AND CONTROLLED BY THE RESISTANCE**

creasing the current reading. The meter deflection may be calibrated in terms of compass points. The chief drawbacks of this arrangement are that the accuracy will vary with the condition of the battery (although the accuracy may be checked by rotating the antenna to the zero-resistance position and readjusting  $R_2$ ) and that the full meter scale cannot be used since the current in the circuit never drops to zero.

This last objection is removed by the circuit of Fig. 2B, which, however, requires an additional wire. This circuit was submitted by Virgil Curkler, W9KLD; August Erickson, W9EVI; and George Stray, W61WU. In this arrangement, rotation of the antenna operates a potentiometer with the meter in series with the arm. With  $R_3$  set at the extreme right,  $R_4$  is adjusted to bring the meter to full-scale deflection. Then, rotation of the antenna will change the voltage across the meter and  $R_4$  in series, varying the deflection. Since this voltage may be reduced to zero by rotation to the extreme left, the full scale of the meter is usable.

The bridge circuit of Fig. 2C, suggested by George Keith, Jr., W9QLZ and Arthur Wrigley, W8AKJ, is quite simple and it eliminates the inaccuracies introduced by changes in battery voltage, although it does not provide an automatic indication of direction. With this circuit, any setting of  $R_3$  will require a similar setting of  $R_6$  to bring the meter reading to zero. The resistances

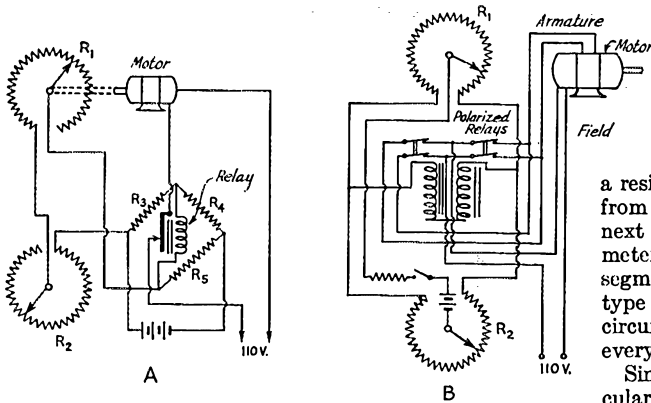

FIG. 5—AN AUTOMATIC SYSTEM

Relays operating in conjunction with automatic resistance bridge control rotation to any desired position when  $R_2$  is set for this position. Motor stops automatically when desired position is reached.

should be identical.  $R_5$  is varied by rotation of the antenna and  $R_6$  is calibrated in terms of compass points. With the antenna set in any selected direction, this direction may be determined by adjusting  $R_6$  until the meter reading falls to zero and the direction is read from the calibration of  $R_6$ . Conversely,  $R_6$  may be set to indicate some particular direction and the antenna, when rotated to the point where the meter reading falls to zero, will be in the desired position.

#### CONSTRUCTIONAL SUGGESTIONS

The variable resistance or potentiometer may be arranged in the form of a ring about the antenna shaft. The arm projects from the shaft and makes contact with the resistance ring. The resistance should be made with the ends as close together as possible to permit as close to 360 degree rotation as possible. If the antenna system is capable of continuous rotation in the same direction, the ends of the resistance should be arranged to prevent a short-circuit when the contact arm passes over them. Otherwise, the resistance must be driven by means of a proper reduction gear or belt drive to reduce the travel while the antenna rotates the full 360 degrees.

It would probably be most satisfactory from a mechanical standpoint to use a tap-switch with resistance units connected between switch-points as suggested by W1CHB, W6IWU and W9KZR. While this will not permit a continuously variable indication, it should be sufficiently accurate for all practical purposes if 8 or more contacts are provided.

W1CHB uses an old automobile generator for the tap-switch. The armature is coupled or geared to the antenna rotating shaft and the commutator bars are used as the switch-points. The armature shaft is equipped with a brass or copper slip-ring for the "arm" connection. With some armatures, the resistance units may be placed in the winding

slots in the laminations resulting in a neat and compact arrangement. In any case, plenty of room can be found for the resistors by removing the field poles and winding which are of no use for this purpose. Short-circuiting of a resistance unit when the brush passes from one commutator segment to the next will cause but a slight error in meter reading if a sufficient number of segments is available. A certain popular type generator has 21 segments. Short-circuiting may be avoided by leaving every other segment "dead."

Since the scale of the meter is not circular, this means that both ends of the scale must denote essentially the same direction. For instance, if we start out with North at the low end of the scale, the meter will indicate successively NE, E, SE, S, SW, W, NW and North again at maximum scale. Continued rotation in the same direction will cause the meter to drop back to minimum reading and to repeat the process. This refers to the circuits of Figs. 3A and 3B. The circuit of Fig. 3C will also have two settings for essentially the same direction. These occur also at the extreme ends of the resistances.

#### Problem No. 19

**O**UR Hero is one of those individuals always looking for new ideas to try. With the introduction of the new vacuum fixed capacities for r.f. tank circuit applications, the business of tuning the tank circuit by varying the inductance has struck his fancy. The idea looks simple on paper, but just how should he go about constructing this variable inductance so that its calibration or indicator readings will be as reliable as those of the tank condensers he has been using? He has seen mention of rotating disks or rings inside the coils and of stretching and collapsing a coil in accordion fashion, but no thought seems to have been given to the problem of returning to any given setting with reliability.

He would like to see some ideas on the construction of a coil of variable inductance with provision for an indicator of some sort, with sufficient mechanical strength to permit reliable indicator readings and with proper insulation between coil and control.

Circuit values will depend upon the range of the meter and the voltage applied. Using the circuit of Fig. 3A, VE3AOR recommends 3000 ohms for  $R_1$  and 1500 ohms for  $R_2$  with a 0-1 ma. scale meter and a 3-volt battery. W2HNP uses 1000 ohms for  $R_1$  and 600 ohms for  $R_2$  with a meter of the same type and a 1.5-volt battery. W9KZR uses a 20-point rotary switch with homemade resistance units connected between the points. Values have been chosen which result in a linear scale. The 19 values of resistance are successively as follows: 5, 5, 6, 7, 7, 7, 9, 10, 11, 13, 14, 16, 20, 22, 28, 33, 42, 53 and 72 ohms.  $R_2$  is 40 ohms with a 3-volt battery and a meter with 0-25 ma. scale and an internal resistance of 85 ohms. Values must be altered for meters of different types.

For the circuit of Fig. 2B, W9EVI suggests 400 for  $R_1$  and 10,000 ohms for  $R_2$  with a 1-ma. meter and 3 to 4.5 volts. W8AKJ recommends 10,000 ohms each for  $R_3$  and  $R_4$  and 4500 ohms for  $R_7$  with a 0-1 ma. meter and a 4.5-volt battery.

#### ADAPTING THE MAGNETIC COMPASS

Although the number of control wires is increased again, the scheme shown in Fig. 4 is quite novel. The idea is furnished by Edward Eggebrecht, W8AOH and it operates on the Selsyn-motor principle.\* An ordinary compass is provided with three windings as shown in the sketch. The variable resistance is connected in such a manner as to provide a rotating field about the compass which is followed by the pointer. The position of the contact arm is adjusted so that its rotation with the antenna will cause the compass needle to assume positions corresponding to those of the antenna. The total resistance of the wire used in the variable resistance should be about 50 ohms. The two contact arms should be insulated from each other. It will be noticed that the resistance is continuous and that it is not necessary to provide insulation between the ends of the resistance as in the systems previously described. The taps should be equally spaced about the circumference of the circular resistance. The three coils wound about the compass should have 200 to 300 turns each No. 38 or 40 enameled wire and should have a diameter of two to three times the length of the compass needle. They should be arranged symmetrically as shown in the sketch.

#### AN AUTOMATIC SYSTEM

The arrangements shown in Fig. 5 are quite unique in operation. The one shown at A is suggested by Dan Reed of Breckenridge, Mo. The resistance  $R_1$  is operated by rotation of the antenna, while  $R_2$  and associated equipment are located at the operating position. To operate the system,  $R_2$  is adjusted to a point corresponding to

\* We understand that the General Electric Co. is soon to announce a d.c. Selsyn instrument designed for amateur work and ideally suited for remote indicating jobs of this kind. — EDITOR.

the desired direction of transmission and the battery switch is closed. If the antenna is not already in the desired position, the electrical bridge will be thrown off balance causing the relay to close and start the motor. Rotation will continue until the arm of  $R_1$  reaches the point where the bridge is in balance, the current through the relay winding will fall to zero and the relay will open the circuit to the motor.

Resistance values will depend upon the type of relay and the voltage used.  $R_1$  and  $R_2$  should be of equal value. Suitable values should be chosen so that the ratio of  $R_3$  to  $R_4$  will be equal to that of the maximum resistance of  $R_1$  (or  $R_2$ ) to  $R_5$ . In operation,  $R_1$  will decrease as  $R_2$  is increased and *vice versa*, keeping the circuit balanced.

This system requires continuous rotation of the antenna in the same direction. A somewhat more complicated arrangement is required if the direction of rotation must be reversed. The circuit is shown in Fig. 5B and was submitted by Harlan Grimes, W8QHW. Two polarized relays are required so that one or the other will operate only when the current is flowing through the relay winding in a certain direction. The direction of rotation of the motor will depend upon which relay operates. Otherwise the operation is similar to that of circuit A.  $R_1$  and  $R_2$  should be equal in value.  $R_1$  is operated by rotation of the antenna and  $R_2$  is at the operating position.

Well, there you are— take your choice.

#### Prize Winners

First—Arthur C. Wrigley, W8AKJ

Second—Edward Eggebrecht, W8AOH

We wish to thank those mentioned previously as well as W2JFA, W6JXX, W9WKM and VE3ND, all of whom deserve honorable mention. Rules under which this contest is conducted are as follows:

1. Solutions must be mailed to reach West Hartford before the 20th of the publication month of the issue in which the problem has appeared. (For instance, solutions of problem given in the May issue must arrive at *QST* before May 20th.) They must be addressed to Problem Contest Editor, *QST*, West Hartford, Conn.

2. Manuscripts must be not longer than 1000 words, written in ink or typewritten, with double spacing, on one side of the sheet. Diagrams and sketches may be in pencil, but must be neat and legible.

3. All solutions submitted become the property of *QST*, available for publication in the magazine.

4. The editors of *QST* will serve as judges. Their decision will be final.

Prizes of \$5 worth of A.R.R.L. station supplies or publications will be given to the author of the solution considered best each month, \$2.50 worth of supplies to the author of the solution adjudged second best. The winners should provide us with a list of the supplies preferred.

# ● ARMY-AMATEUR RADIO SYSTEM ACTIVITIES ●

THE relation between the Corps Area organizations of the A.A.R.S. and the Office of the Chief Signal Officer in Washington was explained in this section in the May issue of *QST*, wherein the organization of the Second Corps Area was described in detail. It is the purpose of this article to continue, somewhat along the same lines, with a brief description of the Third Corps Area organization.

The Third Corps Area, or simply "The Third" as it is affectionately known to its members, comprises the states of Maryland, Pennsylvania, Virginia and the District of Columbia. Since the National Capital is located in the approximate center of the corps area, the Third is in a more or less strategic position from a military angle. In addition to this, there are several danger areas where emergencies have arisen on numerous occasions in the past and where they may arise in the future, requiring the use of amateur radio in general, and the A.A.R.S. in particular, for communication purposes.

One of the danger zones is the eastern shore of Maryland, where Atlantic coast hurricanes have caused much damage in the past and where the Third Corps Area A.A.R.S. has rendered inestimable emergency service on several occasions. Other danger points are in western Pennsylvania in the vicinity of Johnstown and Pittsburgh, where, in case of heavy rains or rapid thaws, the flood danger is considerable. The emergency service rendered in these areas by the A.A.R.S. will not be recounted here, since it has been written up in *QST* and other amateur radio journals and is no doubt familiar to almost everyone. The point is, however, that any amateur organization in the Third must take these facts into consideration.

Prior to 1934 all of the administration was handled from a little shack at Fort Meade, Maryland, by Corporal Robert N. Fox, who was Radio Aide at that time. He received practically no help and it is a compliment to Corporal Fox's interest and ability that he was able to hold the system together as well as he did.

Better days were coming, however. In 1934, one Captain H. O. Bixby came to Baltimore to take the position of Assistant Signal Officer and A.A.R.S. Liaison Agent. He was a ham himself and much interested in things amateur. He immediately brought Corporal Fox to the Baltimore Office, provided a Radio Station there for use of the A.A.R.S. and established Fox as Chief Operator of W3SN-WLQ, the Corps Area Net Control Station. The administrative job of Radio Aide was given to another member and Fox then had only one job to handle rather than two.

The new Radio Aide was brought into the

Headquarters Office the following summer for a period of two months and a complete reorganization took place. A membership drive was put on which resulted in a final membership of approximately 175 stations. Correspondence courses in Cryptography and Net Operation were made available to all members. Specialists ratings were set up, requirements for which were based on member advancement along both operating and technical lines. A method was devised whereby members could obtain spot frequency crystals for their net frequencies at seventy-five cents per crystal. Truly, things in the old Third were picking up.

Since that time, interest has remained at a high pitch, with, of course, the usual changes and turnover in personnel, but with everything in very healthy condition.

The present set-up, which was put into effect some months ago in response to a request from the Office of the Chief Signal Officer in Washington, that the number of nets be reduced to a minimum so as to release some of the frequencies then in use, is as follows: Pennsylvania is divided into four districts, each under its District Net Control Station. The net control stations are W3EDC, W8PAF, W3EWJ and W8UK. All local stations report to their District N.C.S. The District N.C.S. operate in the State Net, reporting to either W8FLA-WLQC, the State N.C.S. or to his Alternate, W8ASW-WLQG. The State N.C.S. reports into the Corps Area net, which is controlled either by the Corps Area Net Control Station, W3SN-WLQ, or by the Radio Aide, W3OK-WLQA. The need for District Nets in Pennsylvania is due to the peculiar distribution of members which places fully 80 per cent of the Corps Area membership in that state, thus requiring more nets.

In Maryland, the membership being smaller, all members report directly into the State Net under the State N.C.S., W3CIZ-WLQD, and his Alternate, W3BKZ-WLQM, who then report into the Corps Area Net.

The Virginia Net has, until recently, been under the control of W3GTS-WLQE, and operates as a State Net similar to Maryland.

In addition to the regular traffic work of the system, the Third makes an effort to maintain the interest of its members by a series of simulated emergencies and War Games and by the use of contests. The War Games and simulated emergencies try as far as possible to simulate actual emergency conditions, in practice for future real emergencies that may arise, so that the members may be trained to do their part when the time comes.

(Continued on page 96)

# HINTS and KINKS for the Experimenter



## A High-Frequency Exciter of Variable Frequency and High Stability

AT the higher frequencies it is common practice to use the electron-coupled oscillator for stable operation with variable-frequency output. An alternative arrangement, making use of the combination of a fixed high-frequency crystal and a low-frequency self-controlled oscillator, is shown in Fig. 1.

Two tubes are used in this device to produce

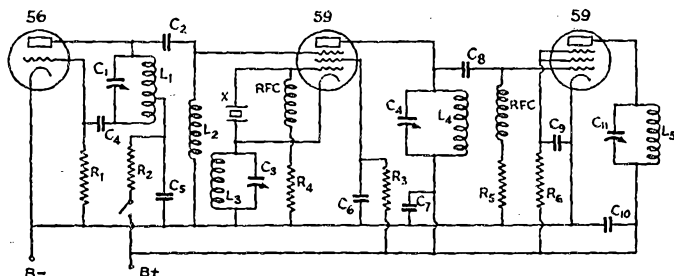

FIG. 1—PA0JMW'S HIGH-FREQUENCY EXCITER

- |  |   |   |
|--|---|---|
| C <sub>1</sub> —500- $\mu$ fd., variable mica.             | C <sub>8</sub> —100- $\mu$ fd., 600-volt mica.    | R <sub>5</sub> —20,000-ohm, 2-watt.   |
| C <sub>2</sub> —100- $\mu$ fd., 600-volt mica.             | C <sub>9</sub> —0.01- $\mu$ fd., 600-volt mica.   | R <sub>6</sub> —25,000-ohm, 5-watt.   |
| C <sub>3</sub> , C <sub>4</sub> —100- $\mu$ fd., variable. | C <sub>10</sub> —0.002- $\mu$ fd., 600-volt mica. | L <sub>1</sub> —Coil from 465-kc. i.f. transformer.   |
| C <sub>5</sub> —0.002- $\mu$ fd., 600-volt mica.           | C <sub>11</sub> —100- $\mu$ fd., variable.        | L <sub>2</sub> —Approximately 1.3 millihenry (use of a 465-kc. i.f. transformer coil is suggested). |
| C <sub>6</sub> —0.01- $\mu$ fd., 600-volt mica.            | R <sub>1</sub> —100,000-ohm, 1-watt carbon.       | L <sub>3</sub> , L <sub>4</sub> , L <sub>5</sub> —Output tank coils.*                               |
| C <sub>7</sub> —0.002- $\mu$ fd., 600-volt mica.           | R <sub>2</sub> —20,000-ohm, 5-watt.               | X—3700-kc. crystal.   |
|  | R <sub>3</sub> —40,000-ohm, 2-watt.               |   |
|  | R <sub>4</sub> —25,000-ohm, 2-watt.               |   |

\* Fig. 813, 1938 Handbook, gives specifications for L<sub>1</sub> suitable for L<sub>2</sub> of this diagram, and specifications for L<sub>2</sub> suitable for L<sub>4</sub> and L<sub>5</sub>.

the frequency for which an electron-coupled oscillator would ordinarily be adjusted. The crystal oscillator is a Tri-tet circuit controlled by a 3700-kc. crystal, using a cathode tank which is entirely conventional for a crystal of this frequency. This crystal oscillator tube is suppressor modulated by the output of a Hartley oscillator, for which a 56 tube is used. The frequency range of the self-controlled oscillator is 200 to 400 kc., requiring that the ratio of maximum to minimum capacity in the plate circuit of the oscillator be at least 4:1.

Whereas the plate tank circuit of the 59 Tri-tet oscillator would ordinarily be tuned to twice the frequency of the crystal, the plate circuit of this oscillator is operated only on a frequency equal

to the difference between 7400 kc. (3700 x 2) and the frequency to which the 56 oscillator is tuned. With the range of the self-controlled oscillator as given above, this means that the useful range of output frequencies of the Tri-tet oscillator is 7000 to 7200 kc.

The stability obtained by use of this system is limited almost entirely by the stability of the self-controlled oscillator, in which a relatively large variation may be tolerated without appreciable change in output frequency of the 59 stage.

Since the suppressor modulation is applied to what is, in effect, an electron-coupled doubler, this modulation does not cause instability of the crystal oscillator.

Although some sacrifice of output of the crystal oscillator is necessary (the output of the 59 oscillator at the frequency used is approximately 30 per cent of the output usually obtained from the same tube when operated as a conventional Tri-tet crystal oscillator), the output power is still comparable to that of an electron-coupled oscillator using the same tube and operating at reduced plate voltage in the conventional fashion.

In order to tune up the exciter the 59 cathode tank, the 59 oscillator plate tank, and the doubler plate tank are tuned to 3700, 7400, and 14,800 kc. respectively, with the 56 oscillator switch off. Modulation voltage is then applied to the suppressor grid of the Tri-tet oscillator by turning on the self-controlled 56 stage, and the plate circuit of the Tri-tet oscillator is tuned to a higher-capacity position at which a small driving power is obtained at the grid of the 59 doubler tube. The doubler plate circuit is then returned to the new position of minimum doubler plate current, completing the process. If a subsequent change of output frequency is desired, the plate circuit of the 56 stage must be retuned in the direction opposite the direction of frequency change desired, and the output tanks of the two 59 stages must be retuned in the direction of frequency

change desired. In other words, the output frequency of the exciter increases with decrease of the 56 output frequency. Thus, in order to obtain output on 14,000 kc., the system would first be tuned in the conventional manner to an output frequency of 14,800 kc., with the 56 stage turned off; and then, with plate voltage applied to the 56, this stage would be tuned toward the high-frequency (low-capacity) end of the tuning range provided by the  $L_1-C_1$  constants chosen, and the 59 oscillator plate and doubler plate tank circuits would be tuned to the lower capacity settings corresponding to 7000 and 14,000 kc., respectively. In order to obtain a somewhat higher output frequency, the 56 tank circuit would be retuned to a somewhat higher capacity and the plate tank circuits of the Type 59 tubes would be retuned to the lower-capacity settings for the new output frequency.

—J. W. A. Oosterbaan, PAQJMW  
Adm. van Gentstraat 6, Utrecht, Netherlands

### Low-Cost Split-Stator Midget Condenser

THE many uses for compact split-stator condensers, including hand-spread tuning and ultra-high-frequency applications, make a low-capacity gang condenser a useful gadget in the amateur station. Such a condenser may be easily made from an ordinary 140- $\mu$ fd. midget variable condenser, such as the Hammarlund

Star or USL, or other single-bearing midget condenser with  $\frac{1}{4}$ -inch stator-supporting pillars.

The stator section is cut in half, and two plates are removed from each half. The first rotor plate, then plates 4, 5, 6, 7, and 8 are likewise removed from the rotor, leaving the 9th and 10th rotor plates. This operation may easily be performed, as the plates are wedge-fitted into slots.

Two bakelite tubes,  $\frac{3}{8}$ -inch o.d. and  $\frac{1}{4}$ -inch i.d., exactly  $\frac{7}{16}$ -inch long are secured next. The projecting stator pillars are filed down to  $\frac{3}{16}$ -inch length, so that the space remaining between the pillars inside the insulating tubes will be sufficient to insure against leakage between the ends. The stator sections are now ready for assembly, and for this purpose, the insulating tubes should be clamped in a vise. Projecting ends of the pillars are now forced into the tubes, and the result should be as shown in Fig. 2.

Some circuits may require a shield between the stator sections. Such a shield as that shown in Fig. 2 (b) may be made and secured in place with a long machine screw fastened to the bronze solder lug attached to the front of the rotor.

Lower capacities may be had by cutting away more plates and using longer bakelite tubes, thus making a more rigid assembly with less stray capacity between stator sections.

—Frank Pray, 1156 Commonwealth Ave.,  
Brookline, Mass.

### A Home-Built Neutralizing Condenser for Large Tubes

FIG. 3 is a sketch showing the construction, from a few odd parts, of a neutralizing condenser. This condenser, patterned roughly after the design of the National NC-150 and the NC-500, was built by Howard W. Andrews, W1GRU, RFD 1, Bridgeport, Conn.

The base of the condenser, cut from  $\frac{1}{4}$ -inch Masonite sheet, is  $1\frac{1}{4}$  inches wide by 4 inches long. A National GS-1 insulator is screwed to this base near one end, and a Birnbach 866 insulator near the opposite end. Flat-head 6-32 screws inserted from the bottom of the base through countersunk holes are used to mount the insulators on the base. Before

mounting the Birnbach insulator, the screw fittings supplied with it are removed, and a 6-32 screw  $\frac{3}{4}$  inch long is screwed from inside the insulator into the bottom of a National GS-2 insulator from which the metal mounting base is first removed. Next, two aluminum discs are secured for the two condenser plates; for this purpose, W1GRU used the tops of two discarded aluminum pistons, which he states are obtainable at 15¢ per pound (6 tops) if pistons with cracked side walls are selected. If this source of aluminum discs is not available, the discs may be cut from

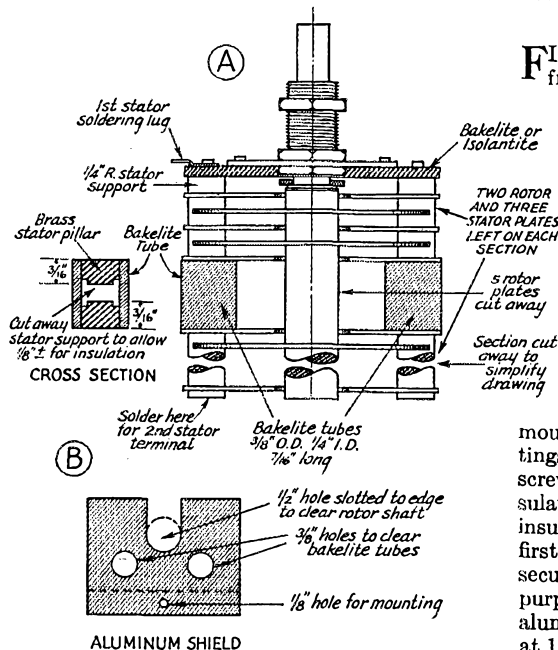

FIG. 2—CONSTRUCTIONAL DETAILS OF THE MODIFIED CONDENSER

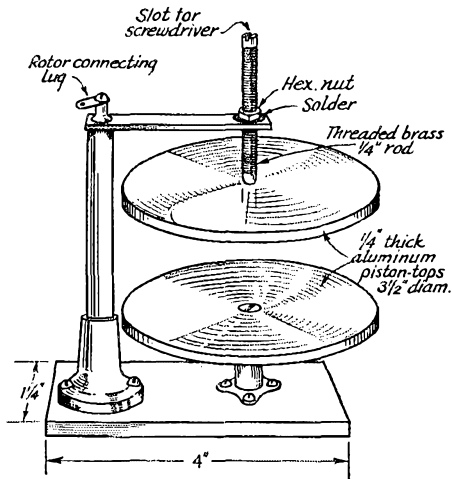

FIG. 3—HOME-BUILT NEUTRALIZING CONDENSER

heavy aluminum sheet with a circle cutter. Old aluminum receiver panels are admirable for this purpose. In order to obtain rounded edges on the discs produced in the latter fashion, the circle cutter should be allowed to cut approximately half through the sheet, and then the sheet should be reversed and the cutting finished from the opposite side. A few strokes of a file may then be used to round the bevelled edge produced by the cutting operation. If piston tops are used, the faces of the tops originally exposed to the explosions should be used as the effective surfaces in the neutralizing condenser, and the reinforcing ribs on the lower surfaces of the tops should be filed down smooth. Center mounting holes should then be accurately punched and drilled, and the plates should be finished by sanding the effective surfaces smooth with fine emery cloth.

The center holes of the discs are next countersunk at the smooth faces. The lug, screw, and spacer supplied on the top of the GS-1 insulator are removed and reassembled with the lug on top of the ceramic body, the spacer inverted on top of the lug, the lower condenser disc (effective face up) next, and finally, a flat-head machine screw through the disc, spacer, and lug into the threaded ceramic body. A flat piece of brass strip 3/32 or 1/8 inch thick by 3/4 inch wide is then cut to a length of 3 inches, and two holes, one 1/4-inch and the other 1/8-inch diameter, are drilled on the center line of the strip with centers separated by the distance between centers of the two base insulators. The metal fittings are then removed from the top of the GS-2 insulator, the strip is placed on top of the ceramic body with 1/8-inch hole above the threaded hole in the insulator, and the fittings are replaced with no alterations.

To support the top disc and allow means of

adjustment of the condenser, a screw 2 1/2 inches long is next provided. This screw is made by cutting a piece of 1/4-inch brass rod to the above length, threading the rod with a 1/4-20 die, drilling and tapping one end to receive a 6-32 screw through the top disc, and sawing a slot in the opposite end for operation with a screwdriver. Care must be used in cutting the drilled end of the rod off squarely, for otherwise the top disc, which depends on its bearing on the screw for alignment, may not be parallel to the lower disc. A 1/4-20 nut is then soldered to the brass strip directly above the 1/4-inch hole, and the rod is screwed into the nut with slotted end at top. The upper disc is then mounted on the bottom of the rod by means of a flat-head 6-32 screw. Finally, the brass strip is rotated around the top of the GS-2 insulator until the upper disc is directly above the lower, and the screw in the top of the insulator is tightened, completing the assembly.

Although not the equal of the manufactured models in appearance and space-efficiency, this condenser makes a satisfactory substitute for use by the amateur of badly limited financial means.

## New Apparatus

### Midget Clip

A NEW midget clip of the "copper" variety, called the Wee Pec Wee, has been announced by the Mueller Electric Company. Measuring 1 1/16 inches long with thin, flat jaws 1/4-inch wide, this clip will find ready use in amateur stations. The unique construction of the jaws makes the clip ideally suited to coil tapping on closely-spaced windings. Two small slots, one laterally across and the other lengthwise of the jaws are provided to prevent the jaw slipping from position. These clips are supplied with or without rubber insulating sleeves (black or red) which cover the entire clip and the end of the clip wire.





# ● I. A. R. U. NEWS ●

Devoted to the interests and activities of the  
**INTERNATIONAL AMATEUR RADIO UNION**

Headquarters Society: THE AMERICAN RADIO RELAY LEAGUE, West Hartford, Conn.

## MEMBER SOCIETIES

American Radio Relay League  
Asociația Amatoriilor Romani de Unde  
Scurte  
Associazione Radiotecnica Italiana  
Canadian Section A.R.R.L.  
Československá Amatérská Vystřední  
Deutscher Amateur Sendo-und-Empfangs  
Dienst  
Experimental Radio Society of Egypt  
Experimenterende Danske Radioamatører  
Fédération des Emetteurs Belges  
Irish Radio Transmitters Society  
日本アマチュア無線聯盟 Japan

Liga Colombiana de Radio Aficionados  
Liga Mexicana de Radio Experimentadores  
Magyar Rövidhullámú Amatőrök Országos  
Egyesülete  
Nederlandsche Vereeniging voor Interna-  
tional Radioamateurisme  
Nederlandsch-Indische Vereeniging Voor  
Internationaal Radioamateurisme  
Newfoundland Amateur Radio Association  
New Zealand Association of Radio Trans-  
mitters  
Norsk Radio Relæ Liga

Polski Związek Krotkofalowcow  
Radio Club Venezolano  
Radio Society of Great Britain  
Rede dos Emissores Portugueses  
Reseau des Emetteurs Français  
Reseau Luxembourgeois des Ama-  
teurs d'Ondes Courtes  
South African Radio Relay League  
Suomen Radioamatööriyhdistys  
Sveriges Sandareamatörer  
Unión de Radioemisores Españoles  
Union Schweiz Kurzwellen Amateur  
Wireless Institute of Australia

Conducted by Byron Goodman

### Amateur Radio Travel Bureau:

It is no news to a radio amateur that his hobby provides a medium for international friendships that is probably not surpassed by any organization. Many an amateur, fortunate enough to travel in foreign lands, has taken advantage of the "open Sesame" of amateur radio and carried his QSL cards and a call book with him on his trip, to his added enjoyment.

To further the relations between amateurs of different countries, the N.V.I.R. has instigated

an "International Radio-Amateur Travelling Office," Postbox 400, Rotterdam, Netherlands. Foreign amateurs planning a holiday in the Netherlands are urged to get in touch with the "IRATO" before their visit, so that suitable arrangements can be made. The exchange-of-holidays plan will afford visiting amateurs an opportunity to mix more closely with PA hams, as well as providing reliable information on customs, foreign currency, passage, housing, etc., at no expense to the visitor.

### Cairo:

Elsewhere in this issue will be found the story of the Cairo conference and the effect and reaction from an American standpoint. In order to see the results as other countries see them, let's look at the editorial of the April, 1938, issue of the E.R.S.E. (Egypt) Bulletin:

"Contained in this issue is a résumé of the discussions and findings concerning the allocation of amateur frequencies which took place at the International Telecommunications Conferences in Cairo last month.

"It will be seen that the commercial interests have made a very determined attack on the amateur bands. This has resulted in amateurs in the European zone losing a portion of some of their bands. The only frequencies which remain intact are those in the 14-Mc. allocation.

"Since the conferences at Washington, tremendous strides have been made in the field of radio communication. All frequencies in the radio spectrum have been explored, consequently, it is impossible to re-allocate to amateurs frequencies which the commercials may consider to be of no practical value. This is what actually

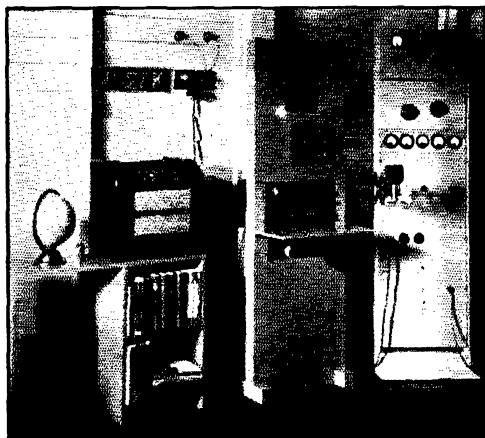

AN OUTSTANDING ASIAN "PHONE STATION":  
VS2AK AT KUALA LUMPUR, FEDERATED MALAY  
STATES

The transmitter features a band-switch exciter for either 14- or 28-Mc. operation, variable frequency crystals, and 100 watts input to a pair of 801's in the final. An antenna switch selects one of three antenna systems; used for receiving as well as transmitting.

happened at the Washington conference during which amateurs were assigned bands in the high frequency spectrum which resulted in the discovery, by amateurs, of the importance of these frequencies for long distance communication, and

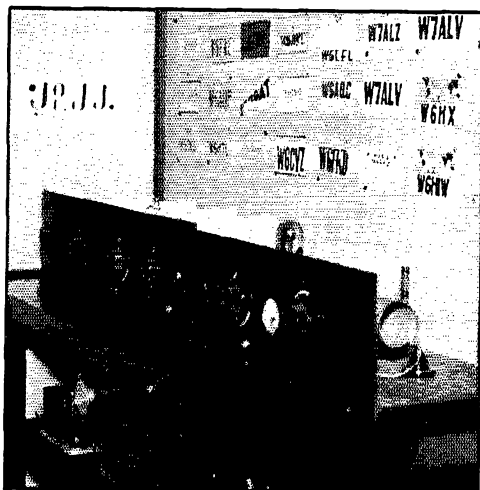

**THE TRANSMITTER AT J2JJ, TOKYO, JAPAN**  
*One of the very consistent Asian stations that has given many stations their WAC, J2JJ uses a 203A in the final of his c.c. rig.*

the subsequent migration of commercial stations to adjacent channels.

"It would appear that, in view of the vast store of data available today it is considered that the amateur can serve no further useful purpose, and forgetting, or ignoring their past experimental work, which has been a valuable contribution to the science, the commercials are endeavoring to take away all, or part of the narrow band of frequencies which should be reserved for their exclusive use as a record of and reward for their past achievements.

"During the discussions it was most gratifying to notice that at least one important country defended the amateur cause in the face of strong opposition. The determination of the American delegation in this direction resulted in the 14-Mc. band being preserved for the use of amateurs throughout the world. The opposition, however, was successful in appropriating substantial portions of the amateur frequencies in the 1.7-, 3.5- and 7-Mc. bands for commercial use. Amateurs will remember with sincere appreciation the attitude of the American delegation during these discussions.

"This determination of the American delegation to champion the amateur movement in the face of such strong opposition leads one to look for the reason. Sentiment holds no place in the sphere of commercial interests, so we may draw the conclusion that the American Government

considers that the amateur, even if he does not play an important part, still serves a useful purpose in the scheme of radio communication.

"There is no doubt that the American amateurs have created this bond of confidence which exists between themselves and their government. During the past few years they have given practical demonstrations of their usefulness in times of emergency by placing their station at the disposal of the government in times of national disaster when the regular means of communication have been interrupted.

"Here lies the whole crux of the position, the amateur will no longer be tolerated on sentimental grounds, our existence in the future will depend upon the extent of our usefulness to the community. The results of these conferences must be taken as a warning, and should have considerable influence on the future policy of amateur radio societies. It should be the aim of every amateur organization to educate its members in the useful application of their hobby to the service of the community.

"There is no need to enlarge on this statement, we have before us the attitude of the American delegation as concrete proof. It is up to every individual amateur to make a determined effort to prove his merit, and a practical contribution to the preservation of the finest of all hobbies, **AMATEUR RADIO.**"

That says it, doesn't it?

## "Look for Me on --- Kc."

*(Continued from page 20)*

bleeder tap used for the e.c. oscillator screen voltage. This method is used to keep the 6J5G plate voltage at a low value and need not be used if the oscillator power supply voltage does not exceed 250 volts or so.

### OUTPUT STAGE

The output stage uses an 807 and gives full output either as a straight amplifier or doubler. If desired this stage may even be used for quadrupling, with an output of 10-15 watts. Considerable care must be taken in laying out a stage using the 807 if self-oscillation is to be avoided. In this unit the entire plate circuit is mounted above the metal base, with the input circuit below. Much of the trouble experienced with self-oscillation in amplifier stages using the 807 and other tubes having extremely high power sensitivity may be traced to the r.f. chokes used. The use of identical chokes in the grid and plate circuits often causes tuned plate-tuned grid oscillations at the resonant frequency of the chokes, usually in the vicinity of the broadcast band. For this reason a 500-ma. choke is used in the 807 plate circuit and a 250-ma. choke in the grid, to prevent any possibility of feed-back between these

*(Continued on page 68)*



# OPERATING NEWS



Conducted by the Communications Department

F. E. Handy, Communications Manager

E. L. Battey, Asst. Communications Manager

More than a score of u.h.f. experimenters may be congratulated on the accomplishment of two-way communication over distances in excess of 1000 miles on 56-60 Mc. during May-June. The work is recounted fully elsewhere in these columns. Carefully planned scheduled tests between Florida and the New York area resulted in success. A week later east-west conditions permitted a duplicate success between numerous ninth district stations and the east coast.

The date may not be far distant when claims will be made for the M.R.A.C.-A.R.R.L. cup trophy to be awarded for the first United States amateur's work two way, over great circle distances of more than 2000 miles, between continents, using the 56-60 Mc. frequency range!

Opportunity is knocking . . . in any one of a number of branches of our amateur radio field. Who will be first to work over the Rockies on the ultra-highs? Who will get the Cup Trophy for 5-meter inter-continental work? The second section of the NKF-tests will be continued (95.6 150 and 275 Mcs.) July 23rd to Aug. 6th. SM5SN's tests from Stockholm (56-57.5 Mcs.) resume starting July 18th. F3MG transmissions are scheduled July 13th-17th. All represent opportunity to find out something. Scheduled tests for experimentation invariably advance knowledge of transmission phenomena. All amateurs who can do so should take part in these tests.

Communication service by amateur radio can be advanced in the general operating (as well as experimental) fields in the summer too. The Field Day testing of equipment in early June should have shown many points for possible improvement of set-ups of equipment for convenience in use. Those results ought to be translated into better utilization of this same equipment afield, or at permanent locations removed from the home station during summer and fall. The sets developed and tested earlier are now ready for emergency — or just to keep schedules with the home city or location. In addition to keeping in touch with relatives and friends and brother amateurs why not also extend the friendly helping hand to neighbors and visitors. Let them make use of your schedules by filing radiograms at convenient intervals. It will give them a thrill, win their respect and appreciation, and a better under-

standing of the capabilities and unselfish service made possible by amateur radio.

Trends in station occupancy of our different frequency bands were discussed in this department in May *QST*. Some subsequent interest has developed in the distribution of operating between radiotelegraph and radiotelephone. Based on analysis of some 7500 questionnaire returns, the accuracy of the figures is high. 'Phone-c.w. percentages (32:67) have changed very little, less than 1% from the figures of a year ago.

### OCCUPANCY REGISTRATION (MAR. 1938)

Band (m)	Radiotelegraph (%)	Radiotelephone (%)
160 m . . . . .	.72	8.91
80 m . . . . .	20.85	6.20
40 m . . . . .	26.86	
20 m . . . . .	17.12	8.06
10 m . . . . .	1.72	4.29
5 m . . . . .	.3	4.76
2½ m . . . . .	.05	.09
1¼ m . . . . .	.02	.05

67.64 32.36

—F. E. H.

## W10XDA Sails Again

CAPTAIN BOB BARTLETT'S Expedition on the Schooner *Morrissey* is scheduled to set sail from West New Brighton, Staten Island, on June 19th, for its annual trip into Arctic regions. This year the *Morrissey* will visit the Western Coast of Greenland, going as far north as ice conditions permit. Harold R. Cooper, W2IKT, will have full charge of the radio shack, using the well-known call letters W10XDA! The 100-watt transmitter will operate on 'phone and c.w. on the experimental frequencies of 6425, 8655, 12,862 and 17,310 kilocycles. For commercial communication only, 8280, 12,240, and 15,560 kilocycles will be used on c.w. The *Morrissey* usually transmits on its experimental frequency of 12,862 kc., communicating with amateurs in the 14-Mc. band. Normally the best hours for contacting W10XDA are between 8:00 and 10:00 p.m., E.D.S.T.

### Continuous Time Signals

Station CHU, Ottawa, Ontario, maintains a particularly valuable schedule of time signal transmissions on 3330 (A2 emission), 7335 (A1 emission) and 14,670 (A1 emission) kilocycles. The time signal, which is transmitted continuously, consists of a short dash for every second, with certain omissions. For the purpose of identification the omissions are grouped in five-minute periods as follows: 29, 51, 56, 57, 58, 59 during the first minute; 29, 52, 56, 57, 58, 59 during the second minute; 29, 53, 56, 57, 58, 59 during the third minute; 29, 54, 56, 57, 58, 59 during the fourth minute; 29, 51, 52, 53, 54, 55, 56, 57, 58, 59 during the fifth minute. At the exact hour a one-second dash is sent, followed by a silent period of about fifteen seconds. The beginning of the dash in all cases constitutes the time signal.

## On Building Club Attendance

By Victor Nelson, W9CCY \*

### PRIZES FOR BEST ARTICLE

The article by Mr. Victor Nelson, W9CCY wins the C.D. article contest prize this month. Each month we print the most interesting and valuable article received marked "for the C.D. contest." Contributions may be on any phase of amateur operating or communication activity (DX, 'phone, traffic, rag-chewing, clubs, fraternalism, etc.) which adds constructively to amateur organization work. Prize winners may select a 1938 bound *Handbook*, *QST* Binder and League Emblem, six logs, eight pads radiogram blanks, DX Map and three pads or any other combination of A.R.R.L. supplies of equivalent value. Try your luck. Send your contribution to-day!

*Scene:* Ten radio amateurs in a hotel room.

*Atmosphere:* Gloomy.

*Time:* Tuesday, early winter evening, 8:00 o'clock.

*Chairman:* "Gentlemen, the meeting is called to order. This meeting is in the order of an emergency. I would suggest that someone move we hold this meeting as an informal meeting."

*First Ham:* "Mr. Chairman, I move that we hold the meeting on an informal basis."

*Second Ham:* "I will second that motion."

*Chairman:* "Discussion?" Silence follows.

*Chairman:* "All those in favor of the motion say, 'Aye.'" Members gloomily mutter "Aye."

*Chairman:* "Those opposed, the same sign." Silence again.

*Chairman:* "Motion passed. Is there any new business?"

*First Ham:* "Mr. Chairman and members: Our club attendance has fallen to ten out of a possible thirty-five. What's wrong?"

*Third Ham:* "WELL . . . I'll be \*\*!# if I know."

*Second Ham:* "We don't have enough programs."

*Fourth Ham:* "Our meeting place was the bunk."

*Fifth Ham:* "Well . . . you know, I like this new place."

*Sixth Ham:* "Too darn much business every time!"

So the discussion went—and out of the suggestions offered, the following items were listed:

1. Proper housing of the club meetings.
2. Short business meetings.
3. Snappy programs with a punch.
4. Educational features for the members studying for exams.
5. Some form of good publicity.

Out of this meeting, activity and work was made for everyone in the membership of the club.

The first step—the meeting place itself, was considered and the rental of a centrally located private hotel room was found to be a minor expense. This meeting place lent the necessary prestige which was so badly needed.

The heart of any club meeting, the program, was

\* 339 Sherman Ave., Council Bluffs, Iowa.

built up. Real worthwhile topics were found and good programs outlined. Educational features were incorporated in these activities. Club members were called upon and talents long dormant were brought to light.

Next, the business meetings were to be held every three months, with provision that a short business meeting might be held at any meeting, should the need arise.

Publicity (advertising to you) of a new type was used. Mimeographed bulletins and cards were sent out to interested amateurs. Photographic type of postal cards (with pictures), attractively lettered, giving a résumé of the coming program features were sent out. One of the members made up these cards at a nominal cost. A large mailing list was used. The use of radio for advertising was not neglected. Club members on the 1.75-Mc. band invited guests to club meetings

### Results:

Fifty persons attended the first meeting. Featured on the program was a working demonstration of electrical recording with one of the club members giving an all request program of musical selections on his accordian. Some of these numbers were recorded and played back to the cheering audience. One local radio wholesale house furnished refreshments for the gang.

Don't not foolin' the next  
**COUNCIL BLUFFS**  
**RADIO**  
**OPERATORS' CLUB**  
MEETING  
APRIL 5th 1938  
HOTEL DAXTON-OMAHA, NEBR.-7:30 P.M.  
Program sponsored by H.C. Noll Co., Omaha.  
Council Bluffs Operators will visit our OMAHA friends..... A big exciting -  
entertaining and mysterious program planned. All amateurs welcome.  
PLENTY OF SHADE and ICE WATER  
- W. BCCY Advt. - Secretary

More meetings followed. One of the club members gave a talk on crystal grinding and crystal control. A 56-Mc. crystal-controlled transmitter was on display. Fifty-eight amateurs attended.

A following meeting featured a broadcast engineer who gave a comprehensive talk, illustrated with slides, on "Equipment Used in a Five Kilowatt Transmitter." Seventy persons were present. Applications for membership came in.

A later meeting was held in our neighboring city, Omaha, in the way of a visit to our amateur friends who have visited our club meetings. At this meeting, a "stunt" committee provided the fun with a short skit. A short talk was given by an Omaha broadcast engineer on the subject of "Amateur Radio Operating." Also, to the complete surprise of the one hundred and twenty-five persons attending, Mr. Jerry Belcher of the N.B.C. Interesting Neighbors program was present to give a talk on his experiences in interview-

ing during many of his broadcasts. A successful evening and a fine time was enjoyed by everyone. By this time you will have thought, "must cost a heap!" It is true that expenses will creep in—but the cost was small and the larger groups made possible the added cost so that expenses were readily met. Through the cooperation of our local radio jobbing houses we have been able to have meetings (in Omaha) at a very nominal cost.

At the time this article is being written, the club plans on a bigger and better annual 56 Mc. treasure hunt, June 12th. Inquiries concerning the hunt are coming in from out of town. We know everyone attending will enjoy this added activity.

Just one thing more—remember the ship will go forward if you will only get out the oars and row!

## 56-Mc. DX!

### W4EDD and W5EHM Lead in Contacting Five-Meter DX During May

#### FLASH

*As we prepare for the press reports begin to pour in from many parts of the country telling of the most extraordinary 56-Mc. performances yet recorded. June 5th would seem to have been the day of days with five-meter signals smearing the country in hair-raising style. This report was prepared just as the first fragments of news came in. It will be followed next month by an extensive review of this history-making 56-Mc. orgy.—*

EDITOR,

FOR the past several years May has been the month when extreme 56-Mc. DX has taken place. With this knowledge as an incentive, the more serious-minded 5-meter men were pointing for May this year and were not disappointed.

First indication of good conditions was on May 8th when W9CLH in Elgin, Ill., worked W9NY, W9ZGD, and W9ANA at Milwaukee. Crystal-controlled transmitters were used throughout. On the 11th W8CIR worked W8PK for a 200-mile QSO.

The first big day for DX was the 15th. W4EDD at Miami, Fla., had been talking for some time of running a 56-Mc. sked with W2AMJ. They set the date for May 15th, and at 1 p.m. W4EDD called for 15 minutes. When he switched over to listen, there were so many fellows calling that the QRM was terrific! Calls were logged for 15 minutes and then another 15-minute transmission was made, reporting those calls that had been identified. During the next stand-by period he heard almost 100 carriers, with QRM so bad that it was impossible to identify most of them. From 2 to 4 p.m. W1EYM, W2BHD, W8CIR, W2JCY, W2HWX, W8YUT, W2CUZ, and W8NED were worked, and W1XP, W3CMA, W3EZM, W3COK, W2AMJ, W3GMZ, W3KHN, W2ISY, W3FOM, and W3GGC were definitely identified among the many heard. Crystal control was used, with a pair of 809's in the final running around 175 watts, and the antenna was a horizontal affair with one reflector and three directors. Tests made with W2CUZ during their QSO tended to show no definite plane of polarization, indicating that the downcoming wave was circularly polarized. W2JCY, who was quite active in the arrangements but skeptical of the outcome, loses the brand-new hat he bet on the possibilities of a QSO. W4EDD says of the results, "It was interesting to find . . . that power did not seem to be an important factor, as some of the strongest stations were using 50 to 75 watts."

May 19th seems to be the next big day. W8EQN in Springfield, Ohio, says, "A local SWL heard W9TZQ, W9DJO, W9EV, W9MPV, W9FP, W9CLH, W9MPU, W8PNU, W9YUT, W8ORT, W8NSS, and W5EHM. He heard W5EHM work W9EU in Chicago and some other stations. He heard a number of other 5's and 9's, but did not get their calls." On the same date, W5FYS heard W9CLH, W9ARN, and some unidentified 8's and 9's. Although we have been unable so far to get a report from W5EHM, W9TZQ stayed with him most of the time he was coming through on the 19th, and besides working him, heard W5EHM contact W8JMS, W8GBU, W8CIR, W8CGV or CQV, W9FP, W9YFG, W9VJO, W9OQE, W9ARN, W9SQE, W9ZGD, W9CLH, W9ZEO, W9RK, W8PNU, W9MPV, and W8FMI. W9TZQ was using 12 watts to a 53. On the same date W9USI at Brookings, S. D., heard an i.c.w. signal around noon signing W8RVB, but has been unable to locate the QTH of the station.

The next good day was May 28, when W9SQE worked W2HWX, W2HGE, W2KLO, W2FZA, W3GQS, W3GEF, W3GPS, W3EET, W3AIR, W3BZJ, and W3AFJ. Other stations active working the east coast were W9HPP W9ZEO, W9AUQ, W9VFO, W9YLV, W9VVE, W9MAI, W9ZDT, W9BEA, W9BON, W9ZXD, W9CX, W9ZCN, W9GYS, and W9VHY. W3AXU worked W9SQE and W9HPP, and heard W9VVE.

June 5th was a particularly "large" 56-Mc. night with DX coming through so fast it was almost hard to keep up with the log! W1CBG, using a super-regen receiver in his car, with half-wave antenna, on Soapstone Mountain, Somers, Conn., logged the following between 8:45 and 10:15 p.m. EDST: W9LDM, W8RSS, W9TMM, W9PPB, W9ARN, W9CLH, W9IBX and W9ZSS. At home in West Hartford, using an indoor antenna and super-regenerative receiver with quench oscillator and audio, 6J5G-37-42 line-up, W1JBJ logged W2JCY, W8EGQ, EJQ, ENV, JRP, RSS, RVT, YX, W9ARN, CJ, CLH, HPP, KEN, KRX, LLL, PQH, VHJ and ZSS, all between 7:00 and 9:30 p.m. EDST. JBJ noted that practically all stations heard were using crystal control. On June 2d, W8RVT, Springfield, Ohio, made contact with W5EHM, Dallas, Texas, at 1:05 p.m.

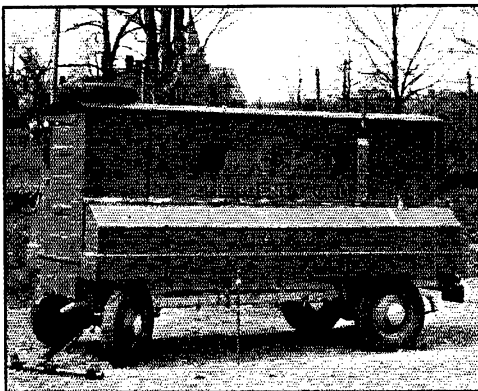

**THIS TRAILER HOUSES ALL COMMUNICATING EQUIPMENT OF THE IRA LOU SPRING POST NO. 149, AMERICAN LEGION EMERGENCY UNIT AT JAMESTOWN, N. Y.**

One of the most complete portable installations, the trailer carries a complete radio station, WANC, with gasoline engine and 500-watt a.c. generator for power, a twenty-line telephone testboard, Morse telegraph equipment, and all associate gear to make possible communication by radio, telephone or telegraph. A 30-foot folding mast is used to support the 162-foot antenna. WANC operates on 2726-kc. 'phone and 3190-kc. c.w. Two 56-Mc. transceivers are also part of the station, as well as several receivers for all bands, including the broadcast. WANC on 2726-kc. 'phone tests with amateurs in the 3.9- and 1.75-Mc. bands each Monday from 8:00 to 10:00 p.m., Eastern Time.

## April O.R.S.-O.P.S. Parties

and again at 1:25 P.M. EST. The rig at W8RVT was a 35T in stabilized oscillator, running 180 watts input, plate-modulated. The receiver was a super-het, antenna was directional, half-wave vertical fed off center with three reflectors, each a quarter wave apart and a quarter wave from the main antenna. Also on June 2d, W1HDF, Elmwood, Conn., worked W9ALE, Chicago, at about 9:00 P.M. EDST; HDF also heard W9ALE between 10:00 A.M. and noon. In his reception of DX stations on "56," HDF observes that crystal-controlled signals are by far the best. Between 10:00 A.M. and noon, June 5th, W2IEK logged W9CX, W9IV, W8NOB, W9NY and W9UTS. W2HKU heard W9OXD and W9NY during the same period.

It is quite likely that some of the calls given above are incorrect because of mistakes made in copying them. This is a further indication of the necessity for clean and frequent signing of call letters, especially when conditions appear to be favorable for long haul work.

### NKF Tests

The Naval Research Laboratory, Bellevue, Anacostia, D. C., will make test radio transmissions on ultra-high frequencies July 23rd to August 6th. It is desired to find the distance at which these transmissions may be heard. All observers are asked to notify the Naval Research Lab by mail or otherwise. Reports of failure to hear these transmissions are desired as well as reports of hearing them.

The frequencies: 94.6, 150.0, 275.0 Mcs., simultaneously. The date: July 23rd to August 6th, inc.  
The times: 8 A.M. to 4:30 P.M. EST, Monday to Friday, inc. Continuously (24 hours) Friday to Monday, inc.

### SM5SN Tests

Starting July 18th, and running for the remainder of the year, SM5SN will transmit continuously on frequencies between 56 and 57.5 Mcs. every day between 0730 and 1600 GMT. A tone modulated carrier will be used, sending a short text and signing the call. Reception reports should be sent to Mr. G. Siljoholm, A.-B. Hammarbylampan, Stockholm 20, Sweden.

### F3MG-F3MZ Mount Blanc Test

From July 13th to 17th inclusive, F3MG will test 5-meter equipment from near the summit of Mount Blanc. The call F3MG will be used on c.w. and F3MZ on 'phone. An attempt will be made to contact as many 56-Mc. stations as possible during the five days of the tests. Any reports of reception will be greatly appreciated.

## Hamfest Schedule

**July 10th, at Reelfoot Lake, Tenn.:** The Moarky Amateur Radio Association will hold its quarterly meeting at Reelfoot Lake (near Tiptonville), Tenn., on July 10th. An old-time fish-fry will be served. An all-day meeting is planned, with field and portable equipment. Further details are available from H. C. Young, Sec'y-Treas., Box 7, Sikeston, Mo.

**July 10th, at Rolling Green Park, Pa.:** The Susquehanna Valley Amateur Radio Club of Selingsgrove, Pa., is holding a hamfest on July 10th at Rolling Green Park, 3 miles south of Sunbury, Pa., on Route 11. Inquiries should be sent to W. Reed Hile, W8RJK, R. D. 2, Sunbury, Pa.

**July 17th, near Rockford, Ind.:** The Annual Illinois-Indiana Radio Picnic and Field Day, under the auspices of the Eastern Illinois Amateur Radio League and the Wabash Valley Amateur Radio Association, will be held Sunday, July 17th, at Turkey Run State Park, near Rockford, Ind. All hams, their XYL's, YL's, and friends are invited to bring a basket lunch and portable equipment (for any band), and join in for a full day of fun and entertainment. Registration fee is only 5¢ "per family."

**July 24th, at Waterloo, Wis.:** Come to Fireman's Park, Waterloo, Wis., on July 24th, for the Annual Hamfest of the Rock River Radio Club. Everybody is welcome. Come early and stay as late as you like. Registration, in advance, 75¢ for YL's, \$1.00 for OM's; at the gate, \$1.00 and \$1.25. Plenty of eats, fun, and a large prize drawing at 6:00 P.M. Reservations and complete information may be obtained from Lester Miller, W9OFL, 275 S. Madison St., Waupun, Wis.

**ACTION** speaks louder than words, and the results of leading scorers in the April O.R.S.-O.P.S. Parties tell their own story of the success of those affairs! Many reported the get-togethers "the best ever." Just look over the tabulations below!!

The O.R.S.-O.P.S. All-Season Competitions, covering performance in various phases of operating between October 16, 1937 and May 15, 1938, are now concluded. A good number of entries are being received, with impressive records claimed. Final results will be reported in the July ORS/OPS bulletins, as well as in a later issue of *QST*.

If you are not already numbered among those proficient amateurs who hold appointments in the A.R.R.L. operating organization, we invite you to communicate with your S.C.M. (see list in front pages of each *QST*) for information on any appointment for which you would qualify. Now is the time to get lined up so that you won't miss any of the activities next season.

The next O.R.S.-O.P.S. Parties are scheduled for July 23rd-24th.

## Official Relay Station Scores

Station	Score	Different Stations	Different Sections	Heard	Power	Section
W1AW (Hal)	12,209,778	192	51	26	500/700	Conn.
W1TB	10,370,495	172	55	20	350	Conn.
W4DWB	8,945,794	159	53	57	75	N. C.
W3GZ	8,521,764	164	48	17	200	M.-D.-D. C.
W3BBS	8,480,418	172	46	21	150-250	E. Pa.
W8KFC	8,282,099	134	54	29	110/55	Ariz.
W8KUN	7,004,558	172	46	31	90	W. Pa.
W4NC (W4WX)	6,770,755	150	47	15	300-1000	N. C.
W1EBO	6,738,930	155	43	16	100	W. Mass.
W8OFO	6,092,709	168	49	13	250/350	W. Pa.

Station	Score	Stations	Sections	Station	Score	Stations	Sections
W8JKO	5,623,200	151	47	W3DGM	2,677,824	110	34
W8JTT	5,459,919	133	44	W9GWK	2,561,892	109	44
W2HZY	5,043,730	130	40	W2JHB	2,554,040	98	36
W1AXB	4,943,258	137	40	W3ADE	2,533,347	109	30
W4AGI	4,682,125	135	40	W2GVZ	2,509,236	108	33
W2HMJ	4,460,926	145	36	W3BDC	2,465,143	106	33
W3CHJ	4,082,240	132	36	W3BYR	2,441,832	104	38
W3GDI	3,950,268	125	39	W1AMQ	2,417,468	118	28
W1KQY	3,640,140	127	35	W6IOX	2,400,914	79	40
W3FBM	3,228,578	125	31	W8MOT	2,339,168	116	33
W4AFU	2,942,114	115	46	W3NPF	2,241,320	107	30
W9HQH	2,818,431	108	39	W9VES	2,227,816	97	39
W3EFH	2,760,523	113	38	W8LCN	2,144,115	111	34
W1GME	2,713,772	115	38	W9YXD	2,120,094	106	32

## Official 'Phone Station Scores

Station	Score	QSO's	Sections	Heard	Power	Section
W3FGJ	5592	41	24	14	500	Va.
W8LUQ	5120	42	20	23	350	W. N. Y.
W1FBJ	4712	36	19	34	300	Maine
W8MOL	3900	46	15	15	400	W. Va.
W8MBW	3893	37	17	32	600	W. N. Y.
W1EAO	3876	40	17	14	225	Conn.
W8ICQ	3808	40	16	19	120/140	Ohio
W9WXL	3798	39	18	8	150	Ky.
W8VZ	3600	45	16	5	500	Ohio
W9UNS	3408	37	16	14	190	Ind.

Station	Score	QSO's	Sections	Station	Score	QSO's	Sections
W8KNF	3255	37	15	W8PUN	2743	33	13
W9TTA	3248	36	14	W1BNO	2610	32	15
W3AIJ	3080	28	20	W9SYJ	2472	40	12
W8HFR	3024	36	14	W8PKS	2304	30	12
W8BTP	2925	37	13	W8AQ	2288	28	11
W2HNA	2912	36	16	W8CDR	2068	32	11
W4CYB	2898	27	18	W8JFC	2028	29	12
W8AHF	2769	31	13	W9MLJ	2002	26	13

# How's DX?

## How:

We've always been a little reluctant to do much preaching ever since we learned at a tender age that one of our uncles had been lynched for cattle rustling. Nevertheless there is a practice in DX circles that we'd like to comment about. It's this business of going to such extremes in trying to wangle cards out of rare DX stations that the rights and privileges of the DX stations are endangered. In case you think we're barking at the moon, take a look at a letter from PZ1AB: "Are U. S. hams going to make a mess of things for us in PZ? It is rumored in PZ that W hams lodged a complaint with the Netherlands consul or *chargé d'affaires* somewhere in the U. S. to investigate why they can't get their QSL cards. This official, it is stated, addressed the Home Government which in turn put the matter in the hands of the governor here in PZ. The Postmaster here has been ordered to hold back all QSL cards addressed to PZ hams, so please warn the boys to QSL under cover, and under cover only, to all of us. Have them QSL via A.R.R.L. . . . . and help us poor guys out of this mess."

There's your story. A few not-so-smart hams in this country, and some sincere amateurs in a more restricted country lose their chance to operate. Some countries just don't like amateur radio, and hams there take a risk every time they hit the key. It's not too much trouble to buy envelopes for your cards, and then not plaster the envelope with "To Amateur Radio Whoosis." Besides PZ, take it easy with cards for I, PJ, SV, YU, and any you aren't sure of. You may save the fun you have for someone else.

## Where:

WIAPA, who spends most of his spare time cracking lobster, managed to work a good one in OY2A (14,430 T6) in the Faeroes. The time was around 7 p.m. and WIACV got him too . . . . . A bunch of the boys, including W2BHW, W6GAL and W8DFH pass along some dope on the Pacific Islanders. Look around for K6NVJ (7185) on Jarvis, K6HCO (8439) on Canton, Phoenix group, K6GNW (7180) on Enderbury, Phoenix group and K6DSF (7080) on Baker; then swing around to VR2FR (7235), VRIAK (7200) and VRIAM (7175, T9) . . . . . And now that it's getting a little later in the morning, drop down to 20 for a crack at K9DMM (14,870, T8), VK9GR (14,110, T7), VK9BW (14,300-14,380, T6) and VK9VG (14,085, 14,110). VG's address is V. Gilchrist, Bulolo Power House, Bulolo, New Guinea . . . . . If you missed UX1CR on Rudolf Island, who incidentally has been QSL'ing, look for UX1CN (14,410, T9) . . . . . W4EIU says that the address of FG8AH (7150 or so, T6) is A. Haan, P.O. Box 125, Pointe-a-Pitre, Guadeloupe. The rig is PP 50's with 75 watts input . . . . . A big question mark goes after this one, worked by W9VDY and W2BHW: PK7FF (14,275, T8c) supposedly at San Maarten Island. But we can't find any trace of a PK7 prefix, or that island . . . . . A much better bet would be PK6AJ (14,120, T9), worked by W6CXW . . . . . We hope G6WY won't be angry if we lift a couple of items out of his excellent DX column in the *T & R Bulletin*, but we thought you'd like to know that ZD2A and ZD2B are genuine, and cards can be forwarded via R.S.G.B. No QRA's can be given; they are operating under strictest secrecy . . . . . W1DF has worked 117 countries . . . . . G6WY also says that the real VP8B ceased operating in 1936, which is why the fellow using that call in 1937 never QSL'd. The other VP8D, worked this year, may be genuine . . . . . W1DF has worked 116 countries . . . . . W2BHW heard a couple of juicy ones: EQ4AC (14,375, T8) and J9CA (14,005, T6) . . . . . W9WCE asks about YB8A (14,060) . . . . . And W8DWV is afraid that there might be two YV2CU's, since he wasn't on the list sent in by the real one and he heard two YV2CU's on one day. Some stuff! . . . . . W3A00 says to send your card for TF2AX (14,200-14,300,

T6) to S. Jansen, Somalka 25, Hekla, Iceland . . . . . Old VP2CD is now VP2AB, Clement de Silvia, 33 Nevis St., St. John's, Antigua . . . . . Send cards for VQ2JC (14,120, T8c) to Jack Christie, Box 95, N'Kana, Northern Rhodesia . . . . . A couple of Trinidad QRA's: VP4TN (7180, T9), A. E. Duuf, 28 Diverteuil St., Woodbrook, thanks to W8OYI; and VP4TI (14,260), Stanley Knowles, Custom House, Port of Spain, thanks to W2KIK . . . . . W9IJW reports that PZ1AB (14,410) has been using that call on a ship he's now working on . . . . . W6GPB wants to count VU7AR (14,410) in Mysore State as another country. Gosh, let's not start any more arguments about countries . . . . . Via the grapevine we hear that VE2AC has been hearing AC4YN (Tibet) on 20 around 2 p.m. That's all the dope we have but no W has worked the fellow as far as we know, so he's worth going after.

## When:

Not much dope on 40 this month, but W7LT tells us that it's good for Asians in the early yawning, W5GJU worked KA1SL (7225, T8) and W8RKM tells about a flock of K4, KM, YV, and VK. Don't forget to look twice at those K6's—they're scattered all over the Pacific.

W9CWW says a QSO with J2JJ (14,400, T9) at noon was unusual for his part of the country. Other good stuff there was XU9MK (14,110), XU8XA (14,350), KA4LH (14,110), TF3C (14,410) and VS6AO (14,340) . . . . . W9VWV worked CT2BM (14,420, T7) and E85C (14,090) . . . . . W8ADG advises looking right under that 'phone of HI5X (14,060) if you want a crack at VS1AF (T9) around 8 a.m. . . . . DX manages to trickle into those mountains down West Virginia way, and W8OXO gives VQ2GW (14,360, T9c), VQ2EJ (14,020, T9c), XU8OL (14,375, T9), VR4AD (14,300, T9) and PK1MF (14,385, T9) . . . . . If youse guys are looking for U's, guys, W3EMA suggests U1CO (14,402), U1AD (14,440), U2NE (14,400), U3CY (14,400), U5KN (14,440), U6VB (14,420), U9MN (14,430), U9AV (14,415) and U9AW (14,420). Some other shots are LY1AI (14,300), VP7NT (14,400), I1RCN (14,405) and YR5VV (14,010) . . . . . Down in Maryland, W3A00 takes a dive into DX and comes up with OQ5AQ (14,380, T9), VQ4KTF (14,075, T9), PK1PK (13,990), XU6LN (14,100), and XU8OL (14,360) . . . . . The copper magnate, W8DWV, shows up with YK7MT (28,350), K6OVN (14,120) in Guam, V8TRF (14,310), and EL2A (14,360). He also got K6NVJ (14,360) at Jarvis at 3 a.m. . . . . W8QQE is working on a quick-freq-change gadget but found time enough to work YN1AA (28,200, T9), PK1GW (14,090, T9), KA1AF (14,100, T9), and hear VU2FH (14,150, T9), J2LL (14,090, T9), and HS1BJ (14,070, T9) . . . . . VQ8AS (14,325, T9c) at Chagos is back on . . . . . W2BHW heard a couple of new ones: XU6PZ (14,310, T7) and XU6TL (14,325, T7c) . . . . . W6MX, who has been trying an 1851 in the input of his receiver, worked VQ8AA (14,000, T7), VR2FF (14,100, T9), F18AC (14,100, T9), CR7AK (14,100, T8), and SPLKM (14,410, T9) for his latest ones.

## What:

W6JMR had a story that seems worth passing along. We'll let you do the explaining, however. It seems that he's one of the faithful followers of the "80-meter Zepp" for DX work, and has had a lot of success with one. When he moved recently he put up an 80-meter Zepp and found it to be good for European DX as before but he couldn't work W's with anything like consistency. One day he was comparing notes with W6JTP (who has the same kind of antenna and in the same general direction) and found that JTP worked W's quite well. More discussion brought out the fact that JTP's was cut for 80-meter operation (133') and JMR's was for 20-meter harmonic operation (137'). They lengthened JTP's Zepp to 137' and he found he

wasn't working the W's as well, got disgusted, and put it back to the original length. But the European heard cards started rolling in, and checking in the log showed that they were all for the period during which the longer wire was used! So the story seems to be: if you're using a harmonic antenna on the higher frequencies, cut it for those higher frequencies. The shifting current distribution on the feeders is probably responsible for the effect.

The other day someone said that they've noticed that when the short skip is in on 10 the high-frequency end of the band doesn't seem to fold like it does under normal conditions. That is, under normal but poor conditions it is possible to get through on the low-frequency end when the high end won't let a signal through, but this effect isn't apparent when short skip is on. We wonder if many others have noticed it.

### Who:

You'd be mighty surprised to know what very well-known DX man has been secretly married for over a year, and is now the proud pappy of a baby boy. He threatens to name him "David Xenias" so the initials will be "DX"! . . . . . W5VV ("the voice of his conscience") thinks it might be funny to print some of the pleading letters that the DX stations get when they don't QSL immediately. Well, Wilmer ought to know—some of his tear-stained letters are really something . . . . . KA1AA (7305, 14,070) writes to say that his correct address is J. B. Carmichael, 91-2, Fort Mills, P. I. . . . . ON4AU needs no introduction to the DX gang. In a nice letter he sings the praises of some of the local boys, including W6KIP, W9ARL and W8GQC, who helped him get through on 40 and 80 to some of the harder districts during the contest. 4AU has worked ZL4DQ on four bands, and would like skeds in Asia, Africa, and South America so that he can complete a FBTOC WAC . . . . . If you want a really heavy heart, you should look at some of the cards J5CC sent in for his CC application. Some of the sweet ones were J9PA (Marshall Islands), CR9AA, V88AJ, U8EC, U8IK, PK5LK, PK6XH, YJ1RV, ZS3D, and VR2NB. We suspect he'll be up among the first few as soon as he fills in a few more Central Americans . . . . . VK2ABJ complains that another VK has been using the call VK2ABL while testing a rough transmitter, and the real fellow would appreciate it if you can give him the QRA of the adopter . . . . . W4BHY has been knocking them off with an RK20 Tri-tet driving a 100TH, and the DX includes CN8AS, YN3AY, K4AAN and FV8AE . . . . . W5GNY thinks it a dirty trick that his first DX outside of the U. S. should be a rare one like ZB20 that no one will believe he worked. We believe he worked him, but we're a mite sceptical about ZB20 being in Gibraltar . . . . . If you've looked around here before you may have noticed that we have a soft spot for the low-power lads. Well, the latest we welcome is W6IAQ who made his WAC with a 30-watt 802 driven by a 42, and G8UT who made his on 6 watts . . . . . Speaking of low power, our speculations about the 210 DX Club finally pulled a letter out of W8GQB. It seems that Win had YL trouble as was rumored, but now he's married the gal and has settled down, so much so that he's going to get going on the club once again. If you're interested in it, and are working your DX with less than 150 watts, write to W8GQB at 15469 Wark Avenue, Detroit, Mich., and tell him about it. In these high-powered days it warms our heart to see the QRP boys still sneaking them out from under. More power—we mean "DX"—to you! . . . . . We thought G16TK (14,384, 14,084) had worked about everything, but it seems that he still needs S. C., Miss., S. D., N. M., Utah, Ariz. and Nevada for his WAS . . . . . And E85C (14,090) needs Ariz., N. M., Nev. and S. C. . . . . W3GHD works stuff like VU2FX, F18AC, FR8VX, HR7WC and PJ3CO, but thinks VP3, VP6 and HI are tougher. Maybe they are—to get cards from! . . . . . According to W6LUJ, HK5JD (7090) needs Ariz., Utah, Wyo., Idaho and Montana for WAS . . . . . A fellow that will have to be reckoned with very soon is VO3X (14,400). He's been knocking off some good DX, working J5CC for the first J-VO, WAC within 24 hours, and things like U6WD, PY5QJ, VK7QZ, CT2BE, VP9J, and he hears XU8KH, PK1MF, and EL2A. But he needs S. D. and Nevada for

WAS . . . . . W6ITH got a nice letter from J2NG and passes along the dope. It seems that the power limit in J is 10 watts in the antenna or 20 to the final (hmmm!), the time is restricted (see March, 1937, QST, page 56), and used Call Books would be greatly appreciated by the J's, as they are very hard to get and quite high-priced . . . . . VE2AX is one of Montreal's best DX-ers, and we finally got him to admit that he's been working VR4AD, FY8AA, TF5C J2LL, U9AV, U6WB and FR8VX and hearing G6IA (28 Mc.), VK4HN (Papua), VS9AM1, PK1PK, XU8NR and



VR4AD. ALAN W. DICKES, TULAGI, BRITISH SOLOMON ISLANDS

*Lack of commercial power facilities has not proved too great a handicap for VR4AD (14,300, T9). The rig is powered by a pair of Genemotors, feeding a 6V6G Tri-tet driving a 6L6 final on 20 and 40, with an input of about 40 watts to the final. The antenna is a half-wave Zepp on 40 using series tuning.*

XU2BM . . . . . Keat of W9KG added VR6AY, TG9AA, VK9VG, LX1AG and—he thought—G5TZ on the Isle of Wight. But the latter isn't a new one . . . . . Maybe it isn't DX, but it might help you in climbing ivy-clad trees to try new skywires during the summer months to know that gasoline on the roots of poison ivy doesn't help the ivy any. Don't light it, says W8JSU, and don't forget that it also kills grass and flowers . . . . . W6GAL figures he got pretty good life out of his old pair of 10's. During 5½ years of service from them he worked 110 countries, with S9 WAC on c.w. and S8 on 'phone. The last two countries before pensioning them off were CN8MQ and ST6KR. But now he's more QRO at a new QTH, and has 119 countries . . . . . Some of the local lads have some good ones. In the evening W182 knocks off LZ11D (14,380, T7c) and OY4C (14,370, T6), W1EH gets LX1AO (14,410, T9), W1FTR heard TA1AB (14,410, T8) and WITS reports VK4KC (14,395, T9x) on again in the mornings. . . . . ZS1AH is 55 years young this year and is retiring and returning to Enzland, so he says "cheerio" to the gang. Good luck, OM. A lot of the boys will miss the good contacts they've had with you . . . . . W8PA, back on the air after 5 years, worked 40 countries in two months, and complains because the only Asians so far are U9's. There are still a couple of boys left who wouldn't mind that so much . . . . . W8OSL managed to get out of bed early enough one morning to find XZ2DY, V87MB, F18AC, VK9BV and a few more, but of course he didn't bother to call them . . . . . Suggested title for story: "DX is where the other guy finds it."

### O.B.S.

The following is a supplement to the list of A.A.R.L. Official Broadcasting Stations in October QST (page 60): W4TO, W7BOZ, W7BWH, W8NEA, W8OUT/QYB, W9VMI.



## Amateurs Coöperate in Air Mail Celebration

On May 19th, the day that the air mail was carried by private pilots all over the United States, the First District of Nebraska was covered by 16 flights. When the first notice of these flights was made public, a meeting of pilots and post-masters of this district was called in Lincoln, April 3rd. W9DLK, his son and their postmaster at Howe, Nebr., attended. W9DLK was introduced to Mr. Charles Doyle, the Secretary of the Aeronautical Commission of Nebraska. W9DLK suggested that the radio amateurs of Nebraska, through their emergency net, dispatch the planes on May 19th. Mr. Doyle agreed.

W9DLK put the project up to the Southeast Nebraska Radio Club and W9WKP, Club President and A.R.R.L. Emergency Coördinator, appointed W9DLK. W9SUS and himself as a committee to line up hams for the job. The committee found that W9EKK of Lincoln would act as master control station with W9FWW assisting at the airport in Lincoln. Every amateur put his shoulder to the wheel and pushed. Of the 30-odd towns having air mail pick-up, over 25 of them were covered and the planes reported in and out of each town with the weight of the mail sent out. All but a few of the hams coöperating were operating portable sets using all kinds and sizes of rigs, with power ranging from "B" batteries to motor generators.

W9RUJ of Auburn acted as control station for three flights; W9OWR at Nebraska City was control for two flights. They received the reports from the field stations and relayed them in to the master station at Lincoln, who in turn transmitted general broadcasts as each plane arrived. To show the swiftness of these dispatches, when flight No. 11 left Nemaha, W9YOI reported it to W9RUJ, he in turn reported to W9EKK at Lincoln and on to the Municipal Airport. W9FWW, who gave it to the announcer of the public address system, all this taking place in less than one minute. Some of the reports were put through and announced by the P.A. system in less than 30 seconds. All the other flights that were covered were reported direct to W9EKK, who in turn gave them to W9FWW.

All in all the amateurs of Nebraska did a wonderful job and put it over in A-1 shape. At the conclusion of the flights, W9EKK, master control, gave a short talk to all taking part, thanking them for their fine coöperation. This was re-broadcast over KFOR.

—Garold Bennett, W9WKP,  
Emergency Coördinator

## 28-Mc. Tests

A series of 28-Mc. tests throughout the summer of 1938 are announced by G6BW and G6VK. Transmissions will be made by one or both of these stations at the following times, followed by a period of listening. The tests will run daily from May 1st to September 18th. All times are G.T.: Sundays, 1000, 1200, 1400, 1600, 1800, 2200. Mondays, 1230, 1330, 1500, 1800. Tuesdays, 1230, 1330, 1500, 1800, 2100. Wednesdays, 1230. Thursdays, 1230, 1330, 1500, 1800, 2200. Fridays, 1230, 1330, 1500, 1800, 2000. Saturdays, 1400, 1600, 1800, 2000. G6BW and/or G6VK will transmit on c.w. and 'phone on either 28,268 kc. or 28,404 kc. (or at frequencies between these). Complete reports of reception are requested, both from amateurs and S.W.L.'s. The latter may forward reports to BRS, 3214, G. A. Clayton, Winscombe, Somerset, England. Licensed amateurs may QSL reception or contacts to G6BW, Capt. Ben Wallich, "White Orchard," Churchill, Somerset, England. All reception reports should be as complete as possible, containing such data as times heard, strength of signals and whether or not QSB was noted, weather conditions, barometrical pressure, phase distortion, etc. G6BW will make a comprehensive study of all results.

## DX Century Club

THIS month congratulations go to W8OQF, ON4UU, W2GT and W2UK, the latest additions to the club roster. Membership now totals thirty-three, with seventy-two in the "below 100" group. Many of the latter are pushing steadily towards the top, and it's just a matter of time—

and QSL's—until they make the main list. W8CRA and W1TW swapped places this month, with CRA again in the lead by one country.

## MEMBERS, DX CENTURY CLUB

	Countries
H. A. Maxwell Whyte, G6WY (No. 5)....	130
Frank Lucas, W8CRA (No. 1)....	124
Jefferson Borden IV, W1TW (No. 3)....	122
John Hunter, G2ZQ (No. 6)....	121
Clark C. Rodimon, W1SZ (No. 7)....	120
Douglas H. Borden, W1BUX (No. 2)....	118
C. E. Stuart, W6GRL (No. 15)....	117
E. L. Walker, W8DFH (No. 14)....	116
Don H. Mix, W1TS (No. 9)....	114
Henry Y. Sasaki, W6CXW (No. 4)....	112
Reeve O. Stork, W2GTZ (No. 12)....	112
Harry G. Burnett, W1LZ (No. 10)....	109
Walton H. Bostwick, W2GW (No. 11)....	108
Jean Lips, HB9J (No. 13)....	108
Keat Crockett, W9KG (No. 16)....	107
Francis J. Walczak, W8DWV (No. 17)....	105
Fred M. Gillett, W6HX (No. 21)....	105
Onne L. Santti, W8DHC (No. 27)....	105
W. H. Alexander, W6KIP (No. 28)....	105
C. L. Williams, W8JMP (No. 22)....	104
Arthur H. Bean, W7AMX (No. 26)....	104
John Marshall, W9ARL (No. 18)....	103
George Grammer, W1DF (No. 29)....	103
Paul de Neck, ON4UU (No. 31)....	103
A. Edward Hopper, W2GT (No. 32)....	102
Guy Grossin, F8RJ (No. 8)....	101
B. W. Benning, W4CBY (No. 20)....	101
Julius Wengler, W8OSL (No. 23)....	101
Ralph H. Summers, W8OQF (No. 30)....	101
Ralph E. Thomas, W2UK (No. 33)....	101
H. Hodgins, EI5F (No. 19)....	100
Jack Clarricoats, G6CL (No. 24)....	100
Richard J. Cotton, W8LEC (No. 25)....	100

The following have submitted proof of contacts with 75-or-more countries:

W6ADP... 99	W8KKG... 88	W8KTW... 82
PAQXF... 99	VK5WR... 88	W2CYS... 81
W5BB... 98	W3JM... 87	W4BPD... 81
W9PST... 98	W8EUY... 87	W1ADM... 80
J5CC... 98	W9AEH... 87	W3BVN... 80
W3EVW... 97	G2DZ... 87	W3EPR... 80
W9EF... 97	W4AJX... 86	W3GAU... 80
W1ZB... 96	W6BAM... 86	W8DGP... 80
W6FZL... 96	F8BAB... 86	W9FLH... 79
W1DUK... 95	VE2AX... 86	W5ASG... 78
W1WV... 95	W1RY... 85	W8FJN... 78
W3EVT... 95	W2HHF... 85	W9UM... 78
W9KA... 95	W4DRD... 85	W1BFT... 77
F8RR... 95	W8ADG... 85	W2DC... 77
W6GAL... 94	W8BOX... 85	W3VX... 77
PAQQF... 94	W8CJJ... 85	W6ITH... 77
W1CC... 93	G6GH... 85	W8BSF... 77
W5VY... 93	PAQOZ... 85	W1BGY... 76
W1JPE... 92	W3EPV... 83	W1EWD... 76
W9ADN... 92	W3AIU... 83	W1GCX... 76
W1ZI... 91	W4CCH... 83	W2CBO... 76
W2GVZ... 91	G5QY... 83	G5BD... 76
G5RV... 90	VE2EE... 83	SUIWM... 76
W3BES... 88	W1FTR... 82	W8LZK... 75

The Century Club and "75-or-more" listings represent the only official confirmed "countries worked" list in existence. There is no guesswork about the records indicated—confirmations have been presented and checked. Check over your confirmations in accordance with the January QST list of countries and send them in as soon as you can present 75-or-more. When sending your confirmations, please accompany them with a list of claimed countries and stations representing each country to aid in checking and for future reference after your confirmations have been returned to you. Please send postage to cover the return of the confirmations. The DX Contest should help many increase their totals. If the fellows you worked send in logs, we'll check same for confirmations, after final contest checking has been completed, provided you have sufficient additional confirmations to make the total 75-or-over.

Members of the Army Amateur Radio System in Ohio on January 31st took part in an "emergency mobilization," in cooperation with the American Red Cross. Mr. John D. Cremer, Jr., Chairman of the Disaster Committee of the Cleveland Red Cross Chapter, was present at W8CIO, along with W8AVH, Emergency Coördinator, W8PWY, who did the operating, and W8LZE. Messages from various Red Cross Chapters were handled back and forth to Cleveland, Columbus and Washington. The entire Ohio A.A.R.S. network participated in the test, which clearly demonstrated the great value of the organization.

## Amateurs Provide Communication in Emergencies

### Nebraska Amateurs Serve

During the storm in Nebraska, April 7th-8th-9th, when telephone, telegraph and multiplex circuits were out due to loading of ice on wires, the Omaha and Council Bluffs amateurs handled traffic between KOIL, Omaha, and KFAB, Lincoln. W9VIG, Omaha, on 1.75 Mc., with W9SEE, W9YYF, W9CCY (intercity emergency control station of District 2, Nebraska Emergency Net), W9GFQ and W9PDM acting as relay receiving points, handled traffic with Lincoln. Traffic was handled on 1.75-Mc. 'phone from Omaha to Nebraska City, Lincoln and other cities, pertain-

ing to telephone line repairs, broadcast program schedules and a few persons. Those participating in the work were W9WDX, W9QVF, W9ZPZ, W8YBX, W9QUJ, W9CQD, W9AXP, W9PDM, W9YYF, W9CCY, W9SEE, W9PGG, W9QAQ and W9GFQ, all on 1.75-Mc. 'phone.

### Indiana Emergency Operation

Late snow and sleet storms disrupted power and communication service to a number of northern Indiana towns from April 7th to 11th, inclusive. The majority of the power lines were repaired within 24 hours. Wire communication lines were down for several days.

A.R.R.L. Emergency Coördinators and their assistant sprang into action. W9VMG, Ft. Wayne Coördinator, acted as nucleus for amateur emergency service since Ft. Wayne was centrally located in the affected zone. An investigation was made to determine what communities were without power and communication facilities. From this information it was determined just what communities were in actual need of communication, and approximately how long they would be without regular wire channels. A.E.C. registrations were consulted, and the nearest and most suitable equipment was dispatched to points where it was needed.

### Flood in Alabama

FRIDAY morning, April 8th, the Coosa River at Wetumpka, Alabama, was rising so rapidly it was apparent that the town (3000 population) would shortly be isolated except for the Power Company's high-line telephone. The National Guard had already been called out and they needed some means of dispatching orders. To give an idea of the part Amateur Radio played in the situation I will outline the setup of the Highway Patrol. At Montgomery there is a station on 2383 kc. which serves the Ala. Highway Patrol, the Montgomery Police and the Montgomery County Sheriff's Office. By means of the station, which has W4HB and W4DGS as operators, cars equipped with police receivers were dispatched to the water's edge at points nearest Wetumpka and several smaller communities. They had no way of getting word back concerning conditions or needs, so early Friday, Pete Sides, W4AUP, O.P.S., was contacted and a National Guard truck sent to his home. Station W4AUP was loaded on and carried to the water's edge. The transmitter was set up in the Wetumpka City Hall, the lower floor of which was under about 3 feet of swift flowing water. About 9:30 p.m., Friday, W4AUP/4 was in operation from this location. All of the business district of the town was under water and a State Woman's Prison was also under water near there. Several receivers tuned to the WMPM frequency were set up in scattered locations with the radio patrol cars at the water's edge. The National Guard under Col. Lewis was set up adjacent to the W4AUP set-up. The system then worked very nicely with W4AUP taking the National Guard and Highway Patrol orders and transmitting them via 3991-ko. 'phone to WMPM, the latter transmitting them on 2382 kc. to the proper point. About 135 orders were transmitted for boats, trucks, guardsmen, patrol cars, doctors, food, cots and blankets. About 25 personal messages were also handled.

W4AUP/4 was set up and put in operation by W4AUP and W4HB while W4DGS was at WMPM. W4AUP operated the portable set-up all of Friday night and W4DGS relieved him about 7 a.m., having been relieved at WMPM by W4HB. The antenna at W4AUP/4 was strung from the top of the City Hall to a flagpole in front of the Post Office.

—Jim Thompson, W4DGS,  
S.C.M., Alabama

## BRASS POUNDERS' LEAGUE

(April 16th-May 15th)

Call	Orig.	Del.	Rel.	Extra Del. Credit	Total
W2EEL	108	460	717	445	1733
W4PL	14	31	1660	21	1726
W6IOX	41	86	1122	73	1322
W7DUE	5	14	1274	—	1296
W7EBQ	10	36	1086	42	1174
K6NXD	529	148	70	142	889
W3CIZ	33	92	645	92	862
W8DH	28	91	678	22	819
W3EML	56	126	524	100	806
W9OUD	23	51	667	41	782
W1JYE	383	33	323	13	752
W6LMD	4	9	724	6	743
W6ITH	38	310	164	190	702
W3BYR	16	16	650	12	694
W3BWT	64	67	516	37	684
W1KQY	526	30	100	17	673
W6LUJ	101	113	353	103	670
W3SN	67	73	526	—	666
W5EOE	10	104	482	26	622
W1HRX	257	35	294	28	614
W1KFN	64	33	487	8	590
W6IMI	61	184	312	150	587
W5MN	71	92	328	81	572
W3BKZ	11	191	332	8	542
W6JTV	54	161	168	144	527
W9EKK	—	321	163	17	501

### MORE-THAN-ONE-OPERATOR STATIONS

Call	Orig.	Del.	Rel.	Extra Del. Credit	Total
K4IHR	858	544	428	—	1830
W9BNT	26	187	421	6	640

These stations "make" the B.P.L. with total of 500 or over. One hundred deliveries+Ex. Del. Credits also rate B.P.L. standing. The following one-operator stations make the B.P.L. on deliveries. Deliveries count!

W2KAK, 205	W8QGD, 134	W6CZO, 117
W6AM, 208	W2HOZ, 133	W6MDI, 113
W4DWB, 200	W8UK, 127	W9PTU, 113
W3QP, 197	K5AA, 127	W1UE, 108
W2GVZ, 148	W5CEZ, 126	W9KJY, 106
W5BN, 136	W3EDC, 122	W3CP, 104
W6MTS, 134	W7APS, 122	W6HSA, 100

A.A.R.S.

WLMI (W6KXM) make the B.P.L. on 185 deliveries.

### MORE-THAN-ONE-OPERATOR STATIONS

Call	Orig.	Del.	Rel.	Extra Del. Credit	Total
WLM (W3CXL)	223	272	3509	84	4088

A total of 500 or more, or 100 deliveries Ex. D. Cr. will put you in line for a place in the B.P.L.

During the amateur cooperation at Belleville, Ill., following tornado there on March 15th (see page 61, May QST) W9NDA and W9DJG drove down from Alton with complete emergency equipment, consisting of a 40-watt 1.75 and 3.9-Mc. transmitter and receiver.

(Station Activities on page 86)



# CORRESPONDENCE

The Publishers of *QST* assume no responsibility for statements made herein by correspondents

## Tremor Recording Approved

Harvard, Mass.

Editor, *QST*:

Following up Dr. Roy R. Campbell's letter in the June issue of *QST*, I should like to say that the seismographic recording stations would welcome any aid which the amateurs could lend in the matter of determining the point of origin of earthquakes. Small quakes are occurring continuously at different points on the globe. These are purely local disturbances and seldom cause much damage. Nevertheless, they are easily recorded on the very sensitive instruments used for this purpose. The data which are assembled are used to determine various facts regarding the behavior of the earth and the gathering of these data is a major problem.

In New England, for instance, there is a network of recording stations in continuous operation. Close coöperation between them gives data for triangulation as a means of determining origins. On the other hand, sometimes the disturbances are so small that only one station records them.

It would be a definite advantage to have some sort of clearing house for earthquake information. Perhaps traffic handling hams with a scientific leaning and who are on the air regularly could do it. Upon experiencing an earthquake, hams could transmit information concerning (1) the time it was felt (as accurately as possible) and (2) the intensity of the shock, that is, whether the shock was just barely felt (some judgment must be exercised that every passing freight train is not cause for alarm!), whether the shock knocked any dishes from shelves, stopped clocks, threw down chimneys, demolished houses, etc.

This sort of relaying of scientific data could further increase the prestige of the amateur, which has already been set at such a high level by his valuable assistance in times of great emergency.

—Zack E. Gibbs, W5GAZ/1

Belleville, Kansas

Editor, *QST*:

A letter in the last issue of *QST* bestirred me to write this, one written by Dr. Roy R. Campbell, W4DFR. He suggested that all hams turn to geology as a second hobby rather than to astronomy or some other pastime. I would like to tell him that I am for the idea 100 per cent. The

very fact that there have been earthquakes, earthquakes that have destroyed whole villages, should have started someone thinking on the subject. . . . Is it not true that if there were more recording instruments along the line and in different places of the United States, a chart could be made of the cities that felt the slightest tremor? As the situation stands now a rough chart can be made with the use of the few instruments that are in use, but would it not be a more complete chart and more perfect if a record was received from hams all over the country?

The construction of the required apparatus would be relatively simple. Any ham . . . could certainly build one of the recorders with the cost running so low that he could stay off the air for two nights and save enough in "juice" to pay for what material he would have to buy, if any. . . .

One more thing, everyone knows that one good turn deserves another, or at least helps in receiving another. All right. Uncle Sam charges us nothing for the privilege of maintaining our ham license. For this privilege we, in turn, do all in our power to help him in an emergency with our homemade rigs. We know that this service is greatly appreciated by him. If we were to do as W4DFR suggested, it is possible that the F.C.C. might realize our importance as far as geological observations are concerned. And if we were helping, they might think twice before changing or altering our ham frequency bands. In any case it would promote friendship and that is what we want. . . .

—Curne Chadwick, W9ZJA

## "Power Lines" Mean "Power"

5463 Goethe Ave., St. Louis, Mo.

Editor, *QST*:

I am writing you as a subscriber to *QST* of some years' standing who has been connected for over twenty years with a large middle-western power company and engaged throughout that time in the construction and operation of transmission and distribution lines and sub-stations.

My particular gripe is the article which appeared in the March 1938 issue of *QST* on page 49 entitled "R.F. Interference from Power Circuits." I have no quarrel with the technical side of the article since, as a matter of fact, it is an unusually accurate presentation of the r.f. interference picture insofar as the power circuit causes are concerned.

I do believe, however, that more editorial judgment should have been used in revising this article prior to publication in that the portion of it beginning with the first paragraph on page 96 is a rather open invitation to any number of enterprising amateurs to get themselves seriously injured or possibly killed by taking it too literally. I take this position since that portion of the article is an invitation and an encouragement to anybody who cares to do so to trespass on power company property which experience teaches us is highly hazardous even to those trained and skilled in the business. Most anyone without too much knowledge about such matters would assume, in reading this portion of the article, that it is perfectly all right for him to climb power company poles, fool around with transformer connections, examine primary cutouts and lightning arresters, even to the point of attempting to determine whether the fuses are loose in the cutouts, check around on the wires themselves and on the pins and insulators and so on to the funeral parlor.

Had this portion of the article been written in a purely informative way as to the most frequent causes of r.f. interference but with a very clear statement incorporated therein that all work on power company structures and circuits should be done by authorized employees of the power company itself properly equipped for the work, trained in the necessary safety precautions and fully appreciating the hazards of what they were doing, I would have no quarrel with it. It would have been helpful also to have presented some statistics which are almost universally available as to the low percentage of troubles originating on the power company distribution system proper and a statement that practically all power companies these days maintain men equipped for the specific function of running down r.f. interference caused by their circuits and equipment.

I hope I have made it rather clear in the above that when circuits of the power company, such as we are discussing, are called power circuits we mean just that, that there is power behind them, and that when we say our stuff is hot we mean that it is hot, and we don't mean maybe! It has been the writer's misfortune to participate in the aftermath of a number of cases where persons either failed to appreciate this fact or temporarily forgot it and possibly this has something to do with our lack of appreciation when such matters are presented in the form given in the latter portion of this article.

—A. L. Strother

## For U.H.F. Stability

176 Nassau Blvd., Garden City, L. I., N. Y.

Editor, *QST*:

After hearing many broadly overmodulated oscillators on the five-meter band, I have decided to retire mine and graduate to crystal control. It's an awful pill to swallow when some wobbulator settles down on that weak station you're trying to work and blankets him with a long CQ.

I've worked some pretty decent DX with my modulated oscillator when the band is open, but I'm anxious to hook a crystal signal on the shack end of my double "J" beam and see what happens then.

Recently I've heard such snatches of conversation as this: "W2ZZZ standing by for a call from any crystal-controlled station," or, "If there are any modulated oscillators on around this vicinity, I don't hear them." Five meters is rapidly turning to crystal control, or at least m.o.p.a. rigs, and selective superhets. These fellows are not high-hating us. They speak with a high degree of truth. It's well-nigh impossible to tune in a signal that drifts as much as 250 kc. on any kind of a superhet or converter ahead of your regular super.

During this past month the DX on five has been rolling in down here in the second call area. We have heard fours, fives, eights, threes and nines, and we always hear the ones. This unusual activity is somewhat freakish, but nevertheless it's liable to keep up during the coming summer, and I for one am lying in wait while working on a new xtal rig. What say, gang? Let's put the modulated oscillator in the junk box and graduate to more stable signals. M.o.p.a.'s sound

good, crystals are cheap, doublers and quadruplers efficient, and the result is a better signal with even lower power.

—Philip C. Erhorn, W2LAH

## More on Motor QRM

1312 Fairmont St. N. W., Washington, D. C.

Editor, *QST*:

Reference is made to a letter of recent date which appeared in *QST* for June, 1938, in which the writer discusses the noise frequently caused by small electrical devices.

He dwells on the advisability of instituting a campaign to educate manufacturers of small electric motors to equip their products with suitable filtering devices to eliminate the all-too-prevalent interference to radiocommunications caused by such machines. There was mentioned one case in which a Singer electric shear proved to be entirely noise-free.

My mother recently purchased the largest home-model machine manufactured by the Singer Sewing Machine Company. The sales price of this de luxe mechanism is just a trifle under \$200 and it is equipped with no noise-reducing devices whatsoever.

My National 100-X receiver is installed about 40 feet from the above-referred-to sewing machine and is equipped with an indoor antenna approximately 15 feet in length. When the foot pedal rheostat of the machine is operated so as to cause it to start, or stop, or to shift from one speed to another, a loud click is heard on all frequencies within the tuning range of the receiver. While the motor has strength sufficient to completely override all high-frequency signals which have been received to date. . . .

The local office of the Singer Company was contacted regarding this matter and their representative subsequently called in my absence. . . . This technician . . . explained, in monosyllabic terms, that all electrical devices, even those employed solely for illuminating purposes, create interference in radio receivers. . . . He escaped with his life and is today, to the best of my knowledge, still at large.

Upon calling at the local headquarters of the firm I was informed that a special eliminator could be ordered from New York at a net price of \$31! The manufacturing cost of this gadget is probably less than 1 per cent of the total cost of the machine. . . .

Someone has said, "Millions for defense but not one cent for tribute." Reasoning along this line, I have decided not to purchase an eliminator and, above all, not to make any adjustments whatsoever on the offending machine, but simply to publicize the matter as much as possible and await results.

—William L. Smith, N3GKP/AA2F

## Coaxial Cable Worth-While

P. O. Box 184, Luke Field, Honolulu, T. H.

Editor, *QST*:

In February *QST* you ran an article entitled "Inexpensive Coaxial R.F. Transmission Line."

In the radio section of the Air Corps bombardment squadron here on Luke Field, we attempted to put into effect that which many amateurs and commercial radiomen have done to great satisfaction, namely, using these coaxial lines in aircraft. The net result was an increase in power output of approximately 40 per cent over the conventional method of feeding our antenna systems, using a quarter-wave doublet fed by this coaxial line.

Here in the Hawaiian Islands there are some spots that have a point of nil in radio transmission and reception, but with the new method of feed we were able to put a signal into here that would do justice to a ground station located within ten miles of the field.

Thanks for the article, and may you be able to publish many more that will be beneficial to the army man as well as to the amateur who reads them.

—Frederick H. Fletcher



SOMETIME ago we were talking to a very capable (and quite expensive) patent attorney, and chanced to ask him if he was ever bothered with cut-price competition. He said "No. Now and then someone does complain that they can get a patent for a tenth of my charge, and I always tell them I can meet that price and better it, — if all they want is a patent. It won't be broad enough to give much protection, but it will have all the seals and trimmings. Trimmings come cheap. But if what they want to buy is protection for their invention, they will have to

pay what it costs, no matter who their attorney is."

This expressed our own case very nicely, for we had decided to make the same answer. National receivers are comparatively expensive, because we have always felt that what we were really selling was performance, not just another receiver. But we realize that there are those (chiefly newcomers, perhaps) to whom price is a foremost consideration, and who are not sufficiently concerned, or sufficiently experienced, to demand those features which contribute to top-notch performance.

Now we at National can build a receiver just as cheaply as anyone else can in the limited quantity production which the amateur market requires. We have never built a cheap receiver, but we are going to build a low-priced one now. We are going to make a \$49.50 set.

It will not be wholly designed by the same engineers who did the HRO, NC-101X, NC-81X, and other National Receivers, because these men think along the wrong lines for a job like this. They always end up by using a better and more expensive part than originally planned, because it is their ingrained habit to design to the standard of performance that they consider is National's heritage. They are being assisted by a very capable engineer in this job, a man who has trained in plants where pennies were important — but who, withal, is an amateur and knows amateur receiver problems. We can trust him to do the very best job possible at the price.

The set will have to use iron-core I.F. transformers and a broadcast-type tuning condenser — it will have a commercial switch and less expensive coils and insulation rather than a cast aluminum coil-shifting catacomb with R39 insulation. Naturally the sensitivity and the signal-to-noise ratio cannot be up to the standards of higher-priced National Receivers — but we do promise you the best receiver we can build for \$49.50. There will be a separate band-spread dial, and there will be dial lights and an attractive cabinet — but no trimmings which do not contribute something to the usefulness of the receiver.

We miss the usual thrill that comes when we add a new receiver to the National line, because we hate to have to cut corners for the sake of price. We are doing it because we want to prove that we can build a better receiver for \$49.50 than anyone else can — and because we know there are many amateurs who have no more than that to spend for a receiver — at least now.

Considered purely from the view-point of value, anyone who buys the set will get his money's worth — even though the features most appreciated in a DX contest will be missing. So to protect those who may buy it to learn, and who outgrow its capabilities as they improve in experience and technique, we are working out a trade-in arrangement by which they will lose but little when the time comes to get a better job. Amateurs doubtless dislike working in the low-price spectrum just as much as we do, and we want to give them all the help we can when they start working up. After all, what helps the amateur, helps us, and what the amateur wants we will supply — even if it happens to be a receiver designed and made to sell at \$49.50.

JAMES MILLEN



# For Longer Life and Greater Dependability

## Insist on

# MALLORY Vibrators

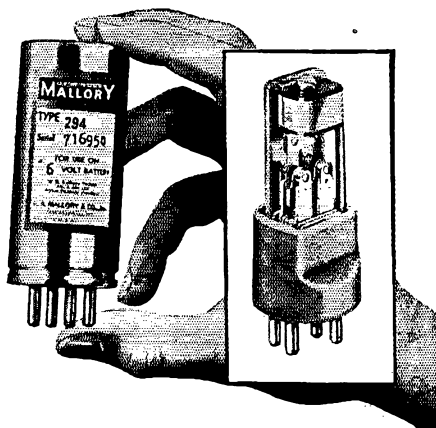

When you buy a Mallory Replacement Vibrator, you are assured of:

1. *Lowest cost per hour of actual use.*
2. *Trouble-free long life.*
3. *Positive starting.*
4. *Easy installation.*
5. *Freedom from lead breakage.*
6. *Freedom from failures due to lead corrosion.*
7. *Absolute freedom from broken reeds.*

Radio amateurs appreciate quality and will recognize the superiority of construction and design of Mallory Replacement Vibrators. They are built by the most highly specialized group of technicians in the vibrator industry. The majority of these employees have been with Mallory since the beginning of the vibrator industry. Such a highly trained personnel can only assure the highest quality of workmanship possible. Mallory pioneered vibrators for automobile radios and has always led in all new developments in the vibrator industry.

For recommendations by receiver make and model number, see your distributor for Folder E-551, or consult the Mallory-Yaxley Radio Service Encyclopedia (Second Edition).

**P. R. MALLORY & CO., Inc.**  
 INDIANAPOLIS INDIANA  
 Cable Address—PELMALLO

Use

**P. R. MALLORY & CO. Inc.**

# MALLORY

APPROVED RADIO  
PRECISION PRODUCTS

---

Use

# YAXLEY

APPROVED RADIO  
PRECISION PRODUCTS

"Look for Me on --- Kc."

(Continued from page 56)

chokes or the small 125-ma. choke used in the oscillator plate circuit, though, of course, the current drawn does not require these larger sizes. As an added precaution the 807 plate choke is enclosed in a separate shield compartment. These precautions may seem unreasonable, but if oscillator keying is to be used no stone must be left unturned to prevent self-oscillation in this stage.

The 807 plate coils were made up from a set of standard Hammarlund XP-53 6-prong receiving coils which happened to be on hand and were easily converted to this use by removing the primary and tickler windings and inter-winding the output coupling links at the cold ends. Complete data on these coils is given in the coil table so that the constructor may "start from scratch" and make his own if he wishes. A variable heavy-duty potentiometer is used in the cathode of the 807 to limit the plate current when keying the oscillator. If full output from the 807 is desired when keying the oscillator a small amount of battery bias should be used on the grid. A 22½- or 45-volt battery may be connected in series with the grid milliammeter if desired. The cathode potentiometer also serves as a means of controlling the excitation supplied to the final stage of the complete transmitter, so that the exciter may be used for driving a wide variety of final stages.

An ideal final stage for this exciter would be a pair of the new medium-power beam pentodes such as the RK-47 or 814. The exciter output is far above the low excitation requirements of these tubes, and the unit therefore could be operated at very low voltage, prolonging tube life indefinitely. If operation on 56 Mc. is not anticipated the output is sufficient to drive a 200-watt or larger final using any of the new triodes now available. The ideal set-up for the 56-Mc. enthusiast would include a separate final of "low-C" design for this band alone. The difference in tuning capacities required and the tremendous difference in coupling efficiencies and excitation requirements at the opposite ends of the amateur range precludes the possibility of using the same final stage for all bands from 160 to 5 meters without a considerable sacrifice in efficiency at both ends of the range.

### ADJUSTMENT

Adjustment of the exciter should not cause any trouble if the layout shown is followed in principle. Meter jacks are provided in the cathode leads and also in the 807 grid circuit. In this way all jacks are mounted directly on the metal chassis, eliminating troublesome high-voltage insulating washers. The 807 cathode jack may be used for keying if this method is preferred to keying the oscillator. Coupling to the 807 grid is through an air dielectric trimmer of the type used for i.f. transformer tuning. Adjustment of this trimmer is not critical; it is simply set to give adequate

(Continued on page 88)



# TRIPLE-PURPOSE *low cost* RK TRIODES

## CHARACTERISTICS OF RK TRIODES

**RK11**—Filament Volts 6.3. Plate Volts 750. Grid Volts 120. Driving Power 3.2 watts. Output Power 55 watts. **\$2.50.**  
**RK12**—Filament Volts 6.3. Plate Volts 750. Grid Volts 0. Load 9600 ohms. Driving Power 3.4 watts. Output Power (Two Tubes) 100 watts. **\$2.50.**

Specially designed for use as  
**1. POWER AMPLIFIERS**  
**2. OSCILLATORS**  
**3. MODULATORS**

**BOY, OH BOY!  
WHAT A VALUE!!**

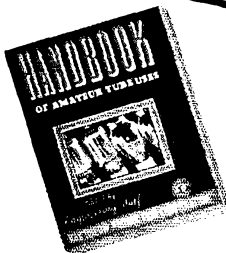

**JUST OUT!**  
**Handbook of Amateur Tube Uses.** An encyclopedia of technical information which will permit you to design your own equipment. Contains a new, exclusive feature, the Raytheon Temperature Color Chart . . . the only one available for amateurs' use! By checking color of plates with the temperature color chart, you can tell whether tubes are being properly operated. Tube characteristics, distortion computations, modulation, oscillation, high frequency work, etc., etc., are all thoroughly covered. Price 50c.

**H**ERE are genuine RK quality triodes at a far lower price than you'd ever expect to pay!

The following information on each tube will convince you of their superior value!

**RK11**—A general purpose triode with an amplification factor of 20. Makes an ideal R. F. power amplifier or oscillator. Requires only 3.2 watts driving power.

Maximum insulation between elements—18.9 watts of thoriated filament—and the fact that it is absolutely gas-free gives extra long service. To insure against voltage breakdown, the plate is brought out of the top, and at the same time reduces inter-electrode capacities. Has an isolantite base. This sturdy construction and thorough engineering permits maximum ratings up to 60 megacycles.

**RK12**—A zero bias triode particularly applicable either as a doubler or final amplifier for telegraphy. When used thus, the driving power is at minimum.

At rated plate voltage, the plate current is so low that the tube is protected (in case of failure of excitation) during tuning-up process. And as a modulator, 2 tubes produce 100 watts at about 5% distortion with extremely low idling current.

Write your nearest Raytheon office for complete data on these types.

NEWTON, MASS. NEW YORK CHICAGO SAN FRANCISCO ATLANTA

# RAYTHEON RK AMATEUR TUBES

**"WORLD'S LARGEST EXCLUSIVE RADIO TUBE MANUFACTURERS"**



SUMMER TIME IS **SPECIAL OFFER TIME** TOO  
(DURING JULY AND AUGUST ONLY)





A.R.R.L. Membership }  
 QST Subscription } \$3  
 and the HANDBOOK }

\$3.25 U. S. Possessions and Canada. \$3.75 elsewhere. Order must be sent direct to A. R. R. L., West Hartford, Conn. Subscriptions may be new or extension of present one.

QST and the HANDBOOK  
 THE BASIS OF  
 EVERY AMATEUR'S LIBRARY

Say You Saw It in QST — It Identifies You and Helps QST

# Inside Information

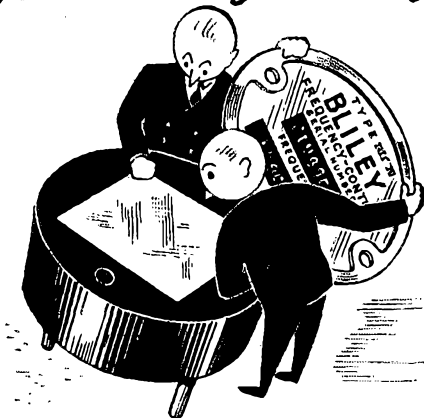

## on BLILEY CRYSTAL UNITS

### DEVELOPMENT

★ Each *Bliley Crystal Unit* is specifically designed for its own particular frequency band. The holder design, the shape of the electrodes, the electrode pressure, the crystal cut and size are all carefully determined for best stability and dependability over long periods of active service. In addition, Bliley Research Engineers are constantly working to improve present designs and to develop new products which will out-perform the old.

### MANUFACTURE

★ Correct design is only beneficial when each step of the manufacturing process is accurately carried out. The quality and performance of all Bliley Crystal Units is assured through the use of the finest materials available, the application of specially designed equipment, the employment of skilled workmen, and strict maintenance of rigid standards.

### INSPECTION

★ But even this is not enough! Each *Bliley Crystal Unit* is subjected to over 31 tests and inspections before receiving approval for shipment. As a final positive check, each unit is tested in a loaded oscillator under conditions more exacting than usually encountered in normal operation.

Nine precision *Bliley Crystal Units* cover operation in every amateur band from 5 to 160-meters inclusively. Each one represents the utmost in crystal value — ask your distributor about them. And don't forget to ask him for your copy of **FREQUENCY CONTROL WITH QUARTZ CRYSTALS** — it's only 10c (Canada 15c).

**BLILEY ELECTRIC COMPANY**

UNION STATION BUILDING

ERIE, PA.

## 1.75-Mc. Phone Transmitter

(Continued from page 17)

two. Close the a.c. toggle switch, putting both power supplies in operation. With the light-bulb clipped to the final tank coil, tune the circuit to resonance and adjust the loading to give a total plate-and-screen current of 100 ma. After the final is running turn on the modulator plate voltage and check the final amplifier and modulator plate currents. The r.f. plate current should not vary with speech input to the microphone. The modulator plate current should behave just as it did with the resistor load. After this the signal may be tuned in on a receiver or monitor and a final check made of the quality.

Since the choice of an antenna system depends upon local conditions to a very considerable extent, it is difficult for us to make specific recommendations on this subject. Suitable antenna arrangements are described in the chapter on antennas in *The Radio Amateur's Handbook*, where the tuning procedures are given as well. The transmitter is readily adaptable to any of the antenna systems recommended for 1.75-Mc. work. In general, a link-coupled tuner is most satisfactory, and the circuit diagram shows an output link for this purpose. The loading in any case should be adjusted to make the final amplifier plate and screen current 100 milliamperes.

### RESULTS

The simplicity and inexpensiveness of this rig may lead a builder to assume that his operation will be limited to a local area. This is not necessarily true for in operation at W1JEQ dependable and pleasant QSO's were carried on with stations several hundred miles away. These contacts were not made under particularly favorable conditions. The antenna used was a 1.7-Mc. quarter-wave grounded system, series-tuned and link-coupled to the final.

## Minimizing Receiver Frequency Drift

(Continued from page 22)

in a position so that a very short connection can be made between the "stator" plate and the stator of the high-frequency oscillator tuning condenser, or to other parts normally connected to the same point, such as a band switch or coil.

The heater element should dissipate a certain amount of power so that the tubing will come to a definite temperature in a given time. In our case the receiver became quite stable after fifteen minutes, therefore the temperature of the tubing also should come to a standstill in this time. The final temperature, and the time required to reach it, must be adjusted for each individual receiver. The temperature increase should be about 50° F. The time required for the tubing to reach the final temperature depends on the heat produced, the surrounding temperature, relative conductivity and the mass of the metal tubing, and conductivity of heat through the brackets, as well as heat radiation through the air.

# Build the NEW WAY with PA-300

HAMMARLUND's new "PA-300" foundation kit has received nation-wide amateur approval. Its time, labor, and money-saving features are revolutionizing amateur transmitter construction.

"PA-300" foundation kits include four metal brackets with all necessary screws, nuts, lockwashers, and instructions for building a 100 to 300 watt final amplifier. These brackets are so designed that all components of the amplifier are fastened together as shown in the above illustration; thus eliminating the chassis and all drilling. The amplifier fastens direct to the panel and is self-supporting. Every part is placed so that its associated connecting leads are short and direct, resulting in greater efficiency.

Whether you are building a new transmitter or re-building the old one, you will find this new foundation kit suits your needs. After installing this new and modern arrangement in your transmitter, you need never change that part of your rig again. All popular tubes such as: 808's, 35-T's, HK-54's, T-55's, T-20's, HY-40's, and many others can be used without a single change. Write Dept. Q-7 for literature, or see the new "PA-300" on display at your dealer's.



**HAMMARLUND MANUFACTURING CO., INC.**

424-438 West 33rd Street, New York City

Canadian Office: 41 West Ave. No., Hamilton, Ont.

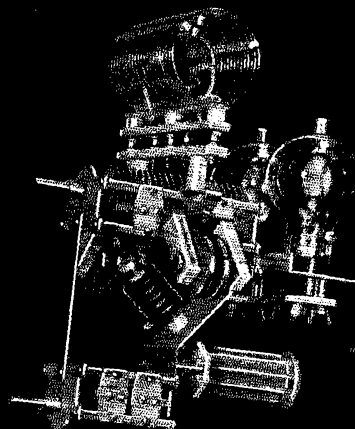

'PA-300'

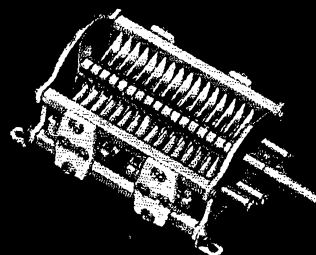

'MTC-D'

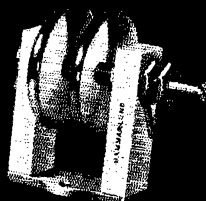

'N-10'

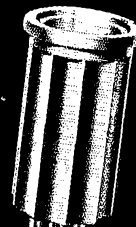

'SWF'



'S'

Say You Saw It in QST — It Identifies You and Helps QST

# POLICE

HAVE YOU HEARD



what Chief of Communications, Lt. Oscar B. Robey, of Anderson, Indiana, says about their **HARVEY POLICE RADIO** installation?

||

This department has been using seven of your UHX-10R transmitters for the past three months on 33,100 kcs. for service from our Police cars to the Headquarters Station and we find them to be the best transmitter we can get for this service at anywhere near the low cost of these units.

We have reliable 2-way service at all times with these units from a distance of 8 to 10 miles in the city area.

We will be very glad to recommend these UHX-10R's to anyone for this type of service.

||

Small departments as well as large can now take advantage of this licensed, trouble-free, reasonably priced equipment. Write to Harvey Radio Laboratories, Inc., 25 Thorndike Street, Cambridge, Mass. and we will send you complete information on the new **HARVEY 2-way POLICE RADIO**.



For the heater, a dissipation of 2 watts or so is satisfactory. For a 6.3-volt filament supply a 20-ohm section of resistor cord would be about right. For a 2.5-volt supply, a lower-resistance heater would be required. Approximately 10 inches of 26-gauge nichrome wire, space-wound on a 5- or 6-inch length of stiff cord about 1/16 inch in diameter, would be satisfactory. A length of small shoestring can be placed over this to insulate the wire from the tubing. As the heating element is only allowed to get a bit more than warm, no precautions need to be taken in regard to this insulator. Possibly a bleeder resistor of sufficient inside diameter slipped over the tubing and connected to the proper potential would work satisfactorily. The connecting leads should be fairly long so that the element can be moved in or out of the tubing to regulate the heat.

After the compensator is properly installed, (of course the trimmer of the high-frequency oscillator should be adjusted to compensate for this extra capacity), the receiver should be set at the highest frequency band to be used. A reliable commercial signal near the band, or a harmonic from a test oscillator tuned to zero beat with a broadcast station whose harmonic frequencies will fall in or near the band, should be used for adjusting the compensator. If the calibration spread of the receiver is not very open, the tuning knob can be marked so that tuning adjustments readily will be visible. Remember, the drift while the receiver is warming up is normally in the negative direction or a decrease in frequency. The receiver, with the beat oscillator on, should be tuned to zero beat with the signal and the dial setting carefully observed. If the drift appears as an increase in frequency (tuning capacity must be increased to obtain zero beat again) the spacing between the plates is probably too small, resulting in over-compensation. However, continue listening to the signal and if, after 15 minutes or so, the receiver does not start to drift in the opposite direction, all is well and the spacing between the plates should be increased a trifle. If the receiver does drift in the opposite direction, it means the expansion was too fast and should be prolonged. This is not likely to happen, however, with 1/4-inch brass tubing if instructions were followed. If the receiver drifts, from the start, in the negative direction, compensation is not great enough and the plate spacing should be decreased, length of tubing increased, or the temperature of the tubing increased.

The increase or decrease in capacitance or inductance with temperature variation is not always such as to cause a proportionate drift in each band. Complete compensation on all bands is unlikely; compensation can be obtained on one, but the other bands probably will be over- or under-compensated. However, in most cases a considerable improvement will result.

All in all this gadget is very simple, costs practically nothing and readily can be installed in most receivers, especially the types that have no major components under the chassis.

One of

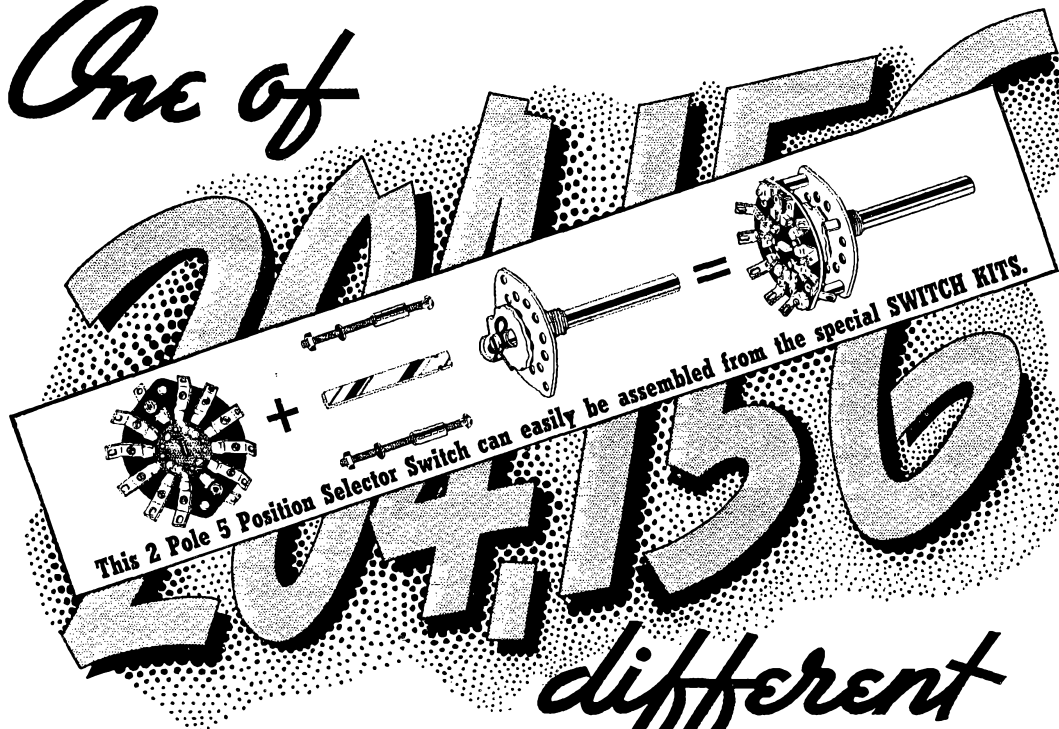

*different*  
**SELECTOR SWITCHES**

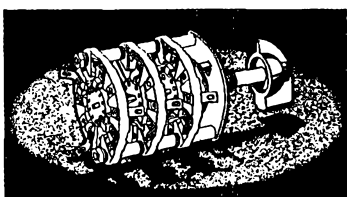

The *New*  
**ISOLANTITE**  
 Selector Switch

is creating a great deal of favorable attention because of its low power factor — high efficiency — low dielectric loss — good circuit stability — low moisture absorption and better performance. NOW AVAILABLE IN KIT FORM AT YOUR JOBBER . . . your choice of Bakelite or Isolantite.

Jobbers carrying the new Selector Switch Kits are able to offer servicemen, experimenters and hams 204,156 different "combinations."

These kits in the hands of the jobbers offer infinite variations and adaptations . . . and give almost instant service for replacements, voltmeters, ammeters, ohmmeters, decade boxes, analyzers, wave changing and Public Address systems.

See your jobber . . . and ask for your particular need in a SELECTOR SWITCH.

**Centralab**  
CRL

**DIV. OF GLOBE-UNION, INC., MILWAUKEE, WIS.**



Here's Mr. Eggenweiler's station, W6PMB. ACT-150 transmitter at right. Some of its features include conservative 150 watts output (c. w. and phone) ... isolated speech amplifier of special design ... 10 to 160 meter operation. Tubes—r-f: RCA 807, 802, two 807's, two 808's; Audio: RCA 6J7, two 6CE's, two 2A3's, two 808's; Rectifiers: RCA 83, 5Z3, 80, two 866's.

## "ELATED AT RESULTS"

... says C. W. Eggenweiler of Los Angeles, Calif., in a letter about his RCA MODEL ACT-150 TRANSMITTER!

Mr. Eggenweiler's station, W6PMB, is located in Los Angeles. He writes the following in connection with his RCA Model ACT-150 transmitter.

"... I am very much elated over the results obtained. I have successfully worked Australia, Alaska, South America, England, Havana, New Zealand, and other DX on 10 meter fone... All of the DX contacts commented very favorably on the quality and strength of the signals... In the ACT-150, RCA presents a highly efficient transmitter... at a very low cost, designed primarily for real amateur communication, but in the writer's opinion, it is really a commercial job."

Everywhere amateurs who really know this transmitter are equally enthusiastic about it. It will do things for you! And at low cost! Net price f. o. b. factory with speech amplifier and one set of coils, \$625, less tubes, microphone, crystal. Extra set of coils \$13.50.

For maximum performance at minimum cost—use RCA radio tubes.



### FOR AMATEUR RADIO

AMATEUR RADIO SECTION

A Service of the Radio Corporation of America  
RCA Manufacturing Company, Inc., Camden, N. J.

## What the League Is Doing

(Continued from page 29)

authorization to operate television transmitters in the amateur bands 1715-2000 kc. and 56,000-60,000 kc., and to open the new bands of amateur frequencies above 112 Mc. to this form of transmission, as well as to Type A-1, A-2 and A-3 emissions and facsimile and picture transmission.

On motion of Mr. Bailey, the Board adjourned at 9:49 P.M., under orders to reassemble at the same place at 9:30 A.M. on the morrow. The Board reassembled at the same place at 9:35 A.M., May 14, 1938, with all directors and other officials in attendance except General Counsel Segal, who joined the meeting at 9:40 A.M.

Mr. Martin, as chairman of the Membership Committee, presented the report of that committee and orally amplified the same. As part of the report of that committee, Mr. Martin moved the adoption of the following statement of policy by the Board:

"The Board of Directors of the A.R.R.L. will from time to time, at their discretion, review or cause study to be made of proposals for the use, division by type of emission, or any general plan of the use of the radio frequencies assigned for amateur communications. The Board upon arriving at conclusions in the usual manner will thereupon order the following procedure before making a request of the F.C.C. to enforce such conclusions.

"The full text of proposed changes shall be published in QST as soon as practicable following the Board meeting. There shall also be printed a ballot in the same issue of QST. This ballot shall itemize all proposed changes by bands, so itemized that an amateur in voting will be able to express his or her desire (affirmative or negative) for one proposed change in one band. Wording of same to be clear and concise so that misunderstanding will be minimized.

"Any licensed amateur radio operator shall be eligible to mark and return a ballot to the Headquarters of the A.R.R.L. using either the printed ballot or facsimile of same. A time limit for return of ballot shall be clearly shown thereon. At the expiration of this time a count shall be made of such ballots under the direction of the Executive Committee.

"It shall be necessary that sixty-six and two-thirds percent of ballots cast shall favor a proposed change to confirm the conclusions of the Board.

"The Board's conclusions being confirmed, the Secretary shall present the request to the Federal Communications Commission in the usual manner, accompanied by a statement as to the method used to confirm the Board's request and showing the percentage ballots of total cast that favored the changes as set forth in the request."

At this point unanimous consent was given to hear the recommendations of the General Counsel concerning contractual relations with the Chicago Area Radio Club Council regarding a national convention. Mr. Segal presented and explained a suggested exchange of letters between the Board and the Council. After extended discussion, on motion of Mr. Mathews, unanimously VOTED that the Board accepts the terms of the arrangement contemplated by the draft letters and authorizes the execution of the same as between the Board and the Council.

Resuming consideration of Mr. Martin's pending motion concerning referenda: After extended discussion, including an examination of the probable legality of the proposal, Mr. Martin, with unanimous consent, withdrew the same. After further discussion, moved, by Mr. Martin, that the following resolution be adopted:

"On any matter, the Board may order the taking of an advisory, informative poll, through the columns of QST, as to the wishes of the amateurs or the members, as the case may require; and thereafter the Board, in acting upon the question presented, shall take into consideration the result of such poll, the number of expressions received and the percentage of votes by which such poll was determined."

After further discussion, Mr. Martin sought unanimous consent to withdraw his motion but, the same being denied, the question was put to vote and the resolution was ADOPTED. Unanimous consent was given Mr. Mathews to withdraw a proposal he had filed with the Board on the same subject.

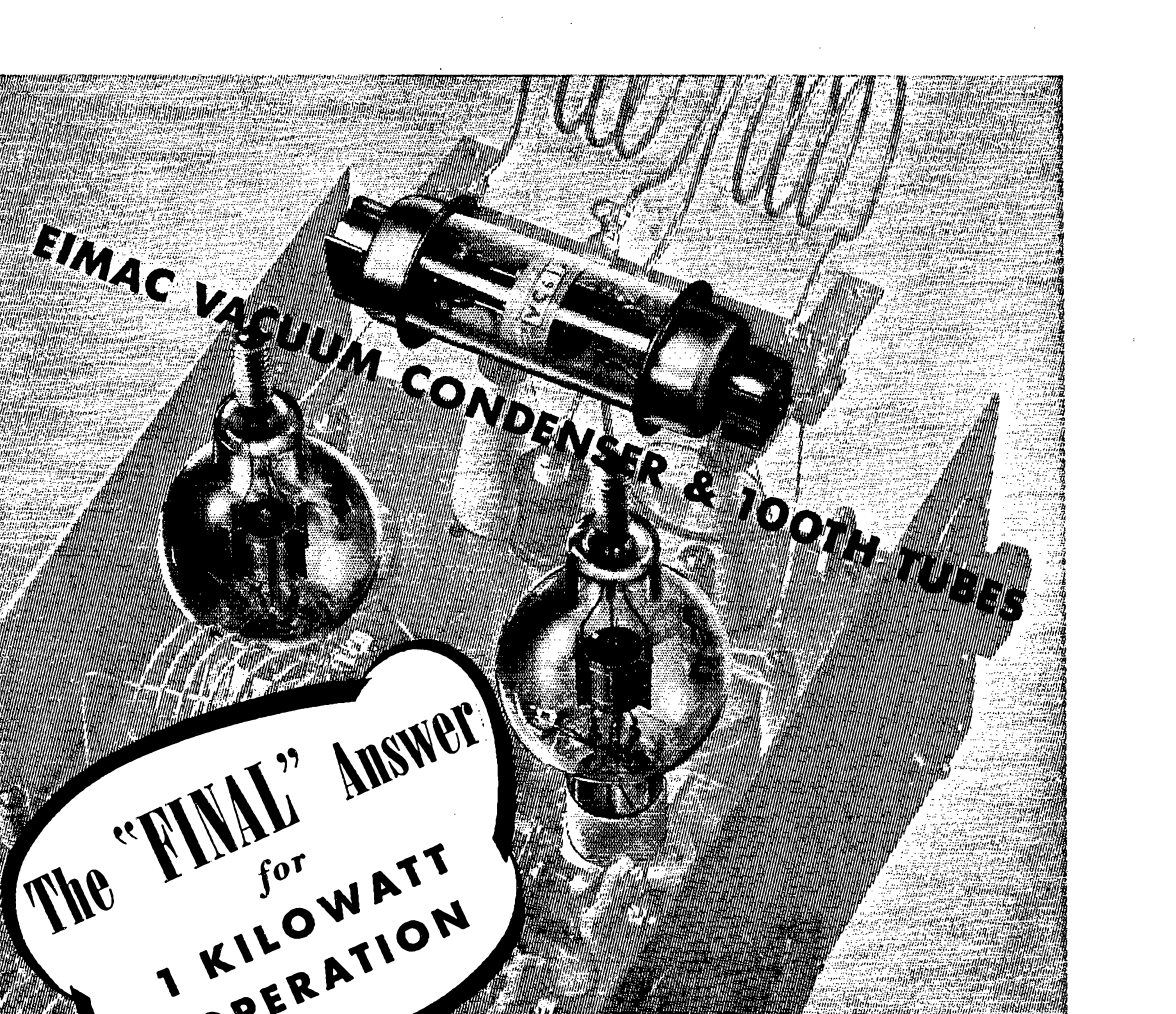

**EIMAC VACUUM CONDENSER & 100TH TUBES**

The "FINAL" Answer  
for  
1 KILOWATT  
OPERATION

Here's the combination every radio operator has been looking for: 1 kilowatt input; 80% plate efficiency; minimum harmonic radiation; ease of excitation; full coverage of all amateur bands (5 to 160 meters); maximum power to the antenna and perfect operation on either phone or CW. At 3000 volts 330 milliamperes, 100TH tubes operate well within their ratings.

Circuit efficiencies in the order of 80% with harmonic radiation at a minimum results from the fact that the tank circuit is designed for optimum "Q." Since the entire tank capacity is confined to a space of but one cubic inch, it is easy to see why difficulties caused by stray capacities and high inherent inductance are eliminated. Tank circuits of optimum "Q" also insure the proper load balance on each of the tubes and reduce phone "splatter" to the very minimum.

With Eimac 100TH's and the new Vacuum Tank

circuit you can expect and get a highly efficient and thoroughly practical 1 kilowatt amateur "rig."

*Complete information about the Eimac Vacuum Tank Condenser is contained in an attractive four page folder. This folder may be obtained from your dealer or by writing directly to the factory. See your dealer today.*

**Eimac**  
**TUBES**

**EITEL-McCULLOUGH, Inc., San Bruno, Calif.**

# LESS HASH! LESS QRM!

WITH

# 'SUPER-PRO'

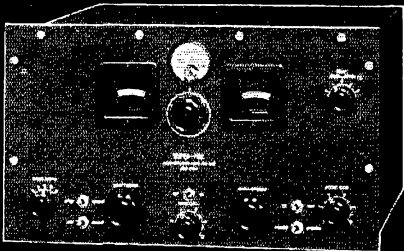

**S**ATISFACTORY radio-phone communication demands a minimum of hash, heterodynes, and general QRM. That is why hams, as well as professional operators, praise the performance of the "Super-Pro". The variable selectivity feature of this outstanding receiver permits the operator to choose at will, the band width (between 3 and 16 kc.) which best suits receiving conditions. As one communication engineer puts it, "Variable selectivity alone places the 'Super-Pro' in a class by itself!"

Standard high frequency model has two stages of R.F., three stages of I.F., and covers a range of from 7½ to 240 meters; special models, covering other ranges, available on order.

Beautiful console cabinet and 15" high fidelity speaker available at special price. Write for details!

"Super-Pro" owners can now obtain this beautiful cabinet and 15" high fidelity speaker.

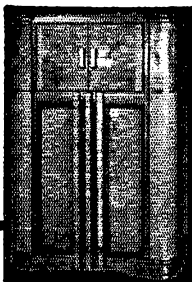

Canadian Office: 41 West Ave.  
No., Hamilton, Ont.

HAMMARLUND MFG. CO., INC.  
424-438 W. 33rd St., N. Y. C.

Q-7-38

Please send me "Super-Pro" Manual

Name .....

Address .....

City ..... State .....



## HAMMARLUND

On motion of Mr. Martin, unanimously VOTED to create a recognition of the affiliated clubs having 100% League membership by periodically listing in *QST* those affiliated societies whose entire membership consists of members of the League.

On motion of Mr. Caveness, unanimously VOTED that the Board accepts the report of the Membership Committee and now dismisses the said Committee with an expression of its thanks.

Moved, by Mr. Noble, and seconded by Mr. Bailey, that some mechanism be created to ascertain in advance of the Board meetings the legality of proposals scheduled for the consideration of the Board at its meeting. But, after discussion, unanimous consent being given, Mr. Bailey withdrew his second; and, there being no other second, the motion was lost.

On motion of Mr. Norwine, VOTED that the Secretary is instructed to approach the Federal Communications Commission to ascertain its sentiments as to the possibilities of appointing amateurs as assistants to radio supervisors to police the amateur bands more effectively, thereby coping more successfully with our growing operating problems.

On motion of Mr. Noble, after discussion, VOTED that the tentative agenda for each meeting of the Board shall appear in *QST* prior to such meeting, with the suggestion that members write their directors concerning the items therein listed.

Mr. Handy presented in extenso the report of the Planning Committee, during the course of which many items concerning amateur operating were examined and discussed, with resulting Board actions as follows:

(1) On motion of Mr. Groves, VOTED that the Federal Communications Commission is requested to add to the amateur operator examination, questions bearing upon amateur emergency work, at the time that regulations dealing with the latter are adopted by the Commission.

(2) Moved, by Mr. Adams, that the Board favors a F.C.C. policy of treating cases of amateur interference with broadcast reception on their individual merits. But, after extended discussion, unanimous consent being given, Mr. Adams withdrew the motion.

(3) On the desirability of requesting the Federal Communications Commission to extend as high as 60,000 kc. the rules regarding the quality and stability of signals now applying as high as 30,000 kc., after extended discussion, on motion of Mr. Bailey, unanimously VOTED that the sentiment of the members on this question shall be polled in *QST* as soon as conveniently possible, by the procedure provided for by an earlier action of the Board.

(4) Moved, by Mr. McCargar, that the Board request the Federal Communications Commission to expand the 1.7-Mc. phone band allocation from 1800-2000 kc. to 1800-2050 kc. effective when the 1715-2000 kc. band is shifted to 1750-2050 kc. But, after extended discussion, the said motion was rejected, 7 votes in favor to 8 opposed. On the further motion of Mr. McCargar, unanimously VOTED that the question of the desirability of this request shall be submitted to a poll of membership sentiment in *QST*, by the mechanism previously created.

(5) On motion of Mr. Mathews, unanimously VOTED that the Board accepts the report of the Planning Committee with its very hearty thanks, and that the committee is continued for another year.

During the foregoing discussions the Board recessed for luncheon at 12:53 P.M. reconvening at 1:57 P.M. with all directors and other officials in attendance.

Moved, by Mr. Blalack, that the 1939 Board meeting of the A.R.R.L. be held in May at a suitable place in San Francisco, California. After extended discussion, a record vote being demanded, the yeas and nays were ordered and the said question was decided in the affirmative: Whole number of votes cast, 16; necessary for adoption, 9; yeas, 14; nays, 2. Those voting for adoption were Messrs. Adams, Arledge, Blalack, Caveness, Gibbons, Hill, Mathews, McCargar, Noble, Norwine, Reid, Stockman, Young and Bailey; those voting opposed were Messrs. Groves and Martin. So the motion was adopted.

On motion of Mr. Martin, after discussion, unanimously VOTED that the Board approves in principle the installation of a system of retirement income for A.R.R.L. employees through the mediumship of an insurance company, and appoints a small committee to work out a plan in detail and present it at the next meeting of the Board. The Chair, with the consent of the meeting, thereupon appointed





# PIGTAILS...



**P**IGTAILS are not really new; they have been standard equipment on pigs and optional on little girls for genera-

tions. These are of the coiled type securely fastened at one end only. The same type, but made of metal and with both ends rigidly attached, has been used for years on variable condensers, switches, wire wound rheostats, etc. The purpose in electrical apparatus is to carry current to the moving part through a positive connection rather than through a lubricated bearing or sliding contact. The importance of the pigtail connection is apparent where currents of any magnitude are involved because any heating or arcing will soon ruin a bearing surface and cause it to freeze.

Until recently, however, the pigtail or spiral spring type connector had not been used in carbon type volume controls because the currents are negligible and no one had recognized the sliding metal-to-metal contact between the "center terminal" of a control and the rotor arm as a major source of noise.

A study of field reports covering all types and makes of volume controls shows that from 50 to 75 per cent of the total complaints are due to noise developing at this one point. Some manufacturers lubricate these contact surfaces, others don't; some silver plate, others gold plate them; still others try Monel metal or stainless steel without any plating.

If the lubricant is left out, there is

mechanical wear which soon develops noise. If used, it is prone to gum up and harden, unless there is just the right quality and amount. Besides this, any particle of dust or grit is caught on greasy contact surfaces and eventually works in between them.

We have tried all the various metals which might be suitable here — brasses and bronzes, nickel silver, stainless steel, Monel, Beryllium, copper, etc. Provided freedom from corrosion, we find one about as good (or as poor) as another. A carbon-against-metal contact is fair, but the contact resistance changes too much. Isn't the answer obvious? Get rid of that sliding contact!

It all seems so easy now — we are using a spiral phosphor bronze spring, silver plated, riveted at one end to the center lug, and at the other end to the rotor. It has four complete turns and no strain on the fixed ends, so there is no chance of breakage. It is insulated from the shaft with a bakelite sleeve; and it *won't* get noisy.

The three years which we at IRC have spent on this development seem somehow repaid by the encouraging reception it has received. You will find our Type "CS" Control in many of the most expensive 1939 receivers, both radio and television, and if you want the same quality for an old set you can get it at your IRC jobber's. We predict that most of next year's controls will have some form of positive rotor connection.

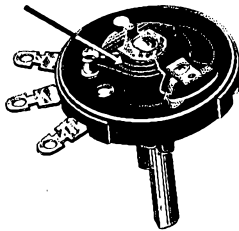

INTERNATIONAL RESISTANCE COMPANY • 401 NORTH BROAD STREET, PHILADELPHIA, PA.

ADVERTISEMENT

Say You Saw It in QST -- It Identifies You and Helps QST

# CARDWELL

## "TRIM-AIRS" ARE IN DEMAND FOR SUMMER PORTABLES

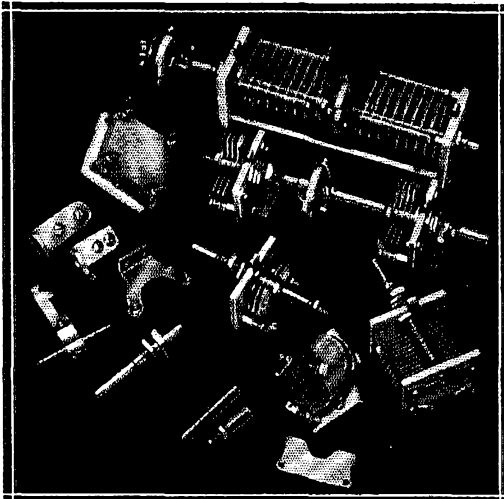

### FLEXIBLE, LIGHT, STURDY AND EFFICIENT UNITS

Typified by a few sample units shown. Note the handy brackets, small couplings, shaft extensions, panel bushings and other handy accessories.

Single "Z" types may be single hole, bracket or stud mounted. Convenient for shielded stages in 5 or ten meter portables, where a variety of gadgets and the simplicity of Cardwell construction, permit the designer to work out an efficient layout with flexible units adapted to his ingenuity and originality.

Single and double spaced "E" type dual "Trim-Airs" for P.P. Finals, with shaft extended at rear for ganging, in line with newest single control, multi-stage rigs, destined to become very popular.

Phos. bronze inductance clips for No. 12 or No. 14 bare wire used for self supporting coils — (Type 804-A shown) are very handy.

Midget fixed air condensers for loading low freq. tanks on 160 meter portables and emergency gear, available in 15 capacities and airgaps to .100".

Ease of modification has endeared this family of small but sturdy condensers to "hams" and H.F. experimenters the world over.

**YOUR DEALER HAS THEM — CARDWELL MAKES THEM  
YOU NEED THEM**

#### Special CARDWELL—G. E. MYCALEX Offer:

CARDWELL dealers now have a new size G.E. Mycalex bar — 12" x 1" x 1/8". Type MN, net to hams..... \$57

Sold Below factory cost by G.E., we pass it on with only a handling charge. Supply limited at this price — see your dealer now!

REMEMBER G. E. MYCALEX CAN BE SAWED AND DRILLED, and it's a DEPENDABLE, LOW LOSS H.F. INSULATION.

**THE ALLEN D. CARDWELL  
MANUFACTURING CORPORATION**  
82 PROSPECT STREET, BROOKLYN, NEW YORK

Messrs. Martin, Bailey and Mathews to constitute the said committee.

On motion of Mr. Stockman, affiliation was granted by unanimous vote to the following societies, whose applications had been duly investigated and approved:

- Hot Wire Ammeter Club..... St. Lambert, P. Q., Can.
- The Kilocycle Club..... Fort Worth, Texas
- The 73 Club..... New York, N. Y.
- Lake Michigan Amateur Radio Reserve..... Chicago, Ill.
- Delaware Valley Brass Pounders Association..... Port Jervis, N. Y.
- Newburgh Radio Club..... Newburgh, N. Y.
- New Jersey QSP Club.....
- Ozark Amateur Radio Club..... Crystal City, Mo.
- Southside Amateur Radio Association..... Atlanta, Ga.
- Hams, Inc..... Alhambra, Calif.
- Trinity College Radio Club..... Hartford, Conn.
- San Isabel Amateur Radio Association..... Pueblo, Colo.

Mr. McCargar suggested that it might be desirable to reconvaas at this time the employment of Mr. Segal as General Counsel of the League. Mr. Segal retired from the meeting. After several expressions of opinion on the part of directors present, on motion of Mr. Caveness, VOTED, 15 to 1, that the Board goes on record as reasserting its confidence in Mr. Segal as the General Counsel of the League. Mr. Young stated that he felt compelled to be recorded in the negative. Mr. Segal was thereupon recalled to the meeting.

On motion of Mr. McCargar, unanimously VOTED that, in view of the reorganization of the San Francisco Radio Club into a new group which does not desire affiliation, and in the interests of avoiding mutual embarrassment, the affiliation of the said club is terminated.

On motion of Mr. McCargar, unanimously VOTED that the affiliation of the following societies is terminated with regret, for non-compliance with the Board's regulation concerning the percentage of licensed membership of the club which must be A.R.R.L. members, and that the said societies are invited to reaffiliate as early as they can meet the requirements of the Board:

- Raritan Bay Radio Club..... Perth Amboy, N. J.
- Hudson City Radio Club, Inc..... Jersey City, N. J.
- North Shore Amateur Radio Association..... Lynn, Mass.
- Radio Bugs Club..... Devon, Conn.
- Glendale Amateur Radio Club..... Los Angeles, Calif.
- Medina County Radio Club..... Medina, Ohio

On motion of Mr. Gibbons, ORDERED that the Board proceeds now to the election of President and Vice-President. On motion of Mr. Mathews, two-thirds concurring, Special Rule A was suspended.

Nominations for President being in order, Mr. Caveness nominated Mr. Woodruff; Mr. Norwine nominated Mr. Bailey. Mr. Bailey withdrew his name. On motion of Mr. Hill, the nominations were closed. On motion of Mr. Bailey, unanimously adopted, the Secretary cast one ballot for Mr. Woodruff, reflecting him as President of the League for a term of two years.

Nominations for Vice-President being in order, Mr. Martin nominated Mr. Bailey. On motion of Mr. Blalack, the nominations were closed. On motion of Mr. Gibbons, unanimously adopted, the Secretary cast one ballot for Mr. Bailey and the Chair declared him reflected Vice-President of the League for a term of two years.

On motion of Mr. Gibbons, the Board adjourned, sine die, at 4:12 P.M.

(In the course of its deliberations the Board also discussed, without formal action, the relations between A.R.R.L. and A.A.R.S., Latin-American 'phones, international conferences, domestic legislation, income taxes, membership solicitation by clubs, methods of expanding the membership, and convention badges. Total time in session, 14 hours, 11 minutes. Total appropriations, \$18,575.)

K. B. WARNER,  
A. L. BUDLONG,  
Secretaries.

(The minutes of the Executive Committee Meetings will appear next month. — Ed.)

## *There is No Substitute*

The penalty of leadership is competitive sharpshooting. Taylor Tubes' position as the leader has been gained by producing and engineering 75,000 better amateur transmitting tubes (commercial and industrial sales not included). Radio amateurs know that Taylor Tubes has constantly worked to produce better tube values for them. The precision engineering and production standards that bring you *better quality tubes* at the present low Taylor Tubes price level was earned only through the experience of TIME and ACTUAL PRODUCTION. In line with an old established policy, Taylor Tubes assures you that today's prices are consistent with a new high standard of quality. We pledge continued service to you, the radio amateurs of the world. We promise continued ingenuity in tube creating, not mere copying. We will always back our product with an absolute satisfaction guarantee. We further pledge allegiance to the *better* radio parts dealer. He is your best radio friend. Support him! *Watch Taylor Tubes in 1938!* Use Taylor Tubes and you'll get

*"More Watts Per Dollar"*

Taylor Tubes, Inc.

Chicago, Ill.

# OPEN UP the 400 Mc. band in your locality!

... with the 316A Tube

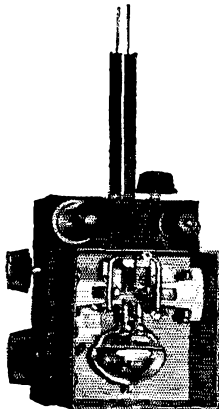

This 400-500 Mc. transmitter was built by an amateur, using the Western Electric 316A "door-knob" triode. It shows how simple such a job can be—and how easily portable, including the antenna. Just plug in the power supply and mike—and talk as far as 100 miles, depending on location.

**The 316A  
delivers up to 8 watts  
at 400 Mc.**

**Typical operation at 400 Mc.**

Filament Voltage .....	2.0 Volts
Filament Current .....	3.65 Amps.
D. C. Plate Voltage .....	400 Volts
D. C. Plate Current .....	80 ma.
Power Output (carrier) .....	8 Watts

Booklet packed with each 316A Tube gives complete operating instructions. For full information, consult your dealer—or write Graybar Electric Co., Graybar Building, New York.

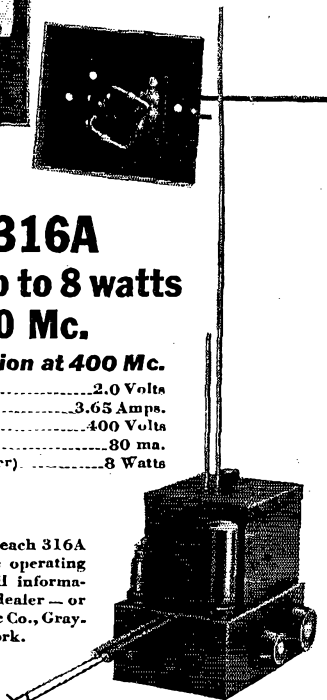

**Western Electric  
Radio Transmitting Equipment**

## The California Flood

(Continued from page 36)

A.A.R.S. nets were tied into other circuits, making for practically complete coverage of the flood area. A.A.R.S. contact with San Bernardino was made through a c.w.-'phone liaison between W6BMC and W6MMW of El Centro. W6MMW had contact with W6CV (Redlands), who in turn was in contact with W6MHW, San Bernardino. W6MMW and W6CV on 3.9-Mc. 'phone worked duplex with W6MHW on 1.75 Mc. Considerable traffic was handled over this route. Broadcasting station KHJ requested a line to San Francisco and San Diego. This was provided through W6FQU, San Diego, and W6CDA, Oakland, using telephone from Oakland to San Francisco. W6NLL/WLV later worked in this circuit. A standby route for N.B.C. was established with W6AOJ, Oakland, and W6GXM, Los Angeles. W6MBJ and W6EFY, the latter A.A.R.S., furnished communication for A.A.R.S. with Riverside. W6EPM, via W6BMC/WLVH to W6MI/W6GXM, provided a daylight circuit for Los Angeles and San Diego Post Offices, furnishing advice as to mail routing between the two cities. W6BMC obtained information on highway conditions for W6DOB, Los Angeles. Much traffic for points outside the flood zone was handled between W6BMC and W9ESA, Denver. A.A.R.S. assistance was given high school authorities in Whittier through W6KTQ, in endeavoring to obtain information from Needles regarding a scheduled game. The message was given to W6NXO/WLJW, Wickenburg, Arizona, who made delivery to Needles by telephone.

A Naval Reserve Net, smoothly functioning, did fine service in covering isolated communities from San Bernardino to San Diego. Among the known participants were W6BXI, W6CVO, W6DSN, W6FM and W6MQE.

A.R.R.L. trunk lines, A.E.C. stations and individuals on 3.5-Mc. c.w. came through with flying colors. In addition to nearly a hundred stations observed handling personal messages to the East, the following stations handled official relief messages: W6FJW, W6HAG, W6IAH, W6JBF, W6JD, W6KNK, W6KMC, W7LDB, W6MBJ, W6NSN, W6OQH and W7FTL/6. W6HAG reported to county authorities, who stated they needed communication badly at Olive View Sanitarium in the San Fernando Valley, which had been unheard from in several hours. W6HAG started for the hospital and, in more than one place, had to carry his portable equipment over his head while wading through streams of water, sometimes waist-high. He rendered a real service to the hospital and its many inmates. W6OQH carried his entire transmitter and receiver 4½ miles down from Frazier Mountain through from 1 to 4 feet of snow, in order, as he put it, "to be in it right."

On 7 Mc. much of the personal message total to the East was put through. Also a major portion of the press emanating from the area went out on this band. A few of those stations working

# 510-X FREQUENCY EXPANDER

by

# R M E

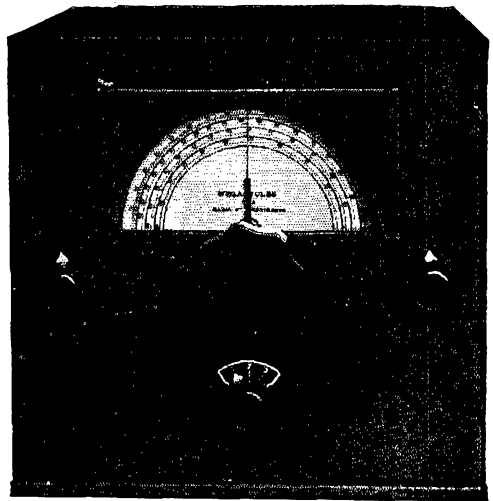

Ant.  
Changeover—  
Switch

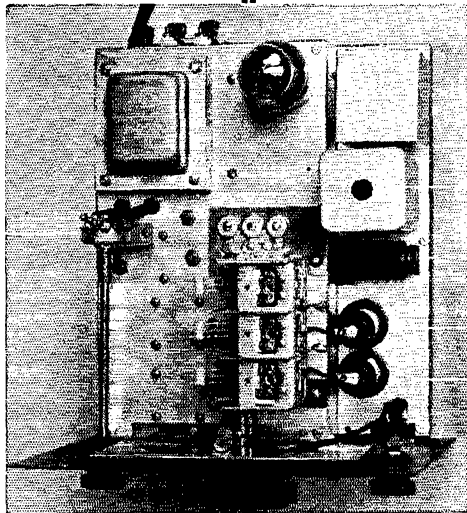

- 10 M C  
IF Trans.
- 6C5
- 6L7
- 6K7

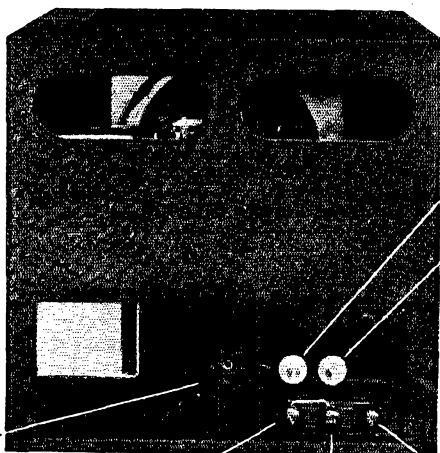

Output  
Socket      Ground      Ant. "B"      Ant. "A"

Ant. "2"

Ant. "1"

Line  
Cord

Ant. "A" and "B" for Band 1 and 2  
Output.

Ant. "1" and "2" for Band 3  
Output.

If single wire is used on Bands 1  
and 2, connect Ant. Lead to Ant.  
"A" and ground Ant. "B".

If single wire is used on Band 3,  
connect Lead to Ant. "1" and  
ground Ant. Post "2".

*Literature and Full Details  
on Request*

**Radio Mfg. Engineers, Inc.**  
111 Harrison Street Peoria, Illinois

Say You Saw It in QST — It Identifies You and Helps QST

# New

## McGraw-Hill

### Books on Radio

### Engineering

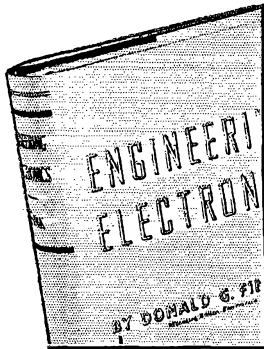

#### Fink's ENGINEERING ELECTRONICS

A practical volume for engineers who wish to take up or review electronic principles and their application in typical engineering problems of tube use and circuit design. Demonstrates the application of tubes and circuits in problems of power transformation, electrical communication, and industrial control. 358 pages, illustrated. \$3.50

#### Brown's RADIO FREQUENCY ELECTRICAL MEASUREMENTS

A combined laboratory textbook and manual for practicing electrical engineers. Explains theory and principles; describes the necessary steps in laboratory manipulation, and discusses the precision attainable, precautions, and general merits of the methods. Second edition. 384 pages, illustrated. \$4.00

#### Maloff and Epstein's ELECTRON OPTICS IN TELEVISION

Develops the theory of electron optics and its most useful application — the television cathode-ray tube. Covers the theory of electron emission and electron optics; and the design of tubes, practical and economical to construct which are capable of producing satisfactory television pictures. 299 pages, illustrated. \$3.50

#### Terman's FUNDAMENTALS OF RADIO

A complete treatment of vacuum tubes and radio, covering first the theory of tuned circuits and secondly specialized radio topics such as receivers, transmitters, wave propagation, antennas, and direction finding. There are chapters on radio aids to navigation. 458 pages, illustrated. \$3.75

#### SEND THIS ON-APPROVAL COUPON

McGraw-Hill Book Co., Inc.  
330 W. 42nd St., New York, N. Y.

Send me the books checked below for 10 days' examination on approval. In 10 days I will pay for the books plus few cents postage or return them postpaid. (We pay postage on orders accompanied by remittance.)

- Fink — Engineering Electronics, \$3.50
- Brown — Radio Frequency Electrical Measurements, \$4.00
- Maloff and Epstein — Electron Optics in Television, \$3.50
- Terman — Fundamentals of Radio, \$3.75

Name .....

Address .....

City and State .....

Position .....

Company ..... QST 7-38

(Books sent on approval in U. S. and Canada only.)

for long periods were W4DIA/6, W6AAE, W6BQO, W6JSL, W6KBF, W6KBP, W6LFX, W6MYK, W6NIZ and W6OTJ. W4DIA/6 worked a triangular net from San Diego to Los Angeles with W6KHZ and W6PPF.

W6NIZ at Earp was called into action when the superintendent of operation of the Metropolitan Water District of Southern California at Banning needed a clearance from Los Angeles on a 66-kv. line. W6NIZ, equipped only for 7 Mc. at the time and being unable to hear any Los Angeles stations on that band, hastily revised the antenna and transmitter to permit 3.5-Mc. work. First contact was with W6BXI, Santa Ana, who could not deliver "because all phones in Orange County have been out for several hours." W6BP, Los Angeles, the second contact, took the message, delivered, and a reply came back, "The Colton-Cabazone 66-kv. line is open at Colton. The disconnects are open and grounded and the line is dead. OK to work on." W6NIZ's later contacts were with W6AAE (7 Mc.), W6MWG (3.5 Mc.) and W6BQO (7 Mc.), all of Los Angeles. Messages totalling over 100 were handled for the Water District, the Santa Fe Railroad, State Highway Commission, Red Cross and many individuals.

Good old 56 Mc. helped tremendously within the confines of the many damaged cities and towns. To this band goes the credit of establishing many "first reports" from several localities: W6CAH, W6CPY, W6EED, W6GWP, W6GZQ, W6KQO, W6LRO, W6MWN, W6DDA, W6NIU, W6OJL, W6OLO, W6OPM, W6PAK and W6PNW. Many of this group assisted the American Legion in coordinating its activities in the San Fernando Valley. W6MWN persisted in remaining at his post until fatigue brought about a collapse. Much splendid mobile work was done in reporting critical situations.

14 Mc. carried its share of personal traffic to the East and Trans-Pacific. 28 Mc. served nobly for short haul and mobile work. On this band W6APU, W6CKR, W6LOB, W6MVL and W6PDB remained active for several days.

W6DZK, Long Beach, and W6KNH, San Francisco, assisted in providing communication between Procter and Gamble Company officials at Bakersfield, Long Beach and San Francisco. This was on 14 Mc. W6KNH also handled emergency traffic for the Red Cross.

W6ELC, Los Angeles, worked with Press Wireless station KPF, San Francisco, all afternoon of March 3rd, handling traffic for the Red Cross, Associated Press and International News Service. Contact with KPF was established through the cooperation of W6MPG, San Francisco. W6ELC also handled traffic with W6MWM, Sacramento, and W6DVD, Oroville.

Contact between W6HAR, Long Beach, and W6HZV, Taft, enabled the General Petroleum Corporation to continue proper operations of its pipe lines between the oil fields and refineries.

W6QFZ, Los Angeles, and W6EJU, Bakersfield, maintained contact for a long period, handling important messages for the Bakersfield

(Continued on page 98)



Only **\$10** DOWN  
 Take YOUR CHOICE of these Fine Sets



### National's NEW NC 100XA

Notice the big, new type, illuminated dial with *direct reading scales* for each band. *Calibrated in Megacycles*. Also continuous running vernier dial with band spread readings from 0 to 1000 at all frequencies. Equipped with "S" Meter. Cabinet restyled and enlarged. Yet with all these fine improvements the NC 100XA costs no more! Send only \$10.00 with order, pay \$17.60 C.O.D. balance easy terms. (See List.) Cash Price \$147.60.

### CHOOSE any one of the dozen fine nationally known

sets in this list and RESOLVE TO HAVE IT... NOW! Regardless of what set you want, just send only \$10 with your order. Make a small additional payment C.O.D. when your set arrives. Balance in six, nine or twelve months as listed below.

	Cash Price	C.O.D. Payment	6 Months Payments	9 Months Payments	12 Months Payments
NATIONAL NC-80X-NC-81X complete with Tubes, Crystal, and 8 in. P.M. Speaker.	\$99.00	\$9.00	\$14.36	\$9.66	\$7.30
NATIONAL NC-100XA complete with tubes, crystal and speaker in cabinet.	\$147.60	\$17.60	\$21.10	\$14.21	\$10.80
NATIONAL NC-100A complete with tubes and speaker in cabinet.	\$125.10	\$19.10	\$18.56	\$17.50	\$9.47
NATIONAL NC-101X complete with tubes, crystal and speaker.	\$129.00	\$14.00	\$18.58	\$12.50	\$9.47
NATIONAL HRO with tubes and coils.	\$179.70	\$19.70	\$26.14	\$17.67	\$13.45
NATIONAL HRO with tubes, coils and power supply.	\$195.60	\$25.60	\$27.84	\$18.83	\$14.33
RME-69 complete with tubes, crystal and speaker in cabinet.	\$151.20	\$16.20	\$21.94	\$14.77	\$11.25
HAMMARLUND SUPER PRO complete with tubes and 8" dynamic speaker.					
Model SP-110 — 15 to 560 meters and Model SP-110S — 7.5 to 240 meters.	\$243.00	\$23.00	\$36.35	\$24.61	\$18.75
Model SP-110X — 15 to 560 meters and Model SP-110SX — 7.5 to 240 meters.	\$261.00	\$21.00	\$38.08	\$25.78	\$19.64
HALLICRAFTER SKY CHALLENGER II complete with tubes, crystal and speaker.	\$99.00	\$9.00	\$14.36	\$9.66	\$7.30
HALLICRAFTER SX-16 SUPER SKY RIDER complete with tubes, crystal and speaker.	\$123.00	\$13.00	\$17.74	\$11.93	\$9.02
HALLICRAFTER SX-17 SUPER SKY RIDER complete with tubes, crystal and speaker.	\$149.50	\$24.50	\$20.26	\$13.64	\$10.36

**NEW LOW PRICED NATIONAL SET!**  
 As soon as released by the manufacturers, you can GET FULL DETAILS FROM US  
 Write us today! Ask us to reserve first shipment for you. No obligation.

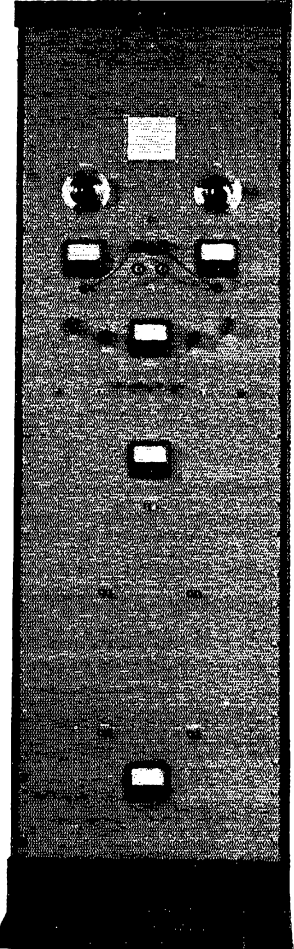

### National's NEW 600-WATT TRANSMITTER

Now Your's on NEWARK'S EASY TERMS

Writes for Time Payment Details — A modern Transmitter available in kit form built around the new National Co. type "NTE" Combination Exciter and Speech Amplifier. Complete descriptive booklet sent upon request.

### Oil Filled, Oil Impregnated FILTER CONDENSERS

Only \$1.00

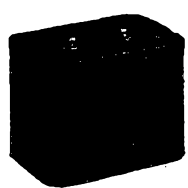

1500 V. DC. 1 1/4 mfd.  
 2" Diameter Round Can. 3/4" high. Weight 1/2 lb. Well Known Make. Bought at a lucky price! Quantities limited. First come, first served. Guaranteed at rated voltages.  
 2000 V. DC. 4 1/2 x 3 1/4 x 1 1/4, 1 1/4 lbs. \$1.50  
 1000 V. DC 5 x 3 1/4 x 1 1/4, 1 1/4 lbs. 1.10  
 1250 V. DC 3 1/2 x 3 1/4 x 1 1/4, 1 1/4 lbs. 1.25  
 1500 V. DC 5 x 3 1/4 x 1 1/4, 1 1/4 lbs. 1.50  
 1500 V. DC 5 x 3 1/4 x 1 1/4, 1 1/4 lbs. 1.75  
 2000 V. DC 5 x 3 1/4 x 3 1/4, 2 1/2 lbs. 2.75  
 0 mfd., 750 V. DC 4 1/2 x 4 1/4 x 1 1/4, 2 lbs. 1.75  
 4 mfd., 750 V. DC 4 1/2 x 4 1/4 x 1 1/4, 2 lbs. 2.00

### NEW LOW PRICE ON RCA-AGR-111

Now Only \$129.50  
 (Originally \$189.50)  
 Only \$10.00 with order! Then pay \$14.50 C.O.D. and \$9.47 per month for 12 months; \$12.50 per month for 9 months; or \$18.58 per month for only 6 months! You save \$60 at this new low price!

**YOUR CALL LETTERS IN GOLD**  
 Hams Look at this! Your Call letters in impressive three dimensional style. Big shadowed letters nearly TWO INCHES high. Put them on your HAM SHACK door, auto window, etc. Send dime for yours today. Be sure to give your call letters.

**FREE! Get This Big New HAM BARGAIN BULLETINI!**  
 Illustrations, prices and full details on nearly 600 separate items, sets, tubes, parts and supplies! MAKE UP A \$60 ORDER and Buy All the supplies you need at present low prices AND PAY ON EASY TERMS. Write for this Special Bulletin Today.

# NEWARK Electric Company

323 W. MADISON ST. CHICAGO, ILL.  
 Dept. Q

Say You Saw It in QST — It Identifies You and Helps QST

## Station Activities

(Continued from page 64)

### ATLANTIC DIVISION

**E**ASTERN PENNSYLVANIA—SCM, John B. Morgan, W3QP—Q.Q.'s: 3EEW, 3FRY, 3ZF, 8BQ; P.A.M.: 3EOZ; R.M.'s: 3AKB, 3AQN, 8ASW; Asst. S.C.M. for E.C.: 3AKB. The traffic ratio, Originations/Deliveries, remains healthy at 439/680. Total points scored was 454. Reports received from 57 stations. WARNING: HIGH VOLTAGE IS DEADLY. . . . MEMBER BADLY BURNED GRABBING 3000-VOLT HOT TANK COIL. . . . DIDN'T KNOW IT WAS LOADED. . . . KNOCKED ACROSS ROOM, DRAGGING FINAL OFF SHELF, SMASHING TWO 250TH's. Gang, at least for the sake of those who love you, PUT A RED BULB AND SOCKET IN PARALLEL WITH YOUR HIGH-VOLTAGE A.C. SUPPLY AND MOUNT IT ON THE FRONT OF YOUR RIG—SO YOU WILL ALWAYS KNOW. And if that isn't enough, RIG YOUR PLATE SUPPLY SWITCH ON THE FLOOR WITH A SHINGLE OVER IT SO THAT IT WORKS LIKE THE ACCELERATOR OF YOUR CAR; AS SOON AS YOU RELAX YOUR RIGHT FOOT THE POWER IS CUT OFF—thus you must stay awake to keep the power on. "It Can Never Happen to Me" generally means that you're next; 25 volts and a pair of wet hands can deliver a violent wallop. There is no more excuse for carelessness with your rig than for turning your back on a crouching tiger: both can kill you without warning.

Traffic: W2ITX-3 38 3ADE 48 3AOC 37 3AQN 161 3BES 23 3BRZ 1 3BYB 30 3CHH 24 3DGC 284 3DGM 11 3DPU-3LXC 23 3ECP 22 3EDC 390 3EFH 26 3EML 806 3EON 6 3EWJ 175 3EZ 464 3GAG 101 3GDI 13 3GMK 95 3GUB 75 3GYK 2 3GYV 4 3HCT 12 3OK 97 3QP 279 3QV 57 3ASW 345 3ATF 12 3AXH 4 3CDT 8 3CVS 22 3EKG 400 3FLA 315 3NPQ 18 3OML 3.

MARYLAND, DELAWARE, DISTRICT OF COLUMBIA—SCM, Edgar L. Hudson, W3BAK—3CXL, 3CQS; R.M.'s. 3BWT: Chief R.M. GKZ received W.A.S. ticket. CDG has 250TH with 600 watts input; he worked VR4AD for 78th country. EPD worked for several weeks as third operator on S.S. Kent, WLLA, Balto, to Boston via Norfolk. HV has played radio chess with both CAB and 8OKL. GWF and GVK leave for West Coast in June. GRX and GKZ leave for New England about the same time.

Traffic: W3CIZ 862 W3CKL 485 (WLM 4088) BWT 684 SN 666 BKZ 542 FPQ 48 GKN 15 8JA-3 14 3GKZ 12 BAK 8 CDG 6 CDQ 5 WU 4 EYX 5.

SOUTHERN NEW JERSEY—SCM, W. Walter Filson, W3BEI—HYR again makes the B.P.L. DNU heard 4EDD on 56 Mc. FFE met several hams at Central Airport; he schedules 9SUC on 14 Mc. through 3US. ETX married BPT's sister May 6th. FCQ is doing a bit of experimenting on 14 Mc. FPA is back in Atlantic City and enjoyed April O.R.S. party. BO is in Pittsburgh for 10 weeks. ZX moved to Medford Lakes where he is on 14 Mc. In addition to the outing of the D.V.R.A., a baseball game has been scheduled between the 2nd and 3rd districts; the 3rd won last year by a score of 13 to 2. The S. J. Net will suspend for the summer to resume again early in Sept. The S. J. R. A. will hold its annual outing some time in the month of August.

Traffic: W3BYR 694 (WLVN 60) ZI 128 EFM 74 (WLNJ 64) QL 41 DNU 31 FFE 24 BEI 21 FPA 15.

WESTERN NEW YORK—SCM, H. E. Preston, W8CSE—R. M.'s: 8BJO, DSS, JTT. P.A.M.: 8CGU. The Auburn Club met at the shack of BWE on May 1st. LDA is now living in Endicott. ERZ is proud papa of a bouncing YL op. ROI and RNG continue to contribute to the QRM on 1.75-Mc. phone. BFG needs one more QSL to be eligible for the DX Century Club. DSU also is a papa now. DME will operate from his camp under the call KCL. HQW is heard now and again on 28 Mc. HI! CTJ will be on soon with a pair of HF100's. BGV and AHC are often heard on 28-Mc. phone. NQC calls CQ on 28 Mc. also. The S.C.M. extends his thanks to NQC and the staff of the Auburn Club's "Bug" for the foregoing dope. More power to you. BDV is new O.R.S. GWZ is new O.P.S. Both are A-1 fellows. LGH is recuperating nicely. RXA of Booneville is on the air looking for 7-Mc. contacts; he has an ACR155 receiver and Utah 100-watt transmitter. RKM in Cortland will be O.R.S. when fall traffic season opens. ONC flew the mail plane from Oneida to Syracuse, May 19th, for the National Air Mail Week celebration. KDI has a junior op now. NNS has

swell new shack. GBY and the Toothpickers (listen 12:30 daily!) will throw their annual shindig at Marathon sometime the latter part of July. CGU schedules YKa MIM. DSS and FCG did some nice work in an intercity bowling match. PWU is getting fixed up with a W.E. 305A e.e. oscillator driving a 35-T. RTX, new ham in Caledonia, is very active on 1.75-Mc. phone. RMR of Mount Morris is getting to be a big DX man; he also is a papa now. MYK rebuilt his rig using a T-125 final. RKA of East Randolph has been revamping both transmitter and receiver. NNJ changed QTH. QWA is fooling around with low power on 1.75 Mc. RBW is having fun with that new half-kw. rig. MVQ is on 1.75-Mc. phone afternoons. PCW is home for the summer and rebuilding. RXU is new ham in Dunkirk. RME has new transmitter going FB on 3.5 Mc. QXS is getting to be quite a traffic man; he is also on 1.75-Mc. phone with 2 or 3 watts. PFM took in the Rochester Convention; he has a new transmitter with RK20's in the final. ACY/8 has another new portable battery operated rig; at present he is in Rochester. FCG, PLA and RKM paid the S.C.M. a visit or two during the month. The S.C.M. returned the visit with PLA and RKM and will soon be with "ole" FCG. NVB joined the A.E.C. and has a nice emergency layout. CTX is catching up on his rag chewing with new 400-watt rig; he says the Utica gang is planning a Field Day and other summer activities. RYY is new ham in Syracuse. MEY is working good DX on 14-Mc. phone. Wish I could hear them on 7 Mc. the way NUY does. FVL, formerly of Cleveland, Ohio, is now living in Owego. RDJ is headed for one kw. now. JPO left 14 Mc. for 3.9-Mc. phone. NXQ is moving. KDY will soon be heard on 1.75-Mc. phone. GZP, OAM and CSE took the exam for Class A ticket. Listen for WANC of the Jamestown American Legion Emergency Unit; they operate on 2726-kc. phone every Monday evening from 8 to 10 P.M. and contact amateurs in the 3.9 and 1.75-Mc. phone bands. The annual hamfest of the Central New York Radio Club of Syracuse was attended by 134 hams. A good time was had by all and a surprisingly large number of prizes were distributed. 8CYT and his committees are to be congratulated on making the affair a huge success. The Auburn Club has been preparing for its usual Field Day in conjunction with the A.R.R.L. Field Day. It is with the deepest sorrow we learn of the death of E. Robert Hipkens, W8KRR, on May 20th, from streptococcus viridans, a blood ailment for which no remedy has ever been found. Bob was an active amateur and past president of the Central New York Radio Club of which he was a charter member. His passing will leave a vacancy in our midst that will not soon be filled.

Traffic: W8PLA 97 FCG 91 BJO 39 LJD 13 QXS 35 DSS 33 CSE 67 (WLVN 83) PCW 3 DHU 25 PWU 18 CGU 10 BDV 22 CTX 6.

WESTERN PENNSYLVANIA—SCM, Kendall Speer, Jr., W8OFO—R.M.'s: 8KUN, 8KWA, 8MOT, 8GBC A.A.R.S. Liaison R.M.: 8UK N.C.R. Liaison R.M.: 8KOB. Emergency Coördinators: Pittsburgh, 8QAN; McKeesport, 8DNF; Erie, 8AQ; St. Marys, 8NDE; Butler, 8DDC; New Castle, NNO; Ohio River Region, 8BBV. New Appointments: O.R.S., KXE, BBW, O.P.S., OUT, O.B.S., NEA, OUT, Prospective O.R.S.; EYY, RQA, RAQ, O.B.S.; RBI. The South Hills Brass Pounders and Modulators Big Hamfest will be held Sunday, August 7th. W. Brad Martin, W3WQ, Atlantic Division Director, will be guest speaker. 8EA, 8OC (assistant director) and 8OFO were speakers at the Altoona Horse-Shoe Radio Club Meeting, May 24th. 8EA spoke on his historic jump from the Brooklyn Bridge in 1910. The Valley Key and Mike Club at Sharon is planning its third annual outing. The Sylvania Radio Club at Bradford is making splendid headway since reorganization. The South Hills B.P. & M. tested its 2-kw. power plant on May 15th with results beyond expectations. UK made B.P.L. on deliveries. FB. OFO enlisted in the N.C.R. ZAE joined the A.R.R.L. QAN is getting some nice DX in on 14 Mc. NDE is scheduling 1JXP twice weekly during the summer. DNX and DDC are busy completing their emergency equipment. KWA is putting up a flat top beam for 14 and 28 Mc.; he is operating some 1.75-Mc. phone with 10 watts input. JMP and OSI, are now members of the DX Century Club. Nice work. CMP will spend the summer in Northern Michigan and the West. IOH will work 7 Mc. during the summer. KXP needs Montana and So. Dakota for W.A.S. EFA is Radioman First Class in the N.C.R. PFW says an old-timer is active in Berlin with the call RUF. MOT is W.A.S. Congrats. The DuBois N.C.R. Unit has seven prospective amateurs ready for their exams in



June. EYY schedules VP5JB. It's a baby boy at GBC and a girl at NZE. Congrats. QAN and QDV joined the A.A.R.S. LDY received his First Class 'phone ticket. RNO says IZG is active again on 14-Mc. 'phone. LGD is unit commander of the new Monessen N.C.R. Unit. NCJ is active with two operators, the OM and the XYL. MWV is Secretary-Treasurer of the Valley Key and Mike Club. QHS has flea-popper 1.75-Mc. 'phone. IYQ has new 808 final working Europe regularly. HLA has new antenna. AOE will work 14 Mc. during the summer. BVP is installing a rhombic beam. IYQ and OAJ took Class A exam. OJY works portable at New Wilmington. BBW is running 7-Mc. schedules during the summer. 4BOU-8 has applied for a W8 call. NUH enlisted in the N.C.R. KOB plans to attend the Atlantic Division Convention. AVY is working out plans with the P.R.R. for amateur emergency assistance. GUY reports that the R.I. closed up a 56-Mc. bootlegger in Elwood City. KNB operates INE occasionally. RBQ is working 14 Mc.; he reports a bootlegger using his call on 1.75-Mc. 'phone. Advise him if you know who the offender is. DYY is active on 3.5 Mc. IZS can be heard on 3.5 Mc. occasionally. FCO injured several fingers cranking the South Hills B. P. & M. emergency power plant. OUT is completing three rigs for use on four bands; the finals are P.P. 35T's, T55 and P.P. 801's. QEP is on 14-Mc. 'phone. ROE will operate 1.75-Mc. 'phone. GKI takes his First Class 'Phone exam in June. QVQ received Class A ticket; he runs 200-watt 'phone on 14 Mc. OKS left for two weeks active duty at the Phila. Navy Yard. NQJ installed a new antenna. FQJ is radio operator at the McKeessport Police station. 4ETX (exBJSY) with Eastern Airlines at Miami is on vacation in Western Pennsylvania. ROA is active on 1.75-Mc. 'phone and 7-Mc. c.w. despite his physical condition which keeps him bedfast. HBG won the miniature 'phone building contest held by the Horseshoe Club at Altoona. The prize was an 809. AXD is rebuilding for remote control. New amateurs: Butler, RXO; Scott Haven, RWO; Clairton, RQP; Berlin, RUF.

Traffic: W8OFO 229 UK 171 QAN 153 NDE 142 DNX 141 KUN 102 KWA 98 YA 83 (WLMA 348) CMP 80 IOH 69 PFW 44 KXP 43 EFA 39 MOT 20 MJK 16 EYX 12 NCJ-QXF 11 AXD 9 MWV 8 BBW 6 4BOU-8 3 8LGD 20.

#### HUDSON DIVISION

**E**ASTERN NEW YORK—SCM. Robert E. Haight, W2LU—Congrats to HYC on his FB total. ITK schedules 8CTX on 3575 Kc. KFB is on 1.75-Mc. 'phone. He did nice traffic handling for National Chief Scout Master West. HNH is erecting special 14-Mc. antenna. HTU, O.P.S., chews the ole rag 90% of time and experiments the other 10%. ALP is greatly interested in G's. ACB interviewed President Woodruff and Director McCargar of A.R.R.L. over W2AXF and W2AXD, May 10th. DVC installed 56-Mc. mobile rig in car for summer use. Ex-W3FWX has call 2LEI. E.N.Y. Section welcomes its new affiliated club, "Delaware Valley Brass Pounders Assn." of Port Jervis, and wishes them success upon their new endeavors. JQI has a new rotary beam antenna. Every E.N.Y. operator is asked to make a special effort to report on July 16th. WLNX is A.A.R.S. station of W2HYC.

Traffic: W2HYC 121 (WLNX 17) LU 51 ITK 18 KFB 2. NEW YORK CITY AND LONG ISLAND—SCM, Ed. L. Baunach, W2AZV—KJY and KXB sent their first reports. EC will keep the East Coast division of the A.P. Net going through the summer. The Tu-Boro Radio Club is planning for their summer Field Days; the first trip was to Woodland Campsite at Phoenicia, N. Y., on Decoration Day. CLA has been heard operating portable at Shelter Island. AZV is operating portable on L.I. KCV has been busy getting his portable rig to operate with the N.Y.N.G. at the summer camp at Oswego, June 26th, to July 10th. PF has been busy with the Hudson Division Convention. GUV, JDF, LIM and a number of stations located near airports have formed the airport network operating on the 3.9-Mc. 'phone band for the purpose of supplying weather information to incoming and outgoing ships and any emergency that may arise. Anyone on 3.9 Mc. who is interested and lives near an airport should get in touch with GUV at the Edwards Flying Service, Flushing. DOG gave a talk on h.f. in Washington, D. C. EEL reports a high traffic total. HMJ is trying 3.9-Mc. 'phone. KIK is on 7299 kc with 125 watts input to a T20. ESO is putting ¼ kw. into a pair of 809's. DBF has a 500-watt c.w. 'phone rig for sale. ADF has a TH250 for sale. IXQ is trying his hand at grinding

crystals. G6QX visited FF. HXT has been traveling through Texas and visiting the "fives." CHK put up a three half-wave antenna on 14,176 kc. and worked 31 Europeans on 'phone in three days. GSC reestablished contact with VP3AA after a long absence. HGO is using break-in by keying the oscillator and buffer. KIF sends O.B.S. at 7:30 p.m. E.S.T. on Mon., Wed., and Fri. on 7145 kc. JZX continues to schedule WANC. KYO has had 879 QSO's in three months. DVU's portable rig is a 61.6 and RK20A. LAP works 56 and 3.5-Mc. cross-band with IJD. HYJ is very active with his 56-Mc. mobile-portable rig. KTF and KLN operated a portable 56-Mc. transmitter at the Baldwin High School. DBQ is still desiring more stations for emergency operation in N.Y.C.

Traffic: W2EEL 1733 JHB 269 DBQ 152 (WLNB 49) PF 72 AZV 64 JZX 52 EC 38 GDF 17 HMJ 15 EXR 14 BYL 13 FID 12 CHK 11 CIT 10 KCV-ADW 9 GRJ-HYL 8 AA 7 DBF 6 LR 5 IHT-DVU-BGO 4 EVA-GUV-DLR 3 HYJ-JDF-IXQ-ESO-HBO-FIF-AZM 2 HGO-AHC-GG-KRG-HJT-BNJ 1.

**NORTHERN NEW JERSEY—SCM.** Fred C. Read, W2GMN—KAK and KTR are new O.R.S. KAK is high traffic man for this period. KAK, GVZ and HOZ made B.P.L. on deliveries. KHA handled lot of traffic at Bayonne High School "Open House." HAE completed his contacts for W.A.C. KNN reports much better results at his new location at Fairlawn. The N.N.J. QSP Club invaded foreign territory by holding its May meeting in Brooklyn. The club is now officially affiliated. IVE will operate portable on 56 Mc. during the summer. ICJ expects to have increased power soon. GVZ made B.P.L. for sixth consecutive month; he is new member A-1 Operator Club. IOZ has gone back to 28-Mc. 'phone. ISW made his first report as O.R.S. First prize in the "QSO Party" was a Mackey, won by JON. GFW collected a \$5 credit, GUM a 7-Mc. crystal and holder, and BCX a \$3 credit. Prizes were donated by the QSP Club and by local distributors. Some very good scores were turned in. CCK is prospective O.R.S. Several fellows have evinced interest in summer traffic schedules. If there are any more we would like to hear from them.

Traffic: W2KAK 453 GVZ 351 KHA 139 KTR 104 GGW 72 HQL 50 (WLNK 78) JKG 22 (Previous period) HDJ 20 BCX 18 (WLNF 17) ISW 14 HRN 12 BZJ 6 JUC 6 HYX 4 HOZ 225 KMI 148 CMC 41.

#### ROANOKE DIVISION

**N**ORTH CAROLINA—SCM, H. S. Carter, W4OG—The following have been appointed as Assistants to 4BXF, the Emergency Coördinator for Charlotte and vicinity: CLB, BLN, DCS, DSY and CQ. The Charlotte Unit has been conducting some fine tests with emergency equipment. FCB applies for O.R.S. DSY has some good schedules that click FB. BRT has a new rig on the air. CYA reports for the State College Club; the station call is ATC with the following operators: IF, CWD, CYA, CXF, AIM, BWD, UB, DCT, CXG, ECB, EZA and FBO. CYB is rebuilding and repainting his shack. BHR sandwiches in some operating with his rebuilding. DZS put up a new vertical. FEU, new ham is operating on 7 Mc. ESO reports a swell time in the O.R.S. Party. BIP's antenna blew down. 3HKG/4 applied in person to the S.C.M. for O.R.S. Welcome to the official ranks. OM. EYA reports progress on his new rig. DWB leads the State in traffic; he has been working some DX on 7 Mc. DGV is working plenty of DX, but spends most of his time rag chewing; he is active on six bands. AHF is working lots of DX. 4NC has been busy with preparations for the Field Day outing. CFR and ACA are very active. OG has about completed rebuilding; the rig will have a pair of '52's in the final. 73.

Traffic: W4DWB 373 ATC 44 FCB 30 CJN 29 DSY 28 BRT 21 ESO 9 3HKG/4 7 BHR 5 CYB-DGV 2.

**SOUTH CAROLINA—SCM,** Ted Ferguson, W4BQE—EPJ will soon be leaving for Indiana for the summer. GB is back on c.w. and has added another 100TH to final. DNR is working 1.75-Mc. 'phone. MN is working on a television unit for demonstration. BZX is working 3.9-Mc. 'phone and says the gang will have a 3.9-Mc. 'Phone Net this fall. EXJ is working 7-Mc. c.w. and 28-Mc. 'phone. DTU is working 28-Mc. 'phone. EDQ is working 14-Mc. c.w. DX and 1.75-Mc. 'phone. DQY says 28-Mc. 'phone is FB. EZF is trying to make W.A.S. BDT is still going to town with his FB traffic. CQG realized a life's ambition, S9 from a VK. PFO will spend the summer in Virginia. CQU con-

(Continued on page 80)

# NEW!! GROSS CB-150 RADIOPHONE TRANSMITTER

Gross presents another fine transmitter having real power at an amazingly low price.

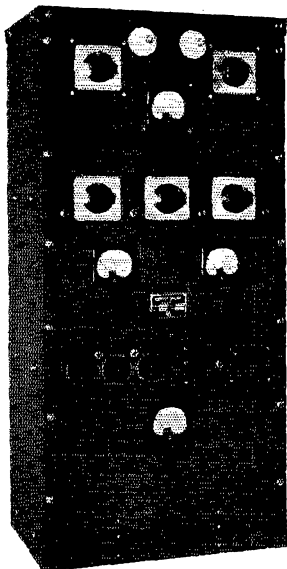

## Gross CB-150

Input — 140 watts  
Coils available for 30, 14, 7, 3.5, and 1.7 mc

Class B modulation  
All the very latest type tubes used throughout

Completely self contained from mike jack to antenna tuning unit

•  
*Descriptive Bulletin on Request*

## "THE STANDBY" (2 to 2000 Meters) 3 TUBE A.C. AND D.C. RECEIVER

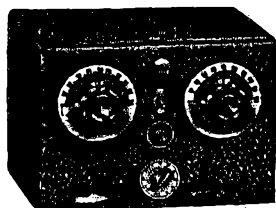

The Standby was designed to supply a need for a receiver to cover all the amateur broadcast and commercial frequencies (2 to 2000 meters). It will fill the requirements for an all round "Standby" receiver. Super regeneration is used from 2 to 15 meters and straight regeneration on the higher wavelengths up to 2000 meters. Loud speaker reception is possible on most stations.

● Power supply incorporated. ● Individual antenna tuning for high and low wave ranges. ● 1-76 super regenerative detector, 1-6J7 regenerative detector, 1-12A7 audio amp. and rectifier.

Complete kit of parts less coils, tubes, cab.....	\$7.59
2-5-10 meter coils (set of 3).....	.95
9.4 to 15 meter coil.....	.39
15-200 meter coils (set of 4).....	1.30
200-310 meter coil.....	.39
310-550 meter coil.....	.36
550-1050 meter coil.....	.60
1000-2000 meter coil.....	.60
Metal cabinet.....	1.50
Kit of three tubes.....	2.40
Wired and tested in our lab., additional.....	2.00

## GROSS RADIO, INC.

51 VESEY STREET NEW YORK

Cable Address: GROSSINC

"Look for Me on --- Kc."

(Continued from page 68)

excitation on the highest frequency at which the exciter is to be operated. The screen voltage on the e.c. oscillator should be held to the lowest usable value and the suppressor tap adjusted to approximately 40 volts. Tuning adjustments are likewise not critical except when the oscillator plate is tuned to 10 meters. Ordinarily if the plate condensers are set for approximately the middle of the band it will be possible to QSY over practically the entire band without readjustment other than that of the oscillator grid tuning (with e.c.o.) for the desired frequency. In this connection it might be well to stress the value of a good dial for this control. An accurate dial is necessary if close calibration is to be attempted; the National Type "N" being ideal for this purpose.

The oscillator power supply voltage should not exceed 350 volts and should be well filtered and of good regulation. If output on 56 Mc. is not desired the plate voltage need not exceed 250 volts, since this value will furnish adequate excitation to the 807 except when it is to be used for doubling to 56 Mc. Oscillator plate current should not be permitted to run much in excess of 35 ma. on the 802. This value is easily controlled by regulating the screen-voltage tap.

This exciter has been operated in a number of "shacks" throughout Western Massachusetts to try its merits under the widely varying conditions encountered in various ham layouts. It has been given an enthusiastic "OK" by a dyed-in-the-wool 80-meter traffic man, a well known 20-meter 'phone operator, a 160-meter 'phone rag-chewer, and a 10- and 20-meter DX hound. In a recent ORS Party, W1EOB used this unit to drive his 125-watt final on 80-, 40- and 20-meter c.w. and worked 210 stations without once resorting to crystal control. Of the 210 contacts all but two gave the signal T9 reports. The two reports of T8 were received on 20. In this case a single 350-volt power supply was used on both oscillator and buffer, with oscillator keying in use at all times.

All who have tried the unit agree that it would encourage them to have a look at the other fellow's band once in a while. Is it not possible that many of us have been passing up something because a major operation is required to get to another band? How many more countries would we have to our credit had we been able to "sneak up" on that elusive DX or, better still, to the frequency of the station he was working? The e.c. oscillator is rightly credited with having brought the fine art of DX "snitching" within the reach of the man who cannot afford a basketful of variable-frequency crystals.

## Strays

"Try using a phonograph scratch filter in the audio circuit of 5-meter receivers to remove super-regenerative 'hiss.'"  
—W8QHW

# THESE BATTERIES ARE NOT SPECIAL



722

Here are regular *stock* batteries. They are *always available*, and conform to the standards for portable radio batteries established by the R. M. A. Standards Committee.



723

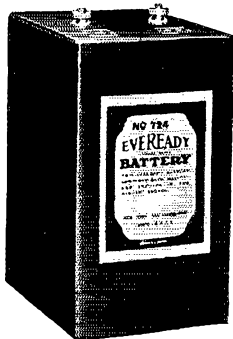

724



733



738



744

**No. 722**—2 cell, 3 volt "A" Battery. Length 2 11/16 in., Width 1 1/2 in., Height 4 1/2 in., Weight 11 oz.

**No. 723**—4-cell, 3-volt "A" Battery. Length 2 3/4 in., Width 2 3/4 in., Height 4 3/8 in., Weight 1 lb. 5 oz.

**No. 724**—8-cell, 3-volt "A" Battery. Length 4 in., Width 2 3/4 in., Height 6 in., Weight 2 lbs. 4 oz.

**No. 733**—45-volt "B" Battery. Tap at +22 1/2 volts. Length 3 3/8 in., Width 1 3/8 in., Height 4 1/2 in., Weight 12 oz.

**No. 738**—45-volt "B" Battery. Tap at +22 1/2 volts. Length 3 3/8 in., Width 2 3/8 in., Height 4 1/2 in., Weight 1 lb. 4 oz.

**No. 744**—7 1/2-volt "C" Battery. Tap at -4 1/2 volts. Length 2 15/16 in., Width 1 1/16 in., Height 1 3/8 in., Weight 2 oz.

*Descriptive sheet mailed on request to:*

**BATTERY HEADQUARTERS**

**NATIONAL CARBON COMPANY, INC.**

30 East 42nd Street, New York, N. Y.

Unit of Union Carbide  and Carbon Corporation

(Continued from page 87)

tinues his activity with the c.w. nets. CZN is doing lots of rag chewing on 7 Mc. FAL is operating portable 1.75-Mc. 'phone at Beaufort. BNN has new RME and is working 1.75-Mc. 'phone. The S.C.M. has information showing that the new club in Charleston is really going places. Keep up the good work, fellows. Your attention is called to the TWO Meetings in JULY: Asheville, N. C., July 3rd, and Charleston, S. C., July 31st. Let's all attend and have a good time. Again, Let's have EVERY ONE IN THIS SECTION A MEMBER OF THE LEAGUE and SUPPORT THE ORGANIZATION THAT SUPPORTS HAM RADIO.

Traffic: W4CZA 197 BDT 125 EWB 69 FDN 35 EUX-CQU 24 DNR 14 FFO-BNN-CZN 12 EMB-EDQ 10 DQY 9 EPJ-BZX 8 CQG 6 EZF 1 DTU 2.

VIRGINIA—SCM, Charles M. Waff, Jr., W3UVA—P.A.M.: 3AJJ—R.M.'s: 3GPC, DJC, GTS. NQ has new T55 final, 'phone and c.w. FBL is on 1.75-Mc. 'phone and 3.5-Mc. c.w. as well as portable 56 Mc. HDQ was in Harrisburg, Pa., with Army maneuvers when he mailed report. BFW is building 1-kw. final with 100-TH's. DZW is using P.P. 809's. EMA wants a schedule with Richmond on 7 Mc.; a windstorm blew down his antennas. GTS is alternate national net control for A.A.R.S. GPC again made the B.P.L. BZE is already rebuilding for the SS! The Richmond Short Wave Club held a transmitter hunt May 15th. Five cars participated. FBL and FJ operated transmitter. CQW took bearing and then went in opposite direction of transmitter: ZU, GE and CFL started out in good spirits, picked out a clear spot, set up their receiver and loop and began taking bearings. Unable to get a bearing they discovered they were directly under the transmitting antenna and within 25 feet of the laughing operators! GKT is leaving the section after a short stay. Good luck, OM. FHF is planning to rebuild with P.P. T40's. BIG has new SX-17 receiver and rack-and-panel transmitter.

Traffic: W3GPC 141 GTS 132 (WLMG 281) BZE 86 HDQ 76 FBL 9.

WEST VIRGINIA—SCM, C. S. Hoffmann, Jr., W8HD-W8NS—With the Spring weather, the gang has turned to "visiting." Visits reported are DYB, BTV to Charleston; PTJ, PSR to Wheeling; KYJ, CLQ, 9YDX, 9OCG, 3ZD, to Wheeling; QQZ to Malden and Huntington; LII to Bluefield; 3ZD, W8MOP to Huntington. LVM visited Fairmont-Clarksburg hams. PQQ moved to Bristol, Va. MLW visited MNX, KFW. HOW is on 14-Mc. 'phone. 3GME (ex-W8ZKZ of Elkins) has a daughter; he schedules NEP. KYJ is helping RDH, a promising O.R.S., rebuild. AHF and MOL are doing fine work on new 'Phone Net. Write them, if interested. DYB and CLQ are doing fine work on Trunk Line. MZD and JRI are operating portable at Maple Lake for the summer. OXO and GBF are neck-and-neck in DX race. ASI is rebuilding. KWV is building higher powered P.A. OXO has 250TH in final! The Grapevine has it that JM is adding an XYL pretty soon! QFN is trying new antenna on 'phone. PQQ, using 800 watts input, is working lots of DX. Prof. KIU-XNR, visited N.Y.C. and Boston for experimental purposes; he made talk to I.R.E. Section at Cambridge, Mass.; inspected u.h.f. link at Mt. Washington; television labs. at R.C.A., N.Y.C.; steerable rhombic arrays at Bell labs. Deal, N. J. The W. Va. Net is still complimented by 8YX's presence. ELJ, LGB, KHB, QQZ, BTV and LCN have been preparing for A.R.R.L. Field Day tests. QQZ is new station on 56 Mc. GAD is going in for 3.5-Mc. traffic and trunk line work. BOW is on 14-Mc. 'phone. HD hopes to get in more visiting, and some rebuilding during the summer.

Traffic: W8BTV 146 HD 109 DYB 63 KYJ 52 PSR 45 BOW 22 KIU 20 NEP 16 OXO 13 PHY 10 BWK 9 MOL-PQQ 4 OLV 2 QQZ 1.

#### NEW ENGLAND DIVISION

CONNECTICUT—SCM, Frederick Ellis, Jr., W1CTI—JYE, KQY, HSX, KFN and UE make the B.P.L. About 1300 messages were handled by the New Haven gang during the Tercentenary Celebration. HSX has a fine schedule with K5AF at Albroom Field, C.Z. on 14 Mc., clearing some of his traffic to JYE cross-band on 3.5 Mc. KQY is working 56-Mc. 'phone and rearranging shack. JQK is DXing on 14 Mc. KFN joined N.H.A.R.A. 3FTK-1 has been assigned WILHE. Rebuilding is under way at AMQ. KKS will be on 56-Mc. 'phone soon. He worked W6OTZ in April, and met him a few weeks later at Brainard Field when he came East on a bomber. JPG-1, formerly 8JLC, reports

from Hamden. After 18 years of brass pounding APA got his W.A.C. certificate. B.A.R.A. held its annual election May 2nd with following results: Pres., APA; Vice-Pres., APW; Treas., KAB; Sec'y, GRU; Activities Mgr., ACV. The biggest event of the month was the Annual New England Division Convention held at the Hotel Bond in Hartford, May 21st and 22nd. Many thanks to the Committee, CSC, JZB, HNO, EAO, IBY, FZA, EJT, IFH, BUE and JAM for a swell time. C.B.A. has its c.w. rig back on the air, thanks to the efforts of Stan Shepherd, who rebuilt all power supplies. HYF resigned his O.R.S. and E.C. appointments, sold his transmitter and receiver and gave up amateur radio. (Norr.—He was among those present at the convention—we expect him back in the ranks inside of a year.) ES schedules 3BWT, 3CDQ and 8CMP. BDI, ES, EAO and GKM participated in a WTIC broadcast on amateur radio and the A.R.R.L. on the Saturday evening of the convention.

Traffic: W1JYE 752 KQY 673 HSX 614 KFN 590 JMY 489 JXP 267 AJB 264 LHE 194 AMQ 156 VK 155 ITI 150 UE 144 ES 85 KKS 58 DMP 46 FAJ 36 GMR 33 BDI 31 JYJ 23 TS 21 GKM 15 JTD 14 AW 10 JPG-1 9 JBJ 9 CTI 9 APO 7.

MAINE—SCM, Winfield A. Ramsdell, W1FBJ—GOJ reports the P.T.N. closed until fall after a very successful season. ISH is attending radio school in Mass. IIE reports for the Damariscotta gang. IFZ is rag chewing on 7 Mc. Remember, gang, the S.C.M. has to make a report on activities during the summer months as well as the winter when activity is at its height. Any news of interest should be sent in by the 20th. TE, KAS and FBJ represented the Section at the Division Convention in Hartford. We should have a larger representation than this. Why not start saving the pennies now and plan to attend next year. "Everything Happens to Us"—again very poor conditions for our last QSO party. Nevertheless, a gang was on and some of the boys ran up good scores. From the reports that are in KMM is the winner with 1422 points, DEG second with 1156, and JRS third with 714. Would like comments on whether or not we should continue in the fall. KOH donated two prizes for the QSO party. KNB is working real DX with the mobile outfit on 30 Mc. This rig is also being used in local tests in connection with the emergency set-up. DOB has the rig on the air again. KJJ has the Class A ticket now and has been doing some work on 3.9 Mc. LEV is new ham in Bangor. JLD, only 12 years at the present time, finds it necessary to have the license renewed, having had it since he was nine. Wonder if that is some sort of a record? About 75 hams, XYL's, YL's and friends attended the Eastern Maine Ham-fest at Brewer. The afternoon was spent by visiting local radio stores and stations. Prof. Creamer of the U. of M. started the evening activities off with a very interesting talk on radio, after which some stunts were pulled off, prizes were drawn and all enjoyed a buffet lunch. UP, QH and AQL had charge of arrangements and did a very FB job. AUC has taken the outfit to the lake again for the summer and expects to be on 3.9 and 14-Mc. 'phone. KKZ has gone into summer quarters at Danville. DVP is giving 28 Mc. a try. KAD gave the boys a break by coming on 3.5 Mc. for the QSO party. CRP was in on the O.R.S. party. EUI rebuilt the rig in a rack and panel job. KRK added a T20 to the 6L6.

Traffic: W1GOJ 280 ISH 187 GVS 109 JCP 80 CFO 72 KOU 60 EFR 35 FBJ 31 KCO 24 LDC 14 HSE 6 DHH 3.

EASTERN MASSACHUSETTS—SCM, Sam Gross, W1IWC—IWC is rebuilding again. KZT keeps weekly schedule with INW during summer. AGX started new crystal rig for 56 Mc. JJJ hitch-hiked to the convention. WV has 96 countries for Century Club. JFS is trying 112 Mc. SW applied for O.R.S. FXB took JJJ's place on net while Bud was job-hunting in Boston. LGG sent in first report. LBH has pair of 35T's on 56 Mc. IZF has new "Sky Buddy." GCN is back from Maine. New officers of South Shore Amateur Radio Club: IYU, pres.; AKY, 1st vice-pres.; CPD, 2nd vice-pres.; FVD, treas.; ALP, sec'y. IZE spends most of his time on 7 Mc. The 56-Mc. gang got quite a thrill when they heard 5CSU, but relaxed when they found he was operating portable at M.I.T. JZN continues sending code practice on 56 Mc. IYT is busy on new 56-28-Mc. rig with two T-55's in final. ILD received his broadcast ticket. IQH has his W.A.S. ALG is waiting for those cards for W.A.S. BSG has new rig perking on 28, 14 and 7 Mc. BSM finds 7 Mc. FB, but needs Delaware QSO. ERH divides his time between 7-Mc. c.w. and 4-Mc. 'phone. EA knocked off 38 countries in April. INO has some cards for the guy bootlegging his call on 28-Mc. 'phone. JIX is now on 14-Mc.

'phone. JYB is making plans for new and better rig. PG is busy holding down N.C.R. circuits. Several of the M.V.A.R.C. boys contributed their time and facilities toward the success of the Second Annual Dr. E. J. O'Brien Memorial 10-mile road race sponsored by the Columbian Club of Methuen. The race was held April 19th. IYT paced the field with car equipped with 56-Mc. portable rig reporting to LBH and LEA, stationed at the Columbian Club. ILD trailed the race and reported those dropping out. The crowd at the club house was kept informed of the progress of the race by public address system. The final results were transmitted to HXE, who delivered them to WLAW for broadcast as a sport flash. The entire set-up worked out very well and was a fine example of one of the many public services that the amateur can give.

Traffic: W1IWC 359 AKS 266 KZT 151 HWE 141 KH 124 AGX 97 JYJ 85 DMF 77 WV 75 KPW 75 JFS 69 JBI 47 BMW 44 HXE 43 SW 32 FXB 26 HIL-LGG 16 BEF 14 LEA 10 LBH 6 FOI 3.

WESTERN MASSACHUSETTS—SCM, William J. Barrett, WIJAH—IOR, IZW and JNA kept Worcester well represented at the convention. BVR attended annual Board meeting of A.R.R.L. and also took in three hamfests, a convention and an A.A.R.S. meeting—more power to you, Perce. EOB ran up about 7 million points in last O.R.S. party. AJ added preselector to his receiver and added a few new prefixes. BNL is confined to 3.5 Mc. due to oscillator power supply trouble. HSK checks his rig by taking portable receiver afield. COI expects to get 804 back on 3.9 Mc. HJR keeps up his reports FB from college in Indiana. AJD is still in Nashua, N. H. DUZ asks that all 1.75-Mc. 'phones interested in forming an A.A.R.S. 'Phone Net contact him or HNP. KJK/9 reports from Racine, Wis. George did all right by himself at Milwaukee Hamfest—copping an HRO. BNO reports lots of fun in his first O.P.S. party. Over 100 hams attended Worcester County Amateur Roundup at Fitchburg, May 7th. The news from Fitchburg: JXN has 200 watts on 56 Mc., T-40's in final. LBR has 200 watts on 28 Mc. ALR got trailer for mobile work. GED has kw. on 14-Mc. T-200's modulated by 822's. From Holyoke we hear that ISL is new W.A.C. and EBF has W.A.S. BGY has cards from 75 countries out of 90 worked. EVZ and IEI are rebuilding. JJO is nearly ready to go on 1.75, 3.9 and 14-Mc. 'phone. JAH attended convention at Hartford. This month set a new high for news in reports, fellows. Thanks, and please keep it up.

Traffic: W1IOT 213 (WLGJ 59) IOR 199 (WLGJ 20) BVR 108 (WLG 106) EOB 88 BIV 34 JAH 29 AJ 28 BNL 15 HSK 10 COI 2.

NEW HAMPSHIRE—SCM, Carl B. Evans, W1BFT—The Mike and Key Club is a new amateur radio association in Nashua. Prospects of a state-wide club organization are "in the wind" if some of the other active amateur centers in the state will get busy and form clubs. Don't forget the date of our annual N. H. Hamfest, to be held in Manchester on September 17, 1938. Our old friend, George Bailey, WKH, Vice-President of the A.R.R.L., will be toastmaster at the banquet. ADR, CPM, EAL, JNC and JSL are active on 56 Mc. in Derby; JSL upholding the "high power" honors. AP has added a pair of T-40's in the final. IP is rebuilding to chase some DX this summer. HTO reports his RK11's in the new final working FB. APK, AVJ, BFT and GKE visited Hartford for the N. E. Division Convention.

Traffic: W1KMH 171 FFL 152 GMM 144 IP 142 IDY 126 CMR 117 BFT 86 JGJ 76 AP 74 KIM 51 AEF 34 JBM 33 GHT 22 KBU-EAL 11 ANS 8 GDE 5.

RHODE ISLAND—Clayton C. Gordon, W1HRC—It is our sad duty to tell you that there is a "Silent Key" at W1GV. "Bob" Benvie was at one time State Control for the A.A.R.S. in Rhode Island as well as one of the P.R.A. boys. He was quite close to IINU and IINT, and all who remember Bob regret that one so young should have to leave our ranks. JEZ and CPV are doing fine jobs as Emergency Coordinators, and our Emergency Corps is growing steadily under their able leadership. KLR is active with T20 final; he has put up a 72-foot wooden lattice tower for his skywire. ETD hooked his first XE. The services of our 56-Mc. crowd were offered during the epidemic of forest fires, but the State had ample communications facilities and declined to bother us, but thanked us for the offer. CPI is very much interested in emergency work. LAK is interested in A.E.C. HRC visited the Green Mountain Radio Club in Rutland, Vt., and was entertained by GAN, FSV and KUV. HRZ is rebuilding a Dodge generator for a.c. output for emergency. We have had some requests for an explanation

of the duties of the members of the "Supporting Division of the A.E.C." We refer everyone to the article in April QST, "When Emergency Strikes"—if you haven't read this, do so now . . . it explains the whole A.R.R.L. emergency set-up.

Traffic: W1INU 225 CPV 183 GTN 163 IEG 125 KYK 108 INT-JUE 86 KWA 75 KTH-LAB 63 JDX 48 HCW 42 CAB 38 JXQ 35 HRC 32 KOG 23.

VERMONT—SCM, Alvin H. Battison, W1GNF—GAE, HRC, IQG, KUY and 2EGF visited at FSV. AVP, AHN and GNF visited at AXL. ELR is back on 14-Mc. c.w. FPS finished the construction of a vibrapak for his A.E.C. transmitter. AZV has a new Sky Challenger II receiver. KXL is a new O.R.S. IJU, KJG, JRU, IQG and E1F are active on 1.75-Mc. 'phone. HRC was guest speaker at the Rutland Radio Club. BNS sold his radio equipment to KUY. GAN visited IRO-2JPO in N.Y.C. GAE is S.R., FSV-S.N.C.S., CBW-S.N.C.2 in the reorganized A.A.R.S. FPS and JVS are QLR with Coordinator work. AHN, AZV, ELR, EMQ and GNF attended the N. E. Div. Convention in Hartford. We who nestle so complacently here in the hills of Vermont find inspiration in the smooth, neat and efficient personnel and plant at Hq. We should all fight to make our section a model of this—our parent.

Traffic: W1FSV 94 GNF 4 KXL 3 AHN 2.

#### SOUTHEASTERN DIVISION

ALABAMA—SCM, James F. Thompson, W4DGS—R.M.'s: 4DS, 4CRF, 4APU. P.A.M.'s: 4DHC, 4BMM. Looking back over two years as S.C.M. and forward to two more years as the same—We want to thank the faithful reporters and the occasional reporters alike and hope that in the next two years those "not too often reporters" will become regular. Welcome to EEU as O.P.S. in Troy; he reports a new RK41 in buffer. ENJ is going strong on 1.75 Mc. FBK, a new amateur, is building 28-Mc. rig. ZI is on 3.9-Mc. 'phone. ECI and some of the other boys running kw.'s wonder what ELQ, who is using T200's, means by low power in the DX contest. BOE, the c.w. man and sworn enemy of 'phones, now has a kw. on 14-Mc. 'phone! ECI had coil spacers catch on fire and nearly wreck the house, not to mention the rig. BRX and ECI are doing quite a bit of 56 Megacycling. DGY got a Class A and Telephone First and is back in Mtgy. KB passed through Mtgy on his way to B'ham to see a doctor, visited with AUP and went on to Cullman to visit BMM. ECP got his final OK to West Point Academy, and enters in August. EFR lost his father. Our heartfelt sympathies, OM. EVJ is on 14 Mc. knocking off the DX. DHG reports for Mobile: The Mobile Club's 5-kw. a.c. generator has been mounted and tested in the room built for it. CIQ, the club rig, is on 1.75-Mc. 'phone. The club code and theory sessions have already produced one ham—FHL, and several others are ready to take the test. FHL has two rigs going, 125-watt outfit and 450-watt rig—both are for 'phone and c.w. and all bards. CBI has better antenna QTH now. COU has model gas-driven airplane which he is trying to radio control. DHG gave FEU the O.P.S. contact test. AUP has nice portable 3.9-Mc. 'phone which he took to B'ham and tested in actual QSO's. APU took contact trip through Florida before going to the Board meeting. DGS has new speech amp. built up all nice, etc. Old BOU reports from way up in Pa. and is doing OK. AUP got all "writtend" up in state newspapers for flood communications work at Wetumpka. EKI visited the National Capital. We would like to hear from all those new hams in the state each month. 73—Jim.

Traffic: W4DGS 21 ECP 15 EFR 4.

EAST FLORIDA—SCM, Lewis A. Connolly, W4DVO—Assistant SCM, John B. Dodd, W4CQD—R.M.: 4COB, P.A.M.: 4DDB. AJX now has worked 83 countries, and is going 'phone to try to QSO TG9AA. FCP, Zeh Bouck, has returned to N. Y. and expects to be back in the fall. EPV hooked J2J for country number 53 and W.A.C.I. ERL also made W.A.C. by hooking a J. Bennett Adams, 4APU Southeastern Director, A.R.R.L., met with amateurs in Tampa, Miami, and Jax, May 7th-9th, to discuss matters for presentation at meeting of the Board at W. Hartford. We are glad to state that his talks were well attended, and enjoyed. DDA is on at Ft. Lauderdale, handling considerable traffic. EFK is rebuilding, final to be TZ-40. DNA schedules PL daily handling traffic for all points. EUF has new portable rig, working 6 bands! DIN is rebuilding emergency rig for DUG. DRK schedules 90AQ. AGR is member of N.C.R. and A.A.R.S. EEP reports 78 hours and 13 mins. spent during the month in rag chewing.

# EXPERIENCE!

is a great teacher. Utah's 16 years experience backs up the precision construction of each plate supply transformer. Amateurs using them know Utah quality is supreme, ratings accurate, and the price is low — Ask your Utah jobber.

Type 1806 (Illustrated) delivers 1280 volts each side of center — tap, 300 m.a. Overall size 6" high, 7 1/4" long, 9" wide.

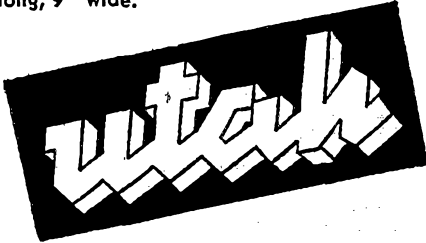
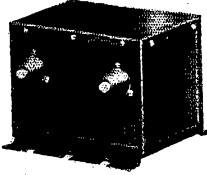

**UTAH RADIO PRODUCTS CO.**  
CHICAGO — CABLE: UTARADIO  
"DEPENDABLE SINCE 1922"

## ? COMMERCIAL RADIO ?

If you are planning to prepare yourself for a job in commercial radio be sure and investigate the advantages offered by Eastern.

**EASTERN RADIO INSTITUTE**

899 BOYLSTON STREET BOSTON, MASS.

## Learn to Send and Receive **CODE**

Learn to send and receive code signals, like operators on ships at sea and at commercial and amateur land stations. Intercept distress signals, news flashes, bulletins, and dozens of other kinds of interesting radio communications.



**MASTER TELEPLEX** teaches you to receive code exactly the way the world's best operators do — by sound. A heavy waxed paper tape, running through a machine, operates an automatic key which sends messages to you, at any speed you desire. As you improve in

speed, the machine sends faster, gradually preparing you for top-speed amateur and commercial signals. With the new All Electric **MASTER TELEPLEX** you learn to send by sending, and the signals you send are repeated back to you, exactly as you sent them, thus enabling you to correct your own errors. We furnish a complete course, lend you the All Electric **MASTER TELEPLEX** and give you personal instruction with a **MONEY BACK GUARANTEE**. Send for our new **TELEPLEX FOLDER Q7** today. **IT'S FREE!**

**THE "HAM" SPECIAL**

Standard Teleplex — a highly efficient code teacher using heavy specially prepared waxed paper tape, having two rows of perforations. Write for Free folder "Q.T.-1."

**TELEPLEX CO.** 72-76 CORTLANDT STREET  
NEW YORK, N. Y.

92

## The California Flood

(Continued from page 84)

Police Department, Los Angeles Weather Bureau and California Highway Patrol, as well as a quantity of personal traffic.

W6NCR, Artesia, with relief station set up in the library next door to his home, functioned on the so-called "990" 1.75-Mc. Net. W6CUU, Beverly Hills, rendered notable service. W6EOA relayed traffic for the sheriff's office. W6KUP, Long Beach, performed valuable service for the Shell Oil Company, being responsible for its telephonic communication. W6AEP, North Hollywood, delivered more than a score of messages during the worst of the flood. Jim Lowe, who is awaiting his call, was on the job in Hollywood with his receiver, giving what service he was able. W6HTO in Needles, assisted by W7FMQ, Medford, Oregon, was active in attempting to establish communication for the isolated areas.

Radiophone W6PIG, Santa Barbara, operated by W6NCT and W6DJS, furnished communication with Los Angeles, transmitting news, official relief messages and assisting the telephone company in its work of repairing lines. W6IOX was also active in Santa Barbara.

The first flood picture out of the area was transmitted by facsimile from W6AM, Long Beach. Fred Reinking, Los Angeles manager of the International News Association, brought his equipment to W6AM at about midnight, March 3rd, and proceeded to make the necessary installation. In the meantime W6AM was locating eastern amateurs on 14-Mc. 'phone. W8HC, Cleveland, was contacted and, with the cooperation of W8RDG International News Photo equipment, was set up there. By the time the set-up was operating suitably, 14-Mc. signals had faded out so it was decided to endeavor to put the picture directly into New York City. Contact was established on 3.9-Mc. 'phone with W8BOW (Wheeling, W. Va.), who telephoned the I.N.S. in New York, only to find the office closed for the night. It was then decided to wait until daylight and establish contact with Chicago. This was accomplished with the help of W9HXY, W9UDO and W9TMH, and Victor Reubhausen, W9QDA, Chicago, was finally lined up to handle the transmission. A line from W9QDA carried the picture to the Chicago office of I.N.S. A fairly decent picture was transmitted showing the wrecked bridges in and about Los Angeles. Numerous amateurs assisted in clearing the various frequencies used. Among them were W6BKY, W8QA and W9KAR.

No report would be complete without a word of tribute to the ladies. Their work at the station telephones, the hot coffee and food they served to keep the OM's strength up, and the words of encouragement were invaluable. Among the licensed YL's and XYL's, "Harriett," W6HEG, "Ruby," W6OJC, "Hildur," W6PGE, and "Ollie," W6PLN were right in the midst, doing their full share of handling traffic.

The amateurs of Southern California can look back with considerable pride on their accom-

## ISOLANTITE FOR EFFICIENT OPERATION

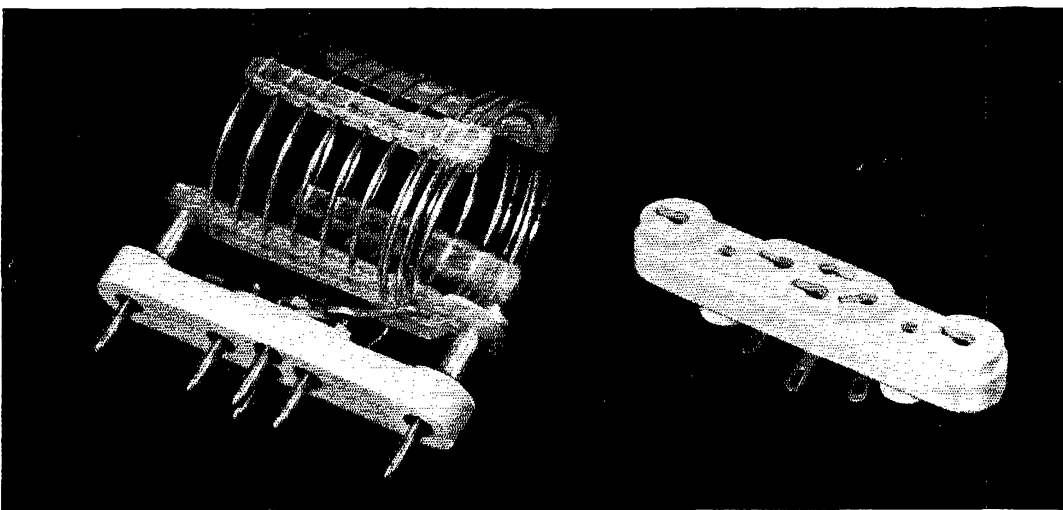
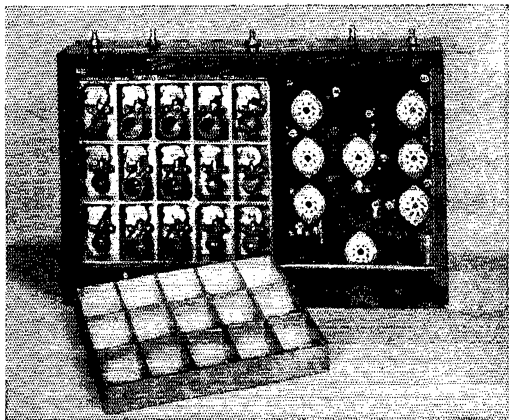

PHOTOS COURTESY OF NATIONAL COMPANY, INC.

**L**OW-LOSS insulation is essential in modern radio design—and leading manufacturers of sets and component parts employ Isolantite\* liberally to insure the highest efficiency. National's latest model receiver NC-100XA and new plug-in inductor bases are typical examples of equipment using Isolantite.

High dimensional precision, mechanical strength, and non-absorption of moisture are some of the other factors which lead to the choice of Isolantite when

ever a dependable high-frequency insulation is needed.

Ask for the products of leading manufacturers to be sure of getting genuine Isolantite.

\*Registered Trade-name for the products of Isolantite Inc.

# ISOLANTITE INC.

## CERAMIC INSULATORS

Factory: Belleville, New Jersey • Sales Office: 233 Broadway, New York, N. Y.

Say You Saw It in *QST* — It Identifies You and Helps *QST*

**FOR HI-FREQ. HEAVY-DUTY**

**TYPE  
86**



**MICA TRANSMITTING CAPACITORS**

**FOR THE AMATEUR**

Your money can't buy you this much in any other capacitor!

- ★ Patented series mica stack: eliminates corona losses
- ★ Soldered foils: afford high current rating
- ★ India ruby mica dielectric: low power factor, high "Q"
- ★ Vacuum impregnated assembly: high insulation, no air voids
- ★ Special low loss filler: reduces stray losses
- ★ Insulated clamp holder: no internal voltage arc-over
- ★ Black glazed porcelain dehydrated case: low r. f. losses

Write today for new C-D catalog No. 161

1013 Hamilton Blvd. So. Plainfield, N. J.  
Cable Address: CORDU

PRODUCT OF THE WORLD'S OLDEST AND LARGEST  
EXCLUSIVE MANUFACTURER OF CAPACITORS

**CORNELL - DUBILIER**



**ELECTRIC CORPORATION**

South Plainfield, New Jersey

**Your Rig is Right with  
OHMITE Resistance Units**

With Ohmite Rheostats controlling filament voltages, you can be sure you're getting maximum tube life and top efficiency. Sizes for all transmitting tubes. Ask your jobber about these and other Ohmite products especially designed for amateur radio transmitters and receivers.

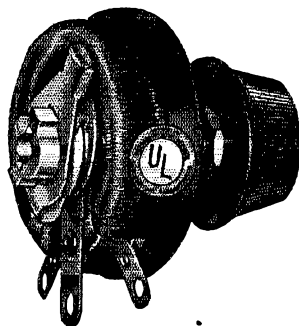

Write for Free Copy  
of New Catalog 17

**OHMITE MANUFACTURING COMPANY**  
4831 West Flounoy Street, Chicago, U.S.A.

**OHMITE**

RHEOSTATS RESISTORS TAP SWITCHES

plishments during those hectic four days when it seemed that the whole world had collapsed and entire oceans dumped in their laps.

Entirely absent was the hysteria on the air that usually follows in the wake of such a catastrophe. A.R.R.L. Emergency Coördinators W6CAH, W6CMN, W6EAH, W6KLN, and W6MQM were working full time in placing stations, establishing networks and routing traffic. Their efforts and the organization work that had already been done proved the value of the A.R.R.L. Emergency Corps beyond any question of a doubt during one of the most severe tests imaginable. The few weak spots evidenced create the objective of working toward a perfect emergency communication organization, smoothly running and effective to the utmost. The lessons learned were not in vain.

**Do's and Don'ts in Power Supplies**

(Continued from page 41)

angles and accompanying volt-ampere ratings of transformers, nor were the equations solved with a great degree of accuracy. In practice, however, these simple calculations lead to quite adequate results in determining correct ratings of components.

Methods of solution similar to the second one given here will be found outlined in slightly different form in *The Radio Amateur's Handbook*.

**An Improved Capacity Bridge**

(Continued from page 43)

The calibration worries you now? Think nothing of it. Get yourself a piece of graph paper and make a curve as in Fig. 2. For those who want to spread it out on a larger paper with lots of squares, a table of average values is given for the particular straight-line capacity condenser used in this bridge. Note that in drawing the curve the points are plotted as though the condenser capacity increased with increasing dial settings, although actually zero represents full capacity of the condenser. This is done simply for the sake of convenience, so that increasing dial readings will indicate a larger unknown capacity.

In operating the bridge the "displacement," or as it is more commonly known, the "substitution" method is used. With the bridge balanced as described with the unknown capacitor connected to the short leads to the "X" or "unknown" binding posts, the dial setting is noted and referred to the calibration chart. For example, null may have been found at 60 degrees, corresponding to 900  $\mu$ fd. on the chart. No, not so fast, that's not the unknown capacity. You must subtract from that value the capacity at 10 on the dial, where the bridge was balanced before the unknown capacitor was connected to the "X" posts. This value, 150  $\mu$ fd., from 900  $\mu$ fd. leaves 750  $\mu$ fd., which is the capacity of the unknown. The advantage of this method is that the calibration of the "standard" need not be absolute so long as the readings taken are on the linear or straight line portion of the curve, 10 to







## Unaccustomed as we are . . .

We're not very good public speakers, but our service speaks for itself.

If you want the latest gadget for your X-mitting system . . . or a flock of new tubes . . . or some "dope" on the latest transformer kink . . . TERMINAL is the place to come!

Experienced amateurs and radio veterans comprise our sales-force. They know your problems.

•  
Are you on our permanent  
mailing list?

**TERMINAL**  
*Radio Corporation*  
80 CORTLANDT STREET, NEW YORK, N. Y.

90 on the dial. You merely read the difference values on a length of capacitance yardstick, which, like a homely piece of yardstick, is ruled off in units the value of which we know, even though it may start at 7 inches and be broken off at 29. The condenser used happens to have a capacity variation of 15  $\mu\text{fd.}$  per dial division, which, although not to Bureau of Standards accuracy, gives us readings well within ordinary commercial tolerances or better.

An improvement well worth the time and trouble it takes is to make up a table for the useful 80 divisions of the dial, subtracting from each value for a given division the capacity value indicated for the 10 degree point.

The simplified procedure then becomes: First, balance the bridge to null with the "X" leads in position to connect to the unknown capacitor and with the "standard" capacitor  $C_1$  set to the 10-degree mark; second, connect in the unknown capacitor and rebalance the bridge to null. The indicated dial setting may then be referred to your table and the correct capacity is read opposite that dial reading.

Just the satisfaction of knowing that one postage stamp condenser from the junk box is 0.0005  $\mu\text{fd.}$  (500  $\mu\mu\text{fd.}$ ) instead of the 0.00005  $\mu\text{fd.}$  (50  $\mu\mu\text{fd.}$ ) that you thought it was, and the knowledge that you saved yourself plenty of grief, which you surely would have had if you trimmed that r.f. coil in your receiver with it, will be worth the time and the few dollars spent in making the capacitance bridge. And remember, a leaky condenser just won't balance worth a cent, so you can segregate the sheep from the goats in your junk box and know that you start right, anyhow.

### Army-Amateur Radio System Activities

*(Continued from page 51)*

It would seem appropriate to close this article with an invitation to any ham in the Third Corps Area to join the system and participate in these activities, since one of the main justifications of ham radio is the service which can be rendered to our country and to the public in time of emergency. Anyone interested should communicate with either of the Third Corps Area Recruiting Agents for the A.A.R.S., W3ECA of Philadelphia, or W8OFO of Lowber, Pa., or direct with the Radio Aide, W3OK, of Bethlehem, Pa.

The following message in unknown key is presented for those interested in the art of cryptanalysis. This message is somewhat harder than those which have appeared in previous issues. Send answers to the Liaison Officer, A.A.R.S., 3441 Munitions Bldg., Washington, D. C.

UQKFA MGDNA IMIKW E WVNN VNXXC  
HLXFW HLBQP RMUNX ZGAGA RMXOW  
E WVNN VN XVA HUOBE MEJYT VKOQJ  
VERRZ OAZJL SAKJH DEJXI VBXWW  
MEJGA GABZH SAZJF RTFRJ YGIKW  
XQOMW WAKRH VEKFS VMXXX



# GAMMATRON

**QUALITY  
TO FIT EVERY  
AMATEUR  
PURSE**

**PRICES OF OTHER  
GAMMATRONS ON REQUEST**



**110 VOLTS AC** Anytime! Anywhere! With **KATOLIGHT PLANTS**  
 350 Watts AC and 8 Volts DC... \$ 29.50  
 500 Watts AC and 12 Volts DC... 220.00  
 1000 Watts AC and 18-32 Volts DC 228.00  
 Other sizes up to 10,000 watts, rotary converters and 2 KW to 8 KW Diesel-driven plants.  
 200 watt AC generator for Ford V8 with driving attachments.  
*Write for special discounts to amateurs*  
**KATOLIGHT, Mankato, Minn., U.S.A.**

## RADIO ENGINEERING

RCA Institutes offer an intensive course of high standard embracing all phases of Radio and Television. Practical training with modern equipment at New York and Chicago schools. Also specialized courses and Home Study Courses under "No obligation" plan.  
 Illustrated Catalog on request

**RCA INSTITUTES, INC.** Dept. ST-38  
 A Radio Corporation of America Service  
 75 Varick St., New York 1154 Merchandise Mart, Chicago

**NEW HOLDER DESIGN**  
 15 SECONDS TO  
 INSTALL CRYSTAL  
**For All Bands**  
**GREATER STABILITY**  
 Plugs in 5 prong tube socket  
 Beautiful Appearance

**MODEL AH HOLDER \$1.00** At your dealer or direct

**HIPOWER LOW DRIFT CRYSTALS:**  
 within 10 kc. or Choice of stock  
 AH-10, 1700-3500 Kc. bands \$2.35  
 AH-10, 7000-7300 " bands 3.90  
**WRITE FOR NEW LITERATURE**

Hipower "Low Drift" Broadcast and Commercial Crystals Are Approved by F.C.C.  
**Hipower Crystal Co., 2035 Charleston St., Chicago**

**The GOOD NAME is your Guide**

The latest improvements and refinements are incorporated in Ken-Rad Tubes. For best results use dependable Ken-Rad Tubes.

**Ken-Rad Radio Tubes**  
**KEN-RAD TUBE & LAMP CORPORATION - OWENSBORO, KY.**  
 Makers of all types of radio tubes and Ken-Rad Electric Lamp Bulbs

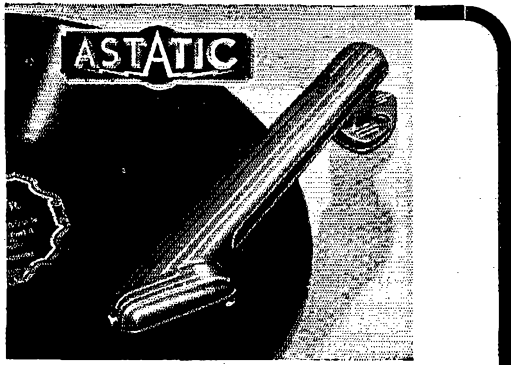

## The Arm That Rests on a Cushion

In the new streamlined Model 0-7 Crystal Pickup, Astatic Engineers have incorporated Axial Cushioning, insulating the playing arm from its supporting base to reduce motor noise and speaker pickup feedback. Other features include Offset Head design to reduce tracking error, Triangular Groove needle loading and free stylus movement. An ideal Pickup for improved amplifier and radio phonograph combinations. Full year guarantee.

**New Low List Price \$6.50**



**Astatic Microphone Laboratory, Inc.**  
830 Market St.  
YOUNGSTOWN, OHIO  
*Licensed Under Brush Development Co. Patents*

# RADIO

**ENGINEERING**, broadcasting, aviation and police radio, servicing, marine radio telegraphy and telephony, Morse telegraphy and railway accounting taught thoroughly. Engineering course of nine months' duration, equivalent to three years of college radio work. School established 1874. All expenses low. Catalog free. **DODGE'S INSTITUTE**, Day Street, Valparaiso, Indiana

## Get True Broadcast Quality

and  
**Studio Appearance**  
with the New  
**TURNER 77**  
**Crystal Microphone**

Model 77 gives you true fidelity with high output level. A unique saddle—commercial design, and rich finish make this an expensive-looking mike. Head adjustable from semi-directional to non-directional. Successful on P. A. setups or out-of-doors. Built-in filter eliminates wind effects and blasting. Absence of peaks reduces feedback.

### Long Mike Lines Possible

High capacity crystal permits lines up to 150 feet of good cable. Shock-absorbing crystal-suspension eliminates breakage and handling noise. Cable connector allows instant removal and changes without splicing. Order today.

**\$16.93**  
net  
with cable  
and  
connector

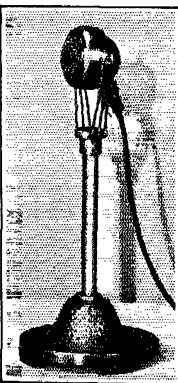

77 on T-6 Stand  
Net \$17.64

**WARREN RADIO CO.**  
Jobbers Radio Supplies  
1014 Madison Ave., Toledo, Ohio

Range — 30-10,000 cycles.  
Level — 54 DB. Connector  
and 8 feet cable furnished.  
Finish — dark copper plate.

*Licensed Under Patents of the Brush Development Co.*

CQ de W10XDA

(Continued from page 26)

about 2½ miles from the village to a cleared field and even though we were a little tuckered from the hike we expected the game to be a cinch. We soon found out that if we wanted to gain any points at all, we had to strain our utmost. Those Eskimos know how to play! When the game was finished, they had beat us, 12-2, much to our chagrin. We returned to the ship tired, happy, and filled with admiration for these young fellows, wishing we could bid for a return match but knowing that we would probably never see them again.

For some time now, we had been receiving New York broadcast stations consistently and it never ceased to be a wonder to us to be able to listen to these long-wave broadcasts in bright daylight some 2000 miles away. On the short waves, we were beginning to get the benefit of the beam antenna at W2OJ as we approached the line of the beam. It was then possible to hold contacts for several hours with W2OJ despite the heavy QRM on the 20-meter band. Parents of the boys who went on the expedition this year had an advantage never before offered, that of speaking direct from their homes to their sons on the ship 'way up North. When conditions were favorable, we were able to patch the land line<sup>1</sup> into the transmitter and thus provide them with ship-to-shore radio telephony.

There were several incidents that were particularly enjoyed from the radio angle, one of which was a quadruplex 'phone contact among VO1I, VO2Z, W2OJ and the *Morrissey*, all four of us being able to work each other and break in on any one of the others at any time. Another was when after almost a week without contact with the States, I happened to hear W9UBB in Lorraine, North Dakota, and finally succeeded in contacting him on c.w. We weren't getting through too well, and soon W9UBB said that he was just home on his lunch hour and had to get back to the key at Western Union. "Don't write—telegraph!" And so I did. He sent a message for me by Western Union land wire to my wife, so that she was reassured as to our safety. Most enjoyable of our ship-to-shore land-line work was the contact made between Captain Bob and his life-long friend, Tom Foley. Such an opportunity to enjoy Captain Bob's spontaneous humor, informal talk and reminiscence has never before occurred, and if anyone happened to hear it, the memory of that contact will always bring a warm feeling as it does to us. Another QSO we enjoyed was with VO1I as we were leaving Brigus, Newfoundland. Oscar used the 10-meter transmitter in his car, and I the regular ship transmitter on 12,862 kc. Oscar left Brigus for St. John's, a distance of 50 miles, the same time the *Morrissey* weighed anchor. We were able to continue our QSO for 2½ hours, perfect duplex 'phone contact, over a maximum distance of probably 40 miles.

<sup>1</sup> Before this is done permission should be obtained from the telephone company.



**TESTED**

**and APPROVED**

\* "After about 2 years of shipping these small but exceedingly sensitive instruments \* to customers all over the country, it has been extremely gratifying to realize that battery trouble has been eliminated since the time we adopted your product exclusively."  
 (Signed) R.S.Hart

\* Vacuum tube voltmeters arranged to classify accurately resistors running in the order of 100,000 megohms.

Here on another delicate instrument, Burgess batteries have proved themselves. You, too, can avail yourself of the same high standards of battery power. Buy Burgess batteries—they are all quality products.

**BURGESS BATTERY COMPANY**  
**FREEPORT, ILLINOIS**

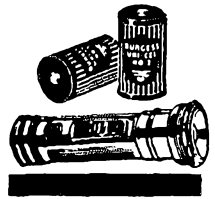

**BURGESS**



Say You Saw It in QST — It Identifies You and Helps QST



**In Stock . . . The New G.T.C. "PEE WEE" TRANSMITTER**

The "Pee Wee" is a complete 25 watt crystal-controlled transmitter kit . . . power and all on a single richly gray finished chassis. Parts are all mounted and ready for wiring. . . . . **\$19.95**

★  
**New EIMAC VACUUM CONDENSERS**

These new vacuum tank condensers make it possible to build a high power transmitter in a relay rack . . . Small enough to fit in the palm of your hand.

6 Mmfd. . . . . **\$7.50** 25 Mmfd. . . . . **\$10.50**  
12 Mmfd. . . . . **8.50** 50 Mmfd. . . . . **12.50**

All capacities are capable of peak voltage of 32,000 volts.

★  
**New R.C.A. 1851 TUBES \$2.10**

★  
**5 METER SUPER-GAINER KIT**

A popular 4 tube ultra high frequency receiver. Noise limiter and 2 IF stages, complete kit including drilled and punched chassis, less panel and tubes. See our ad in *QST*, June issue. . . . . **\$13.26**

★  
**New U.T.C. Line of Transformers**  
designed specifically for the AMATEUR  
Maximum Value at Low Cost

These new transformers and transmitter kits are already receiving splendid reports in the field.

★ **CAMERA DEPT.** ★

So many radio amateurs have adopted this new hobby that we've put in a complete camera department. We can arrange "trade-ins" on camera or radio. What say, O.M.?

OUR *Best* VALUE IS OUR RECORD OF LOYAL SERVICE

**HARVEY**  
*Radio Company of New York*

103 WEST 43rd STREET • NEW YORK, N. Y.

CABLE ADDRESS: "HARADIO"

I might mention that the power input to the automobile transmitter was only 2 watts!

After leaving Newfoundland, the weather had been too good to last, and having a couple of rough days, we were obliged to put in at Buzzards Bay because of head winds. The storm let up unexpectedly, however, and drove us with strong tail winds into the home port a day ahead of the arrival estimated when anchored in Buzzards Bay. Although we arrived at Staten Island late in the evening in a chill rain, friends and family were on the dock to welcome us. We all went below and had a final QSO from the *Morrissey* with VO2Z in Brigus and VO1I at St. John's, two fine friends who had helped us all summer. Then we closed down W10XDA with a strange mixture of melancholy and happiness. We seemed reluctant to realize that the adventure was over, and yet were so glad to be home after the three months' trip in the Arctic.

We want to thank the many amateurs who helped us with traffic, schedules, etc., who are too numerous to mention individually, and we are particularly grateful to VO1I, W2APT, W21JU, W2GBH and also Ralph Brady, a short-wave listener.

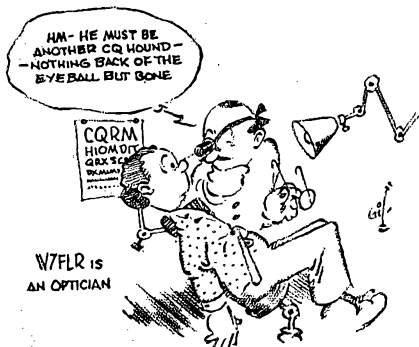

**The "QSL 40" on 14 Mc.**

(Continued from page 31)

It is quite possible that some fellows who have made up the "QSL Forty," following their own ideas, and using a chassis of perhaps, say, 8" by 10" instead of 3½" by 5½" will not duplicate the above results. The rig as described in the February issue has almost no wiring as the parts themselves reach from point to point, which may be an important consideration.

It might be well, here, to refer to an error in the original diagram, in which C<sub>4</sub> was omitted. This goes in the cathode circuit in parallel with R<sub>1</sub> and the key, as shown in the corrected diagram which appeared in the March issue, page 48.

**A FARADAY SCREEN**

Anybody who has finished making up the usual form of Faraday screen (see *Handbook*, 15th edition, or March, 1937 *QST*) realizes that he has done quite a bit of drilling, and also that the ordinary electric soldering iron encounters heavy

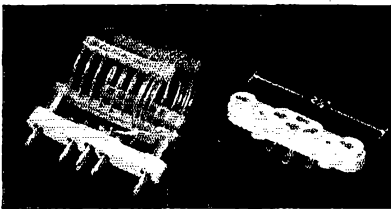
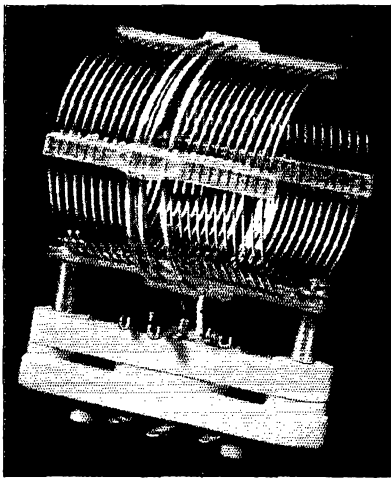

## SMALL PLUG-IN INDUCTORS

Victron insulation, good form factor, and air-spaced bare copper windings give these new coils a high efficiency that makes them ideal for use in buffers, exciters, doublers, and low-power finals. Their compact size (about  $1\frac{1}{2}$ " diameter and about  $1\frac{1}{2}$ " length) adapts them to crowded layouts and portables. The Isolantite plug-in base permits quick and easy band changing. They are available for either push-pull or single stages up to 25 watts and for all amateur bands. A blank unglazed Isolantite coil form ( $1\frac{1}{4}$ " diameter and  $2\frac{3}{8}$ " long) also fits the same mountings. The 5-prong plug-in base and coil-form may be purchased separately.

**NATIONAL COMPANY, INC.**  
Malden, Mass.

## SICKLES COILS

ALL TYPES OF RF AND IF WINDINGS

Manufactured by

**F. W. SICKLES COMPANY**

300 Main Street

Springfield, Mass.

## RIVALS CRYSTAL FILTER!

A unique, single-unit noise- and static-reducing, electro-acoustical device called Selectosphere. Universally adaptable to old and new ham receivers, from tri's to supers. No alterations. Three years proven performance with amateurs, commercials and expeditions. See page 16, Feb. '38, *QST*. Selectosphere sold direct at \$3.95. Write for "dope."

SELECTOSPHERE CO., BOX 3, NEWTONVILLE, MASS.

# SPEED-X

The Complete Line of Telegraph Keys  
"HI-SPEED"  
Semi-Automatic  
Key

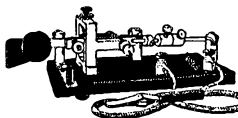

Model No. 510

Complete with switch cord and plug. List price \$10.75.

Other models from \$9.25 to \$17.50. Available at leading jobbers everywhere. Write for new literature and Amateur Discounts.

Will see you in 104 Watt Ave. at the Chicago Show

**LES LOGAN COMPANY**

646 Jessie Street

San Francisco

Say You Saw It in *QST* — It Identifies You and Helps *QST*

## JACOBS ADJUSTABLE SEPARATOR (Improved)



U. S. Patent 1,950,170 — March 6, 1934 — others pending  
Using this improved glass Separator 2 wire R.F. feedlines of any separation from 1" up to and including 9" (used in conjunction with Hertz Antenna Systems) may be rapidly and efficiently constructed. \$1.80 per dozen.

CHARLES F. JACOBS (W2EM)  
270 Lafayette St., New York, N. Y.

**PRACTICAL RADIO ENGINEERING** Complete COURSE in ONE YEAR!

Only Residence School of its kind. For the man who is serious about advancing in Radio. Learn Radio Engineering from the ground up on modern transmitting, receiving and laboratory equipment. Outstanding faculty. Next residence class begins Sept. 19 in our own new building. Write today for complete details. Dept. Q-7, 3224-16th St. N. W., Washington, D. C.

**SEND FOR FREE CATALOGUE**

**CAPITOL RADIO ENGINEERING INSTITUTE**

## A New High-Speed RELAY

- Faster
- Quieter
- More Compact
- Moisture-Proof

Plug-in base fits UX Socket

Only 1 inch wide,  $3\frac{3}{8}$  inches tall

Ideal for use with vacuum tube. Its quiet operation, compactness, and ability to follow at speeds far above the professional "bug" make it a perfect keying relay. Can be used as a time-delay, and in many other circuits. Available in 6, 25, 50, 100, 150 volts.

\$4.50

to

\$10.00

Postpaid in U. S. A.

If your dealer can't supply you, write us

**Gardiner-Levering Co.**



Pat. Pend.

Haddon Heights  
New Jersey, U. S. A.

# TRIED AND PROVEN by AMATEURS EVERYWHERE

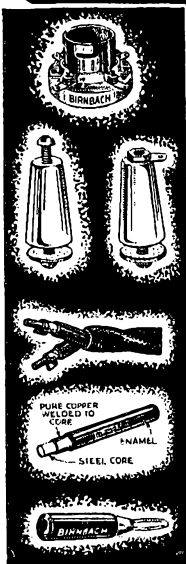

## BIRNBACH 50 AND 10 WATT SOCKETS

Designed especially for U.H.F. work.  
No. 434 — 50-watt socket. List, \$1.25  
No. 435 — 10-watt socket. List, \$ .85

## IMPROVED CONE STANDOFF INSULATORS

In a complete range of heights for condensers, coils, etc. White glaze. Write for prices and discounts.

## EO 1 TRANSMISSION CABLE

Can be used any length to 1000 ft. with negligible loss. Handles any power to 1 KW. Surge impedance of 72 ohms.  
No. 956 — 100 ft. spool. List price \$10.00  
250, 500, or 1000-ft. lengths also available.

## STRETCHLESS COPPERWELD ENAMEL ANTENNA WIRE

Steel case, copper covered, heavily enameled, low R.F. resistance. Fine for X'mitting doublet and directional antennae.  
No. 12 Gauge — 100 ft. List price \$1.58  
No. 14 Gauge — 100 ft. List price \$1.10  
*Special lengths to order*

## BIRNBACH GIANT INSULATED PLUG

No. 392 with insulated handle. Fits into recess leaving no metal to contact hand. 3" overall. Red or black. List each. .50c

# BIRNBACH RADIO CO.

145 HUDSON ST. BIRCO NEW YORK, N. Y.

## SPECIAL TO AMATEURS

Piezo-Electric Crystals — \$2.50 EACH POSTPAID

Until supply is exhausted . . . we offer 80 meter band crystals unmounted; accurate calibration, excellent oscillators. Limited quantity.

## SCIENTIFIC RADIO SERVICE

"The Crystal Specialists Since 1925." University Park, Hyattville, Md.

## LEARN CODE RIGHT

INSTRUCTOGRAPH tapes send you typical messages Radio or Morse any speed. Easy, practical way to improve. Senior Model \$20.25 (also rented). Junior Model \$12.00 (not rented). Complete oscillator equipment less battery \$6.50. Write for details today.

## INSTRUCTOGRAPH CO.

Dept. Q-7 912 Lakeside Place, Chicago, Ill.



## BE SURE TO READ!

# "FREQUENCY CONTROL with QUARTZ CRYSTALS"

A new booklet covering the theory and use of quartz crystals. Only 10c (Canada 15c). Buy Your Copy Now!

At all Biley Dealers 10¢

weather when it comes to soldering 3/32" wires into a 3/8" brass bar. Nothing impossible about it, of course, but the question naturally arises, "Isn't there an easier way to do it?"

In figuring on a Faraday shield for the "QSL-Forty" it occurred to me that an efficient form, one easy to make, would be simply a comb of say, 16-gauge aluminum. From the photograph it will be seen that in this form, the shield consists of a square piece of sheet aluminum, slotted with a hack-saw to form the "comb." And be it noted that a fresh blade cuts 16-gauge aluminum like a hot knife going through butter. The tops of the "teeth" of the comb are held apart, fixed in position, by means of Duco, the comb being pinched between two pieces of board until the cement has *thoroughly* hardened. A second application of Duco is advisable. A 6-32 screw and nut in a lower corner take care of the ground wire.

Don't be discouraged about the rough appearance of the comb when you have finished sawing the slots. A few minutes with sandpaper and a knife blade will take off the burrs and straighten up the teeth all shipshape and Bristol fashion.

The photograph shows how the lower bakelite coil-strip is slotted to permit the comb to be slipped into position. The two upper coil-strips are cut through and these, pinching the comb, hold it in place nicely. The comb occupies the space of one turn of wire so that  $L_1$  and  $L_2$  may be coupled almost as closely as though no shield were interposed between them. To cut slots of various widths, just put two or three blades in your hacksaw frame and you can cut slots of any multiple of the single-blade cut.

Only one shield is needed for a number of coils if it is made large enough for the largest coil.

## Silent Keys

IT IS with deep regret that we record the passing of these amateurs:

W. A. Andrews, G5FS, Bristol, England  
Joseph Artibee, W8GOM, Muskegon, Mich.

Harold E. Bacon, W6KTD, San Diego, Calif.

R. G. Benvie, W1GV, Cranston, R. I.  
Elmer F. Bond, W8MAH, Williamsport, Pa.

Norman P. Brouwer, W8IEL, Muskegon, Mich.

Russell W. Cole, W8KVY, Muskegon, Mich.

W. D. Ferrell, W9CGV, Chicago, Ill.  
E. Robert Hipkens, W8KKR, Syracuse, N. Y.

Frank H. Kimmens, K4FBQ, Miramar, P. R.

Hildric Moore, W4CZJ, Fairfax, Ala.  
George P. Nilson, W6INZ, Berkeley, Calif.  
Emil J. Port, W8DFT, Pittsburgh, Pa.



# ● RADIO OPERATOR'S COURSE ●

TELEGRAPHY  
TELEPHONY  
AVIATION  
TELETYPE  
TELEVISION  
TRANS RADIO  
PRESS

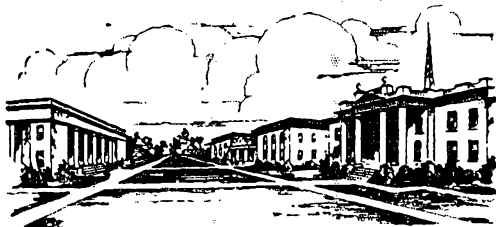

PRACTICAL  
EXPERIENCE  
STUDIO —  
TRANSMITTER —  
ANNOUNCING  
TYPEWRITING

Port Arthur College advertises primarily to Radio Amateurs and the training is too technical for the average student who has not selected Radio as his life's work. The opportunities for positions and advancement are unlimited for men who are interested in Radio and who plan to make this their career and are willing to make the sacrifice and effort necessary to master the training. P. A. C. maintains strict collegiate rank — only high school or college graduates are eligible for enrollment.

*If interested in details about Radio Course, write for bulletin R*

**PORT ARTHUR COLLEGE** ■ **PORT ARTHUR** (*World-known port*) **TEXAS**

## Going Away?

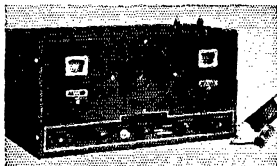

Take one of our powerful portables along . . . and use it at home too . . . interchangeable 6 v.d.c. or 110 v.a.c.

**Radio Transceiver Laboratories**  
8627 115 Street Richmond Hill, N. Y.

## WANTED

Several men experienced in finishing quartz crystal oscillators for radio frequency control purposes. Permanent position. Apply Box C, QST Adv. Dept., West Hartford, Connecticut.

as assurance of . .  
finest PERFORMANCE

**Acme**  **Electric**  
TRANSFORMERS

**THE ACME ELECTRIC & MFG. CO.**  
38 WATER ST. CUBA, N. Y.

## FOR SALE AT SACRIFICE PRICES

Large assortment of Bakelite, Micarta, Micanite, Hard Rubber Sheet, Rod, Tube and Plate. Also apparatus and parts for Electrical Experimentation, including several new WESTINGHOUSE 1/2 h.p. Synchronous Motors 60 cycle — 110 or 220 volts 1800 r.p.m. Can be used as a television scanning disk motor. At \$22.50 each while they last and some 1/10 at \$5.00 each.

A.B.C. DIELECTRICS CO.  
241 Plymouth St., Brooklyn, N. Y. Tel. T Riangle 5-1544

## My Creed . . .

TO give you specialized personal service of genuine value that is not available from other jobbers.

TO finance all my time sales myself so that I can sell all receivers, transmitters, and parts to you on terms arranged to suit you with less interest cost.

TO take your equipment in trade at a fair value.

TO allow you to try any receiver for ten days without obligation and to cooperate with you in every way I can to see that you are entirely satisfied.

## Your Inquiries are Invited

Model and Receiver	Cash Price	Down Payment	12 Monthly Payments
NC80X and NC81X . . . . .	\$99.00	\$19.80	\$6.99
Improved NC101X . . . . .	129.00	25.80	9.11
The NEW NC100A . . . . .	120.00	24.00	8.48
RME-69 . . . . .	151.20	30.24	10.69
Bretling 14AX . . . . .	99.00	19.80	6.99
Sky Champion . . . . .	49.50	9.90	3.49
Sky Challenger II . . . . .	77.00	15.40	5.44
Super Skyrider . . . . .	99.00	19.80	6.99

Also Super Pro, HRO, PR15, Bretling 9, Sargents, others.

Similar terms on Harvey, RCA, RME, Temco transmitters and National, Progressive, Utah, Stancor, All Star kits.

## HENRY RADIO SHOP

211 North Main Street Butler, Missouri

# 3 GOOD REASONS WHY AMATEURS, ENGINEERS AND EXPERIMENTERS BUY AT SUN

No organization is stronger nor better than the men within it... the men who are qualified by years of experience to cater to your particular needs. SUN Radio prides itself, upon not alone the quality of its merchandise, the nationally known lines carried in stock, its great, spaciuous new home... but upon the caliber of the men who are here to serve you.

At SUN you'll always find a welcome plus intelligent, able service that "talks back to you in your own language." Make SUN Radio your headquarters and learn how really satisfying it is to trade here.

## A FEW RAYS FROM THE SUN

- National's latest NC 100-XA in stock for immediate delivery. Other National Receivers in stock.
- Temco announces the new 100A. Write for brand new catalogs. Other models available... Write for our time payment plan.
- Hallicrafters Dual Diversity Receiver... Immediate delivery after July 1st. Write for our time payment plan & free literature.
- Complete stock of Eimac, RCA, Taylor, Raytheon, & Amperex X'Mitting Tubes.
- Gammatron Tubes in stock including the new HK 254
- RCA — ACR111 Receiver.....\$129.50
- Hallicrafters SX16 .....\$123.00
- Hallicrafters SX17 .....\$149.50

Write for Our Time Payment Plan



**SUN RADIO CO.**  
212 Fulton Street, New York, N. Y.  
Cable Address: SUNRADIO NEW YORK



W2JEH  
Ed BERLIANT



W2LFV  
Ed RIMY



W2DXC  
Bill GREEN



## The Battle of Cairo

(Continued from page 46)

note permitting American amateurs to use 7200-7300 if they didn't interfere with broadcasting. So it stood, and at that we were well out of a real mess. That same day the whole allocation ladder went through the main technical committee, and thereafter there was no question of changes.

The changes in allocation made at Cairo are not effective until September 1, 1939, to provide time for the holding meanwhile of a European regional conference on broadcasting.

For three successive days amateur radio, its frequencies, and its value relative to broadcasting, were the chief topics of the allocation meetings. European administrators, greedy at the smell of frequencies, faces livid with rage at being balked in their objective, attacked us in the plainest talk we have ever heard at international conferences. The United States, with very little support from other sources, courageously maintained a determined stand. But for that defence, we would have been torn to shreds. At no time did the possibility exist of enlarging the amateur frequency holdings. Like the Looking-Glass Country, it took all the running anybody could do to stay in the same place.

The division between the supporters and the enemies of amateur radio was clearer at this conference than at earlier ones. Largely this was brought about by the let-down-the-hair attitude precipitated by the shortwave-broadcasting fight. In some measure it was brought about by the refusal of the American group of nations signatory to the Habana agreements to deviate from their Habana commitments as much as Europe would have liked—which stiffnecked stand made the United States unpopular. It is of course generally felt in Europe that amateur radio is primarily a United States institution, and one that therefore ought to use only regional frequencies. Other factors influencing the line-up were the finer development of sheer bureaucracy, fear of the wrath of crack-the-whip dictators back home, the war scare, impending television, the growth of aviation. Whatever the reasons in individual cases the lines were sharply drawn, the number of amateur supporters noticeably less, and the conclusion inescapable that the amateur does not have the support of any major nation in Europe.

The United States did a magnificent job of defending amateur radio. It left nothing to be desired. Credit for this belongs chiefly to Lieut.

# Where to buy it

A directory of suppliers who carry in stock the products of these dependable manufacturers.



- ALBANY, N. Y.** Uncle Dave's Radio Shack 356 Broadway
- BOSTON, MASS.** Radio Shack 46 Brattle Street
- BOSTON, MASS.** 110 Federal Street  
Wholesale Radio Service Company, Inc.
- BRONX, N. Y.** 542 East Fordham Rd.  
Wholesale Radio Service Company, Inc.
- HARTFORD, CONNECTICUT** 227 Asylum Street  
Radio Inspection Service Company
- JAMAICA, L. I.** 90-08 166th Street  
Wholesale Radio Service Company, Inc.
- NEWARK, N. J.** 219 Central Ave.  
Wholesale Radio Service Co., Inc.
- NEW YORK, N. Y.** Gross Radio, Inc. 51 Vesey St.
- NEW YORK, N. Y.** Harrison Radio Co. 12 West Broadway
- NEW YORK, N. Y.** 100 Sixth Ave.  
Wholesale Radio Service Co., Inc.
- NEW YORK, N. Y.** Terminal Radio Corp. 80 Cortlandt Street
- POTTSVILLE, PENN.** E. Norwegian & George Sts.  
Sylvester Radio & Supply Co., Inc.
- READING, PENN.** George D. Barbey Company 404 Walnut St.
- READING, PENN.** 104 North Ninth Street  
Sylvester Radio & Supply Co., Inc.
- SPRINGFIELD, MASS.** T. F. Cushing 349 Worthington St.
- WASHINGTON, D. C.** 938 F Street, N. W.  
Sun Radio & Service Supply Co.



- ALBANY, NEW YORK** Uncle Dave's Radio Shack 356 Broadway

- BINGHAMTON, NEW YORK** 25-27 Sturges Street  
Radio Testing Station
- CONCORD, NEW HAMPSHIRE** Rear, 80 N. State Street  
Evans Radio
- HARTFORD, CONNECTICUT** 210 Chapel Street  
Stern Wholesale Parts Company
- NEW YORK, N. Y.** Harrison Radio Co. 12 West Broadway
- NEW YORK, N. Y.** Terminal Radio Corp. 80 Cortlandt Street

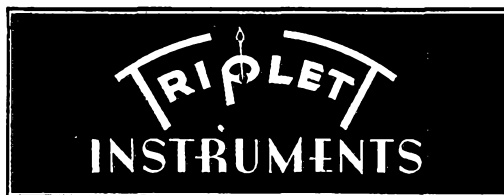

- ALBANY, N. Y.** Uncle Dave's Radio Shack 356 Broadway
- BOSTON, MASS.** Radio Shack 46 Brattle Street
- BOSTON, MASS.** 110 Federal Street  
Wholesale Radio Service Company, Inc.
- BRONX, N. Y.** 542 East Fordham Rd.  
Wholesale Radio Service Company, Inc.
- JAMAICA, L. I.** 90-08 166th Street  
Wholesale Radio Service Company, Inc.
- MONTREAL, CANADA** 285 Craig Street, West  
Canadian Electrical Supply Co., Ltd
- NEWARK, N. J.** 219 Central Ave.  
Wholesale Radio Service Company
- NEW YORK, N. Y.** 100 Sixth Avenue  
Wholesale Radio Service Company
- POTTSVILLE, PENN.** E. Norwegian & George Sts.  
Sylvester Radio & Supply Co., Inc.
- READING, PENN.** George D. Barbey Co. 404 Walnut Street
- READING, PENN.** 104 North Ninth St.  
Sylvester Radio & Supply Co., Inc.
- WASHINGTON, D. C.** 938 F Street, N. W.  
Sun Radio & Service Supply Co.

*quality above all*

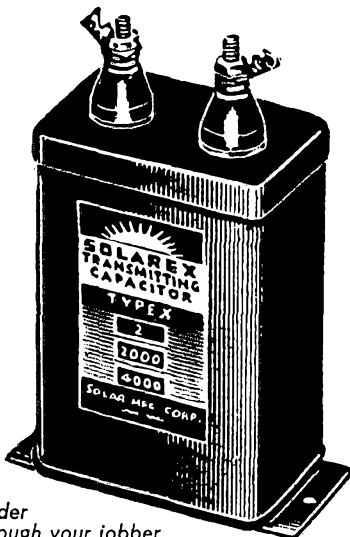

Order  
through your jobber

**SOLAR MFG. CORP.**

599-601 Broadway, New York, N. Y.

**SAVE TROUBLE —**

USE **TRIPOLET**

**POWER LEVEL INDICATORS**

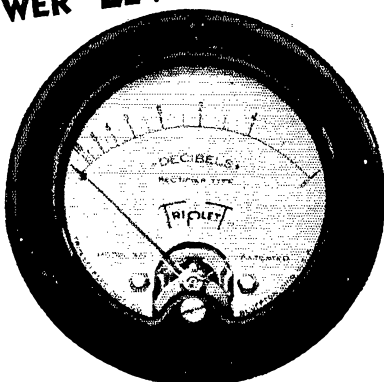

Model 421 — 4" Instrument . . . . \$13.17

Model 321 — 3" Instrument . . . . \$12.00

Standard Calibration

The Triplet Electrical Instrument Co.  
257 Harmon Dr., Bluffton, Ohio

Please send me more information on  
 Triplet Power Level Indicators

Name .....  
Address .....  
City ..... State .....

Ewell K. Jett, chief engineer of the F.C.C., although every member of the delegation, from the chairman to the stencil-cutters, was helpful and splendidly cooperative, and many of them entered the lists and did yeoman service for amateur radio. Other known friends of the amateur, but not particularly articulate, were Canada, Australia, New Zealand, Sweden, Argentina, Brazil, Venezuela, and a very few of the British representatives. Because the membership of the sub-sub-committees was very small, there are many administrations that never had an opportunity to say a word on the amateur subject and of whose attitudes we have no clear knowledge. Definitely and actively hostile to amateur radio must be listed Japan, U.S.S.R., Italy, Switzerland, Germany, Rumania, and most of the French and British representatives. We are inclined to doubt that the Cairo actions of the French and British representatives represent any deep-seated hostility of those administrations; we believe the post offices of those countries have every intention of continuing amateur radio within their own concepts of what is proper for it; but they quite fail to meet our standard of sympathetic friends. The smaller countries of the Americas were generally sympathetic, permitted the U.S.A. to speak for them. The Scandinavian countries, we feel, are also generally sympathetic but did not weigh very heavily and did not often express themselves.

The next conference is to be held at Rome in the spring of 1942. There are many indications that, if war does not intervene, the administrations of some of the major countries in Europe will make a determined effort at Rome to confiscate our long-distance bands. It may be that we are approaching the time when the divergence of philosophies between the Old World and the New will cause radically different provisions for European amateurs than exists in the rest of the world. The Americas from Newfoundland to Magellan, and the British dominions, are the true homes of amateur radio as we know it. In these enlightened democracies we enjoy opportunities to demonstrate the great national value of amateur radio. As a result, our administrations have a proper appreciation of us, an opportunity which itself is generally denied the European amateur. The strength of our position of course resides in our continuing to keep our institution of such nature that it constantly merits the support and encouragement of our governments. We have it largely in our own hands and it is chiefly a matter of our conducting ourselves properly as individual amateurs.

As always on these foreign missions, we met the local amateurs. The SU fellows are a fine bunch of amateurs. Their association, the Experimental Radio Society of Egypt, is a recent addition to the membership of the I.A.R.U. Amateur radio is growing in the Near East, and they include some prime DX men—as the gang on 14 and 28 knows. We are grateful to the officers of the E.R.S.E. for the fellowship of radio amateurs and for many splendid courtesies during our stay in SU.

# HAM-ADS

(1) Advertising shall pertain to radio and shall be of nature of interest to radio amateurs or experimenters in their pursuit of the art.

(2) No display of any character will be accepted, nor can any special typographical arrangement, such as all or part capital letters be used which would tend to make one advertisement stand out from the others.

(3) The Ham-Ad rate is 15¢ per word, except as noted in paragraph (6) below.

(4) Remittance in full must accompany copy. No cash or contract discount or agency commission will be allowed.

(5) Closing date for Ham-Ads is the 25th of the second month preceding publication date.

(6) A special rate of 7¢ per word will apply to advertising which, in our judgment, is obviously non-commercial in nature and is placed and signed by a member of the American Radio Relay League. Thus, advertising of bona fide surplus equipment owned, used and for sale by an individual or apparatus offered for exchange or advertising inquiring for special equipment, if by a member of the American Radio Relay League takes the 7¢ rate. An attempt to deal in apparatus in quantity for profit, even if by an individual, is commercial and all advertising by him takes the 15¢ rate. Provisions of paragraphs (1), (2), (4) and (5) apply to all advertising in this column regardless of which rate may apply.

Having made no investigation of the advertisers in the classified columns, the publishers of *QST* are unable to vouch for their integrity or for the grade or character of the products advertised.

**QUARTZ**—direct importers from Brazil of best quality pure quartz suitable for making piezo-electric crystals. Diamond Drill Carbon Co., 719 Union Bldg., New York City.

**RADIO** engineering, broadcasting, aviation and police radio, servicing, marine and Morse telegraphy taught thoroughly. All expenses low. Catalog free. Dodge's Institute, Byrd St., Valparaiso, Ind.

**QSL'S**, W2SN, Helmetta, N. J.

**QSL'S**, all colors, cartoons, snappy service. Write for free samples today. WIBEF, 16 Stockbridge Ave., Lowell, Mass.

**USED** receivers. Bargains. Cash only. No trades. Price list 3¢. W3DQ, Wilmington, Del.

**CALLBOOKS**—Summer edition now on sale containing complete up-to-date list of radio hams throughout entire world. Also world prefix map, press schedules and new time conversion chart. Single copies \$1.25. Canada and foreign \$1.35. Radio Amateur Call Book, 610 S. Dearborn, Chicago.

**QSL'S**, SWL's, 65¢ hundred, two color. Samples. W1FTM, 268 Piedmont, Waterbury, Conn.

**CRYSTALS**, mounted, 80-160 \$1.25, V-cut 40 \$2.25. R9 Crystals, 338 Murray Ave., Arnold, Pa.

**METER** repair service—d.c. milliammeters: springs \$1.75; new coil \$2.50; new pointer \$1.75. Prices quoted on any repair. Braden Engineering Co., 305 Park Dr., Dayton, Ohio.

**CRYSTALS**: X-cut, 80-160 ± five kilocycles, \$1.50; spot frequency, \$2.50. Special prices to Army, Navy, Red Cross and other round table nets. Three small, 80 meter blanks, including carborundum, \$1.20. Holders, \$1. William Threm, W8FN, 3071 Moosewood St., Cincinnati, Ohio.

**QSL'S**. Cuts. Cartoons. Free samples. Theodore Porcher, 7708 Navahoe, Philadelphia, Penn.

**NEW** NC100X and 500 watt phone complete, \$200. 3 k.v.a. alternator, 75; 7½ k.v.a., \$150.; 24-1500 volt dynamotor, \$15. W5EZF, Alva, Okla.

**SELL** home-built SS Super 8 tubes complete, \$15. W2GNW, Little Falls, N. J.

**WANTED**: Cootie-key commercial sideswiper. W3MG, Oread, Penn.

**ACR-175** receiver, \$50.; perfect condition; need cash. W9ZMY, Minneapolis, Minn.

**SELL**, swap surplus equipment. Eimac tubes, etc. List. Want Model 650 Weston exposure meter. W8PH.

**WILL** trade doctor's diagnostic set for amateur receiver. L. Reiss, 1230 Park Ave., N. Y. C.

**BLILEY** W8DED.

**QSL'S**, **QSL's**. Stamp for samples. W8DED, Holland, Mich.

**FOR** sale: five tube s.w. receiver complete, \$20. Write for details. James Fleetwood, Jr., Galva, Iowa.

**SELL** new Esco motor generator 110/220 volt 60 cycle to 1,000 volts 150 miles plus 12 volts 6.25 amps., rheostat, \$50. RCA and W.E. condenser-mikes with tubes and cables, \$25. WBBR, Brooklyn, N. Y.

**QSL** cards, neat, attractive, reasonably priced. Samples free Miller, Printer, Ambler, Penn.

**METERS**: Brand-new Jewell 3" bake, cased meters. Patt. 88 0-300, 500 microamps, 1 ma., \$3.50. 0-1.5-750 ma., \$3. Patt 88 R.F. 0-100 ma.-20 amps., \$6. W2CXY, Hillside, N. J.

**ATTEND** the Asheville, North Carolina Hamfest July 2.

**BARGAIN**: best cash offer or microscope immediately takes 400 watt phone-c.w. transmitter, receiver, and surplus. Write. W9APJ, 2401 E. Solway, Sioux City, Iowa.

**DOUGLAS** modulation transformers match all tubes. 50 watts audio, \$4.95 pair. 100 watts audio, \$7.75 pair. Guaranteed. Postpaid in U. S. For details write W9IXR, Rice Lake, Wis.

**BARGAIN**: 300 watt c.w. 20 meter or suppressor grid modulated phone in 4 ft. rack uses 807 and two 803's, \$125. Breting 14 receiver, \$70. W2KBX—W2LGA.

**QSL'S**. Free samples. Printer, Corwith, Iowa.

**TRADE** QST excellent condition from April, 1924. Cash or good receiver. Gossett, Greenwood, Ind.

**QSL'S** printed—samples—W2AEY.

**BRUSH** 12 cell broadcast mike—brand-new in factory carton. Sacrifice for cash. W9WPP, Auburn, Ind.

**QSL'S**. Free samples. New address—Maleco, 1805 St. Johns Place, Brooklyn, N. Y.

**SELLING** out—send stamp for list. Southwick, 1176 County, Somerset, Mass.

**TELEPLEXES**, instructographs, omnigraphs, vibroplexes bought, sold. Ryan's, Monroe City, Mo.

**PRINT** any picture on QSL's from your negative in two minutes—complete outfit, \$1. W2KRZ.

**WANTED**: recording equipment. Fulleylove, Central Drive, Port Washington, N. Y.

**ANTENNAS**. 102 pages antenna dope. Practical, understandable. Many arrays, directives, multibands. Complete tables eliminate calculations. Radio Antenna Handbook, continental U. S. A., 75¢; elsewhere, 85¢. Radio, 7460 Beverly, Los Angeles.

**WANTED**: Collins transmitter—30FXC, 30J or other types. Also transceiver or mobile equipment. Give details. W9GLR, Mason City, Iowa.

**COMPLETE** 20 meter phone, push-pull T20S final and 6L6 modulators. Prefer selling to amateur who can come and see it and make cash offer. W1CHB.

**TILTING** beam rotary gives you complete control of your angle of radiation. Feeds thru bearing. Worm drive. Dazzle 'em with a rack, panels, special deep chassis. W8ML.

**WANT** modern 100-150 watt output all-band phone-c.w. transmitter. W2FG.

**WANTED**: receiver—cash. Brookes, 40 S. Broad, Battle Creek, Mich.

**GOT** HRO for a gift. Will sell my Hammarlund Comet Pro xtal AVC model with tubes—excellent condition. First \$50. takes it. W9HBG, 1509 Runyon Ave., Ft. Wayne, Ind.

**QSL'S**—\$1.80 for 300. W8DGH.

**SELL** or trade: 250 watt fone, rack, panel transmitter. R.F. 802, 802a parallel, T55a final; audio 4-46a Class B modulators. Rectifier 4-866 bridge, 1000v-2000v-400ma. WAS photos. Take \$200. Want sound on film recorder, Presto, Universal recording outfit. Unit f.o.b. W9KHC, 1239 Kinsmoor Ave., Ft. Wayne, Ind.

**SELL**: National SW5 complete, good condition—best offer. W2BZB.

**W2CR** wants movie equipment. Sell, swap receivers, parts, sound systems.

**WANTED**: National type N dials. W2GYA.

**NO** mass production but every Eidson T9 crystal is carefully finished and tested to the Nth degree for peak performance; therein lies the secret. High activity type, fracture resisting X-cut; 40 and 80 meter bands, \$1.60, 7301-7500 kc. range \$2. Low-loss T9 ceramic holders, \$1.10. Prices postpaid, c.o.d.'s accepted. Fully guaranteed. Prompt shipment. Various types of fine commercial crystals supplied on order, inquire. Sold by: Pemberton Labs., Ft. Wayne, Ind.; Southwest Radio Supply, Dallas, Texas; Van Radio, 464 E. 117th No. 7, Cleveland, Ohio; Henry Radio Shop, Butler, Mo.; The Hargis Co., Austin, Texas; Hieronymus Radio, 88-34 209th St., Queens Village, N. Y.; or Eidson's, Temple, Texas.

**QSL'S**, SWL's. 100-3 color—75¢. Lapco, 344 W. 39th, Indianapolis, Ind.

**LONGLINES** oscillator. Beautiful workmanship, powerful, stable, efficient, inexpensive. Also non-radiating super-regenerative receiver with preselection. Free bulletins for your QSL. Paradio, 124 Garrison, Jersey City.

**QSL'S**—highest quality—lowest prices. Radio Headquarters, Ft. Wayne, Ind.

**MAGIC** Boy compressor, \$7.95. Increase effective DX as much as 37%. Work maximum undistorted modulation continuously. Complete kit parts including transformers, \$2, with order, balance c.o.d. Information upon request. Great Western Radio Eng. Co., Box 5661, Metropolitan Sta., Los Angeles, Calif.

LISTEN for high frequency broadcast station W9XA, Kansas City, 26,450 kilocycles.

WHEN buying amateur equipment whether you pay cash, trade equipment, or buy on terms it's to your advantage to write me. I finance time sales myself so you can buy with less cost and bother, with only 6% interest. Your inquiries invited. Bob Henry, W9ARA, Butler, Mo.

RECONDITIONED guaranteed sets shipped on ten day trial: HROs \$129.70, RME-69s \$99., NC100s \$79., PR-15s \$79., SX10 Ultra-Skyriders \$69., RME9Ds \$59., PR-16Cs \$59., Breting 12s \$59., PR-10s \$34., McMurdo Silver 5Cs \$29., FB7Xs \$25., FB7s \$19., Super-Skyriders \$19., Sky-Buddies \$19., SW3s \$9., many others. List free. You can buy these sets on Bob Henry's easy 6% terms. W9ARA, Butler, Mo.

HARVEY 80-T \$99., Collins 30FXB \$199., other transmitters. W9ARA.

BRAND new Sky Chiefs in factory sealed cartons, \$29. W9ARA.

IN stock: the new National exciter units and 600 watt transmitters on terms. W9ARA.

CRYSTALS: 80M spot frequency nets. Lots not less than four AT-cuts, mounted, within .03%, \$2.25 each. Ham Crystals, 1104 Lincoln Place, Brooklyn, New York.

WANTED: RCA-906. Will trade transmitting tubes. W2DBQ.

WHAT is offered for complete US School of Music piano course? Cash or parts. W2DBQ.

FOR sale: modern high fidelity radio broadcasting transmitter, 100-250 watts. Approved by F.C.C. under Rule 132. Complete a.c. operation, Class B modulation. Special price—send for photo. WHBI, Newark, N. J.

COAXIAL line specials. New improved designs. Hundred feet type CTL half db ten meters. Circular. Eastern Technical Service, Oriskany, N. Y.

AMATEUR radio licenses, home study course in code and theory—reasonable, efficient, and thorough. Results guaranteed. American Radio Institute, 1430 N. Dearborn Parkway, Chicago, Ill.

NEW and used receivers. W8ANT.

TRANSMITTER headquarters. W8ANT.

ALL lines of new and used amateur equipment bought, sold, exchanged. Write to Southern Ohio's only amateur owned amateur business. Jos. N. Davies, W8ANT, 2767 N. Bend Rd., Sta. A., Cincinnati, Ohio.

QSL—SWL bargains. Fritz, 455 Mason, Joliet, Ill.

WANT transmitter Collins only .30FXC or better; will swap new Leica, Contax or any still or movie camera projector—also 30FXB toward swap. W2GJR.

QSL'S. Better designs; better stock; better workmanship; and—better prices for you. W2FJE, 101 Hanson Place, Brooklyn, N. Y.

VIBROPLEX No. 6 in case. Never used. W9HEN, Anoka, Minn.

NEW crackle enamels. Campbell Specialties Co., Ann Arbor, Mich.

IPS rubber crystal, QSY remotely, varies completely 180 to 10 meters. Approximately 20 watts output, \$19.80. Radio Apparatus Mfg., 1522 N. Clark, Chicago, W9IPS.

WANTED: following copies of Proceedings of I.R.E.: Vol. 13, No. 1, Feb., 1925; Vol. 24, No. 7, July, 1936; Vol. 24, No. 8, August, 1936. A.R.R.L., West Hartford, Conn.

FOR sale: 278 Radio Engineers Lab. receiver, complete, a.c. or d.c., \$30. Carolan, Marmarth, N. D.

## LEARN RADIO

### — TELEVISION —

500 Licensed graduates placed in past 7 years in shipping, broadcasting, aviation, police, etc., we also teach radio servicing and repairing; new term Mar. 14, May 9, day or eve., 52-page catalog free; oldest, largest and best equipped.

## MASS. RADIO SCHOOL

18 Boylston Street, Boston

G. R. Entwistle, Pres.  
Established 1899

R. F. Trop, Treas.  
Hancock 8184

## You'll REALLY Enjoy CW,

WHEN YOU

## LEARN CODE THE CANDLER WAY!

TAKE A TIP FROM THE CHAMPIONS!

If you think you're enjoying your CW — wait until you've practiced the Candler way for a few weeks! Suddenly you'll notice it's no longer an effort to read a speedy operator, your sending becomes faster, more rhythmic — you'll find yourself reading words — yes, even sentences, without strain or conscious effort — as easy as you read print.

Months, even years, of undirected practice won't help, — you need the skilled mental training, that automatic sound sense that Candler gives you, to develop the speed you're really capable of. And, you'll be amazed at your rapid progress, too! Ask any skilled operator. Read what the champions say in your copy of the FREE BOOK OF FACTS. Send for it today!

SEND FOR FREE  
"Book of Facts"



**CANDLER**  
SYSTEM COMPANY

Dept. Q-7, ASHEVILLE, NORTH CAROLINA, U.S.A.

**RADIO POSITIONS** There are good positions waiting for good-type, well-trained men in radio... There are good opportunities for fine futures... but an advanced COMPLETE ACTUAL PRACTICAL TRAINING... as well as high type theory... is essential. Free Bulletin on Positions, Futures and Training.

Frank C. Jones Lecturers Arthur Halloran  
Author "Radio Handbook" Author "Cath. Ray & Tel."

**PACIFIC RADIO SCHOOL**

Dept. A, 735 Larkin Street San Francisco, Calif.

## PRECISION CRYSTALS



Crystal Holder

Highest quality crystals, one inch square, carefully ground for frequency stability and maximum output. Be sure of your transmitter frequency — use PRECISION CRYSTALS.

Crystals can be furnished with square holder as illustrated (fits G.R. type jacks) or with round holder to plug into tube socket. When ordering be sure to state the type holder desired. G.R. jacks to plug illustrated holder into — 15¢ pair.

Low frequency drift crystals (Type LTC) supplied within 0.1% of your specified frequency and calibrated to within 0.03% are priced as follows: 1750, 3500 and 7000 kc. bands \$3.50 each. Holder \$1.00. (State type desired.)

\*X\* cut PRECISION Crystals carefully ground for maximum power supplied within 0.1% of your specified frequency and calibrated to within 0.03% are priced as follows: 1750, 3500 and 7000 kc. bands — \$3.00 each. Holder \$1.00. (State type desired.)

\*AT\* cut crystals for commercial use quoted on at your request. When ordering our product you are assured of the finest obtainable. Now in our ninth year of business.

**PRECISION PIEZO SERVICE**

427 Asia Street Baton Rouge, La.

# Your Nearest Dealer Is Your Best Friend

Your nearest dealer is entitled to your patronage. You can trust him. He is equipped with a knowledge and understanding of amateur radio. He is your logical and safe source of advice and counsel on what equipment you should buy. His stock is complete. He can supply your needs without delay. His prices are fair and consistent with the high quality of the goods he carries. He is responsible to you and interested in you.

Patronize the dealer nearest you—You can have confidence in him

## ATLANTA, GEORGIA

Wholesale Radio Service Company, Inc.  
265 Peachtree Street  
"The World's Largest Radio Supply House"

## MONTREAL, CANADA

Canadian Elec. Supply Co., Ltd.  
285 Craig St., W.  
Quality parts and equipment for discriminating buyers

## BALTIMORE, MARYLAND

Radio Electric Service Co.  
3 N. Howard St.  
Everything for the amateur

## NEWARK, N. J.

Wholesale Radio Service Company, Inc.  
219 Central Avenue  
"The World's Largest Radio Supply House"

## BOSTON, MASS.

Wholesale Radio Service Company, Inc.  
110 Federal Street  
"The World's Largest Radio Supply House"

## NEW YORK, N. Y.

Gross Radio, Inc.  
51 Vesey Street  
Fair dealings plus fair prices. Anything in radio (

## BRONX, NEW YORK

Wholesale Radio Service Company, Inc.  
542 East Fordham Road  
"The World's Largest Radio Supply House"

## NEW YORK, N. Y.

Wholesale Radio Service Company, Inc.  
100 Sixth Avenue  
"The World's Largest Radio Supply House"

## BUFFALO, NEW YORK

Dymac Radio  
216 E. Genesee Street  
Ham and BCL Equipment W8RRL, W8OLB, W8GJ Cl. 2080

## NEW YORK, N. Y.

Harrison Radio Company  
12 West Broadway  
"The Friendly Ham Supply House"

## BUFFALO, NEW YORK

Radio Equipment Corp.  
326 Elm Street  
W80BK — Ham, service and sound equipment

## PHILADELPHIA, PENNSYLVANIA

Eugene G. Wile  
10 S. Tenth Street  
Complete Stock of Quality Merchandise

## ELMIRA, NEW YORK

Miller's Radio Shack  
205 Railroad Avenue  
Fine equipment for amateurs

## RICHMOND, VIRGINIA

The Arnold Company  
Broad at Harrison St.  
W3EQQ—"The Virginia Ham Headquarters"—W3FBL

## JAMAICA, L. I.

Wholesale Radio Service Company, Inc.  
90-08 166th Street (Merrick Road)  
"The World's Largest Radio Supply House"

## ROCHESTER, NEW YORK

Radio Parts & Equipment Co.  
244 Clinton Avenue, North  
Complete stock amateur-BCL parts. Standard discounts

# You Are Protected When You Buy From QST Advertisers

“Advertising for QST is accepted only from firms who, in the publisher’s opinion, are of established integrity and whose products secure the approval of the technical staff of the American Radio Relay League.”

Quoted from QST’s advertising rate card.

Every conceivable need of a radio amateur can be supplied by the advertisers in QST. And you will know the product has the approval of the League’s technical staff.

## The Advertisers

A. B. C. Dielectrics Company	103
Acme Electric & Mfg. Company, The	103
Astatic Microphone Laboratory, Inc.	98
Birnback Radio Company, Inc.	102
Bliley Electric Company	72, 102
Burgess Battery Company	99
Candler System Company	108
Capitol Radio Engineering Institute	101
Cardwell Mfg. Corp., Allen D.	80
Centralab	75
Collins Radio Company	Cov. 2
Cornell-Dubilier Corp.	94
Dodge’s Institute	98
Eastern Radio Institute	92
Eitel-McCullough, Inc.	77
Gardiner Levering Company	101
Gross Radio, Inc.	88
Hallcrafters, Inc., The	1, 2
Hammarlund Mfg. Company, Inc., The	73, 78
Harvey Radio Company	100
Harvey Radio Laboratories, Inc.	74
Heintz & Kaufman, Ltd.	97
Henry Radio Shop	103
Hipower Crystal Company	97
Howard Radio Company	95
Instructograph Company	102
International Resistance Company	79
Isolantite, Inc.	93
Jacobs, Charles F.	101
Kato Engineering Company	97
Ken-Rad Tube & Lamp Corp.	97
Kenyon Transformer Company, Inc.	5
Logan Company, Les.	101
Mallory & Company, Inc., P. R.	68
Massachusetts Radio School	108
McGraw-Hill Book Company	84
National Company, Inc.	Cov. 3, 67, 101
National Carbon Company, Inc.	89
Newark Electric Company	85
Ohmite Manufacturing Company	94
Pacific Radio School	108
Port Arthur College	103
Precision Piezo Service	108
RCA Institutes, Inc.	97
RCA Manufacturing Company, Inc.	Cov. 4, 76
Radio Mfg. Engineers, Inc.	83
Radio Supply Company	96
Radio Transceiver Laboratories	103
Raytheon Production Corp.	69
Scientific Radio Service	102
Selectosphere Company	101
Sickles Company, F. W.	101
Solar Mfg. Corp.	105
Sun Radio Company	104
Taylor Tubes, Inc.	81
Teleplex Company	92
Terminal Radio Corp.	96
Triplet Electrical Instrument Co., Inc.	106
United Transformer Corp.	111, 112
Utah Radio Products Corp.	92
Warren Radio Company	98
Western Electric Company	82
Yaxley	68



# Popular Priced TRANSMITTER and AMPLIFIER KITS

This new series of kits represents the acme in kit value. The circuits are efficient, stable and easy to wire. Large etched plates and modern panel layouts lend beauty to the slate gray crinkle finish of the chassis, transformers, and cabinets.

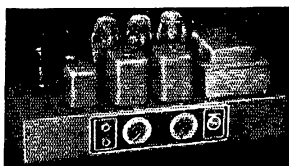

## S-15A AUDIO AMPLIFIER

The S-15A audio amplifier is an ideal kit for PA and modulator service. The power output is 15 watts and the gain sufficient for crystal mike service. Dual input — high or low gain, and tone control are incorporated. Tubes required are one 6J7, one 6C5, two 6V6G's and one 83. The kit is supplied completely mounted, ready to wire, including accessories, less dust cover and tubes.

**Amateur Net Price . . . . . \$24.00**

Kit as above but with universal modulation transformer in place of voice coil output, use kit No. S-15M.

**Amateur Net Price . . . . . \$24.00**

Dust cover for above amplifiers, type S-15D. **Amateur Net Price . . \$1.50**

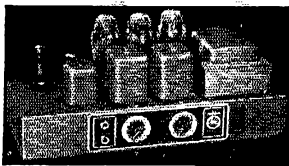

## S-25A AUDIO AMPLIFIER

The S-25A audio amplifier has been designed for high power PA and medium power modulator work. 25 watt output is provided with gain sufficient for crystal mike. Dual high impedance input — high or low gain, and tone control are provided. Tubes required are one 6J7, one 6C5, two 6L6's and one 83. The kit is supplied completely mounted and ready to wire, including all accessories and dust cover, less tubes.

**Amateur Net Price . . . . . \$30.00**

Kit as above but with universal modulation transformer in place of voice coil output, use kit No. S-25M.

**Amateur Net Price . . . . . \$30.00**

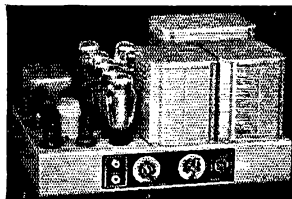

## S-100 AUDIO AMPLIFIER

The S-100 audio amplifier is an ideal low priced high power unit. 100 watt output is provided with gain sufficient for crystal mike. Dual input and tone control is provided and universal modulation output transformer. Tubes required are one 6J7, one 6C5, two 6F6's, four 6L6's and three 83's. The kit is supplied completely mounted, ready to wire, including all accessories, less tubes and dust cover.

**Amateur Net Price . . . . . \$52.50**

Kit as above with PA output transformer for universal voice coil impedance, use kit No. S-100PA.

**Amateur Net Price . . . . . \$55.00**

Cabinet for above to match SX-80 and SX-200. No. S-100C.

**Amateur Net Price . . . . . \$3.75**

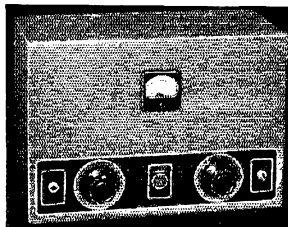

## SX-25

The UTC SX-25 kit represents unprecedented value in a low power transmitter. It employs a crystal controlled oscillator of high power output and stability and will operate on all bands from 160 to 10 meters. Tubes required are one 6L6G and one 83. The unit is supplied completely mounted with self-contained power supply and antenna tuning condenser, ready to wire, including cabinet and all accessories, less meter, tubes and crystal.

**Amateur Net Price . . . . . \$18.00**

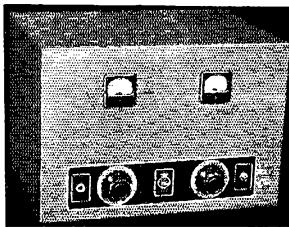

## SX-80

The UTC SX-80 kit is a complete 80 watt CW unit. Operation on all bands is obtainable with plug-in coils. A rugged power supply is provided. The kit may be used as a complete 80 watt CW unit or as an exciter for a high power final. Tubes required are three 6L6G's and one 83. This unit is supplied completely mounted, ready to wire, including cabinet and accessories, less meters, crystal and tubes.

**Amateur Net Price . . . . . \$37.50**

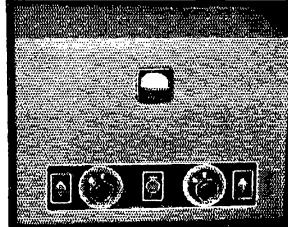

## SX-200

The UTC SX-200 transmitter kit is used in conjunction with the SX-80 or any similar exciter having a power output of 40 watts or more, to form a complete 300 watt CW transmitter. When supplemented by the S-100 modulator it becomes a 200 watt phone transmitter. It will operate on all frequencies up to 30 megacycles and incorporates a highly efficient power supply. Tubes required are two 866A's and four 809's. This unit is supplied completely mounted, ready to wire, including cabinet and accessories, less meter, crystal and tubes.

**Amateur Net Price . . . . . \$43.50**

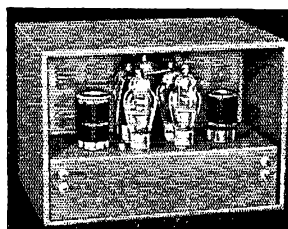
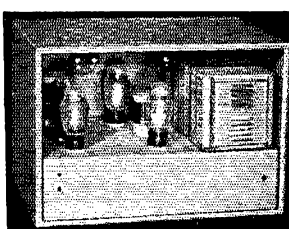
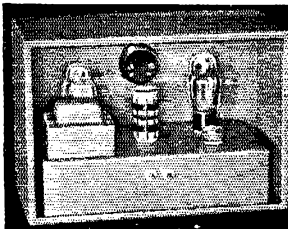

46 BRATTLE ST. **THE RADIO SHACK** BOSTON, MASS.

**UNITED TRANSFORMER CORP.**

# New SERIES of TRANSFORMERS designed specifically for AMATEUR and PA EQUIPMENT

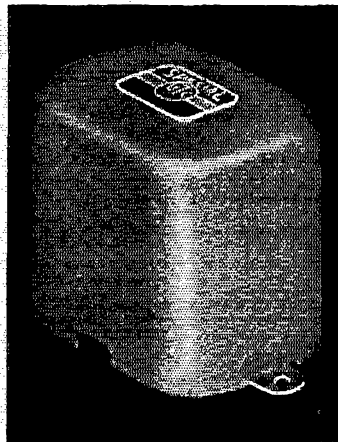

Maximum Value at Low Cost

## FILTER, SWINGING, AND AUDIO CHOKES

Type No.	Service	Inductance	Current	Resistance	Net Price
S-23	Audio P.P.	500 Hy.	5 Ma.	6000 ohms	\$1.35
S-24	Choke C.T.	500 Hy.	3 Ma.	4000 ohms	1.50
S-25	Filter	30 Hy.	30 Ma.	900 ohms	1.20
S-26	Filter	15 Hy.	60 Ma.	230 ohms	1.20
S-27	Filter	30 Hy.	75 Ma.	350 ohms	1.65
S-28	Filter	20 Hy.	100 Ma.	350 ohms	1.65
S-29	Filter	10 Hy.	175 Ma.	95 ohms	1.65
S-30	Swinging	5/25 Hy.	175 Ma.	95 ohms	1.65
S-31	Filter	20 Hy.	225 Ma.	120 ohms	2.10
S-32	Swinging	5/25 Hy.	225 Ma.	120 ohms	2.10
S-33	Filter	20 Hy.	300 Ma.	90 ohms	3.00
S-34	Swinging	5/25 Hy.	300 Ma.	90 ohms	3.00
S-35	Filter	20 Hy.	400 Ma.	85 ohms	3.90
S-36	Swinging	5/25 Hy.	400 Ma.	85 ohms	3.90
S-37	Filter	20 Hy.	550 Ma.	60 ohms	5.40
S-38	Swinging	5/25 Hy.	550 Ma.	60 ohms	5.40

## UNIVERSAL DRIVER TRANSFORMERS

(See Modulator chart for tube types)

Type No.	Application	Net Price
S-8	Single driver plate to pushpull grids	\$1.65
S-9	Pushpull driver plates to grids of class B tubes up to 400 watts output.	2.25
(S-10)	Pushpull 56, 6C6 triode, 6CS, or similar plates to 45's, 2A3's or 6L6's, self or fixed bias.	2.10

## UNIVERSAL BIAS TRANSFORMERS

Primary 115 V. — 50/60 Cycles  
No Filament Windings

Type No.	Application	DC Current	Net Price
S-51	Will supply any bias voltage from 15 to 100 volts DC within approximately 6% of desired value. (See chart.)	200 Ma.	\$3.00
S-52	Will supply any bias voltage from 75 to 400 volts DC within approximately 6% of desired value. (See chart.)	200 Ma.	4.20

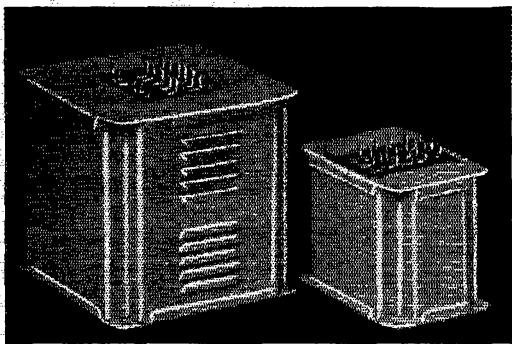

## UNIVERSAL OUTPUT TRANSFORMERS

Any modulator tubes to any RF load. (See chart)

Type No.	Audio Power	Net Price
S-18	12 watts	\$2.10
S-19	30 watts	2.85
S-20	55 watts	3.90
S-21	110 watts	6.00
S-22	250 watts	8.40

## SINGLE SECONDARY FILAMENT TRANSFORMERS

Primary Tapped 105, 115 Volts — 50/60 Cycles

Type No.	Secondary Volts	Secondary Current	Insulation	Net Price
S-53	2.5 VCT	10 A.	1500 V.	\$1.35
S-54	5 VCT	4 A.	2500 V.	1.35
S-55	6.3 VCT	3 A.	1500 V.	1.35
S-56	7.5 VCT	3 A.	1500 V.	1.35
S-57	2.5 VCT	10 A.	10,000 V.	1.80
S-58	2.5 VCT	20 A.	10,000 V.	2.40
S-59	5 to 5.25 VCT	13 A.	5000 V.	2.10
S-60	5 to 5.25 VCT	22 A.	10,000 V.	4.50
S-61	7.5 VCT tapped	8 A.	3000 V.	2.10
S-62	10 VCT	10 A.	3000 V.	2.40
S-63	12 VCT and 14 VCT	10 A.	5000 V.	4.50

## MULTIPLE SECONDARY FILAMENT WINDINGS

Primary Tapped 105, 115 Volts — 50/60 Cycles

Type No.	Fil. 1	Fil. 2	Fil. 3	Insulation	Net Price
S-64	2.5 VCT-5A	2.5 VCT-5A	5 VCT-6A	3000 V.	\$2.40
S-65	2.5 VCT-5A	5 VCT-4A	6.3 VCT-3A	3000 V.	2.40
S-66	2.5 VCT-10A	7.5 VCT-8.5A		3000 V.	2.40
S-67	5 VCT-6A	6.3 VCT-5A		3000 V.	2.40
S-68	6 VCT-3A	6.3 VCT-4A	7.5 VCT-5A	3000 V.	2.70
S-69	6.3 VCT-3A	7.5 VCT-8.5A		3000 V.	2.70
S-70	6.3 VCT-5A	6.3 VCT-5A		3000 V.	2.70
S-71	2.5 VCT-6A	2.5 VCT-6A	2.5 VCT-12A	10000 V.	4.50
S-72	5 VCT-3A	5 VCT-3A	5 VCT-6A	5000 V.	3.00

# UNITED TRANSFORMER CORP.

72 SPRING STREET

NEW YORK, N. Y.

EXPORT DIVISION 100 VAN DYKE STREET NEW YORK, N. Y. CABLES: UATLAF

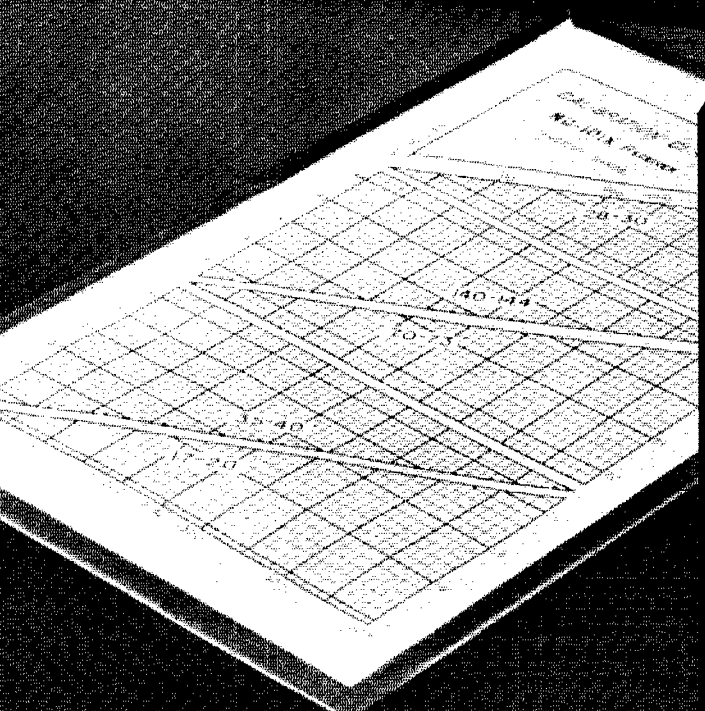

## NC-101X

Every detail of the NC-101X is expressly designed for amateur communication receiver use. Its high precision micrometer dial, calibrated like a fine instrument, is typical of the comprehensive specialization that makes the performance of the NC-101X so outstanding.

**P**  
**R**  
**E**  
**C**  
**I**  
**S**  
**I**  
**O**  
**N**

AVC

# TOPS!..

## FOR HAM SERVICE!

..the RCA

# 806

USE THE RCA-806 for that big job. Its new totally enclosed tantalum anode provides improved efficiency and performance, especially for the higher-frequency amateur bands. The new anode eliminates loss of input power resulting from bulb bombardment and stray electrons. At 30 megacycles this improved construction provides the user with approximately 75 additional watts of useful power per tube.

The RCA-806 is designed to operate at maximum ratings at frequencies as high as 30 megacycles. No effort has been spared to make this tube a leader in performance and quality. High power rigs will be tops with the RCA-806.

For Class C Telegraphy

Maximum Plate Voltage 3000 volts

Maximum Plate Dissipation 150 watts

See your TT3 Manual for complete ratings and operating data.

Have you a copy of our "Air-cooled Transmitting Tube Manual" TT3? If not, ask your distributor, or send 25c to RCA Manufacturing Company, Inc., Harrison, N. J.

RCA presents the Magic Key every Sunday, 2 to 3 P. M., E. D. T., on the NBC Blue Network

\$22<sup>00</sup>

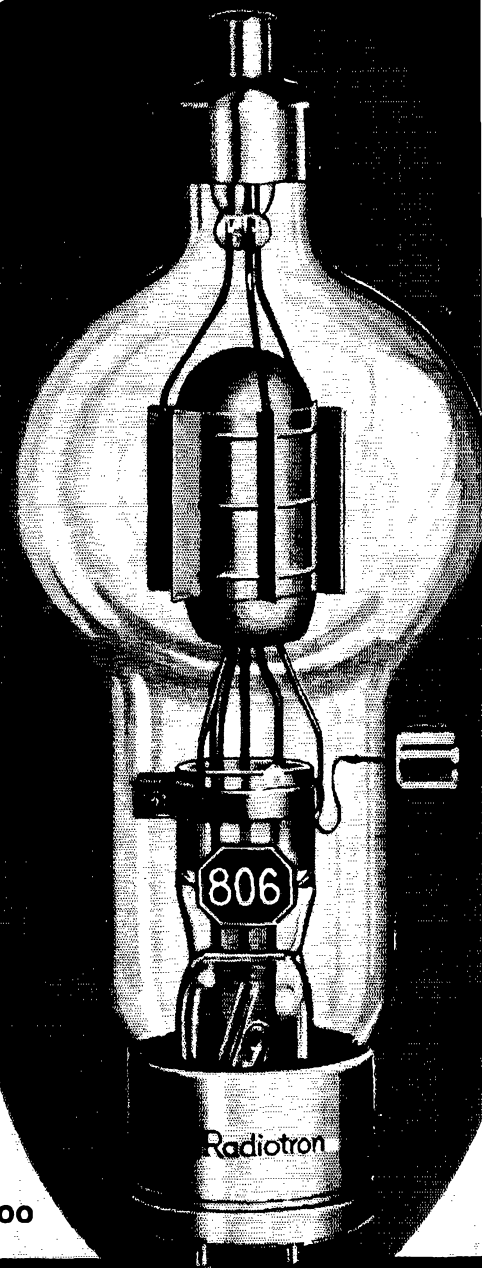

## Radio Tubes

FIRST IN METAL  
FOREMOST IN GLASS  
FINEST IN PERFORMANCE

RCA MANUFACTURING CO., INC., Camden, N. J. • A Service of the Radio Corporation of America